

THIS ISSUE 450,000 COPIES

# POPULAR MECHANICS MAGAZINE

WRITTEN SO YOU CAN UNDERSTAND IT



Copyright

# \$767 Buys The Material

## BUILD TO STAY

## QUALITY ECONOMY SERVICE

## THE HARRIS WAY



The Harris Way includes all that is practical and desirable in modern building methods, in addition to many original and exclusive features. The excellence of our materials *Sensibly Cut-to-Fit*; the completeness and correctness of our plans and specifications; the Harris Service and Harris Economy;—they all make the HARRIS WAY the most perfect modern building method.

*Sensibly Cut-to-Fit* is the keystone in the Harris Way. It means Simplicity with Quality, Economy and Service. To most men building operations are a puzzle, but the Harris Way is acknowledged by builders everywhere to be the most helpful and efficient building system.

In a quarter century of constant study and practical building experience we have brought the Harris Way to its present efficiency and perfection. To learn the interesting history of our business and to get the details of our building methods, send the coupon for our new free Plan Book of Harris Homes, Number EC7.

### No Money Down

We ship your material in one quick shipment from our Chicago factory. You have the privilege of inspecting every piece before you accept it.

For our liberal terms and absolute binding guarantees get our new free Plan Book of Harris Homes, Number EC7.



### Free Book of Harris Homes

Before building you should see our latest designs of new standard American homes. There are over one hundred of them in this free book and in addition you will find much valuable information for every builder. Send the coupon below today for your free copy of Plan Book EC7. If interested in building materials ask for our other free catalogues mentioned in the coupon.

### The House Above

is Harris Home Design No. 161. Six rooms and bath, etc. 26 ft. by 30 ft. A thoroughly modern American Home in every respect.

We furnish clear and knotless lumber in all exposed places, clear millwork, beautiful hardware and all material in harmony with the design.

# Harris Brothers Co. 35<sup>TH</sup> & Iron Sts. Chicago, Ill.

SEND THIS COUPON— H. B. CO. DEPT. EC7. MAIL ME FREE THE BOOKS CHECKED X  
PLAN BOOK ROOFING BOOK PLUMBING MILL WORK

NAME

ADDRESS

# Victor Records



*The superb interpretations of  
artists famous in the world of song*

Victor Records bring you not only the actual living voices of the world's greatest opera stars, but the art and personality of concert singers famous the country over.

These talented artists who charm thousands of music-lovers on their concert tours are also the delight of countless other thousands who know them mainly through their Victor Records.

Victor Records are the actual artists absolutely true to life—ever ready to entertain any one at any time.

There are Victor dealers in every city in the world who will gladly give you a complete catalog of the more than 5000 Victor Records and play any music you wish to hear.

Important warning. Victor Records can be safely and satisfactorily played only with *Victor Needles or Tungs-tone Stylus* on Victors or Victrolas. Victor Records cannot be safely played on machines with jeweled or other reproducing points.



**Victor Talking Machine Co.**  
Camden, N. J., U. S. A.  
Berliner Gramophone Co., Montreal  
Canadian Distributors

New Victor Records demonstrated at all dealers on the 28th of each month

This One



ZXOY-NN4-3WQR

"My attention was first drawn to Cypress several years ago by using some of it for dahlia stakes, along with some ..... etc. and after the ..... had rotted away the Cypress showed no sign of decay. Since then I have used it for boats and canoes and it has been very satisfactory."

(Signed) C. E. ROBBINS

4 Vanden Bosch Avenue,  
Auburn, New York.

THIS IS A SMALL MATTER, BUT IT IS WORTH WHILE  
TO LISTEN TO THE EXPERIENCE OF OTHERS.

Lumber Note— Dress Goods, Cattle, Real Estate, Bonds and Confectionery are bought by the initiated only by careful specification of just what is wanted. Why should not building materials be purchased with equal care? Often a certain kind of lumber is used in a given case where some other kind of wood might be better. The only economic security for the buyer is to know as much as possible about the comparative values of the various species of wood for given uses. The fact that "the wood eternal" (scientifically known as Cypress) is so much the best for so many uses by no means proves that it is best for all. The manufacturers of Cypress lumber take the broad view that the best interest of the actual user of their product is not only a matter of ethics but is also the best sort of merchandising policy for themselves. It is better for *you* to learn than to experiment. The Editor of the Cypress Pocket Library will gladly advise, on matters large or small, if you will address him in care of Popular Mechanics.

*Please Mention Popular Mechanics*

# Popular Mechanics Magazine

6 N. Michigan Avenue, Chicago, U. S. A.

EDITED BY H. H. WINDSOR

England: The International News Co.,  
5 Breams Bldg., Chancery Lane, London, E. C.

Australia:  
The Australasian News Co.

ISSUED MONTHLY

SUBSCRIPTION:

SINGLE COPY, 15 CENTS

In United States, and its possessions, Cuba and Mexico, per year, postpaid . . . . . \$1.50  
To Canada . . . . . 1.75  
To all other countries in the Postal Union . . . . . 2.50

All subscriptions are discontinued at expiration. Please examine the date printed on your wrapper.

Entered as Second Class Matter Sept. 15, 1903, at the Post Office at Chicago, Illinois, under Act of March 3rd, 1879.  
Entered as Second Class Matter at the Post Office Department, Canada.

Published monthly by POPULAR MECHANICS CO.

Copyright, 1916, by H. H. WINDSOR.  
Copyright, in France.

## Contents for March, 1916

Accident, Unusual Motor, When Bridge Opens..	388	Eye Shield, Teaching of Touch System Aided by.	346
Aeroplane Stabilizer That Took French Prize..	400	Fabrics, Apparatus Tests Strength of Various...	426
Aeroplanes, Powerful Battle, Designed for Allies	324	Ferry Uses Chains as Guide across River.....	352
Amusement Park, Model, is Made from Scrap		Filing Cabinet, Steel, is Given Severe Test.....	408
Paper .....	404	Film Box, Fireproof, Has Automatic Lock.....	405
Animals, Simple Execution Chest for.....	407	Filter Rings, Rubber, Have Special Advantages.	434
Annexation of Territory Gives City Odd Shape..	361	Fingers, Maimed, Repairing by Growing New	
Apple Grader Sorts Fruit Rapidly.....	430	Tissue .....	394
Army Transports, Would Make Two Colliers		Fire Alarm, Compressed Air Actuates New Type	
into .....	365	of .....	399
Automobile Costs, War and Heavy Demand at		Fisherman Uses His Sail as Canopy on Land...	346
Home Raise .....	368	Flags, Electric-Lighted, Erected at Factories...	360
Automobile, Small Speedy Has Novel Features..	383	Flies Virtually Unknown in Havana.....	352
Avalanche Wrecks Train High in Cascades .....	367	Flower Box Aerates and Waters Plants.....	390
Barge Loaded with Horses Sinks in Hudson River	397	Forest Service, Communities Cooperate with....	328
Bathub, Concealed, Made for Small Dwelling...	421	Forks and Spoons, New Process for Making....	390
Beds, Disappearing, Hidden by Built-In Furni-		Furnace, New Electric, for Laboratory Use....	422
ture .....	410	Game, Lawn, Holds Interest for Whole Family..	433
Bengalese, How are Told News.....	442	Gas Cook, Accident-Proof, for Stoves and Ranges	430
Bicycle Rider Balances Dinner on His Head...	328	Gear, Internal, Proves Efficient Speed Changer..	341
Bicycles, New Motor Attachment for.....	428	Gold Quartz, Dutch Guiana Paves with.....	394
Blower Softens Hard Seeds for Planting.....	396	Gravel, Wash from Banks for Road Building....	422
Boiler, New Oil Fuel, of Great Efficiency.....	327	Gravestones, Miner Uses to Mark New Claim...	332
Bracket, Removable, for Special Lighting.....	441	Gun Recoil Pad, Improved, for Sportsmen.....	403
Bridge, Any Span in New may Be Lift Span...	342	Gunfire, How Animals are Affected by.....	421
Bridges, Three Span River Side by Side.....	398	Hand Car Driven by Motor Wheel at Low Cost.	353
Building Blocks, Toy, Pegs Hold Together....	419	Handcuff Stays Open in Pocket.....	439
Calculator, Desk, Does Varied Work.....	418	Heater, Portable Electric, for Domestic Purposes	414
Calculator, Elaborate, for Six Currency Systems.	342	Highway, Western, Lighted by Luminous Arcs..	406
Car, Runaway, Performs Curious Feat.....	435	Homestead Moved Twenty Miles Piece by Piece	336
Cliff Dwellings of Colorado, Restoration of....	332	Hospital, Field, can be Compactly Crated.....	401
Coal Handling Plant, New, Loads Mechanically.	424	House Wiring Work, Boring Machine Is Help in	440
Color Printing Simplified by New Apparatus...	408	Immortalizing Chicago's Midway, by Robert H.	
Concrete Strait-Jacket Subdues River Floods...	420	Moulton .....	333
Copper, Germany Trying to Save.....	431	Independence Square, Philadelphia to Restore...	368
Costumes, Comfortable, for the Outdoor Girl...	349	Indicator Helps Motormen to Keep Schedule	
Cutter, Power, Razes Canadian Brush.....	415	Time .....	348
Cycle, Queer, Designed to Carry Five Riders...	332	Interiors, Effective, in Black and White.....	420
Dam, Old Wooden, Still in Use.....	328	Iron, Electrolytic, New Process of Making....	442
Dates of Battle Scars Tattooed on Soldiers...	330	Knee Cushion Increases Floor Worker's Comfort	352
Defense Batteries, Mobile, for Coast Protection.	365	Lease Won by Aeroplane Racing against Motor..	416
Dental Repair Work Affected by War.....	406	Light Dimmers, New Test for Motor Car.....	434
Desk and Record Case Combined.....	351	Log Hoist, New, Supplants Old Method in Saw-	
Dirt Handling Machine Keeps Wagons Busy....	402	mill .....	436
Disinfectant, Find Pine Oil Derivative Valuable.	414	Lumber Piling Apparatus Also Fire Tower....	322
Door, Sliding, Track Protects from Weather...	434	Machine Assists Quick Lacing of Belts.....	408
Doorbell, Electric, Made for House Cat.....	418	Mail Box and Milk Bottle Holder Combined...	414
Dreadnaught "Oklahoma" in Trials.....	354	Mail Box, Giant, a Feature of Promotion Cam-	
Echoes, Scientists Subdue, in Spite of Difficulties	384	paign .....	363
Electricity for Factory Hauled Eleven Miles...	362	Mangle, Safety Attachment for Laundry.....	431

[Continued on Page 6]

Popular Mechanics offers no premiums; does not join in "clubbing offers," and employs no solicitors to secure subscriptions. It is for sale by nearly every newsdealer in the United States and Canada.

## [Contents—Continued]

Manhole Covers, Disappearing Handles for.....	423
Map, New Topographical, for Air Scouts.....	422
Markets, Produce, Highway for Motorists.....	442
Metal Articles, Small, Lacquered in Bulk.....	431
Milk Aerator and Cooler for Dairy Use.....	426
Milking Stool Prevents Spilling of Milk.....	412
Mill, Improvised Stamp, Does Effective Work....	399
Mine Explosions Proven to Be Preventable.....	441
Mining Industry, Alaskan, Has Productive Year	400
Mint, Philadelphia, Coins South American Money	413
Missions, Old California, Shown in Miniature...	427
Monoplane, Baby, Is Driven by Motorcycle En-	
gine.....	353
Motion Picture Producers Erect Platform for	
Visitors.....	438
Motion Pictures, Use to Identify Criminals.....	413
Motor Bus System, New York to Have Model....	385
Motor Cars, Loading Assembled, for Shipping...	429
Motor Cars, War, Dipped in Paint Bath.....	440
Motorcycle, Frame of New Like That of Motor	
Car.....	424
Motorcycle with Sidecar for Mail Carriers.....	421
Motorists' Sign, Moderate Speed Asked by....	405
Novel and Practical Things for the Home.....	436
Office "Checker Board" Promotes Efficiency....	428
Office, Fresh Air, Occupied during Cold Weather	392
Oil Transmission Does Away with Shift Gears...	419
Optical Device Helps Women Choose Gowns....	321
Park Seats of Several Serviceable Designs.....	388
Phonograph, Multiple Disk, Increases Sound	
Volume.....	322
Photograph Studio Has Detached Showroom....	432
Photography of the Planets by Invisible Rays, by	
R. W. Wood.....	347
Pipe Line, Long Natural Gas, for Winnipeg....	350
Plaster Board, Fiber, Made with Anchor Buttons	402
Post Card Vender, Automatic.....	400
Produce Market is Roofed Over by City.....	383
Propeller Mended in Dry Dock Shorter Than	
Ship.....	360
Pump, Plunger, Works with Little Vibration....	406
Radiators, Electrically Heated Portable.....	341
Railroads, Shorter Rails Now Used by.....	439
Range, Two Fuel, Equipped with Ash Chute....	411
Revolver is Mounted in End of Pocketknife....	339
Rifle Range, Electric Indicators Used on German	
Salem Rising from Ashes Surprisingly Quick....	358
Salmon, Propagate Sockeye, in Samish River...	362
Sand Spreader, Icy Walk Made Safe by.....	357
School Children, Italian, Form Insurance Body.	392
Seed Display, Clever, Attracts Trade.....	389
Service Wagon, Folding Steel.....	362
Sewing Machine, Electric, for Domestic Use...	344
Shells, Bursting, Kill Men without Wounding	
Them.....	340
Shingles, Wooden, Rendered Fire Retarding....	412
Sidecar, Luxurious, Built for Motorcycle.....	391
Signaling Device for Rescuers in Mines.....	428
Sled, Child's, Equipped with Limousine Body...	326
Snakes Bottled in Tubes for Study Purposes...	430
Snow Fences of Boards, Tile Walls Surpass....	367
Stationery File Keeps Order in Desk Drawer...	405
Statues in Park to Tell Story of the Nation...	346
Stones Washed from Logs to Prevent Accidents.	330
Storm Water Intakes, Wide, Prevent Street	
Floods.....	404
Street Cars, Japan Adorns, in Ruler's Honor...	359
Street Signs, Large Tile, Laid in Sidewalks...	415
Submarine Tragedy, Hydrogen Gas Cause of...	356
Subways, Would Use Kiosks for Ventilating....	413
Surgical Drill is Driven by Electric Motor....	344
Table Serves Twofold Purpose.....	395
Taximeter Gives Customer Printed Fare Receipt	
"Teddy" Bear, New, Has Electric Eyes.....	385
Telephone Mouthpieces of Black-Glazed Porce-	
lain.....	367
Telephone Service Maintained While Switchboard	
is Moved.....	350
Telephone, Show Window, Secures Many Orders	
Torch, Electric, Makes Useful House Light...	400
Torpedo, Antisubmarine, Used from Aeroplane...	338
Tower, Old Steel, Felled by Fierce Gale.....	392
Towers, High, Lift Wires above River Vessels.	340
Trains Crash When Stray Current Works Signal.	326
Trees, America's Largest, Found during Contest.	386
Truck Designed to Carry Long Steel Strips....	390
Tunnel, Change Grade of, in Los Angeles.....	416
Tunnel, New, Is Longest on This Continent....	342
Tunnels, Village School and Homes Connected by	328
Typewriter Desk Is Aid to Rapid Work.....	431
Voting Booths, Canvas, Used in California.....	385
War, European:	
Allies and Turks as Seen by the Camera.....	371
Battles in Different Theaters, Unusual and	
Thrilling Episodes Enacted during.....	376
Conscription, London Street Crowd Favors,	
While Australians March Miles to Enlist....	374
Fuel, Preparing, for Soldiers in Trenches....	378
Icy Battle Grounds, With Warring Troops on...	372
Monitors, Modern, in Use by British Navy...	370
Poison Gas, Germans Using against Russians...	382
Side Lights on War in the West, Photographs	
Taken within French Lines.....	380
Wash Day, Tommy Atkins', in the Near East	369
Welfare of Private Soldier, Looking after....	379
Winter Campaign in Tyrolean Alps, Austrian...	373
Warships' Sea Control Shown in Court.....	403
Watch and Shelf Clock for Soldiers, Combined...	438
Watch, Wrist, Designed Especially for Men....	417
Watches, Why Even Best Go Wrong.....	440
Water Heater, Electric, is Built for Fountain Use	441
Water Tower, Dairy's, Advertises Milk.....	391
Waterworks Crib, Novel Substructure Built for...	350
Wells, Artesian, Transform Queensland, Aus-	
tralia.....	369
Wheel, Fifth, Increases Auto's Capabilities....	416
Wounds, Simple Electric Device for Probing...	433
Zeppelin Destroyer, The New British, by R. J.	
Bjurstedt.....	386

## SHOP NOTES

Acetylene Generator for a Bicycle Lamp.....	459
Automobile Engine, Easy Way to Start in Winter	
Barn Construction, Modern.....	446
Bronzing Liquid.....	449
Bushing, To Hold a Loose Camshaft.....	444
Carbide Can, Empty, Used for Heating Stove...	450
Door, Translucent.....	460
Doors, Holding Large Open.....	443
Driveway, Making with Tarred Stones.....	448
Fiber, Things to Know about.....	448
Fireplace Screen, Hinged.....	445
Gasoline Filter for Automobile Tanks.....	450
Hat Rim Reflects Lights of Approaching Au-	
tomobiles in Rear.....	457
Home, Building a:	
Part XII—Exterior Finish.....	451
Lathe, Centers for Taper Work on.....	453
Leaks and Blowholes, Filling.....	461
Levels, Accuracy of.....	443
Locomotive Slip Hub Liner.....	457
Motion Picture Film Cement, Receptacle for...	441
Motorboat, Beaching a.....	443
Paint, To Detect Water in.....	461
Pins, Cutting Brass Wire to Length.....	460
Piston Pin Lubrication.....	482
Pressure Gauge, Homemade.....	459
Pulley Block, Emergency.....	444
Pulley, Burlap.....	457
Sandblast, Homemade.....	462
Steam Gauge Pressure Connection, Repairing...	461
Stovepipe, Concealed Support for.....	461
Taps, Odd Fluted.....	449
Tool Grinding Machine, Flexible Pipe Conveyor	
for.....	460
Tracing Cloth, Pounce Dusting Pad for.....	462
Typewritten Sheets, End of Page Marker for...	444
Wheel, Fitting Worn Tightly on Its Shaft....	446

## AMATEUR MECHANICS

Ammeter, Homemade.....	463
Box Cover without Hinges.....	466
Bracket, One Piece.....	468
Bunghole, Stopper for.....	464
Canoe, How to Build a:	
Part I—Specifications and List of Materials...	469
Cupboard for Kitchen Utensils.....	479
Dark Room Light, Emergency.....	478
Fishlines, Waterproofing.....	478
Footstool.....	464
Gas Stove Oven, Substitute for.....	465
Groove Cutter for Wood.....	465

[Contents Continued on Page 8]

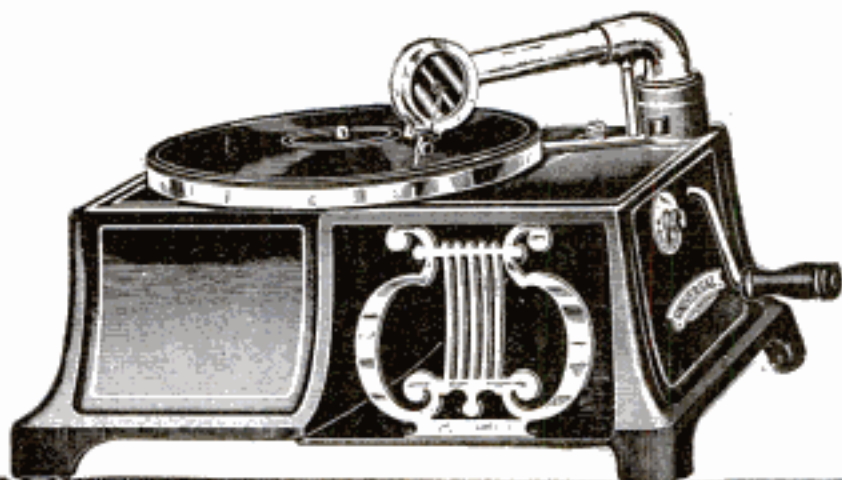

# No Money In Advance

## Sensational Phonograph Offer

We offer you the most sensational, the most astoundingly liberal offer ever made in the history of the Phonograph business. We will send to you without one penny in advance, without one bit of obligation on your part whatsoever, this remarkable Universal Phonograph—this startling new invention—this marvelous all metal machine which is revolutionizing the talking machine world. Just 10,000 of these wonderful Phonographs have been set aside to be sent out on this amazing advertising offer which is made in order to get a machine in each locality of the United States immediately.

Never before—and without doubt never

again—will an offer so liberal be made. Not one cent in advance—no references asked—no C. O. D.—no delay—no red tape—not even your promise to keep the machine. The coupon below is all that is necessary. And with this remarkable machine will be sent eight splendid selections—the regular 65c double disc Columbia records. Play this grand Universal in your home with the superb selections sent with it—give the Universal a thorough ten days' test and then, if after a thorough test and examination you believe it to be the most remarkable, the most wonderful phonograph you ever heard, simply

# Pay Only \$1.00 In Ten Days

and pay balance of our Special Limited Introductory Bargain price of \$16.50 in small monthly payments of \$1.55 each. If for any reason you do not want to keep the phonograph and records simply return to us within ten days after receipt at our expense and you owe us nothing—without the records the Phonograph furnished for only \$13.90.

Think what a remarkable Phonograph this one must be in order to stand such a critical test as this. Songs, Speeches, Instrumental Music, Band and Orchestra Selections, each voice, male or female, each instrument brought out in an actual reproduction exactly as the original, not one sound or syllable blurred or indistinct

—no screeching or buzzing. Gorgeous Harp front-piece and all trimming beautiful silver effect, not one particle of tin or wood in its entire construction; base 15 inches wide by 6 inches high, 11½ inches deep; weight 17 lbs.; has exclusive automatic start and stop. Plays ALL makes and sizes of disk records.

Eight beautiful selections—the regular 65 cent double disc Columbia records—will be sent to you on this offer. A complete list of hundreds of the most famous selections will be sent along with the machine and records. You have the privilege of exchanging immediately any or all of the 8 selections sent to you for those of your own choice.

## No Reference Asked

Remember, no reference asked. On receipt of the coupon we simply ship the phonograph and records right out to you. If you decide that you want to keep the Phonograph and records send us only \$1 within ten days and pay the balance at \$1.55 a month until you have paid us our Special Introductory Bargain Price of only \$16.50. Otherwise return them at our expense. Do not delay in this matter. Send coupon today, then examine and test this beautiful, perfect, new Universal Phonograph in your home on this liberal No Money In Advance offer. This offer is limited—immediate action is necessary—mail the coupon today.

**UNIVERSAL PHONOGRAPH COMPANY,**  
133-37 West 39th Street, Chicago, Ill.

## Send No Money!

**Universal Phonograph Co.,**  
133-37 West 39th St., Chicago, Ill.

Send at once your wonderful new Universal Phonograph and 8 selections of the regular 65c Double Disc Columbia Records. If satisfactory after examination, and I decide to keep them, I will send you \$1 in ten days after arrival. I then agree to pay the balance of \$15.50 in monthly payments of \$1.55 each until paid. Otherwise I will return Phonograph and records at your expense.

Name.....  
Address.....

Popular  
Mechanics

Please Mention Popular Mechanics

# Send



**NOW for DYKE'S**  
**Free 32 PAGE Booklet**

EXPLAINING:

**HOW TO GET INTO  
THE AUTOMOBILE  
BUSINESS & ITS OPPORTUNITIES**  
**HOW TO LEARN DURING SPARE  
TIME BY MAIL AT HOME WITH  
DYKE'S NEW IDEA  
Working Model Method**

This system is endorsed by Barney Oldfield, Elwood Haynes, Chas. Duryea and other motor authorities.

If we prove to you that we have started hundreds of others into the repair business and as chauffeurs—who had no previous experience and who knew no more about an auto than you do right now—you must admit we can do the same for you. Write me today—now—and let me prove it.

**The AUTOMOBILE BUSINESS is Growing**

We Assist Students Getting Actual Driving Experience

More help needed and big pay. No other business offers such opportunities. It's easy to learn. An Auto Repairman is not a machinist—his work consists of adjustments and re-fitting worn parts. "knowing the principle," that's the thing. One of our students writes: "Before I started with your course I was a clerk at \$50 per month. After finishing I followed your instructions, started a repair shop and cleared \$122 the first month—pretty good for the first month." Let us show you this and many other letters. You can learn the same as this young man by

**DYKE'S NEW IDEA OF TEACHING  
BY MAIL WITH WORKING MODELS**

On these models you get actual practice, see the actual operation and learn more than you could from the auto itself—it's easy and quick. You don't have to study hard with this system—we teach through the eye—a new idea. Mr. Dyke is the originator of the system of teaching by mail with models—therefore bears of imitations.

**Our Employment Plan for Students**

represents years of work to provide something that no other school had, namely, a way for the student to get started in the practical line of work.

Mr. Dyke has been identified as a pioneer inventor, supply man, etc., with the auto industry since its beginning. He originated the first auto supply co. and published the first book on autos in America. No other man with such experience is today teaching others.

**Mail This Free  
Coupon Now**

(a postal card will do)  
for Mr. Dyke's 32-Page Booklet. Write for it—now! It is interesting and instructive in itself. Learn how you can get all this training for only \$15. Fill out below or write a postal—but do it now.

This school is a department of the firm:

**A. L. DYKE**  
Pub. & Importer  
St. Louis, Mo.

Dyke's Correspondence School of Motoring  
Box 196, Roe Bldg.  
St. Louis, Mo.

Send me your free 32-page booklet about your New Idea Working Model Course and testimonials and proofs. It is understood I am under no obligations in sending for this

Name.....

Address.....

Deal with the originators. Beware of imitations.

Please Mention Popular Mechanics

(Contents—Continued from page 6)

Ice Creeper.....	478
Lock for Gasoline Tank on Launch.....	477
Lock, Making Chest, More Secure.....	478
Mailing, Proper Way to Wrap Papers for.....	467
Photo Sculptures, How to Make.....	468
Putty, How to Make a Good.....	479
Screws, Driving, in Hard Wood.....	478
Sled, A One Runner.....	465
Sled, Folding Ice.....	467
Table Sockets for Electrical Heating Apparatus.....	479
Thread and Dental Floss, Sanitary Holder for.....	466
Tinware, Cleaning with Milk.....	467
Trick, Diminishing Card.....	479
Trick, Ring and Egg.....	476
Vise, Quick Acting Bench.....	477

**MAKE YOUR OWN  
SIGNS  
and  
SHOW  
CARDS**



**14,000 COPIES SOLD**  
**Spon & Chamberlain**  
123 P. M. Liberty St., NEW YORK

**40**  
**Alphabets**  
Unequaled for  
Commercial  
Lettering  
**55c**  
Postpaid

REVERSIBLE  
**Linene**  
TRADE MARK  
COLLARS

Send 2 Cents  
in U. S. Stamps to pay postage and  
we will send you free a starch-finished  
**SAMPLE COLLAR**  
State size and which style wanted

REVERSIBLE COLLAR CO., Dept. U, Boston, Mass.



**DOUBLE THROAT 10c** New Invention.  
Greatest thing out. Astonish and mystify your friends. Make dogs or cats talk. Neigh like a horse, sing like a canary. Imitate any Bird or Beast of field or forest. Price 10c; 4 for 25c postpaid  
National Co., Dept. 31, 3422 Lyndale St., Chicago, Ill.



**Every Boy His Own Toymaker**  
Greatest boys' book ever written. Tells how to make a Steam Engine, Telephone, Magic Lantern, Balsa, kites, balloons, electrical and mechanical toys, traps, fishing tackle, 350 illustrations—also outside of 100 puzzles, picture cards and "DOUBLE THROAT" warbler and bird call all for only 10c. WESTERN PUZZLE CO., ST. PAUL, MINN.

**AUTO GIVEN  
AWAY**

We want representatives in every locality. No experience or capital necessary. Send us your name and address and by return mail we shall tell you how you can secure one of our new 1916 model 5-passenger touring cars free for demonstrating. Write today—do not delay—a postal card will do. Address

**ECLIPSE MOTOR CAR CO.** 851E Buhl Block  
DETROIT, MICH.





CHARGE OF THE SCOTS GREYS AT WATERLOO

**W**ELLINGTON held this regiment of cavalry in reserve at the battle of Waterloo, awaiting the supreme moment when an overwhelming charge might turn the tide of battle. The instant the French lines wavered the order was given to charge and the Scots Greys Cavalry hurled themselves against the French like a thunderbolt. This same regiment is again in active service in the present European War. All the underlying causes of this conflict — the deep racial antipathies, the commercial rivalries, the sting of past defeats, the vaulting ambitions for world empire — may be discerned from the pages of history. The one great history of every empire, principality, kingdom and power from the beginning of civilization to the present is the world famed publication

## Ridpath's History <sup>OF</sup> THE World

**W**E will name our special low price and easy terms of payment only in direct letters. A coupon for your convenience is printed on the lower corner of this advertisement. Tear off the coupon, write your name and address plainly and mail. We do not publish our special low price for the reason Dr. Ridpath's widow derives her support from the royalty on this History, and to print our low price broadcast would cause injury to the sale of future editions.

### Six Thousand Years of History

**R**IDPATH takes you back to the dawn of history long before the Pyramids of Egypt were built; down through the romantic troubled times of Chaldea's grandeur and Assyria's magnificence; of Babylonia's wealth and luxury; of Greek and Roman splendor; of Mohammedan culture and refinement; of French elegance and British power, to the dawn of yesterday. He covers every race, every nation, every time and holds you spellbound by its wonderful eloquence.

### 46 Page Booklet FREE

**W**E will mail our beautiful forty-six page free booklet without any obligation on your part to buy. It will show Ridpath's wonderfully beautiful style. He pictures the great historical events as though they were happening before your eyes; he carries you with him to see the battles of old; to meet kings and queens and warriors; to sit in the Roman Senate; to march against Saladin and his dark-skinned followers; to sail the southern seas with Drake; to circumnavigate the globe with Magellan. He combines absorbing interest with supreme reliability, and makes the heroes of history real living men and women, and about them he weaves the rise and fall of empires in such a fascinating style that history becomes as absorbingly interesting as the greatest of fiction.

**WESTERN NEWSPAPER ASSOCIATION  
CHICAGO**



**FOLD HERE. TEAR OUT, SIGN AND MAIL.**

NAME .....

ADDRESS .....

**MAIL THIS COUPON**

**FREE  
COUPON**

**Western  
Newspaper  
Association**

H. E. Sevor, Pres.  
140 So. Dearborn St.,  
CHICAGO, ILL.

Please mail, free, 46-page sample booklet of Ridpath's History of the World, containing photogravures of Napoleon, Queen Elizabeth, Socrates, Caesar and Shakespeare, Map of European War Zone, and write me full particulars of your special offer to Popular Mechanics readers.

# THE INTENSE LIFE

How Conscious Energy Makes it Possible for All of Us

**BECOME SUPERIOR TO YOUR PRESENT**

**SELF.** The Swoboda System can make a better human being of you, physically, mentally and in every way. It creates a greater activity of the forces of life which in you are partially dormant, thus compelling them to become more alive and positive, enabling you to grow and evolutionize to a higher state of perfection. The Swoboda System can do more for you than you can imagine. It can so vitalize every organ, tissue and cell of your body as to make the mere act of living a joy. It can give you an intense, thrilling and pulsating nature. It can increase your very life. I not only promise it, I guarantee it.



*Pupils are men and women ranging in age from 14 to 92.*

*Swoboda*

*Originator of  
Conscious Evolution*

**Why Become Prematurely Old in Whole or in Part?**  
**Why Take Less Than Your Full Share of Life and Pleasure?** Are you living a full and successful life? Why not always be at your best?—thoroughly well, virile, energetic. Why not invest in yourself and make the most of your every opportunity? It is easy when you know how. The Swoboda System points the way. It requires no drugs, no appliances, no dieting, no study, no loss of time, no special bathing; there is nothing to worry you. It gives ideal mental and physical conditions without inconvenience or trouble.

**The Swoboda System of Conscious Evolution** is no experiment. I am giving it successfully to pupils all over the world. I have among my pupils hundreds of doctors, judges, senators, members of cabinet, ambassadors, governors, thousands of business and professional men, farmers, mechanics and laborers, and almost an equal number of women

*—more than two hundred thousand people have profited through this system.*

**Your Earning Power**, your success depends entirely upon your energy, health, vitality, memory and will power. Without these, all knowledge becomes of small value, for it cannot be put into active use. The Swoboda System can make you tireless, improve your memory, intensify your will power, and make you physically just as you ought to be. I promise it.

# THE BETTER LIFE

## What Others Have to Say:

"Can't describe the satisfaction I feel."

"Worth more than a thousand dollars to me in increased mental and physical capacity."

"I have been enabled by your system to do work of mental character previously impossible for me."

"I was very skeptical, now am pleased with results; have gained 17 pounds."

"The very first lessons began to work magic. In my gratitude I am telling my croaking and complaining friends, 'Try Swoboda.'"

"Words cannot explain the new life it imparts both to body and brain."

"It reduced my weight 29 pounds, increased my chest expansion 5 inches, reduced my waist 6 inches."

"I cannot recommend your system too highly, and without flattery believe that its propagation has been of great benefit to the health of the country."

"My reserve force makes me feel that nothing is impossible, my capacity both physically and mentally is increasing daily."

"I have heard your system highly recommended for years, but I did not realize the effectiveness of it until I tried it. I am glad indeed that I am now taking it."

"Your system developed me most wonderfully."

"I think your system is wonderful. I thought I was in the best of physical health before I wrote for your course, but I can now note the greatest improvement even in this short time. I cannot recommend your system too highly. Do not hesitate to refer to me."

"You know more about the human body than any man with whom I have ever come in contact personally or otherwise."

"Your diagnosis and explanation of my brain trouble was a revelation to me. I have had the best physicians of my State, but your grasp of the human body exceeds anything I have ever heard or known. I have read your letters to many people, also to my physicians, who marvel at them."

**MY NEW COPYRIGHTED BOOK IS FREE.**  
It explains **THE SWOBODA SYSTEM OF CONSCIOUS EVOLUTION** and the human body as it has never been explained before. It explains my new theory of the mind and body. It will startle, educate, and enlighten you.

My book is not a dry treatise on anatomy and physiology. It tells in a highly interesting and simple manner just what you have always wanted to know about yourself.

You will cherish this book for having given you the first real understanding of your body and mind. It shows how you may be able to obtain a superior life; it explains how you may make use of natural laws for your own advantage.

My book will give you a better understanding of yourself than you could obtain from a college course. The information which it imparts cannot be obtained elsewhere at any price. It shows the unlimited possibilities for you through conscious evolution of your cells; it explains my discoveries and what they are doing for men and women. Thousands have advanced themselves in every way through a better realization and conscious use of the principles which I have discovered and which I disclose in my book. It also explains the **DANGERS OF EXERCISE** and of **EXCESSIVE DEEP BREATHING**.

I offer my System on a basis which makes it impossible for you to lose a single penny. My guarantee is startling, specific, positive and fraud-proof.

Write for my **FREE BOOK** and full particulars today before it slips your mind. Make up your mind to at least learn the facts concerning the **SWOBODA SYSTEM OF CONSCIOUS EVOLUTION** for men and women.

**ALOIS P. SWOBODA**  
1907 Aeolian Hall, New York City, N. Y.



No woman or man is too weak, old, or too well to profit through the Swoboda personal mail instructions.



# A BIGGER JOB For YOU

## Earn from \$35 to \$100 Weekly as a TRAFFIC MANAGER

Modern transportation is a jungle of routes and rates calling for specialists who, like the pathfinders of old, have expert knowledge of the trails of traffic. How to route shipments to obtain shortest mileage and quickest deliveries and how to classify goods to obtain lowest rates are two vital factors in business competition. The man who knows how is so valuable to his employer that he commands respect and big remuneration.

### Big Salaries Paid to Traffic Managers

Expert traffic managers command from \$2,500 to \$10,000 a year. Why not prepare yourself to fill one of these lucrative positions?

### New and Uncrowded Profession

Every railroad and over one half million large shippers in the United States need expert traffic men, and this need is recognized as never before because of the recently enacted railroad rate laws and interstate commerce regulations. The demand for trained and efficient traffic men is many times greater than the supply. There's room for you.

### Study Traffic and Interstate Commerce

Decide now to become a traffic man. Our Interstate Commerce Course enables you to study at home, without leaving your occupation or sacrificing present income, and to become thoroughly versed and proficient in the strategy of shipping, including routes and classifications, interstate commerce rules and regulations, etc. The instruction is given by some of the biggest traffic managers in the country. The course is easy to grasp and thoroughly practical. Anyone with ordinary intelligence, with reasonable application, can master this new profession.

**FREE PORTFOLIO** Clip coupon below, sign and mail at once, and we will send you FREE, postpaid, a handsome portfolio containing complete information concerning the opportunities and requirements of this attractive profession. Get posted at once. Clip coupon.

LaSALLE EXTENSION UNIVERSITY, Dept. 364-C, Chicago

### COUPON

La Salle Extension University  
Dept. 364-C, Chicago, Ill.

I am interested in the new profession—  
Traffic Management. Please send me full in-  
formation and Traffic Book, free of all cost.

Name .....

Occupation .....

## FREE PORTFOLIO



Write Address on the Margin Plainly.  
Please Mention Popular Mechanics



## Music Lessons Sent FREE

You, too, can now quickly and easily satisfy your musical ambitions—learn to sing or play your favorite instrument, whether for pleasure, social prestige or to teach music, by our wonderful home study lessons under great American and European teachers. The lessons are a marvel of simplicity and completeness, endorsed by Paderewski and other great authorities.

### Any Instrument or Voice

Write us the course you are interested in, age, how long you have taken lessons if at all, etc., and we will send you six lessons, free and prepaid, any of the following Complete Courses: Lessons in PIANO (students' or teachers' courses) by the great Wm. H. Sherwood, HARMONY by Dr. Protheroe and Rosenbecker, PIPE ORGAN by Clarence Eddy, VOICE COURSE (with aid of phonograph) by Crampton, PUBLIC SCHOOL MUSIC, by Frances E. Clark, VIOLIN, CORNET, MANDOLIN, GUITAR, BANJO, REED ORGAN, CHORAL CONDUCTING, by equally eminent teachers.

This offer is Free—we do not ask you to pay one cent for the six lessons, either now or later. We want to prove in this remarkable way what fine lessons they are—SEEING IS BELIEVING. This offer is limited, so write today. A few Special Introductory Scholarships now being awarded by our Faculty. Full particulars sent along with free lessons. Send no money.

SIEGEL-MYERS SCHOOL OF MUSIC,

CLARENCE EDDY, Dean

1441 Siegel-Myers Building, CHICAGO, ILL.

## ELECTRICAL ENGINEERING

men with training are always in demand. Having trained over 2000 young men in the past 23 years in the fundamentals of Applied Electricity, The Siles Electrical School, with its well-equipped shops and laboratories, is peculiarly well qualified to give a condensed course in Electrical



including Mathematics, Steam and Gas Engines, Mechanical Drawing, Shop Work, and Theoretical and Practical Electricity, in all branches. Student's actually construct dynamos, install wiring and test efficiency of electrical machinery. Course, with diploma, complete

### IN ONE YEAR

For practical young men with limited time. 24th year opens Sept. 27th. Catalogue on request. 104 Takoma Ave., Washington, D. C.

## DRAWING

Caricature, Cartoon, Comic, Commercial, Fashion, Newspaper and Magazine Illustrating taught by mail. Illustrated book 5c in stamps. THE BOSTON SCHOOL OF DRAWING, 755M Boylston St. BOSTON, MASS.



## LEARN SHORTHAND at HOME

Simple, easy and efficient system. Quickly learned, unexcelled for Court reporting and commercial work. No expense for board or tuition; sold on Money-Back Guarantee. Price reasonable. Easy weekly payments. Write today for complete information.

MOSHER SHORTHAND CO., Desk 4, Omaha, Neb.

## Learn Chemical Oil Painting

AN ART MASTERED IN A DAY BY ANYONE

In two or three days you can earn \$2.00 to \$10.00 a day painting portraits or giving lessons. Everyone who has a photo wants a painting. Done in an hour and selling at \$2.00 to \$10.00. We give all formulas, saving you many dollars, full instructions and methods to make money. Work spare time or set up a regular office, canvass for pictures or travel. Full information about this fascinating art free. BRAM ART CO., Box 176 B, Balboa, Calif.



# Know Your Car—

## It Means Money to You

Audels Automobile Guide—the world's most scientific book on automobiles—will enable you to quickly solve every problem of driving, repairing, locating of trouble. It is recognized as the authority by experts. Its value is unlimited. It tells you everything you should know about your car. Sent to you for free examination.

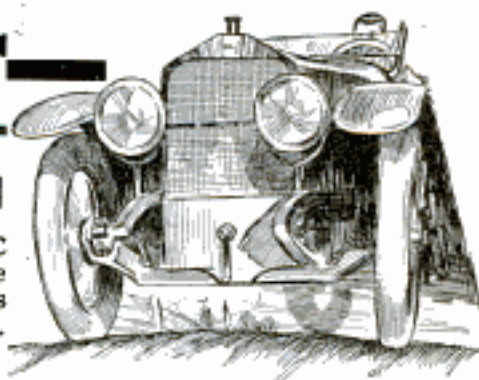

### If you are an Owner

You are losing money every time you run with ill-adjusted Carburetor, with faulty ignition, with your engine at the wrong speed, or with a score of other faults. You may be a careful student of your car and take all the precautions you know of. But unless you know the technical details of driving and operation, and know them right, your car is an expense burden instead of a pleasure.

### If you are a Chauffeur

We don't need to mention the things you must have at your fingers' ends in order to manage your car at top efficiency. Here are a few of the points you may be in doubt about:— How to care for batteries and keep them operating at maximum voltage. How to wire a car for Electric Starting, Lighting and Ignition according to the most modern systems. How to overhaul the car. How a car is best lubricated, etc.

### If you are a Mechanician

Then more than anyone else you will realize the importance of knowing the details of design of every part of your car. New inventions in design and construction are coming up every day, which puzzle the untrained man. Do you know these things?—Methods of cooling—Timing and Balancing—Designing Clutches—Design of ball and roller bearings, etc.

## Audels Automobile Guide

Solves every single one of these problems and solves them in a way that you can understand. It's a value you cannot afford to miss. It will save you many times its cost before you have had it a week.

### Text Arranged in QUESTIONS AND ANSWERS

The story is told in the best known way,—in the form of questions you would ask and the answers to them,—in plain, practical, everyday language, complete, concise, and to the point. The book is

handsomely bound in durable full flexible leather. Pocket Size. It is easy to handle and easy to study. There are 30 chapters covering every single phase of Automobile engineering and Automobile operation. Every chapter is modern, concise, and practical.

### Written by Practical Men for Practical Men

There is no idle theory in Audels Automobile Guide. Every paragraph is written to help you in the easiest, most practical way. The chapters on carburetors, ignition, gas engine operation, How to run an Automobile, overhauling the car, Battery Troubles, and Starting and Lighting Systems, are alone worth the price asked for the 30 complete chapters. There are 700 information-full pages, with 550 illustrations that show you in picture just what you want to see.

#### HERE ARE SOME OF THE SUBJECTS

Parts—Operation—Care—Management—Road Driving—Carburetor—Wiring—Timing—Ignition—Motor Trouble—Lubrication—Tires, etc. Chapters on Storage Batteries—Electric Vehicles—Overhauling Car—Special Chapter on Self-Starters and Lighting Systems, etc., etc.

### Sent to You FREE

We don't ask you to take our word for the merits of this book. Seeing is believing, so we will send you the book without deposit. You will say at once that as books go it is worth at least twice what we ask for it. Use it seven days in connection with your car. Then if you are not satisfied that Audels Automobile Guide is positively the best book on the subject, send it back to us. But if on the other hand you decide that you need it, that it is the one book for you, remit us only \$1.50.

### Mail This Free Coupon TODAY

Do not delay. Put your name and address on the coupon today. The book will be mailed to you at once for FREE examination. Convince yourself of the wonderful assistance this book will be to you. Send for it today—now.

THEO. AUDEL & CO., 72 Fifth Ave., New York

### FREE Examination Coupon

Theo. Audel & Co., 72 Fifth Ave., New York

Without obligation please mail for free examination "AUDELS AUTOMOBILE GUIDE." If I find it satisfactory I will remit \$1.50. Otherwise return it to you.

Name .....

Occupation .....

Address ..... P. M. March

# ELECTRICAL ENGINEERS

## Earn \$125 to \$250 a Month

The demand for Electrical Engineers at \$125 to \$250 a month far exceeds the supply. Engineering and power companies everywhere are searching for specially trained men. No previous experience necessary to take up this interesting work. Decide to fit yourself for one of these high-salaried positions.

The **American School** will train you to be a well-paid electrical worker in a short time at small expense. Our staff of practical engineers will give you individual instruction and advice. You can start in right now to prepare yourself for a better job and bigger pay.

**Earn While Learning** No need to give up your present occupation. We train you at home—solely by correspondence—as we have successfully trained thousands of others in the past eighteen years. Pocket-size textbooks, prepared by famous electrical experts, enable you to study anywhere—at any time. Papers examined and corrected only by experienced technical graduates.

### \$800 to \$2400 in Three Years

"The work I did with you advanced my salary from \$800 to \$2400 in three years." —RURCORN P. KOOP, Dorchester, Mass. (Graduate, Electrical Engineering.)

### Made Chief Electrician

"About two months ago I was appointed Chief Electrician of the Schenectady plant of the American Locomotive Co." —I. A. WARREN, JR., Schenectady, N. Y. (Graduate, Electrical Engineering.)

## Free Book Coupon

American School of Correspondence, Chicago, U. S. A.

Without any obligation on my part, please send me your Free Book and complete information regarding a course in  Electrical Engineering  Telephone Engineering  Hydroelectrical Engineering  Power House Superintendence  Wireless Telegraphy. Pop. Mech. 3-16

NAME.....

ADDRESS.....

## Electrical Book FREE

Send the coupon for your copy of our 56-page Free Book. Tells how easy it is to master Electricity, and gives full particulars regarding the course you are most interested in. **Don't hold back because of the money. The cost is small, and you can pay for your instruction as you progress—in small monthly installments.**

Mark and mail the coupon today. This is a wonderful opportunity to get into a profession that pays big money. No obligation in sending the coupon. **Mail it now!**

**AMERICAN SCHOOL OF CORRESPONDENCE, CHICAGO, U. S. A.**



## "HELP WANTED"

—Uncle Sam.

Railway Mail Clerks  
Postoffice Clerks  
City Mail Carriers  
Clerks in Customs and Internal Revenue Services

Thousands of Appointments Coming

**\$800<sup>00</sup> to \$1800<sup>00</sup> a Year for LIFE**

No "layoffs" without pay, because of strikes, wars, financial flurries or the whims of some petty boss. Excellent opportunities for quick advancement to Higher Government Positions. If you want immediate appointment, send **TODAY** for our free list of positions now obtainable. Any delay means the loss of just so much time in getting appointment.

SEND  
COUPON  
BELOW

FRANKLIN INSTITUTE

Dept. J 104, ROCHESTER, N. Y.

Act at  
Once

This coupon, filled out as directed, entitles the sender to free sample questions; a free copy of our book, "Government Positions and How to Get Them"; a free list of positions now obtainable, and to consideration for Free Coaching for the examination here checked.

### COUPON

..... Railway Mail Clerk	(\$800 to \$1800)	..... Customs Positions	(\$ 800 to \$1500)
..... Postoffice Clerk	(\$800 to \$1200)	..... Internal Revenue	(\$ 700 to \$1800)
..... Postoffice Carrier	(\$800 to \$1200)	..... Stenographer	(\$ 800 to \$1500)
..... Rural Mail Carrier	(\$500 to \$1200)	..... Panama Canal Clerk	(\$1200 to \$1800)
..... Bookkeeper	(\$800 to \$1800)		
..... Canadian Government Positions .....			

Name.....

Address..... J 104

Use this before you lose it. Write plainly



## GET ON THE STAGE

### VAUDEVILLE

I tell you how! Fascinating profession for either sex. Big salaries. Experience unnecessary. Splendid engagements always waiting. Opportunity for travel. Theatrical agents and authorities endorse my methods. Thirty years' experience as manager and performer. Illustrated book "All About Vaudeville" absolutely FREE. Send me your name and address TODAY.

FREDERIC LA DELLE, Sta. 159, JACKSON, MICH.

## FORD JOKE BOOK

All the latest and best funny jokes and stories on the FORD automobile. Hundreds of them and all good ones. Also JITNEY jokes, Moving Picture, and Stage jokes. Laugh till you shake. A neat colored covered book by mail for only **TEN CENTS**.



**PIKE PUBLISHING COMPANY**  
Box 77, So. Norwalk, Conn.



## LEARN TO DRAW

Illustrators—Cartoonists—Designers

are in demand. Many of our pupils obtain paying positions before completing the course. Personal instruction by artist of thirty years' experience. Correspondence and Local School. Send copy of this sketch for free criticism and 6 cents in stamps for illustrated book on Art Study.

Artist's outfit FREE to enrolled students

**Washington School of Art**  
923 F St., N. W. Washington, D. C.



## Buy Nobema Colors and Get

# FREE

Complete Correspondence Course in Show Card and Sign Writing in Chicago School of Lettering—Including nice set of brushes—All FREE. Offer made solely to have you try the famous ready-to-use NOBEMA COLORS. This free course gives practical training and, with NOBEMA COLORS and brushes, you can earn big money or establish paying Show Card and Sign business of your own. Most anyone can learn. Illustrated circulars and information FREE. NOBEMA Pen Ink Co., CHICAGO.

Please Mention Popular Mechanics

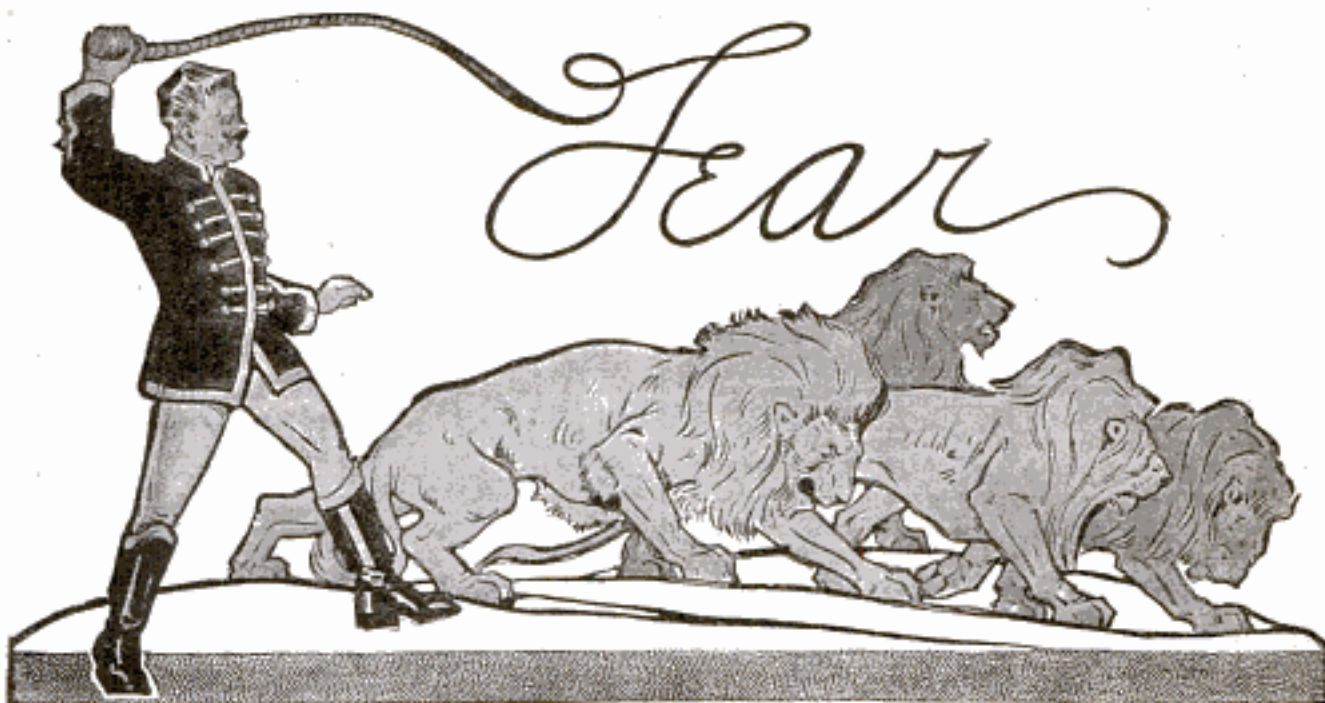

### What This Book Teaches You

- How to overcome Timidity.
- How to conquer Bashfulness.
- How to have "nerve."
- How to demand "your own."
- How to face people you have always felt inferior to.
- How to develop Self-Confidence.
- How to deal with people on their own level.
- How to successfully face embarrassing situations.
- How to "rise to the occasion."
- How to be Forceful and Dominant.
- How to eliminate Nervousness in dealing with big men.
- How to act calmly and naturally on occasions that usually excite you.
- How to banish Fear, physical as well as mental.
- How to stop Worry.
- How to become a Man among men.
- How to get rid of Superstition.
- How to face old age calmly.
- How to maintain poise in public.
- How to assert yourself in Business as well as in the Home.
- How to develop courage to swing big deals.
- How to dominate Circumstances.
- How to defy old-time habits of Hesitation.
- How to insure a healthy, virile, intrepid grade of Brain.
- How to stir into electrical activity, latent leadership qualities which Nature has tucked into the make-up of every normal man or woman.
- How to mass the myriad cell-forces of your Mind into a strong, tearing, goal-gaining plan of conduct.
- How to break open the door to a new world of Thinking—ease in beauty, practical in application.

A complete list of contents would almost fill this page.

# Fear Is a Bully Call His Bluff!

**"Culture of Courage" a Wonderful Book That Takes Out the Scare and Puts In the Dare**

Fear is the meanest bully on earth—he keeps millions on their knees futilely begging for the things of life and the peace of mind which are rightfully theirs, when if they but knew it he would turn tail and run at the first sign of resistance. Fear—the bluffer—has many disguises—sometimes he comes dressed as lack of self-confidence—other times he is superstition—often he makes other people seem dangerous—at other times he is clothed as worry—worry about circumstance, about the future, about what would happen if—but no matter what the cloak, his bluff can be called if you but learn how and the result will prove that there is not an atom of truth in the failure slogan "I haven't the ability." "It can't be done," etc.

## CULTURE OF COURAGE

Send No Money—Only \$3 If You Keep It

is by Frank Channing Haddock, Ph.D.—the famous author of "Power of Will"—a scientist whose name ranks with James, Bergeon and Royce. It is not an inspirational book which merely admonishes you to "destroy your fears" and "be courageous." Instead, it is a practical course in how to overcome each particular kind of human fear, physical as well as mental, to which we are all subjected. It contains actual principles, rules, methods and exercises which anyone can easily follow and become ten times bigger—ten times more successful—ten times happier than you have even dared hope.

### WILL HELP YOU

Never, we believe, has a book of more practical help been written. One man tells us how he had been out of a position for months and had absolutely lost confidence in himself until after reading "Culture of Courage" he went out and secured an excellent position the very same day.

That is only one example. Some say that it has made them self-confident and able to demand what they want, instead of whining for it hat in hand. Others say that for the first time are they able to talk to men they had always held in awe—others, that it has given them courage to take risks they dared not and they have won out—others, that they have banished superstition and fear of things formerly beyond their control—some say that they now have courage to say "no," the hardest word in the English language—and hundreds say it has given them a new grip on life.

What "Culture of Courage" has done for thousands of users, among them many prominent in all fields of endeavor, it will do for you by forever eliminating fear in all its diabolical disguises and putting it its place a brand of courage that will make you well nigh invincible.

### NO MONEY IN ADVANCE

So confident are we that once you examine this great book in your own home, you would never give it up, that we offer to send it on five days' free trial without a cent in advance. Keep it five days—look it over carefully—then if you feel you can afford to be without it, mail it back and you owe us nothing, otherwise remit \$3, the small price of this big 400-page leather bound book. Remember, no money in advance. Merely mail the coupon enclosing business card or giving a reference today.



460 pp.  
Half Leather  
Gold Top  
Leaves

**Pelton Pub. Co.** 70-F Wilcox Block  
Meriden, Conn.

### What Readers Say:

"In it I found rules, principles and regimes which make it worth its weight in gold to me." — District Attorney Goodwin, Oil City, Penn.

"It is a 'wonder.' The more one reads it, the more forceful ideas he can draw from this storehouse." — J. F. Ellis, Pres. Nat. School of Sales'p., Minneapolis, Minn.

"It is simply magnificent; I shall highly recommend it and wish everybody could read it." — L. I. Hall, Rochester, N. Y.

"It stands absolutely at the head of anything I have ever come across; Mr. Haddock is certainly a Master Mind. As a teacher, I can say that no greater good could come than the absorption from superstition this book brings about." — James Straightwell, Reynoldsville, Pa.

"These books are a gold mine of 'energizing material' for the progressive mind" — A. A. Martin, M. D., Pierce, Neb.

"Culture of Courage" is superb. It is clear, forceful, scientific, practical in every form and manner; ALIVE with the rich, the high, the ideal, the sublime. It's an inspiration from beginning to end. IT JUSTIFIES ALL CLAIMS." — F. Stanley Perera, Res. Master, Wesley College, Colombo, Ceylon.

"Enclosed is a check for which send me another copy for one of my friends. Dr. Haddock's works are superior to anything I have ever read for the development of the individual. He is entirely in a class by himself." — Chas. E. Ward, D. C., Houlton, Me.

**Pelton  
Pub. Co.  
70-F Wilcox  
Block, Meriden,  
Conn.**

Gentlemen: Please send me a copy of "Culture of Courage" on approval. I agree to remit \$3 or return the book in 5 days.

Name .....

Address .....

# Learn to Write

GOOD hand-writing has been truly called the "Bread and butter of a business education." It should be the determination of every body to learn to write at least a good business hand. Good writing is the very foundation of business success.

**Easy to Learn** By my system you can become a good penman at home, in your own room during spare time. Don't be content with the notion that good penmen "are born" such. Because one's ancestors may have been noted for poor penmanship, is no excuse for him to remain an illegible scribbler. My system is original, unique, and highly successful—the result of 25 years' experience.

**Your Spare Time** Just your spare moments—that's all I ask. If you follow my instructions you will soon be able to write a beautiful hand that will be a source of pride to yourself and envy to your friends. Notice the improvement shown in Mr. Campbell's writing below.

*Leland M. Campbell*

"I am astonished at the improvement I've made by means of The Tamblin System in so short time."

LELAND M. CAMPBELL,  
Campbelltown, Ohio.

*Leland M. Campbell*

Mr. Campbell wrote his upper signature July 20, and the lower one November 10—a little less than 4 months apart. Hundreds and hundreds of others in all parts of the world are doing as well with my system.

I have had unbounded success in making poor writers good ones and good writers better penmen than they thought possible.

32  
PAGES  
HIGHLY  
ILLUSTRATED.

How to  
Become  
a  
Good  
Penman

FREE  
BOOK  
WRITE  
FOR IT  
TODAY

Penmanship is particularly adapted to correspondence instruction, and I absolutely guarantee satisfactory improvement. Distance no barrier. Ladies taught just as successfully as men.

Don't wait, don't delay, begin now to prepare for that position where good penmanship will be required. Send today for my Free Book, "How to Become a Good Penman," which contains copies and beautiful specimens and tells how others have become good penmen by means of the Tamblin System. Your name will be beautifully written on a card with white ink if you enclose stamp.

F. W. TAMBLYN,  
418 Meyer Building,  
Kansas City, Mo., U.S.A.

## FREE BOOK COUPON

F. W. TAMBLYN, 418 Meyer Bldg., Kansas City, Mo., U. S. A.  
I am interested in improving my penmanship. Please send me free your book "How to Become a Good Penman."

Name .....

Address .....

Sign and mail this today, before you forget it.

Please Mention Popular Mechanics

## Learn Tree Surgery



### Positions Guaranteed

with the Davey organization after completing two-year course. Every city, park, orchard and private estate needs an expert Tree Surgeon. Also many Tree Surgeons are needed by the various States and the National Government. Good men make large annual incomes in this uncrowded field. Students who have attended high school preferred; age, 20 to 28; height, at least 5 feet, 7 inches; must be physically sound and of good character. Tuition moderate, including first year's board. We pay salary second year. Special attention to Fruit Growing. Write promptly for particulars. Address the Secretary.

The Davey Institute of Tree Surgery  
Box 89  
Kent, Ohio

Learn to PAINT  
SIGNS and SHOW CARDS

I'll teach you personally by mail. 17 years' successful teaching. Big field for men and women. You can Earn \$18.00 to \$45.00 a Week. Scherer (Chicago) writes: "Your instruction is great. Highly pleased." Full details promptly on request.

DETROIT SCHOOL OF LETTERING  
Chas. J. Strong, Founder Dept. 233, Detroit, Mich.



## LEARN RAG TIME

Let me teach you Rag-Time Piano Playing by Mail. You learn easily—in just a few lessons, at home. My system is so simple you'll play a real ragtime piece at your 5th lesson. Whether you can play now, or not, I'll teach you to play anything in happy ragtime. "Money Back Guarantee." Write at once for special low terms and testimonials.

AXEL CHRISTENSEN, "Czar of Ragtime,"  
Room 15 526 So. Western Ave., Chicago, Ill.



## DON'T TAKE A COURSE IN MACHINE DRAFTING

till you've read my proposition. Practical, experienced Draftsman, regularly employed in large modern works, will teach a few men by mail. Best way to become a well-paid Draftsman. Special courses in Mathematics also. Instruments furnished. Rates very reasonable. Pay a part after in position. Draftsman, 252 S. Corona St., Denver, Colo.

## Learn Watchmaking At Home



You can learn by our modern and original system of instruction every part of the Watchmaker's Trade at home as good or better than at a shop. You can earn money while learning and secure a well paying position or start in business after completing our course of instruction. Good watchmakers are always in demand and earn from \$20 to \$35 per week. For particulars apply to the Wisconsin School of Watchmaking, Strub Bldg., Milwaukee, Wis.

## Voice Throwing 10 cts

Learn to throw your voice into a TRUNK under the bed, out in the hall or anywhere. Lots of FUN fooling the Teacher, Janitor, Policeman, Parents, Neighbors, or Friends

### The Ventrilo

is a little instrument that fits into the mouth out of sight BOYS or Girls can use it. NEVER FAILS! A 32 page book on Ventriloquism sent with the VENTRILO for TEN Cents.

Royal Novelty Co., Dept. 92 SO. NORWALK, CONN

## ARITHMETIC SELF-TAUGHT

A plain, easily-understood volume for all who have not had the opportunity of learning this subject thoroughly, or who have forgotten what they once learned. 257 Pages. Requires no teacher. This great little book sent postpaid for 60 CENTS. Stamps accepted.

GEO. A. ZELLER BOOK CO.  
Est. 1876, 4472 W. Belle Place., ST. LOUIS, MO.

SPANGENBERG'S  
PRACTICAL  
ARITHMETIC  
Self-Taught



# Succeed Through Electricity

This interesting story shows you the way to greater success in the Electrical Field.

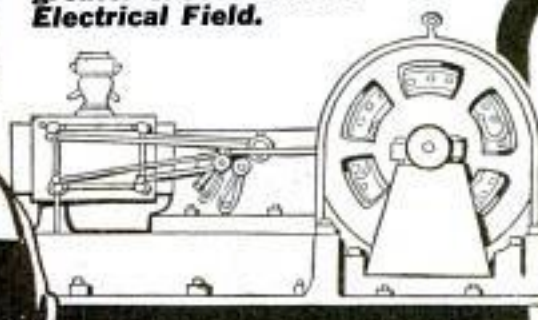

#### Read These Testimonials

"Any Electrician, Operating Engineer, or Student who wants to do his own construction or further advance himself in the Electrical field should have a set of these books."

JOHN KELLEY  
118 Union St., Newark, O.

"For the man not getting a college training and even in that case, I can sincerely say I do not believe there is a better set of books in the market today."

LEO D. HOFFMAN  
Dayton, O.

"We consider Hawkins Electrical Guides the most compact and complete set of electrical references in the market."

NOBLE ELECTRIC WORKS  
Monterey, Cal.

"Hawkins surely knows the art of condensing information."

ELBRIDGE F. BALL  
Buckland, Conn.

## Hawkins Electrical Guides Will Show You How

These books are the standard works on Electrical Science. They are a complete and up-to-date course in Electrical Engineering, presenting the information in a way you can use it. Only \$1.00 per volume and owners of the set say there are no better electrical books published at any price.

**Specially Arranged for Home Study and Reference** They fit your pocket and your pocket book. Beautifully bound in flexible black leather with gold edges. Easy to read and handle. You can carry each single volume about with you until you have mastered the subject it contains. Written in the form of questions you would ask and the answers to them—in plain, practical, everyday language, complete, concise, authentic and to the point. Over 3200 pages and more than 4,000 illustrations.

10 NUMBERS IN ALL

**1.00**  
A Number  
**PAYABLE**  
**1.00**  
A Month



## Shipped to You FREE

**YOUR FREE COUPON**

Send no money. Examine the books first. Decide for yourself that they are the most complete library of Electricity ever published and that you cannot afford to be without them. Every book is complete in itself, but the complete set is the best bargain. The last volumes are just coming off the press. **Eight numbers now ready.**

**Easy Payments**

Accept this unusual offer now—today. Each page—every illustration will convince you of the big value we are offering. See the books first, then decide. If you decide to keep them you can make settlement at only \$1.00 monthly until paid for.

**A FEW OF THE SUBJECTS**  
Magnetism—Induction—Experiments—Dynamoes—Electric Machinery—Motors—Armatures—Armature Windings—Installing of Dynamos—Electrical Instrument Testing—Practical Management of Dynamos and Motors—Distribution Systems—Wiring—Wiring Diagrams—Sign Flashers—Storage Batteries—Principles of Alternating Currents and Alternators—Alternating Current Motors—Transformers—Converters—Rectifiers—Alternating Current Systems—Circuit Breakers—Measuring Instruments—Switch Boards—Wiring—Power Stations—Installing—Telephones—Telegraph—Wireless—Bells—Lighting—Railways. Also many Modern Practical Applications of Electricity and Handy Reference Index of the 10 numbers.

**Theo. Audel & Co.**  
72 Fifth Ave.  
NEW YORK

Signature .....

Occupation .....

Business Address .....

Residence .....

Reference ..... Mar. P. M.

Theo. Audel & Co.  
72 Fifth Ave., N. Y.

Please send me for FREE examination Hawkins Electrical Guides (Price \$1.00 each). Ship at once prepaid the first eight numbers. If satisfactory I agree to send you \$1.00 each month until paid.

Please Mention Popular Mechanics



EDMOND R. MORAS, M. D.

# Autology

*The new scientific word "Autology," coined by Mrs. Moras and myself, has now been accepted by The New Universities Dictionary as a standard word of the English language.*

Doctor Moras has written a Commonsense Book on **Autology**, and by so doing has placed the Standard of the Creed of Health further to the front than any other man who has lived for a thousand years. —*Elbert Hubbard.*

I say this is a book. There are men and men: but there is much difference. When it comes to measuring men by an ideal standard there are but a few; the same is true of books. **Autology**, by E. R. Moras, M. D., is a book.

—*Dr. J. H. Tilden, Editor of "The Philosophy of Health," Denver, Colo.*

We consider **Autology** one of the most wonderful books ever written.

—*"Physical Culture" Magazine.*

I have read your **Autology** with care. It has been of unusual interest throughout, and from beginning to end makes a splendid environment for producing active thought. —*Luther Burbank.*

**Autology** saved my life. Three of the best physicians here told me I would be compelled to have an operation for **Appendicitis**. Nevertheless I have had no pain or indications of it since following **Autology** eight years ago. It has been nothing less than a "Godsend" to me. —*Mrs. C. K. G. (Name on request.)*

I am getting better of the **hardening of the arteries**; all dizziness and heart thumping have disappeared.

—*E. C. C. (Name on request.)*

## Well or Sick, You Need "Autology"

AUTOLOGY is no theory, no fad, no creed. It is the Science of Livingness. It deals with the *practical business of your body and brain* as you have learned to deal with the practical business of your home affairs, plants and flowers, your land and grain, your dollars and cents.

With AUTOLOGY there need be no such thing as pain and sickness in your life. AUTOLOGY means truly "A Happy New-Year—and many of them!" —the supreme happiness of health. AUTOLOGY means bodily and mental freedom. Do you realize what that means? Do you want it? Then write for

### "GUIDE TO AUTOLOGY"

which will give you the priceless information. It is FREE—*Absolutely Free* No matter what ails you it will pay you to investigate.

EVERY SUBJECT is treated not only in a unique way, in plain every-day language, as interesting as any novel, but is as vital to your well-living as breathing and eating.

EVERY CHAPTER is a gem and contains a wealth of information whose *health and brain value* cannot be reckoned in dollars and cents.

AND REMEMBER—IT'S FREE! SEND FOR "GUIDE TO AUTOLOGY" TODAY!

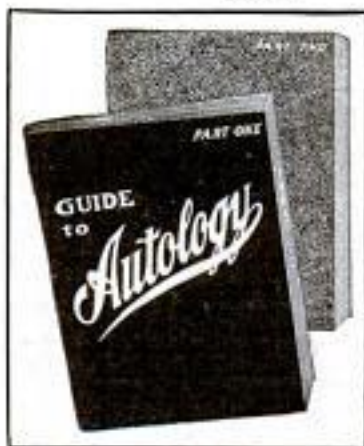

**Address: E. R. MORAS, M. D. 500 SHERIDAN ROAD HIGHLAND PARK, ILLINOIS**

Dr. Moras is a graduate of Harvard University Medical School, '88; College of Physicians and Surgeons (Chicago) '89; Formerly House Physician and Surgeon in Cook County Hospital (Chicago); Professor of Obstetrics, College of Physicians and Surgeons (Chicago).

**\$1** brings you at once  
the most useful thing  
money can buy—  
a complete set,  
the entire

**29**  
Volumes of the new

**Encyclopaedia Britannica**  
in a "Handy Volume" issue at an amazing price.

**T**HE latest (eleventh) edition of The Encyclopaedia Britannica has now been republished in a "Handy Volume" issue at one-third the price at which the Britannica may be bought in its larger form, known as the Cambridge University issue.

On receipt of a first payment of only \$1.00, the complete set (29 volumes, 41,000 articles, 44,000,000 words, 15,000 illustrations and maps), printed on the famous India paper and bound in cloth, will be shipped to your address. If for any reason you are not satisfied with the books, you may return them within three weeks, and we will refund all you have paid, including shipping charges. If you *are* satisfied, 21 monthly instalments of \$3.00 each pay for the set, printed on India paper in cloth binding.

(A letter from an eminent and practical educator)

UNIVERSITY OF CINCINNATI  
OFFICE OF THE PRESIDENT

December 6, 1915

Dear Sirs:

I would not have believed it possible to produce such an issue of the Encyclopaedia Britannica as the Handy Volume edition which you have shown me, if I had not seen it. It is a marvel of compactness, clearness and cheapness. This great work has been reproduced in a series of volumes one-half the size of the original edition, making the books far more convenient to handle and still perfect in type, paper and binding. You have rendered an important service to education and to the American people in putting this encyclopaedia within the reach of every school and of hundreds of thousands of families. This issue must be regarded, therefore, as a great educational, as well as a wonderful publishing, achievement.

Sincerely yours,

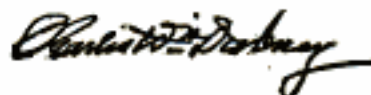

President.

**Sears, Roebuck and Co., Chicago**

Sole Distributors

(See the next page)



**CHARLES M. SCHWAB**  
President of the Bethlehem Steel  
Corporation



**ANDREW D. WHITE**  
Former Ambassador to Germany,  
Ex-President and Founder of Cornell  
University



**ALBA B. JOHNSON**  
President of the Baldwin Locomotive  
Works, Philadelphia



**J. H. VINCENT**  
Bishop of the Methodist Episcopal Church  
Chancellor of Chautauque

**T**HESE successful men,  
—and 75,000 others,—  
**paid three times as much**  
to get the Encyclopaedia  
Britannica as you need to pay  
now for the new “Handy  
Volume” issue with exactly  
the same contents but in a  
more convenient form.



**JOSEPH KRAUSKOPF**  
Rabbi Keneseth Israel Congregation  
Philadelphia  
Founder National Farm School



**A. C. MCGIFFERT**  
President of Union Theological  
Seminary, New York



**RUDOLF BLANKENBERG**  
Mayor of Philadelphia, 1911-1915



**EDWARD BOK**  
Editor of the "Ladies Home  
Journal"



**ELBERT H. GARY**  
Chairman of the Board of Directors of the  
United States Steel Corporation



**HUGO MÜNSTERBERG**  
Professor of Psychology in Harvard  
University

And after using the new Encyclopaedia Britannica they recommend it and the "Handy Volume" form. We will be glad to send you copies of their letters—and of many others—about the popular "Handy Volume" issue of the Britannica.



**ELIHU THOMSON**  
Inventor of Electric Welding; Chief  
Electrician of the General  
Electric Co.



**CHARLES S. WHITMAN**  
Governor of New York State  
Former District Attorney of  
New York City



**MUNROE SMITH**  
Professor of Comparative Jurisprudence,  
Columbia University



**RICHARD MACLAURIN**  
President of the Massachusetts Institute  
of Technology

## You can see sets of the "Handy Volume"

Encyclopaedia Britannica in the different bindings at any one of the following places, and you can leave your order there with a first payment of only \$1.00. That is all you need pay to secure shipment of the complete set.

<b>NEW YORK</b> GIMBEL BROTHERS Broadway, 32d and 33d Sts.	<b>CHICAGO</b> THE FAIR	<b>SAN FRANCISCO</b> "THE WHITE HOUSE" (RAPHAEL WEILL & Co., Inc.)
<b>CHARLES SCRIBNER'S SONS</b> Fifth Ave. at 48th Street	<b>ST. LOUIS</b> BUXTON & SKINNER PRINTING AND STATIONERY CO. Fourth, bet. Olive and Locust	<b>LOS ANGELES</b> A. HAMBURGER & SONS, INC.
<b>HENRY MALKAN</b> 42 Broadway	<b>CLEVELAND</b> THE BURROWS BROS. CO.	<b>SALT LAKE CITY</b> KEITH-O'BRIEN CO.
<b>WASHINGTON</b> S. KANN SONS & Co.	<b>CINCINNATI</b> STEWART & KIDD CO. 121 East Fifth St.	<b>DENVER</b> A. T. LEWIS & SON DRY GOODS CO.
<b>PHILADELPHIA</b> GIMBEL BROTHERS	<b>OMAHA</b> J. L. BRANDEIS & SONS	<b>DALLAS</b> SEARS, ROEBUCK & Co. 801-809 Arnold St.
<b>NEWARK</b> HAHNE & Co.	<b>ST. PAUL</b> ST. PAUL BOOK & STATIONERY Co. 55-59 East 6th St.	<b>KANSAS CITY</b> BRYANT & DOUGLAS BOOK AND STATIONERY CO. 922 Grand Ave.
<b>BALTIMORE</b> THE NORMAN, REMINGTON CO. 308 North Charles St. 10 West Saratoga St.	<b>LOUISVILLE</b> DEARING'S, INCORPORATED 232-236 South 4th St.	<b>DETROIT</b> JOHN V. SHEEHAN & COMPANY 260-262 Woodward Ave.
<b>BOSTON</b> W. B. CLARKE CO. 26 Tremont St.	<b>INDIANAPOLIS</b> THE KAUTZ STATIONERY CO. 116 N. Pennsylvania St.	<b>PORTLAND</b> THE J. K. GILL CO. 133-135 Third St.
<b>PITTSBURGH</b> JOSEPH HORNE CO.	<b>NEW ORLEANS</b> MAISON BLANCHE Co.	<b>SEATTLE</b> LOWMAN & HANFORD Co. 616-620 First Ave.
<b>BUFFALO</b> THE WM. HENGERER Co.	<b>MILWAUKEE</b> GIMBEL BROTHERS	

Or you can see sets and leave your order in the business offices of these newspapers:

<b>HARTFORD (CONN.)</b> COURANT	<b>UNION HILL (N. J.)</b> HUDSON DISPATCH	<b>BERKELEY (CAL.)</b> DAILY GAZETTE
<b>MERIDEN (CONN.)</b> RECORD	<b>AUBURN (N. Y.)</b> CITIZEN	<b>ELMIRA (N. Y.)</b> STAR-GAZETTE
<b>NEW LONDON (CONN.)</b> DAY	<b>POTTSVILLE (PA.)</b> REPUBLICAN	<b>LOCKPORT (N. Y.)</b> UNION SUN and JOURNAL
<b>MONROE (LA.)</b> NEWS-STAR	<b>WARREN (PA.)</b> EVENING TIMES	<b>LONG ISLAND CITY (N. Y.)</b> STAR
<b>ATTLEBORO (MASS.)</b> SUN	<b>COMANCHE (TEX.)</b> VANGUARD	<b>MT. VERNON (N. Y.)</b> DAILY ARGUS
<b>FALL RIVER (MASS.)</b> HERALD	<b>HARRISONBURG (VA.)</b> NEWS-RECORD	<b>NIAGARA FALLS (N. Y.)</b> GAZETTE
	<b>NASHUA (N. H.)</b> TELEGRAPH	<b>ENID (OKLA.)</b> EAGLE
	<b>NEW BRUNSWICK (N. J.)</b> HOME NEWS	<b>LYNN (MASS.)</b> ITEM
	<b>STAUNTON (VA.)</b> DAILY NEWS	<b>MARQUETTE (MICH.)</b> MINING JOURNAL
	<b>ROCKY MOUNT (N. C.)</b> TELEGRAM	<b>GREENSBORO (N. C.)</b> NEWS

SEARS, ROEBUCK AND CO.  
CHICAGO

Please send me

1. A booklet with full information about the "HANDY VOLUME" issue of the new

Encyclopaedia Britannica, sample pages, bindings, prices, terms, etc.

2. Order form, which I will sign on receipt.

Reserve one set for me. \$1 enclosed as first payment.

Name \_\_\_\_\_

Address \_\_\_\_\_

18

A pamphlet describing the work in this popular and attractive form has been prepared for free distribution. Check "1" on the coupon and we will send the booklet as soon as we get your coupon. It contains sample pages, color reproductions of bindings, details of prices, terms of payments, etc. Check "2" on the coupon and mail it with \$1.00 to reserve a set.

# CLASSIFIED ADVERTISEMENTS

WORLD'S BEST WANT AD MEDIUM

We have records to prove that a classified ad in these columns will find a buyer for almost anything which can be sold. Doubtless you have some article of value to some one else which you no longer need. Why not turn it into money?

Advertisements in this section, 15 cents per word, each insertion, minimum 10 words, payable in advance. To insure ads being inserted under proper classified head in the April issue, copy must reach this office not later than March 1st.

Popular Mechanics Magazine, Chicago, Ill.

Gentlemen: We have used Popular Mechanics classified advertising space for a number of years, and we have found it to pull better than any one of the fifty or more other magazines in which we have used advertising space. If there were about a half-dozen magazines like Popular Mechanics, the problem of successful advertising would be solved; but, as there is only one Popular Mechanics, we always use it first when we appropriate for classified advertising. Very truly yours,

WALWEN COMPANY.

## AUTOMOBILES

COME to Seattle, the gateway to Alaska and Orient. Learn practical electrical, gas, steam engineering, mechanical drawing, machine-shop practice, automobile construction. Splendid openings for ambitious students who are competent. Seattle Engineering School, Seattle, Washington.

**AUTOMOBILE Repairs**—Automobile owners, Garages and Repairmen should subscribe for the Automobile Dealer and Repairer; 150-page illustrated monthly devoted exclusively to the care and repair of the car. The only magazine in the world devoted to the practical side of motoring. The "Trouble Department" contains five pages of numbered questions each month from car owners and repairmen which are answered by experts on gasoline engine repairs. \$1 per year; 15 cents per copy. Canadian subscription, \$1.50. Postals not answered. Charles D. Sherman, 30 Windsor Road, Hartford, Conn.

**DRY Clean and Polish your Automobile** like new, in one-fourth the time and one-fifth the work it takes to wash it. Costs only ten cents to do it. Over one hundred per cent profit if you wish to make and sell it. One dollar for the formula. Rifle, 44 West Mansfield, Ohio.

**FOR Sale**—Hupmobile Touring Car. Good condition, \$230 cash. C. J. Fischer, West Buellton, Iowa.

**FOR Sale**—Automobile Buggy just overhauled, \$65. Cash \$15, balance C. O. D. Harry Burk, Berwick, Pa.

**JUST Out**—Modern Starting, Lighting and Ignition Systems—A new book on automobile electricity without an equal. Nearly 400 Pages, 250 Engravings, Cloth. Price \$1.50 postpaid. Complete description sent on request. Popular Mechanics Book Dept., 6 N. Michigan Ave., Chicago.

**DOUBLE tread your old tires**; it's easy; 50c per tire. Just the thing for winter wear. Particulars free. Tire Trading Company, Newark, N. J.

**AUTOMOBILES** at rock bottom prices. Overhauled and Repainted. \$100 down; we ship the car, balance on easy monthly payments. Eureka Auto Co., Rebuilders, Dept. 26, Beavertown, Pa.

**GET into the Automobile business**, as salesman, chauffeur, garage manager, mechanic. Automobile instruction in four weeks' residence course. Send for booklet P. M., West Side Y. M. C. A. Auto School, 318 West 57th St., New York.

**COULD You Sell Gasoline** at 2½ cents a gallon? If so, sell Carbonoid to automobilists for \$1.00; costs \$4.00 dozen, \$1.00 tube equivalent of 40 gallons of gasoline. Removes carbon. Sample 50c. Gasoline going up. Carbonoid Chemical Works, Asbury Park, N. J.

**CYLINDERS** reground, new pistons and rings fitted. Restores lost power. Prompt and efficient service given. Write for prices, giving make and model. The Everts Machine Company, No. 20 Hicks St., Hartford, Conn.

**CYLINDER grinding of the finest quality**; accurately made light pistons and perfect rings inserted. Prompt service assured. New Haven Machine Corp., New Haven, Conn.

**PAINT Your Car Yourself**—Save \$25 to \$75 by doing the work at home with the Arsenal system. Our big free booklet "The Car Beautiful" tells how. Send for it today. Arsenal Varnish Co., Dept. P, Rock Island, Ill.

**AUTO owners and garage men!** Do your Radiators leak? Good formula for compound, also valuable information on Radiators 50c. E. W. Jenny Co., 3823 W. 34 St., S. W., Cleveland, O.

"STANLEY Steamer" 10 hp. New tires. All condition. \$550. N. V. Shane, Jesup, Iowa.

**WRITE Lake Specialty Co.**, Detroit, Michigan, for greatest auto chain connector made. Salesmen, Agents, Jobbers, wanted.

## AUTOMOBILE SUPPLIES

**THE Oxygenerator**—Permanently attached to your engine, automatically removes carbon, saves fuel (10 to 20%), increases power (10 to 15%), no additional cost for operation, nothing to wear out; in use 365 days in the year. Passed by all technical societies—a sale whenever shown. Owners of autos, regardless of make of car, investigate. Price \$5.00. Salesmen wanted everywhere. The Oxygenerator Co., 1510 Ft. Dearborn Bldg., Chicago, Ill.

**DOUBLE Service Tires**. Guaranteed 3,500 miles. Size 30x3 \$5.00, 30x3½ \$6.00, 32x4 \$8.30, 34x4 \$9.00, 36x4 \$9.00, 36x4½ \$10.00, 38x5 \$11.00, 37x5 \$11.00. Non-skid \$1.00 extra. 10% special on C. O. D. orders. State if Q. D. straight bead or clincher type. Special discount to dealers. I. Jaffee, 1319 H. Fifth Ave., New York. Branch 282H. Halser St., Newark, N. J.

"GIDZ." The Modern Auto Fuel: A saving of 20 to 35% in fuel cost. "Gidz," a fuel for increasing efficiency of gasoline engines. One cent per gallon; removes carbon without dangerous motor stimulants; no mixing, measuring or waste. Used from Maine to California, Alaska to Cuba. 100 Tablets \$1.00 prepaid. Agents wanted. Fred M. Giddings, Manufacturer, Wholesale and Retail (no samples), 63 E. Simmons St., Galesburg, Illinois.

**BUILD your own top and save one-half**; we furnish complete knocked-down frames with roof and back curtain; ready to put together. Recover your old frame yourself. We furnish all materials. Roof and back complete Ford Touring \$6.45, Ford Runabout \$5.45. A. A. Top Mfg. Co., 1451 Washington Blvd., Chicago, Ill.

**GASOLINE** reduced 25%. Motor efficiency increased every way. Guaranteed with Parker Vaporizer. Highly successful. Sent on 15-day free trial. No money required for test. Pay when satisfied. Postal request will do. C. Parkop Mfg. Co., Philadelphia, Pa.

**PELLET'S Magneto Exchange** is the oldest and largest concern in Automobile Ignition and Lighting lines. We guarantee all work and only genuine parts used direct from the manufacturers. 1696 Michigan Avenue, Chicago, Illinois.

**FORD Motor \$50; 2-Cycle Engine \$20; De Luxe Searchlight \$3.** Get my list. E. J. Barber, Springfield, Vt.

**GOOD Man, every county**, to manufacture and supply agents with Gas-Aid. Equals gasoline at 3c a gallon, eliminates carbon. Increases mileage, big demand. Mac-O-Chee Mfg. Co., West Liberty, Ohio.

**2 SPARK Bosch, 20-Hp. Flanders motor, \$75. 25-Hp. Buick motor \$130. Bosch Magnetos \$20. Chalmers 20 Unit Power Plant \$125. Model M Velle Motor \$100. 3-speed Brown Lippe trans. \$30. Repairs for 200 different old model autos. Auto Salvage & Parts House, 1438 Wabash Ave., Chicago, Ill.**

**H. B. STOCK Cabinets** save time and parts; made from oak and steel, cost little. Write for folder. Hobart Bros., Troy, Ohio.

**NEW Spiltdorf model X magneto \$9.00**; newly remount coil for same \$9.00; Spiltdorf four-unit vibrator coil \$5.00. H. C. Featherstone, Fergus Falls, Minn.

**A WRITTEN guarantee for 5,000 miles** without puncture. European Motorists are setting 10,000 miles out of their tires by increasing them about one-half inch in size. In eight months 20,000 American Motorists have followed their example. It's so easy that you can do it in your own garage in thirty minutes, no matter what condition your tires are in. Send for free catalog, sample and copy of guarantee. Colorado Tire & Leather Co., 343 Tread Bldg., Denver, Colo.

**ONE Bottle Wood's Auto Polishing Cream**, guaranteed to make and keep your Automobile looking like new a whole year for one dollar prepaid; it does not gum nor gather dust; it preserves the enamel. Agents wanted; no free samples. Wood Auto Polishing Co., Galesburg, Illinois.

**RECTIFIERS for garages.** All sizes. Charge one to eight batteries, \$12 upwards. American Battery Company, 1120 Fulton St., Chicago.

**JUBILEE Spark Intensifier.** Newest automobile specialty. Banishes spark-plug trouble. Sells on sight. Whirlwind success. Fortune to agents. Write quick. Jubilee Mfg. Co., Dept. P, Omaha, Neb.

**MOTORS, 4½ by 5, 4-cylinder, new.** High-class, Rutenberg design. Manufacturing cost \$220. Closing out sale \$95. 237 Collins Ave., East End, Pittsburgh, Pa.

**IF interested in Maxwell two-cylinder** touring-car parts, write W. H. Talcott, Cortland, N. Y.

**STEAM Vulcanizer, capacity \$120 in ten hours.** Garage size. Complete with set of tools \$75. I teach you free. N. M. Anderson, Mgr., Worthington, Ind.

**BIG profits from Battery Chargers.** Engine or Lighting Current operates. Easy payments. Hobart Brothers, Troy, Ohio.

**FOR Sale**—Two-cylinder twelve-horsepower Maxwell Automobile engine with transmission; good condition. Top, lamps, wheel, coil. Address P. O. Box 25, Morton, N. Y.

**OUR Double-Tread Tires are Guaranteed** (written) for 3,500 miles. Two tires in one. Big, strong, extra heavy. 30x3½, \$7.00; 34x4, \$9.25; 36x4½, \$12.00; 37x5, \$13.00. Big saving on other sizes also. Send for list now! State size and type rim. Max Liban & Company, 265B West 48th, New York.

**MOUNT power vacuum cleaner on your auto.** Buy parts, assemble. \$30 cost—earns \$15 daily. Vacuum Supply Co., Ann Arbor, Mich.

**ALL makes engines, magnetos, cylinders, pistons, carburetors, wheels, bearings, etc., and all auto supplies at very lowest prices.** Atlantic Supply Co., Long Branch, N. J.

**SPARK Plug trouble? Pronto Spark gaps** will fire any plug, in any condition, every time. Inexpensive—the most gladly accepted motor accessory ever invented. Salesman, you've hit it. Ask us. Pronto Manufacturing Co., Omaha, Neb.

**VULCANIZER for shop.** Bargain. Vanderpool's, Springfield, Ohio.

**ACT quick!** Automobile gasoline going up. Sell "Gas-Tonic." Equals gasoline at 3c a gallon, eliminates carbon. Dollar an hour profit. Sales guaranteed. White Mfg. Co., Dept. M, Cincinnati, O.

**SASH-BOARD Primer** starts your motor instantly, or saves self-starter from complete ruin. Chamois Strainers, carry one in gasoline tank. Hugh Keenan, West Mystic, Conn.



## Because

*I want ambitious men to become high salaried Draftsmen through my practical working training—therefore:*

# I Will Give You This Set of Drawing Instruments

The Chief Draftsman of a large and well-known company will give you this complete draftsman's outfit absolutely free. It does not cost you a penny. Besides these Imported regular draftsman's instruments shown here, I also give you absolutely free a 20x25 inch drawing board, a 24-inch T-square, a draftsman's triangle rule, supply of drawing paper, 2 triangles and French curve, pencils and erasers, drawing thumb tacks, etc., in fact a complete and first-class regular Draftsman's Working Outfit as soon as you enroll. This is just the same kind of an outfit I use myself. Genuine working instruments. You could not get this outfit for less than \$15. But now on this special offer, I will give it to you absolutely free.

## And Train You For a \$200 Position

I am Chief Draftsman of an old and well known company. There is a constant demand for trained draftsmen all over the country and I will give you just the kind of training that will qualify you to hold one of these big paying positions. \$125 to \$200 a month straight salary is an ordinary pay for a good draftsman. I will give you just the kind of training that you need to hold one of these fine jobs, right in your own home during your spare time. I know the kind of training that you must have in order to get the highest salary—and that is just exactly the kind of training that I will give to you. During the last twenty years I have trained some of the highest paid men. Their success in the profession is well known. You can do as well—or better than they.

### SPECIAL!

For a limited time I am making a special price offer in order to complete a new class ready to start. Send for free book at once, today.

## Send Me the Coupon For FREE New Book

Put your name and address in the coupon or on a letter or postcard now and send to me at once for my new book "Successful Draftsmanship." Find out about the golden opportunities that await you in our profession. Find out how you can get just exactly the kind of training that you need to hold a position paying from \$125 to \$200 a month at once. Absolutely no obligations in getting the book. Just put your name and address on the coupon. But send it now—immediately while I am making this special offer.

**Chief Draftsman Dobe**  
Engineer's Equipment Co.  
Division 1193, CHICAGO, ILL.

Without any obligation to me whatsoever, please mail your book "Successful Draftsmanship," and full particulars of your liberal "Personal Instruction" offer to a few students. It is understood that I am obligated in no way whatever.



Name.....

Address.....

**CHIEF DRAFTSMAN DOBE**  
Div. 1193, Engineer's Equipment Co., Chicago

Please Mention Popular Mechanics



**MAKE** your automobile pay. Attach Vacuum Cleaner to your automobile wheel, go into the Carpet Cleaning Business, earn an income of \$15.00 a day upwards. Thurman Vacuum Cleaner Co., Dept. A, St. Louis.

**TWO** cylinder Metz Engine with magneto \$30.00, two cylinder Ford 17 Horsepower \$25.00, Fitchburg Shaper 1800 lb. \$75.00. Sibson, Marshall, Ill.

**EXPLOSION** Whistle, Fits priming cup. Most powerful signal made. Rapid seller owing to real value. Ruell Manufacturing Co., 1141 E. 46th St., Chicago.

#### TO FORD OWNERS

**TURN** your Ford Runabout into business vehicle without spoiling appearance. All-steel utility bodies take the place of turtle back. Made like a steel safe with shell for packages. Price \$17.50. Ambrose Beard & Son, Detroit, Mich.

**WANTED**—Ford car owner in every county to demonstrate the \$10 Dado Ford Starter; \$30 to \$50 weekly. Write at once for 1916 territory to Dado Ford Starter Co., Keene, N. H.

**THE** American "Ford" Owners Association, National Headquarters, Albany, N. Y., will mail free, 100-page sample copy of their "Official Monthly" on receipt of your address.

#### FORD ACCESSORIES

**IF** you had paid \$12.00 for a starter which exactly suited you after you had tried it thoroughly on your Ford, would you have it taken off your car for \$20.00? Of course not. That's why we send "Startford" C. O. D. \$12.00 total, including express, allowing one-week's trial, instructing Express Company to return your deposit if you return Startford. Test in cold weather, then you know. Salesmen wanted. Liberal commission. Symons Brothers Co., Winnetka, Ill.

**"STEEL** Relief" for Fords. Best accessory, and Ford owners want it. Gives comfort, safety. Big money for agents. Sample \$5, prepaid, with ten-day return privilege. Post & Carr, New London, Ohio.

**STOP!** Look! Read! Exclusive territory open. Every Ford owner wants a "Henes" Atomizer and Economizer. Sells for \$2.50. Big profits. Write now. Henes Sales Corporation, 462 Deming Pl., Chicago, Ill.

**SPECIAL** Offer. Bear Curtain Light for Ford Cars. Attached without tools. 75c per foot. Ideal Mfg. Co., Sabina, Ohio.

**NEW** Ford valve spring remover. Saves time. Sixty cents prepaid. Agents wanted. Bend, Levi, 337 W. Wray, New York.

**TIRE** tool, best made; will loosen the most rusted tire from the rim in an instant. Ford size, \$1.00; your money back if not satisfied. Frank Woodhead, Glen Riddle, Del. Co., Penna.

**REPAIR** Parts for Ford Cars to the trade only at prices that are money-makers, and quality, fit and workmanship guaranteed. Grossman Auto Parts Company, White Plains, N. Y.

**H. & D. SHOCK** Absorbers, \$6.00 set four, formerly \$12.00. Agents wanted. L. M. Peterson, Cambridge, Minn.

**FORD** Owners, owing to greatly increased sales, we have decided to reduce the wholesale price of our celebrated Safety Ford Starter; our price complete \$4.50. Send nine dollars for two starters. Safety Ford Starter Corp., 701 Seventh Ave., N. Y.

#### GYCLECARS AND MATERIAL

**FOR** Sale—Cyclecar parts, very cheap. These are parts of a well-known successful car. Motors, wheels, transmission, axles, etc. Triune Engineering Co., Inc., Owego, Tioga County, N. Y.

**WANTED**—Motor and parts for building a cyclecar. Give full descriptions, etc. Box 381, Hespeler, Ontario.

#### MOTORCYCLES, BICYCLES & SUPPLIES

**MOTORCYCLES** \$35 to \$175, all makes and models, 150 to pick from. Write today; save money by buying now. Largest motorcycle store in the world. Laster Motorcycle Co., Cleveland, Ohio.

**USED** Motorcycles from \$25 to \$200. Money refunded if machine not satisfactory. Write for list today. C. H. Lang, 1704 Michigan Avenue, Chicago.

**BIG** bargains in second-hand motorcycles, \$25 up. Indians, Harley's, Thors, Excelsiors and Metcals. Write for description. Howard A. French & Co., Baltimore, Md.

**MOTORCYCLES** and Accessories. Henderson, fully equipped, \$100; Indian Racer, new tires, compensation sprocket, \$65; 1913 Excelsior, 3-speed, Stewart-Warner horn, Fentress Newton tandem, speedometer, Demonstrator, \$110, Snap, Bosch Magneto to fit any motorcycle, \$10; Heitger Carburetors, \$3.95; Spark plugs, 25c; Folding foot rests, fit any motorcycle, \$3; Tires, Nobby Tread, \$5.50; tubes, \$1.25; Grips, 25c. One hundred used machines. Ask for February Bargain Bulletin. Largest Motorcycle store in United States. Exchange any goods not satisfactory or money refunded. W. E. Wandersee Co., 129 Grand Ave., Branch store, 2996 Woodward Ave., Detroit, Mich.

**DON'T** buy a Bicycle Motor Attachment until you get our catalogue and prices. Shaw Mfg. Co., Dept. 27, Galesburg, Kansas.

**1915** 3-SPEED Excelsior and Rodgers Sidecar, \$225; 1914 Excelsior, \$90; 1913 Indian, \$75; 1911 Emblem, \$40; 1911 M. M., \$30. H. Hendrickson, Greenville, Pa.

**TWIN** Excelsior, almost like new, tandem, \$150. Geo. Laatsch, Altamont, Ill.

**1913** TWIN X, guaranteed in perfect mechanical condition and running order. Fully equipped. \$85.00 cash buys it. Send money, care Popular Mechanics, J. G. Adler, 1947 W. Madison St., Chicago, Ill.

**CLOSING** out stock of second-hand motorcycles at half their value. Sold on easy payments; send for big list. Howard Cycle Co., 152 N. Broad St., Trenton, N. J.

**HARLEY**, belt '11, \$30. Bargain list, 1,000 articles, for stamp. Palek, 2719 E. 35th St., Cleveland, Ohio.

**TWENTY** overhauled Motorcycles, \$50 up. Thors, Indians, Harley's, Excelsiors, etc. H. R. Sawyer, 18 Fleet St., Haverhill, Mass.

**FOR** Sale—1913 Twin, Indian, Excellent condition, \$75. Wm. Houston, Charlestown, Pa.

**1912** MERKEL 8, twin clutch. Fine shape, \$65. Wm. Fleming, Corsica, Pa.

**MOTORCYCLE** Bargains! 1915 Indian twin, Presto tank, lamp, 2-speed, \$145; 1913 Excelsior twin, new tires, like new, \$90; 1914 9-b, p, twin Thor, 2-speed, \$140; 1914 Pope twin, brand new, used less than 500 miles, \$100. Free list, 100 others, \$25 up. Western Supplies Company, 1448-52 Larimer St., Denver, Colo.

**REAL** Bargains—1912 Excelsior single magneto, \$50. 1912 Indian single magneto, \$30. 1910 Thor single battery, \$35. Thor belt drive, \$30. 1912 Thor 7 twin, \$80. Overhauled this winter and ready to use. Send \$10 with order. Anderson's Motorcycle Store, Batavia, Ill.

**SEND** for list of guaranteed used motorcycles. \$40 up. Driscoll & Jeanroy, 209 West 126th St., New York City.

**EASY** terms on rebuilt motorcycles—get new list P 1, \$25 up. Rebuilt Motorcycle Co., Brockton, Mass.

**EXCELSIOR** Light-Weight; will sacrifice \$55. M. B. Faxon, Brookville, Mass.

**MERKEL** Twin—Needs repair—\$20. G. P. French, Melrose Hds., Mass.

**1915** EXCELSIOR 10-H.P. Special \$190; worth \$150. Need the money. Herbert Beal, Abington, Mass.

**UNCLE** Sam does business with us; this should convince you our prices are right. Fifty rebuilt motorcycles, all makes; send for catalogue. United States Motorcycle Co., Abington, Massachusetts.

**A** REAL bargain in second-hand motorcycles. We have an overstock of all makes, such as Indians, Harley-Davidsons, Excelsiors, Pops, Reading-Standards, Merckles and 4-cylinder Hendersons. All are in A-1 condition and fully equipped. If interested in buying a motorcycle, write for our complete list giving description and prices, which is about 1/2 of their real value, \$225 new 1915 twin cylinder Flanders motorcycle, \$138.50. (Catalogue upon request.) Gotham Sporting Goods Co., 37 Warren St., N. Y. City.

**SAVE** one-half on repairs and accessories for all makes. Get circular. Jones "The Paris Man," Brockton, Mass.

**USED** Motorcycles in good running order. Guaranteed. \$25 up. Many makes, all bargains. Send for list. Seeber and Hofheims, Buffalo, N. Y.

**WANTED:** We pay cash for used motorcycles or take them in on exchange for new machines. Write with complete description. State condition of tires, frame, motor, make and model. Shaw Manufacturing Co., Dept. 157, Galesburg, Kans.

**REBUILT** Motorcycles, new parts for all makes 30% discount; second-hand parts, good as new, 50% discount. We buy motorcycles; let us know what you have. Motorcycle Parts Mfg. Co., 2127 Michigan Avenue, Chicago.

**FOR** Sale—4-horse Indian, first-class condition, a bargain for \$37.50, Cash or C. O. D. Newton Cycle & Engine Co., Box 59, Newton, Iowa.

**FOR** Sale—1915 Indian 3-speed and side car, electric equipped. Anton Landergatt, Crandon, Wis.

**1914** SINGLE Harley-Davidson. Perfect condition. He ry Ross, So. Shaftsbury, Vt.

**BRAND** new motorcycles, standard makes, on easy terms—descriptive circular free. Smith, 610 Center St., Brockton, Mass.

**SPRING** Clearance Sale 46 Bargains \$20 up. Bulletin on request. Ludden & Whitten, Brockton, Mass.

**100** MOTORCYCLES \$15.00-\$200.00. Installments. Knights, 3321 Locust, St. Louis, Mo.

**BARGAIN**—1914 Indian and Motorbob. Write. Ben Ferguson, Crandon, Wis.

**MOTORCYCLE** bargains, list free. Latho wanted. C. Russell, Box 92, Milton, Iowa.

**1915** THREE Speed Big Twin Indian Demonstrator. In line shape. \$195. L. R. Smith, Logan, W. Va.

**BARGAINS**—Used motorcycles and motorwheels. Edward Ryan, Poughkeepsie, New York.

**INDIAN** Light-Weight Twin, speedy, \$60. Your opportunity. Cashier, 24 East Elm St., Brockton, Mass.

**FOR** Sale—One twin motor \$25, one single \$15, equipped with Bosch Magneto and carburetor, also fifty used motorcycles. Little Falls Motorcycle Co., Little Falls, N. Y.

**TWO**-speed Thor 9, half price. \$80 Phonograph \$25, Records 10c. Box 240, Ottumwa, Iowa.

**MOTORCYCLE** cylinders reground, fitted with new piston and rings \$5.00, guaranteed. Muncie Piston Co., Muncie, Ind.

**UNUSED** Flexible Sidecar with rigid attachment fittings, \$45.00. Thomas Dunham, Aurora, Ill.

**SEND** for latest Bulletin of real Motorcycle Bargains, used and slightly used, all makes, models and prices; if you have \$25 and really want a powerful Motorcycle, send for this Bulletin; hundreds of machines at all prices, new ones on easy payments; tell us what you want and how much you can pay; we can fix you up. Peerless Motorcycle Co., Dorchester, Mass.

**SEND** for list of used Indian motorcycles. Every one overhauled by expert workmen, and guaranteed right. Geo. H. Buchelder, P. O. Sq., Lowell, Mass.

**NEW** Motorcycle Book—Just Published—Motorcycles, Side Cars and Cyclecars, Their Construction, Management and Repair—550 pages, cloth, 350 illustrations. The Dealer, Mechanic and Rider will find this treatise a work of reference without an equal. Price \$1.50 postpaid. Popular Mechanics Book Dept., 6 N. Michigan Ave., Chicago.

**SUPPLIES**—Our big catalogue with prices lower than usual sent free to motorcycle owners. Meco, Hammondsport, N. Y.

**BIG** bargains in good motorcycles we have taken in exchange on new ones. Send for special bargain list. Shaw Mfg. Co., Galesburg, Kansas.

**WANT** to sell your motorcycle? I have a method which has sold many. Write me today for free information. F. W. Johnson, Room 994, 78 E. Madison St., Chicago.

**BARGAINS** in second-hand Motorcycles—Indians, Reading Standard, Harley-Davidson, etc. Send for price list. John G. Naehling, Reading, Pa.

**1915** TWIN Merkel 1/2 New \$75. D, 1400 West 25th, Cleveland, Ohio.

**1914** INDIAN twin, good condition. Electric equipment \$150. Tracer Shepard, Bradford, Vt.

#### PERSONAL

**BROTHER**—Accidentally discovered root cures tobacco habit. Gladly send particulars. F. Stokes, Mohawk, Florida.

**FOR** identification carry German Silver Key Chain with name and address, 20 cents. Key ring 5 cents. Belco, Martinsville, N. Y.

**FREE**—Stop using Tobacco. Free. We will give free information how to conquer the habit easily and permanently. Results Guaranteed. Anti-Tobacco League, 618 Paxton Block, Omaha, Nebr.

## WELDING

**ATTENTION**, Automobile Mfrs., garage men, repair and welding shops. Amateurs made expert welders—welding made easy for experts. So-Luminum, the new, great welding compound for aluminum. Runs low temperature—no flux—gasoline torch only thing required— $\frac{1}{4}$  time and cost of old way of welding—no parts taken out of alignment—no life taken out of metals. Used by U. S. Navy and Army, Vickers, Ltd. of England, International Motor, and hundreds of largest manufacturing, automobile, aeroplane and welding companies. \$1.50 sample bar, \$3.50 per lb. Guaranteed strongest, cheapest and best aluminum solder ever discovered. So-Luminum Mfg. Co., 1790 Broadway, New York, Sole Manufacturers and Distributors.

**OXY-ACETYLENE** Welding and Cutting apparatuses, Acetylene generators for welding. Our prices will surprise you. Hamilton Welding & Mfg. Co., Hamilton, Ohio.

**COMPLETE** Acetylene Welding Equipment, including gas. Tanks loaned in Central West. Write for printed matter. S. Campbell, 819 Cass Ave., St. Louis, Mo.

**WELDING** Plants. \$25 to \$250. Liberal terms. Write Berzoo Co., Omaha, Neb., U. S. A.

**BRAZING** Torches forty cents each, Welding Torches ten dollars each, postpaid, guaranteed. Auto Welding Company, Omaha, Neb.

**OXY-ACETYLENE** Welding and Cutting is the title of a brand new practical instruction book on the methods of doing this work. It includes the operation and care of Acetylene Generating Plants and the Oxygen Process for removal of carbon. 200 pages, 76 illustrations, pocket size, cloth, \$1.00; leather, \$1.50 postpaid. Popular Mechanics Book Dept., 6 N. Michigan Ave., Chicago.

## AERONAUTICS

**AVIATION** Motors, all makes, up to 150 H.P., \$250 up. Complete aeroplanes, all types, \$500 up. State your needs. Aero Exchange, 38 Park Row, N. Y. C.

**THE** Benoist School of Aviation announces a new Correspondence Course. A thorough training in Aeronautical Construction and Engineering. For particulars write The Benoist School of Aviation, Correspondence Department, 1201 Webster Building, Chicago, Ill.

**FOR** Sale—60 H.P. Aeroplane Motor in good condition, and reasonably priced. L. B. 473, Harlan, Ia.

**BLUEPRINTS**, tractors, flying boats, \$5.00. Monoplanes \$2.00. Chicago Aero Works, Chicago.

**BICYCLE** monoplane drawings, 25c. No stamps. Elmer Hammel, Raspeburg, Maryland.

**FOR** Sale—New 60-H.P. Aerial Maxi 4-Cylinder Motor. Engman-Matthews, South Bend, Ind.

**SEVERAL** Goodyear Aero rims, tubes and outer casings, new, slightly soiled. Bleriot springs, large \$2, small \$1, solid rubber. The Aero Mart, Chicago.

**MILITARY** Tractor \$150. Trade for Motor. Art Roza, 2139 S. 52nd Ave., Chicago.

**GET** our 1916 Aeroplane Book containing full information about "Ideal" Model Aeroplanes, parts, plans, etc. 5c postpaid. Ideal Aeroplane Co., 82 $\frac{1}{2}$  West Broadway, N. Y.

**AVIATION** School, will open at Sandusky, Ohio. Enroll now. Pay after you have learned. Andrew Lambdin, Lefor, N. Dak.

**TRADE**—Thrashing machine for Aeroplane. John T. Johnson, Columbus, Nebr.

**FOR** Sale—Bleriot Monoplane—Curtiss Biplane—Bargains. W. Banning, Lorain, Ohio.

**BARGAIN** Sales in New and Slightly Used Aeroplanes, Motors and Accessories. The Aero Mart, Department G, 327 South LaSalle Street, Chicago.

**WRITE** for our special flight course; we furnish machines and dates for our students. Spruce Ash finished parts and metal fittings to order. Northern Aircraft Co., 311 Center Ave., Bay City, Mich.

**TURNBUCKLES**; all sizes, immediate delivery. National Aeroplane Co., Machinery Hall, Chicago, Ill.

**LIGHT** Weight Gasoline Engines, 2 $\frac{1}{2}$  lbs. Guaranteed  $\frac{1}{2}$  H. P. The Weiss Co., Torrington, Conn.

**CATALOG "H"** off the press, most complete aeronautical catalog ever published, sent for 6 red stamps. Motor Catalog 8c; propeller catalog, 6c. Heath Aerial Vehicle Co., Chicago.

**BUILDING** and Flying an Aeroplane—160-page handbook covering the building of small models and full sized gliders and machines. In both biplane and monoplane models the well-known Curtiss and Bleriot types are followed. Fully illustrated with detail drawings. Price, \$1 postpaid. Popular Mechanics Book Dept., 6 N. Michigan Ave., Chicago.

**HOW** to Make a Biplane Glider—Our book "Amateur Mechanics No. 2" contains a complete detailed description of how to make one. Price of book 25c postpaid. Popular Mechanics Book Dept., 6 N. Michigan Ave., Chicago.

## BOOKS AND PERIODICALS

**PERSONS** Interested in Drafting or Engineering—send stamp for sample copy of "The Compass," devoted to topics of interest to the Drafting and Engineering Professions. Office 304, McLachlin Building, Washington, D. C.

**NEW** Mathematical System—"Herrick & Horton's Comparative Cancellation Calculator." Solves all problems in one solution. Large saving of figures. Easily learned. Easily applied. 150 pages. \$1.00 postpaid. Herrick & Horton, Publishers, Princeton, Ill.

**MAGAZINES** and newspapers. My free catalogue lists 500 periodicals at less than publishers' prices. H. G. Mosher, Schell City, Mo.

**POISON** Ivy. Send \$1.00 for Scientific book illustrated. Learn to identify it, and to cure the worst case of poisoning. A. O. Huntington, Jamaica Plain, Mass.

**BOOKS** on easy payments. Literature free. Aurora Mail Service, Aurora, Illinois.

**BOOKS**, wholesome, instructive and entertaining. Puzzles, Tricks, Novelties. Illustrated catalogues, fine sample trick all for 10c. Auburn Supply Co., Dept. 3B, 7817 Peoria St., Chicago.

**MECHANICAL** Instruction Books. Best published. Lamont Co., Beacon, N. Y.

**ABOUT** South Florida—The Tropic Magazine, Miami, Florida. Copy, ten cents.

**FORD** Joke Book. Screamingly humorous. 10c. Richard Lavery, Asbury Park, N. J.

**MAGAZINES**, lowest prices; write for catalog. Mederic Gaulin, Box 152M, Woonsocket, R. I.

**INTERESTING** Book revealing Character Reading, Palmistry, Astrology, Indian Secrets, etc., 10c. Harmonica Self-Instructor, complete, 15c. G. Elser, Owosso, Mich.

**BOOKS** in modern fiction, Catalogue, 2c. Duff, 2713 Mozart, Chicago.

**BUILD** Yourself a Boat, a Racing Cat or Speed Launch. Send for catalog. Yacht and Boatbuilding Books. Read "The Rudder," the Magazine for Yachtsmen. The Rudder Publishing Co., 256 West 34th Street, New York, N. Y.

**SHOE** Repairing Self Taught. It's easy, interesting, profitable. Price, fifty cents. W. J. Shuman, North Second Street, Chambersburg, Pa. Write for contents.

**PRACTICAL** Hand Books. Automobile Troubles—Gas Engine Troubles—Electric Starters—Ignition and Valve Setting tables. Send for complete catalog. Charles C. Thompson Co., 509 Plymouth Court, Chicago.

**USED** BOOKS—Extraordinary Bargains. Catalog. Higens's, A-2441 Post, San Francisco.

**METAL** Work and Etching—A 96-page hand book for art metal workers telling how to make a great variety of useful and ornamental objects, such as desk sets, art-crafts, jewelry, etc. Price, 50c postpaid. Popular Mechanics Book Dept., 6 N. Michigan Ave., Chicago.

**BINDER** for Popular Mechanics magazines. Best adjustable magazine binder on the market made especially to hold any number from one to six copies of this magazine with name "Popular Mechanics" in gold letters on front cover. No laces or cutting or perforating of pages necessary. Simple, unique adjustment; handsome, durable and neat. We buy in quantities and can offer our readers this regular \$1.50 binder for \$1.25, all shipping charges prepaid. Address Popular Mechanics Book Dept., 6 N. Michigan Avenue, Chicago.

**READ** these great books about the War: 1. Germany and the Next War, by Gen. F. Von Bernhardi (discloses Germany's war plans for crushing England and France. Price 85 cents). 2. Secrets of the German War Office (by A. K. Graves, for twelve years a spy in the Kaiser's service. Price \$1.60). 3. Germany's Fighting Machine (by E. F. Henderson. Divided into three parts. The War, The Army and The Navy. Price \$1.35). 4. Men Around the Kaiser (by F. W. Wile. Tells about those men who figure most prominently in the affairs of Germany at the present time. Price \$1.35). 5. The Germans (by I. A. R. Wylie. A graphic picture of the German people in the eye of the great conflict. Price \$2.15). 6. The War and America (by Hugo Munsterberg, the great German-American. Price \$1.10). 7. War's Aftermath (a study of the deterioration of the quality of stock occasioned by the lamentable waste of war. Price 85 cents). Popular Mechanics Book Dept., 6 N. Michigan Ave., Chicago.

**FIFTEEN** books on Tractor Engineering and Tractor Farming written by experts and published by the largest company of exclusive tractor builders in the world. Sent on 3 days' free approval. No money to pay until you see the books and decide that you want them. This is a complete correspondence school course. Price for the set, \$3.50 or 25c for each book. Master these books and you can run a tractor. Jobs are waiting everywhere for expert tractor engineers. Send name and address. Hart-Parr Co., Box M, Charles City, Iowa.

**ENGINEERS'** questions and answers for license. By Hobson, for twenty-five cents, postpaid. Send stamps. Reilly's Book Store, Philadelphia, Pa.

## EDUCATIONAL AND INSTRUCTION

**STUDY** Bacteriology, Public Health, Hygiene and Sanitation. Positions pay \$3,000 to \$5,000. Interesting home study course. Previous experience unnecessary. Degree granted. We help secure positions. Write for prospectus. American College of Bacteriology, Dept. 201, Chicago.

**GOOD** Opportunities for Veterinarians. Send for catalogue. Grand Rapids Veterinary College, Dept. Z, Grand Rapids, Mich.

**CIVIL** Engineering, spring, summer and fall course. Technical Institute, Greenville, Ohio.

**CALCULATOR** for fractions, multiples, divides, adds, subtracts, absolutely correct. Send for special advertising sample, only 25c. Snyder Calculator, Meadville, Pa.

**LEARN** Inlaying, pattern with instructions, 10 cents. Olney Field, Stratton Park, Colorado Springs, Colorado.

**POOR** handwriting easily changed to good. Particulars free. D. B. Jones, Paducah, Ky., Route 3.

**LEARN** Mechanical Drafting. Cost small. Returns large. Individual instruction by expert. Garfield Drafting School, 543 West 13th St., New York City.

**MECHANICAL** Drawing, 50 cents each lesson, pay as you go. \$20.00 drawing outfit free. Genuine Blueprint lessons. Drawing paper and different data sheet free with each lesson. No contract to sign. Will assist you to secure position. Send for particulars and samples or remit 50 cents for first lesson. Albany Institute Mechanical Drawing, Desk 8, Box 81, Albany, N. Y.

**ARTIFICIAL** Marble Sanitary flooring, ornamental casting, concrete, plaster, papier-mache, interior decorations, garden furniture, statuary, life casting, elastic moulds, electro bronze depositing (immensely profitable work), complete instructions \$1; particulars, 200 illustrations free. Mahler, D-117 Russell St., Brooklyn, N. Y.

**PERSONS** desiring to become expert draftsmen at best salaries enroll in our mail instruction department. Genuine Al-tender drawing instruments free with course. (This offer for limited time only.) Get particulars. Mechanical Dept., Columbia School of Drafting, 10th and G Sts., Washington, D. C.

**PERSONAL** instructions in Show Card Writing by experienced man. Short course. Original methods, results guaranteed. C. J. McKie, Dept. M, Ypsilanti, Mich.

**MECHANICAL** Drafting and Machine Design taught by expert. Small cost, easy payments. Particulars free. Hayner, 3742 Elmwood, Chicago.

**"TRICKS** of Trades," Drawing, Lettering, Painting. \$1.00. Freeburn, Hicksville, Ohio.

**CRAYON** Portraits—Make them at home. Sample and instructions 20c. L. Dallas, Cambridge, Ohio.

**MOULDS** and models for ornamental casting of novelties, statuary, garden furniture, in cement, plaster, Italian marble, etc. Free illustrated catalogue displaying large assortment. Both, A-15 Frost St., Brooklyn, N. Y.

**SCIENTIFIC** Laws of Memory. Health and Personal Attractiveness—Simple—Practical. Send 20 cents. Trimount Supply Co., 30 Broadfield St., Boston, Mass.

**AUTO** Engineering, Chauffeur's and Mechanic's Course. Other courses: Steam and Gas engineering, Preparatory, Commercial, Penmanship, Stenography, Teachers' High School. Free tuition to one student from each Post Office. Write for catalog. Address, University of Southern Minnesota, Dept. M, Austin, Minn.

**NEW** Easy Shorthand and Touch Typewriting by Mail. Write Business Letters after Fourth Lesson. Preparation for Government work a Specialty. Attractive Proposition. Secure Particulars. Home Study School, 415 Caesar Misch Bldg., Providence, R. I.

**LEARN** profession that will give you a business of your own; possibilities unlimited; no job hunting after graduation, when you finish study business is all ready. We teach you free. Our new plan is yours free. Nat'Co, 4307 Lincoln Ave., Chicago.

#### TRADE SCHOOLS

**ELECTRICITY**, Plumbing, Bricklaying, Mechanical, Architectural and other Drafting Courses. Motion Picture Operating taught by practical work. Largest, best equipped practical trades school in America. Short time to learn. Small cost, easy payments. Write for big illustrated book; it's free. Coyne National Trade Schools, Dept. 8193, Chicago, Ill.

**THE** Benoit School of Aviation announces a new Correspondence Course. A thorough training in Aeronautical construction and Engineering. For particulars write The Benoit School of Aviation, Correspondence Department, 1201 Webster Building, Chicago, Ill.

**NEW** Handy Manual on Plumbing, Heating, Ventilating and Mechanical Refrigeration. A practical book for practical men. 280 pages fully illustrated with cuts and diagrams. Pocket size. Cloth. Price, \$1.15, postpaid. Popular Mechanics Book Dept., 6 N. Michigan Ave., Chicago.

#### TELEGRAPHY

**TELEGRAPHY**—Morse and Wireless—taught at home in half usual time. The Omnigraph Automatic Transmitter combined with sounder or buzzer sends you messages, any speed, just as expert operator would. Used by U. S. Gov't to examine all applicants for licenses. Trifling cost. Catalog free. Omnigraph Mfg. Co., 41-G Cortlandt St., New York.

**TELEGRAPHY**—Morse and Wireless—also Station Agency taught. R. H. and Western Union wires and complete Marconi Wireless Station in school. Graduates assisted. Marconi Co. employs our wireless graduates. Low living expense—easily earned. Largest school—established 40 years. Investment \$25,000. Correspondence courses also. Catalog Free. Dodge's Institute, 15th St., Valparaiso, Ind.

#### WIRELESS

**\$10** COMMERCIAL Keys for \$4. Massie Wireless Telegraph Co., Providence, R. I.

#### PICTURES, POSTCARDS, PENNANTS

**MOVIE** Stars' Photos. 605 players. 5x7, hand-colored; choice 3 for 25c. Shinn, 578, Reading, Penna.

**MEMBERSHIP** printed immediately 10c. Pacific Card Exchange, Bryn Mawr, Wash.

**RECEIVE** pretty view cards from many places. Membership and 6 pretty cards, 10c. Riverside Club, Knoxville, Md.

**EXCHANGE** pretty postcards with our members far and near. Best card club. Membership, 10c. Jolly Card Exchange, Eighth St., Decatur, Indiana.

**POSTCARD** Collecting, extremely interesting. Live club. Membership, including magazine stories, etc., 10c. Edite Exchange, R37, 3684 Milwaukee Ave., Chicago.

**IF** you really want to exchange postcards, try our splendid club. Lists circulate in many countries. Membership, 10c. Halcyon Club, Box 133, Erie, Pa.

**MAKE** new acquaintances. Join our postcard club. membership 10c. Worlds Postcard Club, 15 West 42nd, New York.

**206** ILLUSTRATIONS Free. Beautiful art casts. Mahler, K-117 Russell St., Brooklyn, N. Y.

**25** ASSORTED post cards, Views, Holiday Comic, etc. Postpaid 10c. Arthur M. Wheelpler, Belleville, N. J.

**"CHARLIE CHAPLIN"** post cards. Six cards and list of 400 others, 10c. Arthur Carlandere, South Yarmouth, Mass.

**COLLEGE** and state pennants, 8 1/2 x 2 1/2 inches, 15 assorted, 50c; 6 assorted, 25c., postpaid. Lynch Specialty Co., Joplin, Mo.

**9 OF** the most comical Felt Pennants in the world for \$1.00. Catalog for a stamp. Make your wants felt. Sykes Specialties, Los Angeles.

**POSTCARDS** from everywhere. Join our Jolly Club. Send 10c. H. J. Teeple, Decatur, Indiana.

**CROSS-SECTIONAL** view of ocean liner "Britannic," showing interior arrangement of ship in colors, size, 14x20 inches, on heavy plate paper for framing or hanging. Very interesting. Reproduced from front cover design of July issue Popular Mechanics. Will be sent postpaid to any address in the world on receipt of 4 cents in stamps to cover packing and mailing. Popular Mechanics Magazine, 6 N. Michigan Ave., Chicago.

#### CAMERAS AND PHOTO SUPPLIES

**IF** you have a High-grade Camera, Lens, Kodak, or Motion-Picture Camera, and want to turn it into cash, write us today. State particulars, price, etc. We buy and trade, sell or exchange everything in Cameras from Vest Pocket to Graflex. Prompt, satisfactory service and a square deal to all. David Stern Co., 1017M W. Madison St., Chicago, Ill. In business since 1885.

**THE** "Harvey Exposure Meter" is different from all other Meters. Gives exposures for Exteriors, Interiors, Night Photography, Paget and Autochrom Color Plates. Ask your dealer or write to Harvey, 105 S. Dearborn St., Chicago.

**PHOTOGRAPHS** without plates or film. Worked with focusing Plate Cameras without special apparatus. Particulars free. Emil Sprauer, Hamilton, Ohio.

**FILMS** developed, 10c; prints, 2c to 5c. A reputable Incorporated Company conducting largest existing plant. Price list and special offer. Enlargements our specialty. Chicago Photo Finishing Co., 54 W. Lake St., Dept. A, Chicago.

**HAVE** you a Camera? Write for samples of our magazines, American Photography and Popular Photography, which will tell you how to make better pictures and earn money. F. R. Fraprie, 703 Pope Bldg., Boston, Mass.

**PHOTOGRAPHIC** Retouching taught—Cheap course; learn at home. Y. & M. Retouching Co., Dept. M, Marshall, Mich.

**FILMS** developed, 10c per roll, prints 2c each, any size. Post cards 3c each. Prompt service. Allen Armour, Glendower, Virginia.

**8x10 ENLARGEMENTS**, 25 cents; postcard enlargements, 15 cents; send quarter with negative for sample 8x10 enlargement. S. R. Kitchin, Moscow, Conn.

**TRANSFER** pictures to china, etc.; no formulas; particulars, Filmm, 286 West 142nd St., New York City.

**FINE** view-camera and outfit at a bargain. W. Fuller, Newport, Ark.

**ROLLS** developed free. Cards, Prints, 3c. 8x10 negative enlargements 20c; 6, \$1.00. Get List. Sprauer, Stahlheber Road, Hamilton, Ohio.

**WE** buy, sell and exchange Microscopes, Telescopes, Binoculars, Cameras, etc. Send stamp for bulletin. Fine enlargements. Something new. Kahn Optical & Photographic Co., Inc. Founded 1850. 54 John St., New York.

**FOR** Sale—Complete 8x10 New York-Voigtlaender outfit. Chairs, grounds, carrier, etc.; cost \$300, will take \$100. J. I. Bowman, 710 Sherman St., Johnstown, Pa.

**VIEW** Camera complete \$50. Studio Camera complete \$75. Cards material. Make offer. Geneva Optician outfit, leather case, all eye testers. Cost \$175. Will take \$75. Hugh Tail, 3330 Beta Ave., Chicago.

**MAKE** wonderfully beautiful colored photo prints and enlargements by our remarkable new coloring process. Easy, fascinating and profitable. Outfit complete at trifling cost. Satisfaction guaranteed. Get information. Photokrome Co., Box 113, Scranton, Pa.

**"PICTURE** Making"—For pleasure and profit—\$1.25. Free catalogue Home-Study Books. Drift, 60 Washington, Chicago.

**EXPERT** Film Finishing. Our work pleases the most critical customers. Send film or negative with return postage for samples of our work; prices right. Gates Studio, Colebrook, N. H.

**FILMS** developed 10c, prints 3c, all sizes; work guaranteed and returned in 24 hours. L. Bell, 1052 3rd Ave., New York City.

**GET** my tanks, make big money developing films. Cost 1/4c per roll. Particulars free. Gillett, Roscobel, Wis.

**ARGO** rough, cyko gloss enlargements. 8x10, 35c; postal, 10c. Albert Gibson, 11 Sheldon, Chicago.

**KODAK** Films Developed, 10c per roll, any size. Prompt attention given mail orders. Prints, 2 1/4 x 3 1/4 to 3 1/4 x 4 1/4, 2c. 4x5 to 3 1/4 x 5 1/4, 4c. J. M. Manning, Box B, 1052 Third Ave., New York City.

**"RAYDIUM** Photolights" make winter photography dead easy. This month—a "Simplex" Flashlamp Free on Dollar orders for Photolights, Money-back Guarantee. Photo Chemical Co., Lincoln Park, Chicago.

**FREE** sample print from your negative. Films developed, ten cents. Postcard prints, four cents; smaller sizes, three cents. Hall Photo Finishing Co., Dept. C, Chapman, Kansas.

**PHOTO** Tent—complete—14x28. \$35.00. Used cameras, incubators, brooders, guns, books, etc., for sale or exchange. Special—Remington No. 6 typewriter, \$21.00, Berg Typewriter Exchange, Dept. P, Hendrum, Minn.

**GRAFLEX** outfit for sale. Wood, Oakdene Ave., Hackensack, N. J.

**EXTRA** Special Offer: 5x7 enlargements, plain, 20c. In colors, 35c. Prints and postcards, 3c. Money refunded if not satisfied. Kodak Finishing Company, 3159 Indiana Avenue, Chicago.

**"FOLLOW** the Bargains," get Erker's 1916 Camera and Lens Bargain Price List, all sizes used Kodaks, Premos, Graflexes, Motion Picture Cameras; every one guaranteed perfect. Erker's, 609 Olive, St. Louis, Mo.

**DONT** Cry Over Spilled Milk. Send your next batch of films to us. We'll develop and print them in an expert manner and charge you no more, maybe less, than you've been paying. Why not ask us for samples and prices! Barbeau's, 37 East Bridge St., Oswego, N. Y.

**FILMS** developed 10c, all sizes. Prints 2 1/4-3 1/4, 2c; 2 1/2-4 1/4, 3 1/4-5 1/4, 4c; Post Cards, 50c doz. Work guaranteed and returned 24 hours after receiving. Postpaid. Send negatives for samples. Girard's Commercial Photo Shop, Holyoke, Mass.

**CUT** Rate Bargain List for January just out. Send stamp. Willoughby, 810 Broadway, New York City.

**SUBSCRIBE** to Photo-Era Magazine. Best of all, \$1.50 year. Copy with club-offers, five cents, 383 Boylston St., Boston, Mass.

**WE** buy, sell and exchange. Bargains in Microscopes, Telescopes, Binoculars, Cameras, etc. Bargain list sent. Kahn & Son, Opticians, No. 54 John St., New York. Established 62 years.

**LET** me finish your next roll of Kodak Films. Send 10c for trial order. Slocum, 406 Main, Peoria, Ill.

**SEND** us six of your favorite negatives, any size, and 10c (stamps) for 6 prints. Or send any size roll of film for development and 6 prints for 10c. 10-inch mounted enlargements 25c. Mention this ad. Roanoke Cycle Company, Roanoke, Va.

**BIG** Money Saved on Photographic Lenses and Apparatus—goods exchanged; repairing done. Ralph J. Golsen, 5123 Kenmore Ave., Chicago, Department P.

**ROLL** Film developed, 10c a roll. Packs 20c each; Prints, Brownies, 2c; 1a, 3x4, 3x5, and Post Cards, 3c each. Work returned next day. Postage paid. Kodak Film Finishing Co., 112 Merchants Station, St. Louis.

#### TO MANUFACTURERS

**PATENTS** secured through credit system. Free search. Send sketch. Book and advice free. Waters & Co., 4289 Warder Bldg., Washington, D. C.

**SEND** us a list of your line and we will handle it through our mail-order department, first and largest in Hawaiian Islands. Goods bought for cash, sold on commission or consignment. We issue our own catalogue printed in Japanese and English. Send terms, samples and cuts. Hawaii Hochi Shu, Publisher of Hawaii Hochi, Daily Japanese Newspaper, Honolulu, T. H.

## MOTION PICTURES

**ELECTRIC** Arc generator, operates from your engine. Makes current for half the usual charge. Meaning more profits. Easy payments. Hobart Brothers, Troy, Ohio.

**BIG Money Writing Moving-Picture Plays.** Constant demand. Correspondence course; literary ability unnecessary. Write for free booklet, "How to Write Moving-Picture Plays." Universal Publishing Co., 295 Fergus Falls, Minnesota.

**BE a Motion Picture Operator** and earn big money for short hours, easy, pleasant work. We teach by practical work on the finest equipment. Write for free catalog. Coyne Trade Schools, Dept. 7193, Chicago, Ill.

**SPOT cash paid for second-hand high-grade Motion-Picture Cameras, Lenses, etc.** Write us today. David Stern Co., 1047 W. Madison St., Chicago, Ill.

**NEW Moving-Picture Machine.** Portable lighting outfit, etc. Bargain. Atkins Smith, Aspel, Ala.

**MOVING Pictures, 100-foot scenes \$1.** Davis Film Service, Wilkes-Barre, Pa.

**PHOTOPLAYS Wanted.** Big prices paid. We show you how. Details free. Rex Publishers, Box 175 A-1, Chicago.

**WRITE Moving Picture Plays;** constant demand; big prices paid; past experience or literary ability unnecessary; details free. Glens Co., 230 Whiteman St., Cincinnati, Ohio.

**PRACTICAL Instruction Chart.** Teaches you successful operating. Two dimes. C. Leberman, Tiffin, Ohio.

**MAKE big money writing moving picture plays.** Previous experience, literary talent or correspondence course unnecessary. Free details and special offer. E-Z Scenario Co., 609 West 127th St., New York.

**BIG money writing Photo-plays;** details free to beginners. No correspondence course. Producers League, 230 Wainwright, St. Louis.

**MAKE \$50.00 clear nightly.** We start you in the moving-picture business on the installment plan. No experience necessary. Write for free catalog. Monarch Film Service, Dept. P, Memphis, Tenn.

**WRITE Photoplays, Short Stories, Poems.** Big demand. No correspondence course. Start writing and selling at once. Details free. Atlas Publishing Co., 304, Cincinnati.

**MAKE a complete Motion Picture Camera and Projector** from instructions given in our book Amateur Mechanics No. 4. Full details given. Not hard to construct. Worlds of enjoyment taking and exhibiting subjects dear to the heart. Price of book dept. 25c, postpaid. Popular Mechanics Book Dept., 6 N. Michigan Ave., Chicago.

**MOTION Picture Work—A large 618-page book** covering every phase of the moving picture. Its production and its theatre. Indispensable for reference and instruction to the thousands of workers in the motion picture field. Price, \$3, postpaid. Popular Mechanics Book Dept., 6 N. Michigan Ave., Chicago.

**\$25 PROFIT Nightly—Moving Picture Business—small capital starts you, no experience needed.** Teach you—furnish everything. Ralph J. Golsen, 5125 Kenmore Ave., Chicago, Dept. M.

## BUSINESS OPPORTUNITIES

**DON'T experiment; profit by the other fellows that have made good;** \$25 to \$50 weekly Raising Squabs; we are not dealers; instructions on business from A to Z 25c prepaid. Co-operative Co., 192 Charles St., Chester, Pa.

**QUIT Working for Others.** Start a Cleaning and Dyeing Business. No experience and but small capital needed. Tremendous money-maker. Greatest re-order business known. Send for free booklet "M" today. Full details. White Wonder Co., 279 Guardian Trust Bldg., Denver, Colo.

**RE-SILVER Old Mirrors and make \$10 daily.** We Teach and Trust you. Illustrated Prospectus, \$5. Illustrated lesson 25c. Deducted from first order. Hullinger's Institute, Mec. St., Francesville, Ind.

**INVENTORS:** We develop and perfect inventions, make models, dies, tools. Metal stamping and special manufacturing. Gedding Bros., Lion Bldg., Cincinnati, O.

**MANUFACTURERS, Promoters and Patent Buyers** are invited to write us stating the line of invention in which they are interested, as we can supply their wants in any class of patents. Victor J. Evans & Co., 162 Ninth St., Washington, D. C.

**SPOT cash paid for second-hand high-grade Cameras, Lenses, Kodaks, Motion-Picture Cameras, Microscopes, Binoculars, Surveyors' Levels, Transits, etc.** David Stern Co., 1047 W. Madison St., Chicago, Ill.

**DON'T Start Mail-Order Business** until you get 100 special service opportunities, suggestions, propositions, and publication three months—all 10c. Stanford Service, Sebring, Ohio.

**I WILL start you earning \$4 daily** at home, silvering mirrors; free instructive booklet. G. F. Redmond, Dept. 390, Boston, Mass.

**START a business of your own** during spare time. Original successful plans. Details free. E. J. Buchholz, Norwood, Ohio.

**HOW to start and conduct a successful mail-order business.** Address Eureka Novelty Co., 87 Warren St., New York.

**\$15 A DAY making sparkling chipped glass** name and number plates. Big illustrated book sent free. E. E. Palmer, Wooster, O.

**"HIRE Yourself as Boss."** Big corporation will back you in Money-Making Mail-Order Business selling guaranteed Goods. Start spare time. Small capital. No canvassing. Wm. J. Dick, Mgr., Dept. G-10, 29 W. Lake St., Chicago.

**PHOTOPLAYS Wanted.** Big prices paid. We show you how. Details free. Rex Publishers, Box 175, A-3, Chicago.

**DEVOTE your time to money-making** mail order business. New Parcels Post Co-operative accumulative plan. Free start. Dean, 244 W. 41st, N. Y.

**BIG Profit Growing Ginseng and Golden Seal.** Reliable information and book on culture 10 cents. Rising Sun Ginseng Nursery, Box 225, Narrows, Ky.

**START Contracting on \$1.00 capital.** Earn \$5.00 daily. Experience unnecessary. Greenhalgh, Contractor, Brightwood, Indianapolis.

**MARKET your spare time profitably.** High grade opportunity without canvassing. Common education. Commercial Information wanted. Commercial Information Co., Canton, Ohio.

**FORTUNES in this!** If you think all advertised plans impractical or misrepresented, get mine and be undeceived. Make \$30.00 weekly! Easily worked; no canvassing. Complete plan 25c—refunded if dissatisfied! Andrews, 2113 Cornelia Avenue, Chicago.

**VALUABLE patents for sale,** suitable terms. Inventions sold. "Books for Inventors" free. Patent News, Washington, D. C.

**CARPENTERS or handy men can make money.** Home industry plans and specifications \$2.00. Satisfaction or money back. Send today. J. Magill, 343 Page Street, San Francisco.

**X SECRET of making any color stain.** Lacquer, Furniture or Metal Polish, Solid Alcohol, Liquid Celluloid. Each Formula \$1.00. Paint Chemistry Co., Box 20, Indianapolis, Ind.

**15 MONEY making outdoor businesses** fully explained in my free literature. Send for it. Address Black, Sunnyvale, Wash.

**START a Market and Exchange business** at home. Monthly profits from \$100 up. Every community needs one. No selling. No capital. Pleasant, easy, permanent. Pay for instructions from earnings. Send 6c stamps for booklet. Charles Murphy, Bloomington, Indiana.

**ANYONE—Make money—renew old dry** batteries. Guaranteed formula. 24 other valuable money makers. 25c. Northern, 154 Randolph, Chicago.

**OPERATE success-proven mail business** under guarantee bond by reputable corporation—established twelve years. Everything furnished—no stock to carry. Save money—avoid mistakes. Merford Company, Incorporated, Dept. 150, Chicago.

**MIRROR resilvering is a paying trade.** We have best instructions 25c. Auburn Supply Co., Dept. B3, 7817 Peoria St., Chicago.

**3,384 FORMULAS, Trade-Secrets and** money-making plans. 3 Volumes, \$1 prepaid. Ideal Book Shop, 3311-C, Belleplaine Ave., Chicago.

**CANDY making a profitable and** pleasing trade. Be your own employer. Our Candy Book tells how, 55c. Auburn Supply Co., Dept. C3, 7817 Peoria St., Chicago.

**LEARN the real estate business.** Our complete instruction book teaches: listing, appraising, management, salesmanship, insurance, brokerage, advertising, renting agency, forms, etc. 121 subjects. Exceeds \$20.00 correspondence course. Buckeye cover 75c; silk cloth \$1.00, postpaid. Catalogue free. Realty Book Company, 5982 Euclid Ave., Cleveland, Ohio.

**INVENT something; your ideas may** bring wealth; our free book tells what to invent and how to obtain a patent, through our new credit system; write today. Waters & Co., 4102 Warder Bldg., Washington, D. C.

**LEARN a Business that will pay** from \$3,000 to \$6,000 yearly, taught in a few weeks at your home; no goods to buy, job hunting, capital required, soliciting or agency, but a fee-earning professional business for yourself; easily learned by anyone; openings everywhere with all the trade you can attend to; all expense less than \$100. State something of your abilities, occupation, etc., to obtain particulars. Stephenson Laboratory, 5 Irvington St., Boston, Mass.

**RE-SILVERING Mirrors, Renewing Dry** Batteries and 150 Formulas 25c. 1000 Formulas 25c. 29,000 Formulas, 530 p., \$1. Satisfaction guaranteed. "Ideal," 3311-C Belleplaine Ave., Chicago.

**"NUGGETS"—Wonderful journal** of plans, schemes, formulas. Six months, 10c. "Nicholson," Publisher, Bristol, Indiana.

**LET us start you selling books** by mail; big profits. Willis, 76P Pilling, Brooklyn, N. Y.

**EARN \$100 weekly managing clean,** legitimate mail-order business. We furnish everything. Right party need not worry about capital. Splendid chance for intelligent, employed person to control independent business on profit-sharing basis, beginning in spare time, evenings at home. Particulars free. Opportunities Exchange, Buffalo, N. Y.

**OPPORTUNITY Seekers, mail dealers,** beginners—write for free particulars of our money-making proposition. Stamp appreciated. Idaho Sales Co., Twin Falls, Idaho. Sample of latest novelty 10c.

**GREATEST Mail Order Plan.** Big money maker. Investigate. Rizzo, Grand River, Detroit, Mich.

**INVENTIONS advertised free.** 500 best papers. No fee unless sold. Patent News, F. Washington, D. C.

**OPERATE a Mail Order Book Business.** make 90c profit on dollar orders; we show you how. Brand new proposition free. Bamberg's Supply House, Northwestern Building, Chicago.

**I PUBLISH a wonderful magazine** of money-making plans, ideas, suggestions and inspiration! It will show you how to make more money. Sample, 10c. Editor, Booster Magazine, Northwestern Bldg., Chicago.

**ADVERTISE—20 words in 100 months** \$1; 100 weeklies \$2.50; 20 Sunday papers \$5; all \$8. Cape Agency, St. Louis.

**555 MONEY-MAKING Formulas, 10c.** Process Company, Ft. Dearborn Building, Chicago.

**\$6.50 STARTS Premium Toilet Goods** Business similar to Crests and Reed. For 10c I'll send sample circulars with source of supply. "Expert," 2311 N. Kildare, Chicago.

**READ "Good Results"—Greatest Mail** Dealers-Agents Magazine published. Two big issues 10c. Good Results, Industry Building, Chicago.

**"DOLLARS" yearly in your back yard.** No ginseng, mushroom dope. New ideas never before published, particulars free. Metz, 213 East 89th St., New York.

**START a mail-order business; \$1.50 capital.** Runkle, 2511 Maplewood, Chicago.

**\$25,000, I MADE it in Mail-Order Business.** Started with \$5 at home. No canvassing. Free Booklet tells how. 2c postage. Alb. Scott, Cobles, N. Y.

**WANT Big Profits? Learn Tartaric Mirror** Silvering. New process opens enormously profitable business. Particulars free. H. Barstow, 514 23rd Street, Oakland, Calif.

**YOUR Chicago Office maintained for \$2** to \$30 per month. Business cared for. Mail forwarded. Chicago Offices & Service Co., 29 East Jackson, Chicago.

**COLLECTIONS.** Anyone anywhere can build paying collection business. Full plans upon receipt \$5.00 coin. Maine Mercantile Agency, North Anson, Me.

**25c ESTABLISHES you in business.** Remarkable invention. Particulars free. Midget E., Hughesville, Pa.

WE will start you in the cleaning and dyeing business; little capital needed, big profits. Write for booklet, Ben-Vende System, Dept. C, Charlotte, N. C.

**MAKE Big Money.** Start your own Metal Weather Stripping Business. We will show you how and furnish everything. Write today, Morgan, 2218 Pine St., St. Louis, Mo.

WITH a mould of Pres. Wilson or Lincoln and Plastography instructions, you can produce beautiful plastic medallions  $3\frac{1}{2} \times 5\frac{1}{2}$  inch ovals framed. Remit \$1.00. P. P. R. Spahr, York, Pa.

**START** a legitimate business of your own, look after it evenings. A small or large amount invested in our proposition will net you from two hundred to five hundred per cent. Write for particulars and territory. We can easily substantiate our claims to parties who are interested, and also give ample proof of our business and financial standing. National Novelty Company, Minneapolis, Minn.

**EARN** five dollars a day coloring photographs and prints. Any person can easily learn this beautiful art. Fascinating, pleasant, money-making home work. Regular or spare time. Complete, practical instructions and materials furnished. Send today for free booklets giving full particulars. The National Arts Company, 1223 State Street, Alpena, Michigan.

WE start you in business, furnishing everything; men and women, \$30.00 to \$200.00 weekly operating our "New System Specialty Candy Factories" home or small room anywhere; no canvassing. Opportunity lifetime; booklet free. W. Ragsdale Co., East Orange, N. J.

**PATENTABLE** ideas wanted—Send for 3 free books. H. B. Owen, 39 Owen Bldg., Washington, D. C.

**LEARN** to collect money. Good income; quick results. Send for free booklet, "Skillful Collecting." Collectors' Association, Long Street, Newark, Ohio.

I WANT to send you proof of the wonderful pulling power of Popular Mechanics classified pages. What's your proposition? Write me today. F. W. Johnson, Classified Dept., Popular Mechanics Magazine, 6 N. Michigan Ave., Chicago.

IF you work in a shop find out if the company has any lathes, turret lathes, screw machines or milling machines for sale and write me full particulars and price asked. I will pay you \$5 for each machine I buy. Pinner, 122 Water St., New York, N. Y.

WOULD you like to own a good-paying Mail-Order Business? We have a line that gets repeat orders all the time. You can start in spare time; invest a dollar or two a week and soon own a nice business of your own. Particulars free. Nadco, 4313 Lincoln Ave., Chicago.

HOW to Operate a Mail Order Business. 20 Big Profit Plans and year's Mailing service sent for 10c. Mail Dealers' Wholesale House, 521 Fra K'lin Bldg., Chicago.

**INDEPENDENCE** and fortune quickly attained in the Manufacturing Mail Order business. I furnish Formulas, Manufacturing Processes and Trade Secrets in all lines. Sold under positive guarantee; 18 years' practical experience. Revision and improvement of Formulas and Processes—reduction of manufacturing cost—utilization of waste materials, etc., a specialty. Booklet, Formula List, and Valuable Information Free. W. L. Cummings, Ph. D., 127 Standard St., Syracuse, N. Y.

**STOP** Here! Let me start you in a home business that will bring you money every day. Experience unnecessary. Spare time. No canvassing. I furnish everything. Send for proofs. Voorhies, Desk C. R., Omaha, Neb.

LET the parcels post help you. Add \$15 to \$25 weekly to your present salary or income. Start during spare time and build up a permanent mail-order business of your own. We show you how and help you make good. No canvassing. Experience unnecessary. The Parcels Post makes success doubly sure. Our new ideas and up-to-date plans bring the money. No so-called "Course of Instruction" to sell. We give that for free. Write today. Address Pease Mfg. Co., Inc., Dept. A, 70 Broadway, Buffalo, N. Y.

**START** in the carpet or house cleaning business, Thurman Process unequalled for commercial cleaning; show you how. Only \$125 capital needed to earn good income in towns 2,000 and over. Attach one to your automobile wheel. Thurman Vacuum Cleaner Co., manufactures all types cleaners. Dept. B, St. Louis.

**ADVERTISERS, Mail Dealers.** Our 1915 Rate Book lists 2,900 Principal Publications, rates, circulation. Includes 20 Mail-Order Plans. Price 10c. Dearborn Advertising Agency, 210 Franklin Bldg., Chicago.

**\$10.00 EVERY** two hours, men and women can get more when using our new selling plan, one sale makes twenty, you cannot afford to miss this. Write, Dept. C, Hollingsworth Bldg., Los Angeles.

**MAKE** Gaso-Tonic (Carbo-Cide) and other latest Automobile Specialties. I furnish the correct guaranteed formulas for these and many other lines. Latest lists, particulars for stamp, Miller, Analytical Chemist, Tampa, Florida.

**CARPENTER,** become contractor; small contractors clean up \$2500 to \$10,000 yearly; no capital required; I will show you how; complete plan and instructions 50c. C. Maurer, 118 Short Ave., Ludlow, Ky.

**PENDLETON'S** Mail Order System for beginners; stationary free. Pendleton, Box 1005, Atlantic City, N. J.

#### BUSINESS FOR SALE

**FULLY** equipped machine shop. Big business. Box 528, Beach, N. Dak.

**BOAT** and Automobile Supply Business, established over twelve years, more than 2000 mail order customers on our books, large local trade. Good reasons for selling. Address: Oshkosh Marine Supply Company, Oshkosh, Wis.

#### MAIL ORDER SUPPLIES

**NON-ELECTRICAL** Burglar Alarm, recently Patented, works with any night latch. Simple attachment. Sounded only when door is forced. Lasts lifetime. Retails \$1.00. Booklet. Richman Protective Alarm Co., 1368-1370 B'way, New York.

**SELL** Joker's Novelties! 16 samples, 10c. Chambers Works, Plainville, Mich.

**INCREASE** your sales. Place your proposition before the readers of "Cartoons Magazine." 20,000 copies guaranteed every month. Classified rate 2c per word. Mail in a trial ad today. Cartoons Classified Dept., 78 E. Madison St., Chicago.

#### FOR ADVERTISERS

**ADVERTISE** in 65 Michigan's leading weekly newspapers, 25-word ad, one time, \$2.00; four times, \$6.25. Checking sheet showing ad and correct list of papers sent each week. United Weekly Press Association, 59 Market Ave., Grand Rapids, Michigan.

**YOUR** thirteen-word ad, in our 9x12 magazine reaching 20,000 boys for 25c. Extra words, 2c. Country Boy Magazine, 2180 Mallers Bldg., Chicago.

**YOUR** Thirty-Word Ad, in our big post-card magazine, 25c. Inch display, 50c. Elite Exchange, 3894 Milwaukee Ave., Chicago.

**BARGAIN** Advertising rate, 20 words one insertion, 40,000 circulation and one year's subscription 25c. Extra words 1c. Digest, Grand Rapids, Mich.

**ADVERTISE.** Twenty-five words in 100 monthlies, \$1.00. Magazine and newspaper advertising—lowest rates. Particulars, lists free. Stanford Agency, Sebring, Ohio.

**YOUR** advertisements placed in 36 different magazines for 3c per word; displayed, \$1.80 per inch; three times for price of two. List, particulars free, King's Magazine, Box 13-P, Little Silver, N. J.

**ADVERTISE** 50 magazines—\$1.00 per inch—whole list, L. M. Clark, Thomaston, Me.

**ADVERTISERS—Here's** your opportunity. Your proposition placed before the readers of "Cartoons Magazine" for only 2c per word. Circulation 20,000 copies guaranteed. Send a trial ad for our next issue. Cartoons Classified Dept., 6 N. Michigan Ave., Chicago, Ill.

#### COLLECTIONS

**COLLECT** Your Outstanding Accounts Yourself. Our system shows you how to eliminate bad debts. Results guaranteed. Sent on approval. Interesting folder on request. Direct-Adjustment Service, Brooklyn, New York.

**ACCOUNTS.** Notes Collected Anywhere. Collection guaranteed or no charges. May's Collection Agency, Somerset, Kentucky.

#### BUSINESS SERVICE

**CORPORATION** Service System, P. Clarkburg, West Virginia Incorporates, organizes, represents companies. Expert local counsel, offices, agents throughout America.

**INCORPORATE.** Our lawyers do the work, saving you time, annoyance and money in incorporating under the most liberal laws of Arizona. Laws and forms free. Southwestern Securities & Investment Co., Box 1988, Phoenix, Ariz.

**DESIGNER** and Illustrator. David Ryer-son Mozford, Station 24, Dayton, Ohio.

**NEVADA** Incorporations Operate Everywhere. Cost less, superior advantages. Charterguide P Free. Corporation Charter Trust Company, Reno, Nevada.

#### LETTER SPECIALISTS

**YOU** can do much more business by mail. Consult me. I write strong sales-making letters, advertisements. Helpful advice free. Tenth year. Harry Stern, 1127 Gaylord, Denver, Colorado.

#### AGENTS WANTED

**AGENTS!** 500% Profit. \$25.00 to \$50.00 a week; that's what our agents are making selling our new metallic sign letters for office windows, store windows and glass signs. For a quick, easy money making proposition for agents, salesmen and sign painters, there is nothing to equal the selling and putting up of our new metallic letters and numbers. There is no experience necessary to put up these signs. Anyone can succeed and make money right from the start. We will send you full particulars and you will see how easy it is to make money in this business. One agent says: "Have already put up 14 signs in this little burg and more in sight. Your letters are the best thing I have seen in years. Will soon be in a position to buy in 5,000 lots." Another says: "I am getting all the work I can do and the letters have given entire satisfaction everywhere." We are daily receiving such letters from agents who have started in the sign letter business. This is the only field that is not overcrowded. There is a big demand for window and glass signs in every town. You can sell to nearby trade or travel from town to town all over the country as you please. We would be pleased to send you a free sample and full particulars. Write today. Address The Metallic Sign Letter Co., 407 N. Clark Street, Chicago, U. S. A.

**TAILORING** Agents Wanted—Big complete sample outfit and case, nearly 500 large cloth samples, 3 price lists and everything needed for canvassing or use in store, free to live agents. \$25.00 to \$50.00 a week; may make more. Write us today for free elegant outfit to begin, cloth samples, wholesale prices, special offer on a suit for yourself and full information—see our wonderful values, beautiful fabrics and styles. Established 28 years. Every garment made to measure—everything guaranteed and express prepaid. Just send a postal. American Woolen Mills Co., Dept. 314, Chicago.

**ONE** Thousand Dollars Reward. We will forfeit \$1,000 if this is not the greatest money-making house-to-house proposition advertised in these columns. N. R. G. Little Wizard Labor Saver washes clothes in 10 minutes absolutely without rubbing. It contains no paraffin or wax and there is nothing like it on the market. Sells for 15c, enough for five family washings. We supply you with all the free samples you need. All you do is to leave the free sample with the housewife and when you call again she is waiting to become your steady and permanent customer. This is positively the most scientific and wonderful labor saver of the age, and you will make a great mistake if you do not secure territorial rights at once. A one cent postal card brings full particulars. Farquhar-Moon Mfg. Co., Dept. A 200-140 W. Van Buren St., Chicago, Ill.

**AGENTS—Either** Sex. This Is Your Chance. Earnest \$6.00 daily you ever made. New useful article wanted everywhere. Sells itself. Be first in your territory. Somerset Supply Co., Madison, Maine.

**WE** want reliable agents to sell our Automatic device to hotels and restaurants. Three Hundred to Four Hundred per month made, averaging only one sale per day. Little capital required. Sprague Mfg. & Sales Company, Minneapolis, Minn.

**PERMANENT** One-Minute-Puncture-Repair Device. Patented. Guaranteed. Great demand. Other fine specialties. Derrick, Monroe Bldg., Chicago.

**MEN and Women Agents:** Money talks—how much are you making? If you are earning less than \$200 a month, no matter what your locality, you will positively be delighted with our Sentinel Burglar Alarms proposition. Many agents easily earn \$15.00 daily. Brand new invention. Sells quickly on sight to homes, offices. Patented. No competition. Free exclusive territory. Instantly attached any door knob. Impossible turn knob without ringing bell. No batteries, screws, nails. Handsomely nickel-plated. Retail \$1.00. Provides cheap burglar insurance. It's a big money maker. Let us prove why. If you mean business write today for liberal terms to agents. Marshall Dobbins & Co., Manufacturers, 1422 Marquette Bldg., Chicago.

**AGENTS** make big money selling our Electric Lanterns and Egg Testers to farmers and merchants. Rapid Egg Tester Co., 326 W. Madison St., Chicago.

**AGENTS—Steady Income.** Large manufacturer of Handkerchiefs and Dress Goods, etc., wishes representative in each locality. Factory to consumer. Big profits, honest goods. Whole or spare time. Credit given. Send for particulars. Freeport Mfg. Co., 39 Main St., Brooklyn, N. Y.

**AGENTS—Raincoat special.** Umbrella Free. Wonderful seller. Big money-maker. Sample free to wear while demonstrating. State size. Guaranteed Raincoat Co., 962 North St., Dayton, Ohio.

**SUITS \$3.75.** Pants \$1.00. made to measure. For even a better offer than this, if you live in a small town, write and ask for free samples and styles. Knickerbocker Tailoring Co., Dept. 571, Chicago, Ill.

**AGENTS—Average \$5 to \$12 daily** selling astonishing Astec massage machine. New. Just patented. Different. No electricity or water power required. Nothing complicated. Affords exhilarating massage without cent expense. Lowest priced, but best outfit. Retail \$2.50, allowing you big end of the profit. Particulars and "beauty" folder free. Astec Remedy Co., Dept. 132, Toledo, Ohio.

**WRITE** for our profitable agency offering selling automatic pipe and nut wrench. Superior Wrench Co., Box 1320, Marshalltown, Iowa.

**AGENTS Make Big Money.** The best line of food flavors, perfumes, soaps and toilet preparations, etc., ever offered. Over 250 lightweight, popular-priced, quick-selling necessities—in big demand—well advertised—easy sellers—big repeaters—100% profit. Complete outfits furnished free to workers. Just a postal today. American Products Co., 3293 American Bldg., Cincinnati, O.

**JUST show them—The new adjustable floor and wall mops, dustless dusters and sanitary brushes** sell themselves. Big line. Big profits. Agents write Silver-Chamberlin Co., Dept. M, Clayton, N. J.

**STOP Here!** Let us start you in a home business that will bring you money every day. Experience unnecessary. Spare time. No canvassing. I furnish everything. Send for proofs. Voorhies, Desk C. R., Omaha, Neb.

**AGENTS! Agents! Quick, easy money.** Send 25c for three samples of quickest selling 25c novelty picture ever published, and coupon scheme worth \$23.00 or more weekly. Something new. Miller Pm. Company, 906 Hartford Bldg., Chicago.

**SELL Dry Goods Remnants.** Greatest bargains on earth. Remnant Store Co., Cincinnati, Ohio.

**LIVE agents for high grade specialty** for office and home; descriptive booklet and terms, free. The United Sales Co., Box 1, Uphams Corner, Dorchester, Mass.

**WE want capable, live wire General Agents and Crew Managers** to sell an absolutely new Household Specialty guaranteed by \$200,000 Corporation. It's a big value household necessity that no woman can resist. Easy sales mean big profits. Our follow-up is unusual, and we give you exclusive territory, and advertise the business for you. Wm. J. Dick, Dept. G21, 20 W. Lake, Chicago.

**BEAUTIFUL Vicuna rugs** direct from South America. Agents secure exclusive territory. Exporter, Box 1072, Valparaiso, Chile.

**AGENTS Wanted—Agents make 500 per cent profit** selling "Novelty Sign Cards." Merchants buy 10 to 100 on sight. 800 varieties. Catalogue free. Sullivan Co., 1281 Van Buren St., Chicago, Ill.

**NEW \$2.50 pocket adder.** Sell 10 daily easy. Excellent profit. Everyone buys. No competition. A. Bassett, 5271 Indiana Ave., Chicago.

**WONDERFUL "Whispering" Mouthpieces** for Telephones; gives secrecy in conversation. Unlimited field; big profits. Retail \$75; sample 35c postpaid. Write for full selling proposition. Colytt Laboratories, Dept. M, 565 W. Washington Blvd., Chicago, Ill.

**BIG Profits.** New Gold and Silver Sign Letters for store and office windows. Any one can put on. Free samples. Flexible Letter Co., 1642 Division, Chicago, U. S. A.

**AGENTS—233% Profit** selling our 25c Sheet Music at 5c. Particulars Free; 3 samples 10c. Keller, Robson & Munk, 38 W. 118th St., New York.

**OPPORTUNITY! Where? Everywhere,** selling our marked specialties. Make \$50 weekly. Write today. Fitz Mail Order Co., Box 955, Wichita, Kans.

**AGENTS—Send 10c for 25c box** Lutz's Herb Tablets and Terms. C. Lutz Manufacturing Co., York, Pa.

**FAST selling "Kantleak" raincoat** proposition. Cooper earned \$49 in 5 days. Bridge \$88 in 6 days. We deliver and collect. New 1916 swatches free. Write today. Comer Mfg. Co., 100 Paige St., Dayton, Ohio.

**\$1.50 PER day salary** paid one man or woman in each town to distribute circulars and take orders for non-alcoholic flavors in tubes. Permanent—easy work. Ziegler Co., 71 E. Harrison St., Chicago.

**CUSTOM Raincoats.** You can sell them. Big Commissions. Free raincoat to good agents. Imperial Raincoat Co., Clerk 5, Boston, Mass.

**AGENTS—Your line is incomplete** unless you have our fast selling household specialties. 100% profit. Interesting literature, full particulars free. G-M Specialty Co., 2 Porter Block, Brockton, Mass.

**WONDERFUL new invention, just out.** Law demands it. Agents coin money. Free circulars. Edwards, 314 Foster Bldg., Denver, Colorado.

**BIG Textile Mills** want ambitious men and women everywhere to show latest dress fabrics, neckwear, hosiery and underwear. 400 styles. Easy sales. Values beat stores. Many making over \$20.00 weekly. All or spare time. Complete sample outfit starts you. Steadfast Mills, 20 Rensen St., Cohoes, N. Y.

**RELIGIOUS novelties, quick sellers, big profits, fine proposition for Agents.** Write for particulars immediately. Novelty Altar Co., Dept. P, Stamford, Conn.

**AGENTS—Kleanol Sanitary Brushes** pay you big profits; fast sellers; big line. Get information from largest wire twisted brush makers. Kleanol Brush Co., Inc., Dept. 1, Springfield, Mass. Branches at Omaha, Nebr., Dallas, Tex.

**MAKE and sell your own goods.** Formulas by Expert Chemists. Manufacturing Processes and Trade Secrets. Formula Catalogue for Stamp. Blake Mystic Company, Washington, D. C.

**SELLS Like Hot Cakes; New laundry** wax perfumes clothes with lasting violet perfume; working outfit 5c; new offer. Perfume Gloss, 12 Water St., New York.

**\$61.50 WEEKLY** introducing and selling a new gas light burner for kerosene lamps. Beautiful light. No chimney. No mantle. Perfectly safe. Simple in construction. Nothing to get broken or out of order. Will not burn out. Durable. Will last for years. Low price. Easy to sell. 200 per cent profit. Experience not necessary. Sample free. Why not try one on your lamp? Beware of imitations. No branch offices. Luther Manufacturing Co., Dept. 216, Cincinnati, Ohio.

**RELIABLE man 18 to 60** wanted in each locality to represent big sick and accident insurance company with amazing, startling, sensational new selling plan. Apply quick to W. G. Critchlow, Department 2712, Covington, Kentucky.

**AGENTS—Here's a winner.** The Midget Vest Pocket Garment Hanger—sells on sight. The most attractive proposition ever offered. 150% profit. No competition, as article is fully protected by U. S. and foreign patents. Address: Dept. "M," The Silvev Company, 171 Madison Ave., New York.

**AGENTS to sell our Stationary and Portable Vacuum Cleaners** for residences and buildings. Therman Vacuum Cleaner Co., manufacturers. Dept. R. St. Louis.

**LARGE Chicago tailoring house** requires live agents for selling gents made-to-measure suits \$13.50 retail. Most wonderful value in the U. S. \$63 a week easily earned. We help you to build your own business at our expense. Write at once. Kroil & Sons Co., 36-44 N. State St., Chicago.

**AGENTS: You can make big money** taking orders for our fine made-to-measure clothes, so write quick for 60 beautiful cloth samples, 32 smart styles in rich colors, wholesale and retail price lists, lowest prices and best offer to agents. \$5.00 to \$10.00 a day easy. Big outfit, over 250 samples free to live wires. No experience needed—no capital. We furnish everything free—pay postage or express charges—back you, boost you, show you how and clearly explain everything. Costs nothing to try. Let us make you a stylish suit to measure to prove our fine quality and style. Send postal or letter today. Paragon Tailoring Co., Box 314, Chicago.

**\$2,100.00 PROFIT** for Faucet 1915 Selling Feeny Vacuum Cleaners—the Gold Medal Winner San Francisco Exposition. More live agents wanted. We also manufacture Star and Handy Clothes Line Reels. Write for special proposition. Feeny Mfg. Co., B-75, Muncie, Indiana.

**YOUNG Man, would you accept** a tailor-made suit just for showing it to your friends? If you live in a town smaller than 10,000, write Banner Tailoring Co., Dept. 272, Chicago, and get beautiful samples, styles and a wonderful offer.

**PHOTO Pillow Tops, Portraits, Frames, Sheet Pictures, Photo Plates, Pennants, Rejects, credited.** Prompt shipments; samples and catalogues free to agents; 30 days' credit. Jas. C. Bailey Co., Desk A3, Chicago.

**MEN and Women with spare time** can earn big weekly profits by our new advertising plan. No investment. No selling. No soliciting. Write today for details for this new money maker. Crown Mfg. Co., Dept. G1, 20 W. Lake St., Chicago.

**AGENTS Wanted—Spare time—make \$2.00 to \$6.00 per day.** An article that every automobile owner has long wanted. Show it and the sale is made. Send 75c for sample and start today. Money refunded if not satisfactory. One agent in each town. Be first to close contract for agency. Address Publishing and Novelty Sales Company, 14 W. Washington St., Chicago, Ill.

**MARVELOUS Expanding Cuff Button.** Presto, slip your cuffs over elbows without unbuttoning; slip them down; they close automatically; stay where placed upon forearm; greatest laundry and shirt-saver invented. Invisible, durable and strong; fastest selling specialty in United States; sell themselves; Fred DeWilde, Sheboygan, Wis., sold 750 pairs in 10 days, profits \$350. Good-bye old style once you wear these; indispensable to all; an article with real merit, no fake. Wanted—Energetic local agents everywhere to sell direct to user. Flexo Manufacturing Co., Sheboygan, Wis.

**AGENTS—Send for sample "Fretnot"—** the wash day wonder. Be convinced you can do a whirlwind business. You can clear at least \$20 to \$100 weekly, according to spare or whole time. You don't have to talk, if she doesn't buy at sight, leave sample, she will be looking for you long before you are able to make the rounds again. Samples furnished free. Premiums for your customers. Exclusive territory granted to agents who can produce. Credit given. Don't call. P. M. Motter & Sons, 3213 Warren Ave., Chicago.

**AGENTS—Salary or commission.** Greatest seller yet. Every user pen and ink buys on sight. 200 to 500 per cent profit. One agent's sales \$620 in six days; another \$82 in two hours. Monroe Mfg. Co., X6 La Crosse, Wis.

**BRADIUM (Luminous) Pull Chain Bu's** for Electric or Gas Light pull chain or key. Shines at night. Locates your chain in a "Jiffy." Sample 35c. Agents wanted. Aurora Supply Co., Dept. 3 P.C.A. 7817 Peoria St., Chicago.

**AGENTS—Here's a brand new article,** just ready for market. Make over 100% profit with satisfied customers. Every mechanic needs one, sells quickly on sight; no competition. Our proposition is a winner. Don't wait. Write for it now. The Security Aluminum Rule Pocket Co., Ivanpah, Calif.

**JOIN the big Christy organization.** Sell Household necessities. Unlimited demand. Big Specialties. Enormous profits. Apply immediately. Arthur N. Christy & Co., Dept. 5, Newark, New York State.

**AGENTS Wanted—Man or woman** for each town to sell labor-saving, heavily-bought household necessity, either house to house or to dealers. Liberal commissions, big national advertising and other selling helps. Instantaneous seller. Season now on. A great proposition for all or spare time. Exclusive territory to earnest hustlers. Write at once. V. B. Jepson, Dept. "M," Woolworth Bldg., New York.

**SOMETHING** every man needs. Write Chas. Milton Co., Hermosa Beach, Cal.

**AGENTS** to handle remarkable money-makers. Many repeat orders. Particulars, Doris Novelty Co., 560 2nd Ave., N. Y.

**AGENTS!** New Big-Money Winner. Something unexpected; high class; 130 years coming; here at last; wonderful scientific discovery; great household problem solved; clothes-washing ideas revolutionized; Kalomite Laundry Marvel abolishes rubbing, washboards, washing machines; Kalomite is supreme; it's a marvel; simple, sure, scientific and safe; \$1,000 guarantee; protected by trade-mark registration, etc.; valuable territory concessions; all or spare time; \$200 weekly repeat order profits. Bettens, Idaho, writes: "Rush 5,000 packages more." Women astounded, satisfied. Reputable \$50,000 manufacturing corporation. No experience necessary; credit granted; big money; whirlwind repeater; hurry; write today; get overwhelming proof; all free. Equitable Corporation, Dept. 352, 217 W. Superior St., Chicago.

**AGENTS**—Make real money this year; not "paper money." Sell our wonderful Luminous articles. "They shine in the dark." Crucifixes, Match Boxes, Pull Chain Bulbs, Switch Plates, Clocks. Startling! Everlasting! Mysterious! Pioneer Portrait Co. (Luminous Specialists), 1259 West 63rd, Chicago.

**AGENTS**—Sell rich-looking imported 36x 68 Rugs, \$1 each. Carter, Tenn., sold 115 in 4 days. Profit, \$57. You can do same. Write for sample offer selling plan; exclusive territory. Sample rug by parcel post prepaid, 38c. H. Condon, Importer, Stonington, Maine.

**AGENTS Wanted**—Out of town live men can make 15 to 25 dollars weekly evenings or on the side selling my "made to order" men's \$15 and \$20 suits and overcoats. We are delivering quality, fit and work, so you can build up a future business. Try sample suit. Tom Murray, 411 S. Sangamon, Chicago.

**MIRACLE**—Our chemist has discovered a brand new household article. It is positively a miracle. Will be sold under guarantee. Write for particulars, Vivaco Company, 3177 Broadway, Chicago.

**\$40 WEEKLY** easy and 100% profit. Year 'round, repeat sellers. Samples for stamp. M230 East 87th, New York.

**AGENTS**—Deal in Dollars—make dollars. Jules Folding Portable Electric Lamp contains new, exclusive patented features. Sells in homes, offices, hospitals. Rose Strauss Co., 215 W. 48th, N. Y.

**REPRESENTATIVE** desired to handle Oliver No. 3 typewriter. Machine furnished for demonstration. Visible Typewriter Co., Hammondport, N. Y.

**\$1,000.00 FOR** your next 100 days, spot cash. New money-making invention for agents, general agents, managers. Recently invented. 1,000,000 already sold; 200 more salesmen wanted at once. Amazing automatic Compressed Air Washing Machine. Washes tub of clothes in six minutes. No cranks to turn or levers to push—no rubbing. Works like magic. Price only \$1.50—make sale at every house; 200% profit. L. Palmer, Glen Allen, Ala., put out on trial 108 machines, sold 107. Profit \$107.09. Write today. Wendell Co., 1031 Oak St., Leipsic, O.

**AGENTS** wanted; send for particulars of my rapid seller; a new household article; agents making good; information full. M. E. Cooper, 409 Pine St., Susquehanna, Pa.

**PROSPERITY'S** here. Get your share. We show you how. Sample, particulars 10c. Seller Co., 709 Woolworth Bldg., N. Y. City.

**EXCLUSIVE** selling rights for our Wonderful Triplex Folding Handbag and other sellers. None sold in stores. Write for terms and catalogue. Diamond Bros., 35 West 21st Street, New York.

**\$80.00 FOR** your next week if you will distribute 100 free packages of Lice Powder while selling our Foultry Tonic. S. & P. Remedy Co., Saint Paul, Minn.

**\$125.00 PER** month, making two sales per day. Samples free. The J. R. Cotton Co., 56 First St., Frank, Penna.

**\$70.00 TEN** Days—Hedrik's profit. Smith writes, "Sold 24 one house." Rodolph's Patented Curtain Rods. No nails, tacks, screws. Fits any window. Sample 10c. Rodolph, 172 Northwestern Building, Chicago.

**AGENTS** are coinng money selling our big 10c Packages of 20 Assorted Postal Cards. "5,000 Varieties." "Big Profits." Sell everywhere at sight. Sample Packages 10c. Particulars Free. Sullivan Card Co., 1254 Van Buren St., Chicago, Ill.

**OUR** new, unusual value Household Specialty makes easy sales and big profits for live agents. Guaranteed goods, and an unusual follow-up gets the business. Sales Manager, Dept. G-3, 20 W. Lake, Chicago.

**YOU** can do it. What! Make only 2 sales a day, \$3.69 net profit. More sales, more dollars. No limit to opportunity selling latest Aluminum Combination Set at a price the women go wild over. Write today and let me show you how to make at least \$3.60 a day. Sales Manager, 1425 Westmoreland St., Philadelphia.

**LIVE** Agents to sell Automatic Fire Escape. Approved by fire department of New York and other large cities. Used in homes, hotels, factories, institutions, etc. Sells for \$10.00. Fine commission. Sales will bring you from \$7.00 to \$30.00 per day. Address Thomas Mfg. Co., Rockaway, N. J.

**RAINCOATS** direct from factory to wearer. Agent's price \$2.50. Retail price \$6.00. Our agents average 6 coats daily. Sample coat by parcel post prepaid \$2.50. Write for details. Standard Raincoat Company, Cleveland, O.

**AGENTS:** Get an easy seller. Sanitary All-Metal Bread and Pastry Board and Rolling Pin is making big hit. Make \$25 to \$40 every week. Smith, Ohio, sold 38 one day. Profit \$19. Sells at sight. No talking necessary. Free sample to agents. Write quick for appointment and territory. Union Mfg. Co., 167 Main St., Cambridge, O.

**1916'S SENSATION!** Eleven-Piece Toilet Article set selling like blazes at \$1, with \$1 carving set free! Enormous profits! Tremendous hit! Eagle made \$51.00 first week. Write quick! Pierce Co., Dept. P, 906 Lake St., Chicago.

**AMERICA'S** Daily Necessity. Free sample. Simmons Co., American Bldg., Hicksville, Ohio.

**AGENTS** make 400% profit handling new changeable signs; novelty signs; household goods, etc. Catalog Free. Hinton Co., 6142 40th Court, Chicago, Ill.

**READ "Good Results"**—Greatest Mail Dealers-Agents Magazine published. Two big issues 10c. Good Results, Industry Building, Chicago.

**AGENTS**, sell something in demand. Very little competition. We have a big money-maker. Write at once for attractive proposition. B. C. Baker & Co., 26 Farmers Bank Bldg., Prairie Depot, Ohio.

**NOW'S** the time to sell Luminous Crucifix to Catholics for Easter. Old Paducah Co., Paducah, Ky.

**BIG** Profits. New Tartaric Mirror Silvering Process opens enormously profitable business. O. Barstow, 514 23rd Street, Oakland, Calif.

**AGENTS**—New game for cigar stands; easy seller. Repeater. Particulars free. Central State Sales Company, Box 598, Memphis, Tenn.

**AGENTS**—50 Calling Cards 10c. F. Shepard, Rome, N. Y.

**LADY** or gentleman, fair education, to travel for well-established firm. No canvassing. Salary, \$800 per year, payable weekly, pursuant to contract. Expenses advanced. Address G. M. Nichols, Philadelphia, Pa., Pepper Bldg.

**JUST** patented, two best household articles ever shown. Agents wanted everywhere. Specialty Manufacturing Co., Fort Atkinson, Wisconsin.

**WANTED**—Men and Women—to sell Comfort Shoes direct to wearers; easy sellers, good profits. Ideal Shoe Co., Boston, Mass.

**AGENTS**—We manufacture the safety-first Non-Shock Fuse Puller. Schlicker Mfg. Co., Rochester, N. Y., 12 Bloomingdale St.

**BIG** offer for live agents; hurry, grab now. New household specialties, big profits. Particulars free. Write Berma, Box 1393, Pittsfield, Mass.

**DRUNK, Sick or Crazy**—not us, but we let you collect the money and keep it all. Small capital needed to start. U. S. Mfg. Co., Dept. P1, Columbus, Ohio.

**REPRESENTATIVE** wanted in every town. Morris Music Pub. Co., 1500 Linden Ave., Balto., Md.

**FOR** quality, prices and service, on Sanitary brushes, get our proposition. C. Oakes, Zion City, Illinois.

**AGENT'S** free sample and particulars Delbare's Naphtha Washing Tablets. Wash clothes without rubbing. Guaranteed not to injure the finest fabric. No acids, lime nor caustics. Manufactured and sold by Naphtha Washing Tablet Co., 718 So. Dearborn, Chicago, Ill.

**"GOLDINE"** Sign Letters—1,000% profit. Sample free. Johnston Co., Quincy, Ill.

**MECHANICS:** Sell Graduated Beam Calipers and round Levels. Ernst G. Smith, Tampa, Fla.

**CUT** your own hair. Startling novelty. Send 25c for sample. Make money fast. Everybody a prospect. Sommerfield, 555 Traders Bld., Chicago.

**BUILD** up a selling agency. Sell our premiums in your club, school or college. Generous discounts for quantities. Catalogue free. Arthur Mfg. Co., Box P, Louisville, N. Y.

**ORGANIZE** your own business. Sell dealers direct Japsilk nonbreakable Gas mantles. We'll give you manufacturer's prices, lots 500 up. Big profits. Quick turnover. Splendid growing income. Jules, 209 W. 48th, N. Y.

**AGENTS** take orders for new covers on umbrellas. Big profits. Outfit free. L. Hurwitz, 136 East 127th St., New York.

**FOR** Sale—14 high-grade Pea-ut Machines. Big Bargain. Homer Fenton, 1814 Arthur Avenue, New York.

**GET** cash for names, information, ideas, formulas. Turn what you see, hear and know into money. Instructive booklet for stamp. Information System, 223 Marietta, Ohio.

**ABSOLUTELY** New! "Ever Ready" indoor clothesline reel. Sells for 50c; 100% profit. Particulars. Roy Larsen, 175 Glenway St., Dorchester, Mass.

**AGENTS** can make big money selling our waterproof aprons to homes. Wonderful sellers. Fine profits. Pelham Manufacturing Company, N. Pelham, N. Y.

**AGENTS**—Men and women; make \$30 to \$50 weekly selling the New Improved Monitor Self-Heating Iron—the "World's Best." Over 750,000 in use. Positively the easiest, fastest selling, lowest priced, best known iron made. Binding Guarantee. Big profits for all or part time. Evans, N. Car., sold two dozen on Saturday. Mrs. Nixon, Va., sold eight first half day. New low terms. Exclusive territory. Sample free to workers. Write today. The Monitor and Iron Co., 740 Wayne St., Big Prairie, Ohio.

**AGENTS**—Make a big cleanup, selling our household Specials. Quick sales, \$25 to \$75 weekly a cinch. Write for colored circulars and immediate appointment. E. M. Davis, Pres., 664 Davis Bldg., Chicago.

**EASY,** pleasant work for Mechanics, Shop Men, Clerks, during spare hours, will add many dollars to their salaries. Also want persons who can give full time. Big wages assured. Novelty Cutlery Co., 67 Bar St., Canton, Ohio.

**I WILL** start you earning \$4 daily at home, silvering mirrors; free instructive booklet. G. F. Redmond, Dept. 306, Boston, Mass.

**AGENTS** make \$100 monthly selling our 500 handy household articles. Catalogue free. Scheff Company, Desplains, Ill.

**\$35.00 MADE** first day by 13-year-old boy with Shomescope. Woman made \$5.00 first hour. Particulars free. Shomescope Mfg. Co., 525 W. 13th St., Kansas City, Mo.

**AGENTS**—\$5 daily selling our Handy Tool, 12 articles in one. Lightning seller. Sample free. Thomas Mfg. Company, 762 North St., Dayton, Ohio.

**MANUFACTURER'S** Agents for well-known popular Home Exerciser. Furnish experience, territory desired and references. Peerless Athletic Supply Co., 383 Pearl St., Brooklyn, N. Y.

**PORTRAIT** Agents: Our goods will make you big profits. Delivery guaranteed. No rejects credited. Prompt shipments. Low prices. Send for latest catalogue and prices. Adam J. Kroll & Co., 602 Blue Island Ave., Chicago, Ill.

**\$10 DAILY** refinishing chandeliers, brass beds, etc., by new method; producing amazing results; no capital or experience necessary. Information free. Gunmetal Co., Ave. H, Decatur, Ill.

**GENERAL** Agents—Sanitary Sugar Bowls. Greatest 50c article. Sells everywhere. Territory free. Schoenheit & Pease, East End, Pittsburgh, Pa.

**SIGN** Letter Agents and Painters; 500% Profit Gold and Silver Sign Letters for Stores and Office Windows. Anyone can put on. Big demand. Free samples. Metallic Letter Co., 404 N. Clark St., Chicago.

**AGENTS**—Get newest, quickest seller direct from makers—full list free. Nat'l Agents Assn., C122 Michigan Ave., Chicago

**\$7.50 COMMISSION** each sale and repeat orders; traveling salesmen among general mercantile trade; every state; weekly settlement; no competition; pocket sample. Toledo Cable Co., 44 Davis Bldg., Toledo, Ohio.

**SUN Ray-Diator** room heater. No fuel cost. New tremendous seller; every home buys on sight at 50c. Big profits. Act quick. Details free. White Mfg. Co., Dept. S-11, Cincinnati.

**LUMINO** changeable signs—a metal sign with embossed letters. Something new. Every merchant buys. Fastest dollar seller ever invented. 250% profit. Write today. Changeable Sign Co., 581 East 192nd St., Cleveland.

**GET** into your own business. Cut loose from lay-offs, short hours, and wage slavery. Our catchy soap and toilet combinations have put thousands on Prosperity Road. Tremendous saving to consumer—200% profit for you. Send postal quick for details. E. M. Davis Co., K64 Davis Bldg., Chicago.

**AGENTS** make big money and become sales managers for our goods. Fast office sellers. Fine profits. Particulars and samples free. One Dip Pen Company, Dept. 2, Baltimore, Md.

**EVERY** household on farm, in small town or suburbs, where oil lamps are used, needs and will buy the wonderful Aladdin Mantle Lamp. Burns common coal oil (Kerosene); gives a light five times as bright as electric. Awarded gold medal at San Francisco Exposition. One farmer cleared over \$500.00 in six weeks; hundreds with rigs earning \$100.00 to \$300.00 per month. No cash required. We furnish capital to reliable men. Write quick for wholesale prices, territory and sample lamp for free trial. Address nearest office. Mantle Lamp Co., 517 Aladdin Bldg., Chicago, Ill. Mantle Lamp Co., 517 Thermo Bldg., New York City.

**AGENTS**—Sell the Primus, genuine Swedish wickless, coal-oil stoves. Smokeless, odorless. Twice the heat of gasoline at one-eighth the cost. No danger of explosion. Big profits. James Anderson & Sons, Sidney, Ohio, American distributors.

**READ** the Agents Magazine and make more money. 2 issues 10c. Agent's Magazine, Chicago.

**ENDLESS** Neckties—Something new; twelve ties in one; costs no more than old style; man made \$70 three days; woman made \$92 week; write for special agents' offer. Endless Necktie Mfg. Co., Dept. 10, Kansas City, Mo.

**\$1,000 PER** Man per County. Strange invention startles world—agents amazed. Ten inexperienced men divide \$40,000. Korstad, a farmer, did \$2,300 in 14 days. Schreiber, a minister, \$125 first 12 hours. \$1,200 cold cash made, paid, banked by Steneman in 30 days; \$15,000 to date. A hot or cold running water bath equipment for any home at only \$6.50. Self-heating. No plumbing or waterworks required. Investigate. Exclusive sale. Credit given. Send no money. Write letter or postal today. Allen Mfg. Co., 121 Allen Bldg., Toledo, Ohio.

**AGENTS**—Large Manufacturer wants reliable Men, Women, to sell guaranteed Hosiery, Underwear, Shirts, direct to homes. Write for free samples. Madison Mills, 588 Broadway, New York.

**WE** pay \$80 a month salary and furnish rig and all expenses to introduce our guaranteed poultry and stock powders. Bigler Company, X368, Springfield, Illinois.

**AGENTS!** Earn big commissions selling \$20 value all-wool made-to-measure suits for \$10.75 retail. No experience necessary. Chicago Wooden Mills, Dept. 100, 833 Jackson Blvd., Chicago.

**STOVINK**—Agents! Big money! Extraordinary store backing; will not burn off; sells to every home; repeats; rich opportunity; permanent business. Experience unnecessary. Season on. Harden Griffin Co., Toledo, Ohio.

**AGENTS** Wanted Everywhere—To sell our attractive theatre Brass Poster Frames, Changeable Signs, Building Directories, Brass Signs, Brass Ballings, Bank Fixtures, Adjustable Electric Light Brackets. Big demand; easy sales. Established 1882. Newman Manufacturing Company, Cincinnati, Ohio.

**ACT** Quick! Automobile Gasoline going up. Sell Gaso-Tonic. Equals gasoline at 3c a gallon. Eliminates Carbon. Dollar an hour profit. Sales Guaranteed. White Mfg. Co., Dept. M, Cincinnati, Ohio.

**MAKE** your own Extracts and Perfumes. H. Lake Co., Adair, Ill.

**AGENTS** make \$5 to \$10 a day on the spot. Atkinson writes: "The best proposition I have found in my forty years' canvassing." Permanent work. Household necessity. Saving 80%. Write today for General or Local Agents terms. Free sample. C. H. Stuart & Co., 16 Union St., Newark, New York.

**YOU** can be your own boss with our Key Check Outfit. Good for \$5 a day stamping names on pocket key checks, fobs, etc. Sample check with your name and address. 15 cents. Pease Die Works, Dept. M, Winchester, N. H.

**WE** are the largest manufacturers of twisted Wire Brushes in America. Highest grade goods, best service, largest profits. Our new Auto Specials are winners. Send for catalog. Fuller Brush Company, Hartford, Conn.; Rock Island, Ill.

**AGENTS**—Stamping names on Pocket Key Protectors; sample Check with your name and address, 12c. Stamping Outfits, Emblem Checks, Check Fobs, Name Plates. Hart Mfg. Co., Desk 2, 303 Degraw St., Brooklyn, N. Y.

**BIG** Profits for You! Manufacture Barley Crisp, New Confection. 5c package costs you 1c. Machine instructions complete \$7.50 prepaid. Send 10c for samples. Barley Crisp Co., 1293 Broadway, San Francisco.

**MAIL-ORDER** Opportunities: 25 new Propositions. No competition! Make 95c profit on dollar order; complete outfit 10c. Mail Dealers Wholesale House, 521 Franklin Bldg., Chicago.

**YOU** can make \$888 as our general or local agent. Household necessity; saves 80 per cent; permanent business; exclusive territory; salary or commission; free sample; credit. J. Pitkin, 113 Redd St., Newark, N. Y.

**MEDALLIONS**—300% profit. Make up your own goods and be independent. Catalogue free. Resag Co., 1205 Randolph St., Chicago.

**ACCEPT** no agency until getting offer on Ho-Lo-Co Skin and Scalp Soap and Toilet Articles. Our plan new and different. Territory limited; write today. Rothco, 200 N. 2nd. St. Louis.

**AGENTS**—Brand new specialty Aluminum Triplicate Sauce Pan with detachable handle. Cooks 3 different foods on one burner. Saves gas. Lasts lifetime. \$100 to \$300 per month easy. Send for our catalogue of 400 other specialties. American Aluminum Mfg. Co., Div. J. 10, Lemont, Ill.

**AGENTS**: Fastest Money Maker on Earth. \$5.00 to \$15.00 Day Sure. New Ingenious Invention for pick'g up and carrying cuspidors without touching hands or clothes. Users enthusiastic. Endorsed by Boards of Health. Sells quickly by simple demonstration. No sales experience necessary. No capital needed to start. Write quick for exclusive territory appointment. Address. Keith Mfg. Co., 38 C Keith Bldg., Canton, O.

**MAKE** \$30 Weekly Helping Us Introduce our goods among your friends. No investment. Write for particulars. Cole-Conrad Co., Dept. 8, Chicago.

**BIG** Money manufacturing "Flavoring Extracts." 54 Formulas and full working instructions 25c. "Ideal," 3311-C, Belle-plaine Ave., Chicago.

**\$50.00 WEEKLY**, are you a good salesman or saleswoman we offer agents the latest easy selling proposition yet discovered. We can show you \$25.00 for two hours' daily, quit that three dollar all day job, get attached to first class business. Write, Dept. C1, 205 Hollingsworth Building, Los Angeles.

#### AGENCIES WANTED

**CAN** sell latest manufacturers auto and other specialties. O. S. Duncan, 343 Pine Ave., Long Beach, Calif.

**MANUFACTURERS**—List your articles with us. Our agents sell goods. Yakima Sales Agency, 12 Ninth Ave., North, North Yakima, Wash.

#### PARTNERS WANTED

**ADVERTISER** offers young business man unique position as Manager of Shows on the California Beaches; must invest, not speculate, at least \$1,000, large profits; you handle all cash; I absolutely mean business; don't reply unless you do. Fred Archer, 205 Hollingsworth Bldg., Los Angeles.

#### SALESMEN WANTED

**AN Opportunity**—By acting promptly you can secure exclusively one of the few valuable territories we still have open on the greatest proposition ever offered the motoring public. Only keen, far-sighted men, preferably experienced in auto, accessory, or tire selling, need write. No investment necessary. State your qualifications in first letter. International Rubber Company, 1 West Tennesseer, Denver, Colo.

**WANTED**—Hustlers to take orders for made-to-measure high-grade men's tailored suits from \$9.50 to \$22.00. Make \$25.00 to \$50.00 weekly. Elegant large book outfit free. Experience unnecessary. No pocket folder affair. Splendid opportunity to make money. Handy Dandy Line, Dept. 8, Sangamon St., Chicago.

**SALESMEN** wanted to sell Shinnon Products to retailers and jobbers. All trades handle. Consumption big. Lowest prices and attractive deals. 18-year quality reputation. Big commissions net handsome income. All or part time. Shinnon Co., Rochester, N. Y.

**SALESMEN**—Sell Best Ford Steering Wheel Clock Invented. Exclusive territory. Big profits for you. Send \$1.50 for sample now. R. & B. Sales Co., P. O. Box 37, Dayton, Ohio.

**SALESMAN**, Sell beautiful 28x58 Ariz-kraft felt rugs for \$13.50 per doz. Your profit, \$3 per doz. Kelso, Battle Creek, Mich., sold 30 doz. last week. His profit, \$75. Write for exclusive territory and selling plan. Prepaid sample, 75c, refunded on first order. H. Condon, Mfr., Stonington, Maine.

**EXCLUSIVE** county rights. Sell Tankli; modern auto fuel. Profitable. Tankli Chemical Co., Cleveland, Ohio.

**EXCLUSIVE** County High a to sales managers of proven ability to represent manufacturer of aluminum appliance for Business men. Light pocket sample. Schuermann Co., 2028 East 82nd, Cleveland, Ohio.

**SALESMEN**—Make Big Money on our Convex Portraits 38c. Frames 35c. Glass 23c. Largest house in America. Est. 15 years. Samples Free. The Culver Co., Box 104, Westerville, O.

**SALESMEN** Wanted—Salesmen and Manufacturers' Agents to represent us everywhere among the Superintendents, Engineers and Purchasing Agents of manufacturing plants. Federal Graphite Mills, Cleveland, Ohio.

**WANTED**—Traveling Salesmen who will accept clothes made to their measure in payment for placing with merchants "The Line That's Different," an all-wool tailoring line, quoting six special prices; no extra charges. Write for particulars. J. W. Jones & Sons, 100 Mid-City Bank Building, Chicago.

**SALESMEN** Wanted—For Toy and Bell ringing transformers, Magneto charging machines, etc. Write for proposition. Midwest Electric and Mfg. Co., Box 2, South Denver, Denver, Colo.

**EARN** \$5,000 to \$20,000 yearly. New business necessity. Retail \$5 to \$200. 100-200% profit. Purchaser satisfied or money refunded. No competition. Exclusive territory. Free samples. Sagers, 408 Wainwright, St. Louis.

**SALESMEN**—Wanted everywhere by a responsible, established house. If you average sales of one or two machines a week, you make from \$2,000 to \$4,000 a year. Sell Chemical Fire Engines on Wheels to factories, stores, Fire Depts., etc. No capital required; exclusive territory; goods well advertised. Ajax Fire Engine Works, 35 Liberty St., N. Y. City.

**HELP-A-PHONE**: the profitable side line for Salesmen. Write Ebnard, 415 Belden Ave., Chicago.

**WANTED**, Salesmen—To represent manufacturer. Must be wide-awake, energetic and able to produce. Excellent opportunity. Exclusive territory to right man. Box 190, Station C, Cleveland, Ohio.

**WANTED**—Representatives everywhere. Exclusive territory. Gold sign letters for stores and office windows. Any one can put on. Write today for free sample. Metallic Letter Co., 463 N. Clark St., Chicago.

**SALESMEN**—Get our plan for Monogramming Automobiles and Motorcycles by transfer methods. Very large profits. Motorists' Accessories Co., Ashland, O.



## HELP WANTED

\$20 TO \$35 per month extra money to any employed persons without interfering with regular work. No canvassing. No canvassing. Positively no investment. Unemployed need not apply. Address The Silver Mirror Co., Inc., 119 W. Madison Street, Chicago, Ill.

LADY Distributors: We are giving away, to advertise, thousands of full size packages our wonderful Ko-Ko-Foam Shampoo free. Send name and address for your free pkg. No money or experience needed. Big money. Ward Co., 8-730 N. Franklin, Chicago.

WANTED—Men and women to qualify for Government positions. Several thousand appointments to be made next few months. Full information about openings, how to prepare, etc., free. Write immediately for booklet CG-29. Earl Hopkins, Washington, D. C.

PHOTOPLAYS Wanted. Big prices paid. We show you how. Details free. Rex Publishers, Box 175, A-2, Chicago.

GOVERNMENT Jobs open. \$90 month. List free. Franklin Institute, Dep't G-21, Rochester, N. Y.

BE a Detective—Earn from \$150.00 to \$300.00 per month. Travel over the world. Write C. T. Ludwig, 240 Westover Building, Kansas City, Mo.

GOVERNMENT Examinations. Most thorough preparation, \$5; returned if not appointed; particulars free. American Civil Service School, Washington, D. C.

WANTED—Men—Women, \$75.00 month. List Government Jobs open, free. Franklin Institute, Dep't G-21, Rochester, N. Y.

GET a Government Job! See ad on page 48. Write now—today! Patterson Civil Service School, Rochester, N. Y.

YOUNG men to look after our interests in every county; salary starting \$15.00 weekly with expenses; no canvassing. Frontier Mfg. Co., Niagara Falls, N. Y.

CIVIL Service Examinations open the way to good Government positions. I can coach you by mail at small cost. Full particulars free to any American citizen of eighteen or over. Write today for Booklet CE-29. Earl Hopkins, Washington, D. C.

BE a Printer Expert. Be independent. Interesting work. Big opportunities. Herbert Thode, Printer Expert, 2367 Grove St., San Francisco.

I BUY hundreds of insects, butterflies, each summer at 5c to \$7.00 each, for museums, artwork, if properly fixed. Men, women, send 2c stamp for details telling all. Sinclair, Bx. 244, D-6, Los Angeles, Cal.

BELLARJE woman; spare time; distribute free bottles our delightful Lotus Perfume to advertise. Pay every day. No money or experience needed. S. Waverly Brown, Sec'y, 730 N. Franklin, Chicago.

MEN—18 or over—Wanted as railway mail clerks. Sample examination questions free. Franklin Institute, Dep't G-21, Rochester, N. Y.

A POSITION is open for you in the Government service after we have helped you qualify. My money back offer guarantees it. Write quick for big free book DA-29. Earl Hopkins, Washington, D. C.

DO you want a position for life, with big pay, short hours and sure advancement? Then work for Uncle Sam. My free illustrated book, DK-29, tells how to get an appointment. Earl Hopkins, Washington, D. C.

MEN—Women, wanted. \$75.00 month—Government jobs. Vacancies constantly. Write for list position: now obtainable—Franklin Institute, Dep't G-21, Rochester, N. Y.

LEARN Auto Trade in most Modern School on Coast. Courses practical and complete. Expert supervision. Time unlimited. Rates reasonable. Many positions secured. Room and board while learning. Catalog free. National School of Engineering (Est. 1903), Los Angeles.

EARN \$100 weekly managing clean, legitimate mail-order business. We furnish everything. Right party need not worry about capital. Splendid chance for intelligent, employed person to control independent business on profit-sharing basis, beginning in spare time, evenings at home. Particulars free. Opportunities Exchange, Buffalo, N. Y.

CHAUFFEUR'S License—I tell you how to get one. Complete information and sample questions, ten cents. L. I. Lutes, Ex-Senate Examiner of Chauffeurs, Utica, N. Y.

WANTED—An Idea! Who can think of some simple thing to patent? Protect your ideas; they may bring you wealth. Write for "Needed Inventions" and "How to Get Your Patent and Your Money." Randolph & Co., Patent Attorneys, Dept. 144, Washington, D. C.

THOUSANDS—Men—women—wanted for U. S. Government Jobs, \$75.00 month. Steady work. List of positions now obtainable free. Write immediately. Franklin Institute, Dep't G-21, Rochester, N. Y.

DISTRIBUTORS Wanted—of advertising matter everywhere. (Good pay.) Send dime for Contract Magazine. (None free.) Address Oliver A. Barkley, Mount Pleasant, Pennsylvania.

PLEASANT spare-time work; mailing circulars. Good pay. No scheme. Details free. Home Pub. Society, 46 N. 12th, Philadelphia.

INVENT something; your ideas may bring wealth; our free book tells what to invent and how to obtain a patent, through our new credit system; write today. Waters & Co., 5103 Warder Bldg., Washington, D. C.

GENERAL Toolmakers and Machinists, Springfield, Mass. Wanted—Toolmakers, experienced on gauges, jigs, and fixtures; also first-class machinists for setting up and adjusting milling machine fixtures. State references, and wages expected; or call at the New England Westinghouse Company Employment Bureau, Walnut Street, Chicopee Falls, Mass. (Office open week-days, excepting Saturday afternoon, until five o'clock; also Tuesday and Thursday evenings until nine.)

HELP Wanted by U. S. Government, \$75 month. Varied work. Steady work. Common education sufficient. Pull unnecessary. Write immediately for free list of positions now obtainable. Franklin Institute, Dep't G-21, Rochester, N. Y.

COLLECTORS everywhere. Permanent employment. Steadily increasing income. No canvassing. No outlay. Sales Manager, Box 5272, Boston.

MEN wanted to make Toy Soldiers; spare-time work or business. War stopped importation; greatest demand. We buy soldiers all year. Casting form outfit \$2.50. Booklet free. Toy Soldier Manufacturing, 32 Union Square, New York.

LARGEST Automobile School in the East. Send for folder. New York School of Motoring, Utica, N. Y.

EARN \$20 weekly collecting names and information. What you see, hear and know is worth money. Send stamp for instructive booklet. Information System, 232 Marietta, Ohio.

YOUNG Men Wanted to become Automobile Chauffeurs. Hundreds of spring vacancies; \$18.00 week. Learn easily at home while earning. Sample lessons free. Write immediately. Franklin Institute, Dept. G-21, Rochester, N. Y.

FOR Positions between \$2,500 and \$15,000 per year. If actually qualified for technical position, or executive, administrative or manufacturing position above \$2,500, communicate with undersigned counsel, who will negotiate strictly confidential preliminaries for such positions. Not an employment agency; undersigned acts in direct confidential capacity. Send name and address only for prefatory details. R. W. Bixby, 3 Niagara Square, Buffalo, N. Y.

\$7.50 COMMISSION each sale and repeat orders; traveling salesmen among general mercantile trade; every state; weekly settlement; no competition; pocket sample. Toledo Cable Co., 45 Davis Bldg., Toledo, Ohio.

DRAFTSMEN—Become proficient in lettering, and demand best salary. Our course in Topographic Drafting prepares for Government service where demand is great. Request particulars. No obligation. Columbia School of Drafting, 10th and G, Washington, D. C.

I WILL start you earning \$4 daily at home, silvering mirrors; free instructive booklet. G. F. Richmond, Dept. 305, Boston, Mass.

MEN to refinish lighting fixtures, brass beds, etc. All or spare time. No capital or canvassing. Experience unnecessary. Information free. Gunmetal Co., Ave. G, Decatur, Ill.

BECOME Detectives. Large salaries; easy work. Write Chief Wagner, 1243 Lexington Avenue, New York.

SILVERING mirrors, Plating tableware, auto-brass. Home booklet plans free. Clarence Sprinkle, Dept. 28, Marion, Ind.

GO on the Stage. Vaudeville career offered you. Experience unnecessary. Managers endorse my method. Instructive vaudeville book free. Write today. Frederic LaDelle, Sta. 19, Jackson, Mich.

STOP Here! Let me start you in a home business that will bring you money every day. Experience unnecessary. Spare time. No canvassing. I furnish everything. Send for proofs. Voorhies, Desk C. B., Omaha, Neb.

## WANTED

"UNITED Cigar Store Certificates" wanted. Will pay 65c per hundred. State quantity. J. Z., Room 925, 78 E. Madison St., Chicago.

WANTED to borrow \$7,000 or \$25,000 on real estate. Elizabeth Stewart, 12th and Main, Pueblo, Colo.

## FOR SALE

TYPE and Printing Material at bargain prices. Now is the time to buy. All sizes rebuilt Job Presses very cheap. Catalogue free. Philadelphia Printers' Supply Co., 14 So. Fifth St., Philadelphia.

COMPLETE set steel dies for manufacturing buttons, etc. Also photo-button machine. Go at half cost. Oscar Morrison, Polk, Pa.

REAL bargains in high-grade Cameras, Lenses, Kodaks, Binoculars, Microscopes, Surveyors' Transits, etc. All goods used, but equal to new. Away below regular prices. Write us today. David Stern Co., 1047 W. Madison St., Chicago.

FOR Sale—Small Typewriter, Carbon remover, Static machine, Camera and outfit. All very cheap. Harry Fesenfeld, Black Earth, Wisconsin.

FOR Sale—Elk and Deer heads. Reuben Saylor, 497 Broadway, Dayton, Ohio.

FIELD and Marine, Day and Night Glasses, with beautiful case, 25-mile adjustment; \$30 value, only \$7.50. Money back if not satisfied. Well's Curiosity Shop, 20 S. Second St., Philadelphia, Pa.

WANT to sell Merry-go-Round; gasoline power; bargain, \$2,800. A mounted steam engine and boiler, 10 H. P., \$200. A mounted "house-to-house," gasoline power Vacuum Cleaning outfit, cost \$2,500, for \$350. J. J. Barnes, Henry, Ill.

AT a Bargain—3 large Moose heads, 7½, 69, 65 inch spread of horns. Taxidermist, 2001 Market St., San Francisco, Calif.

MANDEL Daydark Post Card Camera. \$12; nickel rim banjo, \$8. Hal Moudy, 101 Gilbert, Danville, Ill.

VACUUM cleaner pumps and parts for assembling, save 75%. Vacuum Supply Co., Ann Arbor, Mich.

CRANKSHAFT and timing gears for Camera 4 cyl. air cooled motor. H. J. Schaefer, Box 22, Cresco, Iowa.

## SALE OR EXCHANGE

WAGNER Motorcycle, 383 Savage Rifle, old Edison Phonograph; want Battery Charging Rectifier or small A. C. Motor. Geyer Garage, Geyer, Mont.

SWAP! Buy! Sell! What's got? What's the want? Free advertising. Three months, dime. Swap Bulletin, Detroit.

FOR Sale or Trade: Miami Motorbicycle, \$65. Cameras, Guns, Motorcycle parts, 50% discount. Write Box 112, Rembrandt, Iowa.

WE have prospects for anything you have to sell or trade. Guaranteed service. Write M. R. P., 391 Mallers Bldg., Chicago.

YOU can sell or exchange almost anything through these classified pages. Tell me what you have and I'll send you some interesting information. No obligation whatever. Write me today. F. W. Johnson, Manager of classified advertising, 6 N. Michigan Ave., Chicago.

## GUNS, SPORTING GOODS, ETC.

SHOOTING Gallery targets for sale at bargain. Albert Fabian, Hallettsville, Texas.

DON'T Be Mushy. Postal will bring catalogue of Famous Home Exercisers, direct from the Manufacturers. Peerless Athletic Supply Co., 383 Pearl St., Brooklyn, N. Y.

FIREARMS—Old-time and modern. Buy, sell, exchange all sorts. Stephen Van Rensselaer, 49 Front St., New York City.

### FLOUR & FEED MILLING MACHINERY

SPECIAL bargains in second hand Attrition mills, burr mills, crushers, corn shellers, bran dusters, dust collectors, purifiers, reels, double, single, 2 and 3-pair high roller mills, sieve bolters, receiving separators, scourers, etc. Write for description and prices. Sprout, Waldron & Co., P. O. Box 429, Muncy, Pa.

### MACHINERY, TOOLS AND SUPPLIES

"BROWNIE" Handy Clamps are small, nickel-plated clamps with die-cut screws. Fully guaranteed. Every mechanic should have them. Five sizes, from  $\frac{1}{8}$ " to  $1\frac{1}{2}$ ". Send us 50c for two No. 44 clamps with free booklet showing all sizes and prices. Money back if not satisfied. Brownie Mfg. Co., 427 W. Randolph St., Chicago, Ill.

ENGINE Lathe, about twelve-inch swing wanted. Will exchange new, English Sun-Beam bicycle, three speeds, brake on front and rear wheels. Cost \$85.00, less duty. Frank Woodhead, Glen Riddle, Del. Co., Penna.

WANT Milling Machine in exchange for welding apparatus. Bertschy, Omaha, Nebr.

STEEL Name Stamps for marking tools, 3 initials, 75c. Names with initials, 20c per letter. Brass and steel dies for all purposes. Partridge Scottford Co., 12A West 10th St., Kansas City, Mo.

PULLEYS, Gears, Sprockets, Shafting, Hangers; see display ad this issue. W. A. Jones Foundry & Machine Co., Chicago.

GLASS Cutter, improved type; cuts any thickness. Saves labor, time, money. Saves the hands. 10c. Smith & Hemenway Co., 141B Chambers Street, New York City.

AMATEURS: Working drawings for building air compressor, speed lathe, etc. La he work only. Henry Parker, 918 Eighteenth Street, Oakland, California.

LATHES, with or without chuck, turret, shrapnel special tooling. Prompt delivery. Cannot accept order under 25. W. Gurley, 4211 Cedar, Cleveland, Ohio.

OLD Parts made new, new parts made too. Bertschy Kan-Fix P., Omaha, Nebr.

AUTO Repair or Machine Shop, a 20-inch back gear drill, \$83. S. Campbell, 819 Cass Ave., St. Louis, Mo.

FOR Sale—"Sturtevant crusher," thirty tons capacity; Smith concrete mixer. Address C. G. Reese, Elizabethtown, Pa.

VACUUM cleaner pumps, tools, etc., for stationary house or wagon outfit. Vacuum Supply Co., Ann Arbor, Mich.

ENGINE Lathe, swings  $9\frac{1}{2}$  in., takes 25 in. between centers. Complete set gears cutting all size threads 3 in. to 40 in., \$43.50. Grammes & Sons, Allentown, Pa.

FOR Sale: New Power Hack Saw, capacity 4"x4", \$15.90. New 10" Sensitive Bench Drill Press, complete with chuck, capacity  $\frac{3}{4}$ ", \$15.00. Passman Bros., 30 S. Green St., Chicago, Ill.

100 NEW Vises \$1.00 per inch width of jaw, all sizes  $2\frac{1}{2}$  to 5 inches. Send for circular. Lucas & Son, Fox St., Bridgeport, Conn.

### ENGINES, MOTORS AND DYNAMOS

ALTERNATING and direct current rebuilt motors. Guaranteed makes only. Wagner, General Electric, Westinghouse, Crocker-Wheeler, Century, Fort Wayne. Tell us your needs. Satisfaction guaranteed or money refunded. Write today for illustrated wholesale price-list supplies and motors. Hyre Electric Co., 613 YC—, South Dearborn St., Chicago.

REBUILT Engines—We have on hand a number of rebuilt "Buffalo" engines, guaranteed, at greatly reduced prices. Write for bargain list. Buffalo Gasoline Motor Co., 1293-1305 Niagara Street, Buffalo, N. Y.

FUELLESS Motor (Spring), up to 33 H. P., simple and inexpensive to operate. Send 10c for booklet. Carl Hanna, Del Norte, Colorado.

ONE  $\frac{3}{4}$ -Horse Marine engine slightly used. \$25. Chas. Retcher, Erie, Pa.

FOR Sale—Chicago Water Motor, 24-inch wheel, also one 10-inch. One Rider-Ericson Hot-Air pumping Engine. All good condition. Cheap. Dieter & Getz, Naperville, Ill.

BELTED engine and dynamo, direct current, 50 hp., excellent condition, worth \$1,000, price \$500. E. P. McKinney, Birmingham, N. Y.

SMALL Dynamo, 165 watt, switchboard, rheostat, bulbs, etc., new. Sell cheap. Alvin Sharbondy, Cloverdale, Ia.

FOR Sale—Engines, new and second-hand. Also Automobile parts. Apply with stamps. B. W. Richardson, Peoria, Ill., R. 26.

NEW Electric Motors Alternating or Direct Current from  $\frac{1}{32}$  to  $\frac{1}{4}$  hp., from \$1.50 up. Polishing and grinding motors. Write for Catalogue. Omega Electric Co., 53 W. Jackson Blvd., Chicago.

STORAGE Sale: Washing Machine Motors—A. C.—110 Volts— $\frac{1}{4}$  Hp., \$12.50— $\frac{1}{2}$  Hp., \$15—other sizes less than factory cost. Write for Bargain List—Motors, Dynamos, Engines, Motor Generator Sets. Johnston, Evans Ave., Ingram, Pa.

AUTO Engines: 15 Hp.—2-cylinder, \$30—Bulck 10, 4-cylinder complete, \$50. Other engine bargains. Johnston, Evans Ave., Ingram, Pa.

USED Motors, Transmissions, Axles and Parts, Bargains. Bertschy, Omaha, Nebr.

$1\frac{1}{2}$  HP. Gasoline Engine, almost new, \$15. W. B. Meeks, Anamosa, Iowa.

FOR Sale—New 40-hp. Knox, 4-cylinder, unit engine and transmission, Bosch Magneto. Price, \$250. J. L. Lucas & Son, Bridgeport, Conn.

CLOSING out entire line of 3-hp. gasoline engines,  $4\frac{1}{2}$ " bore, 6" stroke, hopper-cooled. While they last \$50, with complete equipment. Colborne Manufacturing Co., 153 W. Division St., Chicago.

MOTORS—Aero Type 25 hp, 4 cylinders weight 125 lbs. Electric Motors—2—in good condition. Blower 576 cubic inches per revolution. Send for supply catalog. Auto Supply Co., 371 Fairfield Ave., Bridgeport, Conn.

### ENGINE CASTINGS AND BLUE PRINTS

GASOLINE Engine Castings, with drawings. Cheap. Catalog for stamps. Novelty Manufacturing Co., 853 West 6th St., Cincinnati, Ohio.

SMALL Gasoline Engines and Castings with drawings. Crown Motor Works, Elgin, Ill.

### BOATS, LAUNCHES, ETC.

BUILD your own Steel boat from patterns. Material furnished, also finished boats. Catalogue free. Darrow Boat Co., Albion, Mich.

MOTORCRAFT Encyclopedia—A 150-page book that tells 1001 things every motor boatman should know. How to overcome engine troubles. Price \$1, postpaid. Popular Mechanics Book Dept., 6 N. Michigan Ave., Chicago.

### FOR THE SHOP

JUST Published—Popular Mechanics Shop Notes for 1916—529 Easy Ways to Do Hard Things in every department of mechanics. Over 600 illustrations. 224 pages (size  $8\frac{1}{2}$ x $11\frac{1}{2}$  in.). Price 50 cents, postpaid. Popular Mechanics Book Dept., 6 N. Michigan Ave., Chicago.

FOR That Boy—He will appreciate a copy of the great boy's book "The Boy Mechanic" that tells about 700 different things for boys to do and has 800 pictures. 480 (7x10) pages, cloth, big handsome book for the price, \$1.50 postpaid. Popular Mechanics Book Dept., 6 N. Michigan Ave., Chicago.

### BLACKSMITHS

BLACKSMITHS, Listen: Wear the smile that won't come off, by doing hard jobs easy with Toy's Modern Methods on blacksmithing. Making all welds solid, tempering all tools to a standard with colored tempering charts. All for one dollar. Samples free. W. M. Toy, Sidney, Ohio.

### CEMENT

CONCRETE Building Block Machines and moulds. Free catalogue. 5 Market St., St. Louis, Mo.

### ELECTRICAL

"BOY Electrician" makes Batteries, Motors, Engines. 75 illustrations, 10c. Renew Dry Batteries, 3 guaranteed processes, 20c. Both 25c. "Ideal," 3311-C Belleplaine Ave., Chicago.

GUARANTEED bargains. Write today for illustrated wholesale price-list supplies and motors. Hyre Electric Co., 613AD—, South Dearborn St., Chicago.

INVENT something; your ideas may bring wealth; our free book tells what to invent and how to obtain a patent, through our new credit system; write today. Waters & Co., 4102 Warder Bldg., Washington, D. C.

ELECTRICITY—10 cents coin brings plan and instructions for Simplex Electric Machine. Inexpensive, no tools required, equals medical coil costing \$5.00. L. Jones Co., 2827 Parkwood, Baltimore, Md.

WHAT is Electricity? Answered in "Mechanics of Electricity," \$1.25. Spou & Chamberlain, N. Y.

ELECTRICIANS—Send 50c for 10 Blue Prints of 3-phase, 2-phase, and single-phase motor windings. Winding made easy. Mid-West Electric and Mfg. Co., Box 2, South Denver, Denver, Colo.

### STAMP COLLECTING

AMERICAN Packet Free, Old Issues, Commemoratives galore, Dues, Revenues, etc., 2c postage. Midland Stamp Company, Midland, Ontario.

240 WESTERN Poster Stamps. Cowboys, Indians. Send 15c for 30 stamps and plans to get 250, free. Great West Poster Stamp Co., Denham Bldg., Denver.

25 DIFFERENT British Colonials to applicants for stamps on approval. Postage 2c. Nickles, 122 Florida Ave., Washington, D. C.

10 VAR. Greece for 2c. Graves, Box 858, Providence, R. I.

SPLENDID packet, South American countries, only for dollar bill. No rubbish. Geo. Back, Box 1072, Valparaiso, Chile.

15 VARIETIES Chile Stamps 10c; 25 different Foreign coins 25c; Price list Free. Stamp & Coin Exchange, 65 Nassau St., New York City.

STAMPS—12 different from warring nations 10c; 10 different foreign coins, 15c; 20 Belgian stamps, 13c. Lists free. Toledo Stamp Co., Toledo, Ohio.

FREE! 10 var. Egypt for 2c postage. Providence Stamp Co., Providence, R. I.

LOW priced approvals. Mention paper and receive unused Department Stamp Free. S. E. Colman, 634 Keefer Place, Washington, D. C.

FREE—200 Mixed Stamps, Perforation Gauge, Our Big List Subscription Blanks to Stamp Journals, etc., for two cents postage. Pam Stamp Co., 138 No. Welling-on St., Los Angeles, Calif.

DUTCH Indies 1901, 6 varieties cataloging 15 cents, net 6 cents. Quality approvals. Reference please. M. Noel, 880 Clarkson Ave., Brooklyn, N. Y.

FREE. Choose one, 65 different British Colonials; 25 Persia; 60 Japanese; 50 Asiatic; 101 United States; 201 foreign; 50 Sweden; 50 Australian; with six months' subscription Mikkol's Stamp Weekly, Beverly, Mass. Remit 25c.

FREE—50 different stamps with 60% approvals. Seidenberg, Beecher, Ill.

STAMPS—165 China, etc., stamp dictionary and list, 2c. Bullard, Sta. A, Boston.

FREE, six different Mexico to approval applicants. Athol Cliff, East Stroudsburg, Pa.

FREE! 25 different used United States Stamps including Postage, Revenues, Envelopes and Dues, to applicants for our high-grade approval selections. Send 2c for postage. The Edgewood Stamp Co., Dept. H, Milford, Conn.

STAMPS sent on approval at 70% discount. Precancelled,  $\frac{1}{4}$ c each. Reference required. Emory Renold, Hanover, Pa.

PACKET of 23 stamps; no two countries alike, 500 hinges. Set of \$1 and \$2 U. S. Rev., all for 5c. Mention paper, Miami Stamp Co., Toledo, Ohio.

POSTER Stamps. Art Stamps for collectors. New, instructive, artistic, 25 all different, 10 cents. Ask for circulars. Stone City Poster Stamp Co., 102 Mound St., Joliet, Ill.

BOYS, all approvals 66% discount and premiums. M. Place, Wrentham, Mass.

A STAMP Album. A Collection of rare Mexican War stamps, incl. Madero, etc., 100-page catalog. Perf. gauge and mill. scale, coupons, etc., all for 3c. App. sheets 50% to 80% comm. Agents Wanted. We buy stamps. Hussman Stamp Company, St. Louis, Mo.

24 VARIETIES Cuban stamps, 10 cents. List of 4,000 low-priced stamps free. Chambers Stamp Co., 111 P. Nassau St., New York City.

20 UNUSED stamps free. All different. Postage, 2c. Flisk Stamps, Toledo, Ohio.

STAMPS, 75, all different, free. Postage 2c. Mention paper, Quaker Stamp Co., Toledo, Ohio.

LOW Priced Stamps on Approval. \$10 Confederate bill free to applicants furnishing satisfactory references. G. V. Lovering, 2715 13th St., N. W., Washington, D. C.

PACKET "A" 100 varieties foreign, 20c—worth the money! Desirable stamps on approval, to collectors with satisfactory references. F. J. Pope, Box 45, Charlotte, Vermont.

COLONIAL approvals only. finest grade 1 cent up. Lowest prices. Hanlon, Box 21, Schenectady, N. Y.

#### RARE COINS

THREE Large United States Cents, 25c. Flying Eagle, 10c; Coin book, 15c. Moore Coin Company, Commerce, Texas.

DOLLAR 1798, very good, \$2.45. Large cent before 1821, good, 10c. Price list for stamp. Norman Shultz, King City, Mo.

10 DIFFERENT Coins from the Warring Nations, 25c. Burgess Co., 522-M, Beacon, Toledo, Ohio.

OLD Coins. Spring Catalogue, large list coins for sale. Catalogue quoting prices paid for coins, ten cents. William Hesslein, 101 Tremont St., Boston, Mass.

COINS—Antique Relics, 5 curious rare coins with catalogue, 15c. Ray Chapin, New Berlin, N. Y.

UNITED Profit-Sharing Coupons taken the same as cash for Coins, Notes, Stamps, Indian Relics, Guns, Pistols and curious things. Booklet for stamp. Coin Exchange, New Rochelle, N. Y.

\$4.25 EACH Paid for U. S. Flying Eagle Cents dated 1856. We pay cash premiums on hundreds of Old Coins. Send ten cents at once for New Illustrated Coin Value Book 4x7. It may mean your fortune. Clarke & Co., Coin Dealers, Box 15, Le Roy, N. Y.

ALL for 60c. A 25c. 50c. \$1.00, \$5.00, \$10.00, \$20.00. New uncirculated Mexican Notes. Coin Exchange, New Rochelle, N. Y.

WILL pay \$750.00 cash for \$3 gold piece dated 1822 (without "In God We Trust"); \$50.00 for 1853 half without arrows; \$5.00 to \$50.00 cash for large cent 1799, etc. We pay cash premium for all large cents, eagle cents, 2c pieces, etc., and all rare U. S. and foreign coins, bills and stamps to 1912. Thousands of rare coins wanted. Many valuable pieces are in circulation. Send 4c. Get our Large Illustrated Coin Circular containing valuable information. It may mean much to you. You certainly have nothing to lose. Send to Numismatic Bank of Texas, Dept. H, Fort Worth, Texas.

#### GAMES AND ENTERTAINMENTS

HIGH Class Magical Apparatus. Immense stock. Immediate shipments. 50-page Illustrated Catalog, 1916 New List and New Bargain Sheet No. 58, free. Large 223-page Illustrated Professional Catalog, 10c. A. Rutenberg, 152 West Ontario Street, Chicago.

FUN, Fun, Fun for everybody. Sensational new Novelties, Tricks, Puzzles and Jokers' goods. Fun for all. Be a live one among your friends. Send 6c for our large illustrated catalogue and sample of the Naked Truth, the latest Novelty. J. Grandefeld, Mfg., 1238 Theriot Ave., Bronx, New York.

MAGIC Trick Cards and Jokers' Catalog 10c. McGulness, 109 Wierfield Street, Brooklyn, New York.

CARD Trick and Catalogue 5c. Harvey Arnold, Princeton, N. J.

MAGIC Goods, novelties, sensational escapes. Catalog free. Heaney Magic Co., Berlin, Wisconsin.

WONDERFUL Pack of Magic Trick Cards 10c, with Magic Catalogue. Cabinet of Tricks 35c. Walwen Company, 150 Nassau St., New York.

CACHOO Sneeze Powder, Itching Powder, Explosive Matches, Roll Stage Money, 10c each. Catalog free. Empire Co., Oneville, Rhode Island.

SELLING Out! Largest assortment Tricks and Novelties in South. 40% discount. Catalogs free. Buy now! Douglas, Kiowa, Okla.

WIGS, Makeups, Tricks, Puzzles, Jokes, Magic Goods, Mind-reading Acts, Sensational Escapes, Illusions, and Stage Supplies. Big catalog free. Oaks Magical Co., Dept. 295, Oshkosh, Wis.

TINY Toy Zeppelin. Mouse propels it. Instructions one dime. Stanley Moran, 5 Church St., Bristol, R. I.

FREE! 25c Magic Book, "New Tricks and Sleights." Send stamp for postage. Eagle Magic Store, Minneapolis, Minn.

SECRET Writing Key—Big Magazine 3 months—Catalog, Tricks, Jokes, Puzzles—All for 10c. Novelty House, Rockland, Wisconsin.

WONDERFUL Obedient Ball Trick, 10c. Beauty Squirt Ring, 10c. Stokers, Millersburg, Pa.

MAGIC: We teach you to perform Tricks at home as good as the great professionals. Feature Acts in Mind Reading, Spiritualistic Work, Rope Ties, Escape Acts. Send for New Thumb Tie for stage work—7 illustrations; complete directions, 50c. Catalogue 100 pages, greatest on earth, 10c. Chicago Magic Co., Dept. B, 72 W. Adams St., Chicago, Ill.

SECRET Writing, three codes 25 cents. Box 325, Warren, Ill.

P-L-A-Y-S, Speakers, Dialogues, Drills, Joke Books, Wigs and Beards. Catalogue free. Ames Publishing Co., Dept. 40, Clyde, Ohio.

THE Man Who Lied. Interesting to read and would-be liars. Fifty illustrations. Fifty laughs. 25c. Sketchbook, Little Rock, Ark.

1916 MAGIC Catalog with 350 Illustrations of 800 Tricks and Illusions, including Pocket Trick, free. Send 6c stamps for postage. Hornmanns Magic Co., 349 West 38th Street, New York.

INK erasing blotters fool every one—formula 10c. Hobson, P. O. Box 1543, St. Louis, Mo.

BE a handcuff king. We teach you. Escape from handcuffs, boxes, ropes, etc. Secrets of 20 sensational escapes, \$1. Particulars free. The Magcraft Co., Dept. A, Box 251, Detroit, Mich.

PLAYS, Vaudeville Sketches, Monologues, Dialogues, Speakers, Minstrel Material, Jokes, Recitations, Tableaux, Drills, Musical Pieces, Entertainments for all occasions. Make-up Goods. Large Catalog Free. T. S. Denison & Co., Dept. 11, Chicago.

USED Magic Goods and Supplies that please. Bargain Catalogue free. Gilmore, Morgan Park, Chicago.

FUNABOUT Feeds—The book that contains the funny Ford stories that the whole nation has laughed over. The greatest book novelty of the year. A collection of nearly one hundred of the very latest and best current "Ford stories" in book form. 64 pages, 6 1/2 x 4 1/2 in. Heavy boards. Price 25 cents postpaid. Send for your copy now. Popular Mechanics Book Dept., 6 N. Michigan Ave., Chicago.

"MAGICAL—Entertaining" Free Course (10 lessons) to introduce 50 only. Magical Outfit 50c. Part 25c. Sample Trick 10c. Herrmann "Magicschool," Long Beach Building, New York.

#### FOR BOYS

HERE'S Your Chance, Boys, to earn good money, for that rifle or camping trip. Write us today and learn about a household necessity that sells on sight in every home. We pay you well and teach you how to sell. Don't miss this big opportunity to make a man's wages and show Dad and your pals that you have the right stuff in you. Write to V. P. Jepson, Dept. "P," Woolworth Bldg., New York.

"JITNEY-Bus Game," patented. Ball-bearing Automobile; Garage; in metal box, complete ten cents. Allen, Box 957, Buffalo.

BOYS, will you pay \$2.22 for absolutely solid shoe? Sizes 1 to 6. K-Company, Greenport, N. Y.

BIG New Book for Boys—The Boy Mechanic, Vol. II—Just Out—A sequel to, but containing nothing found in Vol. I. Tells all about 1,000 interesting things to make and do, 480 Pages; 95 Illus. Cloth. Price, \$1.50 Postpaid. Send for descriptive circular. Popular Mechanics Book Dept., 6 N. Michigan Ave., Chicago.

JUST Out—Amateur Mechanics No. 7. For everyone that enjoys building homemade contrivances of every description this book will afford a wealth of practical ideas and suggestions of things both ornamental and useful. Over 200 articles. Fully illustrated, 128 pages (size 4 1/2 x 7 1/2 in.). Price 25 cents postpaid. Popular Mechanics Book Dept., 6 N. Michigan Ave., Chicago.

#### FOR MEN

HAND made pocket knives and razors: send for free catalogue. Address P. W. Oswald, Box 428, Baker, Ore.

\$5.00 GILLETTE Safety Razor Outfit \$3.75 postpaid. Guaranteed perfect. William Berg, 4220 14th Ave., Brooklyn, N. Y.

MR. Cigar Smoker, do you enjoy the taste and aroma of Imported Havana, order a box of White Front Cigars direct from factory. 4 1/2 inch Lonsros hand-made Sumatra Wrapper, 50 box, \$2.00; trial box 25 for \$1.00, prepaid anywhere. White Front Cigar Co., 219 West Chestnut St., Lancaster, Pa.

SEND 50c for stick-pin made from genuine U. S. Dime. Money back if not satisfied. Also have rings and tie-clasps. E. Johnson, Box 349, Erie, Penna.

KENTUCKY'S Best Natural Leaf Tobacco, chewing or smoking, parcel-post prepaid, 4 lbs., \$1; 10 lbs., \$2. L. Rosenblatt, Hawesville, Ky.

OLD Meerschaum Pipes colored cherry red or golden brown \$1.25. New process. Pipes repaired. 20 years' experience. Schultz's Pipe Shop, Toledo, Ohio.

MR. Man, do you wear a shirt? Thousands are wearing our patent Kuff Link. Opens like a glove. Send postal for Circular. The Hub Button Co., Attleboro, Mass.

WAVECURL Hair-Curling Fluid will make your hair beautifully curly. Send 15c for a sample. Wavecurl Co., 16A Saint Paul, Minn.

SAFETY Razor 25c. Satisfaction guaranteed. C. Morrison, 1025 Greenleaf, Chicago.

#### SAFETY BLADES SHARPENED

RESHARPENED by our "New Process" 2c each. Guaranteed better than new. Each blade honed, hair-tested, sterilized, wrapped individually. Jones Keenedge, Dept. A, Jamaica Plain, Mass.

SAFETY razors sharpened; two cents each. Guaranteed. Blade box free. Electro Strapping Co., 121 Shelby St., Detroit, Mich.

#### FOR THE HOME

ARTISTIC Lamps and Shades in metal and art glass easily made by the amateur craftsman from instructions given in our book of 18 designs ranging from ordinary reading lamps to pretentious chandeliers. Expense only slight. Price of book 50c postpaid. Popular Mechanics Book Dept., 6 N. Michigan Ave., Chicago.

BEAUTIFUL arts-crafts lamp—Anyone can make them out of paper, cardboard and wood. 16 designs. Inexpensive yet artistic. Complete book of instructions. Price, 50c postpaid. Popular Mechanics Book Dept., 6 N. Michigan Ave., Chicago.

#### DIAMONDS, WATCHES AND JEWELRY

GEMS that look and wear like diamonds. \$1 each. We are cutters and dealers in fine gems. Robert Bleckford, 5 Main, Norway, Maine.

#### PIANOS AND MUSICAL INSTRUMENTS

PARTS for all Standard Talking Machines. Second Hand machines at Bargain prices. Reliance Repair Co., 220 W. Elm St., Chicago.

FOR Sale—One used \$750 player-piano, in good condition, \$225 cash, no trades. Price includes 29 rolls and bench. W. W. Stuart, 1912 Pleasant St., Des Moines, Iowa.

FINE Violins for quick sale. Low price. Easy payments. Sent on approval. Wilfred Mu k, Watertown, N. Y.

YOU can tune and keep your own piano or player piano in perfect condition. Van Atta's book on The Piano and Player Piano not only tells you but shows you every movement in their care, repair and tuning. 156 Pages. 51 Illustrations. Cloth. Price \$1.50 postpaid. Popular Mechanics Book Dept., 6 N. Michigan Ave., Chicago.

BARGAIN: Buescher Baritone in case. Washburn Mandolin in case, good as new. Write, Horace Waldorf, Hudson, S. Dak.

## MUSIC

"MIDSUMMER Memories"—the beautiful popular new waltz mailed postpaid for 10c. You will like it. Published by Ernest Hand, Williamsport, Pa.

"FM Far Off From Bonnie Scotland," greatest war song since "Tipperary." Sent post-paid 10c. Catalogue free. P. Roscoe Webber, Old South Bldg., Boston, Mass.

"U. S. NATIONAL Guard" March, Piano 25c. Title-page picture Mrs. Canfield, only Lady Mayor in America. Gene Swinbank, Warren, Ill.

RECORDS for Victrola, Columbia and Edison (disc or cylinder) Talking Machines. Edison Standard, 9c; Blue Amberol, 25c; Victrola, 15c; bought, sold and exchanged. Permanent Jewel Needle, \$1; Jewel point attachment for Victrola or Grafola to play Edison disc records, \$2. Send for record list. Well's Curiosity Shop, 29 S. 2nd St., Philadelphia, Pa.

TWENTY-SEVEN Best, Latest Popular Song-Hits in Newest Dance Forms. Fox-Trots, Hesitations, etc. Neatly Bound in Folio. Beautiful Cover in Colors. Only 50 Cents. Agents Wanted. F. Miller, 2091 N. Sixth St., Philadelphia, Pa.

BOYS, 10c for the Big Hit, "Meet Me in the Moo light, Carrie." Knorr Co., Spring Valley, N. Y.

## FORMULAS AND TRADE SECRETS

MAKE Gold, Artificial. Stands test or money back, and 2896 other formulas \$1. P. Ballard, Wallawa, Oregon.

FORMULAS—Latest and best Automobile preparations. Prices reasonable. "Chemist," 409 Fenton Bldg., Portland, Oregon.

1,000 FORMULAS 20c. 75 Manufacturing secrets, 10c. Resilvering Mirrors, Renewing Dry Batteries, 20c each. Guaranteed. All 50c. Catalogue free. "Ideal," 2311-C, Belleplaine Ave., Chicago.

20,000 FORMULAS—Price \$1, postpaid; complete list 4c stamps. Edm. Bromley, Watervliet, N. Y.

200 SELECTED Money-Making Formulas 25c. 3,600 Formulas 50c. Each includes one year's subscription to Digest. Digest, Grand Rapids, Mich.

HIGH Grade Guaranteed Formulas for almost any occasion. Prices reasonable. Cole Chemical Co., Chicago.

10,000 SELECTED scientific, chemical, technological, and practical recipes and processes, including hundreds of so-called trade secrets for every business, alphabetically arranged in one large volume of 800 pages. Price \$3 prepaid. Popular Mechanics Book Dept., 6 N. Michigan Ave., Chicago.

JUST What You Need for Your Guests. A light, sparkling wine made from oranges and equal in flavor to the best champagne. No Alcohol Used. Only the purest and most wholesome ingredients. 50 cents by money order or registered mail will bring you the recipe. The Formula Co., P. O. Box 1931, Bridgeport, Conn.

JUST the Same You Have Been Looking for to Serve with Your Chops and Steaks. Deliciously appetizing. Aids digestion and promotes health. Only the finest taste and the family will want it always. 50 cents by money order or registered mail will bring you the recipe. The Formula Co., P. O. Box 1931, Bridgeport, Conn.

## TYPEWRITERS AND SUPPLIES

TYPEWRITERS, all makes factory-rebuilt by famous "Young Process." Look like new, wear like new, guaranteed like new. Our big business insures "Square Deal" and permits lowest cash prices—\$10 and up. Also, machines rented or sold on time. No matter what your needs are, we can best serve you. Write and see—now. Young Typewriter Company, Dept. 226, Chicago.

GOOD, serviceable typewriters \$7.50 and up. Post card brings list. First class ribbons, any machine, 25c. Hub Typewriter Co., 286 Devonshire St., Boston.

REBUILT Typewriters—all makes. Special—Oliver No. 3, \$24.90 prepaid. Berg Typewriter Exchange, Dept. P, Hendrum, Minn.

TYPEWRITERS, all makes, rebuilt, \$10 up. Guaranteed. Free trial. Catalogue free. References: Dun's or Bradstreet's. Office Equipment Company, Michigan City, Indiana.

EXCEPTIONAL Bargains. Selling Out, \$10.00 typewriters from \$12.00 up. All in first-class order. Write quickly. Atlantic Supply Co., Long Branch, N. J.

OLIVER Typewriters—Guaranteed Factory Rebuilt Machines—look, write and wear like new. Small cash payment and \$2 monthly. Ship anywhere. Write for descriptive circular. Galveston Typewriter Exchange, Galveston, Texas.

LARGEST Stock of Typewriters in America—All makes: Underwoods, Olivets, Remingtons, etc., one-fourth to one-half manufacturers' prices, \$15 up, rented anywhere applying rent on price; free trial; installment payments if desired. Write for catalogue 70. Typewriter Emporium (Established 1892), 34-36 West Lake Street, Chicago, Illinois.

BIG Removal Clearing out sale. Get price list, nifty Bargains. Typewriter Exchange, Cincinnati, O.

## DUPLICATORS AND DEVICES

OUR "Modern" Dupliator—Yours for \$2.40. No Glue or Gelatin. Always ready. All sizes. Free trial. 24,000 users. Standard for 15 years. Booklet free. Sole mfrs., J. E. Durkin & Reeves Co., 339 Fifth Ave., Pittsburgh, Pa.

THE "Universal" reproduces 50 or more from one letter or anything written with pen or typewriter. 50,000 in use everywhere. Letter size, \$3.25. Sample work and booklet free. N. Reeves Dupliator Company, Park Building, Pittsburgh, Pa.

DUPLICATORS, 9x12, price \$1. Make 50 copies from pen or typewritten original. Booklet Free. Scientific Laboratories, Dept. 1, Madison, Maine.

## MAILING LISTS

5,000 BUSINESS Men's names. Others from various states, 20c per 100. Economic Co., 268 Bank St., Newark, N. J.

BOHEMIANS, list of five thousand in Texas—\$10. Albert Fabian, Hallettsville, Texas.

ORIGINAL Letters rented. Stan, 4 West 118th St., New York.

FREE to business men, copy of our comprehensive "Silent Salesman." Contains over 2,000 different classifications of Mailing lists with number and price of each list, and information every business man needs. Accept this free offer. Trade Circular Addressing Co., G. 104 1/2 W. Adams, Chicago.

## PRINTING, ENGRAVING AND MULTIGRAPHING

LETTERHEADS, Envelopes, Cards, \$2—1,000 each. Jostworth & Wenck, 4148 North Campbell Ave., Chicago.

SPECIAL Offer—Beautiful engraved English script visiting cards, \$1.50 per 100 (name only). Glickman & Co., 111 Nassau St., New York.

1,000 3x6 CIRCULARS, 100 words, 85c. 100 Business Cards 25c. Charles Walter, Lancaster, Ohio.

FREE samples of printing. Saunders, 903 Princeton, Washington, D. C.

HIGH Grade Business Stationery. A complete outfit consisting of 500 each letterheads, envelopes, cards, billheads and statements, white or colored, for \$7.00. Money with order. Chas. R. Hartmann, Printer, Box 22 Hudson City Station, Jersey City, N. J.

LEON MILLER, 1925b Germantown Ave., Philadelphia. The Profit-sharing Printer. Price list and samples free. 10,000 3 1/2 x 6 circulars printed \$2.75. Nonconflicting advertisement on back.

QUALITY Printing prepaid. 500 either envelopes, cards, tags, statements, \$1.25; 1,000, \$1.75. 1,000 circulars, \$1.50. 1,000 letterheads, \$2.50. George Forster, 181 Meserole Ave., Brooklyn, N. Y.

PRINTED—500 8 1/2 envelopes, 95c; 500 cards, 95c; 500 statements, 95c; 500 bond letterheads, \$1.50; 1,000 3x6 circulars, \$1.00. T. R. Dickey, 1168 Stout, Denver, Colo.

1,000 COLORED Parchment Circulars, 5 1/2 x 8 1/2, \$1.75; Art Ad Slips, 3 1/2 x 5 1/2, \$1.00; both prepaid. Elegant samples printing free. Good's Printery, Harrisonburg, Va.

1,000 GUMMED labels, 50 cents. Samples Free! Edward Harrison, "Printing," Baltimore, Md.

GUMMED Labels—All kinds. 500 with name and address, 25c. Eastern Label Co., D-1, Clintonville, Conn.

PRINTING Outfits—Presses, type, supplies, type novelties. Send stamp for catalogue. Model Press, York, Penna.

GOOD Printing—2,000 20-lb. bond letterheads or envelopes, \$1. Stocks Press, Odell, Ill.

ROYAL Quality Gummed Labels, 3,600, 75c up. Send for catalog No. 192. Agents wanted. Royal Label Company, 408 Cherry Street, Philadelphia.

250 BOND Letterheads or Envelopes, white, blue or buff, printed to order, \$1.00 prepaid. Both for \$1.75. Samples free. Commercial Press, Beaver Falls, Pa.

NEAT Printing—1,000 Good Bond Letterheads, \$2.25. Billheads, Envelopes, Business Cards \$1.75. Free Samples. Wolverine Press, 37 Harrison, Detroit, Mich.

MULTIGRAPH Letters, Letterheads—1,000 complete, \$3. Letters, purple, heads black. Samples for stamp. Perfection Letter Company, Muncie, Indiana.

NOTEHEADS, billheads, envelopes, statements, tags, \$1.50 per 1,000. Samples free. Wris Company, Laceyville, Pa.

GOOD Printing: Low Prices—Letterheads; envelopes; \$2 thousand, 5,000, \$7.50. Samples sent. Frankfort Sun, Frankfort, Ohio.

PRINTING Presses, Type and Supplies. Low Prices. Big Stock. List for Stamp. Popular Bargains, Richland, Pa.

LETTERHEADS—1,000, \$2.00; 2,000, \$3.50; 5,000, \$7.50; good grade bond paper, 16 pound; others charge more for same quality; samples free. Girard Job Shop, Dept. I-2, Girard, Kansas.

QUALITY Printing Prepaid—500 either envelopes, noteheads, cards, statements, \$1.25; 1,000 \$1.85; 1,000 envelope slips, \$1. 1,000 6x9 circulars, \$1.75. 500 linen finish letterheads or envelopes, \$1.75; 1,000, \$3. Printing prepaid. Imitation typewritten letters. Stamp brings samples. Model Company, Manchester, Iowa.

GOOD Printing at low prices. 1,000 good letterheads, envelopes, cards, billheads, labels, circulars, \$2.50. Samples free. Catalogues, booklets, and circulars our specialty. Ernest L. Fantus Co., 523 S. Dearborn St., Chicago.

REMARKABLE Bargains in Printing. Samples free. Excelsior Printery, Manchester, Maryland.

SEND 4c for portfolio letterheads that give character to your business. White Printing Co., Coudersport, Pa.

GUMMED Labels, 3,000, \$1.00; 40pp. Catalogue, 2c. MacTaggart, 1235 Arch, Philadelphia, Pa.

GUMMED Labels, 3,000 1x2 \$1; 1,000 Billheads, \$1.50. Samples. Irvin Daniel Wolf, 3124P Jasper Street, Philadelphia.

## PATENT ATTORNEYS

PATENT what you invent. It may be valuable. Write me. No attorney's fee until patent is allowed. Estab. 1882. "Inventor's Guide" free. Franklin H. Hough, 522 Loan & Trust Bldg., Washington, D. C.

PATENTS secured promptly. Personal attention. Edward W. Kibbey, Patent Attorney, 503 Victor Bldg., Washington, D. C.

PATENT Your Ideas—\$9,000 offered for certain inventions. Books, "How to Obtain a Patent," and "What to Invent," sent free. Send rough sketch for free report as to patentability. Manufacturers constantly writing us for patents we have obtained. We advertise your patent for sale at our expense. Established 20 years. Address Chandler & Chandler, patent attorneys, 828 F St., Washington, D. C.

INVENTORS have great opportunities, but a patent is not everything. My free books tell what you should know. H. L. Woodward, Attorney, 902 G, Washington.

PATENTS secured through credit system. Free search. Send sketch. Book and advice free. Waters & Co., 4289 Warder Bldg., Washington, D. C.

C. W. GERARD, formerly Patent Office Examiner, Searritt Bldg., Kansas City, Mo.

INVENTORS desiring capital to patent inventions, write 191 Western Fiduciary, Denver, Colo.

NO Attorney fees until patent allowed. Send sketch for free report. Books free. Frank Fuller, Washington, D. C.

C. L. PARKER, Ex-member Examining Corps, Patent Office, Patent Attorney, McGill Bldg., Washington, D. C. Inventor's handbook, "Protecting, Exploiting and Selling Inventions," sent free upon request.

PATENTS That Pay. Proof given. Two wonderful guide books free. E. E. Vrooman & Co., 871 F St., Washington, D. C.

DON'T lose your rights to patent protection. Before proceeding further send for our blank form, "Evidence of Conception," to be signed and witnessed. Book, suggestions and advice free. Lancaster and Allwise, 221 Ouray Bldg., Washington, D. C.

**PATENTS** secured or fee returned. Actual search free. Send sketch. Latest complete patent book free. 1916 Edition. (Ninety pages.) Free sales service. It should never require more than two days to report upon the patentability of your invention; no longer than six days to prepare your case for filing. Longer delay amounts to gross neglect. For prompt personal service write: George P. Kimmel, 212 Barrister Building, Washington, D. C.

**PATENT** your invention, \$10,000 offered for inventions wanted. Booklet and opinion free. Milo B. Stevens & Co., Established 1861, 685 F St., Washington, 353 Mononock Block, Chicago.

**PROTECTIVE** patents procured promptly, 112 page blue book on patents sent on request. Trade-marks registered. Robb & Robb, 211-215 Southern Bldg., Washington, D. C.

**PATENTS:** Send model, sketch or drawing. Advice, 103 Mechanical Movements and 50 Perpetual Motions, Free. Fred G. Dieterich & Co., 61 Ouray Bldg., Washington, D. C.

**PATENTS** obtained through D. Swift being promptly sold to manufacturers. Write today for free books of "Inventions Needed" and surpassing references. D. Swift, 317 Seventh St., Washington, D. C.

**WANTED—New Ideas.** Write for List of Inventions Wanted. \$1,000,000 in prizes offered for inventions. Our Four Books sent free upon request. Victor J. Evans & Co., 166 Ninth St., Washington, D. C.

"**PATENTS and Patent Possibilities**" is a 72-page treatise which tells all about patents, what to invent and where to sell it. It gives honest advice to inventors and tells about the successes of some of my clients, also explaining what are frequent causes of failure. Manufacturers are constantly writing for protective patents upon all kinds of sound inventions. Can you help supply their wants? The book is free. Write for it today. H. S. Hill, 905 McLachlen Building, Washington, D. C.

**INVENTORS:** Do Not Sacrifice Your Inventions. Get full money value. Reliable Book Free. Write R. S. & A. B. Lacey, 629 Barrister Bldg., Washington, D. C.

**PATENTS** that protect and pay. Advice and books free. Rates reasonable—highest references; best results. Watson E. Coleman, Patent Lawyer, 624 F St., N. W., Washington, D. C.

**PATENTABLE Ideas Wanted—Send for 3 free books.** R. B. Owen, 39 Owen Bldg., Wash., D. C.

**THE Patentome** is free. An education in obtaining patents. Established 1865. Anderson & Son, Attorneys, 707 7th St., Washington, D. C.

**PATENTS—Herbert Jenner,** patent attorney and mechanical expert, 606 F St., Washington, D. C. I report free of charge if a patent can be had and its exact cost. Send for circular.

**PATENTS—Trade-Marks.** Send for my free book, "How To Get Them." It's full of information you should know. Joshua R. H. Potts, 8 Dearborn St., Chicago; 929 Chestnut St., Philadelphia; 805 G St., Washington.

**PATENTS—Send sketch** for free search and report. Books on patents and book of reference letters sent free. John S. Duffie & Co., 610 F St., Washington, D. C.

**PATENTS** bring riches; protect your invention. Attorney's fee payable when patent allowed. Correspondence solicited; valuable patent advice free. Trade-marks registered. Jaynes & Jaynes, 635 Kellogg, Washington, D. C.

**JOHN M. McLachlen,** Attorney at Law. Patents, Trade Marks, Union Trust Bldg., Washington, D. C.

#### FOR INVENTORS

**PATENT** Sales Specialists. Best Location and Facilities. Fuller, 560 5th Avenue, New York.

**HAVE You an Idea?** If so, you should protect it by a patent. Send us a model or sketch for free opinion as to patentability. Write for our Four Books sent free to any address, Victor J. Evans & Co., 157 Ninth St., Washington, D. C.

**PATENTS** Wanted—Will purchase or handle on royalty good Automobile Accessories. Box 124, Sta. B, Cleveland, O.

**PATENTS** without advance attorney's fees. Send sketch for free report. Books free. Frank Fuller, Washington, D. C.

**WANTED—An Idea!** Who can think of some simple thing to patent? Protect your ideas; they may bring you wealth. Write for "Needed Inventions" and "How to Get Your Patent and Your Money." Randolph & Co., Patent Attorneys, 629 F St., Washington, D. C.

**INVENTORS** desiring capital to patent inventions, write 102 Western Fiduciary, Denver, Colorado.

**INVENTORS:** Write us immediately if you have patents for sale. La Croix Tool Co., 214 N. 21st, St. Louis, Mo.

**PATENTS** secured through credit system. Free search. Send sketch. Book and advice free. Waters & Co., 4280 Warder Bldg., Washington, D. C.

**INVENTORS:** My patent made a fortune. Particulars free. Let me sell yours. Eugene Pearl, M23 Union Square, New York.

"**THE Patent Salesman**" is saving and making thousands of dollars for inventors. Price 25c. L. R. Schmidt, Box 997, Bakersfield, California.

**GREAT** opportunities exist for inventors, but a patent is not everything. My free books tell what you should know. Horace L. Woodrard, 902 G, Washington.

**PATENT** Applications complete, \$10. Why pay more? Very best service. Patent News, G, Washington, D. C.

**INVENTIONS—Patenting and Promoting.** A book containing practical advice and directions for inventors and manufacturers. Book, suggestions and advice free. Lancaster and Alwine, 221 Ouray Bldg., Washington, D. C.

**INVENTIONS** commercialized on cash and royalty basis. Two free books. Inventors and manufacturers write. Adam Fisher Mfg. Co., 2061 Ry. Ex., St. Louis, Mo.

**INVENTORS:** Patent your inventions through me and I will negotiate the sale of the patent free. Book on patents with List of Needed Inventions 5c. Sanders, 7 Webster Building, Chicago.

**PATENTABLE Ideas Wanted—Send for 3 free books.** R. B. Owen, 39 Owen Bldg., Wash., D. C.

**HAVE you a Patent to sell?** You'll be interested in my proposition. Write now for free particulars. F. W. Johnson, 6 N. Michigan Ave., Chicago.

**PATENTS, Trade-Marks and Copyrights.** Our handbook on patents will be sent free on request. All patents secured through us are described without cost to the patentee in the Scientific American. Munn & Co., Patent Attorneys, 672 Woolworth Bldg., N. Y. Washington, D. C., office, 625 F St.

**MECHANICAL Engineers,** Specialist in designing and perfecting inventions. 15 years experience. Send details for free estimate of cost. Albert S. Kux, 105 W. Monroe St., Chicago.

**WE** are looking for improvements, suggestions and inventions on Player Pianos. What have you? Also inventions, etc., on Player Pianos operated by electricity. Player Piano Patent Purchasers Agency, P. O. Box 178, Madison Square, New York City.

#### INVENTIONS MARKETED

**INVENTORS** desiring capital to patent inventions, write 102 Western Fiduciary, Denver, Colorado.

**YOUR** invention may come within the limits of our Laboratories' work. If so our Business Department will consider it. Copy of patent with stamps for return will receive prompt attention. McCormick Laboratories, Dayton, Ohio.

#### PATENTS FOR SALE

**STEAMLESS—Odorless—Cooking Kettle.** A boon to the housewife. Very practical and convenient. Investigate this now. Chas. Miller, 906 E. Walnut St., Massillon, Ohio.

**FOR Sale—U. S. Patent No. 1,141,031—**A household article—for every home, hotel, restaurant. Send for printed circular. H. Zuber, Murphysboro, Ill.

**PAPER** Clasp, self-locking, office necessity, stamped from single piece of metal. Cash or royalty. H. Bicknell, Petrolia, Ontario.

"**WASH Board**" (Self-soaping). Great convenience. Investigate. Geo. F. Ulrich, Box 533, Missoula, Mont.

**AUTOMATIC** shut-off funnel, stops liquid after tank, etc., is filled. Maki, Canterbury, Conn.

**ROTARY** plow patent for sale. Wish to retire from business. Will exchange for land. Rotary Spading Plow Co., 486 Brandies Bldg., Omaha, Neb.

**FOR Sale—Rubber watch-protection cover.** Patented in 1911. Can be cheaply manufactured and is good proposition for mail order. Best offer takes it. For further information address J. M. White, Lakewood, N. H.

**PATENT** rights (U. S. or Canada), sheet-music turner. Sell outright or royalty, patented 1915, never on market, practical, low manufacturing cost; retail price, \$3 to \$5. Rideout, South Berwick, Me.

**PATENT,** indisputably meritorious accessory for Fords. Weglein Brothers, 916 N. 30th, Phila., Pa.

**UNIFORM** to Mothers and Nurses—"Children's Keep-Covered Blanket Holder." Necessity in every home and hospital. Once used never dispensed with. Will sell outright or royalty. For particulars address Lock Box 85, Maywood, New Jersey.

**FIRST** class Auto Steering Wheel Patent for manufacturing purposes; if interested send for information. Wm. P. Pest, 243 Breckenridge Street, Buffalo, N. Y.

**HAVE** perfected device for turning sheet music on piano or music stand. Will operate in either direction. Will sell outright. Not patented. What is your offer? C. J. Brown, 725 S. Mich. St., South Bend, Ind.

**PATENT** Right Mechanical Starter for Ford car; can be made for \$2.25 each. J. Holland, 209 S. 51st St., Philadelphia.

**WRITE** C. S. Kratz, Caldwell, Idaho, for details and price remarkable labor-saving patent.

**MECHANICAL** Dictionary for Children, defines with crank, model. W. H. Robinson, 1324 Newtown St., Paris, Ky.

**STOVEPIPE** locking device. Small, simple. Box 95, Coleraine, Minn.

**NON-REFILLABLE** bottle, patent No. 1,134,647. M. J. Souza, R. F. D. 2, Box 78, Selma, Calif.

**ELECTRICIAN'S** Splicing Pliers; Patent for sale. Patented Oct. 5, 1915. No. 1,155,632. Frank Woodhead, Glen Riddle, Del. Co., Penna.

"**CUSPIDOR** Cleaning Machine." U. S. Patent for sale. W. J. Ghrames, Anadarko, Okla.

**SHOE-CLEANER.** New rotary brush for the front door. M. Hill, 2403 West Blvd., Los Angeles, Cal.

**U. S. PATENT.** Cash, or with royalty, cheap. Combination-square and Rule-gauge. Several tools in one. Very practical. J. Ickenroth, Box 271, Jefferson City, Mo.

**FOR Sale—Patent** four-wheel drive truck or tractor. Simple and practical. Alpheus Bouas, Coulterville, Ill.

**FOR Sale—Patent** that will revolutionize expense of Air Hose on all Steam and Electric Railroads. Now in use. Fortune for some one. Reasonable. Particulars, if you mean business. Kyle Lawson, Birmingham, Ala.

**NEW** patent one-piece shoe upper; sale or royalty. Shoe easy to make. Any last will do. Michele Lippello, 197 1/2 Morgan-town St., Uniontown, Penna.

**PATENT** Buyers are invited to address our sales department for information on any class of Patents they wish to purchase or lease on a royalty. We have secured a number of valuable patents in all lines of invention. Mail Order, Department Store and Household Novelties a specialty. Victor J. Evans & Co., 169 Ninth St., Washington, D. C.

**SALE** or Royalty—Drill vise of merit; time saver in catching work. Manufactured at low cost. Address, O. B. Gross, Aurora, Ill.

#### MODEL AND MODEL SUPPLIES

**INVENTORS:** We manufacture metal articles of all kinds to order. Also, special machinery, tools and dies, punchings, lathes and screw machine work, metal spinnings, castings, plating, wood and metal patterns, etc. Send sample for estimate and expert advice, free. The Eagle Mfg. Co., Dept. B., Cincinnati, O.

**MODEL** and Experimental work. Inventions developed. Wm. Doffert, Tatamy, Pa.

**IF** you have something to be made write us. Models, Experimental Work and Manufacturing. Quality is the keynote of success. Imperial Machinery Company, Cincinnati, Ohio.

**MODEL** making. Inventions developed. Write for estimate. Stearns, Paxton, Ill.

**FREE** catalogue of model supplies. Castings, metal specialties on contract. North Chicago Tool Works, 15 Grove Ave., North Chicago, Ill.

**PRODUCERS of Results:** Inventions developed, Models, Experimental work, anything special in metal to order, novelties, spinning, forging, castings in any material, electrical devices, patterns of all kinds, plating, general manufacturing, designing, special tools, punches and dies, stampings. Send drawings or sample. Expert information free. The John's Machine & Stamping Works Compa y. Dept. C, Cleveland, Ohio.

**WE make working models for inventors;** also dies and stamping of specialties, and carry a complete stock of brass gears and model supplies. Send for catalogue. The Pierce Model Works, 3405 Pierce Ave., Chicago, Ill.

**SPECIAL Electrical and Mechanical devices** built to order. Models, Tools, Dies. Benj. Levi, 357 West Broadway, N. Y. City.

### MANUFACTURING

**LET Our factory be Your factory.** Metal specialties developed and correctly manufactured. L. K. Nelson Mfg. Co., Peoria, Ill.

**WE are prepared to furnish machined castings of Cast Iron, Brass or Aluminum.** Practical Iron & Machine Works, North Chicago, Ill.

**PATENTED Articles, Models, Brass work, Dies, made, Baum's Metal Specialties, Kansas City, Mo.**

**WANTED—Specialties with merit to manufacture and sell, particularly automobile specialties.** Well-equipped manufacturing and merchandizing facilities. Hastings Mfg. Co., Hastings, Mich.

**INVENTIONS perfected and manufactured.** Reference: Your Banker. Russell Machine Co., Dallas, Texas.

**WIRE Goods, all kinds, made to order.** Cooley Mfg. Co., 533 W. Monroe St., Chicago.

### REAL ESTATE AND FARM LANDS

**EXCEPTIONAL Opportunity** to purchase Southern Virginia Farm, with buildings and improvements. Most desirably located on new National Automobile Highway and Railway, half mile from station and near good markets. 269 acres, \$4,950.00. H. M. Harris, Clarksville, Va.

**BARGAIN Extraordinary—Gulf Coast Winter Vegetable Farm.** San Benito, Texas. No frost, water when needed, 40 acres well improved. Lettuce, cabbage, onions, bring \$400 to \$1,300 per acre. Will sell for half real value. Particulars, E. S. Delaplaine, 1902 Syndicate Trust Bldg., St. Louis, Mo.

**VIRGINIA and North Carolina Farms,** \$15.00 per acre and up. Easy payments. Fruit, dairy, stock. Mild climate. Raise spring lambs for early market. On railroad. Best markets near by. Write for farm lists, information and N. & W. Ry. Homeseeker, all free. F. H. LaBaume, Agri. Agt., Norfolk & Western Ry., 250 N. & W. Bldg., Roanoke, Va.

**320 ACRE Free Homestead Relinquishment—Free Timber—Free Coal.** Chas. C. Wilhelm, Billings, Mont.

**ORANGE and Grape fruit Groves for \$200,** payable \$10.00 per month. Pomelo Gardens Company, Mercedes, Texas.

**WE have 600 farms for sale on easy terms** in Corn Belt of Southern Minn. Morehart Land Co., Mankato, Minn.

**CALIFORNIA** Blue suburban farms for sale. Terms. Write E. R. Waite, Shawnee, Okla.

**TWENTY acres in San Joaquin Valley,** California, in fruits, vegetables, alfalfa, with cows, pigs, poultry and bees, will pay you steady, substantial profits. Delightful climate, rich soil, good schools, churches, fine roads. Thrifty, hospitable neighbors. Write for free books. C. L. Seagraves, Gen. Colonization Agent, AT&SF Ry., 1916 Br. Exch., Chicago.

**SELL your property quickly for cash,** no matter where located. Don't pay big commissions. Particulars free. Real Estate Salesman Co., Desk B, Lincoln, Nebr.

**1/2 BLACK** residence lots, Sioux City, Iowa. Fine location. Bargain. Hugh Tall, 2530 Reta Ave., Chicago.

**RELIABLE Information** about prosperous, growing regions in Alabama, Florida, Georgia, Kentucky, Mississippi, North Carolina, South Carolina, Tennessee, Virginia, Southern Illinois and Southern Indiana will be sent, on request, to homeseekers, manufacturers and investors. M. V. Richards, Commissioner, Room 64, Southern Railway, Washington, D. C.

**WANTED to hear from owner of good farm for sale.** Send description and cash price. R. G. List, Minneapolis, Minn.

**YOUR Opportunity—Eleven-acre bearing Satsuma Orange and Grape-fruit grove,** small bungalow, garage, two miles from Gulf, shell roads, stone's throw from Golf Links. \$7,000 value for \$6,000, \$3,000 cash, balance one and two years. This grove will soon pay \$500 and more per acre. M. R. Hicks & Co., Ocean Springs, Miss.

**FREE Book of Florida Facts.** If interested in Florida, before visiting or settling in this wonderful state of fragrant flowers and sunshine, write Lake County Land Owners' Association, No. 93 Lloyd St., Fruitland Park, Florida, for free book of actual photographs and real conservative facts concerning this State. There is poor, good, better and best land in Florida. This book will teach you what is best and why. The members of the Association are not land agents; they simply wish to tell actual facts to those really interested in the State. They have no time to waste on curiosity seekers, children or people who expect to grow rich without effort, but to those of character, energy, some capital, with a desire to learn more of the opportunities in this most prosperous State we would be glad to give fullest information.

**LANDOLOGY,** a magazine giving the facts in regard to the land situation. Three months' trial subscription free. If for a home, or as an investment, you are thinking of buying good farm lands, simply write me a letter marking it personal and say, "Mail me Landology and all particulars free." Address Lloyd M. Skinner, Gen'l Mgr., Skidmore Land Co., 40 Skidmore Bldg., Marinette, Wis.

**FOR Improved farms and wild land,** write Netzel, Bloomer, Wis.

**FERTILE Farms, near Philadelphia,** Catalog W. Stevens, Perkasie, Pa.

**ARKANSAS—Write today for free literature** about Southwest Arkansas farms. L. E. Smith, Lockesburg, Arkansas.

**FARMS for Sale or exchange** anywhere in the U. S. or Canada, direct from the owners. State where you want to locate. Information free. American Investment Association, 37 Palace Bldg., Minneapolis, Minn.

**MONEY-MAKING Farms** throughout 15 Eastern States; 1 acre to 1,000 acres, \$15 per acre up; several with livestock, tools, and crops included, to settle estates; big illustrated catalogue free. E. A. Strout Farm Agency, Dept. 3343, 47 W. 34th St., New York.

**I HAVE a successful way of selling farms** and farm lands. Write me for free particulars. No obligation whatever. E. J. Zimmer, 325 Tower Bldg., Chicago.

### SEEDS, PLANTS, NURSERY STOCK

**STRAWBERRY Plants—250 Dunlap, etc.,** \$1. 100 Everbearers \$1.25. Postpaid. Kiger's Nursery, Monroe, Iowa.

### GINSENG

**GINSENG Culture, 10c,** Golden Seal estimate \$9,800 an acre. Booklet giving my experience, 10c, W. N. Long, Florence, Ky.

### DOGS, BIRDS, POULTRY, PETS

**MAKE money** breeding Plymouth Rock squabs, 1916 demand biggest ever. How to sell by parcel post, how to get \$6 to \$8 dozen. Start small, grow big. Small space needed. Write today for big free book. Plymouth Rock Squab Company, 634 Howard St., Melrose Highlands, Massachusetts.

**MONEY-MAKING Poultry.** Our new book for 1916 tells about our leading varieties of land and water fowls, also incubators, brooders and squabs. High quality at low prices. 31st year. 95-page catalogue free. H. M. Jones Co., Box 159, Des Moines, Iowa.

**NEWFOUNDLAND, St. Bernard, Collie** and Fox Terrier puppies. Your money back if not pleased. Poultry and Dog Catalog free. Edwin A. Souder, Box P, Telford, Pa.

**MONEY in Cavies.** Breeders, \$1.00 each. Geo. Talbot, Norwood, Mass.

**MONEY in Chickens.** Easy with our methods. No common information or college theories, but actual systems we use that have helped hundreds succeed. 25c for printing and mailing. Irondequoit Fruit Farm, Irondequoit, N. Y.

**RAISE Guinea Pigs.** We furnish stock, show you how and buy all you raise. Big demand. Thousands needed yearly. Easy to raise, very prolific and profitable. Particulars and contract for 40-cent stamp. Cavies Distributing Co., 707 West 74th St., Kansas City, Mo.

**POULTRY Book Free—Contains condensed experience of twenty-five years with poultry.** Houses, Yards, Incubator Operation, Care of Chick and Poultry, Diagnosis and Treatment of Disease, Poultry Secrets, Pointers for the Amateur, Mandy's Poultry School, The \$1,000 Egg, Hatch Record, Egg Record, etc. All free. Geo. H. Lee Co., 400 Lee Bldg., Omaha, Nebr., Mrs. Lee's Lice Killer, Germozone, Lee's Egg Maker, etc.

**DOGS** trained on fox, rabbit, deer, wolf, bear; bloodhounds; 50-page catalog, 5c stamp. Rookwood Kennels, Lexington, Ky.

**GOLDFISH—Rare specimens, artistic aquariums, waterplants.** Circular free. Pioneer Goldfish Hatchery, Racine, Wis.

**FOR Sale—Beautiful white silken toy poodle pups.** Snow Ball Kennel, Pueblo, Colo.

### MISCELLANEOUS

**ATTENTION: New principle collapsible stove and heater.** Suitable for fruit growers, campers, hunters, sportsmen, etc. Weighs 9 lb. complete. Write for bulletin and prices. Mechanicville Metal Company, Mechanicville, N. Y.

**ERADIUM (Luminous) Pull Chain Bulb** for Electric or Gas Light pull chain or key. Shines at night. Locates your chain in a "jiffy." Sample 35c. Agents wanted. Auburn Supply Co., Dept. 3PC, 7817 Peoria St., Chicago.

**HOW to make Printing Cuts cheaply.** 150 selected formulas, 20c. "Ideal," 2311-C, Belleplaine Ave., Chicago.

**LOCKSMITHS, make more money;** send stamp for particulars. L. D. Stotler, Stamford, Conn.

**ALL who are interested in draining flat wet land,** write for descriptive folder of my new invention. V. H. Snodgrass, Collogemound, Mo.

**SOLID Gold Midget Emblem Buttons, 25c.** Every Society. 8 ankle, 45 Cornhill, Boston.

**CORNS and Bunions removed by Mechanical Process, Rubem-Off.** Sent by mail, 25c, H. E. Diehl, Lawton, Oklahoma.

**INVENT something;** your ideas may bring wealth; our free book tells what to invent and how to obtain a patent, through our new credit system; write today. Waters & Co., 4102 Warden Bldg., Washington, D. C.

**CHEAP simple formula.** Will remove white patches from varnished furniture caused by water. Will not mar the finish. Send 20c. Thos. Shea, 403 Pine St., Seattle, Wash.

**BE Patriotic!** Display the American Flag! Five-foot flag, folding pole, rope, holder, \$1 postpaid. Dollar Mail Order Company, Long Island City, New York.

**EMBOSSERS—Steel die for paper,** name and address, \$1.50; name only, \$1.00. R. W. Shoupe, Box 416, Findlay, Ohio.

**CUTS anybody can make.** Simple Etching Process, \$1. Particulars, specimens, for stamp. M. Day, Windfall, Ind.

**INDIAN Baskets, Bells.** Price free. G. Gilham, Highland Springs, Cal.

**I BUY hundreds of insects, butterflies,** each summer at 5c to \$7.00 each, for museums, artwork, if properly fixed. Men, women, send 2c stamp for details telling all. Sinclair, Box 214, D-6, Los Angeles, Cal.

**LATEST Out—Radio electric pocket lamp** 15c. Juron, 2502 Augusta, Chicago.

**\$2.50 POCKET Adder.** Send for circular. Bassett, 5921-K Indiana Ave., Chicago.

**STOP Using Tobacco.** Complete treatment \$1. Sincerely Bros., Des Moines, Iowa.

**RUBBER stamps, photo type, stencils.** Catalogue, 10c. Buckeye Stamp Works, Market, Dayton, Ohio.

**GRANDFATHER'S Clock Works, \$5.** Slightly shop-worn, quantity limited, others with chimes, all prices; also several nice Grandfather's Clock cases, exceptional bargains. Clock Company, 1673 Ruffner St., Philadelphia, Pa.

**TATTOOING Machines, Colors and Supplies** for all interested in the Art. Get My Catalogue Now and be ready for the coming season. Prof. J. Barber, 704 Brush St., Detroit, Mich.

**MY Big Formula Collection—1100 Latest Practical Formulas for Manufacturing Modern Specialties—all lines.** List of Contents, also proposition on Egg-o-Lene—Only real substitute for Eggs, Carbo-Cide (Gasotonic) makes cheaper gasoline and other High-Class "Dollar Getting" Specialties for Stamp. "The Old Reliable." Established 1897. H. Liscomb Miller, Ph. D., Tampa, Florida.



# Learn Electricity

## Earn \$2500 to \$4000 a Year

Your CHANCE has come! Your chance for big money. Your chance to do the kind of work you'll be proud of. Your chance to go into business for yourself. Think of it! You can now qualify AT HOME for that most wonderful of all fields open to the ambitious man—the great field of ELECTRICITY! Yes, no matter who you are, where you live or what you do, I will take you in hand and make you an EXPERT ELECTRICIAN so that you should easily earn \$2,500 to \$4,000 a year and more. And I'll do it so quickly and with so little effort on your part that you'll wonder how it was possible.

## LEARN AT HOME

What if you don't know a thing about electricity! What if you've never had a bit of electrical experience. All I ask is that you give me a little of your spare time. I will instruct you personally and make the whole matter so simple for you that you can't help but learn. You don't have to buy a lot of books or equipment. You can master MY personal instructions easily right at home. I've solved this question of teaching electricity. I'll show you I have by giving you 20 personal lessons ABSOLUTELY FREE. Almost from the very first instructions you will have the knowledge and skill to do practical, electrical work—work that you can demand good money for doing. You can earn as you learn—more than pay for your instruction as you go along.

## Be An Electrician

Think! When you have finished my instructions you are an EXPERT ELECTRICIAN! You are right then and there ready to take a big paying job or start in for yourself. I will train you until you consider yourself competent regardless of the time it takes. I not only show you how to do expert electrical work but show you how to estimate on jobs so you can take contracts at big profits. That's what it means to be personally trained by a man of my practical experience in every phase of electricity. Decide today to take advantage of my big free 20 personal lessons offer. Don't let the question of money bother you. I make the cost so small and the payments so easy that you won't miss the money.

**MEN WANTED** Wherever you go there's always urgent demand for Expert Electricians and at big pay. That's because the watchword of the age is, "DO IT ELECTRICALLY." Electricity advances so fast that there's a big shortage of competent electricians. And the demand is constantly increasing every day.

# 20 Complete Lessons FREE!

That's the sensational offer I am making now to a few more ambitious men. I make it for two reasons. 1st. To show you how easy my personal instructions are to master. 2nd. To secure quick action on the part of a few more prospective students. This offer means that you get 20 complete personal lessons ABSOLUTELY FREE! But you must act quick. The offer closes in 23 days. Send coupon or postcard at once. I'll send full particulars immediately. Mail coupon today—sure!

**A. W. WICKS, E. E., Director Wicks Electrical Institute,  
81 West Randolph St., Dept. 82 Chicago, Ill.**

Send this Coupon  
**A. W. WICKS,  
E. E., Director,  
WICKS ELEC. INSTITUTE,  
81 West Randolph St.,  
Dept. 82 Chicago, Ill.**  
Without any obligation on me whatever, please send me full description of your personal instructions in Electricity and particulars of your special offer of 20 of your lessons free.

Name.....

Street and No.....

City..... State.....

Please Mention Popular Mechanics

# LEARN THE AUTO BUSINESS

## GRASP THIS OPPORTUNITY

Now is the time to plan for your future. Be an Auto Expert. Prepare to accept a splendid salaried position or start a profitable business of your own. Cleveland trained men are always in big demand. We constantly get more calls than we can fill. More *high grade* cars are manufactured in Cleveland than any other city. All the big factory men know us — endorse our school and methods—are glad to get our men. There's money in the Automobile business for you, but you must have the right training.



## Cleveland AUTOMOBILE School

12 Years of Success—Oldest and Best Established  
Latest Equipment—Individual Instruction

We claim to have the most completely equipped auto school in the country. The most practical, experienced and helpful teachers. You make faster time here. We give you practical, individual, painstaking instruction. In 4 weeks' *up-to-date* training we teach you to meet any automobile proposition.

Driving, repairing and testing late model, high powered cars; all leading types of starting, lighting and ignition systems; new 8 and 12 cyl. cars to work on. We claim no other school offers equal advantages or opportunities. Don't delay. Write for Catalog and Terms Now. Better still, get on train—come to Cleveland. We'll help you get settled; make you feel at home.

**Tuition and Board Low** right near School, with congenial company and surroundings. We help you get located. New classes forming now.

**THE CLEVELAND AUTOMOBILE SCHOOL**  
Clyde H. Pratt, President 2338 Euclid Ave., CLEVELAND, OHIO

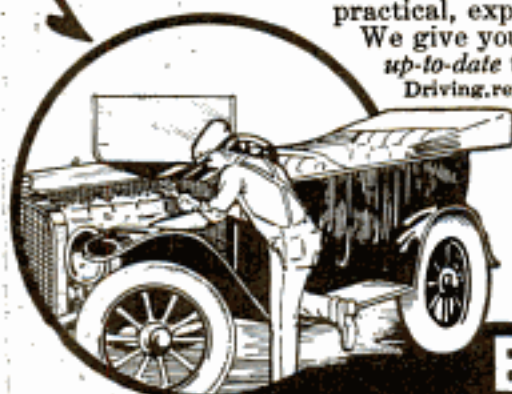

## BE AN AUTO EXPERT

### A New Instrument TEACHES ANYONE TO TUNE PIANOS

No Musical Ear or Training Necessary.

An amazing invention—a marvel of science. Teaches anyone to tune pianos. The New (Tune-a-Phone) method is absolutely accurate. Eliminates guess-work. Positively unfailing. Guaranteed. Endorsed by authorities. Turn your spare time to profit. Learn this well paying, independent profession at home.

**\$5 TO \$15 A DAY—NOW EASY**

Opportunity for you in your town to make BIG MONEY. E. H. Funks, Iowa, made \$21.00 in one day—\$76.00 speaker work. Charges paid for MEN and WOMEN, country over. Work is all profit. INVESTIGATE. Get FREE booklet of interesting facts and records. Send name and address.

FILES BRYANT SCHOOL OF PIANO TUNING, 500 Institute Bldg., BATTLE CREEK, MICH.



### STAMMERERS

Our Home Treatment will permanently cure you. If others have failed

let us show you the way to success. Interesting literature free. CHESHIRE TRAINING SYSTEM, KEENE, N. H.

### CORNET FREE!

We teach you to play by mail and will give you a Beautiful Cornet or any Brass Band Instrument absolutely FREE. You pay weekly as lessons are taken. Instrument is sent with first lesson. Graduates in every state. Hundreds of enthusiastic testimonials. Write to-day for our booklet and wonderful tuition offer.



INTERNATIONAL CORNET SCHOOL  
530 Music Hall, Boston, Mass.



### Be an Artist!

and Draw for Magazines, Newspapers, Etc. Earn Big Money (Send sample of your work for honest criticism.)

All Branches of Art Taught BY MAIL or Local Classes. Write for illustrated booklet, terms and list of successful pupils. ASSOCIATED ART STUDIOS, 2122 Flatiron Bldg., NEW YORK

### LEARN WATCHMAKING AND ENGRAVING



Earn while learning. Most practical watch school. Individual instructions. Graduates in great demand. Book free. Chicago School of Watchmaking, 63 E. Van Buren St., Chicago

# HELP WANTED

**\$65 TO \$150 A MONTH**

Railway Mail Clerks—City Mail Carriers—Postoffice Clerks  
—Rural Carriers—Panama Canal Clerks—Steady Work—  
Vacations with Full Pay—Rapid Promotion—"Pull" unnecessary—Common Sense Education Sufficient—Many Positions for Women

Write today—before you forget—for list and description of positions now open to you; and free sample examination questions. It will cost a 2c stamp—it may bring you thousands of dollars.

FRANKLIN INSTITUTE, Department J 106, ROCHESTER, N. Y.

NAME.....

ADDRESS.....

FRANKLIN INSTITUTE  
Dept. J 106, Rochester, N. Y.

This coupon, filled out as directed, entitles the sender to free specimen questions; a free copy of our book, "Government Positions and How to Get Them," a list of Government positions now obtainable, and to consideration for Free Coaching for the examination here checked.

- COUPON
- .. Railway Mail Clerk .. (\$900 to \$1800)
  - .. Bookkeeper .. (\$900 to \$1800)
  - .. Postoffice Clerk .. (\$800 to \$1200)
  - .. Postoffice Carrier .. (\$900 to \$1200)
  - .. Rural Mail Carrier (\$500 to \$1100)
  - .. Auto Chauffeur ..
  - .. Customs Positions ..
  - .. .. (\$800 to \$1500)
  - .. Stenographer .. (\$800 to \$1500)
  - .. Internal Revenue ..
  - .. .. (\$700 to \$1000)
  - .. Clerk of Panama Canal ..
  - .. .. (\$1200 to \$1800)
  - .. Canadian Gov't Positions ..



# LAW-TRAINED MEN

## Earn \$3000 to \$10,000 Annually

Now is the time for you to begin the study of Law—it offers you more today than ever. The growth of the departments of the government; the extension of commerce; the vast increase of business; the endless multiplication of firms, associations, corporations, combines and trusts, have created new opportunities for thousands of law-trained men. There are **not nearly enough** to fill requirements.

Law has brought wealth, fame and position to the majority of our most successful men in business and political life. Nearly all of our presidents, cabinet officers, congressmen, city and state officials are legally trained. Many were born in poverty and obscurity, but Law put them into positions of power.

## It Is Easy For You NOW!

If you can read and write intelligently, we can train you to become a competent Lawyer—train you in your home, during spare time, by mail, no matter where you live. Don't think that you need natural talent. Don't think that it is an impossible, long, hard climb. It is no great task to become a lawyer by our **simplified, modern course**. You need no longer spend years in preparation and years in college to master this dignified profession. You need not give up nor neglect your present work—you need not deny yourself pleasure. A little spare time at night is all that is required.

### Only Method Endorsed by Colleges

Our Law Text is written in plain language by America's foremost legal authorities and professors of law in big resident colleges such as University of Wisconsin, Leland Stanford University, University of Chicago, Harvard, University of Michigan, Northwestern University, and University of Nebraska. The LaSalle Course is recognized as the foremost home-study Law Course—it follows the method used in the big resident colleges. Former Pres. of the State University of Iowa, George E. McLean, said: "The professors who wrote your text books are men of highest rank in our best colleges." Our improved and simplified method gives you all the advantages of the case and text book systems. It is the same as having the world's great legal professors in your own home to teach you privately. Don't think that the text books are dry or uninteresting. Once you begin to read these fascinating books you will never quit until you have completed them. Many of America's greatest Lawyers learned Law at home. Our Graduates Pass Bar Examinations in Any State and have attained highest records in competition with graduates of leading resident schools. We Guarantee to Coach Free Until Successful.

### BECOME AN LL. B.

The Laws of the State of Illinois authorize us to confer on our graduates the Degree of Bachelor of Laws (LL.B.). The LaSalle Degree and Diploma will make you a recognized legal authority with power and dignity. The great success of our students is due to the service we render them. We have letters from hundreds of successful students everywhere to prove the absolute superiority of our methods of instruction. We enroll more students every month than any other University home-study Law school in the world. The LaSalle Extension University is a powerful, reliable institution—the largest and most complete institution of its kind in the world. Our graduates are recognized as competent, trustworthy lawyers and can be found in every state in the Union. We show actual results—we make no claim that we cannot prove absolutely—letters from successful students verify this.

### Remarkable FREE Book

America's most successful Lawyers. A book that tells you how they succeeded. A book that points the way to great success. If you expect to become a Lawyer, you should have this book, no matter what school you now have in mind.

### Complete Law Library Furnished Great Special Offer!

Each student enrolling now will receive, at once, without additional cost, our complete Law Library—a magnificent set richly bound—14 volumes of American Law and Procedure—completely covering all branches of law. This big set of Law books alone is worth the price of the course—they cost us over \$50,000 to prepare—they are the combined master work of many of America's most noted legal experts. They are given when you enroll—you are not compelled to wait.

### Special Business Men's Course

Every business man should have our special course in commercial law. A knowledge of law is vitally important to every business man. Many of our students are business men who recognize the necessity of legal training and the superiority of our simplified method of teaching commercial law. Write us today about our Special Course for Business Men.

### FREE Complete Course in Public Speaking

For a limited time we are giving, absolutely FREE, to new students our new complete home-study course in Public Speaking. Prepared by Dr. Frederick B. Robinson, A. B., A. M., Ph. D., Professor of Public Speaking, College of City of New York; Editor, Public Speaking Review; Special Lecturer on Public Speaking at various Universities, etc., etc. Be sure to mail coupon today and learn how YOU can get this efficient, complete course absolutely free.

### Start Now!

No matter what your age or occupation—no matter where you live, how small your salary or how little time you have, our method of home training will prepare you to be a successful Lawyer. **DON'T LET COST WORRY YOU—the cost is very small—we make the payments to suit you.**

### Our Guarantee

We guarantee to coach FREE and until successful any LaSalle student failing to pass a bar examination. Our University Extension Course embraces both theory and practice. It follows closely the methods of the large resident Universities with the addition of important special features.



### Mail Coupon—Get Free Books

Opportunities come only to prepared men. Everything must have its beginning. Make YOUR start today by mailing the coupon. Our big free books tell all about our thorough University training in law at home. Don't allow lack of money to interfere. Remember the LaSalle enrolls and graduates more students than any others. There's a reason. Learn why. No "extras"—everything, including the modern LaSalle Law Library, if you enroll now. Send coupon at once. LaSalle Extension University, Dept. 364F, Chicago, Ill.

Name.....

Street and No.....

City..... State.....

# Handy Handbooks for Beginner and Expert

Applied Electrochemistry and Welding . . . . .	\$1.50
Business English and Correspondence . . . . .	1.00
Carpentry . . . . .	1.50
Civil Engineering Specifications and Contracts . . . . .	1.00
Electrical Wiring and Lighting . . . . .	1.00
Elevators—Hydraulic and Electric . . . . .	1.50
Estimating . . . . .	1.00
Machine Drawing . . . . .	1.50
Motion Picture Work . . . . .	3.00
Practical Lessons in Electricity . . . . .	1.50
Reinforced Concrete (Flexible Leather, Pocket Size) . . . . .	1.50
Steel Construction (Flexible Leather, Pocket Size) . . . . .	2.75
Automobile Ignition, Starting and Lighting Systems (Flexible Leather) . . . . .	2.00

Our Practical Handbook Series now numbers 90 live, up-to-date titles. The authors are the biggest and best known engineering experts in America. Written especially for practical self-instruction—so clear that the beginner can understand them and so thorough that the expert can learn from them.

These books are sold at bookstores the world over. Send for our new catalog. If your dealer does not have the particular book of this series you want, ask him to order it for you or order it direct from us. Any book ordered direct will be shipped post paid on receipt of price, and may be returned after a five day examination if not suited to your needs in every way.

**SOLD AT ALL BOOKSTORES**

**American Technical Society, Chicago, U. S. A.**

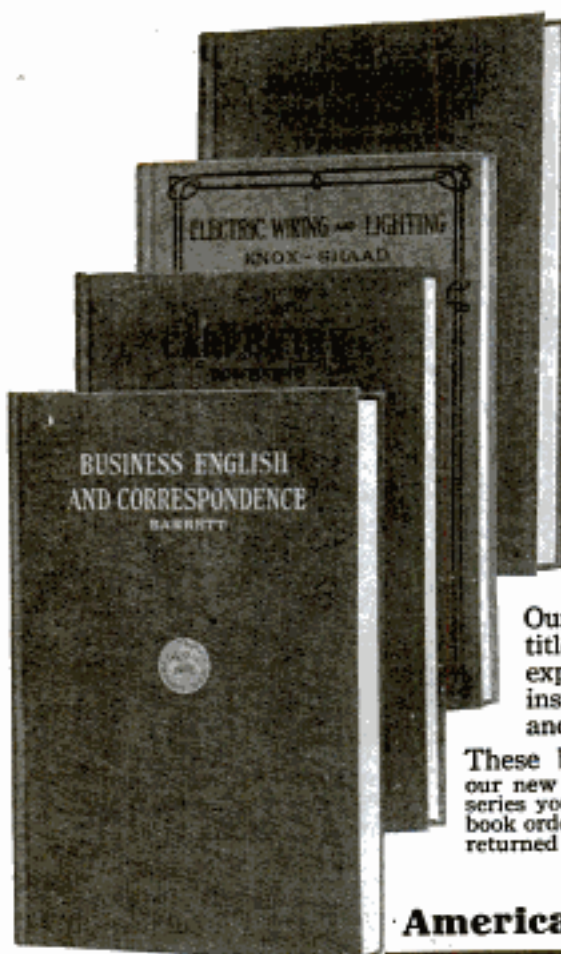

## COPY THIS SKETCH

and let me see what you can do with it. Illustrators and cartoonists earn from \$20 to \$25 a week or more. My practical system of personal individual lessons by mail will develop your talent. Fifteen years' successful work for newspapers and magazines qualifies me to teach you. Send me your sketch of President Wilson with 6c in stamps and I will send you a test lesson plus a collection of drawings showing possibilities for you.

**The Landon School** of Illustrating and Cartooning  
1438 Schofield Building, CLEVELAND, O.



## LEARN WATCH REPAIRING

Be a watchmaker—you can learn this profitable trade by correspondence in a few weeks in your own home by the DeSelms Chart System. After you complete the course you will know a watch from A to Z. You will know just what the matter is and how to repair one. When you graduate you will be a practical watchmaker and repairer and competent to fill any position. Positions for our graduates.

Ask for our Free Book. It explains our system and terms.  
**THE DeSELMS WATCH SCHOOL**  
23 Perry Street ATTICA, INDIANA



## Book on Law Free

Write today for our new 171-page book on "The Power of Law Training". It carries a vital and inspiring message to every ambitious man. Find out about the opportunities that await the law trained man. Find out how you can learn from masters of the law right in your own home. No obligations. The book is free. Write today—now while we are making a special reduced price offer.

**AMERICAN CORRESPONDENCE SCHOOL OF LAW**  
1193 Manhattan Bldg. Chicago, Illinois

## Learn Music At Home!

**New Method  
Learn To Play By Note**

Piano, Organ, Violin, Banjo, Mandolin, Guitar, Cornet, Harp, Cello or to sing. Special Limited Offer of free weekly lessons. You pay only for music and postage, which is small. No extras. Beginners or advanced pupils. Everything illustrated, plain, simple, systematic. Free lectures each course. 16 years' success. Start at once. Write for Free Booklet Today—NOW.

**U. S. SCHOOL OF MUSIC**  
Box 4, 225 Fifth Ave. NEW YORK CITY



## DON'T TRY TO BE A CHAUFFEUR



or go to ANY SCHOOL to learn, or part with your hard earned dollars until you have read our valuable guide FIRST. It tells what you should PAY and what you should GET. Do not be deceived by schools which claim everything and give you nothing. **YOU CAN'T AFFORD TO SPEND ONE CENT TILL YOU GET OUR GUIDE.** It costs nothing and may save you many dollars. Write now for this FREE BOOK.

**PRACTICAL AUTO SCHOOL, 68 Beaver St., New York**



## BE A BANKER

Splendid opportunities. Pleasant work, short hours, all holidays off, yearly vacation with pay, good salary. Learn at home. Diploma in six months. Catalog free. **EDGAR G. ALCORN, Pres.**  
**AMERICAN SCHOOL OF BANKING, 419 E. State Street, COLUMBUS, OHIO**

## BE A DETECTIVE

Earn from \$150.00 to \$300.00 per month; travel over the world. Write **C. T. LUDWIG, 133 Westover Bldg., Kansas City, Mo.**



## LEARNED BY ALMOST ANYONE VENTRILOQUISM AT HOME SMALL COST

Send today 2c stamp for particulars and proof. **O. A. SMITH, Room D 136, 823 Bigelow St., PEORIA, ILL.**

# Learn Electricity! Plumbing—Bricklaying

## Earn \$125 to \$250 a Month

That's what many of our graduates earn right from the start. That's what YOU can earn if you become a COYNE trained man. All of these trades offer exceptional opportunities for starting a business of your own, on very small capital, and becoming entirely independent.

Any man between the ages of 15 and 50 who is ambitious, can learn one of these big paying trades thoroughly in a short time and at small expense. No special education necessary.

## 16 Years of Success



## COYNE TRADE SCHOOLS

### Largest, Best Equipped Trades School in America

For fifteen years we have sent hundreds of men out annually as skilled mechanics to help supply the rapidly increasing demand. Let us train you for one of these big jobs. Our employment bureau assists graduates to big paying positions free of charge.

We teach all these big paying trades under actual working conditions. We do not have classes, do not use books, do not teach by correspondence. Each man is instructed individually right in our big shops. Drafting, Estimating and Plan Reading included in ALL courses.

We charge a small tuition fee which can be made in easy payments if desired. All tools, equipment and material is furnished by the school FREE. Our institution is open Day and Evening. Many of our students earn a part or all of their expenses while attending. Our employment bureau is always ready to assist a man to earn expenses, without charge.

### Motion Picture Operating Drafting Courses

Also PRACTICALLY TAUGHT

These new big paying trades are demanding more and more trained men everywhere and our graduates are sought after by theatre managers and Engineering firms throughout the country.

## Send for Free Book of Trades



MAIN BUILDING

Fill in this coupon and mail today. We'll send you our Book of Trades and full particulars. Free and Prepaid.

Address, B. W. COOKE, Director  
**COYNE NATIONAL  
TRADE SCHOOLS**

Dept. 1193

39-51 E. Illinois St., Chicago

**SEND THIS  
COUPON**

### FREE BOOK COUPON

B. W. COOKE, Director  
**COYNE NATIONAL TRADE SCHOOLS**  
Dept. 1193, 39-51 E. Illinois St., Chicago

Dear Sir:—Without any obligations on me whatsoever please send me your book of trades and full particulars—**ALL FREE.**

Name.....

Address.....

Please Mention Popular Mechanics

# MEN WANTED

## To Drive and Repair Automobiles and Tractors

### Tear Off and Mail the Coupon Herewith Today—Right NOW

It may mean to you all the difference between success and failure. Will you, by training yourself in a few short weeks, become a competent, expert automobile man? **Cash in on your time.** How would you like to have an earning capacity of \$5 a day and up? How would you like to have a trade that will always insure you good wages, independence, opportunity to see the world? How would you like to be in demand? Have employers looking for you—have big opportunities for a successful career spread out before you? Now young man, you can't do this simply by wishing. But you can do it.

### By the Sweeney System You Can Learn in Six Weeks

There's only one place in the world to learn by the Sweeney System; and that is at the School of practical experience where you learn without text books and by doing the work with your own hands; and that's the Sweeney Automobile School of Kansas City, Mo. Learn every young man mechanically inclined to send today for my big catalog. It costs me 50 cents, and is a complete encyclopedia on the subject. It is like a moving picture as the 123 actual photographs show men at work in every department, at every job. It explains the wonderful Sweeney System. I will send it free, to those who answer this announcement, together with a special



#### FREE COUPON

**E. J. SWEENEY, President**  
**SWEENEY AUTO SCHOOL**  
1161 E. 15th St., KANSAS CITY, MO.

Send free tractor scholarship offer and catalog. Also magazine.

Name .....

Address .....

### Earn Big Money in the Automobile Business

The Sweeney School can give you the names and addresses of over 2,000 graduates who are now chauffeurs, repair men, factory experts, garage owners, salesmen, etc. These men came to us untrained. They got interested by reading our advertising, just as you are reading now. They acted on the same impulse that moves you now to investigate. And then after a few weeks' instruction they went out of this school, completely equipped, got employment, and today are **Prosperous, Happy and Respected.** You can do likewise. I will teach you so that you have a chance to qualify yourself for a **Business Success** handling or repairing automobiles. It will cost you nothing to investigate, and let me tell you the actual experiences of my graduates.

**Make \$5 Per Day and Up** 21,000 tractors were sold this year. Over 700,000 automobiles. Who's going to drive and repair them? Men are in big demand. Our school is doing **double** the business it did last year. Nothing succeeds like success. Don't you want to make \$5 a day and up? There's money in the automobile business for you.

**E. J. SWEENEY SWEENEY AUTOMOBILE SCHOOL**  
1161 E. 15th Street, KANSAS CITY, MO.

### The University of Chicago

## HOME STUDY

in addition to resident work, offers also instruction by correspondence.

For detailed information address

24th Year U. of C. (Div. 20) Chicago, Ill.



### EARN TELEGRAPH

Morse and Wireless—R. R. Accounting (Station Agency) taught. Splendid opportunities. Positions secured. Marconi Co. takes our wireless graduates. We own and exclusively occupy two large modern buildings equipped with R. R. and Western Union wires and complete \$1,000 Marconi Wireless Stations. Largest School—established 40 years. Investment \$25,000. Endorsed by Railroad, Marconi and Western Union Officials. Expert practical teachers. Low living expenses easily earned if desired. Tuition low. Easy payments. Correspondence courses also. Catalogs Free.  
**Dodge's Telegraph, Ry. & Wireless Institute**  
8th Street, Valparaiso, Ind.



### Learn a Paying Profession

that assures you a good income and position for life. For twenty years we have successfully taught

## PHOTOGRAPHY

Photo-Engraving and Three-Color Work

Our graduates earn \$20 to \$50 a week. We assist them to secure these positions. Learn how you can become successful. Terms easy—living inexpensive. Write for catalogue—NOW!  
**ILLINOIS COLLEGE OF PHOTOGRAPHY, 999 Wabash Avenue, Effingham, Ill.**

ESTAB. 1892

## BODEE TRADE



## DENTAL SCHOOL

15-17 W. 44th St.

NEW YORK CITY

LEARN IN 3 MONTHS TO EARN \$1300 TO \$4000 A YEAR

Our valuable book "P" tells how. It's Free—write for it. Anyone from 16 to 60 years old can easily learn Mechanical Dentistry. The Demand is like a gold mine. Unexplored. We are constantly called upon to fill good salaried positions. Why not qualify for one? No book study. All practical work. We guarantee that you can earn before completion of the Course. Tuition payable in instalments.

## A GOOD POSITION

with **UNCLE SAM** is most desirable. Life positions, pleasant surroundings, good pay, steady work, short hours, promotions on merit. Both sexes. No political pull. Thousands of appointments yearly. Most thorough preparation \$5. Returned if not appointed. Full information and questions used by the Civil Service Commission free.

**AMERICAN CIVIL SERVICE SCHOOL**

WASHINGTON, D. C.

### LEARN JEWELRY ENGRAVING

In your own home. Earn \$20.00 to \$50.00 Weekly. Personal instructions. Write for free booklet. Chicago Engraving School, 612 Athenaeum Bldg., Chicago

### Practical Electrical Education

Our practical course in Electrical Science and Engineering trains you to get and keep the big-pay jobs. Enter at any time, no matter what your education. Advance as fast as you can master what we teach. Course combines theory with actual practice in all branches of electrical work. Individual instruction. Positions paying \$1,500 a year up, waiting for graduates. Write for FREE ILLUSTRATED CATALOG. Eleventh year. Spring term now open.

School of Engineering of Milwaukee, 242 1/2 St. Bldg., Milwaukee, Wis.



Please Mention Popular Mechanics

FREE



# THE LAW TRAINED MAN

## This Inspiring Book Free To Ambitious Men

**This intensely interesting and instructive 165-page book tells you how a knowledge of law has proved to be the stepping stone for thousands of men to larger incomes and to power and achievement.**

It tells you of the great and increasing demand for lawyers and how you can become one. It tells you why law trained men are now selected for most positions of responsibility in business, public life and social work—and how you can grasp these opportunities.

It shows you how you can become law trained without leaving your home or business by a method which includes the comprehensive features of the best resident law schools and is endorsed by distinguished men throughout the country in whose opinion you have the utmost confidence. Send for your copy of "The Law Trained Man," today.

### Modern American Law Course and Service of Blackstone Institute

Blackstone Institute (Including The Sprague Correspondence School of Law) was founded in 1890, and is by far the oldest and largest law school for non-resident instruction in the world.

We have successfully trained more than thirty thousand men and women in law. Among our graduates are the Governor of a State, United States Senators and Congressmen, State, County and City Officials, many Judges and thousands of successful Lawyers and business men everywhere. This notable record extending over twenty-five years is the most convincing evidence that we produce results—and it is results that count.

Address, Extension Division 1953

**Blackstone Institute**  
20 West Jackson Blvd., Chicago.

Chief Justice Ladd of the Supreme Court of Iowa, says:

"Every person interested in the law will receive from Blackstone Institute an unusually excellent—in fact, the best, non-resident system of instruction."

The Course has been prepared especially for home study by eighty eminent judges and law writers. It is clearly written in simple, non-technical language. It is practical, yet reads like an interesting story. Specific education is not necessary. You can read in spare time at home, and you will benefit from the day you start. Our Course and Service will prepare you on all subjects required in the bar examinations, as it has already done for thousands of others in your own state, and every other state in the Union. It will equip you to become a leader in business or public life—and to attain positions of honor and profit open only to law trained men.

### Special Offer—Investigate Free

The recent union of The Sprague Correspondence School of Law with Blackstone Institute and the resulting increase in our facilities enable us to make you a most important Special Offer. Investigate now by sending post card or letter, or clipping the coupon for our 165-page free book and full particulars. No cost or obligation.

**FREE  
BOOK  
COUPON**

Address, Extension Div. 1953

**BLACKSTONE INSTITUTE**  
20 W. Jackson Blvd., Chicago.

Please send me your 165-page free book, "The Law Trained Man," and full particulars of your Law Course and Service and Special Offer. No cost or obligation.

Name \_\_\_\_\_

Address \_\_\_\_\_

Please Mention Popular Mechanics

Copyrighted material

## Here's YOUR Chance to Learn **DRAFTING**

This Complete \$15 Drawing Outfit and Full Instructions in Mechanical Drawing **FREE**



There's a good job waiting for you. The country is facing greater prosperity than it has ever before experienced. Far-seeing men are getting ready for boom times. Get this training now and share in the coming prosperity.



**CHARLES W. MOREY**  
President of the College  
and Head of a large Chicago  
Firm of Civil, Mechanical and  
Electrical Engineers and  
Contractors.

## Men Wanted AT BIG SALARIES

This is a rare chance for a few wide-awake young men

On account of the rapidly increasing demand for trained draftsmen Pres. Morey has issued orders that instruction be furnished to a limited number of young men who are inclined along engineering or architectural lines. Read about this great offer below—then mark and mail the coupon.

**STUDY AT HOME** Devote your spare hours for a short time only and learn this profitable and pleasant profession, and get in the class drawing the big pay envelope. Hundreds of men are in daily attendance at this old established college. In your own home you can do the same work these men are doing, and the same experts that teach them will guide you toward the big job. These well known engineers prepare your instruction matter. Your work is examined and approved by them. They know exactly the practical training you need and they train you. No books to sell. Live, up-to-date blue prints of work in actual construction. In your own home you work with plans of machinery, buildings, steel work, etc., actually being constructed in Chicago, New York and other large cities.

### ELECTRICAL DRAFTING AND DESIGN

No other similar correspondence course in America has a resident college of National reputation back of it, nor a faculty of active experts actually engaged in municipal and corporation engineering work. These men know exactly the kind of training you need because they are in constant charge of big work.

## \$45 COURSE FREE IN MECHANICAL DRAFTING

This College has set aside a limited number of Free Scholarships and will give the regular \$45 Course in Mechanical Drafting Free with any one of the Home Study Courses named in the coupon below—this is in addition to the complete \$15 Drawing Outfit which is also furnished to students free. Take advantage of this unusually liberal offer today, as it will be withdrawn when the allotted number of Free Scholarships has been awarded. It costs you nothing to get full information. No obligation on you.

### ACT NOW—FILL OUT COUPON TODAY

- |                           |                       |
|---------------------------|-----------------------|
| —Electrical Drafting      | —Builders' Course     |
| —Machine Drafting         | —Plan Reading         |
| —Architectural Drafting   | —Estimating           |
| —Structural Drafting      | —Sheet Metal Drafting |
| —Civil Engineering (1080) | —Surveying            |

Name.....

Address.....

Town.....State.....

College or Home Study Course.....

**CHICAGO TECHNICAL COLLEGE**  
1050 Lake View Building, Chicago, Illinois

Please Mention Popular Mechanics

## LEARN TO PAINT SIGNS and SHOW CARDS



THERE'S  
MONEY  
IN IT

I'll teach you personally by mail 17 years' successful teaching. Five courses: (1) Complete Lettering, Sign and Card Writing; (2) Show Card and Ticket Writing; (3) Lettering; (4) Advanced Show Card and Ticket Writing; (5) Advanced complete Course. You can succeed—big. No limit to the window cards, sale cards, banners, and signs used. Gold lettering on glass and wood valuable feature of course. Teaches everything you need. Pay good, work fascinating, hours short.

### EARN \$18.00 to \$45.00 a WEEK

Schwartz, Del., writes: "You're the only school that really teaches." Weaver, Canada, writes: "Your course has increased my income 50%." Get in on this big thing, too. Your name and address brings full particulars.

**THE DETROIT SCHOOL OF LETTERING**  
Chas. J. Strong, Founder, Dept. 2030, Detroit, Mich.

### Guarantee—

I guarantee to place my graduates in positions paying \$25.00 to \$125.00 when they have graduated and are competent. We have constantly more requests for men at good salaries than we can supply.

## DRAWING

Learn by mail in your own home. Cartooning, Newspaper, Magazine and Commercial Illustrating, also

### Water-Color and Oil Painting

Learn Drawing or Painting for profit and pleasure. We can develop your talent. This school has taught thousands. Free Scholarship Award—special limited offer. Your name and address brings you full explanation and our handsome Illustrated Art Annual by return mail. Don't delay. Write today.

**FINE ARTS INSTITUTE, Studio 213, Omaha, Neb.**

## Chicago Correspondence School of Law

Prepares Students at Home for the Bar. Four Courses of Study: College, Post-Graduate, Business Law and Bar Examination Review. Actual Daily Lessons by a recognized School that is approved by Bench and Bar.

Write today for FREE Catalog and Rules for Admission to the Bar.

520 Reaper Block, Chicago



## JEWELRY ENGRAVING

We teach you, by our new and original method of instruction, this clean, fascinating and profitable business right at your home, and furnish you all tools needed absolutely free. Write for free book to the

**WISCONSIN SCHOOL OF ENGRAVING, 37th Bldg., MILWAUKEE, WI.**

## LEARN TO WRITE ADVERTISEMENTS EARN \$25 to \$100 A WEEK

We can positively show you by mail How to increase your salary. BOOK MAILED FREE. PAGE-DAVIS CO., 112 Page Building Chicago, Ill., or 150 Nassau St., New York

## Learn How to WRESTLE

In Your Own Home  
By Mail

Yes, learn to become an expert wrestler right in your own home, by mail, from the greatest wrestlers the world has ever known. Be an athlete, be strong, be healthy. Learn how to throw and handle big men with ease. Learn to defend yourself. All taught in our course of lessons, and illustrated with hundreds of charts and actual photographs by

### Farmer Burns and Frank Gotch

Farmer Burns, "the grand old man of the mat," taught Frank Gotch, the present World's Champion, all he knows about wrestling, so Gotch says. He will now teach you Scientific Wrestling—Physical Culture—Jiu-Jitsu—Self Defense. Every man and boy in America, no difference what age, needs this wonderful course of lessons. Write today—your name, age and address on a postcard or letter brings you our free book absolutely free—no obligations of any kind. A splendid book on wrestling and physical culture. Write today stating your age.

Farmer Burns School of Wrestling 1193 Range Bldg., Omaha

This  
wrestling  
book  
FREE

# Don't Envy Successful Men Be One!



## THE WAGES

Of Bookkeepers, Clerks and other untrained help is from \$12 to \$20 a Week.

As long as you neglect to obtain special training you will belong to this class. You will be one of the "help." You must "keep your nose on the grindstone." You can't demand a raise because hundreds of men are waiting to take your job—and for less money. No matter how honest or how faithful you are—or how hard you work—the wages will be not more than \$20 a week. That is the limit—you can take it or leave it. If you want more salary you must obtain special training—there is no other way. Why work hard for wages of from \$12 to \$20 a week when you can become a Trained Accountant and draw a salary of from \$3,000 a year up?

## Be An Expert Accountant

500,000 Firms Need Them Only 2,000 in America

TODAY, in America alone, there are over 500,000 large firms that need annual, or semi-annual audits. In every large city there are hundreds of openings for trained accountants. As there are only about 2,000 certified public accountants in America, the demand far exceeds the supply. For this reason the incomes and salaries paid are good. Just as soon as you complete the La Salle Course, your chances for obtaining immediate employment will be excellent—no weeks or months hunting for a job—the position will seek you. If you complete the course with satisfactory grades you will be fully qualified for one of these positions.

### We Will Train and Coach You In Your Home—By Mail—In Your Spare Time

Hold your present position. Earn while you learn. Study when you feel most like it. Advance as rapidly or as slowly as you desire. Study a little every day in your leisure time—part of which is now wasted. You can complete our entire course become a master accountant—in less time than any other because our system will teach you the "working-knacks" and "short-cuts" employed by experts. In this our course differs from all others

**Quit—The "Shirt Sleeve Class"** Why "grind" along, day after day, with the other untrained "help" waiting for a raise that may not come—and will be small even if it does? Determine to get out of the "shirt-sleeve" class. Resolve to bid goodby forever to hard work, long hours, and low wages. Decide to become a trained accountant—to direct others—and to draw a "man's" salary.

**Choose Your Future Today**—The first thing to do is to mail the coupon. Remember that if you don't mail it today—the chances are that you never will. Quit dreaming—and act. Write your name and address on the Coupon. Mail it. We will send you the Free Booklet: "What Every Bookkeeper Should Know," which explains state examinations, state regulations, salaries, etc.—also complete information concerning the course—and by return mail.

La Salle Extension University, Dept. 364-H, Chicago Ill.

### Under Personal Supervision of William Arthur Chase, C. P. A.

You will receive your training under the direct personal supervision of William Arthur Chase, an accountant of National prominence, who is Ex-President of the American Association of C. P. A. Examiners, and Ex-Secretary of the Illinois State Board of Examiners in Accountancy.

**The Course** was prepared by some of the world's most noted accountancy experts. It fully covers the field—Theory of Accounts—Practical Accounting—Cost Accounting—Auditing—Business Law, etc. It will prepare you for the Examination in any state.

## THE SALARY

Of a Trained Accountant is from \$3,000 to \$10,000 Yearly

Trained accountants get large salaries because there are only a few hundred of them—while thousands of firms need them. For this reason an expert can demand and get big pay. Then why don't you become a trained accountant? It is not very difficult, after all. The La Salle System will make it easy for you. Our course is written in a clear and simple manner. Everything is fully explained. You cannot help but learn. Under the personal supervision of our instructors—and the coaching of our experts—you will soon be qualified to earn a good salary. With our help—if you have average intelligence, and are determined—failure is impossible.

### La Salle Special GUARANTEE

We give the student a written agreement signed by our Treasurer, that if the student completes the course with satisfactory grades, and fails to pass the Certified Public Accountants examination held in any state, we will give him special instruction and help—without additional charge—until he does pass.

### La Salle Extension University Dept. 364-H, Chicago, Ill.

Send at once your free Book containing "What Every Bookkeeper Should Know" with full details of your Course in Higher Accountancy; also advise me about Special Reduced Rate. I am obligated in no way.

Name.....

Street No.....

City.....State.....

Please Mention Popular Mechanics

# STUDY LAW

## AT HOME

### Become an LL.B.

*Only Law School of  
Its Kind in America*

### Special and Exclusive Features

**ONLY** recognized resident law school in the United States conferring Degree of Bachelor of Laws—LL.B.—by correspondence. **ONLY** law school in U. S. conducting standard resident school and giving same instruction, by mail. **ONLY** law school giving over 450 class-room lectures to its extension students. **ONLY** law school giving a full 3-year, University Law Course, by mail, having an actual faculty of over 30 prominent lawyers in active practice. **ONLY** law school in existence giving Complete Course in Oratory and Public Speaking, in conjunction with its law course.

### Written Bar Guarantee

We give an absolute written guarantee to prepare our students to pass bar examinations.

The Hamilton College of Law is a regular, thoroughly recognized, bona fide College of Law and NOT an "institute," "correspondence school," etc. It occupies the entire, third floor of the New Advertising Bldg., where its large and commodious resident class-rooms and executive offices are located.



Our Degree Bachelor of Law, LL.B.  
NOT a Diploma or Certificate

### Direct From Class-Room to Student



From Lecture Room to Student

No Other Law School Can Do This

This illustration shows the way we teach law. We are the only school doing this. Our system of teaching is intensely interesting; not dull and dry like the average law course. Our system of conducting examinations is the most thorough, complete and expensive (to us) of any examinations ever given. A student can, if he chooses, take part of our course by mail and finish in our resident school where he will receive full credit for all work done by mail. Our resident school is recognized by all standard law schools in the United States.

The Hamilton College of Law is highly endorsed and recommended by Government Officials, Business Men, Noted Lawyers, Graduates, and Students. We have as students a number of practicing lawyers (not graduates of recognized law schools) who are now earning their degree of LL.B. Many other lawyers are using this course as a review. A probate Judge, one of our active students says: "I am delighted with the course prescribed and your method of teaching law. It is far in advance of what I expected to receive."

### Our Law Library

consists of 24 volumes of Student's Standard Text Books, two volumes bound together under one cover, making a total of 12 books. These books were prepared at an enormous cost especially for the students of the Hamilton College of Law, by one of the largest and best law book publishers in America. This is the only set of law text books ever prepared exclusively for student's use. We would be glad to have you submit these books to any lawyer or judge in the country and get his opinion regarding them.



These 12 Volumes are Free to Students

### Mail Coupon Today

and get our Big, Beautifully Illustrated Prospectus and complete information. Place you under no obligations whatever. This may mean the turning point in your career.

Hamilton College of Law, 327 Advertising Bldg., Chicago, Ill.

Gentlemen: Kindly send me your Illustrated Prospectus and full particulars regarding your method of teaching law by mail

Name.....

Address.....

Write plain and in full

Please Mention Popular Mechanics

## "LEARN BY DOING"

Get a complete training by actual practice. Get the knack of "HOW" together with the theory of "WHY" and the best business methods used in the World of Electrical Activity.

The N.Y. Electrical School is the pioneer and premier school of the "Learn by Doing" method. When you have completed this Course you shall be fully qualified to handle ALL branches of Electrical industry.

The equipment of this School is unequalled and up-to-the-minute. No preparation needed to become a "learner" in this School. You can start to learn on any day of any week throughout the whole year.

Visitors heartily welcomed. Send for catalogue.

44 West 17th St.

New York City

N. Y. ELECTRICAL SCHOOL

## A Civil Service Job For YOU—

A job with Uncle Sam under Civil Service protection means employment for life with good pay, short hours, pleasant work, annual vacations and the assurance that you will get your pay regularly in spite of panics or hard times.

Post Office, Railway Mail, Rural Carrier, Custom - Internal Revenue and other examinations are coming soon.

If you're an American citizen, 18 or over, we can help you secure one of these good jobs. Our 64-page booklet tells how you can prepare for "exams" under personal supervision of a former U. S. Civil Service Secretary-Examiner—a man who knows and whose knowledge is at your disposal.

Write today for booklet. It's free, without obligation.

PATTERSON CIVIL SERVICE SCHOOL  
116 Irving Place ROCHESTER, N. Y.



## "FORGING AHEAD FREE IN BUSINESS" FREE

This 128 page book which we will send you free, tells of the wonderful help which the Modern Business Course and Service is to every man in business from manager to clerk; tells how it helps; tells who are back of this great institution, who are enrolled, and what they say about it.

Send for this Free Book today

ALEXANDER HAMILTON INSTITUTE  
189 Astor Place, New York



## MUSIC TAUGHT FREE

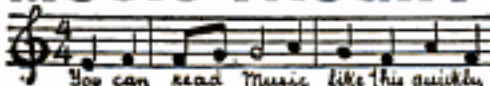

IN YOUR OWN HOME

You can read Music like this quickly

Write today for our booklet. It tells how to learn to play Piano, Organ, Violin, Mandolin, Guitar, Banjo, etc. Beginners or advanced pupils. AMERICAN SCHOOL OF MUSIC, 51 Lakeside Bldg., Chicago



## For Artists and Art Students

Publishes Cash Art Assignments, lessons and articles on Cartooning, Illustrating, Lettering, Designing and Chalk-Talking. Criticises amateurs' work. Interesting, helpful, artistic, UNIQUE. It will please you. Money back if not satisfactory.

Clare Briggs, Ryan Walker, and other noted artists contributors.

Send Now \$1 a Year 10c a Copy

STUDENTS ART MAGAZINE  
Dept. 139, Kalamazoo, Mich.

## I TEACH Penmanship BY MAIL

I won the World's First Prize in Penmanship. By my new system many are becoming expert penmen. Am placing my students as instructors in commercial colleges. If you wish to become a better penman, write me. I will send you FREE one of my Favorite Pens and a copy of the Ransomian Journal. C. W. RANSOM, 525 Essex Bldg., Kansas City, Mo.





Come to Detroit  
the automobile center  
and

**LEARN THE AUTOMOBILE BUSINESS**

Detroit trained men get preference over all others, get jobs quick as soon as ready. *The reason*—study the heart in the center. Realize its tremendous power.

No other city, no other school can give you what Detroit offers. Factories shown are not all. Think what it means to learn at Detroit. Every factory knows us, endorses our school, glad to get our graduates. You're right in the middle of great auto activity. Men are needed everywhere as testers, repairmen, chauffeurs. Splendid chance to start in business. Hundreds of our graduates are doing it.

**Earn \$75 to \$300 a Month**

We teach you to handle any auto proposition. Our equipment is complete. Students actually build cars from start to finish, getting regular factory training in assembling, block-testing, road-testing, etc. That's the Detroit Way. All leading types of starting, lighting and ignition systems in operation. Learn to time motors, adjust carburetors, magnetos, valves, bearings, etc. Six-cylinder Lozier and 8-cylinder King are used for road instruction. We have a new Chalmers "6" chassis with overhead camshaft motor, the latest thing out.

**Detroit is the Place to Learn—Start Any Time**

There are 44 auto factories in Detroit. Our students have the privilege of going through any or all of them, including Detroit electric service department, while taking our course. You can't get these advantages and opportunities anywhere else. Detroit is the automobile center. You make faster time here and you get practical instruction. Come to Detroit and learn the business right. Enter classes any time.

### Great Demand for Detroit Trained Men

Garages throughout the country write us for men. Why not fit yourself for one of these good paying positions?

### Demand Greater Than Supply for Competent Men. Following Clipped from Daily Papers—All Parts of U.S.

Experienced motor mechanics, bearing scrapers, assemblers, repairmen; good wages. Henderson Motorcycle Co., 1158 Cass.

Chauffeur—Must be good driver, steady and reliable; one with knowledge of Pierce-Arrow cars preferred; no other but good mechanic need apply. Address Box E, No. 100 Free Press.

10 road testers, 20 garage repair men, final assemblers. Maxwell Motor Co., Inc., Oakland Ave. Plant.

40 Drivers—Come ready to work. Maxwell Motor Co., Inc., Oakland Avenue Plant.

Block Testers—Apply Continental Motor Mfg. Co.

Wanted—High-grade retail automobile sales manager. Box E, No. 52.

Automobile Repair Men wanted; must be experienced; none other need apply. Come ready for work. Auto-Kraft & Garage Co., rear 78-86 Forest Avenue, East.



### Michigan State Auto School Students are Competent to Fill Every Position and Make Good

Has Studebaker and Maxwell Agency  
La Farge, Wis., February 6, 1915.

Prof. C. G. Arthur,  
Michigan State Auto School, Detroit, Mich.  
Dear Sir:—I am getting along just fine. A friend of mine, Mr. Bioalin, and myself, have opened a garage in our home town, and we have been having all we could do. We have been doing overhauling this winter and have got enough work ahead waiting to keep us going until spring opens up. Thanks to what you have pounded into that old nut of mine, I have never been stuck yet. We have the agency for the Studebaker and Maxwell.

Yours truly, (Signed) O. C. HILL.  
**Starting Garage of His Own, Couldn't Accept Position We Offered**

Elma, Iowa, May 1st, 1915.  
Michigan State Auto School, Detroit, Mich.  
Gentlemen:—I thank you very much for the information sent me and am very sorry because I cannot accept the position as I am busy at the present time, putting up a garage. I am going into the business for myself and was compelled to turn down the position offered me. I am thankful that I went to Detroit to learn the auto business and wish the School the best of success. Sincerely yours, (Signed) CARL WEBER, Box No. 304, Elma, Iowa.

W. C. Garden, Tenn., is Chauffeur at \$25 a week and expenses. E. Livingston is head of government garage at Toronto. Hundreds of others in good paying positions.

### READ OUR GUARANTEE

### GUARANTEE

We guarantee to qualify you for a position as chauffeur, repairman, tester, salesman, demonstrator or garage man paying from \$75.00 to \$300.00 in a short time or refund your money. We have constantly more requests for men, at 6000 salaries than we can supply.

Write for full particulars. Ask for "Auto School News" and new Pictorial catalog—just out. Both free. Or, better still, jump on train and come to Detroit.

**Michigan State Auto School** Dept. 303, 11-19 Selden Ave. Detroit, Mich., U. S. A.

### SEND THIS COUPON TODAY

Michigan State Auto School

..... I expect to leave here about..... for Detroit.

..... I would like to see your new pictorial catalog, (just out) and the Auto School News and will let you know later what I expect to do.

Name.....

Street.....

Post Office..... State.....





## \$125 to \$300 A MONTH

Don't hesitate. Write to us at once and find out about this wonderful opportunity. Hundreds of Signal Men and Signal Engineers are needed right now. Are you able to accept one of these positions? Have you had the training that will enable you to forge ahead and earn big money? All the way from \$125 to \$300 per month. If not, you cannot afford to put off writing us. Send at once for our big book which tells you all about the wonderful new profession of Signal Engineering. After a short time you will be in a position to earn more money. By our plan you can become our Representative immediately. So don't wait. Write us today. Get this special offer NOW.

## More Men Needed

The railroads are constantly looking for competent Signal Men and Signal Engineers. There are not enough men to fill the positions. Thousands and thousands of miles of tracks are to be equipped with automatic signals. More Signal Men are needed to superintend the work. Many new positions will be open and there are not enough men to take them. Besides a profession in which you can make a lot of money, Signal Engineering is the most fascinating work. So don't delay. Write today and find out about this wonderful opportunity.

### FREE BOOK COUPON

Dept. of Signaling  
Room 1193, 1810 Wilson Ave.  
Riverside Station, Chicago, Ill.

GENTLEMEN: Please send me absolutely free and prepaid your big new Signal book. It is distinctly understood that I assume no obligations of any kind.

Name .....

Address .....

Age ..... Occupation .....

## Free Coupon

Just put your name and address on the free coupon and send it to us at once. You are under no obligations of any kind. We will send you the big new Signal Book which tells you all about this wonderful profession absolutely free. This book tells you how you can earn from \$125 to \$300 a month. Don't wait. Write today.

Dept. of Signaling  
Room 1193  
1810 Wilson Ave.  
Riverside Sta.  
CHICAGO,  
ILL.

Please Mention Popular Mechanics

## SHORTHAND IN 30 DAYS

We absolutely guarantee to teach shorthand complete in only thirty days. You can learn in spare time in your own home, no matter where you live. No need to spend months as with old systems. Boyd's Syllabic System is easy to learn—easy to write—easy to read. Simple. Practical. Speedy. Sure. No ruled lines—no positions—no shading as in other systems. No long lists of word signs to confuse. Only nine characters to learn and you have the entire English language at your absolute command. The best system for stenographers, private secretaries, newspaper reporters and railroad men. Lawyers, ministers, teachers, physicians, literary folk and business men and women may now learn shorthand for their own use. Does not take continual daily practice as with other systems. Our graduates hold high grade positions everywhere. Send today for booklets, testimonials, etc.

Chicago Correspondence Schools  
969 Unity Bldg., CHICAGO, ILL.

## SPEAK A FOREIGN LANGUAGE !!!



The War has created unlimited commercial opportunities for those who know Spanish, French, German or Italian. Take advantage of the war situation! Better your position and increase your salary. Extend your business. Establish export trade with South American countries. Equip yourself to read foreign books and papers. Break up on the language you studied at school or college and make it of practical use. Acquire a new language at home, by the

## LANGUAGE-PHONE METHOD

And Rosenthal's Method of Practical Linguistry  
(Highest Award Panama-Pacific Exposition)

This is the natural way to learn a foreign language. You hear the living voice of a native professor pronounce each word and phrase. He speaks as you desire—slowly or quickly, for minutes or hours at a time. It is a pleasant, fascinating study; no tedious rules or memorizing. It is not expensive—all members of the family can use it. You simply practice during spare moments or at convenient times, and in a surprisingly short time you speak, read and understand a new language.

Write for free "Language Treatise," particulars of Trial Offer, Easy Payments. Our records fit all talking machines.

The Language Phone Method, 961 Putnam Bldg., 2 W. 45th St., N.Y.

## Given Given Given

### A 6-Pass. 32 H. P. Bush Touring Car

and the Agency for your Territory. Qualify to make from \$3,000 to \$5,000 selling Bush cars in 1916. Write for my 40-page book giving all details of this wonderful offer. Address

J. H. BUSH, Pres., Dept. 317  
Bush Bldg., No. Clark St. and Chicago Ave., CHICAGO, ILL.



## MEN WANTED

Prepare as Firemen, Brakemen, Electric Motormen, and colored Train Porters. First Class Standard Roads. Hundreds put to work—\$65 to \$150 a month without any experience. 500 more wanted. Uniforms and passes arranged for when necessary. Enclose stamp for Application Blank. Name position you want.

I. RAILWAY C. I., Dept. 35, Indianapolis, Ind.

## SELF-CONSCIOUSNESS

Are you timid? Do you lose your nerve and become confused easily? Do you lack confidence, courage, aggressiveness, faith in your own ability? These faults are a big handicap in social or business affairs. My Illustrated Treatise tells you how they may be overcome. It's FREE! Write for it today.  
M. DeBETTS, Sta. 89, JACKSON, MICH.

## SHOW CARD WRITERS

EARN \$80 TO \$200 A MONTH  
LEARN FREE!



We will furnish a thorough course in Show Card Writing and Lettering absolutely free to introduce our colors if you will purchase an assortment of Alpha Colors to use while practicing. Particulars for stamp.

ALPHA COLOR COMPANY, Inc., Dept. K, 81 East 125th St., N. Y. City

## Young Man! Your greatest opportunity

To the man who wants to improve his condition in life—to increase his earning capacity—to get away from the monotony, grind, and low wages of ordinary occupations—to elevate his social standing, the new profession of Tree Surgery, which is not overcrowded, offers the young man of today his greatest opportunity. The Extension Course given by The Davey Institute of Tree Surgery will fit you to practice this profitable profession.

### LEARN TREE SURGERY AND FRUIT GROWING BY MAIL

You can become proficient in this work without interfering with your present occupation. An hour or so a day will give you a training that will make your future bright and prosperous. The work of a Tree Surgeon is healthful, fascinating and remunerative. The call for men in this profession is far greater than the supply, and the demand is growing. There are positions open at good salary and opportunities everywhere to establish a paying business of your own. Why work for others at small pay when you can be your own boss? Write today for our book, "Adventures in Success." Read what others have done, and learn how easily and quickly you can improve your condition in life.

**THE DAVEY INSTITUTE  
OF TREE SURGERY**  
393 Oak St., Kent, Ohio

Write  
for  
Book  
Today  
It's  
FREE



## LEARN WATCHMAKING

and become independent. Good-paying positions secured.

Easy to learn. Send for FREE CATALOG.

ST. LOUIS WATCHMAKING SCHOOL, Dept. 5, ST. LOUIS, MO.

## AT HOME Learn TO SING

Send 2-cent Stamp for Helpful Booklet, "The Voice Made Beautiful."

HARVEY SUTHERLAND, 813 President St., Brooklyn, N. Y.

## LAW STUDY AT HOME

We give our Complete Resident Course by mail. Guaranteed to prepare for Bar of ANY State. LL. B. Degree Conferred. Indorsed by Bench and Bar. 22 Standard Text-books FREE. Faculty of 45 Distinguished Jurists and Lawyers. CATALOG FREE.

OKLAHOMA UNIVERSITY LAW SCHOOL  
906 Colcord, Oklahoma City, Okla.

## Do You Like to Draw? Cartoonists Are Well Paid

We will not give you any grand prize if you answer this ad. Nor will we claim to make you rich in a week. But if you are anxious to develop your talent with a successful exponent, so you can make money, send a copy of this picture, with 6c in stamps for portfolio of cartoons and sample lesson plate, and let us explain.

The W. L. Evans School of Cartooning  
821 Leader Bldg., Cleveland, O.



## New Jobs \$100 Typewriter FREE

Men and women Confidential Secretaries now needed everywhere—new profession.

Uncrowded Field—\$25 to \$50 Weekly

Big position to start. Learn at home. Qualify through Hoxford New Method Touch Typewriting—write 150% faster. Tuition fees refunded if not satisfied. Write for first lesson free. Shorthand Course also.

\$100 typewriter free while learning. Amazing method doubling salaries. Address Jaz. Patrick Ward, Pres. BOTSFORD Institute, 1102 Botford Bldg., Chicago

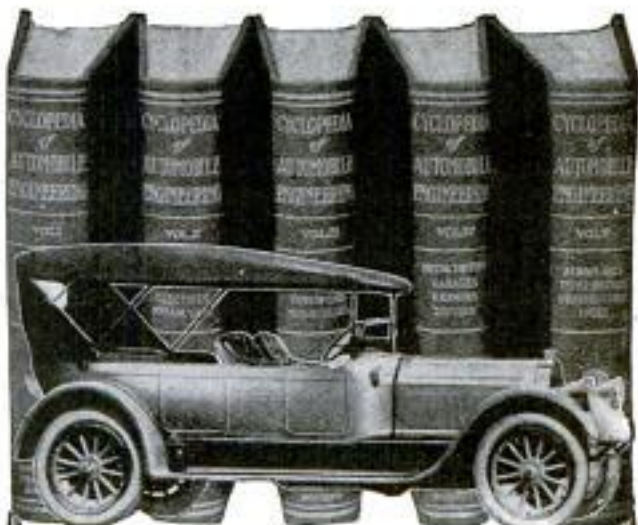

## NEW 1916 EDITION AUTOMOBILE ENGINEERING

No matter what type of motor vehicle you are interested in. No matter what standard make of auto, motor car, motorcycle or motor boat you want to know about.

Here is your opportunity to get a brand new library covering every motor subject. Here is your chance to secure the latest, most practical, most authoritative set of books ever written on automobile and motor engineering at an extremely low, inside price.

If you want help in solving the knotty points you bump up against every day, this set of books is just what you are looking for. If you want to become a Gas Engine expert, this great 5 volume cyclopaedia, written by the biggest men in the business, is the standard text book for you.

### \$25.00 Set Now \$14.80—\$2.00 a Month

This auto library contains 2,000 pages, with 1,600 illustrations that make technical points as simple as A-B-C; full page plates that literally pick the mechanism to pieces before your very eyes; drawings and diagrams that show the working of all the principles employed in the various types of motors. Bound in half red morocco, gold stamped. These five volumes are a most remarkable value at the regular price. Yet we offer a limited number of sets at a special introductory price of \$14.80—payable \$2 a month.

**SHIPPED FREE** Test these books before you buy. You don't buy a motor until you have tried it out. Buy books the same way. We send the full 5 volumes to you, express prepaid, for 7 days' free examination. Use them a whole week free. See if they don't help you work out the problems that come up in your garage or repair shop. If the books are what you want, send us \$2. Otherwise we'll take them back, paying the express both ways ourselves.

### Subjects Covered

Explosion Motors—Gasoline Car Features—Ignition Systems—Lighting Systems—Electric Starters—Types of Automobiles—Electric Pleasure Cars—Storage Cells—Electric Motors—Care and Operation of Electrics—Automobile Driving—Road Troubles—Private Garages—Repairs—Electric Delivery Wagons—Electric Trucks—Gasoline Delivery Wagons—Trucks—Taxis—Tractors—Trailers—Road Trains—Traction Engines—Maintenance and Costs—Steam Cars—Motorcycles—Cycloars—Light Cars—Motor Boats—Glossary.

### FREE !! \$12.00 Consulting Membership

We give you absolutely free our \$12 consulting membership. This privilege puts our whole staff of experts at your service for a whole year without cost to you. Ask them any motor question you want. They will give you practical help. The solution of a single problem might easily be worth more than what you pay for the books—you get this service free.

The moment you see the books you will realize that you need them. There is no limit to the good they can do you every day. It costs you nothing to look them over, to use them for a whole week. You run no risk, you incur no obligation. The books come back at our expense if you say so.

Send in the coupon now—today.

**AMERICAN  
TECHNICAL  
SOCIETY**  
Chicago, U. S. A.

NAME .....

ADDRESS .....

As I have had no previous dealings with you, I refer you to

### FREE COUPON

Worth \$10.20 to You

American Technical Society  
Chicago, U. S. A.

Please send me Cyclopaedia of Automobile Engineering for 7 days' free examination. If I decide to buy, will send \$2 in 7 days and balance \$2 a month until \$14.80 has been paid, when \$25 books and \$12 consulting membership will be mine free. Otherwise will notify you and hold books subject to your order. Title not to pass until fully paid.

Pop. Mec. 3-18

Please Mention Popular Mechanics



H. J. RAHE, President  
Automobile Training School  
Kansas City, Mo.

# Big Money For YOU

**Any Ambitious Man Who Wants to Get Out of the Small Wage Class Can Prepare Himself for the Automobile Business in Six Weeks**

Rahe's Automobile Training School of Kansas City—one of the largest institutions of the kind in the world, has trained thousands. Hundreds of our graduates are in business for themselves as garage owners, factory representatives, agents, dealers, etc. Many are holding responsible positions in some of the largest automobile factories in America. Hundreds more are getting fancy wages as managers of garages, repair men, drivers, demonstrators, tractor and power farming experts. These men earn from

## \$75 to \$300 or More Per Month

They earn big money because they are **TRAINED MEN** in all branches of the automobile business. The same opportunity is before you—you can do as well. The growth of the automobile business is the wonder of the world. Nothing else compares with it. **Thousands of Trained Men are Needed**—the big jobs are open and they pay big money right from the start. No special education is required to take up our course. **Ambition is all you need.**

## Only Six Weeks Required to Train You

That is all we ask—six weeks and you will be ready to start in—ready to enjoy bigger money than you

### FREE SCHOLARSHIP BOOK COUPON

H. J. Rahe, Pres.  
**RAHE'S AUTOMOBILE TRAINING SCHOOL**  
1040 Locust St., Kansas City, Mo.  
Send me your 60-page book "How to Make Money in the Automobile Business."

Name.....

Town..... State.....

Street or R. F. D. ....

are now making. Henry J. Rahe, President and Founder of Rahe's Automobile Training School, is the originator of Rahe's System of Practical Automobile Instruction—the acknowledged standard. We claim to have more expert instructors, more equipment, more floor space and more successful graduates than any other similar school in the entire world. **All Work is Practical.**

**No Charts or Books Used. No Tools to Buy**

Our students work on real cars—not theories. We own and operate two of the largest garages and repair shops in the West. Hundreds of cars and trucks of all makes are at our command. Our students work on these cars—make real repairs.

### FREE—\$50 SCHOLARSHIP—FREE

For a limited time we are giving away a combination course in Tractor and Stationary Engineering. Enroll now and get one of these free scholarships and receive complete instruction in Power Farming in addition to our regular instruction in all branches of the automobile business. There is a tremendous field for men who understand tractors and farm engines. Act promptly and get this added instruction free.

**H. J. RAHE, President RAHE'S AUTOMOBILE TRAINING SCHOOL**  
(Largest in the World) 1040 Locust St., KANSAS CITY, MO.

Send for Big  
Free Book Today

Put your foot on the first rung of the ladder of success **Right Now**—send for our book—"How to Make Money in the Automobile Business."



BE AN ILLUSTRATOR

by mail how to draw for magazines and newspapers  
Send for Catalog

Learn to draw. We will teach you  
School of Illustration  
112 Page Bldg.  
Chicago, Ill.



## IF YOU STAMMER

Attend no stammering school until you get my big FREE book and special rate. Largest and most successful institution of its kind in the world. Two large modern school buildings fully equipped for treatment of stammering under my advanced natural method. No sing-singing or time-beating.

Established 14 years. Known everywhere as the best. Personal instruction given each student. Write today for full particulars. Lee Wells Millard, Pres. North-Western School for Stammerers, 2317 Grand Ave., Milwaukee, Wis.

## CIVIL SERVICE

positions are in all parts of the country. Good pay, steady work, life positions, congenial surroundings, promotions on merit, short hours, annual vacation and sick leave with pay. Many thousands appointed yearly. Both sexes. No political pull. Nearly 300,000 classified positions. Common school education sufficient. Full information and questions used by the Civil Service Commission free.

COLUMBIAN CORRESP. COLLEGE, Washington, D. C.

## Traffic INSPECTORS WANTED

\$4 Per Day

(BY THE R. R.'s)  
Here's a new profession—for 15,000 men ambitious to better themselves by special training. Positions now open pay \$4 Per Day to start; chances for advancement and travel unlimited. We train you thoroughly, quickly; give all necessary experience. Find out how men like you—clerks, salesmen, railroad men—are earning real money and advancement. Here's your big chance! Write for Free Booklet A2 now, lest you forget.

Frontier Prep. School, Buffalo, N. Y.

## Learn Watchwork, Jewelrywork and Engraving.

A fine trade commanding a good salary, and your services are always in demand. Address HOROLOGICAL, Dept. P, Bradley Institute, Peoria, Ill., for our latest catalog.

## Public Speaking Taught at Home

Write for our special offer. Become a powerful speaker in spare time by mail. Overcome "stage fright", enlarge your vocabulary, train your memory, gain self-confidence. Learn how and when to use gestures; how to suit the speech to the occasion. Increase your earning power—become more popular. We have trained hundreds of successful speakers by mail at home.

Write Now for Special Offer. Send quick for details of our special limited offer. No obligation. Write while this offer lasts.  
Public Speaking Dept. American Correspondence School of Law, 9193 Manhattan Building, Chicago, Ill.

## Be the Boss.

Get Into the New Profession  
Thousands of men needed. Meter Engineers in constant demand everywhere. Big money. Learned at home during your spare time.  
A \$3,000 Job For You Electrical Meter Engineering is one of the best paying professions in the industry. Hundreds making \$3,000 and more. You can do the same. Write today.  
Big Book FREE Just your name and address is enough. No obligation. No cost of any kind. Big book and details FREE—absolutely free. WRITE TODAY.  
Fort Wayne Correspondence School, Department 1193, Fort Wayne, Ind.

## I Want Men



Like YOU Who Want to Make \$3,000 a Year, or More

We need a good, live man right now in your territory to handle real estate deals for us. No experience or capital necessary. We teach you the Real Estate Business and appoint you our agent in your locality. Easy work; large profits. WE OPERATE EVERYWHERE. WRITE FOR FREE BOOK.  
MORDEN REAL ESTATE SCHOOL, 409 Palace Bldg., Minneapolis, Minn.

# How I Jumped from \$1500 to \$50,000 Yearly



For obvious reasons this man's identity is withheld name on request.

## "Power of Will" Was My Guide

"Three years ago I was making \$1500 a year and working day and night. Today I make a thousand dollars a week and have time for other things as well. To the lessons in 'Power of Will' more than any other thing do I owe this sudden rise."

These are the exact words of an owner of "Power of Will." His name is not published for obvious reasons, but will be gladly given in confidence on request.

As remarkable as is his experience it might also be called typical of what this wonderful course in Will Training is doing for thousands of men and women in every walk of life who are using "Power of Will" as the stepping stone to greater accomplishment.

## What is "Will Power"?

The Will is the motive power of the brain. Without a highly trained inflexible will, a man has about as much chance of obtaining success in life as a railway engine has of crossing the continent without steam. The biggest ideas have no value without Will Power to "put them over." Yet the Will, hitherto entirely neglected, can be trained into wonderful power like the brain or memory and by the very same method, by intelligent exercise and use.

If you held your arm in a sling for two years, it would become powerless to lift a feather, from lack of use. The same is true of the will—it becomes useless from lack of practice. Because we don't use our wills—because we continually bow to circumstance, we become unable to assert ourselves. What our wills need is practice.

## "Power of Will"

by FRANK CHANNING HADDOCK, Ph. D., a scientist whose name ranks with such leaders of thought as James, Bergson and Royce, is the first thorough course in Will Power ever conceived. It is the result of over 20 years of research and study. Yet you will find every page in the 28 lessons written so simply that anyone can understand them and put the principles, methods and rules into practice at once with noticeable results right from the very start.

## Meant for You

There are over 75,000 people in all walks of life who own "Power of Will." Among them are such master men as Judge Ben B. Lindsey; Supreme Court Justice Parker; Wu Ting Fang, ex-U. S. Chinese Ambassador; Lieut.-Gov. McKelvie of Nebraska; Assistant Postmaster-General Britt; General Manager Christenson of Wells-Fargo Express Company; E. St. Elmo Lewis, now Vice-Pres. Art Metal Construction Company; Gov. Ferris of Michigan, and many others of equal prominence.

Never in the history of self-help literature has there been such a record. And the owners regard it as a veritable text book. It has been instrumental in changing the entire lives of thousands—making them dominant personalities, self-confident and eager, in place of the fearful, unhappy, unsuccessful men and women they formerly were. No matter what your position—whether an errand boy or the president of a mighty corporation—no matter what your age, from 17 to 70, Power of Will can change your whole life—can make a new man of you just as it has for so many others. Whatever you want in life is yours, be it money, power, prestige or happiness, if you but master the wonderful system of will training taught in "Power of Will."

## Send No Money!

Although "Power of Will" is a 400-page leather bound book containing more material than many \$25 correspondence courses, the price is only \$3. The publishers will gladly send a copy free, for five days' inspection.

Send no money now. Merely mail the coupon on the right, enclosing your business card, or giving a reference. If you decide to keep the book, send the money. If not, mail the book back. Tear out and fill in the coupon now, before you turn the page.

Name.....

Address.....

City.....State.....

Gentlemen—Please send me a copy of "Power of Will" on approval. I agree to remit \$3 or remail the book in 5 days.

Pelton Pub. Co.,  
13-F Wilcox Block  
Meriden, Conn.



Pelton Pub. Co. 13-F WILCOX BLOCK  
MERIDEN, CONN.

### Partial Contents

The Law of Great Thinking.  
The Four Factors on which it Depends.  
How to develop analytical power.  
How to think "all around" any subject.  
How to throw the mind into deliberate, controlled, productive thinking.  
Detailed directions for Perfect Mind Concentration.  
How to acquire the Power of Consecutive Thinking, Reasoning, Analysis.  
How to acquire the skill of Creative Writing.  
How to guard against errors in Thought.  
How to drive from the mind all unwelcome thoughts.  
How to follow any line of thought with keen, concentrated Power.  
How to develop Reasoning power.  
How to Handle the Mind in Creative Thinking.  
The secret of Building Mind Power.  
How the Will is made to act.  
How to test your Will.  
How a Strong Will is Master of Body.  
What creates Human Power.

### What Users Say

"I hand you \$3 in payment; from what I have already seen I believe I can get \$300 to \$30,000 worth of good out of it."—C. D. Van Vechten, General Agent, No. West Life Ins. Co., Cedar Rapids, Ia.

"'Will Power' is a compilation of mighty force. My first week's benefit in dollars is \$900.00—cost \$3.00; profit \$897.00."—J. W. Helstand, 916 Tribune Bldg., Chicago, Ill.

"In my judgment 'Power of Will' is wonderful."—Owen J. McCaughey, Secy. of Corp. Securities Co., St. Louis, Mo.

"Enclosed find check; send 15 copies to our New York Office."—W. M. Taylor, Efficiency Expert the Overland Auto Co., Toledo.

"The character of 'Power of Will' is such that he who reads and puts forth effort will soon find himself out of the common herd."—F. A. Good, Pres. of Neb. Lumber Dealers' Assn., Cowles, Neb.

"I have carefully gone over 'Power of Will' and find it admirable."—Chas. Olin, Editorial Rooms, Boston Evening Transcript, Boston, Mass.

Please Mention Popular Mechanics

## "A Train Load of Books" What Clarkson is Doing for the Book Buyer



Because, I have no agents and sell you just the books you want—all new—many at a saving of from 50 to 90 per cent—you examine the books in your own home for five days before paying for them. If not satisfied, return them at my expense—and—owe me nothing.

### Sample Prices:

Five Little Peppers and How They Grew, My price, 25c.  
Their Yesterdays, My price, 35c.  
Brady's Government Collection of Civil War Photographs, Publishers' price, \$1.50. My price, \$1.45.  
Bookkeeping at a Glance, My price, 25c.  
People's New Census Atlas of the World, Publishers' price, \$4.00. My price, 50c.  
The Arithmetic Help, Publishers' price, \$2.00. My price, 15c.

Here are De Luxe Editions, Morocco bound, complete works, many of them at less than 25 cents on the dollar. Hugo, Kipling, Poe, Eliot, Dickens, Thackeray, Scott and scores of others.

### Get My Big, New Catalogue

My new catalog, sent free for the asking, tells you how to save 50 to 90 per cent on thousands of books. It is a course in literature, giving nationalities, date of birth and death of authors, the author's life and standing in literature, etc. Hundreds of sets and thousands of single volumes listed.

I sell more books direct to the booklover—the individual reader—the rich man who insists upon his dollar's worth—the man who watches his pennies—and sell them for less money than any other man in America. Every book new and fresh, and guaranteed to please you—you to be the judge. I do not quibble, and would rather have a book or set of books returned at my expense than to have a dissatisfied customer.

**David B. Clarkson, The Book Broker**

344 Clarkson Building,

Chicago, Illinois

In several hundred thousand libraries in the homes of people in every walk of life—from the day laborer to the college professor and high government official, from the persons who buy a few books of popular fiction to the persons who pride themselves on having the complete works of all the standard authors in De Luxe Editions artistically printed and bound almost every book was bought from me. WHY?

Koran of Mohammed, Publishers' price, \$1.50. My price, 45c.  
Wild Animals of North America, Publishers' price, \$3.00. My price, 45c.

Napoleon's Military Career, Publishers' price, \$5. My price, 45c.  
Boston Cooking-School Cook Book, My price, \$1.35.

What All Married People Should Know, Publishers' price, \$3.00. My price, 75c.

Law Without Lawyers, Publishers' price, \$2.00. My price, 45c.



## Typewrite the New Way 80 to 100 Words a Minute Guaranteed

Totally new system. Based on *Gymnastic Finger Training!* Brings amazing speed—perfect accuracy—**BIG SALARIES.** Easy for anyone. First day shows results. Learn while working. **48-Page Book Free** Illustrates and explains all. Gives letters from hundreds with salaries **doubled and trebled.** A revelation as to **speed and salary** possible to typists. Postal will do, but write today—**NOW.** **Tulloch School of Typewriting, 103 College Hill, Springfield, Ohio**

SEND  
FOR  
FREE  
BOOKS



## DO YOU WANT TO KNOW HOW TO DEVELOP VITALITY, ENERGY, ENDURANCE, NERVE STRENGTH, MUSCULAR STRENGTH PERFECT PHYSIQUE?

My FREE BOOKS, "The 'Whys' of Exercise" and "The First and Last Law of Physical Culture," tell you, if you are weak or underdeveloped, how to grow strong; if strong, how to grow stronger. They explain how to develop lungs and muscle, the strong heart and vigorous digestion—in short, how to improve health and strength internally as well as externally. Send TO-DAY—NOW—for these FREE BOOKS. Enclose 4c in stamps to cover postage.

**PROF. H. W. TITUS,** Department 134  
56-58 Cooper Square, New York City

## Rider Agents Wanted

in each town to ride and show a new 1918 model "RANGER" bicycle. Write for our liberal terms. **DELIVERED FREE** on approval and 30 days' trial. Send for big free catalog and particulars of most marvelous offer ever made on a bicycle. You will be astonished at our low prices and remarkable terms. **FACTORY CLEARING SALE**—a limited number of old models of various makes, \$7 to \$12. A few good second-hand wheels \$1 to \$8. Write if you want a bargain. Tires, lamps, wheels, sundries, parts, motorcycle supplies of all kinds at half usual prices. Write us before buying. **MEAD CYCLE CO., DEPT. P108, CHICAGO**



## 200 KINDS Iron, Wood, Wire & Steel PUZZLES

Catalog and 2 wire loaders and  
trick card only 10c.  
**WESTERN PUZZLE WORKS**  
ST. PAUL, MINN.

## 150 Parodies on Latest Songs 10c

Norway, Anah, O'd Green River, Come Back Dido, Bow-Down Bay, Down Home In Tenn., Down Among the Sheltering Palms, Tully Time In Holies, Dublin Bay. It's a Long Way to Tipperary, I Didn't Know My Boy to be a Soldier, Yule, Little Spark of Love, When You Were a Tally, Michigan, Night in Dreamland, Monday, International Rag, In My Haven & 131 others, including Comic Dialogs, complete 10c; 3 for 20c.

**J.C. DORN, 731 S. Dearborn St., Dept. 155, Chicago, Ill.**



## OSCAR A. FORS PRINCIPAL

and help you pay for your course. Mr. O. A. Fors who is the author of this course and who is recognized as an expert will personally instruct you in this money making profession. Particulars and booklet free. Explains everything. Write today.

The School with a METHOD.

**ILLINOIS SCHOOL OF LETTERING & DESIGN**  
Dept. B, 187 N. Clark Street, CHICAGO, ILLINOIS

## Do You Want More Money?

Learn the art of Sign and Showcard Writing. Branch of Advertising. Men and women make big money. Personal instruction and original methods (copyright) make you expert.

**\$6.00 PER DAY OR MORE**

is the union scale in Chicago and other towns. You can make even more on job work. Have a big business of your own. We show you how by mail.

Mr. O. A. Fors who is the author of this course and who is recognized as an expert will personally instruct you in this money making profession. Particulars and booklet free. Explains everything. Write today.

The School with a METHOD.

**ILLINOIS SCHOOL OF LETTERING & DESIGN**  
Dept. B, 187 N. Clark Street, CHICAGO, ILLINOIS

## Get Into a Business that Pays Big Money

Driving \$80 to \$125 a Month — Repairmen and Salesmen \$300 and Up!

Lots of driving and touring jobs now open in all large cities and good chances (if you are ambitious) to start a garage, do repairing, sell cars, etc. 1,000,000 more automobiles this year than last. Every small town in the country needs a Real Expert Auto Repairman. We teach you—and we do it right—the way you would like to learn. We put you to work in overalls, with tools, on all kinds of automobiles, in a real shop and garage. Plenty of actual driving and repairing. Our method is down-in-the-grease—and out-on-the-road. No time limit—you stay till you learn thoroughly and are perfectly satisfied. Here is a chance to "Double Your Pay." If you are out of work or dissatisfied with your present job, change now—Get into

**THE COMING BUSINESS**  
**NATIONAL AUTO SCHOOL**

2625 Reading Rd.,  
CINCINNATI, O.



Write your name and address on margin of this page, tear out and mail to us—we'll send you our catalog and full information.

# TRAFFIC

The Chain Connecting  
Producer and Consumer

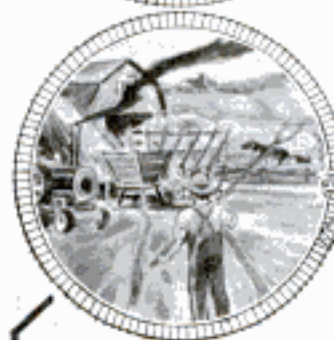

**Efficient Traffic Men Earn  
From \$2,000 to \$40,000 Yearly**

## Young Man, You Have As Much Brains As These High-Salaried Men. Your Brains Simply Require Proper Training

Heretofore Traffic Knowledge could be secured only through years of tedious experience. YOU can now easily acquire this highly profitable knowledge in a very few months, and EARN A BIG SALARY FOR LIFE through membership in the AMERICAN COMMERCE ASSOCIATION. Right now the railroads and shippers are in urgent need of 100,000 trained traffic men. There are 500,000 business concerns in the U. S.—50,000 of these pay freight bills of \$5,000 and over, yearly. Over 2,000 Million Dollars is paid as freight each year to 1,000 railroads. Transportation is the largest single business in the U. S. and employs over 4,000,000 men. Each day it grows bigger. It is the basis of commerce—the life-blood of business. It is interwoven through all the processes of commerce and industry. There is no "fixed" salary for efficient managers—YOU are worth just what you can earn. A number of Traffic Managers receive yearly salaries of \$25,000 to \$40,000. Thousands receive \$2,000 to \$5,000.

### Your Salary in Five Years From Now

Don't envy the man higher up—climb up yourself. Your spare time is worth \$30 per hour—are you wasting it? Use these valuable hours in easily acquiring traffic knowledge. Don't stand still—climb! In five years you can be earning each week your present monthly salary. You can acquire this traffic knowledge in one year. Efficient traffic men receive what they are worth—there is hardly any limit. The AMERICAN COMMERCE ASSOCIATION is a national organization of Trained Traffic Men.

### Traffic Knowledge Earns Big Salaries

The expert traffic man earns his own salary many times over. Transportation either makes or breaks a business. The right places are eager for the right men. Thousands of trained men are needed NOW in the traffic departments of railroads, express companies, and industrial concerns. It is easy to learn in a few months what required numerous experts a life time to learn through actual experience. The cost is less than you should be making in a few years in a single week.

### Note These Opinions About the A. C. A.

Mr. H. G. Wilson, President of The National Industrial League: "Your Association is better equipped to advance the efficiency of traffic men than any other." Mr. A. T. Waterfall, Traffic Commissioner, Detroit, Mich.: "You are to be congratulated on this splendid and important work." Mr. F. A. Barber, Chief of Tariff Bureau, Wabash Railroad: "I do not see how anyone can help but be greatly benefited thereby." Let us send you copies of letters of approval received from dozens of America's foremost traffic men.

## Get Ready to Earn \$200 to \$1,000 Monthly JOIN THE AMERICAN COMMERCE ASSOCIATION

Use your spare time in becoming Traffic Expert. It costs little, is easy to learn, and the work is fascinating. You will enjoy big rewards all your life. You have the brains—fill them with "cashable" knowledge. Look ahead! The years are slipping by fast. Our practical method will make you efficient in a few months. You won't have to neglect your present duties. It is the biggest and best opportunity you have ever had. You will have the assistance of many of America's most prominent traffic men. Your success depends upon your taking advantage of the experiences, technical knowledge and co-operation of these men. After completing your course if you are not entirely satisfied with its value we will refund your money.

**Ask For This Free Book** Simply sign and mail the coupon and we will send you a FREE

COPY of "Opportunities Along The Trails of Traffic" by H. G. Wilson, President of the National Industrial Traffic League. It is intensely interesting and informative. We will also send you full information about becoming a member of the National Fraternity of Traffic Experts. Don't hesitate—act quickly! Clip, sign, and mail coupon—NOW!

**American Commerce Association** Dept. 24, "The Roostery"  
CHICAGO, ILL.

**American  
Commerce  
Association**  
Dept. 24, "The Roostery"  
Chicago, Ill.

Please send me, entirely  
with no charge or obligation,  
H. G. Wilson's book, "Opportunities Along the Trails of Traffic"—  
also explain how your course in  
Traffic Efficiency will train me to become  
a traffic expert.

Name.....

Address.....

Age..... Occupation.....

City..... State.....



## Sennacherib

King of Assyria, 2,600 years ago, inscribed, on sun-baked bricks, his own story of his great siege of Jerusalem, mentioned in the Bible. This curious and ancient record tells also how Sennacherib "made Nineveh splendid," how he constructed irrigation systems and city water-works. But Sennacherib is only one of the thousands of world leaders, thinkers, inventors, and discoverers who tell in their own words of their marvelous achievements and experiences in the great work—

## The Library of Original Sources

(10 beautiful, massive, leather bound volumes)

In this wonderful library Tacitus, for example, tells how he saw the Christians burned before Nero, Plato tells how he watched Socrates drink the death-cup of hemlock. Galileo describes his emotions when looking at the stars through the first crude telescope, and in the same way thousands of others give the inside facts about themselves and the great events they witnessed and took part in—facts which the ordinary history never even mentions. Every account is in the exact language (translated) of the original manuscript, papyrus, clay tablet or inscribed cylinder; every contribution is from an actual eye-witness or participant.

## A GREAT BARGAIN!

Send us the attached coupon AT ONCE, and we will tell you how to get the Library on EASY MONTHLY PAYMENTS, and mail you FREE a book of rare documents showing curious inscriptions of the Ancients. There are only a limited number of sets, so act quickly. Mail the coupon NOW. You assume no obligation. No salesman will call. The book is FREE.

**THIS MARVELOUS WORK** gives the authoritative, rock-bottom sources of our knowledge on ALL SUBJECTS OF HUMAN INTEREST from the earliest civilization down to today—the inside facts which the average person has never even heard of.

OVER 100 RESEARCH SPECIALISTS spent 10 years gathering the contents of this great work. Ancient and remote civilizations in all parts of the globe, age-buried hieroglyphics on monuments, tablets and sun-baked bricks yielded their secrets; untiring workers ransacked the hidden literature of every age, to find these "original documents." Nothing like it has ever been attempted or thought of before. You'll be amazed at the wealth of information this unique library contains.

### MAIL THIS COUPON FOR FREE BOOK

UNIVERSITY RESEARCH, Dept. G, P. M. 3-16  
Milwaukee, Wis.

Send me the FREE book of rare documents showing inscriptions of the Ancients and tell me of your easy payment offer. I assume no obligation, the book and all you send me is to be free, and no salesman is to call.

Name .....

Address .....

# FREE BOOK

## How To Study Music

### Learn Piano 4 Times Faster and Better!

Our interesting 64-page free book shows the keen delight which a musical training will bring you; and how you can obtain this training easily and thoroughly in your own home at one-quarter the usual cost. It explains the social advantages of musical accomplishment, and tells how you can greatly increase your earning power by professional playing or by giving musical instruction in your spare time. It fully describes a method of home study which brings you all the comprehensive features of the best foreign conservatories, at less than 43 cents a lesson. All music furnished free. Write for this valuable book today. It is free.

### Dr. Quinn's COURSE IN PIANO or ORGAN

by the written method, has revolutionized the study of music. By the use of Dr. Quinn's remarkable device, the COLOROTONE (patented) you save three-quarters of the time and effort usually required for learning piano or organ. You play chords immediately and a complete piece, in every key, within a few lessons. The method is scientific and systematic, yet practical and simple. It is endorsed by leading musicians and heads of state conservatories. Equally effective for children or adults, beginners or experienced players. Practice in spare time, whenever convenient. Successful graduates everywhere. Diploma granted. Special reduced terms this month. Investigate without cost or obligation by writing today for free book, "How to Study Music."

QUINN CONSERVATORY, Box 650KO, CHICAGO

CORRESPONDENCE COURSE ON	Freehand Lettering	FOR DRAFTSMEN AND STUDENTS
Don't you want to draw a larger salary each week?		You certainly do. I offer you an absolutely sure way.
Become an Expert on above subject through my Standard System of instruction by mail. Personal criticism by recognized authority. 25 yrs. experience. Inquire or send \$1 for trial lesson.		
C. W. REINHARDT, ARLINGTON, N. J.		

## 300 Songs 10c

IF I HAD A HOME, SWEET HOME; Down Among the Sheltering Palms; Sailing Down the Chesapeake Bay; When I Was a Dreamer; There's a Mother Old and Gray; It's a Long, Long Way to Tipperary; Come Over to Dover; When I Dream of Old Erin; Chinatown; Casey Jones; Sing Me the Rosary; Silver Bell; Red Wing; Silver Threads Among the Gold; California and You; When Maple Leaves are Falling; When I Lost You; This is the Life, etc. Over 300 Song Hits and PIANO MUSIC for only 10c., 3 lots 20c.

ENTERPRISE MUSIC CO., 3348B17 Lowe Avenue, CHICAGO

## OLD AGE CAUSE AND CURE

Are you feeling the signs of old age—stiffening joints, weak eyes, rheumatic pains, poor memory, loss of mental force, weak digestion, lessening bodily powers? A man, young at 75, has a message of untold value for you! Write for our free booklet—or we will send you instructions, book and magazine. Keep the book five days. If you like it, send us your check for \$2.00 for book and a year's subscription to *Physical Culture Magazine*. If not, return the book only and owe us nothing. Address

PHYSICAL CULTURE PUB. CO., 2613 Flaming Blg., New York

## Learn Drafting

Individual study at home may be successfully engaged in with the aid of our new enlarged book

### A Practical Course in Mechanical Drawing

Cloth. 160 Pages. 157 Drawings. Price, 50c Postpaid.

POPULAR MECHANICS BOOK DEPT., 6 X. Michigan Ave., CHICAGO



**SALESMEN  
GET THE  
BIG PAY**



**You can learn sales-  
manship and have  
an opportunity to  
EARN MORE MONEY  
than you ever did be-  
fore—while  
learning**

# BE A TRAVELING MAN

## EARN \$2,500 TO \$10,000 A YEAR

Travel on the finest trains; see the wonders of America; live at the best hotels; wear the latest clothes; interview successful merchants; earn the best salary; save money; be independent.

Everywhere there is an unlimited demand for Trained Salesmen. You can be one. You can learn at home in your spare time and have an opportunity to earn Big Pay while you learn. My easy, practical Course of Instruction in Scientific Salesmanship requires only a very little of your time—an hour or so each day—for a surprisingly short period, to prepare you to fill a position as a Salesman—and my big Free Employment Bureau will assist you to secure a position where you should easily earn more money than you ever before dreamed possible.

My Big Free Illustrated Book, "A Knight of the Grip" tells the whole story. Send for it today. Learn first-hand, and now, just how easy it is for you to fit yourself at your home in spare time, to become a successful prosperous Salesman. Learn how my easy, practical Course fits you to earn more money, and earn it easier, in a single week than most men earn in a whole month. Thousands of men everywhere (like those whose testimonials we publish herewith) have accepted this invitation to "Learn How to Sell," and as a result are today holding permanent, pleasant, big-paying positions as Salesmen, representing the biggest firms in America.

I have received requests from more than 15,000 of the biggest and best firms in America for Trained Salesmen—men I had trained and could personally recommend as competent, and capable of filling good paying positions as Traveling Salesmen. These firms employ thousands of Salesmen every year and are constantly calling on me to supply them. I merely mention this to emphasize the unlimited demand of the business world for Trained Salesmen, and the fact, too, that good Salesmen are always sought instead of the seekers; always the makers of terms and the dictators of salaries. They are the most independent, best paid body of men in the world.

There is a position as a Salesman ready for you—a good position where your Earning Power will be unlimited—when you are ready for it. Prepare yourself now.



**Earns More Than \$100 in a Day**

I took your Course two years ago. Was earning \$15 a week clerking. Am now selling many of the largest firms in the U.S. I have earned more than \$100 in a day. You secured me my position. Our Sales Mgr. is a graduate of yours.

J. L. DEBONIS,  
2635 S. Halsted  
St., Chicago, Ill.

**I am in the \$2,500 to \$10,000 Class**

I was a carpenter, am now a Salesman and can proudly say I am in the \$2,500.00 to \$10,000.00 a year class. Wish could invest more dollars that would bring me the big returns those invested in your Course did.

J. E. WOOD,  
Home 352-54  
Pacific Bldg.  
San Francisco,  
California

**I Made \$200 and Expenses the First Month**

Any ambitious man can become a Salesman and increase his earning power by taking your Course. Your Employment Bureau is a dandy. I had no trouble in securing a good position and will be delighted to be for the N. S. T. A.

J. E. WHITE,  
P. O. Box 1812  
Great Falls,  
Mont.

**I Earned \$6500 This Year**

Last year I only earned \$500.00 as a clerk. This year I have earned \$6500.00 and have been promoted to Salesman and done it by studying your Course during spare time. Your Employment Bureau offers one many good positions.

C. W.  
Birmingham,  
824 S. Center St.  
Henderson Ky.

**Increased Earnings \$300 First Month**

Have derived great benefit from your Course already. Before I enrolled I only earned \$70.00 a month. Your instructions have enabled me to earn over \$270 this month. They will help an old Salesman as well as a beginner.

Max B. Yucht,  
67 E. 114th St.,  
New York, N.Y.

**You Make Your Promises Good**

Was formerly a telegraph operator. Am now a salesman thanks to you. My earnings are more than I ever before thought possible. I cover Penn., N. J. and Del., calling on the big trade—Refer anyone to me.

A. M. LAWLER  
E. Conshohocken, Pa.

*W. M. Dugheerty*

**SEND FOR THIS  
BIG FREE BOOK  
NOW**



**THIS  
FREE  
BOOK  
TELLS  
THE WHOLE  
STORY**

**FREE**

## BE A WINNER—START TO-DAY

You can't give one single, sane reason why you should not be able to earn more money—several times more—than you are now earning, unless it is that you have failed to prepare yourself. This is true, and you know it. You know, too, that no profession offers such wonderful money-making possibilities as does that of Salesmanship. In no profession can one earn so much money, be so independent, or broaden so rapidly as in Salesmanship. It's training that counts—just such a Training as you can get from my Easy Common Sense, Thorough, Practical Course of Instruction in Salesmanship that has enabled thousands of other men to make a success.

The reason for the tremendous demand for our graduates is that they are Trained Salesmen—the kind that make good and that every firm wants and that there is an unlimited demand for, and that get the Big Pay. You can become one of them. Learn how by filling out the coupon and mailing it Today. Our free book, "A Knight of the Grip," tells the whole story; it also contains hundreds of testimonials from our graduates who earn from \$100 to \$1000 a month and a big list of the different lines of business in which there are now good openings for Salesmen—offering opportunities to earn \$2500 to \$10,000 a year.

**NATIONAL SALESMEN'S TRAINING ASSOCIATION**  
DEPARTMENT 507B  
CHICAGO • NEW YORK • SAN FRANCISCO

**MAIL THIS COUPON NOW**

National Salesmen's Training Association,  
Chicago San Francisco  
(Send your request to the office nearest your home).  
With no obligation on my part, please send me your big  
FREE Illustrated Book—"A Knight of the Grip."  
Name.....  
Street No.....  
Town.....State.....  
507B

# YOU Can Earn \$2000 a Year



The demand for trained engineers at \$2000 to \$5000 a year becomes greater every day. Any man with engineering training can practically demand his own price. NOW—as never before—is the time to enter a profession that pays big money—a profession in which the demand for trained workers far exceeds the supply.

The **American School** will make you an expert engineer in a short time at small expense. Our staff of experienced engineers will give you individual instruction and advice. No previous experience necessary. You can start in immediately to prepare yourself for one of the countless high-salaried positions always open. You run no risk—we **guarantee** you more pay.

**Earn While Learning** No need to give up your present occupation. We train you at home—solely by correspondence—as we have successfully trained thousands of others in the past nineteen years. Pocket-size text books enable you to study anywhere—at any time. Papers examined and corrected only by technical experts. Most thorough correspondence instruction in America.

## \$40 Drafting Outfit and Library FREE

First of all we will teach you drafting—the foundation of all engineering professions. We will give you a \$20 drafting outfit and a \$20 drafting library (4 vols.) **ABSOLUTELY FREE!** Then, after you have mastered drafting and are getting actual working experience as an engineer's draftsman, we will train you in your choice of Civil, Mechanical, Structural or Architectural Engineering. Thus, for a little more than the cost of a course in drafting alone, you get the training that enables you to fill a responsible, well-paying position as engineer. **Be sure to investigate this offer if you have been thinking of enrolling in any drafting course.**

### Free Book Coupon

American School of Correspondence, Chicago, U. S. A.

Without any obligation on my part, please send me full particulars of your Engineering Offer and a copy of your 248-page Free Book. I am interested in a course in  
 Architectural  Structural  Mechanical  Civil Engineering.  
 Pop. Mech. 3-16

NAME.....

ADDRESS.....

### Engineering Book FREE

Send the coupon today for your copy of our 248-page Free Book. Tells how easy it is to become an engineer, and gives full particulars regarding the course you are most interested in. **Don't hold back because of the money. The cost is small, and you can pay for your instruction as you progress—in small monthly installments.**

Mark and mail the coupon today. This is a wonderful opportunity to get into a profession in which the possibilities for advancement are unlimited. No obligation, so mail the coupon **now!**

**AMERICAN SCHOOL OF CORRESPONDENCE, CHICAGO, U. S. A.**

**BEGIN NOW!**



## Paint Signs and Show Cards

### Earn \$25 to \$75 Weekly

Become an expert in the fast growing field of commercial art. Command a real job—be a leader—get to be an art director at a fine salary. Publishers, printers, engravers, lithographers, advertisers, merchants, manufacturers, calendar makers, box makers, etc., must have letterers and designers, show card and sign writers.

### UNLIMITED DEMAND FOR TRAINED ARTISTS

The field is wide—and getting greater. Enormous increase in advertising constantly creates new positions. Fascinating work. Course simple—easy. You get my personal experience and guidance. Experience or talent unnecessary. Just practice. Only short time required to learn. Earn money after ninth lesson. I help you get a position when ready. Get out of the rat—aspire to bigger things—quit working where chances to rise are few. **Get into big, new, growing and big-salaried new field.**

**Free Booklet—Send Coupon Today** It tells the whole story—proves the field and the money in it. At least investigate. Mail the coupon. Find out what you can do.  
**THE ROSING SCHOOL OF LETTERING & DESIGN**  
 723 Union Building CLEVELAND, OHIO

**Mr. Rosing:**

Please send me free booklet and your proof.

Name.....

Address.....

Please Mention Popular Mechanics

# YOU CAN OCCUPY THIS CHAIR

All the information you need to get there

The Power Plant Library Will Tell You How to Become Chief Engineer. These Books Are Self-Teachers. You Avoid the Expense of an Instructor. You Save Time. You Get Facts About Actual Practice First Hand

## The Power Plant Library

**Power Plant Engineering COMPLETE** Including Steam, Electrical, Turbine and Refrigerating Engineering

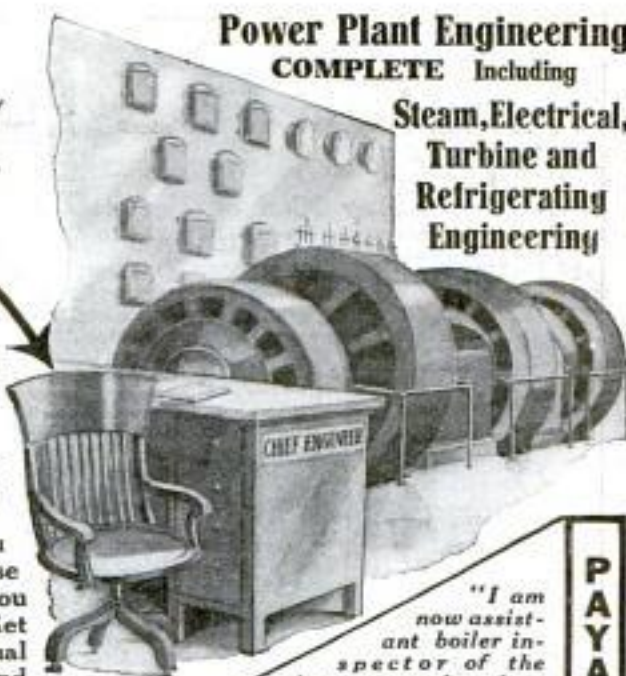

"I am now assistant boiler inspector of the largest powder plant in the world."

McGraw-Hill Book Company, Inc., 239 West 39th Street, New York  
GENTLEMEN: By the use of the Power Plant Library I have advanced to Assistant Superintendent of Boilers for the Dupont Company, Hopewell Works, City Point, Virginia, the largest powder plant in the world. We have here ninety-eight boilers of 550 H. P., which are run at nearly fifty per cent. over rating.  
W. S. RUMFELDT

PAYABLE \$1 PER MONTH IF WANTED

**8 Handy Volumes, 5 1/2 x 8 1/2 in., as follows:**

Practical Mathematics—650 pages. Power Catechism—280 pages (questions and answers on engine running). Valve Setting—210 pages. Boilers, Pipes, Pumps—450 pages. Shafting, Belting, Governors—200 pages. Electrical Catechism—430 pages (an electrical education—questions and answers). Steam Turbines—186 pages. Mechanical Refrigeration—180 pages (including ice making).

**The Power Plant Library is Now the Most Used Engineers' Library in Existence for the Following Reasons:**

Unlike the average technical book, they were written by practicing engineers—leading men in the profession. The eight volumes cover every phase of power plant work, including steam, electricity, turbines and refrigeration—from the simplest duties of the beginner to taking charge of the largest plant. Each subject is treated separately and fully, there being fourteen complete parts. Each item of information in the nearly 3000 pages is directly applicable to actual work in the power plant. There are about 1500 illustrations and drawings, each specially made for these books. There is not a line in the entire eight volumes beyond the understanding of even the man with a limited education.

**Quality of Make**

The eight volumes in the Power Plant Library represent the best in the arts of printing and binding. Size of books 5 1/2 x 8 inches. The books are printed on superfine calendered paper. The type is medium large. Each volume is bound in dark blue Interlaken extra cloth of the tough H pattern, the best to be had. The titles are printed in gold on dark red labels, and the library title is die stamped on front covers. These books are built to last a life time, and are an ornament to any book shelf. Weight about 14 lbs.

**Get It All at One Time**

Instead of buying an occasional book on steam, electricity, turbines or refrigeration, why not get one complete library covering all the information that the power plant engineer must have? From the Power Plant Library nothing has been omitted—nothing has been left to guess-work. No problem in power plant practice is too difficult for you after you have adopted the Power Plant Library as your guide and manual. Whether you are now an engineer earning \$1500 or \$5000 per year, or a beginner—or expect to take up the work—we would like to send you these eight volumes for **FREE INSPECTION**. No matter how much you earn or how much you wish to earn, these books will help you from the very beginning. They can be depended upon absolutely, because they were written by unquestioned authorities, and have been corrected until they are practically perfect.

*McGraw-Hill Book Co., Inc.*

Publishers of Books for Engineers Since 1876  
239 W. 39th Street, NEW YORK

SENT TO YOU PREPAID ON TRIAL

NOT ONE CENT IN ADVANCE

**There Are Near 500,000 Power Plant Engineers in the United States**

The demand for efficient, trained operators is never fully met. With the many new developments in the manufacturing world, where steam, electricity, turbine and refrigerating apparatus are always a part of these improvements, the position of the engineer is more and more becoming an enviable one among the professions of today. The principal demand now is for men with a wide range of knowledge—men who can direct and supervise the entire power plant—men fully conversant with both apparatus and operating expense—those who are able to minimize the latter. The man with these qualifications is constantly sought.

**Instruction Books Must Be Standard**

It is no longer possible to gain this wide range of knowledge and enter these responsible positions through practice alone, for the simple reason that the duties of the beginner, the oiler, the fireman, the electrician or the assistant engineer, do not take him beyond a certain limited scope of work. Study is necessary. But study is usually wasted if devoted to the writings of those unfamiliar with the subjects involved, where theory is too apt to supplant practice.

**The Power Plant Library Is Standard**

For forty years we have studied the needs of the progressive power plant engineer. This Library is the cumulative result of our experience. We have concentrated our efforts toward simplifying for the power plant man all the problems met with in the course of his work. This Library is now known and used as a daily guide in nearly every plant in the country, but there are thousands of other power plant men—and those expecting to take up this work—to be supplied, hence this announcement in Popular Mechanics. This Library is endorsed by thousands of highly paid men as being the direct means of their advancement. It will save you years of experience at low pay. With its aid you can jump to the big position in a small fraction of the time usually required.

**We Trust You — Return Coupon Today**

**FREE EXAMINATION COUPON**

McGraw-Hill Book Co., Inc., 239 W. 39th St., NEW YORK

Gentlemen: Ship the Power Plant Library, eight volumes, for my inspection. If satisfactory after examination, I will send you \$1 in ten days and the balance at the rate of \$1 per month until I have paid the price of the books, \$12. If not satisfactory I will write for shipping instructions.

Signature .....

Residence Address .....

City and State .....

Name of Employer .....

Reference .....

Address .....

## The World's Greatest \$1.00 Practical Electrical Books

By Horstmann, Tousley, Moreton, Lowe  
Fit You for Any Kind of Electrical Work



Written in non-technical language. You don't need a college education to understand them. They are strictly up-to-date in every respect and uniform in type, illustrations, diagrams and binding. A whole electrical library at \$1.00 per vol., postpaid. These books have never been sold at less than \$1.50 and \$2.00 a volume.

All bound in limp cloth, uniform, pocket size, 4½ x 6¼ in.

### Modern Electrical Construction

By HORSTMANN AND TOUSLEY. 440 pages, 268 illustrations.

### Drake's Telephone Handbook

By PROF. MORETON OF ARMOUR INSTITUTE. 286 pages, 161 illustrations and diagrams.

### Armature and Magnet Winding

By HORSTMANN AND TOUSLEY. 260 pages, 153 diagrams and illustrations.

### Electrical Tables and Engineering Data

By HORSTMANN AND TOUSLEY. 300 pages, 150 diagrams, tables and illustrations.

### Drake's Electrical Dictionary

By P. E. LOWE. 320 pages of electrical words, terms and phrases, carefully defined and explained.

### Electricians' Operating and Testing Manual

By HORSTMANN AND TOUSLEY. 300 pages, 211 illustrations and diagrams.

### Electrical Measurements and Meter Testing

By PROF. MORETON. All meters carefully described. 328 pages, 191 illustrations and diagrams.

### Modern Electric Illumination

By HORSTMANN AND TOUSLEY. 274 pages, 40 illustrations and diagrams, 21 tables.

### Wiring Diagrams and Descriptions

By HORSTMANN AND TOUSLEY. 300 pages, 230 illustrations and diagrams.

### Electric Motors, Direct and Alternating

By PROF. MORETON. 250 pages, fully illustrated.

### Motion Picture Operation

Stage Electrics and Illusions. By HORSTMANN AND TOUSLEY. 353 pages, 216 illustrations.

### Alternating Current,

Theory, Practice and Diagrams. By HORSTMANN AND TOUSLEY. 300 pages, fully illustrated.

**Guarantee:** We will send post-paid one or all of these books upon receipt of \$1.00 per copy. If after 5 days' examination you are dissatisfied for any reason, return the

book or books and we will refund your money.

Send for our large catalogue of practical mechanical books for Electricians, Engineers, Telephone Men, Machinists, Railroad Men, Automobilists, Carpenters, Plumbers, Sign and Card Writers, Scene Painters, etc. It is

# FREE

**FREDERICK J. DRAKE & CO.**  
Dept. 8, 1325 Michigan Ave., CHICAGO

## A 'Steel Trap' Memory

One that takes a tight grip on facts, figures, names, details of every kind and hangs onto them through life—that's the kind of memory you ought to have and the kind you can have if you will give me ten minutes of your spare time daily for a few weeks. I will make your mind an infallible classified index of the things it is to your advantage to remember—give you power to concentrate, overcome self-consciousness, enable you to think on your feet, and address an audience intelligently without hesitancy and without notes.



The Key to Success



Henry Dickson, Principal, Dickson School of Memory

During the past 29 years I have trained thousands of people to STOP FORGETTING—aided them to greater business and social success—I know positively that the person with a strong, tenacious memory, though he be far behind at the beginning of the race for success, advances and soon outdistances his forgetful rival. The demands of commercial and professional life are so exacting in their details of facts and figures to be remembered, that to succeed or even hold your own you simply must possess a good memory.

### Get My Remarkable Memory Test Free

I've had this test—most ingenious and most exclusive memory test ever devised—copyrighted. I'll send it to you, free, also a copy of my book "How to Remember" and tell you how to obtain a copy of my De Luxe edition, "How to Speak in Public," a handsomely illustrated \$2 book, absolutely free.

**HENRY DICKSON, Principal,**  
Dickson School of Memory, 705 Hearst Bldg., Chicago



## GREENBACKS \$1570 in Stage MONEY For 10c

A bunch of our Stage Greenbacks (not counterfeit) will make your friends stare. \$1570 for 10c or \$4710 for 20c. **HYDE CO., 3346 Lowe Av., Chicago**



## THE BART CHALK-TALK

Entertains an Audience. Educates you in entertaining. If you draw a little you can do the chalk-talk and make it pay. Bart furnishes you with the ideas, the "patent," the drawings to make, and his own special crayon and equipment—everything he uses in a successful chalk-talk. Write **BART**, Daily News Cartoonist, Minneapolis. He will tell you about the chalk-talk. Copy Bart's ad on page 11, March Cartoonist.

# AUTO BUSINESS

## Learn at Home

in spare time by new improved method. I teach you the business thoroughly and show you how you can make big money handling the agency for a high grade light weight touring car, selling at a popular price. Special offer now. Write today for full particulars. Address **Ralph Birchard, President, BIRCH MOTOR COLLEGE, Inc., 319 Tower Building, CHICAGO**



## WILL YOU TAKE FREE

THIS FIRST LESSON IN  
**MECHANICAL DRAWING**  
AND  
**MACHINE DESIGN**

ALSO INCLUDING FULL PARTICULARS AND INFORMATION ON U. S. AND FOREIGN PATENTS.

**QUALIFY TO EARN \$75 WEEKLY**

I WILL MAIL YOU MY FIRST LESSON ON A

**10 DAY FREE TRIAL**

IF SATISFIED

**PAY AS YOU LEARN**

Over 100 Plates of machinery now in use designed by the author. The entire course takes in the cream of my 27 years' work for U. S. and many foreign governments.

**WRITE FOR PARTICULARS AND FREE LESSON**  
CONSULTING ENGINEER **11 WEIGS BUILDING BRIDGEPORT, CT.**

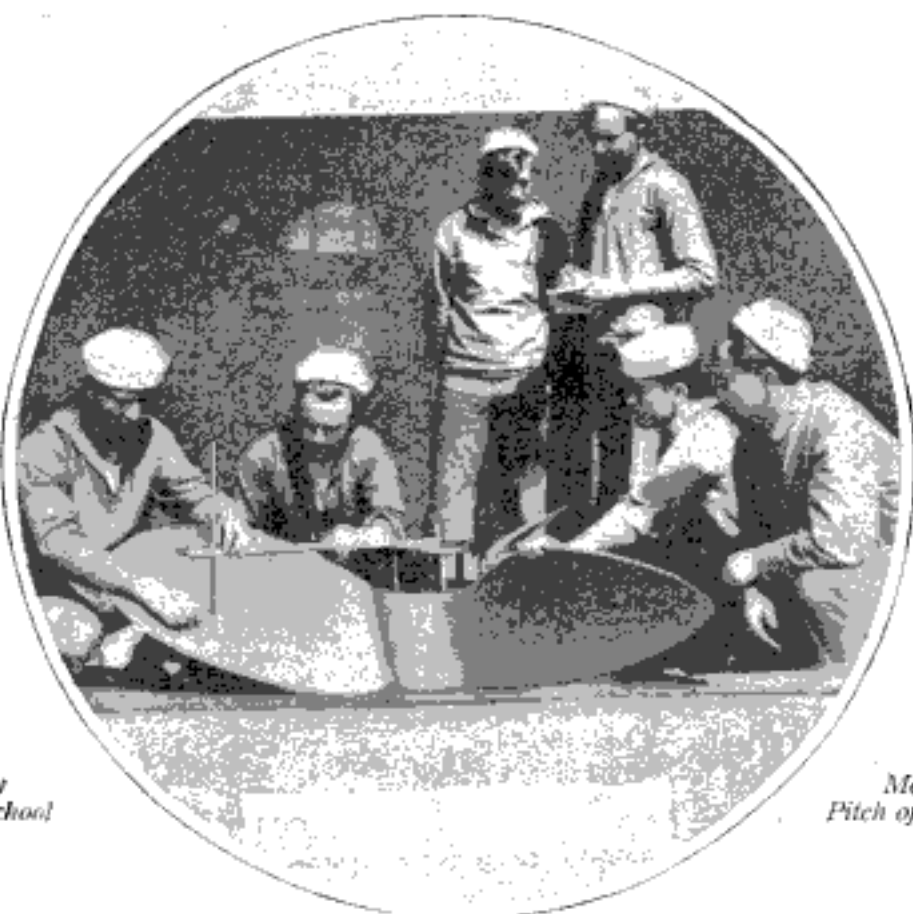

*In the Navy  
Artificer School*

*Measuring the  
Pitch of a Propeller*

## Navy Trades Pay Well

If you are between 18 and 25, ambitious and of mechanical bent, this will interest you:

THE NAVY offers exceptional opportunities for men skilled in mechanical trades. The modern dreadnaught, destroyer and submarine are filled with the most intricate and complicated machinery, requiring expert men in many different trades. Trade schools are maintained by the Navy for the instruction of recruits who show an aptitude for a trade or some special branch of Navy work.

IN THE NAVY you have every incentive to excel in your work; you will find advancement steady and dependent upon your skill and conduct; and you are sure of steady employment and increased pay with each enlistment. Promotion does not stop with the enlisted grades, but continues through the warrant grades and to a commission.

IN THE NAVY you will find the work for which you are best fitted. If you have finished your time at a trade such as machinist, carpenter, coppersmith, etc., you can enter the service at a high rate of pay, the age limit for which is 30 years. If you have but partially completed your trade, you may enlist in one of the lower ratings, and receive a course of instruction at Government expense before being assigned to duty on board ship. Young men between 17 and 25, without knowledge of a trade may enlist as apprentice seamen.

THOUSANDS OF MEN are now enjoying the benefits of good paying positions as the result of Navy training. This opportunity is open to you if you are ambitious.

Apply for particulars at any Navy recruiting station, or address — Box 68

**BUREAU OF NAVIGATION**  
NAVY DEPARTMENT WASHINGTON, D. C.



## Every Amateur Craftsman

has experienced the disappointment of having a beautiful piece of furniture—one on which he has spent many hours—spoiled with improper finishing. **Johnson's Wood Dye and Prepared Wax** are especially adapted for furniture work—they are being used in many of the finest furniture factories. The most inexperienced can use them successfully.

## JOHNSON'S WOOD DYE

is the best stain to use for coloring the wood. It goes on easily, without a lap or a streak—penetrates the wood without raising the grain—is made in 17 standard shades. **Johnson's Wood Dye** is unequalled for staining reed and wicker baskets.

## JOHNSON'S PREPARED WAX

is the proper finish to use over the Dye. It imparts a hard, dry, velvety finish of great beauty and durability. It is impervious to water, dust, scratches, heel marks, finger prints, etc. The finish obtained is sanitary, durable and beautiful.

S. C. JOHNSON & SON, Racine, Wis.

PAS

Please send me free and postpaid a copy of your new 25c Instruction Book containing complete specifications on wood finishing.

Name \_\_\_\_\_

Address \_\_\_\_\_

City and State \_\_\_\_\_

Send this coupon for the new *Instruction Book* telling how to finish new and refinish old work



Please Mention Popular Mechanics

*Inventor*  
*W. Wallace Newcomb, New York*  
*Secretary McCall Co.*  
**Popular Mechanics Magazine**  
*assignor to The McCall Co. Inc.*  
REGISTERED IN U. S. PATENT OFFICE

WRITTEN SO YOU CAN UNDERSTAND IT

*236 W. 37th St.*

Vol. 25 *1655 H*

MARCH, 1916

No. 3  
*New York*

## Optical Device Helps Women Choose Gowns

**T**O assist women in choosing becoming effects when selecting designs for their suits and gowns, a stereopticon apparatus has been developed in the East for displaying patterns. The function of this is to enable a modiste to show a patron exactly how a costume of a certain type

will look upon her when made. It largely eliminates guesswork and re-



The Picture of a Costume Cast upon the Screen by the Projector is Clearly Outlined in the Mirror Immediately below the Reflected Image of the Woman's Head, so That It Appears to Clothe Her Own Figure

lieves a woman of overburdening her imagination by attempting to picture herself in a new creation.

At one end of an unilluminated room with black, nonreflecting walls, a full-length mirror is provided. Some distance in front of this is a screen which may be adjusted to various heights. A stereopticon is mounted in a booth at one side so as to throw images upon the screen. Any picture shown upon the latter is reflected in the mirror.

In making use of the contrivance the patron stands behind the screen, the top of which is level with her chin. A picture of a gown is then projected

in such a way that the mirror reflection gives a composite image of the woman's head upon a body robed in that style of costume. Gowns of different designs may be shown in this manner one after another. A shaded lamp immediately above the screen casts its rays directly upon the patron's head, so that that part of her body is clearly defined in the mirror. At one side a permanently focused camera is provided to enable photographs to be made of the images shown in the mirror in order that a patron may study them carefully at her leisure before having any of them made for her.

### MULTIPLE-DISK PHONOGRAPH INCREASES SOUND VOLUME

Playing two or more phonographs at a time as a means for increasing sound volume has often been tried, but gen-

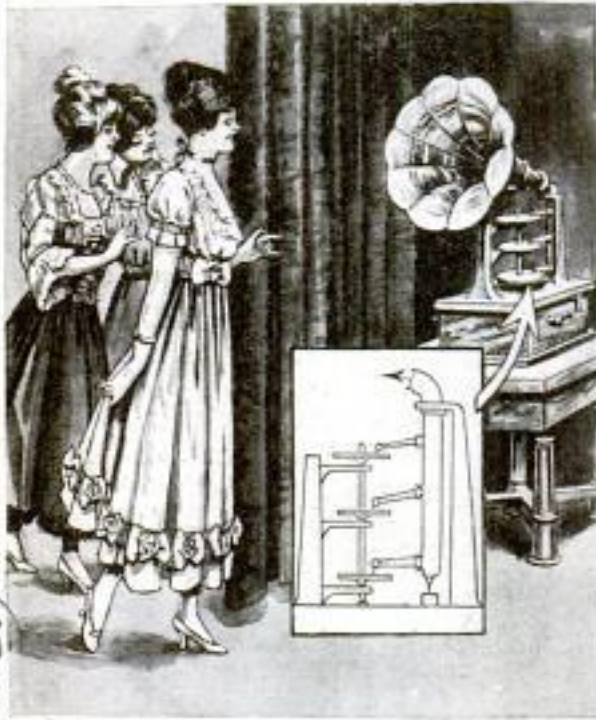

By Playing Disks in Multiple, New Phonograph Produces Great Volume of Sound; a Common Axis Keeps the Disks in Unison

erally with poor success. Only a slight difference in the speeds or timing of the two disks results in throwing the melody into a jarring discord, for one record soon plays far ahead of the other.

To obviate these difficulties, and still secure the larger volume of sound resulting from the use of two or more records at the same time, a Paris inventor has devised a phonograph of a type different from the ordinary kind. All the records are attached to one vertical driving axis, and because of this mechanical connection, must necessarily remain in unison throughout the playing of any given piece. Each disk is provided with its own needle and reproducer. All the sound goes into a common horn by means of suitable connecting arms properly pivoted at the large ends. In addition to greater volume, harmony effects may also be secured. This is done by using disks which individually play soprano, alto, bass parts, etc., the whole blending into one melody when run together on the machine.

### LUMBER-PILING APPARATUS

#### 1267 ALSO FIRE TOWER

Through the utilization of a power-driven piling machine of recent development, lumber stacks in some of the big yards in different cities are being carried to heights as great as 42 ft. The appearance of these yards is very striking, but the significant feature is represented in the economic phase of the change which is taking place. The stacking machine is cutting the cost of piling and unpling lumber, econo-

Coie. Générale de Phonographes & Cinématographes  
 2, N. Richelieu, 98, Paris.  
 (Société Pathé frères)

Try Pathé Freres  
 (New York House)



Hilke Stacar Co., Inc.,  
Middletown N. C.

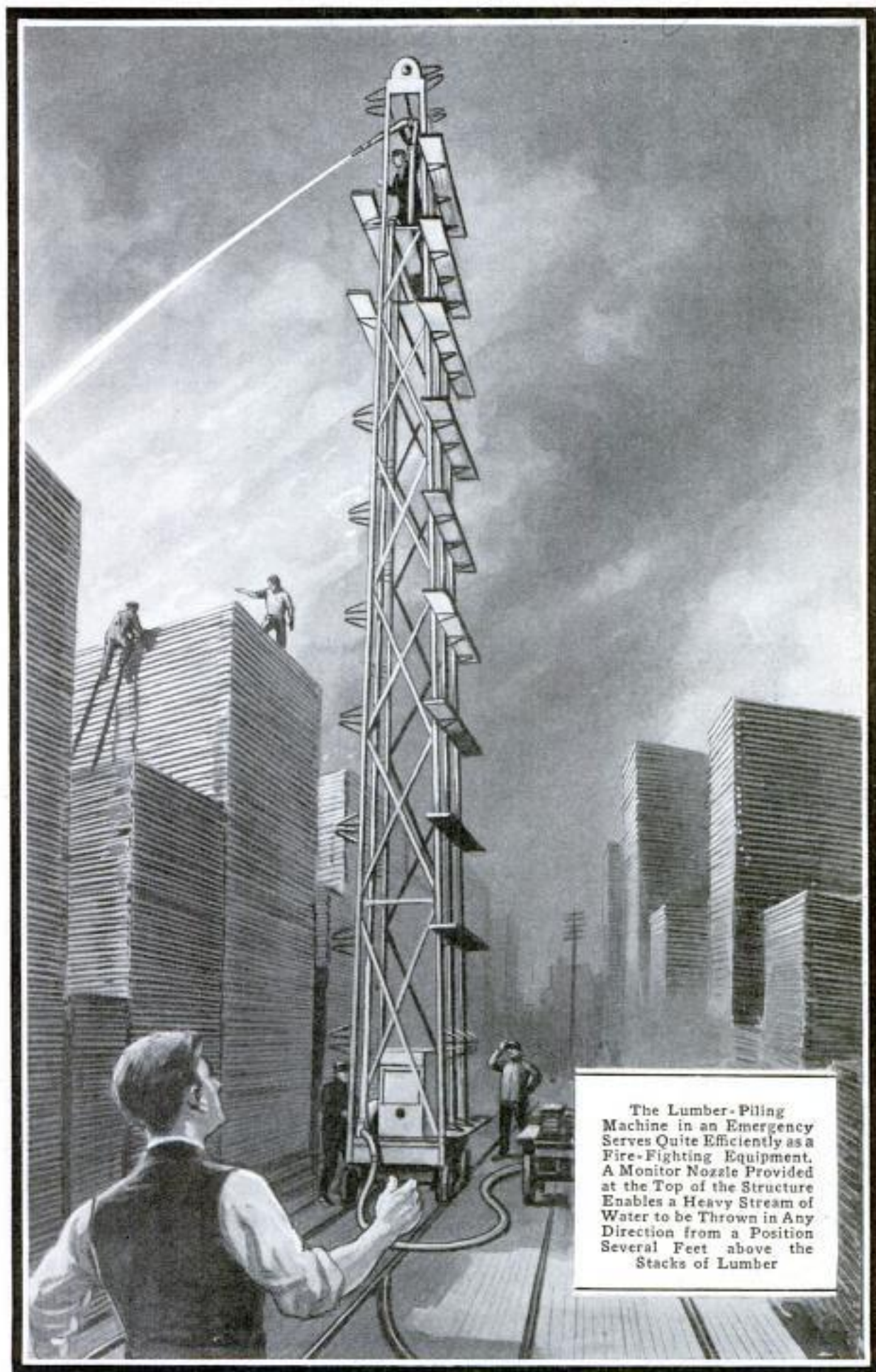

The Lumber-Piling Machine in an Emergency Serves Quite Efficiently as a Fire-Fighting Equipment. A Monitor Nozzle Provided at the Top of the Structure Enables a Heavy Stream of Water to be Thrown in Any Direction from a Position Several Feet above the Stacks of Lumber

mizing space, lessening the cost of roofing lumber and pile bases, and also lowering labor costs.

It consists of a steel tower, mounted on a truck, over which two endless chains, equipped with arms at intervals of 42 in., revolve. A 5-hp. motor mounted on the platform of the carrier drives the conveyor 38 ft. a minute. This speed is sufficient to hoist one plank, or two if two boards are placed on each arm, every six seconds. Four men, two on the ground and two on a stack, work with the machine. In a 10-hour period 125,000 ft. of lumber were piled in one yard where the apparatus is being used.

The machine will handle boards of any width not greater than 18 in., nor

thicker than 4 in., and in lengths from 8 to 24 ft. It may be moved from one stack to another readily and will unpile a stack just as rapidly as it builds it. In addition to its other functions, the apparatus furnishes an effective fire-fighting equipment. At the upper end of a large pipe extending to the top of the stacker a monitor nozzle is mounted. In case of fire breaking out in a yard, a fire hose may be connected at the lower end of the pipe. The machine then becomes a fire-fighting tower from which a blaze may be combated. Since the monitor nozzle can be turned in any direction and the apparatus moved from one point to another, it is a valuable protection for a yard.

## \* POWERFUL BATTLE PLANES DESIGNED FOR ALLIES

1157 According to the claims of a Washington, D. C., air-craft company, a fleet of battle aeroplanes of an exceedingly formidable type is being built at the national capital for the use of the allied aeronautical forces. Twenty-one machines, each having a wing spread of 180 ft. and an over-all length of 104 ft., are understood to be in course of construction. All are to be heavily armored biplanes driven by dual engines developing 1,700 hp., which will give an estimated maximum speed of 90 miles an hour. The armament of each will also be heavier than usual and is to consist of four machine

and two rapid-fire guns, and a pair of bomb-launching tubes.

The model represents the largest heavier-than-air flier so far developed in America. When ready for action its weight will amount to 30,000 or 35,000 lb. The fore and aft cockpits are designed to accommodate a complement of eight men, two of whom will serve as pilots. It will be possible to carry a store of fuel sufficient to keep the cruiser in the air from 7 to 14 hours.

Because of the function it is to play, great care has been taken in designing it to make it as nearly invulnerable as possible. Its two pilots are provided

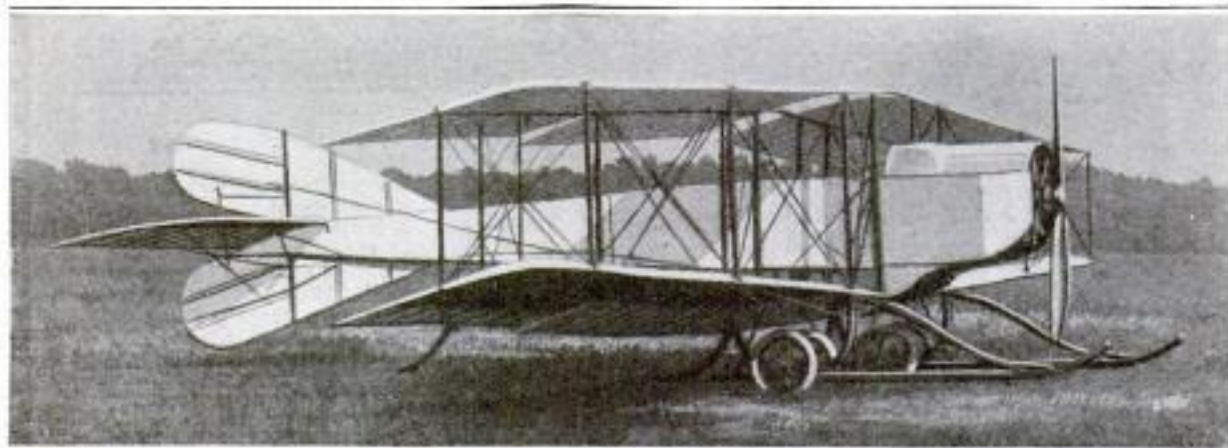

Some of the General Structural Features of the Big Battle Planes will be Similar to Those Represented in This Small Machine Which Is a Product of the Washington Plant

*Christmas Aeroplane Co.*  
*1617 Hobart St., Washington*  
 Copyrighted Material

separate compartments in which are dual sets of manual controls. In addition to these, there is an automatic-control system. This gives the craft five separate means of operation, any one of which might be employed to return it to its base were the other four crippled by shells. The plans provide for the installation of a rapid-fire gun of large caliber at the front of the forward cockpit. Immediately aft of this two machine guns will be mounted, one on the starboard and the other on the port side. Back of the propellers and in the after cockpit another pair of machine guns will be similarly mounted, and at the rear a second rapid-fire gun.

The gun equipment is intended principally for defensive purposes. Bombs of remarkable size will be employed for offensive operations. These are 5½ ft. in length, have a diameter of 14 in., and are filled with 200 lb. of high explosive. Some 25 or 30 projectiles of this kind will be carried in racks arranged on either side of the launching tubes. The two engines comprising the cruiser's power plant will operate independently of each other and drive two 20-ft. propellers of the triple-blade type at a speed of about 600 revolutions a minute. In addition to the armament and military equipment, the cruiser will carry two outfits of radio apparatus and dual sets of instruments, such as clocks, barometers, inclinometers, horizontal and vertical ascent and descent indicators, and drift gauges. Tables and sketching paraphernalia will be at the command of the observers.

If all the claims made for the battle planes are correct, they will be superior in size to any aeroplane ever constructed, so far as is known. The latest cruiser developed by the French is reported to have a wing spread of 130 ft. The world-famed machine built by the Russian designer Sikorsky has a span of only 88 ft. and weighs 6,600 lb., as compared with the accredited 30,000 lb. of the new American craft which, so far as is known, has not as yet been tried out.

## SHOW-WINDOW TELEPHONE SECURES MANY ORDERS

To secure a better hold on passers-by who display a casual interest in the window displays, an eastern store has



Store Uses Clerk and Telephone to Communicate with Persons Displaying an Interest in the Show Window

hit upon an unusual plan which is at present being tried out. The goods are displayed in the window in the usual manner, and at one side sits a clerk at a desk. Outside on the walk, at the edge of the window frame, a telephone is installed, which communicates directly with the clerk. Any information the passer-by may want on the goods displayed is cheerfully furnished, and his order booked if he so desires. Thus far the scheme has been voted a decided success, not only because of its novelty and the discussion resulting, but from the orders received and the many valuable names added to the firm's mailing list as well.

CA touring car is offered to its employees by an automobile company for the most valuable suggestion to the company made during a period of six months.

*Chalmers Motor Co.,  
Detroit, Mich.*

**BICYCLE RIDER BALANCES**

1180 **DINNER ON HIS HEAD**

A bicycle rider who is skilled both as a rider and as a balancing artist was recently employed to advertise a res-

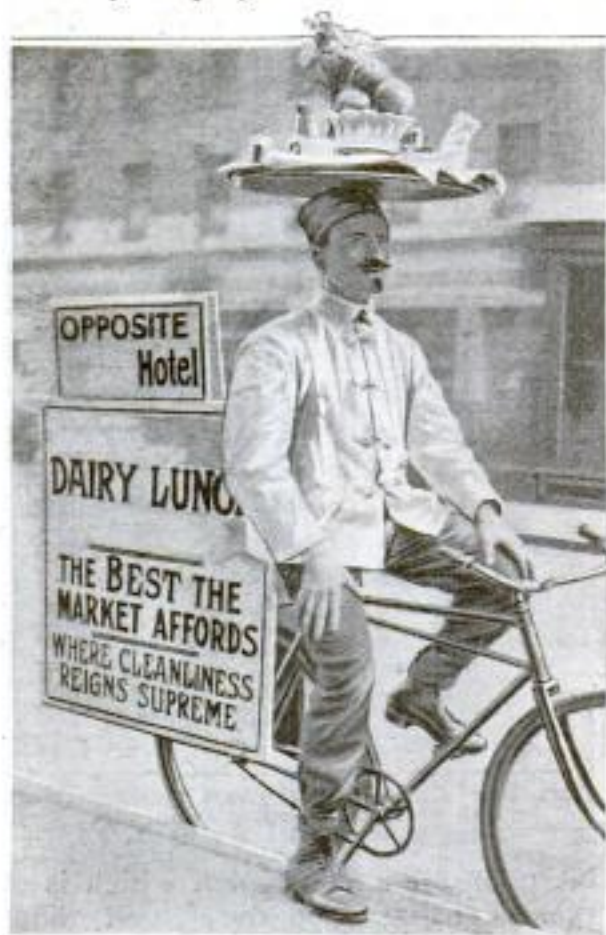

A Restaurant in a Western City Used This Means of Attracting Patrons

taurant in a western city by riding through the business streets dressed as a French chef and balancing on his head a large tray loaded with a full-course dinner. On the rear of the bicycle were large placards calling attention to the location and service of the restaurant. The unusual spectacle aroused a great deal of comment.

1268 **TRAINS CRASH WHEN STRAY CURRENT WORKS SIGNAL**

A fatal collision occurred recently on a southern railway when a stray electric current operated a signal relay and as a consequence two trains crashed into each other. The train movement in the territory in which

*N. C. & So. R. Ry  
Dec 23, 1915  
91 mi So. of Nashville*

the wreck occurred is made under the controlled manual block system. Signals cannot be given opposing trains without the coöperation of the operators at either end of the block. The railway's report declares that the signal to the south-bound freight was not given by the operator but was caused by current from some outside source picking up the signal relay. The signal wires of the railway and the telegraph company's wires are on the same poles, the signal wires being beneath the others. Since workmen for the telegraph company are said to have been working in the vicinity on the day of the accident, it is thought that their work may have been responsible for the stray current. Fifteen persons were killed in the wreck.

1214 **CHILD'S SLED EQUIPPED WITH LIMOUSINE BODY**

A child's sled with an inclosed body resembling a limousine body has been constructed by a New York parent. With it small children can be taken for sled rides without exposing them directly to the rigors of winter. There is plenty of room for the little occupant of such a convenience to sit up, or lie down full length. Windows are fitted to all four sides of the inclosure, the

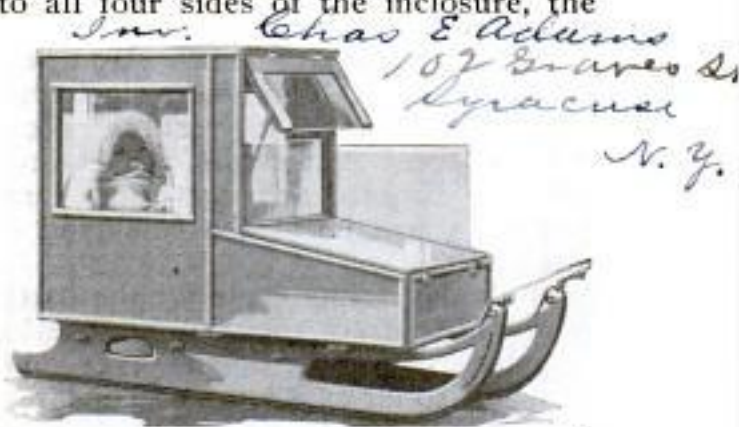

Sled Which Affords Ample Protection against the Cold front one being divided and fitted with a brace so that it can be opened in the same manner as a windshield.

ⓈThe government has opened a branch passport office in New York.

1067D

### NEW OIL-FUEL BOILER OF GREAT EFFICIENCY

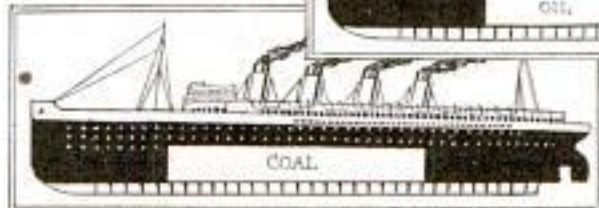
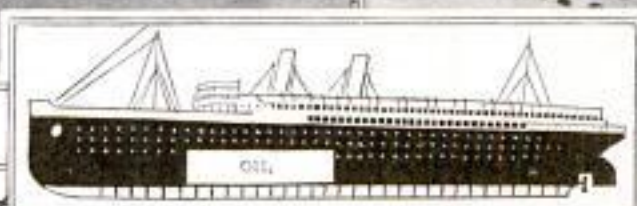

New Concentric-Cone Boilers in Use on Oil-Burning Steamer, Showing Relative Compactness of Arrangement. The Ship Diagrams Indicate Space Saved by Employing This System, While at the Right the Internal Construction of the Boiler is Indicated

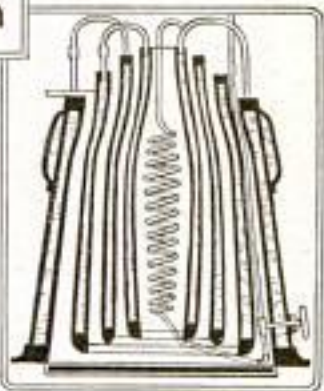

Attention of marine engineers has been drawn to a new type of boiler lately put forth by an English inventor. The curious device makes use not of flues nor of coils of pipe to secure quick steaming, but of hollow concentric cones. According to tests made, a boiler of this type, the size of a hog-head, will generate as much steam and has as high a horsepower rating as the ordinary variety of boiler many times larger. This compactness and high rating make the boiler particularly adapted to marine service, where space is valuable, besides which its ease, and comparative cleanliness, of operation result in a quite substantial saving of labor.

The new generator has a rated evaporation of 17 lb. of water per pound of paraffin oil used as fuel. In one test 100 lb. of steam was raised from the cold in 12 minutes, using a paraffin flame; and occasionally the feat has been accomplished in even half that time. The quick-steaming qualities

are a natural result of the boiler's peculiar form. Being constituted of one hollow cone within another, each of which contains its quota of water, heat from the monster burner beneath reaches all parts of the liquid almost at once. Each cone is cut off at the top, allowing the heated gases to slip up between the broad surfaces and out at the upper end almost without diminishing of draft. Within the center cone is a coil of pipe forming the superheater. Steam circulates from one section to the next through connecting pipes at the top.

Washington authorities have condemned the practice of increasing the size of oysters by allowing them to "drink" quantities of fresh water, as adulteration.

### OLD WOODEN DAM STILL

7657 IN USE

In striking contrast to modern concrete dams is a simple wooden structure, still in use, built 40 years ago in

# Arthur L. Dabel  
1082 Union St.  
San Francisco

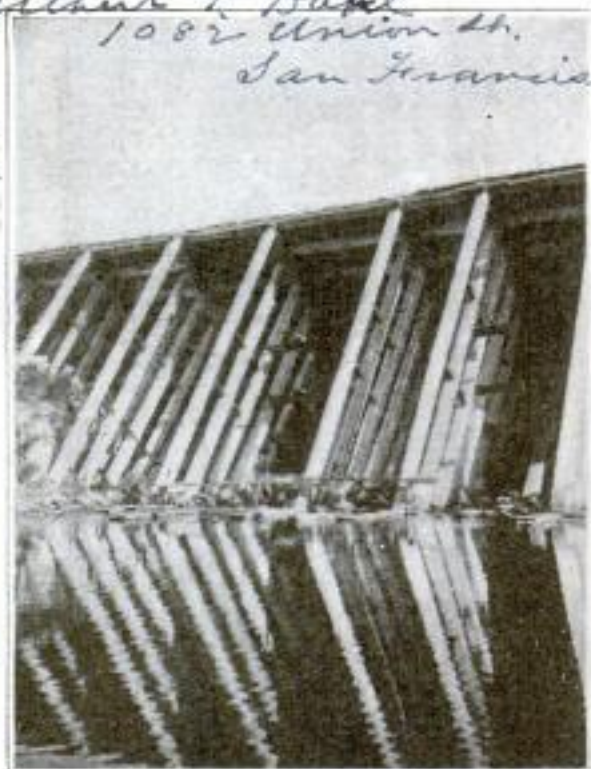

This Wooden Dam was Built 40 Years Ago for Hydraulic Mining but Now Furnishes Water for Irrigating and Domestic Purposes

a mountainous region of California at an elevation of 6,000 ft. In appearance it resembles a high, tight board fence, slanting downstream; it is supported by rows of heavy wooden props. The dam is 550 ft. long and 21 ft. high. The water stored by it fills a reservoir of 90 acres and was originally used for hydraulic mining. Now it furnishes water for domestic and irrigation purposes. Of many dams of this type built in the early days, this is said to be the only one remaining in this region.

### COMMUNITIES COOPERATE WITH FOREST SERVICE

During the past year \$400,000 was spent by the United States Forest Service in the construction and maintenance of improvements in the national forests. This does not include

Annual Report  
Dept of Agriculture

the contribution of the time of the forest officers, which, however, was less than in former years on account of the severity of the forest fires. The service makes a special effort to enlist the interest and coöperation of communities whose welfare is vitally affected by the care and control of the national forests. In the work accomplished in the past year a considerable percentage was furthered by community and individual aid. The projects completed during the twelve-month comprise 108 miles of road, 1,719 miles of trails, 2,287 miles of telephone lines, 166 miles of fire lines, 102 lookout structures, 35 bridges, 267 miles of fence, 23 corrals, 202 water improvements, etc. Severe fires and winter storms have made the upkeep of improvements a heavy expense and the amount of new work possible has been proportionately less.

### VILLAGE SCHOOL AND HOMES CONNECTED BY TUNNELS

At Tye, a small railroad point in northwestern Washington which is usually almost buried during the winter, snowsheds connect a small frame school building with the few houses in which there are children of school age. Through these wooden tunnels the children make their way to and from school in comfort, while blizzards sweep across the snow banks above them. The sheds are made necessary by the character of the hilly village which has no street other than a railroad right of way. When snow is drifted so that it is from 20 to 30 ft. deep in many places, and big rotary snowplows have cleared the railway, leaving high embankments of snow on either side, track walking is dangerous and all communication difficult. Because of this the citizens have constructed the snowsheds through which the children, nine in number, pass. These tunnels beneath the snow also provide the people a ready means of access from one house to another when they are snowbound.

Fancher's River, Nevada Co., Calif.

# James Meekeloh, 4111 Duval St., Seattle.

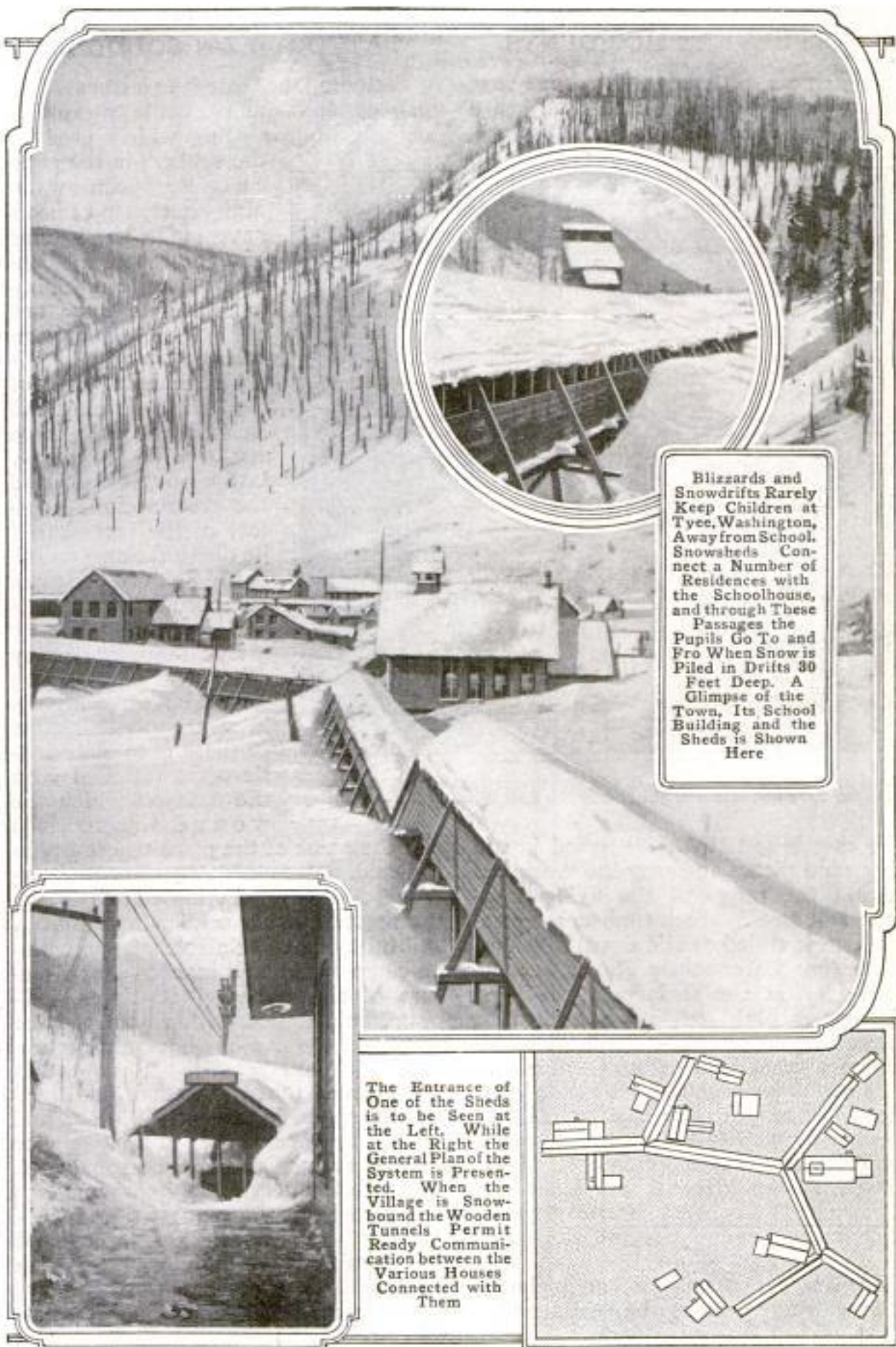

Blizzards and Snowdrifts Rarely Keep Children at Tye, Washington, Away from School. Snowsheds Connect a Number of Residences with the Schoolhouse, and through These Passages the Pupils Go To and Fro When Snow is Piled in Drifts 30 Feet Deep. A Glimpse of the Town, Its School Building and the Sheds is Shown Here

The Entrance of One of the Sheds is to be Seen at the Left. While at the Right the General Plan of the System is Presented. When the Village is Snow-bound the Wooden Tunnels Permit Ready Communication between the Various Houses Connected with Them

## STONES WASHED FROM LOGS TO PREVENT ACCIDENTS

*C. R. Edholm*

When a swiftly revolving buzz saw, tearing its way into a log, strikes a stone, or other hard foreign substance,

## DATES OF BATTLE SCARS TATTOOED ON SOLDIERS

*Pearsons Weekly*

Tattooing, because it furnishes a permanent and unmistakable means of identification, is being widely used by the soldiers in the present European war. Many tattoo artists have made large sums of money since the conflict began, one claiming to have imbedded in the flesh of departing soldiers practically every regimental crest of the British, French, and Belgian armies. These marks will, of course, last through life, and the wearer finds comfort in the fact that if he dies unknown on the battle field his body can be more easily identified.

But there are many other uses of tattooing which have sprung up in recent months. One of these is to have battle scars tattooed with the date on which the wound was received

and the name of the place where it was inflicted. Many a young woman, newly married, has had tattooed on her arm the portrait of her soldier-husband. A skillful tattooist relates that one woman came to him and insisted that a picture of the cathedral at Ypres, Belgium, be tattooed on her skin. In the course of the five one-hour sittings required to comply with the request, it was learned that the woman had lived in Ypres, and in the cathedral she had spent many consoling hours. Hence its ruin seemed to her a personal loss.

Not infrequently soldiers come to tattooists with the request that such a name as "Mary" on the arm be changed to "Bessie." The only way this can be done is to cover the word "Mary" with some design, such as a floral pattern, and tattoo the new name below.



Logs are Given a Shower Bath to Dislodge Stones That might be Imbedded in the Bark and Hence might Shatter the Saw When It Strikes Them

the saw is apt to be shattered into a thousand pieces and may kill workmen within the range of the flying fragments of steel. Much timber, after being cut, is rolled or slid down hillsides, hence not infrequently stones become imbedded in the surface of the logs. A shower bath for logs about to be taken into a sawmill has been designed which washes off all stones and gravel that may have accumulated in the bark. As a log moves on a mechanical carrier on its way to the mill it is passed beneath a number of nozzles from which strong streams of water are thrown so that when it reaches the saw it is washed free of dirt and stones.

England's home office has included baby carriages among the vehicles that must carry lights after dark.



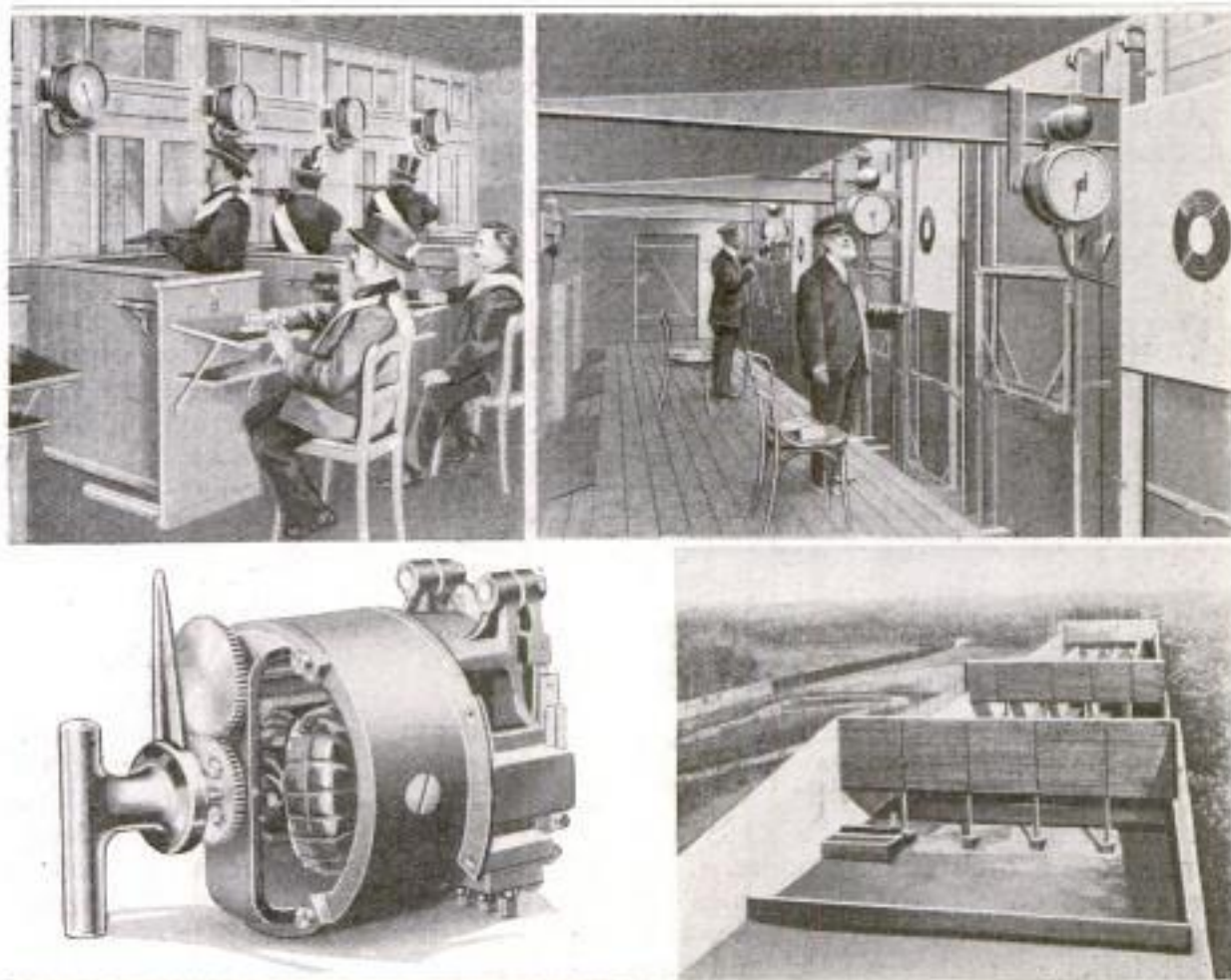

The Receiving and Transmitting Indicators at the Firing Point and Butts are Shown Above, While Below, the Adjusting Mechanism of the Instrument and a Glimpse of the Range are Pictured

## ELECTRIC INDICATORS USED

### ON GERMAN RIEFLER RANGE

Satisfactory results have apparently attended the use of electric indicators installed shortly before the war at the ranges of a rifle club at Spandau, near Berlin, for the purpose of signaling from the butts to the firing points the value of each shot. Separate apparatus is used on each range, and consists principally of two indicators, one acting as a transmitter and the other as a receiver. The dials of each are numbered from 0 to 20 and inscribed with the words "telephone" and "stop." The pointers of both instruments may be moved simultaneously by turning a handle, provided with the transmitter, which is connected with an adjusting device that resembles a small motor and is mounted within the housing. After a marksman has fired a shot he

presses a button to signal the target man who then reads the score and adjusts the index of the transmitter to correspond with the ring number hit by the bullet. This adjusts the pointer on the receiving dial to read the same as the transmitter. A telephone is also included with the system, and when the operator at the target wishes to communicate with the marksman he turns the pointer on the transmitter to "telephone." This informs the latter of the call. The use of the indicator system has greatly increased the capacity of the ranges by cutting the otherwise necessary delay between successive shots.

A shed in which cars of coal may be placed when the weather is cold, and thawed out before being run onto the dumping machines, is to be built by an eastern railroad.

*The Marksmen Society  
Spandau  
Installed by  
Siemens*

Copyright material

Thos. Lister  
mfr. 2639 W 25th St  
332 Cleveland O.

# POPULAR MECHANICS

## QUEER CYCLE IS DESIGNED TO CARRY FIVE RIDERS

## RESTORATION OF THE CLIFF DWELLINGS OF COLORADO

349 H

518

C. J. Morita 8-28-15

As a novelty a Cleveland, O., bicycle dealer has constructed a heptacycle,

Work which is now under way on the repair and restoration of Com-



Seven-Wheeled Cycle Constructed to Accommodate Five Riders: The Queer Conveyance was Designed to be Used Chiefly for Advertising Purposes

a seven-wheeled vehicle built to accommodate a quintette of riders. The conveyance consists of the frames of five bicycles joined side by side, the front forks of each removed and the steering posts mounted securely in a steel bar extending along the front. At either end of this is a wheel supporting the front part of the cycle. These are guided by a steering gear arranged similarly to that of a motor car. Each rider assists in the propulsion of the machine, while the steering devolves upon one person. The machine was used in the city some time ago for advertising purposes.

The frames are so hinged together at the rear that the back wheel of each is free to pass over bumps, or drop into depressions encountered in a road, without affecting the others or damaging the machine. The steering rod connecting the front forks is placed immediately beneath the supporting bar, so as not to lock when a corner is turned. When ridden at a speed of eight or ten miles an hour the cycle is easily managed. Because of its scant wheelbase, however, it cannot be operated at a much greater speed with safety.

munity House, one of the cliff dwellings of the Mesa Verde National Park in southwestern Colorado, is simply a continuation of much work of the same character carried on in recent years by the Smithsonian Bureau of American Ethnology, with the idea of preserving the ruined homes of the cliff dwellers, who are supposed to have been the ancestors of the Pueblo Indians. Three of the ruins, Spruce Tree

House, Cliff Palace, and Balcony House, have already been repaired so that they are available for the inspection of visitors. Some idea of the size of these prehistoric dwellings is given in the fact that the Cliff Palace almost entirely fills a cave having a 300-ft. frontage, and contains more than 200 rooms.

## MINER USES GRAVESTONES TO MARK NEW CLAIM

12067

Tombstones taken from a near-by cemetery were used by a mining prospector recently to mark the location of a valuable strike to which he lays claim. The rich find is of tungsten ore and is located in Mineral County, Nevada. In this region boulders are scarce and consequently the enthusiastic miner purloined several gravestones to use as location monuments. News of the discovery of ore spread rapidly and there was a rush of miners to the neighborhood.

1/2 mi from Colorado

CA n efficient method employed in advertising German cities consists of a brief description of the city printed on the back of a regular mailing envelope.

## IMMORTALIZING CHICAGO'S MIDWAY

1222

By ROBERT H. MOULTON

Room 4 Board of Trade,  
Chicago.

THE Midway transformed—or the metamorphosis of the freak avenue of World's Fair year into the most artistic formal boulevard in the world—is a change which a great many persons are destined to see, provided they were democratic enough to visit the "plaisance" during Chicago's great exposition of 1893, and provided, also, that they live long enough to see Lorado Taft's plan for beautifying the Midway carried to completion. Rapid strides have been made in the work since the plan received official sanction two years ago. But it is a plan so huge that years yet will be required to carry it out. The subject, indeed, is so big and relates to the ornamentation of a territory so large that additions can be made almost indefinitely for generations without decreasing the value of the work done in the early stages. In result the project will carry into permanent effect a mile-long vista of water, lawn, trees, and sculpture, such as has never been approached except in the temporary structures of the World's Fair.

At present the Midway is a grassy strip a mile in length, and about 1,000 feet wide, connecting Washington and Jackson parks. It has always been the intention of the South Park authorities to extend the depression of the Midway from the lagoons of Jackson Park to the small lakes of Washington Park, thus forming a waterway from park to park. Mr. Taft's plan presupposes this straight and formal canal, which is to occupy the present depressions at a lower level than the street.

The Midway Plaisance was thus christened at the time of the World's Fair. On either side it was flanked by the booths of the fakery. It was the favorite promenade of sight-seers. It now adjoins the campus of the University of Chicago, and the proposed scheme will be an appropriate setting for this seat of learning, which possesses some of the most beautiful buildings in America.

The canal bisecting the Midway will fill the present central depression and will be about 100 feet wide. It will be spanned by three bridges of monumental design, to be dedicated to the three great ideals of the race and to be called "The Bridge of Sciences," "The Bridge of Arts," and "The Bridge of Religions," an adaptation of the "Pont des Arts" in Paris. Along the higher strip of land, some distance back of the canal, and on either side, will stand the statues of the world's greatest idealists. Then at the two ends of the Midway will be the great fountains—that of "Time" being at the west end, and that of "Creation" at the east end.

"The Fountain of Time" for the west end was suggested to Mr. Taft by Austin Dobson's lines:

"Time goes, you say? Ah, no.  
Alas, time stays; we go."

It will show the human procession passing in review before the great immovable figure of Time. Father Time will be represented by a rugged, crag-like figure, reviewing a throng of hurrying people; the long processional group will show these people indistinct, but all hurrying and crowding toward a goal they cannot see. A warrior on horseback, flanked by banners and dancing figures, will form the center of the composition, which will fade off at the ends into creeping infancy, or the bent and withered figures of age. The procession will seem to rise from a great jet of water on one side and sink from sight at the other, Time meanwhile standing firm and immovable. There is a suggestion of joyous onward movement in this procession and of the splendor and pageantry which life has achieved since that first day of creation, which the other fountain, "Creation," planned for the opposite end of the Midway, will celebrate.

"The Fountain of Creation" will receive the waters of the canal at a point just west of Jackson Park. It is



Model of the "Fountain of Creation"

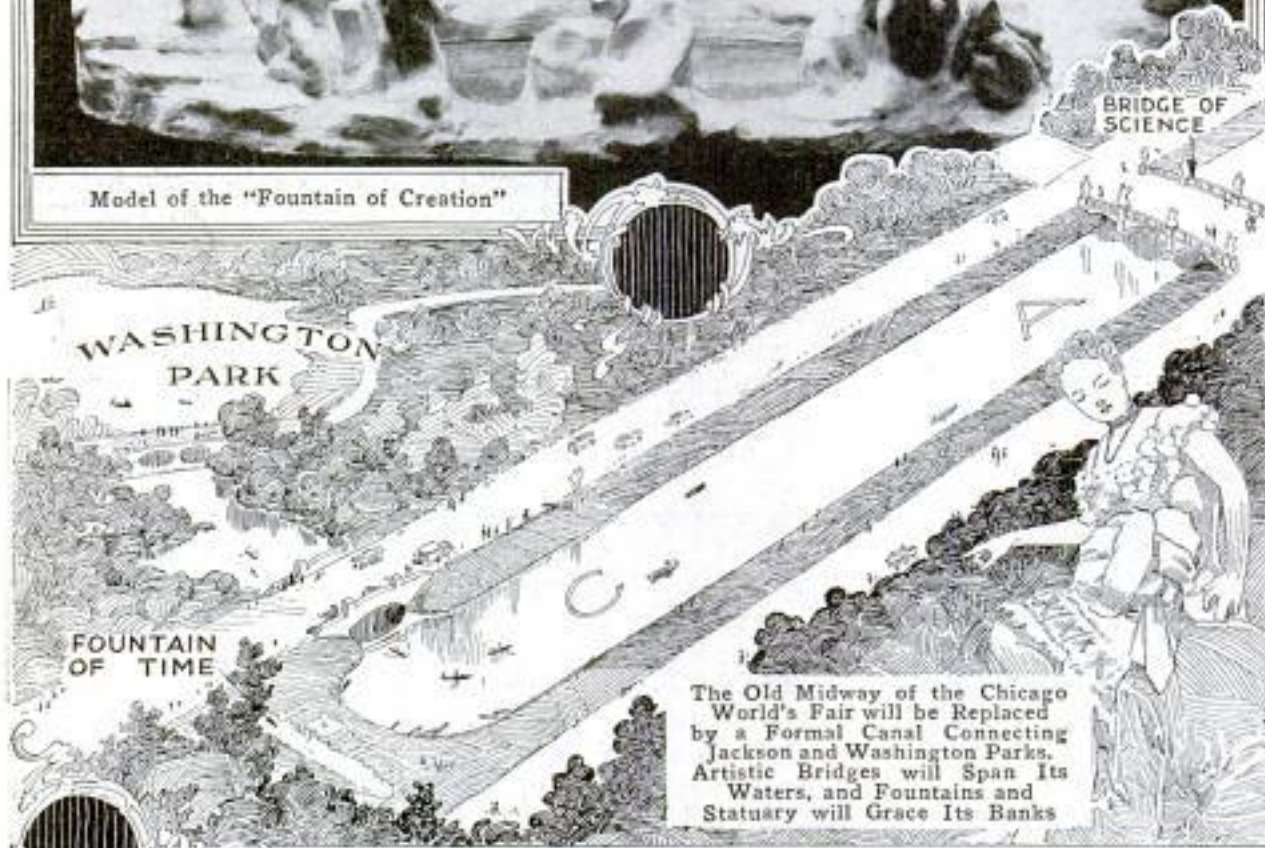

The Old Midway of the Chicago World's Fair will be Replaced by a Formal Canal Connecting Jackson and Washington Parks. Artistic Bridges will Span Its Waters, and Fountains and Statuary will Grace Its Banks

The Human Procession in the "Fountain of Time;" Photograph Taken from a 20-Foot Model. The Procession will be About 120 Feet Long and 20 Feet Tall at Its Highest Point. The Human Figures in the Model Are About 10 Feet High



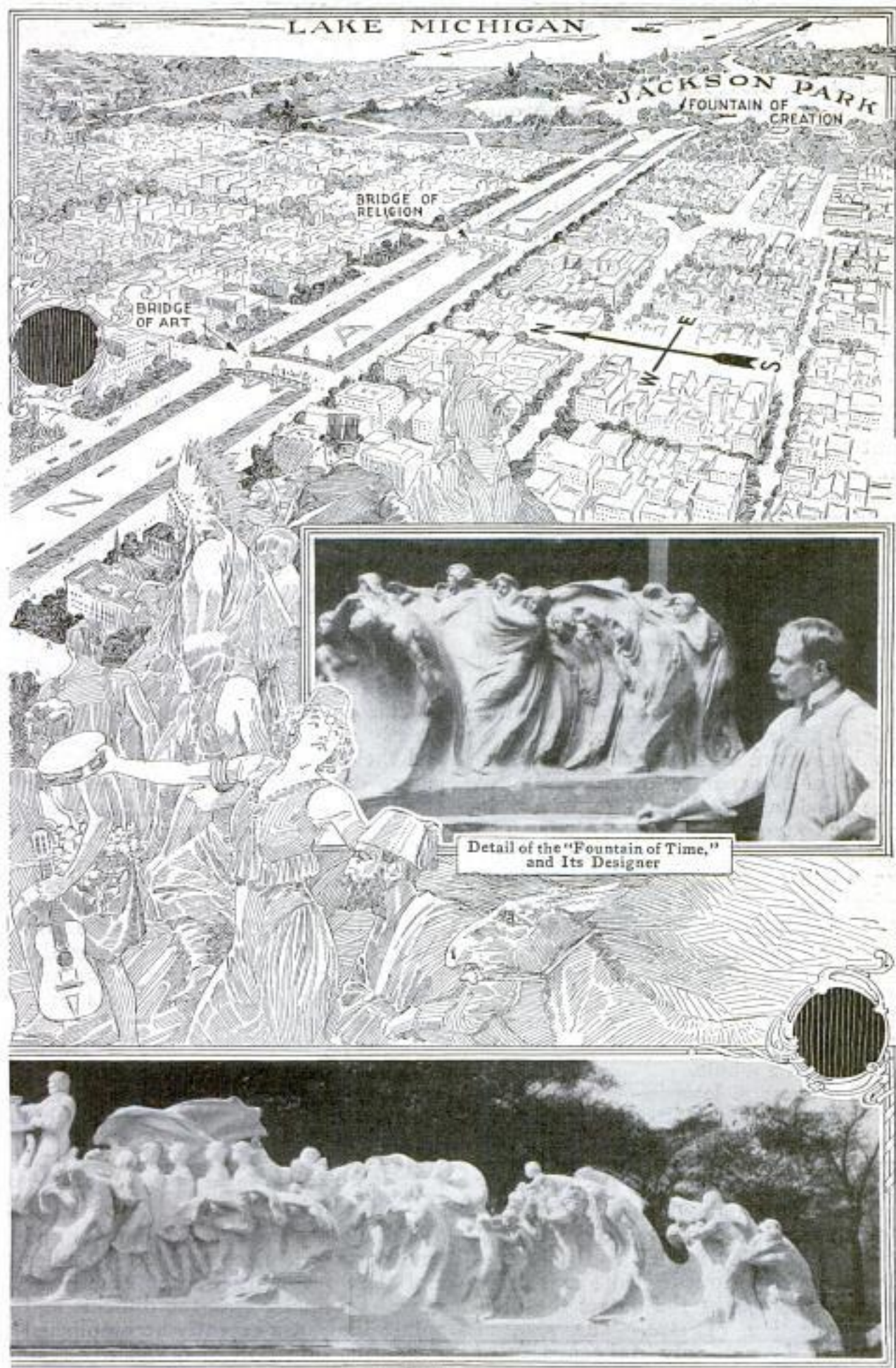

founded on the myth of Deucalion. Deucalion, the Noah of Greek legendry, and his wife, Pyrrha, being the only mortals saved by Zeus after the nine days' flood, stepped out from their frail boat to the top of Mount Parnassus and consulted a convenient oracle as to the best way of restoring the human race. The goddess told them to cover their heads and throw the bones of their mother behind them, and Pyrrha divined that these bones were the stones of Mother Earth. Mr. Taft will show us the moment when these stones, cast by the titan's hand, are changing into men and women, rising out of the clod and flood and fog into life and light. The composition will begin with creatures half formed, vague, prostrate, blindly emerging from the shapeless rock; continuing at a higher level with figures fully developed and almost erect, but still groping in darkness, struggling, wondering; and will reach its climax, with a statue group, at the summit, of beings complete and glorious, saluting the dawn.

"The Fountain of Time," on which Mr. Taft and a happy company of sculptors are now at work, is composed of 89 separate figures, and even the models for these figures are in various stages of incompleteness. The visitor to the Taft studio finds them scattered about in the high-ceilinged, glass-roofed rooms, many of them at the present time looking like little more than hulks of meaningless clay, although others have passed out of this fœtus stage into figures which have begun to suggest the motive that was back of the mind that originated the scheme as a whole.

The average layman—even he who may profess a certain appreciation of sculpture—hardly realizes the amount of labor involved in the making of statuary. In addition to the two chief processes through which it is necessary for all work to pass—the construction, first, of the clay model, and its transformation subsequently into marble or metal—there is at the outset the difficult question of size. The size of statuary is not only a keen test of

artistic judgment under all circumstances, but it is something that must be determined by the environments which the work will have when in place. It has taken costly experience to impress the importance of this feature upon sculptors. When St. Gaudens, for example, made the statue of Diana (the one seen in the Agricultural Building at the World's Fair) for Madison Square Garden at New York, he made it too large—an error that might have been obviated, as he afterward saw, had he taken a model to the park and studied it in relation to the home it was expected to occupy when completed. Mr. Taft estimates that he has spent \$5,000 on these models, which are taken out on the Midway and studied there.

However much of Mr. Taft's general scheme is adopted eventually by Chicago, it is likely to make a Midway that will suggest some strange contrasts to those who saw the Midway of 1893. The home of all the side shows of the big Columbian exposition was an interesting place, but it was not exactly artistic. The streets of Cairo and the Ferris wheel and the Moorish palace drew a vastly greater number of persons, nevertheless, during those summer days of '93 than did the art exhibit in the present Field museum. Perhaps it is only in accordance with the law of compensation, then, that chaste Greek goddesses are to adorn the paths where once there strolled the naughty "nautch" girls; that classic orators will stand on pedestals once occupied by the loud barkers of Dahomey village, and the music of \$250,000 fountains will be heard in place of the tomtoms of the South Sea islanders.

#### HOMESTEAD MOVED TWENTY MILES PIECE BY PIECE

Taking down an old house and transporting it piece by piece 20 miles and then reconstructing it exactly as it was originally was the difficult and painstaking task recently accomplished under the direction of a wealthy resi-

C. C. Bolton

Cleveland, C.

dent of Cleveland. The home which has been moved in this novel manner is one which, for sentimental reasons, the owner desired to preserve after he in-

was constructed 65 years ago on what is now Euclid Avenue, Cleveland, and was the boyhood home of the present owner, who purchased a 60-acre tract near Cleveland upon which to rebuild it.

In taking down the house great care was exercised not to destroy any portion of it. Likewise the relative locations of the various pieces of wood and other material were carefully noted.

Not only has the house been rebuilt exactly as it was originally, but the furnishings have been transferred and placed in the identical positions that they occupied when the mother was

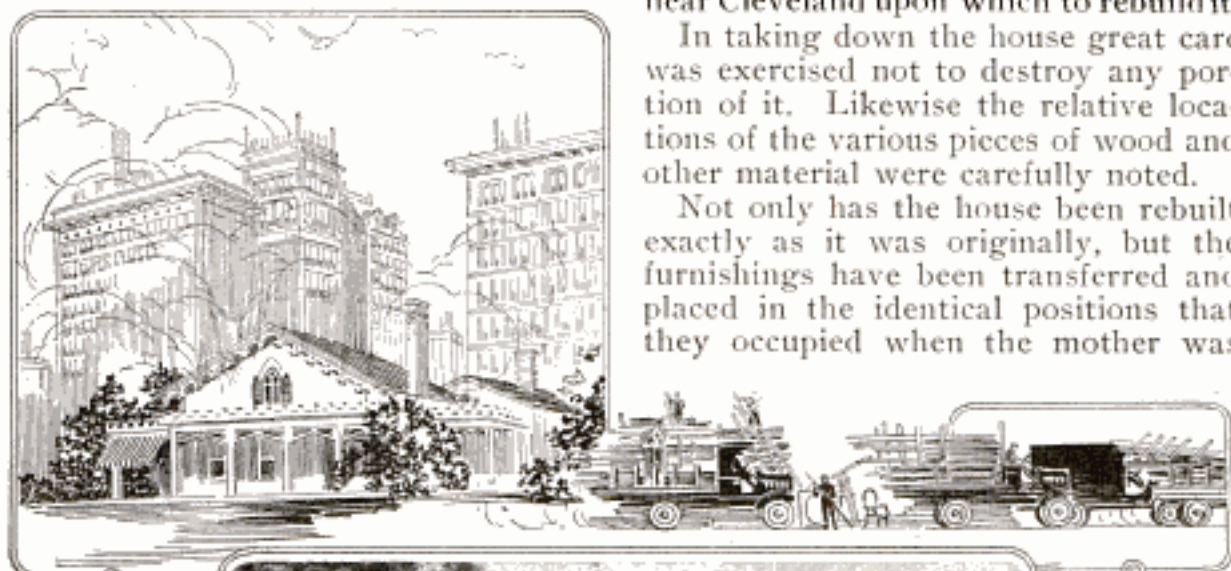

The Old Cleveland Homestead in Its Original and New Location, and Views Showing Old-Fashioned Interiors: It was Carefully Torn Down, Carried 20 Miles on Motor Trucks, and Rebuilt and Refurnished Exactly as It Was Originally

herited it from his aged mother, who died recently. Since her estate had to be settled, the most feasible way of preserving the old homestead seemed to be the one indicated. The structure

alive. The present owner sent east and secured wall paper of patterns which matched perfectly that used in several rooms. In some instances paper was made especially for this house in order to reproduce every detail.

The chairs were reupholstered in horsehair; the blunt-edged screws in the big door hinges have been put back

in place; at either side of the front door have been preserved the long narrow windows through which, in ante-bellum days, many a fugitive slave anxiously peered while in hiding; quaint vases, candlesticks, book racks, mahogany tables and chairs once more stand as their former owner left them, all as a result of the almost mathematical accuracy with which the reconstruction and refurnishing of the house

were accomplished. In the dining-room floor is a border pattern of dark and light woods. When the workmen began to polish this floor after re-laying it they were surprised to find that the dark pieces were mahogany instead of walnut. That indicates something of the quality of the materials used in the building, which doubtless will stand for many years in its new location.

### TAXIMETER GIVES CUSTOMER PRINTED FARE RECEIPT

Arguments between cab drivers and their customers over fares charged are to be done away with by using a con-

the driver, as well as the amount of each individual bill. This record makes for honesty on the part of the driver, and the customer himself knows that in the event of any misunderstanding a complete and automatic record is available for the adjustment of difficulties.



New Taximeter Presents Customer with Printed Bill at the End of a Trip. The Record Kept Prevents Mistakes and Unfairness on the Part of the Driver

trivance recently devised and now being tried out in an eastern city. Its special feature is that a printed slip is automatically delivered to the customer at the end of a trip. On the slip is given the straight fare, any extras that may be due, the meter number, and the date. A duplicate record is kept inside the machine for the company's benefit. This latter is even more complete than the former, and gives among other things the distance in miles traveled while the taxicab was hired; total distance covered by the cab whether hired or not; non-revenue-earning time in minutes, such as time lost in repairing tires, etc., and the total fares in dollars and cents that have been collected by

### ANTISUBMARINE TORPEDO USED FROM AEROPLANE

To enable an air craft to effectively attack an enemy submarine, a New Jersey inventor has developed a rather novel aerial torpedo which will explode at a predetermined depth beneath the water. It is slender and cylindrical in form, and provided with a sharp nose to insure its rapid and straight descent beneath the water after it has been dropped from a height. The head of the bomb is filled with a high explosive, while in a compartment at the opposite end are batteries and a detonator. A light cable, several yards in length, is attached to it and carries a pair of wires connected with the batteries. At the free end of the cable is a small parachute and immediately beneath it a contact device to which the wires leading from the batteries are attached. When this strikes the surface of the water it collapses, allowing two metal pieces to come together and close a circuit. This actuates the detonator and in turn causes the bomb to explode. A series of somewhat similar circuit-closing contrivances is arranged along the length of the cable and fitted with water-tight caps to prevent them from acting except when set to do so. An airman flying at a reasonable height is

John F. Ohmer, President,  
Ohmer Fare Register Co., Dayton, O.



Inv. - Wm. J. Hallock Jersey City, N. J.

1163146 Dec 7, 1915 filed 6/25/15 Ser 36163

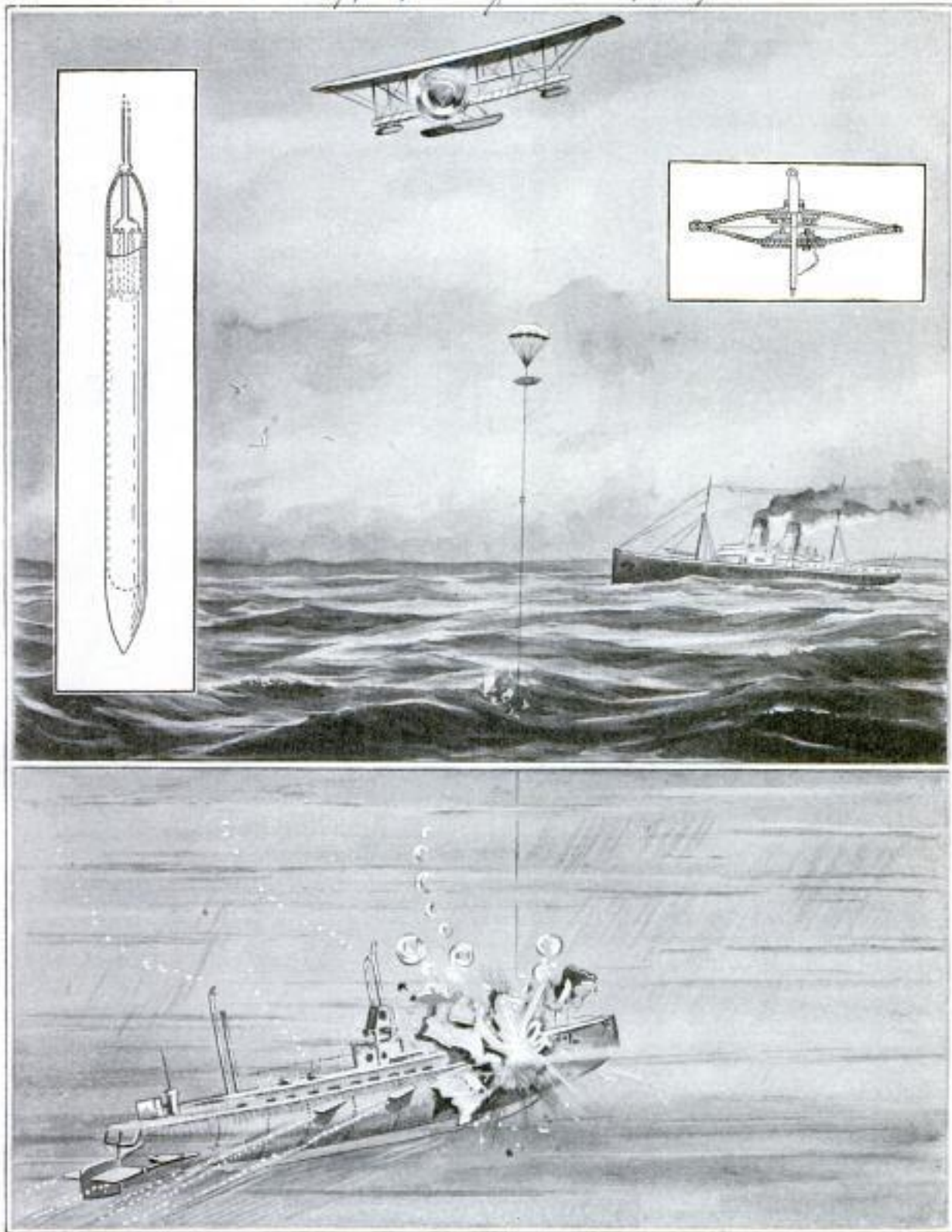

This Aerial Torpedo, Designed to be Dropped from an Aeroplane, can be Exploded at the Proper Depth to Wreck a Submarine: Inserts Show Diagrammatically the Torpedo with Its Battery, and the Contact Device

able to sight an under-water craft and also estimate its approximate depth. By setting one of the cable switches, or by relying upon the device at the parachute, according to the depth at which he wishes the explosion to occur, he

drops the bomb in the course of the submarine. The resistance of the parachute keeps the cable practically straight, but does not interfere with the fall of the torpedo, so that the explosion takes place at the proper depth.

## HIGH TOWERS LIFT WIRES ABOVE RIVER VESSELS

In extending transmission lines across the Ohio River, as well as other navigable streams, it is necessary to

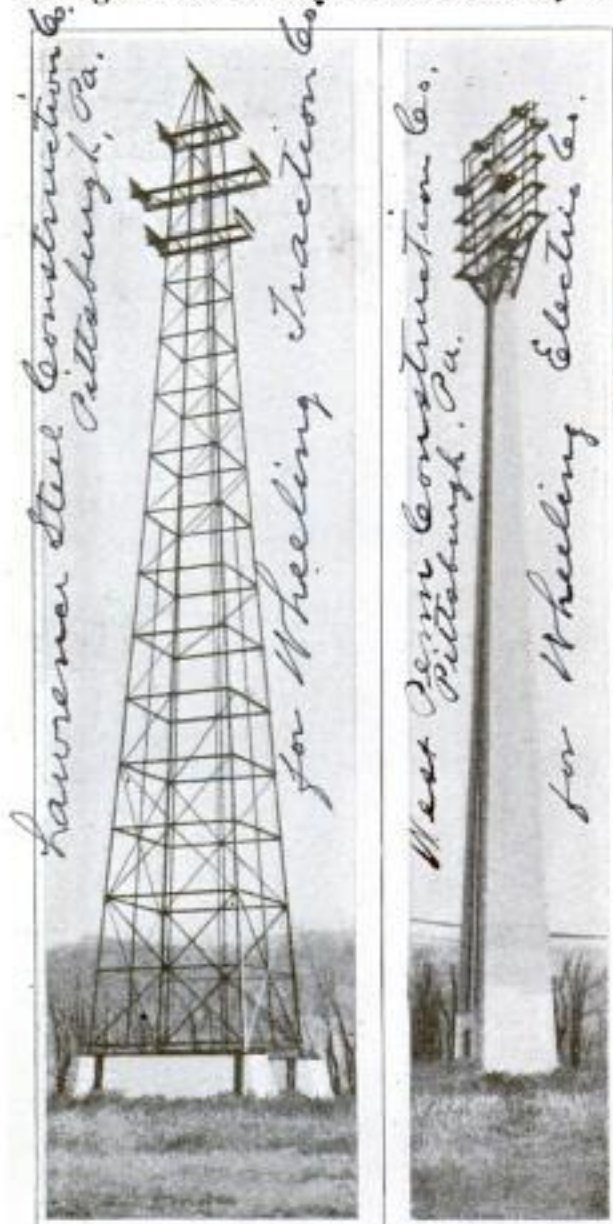

Large Towers Which Carry High-Tension Transmission Lines across Ohio River

carry them at a sufficient height to provide a wide clearance for vessels. Two towers designed for this purpose have been erected on opposite sides of the Ohio River adjacent to Wheeling, W. Va., where there is considerable shipping. One of these is 235 ft. in height and of solid reinforced-concrete construction, while the other, built of structural iron according to the usual

design, rises 250 ft. above its base. Together they support high-tension electric wires which have been projected from West Virginia into Ohio for power distribution. Part of their height is rendered imperative because of the radical changes in the level of the river during certain seasons of the year. A concrete tower of this type and size obviously attracts attention. It serves as another example of the rapid advancement which is being made in this field of construction.

## BURSTING SHELLS KILL MEN WITHOUT WOUNDING THEM

Following nearly every big battle in the European war, bodies of dead soldiers have been found in the trenches in positions the men happened to be assuming when killed. The surprising thing about this has been that the bodies very frequently have borne no signs of external wounds. This has created much discussion and wonder. Lately, however, a report made before the French Society of Civil Engineers apparently explained the cause of these peculiar deaths.

A pocket aneroid barometer was found in the uniform of a dead soldier who had not suffered any wound. An examination of the instrument revealed that two small levers operating the indicator hand were out of adjustment. Plainly a sudden and extreme lowering of the atmospheric pressure was the only thing that could have caused such a disarrangement. In order to check this point, the levers were returned to their proper position and the barometer placed under the bell of a vacuum pump. The levers became disengaged when the pressure was lowered to 16 in., which is about that normally experienced at the summit of Mont Blanc.

From this observation it was concluded that a bursting shell had suddenly reduced the atmospheric pressure about the soldier at least 14 in. This, and nothing else, explained the condition in which the barometer was found. The effect upon the human or-

Lee Electric Radiator Co.,  
327 Wells St. Chicago.  
Nov. 24/23

ganism of such a depression would cause death by setting free oxygen and carbonic-acid gas held in suspension in the blood. These gases would be liberated in the form of bubbles which, on account of their size, would be caught and held in the capillaries. This would instantly stop the blood circulation and cause immediate death.

**ELECTRICALLY HEATED PORTABLE RADIATORS**

A portable electric radiator which in general appearance resembles a steam radiator, has been put on the market.

**INTERNAL GEAR PROVES AN EFFICIENT SPEED CHANGER**

4782

Steam turbines in order to operate at best efficiency must run at relatively high speeds; likewise electric motors. There are many classes of service, however, which demand slow speeds from the source of power. To accommodate these, a manufacturer has now brought out an internal helical gear, designed to reduce the rate of revolution in any desired ratio. Being all contained within one housing the new speed reducer is much more compact than ordinary devices employed for the purpose. The center cogwheel and shaft revolve at the higher speed, while the outer is the slow-speed member. The middle pinion also serves as an oiler of the other members, the lubricant being pumped through a central hole in the shaft and sprayed through small lateral openings as the cogwheels revolve.



These Electric Radiators are Filled with a Commercial Fluid in Which is Submerged an Open Resistance Coil. Current is Secured from an Ordinary Light Socket

The principle involved in its construction is that of an open resistance coil submerged in a circulating, noncorroding, nonfreezing insulating liquid. The entire unit is hermetically sealed, preventing evaporation. The electric coil lies in the bottom of the radiator and when heated causes the liquid to circulate, giving an even temperature. Being mounted on casters, it can be moved about easily. By means of a flexible cord it can be attached to any ordinary light socket. The 500-watt size, the second of four sizes made, can be operated at about two cents an hour where four cents per kilowatt-hour is the charge for current.

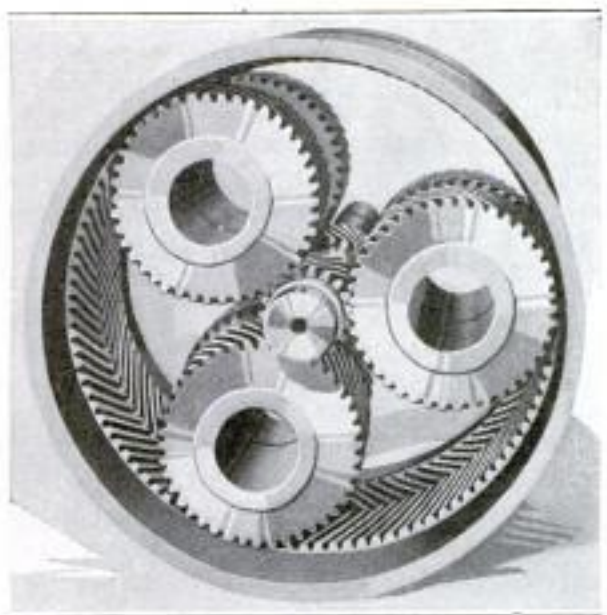

Internal Helical Gear Forms Compact Speed Reducer

Over 87 per cent of the parents participating in a recent post-card vote on the question, favored elementary military training in the Chicago high schools.

Turbo-Gear Co.,  
Industrial Bldg., Balto., Md.

**ELABORATE CALCULATOR FOR SIX CURRENCY SYSTEMS**

*4627*

A calculator which shows not only money values of one country in terms of several other countries, but applies those values to various quantities,

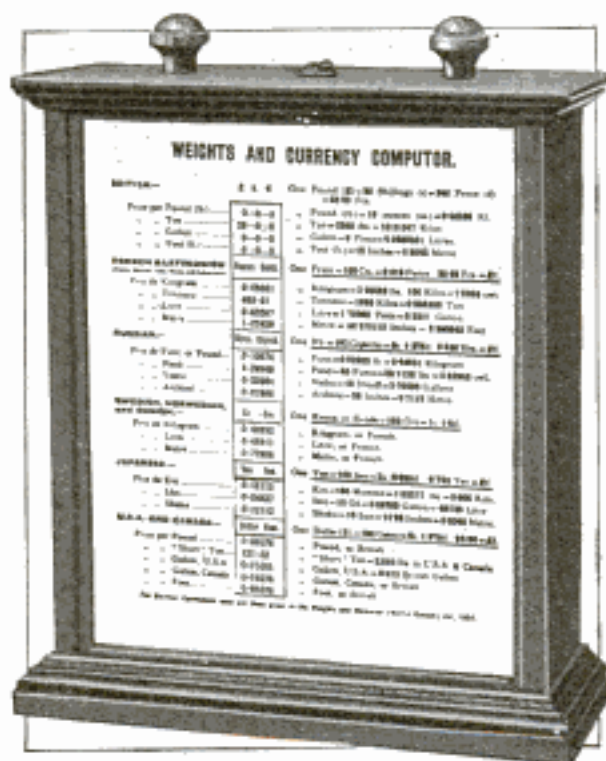

With This Device Prices per Foot, Ton, Pound, or Gallon can be Translated Quickly into Prices Expressed in Foreign-Money Terms Applied to the Proper Foreign Unit of Measure

namely, pounds, tons, gallons, and feet, and likewise to corresponding foreign measurements, has been patented by an English inventor. Thus, if an importer knows that the price of rice, for example, is 3 d. per lb. by English standards, the calculator will show that in Japanese terms the rice is worth .16115 yen per kin (or a trifle over 16 sen per kin). The device consists of a stationary sheet on which the tables of weights and measures of the various countries are printed one above the other. Another sheet placed under the former and wound on two spools set vertically in a case, contains columns of equivalent prices. A slot in the front of the case reveals one column at a time of this sheet, as shown in the illustration, and any column can be brought under the slot by turning the spools, the ends of which project from

the top of the case. Besides tables for England's allies, tables for the following countries are given: Sweden, Norway, Denmark, United States, and members of the Latin Union. Additional comparative data appear on the case.

**NEW TUNNEL IS LONGEST ON THIS CONTINENT**

*12694 C. S. Monitor 1-6-16*

The Rogers Pass tunnel, which is five miles long, has been holed through and now supplants the Hoosac tunnel in Massachusetts as the longest tunnel on this continent, exceeding the latter by about a quarter of a mile. The Rogers Pass tunnel is notable also for the manner in which it was built and the rapid rate at which the work was advanced. Two pioneer tunnels were driven parallel with the main tunnel, but about 50 ft. from it. From these drifts, crosscuts were driven to the center line of the main tunnel and from these the main headings were driven. By this means the work was greatly expedited. In July, 1915, the two pioneer headings were stopped when less than a mile apart, and from these points the main headings were driven forward, meeting December 19, the average advance for each main heading having been 520 ft. per month.

**ANY SPAN IN NEW BRIDGE MAY BE LIFT SPAN**

*1156*

A combined railway and wagon-road lift bridge across the Arkansas River, near Pine Bluff, Ark., has been built with lift towers which may be transferred from one portion of the bridge to another; the reason for this unusual construction being that the navigable channel is likely to change at times, due to the shifting sands that form the river's bed. The lift span is similar in design and dimensions to five other spans, and should the channel shift, the towers are simply transferred to another span. In the case of a near-by bridge such a shifting of the channel rendered a lift useless for passing

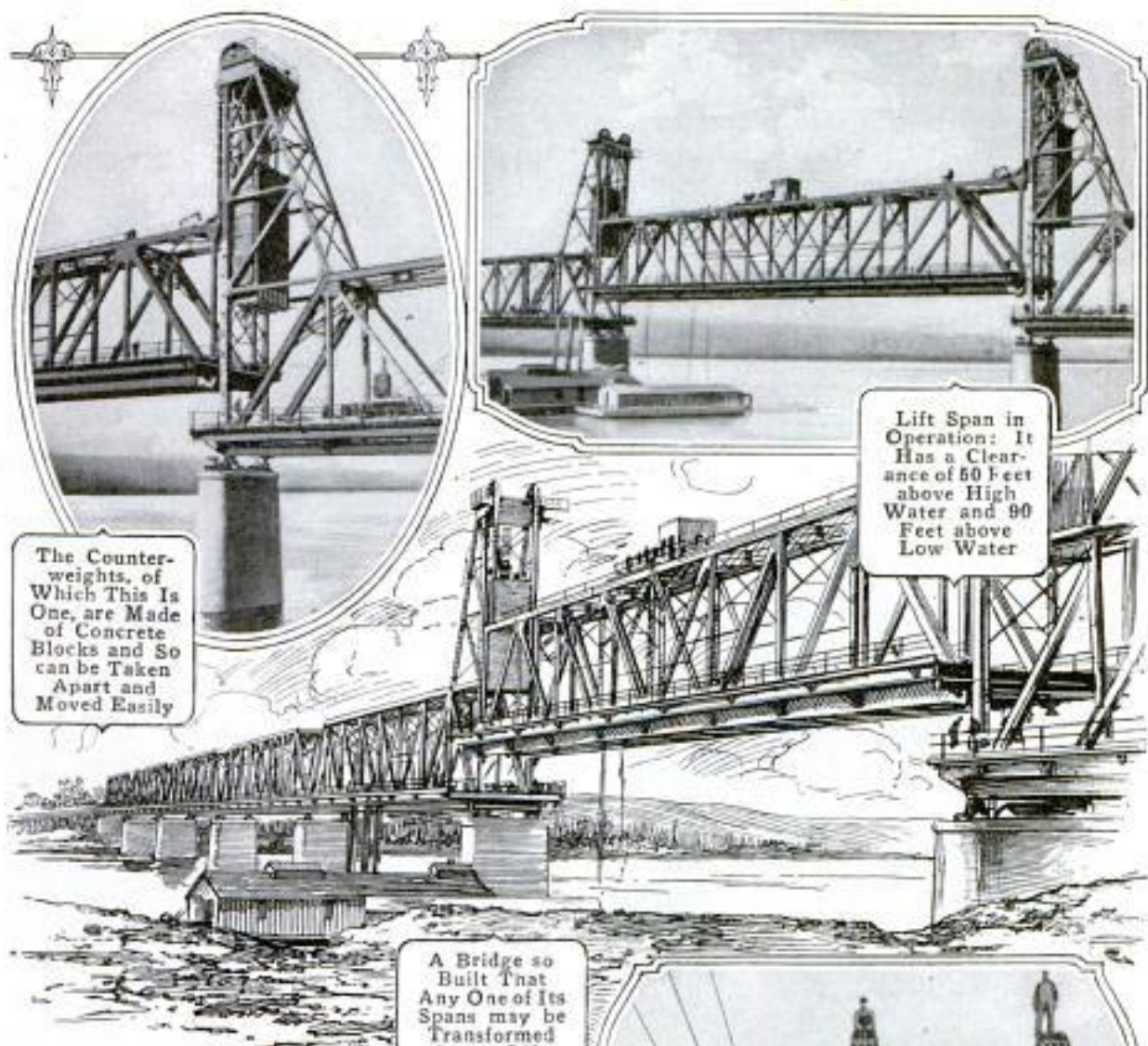

The Counterweights, of Which This Is One, are Made of Concrete Blocks and So can be Taken Apart and Moved Easily

Lift Span in Operation: It Has a Clearance of 50 Feet above High Water and 90 Feet above Low Water

A Bridge so Built That Any One of Its Spans may be Transformed into a Lift Span by Moving the Lift Towers

boats, so that another had to be constructed.

The lift span moves vertically through a height of 49 ft. so as to provide a clearance above high water of 50 ft., and above low water, of 90 ft. The horizontal clearance is 225 ft. between piers. Ordinary vertical-lift bridges operate with wire cables passing over drums to counterweights. In this bridge flat-link chains are used. The main counterweights are composed of pre-cast concrete blocks, supported in a steel frame. These can be taken apart and moved in case it is necessary to move the lift towers.

Another feature of the bridge is the cast-iron supplementary, or folding, counterweights, provided to compen-

One of the Lift Towers Showing Flat-Linked Chains Used Instead of Cables, and the Folding Counterweight, in Center, Which Counterbalances Weight of Chains as They Pass over the Drums

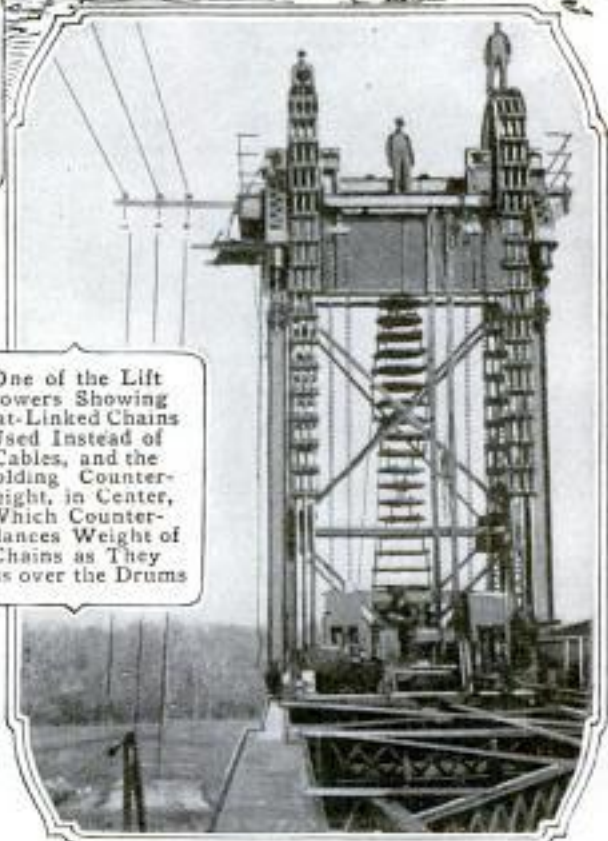

sate for the transfer of the weight of the chains from one side of the drums to the other. Each consists of cast-iron disks, 3 ft. 5 in. in diameter and  $2\frac{1}{4}$  in. thick, with projecting lugs for bolts which link them together. The upper disk is suspended from the tower by two bolts. The second is suspended from the first. The third is suspended from the second, and so on. The bolts in each disk are rotated slightly with respect to the bolts above.

When the main counterweight is at its lowest position, the folding counterweight is extended so that all disks are 1 ft. apart. As the former rises it picks up these disks, one at a time, their loose-fitting bolts permitting them to rest one on the other. When the main counterweight reaches its highest point it carries all the disks which counterbalance the links of the chains extending downward from the other side of the drums.

### 1110 **SURGICAL DRILL IS DRIVEN BY ELECTRIC MOTOR**

For surgical purposes a motor-driven drill has been developed which, among other things, facilitates the operation



of boring into a bone when such procedure is necessary to relieve a fracture. Its parts are entirely inclosed in a metal housing which has somewhat the appearance of a large pistol. It is so constructed that after being used it may be placed in an autoclave with steam at a pressure of 15 lb. and thoroughly sterilized without being injured, providing it is subsequently dried with care. The chuck at the end of its propulsion shaft will receive a drill, or bur of almost any type, up to  $\frac{1}{4}$  in. in diameter. The housing is ar-

ranged so that it may be removed quickly when the motor requires attention. Sunk in a pistollike handle at the posterior end of the device is a button controlling the motor, which has three speeds, varying from 1,200 to 4,500 revolutions a minute. A second handle, which may be adjusted to various positions to suit the demands of the user, is fitted, by means of a broad band, over the forward part of the shell. The instrument weighs slightly less than six pounds, is approximately a foot long, and develops  $\frac{1}{15}$  horsepower.

### 1176 **ELECTRIC SEWING MACHINE FOR DOMESTIC USE**

One of the latest conveniences to be introduced for the modern housewife is an electric sewing machine of moderate cost. This is not an ordinary foot-power apparatus with a motor attachment, but an electrically driven machine specially designed. It may be connected with a house-lighting circuit just the same as a flatiron or fan, and operated at a low charge without any physical exertion whatever. The motor is compactly housed and permanently attached where it is out of sight, but within easy access. A light pressure with a foot upon the treadle starts the machine. Its speed is accelerated by increasing the pressure slightly. The needle stops almost instantly when the foot is removed. It is a matter of but a few seconds to change the machine so that it may be driven by foot power, if desired. This is done by disconnect-

H. Jas. Dawson  
 Htg. & Appliance Dept.  
 Commercial Edison  
 Chicago

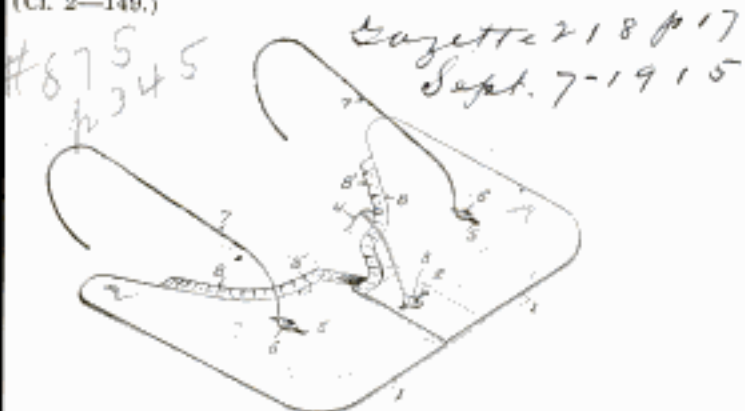

1. As a new article of manufacture, a shield for the purpose described formed of opaque material, and arranged to fit the face below the eyes to entirely obstruct a line of downward vision between the eyes and hands of the wearer.

2. An eye shield comprising a body portion opaque in its entirety, said body portion being provided with a nose-engaging portion, and ear-engaging portions adjustably connected to the body transversely to the length thereof.

3. An eye shield for students of touch systems in keyboard manipulation comprising a pair of adjustably connected opaque sections forming a continuous flat vision interrupting surface that is opaque in its entirety, and means for attaching the body to the face of the user to interrupt the vision between the eyes and hands.

4. An eye shield for use in teaching the touch system of keyboard manipulation comprising a body formed of two complementary slotted sections having their slotted portions arranged in overlapped relation with their slots in alignment, the sections being entirely opaque, a nose ledge having an engaging portion that engages the slots between the two sections, and ear-engaging means carried by the sections.

independently to the flexible planes for diminishing the same to reduce the air opposing areas thereof for regulation of the different speeds of the machine.

[Claims 6 to 17 not printed in the Gazette.]

1,152,433. TIME-SWITCH. THOMAS J. MURPHY, Rochester, N. Y. Filed Aug. 5, 1914. Serial No. 855,341 (Cl. 161—25.)

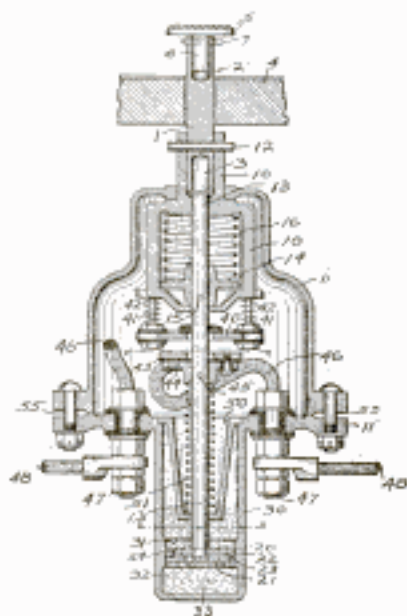

1. The combination of a housing, a contact connected to the housing, a rod movable in the housing, a spring for actuating the rod in one direction relative to the housing, a second contact secured to the rod, a releasable buffer secured to the rod and a second spring for returning the housing, contacts and the rod to their normal positions.

2. The combination of a pair of contacts, a member for holding the contacts, a rod movable in the housing, a spring for actuating the rod in one direction relative to the housing, a second contact secured to the rod, a releasable buffer secured to the rod and a second spring for returning the housing, contacts and the rod to their normal positions.





ing a chain attached to the treadle and changing the belts. The machine itself is of a recent type, having the needle immediately in front of the operator so that there is no necessity of constantly leaning toward the left side while working, as was true with old machines. A pressing board and an electric flatiron are supplied with the equipment.

ⒸAbout 1,000 skilled mechanics have been released from the Canadian contingent in England to work in munition plants.

## TEACHING OF TOUCH SYSTEM AIDED BY EYE SHIELD

875 An eye shield which is worn in a horizontal position below the eyes and prevents the wearer from seeing his hands while operating a keyboard of any kind has been patented as an aid in teaching the touch system of typewriting, piano playing, etc. One design consists of two pieces of celluloid which overlap and are fastened by a pivot or rivet. One edge of the shield is shaped to fit closely against the cheeks and nose of the wearer. A

*Inv. Simon S. Muller  
Watertown, Wis.*

valance of some soft fabric is fastened to this edge. The two parts overlap at the point where the nose fits against the shield and are so fastened that they



This Eye Shield is Designed to Cut Off the View of a Typewriter Keyboard or Piano Which a Pupil may be Playing, and So Aid in Teaching the Touch System

can be adjusted to fit various forms of face. Ear bows, similar to spectacle bows, extend diagonally upward over the ears. The shield is also held in its horizontal position by a diagonal brace reaching from the shield to the nose. Another type is made in one piece and can be cut to fit the face exactly.

### STATUES IN PARK TO TELL STORY OF THE NATION

Groups of statuary, 20 in number, representing great epochs in the history of the United States are to be erected along East River Drive, Fairmount Park, Philadelphia, in compliance with the will of a former resident of that city. The income from approximately \$750,000 has been provided for this purpose, and an association in whose custody the funds are placed is now seeking appropriate designs from leading sculptors for this notable public improvement. It is proposed to erect these works of art 100 ft. apart on the line of the East River Drive. Fully 10 years will be required to com-

# W. M. Watson, Morton, Pa.

# Robert W. Phelps,  
185 Ardmore av.,  
Los Angeles

plete the task. The income from the bequest is more than \$20,000 per year. When the series of historic groups is completed the will provides that the income is to be used in purchasing and placing in the park other works of art. This beautiful recreation spot is already famous for its statuary, and the prospective additions promise to make it one of the most richly embellished parks in America.

### FISHERMAN USES HIS SAIL AS A CANOPY ON LAND

The sun beats down fiercely on certain portions of the Pacific shore line of the United States, but out of the direct rays of the sun the air is cool. An ingenious fisherman who has built a shack in a treeless region on the western coast has found it profitable to use his sail not only to propel his boat but as a shelter for his shack while he is on land. By hoisting it above his abode he protects from the sun both



Western Fisherman Utilizes His Sail to Shade His Shack and Catch of Fish from the Sun

*Journal*

# PHOTOGRAPHY OF THE PLANETS BY INVISIBLE RAYS

1200

By R. W. WOOD

*Johns Hopkins University Baltimore, Md.*

**P**RACTICALLY all sources of light emit rays which make no impression on the eye. If we pass a beam of white light through a prism it is decomposed, or spread out, into a rainbow-colored band or spectrum, and in addition to the colors which we see, there are invisible "infrared" rays adjoining the red, and "ultraviolet" rays beyond the violet. These rays can be detected by photography, and by other means. Objects illuminated by white light reflect these invisible rays to a greater or less degree, depending upon the nature of the substances of which they are composed. By the use of suitable ray filters, or screens, placed before the lens of the camera, which cut off the visible light but transmit the infrared or ultraviolet light, we can secure a picture of the object made by invisible rays, and in some cases draw certain inferences regarding the reflecting material.

**E**xtensive experiments which I have recently made have brought out many interesting facts. For example, it was found that while some white flowers reflect the ultraviolet rays to a considerable degree, the majority come out quite black in the photographs. Certain white pigments (Chinese white,

for example) appear quite black in ultraviolet light, and alterations or erasures on documents, made by chemical ink erasers, are instantly brought out, and in some cases the erased words are faintly visible in the pictures. Applied to astronomical problems, the photography of the moon by ultraviolet light showed an extensive dark deposit near one of the craters, which is quite invisible in yellow light, and

check experiments made in the laboratory indicated that it was probably sulphur, or some sulphur-bearing rock. During the past autumn I have continued the work at the Mount Wilson observatory in California with the largest telescope in the world, a 60-in. reflector with a focal length of 80 ft. Photographs were made of the planets Saturn and Jupiter by infrared, yellow, violet, and ultraviolet light. The infrared screen was made from a combination of aniline dyes,

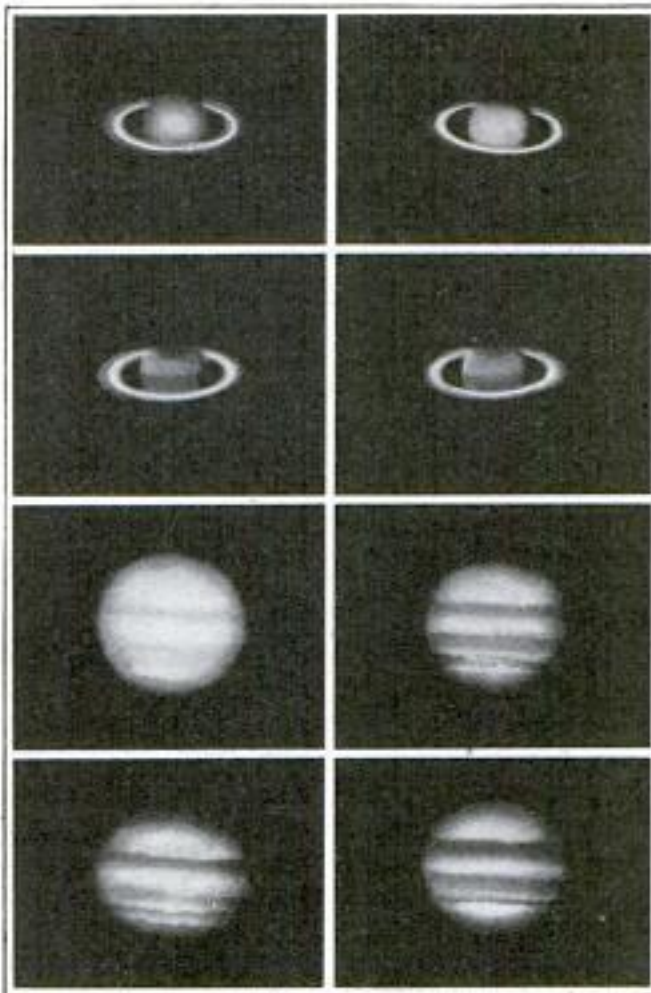

The Four Top Views Are of the Planet Saturn. Reading from Left to Right, They were Taken by Means of Infrared, Yellow, Violet, and Ultraviolet Rays. The Four Lower Pictures Show Similar Views of Jupiter, Arranged in Like Order

and was similar to the screens by which the remarkable photographs of landscapes with snow-white foliage against a coal-black sky were taken.

For the ultraviolet work a new type of screen was used consisting of a rectangular glass cell closed by quartz plates and filled with dense bromine

vapor, which is one of the asphyxiating gases used in the present war. Very remarkable differences in the appearances of the surface markings appeared in each case.

The differences were most striking in the case of Saturn, which in a powerful telescope is seen to be crossed by two or three faint cloud belts parallel to the equator, and the great ring which surrounds the ball of the planet. This appearance is shown in the photograph taken with yellow light. In the picture made by infrared light there is scarcely a trace of these belts, the ball appearing uniformly illuminated, while the picture made by violet light shows a very broad and very dark band below the region occupied by the faint belts seen in yellow light. A dark polar cap also appears. This very remarkable dark belt shows equally well in the ultraviolet photograph, though it is not quite as broad in this case, and the polar cap is smaller and less sharply defined. It seems probable that a spectroscopic study of these markings will be of great assistance in the determination of the materials in the planet's atmosphere which cause these striking differences. It

may be an absorbing gas, such as chlorine, or possibly a fine mist or dust, which refuses transmission to the shorter waves of light (violet and ultraviolet). Jupiter also showed marked differences. The cloud belts, which are visible even in very small telescopes, are barely distinguishable in the infrared photograph; they come out well in the yellow one, while on the records made by violet and ultraviolet rays they are still more marked, and new ones come into view across the upper portion of the planet. A spectroscopic study of the two planets is to be made shortly at the Mount Wilson observatory, and until the results of this are known it would be rash to hazard a guess as to the composition of the atmospheres of these two planets. The photographs have pointed out the importance of making such a study.

Unfortunately the planet Mars was too far away for satisfactory experiments, though one photograph of it was made by ultraviolet light. When it comes into our neighborhood again, it is probable that results even more interesting than those obtained with Jupiter and Saturn will develop.

## INDICATOR HELPS MOTORMEN

### KEEP SCHEDULE TIME

A time-schedule indicator, particularly useful for motormen, is being employed on an English tramway.

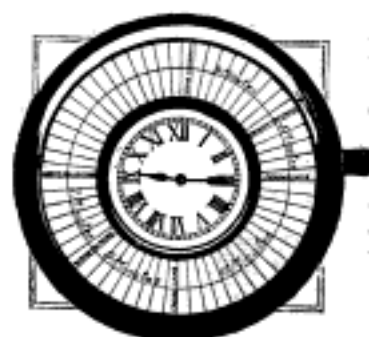

The central portion of the device consists of an ordinary clock. About the face of the clock is a large circular frame into which is fitted a cardboard

ring. This is divided by radiating lines into 60 equal segments corresponding to the minutes of the hour. The names of the stops on the motorman's trip are written in clockwise or-

der on this ring. The number of spaces separating the names corresponds to the number of minutes apart these points are on the schedule. The cardboard is then placed in the frame so that, at the time of starting, the minute hand of the clock will point to the name of the place where the journey begins. As the trip continues the motorman can tell at a glance whether he is ahead or behind his schedule. If desired, the return journey can be indicated on the other side of the cardboard. In case the trip is of more than an hour's duration a second ring can be inserted at the end of the first hour.

Arrangements are being made to supply the United States Coast Guard Service with aeroplanes to assist in locating derelicts and distressed vessels.

*"Time Schedule Indicator"*  
*The Bressford Co., Ltd., Dickinson St., Salford, Manchester, Eng.*  
*used in Salford, Eng.*  
*from Tramway & Railway World, London, Eng.*

Women's Clothing 1927

# COMFORTABLE COSTUMES FOR THE OUTDOOR GIRL



Forestry Cloth Is the Material Used in the Three-Piece Hunting Suit, Consisting of Breeches, Coat, and Skirt, Shown at Left. The Skirt is Made to be Worn Also as a Cape. Polo Coat and Breeches of English Melton are Pictured in the Middle. The Vest is of Hunter's-Green Billiard Cloth with Silk Polka-Dot Sleeves

COPYRIGHT,  
INTERNATIONAL  
FILM SERVICE,  
INC.

A Vest of Hunter's-Pink Duvetyne is Worn with the English Melton Riding Habit Above at the Right. The Derby Is of Hatter's Plush and Boots Black Russian Calf

Smart Three-Piece Sweater Set for Skating or Walking. At the Right the Chic Hat, Cushion, and Mufflike Workbag Compose a Catchy Outfit for the Beach Girl at Winter Watering Places

Underwood & Underwood, 437 Fifth Av. New York 349  
 Int. Film Service, Inc., 238 William St. N.Y.  
 Copyrighted material

*Telephone*  
*11887*

**SERVICE MAINTAINED WHILE SWITCHBOARD IS MOVED**

A telephone switchboard was used in answering calls while being transferred by elevator from a temporary

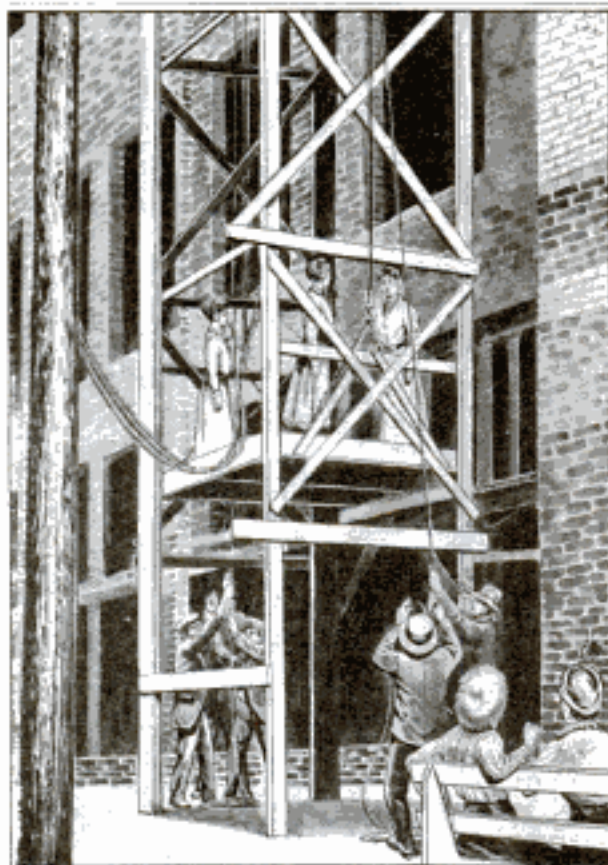

By Lifting Simultaneously a Telephone Switchboard and Two Operators in This Temporary Elevator a Telephone Company Was Able to Give Its Subscribers Uninterrupted Service While Transferring Its Apparatus to the Second Story of Its New Building

shelter to the second floor of new telephone headquarters. This occurred recently in an Oklahoma town. After all the connections had been properly adjusted and after the new location was made ready the switchboard and two telephone girls were placed on a temporary elevator constructed outside the building and hoisted to the second floor. During the transfer not a single connection was lost or delayed. The new building is on the site of the one formerly used. When the time came to tear down the old one, the telephone apparatus was moved entire to temporary quarters without causing the subscribers any inconvenience or loss of service.

**LONG NATURAL-GAS PIPE LINE FOR WINNIPEG**

A natural-gas pipe line, 800 miles long, is being constructed from the wonderfully rich natural-gas fields of southern Alberta to Winnipeg, Manitoba. This project, which ranks with the greatest undertakings of its kind, will cost \$10,000,000. The proposed line has been under consideration for some time, but only recently was it announced that the necessary bonds had been floated. Previous to that action the entire proposed route was examined in detail by expert engineers. When the line is completed it will supply about 20 towns and cities in addition to Winnipeg. These will include Brandon, Regina, and Moose Jaw. Very great reductions in fuel costs are predicted as a result of this big improvement.

**NOVEL SUBSTRUCTURE BUILT FOR WATERWORKS CRIB**

In design, the substructure of a crib recently constructed for the intake connection to a new waterworks tunnel under Lake Michigan at Chicago is novel. It is of a type quite different from any hitherto employed by the city. Instead of entering the tunnel through sluiceways at the level of the tunnel, the water is taken in through ports above the bottom of the lake and rising to the water level inside the crib overflows, through screens, into a vertical well connecting with the tunnel below the crib. Essentially it consists of two concentric steel shells, the inner one cylindrical and the outer conical, joined by radial arms. It is bottomless, has a diameter of 90 ft. at the base and embodies approximately 450 tons of steelwork. The first section is vertical and 17 ft. in height. From this point the outer shell tapers to a height of 45 ft., where it has a diameter of 70 feet.

The erection of the device was started on a scow, 106 ft. long and 26 ft. wide, and four pontoons, each about 15 by 30 ft. in size. When the first,

*Substructure*

# Henry W. Clausen  
 Supt. of Water Works Construction,  
 City Hall  
 at Wilson W. Crib. POPULAR MECHANICS  
 Chicago.

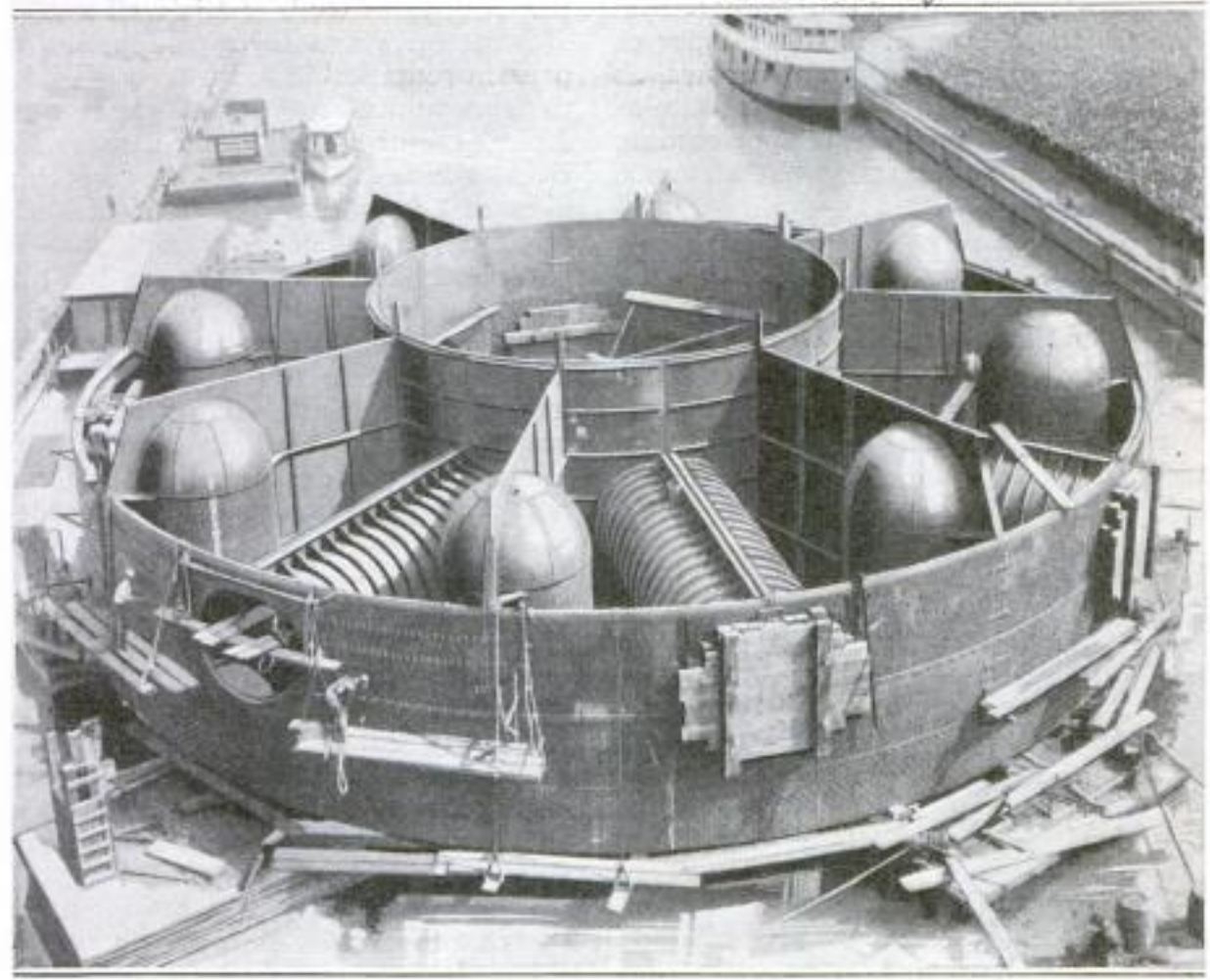

Sealing the Ports in the Substructure in Order to Provide a Sufficient Air Column to Keep the Shell Afloat during the Remainder of Its Construction

or vertical, section of the structure had been completed the ports were covered with bulkheads, the flotation chambers filled with air, and the scow and pontoons flooded and withdrawn by a tug. The rest of the work was then erected and the structure towed into the lake to a point three miles off the foot of Wilson Avenue, where it was sunk 35 ft. by admitting water to its buoyancy chambers. Subsequently the water between the inner and outer shells was pumped out and the space filled with concrete.

the desk roughly resembles a rectangular "U." The person using it sits between the two arms of the "U," facing the connecting portion, which is

**DESK AND RECORD CASE**  
**930-F COMBINED**

A combination desk and record case which is being manufactured has a capacity for several thousand cards, all of which are placed within arm's length of the user. The outline of the top of



This Combination Desk and Record Case Makes Thousands of Cards Almost Instantly Available to the User

Library Bureau,  
 6 No Mich. Av., Chicago.

The Boston Store J. H. Clark 137 W. Laska St.,  
 Albert Piers & Co. 712 W. Randolph St.  
 William Diller 77 N. 5th St.

352

**POPULAR MECHANICS**

Wallbrenn-Kling 317 S. Clark Chicago

smooth-topped like an ordinary writing table. In the top of the remainder of the desk may be set cards in rows, as shown. Any desired card is obtainable very readily, since its approximate location can be determined at a glance.

mosquitoes as well. As is well known, Havana once was fever-ridden, and its present remarkable health record is due to scrupulous municipal cleanliness. No source of flies or other disease carriers seems to escape the watchful eyes of the sanitary staff of the city. Recently an officer reported that he had observed a plant grown in the residential district which apparently was breeding flies. Experiment showed larvæ present in the fruit. If further investigation confirms this finding all plants of this kind in and around Havana will be destroyed and the vigilant officer will be especially rewarded.

**KNEE CUSHION INCREASES FLOOR WORKER'S COMFORT**

606  
D

Cement finishers, tile workers, floor polishers, carpet layers, and many "The Humana"

J. J. Hennessy  
159 W. Illinois St.



Padded Knee Cushions Reduce Discomfort of Kneeling Posture

others, must work most of the time in a kneeling position. For their special convenience a new kind of knee cushion has lately been brought out. It is made of heavy leather, thickly stuffed, and held in position on a man's leg by straps at each end. Using the cushion tends to prevent muscular cramps, "housemaid's knee," and similar afflictions which trouble workers at these trades.

**FLIES VIRTUALLY UNKNOWN IN HAVANA**

"A city without flies"—an ideal of sanitarians still regarded as an impossibility by many—is an accurate description of Havana, Cuba, which not only is free from these pests, but of

**FERRY USES CHAINS AS GUIDE ACROSS RIVER**

2008

To cope with an exceedingly strong current a curious ferry on the River Tamar at Saltash, South Devon, England, makes use of a pair of heavy chains firmly attached to the shores on either side. They lie on the bed of the river and a cogwheel arrangement on the boat worked by steam picks up the chains link by link as the river is crossed. Though very old, the ferry

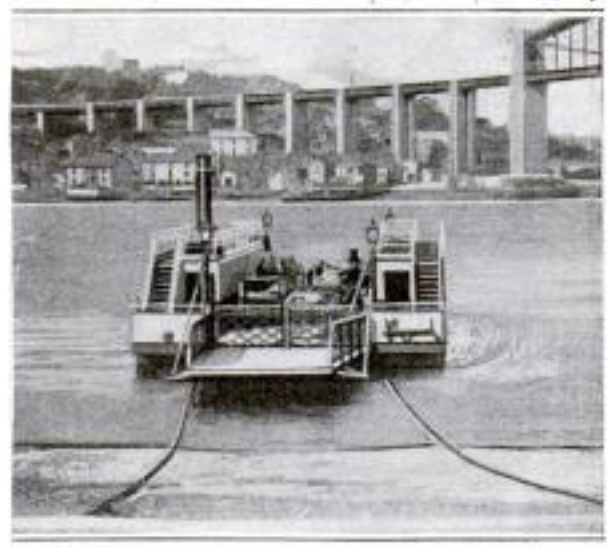

Ferry across River Tamar in England Uses Chains Attached to Shore As Guide in Coping with the Strong Current

is still in successful operation and makes a number of trips each day.

⌈The use of sea-lion hides for leather has been proposed in Canada.

# A. W. Butler, Reed Hill House, Worcester, Eng.

Commerce Reports  
12/13/15



*Inv. Geo. D. White  
1927 No. Broadway 10 Jefferson St  
Los Angeles*

*1314* **BABY MONOPLANE IS DRIVEN BY MOTORCYCLE ENGINE**

*1918/16 White Aeroplane Co. 619 Exchange Bldg. Los Angeles*

What is undoubtedly the smallest successful monoplane in the world has recently been constructed by a Californian. In addition to this distinction the machine is almost as unusual in design as it is in size, for it is driven tail first by an ordinary 7-hp., twin-cylinder motorcycle engine. It weighs, complete with its gasoline tank filled, only 238 lb., has a wing spread of 18 ft., an over-all length of 16 ft., and a supporting area of about 90 square feet. The motor drives a 4½-ft. propeller at about 1,400 revolutions a minute, giving the craft a speed of nearly 60 miles an hour. The power plant is placed at the extreme rear of the machine so that its weight is balanced by that of the pilot who rides several feet ahead of it. In this particular the craft is apparently well de-

signed. The tail-first feature of the machine loses much of its oddity when the early types of the Wright biplane, which had their elevators forward, are recalled. The machine has been driven a number of times, and during these

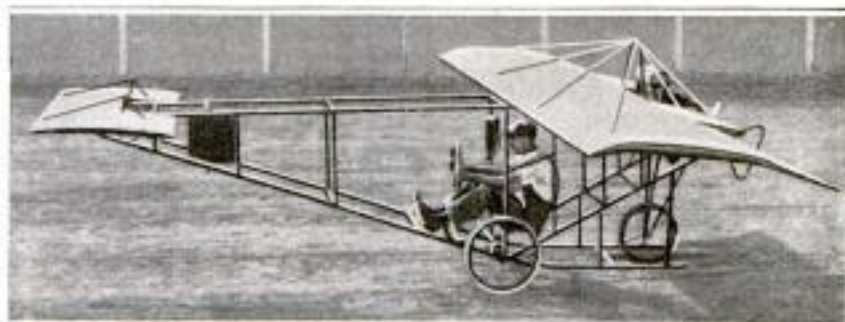

This Tail-First Monoplane, Probably the Smallest Flier in the World, is Propelled by a Seven-Horsepower Motor

flights has remained in the air from 15 minutes to a half hour. To many, at first sight, it might appear impossible for the small motor to even lift the machine off the ground. It should be realized, however, that the craft it has to lift in its new function is more than 100 lb. lighter in weight than the motorcycle from which the engine was taken.

**HAND CAR DRIVEN BY MOTOR WHEEL AT LOW COST**

*1331* *Mudge & Co., Ry. Exch. Bldg., Chicago.*

A power-driven railroad velocipede which is inexpensive to operate and capable of comparatively high speed has been devised by attaching a motor wheel to an ordinary three-wheeled hand car. The power wheel is fastened flexibly to the rear of the velocipede in line with its two main wheels. Its weight is sufficient to keep its rubber tire from slipping on the steel rails. Attached to the handles of the velocipede are the throttle and other controlling apparatus. A speed of 21 miles an hour has been obtained

with this car, and 103½ miles have been traversed with one gallon of gasoline. The wear on the tire is slight.

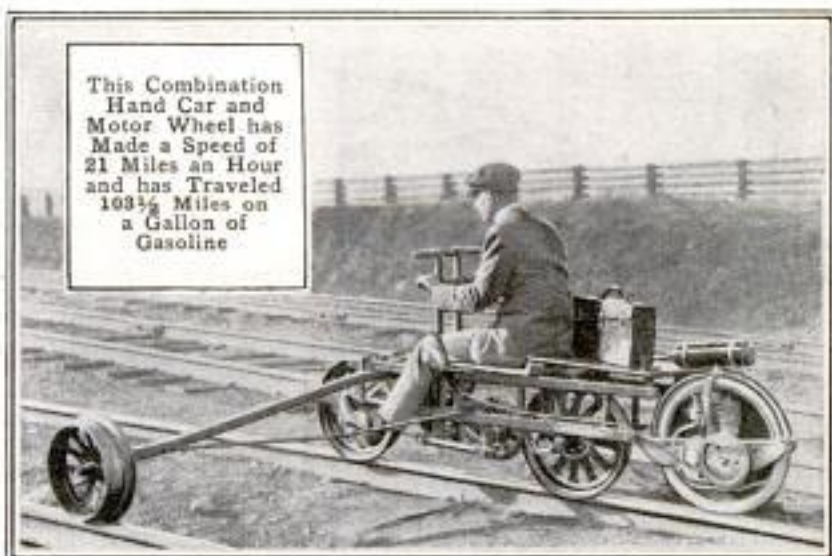

1276

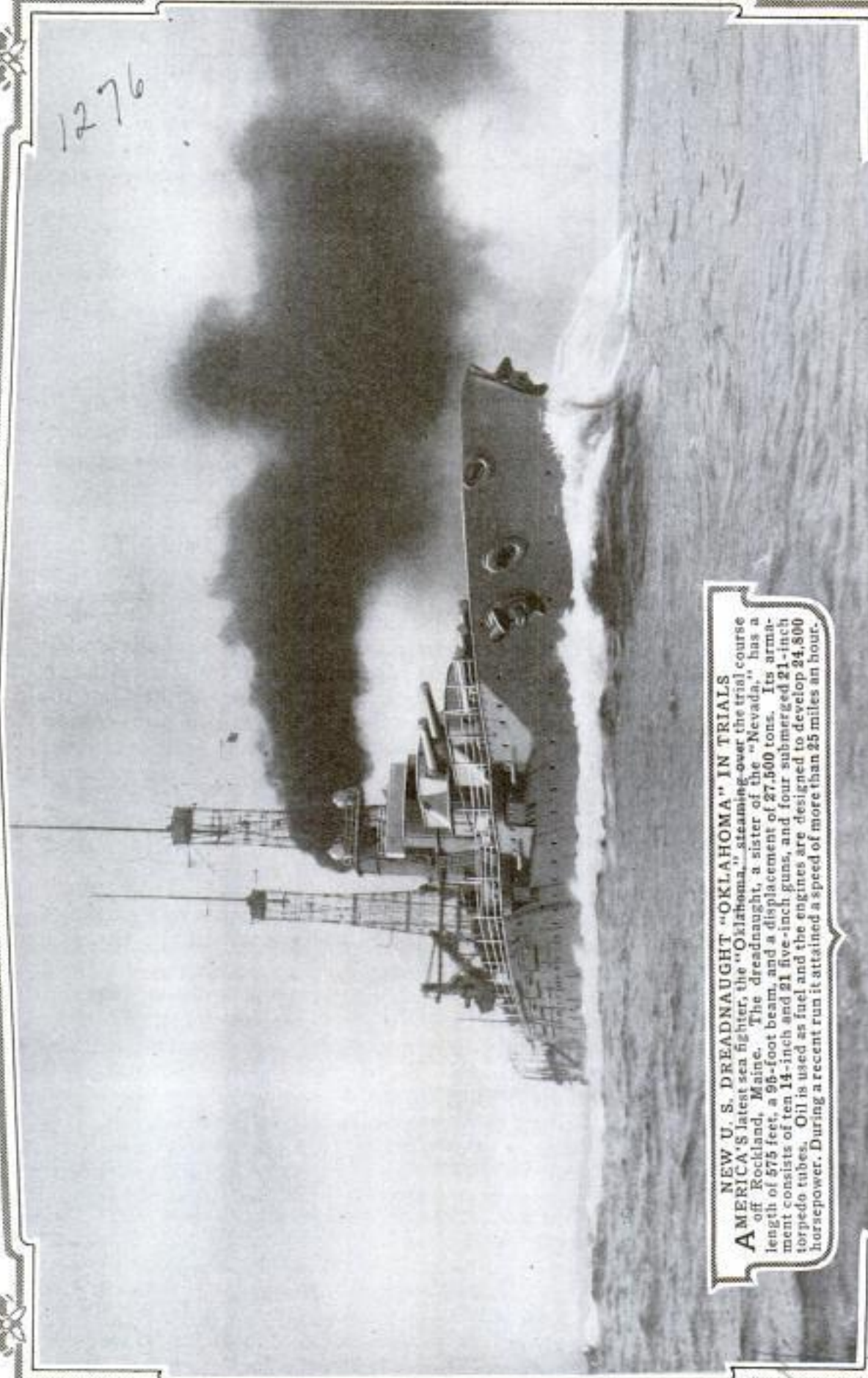

**NEW U. S. DREADNAUGHT "OKLAHOMA" IN TRIALS**  
AMERICA'S latest sea fighter, the "Oklahoma," steaming over the trial course off Rockland, Maine. The dreadnaught, a sister of the "Nevada," has a length of 575 feet, a 96-foot beam, and a displacement of 27,500 tons. Its armament consists of ten 14-inch and 21 five-inch guns, and four submerged 31-inch torpedo tubes. Oil is used as fuel and the engines are designed to develop 24,800 horsepower. During a recent run it attained a speed of more than 25 miles an hour.

P. O. Box 530, New York

COPYRIGHT, E. MULLER, JR.

# Lewis R. Freeman  
(Temporary address) R. H. H. Navarre Hotel,  
New York

## THE NEW BRITISH ZEPPELIN DESTROYER

1336

By R. J. BJURSTEDT

WHY did England have three months immunity from air attack? and why, when these attacks were renewed, did they come in the form of aeroplane rather than Zeppelin raids?

Probably no one person, either in England or Germany, could answer both of these questions definitely, and the best that the writer—who has recently come from the war zone—is able to do will be to tell of one or two developments which have had a considerable bearing on the situation.

That the destructive air raids of the night of Oct. 13, 1915, were not repeated on the several succeeding nights on which the state of the moon was favorable to Zeppelin operations was due to two circumstances: bad weather conditions and the fact that the air-defense squadrons of London—goaded by the taunts and criticisms of the indignant populace—took the desperate risk of night flights. The whizz of propellers was heard over all of the southern and eastern suburbs of the metropolis during each of the several nights following the big raid, and on at least two occasions the "pride of place" thus attained was responsible for the turning back of reconnoitering Zeppelins.

What the cost of this reckless expedient was, only Sir Percy Scott and those intimately associated with him in the air defense of London are able to tell, but it is certain that it was very heavy. Outside of a few guiding lights in Hyde and Regent parks, and at Hendon and other of the suburban flying stations, London—unlike Paris, which has adequate facilities for flying at all times—has no provisions for night landings. The number of accidents on the occasion in question—judging from the reports on the streets of London spread by those who claimed to have actually seen the wreckage of aeroplanes at widely separated points in the environs of the metropolis—was very considerable. The writer was taken by a friend to

the country place of a neighbor of the latter where an aeroplane had crashed down into a huge beech-tree at five o'clock on the morning of October 15, supposedly as a consequence of engine trouble. Both occupants had been killed and the machine torn to pieces. Every vestige of the wreckage—including souvenir fragments taken away from the owner of the place—had been removed by the air-defense men before 10 o'clock of the following day, and only the battered and scarred old beech remained to bear its silent evidence of the tragedy.

This measure won London a dearly bought immunity during the remaining moonless nights of October (the Zeppelin menace is considered almost negligible on nights when the moon is sufficiently bright to allow safe aeroplane action), and by the time the "open season" of November had arrived, a new instrument had begun to figure in the air defense of England. This is what might be called a Zeppelin destroyer. No official statement has yet been made regarding it, but the writer has learned enough to be able to state that the new machine is a small, heavily engined and extremely fast dirigible which is calculated to bear about the same relation to the great German airship, against which it is built to operate, as the submarine boat does to a battleship or cruiser.

Not until the war was well launched did the government of Great Britain realize that, in neglecting to develop a large rigid-framed airship as an offset to the Zeppelin, it had been guilty of almost as great a neglect as Germany would have been chargeable with had it failed to follow England's dreadnaught lead on the water. Had the Zeppelin proved a sweeping success as an offensive instrument, England would have been left helpless, as indeed she may yet be should time and events prove that large Zeppelin squadrons can cross the North Sea and attack with the same impunity enjoyed by the scattered units so far employed.

Realizing the futility of endeavoring to develop during any probable duration of the war an adequate rigid-framed airship capable of meeting the Zeppelin on equal terms, the British bent their efforts—once order began to resolve out of the chaos of the first few months of the war—to the construction of a Zeppelin destroyer. As the Zeppelin itself—with its large crew, heavy engines, and huge fuel supply—must, to a certain extent, sacrifice speed and mobility to weight-carrying capacity, the way seemed open for the construction of a swift non-weight carrier which, while able to out-speed and out-maneuver the Zeppelin, would still be far more stable and generally safer than the aeroplane. This is the type the British have striven to perfect, and, from what I have been able to gather in England, not without considerable promise of success.

No one has yet reported seeing one of the new machines in the immediate vicinity of London, but in November, 1915, the writer, on a short visit to a port near the mouth of the Thames, saw pass in the twilight a strange "hybrid" which bore close resemblance to the descriptions that had been given him of the Zeppelin destroyer. From this glimpse I would describe it as either a heavily planed dirigible or a "ballooned" aeroplane. Whether the gas envelope had a rigid frame or not

I was unable to judge, and on this point there is a good deal of diverse opinion. It is agreed, however, that the destroyer has the speed of a very fast aeroplane, and, what is especially important in the work for which it is designed, can rise even more quickly than aeroplane or Zeppelin. The great points claimed for it are that, unlike the aeroplane, it can stay out all night and wait till daylight to pick a landing and, unlike the Zeppelin, can plane down to safety in case its gas bags are riddled. Being designed for defense, and having, therefore, no great fuel supply to reckon with, it is able to "run" to guns and engines, in both of which it is very powerful. The crew I have heard estimated as running all the way from a half dozen to twenty, and it is, of course, by no means unlikely that the machine has been built in different types and sizes.

I heard no definite account up to the time I left England at the beginning of this year, of an encounter between destroyers and Zeppelins, but I do have information that the presence in the air of these machines was responsible for turning back Zeppelin attacks at the coast on at least three occasions in November and December. Their real test, however, will only come when, or if, Germany essays her long-threatened big raid on London, and this may well have eventuated before these lines are in print.

## HYDROGEN EXPLOSION CAUSE OF SUBMARINE TRAGEDY

America's second submarine disaster occurred at the New York Navy Yard, January 15, when a gas explosion in the engine compartment of the "E-2" partly wrecked the interior of the craft and caused the death of five men, as well as the injury of several others. The submersible was in dry dock undergoing a general overhauling when the accident happened.

Hydrogen, generated by the storage batteries, accumulated in the engine room, forming with the air a highly

explosive mixture which became ignited by a spark of unknown origin. The boat is equipped with the new Edison batteries which are intended to prevent the generation of chlorine and other deleterious gases when the submarine is beneath the surface. Owing to the low voltage and amperage at the time, it is deemed probable that there was a reversal of the voltage in some of the cells, and that this was responsible for the development of an excessive amount of hydrogen.

During the official inquiry it was found that the starboard ventilating motor had not been running, and that

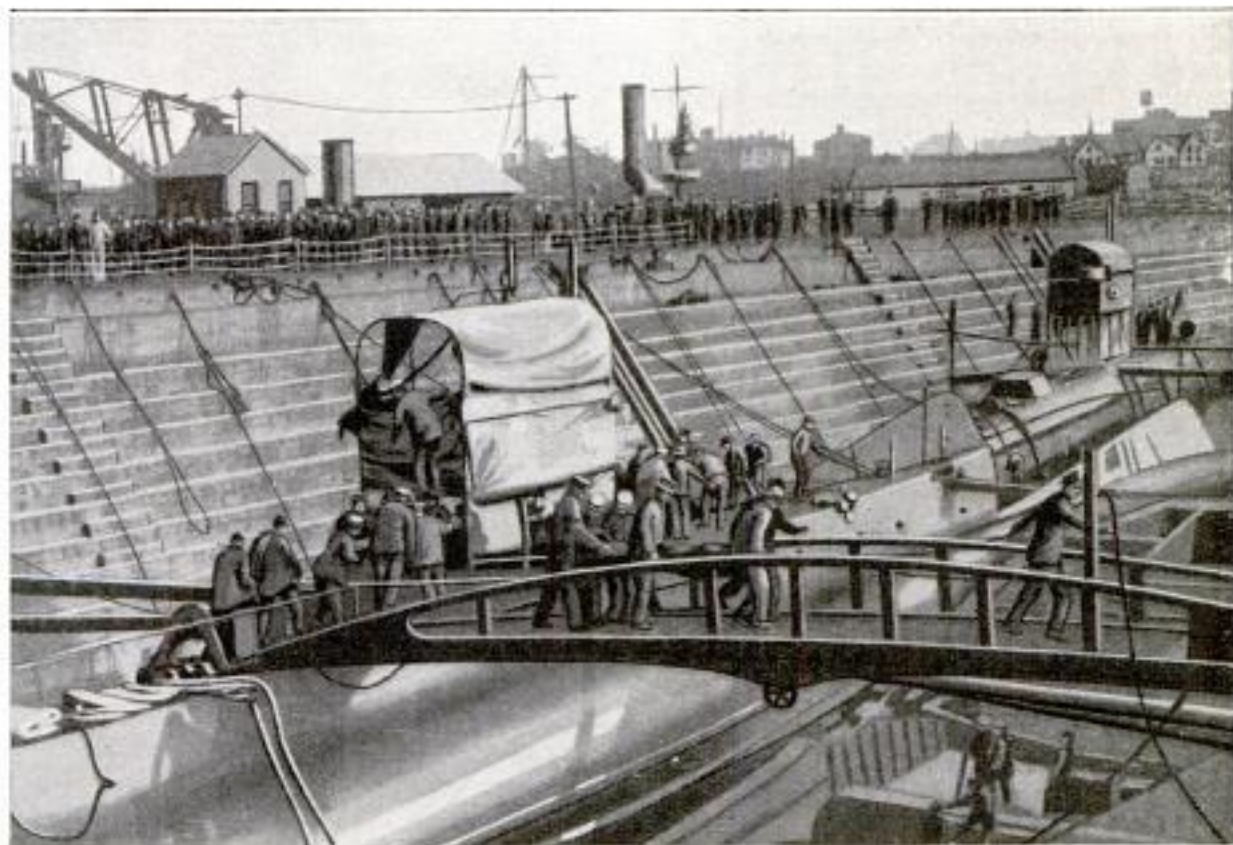

COPYRIGHT, INTERNATIONAL FILM SERVICE, INC.

Carrying the Dead and Injured from the Submarine after the Fatal Explosion.  
The Picture Shows the Craft Below

the starboard outtake of the after battery, through which hydrogen should be discharged into the open air, was closed. From these and other facts it was reasoned by one expert that the gas from the after battery passed from the compartment through a companion way, into the engine room, where the explosion was most severe. The board in its report stated, "that there were two pockets of this mixture, one at the after end of the after battery and the other at the forward end of the forward battery; and it appears that the initial explosion occurred at the after end of the after battery."

The batteries in the "E-2" were the only ones of the kind so far installed in a submarine. The same type, however, is being placed in the new "L-8," now under construction. When it is determined whether the batteries themselves were responsible for the explosion, the future policy regarding their use will be settled. According to the chief engineer of the Edison works, the batteries were not at fault. Before the disaster they had proved satisfactory.

## ICY WALKS MADE SAFE BY 1257 SAND SPREADER

The dangers due to icy sidewalks and pavements have been eliminated in Grand Rapids, Mich., through the use of a simple sand sprinkler drawn by one horse. It consists essentially of a heavy wooden bin, narrow at the bottom, with a capacity of a cubic yard of sand. This is mounted on an axle, connecting a pair of heavy wheels. In the bottom of the bin are about fifteen  $\frac{1}{4}$ -in. holes, 4 in. apart, which may be



This Device is Used for Sprinkling Sand on Icy Pavements: The Flow of Sand is Controlled by the Lever at the Rear

# Chester W. Shaper of The News  
Grand Rapids Mich.  
Copyrighted material

# J. Frank Reynolds,  
Box 101 Salem, Mass.

opened and closed by means of a lever fastened to the back of the bin as shown. By drawing the device about, thin trails of sand can be sprinkled wherever desired.

of the new structures are built of brick, and none of them is roofed with wooden shingles. Salem still bears many scars of its great disaster, for crumbled foundations of former buildings and charred trunks of trees are to be seen throughout the fire area. These marks, however, are rapidly being eradicated and a new and better-built city is springing up with surprising quickness.

*H* SALEM RISING FROM ASHES  
*1250* SURPRISINGLY QUICK

In a little more than a year and a half, Salem, Mass., has risen from a vast ash heap to a city of new buildings, a large percentage of which are at least semi-fireproof. The great conflagration which razed the historic place late in June, 1914, destroyed some 1,800 buildings and 41 factories. Already approximately 700 structures and 11 industrial plants have been erected in the midst of the ruins. One of the interesting features of this reconstruction is to be found in the fact that the taxable value of the new buildings exceeds by nearly \$1,000,000 that of the property which was destroyed. This is a graphic manifestation of the spirit which is being exercised by those who are rebuilding the city. The majority

*1293*  
*7* MUSIC TRANSMITTED BY  
*1234* WIRELESS TELEPHONE

A young California inventor has designed an apparatus whereby selections played on a phonograph have been transmitted to several neighboring homes which are equipped with special receiving instruments. In some instances the instruments have been installed in the dining room and by this arrangement the neighbors have been entertained at mealtime. A wireless-telephone apparatus upon which the inventor has been working several years is used at his central station. A

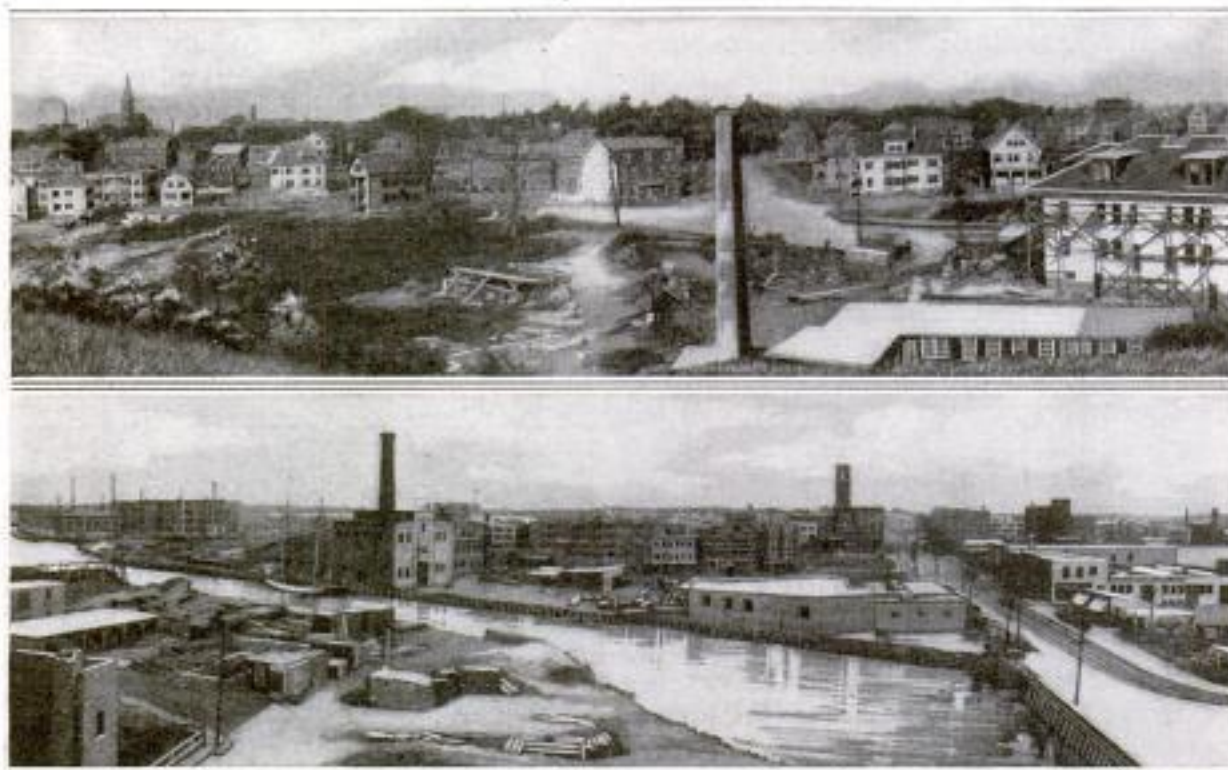

Top View: All the Buildings Included in This Panorama Are New except the Church in the Background at the Left, Which Withstood the Flames during Salem's Great Conflagration. Lower View: The Power House at the Left, in the Foreground, Is a Remnant of Salem before the Fire. The Rest of the Buildings, Most of Which Are of Brick Construction, Are New

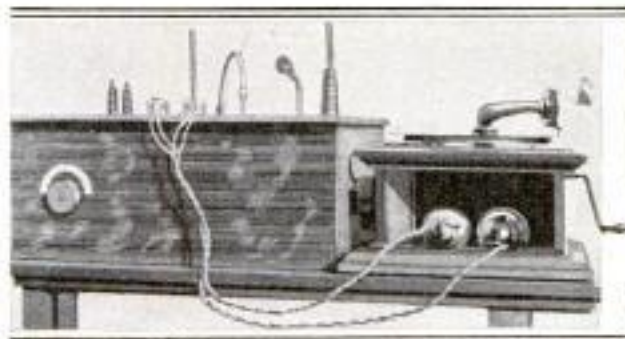

Wireless-Telephone Apparatus at the Sending Station Showing Transmitters Placed in the Horn of a Phonograph, Music from Which was Transmitted to Several Receiving Stations

phonograph, in which the horn is an integral part of the body of the instrument, is used in producing the selections. The slats are removed from the mouth of the horn and within it are placed two ordinary telephone transmitters, from which the sounds are carried by wires to the wireless-telephone outfit which, after serving as an amplifier, sends the waves through a cable to the aerial on the roof, whence they are discharged into the air.

The waves are caught by the various receiving stations and conveyed by wires to receivers, each of which is fitted with a small megaphone. In several instances head appliances with a pair of receivers were used. In others a single megaphone was sufficient for a group of persons. The inventor claims that the music heard at the receiving stations is fully as loud as that at the central station. By increasing or diminishing the amount of electrical energy used the volume of sound heard through the receivers is correspondingly varied.

### JAPAN ADORNS TRAMCARS IN

### 1246 *f* RULER'S HONOR

In the principal cities of Japan the street cars were decorated in celebration of the emperor's enthronement last November, many of them carrying curious emblems which brought into vivid contrast the ancient and modern aspects of that oriental country. In Tokyo and Kyoto the flower cars were particularly beautiful. Chrysanthe-

*# Elsie H. Weil, 4631 Ellis Av., Chicago.*

Library Table Equipped with a Receiver and Megaphone through Which was Heard Music from a Distant Phonograph Attached to a Wireless-Telephone Outfit



mums, cherry blossoms, wistaria, and Japanese flags were used profusely. Inscriptions on pennons proclaimed "Long Live the Emperor!" Symbolism played an important part in all the decorations. One car carried a "Feng-whang," a mythical bird, often called the Chinese phoenix, which according to Japanese tradition will appear only in countries ruled by a

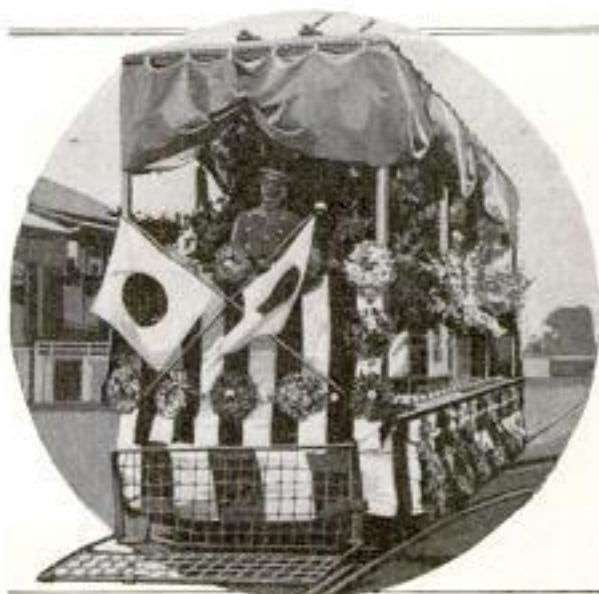

A Japanese Street Car Decorated with Flags, Chrysanthemums, and Electric Lights in Celebration of the Emperor's Enthronement

wise monarch. A turtle and a crane, symbols of long life and good fortune, were stationed on another car. Folk dances were performed on some of the trams by little girls.

7  
1296  
GIANT MAIL BOX A FEATURE  
OF PROMOTION CAMPAIGN

A United States mail box, 18 ft. high, 12 ft. wide, and measuring 6 ft. from front to back, has been erected on a



This Mail Box, Which Is 18 Feet High, was Erected in Portland, Ore., as a Feature of a Letter-Writing Contest Inaugurated by the Chamber of Commerce

X  
X  
business street in Portland, Ore., for the purpose of calling attention to and inviting contributions for a letter-writing contest which has been inaugurated by the chamber of commerce of that city. In design and appearance the box very closely resembles standard mail boxes used in many parts of the country. So tall is the receptacle that cleated ramps leading to a platform have been built in front of it for the convenience of its users. In the contest of which the mail box is a publicity feature, prizes have been offered for the best letters setting forth reasons why people in the eastern states should move to or visit Portland and vicinity.

CA society woman was badly burned recently when the spangles on her dress, which are supposed to have been celluloid, caught fire.

1323  
ARTESIAN WELLS TRANSFORM  
QUEENSLAND, AUSTRALIA

A great transformation has been wrought in the western part of the state of Queensland, Australia, since the practicability of tapping vast supplies of artesian water has been demonstrated. Now great tracts which have only a limited rainfall are well grassed and stocked with cattle and sheep. At the beginning of 1914, there were more than 2,000 artesian wells in Queensland, with an average depth of 1,061 ft. The deepest bore is over 5,000 ft. and yields 70,000 gal. per day, while in one instance 2,000 gal. per day is obtained at a depth of only 10 ft. The aggregate depth of all the wells is 417 miles. Analyses of the water show various results. Some of the bores yield

water that is good both for irrigation and domestic purposes; the supply from others can be used in irrigation only, and from still others is not suitable for either purpose.

H  
1257  
ELECTRIC-LIGHTED FLAGS  
ERECTED AT FACTORIES

In an endeavor to instill a sense of loyalty to America in the minds of the thousands of foreign-born workers employed in industrial plants throughout the country, a movement is being started to erect electrically illuminated flags on factory buildings in various parts of the United States. The propaganda is credited with having had its origin at Cleveland where the president of a factory had a massive electric flag placed on top of one of the company's biggest buildings. His reason for doing this was that the several hundred



*Frantz - Premier Co., Cleveland, O.*

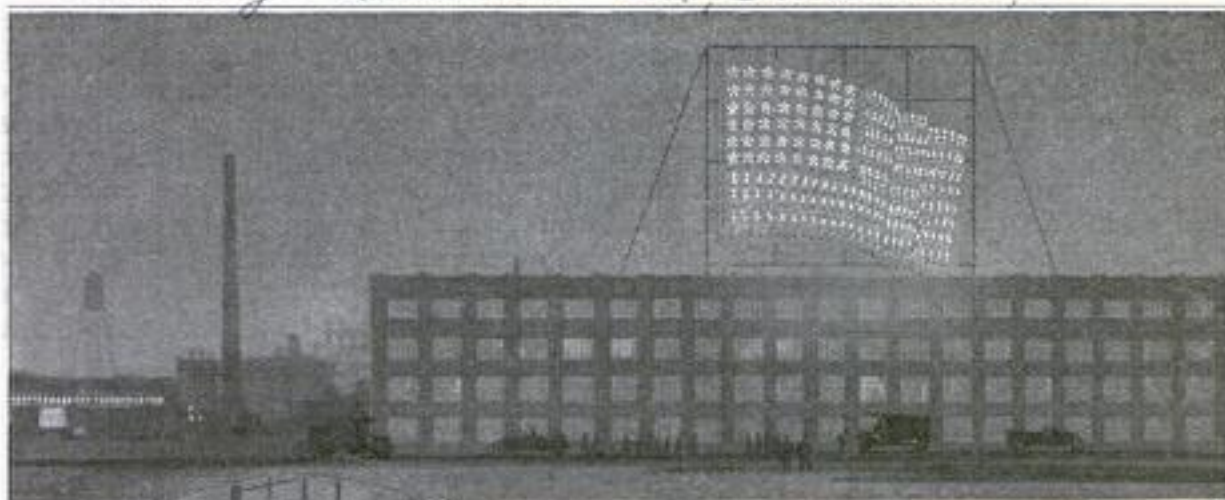

This Emblem, One of the Largest Electric Flags in America, "Floats" from the Top of a Factory Building at Cleveland

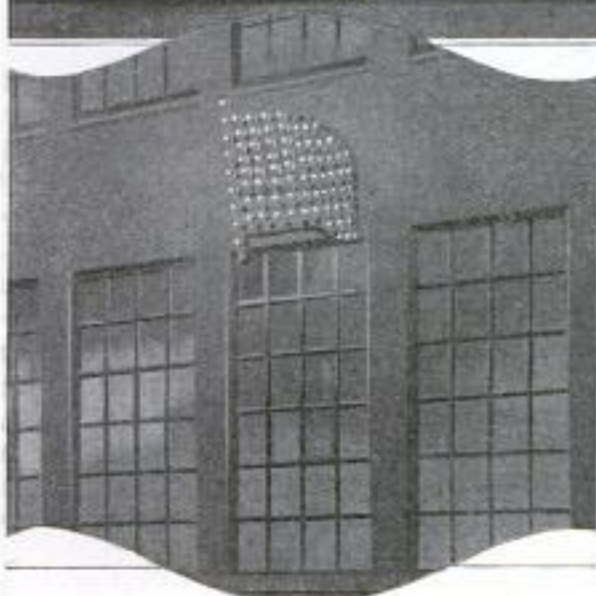

One of 22 Illuminated Flags Placed Inside and Outside of a Big Motor-Car Plant at Toledo

*Wilby - Overland Co., Toledo, O.*

employees of the institution labored day in and day out and rarely saw the national emblem. The man had no idea of starting a country-wide movement. As soon as publicity was given the matter, however, the idea was carried out at other places. At Toledo, for instance, a prominent motor-car company has lately had 22 electric flags installed on both the outside and inside of its buildings. Many of those placed in the interior of the structures remain lighted day and night, and are seen continually by hundreds of workmen.

CA shortage of licorice, which in times of peace comes from Greece, Turkey, and southern Russia, threatens to affect the tobacco market, since that ingredient is an important element in tobacco products.

H 1235 **ANNEXATION OF TERRITORY GIVES CITY ODD SHAPE**

Through the recent annexation of the San Fernando Valley, Los Angeles has acquired a most peculiar shape. The outline of the city as now constituted is not merely unusual, but strikingly odd. By bringing a large district to the northwest, consisting of a number of towns and large ranchos, within its corporate limits, it has spread out



Map of Los Angeles and Environs Showing Unusual Shape City has been Given through the Annexation of Additional Territory

until it contains approximately two square miles more territory than does New York. The total area of the city is 288 square miles. The annexation was put through in order to enable it to take water from the Owens River aqueduct to operate municipal power stations along the latter's course. The legality of taking more water than was used within its boundaries was questioned, and this brought about the annexation of the adjacent territory. An interesting point in this connection is that two towns within the San Fernando district failed to vote in favor of annexation. This has left them entirely surrounded by the city of Los Angeles. "The Shoestring," a narrow connecting link extending between the city proper and the waterfront, does much to give the place its freak shape.

**FOLDING STEEL SERVICE WAGON**

An ornamental and convenient piece of furniture that can be used to save many steps to and from the kitchen is a steel service wagon which may be folded into small space. When so folded it will stand alone. The wagon is fitted with either two or three trays,



This Steel Service Wagon can be Folded into Very Compact Form  
#675

which are of wood and can be removed when desired. The wagon is designed to carry dishes, food, etc., and usually is placed within reach of the hostess while she is serving. It rolls on two large rubber-tired wheels and two small metal wheels. The steel is given any desired wood finish to match the trays. In construction the article is simple and substantial and at the same time pleasing in appearance.

**ELECTRICITY FOR FACTORY HAULED ELEVEN MILES**

Following a disagreement with a gas company as to the equity of its gas rates, the proprietor of a candy factory and store in St. Paul daily has been hauling electricity 11 miles for the purpose of operating his establishments. Each morning he has sent from two to four small motor cars loaded with storage batteries to his branch store in Minneapolis, where the batteries are charged, and then back to St. Paul. This unusual arrangement has been maintained for some time, and though the gas company has discontinued its service, the plant has been lighted and the candy kettles have been heated without apparent inconvenience. It is said that the candy maker also has had current from an underground wire. He claims that the electricity secured through storage batteries has cost him about the same as he would have to pay the gas company. In order that he may be permanently independent in the matter of lighting facilities the manufacturer contemplates erecting a windmill on the top of his factory to run an electric plant in the basement.

**PROPAGATE SOCKEYE SALMON IN SAMISH RIVER**

Efforts are being made by the fish commission in the state of Washington to cause the blueback salmon, commercially known as the sockeye, to propagate in the Samish River, a small stream which empties into Samish Bay some distance south of Bellingham.

*J. George Smith, St. Paul, Minn.*

*Fulton Mfg Co. Bay City, Mich.*

This move has been made in an attempt to prevent the supply of this variety of fish from diminishing. The inherent trait of the salmon to return to its birthplace to spawn makes the success of the venture probable. The young are always hatched in fresh water, where they spend a number of months and then swim to the ocean, remaining there until they reach maturity. The sockeye stays at sea for four years, after which it returns to its native stream, lays its eggs, and dies.

Tens of thousands of these fish race through the Strait of Juan de Fuca and on up to the Fraser and other rivers annually. It is when the big schools make their runs, going on both sides of the international line, that the fishermen make a harvest. The idea of the Samish River undertaking is to cause more of the bluebacks to return to American waters than now, which in this case would divert into the Samish a proportion of those passing through the strait.

In carrying out this plan, a large number of sockeyes were caught some time ago and placed in large floating

crates which were towed to the mouth of the Samish, where the fish were released. A dam had been constructed across the river some distance up the stream to divert the fish into Friday Creek, where one of the state hatcheries is located. When the fish arrived at that point they were seined, the eggs extracted and fertilized, and then allowed to develop. The source of the creek is a fresh-water lake, and there the young fish stayed for a number of months before making their way to the ocean. There is little doubt that after the allotted period they will return to the Samish to spawn, instead of going to the Fraser, for which their parents were bound when captured.

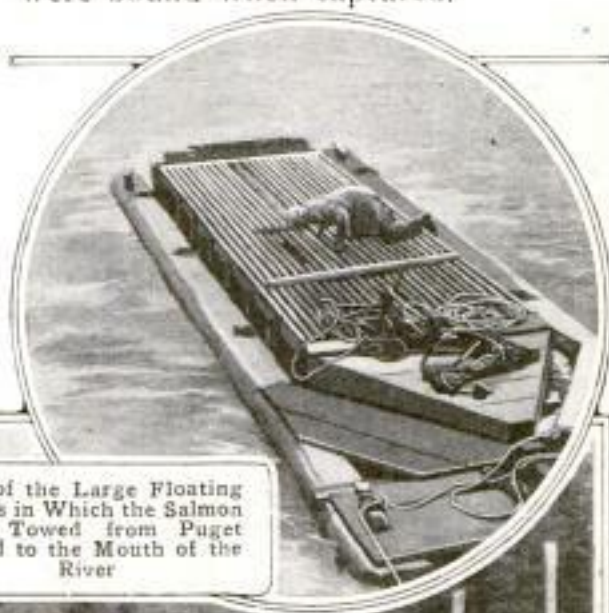

One of the Large Floating Crates in Which the Salmon were Towed from Puget Sound to the Mouth of the River



Taking the Sockeyes from the Nets near the Hatchery After They had been Brought to the Samish from Salt Water. The Eggs were Removed and Cared For Until the Young Fish were Hatched

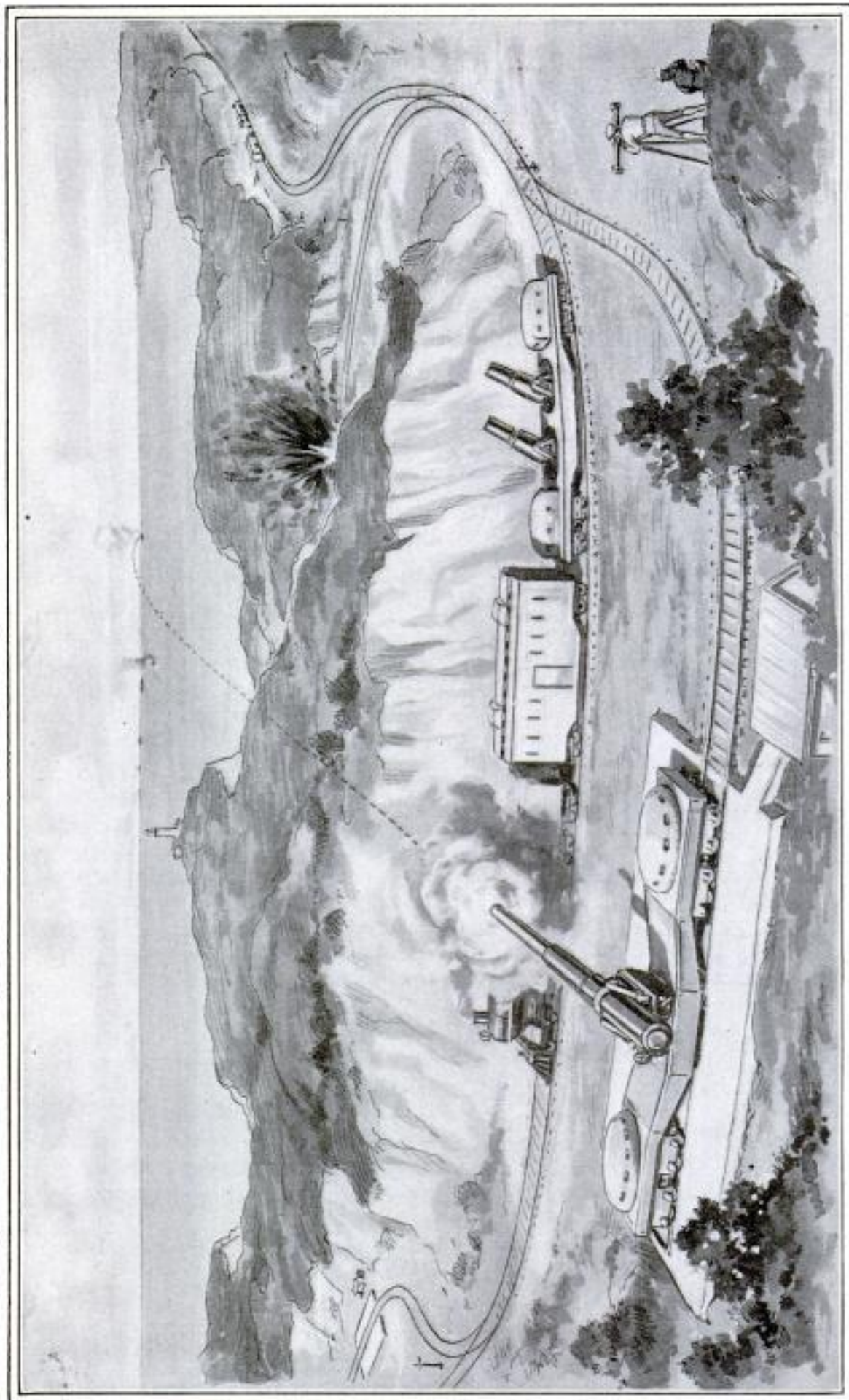

The Artist Illustrates Herewith the Latest Plan That has been Evolved for the Defense of Our Expansive and Now Almost Unprotected Seaboard: An Eastern Inventor Proposes the Construction of a Large Number of Gun-Carrying Railway Cars So Designed That They might be Locked to Concrete Bases Established at Frequent Intervals along Transportation Lines Skirting Our Coasts. These Mobile Batteries would Provide a Dependable Means of Resisting an Invasion at Any Point on Either the Atlantic or Pacific Sides. The Plan has been Thoroughly Worked Out on Paper and Already Submitted to the War Department at the Request of the President

1303 H

## MOBILE DEFENSE BATTERIES FOR COAST PROTECTION

Serious attention is being given by military authorities to a comprehensive system of coast defense which has been conceived by a New York inventor and recently submitted to the War Department at the request of the president. In brief, the plan contemplates the construction of a special type of railway car on which heavy ordnance would be permanently mounted; the establishment of concrete bases at prescribed intervals and at strategic points along the seaboard; the utilization of existing railway lines, and, wherever necessary, the projection of new tracks.

The general idea is not altogether an original one, but the details of the scheme, particularly as applied to the equipment, are. The concrete foundations would serve as fixed mountings for the big guns, each being so designed that a car could be locked to it quickly and its armament brought into action almost immediately. These bases would be built on spurs radiating from main-line tracks and extensions, and concealed singly or in groups behind hills or woods, and in cuts. The armed cars would be kept at conveniently located stations from which they could be rushed at high speed to any point where they might be needed to resist an invasion.

Two of the most attractive features of the system are its flexibility and the comparative reasonableness of the cost of establishing it. Once in effect, the plan could be extended to protect the interior of the country, thus providing a defense system for our inland cities, railway centers, and industrial points, which are now entirely unguarded. Existing railway facilities margining the coasts of Massachusetts, Rhode Island, Connecticut, New York, and New Jersey, are so situated that 140 gun bases could be established and, without grouping, present at least six long-range batteries to a hostile force which might attempt a landing at any point. This scheme could be worked out, it is estimated, for a little more than the cost of one modern dreadnaught. At

the present time only about 300 miles of our 5,000-mile coast are protected.

About 300 gun-carrying cars would be needed on the Atlantic seaboard to adequately defend it against attack. Each of these cars would cost approximately \$150,000, while the expense of building the necessary concrete bases would vary between \$3,000 and \$4,000 each. The weight of one of the cars would amount to about 100,000 pounds, while its ordnance would weigh approximately 170,000 pounds. A complement of about 30 men would be assigned to each car during war time. In case of an enemy gunner getting the range of one of the mobile defense batteries the car could be unlocked in a moment's time and moved to another base. This constitutes an additional advantage which the proposed system apparently has over the fixed fortification, already proved by the European war to be far from impregnable.

### WOULD MAKE TWO COLLIERIES INTO ARMY TRANSPORTS

*A. N. Tule, Jan 1916* 13267

The secretary of war has recommended to Congress enactment of necessary legislation giving the army instead of the navy possession of the ships "Ancon" and "Cristobal," now located at the Panama Canal. The original legislative provision was that on completion of that waterway the vessels were to be turned over to the Navy Department to be used in the coaling service. But owing to the steadily increasing use of oil as fuel, it is said that soon the navy will have very little use for the present type of naval colliers. Since the transport service of the army is not adequate even for the regular army, an agreement has been reached between the two interested branches of the government to transfer these two boats to the War Department. By an expenditure of \$500,000 these boats can be transformed into what will be the largest and fastest transports possessed by our land forces.

*Anti*

PROPELLER MENDED IN DRY WAR AND HEAVY DEMAND AT DOCK SHORTER THAN SHIP

1227 *JNT. MAR. ENG'G 1915-40*

Less than 24 hours were required to dry-dock the United States army transport "Thomas" in Honolulu and repair its broken propeller, during a recent voyage from San Francisco to Manila. The floating dry dock used for this task has a capacity of 4,500 tons while the "Thomas" is an 11,000-ton vessel, and is 118 ft. longer than the dry dock. But by allowing the bow to overhang the excess length, the dry dock was able to raise the stern so as to bring the propellers out of the water, permitting three blades to be removed and new ones substituted. The service performed by this dock could not have been rendered by a basin dry dock of the same dimensions because a vessel placed in a dock of the latter type must be shorter than the dock, to permit the gates to be closed.

1329 HOME RAISE CAR COSTS

*Chgo Herald 1-26-16*

Because of the heavy demand for motor cars and the high prices of motor-car materials, a number of manufacturers have announced increases in the prices of their products to take effect immediately or within a few months. A number of factors have contributed to this reversal of a tendency which has characterized the motor-car market in recent years. The war has been one of the causes which have occasioned a sharp rise in the price of various grades of steel, aluminum, copper, etc. The allies have been heavy buyers of cars and at prices which have reacted on the home market. Consequently those manufacturers who have only a limited supply of raw materials on hand have been compelled to raise the price or lower the quality of their products.

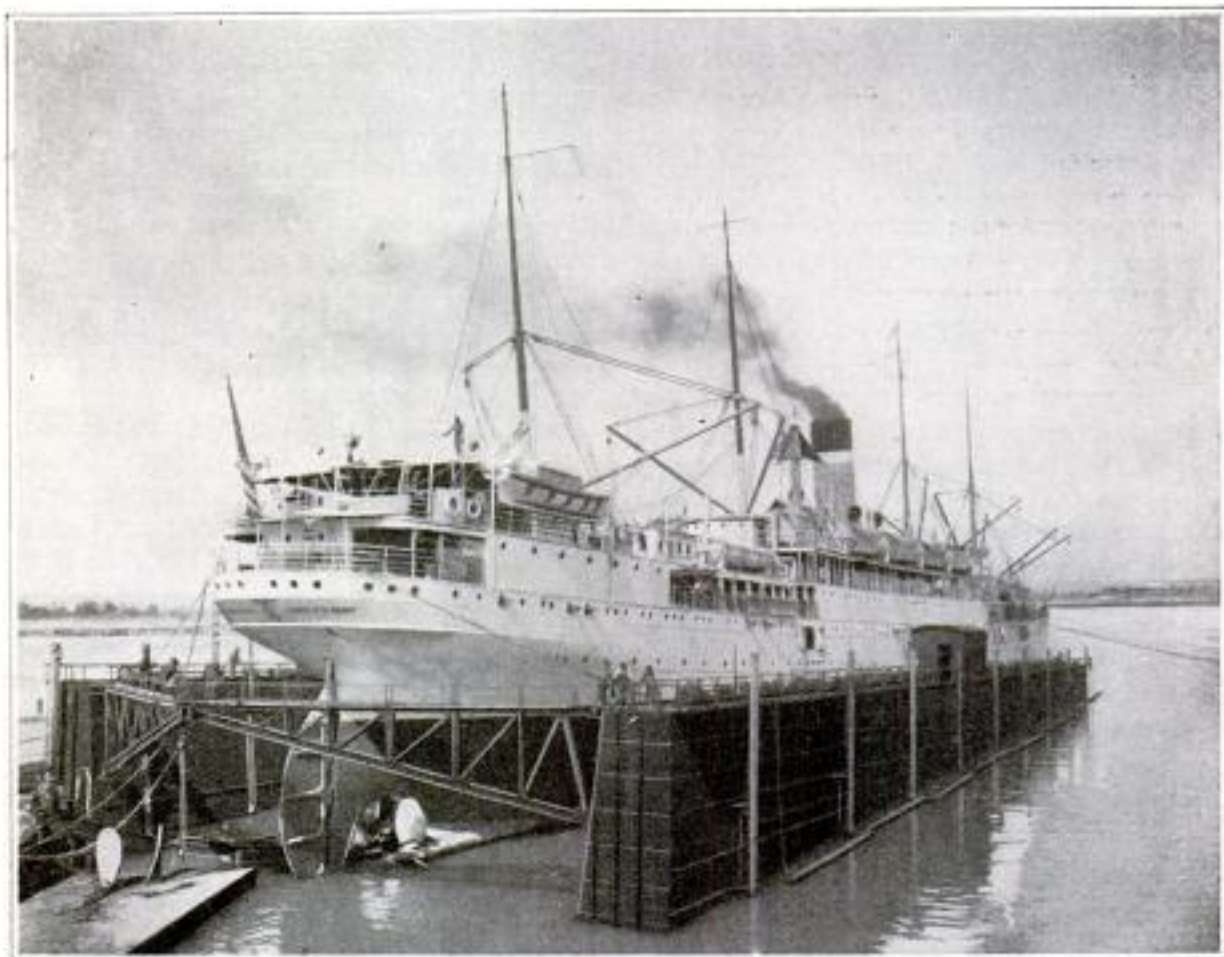

The Transport "Thomas," an 11,000-Ton Ship, is Here Shown being Repaired in a Floating Dry Dock Which Has a Capacity of Only 4,500 Tons. The Boat is 118 Feet Longer than the Dry Dock.



Rescue Party Digging about Cars Clinging to Outer Rail on Side of Slope After Avalanche had Struck Train and Knocked Other Cars down Mountain Side

## AN AVALANCHE WRECKS TRAIN 1354 HIGH IN CASCADES

Within a short distance of the point where a similar disaster occurred several years ago, a passenger train bound from Spokane to Seattle was struck by an avalanche on the west slope of the Cascade Mountains near Coreia, Wash., late in January. A dining car and day coach, which were at the rear of the train, were caught by a great, rushing mass of snow, boulders, and trees, and swept into a gulch 300 ft. below, where they were buried. A third car, a Pullman, was thrown on one side and knocked to the edge of the gully. Several persons were killed and about a score injured. The tragedy happened on a horseshoe curve, where the train had been flagged shortly before and was being held until the track ahead could be cleared of the debris of a previous slide. While the train was waiting the avalanche broke loose in the mountains and came roaring down the slope at terrific speed, snapping off tall pines and dislodging boulders in its path.

American machinery, costing \$100,000, is to be used in equipping two new cotton mills in China.

Shanghai & Tientsin  
25000 spindles coal  
Sais-Lowell Shop 77 Franklin St  
Power plant elsewhere  
Bu. A & D. Commerce  
Boston Mass

## TELEPHONE MOUTHPIECES OF BLACK-GLAZED PORCELAIN

Telephone mouthpieces of black-glazed porcelain, and several other articles made of this material instead of hard rubber, have been produced by an eastern pottery company, which believes that for many purposes black-glazed porcelain will prove superior to hard rubber. All but the threads of the porcelain mouthpieces are black. The material has, of course, all the well-known insulating qualities of porcelain, is impervious to moisture, and will withstand extremes of temperature, especially heat, better than rubber. It is nonabsorbent, can be kept clean easily, and besides has the not unimportant advantage that its cost of production, so the manufacturer claims, is much lower than that of hard rubber.

## TILE WALLS SURPASS SNOW FENCES OF BOARDS

Successful experiments have been made in Iowa in the use of hollow tile for snow fences, the results showing that such barriers will hold back about twice as much snow as the board snow fences. This barrier is made of six or seven layers of tile, the open ends forming the two faces of the wall,

Inv.: H. R. & Co. Inc.  
Adel, Ia.

Horace Wells Sellers  
Proc. Phila. Chapter Am. S. of Arch.  
Stephen Girard Bldg.,  
Phila.

which is slightly serpentine to permit expansion. Wires are used for reinforcement. The tiles are molded in such a manner that air spaces extend through them at an angle of about 20°. The tiles are so laid that all the air

**PHILADELPHIA TO RESTORE INDEPENDENCE SQUARE**

The surroundings of historic Independence Hall are to be more fully restored to their original colonial aspect,

according to plans recently drawn up on behalf of the Philadelphia city authorities. The present flagstones in front of Independence Hall and along Chestnut Street will be retained. But the areas between the State House, as it is sometimes called, and Congress Hall, on the west, and the city buildings on the east, will be paved with brick as they were originally. On two lines parallel with Chestnut Street, where the brick and flagstones meet, will be set rows of cast-iron posts similar to those formerly existing in the square, the purpose being to give a sense of inclosure without interfering with the traffic. Back of Congress Hall the old drive will be restored with cobblestones, protecting chains, posts, etc. In a portion of the central area of the square the

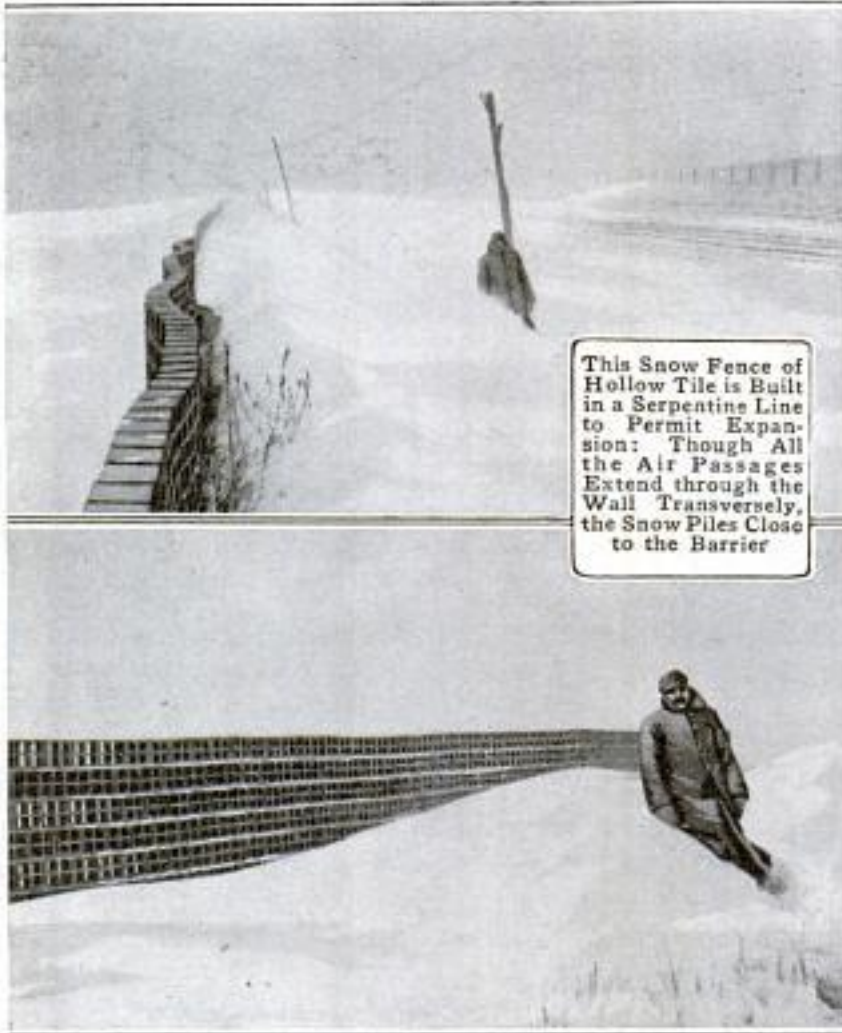

This Snow Fence of Hollow Tile is Built in a Serpentine Line to Permit Expansion: Though All the Air Passages Extend through the Wall Transversely, the Snow Piles Close to the Barrier

This Hollow-Tile Snow Fence Acts as a Splendid Windbreak Because the Angles at Which the Various Air Passages are Placed are Such That They Produce Conflicting Currents of Air That Neutralize One Another

passages lie in a plane parallel with the earth's surface but those of adjoining layers lie at opposing angles. When the wind passes through this fence, these diverging openings form conflicting strata of air which neutralize each other's force so that it is comparatively calm at the leeward side of the shelter. This accounts for the large amount of snow that collects behind these shelters, which will last longer than wooden ones, and in summer may prevent the spread of fires started by passing engines.

flagstones will be relaid. A number of paths, which have been made in recent times and serve no useful purpose, will be obliterated, the whole intention being to simplify the treatment of the square and bring it in closer harmony with Independence Hall as well as the other adjoining buildings.

CA letter-carriers' association has petitioned Congress for the privilege of wearing a tiny American flag on the left coat lapel.



## TOMMY ATKINS' WASH DAY IN THE NEAR EAST

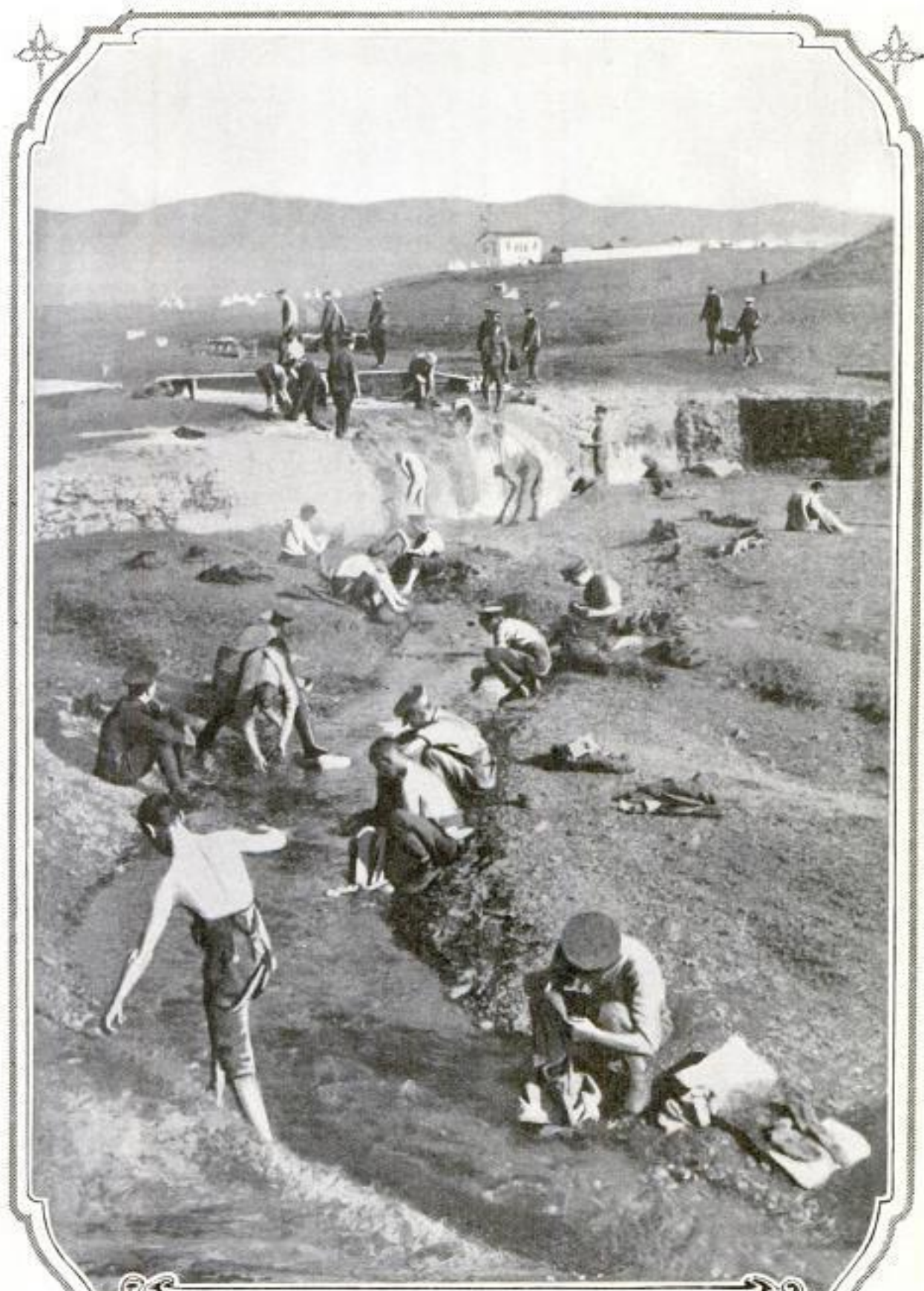

British Soldiers Encamped Outside of Saloniki Making the Best of Their Opportunities to Bathe Themselves and Free Their Uniforms of Some of the Filth Gathered in the Trenches. A Small Brook Not Far from Their Camp Was a Welcome Substitute for the Marble Baths and Steam Laundries of Peaceful Times

## MODERN MONITORS IN USE BY BRITISH NAVY

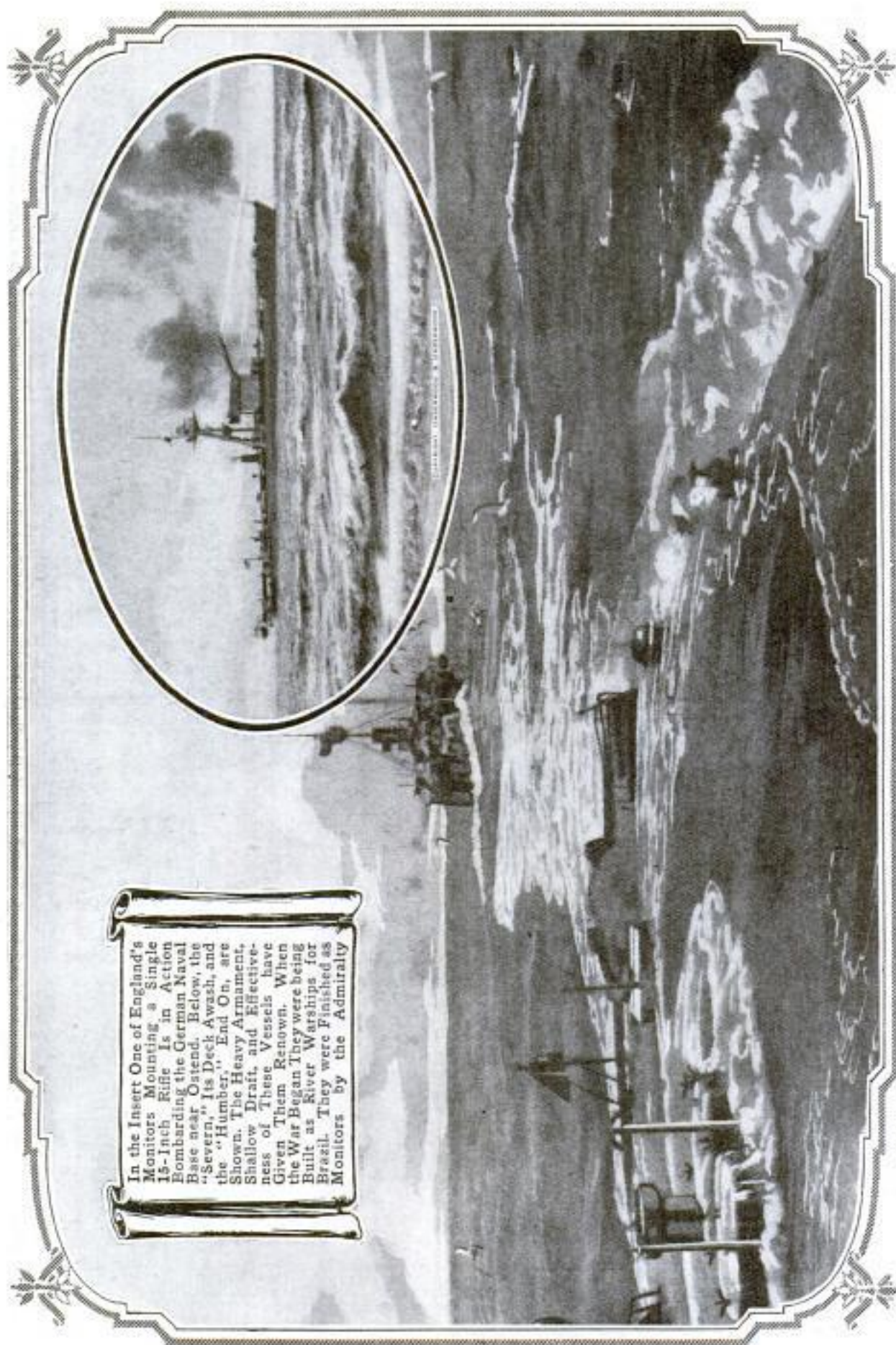

In the Insert One of England's Monitors Mounting a Single 15-Inch Rifle Is in Action Bombarding the German Naval Base near Ostend. Below, the "Severn," Its Deck Awash, and the "Humber," End On, are Shown. The Heavy Armament, Shallow Draft, and Effectiveness of These Vessels have Given Them Renown. When the War Began They were being Built as River Warships for Brazil. They were Finished as Monitors by the Admiralty

COPYRIGHT, THE ILLUSTRATED LONDON NEWS

# THE ALLIES AND TURKS AS SEEN BY THE CAMERA



Above: Cans of Water Piled at a Station in the Desert for the Use of the Turkish Forces upon Their Arrival at the Point



Left: British Colonial Troops and Senegalese in Street of Town on Island of Lemnos Ready to Embark for Dardanelles

COPYRIGHT, GEORGE GRANTHAM GAIN



One of the Turkish Strongholds on Gallipoli Peninsula: The Troops Seen at the Right Are Almost in Readiness to March to the Trenches Some Distance Away

# WITH WARRING TROOPS ON ICY BATTLE GROUNDS



COPYRIGHT, UNDERWOOD & UNDERWOOD  
**Austrian Ski Patrol Resting on Snow-Clad Slope: These Men Cover Distance Quickly and Form a Valuable Arm of the Service**



**Laborers with Germans in Poland Armed with Shovels**



**German Ski Patrol Crossing Improvised Bridge in Vosges**



**White Coats Conceal Austrians Operating in Carpathians**



**Russian Soldiers Snatching a Few Minutes' Sleep in the Snow**



**German Infantry in Snow-White Uniforms**

COPYRIGHT, UNDERWOOD & UNDERWOOD

COPYRIGHT, INTERNATIONAL PRESS EXCHANGE

# AUSTRIAN WINTER CAMPAIGN IN TYROLEAN ALPS



One of the Desolate Mountain Positions Held by the Austrian Troops Operating against Italians: The Trench Is More than a Mile and a Quarter above Sea Level on Stillfer Joch



COPYRIGHT INTERNATIONAL PRESS EXCHANGE  
Constructing a Suspension Pass along Side of Cliff to Provide New Avenue of Attack



Mountain Artillery Battery Descending from Stronghold near Frontier to Establish New Position and Check Movement of Italian Forces

## LONDON STREET CROWD FAVORS CONSCRIPTION

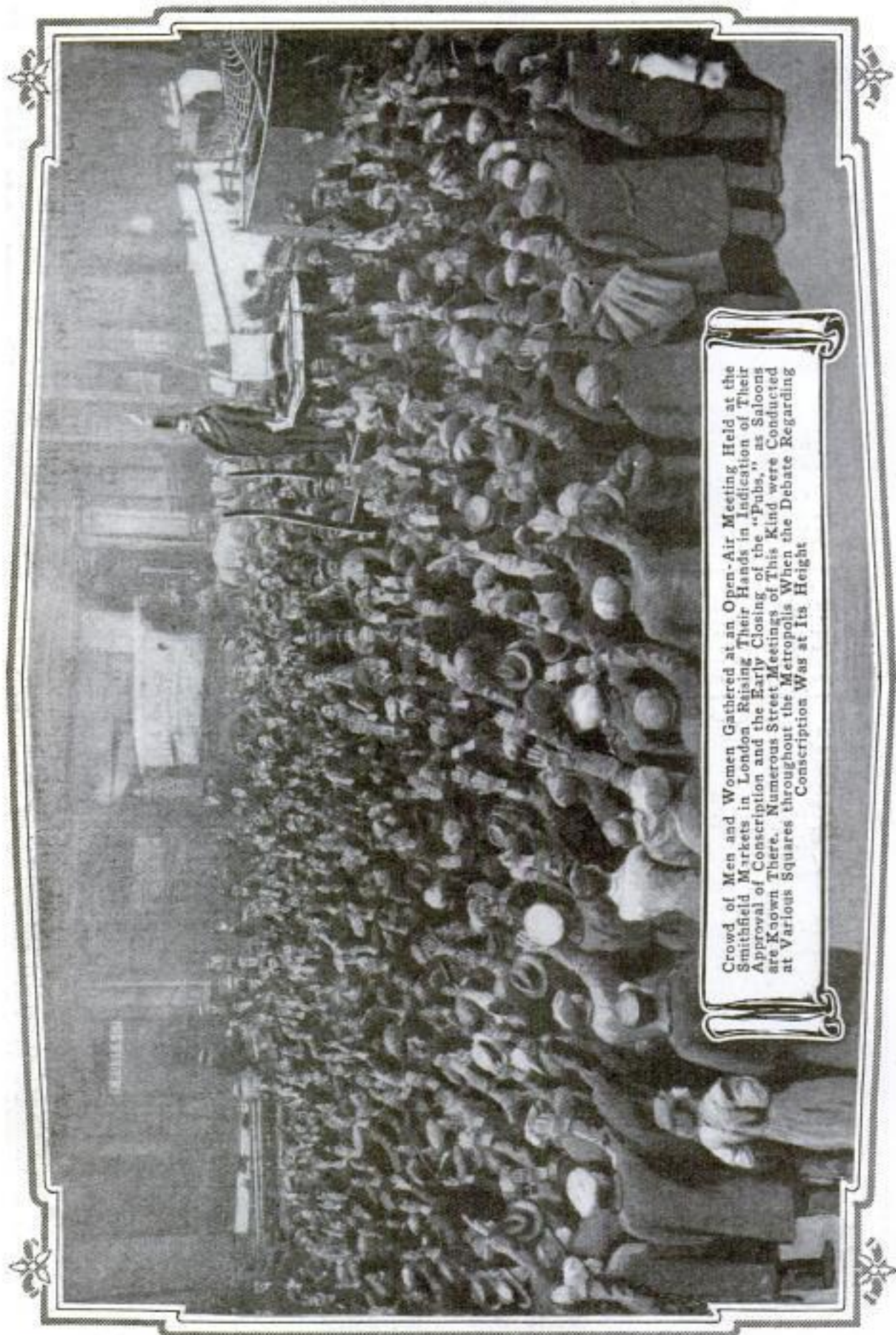

Crowd of Men and Women Gathered at an Open-Air Meeting Held at the Smithfield Markets in London Raising Their Hands in Indication of Their Approval of Conscription and the Early Closing of the "Pubs," as Saloons are Known There. Numerous Street Meetings of This Kind were Conducted at Various Squares throughout the Metropolis When the Debate Regarding Conscription Was at Its Height.

## WHILE AUSTRALIANS MARCH MILES TO ENLIST



Australians  
Marching 320  
Miles to  
Volunteer  
Their Services  
to British  
Crown



Reception Given  
Volunteers upon  
Arrival at Sydney:  
Starting with 30  
Men, Band Grew to  
Several Hundred



Many British  
Girls have  
Sweethearts'  
Regimental  
Insignia Tat-  
tooed on Arms



Transport Departing from Sydney  
with Troops for Eastern War Zone. The  
Event Bore Every Appearance of a Gala  
Affair. Piers were Jammed with  
Thousands of Cheerers

## UNUSUAL AND THRILLING EPISODES ENACTED



Large Austrian Shell Bursting Close to an Italian Artillery Shelter Which It Wrecked

Team of Terrified Ambulance Horses, the Driver Dead, Lunging toward a British Trench during the Heat of Battle. The Animals were Stopped on the Brink of the Excavation

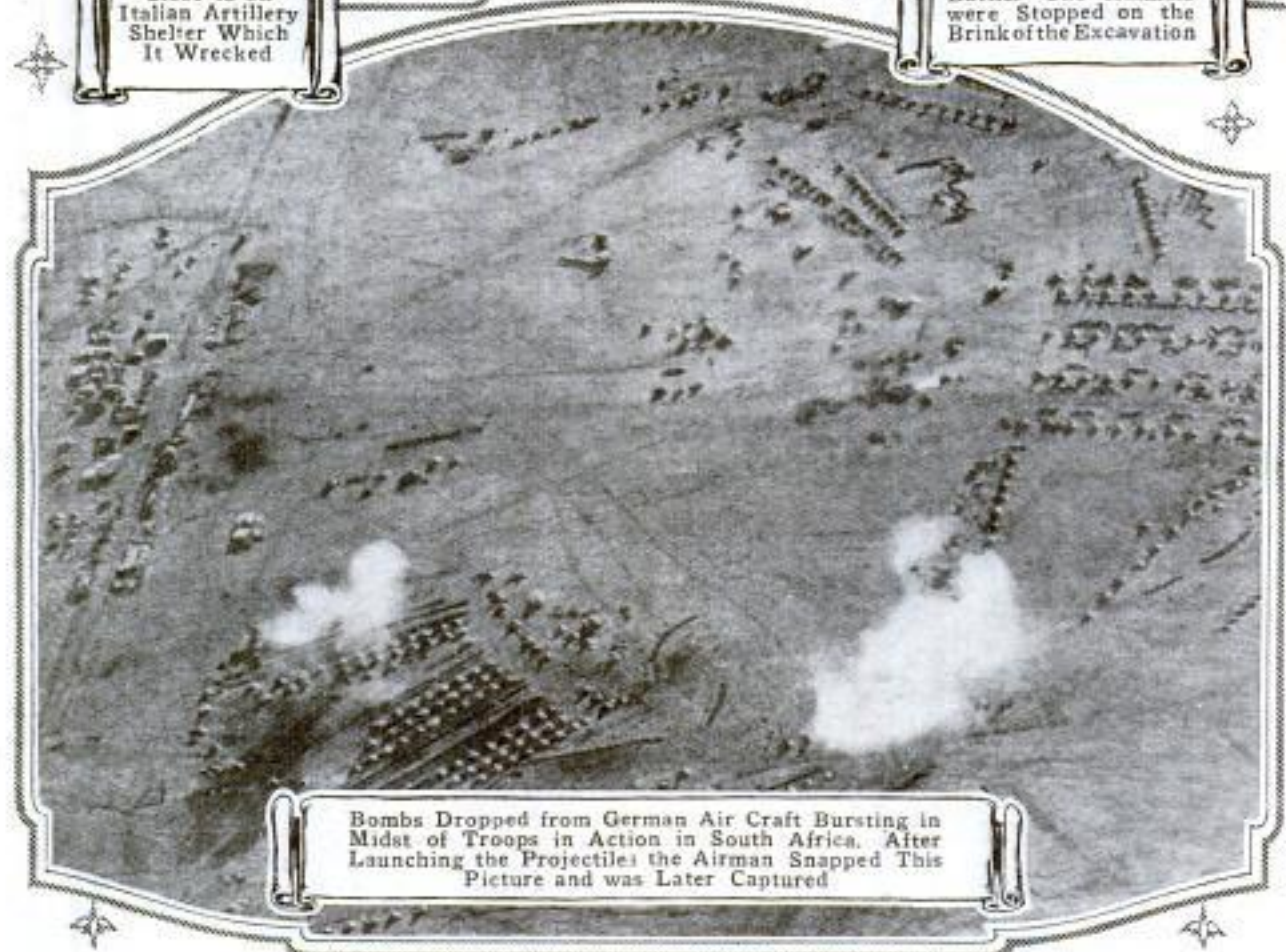

Bombs Dropped from German Air Craft Bursting in Midst of Troops in Action in South Africa. After Launching the Projectiles the Airman Snapped This Picture and was Later Captured



# DURING BATTLES IN DIFFERENT THEATERS



DRAWN BY  
U. MATANIA FOR  
THE SPHERE, LONDON,  
AND COPYRIGHTED IN  
THE UNITED STATES BY THE  
NEW YORK HERALD COMPANY

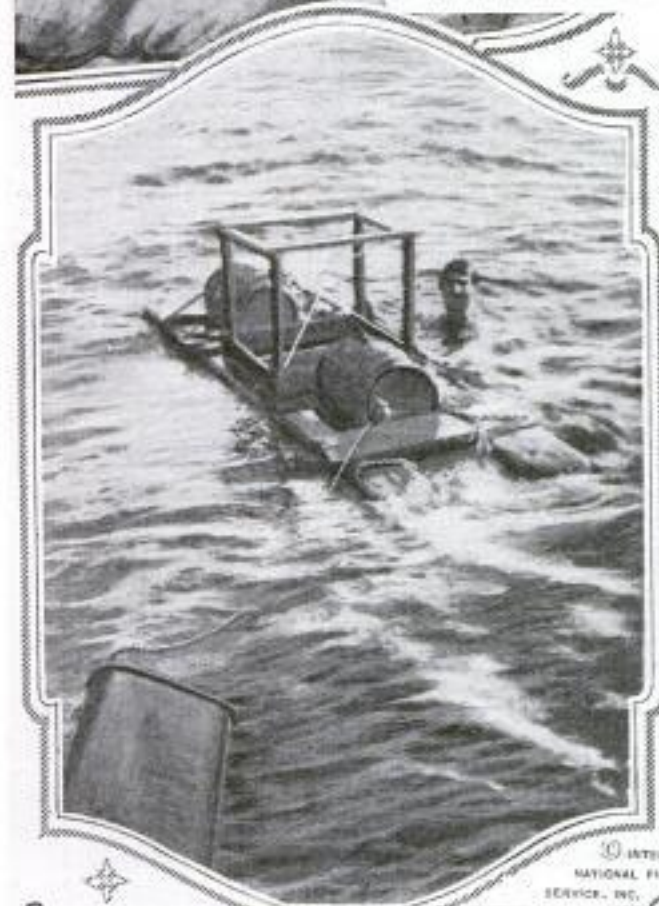
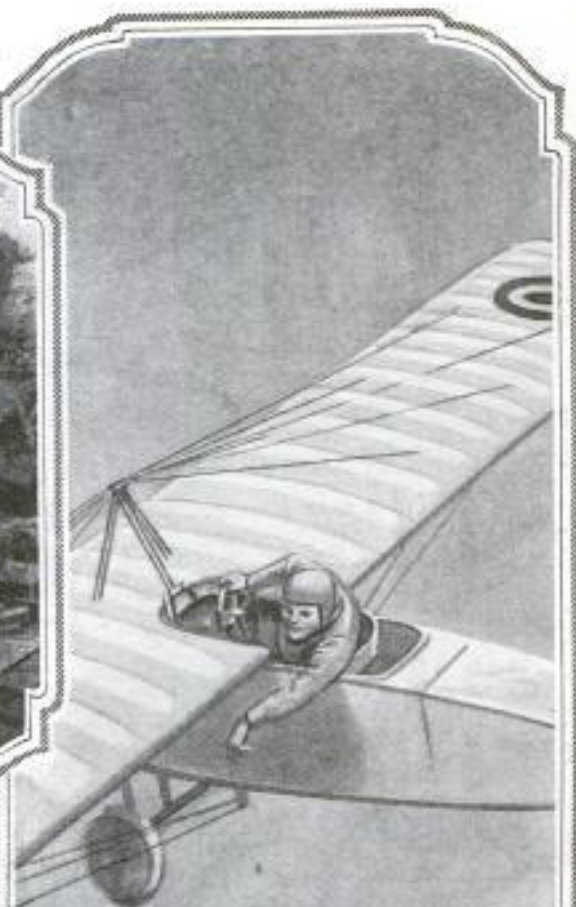

INTER-  
NATIONAL FILM  
SERVICE, INC.

English Lieutenant Swimming from Subma-  
rine in Sea of Marmora with a Raft Loaded  
with Explosives with Which He Succeeded in  
Demolishing a Dardanelles Railway Viaduct



Airman Tossing Wreath  
for Comrade's Grave  
within German Lines  
After Enemy Flier had  
Dropped Note to British  
Telling of Pilot's Death

## PREPARING FUEL FOR SOLDIERS IN TRENCHES



Italian Boys and Girls Pasting Sheets of Paper Together and Winding Them into Long, Hard Rolls to be Used as Fuel by Troops



Paper Sticks are Cut and Used Like Coal



Children Packing Paper Fuel in Individual Bags to be Distributed among the Soldiers



Both Ends of Matches Supplied German Soldiers are Dipped



Making Charcoal in Britain for Men in Trenches: This is the Ideal War Fuel, for It Provides Abundant Heat without Producing Smoke

# LOOKING AFTER WELFARE OF PRIVATE SOLDIER



To Ward Off  
Fever, Quinine  
is Distributed  
to Indian  
Soldiers  
Operating in  
Africa



German  
Christmas  
Box  
Containing  
Apparel,  
Sweets,  
and Cigars



The Footwear  
of French  
Soldiers is  
Inspected  
Regularly

COPYRIGHT,  
UNDERWOOD &  
UNDERWOOD



The Bag Keeps  
Soldier Warm and  
Dry When Sleep-  
ing in the Open



Making Sheepskin Sleeping Bags for  
Allied Soldiers: These are Covered with  
a Waterproof Fabric and Are Snug and  
Comfortable during Cold Weather

PHOTOGRAPHS TAKEN WITHIN FRENCH LINES



Abandoned German Gun with Muzzle Blown Off to Prevent Its Use by Enemy

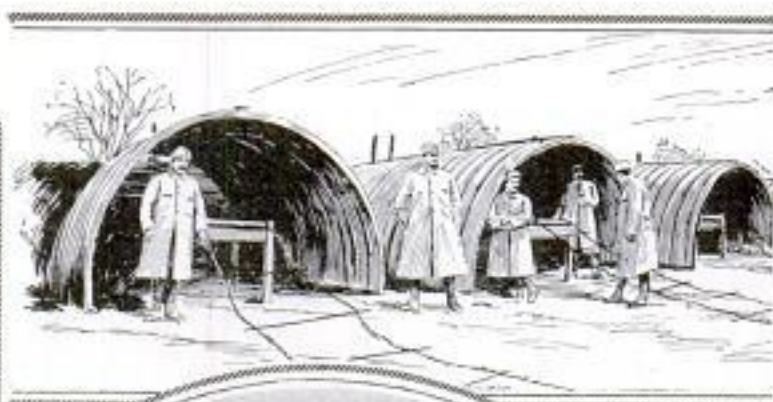

COPYRIGHT, MEDEM PHOTO SERVICE

A Public Motor Bus Now Serving at the Front as a Pigeon Loft



The Red-Cross Dog Shown Here has Found a Wounded Soldier and is Bringing Back the Latter's Helmet. These Animals are Trained to Lead Searchers Back to the Men They Find



Group of Box Kites Used to Lift Man above Field for Observation Purposes



## GIVING SIDE LIGHTS ON WAR IN THE WEST

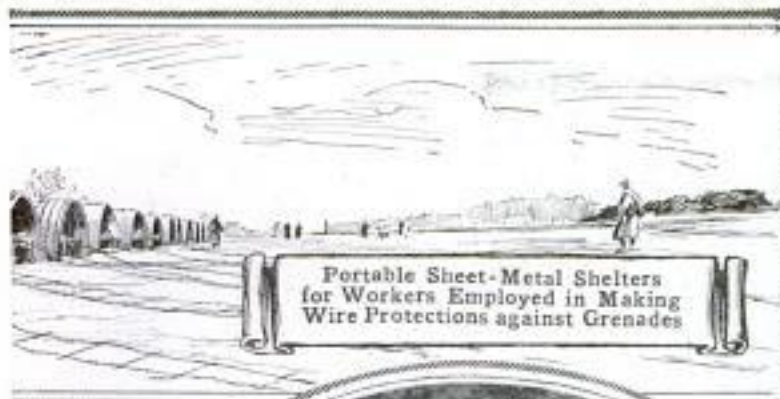

Portable Sheet-Metal Shelters  
for Workers Employed in Making  
Wire Protections against Grenades



German Ammu-  
nition Captured  
by French  
during Offensive  
in Champagne  
District



COPYRIGHT, MEXEM  
PHOTO SERVICE

Subterranean  
Sleeping Quar-  
ters of French  
Soldiers on  
Western Front



Wooden Mortar and Dummy Artillery-  
men Divert Airmen from Real Battery:  
By Pulling Cords Distant Soldier Moves  
Figures and Causes Smoke to Issue  
from Gun on Approach of Scout



Detachment of Reinforcements  
Hastening to Back Up a Weakened  
Point in Line in Northern France

## GERMANS USING POISON GAS AGAINST RUSSIANS

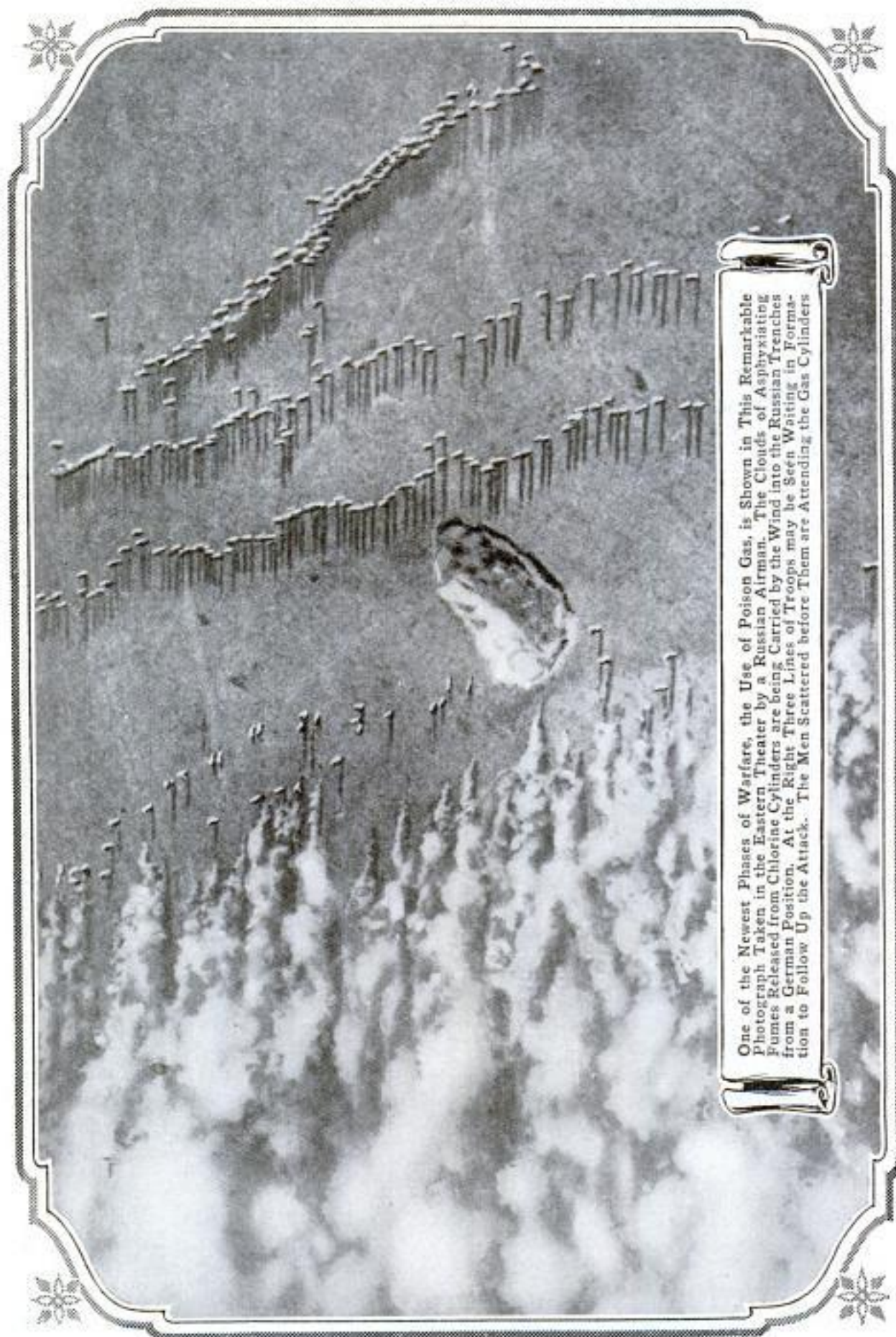

One of the Newest Phases of Warfare, the Use of Poison Gas, is Shown in This Remarkable Photograph Taken in the Eastern Theater by a Russian Airman. The Clouds of Asphyxiating Fumes Released from Chlorine Cylinders are being Carried by the Wind into the Russian Trenches from a German Position. At the Right Three Lines of Troops may be Seen Waiting in Formation to Follow Up the Attack. The Men Scattered before Them are Attending the Gas Cylinders

COPYRIGHT, INTERNATIONAL FILM SERVICE, INC.

## PRODUCE MARKET IS ROOFED 100% OVER BY CITY

The proper marketing of fresh vegetables, fruits, and other farm produce, is becoming a problem of some importance to cities. When weather conditions are good, open-air selling from the wagon is the cheapest and usually the most satisfactory method. In inclement weather, however, but few patrons will brave the elements to make their selections, preferring rather to go to the various stores and there pay the additional percentage of cost the increased handling makes necessary. For a number of years past the city of Pittsburgh allowed farm wagons to congregate on the river wharves in all weathers and dispose of their products as best they could. Realizing the in-

efficiency and numerous shortcomings of this plan, a large roofed-over area has been provided especially for their benefit. A cement walk down the center provides a vantage point from which customers may view the wagon



City Market is Roofed Over for Convenience of the Wagon Merchants and Their Customers

stocks with ease. Between 75 and 100 wagons may be sheltered beneath the structure, safe from weather interferences or the crowding of city traffic.

## 1062 <sup>F</sup> SMALL SPEEDY MOTOR CAR HAS NOVEL FEATURES

A small car designed for fast touring and speed contests, which in cer-

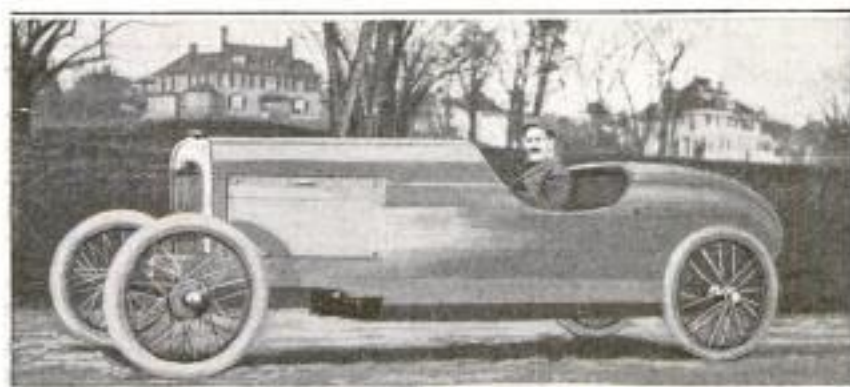

The Streamline Body of This Small Speedy Car Is of Wood Covered with Canvas, and is Built in Combination with the Chassis

tain points of construction resembles an aeroplane, has been put on the market. The body is built in combination with the chassis, the whole being a single streamline shell resembling that of certain aeroplane types. Thin

wooden strips, laid diagonally and covered with canvas, form the body.

Power is furnished by a small four-cylinder, water-cooled engine with three forward speeds transmitted by a bevel-gear drive. Steering is accomplished by means of a steel cable running over a drum, the front axle swiveling about a central pivot which combines in its construction the front spring

and shock-absorbing device. The rear springs are of cantilever type, and, like practically all the mechanism, are completely inclosed in the streamline body. The seat is less than 12 inches from the ground.

*The Projecta Co., East Milton, Mass*

## SCIENTISTS SUBDUE ECHOES IN SPITE OF DIFFICULTIES

91387  
Scientists who recently completed an investigation into the subject of architectural acoustics at Harvard University had a varied experience. The work was undertaken because of the prevailing lack of data and general knowledge as to why many auditoriums and assembly halls have such poor acoustical properties. Because of these, speakers find it difficult to make themselves understood above a din of echoes and reverberations. As a result of the research it was definitely established that this seemingly intangible, abstract subject could be reduced to a series of perfectly definite propositions, a knowledge of which would enable an architect to avoid poor acoustical properties even in the initial designing of a hall. The work proceeded with scientific accuracy and close attention to minute detail. It proved, however, to be far from a prosy proceeding.

At the beginning of the research a troublesome lecture room in the university itself was the main object of investigation. Using an organ pipe as a source of sound, initial operations consisted simply in determining how long a given note would reverberate with the room entirely empty. By means of suitable instruments, this period was found to be 5.62 seconds, an unusual length of time. Crowds of people being scarce, and needing something to deaden or absorb the sound for further experiment, the scientists resorted to lugging over chair cushions from a near-by theater. These were installed in the seats in place of people. Later additional cushions were laid in the aisles and at other available points. By such means the duration of audibility was reduced to 1.14 seconds, a remarkably short time considering the former figure. Then the cushions were removed and curtains of chenille, oriental rugs, cretonne cloth, canvas, and hair felt, successively substituted, and their effect compared with that of the theater cushions. All this involved work, and strenuous work, but by us-

ing the chair cushions as a basis for comparison in each case it was possible to secure absolute data.

As a check on previous operations, and undaunted by the amount of labor already expended, it was determined to get an actual audience together and experiment on them instead of inanimate chair cushions. A free lecture on wireless telegraphy attracted the desired number of people, who, at the conclusion of the talk, were induced to remain for the experiments immediately to follow.

Woe, however, attended the experimenters' efforts. A thunderstorm outside outclassed the attempts of those within to make a noise. The night being sultry, it was necessary to have the windows open, which proved a further ally of the thunderstorm. The combination proved too much for the audience, and it departed. Thus ended one of the more ludicrous incidents of the investigation. A later attempt was, however, more successful.

An effort some time afterward to determine the sound-absorbing powers of wood sheathing was productive of an additional interesting episode. To get a suitable room proved a difficult matter, and the entire city had to be searched before a place possessing the desired qualities could be located. The room chosen happened to adjoin a night-lunch emporium, and it was necessary to buy out this establishment for two nights in order to stop clatter of dishes and other disturbing sounds. Even then street traffic proved an annoyance, except for a brief period shortly after midnight. An occasional policeman added to the troubles by pounding peremptorily on the door, demanding to know the nature of the curious musical sounds coming from within. In spite of such interruptions the scientists eventually managed to secure data of considerable value.

By thus doing pioneer work as to how much sound the walls, ceiling, seats, audience, and other attributes of a lecture hall are capable of absorbing, the workers gave architects something tangible to go on in future designing.



#T.T. Sturgeon,  
628 So. Breed,  
Los Angeles.

7600 NEW YORK TO HAVE MODEL MOTOR-BUS SYSTEM

All busses to be kept carefully clean, no advertising to be allowed, a seat to be provided for each passenger, additional busses to be installed whenever the city desires, in winter a 16-ft. path to be cleared off along its lines immediately after each snowstorm—such are some of the almost utopian promises New York City recently exacted in granting a franchise for a motor-bus line. The service is to supplement that already given by surface cars, and the city hopes in establishing the line materially to better transportation facilities about town. The busses used will resemble in some respects those now in use in London, but are to be improved by the addition of several American conveniences.

84m CANVAS VOTING BOOTHS USED IN CALIFORNIA

Considerable savings in election costs are made in Los Angeles County, California, by the use of portable canvas voting booths for precincts outside the most thickly populated sections.



One of the Portable Canvas Voting Booths Erected on a Sidewalk in Los Angeles

Each booth consists of one rectangular tent, or more, as circumstances require, and where more than one tent is used they are connected end to end. The tents are 20 ft. long and 12 ft. wide, and are equipped with collapsible frames, bottom sills, top plates, ridge poles, and rafters. No pegs or guy ropes are required. Along one side are stanchions about three feet apart carrying brackets that support the shelves used by the voters. The tents are delivered at the various sites by a motor truck, a few days before the election, and are usually erected on the public sidewalks.

10867 NEW "TEDDY" BEAR HAS ELECTRIC EYES

A new species of the popular "Teddy" bear has been placed on the market, the distinctive feature of which is electrically lighted eyes. These can be illuminated by pressing the chest of the toy. These eyes are in reality small bulbs similar to those in small pocket flash lights and can be replaced easily.



A small dry-cell battery, which can be replaced also, is concealed in the toy and furnishes current for 5,000 flashes.

Manual-training pupils of a Glasgow industrial school have designed and made periscopes, provided with a device that eliminates the glitter of the sun on the exposed mirror, which have been approved by the British military authorities and distributed in large numbers in the trenches.

Interstate Electric Novelty Co., 29 Park Pl., New York  
541 Wash. Blvd., Chicago  
"Franco Products" Copyrighted material

## AMERICA'S LARGEST TREES FOUND DURING CONTEST

MUCH data of general interest and of considerable value to foresters has been collected as a result of a big-tree contest recently conducted by the American Genetic Association. Several hundred photographs and descriptions of large and unusual native trees in various parts of the country were submitted to the organization during the course of its competition, and through the information thus gathered a number of exceptional specimens of certain species have been "discovered." The contest embraced a search for the largest nut-bearing and non-nut-bearing trees in this country, excluding the gigantic Sequoias of the Pacific coast, which for size surpass all other trees in the world. What undoubtedly



Exceptional  
Catalpa, 16  
Feet in Circum-  
ference and 75  
Feet in Height,  
Standing near  
Luxora,  
Arkansas



This Is  
One of the  
Finest Yellow  
Poplar Trees in  
the Country and  
Undoubtedly  
the Largest  
Growing



Here Is  
America's  
Largest Shade  
Tree. It Is an  
Indiana Syc-  
amore with a  
Girth of More  
than 42  
Feet

is the largest deciduous tree now growing in the United States is a sycamore near Worthington, Ind., which at 5 ft. from the ground measures 42 ft. 3 in. in circumference. Its height is approximately 150 feet. According to local claims this remarkable specimen is inferior to one long since felled in the same district which had a girth of 67 ft. A valley oak which measures 37 ft. 6 in. in circumference was the largest nut-bearing tree found during the contest. This is situated in San Benito County, Cal., and reaches to a height of 125 ft. In a good season it bears a ton of acorns. America's largest elm seems to be "The Great Elm" at Wethersfield, Conn., which at the base has a circumference of over 55 feet. It is supposed to be about 250 years old. Next to the valley oak found in California, the largest nut-bearing tree uncovered is a chestnut near



Probably  
the Largest  
Nut-Bearing  
Tree in America:  
A Valley Oak in  
San Benito  
County,  
California

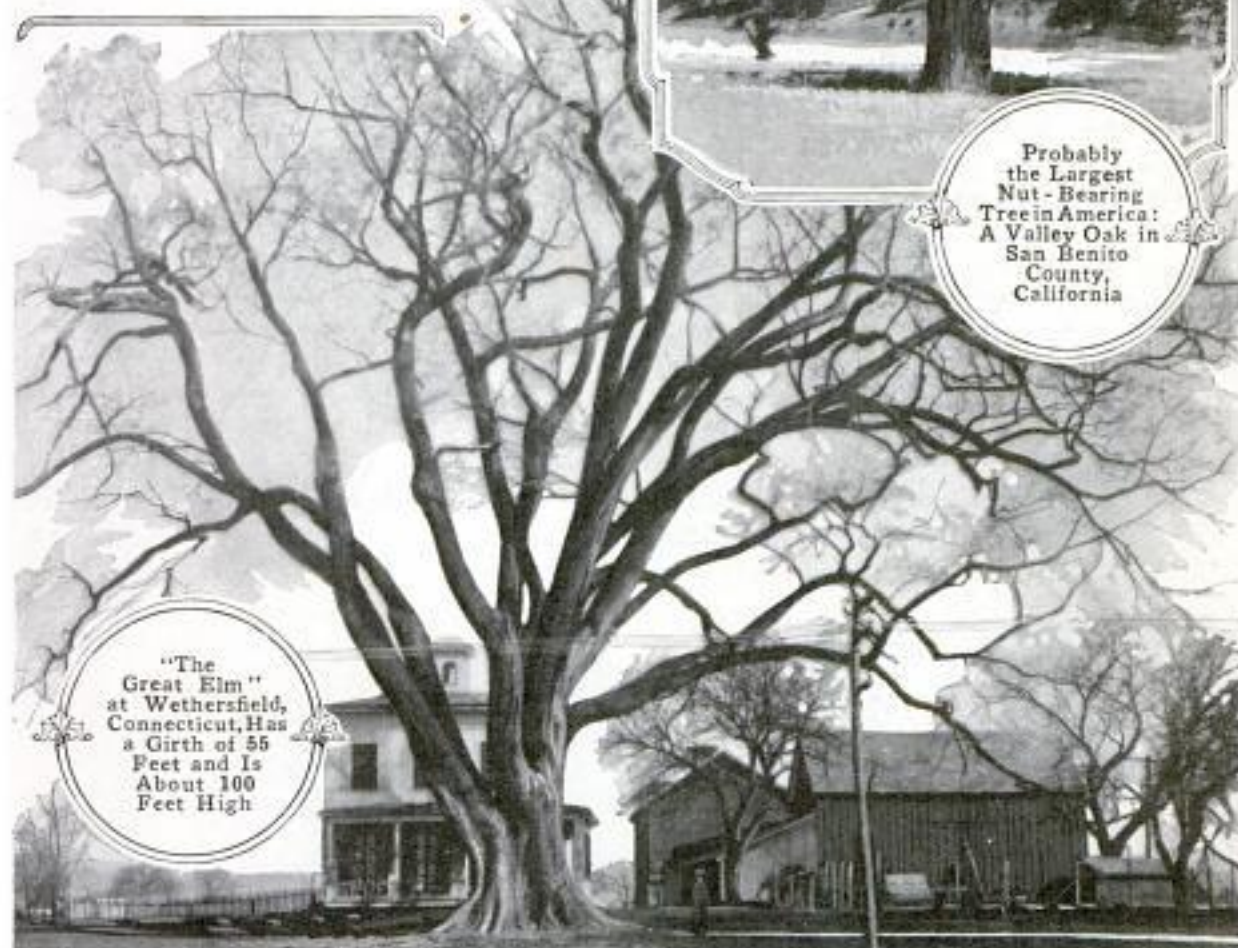

"The  
Great Elm"  
at Wethersfield,  
Connecticut, Has  
a Girth of 55  
Feet and Is  
About 100  
Feet High

Crestmont, N. C., which measures 33 ft. 4 in. in circumference at 7 ft. above the ground. Many other trees almost as interesting as these were brought to light. Among them are splendid specimens of the persimmon, holly, sassafras, catalpa, and white-birch trees. In commenting upon the two prize-winning trees, the California oak and the Indiana sycamore, the forest

service draws attention to the desirability of planting the latter for shade purposes in cities because of its rapid growth and peculiar ability to withstand the effects of smoke and gases. It points also to the fact that, while very beautiful, the valley oak is not adapted to this field because it requires from 300 to 400 years to attain maturity.

### UNUSUAL MOTOR ACCIDENT WHEN BRIDGE OPENS

1103 An unusual motor-car accident occurred recently on a bridge spanning the Cape Cod Canal at Sagamore, Mass., when a car with three passengers attempted to cross the bridge just as the draws began to rise so that a boat could pass beneath. The steep incline of the span on which the car was moving caused the car to roll backward. The leaves of the bridge are so pivoted that when they stand at an angle of about 45° there is a gap between their landward ends and the approaches to the bridge. Through one of these gaps the car and its occupants plunged into the river below. Two of the three per-

sons were rescued, the third being carried away by the swift current and drowned. The accident took place at night during a snowstorm.

### 4 1015 PARK SEATS OF SEVERAL SERVICEABLE DESIGNS

Outdoor seats of several unusual and serviceable designs have been constructed for the parks of Hartford, Conn. Among those most used are benches for band concerts. As these musical programs are given in one park and then another it was desirable to have seats that can be easily transported from place to place. After much experimenting, a design was adopted which included two rearwardly extending legs, as shown. These benches do not tip over easily and can be loaded compactly, it being possible to carry seats for 1,000 or 1,200 persons on a single wagon.

For the hillsides, benches in which the spreading legs rest on two members that lie flat on the ground have been designed. The legs are hinged and the lower ends of the legs on one side of the bench are unattached, so

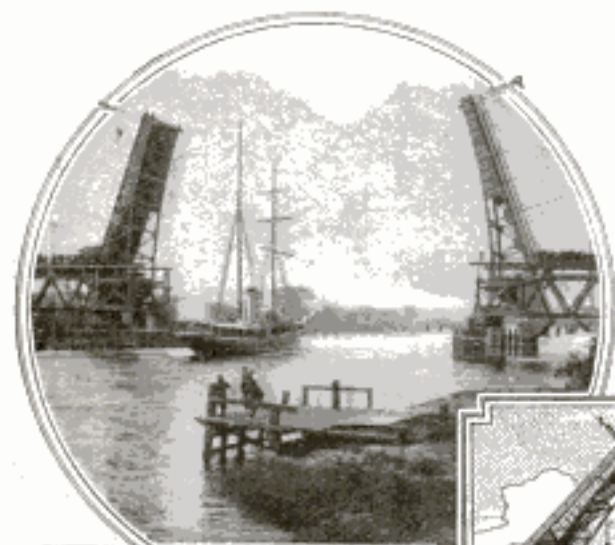

A Motor Car and Three Passengers were Plunged into the Water through the Gap at the Landward End of One Leaf of This Bridge Because It Opened When the Vehicle was Passing over It

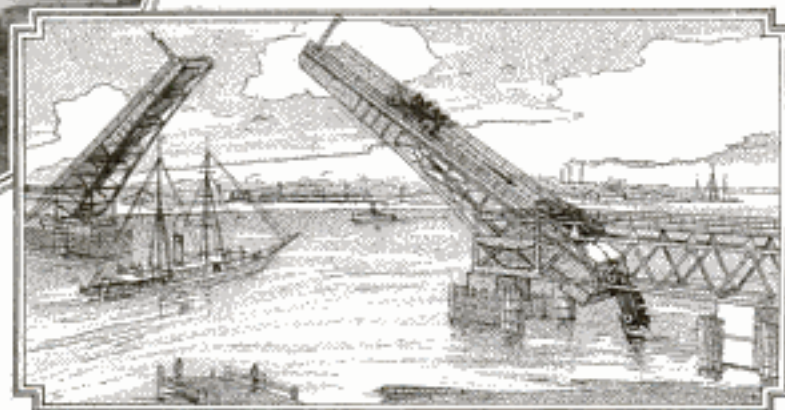

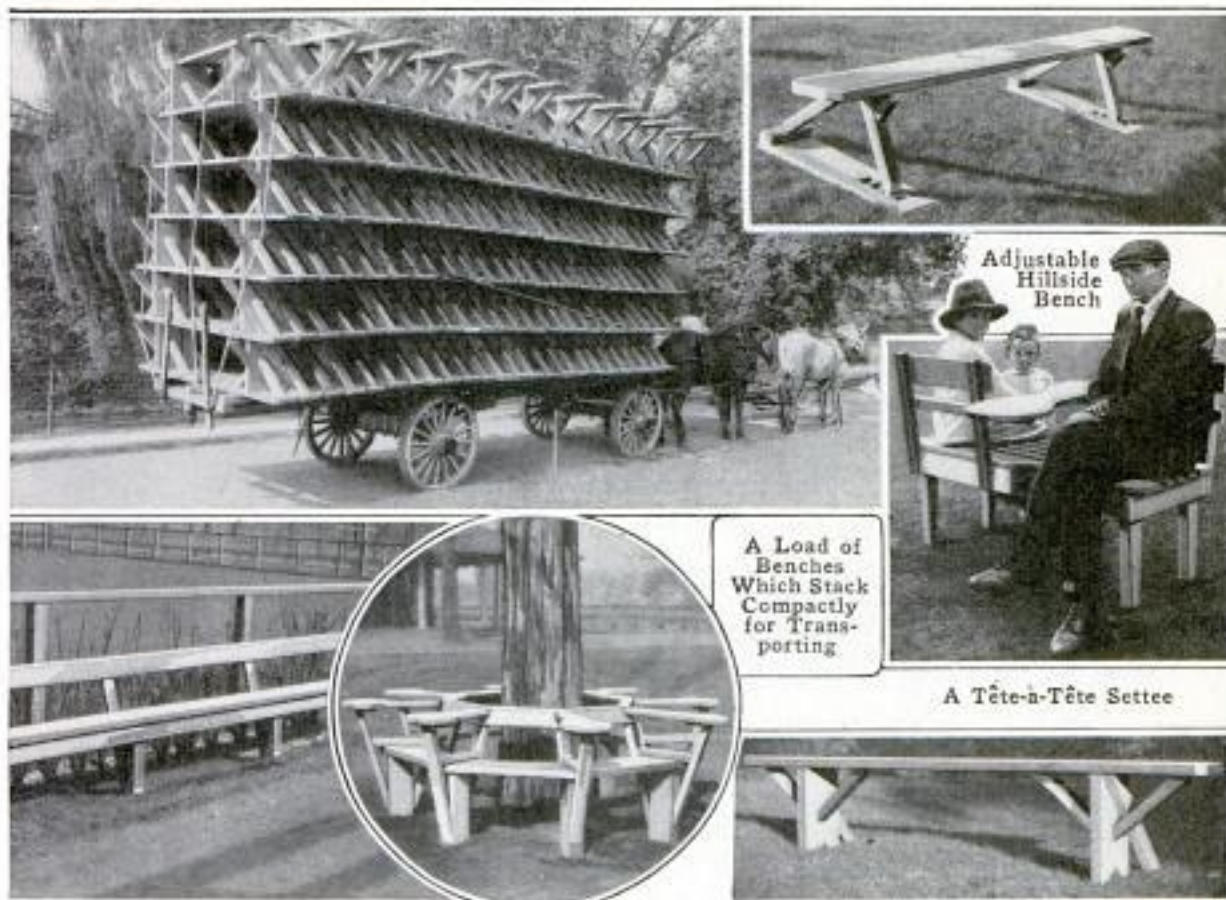

Fence Bench: The Second Rail Forms the Back Rest

Octagonal Seats with Broad Arms

A Load of Benches Which Stack Compactly for Transporting

A Tête-à-Tête Settee

Bench That can be Loaded Compactly

that these ends can be placed in various notches in the upper side of the pieces which rest on the ground. By this means the seat can be made level regardless of the slope of the hillside. The flat members also act as a protection to the grass. This bench can be folded into small space.

About many of the trees artistic octagonal seats have been built with broad arms on which luncheon can be spread. A tête-à-tête settee with a broad arm extending through the middle can be used in the same manner. Along some 2,000 feet of fence benches have been built of such a design that the second fence rail constitutes a back rest, and the posts act as the rear supports for the seat.

Only those whose homes are un-equipped with electric or gas-lighting facilities, or who need the product in order to earn a living, are now permitted to use petroleum in Germany, according to recent advices.

### CLEVER SEED DISPLAY

347.7 ATTRACTS TRADE

An effective display, used by a western merchant to announce the fact that he had installed a line of seeds as part of his stock, was composed of seeds of various kinds and colors so arranged on the floor of the display window as to spell the word "seeds" and form a border and geometric de-



Seeds of Many Colors Arranged in Geometric Designs Prove Business Getters for Western Merchant

signs. Each figure or letter was composed of seeds of one kind and color. The display attracted a great deal of trade.

*Monarch Seed & Feed Co.  
Medford, Oregon.  
Copyrighted material*

NEW PROCESS FOR MAKING  
10827 FORKS AND SPOONS

A process which greatly reduces the amount of scrap obtained in the manufacture of spoons, forks, and other

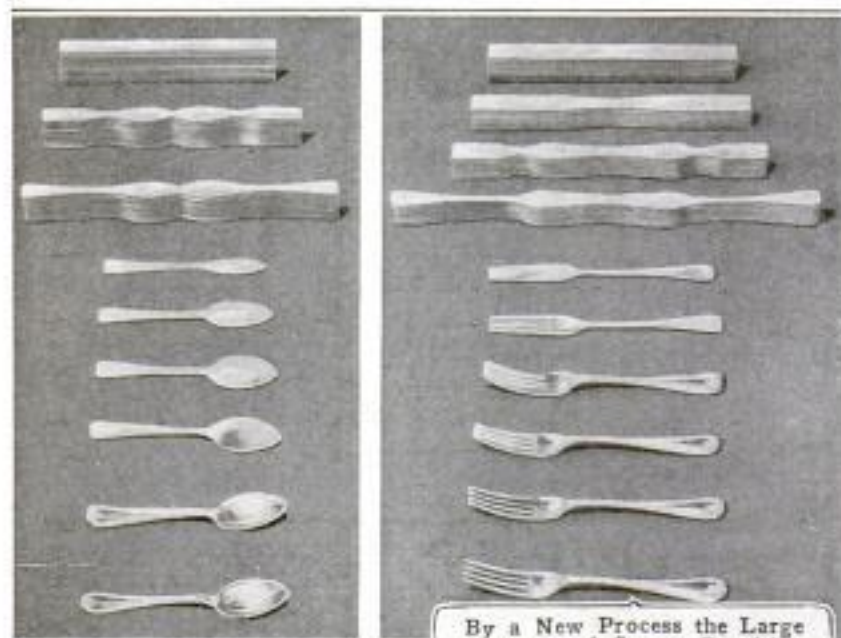

By a New Process the Large Amount of Scrap Resulting from the Making of Blanks for Flatware is Almost Entirely Eliminated

flatware has been developed in France. With the usual methods in such manufacture the scrap is from 40 to 45 per cent of the original metal used. The new method reduces the amount of scrap to five or six per cent. It is essentially cold-drawing and coining under heavy pressure; sterling silver, German silver, steel, and aluminum being metals used. The tools are simple, easily adjusted, and quickly changed or replaced; the amount of labor involved is comparatively small.

By the usual American method finished blanks for forks, spoons, etc., are cut from pieces which have been enlarged by rolling. To cut a finished blank of the desired form from such material makes unavoidable a large amount of waste, or scrap. By the new process the original strips of metal used contain very little metal in excess of the amount needed in the articles to be made. At a considerable saving of labor "double blanks"—strips sufficient to make two articles—are usually used. From 8 to 18 of these double blanks,

according to size, are assembled in a bundle, or "package," and placed on edge in a quadruple-expansion profiling press. From four sides they are subjected to a pressure of from 150 to 250 tons for the purpose of giving each blank a profile somewhat like the article into which it is to be made. This pressure does not change the thickness of the blank but causes the metal to flow longitudinally, at the same time removing pores and other defects.

For spoons, two profiling operations, with one change of dies, are required; for forks, three operations with two changes of dies. So accurately can these operations be performed, that the blank needs only a very little trimming to make it into the desired shape.

The remaining processes include additional shaping of the ends, flat polishing, stem upsetting, embossing, trimming off the flash, or thin edge, of scrap, and the final polishing.

9590 D FLOWER BOX AERATES AND WATERS PLANTS

Water spilling out of flowerpots and plant boxes is a continual source of annoyance to the housewife. With a view of lessening this trouble a new type of plant container has been invented. It consists of a metal box of the desired size, shape, and finish, in the bottom of which a flat tank is placed. A pipe from the upper surface of the box leads down to



"In the time of Old Kansas - are you on?"

Vertical handwritten notes on the right margin, including "Illinois Flower Box Co. St. Louis, Mo." and "No. 8000".

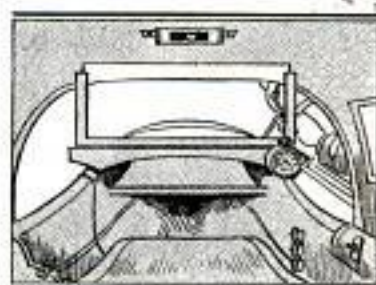
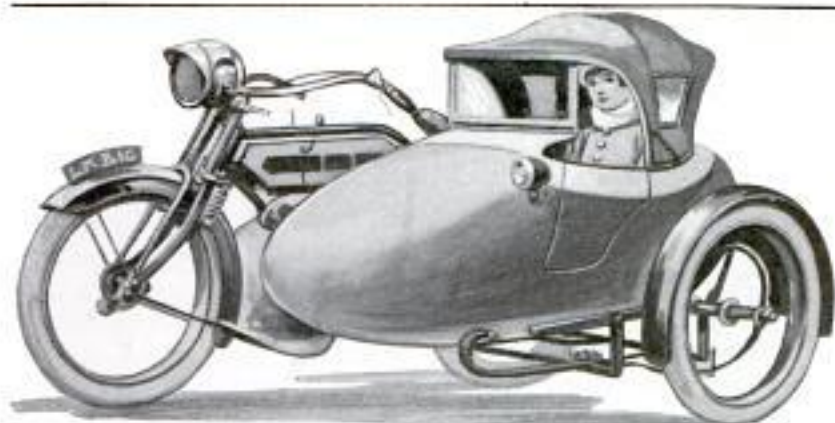

Besides Being Neat and Attractive in Appearance, the Sidecar Is Roomy and Comfortable

this tank, and through it water may be poured even after the rest of the box has been filled with soil. Filling the tank occasionally is all that is necessary to supply water to plants growing in the boxes, as a wicklike, or nozzle, arrangement leads up from the tank into the soil, permitting water to work gradually up to the roots. Corrugated linings of porous clay or cypress wood may also be placed in the boxes to assist in the circulation of moisture and in aeration processes. Since the porous nature of the linings causes water to be absorbed, additional moisture, along with air, is made to go into the soil to supplant that taken up.

#### LUXURIOUS SIDECAR BUILT 1065 H FOR MOTORCYCLE

One of the neatest and best appointed sidecars so far designed for use with motorcycles has been introduced in England. Its streamline body is finished in black and white, well upholstered inside and covered by a very shapely top which is held in position by elbow struts. A glass windshield protects its occupant from the rain and cold, while small windows at the sides admit light during the daytime and give a broad scope of vision. A bullet-shaped headlamp is mounted on the left side, while the interior is fitted with an overhead electric light and supplied with a small clock. At the rear is a roomy compartment in which tools and small packages may be carried. The finish and workmanship are

especially good throughout. Although no objection would perhaps be found to it on paved streets, the clearance of certain parts of the chassis is very slight, being only 2 in. from the ground.

#### DAIRY'S WATER TOWER 1101 F ADVERTISES MILK

A water tank, 32½ ft. high, shaped and painted to resemble a huge milk bottle, has been erected high above a Canadian dairy to serve as an advertisement and for fire protection. The "bottle" is constructed of quarter-inch boiler iron and stands on a tower 75 ft. high; its diameter at the bottom is 13 ft. and at the top 6½ ft. The tank has a capacity of over 25,000 gallons, and the combined weight of the tower and tank when filled is 236,000 lb. The cost of erecting this striking tower was slightly more than for the ordinary type.



City Dairy Co.,  
Toronto,  
Ont.

The Sidecar Co.  
895 Fulham Rd., S.W.,  
London.

## OLD STEEL TOWER FELLED

10703 BY FIERCE GALE

A terrific gale recently demolished a 265-ft. steel tower which had stood as a conspicuous landmark in San Jose,



Above: San Jose's Steel Tower, 265 Feet High, As It Appeared at Night Before It was Destroyed.  
Below: Wreckage of the Tower After a 57-Mile Gale Swept the City

Cal., since 1881. Engineers estimated that a 60-mile gale would subject each of the corner supports to a pressure of 23 tons. The tower withstood for five minutes a wind blowing at the rate of 57 miles an hour, but a little later, when the wind had subsided to 51 miles per hour, it collapsed. Careful examination after the storm showed

that the hollow steel tubes constituting a part of the structure had crystallized. It is believed that this was due to constant vibration caused by traffic in the streets beneath. Less than a year before this recent storm a fierce gale bent and wrenched the tower. At that time \$5,000 was raised by public subscription to repair it. Two expert examinations of the structure were made, one four months and one a few weeks before it fell. On both occasions broken parts were discovered, leading engineers to conclude that the tower's strength was deteriorating. It was built as a part of a method of street illumination now abandoned. In recent years it had served ornamental purposes only, being adorned with thousands of incandescent lights, and had been a conspicuous decorative feature on many occasions.

## H 1220 ITALIAN SCHOOL CHILDREN FORM INSURANCE BODY

In the interest of the pupils a mutual-benefit system of insurance has been inaugurated in the elementary schools at Rome and also in those of a few other Italian cities. Although still comparatively new the plan is growing very rapidly and has been received so favorably by the government that action has been taken authorizing the introduction of the idea into the state schools and bringing it there under state supervision. The pupils contribute a small weekly fee to a general fund from which sick, accident, and death claims are paid. The fund simultaneously lays a foundation for old-age benefits, and it is hoped to encourage the children to continue their payments after leaving school and until reaching maturity. The scheme is considered to have a valuable psychological effect upon the child at its most impressionable age. Among the lower classes, it is thought, this effect undoubtedly will be felt also in the home, for the parents in giving a child money with which to pay its insurance premiums are continually presented with the thought of providing for the future.

*Commercial Reports*  
12/21/15



## FRESH-AIR OFFICE OCCUPIED DURING COLD WEATHER



Above: Operating Typewriters with Curved Sticks, While Wrapped in Heavy Coats  
Below: Exterior View of the Fresh-Air Office, Showing Window Arrangement

COPYRIGHT BY INTERNATIONAL FILM SERVICE

At Wellesley Hills, Mass., a prominent statistician and writer has established an open-air office in which he and his immediate assistants do their work. It is virtually a fresh-air parlor and consists of a frame building provided with numerous windows which

during the daytime are thrown wide open, irrespective of the outside temperature. During the winter everyone engaged in the office wears a heavy woolen coat and mittens. In order that the stenographic force may be able to operate the typewriters with gloved

hands, small, curved sticks are employed instead of the fingers in striking the keys. Each typist uses a pair of these implements, hitting with them just as if they were tack hammers.

While it is obvious that correspondence is turned out comparatively slowly in this way, the members of the office force keep in good health and mental trim.

### REPAIRING MAIMED FINGERS

#### BY GROWING NEW TISSUE

320 H *Jul Am. Med. Assn 9/15/15*  
By making use of a tapering celluloid tube, a Baltimore surgeon has accomplished interesting work in adding length to a finger after the terminal phalanx, or tip end, has been accidentally amputated. The treatment consists of stimulating granulation tissue to grow in the desired direction by training it. This phase of the operation is facilitated by the tube, which fits snugly about the edge of the wound. A sheet of celluloid, .005 in. thick, is employed. It is cut to a certain pattern, wrapped about the finger and secured with strips of adhesive tape. It does not adhere to the wound, is transparent, and serves both as a splint and guard. When possible a blood clot is allowed to form as a scaffold for the granulations. A review of some 15 cases treated in this way shows that

the length of the soft part of the terminal phalanx was increased in each instance, while in a fourth of the cases the bone grew slightly. Furthermore the stumps healed so that they were not painful to the patients. It is stated that if the joint is not injured a small piece of bone can be made to form a shortened phalanx which may be used readily.

### DUTCH GUIANA PAVES WITH

#### 94230 GOLD QUARTZ

In Dutch Guiana a satisfactory method of paving has been worked out, even though little of the capital and satisfactory construction materials road builders ordinarily use are available. Paramaribo, the capital, being in need of a stretch of pavement, local engineers set out to find something to build with. The only suitable material within reasonable distance proved

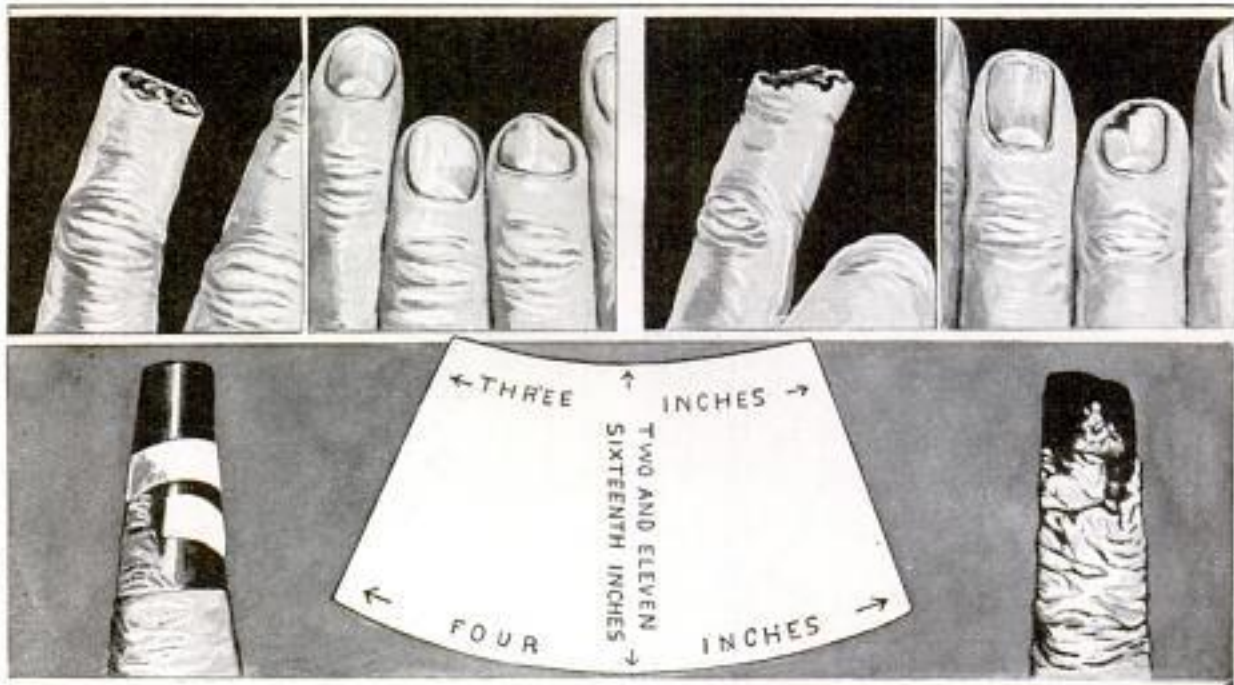

COURTESY JOURNAL OF THE AMERICAN MEDICAL ASSOCIATION

Top: Mangled Fingers before and after Treatment. Below: Tube in Place, and Removed Showing Line of Amputation. The Tube Fits Snugly about Wound and Permits New Tissue to Grow in Desired Direction

John Staige Davis, M. D.,  
Preston Heights,  
University, Va.  
(Fellow Am. College of Surgeons)  
Chattottesville, Va.  
Copyrighted material

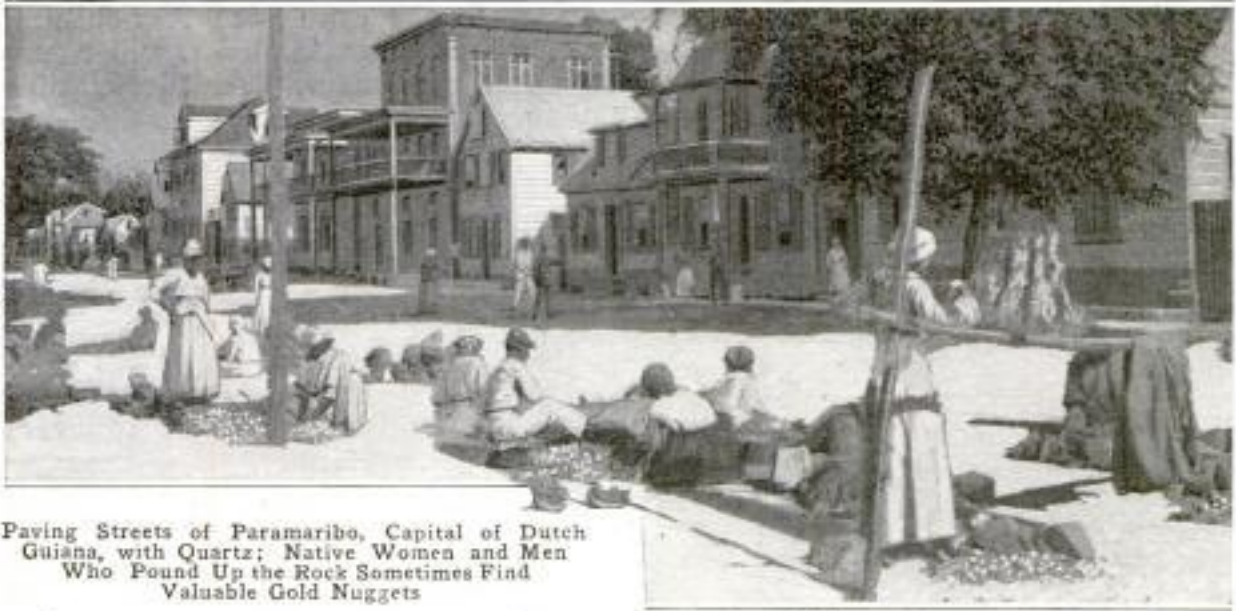

Paving Streets of Paramaribo, Capital of Dutch Guiana, with Quartz; Native Women and Men Who Pound Up the Rock Sometimes Find Valuable Gold Nuggets

to be quartz, a mineral glassy in appearance and almost as hard as diamond. To get this to the city entailed an expense of \$2 per ton. No rock-crushing machinery being available, the quartz was dumped at convenient intervals along the street, and natives hired to break it up piece by piece with small hammers. The women and youngsters took particular interest in this employment, squatting in the dust and hot sun and pounding lustily for 12 hours at a stretch. Though receiving but 50 cents a day for such work, individuals sometimes added to their earnings by finds of gold in the bits of quartz. Cases are on record of an occasional dusky lady accumulating as much as \$150 in this way in six weeks' time.

*Creative*

**TABLE SERVES TWOFOLD  
 100% PURPOSE**

In flats and apartment buildings economy of space is important. For this reason combination furniture is frequently purchased for such places. One of the latest developments in the combination line consists of a table designed to serve both for dining purposes and for library use. This is made possible through the fact that the top is equipped with concealed leaves which may be folded out to give the larger area necessary for a dining table. A hidden lever beneath the leaves con-

trols the folding functions. When the extra leaves are beneath the regular top, and the latter closed down, the table appears no different from the ordinary library type.



Convertible Table Serves Both for Library and Dining Room

*Sold by Twin City Mission Furniture Co. St. Paul*  
*A. H. Revell & Co.*

538 **BLOWER SOFTENS HARD SEEDS FOR PLANTING**

Certain seeds, such as sweet clover, burr clover, vetch, and alfalfa, have hard brittle coverings almost imper-

ducted by the Iowa State Agricultural College, at Ames, Ia., has recently constructed a mechanical scarifier capable of breaking or scratching each seed to such extent that water will find ready entrance upon planting, thus starting germination.

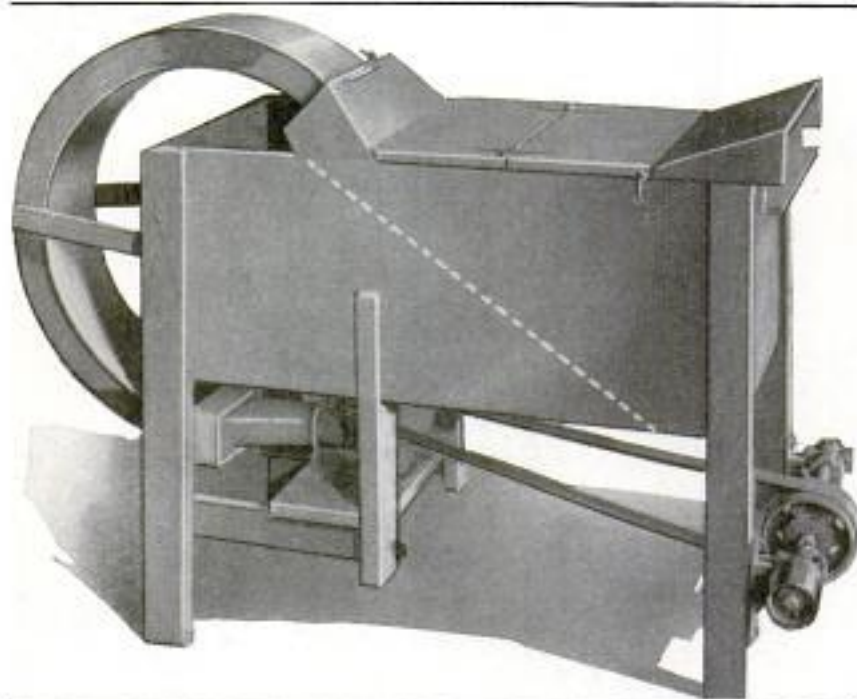

This Machine Scratches Hard-Coated Seeds by Hurling Them Against Sandpaper. With Their Covering Broken Such Seeds Germinate More Quickly

The new contrivance much resembles a washing machine in external appearance, or perhaps the fanning mill familiar to every farmer. The seeds to be scarified are poured in at one end, caught by a fan revolving at a rapid rate and hurled around a circular pathway lined with sandpaper. The result is that they emerge from the upper end considerably scratched up and rough-handled in general. Falling upon a screen at the end of the circular pathway, their velocity rapidly lessens, until, at the

vious to water. Farmers sometimes experience considerable difficulty in getting these to germinate promptly, causing, as a result, a poor stand in the hay crop derived therefrom. To get these seeds into shape before planting, an experiment station con-

end of the screen, they tumble into a basket ready to go to the seeder out in the field. The machine will handle 30 to 40 bushels of unhulled seed per hour, or about 20 bushels of the hulled variety. Seeds run through this machine have given some wonderful yields.

*Body*  
**TRUCK DESIGNED TO CARRY 1178' LONG STEEL STRIPS**

A large steel company has recently added to its equipment a motor truck with a body especially designed for carrying steel strips of various lengths.

The platform body of this truck is 16 ft. long. The sills are of heavy oak faced with steel. At either side are removable panels, 10 in. high and bound on the top with angle iron. The end gate swings down. The front cross panel of the platform is in three sections, the end sections being removable so that long pieces of steel may

Truck Adapted to Carrying Extra-Long Steel Bars

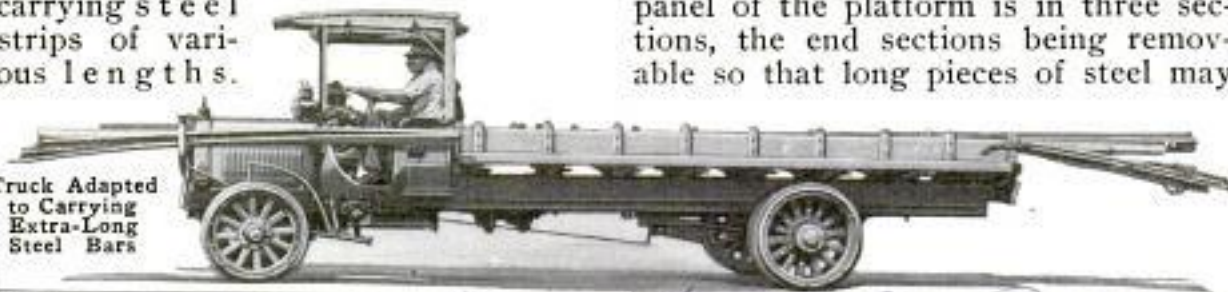

*James Laughlin Steel Co., Pittsburgh, Pa.  
Packard Motor Car Co., Detroit, Mich.*

be laid on the platform and allowed to extend forward either side of the driver's seat. Attached to the bumper at either side are cradles, or brackets,

Californian," listed to port and suddenly sank without warning. The affair happened at the same spot where the steamer "Craigside," loaded with sugar for the allies, was burned last

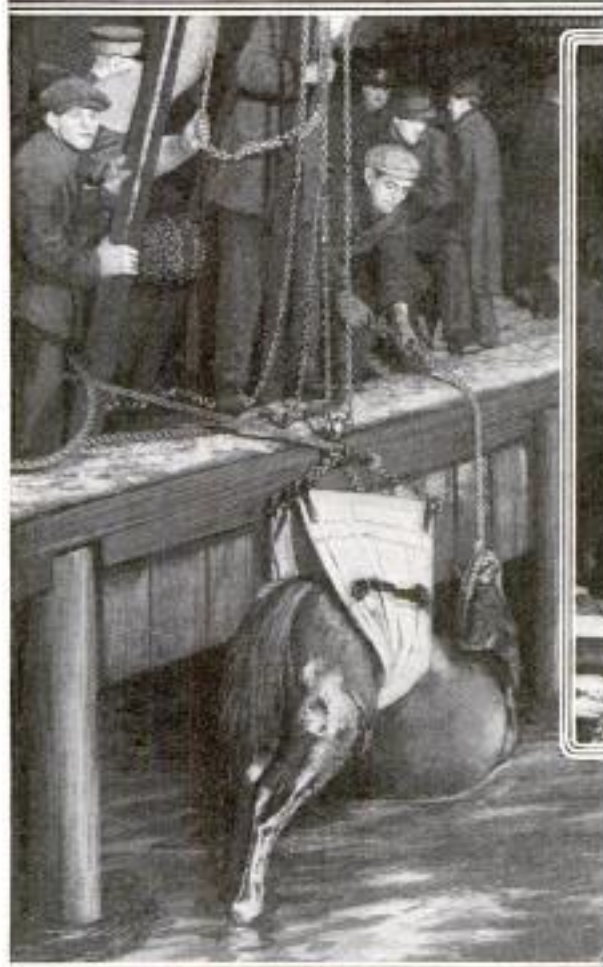

COPYRIGHT, UNDERWOOD & UNDERWOOD

Lifting One of the Horses from River by Means of Block and Tackle. This Picture Gives an Idea of the Great Difficulty under Which the Rescuers Worked

which carry a demountable cross bar for supporting the forward ends of very long strips of steel. Two rows of extra standards are fitted in the platform to aid in holding a load securely. The platform with the brackets furnishes a supporting length of 23 ft. and over.

### BARGE LOADED WITH HORSES SINKS IN HUDSON RIVER

1127 H More than 500 horses consigned to the French government for war purposes were recently drowned in the Hudson River at New York when a barge, from which they were being transferred to the steamship "Anglo-



Attempting to Revive One of the Animals Pulled from the Water after Long Exposure

summer. This coincidence, coupled with peculiar circumstances surrounding the sinking of the lighter, gave rise to a belief that the animals perished as the result of the activities of alien plotters. The barge was a remodeled freight-car float which had been roofed and boxed in. According to reports, 300 horses were carried on the first tier and 320 on the upper one, both being below the deck. Some of those on the top tier managed to keep their heads above the icy water for several hours, while scores of men worked with derricks and pulled them one by one through a hole cut in the roof of the barge. The beasts imprisoned beneath, however, had no chance whatever of rescue. When the workers succeeded in slipping a wide canvas belt about the body of an animal and putting a rope about its neck, it was drawn from the water. Only three horses were rescued in this manner, however, during the first two hours, and the total number saved was very small.

*Barge "Virginia" - 2 3rd St. - North River*

# H. W. Humphrey, Sec of Br. No. Am., S. John, N. B.



#### THREE BRIDGES SPAN RIVER SIDE BY SIDE

At St. John, N. B., three large bridges, each of a different type of construction, span the St. John River at its mouth and connect two narrow necks of land overlooking the harbor, which is on the Bay of Fundy. The oldest of these is a suspension bridge, which was erected in 1862. This structure has a span of 640 ft. and a clearance of 72 ft. at high tide. The central bridge of the group, which has only recently been completed, is a single-span arch of the same length as the former one. The other structure represents, it is said, one of the first large inverted cantilever bridges to be built. It is approximately 811 ft. long and was erected in 1895. Below these structures are the somewhat famed reversing falls. At half tide the water rises above the rocks and flows up the stream.

9795  
D  
**COMPRESSED AIR ACTUATES  
NEW TYPE OF FIRE ALARM**

A recently marketed automatic fire alarm applies a well-known principle in an unusual way. A long metal tube about  $\frac{1}{40}$  in. in internal diameter is placed around the upper part of a room back of the picture molding or other convenient support. Should a fire break out, the increased temperature of the room at once expands the air imprisoned within the tube and pushes out a thin metal diaphragm in a special detector instrument mounted at one end of the pipe line. The diaphragm in expanding makes an electrical contact which rings an electric bell or turns on a light in an annunciator, thus giving the alarm. A regulating valve is mounted on the end of the tube not occupied by the detector. This valve

allows such minute quantities of air to enter or leave the tube as may be required by ordinary temperature changes within the room. A pump set up in connection with the valve permits an occasional injection of com-

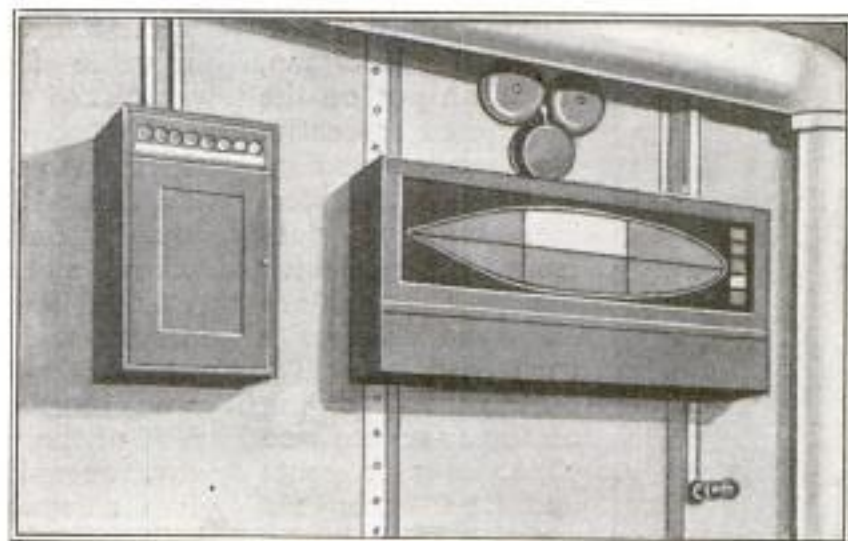

An Automatic Fire Alarm Operated by Compressed Air: The Device is Connected with a Small Air-Filled Tube, the Contents of Which Expand Under Heat and Set Off a Gong or Turn On a Light

1164  
X  
**IMPROVISED STAMP MILL  
DOES EFFECTIVE WORK**

An old upright boiler, a pump, and an air drill proved of substantial aid to a prospector engaged in working an unexpected find of gold-bearing ore recently. The vein was rich but too small to warrant the purchase of elaborate equipment, and with the exercise of ingenuity the improvised stamping and washing machinery served excellently. By mounting the air drill in a frame and fitting its piston with a shoe, as much as a ton of ore

pressed air, that the pipe line and its proper operation may be tested. The system has been installed in a number of notable buildings in the country.

per day could be crushed in the small mortar rigged up beneath. The rapid hammering of the shoe crushed the ore to a fine powder, and the bits of gold were easily removed by amalgamation.



Curious Stamping Mill Which Paid Large Dividends: Old Boiler and an Air Drill Used to Crush Gold-Bearing Ore

General Utilities Co. Inc.  
 1007-9 W. 48th St. (ex. act 13)  
 (R.W. Bost. Sec. - Ins.) Los Angeles (p. 578-2402)

1833 W. 46th St  
 Los Angeles, Calif.  
 Inventor  
 C. M. Jewell

400

POPULAR MECHANICS

**AUTOMATIC POST-CARD**

VENDER  
*0.07 1/2*  
*May 1916*

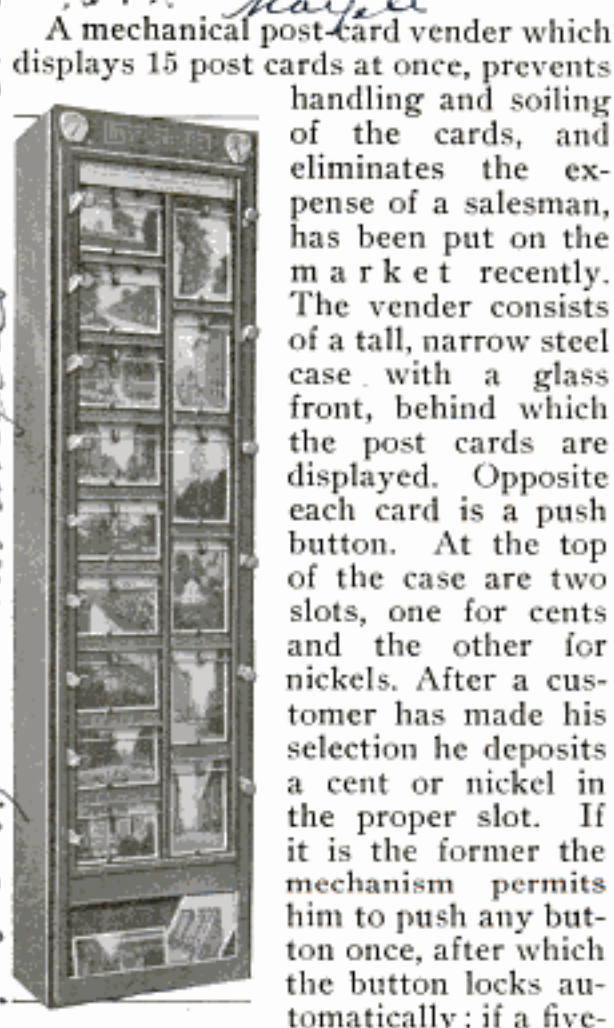

A mechanical post-card vender which displays 15 post cards at once, prevents handling and soiling of the cards, and eliminates the expense of a salesman, has been put on the market recently. The vender consists of a tall, narrow steel case with a glass front, behind which the post cards are displayed. Opposite each card is a push button. At the top of the case are two slots, one for cents and the other for nickels. After a customer has made his selection he deposits a cent or nickel in the proper slot. If it is the former the mechanism permits him to push any button once, after which the button locks automatically; if a five-cent piece has been inserted he may have six "pushes" distributed among the buttons as he sees fit, each button controlling the card nearest it. The cards selected drop to an open receptacle. Adjustments of the mechanism to correspond to other prices can be made easily.

**ALASKAN MINING INDUSTRY HAS PRODUCTIVE YEAR**

According to preliminary estimates prepared by the Geological Survey, the year just ended proved to be the most productive twelve months thus far experienced by the Alaskan mining industry. The value of the total mineral output for the period exceeded that of 1914 by more than \$12,000,000. An unusual amount of copper was produced, and this was largely responsible for the

*Commerce Reports*  
 1-3-16

big showing. The aggregate output of all minerals is estimated to have been \$32,000,000 as compared with \$19,064,963 for the previous year. Of this amount approximately \$14,400,000 was derived from copper alone. The significance of this may best be appreciated when it is remembered that the value of copper mined during 1914 was placed at only \$2,852,934. About \$16,900,000 of gold was also mined, which represents the greatest production since 1912 when the output was valued at only a few hundred thousand dollars more. Silver worth about \$400,000 was produced, while other outputs, such as tin, antimony, marble, gypsum, coal, and petroleum, had a value of about \$300,000. The high value of the mineral production for the year, according to the government, gives assurances of continued operations on a big scale in both copper and gold. The showing is not looked upon as a temporary expansion due to the present high price of copper.

**ELECTRIC TORCH MAKES USEFUL HOUSE LIGHT**

A few years ago small house lamps operated by batteries were expensive and unsatisfactory because of the large amount of current consumed by carbon filaments. The advent of tungsten, however, has changed this. Sharply in contrast with the older impracticality, a line of small electric lamps is now being manufactured, which may serve admirably and economically to illuminate dining tables, clocks, or in a variety of household ways. They are made up to resemble candles—with the battery where wax or tallow ordinarily is. A push button at the top turns the light on or off.

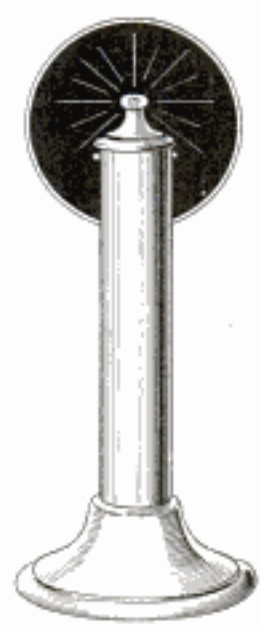

*Wm. M. Dycker, (Inv.)*  
*Dycker Co.*  
*277 Broadway*  
*(Field Hospital Bldg.)*  
*New York*  
 Copyrighted material



11247 *Pr...*

FIELD HOSPITAL CAN BE COMPACTLY CRATED



The Entire Building is Shown Here Crated so That It can be Transported on a Motor Truck



Exterior View of French Portable Field Hospital, the Gift of an American Woman and Built in America



The Hospital in Process of being Erected, Showing the Manner in Which the Panels and Framework Fit Together



This Building can Accommodate More than a Score of Cots. Air Spaces in Walls and Roof Make It Comfortable in Any Weather



The Foundation of the Hospital is Composed of the Crates in Which the Building is Shipped

A portable field hospital which can be erected by two men in about 90 minutes and when packed can be carried on a motor truck, is the gift of a New York woman to the French army. For its construction the United States government's portable houses for use in

Panama and Alaska furnished suggestions. The structure is entirely of wood and indurated-fiber panels. Bolts are employed throughout instead of nails or screws.

A feature which contributes to the hospital's compactness when ready for

shipment is the use of the packing cases to form the foundation and floors. The tops of these cases are employed in constructing the roof. The building measures 17 ft. by 44 ft. and has a capacity for 26 cots and chairs and tables. It is lighted at the sides and ends by glass windows. The walls and roof have a 2-in. air space which, with the closely fitting joints, makes the building suitable for use in cold or warm weather.

All the material has been treated with a preparation which makes the building water and vermin-proof, as well as sanitary and fire-resisting. The building, with the necessary furnishings, is said to supply every requisite for the care of the sick and wounded in the immediate vicinity of a battle field. In it the urgent and essential preliminary ministrations to the suffering can be performed for large numbers before they are sent to permanent hospitals.

*Britton Lath Mfg. Co. 314 Central Bldg., Los Angeles*  
**FIBER PLASTER BOARD MADE WITH ANCHOR BUTTONS**

1106 One of several advantages offered by a new plaster board, which is being utilized for both interior and



exterior building purposes along the Pacific coast, is the ease with which it may be applied. It is readily cut either with a saw or hatchet, and may be nailed to a joist as securely as a pine lath. It is made of a fibrous material in sheets, 32 in. long, 24 in. wide, and  $\frac{3}{8}$  in. thick. What are termed composition buttons are set

in depressions on one surface of the board. There are some 530 of these to a square yard, each supposed to be capable of supporting a 50-lb. weight without breaking, which in conjunction with the board itself make a good bond when plaster is applied. It is very

rigid and when properly nailed in place will not sag. When employed on the exterior of a building which is to be finished in stucco, the board is covered with a loosely stretched wire netting, which serves as reinforcement.

**DIRT-HANDLING MACHINE KEEPS WAGONS BUSY**

9198 An interesting machine for plowing up and loading dirt has been designed and built by a middle-western inventor. The machine finds special application in railroad-construction work, on irrigation ditches, and wherever large amounts of dirt have to be loaded onto wagons and transported a considerable distance.

The machine is pulled by a heavy traction engine. In use it advances about seven or eight feet at a time, tearing up the soil into seven wide furrows with a gang plow mounted at the front end. The machine then halts, and a scraper at the rear end, on which the loosened dirt has been accumulating, travels up an inclined track and deposits its load on a short crosswise conveyor. This runs the dirt out over the side of the machine and dumps it into a waiting wagon. Power for elevating the scraperful of dirt comes from a winding drum operated by the traction engine. The conveyor, however, is run by a small gasoline engine on the machine itself, the latter power also raising and lowering the plow, operating the steering mechanism, and performing other heavy duties of the kind about the contrivance. One man is re-

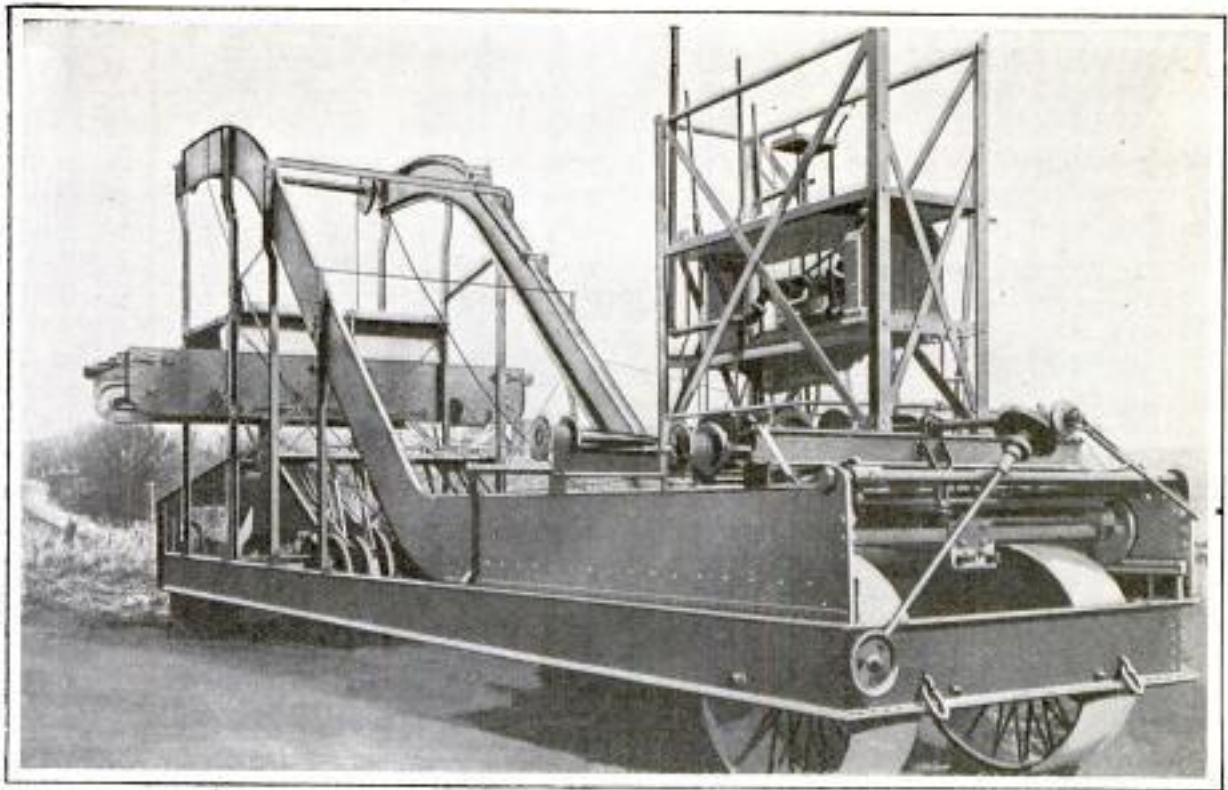

Machine Plows Up Dirt and Loads It into Wagons for Constructing Railroad Embankments and Such; It Is Capable of Delivering 80 or More Two-Yard Loads per Hour

quired to operate this machine, and two on the traction engine. A complete wagon load of 2 cu. yd. can be delivered in 20 seconds, according to the builder, the average, however, being 80 to 100 loads per hour.

### WARSHIPS' SEA CONTROL

#### 1095 $\frac{1}{2}$ SHOWN IN COURT

Striking evidence of the effectiveness with which the warships of a dominating naval power can control the seas in time of war was given in the recent trial of a German official. One steamship line, according to admissions in court, paid out nearly a million and a half dollars for food, coal, and ship charters for 16 vessels. But the attempt to provision foreign sea raiders from United States ports by this means proved an expensive failure. Of all the ships sent out, only one reached the raiders and discharged its cargo. Immediately after this transfer of provisions, etc., had been made, the auxiliary cruiser that had received the supplies was attacked and sunk at the end of a two-hour naval battle.

### IMPROVED GUN-RECOIL PAD 983 $\frac{1}{2}$ FOR SPORTSMEN

A gun-recoil pad which is said to possess qualities equaled by none other has as an important feature a long air chamber between a hard-rubber base and a soft-rubber cushion. These two parts are held together by a particularly strong adhesive strip which, it is said, will not give way. The long air chamber greatly increases the shock absorption, and sportsmen using this device will find that much, if not all,

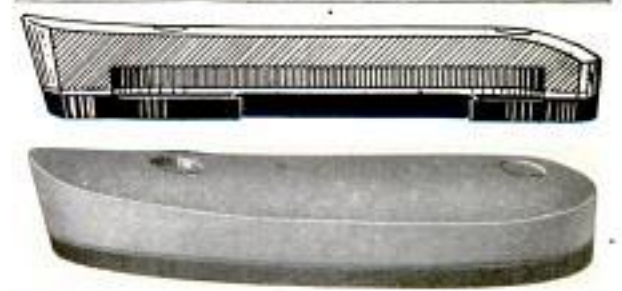

Large Air Chamber in This Recoil Pad Makes It an Effective Shock Absorber

the discomfort occasioned by frequent discharge of firearms has been eliminated.

B. F. Goodrich Co.  
Akron  
Copyrighted material

1107 **WIDE STORM-WATER INTAKES  
PREVENT STREET FLOODS**

By constructing broad sewer intakes in the curbs adjacent to street inter-

sections, the city engineer of Pasadena, Cal., has devised a very satisfactory method of handling great volumes of storm water and preventing the crossings from becoming flooded during heavy downpours. The openings are 30 ft. wide and 9 in. high, while the

flow line of the guttering is lowered 3 in. At the end of the intake which is farthest from the street corner the difference in the levels is taken up in a rise 6 ft. in length. At the other extremity the gutter is elevated so that it is only 2 in. lower than the sidewalk level, thus providing a smooth and high crossing for pedestrians. That section of the sidewalk which is immediately over the intake consists of a 3-in. slab of reinforced concrete and is supported on a pair of steel struts placed about 10 feet apart.

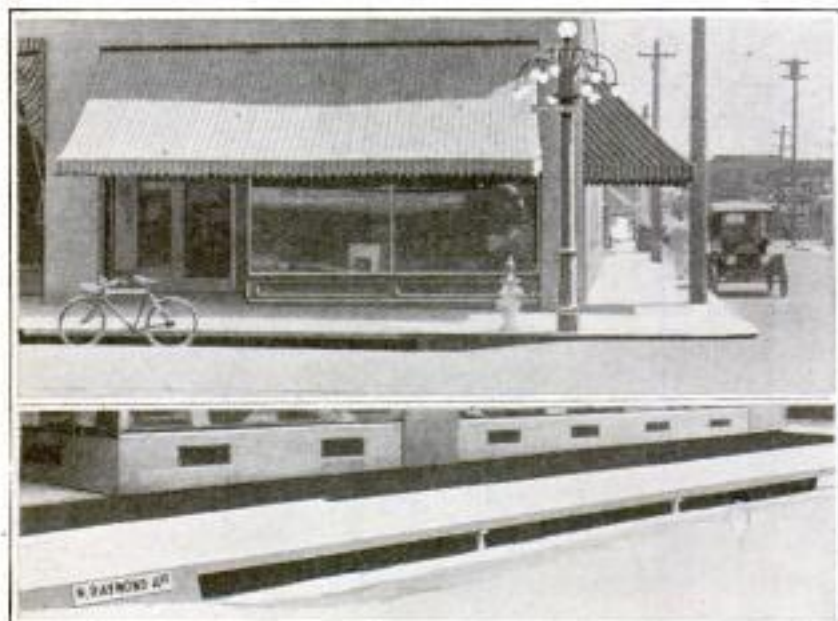

Storm Sewers of Adequate Capacity and Large Intakes Keep Streets from being Flooded during Heavy Rains

sections, the city engineer of Pasadena, Cal., has devised a very satisfactory

method of handling great volumes of storm water and preventing the crossings from becoming flooded during heavy downpours. The openings are 30 ft. wide and 9 in. high, while the

9584 **MODEL AMUSEMENT PARK IS  
MADE FROM SCRAP PAPER**

A pocketknife, a pair of scissors, and a one-foot rule were the only tools used in making a model amusement

park which attracted considerable attention as a window display in a western city recently. Though built of such a flimsy material as scrap paper, with the help of occasional bits of pasteboard and glue, the model had a

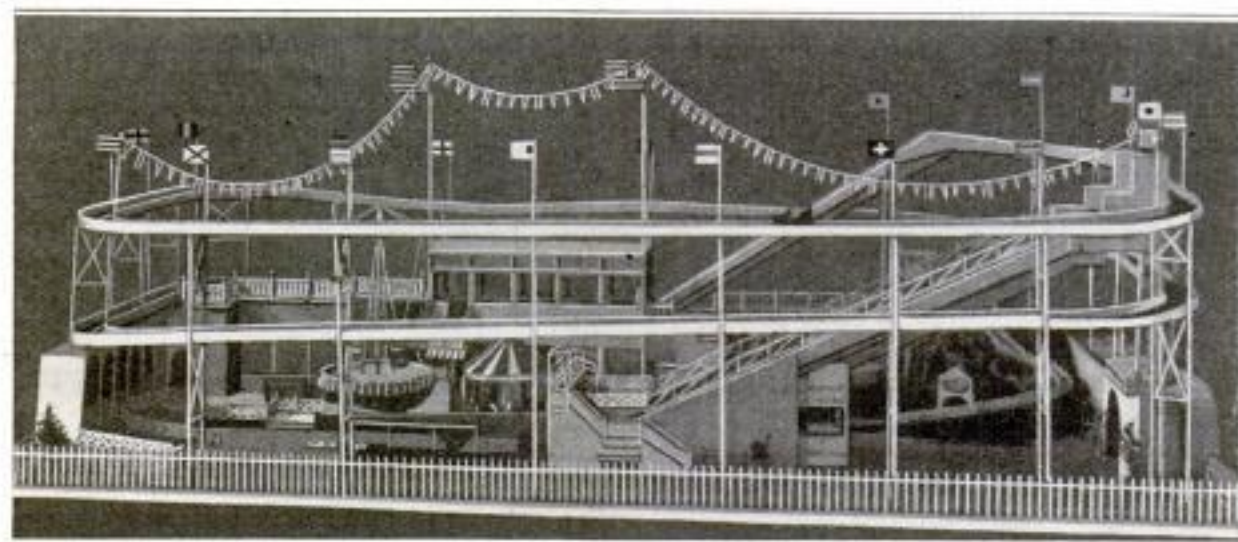

Model Amusement Park Made from Scrap Paper and Glue Which Attracted Attention as Window Display

Made by  
Fred Herrguth  
309 Clement St., San Francisco.  
Copyrighted material

full complement of the usual side shows and amusement devices, each running full blast as in a genuine park. These diversions included a scenic railway, a "shoot-the-chute," a "devil's slide," a merry-go-round, and a circle swing, all propelled by a small electric motor. Miniature electric lights illuminated the display, the whole affair proving a decided attraction to passing crowds.

be made with any desired number of compartments, the standard size, however, having eight. Each space is lined

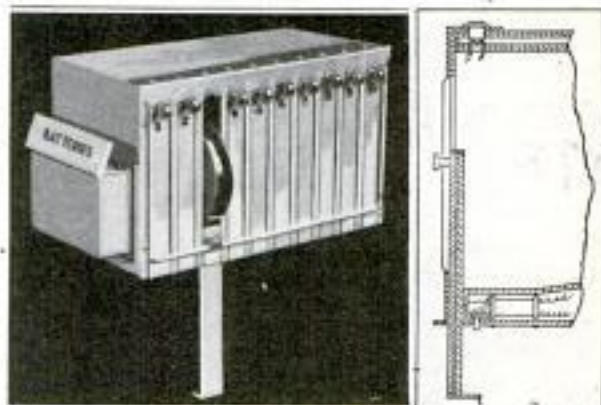

Storage Case for Moving-Picture Films is Asbestos-Lined and Equipped with Electrically Interlocked Doors of Which Only One can be Opened at a Time

with asbestos and provided with a separate door controlled by an electrically operated lock. This is so made that only one door can be opened at a time, and then only when the other doors are tightly closed. A battery box at the side of the case provides current for operating the several locks.

**STATIONERY FILE KEEPS ORDER IN DESK DRAWER**

Designed to eliminate the trouble of hunting for writing materials, a metal file for holding letterheads, envelopes, and business stationery was recently invented. It is so shaped as to fit readily into a desk drawer, from which it may easily be removed for adjustment of contents or adding quantities



Stationery File Allows Ready Access to Letterheads When Wanted

of new material. A number of compartments are provided, each one on a slant, so that quick access to all filed stationery is possible. The principal joints in the device are electrically welded.

**MODERATE SPEED ASKED BY MOTORISTS' SIGN**

An automobile club composed of many motorists in an eastern state has erected conspicuous signs at approaches to various villages and towns in which the local police are, in the judgment of the club, endeavoring to administer speed laws fairly. These signs notify motor-car drivers of this fact and ask their cooperation in an effort to continue the amicable relationship. It is said that numerous instances of unjust arrest by authorities

**FIREPROOF FILM BOX HAS AUTOMATIC LOCK**

A fireproof, self-locking film box, divided into compartments, each holding one reel of film, was recently invented for use in the projection booths of moving-picture theaters.

The idea in such a contrivance was to provide a safe storehouse for the films so that their highly inflammable nature might not endanger other objects within the booth. The box may



An Automobile Club has Erected Many Signs Like This to Enlist the Cooperation of All Motor-Car Drivers in Observing Speed Regulations That Are Reasonable

*781*  
*Carrier Sales Co.,*  
*1104 1/2 St. N.W., Wash., D.C.*  
*7897*  
*Vicing Sales Co.,*  
*1104 1/2 St. N.W., Wash., D.C.*

*Inventor: E. A. Rupert,*  
*Aberdeen, Wash.*

of small communities caused the club's representatives to make a state-wide investigation, after which these signs were erected to mark the villages with fair police officials.

### PLUNGER PUMP WORKS WITH 887 ~~PLUNGER~~ LITTLE VIBRATION

With the ordinary plunger pump vibration is characteristic. The reciprocating pistons propel the water with

ing, a feature which makes for long life and smooth working. The new pump is especially designed for use in inaccessible places and on temporary work. It may be suspended from a cable where desired. Even in such positions its action is said to be so smooth that a nail may be stood upright on the main frame without toppling over from the jar. An electric motor geared directly to the cam shaft supplies the power.

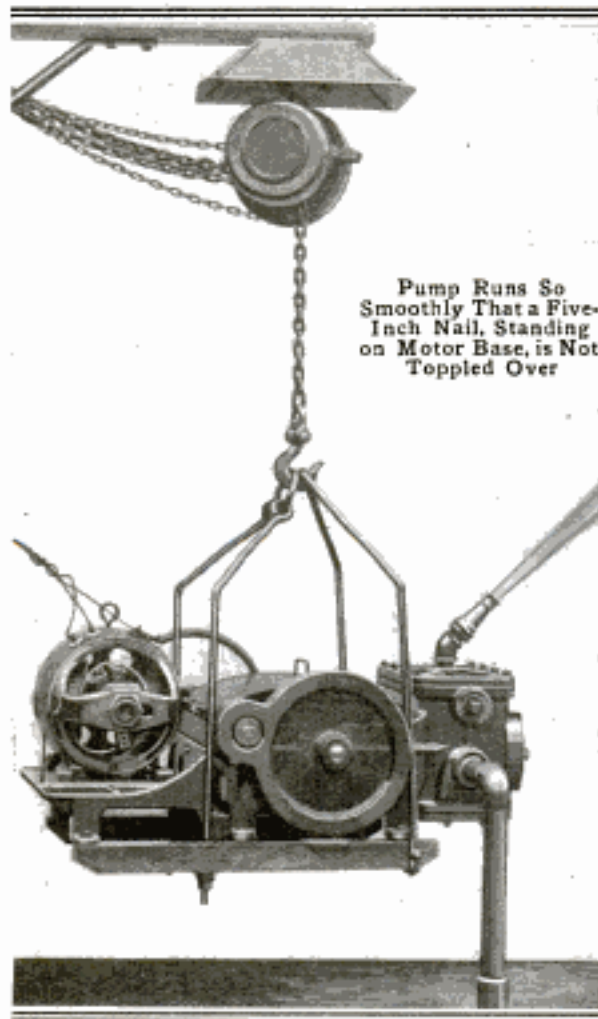

Pump Runs So Smoothly That a Five-Inch Nail, Standing on Motor Base, is Not Topped Over

such energy that their jerky motion is communicated to the whole machine. A pump of new design has been brought out, however, which overcomes the vibration by using cams instead of cranks to drive the pistons. The cams are so shaped that the water moves at the same velocity in all parts of a cycle. Thus convulsive motions are avoided, and since the cylinders are double-acting, the cam shaft is float-

### DENTAL REPAIR WORK

#### 9846 ~~DENTAL~~ AFFECTED BY WAR

Some years ago gold was considered the material par excellence for filling teeth. Recently, however, it has been more or less superseded by a porcelain preparation manufactured in Germany, the latter material closely resembling natural ivory and dentine. Owing to the war the German supply of porcelain is now cut off, and the possibility that the precious yellow metal will resume its place in the field is said to assume considerable proportions. Thus the aversion some people have to displaying a mouthful of gold fillings will have to be conquered unless an American experimenter shortly discovers a process for making the porcelain preparation in this country.

### WESTERN HIGHWAY LIGHTED

#### 1128 H BY LUMINOUS ARCS

By employing luminous arcs fitted with prismatic refractors and high-efficiency electrodes, very favorable results have apparently been accomplished in lighting the state highway between Chico and Red Bluff, Cal. The lamps are 650 ft. apart and 25 ft. above the roadway. Their rays are thrown upon the turnpike in such a manner that its full surface is illuminated and vehicles clearly silhouetted, permitting them to be seen distinctly at a considerable distance. The refractors used with the lighting units replace the customary reflectors. One of these consists of two layers of prisms, the inner horizontal and the outer vertical, set



Section of California State Highway between Chico and Red Bluff Which is Well Lighted by Luminous Arcs

together with the grooves inside. The rays of light striking the first prisms are redirected and emerge at a 10° angle below horizontal, and are then diffused at a wide angle by the outer prisms. The spaces intervening between the arcs along the road are thus adequately illuminated and the glare of the units lessened to the extent that a driver is not blinded by their intensity.

A small circular hole to which a cork is fitted provides a means for pouring additional anesthetic on the sponge without disturbing the animal. The box is 2 ft. by 18 in., by 20 in. deep.

### SIMPLE EXECUTION CHEST

10167 FOR ANIMALS

A zinc-lined chest, one end of which is partitioned off with heavy wire netting, is the device constructed by a humane Massachusetts veterinarian in which he chloroforms kittens, puppies, and other animals brought to him to be put to death. In the small compartment is placed a sponge saturated with chloroform; the animal is then placed in the larger compartment, and the cover, which is practically air-tight, is closed. A glass panel in the top enables one to watch the animal within.



Cats, Dogs, or Other Small Animals can be Killed Humanely in This Chest, Which Has Separate Compartment for the Anesthetic

Inv.: Dr. A. Burlingame,  
 Springfield, Mass.

*Journal Franklin Inst.*  
*Dec 15*

*Engineer & Electrician*  
*Vol 15 (du Corol)*  
*for Oct 15 1914*

### STEEL FILING CABINET IS

#### 9210 GIVEN SEVERE TEST

To demonstrate the wearing qualities of steel filing cabinets offered for sale, a dealer in a mid-western city recently resorted to an ingenious experiment. A

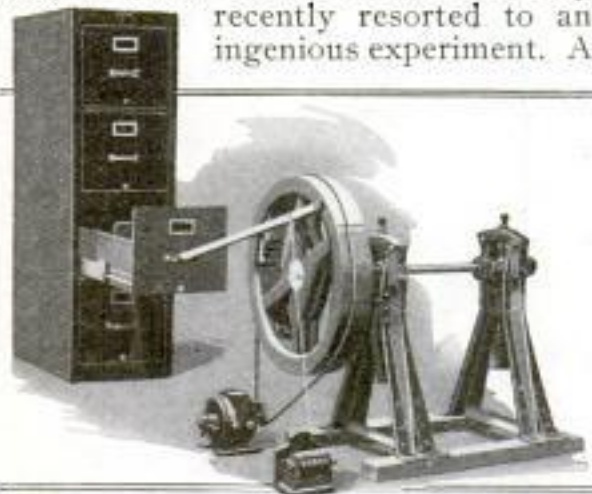

Machine Tests Filing Cabinet by Running Drawer In and Out 361,321 Times

cabinet was set up in the show window, and to the handle on one of its lower drawers an arm was attached. This connected with a crank pin projecting from the side of a large wooden pulley, a small electric motor driving the pulley. When the current was turned on, the pulley revolved at a brisk rate, moving the drawer in and out through the aid of the connecting arm. This operation was kept up continuously for a period of nearly three weeks. During this time the drawer made 361,321 trips in and out, a fact recorded by a mechanical counter attached to the connecting rod with a piece of string. The exhibition drew a large crowd of passers-by.

### COLOR PRINTING SIMPLIFIED

#### 1216 BY NEW APPARATUS

The three primary colors can be printed at the same time by a machine lately developed in Japan which is claimed to be able to complete its operation on small sheets in less time than is ordinarily consumed in printing a single color on large sheets. The blocks for the three colors are placed side by side on the form bed, and the ink ducts are arranged to distribute the

colors to those portions of the rollers which cover the respective plates. Three sheets of paper are used on the cylinder simultaneously, one receiving its first color, while another gets its second impression, and the third the last. Either a two-revolution or stop-cylinder type of press may be employed, and at each revolution a tri-colored sheet is produced. The proper register is enabled by the cylinder grippers retaining their hold upon a sheet of paper from the time it is fed to them until it is delivered from the press. After the first impression is made the paper is moved along the cylinder to the proper position to get its second color on the next revolution. Following this it is again moved into place for the third plate and is subsequently discharged from the machine. One of the advantages claimed for the process is that the paper, by receiving its three colors one after the other without delay, is not subjected to the action of the atmosphere, and its size therefore remains the same, eliminating a difficulty frequently encountered in securing the proper register.

### MACHINE ASSISTS QUICK 202 LACING OF BELTS

A belt tightener has lately appeared which is designed for the express purpose of holding the two ends of a belt together for

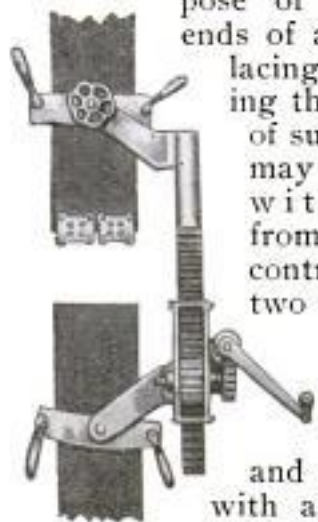

lacing or otherwise joining them. With the aid of such a device repairs may be made to a belt without removing it from the pulleys. The contrivance consists of two clamps which grip the belt ends, and draw them together by means of a rack and pinion operated with a crank and worm gear. Considerable and equal pull may thus be exerted on the two ends of the belt and it may be brought to any desired tension.

*Cleveland Fabric Belting Co.*  
*1473 W. 110th St.*  
*Cleveland, O.*

*James F. Johnson*  
*7. Rubber Machine, 13 Mercantile - machi, Ag. adu,*  
*Not patented U. S. P.*  
*Nov 1914 - 270*

Copyrighted material



*Sperry Gyroscope Co.*  
~~126 Nassau St.~~ Brooklyn  
711 711 POPULAR MECHANICS 469  
*Manhattan Bridge Plaza* N. Y.  
**AEROPLANE STABILIZER THAT TOOK FRENCH PRIZE**

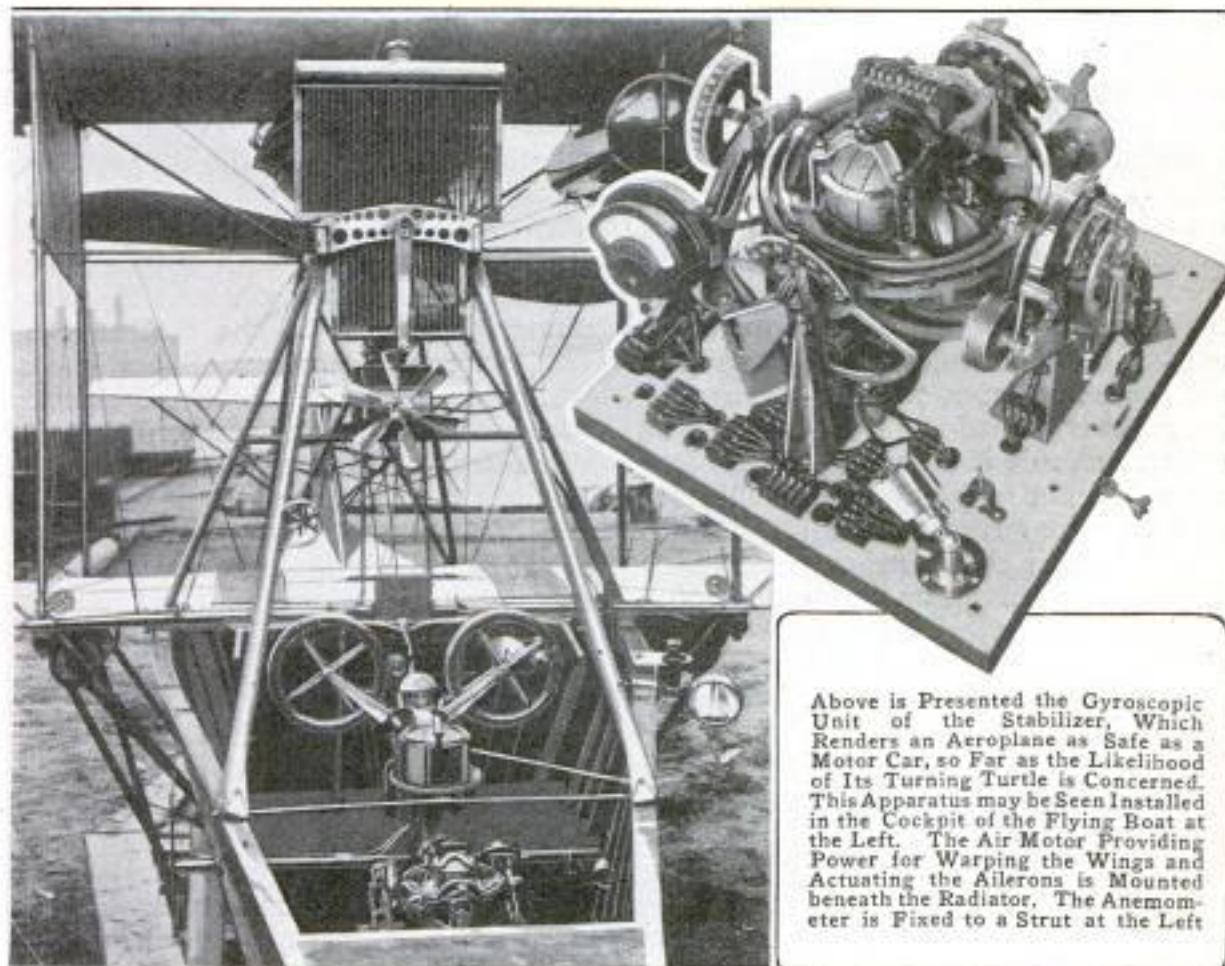

Above is Presented the Gyroscopic Unit of the Stabilizer, Which Renders an Aeroplane as Safe as a Motor Car, so Far as the Likelihood of Its Turning Turtle is Concerned. This Apparatus may be Seen Installed in the Cockpit of the Flying Boat at the Left. The Air Motor Providing Power for Warping the Wings and Actuating the Ailerons is Mounted beneath the Radiator. The Anemometer is Fixed to a Strut at the Left

When it is remembered that the Sperry gyroscopic stabilizer makes an aeroplane as safe, so far as upset is concerned, as an automobile, and safer than a small water craft, it is surprising to learn how comparatively simple this apparatus is. The stabilizer was awarded a prize of 50,000 francs by the French government after a series of remarkable tests in 1914, but the full details have only recently been given out. With this apparatus the question of balance, or stability, takes care of itself, and the airman is free to devote all his attention to navigating his machine. The stabilizer is made up of several distinct machines, among them, being the gyroscopic unit, which might be called the "brains" of the apparatus; an electric generator that is driven by the engine and drives the gyroscopes; a wind motor that supplies the power for warping the wings or changing the

position of the ailerons under the "direction" of the gyroscopic unit, and an anemometer that sets the apparatus in action to volplane the machine when the speed drops to a dangerously low point. Added to these is a control lever that enables the airman to navigate the machine without interference, within safe limits, but prevents him from doing dangerous things, such as making a climb at too steep an angle.

The gyroscopic unit, which instantly detects the slightest deviation from a normal position of flight and acts promptly to have the deviation corrected, consists of a cardan ring in which are nested four gyroscopes. The cardan ring is a device made up of two horizontal rings, one mounted within the other, the inner ring being pivoted to the outer and the outer ring to standards that are supported on the aeroplane frame. Two gyroscopes, re-

volving in opposite directions, serve to keep each ring horizontal regardless of the position of the aeroplane. One line of pivots is at right angle to the other, so that one ring detects lateral and the other longitudinal deviations. Fixed to the end of the axle of each ring is a contactor segment on which bears an electric brush that is mounted on the aeroplane frame. So long as the aeroplane is in a normal position of flight the brush bears on an insulated section of the contactor, but the slightest deviation from normal swings the brush over a section through which an electric circuit is formed. This is the secret of the apparently "intelligent" action of the gyroscopic unit.

The circuit thus formed serves simply to set a clutch on the wind motor, which is driven by the pressure of the air caused by the motion of the aeroplane. Forming part of the wind motor are drums over which are wound lines that control the elevator rudder and the wings, or ailerons, these lines performing the same functions as those used with a manual control. The clutch operated by the gyroscopic unit in any particular case causes the drum required for righting the machine to revolve, and to revolve in the required direction. The instant the machine is brought back to normal position the brush is again over the insulated section of the contactor, the circuit is broken, and the clutch is released. In this way there is a constant setting and

releasing of the clutches as required by the changing position of the aeroplane.

Climbing and volplaning, as well as banking on a turn, are accomplished by rotating the contactor segments on their bearings, and to do this the airman has only to push the control lever forward or backward or to one side. The rotation of the contactor causes a current to pass through the brush to the proper clutch, by which the aeroplane is brought to the desired position, where it remains until the control lever is shifted, since the brush is then over the insulated section of the contactor. Automatic volplaning is brought about through the action of the anemometer. So long as the speed of the aeroplane is kept at a safe point the pressure of the air against the vanes of the anemometer overcomes the force of a spring that tends to turn it, but the moment the pressure drops below a certain point the spring causes the anemometer to revolve slightly, throwing an electric switch. The switch closes a circuit that rotates the contactor connected with the longitudinal control and the aeroplane is instantly turned to a volplaning angle. With the increased speed that comes from volplaning, the pressure of the air eventually throws the anemometer back to its original position, whereby the electric circuit is broken, and the apparatus automatically acts to bring the aeroplane back to a level position of flight.

## DISAPPEARING BEDS HIDDEN BY BUILT-IN FURNITURE

796H  
Some of the late schemes devised for closeting disappearing beds in small houses and cramped city flats seem almost as convenient as they are ingenious. In one instance the lower part of a built-in writing desk is used to conceal a full-sized iron bed. When the latter is not in use the desk appears to have a series of three compartments at the bottom, each provided with a separate door. The floor of the room on the opposite side of the wall, in this case a dressing room and closet, is ele-

vated sufficiently to provide a space for the bed. Quite similar to this is a plan which utilizes the lower portion of a dining-room buffet. The deception here is made even more complete by two drawers built immediately above the space into which the bed is pushed. That part of the buffet which covers the opening is permanently fixed to one end of the bed, so that the latter is drawn out and pushed in precisely the same as if it were a great drawer. For a living room a practical

Holmes Disappearing Bed Co.  
Los Angeles, Calif.

Corrected  
2/10/17  
411

1020 The Lee St. Kansas City, Mo.

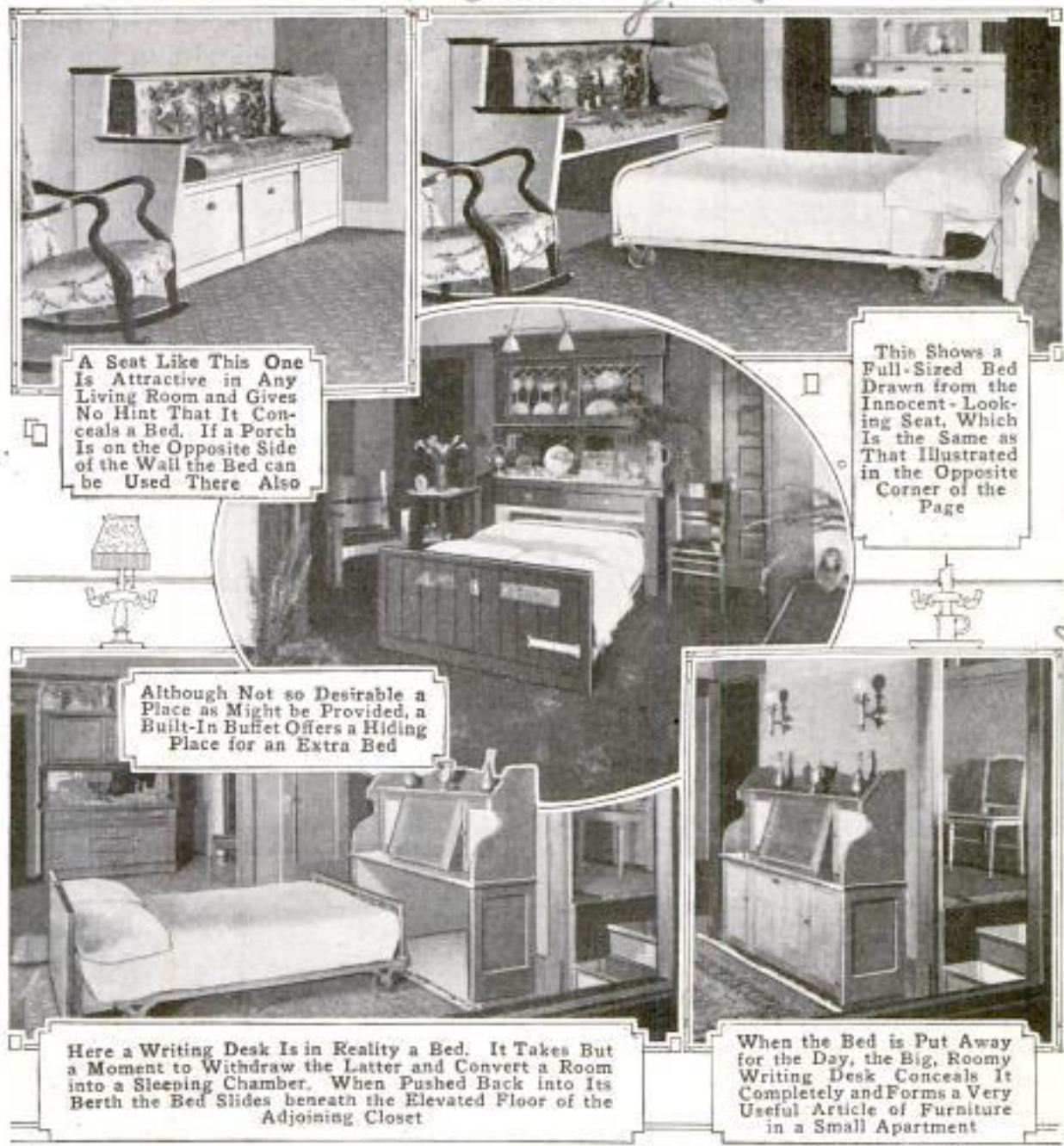

A Seat Like This One Is Attractive in Any Living Room and Gives No Hint That It Conceals a Bed. If a Porch Is on the Opposite Side of the Wall the Bed can be Used There Also

This Shows a Full-Sized Bed Drawn from the Innocent-Looking Seat, Which Is the Same as That Illustrated in the Opposite Corner of the Page

Although Not so Desirable a Place as Might be Provided, a Built-In Buffet Offers a Hiding Place for an Extra Bed

Here a Writing Desk Is in Reality a Bed. It Takes But a Moment to Withdraw the Latter and Convert a Room into a Sleeping Chamber. When Pushed Back into Its Berth the Bed Slides beneath the Elevated Floor of the Adjoining Closet

When the Bed is Put Away for the Day, the Big, Roomy Writing Desk Conceals It Completely and Forms a Very Useful Article of Furniture in a Small Apartment

American Disappearing Bed Co.  
615 So Main St. Los Angeles

recess is provided by building a large, roomy seat and utilizing the space beneath it. To completely conceal the bed, in case this plan is followed, a similar seat may be constructed on the opposite side of the wall. Should a sleeping porch be opposite, the same plan may be adopted. In either of these instances the bed could be drawn from both sides, and in the latter case used in a room or on a porch.

©Silk treated with oil varnish and tinted the color of meat constitutes a new sausage skin invented in England.

**TWO-FUEL RANGE EQUIPPED WITH ASH CHUTE**

Features which are very convenient for a housewife are to be found in a combination gas and coal range which has lately been developed for domestic use. It is provided with an ash chute which is permanently installed beneath the grate and discharges into a medium-sized sheet-metal receptacle in the basement of a building. All the dust and trouble which usually attends the removal of ashes from a range is in this way completely eliminated. At

Fuller & Warren Co.  
Troy, N. Y.

the right side of the stove is a three-hole gas cooking top which is supplied with a drip pan. Elevated above the

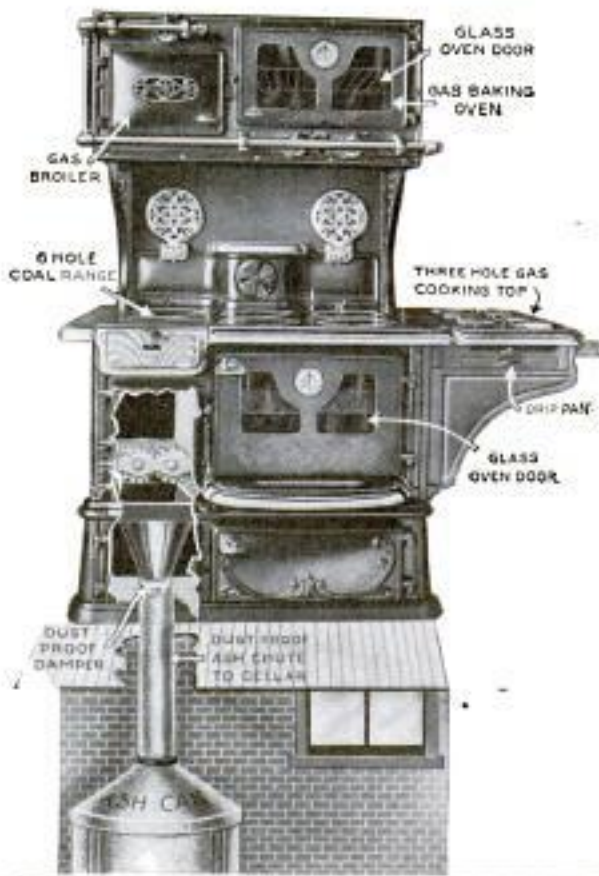

When the Grate is Shaken the Ashes are Discharged into the Chute and Deposited in a Can Provided in the Cellar

top of the range proper are a large gas oven and broiler, the former fitted with a glass door and a dial thermometer. The coal-heated oven, which is similarly equipped, is below in the customary position.

### WOODEN SHINGLES RENDERED

#### 1148 J FIRE-RETARDING, 2/11/15

Successful experiments in making wooden shingles fire-retardant have been conducted in a state laboratory recently. Air-dried shingles are treated with a solution of borax in water. The shingles are then kiln-dried to about 10-per-cent moisture, and a second treatment of zinc-chloride solution applied. After being again dried the shingles are ready for use. The solutions must be applied under heavy pressure, and since that process involves strong re-

Forest Products Laboratory  
Madison Wis

torts, measuring tanks, etc., it will be profitable to treat shingles in this way only in large quantities. The fire-retardant qualities are secured by the formation of an insoluble salt, sodium borate. While shingles treated in this manner will burn when subjected to very strong heat, they will not burn with a flame, the salt having fused and coated the cell walls of the wood fiber.

### MILKING STOOL PREVENTS

#### 1877 SPILLING OF MILK

A combination milking stool and pail holder which by preventing the spilling of milk makes possible a considerable saving, has been patented. It consists of a metal frame, aluminum painted, with four spreading legs which can be folded under the frame when not in use. On the frame is a seat resting on ball bearings which permit it to be moved forward or backward a distance of 4 in. At the opposite end of the stool from the seat is a circular holder that can be adjusted to hold a pail of

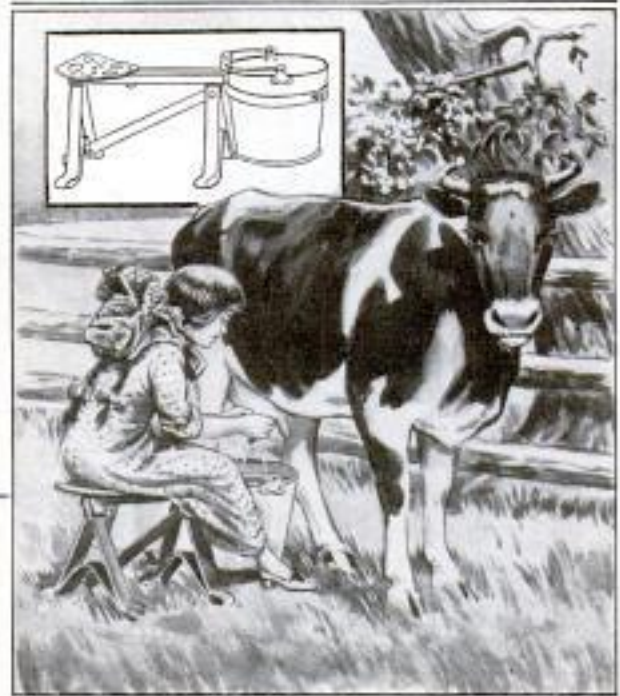

The Seat of This Milking Stool can be Moved Forward or Backward Easily, and the Pail can be Swung to One Side Out of the Way of the Cow

any size. It is so hinged that the pail can be quickly swung to one side in case the cow begins to move about.

J. E. Paul (Mfr.)  
903 Washington St.,  
Waterloo, Ia.

*Handwritten:* Municipal Use

*N. Y. Pub. Service Comm., New York City.*

**7 USE MOTION PICTURES TO IDENTIFY CRIMINALS**

*1074 Ch. Trib. 10/20 - 11/19/15*

The use of motion pictures as a means of identifying criminals to supplement ordinary photographs, finger prints, and other methods now employed, has been tried experimentally by the police force of Chicago. Heretofore only a limited number of police officers could personally familiarize themselves with the general appearance of criminals and suspects under arrest. But by taking motion pictures of these men their whole figures and their manner of movement can be made familiar to an entire force. The method has this special advantage of making identification dependent not alone on facial likeness, etc., but portrays numerous other identifying characteristics such as step and posture.

**7 PHILADELPHIA MINT COINS SOUTH AMERICAN MONEY**

*1174 E. S. Morita 12/20/15*

Pleasing evidence of the increasingly friendly feeling between the United States and South American republics is found in the fact that the Philadelphia mint made coins for more foreign countries in 1914 than in any previous year, and that this foreign trade came from Cuba, Costa Rica, Salvador, and Ecuador. Before the war several of the South American governments patronized European mints, but it is believed that the coining business secured by the United States mints will continue after the war. Every effort has been made to furnish the new patrons with satisfactory shipping facilities and simplified methods of payment.

During a five-week period last fall the Russian fortress at Dvinsk was captured 15 times. The stronghold is constructed of sand, and near the close of the year still existed. Incessant bombarding which would have demolished any ordinary position reduced the size of this one by half without weakening the remaining portion.

**925 WOULD USE KIOSKS FOR VENTILATING SUBWAYS**

The use of kiosks, or small round towers perched on sidewalk or curbing, has been proposed as a ventilating system for New York's subways. Under existing systems the air simply rushes in and out of gratings along the curbing as the trains pass beneath. The result is that foul air is discharged directly in the way of surface pedestrians, causing discom-

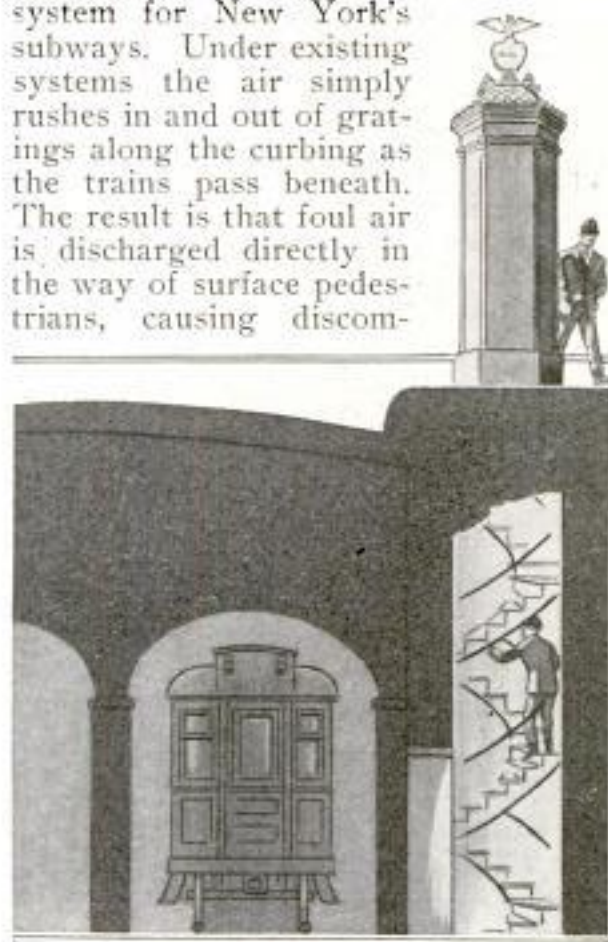

By Constructing Kiosks as Shown Here, It Is Proposed to Furnish Ventilators for New York's Subways That may Also be Used as Exits

fort. Also the gratings have proved insufficient to keep air within the tunnel properly cooled and purified. Kiosks, it is claimed, will overcome these difficulties. Being 12 ft. high, and equipped with electric fans, they may discharge accumulated dust and moisture high over the heads of street crowds, as well as take in purer air from those regions on demand. As at present designed, they will be 5 ft. in diameter and placed one in every block. Their large size will permit of installing winding stairways for use as emergency exits in case of subway accidents. To defray in part the large expense of installing the kiosks, it is proposed to lease their exterior panels

*Surgeon John F. Anderson,  
 Director Hygienic Laboratory,  
 United States Public Health Service,  
 7 5th + E. Sts.,  
 Washington, D. C.*

to advertising concerns, possibly retaining one surface on each structure to serve as neighborhood directories. When neatly made, advertisements do not detract from the artistic appearance of the kiosks, as has been demonstrated in the case of Berlin, where many such structures have already been erected.

**PORTABLE ELECTRIC HEATER FOR DOMESTIC PURPOSES**

Electric radiators which are especially suited for use during the spring and fall when large heating plants are not altogether dependable, are being



The Electric Heater may be Used on a Table or Floor in Any Room Desired

developed in many sizes and styles. One of these, which is of convenient proportion, is supplied with two resistance coils in a bowl-shaped reflector supported about a foot and a half high on a standard. The heating elements are protected by a substantial wire guard to prevent accidents. It weighs only a few pounds, so it may be conveniently employed wherever it is needed in a home by connecting it with a light socket. According to the wishes of the user, it may be set on a table or placed on a floor. The initial cost is about the same as that of a small electric fan, and the operating expense is not excessive.

*Empire Electric Co.  
 28 E. Jackson Blvd.,  
 Chicago.*

**FIND PINE-OIL DERIVATIVE VALUABLE DISINFECTANT**

Announcement has been made of the discovery of a new disinfectant which is derived from pine oil, a by-product obtained in the manufacture of turpentine. Besides costing only 50 cents a gallon to produce, it is nontoxic and possesses four times the disinfecting properties of carbolic acid. It was found during a series of experiments conducted by the United States Public Health Service at the hygienic laboratory and is easily prepared by combining the oil with resin and a solution of sodium hydroxide. The product is a reddish-brown liquid which has an oily appearance and is somewhat thick. When diluted with water it makes a milk-white emulsion which is not objectionable to taste and gives off a pleasing odor. The liquid will not attack fabrics nor metal, and may be safely used as a mouth wash or spray.

**MAIL BOX AND MILK-BOTTLE HOLDER COMBINED**

Many housewives have been annoyed by cats and dogs which have overturned or otherwise disturbed the milk which has been left at the door in the early morning. Doorstep thieves frequently cause more serious inconvenience. To overcome these difficulties there has been invented a combined mail box and milk-bottle holder. This permits one or two bottles to be hung immediately beneath the box on a rack which locks as soon as the bottle is slipped into place. The flange running around the top of the bottle prevents it from dropping from its place. Only a person with a proper key can take away the bottle.



*Inventor:  
 Frank T. Wakefield,  
 Fairhaven, Pa.*

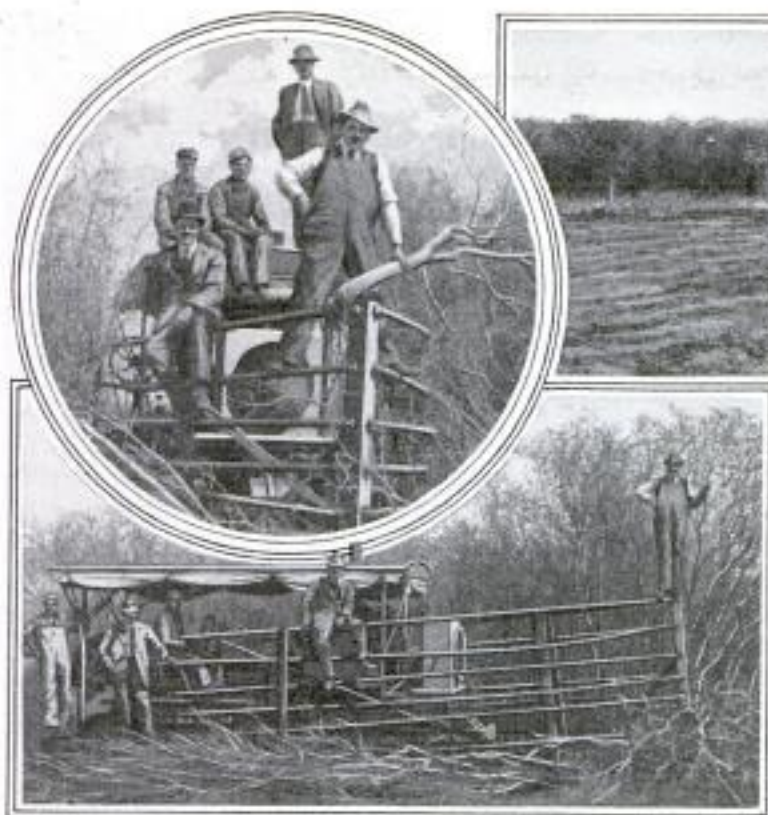

Above, and in the Insert, the Brush Cutter is Shown in a Dense Thicket Leveling the Undergrowth and Piling It on One Side of the 16-Foot Path It Cuts



Here is a Strip of Land over Which the Machine has Passed. Formerly It was Covered by a Thicket as Heavy as That to be Seen at Some Distance in the Background

### POWER CUTTER RAZES 86 CANADIAN BRUSH

In certain sections of western Canada brushwood and young timber cover whole areas in thick mats, making the district of little value for agriculture, even though possessing a rich soil. To rid these regions of the incumbrance in a practical manner, a power cutter has

been invented, intended to displace the older hand ax and kindred slow tools. A gasoline tractor furnishes the motive power, and to its front end a sort of "cow-catcher" arrangement is fastened. On the front edges of this triangle-shaped framework, long, sharp knives present razor edges. In going through brush the long caterpillar wheels on the tractor catch a firm grip in the soil and force the knife-edged prow in among the saplings. The result is that they are sliced off neatly and smoothly close to the ground, leaving the soil in satisfactory condition for plowing. The machine also automatically piles the trees in neat windrows.

### LARGE TILE STREET SIGNS 594 LAID IN SIDEWALKS

Street signs of the ordinary type, which necessitate the erection of posts at intersections, are usually unsightly and rarely remain intact more than a few years. For a long time different cities in climates untroubled by snow have attempted to overcome the latter difficulty by inlaying street names in cement sidewalks. Most often this plan has been unsatis-

factory, because, for the sake of appearance, the signs have been made too small. A Pacific coast city is now trying out a tile sidewalk sign, 4 ft. long and 1 ft. wide, which may be easily read at night on well-lighted



The Sign, Made of Tile and Sunk into the Sidewalk, is Large Enough to be Easily Read

streets. So far as is apparent, it serves its purpose satisfactorily.

### LEASE WON BY AEROPLANE RACING AGAINST MOTOR

10917 An oil lease, said to be very valuable, was the prize in a race between a motor car and an aeroplane in Oklahoma recently, and the aeroplane won in spite of the fact that the car had a handicap of four miles. The driver of the automobile learned that an Indian's oil lease was about to be renewed and started posthaste to secure the rights for himself, when a representative of an oil company, also desirous of obtaining the lease, procured an aeroplane from a near-by aviation school and reached the owner of the oil fields first, with the result that he secured the lease.

### CHANGE GRADE OF TUNNEL IN LOS ANGELES STREET

11294 Quite an interesting piece of engineering work was recently undertaken at Los Angeles when the task of changing the level of an old tunnel was commenced. The bore accommodates vehicle traffic on one of the city's thoroughfares and was originally about 25 feet higher at the south end than at its opposite portal. A cut of some 15 feet was made in the street at this entrance,

*No. Broadway Tunnel*



This Photograph Gives a Clear Idea of the Method of Construction Followed in Correcting the Grade of the Tunnel to Correspond with the New Street Level

making it necessary to correct the level of the tube correspondingly. This was done by constructing virtually a new tunnel beneath a part of the old one and carrying its arched walls along to the point of their union with the original structure. The plan included the sealing of the upper archway.

### FIFTH WHEEL INCREASES AUTO'S CAPABILITIES

6428 An old-fashioned part of the ordinary horse-drawn wagon has recently been adapted for use on a motor truck for the purpose of attaching a trailer in a manner that seems to be an improvement upon other means to the same end. The new device is simply a "fifth wheel," and is intended to be mounted on the chassis of an automobile just above the rear axle. With its aid a two-wheel trailer may be attached to the machine, and a load several times the ordinary size carried safely.

The attachment consists principally of two flat steel rings, two to three feet in diameter, one of which rotates upon the other, and both being connected by a kingbolt at the center, as in the ordinary fifth wheel. The under ring is supported by an axle and bearings attached to the motor truck. The



*Mfrs:*  
 C. H. Martin, 293 Bridge St.,  
 POPULAR MECHANICS *Springfield, Mass.*

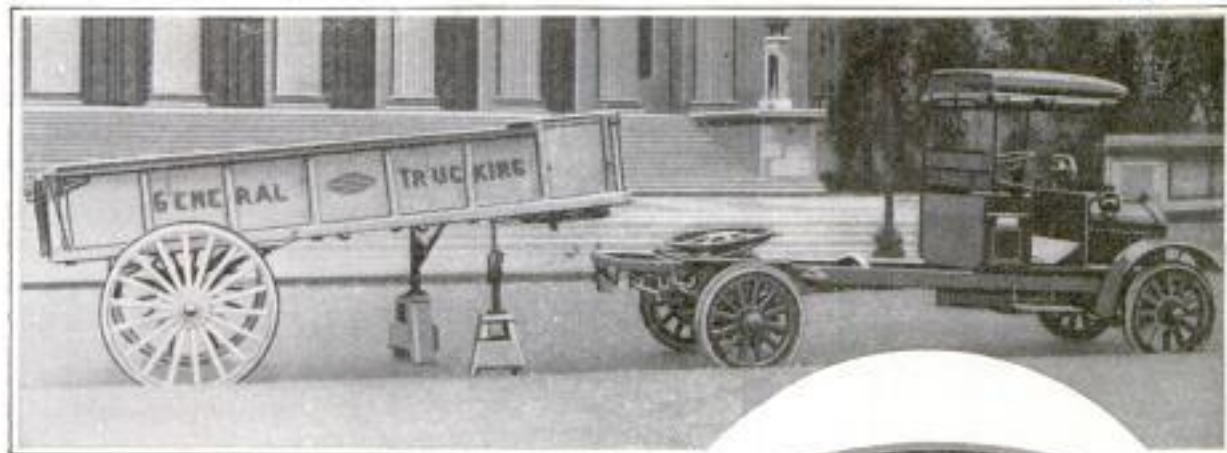

By Means of This "Fifth Wheel," Which Has Several Distinctive Features, a Two-Wheel Trailer can be Easily Attached to or Detached from a Motor Truck

front end of the trailer is attached to the upper ring. The flexibility provided by the cross axle allows free movement of the trailer in going over uneven roads, the cross axle serving this purpose better, in the opinion of the inventor, than would the universal joint sometimes advocated for the purpose. Aside from increased carrying capacity, several other advantages are claimed for the arrangement. One trailer may be loaded while another is being hauled to destination; half, or more, of a truck load is carried on the steel-tired wheels of the trailer, correspondingly reducing bills for rubber tires on the truck itself; and, since part of the load is bearing on the driving wheels, tractive effort and load-pulling powers are increased, instead of possibly lessened, as when a four-wheeled trailer is used. The increased usefulness of a farmer's light automobile with a two-wheel trailer has caused considerable interest in attachments of fifth-wheel nature.



straps are attached to projecting loops which are an integral part of the case, which is of 14-carat gold and hence will not corrode or discolor. A heavy engine turning on the back of the case allows an air space between the wrist and the watch. The men of the United States have been less ready to adopt wrist watches than those of European countries, but it is believed that the great convenience of the wrist time-

*Waltham Watch Co.,  
 Waltham,  
 Mass.*



This Wrist Watch Is Heavier and More Plain than Those Designed for Women

pieces, which have already gained some favor with police and army officers and sportsmen, will make their use common among the men of this country.

*7* **WRIST WATCH DESIGNED  
 1027 ESPECIALLY FOR MEN**

A new type of wrist watch, designed especially for men, has been placed on the market by a large watch manufacturer. It is strongly made, almost severe in design, with plain Roman numerals, and without the leather case that has been in common use. The

*E. O. Catford  
Platte Fougère Lighthouse,*

*Guernsey, Eng.*

**ELECTRIC DOORBELL MADE**

**898 H FOR HOUSE CAT**

When a cat, owned by the keeper of the Platte Fougère lighthouse on the Island of Guernsey, wishes to enter its master's dwelling it rings an electric bell to summon a member of the household to the door. This has been made possible by the construction, near the bottom of a door, of a shelf which actuates a switch when a slight weight is placed upon it. Thus, when the cat jumps onto this small ledge, which is supported by a bracket, the circuit is closed.

After the installation had been made it took but a short time to train the pet to make use of its rather modern convenience. The scheme was worked out because the roar of the



wind and sea drowned the cat's cries and made it impossible for those within the house to hear it when it wished admittance.

**DESK CALCULATOR DOES  
995 VARIOUS WORK**

A contrivance that will add, subtract, multiply, and divide, all within a desk space a little over a foot square, is a convenience lately devised for business use. The new machine is driven by a 1/12-hp. motor. Five rows of nine keys each supply the adding and subtracting element, this part operating much as in the ordinary adding machine. In multiplying, a number is first set up among the keys of the adding section. Afterward the multiplier, digit by digit, is registered on a single row of keys at the right. The product of the two numbers is at once given by indicators at the top of the machine. Through the fact that operations may be reversed, proof of a given multiplication may readily be obtained by division, as in ordinary arithmetic. When it is desired to keep a given number set up continuously throughout a series of computing operations, a key marked "C" may be depressed. This holds the number "constant" until a change is desired. The motor driving the machine is cut out except when an operation is being performed, thus saving power.

*Everett Mfg. Co., Boston, Mass.*

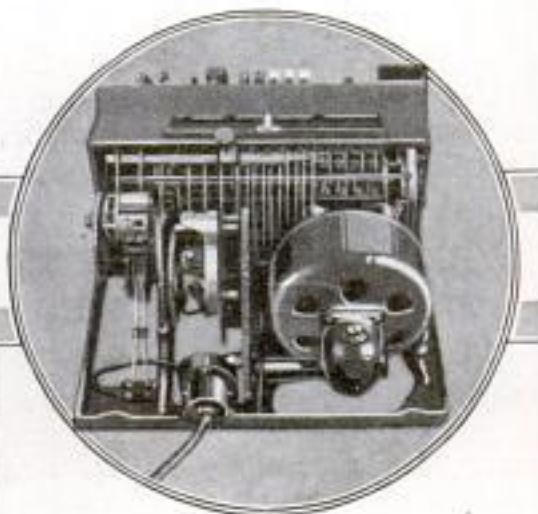
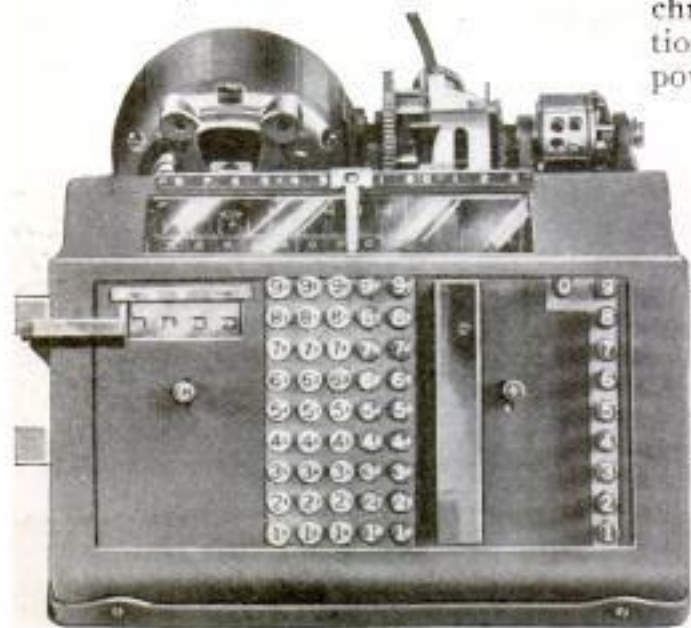

**Addition, Subtraction, Multiplication, and Division are All Performed on This Small, Electrically Driven Desk Machine**

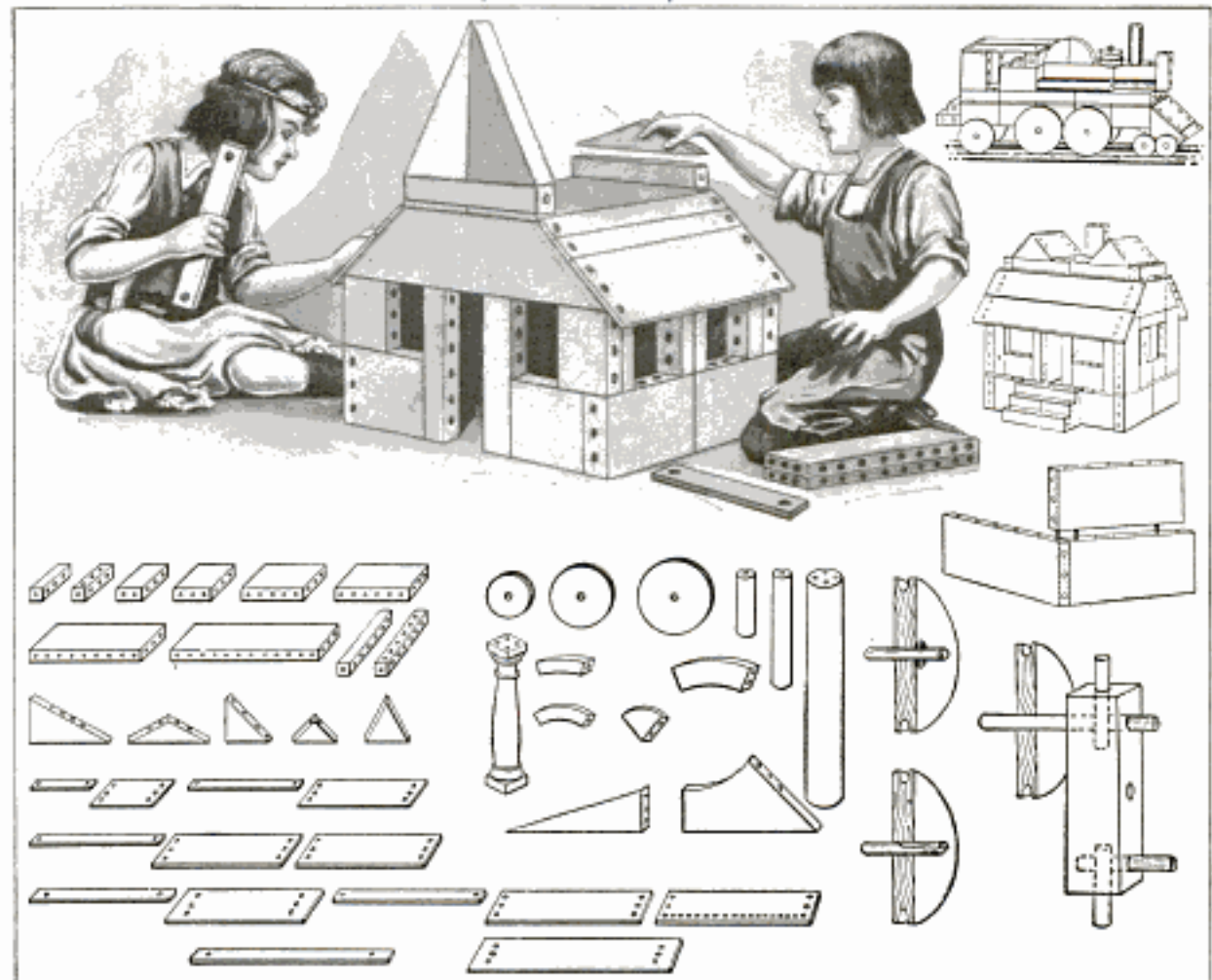

Model Amusement Parks, Pavilions, and the Like, may be Built with This New Form of Architectural Toy

**PEGS HOLD TOY BUILDING  
 BLOCKS TOGETHER**

945 R

Most construction toys on the market are patterned after structural-steel shapes, or else the simpler kinds of machinery, thus being particularly concerned with the engineering field. A form of toy lately brought out caters more especially to architectural interests. The various pieces forming a set are made of wood and when fitted together are held by especially designed pegs, or dowel pins. All sorts of elaborate buildings may be erected by the small builder at will, and at the same time a number of interesting effects secured. The blocks in one type of set are especially designed for making a model amusement park, the several pavilions, shoot-the-chutes, Ferris wheels, etc., being realistically produced.

**OIL TRANSMISSION DOES  
 AWAY WITH SHIFT GEARS**

344 R

Remarkable things are claimed for an oil-transmission device recently invented. Going down a 23-per-cent grade at the rate of 25 miles per hour, an automobile equipped with the device was able to stop almost instantly, reverse, and back up the hill with scarcely any of the jar or grinding of brakes usually associated with such an operation. The contrivance permits of any range in transmission ratio from absolute disconnection to a stage where engine and



1105792 - Aug 21/104  
 Gazette V. 205 p. 71

Inv. Arnold H. Jessen,  
 4302 Fern Drive,  
 Los Angeles

driving shaft are directly coupled together. There are no set speeds forward and reverse. These may have any value, dependent upon the position of a certain lever, convenient to the hand of the driver, which controls the position of an oil valve on the interior of the machine.

The contrivance accomplishes its purpose on a principle somewhat similar to an idler pulley operating on a loose belt, as, for instance, in the common example afforded by a belt-driven motorcycle. Here the tighter the idler pulley is pressed against the belt, the more in unison do hind wheel and engine rotate. Loosening the idler permits a certain slippage between engine and belt, and the motorcycle travels slower as a result.

In the same way this oil transmission provides a "slip medium" between engine and rear wheels of an automo-

bile. One half is coupled to the engine, and the other half to the driving shaft. A hollow cam within one part, rotated at slow speed by a set of gears, causes certain pistons to go in and out of cylinders connected to the other part. Oil is accordingly driven in and out of the cylinders, and the ease with which it makes entrance and exit determines how directly coupled the two halves of the transmission are. An oil valve controlling the exit and entrance ports governs the whole contrivance, and it is only necessary partly to open or close this with the lever at the chauffeur's seat in order to secure any desired speed ratio between engine and driven shaft. Reversals are accomplished by the simple expedient of clamping a brake strap to the outside shell of the mechanism, holding it stationary, and causing the interior to rotate in a backward direction.

### CONCRETE STRAIT-JACKET SUBDUES RIVER FLOODS

Caprices of the Arroyo Seco, a tributary of the Los Angeles River, are to

be controlled by a high concrete wall hereafter. A year ago it overran its banks in a sudden flood, tearing up bridges, railroads, and buildings, as well as endangering many human lives. During the summer of 1915

large crews of men were at work with dredges at the point of overflow, digging a new and deeper channel. Over a mile's length of such excavations had to be made, the depth varying from 10 to 20 ft. Alongside of these the concrete walls, or strait-jackets as they might be termed, were erected. It is expected that these will be sufficient to keep the floods within bounds, though



be controlled by a high concrete wall hereafter. A year ago it overran its banks in a sudden flood, tearing up bridges, railroads, and buildings, as well as endangering many human lives. During the summer of 1915



Showing a Section of the Completed Concrete Wall Which will Confine the Arroyo Seco River to Its Channel; Also the Method of Erecting Forms for the Work

the mountain snows melt so fast that the waters are hard to control. Material removed in making the channel was put to interesting use. Most of it was gravel and rock. The latter was run through crushers and later assorted to size with the aid of a tower 100 or more feet high which contained sizing screens. A continual stream of auto trucks carried the material, as fast as obtained, to various parts of adjacent cities, where it found ready use in the construction of roads and pavements.

**HOW ANIMALS ARE AFFECTED**

*11667* **BY GUNFIRE**

Persons who have seen considerable service in the present war have observed that gunfire has various and interesting effects on different animals. Dogs as a rule show great distress when shells burst near them and howl piteously, but during rifle fire have been known to dash along in front of a trench barking vigorously, apparently enjoying the noise. Cats seem to be indifferent to the character of the conflict about them so long as they have a corner in which to sleep and eat. Lost dogs and cats have actually ventured into the trenches during engagements. Some of these pets once lived in cottages destroyed by earlier fighting. The marks on the collars of others showed that they had traveled long distances. A yeomanry regiment from the west of England possesses a black cat which came to it in the midst of a bombardment that killed many men. It lives sumptuously.

**MOTORCYCLE WITH SIDECAR**

*11797* **FOR MAIL CARRIERS**

A motorcycle with an especially designed sidecar is now in use on certain rural free-delivery routes. The sidecar is of steel, completely inclosed. Near the top are drawers opening toward the driver, in which mail can be packed in the order in which it will be needed on the route. Below the drawers is a



The Sidecar of This Motorcycle Has Several Compartments and is Designed Especially for Rural-Mail Carriers

more spacious compartment. By using one of these motorcycles a carrier saves much time and inconvenience.

**CONCEALED BATHTUB MADE FOR SMALL DWELLING**

By utilizing the space ordinarily wasted beneath a kitchen sink as a place of concealment for a bathtub, a curious plan has been evolved for providing bathing facilities in cramped houses which are without toilet rooms. The sink and its accompanying drain board occupy the top of a movable cabinet of neat appearance. The back-board of this is permanently fixed to a wall, and water faucets are attached to

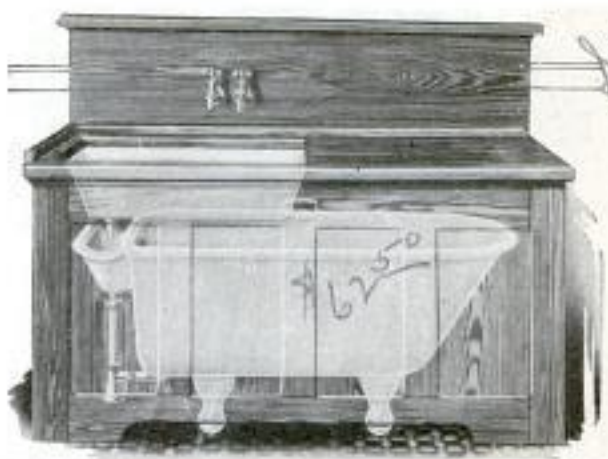

When Not in Use the Sink Cabinet Completely Hides the Bathtub from View

*Standard Kitchen Bath Fixtures Co.*

*2d fl. 21011. 4th Ave. N.Y. Copyrighted material*

*See Nov 1911  
p. 618*

it immediately over the sink. The bathtub is permanently installed beneath the cabinet and at the front end supports a small basin, connected with the waste pipe, into which the water from the sink is drained. Normally the bathtub is entirely out of sight. When it is to be used, however, the cabinet, holding the sink, is moved away from the wall to give free access to it. Water is then supplied through faucets attached to the board above.

### NEW ELECTRIC FURNACE FOR LABORATORY USE

9546 m

With a new electric furnace designed for laboratory work it is easily possible to obtain temperatures ranging from 2,000° F. to 2,900° F. This furnace is of the vertical type, and is 13 in. in diameter and 18½ in. high. It consists of three main parts—a graphite heater unit, an inner compartment of molded refractory material into which the heater unit fits, and an outer compartment filled with powdered refractory material. A feature of the furnace is that it is of the nonvacuum type, the furnace itself automatically developing an atmosphere of carbon monoxide in the heating chamber. The outer jacket is made of polished monel metal. The power may be supplied

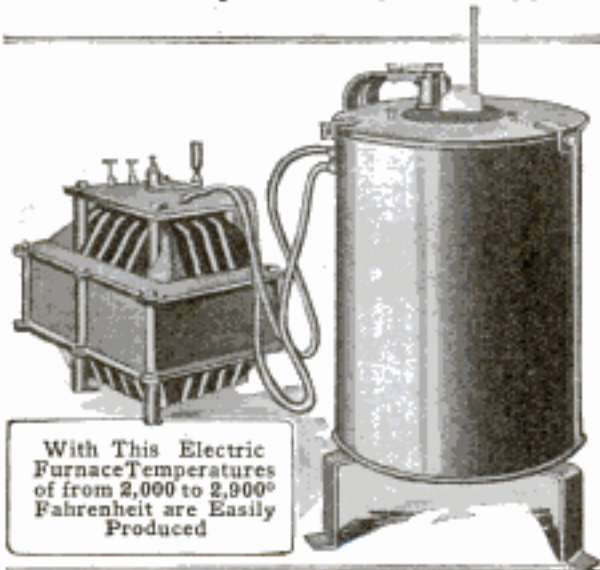

With This Electric Furnace Temperatures of from 2,000 to 2,900° Fahrenheit are Easily Produced

from storage batteries, but an alternating current with a transformer is generally employed. By means of a "cas-

cade" attachment used in connection with the furnace, temperatures higher than 6,500° F. can be obtained.

### NEW TOPOGRAPHICAL MAP FOR AIR SCOUTS

1096 J A & N Jul 12/4/15

A portable topographical map for the use of air scouts, which will enable them to make quick, realistic reports of observations, has been invented by a marine sergeant at Washington. The problem of reproducing on a desired scale the elevations and depressions, the outlines of bodies of water, and the contour of valleys, as an aviator is able to ascertain them, has been solved, it is believed, by this device. An essential feature is a worm gearing operated by telescopic thumbscrews, by means of which the desired variations in the surface of the map are secured. The map is light but strongly built, and military men believe that the effectiveness of the aviation service for scouting purposes will be greatly increased with the aid of this invention.

### WASH GRAVEL FROM BANKS FOR ROAD BUILDING

1141

Washed and screened gravel for highway-construction purposes is being obtained by a county-road commission in Michigan by a hydraulic mining process. The plan has been found to be both practical and economical, because the material is collected ready for use and loaded without hand labor. The apparatus used in the work is simple in construction and comparatively inexpensive. At one gravel pit, illustrated herewith, water is carried across a marsh under pressure to a bank on the opposite side. The stream is directed against the wall so that the formation is washed into sluice boxes. A second jet of water at the mouth of the trough forces the material along to a point where it flows into the screened pockets of a conveyor, which is operated by a small gas engine. The gravel, thus separated, is carried by the elevator into a hopper provided with an

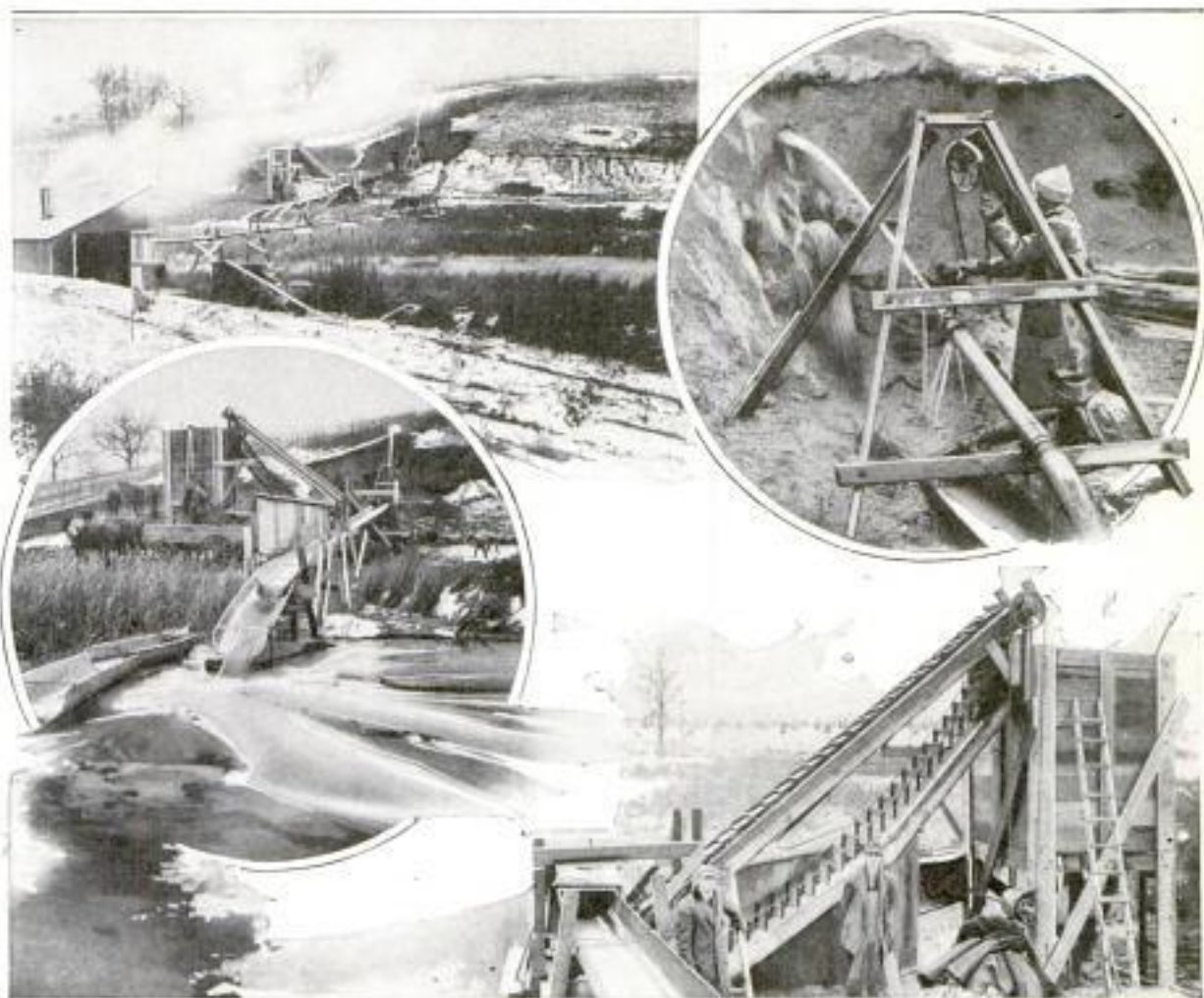

The Photographs Above Illustrate the Hydraulic Process of Mining Gravel for Use in Road Building: At Top, on the Left, Is a View of a Plant Operating near Battle Creek, Michigan. The Insert at the Right of This Shows How the Water Cuts into the Embankment and Carries the Gravel and Sand into Sluice Boxes. The Former is Caught in the Screened Pockets of a Conveyor, Washed, and Elevated into a Hopper, as Indicated Below at the Right. In the Other Insert the Sand and Dirt are being Sluiced into a Hollow

inclined bottom and trapdoor, through which the gravel is chuted into a wagon. The sand and earth are sluiced into the hollow to fill and reclaim the waste land.

the new cover can be easily and firmly grasped and, being countersunk, do not furnish any unevenness on the street surface.

### DISAPPEARING HANDLES FOR 10847 MANHOLE COVERS

There are many objections to the ordinary type of manhole cover which, it is believed, are overcome in the construction of a cover fitted with disappearing handles. To raise a cover of the common type requires the use of a crowbar or other sharp-pointed heavy tool. Frequently such means are not at hand and a rusted or tightly fitting cover will cause annoyance and sometimes accident by injuring the hands of the workman. The handles fitted to



COURTESY OF SAFETY NEWS

A New Type of Manhole Cover is Fitted with Disappearing Handles Which Save Much Inconvenience and Prevent Accidents

"Safety News"  
United Gas Improvement Co.  
Broad & Arch Sts., Phila.

## FRAME OF NEW MOTORCYCLE LIKE THAT OF MOTOR CAR

662  
H Several novel ideas have been applied in designing a new four-cylinder motorcycle, an approved model of which has recently been displayed. In many particulars the machine departs

The fore part of the frame is bowed out in a "V" shape from the forward motor supports, to allow the front wheel to swing within it.

An 11.23-hp. motor, with selective sliding-gear transmission, is mounted on the frame immediately back of the front wheel, leaving an open space before the seat. A propulsion shaft replaces the driving chain. The front forks are of peculiar construction, as well as the front axle, which is a large hollow affair. A curved bar attached to the middle fork member passes through this and serves as a brace

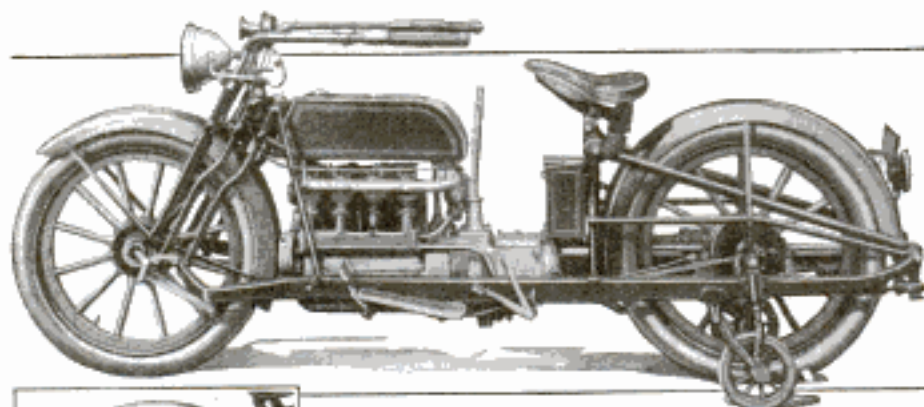

New Motorcycle with Motor-Car Frame, Wooden Wheels, Shaft Propulsion and Selective Transmission

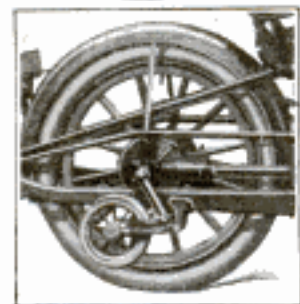

radically from the established form of construction and embodies features characteristic of an auto.

One of its most salient points is its frame, which is entirely different from the diamond, or loop, type, commonly used. It is similar only to that of a car and extends back of the rear wheel, forming a point to which cantilever arms supporting the seat are pivoted.

to prevent the steering fork from being sprung. Idler wheels are provided at the rear, making it possible for a rider to stop or back up without placing his feet on the ground to support the machine. A 3-gal. gas tank is mounted over the motor. A self-starter is contained within the clutch compartment of the transmission case. The machine is a modification and improvement upon one of somewhat similar construction which was promoted several years ago.

## NEW COAL-HANDLING PLANT LOADS MECHANICALLY

1058  
7 What is said to be the first coal-handling plant of its size on the eastern seaboard, which is arranged for mechanical handling of coal, instead of for gravity loading, has been erected at Charleston, S. C., by a southern railroad. One important advantage claimed for this plant is that it can be erected at a much lower cost than a high gravity pier plant; also the breakage of the fuel is said to be less. The plant consists of a wooden railroad trestle built out into a bay about half a mile to reach deep water. At the end of the trestle, and standing alongside it,

is a pier about the length of a coal freighter. The loading machinery is located on this pier. At its outer end the railroad trestle carries the cars to about 17 ft. above the pier. On the top of the trestle is located a movable car dumper of the standard type. A movable loading tower stands beside the car dumper but rests on a track on the pier. From the railroad trestle the coal cars are dumped into a "V"-shaped hopper of 100-ton capacity, which is part of the loading-tower equipment. A movable false bottom in the hopper prevents excessive coal breakage by



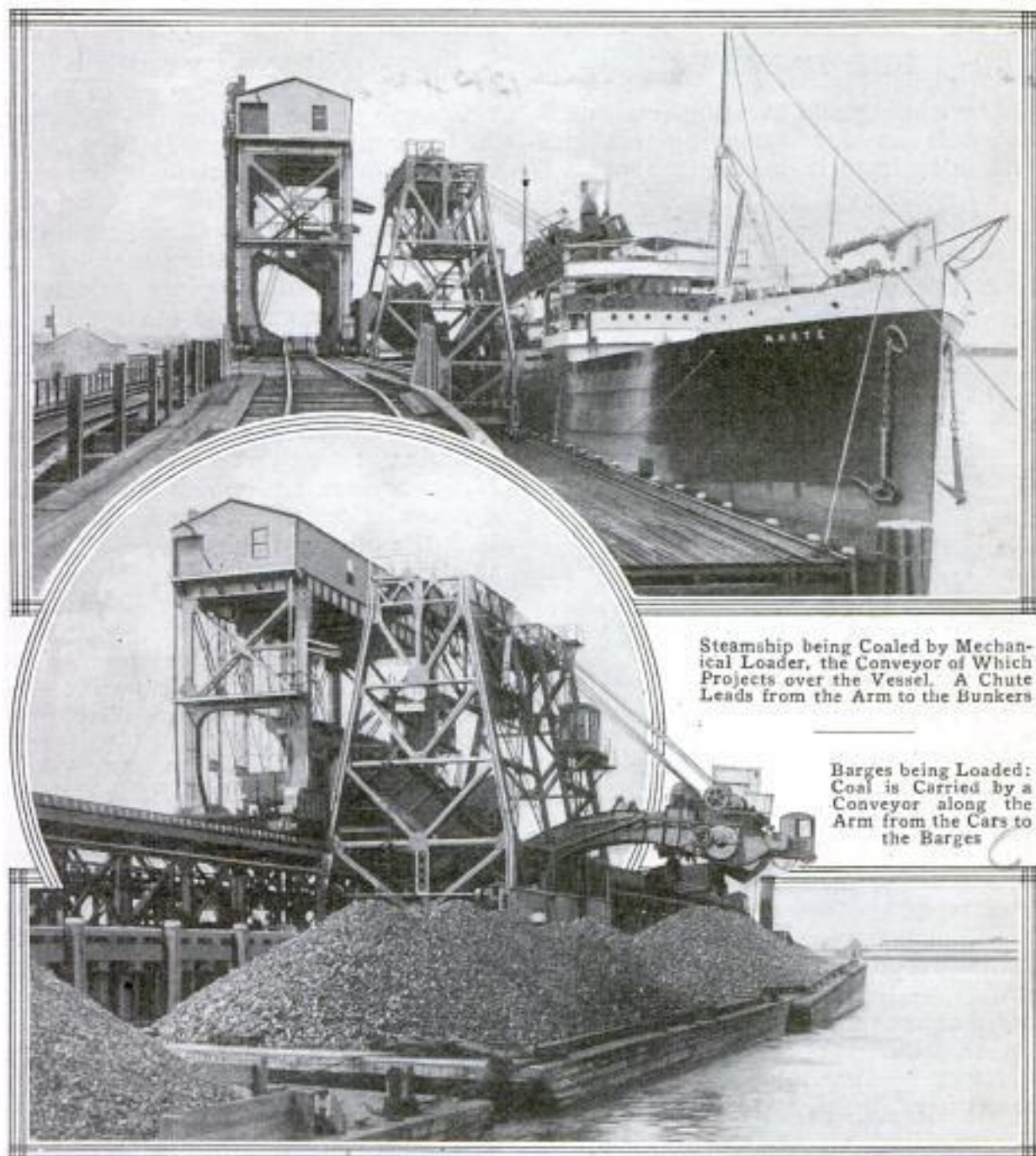

shortening the fall of the coal. From the hopper the coal is discharged into a conveyor which carries it through a long curved arm that extends out over the barges or ships to be loaded. A long telescopic chute for the coal is let down from the end of the arm into the hold of the vessel to be loaded and is gradually shortened as the bunkers fill. This conveying arm is arranged for hinged vertical motion and also has an 8-ft. horizontal movement so that it can be adapted to ships of various

heights and widths. The plant is electrically operated, alternating current being converted by a substation into low-voltage direct current. Three men are required to operate it. One, in the cab at the end of the arm, has control of the hopper motor and other loading motors and loads the boats; a second operates the car dumper, and a third regulates the moving of the car along the track. The entire plant is designed to handle 30 cars an hour in capacities up to 100 tons each.

**MILK AERATOR AND COOLER**

660 H FOR DAIRY USE

For cooling and aerating fresh milk, as well as for removing the animal odor from it, a simple apparatus,



The Milk Passes from the Reservoir down the Outside of the Cooler and into a Can

has been designed for dairy purposes. It is made in four sizes, the largest of which has a capacity of 80 gal. an hour. The cooler, which is of the corrugated type, is set on brackets immediately under a reservoir. A faucet in the latter permits the warm milk to flow into a perforated trough which distributes it along the cylindrical top of the cooler. It then passes down the outside in a thin sheet, dripping into a trough at the bottom and draining into a can. Water enters the cooler at the bottom, circulates through it and passes out through a hose at the top. The temperature of the milk is lowered to within approximately two degrees of that of the water used. The device is made of heavily tinned copper and is provided with removable troughs which may be easily sterilized after use.

**APPARATUS TESTS STRENGTH**

1215 H OF VARIOUS FABRICS

At one of the great worsted centers in England a machine has been developed for determining the wearing qualities of different fabrics. The apparatus is simple in principle and automatic in action. When testing a sample of cloth one end of the piece is fastened in a rigid jaw and the other clamped to a roller. Weights are so suspended from the latter that the goods is drawn taut and brought against a rubbing device. This consists of a motor-driven cylinder, in which a series of dull-edged blades are set, and which makes a single revolution in first one direction and then the other. Each two-way turn of this kind is called a rub and recorded by a mechanical counter. When a fabric is worn through by this process the machine is automatically stopped. The number of so-called rubs it has received indicates its degree of durability.

**NEW LOG HOIST SUPPLANTS OLD METHOD IN SAWMILL**

1009 A simple log hoist which has been in use in an Oregon lumber mill for more than a year is said to be superior to the common method of carrying logs into a mill by means of an endless chain, with dogs, which engages the

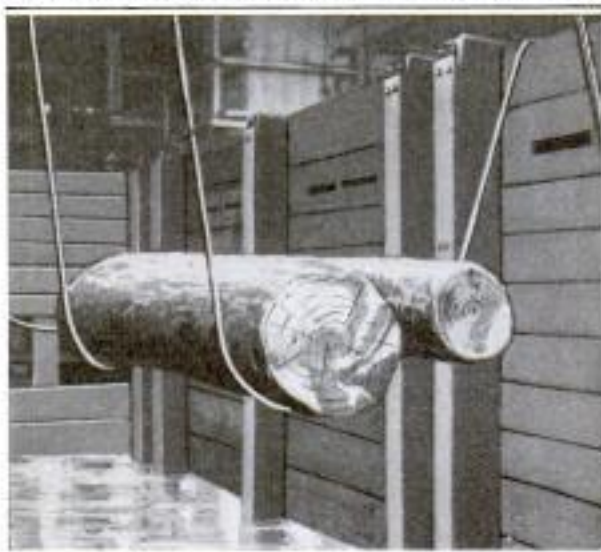

Logs are Easily Raised into a Sawmill by Means of Cables Shown Which are Wound on a Revolving Drum

used by  
Booth - Kelly Lbr Co.  
Springfield, Oregon.  
Copyrighted material

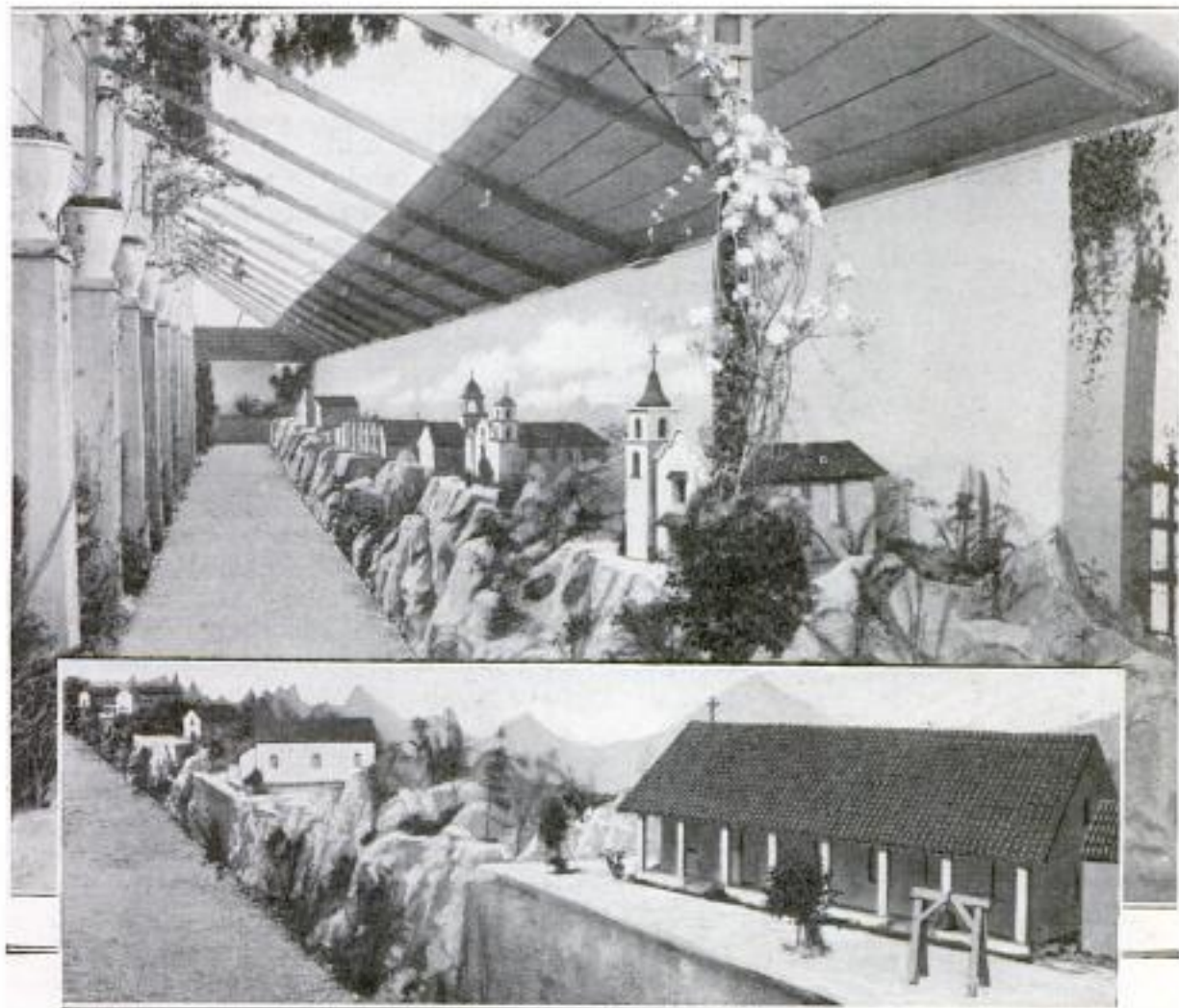

These Picturesque Models of the Old Spanish Missions of California are Arranged in a Portico about a Theater Erected for the Purpose of Presenting Dramatically the Story of the Missions

logs and draws them up an incline. By the new method the logs are floated into a narrow slip by the action of an artificially created current. Lowered into the slip before the logs enter are wire cables, as shown in the illustration. When the logs are in position above the cables the latter's free ends which are attached to a revolving drum are wound up, thereby raising the logs from the water and finally rolling them onto a dock in front of the main saw.

### 576 OLD CALIFORNIA MISSIONS SHOWN IN MINIATURE

The famous old Spanish missions of California have been reproduced in miniature which forms a feature of a portico surrounding three sides of an unusual theater built near Los An-

geles. This theater was erected for the purpose of presenting a historical play which tells of the varying fortunes of those who built the missions. That the public might more vividly appreciate the setting for the incidents in this pageant play, the author caused these picturesque models to be constructed. Side doors invite the theater patrons from the playhouse during intermissions to promenade along the sheltered gravel walk and view representations of places alluded to in the drama. To construct these models cost approximately \$10,000.

It is stated that the life of a French 75-mm. gun is about 10,000 rounds. All of these pieces at the front have been replaced at least once since the war began.

*Made by John S. McGoarty*



111 H

## LOADING ASSEMBLED MOTOR CARS FOR SHIPMENT

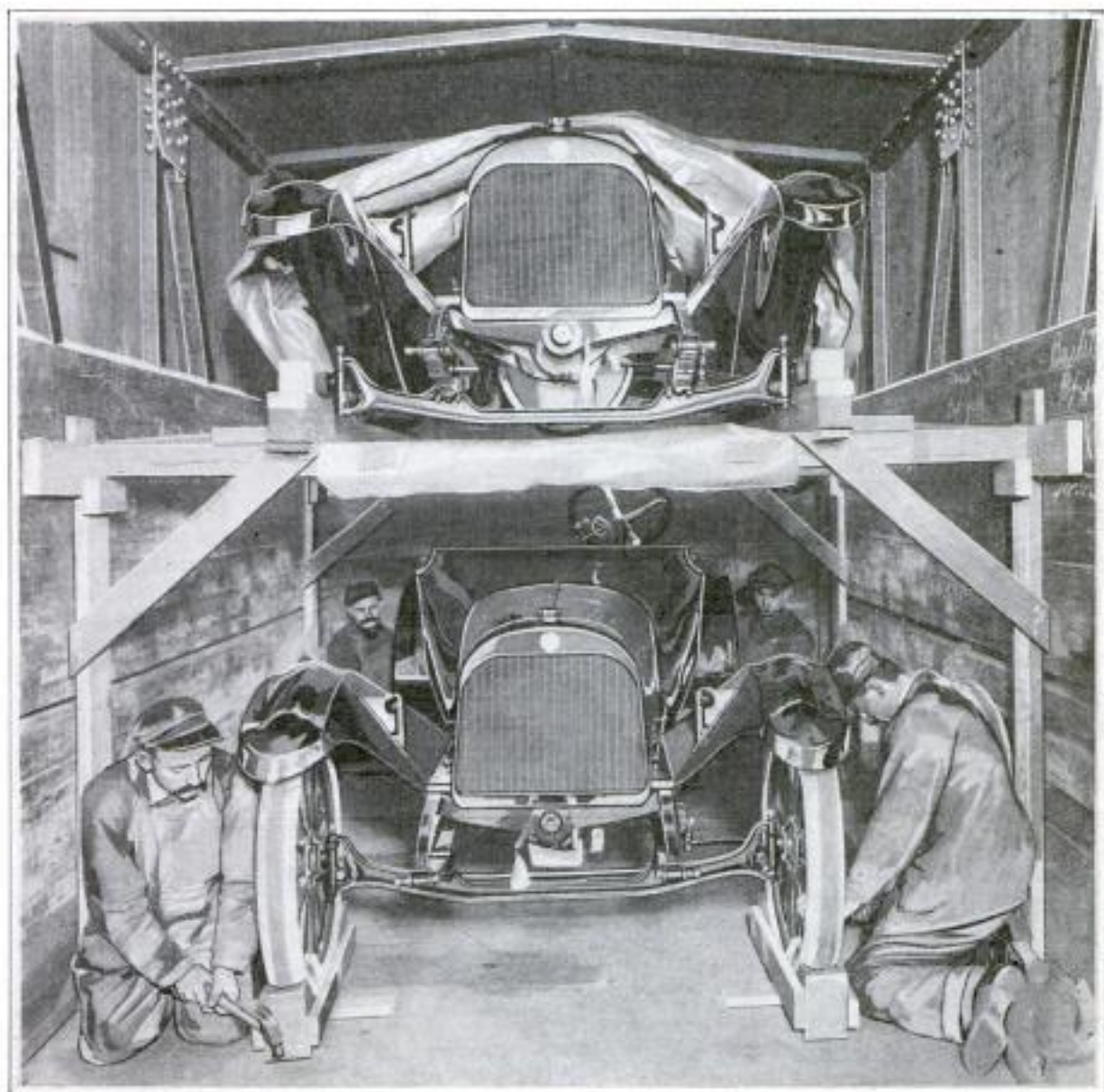

Five Machines of the Size of These can be Loaded into One Car and Shipped without Difficulty: Two are Placed at Either End, as Shown, and One in the Middle of the Car

Very little space is wasted in a railway car when fully assembled automobiles are being shipped to dealers from a factory. Obviously the number of machines which it is possible to pack into one car varies in accordance with their size. Five motors of medium wheelbase, however, can ordinarily be loaded with safety into a single carrier. This is accomplished by placing one machine over another in each end of a car and putting the odd one in the middle. In doing this an automobile is backed into one end of a car and then

drawn to the ceiling by means of block and tackle. Its wheels are removed and a stanch staging erected to support it. When it has been securely blocked up and braced, another machine is pushed into the lower space. The wheels are not removed from this vehicle, but are made fast to prevent it from breaking loose during transit. The same procedure is repeated at the opposite end of the car. The body of each machine is carefully wrapped in heavy paper before being shipped, to protect the enamel from scratches.

### SNAKES BOTTLED IN TUBES

#### 1135 H FOR STUDY PURPOSES

For lecture-room purposes in the biological department of a Florida college,

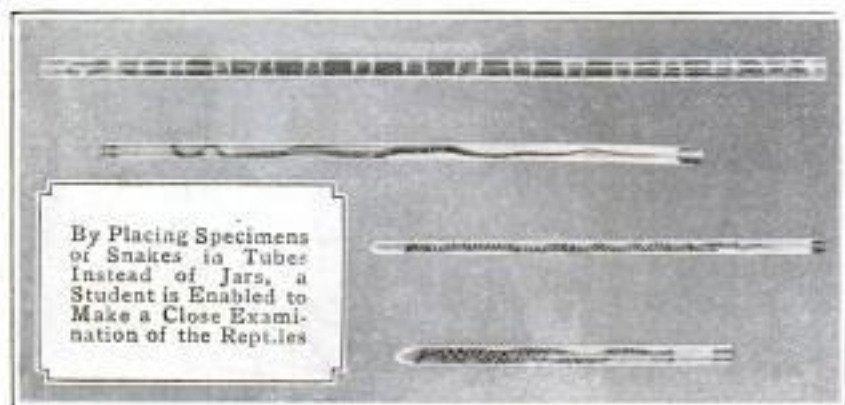

small snakes are preserved in slender glass tubes instead of being coiled in

hermetically sealed jars, as is more commonly done. The receptacles are of a diameter only slightly greater than that of the serpent placed within them, and of a length corresponding to the specimen. The advantage of this scheme is that a student is enabled to make a closer examination of the external characteristics of a snake than would be possible were it placed in an ordinary jar. Obviously the tubes cannot be used so successfully for preserving large specimens, but for serpents of suitable

size the plan has proved admirable in both the classroom and museum.

### APPLE GRADER SORTS

#### 979 D FRUIT RAPIDLY

A machine that will grade apples into seven different sizes at the rate of 50

barrels an hour is now being marketed. It operates on an odd principle. Two chains having links with semi-circular inside edges run alongside each other in the same direction. At the end where apples roll onto the chains from a chute the links are close together. But farther along the chains separate, causing larger and larger areas to be spanned by the scalloped edges of the several links. Thus small apples drop through, while the space between the chains is narrow, and the larger sizes are carried farther until the distance between the links widens. This results in an accurate grading

of the fruit. Two pairs of chains are ordinarily mounted in the same machine to increase the capacity. In commercial orchards the sizing of apples has become a big factor and hence the de-

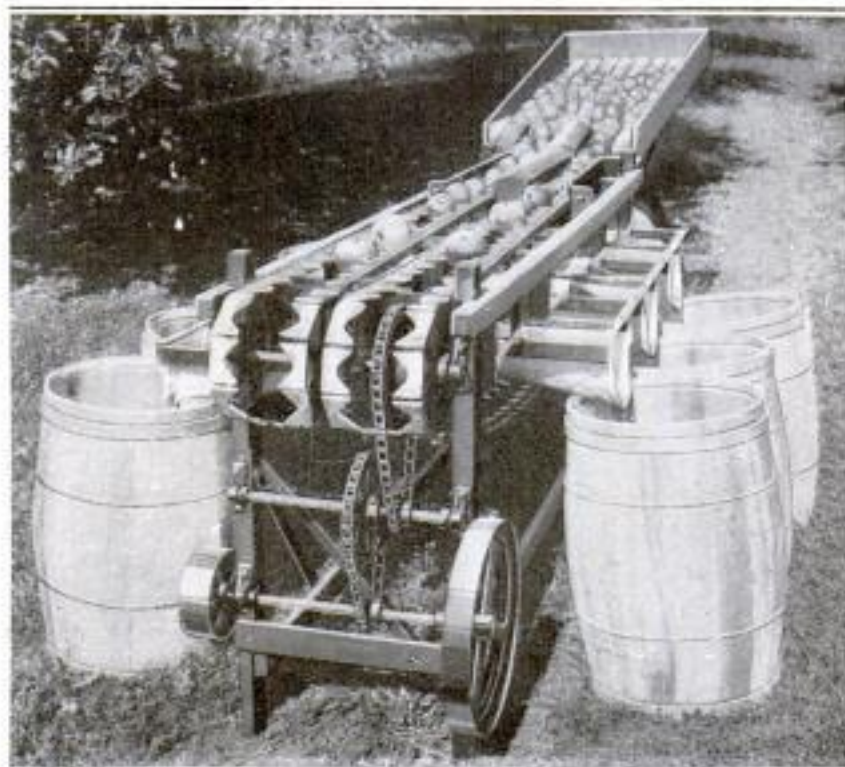

This Machine Sorts Apples at the Rate of 50 Barrels per Hour

mand is great for machines of this character.

**GERMANY TRYING TO SAVE SAFETY ATTACHMENT FOR  
1076 ALL HER COPPER '0/15/15 470 LAUNDRY MANGLE**

A circumstance, which would seem to indicate that there is a lack of copper in Germany, attended the transfer recently of some locomotives purchased by a Norwegian railway from German contractors. The latter first demanded, it is said, that the locomotives should be exchanged for copper. This the purchasing company declined to do on account of export restrictions. It was then suggested, according to the report, that an equal quantity of copper to that used in the locomotives should be returned. This request being denied, the manufacturers proposed that the whole amount of the purchase be paid in copper coin. The company refusing, the locomotives were reluctantly delivered against ordinary payment.

One of the safety features of the laundry in the new \$4,000,000 hospital in Cincinnati is a guard for the mangle.

With This Guard in Place  
Practically All Danger  
That the Fingers, Hands,  
or Sleeves may be Drawn  
into the Machine is  
Eliminated

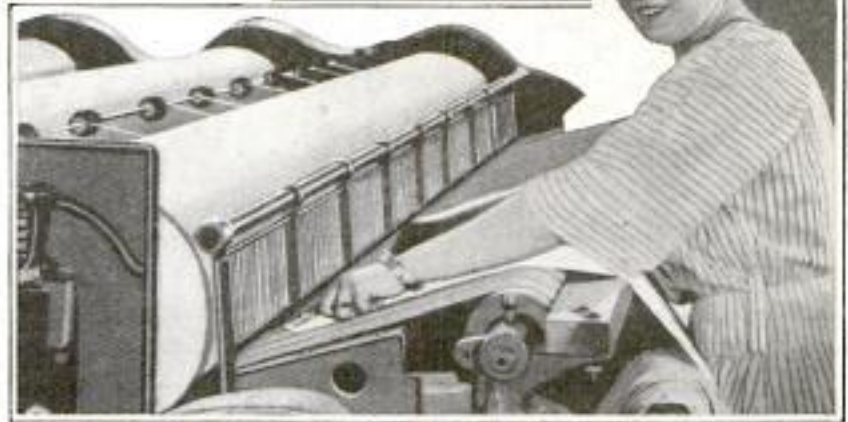

This device is so designed that it makes practically impossible the distressing accidents that sometimes occur with these machines when they are not guarded. It consists simply of a small steel fence mounted in front of the big roller and running the full length of it, and with this guard in place all danger that the worker in a moment of carelessness may have the fingers, hands, or sleeves drawn into the machine is practically eliminated. The linen is passed into the machine through the space under the guard.

**SMALL METAL ARTICLES**

**11484 LACQUERED IN BULK**

Certain large corporations which have quantities of rings, buckles, and other metal accessories which are liable to corrosion, have found it profitable to give these articles a cheap coat of lacquer. The method employed is to secure two oil drums, one of which is smaller than the other. One head is removed from each drum, and a number of 1/2-in. holes punched in the bottom and sides of the smaller drum. Into the larger drum is poured a mixture of one part cheap varnish and one or two parts denatured alcohol. The articles are then placed in the perforated receptacle and immersed in the preparation, after which they are withdrawn immediately. By placing them on a draining screen for 15 minutes they are ready for use. The thin coating is scarcely noticeable.

**TYPEWRITER DESK IS AID**

**8298 TO RAPID WORK**

A typewriter desk lately marketed is especially designed to facilitate rapid dispatch of routine work. In the center, as with the ordinary desk, is an open space for the typewriter. Flanking it on either side, however, are pigeonholes and a number of other conveniences within unusually easy reach of the operator. At the left is a receptacle for work to be done, and

Byron Typewriter  
Cabinet Co.,  
Hatch Creek  
Mount Clemens, Mich.

American Laundry  
Suits, O.  
Nashley Co.

just beyond it a small bracket supports a desk phone ready for immediate use. In the back of the cabinet are more pigeonholes, these being in a

and additional compartments which may serve the same purpose. When not in use the rear portion of the desk and the sides fold in, making a cover for the typewriter and stationery.



A Copyholder, a Bracket for the Telephone, Especially Arranged Pigeonholes, and Drawers of Unusual Design are Features of This Convenient Desk

vertical position and capable of holding ordinary-sized letterheads, and legal forms. Directly above the typewriter a copyholder aids the operator in rapid transcribing of copy. At the extreme right is a shelf for finished work, while underneath are drawers

## PHOTOGRAPH STUDIO HAS DETACHED SHOWROOM

A California artist, who for esthetic reasons built his studio about 30 feet back from the sidewalk, soon found that passers-by were reluctant to take the necessary additional steps to view his window display. Consequently he devised a separate structure to house samples of his work. This was built of brick, flush with the sidewalk, measuring 10 by 11 ft., by 10 ft. high. In style it conforms with the front of the studio and consists of a lobby having a beamed ceiling and open on three sides. The fourth side, that nearest the studio, contains inclosed display space, the side of this inclosure facing the street being of plate glass. Access to the display for the purpose of changing photographs, and the like, is gained through a concealed door at the rear. This novel and artistic method of displaying photographs has attracted much attention to the artist's studio.



Photograph Studio Placed Back from Street and Easily Accessible Showroom, Built Flush with the Sidewalk, to Attract Passers-By

*Hoover Art Co., Hollywood, Calif.*



Inventor: A. B. Stewart  
Co. Mechanical Products Co.

POPULAR MECHANICS

2016 - 122 So. Mich Blvd Chicago

433

bercher  
165-167 N. La Salle  
Chicago

Derzo(?)



39  
LAWN GAME HOLDS INTEREST FOR WHOLE FAMILY

Suited both for the lawn and gymnasium, a new game has been devised which should prove interesting to children, and more or less entertaining to some of their elders, as it furnishes mild exercise and requires a certain amount of skill. The outfit is simple and inexpensive, consisting merely of four light rods, or pointers, and a hoop, 7 in. in diameter. Each of the two players uses a pair of rods, and one, placing these implements through the ring and crossing them, throws the hoop through the air to his opponent by a quick, spreading motion which separates the pointers and projects the former. The other player, holding the points of his sticks together, is supposed to catch the ring. When it is sent through the air in a perpendicular position and caught on both rods, one point is scored. Catching it with only one stick counts nothing, while if it is missed the player forfeits a point. If the ring is thrown in a horizontal, or flat, position, one point is made, even if the catch is made with only one rod, while failure to do this does not count against the player. When the hoop turns on its axis during its flight the pitcher forfeits a point. In case it is not caught, the other player loses nothing,

The New Game is Suited Either for the Lawn or Gymnasium, and Therefore Is Just as Interesting in Winter as in Summer

ing, but by catching it with both rods receives two points, or one credit if a single stick is used. A total of 24 points comprises a game.

909  
SIMPLE ELECTRIC DEVICE FOR PROBING WOUNDS

An electric probe that commends itself through its simplicity and ease of handling has just been invented by a German surgeon. The entire apparatus

In This Electric Probe the Lighting of the Lamp Shows When the Probe Is in Contact with a Bullet or Other Piece of Metal

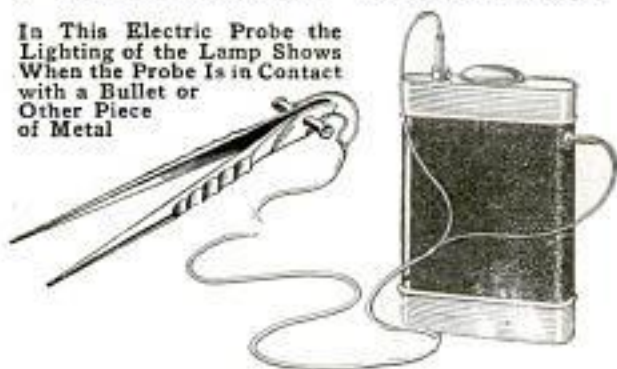

ratus consists simply of an electric pocket lamp from which insulated wires lead to the two legs of a pair of

Inv. Dr. P. Jodicks

pincers used in probing the wound. When the pointed legs of the pincers touch a bullet, a fragment of shrapnel, or other piece of metal, an electric circuit is formed through it and the lamp is lighted. One of the great advantages in this device is that it can be carried in the pocket and used in the field without the preparations usually required with other devices. Another device, based on the same principle, shows by the deflection of a needle not only when the probe is in contact with the bullet, but when it is approaching or receding from it.

### TRACK PROTECTS SLIDING DOOR FROM WEATHER

A new track, designed to protect as well as support a sliding door on barn or garage, is being marketed. It con-

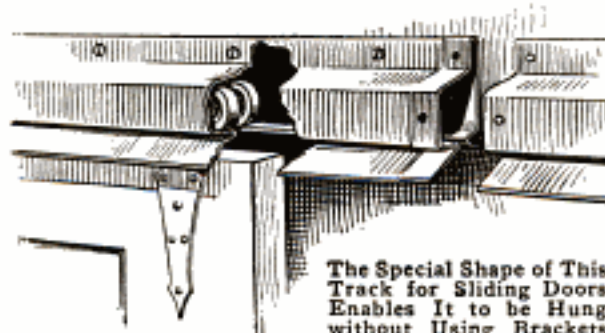

The Special Shape of This Track for Sliding Doors Enables It to be Hung without Using Brackets

sists of two sheet-steel stampings so formed and riveted together that a track of sturdy construction is produced. Between the stampings, on ridges made in the metal, the trolleys supporting the door ride. Since the various sections of the track are fitted together with lap joints, the entire runway where the trolleys travel is protected from the weather at all times. This is in contrast to the way ice and sleet sometimes make a door inoperative in winter weather, when ordinary track is used. No brackets or joint splices are necessary in erecting this runway, since the stampings are nailed, or screwed, directly to the surface of the building. The outer part of the track is especially shaped to keep water from running down onto the upper edge of the door and rotting the wood.

### NEW TEST FOR MOTOR-CAR

#### 1145 y LIGHT DIMMERS

A test of light dimmers for motor cars was made recently by a Massachusetts automobile club to ascertain what devices come within the requirements of the new state law. This law specifies that motor lights shall not dazzle or glare  $3\frac{1}{2}$  ft. above the ground or 50 ft. ahead, but shall reveal clearly objects 150 ft. ahead and also at the sides. For the test, lights were mounted on a stand at the end of a darkened room, 140 ft. long. At either side of an imitation roadway, and 10 ft. in front of the lights, were stationed figures representing pedestrians. Just 50 ft. in front was a crossbar,  $3\frac{1}{2}$  ft. high. At the far end of the room were other figures to represent pedestrians. The consensus of opinion was that many commonly used dimming devices do not comply with the new requirements, which demand a lamp that will throw a broad, low-sweeping fan of light far ahead. In several cases the devices tested removed the glare and lighted sufficiently objects at the roadside, but failed to reveal the figures in the road 150 ft. ahead. Others showed clearly the distant objects but were too dazzling. Lenses, all frosted, were sufficiently subdued but lacked range. The club will test other devices from time to time.

### RUBBER FILTER RINGS HAVE SPECIAL ADVANTAGES

Rubber rings for holding filtering crucibles in such a way that practically the entire side and bottom of the crucible are unobstructed, as is often desired by druggists, chemists, etc., have been placed on the market. They are made in two styles and will fit any  $60^\circ$  funnel. The plain ring is of hard rubber so designed that it grasps only



Wagner Mfg Co.

Cedar Falls, Ia.

E. N. Sargent & Co.

125 W. LaSalle St.

Chicago

about one-eighth of an inch of the upper edge of the crucible set into it. The other type is similar to the plain style, but its hard-rubber ring is supplemented by soft-rubber flanges which can be replaced. The illustration represents the latter type.

## RUNAWAY CAR PERFORMS 1018 CURIOUS FEATS

A street car took a leading part in an odd runaway in Seattle recently. Plenty of adventure resulted from the impromptu excursion. Before events reached an end one man had been struck and fatally injured, another severely bruised, and a collision with a second car full of people narrowly averted.

The accident happened at the top of a hill. In passing over a switch the car's front trucks went properly up the main line, while, for some reason or other, the rear pair turned off into a side street. As a result the car stopped with a jerk, its rear end halfway around the corner. Instead of getting back onto the main line the way it had come, the car, as a result of the downhill incline of the track, started out on a new tack. Slowly the front end swung past the rear portion planted on the side street, and started down the hill, afterward dragging the rest with it. Besides being a new and entirely original method of turning around, this

action had a most disastrous effect on the brakes and other appliances beneath the car which might have been capable of stopping the runaway. At every turn of the wheels, the car ran faster. A motorman on an approaching car, seeing the runaway, promptly reversed and attained some speed in a backward direction with a view to lessening the approaching impact. At the moment when the runaway caught up with the backing car, both were running at nearly the same speed, hence the collision became but a slight jar. Upon applying brakes to the car under control, both were speedily brought to a stop. The motorman's quick wit had averted a serious collision, but did not prevent injury to two people who were unable to get out of the way of the racing cars. One of these later died.

One of the specialty plants in this country turns out 5,000,000 steel balls for ball bearings every 24 hours.

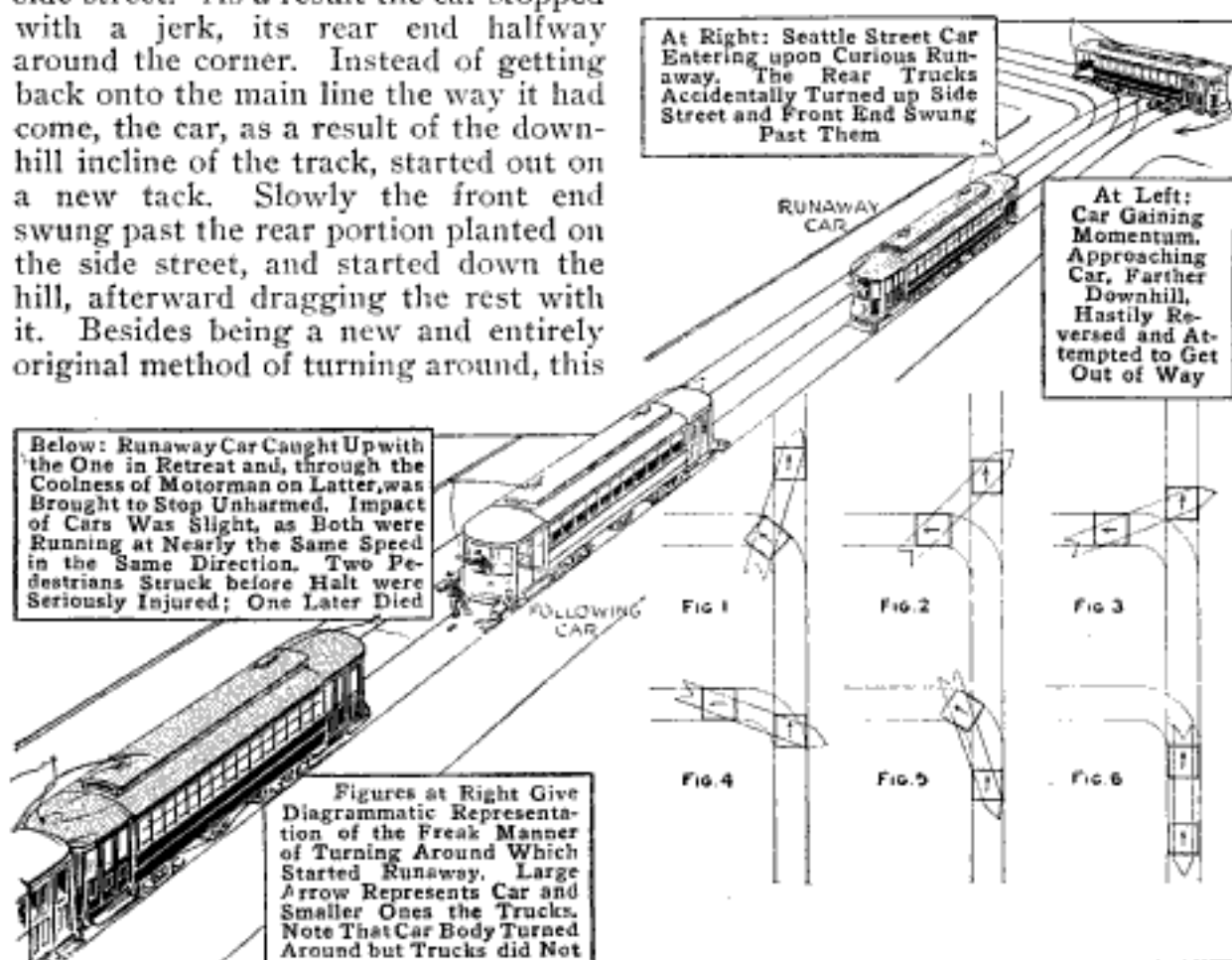

## NOVEL AND PRACTICAL THINGS

## 11317E FOR THE HOME



Ingenious Ring Guard  
Hidden When Worn

Being comfortable and conforming to the shape of a finger, a new type of ring guard lately devised is concealed from view when worn. It is made of gold and fits securely to the inner rim of a circlet, pressing against the fleshy part of the finger and preventing the ring from turning.



Compact Case for Tooth-  
brush and Paste

Among the new toilet accessories is a short-handled toothbrush and a small tube of paste neatly packed in an attractive silver case. The compactness of the article allows it to be carried conveniently in a woman's handbag, should this be desired. When traveling, it occupies a minimum of space in a toilet case.



Auxiliary Handle Used  
with Saucepans

Trouble and burned fingers are both materially lessened by the use of an auxiliary handle which may be employed when preparing food in saucepans and baking dishes. It clamps to the wall of a vessel and may be locked in place, or not, as is desired. It holds securely, and if properly applied will not crack enamel ware.

Silver baskets garnished with artificial greenery, in the midst of which are clusters of black-headed pins that

look like large, luscious loganberries, form attractive pincushions for a lady's dressing table. These are being shown in different patterns and in sizes varying from approximately three to five inches in height. After the pins have been used the cushion may be removed and the basket filled with bonbons or almonds.



Pincushion Looks Like  
Basket of Berries

Large, durable garbage receptacles constructed of reinforced concrete are being manufactured for general use.

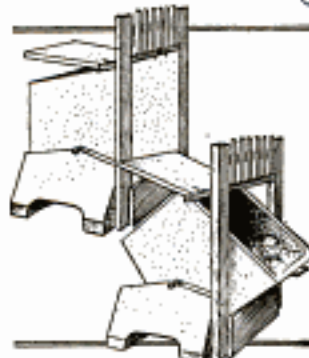

Garbage Receptacle Made  
of Heavy Concrete

They are mounted on concrete blocks and may be easily tilted to an inclined position to facilitate the removal of their contents. When a square opening is cut in a back fence and the device properly installed, the box may be tilted through the space and the refuse taken out from the alley side.

Real convenience is embodied in a new tatting shuttle, lately introduced, which is made in two parts. This arrangement permits the device to be opened and thread wound about its



Convenient Shuttle Made  
in Two Parts

the device to be opened and thread wound about its

- 1 RING GUARD-- Schwartzchild & Co., Chicago. 79 E Madison St.  
*Sell Trade only*
- 2 TOOTHERUSH OUTFIT-- Balleu Mfg. Co., Attleboro, Mass. ("Eveready")
- 3 "O.K." PAN-HANDLE-- Dandy Mfg. Co., 2317 Monroe St., Toledo. O. <sup>10</sup> X  
*Pat. June 6, 1915 JOHN F. DUKET  
filed May 21-1914 ser. 839926 - 207. 216 p 31*
- 4 PINCUSHION-- Contributed by Mrs. Telford.  
*Gosham Mfg Co., Providence, R.I.*
- 5 GARBAGE BOX- Mfg by Chas. Wesely Co., 3116 S. Canal, Chi. <sup>800 del'd.</sup>  
*Bob. O. Lim. 45 gal. 26" x 28" x 24" (larger sizes to order) F.O.D. Chi.*
- 6 SHUTTLE- Eisenstadt Mfg. Co., Olive & 12th., St. Louis.  
*Pat. June 22, 1915*
- 7 DISH DRAINER- J. M. Sherwood Co., 154 Chambers St. N. Y. C.
- 8 EXTENSION NOZZLE- With Western Electric Vacuum Cleaner.
- 9 THERMOR-- Royal Thermopher Sales Co., 7 Desbrosses St. N. Y. C.
- 10 DISH BRUSH- Sanitary Suds Brush Co., 420 Ogden St. Newark, N. J. <sup>500</sup>
- 11 BOTTLE STOPPER-- (*James C. Oram & Co.*)  
ORAM'S SANITARY AIR-TIGHT MILK AND BOTTLE STOPPER,  
100 W. S. WATER ST. CHICAGO.
- 12 Ash Tray-- Contributed by Hugo Pick, 5482 Everette Ave., Chicago.  
*H. R. White Inv.*



spool without any difficulty whatever. The two sections are held together by a telescoping, oval spindle, the shape of which prevents oscillation and keeps the points in alinement.

For domestic purposes a dish drainer and drying rack has been brought out which consists of a sheet-metal pan fitted with a frame for china and a wire receiver for silver. A hole in one end of the pan allows hot rinsing water to drain into a sink. Its chief advantage is that it catches the water as it is poured over the dishes, preventing it from slopping onto a floor, and also permits the drainer to be moved without dripping the water.

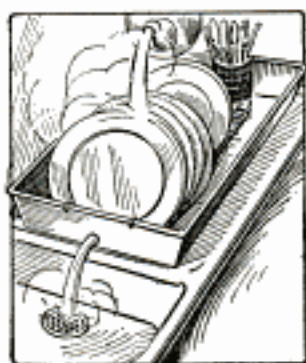

Dish Drainer and Drying Rack for Kitchen

So that a rug may be gone over without moving heavy furniture, such as a davenport, couch, or music cabinet, an extension nozzle is provided with one type of vacuum cleaner. This enables the operator to reach



Extension Nozzle Used with Vacuum Cleaner

out-of-the-way places without bending into uncomfortable positions, as is usually necessary, when the task is attempted with a broom.

Dry, even heat is radiated for 12 hours or more by a metal, disk-shaped bottle

which may be employed as a bed warmer. The device is 8 in. in diam-

eter,  $1\frac{1}{4}$  in. thick, and weighs a trifle more than three pounds. It is filled with a heat-retaining chemical and is intended to be placed in boiling water for a period of about 10 minutes before being used. It is not meant by this, however, that water is filled into it.

In an attempt to simplify dishwashing without resorting to a large and expensive machine, a dish brush has been developed which may be connected with a rubber tubing to a hot-water faucet. It is provided with a soap chamber through which water passes before being discharged through the bristles. A spray of clear, hot water is produced by pressing a button in the handle.

For milk bottles an air-tight stopper has been invented which is intended to be inserted after the customary pasteboard cover has been removed. It consists of a ball-valve spigot mounted in cork.

A match stand and tray lately designed has sliding leaves on either side which permit cigarette and cigar stubs to be discharged into the interior of the receptacle. By pushing down upon the match holder the leaves are moved back and ashes dropped.



Dishwasher Brush of Simple Construction



Air-Tight Stopper Designed for Milk Bottles

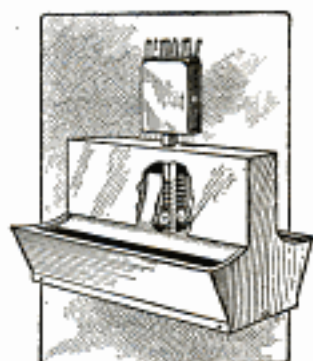

Combination Match Stand and Ash Receiver



Bed Warmer Radiates Heat throughout Night

**COMBINED WATCH AND SHELF  
CLOCK FOR SOLDIERS**

893R

A novelty being offered the English trade consists of a watch designed particularly for soldier use. The watch



English Watch for Soldiers in Trenches Tilts Up on Inner Hinge for Use as Shelf Clock. Nurses Use Another Type Having Pulse Second Hands

proper is oval in shape and is mounted within a metal case of durable construction. By opening the cover and

raising it on an interior hinge it is possible to tilt the watch at an angle and set it on a table or shelf where it may be made to serve in place of a clock. The timepiece has self-luminous hands and numerals. As presents for soldiers in the field, these watches have attained some popularity. Another watch of the wrist variety, having pulse second hands, is also being offered for the use of doctors and nurses.

**PICTURE PRODUCERS ERECT  
PLATFORM FOR VISITORS** 977R

In southern California an unusual industry has sprung up, the wholesale production of motion pictures. The principal reasons for this are the wonderful variety of natural scenery found in the region and a climate noted for its brilliant sunlight. Hundreds of visitors intent on seeing motion-picture actors actually at work flock to the district each month, and the handling of these proves a considerable problem.

One of the companies which allows visitors has adopted an innovation of some interest. Opposite a 300-ft. stage upon which the actors are performing, an observation platform has been erected. Visitors are permitted to

*Universal Film Co.*



*Universal City  
Calif.*

Observation Platform at California Studio Enables Visitors to See Motion Pictures in the Making



gather on this and watch the various scenes being filmed. Thus the strangers' innocent venturing in upon property rooms, scenery departments, camera quarters, or the stage, is prevented, and at the same time their interest and curiosity satisfied. The lower portion of the observation platform, which is of cement, serves as a convenient dressing apartment for the actors.

### SHORTER RAILS NOW USED

10807 BY RAILROADS  
ENGINEER 1915/15

The use of shorter rails seems to be a general tendency among American railroads at the present time. There are, however, a few conspicuous exceptions to this practice. Pronounced variations in temperature causing excessive expansion and contraction are the chief reason for preferring the shorter rail. Formerly a number of steam lines laid rails 60 ft. long, but many of these have been supplanted with much shorter material. In one instance 60-ft. rails were taken up and cut in two and then relaid. Rails 33 ft. in length are commonly used. Several lines have recently placed orders for 39-ft. rails and one road has specified 40 ft. for new rails. The usual length of rail now used in England is 45 ft., though one of the leading roads of that country uses 60-ft. rails. A railway in northern France is said to be laying rails 78 ft. 9 in. in length.

### REVOLVER IS MOUNTED IN 8090 END OF POCKETKNIFE

A novelty of recent appearance combines the functions of a revolver and pocketknife in one article. One end of the invention resembles an ordinary jackknife, having the usual hinged blades of assorted sizes. In the other end, however, is mounted a steel block bored out to receive a .22-caliber cartridge, either blank or ball. Attached to the back of the knife is a suitable trigger arrangement for firing the cartridge. Though intended primarily for emergency use, and to avoid the necessity for carrying a heavier gun,

the contrivance is also a convenient accessory on hunting and fishing trips.



Combined Jackknife and .22-Caliber Gun

Several different styles are manufactured.

### HANDCUFF STAYS OPEN IN 6560 POCKET

A handcuff, designed to prevent accidental locking when carried around in a coat pocket, is a recent invention. Means are provided for adjusting the "bracelets" to different-sized wrists as in the ordinary handcuff, but the shackles cannot become locked except



This Handcuff Is Adjustable, but will Not Lock Accidentally

upon deliberate intention. Thus the cuffs are always open ready for instant use.

British authorities have denied that British motorcyclists are used in the war as scouts. The 15,000 motorcyclists in the British army are all dispatch bearers, it is said.

2/17  
United States Small Arms Co., Inc.,  
Eastern Trading Co.

1790 Broadway (at 58th St.)  
New York

### BORING MACHINE IS HELP IN HOUSE-WIRING WORK

In house-wiring work boring holes in ceiling supports to permit the pas-

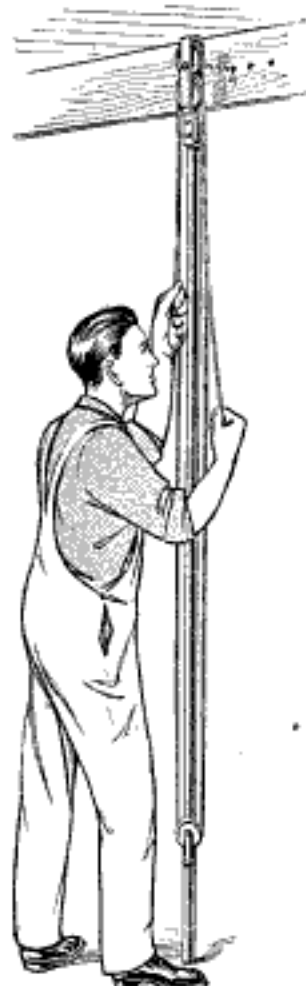

sage of a wire is a slow and tiring task. Many machines have at one time or another been devised to make this work easier. A late one consists of an upright rod extending from floor to ceiling and having at its upper end the usual chuck for holding a bit. The method of operating this is interesting. It is done with the aid of a rope passing over pulleys connecting with the upper chuck. The operator seizes two handles connecting with this rope and works them

up and down, a ratchet arrangement forcing the bit into the wood at each pull. With such a tool, work may be done more quickly and in greater ease than with the ordinary brace and bit.

### WAR MOTOR CARS DIPPED IN PAINT BATH

The exigencies of the war in Europe which demand speed in production have resulted in the employment of a method of painting motor trucks which turns out several hundred vehicles a day with small labor expenditure. To give the motor trucks, motorcycles, etc., used at the front the desired gray or khaki hue they are lifted bodily by a heavy crane and immersed for a few

minutes in a paint bath. Tanks holding hundreds of gallons of paint are provided for the purpose. Of course the coating so administered is much inferior to that put on by brushes, and it peels off much more readily, yet for war purposes it seems to be satisfactory. Motors and other delicate mechanism are installed after the bath.

### WHY EVEN BEST WATCHES GO WRONG

The reasons for variations in the time-keeping qualities of a well-regulated watch have been the subject of investigation by scientists recently. The popular theories, often circulated by jewelers and other tradesmen, that animal magnetism and bodily temperature are causes, are denied by these investigators. Rather, different rhythms of movement as well as the angle at which a watch hangs are given as real causes for irregularities. It has been found, for example, that a watch so accurately adjusted that, when worn by its owner, it will not vary more than a second a day, will gain or lose a quarter of a minute in 24 hours if hung on a bedpost.

### ACCIDENT-PROOF GAS COCK FOR STOVES AND RANGES

Designed for safety purposes, so as to minimize the danger of the gas being turned on accidentally in a gas range, a cock has been made which automatically locks when it is closed. This prevents the knob from being moved and a flow of gas started by a person unconsciously brushing against it. Until it is raised so that the lock is released, the handle cannot be turned. This causes no inconvenience and gives assurance against accidents.

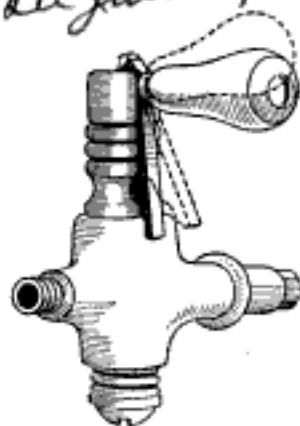

turned on accidentally in a gas range, a cock has been made which automatically locks when it is closed. This prevents the knob from being moved and a flow of gas started by a person unconsciously brushing against it. Until it is

raised so that the lock is released, the handle cannot be turned. This causes no inconvenience and gives assurance against accidents.

Shapiro & Thompson  
20 Warren St  
New York

**MINE EXPLOSIONS PROVEN TO BE PREVENTABLE**

1147 *Engineer 12/3/15*

That mine explosions from ignition of gas are something which cannot be guarded against and hence may be considered as "acts of Providence," is now generally regarded as a false assumption. The mines of Belgium are striking illustrations of the advantages of carefulness. There sudden outbursts of inflammable gas are frequent, and yet there have been no serious explosions from ignition of gas for the past 20 years, though prior to 1893 when less precaution was observed, there were many great disasters. It is stated that without open light of some sort there would be no explosions, and British statistics indicate that 90 per cent of the explosions or inflammations have occurred in what are called open-light mines, designated as "nongaseous."

**REMOVABLE BRACKET FOR SPECIAL LIGHTING**

925 *Just*

A removable lamp bracket which is particularly adapted for use in hotels where it is desirable to furnish strong lighting in sample rooms, has been manufactured by an eastern concern. This bracket is made to fit into receptacles of the disappearing type, so that when the lights and brackets are removed, the sample room is no different in appearance than the other rooms. The receptacles are equipped with special eyelets to receive the hooks of the brackets. Even if the receptacles are not covered up while not in use no exception can be taken to their presence. Similarly constructed receptacles, located at the head of a bed, have proven convenient for a bed-reading light and permit the light to be removed easily.



**ELECTRIC WATER HEATER IS BUILT FOR FOUNTAIN USE**

An electric water heater, designed particularly for the use at soda fountains, is a late addition to the list of

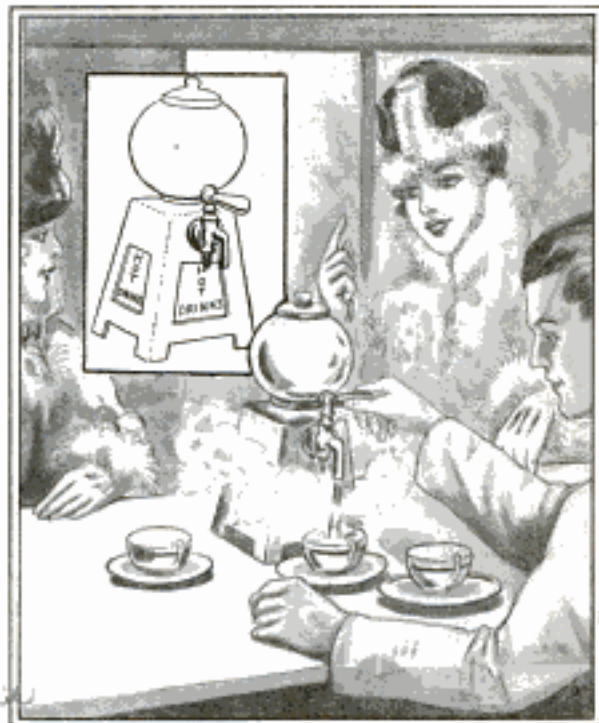

Electric Water Heater Assists Fountain Proprietors in Serving Hot Drinks at All Times. Coil of Wire in Base Provides Heat as Required

electric appliances now on the market. It consists of an upper glass globe which opens up into a well. This is situated within a pyramidal frame forming the base. Here the coils of wire providing the heat are located, which is a point of vantage because of the fact that the faucet opens directly out of the well and the close proximity of the heater always assures hot water on demand. Two rates of heating the water are made available; one a "low" and the other "high." A pilot lamp in the base indicates by its degree of brightness which is on at a given time. The low heat consumes about 95 watts, while the high takes 660 watts.

What is said to be the longest salmon-canning season in a decade on the Fraser River, B. C., came to a close recently with a total salmon pack of 1,132,201 cases, an increase of more than 20,000 cases over 1914.

*Bryant Electric Co.,  
Bridgeport, Conn.*

## HOW THE BENGALESE ARE TOLD THE NEWS

The language spoken in Bengal is a modern Indian tongue somewhat resembling Sanskrit, and is written in an

### ঢাকাই সংবাদ ।

আমাদের সংবাদপত্রের পত্র । )

মানহানির যোকদ্দমা :—

ঢাকার অতিরিক্ত জেলা ম্যাজিস্ট্রেট মিঃ ওয়াডেল মহোদয়ের এজলাসে ভারতবর্ষীয় দণ্ডবিধি ৫০০ ধারানুসারে একটি মানহানির যোকদ্দমা রুজু হইয়াছে। এই যোকদ্দমায় অত্র জেলার মুন্সীপঞ্জ মহকুমার সাবডেপুটি জিহুত পূর্বজন্ম দাস রাদী এবং জিহুত সাহা বিবাদী। অভিযোগের বিবরণ এই—রেকাবী বাজারের হরিদাস গোপ পূর্ববাবুর এজলাসে রূমণের বিরুদ্ধে এক অভিযোগ হায়ের করে। আসামী এই মর্মে এক এন্ডিভেবিট করে যে বাদী পক্ষ বিচারের পূর্বেই উক্ত পূর্ববাবুকে ঘৃত এবং ক্ষীর উপঢৌকন দিয়াছে। এক্ষণ অবস্থায় পূর্ববাবুর নিকট যোকদ্দমার স্তানী হইলে তাহার

Reproduction of a News Item That Appeared in a Recent Number of "Darshak," a Journal Printed in the Bengali Language and Published at Calcutta

alphabet known as Nagari. Like all the languages of the Orient, it has a strange and incomprehensible look to an English-speaking person, as will be seen from the accompanying reproduction of a news item taken from "Darshak," a journal published in Calcutta. The name Bengali is English. The Bengalese call the language Banga-Bhasa. It is the native tongue of Rabindranath Tagore, one of the winners of the Nobel prize in literature, who writes both in this language and in English.

## NEW PROCESS OF MAKING ELECTROLYTIC IRON

The production of sheets and tubes of electrolytic iron by a process in which ordinary cast iron serves as a basis and the product consists of iron in a very pure state is being perfected

in France. The cathode rotates in a solution of ferrous salt so as to have a layer of iron deposited on the surface. The solution is kept neutral by placing iron turnings in the bottom of the tank and by adding oxide of iron as a depolarizer. The iron thus produced is very hard at first and contains some gas, but it is then annealed so as to expel the gas and make a soft, malleable metal. By using a rod as a core, iron pipe can be made direct, but the making of sheet iron is not yet in a commercial stage, though it is expected to produce sheets of soft, pure iron without rolling.

## HIGHWAY PRODUCE MARKETS

### FOR MOTORISTS

The elimination of the middleman and some reduction in the cost of living have been accomplished by resourceful farmers in the East and elsewhere through the wayside markets which they established during the past season, for the patronage of motorists. Simple shelters of various styles were built along popular highways, housing all sorts of fresh vegetables and, in some cases, also butter, eggs, and fruit. Because there was no cartage and because the produce was sold directly to the consumer the prices often were less than in retail stores. One farmer displayed his fruit in small baskets and placed above it a sign which read: "10 cents a basket. Take your pick and put your money in the box." Another farmer is said to have taken in \$162 in one day.

Ⓒ In testing shrapnel shells they are subjected to a temperature of 120° F. for 24 hours. In one of the government arsenals this has been done in an electric furnace whose temperature is controlled by a thermostat. Arcing has been reduced to a minimum by a condenser shunted across the contacts. The heat variation in a 24-hour test was not more than one degree, it is claimed.



### Accuracy of Levels

It is really surprising how accurate one can be with a good level. With a first-class level, made of cast iron and having a graduated bubble glass, an erecting contractor would think twice before passing the job of installing a piece of machinery or lining a shaft if the bubble showed  $\frac{1}{32}$  in. off center. Yet, in a level only 18 in. long, the bubble would indicate that one end was .001 in. higher than the other. Realizing this, it is little wonder that the ways of large planers and lathes are leveled up with an accurate level as recommended by the manufacturers.

### Holding Large Doors Open

Large and heavy shop doors are, when caught by sudden gusts of wind, about as dangerous as anything around the establishment. A good many ways are employed to hold them open, but a strong wind readily tears a heavy door free from its anchor.

The illustration shows how a cheap, practical, and simple lock-open arrangement can be made from a piece of  $\frac{7}{8}$  or 1-in. round iron. It is capable of holding a door of considerable size



Holder Made of a Rod to Keep a Large Door Open against a Strong Wind

open, no matter how strongly the wind blows, and on account of its shape it will not break loose.

### Beaching a Motorboat

The device shown consists of a piece of 3-in. pipe, about 18 in. long, placed so that it will revolve on four inverted casters which are screwed to a board.



Inverted Truck Casters Placed on a Plank in Position to Hold a Length of Pipe

When the boat has been run aground, the device is placed under the keel; and the boat is pushed by hand until the entire length of the keel has traversed the roller. The device is again shifted forward and the process repeated until the boat is high and dry. If two sets of rollers are used the process is considerably easier. The outfit is small and can be readily carried in the boat for use wherever it is desired to beach it.—Contributed by J. J. O'Brien, Buffalo, N. Y.

¶To make a first-class oil for light machinery, take a bottle about half full of pure olive oil, place in it some thin strips of sheet lead, and expose it to the sun's rays for a month, then pour off the clear oil.

### End-of-Page Marker for Typewritten Sheets

Many typists have often felt the need of a page-end indicator to enable them to see when the bottom of the page being

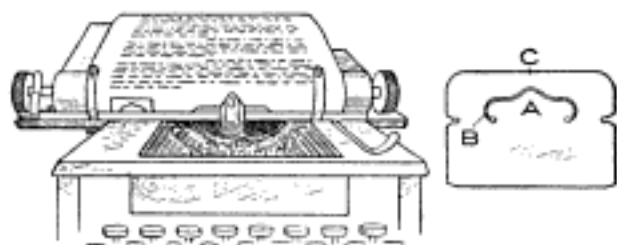

Indicator Made of Celluloid to Fasten on Page End of a Typewritten Sheet

typewritten is approached. Such an indicator can be made of thin celluloid, the celluloid cards given out as advertisements being suitable for the purpose. The celluloid is cut out, as shown, and bent back at the notches at the sides.

To operate, the page is started in the typewriter, and the edges of the indicator are pressed together between the fingers. If properly made, the indicator will give a click as the flap A bends through the opening B. The indicator is then slipped over the end of the page, with the flap A facing the typist. This sounds complex, but is in reality very simple. The edge C may be colored red to catch the eye as it appears.

### To Hold a Loose Camshaft Bushing

The bushings within which the camshaft of a gasoline engine rotates are in quite a few cases merely pressed into

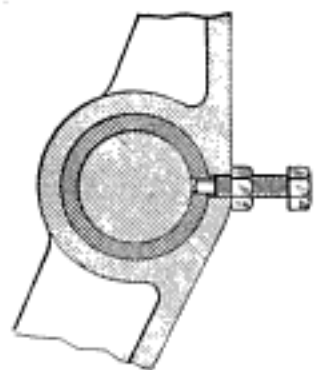

the aluminum crank case, and constant vibration, together with a difference in expansion of the bronze and aluminum, has in many instances caused the bushing to come loose. In such cases a new bushing would probably be the best solution. A similar case

came to our shop, and it was decided to try holding the loose bushing by means of a setscrew. A  $\frac{1}{4}$ -in. screw was turned down on the end to make a projection  $\frac{3}{16}$  in. in diameter and of such length that the end came  $\frac{1}{64}$  in. under the inner surface of the bushing. The screw was held with a lock nut, as shown.—Contributed by Adolph Kline, New York City.

### An Emergency Pulley Block

In an emergency, where I had to lower a large sheave wheel a distance of 50 ft. from its bearings, I used

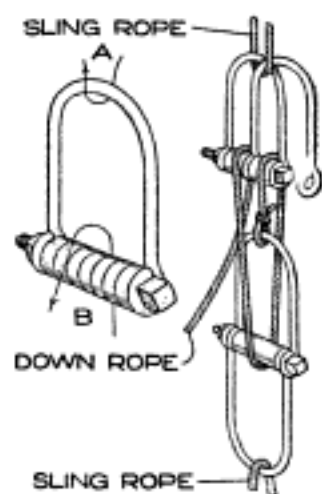

blocks made up as shown in the illustration. Clevises taken from a double-tree of a wagon were formed into pulley blocks by filling the pins between the yoke ends with washers. The rope was tied through the clevis, at A, as shown by the arrow, and the down rope, as at B and to the sheave wheel, the opposite end being given a couple of turns around a cross timber. The washers revolved on the bolt like a small wheel. A double block can be made with four of the clevises, as shown.—Contributed by E. C. Lane, El Paso, Tex.

### Receptacle for Motion-Picture Film Cement

Take an ordinary oil, or sewing-machine, can with an opening in the spout not over  $\frac{1}{16}$  in., and put the cement in the can. When wanted, press the bottom as in oiling and draw the spout along on the edge of the film to be patched. The can not only saves time for those engaged in film rewinding, but also prevents evaporation of the cement.—Contributed by Geo. Yaste, Lonaconing, Md.

### Things to Know about Fiber

Fiber in sheets, tubes, rods, and special shapes, plays an important part in mechanical work at present. It is an insulating substance and finds a large field in electrical work. It withstands the action of oil very well, and has another field in friction surfaces of machines, where a material is needed that is substantial enough to transmit power but at the same time smooth and true enough to slip under great pressure without cutting the metal faces. For this purpose it is a rival of bronze.

Fiber is also supplanting hard rubber for handles, ferrules, and special shapes. For this work it is as light as rubber and has the great advantage of not being brittle, for which reason it can be handled by unskilled labor and applied in places where rubber cannot be used. Manufacturers of fiber will supply special shapes, such as grips for bicycle handlebars.

Gears are also made of fiber. The rawhide and cloth gears are noiseless and have good wearing qualities, and the same may be said of fiber gears, the wearing qualities of the latter being somewhat better. In a certain leather-manufacturing plant a tanning apparatus was driven by a 6-in. cast-iron pulley on a motor driving a 24-in. cast-iron gear. The pinion had to be renewed every four months and the gear every year. Rawhide, bronze, and cloth pinions were tried, and while they stopped the noise, they did not wear much better. A fiber pinion, after running 32 months, appears to be good for as many more months.

Fiber can be worked at high speed in lathes, milling machines, saws or drills, but in drilling out rods of fiber trouble may be experienced. This is due to the nature of the material. All of the so-called hard, or red, fiber is made of sheets of cloth, chemically treated and subjected to great pressure, which almost, but not quite, unites the sheets. In drilling rods, this little lack of union asserts itself, and unless the hole is comparatively shallow and small, the rod is apt to split along the line of the

original sheets. If a rod is threaded with a die, the same trouble is encountered; in fact, it is well-nigh impossible to cut such a thread, due to the spreading and twisting strains set up by the die.

### Hinged Fireplace Screen

Ordinarily a fire screen is not fastened to the fireplace and is open to the objection that through forgetfulness one may neglect to return it to its place after attending to the fire. Where there are small children about, this is dangerous because of the chance of their



A Hinged Fire Screen That cannot be Forgotten and the Fire Left Unprotected

meddling with the fire and getting burned. However, if the screen is hinged, as shown, its unsightly appearance when raised will cause it to be lowered as soon as possible after the fire is fixed.

☞ To run a tap into a hole in hardened metal, even if it can be scratched with a file, will many times ruin the tap.

# Modern Barn Construction

By W. E. FRUDDEN

THE framing of a barn has gone through an evolution in which the heavy timber barns of former years have passed out of existence, and trussing has taken the place of the large beams that have become exceedingly expensive. The first truss illustrated is for a standard-width barn of about 36 ft., and is, both in materials and labor, very economical. It gives a maximum of storage room in the mow; it is convenient, and will give the most space and best barn for the money.

The joists in this design are the heaviest pieces of timber in the whole frame, 16 ft. being the longest dimension required. Barns like these are stiff, safe, sound, and serviceable for a great number of years.

The scarcity and the poor quality of the long timbers that can be had now make this plan of construction very sensible, as it uses only short lengths of 2-in. planks. In the old timber barn, the mortise-and-tenon joints are the weak places in the building. They are not nearly as strong as they appear. It takes skill and a great deal of experience to master the art of barn framing under the old methods, where long and cumbersome timbers are to be mortised and tenoned, then pinned at the joints. The truss shown is so simple that four men have erected a large barn of this type without any other help. As the roof arches go up into place one at a time, it will appear that even a carpenter is not necessary to put such a barn together, since there is nothing at all complicated about the whole structure.

The rafters, the studding, and the floor joists are all spaced 2 ft. center to center in this balloon-frame barn. There are no cross braces in the mow space so that this is left entirely open for hay storage.

The floor and footings are of concrete and extend 2 ft. above the grade line, so as to keep all the woodwork away from the soil moisture, which causes rot and decay. The sills and plates are double 2 by 6-in. material, as are also the studs and the rafters, all

being spaced 2 ft. on centers. The roof arches are built up on the ground and are braced at the hips with two 1 by 8-in. boards. When the side walls have been all raised and sided, the roof arches are pulled up with a block and tackle, one man handling one arch at a time. They are spaced directly over the wall studs. The walls are sided horizontally; the roof is covered with sheathing and shingles, or with prepared roofing, and the 2 by 12-in. floor joists are covered with ship-lap flooring. The two girders which support the floor are made from four planks. The material list is for a 14-ft. section of a standard barn. If a longer barn is required, figure on proportionate amounts, and add the materials for the two ends.

112 cu. ft.	concrete	foundation.
504 sq. ft.	concrete	floors.
56 ft. 2 by 6-in.		16-ft. sills.
56 ft. 2 by 6-in.		16-ft. plates.
28 ft. 2 by 6-in.		16-ft. rib plates.
256 ft. 2 by 6-in.		16-ft. studding.
256 ft. 2 by 6-in.		16-ft. braces.
256 ft. 2 by 6-in.		16-ft. rafters.
192 ft. 2 by 6-in.		12-ft. rafters.
48 ft. 2 by 6-in.		6-ft. collar beams.
43 ft. 2 by 4-in.		4-ft. lookouts.
256 ft. 1 by 8-in.		12-ft. hip braces.
116 ft. 1 by 8-in.		2-ft. cleats.
32 ft. 2 by 8-in.		2-ft. struts.
384 ft. 2 by 12-in.		12-ft. floor joists, sides.
224 ft. 2 by 12-in.		14-ft. floor joists, center.
224 ft. 2 by 12-in.		16-ft. for girders.
540 ft.	drop siding,	6 in. wide.
650 ft.	roof sheathing.	
7,000	cedar shingles.	
600 ft.	ship-lap flooring.	

Materials for the two ends of a 36-ft. barn:

200 cu. ft.	concrete	foundation.
144 ft. 2 by 6-in.		16-ft. sills.
240 ft. 2 by 10-in.		16-ft. plates.
1,250 ft. 2 by 6-in.		16-ft. studding.
100 ft. 2 by 8-in.		16-ft. braces.
2,500 ft.	drop-siding	lumber.

The Shawver system of barn framing gives the barn builder a stiff, plank-framed barn with an unobstructed mow space that will hold an abundance of hay or rough feed. It is a plan that is particularly well-fitted for use in larger structures. The details show a barn that is 36 ft. wide, a width that is now generally accepted as being the best all-around size for two rows of stock. Wider barns may be built, however, and the same general idea of construction may be followed out if desired.



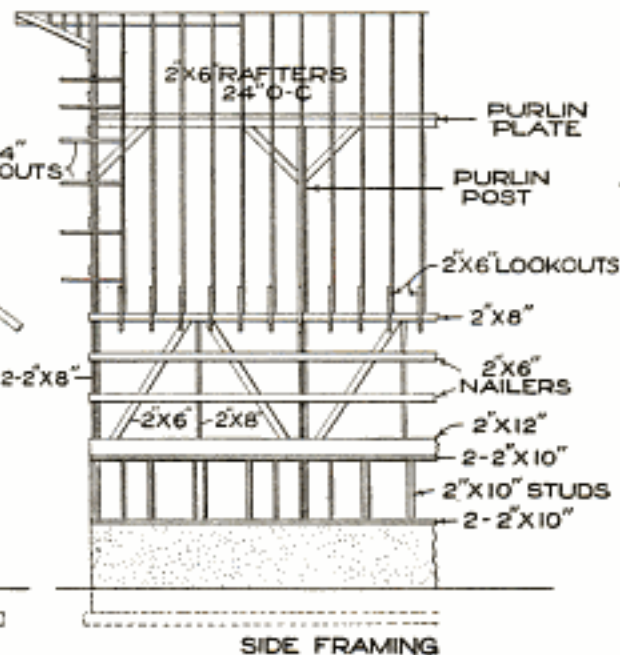
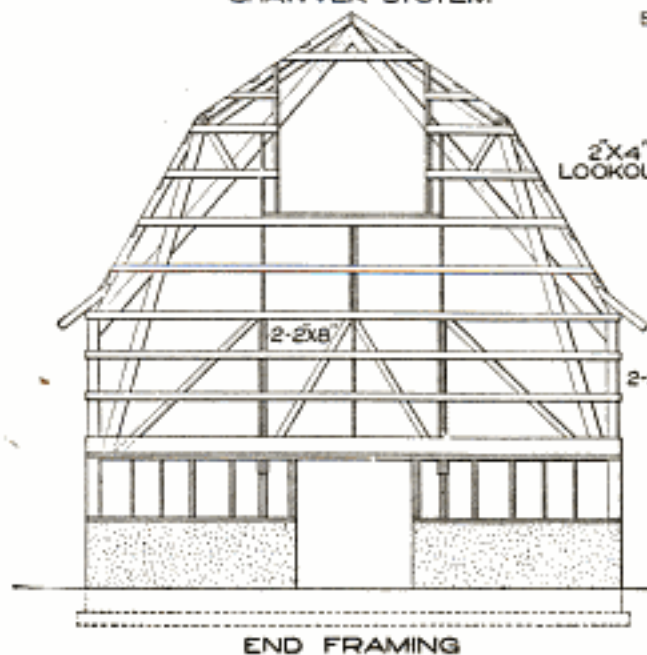
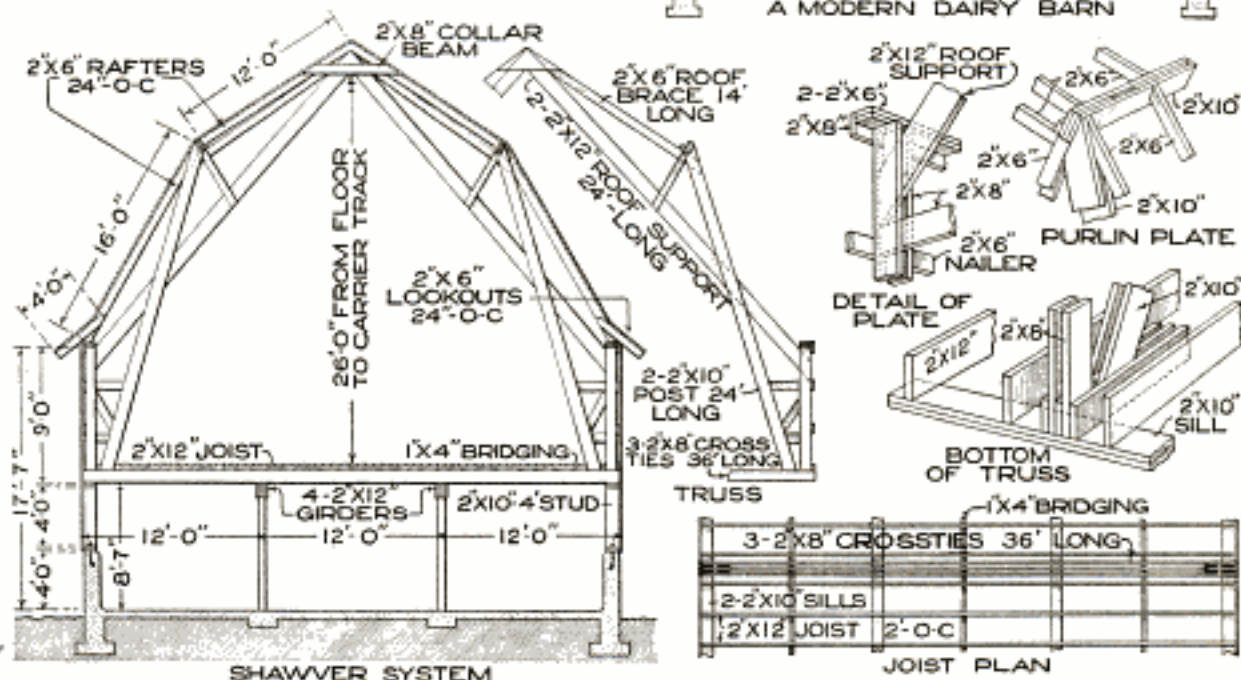
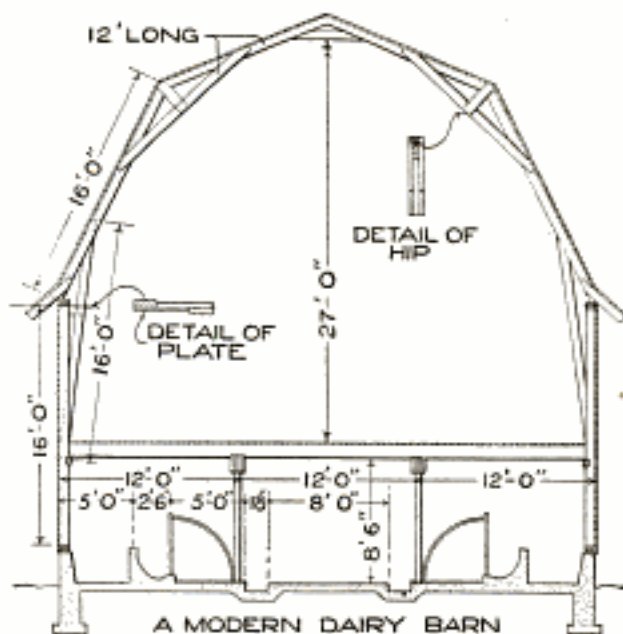
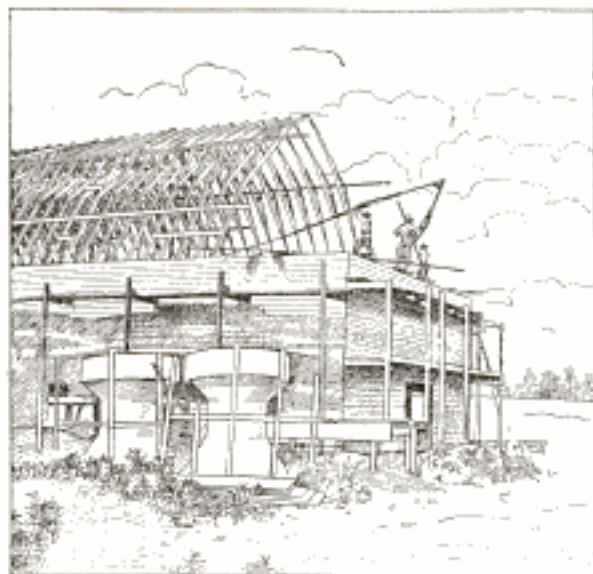

The concrete work runs up 4 ft. above the grade line. The ground-floor walls, above the concrete work, have 2 by 10-in. studs placed 2 ft. center to center. The double-thick sills are bolted to the concrete every 6 ft., and the plate at the top of the 4-ft. studding is made from two 2 by 10-in. planks, spiked firmly together. The roof trusses are shown in the cross section. These are spaced every 14 ft. in the length of the barn.

The rafters are of 2 by 6-in. material and spaced 2 ft. apart from center to center, after the roof trusses and purlin plates have been put in place. The lower rafters rest on the side-wall plates, and are supported at the hip by the heavy purlin plate, which is carried by the trusses. The floor joists are 2 by 12-in. planks and are spaced every 2 ft. from center to center, running crosswise with the barn. The continuous girders, made of 2 by 12-in. planks, spiked together, are supported by columns in the center, spaced 12 ft. apart across the barn.

If the barn has been braced as shown, and a good quality of material used together with good workmanship, it will stand the pressure of wind and snow.

As a basis for estimate, a 14-ft. section of a 36-ft. barn has been taken. To compute the amount of materials required and to obtain only a general idea of the cost for any other length barn, multiply the amounts listed by the number of times that 14 is contained in the length of barn that is desired. As an example, a 70-ft. barn that is 36 ft. wide would contain five

times the material for a 14-ft. section, not counting the ends, which are added to the amount obtained for any length of barn. The builder may add about 50 per cent to the cost of the material for labor, barn equipment, windows, doors, hardware, and paint where up-to-date construction is wanted. The following materials are required for a 14-ft. section:

224 cu. ft. concrete walls.
504 sq. ft. concrete floor.
95 ft. 2 by 10-in. sills.
95 ft. 2 by 10-in. plates.
150 ft. 2 by 10-in., 4-ft. studding.
56 ft. 2 by 12-in., 14-ft. nailers.
56 ft. 2 by 6-in., 14-ft. nailers.
112 ft. 2 by 8-in., 14-ft. plates.
256 ft. 2 by 6-in., 16-ft. rafters.
192 ft. 2 by 6-in., 12-ft. rafters.
53 ft. 2 by 8-in., 10-ft. center posts.
64 ft. 2 by 6-in., 4-ft. lookouts.
85 ft. 2 by 8-in., 6-ft. collar beams.
92 ft. 2 by 10-in., 14-ft. purlin plates.
19 ft. 2 by 4-in., 14-ft. purlin plates.
144 ft. 2 by 6-in., 12-ft. braces.
400 ft. 2 by 12-in., 12-ft. joists.
224 ft. 2 by 12-in., 12-ft. girders.
470 ft. barn-siding lumber.
650 ft. roof sheathing.
7,000 cedar shingles.
600 ft. ship-lap flooring.

#### Materials for the two ends:

576 cu. ft. concrete wall.
120 ft. 2 by 10-in., 16-ft. sills.
120 ft. 2 by 10-in., 16-ft. plates.
400 ft. 2 by 10-in., 4-ft. studding.
288 ft. 2 by 8-in., 36-ft. crossties.
96 ft. 2 by 8-in., 9-ft. posts.
320 ft. 2 by 10-in., 24-ft. purlin posts.
224 ft. 2 by 10-in., 28-ft. roof supports.
14 ft. 2 by 10-in., 4-ft. ties.
48 ft. 2 by 8-in., 16-ft. braces.
38 ft. 2 by 6-in., 14-ft. roof braces.
386 ft. 2 by 8-in., 36-ft. nailing girts.
556 ft. 2 by 6-in., 12-ft. nailing girts.
75 ft. 2 by 4-in., 4-ft. lookouts.
2,265 ft. barn-siding lumber.

#### Materials necessary for one Shawver barn truss, 36 ft. wide:

144 ft. 2 by 8-in., 36-ft. crossties.
48 ft. 2 by 8-in., 9-ft. posts.
160 ft. 2 by 10-in., 24-ft. purlin posts.
112 ft. 2 by 12-in., 28-ft. roof supports.
7 ft. 2 by 10-in., 4-ft. ties.
24 ft. 2 by 8-in., 16-ft. braces.
29 ft. 2 by 6-in., 14-ft. roof braces.

#### Making Driveway with Tarred Stones

With a solid foundation of stone to begin with, spread about 3 in. of fine crushed stone at the center of the driveway, and rake it off to the outer edges until it is about 1 in. deep; then make the center about 3 in. high with the stone. The depth of this stone will depend on circumstances, but the amount mentioned will give a very

lasting road. The stone should be rolled down firmly, forming a slight rounding of the bed so that the water cannot form pools. Saturate the bed with water and then roll again. After the water is pretty well dried out, though not entirely so, spread thin tar, or crude asphaltum, over the bed, using a coarse-rose watering can. The stones should be well covered, yet not enough applied to cause the liquid to run off.

Over this, sprinkle some fine-crushed stone, after which allow the roadway to remain unused for a few days. In about a year, another coating of asphaltum should be applied, and no further attention will need to be given it, barring accidents.—Contributed by A. A. Kelly, Frazer, Pa.

### Fitting Worn Wheel Tightly on Its Shaft

A certain wheel used on a gasoline engine was brought to my shop for repairs. The wheel originally was fastened to the shaft with a key, but it had become worn so badly that the hole was too large for the shaft. The owner wanted the wheel put on the shaft to stay and run true, and offered a box of cigars as a premium over the cost of the repair if I could do it for him. I first drilled a hole in the shaft end to a depth a little more than the



length of the wheel hub, then the shaft end was split with a hacksaw cut, down to the bottom of the hole two ways, as shown. A piece of sheet metal was used to bush the hole in the wheel and take up the wear. After fitting on the wheel as tightly as possible by this means, a pin slightly larger than the drilled hole was driven into it. The wheel was set tightly and in such a manner that it ran true.—Contributed by H. T. Mitchell, Toyah, Tex.

### A Bronzing Liquid

A good bronzing liquid is made from gum dammar with benzol, and a small portion of raw oil to give it elasticity. Coat the object with this and dust on the bronze. When the bronze is dry, coat it with thin shellac varnish to protect it from the atmosphere. In this way the bronze will retain its brightness for a long time.

### Easy Way to Start an Automobile Engine in Winter

To facilitate starting an automobile motor in cold weather, the device shown in the illustration has been used. It can be made by any automobile owner. It consists of two asbestos gaskets with a coil of wire between them. This takes the place of the regular gasket between the carburetor and intake pipe. The iron wire is connected through a switch to the six-volt ignition battery. This switch is closed just before cranking the motor, and the wire gets hot enough to vaporize the gasoline as it issues from the carburetor. About 9 in. of No. 24 gauge wire will be found quite satisfactory.

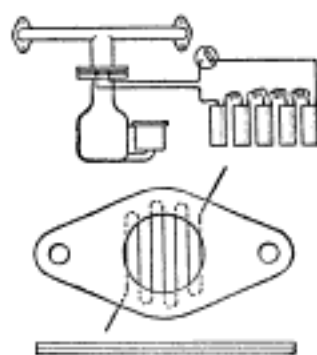

### Odd-Fluted Taps

Except in the smaller sizes,  $\frac{3}{16}$  in. or under, taps for all ordinary work are made with four flutes. Where the hole being tapped does not run through solid metal, or, as is frequently the case, two openings are opposite, an even-fluted tap makes poor work and often breaks for the reason that two opposite flutes drop into the opening at the same time and then engage two sections of metal with so great a strain as to cause a break.

For such work odd-fluted taps are preferable and can be obtained at a slight advance in price. On one particularly difficult piece of work, as shown, several thousand steel pieces were tapped with a seven-fluted tap without breakage.—Contributed by Donald A. Hampson.

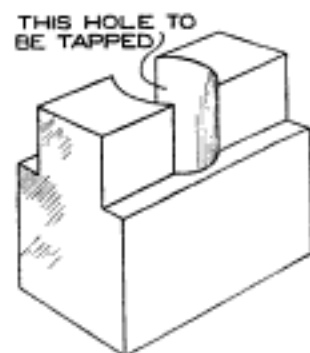

### Homemade Pressure Gauge

In the construction of all pressure gauges a bent tube is used to operate the pointer, its movements being actu-

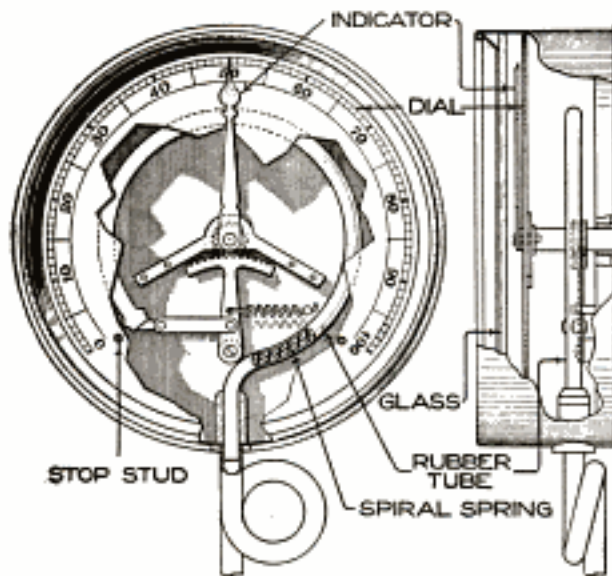

The Bent Tube, Which Is Difficult to Make, Is Replaced by a Coil Spring and Rubber Tubing

ated by the tendency of the tube to straighten out when pressure is applied. The gauge illustrated can be easily made, as the tube is constructed of a small coil of brass or copper wire over which a rubber tube is drawn. This makes a tube sufficiently sensitive to record the low pressures used on gas and liquids in the home workshop.

The end of the tube is closed with a cap, and to this cap the connecting link and the gearing are attached. The gear and rack and the method of connecting them are shown clearly, and anyone capable of building the gauge will require very little instruction in addition to the sketch. The small gear is  $\frac{1}{2}$  in. in diameter.

Studs are set in the dial to stop the pointer so that the sector and gear will not get out of mesh. The gauge is graduated to show a few pounds over the high limit. The pressure tube must be of a size to give a sectional area of 1 sq. in. The small spiral retaining spring must be of No. 16 gauge spring brass, and the pounds-per-square-inch graduations should be  $\frac{1}{8}$  in. apart, but as there will be considerable variation in the springs and connections, it is

best to attach a raised vent near the gauge and leave the top open, placing upon it a soft leather pad, and on the pad, a 1-lb. weight. When the pressure raises this weight and escapes, mark the 1-lb. graduation on the dial. Then add 1 lb., making 2 lb. on the open vent, and so on.

It is not necessary to have a number of 1-lb. weights; stones, or anything, will do, just so the weights applied are known.—Contributed by J. B. Murphy, Plainfield, N. J.

### Gasoline Filter for Automobile Tanks

When a gasoline filter is fitted to a car it is usually placed somewhere in the pipe line from the tank to the carburetor. A better position is at the base of the tank and projecting inside, where the gauze is constantly washed by the swaying of the gasoline caused by the motion of the car. The finest copper gauze should be used, and it is best shaped by wrapping it on a steel rod, about  $\frac{5}{16}$  in. in diameter, while soldering the seam and top. The only difficulty in fitting up this type of filter is in removing the pipe union at the base of the tank, but this trouble is more

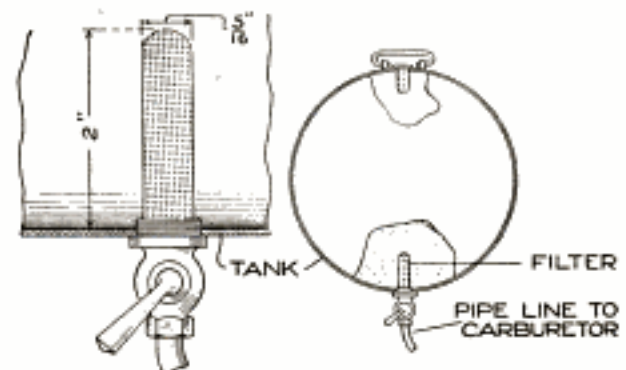

The Place for a Filter Is in the Tank Bottom, Where It will be Kept Clean

than offset by the absence of a stopped jet in the future.—Contributed by Morris G. Miller, New Rochelle, N. Y.

CA handkerchief, or any piece of cloth, wadded into the canopy of an electric fixture when installing prevents it from catching the dirt which mars the stem when the canopy is pushed up in place.

# BUILDING A HOME

By Geo. M. Petersen

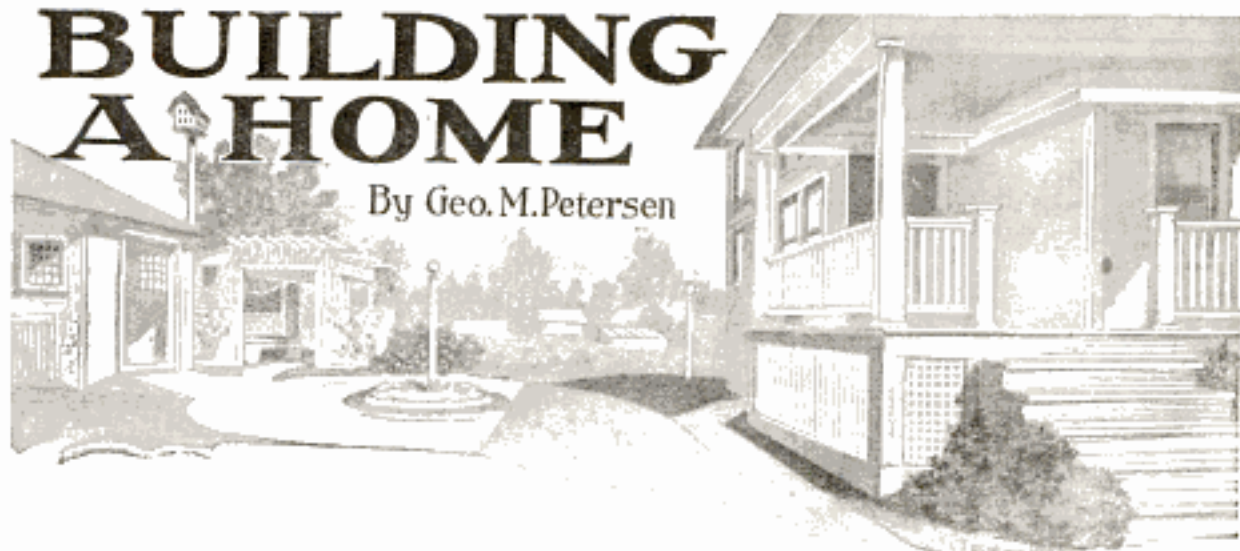

## PART XII—Exterior Finish

**I**N no branch of the building game is poor material and workmanship so common as in exterior painting. Almost every person who has handled a brush of any kind thinks he is capable of quickly becoming a first-class painter. In reality, however, such is not the case, for in this day of substitution of inferior paint ingredients, it is necessary for the painter to be familiar with all kinds of painting materials, as well as with the tricks used by the unreliable painter.

Architects' specifications for painting generally set forth that the painting contractor must provide all the materials of every description, including ladders, scaffolding, ropes, brushes, etc., for the proper performance of the work in a substantial and workmanlike manner; all the materials to be the best of their respective kinds, and all woodwork to be thoroughly cleaned before being painted; all nail holes, joints, cracks, and defects in materials to be filled with putty; all jointed work to be sanded smooth before applying the second coat. The specifications then itemize what work is to be done, and how, as follows. All outside woodwork to be given a certain number of coats of good white-lead and linseed-oil paint, mixed to correspond with the color selected by the owner on outside blinds or shutters, exterior of sash, window screens, door screens, outside doors, tin and galvanized ironwork, ironwork, roofs, and cement work.

It is the purpose of this article to enlighten the owner so that he will be able to know whether his specifications are rightly drawn and whether they are being followed by the painting contractor.

Undoubtedly the best way of knowing if the work is being rightly done, is to know how to do it. There are many men who, through a desire to save money, or because they want to do some of the work themselves, pick out the exterior painting as being the easiest thing to do. Like every other trade, however, it is not as easy as it appears. Painting means to protect with paint, and not merely to decorate the surface. All paints do not protect, and therefore many buildings which appear really beautiful upon completion, will present a bad appearance in a few weeks or months. A well-painted building will seem to improve as time goes on, and is well worth the extra expense of having it painted properly and by an experienced person. Probably the houses most attractive to the amateur painter are summer homes, cottages, or bungalows, which can be painted by the owner Saturday afternoons, holidays, or while on his vacation, necessitating no lost time from his business activities.

Exterior paint is composed of white lead, usually sold in paste form, being ground in about 10 per cent, by weight, of boiled linseed oil, zinc white, boiled linseed oil, turpentine, and japan drier.

White lead, when used alone with the oil, has a tendency to "chalk," that is, after a short time, the lead becomes a white powder on the surface and rubs off. Zinc never rubs off, but if used without other pigment, it becomes extremely hard with a tendency to peel off. Exhaustive tests have been made by the leading paint manufacturers, and also by the Department of Agriculture, to determine just what proportions of lead and zinc to use. The result of these tests has proven that if about 75 per cent of white lead and 25 per cent of zinc white are used, the paint will be very durable. This combination will not chalk off, but will set hard without danger of peeling.

A very satisfactory formula for exterior paint is as follows:

Pure white lead, ground in oil.....	75	lb.
Pure zinc white, ground in oil.....	25	lb.
Boiled linseed oil.....	4½	gal.
Spirits of turpentine.....	½	gal.
Japan drier.....	½	pt.
Color ground in oil.....	Sufficient quantity.	

Care must be exercised by the amateur to prevent getting too much drier into the paint. A large quantity is sometimes used on temporary work where the paint must dry quickly and durability is not considered. Make it a point to use as little drier as possible, and never more than 10 per cent, by volume, of the amount of linseed oil. A large quantity of drier makes the paint dry very quickly, but it takes the life out of it.

Before commencing to paint the exterior of a house, be sure that the woodwork is thoroughly dry, as it is almost impossible to get a good job when the dew, or any other dampness, is in the wood, since this will swell it and prevent the lead from sticking to the grain. When the surface is dry, all knots should be coated with shellac varnish, to prevent the rosin from working through and discoloring the paint, and also to keep the paint from soaking into the soft places surrounding the knot, which will cause a flat, or dull, spot to show when the job is finished. The entire house is then given a priming coat, which is mixed in accordance with the formula already given, excepting that the turpentine is

left out and the quantity of linseed oil is doubled. After the priming coat is set, all imperfections in material are filled with putty, and the second and third coats are applied. Each of these coats should be about one shade lighter than the desired color, as the paint always darkens in drying.

At present, most of the buildings which are to be finished in anything but really light colors, such as white, canary yellow, French gray, and the like, are only given two coats of paint instead of the customary three coats. When only two coats are used, the priming coat is omitted, and the first coat is thinned out a little to make it penetrate the wood. The paint should be almost the finished color. The first coat is thinned with turpentine and boiled linseed oil, instead of double the amount of oil. For example, if the first coat contains 1 gal. of oil, use 1 qt. of oil and 1 qt. of turpentine as a thinner. This change is due to the fact that the regular priming coat has little body, being only a base for the succeeding coats, whereas two-coat work requires that the priming coat have both color and body. When medium-light colors are to be applied to a dark-colored surface, such as redwood, three-coat work should always be used if a satisfactory job is desired. To obtain the best results, the paint must be thoroughly mixed, well brushed out, and at least a week given each coat to dry before the following coat is put on.

When colors are to be used, the following formulas will be useful to the inexperienced painter. The amounts are given in parts which can be determined by weight, as this is the usual method of measuring colors in dry form or those ground in oil; only mixed paints being measured by the gallon. The quantity of paint needed is calculated by first figuring out in square feet the surface to be painted and dividing this by 600, the quotient being the number of gallons of paint required. By referring to the paint formulas given, the number of pounds of lead, and other pigments, necessary to make up the paint in the desired



quantity is obtained. The following formulas are given in parts:

Acorn yellow: White lead, 1 part; raw sienna, 1 part.  
Armenian red: Venetian red, 2 parts; yellow ocher, 1 part.

Brown: Red and black, shade to tint.  
Buff: White lead, 2 parts; yellow ocher, 1 part.  
Canary: White lead, 80 parts; lemon chrome yellow, 1 part.

Cream: White lead, 98 parts; French ocher, 1½ parts; lemon chrome yellow, ¼ part.  
Fawn: White lead, 94 parts; French ocher, 5 parts; burnt umber, 1 part.

Gray: White tinted with ultramarine blue.  
Brilliant green: White and emerald green.  
Ivory: White, 98 parts; raw sienna, 1 part; lemon chrome yellow, 1 part.

Lead color: White, 98 parts; lampblack, 2 parts.  
Mahogany: Golden ocher, 5 parts; Venetian red, 2 parts.

Maroon: Carmine, yellow chrome, and burnt umber.  
Olive drab: White, 75 parts; raw umber, 13 parts; medium chrome green, 7 parts; drop black, 5 parts.  
Olive green: French ocher and lampblack.

Orange: Orange chrome yellow, or red and yellow chrome.  
Pearl: White, vermilion, and Prussian blue; tone with drop black.

Pearl gray: White, 98 parts; drop black, 1½ parts; Tuscan red, ¼ part.  
Purple: Zinc white, 4 parts; ultramarine blue, 2 parts; carmine, 1 part.

Salmon: White, 36 parts; golden ocher, 4 parts; English vermilion, 1 part.  
Deep-scarlet tint: Vermilion, 8 parts; carmine, 1 part; white, 1 part.

Silver gray: White, 97 parts; ocher, 2 parts; lampblack, 1 part.  
Slate: Tone white with red, and darken with drop black.

The proper way to paint a house is to coat the trim, such as cornice, window and door frames, corner boards, water table, veranda work, and the like, first, and then lay the body color up to meet it. The sash are generally "cut in," or painted black, and should be first fitted to the frames and then removed and painted. The majority of stock sash comes with an oiled finish that greatly protects the sash from dampness, and causes it to require only one coat of paint. The meeting rails of the windows should never be painted, but may be oiled, or stained, to add to their appearance, and protect them from the weather. Paint should always be applied with the grain of the wood where possible, and well brushed out and allowed to dry thoroughly before applying the next coat.

All tinwork, such as roofs, gutters, conductor pipes, and flashing, should receive one or two coats of good red lead before being put in place, and two coats of regular lead and oil paint when the house is painted. Iron and steel, although often more perishable than wood, are often left without paint, either through a desire for a natural

finish or from neglect, usually the latter. Tinwork is best left exposed to a couple of rainstorms, to wash the grease from the surface, before applying any paint, but iron and steel should be given at least one coat before leaving the shop. The best-known paint for metal work is red lead, which is especially valuable when used as a first coat and covered with a regular lead, mixed about 30 to 35 lb. of dry red lead to the gallon of oil. It should be mixed fresh every day. This paint sticks to the surface and dries like a cement.

As a good painting job cannot be obtained with poor materials, it will pay the owner to investigate carefully any prepared, or ready-mixed, paints before buying them or allowing them to be bought for his building, as comparatively few of them are fit to use. The manufacturers of these prepared products claim that, because the pigments are broken up and ground and mixed by machinery, they are more thoroughly mixed than are paints broken up and mixed by hand with a wood paddle. This statement is true as far as it goes, but it is readily understood that, no matter how thoroughly paint is mixed, it will never be paint unless the ingredients are right and mixed in the proper quantities.

A good lead and oil paint weighs about 21 lb. to the gallon, and in order to bring the paint up to the standard weight, many of the manufacturers use some inert material which is absolutely useless so far as making paint is concerned. The writer has had experience with almost every well-known brand of ready-mixed paint, and is now having the paint mixed by hand on the job, not for the reason that there is no pure ready-mixed paint on the market, but because the brands that are really good are too high in price, while the low-priced goods are unfit for use. The cost of ready-mixed paints ranges from 85 cents per gallon up, while the cost of mixing one's own paint, including labor, is about \$1.75 per gallon, and then the painter knows what he has and how it will wear. A favorite trick





FIG. 9

FIG. 10



FIG. 11

FIG. 12

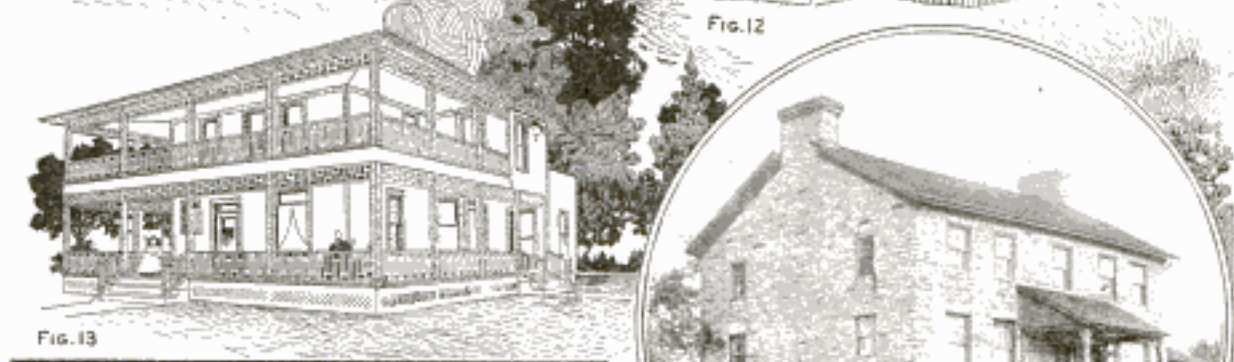

FIG. 13

FIG. 14

of the ready-mixed paint salesman is to remove the cover from a paint can, stir up the contents, and place a piece of plate glass in the center of the can. The glass practically stands alone, and one is easily convinced that, because the paint has such a heavy body, it can be greatly diluted so that one actually gets two gallons for one, or at the cost of an extra gallon of oil, but in trying to use the paint it will be found that it is too heavy, just as the salesman said; and even if diluted with oil, when laid on, it is still heavy and will not cover properly. A chemist, having made a test for me, said that the only pure material put in was the oil, and that the body material was no good for a paint.

A great many prefer stains for the

exterior of their homes and these can be readily obtained at small expense. Creosote oil gives a very beautiful dark-brown shade to siding or shingles, as do burnt umber and linseed oil. Creosote oil, 1 part, and crude oil, 1 part, make a rich, light-brown stain. This creosote and crude-oil combination will also take color, so that the preserving quality of the creosote can be obtained with the artistic effect of the color desired.

Probably the best method of explaining the various color schemes is by illustrations of cottages actually built. The one shown in Fig. 1 has a shingled exterior, with field-stone columns, stone chimney, and stone foundation wall. This house would not have looked half so well, or pleased the owner so much, with any other color scheme than that used. The shingles are stained light stone-gray, and the trim is white. The roof shingles are stained green, to add to the appearance and to protect them from dampness.

A very small and cheap house, having a pleasing exterior, is shown in Fig. 2. It has a shingled gable, wide siding, and novelty rail. The body is stained a medium-dark brown, while the trim is about two shades darker. There is no need of a cottage being unattractive because it is cheap.

In Fig. 3 is shown a direct color contrast which, while a little startling in the illustration, really looks very good. Notice how much better the large octagon columns appear than those shown in Fig. 6. The color scheme of the house is white body and trim, excepting the upper veranda rail, which is dark brown.

The cheapest exterior-painting job in the experience of the writer is that on the house shown in Fig. 4. The trim is white, while the shingles were left natural, exposed to the weather for a weathered effect. If these shingles had been touched with a little creosote, or crude oil, they would have weathered without checking and curling, but a contractor must do as he is told, even though he knows it is not right.

A very neat bungalow with white trim and dark-brown shingles, which give a pleasing contrast to the stone wall and stone columns, is shown in Fig. 5. While, at first glance, there may appear a strong resemblance between the exterior of this house and the one shown in Fig. 1, which is stone-gray, a careful comparison will show that the latter would appear very much the worse if painted as the former, while Fig. 5 might be benefited by the color scheme of Fig. 1.

The house shown in Fig. 6 is used merely to show the effect of a solid-color house, and also the error, so often made, of darkening the entire first floor of a house in order to get a large amount of covered veranda which is little used. This house is all white, with the exception of the veranda floor and lattice work.

A small cottage cannot be loaded up with a lot of ornaments without making it appear "fussy." Such a one is shown in Fig. 7. Another thing that makes the house appear peculiar is the veranda railing. It will be noticed that the balusters in this rail are painted with the trim color instead of the body color.

A very pleasing little cottage, having a dark-green body and white trim, is shown in Fig. 8. This house has the popular side-gable with the exposed rafter ends to the front and rear.

The house shown in Fig. 9 is painted in two shades of gray. Although the outside chimney sets off the house to a certain extent, the shape of the roof greatly detracts from its side elevation without interfering with the front.

A sort of half-timbered effect in the gable, with brackets supporting the wide overhang, is shown in Fig. 10. This house has a green-shingled body with white trim and brackets.

A neat cottage with a tight board railing and tight skirting is illustrated in Fig. 11. Diamonds may be cut in the skirting for ventilation. This house is white, trimmed with green.

A very attractive little bungalow is shown in Fig. 12. The shingles are a light tan, and the trim white. Notice the white-slat skirting, the heavy square columns, the exposed rafter ends, and the doubled-coursed shingles.

An example of what results when the owner has his own way is illustrated in Fig. 13. This house would have been much more attractive and quite a bit cheaper if the intricate rails had been omitted. Trust the architect or contractor, and prevent duplicating the house shown. This house has a light-gray body and dark-gray trim.

An old house, built 100 years ago, is shown in Fig. 14. This house is still in the hands of descendants of the man who built it. It is said that only two gallons of paint have ever been used on its exterior. About the only thing paintable is the window and door frames, but even at that, once in 25 years is hardly sufficient to keep the woodwork in good shape. Keep a house well painted, and there will be little use for the carpenter or the lumberman.

### A Locomotive Slip Hub Liner

Locomotives have hub liners cast on the driving boxes of brass to overcome lateral, or end, play between the hub of the driving wheel and the driving box. After engines have been in service, the hub liner wears off and allows excess lateral movement, which is dangerous to the operation of the engine. It is quite an expensive operation to place the engine over drop pits and lower the wheels to put new liners on the boxes, so a slip hub liner was devised which is a very simple affair, as shown in the sketch. The liner is cast of brass in two pieces, and a slot is cored for admission of a key, to hold the two parts of the liner together. These can be made of any desired diameter and thickness, and after being machined, they can be applied in a few minutes. These liners are used on

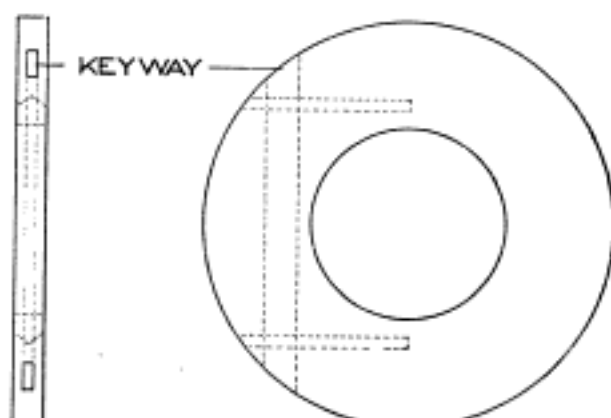

A Two-Piece Hub Liner for Insertion without Removing Locomotive Wheels from Their Frame

trailer, driving, and engine-truck wheels.—Contributed by J. R. Minter, Washington, Ind.

### Hat Rim Reflects Lights of Approaching Automobiles in Rear

While out riding my motorcycle one night on a little-frequented road, I thought I was alone until I looked

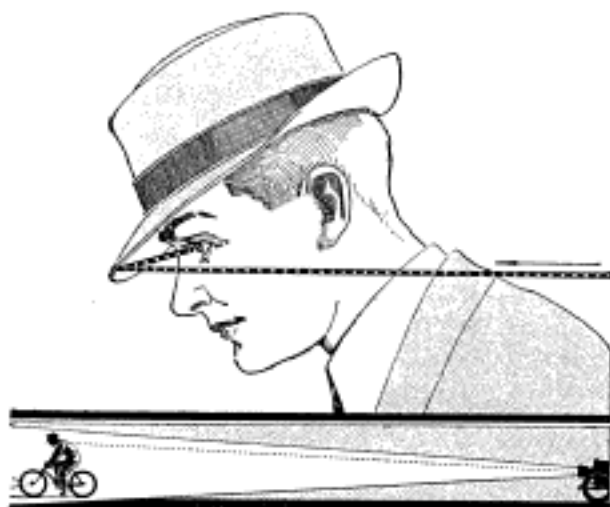

The Lights from the Approaching Automobile will be Seen without Turning the Head

down at my watch and the reflection of the lights from an automobile in the rear showed on my hat rim. I have tried this out a number of times with good results. Tip the head forward and to one side and the lights of approaching automobiles in the rear will be reflected on the visor or hat rim.—Contributed by H. W. Potter, Oakland, California.

### A Burlap Pulley

Sometimes it is desired to use a pulley which is only slightly greater in diameter than the shaft on which it is to be mounted. In this case the usual method is to forge a steel sleeve which must be bored, turned, and fastened to the shaft with a setscrew. A far simpler and equally efficient way is to paint the shaft with good leather cement and then wrap it with a strip of burlap until the desired diameter is reached, gluing the surface of the burlap as it is rolled on so that each lap is cemented to the preceding one. Care must be taken to wrap the burlap in the direction of rotation on a driven shaft, and in the opposite direction on a driving shaft.

### Acetylene Generator for a Bicycle Lamp

Having need of an acetylene generator for a bicycle lamp and not wishing to purchase one, I made a very effective generator at the actual cost of 30 cents and a few odds and ends from my scrap box, and while simple

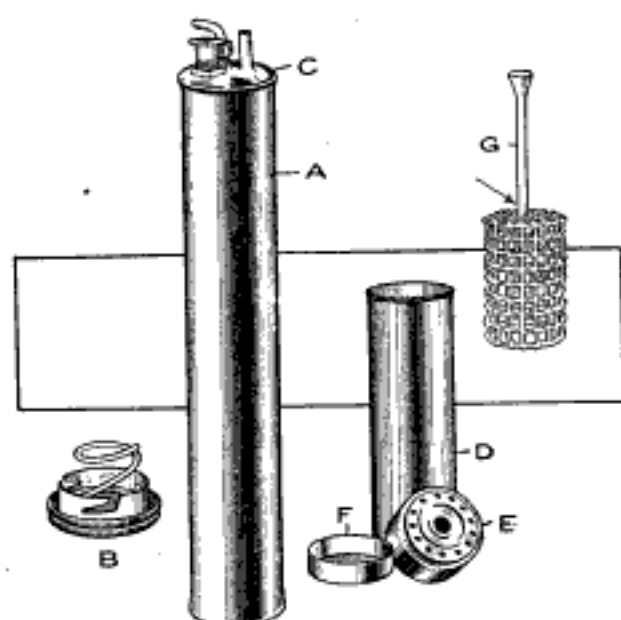

An Acetylene Generator That Applies Water to the Lower Part of the Carbide

in construction it has proved to be more economical in the consumption of carbide than most of the factory-made articles.

As shown in the illustration, the generator A consists of a piece of seamless brass tubing,  $1\frac{15}{16}$  in. in diameter and  $11\frac{1}{2}$  in. long, with walls about  $\frac{1}{32}$  in. in thickness, which cost 30 cents. The bottom cap B was taken from an old bicycle lamp, while the top cap C, which just fits the tube, once kept the dirt out of the works of a dollar watch. The stuffing box and valve stem were parts of the burner of a kerosene heater lamp, while the filler cap and nipple came from a small oil lamp.

The carbide magazine and gas retort D was made from sheet brass,  $1\frac{3}{4}$  in. in diameter and  $5\frac{1}{2}$  in. long. The top cap E of the retort was taken from an old worn-out wall snap switch, with several  $\frac{1}{8}$ -in. holes punched in it to permit the free flow of gas, and an old tin pill box, F, did duty as the bot-

tom cap of the retort and as holder for the slaked carbide.

The secret of the economy of this generator lies in the method of feeding the water to the bottom of the carbide instead of letting it drip on the top. The water drips from the needle valve into the funnel tube, shown at G, and passes down the tube to the point indicated by the arrow where several slits,  $\frac{1}{4}$  in. long, permit it to reach the bottom layers of the carbide only. Also there is a small hole, about the size of a needle, in the bottom of the tube which lets a small portion of the water drip into the pan below. As the carbide slakes, it sifts through the grate into the space formed by the screen cage, where it is separated from the fresh carbide by an air space. Therefore, when the water is stopped, the slaked particles jolt through the grate and leave the solid unused particles in the magazine dry, while the lamp goes out almost as soon as the water is stopped. The water dropping into the pan from the small hole in the end of the tube, slakes all the particles that may pass through unslaked.

A  $\frac{1}{8}$ -in. copper tube, 3 in. long, with a small funnel soldered to the upper end forms the feed tube, while the grate and its supporting cage are made of ordinary  $\frac{1}{4}$ -in. galvanized screen, although the grate has extra wires woven in to reduce the mesh to  $\frac{1}{8}$  in. The size of the cage and grate is  $2\frac{1}{4}$  in. long by  $1\frac{1}{2}$  in. in diameter, which permits it to slip into the shell of the retort easily.

The illustration shows all the parts of the generator except the water chamber and control valve. The water chamber is formed by soldering a disk of brass, ground perfectly round on a grindstone, 6 in. from the bottom of the large tube, the disk having a hole drilled in the center to take the adjusting valve of an old Welsbach burner, which made a splendid needle valve. The disk also has a hole drilled in it to take a  $\frac{1}{8}$ -in. copper tube, which passes through the water chamber and through the top cap to form the gas supply pipe.

The only difficult part in the construction of this generator is the soldering of the disk in the tube, and this was accomplished in the following manner: First, the needle valve and the gas pipe were soldered in the disk. The inside of the tube and the disk were cleaned with emery and soldering flux was applied; then both were tinned where the solder was to run. Next, the valve stem was soldered to the movable part of the valve and screwed home; and the stuffing box was then soldered to the cap and the valve stem run through the stuffing box. The cap was not fastened permanently, however; only enough to center the valve stem, the stem holding the disk so that the valve would turn true. The gas pipe running through the top cap tended to hold the disk in place while running the solder. By means of the stem the disk was raised and lowered in the tube until it was at the exact point where it was to be permanently fastened. Then a ring of wire solder was placed on, with the bottom of the tube up, and a gasoline torch used on the outside to heat the solder until it flowed into place. Care must be taken to prevent the disk from getting too hot and loosening the solder out from the valve and gas pipe fastenings. After testing for leaks, the top cap was soldered in place, and the generator was complete.—Contributed by T. T. Sturgeon, Los Angeles, Cal.

#### Empty Carbide Can Used for a Heating Stove

In Mexico most of the fireplaces produce more smoke than heat, but while the natives do not mind that, we did, and proceeded to make a heating stove from a carbide can, which gave very satisfactory results. We have made quite a number of them as shown in the illustration. A circle was drawn at the place where the stovepipe was to be attached, and the metal cut inside of the circle like cutting the pieces of a pie, and these were bent out so that the joint of pipe could be set over them. The cover was hinged to the

front with bent wire, and a hook made to hold it up. Supports of brick, or

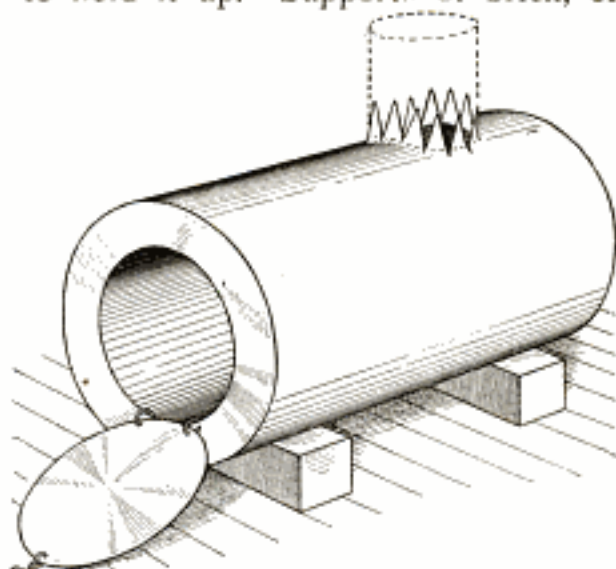

An Improved Stove, Formed from a Discarded Carbide Can, Used Instead of a Smoking Fireplace

stone, were used to raise the stove from the floor.—Contributed by W. A. Lane, El Paso, Tex.

#### Centers for Taper Work on a Lathe

To turn a taper between centers on a lathe necessitates the shifting of the tailstock, and to do this with the ordinary lathe centers, as shown at A, is not the best method, as the centers wear on the point and will not run true. A good way is to have a center with a ball point, as shown at B. This center will keep the work true and it can be run at high speed for the softer metals. The method of using the bor-

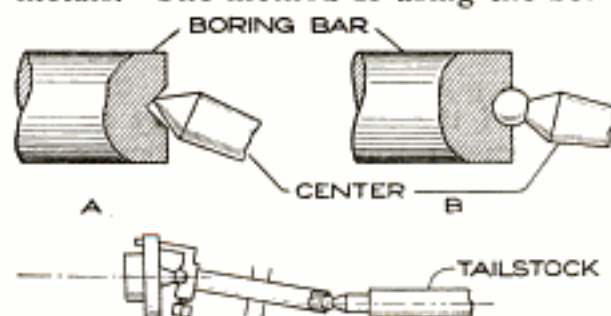

Ball Centers for Use on a Boring Bar in a Lathe to Prevent Wear

ing bar is clearly shown at C.—Contributed by Arthur L. Kerbaugh, Allentown, Pa.

Use sharp cutters for finishing a milling-machine job.

### A Translucent Door

A good substitute for a frosted-glass door, or window, may be made as shown in the illustration. Two panes

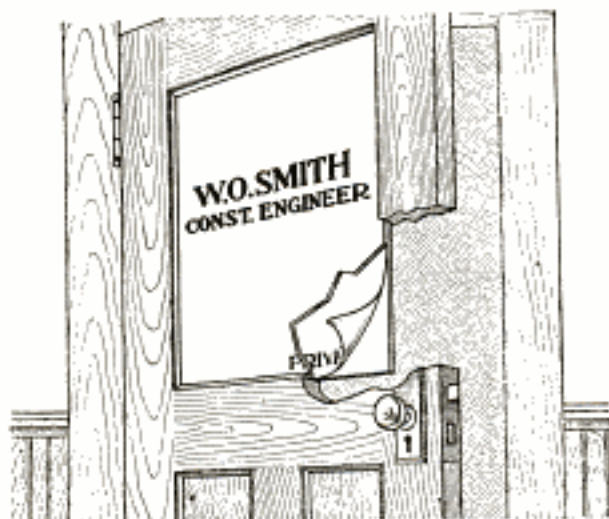

Tracing Linen Well Lettered and Placed between Two Panes of Glass Makes a Translucent Window

of ordinary window glass are used, and a piece of tracing linen, or oiled paper, the same size, is inserted between them. Any lettering necessary for the door can be placed on the linen or paper. The rear glass may be omitted if desired and the cloth stretched as tightly as possible to a single pane of glass, but the former method makes the more permanent job.—Contributed by Walker O. Nettleton, Washington, D. C.

### Flexible-Pipe Conveyor for a Tool-Grinding Machine

This pipe was designed to take the place of the stiff, but slightly adjustable, metal tube used to convey the dust from a tool-grinding machine to the main blowpipe. In making the pipe, a broom handle was used for the arbor, and on this was wrapped soft-iron wire while it turned in a lathe, as in winding a spring. Over this spring was wrapped light canvas and an outside wrapping of strong twine.

At each end, the first two or three turns of wire were fastened with light copper wire, while the twine wrappings were merely tied together. To attach the sections, a piece of light

canvas, large enough to lap over the ends of the tubes, was wrapped around the tubing twice and bound tightly with soft-iron wire. The inside wire lining, the twine wrapping, and the wire of the coupling, all mesh together and form a thoroughly tight joint. Such a tube will give first-class service, but is for inside work only, as it is not made to stand exposure to the weather.

### Cutting Brass-Wire Pins to Length

A laborer was set to work in a shop cutting pins from No. 16 gauge brass wire, each to be  $5\frac{1}{4}$  in. long. Having no special tool for this work he made one as shown. A square piece of metal, A, was drilled to fit the plier handle, then drilled and tapped on one side for a setscrew, B. Two holes were tapped for the screws C and the two upper corners rounded off. A piece of sheet metal D was drilled and shaped as shown and then fastened with the screws to A. The stop was set on the lower handle to the required distance from the cutting edge, and a vise held the lower handle. By feeding the wire against the stop, cutting it off, and letting the pieces drop into a box, the

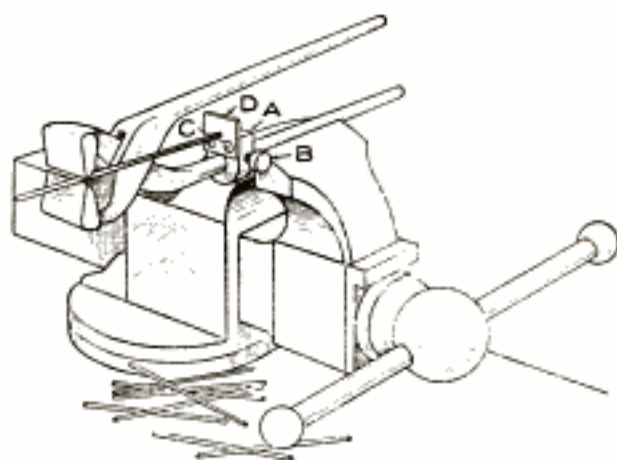

Stop on a Plier Handle for Gauging Pins as They were Cut from the Wire

work was accomplished quickly.—Contributed by Mark Gluckman, Jersey City, N. J.

Do not be stingy with varnish, for the more coats applied the better will be the gloss and finish.

### Filling Leaks and Blowholes

Where it is necessary to fill a small crack, or leak, in a difficult place, or if soldering cannot be used as a means of closing the opening, an amalgam composed as follows may be used with good results. Melt together 30 parts of zinc and 20 parts of tin, then granulate the mass. A good method is to use filings from the metal combination; however, the granulation can be done by pouring the melted metal through a strong stream of water issuing from the nozzle of a hose. These are well kneaded with mercury until the amalgam, like a dough, is formed. The excess mercury is squeezed out, and the plastic mass forced into the hole and given time to harden. When hard, it can be filed the same as the metal about it. Because of the hardening action, only enough of the amalgam should be mixed for the work at hand.

### Repairing a Steam-Gauge Pressure Connection

The nipple by which the steam-gauge pressure pipe connects to the gauge is frequently broken. The mishap occurs commonly as a result of an accidental fall, and sometimes through the too vigorous application of a wrench in drawing up the brazing collar, or nut, of the pipe. After such an accident it is often the practice to order a new tube casting, as the nipple in most standard gauges is a part of the casting. If the lengthwise cross section of the casting were examined, the practical method of repairing such a break would in the majority of cases be readily apparent. There is plenty of stock in the casting for drilling it out deep enough to take a  $\frac{1}{4}$ -in. pipe tap, after which a common  $\frac{1}{4}$ -in. gas-pipe nipple can be screwed in tightly. This will afford, in almost every case, a connection for the gauge which can be easily made.

I was in a contract shop where a great number of gauges were sent in for repair, and the breakage on 60 per cent of them was of the above-men-

tioned kind. The method described and illustrated was put into practice and resulted in a much cheaper job that was just as satisfactory, as well

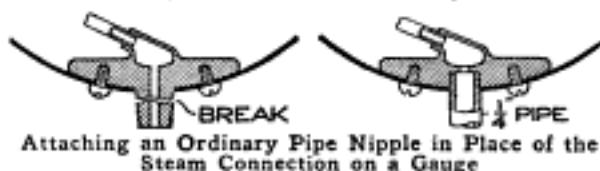

Attaching an Ordinary Pipe Nipple in Place of the Steam Connection on a Gauge

as in a quick return of the gauge to the firm, which usually had no other gauge on hand and was therefore eagerly waiting for it.—Contributed by F. W. Bentley, Jr., Missouri Valley, Iowa.

### To Detect Water in Paint

The presence of water in white-lead paint, paste or mixed paint, may be discovered by adding a little eosin dye and rubbing it up on a porcelain slab. The water, if present, will cause the dye to stain the paint. The maximum amount of water in pure white lead should be two per cent, and any amount in excess of this may be regarded as adulteration.

### Concealed Support for a Stovepipe

The illustration shows a successful way of keeping a long horizontal length of stovepipe from sagging in an unsightly manner. A piece of old water or gas pipe is inserted as shown and lashed to the stovepipe with loops of copper wire passed through small holes punched in it. The method of assembling is to slip the stovepipe sec-

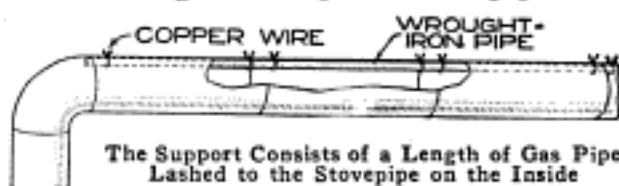

The Support Consists of a Length of Gas Pipe Lashed to the Stovepipe on the Inside

tions over the wrought-iron pipe one at a time and lash each section as it is added. It is advisable to use copper wire, as it will not corrode.

ⒸPaper or wood used to hold putty will absorb the oil and cause it to harden quickly.

### Pounce-Dusting Pad for Tracing Cloth

Tracing cloth used by draftsmen often has a glossy surface which will not take ink readily. The gloss is re-

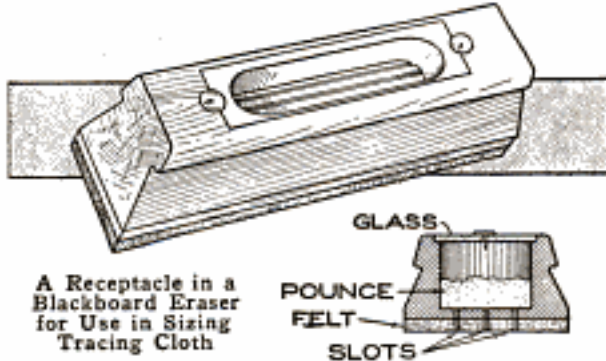

moved by various means, one of which is to dust the surface with pounce, powdered chalk, or talcum powder, rubbing it over the surface of the cloth with chamois, cloth, or a piece of blotter, then brushing off the excess. One of the handiest ways is to sift a quantity of the pounce on the cloth from a can with a perforated top and then spread it with an ordinary blackboard eraser.

The sketch shows an improvement on this method. A powder magazine is formed in the body of the eraser. Tapping the eraser on the cloth causes a small amount of the powder to sift out, and then it is spread and worked in with the eraser.—Contributed by Donald P. Maxwell, McKeesport, Pa.

### Homemade Sandblast

Where compressed air is available, a very convenient sandblast arrangement can be made of pipe and fittings. The main body consists of a 1-in. tee, into which is turned a 1-in. pipe, A. The other two openings of the tee are reduced to  $\frac{1}{2}$  in., and  $\frac{1}{2}$ -in. pipe connections made to them. A long thread is cut on the end of the air con-

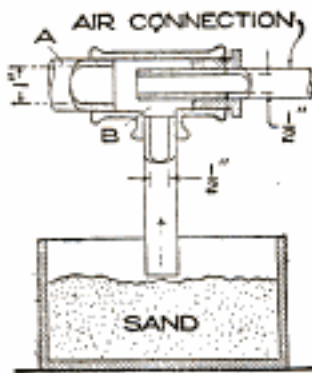

nection so that it can be turned in far enough for the end to pass the sand connection B. The intensity of the blast may be regulated by turning the pipe A in far enough partly to cut off the sand supply.—Contributed by E. K. Marshall, Oak Park, Ill.

### Piston-Pin Lubrication

In the case of vertical-cylinder automobile motors where the piston pin is fastened to the piston, the usual construction of a hole in the top of the connecting rod is not always suitable to insure a good supply of oil to the pin. This is because the oil supply is in the form of a fine spray, or mist, churned up from the splash pockets, and the hole in the top of the connecting rod is usually too small to admit enough of the spray for good lubrication.

The illustration shows a remedy for this condition, which can be applied to existing motors of the type mentioned

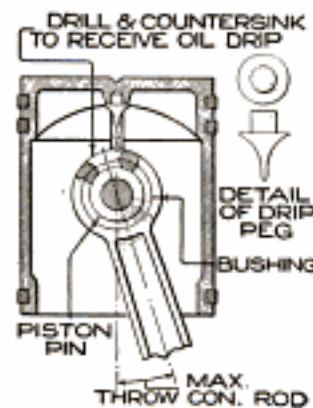

without changing the design or adding too much weight to the piston. The remedy is to place a taper pin in the center of the under side on the piston head. This pin will collect the drops of oil

which form from the spray and allow them to drop off the end into a hole in the top of the connecting rod.

The pin, or "drip peg," should be made of steel and well finished. It may be driven, or screwed, into the center of the piston head. Plenty of stock will be found at this point, as the makers have allowed material for the center hole. The top of the connecting rod should be drilled about  $\frac{3}{8}$  in. and countersunk generously. This will not lower the effective strength of the rod, as its bearing is on the lower side.—Contributed by W. Burr Bennett, Bridgeport, Conn.





## A Homemade Ammeter

By JOHN D. ADAMS

WHERE a high degree of accuracy is neither desired nor necessary, a very satisfactory ammeter may be made at the cost of a few cents, and without using hairsprings, permanent magnets, or other articles usually not at hand.

The actuating device consists of a small coil of coarse, insulated wire, with a bundle of soft-iron wires for a core, which attracts a curved, soft-iron, wedge-shaped armature. The moving system is so balanced that the armature will hang as illustrated when no current is passing. On account of its shape, the higher the armature rises, the more iron it presents to the influence of the magnet, and, on the other hand, the greater will be the effect of gravity. The advantage of this type of control is the elimination of the irregular readings of the scale, due to the law of inverse squares, that usually follow when any method depending upon a variable distance is used. Further, the readings can be had as desired by altering the taper of the armature, its thickness, or its distance from the magnet, and also by adding a small weight of nonmagnetic material at the bottom. As most commercial circuits supply alternating current, the friction of the bearings does not affect the readings, since the alternations set up a decided vibration in the entire moving system, thus eliminating static friction.

In view of the variations above referred to, it will be evident that it is not very essential of what dimensions the apparatus is made. The instrument that I use has a base measuring  $2\frac{1}{2}$  in. by 5 in. The coil is built on a tube of glued paper, and contains about 15 ft. of No. 16 gauge wire. The

terminals consist of the brass bolts taken from discarded dry cells. A steel sewing needle serves as a shaft, and a piece of wire for the pointer. The

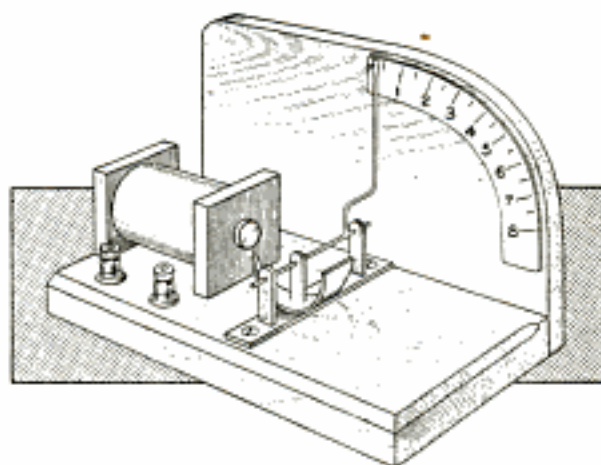

A Very Satisfactory Ammeter for Use Where Accuracy is Not Desired or Necessary

various joints are made with soft solder, and suitable stops are provided to keep the armature from shifting laterally. In calibrating, a blank scale should be glued in position and as many 55-watt lamps as possible arranged so that they can be placed in the circuit, one at a time. On a 110-volt line, each lamp added will mark a half-ampere point. If a sufficient number of lamps to carry the scale high enough cannot be secured temporarily, a resistance of some 20 or 30 ohms should be placed in the circuit without any lamps. Note the reading in amperes on the scale thus far constructed, and then begin adding the lamps again, making a mark on the scale as each lamp is added. In this manner a scale may be built up sufficiently accurate for all practical purposes.

If two identical coils are made in

place of one, the additional coil can be placed in parallel with the instrument as a shunt, thus doubling its capacity and making it necessary, of course, to multiply all readings by two.

### Footstool

The material necessary for the footstool shown in the illustration is as follows:

- 2 end pieces, 1 by 10 by 15 in.
- 3 cross braces, 1 by 4 by 12 in.
- 2 end braces,  $\frac{3}{4}$  by 4 by 8 in.
- 1 top board,  $\frac{1}{2}$  by 10 by 14 in.
- 1 piece of leather, 11 by 16 in.
- Round-head wood screws and nails.

The two end pieces should be marked to a suitable pattern, and may be cut out with a scroll or coping saw, or, if these are not available, with a keyhole saw. The center opening should first be bored at one end and then cut out with the saw. The three long braces should be accurately squared and finished at the ends; the rigidity of the stool depending on this work. The seat consists of a box form with the open side down. The top is a  $\frac{1}{2}$ -in. board, 8 in. wide by 12 in. long; the sides are formed by two of the long braces, and the ends are the short braces. This box is securely put together with nails, and then screwed in position with round-head

wood screws so as to be flush with the top edge of the end pieces. The lower brace is secured in place with screws. In putting on the leather top,  $\frac{1}{2}$  in. should be turned under at each end, and  $1\frac{1}{2}$  in. brought down on each side. This will provide sufficient looseness to pad the seat properly. Large round-headed brass nails can be used, producing a neat appearance. The stool is then ready for a suitable stain or finish.—Contributed by Stanley B. Furbeck.

### Stopper for a Bunghole

While we were filling our barrels at the cider mill it was discovered that one barrel had no stopper. This did not bother the cider-mill man, who took up a sound apple of about the dimensions or diameter of the bunghole and squeezed it in, tight as a cork, then shaved it off flush with the barrel staves. We started home and rolled it around a great deal with the other barrels, yet it held as tightly as any wood stopper.—Contributed by A. A. Kelly, Frazer, Pa.

☞ An open umbrella placed on the floor upside down makes an excellent receptacle for catching dirt and plastering when installing electric fixtures.

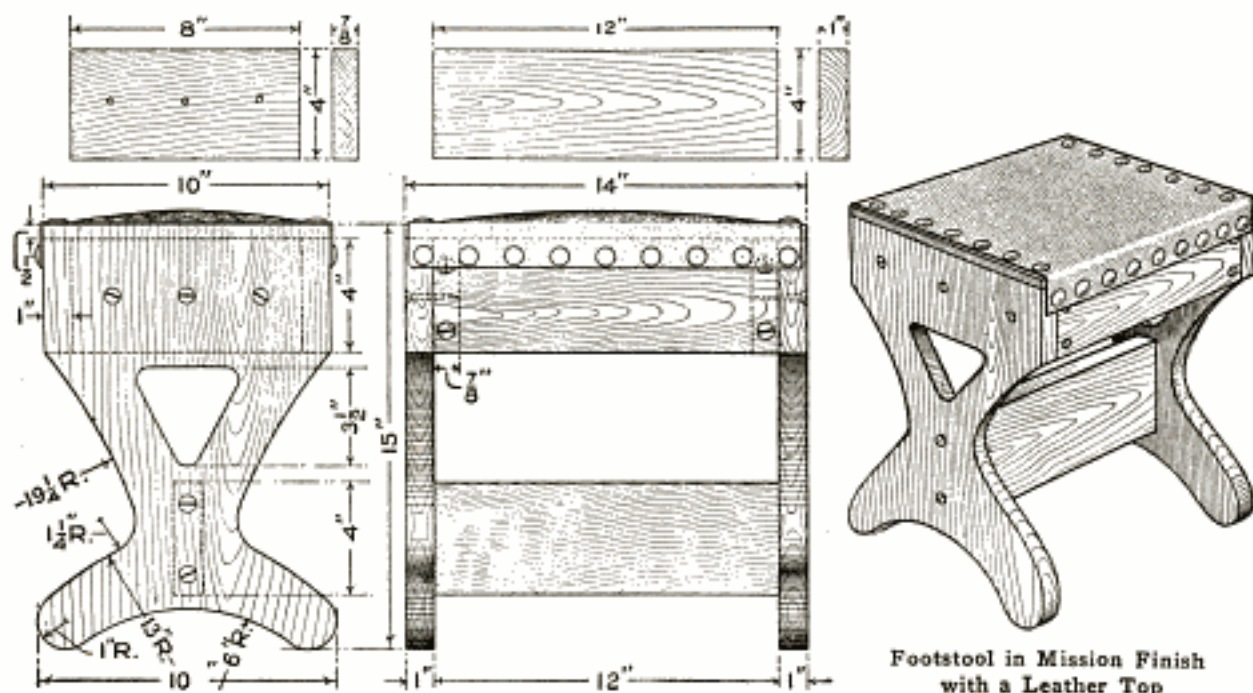

Footstool in Mission Finish with a Leather Top

### Groove Cutter for Wood

Having occasion to cut some grooves in a board and not being properly equipped for such work, I made the tool shown in the sketch. Although rather crude in appearance it will do good work if properly made. It consists of a handle, A, shaped to afford a comfortable grip for the hand, and a cutter, B, made of a short piece of hacksaw blade, clamped along the left side of the handle by the strip C, which is held with screws. A pin, D, driven into the handle and allowed to project about  $\frac{1}{16}$  in., prevents the blade from sliding back under the clamp. For guiding the blade, the arrangement F is employed. An extension, E, is nailed on the right side of the handle, and holes made near each end for two screws having round heads, such as may be obtained from discarded dry batteries. These screws are for securing the sliding stop F, which is a flat piece of hardwood with slots cut near the end for screws to pass through to provide for adjustment.

In use, the guide F is adjusted until it is the desired distance from the cutter and then secured by the screws. The tool is handled like a plane, care being taken not to bear down too hard,

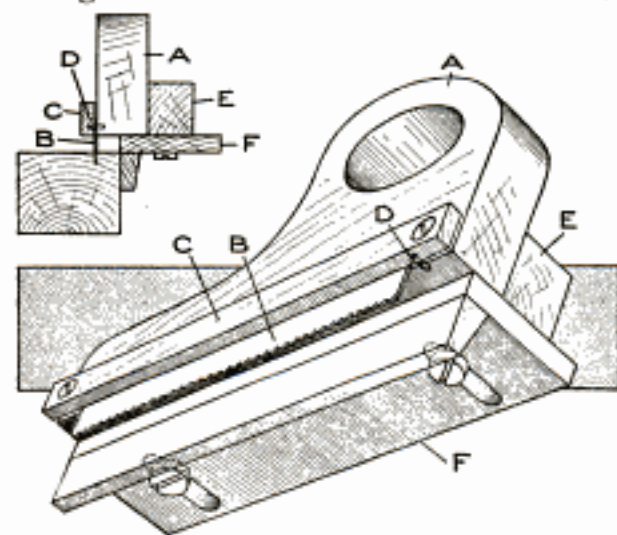

Two Slots are Made with the Cutter, and the Stock between Them Removed with a Chisel

as the cutter may bind and cause it to be pulled from the clamp. In cutting a groove, two slots are cut and the stock between them removed with a chisel.

### A One-Runner Sled

Just an ordinary barrel stave, with a center post and a crossboard for a seat, makes a good one-runner sled.



The Barrel Stave Has a Sufficient Curve to Make It Pass Smoothly over Hard Snow

Select a good, smooth stave for the runner and securely fasten the upright, which is 1 ft. long, to it in the center. The seat is made of a board, about  $1\frac{1}{2}$  ft. long, nailed to the upper end of the upright.

### Substitute for a Gas-Stove Oven

Wishing to bake a nice loaf cake one afternoon for dinner, and finding that the fire in my range had gone out, I remembered an oven shown me at one time for use on a small gas plate, which consisted of a cover, a bottom piece, and a support for the pan. The thought came to me that with all my pots and pans I ought to be able to get some results by the combination of two pie tins, a cake pan, and a stew pan, and on trial it baked as fine a cake as anyone could wish.

A small pie tin was placed in a larger one, as shown; on this was placed the cake pan filled with the cake batter,

and over the whole was placed the stew pan, which acted as a heat retainer or oven. A good hot flame was used at

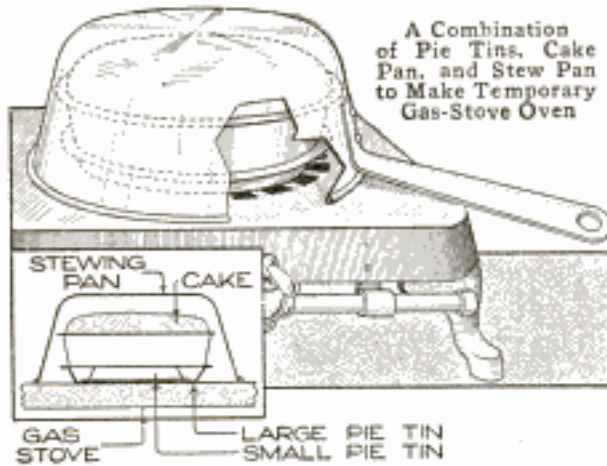

first, and was then gradually turned lower until the cake was finished.—Contributed by Mrs. Anna M. B. Romig, Allentown, Pa.

#### Box Cover without Hinges

Two ordinary boxes may be fitted together as one without using hinges, if nails or screws are inserted at points along the edges so that they will slip into holes bored at corresponding points in the edges of the other box.

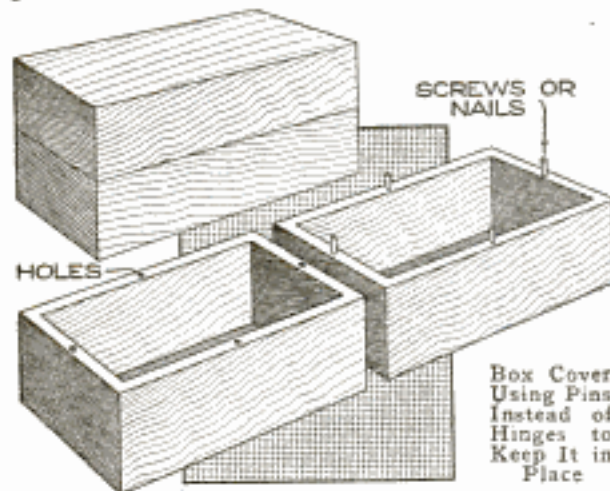

The nail heads or screw heads should be filed off or cut off after being placed in position.

Call metal patterns should be thoroughly cleaned with a stiff brush having plenty of beeswax on it and dipped in powdered plumbago. Brush the pattern well, and it will draw easily and make a smooth casting.

#### Sanitary Holder for Thread and Dental Floss

A simple and convenient method of protecting a spool of thread, or dental floss, from collecting dirt and germs is shown in the illustration. A small glass jar, with a metal screw top, is procured, of such a size that it will easily accommodate the spool of thread desired to protect, with at least  $\frac{1}{8}$  in. clearance all around the edge of the spool. Procure a short piece of stiff wire, not more than  $\frac{1}{16}$  in. in diameter, and make a frame similar in form to the one shown. The center portion of this frame should be just a little longer than the spool, so that a small wood key may be placed through the eye formed in the wire and thus hold the spool firmly on the frame. The outside portions of the frame should be such a distance apart that they will rest against the sides of the jar and of such a length that they will reach from the bottom to the top of the jar when the lid is screwed down tightly. If these dimensions are observed, the spool and frame will remain in a fixed position in the jar.

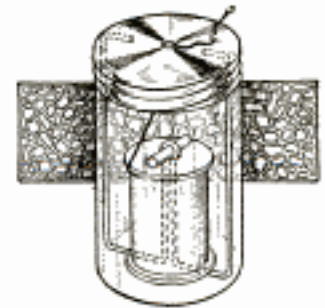

A small opening, just a little larger than the thread, is made in the center of the lid, through which the thread is to pass. The edges of this opening are smoothed off so that they will not cut the thread when it is being drawn out. A small cutter may be made by forming a V-shaped opening in the lid, through which the thread is to pass. The edges of the V-shaped piece are sharpened to serve as a cutting edge. The end of the thread will be held under the V-shaped piece after it is cut, thus preventing it from falling back into the jar.

The word "diameter" when applied to gears is always understood to mean the pitch diameter.

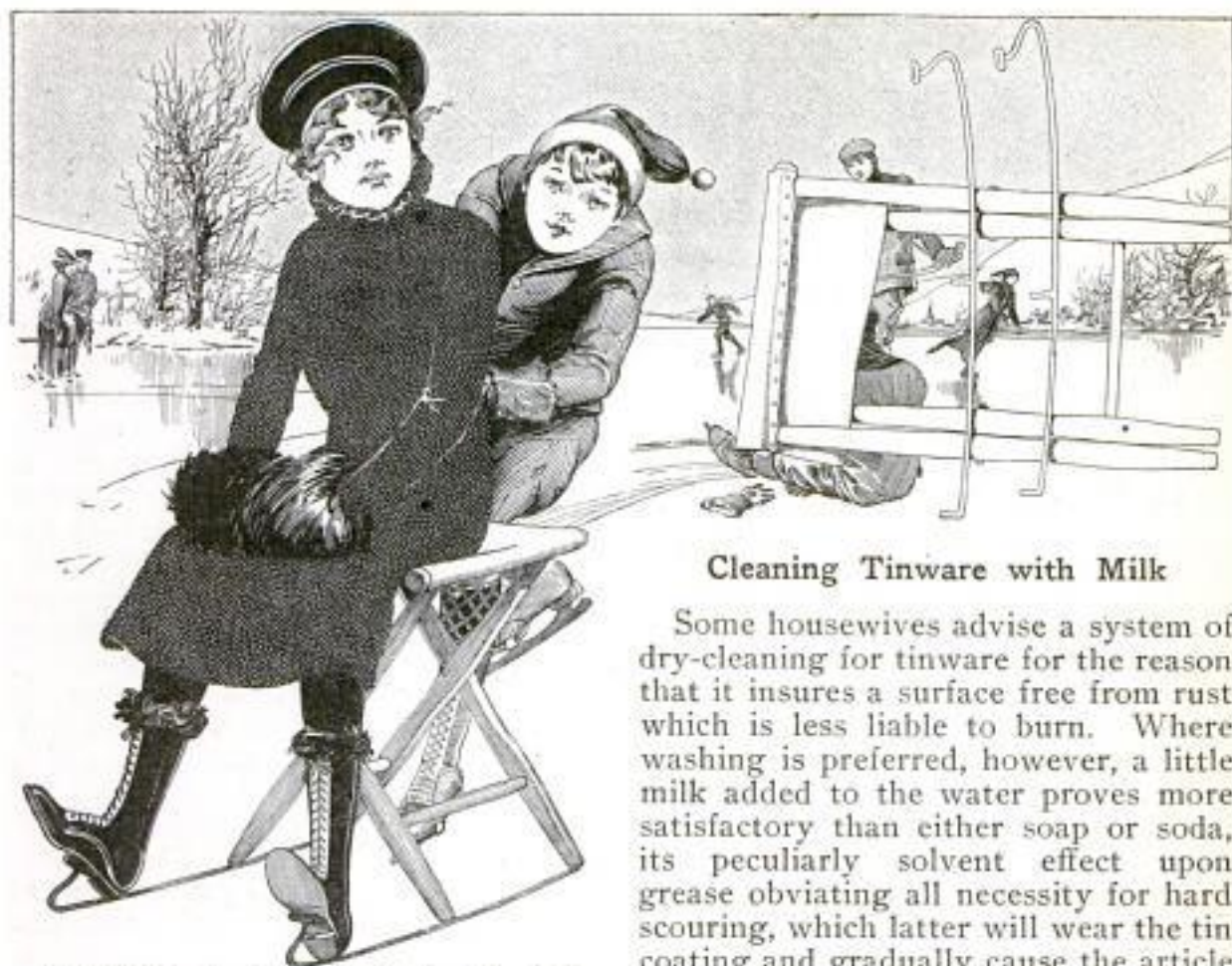

A Camp Chair Constitutes the Body of the Sled and the Legs are Equipped with Runners

### A Folding Ice Sled

On a smooth ice surface, or on hard snow, the sled shown will run easily, and a skater can push another with surprising speed by a light push on the shoulders while the rider rests his feet on the front of the runners. The sled is light, and it can be folded up and carried under the arm. It is also handy for putting on the skates, or for use in a crowded car.

Any camp stool will do for the main part of the sled. Holes are bored in the ends of the legs to receive the lugs on the runners snugly. If the builder is not equipped with a forge, a blacksmith will make the runners cheaply. The sliding surfaces of the runners are smoothed with a file.—Contributed by Thomas Lappin, Portland, Ore.

☞ A column of water 27.6 in. will have a pressure of 1 lb. per square inch.

### Cleaning Tinware with Milk

Some housewives advise a system of dry-cleaning for tinware for the reason that it insures a surface free from rust which is less liable to burn. Where washing is preferred, however, a little milk added to the water proves more satisfactory than either soap or soda, its peculiarly solvent effect upon grease obviating all necessity for hard scouring, which latter will wear the tin coating and gradually cause the article to become useless for holding food and more apt to rust into holes.—Contributed by J. E. Pouliot, Ottawa, Can.

### Proper Way to Wrap Papers for Mailing

In using a homemade paper wrapper for mailing purposes cut a triangular section from each end of it before applying the paste or mucilage. This prevents the adhesive from oozing out

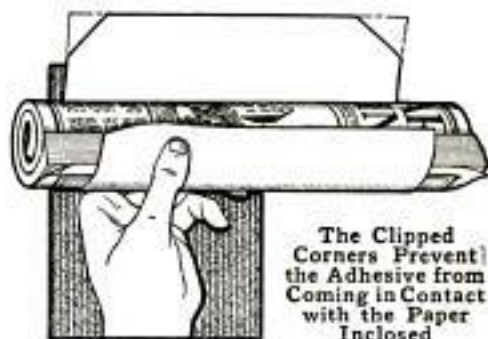

The Clipped Corners Prevent the Adhesive from Coming in Contact with the Paper Inclosed

at the edges and sticking to the paper it incloses. This also permits the easy withdrawal of the paper.

## How to Make Photo Sculptures

By CHARLES I. REID.

*Millersburg, Penna.*

The making of photo-sculpture reliefs in plaster of Paris is something that the average amateur photographer seldom attempts, although the process is quite simple, and there is a novelty to the thing that makes the effort

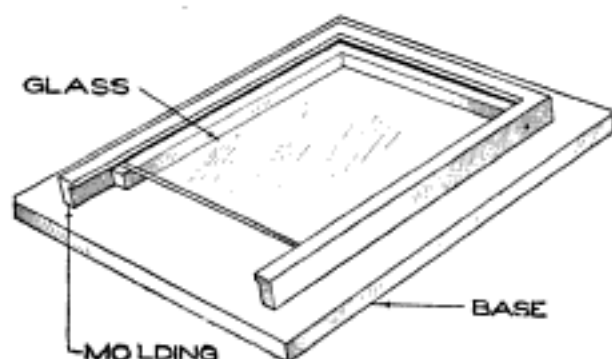

Mold for Making the Cast of Gelatin and Then the Final Plaster Cast

worth while. The only special apparatus required is a sheet of glass of the same size as the negative to be reproduced, and a wood frame to hold the glass in a horizontal position and provide an edge around it, to hold the emulsion which is to be coated on the glass. The frame is made of molding, attached to a baseboard, with one end left loose for making it easy to insert and remove the piece of glass.

The chemical part of the operation consists in dissolving  $\frac{1}{2}$  oz. of potassium bichromate in 10 oz. of water. Some ordinary gelatin is soaked in cold water until it is soft. The cold water is then poured off and hot water, equal in volume to the gelatin used, is added, which will turn it into a thick, viscous mass. A sufficient amount of bichromate solution is added to the gelatin to color it a decided orange, and the whole mixed thoroughly. Enough of the gelatin is poured on the glass in the frame to cover it to a depth of about  $\frac{1}{8}$  in. The frame is set on a level place in a dark room until the gelatin is hardened, which will take several hours, according to the temperature of the room. The sheet of hardened gelatin is then removed from the frame and glass and placed on the

negative to be reproduced. The two are held in contact in a printing frame and exposed to the sunlight in the same manner as when making a print on printing-out paper, until the image is plainly visible on the gelatin.

The sheet of printed gelatin is then placed in a tray of cold water where it will begin to swell, the exposed parts having been rendered insoluble in printing, and vice versa. The water is changed from time to time until the gelatin no longer tinges it yellow, when the gelatin is removed from the bath and carefully blotted. The image will then stand out in relief clearly. After it has hardened a little, the surface of the relief is coated with sweet oil, to prevent it from sticking to the final cast. Mix some plaster of Paris with water to form a thick solution. The gelatin relief is surrounded with a wall of putty, or dough, to form a retainer for the liquid plaster, which is now poured into the mold, using a sufficient amount to make the cast  $\frac{1}{4}$  in. thick. After the plaster has hardened, the gelatin is removed, and the plaster relief is complete. Every detail of the negative is recorded in relief on the plaster cast with a soft, smooth effect.

## A One-Piece Bracket

Where looks are not to be considered, the one-piece bracket shown in the illustration makes a simple device for supporting a shelf, or the like. It is made of a single piece of sheet iron of a thickness to hold what is desired, cut and bent to the shape shown. If made of material thick

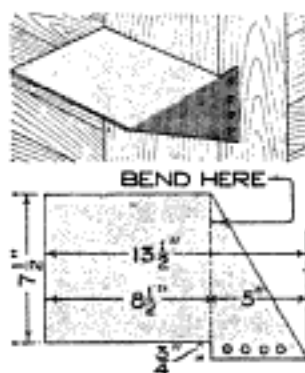

enough, it makes an excellent support for an electric fan.



By Stillman Taylor

## PART I

### Specifications and List of Materials

CANOE making is commonly considered more difficult than building the larger and heavier craft but many amateurs with only ordinary experience and tools have turned out satisfactory canoes, and if the simple directions given here are carefully followed out, the work will proceed rapidly and no difficulty will be encountered. Working with light materials, the canoe builder must pay particular attention to the workmanship, and, as it is many times more difficult to patch up mistakes in a canoe than it is in rowboats or other heavier craft, the work must not be hurried, but plenty of time taken to do each and every part well and in a workmanlike manner.

The craft described, which is the regulation open or Canadian model, is comparatively light and draws very little water. It is not a flimsy makeshift, but a stiff and thoroughly de-

pendable canoe designed for long service, which, barring accidents and given reasonably good care, will continue to give satisfaction for many years. The tools needed are the common ones found in most homes, consisting of a rip and cross-cut saw, chisel, screwdriver, drawknife, awl, brace and bits, rule, hammer, vise, plane, and three or four cheap wood, or metal, screw clamps. The list of material given is for a canoe having a length of about 16 ft., 31-in. beam, 18-in. depth at the ends, 12½-in. depth amidships, and weighing from 60 to 70 lb., according to the material.

While oak or ash makes the best stems, other woods may be used, rock elm and fir being very satisfactory substitutes. Where cedar is specified, spruce pine, cypress, or fir may likewise be employed. The materials for molds and ribbands, which are required

- STEM, 1 piece oak or ash, 6 ft. long and ¾ in. square.  
 KEELSON. (inside keel) 1 piece oak or ash, 14 ft. long, 3¼ in. wide, ¾ in. thick.  
 GUNWALES, 2 pieces oak or ash, 16 ft. long, ¾ in. wide, ½ in. thick.  
 SEAT RISINGS, 2 pieces oak or ash, ½ in. square.  
 FENDERWALES, 34 ft. ½-in., half-round molding. Oak or ash best for hard knocks.  
 OUTSIDE KEEL (may be omitted if desired), 1 piece oak, 14 ft. by 1 in. by ½ in. thick.  
 DECK BEAMS, 2 pieces oak or ash, 8 in. long, 1½ in. wide, ¾ in. thick.  
 SEAT FRAMES, 2 pieces oak or ash, 30 in. long, 3 in. wide, ¾ in. thick.  
 SEAT FRAMES, 2 pieces oak or ash, 12 in. long, 2¼ in. wide, ¾ in. thick.  
 PLANKING, cedar or pine, 100 sq. ft., ½ in. thick. Best secured by purchasing 25 ft. of 1-in. lumber, and having same dressed on two sides to ½ in. thick, and in lengths of 12, 14, and 16 ft. This will give the minimum amount of waste.  
 BACKBONE, 1 piece cedar or pine, any cheap stuff, 16 ft. long, 4 in. wide, ¾ in. thick.  
 MOLDS, 1 piece any cheap stuff, 16 ft. long, 1 ft. wide, ¾ in. thick.  
 RIBBANDS, 8 pieces any cheap stuff, 14 ft. long, ¾ in. wide, ½ in. thick.  
 RIBS, 300 running feet, cedar, 1¾ in. wide, ½ in. thick.  
 BREAST HOOKS OR DECKS, 1 piece cedar or oak, 32 in. long, 9 in. wide, ¾ in. thick.  
 1 lb. 2-in. wire nails to make form for keel.  
 1 lb. ¾-in. copper clout nails, for fastening ribs.  
 ½ lb. ¾-in. copper clout nails, for fastening seat risings.  
 18 1¼-in. No. 8 brass screws, for fastening decks and deck beams.  
 24 1-in. No. 6 brass screws, for fastening seats.  
 4 lb. patent marine glue to cement canvas to planking.  
 3 oz. No. 2 ounce copper tacks to fasten canvas with.  
 11¾ yd. No. 6 ounce canvas for covering hull.  
 1 lb. ¾-in. copper tacks to fasten planking to ribs.

to give form to the craft, may be cut from any cheap stuff, and this will reduce the cost somewhat.

#### The Backbone and Molds

The first step in the construction of a canoe is to get out the backbone and

#### The Molds or Forms

The molds which give the form to the hull are shown and numbered in the order that they are fastened to the backbone. To get out No. 1 mold draw a rectangle on a sheet of stiff paper exactly  $13\frac{5}{8}$  in. long and 11 in. wide as

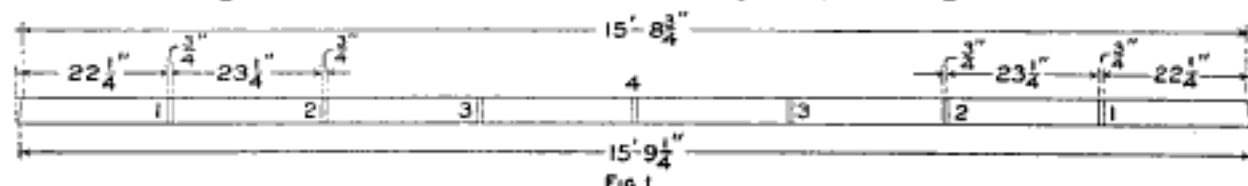

FIG. 1  
The First Step in the Construction of a Canoe Is to Get Out the Backbone and the Molds, or Forms, Which Give the Correct Dimensions and Shape of the Craft

the molds, or forms, which give the correct dimensions and shape of the craft. The backbone may be made from any inexpensive soft wood, such as cedar, spruce, pine, or cypress; and for making it a piece of lumber, 16 ft. long, 4 in. wide, and  $\frac{7}{8}$  in. thick, is used. By referring to Fig. 1 it will be seen that the upper edge measures exactly 15 ft.  $8\frac{3}{4}$  in., and that the lower edge is  $\frac{1}{2}$  in. longer, giving a total length of 15 ft.  $9\frac{1}{4}$  in. The spaces numbered from each end of the backbone toward the center, as 1, 2, 3, and 4, indicate where the corresponding molds are to be placed. Seven molds are used and as a canoe is tapered alike at both ends the molds are numbered alike and are made exactly to the same dimensions.

A good way to lay out the backbone accurately is first to mark the total length, making the lower edge 1 in. longer than represented in Fig. 1, then measure along the top edge exactly  $22\frac{1}{4}$  in., and run a pencil line across. From this line measure off  $\frac{3}{4}$  in. and draw a second line across the width of the board parallel with the first. This space represents the thickness of the mold, and it is marked 1. Measure off  $23\frac{1}{4}$  in. and make two parallel lines as before and number it 2, measure another  $23\frac{1}{4}$ -in. length and number it 3. Begin measuring from the opposite end of the board as in the first instance,  $22\frac{1}{4}$  in. and give it number 1, then mark off 2 and 3 the same as for the end already marked. The board is then cut off at the bevel mark at each end.

shown in Fig. 2. Run cross lines to divide it in quarters and mark out the center mortise for the backbone, which is 5 in. deep and  $\frac{7}{8}$  in. wide. Measure 4 in. toward each side from the outside edge of the backbone mortise and mark the mortises for receiving the gunwales, which are  $1\frac{5}{8}$  in. long and  $\frac{3}{4}$  in. wide or deep. To obtain the correct bilge curve lay the rule on the bottom line and measure off exactly 1 in. to the left of the center dividing line and make dot 0. Measure  $2\frac{3}{4}$  in. farther to the left, to A; turn the rule at right angles and measure  $2\frac{1}{8}$  in. inside the line and make dot 1. Measure  $11\frac{1}{2}$  in. to the left of A, turn rule at right angles and measure up the sheet exactly  $4\frac{7}{8}$  in. and make dot 2, which will be  $\frac{1}{4}$  in. inside of the left vertical line. On the center horizontal line, which is  $1\frac{15}{16}$  in. above dot 2, mark dot 3,  $\frac{1}{16}$  in. from the left vertical line. Measure off 2 in. above the horizontal center line and make dot 4 on the vertical line. The space between these two dots is the widest part of the bilge curve. Lay the rule on the bottom line of the gunwale mortise and measure off  $\frac{3}{16}$  in. from the outside line and make dot 5. Pencil the angle from dot to dot and draw in the full curve. Cut out the half section, fold on the vertical center line, and draw the right side.

Two complete No. 2 molds are required, but it is more convenient to make each mold in two sections. Each half is made  $11\frac{1}{2}$  in. wide and 12 in. deep, as shown in Fig. 3. First draw a rectangle to these dimensions and



run cross lines to divide it into quarters. Beginning at the upper right-hand corner, mark the mortises for gunwales and backbone, which, being only one-half of the complete form, will be  $\frac{7}{16}$  in. wide and  $3\frac{1}{4}$  in. deep. Laying the rule on the outside line immediately below the mortise, draw a second mortise for the keel, which is  $\frac{3}{8}$  in. deep and  $1\frac{1}{2}$  in. wide in the half section. Measure off  $1\frac{3}{4}$  in. to the left along the bottom line from keel mortise and make dot 1. The dot 2 is made by measuring  $2\frac{1}{2}$  in. to the left of 1, turning the rule at right angles at B and measuring  $\frac{5}{16}$  in. inside the line as shown in the sketch. Make the dot 3 at a point  $1\frac{3}{4}$  in. to the left of 2 and  $\frac{3}{4}$  in. inside of the line. The dot 4 is  $1\frac{3}{4}$  in. from C and  $1\frac{3}{4}$  in. inside of the line. The dot 5 is  $1\frac{1}{4}$  in. farther to the left and  $3\frac{1}{4}$  in. inside of the line. The dot 6 is  $\frac{5}{8}$  in. from dot 5 and  $4\frac{3}{4}$  in. inside of the line, which will bring it  $\frac{3}{8}$  in.



Fig. 2

inside of the left vertical line. At a point  $11\frac{1}{2}$  in. above 6 make dot 7 on the marginal line, and dot 8,  $1\frac{1}{4}$  in. above it. Between the dots 7 and 8 is the widest part of the bilge curve. Dot 9 is exactly  $\frac{1}{4}$  in. inside of the vertical marginal line. These dots produce the angles, and it is only necessary to trace in the full curve and cut it out to make a pattern for the other three half sections needed.

The molds No. 3, Fig. 4, are located near the center of the canoe and are made a trifle wider. Make a rectangle  $14\frac{3}{8}$  in. long by 12 in. wide and draw cross line dividing it into quarters. Trace the half mortises for the backbone, gunwale, and keel from the No. 2 mold pattern. Lay the rule on the bottom line and measure off  $\frac{1}{2}$  in. to the left from the center vertical line and mark dot 1, which is the beginning of the bilge curve. At a point  $2\frac{3}{4}$  in.

to the left and  $\frac{3}{4}$  in. inside of the line place dot 2, and 2 in. to the left of this and  $2\frac{1}{4}$  in. inside of the line place dot 3, then  $1\frac{1}{8}$  in. farther to the left turn

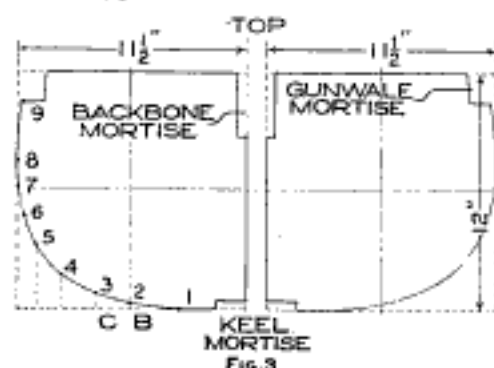

Fig. 3

It Is More Convenient to Make Each Mold in Two Sections, as Two Complete Molds are Required

the rule at right angles and measure up 4 in. inside of the line for dot 4, which is  $1\frac{3}{16}$  in. inside of the left marginal line. At a point 2 in. above dot 4 make dot 5 on the marginal line and  $2\frac{1}{8}$  in. above it make dot 6. The space between gives the widest part of the bilge curve, with dot 7 exactly  $\frac{1}{4}$  in. inside of the marginal line, measuring along the bottom of the gunwale mortise. Trace the angle and from it run the full curve and use this for a pattern for cutting out the other molds.

Mold No. 4 is placed amidships in the center of the canoe and only one complete mold is required, as shown in Fig. 5. To make a pattern draw a rectangle 15 in. long and 12 in. wide, and divide it into four equal parts as before. From the No. 3 mold pattern trace in the mortises for the gunwale, backbone, and keel. Lay the rule on the bottom outside line and measure

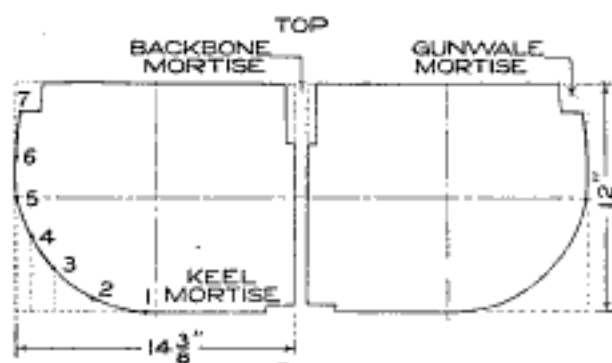
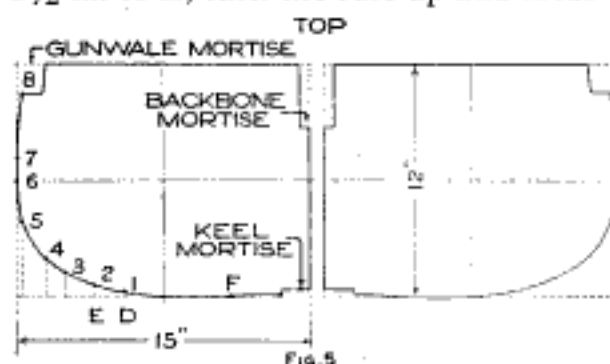

Fig. 4

This Mold is Located near the Center of a Canoe and is Made a Trifle Wider

2 in. from the center line to the left at D and turn the rule at right angles and

measure off  $\frac{5}{16}$  in. inside of the bottom line and make dot 1. Measure, from D,  $1\frac{1}{2}$  in. to E, turn the rule up and meas-



This Mold is Placed Amidships, in the Center of the Canoe, and Only One is Required

ure off  $\frac{5}{8}$  in. inside the line and make dot 2. The dot 3 is  $1\frac{1}{2}$  in. farther to the left and  $1\frac{1}{4}$  in. inside the line and dot 4 is 1 in. to the left of 3 and 2 in. inside of the line. The dot 5 is  $1\frac{1}{4}$  in. to the left of dot 4, and 4 in. inside of the bottom line, which will bring it  $\frac{1}{4}$  in. inside of the left vertical side line. At a point 2 in. above dot 5 make dot 6 on the outside vertical line and  $1\frac{1}{4}$  in. above it make dot 7. The space between dots 6 and 7 gives the widest part of the correct bilge curve. Exactly  $3\frac{3}{4}$  in. above dot 7 and  $\frac{1}{4}$  in. inside of the vertical side line make dot 8, which marks the beginning of the bilge curve above the water line and at the gunwale mortise. The curve of the canoe floor is quite flat, but not exactly a straight line. Lay the rule on the bottom line and measure up, on the inner edge of the keel mortise,  $\frac{1}{8}$

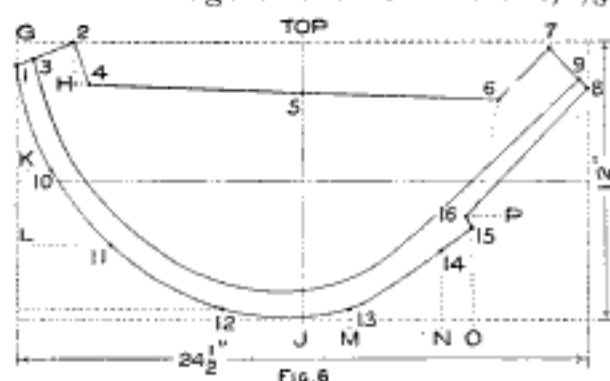

Straight-Grained Material must be Selected for the Stems, as It is Necessary to Bend Them to Shape

in., then  $2\frac{1}{2}$  in. to the left make a mark, F,  $\frac{1}{16}$  in. inside the bottom line and a pencil line drawn between them will enable one to trace the correct curve.

Having cut out the pattern make two wood forms exactly alike to have it complete, as shown. After finishing the seven complete molds, fasten them securely together by nailing a couple of battens across the halves.

#### The Ribbands and Stems

The ribbands are merely strips of wood,  $\frac{3}{4}$  in. wide,  $\frac{1}{2}$  in. thick, and 14 ft. long. Any cheap stuff will do because they are only used to give the correct shape of the canoe curve while building it. Six ribbands are necessary, and it is best to use eight lengths in order to make sure that the ribs are bent at the required angle and that both sides of the canoe are ribbed at the one uniform curve. For the stems ash or oak,  $\frac{3}{4}$  in. square, is used, and straight-grained material must be selected since it is necessary to bend them to obtain the requisite curve.

To make the pattern for the stem mold, shown in Fig. 6, draw a rectangle,  $24\frac{1}{2}$  in. long by 12 in. wide, and divide it into four equal parts. Lay the rule on the left side at the upper corner, at G, measure down 1 in. and make dot 1. Lay the rule along the top horizontal line and measure  $2\frac{1}{2}$  in. from G and make dot 2, then draw a pencil line between them. From dot 1 measure along this line exactly  $\frac{3}{4}$  in., and make dot 3. From dot 2 measure straight down  $1\frac{3}{4}$  in. to H, turn at right angles and measure off  $\frac{5}{8}$  in. to the right and make dot 4, and make a pencil line from 2 to 4 as shown. From dot 2 lay the rule parallel with the top horizontal line and measure off  $9\frac{3}{4}$  in., turn at right angles and measure down on the center line  $2\frac{1}{4}$  in. and make dot 5.

Lay the rule at the upper right corner and measure down the vertical line  $2\frac{3}{4}$  in., turn the rule at right angles and measure off  $3\frac{7}{8}$  in. and make dot 6. From the upper right-hand corner measure off  $1\frac{5}{8}$  in. and make dot 7 exactly  $\frac{1}{4}$  in. inside the top horizontal line. Again place the rule at the right-hand corner, measure down the vertical line exactly 2 in. and make dot 8. Draw the line from dot 7 to 8, and  $\frac{1}{2}$  in. from dot 8, make dot 9. This gives

the correct contour of the stem where it joins the splice of the keel.

The greatest curve and width of the

amidships. It is unnecessary to go to the trouble of making a paper pattern for this because the keel is merely ta-

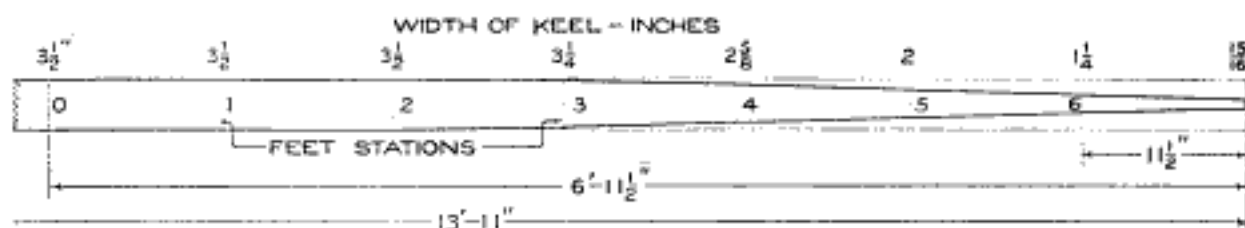

FIG. 7

It is Not Necessary to Make a Paper Pattern for the Keel, or Keelson, as the Piece is Merely Tapered Uniformly from Center to Ends, and It can be Drawn Direct on the Board

stem is at J on the lower line. To obtain the correct curve begin at the upper left corner and measure from dot 1 down the vertical line  $4\frac{1}{2}$  in. to K, turn the rule at right angles and measure  $1\frac{1}{4}$  in. inside the line, and make dot 10. The dot 11 is placed by measuring down from K exactly  $3\frac{1}{4}$  in. to L, when the rule is turned at right angles and a length of 4 in. measured off inside of the line. The dot 12 is located in the same manner by measuring  $2\frac{3}{4}$  in. below L and running  $8\frac{3}{4}$  in. inside the line, as shown.

To finish the irregular curve of the stem, measure from J at the center of the lower horizontal line 2 in. to M, turn the rule up and measure off  $\frac{1}{2}$  in. inside of the line, and make dot 13. The dot 14 is made by measuring off 4 in. from M to N and turning the rule to a point 3 in. inside the line, as shown. Then from point N measure to O  $1\frac{1}{4}$  in., and then measure up 4 in. to dot 15. From the dot 14 to 15 run a straight line. The dot 15 should be exactly 5 in. inside of the right vertical line.

Allowance for the beveled splice of the stem to the inside keel must now be made, and the beginning is to run a light pencil line from dot 15 to dot 6. From dot 15 measure up  $\frac{1}{2}$  in., turn the rule at P and make dot 16 exactly  $\frac{1}{4}$  in. to the left of the upright line. From dot 16 a line is run to dot 8 which completes the angle of the curve. The full curve is then easily traced in.

#### The Inside Keel, or Keelson

The inside keel, or keelson, is made exactly 13 ft. 11 in. long and  $3\frac{1}{2}$  in. wide in the center, which is, of course,

pered uniformly from center to ends, and this may be drawn on the surface of the board direct. The board being 13 ft. 11 in. long and  $3\frac{1}{2}$  in. wide, it is only necessary to make cross lines exactly in the center both ways. From the center measure 1 ft. toward one end and make the width at that point  $3\frac{1}{2}$  in. Measure 1 ft. farther along, and again make the width  $3\frac{1}{2}$  in. as before. Continue in this manner, making the third station  $3\frac{1}{4}$  in.; the fourth,  $2\frac{5}{8}$  in.; the fifth, 2 in.; the sixth,  $1\frac{1}{4}$  in., and the width at the ends  $\frac{15}{16}$  in. This detail is well shown in Fig. 7. Bend the stem on the mold and fasten it to the keel by means of a couple of  $\frac{3}{4}$ -in. No. 10 screws at each end.

#### The Ribs and Gunwales

The ribs are best made of cedar, cut from the same material as the planking. They are  $1\frac{3}{4}$  in. wide and  $\frac{1}{8}$  in.

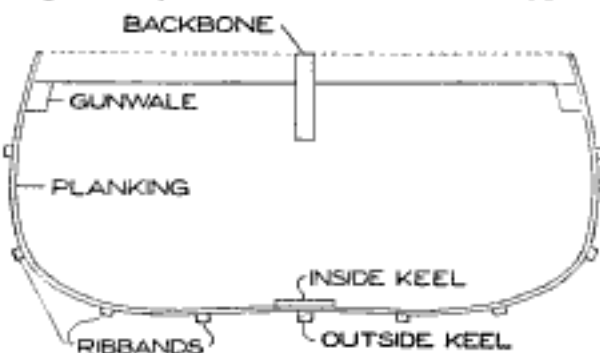
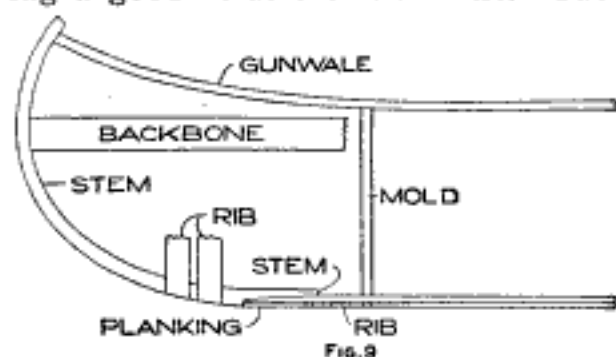

FIG. 8

The Ribs are Fastened to the Outside of the Keelson and are Curved under the Ribbands

thick. It is a good plan to saw out several long lengths and cut them off as required, the length being determined by measuring from gunwale to gunwale around the curve over the ribbands. The ribs are put in under the

ribbands, and the thickness of the latter will allow sufficient wood for making a good fit at the sheer line. The



The Bent Stem is Fastened to the Keel with Screws at Both Ends

gunwales are two straight strips, 16 ft. long,  $\frac{7}{8}$  in. wide, and  $\frac{1}{2}$  in. thick.

#### Setting Up the Canoe

Having made all the material ready, the work of setting up the canoe may begin, and as it is built upside down, place the backbone on boxes, about 1 ft. or more above the floor, and place the molds in the numbered places on the backbone, allowing the backbone to rest upon the bottom of the mortises cut in the top of the molds. Study Figs. 8 and 9 before beginning the work of setting up the hull.

True up the molds with a square and fasten them firmly by toenailing them to the backbone. Put the keelson in place, allowing it to fit down in the mortises cut in the molds to receive it. Take particular care that the stems are a good fit with the angle of the backbone at the ends, then fasten by nailing through the top edge of the mold into the stems. As shown in the stem-mold drawing, Fig. 6, the splice where the stem fits the keelson must be cut out after it is bent into place. This is easily done by marking around the outside edge of the stem and then beveling from the inside on each side. The outer edge is left about  $\frac{1}{8}$  in. wide, and the bevel runs out to the width of the keel at the lower end.

The gunwales are next put on at the sheer line, and fastened to the molds and stems, leaving sufficient of the nails exposed to make them easily withdrawn later on. The four ribbands

are then put on each side, at equal distances apart, between the gunwale and keel, or at 5-in. centers, measuring from the keel up toward the gunwale. Fasten the ribbands by driving  $1\frac{1}{4}$ -in. brads through them into the mold. Measure off the keel for the ribs, which should be put on 3 in. apart, measuring from the centers. The ribs are fastened to the outside of the keelson and are curved under the ribbands. Fasten each rib to the keel by means of two  $\frac{5}{8}$ -in. copper clout nails, then spring them into place and fasten to the gunwales. Put in all the ribs in the same way, spacing them so that a rib will be placed over each mold. When all the ribs are put in, remove the ribbands, and begin planking the hull.

#### Planking the Canoe

As a canoe is planked with  $\frac{1}{8}$ -in. cedar it is easily bent to the curve of the ribs while cold, thus doing away with the trouble of steaming. Unlike heavier-planked craft the planking is not rabbeted at the stem but is nailed to the beveled surface. For strength and to give a perfectly smooth skin on which to lay the canvas, it is advisable to run the planking the full length from stem to stem. Begin by putting on the garboard strake, which is the bottom plank at the keel. Punch holes in the plank with an awl, not directly in line, but staggered from side to side along the ribs. This will prevent the possibility of splitting. Drive in the copper clout nails while the plank is kept in place with a clamp to facilitate

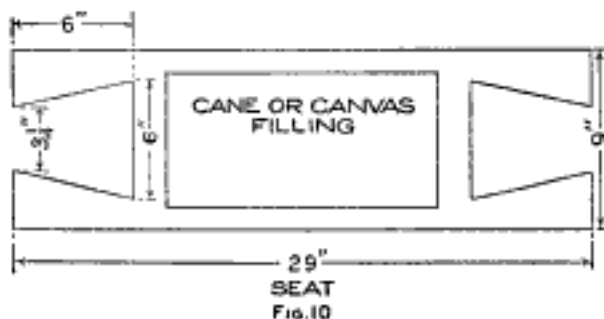

The Seat Frame may be Caned, or a Canvas Seat Tacked On, as Preferred

the work. Hold a clinch iron, or any handy piece of iron, inside and clinch the nails so that the ends are well im-

bedded in the rib on the inside. It is a simple matter to fit each plank in place, because they are merely a close fit at the edge, butted together without beveling. The number of planks required will depend upon the width, and while wider strips may be used, planking cut to the width of 3 in. is generally employed. In any case the top plank or sheer strake should be level with the gunwale from one stem to the other. When the hull is completely planked, cut off the ends of the planking to the curve of the stems and gunwales. The backbone and molds may now be taken out by sawing the backbone in two. Tack a couple of strips across the gunwales to keep the hull from sagging out of shape, then drive the nails over the sections the molds occupied, since these forms prevented doing this work before.

#### Seat Risings and Seats

The seat risings are simply straight sticks,  $\frac{1}{2}$  in. square, and are fastened on the inside for the seats to rest upon. They are about 4 in. below the gunwale. Oak or ash is the best material, and the length is 14 ft. To fasten in place, first bore a small hole and then nail through the planking and ribs, and clinch on the inside of the rising.

The seat frame is fashioned as shown in Fig. 10, and may be caned, or a canvas seat tacked on, as preferred. Many canoeists prefer to kneel, in which case a seat bar, about 4 or 5 in. wide, is run athwartships for the paddler's back and thighs to rest against while paddling.

#### The Deck Beams and Decks

The deck beams are merely straight pieces, about 8 in. long,  $1\frac{1}{8}$  in. wide, and  $\frac{3}{8}$  in. thick. These are notched at the ends as shown in Fig. 11, so that they will come up and wedge against the sides of the gunwales about  $\frac{1}{2}$  in. Put them in by boring a hole through the gunwale and fasten with a  $1\frac{1}{4}$ -in. No. 10 screw at each end. Two are required, one at each end.

The deck, or breast, hooks are made 16 in. long by 8 in. wide and of the

shape shown in Fig. 12. To fasten them in place bore three holes through the deck into the deck beam and se-

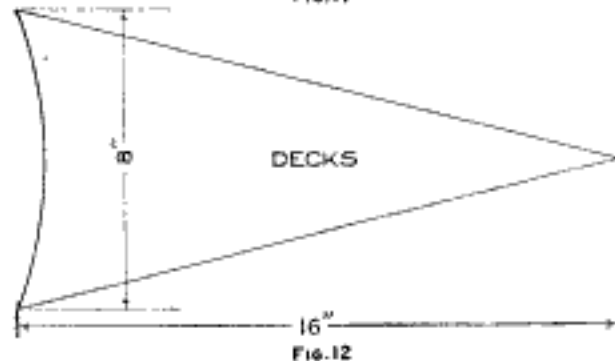

The Shape of the Deck or Breast Hooks and the Beams That Support Them

cure them with three  $1\frac{1}{4}$ -in. No. 10 screws. Bore three holes along the gunwale on each side and turn three  $1\frac{1}{4}$ -in. No. 10 screws into the deck.

#### A Center Thwart

To strengthen and stiffen the hull a center thwart, or cross bar, should be run across the canoe amidships. A piece of oak or ash,  $\frac{3}{8}$  in. thick and tapering from 2 in. in the center to 1 in. at the ends, should be screwed to the lower side of the gunwale. Although not exactly essential, it is a good plan to run another thwart across the canoe just back of the forward seat, and a rear thwart some 3 ft. forward of the rear seat, or paddling bar. This will make the craft very stiff when a heavy load is carried, and likewise prevent the lightly constructed hull from



The Manner of Shaping the Ends of the Canvas to Fit over the Canoe Ends

sagging, or "hogging," when stored for the winter.

#### Applying the Canvas

The canvas is put on with marine glue, the black kind being the best for

this particular purpose. Before gluing the canvas, lay it smoothly on the hull and trim so that it will fold nicely at the stems, as shown in Fig. 13. Melt the glue in a can over a moderately hot fire and spread it on one side of the canvas with a stiff brush. Of course, the glue will be too thick to spread evenly, but be sure to apply it as evenly as possible, and touch every bit of the canvas with a fairly heavy coating of glue. Lay the glued canvas in place, and iron with a moderately hot flatiron. This melts the glue, and the canvas will adhere smoothly to the planking. Finish by tacking the edge of the canvas along the edge of the gunwales, and fold the canvas as smoothly as possible at the stem, and tack in place, running the line of tacks exactly down the center line of the stem.

#### Fenders or Covering Strips

Fenders of  $\frac{1}{2}$ -in. round molding may be tacked on to cover the edge of the canvas, or a strip, 1 in. wide, may be sawed from the same material as the planking and tacked to cover the edge by using  $1\frac{1}{4}$ -in. brads every 2 or 3 in. along the edge.

#### Stem Bands and Outside Keel

The stem bands may be made from wood if desired and bent to shape, but the brass oval stem or bang iron,  $\frac{3}{8}$  in. wide, makes a stronger and better finish. The wood stem band should be about  $\frac{3}{8}$  in. square, and rounded on the outside. Put this on with  $1\frac{1}{4}$ -in. brads and fasten the brass band with  $\frac{3}{4}$ -in. screws.

The outside keel may or may not be used, according to preference. It strengthens the canoe to a certain extent and keeps the bottom from many a scratch while pulling out. The usual outside keel is about 1 in. wide and  $\frac{1}{2}$  in. thick, of oak or ash, and tapered at the stems to the width of the stem bands, which are screwed on over it. The most serviceable keel is about  $2\frac{1}{2}$  in. wide in the center, and tapers to fit the bands at either end. When made of  $\frac{3}{8}$ -in. oak, or ash, it makes a splendid protection for the bottom of the

hull, especially when the craft is used in rocky waters. Unlike the narrow keel, the flat keel makes the canoe easier to turn with the paddle, but any form of keel will add several pounds to the weight of the craft and is for this reason often omitted.

#### Painting the Canoe

The canvas should be given a coat of shellac before the paint is applied. This makes it waterproof. Then four coats of paint are applied to fill the fibers of the canvas. To make a smooth finishing coat, rub down the second and third coats with fine sandpaper. The entire woodwork of the canoe should be finished with three coats of good-quality outside spar varnish.

A slatted grating, made of soft-pine lattice stuff, about  $1\frac{1}{8}$  in. wide and  $1\frac{1}{4}$  in. thick, will afford protection to the bottom of the canoe. For summer use this is desirable, but may be omitted on long trips and when soft footwear is worn. The grating should not be fastened to the ribs, but the parallel strips screwed, or nailed, to cross strips, curved to fit the contour of the canoe's bottom. The grating should extend from well under the stern seat up to the stem splice in the bow, and should be nicely tapered to make a neat appearance. By fastening two or three little blocks of wood so that they will extend up between the slats, one may screw small brass buttons into these blocks to keep the slatted floor in place, thus making it easily removable when washing out the canoe.

#### A Ring-and-Egg Trick

This trick consists in borrowing a ring and wrapping it in a handkerchief from which it is made to disappear, to be found in an egg, taken from a number in a plate.

Obtain a wedding ring and sew it into one corner of a handkerchief. After borrowing a ring, pretend to wrap it in the center of the handkerchief, but instead wrap up the one concealed in the corner, retaining the borrowed one in the hand. Before

beginning the performance, place in the bottom of an egg cup a small quantity of soft wax. When getting the cup, slip the borrowed ring into the wax in an upright position. An egg is then chosen by anyone in the audience. This is placed in the egg cup, the ring in the bottom being pressed into the shell. With a button hook break the top of the shell and fish out the ring. The handkerchief is then shaken out to show that the ring has vanished.

### Lock for Gasoline Tank on a Launch

Having trouble by thefts of gasoline from the tank in my launch, I made the following device to prevent them, which proved very effective. A strap hinge, about 12 in. long, was procured, and on one wing, near the outer end, I fastened a staple made of a large nail, and near the center a large hole was drilled to fit over the pipe, or opening, to the tank. The other wing of the hinge was bent to the shape shown, and an oak block was fastened in the bend with wood screws. A hole was bored in the block to fit over the end of the pipe. A slot was cut in the same wing at the end to receive the staple. In turning the wing over to cover the pipe end, the staple was brought into position for a padlock. After locking the device, most of the screws are cov-

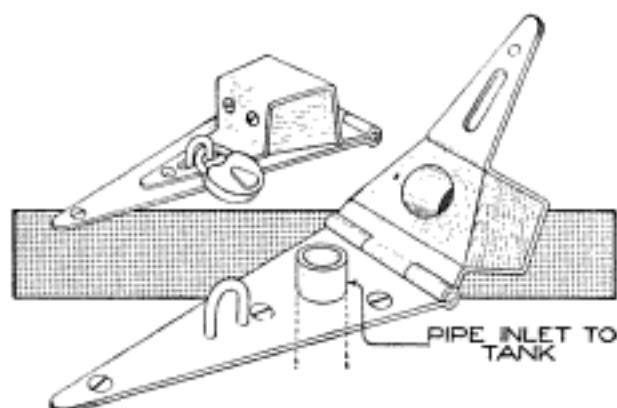

Filler-Pipe Cover Lock to Prevent the Theft of Gasoline from a Motorboat

ered so that it is almost impossible to remove them without taking off the lock.—Contributed by Stephen H. Freeman, Klamath Falls, Oregon.

### A Quick-Acting Bench Vise

For those who desire a quick-acting vise and cannot afford the price of a manufactured one, I designed the vise

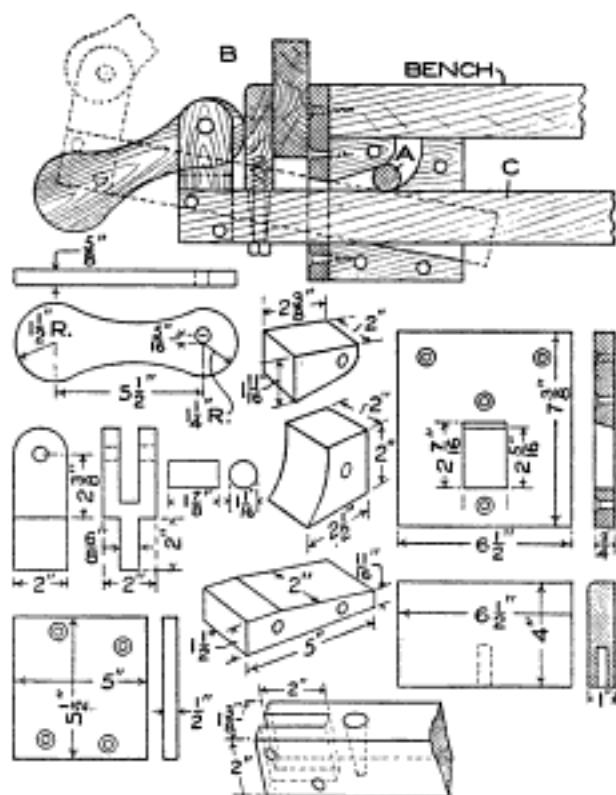

A Quick-Acting Vise Made of Hard Wood for the Home Worker's Bench

shown in the illustration. A detail is given of each part, with dimensions, so that it is not difficult to make it from hard wood. The roll A binds the vise so that it remains rigid, while the cam in front gives the necessary play, to release or tighten as preferred. The clamp jaw B is pivoted so that it swings loose, thus making it fit any surface that may not be parallel with its opposite side. In releasing the stock, the cam is first turned, and then the front part of the vise is pulled up to relieve the roll A. The front jaw can be then moved back and forth to take stock of any size desired. As soon as the stock is placed, the roll A falls into place and clamps the jaw arm C.—Contributed by J. C. Hansen, Maywood, Ill.

ⒸA practical vacuum will raise water 30 feet.

### An Emergency Dark-Room Light

The traveling man who "lives in a suitcase" and at the same time wishes to enjoy the pleasures of amateur photography sometimes experiences difficulty in developing films in a hotel room. Soup plates borrowed from the steward, or even the bowl pitcher and the ice-water



pitcher in the room, can be used for development, but it is very hard to improvise a ruby lamp. My emergency lamp is a small vest-pocket flash lamp over which two yellow envelopes, one inside of the other, are slipped, as shown. The lower edges are cut perfectly square and rest on the table, or shelf, in the closet, and all white light is excluded. At night, the shades may be drawn, and a yellow-paper sack may be tied around the electric light.—Contributed by J. L. Pinkston, Granite Hill, Ga.

### An Ice Creeper

The illustration shows a one-piece ice creeper for the heel of a boot or shoe. It is made from sheet steel with the arms bent up to receive a strap for buckling it in place on the boot heel. The zigzag cuts in the bottom part are turned down for engaging the ice.

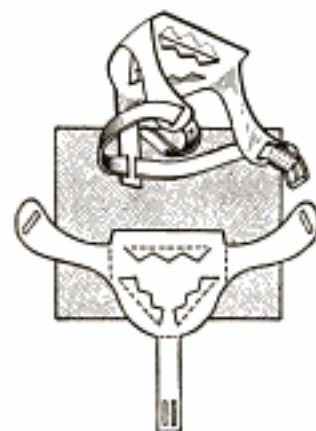

—Contributed by Chas. S. Snell, Lewiston, Me.

¶ In machine work a way must be provided for removing dowel pins before they are driven in place.

### Waterproofing for Fish Lines

Dissolve  $\frac{1}{2}$  oz. of orange shellac in  $\frac{1}{2}$  pt. of alcohol, and add 1 teaspoonful of Venice turpentine, the same quantity of raw linseed oil, and 2 oz. tincture of benzoin. Shake well, and set in a varnish can in hot water.

Soak the coiled line in the varnish for two hours, then hang it up to dry. Thin the varnish with alcohol, and repeat the dipping. When the line is dry, rub it down well with a wool rag greased with tallow. Silk lines treated in this manner are pliable, and the fibers of the silk are so united by the varnish that the strength of the line is almost doubled.

### Making Chest Lock More Secure

As a rule, ordinary chest locks cannot be relied upon, since almost any kind of a similar key will unlock them. I found a good remedy by taking out the pin on which the key fits, and making a new one twice as long as the one removed, then drilling a hole in

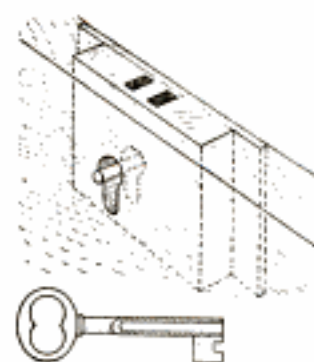

the key deep enough to fit over the new pin. In case the pin extends too far, a piece of wood block, with a hole in it to admit the key, can be fastened over it to prevent bending the pin. No ordinary key will pass on the pin far enough to turn the lock.—Contributed by Chas. G. England, Washington, Pa.

### Driving Screws in Hard Wood

Keep the supply of screws in a box containing a small amount of powdered soapstone. Shake the box occasionally, and the screws will be dusted with the powder, which acts as a lubricant. This is a much cleaner and more convenient method than the ordinary one of rubbing each screw on a bar of soap before driving it in hard wood.



### How to Make a Good Putty

To make a good putty the following formula should be used: Mix equal parts of firmly ground whiting and white lead with enough linseed oil to make a thick liquid; add enough commercial putty to this to make the consistency of regular putty. This putty will not crack or crumble, and it costs very little to make. If desired, the commercial putty may be left out and enough whiting added to take up the liquid. The life of this putty is four times greater than a commercial putty.—Contributed by L. E. Fetter, Portsmouth, N. H.

### Cupboard for Kitchen Utensils

The illustration shows a style of a cupboard in which kitchen utensils

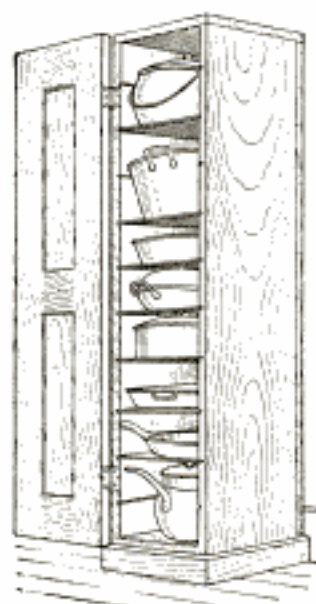

can be kept in an orderly manner without taking up a great deal of space. The cupboard is tall and narrow, and the interior face of each side is scored at even intervals with saw cuts,  $\frac{1}{4}$  in. deep. In the grooves are placed shelves, which are merely squares of galvanized iron. By placing the shelf

### A Diminishing Card Trick

The illustration shows a style of a cupboard in which kitchen utensils can be kept in an orderly manner without taking up a great deal of space. The cupboard is tall and narrow, and the interior face of each side is scored at even intervals with saw cuts,  $\frac{1}{4}$  in. deep. In the grooves are placed shelves, which are merely squares of galvanized iron. By placing the shelf in the proper grooves the space is adapted to the size of the utensil. The small floor space occupied allows the cupboard to be placed in the part of the kitchen that is most convenient.

done quickly it will not be noticed. A piece of paper is used the size of a regular playing card, and an ace is made on one side. When it is folded over, one side of the reduced size is made to

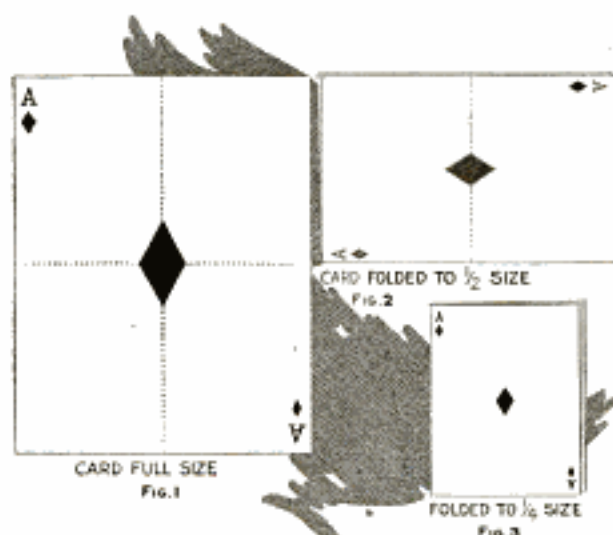

Reducing the Size of a Playing Card While Holding It in One Hand

show the same ace, then another fold is made and the smaller ace is made.—Contributed by Louis Waherer, Tiffin, Ohio.

### Table Sockets for Electrical Heating Apparatus

The usual method of running a wire from a chandelier or wall bracket to a heating device on the dining-room table is inconvenient as well as unsightly. This I overcome by making a special narrow leaf to put in the extension top into which sockets are set flush for

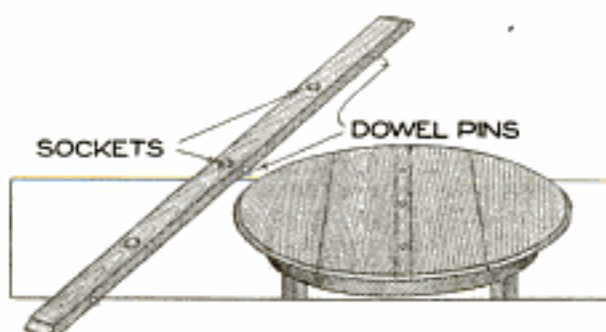

The Extra and Narrow Table Leaf Carries the Electric Sockets for the Cooking Apparatus

extension wires. These are connected to a floor socket, or a line can be run under the carpet or rug.—Contributed by Maurice Baudier, New Orleans, La.

Marshall Field & State, Wash. & Wabash, Chgo.

EFFECTIVE INTERIORS IN BLACK AND WHITE

1204  
Illustration H

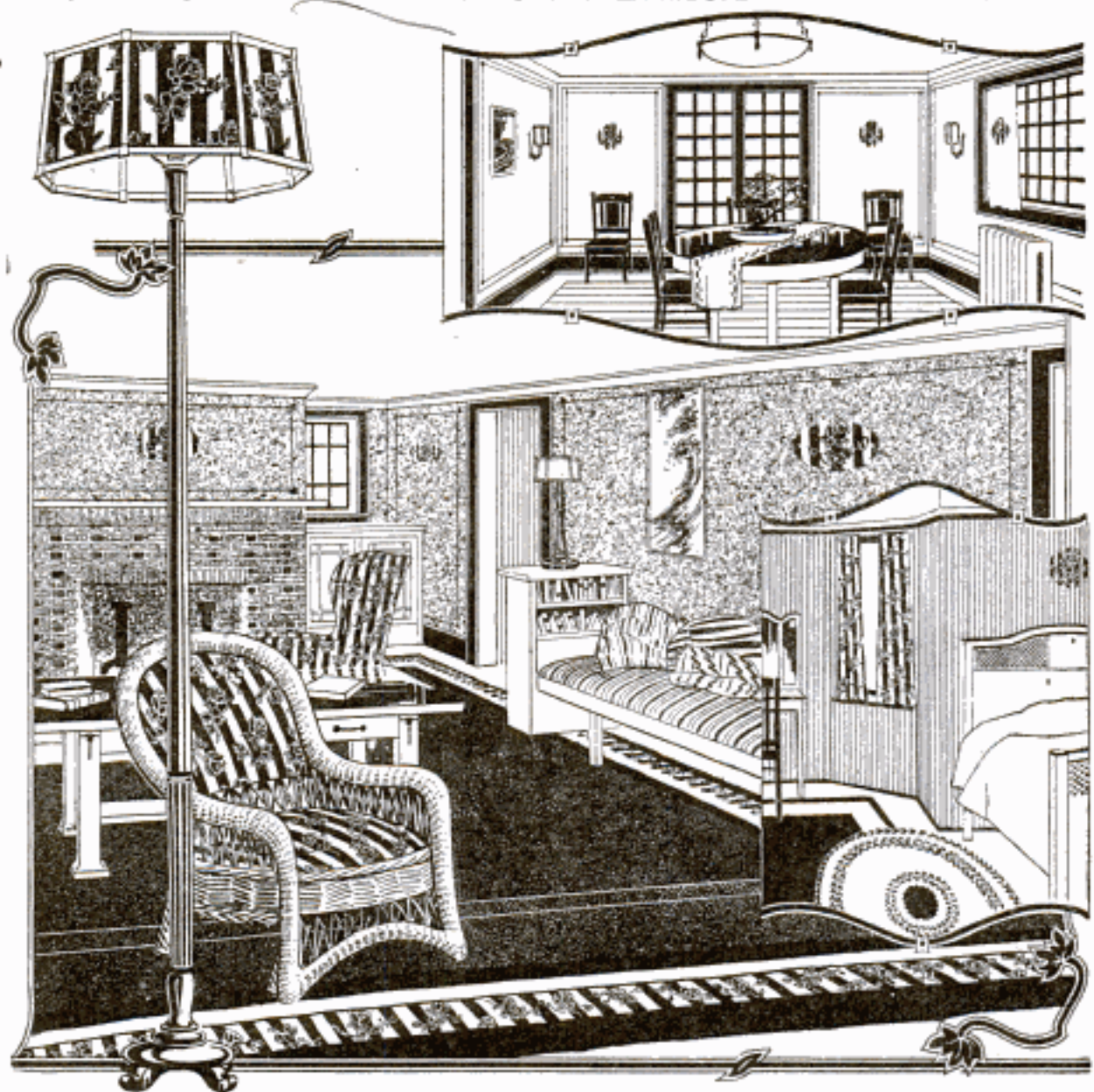

**D**ECORATIVE schemes in black and white produce distinctive interiors which have a peculiar appeal, especially to those who admire the modern trend in this art. The drawing above illustrates one way of carrying out the scheme. Here black and white is the predominating note, the complete absence of color on the one hand and the presence of all color on the other producing a sharp contrast which is relieved by the use of orange, grays, and dark reds. The design used on the walls throughout gets its motif from the fabric used as an upholstering material for the chairs, and also as a covering for the floor lamp, the post of which is finished in black and white. The floral part of this design is worked out in a deep orange. It will be observed that this pattern is also used as a border for the low-toned rug in the living room, and for the hangings in the bedchamber, and elsewhere to an extent, although not pictured. The walls of the living room are mottled in grays and black and given a panel effect. No pictures are used, two pen-and-ink sketches of a conventional order alone being placed on opposite sides of the room. The upholstering of the seat continues the black and white scheme, while the pillow coverings are deep-colored. A white table with an ebony top, and black woodwork margined with white, complete the room. Light-gray paneled walls, a dark-topped table that blends with the gray used on the walls, and black chairs, are used in the dining room. The walls of the bedchamber are covered with a narrow-striped, black and white paper. On the floor a black rug with a white border is used.

**I**N accordance with the editorial policy of this magazine never to accept compensation in any form for what appears in our reading pages, and also to avoid all appearance of doing so, we are obliged to omit the name of the maker or the seller of any article described. This information, however, is kept on file and will be furnished free, by addressing Bureau of Information, Popular Mechanics Magazine, Chicago. [Editor.]



**\$497** for this Complete **ALADDIN Bungalow**

Contains Living Room, Dining Room, Kitchen, Two Bedrooms, Closet

**Saved \$600 on Dealer's Price**

"I saved in round numbers \$350 and I have the estimates from several different lumber concerns and contractors to support my figures," writes Mr. G. E. Farmer, of Iowa, owner of the Aladdin Maples bungalow shown above.

"I had a builder estimate on my house and I saved \$500 on his figures," writes Hugh H. Loughlin, of Connecticut, owner of the Maples.

"I saved \$280 on our lumber yard's figures," writes Dr. E. E. Gregory, of South Dakota, another owner of the Maples.

"My lumber dealer wanted \$600 more for the Maples. The Aladdin System made it possible for me to own my home five years sooner," writes Mr. Frank Burks, of Illinois, another owner of the Aladdin Maples.

In every case Aladdin Houses saved the builder from \$200 to \$800. Saved him a third of the time of erection, as Aladdin lumber is cut to fit—no sawing, no cutting—no fitting. Better, cleaner and heavier lumber. Better and purer paints. Better and more costly hardware, ample quantities of nails in all sizes, better lath, highest quality of hard wall plaster. And all this for less than the price of regular, cheaper stock usually furnished. But, don't stop here. Get the big Aladdin catalog of 100 homes. See the beautiful homes, excellent plans. Write to Aladdin customers. Get the complete story in their own words. Send stamps for the Aladdin catalog today.

Highest  
AWARDS  
WORLD'S  
FAIR

**\$1 a Knot Guarantee**

Why should you pay the dealer's price for ordinary quality of lumber when you get the best obtainable—Aladdin lumber—at a saving? Aladdin lumber is the finest that grows. It is the choicest from the log.

**\$298**  
for this  
5-Room  
Home



The best is taken for Aladdin Houses and the second quality is not used by us. That's why we can offer you the Dollar-a-Knot guarantee. Where else can you get lumber equal to Aladdin quality and at Aladdin's price?

**\$797**  
Complete



**Complete House—Better Material—at a Saving of One-Third**

Aladdin houses are complete. You get material absolutely guaranteed to be sufficient for the completion of your house, as follows: Sills, cut to fit; joists, cut to fit; studding, cut to fit; building paper; sub-floor, cut to fit; rafters, cut to fit; roof sheathing, cut to fit; siding, cut to fit; outside finish; knotless flooring, cut to fit; lath and plaster or plaster board; knotless inside finish, knotless doors, knotless casings, knotless baseboards, windows, sash, glass, nails of all sizes, locks, hinges, tin flashing, paints, oils, varnishes, stains, putty and shellac, with complete drawings, illustrations and instructions for erection.—The Complete House. Send stamps today for the Aladdin Catalog No. 150—it tells all the interesting facts.



**North American Construction Co. Homebuilders to the Nation**

295 Aladdin Ave., BAY CITY, MICH.

Can. Branch, Sovereign Cons't Co., C. P. R. Bldg., TORONTO, CAN.

# Fastest Boat in the World



**\$45**

**17-Footer**

Buys this complete knock-down boat (open cockpit) selected oak frame, clear cypress planking, decking and interior finish. Cut to shape and fitted, including hardware (everything except paint).



**\$95**

**17-Footer**

Buys this finished boat, painted and varnished, polished brass fittings, fully equipped. Ready for the water (excepting motor and auto top.) Catalog quotes prices with various motors installed.

*10 to 32 Miles With 4 to 25 h. p.*

**W**ITH from 4 to 10 horsepower the 17-footer is a comfortable family launch, semi-V-bottom design, roomy, staunch and seaworthy. With 12 or more horsepower the boat becomes in effect a stepless hydroplane, which is the fastest model yet developed. The speed is limited only by the power and weight of motor used.

When motor is purchased with the finished boat it is installed and connected up ready to run.

Send for our catalog giving full particulars.

# Lowest-Priced Boat in the World



**\$25**

**15-Footer**

Buys this complete knock-down boat, oak frame, clear cypress planking, cut to shape and fitted. All hardware included. Finished boat painted and varnished, ready for the water, \$45.



**\$89**

**15-Footer**

Buys this finished boat, painted and varnished, fully equipped, as shown above with outboard motor or 2 horsepower inboard motor installed.

*For Inboard or Outboard Motor*

**T**HESE 15-footers are also of the semi-V-bottom type. The model is designed especially for outboard motor, eliminating the defects of the ordinary rowboat. It has an extra strong reinforced stern.

With a light inboard motor installed it makes a "natty" and serviceable runabout. Just the thing for resorts and liveries. The prices quoted with either motor represent the greatest motor boat value ever offered. Without motor it makes a first class, all-around rowboat, light and roomy. Full particulars on request.

Our **Big Free Catalog** shows cruisers, launches, sailboats, rowboats and canoes. Over 100 designs. A postal brings it.

**Brooks Mfg. Co. 8203 Rust Ave., Saginaw, Mich.**

# Build Your Own Boat

## The Home Workshop

**T**HOUSANDS of fathers and mothers recognize the clean, healthy, educational value of the home workshop. Swinging a hammer is just as good exercise as pulling a chest weight, and there's profit and pleasure in the hammer movement. Any room of sufficient size will serve as a workshop, and the building of a single boat will demonstrate the value of the venture. *Any 14 year-old boy can build these boats.*

The knock-down materials, which we furnish, are in effect the raw materials required. We do all the difficult part of the work and send full illustrated instructions to assemble the shaped parts which we furnish. You don't need to know anything about boats or carpentry. The tools required are common to every household. Catalogue gives full particulars.



As you receive it. Keel marked and bored for the ribs shown below.



About one hour later. Each rib comes notched, shaped and fastened together with cross-tie.



About two hours later. The stringers or battens are laid and fastened in the mortises which are provided.

# Builder-Agents Wanted

## A Business Opportunity

**T**HIS is a rare chance to engage in a pleasant and profitable business. By turning our knock-down materials into finished boats, the value is more than quadrupled. Practically no investment is necessary. About two-thirds of the value of a well-finished boat is in the labor and builder's profit. Besides, a local builder overcomes high freight rates that must be added to the cost of the finished boat shipped from distant factories.

If you are making less than \$10 per day, give this business opening a trial, test it during spare time. There's hundreds of localities that will keep you and many employees busy. Estimate how many dozens or hundreds of these low-priced, popular, speedy, best all around boats ever produced, can be sold in your vicinity. Send for our **Big Free Catalogue.**



About two days later. The planks come cut to shape, each marked for its location. Nothing difficult but lots of nailing.



Now ready for interior finish and painting.



These few illustrations are greatly reduced in size. Our regular instructions completely cover every detail.

**Brooks Mfg. Co. 8203 Rust Ave., Saginaw, Mich.**



## Wear gloves that give *real* hand protection

Any tool that enables you to do your work easier and better, is a good investment. The same holds true of gloves. Choose your gloves as you would your tools—to make your work easier, and protect your skilled hands.

# Grinnell Gloves

*Best for every purpose*

The Rezistol Glove is soft, pliable and durable—made especially for mechanics. It is a big favorite with electrical workers, telegraph and telephone linemen and mechanics in all lines. This leather has been tested by a famous engineer to withstand 4,000 volts of electricity. Washable in soap and water or gasoline, drying out soft and pliable as new.

### Gloves for every use

Whatever your needs or taste, you can find the glove you need in the Grinnell line—over 900 styles. Special gloves for dress, street, motoring, sports. Work gloves that wear like rawhide. Mittens of every description. Ask your dealer.

### New glove booklet free

on request. Our new booklet "Glove Styles" is handsomely illustrated, and puts before you all leading styles of Grinnell Gloves. Write for it today, mentioning your dealer's name.

### Morrison-Ricker Mfg. Co.

(Established 1856)

141 Broad St. GRINNELL, IA.



4315 P. R. F. "Rezistol"

Please Mention Popular Mechanics

# BLUE STREAKS



## "Best," Say the Makers of Motorcycles

Goodyear Blue Streak Motorcycle Tires hold a distinction never before awarded to any tire.

They are specified as standard equipment by every leading motorcycle manufacturer.

They have won their way to this extraordinary position not alone because every world's record for motorcycle endurance and speed has been made on them.

In the rider's every-day service they have proved their ability to go farther with less trouble.

It is this goodness that motorcycle manufacturers now recognize.

Get Goodyear Blue Streaks on your new machine, or for your spring equipment. Any dealer can supply you.

Goodyear Tire & Rubber Company, Akron, Ohio

*Please Mention Popular Mechanics*

## Stored-Up Miles of Boat Rides

Long, healthful hours of water sport, are yours in the Evinrude. Where you will and when you will, in any rowboat or canoe, on ocean, lake or river! No more rowing—you're captain, not crew. Just a turn of the fly-wheel, and you're off for a cruise, with no dread of a long row home again.

# EVINRUDE

DETACHABLE ROWBOAT & CANOE MOTORS

There's more speed, more power in the new Evinrude Four-Cycle Twin—a two-cylinder motor that runs smoothly and quietly, with almost no vibration.

There's more speed, too, and other improvements, in the Single

Cylinder Models for 1916. The Evinrude Magneto—Built-In Fly-Wheel Type—is entirely insulated and waterproofed, furnishing perfect ignition at high or low speed, no matter how heavy the rain or how drenching the spray.

Evinrude Motor Co. <sup>315</sup> Evinrude Bldg. Milwaukee, Wis., U.S.A.

[DISTRIBUTING BRANCHES:]

69 Cortlandt Street, New York.  
214 State Street, Boston, Mass.

436 Market Street, San Francisco, Cal.  
Front and Morrison Streets, Portland, Ore.

OVER 60,000 SOLD

**Evinruding—  
is Rowboat  
Motoring**



A post card  
will bring you the  
**1916**  
Evinrude Catalog.  
Just off the press  
— beautifully  
illustrated



Please Mention Popular Mechanics



## All the Wild Game You Want

FOR many years we in America have spent much time bemoaning the disappearance of our feathered game. But the fact that we have little game to shoot and little to eat is due solely to our own lack of initiative. We should have an abundance of game in the fields and on the market. We may obtain such an abundance by creating a supply equal to the demand. This can be done by increasing nature's output through game farming. And moreover, the demand may be much greater than at present, and still be easily met.

We have the land available to make America the greatest game producing country in the world. Utilize it, and everyone will have more opportunities to indulge in field sports. There will be more shooting for of all us, whether or not we have access to a preserve, because game that is raised for sporting purposes can not be confined in any restricted area. Wherever game is intensively cultivated, we find improved shooting in all the surrounding territory.

To anyone who has a small amount of land, game farming will prove profitable. The demand for eggs and for breeding stock is much greater than the supply, and will be for years to come. Pheasant eggs sell today at from \$20 to \$25 a hundred. Live birds bring from \$5 to \$7 a pair.

To those who own large acreage, game farming will either provide sport, or profit from those who will pay for the sport.

To the city man, it opens the possibility of enjoying good hunting near home.

To everyone who shoots, it will bring increased pleasure afield.

Game farming means an addition to our food supply that will be welcome to all.

But this subject is too big to be properly treated in this space. Write for the book, "Game Farming for Profit and Pleasure," which will be sent to you without cost. It tells of the subject in a most interesting and informative manner. Fill out the coupon below and a copy will be mailed you at once.

Game Breeding Department, Room 100  
**HERCULES POWDER CO.**

Manufacturers of Explosives; Infallible and "E.C." Smokeless Shotgun Powders; L. & R. Orange Extra Black Sporting Powder; Dynamite for Farming.

Wilmington, Delaware

Game Breeding Department, Room 100  
Hercules Powder Company, Wilmington, Del.

Gentlemen:—Please send me a copy of Game Farming for Profit and Pleasure. I am interested in game breeding from the standpoint of.....

Very truly yours,

Name.....

Address.....

Ring-Necked  
Pheasant.

First imported  
from China in  
1881. Now being  
bred in fairly  
large numbers



Please Mention Popular Mechanics

Copyrighted material



## Satisfy That Wanderlust

When it gets you, it gets you good — that longing to be any place in the world but where you are — that's Wanderlust. There is one way you can satisfy that hankering for the long, open trail. Ride a

# Harley-Davidson

the three-speed Silent Grey Fellow that breaks speed records, climbs "impossible" hills, and gives the longest run for the money. Then you can go anywhere—any time.

If you knew all that a Harley-Davidson motorcycle with sidecar would do for you, you too, would realize that it is easier to own one than to do without.

### Get Rid of that "Pinned-Up" Feeling

Most dealers will make terms to suit your convenience. If you do not know your local Harley-Davidson dealer write the factory for catalog and full particulars.

## HARLEY-DAVIDSON MOTOR COMPANY

*Producers of High-Grade Motorcycles for More Than Fourteen Years*

453 B STREET

MILWAUKEE, WIS.



**I**F you are planning to build a home you will find it to your advantage to read this booklet before you decide on the material you are going to use. It is beautifully illustrated, full of valuable suggestions, and gives a short, concise statement of the merits of

## WHITE PINE

Three centuries of building in America have proved that no other wood so successfully withstands exposure to the weather as White Pine. And it is more than simply durable; it holds its place perfectly for more than a lifetime, without warping or checking or opening at the joints. This long and satisfactory service makes it the most economical wood for home-building.

Despite an impression of its scarcity, White Pine is still abundantly available today, as it always has been, in any quantity desired. If your lumber dealer is unable to supply it, we would appreciate the opportunity of being helpful to you in securing it. Send for bookle now. There is no charge for it to prospective home-builders.

Representing  
The Northern Pine Manufacturers' Association of Minnesota, Wisconsin and Michigan, and The Associated White Pine Manufacturers of Idaho

Address, *WHITE PINE BUREAU,*  
*1326 Merchants Bank Building, St. Paul, Minn.*

Please Mention Popular Mechanics

Men—Will you write us this  
letter?  
(Or just tear this out and mail it)

Mennen Chemical Company,  
2001 Orange St.,  
Newark, N.J.

Dear Sirs:

I am sceptical from the word "go". You say Mennen's Shaving Cream will give a more rapid and pleasant shave than anything else, because it is radically different in composition. You say it has no "free" caustic in it, that it is a neutral soap, and will make my face feel great. You say it has properties that soften the beard, without "rubbing in", and that with it I can even use a dull razor without unpleasantness. All this is hard for me to believe, for shaving is a "cussed" nuisance to me now, and if you're there with some real relief, I'm your customer. So I'm willing to give your cream a trial. Enclosed is 10c, for which send me a medium-sized tube. Also send me, free, a trial can of your Mennen Talcum for Men, which you say is so desirable for after-shaving, because it's a neutral tint and doesn't show.

Yours for a better shave.

Name.....

Address.....

City.....State.....

## MENNEN'S SHAVING CREAM



Please Mention Popular Mechanics

# ARROW COLLARS

*have the domestic satin  
laundry finish that is  
the quality mark of the  
higher priced collar*

2 FOR 25 CENTS

# ARROW SHIRTS

*are made in metropolitan  
styles of dependable fast  
color fabrics*

\$1.29 UPWARDS

CLUETT, PEABODY & CO., INC., *Makers*



*Please Mention Popular Mechanics*

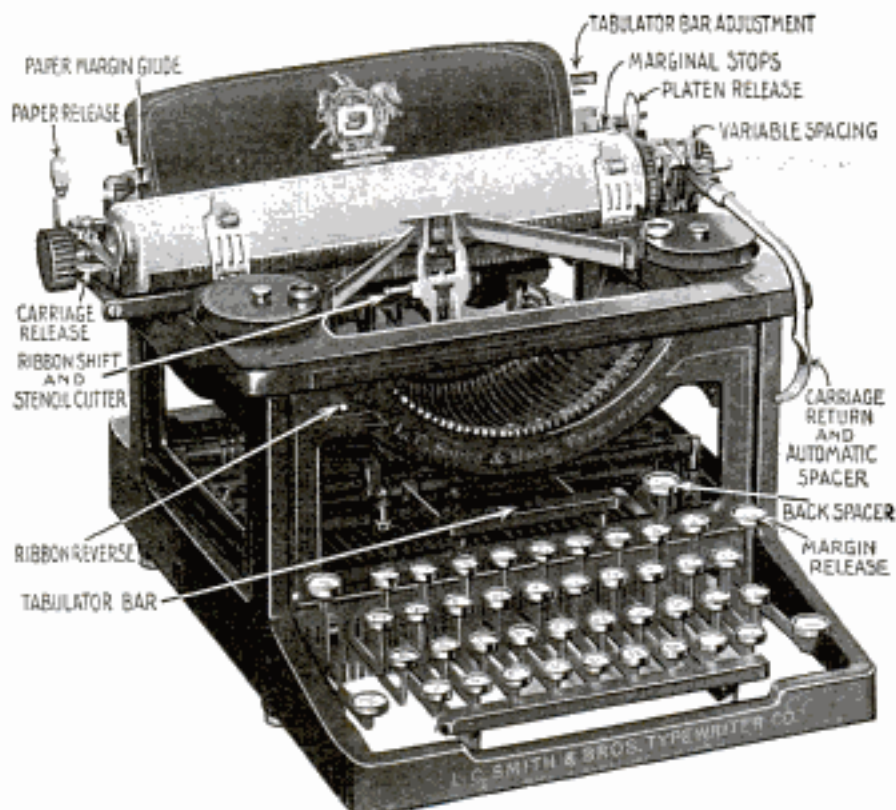

# TYPEWRITER SENSATION

**Free TRIAL—Use As You Pay**  
**Only \$2.50 a month until the low total price of \$48.80**  
**is paid, and the machine is yours**

This is absolutely the most generous typewriter offer ever made. Do not rent a machine when you can pay \$2.50 a month and own one. Think of it—Buying a \$100.00 machine for \$48.80. Cash price, \$45.45. Never before has anything like this been attempted.

**Standard Visible L. C. Smith**

Perfect machines, not damaged or shop worn. Standard size, Keyboard of Standard Universal arrangement writing 84 characters — universally used in teaching the touch system. The entire line of writing completely visible at all times, has the tabulator, the two color ribbon with automatic reverse, the Back Spacer, Ball Bearing type bars, Ball Bearing shift action, the carriage runs on Ball Bearings, in fact every late style feature and modern operating convenience. Comes to you with everything complete, tools, cover, operating book and instructions, ribbon, practice paper — nothing extra to buy. You cannot imagine the perfection of this beautiful reconstructed Ball Bearing typewriter until you have seen it. I have sold several thousands of these perfect latest style Model No. 2 typewriters at this bargain price and every one of these thousands of satisfied customers had this beautiful, strictly up-to-date, visible machine on five days' free trial, before deciding to buy it. I will send it to you f. o. b. Chicago for five days' free trial on receipt of your request, without obligation of any kind on your part to purchase. It will sell itself, but if you are not satisfied this is the greatest typewriter bargain you ever saw, you can return it at my expense — but — you won't want to return it after you try it — you cannot equal this wonderful value anywhere.

**H. A. SMITH**  
**510-231 N. Fifth Ave.**  
**CHICAGO, ILL.**

Ship me a No. 2 L. C. Smith f. o. b. Chicago, as described in this advertisement. I will pay you the \$40.00 balance of the SPECIAL \$48.80 purchase price, at the rate of \$2.50 per month. The title to remain in you until fully paid for. It is understood that I have five days in which to examine and try the typewriter. If I choose not to keep it I will carefully repack it and return it to the express agent. It is understood that you give the standard guarantee for one year.

**You Take No Risk—Put In Your Order Now**

When the typewriter arrives deposit with the express agent \$8.80 and take the machine for five days' trial. If you are convinced that it is the best typewriter you ever saw, keep it and send me \$2.50 a month until our bargain price of \$48.80 is paid. If you don't want it, return it to the express agent, he will return your \$8.80 and return the typewriter to me. I will pay the return express charges. This machine is guaranteed just as if you paid \$100.00 for it. It is standard. Over one hundred thousand people own and use these typewriters and think them the best ever manufactured.

The supply at this price is very limited, the price will probably be raised when my next advertisement appears, so don't delay. Fill in the coupon today—mail to me—the typewriter will be shipped promptly. There is no red tape. I employ no solicitors—no collectors—no chattel mortgage. I deal direct with you — by mail only. It is simply understood that I retain title to the machine until the full \$48.80 is paid. You cannot lose. It is the greatest typewriter opportunity you will ever have.

Get the coupon in the mail today — sure

**HARRY A. SMITH, 510-231 N. Fifth Ave., Chicago**

Name .....

Address .....

Pop. Mech. Mar.

# TRAVEL FIRST CLASS!

## THE CLEAN, CARE-FREE MOTOR-WHEEL WAY

**THE SMITH MOTOR WHEEL** brings travel independence. For pleasure and utility it is always at your service.

Power-bicycling, safe and fast, without motor vibration or dirt—that's **MOTOR WHEELING**—the clean, care-free way of travel!

The motor attaches in a jiffy to any coaster-brake wheel. Your bicycle pulses with new power, after two easy pedal-turns. And then your thumb lever rules.

A touch—and away you go! You may saunter along at four miles, or sail at a speed of twenty-five miles an hour. And always, the control is simple and safe—no troublesome

*Smith* **Motor Wheel**  
DETACHABLE

cranks, clutches or belts.

This magic motor whips up to 125 miles from one gal-

lon of gasoline. To and from business or pleasure—at six miles for one cent—you ride in comfort and ease. No special togs, for there is no grease or dirt.

The **SMITH MOTOR WHEEL** laughs at tardy street cars and is a stranger to garage delays, and breakdowns—just constant, willing service.

One ride tells the story. Try it at your dealers, or write for "Motor-Wheeling," our free book.

Dealers: A few exclusive territories are still open. Write for full particulars.

Motor Wheel Division

**A. O. Smith Company, Milwaukee, Wisconsin**

World's Largest Manufacturers of Automobile Parts

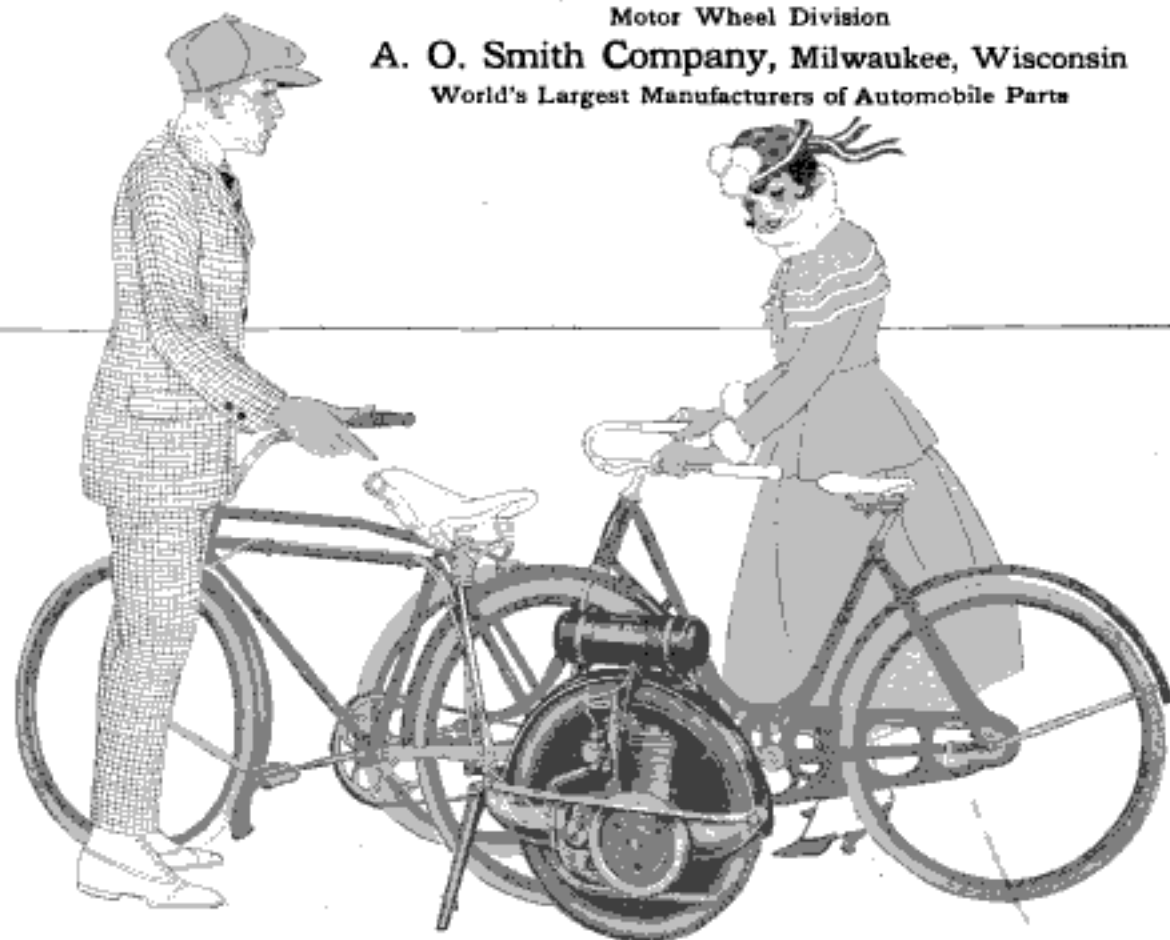

Please Mention Popular Mechanics

# The Next Great Business

# DOMELRE

## Domestic-Electric-Refrigerator

**T**HE better living American public has been waiting to pass up the ice man and delivered ice. Are you the man who will control this demand in your territory? We will turn over an **exclusive** and **perpetual** sales contract to the financially responsible man who knows the present and future possibility of practical and economical electric refrigeration for the homes.

### HERE IT IS— READY FOR DELIVERY

Not a laboratory experiment but a machine with two summers' proof of service behind it. Not a model but a manufactured product of interchangeable parts.

A silent, sturdy, electrically driven apparatus that keeps **your present refrigerator** at a uniformly low temperature night and day, without any attention or regulation.

Makes ice in cubes for table use from your favorite drinking water.

Maintains the safe and sanitary **low** temperatures insisted upon by the health experts—temperatures and dryness impossible with ice.

**And the first new use of electric current that is cheaper than the service it supplants.**

Don't write us if you are looking for a job, but if you want the most profitable business in your locality and have the ability or capital to finance a real monopoly, write for our proposition.

We have nothing to sell but machines and we have **opportunity** for the man who knows he can place domestic electric refrigeration in the good homes of your territory.

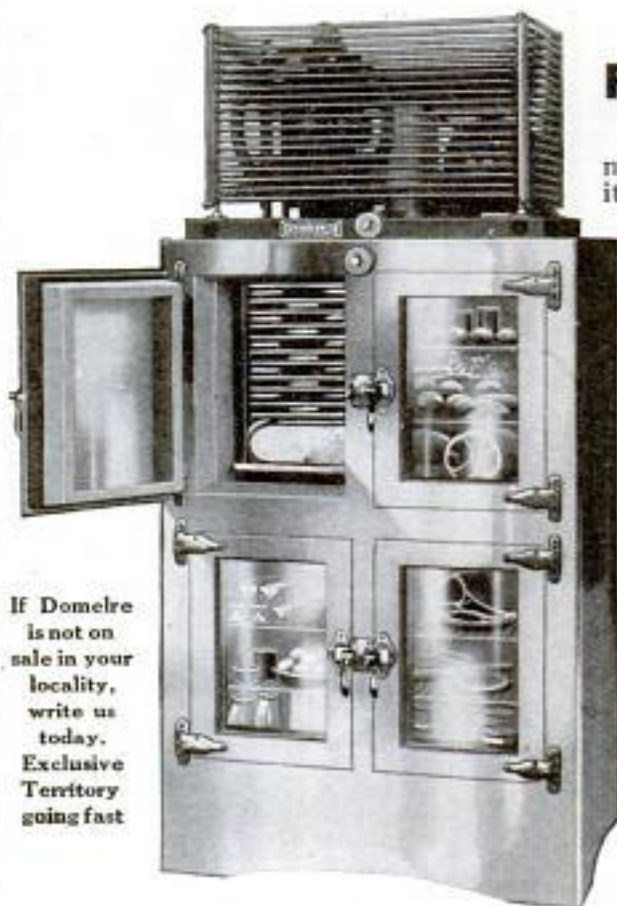

If Domelre is not on sale in your locality, write us today. Exclusive Territory going fast

*Cleaner, Colder, Cheaper than Ice*

## The Mechanical Refrigerator Company

718 Fisher Building, Chicago

FACTORY: CLYBOURN AVENUE AND WILLOW STREET, CHICAGO, ILL.

*Issco, Inc.  
(See Apr 15-412) 1735 Mt. Elliott Ave. Detroit Mich.*



# Money Grows if rightly planted



## A Yearly Income For Every Man and Woman

Would you save \$10.00 monthly for a few years if you felt assured it would earn for you an income of \$1,500 to \$2,000 yearly? This without a stroke of work on your part. *You do not have to leave your present business or employment unless you choose.*

That is what a Dixie Estate planted to fancy grapefruit, oranges, and avocados should earn after it begins bearing. Past and present prices for these fruits prove this an **EXTREMELY CONSERVATIVE ESTIMATE.**

Picture for yourself a cozy home in balmy Florida, beneath beautiful skies, among flowering shrubs and luxuriant money-producing fruit trees. SUCH IS A DIXIE ESTATE, which awaits you whenever your inclination draws you to it.

### SAVE NOW—SMILE LATER

We expect to plant at least 1,000 of these Dixie Estates this year and bring them into bearing for their fortunate owners. Will you be one? Think of this great and unparalleled opportunity!!!

## \$10.00 Monthly Is All You Have to Invest

You are not paying out or spending this money, but saving and investing it in a safe, money-making property—a highly developed fruit grove, which according to statistics should within a few years bring you a substantial income. Think what this really means to you—figure it out for yourself.

## A Dixie Estate Will Insure Your Future

**HERE IS THE ONE INVESTMENT** which must appeal to every man and woman. Whether you are drooping along for a mere living wage—whether you are a merchant or farmer—or whether you have an independent income, you cannot afford to miss this chance to own a Dixie Estate.

Citrus fruit and avocado trees are long lived. This is not a temporary investment, but one which will bring a permanent income and continue to increase in value yearly. Compare this with any investment you have ever heard of—you will have to admit a similar offer has never before been made.

### You Are Planting Money Rightly When You Invest in Dixie Estates

**LOCATION**—the best in all Florida, in the vicinity of Tampa—population, including suburbs, 70,000; growing so rapidly that it is destined to become the Los Angeles of the South. Dixie Estates will be near paved boulevards, railroad stations, schools and churches.

**THE SOIL** is as good as any of the best fruit land in all Florida. You could not buy better land for fruit growing no matter how much you paid for it.

**THE CLIMATIC CONDITIONS** are ideal for fruit growing. A more health giving, charming climate could not be desired.

**THE TREES** are the very finest obtainable—budded, pedigreed stock, grown by experts. Owning extensive nurseries and having years of experience developing Florida lands enables us to develop these Dixie Estates in the most approved, up to date manner.

Fancy oranges and grapefruit are well known money producers, when brought into bearing by expert, scientific methods.

The Avocado (commonly called alligator pear) is known as the aristocrat of fruits. The supply is so limited that in Northern Cities only the rich can afford to pay the extravagant prices it sells for. In December, 1915, Avocados sold in Chicago at the almost unbelievable price of \$3.00 to \$4.00 each. It is no doubt the highest priced fruit known.

**NORTH TAMPA LAND CO.**  
8th Floor Marquette Bldg. CHICAGO, ILL.

**ONE SINGLE AVOCADO TREE HAS PRODUCED \$1,500 IN FRUIT ANNUALLY.** When you realize what a wonderful fruit the avocado is you will understand why we claim that in Dixie Estates (which will contain 20% avocado, 40% grapefruit and 40% orange trees) you are offered a heretofore unheard of opportunity to derive a splendid **YEARLY INCOME FOR A SMALL INVESTMENT.** The proof is what you want!!! We have it and will gladly send it to you **FREE.**

**YOUR DIXIE ESTATE** receives expert and scientific care and attention for three years. A grove manager then takes charge if you do not wish to look after it personally. He will care for your Dixie Estate—its development and marketing of fruit indefinitely—for a percentage of the profits. You can receive the benefits of this truly marvelous proposition even if you never intend to live in Florida.

Every one of the several hundred thousand readers of this paper who mail us the coupon below will want a Dixie Estate after reading our illustrated booklet giving detailed information—therefore act at once and be certain of obtaining one of the first locations.

**MAIL THE ATTACHED COUPON TODAY.** We will mail you **FREE** full information showing you how easily you can become owner of a splendid money making Dixie Estate in the most attractive, most healthful, and delightful district to be found anywhere in America.

\*\*\*\*\*FILL IN AND MAIL COUPON NOW\*\*\*\*\*

**NORTH TAMPA LAND CO.,** P. M. 3-16  
8th Floor Marquette Bldg., Chicago

Please mail me detailed information and free Booklet on Dixie Estates. This does not obligate me in any way.

Name .....

Street No. ....

City ..... State .....

## Only \$8.75 To Make Your Push Button An Office Telephone

Use the same wires, the same bell or buzzer, the same batteries. Just get these two simple little Western Electric Inter-phones, and hook them onto the buzzer wires—one at your desk, the other near the buzzer.

You can then telephone for what you want and get your answer on the instant, without having the office boy or clerk waste his time in coming for your message. This simple arrangement saves time at both ends of the line. Most convenient, and stops the confusion of running back and forth.

We Will Send on Approval

### Western Electric Company

463 West Street, New York  
500 S. Clinton Street, Chicago

We will ship you these Inter-phones by parcel post, all ready to connect, on receipt of \$8.75. Your money back if not satisfied. For full particulars and directions for attaching these Inter-phones, write for Booklet No. 60-AW



## YOU Can Now Be a TRAFFIC MANAGER



**Earn \$35 to \$100 Weekly**

Thousands of large shippers and all railroads need trained Traffic Experts and Managers who know how to ROUTE SHIPMENTS to obtain SHORTEST MILEAGE, QUICKEST DELIVERIES, LOWEST RATES. Newly created positions are open with salaries of \$35 to \$100 weekly. The demand is greater than the supply.

**We Train You By MAIL!**

at home, in spare time, without giving up your position or income. Cost is small—we make payments to suit you. No matter where you live, what you work at now, how small your pay—our intensive Courses will train you expertly to handle profitably a big Traffic job. The LaSalle method is simple, practical, logical—anybody with intelligence can readily master it. It is the work of some of the greatest Traffic Experts in America.

**New, Uncrowded Occupation**

This is a new, UNCROWDED occupation—there's room for you if you prepare at once. Let us train you NOW for a big future, with power, big income, and almost unlimited possibilities.

**"10 Years' Promotion In One"** Write quick for great book—"10 Years' Promotion In One"—learn about the remarkable opportunities afforded Traffic Experts with our training—learn about big opportunities now open—learn how easy it is for us to make YOU a traffic specialist. Remember, only trained men can secure the big positions—remember that employers are seeking trained and competent traffic men. Send no money—everything is free. This is your grand opportunity.

**ACT NOW!**  
LaSalle Extension University, Dept. 364CA Chicago

**The Litt Sho-Fur for FORD CARS**

This flat spring does the trick.

Safety assured. No more tired wrists. Simplest, lightest, safest, and cheapest, perfect steering device on the market. Every Ford owner must have one. Write for full description. This is a gold mine for you. Ford Owners buy at sight. Dollar an hour profit. Sales guaranteed. Full details free.

**Price \$3**  
Prepaid

White Mfg. Co., Dept. P, Cincinnati, O.

## Health? Take Turkish Bath at Home—Only 2 Cents



Physicians are abandoning drugs for this new treatment. If your mind or body is tired, open your pores and feel the rapid change in your condition, at cost of 2c a bath. The Robinson Bath Cabinet is the only scientifically constructed bath cabinet ever made for the home. Great \$2 Book Sent Free—"The Philosophy of Health and Beauty." Write today. Agents Wanted.

**ROBINSON MFG. CO.**  
857 Factories Bldg. TOLEDO, O.

## AGENTS-Salesmen New-Just Out

**NO CAPITAL NEEDED to START**

A wonderful invention—for picking up and carrying Caspidors without touching hands or clothes. Sells without using to office buildings, hotels, depots, railroad offices—everywhere caspidors are used. Users enthusiastic. Endorsed by Boards of Health. Fast money maker.

**\$10.00 TO \$20.00 A DAY**  
100 PER CENT PROFIT

No experience necessary. Demonstration sells eight out of ten. Every building to be supplied. Janitors buy on sight. WRITE QUICK FOR TERRITORY APPOINTMENT.

**KEITH MANUFACTURING COMPANY**  
37 D Keith Bldg. CANTON, OHIO



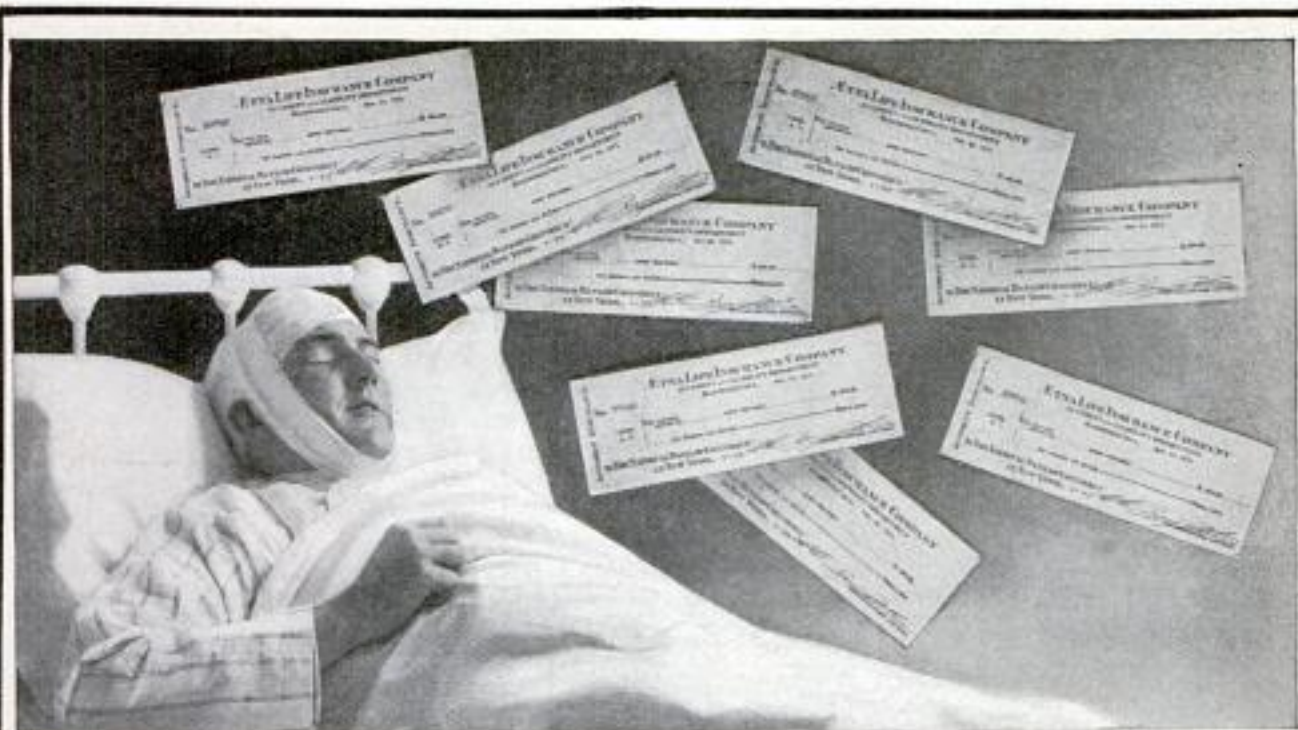

## The Checks That Helped to Make Him Well

**B**EFORE the accident, when he was earning money regularly each week, he had the foresight to pay a small sum to the Aetna. Calm, every-day life—and then a fall down the cellar steps. Now he gets a check for \$100 from Aetna each four weeks—and the avoidance of money worry is helping him to get well.

Follow his example—protect yourself against accident—and sickness, too—



# AETNA-IZE



In the hurried life of this day, accidents and sickness are inevitable, and they give no warning of their coming. You can't avoid them. But you can be sure you have money when they do come.

Aetna-ize! Draw a weekly income from us and cancel the danger. If you are engaged in a "Preferred" occupation, and are under 51 years of age, \$60 a year is all it will cost you. For that small sum—

**We will pay you \$50 a week as long as you live if you are disabled by a railway, steamship or burning building accident, or \$25 a week for life if you are disabled by an ordinary accident. And we will pay you \$25 a week, up to 52 weeks, if you are sick. We will pay hospital charges or for a surgical operation.**

**If you are killed in an accident, we will pay your wife from \$5,000 to \$15,000, depending on the number of years you have carried the insurance, and whether the accident was an ordinary one or happened while you were traveling or in a burning building.**

**If you lose two limbs or both eyes by accident we will pay you the same amounts. One-half of these amounts will be paid you for loss of one hand, one foot or one eye by accident. We also pay the weekly indemnity between date of accident and date of death or other loss described.**

**The coupon cost you nothing and it puts you on the road to safety. Send it today.**

**AETNA LIFE INSURANCE COMPANY**  
 Drawer 1341 HARTFORD, CONN.

*The largest company in the world writing Life, Accident, Health and Liability Insurance*

Agency opportunities for all Casualty and Bonding lines

An Aetna agent has a national advertising campaign working for him all the time.

Name .....  
 Occupation .....  
 Bus. Address .....  
 AETNA LIFE INSURANCE COMPANY  
 Drawer 1341  
 I have marked the kinds of insurance  
 I wish to know about: Accident   
 Health  Disability   
 My age is ..... years.  
 I am in good health.

P. M. 3-12

Please Mention Popular Mechanics

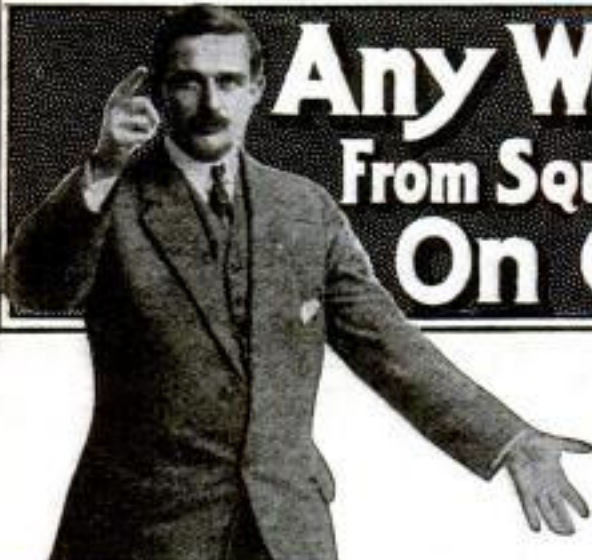

# Any Watch You Want From Square Deal Miller On CREDIT

**Waltham  
Hamilton  
Howard  
Elgin**

**Illinois, Seth-Thomas, Rockford**



## I SMASH THE TERMS!

I have well earned My title of "Terms Smashing Miller." No catalog published offers **Any Make of Watch You Want** on as Easy and as Liberal Credit Terms as the New Book sent to you Free for your name and address.

**Your Choice of  
Inlaid Enamel Cases**

**30 Days Free Trial—No Money Down  
Express Prepaid in Advance by Me**

That is the test that tells. Suppose you want a watch? Any make, any grade, any size, any case. I have it for you—just the watch that you want. **NO MONEY DOWN, Express Prepaid.** You can try any one of America's best known timepieces for 30 Days. **A Free Trial, a Full Month to Carry It in Your Pocket.**

**An Open Account—No References Demanded**

The same kind of credit you get from your grocer liberally and cheerfully given. Arrangements are made for an Open Account as soon as you write. No red tape, no publicity, notes or collectors. Every transaction is strictly confidential on terms made to suit you.

**Send Coupon for Watch and Diamond Book**

**Why You Should Have This Book.** It is the Encyclopedia of watches; a Dictionary explaining watch words; a History of Watch Making in America; the only Index Book of a **Good Watch** and an Absolute Authority on Watch Buying. Use a postcard, a letter or the convenient coupon. **Know Facts** on All makes of watches before buying anywhere. This book is a Key to watch buying. It tells you how to judge a good watch. Write for it today and get a letter from Square Deal Miller that makes you a friend for life.

**Square Deal MILLER, Pres.**

**Miller-Hoefler Co., 631 Miller Bldg.  
Detroit  
Mich.**



**FREE  
CATALOG COUPON**

**Square Deal Miller, Pres.  
631 Miller Bldg., Detroit, Mich.**

Dear Sir: Please send me, without cost or obligation, your Big Book of Facts on all makes of High Grade Watches, Genuine Diamonds and Jewelry and full information on your Easy Payment, No Money Down and 30 Days Free Trial Plan.

Name \_\_\_\_\_

Address \_\_\_\_\_

Please Mention Popular Mechanics



# Genuine Imported English Serge

Made - **\$14.50**  
to-Order  
For Only

**G**LENN Urquart Plaids—Tartan Plaids, Shepherd Plaids, Fancy and Pencil Stripes, Two tone stripes. Your choice of any cloth, plain or fancy weaves, rough mill finish or smooth finish—tailored to your own measure at prices that will astound you.

Send the coupon for our new Style Book and read of the remarkable bargains in tailored-to-measure clothing. Newest fabrics—at prices never before equaled by any other high-grade house.

The Imported English Serge is but one of the bargains we offer. Just think of it! A genuine Imported English Serge—made to your measure for only \$14.50.

Pay \$4.50 first and the balance in small monthly payments. Your credit is good.

## On Credit!

You do not pay a cent unless you are delighted with the suit—after it has been tailored to your own measure. See for yourself before you decide to buy. Note the perfect fit—note how carefully it is made in the latest style—compare it with any other suit you ever bought—then, if you are not satisfied, send it back.

If you decide to buy—you may pay the bargain price—a little each month. Your credit is good

## New Style Book

and Samples of the Latest Fabrics—FREE

Send the coupon for our Style Book and samples at once. See for yourself the astounding bargains

we are making. Examine carefully the newest fabrics. See handsome illustrations of the latest New York styles. The Style Book is free—write for it today. You will be under no obligations—and your name will be recorded so that you can take advantage of these great price reductions made for introductory purpose.

### Send the Coupon

For free colored Style Book and samples of the newest fabrics for suits and overcoats. We can have your suit ready in 10 days. Send for booklet and free imported samples.

**Babson Bros.** Dept. 1193 19th Street Chicago

**Babson Bros.**  
Dept. 1193 Chicago

Gentlemen:—Please send me your free colored Style Book and samples of fabrics for suits and overcoats. Also explain your easy credit terms.

Name .....

Address .....

# A Good Bookcase for the price of a good book!



This Combination:  
3 Sections, glass doors, top, and  
base, (Solid Oak) **\$775**  
ON APPROVAL

## Lundstrom IT GROWS WITH YOUR LIBRARY SECTIONAL BOOKCASE

Our "Universal Style" combines a pleasing, enduring design with latest practical improvements. Adapted for home or office library; beautifully finished in SOLID OAK with non-binding, disappearing glass doors, at \$1.75 per section; open, without doors \$1.25; top and base \$1.25 each. Greatest value we have ever offered. On orders amounting to \$10.00 and over we pay freight; freight equalized to extreme Western States. Other styles and grades at correspondingly low prices. Sold only direct from our factory at a considerable saving to you. Hardly a village in the country left where there are no Lundstrom Bookcases. Endorsed the best by over 75,000 users — many prominent citizens, governors, senators, doctors, lawyers and clergymen. Lundstrom Bookcases have been made for 15 years and have always given full satisfaction. Write for our new catalog No. 21-M.

PER SECTION  
**\$1.75**

THE C. J. LUNDSTROM MFG. CO.  
LITTLE FALLS, N. Y.  
Mfrs. of Sectional Bookcases and Filing Cabinets  
Branch Office: Flatiron Bldg., N. Y. City.

### BUY PLUMBING and HEATING SUPPLIES



at WHOLESALE Will Save You 30%  
Don't pay retail prices. Full stock on hand for prompt shipment. Send for free catalog.

B. P. KAROL, 800-802 South Kedzie Ave., CHICAGO



### Typewriters

-- All makes, factory rebuilt by the famous "Young Process"; look like new, guaranteed like new. Our big business insure "Square Deal" and permits lowest cash prices -- \$10 and up; also machines rented -- or sold on time. No matter what your requirements are, we can best serve you. Write and see -- NOW.  
YOUNG TYPEWRITER CO., Dept. 357 CHICAGO

Please Mention Popular Mechanics



One of 38 Styles

# 4 Weeks' Trial

Choice of 38 Styles

Yes, we will ship you on four weeks' absolutely free trial direct from our own factory your choice of 38 new styles of the highest-grade Wing Piano or

Player Piano. No money down — no C. O. D. — no security.

**No Money Down — Not a Cent of Freight**

Use it and enjoy it four full weeks; then, if you wish, ship it back at our expense. You alone are the judge. You will be amazed at our rock-bottom, direct price on the superb Wing, guaranteed 40 years. Easy monthly payments or cash. Write today.

**Valuable Book — FREE** "The Book of Complete Information About Pianos" sent free and post-paid. Valuable 136-page book. Tells how to judge pianos. Beautiful art catalog also sent and particulars of great Free Shipment Offer. Write today.

Wing & Son (Est. 1868), Wing Building, 9th Ave. & 13th St., Dept. 1193, New York

## 40 to 50% off Market Prices

Our Customers Letters Continually Praise This  
A firm of over 60 years of unquestioned integrity, backed by \$750,000, is offering diamonds of the finest grade — fully 50 per cent below normal price. Fully guaranteed. Write for bulletin.

**Diamond Banking** Lending money on diamonds enables us to quote amazing low prices.

**Free Examination** We will send prepaid the gem or watch of your choice on approval. If not satisfied with article after seeing it, return at our expense.

**Write Today for Latest Bulletin** Send your name and address for latest bulletin of diamond bargains. No obligations — write today — now.

**Jos. DeRoy & Sons** Only Opposite Post Office  
1912 DeRoy Bldg., Pittsburgh, Pa.  
Reference by permission — Farmers' Deposit National Bank, Marine National Bank or any Pittsburgh daily Newspaper.

A SPRING THAT FLOWS ON SUNDAYS ONLY—  
Such a spring—fanciful as the statement may seem—actually exists in Connecticut, according to a report to the Society of Civil Engineers of that state. This spring,

## TYPEWRITERS ALL MAKES ALL PRICES

Look at these bargains! Typewriters Rebuilt in our own factories and guaranteed for one year.

Remingtons \$15 to \$65	Smiths \$18 to \$50
Underwoods \$25 to \$65	Royals \$30 to \$40
L. C. Smiths \$28 to \$60	Olivers \$33 to \$40
Brand new No. 2 Smith-Premiers \$45	

We have others, of course. Send for catalog describing them. Branch offices in principal cities.  
American Writing Machine Co., Inc., 345 Broadway, N. Y.

## CLASS PINS

FACTORY TO YOU

RE-3249 Made to your special order, any style or material. Write to-day for free catalog of 1915 designs. Special offer, either style of pins here illustrated with any equal number of letters and figures, with one or two colors of best hard enamel. SILVER PLATE, \$ .15 each, \$1.50 per dozen; STERLING SILVER, \$ .30 each, \$3.00 per dozen; GOLD PLATE, \$ .35 each, \$3.50 per dozen; SOLID GOLD, \$1.50 each, \$15.00 per dozen.  
BASTIAN BROS. CO. 825 BASTIAN BLDG., ROCHESTER, N. Y.

SUPERIOR SINCE 1904

A limited number of slightly Trial-Worn and agents' demonstrating samples, will be sold, while they last, for

# \$5 CASH WITH ORDER

subject to refund after 10-day trial. Guaranteed to be in perfect operating condition for at least 1 year.

**Golden Gem** PORTABLE Adding Machine  
Multiplies - Subtracts

E. Goucher A.A.M. Co., 148 Duane St., New York

**300  
Home Plans  
FREE**



**Standard Home No. 106**—All lumber, millwork, hardware and paint for this attractive bungalow; five rooms and bath; balcony; big hall; Craftsman slash grain fir finish; Craftsman hardware; complete **\$1062**



**Standard Home No. 301**  
All material with complete plans at wholesale, direct-to-you price of **\$744**



**Standard Home No. 121**  
All material with complete plans at wholesale, direct-to-you price **\$1026**



**Standard Home No. 193**  
All material with complete plans at wholesale, direct-to-you price **\$957**

# Save \$200 to \$500 On Your Home! Shipped Anywhere

**—Safe, Prompt Delivery and Satisfaction or Money Back!**

We have letters from hundreds of home owners telling how Gordon-Van Tine methods have saved them from \$200 to \$500 and even \$800. Cozy houses \$300 up! Send coupon; learn what we can save you. Get our 2 big plan books. (300 plans, photos, color schemes, exact costs). **FREE!** We sell

**Ready-Cut Homes**—All Material Cut to Fit

**Standard Homes**—Material Furnished in the Standard Way

Our two big new plan books fully describe both ways. No bothering with architects. Local lumber yard delays eliminated. Highest grade materials. Convenience ideas, well-planned kitchens, pantry cases built-in; no \$35 kitchen cabinets needed. Linen closets; beautifully grained 2-panel fir doors; bungalow trim; for mahogany or other finish. Many labor-savers appealing to women. All at

**Wholesale Prices!** Save enough to pay your carpenter labor.

We sell through catalog only. Lowest selling expense makes prices rock-bottom. Over 100,000 home owners and 10,000 contractors buy regularly from us. Do the same.

**Get These 3 Books FREE**

Two big plan books. This is cheap building year. Build now. Also get free our 5,000 Bargain Catalog of Building Material—156 illustrated pages of money-savers. Send coupon **NOW!**

**GORDON-VAN TINE CO.**

804 Federal St., Davenport, Iowa  
Established Half a Century!

**Corporations and Other Quantity House Buyers**

We are in a position to deliver big quantities of houses, varied in plan and appearance, on short notice. Standard Homes or Ready-cut Homes. Corporations, Townsite Development Companies, Boards of Trade and others interested are invited to visit our plant at Davenport, inspect our grades, investigate our facilities and look into our wholesale prices.

**Gordon-Van Tine's  
Standard Homes**

**Gordon-Van Tine's  
Ready-Cut Homes**

**GORDON-VAN TINE CO.,**

804 Federal St.,

DAVENPORT, IOWA

Standard Home Plan Book

Garages—Ready-Cut or Portable

Ready-Cut Plan Book

Hotbeds and Greenhouses for the Home Grower

5,000 Building Material Bargain Catalog

Summer Cottages

Please send me specific information about:

Mention here articles in which you are most interested.

Name..... Street No.....

City..... State..... Occupation.....

Please Mention Popular Mechanics

## Don't Write It On Your Cuff!



**Jot It Down Here**

### MEMO BOOK HP LEAF BOOK

Fits the vest pocket without bulging. Always ready. Ideal way to jot down and preserve valuable data. Covers last for years. Bound in handsome, durable Morocco. Sheets can be obtained anywhere. Six styles of ruling. Easy to insert fresh sheets when needed.

No. 1101, End Opening, 2 x4, .....	\$0.65
No. 101 $\frac{1}{2}$ , Side Opening, 4 $\frac{1}{2}$ x2, .....	.70
No. 1102, End Opening, 2 $\frac{1}{2}$ x4 $\frac{1}{2}$ , .....	.75
No. 103, Side Opening, 5 x3, .....	.85
No. 1103, End Opening, 3 x5, .....	.85

As Useful as Your Pencil — Acknowledged the Best.

At Your Stationers — or Prepaid on Receipt of Price.

**Irving-Pitt Manufacturing Company**  
Largest Loose Leaf Manufacturers in the World  
407 Eighth Street KANSAS CITY, MO.



**THIS IS THE WAY**

## TO MAKE MONEY

To any woman who has no special training and wants to earn money, I would recommend nothing better than selling World's Star goods. When I started in this work I had never done any soliciting of any kind. The commission on my first day's orders came to \$7.00. What other work is there that a woman can do to earn that amount? One cannot help but succeed with World's Star goods and enthusiasm. Both will lead to success. So writes Mrs. G. H. Littlefield, of Oregon.

From Mill to Home

## World's Star Hosiery and Klean-Knit Underwear

Lower Prices Higher Values

In more than 9000 cases we have helped ambitious, deserving women. You can do the same as they have done. Sell World's Star Hosiery and Klean-Knit Underwear in your home town. No previous experience is necessary—we show you how to make money in an easy, congenial and profitable way. World's Star Hosiery and Klean-Knit Underwear are known everywhere. Our advertising makes sales easy—the quality holds the trade.

Prompt Deliveries and Protected Territory  
Our free catalog tells whole story. Write today.

**WORLD'S STAR KNITTING CO.**  
DEPT. 141  
DAY CITY, MICH.

We have been in business here for twenty-one years.

## $\frac{1}{3}$ SAVED Buy Direct From MANUFACTURER



FREE BOOK

### Do Your Own Plumbing and Heating

NEW HARDIN EASY WAY

Get our "Handy-Man" Free Book. Every home needs it. Shows new home improvements and everything in plumbing and heating supplies EXCLUSIVELY at wholesale prices—complete heating plants, bathroom outfits, sinks, pipe, fittings, water systems, lighting plants, etc. Any handy man can install our goods with this free book and free easy installing plans. \$500,000 plants behind our guarantee. Write today.

The Hardin-Lavin Co. 40 years at 4540 50 Cottage Grove Ave. Chicago

which is located in a picnic ground, formerly flowed perpetually, but now its activity is confined to Sundays and holidays. The explanation is that artesian wells have been drilled in the vicinity of the spring to supply water to near-by silk-dyeing establishments. Only when the pumps stop for a day the water rises sufficiently for the spring to flow.



## 3 YEARS TO PAY

Meister Piano 30 days free trial in your own home

\$1 A WEEK or \$5 A MONTH Price \$175.00

No cash payment down. No interest — no extras. Piano stool and scarf free

ROTHSCHILD & COMPANY  
Dept. 165 CHICAGO, ILL.

## Runs on Alcohol

At Cost of Less than  $\frac{1}{2}$ ¢ an Hour

anywhere without electricity, springs or batteries. Superb construction. 12-inch blades. Adjustable roller bearing. Reliable. A proved comfort. Prompt delivery. The original and only Lake Breeze Motor manufactured according to the design of the inventor and under his direct and personal supervision.

Keep Cool

\$15 Cash with Order

Lake Breeze Motor, 122 N. Jefferson St., Chicago



**HERE YOU ARE, BOYS** A medallion pin of Foxy Grandpa. Everyone will notice it on the lapel of your coat and try to get a closer look at it. All you have to do is press the bulb.—Foxy Grandpa will finish the job by squirting a fine stream of water over the inquisitive one. Will squirt 20 feet. Greatest joke out. Order one today and fool your friends. Price 15c. Foxy Grandpa and Hooligan both for 25c. 5 for 90c or 1 doz. for \$1.00. A beautiful fountain pen free with every \$1.00 order.  
AMERICAN SUPPLY CO., 918 Union St., St. Paul, Minn.

# DIAMONDS

ON CREDIT

20% DOWN

10% A MONTH

The most beautiful Diamonds are the Blue-white, especially if absolutely perfect. LYON DIAMONDS are 1st Quality, Blue-white. A certificate furnished with every Diamond guaranteeing its value and providing for exchange at full purchase price. Goods sent prepaid for examination and approval. Write for Catalog No. 3.

J. M. LYON & CO., (Incl. 1942), 71-73 Nassau St., NEW YORK.





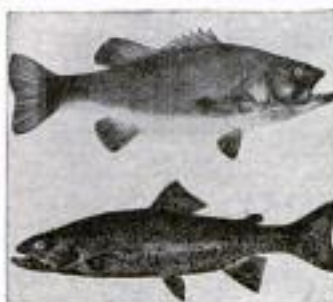

## Learn to Mount Specimens Like These

This advertisement is for every *sportsman* and *nature lover*, everywhere. *Write to-day. Send the coupon* for our *free books*. They contain something of great value to hunters, trappers and all people who love the out-of-doors. *You* should have this book. *Write for it today.*

## Do You Shoot or Fish?

If so, you should be able to save your beautiful and valuable trophies. *We can teach you how.* We have taught over 35,000 of the sportsmen of the country, and they are now doing their own taxidermy work with wonderful success. They save taxidermists' bills and enjoy their spare time as never before. Taxidermy is the most fascinating of all professions. *We can teach you to mount all kinds of game specimens* absolutely true to life, by the latest and best methods. Easily, quickly and perfectly learned, in your own home *during your spare time.* No need of leaving your present employment. You can decorate your home with Nature's best art; you can double your interest in sportsmanship. Let your gun and rod pay for your vacation.

**BIG PROFITS** You can easily make from \$25 to \$50 a month during your *spare time*, practicing Taxidermy, or if you go into the work as a profession you can make \$5,000 or more per year. You can sell your own mounted specimens for big profit. You can make big money doing mounting for others. You should investigate this remarkable offer.

## This Taxidermy Book FREE

We will send you this book on taxidermy absolutely free. It tells you all about our school and the most fascinating profession of Taxidermy. It will tell you how you can learn to become an expert taxidermist in a few months—*by mail—in your own home*—during your spare time. You need this book and it costs you *absolutely nothing.* Merely send in the *free coupon.* Write for it today—it is free—we will also send you the famous *Taxidermy Magazine* and hundreds of letters from our delighted graduates. Write today—*now—immediately—before you lay aside the paper.*

**NORTHWESTERN  
SCHOOL OF TAXIDERMISTRY**  
1193 Elwood Building  
OMAHA, NEB.

"A school for sportsmen  
by sportsmen."



**FREE  
COUPON**

Northwestern School  
of Taxidermy  
1193 Elwood Bldg.  
Omaha, Neb.

Gentlemen:—Please send me your new book on Taxidermy and the Taxidermy Magazine, also full particulars of your special offer. All Free and prepaid. No obligations on me whatsoever.

Name.....

Address.....

Please Mention Popular Mechanics

# \$1<sup>00</sup> DOWN

Billiards and Pool are fine, clean, interesting games—games that fascinate with their close, exciting, constantly changing situations—games that test the skill of hand, eye and brain, and arouse the keenest sort of friendly rivalry—games that the whole family will enjoy.

Under our easy payment plan you will be surprised to find how easily you can own a handsome Burrowes Billiard and Pool Table. No special room is needed. The Table can be mounted on dining or library table or on its own legs or stand, and quickly set aside when not in use.

## BURROWES Billiard and Pool Table



is splendidly built, on scientific principles, and correct to the minutest detail. The rubber cushions used are the Burrowes Regis High-Speed Cushions—great experts say there is nothing better made. The most delicate shots, calling for skill of the highest order, can be executed with the utmost precision.

**FREE TRIAL** Prices are from \$15 up, on easy terms of \$1 or more down (according to size and style) and a small amount each month. You can play while you pay. Sizes of Tables range up to 4½ x 9 feet (standard). Cues, balls, etc., free with each Table.

**WRITE FOR ILLUSTRATED CATALOG**

Containing free trial offer, prices, terms, order blank, etc. Don't delay—write today!

**THE E. T. BURROWES CO.**  
165 SPRING STREET  
PORTLAND, ME.

*Mfrs. Burrowes Rustless Screens,  
Burrowes Folding Card Tables,  
Burrowes Cedar Chests.*

# BE A BIG MAN IN YOUR OWN TOWN

**START A HAYWOOD  
TIRE REPAIR PLANT**



## MAKE \$3000 A YEAR TO START

Sounds like a whole lot of money, and it is—looks pretty big from where you stand if you are earning just an ordinary salary at an ordinary job, but why continue the job? Why be on that side of the fence?

**It is not every business that will permit you to start with a very small investment.** Most manufacturing businesses require big capitalization. And rich men take the profits, while you the producer, get a salary and the small end. But here is a business that gives **big returns, quick returns,** and the demand for your product is ahead of the supply and increases every day in the year.

### YOUR WONDERFUL OPPORTUNITY

The certainty of success in this business is about as sure as anything in the world can be. Automobile owners increase by the thousands each year and the tires are still the least durable part of the car. Every owner tries to cut down his tire expense—every owner tries to repair his tires as long as they will hold together. Make up your mind and send for our catalog TODAY. Learn of the wonderful money making possibilities in this fascinating new business. Make something—supply a want—become a manufacturer. This is your chance. **Send today for FREE catalog.**

**The Haywood Tire & Equipment Co., 607 N. Capitol Avenue, Indianapolis, Ind.**



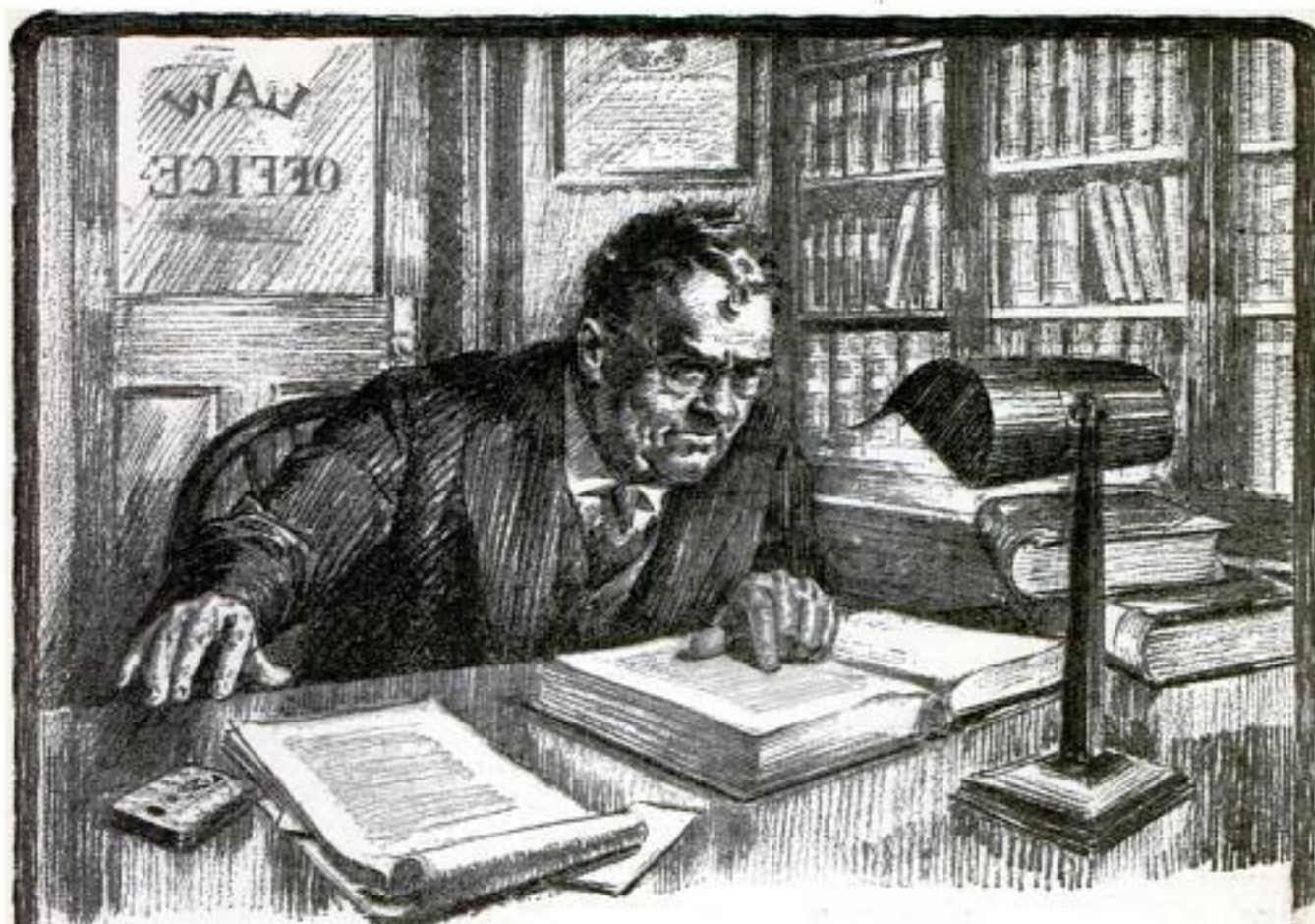

## Take Counsel of "PIPER"

It's wonderful how the quiet companionship of "PIPER" clears away brain-cobwebs and gets a man's mind right down to brass tacks. That's why thousands of the brainiest men in America chew

# PIPER Heidsieck

CHEWING TOBACCO—Champagne Flavor

There's soul-soothing, body-comforting friendliness to "PIPER" that makes you work better because you feel better. You don't get this same gratifying enjoyment from any other form of tobacco—or from any other chew.

"PIPER" is different—its distinctive, wine-like *flavor*, blended with the richness and mellowness of ripe, selected leaves of the finest white Burley, make "PIPER" the world's highest type of chewing tobacco. Try "PIPER" today—for helpful, wholesome pleasure and lasting satisfaction.

5c and 10c cuts, foil-wrapped, in slide boxes. Also 10c cuts, foil-wrapped, in metal boxes. Sold everywhere.

THE AMERICAN TOBACCO COMPANY

Please Mention Popular Mechanics

Copyrighted material

# It's Easy Now to Own a WITTE ENGINE

Kerosene, Distillate, Gasoline, Naphtha & Gas

Let me send you a WITTE Engine to earn its own cost, while being paid for. WITTE Engine power is cheaper than muscle or brute power, for any work that can be hitched to a belt. No need to let any such work go undone, for lack of dependable hired man, or team help.

## Look at These New Prices

Direct from Factory to User

2 H.P. \$34.95; 4 H.P. \$69.75; 6 H.P. \$97.75  
8 H.P. 139.65; 12 H.P. 197.00; 16 H.P. 279.70  
22 H.P. 359.80. *Portable Engines proportionately low.*

For 29 years the WITTE has set the standard of engine quality. It has **always** proved itself **dependable**—so simple in construction that you can easily understand, start, and run it, whether you are experienced with any engine or not. Guaranteed steady power with small fuel consumption. No gas or oil engine has outlasted the WITTE, and few, **very** few, of them work for an equally low fuel cost.

## 60 DAYS' TRIAL Liberal Five-Year Guarantee

I don't consider any sale closed until the engine has made good—proved itself under actual test.

Under my New Plan, you are sure of knowing what any engine **ought** to do, besides knowing what my engine **can** do, before your engine purchase is finally closed.

I am the only man in the U. S. who makes his own engines, in his own debt-free factory, from his own designs, using his own special machinery and selling his output **under his own name, direct from factory to user.**

I don't owe any money for stock, bonds, notes or mortgages, or for anything else. My entire plant and every other dollar I have—a total of over half a million—is behind my **five-year guarantee.** I have never done anything else but make WITTE Engines. When I started making WITTE Engines, 29 years ago, the gasoline engine business was new. Today, I am the only man in the business who started when I did, and my factory is the only one which has come through successfully under the continuous management of the man under whom it was started and who made his own first engine. WITTE engine-quality is the only thing that did it. I challenge anyone to show stronger proof of reliable engine-quality.

Mail this  
Coupon  
Today

ED. H. WITTE,  
Witte Engine Works,  
1749 Oakland Ave., Kansas City, Mo.  
1749 Empire Bldg., Pittsburgh, Pa.

With no obligation on my part, I should like to receive your latest and finest Engine Book, with your new liberal Selling Plan.

## Get My Complete New Offer and Copy of My New Book FREE

You should have a copy of my new Engine Book—the finest in the business. Explains fully my liberal easy terms and sales plans—tells how to judge an engine. Mail coupon today and I will send you the whole WITTE story by return mail.

ED. H. WITTE, WITTE ENGINE WORKS  
1749 Oakland Avenue Kansas City, Mo.  
1749 Empire Bldg. Pittsburgh, Pa.



### WITTE Gasoline and Naphtha Engine Stationary

Shown mounted on iron sub-base which makes a permanent foundation where it is impractical to use masonry construction.

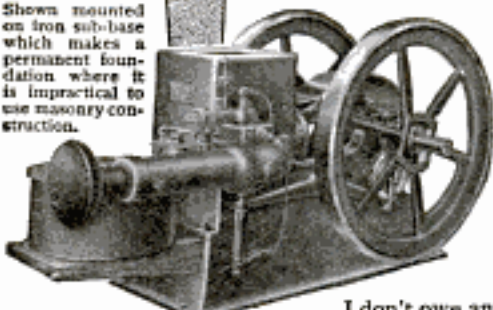

### WITTE Kerosene Engine— Stationary

Burns Kerosene, Distillate, Solar Oil, Toppings and all fuels of like grades. Also Gasoline, Naphtha and Gas.

NAME.....

ADDRESS.....

# The Burlington SMASHES ALL WATCH PRICES



## Look!

- ☞ 19 Ruby and Sapphire Jewels—
- ☞ Adjusted to the second—
- ☞ Adjusted to temperature—
- ☞ Adjusted to isochronism—
- ☞ 25-year gold strata case—
- ☞ Genuine Montgomery Railroad Dial—
- ☞ New Ideas in Thin Cases.

# Only \$2.50 A Month

And all of this for \$2.50—only \$2.50 per month—a great reduction in watch prices—direct to you—positively the exact prices the wholesale dealer would have to pay. We do not care to quote these prices here, but write—write before you buy. Think of the high grade, guaranteed watch we offer here at such a remarkable price. Indeed, the days of exorbitant watch prices have passed.

## See It First

You don't pay a cent to anybody until you see the watch. We won't let you buy a Burlington Watch without seeing it. Look at the splendid beauty of the watch itself. This model, handsomely shaped—aristocratic in every line. Then look at the works. There you see the pinnacle of watch making. You understand how this wonder timepiece is adjusted to the very second.

Every fighting vessel in the U. S. Navy has the Burlington Watch aboard. This includes every torpedo boat—every submarine as well as the big Dreadnaughts.

## Send Your Name on This Free Coupon

Get the Burlington Watch Book by sending this coupon now. You will know a lot more about watch buying when you read it. You will be able to "steer clear" of the double-priced watches which are no better. Send the coupon today for the watch book and our offer.

**Burlington Watch Co.**  
19th St. & Marshall Blvd., Dept. 1193, Chicago, Ill.

**Burlington Watch Co.**

19th Street and Marshall Blvd.  
Dept. 1193 Chicago, Ill.

Please send me (without obligation and prepaid) your free book on watches with full explanation of your cash or \$2.50 a month offer on the Burlington Watch.

Name.....

Address.....



*There's old-fashioned*

*honesty in these*

## GOOD TOOLS

**T**HE mechanic who comes across any Goodell-Pratt tool is brought face to face with the same conscientious material, workmanship and finish that characterized the work of our forebears two or three generations back.

In the Goodell-Pratt line of over 1500 Good Tools are to be found many whose accuracy of measurement and detail call for unusual skill, labor and patience—slow, careful work. And we put the same old-fashioned honesty into every tool that bears this label.

**GODELL  
PRATT**  
1500 GOOD TOOLS

The  
Goodell-Pratt  
line includes:

Hacksaws  
Saw Sets  
Gauges  
Punches  
Micrometers  
Grinders  
Vises  
Drills  
Levels  
Lathes  
Bit-Braces  
Calipers  
Squares

We are constantly adding new tools to our list—constantly on the lookout to supply the latest demands of the carpenter and other mechanics.

No matter what your needs are in tools—the safest and most economical way to get the best is to specify Goodell-Pratt to your dealer.

*Write today for complete illustrated catalogue*

**Goodell-Pratt Company, *Toolsmiths***  
**GREENFIELD, MASS.**

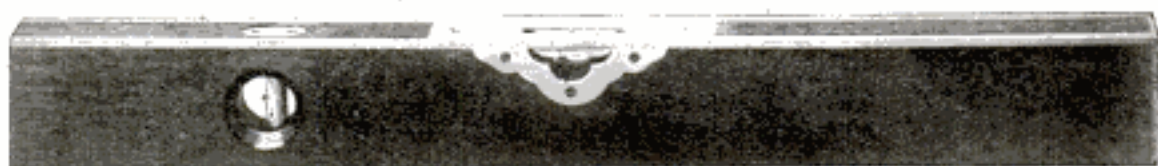

*Please Mention Popular Mechanics*



## The Brisk Smoke—"Bull" Durham

When you see an alert-looking young man in a lively argument roll a "Bull" Durham cigarette—it's the natural thing. He likes to punctuate a crisp sentence with a puff of "Bull" Durham. His mind responds to the freshness that's in the taste of it, and his senses are quickened by its unique aroma. A cigarette of "Bull" Durham just fits in with keen thinking and forceful action.

GENUINE

# "BULL" DURHAM

SMOKING TOBACCO

Ask for FREE  
package of  
"papers" with  
each 5c sack.

You get more wholesome, lasting satisfaction out of "Bull" Durham than from any other tobacco ever rolled up into a cigarette. Made of "bright" Virginia-

North Carolina leaf, "Bull" Durham is rich, fragrant, mellow-sweet—the mildest, most enjoyable of smokes.

"Roll your own" with "Bull" Durham—so good a cigarette cannot be obtained in any other way.

THE AMERICAN TOBACCO COMPANY



Please Mention Popular Mechanics

## The Truth About Poultry



Get the Facts by Reading **The One-Man Poultry Plant**

Successful Methods of Men on Farms or Small Acreage. Complete in twelve parts; printed in one volume.

By **DR. N. W. SANBORN**

**REAL** work, with real poultry, on a real New England Farm. This is a simple story of what has been done by a man, at forty-five years of age, town bred and city educated, getting out of practice of medicine, buying a small farm in the hill country, and making a success of the venture. Not only is the rearing of chicks and the management of adult fowl completely covered, but the interesting side issues of fruit growing, grain raising and the production of milk, that cannot be escaped on a real farm. You get rugged facts—rarely found in print. The truth about poultry as found in actual life on a one-man poultry farm.

**You Can Do the Same, Book Tells How**

**OUR SPECIAL OFFER**—The One-Man Poultry Plant, in twelve parts (book form), and the American Poultry Advocate, one year, for only 50 cts., book and Advocate, three years, for only \$1.00, if order is sent at once.

Our paper is handsomely illustrated, practical, progressive and up-to-date on poultry matters. Established 1892. 44 to 132 pages monthly. 50 cents a year. 3 months' trial 10 cts. Sample copy free. Catalogue of poultry literature free. Address

**AMERICAN POULTRY ADVOCATE, 523 Hodgkins Bldg., Syracuse, N.Y.**



## PRICES SMASHED!

Write for the Greatest Incubator Bargain ever offered, on the most successful incubator ever built.

**OLD RELIABLE INCUBATOR!**

34 years the standard—holds over 1200

First Premiums, awarded on superior merit. Guaranteed successful in your hands or your money back. Get Free Poultry Book and my low price before you buy.

**J. W. Myers, Pres.** Reliable Incubator & Brooder Co. Quincy, Ill.

## MAKING POULTRY PAY

depends more on the knowledge you have of Poultry Culture than on expensive equipment or extensive space.

Let Director Quisenberry teach you how to raise poultry successfully and make a good living and a nice profit from a flock of thrifty hens.

If you want to save money and make money in the poultry business write us today for our large illustrated Free Book, "Dollars and Sense in the Poultry Business." It points the way to success.

**American School of Poultry Husbandry**  
Box 75 Mountain Grove, Missouri



## A Constant Water Supply For Your Farm Home

Don't depend on a windmill or the back-breaking hand pump to fill your water tank. It's more reliable and economical to install a

## RIFE RAM

and be sure of a constant supply of fresh water, without fuel or attention. The Rife Ram operates by the flow of any stream having a fall of 3 feet or more and a supply of 3 gallons or more per minute. Will maintain air pressure system. Simple to install. Over 11,000 in use. Satisfaction guaranteed.

Write today for catalog and free estimate

**RIFE ENGINE CO.**  
3131 Trinity Building NEW YORK



## 650,000 Owners SAY GET Old Trusty for Chicken Profits



Invented by a practical engineer and poultry raiser. Makes big hatches in any weather.

**WRITE FOR FREE This BOOK FREE**

136 pages full of money-making ideas with poultry. Also get 1916 offer on **Old Trusty**. Still less than \$10—freight paid east of the Rockies—a trifle more farther west.

**M. M. JOHNSON CO.**  
Clay Center, Neb.



## LICE PROOF NESTS

Knudson's wonderful patented galvanized Steel Nests (not trap nest) banish lice and mites, keep hens healthy, make more eggs. Six nests per section. Sold on money-back guarantee.

18 Nests \$10.00



## More Eggs

That's the name of our new booklet. Send for it today. Tells how to increase your egg production. Ask for book or

send \$3.50 one set or \$10.00 set of three sections (eighteen nests).

**KNUDSON MFG. CO., Box 700, ST. JOSEPH, MO.**

**SPENDING POWER OF ENGLISH WOMEN**—American business men would do well to consider the fact that to an unprecedented extent the purchasing power of the British Isles has passed into the hands of the women, says a recent consular report.

Wives of men who have enlisted are receiving all, or

## FOY'S BIG BOOK FREE



**POULTRY AND SQUABS FOR PROFIT.** An encyclopedia of poultry information. Written by a man who knows. Leading varieties of poultry and pigeons in natural colors. Low prices on fowls and eggs. **FRANK FOY POULTRY FARM, Box 78, Clinton, Iowa**



## GREIDER'S FINE CATALOGUE

of pure bred poultry: 70 breeds illustrated and described, many in color. Perfect poultry guide—all facts. Low prices on stock and hatching eggs. Incubators and brooders. 22 years in business. You need this book. Send 10c for it—today.

**B. H. GREIDER** Box 19 RHEEMS, PA.

## Poultry Book FREE

"The Profits in Poultry Keeping," 172 pages. Describes our popular-priced incubators—3 styles, 3 sizes. 20 years leadership. Write today **Cyphers Incubator Co., Dept. 161, Buffalo, N.Y.**



## SHOEMAKER'S BOOK ON



## POULTRY

and Almanac for 1916 has 200 pages with many colored plates of fowls true to life. It tells all about chickens, their prices, their care, diseases and remedies. All about incubators, their prices and their operation. All about poultry houses and how to build them. It's an encyclopedia of chickendom. **C. C. SHOEMAKER, Box 1107, FREEPORT, ILL.**

25 Times World's Champion

**402,000** in Use

Get all facts, proofs, particulars—my low prices—money-back guaranty—also my **\$1300.00 Gold Offers**—all come with my big illustrated Free Book, "Hatching Facts," in color. Write me today. **JIM BOHAN, Pres., BELLE CITY INCUBATOR CO., Box 164, Racine, Wis.**



**Belle City Incubators and Brooders**



# Coal Bill \$40 Less

More Heat - Few Ashes - Healthful Air

## Here's the Letter

"The UNDERFEED is giving the best of satisfaction, and it is with pleasure that I write you regarding it. We use soft coal costing \$4.50 per ton. Hard coal here is \$5.50. I estimate we saved \$40 on our coal last winter. Furnace is easy to manage. No waiting until 10 A. M. to get heat up as with our old top-feed. I remove ashes once or twice a week, and only a small quantity. Before we could not grow flowers on account of gas from other furnaces. Now we can. To my mind it is the best heat up apparatus to be had. I am proud to be the owner of one."  
(Signed) R. E. LORD, Peterboro, Canada

## Saving of 1/2 to 2/3 Coal Cost Guaranteed the UNDERFEED Way

When a big, successful concern says to you: "We guarantee to cut your coal bills 1/2 to 2/3," you've simply got to listen.

And when on top of this saving you can have cleaner and better heat, it all means that you cannot afford to let the opportunity go unnoticed.

For instance, read the letter shown to the left. It is from a cold part of Canada. It tells of more and better heat for less money the UNDERFEED way. And it is only one of thousands of just such others which we will send you for the asking.

Please don't ignore this, but sign and mail the attached coupon and get more money-saving facts about the Williamson UNDERFEED which today is saving money in 35,000 homes all over the country. You incur positively no expense or obligation in sending the coupon.



A Big House in a Cold Part of Canada

**WILLIAMSON CUT COAL BILLS**  
NEW-FEED UNDERFEED  
Furnaces and Boilers 1/2 to 2/3

### The "Candle" Principle

Coal is fed from below in the New-Feed UNDERFEED. That means the clean, live coals are always on top—never smothered—but in direct contact all the time with the most effective heat-radiating surfaces.

No smoke, gas or dust, because these valuable heat elements must pass up through the fire and be converted into clean usable heat.

### Easy to Operate

A boy of twelve can easily operate the UNDERFEED. No stooping. Everything wonderfully simple and effective. Adapted to warm air, hot water or steam. Because of its scientific feed principle the UNDERFEED will burn the cheaper grades of coal as effectively as the more expensive grades. That's a first great saving you're always sure of.

Send the coupon today—NOW. Remember, the saving of one-half to two-thirds coal cost is actually GUARANTEED the UNDERFEED way. The coupon also brings a very interesting book, "From Overfed to UNDERFEED," free, which pictures and describes it all.

### THE WILLIAMSON HEATER COMPANY

85 West Fifth Avenue

CINCINNATI, OHIO



The Williamson Heater Co., 85 West Fifth Ave., Cincinnati, O.

Tell me how to cut my coal bills from 1/2 to 2/3 with a Williamson New-Feed.

Warm Air..... Steam or Hot Water..... (Mark X after System interested in)

Name..... Address.....

My Dealer's Name is.....

DEALERS: Let us tell you about the New-Feed UNDERFEED and our 1916 proposition. Both are winners.

## PLAY GOLF WITH CARDS

"Golf Bug"—the only game of golf with cards! Real golf—slicing, ditching, lofting, etc. Lots of fun for everyone. Teaches the outdoor game. Complete outfit only \$1. At your dealer's or send direct to us. Money back if not delighted. GON P. CURRAN PTG. CO., Walnut St., ST. LOUIS, MO.

## Mammoth Jubilee Book Free

Picturing 5152 Home Things  
Make your own Credit Terms—1 to 3 years' time.  
SPIEGEL, MAY, STERN CO., 1409 W. 35th St., Chicago

## THIS BUNGALOW \$900 CAN BE BUILT FOR

This and many others in my new book, Building Plans for Modern Homes, will save you hundreds of dollars. One of the most complete and comprehensive books of plans ever published by any architect. Fifth edition just off the press. Two hundred and fifty floor plans and photographs of bungalows, etc., costing from \$200 up; gives sizes and cost to build. Sent postpaid for \$1.00



FREDERICK H. GOWING  
ARCHITECT

18 Tremont St., BOSTON, MASS.

IF IT ISN'T

## AN EASTMAN

IT ISN'T A KODAK

## Big \$2 Offer—KEITH'S



The magazine for home builders, the recognized authority on planning, building and decorating Artistic Homes.

Each number contains 7 to 10 PLANS by leading architects. Subscription \$2. Newsstands, 20c copy. Twelve big house building numbers and your choice of

### KEITH'S BOOKS for the HOME BUILDER

140 Bungalows and Cottages	175 Plans costing below \$6000
140 Plans of Cottages	125 " " over \$6000
125 " " costing below \$2000	100 " " Cement and Brick
175 " " " " \$2000	50 Garages, 40 Duplex and Flats

Any one of these \$1.00 Plan Books Free with a year's subscription, \$2.00  
KEITH'S, 873 McKnight Bldg., Minneapolis, Minn.

## "IDEAL" Lawn Mower Grinder

Grinds all makes of Mowers perfectly in 15 minutes without removing wheels, ratchets or reel-knife. Ball-bearing; operated by either hand or power. Skate Sharpener Attachment for sharpening skates.

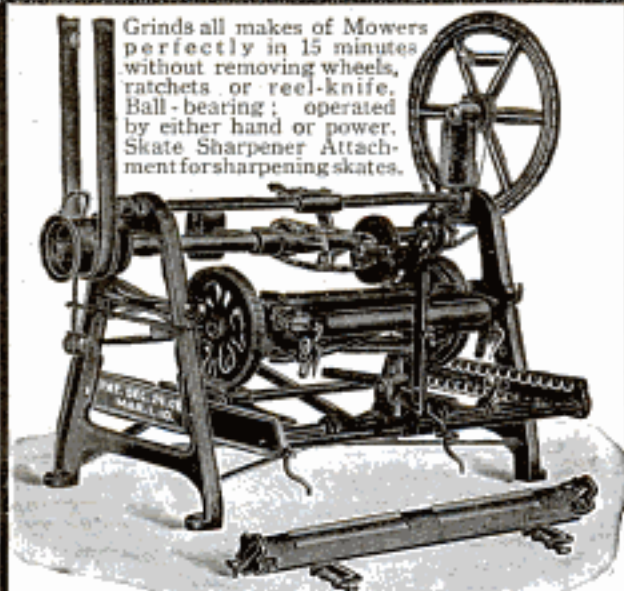

"You Grind It As You Find It"

**Write Today** for full information of this great labor-saver and money-maker. Will do the work so much better, quicker and easier you cannot afford to do without it. The only practical machine for sharpening Lawn Mowers on the market. Over 7000 in use. Fully warranted. Sold on easy-payment terms. Write today. Don't delay.

**THE ROOT-HEATH MFG. CO., Plymouth, O.**

**DO YOU HAVE KNIVES TO GRIND, SILVER TO POLISH, SMALL TOOLS TO OPERATE, WASHING MACHINES OR WRINGERS TO RUN? LET THE RED DEVIL**

**DO YOUR WORK**

Attached to any water faucet will develop up to 3 Horse Power according to size of pipe and water pressure. Only perfect small motor made. Improved bucket wheel construction.

6 in. Motor for Mechanics and Tradesmen. Washing Machines, 4 H. P. on 1/2 in. pipe, 80 lbs. water pressure; 1 H. P. on 3/4 in. pipe, 100 lbs. pressure, 2 in. pipe. Net price \$5, cash with order.

No. 1490 - 4 in. Motor for grinding, polishing, farm, sewing machines; for Doctors, Dentists, Druggists, etc., with emery, buffing wheel, silver polish and pulley, \$3.

No. 1490 - 4 in. Motor and pulley only \$2.50, cash with order.

Money back for any reason. Order your motor from dealer or from us. Send your water pressure and size of supply pipe. Active Agents wanted. Catalog free.

Only Motor to do this work



6 in. Motor

**DIVINE WATER MOTOR CO.  
DEPT. P. UTICA, N. Y.**



## A Handy Pair of Pliers for the Practical Man

One of the handiest motor pliers made from forged tool steel. Spring tempered handles, hardened nose for reaming holes in wood and metal. Cutting edges sharp enough for stripping insulated wires. This is just one of the popular styles of

### "RED DEVIL" Dependable Tools

Style No. 652, size 6 in., sample 80c.

**BOOKLET FREE**

**Smith & Hemenway Co., Inc.  
161 Chambers St., New York City**

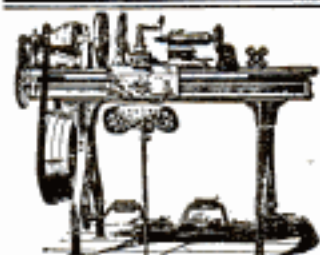

## LATHES

9 to 18-inch Swing

List price \$75 and up according to size. When ready to buy send for Lathe Catalog and prices.

**W. F. & John Barnes Co.  
100 Ruby Street, ROCKFORD, ILL.**

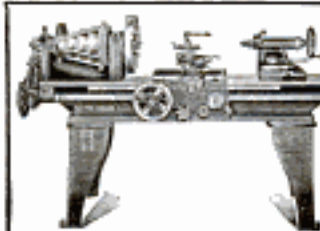

## South Bend Lathes

For the Machine and Repair Shop

**How to Run a Lathe**  
A 50 cent book for 10 cents. Postpaid, stamps accepted.

Straight or Gap Beds. Send for free catalog giving prices on entire line.  
**SOUTH BEND LATHE WORKS  
423 Madison St., South Bend, Ind.**

a good part, of their husbands' pay, as well as the allowances made in many cases by their employers. The latter amounts to about one-half of their regular pay. With these funds the women are better supplied with money, to spend in such manner as they see fit, than they ever have been before. One result, landlords say, is that they are receiving their rents more regularly. Another result, no doubt, is that the money is being spent in a different way than it was when the men chiefly or wholly directed its expenditure.



## Crescent Universal Wood Workers

are satisfying a lot of particular users of wood working machinery. You can use this machine to good advantage and should find out all about it.

Ask today for our catalog telling of our splendid line of hand saws, jointers, saw tables, planers, planers and matchers, disk grinders, variety wood workers, swing cut off saws, shapers, borers, hollow chisel mortisers, bench jointers.

**The Crescent Machine Co.  
93 Columbia St. Leetonia, Ohio**

# SEBASTIAN LATHES HIGH QUALITY LOW PRICES

If you delight in good tools you will delight in Sebastian Lathes. For 25 years we have built lathes, and lathes only, employing skilled labor always, and improving equipment and machinery every year. Sebastian Lathes are **STANDARD FOR QUALITY—LOW IN PRICE**

They are accurate, economical, simple and durable. Many re-orders and voluntary letters from users of Sebastian Lathes prove this. The Sebastian reputation is back of every Sebastian Lathe. You are judge and jury when you buy a lathe. We are not satisfied until you are. Look over the complete line in our new catalog. It shows Lathes for general repair work, garage and automobile work, etc.

**When you buy a lathe, say "Sebastian"**

ADDRESS (FOR THE CATALOG)

**THE SEBASTIAN LATHE COMPANY, 107 Culvert St., Cincinnati, Ohio**

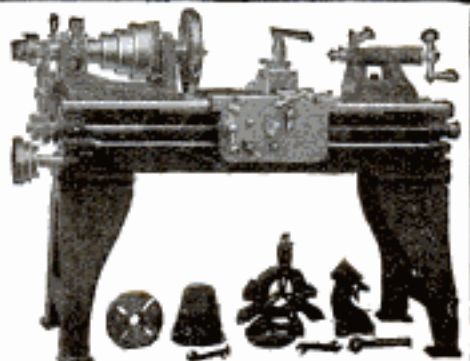

# The CALDWELL AUGER BIT

IS AN

## EFFICIENT TOOL

To the ordinary user, all bits are much alike until they are put into use. When this is done, the superiority of The CALDWELL is evident.

*This is because of the exclusive mechanical features in its construction.*

Regular Prices	4	5	6	7	8	9	10	11-12	13-14	15-16-16ths
	30	32	35	38	40	45	50	55	60	65 cents

**COMPLETE SET OF 13 BITS \$5.00.**

Until your dealer is supplied, remit direct to us. We will deliver without further cost to you.

Send for Catalog  
**THE CALDWELL AUGER BIT CO.**  
 LEBANON - N. H.

(Fourth in Factory to Financier Series)



The construction, as shown in detail above, enables The Caldwell to work several times faster and with less friction than any other known bit.



**ToolCases for Toolmakers and Machinists**  
 Keep your tools orderly arranged in a Gerstner Portable Tool Case. There's a place for every tool in one of the felt-lined drawers. Every up-to-date mechanic needs one and you'll find our Cases the best built, neatest and most practical on the market. We guarantee to please or refund all money. Write for our free booklet.

*Gerstner & Sons*  
 Mfrs. of Mechanics' High Grade Tool Cases  
 808 Columbia St., DAYTON, OHIO

### Sharp Tools All the Time Luther Hummer Tool Grinder

Puts keen cutting edge on all tools—easy and quick. No water needed. Won't draw temper. Enclosed dust-proof bearings and gears. Steel shaft drive. Perfect lubrication. Patented tool rest. 14 special attachments. Write for Big Free Book.

LUTHER GRINDER MFG. CO., 921 Point St., MILWAUKEE, WIS.



## AUTO GIVEN AWAY

We want representatives in every locality. No experience or capital necessary. Send us your name and address and by return mail we shall tell you how you can secure one of our new 1916 model 5-passenger touring cars free for demonstrating. Write today—do not delay—a postal card will do. Address

**ECLIPSE MOTOR CAR CO., 851F Buhl Block, DETROIT, MICH.**

## Look Men! A New Work Suit!

The most comfortable on earth! Neatest looking. No belt to bind. No suspender straps to tire shoulders. No coat tails to bunch or get caught in machinery. No double thickness at waist or front. Better than overalls and jacket.



Patented button-down skirt showing neat jacket effect.



Skirt upshowing suspenders which are attached to back of jacket.



Showing the convenient drop seat arrangement.

**Union Made**  
**Comfortable, Safe, Convenient**

Order from your dealer or direct from us. Express stripe \$2.50; Stifel blue \$2.25; Government standard khaki \$3.50. Money back if not delighted. Write for descriptive circular.

**JOHNSTON & LARIMER**  
**MFG. COMPANY,**  
 Dept. PM Wichita, Kan.

**SENSIBLE**  
 COMBINATION WORK SUIT

**The Modern Work Garment**  
 Pat. June 8, 1915



Please Mention Popular Mechanics



## What Tools Do You Use?

**A** GOOD workman can always do good work but he does his best work with good tools. The conscientious man always wants to do his best work. The inference is obvious. Good men always have good tools.

### Starrett Tools

and Instruments of Precision are recognized throughout the world as standard. Wherever accuracy counts, you will find Starrett Tools widely used.

To better understand the whole line send for free catalog No. 20-A.P.

**The L. S. Starrett Company**  
*"The World's Greatest Tool Makers"*  
 Athol, Massachusetts

New York London  
 Chicago

## The Carborundum Round Combination Bench Stone

**T**HINK of the advantage of the combination stone over the ordinary sharpening stone. The ordinary stone is made of the same grit throughout. As a result, it is not adapted to both sharpening and finishing your tool edges.

The combination stone is made with one side of coarse grit and the other of fine grit. A few strokes over the coarse side take out the nicks and sharpen your tools, and the fine side gives a keen, finished edge.

And then, too, these stones are all made from Carborundum, diamond-like in its hardness and sharpness, and the very best sharpening agent known.

—  
 Send for catalog of Carborundum Products

—  
**The Carborundum Company**  
 Niagara Falls, N. Y.

Please Mention Popular Mechanics

# "YANKEE" TOOLS



"YANKEE" No. 130 is the *Quick Return* Spiral Ratchet Screw-driver. Spring in handle brings it back for next stroke; firmly keeps bit in screwhead. Worked with one hand. Right and left ratchet movements; and rigid. Price, \$1.85.

Three bits with tool. Special attachments obtainable for countersinking, drilling, etc.



"YANKEE" No. 44 is the push drill that saves breakage or drill-points, time and trouble. Has *adjustable* tension—low to high resistance. By turning the cap (at the end of the tool) you set it to suit hard or soft wood, large or small drill. Price, \$1.75

Eight "YANKEE" Drill-points,  $\frac{1}{8}$  to  $\frac{1}{4}$ , held points up, in magazine in handle 

**"YANKEE" TOOLS Make Better Mechanics**

Your dealer can supply you

North Bros. Mfg. Co., Philadelphia

Write us for "Yankee" Tool Book," showing all the "Yankee" wood- and metal-boring and screw-driving tools



## Portable Cases

FOR TOOL MAKERS  
AND MACHINISTS

Twelve styles, felt lined drawers, solid brass trimmings, best of material, beautiful finish, low prices, satisfaction guaranteed. Ask for booklet of cases built for service.

The Pilliod Lumber Co.  
SWANTON, OHIO

## THE AWL YOU WANT

See That Reel



Is the genuine MYERS \$1.00 "Lock Stitch" Sewing Awl with the exclusive feature. See thread reel in front of handle under the fingertip. Natural tension. Sews heavy or light material, diamond point, full grooved needles used to protect the thread when sewing. C. A. MYERS COMPANY, 6339 University Ave., Chicago, Illinois

50 Mends for 50 Cents	 <p>WHEN YOU SOLDER SOLDER WITH SOLDERALL</p> <p><b>SOLDERALL</b></p> <p>TRADE MARK</p> <p>PATENT APPLIES FOR</p>	Price 50c
-----------------------------------	--	--------------

## Genuine Solder

With an ordinary match it easily mends and solders metals permanently. Used by the housewife, farmer, electrician, automobilist, moving picture operator, jeweler, merchant and mechanic.

### AGENTS WANTED

Show what it will do and it sells itself. Everybody wants SOLDERALL. Send 50c for large tube. Your money back if dissatisfied.

EMENAR CO., 53 E. 23rd St., New York City

## Build a Boat This Spring with a Simonds Saw

The boating and canoeing season is coming soon, and there's no better sport for the hustling young American than building his own canoe or flat-bottom boat. It's a lot more satisfying to cruise about in the neighboring lakes and streams in a craft built by yourself than in a purchased one. We will send you free of charge an interesting booklet telling in detail how to build a canoe and row boat, and

# SIMONDS SAWS

are the best saws you could use in boat-building or any other kind of work. They run easily, their razor-edge goes fast and true through the toughest wood, and they do not bind or scrape or require frequent filing. They are made of the finest steel specially tempered, and are absolutely guaranteed.

**Prizes for Boys** We offer three \$30.00 cabinets of tools and 54 other tool prizes to boys who build useful or ingenious articles of wood. Write for free Label No. 11, giving all particulars about the prize contest. No expense whatever.

"If you want saws that cut like diamonds  
Ask for saws that are branded Simonds."

Write for Booklet No. 11, "The Professor and the Saw," which tells how to build many useful things.

**Simonds Manufacturing Co.**

"The Saw Makers"

5 Factories FITCHBURG, MASS. 11 Branches

Please Mention Popular Mechanics



## Brown & Sharpe Rules

You will find them good Rules to use.

### Accurate Graduations

Skill and ingenuity in making the special dividing engines, patience and care in dividing each Rule, have caused them to be called "Standard for Accurate Measurements."

### Clear to Read

The figures are bold, the deep, clean-cut graduation lines are uniform and true, so that it is easy to take dimensions quickly and without error.

### Well Finished

The carefully smoothed edges and corners, and satin-polished surface make them handy and pleasant to use.

### Many Styles

Over 350 different styles and sizes to choose from; a Steel Rule for practically every purpose.

### Wish a Catalogue?

Ask the Hardware Dealer for our Free Catalogue No. 26, showing the complete line of Mechanics' Tools, or write us for copy.

## Brown & Sharpe Mfg. Co.

PROVIDENCE, R. I.

## CRESCENT TOOLS



### The Crescent Universal Plier



The Grooved Jaw



Wire or Rods



Triangular Objects



Round Objects

JUST what its name implies—a universal tool.

On account of the peculiar jaw construction, it will take all work possible to handle with ordinary pliers and all kinds of odd shapes impossible to handle with the regular tool besides.

Drop forged of the finest tool steel and nickel plated.

We will replace or refund the money on this or any other Crescent Tool which is not satisfactory in every respect.

PRICE 50c.

At your dealers' or sent, prepaid, upon receipt of the price.

### Crescent Tool Company

Mfrs. of the famous Crescent Wrench  
Jamestown, N. Y.

**YEAR'S RECORD OF LIFE-SAVING BY WIRELESS**—During the fiscal year 1915 the radio inspectors of the United States Bureau of Navigation reported 26 cases of vessels leaving American ports which met with accident or disaster requiring the use of wireless to summon assistance. Four of these were from fire; 12 from running ashore, stranding, or getting into an ice jam; one

### Will You Take Orders?



Your spare time is worth \$10 a day demonstrating the 1917 Model, Steel, 18-in-1 Automatic Handi-Tool. Equals separate tools costing \$160. Lifting and pulling jack; fence building tool; stamp and post puller; baler; press; hoist; vise; etc. No experience needed. Demonstrator free. Credit given. Exclusive territory. Write for special factory agency offer.

Chas. E. Benefiel Co., 293C Industrial Bldg., Indianapolis, Ind.



## TOOL CASES

For Up-to-Date TOOLMAKERS and MACHINISTS

We carry the finest and most complete line of mechanics' toolcases and tools in the country. We guarantee to please you or refund money. Write for free catalogue.

J. M. WATERSTON

177 Jefferson Ave., E. Detroit, Mich.

## The Neverip and the Speedy Stitcher

SAMPLE



50c

The two greatest inventions with which the unskilled man can repair leather goods or any heavy material. Needles and thread are inside the handle. FAST SELLERS.

**Agents Wanted** Foreign trade solicited. Advertising circulars in different languages.  
Stewart-Skinner Co., 26 Hermon St., Worcester, Mass., U. S. A.

Please Mention Popular Mechanics

"Sure, the Whiting-Adams Floor Brushes do beat them all for cleaning house"

**WHITING-ADAMS** Methods of Manufacture produce perfect

# BRUSHES

which are guaranteed to live long and please all users  
Over 10,000 Kinds and Sizes made

FOR SALE BY DEALERS EVERYWHERE

Send for illustrated literature

**JOHN L. WHITING-J. J. ADAMS Co.**  
BOSTON, U. S. A.  
Brush Manufacturers for Over One Hundred Years

Whiting-Adams Brushes Awarded Gold Medal, the highest award at Panama-Pacific Exposition, 1915



PATENTED  
OCT. 19, 1915

## THE LIGHTNING CALCULATOR

This new calculating device will quickly give the solution of any problem involving multiplication, division, proportion, even and uneven roots and powers, Logarithms of numbers and Bases and Tangents of angles. It surpasses any pocket slide rule in accuracy, and it is more convenient than Log Tables. Anyone can learn to use the Lightning Calculator in a few minutes and can easily solve any mathematical problem, for example—Find the cube root of 763.16—Answer, 9.14. Time required using the Lightning Calculator, 15 seconds. The Lightning Calculator is made of heavy waterproof bristol, and just fits the pocket, size 4" x 7". Send for free descriptive circulars. Price with complete instructions 50c.

GILSON SLIDE RULE COMPANY, NILES, MICH.

## BILLINGS & SPENCER

### TOOLS

In a tight place the best is not too good.

TRADE MARK **HARTFORD, CT.**

Wrenches  
Pliers  
Sc. Drivers  
Hammers  
Ratchets  
Wrench Kits  
Tool Kits

from shifting of cargo; one vessel was storm-battered and waterlogged; and one was torpedoed. Excepting in the case of the "Lusitania," which was torpedoed, the assistance thus rendered resulted in but two lives being lost.

## YOU NEED THIS TOOL

### GASOLINE SOLDERING IRON BLOW-TORCH



Address Dept. 1, Emmelmann Bros. Mfg. Co., Indianapolis, Ind., U.S.A.

### THE HARRISON M. I. P. KEY FILING MACHINE

Makes duplicate Pin Tumbler Keys with absolute accuracy, and without injuring the original key. Price \$3.00. Special diamond shaped files 35c each or 4 for \$1.00. Net Cash. \$4.00 for the outfit complete.

### THE HARRISON C. K. KEY CLAMP

will make duplicate Common Keys of all kinds for Doors, Padlocks, Trunks, Cabinets, Lockers, etc., quickly and accurately. Price \$1.00. Both machines unconditionally guaranteed. Parcel Post Prepaid.

HARRISON & CO., 81 New St., New York

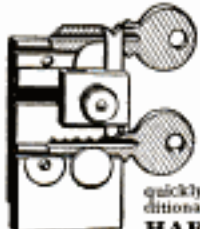

## MILLERS FALLS TOOLS

Braces      Hack Saws  
Drills      Mitre Boxes

Do Better Work and Last Longer

Write for catalog showing complete line

MILLERS FALLS CO., Millers Falls, Mass.

### Large Profits from Small Capital

A Business of your own bringing you an income of at least \$10.00 per day with practically no experience or overhead expense.

### THE GREEN AUTOMATIC MACHINE

sharpens, hones and stroges all kinds of safety razor blades, all in one operation, at the rate of 150 to 200 blades per hour; you can readily figure your profit. Let us send you our free booklet explaining everything.

Am. Sharpening Machine Co. (Inc.)  
Dept. 3, 184 Washington St., Chicago



## PIPE-THREADING

Oster Pipe-Threading Machines give the widest range of usefulness concentrated into the smallest floor-space. The machine shown below, Oster No. 306B, threads pipe and nipples from 1 1/4 to 6 inch and bolts 3/4 to 2 inches; and yet it requires only a little room in a corner. The special Oster features insuring speed and ease of operation, together with the uniform accuracy of Oster-cut threads have made these tools standard equipment the world over.

47 distinct die-stocks, pipe-threading machines, and screw plates.

WRITE FOR CATALOG  
**OSTER NO. 306B**



**The OSTER MFG. CO.**  
2100 E. 61st St.  
CLEVELAND, OHIO

## UNION Tool Chests

Over 15 Different Styles and Sizes

Plain or Quartered Oak or Leatherette covered. Design, material and workmanship of the best.

**Let Us Save Your Tools and Money**

If dealer does not carry, we have a special offer that will interest you. You cannot afford to go without a Union Chest guaranteed to meet your entire approval or money back.

WRITE TODAY—CATALOG FREE

**UNION TOOL CHEST WORKS**  
22 Railroad St.      Rochester, N. Y.



Please Mention Popular Mechanics

**Stanley  
Tools**



## Stanley Rabbet Plane No. 278

The sides and bottom being square with each other, the plane will lie perfectly flat on either side.

It has an adjustable fence which slides under the bottom, regulating the width of the cut.

It is fitted with two spurs, one on each side, for working across the grain — also an adjustable depth gauge.

As both the fence and the depth gauge can be attached to either side, the plane is suitable for either right or left hand work.

The front part of the Plane can be easily detached, thus providing a bull nose plane for working close up into corners or other difficult places. The cutter is one inch wide and is adjustable.

Length over all, 6 $\frac{3}{4}$  inches; weight 2 lbs.

**Price Each \$1.75**

If you cannot procure same from your hardware dealer, we will be pleased to forward you one, postage prepaid, upon receipt of price.

ADDRESS

**STANLEY RULE & LEVEL CO.  
NEW BRITAIN, CONN. U.S.A.**

**UNCLE SAM  
WANTS YOU**



## Get a U.S. Government Job \$75 to \$150 a Month

Rapid advancement to higher Government Positions.

No "Layoffs" because of STRIKES, WARS, FINANCIAL FLURRIES or THE WHIMS OF SOME PETTY BOSS. THE POSITION IS YOURS FOR LIFE.

Country residents and city residents stand the same chance for immediate appointment.

Common sense education sufficient.

Political influence NOT REQUIRED.

**We Will Coach 25 Candidates Free of Charge**

Write immediately for full list of many positions now obtainable. Don't delay. Every day you lose means the loss of just so much chance of early appointment.

### FREE COACHING COUPON

FRANKLIN INSTITUTE, Dept. J97, Rochester, N. Y.

This coupon, properly filled out, entitles the sender to free sample examination questions, full list of positions now obtainable, a free copy of our valuable copyrighted book, "GOVERNMENT POSITIONS AND HOW TO GET THEM," and to consideration for FREE COACHING for the Civil Service Examination here checked.

... Railway Mail Clerk	\$1000 to \$1800	... Customs Positions	\$600 to \$1500
... Postoffice Clerk	\$800 to \$1200	... Internal Revenue	\$700 to \$2800
... Postoffice Carrier	\$800 to \$1200	... Stenographer	\$800 to \$1200
... Rural Mail Carrier	\$600 to \$1200	... Panama Canal Clk's	(\$1200 to \$1800)

Name.....

Address.....

Use this before you lose it. Write plainly.

**\$8,000 to \$10,000  
YEARLY**



## Make Money Out of Others' Fun

Pleasing the Public Pays Big Profits and owners of our famous attractions frequently make from \$8,000 to \$10,000 every year. We make everything in the Hiding-Gallery and Carouselle line from the smallest to the highest grade. Bring in hundreds of dollars daily. It is a delightful, attractive, big paying, healthful business. Just the thing for the man who can't stand indoor work, or is not fit for heavy work.

Just the business for the man who has some money and wants to invest it to the best advantage. Our goods are finest appearing, easiest running, and most attractive line manufactured. They are simple in construction and require no special knowledge to operate. Our latest new 1916 Carouselle is mounted on trucks to facilitate and reduce cost of moving and shipping. If you want to get into a money-making business write today for catalog and particulars.

**HERSCHELL-SPILLMAN COMPANY**

PARK AMUSEMENT OUTFITTERS

333 Sweeney St., N. Tonawanda, N. Y., U. S. A.

**NEW AND SAFE METHOD OF DESTROYING THE LARVAE OF FLIES**—It has long been known that flies breed in manure, but previous methods of destroying the larvae there by the use of strong chemicals have been open to the objection that the treatment under some conditions lessened the fertilizing value of the manure or actually injured vegetation. A simple, safe, and effective weapon against the typhoid or house

## BIG CHANCE FOR AGENTS



**You can earn BIG MONEY**

selling the most complete line of guaranteed transparent handle Knives and Razors with Photo, Name and Lodge Emblem — also full line of cutlery. Write today for catalogue and terms. Golden Rule Cutlery Co., 554 W. Lake St., Dept. 326, Chicago, Ill.

## FORD AUTO GIVEN TO AGENTS

Here's an opportunity to earn big money — \$6 to \$12 a day, with easy work, all your time or spare time and get a Ford Auto without cost besides. A straightout from the shoulder business proposition. No voting or guessing contest. We want wide-awake men and women to introduce into every home our famous ZANOL Pure Food Products, Non-Alcoholic Food Flavors in tubes, Toilet Preparations, Perfumes and Soaps; 250 other light weight household necessities.

**MAKE \$50 A WEEK EASY**

No experience necessary—we teach you how, give you the right start and help you make a success. Absolutely no limit to your earning power. We can use only a certain number of General Agents, so get in touch with us at once. We furnish our agents an automobile without cost. Just send postal for particulars and money making offer.



**AMERICAN PRODUCTS CO.**  
4145 Third St., Cincinnati, Ohio



# WORTH HAVING

## MECO 1916

Have you received your copy? If not, write today—IT'S FREE. You can't be up-to-date without this big catalog of 3165 articles priced lower than ever.

### Motorcycle Supplies

Write Today to

**Motorcycle Equipment Co.**  
Hammondsport, N. Y.

PAC. COAST BRANCH, 3664 So. Main St., LOS ANGELES, CAL.



**Convert Your Bicycle into a Motor-Cycle** Motor fits any wheel. BEST, MOST RELIABLE. Best hill climber. More STEFFEYS in use than all others. Stamp for circulars. STEFFEY MFG. CO., 5007 Brown Street, PHILA., PA.



**MOTORCYCLES \$25 to \$175**

All reliable makes. Some as good as new. Write today for full particulars and catalog. We repair and exchange motorcycles.

HARRY R. GEER CO., 898 McLaren Ave., St. Louis, Mo.

**5-16 H. P. 1916 Peerless Motorcycles**



with Free Engine, Bosch Magneto, together with the best there is in Motorcycle construction, Power, Speed, Silence, Endurance, and those wearing qualities so essential for low cost of maintenance.

5 MILES FOR ONE CENT  
Agents Wanted—Liberal Discount!

PEERLESS MOTORCYCLE CO., 179 Huntington Ave., Boston, Mass.

**SOME CAR! BOYS!** Send for Booklet Today



**The Lad's Car**

Send 20c today for Booklet, telling how to build this automobile. Complete instructions and descriptions of parts and sizes, illustrated with diagrams, blue print, cuts made from photographs, and price list of parts.

**SPECIAL INDUCEMENT** to first boy in your town  
Niagara Motor Car Corp'n, Dept. A, Niagara Falls, N. Y.

Please Mention Popular Mechanics

The 1916  
←ARROW←

Electric Light

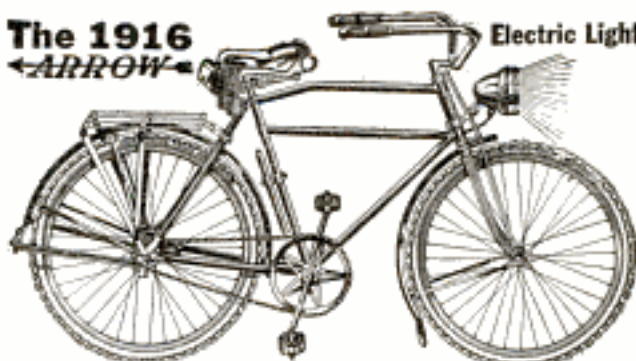

## The Wonderful New Motorcycle Type

Send the coupon below today for free catalog of the new 1916 "Arrow" Bicycle. Read the sensational improvements in the new 1916 model. Other features, too. Everything to make bicycle riding convenient and a pleasure. Send the coupon for free catalog.

### 1916 Features

#### Electric Light

Reinforced motorcycle frame—large, easy motorcycle saddle—long, rubber grip, motorcycle handlebars—New Departure coaster Brake—special motorcycle pedals—motorcycle mudguards, stand and luggage carrier—imported anti-friction chain—Fisk, Thorn Proof, Non-Skid Tires—beautiful enamel finish—other new features. Write now.

Nothing like this bicycle has ever been offered before. Built with all the durability and elegance of the very highest grade motorcycles. A positive wonder for speed, easy riding and comfort. The biggest bicycle value ever built. All sizes for boys, men and women. Send the coupon today for free catalog.

## Pay As You Ride

Find out about our special rock-bottom direct offer on this New 1916 Arrow. A special 30-day, reduced price offer. We ship the bicycle to you without a penny down. Start riding and enjoying the Arrow right away. And pay the special rock-bottom price—a small amount each month—while you ride. If you do not agree when you see the 1916 Arrow that it is the biggest bicycle bargain you ever saw, send it back at our expense. You be the judge. Send the coupon for free catalog.

**Pays for Itself:** The coupon brings our liberal rider-agent proposition. The easiest ever! Just ride your Arrow around. People will admire your handsome bicycle and ask about it. Just answer their questions. You can pay for your Arrow and get extra money besides. Just send the coupon for full particulars and New Catalog.

## Send the Coupon Now!

Don't delay. Learn about the sensational 1916 Arrow right away. Take advantage of our special, 30-day rock-bottom price offer. Get the free catalog and details of easy Rider-Agent offer. Send the coupon now while this offer lasts.

**Arrow Cycle Co.**  
Dept. 1193, 19th St.  
and California Ave.  
Chicago, Illinois

Please send me free catalog of the New 1916 Arrow and particulars of your 30-day rock-bottom "Pay-As-You-Ride" Offer and Rider-Agent Proposition.

**Arrow Cycle Co.**

Dept. 1193  
19th Street and  
California Ave.  
Chicago, Ill.

Name.....

Address.....



**4** out of **5**  
are **Champion**  
Dependable Spark Plugs

**IF YOU** look at the spark plugs in all the new motors as they leave their makers' shops you would find four Champions to one of any and all other kinds.

The men who build Fords, Overlands, Studebakers, Maxwells, and over eighty-five others, equip their motors with Champions—to get results which their tests show that Champions alone will give.

There is a Champion Spark Plug designed to get results in your motor—better results than you can get with any other plug—or it wouldn't be branded "Champion."

Your dealer knows which plug to sell you when you tell him what car it's for.

Look for the name Champion on the porcelain—not merely on the box.

### The Champion Guarantee

*Perfect satisfaction to the user—free repair, replacement or money back.*

**CHAMPION SPARK PLUG COMPANY**  
404 Avondale Ave. TOLEDO, OHIO

## Defeats Rust and Tarnish

A few drops of 3-in-One on a flannel cloth works wonders on escutcheons, door knobs and locks, electric push buttons, andirons and black iron ornaments of every kind.

Use

### 3-IN-ONE OIL

on nicked and brass faucets. Also on guns, revolvers, musical instruments, everything metal. 3-in-One is the foe of tarnish—the absolute preventive of rust everywhere. Keeps all metal surfaces bright, indoors or out.

Sold in hardware, drug, grocery, housefurnishing and general stores: 1 oz., 10c; 3 oz., 25c; 8 oz. (½ pt.), 50c. Also in Handy Oil Cans, 3½ oz., 25c. If your dealer does not have these cans, we will send one by parcel post, full of 3-in-One, for 30c.

**FREE:** Write for free sample and 3-in-One Dictionary.

**THREE-IN-ONE OIL CO.**

422 N. Broadway, New York

fly, to which none of these objections can be made, has been found in powdered hellebore by scientists of the Department of Agriculture. Powdered hellebore, mixed with water and sprinkled over the manure, will destroy the larvae which are hatched from the eggs. It will not, however, kill adult flies, which must be swatted or trapped.

In 10 years one of the dogs of the St. Bernard Hospice saved no less than 40 lives.

### \$1000 FOR RIGHT MAN

The man who is energetic and knows automobile owners fairly well can soon make \$1000 and always be assured of a handsome income. Large manufacturer of nationally demanded automobile necessity offers this opportunity to that man. City of Chicago uses it. Others must have it. Write today.

**LENOLITE MFG. CO., Dept. "C," 6 N. Clark St., Chicago**

## U. S. "Chain Tread" Motorcycle Tire

All the Strength of the "Chain Tread" Automobile Tire.  
**UNITED STATES TIRE CO., New York City**

### \$4.00 SEISS

Powerful, Commanding, Warning Signal. Operated by touch of hand, either right or left—for short blast or long, continuous sound, same as a Motor-Driven Horn.

**THE SEISS MFG. CO.**  
439 Dorr St., TOLEDO, O.

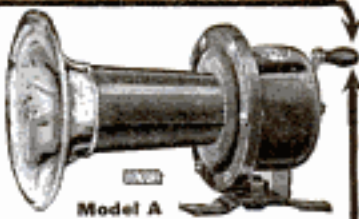

# PREST-O-LITE

## FOR MOTORCYCLES



### Brilliant Light that Stands the Jolts

Prest-O-Lite enables you to drive safely on any road, never fails you in emergencies.

Furnishes you ideal riding light—yet costs less to buy and less to use than any other system for brilliant lighting.

Prest-O-Lite gives you the utmost in practical convenience and reliability. It is as sturdy as your motorcycle itself—requires but slight attention, and that, such as you yourself can give, easily and quickly.

### Your Satisfaction Guaranteed

Use Prest-O-Lite on your machine. Give it every test in your daily riding. Then, if you're not satisfied, you get your money back.

### In any "complete" equipment get Prest-O-Lite

The combination of "complete equipment" most popular with experienced riders is "Prest-O-Lite, a lamp and a mechanical horn." You can get this from your dealer on any make of machine, at a very attractive price.

Get our booklet on motorcycle lighting. Your name and address on the margin of this page will bring it to you. Write today.

### The Prest-O-Lite Co., Inc.

The World's Largest Makers of Dissolved Acetylene  
265 Speedway, Indianapolis, Ind.  
Canadian Office & Factory, Merritton, Ontario  
*Prest-O-Lite Exchange Agencies Everywhere*

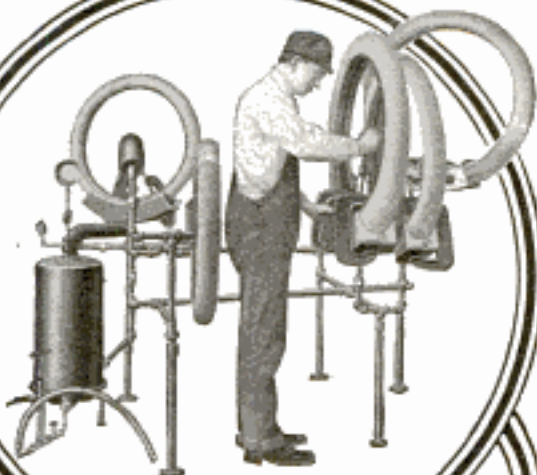

### Make This Your Business At \$3,000 Per Year

Repairing and Retreading Automobile Tires. There isn't a business you could get into that offers such sure possibilities of success and fortune. One man and a Haywood Tire Repair Plant can make \$250 a month and more. Scores already have done it and this year there is a greater demand than ever for tire repair work.

### 15 Million Tires to Repair

That's not a myth nor some man's dream. It's an actual fact. Tire factories everywhere are building new buildings—enlarging their plants for the biggest period of prosperity in the automobile business. 15 million tires will be built and every one will need repairing.

### Punctures and Blow Outs Are Common

Why not cash in on this opportunity? Start in the business while it is yet young. A business that's growing and getting bigger and better. As it grows it will make big money for you.

### No Experience Necessary

No previous training, no apprenticeship, is required to enter this business,—not even the faintest knowledge of tires. If you have a little mechanical turn of mind, you can quickly become an expert. We teach everything. You learn in a week. Handle all kinds of jobs—figure prices at big cash profits. Nothing is easier to master completely.

### A Rich Opportunity

Awaits ambitious men everywhere. No city too large—no town too small—everywhere the same opportunity exists. A Moderate investment starts you. Get one machine and build the business from there. Business comes easy. We show how to get it. You grow and grow. You're soon a Real Manufacturer—A Success—a mighty big factor in your community.

### Write for the Facts

INVESTIGATE. Send the coupon below, a letter or postal. This brings full information—and a big interesting catalog. Tells all about tires and how to repair them. Shows how to make money—to become independent. Do this today—NOW—before you forget it.

**HAYWOOD TIRE & EQUIPMENT COMPANY**  
539 Capitol Avenue INDIANAPOLIS, IND.

### FREE CATALOG COUPON

HAYWOOD TIRE & EQUIPMENT CO., 539 Capitol Ave., Indianapolis, Ind.  
Gentlemen:—Please send me your catalog, details and plans for starting ambitious men in the Tire Repair business.

Name .....

Address .....



### The Dread of Dentistry is Pyorrhea

(Sometimes called Riggs Disease)

It is characterized (among other symptoms) by bleeding, discolored gums, receding gums, sensitive teeth, bad breath and finally loosening and dropping out of the teeth.

DO YOU KNOW that 90 per cent of the people have it in the first, second or third stage—

DO YOU KNOW what causes it or what a terrible menace it is to your health—You should know how to recognize Pyorrhea when you see it and how to prevent and overcome it.

SEND ME YOUR NAME and without obligation of any kind I will send you FREE my illustrated booklet about this most common but dreadful disease of the gums. Also testimonial letters from hundreds of people who have treated themselves at home avoiding pain, loss of time, expensive treatment and false teeth. 25 years' success.

DR. F. W. WILLARD, C872, Powers Bldg., Chicago, Ill.

### WHITE FLAME

**BURNERS** make your old kerosene lamps and lanterns give a brilliant white light better than electricity or gas. Doubles your light. Saves oil. **NO MANTLE TO BREAK.** Guaranteed Safe and Reliable. Delights every user. Send now for complete sample postpaid 35 cts., stamps or coin. 3 for \$1. **MONEY BACK IF NOT SATISFACTORY.** Live Representatives Wanted. Exclusive Territory.

WHITE FLAME LIGHT CO., 68 Clark Bldg., Grand Rapids, Mich.



### BEACON FREE BURNER

**FITS YOUR OLD LAMP**

**100 Candle Power Incandescent** pure white light from (kerosene) coal oil. Burns either gas or electricity.

**COSTS ONLY 1 CENT FOR 6 HOURS**

We want one person in each locality to whom we can refer new customers. Take advantage of our Special Offer to secure a Beacon Burner **FREE.** Write today. **AGENTS WANTED.**

HOME SUPPLY CO., 111 Home Bldg., Kansas City, Mo.

### 300 Candle Power of Light at a Cost of 1-8c Per Hour

Burns Kerosene or Gasoline This lamp generates and burns its own gas from ordinary kerosene. "QUICKLIT" gasoline lamps can be lit with an ordinary match like city gas.

Write today for illustrated catalog of our complete line of kerosene and gasoline lamps, lanterns **Agents Wanted** and lighting systems.

**The Nagel-Chase Mfg. Co.**  
176 East Erie St., Chicago



### AGENTS—\$5.00 to \$25.00 a Day—It's Easy

**Grand Invention. 150% Profit. Great Excitement Recognized as most phenomenal seller**

Experience Unnecessary. Spare time can be devoted if desired

**LISTEN:** One man's orders \$2,650.00 one month—profit \$1,650.00

Lowry, of Montana, who sold 25 dozen the first two weeks (without previous experience) and made \$187.50, enthusiastically writes: "Why, I could sell this article blindfolded and with a gag in my mouth." Mere boy in Pa. made \$9.00 in 2 1/4 hours. "I do not see how a better seller could be manufactured," reports Parker J. Townsend, Minn. "Started out at 10 a.m., sold 35 by four o'clock," says J. R. Thomas, Colo. "Sold 131 in two days."

G. W. Handy, New York. See what a wonderful opportunity. These remarkable reports proven absolutely true by oath-covered evidence—proven to satisfy you beyond a doubt. You can make this money. Work for us and get rich. We want representatives—Agents, Salesmen, Managers—everywhere. Write today. Territory in all sections of the United States, Canada, Mexico and foreign countries to be assigned. The New Easy Wringer Mop tremendously in demand by housewives. Every woman exclaims in delight: "Just what I want!" No more tiresome, back-breaking, miserable mopping days. Drudgery actually transformed into pleasure. The greatest, grandest, most necessary household article ever invented. No need to recite selling arguments. Talking hardly necessary at all. Simply show—order's landed.

This is indeed a wonderful opportunity. Establish yourself in this business at once. Send your name and address on a postal now—right now.

**Think of It**

A Self-Wringing Mop. Two turns of the crank wrings out every drop of water. Mopping is now a pleasure.

The Easy Wringer Mop (Patented) Hands do not touch the water.

U. S. MOP CO., 392 Main St., TOLEDO, OHIO

**PAINTING BOILER DRUMS TO PREVENT PITTING**—Considerable saving in time and labor in cleaning is the result, according to Power, of the following recently tested method of treating boilers. The interiors of the drums were scalded, painted both above and below the water line with silica-graphite paint, and

**AGENTS \$10 to \$20 PER DAY!**

New Pure Aluminum Hot Water Bottle—will outwear 100 Rubber ones. Lasts a lifetime. Low price makes quick sales. Write for sample and large catalog of 400 other Specials.

**AMERICAN ALUMINUM MFG. CO.**  
Div. B. M. LEMONT, ILL.

**KEROSENE Gas Lamps**

Make Your Business Prosperous and Your Home Cheerful

by using our "Safety" Kerosene and Gasoline Gas Lamps. If we are not represented in your town we want an agent.

**BRILLIANT GAS LAMP CO.**  
1092X So. Wabash Ave., CHICAGO, ILL.

**Sunshine Lamp FREE!**

**300 Candle Power**

To Try in Your Own Home Turns night into day. Gives better light than gas, electricity or 18 ordinary lamps at one tenth the cost. For Homes, Stores, Halls, Churches. A child can carry it. Makes its own light from common gasoline. Absolutely SAFE.

**COSTS 1 CENT A NIGHT**

We want one person in each locality to whom we can refer new customers. Take advantage of our SPECIAL FREE TRIAL OFFER. **Agents Wanted.**  
**SUNSHINE SAFETY LAMP CO.**  
616 Factory Bldg. Kansas City, Mo.

Copyrighted material

# PATENTS

**IF YOU HAVE AN INVENTION** which you wish to patent you can write fully and freely to Munn & Co. for advice in regard to the best way of obtaining protection. Please send sketches or a model of your invention and a description of the device, explaining its operation.

All communications are strictly confidential. Our vast practice, extending over a period of seventy years, enables us in many cases to advise in regard to patentability without any expense to the client. Our Hand-Book on Patents is sent free on request. This explains our methods, terms, etc., in regard to *Patents, Trade Marks, Foreign Patents, etc.*

All patents secured through us are described without cost to the patentee in the *SCIENTIFIC AMERICAN*.

**MUNN & CO.**  
SOLICITORS OF PATENTS  
672 WOOLWORTH BLDG., NEW YORK  
and 625 F STREET, WASHINGTON, D. C.

WEAR

Trade Mark  
Registered

**B.V.D.** U. S. Patent Office  
and Foreign Countries

UNDERWEAR



**Print Your Own** Cards, circulars, book, paper. From \$5. Larger \$18. Rotary \$80. Save money. Print for others, big profit. All easy rules sent. Write factory today for catalogue of presses, TYPE, cards, paper, samples. It will pay you well. **THE PRESS CO.** Meriden, Connecticut



Go into **MOVING PICTURE BUSINESS**

**Small Capital Starts You**

on our easy payment plan. Begin now and get your share. We sell everything. Write TODAY.

**Atlas Moving Picture Co.**  
Dept. 40 525 S. Dearborn St., Chicago



**Be Your Own Boss**

Do as many others have—Operate a Kingery Peanut Roaster and Corn Popper. Over 50 styles. Liberal terms, excellent profits.

No. 50 catalog tells you all about it.

**KINGERY MFG. CO.,** Pearl, East of Broadway, Cincinnati, O.



**SMALL ENGINES**

Perfect Gasoline Engines— $\frac{1}{2}$ , 1 and 1 $\frac{1}{2}$  h. p.—for Farm and Shop use. Price \$19.50 and up. Also

**INCUBATORS**

All prices—\$7.50 and up. Sieverkropp engines and starters for Ford Cars are shipped on trial. Send for Booklet and Special Offer.

**SIEVERKROPP ENGINE CO.**  
1224 18th St. RACINE, WIS.

**STARTER for FORD CARS**

## Have Your Suit Made To Order and Take

# 6 MONTHS TO PAY.



Here it is—the biggest sensation in the history of high class tailoring! Think of getting a suit tailor made strictly according to your own individual measurements and having six whole months to pay for it! Yes, no matter who you are, where you live, or what you do, we will make you the finest, the richest, the snappiest suit you ever saw and give you an entire half year to pay for it! Don't miss this amazing opportunity.

## Save Half

You actually and positively get the suit at about half of what it would ordinarily cost you! Our tremendous woolen buying gives us the pick of the world's greatest mills at lowest prices known. Therefore we can cut the price in half and still give you six months to pay. Don't buy cheap "ready mades" and pay double our price. Don't pay other tailors two or three times as much as we charge.

## Only \$2.50 Per Month

You wear the suit while paying for it. Payments so marvelously easy you won't miss the money. We trust you absolutely. Your word is all the security we ask. No reference, no red tape, no delay, no collectors. No strings attached to this credit whatever. It's yours to use as freely as you wish. Don't class us with ordinary tailoring houses. We are "different!" You'll be delighted.

## Get This Free Sample Book

The most sumptuous style book ever published—our 1916 Spring and Summer Style Book! See the actual cloth samples of most beautiful weaves and patterns—the newest and latest. Also illustrations of choicest designs from world's greatest style centers. You'll marvel

at this wonderful book.

## Send Coupon

or postal or letter if you wish—but do it NOW! Get the magnificent free style book and full particulars of our startling offer. Don't delay! Write today.

**Stanley Rogers Company,**  
544 S. Clark St.  
Chicago, Ill.

**STANLEY ROGERS CO.,**  
544 S. Clark St., Chicago, Ill.

Please send me, FREE, your new DeLuxe Style Book and full particulars of your great offer.

Name.....

Address.....

City..... State.....

Please Mention Popular Mechanics

## Does the Work



of  
40  
Brooms

Over fifteen years of faithful service is no uncommon record for Bissell's Carpet Sweeper; our files contain many letters telling of sweepers in use for even twenty years and more. Think of the brooms that would have been worn out and thrown away in those long years; think of the back-aches and weariness saved; the gain in comfort; the actual saving of money. It's no exaggeration to say that *Bissell's* does the work of 40 or 50 brooms—the dustless, efficient, thorough

## BISSELL'S Carpet Sweeper

Now this cleaning stand-by has a companion in *Bissell's Vacuum Sweeper* that is easy to operate; that empties from the rear of the dustbag, without soiling the hands; that in every detail offers the general *mechanical superiority* guaranteed by the name *Bissell's*.

Use the Vacuum Machine for general cleaning, the Carpet Sweeper for daily sweeping—The ideal, dustless, sanitary, efficient *Bissell's Combination*.

Carpet Sweepers are \$1.75 to \$4.75; Vacuum Sweepers and Cleaners (with and without brush) \$7.50 to \$9.00. Slightly higher in the West, South and Canada. Sold by dealers everywhere. Booklet on request. (25)

**BISSELL CARPET SWEEPER CO.**

Largest and Oldest Exclusive Manufacturers  
of Carpet Sweeping Devices in the World

Dept. 149, Grand Rapids, Mich. Made in Canada, too

## Here's a New Business



Reproduce Photographs of persons and scenes upon watch caps, dials, china, etc. Work easily done. Knowledge of photography not necessary. **TRIAL OUTFIT with directions, \$2 postpaid**—Contains enough solutions to make 15 reproductions (watch cap size) that you should sell from \$1.50 to \$2.50 each. Satisfaction guaranteed. **ORDER TODAY**

American Arts & Crafts Company, Dept. D1, Boston, Mass.



## 300 SONGS FOR 10c

### LOVE, WAR, SENTIMENTAL

I Didn't Raise My Boy to Be a Soldier  
As the Lusitania Went Down  
It's a Long, Long Way to Tipperary  
Don't Take My Darling Boy Away  
They All Sang "Annie Laurie"  
I'll Return, Mother Darling, to You

I'm On My Way to Dublin Bay  
There's a Girl in the Heart of Maryland  
Rebecca of Sunnybrook Farm  
Ballad Down the Chesapeake Bay  
When It's Apple Blossom Time in Normandy

Till Sands of Desert Grow Cold—Will the Angels Let Me Play—Silver Threads Among the Gold—When Maple Leaves Were Falling—When I Dream of Old Erin—Come Over to Dover—This is the Life—Little Lost Sister—California and You—Sing Me the Rosary—When I Lost You—Chinatown, My Chinatown—I Want a Little Bungalow—Roll Along, Harvest Moon—Casey Jones—Silver Bell—and 260 other **BIG HITS**, and **PIANO MUSIC**. **ALL for 10 CENTS**—\$ for 20c. Address **HOME MUSIC CO.**, 29 S. Clinton St., **CHICAGO**

**FREE** Photos of 100 MOVING PICTURE STARS—Mary Pickford, Anita Stewart, Ruth Stonehouse, Francis X. Bushman, Chas. Chaplin, etc., and the new song hit "MOTHER" sent free with each Song Book.

Write for  
Manufacturer's  
Prices

Book  
FREE



Save \$5—\$15 to \$40—get unbeatable quality—500 styles stoves and ranges—cash or easy payments, 30 days' trial, 360 days' approval test, \$100,000 guaranty. We pay freight and ship in 24 hours.

**Kalamazoo Stove Co.**  
Mfrs.  
Kalamazoo, Mich.

Ask for catalog  
No. 473

We also make  
Malleable Steel Ranges

**A Kalamazoo**  
Direct to You

## Try My *Rapid* Fireless Cooker 30 Days—FREE



Cook every meal on it. If you are not satisfied and delighted I will refund every cent. Get my

**SPECIAL LOW FACTORY PRICE**

direct to you. Cooker is aluminum lined throughout. Full set of famous "Wear Ever" aluminum cooking utensils comes with it. Ask for free book of valuable recipes.  
**WILLIAM CAMPBELL CO.**  
Dept. 64, DETROIT, MICH.

## AGENTS—Make \$100 to \$300



per month easy selling our new Triplecote Sauce Pan. Cooking utensil for 3 different foods on one burner. 400 Specialties—all Whirlwind sellers. Write quick for exclusive territory and large catalogue.  
**AMERICAN ALUMINUM MFG. CO.**  
Div. 5 61 LEMONT, ILL.

allowed 48 hours to dry thoroughly. This treatment was repeated every 10 months. Pitting stopped, and where it had previously taken six men seven days to clean the drums of one boiler, two men now clean them in a day.

## Bohner's Self-Cleansing Filter



Agents Make \$25 to \$40 PER WEEK

Easy Money. Takes less than 5 minutes to attach, demonstrate and sell. Protects Health against danger of disease germs in unfiltered and impure water. Every Home needs one.

**Bohner Manufacturing Co.**  
1009X So. Wabash Ave., Chicago, Ill.

## Free Book on WASHING

Tells how to get a good-sized washing done in an hour with the **Thor Electric Washing Machine**. Also tells how the Thor pays for itself by saving wear on clothes and cost of help. Write for this big 48-page book, fully illustrated. Sent *absolutely free*. And we will also tell you about the special offer we are making. **Write Today**

**HURLEY MACHINE CO.**, Dept. 1193, Chicago, Ill.

There's a Mother Old and Gray  
Who Needs Me  
Down Among the Sheltering Palms  
When You're a Long, Long Way  
from Home  
When You Wore a Tulip and I  
Wore a Big Red Rose  
If I Had a Home Sweet Home  
When I Was a Dreamer  
Where the River Shannon Flows  
I Want to Go Back to Michigan  
I Love the Whole United States

# Wanted—Ideas

## Inventors! Send for these Remarkable FREE BOOKS, Today

Complete and full information about patents, everything the inventor or manufacturer should know, has been included in these books. Never before has such an inexhaustible fund of valuable information been at the inventor's disposal. Regardless of the fact that the compilation of this information cost us thousands of dollars, we will send to all interested persons, any or all of these books, entirely without charge or obligation.

### "Millions In Patents"

This volume, 192 pages, tells the story of the romance of invention. The brain of the inventor is the magician that has made the ancient fairy tales come true. Millions have been paid for a hook, fortunes have come from a toy. Read "Millions in Patents," and you will realize that this country and all the nations of the world are ready to enrich you beyond your wildest dreams if you can contribute one useful or amusing thing.

### "What Is a Trademark?"

It is not an exaggeration to say that billions of dollars have been made out of trademarks, labels and copyrights. He who can fashion a trademark or design a label which will make a product stand out above all similar products, is indisputably a genius for whose brains the world offers almost unlimited money.

### "Foreign Patents"

A good invention is bought not by one country but by the world. "Foreign Patents" shows you how the inventor may be paid by other countries and other peoples, as well as by this nation, for his ideas and his inventions. It explains how we, through our representatives in the capitals of the world, maintain for your benefit an endless chain of opportunities which, if you take advantage of them, will girdle the earth and make of your product an agent that may bring back to you rich rewards.

### "Inventions Needed"

This book, 256 pages, lays before you a description of the active and profitable field of invention. It tells you the inventions the world needs today, the devices manufacturers are seeking for their business, the ideas for which the public will pay big money. It gives great men's ideas of the most important things needed in inventions now. Science is the key to wealth, and this key can be turned best by the inventor. This book tells you why.

### "How to Get Your Patent and Your Money"

The man who invents needs the co-operation of the man who invests. This book, 132 pages, is a guide to the inventor. It describes, according to the teachings of our experience and the lessons of men made rich by patents, how the inventor may secure money; the right amount of money, for the device which his brain has constructed. If you have invented something and desire to learn what it will cost you to get your patent and what you must do to find your market, read this book.

### "Special Bulletin of Patent Buyers"

This bulletin, 64 pages, contains copies of hundreds of letters from wealthy men who are seeking to purchase patents. Next to the idea of the invention itself, the most valuable thing to the inventor is a hint of where there is a man ready to buy the invention or to finance the inventor so that his device can be readily marketed. We act as intermediary, without one cent of charge, between the man who invents and the man who invests.

We Secure Reliable Patents, Trade Marks,  
Copyrights, On Most Liberal Terms  
Ever Offered

Send Model or Sketch and Description of  
your invention for Free Search of  
the United States Patents

Rejected and Difficult Cases are Our Specialty

**RANDOLPH & CO.**  
600 F St., N. W., Washington, D.C.

**RANDOLPH & CO.,**  
WASHINGTON, D. C.

Gentlemen: Please send me, without obligation on my part, the books indicated on margin of this coupon. (Write on margin of coupon, names of books desired.)

NAME.....

STREET.....

CITY.....

STATE.....



# World-Wide Call for New Inventions

By a WASHINGTON PATENT ATTORNEY

## War Closes Factories in Europe—America Becomes World Market—Golden Opportunity for Inventors

Europe's factories are closing. The war has taken its toll of industries as well as of men, and with hundreds of foreign factories idle, America has become the market-place of the entire world. The highest daily exports from America were reached during the past few months and this may be taken as a significant indication of what American manufacturers will be called upon to supply when the conflict is over.

Hundreds of manufacturing concerns realize this, and are on the look-out for articles patented here, which will give them the exclusive right to manufacture and ship abroad. It is up to the American inventor to supply the demand.

Not only are articles wanted for export, but for home consumption as well. There is a demand for devices in almost all lines. Many inventors have already heeded the call and have made good. There is equal opportunity for others.

The rubber-faced metal clip to go on the end of the curtain-shade stick to prevent noise when it blows against the window frame is having wonderful success and shows what may be done with even a simple article. Another simple thing is the Sure-Grip Towel Holder that the inventor is selling with wonderful returns. The Concrete Cesspool illustrated has brought the inventor more than \$50,000 in the sale of state and county rights in addition to royalties.



### THE BIG DEMAND

The demand for good patents seems to be bigger at present than ever before. The firm of attorneys of which the writer is a member is constantly receiving requests from manufacturers for inventions in all lines. For instance, a New York Specialty Co. wants a dish washer, odorless garbage can and mail order articles, while a man from Illinois asks for any-thing that can be manufactured in a

wood-working factory. A Lockport concern wants patents on articles for household and office use, while a Newark concern writes: "What have you in a peanut vending machine that can be bought from the owner?" A Chicago man says: "I wish you would put my name on your list and keep it there. I wish to buy a patent or operate on a royalty."

We have more than forty requests for patents on dish washers and drainers, six-

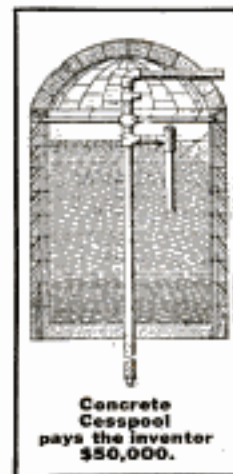

teen requests for devices for turning sheet music, twenty-eight for attachments for automobiles, twenty-four for vacuum cleaners, and many others for advertising novelties, ash receptacles, clothes pressing devices, envelope fasteners, fly traps, fruit pickers, games, mail boxes, toys, vegetable slicers, water filters, window cleaners, window screens, and other things.

There are hundreds of other requests. Some mention particular inventions; others want any good patented article. This proves the wonderful present demand.

Our firm has compiled a booklet entitled, "What to Invent," giving a list of many inventions about which inquiries have been made. We are always glad to mail it free to anyone, together with "How to Obtain a Patent," another book which explains how to protect inventions. We also give opinions regarding the patentability of inventions, without charge. Any reader of this article is at liberty to send us a sketch and description or model of any invention that he may have, when we will at once render an opinion concerning its patentability. To those who become our clients, we supply the names and addresses of the above mentioned manufacturers, without cost.

Both our books and opinions concerning patentability are free, and we are always glad to hear from anyone who wishes information on patent matters. The address is Chandlee & Chandlee, 969 F Street, Washington, D. C.



# WANTED IDEAS



Inquiries from Manufacturers and Other Buyers of Patents  
Who Are Looking for Good Ideas

## Protected by Owen Patents

Are constantly being received. Hundreds of ideas are wanted—a market exists for them to-day. YOURS may be one of them. Send for my free books and see for yourself—read the requests for inventions protected by me. Many are simple. You can help supply this demand.

As soon as my clients' rights are protected I aid in every practicable way, **without charge**, to sell. Their **applications** are advertised free—their patents are called to the attention of the proper prospective buyers—every necessary thing is done. Get my booklets and see.

## THESE ARE FREE

You will incur no obligation by writing me. A simple request will bring them to you—the finest, most reliable and instructive patent books published. A postal will do.

**"Successful Patents"**—a 72 page guide book, tells how to proceed; describes my advantageous business methods; gives references, testimonials, etc.

**"Stepping Stones"**—gives hundreds of hints of inventions wanted; articles from interviews of noted authorities; tells the truth about prizes for inventions.

**"Patent Promotion"**—tells you how to sell; why some inventors fail; discusses the value of your idea; how I aid my clients; manufacturing aids furnished you; recent successful patents, etc.

You will also be sent from time to time, as new inventions are wanted, full information concerning them. Only in this way can you keep up to date.

### Write for These To-day

Advice costs nothing. All communications confidential. Your work will receive my personal supervision—but my fees are no higher than others.

### Results Speak Loudest—But Here Are Some References

Columbia National Bank,  
Washington, D. C.  
National Locktite Co.,  
Washington, D. C.  
The Carnahan Press,  
Washington, D. C.  
Lightning Gun & Cycle Works,  
Oklahoma City, Okla.  
Antholene Mfg. Co.,  
Hutchinson, Kans.

National Rack Co.,  
61 Hannover St.,  
Boston, Mass.  
The C. J. Loftus Co.,  
13 Spring Common,  
Youngstown, Ohio  
Whitehead Hosiery Mills,  
Burlington, N. C.  
Dickinson Mfg. Co.,  
Des Moines, Iowa.

A LARGE NUMBER OF OTHERS IN MY BOOKLETS.

**RICHARD B. OWEN** 9-303 OWEN BLDG.  
WASHINGTON, D. C.

Inventors submitting their inventions to me are protected in a tangible manner until their applications are filed.



### SPECIAL FREE REPORT

Send sketch or model of your invention for free report on patentability, practicability, etc.

# PATENTS THAT PROTECT and PAY

Advice free. Terms reasonable. Highest references. Best results.  
Send sketch or model for FREE examination and opinion.

BONDED and recommended Patent Lawyer in the Rand-McNally Directory of Bankers and Attorneys Published by Rand-McNally & Co., Chicago, Ill. Recommended Patent Attorney in the Bankers Register and special list of selected lawyers published by the Credit Company, Pontiac Building, Chicago, Sharp & Allen's Directory of Lawyers and Bankers of Philadelphia, Martindale's American Legal Directory of New York City, and the Con. P. Curran Directory of Bankers and Lawyers of St. Louis.

**ALL BUSINESS GIVEN PROMPT AND PROPER ATTENTION**

A large list of strong recommendations furnished free

**WATSON E. COLEMAN, Patent Lawyer, 624 F St., Washington, D. C.**

## Inventors

Do Not Sacrifice  
Your Inventions

Get full money value.  
RELIABLE Book Free. Write

R. S. & A. B. LACEY  
624 Barrister Bldg., Washington, D. C.

## PATENTS

procured for electrical, chemical, automobile, engineering and other inventions. Booklet free. Best references.  
**MASON, FENWICK & LAWRENCE**  
Established 1861. Washington, D. C., New York and Chicago



**IDEAS = MONEY**

**PATENTS THAT PAY**

Over \$600,812.00 made  
by clients. Proof given.  
Send data for free advice.



**2 WONDERFUL GUIDE BOOKS FREE**

Don't miss these books. Mail postal today.

**E. E. VROOMAN & CO., 871 F St., WASHINGTON, D. C.**

## PATENTS

**C. L. PARKER**  
Formerly Member Examining  
 Corps, U. S. Patent Office  
**PATENT LAWYER**  
MCGILL BLDG.  
WASHINGTON, D. C.

Patents, Trade Marks, Copyrights, Patent Litigation  
Handbook for Inventors, "Protecting, Exploiting  
and Selling Inventions" sent free upon request.

## SAFE METHODS

No catches resulting in useless patents. Large lists of manufacturers and inquirers. Nearest patents and report in each case to be filed; no extra charge. **Easy payment plan.**

To be sure of honest guidance before, and a good attorney after, filing application, is more important than stories of fortune.  
Send for **FREE BOOK** { **WHAT TO INVENT**  
                                  **WHAT NOT TO INVENT**  
                                  **HOW TO SELL YOUR PATENT**  
**H. L. WOODWARD, Att'y, 9th and G, Washington**

The Congressional Library at Washington contains 2,125,255 books, 135,323 maps and charts, 670,790 volumes and pieces of music, and 300,790 prints.

The "sneeze-wood" tree, growing in South Africa, is so called because the dust produced by sawing the wood has the effect of snuff. No insect or worm will touch it.



## MODELS BUILT FOR INVENTORS

Practical, economical and modern methods of Model and Machine construction. Scientific Experimental Work. Expert designing and building of special Models, Tools and Machinery. Our staff of Skilled Mechanics assist customers to develop and perfect ideas, Patents and Inventions, etc. Let us take care of your mechanical requirements.  
**Regal Model & Tool Works, 122 S. Clark St., Chicago**

## Protective Patents

Procured Promptly. No fee refund, no guarantee certificate, no so-called prize or free search schemes used in our business. Inventors 112 page Blue Book sent on request.  
**Robb & Robb, 211-215A Southern Bldg., Washington, D. C.**

# PATENTS SECURED OR FEE RETURNED

Compare My SERVICE and TERMS with Those of Any First Class Attorney

Send Sketch, Photograph, or Model of your invention for an ACTUAL SEARCH of the Records of the Patent Office and report as to patentability — FREE. I give every detail of every case my closest personal attention and do not entrust your interests to assistants. Impartial advice on your ideas. I help you sell your patent. Terms moderate. My 90-page book tells what inventors should know before they apply for a patent.

**GEORGE P. KIMMEL, Patent Lawyer, 200 Barrister Bldg. Washington, D. C.**

Latest and  
Most Complete  
Patent Book  
Ever Published  
for Free Dis-  
tribution

WRITE FOR IT

## THE CYCLEMOTOR IS THE ONLY 2 CYCLE, HIGH-SPEED MOTOR BUILT FOR BICYCLES



Which means maximum amount of power at lowest running cost and total absence of vibration.

It is the lightest attachment ever offered for practical use, weighing but 21 pounds, including magnets.

Develops 1 h. p., speeds up to 25 miles per hour, runs 80 to 100 miles per gallon of gasoline.

Engine controlled entirely by one thumb lever. Write for our catalogue and compare the Cyclemotor's superior features with any other make on the market. A few choice territories are still open for wide-awake dealers. Particulars, and Booklet "R" sent upon request.

**CYCLEMOTOR CORPORATION** Arlington Bldg.  
ROCHESTER, N. Y.

## PATENT YOUR IDEAS

through me and secure the advantages of my manufacturing and sales facilities. Free advice as to patentability, commercial value, etc. Send sketch for search. FREE, reliable booklet.

**CARROLL BAILEY, Patent Attorney**  
Jenifer Building WASHINGTON, D. C.

## INVENT SOMETHING IT MAY BRING WEALTH

Our FREE BOOK tells what to invent and how to obtain a patent through OUR NEW CREDIT SYSTEM.  
**WATERS & CO., 4102 Warder Building, WASHINGTON, D. C.**

**CARLISLE, PA., IS A MODERN BABEL**—With some 80 different languages and dialects in daily use at Carlisle, this city can lay claim to the distinction of being a modern Babel. Virtually every Indian tribe has representatives at the Carlisle school, and the language forms at that institution number 65, exclusive of the English taught.



**MECHANICAL SUPPLIES AND MATERIAL** of all kinds.  
**EXPERIMENTAL AND LIGHT MACHINE WORK** to order.  
132 MILK STREET, BOSTON



## Models and Supplies

We make working models of any description and material, also dies, tools and sheet metal stampings. Send your drawing or sample for estimate. Write for catalog of gears and model supplies.

The Pierce Model Works, 3405 Pierce Ave., Chicago, Ill.

## Models and Gears

## Experimenters—Inventors

Developing inventions and making working models our specialty. Well equipped shop and staff of experts at your service. Carry complete stock of gears. Shipments same day order received. Send 4c stamp for booklet of inventors' supplies.  
UNION MODEL WORKS, Est. 1882, 121 S. Clark St., CHICAGO



## BRASS GEARS

Cut by an entirely new process. The most accurate made and at prices that cannot be equaled by others. Every gear has a hub, center painted ebony black, edges turned true, highest grade red brass, and much heavier than others. We carry the largest stock in the world and every gear listed is always shipped on date of order.

SEND FOR CATALOGUE  
**CHICAGO STOCK GEAR WORKS**  
16 S. Fifth Av. Chicago



## INVENTORS

Our Brain Belongs to You. Our Ideas Are Free of Charge. All we want in return is to build your model, special machinery, dies, tools and jigs to manufacture sheet metal goods, etc. We are expert mechanics, over thirty years' experience and have one of the best equipped shops in the country. Ask for Booklet No. 17. Consultation free. Experimental work strictly confidential.

**A. Nacker & Son, J. Uhrman, A. Heldrich, Prop's**  
236-242 S. 9th St., Philadelphia, Pa.



## "New-Skin"

—to prevent infection

New-Skin is an antiseptic liquid for cuts, scrapes and little hurts. When it dries, it forms a water-proof "film" that protects the cut and allows it to heal.

Carry it with you always. Keep a bottle in the house.

Genuine New-Skin →

See directions and circular. Many uses. Prices (in U. S.): 10c., 25c. At druggists. Or send us 25c. in stamps for the larger size by Parcel Post. Address Newskin Company, New York, (Dept. L).



Always in glass bottles; red and gold paper cartons

## U.S. PATENTS



**FREE** →  
**BOOK-BULLETINS & ADVICE**

**REGISTERED ATTORNEYS**

**LANCASTER & ALLWINE**

204 OURAY BLDG. WASHINGTON, D. C.

## Don't Lose Your Rights

We publish forms called "Evidence of Conception" by which you can establish your rights before sending the invention to anyone. It is your best protection. We issue up-to-date bulletins of improvements wanted; aid inventors to promote their rights; render reliable opinions free of charge and secure valuable patents and trade marks on reasonable terms. Personal service assured by our Service Guarantee Contract. References: 2nd National Bank, Washington, J. F. Roth Packing Co., Cincinnati.

### SIMPLY MAIL COUPON

LANCASTER & ALLWINE, 204 Ouray Bldg., Washington, D. C.  
Send me free, book "Inventions—Patenting and Promoting," Bulletin of Improvements Wanted and blank form, "Evidence of Conception."

Name.....

Address.....

Please Mention Popular Mechanics



MR. TALBERT  
MANAGER  
AND PATENT LITIGATION



MR. MAHONEY  
CHIEF OF SEARCH DEPT.



MR. KOEHL  
MANAGER OF PATENT



MR. ACKMAN  
CHIEF OF PATENT



MR. HOSTER  
MANAGER OF PATENT



MR. SMITH  
ENGINEER



MR. PARKER  
PHYSICAL INSTRUMENTS

# PATENT SPECIALISTS

## VICTOR J. EVANS & CO.

### LARGEST PATENT AGENCY IN THE WORLD



MR. GARNER  
GLASS INDUSTRY



MR. HOUGH  
ORDNANCE

THE largest Patent Agency in the world is the firm of Victor J. Evans & Company, of Washington, D. C., with branch offices in New York City, at Nos. 189, 191 Broadway; in Philadelphia, at No. 1429 Chestnut Street, and in Pittsburgh, at No. 514 Empire Building. The growth of this firm has reached such proportions as to necessitate the erection of a special building, the Victor Building, Nos. 720, 724 Ninth St., N. W., Washington, D. C., opposite the United States Patent Office, is the finest and most perfectly equipped office building in the country devoted exclusively to the patent business.

Evans & Company are but following the practice of the Patent Office, who, realizing the impossibility of any one man having a general knowledge sufficient to handle all classes of cases, have divided the Patent Office into forty-two divisions, each handling several classes of inventions, and it is through this system of specialists and experts forming the technical corps of their offices that this firm is enabled to secure



MR. ROETH  
ELECTRIC EQUIPMENT



MR. KING  
ELECTRIC EQUIPMENT

### Specialization

The field of invention is so vast that it is impossible for any one man to become an expert in all the different classes of invention. Only those practically skilled in the class to which an invention relates are capable of rendering efficient service. For this reason, this firm employs a number of patent lawyers and mechanical experts who have been selected for their special knowledge and ability in a certain line of invention.

### Patents that Protect and Pay

Any one will appreciate the advantage of this corps of experts over other attorneys, where one man has to handle all classes of patents submitted. This firm is enabled to direct a particular invention from the time it is submitted until the patent is secured, in the hands of experts in the class to which the invention relates, thus securing the best possible services. This firm has also helped a number of inventors who were in need of financial aid to obtain patents. This was accomplished by means of their Certificate of Patentability, which furnished the necessary proof of patentability, and thus enabled their clients to interest partners or secure financial assistance to protect their ideas.



MR. GOULD  
ELECTRIC EQUIPMENT



MR. YEAGER  
CITY AND ROADS

In equipping their offices with experts and specialists who devote their time to one or two inventions, Messrs. Victor J.



VICTOR J. EVANS



MR. EDMISTON  
TEXTILES

### Assist Their Clients to Sell Their Inventions

Victor J. Evans & Company also assist their clients to sell their inventions by connecting the inventor with capital. They are constantly in receipt of requests from manufacturers, promoters, mail-order houses and others who are in the market for patents secured by them. They give their clients a list of Patent Buyers containing names and addresses of the persons desiring to purchase patents. This firm also advertises their clients' inventions free in Manufacturing Journals.

### Our Four Books Mailed Free

"HOW TO OBTAIN A PATENT" contains one-hundred mechanical movements illustrated. "WHAT TO INVENT" contains a valuable list of inventions wanted; also information concerning prizes offered for inventions amounting to \$1,000,000. "PATENTS THAT PAY" contains letters from clients for whom we have secured profitable patents. "FOREIGN PATENTS" contains full information regarding patents in foreign countries. Persons interested in patents should write for these books, which will be sent upon request, entirely without charge, by filling out the annexed coupon.



MR. M. CARTHY  
ELECTRICITY



MR. SMITH  
MANUFACTURING JOURNALS



MR. JONES  
FOREIGN PATENTS



MR. HINES  
AERONAUTICS

**FREE COUPON!**  
**VICTOR J. EVANS & CO., Patent Attorneys**  
 New York Offices: 189-191 Broadway Philadelphia Offices: 1429 Chestnut St.  
**ADDRESS MAIN OFFICES: 765 Ninth St., N. W. WASHINGTON, D. C.**

This Coupon, accompanied by model or sketch, with description of invention will entitle the sender to Free Opinion as to Patentability.

GENTLEMEN: Please send me FREE OF CHARGE your FOUR Books as described above.

NAME .....

ADDRESS .....



MR. BAGGER  
AERONAUTICAL EXPERT



MR. RUPPERT  
MECHANICAL EXPERT

Please Mention Popular Mechanics

# LAW BOOK FREE



Do you know that the incomes of many lawyers exceed that of the President of the United States? Are you aware that the President himself, as well as practically every other man prominent in public life, is a lawyer? Then you owe it to yourself to get and read this interesting 80-page Law book. Doing so may change your whole future! It shows that the demand for legally-trained men in business and public life was never greater than today, and points out the importance of a thorough knowledge of law in many lines of work. It compares resident and correspondence instruction, and explains just what a law course should contain to give you the training absolutely necessary to succeed. It enables you to weigh and judge the claims of correspondence schools; shows you how to choose the best school in which to take up the study of law, and describes thoroughly the American School's new and efficient method of acquiring a legal education at home—in your spare time.

## FREE 13 Volume Law Library and 60 Text Books

With each course we furnish 60 new pocket size text books, 36 Case Books, and instruction for five years if necessary. Our big 13-volume Law Library—the most splendid reference work of its kind ever published covering the entire field of American law and practice—is included absolutely free. Course contains 28 more subjects and 30 more authors than any other correspondence law course. Written in plain, simple, easily understood language—the easiest, best, most complete and practical correspondence law course ever devised. Only law course ever written especially for correspondence instruction. Send for "How To Acquire a Legal Training" today. It is absolutely free—just mail the coupon.



This 13-vol. Law Library and 60 Text Books Free with every Course

**American School of Correspondence**  
Chicago  
U.S.A.

**FREE BOOK COUPON**

Pop. Mech. 8-16  
A.S. of C.

Gentlemen: Please send me your FREE Law Book, "How To Acquire a Legal Training," and full particulars regarding your wonderful new system of correspondence law instruction.

NAME .....

ADDRESS .....

The manufacture of moving pictures abroad has been almost stopped by the war. More than 90 per cent of the films shown in England are said to be made in the United States.

## RELIEF TO TRUSS USERS



Any appliance is a truss. Ruptured people must wear some kind of support. Our New Sponge Rubber Pad (pat'd) is velvety, soft to the skin, pliable, cannot slip, extremely comfortable. It adapts itself to ruptured parts with less pressure, is sanitary, long lived, massages and strengthens muscles, allows blood circulation and produces many cures.

### New Scrotal Pad Needs No Leg Strap

Our new scrotal pad (pat'd) holds hernia perfectly without strap between legs in 8 out of 10 cases.

**FREE SAMPLE PAD** A Sample Akron Sponge Rubber Truss Pad (pat'd) will be sent absolutely FREE upon request, also booklet "Help to Truss Wearers." It's full of help. Ask your dealer, or write us. **THE AKRON TRUSS CO., Dept. 103, AKRON, OHIO**

## The Acetylene Blow Torch Prest-O-Torch



Costs less to buy than a good gasoline blow torch and costs less to use

In all soldering and brazing, the Prest-O-Torch avoids the delays and uncertainties of gasoline outfits. Provides a concentrated, intense flame that doesn't blow out even in a high wind. Needs no attention whatever. Used with handy sizes of Prest-O-Lite cylinders—ready-made gas. Style "A" sells for 75c (Canada 85c). Used with the small MC size Prest-O-Lite. Will braze up to 3/4 inch round rod. Can be fitted with handle and hook for added convenience in bench and overhead work. Style "C" Prest-O-Torch, for use with the larger sizes of Prest-O-Lite, is recommended for large work. Will braze up to 3/4 inch round rod. Sells for \$2.25 (Canada \$2.75).

Write for special literature and learn where you can see the Prest-O-Torch in operation.  
**THE PREST-O-LITE CO., Inc., 816 Speedway, Indianapolis, Ind.**  
Canadian Factory, Merrilton, Ont. Exchange Agents Everywhere

## GENUINE PERFECT CUT DIAMONDS \$97.50 Per Carat

**A CLEAR SAVING OF 35%.** Only from Basch can you get genuine perfect-cut diamonds at the world's competition-smashing price, \$97.50 per carat. Full \$130.00 per carat value at retail.

**And here's the reason:** no middlemen's tax included in our extraordinary low direct import price! Cash buying from the diamond cutters, plus our "Small profits, many sales" plan, give you a clear saving of 35 per cent of regular retail prices.

### Free Examination—Send No Money!

You prove our claims yourself at our expense. Here's the popular Basch plan: Select any carat size diamond—choose any mounting from the thousands we illustrate in our catalogue. We ship entirely at our expense—allow full examination and comparison, without obligating you to buy. Absolute satisfaction assured you by trying the Basch way.

**L. BASCH & CO.**  
Dept. T2470 State and Quincy Sts.  
**CHICAGO, U. S. A.**



This 14K solid gold mounting complements with

1-8 c. Diamond	\$12.00
1-4 carat Diamond	\$12.25
3-8 carat Diamond	\$5.00
1-2 c. Diamond	\$8.75
3-4 c. Diamond	\$7.25
1 carat Diamond	\$101.25

**Money Back Guarantee!** A written Legal Contract to return your diamond any time within one year; also guarantee full price in exchange any time. Certifies carat weight and value. No protection equal to this in the whole diamond business. See that your diamond is Basch guaranteed.

## 1916 BASCH DE LUXE DIAMOND BOOK, FREE COUPON

Complete, valuable, and authoritative! Gives you expert facts needed to buy intelligently. Helpful guide to select gifts for all occasions. Thousands of illustrations of diamonds, watches, platinum and gold jewelry, silverware, cut glass, etc.—all priced to you at remarkable low figures. You cannot afford to buy your diamond or jewelry without a copy of this complete catalogue. Mail coupon or write us a letter or post card for your FREE copy, NOW.

**FREE DIAMOND BOOK COUPON**

Please mail me FREE, without obligation, 1 Basch De Luxe Diamond Book.

Name .....

Address .....

BASCH Dept. T2470 State & Quincy Sts. Chicago, Ill.

Please Mention Popular Mechanics



No. 421

Fern Stand  
30 in. high  
Top 16 in. sq.Our Price **\$4.25**

Dealer's Price \$7

# Cut Cost of Your Furniture In Two

Shipped in sections, knock-down—saves factory space—packing costs and freight charges.

Direct from factory to you saves dealer's expenses and profits.

"Period Furniture"—over 100 designs—everything for the home, office or club. Every piece from *selected quarter sawed oak*.

Hundreds of dealers are assembling Brooks "Master-Built" Furniture in their stores and selling it from forty to fifty per cent above our prices.

## Home Exhibitors Wanted

Exchange spare time for furniture or cash commissions. A new business for men or women. We ship from a single piece to carload lots. **Free Catalog** with full particulars.

**Brooks Manufacturing Company**

2703 Rust Avenue, Saginaw, Mich.

*Largest Plant of Its Kind in the World*



No. 450

Genuine Red Cedar Chest  
48x22x20 in.Our Price **\$10**

Dealer's Price \$18



No. 308

30 in. high; top 29x43  
Library TableOur Price **\$12.75**

Dealer's Price \$25

Our Price **\$9.75**

Dealer's Price \$17

Rocker No. 10  
Height, 35 in.  
Width, 31 in.; Depth, 21 in.

No. 314

Our Price **\$19.75**

Dealer's Price \$40

Extension 48 to 84 in.  
50x63x15 in.

No. 426

Desk and Bookcase

Our Price **\$29.75**

Dealer's Price \$60

## 30 DAYS FREE TRIAL

Total cost only **\$7.50** By Our  
to prove to you that this magnificent Royal has the SWEETEST, PUREST, LOUDEST and CLEAREST TONE—  
to prove to you that it is as large and handsome as the trust machines that sell at \$25.00—

7 MONTHS TIME Purchase Plan  
to prove to you that it has the strongest motor, the best reproducer and tone arm and the most ingenious devices to start, stop and control the music.

Shipped with a supply of 10-inch double disc records of your selection, so you can enjoy the finest entertainments for one whole month. Return the outfit **AT OUR EXPENSE** if for any reason you do not wish to keep it. Drop a postal for our big list of unsolicited testimonials, record book and other literature—all free.

Central Distributing House  
Dept. H 41 6101-11 May St., CHICAGO



## ALORRA DIAMONDS

SPARKLE LIKE THE GENUINE—AT 1-40 THE COST  
**SOLID GOLD RINGS**

—stand solid, fire and expert examination. See them before paying. Any style ring, pin or stud. Catalog FREE. The Alorra Co., Dept. A7, 140 S. Dearborn St., Chicago

## Delivered to You Free

1918 Model A sample 1918 model "Ranger" bicycle, on approval and 30 DAYS TRIAL, and free riding test.

Write at once for large illustrated catalog showing complete line of bicycles, tires and supplies, and the most marvelous offer ever made on a bicycle. You will be astonished at our low prices and remarkable terms.

RIDER AGENTS Wanted—Boys, make money taking orders for Bicycles, Tires and Sundries from our big catalog. Do Business direct with the leading bicycle house in America. Do not buy until you know what we can do for you. WRITE TO US.

MEAD CYCLE CO., DEPT. P108, CHICAGO

## \$30 a Week EASY MEN AND WOMEN WANTED TO SELL PERFECTO Kerosene Irons



No experience necessary. Big profits selling this wonderful self-heating satisfaction guaranteed iron. Easy to operate and demonstrate. Sell it! Use Kerosene (Coal Oil) or Gasoline with same satisfactory results. Absolutely safe, no smoke or odor. Get facts in detail and let us tell you how to obtain Free Sample and start you in a big paying business. Sample case FREE to Agents.  
PERFECTO SADDLE IRON FACTORY  
Dept. P, 126 So. Clinton St., CHICAGO, ILL.

## MEN WANTED

To sell "Wear-Ever" aluminum ware.  
**\$6.23**

per 7 hour day is the average profit made by  
**3,792 men**

R. L. Boone of Virginia says, "Selling 'Wear-Ever' gave me valuable experience and a profit of \$2.35 an hour." For particulars write

THE ALUMINUM COOKING UTENSIL CO.  
Dept. F, New Kensington, Pa.



Mr. R. L. Boone

## VULCAN INK-PENCIL



**\$1 Dependable for a life time. Made right to write right. Long or Short—Red or Black. \$1**  
Absolute necessity to any business man or woman. Promotes efficiency. Unequaled for general writing, billing, ruling and manifolded. Made of pure vulcanized rubber with non-corrosive, durable writing point. Lock-Cap prevents leaking. Extra size, 8 inches, black only, \$1.25. Complete Pen Catalog and Agent's Proposition on request. J. C. ULLRICH & CO., 27 Thames St., New York

# TIFNITE GEMS

## Brilliant as Diamonds

A Tifnite Gem and a diamond are as near alike as two peas. Nothing else in the world so near a diamond in looks, brilliancy and every diamond test. Tifnite Gems cut glass like diamonds, won't file, won't melt. Guaranteed to last forever. Not one particle of glass in them. To quickly introduce them to 10,000 men and women, we make a test never before heard of. We have made up four exquisite items, latest style designs, guaranteed solid gold mountings and each set with a genuine Tifnite Perfect Diamond Cut Gem. We will send you

**YOUR CHOICE FREE**  
Without Deposit

Send no money whatever. Just state which item you prefer—Ring, Pin or La Valliere—and we will send it to you promptly. If ring, send string showing size around your finger. State lady's or gent's. If you think it's worth all we ask, simply send us \$1.25 within 10 days after arrival and pay the balance, \$2.00 per month, until these Special Limited Bargain Offers are paid in full, otherwise return to us. Send no references—no money—simply your request. You be the judge of this wonderful gem. These pictures show the mountings and rock-bottom prices. Send for yours today—now—while supply lasts.

**THE TIFNITE GEM CO.,**  
1015 Jackson Blvd., Dept. 9 Chicago

**LA VALLIERE**—Solid Gold, 15 in. Chain, one-half carat Tifnite Gem, black ornate mounting, \$14.25. Nothing down, \$2 Per Mo.

**Ladies' Ring**  
Tiffany Mounting  
Solid Gold. One  
Carat Tifnite Gem  
\$11.25 Nothing  
Down, \$2 Per  
Month

**Gent's Ring**  
Claw Mounting  
Solid Gold. One  
Carat Tifnite Gem  
\$12.25 Nothing  
Down, \$2 Per  
Month

A Baseball Jersey



## Be the First in Your Club

School, City or Town, to wear this pure, all wool sweater, double collar and cuffs. Your choice in colors. This jersey was selected by 10,000 of my customers for last season. Your club will recommend it. My 1915-1916 catalogue is now ready. Write me and learn my offer for your club's order. Popular Prices. Best Grade Sporting Goods—Baseball, Basketball, Tennis, Golf, etc.

WRITE ME NOW.

**JACK SHANNON CO.,** Dept. 46, 54 E. Monroe St., Chicago

**FREE 10 Day Trial—No Money Down**

BRAND NEW—1916 STANDARD \$100

## REX VISIBLE



Two-color ribbon, back spacer, tabulator, wide carriage, auto. line lock, etc. At lowest price ever made on a Brand New Standard machine. Terms only **8 CENTS A DAY**. To best sales for 10 days—complete \$30 Typewriting course with every 10 day FREE trial. Don't pay even \$10 for a typewriter until you get our price.

**REX TYPEWRITER COMPANY**

Dept. 74 1804 Stager Building CHICAGO

## Made-to-Measure

**EXPRESS PREPAID \$2.75**

Pants cut in the latest style. Made to your individual measure. Fit, workmanship and wear guaranteed.

### No Extra Charge

for peg tops, no matter how extreme you order them.

**Agents** A good live hustler in every town to take orders for our **Wanted** celebrated made-to-measure clothes. Samples of all latest materials FREE.

### We Pay Big Money

to our agents everywhere. Turn your spare time into cash by taking orders for our stylish clothes. Write today for beautiful FREE outfit.

**THE PROGRESS TAILORING CO.**  
Dept. 870, CHICAGO, ILL.



# APPLIED ELECTRICITY



## ONLY 50c A WEEK

Send today for your set of the greatest electrical reference library ever published. The new edition, just off the press, is recognized by big men in the electrical field as the most practical work of its kind. Covers completely the generation and use of electricity for power, light, transportation and communication, the construction and operation of dynamos and motors, central station engineering and telephone work, as well as **wireless telegraphy and telephony** and land and submarine telegraphy. Valuable alike to the beginner and expert.

The seven big volumes, written by thirty-two famous experts, contain 3,500 pages and 3,000 illustrations, full page plates, diagrams, simple explanations, etc., with hundreds of valuable facts and figures. Substantially bound in half red morocco, gold stamped.

## Sent Absolutely Free

To prove to you that these books will help you in your own work every day, we'll trust you for seven days before you spend one penny. Simply fill in and mail the coupon below, and your set will be sent you immediately, express prepaid. Keep the books an entire week. Give them the hardest test you possibly can. They must make good with you or we take them back without question or annoyance. Despite the fact that the new edition is greatly enlarged, the price remains the same—\$35. Those, however, who take advantage of this great offer now are entitled to the special introductory price of \$19.80, payable in monthly installments of \$2 each. So don't delay, but send in the coupon now.

### Read These Subjects Carefully

Elements of Electricity—Electrical Measurements—Underwriter's Requirements—Theory, Calculation, Design and Construction of Direct Current Generators and Motors—Types of Generators and Motors—Management of Dynamo-Electric Machinery—Electric Lighting—Alternating Current Machinery—Power Transmission—Electric Railways—Self-Propelled Railway Cars—Power Stations—Switchboards and Switching—Storage Batteries—Applied Electro-chemistry—Electric Elevators—Electric Welding and Heating—Wire and Wireless Telegraphy.

## Free \$12.00 Consulting Membership

Our staff of 32 electrical experts answer every question you want to ask on electrical subjects absolutely free for a full year to every holder of a set of these books.

This privilege has always cost \$12.00 and men tell us it is worth twice that amount in settling one problem alone. You get this service free if you buy the books after examination. This means \$12.00 saved if you act now. Read the coupon carefully. Then fill it out and mail today. The books will reach you promptly—express paid by us. After seven days send us \$2.00; otherwise, notify us for their return. Don't wait. You take no chances whatever. It costs nothing to inspect and you are nothing out if you do not care to buy. Mail the coupon today.

## Free Coupon Worth \$15.20 to You

American Technical Society

Please send me Cyclopedic of Applied Electricity for seven days' free examination. If I keep the books will send \$2.00 within seven days and \$2.00 a month until \$19.80 has been paid, when \$35 books and \$12 consulting membership will be mine. Otherwise will notify you and hold books subject to your order. Title not to pass until fully paid. Pop. Mech. 3-16

**AMERICAN TECHNICAL SOCIETY**

Chicago U. S. A.

NAME .....

ADDRESS .....

As I have had no previous dealings with you, I refer you to

Please Mention Popular Mechanics



## Hansen Gloves

Whether you drive a car or help make one—whatever work you do—a Hansen means freedom of action and keeps your hands well.

A Hansen makes you proud—proud of your efficiency in work and your appearance in leisure.

### Double-Up Gauntlet for Motorcyclists

Fold them easily in pocket for safe keeping. Serviceable, stylish, no extra bulk.

#### Write for Free Book

Shows many of 500 styles. Don't buy shapeless makeshifts. Hansen gloves last. If your dealer is not supplied, write us.

O. C. Hansen Mfg. Co.  
291AM Milwaukee St.  
Milwaukee Wisconsin



## Meco ENGINES

Gasoline, Kerosene & Gas

### Prove Their Quality

Write us, giving dealer's name and we will tell you how to get a high-grade Meco Engine for trial, and send you our Engine Catalog to select the kind of engine you want.

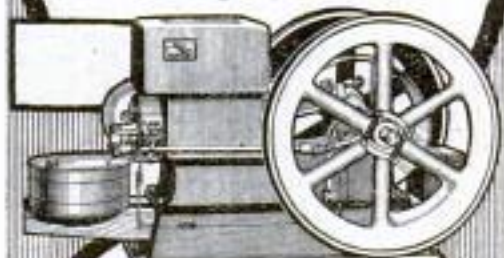

### COSTS YOU LESS

2 H-P, \$35.10; 3 H-P, \$52.65; 4 H-P, \$70.20;  
6 H-P, \$100; 8 H-P, \$140.40; 12 H-P, \$210.50.

Built for hard, heavy work, compact, easy to run; few parts, and save their cost in fuel first year.

### Guaranteed 5 Years

Don't pay more than our prices for any high-grade engine until you have tried the Meco. Write for Catalog today.

### Manufacturers Engine Company

1821 Crystal Avenue, Kansas City, Missouri.

**LINE-THROWING GUNS FOR ALASKA LIGHT STATIONS**—Great difficulty has been experienced in the past in landing supplies and mail at the Scotch Cap and Cape Sarihof Light Stations, Alaska. Owing to the situation of the stations, the condition of the sea is very

## FARM VIM MARINE ENGINES

Get a VIM Engine and save money. VIM Midport 1 1/4 H.P. Farm Motor shown below does all the churning, curdling, washing, pumping, separating, spraying, etc. Women operate easily. No complicated parts. Weighs only 70 lbs. Water cooled, automatic lubrication. Comes ready to run. Guaranteed. Full line marine engines 5 to 27 H.P.; 1, 2 and 3 cyl.; Speed, pleasure and heavy duty types. Gasoline or kerosene.

Double Ignition, Non-backfiring. Strong, simple, accessible—absolutely dependable. Built for a lifetime. The boat-builder's stand-by, the boat-owner's pride. When writing for catalogs, please mention whether interested in stationary or marine engines, or both. Ask for attractive agency offer. The Vim Motor Company, 103 Water St., Sandusky, Ohio



50 Light Plant

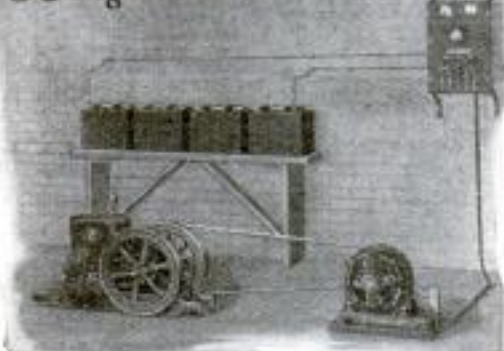

## Electric Lighting Plants

For Farm and Country Homes

Complete—Independent  
Easy to Operate

Give 24-hour Service

## Fairbanks, Morse & Co.

New York CHICAGO San Francisco  
and other principal cities



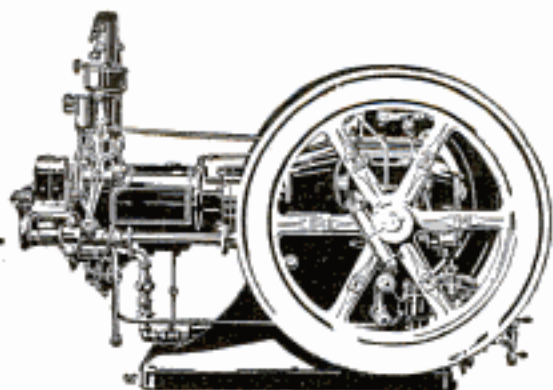

## Own a Mogul Kerosene Engine

Do you want a really economical engine—that is, one that does the most work at the least expense? If you do, don't miss an opportunity to compare Mogul kerosene engines with any others when you need new power or more power.

Learn enough about Mogul engines so that you can make comparisons of weight distribution, valve sizes, fuel systems, bearing materials and sizes, equipment, oiling systems, safety devices, etc.

Then you can buy surely, safely, and easily, the really cheap engine you need—a Mogul kerosene engine of the right size and style for your work.

International Harvester Mogul engines are made in sizes from 1 to 50 horse power, and in every approved style. They operate perfectly on kerosene and even lower grade fuels, and on gas or alcohol.

When you buy this engine, the engine is not all you get for your money. Our service also has built up a reputation. Write us for full information.

**International Harvester Company of America**

(Incorporated)

**16 Harvester Building Chicago U.S.A.**

often unfavorable to making landings through the surf for days at a time. Measures have therefore been taken recently by the Bureau of Lighthouses for the

## POWER

for farm, ranch, shop, to pump, saw, excavate, hoist, irrigate, can be had in Galloway engines from 1½ to 16 h.p. All styles. 200,000 customers testify to quality. Prices from ½ to ¾ what's usually asked. Low freight.

**WM. GALLOWAY COMPANY**  
Box 965 WATERLOO, IOWA.



**2 H.P. \$35 Auto Throttle Governed**  
not hit and miss governed. One of the many exclusive features found in no other low priced engine.

Auto Throttle Governor means smooth, even, economical power for every work. Wonderful engine valve. Will operate electric light plant, run machinery, pump water, etc. Hopper coated. Price complete with gasoline tank, electrical equipment, etc., ready to run, only \$35. Further details and catalog free. Write today.

**C. BENNINGHOFFEN & SONS, Dept. 125, Hamilton, Ohio**

**4 H.P. Cushman Weighs Only 190 lbs.**  
**8 H.P. 2 Cylinder Only 320 lbs.**

Discussing light-weight motors recently, the Scientific American said: "Efficiency means light weight, reduced friction, and above everything else, lowered operating cost." Cushman Light-weight engines are today recognized as the leading American

Double Cylinder 8 H.P. Weight 320 lbs.

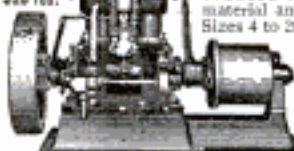

light-weight, high efficiency, all-purpose motors, challenging comparison in minimum weight per horsepower, reduced friction, quality of material and workmanship and cost of operation. Sizes 4 to 20 H. P. Throttle Governor. Schebler Carburetor. Forced Water Cooling System. Moving parts enclosed and run in bath of oil. Not cheap engines, but cheap in the long run. ENGINE BOOK FREE.

**Cushman Motor Works**  
832 N. 21st St., LINCOLN, NEB.

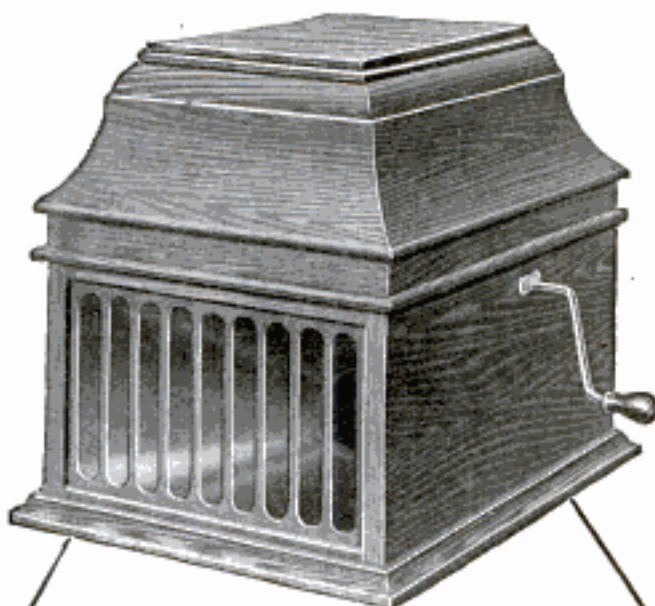

# \$100

and You Keep This Superb  
**New Edison**

An astounding offer—the great New Edison with the new Diamond Stylus reproducer and your choice of all the brand new Diamond Amberol Records will be sent to you on **free trial without a penny down**. The finest, the best that money can buy at very very much less than the price at which imitations of the genuine Edison are offered—a **rock-bottom offer direct from us**.

## Entertain Your Friends

Hear all the latest up-to-date song hits of the big cities. Laugh until the tears stream down your face from laughing at the funniest of minstrel shows. Entertain your family and your friends with everything from Grand Opera to Comic Vaudeville — then if you choose, send the outfit back to us at our expense.

## Rock-Bottom Direct Offer

If you wish to keep Mr. Edison's superb new instrument, send us only \$1.00 after the free trial. Pay the balance on the easiest kind of monthly payments.

Think of it — a \$1.00 payment, and a few dollars a month to get this brand new style outfit—the Diamond Stylus reproducer, the musical quality—the same Diamond Amberol Records—all the musical results of the highest price outfits—yes, the greatest value for \$1.00 down, balance on **easiest monthly terms**. Convince yourself — a free trial first! No money down, no C. O. D., not one cent to pay us unless you choose to keep the instrument.

## Our New Edison Catalog Sent Free

Your name and address on a postal or a letter (or just the coupon) is enough. No obligations in asking for the catalog. Get this offer — while this offer lasts. Fill out coupon today.

**F. K. BABSON**  
Edison Phonograph Distributors  
1193 Edison Block  
Chicago, Ill.

Canadian Office:  
255 Portage Ave.  
Winnipeg,  
Manitoba.

To  
**F. K. Babson**  
Edison  
Phonograph Distributors  
1193 Edison Bk.  
Chicago, Ill.

Gentlemen: Please send me your New Edison Catalog and full particulars of your free trial offer on the new model Edison Phonograph.

Name.....

Address.....

Please Mention Popular Mechanics

## A Real Kerosene Engine

Here's the biggest engine value ever offered in a 1½ H. P. engine. Same cylinder capacity as many 2½ H. P. engines. Throttling governor adjustable while running; crankshaft extends on both sides. Runs either way. Starts without cranking. Equipped with Ellis Patent Fuel Device, guaranteeing successful operation on cheap oils. Beautifully finished in genuine engine enamel.

### Runs on 9c a Day

Just the engine for pumping, separating, churning, corn-shelling, sawing, shop work, electric lighting and dozens of other light jobs. Sold on 30 days' trial. Guaranteed for 10 years. We make other sizes from 3 to 18 H. P., vertical and horizontal, single and double cylinders.

Ask for our free book, "ENGINE FACTS," telling how to judge and buy an engine.

**ELLIS ENGINE CO., 2873 E. Grand Blvd., Detroit, Mich.**

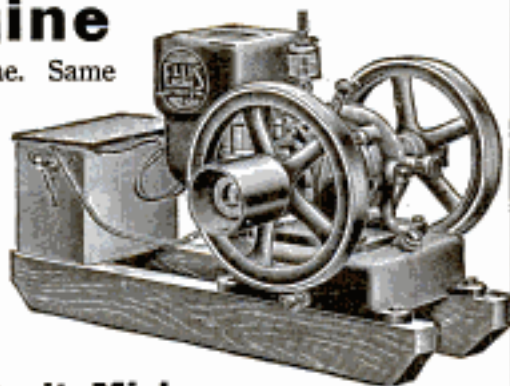

## Don't Throw Away Your Worn Tires

You can get 5,000 miles MORE service out of them

For over three years European motorists have been getting from 10,000 to 15,000 miles out of their tires by "half-soling" them with Steel Studded Treads.

In eight months 20,000 American motorists have followed their example and are saving \$50 to \$200 a year in their tire expense.

**We Deliver Free** Without a cent deposit, prepay the express and allow you to be the judge. Durable Treads double the life of your tires and are sold under a signed guarantee for 5,000 miles without puncture. Applied in your own garage in thirty minutes.

**Special Discount** offered to motorists in new territory on first shipment direct from factory. Don't take any more chances with your tires. Mail the coupon Today and find out how to get 5,000 more miles out of them.

Mail Today—Save the Discount

**THE COLORADO TIRE & LEATHER CO.**

344 Tread Bldg., Denver, Colo. Dept. C44, Transportation Bldg., Chicago, Ill.  
Suite 720-443 Woolworth Bldg., New York, N. Y.

Gentlemen—Please send me without obligation, full information, sample and guarantee.

Name .....

Address .....

My Tire Sizes are .....

## WEBER THROTTLE-GOVERNED KEROSENE ENGINES

4-Cycle

Lowest Priced Throttle-Governed Engine on the Market—Cash or Payments

Save Half In Fuel. The 1916 model Weber solves the problem of low cost power for all time. Power and speed controlled by throttle, same as steam. No waste of fuel—no violent explosions. Throttle regulates amount of fuel to size of load.

Sold on a Five-Year Guarantee—Two Months' Trial in shop or on farm. Shipped direct from factory at a big saving.

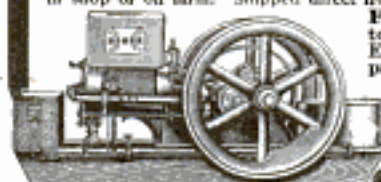

**FREE BOOK**—"How to Use Kerosene" and Engine Folder, sent post-paid. Address

**WEBER ENGINE CO.**  
Dept. 1773  
Kansas City, Mo.

Velvet

THE SMOOTHEST SMOKING TOBACCO

purchase of line-throwing guns for these stations, and for the Cape St. Elias Light Station, Alaska, now in course of construction, which, it is believed, will be very useful in landing mail and in connection with landing supplies and transferring the keepers to and from the stations during unfavorable weather.

## Pay as You Wish

We'll send you a genuine Lachnite for you to wear for 10 full days. If you can tell it from a real diamond send it back at our expense. Costs but 1-30ths as much. If you decide to keep it pay only a few cents a month. Write for catalog.

**Genuine Lachnite Gems**

keep their dazzling fire forever. Set in solid gold. Cut by world renowned diamond cutters. Will stand fire and acid tests. All kinds of jewelry at astounding low prices. Easy payments. **WRITE TODAY.** H. Lachman Co., 12 N. Michigan Ave., Chicago Dept 1183



LOWEST FUEL COST

## BESSEMER A REAL KEROSENE ENGINE

It's not the first cost, but the running cost that counts. Bessemer Kerosene Engines run on lowest fuel cost—and run for years, because they are built to run on Kerosene and are not a converted gasoline type. Equipped with famous Bessemer Universal Fuel Feeder, which obviates carburetor trouble. They do all your odd little power jobs and can be utilized in a dozen ways you've never thought of. Sizes 2 to 10 H. P.; also direct connected to all kinds of machinery. Get our facts in our free Catalog "K".

## BESSEMER OIL ENGINE

recommended where power from 15 to 200 H. P. is required. Burns crude and fuel oil and runs at about ½ to ¼ cost of gasoline. Now being used in irrigation, flour mills, factories, lighting plants. This engine is revolutionizing the power question. Get the facts by writing for Catalog "O".

**The Bessemer Gas Engine Co., 121 Lincoln Ave., Grove City, Pa.**

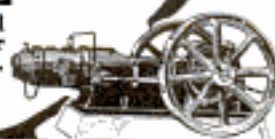

30 DAYS FREE TRIAL

**NEW OIL LIGHT****Beats Electric  
or Gasoline****WRITE FOR FREE BOOK**

telling all about the wonderful new Aladdin Mantle Lamp that burns 50 hours on a gallon kerosene (coal oil). No odor, smoke or noise. Tests by Government and 33 leading universities show it gives twice as much light as best round-wick lamps on half the oil. Lights entire room with pure, white, steady light that saves the eyes. Won Gold Medal at the Panama Exposition. Guaranteed.

**10 Days Free—Send No Money**

When we send you the Free Book, we will tell you how you can try the Aladdin 10 days in your own home without making a cent—we even pay postage charges. Be the first to write from your locality and get our special introductory offer. Write our nearest office today for Free Book and particulars of free trial.

**MANTLE LAMP CO., 1259 Aladdin Building, CHICAGO**  
Largest Coal Oil Mantle Lamp House in the World  
Also offices at New York City, Portland, Montreal, Winnipeg

**YOU CAN MAKE BIG MONEY** delivering the Aladdin Mantle Lamp. Sample Free to responsible men who show us they mean business. Give full information how long you have lived in community, whether have title or auto to work in country, what territory you prefer, etc. We furnish capital—no investment necessary. Write quickly before territory is taken.

**Colorado Diamond****Newest Product of Our Gem Mines**

A beautiful Genuine Topaz, of purest white color, finest Diamond cut, wonderful brilliancy and great hardness. Endorsed by leading experts. Far superior to the best imitation Diamond ever produced. Remember we guarantee these stones to be genuine. Special price, \$2.00 each. Size, up to two carats. FREE booklet. Address

**COLORADO JEWELRY MFG. CO.**  
1526 1/2 Champa St. Dept. 47 Denver, Colo.

Rats, it is stated, every year destroy at least a twentieth part of the sugar cane in Jamaica.

A bank, to be managed entirely by students, is to be opened at Wesleyan University, Middletown, Conn., according to a recent report.

**FREE BIG BOOKLET TELLING  
HOW TO GROW  
MUSHROOMS**

at home all the year. Big profits. Take advantage of this wonderful opportunity to become independent. Write Nat'l Spawn Co., Dept. 12, Boston, Mass.

**\$2.00 and you get this Superb Cornet**

An astounding offer. This Triple Silver Plated Lyric Cornet will be sent to you for only \$2.00. Pay the balance at the rate of only 10c a day. Free trial before you decide to buy.

**WURLITZER FREE Band Catalog!**

Send your name and address and get our big 100-page Band Catalog. Buy direct from the manufacturer. Rock-bottom prices on all kinds of instruments—easy payments. Generous allowance for old instruments. We supply the U. S. Gov't. Write today for Free Band Catalog.

**THE WURLITZER CO.**  
Cincinnati, Ohio Dept. 2123 Chicago, Illinois

**The BEST LIGHT**

A soft, luminous light, which casts no shadow. Brighter than electricity or acetylene. Makes and burns its own gas. Costs 2c a week.

No dirt, smoke nor odor. Over 200 styles, ranging from 100 to 2000 candle power.

Absolutely guaranteed. Write for illustrated catalog.

**AGENTS WANTED EVERYWHERE**  
**THE BEST LIGHT CO.**  
324 E. 5th St., Canton, O.

**FREE TO YOU****FOR 10 DAYS****The  
World  
Famous****Frantz  
Premier  
Electric Cleaner**

Yes, Madam, that is exactly what we mean. We will send you one of our superb, BRAND NEW easy gliding and deep cleaning Frantz Premier Electric Cleaners on 10 days' FREE Cleaning trial. We are going to

loan you free, this splendid cleaner for 10 whole days. Remember, this free loan won't cost you a penny. We even pay all delivery charges. We bear every expense. All you have to do is to use it to your heart's content for all cleaning purposes about the house!

**Without Cost To You**

Simply sign and mail the coupon below or write us and we will send you the full details of this wonderful free loan offer, and also our beautifully illustrated booklet.

No strings are attached to this free loan offer. We want you to use the Frantz Premier for 10 full days just as though it were your own. Clean your carpets and your rugs with it. Try it on your furniture, mattresses and walls. Use it in all the nooks and corners. We want you to see for yourself how it picks up threads, lint and ravelings and every speck of dust and dirt.

And then, at the end of 10 days' free trial if you are not more than delighted with the cleaner, you may return it, or we will send for it, without a cent of cost or obligation on your part. But if you decide that you simply cannot get along without it, then you may keep the cleaner and pay for it on

**Easy Monthly Payments**

The cleaner goes to you right from our factory, or direct from our dealer if we have one in your town. First you get the free trial and then the easy monthly payments. And, remember, you get the rock bottom factory price—you do not pay a penny more because of this special Easy Monthly Payment Plan.

We expect to be so swamped with Free Trial requests that we reserve the right to withdraw this offer after a reasonable length of time. So send at once for your Free Trial. Remember—absolutely no obligation to buy.

**MAIL THIS COUPON** Sign this coupon and mail it to us at once. The minute we hear from you we will mail you the full details of this great free trial offer and easy payment plan. We will also send you Free, the Beautifully Illustrated Literature. Send coupon or write today—at once.

**The Frantz Premier Company**  
Dept. 1199, Cleveland, Ohio

**Sign this Coupon NOW!**

**THE FRANTZ PREMIER COMPANY**  
Dept. 1199, Cleveland, Ohio

Without expense or obligation to me send full and complete details of your wonderful Free Trial and Easy Payment offer. Also your beautifully illustrated booklet.

Name.....

Address.....

Please Mention Popular Mechanics

# DUCK'S New Big No. 9, 320-Page Electrical and Wireless CATALOG



15,000 of our catalogs ready for delivery to eager electrical and wireless enthusiasts in all parts of the world. One of ten consecutive shipments of catalogs to our patrons early in last November.

**THE WM. B. DUCK CO., 223-227 Superior Street, TOLEDO, OHIO**

**150 Pages  
Wireless Instruments**

**170 Pages  
Electrical Supplies**

**Over 40 Pages of New  
Wireless Instruments**

Only 8c in stamps will bring this unrivaled catalog to your home. The great cost of catalog and the exceptionally low prices (oftentimes fully 25% below usual retail price) prohibits its distribution otherwise. You may deduct the 8 cents on first \$1.00 purchase.

## Murdock Wireless Receivers

**SPECIAL No. 55**

**2000 OHM COMPLETE SET  
ONLY \$4.00**

**FOURTEEN DAYS' TRIAL ALLOWED**

Better receivers cannot be bought for the money. Absolutely guaranteed. Satisfaction certain. *Catalog Free.*

**WM. J. MURDOCK CO.**  
10 Carter Street      221 Second Street  
CHELSEA, MASS.      SAN FRANCISCO



**Boy Electrician** with 75 illustrations for making Batteries, Dynamos, Motors, Telegraph apparatus, Telephone, Lights, Bells, Alarms, Coils, "Wireless" Current Reverser, Electric Engine, Etc. By Electrical Experts so that anyone can understand it. With Cat. All 10c Ppd.

J. C. DORN, 705 So. Dearborn St., Dept. 100, Chicago, Ill.



**Big Entertainer** 320 Jokes and Riddles, 153 Parlor Games and Magic, 15 Tricks with Cards, 73 Toasts, 7 Comic Recitations, 3 Monologues, 22 Funny Readings. Also Checkers, Chess, Dominoes, Fox and Geese, 9 Men Morris. All 10c. postpaid.

J. C. DORN, 709 So. Dearborn Street, Dept. 17, Chicago, Ill.



**Boys' Own Toy Maker**

Tells how to make a Talking Machine, Camera, Electrical Motor, Bicycle Boat, Canoe, Boomerang, Bobbed, Wind Mill, Microscope, Water Wheel and Motor, Stills, Toboggan, Snow Coaster and Sail Boat, Telephone, Electric Bell, Railroad Wind Mobile, Paddle Raft, Traps, Kites, etc. All 10c, postpaid.

J. C. DORN, 707 So. Dearborn St., Dept. 80, Chicago, Ill.

**ELECTRIC LIGHT PLANTS** Complete gasoline engine, dynamo, switchboard and storage battery \$240.

Agents wanted. American Battery Co., 1120 Fulton St., Chicago (Estab. 1889.)

**ELECTRIC HOME, FARM, THEATRE, STORE and TOWN LIGHTING PLANTS.** \$18.00 Rectifier Charges Storage Batteries from Lamp Socket! Lighting Your Auto Electrically for ONE CENT an hour. Lamps; Dynamos; Engines; Bells; Medical and Storage Batteries; Bells; Books; Sewing Machine and Power Motors; Railways; Bikes, Carriage, Fish, Hunting, Auto and Xmas Lights; Massage and Crane Machines; Telephones.

**MOTION** Picture Theatre Traveling and Permanent Equipments. Big Profits. Ten Cents an Hour lights Theatre and M. P. Machine. Catalog 3 cts.

**OHIO ELECTRIC WORKS, CLEVELAND, OHIO**

**GACHOO!** Make the whole family and all your friends "just sneeze their heads off" without knowing why, with Gachoo, the new long distance harmless snuff. Sent anywhere for 10c. 3 for 25c. 1 doz. and special premium for 90c. AMERICAN SUPPLY CO., St. Paul, Minn.



**Build a WAR Aeroplane**

"Ideal" accurate Scale Drawings enable you to EASILY build 3 Fl. Flying Models of Aeroplanes now used in the European War.

Students of Aeronautics, everyone with an inquiring turn of mind, should construct one of these fascinating Models.

**Prices of 3 Ft. Scale Drawings**

Curtiss Flying Boat 25c	Bleriot Monoplane 15c
Curtiss Military Tractor 25c	Taube Biplane 25c
Hydroaeroplane 35c	Wright Biplane 25c
Nieuport M'n'plane 25c	Ce il Peoli Racer 25c

Complete Set of Eight, \$1.50 postpaid. Get 50-page Aeroplane Book, containing full information about models, parts, etc. 5c postpaid.

**Ideal Aeroplane & Supply Co., 85-87 West Broadway, New York**

## Send 10c for Copy of Our New Wireless Manual No. 2

**YOU GET YOUR MONEY BACK ON AN ORDER OF \$1.00**

It contains 120 pages and tells how to erect and maintain wireless telegraph stations. Shows a number of diagrams. Has the Morse and Continental Telegraph Codes. Illustrates the best instruments to use; tells what they are for and how to use them. Has many new diagrams and other valuable information not contained in any other book. Do not wait. Send your request now. Get the best 10c value you will ever buy.

## Send for Our Pocket Catalog P28

It contains 212 pages, with over 1,000 illustrations, and describes in plain, clear language all about Bells, Push Buttons, Batteries, Telephone and Telegraph Material, Electric Toys, Burglar and Fire Alarm Contrivances, Electric Call Bells, Electric Alarm Clocks, Medical Batteries, Motor Boat Horns, Electrically Heated Apparatus, Battery Connectors, Switches, Battery Gauges, Wireless Telegraph Instruments, Ignition Supplies, Etc.

**MANHATTAN ELECTRICAL SUPPLY COMPANY**

NEW YORK, 17 Park Place      CHICAGO, 114 So. 5th Ave.      ST. LOUIS, 1106 Pine St.      San Francisco, 604 Mission St.

Please Mention Popular Mechanics

# WIRELESS

**T**WELVE YEARS ago we started to sell Wireless and Electrical Experimental apparatus. Today we are the largest in that business and all because we faithfully have lived up to our trade motto

## "Everything for the Experimenter"

Send for our big 275 page Electrical Cyclo-pedia containing 658 illustrations, *Treatise on Wireless Telegraphy*, complete code chart of Morse, Continental and Navy Codes, besides list of call letters of all the U. S. Ship and Shore wireless stations. This wonderful book sent for 4c in stamps or coin to cover postage only.

It's the "Largest Catalog in America," and one book you simply must have.

**The Electro Importing Co., Mfrs.**  
233A Fulton St., New York City

Retail Stores { 317H Livingston St., Brooklyn, N.Y.  
69H W. Broadway, New York City

# ELECTRICITY

**HOW MANY MILES OF ROADS HAS THE UNITED STATES?**—The Department of Agriculture is now gathering information which is expected to give the total mileage of public roads in the United States and their cost, and to serve as a basis for estimating the relative value of the different kinds of highways. For the

## New WIRELESS WONDER

**THE INSTANT RADIOGRAPH.** Greatest Invention of the Age. The Result of Years of Experimentation. **Abolishes Detector Troubles** and Adjustments. No more delays—no more lost time and messages. No cost to operate. Pick up your receivers any time, Summer or Winter, in any atmospheric conditions.

You Can Receive Instantly Without Any Adjusting

**INTRODUCTORY \$3.00**  
**PRICE for March 3.00**



3000 MILES is latest record. Vibrations, Jars, Knocks cannot affect it as there are no fine adjustments to make—no batteries. FREE—Send for Instant Radiograph—holder P.M. A book you need, complete list of call signals public wireless stations. Price 50c.

Universal Wireless Company  
19 East 32nd St., New York

## The Electrical Experimenter



**T**HE big electrical Magazine for those who dabble in electricity and Wireless. The "How-to-Make-It" magazine, chock full of experiments and the latest electrical progress. Foremost authority on WIRELESS in the United States. Official organ of the **Radio League of America**. Over 200 wonderful illustrations with over 100 articles in each number. You are not keeping abreast with the times unless you read the **Electrical Experimenter**. One copy will convince you. Every issue also contains the snappiest and most up-to-date scientific stories that will delight you.

\$1.00 a Year, 10c at Newsstands  
Send 10c for three numbers

**THE ELECTRICAL EXPERIMENTER**  
234 Fulton St., NEW YORK CITY

# 10 Days Free Trial



**YES**, we will send you the Violin of your choice for full 10 days' free trial. Play on it—test it in every way before you decide whether you wish to buy or not. Compare it with other instruments—then if you are not more than satisfied, Send it back at our expense. You do not pay us a penny for the use of the violin. Write for circular.

## Your Choice of Instruments

Write today for our new Violin catalog and see handsome illustrations in full color of all the superb instruments that you have to choose from.

There you will find illustrated products of the leading violin makers of the world—Farny, Bader, Glier, Heberlein,

Fiedler, Wurlitzer and many others. Violins of the highest grade, as well as those of moderate prices—all special values. Priced from \$2.70 to \$30.00, and from \$30.00 to \$250.00.

**Rare Old Violins**  
Our collection of rare old violins is one of the largest in America. Write today for Special Art Catalog.

# WURLITZER

200 years of instrument making

Get the benefit of our mammoth facilities for buying in large quantities. The house that supplies the United States Government now makes a startling money-saving offer direct to you. Write for circular.

## Pay as You Wish

If you decide to keep the violin you have selected after you have tested it out for ten full days, pay the rock bottom price at the rate of **only a few cents a day**. No red tape. No collectors or mortgages. Your credit is good with the House of Wurlitzer.



**10c a Day**

now buy this superb Lyrice Cornet. Excelsior triple silver-plated long model Lyrice Cornet direct to you on a starting offer. Ten days free trial before you decide to buy. Liberal allowance for old instruments. Write today for 255-page Cat. Log—showing 2261 instruments that you have to choose from.

## Send the Coupon

Put your name and address on the coupon now and indicate catalogue matter you wish us to send you. Absolutely no obligation in sending the coupon. Do it now. Find out about the startling money-saving offer we are making. Write today—send **Coupon or a Letter or a Post-card.**

## The Rudolph Wurlitzer Co.

Dept. 1193  
East 4th Street,  
Cincinnati, O.  
So. Wabash  
Avenue,  
Chicago

## The Rudolph Wurlitzer Co.

Dept. 1193  
S. Wabash Av., Chicago  
4th St., Cincinnati

Gentlemen:—Please send me without obligations, free and prepaid the catalog matter checked below:

- The special violin circular.  
 Special low priced violins under \$15.00  
 Your 255 page illustrated catalog of musical instruments.  
 Catalog of music stands, cases and other stringed instrument accessories.  
 Art catalog of rare old violins.

Name.....

Address.....

Please Mention Popular Mechanics

WE ARE HEADQUARTERS FOR

**ELECTRICAL GOODS and WIRELESS APPARATUS**

OUR NEW 224 pp. No. 7 CATALOG IS THE BEST ONE PUBLISHED

**EXPERIMENTERS**

THIS IS THE Experimenter's Reference Book

It's the latest edition of the famous **Amco Catalogue**, contains over 200 pages and is fully illustrated. Complete description and prices of the latest electrical and experimental apparatus—Storage Batteries, Rectifiers, Transformers, Induction Coils, Wireless Apparatus, Lamps, Flashlights, Motors, X-Rays, Books, Tools, Electric Railways, Steam Engines, Water Motors, Dynamos, Motors, Telegraphs, Telephones, Electrical Supplies, Model Aeroplanes and parts for building your own apparatus. **6c in stamps will bring you this wonderful book.** Contains a complete list of Wireless Calls, gives Codes, Wiring Diagrams, tells how to put up an aerial and install apparatus, etc.

**Best catalog of Wireless and Electrical Apparatus, etc., published. Send for this catalog right away. Our prices will save you money.**

**6c in stamps brings it by return mail.**

**FUN WITH ELECTRICITY**

Here is a rare chance to get started right in your study of electricity. This wonderful outfit contains 56 page book of instructions and all the apparatus for performing 60 interesting and spectacular experiments which will give any boy a practical knowledge of electricity.

Price Only 50c. Postage 10c Extra

**FUN WITH MAGNETISM**

This outfit contains 32 page book of instructions and all the apparatus for performing 31 fascinating experiments. It will give you some new ideas about electricity and magnetism in such an interesting way you can't help remembering it. Price only 25c.

Postage extra 5c

**LOTS OF FUN FOR BOYS!**

2 1/2 volt, 2 C. P. TUNGSTEN lamp, switch, socket, 20 ft. insulated wire and 3 cells of dry battery all ready to install. May be used to light a dark closet or hall.

Price only 60c. Postage extra 15c

**LITTLE GIANT MOTOR**

Is nearly 5 in. high. Runs at high speed on a single cell of battery. Very powerful and may be used to run small toys, etc. Just the motor every boy has been looking for. Sent postpaid for only 50c

**THE SIMPLEX TELEGRAPH OUTFIT**

An opportunity for every boy to learn to telegraph and to put up a line with his class. This is a full sized telegraph set, consisting of a fine key and sounder, mounted on a polished base. Will work any distance. An excellent Field Telegraph for Boy Scouts. Price, 95c. Postage Extra. Wt. 2 lbs.

**UPRIGHT STEAM ENGINE**

A fine engine of the best materials. 9 in. high. The Right Engine for Any Boy. Runs at high speed. Each engine tested at factory and fully warranted. Sent postpaid for only 90c

**SIMPLEX WIRELESS OUTFIT**

Every boy wants a wireless. Get in this interesting game and read the messages flying around you. This outfit is the greatest bargain ever offered. Consists of a large double slide tuner, a sensitive detector, condenser, telephone receiver and cord. Weight 3 lbs. Special Price, Complete, \$2.25. Postage Extra.



SEND 6 cents for our mammoth catalog

**ADAMS-MORGAN COMPANY** "The Experimenter's Supply House"  
25 Alvin Place UPPER MONTCLAIR, N. J.

## Complete Wireless Sending and Receiving Station \$10<sup>10</sup>

Receives hundreds of miles. Sends 8 to 20 miles.

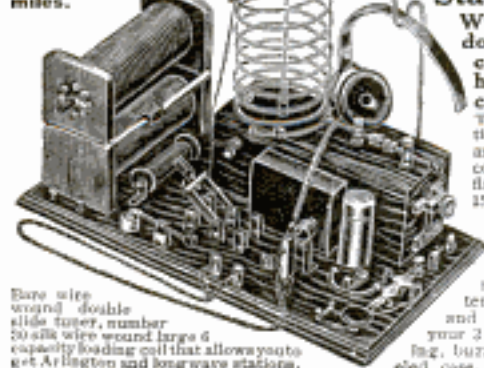

Rare wire wound double slide tuner, number 20 silk wire wound large capacity loading coil that allows you to get Arlington and long wave stations.

Send stamp for our large catalog "P" of remarkable values. If possible call and see our stock.

**Wireless Stations from \$1.95 Up**

THE MANDEL ELECTRIC CO., 138-140 Centre Street, N. Y.

With 1000 ohm, double pole, receiver, nicked head-band and cord.

This remarkable station consists of a guaranteed 1 1/2 in. spark coil, machine turned fluted spark gap, our 1501 key, a flat plate condenser, assembled in an oak case, a large capacity helix, DPDT switch, 500 ohm potentiometer, buzzer and switch to tell if your 2 detectors are working. Buzzer battery in nickel case, tubular condenser.

## Tobacco Habit Banished IN 12 to 120 HOURS

**DR. ELDER'S TOBACCO BOON BANISHES** all forms of Tobacco Habit in 12 to 120 hours. A positive and quick relief. A home treatment easy to take. Sure, lasting, harmless, no habit forming drugs. Hundreds of letters from satisfied patients. We guarantee results in every case or refund money. Send for our **Free Booklet** giving full information. Write today, this hour.

**ELDER'S SANITARIUM, Desk 36, ST. JOSEPH, MO.**

purpose some 15,000 sets of inquiry blanks have already been distributed through the state highway commissions. When the information in regard to the existing roads is

## Working Models WE MAKE AND SELL



**Model Torpedo Destroyers, Warships, Sailing Yachts, Steam Boats, Launches, Steam Engines, Boilers, Locomotives, Turbines, Dynamoes, Motors, Flying Machines.**

Also we supply all the castings, materials and parts for making and fitting the above working models.

Send for our large copyright Catalogue, 900 illustrations. By mail, 10c. You will then see what we can do for you.

**STEVENS'S MODEL DOCKYARD**  
22Q, ALDGATE, LONDON, ENGLAND

Remit by International Postal Money Order. If coin is sent, letter must be registered.

## Make Music Rolls

10 each. Inexpensive Legorian Performance makes player-piano rolls from any piece of music written. Music knowledge unnecessary. Pleasure of profit. Details free.

LEGORIAN MANUFACTURING CO., DEPT B, HAMILTON, OHIO

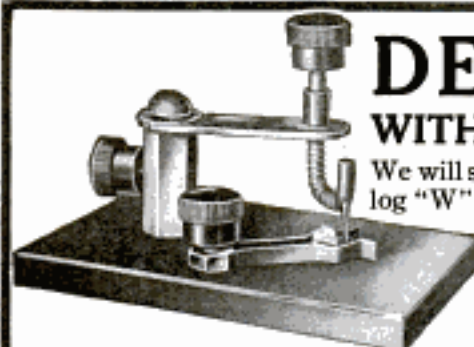

Blitzen Detector Stand. Holds any crystal, universal adjustment. High grade throughout. Price . . . **\$1.00**

**CLAPP-EASTHAM CO.** Manufacturers and Distributors  
147 Main Street, Cambridge, Mass.

## DEAL DIRECT WITH THE MANUFACTURER

We will save you time and money. Our new catalog "W" is filled with "up to the minute" wireless apparatus. Our new 112 page "Book of Electrical Apparatus" contains motors, dynamos, parts and materials, meters, lighting plants, storage batteries, phonographs, motion picture cameras, etc., at prices that will positively save you dollars. Both books sent for 6c stamps to cover mailing.



The best made, small Variable Condenser in the world. Glass case, Aluminum plates and base. Price . . . **\$4.00**

# Diamonds Watches on Credit

Pay a Little Each Month

Special Selection of Diamond-set Jewelry, at a great saving in price. Gorgeously beautiful Diamonds, perfect in cut and full of fiery brilliancy, set in solid gold or platinum mountings. CREDIT TERMS: One-fifth Down, balance divided into eight equal amounts, payable monthly. We pay all delivery charges. If not entirely satisfactory in every way, return at our expense and your money will be promptly refunded. Or, if you prefer, we will send C. O. D. for your examination. You will be under no obligations to buy.

**SEND FOR FREE 116-PAGE JEWELRY CATALOG**

Over 2000 illustrations of the new styles in jewelry—rings, studs, scarf pins, watch bracelets, watches, chains, silverware, etc. A DIAMOND is the best investment you can make. It constantly increases in value and lasts forever. Our Guarantee Certificate, given with every diamond we sell, is the strongest and broadest ever issued by a responsible house. Send for Catalog today. It tells about our easy credit plan.

**LOFTIS BROS. & CO., National Credit Jewelers**  
Dept. L894, 100 to 108 N. State St., CHICAGO, ILL.  
(Established 1888) Stores also in: Pittsburgh; St. Louis; Omaha.

## A NEW WAY To Get Your Clothes Free

### Make Big Money During Spare Time

Something Different, bigger, more liberal than any offer ever made. Lower prices—better clothes—bigger cash profits—Express paid on everything.

### Double Pay

FREE clothes and cash besides. We don't ask you to use your cash profits for your own clothes. Ours is a new and better plan. An Extra Present with every order. Not a prize scheme. Choose what you want, work for it and get it besides your Cash Profits. Complete Outfit FREE, 50 real cloth samples, 50 Fashion Plates. Inside wholesale prices. Get the big money. Your name on a post card brings everything FREE.

SPENCER MEAD CO., Dept. 270, Chicago



## BUY YOUR HEAT BY THE CAN EXCELLO HEAT

A complete stove with a can of Excello heat—alcohol in solid form, non-explosive, non-leakable, no wicks or burner necessary. This complete stove is a necessity in the home, nursery, shop, store, laboratory, to the motorist, sportsman, dentist, physician, boy scout, mechanic, etc. It will cook soups, eggs, cereals, etc.



To demonstrate this wonderful, non-explosive, solidified alcohol stove, we will send you a complete stove, consisting of a quart boiler, a collapsible stand, and one can of Excello heat. Stove complete—50c.

Excello heat per can 15c or 3-cans for 40c.

### AGENTS WANTED—BIG PROFITS

Our agents clean up record sales. Excello sells at sight. Everybody in your community a prospect. Write us today for exclusive territory and information about other rapid sellers in our line.

KANDEM ELECTRIC COMPANY, Inc.  
49-53 East 21st St. New York City

complete, it is intended to continue the inquiry year after year in order to ascertain the durability and economy of the various kinds of highways. The data thus collected should be useful to road engineers all over the country.



## Amazing Profits In Mushrooms

Anybody can add \$10 to \$40 per week to their income. In spare time, enter your growing mushrooms in cellars, sheds, barns, boxes, etc. I tell you where to sell, at highest prices. Free Illustrated Instruction Booklet

HIRAM BARTON

Desk 2, 329 W. 48th St., New York

## High Grade Violins 30 Days' Free Trial

Your choice from a large and carefully graded stock of representative instruments from the leading Jersian violin makers. Strictly hand made and of superior tone, these violins are far superior to the average old violins sold at four times the price.

Write Today. Don't fail to send your name and address today for the superb Lewis catalog sent free and postpaid. Of value to everyone interested in high grade instruments. Learn how you can have your choice of these superb instruments on a free trial in your home. Write today.

Wm. Lewis & Son, Inc., Dept. 1193, 225 S. Wabash Ave. Chicago

OUR SPECIALTIES: Imported wood-varnishes and tools for violin makers.

Hand Forged Razor Steel Blades. No. 57



## This \$2 KNIFE 83¢

DIRECT AT FACTORY PRICE POST PAID

Handy shaped blade makes this knife best for mechanics, sportsmen and farmers; light but strong; resharpened easily. Stag handle, German silver finish; blades file tested, hand forged from razor steel and warranted. Sample No. 3 for \$2 postpaid. Cheapest razor \$2 each.

Send for our 80 Page List and "How to use a Razor" FREE

MAHER & GROSH CO., 106 A. St., Toledo, Ohio.



Lubricant, Powder Solvent and Rust Preventive. Cannot gum. For guns, typewriters, razors, and all fine mechanisms. Write for folder. Invented, made and guaranteed by the

Remington Arms-Union Metallic Cartridge Co., New York



## BOYS!

### Automatic-Repeating Pistol

SHOOTS a hole in a paper tape—fifteen hundred loud reports from one charge. Made of blued gun-metal—8 inches long—easy action—absolutely harmless—no powder or projectile—permitted in any community.

FIVE EXTRA ROLLS FREE

THE AIRMATIC PISTOL CO.  
370 Citizens Building CLEVELAND, OHIO

\$1.00

Postage prepaid anywhere U. S. or Can.



Find out about  
the **GLACIER** before  
You Spend Your Refrigerator Money

Send for the wonderful free Glacier Book — a Nature-story of the frozen North and greatest presentation of refrigerator facts ever written. Learn why the Glacier Refrigerator keeps food cold, clean, sanitary. Why the solid one-piece white porcelain lining, and ten walls keep out heat and keep in cold. See how easily cleaned. Approved by Good Housekeeping Institute. 100 styles. We pay freight.

### GET THE BOOK

The Glacier Book tells how to protect health by storing food in circulating fresh air. Get it BEFORE you spend that refrigerator money. The Glacier Book tells you why the Glacier is YOUR kind of a refrigerator — full of hard-fisted truths. Write today. It will PAY you WELL.

**NORTHERN REFRIGERATOR CO.**  
776 Crofton Ave., Grand Rapids, Mich.

## "I Would Not Part with It for \$10,000"

So writes an enthusiastic, grateful customer. "Worth its weight in gold," says another. In like manner testify over 100,000 people who have worn it.

### The Natural Body Brace For MEN and WOMEN.

Develops erect, graceful figure, overcomes **WEAKNESS** and **AILMENTS** of Women & Men.

Brings womanly beauty and manly strength, restful relief, ability to work and enjoy life.

#### Banishes All These Troubles

Does away with the strain and pain of standing and walking; replaces and supports misplaced internal organs; reduces enlarged abdomen; straightens and strengthens the back; corrects stooping shoulders; develops lungs, chest and bust; relieves backache and nervousness. Comfortable and easy to wear.

#### Wear It 30 Days Free at Our Expense

Write today for illustrated booklet, measurement blank, etc., and read our very liberal proposition.

**HOWARD C. RASH, Pres. Natural Body Brace Co.**  
223 Rash Building SALINA, KANSAS



For Children Also

## EXTRA WATCH OFFER

We will send you the Santa Fe Special watch WITHOUT ONE CENT DOWN. We want you to see the FAMOUS

### "Santa Fe Special"

The REAL Triumph of Watch Manufacturing

A marvel of beauty, dependable to the last degree, accurate to the second. Write today for the story of the "Santa Fe Special." Our beautiful 52-page, four-color watch book shows every feature of this remarkable watch, tells **inside facts** about the jewelers' trade, explains what a standard watch should be and describes in detail the **best watch on earth**, the

## Santa Fe Special

The **one** watch that's **guaranteed** to last you all your life. Thin model—either 17 or 21 jewels, **adjusted** to positions, **adjusted** to temperature, **adjusted** to isochronism. Guaranteed to pass railroad inspection.

### EASY PAYMENTS TO SUIT YOU

Our "Direct to You," easy payment plan is explained fully in the Santa Fe Special catalog. Payments are so small you will not miss the money, only \$1.00 a month and you wear the watch right from the start.

Sent on Approval without One Cent Down

#### NEW CASE DESIGNS

The new watch book shows all the very latest designs of the world's most talented engravers, each case illustrated in beautiful color combinations, showing three color inlay monograms, engraved monograms, fraternity emblems, French art and special designs.

A postal brings the new watch book. Address Dept. M-100

**SANTA FE WATCH CO.**  
Topeka, Kan.



## WHEEL CHAIRS AND TRICYCLES

A Wheel Chair is often an invalid's greatest comfort. We offer over 75 styles of invalid's rolling chairs and tricycles with latest improvements.

Ship direct from factory to you and sell on

#### THIRTY DAYS' TRIAL

Liberal discounts to all sending for

FREE Catalog now.

**GORDON MFG. CO.**

353 Madison Ave. Toledo, Ohio

## Deaf?



The day of imperfect hearing is past. Science rivals nature in the marvelous new 1916 Mears Ear Phone, "Intensitone" model—the world's greatest hearing device. It transmits sound without blur. Write today for our 15 days' free trial offer.

### Perfect Aid to Hearing

The Mears is the only scientific instrument for the deaf. It marvelously covers 90 degrees of sound, every range of tone of the human ear.

**Write for Free Book** Our free book is a highly valuable treatise on deafness.

Write for it today—learn all about our 15 days' free trial offer and low direct laboratory price. If convenient to New York call for demonstration.

**MEARS EAR PHONE CO., Inc.**  
Desk 1193, 45 W. 34th St., New York



## DIAMONDS ON CREDIT

BEAUTIFUL DIAMONDS SENT ON APPROVAL

NO MONEY DOWN

Order any diamond from our catalog; we will send it, all charges paid. After you have made a thorough examination and are satisfied as to the quality and value, pay 20% of the price and only 10% per month thereafter. If not satisfactory, return it at our expense. Don't pay a cent until you are satisfied. Certificate furnished guaranteeing the quality of every diamond. Exchangeable any time for any other article of an equal or greater value. Send for our catalog Deluxe No. 6, it's free. **L. W. Sweet & Co., 2 & 4 Maiden Lane, New York City**





# REFLEX

## Quality Counts



Quality counts in Spark Plugs more than in any other part of motor car equipment. Reflex Spark Plugs are built to meet the growing demand for better plugs than usually furnished with the car. Standard equipment on White, Winton and other high grade cars, and on Henderson Motorcycles. More than 90 per cent of all Reflex Spark Plugs are sold direct from our dealers to discriminating car owners.

The Reflex Line is complete. A correctly designed Plug to meet the exact needs of every motor. All built of the best materials obtainable—made with Cromite Porcelain

Cores—the greatest heat-resisting insulator known. Your protection lies in the unusually broad and liberal guarantee of

## Spark Plug Service

"Reflex Spark Plugs are fully guaranteed against defects in material and workmanship. Any Plug that proves defective will be repaired or replaced free of charge. Your money back if not entirely satisfied."

The Reflex Dealer in your community carries the best of all automobile accessories. Don't fail to see him, or write us. We'll gladly give you full information.

Dealers and local representatives wanted everywhere.

**The Reflex Ignition Co.**  
1713 Payne Ave., Cleveland, Ohio



# MECCANO

## Toy Engineering for Boys

Have piles of sport building working models of towers, bridges, cranes, derricks and anything you want to; build models of real things and learn how they work. Fine fun, too. MECCANO builds more models, better ones; builds easier and quicker. Every part is interchangeable; girders are ready to use, strong and rigid. It's the most practical, instructive and amusing construction toy for boys.

## 10,000 Models

were entered in our last prize contest. Build a new model and enter it in our \$1,000.00 Prize Contest. Now on—Contest closes March 1st, 1916.

MECCANO outfits cost \$1.00 to \$16.00. Some, costing \$3.00, \$5.00 and \$7.50, have the MECCANO Electric Motor. See them at your dealer's. Get one and build models! Sent express paid on receipt of price if you cannot procure from your dealer. Send the names and addresses of five boys and get the 144 page, story-book catalogue free.

Send the names today!

**MECCANO COMPANY, Inc.**

Room 15  
71 West 23rd Street  
New York City



## FACTORY TO RIDER



Saves you big money. Buy direct and save \$10 to \$20 on a bicycle. **RANGER BICYCLES** now come in 94 styles, colors and sizes. Greatly improved; prices reduced. Other reliable models, \$11.95 up. **WE DELIVER FREE** to you on approval and 30 days trial and riding test. Our big **FREE** catalog shows everything new in bicycles and sundries. Write for it. **TIRES, lamps, wheels, parts and supplies at half usual prices.** Do not buy a bicycle, tires or sundries until you write and learn our wonderful new offers, low prices and liberal terms. A postal brings everything. Write now. **MEAD CYCLE CO. DEPT. P108 CHICAGO**

## THIS MACHINE WILL EARN \$20 to \$50 Daily Profit For You

### Making Cement Bricks and Blocks

Factory owners are the biggest money makers in America and this machine will place you in their ranks. You can start with little capital and even without experience. This machine makes pressed cement bricks and blocks under 80,000 pounds pressure. No tamping and easy work. It makes 1,000 blocks or 10,000 bricks daily. No burning required. Ready for the market in a few days' time. They are necessary for the



## Helm DRY WALL Building System

This is the system that appeals to builders, contractors and architects. It overcomes the opposition to concrete because it offers absolutely **DRY WALL** construction. It saves money for builders, as **no furring and lathing are required**, and it makes **rigid walls and fireproof walls**. This is the system which is bound to get you business and give you the advantage over all other products.



### Send for This FREE CONCRETE BOOK

Tear off the corner coupon right now before you turn the page. Let this free book tell you all about

this great opportunity which is open to you today. It will tell you all the details of this system about the Helm Press and the DRY WALL building system. It will show you how easy it is to start a profitable business. It tells how each product is made, how it is cured and sold. Write today. Do it now.

**HELM BRICK MACHINE CO.**  
223 Mitchell St.  
CADILLAC, MICH.

**Helm Brick Machine Co.**  
223 Mitchell St.,  
Cadillac, Mich.

Please send FREE the book on concrete and Helm Presses.

Name.....

Address.....

Please Mention Popular Mechanics

## Comfort Indoor Closet

### ODORLESS, SANITARY GERM-PROOF

Every home without sewerage needs one. Most convenient, meritorious home necessity in a century. A boon to sick people. Can be placed anywhere in house.

### Makes Outdoor Privy Unnecessary

Put a warm Comfort Toilet in your home; a guarantee of healthy, sanitary conditions. Germ-life killed by chemicals in retort. Emptied once a month—no more trouble than throwing out coffee grounds. Needs no other attention. Boards of Health endorse it. **WRITE NOW** for literature, prices, etc.

### AGENTS CAN EARN \$10 TO \$25 DAILY

Here's something going like a prairie fire. Best thing that ever headed your way—big chance to clean up \$25 a day if you will hustle. Sale sure in every home without a toilet. Hardly any limit to your earning. Don't sleep over this. Send postal by next mail. Biggest money-making, easiest selling proposition ever put up to an agent. Exclusive territory. Write now for agents' proposition.

**COMFORT CHEMICAL CLOSET CO.** 383 Factoria Bldg. TOLEDO, OHIO



Sent on 30 Days' Free Trial

# 2c a Week Pays Wash Bill!

## Electricity or Water-Power Does the Work

Write for  
FREE Book

### Just a "Twist of the Wrist" Starts or Stops the Machine!

The 1900 Motor Washers are now at work in thousands of homes. They are doing the work formerly done by women, at a cost of 2c a week for power! Saving thousands upon thousands of dollars in wash bills. Saving worlds of wash-day troubles. Leaving the women free to do other work while the machines are doing the washing.

## The 1900 Motor Washer

1900 Water Motor Washer  
Can be connected with  
any water tap instantly



### Washes a Tubful in Six Minutes!

#### Handles Heavy Blankets or Dainty Laces

The outfit consists of the famous 1900 Washer with either Electric Motor or Water Motor. You turn on the power as easily as you turn on the light, and back and forth goes the tub, washing the clothes for dear life. Then, turn a lever, and the washer does the wringing. All so simple and easy that it is mere child's play.

### A Self-Working Wringer Sent With Every Washer!

The motor runs the Washer and Wringer. We guarantee the perfect working of both. No extra charge for Wringer, which is one of the finest made. Write for FREE BOOK and 30 Days' FREE TRIAL. OFFER! Don't doubt! Don't say it can't be done. The free book proves that it can. But we do not ask you to take our word for it. We offer to send a 1900 Motor Washer on absolute Free Trial for an entire month to any responsible person. Not a cent of security—nor a promise to buy. Just your word that you will give it a test. We even agree to pay the freight, and will take it back if it fails to do all we claim for it. A postal card with your name and address sent to us today will bring you the book free by return mail. All correspondence should be addressed to

Doing the wringing with  
1900 Electric Motor Washer



1900 WASHER CO., 6248 Court St., BINGHAMTON, N. Y.

OR, IF YOU LIVE IN CANADA, WRITE TO THE CANADIAN WASHER CO., 325 YONGE ST., TORONTO, CANADA.

(22)

## Free Try-On of These Everwearing RACINE Aluminum Shoes

These shoes save doctor's bills by keeping your feet dry and warm. Outwear many pairs of leather. Racine Aluminum shoes wear better than any other metal shoe.

#### Patent Rocker Bar Helps You Walk

Makes walking easy. Comfortable on carpet slippers, yet waterproof, slip-proof, puncture-proof. Protect you from Cobble, Bismuthium, Lumbago, Pneumonia. Write for FREE BOOK: Aluminum the Sole of Health.

RACINE ALUMINUM SHOE CO., 73 12th St., Racine, Wis.



Save Your  
Shoe Money

## START A MOVING PICTURE SHOW

### MAKE MONEY FAST

COMPLETE OUTFIT, MACHINE, FILM AND EVERYTHING FURNISHED. EASY PAYMENT PLAN. NO EXPERIENCE NEEDED. WRITE FOR FREE CATALOG

NATIONAL MOVING PICTURE CO. Dept. P., Ellsworth Bldg. CHICAGO



## BOYS GET THIS NEW WIRELESS BOOKLET

Tells important facts about wireless receivers that every amateur operator wants to know. Explains "Matched Tone," "Theory of Wireless," Gives Construction of Antennae; Diagrams of Connections, etc. Send 4c in stamps for copy today. Ask for catalog. C. BRANDES, Inc., Room 817, 22 Eason Square, New York. Makers of Brandes Wireless Receivers

## BRANDES WIRELESS HEAD SETS

## 30 Days FREE TRIAL

and freight prepaid on the new 1916 "RANGER" bicycle. Write at once and get our big catalog and special offers before buying.

Marvelous Improvements. Extraordinary values in our 1916 price offers. You cannot afford to buy without getting our latest propositions. WRITE TODAY.

Boys, be a "Rider Agent" and make big money taking orders for bicycles and supplies. Get our liberal terms on a sample to introduce the new "RANGER."

Tires, equipment, sundries and everything in the bicycle line at half usual prices.

MEAD CYCLE CO., DEPT. P108 CHICAGO



## Bristol The Prize Winning Rods

There is no getting around the fact that "BRISTOL" Steel Fishing Rods have established their overwhelming superiority in every National Fishing Contest for the last 4 years. Their strength; ability to stand the strain and do hard work; resiliency in catching and hanging on to game fish; their elegance and beauty; national reputation for fine service, and everything else make them the national favorites. 25,000 dealers sell 38 different styles of "BRISTOL" Rods ranging from \$3.50 to \$25.00 each. Everyone guaranteed. If your dealer can't supply you, write us.

### CATALOGUE FREE

New Art Calendar—Philip B. Goodwin's famous oil painting "Team Work," reproduced in full colors in a 1916 Calendar, sent only on receipt of 15 cents.

THE HORTON MFG. CO.  
196 Horton Street Bristol, Conn.

25 lb., 47" long Muscalonge caught on a No. 16 "BRISTOL" Rod at Ottawa, by Frank Ault of Ottawa, Canada.

## Put Perrin "No Glares" On Your Car's Headlights

Avoid all danger from light-dazzled oncoming. Enjoy long, low, powerful light on both streets and country roads, with complete safety. Recommended by Police officials. Placed on lamp bulb permanently—always working—no buttons or levers. Over 100,000 in use.

\$1 per set of two. At your Dealer's or Garage or sent postpaid. Patented. Reject imitations. Insist on the Perrin "No Glare."  
PERRIN MFG. CO., Detroit, Mich.



Please Mention Popular Mechanics

## Row Boat Motor Agents Wanted

We want a hustler in every town to demonstrate and take orders for the

### Wisconsin Detachable Row Boat Motor

Backed by 15 years' marine motor experience

Attach one of the speedy little Wisconsin Juniors to a canoe or row boat—skim through the water. Sales come easy. Every boat owner that sees it in action is interested at once. It's the only motor with the self-locking tiller—a twist of the wrist holds the boat in any course you set. The Wisconsin patented adjustment at top of motor is another exclusive and sales winning feature.

The Wisconsin Junior is the sturdiest, most compact motor built. It's low in price—high in quality, powerful—simple—easy to operate—starts with a half turn of fly wheel. Equipped with Wisconsin Silencer. Can be easily and quickly attached to any size or shape of boat. Thousands in use.

#### Apply now for agency

Wisconsin agencies are being snapped up in a hurry—better write at once and get in on a good profit maker. Sales helps furnished. Write for catalog U.

**Wisconsin Machinery & Mfg. Co.**  
11 Minor St., Milwaukee, Wis.

Highest Award, Pan-Pac-Pacific Exposition,  
Purchased by U. S. Government, after competitive tests.



Model J,  
2 H. P.,  
Weight,  
50 lbs.



Playable  
Without  
Previous  
Experience

Everyone  
Can Play  
The  
Symphonic

## Symphonic Pianos and Player Pianos

On Easy Payments—Without Interest

Ours is the only plan whereby you can get a Knabe Bros. built Piano the factory-to-family way. All Symphonics are shipped direct from the factories of Knabe Bros., former makers of the Wm. Knabe piano. May we quote you the low factory-to-family price?

"Sweeter as the days go by"

Summed up in this triple from the sunny Southland as recited by Mr. A. P. Meeker, of Aiken, South Carolina, is represented all that the piano should be, which is to grace your home. Of course, you want a well-built, beautifully finished piano, but more than that you want a superior musical instrument unsurpassed in tone-quality. The Symphonic is such a piano.

### Symphonolas Play

All Victor and Columbia Records

With such records to select from, all playable on this full-sized cabinet Symphonola, your home will resound with the world's best vocal and instrumental music. Send the coupon today for the complete Symphonic and Symphonola catalog. Then you'll soon know why thousands of music lovers have found it profitable to buy these instruments.

MAIL THIS TODAY

**Larkin Co.** Dept. P. M. 316  
Buffalo, N. Y.

Tell me about offers on instrument checked and send the Musical Instrument Catalog.

Piano  Player  Symphonola

Name.....

P. O. ....

State .....

St. or R. D. ....

Address .....

### SMALL CRUISERS

and boats of all sizes for pleasure or work, from the sturdy 16 footers to the big palatial cruising yachts and house boats are shown in the Specialized Boat Book issued by the Gray Motor Co., in conjunction with 130 of the leading boat builders of the country. Four times as many boats shown as you see at any Motor Boat Show. Two other books on Marine Engines. Any or all sent on request to

**GRAY MOTOR CO.,** Detroit, Michigan  
398 Gray Motor Bldg.

### Hildebrandt Baits Hook & Land Bin



Made in 3 shapes, 11 sizes and 6 finishes. Reversible blades, interchangeable flies, providing outfits for any kind of game fishing

Send for Tackle Catalogue with color sheet, Logansport, Ind.  
John J. Hildebrandt Co. 1333 High St

## This Canoe Brings a Summer Full of Fun

If you want to know what pleasure canoeing is—get an "Old Town." \$30 up will buy an "Old Town Canoe" and you can't beat it at any price. It's safe, graceful and easy to paddle; won't leak or absorb water. 4000 "Old Town Canoes" ready. Easy to buy from dealer or factory.

Send for catalog of canoe views and facts.

**OLD TOWN CANOE CO.,** 1563 Middle St., Old Town, Maine, U. S. A.

# "Old Town Canoes"



# MULLINS

## STEEL BOATS CAN'T SINK

**R**EST from business cares—hours and hours, miles and miles of keen, invigorating pleasure in the by-ways of the world. Days and evenings crowded with healthful recreation—unhampered freedom. All these will come to you when you own a Mullins boat.

And you'll be proud of it because of its beauty, grace, speed, efficiency and safety. Designed by America's foremost naval architects and built in the world's largest boat factory.

Mullins steel boats can't sink, leak or water-log—never need calking. Two and four-cycle engines—silent, under-water exhaust. 60,000 in use. 1916 models ready for delivery.

**THE W. H. MULLINS COMPANY**  
707 FRANKLIN STREET, SALEM, OHIO

Handsome,  
interesting  
catalog on  
request.

Write today.

World's Largest Manufacturers  
of Steel and Wooden  
Pleasure Boats



## ROWBOAT MOTOR

# FERRO

### Make Your Own Motorboat—It's Easy

You can equip it with a complete power plant, Bosch high-tension magneto, full-size fuel carburetor, noiseless mudler, wood-proof propeller, rudder and tiller at small expense. Simply clamp the Ferro on your rowboat. Speedy, reliable, easy to operate. Selling Ferro Motors is pleasant, profitable work. You only need buy one motor for demonstration. Some fine territories open for the first-owners. Ask for agency proposition No. 215.

\$85 with Bosch high-tension magneto.  
\$66 with water-proof batteries.

The Ferro Machine & Foundry Company  
348 Hubbard Avenue Cleveland, Ohio



**DON'T GO ROWING - GO FERROWING**



## Motor Perfection

is what you get in Watkins Class "B" all iron motors. Especially fine for canoes and light boats. Constant and efficient.

3 H. P. single cylinder . . . 45 lbs.  
6 H. P. double cylinder . . . 85 lbs.  
12 H. P. four cylinder . . . 155 lbs.

Are light, at the same time strong, accomplished by using semi-steel castings, high carbon steel shaft, bronze bearings, high class workmanship.

**THE WATKINS MOTOR CO.**

837-839 W. 6th Street

Cincinnati, Ohio



### GET THIS CATALOG

FULL OF VALUABLE INFORMATION TO EVERY BOAT OWNER ON

**RACING PROPELLER WHEELS,  
REVERSE GEARS AND  
MARINE ACCESSORIES**

LARGE CATALOG FREE. SEND TODAY  
**MICHIGAN WHEEL CO.**

1139 MONROE AVE., GRAND RAPIDS, MICH.



## Get the Newest L-A Engine Book

The question of selecting the right engine for that boat of yours is an important one. It will pay you well to get all the information possible before making your final decision, as the satisfaction you get from your outfit will depend largely upon the care you take in choosing your motor. You will find the new L-A engine book brims full of valuable hints and interesting engine information. It describes the complete line of L-A inboard and outboard motors for canoes, rowboats, pleasure boats, work boats, etc., and gives complete details of our liberal

### 30 DAYS' TRIAL PLAN

whereby you can have the privilege of proving out the quality of L-A Motors before making your final decision. Write for YOUR copy to-day.

**Lockwood-Ash Motor Co.**

1320 Barton Av. Jackson, Mich.

AN L-A ENGINE  
FOR EVERY PURSE  
AND PURPOSE



## Caille 5 Speed 1916 Model Motor WITH STARTER

Fits Any Rowboat. Speed  
7 to 9 Miles Per Hour

It's the final word in outboard motor design. To start simply pull a little handle on a strap. The coil starter on the flywheel does the rest. No more bilsteed hands. No more aching back and arms. No more knocks from a flying cranking handle.

### Has Five Speeds

Two forward, two reverse and a neutral. Speed changes made while motor is running at normal speed by pressing button at end of steering handle. Pressing another button stops it. When set at neutral, boat stands still while motor remains running.

### Other Caille Features

Magneto in Flywheel; Water Cooled Silencer on Exhaust; Self-lubrication; Woodless Propeller; Water-tight Gear Housing; Cushioned Steering Handle; these and many other features fully described in our beautiful 1916 Catalog No. 10. Send for it. Dealers wanted in open territory.

### For Larger Boats

We build a complete line of marine motors from 2 to 30 H. P. Details in special free catalog No. 24. When writing, tell us the size, style and purpose of boat to be powered.

The Caille Perfection Motor Co.  
1523 Caille Street  
DETROIT, MICH.



**PALMER MOTORS AND LAUNCHES**  
2 AND 4 CYCLE

Catalogue M Free of Motors.  
Catalogue B Free of Boats.

ENGINES FROM 2 TO 40 H.P. PALMER BROS.  
IN STOCK. COS COB, CONN.

**Toledo MARINE MOTORS** NONE BETTER

"Nothing Cheap but the Price"

3 H.P. 1 cyl. complete	\$ 65.00
6 H.P. 1 " "	84.00
6 H.P. 2 " "	125.00
12 H.P. 2 " "	160.00
18 H.P. 3 " "	250.00

Fully guaranteed by a responsible concern. 2 cycle, 2 part, 3 1/2 x 3 1/2 and 4 1/2 x 4 1/2. Send for free catalog "C."

THE UNIVERSAL MACHINE CO., Pike Ave., Bowling Green, O.



**\$575.00** Buys This Beautiful 26 ft. RUNABOUT  
Equipped with high grade, 4 cylinder, 4 cycle motor, high tension Dual magneto, bulkhead starter and controls, nickel trimmings, life preserving cushions and linoleum floor covering.

**\$48.00** BUYS THE COMPLETE FINISHED K. D. FRAME  
ready for planking. Carefully prepared scale drawings and all necessary patterns and instructions for assembling and completing the boat. Every piece is fitted, marked and numbered. A few hours' work with hammer and screw driver and you have frame ready for planking.

**WRITE FOR OUR 1916 CATALOG**  
showing our line of Cruisers, Family Runabouts, Speed Boats, Passenger Boats, Outboard Motor Boats, Row Boats and Canoes.  
DUNPHY BOAT MFG. CO., Box 19, Eau Claire, Wis.



WHAT you don't know about white lead doesn't hurt, so long as your painter continues to use it on your house.

## Dutch Boy White Lead

protects many a house whose owner thinks of it only as "mighty good paint my painter uses."

It's an absorbing story, though.

Paint Tips No. 32 tells it.

NATIONAL LEAD COMPANY

New York Boston Cincinnati Cleveland  
Buffalo Chicago San Francisco St. Louis  
JOHN T. LEWIS & BROS. CO., Philadelphia  
(NATIONAL LEAD & OIL CO., Pittsburgh)

# No Money In Advance

## This Marvelous Camera ON FREE TRIAL!



Only 10,000 of these marvelous, instantaneous picture-taking and making cameras to be sent out absolutely on approval without a penny in advance just to prove that it is the most wonderful invention—the camera sensation of the age. Just think of it—the Mandel-ette takes and makes finished pictures

### INSTANTLY!

You press the button, drop card in developer and in one minute take out a perfect, finished post card photo 2 1/2 x 3 1/4 inches in size. Camera itself is about 4 1/2 x 5 1/2 inches. Loads in daylight, 16 to 30 feet camera one time. No Flash—No Faint—No Dark Room. It is instantaneous photography. Universal focus lens produces sharp pictures at all distances. Pictures develop and print automatically. Can't overdevelop; results amazing.

### We Trust You

We will send you the complete Mandel-ette outfit absolutely on approval, no references required, and give you 10 days to test it. If not satisfactory return it at our expense. If you keep it simply pay \$1 when you get camera and \$1 per month until our special price of only \$5 is paid. No experience required. Plain instructions and everything complete with outfit so you can begin taking pictures the moment it arrives. We guarantee that even a child can operate it. Send coupon for camera.

### — THE CHICAGO FERROTYPE COMPANY —

Desk 163 Ferrotyping Bldg., Chicago, Ill.

Send me one complete Mandel-ette Camera outfit including supply of post cards and instructions. I agree to pay \$1 when I get the camera, and if satisfied keep it and pay you \$1 a month until your special price of \$5 is paid. Otherwise I will return it at the end of 10 days.

Name.....

Address.....



## BEAVER BOARD

If it hasn't this trade-mark it isn't Beaver Board.

### Let Us Help You Plan

If you're planning to build or remodel anything, from an attic bedroom to a \$20,000 house, the free Beaver Board Design and Decoration Service will help you.

Incidentally, we will show you the kind of walls and ceilings you can get with Beaver Board—more durable than lath and plaster, more beautiful, more sanitary. Warmer in winter, cooler in summer. Easiest of any wall and ceiling material to apply.

Ask us about this free service.



The Beaver Board Companies

630 Beaver Rd., Buffalo, N. Y.  
Branches in Principal Cities



## KENNEBEC

CANOE BOOK FREE

Send for it at once and insure a fine summer and a healthful one.

This new booklet is of vital interest to you. Tells all about our paddling, sailing, motor and sponson models; tells you just what a canoe should be for a given purpose.

Kennebec models are the result of years of experience in canoe building, and an intimate knowledge of canoeing. The materials used are the best that can be obtained.

Write now for booklet. Address

KENNEBEC CANOE COMPANY, 49 R. R. Sq., Waterville, Me.

## Universal The Motor For You

Greatest value ever offered in this 4-cylinder, 4-cycle Universal Motor; 9 to 12 H. P., \$125 to \$160. Fits boats from 14 to 26 ft. Magneto, propeller equipment and rear starter. Absolute satisfaction guaranteed. Write NOW for catalog.

UNIVERSAL MOTOR COMPANY  
Dept. P  
OSHKOSH, WIS.

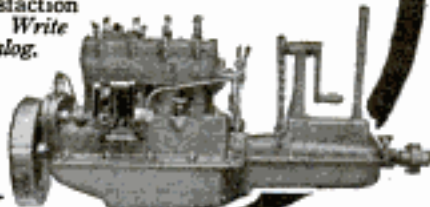

## "Body Blows" Sent Free

Send us your business card and we'll be glad to mail you, Free, photographs of a standard Highland commercial body that will exactly suit your delivery needs—together with "Body Blows"—our famous booklet on body construction and destruction.

No matter what truck you're thinking of purchasing, it will pay you to insist on a Highland standard body, "built for service." In fact many prominent truck-makers sell dependable Highland bodies with their chassis in preference to any other.

### Special Line for Ford Chassis

Our line of Ford commercial bodies is comprehensive and complete, combining style, sturdiness and satisfaction. Thousands are in use.

### More Dealers Needed

We want 500 more dealers, wherever motor-trucks are used. The public generally has come to recognize the Highland trade-mark as the sign of supremacy. The demand is country-wide and rapidly increasing.

### The Highland Body Mfg. Company

302 Elmwood Place

Cincinnati, Ohio



## CORONA

FOLDING TYPEWRITER  
CORONA TYPEWRITER CO., Inc., BROTON, N. Y.

Weights 6 lbs. Occupies little space. Durable, efficient. Costs but \$50. Write for booklet No. 13.

New York: 141 West 42nd Street

## THROW YOUR VOICE!



into a trunk, down cellar, upstairs, into the next room or anywhere desired; imitate Dog, Cat, Bird, Squirrel, Indian, etc. You can fool and put it over your friends and have a lot of fun. The

### VENTRILOQUOY

is a small instrument which is concealed in the mouth and cannot be seen. Any boy or girl can use it. Be a wizard. Sent postpaid with complete instructions and information about Ventriloquism together with big 24-page book of novelties—all for 10c.

ROCKWELL NOVELTY CO.  
Dept. 5 328 Madison St., CHICAGO, ILL.

## A Wonderful Combined Tool

is this STEWART HANDY WORKER



It combines: A strong and powerful vise, steel faced; a steel pipe vise for up to 1½-inch pipe; big, sturdy anvil; cutting hardie; corundum grinding wheel 5" x 1", 2 speed drill press; 3 speeds, direct, 4 to 1 and 15 to 1.

Weights, boxed, 90 pounds; price f. o. b. Chicago, \$12.50. Send \$2.00 and pay balance when outfit arrives. All money back if not highly pleased. It's a marvelously valuable outfit. Write for circular.

Chicago Flexible Shaft Co.

A617 N. La Salle St.

CHICAGO

## Be Prepared

—for this summer's sport by equipping your bicycle with a

# ORBIN Duplex Coaster Brake

The brake that brings the wonderful, body-building pastime of bicycling to perfection. Absolute control assured on the steepest grades and most crowded streets, always ready, always dependable — the most valuable equipment a bicyclist ever had.

You know the reputation of the Corbin Duplex! All bicyclists know its reputation. Ask any of them. The answer will always be the same — "the most all around satisfactory coaster brake on the market." Unequaled for power of grip, ease of operation and durability.



Specify it for your new wheel, equip it to your old one. Sold and equipped by all dealers. Write for illustrated catalog.

**The Corbin Screw Corporation**  
The American Hardware Corporation, Successor  
201 High St. NEW BRITAIN, CONN.  
BRANCHES: New York Chicago Philadelphia  
Makers of Corbin-Brown Speedometers

One resident in seven in the United States was born outside its borders.

## Bausch and Lomb BALOPTICON

THE PERFECT STEREOPTICON

Bausch & Lomb Optical Co., 576 St. Paul St., Rochester, N. Y.

## QUICK MONEY

Growing Mushrooms



How to really make big money in mushrooms, is fully explained in the wonderful book, "The Truth About Mushrooms." Everything explained from A to Z, at first hand, from the greatest practical authority in America. Add \$10 to \$70 a week to your income. Demand exceeds supply. Grow in cellars, sheds, boxes, etc. Small capital to start. Profits bigger and quicker. Average can do it. Women and children, too. Now

is the best time. Send for FREE book of information. Bureau of Mushroom Industry, Dept. 260, 1342 N. Clark St., Chicago

## MAKE \$60 A WEEK

We want Special Agents to travel by automobile selling our new gas-generating Coal-oil lamp. Absolutely safe. Big money saver.

**300 CANDLE POWER**

It's simply wonderful the way this new lamp is selling. Every home a possible sale. \$60 a week easy. Lowest priced high grade lamp on the market.



This Auto **GIVEN**

Write for plan how we furnish each representative with an automobile.

This is no selling contest, where only one person wins. ANYBODY CAN EARN THIS AUTO

THOMAS MFG. CO., 1248 East St., DAYTON, OHIO



## Net

Prices Direct to You

**A**BSOLUTELY net terms on any diamond you choose. You can now buy direct. No jobbers, no retailers to pay. Write for our net price catalog listing an exquisite collection of pure, blue-white

## Diamonds

Tiffany and Belcher rings, La Vallieres, brooches and other diamond jewelry. Every diamond a perfect gem. Selected by a famous expert. Perfectly cut to give maximum brilliancy. Richly mounted in solid gold settings.

**Free Examination** Not a cent down—before you accept it. We want you to compare these diamonds with others at twice their price.

**\$2<sup>50</sup> Monthly** Only \$2.50 a month will make you the wearer of a

beautiful diamond ring. Other terms, \$3.50 \$4.50 and up—and middle-men's profits cut out.

## Write

For Net Price List and Diamond Book

Shows the different gems, styles of mountings and gives our importer's net prices with terms of payment. Do it now.

**BURLINGTON WATCH CO.**  
Dept. 1193  
Chicago, Ill.

**Burlington Watch Co.**  
Dept. 1193  
Chicago, Ill.

Without obligations send me your net price offer on diamonds; also send **Diamond Book**.

Name .....

Address .....

## Tends Your Furnace Day and Night



and increases the comfort and convenience of your home 100 per cent for

**\$7<sup>50</sup>**

The Little Draft-Man gives you easy regulation of your furnace during the day and opens it for you in the morning before you get up. Start the day right by getting up in a warm room.

You don't have to go down stairs on cold winter mornings to open your furnace. The Little Draft-Man opens it for you, thereby eliminating this unpleasant task. Just set the time at which you wish your furnace opened and it does the rest. You can go to bed at night with the satisfaction of knowing that your house will be nice and warm when you get up in the morning.

The Little Draft-Man is an absolutely reliable yet simple device with nothing to get out of order or need attention. The spring motor is self-winding, compact and durable. All the mechanism is enclosed within a beautiful art bronze case as pictured above. The time clock is made by one of the largest clock manufacturers in the country and is guaranteed to keep correct time. The beautiful clock alone is a welcome addition to any home. The Little Draft-Man can be installed in connection with any furnace by anyone in a few minutes. It can be attached directly to the present furnace chains.

Don't be without this household necessity any longer. \$1.50 gets it complete, with directions for installation. If you are not satisfied after ten days' use, your money will be refunded on return of Draft-Man.

**STALKER FURNACE REGULATOR CO.**  
309 East Liberty St., Ann Arbor, Mich.

**AGENTS & DEALERS**  
Attractive Proposition

### LYON & HEALY

23-28 E. Adams St., Chicago

Send me your Catalog of Band Instruments.

Name .....

Address .....

I am interested in .....

## The Climax Cornet

is made in the U. S. A.  
and guaranteed.

None on the market to equal it at the price, **\$18.00**. Write us for—

**Catalog of Low-Priced, American-Made Band Instruments**

Tell us what instrument you are interested in.

"I think your Climax Cornet is the easiest blowing instrument I have ever played."  
(Signed) FRANK MUNDAY.

**LYON & HEALY, Chicago**



## An Authentic Souvenir of the Panama Pacific Exposition

The great central feature of the Panama Pacific International Exposition was the *Tower of Jewels*. It was the beauty and scintillating grandeur of the Jewels on the tower that gave the Exposition its name—the "Jewel City."

These jewels were cut by hand and imported direct from Europe to beautify the greatest Exposition of all time. They are two inches in diameter, and each facet is as carefully cut as the finest diamond. The jewels just as they hung on the tower, with brass pendant backed with mirror will be sold to you at **only \$1.00 EACH, or 5 FOR \$5.00**

Attached to each jewel is a bronze metal seal bearing a Certificate of Mr. D'Arcy Ryan, the Chief of Illumination at the Exposition, certifying that it came off the Tower of Jewels.

Your choice of five colors—White, Ruby, Canary, Emerald, Aquamarine—**at only \$1.00 each**. To those who send five dollars for five jewels we will present **FREE** one of the smaller jewels—a beautiful, brilliant jewel one inch in diameter. If you are not satisfied we will cheerfully refund your money.

Send for a Jewel today. Don't wait. The supply is limited and cannot be replenished. Remember these Tower Jewels will increase in value as the years roll by. Sent by parcel post, all charges paid. Orders will be filled in order of receipt. To make sure of yours order today.

**NOVAGEM JEWEL COMPANY**  
1037-38 Phelan Bldg.  
SAN FRANCISCO, CAL.



1/2 ACTUAL SIZE



I hereby certify that the Jewel purchased will be delivered in its original holder just as it was taken from its location on the Tower of Jewels.

*D'Arcy Ryan*  
Chief of Illumination, Panama Pacific Exposition, 1915

## PIGEONS PAY

**Better Than Chickens**  
Young pigeons squabbling bring \$1 to \$10 each when 3 to 4 weeks old. Big demand in city markets. Each pair of pigeons easily clear \$4 per year. Always peeped up. Very little space and money needed to start. Free Book explains all. **MAZARIC SQUAB CO., Dept. 55, ADA, IOWA.**



## "Interlox" SAVES TIME, TEMPER AND TROUBLE

**MASTER SLIDE RULE**

The Only Interlocking Rule made—and the Only one whereby inside measurements of doors, windows, etc., can be taken rapidly and accurately. Also superior to all others for outside measurements of walls, ceilings, etc. If your hardware dealer hasn't this Rule, send us his name and 15c per foot (in any length from 2 to 8 ft.) and it will be sent prepaid.

**Liberal Proposition for Dealers and Agents**

**DAHL MFG. CO., 51 E. 42nd St., NEW YORK**

## AUTO GIVEN AWAY

We want representatives in every locality. No experience or capital necessary. Send us your name and address and by return mail we shall tell you how you can secure one of our new 1916 model 5-passenger touring cars free for demonstrating. Write today—do not delay—a postal card will do. Address

**ECLIPSE MOTOR CAR CO. 851G Buhl Block DETROIT, MICH.**





**Clip this Coupon**  
and **SAVE \$6.50**  
On **YOUR** new Spring **SUIT**

GET the latest New York styles, made to your measure by the most expert tailors and save at least \$6.50 in hard cash. Because we deal with you direct, eliminating all middleman's profit, expenses and agents' commissions, we guarantee you

**\$20.00 Suit** Made to Measure for **\$13.50**

We guarantee to fit you perfectly from the measurements you send us, and please you in every respect—otherwise you pay nothing.

Send for **FREE Spring Style Book and 76 Smart Samples.** They will save you at least \$6.50 on your new Suit.

Buying from our handsome big Style Book, with samples, is like shopping at the best tailor shops in New York. Write for Style Book to-night.

**BELL TAILORS of NEW YORK, Dept. M, 130 Walker St., NEW YORK**

Send me FREE Style Book and 76 samples.

**BEST TAILORS Dept. M, 130 Walker St., N. Y. C.**

Style Book & 76 Samples

**FREE!**



**Superior Small Engines**



Our Stewart small engines, made only in 1/2, 2 and 3 h. p. are marvelously perfect. Design, materials, workmanship and finish of a high order. Use a minimum of fuel for a maximum of work; gasoline only. Write for special engine booklet.

**Chicago Flexible Shaft Co.**  
A617 N. La Salle St., Chicago

A GOOD GUN MEANS A GOOD BOY  
Nothing satisfies that unborn craving for "something that shoots" like the new production.

**DAISY**  
Pump Gun  
50 Shot Repeater **\$3.00**  
Other Daisy Air Rifles 50c to \$2.25

At all Dealers, or direct from Factory  
**DAISY MANUFACTURING COMPANY**  
PLYMOUTH, MICHIGAN



"The Happy Daisy Boy"

**Sharpen Your Razor in 10 Seconds**



This picture shows an ordinary razor edge magnified 100 diameters. You are scraping your face with a ragged edge like this unless you are using a Balihone. This picture explains why your razor dulls and scrapes and cuts your face. The ordinary strop makes a rounded edge like this nearly every time, even in the hands of experts. Your dull razor is always ragged. It's dangerous.

Hone and strop it yourself. Regular or safety. New idea. New principle in the Balihone. Makes your old razor as good as new. Makes your safety blade better than new. Gives a hair-test edge. Balihone operates automatically. Hugs the hollow ground blade. Follows the bevel of the safety. Produces a marvelous edge every time in 10 to 20 seconds. You can't fail with it. Send for one today and make your shaving a joy. Send coupon.

**Balihone**

A Balihone is a hone and a strop all in one. Both sides work automatically. It will make your poor razor shave beautifully. It will save you from the danger and discomfort of a ragged edge. It will keep your razor in perfect shape. It works almost instantly. If you don't shave yourself tell your barber to get a Balihone. On this special free trial offer it will be sent prepaid to you for only \$1. Send coupon today.

**Free Trial** Use the Balihone 30 days. If you don't feel that it is worth ten times the price return it and get your dollar back in the next mail. The marvelous Balihone sent to you postpd. on this special offer for only \$1.

**BALIHONE COMPANY, Dept. 5247, WILMETTE, ILLINOIS**

Name .....

Address .....

**BALIHONE CO.**  
Dept. 5247 Wilmette, Ill.

GENTLEMEN:  
On your special free trial offer send me prepaid one Balihone. I may return it in 30 days and get my dollar back for any reason whatever. Enclosed is \$1.

**Use This Coupon**

Send Today Send only \$1 on this special offer. Your money returned if not delighted. Send the coupon or copy it on a piece of paper. Send only \$1. Send it now.



**Out  
of  
the  
Shop  
—Into  
the Open**

Down roads that are always inviting—through towns you never visited before—you travel in ease when you ride a Pope Motorcycle.

Carfares, high cost of upkeep, and other needless expenses, all these are wiped out for the owner of a Pope.

And a speedy, dependable

**Pope Lightweight Motorcycle**  
Costs only \$150.00

This is a single cylinder, single speed, with 3"x3-1/16" bore and stroke, side pocket auto intake valve, mechanical exhaust and Schebler carburetor. Its transmission is by large Spartan V-belt, direct to the rear wheel, and it is fitted with the Eclipse clutch. It has a grip control, special saddle with spring post, 51" wheel base, 26" wheels, gasoline capacity 2 gallons, oil capacity 2 quarts. It is equipped with United States tires and imported magnets. Pope Twin gray striped finish.

As indicated by these brief specifications, the equipment and material used throughout are of the very highest quality—in fact, there could be no better motorcycle made for the money. That is why the Pope Lightweight, now in its sixth year of manufacture, is recognized as the most popular lightweight in America.

Write for our latest catalog

**Westfield Manufacturing Company**

Successors to the Pope Mfg. Co.

15 Lozier Ave. WESTFIELD, MASS.

Largest Manufacturers of High-Grade Bicycles in the World.  
Makers of Columbia, Crescent, Rambler, Cleveland  
and Pope Bicycles.

# Prosperity in Canada

## \$900,000,000

### in New Wealth Added in 1915

**ENORMOUS CROPS and LOW  
TAXATION Make Farmers Rich**

CANADA, enjoying wonderful prosperity from the products of the farm, the orchard, and the centers of industry—Canada has come into her own. No country wrote a brighter page of history in agricultural and industrial development during 1915 than Canada. All industrial plants working overtime. Wheat average, 36.16 bushels per acre in Alberta; 28.75 bushels per acre in Saskatchewan; 28.50 bushels per acre in Manitoba. All other grains showed similar large yields per acre. Taxes average \$24 to \$35 per quarter section; includes all taxes. No taxes on improvements.

### Come and Get Your Share of This Prosperity

—the greatest wealth-producing era the Dominion has ever known. Free schools and full religious liberty. Good climate. World-renowned livestock. Prizes won at International Fairs prove this. Here is your opportunity! What chance have you to provide a farm for your children in your present location, where land prices are so high?

### Get Your Farm Home from the Canadian Pacific Ry.—20 Years to Pay

Good land from \$11 to \$30 per acre. Irrigated lands from \$35, and the Government guarantees your land and water titles. Balance after first payment extended over nineteen years with interest at 6%. Privilege of paying in full at any time. Long before final payment becomes due your farm should have paid for itself.

**\$2000 Loan for Improvements.** We will lend you up to \$2000 for improvements in certain districts with no security other than the land itself. Particulars on request. Twenty years for repayment of loan with interest at 6%.

**Ready-Made Farms for Sale.** Farms which we have developed by providing house, barn, well and fencing and in some cases cultivation for sale. Special easy terms.

**\$1000 Loan for Livestock.** In defined districts after one year's occupation under certain conditions, we advance cattle, sheep and hogs to farmers up to a value of \$1000.

**We Want You, We Can Afford to Help You.** We own the land. We want the land cultivated. Our interests are mutual. Buy direct and get your farm home from the Canadian Pacific Railway. Send for free book.



J. S. DENNIS, Assistant to the President

**Canadian Pacific Ry.**

39 Ninth Avenue

CALGARY, Alberta, Can.



## LEARN TO PITCH

Lessons by "MATTY," ED. WALSH, "DOC" WHITE, WALTER JOHNSON, "NAP" RUCKER, "SMOKEY JOE" WOOD.

**PITCH THE FADEAWAY,**  
SPITTER, KNUCKLER, SMOKE BALL, etc.

Clearly described and ILLUSTRATED by  
56 Pictures. Entire COURSE OF LESSONS  
SENT POSTPAID for 50 cents.

J. C. DORN, 721 S. DEARBORN ST., DEP. 270, CHICAGO, ILL.

# DEAF?



## There Is No Standard of Sound!

Therefore the only way that you who are hard of hearing can possibly know whether a hearing device will make you hear clearly, is to try it in your own home under all conditions—And if the maker of it thoroughly believes in its ability to do this, he will let you make that trial without a penny of cost or even a deposit. That's one reason we are eager to have you try the

## "1916" ACOUSTICON No Deposit **FREE** No Expense

Another reason is that this "1916" Acousticon is not only protected beyond competition by U. S. Patents, but has so many improvements and refinements, all making for greater efficiency, that many of our old customers who have tried it say that its effectiveness far exceeds even that of their old instrument which made them hear so well.

**WARNING!** There is no good reason why everyone should not make an liberal trial offer as we do, so do not send money for any instrument for the deaf until you have tried it.

Our fearless offer sometimes puts us a little behind in production. So we suggest that you send for your free trial today, while you think of it—just say "I am hard of hearing, and will try the '1916' Acousticon, if the trial costs me nothing." Address

**GENERAL ACOUSTIC CO., 1307 Candler Bldg., N. Y.**  
Toronto, Ont. Office, Royal Bank Bldg.

**CONTRACTS FOR WIRELESS TOWERS APPROVED**—Contracts for the construction of wireless stations at San Diego, Cavite, Philippine Islands, and Pearl Harbor, Hawaii, designed primarily for keeping the government in touch with all Pacific island possessions and secondarily for public use, were recently approved by the Navy Department. The Cavite and Pearl Harbor stations will be the most powerful in existence and will have a radius of 4,700 miles.



## WOULD YOU

show this standard high grade 42 key fully visible typewriter to your friends and let them see wherein it excels any other \$100 typewriter, if by doing this and rendering other small assistance, you could easily have one to keep as your own? Then by post card or letter to us simply say, "Mail Particulars."

**GIVEN YOU**

**WOODSTOCK TYPEWRITER CO., Dept. M 204, Chicago, Ill.**

## FINE OLD VIOLINS

**On Easy Payments  
30 Days Free Trial**

allowed, no matter where you live. If not more than pleased with our values return violin **AT OUR EXPENSE**—and no harm done. Ability to play the violin brings social and financial success. Get a violin with a rich, mellow tone and it will create in you a desire to master it.

## Free! Magnificent Album-Catalog

containing portraits of the world's greatest violinists since Paganini's time, a half-tone of "Stradivarius in His Workshop," and the romantic story of The King of Musical Instruments. A postal brings all to you **FREE**—no obligations.

**CREMONA VIOLIN SHOP  
Dept. F541 CHICAGO**

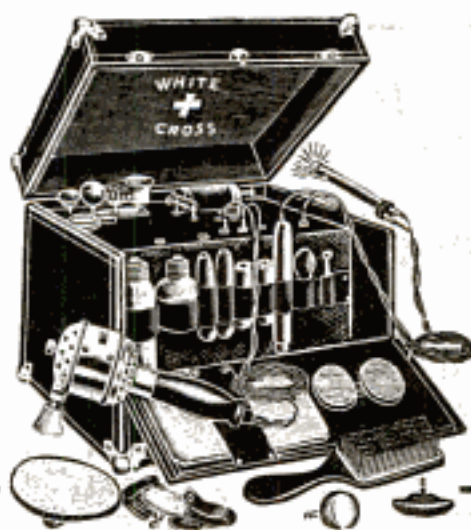

## Wake Up!

**D**RIVE out that tired feeling. Enter into the day's activities with a keen, wideawake brain. Enjoy to the utmost every minute you live. When your brain is fagged and when you are only half awake your senses are dull.

Try vibration just once. Let it "tune up" every nerve and fibre in your body. Then you will declare with thousands of men and women in all walks of life the White Cross Electric Vibrator is one of the greatest aids to health and happiness ever invented.

## Vital Strength

The virile force of robust manhood—the dynamic energy that gives man the power to do things may be yours through vibration. Write today for our new book that tells you what this great force has done for others.



This remarkable invention has accomplished wonderful results. Physicians the world over endorse it. So simple is it constructed and so easy to operate that anyone can give himself vibratory treatments right in his own home. The fact that over 80% of the vibrators now in use bear the name White Cross is conclusive evidence of their excellence.

## Send the Coupon for New Book

Send your name and address in the coupon or on a letter or post card and get our new book "Health and Beauty" absolutely free. No obligations. Find out about this marvelous force that has been such a help to thousands. Also find out about our special reduced price and free trial offer. Write today.

**Lindstrom-Smith Co.**  
Dept. 1193  
1100-10 S. Wabash Ave.  
CHICAGO, ILL.

We also manufacture White Cross Electric Stoves, Irons, Hair Dryers, Electric Lamps, Electric Fans, Electric Automobile Horns, Electric Curling Irons, Heating Pads, Small Motors, etc., etc.

**Dealers  
Write**

## SPECIAL!

Special free trial and reduced price offer now being made. Send the Coupon.

Lindstrom-Smith Co.  
1100-10 S. Wabash Ave.  
Dept. 1193, Chicago, Ill.

Without any obligations on my part, please send me free and prepaid detailed description of the White Cross Electric Vibrator and full particulars of your free trial offer. Also your **FREE** book, "Health and Beauty."

Name .....

Address .....

My Electrical Dealer's Name is .....



## Best Road Book Free

**T**HE good roads movement is alive all over the country. To meet the big demand for definite information and practical help, we have published this book on road construction and maintenance.

It is the only work of its kind, dealing particularly with the building and up-keep of country roads as distinguished from pavements.

It tells how to locate a road, clear the right of way, eliminate curves and grades, ensure correct drainage, and how to build the best types of country roads. Covers the use of all up-to-date methods and machines.

Every farmer, path-master, supervisor, engineer or other person interested in good road construction should have it.

All you have to do to get this valuable authoritative book is to write for Road Building Book No. 248. Do it now before the edition is exhausted.

Address Good Roads Dept.

**E. I. du Pont de Nemours & Co.**  
Wilmington, Delaware

Please Mention Popular Mechanics

## Quicker Results — Doubled Efficiency

When you work with electricity.

First cost and operating expense are both low.

Attaches to any Electric Light Socket.

### Garageman's Machine Shop

Hundreds of automobile repair men declare that the Temco Model B Drill is the best part of their shop equipment. Built to use emery wheel and reseater attachments. Has multitude of uses. Does away with tiring hand work.

## TEMCO Garage Outfit

Drilling, tapping, valve grinding, sharpening tools, etc., all performed quickly and cheaply with these wonderful tools. Weighs only 12 pounds. Connect to any lamp socket (AC or DC). Cheap to operate. Reverses instantly on full speed. Guaranteed not to burn out. Doubles working capacity of your shop.

Ask your jobber for one today, or write us. The sooner installed, the quicker your profits will increase.  
**The Temco Electric Motor Company**  
Main Office and Factory, 124 Sugar St., Leipsic, Ohio

### MECHANICS' COMPUTING DEVICE



By rotating cap on end this Thread and Tap Gauge shows at a glance the size of drill to use for taps; also number of threads per inch. 4 Types—U. S. R.  $\frac{1}{8}$ " to 2"—Pipe,  $\frac{1}{8}$ " to 3 $\frac{1}{2}$ "—A. L. A. M. to 1"—S. A. E.  $\frac{1}{4}$ " to 1 $\frac{1}{2}$ ". Price of any type 50c postpaid. Please avoid sending stamps if possible. Patent for Sale. Patented. Made and sold only by **WM. J. RAINEY, Box 138, GROVE CITY, PA.**

### MECHANIC'S POCKET SECRETARY

Constructed of finest steel. Just push the button and out comes the article you require. Worth \$1.00. Postpaid

15c

Get One To-day



15c

10 in 1 —

Adjustable Pencil pen, paper knife, ink eraser, pencil sharpener, nail file and cleaner, mechanic's marking point, fine compass with screw attachment, foot rule.

**ARDEE CO., Dept. 792, STAMFORD, CONN.**

## STOP Throwing Away Old Safety Blades

A Stag Sharpener makes old blades better than new—gives you a head barber shave every morning. The only sharpener that both hones and stropps. Note wheel in holder sets blade always at proper angle. Highest Awards Panama-Pacific Exposition. Sharpens Any Make Safety Blade. Lets a Barber. Complete, nickel holder, barber's hone and stropp, in neat case, \$1.00. Money back if not satisfied. Dealers and Agents—write for our money-making proposition.  
**STAG COMPANY, 34 S. State St., CHICAGO, ILL.**

\$1

Post Paid



## Firestone CYCLE TIRES

Toughest, thickest, most resilient tread. Built like a motor-car tire. All sizes: Non-Skid and corrugated tread.

**Firestone Tire and Rubber Company**  
Akron, Ohio—Branches and Dealers Everywhere

# Electric Light for Your Home

This newly invented system enables every rural home to make their own electric current; operates from one to fifty lights; and will drive small electric motor, electric iron, toaster, etc. Everything complete in one compact unit; no batteries or switchboard. Uses standard lamps and fixtures that any dealer can supply. Nothing to watch but the small, high-speed gasoline motor, which requires slight attention once a week.

The ideal electric lighting system for country homes. Nothing like it ever sold before. Costs less than other systems to buy and to operate. Will last for years.

**WATERMAN MOTOR COMPANY**  
182 Mt. Elliott Ave. DETROIT, MICH.

Write today for descriptive literature and prices.

**Uni-Lectric**  
GASOLINE-ELECTRIC UNIT  
LIGHTING SYSTEM



**DID NOT SHOOT TROUBLE**—A telephone subscriber on Sheridan Road, Chicago, has found the telephone drop wires in an advantageous position to be used as an overhead trolley for his dog, says the Bell Telephone News. A ring slipped over the twisted-pair drop had attached to it a long rope and at the end of the rope a large dog. This unique trolley allowed the canine to roam over a large territory, but as might have been expected, a case of "noise on the line" soon developed. The trouble man of the local exchange says he did not "shoot the trouble."

**Be a Merchandise Broker** Earn \$2000 to \$5000 a Year  
NO CAPITAL. Experience Unnecessary. Send for Free Book.  
**AMERICAN SCHOOL OF BROKERAGE, DAVENPORT, IOWA**



## AGENTS GOOD INCOME

Wide Awake Men and Women to sell our Gasoline Table Lamps, Lanterns and Self Heating, Quick Lighting, Stay Hot and Irons. Positively the simplest and most practical iron on the market. We challenge competition. Your Chance. Terrific is being rapidly taken. If you want a good, steady income, write to us TODAY.

International Light, Novelty & Specialty Co.  
426 So. Clinton St. Dept. 80 Chicago, Ill.



## THE WONDERFUL TAB-FIL FOUNTAIN PEN GIVEN AWAY FREE

Regular \$2.50 Guaranteed Pen — Solid Gold Point



The pen that makes its own ink. Carries ink in the cap—fills with water. JOIN THE DELUXE CLUB—introduce

**DELUXE INK TABLETS**

to your friends—the modern writing ink—"just add water." ENROLL TODAY

DELUXE MFG. CO., 234 Manhattan Bldg., CHICAGO, ILL.

# Lowest Prices Ever Made on World's BEST Roofing

Absolute "rock bottom" prices have now been reached on the greatest roofing. Don't invest a cent in new roof covering, siding or ceiling for any building until you first get Edwards wonderful freight prepaid money-saving offer direct from the world's largest factory of its kind.



Reo Steel Cluster Shingles

## EDWARDS TIGHTCOTE REO STEEL SHINGLES

outlast three or four ordinary roofs — yet they actually cost less! No painting or repairs necessary; rot-fire-weather-rust-proof. Insurance cost is less because Edwards guarantee their roof against lightning. Easy to lay—no special tools needed.

Every sheet of Edwards Galvanized Steel Shingles, Roofing, Siding, Ceiling or finish is extra heavy galvanized, piece at a time, by our exclusive Tightcote patented process after sheet has been stamped and resquared. Side and edges are as heavily galvanized as body of sheet. Means no weak spots to rust and corrode. Edges and nail holes can't rust.



Spanish Metal Tile



Edwards Patent "Grip Lock"

## Garage \$69.50 Up

Wide variety, many styles, all sizes of Portable, Fireproof Metal Garages, \$69.50 and up. Lowest prices ever made. Postal brings 64-page Garage Catalog — FREE.



Corrugated

## FREIGHT PREPAID OFFER

on the lowest prices ever made on world's best roofing. We make and sell direct from biggest factory of kind, Edwards Reo Tightcote Steel Shingles, V-Crimped, Corrugated, Standing Seam, Painted or Galvanized Roofing at bed-rock bargain prices, saving you all "in-between" middlemen's profits. Write for Free Roofing Samples and your copy of Roofing Catalog No. 350.



Garage

**THE EDWARDS MFG. CO.**  
300-350 Pike Street  
Cincinnati, Ohio

**WORLD'S GREATEST ROOFING BOOK**

Note construction of Patent Interlocking Device protecting nail heads from the weather and making the roof absolutely water-tight.

## SPECIAL OFFER COUPON

THE EDWARDS MFG. CO.,  
300-350 Pike St., Cincinnati, O.

Please send FREE samples Freight-Paid prices and World's Greatest Roofing Book No. 350.

Name.....

Address.....

Largest Makers of Sheet Metal Products in the World

# AGENTS

SALESMEN  
MANAGERS  
YOUNG OR OLD  
NEW BUSINESS



# NEW BUSINESS JUST OUT

DROP THE DEAD ONES. AWAKE! START WITH THIS NEW INVENTION, THE 20th CENTURY WONDER

Get started in an honest, clean, reliable, permanent, money-making business. Sold on a money-back guarantee

*The Blackstone Water Power Vacuum Massage Machine*  
For the Home. No Cost to Operate. Lasts Life-Time

**LISTEN** No Competition, New Field, New Business. Price within reach of all. That's why it's easy to sell. Endorsed by Doctors and Masseurs. Removes Wrinkles, rounds out any part of the face or body, brings back Nature's beauty. Almost instant relief can be given all kinds of pains. A demonstration convinces the most skeptical person. Sales easily made.

**Read On! What Others Do, So Can You.**

Parker writes, sold eight machines first day. Margwarth says, I am making \$19.00 per day. Schermerhorn, eight dozen machines first month. Shaffer writes, am selling four out of five demonstrations. Vaughn, orders one dozen, four days later wires "ship six dozen by first Express." Lewis, sells four first hour. Men, women, everybody makes money. No experience necessary. Protected territory to active workers. We own all patents. Big book entitled, "The Power and Love of Beauty and Health" Free. Investigate now, today. A postal will do. A big surprise awaits you. Address, BLACKSTONE MFG. CO., 146 Meredith Bldg., Toledo, Ohio

# AGENTS

GENERAL AGENTS  
ROAD MEN  
MAKE MONEY HERE  
Start Now - Today



# STOP USING A TRUSS

Do Away With Steel And Rubber Bands

# FREE TRIAL



It's the Non-Slip-Rigid Pad and What is Within It That Counts

Inner surface is made adhesive to secure the PLAPAO-PAD firmly to the body, keeping the PLAPAO continually applied and the pad from slipping. No straps, buckles or springs attached. Soft as velvet—easy to apply.

PATD  
APRIL 6  
1909

## FREE to 5,000 Truss Sufferers

To the first 5,000 Sufferers who write, I will send, ABSOLUTELY FREE, a sufficient quantity of the Plapao to positively convince them that this is the only logical, common-sense way of treating rupture. Plapao is a highly astringent medication placed within the Plapao-Pad and being absorbed through the skin, creates a wonderful feeling of relief and at the same time tends to strengthen the weakened muscles and thus permanently close the rupture opening. The process of recovery is natural, so you'll have no use for a truss—you can throw it away forever! Old and young have testified under oath that the Plapao-Pads cured their rupture—many of them long-standing, aggravated cases—without delay from work. Patent allowed in U. S. and foreign countries. Awarded Gold Medal at Rome and Grand Prix at Paris.

**Send No Money**—for a sufficient quantity of the Plapao is sent without charge to enable you to give it a thorough test; you pay nothing for this trial now or ever. Write for it and full information today. Address Plapao Laboratories, Block 1427 St. Louis, Mo.

# Deafness



Perfect hearing is now being restored in every condition of deafness or defective hearing from causes such as

Relaxed or Sunken Drums, Roaring or Hissing Sounds, Perforated, Partially Destroyed Drums, etc.

## Wilson Common-Sense Ear Drums

"Little Wireless Phones for the Ears"—require no medicine but effectively replace what is lacking or defective in the natural drums. They are simple devices, which the wearer easily fits into the ears where they are invisible. Soft, safe and comfortable to wear at all times.

Write today for our 168 page FREE book on DEAFNESS, giving you full particulars and plenty of testimonials.

WILSON EAR DRUM CO., Incorporated  
593 Inter-Southern Building LOUISVILLE, KY.

Please Mention Popular Mechanics



# Don't Wear a Truss

Brooks' Appliance, the modern scientific invention, the wonderful new discovery that relieves rupture will be sent on trial. No obnoxious springs or pads.

## Brooks' Rupture Appliance

Has automatic Air Cushions. Binds and draws the broken parts together as you would a broken limb. No salves. No lies. Durable, cheap. Sent on trial to prove it. Protected by U. S. patents. Catalogue and measure blanks mailed free. Send name and address today.

C. E. BROOKS, 1817A State Street, Marshall, Mich.



We are Under Govt. Bond

The record stay under water by a swimmer is said to be 6 minutes 28 4-5 seconds.



# Strong Arms

I will send my 25c Book for 10c in stamps or coin

Illustrated with twenty full-page half-tone cuts showing exercises that will quickly develop, beautify and gain great strength in your shoulders, arms and hands, without any apparatus.

PROF. ANTHONY BARKER  
647 Barker Building, 110 W. 42nd St., NEW YORK

For MEN, WOMEN and CHILDREN

# NO MORE BALD HEADS



WHEN our VACUUM CAP is used a few minutes daily. We accept no pay until you have tried the Cap 60 days and are satisfied. The Vacuum Cap is an appliance that draws the blood to the Hair Roots and starts a new healthy crop of hair. It stops Dandruff, stops the hair from falling out.

Bought by Doctors and men who know that it is the only reasonable HAIR GROWER known to science. No Drugs Used. Write for application blank, testimonials, and booklet on "HAIR," sent sealed in plain envelope, FREE.

THE MODERN VACUUM CAP CO.  
B. 559 BARCLAY, DENVER, COLO.



# Tobacco Habit BANISHED

## in 48 to 72 Hours

### Immediate Results

Trying to quit the tobacco habit unaided is a losing fight against heavy odds, and means a serious shock to your nervous system. So don't try it! Make the tobacco habit quit you. It will quit you if you will just take Tobacco Redeemer according to directions.

It doesn't make a particle of difference whether you've been a user of tobacco for a single month or for 50 years, or how much you use, or in what form you use it. Whether you smoke cigars, cigarettes, pipe, chew plug or fine cut or use snuff Tobacco Redeemer will positively remove all craving for tobacco in any form in from 48 to 72 hours. Your tobacco craving will begin to decrease after the very first dose—there's no long waiting for results.

Tobacco Redeemer contains no habit-forming drugs of any kind and is the most marvelously quick, absolutely scientific and thoroughly reliable remedy for the tobacco habit.

### Not a Substitute

Tobacco Redeemer is in no sense a substitute for tobacco, but is a radical, efficient treatment. After finishing the treatment you have absolutely no desire to use tobacco again or to continue the use of the remedy. It quiets the nerves, and will make you feel better in every way. If you really want to quit the tobacco habit—get rid of it so completely that when you see others using it, it will not awaken the slightest desire in you—you should at once begin a course of Tobacco Redeemer treatment for the habit.

### Results Absolutely Guaranteed

A single trial will convince the most skeptical. Our legal, binding, money-back guarantee goes with each full treatment. If Tobacco Redeemer fails to banish the tobacco habit when taken according to the plain and easy directions, your money will be cheerfully refunded upon demand.

### Let Us Send You Convincing Proof

If you're a slave of the tobacco habit and want to find a sure, quick way of quitting "for keeps" you owe it to yourself and to your family to mail the coupon below or send your name and address on a postal and receive our free booklet on the deadly effect of tobacco on the human system, and positive proof that Tobacco Redeemer will quickly free you from the habit.

Newell Pharmacal Company  
Dept. 300, St. Louis, Mo.

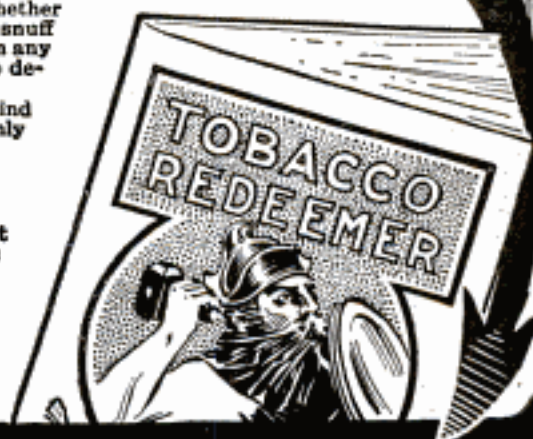

## Mail Coupon NOW for FREE Booklet

NEWELL PHARMACAL CO.,  
Dept. 300, St. Louis, Mo.

Please send, without obligating me in any way, your free booklet regarding the tobacco habit and proof that Tobacco Redeemer will positively free me from the tobacco habit.

Name .....

Street and No. ....

Town..... State.....

Please Mention Popular Mechanics

# HEADLIGHT OVERALLS

(Union Made)

**\$1.25** per pair  
**GENUINE INDIGO FAST BLUE DYE**

(In Canada \$1.35)

Will outwear two pairs of ordinary kinds.



"A Smile of satisfaction with every pair"



Look for this ticket

Larned, Carter & Co., Detroit

World's Greatest Overall Makers

Factories: Detroit and Port Huron, Mich.,

St. Louis, Mo., San Francisco Cal.

Canadian Factory,

Sarnia, Ont. [11]

Please Mention Popular Mechanics

## Veeder CLUTCH SPEED Counter

No. 21



Two-Third Size

This is the best instrument for finding revolutions per minute of a shaft or any revolving part. Will measure high or low speeds. No stop-watch required. Absolutely accurate. Cut is two-thirds size. Price **\$3**

We make counters that will give you facts about your machinery. Write and tell us your problem and let us give you good counter advice that will fit your individual size. We will be glad to send you free our illustrated booklet with information about these wonderful instruments. Send for it.

Cyclometers, Odometers, Tachometers and all kinds of counters. Fine Die Castings.

Veeder Mfg. Co. 4 Sargeant Street HARTFORD, CONN.

Buy Direct **SAVE** Big Money

**Auto Tops** 1/2 USUAL PRICES

FIT ANY CAR, \$7.25, \$9.25, \$10.25 up, without frame.  
 Ford Regular Tops, complete, \$14.25, \$16.50 up.  
 Ford One Man Tops, complete, \$19.25, \$23.00 up.

**SEAT COVERS** For Fords, \$3.45, \$5.60, \$7.00 up;  
 Buicks, \$5.00, \$7.00, \$10.50 up. All others same rate.  
 Overlands, \$4.85, \$5.80, \$9.45 up.

Our local representative will give you expert advice free and save you big money. Write for his address with free catalogs and samples.

**SEE OUR AUTO EXPERT**

**AUTO SPECIALTY FACTORY**, 1020 Spring St., Cincinnati, O.  
 Limited territory still open. Write today for exclusive agency proposition.

**DEALERS AND AGENTS**

Does The Socket Chafe Your Stump?

Buy you an **SOFT** socket

**BUCHSTEIN'S VULCANIZED FIBER LIMB** which is soothing to your stump, cool, neat, light, walls not much thicker than a silver dollar, strong

Sold on easy payments to good people. D. Buchstein

Co., 113 6th St. S., Minneapolis, Minn. **Guaranteed 5 Years!**

**TOOTH-ACHE STOP** Stops the Pain & Stops the Tooth

Agents Wanted

**TOOTH-ACHE STOP**

PRICE **25 CENTS** 3 for 50 Cents

ENOUGH TO STOP 30 TOOTHACHES

Easy to use.

Insert a little of this paste into hollow in the tooth and the **ACHE STOPS INSTANTLY**, then the paste hardens, forming an antiseptic Stopping for the Tooth, excluding the air and preventing a recurrence of the agony. **Guaranteed Absolutely Harmless** - will not spread and burn mouth. Does not decay the tooth. **Use** Have it ready for the next bad attack. A perfect godsend at two in the morning.

**NATIONAL CHEMICAL CO.**, 7129 N. Clark Street, CHICAGO

**Garage \$69.50**

10x12feet "Steelcote" Edwards ready-to-use garage, \$69.50 complete. Factory price. Fireproof. Portable. Quickly set up. All styles and sizes of garages and portable buildings. Send postal for illustrated catalog.

**THE EDWARDS MFG. CO.**  
 320-370 Eggleston Ave., Cincinnati, O.



# 7 Cents a Day Buys This Standard Visible Oliver Typewriter

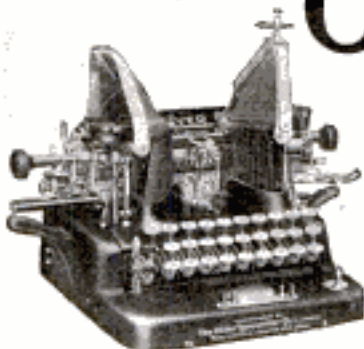

## Sensational Reduction

Our enormous purchasing power, tremendous output and the simplicity of our methods make this truly remarkable saving to you possible. Such an offer needs no high-priced salesman; no collectors. We are willing to let the typewriter do the talking and sell itself. We know from experience that a satisfied customer will pay. The simple coupon tells the story. Sign it and we will ship you one of the splendid machines—perfect in every detail. If it is not what you expected, if it fails to please you in any way, if you are not satisfied that it is the greatest bargain you were ever offered, get your money back. Read the coupon.

## Much Less Than Half Price FREE Trial—10 Year Guarantee

This is positively the best typewriter offer ever made. The typewriter is the genuine Model No. 5 Standard Visible Oliver, with complete and brand new equipment. Perfect machines only. Not shop worn, not damaged, inferior in no way. Back Spacer, Tabulator, Disappearing Indicator, not a feature lacking. Equal in quality in every respect to the \$100 article.

This amazing offer is not on some ancient style of blind typewriter, but on the wonderful Model 5 Oliver, the kind thousands of the world's best business firms are using today.

## Trial Order Coupon

UNITED STATES TYPEWRITER EXCHANGE

Dept. 345, All-Light Building, Chicago, Ill.

Send me by express a No. 5 Oliver Typewriter on approval. I will leave \$3.80 with the express agent when I get the machine, the same to be returned to me in full if I return the typewriter within 10 days. If I keep it, the \$3.80 will apply on the purchase price of \$39.80, and I will pay the balance of \$36 in 18 consecutive monthly payments of \$2 each, commencing 1 month from delivery, title to the typewriter to remain in you until it is totally paid for. (342)

Name..... Address.....

Two References.....

## NOW You Need a Really Good ATLAS

Never before in the World's History has an atlas been so constantly necessary to an intelligent understanding of the World's News.

## HERE IS THE IDEAL ATLAS

Hammond's Comprehensive Atlas of the World is a compact, octavo volume, convenient to handle, handsomely bound in genuine flexible leather. It overcomes the objections to large unwieldy atlases and solves the problem of

## Large Scale Maps in a Book of Handy Size

Each map occupies two, four, six or eight pages as required, thus achieving this long sought ideal. It contains 512 pages, 256 pages of large scale maps of all States, Canadian Provinces, Countries of the World, etc., printed in four colors, showing Cities, Towns, Counties, Railroads, Lakes, Rivers, etc., all thoroughly up-to-date with

## Special New Maps Showing the Several War Zones

Also 256 pages of text, index and compilations giving population of principal cities of the World, a comprehensive Gazetteer, World statistics, description and history of Panama Canal, latest official population of American towns, cities and counties

## Self-Revising After the War

Each copy contains a certificate entitling the purchaser to a supplement of maps showing the new boundaries of the Countries affected as determined by the Peace Treaties, to be mailed free within sixty days after the war is over. This supplement will bring your atlas up-to-date.

## Return Privilege

Any purchaser who is not more than satisfied with his atlas in every way may return same and have his money promptly refunded.

POPULAR MECHANICS BOOK DEPT., 6 N. Michigan Ave., Chicago

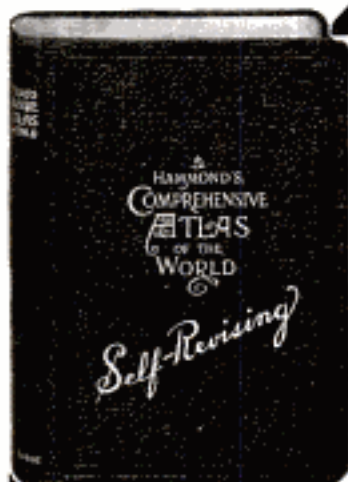

Size 9 1/2 x 6 3/4 x 1 1/4 Inches

Price \$1.50

Postage 15 cents extra

Get your atlas now. Use it during the great war when you need it most.

## Oxy-Acetylene Welding and Cutting



Welding frame of automobile top by oxy-acetylene process. Done quickly, and secures neat finish and quality of joint impossible by any other process.

## Metal Manufacturing Simplified by Welding

Because of its greater economy and the better quality of work done, oxy-acetylene welding is being adopted, in preference to older methods, by thousands of manufacturers of metal products.

It is replacing riveted, threaded and brazed joints with better unions at less cost. Practically every metal manufacturer can avail himself of this economy in metal production.

In nearly all cases where two pieces of metal are to be joined, in manufacturing, construction or repair work, oxy-acetylene welding provides the best and cheapest way.

Quick, emergency repairs on important machinery, right on-the-spot by oxy-acetylene welding, oftentimes more than pays for necessary apparatus by avoiding tie-ups in production and expensive replacements and attending delays.

## Prest-O-Lite PROCESS

Employs both gases (acetylene and oxygen) in portable cylinders. Prest-O-Lite Dissolved Acetylene (ready-made carbide gas) is backed by Prest-O-Lite Service, which provides dry, purified gas, insuring better welds, quicker work, and lower cost, and also avoids the large initial outlay and heavy depreciation incurred in making crude acetylene in a carbide generator.

The necessary equipment is not expensive. We furnish high grade welding apparatus for \$60 (Canada, \$75); acetylene service at additional cost. Also adaptable for oxy-acetylene cutting by the purchase of a special cutting blow-pipe. Thorough instructions are furnished free to every user—any average workman can learn the process quickly. We will train your operators at our shops if you desire.

## Get Started Doing Job Welding

Job welding offers a splendid opening for enterprising men to get into business for themselves. Profits are substantial. Does not require a heavy investment when you start. Ask for particulars.

There are important savings possible in all metal manufacturing, repairing and construction work. We have thoroughly illustrated literature on Oxy-Acetylene Welding and Cutting for free distribution to interested persons. Ask for it.

## The Prest-O-Lite Co., Inc.

The World's Largest Makers  
of Dissolved Acetylene

Main Offices and Factory  
816 Speedway, Indianapolis, Ind.

Canadian Office and Factory  
Merritton, Ontario

53 Branches and Charging Plants



## ROBINSON

NEEDED IN  
EVERY  
HOME

## FOLDING BATH TUB

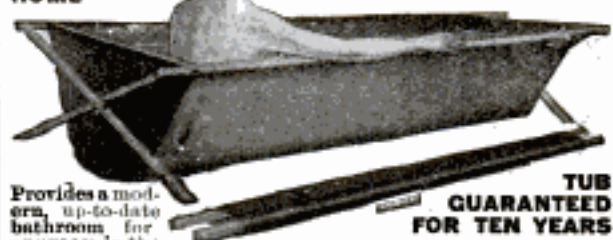

Provides a modern, up-to-date bathroom for any room in the house. No plumbing or water works needed. Have one for each of your rooms; splendid for summer cottages, camping, etc. Positively non-leakable. Folds in small roll, compact as umbrella, self-emptying. Positively guaranteed for ten years. Not sold in stores. Only through our authorized agents, or direct where we have no agent. Write today for price and full description.

TUB  
GUARANTEED  
FOR TEN YEARS

AGENTS  
\$60 A WEEK  
AND THIS  
AUTOMOBILE GIVEN



Every Agent Can Earn an  
AUTO FREE. No Contest

I want hustling, energetic, ambitious fellows, anxious to make money, who are willing to work, not for me, but with me. Are you that kind? I want you to advertise, sell, and appoint local agents for the biggest, most sensational seller in 50 years—the ROBINSON FOLDING BATH TUB. Demonstrating Tub Furnished. An absolutely new invention—nothing like it. Sells easily. Remember, fully 70% of homes have no bath rooms. Two sales a day means \$300 a month. Breeze of Idaho, made \$400 profit in 30 days. Rev. Otto Schulze, Mo., got \$1600 to date. Burkholder, Mont., orders \$10,72 in 17 days. Hamilton, of Wyo., made \$60 first two days. Hundreds like that. Pleasant, permanent, fascinating work. No experience needed, no capital. Your credit is good if you mean business. But you must be ambitious to make money. That's all. Write a post card now. Get \$50.50 weekly.

H. S. ROBINSON, Pres. the Robinson Cabinet Mfg. Co.  
4061 Factories Building TOLEDO, OHIO

## DIAMONDS \$70 PER CARAT

DIRECT FROM THE CUTTERS  
BY MAIL TO YOU—SAVE 40 PER CENT



Buy value—don't buy profits and commissions. As direct diamond importers, cutters and wholesale jewelers, our prices positively save you at least 40 per cent. Send for our big money saving 1916 Catalog.

MILITARY HAMILTON, ILLINOIS WATCHES AT WHOLESALE PRICES.

IPRESS-SONS  
777 CHESTNUT ST.  
PHILADELPHIA, PENNA.

## PAY FOR IT OUT OF YOUR PROFITS



## First Small Payment Starts Your Success

Marvelous money-maker! Prosperous, independent business—no experience needed—"snap shot" post card photos by wonderful new methods. Tremendous hit! Coin money—quick—sure—cash rolls in—harvest of silver at picnics, circus crowds, conventions, fairs, on the beach, etc. Pay a little down—balance small monthly installments from your big earnings.

## \$5 TO \$15 A DAY WITH THE Mandel Post Card Machine

Hustlers easily pick up \$5 to \$15 a day with this latest triumph of instantaneous photography. "Press the bulb"—takes, makes and finishes perfect post card pictures in one minute! No films, plates or dark room. Material for taking 250 worth of pictures delivered with machine on first small payment. Big chance—don't miss this. INVESTIGATE AT ONCE—NOW!

Write For Easy Payment Plan  
THE CHICAGO FERROTYPE COMPANY,  
1455 Congress Street, Dept. 7 CHICAGO, ILLINOIS



Bungalows, Camps  
and  
Mountain Houses

(7 1/2 x 10 1/4 actual size)

## "Planning the Bungalow"

A feature of the new edition is a condensed account of the requirements for planning a bungalow. It contains a plate showing 22 different schemes for laying out the floor plans of a bungalow, and in addition a lot of little detail sketches showing how to plan conveniences in the house, such as built-in furniture, kitchen arrangements, closet space, cupboards, etc.

**Part I — Bungalows** | **Part II — Bungalows** | **Part III — Camps, Log of Cottage Type** | **Cabins, Lodges**

The subject matter is treated in these three parts. The first shows the true bungalow; the second, the bungalow with a second story, and the third, lodges and log cabins suitable for the mountains, lakeside and seashore. Descriptive text accompanies the illus., giving costs and telling the kinds of materials used.

200 Illus., 80 Designs, 126 Pages, Cloth, Price \$2.00 postpaid

**Popular Mechanics Book Dept.**  
6 N. Michigan Ave., CHICAGO

## The Best Book on Bungalows

This is the new revised and enlarged edition of "Bungalows, Camps and Mountain Houses."

This book presents the thoughts and ideas of 32 different architects, all recognized designers of Bungalows. The new edition contains 200 illus., showing 80 designs with exteriors, interiors, plans.

## Books for Home Builders

### HOME BUILDERS' GUIDE

By WM. ARTHUR

A book that will give those who are not professional builders or contractors a thorough understanding of the value of good construction. All types of construction are taken up. The best planning of a house is explained. 186 Pages. 40 Illustrations. Cloth. \$1.00 Postpaid.

### BUILDING BY A BUILDER

By B. A. HOWES

Practical and economical considerations for the man about to build. Cloth. 224 Pages. \$1.20 Postpaid.

### The BOOK of LITTLE HOUSES

This little book sets forth some very helpful advice on the building of the small house, and there are a number of well worked out plans.

107 Pages. Illustrated. 60 Cents Postpaid.

### BUNGALOWCRAFT

By HENRY MENKEN

A book on bungalows and cottage building in its latest development. Illustrated with half-tone and line engravings of the charming bungalows of Los Angeles and Pasadena which are famed the world over.

120 Pages. \$1.00 Postpaid.

### SUBURBAN HOMES

With Constructive Details

Complete working plans and sets of specifications with actual costs of construction and details of both interiors and exteriors of houses ranging in cost from \$3,000 to \$24,000. 200 Pages. Cloth. \$1.50 Postpaid.

Sent postpaid to any address by

**POPULAR MECHANICS BOOK DEPT.**  
6 N. Michigan Ave., CHICAGO

# Self Starting

The latest improvement  
in rowboat motors

*Operates from the seat without  
touching the flywheel*

THE Koban  
Rowboat Motor  
fitted with self-  
starter, solves  
the problem of  
cranking rowboat  
motors. It is one  
of the big 1916  
improvements.

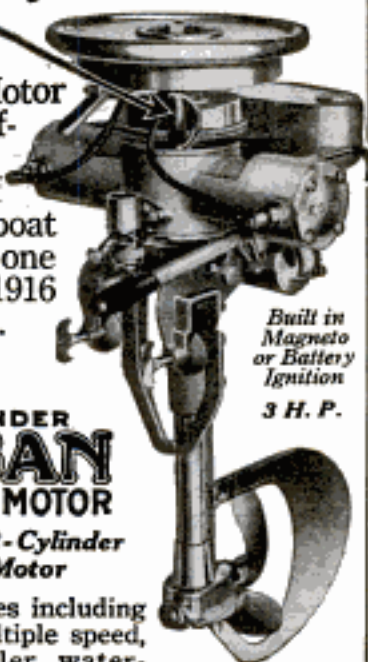

Built in  
Magneto  
or Battery  
Ignition  
3 H. P.

The Great  
2-CYLINDER  
**KOBAN**  
ROWBOAT MOTOR

The Original 2-Cylinder  
Rowboat Motor

Other new features including tilting device, multiple speed, side steering tiller, water-proof timer, fool proof carburetor, aeroplane breaker point magneto and many others.

## Doesn't Shake the Boat

The opposed cylinders fire at the same time, thus taking up the shock, one stroke against the other. No other motor but the Koban is free from vibration.

## Has the speed—and then some

It's a demon for speed. Indeed, so fast that it pays the penalty of a handicap in most races.

*"It can pass any motor on our lake,"*  
is the message from Hibbing, Minn.

*"It blows right by all of them,"* is  
the report from Glens Falls, N. Y.

This is typical of hundreds of other letters on the point of speed, from all parts of the world.

*It is a real motor—built  
on sound engineering lines*

Write for the new, free 1916 catalog.

Dealers and agents wanted in unoccupied territory

## KOBAN MANUFACTURING COMPANY

291 South Water Street Milwaukee, Wis.

Our line also includes a 2-cylinder, 3 H. P. vibrationless inboard marine engine for small launches, canoes, etc.

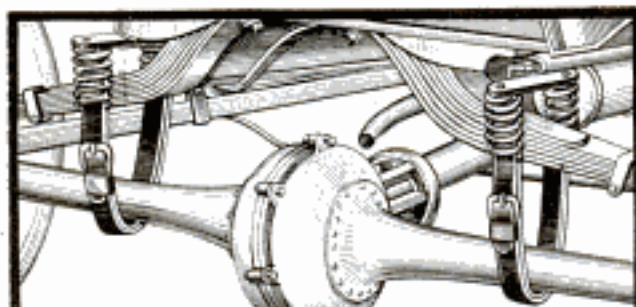

## \$5 Buys This New Shock Eliminator

Stops the shock before it starts. Saves springs. Makes cars ride 100% easier. Put on in five minutes with a monkeywrench. Particularly good for country driving.

### For Fords and Overlands

For Fords, complete set of two for rear and one for front furnished. For Overlands, set of two for rear only.

**Agents Wanted** in every county. Write for proposition. Address A. J. Baker, 3042 Cleinview Avenue, Cincinnati, Ohio.



Sign on the huge engine which "ran" the San Francisco Fair:

"This engine was officially started on opening day by wireless, and will be stopped by President Moore closing day, after ten months' operation, using

## THORDARSON WIRELESS TRANSFORMER

When this engine stopped, Dec. 4th, every electrical activity in the whole Fair ceased. The THORDARSON ended the World's Greatest Exposition. Improve your own wireless set with a THORDARSON Wireless Transformer. Ends all battery trouble. Write today for interesting Booklet. Thordarson Electric Mfg. Co., 518 S. Jefferson St., CHICAGO

# BRISCOE

TWENTY-FOUR

## "The Latest Briscoe Beauty"

Full stream-line body; electric starting and lighting; 104-inch wheelbase; 3 1/8 x 5 1/8 long-stroke motor; full equipment.

**\$585** f. o. b. factory

Correspondence invited from responsible dealers.

BRISCOE MOTOR COMPANY, 117 Wildwood Ave., JACKSON, MICH.

## RUNATIRE REPAIR SHOP

### BIG MONEY - FROM THE START

Every auto owner needs frequent tire repairs. Badger Equipment makes the work quick and easy. Small investment puts you into a business of your own—paying up to \$200—\$300 a month.

### WE TEACH YOU FREE

No experience needed. We teach you at factory or by mail. Show you how to get the business and handle your shop. Best system, best machines and money-making FREE AID SERVICE.

Write for Telle how to get into this lucrative field right. Full description of Badger outfit. It's free—write. Catalog TIRE REPAIR EQUIPMENT CO. 601 Johnson St. Appleton, Wisconsin



**PFILE'S 65 VARIETIES** farm-raised Land and Water-Fowls. Eggs in season. Illus. Catalogue, and "Grower's Guide," 2c. An honest deal. Write today. HENRY PFILE, Farmer-Poultryman, Box 720, Freeport, Ill.

## SAVE YOUR EYES!

BY USING THE

### AMBER-LITE Shade

It slips over any electric globe and filters the light, destroying the harmful rays. The Greatest Blessing conceivable to Students, Stenographers, Office Men, Postal Clerks, or any one working hours under artificial light. Eliminates eye strain and makes reading and working comfortable. 2 for 50 cents (checks must include exchange). Your money back if not satisfied. Special quantity prices to Firms or Agents.

AMBERLITE COMPANY OF AMERICA  
618-619-620, 5 So. Wabash Ave., CHICAGO

## IF \$10 to \$20 a Day Profits LOOKS GOOD TO YOU

Let us send you a Free Booklet of our Automatic Card Printing Press

Printing is ever-lastingly a big money-making enterprise anywhere. Don't delay. Write today.

S. B. FEUERSTEIN & CO.

Patentees and Manufacturers  
542 West Jackson Boulevard CHICAGO



# Germany Wanted 100,000

For Use in the Trenches

This \$2.25 Flashlight, Postpaid for **\$1**

We made them, but as you know, could not make delivery. Now we are commissioned to sell this special \$2.25 gun metal case Flashlight fitted with Mazda Lamp and battery that can't short-circuit, postpaid for \$1. They will not last long at this price. Send your dollar today.

DETROIT FLASHLIGHT CO., Dept. B, DETROIT, MICH.





# EXCELSIOR LIGHT WEIGHT



\$135<sup>00</sup>

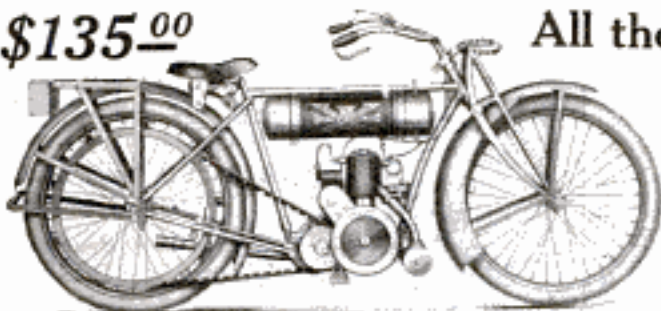

All the **SPEED** and **POWER**  
You Need at Minimum  
Cost and Maintenance  
*Everybody's Motorcycle*  
*Fast and Powerful*  
*enough for any man.*  
*Simple enough for*  
*a boy or a lady.*

Over a thousand Excelsior Lightweights are now in the hands of the user.

They have been thoroughly tried in all parts of the country and under all conditions.

The results have shown conclusively that they take you anywhere you want to go at any speed within safety.

The simplicity of the two stroke motor, without valves, complicated lubricating system and similar mechanism, entirely eliminates

**WRITE TODAY FOR CATALOG FULLY DESCRIBING THIS AND FIVE OTHER MODELS**

the necessity of technical knowledge and mechanical experience. The light weight enables any one to easily handle the machine either on the road or taking it to and from storage.

The quality is **Excelsior** throughout and the low price is attained solely through simplicity of construction.

In this machine is the same nickel steel drop forged frame construction, accuracy of workmanship and excellence of material that has built for the **EXCELSIOR AUTOCYCLE** the world-wide reputation as the machine that **Always Makes Good**

**Excelsior Motor Manufacturing & Supply Co.**  
3702 Cortland St., CHICAGO

## FOR 17<sup>00</sup> a Day The Extra-Capacity Typewriter

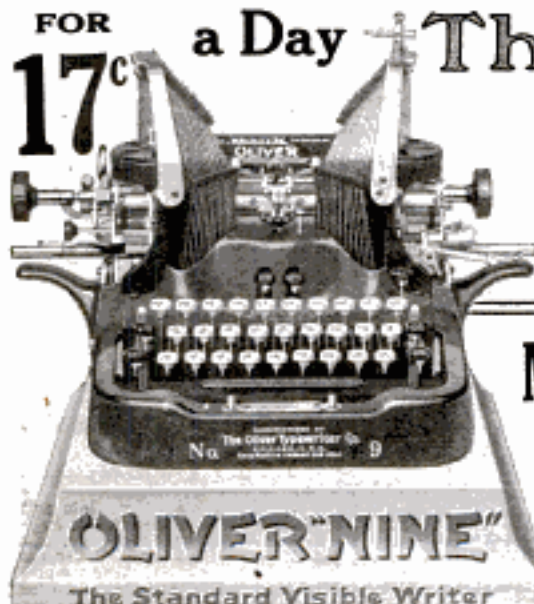

That Brings a Bigger Day's Work  
With Nearly a Third Less Effort

### More Local Agents Needed at Once

When experts first saw this revolutionary typewriter they predicted that we would have to raise our price.

But we equalized the extra cost to us—partly by simplified construction, partly by quantity production. Hence we're selling the "NINE" at the old-time price and for 17 cents a day!

#### Agent's Sample

Anyone who has use for a typewriter, and would be willing to take orders from the sample that we supply agents on attractive terms,

should write us today for "Opportunity Book." It tells all about our exclusive agency offer.

Salesmen, storekeepers, bankers, clerks, office and professional men, etc.—nearly every occupation is now represented in Oliver's world-wide sales army.

#### No Experience

We send the "Oliver School of Practical Salesmanship" FREE. Thus new agents can soon master the methods that are making good money for scores of others.

#### Apply Today

Don't wait till some other wide-awake person is awarded the vacancy where you live. Life's prizes come to men of action. No obligation—MAIL THE COUPON NOW!

THE OLIVER TYPEWRITER CO.,  
1257 Oliver Typewriter Bldg., Chicago

Send free, the book I have marked in the square.  
 "Opportunity" with Oliver agency offer.  
 Oliver Typewriter book de luxe.

Name .....

Address .....

#### Features That Are Winning Thousands

New Bi-Manual Duplex-Shift multiplies speed and makes touch-writing 100 per cent easier.

Selective Color Attachment writes two colors at option and performs the work of a special check protector.

20-Copy Manifest Feature—All-Color-Line Ruler—In-Built Calculator, Visible Down-glance reading and PRENTYPE rest the eyes.

Lightest Standard Touch rests the muscles.

Automatic Spacer reduces labor and prevents mistakes.



# Strawberries and Oranges Are Ripe in FLORIDA

**Northern born men** who shivered at uncongenial jobs a year ago are gathering oranges, strawberries and grapefruit at Sarasota this morning.

**These men did** as you ought to do. They got away from blizzards and a slim pay envelope and came to this land of flowers, where orange and grapefruit groves and vegetables between the trees pay \$3,000, \$5,000 and more a year.

**Follow their lead**—Come to the famous Sarasota Bay District, on Gulf Coast, where the mean annual temperature (21 year record) is 71.2 degrees.

**In this ideal** part of the state we have land that is so rich in vegetable mold and certain chemical elements that it grows grapefruit and oranges, small fruits and vegetables **at the same time** and with the same degree of certainty and perfection.

**On this land** are wonderful grapefruit and orange groves 40 years old; some 20 years old, others 1, 2, and 3 years old, and still others just being set out. Between the trees are being raised **top-priced** strawberries, melons, celery, lettuce and cauliflower.

**A few acres** of this great soil will give you financial independence—a home amid oranges and sunshine.

**While waiting** for your orange and grapefruit trees to mature you can “farm between the trees” and thus more than pay your way. E. B. Tucker sold \$522.00 worth of tomatoes from one acre. A. D. Albritton cleared \$524.00 on three-quarters of an acre of strawberries.

**You have cash market** for everything. Rail and water transportation. Shippers' protective associations. Twice daily express and freight service.

**Abundant rainfall** to mature all crops, but in addition anyone may have flowing artesian wells of pure, sweet water.

**Social life** at Sarasota is ideal. Churches, schools, lodges, good neighbors, a modern town. The climate and recreations tourists travel far for and pay dearly.

**Come to Sarasota**—We want you and will give you 10 year's time on your land payments. We will not permit you to purchase blindly; we give you a year's time to examine your land and **refund any payments you have made with 6% interest if you are not entirely satisfied.**

## Ask for Illustrated Book

It explains all about our liberal, easy, safe payment plan. Contains many photographic scenes of Sarasota Bay District grapefruit and orange groves, with vegetables between the trees. Shows scenes in town of Sarasota—paved streets, modern stores, handsome dwellings, \$25,000 school. Pictures of fishing, hunting, and other sports.

**Sarasota-Venice Company**  
202 Pineapple Ave., SARASOTA, FLORIDA

### SARASOTA-VENICE COMPANY

202 Pineapple Ave., Sarasota, Florida

You may send me Free Illustrated Book about lands suitable for grapefruit, oranges, small fruits, and vegetables.

Name.....

Address.....

Town..... State.....

## On the Ground as Needed

You want to put up your new building on schedule time. That means the windows as well as the other building material must be on the ground when needed.

**Fenestra**  
SOLID STEEL WINDOWS  
"REG. U.S. PAT. OFF."

### Standard Units

can be shipped to you in ten days after receipt of order in Detroit.

Forty-five types and ninety different sizes give a variety which is sufficient for all ordinary building needs. Undoubtedly you will find among these types just the window you want.

Besides prompt shipment, low cost is an additional inducement to use Fenestra Standard Units. They can be purchased at a price that compares favorably with wood sash.

*Write for list of stock types and sizes mentioned above.*

**Detroit Steel  
Products Co.**

Dept. C 6

Detroit,  
Mich.

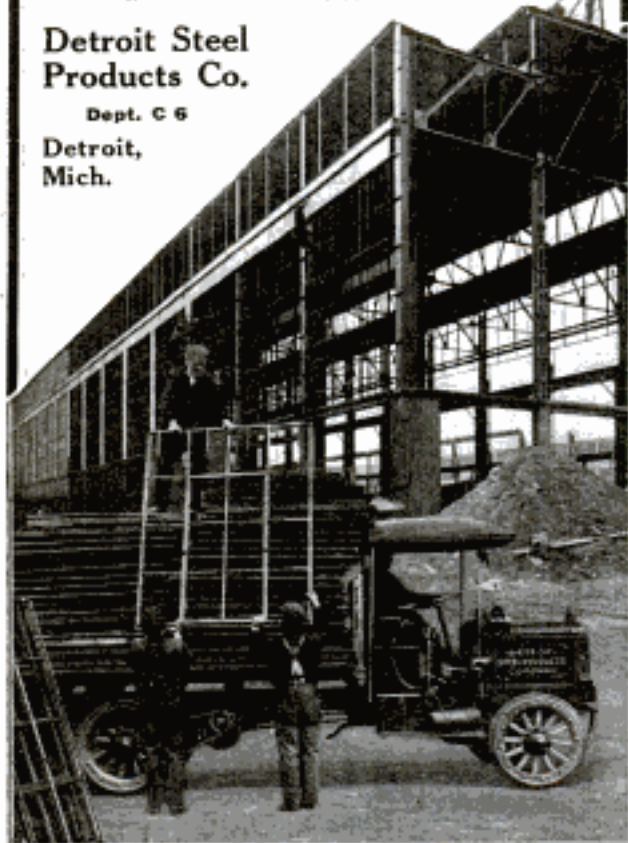

## YOUNG MAN! LEARN DRAFTING!

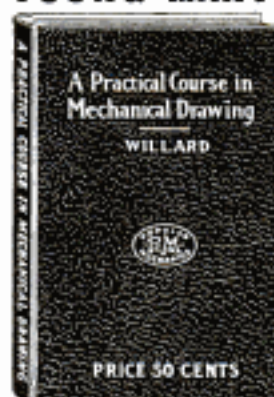

ONE of the most practical subjects of study today; an essential in most lines of engineering; indispensable in many occupations and often the secret of successful advancement; of no less importance to the farmer than the mechanic. There is bound to come a time when you will feel the need of the ability to "lay out" something in accordance with the rules and conventions used in the drafting profession.

### Individual Study

may be successfully engaged in with the aid of our new enlarged edition of the book

## A Practical Course in Mechanical Drawing

By WM. F. WILLARD

(For several years instructor in Mechanical Drawing at Armour Institute of Technology, Chicago)

160 PAGES — SIZE 5x7 — 157 DRAWINGS — CLOTH COVER

### Price 50 Cents, Postpaid

There has been a real need for a book of this kind, as it clinches each problem in the mind of the student by giving the practical application of that problem to every day practice in some phase of the world's work. It meets every modern requirement and is in advance of any other work on the subject. Excellent for use in shop, classes, trade or high schools. A complete detailed description of the contents of this book sent free upon request.

Order of your Book Dealer or direct from the publishers

**POPULAR MECHANICS BOOK DEPT.**  
6 N. Michigan Ave., CHICAGO

## A BOOK OF NEW MISSION FURNITURE DESIGNS



### Part 3 — Mission Furniture HOW TO MAKE IT

A 128 page collection of 36 excellent new designs that have never before been published and that are entirely different from those in the books Parts One and Two previously issued.

Handsome Cloth Binding

Price 50c Postpaid

This new number has just been published and those already in possession of Parts One and Two will find this an even greater value in variety and excellence of the plans.

### A feature of the New Book is a Complete Set of Dining-Room Furniture Designed to Harmonize Perfectly

If you are at all handy with tools, you will find that the plainly written directions, dimension drawings and half-tone illustrations will enable you to

**Make Your Own Furniture and Save Two-Thirds**  
The many who use tools for pleasure will find this book a working guide which will furnish many moments of delightful and profitable occupation while several of our readers have been able to devote their entire time to this work by disposing of what they have made at a nice profit. One man made and sold \$400 worth of one piece alone.

Parts One and Two in this series are also 50 cents each postpaid

Ask Your Book Dealer or Address the Publishers

**POPULAR MECHANICS BOOK DEPT.**  
6 N. Michigan Ave. CHICAGO



# Most Remarkable Bargains



**3-Piece Library Set**

**\$1.00 Per Month**

No. MK201. Choice quality solid oak, fumed finish. Table top 36x24 in., 2 roomy book ends, 7 in. connecting shelf. Panels at sides of book ends match panels on chairs. Chairs have 2-in. front posts fitted to genuine quarter-sawn oak arms, 25 1/2 in. wide. Seats and backs upholstered with imitation Spanish leather. Heavy steel springs. Complete set. **\$12.65**

**Porch Swing Bargain**

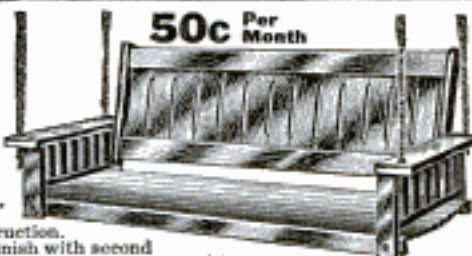

**50c Per Month**

No. MK203. Substantial solid Oak Porch Swing, made with bolted construction. Fumed oak finish with second coat of lacquer. Has shaped seat with 4 braces and rounded slats; paneled ends and back; and comfortable arm rests. Is 60 inches wide; 43 inches between arms. Seat is 17 inches deep. Comes complete with non-rusting 3/4 ft. adjustable chains and ceiling hooks. Here is a swing that is well made and one that will give you great comfort. Our exceptionally low price of **\$2.80**



**Refrigerator**

No. MK206. Made of genuine ash, paneled front and sides, golden oak finish. Removable 5 ft. lid; all-metal cushion ice chamber support. Sliding wire shelves; removable waste pipe and patent syphon. Galvanized iron ice rack, holds 25 lbs. Hardware genuine brass, nickel plated. It is 43 in. high, 25 1/2 in. wide, 18 1/2 in. deep.

Price **\$12.85** **\$1 Per Month**

**5-Piece, 2-inch Post Steel Bed Outfit Bargain**

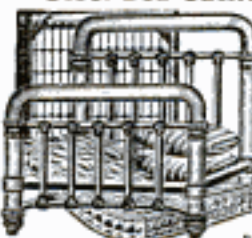

No. MK148. Elegant 2-inch continuous post steel bed, 34-50. Sillers in artistic design, height head end 52 in.; link fabric steel frame springs, cotton top mattress and two 4 1/2 lb. hen feather pillows 18 x25 in. All sizes, 3 ft.; 3 ft. 6 in.; 4 ft. or 4 ft. 6 in., full size. Colors, White, Pea Green or Vernis Martin. A remarkable bargain at our low price of only **\$8.98** **75c Per Month**

**Oak Rocker**

No. MK185. Solid oak; genuine quartered oak arms; rich golden finish. Front posts and front rail, top rail and side wings richly carved. Seat and back upholstered with brown imitation Spanish leather. Filling of wood fibre and moss. Seat 19 1/2 x19 in., six spiral springs, 28 in. high. Strong runners, heavy posts. Price.. **\$3.97**

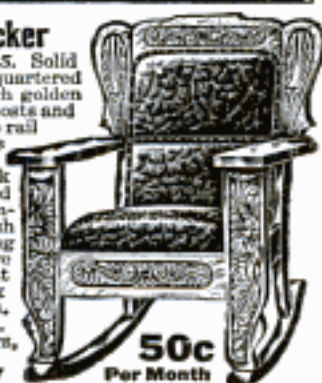

**50c Per Month**

# No Money In Advance



**21-Piece Enamel Ware Set**

No. MK202. Genuine Gray Enamel Ware, guaranteed to give long, satisfactory service, made of the finest materials. Utensils for practically every kitchen need. Consists of Berlin kettle and cover, teakettle and cover, coffee pot, preserving kettle, pie plates, wash basin, tea pot, sauce pan, dish pan, colander, covered pail, padding pans, cup, spoon, Per dipper, ladle. Price only **\$2.79** **50c Per Month**

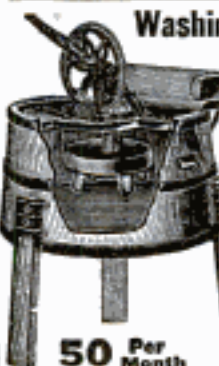

**Washing Machine Bargain**

No. MK105. Tub is 8 shirt capacity, of Louisiana red cypress, corrugated on inside for effective rubbing surface. Finished in natural color and bound by 3 steel hoops, 4-pronged, 10-in. cypress dasher block, cannot slip or crack. Gearing is durable; roller bearings. Very easy to run. Tub is supported by 3 legs bolted into iron sockets. Does not tear clothes. Price **\$4.50** **50 Per Month**

Here is perfect credit and the most wonderful bargains ever offered. Remember, we say to you, "Order any of these bargains and send no money with your order—not one cent—see before you buy." Hartman's Mammoth Organization, with its \$12,000,000 Capital and Resources, makes it EASY for every one to furnish the home completely at SMALLEST COST and on terms positively unapproached by any other concern in the world.

## Hartman Will Trust You

No matter who you are or where you live. The proof is on this page. Order any of the articles shown here and it will be shipped at once without one penny sent in advance! USE IT AS YOUR OWN FOR 30 DAYS. If not fully convinced that it is the most remarkable bargain you ever heard of, return it at HARTMAN'S freight expense both ways and the trial will cost you nothing. If you are perfectly satisfied, keep the goods and pay for them in small monthly sums.

## Hartman's Mammoth Bargain Book Free

We can ship but one of these bargains to each family at these amazing terms but when you get our Mammoth Bargain Book, you may order any amount WITHOUT RESTRICTION—and pay a little each month. The HARTMAN BARGAIN BOOK is unlike all others. Hundreds of pages—in colors—over 8,000 wonderful bargains in Furniture, Eggs, Carpets, Draperies, Beds, Jewelry, Clocks, Stoves, Sewing Machines, Tableware, etc. Send for it at once. Ask for Catalog No. 86

## HARTMAN

Furniture & Carpet Co.,  
8945 Wentworth Ave.,  
CHICAGO, ILL.

**MAIL COUPON NOW!**

## "Wonder" Vacuum Sweeper

No. MK182. Noiseless fibre bearings and bellows lifting rods, steel frame dust bag, wide opening dust pan, pressed steel top, 4 drive wheels on brush, 3 bellows and 12 in. nozzle, Nickelod. Fully guaranteed. Price.. **\$3.97**

**50c Per Month**



HARTMAN FURNITURE AND CARPET CO.,  
3945 Wentworth Ave., Chicago, Ill.

If only catalog is wanted, place an X in this .  
If you wish any bargain shown here, fill in below. Write plainly. Send me Article No. .... (Fill in name and number)  
If I keep it I will pay \$..... in 30 days after arrival and \$..... per month.  
Name .....  
Address.....  
City..... State..... 86

# The Roof of the World



Every third roll of roofing used in the world is made by "The General."

Unequaled manufacturing facilities, expert knowledge of how to blend asphalts and the use of the best materials have made Certain-teed "the Roof of the World."

Guaranteed for 5, 10 or 15 years according to ply (1, 2 or 3)

## General Roofing Manufacturing Co.

The World's Largest Manufacturers of Roofing and Building Papers

### Private Weather Bureau

IN EVERY HOME  
A Reliable Barometer  
An Accurate Thermometer  
Actual Size 13 Inches High

Indispensable to the farmer, business man, professional man, automobilist, in fact, to everybody who should know in advance what the weather will be. Will save you money and time.

FORECASTS WEATHER

## WEATHEROMETER

HOURS IN ADVANCE

**\$1.00 ONLY** — Reduced from \$3.00

Send us no money. Mail your order today and Weatherometer will be sent to you C. O. D. (10c extra). If you prefer you may enclose \$1.00 bill or money order with order. Satisfaction guaranteed.

This Instrument Imprinted Makes an Excellent Advertising Article

**WITHINGTON INSTRUMENT CO.**  
5 South Wabash Avenue, Dept. 24, CHICAGO

### ACORN UNI-LITE FREE



Turns night into day. 300 candle power. Carry as a lantern; use anywhere as a lamp. Weather proof. For house, barn, garage, camp and around the farm. Write for big free offer. Special opportunity to farmers, stockmen and motorists. Agents make big money.

WRITE TONIGHT

**ACORN BRASS MFG. CO., 605 Acorn Bldg., Chicago**

### ALL STEEL GARAGE

#### The Butler "Round Ruf"

Full protection and at least cost. Fire-proof. Corrugated. Easily put up. Attractive in appearance. Portable. Useful as a machinery, tool or storage building. Additional sections to increase length furnished at any time. If your dealer does not handle, write us for full information and prices.

**BUTLER MFG. CO., 204 Butler Bldg., Kansas City, Mo.**

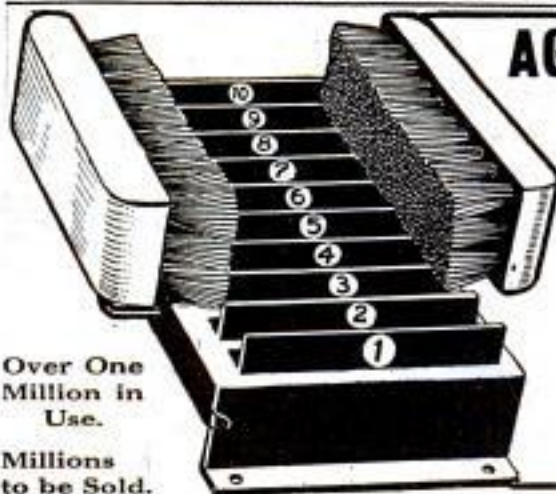

Over One Million in Use.

Millions to be Sold.

## AGENTS — The Million Dollar Hit!

New, wonderful home invention, just introduced, yet million sales already recorded. Tremendous, rapid sales stagger country. Agents happy — banking enormous profits daily. Mighty opportunity for you to get the mighty dollar. Failure impossible. Experience unnecessary. Money rolls in first hour — \$10 to \$30 daily. Amazing cash records made. Walters received

### \$50.00 FOR 7 HOURS' WORK

Never sold goods before. Arnold sold 160 in 2 days; Hagen 100 same time; Webb 10 per hour; O'Connell 25 first day. Hundreds like these. You, too, can have money in abundance. Grab's Scientific Shoe Cleaner sells itself — you take orders — that's all. Every family wants one on their doorstep. Replaces unsightly, unsanitary, crude door mat. Automatically removes mud, dirt, snow from shoe in one operation. Cleans sole, sides, heel. Works like magic — sells like sixty. Saves drudgery, time, money, shoes — saves carpets, floors. Mechanical wonder. Has 7 new patented features not found in any other scraper — 10 steel blades — 10 dirt outlets — twin adjustable and removable brushes — compound springs. Rotates for sweeping. Can't clog — practically self-cleaning. Handsomely encased. Nothing else like it. Nothing so popular — so easy to sell. Selling price only \$1.00. You make half — 100 per cent. Satisfaction guaranteed. Write quick for free catalog — exclusive agency. Better still, send order, naming territory. Investigate anywhere.

**SECURITY MFG. CO., Dept. 242, TOLEDO, OHIO**



### Your Opportunity Coupon

Mark the position you want  
and mail the coupon now

....Electrical Engineer	....Lawyer
....Elec. Light & Power Supt.	....Business Law
....Hydroelectric Engineer	....Business Manager
....Telephone Engineer	....Auditor
....Architect	....Accountant
....Architectural Draftsman	....Civ'l & Public Acc't
....Building Contractor	....Private Secretary
....Building Superintendent	....Stenographer
....Structural Engineer	....Bookkeeper
....Structural Draftsman	....Fire Ins. Inspector
....Mechanical Engineer	....Fire Ins. Adjuster
....Mechanical Draftsman	....Fire Ins. Expert
....Civil Engineer	....Sanitary Engineer
....Steam Engineer	....Plumber
....Shop Foreman	....Reclamation Eng.
....Shop Superintendent	....Textile Boss
....Sheet Metal Draftsman	....College Preparatory

We also prepare for civil service examinations in all engineering subjects

NAME .....

ADDRESS .....

Pop. Mech. 3-15

# Put YOUR Punch into Special Training

You won't ever amount to much if you're content to go on punching a time clock day in and day out. Time-clock punchers are little fellows; the men who hold down the big jobs generally come and go when they please.

If you are ambitious to get out of the time-clock class, prove it by marking and mailing the coupon above. Putting your punch into special training will give you the punch necessary to get and fill a responsible, high-salaried position.

## How you can get this special training

Since 1897 the *American School* has been helping men everywhere to get out of the underpaid time-clock class. It has prepared thousands for entrance into the big resident colleges. It has trained even more in all branches of *Engineering, Business and Law*. No matter where you live or what you do, the *American School* will prepare you for a better job and bigger pay. You won't have to give up your work—we'll train you at home, in your spare time.

Decide to put *your* punch into special training—show that you're really ambitious by marking and mailing the coupon today—*now!* There's absolutely no obligation and no agent will bother you at your home or work. The *American School* does not employ agents or collectors.

# American School

of Correspondence, Chicago, U.S.A.

Please Mention Popular Mechanics

# Easy to own this good engine now

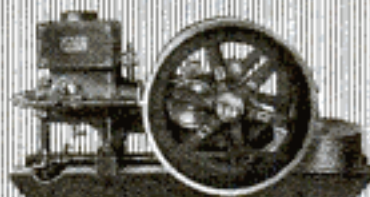

Send for my new, money-saving offer, before you arrange to try any engine, for any price. Compare my engine with

any other, consider my low prices—(easy terms, if you wish), and you will see your advantage in having one of my

## BAUER ENGINES.

**Gasoline, Kerosene, Distillate, Gas**

Sizes, 2, 3, 5, 7, 9, 12, and 16 horsepower. Now sold only direct from my own factory at surprisingly low prices. All sizes are of the up-to-date, long-stroke, valves-in-head, even speed type of engine. You can more intelligently select your engine after you have studied my engine book and my newest offer.

## Guaranteed 5 Years Sold Direct from Factory to User

Over 20 years ago I made my first engine with my own hands, and the many thousands I have since made by their record of easy usefulness and great durability, prove that you take no risk when you get a Bauer engine.

## Write for My Free Book

Send me your full address, now, so I can send you by return mail, my free book, which fully explains my engines, and shows how easy you can own a good engine, for a live-and-let-live price. Send the coupon or write me today.

**A. F. BAUER  
ENGINE CO.**  
477 Bauer Block  
KANSAS CITY, MO.

Gentlemen:— Please send me without obligation on my part, your Free book and latest offer.

**A. F. Bauer  
Engine Co.**  
477 Bauer Block  
Kansas City, Mo.

Name.....  
Address.....  
City.....State.....

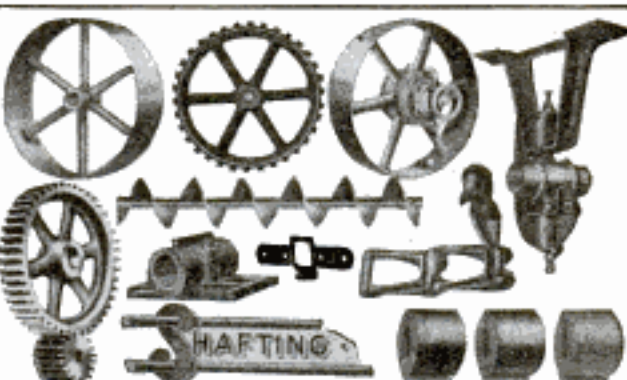

A complete line of appliances for the transmission of Power. Anything from a bolt to a complete mill or factory outfit. Send for catalogue. Largest Manufacturers of Pulleys in the country.  
**W.A. Jones Foundry & Machine Co.** 1403 W. North Ave. CHICAGO

## DIAMONDS- AND WATCHES ON CREDIT



### GREAT DIAMOND SALE

The most astounding sale of perfect cut diamonds ever offered.

**TERMS LOW AS \$1.50 PER MONTH**

This is your opportunity to get that long wanted diamond at a bargain.

**This is an extraordinary saving.  
SPECIAL \$39.50 GENUINE  
DIAMOND RING**

A wonderful value \$4.50 per month. A written guarantee with every purchase you make from **ALFRED WARE.**

**SENSATIONAL ELGIN WATCH SALE.**

\$12.50 Elgin Watch 17 Ruby Jewels 25 year guaranteed double gold strata case. Factory tested and adjusted.

Payments \$2.00 Per Month.

**30 Days Trial**

**No Money Down Express Paid**

Any watch you want on easy payments. Be sure to send for our 96 page catalogue. Over 2000 suggestions, Watches, Jewelry, Diamonds. This book describes our big bargains in all lines. All sold on Easy Payments and Free Trial. Send for it this minute. A postal will bring it.

ALFRED WARE COMPANY, Dept. 527 St. Louis, Mo.

## Big Free Catalog

### MAZDA

Always etched on electric lamps to which MAZDA Service has been applied.

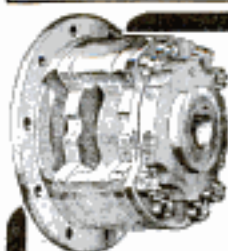

## Stop Skidding— Slipping and Sidesway

You can drive your car over snowy, slushy, sleety, slippery roads in safety, if it's equipped with the

### BAILEY Gearless Differential

In uneven going, power is always delivered to the solidly-grounded wheel—the loose wheel doesn't spin—and you pull right out of bad spots. Shipped on 30-day money-back offer. See dealer or write for circular.

**Ford, Overland and Chevrolet 490  
Replacements Now Ready.**

Gearless Differential Co., 892 Woodward Ave., Detroit, Mich.

# Make Your Bike a MOTORCYCLE

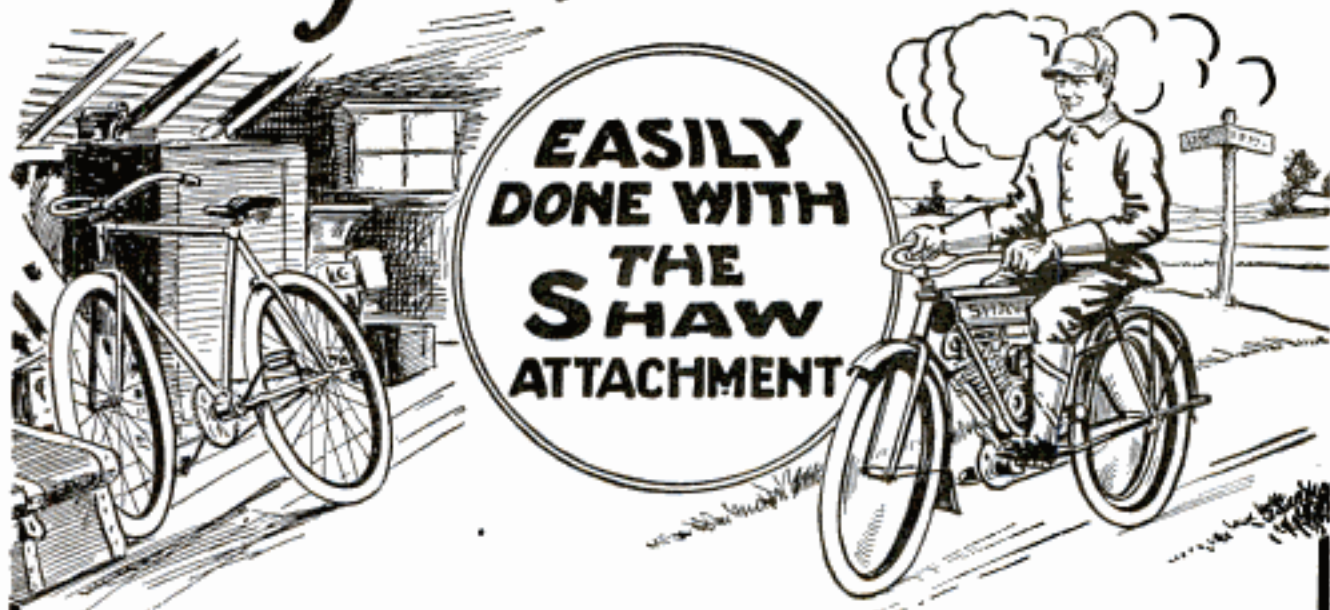

Don't envy the fellow who has a dependable motorcycle any longer. Don't sit back while your friends speed over city streets or country roads and enjoy the great out-of-doors without effort, just because you own a "foot-power" machine.

Your bicycle can be quickly transformed into a speedy, easy running, light weight motorcycle by using the Shaw Motor Attachment. There is no need for you to invest your money in a high priced motorcycle, because for a very small amount you can ride with them anywhere. Here is your opportunity.

## The Shaw Attachment Low in Price and Fits Any Bicycle

Anyone who can use an ordinary wrench and a screw driver can fit the Shaw Attachment to any bicycle in a short time. No brazing or changing of frame is needed. The Shaw Attachment weighs less than other motors and is arranged to balance perfectly, thus avoiding the vibration so common in most motors. The control is simple and dependable—absolute safety at all times is thus assured. The price is very low, and your old bike equipped as a motorcycle, will represent a big saving in comparison with the price of any motorcycle of equal speed and dependability.

### MAGNETO

The smallest electrically efficient magneto ever produced. High tension type. ONE PIECE FRAME of die cast aluminum, absolutely water-proof, dust-proof and oil-proof. Magnets of high-grade imported steel. This wonderful magneto is supplied with the SHAW MOTOR-CYCLE ATTACHMENT.

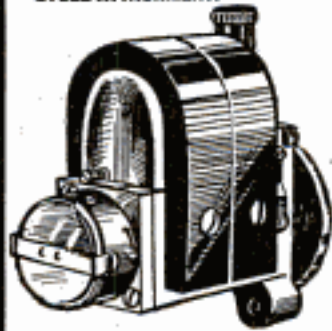

pulling power. No ordinary road is too rough for it, nor hill too steep. Every piece and every part represents only the highest grade materials that can be had. That is why we do not hesitate to cover each piece and each part with our broad and liberal guarantee against any defect in material or workmanship. We will replace any defective part within one year from date of purchase.

**Shaw Manufacturing Company**  
Dept. 158 Galesburg, Kansas

### What the SHAW Attachment Really Is

The Shaw Motorcycle Attachment consists of the famous Shaw motor—2½ H.P., all finished, assembled and tested, ready to be clamped to any bicycle frame. This motor is durably built, air cooled, of the four cycle type. The Shaw weighs much less than other motors.

Lunkenheimer Carburetor, simple and reliable. Muffler, reduces exhaust to a soft puffing, a very desirable feature. Belt, "V" shaped of special tanned, tough and flexible leather. Rear Pulley Rim of steel, complete with stays. Combination Tank for gasoline and oil (two compartments). Battery Case of strong fiber insulation, protecting battery and preventing short circuiting. The equipment is also offered with the Shaw Magneto, the smallest and most electrically efficient magneto on the market—weighing only 3 pounds, 11 ounces. Spark Plug,

Grip Control, Oiler, Clamps, etc. The entire outfit comes to you ready to be attached to your bicycle.

The Shaw Motorcycle Attachment will take you up hills of 20% grade—will go through sandy roads and surprise you with its

### WRITE TODAY

for our interesting and instructive book "Convert Your Bike into a Motorcycle"—tells all about the SHAW equipment and the wonderful SHAW MAGNETO—the marvel of marvels. There is no reason why you should pay the high prices demanded for a motorcycle if you have an ordinary bicycle. The SHAW ATTACHMENT will make it easy for you to possess a motorcycle of the highest type. Thousands of these attachments are in use in the United States, Canada and other Foreign countries.

### Use the Coupon and Mail Today

We will send you full information about this remarkable attachment, prices, etc., also list of second hand motorcycles.

## Free Book Coupon

SHAW MFG. CO., Dept. 158, Galesburg, Kans.

Send me your free book "Convert Your Bike into a Motorcycle," giving full particulars about the Shaw Attachment, also special list of used motorcycles of all makes.

Name.....

Post Office.....

Street or R. F. D..... State.....



## GET ACQUAINTED WITH US ON THE NEWS-STANDS

**I**F you are a Man of Affairs, and would like to know what the world is thinking—if your time is limited, and you want a "Cook's Tour" through the realm of world thought—if a Monthly Review in Cartoon and Comment of Current Events appeals to you—if you want the viewpoint of other nations—if you would like to read history in the making in its most attractive form

GET A COPY OF

# CARTOONS MAGAZINE

(Published by H. H. WINDSOR, Publisher of Popular Mechanics Magazine)

It is the only magazine in the field mobilizing the pen-and-ink satirists from the four corners of the world, men who are fighting silent battles on their drawing boards.

So great has been the demand for back numbers of this periodical that several issues published early in the war have been exhausted. The file of *Cartoons Magazine* will be almost priceless a few years hence. It is a magazine for your library and reading table.

25c A COPY

\$3.00 A YEAR

This Coupon and \$3 brings it to you for a Year

CARTOONS MAGAZINE  
6 N. Michigan Avenue, Chicago

Enclosed please find \$3.00, for which enter me for a year's subscription to your magazine.

Name.....

Street.....

City.....



**5**  
**DAYS'**  
**FREE**  
**TRIAL**

That's all there is to the proposition we make you on the **SPLENDID, GENUINE**

**Underwood** Latest Style **\$58<sup>50</sup>**  
**Standard** Back Spacer  
**Visible Typewriter**

Don't send a cent, just write us if you want to take advantage of our five days' free trial offer. No deposit is required. All we want is your permission to send you one of these machines on approval. The machine must then sell itself. The decision rests entirely with you.

You have never seen such typewriter value as we are offering in these Underwood machines. If we were to tell you how good they are you would say we were exaggerating. So we want you to see and use one right in your own office. That's the reason we are making, and can make, this five days' free trial offer.

If you like it send us only four dollars a month. But you pay not one cent till you have seen and used the machine for five days!

This machine we are offering is not the old style Model No. 4, but the latest style Underwood typewriter with the **Back Spacer** (the greatest improvement in typewriting since visible writing was introduced); this machine also has the two-color ribbon, the automatic ribbon movement, in fact every late style feature and improvement of this famous and most popular typewriter. Over one million of them have been manufactured and sold.

Every machine is complete with waterproof cover, tools, instruction book, etc. Remember, these machines are guaranteed to be absolutely perfect. They are guaranteed for one year, which is as long as any guarantee. And they are shipped anywhere on approval, without deposit, subject to five days' free trial and examination in your own home or office.

If you find the slightest thing to criticize, if you think you can get better value elsewhere for your money—return the machine at our expense. Surely no fairer offer could be made. And, bear in mind, this liberal proposition is made on the Underwood, the acknowledged leader of visible writers, of which over 10,000 are sold every month. And if you are renting a typewriter you can, by paying us a little more each month, own one of these high-grade, standard visible writers in a short time. Just think of it! A few cents a day for ten months and one of these typewriters is yours!

**SPECIAL!** No. 3 Model Underwood with 14-inch carriage, the regular way-bill machine with standard pica type, at a special low price of \$65.00—\$5.00 down, and \$5.00 a month, or less 6% for cash.

Fill out the coupon and mail it today. You take no chances. If the machine is not the greatest value you ever saw, just send it back at our expense. **ACT NOW**, as we have only a limited number of machines, and they will go like hot cakes on this wonderful offer.

**ACCUMULATED STOCK DEALERS**

When you write, just give us the names of two or three people who know you, merely as an evidence of good faith, etc.

**ACCUMULATED STOCK DEALERS**

**TYPEWRITER INST. COMPANY, 229 No. Wells St., CHICAGO**

**FREE TRIAL ORDER BLANK**

Typewriter Inst. Co., 229 No. Wells St., Chicago

Gentlemen—Please ship me a No. 4 Underwood Typewriter, P. O. B. Chicago, per your Ad. in Popular Mechanics Magazine. I will either accept the typewriter within five days of its receipt, or I will return same to you at your expense. If I accept the typewriter I will remit \$6.50 within the five days and pay the balance in monthly installments of four dollars each until the price \$58.50 has been paid. Title of machine to remain in your name until machine is fully paid for. **Cash price, 6% off, or \$55.00 cash.**

Name..... Address.....

References Required.....

## Free Motorcycle Book

A book you ought to have, whether you are a motorcycle enthusiast or merely considering the purchase of a machine. Full from cover to cover of interesting and instructive information about the buying and care of a machine. Describes in detail the construction of our machine and explains why it is today the choice of every discriminating rider from Maine to California.

### EMBLEM

Motorcycles are built for the red blooded, outdoor man who appreciates the throb of a powerful motor; the unhesitating sweep up and over the worst sort of hills; the unflinching, faithful drive that sends the Emblem without faltering through sandy and treacherous roads.

The Emblem has a stout heart — it will take you where no other machine will attempt to go, and will bring you back. It is the motorcycle for you. Your name on a postal NOW will bring our Motorcycle Book and a full description of the Emblem by return mail.

**EMBLEM BICYCLES** are made by the same organization that builds the Emblem Motorcycle. They embody the same sturdiness of construction; the same ability to stand up and perform under every sort of hard work and abuse. Bicycles are once more coming into their own — and the Emblem is leading the way. We have an Emblem Bicycle Book here for you and will send it as soon as we get your name — a postal will do.

**Emblem Manufacturing Company**

Station A  
ANGOLA, Erie County, N.Y., U.S.A.

Pack of EMBLEM 50c Playing  
Cards sent on receipt of 3c in  
stamps.



## 10 NEW FEATURES in the 1916 Waterman Porto

Our new catalog describes in detail all the latest features of the 1916 Waterman Porto, including built-in high tension fly-wheel, magneto, unlimited speed control, automobile type carburetor, double capacity fuel tank, larger bearings, newly designed pump, etc., etc. The Waterman Porto has the perfect speed control of an automobile. Simply shift lever to get any speed desired, forward or reverse. Wonderful flexibility. You can stop your boat in half its length — dock without stopping your engine. Trawl at any speed with any type or size of boat.

*Demand these essentials  
or you will not be getting  
full value  
for your  
money.*



Send for  
this book  
today

You will find it full of valuable and interesting information about the new features of this original outboard motor, and it also tells the story of the first outboard motor ever built.

**Waterman Motor Company**  
230 Mt. Elliott Ave., Detroit, Mich.

## The Real Estate Educator

By F. M. PAYNE

A book for hustling Real Estate "Booters," Promoters, Town Builders, and everyone who owns, sells, rents or leases real estate of any kind.

Containing inside information not generally known, "Don'ts" in Real Estate, "Pointers," *Specific Legal Forms, For Sale, Exchange, Building and Security Contracts, Bonds, Mortgages, Powers of Attorney, Leases, Landlord's Agreements, Notice to Quit, Deeds, Chattel Mortgages, etc.* It gives, in the most condensed form, the essential knowledge of the Real Estate Business.

Apart from the agent, operator or contractor, there is much to be found in its contents that will prove of great value to all who wish to be posted on Valuation, Contracts, Mortgages, Leases, Ejectments, etc. The cost might be saved five hundred times over in one transaction.

**Cloth. 256 Pages. Price \$1.00 Postpaid**  
POPULAR MECHANICS BOOK DEPT., 6 N. Michigan Ave., Chicago



## Big Money for Live Agents

Marvelous, new Radiosene Lamp—valveless, wickless, smokeless. Burns vaporized kerosene by means of mantle—newly invented process. First of its kind on the market. Gives more light than Tungsten electric bulb from cheapest, safest of fuels—10 cents worth of oil lasts average week.

### RADIOSENE

Simple and reliable to use. Perfectly safe, lighted or extinguished. Gives 150 candle power of white brilliant light—steady and restful to the eyes. Splendid money making proposition for agents. Write at once for terms and exclusive territory.

**SUPERIOR MANUFACTURING CO.**  
294 Second St. Ann Arbor, Mich.



\$7.50

Canadian  
Price \$9.50

The  
NEW  
VALVE-  
LESS  
WICK-  
LESS  
LAMP



JUST PUBLISHED!

## Motorcycles, Side Cars and Cyclecars

Their Construction,  
Management and Repair

BY  
**VICTOR W. PAGÉ, M. E.**

Author of "The Modern Gasoline Automobile"

Contains over 350 specially made illustrations showing the most valuable series of drawings pertaining to motorcycle design and construction ever published.

**550 Pages Price \$1.50 Postpaid 3 Folding Plates**

The only complete work published for the Motorcyclist and Cyclecarist. Describes fully all leading types of Machines, their Design, Construction, Maintenance, Operation and Repair.

This treatise traces the motorcycle from its earliest forms to the approved models of the present day. It outlines fully the operation of two and four cycle power plants and all ignition, carburetion and lubrication systems in detail. Describes all representative types of free engine clutches, variable speed gears and power transmission systems. Gives complete instructions for operating and repairing all types. Considers fully electric self-starting and lighting systems, all types of spring frames and spring forks and shows leading control methods.

The Dealer, Mechanic and Expert Rider will find this treatise a work of reference without an equal.

**POPULAR MECHANICS BOOK DEPT.**  
6 N. Michigan Ave., CHICAGO



The Arrows Show Why  
a Million Wearers Prefer

# FINCK'S DETROIT SPECIAL Overalls and Work Garments

The famous garments which "WEAR LIKE A PIG'S NOSE"

If you want a new definition of real overall comfort and satisfaction go to your dealer today and try a pair.

If he can't supply you, we'll be glad to send them by prepaid parcel post on receipt of price. Buy now before prices go even higher.

Union-made, in the largest factory in the world devoted exclusively to the manufacture of men's work garments.

High Back Overalls . . .	\$1.25	Combination Suits . . .	\$2.25
Suspender Overalls . . .	1.25	Vest High Back Overalls .	1.50
Jacket . . . . .	1.25	Light or Dark Blue Denim— or Khaki	

Also an unusually attractive proposition for dealers

W. M. FINCK & COMPANY, 1154 Gratiot Ave., Detroit, Mich.

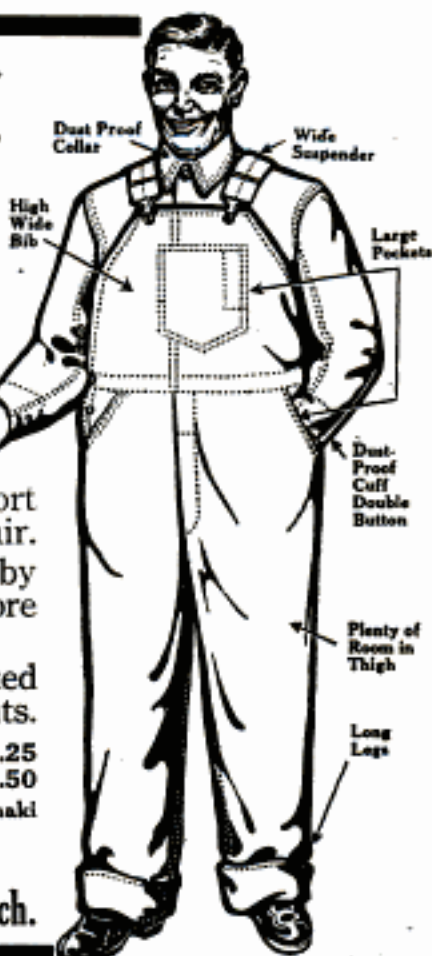

**\$5 Prize Fun and 10c Game Package**

This BIG BUDGET of FUN and GAMES is a WONDER in the Amusement Field—Will ENTERTAIN the Whole Family!

300 Great Jokes and Riddles. How to tell Gypsy fortunes, 12 Model Love Letters, 175 Ways to Flirt, How to make others obey you, Marriage Looking Glass, Husband and Wife Commandments, 396 Popular Songs, 100 Fine Parlor Games, Fox and Geese, Chess, Checkers, Dominoes, 9 Men Morris, Authors, Chinese Puzzle, Star Puzzle, 38 Prize Puzzles, 12 Puzzle, Roman Cross, 7 Wonders of the World, 16 Comic Cards, 48 Magic Tricks, 70 Puzzles, 40 Experiments, 174 Dreams, Parlor Magic, How to Throw Your Voice, How to Hypnotize and \$10.00 in spare money. All this great collection and 500 other things to amuse for 10 cents, 3 for 20 cents, postpaid.

ROCKWELL GAME CO., Dept. K, 326 Madison St., CHICAGO

**POWERLIGHT**

Highest Award World's Exp. 335 C. P.—20 Hrs. 1 qt. Kerosene or Gasoline. Read and sew without spectacles.

**Daylight's GREATEST COMPETITOR**

5 yr. Guaranteed—20 styles—5 finishes. Everybody buys—Sure sale when seen.

**RETAILS \$5 AND UP**

AGENTS—Contract exclusive territory. Big Profit—Samples Loaned.

POWERLIGHT CO., 543 Broadway, NEW YORK

12, 16 or 18 size **\$2.50 a Month**

Here's your chance to own a world standard Masterpiece at the lowest price on the Easiest Terms ever offered. We'll send you your choice of a fine \$30.00 Factory New 17-Jewel Illinois, Elgin or Waltham, exactly timed; regulated to the second, guaranteed accurate and durable, in a Superfine 20-year Gold-filled Case, for only \$2.50 down and \$2.50 a month for 7 months. You save \$10. Send now for your choice of these fine watches for Free Inspection before you pay a penny. Satisfaction or money back.

SUTTON WATCH CO., 202 Keller Bldg., Louisville, Ky.

## SEND THIS COUPON!

THE RELIABLE TIRE REPAIR CO.,  
103 Reliable Building, DETROIT

Please tell me more about your proposition. Send catalogs and particulars as to how I can get into the tire repair business.

Name.....

Address.....

## BE AN AUTOMOBILE MAN

(Cut off here)

A million a year! That's how many automobiles will be made in 1916. Next year—nobody knows how many. It's by far the biggest business that has ever struck this country—and it's making some men mighty rich; yes, rich.

"Here's an idea—get into this business myself!" Save, do it. DON'T be a wage earner any longer. You don't have to.

## BE A BUSINESS MAN!

If you want to succeed the auto tire repair business is your chance. Every car that passes your door requires repair work at some time or other. If you're prepared you get the job. And regular trade, too. It's easy enough to get prepared. The coupon above is the first shot. *Shoot it today.*

The tire repair business is growing with the automobile industry—by leaps and bounds. Any place—city, town or village—has its many opportunities for men who see the chance and grab it. There are nowhere near enough repair plants to take care of the business. Get in the game and make your three hundred, four hundred or five a month too.

Nearly everything good in the auto business of Detroit. The instruction we will give you will fit you to start building your own "pile." We furnish materials and all. Get ready to go into business in a few weeks. Mail that coupon TODAY. Send it to

THE RELIABLE TIRE REPAIR COMPANY  
103 Reliable Building DETROIT, MICHIGAN

# BOYS! BUILD THINGS!

THIS BIG NEW BOOK

Vol. II — **THE BOY MECHANIC** — Vol. II

Tells All About 1000 Interesting Things To Make and Do

A SEQUEL TO, BUT CONTAINING NOTHING FOUND IN VOLUME I

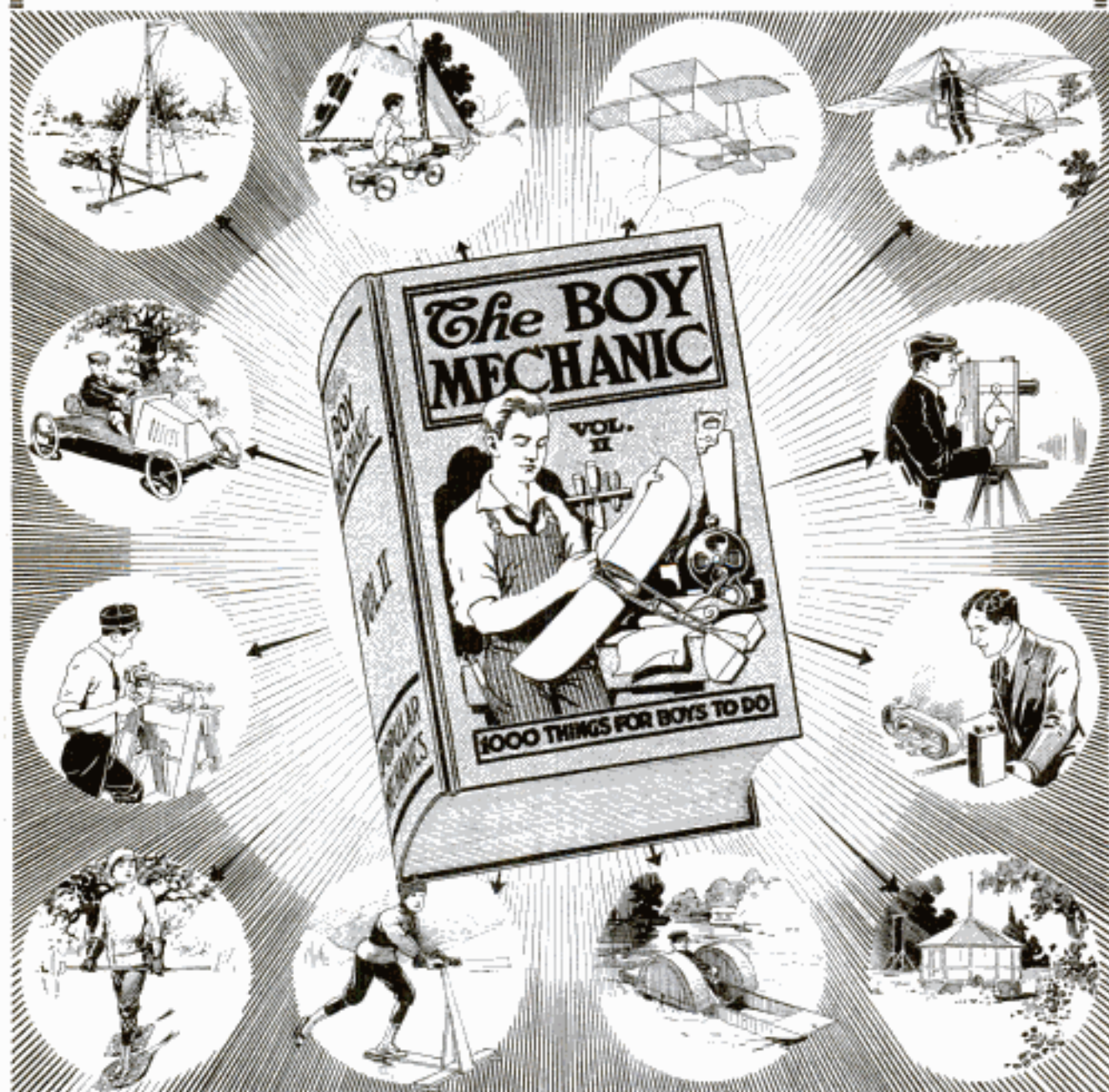

**480 PAGES** (6 $\frac{3}{4}$ x9 $\frac{3}{4}$  in.) — **995 ILLS.** — **CLOTH** — **PRICE \$1.50**

## HOW TO MAKE

Bobsleds — Snowshoes — Ice Boats — Ice Gliders — Boats — Camps — Fishing Tackle — Houses of Poles — Kites — Aerial Gliders — Motion-Picture Camera — Spot-Light Lantern — Mile-O-View Camera — Photographic Appliances — Indoor Games — Tricks — Cyclemobile — Pushmobile — Flymobile — Roller Coaster — Ferris Wheel — Sunlight Flasher — Reed Furniture — Electrical Devices — Mechanical Contrivances — Art-Craft Work and hundreds of equally interesting things.

SENT POSTPAID UPON RECEIPT OF PRICE BY PUBLISHERS

**POPULAR MECHANICS BOOK DEPT., 6 NORTH MICHIGAN AVE., CHICAGO**

# Now There's An Indian For Everybody!



1916 Powerplus Indian  
—Four models—  
\$215 to \$275.



1916 Indian Featherweight—2½ Horse Power—3 speed—\$150.



1916 Indian Bicycle—  
11 models, adult and  
juvenile—\$25 to \$40

THE enlargement of the Indian line offers the purchaser of any type of two wheeler more certified value for his money and greater service protection than ever before.

To motorcyclists, it introduces a new standard of twin cylinder efficiency in the new Indian

## Powerplus Motor

Stock Powerplus motors develop 15 to 18 horsepower, dynamometer test, and roll 70 miles an hour without "tuning up."

Fewest parts in construction mean least wear; all enclosed moving parts mean cleanliness and silent generated power. Built-in endurance gives long life. Indian has 81 steel drop forgings throughout—more than any other motorcycle.

In comfort it is the "Pullman of Motorcycles." The exclusive Cradle Spring Frame absorbs road shocks, increases life of machine and tires.

To those who desire a motorcycle of moderate speed, simple mechanical design, and small initial cost, Indian offers the

## 1916 Featherweight

A real motorcycle—not a motor bicycle. Indian quality throughout. Designed to give power and speed in modified form; comfort, convenience, practical locomotion, lightness and consequent ease of handling.

Then come the little brothers of the big Indian Motorcycle—

## Indian Bicycles

Clean, strong, graceful. Indian through and through. Same advanced style throughout as the famous Motorcycle. A full hundred cents worth of Indian value for every dollar you spend.

Send for handsome Motorcycle and Bicycle Catalogs.

**HENDEE MANUFACTURING CO.** 711 State Street  
Springfield, Mass.

(Largest Motorcycle Manufacturers in the World)

# "Count the Indians on the road!"

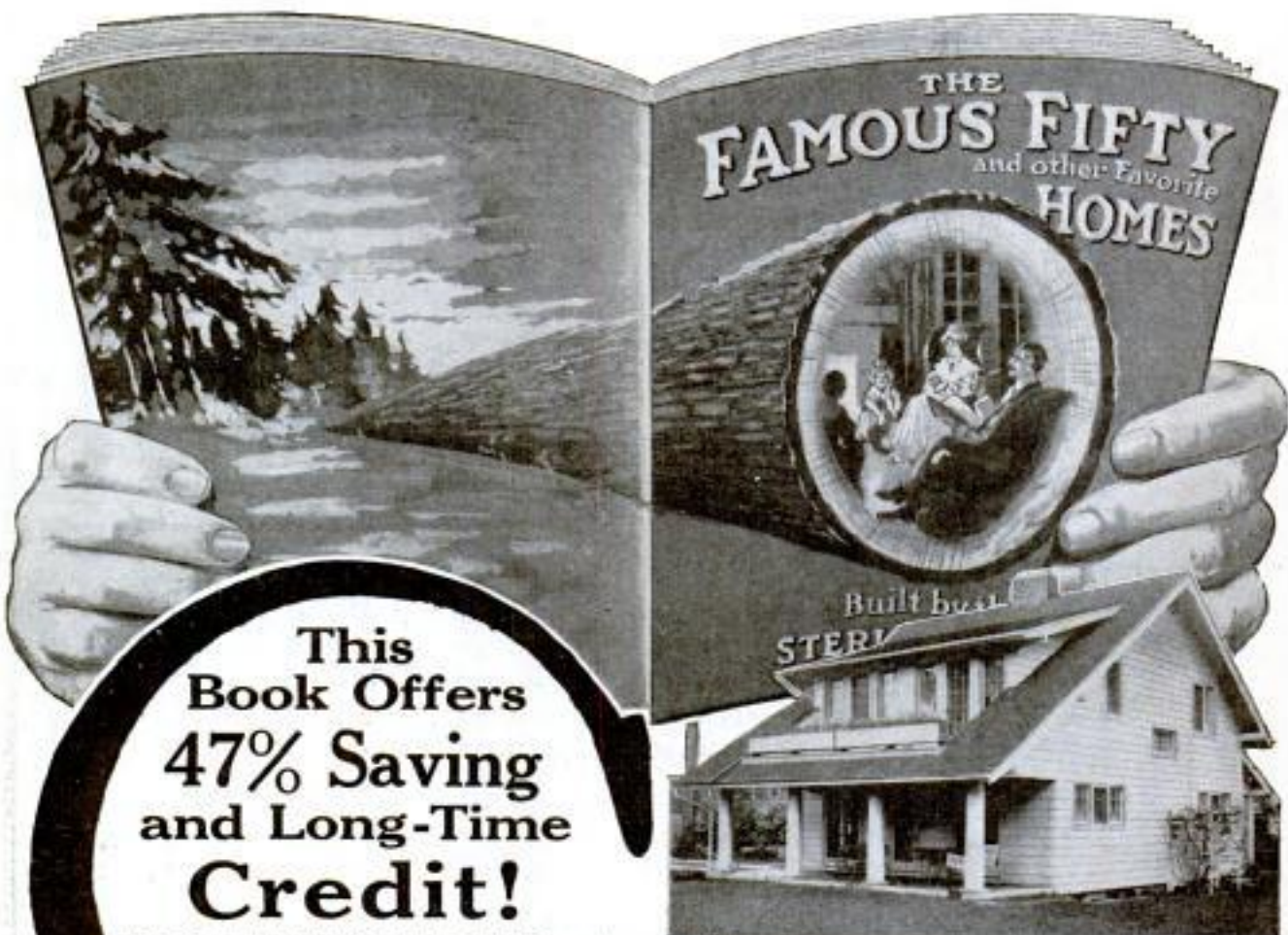

**This Book Offers  
47% Saving  
and Long-Time  
Credit!**

Write for a wonderful Book in which Sterling customers tell how they saved **47%** on their Homes—almost half. Often a thousand dollars on a single home. Learn how to buy on long-time credit—cash payment down and easy, monthly settlements, less than rent. Find, if you can, another concern that offers such financial accommodation. Or one that is willing to let you hold your building money while you build—as a guaranty of quality and satisfaction. The new Sterling Book tells all. Why not get it!

# Sterling

## System of Home Building

offers the pick of 8000 Plans—beautiful Homes—substantial Homes—Homes of utmost convenience and comfort. Homes built of unsurpassable materials direct from the forest tree. Homes of double-strength construction—110 special structural features.

The Price includes all Lumber, all Hardware, Glass, Paint, Nails, Plans, Blue Prints, etc. And each board and timber comes scientifically cut-to-fit. You waste no materials; you pay but half the usual carpenter cost. Your **TOTAL** saving is big. And you get a real Home—not a make-shift House!

No matter where you live or what type Home you want or what you care to pay (up to \$3000) don't close the contract under any circumstances, until you have seen this new Book—the Plans, the Specifications, the Prices, the Liberal Credit Terms, the multitudes of Customers' letters. Write for the "Famous Fifty and Other Famous Homes" today. Enclose 10c in stamps to cover postage and packing.

### Liberal Credit

A year ago we introduced Credit to the Cut-to-Fit House industry. This year our Credit Plan is even more inviting. A few hundred dollars and a small amount per month buys a handsome, modern Home. Why pay rent? Why live in an undesirable house? Write for full particulars of our "Two-Years-To-Pay" Plan.

**International Mill  
& Timber Co.**  
Dept. Q-30  
65 Sterling Place  
Bay City - - Michigan

**The "Pilgrim"** Built like a palatial \$5000 Residence—eight artistic and commodious rooms—model kitchen with 5 glass openings and built-in cupboards. Large, well-lighted Dining Room, Living room with French doors opening upon beautiful porch. Four sizable upstairs bedrooms—big closet in each (one cedar-lined)—central Bath. Note artistic terrace and flower-boxes. Price \$789 down and \$34.52 per month.

Mr. L. C. Wilson writes: "My carpenter says my Home would have cost me \$200 more if put up by a contractor."  
Mr. Samuel Way: "Had I bought everything here my home would have cost nearly \$1000 more."  
Mr. Barker: "We cannot buy any such materials anywhere in the city. I think I saved \$900 to \$1000."  
The addresses of these people can be had on request.



**The "Miracle"** The beauty of this picturesque 5-room bungalow wins every Home builder. Note the handsome porch with its large columns. Then the artistic taper trim. Inside—a cozy arrangement with living-room and dining-room, two bedrooms and bath and a spacious kitchen. All for \$656—saving you an average of \$320! Cash payment and \$18.22 per month.

Mr. Ewing: "There was a saving of at least \$500 in building this way."  
Mr. Golden: "I never saw better materials and I saved \$400 to \$500."  
Mr. O. C. Driesbach: "The labor saving was a big item—between \$300 and \$400."  
The address of each writer can be had upon request.

You  
May  
Rent an  
Underwood  
Applying  
Rent on  
Purchase  
Price



10  
Days'  
Free  
Trial

# Rent or Buy an UNDERWOOD Standard Typewriter at Less than Half Price

Rent an Underwood—Buy it at half regular price on easy terms later, if you decide to keep it. Rent you have paid will be applied on purchase price. Don't neglect this splendid opportunity. Let us send you a Standard Underwood Typewriter on

## 10 Days' Free Trial

If you are not thoroughly pleased with it, send it back at our expense—in no way will you be obligated. Should you decide to keep it, you may rent, then—remember this—should you finally decide that you want to own it, every cent of the rental you have paid for six months will be applied on the purchase price.

### Make Extra Money—Many Uses

You won't know until you try an Underwood how many uses you will have for it. In addition to doing your own work, you can type manuscript for others—usual price 20c a page—write photo plays—\$25 to \$100 paid by producers. Short stories for newspapers and magazines—\$100 is not an unusual price for a good story.

**Typewriter Emporium**  
Established 1892 CHICAGO

**SEND COUPON TODAY** and let us tell you how we can sell Standard Underwood Typewriters at less than half regular price. We are the

### Largest Independent Typewriter Dealers in the World

and, remember, we do not ask you to buy an Underwood at once; you may rent them; if you decide to buy, the rental you have paid will be applied on purchase price. Send for special Bargain Offer No. 152.

#### Typewriter Emporium, Chicago

Without expense or obligation to me you may tell me all about your Underwood Offer No. 152.

Name.....

Address.....

Town..... State.....



# Ask Your Dealer For January Erector Tips

*Tells all about my new \$5,000.00 Prize Offer*

Boys, here's where I break another world's record! The \$3000 Prize Offer for the best and most original steel construction models, which closed March 1, 1916, was the biggest ever made by any toy manufacturer.

Now I am making a new offer which is still bigger. This year I offer 500 prizes worth \$5000. Think of it—200 prizes more than last year at a total cost of \$2000 more! This new Prize Offer begins March 2, 1916, and ends March 1, 1917.

## ERECTOR

**The Toy Like Structural Steel**

The prizes are now divided into two classes. Boys over 12 years of age will compete for one set of 250 prizes. Boys of 12 years and under will compete for another set of 250 prizes.

The first Senior Prize is a Saxon automobile worth \$395; the other 249 Senior Prizes include motorcycles, camping outfits, canoes, hockey skates, magic sets, Erector sets, etc. The first Junior Prize is a handsome Shetland Pony valued at \$350; the other 249 Junior Prizes include bicycles, tents, air rifles, flashlights, magic sets, Erector sets, etc.

Remember, you need not buy Erector to enter the Contest. You can build models with any material. But you will like Erector the best because it is the only construction toy with girders like real structural steel—gives the 100 lbs. lifting motor free with most sets—builds the biggest, strongest and most models.

### Ask Your Dealer Today for January Tips

The January issue of my boys' magazine, *Erector Tips*, illustrates and describes the prizes, tells what you must do to compete, etc. Ask your toy dealer now for a free copy. If he hasn't any, write me (giving dealer's name) and I will mail you a copy without a penny of charge.

A. C. GILBERT, President

THE A. C. GILBERT CO., Formerly THE MYSTO MFG. CO., 104 Fox St., New Haven, Conn.



# GENUINE DIAMONDS

BLUE WHITE PERFECT CUT

# \$ 88

**SPECIAL**  
**1/4 Carat**  
 Genuine Blue White Perfect Cut Diamond, Engagement solitaire ring. Value \$30. Our price complete,  
**\$17.25**

**1/2 Carat**  
 Genuine Blue White Perfect Cut Diamond, Engagement solitaire ring. Value \$70. Our price complete,  
**\$42.75**

**3/4 Carat**  
 Genuine Blue White Perfect Cut Diamond, Engagement solitaire ring. Value \$100. Our price complete,  
**\$67.13**

**1 Carat**  
 Genuine Blue White Perfect Cut Diamond, Engagement solitaire ring. Value \$150. Our price complete,  
**\$90.88**

**3/4 Carat**  
 Genuine Blue White Perfect Cut Diamond, pierced engraved solitaire ring. Value \$110. Our price complete,  
**\$71.13**

**1 Carat**  
 Genuine Blue White Perfect Cut Diamond, 6 tooth "IDEAL" solitaire ring. Value \$160. Our price complete,  
**\$92.50**

All mountings 14 karat solid gold. Priced without profit at factory cost. Illustrations exact size.



Small Sizes \$6.25 as low as **PER CARAT**

Because we import fine diamonds direct to you from the European cutters, you can now buy at **Import prices** — 35% less than the jeweler's price; less by far than jewelers must pay **wholesale**. Vast cash buying power, then direct nation-wide selling at smallest profit, have enabled us to smash down the price for **GENUINE Perfect Cut Blue White Diamonds** to only \$88 per Carat. Same quality that the old middleman-to-jeweler method demands \$150 per carat for! Small sizes now down to \$6.25. Note especially we guarantee the popular **BLUE WHITE** quality, at \$88 per carat. Others demand far more for inferior, orange-white and other off-color stones. Get our guarantee of fine Blue White color, perfect cutting, best brilliancy!

- 1 Carat \$88
- 1/2 C. - \$64.25
- 3/4 C. - \$40.25
- 1/2 C. - \$29
- 1/4 C. - \$15.25
- 1/4 Carat \$6.25

## NO MONEY IN ADVANCE

Send no money, not even a deposit. No references, no waiting, red-tape or formalities. Our simple plan is the only safe way to buy your diamond. We actually show you the diamond and mounting you select from our Book or this ad. We'll ship to you for Free examination — entirely at our expense. We want you to see for yourself the tremendous value we give for the world's lowest price. Return or accept as you wish. You are the sole and only judge.

## LEGAL MONEY-BACK GUARANTEE

The only **BANKABLE** cash refund contract in the whole diamond business! Here finally is **PERFECT SAFETY**. Note how we protect you against loss or even dissatisfaction: you get this legal written guarantee contract with every diamond we sell — **YOU CAN RETURN DIAMOND DIRECT TO US, or through any bank in America** for instant **CASH REFUND!** No quibbling, red tape or delay. Full price guaranteed in exchange for larger diamond anytime! Color, true carat weight and fine quality **legally** guaranteed, all in writing and under the supreme protection of the U. S. Postal Laws. We stand back of our values with this wonderful guarantee, knowing after years of test, that our direct importing system has outclassed all competition!

## Send Coupon For This Free Book

Be sure to see this remarkable book before investing in a diamond. Every prospective buyer of Diamonds should have it. It is your authoritative guide. A real gold titled bound volume, profusely illustrated, full of diamond expert's facts. Now in its third edition! First in the field with the new 1916 styles. Tells you how to judge, buy, tell value of diamonds. Comes to you free and of course without obligation. Mail handy coupon or write; or a postal will bring it by return mail. Write **NOW** to be sure of getting your free book.



**OUR REFERENCES** Rogers Park National Bank, Chicago; your own banker, or any Commercial Agency, Magazine Publisher or Advertising Agency will certify to our high standing, honest methods and absolute reliability.

### Mr. Barnard's Personal Attention

By specializing exclusively in Diamonds and Diamond Jewelry every customer gets the same personal attention and expert service as those who call at our Chicago establishment. Entrust the selection of your Diamond to Mr. Barnard. Years of experience have qualified him to serve you best. Write for our DeLuxe Book (free) and see all that it means to secure your diamond from us.

**BARNARD & CO.**  
 Dept. 388C, S. W. Cor. Wabash & Monroe St., CHICAGO



## USE THIS COUPON FOR FREE BOOK

**BARNARD & CO., Dept. 388C, S.W. Cor. Wabash & Monroe St., Chicago**  
 Without obligation on my part, please send me free and postage prepaid by you, DeLuxe Book of Diamonds, 3rd 1916 Edition.

Name .....

Address .....

**BERNARD-HEWITT & CO.**  
Desk E23, 564 W. Monroe St.,  
CHICAGO, ILL.

Please send me your new Spring style book with 70 samples free—also full details of your special lining offer.

Name .....

Address .....

## MAIL COUPON

For Spring and Summer  
STYLE BOOK

**70** SAMPLES  
**FREE**



# Handsome \$25 Blue Serge Suit Made to Measure only \$15

A SPECIAL proposition to introduce the wonderful values offered by our new system of tailoring. We have no agents—no dealers—no traveling salesmen—our values make their own customers—and once a Bernard-Hewitt customer always a Bernard-Hewitt customer. That's why, to secure your first order, we are willing to make to your individual measure, a handsome, all pure wool worsted blue serge suit (usual \$25 value) for only \$15 and line it with a

**WE PAY  
SHIPPING  
CHARGES**

**\$4 SATIN LINING FREE**

Remember this suit is made to your individual measure from the very finest all wool blue, light blue, black or gray serge, in the latest approved Chicago style, and by the very best tailors in this whole city.

But perhaps you don't care for a serge suit. Well, our big book which we will send you free contains generous samples of the latest fabrics; plain and fancy mixtures, the up-to-the-minute offering of leading woolen mills.

The \$4.00 Satin Lining free offer goes no matter what selection you make—and we pay all shipping charges. We take all the risk—you none—for this is



**OUR GUARANTEE** You Don't Pay  
Us One Cent

Unless you are more than pleased in every particular in fit—in style—in workmanship and in materials. Could anything be fairer? Write today—wear real tailor-made clothes—dress better and save money.

**Take Your Own \$10  
Measure—Save \$10**

**Write for Your Copy of Our Big Book Today**

Our big new Spring and Summer book is ready for you—contains 70 samples latest woolens—also lowest prices on men's hats, shoes and furnishings. It is your guide to correct and economical clothes buying. Mail coupon above or send post card for your copy. Please mention POPULAR MECHANICS so that we can identify this special offer.

**BERNARD-HEWITT & COMPANY**

564 West Monroe Street

Desk E23

CHICAGO, ILLINOIS





## His Favorite Remedy—

These days physicians prescribe Home Billiards to keep the whole family *rolling in health!* All that the doctor calls for now is to take his own medicine on the Brunswick "Baby Grand." This famous home table brings 33 carom and pocket billiard games. Year-round sport that banishes brain fag, aids digestion and *puts new blood into folks who work all day!*

Send for our catalog at once, and join this movement for "home preparedness."

# BRUNSWICK Home Billiard Tables

Now \$27 Up—Pay 10c a Day

Whether mansion or cottage—there's a grown man's Brunswick made to fit your home.

Brunswick "Grand" and "Baby Grand" are made of genuine San Domingo mahogany richly inlaid.

Our "Quick Demountable" can be set up in a jiffy anywhere, and taken down quickly when not in use.

"Convertible" Brunswicks serve as perfect dining and library tables when not in play for carom or pocket billiards.

### Scientific Qualities

Every Brunswick is a scientific table with ever-level billiard bed, celebrated Monarch cushions—life! speed! and accuracy! Why be content with a toy billiard table when 10c a day buys a genuine Brunswick!



Brunswick "Baby Grand"  
Combination Carom and  
Pocket Table

### Balls, Cues, Etc., FREE!

Complete High Class Playing Outfit included without extra cost—Rack, Markers, Balls, Cues, Cue-Clamps, Tips, Chalk, expert book of 33 games, etc.

### 30-Day Home Trial

Accept our trial offer and let the Brunswick win every member of the family. Factory prices, easy payment plan and all Brunswick Home Tables shown in our handsome color-book—"Billiards—The Home Magnet." It's FREE. Write or mail the coupon today.

### This Brings Billiard Book FREE

■ The Brunswick-Balke-Collender Co. (514)  
■ Dept. 285 623-633 S. Wabash Ave., Chicago

■ Send free, postpaid, your color-book—

■ "Billiards—The Home Magnet"

■ and tell about your free trial offer.

■ Name.....

■ Address.....

Please Mention Popular Mechanics



1775

1916

## We Are Prepared

Within the wide boundaries of our country, embracing more than three million square miles, dwell a hundred million people.

They live in cities, towns, villages, hamlets and remote farms. They are separated by broad rivers, rugged mountains and arid deserts.

The concerted action of this far-flung population is dependent upon a common understanding. Only by a quick, simple and unfailing means of intercommunication could our people be instantly united in any cause.

In its wonderful preparedness to inform its citizens of a national need, the United States stands alone and unequalled. It can command the entire Bell Telephone System, which

completely covers our country with its network of wires.

This marvelous system is the result of keen foresight and persistent effort on the part of telephone specialists, who have endeavored from the first to provide a means of communication embracing our whole country, connecting every state and every community, to its last individual unit.

The Bell System is a distinctly American achievement, made by Americans for Americans, and its like is not to be found in all the world.

Through it, our entire population may be promptly organized for united action in any national movement, whether it be for peace, prosperity, philanthropy or armed protection.



**AMERICAN TELEPHONE AND TELEGRAPH COMPANY  
AND ASSOCIATED COMPANIES**

*One Policy*

*One System*

*Universal Service*

*Please Mention Popular Mechanics*

# Earn over \$60 a week

## Repairing Auto Tires

**No Experience Necessary—  
We teach you everything Free!**

Here's the chance of a lifetime—an opportunity to cash in on the great amount of money spent for automobile repairs, 90% of which goes for tires. Every car owner in your town is a possible customer. Tires blow out every day. Jobs are plentiful—always. The money will come rolling in fast. There's no stopping it once you are known as a tire repair man.

### Be Your Own Boss

No other proposition ever laid before you offers such a chance to make money without capital or previous experience. You can start right in making money the day you receive the outfit. No need to solicit trade. Your sign "Tires Vulcanized and Repaired" will bring your customers coming to you. If you have a repair shop—so much the better. This outfit will treble your ordinary profits in no time. Work can be done by your present help.

## SHALER Vulcanizing Outfits

are coining money for thousands of enterprising men in every part of the country where automobiles are used. Shaler Vulcanizers are the accepted standard and known everywhere. They do as much and as good work as the very high-priced-vulcanizing outfits. Instructions are complete and easily understood. Anyone with ordinary intelligence can make a perfect repair the first time they try. Everything is automatic so mistakes are practically impossible.

### Week's Business Pays For the Outfit

Think of that! The expense involved in getting started is so small that just about a fair week's business will pay for the Shaler Outfit. Then what you take in afterwards is all "velvet." And the profits are enormous. You will be surprised how easily the money will keep rolling in—the year round.

### Send the Coupon for Free Book

Write today—at once. Don't delay—the automobile season is just starting to open up big. Tire repairs will soon be needed every hour of the day. You can get all the business in your neighborhood if you want it. **Send the coupon today—now—at once.**

C. A. SHALER CO., 2001 Seventh St., Waupun, Wis.



**Complete Shaler Outfit, \$60**  
Subject to Trade Discount

### Send No Money

Investigate this now before some other wide-awake fellow gets ahead of you. Don't send a penny. Read the free book. Get all the particulars first. Learn the big possibilities in the tire repair field.

### Opportunity Coupon

C. A. Shaler Co.

2001 Seventh St., Waupun, Wis.

Without any obligation on my part, please send me your Free Book "How to Open a Tire Repair Shop" and details of the Shaler improved methods of tire repairing.

Name .....

Address .....

Choose the  
method you  
prefer — at  
your dealer's

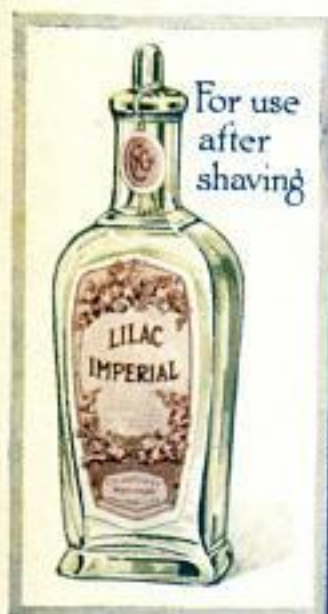

Or send 6¢ in stamps  
for trial size of any one  
and a small bottle of  
Lilac Imperial.

**Colgate & Co.**  
Dept. 81, 199 Fulton St., N.Y.

Copyrighted material