

December

Bandit-Proof Treasure Cage for Motor
Express — Page 833

15 Cents

THIS ISSUE 440,000 COPIES

POPULAR MECHANICS MAGAZINE

WRITTEN SO YOU CAN UNDERSTAND IT

TRADE MARK

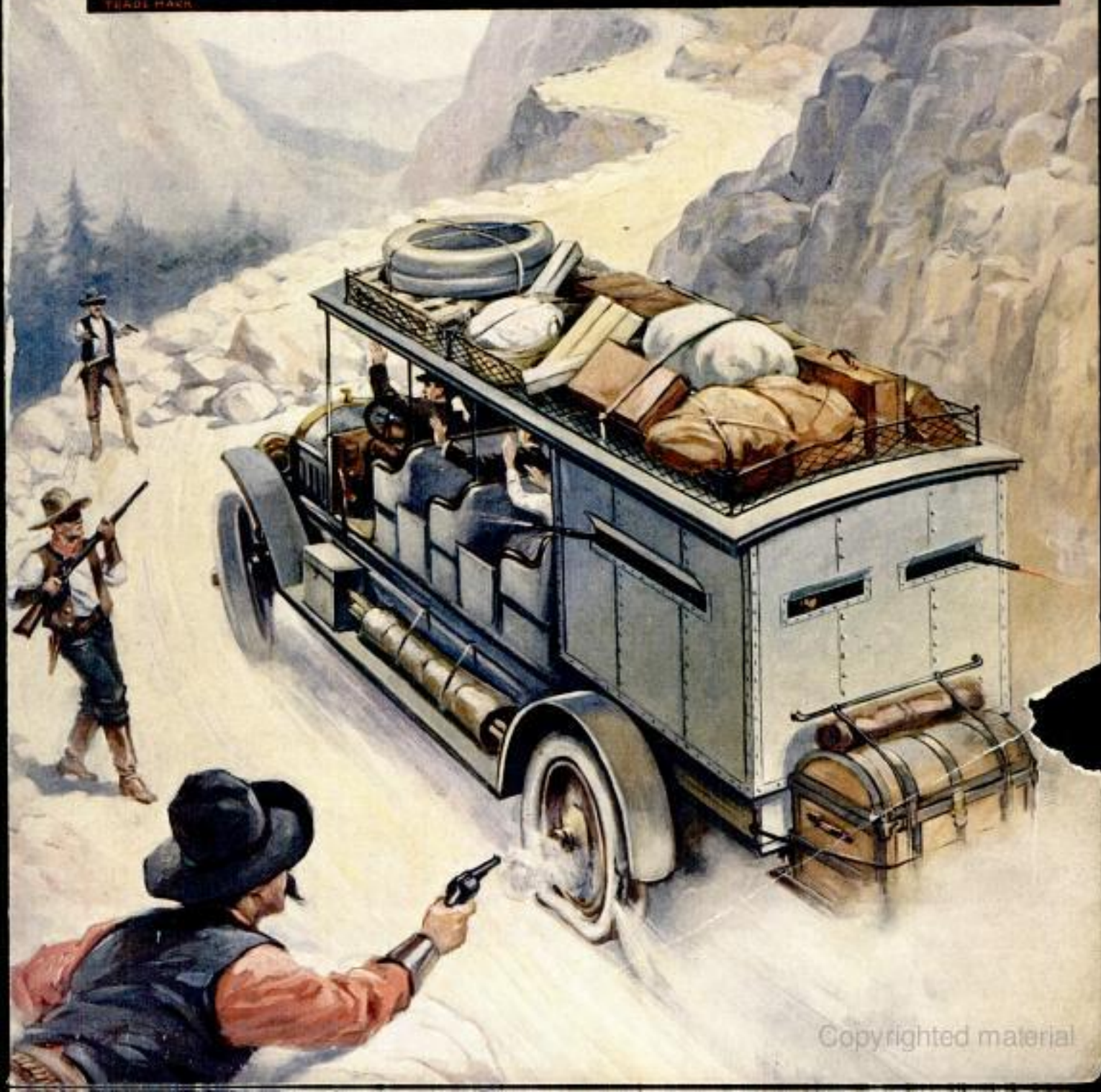

Copyrighted material



MATERIAL—The beauty of this distinctive bungalow is enhanced by the excellence of the materials. For the outside:—we furnish clear knotless finishing lumber, Red Cedar or Cypress shingles, No. 1 dimension lumber, Guaranteed Rawhide roofing. Inside: Clear Modern Craftsman style thoroughly kiln-dried trim; clear, perfectly manufactured flooring, beautiful doors, satin finished hardware. Everything selected to harmonize with the design.

BUILD TO STAY

QUALITY ECONOMY SERVICE

THE HARRIS WAY

\$769.

BUYS THE MATERIAL
Sensibly Cut-to-fit

We manufacture and ship direct—to you, saving you substantial amounts. That's why you should build the reliable, practical HARRIS WAY. Protect yourself from disappointments, wasteful methods and big bills. Insure yourself with a binding guarantee backed by our \$10,000,000 capital. Get our clear, straightforward proposition in our handsome new *Book of Plans* which explains the HARRIS WAY in detail with illustrations and floor plans of over 100 bungalows, houses, barns and other buildings. Send for it now! These special introductory prices soon advance.

Free Plan Offer

Blue Prints, Material Lists and exact Specifications of any Harris Home on this page or in our Plan Book with illustrations of every item mailed on request. Send \$1.00 temporary deposit—as evidence of good faith. If plans do not suit, we refund \$.50. If you purchase material, plans are free.

No Money Down

We ship direct to you without any money paid in advance. You have the privilege of inspecting the material before paying one cent. Our other liberal terms are explained in our free *Book of Plans*.

DESIGN—"Picturesque, elegant and practical," the verdict of the expert critics. Any man would be justly proud to call this Harris Home (No. 181) his own. It has a large living room across the front, then two big bed rooms, numerous closets, spacious dining room, pantry, ice box room and a large modern kitchen. But this is only one of the hundred or more homes to be found illustrated and described in our big free *Book of Plans*.

\$564

No. 182
Five rooms
bath



Roofing Bargains

We have no competition in roofing bargains. Rubber surfaced roofing as low as 40c per roll. Galvanized roofing at \$1.75 per square. Write for our big free *Roofing Book* which explains the inside secrets of the roofing business and shows you how to save from 30% to 50%.

\$867

No. 185
Eight rooms
bath



Plumbing and Heating

You can easily install your own Heating Plant and Plumbing material with the assistance of our free expert engineering service. Complete Bath Room Outfits as low as \$37.00. Heating Plants \$67.00. Ask for our money-saving *Plumbing and Heating Book*. Mailed free.



\$998

No. 193
Seven rooms
bath

Lumber and Millwork

Our enormous facilities and great new manufacturing plant enable us to ship lumber and millwork direct to you at tremendous savings. Send us your lumber bill for freight paid prices. Get our DIRECT-TO-YOU Lumber Price List. Make us prove our great money-saving ability.



\$669

No. 171
Five rooms
bath

Send This Coupon!

HARRIS BROS. CO., Dept. AT-7

Send me free the books checked:

- | | |
|----------------------------------------|-----------------------------------------------|
| <input type="checkbox"/> Book of Plans | <input type="checkbox"/> Plumbing and Heating |
| <input type="checkbox"/> Roofing Book | <input type="checkbox"/> Lumber and Millwork |

Name.....

Address.....

HARRIS BROS. CO.

35th & Iron Sts., Chicago

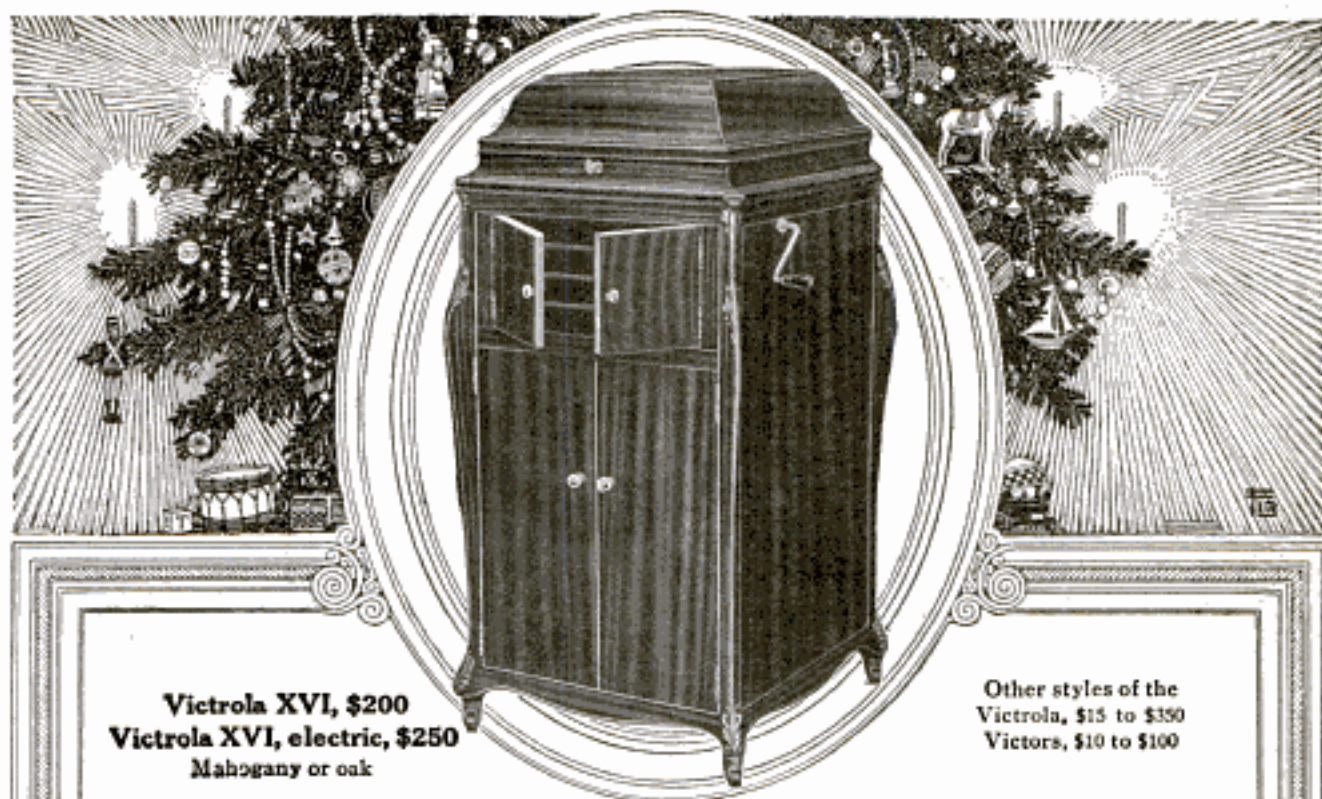

Victrola XVI, \$200
Victrola XVI, electric, \$250
 Mahogany or oak

Other styles of the
 Victrola, \$15 to \$350
 Victors, \$10 to \$100

Will there be a Victrola in your home this Christmas?

The instrument that brings you the world's best music in all its beauty.

The actual living voices of Caruso, Farrar, Gluck, McCormack, Melba, Schumann-Heink and other famous singers. The superb art of Elman, Kreisler, Paderewski and other noted instrumentalists. The brilliant music of Sousa's Band, Pryor's Band, Vessella's Band, Victor Herbert's Orchestra and other celebrated organizations. The inimitable witticisms of Harry Lauder, Nora Bayes, De Wolf Hopper, Raymond Hitchcock and other leading comedians.

Only the Victrola brings you all this wonderful variety of music—a delight every day in the year to every member of your family.

Any Victor dealer in any city in the world will gladly demonstrate the Victrola and play any music you wish to hear.

\$15 \$25 \$40 \$50 \$75 \$100 \$150 \$200 \$300

Always use Victor Machines with
 Victor Records and Victor Needles
 —the combination. There is no
 other way to get the unequalled
 Victor tone.



Victor Talking Machine Co.
 Camden, N. J., U. S. A.
 Berliner Gramophone Co., Montreal
 Canadian Distributors

New Victor Records demonstrated at all dealers on the 28th of each month

Please Mention Popular Mechanics

This One



XWYE-CF8-CELY



WHY NOT
REBUILD and
MODERNIZE
THE OLD HOME
ONE ROOM AT A TIME?

"We can have it done this winter, without upsetting the house, and perhaps in the Spring we can reshingle the roof with Cypress, 'the Wood Eternal,'" (You know it was only last year that historic Mount Vernon, Washington's old home, was reshingled with Cypress for the second time since its erection in 1743.) But to get back to the matter of New and Artistic Interiors, why not **LET US HELP** by sending you, with no charge or obligation at all, our booklet on

"New Insides for Old Homes"?

This is the title of VOL. 39 (VOLUME THIRTY-NINE) of the internationally famous Cypress Pocket Library, a series of authoritative text books on the Intelligent Use of Lumber, in which our particular product, Cypress, "the Wood Eternal," is recommended *ONLY* where it is the very best wood for the given use.

VOL. 39 contains 40 pages, with 10 pictures, an art supplement in tint (showing the beauty of Cypress grain), Detailed *Working Drawings* on a sheet 24 x 36 inches, with *Full Specifications* for rebuilding the *Hall, Library, Dining Room and Living Room* with architectural correctness and artistic finish without resort to expensive hardwoods. (Cypress works easily and is wonderful under stains.) Each design by an authority—on our special order. No "stock patterns." Write for Vol. 39. Study it. *Use it.*

When planning a Pergola, Mansion, Bungalow, pasture-fence or sleeping porch, remember—"With CYPRESS you BUILD BUT ONCE."

Let our "ALL-ROUND HELPS DEPARTMENT" help YOU. Our entire resources are at your service, with Reliable personal Counsel.
SOUTHERN CYPRESS MANUFACTURERS' ASSOCIATION
 1219 HIBERNIA BANK BLDG., NEW ORLEANS, LA. or 1219 HEARD NAT'L BANK BLDG., JACKSONVILLE, FLA.

INSIST ON CYPRESS AT YOUR LOCAL LUMBER DEALER'S. IF HE HASN'T IT, LET US KNOW IMMEDIATELY.

Please Mention Popular Mechanics

Popular Mechanics Magazine

6 N. Michigan Avenue, Chicago, U. S. A.

EDITED BY H. H. WINDSOR

England: The International News Co.
5 Beams Bldg., Chancery Lane, London, E. C.

Australia:
The Australian News Co.

ISSUED MONTHLY

SUBSCRIPTION:

SINGLE COPY, 15 CENTS

In United States, and its possessions, Cuba and Mexico, per year, postpaid \$1.50
To Canada 1.75
To all other countries in the Postal Union 2.50

All subscriptions are discontinued at expiration. Please examine the date printed on your wrapper.

Entered as Second Class Matter Sept. 15, 1903, at the Post Office at Chicago, Illinois, under Act of March 3rd, 1879.
Entered as Second Class Matter at the Post Office Department, Canada.

Published monthly by POPULAR MECHANICS CO.

Copyright, 1915, by H. H. Windsor.
Copyright, in France.

Contents for December, 1915

Africa, Great Sections of Made Desert by Drying Up of Surface Waters.....	863	Defense, National, To Mobilize Machinery for..	836
Alfalfa, New Machine for Shocking.....	909	Detroit Gets Government Foreign Trade Office..	802
Anodes, New, Making from Scrap Nickel.....	897	Disconnecter, Ground Line, Safeguards Linemen.	820
Automobile Body Made Like River Launch....	844	Doors, Apparatus for Fitting.....	869
Automobile, Device Makes into Power Plant....	863	Drainage, Land, is Problem of Egyptian Farmers	820
Automobile Door, Hingeless, Disappears When Opened.....	914	Electric Projector, Small, for the Motorist.....	811
Automobile Robe Bracket with Locking Jaws..	875	Electrical Standards, Extreme Accuracy of.....	821
Automobile Wheels Roll to Their Cars.....	893	Electricity to Haul Huge Trains over Rockies..	842
Automobiles, Direct Control Steering Attachment for.....	901	Elevators, Device for Closing Doors of Auto- matically.....	815
Automobiles Get Business of Steamship Lines..	886	Engine, Crude Oil, Works at Low Pressure.....	865
Barrel, Divided, Permits Easy Handling of Fruit.....	816	Engine Discarded after Century of Service.....	814
Baseball Park, Boston's New Has Novel Features.....	872	Engine, Gas, Power from is Lessened by Altitude.....	812
Betrayer of His Country, The End of a.....	848	Estate, Jersey, New National Summer Capital..	847
Boil Weevil, Rapid Spread of.....	893	Explosion of Tank Car Tears Hole in City.....	812
Boulders, Rough, are Used as Water Basins....	886	Fence, New Sectional Wire, Easily Erected.....	886
Bow and Arrow Made Safe Toy for Children..	915	Fence, Steel, Trains Protected against Bullets by	874
Bridge, Building Quebec, Colossal Task.....	808	Ferry, Ice Breaking Car, Has Passenger Quar- ters.....	884
Bridge Girder of Unusual Length.....	900	Filing Case, New, Index Cards Kept Clean in..	912
Bridge, Novel Railroad for River in Java.....	878	Finger Exercising Device for Piano Beginners..	894
Bridge within Bridge Spans Western River....	870	Fire Station, Denver, is Housed in Bungalow..	897
Bridges, Old, Transformed with Concrete.....	908	Forest Fire Station on Summit of Mount Hood.	826
Building, Government, Steam Shovel Begins Work for.....	904	Fountain, Water, Provided in Front of Building.	912
Burros Aid in Marketing Huge Timber Reserves	884	Furnace of New Design for Stump Burning....	918
Cable, Device Keeps Taut by Removing Slack..	920	Furnace, Rotary, Accurate Heat Treatment in..	866
Cableway, Crude Aerial for Carrying Water....	828	Garage Roof, Garden and Tennis Court on....	894
Café, Movable Quick Lunch, of Bungalow Type.	882	Gas Range may be Remodeled to Suit One's Flat	825
Camera, Movie, Flexible Operating Shaft for..	897	Grape Juice Concentrated by Freezing Method..	866
Car, Electric, Stood on End in Swollen Creek..	844	"Groceries," Latest Type of Grocery Store....	908
Casting, Takes Twenty-Six Horses to Move....	816	Gun, German 42-Centimeter, Details of.....	846
Ceiling Beams Made of Veneered Strawboard..	820	Gutter, New Form of Keeps Dirt from Cistern Pipes.....	818
Cement Tree Stumps Used for Fence Posts....	821	Harp Orchestra Organized by Philadelphians..	815
Chair, Theater, Designed to Fit Needs of Child.	812	Horse Imprisoned by Fall through Coathole....	842
Clamp, Convenient for Construction Work.....	822	Horsemanship, Good, Shown in Odd Hurdling Event.....	801
Comment and Review, by H. H. Windsor:		House Plan—Residence, Concrete, Built at Small Cost.....	960
Arsenals in the Central West.....	831	Irrigation Systems, New, in Hawaii.....	909
Law, An Absurd.....	832	Junk from Battle Fields, Germans Offer Money for.....	817
Preparedness.....	830	Lemon Crop, New California Plant will Utilize..	902
Submarines and Aeroplanes Star Actors.....	830	Library Has Telephone Information Bureau....	825
War Machines Need Men.....	822	Locomotive, Model, Built by Boy Mechanics..	897
Concrete Mixtures, Scale for Computing.....	824	Machinery, Subway, Taking through Streets....	895
Culvert, Concrete, Made in Interlocking Sections	916	Mail and Express Carried in Handit Proof Cars.	833
Curtain Stretcher, Lace, Needs No Adjusting..	901	Mail Boxes Roost like Birds in Colonies.....	904
Cut-Out Box That can be Built to Size on Job..	904	Mail, New Mechanical Plant for Handling.....	898
Death Rate, Gotham, Shown by Electric Chart..			

[Continued on Page 6]

Popular Mechanics offers no premiums; does not join in "clubbing offers," and employs no solicitors to secure subscriptions. It is for sale by nearly every newsdealer in the United States and Canada.

[Contents—Continued]

Maps, War, on Large Scale Give Useful Instruction	883	War, European:	
Mats, Rubber, Garden Hose Utilized for Making	903	Burial Grounds of Europe's Fallen Soldiers..	862
Milk Station, Municipal, Planned for Nuremberg	882	Champagne District, With the Allies in.....	850
Miners Drill Holes in Rock for Pastime.....	814	Dead Litter the Ground after Teuton Drive..	851
Motorboat, Armored, Possible War Value Seen in	879	Gas Masks, Fighters with Are Weird Figures..	849
Motorboat—Power Craft Sweeps Water at Mile-a-Minute Clip	846	Hospital, War, Gay London Resort Becomes..	854
Motorcycle, Comfortable Tandem Seat for.....	919	Italian Infantry Advancing in Alps.....	853
Motorcyclist is Shielded from Air by Deflector..	909	Italy's Advance in Alps, How Combated.....	852
Movie, Defying Death to Put Realism in.....	845	Prisoners Seen in Camps of Their Enemies...	860
Music Still Printed from "Punched Plates".....	877	Races, Homeless, Harried by War.....	855
Novel and Practical Things for the Home.....	916	Russian Capital, War Demonstration in.....	856
Oil, Valuable, is Trapped by Simple Method...	882	Slavic Lines, Interesting Glimpses behind...	857
Oils, Mineral, Shown to Be Superior for Hardening	900	Teutons during Their Fierce Eastern Drive..	859
Panama-Pacific Exposition Features, Best, to Be Permanent	825	War, Curious Makeshifts of Seen at Random	861
Pier, Chicago's Municipal, Nearing Completion..	868	Winter Quarters, Abandoned, of Czar's Forces	858
Platinum, Properties of are Studied by Experts..	878	Weeds, Using Chemical to Kill along Railroad..	910
Porcelain Factory, Ancient, Reopens in China...	870	Windmill, Constant Speed, Runs Electric Generator	816
Poultry, Clock Regulates Device for Feeding...	919	Wireless Mast is Wrecked by Heavy Wind.....	805
Prune Gathering Machine for Large Orchards...	901	Wireless, Talking across Ocean with, by Joseph E. Murphy	833
Pump, Acid-Proof, Designed for Use in Mines...	878		
Railroad Crossing Gates Barricade Tracks.....	877		
Railroad Locomotive Crew, Life Saving Apparatus for	802		
Railway System Test Plant, New, Model of Efficiency	806		
Razor Blades, Machine for Resharpener.....	882		
Reservoir, Unused, Serves as Dance Hall.....	869		
Road Marker, Cycling Club Uses.....	902		
Salt Beds, Salduro, Plowing Up.....	820		
Sand Sifter, Electric, That Outworks Ten Men.	872		
Saw, Band, for Cutting Metals.....	824		
School, Model, Housekeeping Mechanics Taught in	874		
Searchlights Flash Messages across Panama.....	880		
Semaphore, Street, Has Interlocking Action.....	870		
Shim Block, New, is Made in Convenient Form...	918		
Ship, Ocean Survey, Built at Inland Lake Port.	810		
Ship's Position, Instrument for Finding.....	895		
Ship's Stability, How Determined, by Joseph R. Oldham, N. A.	913		
Ships—Steamers, Large Coastwise Are to Burn Oil	807		
Ships—Steamers' Sides, Illumine with Motor-Car Lights	876		
Ships Using Panama Canal should Signal Approach	910		
Sink, Kitchen, Refuse Collector Built in.....	871		
Solder, New, for Welding Aluminum Parts.....	880		
Sponge, Fountain, Devised for Various Uses...	879		
Storm, Tropical, New Orleans Swept by.....	823		
Street Lamps, Gas, Have Clocks to Control.....	822		
Streets, City, are Closed so Children may Play..	810		
Stretcher, Hydraulic, Made for Hospital Uses..	902		
Submarine "F-4," Pictorial Story of the Raising of	838		
Submarines, American Built, Cross Atlantic...	818		
Sun Heat, Each Day's, Instrument Records.....	911		
Survey, Canadian, Large Triangles are Used in.	868		
Target, New Flying, Made for Trap Shooters...	918		
Telephone Outfit, Compact Field, Used by French	817		
Telephone Toll Calls, Simple Device for Timing.	812		
Tile, Building, Enormous Nutcracker Tests....	896		
Tile, Cement Drain, How Alkali Affects.....	905		
Tire, Cord Layers Aid to Withstand Hard Usage	804		
Toys, American, The War's Influence on, by Searle Hendee	887		
Trap, Rabbit, Made of Wire Netting.....	920		
Tree, Tall, Marksman Trims with High Power Rifle	865		
Trees, Evergreen, Shroud to Protect from Sun..	804		
Truck, New Steam, Uses Coke as Fuel.....	902		
Tube, Ballooned Motor Car, Resembles Huge Sausage	869		
Tug, Powerful, Breaks Ice for Fishing Fleet...	874		
Tunnel, Pipe, Back Filling through Auger Holes..	865		
Typewriter, Portable, Folding Stand is Devised for	905		
Vehicle, New, Roller Skate and Toy Auto Combine in	896		
Vise, Swivel, is Designed for Bench and Machine	878		
		SHOP NOTES	
		Automobile Brake, Repairing.....	929
		Automobile Switch Key, Place for.....	922
		Batteries, Lead Storage, How to Mix Electrolyte for	930
		Belts, Homemade, for Cyclecar.....	929
		Bolts, Foundation, Cutting Threads on.....	923
		Buzzers without Contacts.....	928
		Casters, Attaching to Angle Iron Posts.....	931
		Center to Face and Polish in Lathe.....	929
		Clamp, Carpenter's.....	940
		Dial to Locate Swing of Oil Cock Control.....	924
		Drawing Outfit, Portable.....	922
		Faucet Lever.....	927
		Fillet Lines, Aid in Drawing.....	930
		Fountain Pipe, Drinking, Cover for.....	921
		Furnaces, Portable Fan Outfit for Cooling.....	921
		Glass, Working in Machines.....	926
		Hammer Handles, Reinforcing.....	934
		Hatrack for Clothes Closet.....	934
		Holes, To Remove Burrs from.....	924
		Home, Building a:	
		Part IX—Interior Decorations.....	935
		Key Seats, Cutting in Taper Holes.....	933
		Ladder Ends, Removable Spurs on.....	939
		Ladder, Round Rung, Flat Step for.....	940
		Light, Hall, Two-Way Switch for.....	933
		Liquid, Shifting Continuous Flow of without Loss	934
		Lubricant, Lathe Center.....	934
		Magneto Coupling, Homemade.....	927
		Paint, Covering in Pots Overnight.....	924
		Planer, Large, Using for Press.....	940
		Planer Work, Locating Point on to Set Pin Gauge	938
		Reamer, Making Cut Oversize.....	924
		Screens, Window, Stretching on Frames.....	927
		Steel, Cleaning of Burnt Oil.....	934
		Stencil, Long, To Keep from Sagging.....	939
		Stovepipe Elbow, To Make.....	939
		Studs, Threaded, Holding in Bolt Cutter.....	939
		Templates, Economy in Making.....	923
		Threading Tool for Taper Work.....	932
		Tools, Heating Tips of for Hardening.....	940
		Wall Board, Thin, Stiffening.....	939
		Window, Automatic Draft Deflector for.....	932
		Windows, Washing Unopenable.....	921
		Wood, Cutting Long Square Holes in.....	921
		Workshop, Small Farm.....	925
		AMATEUR MECHANICS	
		Ash Tray, Snapper Shell.....	948
		Bookcase and Writing Desk.....	950
		Card Tossing at Mark Accurately.....	949
		Chair, High.....	942
		Comb Cleaner.....	952
		Curtain, Raising and Lowering at Distance.....	956
		Curtains, Spring Roller, Automatic Stop for.....	951
		Dies for Cutting Cardboard.....	957
		Electrical Experiment—Measuring Resistance with a Lead Pencil	941
		Fireplace, Blower for.....	942



THE STRANGEST WOMAN IN ALL HISTORY

HAVE you read about **CATHERINE THE GREAT** of Russia—the auburn-haired queen—the queen of romance? Was she the great queen—ardent lover—faithless wife—rumor has told? Was she twenty women in one—more beautiful than Helen of Troy—more brilliant than Cleopatra—more ruthless than Catherine de Medici—greater than Queen Elizabeth of England—this woman who came from a modest German duchy to rule over a wild Russian court and a wilder Russian land? What is the truth? The story of her life and every other character in history is to be found in the world-famous publication

Ridpath's History of the World

Dr. John Clark Ridpath is universally recognized as America's greatest historian. Other men have written histories of one nation or period; Gibbon of Rome, Macaulay of England, Guizot of France, but it remained for Dr. Ridpath to write a history of the entire World from the earliest civilization down to the present.

Never Again Such A Book Bargain

We will name our special low price and easy terms of payment only in direct letters. A coupon for your convenience is printed on the lower corner of this advertisement. **Tear off the coupon, write your name and address plainly and mail now before you forget it.** We will mail you 46 free sample pages without any obligation on your part to buy. These will give you some idea of the splendid illustrations and the wonderfully beautiful style in which the work is written. Our plan of sale enables us to ship direct from factory to customer and guarantee satisfaction. We employ no agents, nor do we sell through book stores, so there is no agents' commission or book dealers' profits to pay.

Six Thousand Years of History

Ridpath takes you back to the dawn of History, long before the Pyramids of Egypt were built; down through the romantic troubled times of Chaldea's grandeur and Assyria's magnificence; of Babylonia's wealth and luxury; of Greek and Roman splendor; of Mohammedan culture and refinement to the dawn of yesterday. He covers every race, every nation, every time, and holds you spellbound by his wonderful eloquence.

The European War

If you would know the underlying causes which have led up to this conflict, the great racial antipathies, the commercial rivalries, the sting of past defeats, the vaulting ambitions for world empire, you will find them all in Ridpath's History of the World.

Ridpath's Graphic Style

Ridpath pictures the great historical events as though they were happening before your eyes; he carries you with him to see the battles of old; to meet kings and queens and warriors; to sit in the Roman Senate; to march against Saladin and his dark-skinned followers; to sail the southern seas with Drake; to circumnavigate the globe with Magellan. He combines absorbing interest with supreme reliability.

**WESTERN NEWSPAPER ASSOCIATION
CHICAGO**

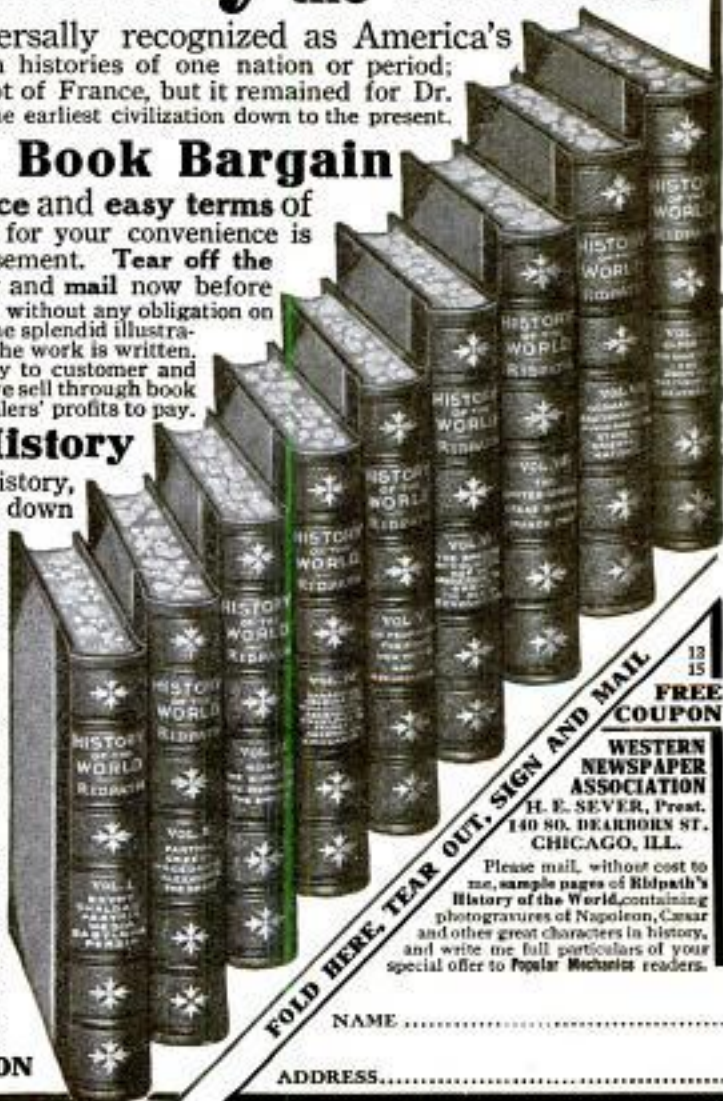

FREE COUPON
13
15
WESTERN NEWSPAPER ASSOCIATION
H. E. SEVER, Pres't.
140 SO. DEARBORN ST.
CHICAGO, ILL.
Please mail, without cost to me, sample pages of Ridpath's History of the World, containing photographs of Napoleon, Caesar and other great characters in history, and write the full particulars of your special offer to Popular Mechanics readers.

NAME

ADDRESS

Write



for This Free
32
PAGE Booklet

explaining how to get into the

AUTOMOBILE BUSINESS AND ITS OPPORTUNITIES

Just Mail the Coupon Below. This booklet is interesting and instructive in itself. Learn how you can get all this training for only \$15. Fill out coupon below or write a postal—but do it now. Hundreds have learned the

AUTOMOBILE BUSINESS AT HOME During Their Spare Time By Mail With Dyke's New Idea Working Model Method

If we prove to you that we have started hundreds of others into the repair business and as chauffeurs—who had no previous experience and who knew no more about an auto than you do right now—you must admit we can do the same for you. Write me today—now—and let me prove it.

The AUTOMOBILE BUSINESS is Growing

We Assist Students Getting Actual Driving Experience



More help needed and big pay. No other business offers such opportunities. It's easy to learn. An Auto Repairman is not a machinist—his work consists of adjustments and re-fitting worn parts, "knowing the principle," that's the thing. One of our students writes: "Before I started with your course I was a clerk at \$50 per month. After finishing I followed your instructions, started a repair shop and cleared \$122 the first month—pretty good for the first month." Let us show you this and many other letters. You can learn the same as this young man by

DYKE'S NEW IDEA OF TEACHING BY MAIL WITH WORKING MODELS

On these models you get actual practice, see the actual operation and learn more than you could from the auto itself—it's easy and quick. You don't have to study hard with this system—we teach through the eye—a new idea. Mr. Dyke is the originator of the system of teaching by mail with models—therefore beware of imitators.

Our Employment Plan for Students

represents years of work to provide something that no other school had, namely, a way for the student to get started in the practical line of work.

Mr. Dyke has been identified as a pioneer inventor, supply man, etc., with the auto industry since its beginning. He originated the first auto supply co. and published the first book on autos in America. No other man with such experience is today teaching others.

Dyke's Correspondence School of Motoring
Box 196, Roe Bldg.
St. Louis, Mo.

Send me your free 32-page booklet about your New Idea Working Model Course and testimonials and proofs. It is understood I am under no obligations in sending for this.

Mail This Free Coupon Now

for Mr. Dyke's 32-Page Booklet. Write for it—now! It is interesting and instructive in itself. Learn how you can get all this training for only \$15. Fill out below or write a postal—but do it now.

Dyke's Correspondence School of Motoring
Box 196, Roe Bldg.
St. Louis, Mo.

Name

Address

(Contents—Continued from page 6)

Gold, Surface Mining for:	
Part III—Assaying	953
Ironing Board for Use on Table	957
Ironing Board Wall Fastening	942
Key, House, Concealing	952
Knife Sharpener, Table	958
Screen, Portable Fire	948
Screws with Nuts, Brass Machine	948
Shotgun and How to Use It:	
Part II—The Choke and Pattern of a Gun	943
Spoon Attachment to Prevent Child from Using Left Hand	951
Trick—Mystic Climbing Ring	956
Tube, Sanitary Drinking	949
Vacuum Pail, How to Make	957
Watch, Mysterious	952

PATENTS

Automobile Headlight, Deflector and Dimmer for	958
Automobile Tires, Device for Checking Mileage of	959
Blowgun with Ammunition Magazine	959
Bread Board, Sanitary	959
Door Holder	958
Electrolier and Telephone Cover, Combined	958
Encase Post	958
Gun, Muzzle Support for	958
Knife Sharpener	958
Lemon Squeezer	959
Phonograph, Attachment for	959
Shoehorn and Buttonhook, Combined	958
Silo with Hinged Roof	959
Sled, Motor Driven	959
Springs, Vehicle, Repair Attachment for	959
Streets, City, Method of Removing Snow from	958
Suitcase, Extensible	959
Typewriter, Erasing Attachment for	959
Undertow Indicator	958
Water Pipes, Frost-Proof Box for	958



MEN WANTED

Prepare as Firemen, Brakemen, Electric Motormen, and colored Train Porters. First Class Standard Roads. Hundreds put to work—\$65 to \$150 a month without any experience. 500 more wanted. Uniforms and passes arranged for when necessary. Enclose stamp for Application Blank. Name position you want.

I. RAILWAY C. I., Dept. 35, Indianapolis, Ind.

CIVIL SERVICE

positions are in all parts of the country. Good pay, steady work, life positions, congenial surroundings, promotions on merit, short hours, annual vacation and sick leave with pay. Many thousands appointed yearly. Both sexes. No political pull. Nearly 300,000 classified positions. Common school education sufficient. Full information and questions used by the Civil Service Commission free.

COLUMBIAN CORRESP. COLLEGE, Washington, D. C.

SHOW CARD WRITERS

EARN \$80 TO \$200 A MONTH
LEARN FREE!



We will furnish a thorough course in Show Card Writing and Lettering absolutely free to introduce our colors if you will purchase an assortment of Alpha Colors to use while practicing. Particulars for stamp.

ALPHA COLOR COMPANY, Inc., Dept. K, 81 East 125th St., N. Y. City

LEARN RAG TIME

Let me teach you Rag-Time Piano Playing by Mail. You learn easily—in just a few lessons, at home. My system is so simple you'll play a real ragtime piece at your 5th lesson. Whether you can play now, or not, I'll teach you to play anything in happy ragtime. "Money Back Guarantee." Write at once for special low terms and testimonials.
AXEL CHRISTENSEN, "Car of Ragtime,"
Room 15, 526 So. Western Ave., Chicago, Ill.





You can Break the Shackles of Fear!

What This Book Teaches You

- How to overcome Timidity.
- How to conquer Bashfulness.
- How to have "nerve."
- How to demand "your own."
- How to face people you have always felt inferior to.
- How to develop Self-Confidence.
- How to deal with people on their own level.
- How to successfully face embarrassing situations.
- How to "rise to the occasion."
- How to be Forceful and Dominant.
- How to eliminate Nervousness in dealing with big men.
- How to act calmly and naturally on occasions that usually excited you.
- How to banish Fear, physical as well as mental.
- How to stop Worry.
- How to become a Man among men.
- How to get rid of Superstition.
- How to face old age calmly.
- How to maintain poise in public.
- How to assert yourself in Business as well as in the Home.
- How to develop courage to swing big deals.
- How to dominate Circumstances.
- How to defy old time habits of Hesitation.
- How to insure a healthy, virile, intrepid grade of Brain.
- How to stir into electrical activity, latent leadership qualities, which Nature has tucked into the make-up of every normal man or woman.
- How to mass the myriad cell-forces of your Mind into a strong, daring, goal-gaining plan of conduct.
- How to break open the door to a new world of Thinking—rare in beauty, practical in application.
- How to blaze the way to unthought-of fields of self-expression.
- How to add to your physical buoyancy a tingle and zest hitherto missing.
- How to impress others with your poise, purpose and power.

A complete list of contents would almost fill this page.

Do you lack confidence in meeting other people? Are you conscious of another's personality and your own lack of it? Do you feel inferior to others? Are you superstitious about anything? Do you worry about your loved ones or about conditions? Are you afraid of approaching old age? Do you seem to be blinded by petty fears? Are you frightened in public? Are you afraid of your ability to "put things over"? Are you afraid to assert yourself in your home or in business? Do you fear the opinion of others? Have you the courage of your convictions? Do things that other men and women are doing seem impossible of accomplishment by you? Are you afraid to go in business for yourself or afraid to take the risks you used to? Are you able to brush aside all obstacles in order to arrive at your destination? Are you conscious of your power, self-confident and eager, demanding what you want, or do you stand cringing, hat in hand, and whine for it? If any of these subjects even touch on your condition, "Culture of Courage" will prove a godsend!

Fear of self—fear of people—fear of the future—fear of things—fear for others (worry)—are what keep men and women down when they should and could be on top.

But not until the shackles are broken—not until fear is eliminated—not until courage is properly cultivated, can man come into his own.

"Culture of Courage"

by Frank Channing Haddock, Ph.D.

This great work by the famous author of "Power of Will"—a scientist whose name ranks with James, Royce, and Bergson, is not an inspirational book which merely admonishes you to "Destroy Your Fears" and "Be Courageous." Instead, it is a practical course in how to overcome each particular kind of human fear, physical as well as mental, to which we are all subjected. It contains actual principles, rules, methods, and exercises which any one can easily follow and become ten times bigger—ten times more successful—ten times happier than you had even dared hope.

A Ghost-Scattering Searchlight

In "Culture of Courage" the author opens up into some of the most important problems of existence; he throws a ghost-scattering searchlight into the shadows that have scared people from rich fields of life; he tears away the straw-and-gossamer entanglement which has held men and women in subjection; he pulls off the imagination-created masks of various fears, superstitions and bugaboos which in all ages have paralyzed the brain's energies and constantly dinned into eager ears the failure slogans: "I'm afraid," "I dare not try," "I haven't the ability," etc.

As you study this new system, you will learn definitely how Reason, Thought, Analysis, and Sanity can scatter to the high heavens the senseless visions of fear that are causing unutterable losses, embarrassments, and failures.

This book will startle you, will awaken strains of thought that may easily change the entire course of your career, just as it has that of thousands of other men and women in all walks of life who have learned its wonderful back-bone-building secrets.

Send No Money While published in book form, "Culture of Courage" is a comprehensive system of courage-building and contains more material than many \$25 correspondence courses. It has 14 main divisions, and fills 460 pages. Beautifully bound in half-leather, gold top leaves, big readable print—yet the price is only \$3.00, and we are offering it for five days' examination without a penny from you in advance.

Send no money—merely mail the coupon enclosing your business card or giving a reference. If, after you have it in your own home, you feel you can afford not to own this wonderful guide to a broader life, to things worth while, send it back. The examination will not have cost you a penny. Tear out, fill in and mail the coupon right now before you turn this page, as this announcement may not appear in this magazine again.



460 pp.
Half Leather
Gold Top
Leaves

Pelton Pub. Co. 130L Wilcox Block
Meriden, Conn.

What Readers Say:

"In it I found rules, principles and regimes which make it worth its weight in gold to me." — District Attorney Goodwin, Oil City, Penn.

"It is a 'wonder.' The more one reads it, the more forceful ideas he can draw from this storehouse." — J. F. Ellis, Pres. Nat. School of Sales'p, Minneapolis, Minn.

"It is simply magnificent; I shall highly recommend it and wish everybody could read it." — L. I. Hall, Rochester, N. Y.

"It stands absolutely at the head of anything I have ever come across; Mr. Haddock is certainly a Master Mind. As a teacher I can say that no greater good could come than the absolute freedom from superstition this book brings about." — James Stratwell, Reynoldsville, Pa.

"These books are a gold mine of 'emerging material' for the progressive mind." — A. A. Martin, M. D., Pierce, Neb.

"Enclosed is my check; send another copy." — W. H. Smith, Pres., Herring Hall, Marvin Sale Corp., New York.

"I have read 'Culture of Courage.' Shall want anything its author may produce. This is the most sincere tribute I can pay the books." — C. A. Drinkwitz, Evanston, Ill.

"'Culture of Courage' is superb. It is clear, forceful, scientific, practical in every form and manner; ALIVE with the rich, the high, the ideal, the sublime. It's an inspiration from beginning to end. IT JUSTIFIES ALL CLAIMS." — F. Stanley Peters, Res. Master, Wesley College, Colombo, Ceylon.

"Enclosed is check for which send me another copy for one of my friends. Dr. Haddock's works are superior to anything I have ever read for the development of the individual. He is entirely in a class by himself." — Chas. E. Ward, D.C., Houston, Mo.

Pelton Pub. Co.,
130L Wilcox Block
Meriden, Conn.

Gentlemen: Please send me a copy of "Culture of Courage" on approval. I agree to remit \$3.00 or return the book in 5 days.

Name.....

Address.....



Earn \$125 to \$250 a Month

in the Steam Engineering field. Prepare in your spare time for a Stationary or Marine Engineer's License, or position as Locomotive Engineer. These great books, written by 27 experts, contain all the information necessary to take up this well-paid work.

Steam Engineering

7 volumes; 3360 pages, 7x10 inches; 2500 illustrations, full page plates, diagrams, etc.; hundreds of valuable tables and formulas. Handsomely bound in half red morocco, gold stamped. Covers the construction and operation of stationary, locomotive and marine engines and boilers; the use of gas and gasoline engines for power and locomotion; the transformation of steam and gas power into electricity, and the application of steam and gas power to refrigeration, compressed air, etc.

Examine These Books Free of Charge

The entire seven volumes, not a sample volume, will be sent, express prepaid, on receipt of the coupon below. Look these books over for a whole week free. Then decide whether or not you want them. If you do, send us \$2.00 within seven days and \$2.00 a month—50c a week—until the special advertising price of \$19.90 has been paid. Otherwise we'll take them back at our expense. In addition to this liberal discount from the regular price of \$35.00, we include with each set a \$12.50 Consulting Membership. This entitles you to the advice of a staff of experts for a whole year free.

American Technical Society, Chicago:

Please send *Cyclopedia of Steam Engineering* for 7 days' free examination. I will send \$2.00 within 7 days and \$2.00 a month until I have paid \$19.90; otherwise I will notify you and hold the books subject to your order. This not to pass until fully paid. Pop. Mech. 12-15

NAME.....
ADDRESS.....
REFERENCE.....

You Can Earn

5-Pass. 28 H.P.



This Magnificent BUSH MOTOR CAR

And the Agency for Your Territory
Get a Car and qualify to make \$3000 to \$5000 a year and up in the Automobile Business. A Postal brings full details of this great Auto Offer. Write quick—before your territory is taken. Address me like this—

J. H. BUSH, President

Bush Motor College, Inc. DEPT. 1217
BUSH BLDG.
North Clark Street and Chicago Avenue, CHICAGO, ILL.

You're a Human Dynamo

full of undeveloped power, capable of mastering the forces about you. If you are not getting full mental and physical efficiency from your mind and body, the wires are crossed somewhere. LEAVITT SCIENCE tells how to develop your dynamic forces, get perfect adjustment. Its vital message has helped others to complete self-mastery—why not you? 24c in stamps brings this handsome 48-page de luxe book. Write to-day to
C. Franklin Leavitt, M. D., Suite 946, 14 W. Washington St., Chicago



SHORTHAND IN 30 DAYS

We absolutely guarantee to teach shorthand complete in only thirty days. You can learn in spare time in your own home, no matter where you live. No need to spend months as with old systems. Boyd's Syllabic System is easy to learn—easy to write—easy to read. Simple. Practical. Speedy. Sure. No ruled lines—no positions—no shading as in other systems. No long lists of word signs to confuse. Only nine characters to learn and you have the entire English language at your absolute command. The best system for stenographers, private secretaries, newspaper reporters and railroad men. Lawyers, ministers, teachers, physicians, literary folk and business men and women may now learn shorthand for their own use. Does not take continual daily practice as with other systems. Our graduates hold high grade positions everywhere. Send today for booklets, testimonials, etc.

Chicago Correspondence Schools
969 Unity Bldg., CHICAGO, ILL.



TRAVELING MEN

EARN \$2,000 TO \$10,000 A YEAR

We will teach you to be a high grade salesman, in eight weeks at home and assure you definite proposition from a large number of reliable firms who offer our students opportunities to earn Big Pay while they are learning. No former experience required. Write today for particulars, list of hundreds of good openings and testimonials from hundreds of our students now earning \$100 to \$500 a month. Address nearest Office, Dept. 507, NATIONAL SALESMEN'S TRAINING ASSN., Chicago New York San Francisco

BE AN ILLUSTRATOR

by mail how to draw for magazines and newspapers
Send for Catalog

Learn to draw.

We will teach you
School of Illustration
112 Page Bldg.
Chicago, Ill.



BE A DETECTIVE

Earn from \$150.00 to \$300.00 per month; travel over the world. Write

C. T. LUDWIG, 133 Westover Bldg., Kansas City, Mo.



WE TEACH YOU TO DRAW A GOOD SALARY

Most Art Schools merely teach you how to draw pictures—we teach you how to draw a good salary as well. PRACTICAL and PERSONAL INSTRUCTION Study during your spare time and learn How to Make Pictures That Will Sell. Artists earn from \$25 to \$100 a week. Send copy of picture on left for free criticism and 6 cents in stamps for illustrated catalog.

Correspondence and local school.
WASHINGTON SCHOOL OF ART 911 F. Street N. W.
WASHINGTON, D. C.

Public Speaking

Taught at Home Write for our special public speaking offer. 15 minutes a day, spare time, will make you a

powerful, convincing speaker. You can be at ease before any audience—enrich your vocabulary—increase your earning power—become more popular. We have trained hundreds of successful speakers by mail at home.

Write Now for Special Offer Send quick for details of our special limited offer. No obligations. But you must hurry. Write now while this offer lasts.
Public Speaking Dept. American Correspondence School of Law
1199 Manhattan Building, Chicago, Ill.



LEARN TO BE A

Show Card Writer

Unlimited Demand. \$18 to \$45 a Week

Pleasant, Fascinating, Profitable Work. Earn money after first few lessons. Expert teaches personally by mail. \$1 per lesson.

EASY SHOW CARD SYSTEM
Dept. G, 105 Chambers St., NEW YORK

SENT FREE

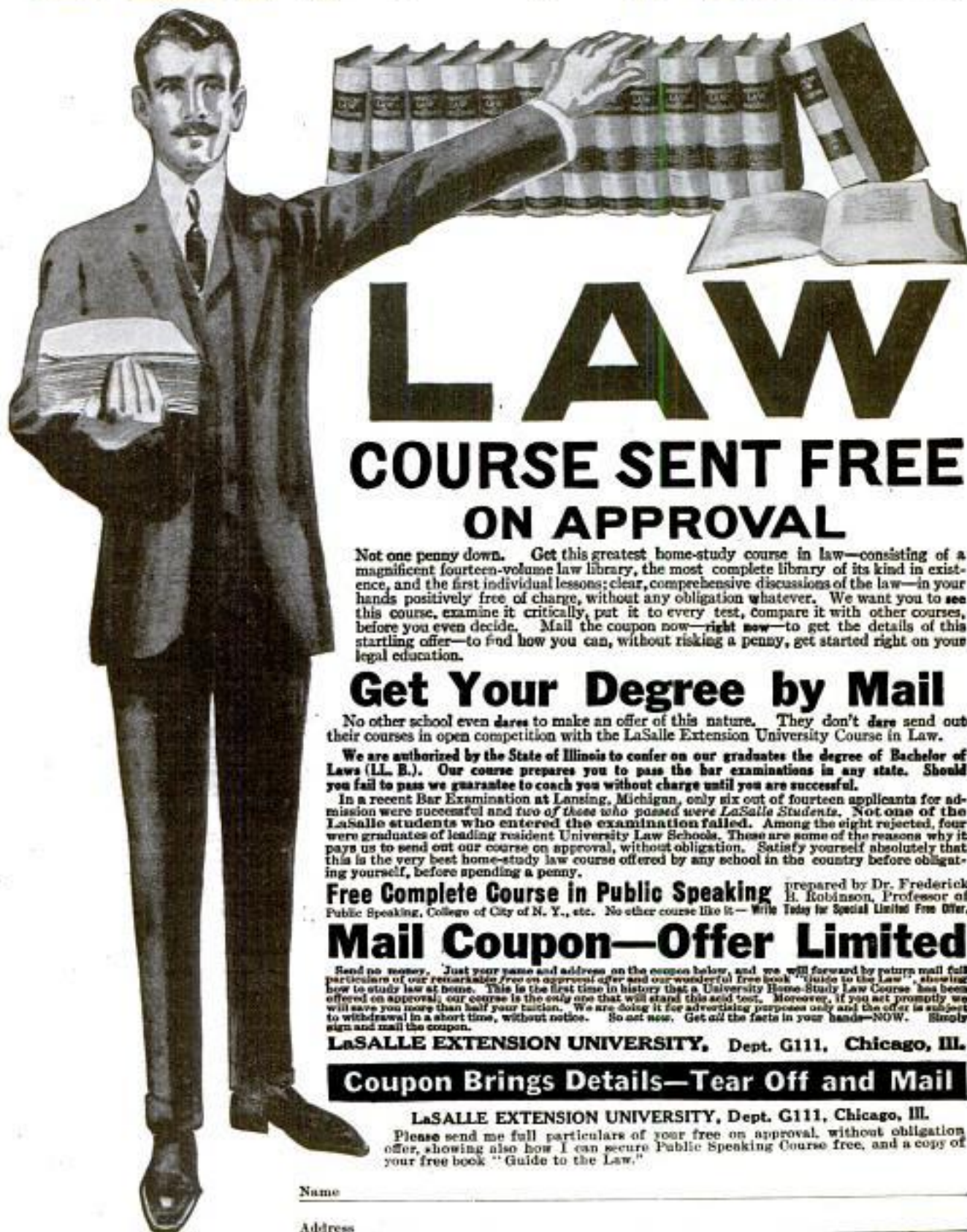

LAW

COURSE SENT FREE ON APPROVAL

Not one penny down. Get this greatest home-study course in law—consisting of a magnificent fourteen-volume law library, the most complete library of its kind in existence, and the first individual lessons; clear, comprehensive discussions of the law—in your hands positively free of charge, without any obligation whatever. We want you to see this course, examine it critically, put it to every test, compare it with other courses, before you even decide. Mail the coupon now—right now—to get the details of this startling offer—to find how you can, without risking a penny, get started right on your legal education.

Get Your Degree by Mail

No other school even dares to make an offer of this nature. They don't dare send out their courses in open competition with the LaSalle Extension University Course in Law.

We are authorized by the State of Illinois to confer on our graduates the degree of Bachelor of Laws (LL. B.). Our course prepares you to pass the bar examinations in any state. Should you fail to pass we guarantee to coach you without charge until you are successful.

In a recent Bar Examination at Lansing, Michigan, only six out of fourteen applicants for admission were successful and two of those who passed were LaSalle Students. Not one of the LaSalle students who entered the examination failed. Among the eight rejected, four were graduates of leading resident University Law Schools. These are some of the reasons why it pays us to send out our course on approval, without obligation. Satisfy yourself absolutely that this is the very best home-study law course offered by any school in the country before obligating yourself, before spending a penny.

Free Complete Course in Public Speaking prepared by Dr. Frederick H. Robinson, Professor of Public Speaking, College of City of N. Y., etc. No other course like it—Write Today for Special Limited Free Offer.

Mail Coupon—Offer Limited

Send no money. Just your name and address on the coupon below, and we will forward by return mail full particulars of our remarkable free on approval offer and our wonderful free book "Guide to the Law", showing how to study law at home. This is the first time in history that a University Home-Study Law Course has been offered on approval; our course is the only one that will stand this acid test. Moreover, if you act promptly we will save you more than half your tuition. We are doing it for advertising purposes only and the offer is subject to withdrawal in a short time, without notice. So act now. Get all the facts in your hands—NOW. Simply sign and mail the coupon.

LaSALLE EXTENSION UNIVERSITY, Dept. G111, Chicago, Ill.

Coupon Brings Details—Tear Off and Mail

LaSALLE EXTENSION UNIVERSITY, Dept. G111, Chicago, Ill.

Please send me full particulars of your free on approval, without obligation offer, showing also how I can secure Public Speaking Course free, and a copy of your free book "Guide to the Law."

Name _____

Address _____

Please Mention Popular Mechanics

Power Plant Engineering

Steam, Electrical, Turbine and Refrigerating Engineering
NOW EASILY LEARNED

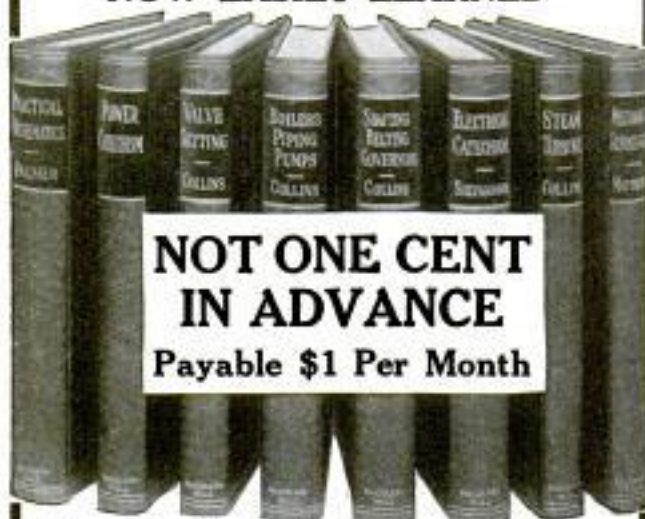

**NOT ONE CENT
IN ADVANCE**
Payable \$1 Per Month

*Now the Most Used Engineers' Library
in Existence—Because It Is Best*

The power plant field is one in which the salary of the capable engineer depends entirely upon himself—his training. His responsibilities are increasing year by year—likewise his income. It is a field in which the demand for competent men is never fully met.

It is no longer possible for the engineer to climb to the higher places through the knowledge he gains through practice alone. He must study, but he must study standard literature only—books written from actual practice by practicing engineers.

The Power Plant Library covers every phase of power plant work, including a complete self-educating course in **Mathematics, Engine Running, Valve Setting, Boilers, Pipes and Piping, Pumps, Shafting, Belting, Governors, Electricity, Turbines, Refrigeration, etc.**

If you are a power plant engineer or expect to become one, any one of the eight volumes in this set will be worth to you the small price we are asking for the entire library.

Nearly 3,000 pages of facts—facts for study or reference—facts for the beginner as well as the \$5000-per-year chief engineer. Nothing in power plant practice of today is omitted. Nothing is beyond your understanding.

Upon receipt of coupon below we will send the set weighing fourteen pounds, charges paid, for your inspection. You do not obligate yourself in any way to purchase.

FREE EXAMINATION COUPON

McGraw-Hill Book Co., Inc., 239 W. 39th St., New York

Gentlemen:—Ship the Power Plant Library, eight volumes, for my inspection. If satisfactory after examination, I will send you \$1 in ten days and the balance at the rate of \$1 per month until I have paid the price of the books, \$12. If not satisfactory I will write for shipping instructions.

SIGNATURE.....

RESIDENCE ADDRESS.....

CITY AND STATE.....

NAME OF EMPLOYER.....

REFERENCE.....

ADDRESS..... P. M. Dec.

THE BOY ELECTRICIAN

Practical Plans for Electrical Toys and Apparatus, with an Explanation of the Principles of Every-Day Electricity

By ALFRED P. MORGAN

With full-page illustrations, and 324 working drawings and diagrams by the Author. 8vo. Cloth.

Price, Net, \$2.00; Postpaid, \$2.25

This is the most complete, the best illustrated, the most correct and the most entertaining work on the subject of electricity, its uses, and the economical making at home of practically all kinds of electrical appliances that has ever been produced. It also tells very clearly how electrical matters are handled on a large scale.

At all Bookellers. Send for Free Catalog.
LOTHROP, LEE & SHEPARD CO., BOSTON

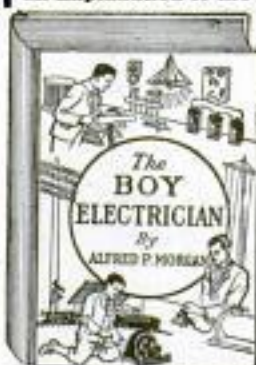

40 ALPHABETS



14,000 COPIES SOLD

Spon & Chamberlain

123 P. M. Liberty St., NEW YORK

Contents:

Block Letters:

Heavy, Outline, Condensed, Expanded, Fancy, Shaded and Italics.

Gothic:

Condensed, Expanded, Italics.

Roman:

Fancy, Italics.

Script: Modern, Architectural.

55c

Postpaid

MAGIC

TRICKS

Let us send you two clever card tricks—puzzling to your audience, yet easy to do. Also booklets illustrating numerous Magic and Card Tricks. All For 10¢. We have a selected number of new Card Tricks sent for \$1.00 postpaid.

THE MAGIC SHOP 52 N. 13th St. Phila., Pa.

FREE

"Linene" COLLAR

State size on postal and whether you want collar like cut or low turnover style.
REVERSIBLE COLLAR CO., Dept. U, Boston, Mass.

If You Are a Shallow Breather

You most certainly are in need of Conscious Evolution to become fully alive and have the benefit of living in full. Why live an inferior life when you can become superior to yourself through Conscious Evolution?

MY NEW BOOK explains the human body as it has never been explained before. It tells of the dangers and after effects of exercise and conscious deep breathing. My free book will prove of great value to you. If you desire to be more successful, to have greater will power and the successful powers, physical, physiological and mental, you cannot afford to be without my free book. Write for it today.

ALOIS P. SWOBODA
1314 Aeolian Hall NEW YORK CITY

Please Mention Popular Mechanics

Trained Traffic Men Direct The World's Commerce



Salary

\$35 to \$100 Weekly

For the competent traffic manager there are no "little jobs"—no sticking at the "bottom of the ladder." This because he, **alone**, knows all the factors governing shipments. Because, he, **alone**, knows the factors to employ in reducing transportation costs to the lowest possible basis. The others are only "guessing." Thus he is consulted by the "big heads." They are dependent upon him. He **advises—directs**. Others carry out his orders. He is a "big" man because he saves thousands of dollars in each year. He draws a large salary because he holds a big position.

You can be the man who "knows." You can advise and direct. You can be a big man in an important position and draw a large salary—if you will only gain this training. We will teach you—advise you—direct you. If you make an honest effort you cannot help but succeed.

A Traffic Manager

Can Get a Position any Place in the World at Good Salary. Be One. Train by Mail Under Expert Guidance

Without trained traffic men, commerce—in its present efficient state of development could not possibly be carried on. For the efficient traffic manager—no matter where he may be, north or south, east or west—there is work and at high salary. The profession is permanent. It grows better and pays more money each year because commerce is a huge giant, still growing. In America, alone, is a vast field. Recently enacted railroad and interstate commerce regulations and laws have created thousands of new positions. Hundred of these positions cannot now be filled because there is a great scarcity of really competent traffic men. Think of this—at the close of the present great European war, the commerce of a greater part of the world will require re-establishment. This great task will require thousands of highly trained traffic men. America will be greatly affected by these changes. Now is the time to enter this profession.

Simple—"Progressive" Lessons You Can't Help but Learn

Our lessons were prepared by practical traffic managers and traffic experts who do the things they write about. Thus the lessons contain just the things that a traffic manager **must know**—and our experts will **train you** in doing them. Our students get **actual practice**—are qualified to obtain a position and to hold it. By the La Salle System there is nothing beyond your capacity to learn. With our help your progress will be easy and rapid; your success, certain.

An Unusual Book FREE—"Ten Years' Promotion in One"—also copies

of students' letters and full information concerning the course—just mail the coupon. This unusual book was written especially to give you facts concerning conditions in the business world—facts that are known only to those few men who have learned them through bitter experience. Written by a man who has "been through the mill." Don't go "up against a stone wall"—get this book—it will "open your eyes." Determine now to become a traffic manager—to take the La Salle Course—to be a man among men—and draw a "man's" salary. Don't complain about the low pay of your present position—prepare to get out of it. We will help you. Send the Coupon and receive the Book and full information by return mail.

LA SALLE EXTENSION UNIVERSITY
Dept. C.163 Chicago, Ill.

LaSalle
Extension
University,
Dept. C.163
Chicago, Ill.

Send Free proof about opportunity open to TRAFFIC EXPERTS with LaSalle training; also Free copy of "10 Years' Promotion in One."

Name.....

Occupation.....

Address.....

City.....State.....

La Salle Graduates Hold Big Positions

Our graduates are successful because the instruction is complete and thorough. They are taught just those things they need in their daily work either as railroad or industrial traffic expert or manager. Because our experts coach and direct them in making practical application of things they learn. We want to send you copies of letters they have written us—let them tell you—in their own words—of the progress they have made, of the positions obtained, of promotions and raises, in salary.

You Will Like To Read These Letters

One from a La Salle graduate, Alex. Denholm, wherein he explains how he saved his firm \$3,958.00 on a single shipment of steel rails and cross-ties—a letter from a traffic manager of a big wholesale house, who received a one-third increase in salary through study of the La Salle Course—one from the manager of a brick company who says that one of our students saved his firm \$1,000 on the shipment of brick covering a single contract—these and many others, teeming with "human interest," that tell of success coming to our students and graduates as the result of La Salle training. The La Salle is a long-established, powerful institution—financially strong and reliable. We prove all our claims—fulfill all our promises. We will show you the way to good salary—stand behind you—help you to "make good."

Please Mention Popular Mechanics

STUDY LAW

AT HOME

Become an LL.B.

*Only Law School of
its Kind in America*

Special and Exclusive Features

ONLY recognized resident law school in the United States conferring Degree of Bachelor of Laws—LL.B.—by correspondence. **ONLY** law school in U. S. conducting standard resident school and giving same instruction, by mail. **ONLY** law school giving over 450 class-room lectures to its extension students. **ONLY** law school giving a full 3-year, University Law Course, by mail, having an actual faculty of over 30 prominent lawyers in active practice. **ONLY** law school in existence giving Complete Course in Oratory and Public Speaking, in conjunction with its law course.

Written Bar Guarantee

We give an absolute written guarantee to prepare our students to pass bar examinations.

The Hamilton College of Law is a regular, thoroughly recognized, bona fide College of Law and NOT an "institute," "correspondence school," etc. It occupies the entire third floor of the New Advertising Bldg., where its large and commodious resident class-rooms and executive offices are located.



Our Degree Bachelor of Law, LL.B. NOT a Diploma or Certificate

Direct From Class-Room to Student



From Lecture Room to Student
No Other Law School Can Do This Illustration

is the way we teach law. We are the only school doing this. Our system of teaching is intensely interesting; not dull and dry like the average law course. Our system of conducting examinations is the most thorough, complete and expensive (to us) of any examinations ever given. A student can, if he chooses, take part of our course by mail and finish in our resident school where he will receive full credit for all work done by mail. Our resident school is recognized by all standard law schools in the United States.

The Hamilton College of Law is highly endorsed and recommended by Government Officials, Business Men, Noted Lawyers, Graduates, and Students. We have as students a number of practicing lawyers (not graduates of recognized law schools) who are now earning their degree of LL.B. Many other lawyers are using this course as a review. A probate Judge, (one of our active students) says: "I am delighted with the course prescribed and your method of teaching law. It is far in advance of what I expected to receive."

Our Law Library

consists of 24 volumes of Student's Standard Text Books, two volumes bound together under one cover, making a total of 12 books. These books were prepared at an enormous cost especially for the students of the Hamilton College of Law, by one of the largest and best law book publishers in America. This is the only set of law text books ever prepared exclusively for student's use. We would be glad to have you submit these books to any lawyer or judge in the country and get his opinion regarding them.



These 12 Volumes are Free to Students

Mail Coupon Today

and get our Big, Beautifully Illustrated Prospectus and complete information. Places you under no obligations whatever. This may mean the turning point in your career.

Hamilton College of Law, 327 Advertising Bldg., Chicago, Ill.

Gentlemen: Kindly send me your Illustrated Prospectus and full particulars regarding your method of teaching law by mail

Name.....

Address.....

Write plain and in full

Please Mention Popular Mechanics

New Positions Ready

\$25 to \$45 Weekly



New profession just being created—only uncrowded field. Big positions with lucrative salaries to start for men and women. You are needed now—learn at our risk—

Be a CONFIDENTIAL SECRETARY

— the new executive position — right-hand aid to the big boss. Learn his secret methods — step into official position. Thousands now needed in large and small towns. You can qualify through the remarkable new discovery—the salary-raising Botsford

NEW METHOD IN TOUCH — the speed system that amazed employ-
Typewriting. New idea—write 150 per cent faster without looking. Steno-
graphers everywhere will soon discard slow, old-time sight systems.

Big Position While Learning

by mail, in spare time. W. F. Gessler, 1123 Drummond Pl., Chicago, wrote: "An only fall through course and I secured high-salary position as Confidential Secretary to Gen. Mgr. of largest firm of its kind in the world. Know nothing before about Typewriting." Write for other letters like this. No matter what your present work, we qualify you easily — quickly. Stenographic or office experience unnecessary. If already a stenographer, double your salary.

SUCCESS OR MONEY BACK — you risk no money —
Write for back proof. Don't hesitate—full payment to suit you. One of these big positions is possible for you. Begin now while the need is great.

START FREE SEND NO MONEY — No obligation—
simply write for complete first lesson FREE.

Special limited offer — act NOW! Write for proof of graduate needed and letters of success. Learn how we loan \$100.00 Typewriter while learning. Shorthand—FREE first lesson. If you wish to learn Short Hand only, write for special offer on Botsford Simplified Course—used by world experts. Address James Patrick Ward, Pres. BOTSFORD INSTITUTE 1102 Botsford Building CHICAGO

\$100.00 Typewriter FREE While Learning

GOVERNMENT POSITIONS

offer employment for life at a salary ranging from \$800 to \$1800 per year, with short hours under pleasant conditions and no fear of "lay-offs" or strikes. American citizens 18 or over are eligible. Our 64-page booklet contains list of positions, requirements, etc., and tells how you can prepare for "Exams" under the personal supervision of a former U. S. Civil Service PATTERN—Examiner. Booklet is FREE, without obligation. Write today.

PATTERSON CIVIL SERVICE SCHOOL
112 Irving Place ROCHESTER, N. Y.



DON'T TRY TO BE A CHAUFFEUR

GET THIS BOOK FIRST.
or go to ANY SCHOOL to learn, or part with your hard earned dollars until you have read our valuable guide FIRST. It tells what you should PAY and what you should GET. Do not be deceived by schools which claim everything and give you nothing. YOU CAN'T AFFORD TO SPEND ONE CENT TILL YOU GET OUR GUIDE. It costs nothing and may save you many dollars. Write now for this FREE BOOK.

PRACTICAL AUTO SCHOOL, 68 Beaver St., New York

LEARN WATCH REPAIRING

Be a watchmaker—you can learn this profitable trade by correspondence in a few weeks in your own home by the DeSelms Chart System. After you complete the course you will know a watch from A to Z. You will know just what the matter is and how to repair one. When you graduate you will be a practical watchmaker and repairer and competent to fill any position. Positions for our graduates.

Ask for our Free Book. It explains our system and terms.
THE DeSELMS WATCH SCHOOL
23 Perry Street ATTICA, INDIANA



DO YOU WANT MORE MONEY?

Learn the art of Sign & Showcard Writing. Branch of Advertising. Men and women make big money. Personal instruction and original methods (copyrighted) make you expert. \$6.00 PER DAY OR MORE

is the union scale in Chicago and other towns. You can make even more on job work. Have a big business of your own. We show you how by mail and help you pay for your course. Particulars and booklet free. Explains everything. Write today. The School with a METHOD.
ILLINOIS SCHOOL OF LETTERING & DESIGN
Dept. B, 107 N. Clark Street Chicago, Illinois



OSCAR A. FORS PRINCIPAL

Big Money For TRAINED MEN!



Only Six Weeks is Required to prepare you for a position that will enable you to earn \$75.00 to \$300 monthly. Do you know that the demand for **trained men** far exceeds the supply? **The motor car is today as large a factor in everyday life and business as are the railroads.** Do you realize what this means?

The Automobile Training School of Kansas City is the Largest Institution of Its Kind in the Entire World. Graduates of this school are in demand. Many of our graduates are now holding high salaried positions in some of the largest automobile factories in America. Many are in business for themselves and are making big money.



ALL PRACTICAL WORK—NO BOOKS USED—NO TOOLS TO BUY



Thousands of graduates and every one of them possessing a thoroughly practical education in the various branches of the automobile business. We use no books—no charts. Our students are real workers—working hand in hand with the very best trained instructors—men who have given the best years of their lives to this work. The Automobile Training School owns and operates two of the largest garages and repair shops in Kansas City, the metropolis of the great Southwest.

MORE FLOOR SPACE: MORE INSTRUCTORS: MORE EQUIPMENT

than any other automobile training school in the United States. Three big buildings are required to take care of the various departments of The Automobile Training School. You get a real practical education here—there is nothing but real work and real instruction, that will enable you to master the technical and mechanical side of the most remarkable business the world has ever known.

FREE—\$50 SCHOLARSHIP—FREE

In order to bring our enrollment up to capacity without delay, we are giving away a com-

ber of these Free Scholarships will be given in addition to our regular automobile course. The development of Power Farming is the wonder of the age. **WRITE TODAY** for full information regarding this special Free Scholarship offer and big Sixty Page Book, "How to Make Money in The Automobile Business." Sure success awaits you—Use the coupon.

HENRY J. RAHE, President
AUTOMOBILE TRAINING SCHOOL
1055 Locust St., KANSAS CITY, MO.

FREE SCHOLARSHIP AND BOOK COUPON

Henry J. Rahe, Pres., AUTOMOBILE TRAINING SCHOOL, 1055 Locust St., Kansas City, Mo. Send me, free and postpaid, your big, 60-page illustrated book, also the free \$50.00 Scholarship Certificate covering Course in Tractor and Stationary Gas Engineering and Electric Starting and Lighting, as offered in your advertisement. This request does not obligate me in any way.

Name..... R. F. D.....
Postoffice.....County.....State.....

You Can Make This Jump Easy!



Become an EXPERT ACCOUNTANT

\$3,000 to \$10,000 Yearly Right now railroads, corporations and other big firms need Expert

Accountants at salaries of \$3,000 to \$10,000 yearly. The need for experts is greater than the supply, and possibilities for advancement into big, powerful executive positions of prosperity are excellent everywhere. Become an Expert Accountant and name your own salary—be your own boss—build a future of prosperity and independence. Be a big man—an important factor.

We Train You By MAIL!

You can become an Expert Accountant—we make it easy, no matter what you work at now, your wages or education. If you can read and write English, the LaSalle Extension University can qualify you for this remarkable vocation at home, in spare time. It is not necessary that you already understand bookkeeping. For those who need elementary training, we have devised a general Course in Bookkeeping that prepares you from the ground up for more advanced work in Higher Accountancy. The LaSalle Course is thorough, advanced, comprehensive. Prepared by some of the world's most noted Expert Accountants and covers Theory of Accounts, Practical Accounting, Cost Accounting, Auditing, Business Organization and Management, Business Law, etc. Administered under the supervision of William Arthur Chase, a nationally recognized leader, Ex-President American Association C. P. A. Examiners and Ex-Sec'y Ill. State Board Examiners in Accountancy. Prepares you for C. P. A. examinations in any state.

Remarkable Book FREE—What Every Bookkeeper Should Know—tells information you need to be had, etc. Send coupon now for free copy.

Special Reduced Rate

LIMITED OFFER! Let us tell you how, for a limited time only, to secure Special Extra Reduced Rate Scholarship. This offer is limited and might be withdrawn any day, so do not delay. Send NOW for facts.

ACT

today. Let us tell you about the success of LaSalle students and the success possible now for Expert Accountants with LaSalle training. Let us prove that we can qualify you for one of these opportunities. Don't let money worry you—we make terms to suit you. Mail coupon now. Send no money—all free.

LaSalle Extension University Dept. H. 144 Chicago, Ill. Name..... Address.....

MONEY-BACK GUARANTEE BOND

So thorough is the LaSalle Home Study Course—no exceptional has been the success of LaSalle students—that we issue with each LaSalle Course a bond, binding guarantee to refund the entire tuition fee if after you complete the Course you are not perfectly satisfied. This guarantee is backed by our entire capital and resources of more than one million dollars, which assures your absolute success.

Please Mention Popular Mechanics



\$100.00 EARNED BY YOUNG ARTIST IN 2 DAYS

Commercial Artists practically trained by members of our faculty have earned \$100.00 in two days — often more.

High Authorities Endorse This Great Course
Earn from \$25.00 to \$75.00 per week. Become a Commercial Designer — uncrowded field — dignified profession. Learn to draw during your spare time by our home study method.

Easy to Learn — Easy to Apply
Send today for our beautiful catalog in colors. Also our folio of commercial illustrations. Free for the asking.
FEDERAL SCHOOL OF COMMERCIAL DESIGNING, Inc.
608 Warner Bldg., MINNEAPOLIS, MINN.

Be An Advertising Man

You must specialize nowadays to earn a good salary. Learn Advertising and get into a profession which is filled with splendid opportunities — Write for our free booklet.

It tells how you can become an advertising man through our home-study course.

AMERICAN COLLEGE OF ADVERTISING, 81 E. Madison St., CHICAGO



Students Art Magazine

FOR ARTISTS AND ART STUDENTS

Publishes Cash Art Assignments, lessons and articles on Cartooning, Illustrating, Lettering, Designing and Chalk-Talking. Criticisms amateurs' work. Interesting, helpful, artistic, UNIQUE. It will please you. Money back if not satisfactory. Clara Briggs, Brian Walker and other noted artists contributors. \$1 per year. Send \$1 NOW, stamps or bill, to
LOCKWOOD PUB. CO., Dept. 53, KALAMAZOO, MICH.

FEAR STAMMERERS!

Consult Foote, the trained expert Psychologist. If you have tried many other methods and failed know that you cannot fail if you place yourself in my hands — either for personal treatment or by correspondence. I have studied psychology in the greatest Universities in the World. It is now recognized that the trained Psychologist is the only one who can successfully treat stammering. Mine is the only scientific method of treatment which will permanently eradicate your "FEAR." Write for booklet, "The Cure of Stammering."

Prof. F. B. Foote, Michigan Boulevard Building, Chicago, Illinois

VIOLIN, MANDOLIN, GUITAR or CORNET

FREE FINE TONE

To introduce our wonderful new system of teaching

note music by mail, Violin, Guitar, Mandolin, Piano, Organ or Cornet, will give you a dandy instrument absolutely FREE and guarantee to make you a player or no charge. Complete outfit FREE. Write at once. Special offer to first pupil. No obligation. SLINGERLAND'S CORRESPONDENCE SCHOOL of MUSIC, Dept. 9, Chicago, Ill.

A GOOD POSITION

with UNCLE SAM is most desirable. Life positions, pleasant surroundings, good pay, steady work, short hours, promotions on merit. Both sexes. No political pull. Thousands of appointments yearly. Most thorough preparation \$5. Returned if not appointed. Full information and questions used by the Civil Service Commission free.

AMERICAN CIVIL SERVICE SCHOOL WASHINGTON, D. C.



THIS COURSE MEANS MORE MONEY FOR YOU

Increase your income writing show cards. Big opportunity for ambitious men and women. Experience unnecessary. Our practical course teaches you quickly and explains the remarkable results obtained with Litholia Colors. Whatever your position, write for FREE BOOKLET now.

LITHOLIA COLOR CO.
1040 Flatiron Building NEW YORK

SHOW CARD WRITERS
EARN FROM
\$2 TO \$50 WEEK

Big Profits IN THE Auto Business

400,000 more cars this year than last. Thousands of new jobs as drivers, repair men, garage managers, etc.

NATIONAL AUTO SCHOOL

prepares for these jobs. Splendidly equipped workshops. Teaches its students everything about the automobile. For complete information and catalogue address

NATIONAL AUTO SCHOOL
2625 Reading Rd. Cincinnati, Ohio



CORNET FREE!

We guarantee to teach you to play by mail and will give you a Beautiful Cornet or any Band Instrument absolutely FREE. You pay weekly as lessons are taken. Instrument is sent with first lesson. Write today for our booklet and wonderful tuition offer.
INTERNATIONAL CORNET SCHOOL
502 Federal St., Boston, Mass.

Learn Piano Better and Faster

at 1-4 usual cost, in your own home, by Dr. Quinn's famous WRITTEN METHOD. Endorsed by leading musicians. Play chords in first lesson, complete piece within a few lessons. Successful for 25 years. Graduates everywhere. Diplomas granted. Reduced terms this month. Send for FREE book.
M. L. QUINN CONSERVATORY, Box 650 K.Y., CHICAGO

Be A Salesman
Earn \$20 to \$50 per week. We find positions for our graduates. Write for catalog and particulars.
Brown's Home-Study School, 100 Brown Bldg.
Peoria, Illinois

The Library of Original Sources

at a great bargain 10 beautiful, big volumes. Easy monthly payments. See our ads on page 7 October issue and page 31 November issue Popular Mechanics.

UNIVERSITY RESEARCH, Dept. G, Milwaukee, Wisconsin

LEARN WATCHMAKING

and become independent. Good-paying positions secured. Easy to learn. Send for FREE CATALOG.

ST. LOUIS WATCHMAKING SCHOOL, Dept. 5, ST. LOUIS, MO.

LEARN TO WRITE EARN \$25 to \$100

ADVERTISEMENTS A WEEK

We can positively show you by mail

How to increase your salary. BOOK MAILED FREE.

PAGE-DAVIS CO., 112 Page Building Chicago, Ill., or 156 Nassau St., New York

AT HOME Learn TO SING

Send 2-cent Stamp for Helpful Booklet, "The Voice Made Beautiful."

HARVEY SUTHERLAND, 813 President St., Brooklyn, N. Y.

WEAR

Trade Mark Registered B.V.D. U. S. Patent Office and Foreign Countries

UNDEWEAR

LEARNED BY ALMOST ANYONE

VENTRILOQUISM AT HOME

SMALL COST

Send today 2c stamp for particulars and proof.
O. A. SMITH, Room D 131, 823 Bigelow St., PEORIA, ILL.



Learn a Paying Profession

that assures you a good income and position for life. For twenty years we have successfully taught

PHOTOGRAPHY

Photo-Engraving and Three-Color Work

Our graduates earn \$20 to \$50 a week. We assist them to secure these positions. Learn how you can become successful. Terms easy—living inexpensive. Write for catalogue—NOW!

ILLINOIS COLLEGE OF PHOTOGRAPHY, 999 Wabash Avenue, Effingham, Ill.

LEARN IN 3 MONTHS TO EARN \$1300 TO \$4000 A YEAR

Our valuable Book "P" tells how. It's Free—write for it. The Demand is like a gold mine Unexplored. We are constantly called upon to fill good salaried positions. Why not qualify for one?

ESTAB. 1892

BODEE TRADE



DENTAL SCHOOL

15-17 W. 44th St. NEW YORK CITY

Anyone from 16 to 60 years old can easily learn Mechanical Dentistry. No book study; no previous schooling necessary. All practical work. We guarantee that you can earn before completion of the Course. Tuition payable in moderate monthly instalments. Start any time.

ELECTRICITY

CONDENSED COURSE IN ELECTRICAL ENGINEERING

Complete in One Year

Bliss Electrical School



Studies restricted to theoretical and practical electricity, mechanical drawing and necessary engineering work. Teaches simplicity, concentration, hard work. For young men of energy and character. 23 years of greatest success. Graduates hold first-class positions.

Opens Sept. 27th. Write for new catalog.

104 Takoma Avenue, WASHINGTON, D. C.

The University of Chicago

HOME STUDY

in addition to resident work, offers also instruction by correspondence.

For detailed information address

24th Year U. of C. (Div. 20) Chicago, Ill.



LEARN WATCHMAKING AND ENGRAVING



Earn while learning. Most practical watch school. Individual instructions. Graduates in great demand. Book free. Chicago School of Watchmaking, 63 E. Van Buren St., Chicago

EARN TELEGRAPH

Morse and Wireless—B. R. Accounting (Station Agency) taught. Splendid opportunities. Positions secured. Marconi Co. takes our wireless graduates. We own and exclusively occupy two large modern buildings equipped with B. E. and Western Union wires and complete \$5,000 Marconi Wireless Station. Largest School—established 40 years. Investment \$25,000. Endorsed by Railroad, Marconi and Western Union Officials. Expert practical teachers. Low living expenses; easily earned if desired. Tuition low. Easy payments. Correspondence course also. Catalogs Free.

Dodge's Telegraph, Ry. & Wireless Institute
208 Street, Valparaiso, Ind.

BECOME AN EXPERT ELECTRICIAN

Earn \$2,500 To \$4,000 a Year Learn At Home



Albert Wood Wicks,
M. S., E. E.

Former Sales Engineer of the General Electric Co., former General Manager of company manufacturing Jenney Electric Motors; former Sales Engineer of Fairbanks, Morse & Co.; now Consulting Engineer, also President and Director of the Wicks Electrical Institute.

This is the Age of Electrical Miracles! Electricity rules supreme as the motive power of the world. It's wonders are growing every day, on every side of us, in every aspect of modern life and industry. It is opportunity! And still, as Thos. Edison says, the field of Electricity is only in its infancy. The student of Electricity today will startle us with new marvels tomorrow. Right now we need men who know Electricity. There are not enough electrical workers to fill the big paying positions open. Every day the call for men grows more insistent. Feeling the pressure of this demand we are now making a very special offer to students at this time.

20 Lessons FREE Special Limited Offer

Never before has an offer so liberal been made on a Course in Electricity—probably will never be made again. I make it now because at the present time there is an unusual demand for trained Electricians and it is to my advantage to offer exceptional inducements to prospective students. I want to make it so easy for ambitious men that no possible excuse can be had for not accepting my wonderfully liberal offer. But this Free Lesson offer is limited, good for only 23 days. And there are only a limited number of these lessons to be given away free. So send the coupon at once. Let the free lessons themselves prove how easy it is for you to become an expert electrician by my methods.

I Will Teach You Personally

I will give you my personal and individual attention. Makes no difference who you are, where you live or what you do, I will train you by mail to become an Expert Electrician capable of earning \$2,500 to \$4,000 a year. My instruction is based on my own extensive, practical, everyday experience. I know just the kind of training you need for the big money job. No needless theory—no drudgery. You don't have to take a minute from your regular work. Your spare moments will do.

Short Time—Small Cost

You will marvel at the progress you will make under my instructions. Each lesson makes you more eager for the next. And in an astonishingly short time you have mastered the entire course and become an Expert Electrician! The cost to you just now is so small as to be insignificant. You can pay the small tuition fee in payments so easy that you will scarcely miss the money.

Write today for full description of course

and particulars of our amazing offer of 20 lessons Free. Even if you had not planned to enter the Electrical field don't fail to get all facts of this remarkable opportunity. Send coupon or postcard. No obligations on your part. Act at once—while this offer is open.

A. W. WICKS, M. S., E. E.,
Pres and Director, Wicks
Electrical Institute
81 W. Randolph St.,
Dept. 51
Chicago,
Ill.

Without obligation on me whatever, please send me full description of your course in Electricity and particulars of your special offer of 20 lessons free!

**FREE
Coupon**
A. W. WICKS,
M. S., E. E.

Pres. and Director
WICKS ELECTRICAL INSTITUTE,
Dept. 51 81 W. Randolph St.,
Chicago, Illinois

Name.....

Address.....

Please Mention Popular Mechanics

\$60 Drafting Course Free

I AM offering an opportunity to a few workers to get my entire Drafting Course, (value \$60,) absolutely free. Write and I will tell you all about it—how, by my system for enrolling other students, you may get my complete course of instruction without paying a penny in money. Almost no time or trouble.

Notice the other big offers I am making in this announcement. I am giving away a \$15.00 draftsman's outfit without cost.

\$125 a Month Draftsman's work is pleasant and profitable. \$125 a month is an ordinary salary.

Positions are open to intelligent men in the best surroundings. They are open everywhere. Men are needed who have just the kind of training I will give you. You can get this training during your spare time in your own home.

Mail the Coupon

for my valuable book—"Successful Draftsmanship." It explains how YOU can become a successful draftsman in a short time. This book is free at present, so write at once—NOW.

Chief Draftsman Will Train You Personally

on practical Drafting-room work *until* you are competent and *until* you are in a permanent position at a salary paying at least \$125 per month. This is an exceptional opportunity for a few selected ambitious men, between the ages of 16 and 40, whom I will train personally.



FREE!

This \$15 Draftsman's Working Outfit

These are regular working instruments, the kind I use myself. I give them free to you if you enroll at once. Besides these instruments I also give you free a 20x25 inch drawing board, a 24 inch T square—a 12 inch rule, a supply of drawing paper, two triangles, French curve pencils, erasers, thumb tacks, etc. All FREE. Send coupon today.

Chief Draftsman Dobe
Engineer's Equipment Co.
Div. 1199 Chicago, Ill.

Without any obligations to me whatsoever, please mail your book "Successful Draftsmanship," and full particulars of your liberal "Personal Instruction" offer to a few students. It is understood that I am obligated in no way whatever.



Name

Address

Pay as You Wish!

What I want is the RIGHT KIND of men. Don't bother about expense. I will give you the working outfit free if you get in at once. I charge a very small fee for training you to be an experienced draftsman. You can pay the small cost as suits you best. My object is to develop experienced draftsmen.

Mail the FREE Coupon

at once for my book, "Successful Draftsmanship," also list of open positions and for the free offer to be earning good money at once while learning at home. This offer is limited, and, in order to benefit thereby, act at once.

Chief Draftsman Dobe
Engineer's Equipment Co. (Inc.) Div. 1199, Chicago

CLASSIFIED ADVERTISEMENTS

Advertisements in this section, 15 cents per word, each insertion, minimum 10 words, payable in advance. To insure ads being inserted under proper classified head in the January issue, copy must reach this office not later than December 1st.

AUTOMOBILES

PAINT Your Car Yourself—Save \$25 to \$75 by doing the work at home with the Arsenal system. Our big free booklet "The Car Beautiful" tells how. Send for it today. Arsenal Varnish Co., Dept. P, Rock Island, Ill.

CYLINDER regrinding or reboring. Extra light pistons and perfect rings fitted. Advice, make and model, and number of bores, so we may quote. The Everts Machine Company, 14 Hicks Street, Hartford, Conn.

LEARN to be a chauffeur. Get this booklet—tells how to take care of an auto. Price 25c silver. Auto Publishers, P. O. Box 144, Indianapolis, Ind.

22 PASSENGER pay-enter bus; three ton chassis, dome lights, drop windows, inside curtains, \$850. Pugh, 384 Massachusetts Avenue, Buffalo, N. Y.

\$50.00 BUYS light runabout; good tires, electric lights, running order. Must sell. V. E. Gridley, Three Oaks, Mich.

AUTO owners double tread your own old tires; two in one; it's easy; 50c per tire per 1,000 miles; repair men make big money at this business. Agents Wanted. Tire Trading Co., Newark, N. J.

CYLINDER Regrinding—First-class equipment, fifteen years' experience, and specializing in this work enables us to do high-grade work at lowest prices. We manufacture the "Neverleak" individual cast piston rings. Prices will interest you. Bridgeport Piston Ring Co., 346 Connecticut Ave., Bridgeport, Conn.

AUTOMOBILE Instruction—\$55.25. Four weeks' course. Best-equipped school in the country. Men enrolled from all parts of the U. S. Booklet P. M. on request. West Side Y. M. C. A., 318 West 57th Street, New York.

1 AXLE and transmission, one pair heavy axles, 1 Mitchell automobile. All cheap. F. E. Alford, Goshen, Ind.

TEN 3 1/2 x 4 1/2" air compressors, \$20 each. J. D. Silbermann, Toledo, Ohio.

AUTOMOBILE SUPPLIES

THE Modern Auto Fuel—"Gidx"—Fuel for Increasing Efficiency of Gasoline Engines. Registered U. S. Patent Office No. 165,313. 1,000 Agents Wanted. Repeat proposition, exclusive territory. One cent per gallon, eliminates carbon troubles, increases power and mileage, facilitates starting. Ask what "Gidx" users say of its merits. Absolutely non-injurious. 100 Tablets One Dollar, prepaid. Fred M. Giddings, Mfg., 63 E. Simmons St., Galesburg, Illinois.

1911 CHALMERS unit power plant \$150. 60 hp, Royal Tourist Motor \$150. 6 cyl. 40 hp, Thomas Eng. \$175. Bosch Mag. \$50. 1909 Mitchell parts. Buick 10 parts. Auto Salvage Co., 1436 Wabash Ave., Chicago.

DOUBLE Tires give 6,000 miles and upwards. 30% to 50% saved. Positive guarantee. Some prices, 28x3 \$6.75, 30x3 1/2 \$8.50, 32x3 1/2 \$9.25, 33x4 \$11.50, 34x4 \$12.00, 36x4 1/2 \$15.25. Send for list now! State size. Anglo Tire Company, 838 7th Ave., New York.

SALE or Exchange—Light car chassis. Frank Schock, Mt. Joy, Pa.

ANY magneto, coil, lighting and starting system repaired. Work guaranteed. Estimates cheerfully given. Pellet's Magneto Exchange, 1996 Michigan Avenue, Chicago, Illinois.

BATTERY Charging Dynamics earn big profits. Operated by gasoline engine or cty current. Small monthly payments. Hobart Bros., Troy, Ohio.

AUTO Dealers, if interested write on business stationery for Auto Supply Catalogue. A. Campbell Iron Co., 819 Cass Ave., St. Louis, Mo.

MEtz Engine with Bosch magneto \$50. Other Metz parts cheap. Box 225, Sutherland, Orst.

BUILD your own auto top and save money. We furnish complete knocked down frames for any make of car with roof and back curtain ready to put together. You save half. A. A. Top Mfg. Co., 1449 Washington Blvd., Chicago, Ill.

INVENTIONS sold on commission. No advance fee. Patent News, C, Washington, D. C.

SPARK Plug trouble? Pronto Spark Gaps will fire any plug, in any condition, every time. Inexpensive—the most gladly accepted motor accessory ever invented. Salesman, you've hit it. Ask us. Pronto Manufacturing Co., Omaha, Neb.

EXPLOSION Whistle. Fits priming cup. Most powerful signal made. Rapid seller owing to real value. Baell Manufacturing Co., 1141 E. 46th St., Chicago.

AUTOMOBILE Wind Shield Cleaner; neat, durable and simple, cleans both sides at once, now ready for the market. Agents wanted for all territories. Standard Accessories Co., 81 New Street, New York.

SOMETHING new: Magneto magnets changed instantly with alternating current, any voltage. Send stamp for full particulars. W. B. Jeslyn, 2219 South Main St., Los Angeles, Cal.

ACT quick! Automobile gasoline going up. Sell "Gaso-Tonic." Equals gasoline at 3c a gallon. Eliminates Carbon. Dollar an hour profit. Sales guaranteed. White Mfg. Co., Dept. M, Cincinnati, O.

RECTIFIERS for garages. All sizes. Charge one to eight batteries, \$12 upwards. American Battery Company, 1129 Fulton St., Chicago.

GOOD Ford chassis wanted; must be cheap. C. L. Eubank, Eastman, Ga.

AUTOMOBILE tires, tubes or any mechanical part for any car at cut prices. Specializing on parts for Ford and Maxwell cars. Write for prices to Grossman Auto Parts Co., White Plains, N. Y.

OUR Double-Tread Tires are Guaranteed (written) for 3,500 miles. Two tires in one. Big, strong, extra heavy, 30x3 1/2, \$7.00; 34x4, \$9.25; 36x4 1/2, \$12.00; 37x5, \$13.00. Big saving on other sizes also. Send for list now! State size and type rim. Max Labeu & Company, 205B West 48th, New York.

VULCANIZER for shop. Bargain. Vanderpool's, Springfield, Ohio

FORD ACCESSORIES

J. P. TIRE Tool removes Ford Tires in half a minute. Every Ford owner wants it. Sells on sight. Write for our profitable agency offer. Sample prepaid \$1.50. Marshall Oil Co., Box 1060, Marshalltown, Iowa.

MEN with Ford Cars preferred to demonstrate and sell other Ford-owners "Best Automatic Shock Absorbers," \$5.00 set four; "Best Safety Steering Devices," \$5.00; "Best Automatic Starters," \$10.00; "Shur-fire Spark Gaps," "Tiger Horns," etc. Liberal commissions; secure territory for "Best" line. Jack's Campbell Co., Minneapolis, Minn.

GOOD second-hand N. Ford parts for sale at 1-3 list price. J. O. Turner, Franklin, Ky.

FORD owner, at last a real Ford Starter, just completed, ready to deliver, 12 dollars. Money refunded if you are not satisfied. Good opportunity for salesmen and dealers. J. H. C. Auto Supply Co., Columbia Theatre Bldg., Broadway & 47th St., New York City.

"FORD" comic postals! Best jokes, 3 samples, dime, 12 for quarter. Agents wanted. Burkhardt Sales Co., Milbank, S. D.

"STEER Relief" for Fords. Guaranteed Best Made. Want Agents. Sample \$3.00; prepaid. C. B. Post, New London, Ohio.

DIFFERENTIAL ring gear, \$3.00, and any and all other parts for Ford cars at equally astonishing low prices. Write for bargain sheet. Grossman Auto Parts Company, White Plains, N. Y.

CHILLY Weather is when motors begin to have Whooping Cough. (Starting hard). "Gidx," the Modern Auto Fuel, makes them start easier. One cent per gallon eliminates Carbon Troubles. Increases Power and Mileage. 100 Tablets \$1.00 Prepaid. Fred M. Giddings, Mfg., 63 Simmons St., Galesburg, Illinois.

CYCLECARS AND MATERIAL

CYCLECAR Friction Transmissions and parts. Cogswell Manufacturing Co., Hall St., Springfield, Mass.

MOTORCYCLES, BICYCLES & SUPPLIES

MOTORCYCLES and bicycles at cut prices; singles and twins \$25 to \$50. Motorcycle tires \$3; automobile tires \$3. Second-hand bicycles \$5; tandems \$10. New bicycles and motorcycles at factory prices. Buy direct, save dealer's profits. Send for catalog. Deinger Cycle Co., Rochester, N. Y.

BIG bargains in second-hand motorcycles, \$25 up. Indians, Harleys, Thors, Excelsiors and Merckels. Write for description. Howard A. French & Co., Baltimore, Md.

WRITE today for our list of Motorcycle Bargains. The greatest values in the country. Every machine fully warranted in perfect running order. David Stern Co., 1947 W. Madison St., Chicago, Ill.

SUPPLIES—Our big catalogue with prices lower than usual sent free to motorcycle owners. Mero, Hammonton, N. Y.

DON'T buy a Bicycle Motor Attachment until you get our catalogue and prices. Shaw Mfg. Co., Dept. 27, Galesburg, Kansas.

ALL Used Motorcycles and New and Used Bicycles for sale at lowest possible prices. Send for list. Seeber & Hofhelms, Buffalo, New York.

1913 INDIAN Twin, re-enameled, factory overhauled, like new, \$135. Spring frame Merkle Twin, good condition, bargain; \$95. W. F. Issacson, Hiawatha, Kansas.

WILL sell my Twin Indian Motorcycle, guarantee good condition, good tires, looks like new, for \$75. J. L. Moritz, 4538 Detroit Ave., Cleveland, Ohio.

WE'LL give you a Motorcycle, less than agent's cost. Need room; 150 on hand, \$50 up. Write today for newest list. Western Supplies Co., 1150 Larimer, Denver, Colo.

SHAW Motorcycle, bargain, hundred miles, reason in letter. Howard Hubler, Iron Mt., Wyo.

INDIAN 4 H. P. lamp, horn, equipped \$25. Emblem 5 H. P. magneto and clutch, electric light, horn, etc. \$35. Yale 8 H. P. twin magneto and clutch, fully equipped, snap \$65. Henderson 4 cylinder police machine, fully equipped \$130. Harley-Davidson, 1915 three speed, electric demonstrator \$175. Motorcycle casings 28x3, \$5.50. Tubes 28x3, \$1.98. Spark Plugs, any size \$2.5. Grips, long style \$2.25. Motorcycle saddles \$2.25. Heliger carburetors model H \$1.95. Stewart-Warner Signals for motorcycles and automobiles \$2.40. We guarantee goods as represented or money refunded. Wandersee Co., 129 Gratiot Ave., Branch Store, 2995 Woodward Ave., Detroit, Mich. Largest motorcycle and accessory store in Michigan. Ask for November bargain sheet. Free upon request.

MOTORCYCLES, accessories, repair parts for all makes. Thousands of dollars given away by our special profit sharing plan. Write for it. Motorcycle Parts Mfg. Wks., 2127 Michigan Avenue, Chicago.

HELP! Help! Bring our 1915 Season to a close. All Models listed in our Circular No. 49, reduced 5% from list. Do not delay your reply, but write at once. All makes and models at \$10 to \$200. Trucks, Side Cars, Side Vans and Bicycles. Mueller Cycle & Supply Co., 726 National Ave., Milwaukee, Wis. Oldest and Largest Dealers in the Northwest.

MONARCH 5-Horse Magneto, clutch, speedometer, \$85. Oscar Stromer, Gillett, Wis.

1914 JEFFERSON Twin, fully equipped, Prest-O-Lite headlight, etc. Factory overhauled. A No. 1 running condition. \$100 cash. Dean Chandler, Belvidere, Ill.

FOR Sale—1914 Two-speed Indian in excellent condition. Price \$150. Ben Ferguson, Cranston, Wis.

HARLEY-DAVIDSON twin, 8 H. P., good condition, complete outfit. Cost \$350, sell for \$175 cash. Ray C. Hammond, Wyoconna, Wis.

EXCELSIOR 2-cyl., including extras. Very speedy. Practically new. Big bargain. Harold L. Coates, 203 Semineau St., Saginaw, Mich.

MUST Sale, Cheap—Excelsior Twin, magneto, tandem, fine shape, \$70.00. Box 34, West, Iowa.

FIRST check for \$30 takes 4 horse motorcycle, magneto, clutch, etc. Joseph Camlet, 311 Lincoln St., Carlstadt, N. J.

FOR Sale—1914 Twin Indian 2-speed fully equipped; Dunham Side Car. S. A. Shappi, 2518 North Fairfield Ave., Chicago, Ill.

CLOSING Out Sale of high-grade slightly used motorcycles. This time of year we close out all our used motorcycles. All standard makes, twins and singles, belt and chain drives. Prices \$25 and up. Write for complete list, Gotham Sporting Goods Company, 57 Warren St., New York City.

USED Motorcycles from \$25 to \$255. Small deposit required. Money refunded if machine not satisfactory. Write for list today. C. H. Lang, 1704 Michigan Avenue, Chicago.

\$50 TO \$150 buys the best motorcycles; every make and model in our large stock must be cleared. Half price. Send for list today. Brown Music Co., 3918 E. 91st St., Chicago, Ill.

I HAVE two motorcycles I will sell for \$150. They are 1913 Indian and Excelsior, both in good running condition. First check for same will get bargain. Emil J. Kriznsky, 1421-26 So. Michigan Ave., Chicago.

BARGAINS in new and used motorcycles. Get bulletin M-80. Sterling Motor Co., Brockton, Mass.

MOTORCYCLE Accessories. Long leather leggings \$1. Spark plugs \$.25. Bulb horns \$.75. Saddles \$2.25. Grips \$.30. Heitger model H carburetors \$4.95. 28x3 tubes \$1. Studded casings \$5.50. Stewart Warner Signals \$2.50. Motorcycle clothing. Coat and pants \$2. Indian motorcycle \$25. Emblem 5 H.P. magneto and clutch fully equipped, good tires, \$35. Ask for November bargain sheet on request. Free. Largest motorcycle store in Michigan. Wandersco Company, 129 Gratiot Ave., Branch Store, 2096 Woodward Ave., Detroit, Mich.

BIG bargains in good motorcycles we have taken in exchange on new ones. Send for special bargain list. Shaw Mfg. Co., Galesburg, Kansas.

SEND for latest Bulletin of real Motorcycle Bargains, used and slightly used, all makes, models and prices; if you have \$25 and really want a powerful Motorcycle, send for this Bulletin; hundreds of machines at all prices, new ones on easy payments; tell us what you want and how much you can pay; we can fix you up. Peerless Motorcycle Co., Dorchester, Mass.

MOTORCYCLE cylinders ground, fitted with new piston and rings \$5.00, guaranteed. Muncie Piston Co., Muncie, Ind.

WANT to sell your motorcycle? I have a method which has sold many. Write me today for free information. F. W. Johnson, Room 900, 75 E. Madison St., Chicago.

EXCEPTIONAL Bargains: Three-Speed Harley Twin, Fully equipped, Like New—\$190—Thor Twelve—Nearly New—\$160—Guaranteed. Lists Free. All Makes. Childster & Company, Ottumwa, Iowa.

100 **MOTORCYCLES**: new and second-hand; all makes; \$25.00 and up. Write for complete list and prices. Machines sent on approval. Guy W. Campbell Co., Waterloo, Iowa.

USED Motorcycles. List of bargains free. Motorcycle Exchange Co., Box 964, Logan, W. Va.

1913 **TWIN** Merkle equipped \$68. Fast ported racer cheap. L. D. McEwen, 244 26th St., Des Moines, Ia.

1913 **HARLEY** Twin fully equipped \$150.00. F. Eike, 4124 Louisiana, St. Louis, Mo.

FOR Sale—Harley Twin \$80.00. Joseph Trabold, Coldwater, N. Y.

\$100 **TAKES** Harley-Davidson Motorcycle, nearly new. Cost \$310. Henry A. Swanson, Star B, 1, Cushing, Wis.

WELDING

WELDING Plants, \$25 to \$250. Liberal terms. Write Bermo Co., Omaha, Neb., U. S. A.

\$1.00 **BRINGS** a preliminary lesson on Electric Arc Welding, \$5.00 to \$15.00 per day is paid first class welders. Easy to learn. Field not overcrowded. General Welding Supplies Co., Westfield, New Jersey.

WELDERS, make money selling acetylene welding torches. Reich Welding Works, New York.

WELDING Plants, \$25 to \$250. Liberal terms. Write Bermo Co., Omaha, Neb., U. S. A.

COLLECTIONS

ALL Kinds Claims Collected Anywhere. Fidelity Credit Co., Richmond, Va.

AERONAUTICS

EXACT 3-ft. Model War Aeroplanes. Guaranteed to Fly. Complete plans, scale drawings, precise, understandable instructions: Curtiss Military Tractor 25c; Taube 25c; Bleriot 15c; Nieuport 25c; Curtiss Flying Boat 25c; Wright 25c; "Peoli" 25c. Any or all parts at small cost. Our 1916 Aeroplane Book contains full information. 5c postpaid. Ideal Aeroplane Co., 82½ West Broadway, N. Y.

BICYCLE Monoplane prints, 25c coin; Material \$10. Big prize offered for the longest flight. Elmer Hammel, Raspeburg, Md.

AIRSHIPS, involving powerful natural forces perfected. Absolutely safe and will fly indefinitely. Early deliveries. Low cost, no complications. A. Kouasko, 180 Mack St., Detroit.

WILL Trade Flying-boat without motor for Auto. Ralph Cole, Norwalk, O.

MODEL Aeroplanes—7c brings greatest handbook and catalog. Cheapest supplies. Walter Phipps, 593 5th Ave., New York.

CLEMENT-Bayard 50 H.P., two cylinder motor. Magneto, carburetor, water pump, 108 pounds. Brand new. C. H. Wetzel, Wayne, Pa.

AVIATION Motors, all makes, up to 150 H.P., \$250 up. Complete aeroplanes, all types, \$500 up. State your needs. Aero Exchange, 38 Park Row, N. Y. C.

CATALOG "H" off the press, most complete aeronautical catalog ever published, sent for 6 red stamps. Motor Catalog 8c; propeller catalog, 6c. Heath Aerial Vehicle Co., Chicago.

TURNBUCKLES: National Aero Varnish. National Aeroplane Company, Machinery Hall, Chicago.

LIGHT Weight, Gasoline Engines, 2½ lbs. Guaranteed ½ H. P. The Weiss Co., Torrington, Conn.

BOOKS AND PERIODICALS

MY book with hundreds of troubles and remedies—for car owners, auto schools, garage, repair and salesman. Prepares you to pass Civil Service Examinations. Satisfaction or money refunded. Postpaid for 30c. Wm. B. Wiedhoff, 2332 Larrabee St., Chicago.

ENGINEERS' questions and answers for license, by Hobson, for twenty-five cents, postpaid. Send stamps. Reilly's Book Store, Philadelphia, Pa.

AUTOMOBILE Patents, Allen, 1789-1992, \$18; Knight's Mechanical Dictionary, \$19; Henley's Encyclopedia Engineering, \$16; Wagner's Chemical Technology, \$5; Industrial Chemistry, International Correspondence School Library, Vol. 78-Vol. 85, \$12; Century Dictionary, Encyclopedia, Atlas, 1900, \$18. Benjamin Webster, 600 22nd St., Washington, D. C.

AIRCRAFT, America's aeronautical authority, illustrated, monthly. Two dollars per year. Send for sample. 37 East 28th St., New York.

PRACTICAL Brief Figuring. Best book of kind. Figuring made easy. Needed by every business man and all students. Contains Leary's "One Rule for Interest"; short cuts for costs, profits, estimates, etc. Mailed for 25c. Reilly & Britton, Publishers, 1012 Michigan Avenue, Chicago.

CORRESPONDENCE Courses Technical Books Bought, Sold. Catalogue Free. C. Bubb, Detroit, Michigan.

BOOKS, Bargains, Catalogue. Higene's, A-2141 Post, San Francisco. (Books bought.)

MAKE Your Own Wireless Set—This new book "How To Make a Wireless Receiving Set for Time Signals" gives accurate, simple directions and diagrams covering every step. You use ordinary tools and require very small outfit. Send 25c coin today. C. Brandes, Inc., Room 817, 32 Union Square, New York.

BOYS—10c brings large 9x12 boys' magazine one year. Canada, 25c. Dandy stories, mechanics, stamps, electric. Youths' Magazine, 2122 Mallers Bldg., Chicago.

MONEY-Making Books. Catalogue free. W. H. Garner, 1276 West 24th St., Los Angeles, Calif.

FORD John Book, 64 pages, 10c. Agents wanted. Richard Lavery, Asbury Park, N. J.

BOOKS worth while; instructive and entertaining. Puzzles, Tricks, Novelities. Illustrated catalogue, free. Auburn Supply Co., Dept. 12B, 7817 Peoria St., Chicago.

VOLUMES and sets on all technical subjects bought, sold, exchanged, rented. Correspondence-school books specialty. Boston Book Exchange, 1236 Washington St., Boston, Mass.

LATEST in Mathematics. Work all Arithmetical and Geometrical calculations with ease, accuracy and large saving of figures by "Comparative Cancellation." Thoroughly demonstrated. 150 pages. \$1.00 postpaid. Circulars free. Herrick & Horton, Publishers, Princeton, Ill.

MECHANICS riggers sailors complete handbook on knots, hitches, rope splicing; 100 illus. By mail 10c coin. G. S. Brady, 764 Jackson Blvd., Chicago.

"STRUCTURAL Drafting," \$1.00; "Lettering," 25c. W. B. Browning, Memphis, Tenn.

HUNDRED Premiums for Magazine Subscribers. Premium list. Catalogue of Three thousand publications free. Postage five cents. Edwards Magazine Agency, Atlantic City, N. J.

CHAUFFEURS' Questions and Answers to Prepare for License, 39c postpaid. W. E. Moody, Box 473, Rochester, N. Y.

SHOE Repairing, Self Taught. It's easy, Fascinating, Profitable. Price 50 cents. W. J. Shuman, North Second Street, Chambersburg, Pa. Write for contents.

AUTOMOBILE Troubles and how to remedy them. Cloth, \$1; leather, \$1.50. Many other practical and reliable mechanical books. Send for circular. Chas. C. Thompson Co., Dept. C, 501-509 Plymouth Ct., Chicago.

SEND ten cents for the liveliest outdoor magazine published. Hunter-Trader-Trapper, Box 38, Columbus, Ohio.

EDUCATIONAL AND INSTRUCTION

CLIMBERS' correspondence course in English. Individual attention by experienced teacher. All written work corrected and returned. No books to buy. 30 lessons \$10.00. Endless chain system cheaper. First exercise corrected free. M. George Wright, Box 553, Chicago.

FOUR handwriting easily and quickly changed to good. Particulars free. Address D. B. Jones, Florence Station, Ky.

ELECTRIC Starter course. Finest ever given. Designed by practical Auto and Starter experts. Learn at home during spare time. P-A Electric Works, 623 North 47th St., Omaha, Neb.

LEARN Mechanical Drafting. Complete Courses. Personal instruction until position is secured; also short Courses for Shop Men. Detroit School of Drafting, Detroit, Mich.

WRITING Lessons for Home Practice. Over 250 copy lines, postpaid, 50c. Circulars free. Patrick Commercial School, Desk 14, York, Pa.

WONDERFUL Mathematical Marvel; quit adding, let Halsey's Adding Chart show footings; mental addition unnecessary. Price twenty-five cents each. Agents wanted. J. G. Halsey, 6248 Drexel Ave., Chicago.

ARTIFICIAL Marble, Sanitary flooring, ornamental casting, concrete, plaster, papier-mache, interior decorations, garden furniture, statuary, life casting, elastic moulds, electro bronze depositing (immensely profitable work), complete instructions \$1; particulars, 200 illustrations free. Mahler, D-117 Russell St., Brooklyn, N. Y.

PERSONAL instructions in Show Card Writing by experienced man. Short course. Original methods, results guaranteed. C. L. McKie, Dept. M, Ypsilanti, Mich.

LEARN Gregg Shorthand by mail. America's leading system. Send for free lesson and particulars. M. B. Barr, Pelham, N. Y.

MECHANICAL Expert Teaching Drafting, modern machine work and die making. Lessons 50 cents, 12 lessons \$5. Boma Co., 207 E. 77 St., Cleveland, Ohio.

STAMPERERS—Let me cure you at home. New, sure method. Expense small. Results permanent. Write immediately. My terms will please you. R. Arnaud, Keene, N. H.

RAISED letter signs. Send 25c for complete instructions. Eastern Exchange, Bridgeton, Maine.

DETROIT Technical Institute offers courses university grade in Automobile, Chemical, Electrical, and Mechanical Engineering, Law, Accountancy, Business Administration, Pharmacy, Salesmanship, Advertising, Real Estate, Credits, and Watchmaking. Bulletin free. Address Director of Education, Room 311, Y. M. C. A., Detroit, Mich.

NEW, easy shorthand. Students write business letters after fourth lesson. **Teach Typewriting, English.** Personal correction of work. Investigate. Home Study School, 469 Caesar Mich Building, Providence, R. I.

MOULDS and models for ornamental casting of novelties, statuary, garden furniture, in cement, plaster, Italian marble, etc. Free illustrated catalogue displaying large assortment. Roth, A-45 Frost St., Brooklyn, N. Y.

STUDY Bacteriology, Public Health, and Sanitation. Positions pay \$3,000 to \$5,000. Interesting home study course. Previous experience unnecessary. Degree granted. We help secure positions. Write for prospectus. American College of Bacteriology, Dept. 29, Chicago.

TRADE SCHOOLS

PAINTING, Decorating, Paper Hanging taught by actual practice. Free catalogue. Chicago School of Painting, 150 West Austin Ave., Chicago.

ELECTRICITY, Plumbing, Bricklaying, Mechanical and Architectural Drafting taught by practical instruction. This is largest and best equipped practical school in America. Short time required and small expense. Positions secured. Earn expenses while learning. Write for big illustrated book. It's free. Coyne Trade School, Dept. 8199, Chicago.

LEARN Sign Painting and Card Writing in Practical School in short time. Earn expenses while learning. Sign Card School, Dept. A., 131 N. 34th Ave., Chicago.

TELEGRAPHY

TELEGRAPHY—Morse and Wireless— taught at home in half usual time. The Omnigraph Automatic Transmitter combined with sounder or buzzer sends you messages, any speed, just as expert operator would. Used by U. S. Gov't to examine all applicants for licenses. Trifling cost. Catalog free. Omnigraph Mfg. Co., 41-G Cortlandt St., New York.

TELEGRAPHY—Morse and Wireless— also Station Agency taught. R. H. and Western Union wires and complete Marconi Wireless Station in school. Graduates assisted. Marconi Co. employs our wireless graduates. Low living expense—easily earned. Largest school—established 40 years. Investment \$25,000. Correspondence courses also. Catalog free. Dodge's Institute, 15th St., Valparaiso, Ind.

WIRELESS

WIRELESS Telegraphy taught by mail. High-grade instruction. Write for particulars. New York Wireless School, 342 West 56th Street, New York.

PICTURES, POST CARDS, PENNANTS

14 FELT Comical Pennants, Charlie Chaplin, Billie Burke, Brinkley Beauties, San Francisco-San Diego Expositions, September Morn, etc., \$1.00, Sykes Specialties, Los Angeles, Cal.

OUR Members Everywhere would like to exchange view postcards with you. Membership 10c (Coin). Buckeye Club, Box 340-X, Cleveland, Ohio.

BOOKS and Pictures. Samples and illustrated catalogue, 10c. Taylor Brothers, M2139 Clifton, Chicago.

29 COMIC Felt Pennants \$1.20. Hundred \$5.00. Catalog free. Sykes Specialties, Los Angeles.

EXCHANGE post cards. Get acquainted. Membership and 6 pretty cards, 10c. Riverside Club, Dept. 10, Knoxville, Md.

POSTCARD Collecting, extremely interesting. Live club. Membership, including magazine stories, etc., 10c. Elite Exchange, R57, 3684 Milwaukee Ave., Chicago.

LEARN how you may obtain a genuine Water Color Marine view, size 10x21 inches, absolutely free. W. G. Starkey, Dept. C, 275 Morris Ave., Elizabeth, N. J.

50 POST-CARDS showing trip around world, 30c. Economy Co., Charlotte, N. C.

200 ILLUSTRATIONS free. Beautiful art casts, Mahler, K-117 Russell St., Brooklyn, N. Y.

MEMBERSHIP printed immediately, 10c. Pacific Card Exchange, Bryn Mawr, Wash.

10 ELEGANT Postcards and catalogue, 10c. Stewart Co., Providence, R. I.

IF you really want to exchange postcards, try our splendid club. Lists circulate in many countries. Membership, 10c. Halcyon Club, Box 133, Erie, Pa.

CAMERAS AND PHOTO SUPPLIES

SAVE 40% on Photo Paper from factory, prepaid. "Instanto" has a sparkling quality no other gaslight paper possesses, quick printing develops easy. Money back guarantee. Send 25c for 3 dozen postals or 4x5 size, price list and full directions. Photo Products Co., Dept. J, 6190 La Salle St., Chicago.

HAVE you a Camera? Write for samples of my magazines, American Photography and Popular Photography, which tell you how to make better pictures and earn money. F. R. Fraprie, 143 Pope Bldg., Boston.

IF you have a High-grade Camera, Lens, Kodak, or Motion-Picture Camera, and want to turn it into cash, write us today. State particulars, price, etc. We buy and trade, sell or exchange everything in Cameras from Vest Pocket to Graflex. Prompt, satisfactory service and a square deal to all. David Stern Co., 1047M W. Madison St., Chicago, Ill. In business since 1885.

FILMS developed 5c per roll. Prints 3¼" x 5½" or smaller, 3c. Satisfaction guaranteed. 6 years' experience; return postage paid. Philip Hochm, St. Charles, Mo.

BEAUTIFUL Christmas Kodak Enlargements for Gifts, 8x10 mounted, 25c. Send only the negative. Kodak Finishing, 50c offer for 10c. Send 10c (stamps) and roll of film, any size, 6 or 12 exposure; will develop film and send you 6 pictures from best negatives. Mention this ad. Roanoke Cycle Company, Roanoke, Va.

FILMS developed, ten cents per roll; film packs, twenty cents. Postcard prints, four cents; smaller sizes, three cents. Guy Hall, Chapman, Kansas.

CHIBOSS Co., 3817 Delmar, St. Louis. Rolls developed, 10c. Prints, 2½"x4¼, 3c; 3¼"x4¼, 3½"x5½, 4c. Send for commission offer.

INSTRUCTIONS and formulas for Phosphorescent Photos, Disappearing Photos, Photos on Apples, Cloth, Chinaware, etc. Simple Enlarger, Trick Pictures, 25 in all, for 25c. Disappearing Photo Free with each order. Money-back Basis. P. Benson, Stewartville, Minn.

FILMS developed, 10c; prints, 3c to 5c. A reputable incorporated company conducting largest existing plant. Price list and special offer. Enlargements our specialty. Chicago Photo Finishing Co., 54 W. Lake St., Dept. A, Chicago.

SPECIAL—Guaranteed Electric Flash Lamp \$1.10 postpaid, and samples best developers. Worth \$2.65. Act quick. Photo Chemical Co., Lincoln Park, Chicago.

8x10 ENLARGEMENTS 25c; 6, \$1.00. Sprauer, Stahlheber Rd., Hamilton, Ohio.

FOR Sale.—3A Special Kodak \$59. Arthur Sage, 941 Superior St., Appleton, Wis.

KODAK Films Developed, 10c per roll, any size. Prompt attention given mail orders. Prints, 2½"x3½, 3¼"x4¼, 3c, 4x5 to 3½"x5½, 3c. J. M. Manning, Box B, 1642 Third Ave., New York City.

CAMERA and Lens Bargains. Cut Rate Photo Bargain List just off the press. Send stamp. Willoughby, 819 Broadway, New York.

FILMS developed 5c, prints 3c, all sizes. Johnson's Studio, Oswego, N. Y.

SECOND-HAND Lenses. All makes and sizes. Work just as well as new ones. Send for our bargain list. Hyatt's Photo Supply House, St. Louis, Mo.

EXTRAORDINARY Offer. Your next kodak film roll developed, five cents. Prints from same, two cents each. Only one roll developed at this price for each customer, to show quality of our work. Moser & Son, A 29 Arcade, Cincinnati, O.

BIG Money saved on Photographic Lenses and Apparatus—goods exchanged; repairing done. Ralph J. Golsen, 5123 Kenmore Ave., Chicago, Department F.

WE buy, sell and exchange. Bargains in Microscopes, Telescopes, Binoculars, Cameras, etc. Bargain list sent. Kahn & Son, Oriskany, No. 54 John St., New York. Established 62 years.

LET me finish your next roll of Kodak Films. Send 10c for trial order. Slocum, 406 Main, Peoria, Ill.

FILMS developed 10c, all sizes. Prints 2½-3¼, 3c; 2½-4¼, 3½-3¾, 3¼-4¼, 4c; Post Cards, 50c doz. Work guaranteed and returned 24 hours after receiving. Postpaid. Send negatives for samples. Girard's Commercial Photo Shop, Holyoke, Mass.

MOTION PICTURES

SPOT cash paid for second-hand high-grade Motion-Picture Cameras, Lenses, etc. Write us today. David Stern Co., 1947 W. Madison St., Chicago, Ill.

WRITE Moving-Picture Plays, Good prices. Devote all or spare time. No correspondence school. Details free. Atlas Publishing Co., 304, Cincinnati.

BIG Money Writing Moving-Picture Plays. Constant demand. Correspondence course; literary ability unnecessary. Write for free booklet. "How to Write Moving-Picture Plays." Universal Publishing Co., 292 Fergus Falls, Minnesota.

HOW to Write Photoplays is a brand-new volume devoted to motion-picture playwriting. Contains model scenario, a list of 36 scenario buyers, and all information necessary. Price 35c. Photoplay Pub. Co., PM-3348 Lowe Ave., Chicago.

ELECTRIC Generators for MP theatre—anyone can operate with gasoline engine. Save half your lighting bills. Easy payments. Hobart Bros. Troy, Ohio.

BIG money writing Photo-plays; details free to beginners. No correspondence course. Producers League, 230 Wainwright, St. Louis.

WRITE Moving Picture Plays; constant demand; big prices paid; past experience unnecessary; details free. Gleason Co., 223 Whiteman, Cincinnati, Ohio.

\$35 PROFIT Nightly—Moving Picture Business—small capital starts you, no experience needed. Teach you—furnish everything. Ralph J. Golsen, 5123 Kenmore Ave., Chicago, Dept. M.

MAKE big money writing moving picture plays. Previous experience, literary talent or correspondence course unnecessary. Free details and special offer. E-Z Scenario Co., 609 West 127th St., New York.

MAKE \$50.00 clear nightly. We start you in the moving-picture business on the installment plan. No experience necessary. Write for free catalog. Monarch Film Service, Dept. P, Memphis, Tenn.

WRITE Photoplays—earn a big income. Our book tells how. Details free. Enterprise Co., PM-3348 Lowe Ave., Chicago.

BUSINESS OPPORTUNITIES

START in the carpet or clothes cleaning business Now. Thurman Vacuum Process unequaled for commercial cleaning. We show you how. Easily learned. Only \$125 capital needed to earn good income in towns of 2,000 and over. Write today. Thurman Vacuum Cleaner Co., manufacturers of all types Vacuum Cleaners. Dept. H, St. Louis, U. S. A.

RESILVERING Mirrors; guaranteed process; 150 formulas. 20c. "Ideal," 3311-T, Belleplaine Ave. Chicago

MAIL order leader of the season—"\$150 Yearly Average Wage." fastest selling booklet ever written. Every copy sold sells several more. Like an "endless chain." It brings you thousands of live names and addresses, accompanied by coin. Helps your sales of other goods. Sample and complete proposition, 10c. Jack Panser, Author, Box M-307, Grand Rapids, Mich.

OPERATE success proven mail order business under guarantee by reputable corporation—established eleven years. Everything furnished—no stock to carry. Safe money—avoid mistakes. Merford Company, Incorporated, Dept. 156, Chicago.

CONTRACT—San-o-tex, modern, sanitary, fire proof floors. Have monthly income \$150 to \$300, on kitchen floors alone. Instructions, \$3. San-o-tex Company, Washington, Indiana.

AUTOMOBILE wanted in exchange for Remington typewriter, patterns, mail-order proposition worth \$500. W. H. Forse, Anderson, Indiana.

TEN successful workable plans that are making big money for others. Small capital required; positively guaranteed. Mailed complete for 10c. Address at once, Publisher, 1654 College, Racine, Wis.

DOLLARS in used dry batteries, new proposition. Certain ingredients double usual value, on account war prices. Write today for information. Better still, send one dollar for chemists analysis giving exact values, instructions, etc. F. Cook, Box 159, Greensboro, N. C.

I PUBLISH a wonderful magazine of money making plans, ideas, suggestions and inspiration! It will show you how to make more money. Sample, 10c. Booster Magazine, Northwestern Bldg., Chicago.

WE start you in a real mail order business. Send 25 cents for samples of our own manufacture. R. F. D. No. 4, Box 191B, Shaylor Mfg. Co., Portland, Me.

\$300 PUTS you next to the biggest legitimate money-maker in country; wonderful new secret process for removing rust; unlimited market. Bushever Sales Company, 95 Liberty St., New York.

BIG Kansas company will start ambitious man or woman in fast growing Mail Order Business; any locality; \$3,000 yearly; spare time; no canvassing; no experience. We furnish everything. Write for Unique Selling Plan, Keystone, Pres., 402 W. 7th, Pittsburg, Kansas.

I MADE \$50,000 in five years with a small mail order business; began with \$5 in my own home. I will show you how to do the work; no canvassing. Send for free booklet; tells how. Heacock, Box 867, Lockport, N. Y.

QUIT Working for others. Start a Cleaning and Dyeing Business. No experience and but small capital needed. Tremendous money-maker. Greatest re-order business known. Send for free booklet "D" today. Full details. White Wonder Co., 279 Guardian Trust Bldg., Denver, Colo.

MIRROR resilvering is a paying trade. We have best instructions 50c. Auburn Supply Co., Dept. 12R, 7817 Peoria St., Chicago.

HOME manufacturing; light work, good profit. "Genuine." Wharton, 669 Granville St., Vancouver, B. C.

WONDERFUL Investment Opportunities in Texas. The Lone Star Magazine gives the facts. Write for free sample copy. E. O. Glenn, Publisher, Union Bank Bldg., Houston, Texas.

PATENT Applications \$10. Why pay more? Best, surest, quickest service. Patent News, Dept., Washington, D. C.

MARKET Spare time intelligently. \$500 annually furnishing commercial information; particulars free. "Cleo" Pmc, Evansville, Indiana.

IF you work in a shop find out if the company has any lathes, turret lathes, screw machines or milling machines for sale and write me full particulars and price asked. I will pay you \$5 for each machine I buy. Pinner, 122 Water St., New York, N. Y.

AGENTS! Dealers! Make Big Xmas money! See our ad under Agents. Dealers Wholesale House.

ADVERTISE—21 words in all of 60 family weeklies, \$1; 3 weeks \$2. Cape, St. Louis.

THERE'S a fortune in this! If you think all advertised plans are impractical or misrepresented—get mine and be undeceived. Make \$40 weekly! No canvassing; easily worked; suitable for men and women. 25c takes the plan! I'll refund it if disappointed. Andrews, 2115 Cornelia, Chicago.

READ "Good Results"—Greatest Mail Order Agents' Magazine published. Helping others; should help you, too! Two big issues worth dollars. 10c. Good Results, 156P, Washington, Chicago.

CANDY making a profitable and pleasing trade. Be your own employer. Our Candy Book tells how, 25c. Auburn Supply Co., Dept. 12C, 7817 Peoria St., Chicago.

START a market and exchange business at home. Monthly profits \$100 up. Every community needs one. No selling. No capital. Pleasant, easy, permanent. Pay for instructions from earnings. Send for free booklet. Chas. Murphy, Bloomington, Indiana.

HOW to make a duplicator and 300 other manufacturing secrets only 25 cents. Beckstrom Manufacturing Company, St. Paul, Minn.

CONDUCT Magazine Subscription Agency. Big profits. Free supplies. Particulars stamp. Nicholson, Bristol, Indiana.

INVENTIONS sold on commission. No advance fee. Patent News, E. Washington, D. C.

HERE'S a Real Opportunity! First-hand information about how to obtain government positions, contracts, patents; Congressional and Departmental information—anything. Write for our Free Book, "It Pays to Know." Washington Information Bureau, 612 14th St., Wash., D. C.

WOULD you like to own a good-paying Mail-Order Business? We have a line that gets repeat orders all the time. You can start in spare time; invest a dollar or two a week and soon own a nice business of your own. Particulars free. Nadico, 4313 Lincoln Ave., Chicago.

SPOT cash paid for second hand high-grade Cameras, Lenses, Kodaks, Motion-Picture Cameras, Microscopes, Binoculars, etc. David Stern Co., 1047B W. Madison St., Chicago, Ill.

BE Wise. Don't experiment in mail order. I can tell you how to succeed. B. Newham, Waukegan, Ill.

HOW to make Paint, Enamel, Varnish, Stain, Polish, Filler, Liquid Celluloid, or Solid Alcohol. Formula and complete process, \$1.00. Paint Chemistry Co., Box 28, Indianapolis, Ind.

HOW to Operate a Mail Order Business. 50 Big Profit Plans and year's Mailing service sent for 10c. Mail Dealers' Wholesale House, 521 Fra-Klin Bldg., Chicago.

BUILD a \$5,000 business in two years. Let us start you in the collection business. No capital needed; big field. We teach secrets of collecting money; refer business to you. Write today for Free Pointers and new plan. American Collection Service, 101 State Street, Detroit, Mich.

WRITE Moving-Picture Plays. Good prices. Devote all or spare time. No correspondence school. Details free. Atlas Publishing Co., 3046, Cincinnati.

BARGAINS! Bargains! Send for free magazine, 1,200 bargains, Farm lands, business chances; any kind, anywhere. Our services free to buyers. Western Sales Agency, Minneapolis, Minn.

WE will start you in the cleaning and dyeing business, little capital needed, big profits. Write for booklet. Ben-Vonde System, Dept. C, Charlotte, N. C.

MAKE Jumbo Salted Peanuts, Particulars Free. C. H. Reynolds, State College, Pa.

START Profitable Mail-Order Book Business. Catalogue and further information sent for stamp. Sheridan Company, 417 E. 151st St., New York.

NEW Way to Paint Signs—Our patterns do the work. Complete alphabet 50c. Butts Advertising Co., 15 W. 10th St., Kansas City, Mo.

WANT Big Profits? Learn Tartaric Mirror Silvering. New process opens enormously profitable business. Particulars free. H. Barstow, 514 23rd Street, Oakland, Calif.

WE Start You in Business, furnishing everything; men and women, \$30.00 to \$200.00 weekly operating our "New System Specialty Candy Factories" home or small room anywhere; no canvassing. Opportunity lifetime; booklet free. W. Bagsdale Co., East Orange, N. J.

"SELL Books by Mail." Best proposition for mail-order business; only spare time necessary. Particulars free. M. Metz, 313 East 89th St., New York.

I NEED branch managers for my worldwide mail-order business; operate from your own home in spare time; no canvassing or peddling; experience unnecessary; you should make \$50 weekly. Butler, 510 Factories, Toledo, Ohio.

OPERATE Mail-Order Book Business. Easiest, best paying line in Mail Order Field; everything furnished; folders, wholesale price lists, free. Bollins, Box 5272, Boston.

"HIRE Yourself as Boss." Big corporation will back you in Money-Making Mail-Order Business selling guaranteed Goods. Start spare time. Small capital. No canvassing. Wm. J. Dick, Mgr., Dept. D-10, 20 W. Lake St., Chicago.

WANTED to hear from owner of some good patent right for sale cheap. O. O. Mattson, 201 Andrus Bldg., Minneapolis, Minn.

INDEPENDENCE and fortune quickly attained in the Manufacturing Mail Order business. I furnish Formulas, Manufacturing Processes and Trade Secrets in all lines. Sold under positive guarantee; 18 years' practical experience. Revision and improvement of Formulas and Processes—reduction of manufacturing cost—utilization of waste materials, etc., a specialty. Booklet, Formula List, and Valuable Information Free. W. L. Cummings, Ph. D., 127 Standard St., Syracuse, N. Y.

LEARN the real estate business. Our complete instruction book teaches: listing, appraising, management, salesmanship, insurance, brokerage, advertising, renting agency, forms, etc., 121 subjects, Exceeds \$20.00 correspondence course. Buckeye cover 15c; silk cloth \$1.00, postpaid. Catalogue free. Realty Book Company, 5982 Euclid Ave., Cleveland, Ohio.

STOP Here! Let me start you in a home business that will bring you money every day. Experience unnecessary. Spare time. No canvassing. I furnish everything. Send for proofs. Voorhes, Desk C. R., Omaha, Neb.

LET the parcels post help you. Add (\$15 to \$25 weekly) to your present salary or income. Start during spare time and build up a permanent mail-order business of your own. We show you how and help you make good. No canvassing. Experience unnecessary. The Parcels Post makes success doubly sure. Our new ideas and up-to-date plans bring the money. No so-called "Course of Instruction" to sell. We give that free. Write today. Address Pease Mfg. Co., Inc., Dept. A, 70 Broadway, Buffalo, N. Y.

ADVERTISERS, Mail Dealers. Our 1915 Rate Book lists 2,000 Principal Publications, rates, circulation. Includes 30 Mail-Order Plans. Price 10c. Dearborn Advertising Agency, 210 Franklin Bldg., Chicago.

MANUFACTURERS, Promoters and Patent Buyers are invited to write us stating the line of invention in which they are interested, as we can supply their wants in any class of patents. Victor J. Evans & Co., 162 Ninth St., Washington, D. C.

MAKE Money Repairing. Particulars, stamp. Boulgate, 1010 Cypress, Pasadena, Calif.

LEARN to collect money. Good income; quick results. Send for free booklet, "Skillful Collecting." Collectors' Association, Long Street, Newark, Ohio.

\$500 WEEKLY my income from Collection Business (by mail), started two years ago. Independent managers, district managers and solicitors wanted everywhere. Booklet "My System" free. Geo. Macomber, Box 189, Washington, D. C.

BRYAN Plastographed—plastography instructions with formulas enable you to make life busts of your friends, portraying more delicate lines and shadows than photos or paintings. With it free mold of President Wilson, Lincoln or Victor Emmanuel. Very profitable work, easily learned. Price, \$1. School Plaques made to order. P. P. P. Spahr, York, Pa.

\$25,000—I MADE it in mail-order business. Had \$3 to start. I'll loan you \$5. Free Booklet tells how. Alb Scott, Cohoes, N. Y.

I WILL start you earning \$4 daily at home, silvering mirrors; free instructive booklet. G. F. Redmond, Dept. 206, Boston, Mass.

MISTAKES are expensive—We have indispensable information for anyone in or about to start in the Mail Order Business. Be sure to investigate this before taking up any Mail Order Proposition, Premium Sales Co., 4309 Lincoln Ave., Chicago.

INVENTORS: We develop and perfect inventions, make models, dies, tools. Metal stamping and special manufacturing. Gerding Bros., Lion Bldg., Cincinnati, O.

PATENTABLE Ideas wanted—Send for 3 free books. R. B. Owen, 30 Owen Bldg., Washington, D. C.

20,000 FORMULAS, recipes, etc. 530 p. volume, alphabetically indexed, \$1 prepaid. "Ideal," 3511-T, Belleplaine Ave., Chicago.

FORMULAS for Gasotonic, and full line Guaranteed Automobile, and latest specialties in all lines. Lists for stamp. Miller, Chemist, Tampa, Florida.

DRY cleaning, scouring, spotting, pressing taught. 15 years' experience. Illustrated book \$3.50. Star Cleaners & Dyers, Allentown, Pa.

25 WORD advertisement in 100 monthly magazines, 3 months, \$1. Quadri Co., 391 East 149th St., New York.

MAKE big money opening safes and setting combinations. Wayne Strong, Box 1430, Los Angeles, Calif.

EARN \$100 weekly managing clean legitimate mail order business. We furnish everything. Right party need not worry about capital. Splendid chance for intelligent, employed person to control independent business on profit-sharing basis, beginning in spare time, evenings at home. Particulars free. Opportunities Exchange, Buffalo, N. Y.

MAKE \$10,000 yearly connecting land buyers and sellers by mail. Dunning System, \$200. Particulars free, Dunning Co., Windsor, N. C.

INVESTMENTS

10 CENTS buys \$100 mortgage. Part of first mortgage on real estate in San Francisco or country, California, paying 6% per annum interest. Guaranteed by oldest, largest mortgage and guaranty company on Pacific Coast. Payments of only 10 cents day. Your interest begins with first payment of \$3. For interesting particulars, Howard H. Hogan, 785 Market St., San Francisco.

TO MANUFACTURERS

"HENDRICKS Commercial Register" of the United States, 24th annual edition, 1503 pages, for buyers and sellers. The standard reference book containing a classified list of all manufacturers, by names, by states and by products, with trade names of products. Write for circulars giving full details of this mammoth undertaking. Address the publishers, S. E. Hendricks Co., 2 West 13th St., New York City.

MANUFACTURERS, we want specialties to sell through agents. Useful articles. Give price, terms, details. Otto Protz, Gen. Del., Toledo, Ohio.

MANUFACTURERS of trust scheme goods send me prices complete outfits, including printing. Box 426, Griffin, Ga.

MAIL ORDER SUPPLIES

SELL Joker's Novelties! 16 samples, 10c. Chambers Works, Plainwell, Mich.

FOR ADVERTISERS

YOUR advertisements placed in 36 different magazines for 3c per word; displayed, \$1.80 per inch; three times for price of two. List, particulars free. King's Magazine, Box 13-P, Little Silver, N. J.

YOUR Thirty-Word Ad in our big post-card magazine, 25c. Inch display, 50c. Elite Exchange, 3694 Milwaukee Ave., Chicago.

BARGAIN—20-word advertisement, one insertion, 35,000 circulation, and one year subscription, 25c; extra words one cent. Digest, Grand Rapids, Mich.

ADVERTISE! Twenty words in 100 monthlies, \$1. Sample Magazine Free. Stanford Agency, Sebring, Ohio.

ADVERTISE—Your 20 word ad in 20 big Sunday papers, \$5. Coppe, St. Louis.

YOUR fifteen-word adv. in our 9x12 magazine reaching 20,000 boys for 25c. Extra words 1c each. Youths' Magazine, 2186 Maiters Bldg., Chicago.

BUSINESS SERVICE

INCORPORATE. Our lawyers do the work, saving you time, annoyance and money in incorporating under the most liberal laws of Arizona. Laws and forms free. Southwestern Securities & Investment Co., Box 1488, Phoenix, Ariz.

DESIGNER and Illustrator. David Ryerson Morford, National Military Home, Ohio.

AGENTS WANTED

MEN and Women Agents: Money talks—how much are you making? If you are earning less than \$200 a month, no matter what your locality, you will positively be delighted with our Sentinel Burglar Alarm proposition. Many agents easily earn \$15.00 daily. Brand new invention. Sells quickly on sight to homes, offices. Patented. No competition. Free exclusive territory. Instantly attached any door knob. Impossible turn knob without ringing bell. No batteries, screws, nails. Handsomely nickel-plated. Retail \$1.05. Provides cheap burglar insurance. It's a big money maker. Let us prove why. If you mean business write today for liberal terms to agents. Marshall Dobbins & Co., Manufacturers, 1422 Marquette Bldg., Chicago.

AGENTS Wanted—No matter who you are, or where you live, or what you do, right now before you turn the page, before you do another thing, send us your name and address so we can send you free our beautiful, heavy sample book, crowded with wonderful bargains in men's made to measure clothes, all the latest fabrics, advance styles, inside prices, measuring chart and everything needed to make \$5.00 to \$10.00 an hour in your spare time. Special offer on your own suit to advertise us. Don't miss this. We pay express and guarantee satisfaction. Send a postal now. American Woolen Mills Co., Dept. 1214, Chicago.

AGENTS make \$5 to \$10 a day on the start. Atkinson writes: "The best proposition I have found in my forty years' canvassing." Permanent work. Household necessity. Saving 80%. Write today for General or Local Agents terms. Free sample. C. H. Stuart & Co., 16 Union St., Newark, New York.

AGENTS wanted—Men Mechanically inclined—to learn sanitary metal tile construction (which is cemented on walls and ceilings) to eventually take our agency. Big profits and a competency for life. Takes a little money to pay for material, all of which will be deducted on future orders. Write for full particulars. Phoenix Metallic Tile Co., 193 Pearl St., Brooklyn, N. Y., only makers of sanitary metal tile in America.

AGENTS: To celebrate our 20th year we are sharing Profits with our agents. To illustrate—write today—you will receive free coupon (\$20 value) towards any Premium in our Profit-Sharing Catalog, all given absolutely free in addition to 150% to 200% profit on sales. Largest manufacturers of Soaps and Toilet Goods, selling exclusively through agents. Our Packages have the class and snap that gets the money. \$25.00-\$75.00 weekly easy. Crew Managers double that. Great Xmas rush now on. Write for our Wonderful Plans. Be sure to ask for that \$20 coupon. Davis Soap Co., P64 Davis Bldg., Chicago.

YOU can be your own boss with our Key Check Outfit. Good for \$5 a day stamping names on pocket key checks, fobs, etc. Sample check with your name and address, 15 cents. Peas; Die Works, Dept. M, Winchester, N. H.

AGENTS: Kleanol Sanitary Wire Twisted Brushes pay big profits; new low prices; freight paid and delivery guaranteed; quick service; exclusive territory; profit-sharing; full line fast sellers; oldest, largest wire brush makers. Kleanol Brush Company, Inc., Dept. 1, Springfield, Mass.

AGENTS of ability and high character wanted on a new household article. Over 100 per cent profit. Special selling plan that pulls results. Address Merritt & Brock, 59 to 69 Temple Place, Boston, Mass.

HAVE you seen it? What? The newest proposition on the market. The Goodrich Ear Cushion, stops all outside noises. Every telephone user a prospect. Stamped envelope brings proposition, but fifty cents gets a sample outfit—worth 75 cents. Premium Pencil Sharpener, book on Salesmanship and proposition, and a chance of getting a State on it. Show one in an office and sell a dozen. If you don't believe it send for sample, which you can return, but you will not, but will order a dozen and then a gross. Six states gone already. Live ones get busy. Franco Co., Majestic Bldg., Detroit.

WE are the largest manufacturers of twisted Wire Brushes in America. Highest grade goods, best service, largest profits. Our new Auto Specials are winners. Send for catalog. Fuller Brush Company, Hartford, Conn.; Rock Island, Ill.

FREE Samples for Men and Women agents: Deibare's Naptha Washing Tablets; washes clothes without rubbing; cleans floors, woodwork, polishes silverware; send for sample and particulars; not sold in stores. Sold only by Naptha Washing Tablet Company, 716 So. Dearborn St., Chicago, Ill.

AGENTS—Stamping names on Pocket Key Protectors; sample Check with your name and address, 15c. Stamping Outfits, Emblem Checks, Check Fobs, Name Plates. Hart Mfg. Co., Desk 2, 305 Degraw St., Brooklyn, N. Y.

BIG Profits for You! Manufacture Barley Crisp, New Confection. 5c package costs you 1c. Machine instructions complete \$7.50 prepaid. Send 10c for samples. Barley Crisp Co., 1205 Broadway, San Francisco.

YOUNG Man, would you accept a tailor-made suit just for showing it to your friends? If you live in a town smaller than 13,000, write Banner Tailoring Co., Dept. 214, Chicago, and get beautiful samples, styles and a wonderful offer.

MAIL-ORDER Opportunities: 25 new Propositions. No competition! Make 25c profit on dollar order; complete outfit 10c. Mail Dealers Wholesale House, 521 Franklin Bldg., Chicago.

AGENTS are coinng money selling our big 10c Packages of 26 Assorted Postal Cards. "5,000 Varieties." "Big Profits." Sell everywhere at sight. Sample Packages 10c. Particulars Free. Sullivan Card Co., 1234 Van Buren St., Chicago, Ill.

AGENTS Wanted: Auto heater for winter driving—sells on sight. Write before all territory is gone. Hill Pump Valve Co., 18 E. Kinzie St., Chicago.

AGENTS—We've had 100% sales on "Midgit" American Flags—1/16 inch size. Enamelled in colors. Made in screw-backs. Solid Gold, \$4 dozen; \$30 gross. Sells for 50c. Gold-Plated, \$1.50 dozen; \$13 gross. Sells for 25c. Sample 10c. Philadelphia Badge Co., 172 N. 8th St., Philadelphia, Pa.

WE manufacture an article for house use, equal to, if not superior to, anything of its kind on the market, and which soon pays for itself. Will assign exclusive territory to producing canvassers. Address H-A Mfg. Co., 4951H Wornall Road, Kansas City, Mo., stating experience in house to house work. Good money in it.

AGENTS—New, Big Money-making marvel; Kalomite Laundry Marvel is something new; unexpected; wonderful scientific discovery; different, high class; no disappointments; it is fool proof; Kalomite Laundry Marvel revolutionizes clothes-washing ideas; nothing to compare with it; it's absolutely supreme; positively abolishes drudgery, rubbing, washboards, washing machines, etc.; nature's mighty elements work wonders; women simply delighted; Franklin, Idaho, realizes \$345 in 30 days. \$1,000 guarantee; reputable \$53,000 corporation, inventors and manufacturers; exclusive territory; no experience necessary; credit granted; own a fascinating repeat order business; pocket big profits. Hurry. Write today. Get over-washing proof; all free. Equitable Corporation, Dept. 343, 215 W. Superior, Chicago.

AGENTS Wanted—to advertise our goods by distributing free sample to consumer. 90 cents an hour. Write for full particulars. Thomas Mfg. Co., 362 North St., Dayton, O.

GENERAL Representatives with little capital for Jap Silk nonbreakable Gas Mantle; America's latest invention; throws greater light; outlives others; substantial income assured handling sub-agents and trade. Jules, 209 W. 48th, N. Y.

"RED Hot Seller." "Damascus Razor Strop Dressing." Choice Territory reserved for live agents. Send 25c for sample and full particulars. Brandenburg Chemical Works, Manitowoc, Wis., Dept. C.

TAILORING Agents Wanted. If \$10 to \$50 a week for your spare time interests you, write us quick for beautiful new sample outfit, 60 nifty fabrics, 32 swell styles, wholesale prices, measuring chart, tape line, etc., all free to you by return parcel post. We pay express charges and guarantee satisfaction on all our clothes. Your own suit special to show your friends, made to your measure and the finest you ever saw; new, nifty, stylish and first-class in every way. Write us quick. Even if you can't be our agent, get our proposition on a suit for yourself. Paragon Tailoring Company, Box 1214, Chicago.

TAILORING Agents Wanted—Everywhere. Spring season 1916. Take orders for guaranteed Made-to-measure clothes. "Nelson System, of Special Values." "Four prices only"—\$15, \$20, \$25 and \$30. Agent's profit 30%. Special Raincoat Premium offer. Fine opportunity to earn big money and establish permanent business. Nelson Tailoring Company, 241 W. Van Buren St., Chicago.

AGENTS—Here's the best line of food flavors, perfumes, soaps, toilet preparations, etc., ever offered. No capital needed. Complete outfits furnished free to workers. Write today for full particulars. American Products Co., 3136 Third St., Cincinnati, O.

\$150 PER month and expenses—Salary or Commission—Introducing our King Butter Separator. Produces best grade of butter from cream or milk, sweet or sour, in less than 5 minutes. Retail \$5 up. Write for free sample and salary proposition. De King Mfg. Co., Dept. 13T, Chicago, Ill.

I NEED branch managers for my worldwide mail-order business; operate from your own home in spare time; no canvassing or peddling; experience unnecessary; you should make \$50 weekly. Butler, 539 Factories, Toledo, Ohio.

ELECTRIC and non-electric changeable window signs. Lowest prices. Mandeville, 67 West Schuyler Street, Oswego, N. Y.

AGENTS: New invention!—clothes-washer that fits set tubs or any tub. Won medal at Panama-Pacific Exposition. Sells for \$10, with big profit. Large field. Write for proposition and descriptive folder. Home Devices Corp., 211 Bush Terminal, Brooklyn, N. Y.

EVERYBODY Wants to look into 5 in. Nonparel Novelty Mirror. Mounted on cork with Thermometer or calendars, makes fine present. Agents wanted. Price 50c. Frank R. Hewett & Co., 2250 Aqueduct Ave., New York.

AGENTS—Get newest, quickest sellers direct from makers—full list free. Nat'l Agents Assn., 1122 Michigan Ave., Chicago.

AGENTS: Handle our Home Altar; has music and light; do a big Xmas business. A great seller to Catholics. Inquire proposition. Novelty Altar Co., Stamford, Conn.

DRUNK, Sick or Crazy—Not us, but our plan lets you collect the money and keep it all. We get ours later. U. S. Mfg. Co., Dept. P2, Columbus, Ohio.

AGENTS Wanted—to handle remarkable money-makers, easy to handle, easy to sell, many repeat orders; write quickly. Dora Novelty Co., 500 2nd Ave., New York City.

AGENTS—Our Line of Individual Stationery Embossers a winner. So is our proposition. Samples and particulars free. Millar Sales Company, Lexington, Ky.

GET cash for names, information, ideas, formulas. Turn what you see, hear and know into money. Instructive booklet for stamp. Information Systems, 232 Marietta, Ohio.

AGENTS, or will sell mfg. rights. Best headlight deflector on market. New, patented. A few hundred dollars invested will net you thousands. Write at once, Mitchell De-Ro-Flector Co., 1363 Main St., Los Angeles.

GENERAL Agents—Sanitary Sugar Bowls. Greatest 50c article. Sells everywhere. Territory free. Schoenholt & Pease, East End, Pittsburgh, Pa.

MAKE and sell your own goods. Formulas by Expert Chemists. Manufacturing Processes and Trade Secrets. Formula Catalog for Stamp. B. Mystic Company, Washington, D. C.

NEW \$2.50 pocket adder. Sell 10 daily easy. Excellent profit. Everyone buys. No competition. O. Bassett, 5921 Indiana Ave., Chicago.

AGENTS—We have the best money-making Xmas articles on the market. Let us tell you about them. Lewis Company, 1839 South Leland, Chicago.

I PROMISE any man or woman who will go out tomorrow—call at ten houses, at least two sales, which net \$1.80 apiece. Ten calls—\$3.60 for your day's work. It's that aluminum combination set that you are to offer—aluminum the women are crazy for; at a price they go wild over. Experience in selling or not—doesn't matter. Drop a card and let me post you on my \$3.60 a day offer. Manager, Perfection Products, 1423 Westmoreland St., Philadelphia.

AGENTS—Send for sample "Fretnot"—the wash day wonder. Be continued you can do a whirlwind business. You can clear at least \$20 to \$100 weekly, according to spare or whole time. You don't have to talk, if she doesn't buy at sight, leave sample, she will be looking for you long before you are able to make the rounds again. Samples furnished free. Premiums for your customers. Exclusive territory granted to agents who can produce. Credit given. Don't call. P. M. Motter & Sons, 3213 Warren Ave., Chicago.

AGENTS! Coin Money Selling Christmas Packages. Think of it! An 88 piece package of Post Cards, Tags, Seals, Stickers, Folders, Cut Outs, etc., sells for 10c. Costs you \$4 hundred; \$39 per thousand. Every body grabs them. \$10 a day easy. Send dime quick for samples and particulars. Dealers Wholesale House, 325 S. Dearborn, Chicago.

AGENTS Wanted—Out of town live men can make 15 to 25 dollars weekly evenings or on the side selling my "made to order" men's \$15 and \$20 suits and overcoats, because I am delivering quality, fit and work, so you can build up a future business. Tom Murray, 598 So. Clark St., Chicago.

A PRACTICAL Novelty. An attractive Christmas Novelty. "Dagdex Swedish Pencil Sharpener." No Bittered Flour-cut or soiled fingers. Every bank, office, home, school or individual will buy on demonstration. No competition. Write quick for interesting proposition. W. J. Gibson & Co., Fisher Bldg., Chicago.

OUR Line-finding Copy Holder for Stenographers is a big money getter. Entirely new. Over 100% profit. Field unlimited; business houses order in quantities. Write at once for exclusive territory. Lineguide Mfg. Co., 160 North Fifth Ave., Chicago.

NEW Invention, Sharp-Shod Overshoes for Horses. Guaranteed to prevent slipping on icy streets. Buckled on over old shoe in a minute. Every horse owner wants them: big money for agents. Our new patent Auto and Truck Skid Chains are the fastest seller out. Write for particulars. Herman Mfg. Co., Desk No. 3, Penna. Ave., Washington, D. C.

OUR Reporters always welcome—Big Money, easy, distributing California Bungalow lots as Premiums. Send for starting details today. The Pilgrim Magazine, 1531 Westminster Bldg., Chicago.

ROBE Rail Lock (New). Unlimited Territory. Bonanza for Agents. Write for particulars. Inventors Sales Company, 101 Main St., Smithport, Pa.

EGG Insurance is what our agents offer their customers. Big money with this new specialty. - Particulars free. Sample 15 cents. Standard-A, 4 West 118th St., New York.

100% PROFIT handling polishing cloths for silverware, brass, pianos, furniture, etc. Globe Chemical Co., 220 South New Jersey, Indianapolis, Ind.

YOU can make big profits selling our Pure Aluminum Kitchen Utensils—Guaranteed for 20 years. Our specialties are not sold in stores, and they get the business for you. \$200,000 firm and liberal credit plan backs you. We have an attractive General Agency offer. Wm. J. Dick, Manager, Dept. D-21, 20 W. Lake St., Chicago.

AGENTS—Sells itself—millions will be sold—household necessity with premium—big profit—write quick. Glock, 180 Woodward Ave., Buffalo, N. Y.

33% PROFIT selling our 25c Sheet Music at 5c. Particulars Free; 3 samples 10c. Keller, Robson & Munk, 36 W. 118th St., New York.

\$32.84 PROFITS on each full order daily—sells every home. Amazing invention. Brilliantly lights home. Something new. Everybody pleased. Demonstration outfit 35c. Plans free. International Mfg., Dept. 527, Toledo, Ohio.

BIG Money easily made selling Jules Folding Portable Electric Lamps, containing 10 ft. concealed extension cord automatically lengthened or shortened. Other features. Demonstration insures sales. Homes, Offices, Factories, Hospitals, Students. Rose-Strauss Co., 215 W. 48th, N. Y.

\$1.50 WEEKLY introducing and selling a new gas light burner for kerosene lamps. Beautiful light. No chimney. No mantle. Perfectly safe. Simple in construction. Nothing to get broken or out of order. Will not burn out. Durable. Will last for years. Low price. Easy to sell. 200 per cent profit. Experience not necessary. Sample free. Why not try one on your lamp? Beware of imitations. No branch offices. Luther Manufacturing Co., Dept. 128, Cincinnati, Ohio.

AGENTS Wanted—Agents make 500 per cent profit selling "Novelty Sign Cards." Merchants buy 10 to 100 on sight. 800 varieties. Catalogue free. Sullivan Co., 1234 Van Buren St., Chicago, Ill.

We start you in the mail order business and show you how to succeed; attractive 61-page catalogue of 200 novelties, with your imprint; exceedingly reasonable; all goods wholesale. Send for my plan and particulars. Cunningham Co., Stamford, Conn.

PHOTO Pillow Tops, Portraits, Frames, Sheet Pictures, Photo Plates, Pennants. Refects credited. Prompt shipments; samples and catalogues free to agents. 30 days' credit. Jas. C. Bailey Co., Desk R-6, Chicago.

AGENTS—Fast-selling Household Specialty. \$2.53 Premiums with each \$1.98 sale and 70 cents profit for Agent. Free Selling Sample. Caldwell Specialty Company, Lenoir, N. C.

AGENTS—Make and sell your own preparations. Tested formulas, complete instructions for making, labeling, packaging. Stamp for list. B. W. Baker, 100 Ross St., Brooklyn, N. Y.

AGENTS—Something new—Fastest sellers and quickest repeaters on earth. Permanent, profitable business. Good for \$50 to \$75 a week. Address, American Products Co., 3135 Third St., Cincinnati, O.

AGENTS Make quick sales, large profits. Sample and terms 10c. C. Lutz Manufacturing Co., York, Pa.

AGENTS—Make big "Clean Up" selling our Xmas Specials. Quick sales. \$25.00-\$75.00 weekly a cinch. Write for colored circulars and immediate appointment. E. M. Davis, President, K64, Davis Bldg., Chicago.

BEST 25c Repeat Seller made: 200% profit. Reese Sales Co., Mount Pleasant, Pa.

AGENTS are making big money selling our raincoats; sales are easy; satisfaction guaranteed or money refunded. Address Reliance Rain Coat Co., The Temple, Chicago.

AGENTS—If you want to "Clean Up" on most wonderful invention of age, send 10c for samples. Sells everybody—Stores, Offices, Homes, No Fake. The Edison Company, Dept. 51, 1709 Michigan Ave., Chicago.

SELL Washclean: Abolishes rubbing. Steam bubbles blow out stubborn sifting-grit. Leads everything. Won Gold Medal in actual tests. Only washing preparation using steam bubble principle. Biggest profits. More value. Sample and particulars free. Washclean Co., W. 7th, Pittsburg, Kansas.

AGENTS—Salary or commission. Greatest seller yet. Every user pen and ink buys on sight. 200 to 500 per cent profit. One agent's sales \$520 in six days; another \$32 in two hours. Monroe Mfg. Co., X8, La. Crosse, Wis.

AGENTS wanted to sell men's hats direct from factory. Send for style book. Guarlin Bros., Dept. A, Hat Manufacturers, Orange, N. J.

AGENTS—Here's a money maker. New Low-Price Portable Oil Gas Stove. Light in weight, compact, practical. Every home a possible customer. Cooks, bakes, heats, sells both in summer and winter. Write today for our Money Making Proposition. The World Mfg. Co., 6398 World Bldg., Cincinnati, O.

SELL Christmas Packages! Everybody buys them, 200% profit. \$10 day easy. Send dime for samples and particulars. Get busy now. International Distributing House, 5238 Larkin, Chicago.

NEWEST wonder of the age! Silveron, the polish that silver-plates. Actually rubs on sterling silver. Used everywhere. Sells on sight. Repeat orders. Big profits. Protection. Send 10c for sample and introductory offer. Carisa, 157 Cedar, New York, Dept. D.

OWN your own business. Make \$500 monthly, carry no stock, just sample. S. O. S. Electric Pulser, new, powerful, making agents rich. Write quick for big special proposition. Commonwealth Mfg. Co., 460 Kaito, St. Louis, Mo.

INVENTIONS sold on commission. Advertised free. No advance fee. Patent News, A. Washington, D. C.

MARVELOUS Expanding Cuff Button. "Fresto" slip cuffs over elbow without unbuttoning, pull them down they close automatically; invisible. Reduces laundry bills, combines utility with convenience. Endorsed and demanded everywhere. They never tarnish nor blacken and last forever. Thomas, Sheboygan, Wis., sold 750 pairs in 10 days, profits \$315. Fast Holiday seller. No money required, just take orders. High grade agents wanted everywhere. To eliminate triflers, enclose red stamp for particulars, none others considered. Flexo Links, Sheboygan, Wis.

AGENTS to sell latest household specialties. For catalogue and prices, address Richebunch Supply House, Oregon, Ill.

"SHINE-Rite" absolutely new combination device. Men, Women, \$5 daily. Every home; everybody. Useful gift. Shine-Rite Co., LaCrosse, Wis.

AGENTS make big profits handling our "Fast Selling Holiday Post Cards," "Novelty Signs," "Holiday Decorations," "Pennants," etc. 5,000 varieties. Demand unlimited. Write today for Free Catalog. Hinton Co., 6142 40th Ct., Chicago.

ACT Quick! Automobile Gasoline going up. Sell Gaso-Tonic. Equals gasoline at 3c a gallon. Eliminates Carbon. Dollar an hour profit. Sales Guaranteed. White Mfg. Co., Dept. M, Cincinnati, Ohio.

ADVERTISE—20 months in 100 months \$1; 3 months \$2. Cope, St. Louis.

\$5.00-\$8.00 DAILY selling our household necessities; particulars Free. Summer Specialty Company, X-5446 Augusta Street, Chicago.

SELL Changeable Signs. \$10 Daily. Excellent Sideline. Write Powell Bros., 4150 Madison St., Chicago.

GET rich profits—own a business. Big Kansas company offers fast selling Mail Order Line. Factory prices. Unique selling methods pull quick, big paying business. No canvassing. Spare time. We furnish everything. Copyrighted prospectus free. Eystone, Pres., 401 W. 7th, Pittsburg, Kans.

RELIABLE people wanted to place our Eggine in Stores and appoint sub-agents. Takes place of eggs in baking and cooking, at less than be dozen. Package and particulars 10c postpaid. Morrikey Co., 4443-5 Madison St., Chicago.

TREMENDOUS seller, big profit. German silver tea forms. Sample sent for 10c. H. Fenton Company, 1084 Amsterdam Avenue, New York.

\$12.00 DAILY till Christmas. Wonderful everlasting plants in brass jardiniere. Sample, prepaid, 25c. Rodolph, 464 North-Western Building, Chicago.

DON'T be an Agent—Own your own business. We furnish complete, practical, low-price outfits for plating in Gold, Silver, Copper, Nickel, etc. We furnish recipes, formulas, trade secrets. Work easy, profit enormous. Send today for particulars. Gray & Co., Plating Works, 944 Gray Bldg., Cincinnati, O.

200% PROFIT. You can't beat it. Sells everywhere. Free pocket sample. Our goods get the orders. Wm. J. Dick, Mgr., Dept. D-4, 29 W. Lake St., Chicago.

WONDERFUL Opportunity—Start as our agent, become manufacturer. Everyday necessities. Fastest repeat sellers. Marvellous profits. Proposition worth at least \$10 weekly. Samples free. Frederick Loid Company, 328 Warren St., Boston, Mass.

CHRISTMAS and New Year Post Cards, Booklets, Fancy Cards, Tags, Seals, etc. Samples free. Gross Guard Co., 2147 Arthur Ave., New York.

AGENTS—Get particulars of the best Self-Heating Iron on the market. Low in price—absolutely practical. Three sales a day means \$40 a week profit to you. Send postal today. C. Brown Mfg. Co., 4708 Brown Bldg., Cincinnati, O.

A MIRACLE. We have a preparation that will absolutely keep steam and frost from windows, mirrors and eye glasses. Leaves no dust or dirt. Wanted by all stores, offices, doctors, dentists, opticians, etc. Almost every call a sale. \$30 to \$50 weekly easily made. Write, Vivace Company, Dept. P, 3157 Broadway, Chicago.

FIND out how easy it is to make big money taking orders for brushes needed in every home. Our representatives are averaging \$15 to \$50 a week. We have a few open territories. Write, naming county wanted. J. I. Holcomb Brush Mfg. Co., 5110 Draper, Indianapolis.

SLICKEST Needle Threader you ever saw, 10c. Stovers, Millersburg, Pa.

MEN to refinish lighting fixtures, brass beds, etc. All or spare time. No capital or canvassing. Experience unnecessary. Information free. Gummel Co., Dept. G, Decatur, Ill.

AGENTS—Household articles, 50 fast sellers. Catalog free. Kimo Sales Agency, 359 Aylesford, Lexington, Ky.

GREAT Side-line for active canvassers. Premiums free with every sale. Goods light. Big money establishing subagents. Klittredge Co., 40 East Tamkhanock, Pa.

MECHANICS to sell sliding calipers; liberal commission. Ernst G. Smith, Tampa, Fla.

50c BOOK free, "1,000 Christmas Suggestions." Craft, Printer, Dallas, Texas.

AGENTS—Sell up-to-date household specialties. Big profits. Particulars and samples free. S. V. Phillips, Box 17, Minneapolis, Minn.

ENERGETIC agents manufacture. Greatly increased profits. Write for plans. Eastern Exchange, Bridgton, Maine.

\$1,000 PER Man per County. Strange invention startles world—agents amazed. Ten inexperienced men divide \$40,000. Korstad, a farmer, did \$2,200 in 14 days. Schlichter, a minister, \$195 first 12 hours. \$1,200 cold cash made, paid, banked by Stoneman in 30 days; \$15,000 to date. A hot or cold running water bath equipment for any home at only \$6.50. Self-heating. No plumbing or waterworks required. Investigate. Exclusive sale. Credit given. Send no money. Write letter or postal today. Allen Mfg. Co., 4137 Allen Bldg., Toledo, Ohio.

YOU can make \$888 as our general or local agent. Household necessity; saves 80 per cent; permanent business; exclusive territory; salary or commission; free sample; credit. J. Pitkin, 113 Becht St., Newark, N. Y.

MEDALLIONS—300% profit. Make up your own goods and be independent. Catalogue free. Resag Co., 1205 Randolph St., Chicago.

500% PROFIT selling our wonderful sign letters for office windows, store fronts and glass signs; resembles finest gold leaf; easily applied; samples free. Metallic Letter Co., 408 N. Clark St., Chicago.

AGENTS make \$100 monthly selling our 500 handy household articles. Catalogue free. Scheff Company, DesPlaines, Ill.

PORTRAIT Agents: Our goods will make you big profits. Delivery guaranteed. Refunds credited. Prompt shipments. Low prices. Send for latest catalogue and prices. Adam J. Kroll & Co., 692 Blue Island Ave., Chicago, Ill.

AGENTS—\$50.00 weekly. The only knife sharpener made on correct principles. Wonderful seller, 129 to 300% profit. Simply demonstrate. No talking. General agents, \$150.00 week. Particulars free. 50c sample by mail. 25c. Thiele Co., 5 Austin Ave., Chicago.

SELL Dry Goods Remnants. Greatest bargains on earth. Remnant Store Co., Cincinnati, Ohio.

STOP Here! Let me start you in a home business that will bring you money every day. Experience unnecessary. Spare time. No canvassing. I furnish everything. Send for proofs. Voorhies, Desk C. R., Omaha, Neb.

KEROSENE Gas Burners in Cook Stoves or Ranges stop use of wood or coal. Recently patented. Money-Maker for Agents. The Vapor-Gas Burner Co., Desk 8, Columbus, Ohio.

AGENTS—Air Cell Washing Machine. New, marvellous invention. Exceeds work of washers costing \$25.00 and up. Sells only \$1.00. No wonder every home buys. Exclusive territory free. Nearly 200% profit. Write today. Air Cell Washer Co., 3057 Detroit Ave., Toledo, Ohio.

DON'T hesitate—Get our new catalogue; contains Six Corking Propositions. Each a winner. Berg & Beard, Inc., 61 Fleet Place, Brooklyn, N. Y.

AGENTS—Average \$5 to \$12 daily selling astonishing Anzac massage machine. New. Just patented. Different. No electricity or water power required. Nothing complicated. Affects exhilarating massage without cent expense. Lowest priced, but best outfit. Retail \$2.50 allowing you big end of the profit. Particulars and "beauty" folder free. Anzac Remedy Co., Dept. 132, Toledo, Ohio.

AGENTS—Make \$30 to \$60 weekly selling our 300 candle power gasoline table and hanging lamp for homes, stores, halls, churches; no wick, no chimneys, no mantle trouble; costs 1c per night; exclusive territory; we loan you sample. Sunshine Safety Lamp Company, 925 Factory Bldg., Kansas City, Mo.

AGENTS—Coin money selling self-filling fountain pens for \$1; 150% profit; sell on sight. Sample 25 cents coin. W. Hurley, Box 512, Longbe, California.

"STEAM-NO-MORE" for eye glasses. Everyone who wears glasses buys. Live agents 200% profit. Send 10 cents for 25c sample. Gray's Sales Agency, Port Huron, Mich.

AGENTS—Here's a brand new article, just ready for market. Make over 100% profit, with satisfied customers. Every mechanic needs one, sells quickly on sight; no competition. Our proposition is a winner. Don't wait. Write for it now. The Security Aluminum Rule Pocket Co., Ivanpah, Calif.

ACCEPT no agency until getting offer on Ho-Lo-Co Skin and Scalp Soap and Toilet Articles. Our plan new and different. Territory limited; write today. Rothco, 209 N. 2nd, St. Louis.

AGENTS send for prices on our quality Photographic Portraits. Myland, 2125 Front St., Philadelphia, Pa.

EVERY household on farm, in small town or suburbs, where oil lamps are used, needs and will buy the wonderful Aladdin Mantle Lamp. Burns common coal oil (Kerosene); gives a light five times as bright as electric. Awarded gold medal at San Francisco Exposition. One farmer cleared over \$500.00 in six weeks; hundreds with rigs earning \$100.00 to \$300.00 per month. No cash required. We furnish capital to reliable men. Write quick for wholesale prices, territory and sample lamp for free trial. Address nearest office. Mantle Lamp Co., 517 Aladdin Bldg., Chicago, Ill. Mantle Lamp Co., 517 Thermo Bldg., New York City.

BIG Textile Mills will employ everywhere reliable people to take orders for dress fabrics, hosiery, underwear, sweaters, waists and skirts from samples. Factory prices. Spare or all time. No experience. Permanent. Many making over \$50.00 weekly. Steadfast Mills, 30 Renssen St., Cohoes, N. Y.

MAKE your own Extracts and Perfumes. H. Lake Co., Adair, Ill.

VACUUM Cleaner Men: You all know Hugro. Biggest Vacuum factory in world. Best and latest models. All styles. Blue bird indoor and outdoor clothes reela. Lowest factory prices. Hugro Mfg. Co., Warsaw, Indiana.

AGENTS—Large Manufacturer wants reliable men, women, to sell guaranteed Hosiery, Underwear, Shirts, direct to homes. Write for free Samples. Madison Mills, 585 Broadway, New York.

AGENTS—Steady Income. Large manufacturer of Handkerchiefs and Dress Goods, etc., wishes representative in each locality. Factory to consumer. Big profits, honest goods. Whole or spare time. Credit given. Send for particulars. Freeport Mfg. Co., 59 Main St., Brooklyn, N. Y.

"GOLDINE" Sign Letters—1,000% profit. Sample free. Johnston Co., Quincy, Ill.

AGENTS—Brand new specialty Aluminum Triplicate Sauce Pan with detachable handle. Cooks 3 different foods on one burner. Saves gas. Lasts lifetime. \$100 to \$300 per month easy. Send for our catalogue of 400 other specialties. American Aluminum Mfg. Co., Div. J. 10, Lemont, Ill.

SOAP Agents—Our Vegetable Soap, Toilet Goods, Remedies, Flavorings, Excel—Outsell. Sample Free. F. A. Buchanan & Co., Dept. 51, St. Louis, Mo.

AGENTS—Biggest hit ever! Eberon-piece Toilet Article Set, selling like blazes at \$1; with \$1 Carving Set Free! Enormous profits! Tremendous sensation! Experience unnecessary. Eagle made \$51.00 first week. Write quick! Pierce Co., Dept. F, 906 Lake St., Chicago.

OUR line of brushes is a winner. So is our proposition. We want live brush agents everywhere. United Brush Company, 622 W. Lake St., Chicago.

SIGN Letter Agents and Painters; 500% Profit Gold and Silver Sign Letters for Stores and Office Windows. Anyone can put on. Big demand. Free samples. Metallic Letter Co., 404 N. Clark St., Chicago.

ENDLESS Neckties—Something new, twelve ties in one; costs no more than old style; man made \$70 three days; woman made \$92 week; write for special agents' offer. Endless Necktie Mfg. Co., Dept. 10, Kansas City, Mo.

AGENTS—\$5 daily selling our Handy Tool, 12 articles in one. Lightning seller. Sample free. Thomas Mfg. Company, 702 North St., Dayton, Ohio.

JUST show them—The new adjustable floor and wall mops, dustless dusters and sanitary brushes sell themselves. Big line. Big profits. Agents write Silver-Chamberlin Co., Dept. M, Clayton, N. J.

EASY, pleasant work for Mechanics, Shop Men, Clerks, during spare hours, will add many dollars to their salaries. Also want persons who can give full time. Big wages assured. Novelty Cutlery Co., 67 Bar St., Canton, Ohio.

\$15.00 MADE first day by 13-year-old boy with Shomescope. Woman made \$8.00 first hour. Particulars free. Shomescope Mfg. Co., 523 W. 13th St., Kansas City, Mo.

MEN and women earn up to \$3,000.00 yearly distributing Guaranteed Hosiery from mill to wearer. All or part time. Repeat orders insure permanent increasing business. No capital or experience needed. D. Parker Mills, 2738 No. 12th St., Philadelphia, Pa.

NEW 1915 Model—Send no money, just your name on a postal card, and learn by return mail how to get the best Vacuum Cleaner made, without costing you one cent. Shipped direct from factory, guaranteed for 5 years. Reliable, live agents wanted. The Warner Company, Dept. Z, Muncie, Indiana.

AGENTS—Sell the Primus, genuine Swedish wickless, coal-oil stoves. Smokeless, odorless. Twice the heat of gasoline at one-eighth the cost. No danger of explosion. Big profits. James Anderson & Sons, Sidney, Ohio, American distributors.

AGENTS make big money and become sales managers for our goods. Past office sellers. Fine profits. Particulars and samples free. One Dip Pen Company, Dept. 2, Baltimore, Md.

READ the Agents Magazine and make more money. 2 issues 10c. Agent's Magazine, Chicago.

AGENTS—Sell rich-looking imported 30x 65 Rugs, \$1 each. Carter, Tenn., sold 115 in 4 days. Profit, \$57. You can do same. Write for sample offer selling plan; exclusive territory. Sample rug by parcel post pre-paid. 6c. Condon, Importer, Stonington, Maine.

AGENTS—150 per cent profit selling new, easy wringer mop; every home buys; Martin sold 131 in 2 days; Handel sells 18 in 4 hours; Baker made \$9 in 2 hours; one man's orders \$2,450 in one month; get details, U. S. Mop Co., 323 Main St., Toledo, O.

AGENTS and Painters—New gold and silver letters. Any one can put on. Free samples. Flexible Metal Letter Co., 1642 Division St., Chicago.

MAKE More Money—Making Your Own Goods. I supply Original, Guaranteed Formulas.—Trade-Secrets for Latest Specialties in all Lines. Latest Lists for Stamp. Liscombe Miller, Chemist, Tampa, Florida.

BIG profits, selling Clothes-Line Fastener, eliminates knots, adjusted quickly, tight grip, everybody wants it. Write for sample. Gregory O'Kelly, Manufacturer, Old Colony Building, Chicago.

MAKE Money Today. Make Dollars Tomorrow. Secure exclusive sales rights for Leswerk Laundry Tablets which repeat and repeat after introduction; sold to stores they yield permanent increasing income without personal canvass; guaranteed satisfactory or cost refunded. Send 10c for whole month's supply and Tried and Proved Sales Plan, Leswerk Manufacturing Company, Richmond Hill, New York.

WONDERFUL New Invention—Our "No Talk" system guarantees sales. Sample 25c. Reinhardt Sales Co., 1337-39 Hull St., Baltimore, Md.

HEATLESS Trousers Press. Guaranteed to press trousers in 5 minutes without labor or heat. Big profits, \$1.00 prepaid. Patented Goods Co., Dept. P, 116 East 63rd St., New York City.

AGENCIES WANTED

FIRST Class good articles wanted from Mfg. Co., only. Samples and catalogs required, send particulars. Frank Stahl, Mogollon, New Mexico.

SALESMEN WANTED

WANTED, Salesmen—To represent manufacturer. Must be wide-awake, energetic and able to produce. Excellent opportunity. Exclusive territory to right man. Box 150, Station C, Cleveland, Ohio.

SALESMEN wanted everywhere selling new patent automobile device, \$10.00 per day summer and winter. Acmeo, 1410-12 W. 53rd St., Chicago, Ill.

SALESMEN Wanted—Pay biggest commission ever received. Sell Oil land near Beaumont, Texas. New proven territory. Box 160, Stowell, Texas.

SALESMEN: Acquainted with merchants. Large demand. Lib. comm. Pocket samples. Write Salesbook Co., Chicago.

SALESMEN Wanted—Salesmen and Manufacturers' Agents to represent us everywhere among the Superintendents, Engineers and Purchasing Agents of manufacturing plants. Federal Graphite Mills, Cleveland, Ohio.

WANTED—Traveling Salesmen who will accept clothes made to their measure in payment for placing with merchants "The Line That's Different," an all-wood tailoring line, quoting six special prices; no extra charges. Write for particulars. J. W. Jones & Sons, 379 Midcity Bank Building, Chicago.

GREAT opportunity for General Agents selling New Specialty to merchants. Retail \$5, \$10, \$15 each. Your profit 200%. No competition. Exclusive territory. Free samples. Sayers Co., 408 Wainwright, St. Louis, Mo.

WANTED—Representatives everywhere. Exclusive territory. Gold sign letters for stores and office windows. Any one can put on. Write today for free sample. Metallic Letter Co., 405 N. Clark St., Chicago.

SALESMAN. Sell beautiful 28x58 Artz-kraft felt rugs for \$13.50 per doz. Your profit, \$3 per doz. Kelso, Battle Creek, Mich., sold 30 doz. last week. His profit, \$90. Write for exclusive territory and selling plan. Prepaid sample, \$1.50, refunded on first order. H. Condon, Mfrg., Stonington, Maine.

HELP-A-PHONE. Salesmen make \$100 weekly. Write Edward, 415 Belden Ave., Chicago.

SALESMEN—Get our plan for Monogramming Automobiles and Motorcycles by transfer method. Very large profits. Motorists' Accessories Co., Ashland, O.

SALESMEN — Make Big Money on our Convex Portraits 38c, Frames 35c, Glass 20c. Largest house in America. Est. 15 years. Samples Free. The Culver Co., Box 104, Westerville, O.

SALESMEN and agents are clearing \$40 to \$100 weekly with our flashing electric signs. Wonderful opportunity now. Also great side line, no samples necessary. The Telesign Co., 6 N. Clark St., Chicago.

HELP WANTED

LEARN Automobile trade in reliable School. Overhauling, Ignition, Machine Shop Work, Driving, up-to-date cars. Special Exposition rates. Many positions filled. Room and board while learning. Catalog free. National School of Engineering, Los Angeles. Established 1905.

WANTED—Young man, every locality, willing to learn Mechanical Drawing, for Representative. Good Salary. Engineer, 4611 McMillan, St. Louis, Mo.

GO on the Stage. Vaudeville career offered you. Experience unnecessary. Managers endorse my method. Instructive vaudeville book free. Write today. Fred-eric LaDelle, Sta. 10, Jackson, Mich.

CHAUFFEURS get \$18.00 week. Earn while learning. Sample lessons free. Franklin Institute, Dept. D-892, Rochester, N. Y.

EARN \$20 weekly collecting names and information. What you see, hear and know is worth money. Send stamp for instructive booklet. Information System, 231 Marietta, Ohio.

BE a Detective—Earn from \$150.00 to \$300.00 per month. Travel over the world. Write C. T. Ludwig, 349 Westover Building, Kansas City, Mo.

RAILWAY Mail Clerks Wanted. Commence \$75.00 month. Sample examination questions free. Franklin Institute, Dept. D-21, Rochester, N. Y.

WANTED—Circular Distributors send 10c for a Contract Magazine. Oliver A. Barkley, Mount Pleasant, Pennsylvania.

MANAGERS wanted, small Capital required; Merchandise in your possession is your security. Harrison Co., Worcester, Mass.

I NEED branch managers for my worldwide mail-order business; operate from your own home in spare time; no canvassing or peddling; experience unnecessary; you should make \$50 weekly. Butler, 511 Factories, Toledo, Ohio.

WANTED—Railway Mail Clerks. \$75 month. Examinations coming everywhere. Sample questions free. Write immediately. Franklin Institute, Dept. D-21, Rochester, N. Y.

RARE opportunity, start in business; big profits, small cost. Particulars 2c stamp. Ideal Sign Co., 609 McKay Bldg., Portland, Ore.

SILVERING mirrors, Plating tableware, auto-brass. Home booklet plans free. Clarence Sprinkle, Dept. 28, Marion, Ind.

"DOLLARS" yearly in your back yard. No ginseng, mushroom dope. New ideas never before published, particulars free. Metz, 313 East 89th St., New York.

\$75.00 MONTH paid Railway Mail Clerks. Examinations announced Jan. 15th. Sample questions free. Write immediately. Franklin Institute, Dept. D-21, Rochester, N. Y.

GET a Government Job! See ad on page 14. Write now—today! Patterson Civil Service School, Rochester, N. Y.

BE a Traffic Inspector; We Teach You; a New Profession. \$4 a Day to Start. Unlimited Opportunities for Travel and Advancement. Positions Now Open. Frontier Prep. School, Dept. A3, Buffalo, N. Y.

INCREASE your present income \$50.00 to \$150.00 monthly. Stamp for particulars. Menard Supply House, Dept. A, 1023 No. Menard Avenue, Chicago.

MEN, women, common schooling, desiring Government positions, \$70 monthly, write for list \$12 immediately. Philadelphia Civil Service School, Philadelphia.

INVENTORS wanted. Your ideas may mean fortune. Send sketch. Patents secured through new credit system. Book and advice free. Waters & Co., 4102 Warder Bldg., Washington, D. C.

FIREMEN and brakemen; \$100 monthly. Experience unnecessary; hundreds needed by the best railroads everywhere. Particulars free. \$10 Railway Bureau, East St. Louis, Ill.

INVENTIONS sold on commission. No advance fee. Patent News, D, Washington, D. C.

MARKET Spare Time intelligently: \$500.00 annually furnishing commercial information; particulars free. "Cleo" Pmc, Evansville, Indiana.

THOUSANDS Government Jobs Open to Men, Women. \$75 month. Short hours. Steady work. Common education sufficient. Write immediately for free list of positions now obtainable. Franklin Institute, Dept. D-21, Rochester, N. Y.

OUR 49 article premium mail order catalogue tells you how to make extra money in spare time. Both sexes. No canvassing. No capital. Vulcan Co., Dept. 1, 101 S. 5th Ave., Chicago, Ill.

MEN wanted for detective work. Also instructed by former U. S. Govt. detective. Write J. Ganor, 2309 Calumet, Chicago, Ill.

IF salary of \$100.00 per month and commissions, with liberal expenses, interest you, address Dept. N. Y., 2907 Indiana Ave., Chicago.

BE a detective; earn \$50 to \$100 weekly; travel all over the world. Write Dept. A, United States Detective & Adjusting Agency, Chemical Bldg. St. Louis, Mo.

MEN; co-operate and become Detectives; experience unnecessary; particulars for stamp, W. A. Brouk, 1821 Ave. A, New York.

SPARE time money-making business. Started without capital. Success proven. Instructions free. Norman Co., 157 East 47th Street, New York.

MOTORMEN—Conductors; \$80 monthly; Interurbans everywhere. Experience unnecessary; qualify now; state age; Booklet free. Electric Dept., 750 Syndicate Trust, B., St. Louis, Mo.

U. S. GOVERNMENT wants clerks. Men—Women, 18 or over, \$73.00 month. Vacations. List of positions now obtainable free. Write immediately. Franklin Institute, Dept. D-21, Rochester, N. Y.

GOVERNMENT Examinations. Most thorough preparation, \$5; returned if not appointed; particulars free. American Civil Service School, Washington, D. C.

STOP Here! Let me start you in a home business that will bring you money every day. Experience unnecessary. Spare time. No canvassing. I furnish everything. Send for proofs. Voorhies, Desk C. R., Omaha, Neb.

WANTED—An Idea! Who can think of some simple thing to patent? Protect your ideas; they may bring you wealth. Write for "Needed Inventions" and "How to Get Your Patent and Your Money." Randolph & Co., Patent Attorneys, Dept. 144, Washington, D. C.

PLEASANT spare-time work; mailing circulars. Good pay. No scheme. Details free. Home Pub. Society, 46 N. 12th, Philadelphia.

EARN \$25 to \$75 weekly. Own a business. Complete set of illustrated lessons, "Be a Tree Expert," mailed for \$2. Money refunded should you fail to learn. Those desiring correspondence course with personal instructions, write immediately for free booklet. Wilmette School of Tree Dentistry, Wilmette, Ill.

FIREMEN, Brakemen Wanted, all railroads; \$120 monthly. Experience unnecessary. Railway Association, Dept. 208, Brooklyn, N. Y.

BECOME Detectives. Large salaries; easy work. Write Chief Wagner, 1248 Lexington Avenue, New York.

YOUR services are needed as Topographic Draftsman at excellent salary. You can learn from us soon. Get particulars, Columbia School of Drafting, McLachlen Bldg., Washington, D. C.

WRITE Moving-Picture Plays. Good prices. Devote all or spare time. No correspondence school. Details free. Atlas Publishing Co., 2045 Cincinnati.

MEN wanted to make Toy Soldiers, Indians, Cowboys, etc. Germany's great industry. War stopped importation. Big demand. Greatest homework proposition. Big business on larger scale. Coming complete with pedestals, about 100 per hour, from the casting form. Complete outfit \$2.00 up. Tools, experience unnecessary. We buy soldiers all year at fixed prices. Booklet, pattern-sheet, payroll free. Toy Soldier Manufacturing, 32 Union Square, New York.

500 MEN wanted, 20 to 40 for electric railway motormen and conductors. \$60 to \$100 monthly, experience unnecessary. No strike. Write for application blank. National Railway Training Association, Dept. 47, Kansas City, Mo.

LADIES you can earn a beautiful decorated china dinner set by working for us an hour or two. For particulars address, Ha-Wa-Co Specialty Co., East Liverpool, O.

EARN \$100 weekly managing clean legitimate mail order business. We furnish everything. Right party need not worry about capital. Splendid chance for intelligent, employed person to control independent business on profit-sharing basis, beginning in spare time, evenings at home. Particulars free. Opportunities Exchange, Buffalo, N. Y.

SALE OR EXCHANGE

WILL exchange Moving Picture Outfit now in use for second-hand Automobile in good condition. W. L. England, Lenoir, N. C.

UPRIGHT Piano to exchange for diamond or stamp collection. Raymond Stiles, Schenectady, New York.

COINS, Notes, Stamps, Indian Relics, Guns, Pistols, Knives and all kinds of curious things exchanged for United Profit Sharing coupons. Booklet for stamp. Coin Exchange, New Rochelle, N. Y.

LIVE prospects to sell or trade anything anywhere. Write for plan. Mathews Rauch Publicity, 393 Mailers Bldg., Chicago.

FOR SALE

15-LIGHT Acetylene Gas Plants, Generator, Fixtures, Chandeliers, Pipe, Cheaper than Electricity. Fully Guaranteed, easily worth \$60.00. All complete for \$31.50. Write Daniel Zimmerman, Magley, Indiana.

ONE 80-Ton 42' Rebuilt Fairbanks Track Scale with 18" 55 I-Beams, thoroughly refitted, \$250.00. F. O. B. Cars, St. Louis, Mo. Howe Scale Co., 409 No. 4th St., St. Louis, Mo.

FOR Sale—Ohio Corliss engine, 250-h. p., heavy duty type, in perfectly good working condition. Faultless Rubber Co., Ashland, O.

FOR Sale—W. Z. Long's Crispette machine with rotary popper. H. Hamilton, 1817 S. State, Syracuse, New York.

\$150.00 BECK, London, Research Binocular Microscope, complete equipment. Price \$275.00. Wall, 307 E. 61st Street, Chicago.

SLOT Machines, Mills Operator Bells, \$10. Floor Venders, \$14. Each to close out quick. Auto Vending Co., Minneapolis, Minn.

TYPE and Printing Material at bargain prices. Now is the time to buy. All sizes rebuilt Job Presses very cheap. Catalogue free. Philadelphia Printers' Supply Co., 14 So. Fifth St., Philadelphia.

FIELD and Marine, Day and Night Glasses, with beautiful case, 25-mile adjustment; \$30 value, only \$7.50. Money back if not satisfied. Well's Curiosity Shop, 20 S. Second St., Philadelphia, Pa.

GUNS, SPORTING GOODS, ETC.

FIREARMS—Old-time and modern. Buy, sell, exchange all sorts. Stephen Van Rensselaer, 49 Front St., New York City.

TEMPERING Gun Springs, coils, etc. Perfect system, \$2. C. M. Becker, Gunsmith, Port Rowan, Canada.

FLOUR & FEED MILLING MACHINERY

SPECIAL bargains in second hand Attention mills, burr mills, crushers, corn shellers, bran dusters, dust collectors, purifiers, reels, double, single, 2 and 3-pair high roller mills, sieve bolters, reciting separators, scourers, etc. Write for description and prices. Sprout, Waldron & Co., P. O. Box 429, Muncie, Pa.

MACHINERY, TOOLS AND SUPPLIES

ENGINE Lathe, swings 3/4 in., takes 25 in. between centers. Complete set gears cutting all size threads 3 in. to 40 in., \$43.50. Grammes & Sons, Allentown, Pa.

"RED Devil" Mechanic's piler (drop forged steel). Most efficient. 5" size 60c. Style 50. Tool booklet free. Smith & Hemenway Co., 161B Chambers Street, New York City.

OTTO Stationary Gasoline Engine, 60 h. p., fine order, self starter, \$450.00. A. Stainforth, Winthrop, Mass.

FOR Sale—Berlin Double Surfer. Good condition. Willingham Sash & Door Co., Macon, Ga.

FOR Sale; New Power Hack Saw, capacity 4"x4", \$15.00. New 10" Sensitive Bench Drill Press, complete with chuck, capacity 3/4", \$15.00. Passman Bros., 30 S. Green St., Chicago, Ill.

PULLEYS, Gears, Sprockets, Shafting, Hangers; see page 164. W. A. Jones Foundry & Machine Co., Chicago.

ENGINES, MOTORS AND DYNAMOS

EIGHT Electric Motors practically new, from 1/2 H. P., 110 volts, to 1 H. P., 110 volts, from \$25 to \$85. Three of them have reversible starting boxes for lathe work—direct drive. Write for descriptive list. C. H. Lang, 1704 Michigan Ave., Chicago.

ELECTRIC light dynamo—use your spare power, and save half your lighting bills. Easy monthly payments. Hobart Bros., Troy, Ohio.

GREAT bargain. Sell or trade. Complete vertical Nash 3-cyl. 75-H.P. producer, or natural-gas power plant for Electric motors. Wolters Bros., Fremont, Mich.

FOR Sale—50-H.P. Atlas engine \$75. 4-ton gasoline motor, new. Address Box 125, Muncie, Ind.

FOR Sale—25-H.P. steam engine and boiler with all the equipments. One New 3-H.P. Olds Gasoline Engine. Write H. Murray, Goodland, Ind.

STORAGE Sale—Small motors and dynamos, all new, 110 volts. 3/4 H. P.—A. C., \$13.50; 1/2 H. P.—A. C., \$13.50; 1/2 H. P.—D. C., \$6.50; 8 light dynamo, \$12.00; motor generator sets, \$35.00. Other sizes, all voltages less than half price. Johnston, Evans Ave., Ingram, Pa.

ALTERNATING current, rebuilt motors. Reliable makes only. General Electric, Fort Wayne, Emerson, Wagner, Westinghouse. 1/2 H. P.—\$13.00; 3/4 H. P.—\$15.00; 1 H. P.—\$18.00. Direct-current bargains. Satisfaction guaranteed or money refunded. Write for illustrated list supplies and motors. Hyre Electric Co., 613L South Dearborn St., Chicago.

1 1/2, 2 1/2 AND 18 hp. gasoline engines cheap. J. T. McCarthy, Waukesha, Wis., R. Number 4.

FAIRBANKS-MORSE 2-hp. 2 Phase 220-Volt Motor, Starting Box, Steel Pulleys, Shaft, Belts, two 1kw. Westinghouse 2200-V. to 220 and 110 Transformers, \$69. H. Harland, Burlington, Wash.

REBUILT Engines—We have on hand a number of rebuilt "Buffalo" engines, guaranteed, at greatly reduced prices. Write for bargain list. Buffalo Gasoline Motor Co., 1295-1295 Niagara Street, Buffalo, N. Y.

GASOLINE Engine, 1/2 Horse Power \$12.00. L. Zehrlach, Leipzig, Ohio.

1/2 H. P. MOTORS and Generators. Alternating and Direct. Bargains. Geo. Black, 601 Lorenz Ave., Pittsburgh, Pa.

ENGINE CASTINGS AND BLUE PRINTS

SMALL Gasoline Engines and Castings with drawings. Crown Motor Works, Elgin, Ill.

GASOLINE Engine Castings, with drawings. Cheap. Catalogue free. Novelty Manufacturing Co., 855 West 6th St., Cincinnati, Ohio.

BOATS, LAUNCHES, ETC.

BUILD your own Steel boat from patterns. Material furnished, also finished boats. Catalogue free. Darrow Boat Co., Albion, Mich.

2 H.P. Marine Engine, good order, \$20.00. Cash with order. Stainforth, Winthrop, Mass.

BLACKSMITHS

BLACKSMITHS. Listen: Wear the smile that won't come off, by doing hard jobs easy with Toy's Modern Methods on blacksmithing. Making all welds solid, tempering all tools to a standard with colored tempering charts. All for one dollar. Samples free. W. M. Toy, Sidney, Ohio.

CEMENT

CONCRETE Building Block Machines and moulds. Free catalogue. 3 Market St., St. Louis, Mo.

ELECTRICAL

WHOLESALE prices on supplies and motors. Send for illustrated bargain sheet. Hyre Electric Co., 613D South Dearborn St., Chicago.

"BOY Electrician" make Batteries. Motors, Engines, 75 illustrations, 10c. Renew Dry Batteries, 3 guaranteed processes, 20c. Best 25c. "Ideal," 3311-T Belleplaine Ave., Chicago.

TOY transformers while they last, \$1.60; also a few Bell-ringing transformers, \$1.10. A. R. Darling, 1532 N. Capitol Ave., Indianapolis, Ind.

ELECTRICAL Information Furnished. Any Three Questions Twelve Cents. Howard T. Cooper, P. O. Box 238, Chicago.

TRANSFORMER, wireless, and electrical supplies at half price. Trippe, Tonawanda River, N. J.

TATTOOING Outfits, Electric and Hand, \$1 up. Roberts Company, 635 West Ave., Buffalo, N. Y.

FOR THE HOME

FIFTY Calling Cards 25c. Gold or black ink. Bridgen Company, Waltham, Mass.

PURE best quality maple syrup \$1.10 per gallon. R. F. Oldham, Chagrin Falls, Ohio.

RUGS—the Famous Navajo Indian rugs for Library, Den, or Card-room. 27"x54" well valued—\$3.50, also other larger sizes. Wells Curiosity Shop, 20 S. 2nd St., Philadelphia, Pa.

STAMP COLLECTING

PACKET "A" 100 varieties foreign, 20c—worth the money! Desirable stamps on approval, to collectors with satisfactory references. P. J. Pope, Box 45, Charlotte, Vermont.

STAMPS—103 China, etc., stamp dictionary and list, 2c. Bullard, Sta. A, Boston.

STAMPS sent on approval at 10% discount. Precancelled, 1/2c each. Reference required. Emory Renoll, Hanover, Pa.

FREE; dandy packet to approval Applicants. Murray, Rock Island, Ill.

37 DIFFERENT from 18 warring countries 15c. Lufbery, Wallingford, Conn.

OVER 300 Stamps, Album, Perforation Gauge and big list 10c. Payn Stamp Co., 128 No. Wellington St., Los Angeles, Calif.

FREE Packet, Canada, Newfoundland, China, West Indies, etc., with request for approval selections; enclose 2c. George Flagg, 28 School St., Boston.

CANCELLED Postage Stamps wanted. Latest Buying Catalog 10 cents. Michigan Stamp Co., Detroit.

WAR Stamps, etc., fine packet, ten cents. Raymond Stiles, Schenectady, New York.

FREE—Five different Newfoundland to approval applicants sending reference. Linton, Rock Island, Ill.

321 FINE different foreign stamps, 32c; 54 different unused 24c; pictorial set Nyassa, 1901—13 varieties unused, 25c; other dandy pictorial sets cheap; send for our choice approvals. Graeme Ten, 2013 Palmer Ave., New Orleans, La.

STAMPS, 60 2/3% discount and premiums. Reference required. M. Place, Wrentham, Mass.

25 DIFFERENT U. S. Revenues, 8c. Sholley, L. H. Station, Minneapolis.

UNUSED U. S. Postage Stamps bought, any quantity; ask rates. O. Nestle, 3411 Wilson Ave., Chicago, Ill.

FREE Poster Stamps. 1 Package 50 Advertising Stamps Free with each order. 10 beautiful Stamps of Minneapolis; 20 beautiful Stamps of St. Paul; 28 beautiful Stamps of U. S. Presidents; all for 25c. Art Poster Stamp Co., Dept. 4, 152 E. 5th St., St. Paul, Minn.

500 OLD mixed U. S. Stamps, 15c. 65 varieties, 10c. Charles Preugh, Elma, Wash.

FREE 50 Asiatic, 62 Japanese, 101 United States, 201 foreign, 50 Sweden, 51 Norway-Denmark, Remit 25c. Six months' subscription Meckle's Stamp Weekly, Boston, Mass. All different. Choose one.

LOW priced approvals. Mention paper and receive unused Department Stamp Free. S. E. Colman, 434 Keefer Place, Washington, D. C.

STAMP Album with 538 Genuine Stamps, incl. Old Mexico, Malay (tiger), China (dragon), Tasmania (landscape), Jamaica (waterfalls) etc., 10c, 100 diff. Jap. N. Zed., etc., 5c. Big List, Coupons etc., Free! We buy Stamps. Hussman Stamp Co., St. Louis, Mo.

PACKET of 23 stamps; no two countries alike, 500 hinges. Set of \$1 and \$2 U. S. Rev., all for 5c. Mention paper. Miami Stamp Co., Toledo, Ohio.

STAMPS Free—5 different Nyassa (giraffes, camels), or 5 different Japanese-China, or 1916 Hungarian War Stamp, big price lists, bargain lists, \$2 premium coupon, etc., free for 2c postage. W. C. Phillips & Co., Glastonbury, Conn.

STAMPS—12 different from warring nations, 10c; 10 different foreign coins, 15c; 20 Belgium stamps, 10c. Lists free. Toledo Stamp Co., Toledo, Ohio.

FOREIGN Stamps Free; 52 different foreign, including China and Venezuela, to all who apply for our high grade approval selections. Send two-cent stamp for return postage. Edgewood Stamp Co., Dept. H, Millford, Conn.

25 DIFFERENT British Colonials to applicants for stamps on approval who send 2c postage. Nickles, 122 Florida Ave., Washington, D. C.

STAMPS, 100, all different, free. Postage 2c. Mention paper. Quaker Stamp Co., Toledo, Ohio.

24 VARIETIES Cuban stamps, 10 cents. List of 6,000 low-priced stamps free. Chambers Stamp Co., 111 P. Nassau St., New York City.

FREE; Premium for requesting approval bargains. Selling out. Paul Riedell, Schenectady, N. Y.

RARE COINS

WILL pay \$750.00 cash for \$1 gold piece dated 1822 (without "In God We Trust"); \$50.00 for 1853 half without arrows; \$5.00 to \$50.00 cash for large cent 1799, etc. We pay cash premium for all large cents, eagle cents, 2c pieces, etc., and all rare U. S. and foreign coins, bills and stamps to 1912. Thousands of rare coins wanted. Many valuable pieces are in circulation. Send 4c. Get our Large Illustrated Coin Circular containing valuable information. It may mean much to you. You certainly have nothing to lose. Send to Numismatic Bank of Texas, Dept. H, Fort Worth, Texas.

BUFFALO Nickels. Original buyer of them and Lincoln pennies, certain kinds, at 25c each, and hundreds of other old coins, has coin catalog quoting highest prices. Send 1c for this catalog and full particulars. Means \$5 to you. National, Dept. 15, Olney, Ill.

1798 DOLLARS—each \$3.10. Coin Premium Book, 15c. Moore Coin Company, Commerce, Texas.

OLD Coins Wanted—I pay highest prices for rare coins. E. B. Knights, Monmouth, Ill.

TEN \$1.00 Mexican Bills (Villa) 35c. Liberal, Lordsburg, New Mexico.

\$4.25 EACH Paid for U. S. Flying Eagle Cents dated 1856. We pay cash premiums on hundreds of Old Coins. Send ten cents at once for New Illustrated Coin Value Book 4x7. It may mean your fortune. Clarke & Co., Coin Dealers, Box 15, Le Roy, N. Y.

ALL for 30c. A 25c California gold taken, a Columbia Nickel coin book, Lucky Seed, C. J. Carey, New Rochelle, N. Y.

COINS—Antique Relics, 5 curious rare coins with catalogue 10c. Ray, Chapin, New Berlin, N. Y.

OLD Coins Bought and Sold. Full catalogue list of coins for sale, free to collectors only. Buying catalogue quoting prices I pay for coins, 10 cents. Wm. Hesselin, 101 Tremont St., Boston, Mass.

GAMES AND ENTERTAINMENTS

BECOME a Shadowgraphist; anyone can learn it. Book of instructions fully illustrated postpaid, 50c. M. Germanor, Box 420, Bridgeport, Conn.

470 TRICKS, Jokes, Riddles, Fortune-telling Secrets and big catalogue 10c. "Ideal" Shop, 3311-T Belleplaine Ave., Chicago.

MAGIC Pocket Trick, including professional catalog, 6c. Magic Co., Sta. 19, 249 West 38th St., New York.

MAGICIANS' tricks, escapes, Ventriloquist and Punch Figures. All the latest. Prices low. Big catalog free. Magic Parlors, 192 Clifford, Providence, R. I.

FREE! "Modern Mystery," new book on Magic—just off the press. Hints, Suggestions, Explanations of Tricks, Magical Secrets, etc. Also Big Bargain Sheet of over 400 Magic Tricks and Books at lowest prices. Send 4c postage. Douglas, Kiowa, Okla.

MAGIC: We teach you to perform Tricks at home as good as the great professionals. Feature Acts in Mind Reading, Spiritualistic Work, Rope Ties, Escape Acts. Send for New Thumb Tie for stage work—7 illustrations; complete directions, 50c. Catalogue 160 pages, greatest on earth, 10c. Chicago Magic Co., Dept. B, 72 W. Adams St., Chicago, Ill.

THE Spirit of Play. Playground Games (For Rural Schools) 10 cents; Game of Tames (Tables and Factoring) 15 cents; Uncle Will's Magazine, 50 cents a year, 4 cents a copy. W. G. Crocker (Uncle Will), Box M, Lisbon, N. D.

MECHANICAL Puzzles, Sample 10c. Lamont Co., Beacon, New York.

RUBBER hatchets, razors, daggers; look like real thing. Loads of fun, 25c each and catalogue. Agents wanted. The Specialty Mfg. Co., Cedar Rapids, Ia.

ORIGINAL sensational new novelties. Tricks, puzzles and jokers' goods; fun for all. Be a live one among your friends. Send for large illustrated catalogue. J. Grandfield Mfg., 1238 Theriot Ave., Bronx, New York.

BASEBALL-O makes home runs, triple plays, etc., 12c. Carlson, 1838 Holly, Kansas City, Mo.

GREENBACKS—Big bunch 10c; 4—25c. Downey, 537 Union Ave., Chicago.

BE a handoff king. We teach you. Escape from handcuffs, boxes, ropes, etc. Secrets of 20 sensational escapes \$1. Particulars free. The Magicraft Co., Dept. A, Box 251, Detroit, Mich.

CHARLEY Chaplin Puzzle. Big laugh every move. Price 15c. Park Novelty Co., 4233 Lako Park Ave., Chicago.

SEND 6c, Home of Magic, Binghamton, N. Y. Get two good tricks and three catalogues postpaid.

PLAYS, Vaudeville Sketches, Monologues, Dialogues, Speakers, Minstrel Material, Jokes, Recitations, Tableaux, Drills, Musical Pieces, Entertainments for all occasions. Make-up Goods. Large Catalog Free. T. S. Denison & Co., Dept. 11, Chicago.

TRICKS, Puzzles, Jokes, Magic Goods, Sensational Escapes, and Illusions, Big catalogue free. Oaks Magic Co., Dept. 257, Oshkosh, Wis.

"MAGICAL—Entertaining" Free Course (10 Lessons) to introduce 50 only. Magical Outfit 50c, Part 25c. Sample Trick 10c. Herrmann "Magicschool," Long Beach Building, New York.

TRICKS—50c Worth of Our Latest Tricks, Novelties, Puzzles, etc., 20c. Brown Mfg. Co., Ft. Atkinson, Wisconsin.

CHRISTMAS SUGGESTIONS

SOMETHING New: Hand-modeled high relief fox-head or cherub-head, indestructible composition, antique gold or bronze finish. Beautiful home decoration. Pleasing Christmas gift. 8x7x1 inches. Price 50c. Douglas & Winter, 302 W. 55 Street, New York City.

GENUINE Indian Beaded Leather Moccasins. Ladies sizes \$1.25 pair. Men's \$1.50 pair. Agents wanted. Richard Lavery, Astory Park, N. J.

FOR BOYS

ONE Million Boys have made Christmas gifts, and 500 other things, from A. Neely Hall's plans. A few cents each. Illustrated catalogue. Put-Together Handicraft Shop, 8, Oak Park, Ill.

BIG New Book for Boys—The Boy Mechanic, Vol. II.—Just Out—A sequel to, but containing nothing found in Vol. I. Tells all about 1,000 interesting things to make and do. 480 Pages; 995 illus. Cloth. Price, \$1.50 Postpaid. Send for descriptive circular. Popular Mechanics Book Dept., 6 N. Michigan Ave., Chicago.

FOR MEN

REAL Home-Grown Tobacco as it comes from the farm, 3 lbs. \$1.00 postpaid. Send money today, to Leaf Tobacco Co., Box 5, Mayfield, Ky.

GENUINE Havana Cigars; soothing, fragrant, direct from factory, \$4 and up per 100 delivered. A. Ramirez & Co., Manufacturers, Dept. M, Box 998, Tampa, Fla.

NICKELPLATED Safety Razor with four blades 25c. Extra blades free. Order from Beyer Safety Razors, 23 West 47th Street, Bayonne, N. J.

\$5.00 GILLETTE Razor at \$3.95. Guaranteed genuine. Vapco, 1456 Otto Street, Chicago.

\$1.00 ENDERS Safety Razor, 7c. Money Order, Phil-Ray Co., Marile Falls, Tex.

DEERSKIN Vests. Made to measure. Lined throughout with silk finish. Neat, comfortable and attractive in appearance. Outwears dozen cloth vests. \$4. Particulars free. Write now. Indian Deadwork Co., Poplar, Mont.

FOR Sale—10,000 pounds best leaf tobacco. Mail stamps for samples. Anton Wavrin, Franklin, Ky.

CANVAS or Jersey Gloves—Buy from Manufacturer and save money. One dozen pairs by mail on receipt of \$1.00. Oswego Glove Co., Oswego, N. Y.

DIAMONDS, WATCHES AND JEWELRY

GENUINE Perfect Cut Diamonds, \$97.50 per carat! Direct from the importer to you. We eliminate middlemen's profits and thus save you 35%. Any selection shipped for free examination without obligating you to buy. Written Money-Back Contract with every diamond. In this we certify carat weight and value; allows full price in exchange any time; allows 99% cash refund any time within one year. Write for our big valuable Basch De Luxe Diamond Book free! Beautiful illustrations of thousands of articles of jewelry. Shows how to buy diamonds intelligently. Write to L. Basch & Co., Dept. M2400, State and Quincy Streets, Chicago.

ELGIN, Waltham, Hampden and other high grade watches cheaper than other mail order houses. Write for price list. Minneapolis Watch Co., 2717 Girard Ave., S., Minneapolis, Minn.

MUSIC

VOCAL Instruction, Systematic Studies in "Tone Production." 25c coin brings three sample lessons. A. Francke, Voice Builder, 61 Auditorium Bldg., Chicago.

"DREAMS," the greatest waltz ballad in years. For sale everywhere or direct from us, 10 cents. Marks-Goldsmith Co., Dept. 91, Washington, D. C.

LEARN Harmonica (mouth-organ). Complete self-instructor, 15c. G. Elsen, Owosso, Mich.

POPULAR Songs—15c each. "Long, Long Letter 'Bout Home, Sweet Home," "In the Land of the Rising Sun," "Fight for Motherland." D. D. S. Music Co., 5123 Third Ave., Brooklyn, N. Y.

"COME Now"—Beautiful sacred solo, or solo, duet and chorus, 17c. Address L. C. Credit, Quenemo, Kansas.

SIX 2c stamps brings you the biggest song hit of the year. "The Little Grey Mother," the wonderful mother-march-war ballad that is being sung by the great popular singers all over the country. With it we send free a copy of the valuable book, "Music by Mail," containing everything in music, to play and select from. Get this now. M. Witmark & Sons, Suite F, Witmark Bldg., New York.

RECORDS for Victrola, Columbia and Edison (disc or cylinder) Talking Machines. Edison Standard, 9c; Blue Amberol, 25c; Victrola, 15c; bought, sold and exchanged. Permanent Jewel Needle, \$1; Jewel point attachment for Victrola or Grafonola to play Edison disc records, \$2. Send for record list. Weil's Curiosity Shop, 20 S. 2nd St., Philadelphia, Pa.

MAKE Money Mailing Music Circulars. Plan free. Write Needham Music Co., D61, St. Louis, Mo.

FORMULAS AND TRADE SECRETS

1,000 FORMULAS 20c, 75 Manufacturing secrets, 10c. Restoring Mirrors, Renewing Dry Batteries, 20c each. Guaranteed. All 50c. Catalogue free. "Ideal," 3311-T, Belleplaine Ave., Chicago.

THE Century Wonder. Prevents eye glasses from steaming or frosting in the coldest freezing weather. Send 10c for sample cake. Formula secret 50c. Address A. Sobey, 128 W. Brighton Ave., Syracuse, N. Y.

HIGH Grade Guaranteed Formulas for almost any occasion. Prices reasonable. Cole Chemical Co., Chicago.

LUMINOUS Ink—New and startling. Shines in Dark! A money-maker. Formula reduced to 15c. J. Byron Long, Salem, Iowa.

NICKELPLATING instructions, \$0.50. Detailed—Successful—Satisfactory—Different. Ballico, Buckland, Conn.

150 SELECTED formulas and big catalog, 10c. "Ideal," 3311-T, Belleplaine Ave., Chicago.

MAKE good writing ink at 1c per quart. Guaranteed instructions, 10c. Oscar Hanson, Mentor, Minn.

TYPEWRITERS AND SUPPLIES

WE have several makes of typewriters to sell at once, \$10.00 to \$15.00, shipped on trial. Northern Office Equipment Co., Dept. 5, Northern Office Bldg., Chicago.

SPECIAL Note: If you want a real bargain in a dandy, high-class, substantially guaranteed rebuilt typewriter of any make—on time, rental or cash—be sure to write the B'g house today. Young Typewriter Co., Dept. 223, Chicago.

SELLING Oliver Typewriter. Fine condition. Bargain. Write "Webb," Perry, Ohio.

REMINGTON Typewriter No. 10, slightly used, \$39.00. J. A. Stewart, Mattoon, Ill.

GOOD, serviceable typewriters \$7.50 and up. Post card brings list. First class ribbons, any machine, 25c. Hub Typewriter Co., 286 Decesshine St., Boston.

TYPEWRITER ribbons, 35c; 3 for dollar; Carbon 75c hundred sheets. Smiley, Best Ave., Chicago, Ill.

LARGEST Stock of Typewriters in America—All makes; Underwoods, Oliviers, Remingtons, etc., one-fourth to one-half manufacturers' prices, \$15 up, rented anywhere, applying rent on price; free trial; installment payments if desired. Write for catalogue 70. Typewriter Emporium (Established 1892), 34-36 West Lake Street, Chicago, Illinois.

SAFETY BLADES SHARPENED

SAFETY razors sharpened; two cents each. Guaranteed. Blade box free. Electro Strapping Co., 134 Shelby St., Detroit, Mich.

DUPLICATORS AND DEVICES

OUR "Modern" Dupliator—Yours for \$2.49. No Glue or Gelatin. Always ready. All sizes. Free trial. \$4.00 users. Standard for 15 years. Booklet free. Sole mfrs., J. E. Durkin & Reeves Co., 339 Fifth Ave., Pittsburgh, Pa.

MAKE your own duplicator. Cost small. 50-100 copies. Guaranteed formula 25¢ coin. Chemist, 414 Richmond Terrace, S. I., N. Y.

DUPLICATORS, 9x12, price \$1. Make 50 copies from pen or typewritten original. Booklet Free. Scientific Laboratories, Dept. 1, Madison, Maine.

MAILING LISTS

FARMERS, Guaranteed. Multigraph Work. Mailing. "The Letter Shop," 517 Main, Danversport, Ia.

5,000 FARMERS' names in best section of Georgia, \$5; 1,600 for \$1.50. Box 426, Griffin, Ga.

BUY "Quality-Names;" Deliveries Guaranteed; trial of 250 any class, \$1.00 delivered. Order trial list today. "Cico," Evansville, Indiana.

MAIL Beginners' names. Write for prices. B. Collins, Viola, Iowa.

FREE to business men, copy of our comprehensive "Silent Salesman." Contains over 2,000 different classifications of Mailing Lists with number and price of each list, and information every business man needs. Accept this free offer. Trade Circular Addressing Co., G 164½ W. Adams, Chicago.

PRINTING, ENGRAVING AND MULTIGRAPHING

HIGHEST class of engraving (Wedding Announcements, Invitations, Visiting, Business Cards, Office Stationery), also makers of wood cuts. Most reasonable prices. Send for samples. Glickman & Co., 111 Nassau St., New York.

GOOD Printing at low prices. 1,000 good letterheads, envelopes, cards, billheads, labels, circulars, \$2.50. Samples free. Catalogues, booklets, and circulars our specialty. Ernest L. Fautus Co., 523 S. Dearborn St., Chicago.

1,000 ENVELOPES, Letterheads, Statements, Billheads, \$1.50. Samples. Ross, Culberson, N. C.

50 CARDS, Name, Address (Business), 20¢. Prompt, Stylish. Will Please. Royal Print, Mount Carmel, Pa.

25 BUSINESS Cards 10¢; 1,000 3x5 circulars, 100 words, 85¢ postpaid. Chas. Walter Lancaster, Ohio.

1,000 LETTERHEADS, envelopes, cards, billheads, \$2.40. Samples. McCleery Printing Co., Strassburg, Neb.

GOOD Printing; Low Prices—Letterheads; envelopes; \$2 thousand, 5,000, \$7.50. Samples sent. Frankfort Bus. Frankfort, Ohio.

2,000 125-WORD circulars printed and mailed to good list, \$1.30. Sample free. Miller, 1952b Germantown Ave., Philadelphia.

250 FINE lined Letterheads and Envelopes printed, \$1.65. Samples free. Francis Jackey, Eaton, Ohio.

CIRCULARS, Folders and Booklet Printing a specialty. Prices lowest. Write us your wants. Printery, Grimmer, Mo.

50 CALLING Cards 10¢. 30 Christmas Cards 10¢. F. Shepard, Rome, N. Y.

225 TWO-COLOR Letterheads with Envelopes \$1. Blazo, 361 Grand River, Detroit, Mich.

1,000 NATURAL Typewritten Letters for \$2.00. No good reason why you should pay more. Price list, sample letter mailed on request. Stock's Press, Odell, Illinois.

ALL for \$5.00—1,000 letterheads, \$1.75, 1,000 envelopes (6 3/4) \$2.25, 1,000 cards \$1.50; first-class work; union shop; samples for stamp. Imperial Printing Company, 906 Penn. Ave., East, Washington, D. C.

1,000 GUMMED Labels, size, 1x2 inches (printed to order) 50 cents, postpaid. Catalog Free! G. P. Edward Harrison, Baltimore, Md.

SAVE 25%—Printing—Multigraphing. United Letter Co., Minneapolis, Minn.

REMARKABLE Bargains in Printing. Samples free. Excelsior Printery, Manchester, Maryland.

ENVELOPES, billheads, noteheads, 1,000 \$1.50. International Trading Agency, 218-D Jefferson Ave., Rochester, N. Y.

200 BOND Letterheads, 200 envelopes, \$1.50; 500 either, \$1.50. Mack Press, 1073-P East Main, Columbus, Ohio.

PRINTING—Envelopes, Noteheads, Billheads, Business Cards, 1,000 either, \$1.65; 500, \$1.10; 250, 75¢ prepaid. Fine quality. Samples for stamp. Wayside Press, Carlsbad, Mass.

ILLUSTRATE your printing; cuts made from photographs, 85¢. We print anything. Samples free. Commercial Press, Batavia, Ohio.

PREPAID, 250 each bond letterheads and envelopes, \$1.00. Multigraphing Print, Princeton, Illinois.

PROPER Printing. Not cheaper but better. 1,000 envelopes, letterheads, billheads circulars, \$2.50 per 1,000. Samples. Robinson Printery, Curwensville, Pa.

PRINTING Outfits—Presses, type, supplies, type novelties. Send stamp for catalogue. Model Press, York, Penna.

BOYS—Earn Christmas money. Presses and printing outfits \$5 and upward. Catalogue free. Excelsior Press Co., 14 So. Fifth St., Philadelphia.

QUALITY Printing Prepaid—500 either envelopes, noteheads, cards, statements, \$1.25, 1,000 \$1.85; 1,000 envelope slips, \$1. 1,000 6x9 circulars, \$1.75. 500 linen-finish letterheads or envelopes, \$1.75; 1,000, \$3. Printing prepaid. Imitation Typewritten Letters. Stamp brings samples. Model Company, Manchester, Iowa.

1,000 BOND Letterheads, 8 1/2x11, \$1.00. Samples free. Burton Bros., Louisville, Ky.

MULTIGRAPHED Letters, complete—heading black, body purple, 25 lines copy, 1,000, \$3.50; 500, \$2.35; 250, \$1.75. Quick delivery, perfect work. Samples free. Franklin Letter Press, Waukegan, Ill.

MULTIGRAPH Letters, Letterheads—1,000 complete, \$3. Letters purple, heads black. Samples for stamp. Perfection Letter Company, Muncie, Indiana.

ADVERTISERS—Here's your opportunity. 25 word classified ad inserted in "Cartoons Magazine" for 50¢; one inch display ad \$1.25. 20,000 copies guaranteed. Send in your ad for the next issue. Cartoons Classified Dept., 78 E. Madison St., Chicago.

BETTER Printing—Linen Finish Letterheads, Envelopes (white, blue, buff, gray, russet, pink) 100, 65¢; 500, \$1.75; 1,000, \$2.85. Noteheads, envelopes, cards, tags, statements, circulars, 1,000, \$1.75. Postpaid, Samples, 2¢. Klapress, Mountrose, Iowa.

GUMMED Labels, 3000 60¢. 40pp. Catalogue 2cts. MacTaggart, 1245 Arch, Philadelphia, Pennsylvania.

SAMPLE Package "Courtesy seals" two cents. Labels of all kinds. Exceeding, 419 West 42nd Street, New York.

500 EACH of Letterheads, Envelopes, Billheads and Cards, \$5.50, cash with order. Monitor, Morrisville, Pa.

EMBOSSE your own letterheads, envelopes and circulars. Particulars free. Hutton Co., Box 433, Springfield, Mass.

PATENT ATTORNEYS

"PATENTS and Patent Possibilities" is a 72-page treatise which tells all about patents, what to invent and where to sell it. It gives honest advice to inventors, and is full of valuable and interesting information. Write for it today. It is Free. H. S. Hill, 705 McClatchie Bldg., Washington, D. C.

PATENTS that protect and pay. Advice and books free. Rates reasonable—highest references; best results. Watson E. Coleman, Patent Lawyer, 624 F St., N. W., Washington, D. C.

PATENTS explained in my free books, telling what you should know—what to invent—what not to invent—how to sell your patent, etc. Write today. H. L. Woodward, 502 G St., Washington, D. C.

C. L. PARKER, Ex-member Examining Corps, Patent Office, Patent Attorney, 910 G St., Washington, D. C. Inventor's handbook, "Protecting, Exploiting and Selling Inventions," sent free upon request.

PATENTS That Pay. Proof given. Two wonderful guide books free. E. E. Vrooman & Co., 871 F St., Washington, D. C.

PATENTS—Herbert Jenner, patent attorney and mechanical expert, 606 F St., Washington, D. C. I report free of charge if a patent can be had and its exact cost. Send for circular.

PATENTS—Trade-Marks. Send for my free book, "How To Get Them." It's full of information you should know. Joshua R. H. Potts, 8 Dearborn St., Chicago; 929 Chestnut St., Philadelphia; 805 G St., Washington.

PATENTS—Send sketch for free search and report. Books on patents and book of reference letters sent free. John S. Dufflo & Co., 610 F St., Washington, D. C.

PROTECTIVE patents procured promptly, 112 page blue book on patents sent on request. Trade-marks registered. Robb & Robb, 211-215 Southern Bldg., Washington, D. C.

PATENTABLE Ideas Wanted—Send for 3 free books. R. B. Owen, 30 Owen Bldg., Wash., D. C.

INVENTORS will receive prompt attention and advice from Edwin S. Clarkson, Pat. & Lawyer, 505 Victor Bldg., Washington, D. C. Established 1890.

CANADIAN-Foreign Patents and Trade-marks. Facilities unsurpassed. F. Max Gress, Trenton, New Jersey.

DON'T Lose Your Rights to patent protection. Before proceeding further send for our blank form, "Evidence of Conception," to be signed and witnessed; Book, suggestions and advice, free. Lancaster and Altwine, 221 Ouray Bldg., Washington, D. C.

THE Patentome is free. An education in obtaining patents. Established 1865. Anderson & Son, Attorneys, 707 7th St., Washington, D. C.

PATENT What You Invent. It may be valuable. Write me. No attorney's fee until patent is allowed. Estab. 1882. "Inventor's Guide" free. Franklin H. Hough, 522 Loan & Trust Bldg., Washington, D. C.

PATENTS secured promptly. Personal attention. Edward W. Kibbey, Patent Attorney, 505 Victor Bldg., Washington, D. C.

PATENTS obtained through D. Swift being promptly sold to manufacturers. Write today for free books of "Inventions Needed," and surpassing references. D. Swift, 319 Seventh St., Washington, D. C.

PATENT your invention, \$10.000 offered for inventions wanted. Booklet and opinion free. Mimi B. Stevens & Co., Established 1864, 635 F St., Washington; 355 Mount-nock Bldg., Chicago.

NO Attorney fees until patent allowed. Send sketch for free report. Books free. Frank Fuller, Washington, D. C.

PATENTS bring riches; profit your invention. Attorney's fee payable when patent allowed. Correspondence solicited; valuable advice free. Jaynes & Jaynes, 655 Kellogg, Washington, D. C.

UNPATENTED Inventions sold on commission. No advance fee. Patent News, F, Washington, D. C.

PATENTS secured through credit system. Free search. Send sketch. Book and advice free. Waters & Co., 4102 Warder Bldg., Washington, D. C.

PATENT Applications bring results when addressed to Snow Church Co. and Percy Metzger, Washington, D. C.

WANTED—New Ideas. Write for List of Inventions Wanted. \$1,000,000 in prizes offered for inventions. Our Four Books sent free upon request. Victor J. Evans & Co., 166 Ninth St., Washington, D. C.

PATENTS secured or fee returned. Send sketch for free search. Latest and most complete patent book ever published for free distribution. George P. Kimmel, attorney, 212 Barrister Bldg., Washington, D. C.

PATENTS—100 mechanical movements, 50 perpetual motions. Free. Send 10 cents postage for mailing. P. G. Dieterich & Co., 60 Ouray Bldg., Washington, D. C.

FOR INVENTORS

PATENTS, Trade-Marks and Copyrights. Our handbook on patents will be sent free on request. All patents secured through us are described without cost to the patentee in the Scientific American. Munn & Co., Patent Attorneys, 672 Woolworth Bldg., N. Y. Washington, D. C., office, 625 F St.

INVENTORS: We are in position to manufacture and help you market your products. Our manufacturing facilities are such that we can manufacture your article cheaper than you can yourself. Sheet Metal Specialty Company, Goshen, Ind.

INVENTIONS developed; drawings, tracings, blue prints, United States and Canadian patents secured. Standard Drafting Co., 560 Fifth Ave., New York.

PATENTS and Patentable Ideas sold. Best location and facilities. Fuller Company, 500 5th Avenue, New York.

SELL your patent through the Patent Publicity Company, Browning Building, New York City. Particulars free.

WORKING drawings, tracings, blueprints, from your ideas, sketches or models. Light machinery designed. Henry Parker, 918 Eighteenth Street, Oakland, California.

INVENTIONS—Patenting and Promoting. A book containing practical advice and directions for inventors and manufacturers. Book, suggestions and advice free. Lancaster and Albright, 221 Ouray Bldg., Washington, D. C.

INVENTORS: My patent made a fortune. Particulars free. Let me sell yours. Eugene Pearl, 223 Union Square, New York.

PATENTS without advance attorney's fees. Send sketch for free report. Books free. Frank Fuller, Washington, D. C.

MONEY Advanced to develop, patent, and commercialize good inventions. Pay when sold. Simpson, Union Building, Cleveland.

INVENTIONS sold on commission. No advance fee. Patent News, B, Washington, D. C.

MECHANICAL Engineers. Specialist in designing and perfecting inventions. 15 years experience. Send details for free estimate of cost. Albert S. Kux, 105 W. Monroe St., Chicago.

WANTED—An Idea! Who can think of some simple thing to patent? Protect your ideas; they may bring you wealth. Write for "Needed Inventions" and "How to Get Your Patent and Your Money." Randolph & Co., Patent Attorneys, 620 F St., Washington, D. C.

HAVE You an Idea? If so, you should protect it by a patent. Send us a model or sketch for free opinion as to patentability. Write for our Four Books sent free to any address. Victor J. Evans & Co., 137 Ninth St., Washington, D. C.

COMMERCIALIZE Your Patents and get your income. We make it easy for you to interest capital or to exploit your invention yourself. Write for particulars. DeCamp & Sloan Mfg. Co., 422 Ogden St., Newark, N. J.

SECRETS and original ideas safely developed. We advise, plan, develop and execute original ideas in strict confidence. We are specialists in appliances and apparatus for reducing operating costs. We design, build or improve experimental machinery, dies, tools, etc., for manufacturers and inventors. Confide in us and we will respect your rights. Farrand Engineering Company, 44 No. 4th Street, Philadelphia, Pa.

WANTED—Models, Tools and Light Special Machinery to build. We have the Experienced Mechanics and Facilities to build perfect Working Models. Accurate, reliable and confidential work of every description. Regal Model & Tool Works, Chicago.

PATENTABLE Ideas Wanted—Send for 3 free books. R. B. Owen, 39 Owen Bldg., Wash., D. C.

WIRE goods all kinds made to order. Cooley, 553 W. Monroe, Chicago.

HAVE you a Patent to sell? You'll be interested in my proposition. Write now for free particulars. F. W. Johnson, 6 N. Michigan Ave., Chicago.

INVENTIONS commercialized on cash and royalty basis. Inventors, manufacturers and agents write: Adam Fisher Mfg. Co., 61 Fisher Bldg., St. Louis, Mo.

INVENTIONS MARKED

YOUR Invention may come within the limits of our Laboratories' work. If so our Business Department will consider it. Copy of patent with stamps for return will receive prompt attention. McCormick Laboratories, Dayton, Ohio.

PATENTS FOR SALE

LAST Winter the Nations at War in Europe bought half million camp stoves for use in trenches. Have patented Collapsible Camp Stove. Sale or Royalty. Chas. Harding, 2318 Prospect St., Cleveland, Ohio.

"COLLAPSIBLE Drum." Quickly assembled. Can be packed in small case. A Boon to Musicians. Investigate this money-maker. Frank E. Thompson, Lake City, Fla.

IF you want to buy or manufacture household article, Big seller, Friend to every housekeeper. Address L. Ryan, Smithfield, Neb.

MECHANICAL Dictionary; defines for children; see model. Robert E. Fuller, 500 Fifth Ave., N. Y.

POST Office Chiefs of all Countries! New plan Letter and Paper Cabinet for letter carriers sorting mail in Postoffices. Very convenient. Great time saver. Will sell at reasonable price or accept royalty offer. M. J. Cleary, Box 46, Ogden, Utah.

MORTON'S Excellent pipe vulcanizer. Just out. Every Ford owner will buy on sight. Nothing on record like it. Will sell it all or county rights. Send \$2.00 for sample. Morton Vulcanizer Co., Murfreesboro, Tenn.

PATENT—Royalty basis. Automatic hitching device for delivery horses; nothing on market like it; something everybody wants for delivery wagons. Investigate. Swanson, 2645 Elliott, Minneapolis.

SALE or Royalty: Patented cards for playing 14 games. Ora Lewis, Rushville, Illinois.

FOR Sale—United States Patent 1,154,588, Snow-Removing Device just issued Sept. 21st. Will save cities thousands of dollars. Every city will want it. Address Eckardt, 17 South Essex Street, Dover, N. J.

RAILROAD Tie: Securely holds rails. Very substantial bed for rails. Constructed of concrete, reducing cost. Superior to anything now on market. Will sell outright. Wm. Kirkwood, Coal Harbor, N. D.

ECONOMICAL oil burner, simple construction, efficient on low gravity system. G. W. Stenhouse, Bayside, Calif.

U. S. AND Canadian patent for Rotatable Fireplace for sale or royalty. Herbert J. Pender, 410 Simcoe St., Victoria, British Columbia.

WILL sell allowed patent. Dish-washing machine. C. Stone, Takoma Park, D. C.

NEW "Toy," outright or royalty. F. J. Boyle, 1614 Ave. K, Galveston, Tex.

DOOR for Grain Cars. Practical and convenient. U. S. Patent recently allowed. Canadian patent pending. Accept best offer. Irwin E. Rice, L. Box 346, Greybull, Wyo.

FOR Sale—Patent of household article just out. Donnelly, 4283 Penn Street, Frankford, Phila.

SALE or Exchange—U. S. and Canadian Patent on Water Wheel. Make offer. Matt Anderson, Dallas, Wis.

PATENT Buyers are invited to address our sales department for information on any class of Patents they wish to purchase or lease on a royalty. We have secured a number of valuable patents in all lines of invention. Mail Order Department Store and Household Novelties a specialty. Victor J. Evans & Co., 160 Ninth St., Washington, D. C.

SPLENDID opportunity for some individual or manufacturer to purchase patent on automatic wind mill generator, for generating electricity. In time this method of generating electricity will supplant the present system of distributing electricity from Central Power Stations. Farmers, Railroads, Mines, etc., are all prospective purchasers. The field is practically unlimited. Cost of production low enough to leave a substantial margin of profit for the manufacturer. Will accept reasonable offer. Investigation invited. Will not deal with patent promoters or brokers. Waters, 215 W. Illinois St., Chicago.

PATENT for sale on Paine's Automatic Change Tray, the greatest money-making novelty in years. Universal sale. Enormous profits. Fortune for the right party. Address, T. L. Paine, 30 Sentinel Bldg., Milwaukee, Wis.

WATER clarified by electricity. Patent allowed Oct. 2, 1915. Dyes, patterns, stock and tools for sale. Doing fine business. Must sell on account of poor health. The Electric Purifying Water Co., East Liverpool, Ohio.

MODELS AND MODEL SUPPLIES

WE make working models for inventors; also dies and stamping of specialties, and carry a complete stock of brass gears and model supplies. Send for catalogue. The Pierce Model Works, 3105 Pierce Ave., Chicago, Ill.

INVENTORS: We manufacture metal articles of all kinds to order. Also, special machinery, tools and dies, punchings, lathes and screw machine work, metal spinnings, castings, plating, wood and metal patterns, etc. Send sample for estimate and expert advice, free. The Eagle Mfg. Co., Dept. B., Cincinnati, O.

SPECIAL Electrical and Mechanical devices built to order. Models, Tools, Dies. Benj. Levi, 357 West Broadway, N. Y. City.

MODEL Steam Engine, $\frac{1}{2}$ H. P. \$13.00 cash with order. Stainforth, Winthrop, Mass.

FREE catalogue of model supplies. Castings, metal specialties on contract. North Chicago Tool Works, 15 Grove Ave., North Chicago, Ill.

PRODUCERS of Results: Inventions developed, Models, Experimental Work, anything special in metal to order, novelties, spinning, forging, castings in any material, electrical devices, patterns of all kinds, plating, general manufacturing, designing, special tools, punches and dies, stampings. Send drawings or sample. Expert information free. John's Machine & Stamping Works, Dept. C, Cleveland, Ohio.

WE develop and perfect working models for inventors. Light machinery building, scientific experiment work. Dies made and stamping done. Modern Die & Tool Company, 70 Ship St., Providence, R. I.

MODELS, dies, and manufacturing for inventors, by builders of "Tools That Work." La Croix Tool Co., 214 N. 21st St., St. Louis, Mo.

MODELS made for inventors; general machine work; designing and perfecting; developing automatic devices and machinery. In a position to do all kinds of light tool and machine work. Prices reasonable; estimates cheerfully given. Ideal Machine Works, 62 Ann Street, New York City.

MANUFACTURING

CONTRACT Manufacturers of Hardware, Castings in Iron—Brass—Bronze. Stampings in Sheet Steel, Assembling and Finishing in Japan, Enamel and Electro Plating. We are equipped with Foundry, Pattern Shop, Press Room, Electro Plating and Japanning and wish to secure contract work. Tuttle & Bailey Mfg. Co., 52 Vanderbilt Avenue, New York City.

INVENTIONS perfected and manufactured. Reference: Your Banker. Russell Machine Co., Dallas, Texas.

WANTED—To manufacture: Good new metal specialty. We have enormous mfg. and selling organization. What have you? Hugro Mfg. Co., Warsaw, Ind.

WIRE Goods, all kinds, made to order. Cooley Mfg. Co., 553 W. Monroe St., Chicago.

LET Our factory be Your factory. Metal specialties developed and correctly manufactured. L. B. Nelson Mfg. Co., Peoria, Ill.

STAMPINGS, dies, manufacturing, sometimes selling. Emco, 523 Monroe St., Chicago.

REAL ESTATE AND FARM LANDS

FOR Sale—Lots in South Florida Gulf Coast waterfront town, Bayonne, on Sarasota Bay, Manatee County. Great development starting in adjoining fruitlands. \$500 lots now \$20 and \$300 prior to completion of improvements. Year-round boating, fishing. Year option, easy terms. Illustrated description free. Sarasota-Venice Company, Box 57, Sarasota, Florida.

FARMS for sale or exchange anywhere in the U. S. or Canada, direct from the owners. State where you want to locate. Information free. American Investment Association, 57 Palace Bldg., Minneapolis, Minn.

FARMS in Virginia \$15 acre and up. Easy payments. Mild climate. No long cold or hot spells. Social life, fertile soil, good markets, high prices—on railroad—convenient to trains. Write for free magazine and other information. F. H. LaBaume, Agri. Agt., Norfolk & Western Ry., Room 250, N. & W. Bldg., Roanoke, Va.

COLORADO, Montrose County, 165 irrigated. Rich soil. Wheat, oats, alfalfa, potatoes. Mild winters, ideal summers. No floods, no cyclones. \$125.00 per acre. Particulars, W. S. Core, Owner, 2680 Clarkson, Denver.

ARE you weary of the North?—Then come to Fruitland Park, Florida, a vicinity ideal for a home and for grapefruit and orange growing with big profits, where you can develop a grove with practically no expense and where the first crop you raise should pay for your land. For book of actual photographs and conservative data write today. Lake Co. Land Owners' Association, No. 93 Mack St., Fruitland Park, Florida.

GOOD sixty-five acre irrigated farm, well stocked, in the finest agricultural section of the West. For sale cheap. George Georgaekis, Taft, Utah.

SAN JOAQUIN VALLEY, California—your place. 20 acres here in fruits, vegetables, alfalfa, with cows, pigs, poultry and bees will pay you steady, substantial profits. Delightful climate, rich soil, good schools, churches and roads. Thrifty, hospitable neighbors. Health, wealth and happiness await you. Why don't you go? Write for free booklet. C. L. Seagraves, Gen. Colonization Agent, AT&SF Ry., 1895 Ry. Exch., Chicago.

80 ACRES partly improved on State Road. Arnold Pennabecker, Strafford, Wis.

CALIFORNIA Land, \$1 acre cash, balance entire purchase, 90 cents a month per acre; immediate possession given; no taxes; no interest; Merced County; 5-acre tracts up; clear; ready to plow; gravity irrigation \$1 acre per annum. Particulars, maps free. Stevinson Colony, 785 Market St., San Francisco.

SELL your property quickly for cash, no matter where located. Don't pay big commissions. Particulars free. Real Estate Salesman Co., Desk B, Lincoln, Nebr.

SOUTHERN lands are low in price but high in productive value, make two to four crops a year and give largest profits in grain, vegetables, fruits, live stock and dairying. Unsurpassed climate, good markets. Southern Progress is on the Southern Railway. Publications on request. M. V. Richards, Commissioner, Room 64, Southern Railway, Washington, D. C.

MONEY-MAKING Farms throughout 15 Eastern States; one acre to 1,000 acres, \$10 per acre up; many with livestock and tools included; big illustrated catalogue free. E. A. Strout Farm Agency, Station 3043, 47 W. 34th St., New York.

I HAVE a successful way of selling farms and farm lands. Write me for free particulars. No obligation whatever. E. J. Zimmer, 925 Tower Bldg., Chicago.

GINSENG

GINSENG Culture, 10c. Golden Seal estimate \$6,000 an acre. Booklet giving my experience, 10c. W. N. Long, Florence, Ky.

DOGS, BIRDS, POULTRY, PETS

RAISE Guinea Pigs. We furnish stock, show you how and buy all you raise. Big demand. Thousands needed yearly. Easy to raise, very prolific and profitable. Particulars and contract for two-cent stamp. Carles Distributing Co., 707 West 74th St., Kansas City, Mo.

BEAGLES—Rabbit, Fox Hounds, Setters, Pointers, Coon, Skunk, Squirrel, Bear, Deer, Wolf Hounds, Ferrets. Catalogue 10c. Brown's Kennels, York, Pa.

GOOD Rat and Rabbit Ferrets. Catalogue free. Glendale Ferret Co., Wellington, O.

FOX Terriers—Best pet or watchdog. Forrest Meek, Mearns, Minnesota.

FEMALE Collie puppies—beauties, \$8.00. G. F. Corrigan, Wheaton, Ill.

GUINEA Pigs—Fine pets. Profitable. \$2.50 pair. Particulars free. F. Trump, Springfield, Ohio.

SPORTSMEN send for handsome free catalogue of dogs. John Cluck, Newport, Pa.

FERRETS—Thoroughbred stock. Write for catalogue; it's free. C. H. Koefler & Co., Greenwich, Ohio.

NEWFOUNDLAND, St. Bernard, Collie and Fox Terrier puppies. Your money back if not pleased. Poultry and Dog Catalogue free. Edwin A. Souder, Box P, Telford, Pa.

RAISE Belgian hares for us; big profits. We furnish stock and pay you \$2 each, also caviar, milk, skunk, fox, squabs, frogs, etc. 2 booklets and contract for dime. Particulars free. The Belgian Hare, Box 47, Holmes Park, Me.

GOLDFISH—Rare specimens, artistic aquariums, waterplants. Circular free. Pioneer Goldfish Hatchery, Racine, Wis.

COON, Fox and Rabbit Hounds sold on trial. Good as lives. Illustrated catalog 10 cents. Homestead Kennels, Plainfield, Ind.

PERSONAL

ANTINIC, the only Nicotine-Neutralizer for Pipe and Cigarettes; better, safer and cheaper than Tobacco-habit cure. Send for particulars. Box 1139, Los Angeles, Calif.

BROTHER—Accidentally discovered root cause tobacco habit. Gladly send particulars. F. Stokes, Mohawk, Florida.

FREE—Stop using Tobacco. Free. We will give free information how to conquer the habit easily and permanently. Results Guaranteed. Anti-Tobacco League, 618 Paxton Block, Omaha, Nebr.

MISCELLANEOUS

LOCKSMITHS: My tool and instructions guaranteed to open any door using cylinder lock. Price \$6.50. Particulars for stamp. Chas. E. Williams, Box 1091, Atlanta, Ga.

LION Heel Plates. Sample Pair 10c, coin, prepaid. Folding umbrellas. Harry W. Birch, 403 Lincoln St., Hoopston, Ill.

CUTS anybody can make. Simple, cheap process. Numerous specimens, convincing particulars, for stamp. M. Day, Windfall, Ind.

RUBBER stamps, photo type, egg dates, steel dies, metal badges, seals, stencils; catalog 10c. Buckeye Stamp Works, Market, Dayton, Ohio.

\$75.00 MONTH paid Railway Mail Clerks. Examinations announced Jan. 15th. Sample questions free. Write immediately. Franklin Institute, Dept. D-22, Rochester, N. Y.

FURS—Trapper to Wearer—European markets closed. Send dollar for three ermine skins (for collar and cuffs). Catalogue. British Columbia Trappers, Fort George, B. C., Canada.

MOTOR-SLEIGHS, ice-boats, 2-4 and more passengers, from \$393 up. Safe and speedy. Send for particulars. U. S. Aero, 38 Park Row, N. Y. C.

"**ART of Cut-Making**." Simple etching process. Guaranteed. Regular price, \$1. New 25c. "Ideal," 3311-T, Belleplaine Ave., Chicago.

ERADIUM (Luminous) Pull Chain Bulb for Electric or Gas Light pull chain or key. Shines at night. Locates your chain in a "jiffy." Sample 35c. Auburn Supply Co., Dept. 12, 7817 Peoria St., Chicago.

WIREMEN, Plumbers, mix brains with your work. Saves your time, your helper's energy. 10 cents. Robertson, Box 220, Santa Barbara, Calif.

HOW to make your own movies. Wireless Telephone, Model Submarine. Also Kinks for Motorists and score of practical hints, all in new 96 page book sent for 50 stamps. We want you to know us. Technical Press Ass'n, Aeolian Bldg., New York.

GOLD teeth, Secret photos, Brazilian diamond scheme, bargain list, all for silver dime. Sherries, Patnam, N. Y.

100 MONEY-MAKING Formulas, 10c. Process Company, 414 Ft. Dearborn Building, Chicago.

GENUINE Sioux Indian Beadwork and Curios, also Elk Teeth, Moccasins, Fobs, Belts, Hatbands, Pouches, Warclubs, Indian Costumes. Send 10c for price list. Strong Curio Co., Gordon, Neb.

GENUINE Mexican War dollars; three for 15c; \$8.30 for 25c. Excelsior Exchange, Albuquerque, New Mexico.

MILLION volts through body. Make money on stage. My big new book tells you how. Send \$2.00 on moneyback guarantee. T. S. Curtis, Aeolian Bldg., New York.

LOCK Picks—10, \$1.50; 50, \$5. McDougald, 5322 Windsor Ave., Chicago, Ill.

VIEW Card seekers' membership, 10c. Pacific Exchange, Bryn Mawr, Wash.

GREYGO Hair Tonic positively restores Gray Hair to its natural color, prevents dandruff and falling hair. Gives needed nourishment to the hair-cells, insuring a healthy growth. Absolutely Not a Dye and guaranteed harmless. Testimonials, 50c and \$1.00 bottle postpaid in plain wrapper. Liberal sample bottle 25c. Vanro Laboratories, 823 N. 5th St., Camden, N. J.

INDIAN Baskets, Relics. Price free. G. Gilham, Highland Springs, Cal.

GRANDFATHER'S Clock Works, \$5. Slightly shop-worn, quantity limited, others with chimes, all prices; also several nice Grandfather's Clock cases, exceptional bargains. Clock Company, 1673 Ruffner St., Philadelphia, Pa.

WRITE for Free Information regarding any Formula or Product and my latest lists of Guaranteed Reliable Formulas and Trade-Secrets for new Specialties in all lines. Harry Liscombe Miller, Ph. D., Tampa, Florida.

THE Handy Alder, Just completed. Only low priced machine adding two columns at once. Simple, speedy, accurate. Price two dollars. McClelland & Knoll, Springfield, Ill.

AGENTS!

Here is Your Chance to make money by saving money for others. Our new discovery, **EGGINE Powder**, takes the place of Eggs in baking and cooking at less than 9c a doz. A 25c package equals 3 doz. An absolutely Pure Food Product fully guaranteed. Derived principally from milk and corn. Convenient, economical and always fresh. Satisfaction certain, thus steady customers. Send 10c for trial package and terms postpaid.

CHAS. T. MORRISSEY & CO.
4414 Madison St. CHICAGO, ILL.

LANGUAGES

German—French—English—Italian—Spanish or any other language learned quickly and easily by the Cortina Method at home with **Disk Cortina-Records**. Write for free booklet today; easy payment plan.

CORTINA ACADEMY of LANGUAGES
1611 Mecca Bldg., 1909 Broadway,
Corner 48th Street, New York

CORTINA-PHONE

Quickly Learned AT HOME by the Original Phonographic Method



DRAWING

Copyature, Cartoon, Comic, Commercial, Fashion, Newspaper and Magazine Illustrating taught by mail. Illustrated book 9c in stamps. **THE BOSTON SCHOOL OF DRAWING**, 755M Boylston St. BOSTON, MASS.



LEARN The AUTO BUSINESS

EARN A SPLENDID SALARY

Over 3000 graduates of our school are now receiving big salaries as Chauffeurs, Testers, Mechanical Experts, Demonstrators, etc., etc. There are greater opportunities now than ever before in the auto business—for properly trained men.

UP-TO-DATE TRAINING IN 4 WEEKS

Including expert instruction on latest starting and lighting systems, newest types of motors, etc., and repairing and driving high powered cars. 11 years of success—oldest and best established school west of New York. Tuition and board reasonable.

CALL OR WRITE US TODAY FOR CATALOG
Cleveland Automobile School, 2338 Euclid Ave., Cleveland, Ohio





GET ACQUAINTED WITH US ON THE NEWS-STANDS

IF you are a Man of Affairs, and would like to know what the world is thinking—if your time is limited, and you want a "Cook's Tour" through the realm of world thought—if a Monthly Review in Cartoon and Comment of Current Events appeals to you—if you want the viewpoint of other nations—if you would like to read history in the making in its most attractive form

GET A COPY OF

CARTOONS MAGAZINE

(Published by H. H. WINDSOR, Publisher of Popular Mechanics Magazine)

It is the only magazine in the field mobilizing the pen-and-ink satirists from the four corners of the world, men who are fighting silent battles on their drawing boards.

So great has been the demand for back numbers of this periodical that several issues published early in the war have been exhausted. The file of *Cartoons Magazine* will be almost priceless a few years hence. It is a magazine for your library and reading table.

25c A COPY

\$3.00 A YEAR

This Coupon and \$3 brings it to you for a Year

CARTOONS MAGAZINE
6 N. Michigan Avenue, Chicago

Enclosed please find \$3.00, for which enter me for a year's subscription to your magazine.

Name

Street

City

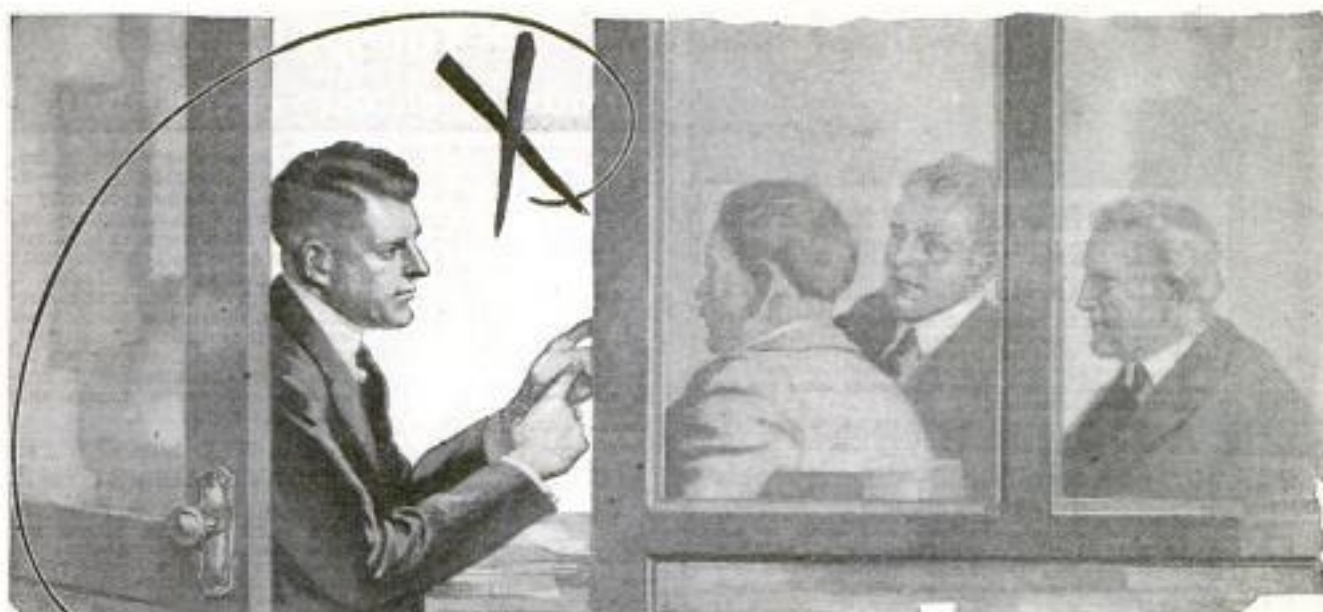

The Mark That Helped Him Make His Mark

The picture of the man at the head of the table is that of a real flesh-and-blood man. Not so long ago he was only "one of the hands" of a big manufacturing company. He drew just so much pay, and no more. He never knew which pay-day would be the last. He didn't have special ability.

One day he marked the coupon of an *American School* advertisement, and now he's Assistant Chief Engineer of the same company—master of men—salary multiplied by *four*. The *American School* trained him for this important job at home, in his spare time. He didn't have to give up work or play—he wasn't obliged to exhaust his savings. Marking the coupon enabled him to make his mark in the occupation of his choice.

Multiply this man's case by thousands of others and you'll begin to understand how the *American School* can raise *your* salary—better *your* position—ease *your* mind—no matter who you are, where you live, what you do, or what your age.

Mark the coupon and make your mark

The coupon in this advertisement brings eye-opening facts. Mark and mail it today! Doing this simple thing will cost you nothing—will place you under no obligation. It will be the first step toward making your mark in the world.

Look over the list. *Your* chosen job is there. Whichever it is, just mark and mail the coupon. Then the *American School* will show you how easy it is to succeed—the same as the man in the picture.

Remember, no charge—no obligation—no agents. Mark and mail the coupon today—*now!*

American School

of Correspondence, Chicago, U.S.A.

Your Opportunity Coupon

Mark the position you want and mail the coupon now

- | | |
|---------------------------------|----------------------------|
| Electrical Engineer | Lawyer |
| Elec. Light & Power Supt. | Business Law |
| Hydroelectric Engineer | Business Manager |
| Telephone Engineer | Auditor |
| Architect | Accountant |
| Architectural Draftsman | Cert'd Public Acct't |
| Building Contractor | Private Secretary |
| Building Superintendent | Stenographer |
| Structural Engineer | Bookkeeper |
| Structural Draftsman | Fire Ins. Inspector |
| Mechanical Engineer | Fire Ins. Adjuster |
| Mechanical Draftsman | Fire Ins. Expert |
| Civil Engineer | Sanitary Engineer |
| Steam Engineer | Plumber |
| Shop Foreman | Reclamation Eng. |
| Shop Superintendent | Textile Boss |
| Sheet Metal Draftsman | College Preparatory |
- We also prepare for civil service examinations in all engineering subjects.

NAME

ADDRESS

Pop. Mech. 12-15



AUTOMOBILE DRIVERS AND REPAIRERS EARN \$75 TO \$150 A MONTH

The demand for automobile drivers and repairers exceeds the supply. Decide now to fit yourself for one of these well-paying jobs. You can do it—easily—in your spare time. These brand new books—the most practical ever written on automobile engineering—will quickly make you an expert driver or repairer.

AUTO ENGINEERING

\$25.00 Set Now \$14.80—50c a Week

This auto library contains 2,000 pages, with 1,800 illustrations that make technical points as simple as A-B-C; full-page plates that literally pick the mechanism to pieces before your very eyes; drawings and diagrams that show the working of all the principles employed in the various types of motors. Bound in half red morocco, gold stamped. These five volumes are a most remarkable value at the regular price. Yet we offer a limited number of sets at a special introductory price of \$14.80—payable \$2 a month.

SHIPPED FREE Test these books before you buy. You wouldn't buy a car until you had tried it out. Buy books the same way. We send the full 5 volumes to you, express prepaid, for 7 days' free examination. Look them over for a whole week free. See if they don't contain everything a driver or repairer should know. If the books are what you want, send us \$2. Otherwise we'll take them back, paying the express both ways ourselves. In addition to this liberal discount from the regular price of \$25.00, we include with each set a \$12.00 Consulting Membership. This entitles you to the advice of a staff of experts for a whole year free.

American Technical Society, Chicago:

Please send Cyclopedia of Automobile Engineering for 7 days' free examination. I will send \$2.00 within 7 days and \$2.99 a month until I have paid \$14.80, otherwise I will notify you and hold the books subject to your order. Title not to pass until fully paid. Pop. Mech. 12-16

NAME.....
ADDRESS.....
REFERENCE.....



LETTERING AND DESIGN

Invest your spare time. Learn Card Writing, Sign Painting or Commercial Lettering and Design. Earn a steadily increasing income or start in business. Raising a personal inscription makes Course self-paying. F. Wernstrom writes "Your lessons are great." Constant demand for graduates. Assistance in obtaining positions. Investigate now. **FREE BOOK, THE ROYAL SCHOOL OF LETTERING & DESIGN**

132 Union Building Cleveland, Ohio

MUSIC TAUGHT FREE AT YOUR HOME
Write Today
for our booklet. It tells how to learn to play Piano, Organ, Violin, Mandolin, etc. Beginners or advanced pupils.
AMERICAN SCHOOL OF MUSIC, 50 Lakeside Bldg., Chicago, Ill.



Learn to Write

I can make a good penman of you at home during spare time. Write for my free book, "How to Become a Good Penman." **FREE** Write for it Today

It contains specimens and tells how others mastered penmanship by the Tamblin System. Your name will be elegantly written on a card if you enclose stamp to pay postage.

F. W. Tamblin, 418 Meyer Bldg., Kansas City, Mo.

LANDA "Prosperity" BILLFOLD
ELEGANT, Practical Xmas Gift—order one also for yourself. Combines currency fold, coin purse, card case, loose leaf memo pad, 1916 calendar, transparent identification card and photo holder. Made of finest soft, genuine black Seal Grain Leather. Any name beautifully engraved in 23-Kt. Gold—splendid, lasting gift.

Size closed 3x3 1/2 inches, open 8x3 1/2. Compact, flexible—will fit any pocket. For ladies and gentlemen. Special price 50c postpaid—ordinarily \$1.00. Attractively packed in handsome gift box.

"DeLuxe," made of genuine Morocco Leather, \$1.00—worth \$2.50. Send M.O., draft or postage stamps. Order shipped day received. Satisfaction guaranteed. Write for Xmas Gifts catalog.

A. LANDA & SONS CO., Leather Goods Mfrs., Dept. B2, Chicago

Young Man!
Your greatest opportunity



Write for Book Today It's FREE

To the man who wants to improve his condition in life—to increase his earning capacity—to get away from the monotony, grind, and low wages of ordinary occupations—to elevate his social standing, the new profession of Tree Surgery, which is not overcrowded, offers the young man of today his greatest opportunity. The Extension Course given by The Davey Institute of Tree Surgery will fit you to practice this profitable profession.

LEARN TREE SURGERY AND FRUIT GROWING BY MAIL

You can become proficient in this work without interfering with your present occupation. An hour or so a day will give you a training that will make your future bright and prosperous. The work of a Tree Surgeon is healthful, fascinating and remunerative. The call for men in this profession is far greater than the supply, and the demand is growing. There are positions open at good salary and opportunities everywhere to establish a paying business of your own. Why work for others at small pay when you can be your own boss? Write today for our book. "Adventures in Success." Read what others have done, and learn how easily and quickly you can improve your condition in life.

THE DAVEY INSTITUTE OF TREE SURGERY
373 Oak St., Kent, Ohio

SPEAK A FOREIGN LANGUAGE!!!

The War has created unlimited opportunities for those who know Spanish, French, German or Italian. Better your position or increase your business. You can learn quickly and easily, at home, during spare moments, by the

LANGUAGE-PHONE METHOD
And Rosenthal's Practical Linguistry
(Highest Award Panama-Pacific Exposition, 1915)

You listen to the living voice of a native professor pronounce the foreign language, over and over, until you know it. Our records fit all talking machines. Write for Booklet, particulars of Free Trial.

IDEAL XMAS GIFT The Language-Phone Method, 601 Putnam Bldg., 2 W. 45th St., N.Y.

IF YOU STAMMER

Attend no stammering school until you get my big FREE book and special rate. Largest and most successful institution of its kind in the world. Two large modern school buildings fully equipped for treatment of stammering under my advanced natural method. No sing-songing or time-beating.

Established 14 years. Known everywhere as the best. Personal instruction given each student. Write today for full particulars. **Lee Wells Millard, Pres**
North-Western School for Stammerers, 2317 Grand Ave., Milwaukee, Wis.

Learn Watchmaking At Home

You can learn by our modern and original system of instruction every part of the Watchmaker's Trade at home as good or better than at a shop. You can earn money while learning and secure a well paying position or start in business after completing our course of instruction. Good watchmakers are always in demand and earn from \$30 to \$35 per week. For particulars apply to the **Wisconsin School of Watchmaking, Strub Bldg., Milwaukee, Wis.**



Money Cheerfully Returned

50c Postpaid
Name Engraved Free in 23-kt Gold For Ladies and Gentlemen



Can You Accept a Position Paying \$125 to \$300 a Month?

ARE your services in demand today? Have you the the training that equips you to hold a position paying \$125 to \$300 a month? Have you the same knowledge as the man who gets the fat pay envelope? If you are ambitious—send the coupon below and find out about the opportunities that await you in the profession of Signal Engineering. Salaries are paid to men who know. You can get just the kind of training you need to accept one of the big jobs, right in your own home—during your spare time. We need men. Send the coupon for the book that tells you all about it. Do not delay—send today—now.

Be a Signal Engineer

Be the man who gets the fat pay envelope. The profession of Signal Engineering is only in its infancy. There are thousands of miles of block signals to be installed. Signal Engineers, supervisors, inspectors and foremen are required to superintend this installation. Hundreds of maintainers and battery men are needed to maintain the systems already in use.

Your duties may take you from coast to coast. Railroad men are always in a fortunate position to travel and see the world because free transportation is liberally awarded. You can accept a position where you will be located steadily at one place, if you prefer—the position of authority—the high place and the fat pay envelope may be yours. Send the coupon for the free Signal Book.

\$125⁰⁰ to \$300⁰⁰ a Month

That is an ordinary salary for Signalmen—many Signal Engineers make much more. In the Signal Department, supervisors, inspectors, maintainers, battery men, positions of authority ranging from \$75 a month up, all open to the men who have had the kind of training you can get right in your own home. Even while you are learning you may hold one of the positions in the Signal Department under a Signal Engineer. Send the coupon for the Free Signal Book.

Send Coupon for Big New Book

Put your name and address on the coupon or on a letter or a post card now, and send it to us. Absolutely no obligations of any kind. We will send you our big new book absolutely free, and prepaid. Read about this fascinating profession. Read about the opportunities that await you. The book is free. Send the coupon for it now—it's the first step toward the realization of your ambition. Get your name and address in at once.

Department of Signaling
Room 1199, 1810 Wilson Ave., Ravenswood Station, Chicago

We Need Men

The profession of Signal Engineering is calling to ambitious men. Our ranks are not over-crowded. There are opportunities—golden ones, awaiting the men who answer the call. Block signal systems are no longer in the experimental stage. All over the country they are being installed. Some States have legislated to compel the railroads to install systems immediately. In our profession you will have the chance you have been looking for.

We are calling you. Don't fail to send the coupon today for our big free Signal Book and full particulars.

Two Big Outfits FREE

Complete Signal
Engineer's Outfit
and Complete
Draftsman's Outfit
given away absolutely free to our students.

Department of Signaling

Room 1199 1810 Wilson Ave.
Ravenswood Station, Chicago

Gentlemen:—Please send me absolutely free and prepaid your big new book on Signal Engineering. Also full particulars about your great special free outfit offer. It is distinctly understood that I assume no obligations of any kind.

Name.....

Address.....

Age.....Occupation.....

Please Mention Popular Mechanics

DRAKE'S Practical Mechanical Books



Electrical Measurements and Meter Testing

By PROF. MORETON
of Armour Institute
Pub. Aug. 1915. 328 pp.
Pocket size. Leather \$1.50; Cloth \$1.00.

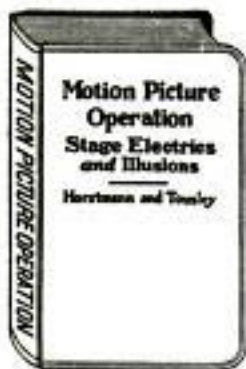

Motion Picture Operation

By HORSTMANN AND
TOUSLEY
All machines fully described and illustrated.
393 pp. Pocket size.
Leather \$2.00.



Drake's Telephone Handbook

By PROF. MORETON
of Armour Institute
Just published. 286 pp.
161 illustrations. Pocket
size. Leather \$1.50.
Cloth \$1.00.

FOR HOME STUDY

All Written in Non-Technical Language
For Electricians, Engineers, Telephone Men,
Machinists, Automobilists, Carpenters,
Plumbers, Sign and Card Writers, etc.

OUR GUARANTEE

We send all books postpaid upon receipt of price. Keep them five days, and if you are not entirely satisfied we will refund your money.

These are the
BOOKS that
Increase your
Earning Power

Other New Books and New Editions

Brookes' Machine Shop Practice
1915 Edition. Cloth, \$2.00.

Armature and Magnet Winding
By HORSTMANN & TOUSLEY, \$1.50.

Drake's Electrical Dictionary
By LOWE. 320 Pages. Cloth, \$1.00.

20th Century Toolsmith and Steelworker
By HOLFORD. 240 Pages. Cloth, \$1.50.

Practical Gas and Oil Engine Hand Book
By BROOKES. 230 Pages. Cloth, \$1.00.

Brookes' Automobile Hand Book
720 Pages. Leather, \$2.00.

Swingle's Hand Book for Steam Engineers and Electricians
1500 Pages. Leather. Pocket-book style, \$3.00.

Traction Farming and Traction Engineering
1915 Edition. 330 Pages. Cloth, \$1.50.

Operation of Trains and Station Work
By PRIOR. 618 Pages. Leather, \$1.50.

Hodgson's Estimator and Contractors' Guide
318 Pages. Cloth, \$1.50.

Hodgson's Hardwood Finisher
320 Pages. Cloth, \$1.00.

Hodgson's Concretes
520 Pages. 12mo Cloth, \$1.50.

Atkinson's The Art of Sign Painting
1915 Edition. 370 Pages. Cloth, \$3.00.

Practical Up-to-Date Plumbing
By CLOW. 310 Pages. Cloth, \$1.50.

Builders' Architectural Drawing Self-Taught

By HODGSON. 336 Pages. 250 Illustrations. 12mo Cloth, \$2.00.

Painters' Cyclopedic By MAIRE. 12mo Cloth, \$1.50.

Write today for any book listed above. Remember our guarantee. Or send for our large catalogue of practical mechanical books. It is **FREE**.

FREDERICK J. DRAKE & CO.
1325 Michigan Ave. Dept. 8 CHICAGO



Automobile Mechanician's Catechism and Repair Manual

By
SWINGLE and TARANTOUS
Answers every question.
Shows how to make all
repairs and adjustments.
Pocket size. Leather \$1.25.



Wiring Diagrams and Descriptions

By
HORSTMANN AND TOUSLEY
Revised edition. 300 pp.
230 illustrations. Pocket
size. Leather \$1.50.



A Show at Sho' Cards

A Practical Guide to Show Card Writing
By ATKINSON
Includes 120 designs, 35
alphabets, air brush work.
320 pp. 9x12". Cloth \$3.00.

YOU ARE WANTED

at a **BIG SALARY!** GET READY FOR PROSPEROUS TIMES



CHARLES W. MOREY
President of the College
Head of the firm of
Charles W. Morey & Co.,
Consulting Engineers.



WM. T. HOOPER
Architect, Vice-Pres.
of College, Head of
Dept. Architecture.



E. OTTOMANN, JR.
Consulting Engineer
Secretary of College



M. M. CASE
Consulting Engineer
Head of Mechanical and
Electrical Depts.

Prosperous times are coming—they're here now. Far-seeing men are getting ready for boom times. You can—you must—share in this prosperity. You will if you are ready. Training is the key.

Here are men who can help you The men at the head of this school are doing real work—big work—every day. They are in active touch with big contractors where trained help is needed. They conduct their own offices and are in charge of important construction work at all times. They are the men you get to know personally. Let them help you to

Earn from \$3000 to \$5000 a Year.

You can do it. There is such a position for you if you have the training. All branches of **DRAFTING, ENGINEERING** (Civil, Electrical, Mechanical, Architectural) are calling for trained men. We can't fill all the applications we get. If you will put in your spare hours in study for a short time we will help you.

**HERE'S
YOUR
CHANCE
TO LEARN**

DRAFTING

Hundreds of men are in daily attendance in the day and evening schools of the College. In your own home you can do the same work these men are doing and the same experts that teach them will teach you. These well known architects and engineers know exactly the practical training you need, and they train you—they prepare your instruction matter—your work is examined and approved by them.

STUDY AT HOME Your Spare Time is Enough

It will cost you nothing to get full information; an inquiry will not obligate you in any way. It is up to you and you alone whether you fit yourself for the big job—whether you draw the big pay. Let us make you a big earner. Prosperity and opportunity are here NOW. Fit yourself to grasp big things. Sign, tear and mail the coupon now.



Complete \$15 Drawing Outfit **FREE**

MAIL COUPON TODAY!

A few readers of this magazine—only a few—who are prompt in making application will secure a

\$45 Scholarship Free
In Mechanical Drawing.

This offer will be withdrawn as soon as the limited number of scholarships have been awarded.

BIG SALARY COUPON

CHICAGO TECHNICAL COLLEGE
1050 Lake View Building

Without any obligation on me, please send me full particulars about your **FREE SCHOLARSHIP.**

I have marked subject in which I am interested.

- Machine Drafting
- Electrical Drafting
- Architectural Drafting
- Structural Steel Drafting
- Builders' Course
- Plan Reading
- Estimating
- Sheet Metal Drafting
- Civil Engineering
- Surveying

Name

Address

Town.....State

College or Home Study?.....

CHICAGO TECHNICAL COLLEGE
1050 Lake View Building, Chicago, Ill.

Please Mention Popular Mechanics

Why Didn't We Give Smith That \$1,000 Raise?



A Traffic Man Must Be Found

"We have lost several times \$1000 on our freight charges since Smith left us. We MUST find a man to take his place."

Why not fill one of the 95,000 positions as Traffic Manager yourself? It's easily possible. We're talking facts now—not theories. There's no vivid imagination behind these words. You can prove them before you answer this advertisement if you wish.

95,000 Trained Traffic Men Needed

Here's the proof. There are 500,000 shippers in the United States. 100,000 of them are big enough to employ individual Traffic Managers. There are now 3000 to 5000 Traffic Managers in the country. That leaves 95,000 shippers without a Traffic Manager to fill one of the most important positions in their entire organization; a man they need; a trained man who can save them money.

SALARIES:

\$1800 to \$4000 and Up

When you have mastered tariffs and freight rates, you can land in a job, paying at least \$1800. If you get with a big firm, your services will save them lots of money, then you can earn as high as \$10,000.

Unlimited Demand

Thousands of shippers are coming to realize their need of an expert, trained traffic manager. But the supply of trained men, who know all the ropes, doesn't begin to meet the demand.

Ask any shipper you know if the trained Traffic Manager isn't one of the most important and best paid men in the shipper's service. Ask him if it wouldn't be a good thing for you to get into.

Prepare now to fill one of these splendid positions. Send for our free catalog. It tells who we are, what we teach and how we do it. We'll train you to earn \$1800 to \$4000 a year as a Traffic Manager.

Special Talent Unnecessary

Thousands upon thousands of men in America are in the wrong job, right perhaps, as far as the work is concerned, but wrong where the pay comes in. Few men can be contented in a job that doesn't pay well or offer a good chance for steady and sure advancement.

This is the day when far sighted, ambitious men climb out of ruts and seek opportunities where the going is good.

To become a successful and highly paid Traffic Manager, just three things are essential. A common school education, intelligence and training. You don't need to have "special talent." It's a simple proposition. This isn't theory—it's facts—cold facts.

Send for New Book—It's FREE

There's no technical knowledge to learn. No hard study — just learn to get traffic facts from the Inter-State Commerce Reports and published transportation rates. Our Free Book on Traffic tells all about it, explains clearly and concisely. Don't waste this opportunity to enter this new profession. Use the coupon right NOW—You'll never regret it.

Interstate Traffic School Dept. 172 Ft. Wayne, Ind.

**Interstate
Traffic School**
Dept. 172, Ft. Wayne, Ind.

GENTLEMEN: Send me absolutely free and prepaid your new book on the Traffic Profession.

Name

Address

BING'S MECHANICAL TOYS

**BOYS, HERE
ARE THE MOST WONDER-
FUL ELECTRIC AND MECHANICAL
TRAINS YOU EVER HEARD OF, SOLD
UNDER A WHOLE YEAR'S GUARANTEE.**

The most fascinating and educational toys of the age are these working models of actual trains. All who see them marvel at their perfect operation and life-like resemblance to the great railroad trains of America.

Electrically-driven "Twentieth Century Limited"

The power for this beautiful train is supplied either from your *ordinary house current* or from dry batteries. This train which is

Nearly Four Feet Long

consists of extra-heavy locomotive, tender and three cars. Twelve pieces of *third-rail track*, specially banked at the curves to prevent derailment, complete with wiring connections, *five-speed regulator* and book of instructions, are supplied with it.

VARIOUS SIZES AND PRICES

The trains are made in various sizes priced at \$4.00, \$5.00, \$8.00, \$10.00 and \$15.00. *All our trains are fully equipped.*

MECHANICAL POWER ALSO

If you do not possess facilities for electric power *we have models of the same trains operated by mechanical power* at \$1.50, \$2.00, \$3.00, \$5.00, \$7.50, \$10.00 and \$15.00.

GUARANTEED FOR TWELVE MONTHS

All the trains are sold under our guarantee that they will operate perfectly with proper use for twelve months. You could get no fairer proposition.

BING'S TOYS

are known throughout the country for quality. If your store cannot show you these wonderful trains, send your check for one you want to

JOHN BING

389 Fourth Ave., New York

He will personally see that you are supplied.



Backed by a Solid Guarantee—Read It!

Get The Big Job-



Earn \$1200 to \$3000 a Year As Electrical Meter Engineer

Get the big job. Earn the big salary. Get into the new profession. Where high salaried positions are seeking the men. Train yourself to fill one of these big jobs. There is one or more in every Electric Light Plant. The demand is growing daily for Meter Engineers. We have trained hundreds of others and placed them in big jobs. We can do the same for you.

Learn at Home

Just a few short months at home during spare time. You learn while you earn. Course is interesting, concise, thorough. You learn all about meters and instruments. No problem will stump you. Step into an Electric Light Plant as Meter Engineer. Our course prepares you for every emergency.

From \$65 to \$125

Three Raises in Salary

No Experience Needed

Course so clear anyone can understand it. You only need a common school education. No previous experience in electricity or meter work is necessary. No matter what you are doing now you can become competent in this new profession. The course is based on the practical knowledge of Big Men in the Electrical Meter Engineering field. Men who were first to realize the demand for Meter Engineers.

Offer of Big Job

Promoted—Raised 10%



When I began your course I was making \$65 a month. Through your course I was soon able to take charge of

the standardizing department and my salary was raised to \$90. E.D. HENLEY



Am getting along fine here and your course has certainly been a great help. My salary now is three

times what it was when I started your Course. M. EVNRUD



I have just received an offer of a good position as Meter Engineer due to your recommendations. When

my employer heard of it he immediately increased my salary. A. NELSON



Since I began working in the Meter Department of Duquesne Light Company I have been promoted twice

—the last promotion being to assistant foreman at 10% increase. H.M. SMELTZER

Full Information FREE

Get the School Literature, terms, testimony from students and graduates. Outline of course. Duties of Meter Engineer—All Free—no obligations. Use the coupon.

Write Today—"NOW"

Don't wait—get started toward the **Big Job**, —get the increased salary—but start today—"NOW."

The Ft. Wayne Correspondence School
Dept. 192 Ft. Wayne, Ind.

Our Money Back Guarantee

We guarantee to furnish you with our complete course of instruction in Electrical Meter Engineering and train you without charge, other than tuition as specified in our Enrollment Blank, until you are qualified to accept a position paying from \$75 to \$300 a month. Furthermore, we guarantee to assist you in securing a high grade position after you receive your Diploma. If after receiving all supplies and instructions to which you are entitled, and after fulfilling all of your agreements, you are not perfectly satisfied, we are to refund the full amount of your tuition.

The Ft. Wayne
Correspondence School
Dept. 192, Ft. Wayne, Ind.

Gentlemen:— Send me, absolutely free and prepaid, your new literature on the Meter Engineering.

Name.....

Address.....

Do It Electrically



The applications of electricity are increasing every day. The man who has an exact knowledge of electrical science has ever growing opportunity for profit. Ten years ago practically all machines in use were run by steam engine and countershaft. Statistics now show that most of the machines used are now operated by the electric drive. A generation ago gas was the only known means for lighting and cooking. Now almost every modern house is lighted by electricity, and electric cooking utensils are coming more and more in use. Even the steam locomotive, that great achievement of the twentieth century, is being gradually replaced by electric power. Whether it be for driving machines, for railway transportation, for lighting, for heating, for cooking, for a thousand daily necessities, the watchword of the age is "Do It Electrically."

Hawkins Electrical Guides Will Show You How

Electrical knowledge means money to you and these books will show you how to get it. Hawkins Electrical Guides are the standard works on Electricity. They cover every single phase of the subject and they are written in a way you can understand. The text matter is arranged in questions and answers, and contains several thousand illustrations. No more groping for a solution of your electrical problem. You find the answer at once, clearly and concisely.

A Most Complete Library of Electricity at the Lowest Cost

Look at the titles and convince yourself that Hawkins Electrical Guides tell you everything you want to know in Electricity. They are a complete course in Electrical engineering, written especially for the ambitious man who is training himself for advancement, for the wide awake man who is likely to be called in for work outside of his regular line, for the man who needs at his elbow, for ready reference, an accurate up-to-date work on electricity. An examination of these books will convince you of their value instantly. They cost \$1 per volume. They are a wonderful buy at this price, and they are the best electrical books at any price. Don't take our word for their merits. Fill out the coupon today and the books will be sent you absolutely FREE for your own examination. You have seven days full use before you pay a cent.



In Handy Separate Volumes The binding is in flexible black leather with gold edges—very durable and attractive. The books are easy to handle and easy to read. They fit your pocket and your pocket-book as well.

Shipped to You FREE

Send no money. Examine the books first. Decide for yourself that they are the most complete library of electricity ever published, and that you cannot afford to be without them. Every book is complete in itself. The price is only \$1 per copy, but the complete set is the best bargain. Settlement can be made at only \$1 per month. EIGHT NUMBERS ARE READY.

A FEW OF THE SUBJECTS
 Magnetism—Induction—Experiments—Dynamoes—Electric Machinery—Motors—Armatures—Armature Windings—Installing of Dynamoes—Electrical Instrument Testing—Practical Management of Dynamoes and Motors—Distribution Systems—Wiring—Wiring Diagrams—Sign Flashers—Storage Batteries—Principles of Alternating Currents and Alternators—Alternating Current Motors—Transformers—Converters—Rectifiers—Alternating Current Systems—Circuit Breakers—Measuring Instruments—Switch Boards—Wiring—Power Stations—Installing—Telephone—Telegraph—Wireless—Bells—Lighting—Railways. Also many Modern Practical Applications of Electricity and Ready Reference Index of the 10 numbers.

Easy Payments

Accept this great offer now—today. Each page—every illustration will convince you of the big value we are offering. See the books first, then decide. If you decide to keep them you can make settlement at only \$1 monthly until paid for.

Mail Coupon Today

THEO. AUDEL & CO. 72 Fifth Avenue NEW YORK, N.Y.

FREE COUPON

Theo. Audel & Co.
 72 Fifth Avenue
 NEW YORK

Please submit me for examination Hawkins Electrical Guides (Price \$1 each). Ship at once, prepaid, the first eight numbers; if satisfactory I agree to send you \$1.00 each month until paid.

Signature

Occupation

Business Address

Residence

Reference Dec. P. M.

Please Mention Popular Mechanics

BOYS! BUILD THINGS!

THIS BIG NEW BOOK

Vol. II — **THE BOY MECHANIC** — Vol. II

Tells All About 1000 Interesting Things To Make and Do

A SEQUEL TO, BUT CONTAINING NOTHING FOUND IN VOLUME I

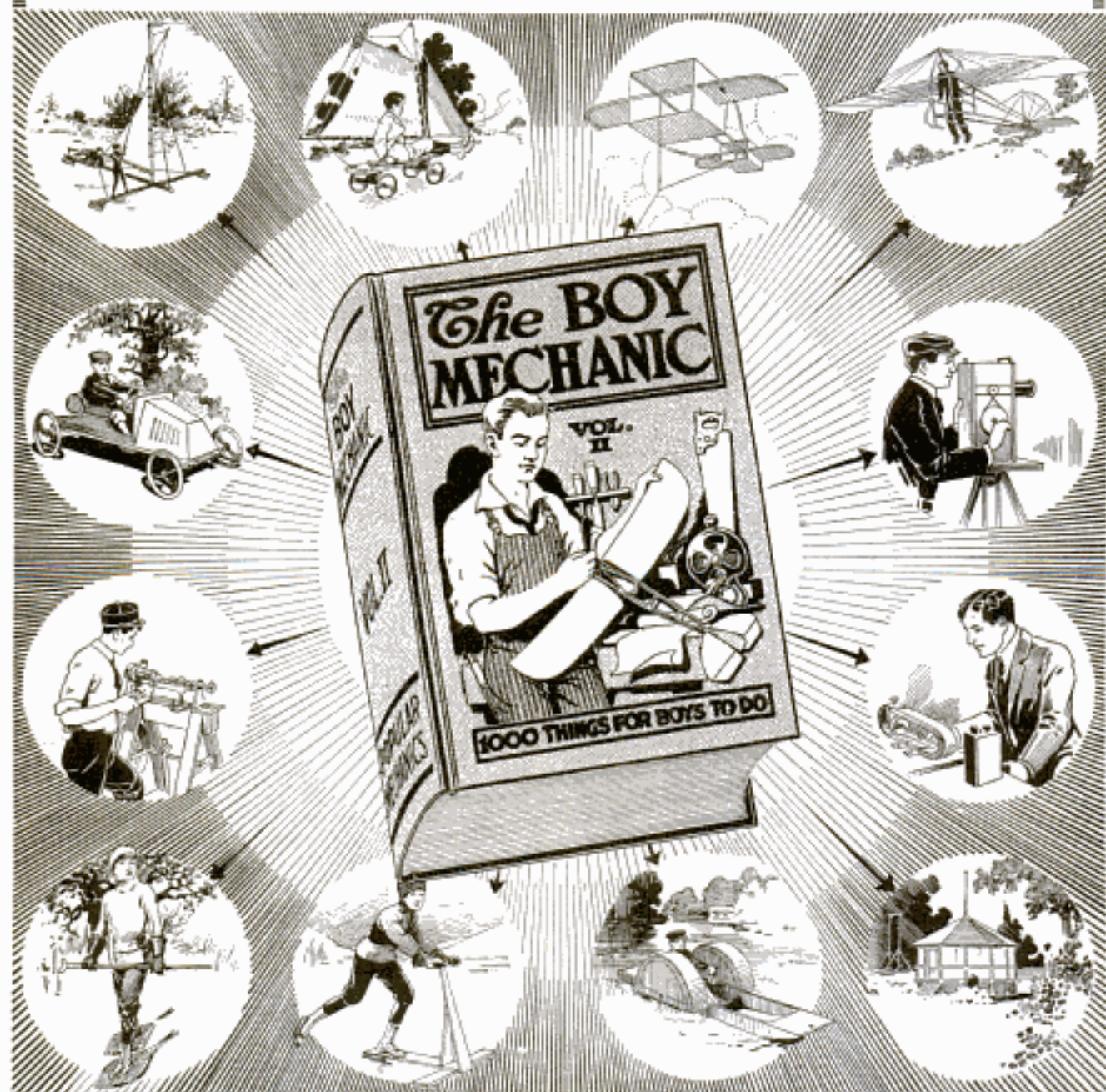

480 PAGES (6 $\frac{3}{4}$ x9 $\frac{3}{4}$ in.) — 995 ILLS. — CLOTH — PRICE \$1.50

HOW TO MAKE

Bobsleds — Snowshoes — Ice Boats — Ice Gliders — Boats — Camps — Fishing Tackle — Houses of Poles — Kites — Aerial Gliders — Motion-Picture Camera — Spot-Light Lantern — Mile-O-View Camera — Photographic Appliances — Indoor Games — Tricks — Cyclomobile — Pushmobile — Flymobile — Roller Coaster — Ferris Wheel — Sunlight Flasher — Reed Furniture — Electrical Devices — Mechanical Contrivances — Art-Craft Work and hundreds of equally interesting things.

SENT POSTPAID UPON RECEIPT OF PRICE BY PUBLISHERS

POPULAR MECHANICS BOOK DEPT., 6 NORTH MICHIGAN AVE., CHICAGO

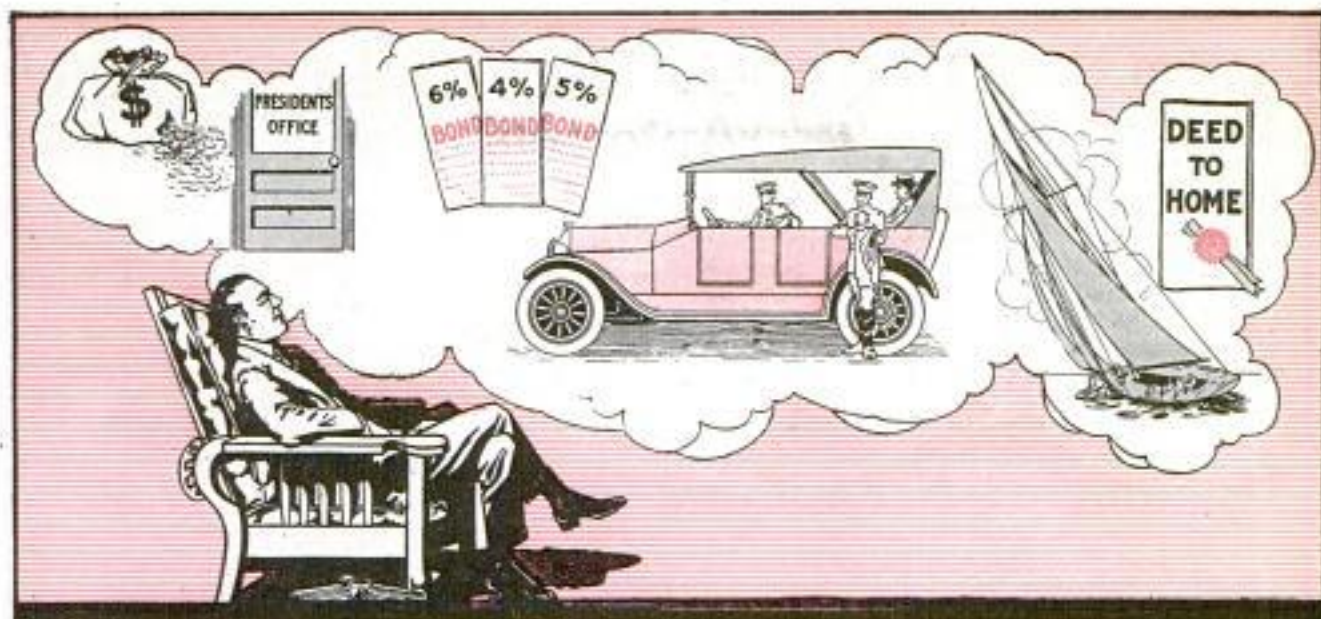

Partial Contents

- The Law of Great Thinking.
- The Four Factors on which It Depends.
- How to develop analytical power.
- How to think "all around" any subject.
- How to throw the mind into deliberate, controlled, productive thinking.
- Detailed directions for Perfect Mind Concentration.
- How to acquire the Power of Consecutive Thinking, Reasoning, Analysis.
- How to acquire the skill of Creative Writing.
- How to guard against errors in Thought.
- How to drive from the mind all unwelcome thoughts.
- How to follow any line of thought with keen, concentrated Power.
- How to develop Reasoning power.
- How to handle the mind in Creative Thinking.
- The secret of Building Mind Power.
- How the Will is made to act.
- How to test your Will.
- How a Strong Will is Master of Body.
- What creates Human Power.
- The Six Principles of Will Training.
- Definite Methods for developing Will.
- The NINETY-NINE METHODS for using Will-Power in the Conduct of Life.
- Seven Principles of drill in Mental, Physical, Personal Power.
- FIFTY-ONE MAXIMS for Applied Power of Perception, Memory, Imagination, Self-Analysis, Control.
- How to develop a strong, keen gaze.
- How to concentrate the eye upon what is before you—object, person, printed page, work.
- How to become aware of Nerve Action.
- How to keep the body well poised.
- How to open the Mind and Body for reception of incoming power.

This is only a partial list—a complete list of contents would almost fill this page.

Power of Will Makes Dreams Come True

Send No Money—Examine Book Free

Will Power, properly cultivated and directed, is the driving force behind your brain that turns empty air castles into happy realities. No man since the world began has ever achieved anything worth while without an inflexible will.

What do you want most in life? Money and all that goes with it? Reputation, Prestige, Power? Greater mental and spiritual happiness? Better self-control? More confidence in yourself? Whatever you want—whatever you have dreamed about some day having—can be yours, if you will only train your will as thousands of others have done with unflinching result.

Your Will Needs Practice

If you should stop work for two years and have no occasion to use your brain in solving business problems, you would gradually become unable to use it as you do now, simply from lack of practice. It's continual practice that makes it possible for you to arrive at quick decision and enables you to see the solution of vexing problems quickly. And you'd be surprised how soon the gift would leave you were you to get out of the harness for a few years.

The same is true of the Will. Because we don't use it, we don't know how. Most of us float along carrying out other people's wills simply because our own will has become scotched and dormant from lack of use. Yet the Will is just as susceptible to training as the brain or memory and by the very same methods, by intelligent exercise and use.

"Power of Will"

by Frank Channing Haddock, Ph.D., a scientist whose name ranks with such leaders of thought as James, Bergson and Royce—is the first thorough course in Will training ever conceived. It is based on a most profound analysis of the Will in human beings. Yet every step in the 28 fascinating lessons is written so simply that anyone can understand them and apply the principles, methods and rules set down with noticeable results almost from the very start.

May Transform Your Life

The users of "Power of Will" have experienced results through its study which border on the miraculous—it has enabled thousands to win out with big plans which they had worked on unsuccessfully for years—it has made active men of affairs out of pitiable down and outs—it has transformed those who had always been the pawn of others into self-confident powerful leaders—it has enabled men and women held down by petty fears—by trivial daily incidents—to brush them aside as though made of paper-mache—it teaches self-mastery—control of appetites and desires and it has enabled strong, successful men by the thousand to accomplish *bigger things* by giving them even greater power to use in their dealings with others.

No matter what your occupation in life—no matter what your age—"Power of Will" can help you by giving you the power to become the dominant factor in your every undertaking—by enabling you to make those with whom you come in contact work for your ends, instead of your filling in with their plans, and what is equally important, it teaches you to so control your own actions that you can accomplish whatever you set out to do in spite of all obstacles. It invariably makes dreams come true—as over 75,000 men and women owners of "Power of Will" can tell you.

Send No Money—Examine Book First

Although "Power of Will" is a 400-page, leather-bound book containing more material than many 320 correspondence courses, the price is only \$3.00. The publishers will gladly send a copy free, for five days' inspection. Send no money now. Merely mail the coupon on the right, enclosing your business card, or giving a reference. If you decide to keep the book, send the money. If not, mail the book back. Tear out and fill in the coupon now, before you turn this page.

THE PELTON PUB. CO., 131 Wilcox Block, Meriden, Conn.

Over 75,000 Users

"Power of Will" has already helped over 75,000 people—a record equaled by no other single course of any kind in the world. Such men as Judge Ben B. Lindsey; Supreme Court Justice Parker; Wu Ting Fang, ex-U. S. Chinese Ambassador; Lieut.-Gov. McKeivie, of Nebraska; General Manager Christeson of Wells-Fargo Express Co.; Ernest Knoebel, Asst. Atty.-Gen. of the U. S.; Asst. Postmaster-General Britz; H. St. Elmo Lewis, now Vice-Pres. Art Metal Construction Co., are owners and literally thousands of other successful men like them have voiced their praise of this great work.

"From what I have already seen I believe I can get \$300 to \$500,000 worth of good out of it."—C. D. Van Vechten, General Agent, No. West Lisle Ins. Co., Cedar Rapids, Ia.

"'Will Power' is a compilation of mighty force. My first week's benefit in dollars is \$500—cost \$3; profit \$497."—J. W. Heistand, 916 Tribune Bldg., Chicago, Ill.

"Send 15 copies to our New York office."—W. M. Taylor, Efficiency Expert, the Overland Auto Co., Toledo.

"He who reads it and puts forth effort will soon find himself out of the common herd."—F. A. Good, President of Nebraska Lumber Dealers' Assn., Cowles, Neb.

"Here is \$3 for you. 'Power of Will' received. It is the book I've wished for for years."—J. L. Seawall, Clerk of Supreme Court, State of N. Carolina, Raleigh, N. C.

"I've wished for for years."—J. L. Seawall, Clerk of Supreme Court, State of N. Carolina, Raleigh, N. C.

"I've wished for for years."—J. L. Seawall, Clerk of Supreme Court, State of N. Carolina, Raleigh, N. C.

"I've wished for for years."—J. L. Seawall, Clerk of Supreme Court, State of N. Carolina, Raleigh, N. C.

"I've wished for for years."—J. L. Seawall, Clerk of Supreme Court, State of N. Carolina, Raleigh, N. C.

"I've wished for for years."—J. L. Seawall, Clerk of Supreme Court, State of N. Carolina, Raleigh, N. C.

"I've wished for for years."—J. L. Seawall, Clerk of Supreme Court, State of N. Carolina, Raleigh, N. C.

"I've wished for for years."—J. L. Seawall, Clerk of Supreme Court, State of N. Carolina, Raleigh, N. C.

"I've wished for for years."—J. L. Seawall, Clerk of Supreme Court, State of N. Carolina, Raleigh, N. C.

"I've wished for for years."—J. L. Seawall, Clerk of Supreme Court, State of N. Carolina, Raleigh, N. C.

"I've wished for for years."—J. L. Seawall, Clerk of Supreme Court, State of N. Carolina, Raleigh, N. C.

"I've wished for for years."—J. L. Seawall, Clerk of Supreme Court, State of N. Carolina, Raleigh, N. C.

TEAR ALONG THIS LINE

The Pelton Pub. Co.
131 Wilcox Block
Meriden, Conn.

Gentlemen: Please send me a copy of "Power of Will" on approval. I agree to remit \$3.00 or return the book in 5 days.

Name.....

Address.....

MEN WANTED To DRIVE and REPAIR Automobiles and Tractors

The Sweeney Automobile School

equips you with a splendid paying trade in six weeks—hundreds of good jobs open to young men mechanically inclined. My big illustrated book fully explains the opportunities open to you as a mechanic, chauffeur, repair man, salesman, garage owner, etc.

Tear Off and Mail the Coupon Herewith Today—Right Now

It may mean to you all the difference between success and failure. Will you, by training yourself in a few short weeks, become a competent, expert automobile man? **Cash in on your time.** How would you like to have an earning capacity of \$5 a day and up? How would you like to have a trade that will always insure you good wages, independence, opportunity to see the world? How would you like to be in demand? Have employers looking for you—have big opportunities for a successful career spread out before you? Now young man, you can't do this simply by wishing. You have to **take action.** This Automobile School has over 2000 successful graduates. Practically all came here without the slightest experience. But all had **ambition and resolution.** If you have these qualities you can be sure of success. The **first step** is to send the coupon and get the big free book. It obligates you in no manner—binds you to nothing. But it gives you without cost or trouble all the facts you should know. Learn how others have made good. A post card or coupon brings this book today.



The Sweeney System of Practical Auto Instruction

is now universally recognized as a most thorough, practical and interesting course of automobile instruction, leading to certain and profitable EMPLOYMENT. It embraces every point worth knowing, including vulcanizing, brazing, oxy-acetylene welding, lathe work, machine shop practice, testing, driving, truck repairing and operating, etc. **AND YOU LEARN** by doing the work on **REAL CARS** under the watchful eyes of skilled instructors.

Make \$5 Per Day and Up

21,000 tractors were sold this year. Over half a million automobiles. Who's going to drive and repair them? Men are in big demand. Our school is doing *double* the business it did last year. Nothing succeeds like success. Don't you want to make \$5 a day and up? There's money in the automobile business for you. Read this letter from one of our boys. We have hundreds like it.

Hollis Motor Company, Delphos, Kansas

Oct. 12, 1915.

Dear Sweeney:—I left your school two years ago this month, and have been making some real money since then. Was out of school about a week when I landed a job at \$20.00 per week to start; the past year my brother and I have been selling Maxwells in Hosh county as per letterhead.

Now I can recommend your school to anyone that wants to get in a business where they can make real money all of the time. Also you can use this letter in any way you see fit.

Yours truly,

S. F. HOLLIS.

Experience Is the Best Teacher

This is the only way to learn. Do things with your own hands. Practice beats theory. We do not merely tell you how; we show you how, and you then do the work yourself. We have over 40 cars of all makes on our floor, eight trucks, five tractors, and our **DRIVING TEACHERS** keep out on the road nearly twelve hours a day. **YOU GET PLENTY** of WORK of all sorts.

No Books Used; Tools Furnished Free

The tuition is low and after you have paid that there are **NO MORE** expenses or extras you have to buy. If you could learn from a book there are lots published you could read at home, but **practical work** is the only method, and this is what makes my School so successful.

This Big Book Costs Me 50 Cents BUT I SEND IT FREE

If you are interested in planning your future and mean to investigate the opportunities before you, I will gladly send you my automobile book. This book is almost like a visit as it has 123 illustrations showing men at work in every department. It pictures the wonderful equipment of the Sweeney School. It shows how you are taught, shows the class of men you will associate with, portrays various phases of the automobile industry, explains how, when and where you begin to earn money, in a word is a complete encyclopedia of the subject. Simply send name and address today.

E. J. SWEENEY

SWEENEY AUTOMOBILE SCHOOL
1167 E. 15th Street KANSAS CITY, MO.



FREE

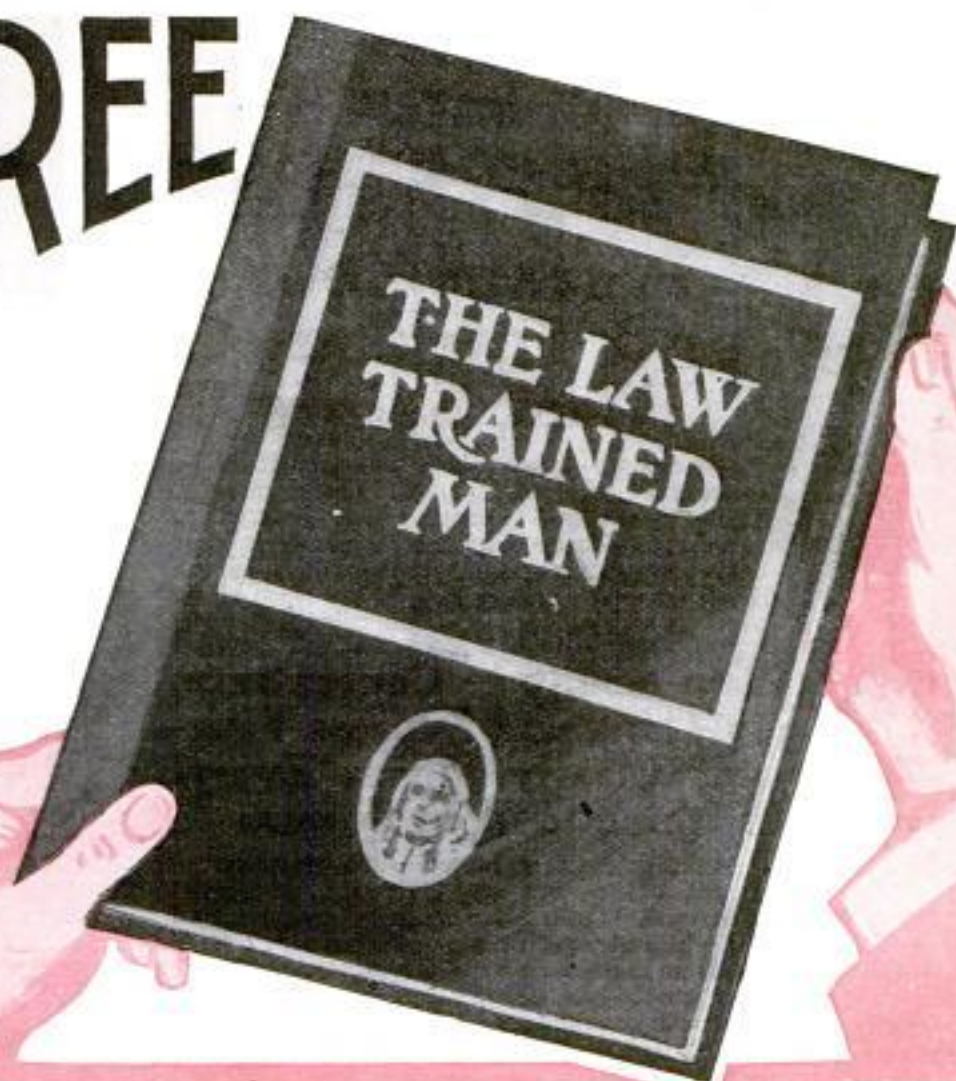

This Inspiring Book Free To Ambitious Men

This intensely interesting and instructive 165-page book tells you how a knowledge of law has proved to be the stepping stone for thousands of men to larger incomes and to power and achievement.

It tells you of the great and increasing demand for lawyers and *how you can become one*. It tells you why law trained men are now selected for most positions of responsibility in business, public life and social work—and *how you can grasp these opportunities*.

It shows you how you can become law trained without leaving your home or business by a method which includes the comprehensive features of the best resident law schools and is endorsed by distinguished men throughout the country in whose opinion you have the utmost confidence. Send for your copy of "The Law Trained Man," today.

Modern American Law Course and Service of Blackstone Institute

Blackstone Institute (including The Sprague Correspondence School of Law) was founded in 1890, and is by far the oldest and largest law school for non-resident instruction in the world.

We have successfully trained more than thirty thousand men and women in law. Among our graduates are the Governor of a State, United States Senators and Congressmen, State, County and City Officials, many Judges and thousands of successful Lawyers and business men everywhere. This notable record extending over twenty-five years is the most convincing evidence that we produce results—and it is results that count.

Address, Extension Division 1359

Chief Justice Ladd of the Supreme Court of Iowa, says: "Every person interested in the law will receive from Blackstone Institute an unusually excellent—in fact, the best, non-resident system of instruction."

The Course has been prepared especially for home study by eighty eminent judges and law writers. It is clearly written in simple, non-technical language. It is practical, yet reads like an interesting story. Preliminary education is not necessary. You can read in spare time at home, and you will benefit from the day you start. Our Course and Service will prepare you on all subjects required in the bar examinations, as it has already done for thousands of others in your own state, and every other state in the Union. It will equip you to become a leader in business or public life—and to attain positions of honor and profit open only to law trained men.

Special Offer—Investigate Free

The recent union of The Sprague Correspondence School of Law with Blackstone Institute and the resulting increase in our facilities enable us to make you a most important Special Offer. Investigate now by sending post card or letter, or clipping the coupon for our 165-page free book and full particulars. No cost or obligation.

**FREE
BOOK
COUPON**

Address, Extension Div. 1359

BLACKSTONE INSTITUTE

20 W. Jackson Blvd., Chicago.

Please send me your 165-page free book, "The Law Trained Man," and full particulars of your Law Course and Service and Special Offer. No cost or obligation.

Blackstone Institute

20 West Jackson Blvd., Chicago.

Name _____

Address _____

Please Mention Popular Mechanics

Stop Forgetting!



Prof. Henry Dickson

America's foremost Authority on Memory Training, Public Speaking, Self Expression, Lecturer and Principal of the Dickson Memory School, Hearst Building, Chicago.

The Executive



Mr. William H. Weeks, District Attorney of Putnam County, N. Y., writes:

"After a thorough trial of your method of mental and memory training, I find it to be not only first class—simply wonderful. I can truthfully say that I would not be again without the benefits I have received from your study for \$10,000."



The Key To Success

Stop Forgetting

Prof. Henry Dickson, Pres. Dickson School of Memory, 705 Hearst Bldg., Chicago, Ill.

Please send me free of charge and without obligation your booklet, "How to Remember," also your remarkable copyrighted "Memory Test." Give me facts on your special offer of a free copy of "How to Speak in Public."

Name.....

Street and No.....

City..... State.....

Perfect Your Memory and You Can Command What Salary You Will

Your salary—what it is today—what it will be tomorrow—depends very much on your memory. Tricky memories—wandering minds—unable to grasp detail—have thwarted thousands in their battle for success—have held them down to bare living wages—working long hours with slight prospect of advancement—subordinates for life.

The Ability to Concentrate, to Think and Express Yourself Clearly Means Everything to Your Success

America's men of power—in business, social or public life—are uniformly men of **trained memories**. Train your memory properly and you will find yourself able to concentrate absolutely on matters at hand—to think and speak connectedly—to develop self control, to overcome self consciousness—to make your **PERSONALITY DOMINATE**. Think what this means—a better position—bigger pay—social and business success—the **EFFICIENT LIFE**.

Give Me 10 Minutes a Day and I Will Give You a "Steel Trap" Memory

That is all I ask—just ten minutes a day for a few weeks and I will train your memory just as I have trained the memories of 50,000 others. I will make your mind an infallible classified index from which you can instantly select facts, figures, faces, arguments. No matter what your age—your education—your vocation—your place of residence—I can make you "forget proof"—can train your memory for **SUCCESS**.

SPECIAL OFFER!

"How to Speak in Public"—FREE!

For a limited period I am offering "How to Speak in Public," a de luxe edition, handsomely bound book—regularly priced at \$2.00—FREE to every student enrolling in my course. Full particulars of this unusual offer—together with a copy of my famous Memory Test and my remarkable book "How to Remember" will be sent FREE—simply for the mailing of the coupon or a postal. This is **YOUR** opportunity—mail it **NOW**.

The Public Speaker



Carl F. Schaefer, one of California's biggest men, writes:

"I have been improved physically and mentally beyond my own expectations by the continued study of your course. Every business man, especially those called upon to talk at Chambers of Commerce, realty boards, advertising clubs and other meetings should take your course. I unhesitatingly recommend it to my many friends."

In Social Life



Roland Miller, of New York City, writes:

"What I have written from your method has advanced me both socially and financially and I feel it my duty to tell you of those excellent results."

The Salesman



O. G. Wehmeier, of the American Miners' Accident Association, Indianapolis, Ind., writes:

"I can honestly and truthfully say I am a new person. I have more friends than I really expected I could have. Everyone who has known me says that a wonderful change has come over me in the last six months. It is all due to the Dickson School of Memory."

Learn Electricity

Earn \$100 to \$300 a Month

Electricity, now but in its infancy, is destined to become the greatest factor in human existence during the present generation.

The opportunities for thoroughly trained men in this wonderful field are absolutely unlimited—the demand for such men, enormous. Big jobs, \$100 to \$300 a month, opening up all the time—our Free Employment Bureau unable to supply the demand at times.

We Train You For a Big Job In Short Time— At Small Expense

You get your training under actual working conditions in our big shops—under the personal guidance of expert instructors who will fit you, in a remarkably short time, to take one of the big jobs opening up every day. Day and Evening classes, open all the year. Enter any time.

Our course of instruction is simple, clear and concise—no correspondence or text books to tangle you—you get real, every day shop work and master all its problems with the tools right in your own hands. All Tools and Materials Furnished FREE.

Tuition Met By Easy Payments Don't pass up this opportunity for lack of ready money. Our easy payment plan is for you if you need it and is strictly confidential. Because of the enormous demand, we are making a very special offer to new students. Mail the Coupon below—ask us to tell you all about it.

Coyne National Trade Schools

Men Wanted FOR THESE TRADES Plumbing, Bricklaying, Drafting Courses, Motion Picture Operating

CHOOSE YOUR OWN FUTURE TODAY. There are unlimited possibilities in any one of these trades. It's up to you—up to you to drift along at some job yielding mighty small pay—liable to a "let-out" every time times are tight—or you can sign the coupon below as the first step toward a big future—a big job at big pay. We train men by actual shop work in all of the above trades. Our graduates are qualified to demand from \$5 to \$8 a day right from the start or go into business for themselves—to the growth of which there is absolutely no limit.

FREE TOOLS
We furnish all material and tools you use in taking any course **ABSOLUTELY FREE.** All we charge is a very small amount for tuition. Many of our students earn their expenses while taking their course.

No Experience Needed Don't allow yourself to be misled by a notion that you need previous experience—because you don't. Don't think you are either too young or too old—our successful students range from 15 to 50. We train you from the ground up—train you by the most fascinating actual shop work possible. All fully explained in our catalog.

Send the Coupon Today For Our New Big FREE Book
Send no money—you don't obligate yourself in any way. Just allow us to send our big FREE Book fully explaining the work of the Coyne National Trade Schools and the remarkable opportunities constantly opening for their trained men.

Don't be satisfied to work for mere living wages—don't be at the mercy of every adverse wind that blows. Get into a good trade—become an expert by our training, command your own salary—create a big future—mail coupon today.

B. W. COOKE, Director
COYNE NATIONAL TRADE SCHOOLS
39-51 E. Illinois St., Dept. 1199, Chicago, Ill.

WE OCCUPY
ENTIRE BUILDING

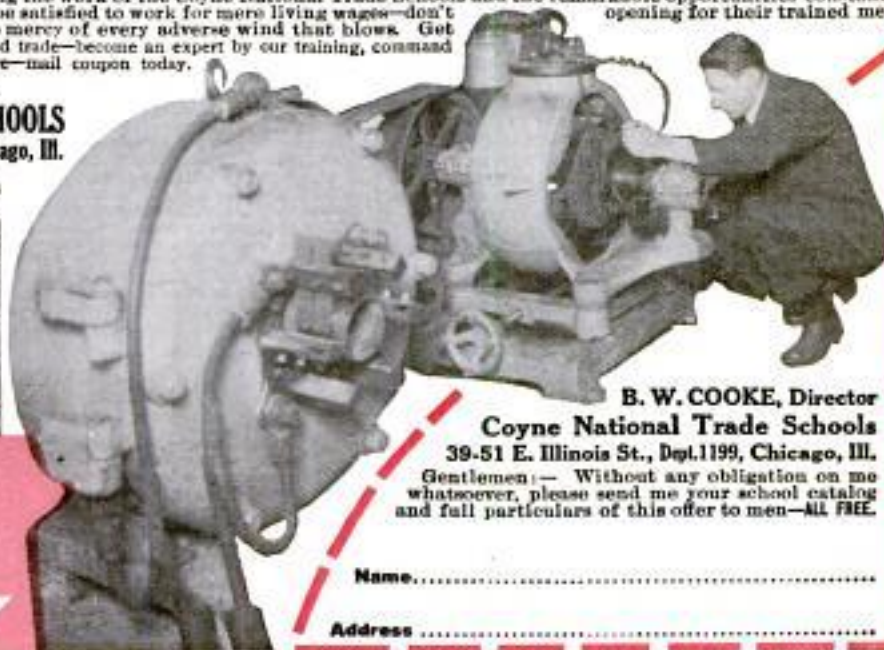

B. W. COOKE, Director
Coyne National Trade Schools
39-51 E. Illinois St., Dept. 1199, Chicago, Ill.

Gentlemen:— Without any obligation on me whatsoever, please send me your school catalog and full particulars of this offer to men—**ALL FREE.**

Name.....

Address.....

**Mail This
Coupon
NOW** →



Frank Gotch applying his world-famous "toe-hold"

LEARN Expert Wrestling and Physical Culture

The most wonderful course of lessons in existence. Learn at home—by mail—from **Actual World's Champions**. Develop your body by the greatest methods ever devised. Be strong, healthy and athletic. Learn to defend yourself, and handle large, strong men with ease. Where all other systems fail, the wonderful **Gotch-Burns** course **Succeeds**.

Here is your opportunity. Investigate. Write today for **Free Booklet and Full Particulars**.

Farmer Burns and Frank Gotch

The original **Farmer Burns**, the best known, and most scientific wrestler that ever lived, trainer and manager of the marvelous and undefeated **World's Champion Frank Gotch**, will teach you at home **By Mail**, all the science, holds, breaks, defenses, and tricks of the wonderful art of **Wrestling and Self Defense**. Hundreds of heretofore professional secrets now fully revealed. This course of lessons is creating a sensation. Students are enrolling from every State in the Union and many foreign countries. Never before have **Actual World's Champions** offered their most secret methods of training to the public. **Grasp this unequalled opportunity**. Get in touch with the school **Now**.

What the Lessons Teach

This unique and interesting course teaches in a wonderful way **Physical Culture** as it was never taught before. If other courses have failed with you, **This Course Will Succeed**. You learn to develop **All Parts of the Physique Equally**. You learn to become an **Expert Wrestler**. You learn **Jiu-Jitsu** and self-defense. You learn to live properly, to eat, breathe, exercise and sleep as you should. Easily, quickly learned, and intensely interesting and fascinating.

If you want to be a great athlete, to have splendid robust health, to drive away old age, to be a skilled, scientific wrestler, then write **Today** to this school for the **Free Book** and liberal **Introductory Offer**.

GREAT ATHLETIC BOOK FREE

Send Now for our fine illustrated **Free Book**. It tells all about this popular school and how you can join at small cost. It shows you how to become the kind of an athlete you want to be, and how you can associate yourself with the best known athletes and instructors in the world.

Every Man and Boy in America Should Have This Splendid Book. Write for your copy this minute. You will be astonished at the marvelous results attained by our students from our **Combined Course of Lessons in Physical Culture and Scientific Wrestling**.

If you read **POPULAR MECHANICS MAGAZINE**, and are interested in good health and physical development, you will find this the most important announcement ever published in these columns. **Let Us Hear from You Immediately**.

What They Say: The most famous of all athletes **know** and **endorse** the **Burns School**.

Christy Mathewson Says: "I am delighted to know you are giving the American public the benefit of your wonderful knowledge of wrestling and other branches of physical culture."

Frank Gotch Says: "The grand old man, **Farmer Burns**, knows more about developing the human body, and about scientific wrestling than any man that ever lived. He took me as a farm boy and made me **World's Champion**."

Hank Gowdy Says: "I consider **Farmer Burns** the greatest of all wrestlers and athletic instructors."

Yusuff Hussane Says: "He took me as an ordinary wrestler and quickly made me aspirant to **World's Championship Honors**. His methods are the most wonderful of all Europe and America."

Thousands of Students endorse the school unreservedly, and recommend the lessons to every man and boy desiring perfect health and scientific athletic training.



FRANK GOTCH



FARMER BURNS

Physical Culture Magazine Says:

"If any man in this country is especially qualified to teach the finer points as well as the rudiments of wrestling, it is **Farmer Burns**."

"From his own prowess as a wrestler, **Burns** has proven his ability to communicate his skill to others—as is proven by the career of that splendid exponent of his methods, **Frank Gotch**."

FREE COUPON

FARMER BURNS SCHOOL OF WRESTLING,
1199 Ramage Bldg., Omaha, Nebr.

Mail your **Free Book**, and full particulars about your great course of lessons in **Physical Culture and Scientific Wrestling**. No obligation on my part.

Name.....

Address..... Age.....

Ask for Free Book

Send the Coupon, or your name in a letter or on a post card will do. Give your age. No obligation, no cost whatever to you. Better send **Right Now**—this minute, before you forget it. You will find the literature intensely interesting, and you owe it to yourself to investigate this great opportunity **Fully and Carefully**. Address,

FARMER BURNS SCHOOL OF WRESTLING
1199 Ramage Building, Omaha, Nebr.

Come to Detroit
the automobile center
and

LEARN THE AUTOMOBILE BUSINESS

Detroit trained men get preference over all others, get jobs quick as soon as ready. *The reason*—study the heart in the center. Realize its tremendous power.

No other city, no other school can give you what Detroit offers. Factories shown are not all. Think what it means to learn at Detroit. Every factory knows us, endorses our school, glad to get our graduates. You're right in the middle of great auto activity. Men are needed everywhere as testers, repairmen, chauffeurs. Splendid chance to start in business. Hundreds of our graduates are doing it.

Earn \$75 to \$300 a Month

We teach you to handle any auto proposition. Our equipment is complete. Students actually build new cars from start to finish, getting regular factory training in assembling, block-testing, road-testing, etc. **That's the Detroit Way.** All leading types of starting, lighting and ignition systems in operation. Learn to time motors, adjust carburetors, magnetos, valves, bearings, etc. Six-cylinder Lozier touring car is used for road instruction. We have a new 8-cylinder King chassis, the latest thing out.

Detroit is the Place to Learn—Start Any Time

There are 44 auto factories in Detroit. Our students have the privilege of going through any or all of them, including Detroit electric service department, while taking our course. You can't get these advantages and opportunities anywhere else. **Detroit is the automobile center.** You make faster time here and you get practical instruction. Come to Detroit and learn the business right. Enter classes any time.

Great Demand for Detroit Trained Men

Garages throughout the country write us for men. Why not fit yourself for one of these good paying positions?

Demand Greater Than Supply for Competent Men. Following Clipped from Daily Papers—All Parts of U.S.

Experienced motor mechanics, bearing arrangers, assemblers, repairmen; good wages. Henderson Motorcycle Co., 1158 Cass.

Chauffeur—Must be good driver, steady and reliable; one with knowledge of Pierce-Arrow cars preferred; no other but good mechanic need apply. Address Box B, No. 100 Free Press.

10 road testers, 20 garage repair men, final assemblers. Maxwell Motor Co., Inc., Oakland Ave. Plant.

40 Drivers—Come ready to work. Maxwell Motor Co., Inc., Oakland Avenue Plant.

Block Testers—Apply Continental Motor Mfg. Co.

Wanted—High-grade retail automobile sales manager. Box E, No. 52.

Automobile Repair Men wanted; must be experienced; none other need apply. Come ready for work. Auto-Kraft & Garage Co., near 76-86 Forest Avenue, East.



Michigan State Auto School
Students are Competent to Fill
Every Position and Make Good

Has Studebaker and Maxwell Agency
La Farge, Wis., February 6, 1915.

Prof. C. G. Arthur,
Michigan State Auto School, Detroit, Mich.
Dear Sir—I am getting along just fine. A friend of mine, Mr. Stoolin, and myself, have opened a garage in our home town, and we have been having all we could do. We have been doing overhauling this winter and have got enough work ahead waiting to keep us going until spring opens up. Thanks to what you have pounded into that old nut of mine, I have never been stuck yet. We have the agency for the Studebaker and Maxwell.

Yours truly, (Signed) O. C. HILL.

Starting Garage of His Own, Couldn't
Accept Position We Offered

Elma, Iowa, May 1st, 1915.
Michigan State Auto School, Detroit, Mich.
Gentlemen:—I thank you very much for the information sent me and am very sorry because I cannot accept the position as I am busy at the present time, putting up a garage. I am going into the business for myself and was compelled to turn down the position offered me. I am thankful that I went to Detroit to learn the auto business and wish the School the best of success. Sincerely yours, (Signed)
CARL WEBER, Box No. 304, Elma, Iowa.

W. C. Garden, Tenn., is Chauffeur at \$25 a week and expenses. E. Livingston is head of government garage at Toronto. Hundreds of others in good paying positions.

READ OUR GUARANTEE

GUARANTEE

We guarantee to qualify you for a position as chauffeur, repairman, tester, salesman, demonstrator or garage man paying from \$75.00 to \$300.00 in a short time or refund your money. We have constantly more requests for men, at \$600 salaries than we can supply.

Write for full particulars.
Ask for "Auto School News"
and new Pictorial catalog—
just out. Both free. Or,
better still, jump on train
and come to Detroit.

Michigan State Auto School Dept. 310, 11-19 Selden Ave.
Detroit, Mich., U. S. A.



SEND THIS COUPON TODAY

Michigan State Auto School

..... I expect to leave here about.....
for Detroit.

..... I would like to see your new pictorial
catalog. (just out) and the Auto School
News and will let you know later what I
expect to do.

Name.....

Street.....

For Office.....

City.....

FREE!

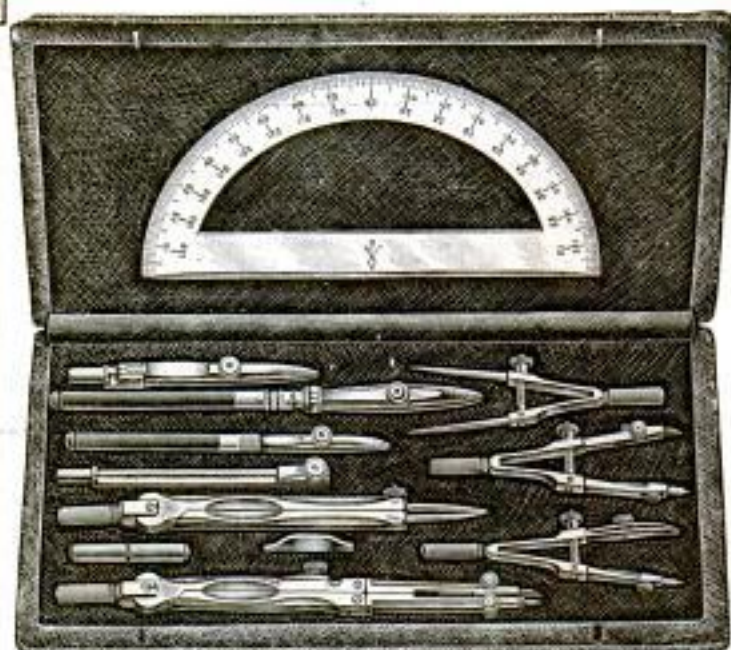

Yes, I mean just exactly what I say—that I will give you this magnificent set of Draftsman's Drawing Instruments positively and absolutely free. And besides the instruments in this beautiful plush lined leather case, I will **also** give you absolutely **free** a 20x25 inch drawing board, a 24 inch T square, a 12 inch rule, two triangles, a French curve, two bottles of drawing ink, a supply of paper, pencils, erasers, thumb tacks, etc., etc.—a complete draftsman's working outfit, the very same kind that I use myself.

This superb set is valued at \$17.50. It goes absolutely free to those who get my personal instructions in Draftsmanship.

Become A Draftsman

I Will Train You By Mail

I am Chief Engineer of a large firm. **Draftsmanship** brought me to my position. I know just the kind of training you need to get a big salary. I will give you personal instruction by mail—instruction based on my own every day practical experience. You need no special talent or requirements. You do not have to take a minute from your regular work. No matter who you are or where you live, if you can read and write and are ambitious I will take you in hand and make a real draftsman out of you. Write for my free book and see what I have done for others. Send the coupon or postcard.

MAIL COUPON TODAY

CHIEF ENGINEER COOKE
Dept. 1Y, 455 Cass St., Chicago, Ill.

Without obligation or cost to me send prepaid your free book "The Road to Success" and particulars of your very extra special offer.

NAME

ADDRESS

The need **now** is for draftsmen! Companies everywhere are looking for skilled draftsmen to fill positions paying from \$125.00 to \$175.00 per month. The work is light, pleasant and profitable. Look at the want ads of our metropolitan newspapers and see for yourself what an urgent demand there is for draftsmen. This is the "Construction Age"—the epoch of a new pace in every field of industrial endeavor. The services of the draftsman are needed more than ever before. Give me a few minutes of your spare time for a few months and I will qualify you for a big salary and a real future.

Take Your Time To Pay Me

Let me count on you as an earnest student and you won't have to bother about the money question. I'll help you take care of that. To secure the quick enrollment of a few more ambitious men I'll cut my tuition price to an extremely small figure and give the privilege of paying this small cost on terms so easy that you'll scarcely miss the money. Remember you get the draftsman's outfit **free**, so that you can start in right away. Send the coupon for my amazing free book and full particulars of my special offer.

CHIEF ENGINEER COOKE

Chicago Engineering Works, Dept. 1Y, 455 Cass St., CHICAGO, ILL.

Please Mention Popular Mechanics

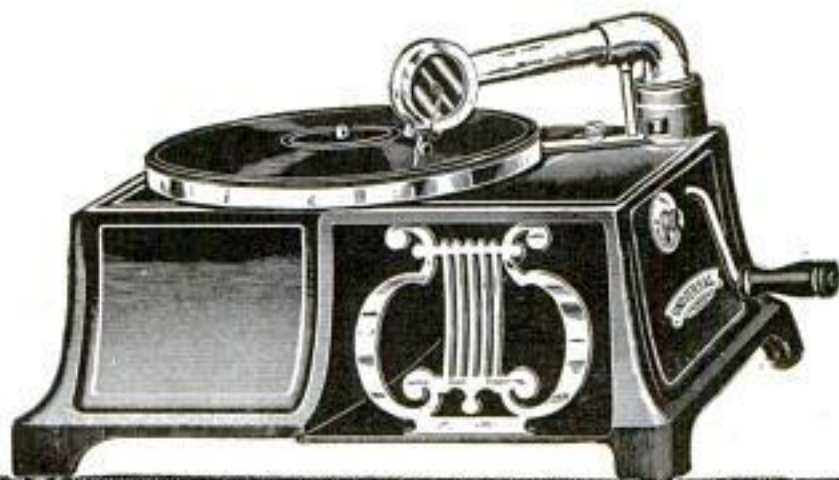

No Money In Advance

Sensational Phonograph Offer

We offer you the most sensational, the most astoundingly liberal offer ever made in the history of the Phonograph business. We will send to you without one penny in advance, without one bit of obligation on your part whatsoever, this remarkable Universal Phonograph—this startling new invention—this marvelous all metal machine which is revolutionizing the talking machine world. Just 10,000 of these wonderful Phonographs have been set aside to be sent out on this amazing advertising offer which is made in order to get a machine in each locality of the United States immediately.

Never before—and without doubt never

again—will an offer so liberal be made. Not one cent in advance—no references asked—no C. O. D.—no delay—no red tape—not even your promise to keep the machine. The coupon below is all that is necessary. And with this remarkable machine will be sent eight splendid selections—the regular 65c double disc Columbia records. Play this grand Universal in your home with the superb selections sent with it—give the Universal a thorough ten days' test and then, if after a thorough test and examination you believe it to be the most remarkable, the most wonderful phonograph you ever heard, simply

Pay Only \$1.00 In Ten Days

and pay balance of our Special Limited Introductory Bargain price of \$16.50 in small monthly payments of \$1.55 each. If for any reason you do not want to keep the phonograph and records simply return to us within ten days after receipt at our expense and you owe us nothing—without the records the Phonograph furnished for only \$13.90.

Think what a remarkable Phonograph this one must be in order to stand such a critical test as this. Songs, Speeches, Instrumental Music, Band and Orchestra Selections, each voice, male or female, each instrument brought out in an actual reproduction exactly as the original, not one sound or syllable blurred or indistinct

—no screeching or buzzing. Gorgeous Harp front-piece and all trimming beautiful silver effect, not one particle of tin or wood in its entire construction; base 15 inches wide by 6 inches high, 11½ inches deep; weight 17 lbs.; has exclusive automatic start and stop. Plays ALL makes and sizes of disk records.

Eight beautiful selections—the regular 65 cent double disc Columbia records—will be sent to you on this offer. A complete list of hundreds of the most famous selections will be sent along with the machine and records. You have the privilege of exchanging immediately any or all of the 8 selections sent to you for those of your own choice.

No Reference Asked

Remember, no reference asked. On receipt of the coupon we simply ship the phonograph and records right out to you. If you decide that you want to keep the Phonograph and records send us only \$1 within ten days and pay the balance at \$1.55 a month until you have paid us our Special Introductory Bargain Price of only \$16.50. Otherwise return them at our expense. Do not delay in this matter. Send coupon today, then examine and test this beautiful, perfect, new Universal Phonograph in your home on this liberal No Money In Advance offer. This offer is limited—immediate action is necessary—mail the coupon today.

UNIVERSAL PHONOGRAPH COMPANY,
133-37 West 39th Street, Chicago, Ill.

Send No Money!

Universal Phonograph Co.,
133-37 West 39th St., Chicago, Ill.

Send at once your wonderful new Universal Phonograph and 8 selections of the regular 65c Double Disc Columbia Records. If satisfactory after examination, and I decide to keep them, I will send you \$1 in ten days after arrival. I then agree to pay the balance of \$15.50 in monthly payments of \$1.55 each until paid. Otherwise I will return Phonograph and records at your expense.

Name.....
Address.....

P-M

Please Mention Popular Mechanics

My \$3 Exerciser \$1⁰⁰ Reduced to



Until further notice I will send one complete **Muscle Builder Outfit**

to any reader of Popular Mechanics upon receipt of \$1.00—just one-third the regular price. I will also include a complete body-building course of instructions containing 24 selected exercises. The **Muscle Builder** will meet the requirements of any person—weak or strong—man, woman or child. Can be used to exercise any muscle in the body.

A Chest Expander Also

with each outfit, I will give an extra handle, without charge, by which the **Muscle Builder** can instantly be converted into a most effective Chest Expander to be used for developing the chest and lungs. Take advantage of this opportunity while it lasts. Send your order today.

Prof. Anthony Barker
Studio 6, 110 West 42d Street, New York



The Truth About Poultry



Get the Facts by Reading

The One-Man Poultry Plant

Successful Methods of Men on Farms or Small Acreage. Complete in twelve parts; printed in one volume.

By **DR. N. W. SANBORN**

REAL work, with real poultry, on a real New England Farm. This is a simple story of what has been done by a man, at forty-five years of age, town bred and city educated, getting out of practice of medicine, buying a small farm in the hill country, and making a success of the venture. Not only is the rearing of chicks and the management of adult fowl completely covered, but the interesting side issues of fruit growing, grain raising and the production of milk, that cannot be escaped on a real farm. You get rugged facts—rarely found in print. The truth about poultry as found in actual life on a one-man poultry farm.

You Can Do the Same, Book Tells How

OUR SPECIAL OFFER—The One-Man Poultry Plant, in twelve parts (book form), and the American Poultry Advocate, one year, for only 50 cts., book and Advocate, three years, for only \$1.00, if order is sent at once.

Our paper is handsomely illustrated, practical, progressive and up-to-date on poultry matters. Established 1892. 44 to 132 pages monthly. 50 cents a year. 3 months' trial 10 cents. Sample copy free. Catalogue of poultry literature free. Address

AMERICAN POULTRY ADVOCATE, 523 Hodgkins Bldg., Syracuse, N.Y.

MAKING POULTRY PAY

depends more on the knowledge you have of Poultry Culture than on expensive equipment or extensive space.

Let Director Quisenberry teach you how to raise poultry successfully and make a good living and a nice profit from a flock of thirty hens.

If you want to save money and make money in the poultry business write us today for our large illustrated **Free Book, Dollars and Sense in the Poultry Business.** It points the way to success.

American School of Poultry Husbandry
Box 75 Mountain Grove, Missouri



Every Boy His Own Toymaker

Greatest boys' book ever written. Tells how to make a Steam Engine, Telephone, Magic Lantern, Boats, Kites, balloons, electrical and mechanical toys, traps, fishing tackle, 200 illustrations; also catalog of 150 puzzles, puzzle picture card and "DOUBLE TUNDRAY" warbler and bird call all for only 10c. **WESTERN PUZZLE CO., ST. PAUL, MINN.**

J-M ASBESTOS ROOFINGS

Sometimes called "The Everlasting Roof." Investigate J-M Roof Registration always mindful of J-M Roofing Responsibility.

H. W. JOHNS-MANVILLE COMPANY
3186 New York and Every Large City

MEN and WOMEN WANTED

GOVERNMENT JOBS

\$65.00 to \$150.00 a Month

WE GIVE FREE SCHOLARSHIPS

Steady Work—Vacations with Full Pay—Rapid Promotion—“Full” Unnecessary—Common Sense Education—Sufficient—Mail Courses today before you forget. It will cost a cent to stamp; it may bring you thousands of dollars.

FRANKLIN INSTITUTE
Dept. F104, ROCHESTER, N.Y.

This coupon, filled out as directed, entitles the sender to free sample questions; a free copy of our book, "Government Positions and How to Get Them," free list of positions now obtainable; and to consideration for Free Coaching for the examination here checked.

COUPON

..... Railway Mail Clerk (\$900 to \$1000) Customs Positions (\$800 to \$1500)
..... Postoffice Clerk (\$800 to \$1200) Internal Revenue (\$700 to \$1800)
..... Postoffice Carrier (\$800 to \$1200) Stenographer (\$900 to \$1500)
..... Rural Mail Carrier (\$500 to \$1200) Clerk in the Departments at Washington (\$900 to \$1500)
..... Bookkeeper (\$900 to \$1000) Canadian Government Positions

Name
Address

Use this before you lose it. Write plainly.

Please Mention Popular Mechanics

Don't Wear a Truss

Brooks' Appliance, the modern scientific invention, the wonderful new discovery that relieves rupture will be sent on trial. No obnoxious springs or pads.

Brooks' Rupture Appliance

Has automatic Air Cushions. Binds and draws the broken parts together as you would a broken limb. No salves. No lies. Durable, cheap. Sent on trial to prove it. Protected by U. S. patents. Catalogue and measure blanks mailed free. Send name and address today.

C. E. BROOKS, 1817A State Street, Marshall, Mich.





Young Man, it Pays Big To Know TRAFFIC

You Can Learn it Easily and Earn From \$50 to \$100 Weekly. The Transportation Field is Uncrowded—Thousands of Efficient Traffic Men Are Needed Right Now.

Traffic—Transportation—grows bigger and more important each day. There seems to be no limit, nor is there any limit to the Salaries

Expert Traffic Men are paid. A good Traffic Manager, capable of preventing losses and saving profits, is paid what he is worth. Thousands of splendid, high salaried

positions are open for the men who know correct routings and proper classifications of

Freight. 100,000 trained traffic men are needed NOW.

Millions of Dollars Are Lost Yearly Through Lack of Traffic Knowledge

Earn \$200 to \$1000 Monthly

Join the American Commerce Association. The cost is trivial—indeed it is smaller than you should be making in a single week after you have completed your course. The work and studies are pleasant and intensely interesting. You can use your spare time during the evenings. This is really a big opportunity for every young man. Everyone should investigate fully—get all of the details.

American Commerce Association

is ready and anxious to help ambitious men to become proficient traffic men. It is far better equipped than any other to render practical assistance—it offers the broadest and most complete traffic training in America. Through its methods any young man can acquire the same knowledge which required many experts a life time to acquire through practical experience.

**American Commerce Association
Dept. 24, The Rookery, Chicago, Illinois**

Ask Us for a FREE Copy

of one of these valuable books, "Opportunities Along the Trails of Traffic" by H. G. Wilson. Straightforward and Informative. "Traffic Efficiency," 32 pages. Tells the need of high salaried efficient Traffic Men. "Millions Wanted in Traffic." (Give actual cases. Intensely interesting. Tells of Traffic Savings Opportunities.

MAIL THIS TODAY

AMERICAN COMMERCE ASSN.

Dept. No. 24, "The Rookery," Chicago. Please send me entirely without charge or obligations, book as checked . . . "Opportunities Along the Trails of Traffic" . . . "Traffic Efficiency" . . . "Millions Wanted in Traffic." Also explain how your course in Traffic Efficiency will train me to become a traffic expert.

Name.....

Address.....

Do You Like to Draw? Cartoonists Are Well Paid

We will not give you any grand prize if you answer this ad. Nor will we claim to make you rich in a week. But if you are anxious to develop your talent with a successful cartoonist, so you can make money, send a copy of this picture, with five in stamps for portfolios of cartoons and sample lesson plate, and let us explain.

**The W. L. Evans School of Cartooning
821 Leader Bldg., Cleveland, O.**



Learn to PAINT SIGNS and SHOW CARDS

I'll teach you personally by mail, 16 years' successful teaching. Big field for men and women. You can **Earn \$18.00 to \$45.00 a Week** Scherer (Chicago) writes: "Your instruction is great. Highly pleased." Full details promptly on request

DETROIT SCHOOL OF LETTERING
Chas. J. Strong, Founder Dept. 212, Detroit, Mich.



LAW BOOK FREE



Be Sure to Get This 80-page Free Book Before You Enroll for Any Law Course: No matter which school or which course you may be considering—no matter which method of instruction you may favor—be sure to read "How to Acquire a Legal Training" before you enroll. One of the greatest free books on law ever offered. Tells how to weigh and judge the claims of correspondence schools. Tells just what a law course should contain to give you the training absolutely necessary to succeed in the legal profession. Tells the easiest and best way to become a lawyer by studying at home, and explains all about the American School's simple method of home law instruction. Prepared by 56 of America's greatest legal authorities—25 more subjects and 30 more authors than any other correspondence law course.

FREE 13 Volume Law Library and 60 Text Books

With each course we furnish 60 new pocket size Text Books, 36 Case Books, and our big 13 volume Law Library. Written in plain, simple, easily understood language especially for correspondence instruction. Don't fail to investigate this wonderfully complete and practical course before taking up the study of law—send for your free book today. Just drop us a postal—there is no obligation—it is absolutely free for the coupon.

American School of Correspondence, Chicago, U.S.A.

FREE BOOK COUPON

Pop. Mech. 12-15
A. S. of C.
Gentlemen: Please send me your FREE Law Book, "How To Acquire a Legal Training," and full particulars regarding your wonderful new system of correspondence law instruction.

NAME.....
ADDRESS.....

CRIPPLED CHILDREN

Mr. Henry W. Irvin, a railway postal clerk on the B. & O. R. R., wants all to know what this Sanitarium did for his 6-year-old daughter Marjorie. She had INFANTILE PARALYSIS when six months old. Her left foot was badly deformed and left limb affected. Read his letter:

We had tried everything we heard of without success. Finally, we took Marjorie to The McLain Sanitarium, where six months' treatment fully corrected the deformity, improved the foot so that she could move it (something she had never done before) and gave the limb better circulation and color. We watch for opportunities to tell others what you did for Marjorie. Yours gratefully,

HENRY W. IRVIN, Flora, Ill.

Don't hesitate to write Mr. Irvin and ask questions. Remember, for 30 years this private institution has been exclusively devoted to treating

DEFORMITIES

such as Club Feet, Spinal Diseases and Curvature, Infantile Paralysis, Hip Disease, Bow Legs, Knock Knees, Wry Neck, etc., especially as found in children and young adults. Complete modern equipment.

Write for information and our book, "Deformities and Paralysis"—also book of references. Both free.

THE McLAIN ORTHOPEDIC SANITARIUM
902 Anbert Ave. ST. LOUIS, MO.



Health? Take Turkish Bath at Home—Only 2 Cents



Physicians are abandoning drugs for this new treatment. If your mind or body is tired, open your pores and feel the rapid change in your condition, at cost of 2c a bath. The Robinson Bath Cabinet is the only scientifically constructed bath cabinet ever made for the home. Great \$2 Book Sent Free—"The Philosophy of Health and Beauty." Write today. Agents Wanted. ROBINSON MFG. CO., 1027 N. 12th St. TOLEDO, O.

Pay as You Wish

We'll send you a genuine Lachnite for you to wear for 10 full days. If you can tell it from a real diamond send it back at our expense. Costs but 1 cent as month. If you decide to keep it pay only a few cents a month. Write for catalog.

Genuine Lachnite Gems

Keep their dazzling fire forever. Set in solid gold. Cut by world renowned diamond cutters. Will stand fire and acid tests. All kinds of jewelry at astounding low prices. Easy payments. WRITE TODAY. H. Lachnite Co., 12N. Michigan Av., Chicago Dep. 1199



Deafness



Perfect hearing is now being restored in every condition of deafness or defective hearing from causes such as

Relaxed or Sunken Drums, Roaring or Hissing Sounds, Perforated, Partially Destroyed Drums, etc.

Wilson Common-Sense Ear Drums

"Little Wireless Phones for the Ears"—

require no medicine but effectively replace what is lacking or defective in the natural drums. They are simple devices, which the wearer easily fits into the ears where they are invisible. Soft, safe and comfortable to wear at all times.

Write today for our 168 page FREE book on DEAFNESS, giving you full particulars and plenty of testimonials.

WILSON EAR DRUM CO., Incorporated

379 Inter-Southern Building LOUISVILLE, KY.

STOP USING A TRUSS

Do Away With Steel And Rubber Bands

FREE TRIAL



Inner surface is made adhesive to secure the PLAPAO-PAD firmly to the body, keeping the PLAPAO-PAD continually applied and the pad from slipping. No straps, buckles or springs attached. Soft as velvet—easy to apply.

It's the Non-Slipping, yet Non-Rigid Pad and What is Within It That Counts

FREE to 5,000 Truss Sufferers

To the first 5,000 Sufferers who write, I will send, ABSOLUTELY FREE, a sufficient quantity of the Plapao to positively convince them that this is the only logical, common-sense way of treating rupture. Plapao is a highly astringent medication placed within the Plapao-Pad and being absorbed through the skin, creates a wonderful feeling of relief and at the same time tends to strengthen the weakened muscles and thus permanently close the rupture opening. The process of recovery is natural, so you'll have no use for a truss—you can throw it away forever! Old and young have testified under oath that the Plapao-Pads cured their rupture—many of them long-standing, aggravated cases—without delay from work. Patent allowed in U. S. and foreign countries. Awarded Gold Medal at Rome and Grand Prix at Paris.

Send No Money—for a sufficient quantity of the Plapao is sent without charge to enable you to give it a thorough test; you pay nothing for this trial now or ever. Write for it and full information today. Address Plapao Laboratories, Block 1427 St. Louis, Mo.

Tobacco Habit Relieved Forever

Positive relief! Tobacco Abstainer—new scientific treatment. Relief in 10 to 24 hours. Cigarette smoking, chewing, snuffing or tobacco in any form. No desire after first dose. Not a substitute. Pleasant to take. No bad after-effects. Non-poisonous. No habit-forming drugs. Relief guaranteed or money refunded. Honest, bonafide guarantee. Don't continue to be a slave to nicotine when relief is within your reach. Write today for astonishing facts. Book postpaid free.

Herwin Pharmacal Co., Dept. 90, St. Louis, Mo.

Erickson Artificial Limb Co., 38 Wash. Av. No. Minneapolis, Minn.



We are Under Govt. Bond

Mammoth Jubilee Book Free

Picturing 5152 Home Things
Get your book while the edition lasts.
SPIEGEL, MAY, STERN CO., 1401 W. 35th St., Chicago

NO MORE BALD HEADS



WHEN our VACUUM CAP is used a few minutes daily. We accept no pay until you have tried the Cap 30 days and are satisfied. The Vacuum Cap is an appliance that draws the blood to the Hair Roots and starts a new healthy crop of hair. It stops Dandruff, stops the hair from falling out.

Bought by Doctors and men who know that it is the only reasonable HAIR GROWER known to science. No Drugs Used. Write for application blank, testimonials, and booklet on "HAIR," sent sealed in plain envelope, FREE.

THE MODERN VACUUM CAP CO.

Y. 559 BARCLAY, DENVER, COLO.

Don't Be a Draftsman!

Learn these facts before you enroll for any Drafting Course

Are you planning to learn Drafting? Have promises of light, pleasant work at a big salary tempted you to become a Draftsman? THEN YOU OWE IT TO YOURSELF TO KNOW THE FACTS BEFORE ENROLLING FOR ANY DRAFTING COURSE!

Drafting alone will never get you anywhere! You can't earn more than a decent living as a mere Draftsman. The big money goes to the man who tells you what to draw—the Architectural, Structural, Mechanical or Civil Engineer.

Drafting Only a Beginning All Engineers are expert Draftsmen. Drafting was the first thing they learned. But they weren't satisfied to spend their lives drawing other men's plans. They didn't stop when they learned Drafting—they went right ahead and got the special training that enables them to hold down big jobs and draw big pay. YOU, TOO, CAN GET THIS TRAINING, and it will cost you only a little more than a course in Drafting alone

Be an Engineer—Earn \$2500 to \$5000 a Year! We will train you—in your spare time—to earn \$2500 to \$5000 a year as an expert Engineer. First of all we will teach you Drafting, furnishing a \$20 Drafting Outfit and a \$20 Drafting Library (4 Vols.) ABSOLUTELY FREE! Then, after you have mastered Drafting and are getting actual working experience in an Engineer's office, we will train you in your choice in Architectural, Structural, Mechanical and Civil Engineering. Why stop at a Draftsman's pay when a little more study will make you an Engineer, competent to fill a responsible, well-paying position?

This is the big advantage which the American School offers. A staff of highly-trained instructors—men who have been graduated from the country's greatest technical schools—enables us to prepare you in any branch of Engineering you select. Remember, we train you—in your spare time—to become a high-salaried Engineer, not an ordinary Draftsman. It will cost you only a trifle more than a course in Drafting alone, and you can pay for your instructions as you progress—in small monthly installments.

Don't enroll for any Drafting Course until you have thoroughly investigated this remarkable offer. The coupon will bring you full particulars and a copy of our 248-page Free Book. Mail it today—NOW! You have no time to lose if you are to get the free set of Drafting Instruments and the free four-volume Drafting Library.

AMERICAN SCHOOL OF CORRESPONDENCE, CHICAGO, U. S. A.

Free Book Coupon

American School of Correspondence, Chicago, U. S. A.

Without any obligation on my part, please send me full particulars of your Engineering Offer and a copy of your 248-page Free Book. I am interested in a course in Architectural Structural Mechanical Civil Engineering. Pop. Mech. 12-15

NAME

ADDRESS

JEWELRY ENGRAVING

We teach you, by our new and original method of instruction, this clean, fascinating and profitable business right at your home, and furnish you all tools needed absolutely free. Write for free book to the

WISCONSIN SCHOOL OF ENGRAVING, 32nd Bldg., MILWAUKEE, WIS.



BE A BANKER

Splendid opportunities. Pleasant work, short hours, all holidays off, yearly vacation with pay, good salary. Learn at home. Diploma in six months. Catalog free. EDGAR G. ALOORN, Pres. AMERICAN SCHOOL OF BANKING, 413 E. State Street, COLUMBUS, OHIO

LEARN PIANO TUNING AT HOME

A LUCRATIVE PROFESSION EASILY ACQUIRED BY SPARE-HOUR STUDY. Clear instructions. No guess-work. Anyone can learn. Our PATENTED TUNE-A-PHONE METHOD makes success more certain than best oral instruction. Guaranteed. In plans to graduates. Write for FREE BOOKLET, telling how our STUDENTS MAKE BIG MONEY.

Niles Bryant School of Piano Tuning, 15 East Bldg., Battle Creek, Mich.



COPY THIS SKETCH

and let me see what you can do with it. Illustrators and cartoonists earn from \$20 to \$125 a week or more. My practical system of personal individual lessons by mail will develop your talent. Fifteen years' successful work for newspapers and magazines qualifies me to teach you. Send me your sketch of President Wilson with six cents and I will send you a test lesson plus, also collection of drawings showing possibilities for you.

The Landon School of Illustrating and Cartooning
1438 Schofield Building, CLEVELAND, O.



LAW LEARN AT HOME

SPARE TIME ONLY

Graduate correspondence students most successful at bar examinations. Our method of instruction same as HARVARD, MICHIGAN and other big Law Schools. GUARANTEE to coach FREE graduates failing to pass Bar Examinations. Write today for special offer and catalog. Send FREE. Offer limited -- WRITE IMMEDIATELY.

AMERICAN CORRESPONDENCE SCHOOL OF LAW, Dept. 1199, Manhattan Bldg., Chicago

WANTED

Railway Mail Clerks
\$900 to \$1800 a Year
(\$75 to \$150 a month)

Rapid advancement to higher Government Positions. "No lay-offs" because of STRIKES, WARS, FINANCIAL FLURRIES or the WHIMS OF SOME PETTY BOSS. THE POSITION IS YOURS FOR LIFE.

Country residents and city residents stand the same chance for immediate appointment. Common-sense education sufficient. Political Influence NOT REQUIRED.

Write immediately for schedule showing the places and dates of THE COMING GOVT examinations. Don't delay. Every day you lose means the loss of just so much coaching before the rapidly approaching examinations.

FRANKLIN INSTITUTE, Dept. F 106, Rochester, N. Y.



Pleasant Work—Continually Traveling

FRANKLIN INSTITUTE (The Pathway to Plenty), Dept. F 106, ROCHESTER, N. Y. This coupon, filled out as directed, entitles the holder to free specimen questions; a free copy of our book, "Government Positions and How to Get Them," a list of Government positions now obtainable, and to consideration for Free Coaching for the examination here checked.

COUPON

- Railway Mail Clerk... (\$900 to \$1800)
- Bookkeeper... (\$900 to \$1800)
- Postoffice Clerk... (\$800 to \$1200)
- Postoffice Carrier... (\$800 to \$1200)
- Rural Mail Carrier... (\$600 to \$1200)
- Auto Chauffeur.....
- Customs Postoffice... (\$800 to \$1500)
- Stenographer..... (\$800 to \$1500)
- Internal Revenue... (\$700 to \$1800)
- Clerk in the Departments at Washington..... (\$900 to \$1500)
- Canadian Gov't Positions.....

Name..... Address..... F106

Use this before you lose it. Write plainly.

Which Book Shall We Send?



If you're a mechanic

or clerk, a salaried, business or professional man, who wants to get out of the "rut" and enjoy the freedom, independence, healthfulness and prosperity of a successful farming business and give your children a real chance in

life by bringing them up in the ideal environment of the country—then our book, "Modern Farming—the Salaried Man's Opportunity" is the one you want. It will show you how to apply your city business training to the farming business to make it pay—how to sidestep the long, wearisome, costly experience route in farming, how to make the short cut to success, how and why you can study proven scientific farming methods at home, by mail, during your spare time, under the personal guidance of agricultural experts, the same as you would at

an agricultural college. It also tells you how you can make a start toward an independent farming business of your own by getting a good salaried position in agricultural work, or starting a poultry, truck, fruit, ginseng, mushroom or flower garden for profit as a sideline to your present work.

If you're a farmer, our book, "How to Make the Farm Pay More" will open your eyes to undreamed-of possibilities that exist right on your own farm; will show you how A. F. S. courses have enabled hundreds of farmers to increase and improve their crops and to enlarge their incomes.

Fill out and mail the coupon today. No obligation. No agents to bother you.

American Farmers School
606 Laird Bldg. Minneapolis, Minn.

Original and Largest School Exclusively Teaching Farming by Mail.

Farming Opportunity Coupon

American Farmers School, 606 Laird Bldg., Minneapolis, Minn. Check which book and which course interests you:

- "How to Make the Farm Pay More"
 - "Modern Farming—the Salaried Man's Opportunity"
 - General Farming
 - Fruit Growing
 - Soils and Fertilizers
 - Poultry Culture
 - Small Farm Course
 - Live Stock
 - Farm Engineering
 - Farm Management
 - Gain Farming
 - Dry Farming
 - Irrigation Farming
 - Citrus Fruit
 - Flowers for Profit
 - Squabs for Profit
 - Dairying
 - Stock Judging
 - Ginseng Culture
 - Melon Culture
 - Forestry
 - Celery Culture
 - Cotton Culture
 - Strawberry Culture
 - Mushroom Culture
 - Traction Engine
 - Farm Book-keeping
 - Hoe Keeping
 - Agricultural Journalism
 - Greenhouse Management
 - Landscape Gardening
- 4 short courses—beef cattle, swine, horses, sheep

Do You Want a Free Sample Lesson?

Name.....

Town..... State.....

Street or R. F. D.....

Occupation.....

Study Farming by Mail

"LEARN BY DOING"

Get a complete training by actual practice. Get the knack of "HOW" together with the theory of "WHY" and the best business methods used in the World of Electrical Activity.

The N.Y. Electrical School is the pioneer and premier school of the "Learn by Doing" method. When you have completed this Course you shall be fully qualified to handle ALL branches of Electrical Industry.

The equipment of this School is unequalled and up-to-the-minute. No preparation needed to become a "learner" in this School. You can start to learn on any day of any week throughout the whole year.

Visitors heartily welcomed. Send for catalogue.
44 West 17th St. New York City
N. Y. ELECTRICAL SCHOOL

GOOD MEN WANTED

at once to learn the auto business. Big future for you or anyone who makes himself an auto expert. You learn here by doing the work yourself. Lifetime opportunity to learn the highest and most expensive auto work ever given. Omaha's NEW Auto Training College, one of the largest in the west, conducted by experienced Automobile men of Omaha, giving the highest and finest practical auto training work to be found anywhere. Experienced repairmen come and take to become experts. We teach expert higher training here regular auto repair men that they don't who teach you prin-

AUTO

don't even know. **\$900 to \$3,000 a YEAR, Salary or Bus. Profits** in Repairshop or Garage, or as Salesman, Factory Testers, Chauffeurs, Repairmen, Starter Experts or Garage Manager. If ever you are going to make a change to get into a higher paying and more pleasant line of work, DO IT NOW, the opportunities are the best that they have ever been. Take our wonderful training course now until you are competent, and then go right into the automobile business from here. Positions now open needing capable men, and we want some good men at once to take up this work. Special \$50 course in Elec. Starting and Tractorworking FREE with regular course. Learn here in 6 wks. or more. Tuition small. Life scholarship. Work easy and interesting. Many make expenses while learning. Free catalog at once.

AMERICAN AUTO COLLEGE, 553 Auto Bldg., Omaha, Neb.

Practical Electrical Education

Our practical course in Electrical Science and Engineering trains you to get and keep the big-pay jobs. Enter at any time, no matter what your education. Advance as fast as you can master what we teach. Course combines theory with actual practice in all branches of electrical work. Individual instruction. Positions paying \$1,500 a year up, waiting for graduates. WRITE FOR FREE ILLUSTRATED CATALOG. Eleventh school year now open.



School of Engineering of Milwaukee, 228 8th Bldg., Milwaukee, Wis.

DRAWING

Learn by mail in your own home. Cartooning, Newspaper, Magazine and Commercial Illustrating, also Water-Color and Oil Painting



Learn Drawing or Painting for profit and pleasure. We can develop your talent. This school has taught thousands. Free Scholarship Award—special limited offer. Your name and address brings you full explanation and our handsome illustrated Art Annual by return mail. Don't delay. Write today.
FINE ARTS INSTITUTE, Studio 219, Omaha, Neb.

Learn Watchwork, Jewelrywork and Engraving.

A fine trade commanding a good salary, and your services are always in demand. Address HOROLOGICAL, Dept. P, Bradley Institute, Peoria, Ill., for our latest catalog.

DON'T TAKE A COURSE IN MACHINE DRAFTING

til you've read my proposition. Practical, experienced Draftsman, regularly employed in large modern works, will teach a few men by mail. Best way to become a well-paid Draftsman. Special courses in Mathematics also. Instruments furnished. Rates very reasonable. Draftsman, 252 S. Corona St., Denver, Colo. Pay a part after in position.

Chicago Correspondence School of Law

Prepares Students at Home for the Bar. Four Courses of Study: College, Post-Graduate, Business Law and Bar Examination Review. Actual Daily Lessons by a recognized School that is approved by Bench and Bar.

Write today for FREE Catalog and Rules for Admission to the Bar.
520 Reaper Block, Chicago



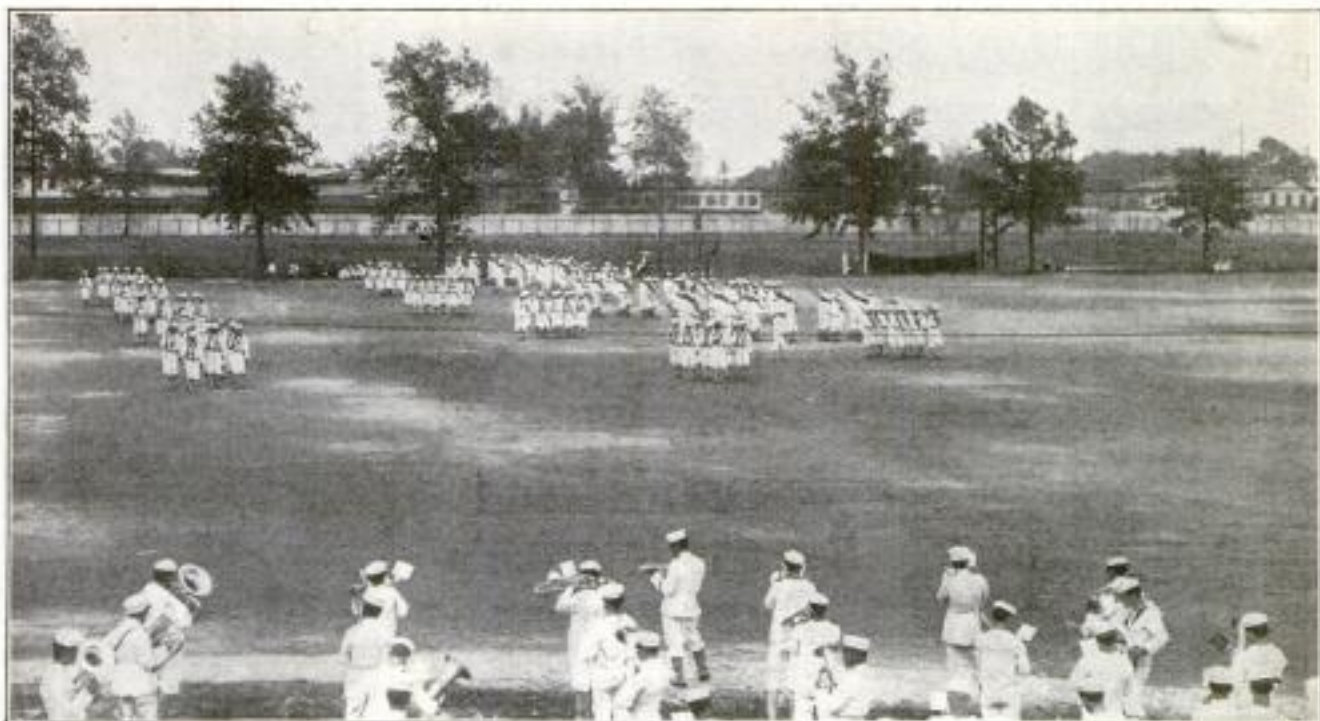

ST. HELENA TRAINING STATION INFANTRY DRILL

The Value of Navy Training

☐ The training a young man receives in the U. S. Navy will be of the greatest help to him in his later career. At the Navy Training Stations, where all apprentice seamen go, the recruit receives a practical course of instruction for a period of six months before being assigned to sea duty. The drills are interesting, the life is healthy and invigorating, and the work is not arduous.

☐ There is plenty of time for play, and plenty of recreation, boxing, baseball, track athletics, swimming, rowing, sailing, and "movie" exhibits.

☐ Besides seamanship, many trades are taught in the Navy. The man-o'-war of today needs skilled artisans, and the Navy trains its men to fill these jobs.

☐ The sea has always possessed a fascination for adventurous young men, and this fascination has nowise lessened by the modern equipment of the dreadnaught, with her powerful radio, her excellent messing arrangements, her shower-baths, her steam laundries, and countless other improvements for the comfort of the enlisted men.

You'll be interested in knowing more about the Navy. Recruiting stations are located in nearly all the cities. Look up the address in the want columns of the daily papers, visit the nearest office, and have a talk with the men there. Or write to—Box 65

BUREAU OF NAVIGATION
NAVY DEPARTMENT WASHINGTON, D. C.



Finish
Your
Christmas
Gifts With
Johnson's Wood
Dye and Johnson's
Prepared Wax

Only one day is required for the finishing operation, and you can work on your models up to 3 or 4 days before Christmas. *No experience is required to use Johnson's finishes.*

Johnson's Wood Dye

is just the preparation for dyeing wood, reed, etc. It makes inexpensive soft woods look as beautiful and artistic as hardwood. Made in seventeen shades, including Mahogany, Mission, Early English, Fumed, etc. Ask your dealer to show you panels of wood finished with it.

Johnson's Prepared Wax

is the proper finish to use over the dye. It imparts that soft, artistic polish so appropriate to Craftsman furniture. It is impervious to water, dust, scratches, finger-prints, etc. Furniture finished with it can easily be kept in perfect condition.

Johnson's Cleaner cleans the finish perfectly of all stains, spots and discolorations, making it ready for the beautiful polish imparted by Johnson's Prepared Wax. Equally good for cleaning furniture, floors and woodwork.
Piano, Linoleum, Woodwork, Automobiles, Desks, Floors, Furniture, Leather Goods
Use coupon for trial can — enough for polishing several pieces of furniture, a small floor or an automobile.

S. C. Johnson & Son, Racine, Wisconsin

"The Wood Finishing Authorities"

S. C. Johnson & Son, Racine, Wis. P.A.12

I enclose 10c for a can of Johnson's Prepared Wax — sufficient for polishing several pieces of furniture, a small floor or an automobile. Also send Instruction Book on Wood Finishing free.

Name _____

Address _____

City and State _____

Popular Mechanics Magazine

REGISTERED IN U. S. PATENT OFFICE

WRITTEN SO YOU CAN UNDERSTAND IT

Vol. 24

DECEMBER, 1915

No. 6

Good Horsemanship Shown in Odd Hurdling Event *657H*

DURING the course of a fashionable horse show recently held at an eastern city, the spectators were surprised by the introduction of a strikingly unusual hurdling event. It was a distinct innovation and a contest fraught with tenseness, both for the onlookers and riders.

A long, rectangular table, painted white, spread with linen and set with china and glassware, as if for a formal dinner, was placed on the far side of a hurdle. The position of the table made it difficult for the horses to see the additional obstruction until they were in the act of leaping. It was so placed that it was also necessary for them to take both the hurdle and table at the same time.

There were six entries in the event. The rules provided for the award of a prize to the trio which should simultaneously take the hurdle and table at one jump without upsetting any of its dishes or decorations. The requirement that each group negotiate the hurdle at the same time obviously imposed an additional handicap for the horses and huntsmen alike. Either a slight tendency to drag the hind feet, or a premature forward movement of the limbs for recovery, by any one of the animals would undoubtedly end in a mishap and the disqualification of the trio. This is precisely what occurred in one instance. The other group hurdled cleanly and captured the honors.



Winning Trio of Horses Taking Hurdle and Dining Table Simultaneously during Unusual Contest

*G. H. Davis Jr. 15 Putnam Ave.
Braintree, Mass.*

801

Copyrighted material

CYCLING CLUB USES ROAD MARKER

A sticker on which is a diagram representing every possible crossing, fork, or turn in the road is being used



by a cycling club in St. Louis, and is proving of the greatest value in connection with club tours over unfamiliar roads. These stickers are posted in a conspicuous place at the intersections by some one in the leading division familiar with the road, who marks the figure with the route taken, the names of those comprising the division, and the time when the division passed. In this way, those following lose no time in inquiring the road, and are able to determine whether or not it is possible to overtake the division preceding them.

679 ——— DETROIT GETS GOVERNMENT FOREIGN-TRADE OFFICE

The fourth branch office of the United States Bureau of Foreign and Domestic Commerce is shortly to be established in Detroit, through the efforts of that city's board of commerce. The three other cities having a similar foreign-trade bureau are Cleveland, Cincinnati, and Los Angeles. The Great Lakes states will therefore have three out of the four existing bureaus.

Emily Comstock
9-29-15

558H LIFE-SAVING APPARATUS FOR LOCOMOTIVE CREW

In an attempt to provide a means of safeguarding locomotive engineers and firemen against serious injury and death in railway accidents, a southern inventor has developed a mechanical apparatus which has elements of novelty and interest, even though the practicability of all its features may be contested in some degree.

Under the usual conditions the members of an engine's crew are afforded two alternatives when a collision is seen to be inevitable. They may jump, and probably be killed in so doing, or they may stick with the locomotive and take their chances. Providing the new appliance works as it is intended to do, the life of an engineman, in such an instance, depends upon a brief warning of impending danger. Not infrequently a wreck occurs entirely without warning, and in such a case the present invention is worthless. Given ten seconds, or possibly even less, in which to act, however, and the safety apparatus seemingly affords a good opportunity for an engineer and fireman to save themselves.

Primarily the contrivance consists of two large steel cylinders mounted in a frame attached beneath and at the sides of an engine cab, immediately under the seats. The cylinders are made of boiler plate reinforced on the inside with a series of channel irons that enable it to withstand a crushing force of as much as 500 tons. By pulling a lever, the seat upon which an operator is sitting is released. This drops him, seat and all, into the cylinder, which is then closed mechanically and thrown free from the train.

The interior of the tank is lined with coil springs heavily upholstered with pneumatic cushions. This prevents the injury of the occupant, so far as shocks, bruises, and the possibility of laceration are concerned. In addition there is a thick lining of asbestos insulating the compartment against fire and heat.

If a heavy locomotive should fall on one of the cylinders, the impact would

Inventor: W. A. Utz 2109 Jennings Ave. Ft. Worth, Texas
58

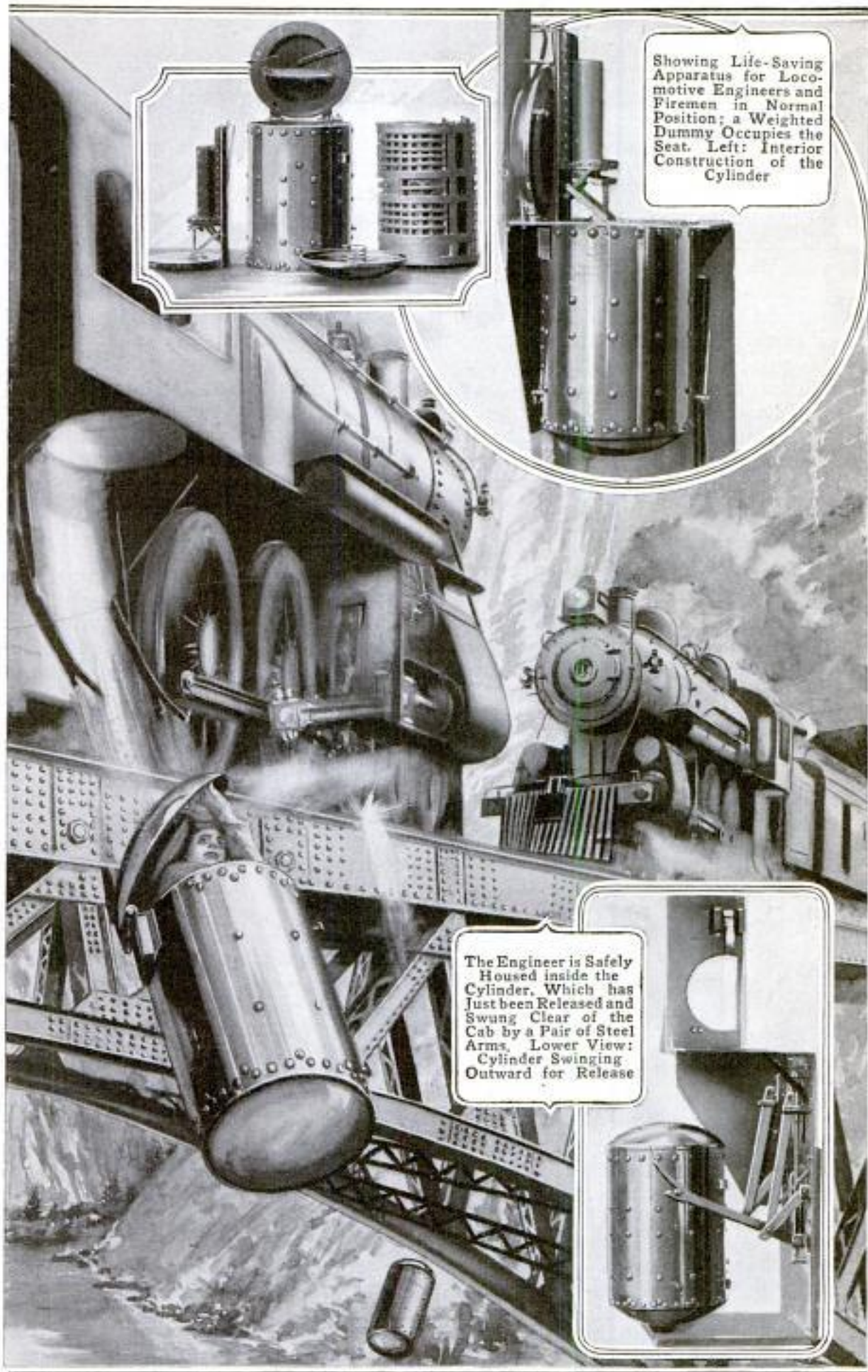

not be sufficient to crush it. Neither could escaping steam, boiling water, nor hot coals from the fire box penetrate it. Should a wreck occur on a trestle over water, or a train go through an open bridge, the occupant would not be drowned, for the cylinder will float and sustain a burden of 600 lb., according to the inventor's claims. Asphyxiation is guarded against by air valves which may be operated from the inside. There is also an oxygen tank for use in the event that submersion makes the valves incapable of action. Space is provided for carrying an electric flash light, a life belt, and an emergency medicine chest. The device may be opened from either the inside or exterior.

649

SHROUD EVERGREEN TREES TO PROTECT FROM SUN

The park superintendent of a southwestern city undertook a short time

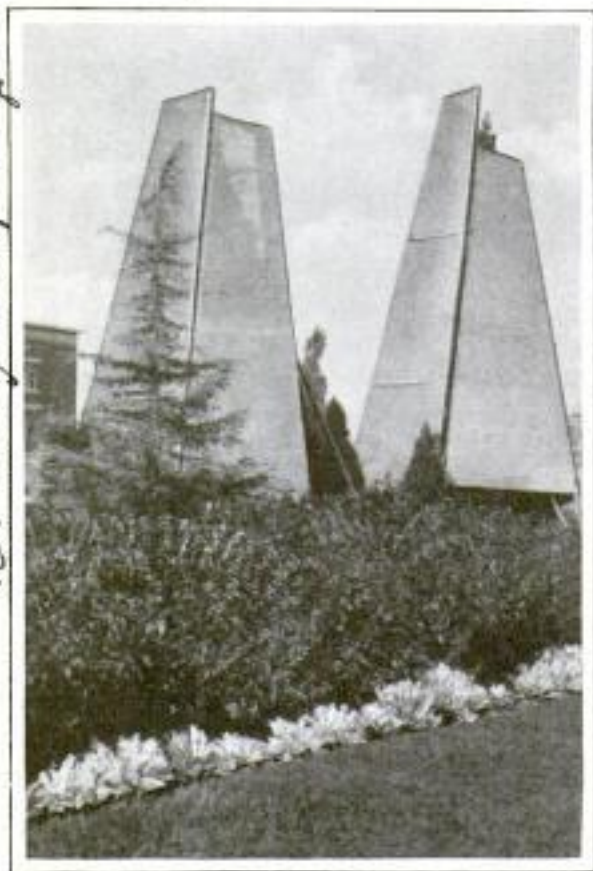

Recently Transplanted Evergreen Trees were Covered with Hoods as a Protection against the Hot Southwestern Sun

Besides offering an engine crew an avenue of escape, the apparatus performs the duties of both the engineer and fireman after they have abandoned a locomotive. In this way the welfare of passengers aboard a train is looked after. When, in order to save his life, an engineer draws back the lever that drops him into the cylinder, the action simultaneously throttles the engine, applies sand to the rails, sets the air brakes, dumps the fire, and pours extinguishing agents upon it.

The cylinders vary in size. One type is 5 ft. in height, has a diameter of 36 in., and weighs approximately 2,000 lb. The equipment, which includes two of these devices for each engine, costs between \$500 and \$600.

ago to transplant several large evergreen trees. The trees did very well for a while, but the hot September sun seemed to be too much for their impaired vitality, and a general wilting resulted. In an effort to tide the trees over to the cooler weather later on, the superintendent had large portable hoods, or shields, made, which he placed bodily over the trees. These have proven a success, and the trees will be able to hold out until the winter rains come and give them a firm hold on life.

653

CORD LAYERS AID TIRE TO WITHSTAND HARD USAGE

A single-tube bicycle tire has lately appeared on the market which the manufacturer claims to be of especially durable nature, due to its being built up of corded layers. The inner tube of black rubber is surrounded with a spiral winding of cotton cord, over which a second layer of rubber is placed, covered with another spiral winding. Over the outside a thick layer of white rubber is molded, forming the tread. Such construction is claimed to possess greater resiliency and strength than tires built up of cloth layers.

Koscoma Rubber Co.
10th St. Koscoma, Ind.



Left: The Slender Mast as It Appeared on the Day Previous to Its Collapse. Right: Ironworkers Racing down the Great Framework after Unfurling Flags at the Top

Lower View: A Section of the Twisted Steelwork after Toppling Over in the Wind; It Fell Directly in the Path of an Approaching Express Train, as Shown Above

WIRELESS MAST IS WRECKED BY HEAVY WIND

On the day following its formal dedication, a 300-ft. wireless tower under construction at Tufts College, Mass., was completely wrecked during a severe windstorm. The upper section of the steel mast was inadequately steadied by temporary guy wires which snapped on the windward side during a 38-mile gale that blew the structure across an adjacent railway track in front of a speeding express train. The locomotive was derailed, but without serious results.

The tower was $3\frac{1}{2}$ ft. square and was built of 3 by 3 by $\frac{1}{4}$ -in. angle-iron uprights having horizontal and diagonal bracing members, the former spaced 4 ft. apart in the vertical. There were to be three sets of permanent guys, each consisting of three cables held by concrete anchors set 120° apart and about 150 ft. from the base. These wires were to be secured to the mast at intervals of 100 ft. The lower sets, which were already in place, had a diameter of $\frac{5}{8}$ in., while the top

ones were to have been $\frac{3}{4}$ in. in cross section.

Although it was torn from the ground, a reinforced-concrete base on which the mast was anchored was not injured. This block is $5\frac{1}{2}$ ft. square and 1 ft. thick and remained firmly fastened to the steelwork. In falling, the tower twisted somewhat, but did not buckle.

An interesting feature in connection with the dedication of the mast was a scaling race indulged in by three structural ironworkers. Each competed in climbing the framework and fastening a flag at the top. The first to reach the ground after accomplishing this feat was declared the winner.

The reconstruction of the mast will be commenced immediately. It is believed that about a third of the steel in the wrecked structure can be used in this work. When completed, the plant will have a sufficient radius to permit an interchange of messages with European stations. The mast will hold an antenna of the umbrella type and it is planned ultimately to carry it to a height of about 500 feet.

*Geo. H. Davis Jr. 15 Putnam Ave., Braintree, Mass.
Inter. News Service, 238 William St. N. Y. C.*

Engineering Record 7-19-15
Engineering News 8-12-15
Chicago Record Herald 9-21-15

POPULAR MECHANICS



PHOTO BY CHICAGO HERALD

708 CHICAGO'S MUNICIPAL PIER NEARING COMPLETION

BY the time that navigation is opened on the Great Lakes next spring, Chicago's new municipal pier, designed for steamship and recreation purposes, will be ready for use. The completion of this work will mark an important step in carrying out the city's plan for a comprehensive outer harbor. The pier, also, will be the longest municipally owned one in this country and will represent an expenditure of approximately \$4,000,000.

It is situated a short distance north of the mouth of the Chicago River and extends 3,000 ft. into Lake Michigan. The approach on the shore side includes 21 acres of filled land, which will eventually be used for commercial purposes.

The pier has a width of 292 ft., and carries, at the rear of a large head house, which serves both as an entrance and administration building, two parallel, double-decked sheds, each 2,335 ft. in length. These long structures are separated by a central driveway that is flanked on either side by railway tracks. At the extreme end of the pier a space, 665 ft. long, is reserved for recreation purposes. All freight will be handled on the lower level, while the second deck of each shed will be used for the accommodation of pas-

senger traffic. By this arrangement freight may be unloaded onto the docks and taken through the sheds to cars on the same level in the areaway. Likewise passengers will be discharged from the main decks of steamers onto the upper level and into street cars on the court side.

Steel and concrete have been used throughout in the construction work. The head house is faced with brick, the sheds are inclosed in glass set in steel sashes, and roofed with reinforced-concrete slabs covered with a composition surfacing material; the freight houses paved with wood blocks, and the passenger sheds finished with cement floors. Broad, winding concrete ramps replace stairways in the head house. At either side of this three-story building is a massive, octagonal tower, housing a steel tank of 60,000 gal. capacity, which is connected with the freight-house sprinkling system. Extending along the water side on the top the entire length of each shed, is an 8-ft. board walk, terminating on the roof of the recreation pavilion. This provides a delightful promenade more than a mile in length.

The recreation building at the far end of the pier will be used purely for



General View of Chicago's Municipal Pier: A Part of the City's Scheme for a Comprehensive Outer Harbor. Below is shown the Switching and Warehouse District on the Lake Front, the Arrow Indicating the Relative Location of the Pier

pleasure purposes. One of its principal features is a hall, 140 by 140 ft., which will be open to the public for dancing and other entertainments. There is also a large concert stand, and the design of this gives the end of the building a semicircular form. A generous open space surrounds the structure and is concreted and terraced. This will give access to the extreme end of the pier, where small pleasure boats will dock, and will be provided with comfortable seats and benches. In the terminal building, joining the two sheds immediately back of the recreation building, will be a restaurant with accommodations for several hundred persons. An emergency hospital and large concourse are also provided in this structure. Two ornamental towers, each 100 ft. in height, will grace the end of the pier.

The massive structure is carried on a pile foundation independent of the fill. In a period of nine months, approximately 17,000 piles were driven,

1,000,000 cu. yd. of earth filled, and $1\frac{1}{4}$ miles of concrete dock constructed. The greater part of the work has been completed.

LARGE COASTWISE STEAMERS 712 ARE TO BURN OIL

Announcement has been made that the steamships "Kroonland" and "Finland," engaged in passenger and freight service between New York and San Francisco, via the Canal, are to be equipped with low-pressure, fuel-oil burning systems. This is to be done in order to increase the speed and efficiency of the vessels as well as to reduce the cost of their operation. Each is 580 ft. in length and has a 22,000-ton displacement. When the installations have been made, these vessels, it is claimed, will be the largest merchant ships thus equipped. It is estimated that by burning oil, the fuel cost will be cut 40 per cent, and the fire-room staffs perhaps 80 per cent.

*"White" Mechanical Fuel Oil Burning System
Mfd. by: Washington Engine Works, Washington & Leroy Sts.
New York.*

566 BUILDING QUEBEC BRIDGE A COLOSSAL TASK

IN its general dimensions as well as in the enormous size and weight of the structural members composing it, the Quebec bridge, now in an advanced stage of construction, surpasses any other structure of the kind ever erected. The one bridge structure in the world that approaches it in magnitude is the famous Firth of Forth bridge in Scotland, the main-channel span of which is nearly 100 feet shorter than that of the Quebec bridge. Both structures are of the cantilever type. The channel span of the Quebec bridge, measured between centers of towers, is 1,800 ft. The design and fabrication of the steel for the structure therefore presented engineering problems for which no precedents existed, and the first attempt to build the bridge, made by a private company, resulted in 1907 in a collapse of the structure in which many lives were lost. Following that catastrophe, the Dominion government

took over the work, and a year later undertook the construction of the bridge. The present bridge is on the same site as the original structure, but owing to an increase of 21 ft. in the width between trusses and to a considerable increase in the weight of the superstructure, new piers were necessary and these were built immediately south of, and adjacent to, the original piers. The two main piers alone contain approximately 60,000 cubic yards of masonry, and cost in the neighborhood of \$1,500,000. One of these piers goes to a depth of 60 ft. below the bed of the river, and the other to a depth of 80 feet.

Owing to the fact that the principal members of the bridge were larger than any ever before made, it was necessary to erect a special plant for the fabrication of the steelwork. This plant was installed at a cost of about \$1,000,000 and is equipped with the

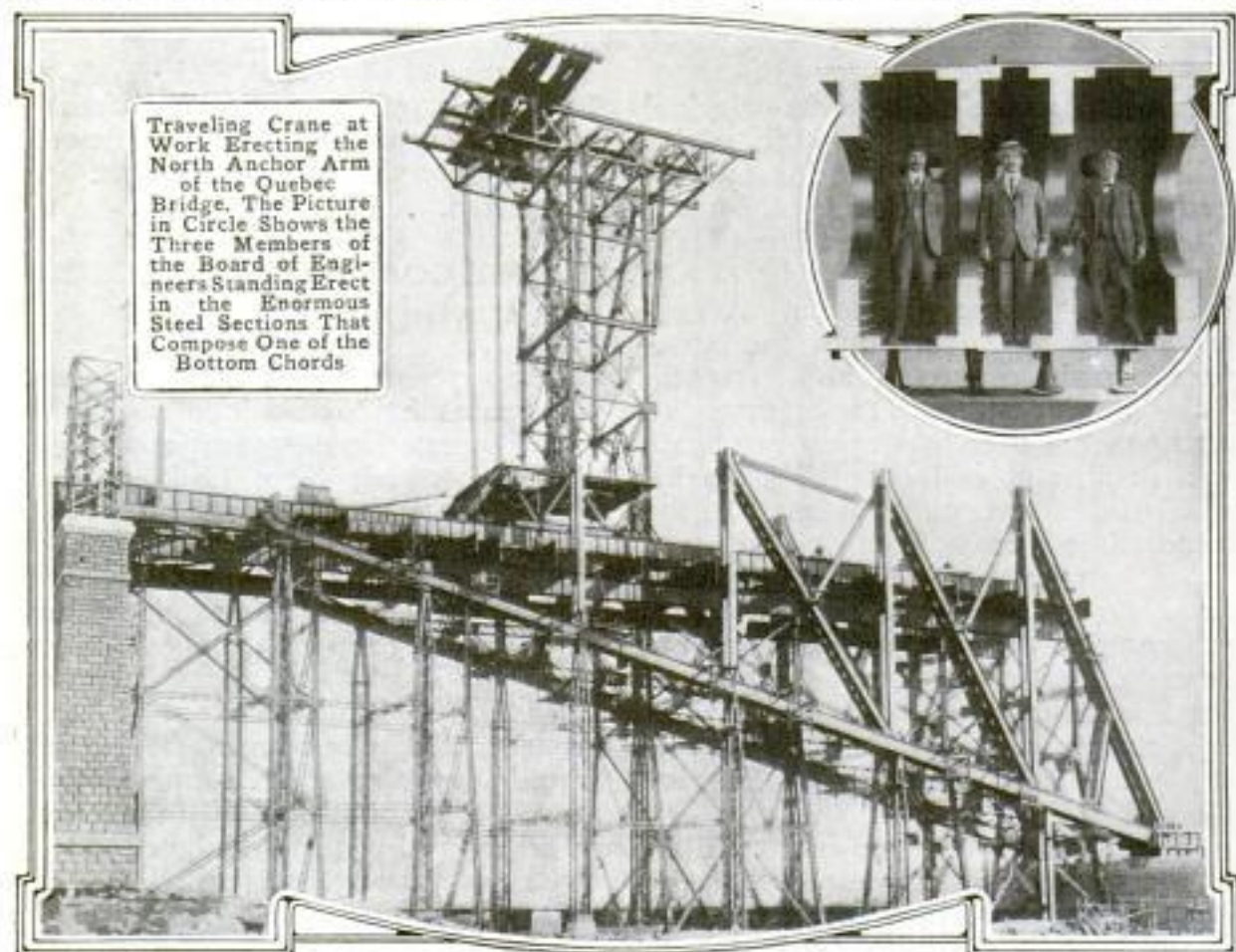

H. P. Borden, 709 new Birke Bldg.
Montreal, Canada

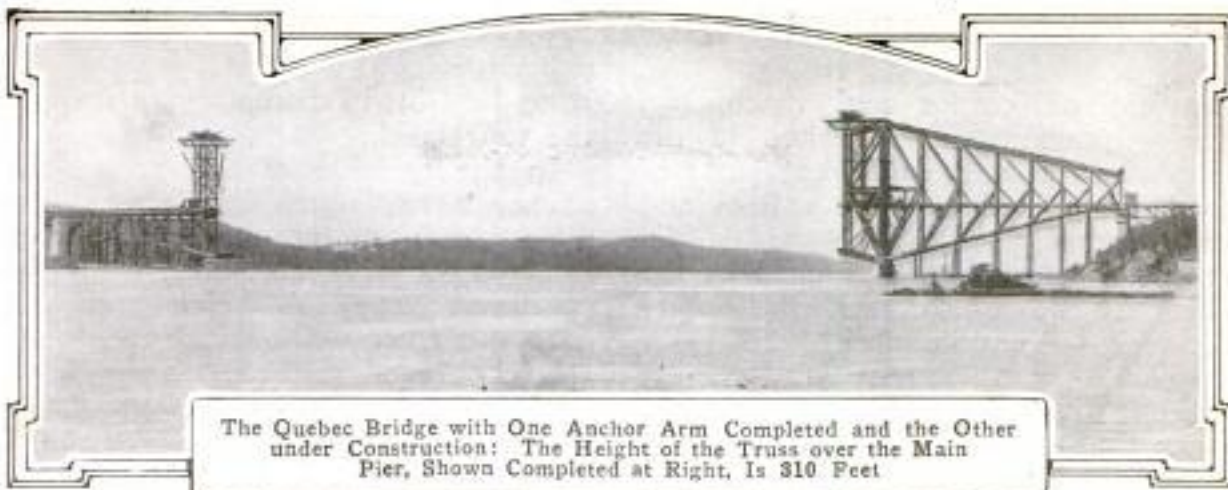

The Quebec Bridge with One Anchor Arm Completed and the Other under Construction: The Height of the Truss over the Main Pier, Shown Completed at Right, Is 310 Feet

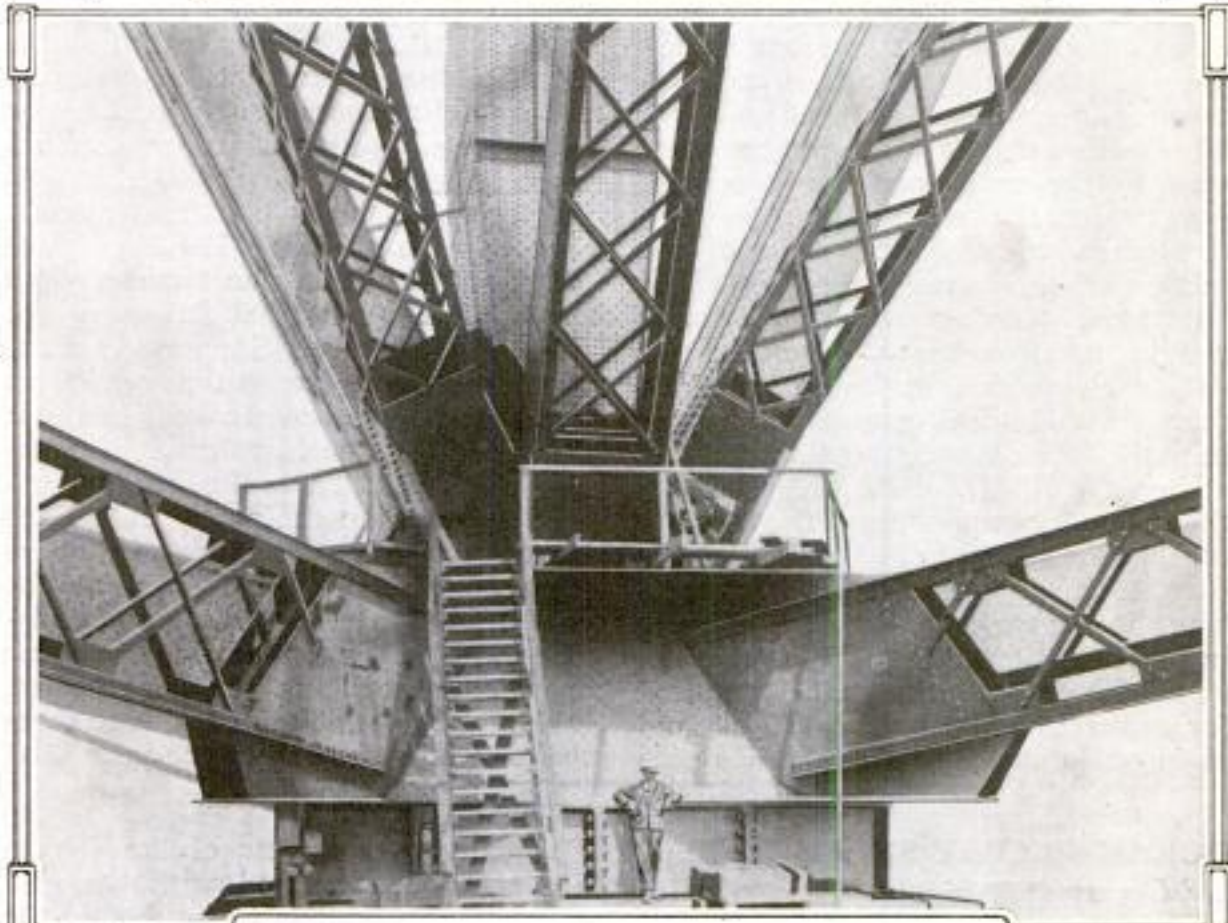

In This Photograph are Shown Ten Truss Members Where They Come Together over One of the Main Piers. Their Enormous Size can be Appreciated by Comparison with the Man Shown in the Picture; the Steel Shoe on Which These Members Rest Weighs 400 Tons and was Made and Shipped in Seven Sections. The Bridge as It will Look When Completed is Shown in the Picture Below

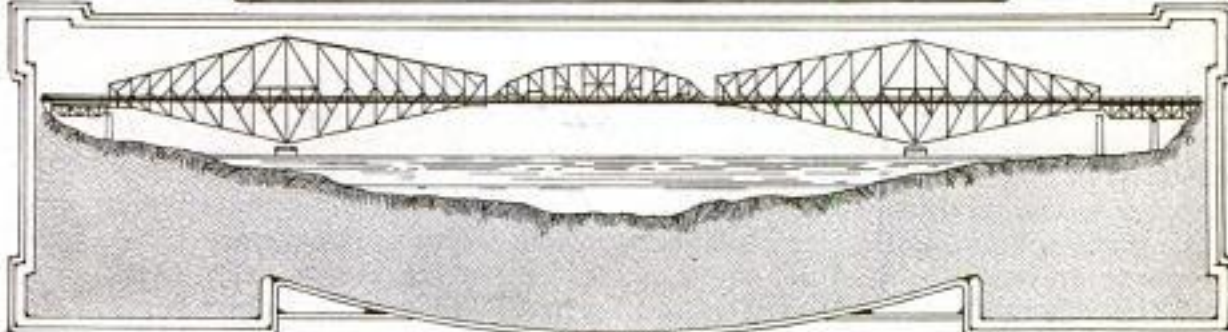

heaviest of cranes and machinery. Every precaution was taken in the manufacture of the different parts of the bridge, and all field splices and connections were drilled to fit accurately before being shipped to the site. An idea of the task confronting the designers and builders of the bridge is given by the dimensions and weights of some of the principal members. The posts that spring from the main piers and form the central feature of the gigantic cantilever structures are each 310 ft. high and 10 ft. square at the base. The making and erecting of these four posts cost nearly \$1,000,000. The bottom chords of the bridge adjacent to the main piers are approximately 86 feet apart, and are 7 ft. high and 10 ft. wide. The weight of one section of the bottom chord is about 400 tons. Owing to its size and weight, it was necessary to make and ship each section in four pieces and then assemble and connect the pieces in place. The longest tension member shipped is 137 ft. in length. Each of the shoes for supporting the structure on the main piers is 21 by 26 ft. at the base, 19 ft. high, and weighs 400 tons. The shoes were each made and shipped in seven sections. Pins 30 in. in diameter, with 45-in. bushings, are required for connecting the bottom chords and main posts with the shoes, while pins

15 and 16 in. in diameter are used in the top chord.

In the erection of the bridge the anchor arms, which lie between the main piers and the shore, were constructed on steel falsework, while the cantilever arms are being built out over the river without falsework, by the cantilever method. The 640-ft. suspended truss to connect the cantilever arms will be built on shore, floated into position on pontoons, and then raised by powerful jacks and connected with the cantilevers. For the erection of the heavy bridge members two traveling cranes, one working on each side of the river, are used. Each traveler weighs about 1,000 tons and is equipped with two hoisting machines each capable of lifting 100 tons. The principal feature of the travelers is a tower that stands 200 ft. above the floor of the bridge. Supported on top of the tower are cranes through which the lifting lines are worked. All the machinery on the travelers is electrically operated. To avoid bringing uneven stresses on the partly completed structure, similar members on the two sides of the bridge are lifted by the cranes and erected simultaneously. The total length of the bridge between abutments is 3,239 ft. As now planned, it should be possible for trains to cross the bridge by the end of the year 1916.

OCEAN-SURVEY SHIP BUILT AT 680 INLAND LAKE PORT

It is unusual, perhaps, for a boat-building firm on inland waters to figure much in construction of ships for deep-sea use. Yet a concern at a Lake Michigan port recently secured a contract to build an ocean-going vessel, which, curiously enough, is not to operate on the Atlantic, the nearest ocean, but far over on the Pacific coast in Alaskan waters. The government desires the boat for coast and geodetic-survey work, and it is to be built strong enough and will carry sufficient stores to cruise three months, or more, at a time through all kinds of weather.

The dangerous waters of the Bering Sea are to be charted with the new craft. The vessel is to be named the "Surveyor," and will be made of steel with 1,000 tons displacement. Crude oil is to be used as fuel, and the engines will be of the triple-expansion type. A crew of 66 officers and men are required to operate the boat.

CITY STREETS ARE CLOSED SO 647 CHILDREN MAY PLAY

In the congested tenement and foreign districts of some of our large cities, certain streets are being roped off for a few hours each afternoon to provide safe playgrounds for the chil-

H. E. Delaney, 35 Garner Ave.
Buffalo, N. Y.

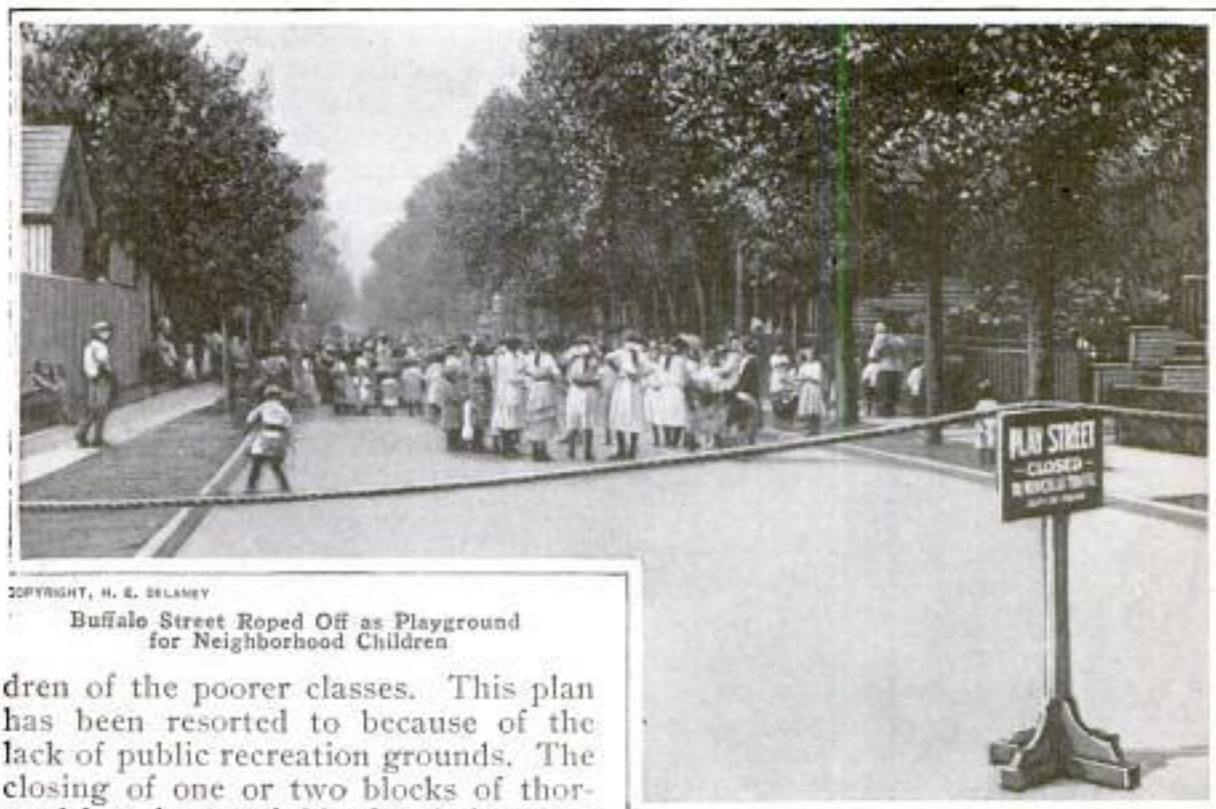

COPYRIGHT, H. E. DELANEY

Buffalo Street Roped Off as Playground for Neighborhood Children

dren of the poorer classes. This plan has been resorted to because of the lack of public recreation grounds. The closing of one or two blocks of thoroughfare in a neighborhood does not materially interfere with vehicular traffic, while it does give hundreds of youngsters an opportunity to exercise themselves without danger of being struck by motor cars and trucks. At Buffalo sections of some of the streets are closed from three to six o'clock each afternoon, during which time children from the surrounding neighborhood are allowed to play under the care of a director.

SMALL ELECTRIC PROJECTOR 559 FOR THE MOTORIST

As an accessory for motor cars, a small electric searchlight has been introduced which may be attached to a windshield and used for illuminating turns in a road, or house numbers from a distance. It is tubular in shape, 6 in. in length, and has a diameter of $2\frac{1}{2}$ in. By employing a projecting lens in conjunction with a focusing lens, the necessity of a reflector has been eliminated. Current is supplied either by the regular lighting circuit or a 6 or 7-volt storage battery. The compact housing, and the fact that the lamp may be removed readily from its sup-

porting bracket, makes it convenient when engine or tire trouble develops on the road at night. The lamp is so mounted that it may be turned in any

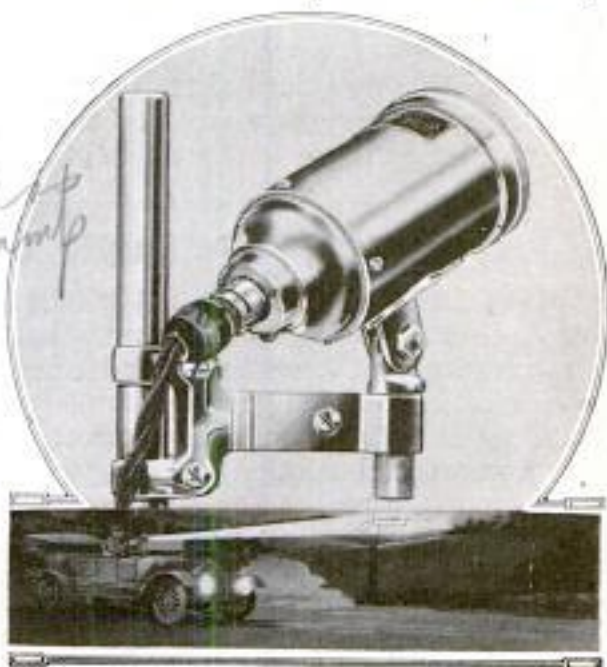

A Compact Auxiliary Searchlight of Very Small Diameter Designed as Aid to Motorist

direction by a driver when he requires an auxiliary light. Since it is detachable, it may be carried in a tool box during the daytime.

*Pittsburgh Electric Specialties Co.
Pittsburgh, Pa.*

Raymond D. Weakley (Architect)
Central National Bank Bldg.
St. Louis, Mo.

812

POPULAR MECHANICS

THEATER CHAIR DESIGNED

571 TO FIT NEEDS OF CHILD

For the benefit of the children patrons of motion-picture houses, an ad-

This Shows How
Readily the Seat
may be Converted
to Accommodate
a Child



justable theater chair has been invented which may be converted to suit the requirements of either an adult or

a child. The front two-thirds of the seat is attached to a pair of arms which are hinged to the forward ends of the regular supporting members. This permits the fore part of the seat to be raised to the proper position for a child, where it automatically locks. In its normal position the seat is 17 in. from the floor, but when adjusted for a small child it is 24 in. high. As the seat is raised a wooden bar, intended as a foot rest, moves into position simultaneously. By the installation of a chair of this type, a child does not need to sit on the arm in order to get an unobstructed view of the screen.

634

POWER FROM GAS ENGINE IS

LESSENER BY ALTITUDE *out's*

Gas Power
The curious fact has been demonstrated that high altitudes apparently have a marked effect on the power obtainable from a gas engine. Recently one was erected several thousand feet above the sea level, but upon testing, failed to give the desired power. An investigation followed, and the loss in power was attributed to the height at which the engine was operating. The general conclusion was reached that a gas engine loses about one per cent of its indicated horsepower per 1,000 feet of elevation.

745 EXPLOSION OF TANK CAR TEARS HOLE IN CITY

Many business buildings in the heart of Ardmore, Okla., were demolished and more than 50 persons killed when a tank car filled with gasoline exploded recently in a railway yard adjacent to the commercial section of the town. The terrific force of the blast caused the discharge of 400 lb. of dynamite which was stored in a freight station near by. The double detonation damaged structures over a large area, crumbling brick walls, shattering the windows of practically every store in the community and razing an entire block of buildings. Without warning, the roofs of business houses caved in upon their occupants, burying many beneath the debris and injuring more

than 200 persons. The tank car was blown far into the air and flaming gasoline belched out in every direction, setting many of the partly demolished buildings afire and adding to the terror of the city. All business was stopped, and the town virtually placed under martial law. The property damage has been estimated at between \$500,000 and \$1,000,000. The explosion is thought to have been caused by a workman who was endeavoring to repair the tank car, which, it is reported, had sprung a leak. It is supposed that in pounding against the container, a spark flew from his hammer and ignited the gas rising from the volatile liquid that had escaped.

Inter. News Service

Joe Warren, Star-Telegram, Fort Worth, Texas

J. E. King, 202 S. Winnetka, Dallas, Texas

Copyrighted material



Section of the Railway Yards at Ardmore, Oklahoma, Where the Explosion of a Tank Car Recently Occurred, Wrecking a Large Part of the Town's Business District and Killing Many Citizens. Immediately Below is Shown the Railroad Station, Which was Practically Demolished. Blazing Gasoline was Spouted in Every Direction, Kindling Several Fires and Adding to the Horror



Great Hole Torn in East Wall of One of the Hotels



Although a Large Part of the Stock in This Dry-Goods Store was Completely Ruined When the Roof Caved In, No One was Injured. Elsewhere, However, Persons were Caught by Falling Debris

Arthur Chapman
2612 Cleymont St.,
Denver, Colo.

MINERS DRILL HOLES IN ROCK
FOR PASTIME

Pounding holes in granite would perhaps not appeal to the average man as an enjoyable recreation, but the miners of Cripple Creek, Leadville, and other Colorado towns, seem to



Contesting for Prizes as Champion Sledge Artists in Colorado Mining Towns

enjoy it as a sport, and at Fourth-of-July and other celebrations are in the habit of getting up contests to see who is the fastest in the driller's art. One man will hold a chisel-shaped drill, and his partner will hit it with a sledge, several such pairs undertaking to pound their way through the same-sized piece of granite at one time. Some wonderful records are made at these contests.

☞ The teaching of chorus music is a new feature in the university extension work of the University of Kansas.

ENGINE DISCARDED AFTER
CENTURY OF SERVICE

An "atmospheric" engine that has been in service hoisting coal at a colliery near Rutherglen, Scotland, since 1809 has just been discarded to make place for a steam engine of a modern

type. During the 106 years that it was in service this interesting relic of the early days of steam is reported to have given entire satisfaction and to have required no renewals other than that of two spur wheels that were broken by accident. The atmospheric engine represents one of the earliest successful attempts to make practical use of steam power. Steam at a pressure little greater than that of the atmosphere was used, and simply performed the work of pushing the piston to the upper end of the cylinder. In this work it was assisted by a weight hung to the opposite end of the walking beam operated by the piston. As the piston reached the upper end of the cylinder the valve was closed,

and the steam in the cylinder was condensed quickly by a jet of cold water. This operation created a partial vacuum so that the piston was forced back to its original position by the pressure of the air, the water being then forced out of the cylinder by the incoming steam at the beginning of the next upward stroke. The engine just discarded at Rutherglen was the oldest engine in Scotland and the only atmospheric engine in service in Great Britain. It is to be installed as a permanent exhibit in a park in the city of Glasgow.

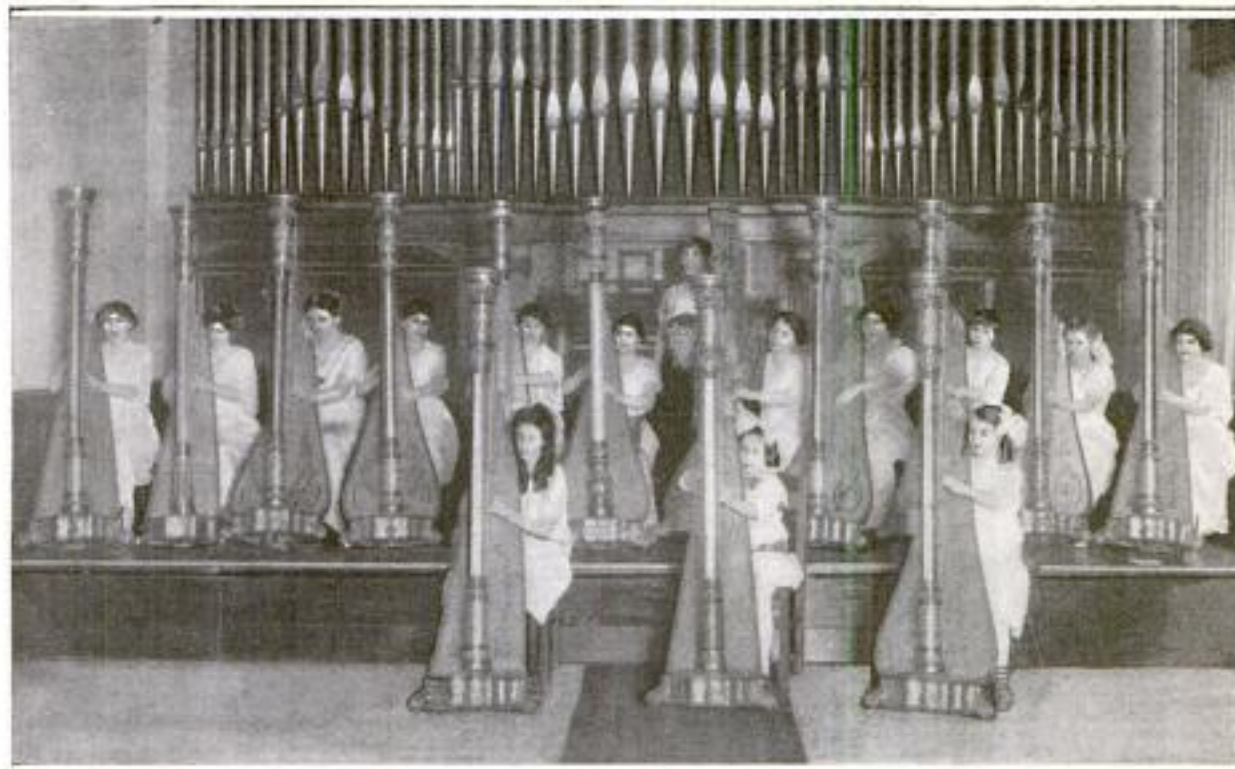

Philadelphia's Harp Orchestra, Possibly the Only Organization of Its Kind in America

643 HARP ORCHESTRA ORGANIZED BY PHILADELPHIANS

Philadelphia has the distinction of supporting a harp orchestra. A musical organization of this character is doubtless very unusual as a permanent institution, although a band of harps only may have been heard occasionally both here and abroad. The orchestra, consisting of 14 harpists, is composed entirely of women and girl players who have been banded together through the endeavors of a local musical club. Its concerts are strikingly new to Philadelphia and have attracted considerable interest.

251 DEVICE FOR CLOSING DOORS OF LIFTS AUTOMATICALLY

To meet the New Jersey state law which requires that the gates at the entrances of elevator shafts shall be semi-automatic or automatic in their action, a very simple device has been invented which may be used with either sliding or swinging doors. It is a locking arm which holds a self-closing door open until an elevator is started, when it is

tripped, allowing the door to close. As a door slides into place across a shaft entrance, the arm drops into a slot provided for it and locks the former on the inside. The disengagement of this

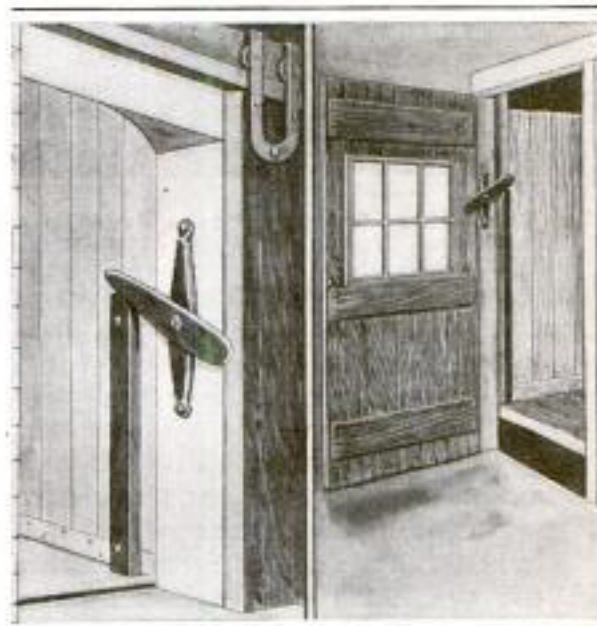

This Shows How the Device may be Applied to Both Sliding and Swinging Doors

pivoted arm is effected by means of a tripping member fixed to one wall of the elevator.

Thomas A. M. Co.
10-18 Cass St.
Newark, N. J.

467
**CONSTANT-SPEED WINDMILL
 RUNS ELECTRIC GENERATOR**

With the idea of extending a windmill's usefulness, a farmer living on the wide plains of North Dakota has

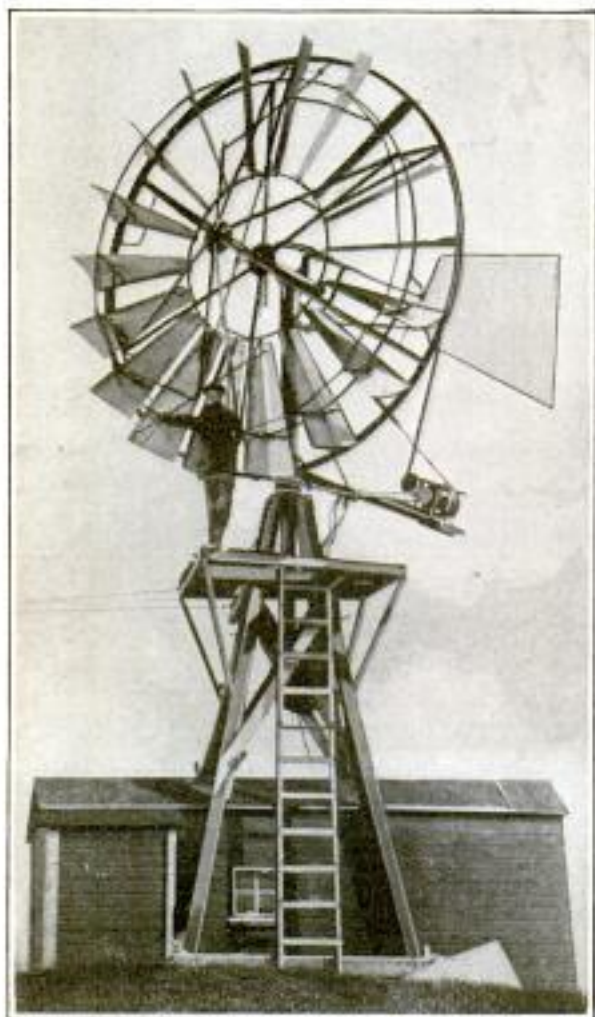

This Windmill and Generator Furnish Power for a Whole Farm. The Wheel Is Self-Governing

harnessed one of the machines to an electric generator. The current from this generator is made to operate a number of machines about the farm, as well as to light the whole place. The generator is mounted on a swinging boom and turns about the central standard along with the wheel and fan when the wind changes direction. In the rear of the wheel is a large pulley over which the belt from the generator runs, thus making a direct connection. The blades are movable about radial axes, and turn more and more edgewise to the wind as it gets stronger, thus keeping the speed prac-

tically constant. A suitable governor controls this function. Storage batteries receive the current when it is not otherwise being used, suitable circuit breakers being cut in on the circuit to keep the batteries from running the generator when the wind dies down below the speed necessary to force current into the batteries against their opposing electromotive force.

689
**DIVIDED BARREL PERMITS
 EASY HANDLING OF FRUIT**

A barrel with two partitions in the middle was recently devised by a Canadian inventor. His object was to provide a safe and convenient container for fruit. The two center partitions of the device were placed close together, enabling a filled barrel to be sawed in two between the partitions if desired, permitting a retail dealer to sell only a half barrel to a customer should that be all the latter cared to purchase. Besides these advantages, the inventor claims that a barrel-shaped container is easier to handle than either baskets or boxes, and that by sawing his type of barrel in two after delivery to a retail store, all the virtues of boxes and baskets are retained. In addition, these barrels may be made of cheap sawed lumber, and shipped in a knocked-down state to the fruit growers' packing plant. *Commerce Reports*

575
**TAKES TWENTY-SIX HORSES
 TO MOVE CASTING**

Twenty-six horses were recently employed in moving a huge mine-hoist casting through the streets of Grass Valley, Cal. Two big logging wagons, coupled together, conveyed the casting, which weighed 23 tons. In making a turn at a street corner on a stiff grade, eight of the horses pulled upon a cable running through a pulley. The greatest difficulty was the tendency of the broad wheels to sink into the asphalt pavement. During a halt at the top of a grade, the wheels sank to such an extent that it was found im-

#Edmund G. Kinyon
 The Morning Union (Union.)
 Grass Valley, Calif.
 Copyrighted material

Invention, Rev. Haristowere Mooreton, N. D.



Huge 23-Ton Mine-Hoist Casting being Pulled through the Streets of a Western Town by 26 Horses

possible to get a new start by horse-power alone. Fortunately the wagons stood close to the track of an electric car line, and it was found practicable to give the needed boost by means of an ordinary street car pushing upon a timber adjusted between its front sill and the rear axle of the rear wagon.

685

GERMANS OFFER MONEY FOR JUNK FROM BATTLE FIELDS

Recent reports indicate that Germany, with characteristic thriftiness, is offering so much per pound for scrap metal gathered up from the battle fields within her territory. Civilians who turn in brass articles, such as used rifle and gun-cartridge cases, and bits of copper, aluminum, and zinc, get about six cents per pound for the collection. For tin cans, and similar articles, about six cents per 10 lb. is paid. Those in the army who do such collecting get only one-fifth the prices paid civilians, thus encouraging the unemployed among the latter to engage in the work.

Engineering
9/17/15

Under an order recently issued, kapok, a vegetable fiber possessing a high degree of buoyancy, will in future be employed as a filling for all mattresses, pillows, and hammock mattresses used in the United States Navy.

COMPACT FIELD-TELEPHONE OUTFIT USED BY FRENCH

Field-telephone equipment for the use of the French signal corps has been reduced to a very compact form and arranged so that all of the necessary apparatus is carried in pockets fixed to a belt worn by the soldier. The paraphernalia is well protected against injury, and fur-



Special Telephone Equipment of French Signal Corps

thermore does not interfere with the freedom of movement of the wearer. At the right side of the belt, as it is worn, is a scabbard in which is carried a long metal spike that is intended to be pressed into the earth when it is desired to establish a ground connection. In a case next to this is fitted a

La Nature 4/17/15

small battery, while in a pocket at the middle is carried an induction coil. The telephone instrument itself is held in a holster worn over the left hip, and when the device is removed from this or returned to it the current is automatically turned on or off. To use the instrument it is only necessary to connect one of its terminals with a wire and the other with the ground.

567
**NEW FORM OF GUTTER KEEPS
 DIRT FROM CISTERN PIPES**

By the simple expedient of using the attraction most liquids have for the surface of the plane upon which they run, an inventor has recently brought forth a device which he claims will keep dirt, leaves, ice, and other undesirable matter, out of eave troughs, and prevent their being carried into cisterns. As can be seen from the cut, he places a metallic cover over the eave trough, the outer edge of the cover being bent inward and down into the trough. Water coming from the roof strikes this cover and follows



Water Sticks to the Cover on This Trough and Runs Inside, while Leaves and Dirt Bound Off

it down into the gutter by a species of capillary attraction. Dirt, leaves, etc., will not follow the surface, but bound off the metal instead of entering the trough.

Record Herald
 British
AMERICAN-BUILT SUBMARINES

690
CROSS THE ATLANTIC

The crossing of the Atlantic by four of the American-built submarines contracted for by the British admiralty is a remarkable feat for vessels of this class. It is also a matter to give a considerable degree of reassurance to Americans, for if we can build submarines like these for other nations we can build them as well, or better, for ourselves. Ten of the submarines were contracted for, and all have been completed. Under a ruling of the State Department the submarines could be designed and the parts made in the United States, but the parts could not be assembled in the form of complete war vessels without violating the neutrality of this country. Accordingly the work of assembling and erecting the submarines was done in Canada. Until all the vessels had been completed, the place where this work was done, now known to be Maisonneuve, near Montreal, was kept secret, and the plant was the most heavily guarded in Canada. Definite details of the voyage of the first four of the submarines from Montreal to Gibraltar, which occurred in the early part of the summer, have been given out, but no information is available as to the present whereabouts of the others. The first four to cross the Atlantic are supposed to be operating in the Dardanelles and are credited with being responsible for the sinking of two Turkish transports in the Sea of Marmora on August 29. Each of the submarines is 160 ft. in length, and is propelled by crude-oil engines when traveling on the surface, and by electric power when submerged. The voyage from Montreal to Gibraltar was made without trouble of any kind and without any great discomfort for the crew. The little flotilla was convoyed by larger warships, and the submarines made the entire trip under their own power, going down the St. Lawrence River to St. John's, Newfoundland, where a stop was made, and then to Gibraltar, where they joined the British naval forces.



Repts. Copyright UNDERWOOD & UNDERWOOD

AMERICAN-BUILT submarines in the river at Maisonneuve, near Montreal, preparing to put to sea: These five vessels are the last of the flotilla of ten submarines contracted for by the British admiralty and made in the United States from American designs, but finally assembled and erected in Canada to avoid a violation of the neutrality of this country. The first four to be completed made the trip, under their own power, across the Atlantic to Gibraltar early in the summer, going finally to the Dardanelles. They are credited with having taken a leading part in the fighting in Turkish waters.

GROUND-LINE DISCONNECTOR SAFEGUARDS LINEMEN

Designed for the protection of linemen, a disconnecting device for ground wires used on electric poles with lightning arresters has been invented. Primarily it consists of a small brass casting which may be screwed to a pole several inches above the customary ground pipe. At the top of it there is a lug into which the wire extending down from a lightning arrester is soldered. A slot is provided in the bottom to receive a split plug connected to a flexible wire which is fastened to a cap in the upper end of the pipe. When it is necessary for a lineman to climb a wet pole, which is thus equipped, he pulls out the plug. This breaks the ground connection and eliminates the danger of his crossing himself with the ground line and a live wire. The latter is a contingency which is always possible during rainy or excessively damp weather.



GARTON-DANIELS

637 PLOWING UP THE SALDURO SALT BEDS

With equipment consisting of a motor truck and a plow the salt beds at Salduro, Utah, which are said to constitute the greatest single deposit of pure salt in the world, are being broken up and utilized as a source of supply for the salt market. The salt in these beds is reported to be 98.21 per cent pure. It is closely packed and is as hard as silica, with a surface as smooth as glass. The beds are about 65 miles long, vary in width from one to 25 miles, and are in places as much as 25 ft. deep. The salt is loosened by an ordinary riding plow attached by a chain to the rear of a motor truck. As fast as the salt is plowed up, workmen with shovels follow and put it into piles. After a sufficient quantity has been made ready in this way, the truck is unhitched from the plow and makes the round of the piles, the salt being loaded into the truck and taken to the refinery. In this way the truck furnishes both the motive power for digging up the salt and the transportation for taking it away. This use of a motor-driven vehicle on the salt beds is in marked contrast with that which made the beds famous in 1914, when an automobile was driven over their smooth and blinding white surface at the record-breaking speed of 143 miles an hour.

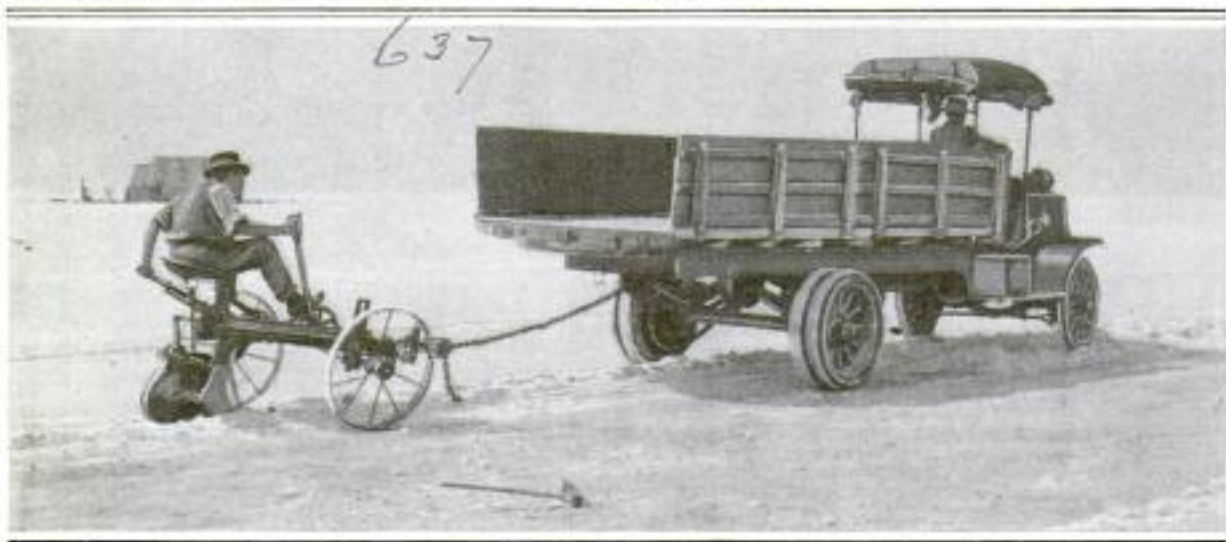

How the Salt is Loosened in the Salduro Salt Beds of Utah: After Furnishing the Motive Power for This Work, the Truck is Used for Transporting the Salt to the Refinery

O. J. Grimes, Snow Apts.
Salt Lake City, Utah.

Chas Alma Byers
**CEMENT TREE STUMPS USED
 607 FOR FENCE POSTS**

The owner of a California estate has hit upon a neat idea for a fence to surround his grounds. A number of heavy cement posts, molded and colored to resemble tree stumps,

standard ohms recently made by the United States Bureau of Standards furnish a good example of the extreme accuracy that can be attained in the making of such units. As defined by the International Congress on Electrical Units and Standards, the ohm is the resistance offered to the

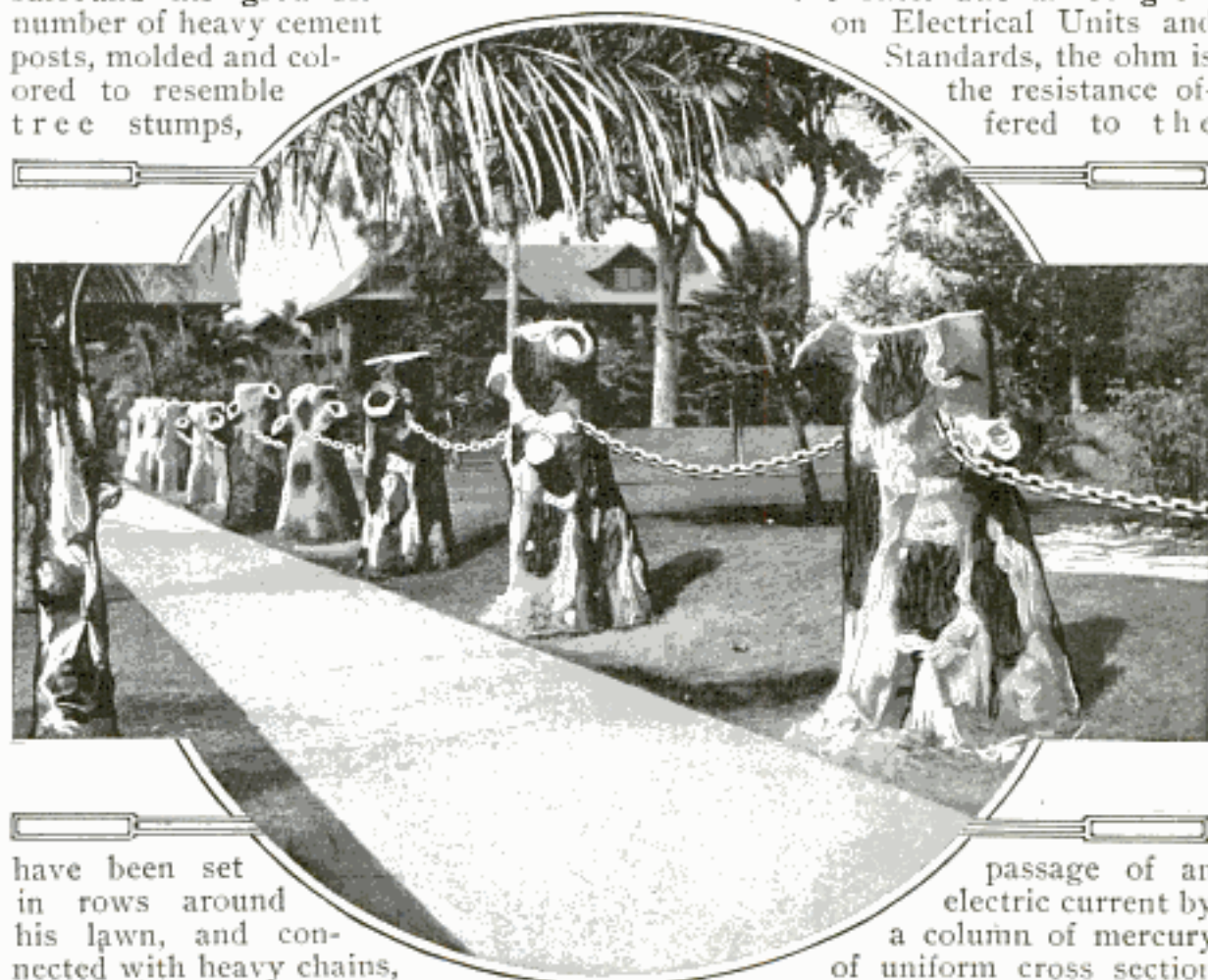

have been set in rows around his lawn, and connected with heavy chains, forming a fence of substantial construction.

Flowers and vines will be permitted to grow in these odd posts, adding a further artistic touch to the fence.

Tree Stumps of Cement Make an Artistic Fence for California Lawn

passage of an electric current by a column of mercury of uniform cross section having a mass of 223.0248 grains and a height of

41.8503 in. For making the measurement, the mercury must be at the temperature of melting ice. In each of the ohms made by the Bureau of Standards the column of mercury is inclosed in a glass tube, and the unit as a whole is made with the highest degree of accuracy possible to modern science. In making measurements at the temperature of melting ice, as required, the ice used is made from specially purified water in order to avoid any temperature uncertainties due to impurities in the ice. When the standards were tested electrically the average deviation of the individual standards from their mean value was found to be less than .00001 ohm.

**672 THE EXTREME ACCURACY OF
 ELECTRICAL STANDARDS**

The fundamental units used in computing the amount of electric current consumed are now established and standardized to a degree of accuracy that goes beyond all possible commercial requirements. Three units are in use. These are the ohm, which measures the resistance, the ampere, which measures the amount of current flowing, and the volt, the unit used in measuring the electric pressure. Four

*Information sheet
 Dept of Commerce*

9433
A CONVENIENT CLAMP FOR CONSTRUCTION WORK

A clamp recently invented embodies convenient features. Its principal function is to clamp boards to rods or

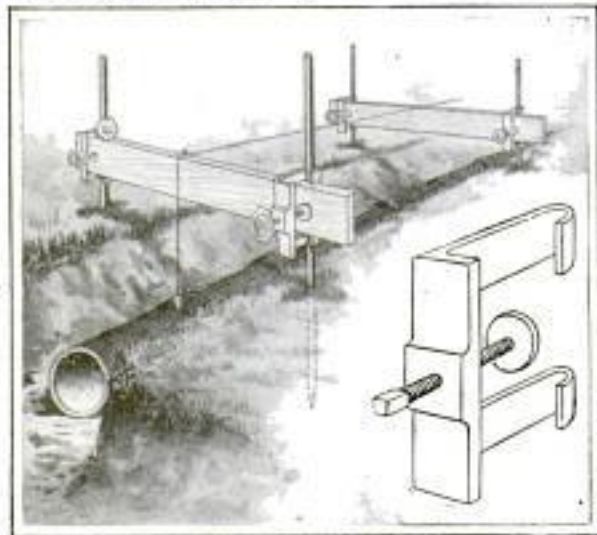

The Clamp Is Convenient for Giving Lines and Grades to Sewers, or the Like, as Well as in Heavier Construction Work

stakes driven in the ground. In temporary construction work this is frequently just what is desired, as bolting or nailing parts together often calls for too great an expenditure of time and labor. The tightening wheel which operates the clamp may be removed to prevent unauthorized parties from tampering with the apparatus while in use.

HAVE CLOCKS TO CONTROL GAS STREET LAMPS

An eastern firm has devised a way to rid gas-lighted cities of a large share of the trouble attendant on lighting and extinguishing individual gas lights each night. A small clock is installed at a convenient point on a lamp-post, and this clock is equipped with a dial and mechanism which works a valve on the gas supply. A pilot light burns when the lamp itself is extinguished, and serves in the usual manner to light the latter when a full supply of gas is turned on. The statement is made that one man can easily look after 250 of these clock-equipped street lights, doing all the inspection, cleaning, winding, replacing of mantles, etc.

Automatic Gas Lighting Equipment Co. Boston, Mass.

It is further maintained that the annual cost per light to a city can be reduced from \$24 to \$30 to between \$15 and \$21 by use of the mechanism.

SCALE FOR COMPUTING CONCRETE MIXTURES

With a new computing scale that has just appeared on the market the amounts of the ingredients required for different quantities and mixtures of concrete are read off directly without the necessity for computation of any kind. The scale is made for three different mixtures of concrete. It consists simply of a square piece of cardboard to the center of which is pivoted a cardboard disk. On the lower cardboard are three sets of figures, each set consisting of three circular rows, while outside the whole is a single row of figures giving the quantities of concrete to be mixed. All the figures except the outside row are covered by the disk. The individual figures of each set fall on radial lines so that they can be read through one of the slots in the disk. In using, the slot corresponding to the mixture required



In Using This Scale for Computing Concrete, the Slot Corresponding to the Required Mixture is Set Opposite the Quantity of Concrete to be Mixed, and the Proportions of the Ingredients are Read through the Slot

is set opposite the quantity of concrete to be mixed, and the proportions of stone, sand, and cement are then read directly through the slot.

Inventor: Russell H. Peck & Co. 555 Riverside Drive New York

Harry E. W. Hooley - 12-14 Spinnaker St. New York

NEW ORLEANS SWEEPED BY TROPICAL STORM

720

U. & U.



Wreckage of Buildings at West End of Lake Pontchartrain, Caused by Gulf Storm of September 30, 1915, in Which the Wind Attained a Velocity of 86 Miles an Hour

U. & U.



This Photograph Shows How the Shipping was Driven into the Wharves and Wrecked by the Fury of the Storm

BAND SAW FOR CUTTING METALS

For sawing metal a band saw having a number of novel features has been invented and placed on the market.

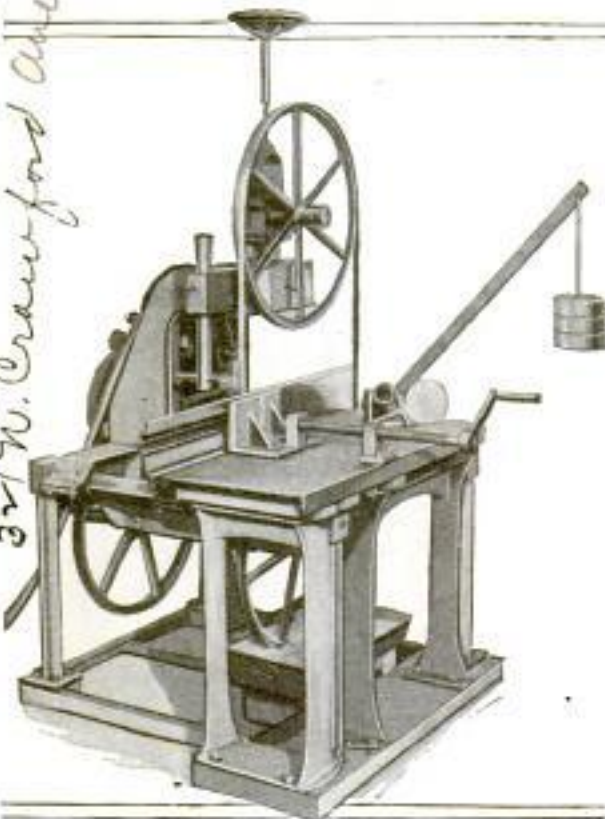

In This Metal Band Saw the Sawing Mechanism Slides on a Track against the Material, Thus Doing Away with the Moving of Heavy Pieces in Feeding

This machine will cut metal from 1/8 in. to 8 in. square, or of an equivalent diameter, and is particularly adapted to cutting disks. The table carrying the work is stationary, the frame carrying the wheels, with saw and driving mechanism, being arranged to slide on a track on the table. With this ar-

*O.S. Hall
Patenter*

angement it is not necessary to move heavy pieces in feeding. The pressure of the saw is obtained by weights hung

on a slanting arm attached to one side of the frame, and this pressure is varied by taking off weights or putting on additional weights. The blade is tightened by means of a handwheel at the top of the machine. The limit of the length of a cut is 20 in. Since the table stands only 26 in. from the floor it is comparatively easy to handle material to and from the machine.

590

CONCRETE CULVERT MADE IN INTERLOCKING SECTIONS

One difficulty in the making of concrete culverts is that the mixers, forms, etc., have heretofore had to be assembled on the site of each job. Since culverts are ordinarily small jobs, such continual moving around of men and machinery is inefficient and wasteful of time. With the idea of keeping culvert manufacture localized at one place, and assembling the culverts as needed, and at the place of erection, a Chicago firm has recently put a culvert on the market which is made up of separate and interlocking sections.

It is claimed that the new culvert has all the features of the older styles, including expansion joints as a protection against temperature changes, flat bases, straight sides, and a smooth in-



The Ends of This Culvert, as Well as the Intermediate Sections, Have Interlocking Joints



terior. It is easy to make, and of course any number of sections may be assembled to suit the requirements of a given job. Thus long or short culverts may be made with equal ease.

*Schulz & Hodgson
29, 8 Association Bldg., Chgo.
(Eastern Distributors)*

*H. C. Williamson
1840 W. Lawrence St., Chicago, Ill.
3rd W. Crawford Ave.*

(Cookeasy)

RANGE MAY BE REMODELED
618 TO FIT ONE'S FLAT

A gas range having interchangeable parts was put on the market a short

from Lincoln Highway
BEST EXPOSITION FEATURES

669 TO BE PERMANENT Bulletin

A movement is under way to preserve the best features of the Panama-



Same Oven Units, Cooking Top, Burners, and Extension Shelves Made into a Double Oven

Gas Range Presenting Usual Features in the Way of Ovens and Cooking Space

Some of the Left-Over Parts Made into a Convenient Stand



By Adding a Few Parts the Stand is Converted into a Kitchen Table

time ago. With the expenditure of only a few moments' time, a plumber or gas fitter can convert this range into any one of a variety of shapes. For instance, if the owner of the range should happen to live in a house whose kitchen is best fitted for a stove with an oven on the right side, the various parts may be assembled with the oven so placed. If, on moving to another apartment, the oven or other part would be better if differently mounted, the parts can be reassembled to suit. If there is a surplus of parts, sometimes enough can be had to make a handy zinc-topped kitchen table.

**LIBRARY HAS TELEPHONE
INFORMATION BUREAU**

The public library at Seattle has installed a special telephone service for the answering of miscellaneous inquiries and requests for information. All over the city neatly printed notices have been posted inviting the public to make use of this service in their daily work. So often an emergency arises in which a citizen finds it important to know a date or the facts regarding some happening. Any such information this library intends to furnish.

Donald Shumway Rockwell
Seattle, Wash.

Pacific Exposition as a permanent addition to the park system of San Francisco. One of the leading reasons being advanced for so doing is that the Lincoln Highway has its western terminus at that city. Local residents believe that the thousands of tourists who come over it each year should be treated with the best in the way of attractions that the city can provide. This is thought equally applicable to those hundreds who every month come up from the newly opened Panama Canal. The plans at present are said to be to preserve at least the Fine Arts Building, the Avenue of Palms, and the Lagoon, and to secure from the Federal government the use of the bay shore of the Presidio as a park and driveway. Support for the project is said to be coming from all over the whole state of California as well as from San Francisco itself. Thus a valued property will be kept for future generations.

Sale & Kilbuck Co. (Minn)
for sale by
United Gas Improvements Co., Phila., Pa.

600 FOREST-FIRE STATION ON SUMMIT OF MOUNT HOOD

DURING the summer of 1915 an innovation in the work of fighting fires in the national forests was brought about by the installation of a fire observatory on the summit of Mt. Hood, one of the five highest mountains of the Pacific Northwest. Mt. Hood stands 11,225 ft. above sea level, and even in midsummer the weather conditions at the summit are at most times severe. The establishment of the station was largely an experiment on the part of the government, there having been a great deal of doubt before the experiment was tried as to whether an observer could stand, for an entire season, the lonely existence, the high altitude, and the storms. This point was conclusively settled by a mountain guide whom the government employed as an observer. This guide, who had already made 350 ascents of the mountain, succeeded in establishing a camp on the summit and spent the entire summer there in comparative comfort. So successful did the experiment prove that toward the end of the season the government built a wooden observatory building on the summit. This building will serve as permanent quarters for the Forest Service, and in addition to this, will be used as an observatory for the United States Weather Bureau. As a result of the satisfactory outcome of the experiment, plans have also been made for the installation during the year 1916 of a number of other snow-peak observatories.

When it came to establishing the fire observatory on the summit of Mt. Hood, the work of getting the necessary equipment and supplies to the top proved to be a big undertaking. Above the 6,000-ft. level the mountain is continually covered with snow, while the slopes are so steep and treacherous as to tax the resources of the most skillful mountain climber. There are two routes to the summit, one up the south side of the mountain and the other up the northeast side. Just below the summit, on each of the routes, where the slopes are particularly steep

and perilous, a steel cable has been anchored to the mountain side, and it is only with this that the climb can be made with any degree of safety. The cable on the south route is 800 ft. long, and that on the northeast route, 1,800 ft. long. The 4,000 lb. of material required for the camp was taken up the south route. Pack mules were used for transporting it up the mountain side and across $2\frac{1}{2}$ miles of the snow zone to the 8,000-ft. level. From this point the climb was too steep and dangerous for this mode of transportation, and the material was carried the remainder of the way to the summit on the backs of the observer and an assistant. Dangerous crevasses in the area crossed by the cable made the work of transport extremely trying, but after five days of strenuous work the material had been carried to the top without accident of any kind. At the summit there is a scant two acres of fairly level snow-covered ground with little in the way of mounds or depressions to furnish shelter. The daily east winds swinging down from the Columbia River, a short distance to the north, often tear at the peak with the fury of a hurricane, while even in midsummer the temperature sometimes drops nearly to zero. To resist the high winds, the tent, 12 ft. square, was not only securely guyed but was heavily weighted around the sides. It was provided with a double floor. A comfortable bed of Hudson Bay blankets and a sleeping bag, a liberal stock of food, instruments for making observations, and a few books, constituted the living and working equipment of the observer. With the pioneer work done, the transporting of material for the permanent wooden building at the summit was carried out with less uncertainty and danger. An adequate and well-organized force of men was employed, but even under these conditions the transportation of 5,000 ft. of lumber to the summit was a big task.

With the camp established, it was next necessary to bring a telephone



One of the Two Observation Stations on the Summit of Mount Hood, from Which the Forests for Hundreds of Miles in Every Direction are Watched Constantly. When a Fire is Discovered a Sight is Taken with the Instrument Mounted on the Top of the Post and the Bearing is Telephoned Immediately to the Supervisor's Office

Party of Mountain Climbers Working Their Way to Summit with Aid of Cable

Cable and Telephone Line Spanning a Large and Dangerous Crevasse



Extending Telephone Line to 9,000-Foot Level



How the Telephone Line was Carried to Summit



This Tent, in Which the Fire Observer Lived during His Long Watch on the Summit, Is the First Habitation Ever Maintained on a Snow Peak in the United States

line up to the summit. For several years a lookout station had been maintained on the south side of the mountain at an elevation of 6,300 ft., the wires leading from the valley below to this station being strung from tree to tree along the trail after the usual manner of forest-telephone construction. This line was first extended to the 9,000-ft. level, the reels of wire being carried on the backs of pack mules. From this point the wire was dragged to the summit by the observer and his assistant, the last 800 ft. being so steep that the wire was pulled to the top with ropes. Five miles of line was required for connecting the lookout station with the summit. The wire used is of copper and is covered with a rubber weather insulation. No attempt was made to use poles, the wire being rested on the rocks and snow and stretched across chasms as they were met. Owing to its weight the wire sank into the snow from 10 to 14 inches, and with the continual melting and freezing soon became imbedded

and anchored in solid ice. Several times during the summer the ice split in crevasses, breaking the wire, and this caused the rangers a great deal of trouble in making repairs. Next year a heavier telephone cable is to be installed, and, if it is found feasible, poles will be set in the solid rock to carry it.

At the summit there are two observation stations, one being located at the eastern and the other at the western edge of the plateau, and with this arrangement the forests for hundreds of miles in every direction are visible. At each station there is an instrument for sighting on a fire and getting its bearing with reference to the points of the compass. This bearing is reported by telephone to the supervisor's office where it is combined with a bearing taken in a similar manner from some other mountain top, and the exact location of the fire is quickly determined. During the summer the observer on Mt. Hood discovered and reported hundreds of fires.

8769
**CRUDE AERIAL CABLEWAY
 FOR CARRYING WATER**

A crude but efficient aerial cableway is used by a mountaineer living near Asheville, N. C., for transporting water from a spring, located in a deep ravine, to his house, 289 ft. distant, the whole apparatus being operated by a single haulage rope that winds around a windlass at the top of the hill. The cable is simply a strong steel wire on

which runs a bracket with the water bucket suspended beneath. When water is needed, the bucket is let down to the end of the line, where it stops under a spout fed by the spring, and as

The Bucket is Filled at the Lower End of the Cableway and is Drawn to the Top of the Hill by Means of a Windlass



soon as it is filled it is drawn back by means of the windlass.

German farmers have been advised to conserve nuts and fruit seeds, from which the government probably will attempt to extract vegetable oils.

#7. Buckner, Asheville, N. C.

COMMENT AND REVIEW

THE big guns and the gas bombs have been in the spotlight at intervals, but submarines and air craft are unmistakably the star actors in the present war. For the first time each has a record of really practical work and valuable results. In the air, the aeroplane is acknowledged to be the real dependence. As predicted in these pages a year before the war, the dirigible as a war weapon can be counted a failure. True, a few trips have been made in good weather, crossing the English Channel, and dropping a few bombs, which have in the whole year's war killed less than 200 people, and these mostly women and children. For a large fleet, each vessel of which cost \$500,000 or over, this cannot be considered much in the way of result. No battle has been won or even affected by use of a dirigible. It has unquestionably been an awful nightmare to the British, but when the worst it has done and all it has accomplished are summed up, the dirigible to date must be declared more a menace than a real danger, and largely a fiasco. In fact, every German dirigible which has crossed into England has easily recruited 10,000 men to the British colors. Therefore, on account of cost, dependence on good weather, its size as a mark, and small results, it is now fairly well established that the dirigible, as a military weapon, has lost out.

*Submarines
and
Aeroplanes
Star Actors*

The aeroplane, on the contrary, that far-reaching eye that sees over mountains and around corners, has more than justified itself. Within the zone of activities an army can no longer begin any important change of base, or advance, or even start a retreat, without its being almost instantly known to the enemy. The perilous work of the spy, so important a few years ago, is now largely taken over by the aviation corps, for a single aeroplane with one pilot and an observer can in fifteen minutes bring in more accurate information than a dozen spies could secure in twenty-four hours, with the additional great advantage of the report being right up to the minute. And as for bomb dropping, if homes and hospitals and churches are still to be destroyed in so dastardly a fashion, the aeroplane is capable of enough mischief to quite compete with the dirigible. The aeroplane is so small a mark, so hard to see, and can change its course so suddenly and often, that the aerial guns have fallen far short of their expected efficiency.

While the submarine has sent a large number of unarmed merchant and passenger boats to the bottom, it has as yet, perhaps for want of opportunity, shown meager results as against men-of-war. All life is alert to protect itself against attack and destruction. As Burbank says, the cactus had no spines until it was threatened with annihilation by antelopes, and the submarine had free hand until recently. Already means have been devised which tend to limit the possibilities of under-sea craft: They are taken like fish in wire nets; they are set upon by a mosquito fleet of small speed boats, armed with one-pounders, when they show themselves. On the other hand, the submarine has demonstrated most satisfactory abilities for long voyages, as, for instance, one of our own submarines recently made the

voyage from San Francisco to Honolulu, a distance of over 2,000 miles, without once stopping its engines. However, for protection of our enormous coast line, a large fleet of submarines seems inevitable.



BY reason of his past achievements and well-earned renown, the words of Thomas Edison, chairman of the General Science Board, printed on another page, are those of one speaking with authority. When he declares for largely increased arsenals, located at places not easily accessible to an enemy; for machinery of vast capacity, and a supply of raw materials on hand with which to work, he unquestionably voices a sentiment approved by the great majority. All these provisions should be made, and promptly, and a great deal more. He says we are a nation of machinists and hopes to find our defense in machines instead of men.

*War
Machines
Need Men*

But can we? The present war has had at its service all the known means of combat of former wars, as well as aeroplanes, wireless, electric lights, motor cars, submarines, telephones, gas bombs, liquid fire, and high-power, long-range guns. Never were so many mechanical devices employed in any war and never were so many men required to work them; never the fatalities so large.

There is a bit of delusion about labor-saving machinery making labor unnecessary. There never were so many labor-saving devices nor so many occupations for the human hand and brain as today. The labor-saving machine transfers labor, but does not permanently displace it. Hence, however ideal Mr. Edison's hope for invention to supply machinery of defense, machines can never, unfortunately, take the place of large bodies of trained men. The nation with both machinery and men will defeat the nation with men only or machines only.

Let us have all the machinery possible, but let us not delude ourselves by placing too much reliance on machines and motors instead of on mind and muscle.



AT last as a nation we are waking from long years of comfortable, indifferent lethargy, and the cold fact is staring us in the face that our boasted strength is a myth. If attacked today we have, as compared to other large countries, very little in the shape of coast defense. We could be whipped a dozen times while we were organizing for protection. The kind Providence which has watched over us thus far should not be overworked; we must now do for ourselves.

*Prepared-
ness*

The plan for increased army and navy which the President will send to Congress will meet with approval by the large majority of Americans. Such substantial increase in equipment calls for a corresponding increase in men. Privates and sailors can be trained to a fair degree of usefulness in a few months; but officers,

such as this country needs, require several years in the making. At present we have one military school, West Point, and one naval academy, Annapolis.

The present capacity of West Point is about 700, with an average annual graduation of only 130.

During the present war the English have frequently lost in a few days more officers than the entire yearly graduation at West Point. In view, therefore, of the fact that the training a young man receives at the military academy specially fits him for life work of a high order as a civilian, it would seem advisable to increase the number of military academies by establishing one in the central West and one on the Pacific coast. The graduations of all three would in time produce 600 or 800 trained officers per year. Even at this rate, deducting deaths and disabilities, it would require at least 10 years to produce a total of 5,000 officers; and this assumes doubling the capacity of West Point and building two more schools equally large.

In these days, mere courage, of however high an order, will not compensate for lack of training in the officer; and now that armies are spelled in millions instead of thousands, the necessity for officers by the thousand becomes evident.

The United States Naval Academy at Annapolis, established in 1854 and enlarged a few years ago, has a capacity of 1,200 and an average annual graduation of 165. Somewhere on the Great Lakes and on the Pacific coast sister naval academies could well be operated to advantage, providing in time reserves of trained men available when needed, but who otherwise would engage in various industrial, professional, or engineering occupations.



PRACTICALLY all the great powder mills in this country are along the Atlantic coast within easy striking distance by an enemy. Mr. Edison's suggestion that new arsenals of ample size, capacity, and numbers should be erected in the central West will find general acceptance. Most people will go a step farther and, also, in addition to vast stores of raw material, will want generous supplies of the manufactured product ready for instant use.

*Arsenals
in the
Central
West*

In a way, the present war has accomplished for us, automatically, the construction of a large number of machines for producing ammunition and the training of men in their use. At the end of the war it might not be desirable or economical for our Government to purchase such machines as are still in excellent condition; but at least we can do what Germany has done. For years every new lathe which has gone into a German machine shop has been so constructed that it could be quickly changed from its normal use to that of making shrapnel. With their usual thoroughness, the war office knew at all times the location, number, size, capacity, and condition of all these machines. Thus it had at instant command, with trained men to operate them, thousands of machines already organized for service. Our own machine shops may well cooperate with our Government in a like manner to the good of each.

IT is getting to be almost a misdemeanor to possess an American flag in Massachusetts; and Boston, with memories of Paul Revere and Bunker Hill and Lexington and Concord, is the chief exponent of a most absurd law. It is ruled that the use of the American flag as any part of the illustrated front cover of a magazine is a debasement of the flag to purposes of advertising. Even a glass paper weight, devoid of a single word, cannot be sold or given away, if it contains the flag.

*An
Absurd
Law*

During the past few months three excellent magazines, of national reputation, were barred from circulation in Boston, under penalty of heavy fines—and what was the “offense”? On one a group of aged women were portrayed in the diabolical act of sewing an American flag; in another a Fourth-of-July girl had two small American flags in her hair, and the third showed the flag with patriotic quotations from the President of the United States printed below.

In each instance the flag was used in a dignified manner. What more impressive than the bent form of white-haired motherhood fashioning with trembling fingers the stars and stripes? What more beautiful than young womanhood, with all the charm of grace and beauty, espousing the flag which has given more to daughters and mothers than any other flag on earth? What more appropriate than that the momentous words of the commander of the Army and Navy should find expression beneath Old Glory, to honor and protect which he has taken his solemn oath?

At heart we are sound, but in our desire to avoid the semblance of devotion to royalty we have gone to the other extreme.

For fear of appearing sentimental, we reluctantly arise when the national anthem is played; we see its folds break from the peak with covered heads and faint applause. Must we have another scourge of shot and shell to teach us the lesson of its worth?

What we need in this great melting pot of nations is not less American flag but more of it. Let it fly from every schoolhouse, in every state; let it unfurl when our courts of law convene; let its folds drape our pulpits; give it a place in every shop, and office, and home. Let our girls wear it in their hair, and our boys wear it on their breast. Let it not be the emblem of a holiday, but let it find its response from the first words of first-born all the way through life, and with his last breath let him praise its grandeur and bequeath its trust to children's children.

H. H. WINDSOR

November 1, 1915





Motor Stage in Service in Colorado: As a Protection against Robbery, the Mail, Express, and Other Valuables are Carried in the Wire-Mesh Cage at the Rear

699
**MAIL AND EXPRESS CARRIED
 IN BANDIT-PROOF CAGE**

In a section of Colorado that is without railroad facilities there is in regular service a motor stage equipped with a bandit-proof cage for carrying the mail and express and other valuables. The cage occupies the rear of the car, leaving space at the front for 16 passengers. It is made of wire mesh and is so strongly built that it would require much time and labor for a bandit to break into it, and it is on the latter feature that dependence is mainly

placed for the safety of the valuables. While it might be an easy matter to overcome the single armed messenger, who rides in the cage, it is not believed that any bandit would risk spending the time required for breaking through the heavy wire mesh. For service in less thickly populated sections where this consideration might not act as a deterrent, the plan has been suggested of substituting for the cage a heavily armored compartment equipped with loop holes. The car as proposed is shown on the front cover of this magazine.

773
TALKING ACROSS THE OCEAN BY WIRELESS

By JOSEPH E. MURPHY

SIX months ago experts were talking of the tremendous obstacles in the way of transmitting the human voice over long distances by means of wireless. This seemingly impossible feat has now been accomplished, and the accomplishment has come with startling suddenness. On September 29, in a test of a new apparatus, the details of which have not yet been made public, a telephone message was transmitted from the wireless station at Arlington, Va., to the navy yard at Mare Island, near San Francisco, a distance of 2,500 miles. Remarkable as

this feat seemed at the moment, the actual accomplishment was found to be tremendously greater than supposed, when, on the following day, a cable message was received from Pearl Harbor, Hawaii, about 4,800 miles from the source of the wireless waves, saying that the conversation had been heard at that point. Subsequently it was found that several other distant wireless stations, among them the one at Darien, Panama, had also picked up the message. Three days later, when communication was established with the Eiffel tower in Paris, the first wire-

Inventor: Dr. Lee De Forest, 159, Sedgwick St.,
 N. Y. City

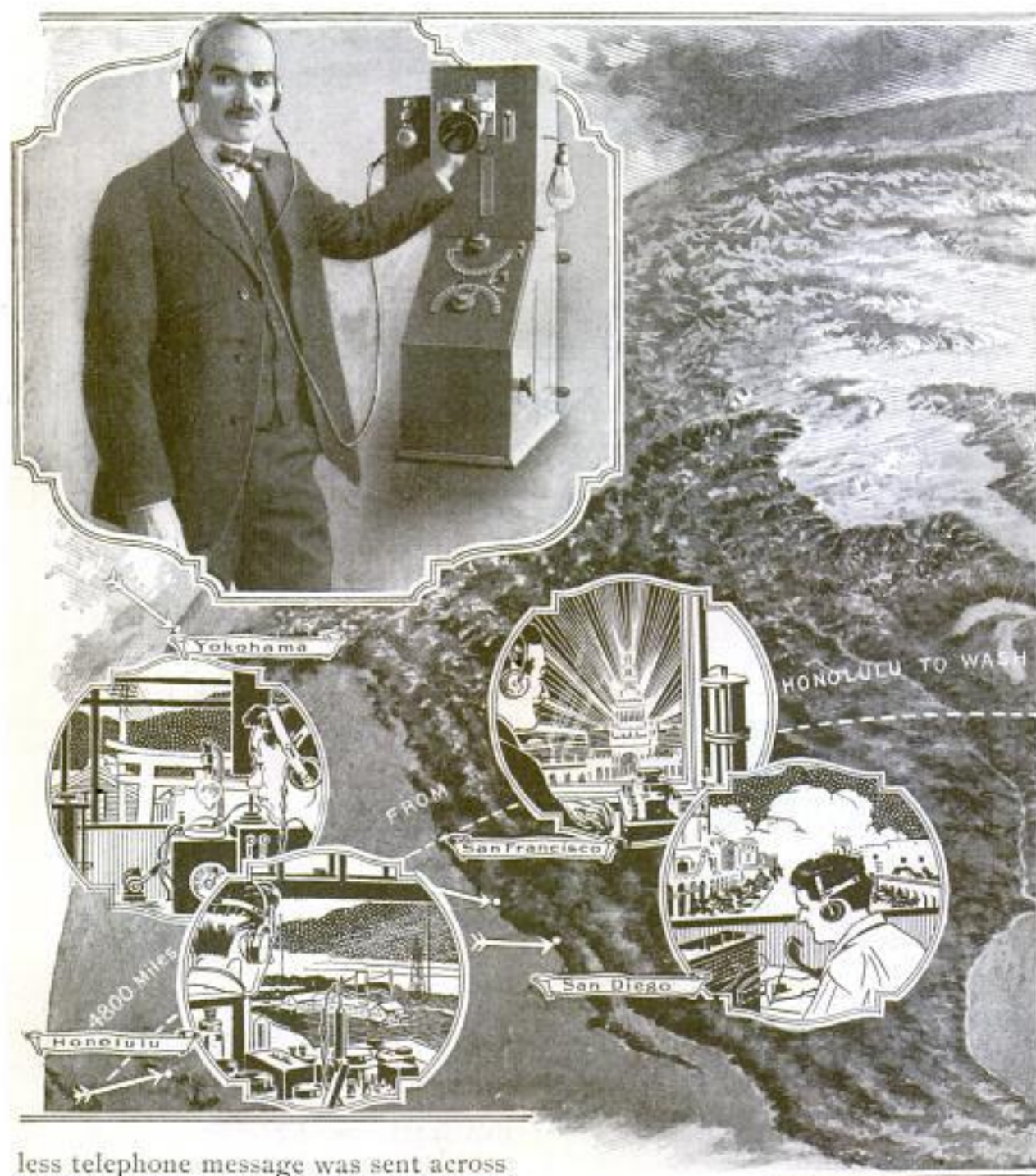

less telephone message was sent across the Atlantic. This message was also picked up at Pearl Harbor, the voice at Arlington being thus heard at two points about 8,000 miles apart. At the present writing, plans are being made to attempt wireless conversation with stations in China and Japan. As a preliminary to this supreme test communication will first be established with Alaska. A hint as to the revolutionary changes likely to be brought about as a result of these accomplishments is given in a statement credited to the

secretary of the navy, in which it is predicted that as soon as the new apparatus is perfected it will be installed on the ships of the American navy, where it is likely in large degree to supplant the wireless telegraph. In this wireless apparatus, as well as in the new transcontinental telephone line, a device known as the incandescent audion amplifier is an essential part of the equipment.

What is perhaps as striking a feature



as the distance over which the voice was transmitted in the first test, is the fact that the message was started from a telephone in an office building in New York City and made the first lap of its long journey over an ordinary telephone line, the electrical impulses carried over the wires being automatically converted into wireless waves by a transformer at the Arlington station. Such a combination of new apparatus opens practically unlimited possibili-

ties. Sitting at a telephone a thousand miles inland and talking with Europe or Asia, or with a ship at sea, by means of a combination of wire and wireless transmission is a possibility of the immediate future, and is apparently only a matter of building apparatus having the required power.

Simultaneously with these developments in wireless telephony, long-distance telephony by wire has been making enormous strides. One of the fea-

tures of the Panama-Pacific Exposition is a theater in which the audience listens to conversation in New York and to the roar of the surf on beaches of the Atlantic, all this being transmitted over the new transcontinental telephone line. Recently a chorus composed of 5,000 voices in Boston sang "America" and "The Star-Spangled Banner" to an audience in this theater, and both the singing and the applause that it elicited were distinctly heard across the continent.

An added touch of interest is given to these various accomplishments through the fact that they occurred at the same time as the first successful use of the long-distance telephone by Thomas A. Edison, an impossible pro-

ceeding for the famous inventor, on account of his deafness, until the sound amplifier had been placed in service. At the instant the first wireless telephone message was being transmitted to Paris, Mr. Edison was talking from San Francisco with his home in Orange, N. J., and a few moments later the line at Arlington was "cut in" with Mr. Edison's line, and he was informed of the feat. In his first talk across the continent the inventor used a line in which were many relics of the early days of electricity, among them being a short stretch of wire over which Samuel Morse sent his first telegraphic message, and another section of wire used by Alexander Graham Bell in sending his first telephone message.

TO MOBILIZE MACHINERY FOR 785 NATIONAL DEFENSE

That machines—not men—are to be the determining factor in any future war that this country may be called upon to fight is the opinion expressed by Thomas A. Edison in a recent interview. On the basis of that opinion he believes that the country should depend for its safety, not on a large standing army, but on facilities constantly maintained and ready for instant use, with which the machinery of war could be quickly produced on an enormous scale in case of a crisis. Equipped in this way, a volunteer army is all that the country needs, provided—and this point is emphasized as one of vital importance—there are enough trained officers, ready for service within 48 hours, to lead and drill the new men. This, in a general way, is the inventor's solution of the problem of national preparedness, a problem that is claiming the attention of the American public as never before in the history of the country. In his opinion "the soldier of the future will not be a saber-bearing, bloodthirsty savage, but a machinist."

"Consider the great amount of powder that is being shot off on the European battle front every day," Mr. Edi-

son said in explaining the details of his plan. "I would have great factories built in which twice as much powder as that could be manufactured, and I would locate and have stored away enough material to make up that powder. As to shells, I think it is a wasteful thing to make them on lathes as they are made now. We should get up special machines for making them rapidly and in enormous quantities. Then I would grease the machines and store them away with a great quantity of steel billets ready to be worked up on short notice. In fact, I would make my preparation potential rather than kinetic, and I would do it right away. The problem should not be a military one at all. It should be done solely on a business basis. But I would keep this in mind in preparing to make stores and ammunition: I would prepare to turn out right along twice as much as is being used now on the whole European battle field—then not make it."

"The people of this country are the greatest machinists," Mr. Edison explained further, "and they can invent machinery faster and have it more efficient than any other two nations combined. This is a machine nation—its battle preparations should therefore be with machinery."

Chicago Tribune, Herald, American 10/16/18

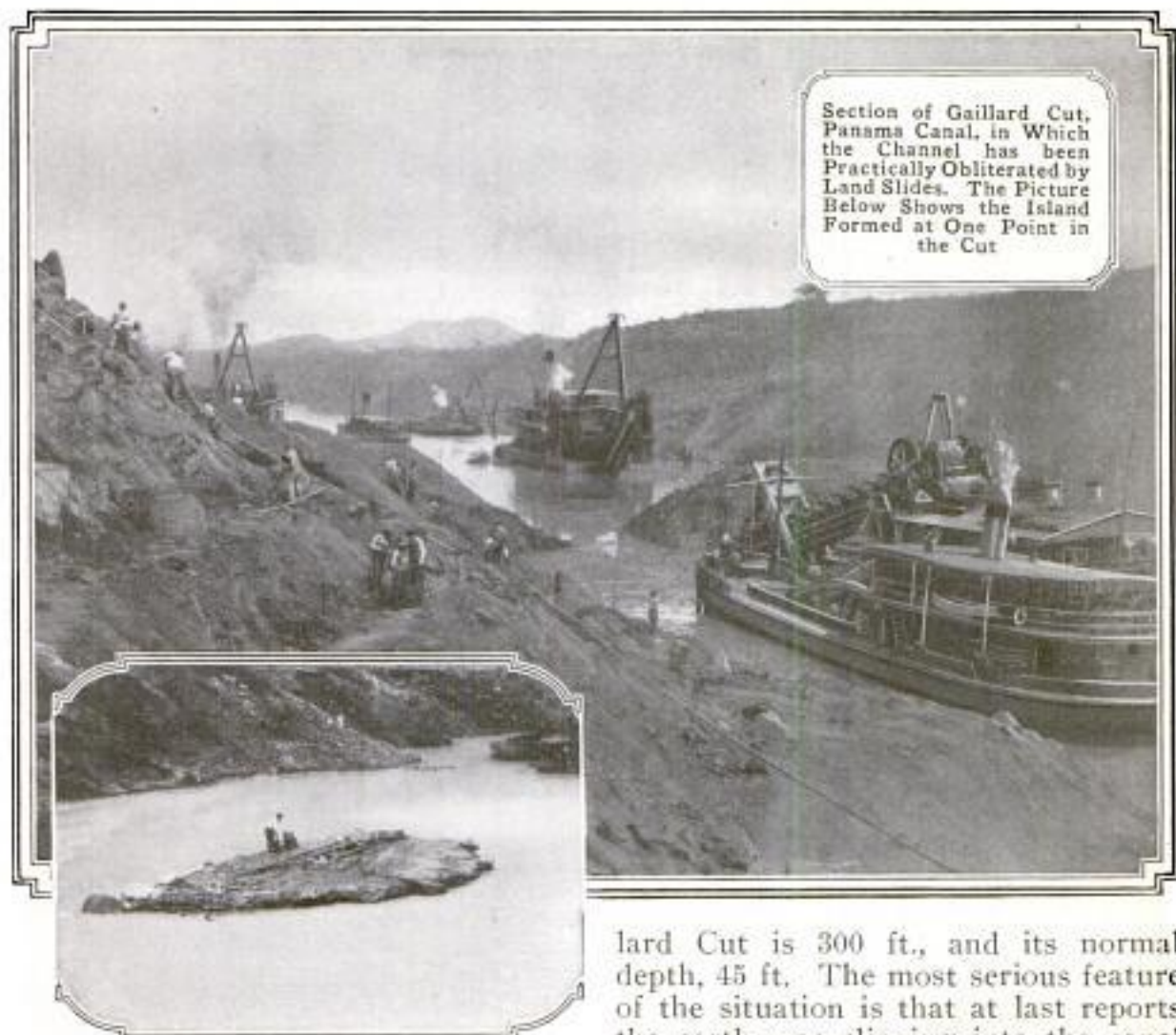

Section of Gaillard Cut, Panama Canal, in Which the Channel has been Practically Obliterated by Land Slides. The Picture Below Shows the Island Formed at One Point in the Cut

PANAMA CANAL BLOCKED BY 774 EXTENSIVE SLIDES

As the result of a succession of slides in the Gold Hill section of Gaillard Cut, that began on Sept. 18, 1915, the Panama Canal is blocked to all traffic and, according to present estimates, will probably remain so until the end of the year. This is by far the most serious incident that has occurred since the opening of the canal more than a year ago, the slides having practically obliterated a 1,300-ft. section of the channel. According to latest reports, about 200 feet of this section has a width of only 25 ft. and a depth of from three to 15 feet. At one point an island has formed in the middle of the canal, leaving a channel on each side in which the maximum depth does not exceed 15 ft. The normal width of the canal through Gail-

lard Cut is 300 ft., and its normal depth, 45 ft. The most serious feature of the situation is that at last reports the earth was slipping into the canal as fast as the dredges were taking it out. Something like 175 acres of land is involved in the slide, and it is estimated that 10,000,000 cu. yd. of earth is in motion. The present rate of excavation is about 1,000,000 cubic yards a month. Before a permanent channel can be opened, all this, and probably more, must be dug out, although the canal can be opened to traffic as soon as a channel 100 ft. wide and 30 ft. deep has been made. The time required to do this is uncertain, since it depends entirely on the future action of the moving earth above the canal prism. One of the measures taken to diminish the cause of the slides is that of blasting away the tops of the hills, thus taking away some of the weight on the affected section and bringing down immediately as much as possible of the loose earth that might cause trouble in the future.

H. R. Jackson, Hospital Steward, U. S. Navy

732

HOW THE SUNKEN SUBMARINE "F-4" WAS RAISED

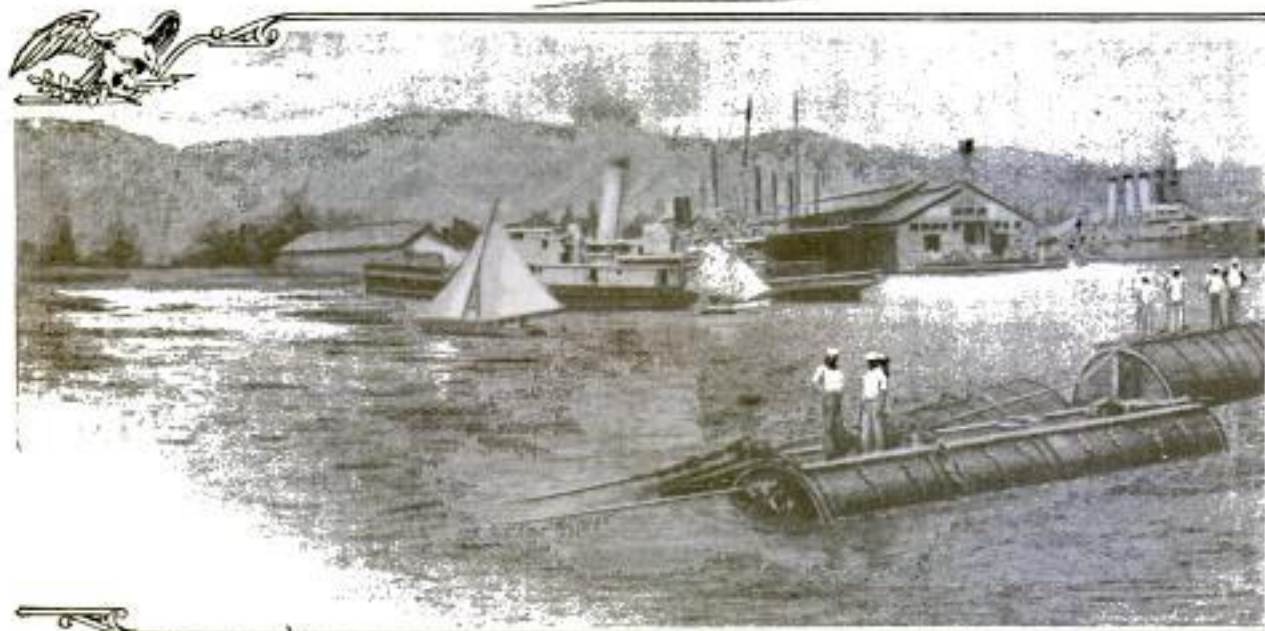

The pontoons at the right are lifting the bow of the submarine, while those just coming to the surface are attached amidships.



One of the six steel pontoons being filled with water and nearly ready for sinking alongside the submarine.

The automatic torpedo-launching cap removed from the bow of the "F-4" for inspection.

AND MADE READY TO BE TOWED TO DRY DOCK

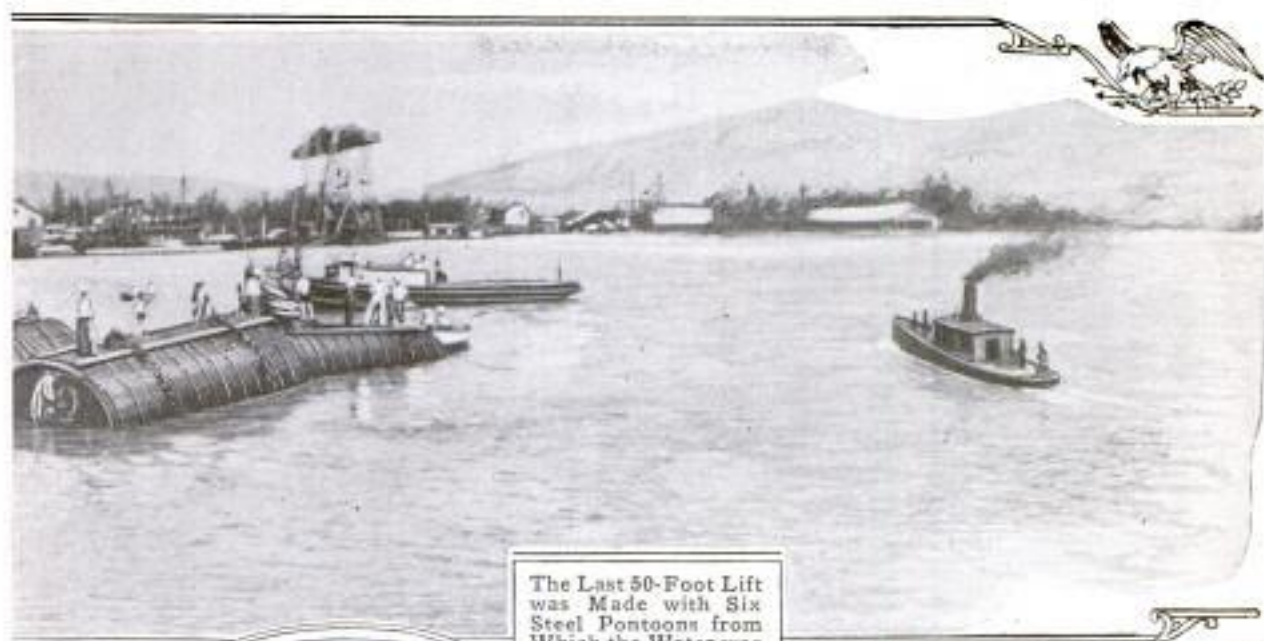

The Last 50-Foot Lift was Made with Six Steel pontoons from Which the Water was Expelled After They had been Sunk alongside and Attached to the Vessel

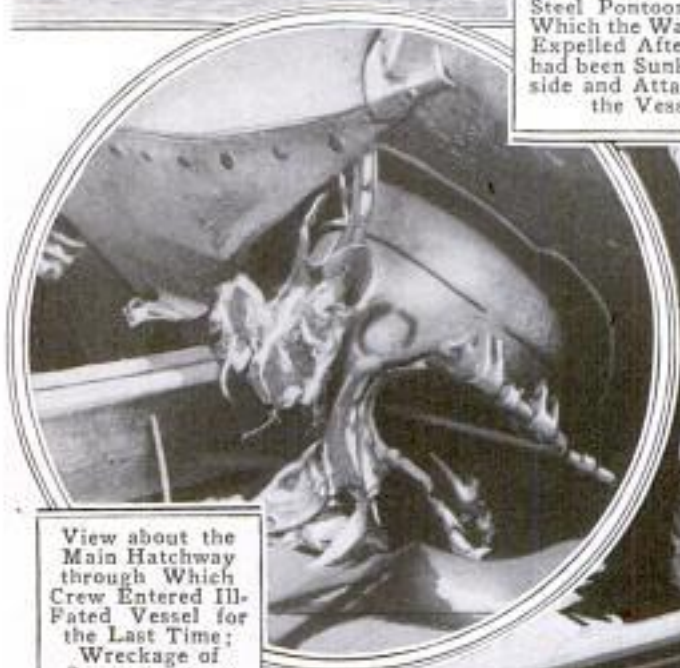

View about the Main Hatchway through Which Crew Entered Ill-Fated Vessel for the Last Time; Wreckage of Superstructure was Caused by Salvage Operations



Copy of Honolulu Newspaper Recovered from the Submarine; This Paper is Dated March 25, 1915, the Day When the "F-4" Made Its Last Dive



Deck of Scow with Equipment Used in Forcing Air at a Pressure of 150 Pounds into the Sunken pontoons

THE "F-4" AFTER FIVE MONTHS UNDER WATER

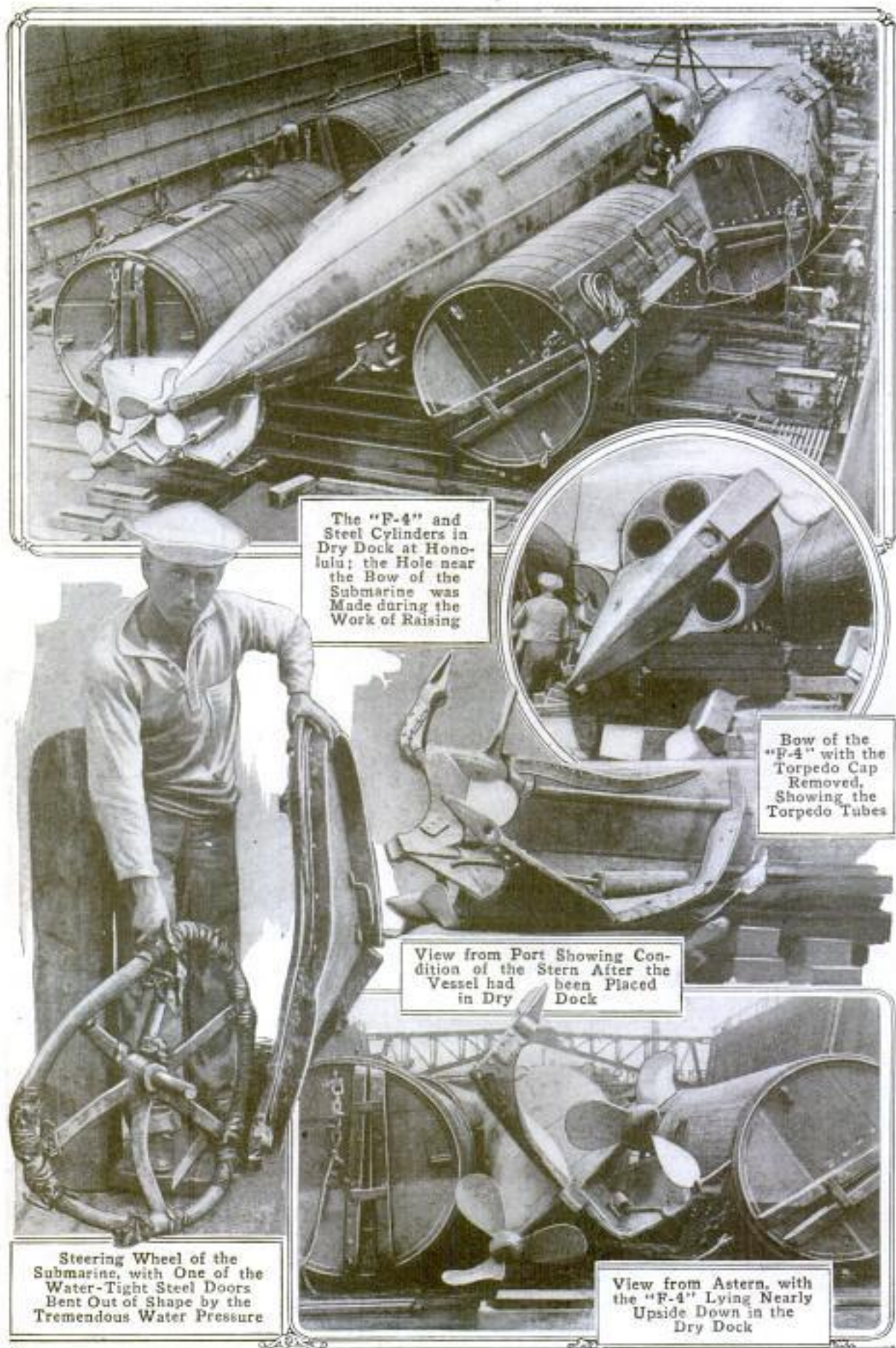

The "F-4" and Steel Cylinders in Dry Dock at Honolulu; the Hole near the Bow of the Submarine was Made during the Work of Raising

Bow of the "F-4" with the Torpedo Cap Removed, Showing the Torpedo Tubes

View from Port Showing Condition of the Stern After the Vessel had been Placed in Dry

View from Astern, with the "F-4" Lying Nearly Upside Down in the Dry Dock

Steering Wheel of the Submarine, with One of the Water-Tight Steel Doors Bent Out of Shape by the Tremendous Water Pressure

TAKING THE TORPEDOES FROM THE SUBMARINE

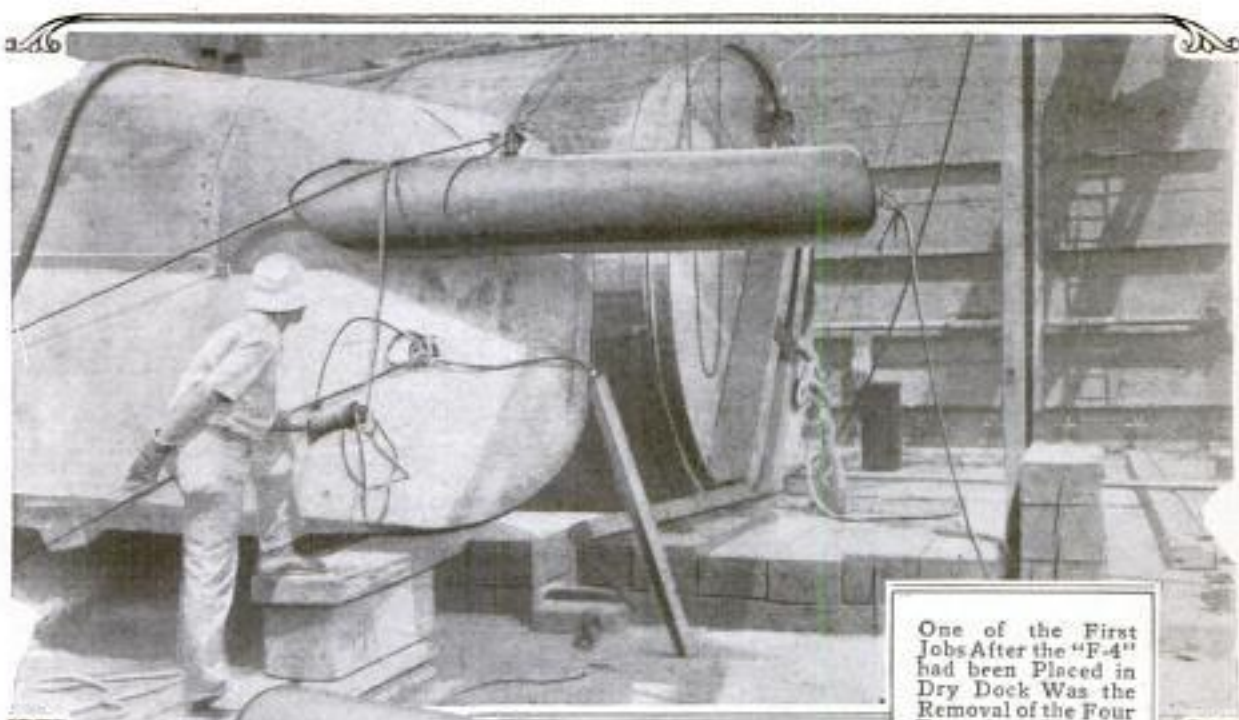

One of the First Jobs After the "F-4" had been Placed in Dry Dock Was the Removal of the Four Torpedoes That the Vessel Carried



Divers Who Made It Possible to Raise the "F-4." One of the Men Descended 215 Feet with No Protection but a Helmet

This Was the Condition of One of the Torpedoes When It was Taken from the Submarine



These Torpedoes Were in Good Condition and had Retained Their Full Charge of Compressed Air in Spite of Their Five Months under Water

Hoe Hart Pioneer Press, St. Paul, Minn.

P. Edelman, 1802 Hague Ave. St. Paul, Minn.

842

648

POPULAR MECHANICS

HORSE IMPRISONED BY FALL THROUGH COALHOLE

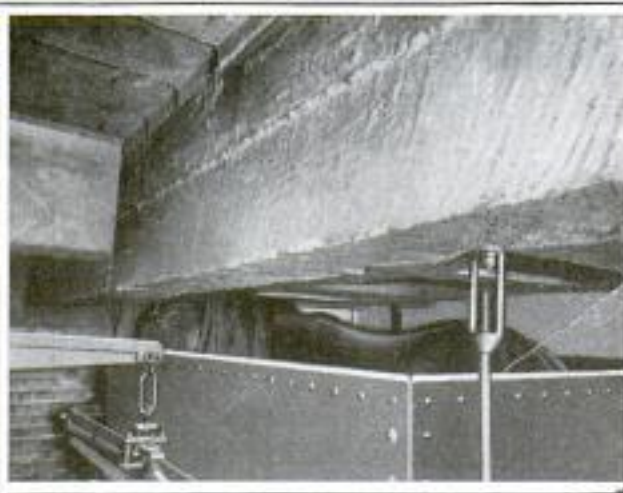
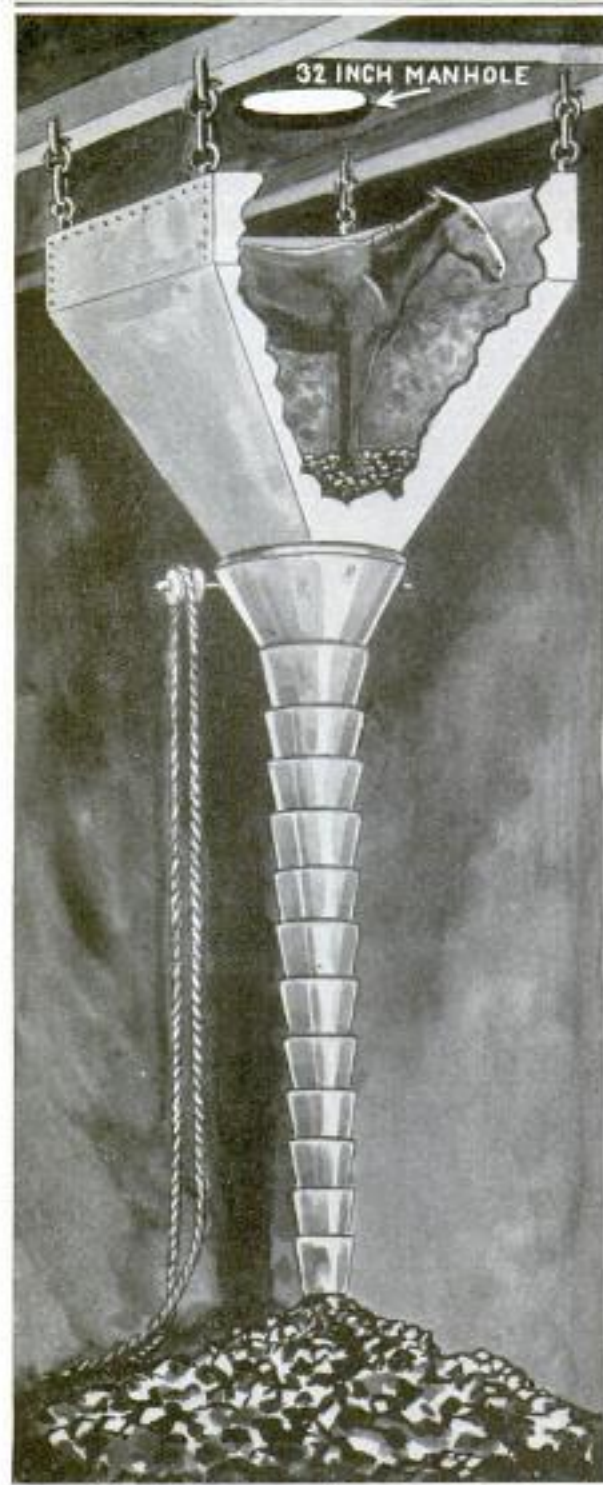

the sidewalk. This hopper consists of an iron box, suspended in the basement of the structure, in which fuel is automatically weighed before it is allowed to pass into a chute. The coalhole through which the animal fell is 32 in. in diameter, while the only other exit from the hopper is the trap at the mouth of the chute, approximately a foot square. The horse tumbled in hind foremost and in so doing slipped out of his harness. He was uninjured by the accident. The problem of removing him was a vexing one. It was finally solved, however, a day later by tearing a hole through the concrete sidewalk and basement ceiling and hoisting the horse by means of a small derrick, after he had been blindfolded and bound. An unsuccessful attempt was first made to remove the animal by drawing him back through the manhole. The impracticability of this was soon made apparent. While he was imprisoned, food and water were lowered to him through the coalhole.

718

ELECTRICITY TO HAUL HUGE TRAINS OVER ROCKIES

The Drawing and Photograph Show Horse Imprisoned in Coal Hopper, and the Manhole through Which He Fell

One of two heavy draft horses hitched to a coal wagon, which was being unloaded at a St. Paul, Minn., bank building recently, became frightened, backed into a manhole, and fell into a large scale coal hopper beneath

During the months of 1916 a curious procession will be making its way across the United States. One by one, and about ten days apart, 42 of the largest electric locomotives in the world are to be freighted cross-country from the shops of an eastern manufac-

Geo. B. Haynes, N. O. A. C. M. + St. P.
Chicago

turer to the lines of the Chicago, Milwaukee and St. Paul Railway in Montana. - There a stretch of 440 miles of most difficult mountain railroad was recently electrified, and over the long, steep hills of this line these locomotives are to run, oftentimes single-handed, to do the work that the united efforts of two to three steam locomotives can barely accomplish at present.

Direct current at 3,000 volts is to be supplied to the trolley on this new stretch of electric railroad, a new and unusual practice. Eight huge motors, connected to as many pairs of drivers, will propel each locomotive. Because of the high potential from the trolley, the eight motors have to be grouped in four pairs, the two motors in each pair being connected in series so that no more than 1,500 volts can be im-

pressed across each motor at any one time. Each locomotive will be capable of exerting more than 3,500 hp., and those of passenger design are intended to pull an 800-ton train at 65 miles per hour on level track, or the same load at 25 miles an hour up a two-per-cent grade. In external appearance the locomotives much resemble steel passenger coaches, and are divided in the middle to permit easy turning of curves. Each is 112 ft. 8 in. long, which is said to be over 22 feet more than the largest Mallet locomotive now in service.

An additional and unusual feature of these locomotives has been called "regenerative braking." That is, when a heavy train pulled by one of the engines starts down grade, the power to the motors may be shut off and the motors themselves turned into generators, thereby supplying the line with power instead of taking it away. Thus on this new kind of a railroad, a train going down a mountain may furnish a portion of the power to pull another up. By this system, not only will power be saved, but wear on brake shoes will be lessened because of the braking effect of motors acting as generators. The power will come from mountain hydroelectric plants.

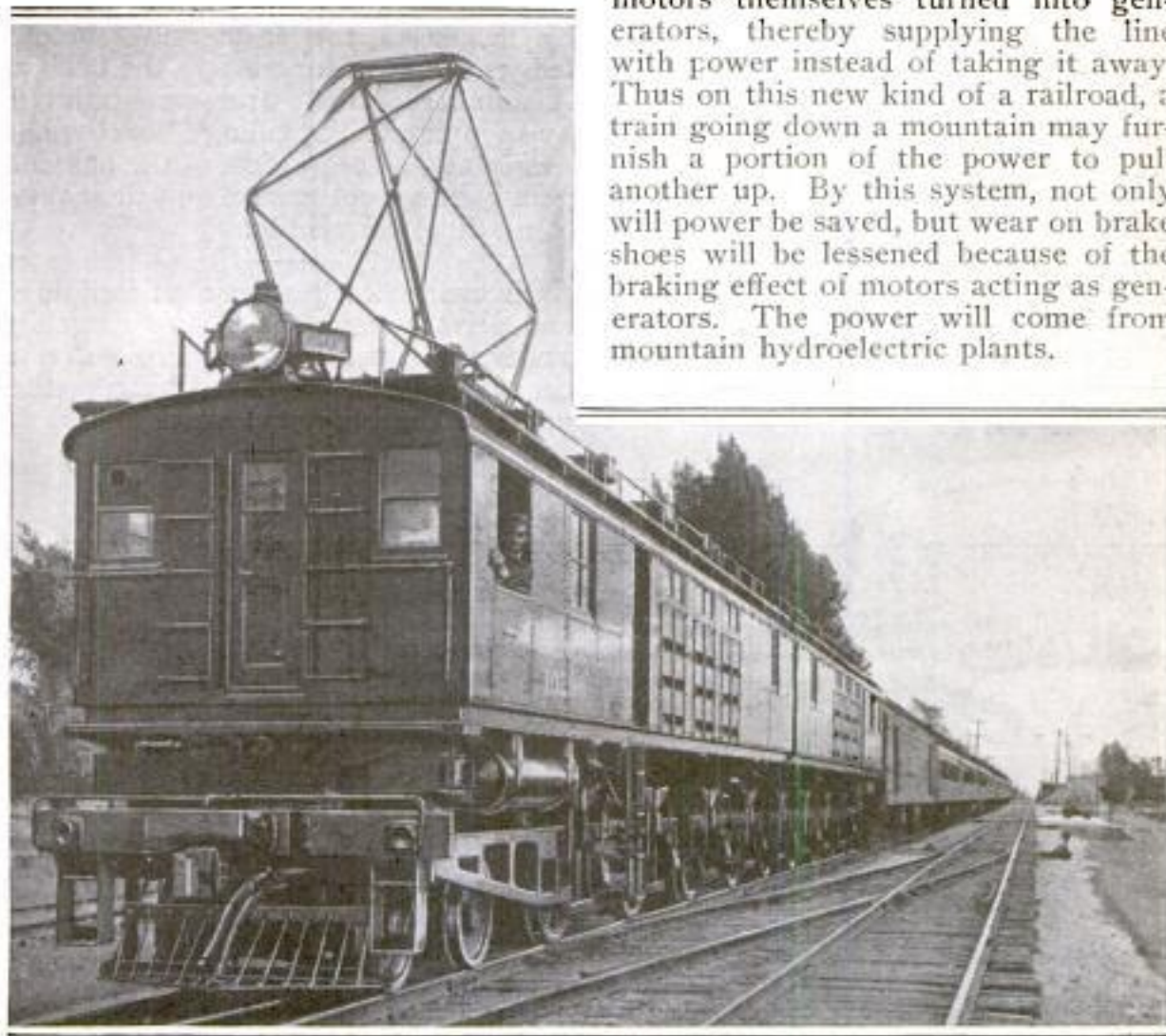

One of 42 Largest Electric Locomotives in the World

General Electric Co
Schenectady, N. Y. Copyrighted material

E. D. Keilman % Nationalist
Manhattan, Kans.
Manhattan - Lincoln - Suburban Line

844

POPULAR MECHANICS

**ELECTRIC CAR STOOD ON
END IN SWOLLEN CREEK**

Out of 67 passengers riding in a motor car on an electric line near Randolph, Kan., few escaped unhurt when



Position of Electric Car After It had Plunged through the End of a Washed-Out Bridge

the car, traveling at high speed, plunged through the end of a bridge that had been washed out a few moments before. The washout was caused by a flood in the creek, in which the water rose 4 ft. in a period of two hours. The first warning given the motorman came when the shock caused by the dropping of the forward end of the car threw him through the window of his vestibule. Following this, the car hung for a moment on the end of the bridge. It then toppled and slid forward into the creek and finally stood on end in 12 ft. of water, the passengers being piled in a heap in the forward end of the car. Seventeen of the passengers were killed and 37 injured. A few of the survivors smashed the windows and jumped into the water, but most of them made their escape by climbing up to the rear end of the car by means of the seats and window ledges and then jumping to the bridge. A number of the latter were injured by slipping and falling back when nearly at the top. Most of the passengers were school-teachers on their way to a school convention.

On every hotel, apartment building, and private residence in Los Angeles, under the terms of a new ordinance, a tin tag must be displayed bearing the name of the property owner.

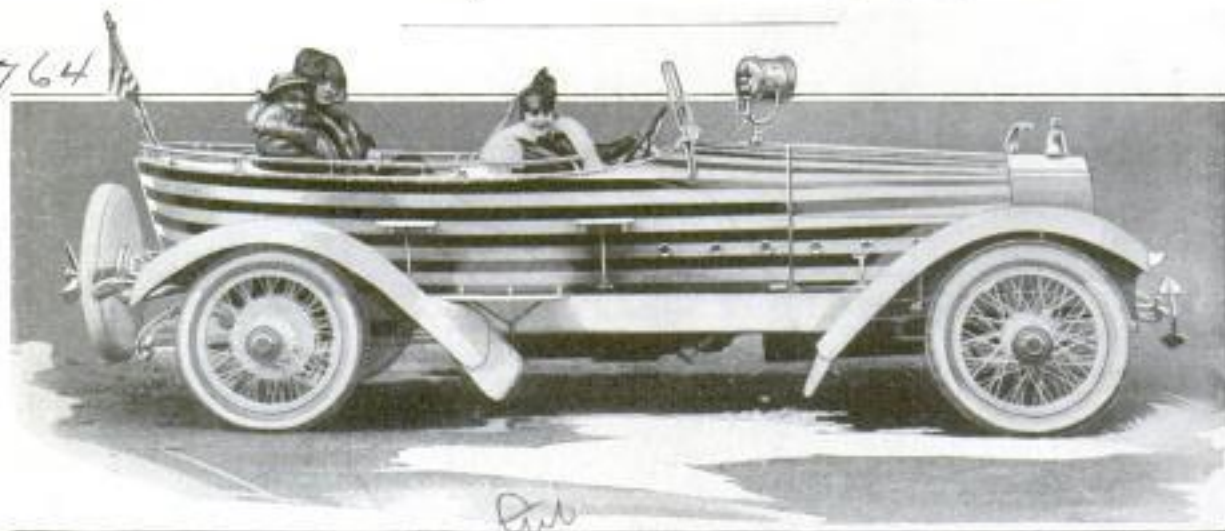

MOTOR-CAR BODY MADE LIKE RIVER LAUNCH

In This Novel Car the Body is Made to Resemble the Hull of a River Launch and All the Fittings are Designed to Carry Out the Nautical Idea. The Boatlike Fittings Include a Ship's Bell Carried on the Radiator and Bumper Irons Made in the Form of Anchors and Oars. The Spare Wheel is Carried in a Cover That is Held in Place by a Three-Bladed Propeller

owned by
Grace Darling (Film Star)

DEFYING DEATH TO PUT REALISM IN MOVIE

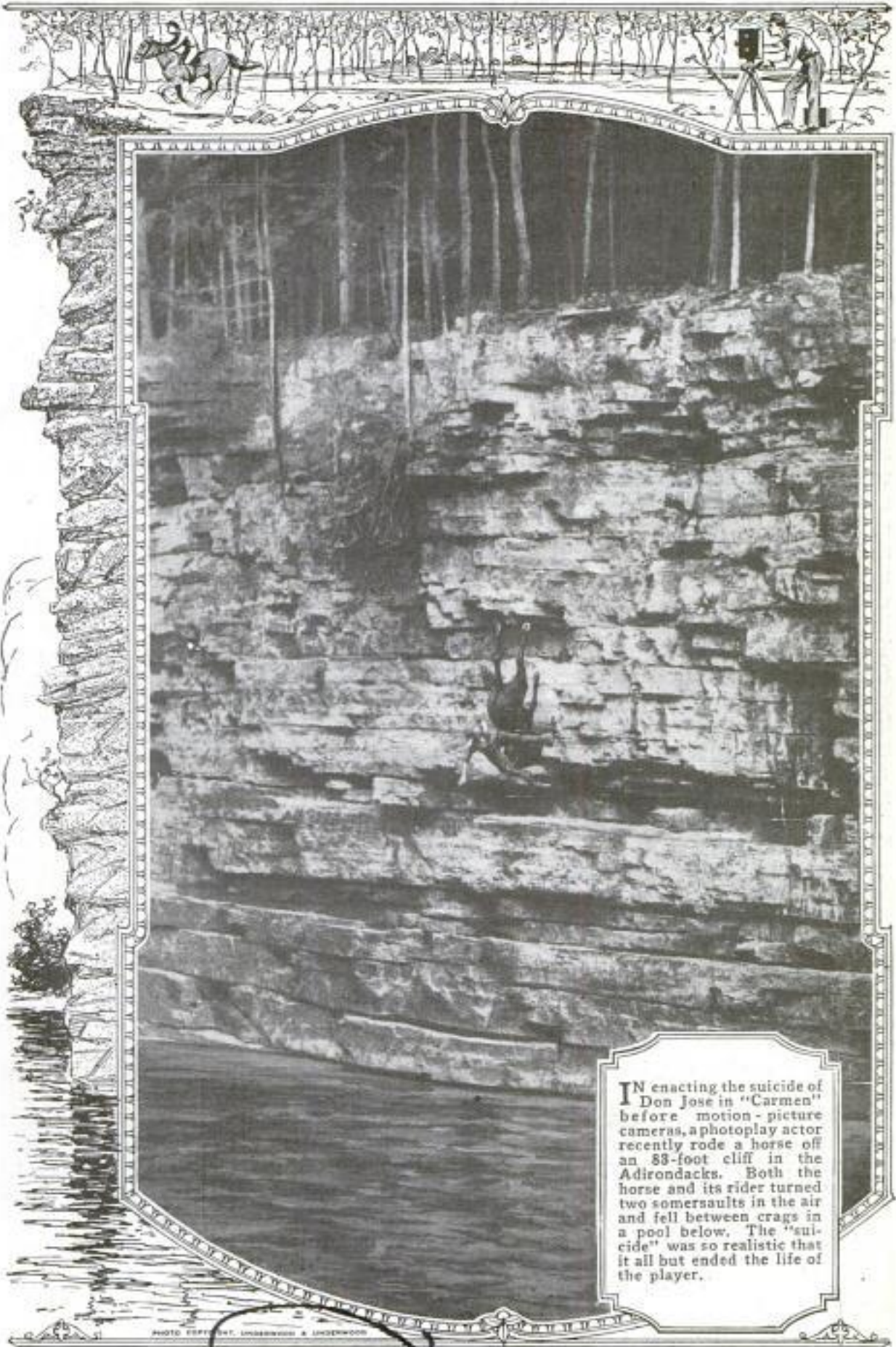

IN enacting the suicide of Don Jose in "Carmen" before motion-picture cameras, a photoplay actor recently rode a horse off an 83-foot cliff in the Adirondacks. Both the horse and its rider turned two somersaults in the air and fell between crags in a pool below. The "suicide" was so realistic that it all but ended the life of the player.

PHOTO BY FRANK UNDERWOOD & UNDERWOOD

#Theodore M. R. von Keler,
Bloomfield, N. J.

DETAILS OF THE GERMAN

784 42-CENTIMETER GUN

Although the 42-cm. gun used by the Germans in battering down the fortifications at Liège and Namur attracted world-wide attention during the early stages of the war, the secret of its dimensions and other features has been so jealously guarded that practically nothing has been made public in regard to this monster mortar, beyond the terrible destruction wrought by it. At a recent meeting of artillery engineers at Düsseldorf, Germany, an engineer of the Krupp works delivered a lecture on the making of heavy artillery and particularly on the making of the 42-cm. guns, or the "Big Berthas" as the Germans call them, and an apparently reliable report of this lecture has been transmitted to this country. According to this report, the big gun weighs about 97½ tons, while the base on which it stands when in firing position weighs 41¼ tons. The barrel is 16 ft. long, and the shell fired from it is about 50 inches long and weighs 880 lb. The gun is far too big to be transported on any kind of gun carriage. It is made up of considerably more than 100 pieces, and must be taken apart and loaded on motor trucks, of which 12 are said to be required, when it is to be moved.

Unloading, assembling, and mounting the gun is a big undertaking that can only be done by specially trained workmen, and that requires more than 26 hours of continuous work. A pit of large diameter and about 26 feet deep is first dug, and in this a massive foundation is built of heavy wooden beams. On this the base of the gun is mounted. Within the foundation are placed specially prepared packages of dynamite for blowing up the gun and its accoutrements in case the enemy gains control of the position. For this purpose electric wires are led to a concealed and protected position more than a mile from the site.

Owing to the terrific concussion the gun can only be fired by electricity and from a distance exceeding 300

yards. Even at this distance the crew must wear eye, ear, and mouth protectors, and must lie prone when the shot is fired. There are said to be 25 of these mortars in existence at the present time. A crew of about 200 men is required, and each shot costs about \$2,750.

A large part of the destruction attributed to the "Big Berthas" was in fact caused by the less ponderous 30.5-cm. (approximately 12-in.) Krupp and Skoda mortars. The 42-cm. guns have been fired only a few times, but on these occasions the destruction has been almost unbelievable. The first shot, which was fired at one of the Gruson turrets at Liège, killed 1,700 men, the shell striking about 15 feet in front of the cupola and exploding with such terrific force that the turret and armored chamber below were literally torn to pieces. This shot was fired from a distance of over 13 miles. The second shot fired is said to have killed or disabled more than 2,200 men. No one not connected with the German artillery is ever permitted near the 42-cm. gun when it is in firing position. It is said that no photographs have ever been made of it, the pictures purporting to represent this gun, widely published at the beginning of the war, being in fact photographs of the 30.5-cm. Krupp and Skoda mortars.

814

POWER CRAFT SWEEPS WATER AT MILE-A-MINUTE CLIP

After carrying off the honors in the American speed-boat championship races at Chicago, the "Disturber IV," a 40-ft. hydroplane, recently attained the remarkable speed of 62 miles an hour in a trial over a half-mile course in Lake Michigan. This establishes the craft, which was built in 1914 to contest for the British international trophy, as the world's fastest boat.

It is equipped with two 12-cylinder motors which develop approximately 1,800 hp. It is considered very seaworthy and rides beautifully on an even keel.

782 - U. & U.

JERSEY ESTATE NEW NATIONAL SUMMER CAPITAL



ACCORDING to unofficial announcements, President Wilson will spend the coming summer with his bride at "Shadow Lawn," a splendid estate at Elberon, New Jersey, near Long Branch. Use of the place was recently tendered the Chief Executive by a special committee which carried a letter of invitation from the governor of the state. "Shadow Lawn" includes a small lake and some 30 acres of lawns and terraced gardens. Above is a front view of the mansion and at the right a fountain that graces its approach. The photograph below gives a glimpse of the interior of the residence.

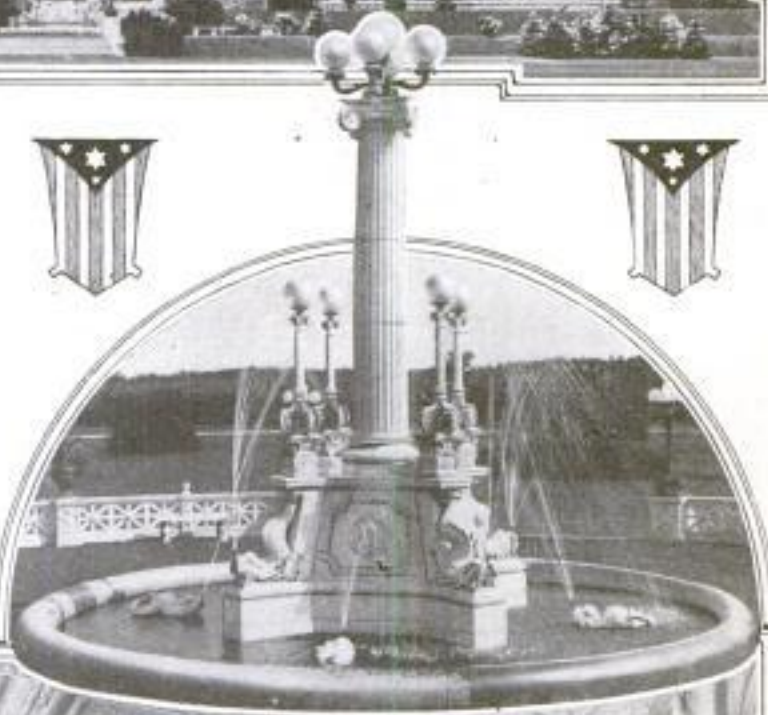

THE END OF A BETRAYER OF HIS COUNTRY



After the
Betrayal
had Faced
the Firing Squad

Type of
Windmill
Used in
Transmitting
the Signals

IN this grim scene is illustrated not only the swift and certain punishment meted out to spies whenever caught, but also one of the many ingenious methods used for transmitting information across the battle lines to the enemies of the country in which the spy is operating. This case was the particularly aggravated one in which a man betrays his own country. The man, a French miller, had been keeping the Germans informed in regard to the positions of the French forces, using the wings of his windmill for transmitting the signals. A few moments after being detected he had paid the supreme penalty, the story of his double offense being told silently and concisely in the words "Spy—Traitor to His Country," contained in the notice fixed to the post.

As a compensation for this betrayal of his country, the man had received in advance the sum of 100 francs, equivalent to about \$20.

FIGHTERS WITH GAS MASKS ARE WEIRD FIGURES



COPYRIGHT, UNDERWOOD & UNDERWOOD
French Regimental Band Wearing Respirators While at Practice during a Lull in Fighting in Argonne District, Where Gas has been Used Continually



These "Monkeylike" Men Are French Soldiers Equipped with Gas Protectors. The Devices are Made of Aluminum and Filled with a Chemical Which Neutralizes the Chlorine Vapor Used by the Germans

WITH THE ALLIES IN THE CHAMPAGNE DISTRICT



DEAD LITTER THE GROUND AFTER GERMAN DRIVE



In Front of the Allies' Lines, Showing How the German Dead were Hauled Away for Burial after a Futile Attack was Made against the French Positions near Bois-le-Pretre by the Crown Prince's Forces



PHOTO COPYRIGHT, UNDERWOOD & UNDERWOOD
This Shows What Happened on the French Side When the Germans Made Their Costly Drive with Insignificant Results: The Men Fell While Defending a Strategic Trench against the Severe Offensive Movement of the Enemy

HOW ITALY'S ADVANCE IN THE ALPS IS COMBATED

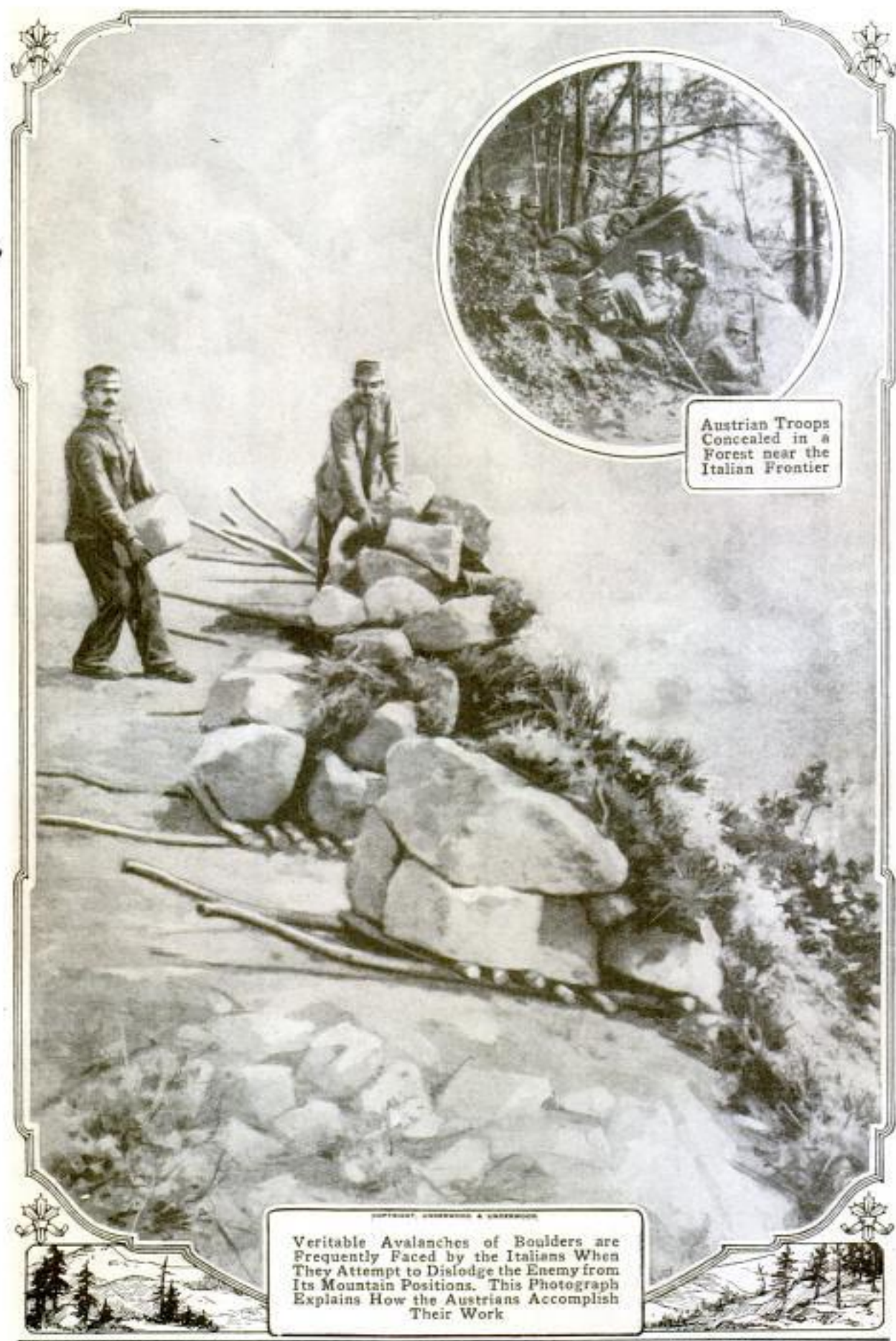

Austrian Troops
Concealed in a
Forest near the
Italian Frontier

Veritable Avalanches of Boulders are
Frequently Faced by the Italians When
They Attempt to Dislodge the Enemy from
Its Mountain Positions. This Photograph
Explains How the Austrians Accomplish
Their Work

ITALIAN INFANTRY ADVANCING IN THE ALPS

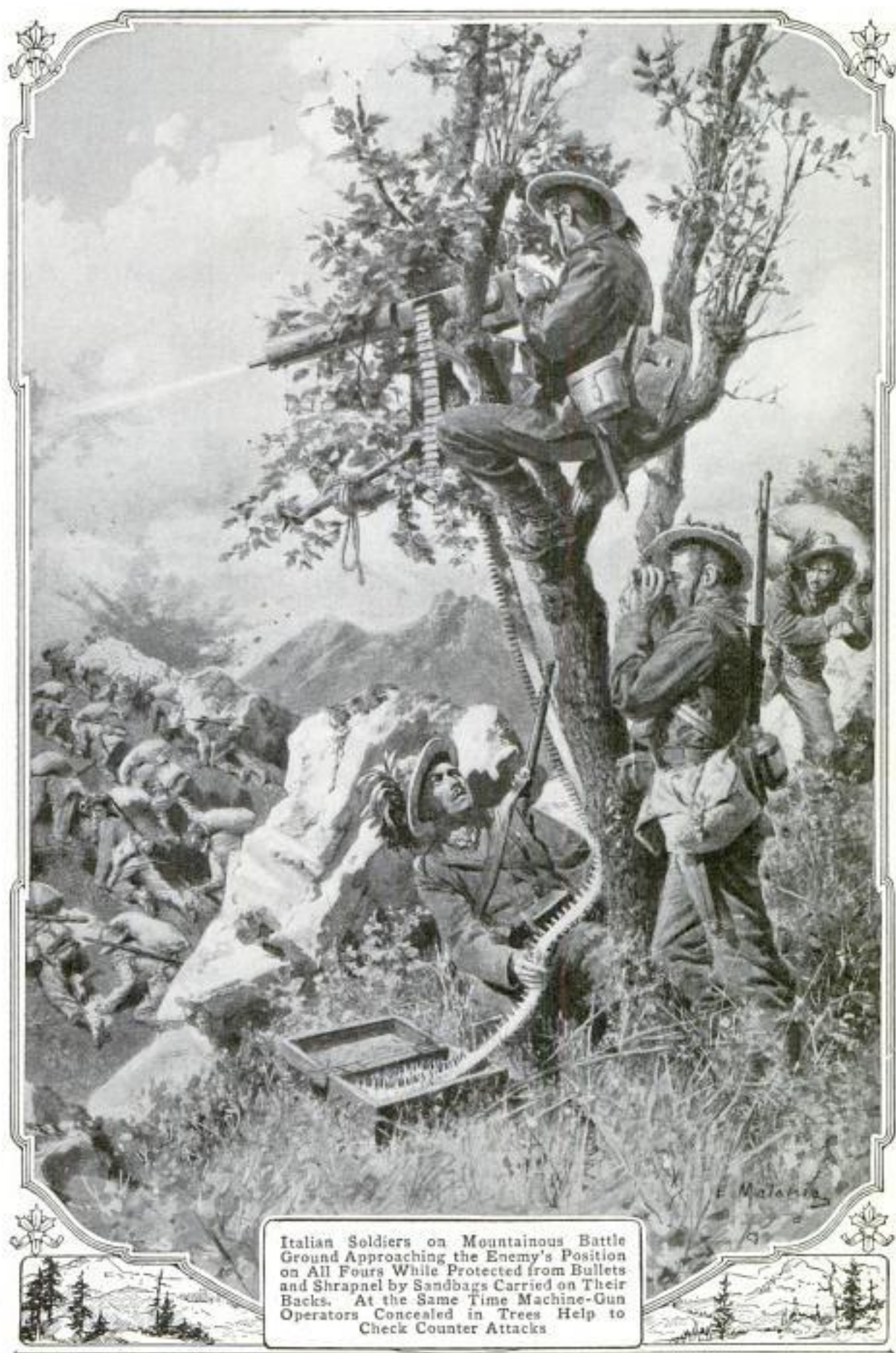

Italian Soldiers on Mountainous Battle Ground Approaching the Enemy's Position on All Fours While Protected from Bullets and Shrapnel by Sandbags Carried on Their Backs. At the Same Time Machine-Gun Operators Concocted in Trees Help to Check Counter Attacks

GAY LONDON RESORT BECOMES WAR HOSPITAL

This Strange-Looking Hospital Is an Emergency Institution Which Has Lately Been Established at Earl's Court, the Famed Recreation Park at Kensington, London. The Resort has Long Been One of the City's Popular Amusement Places and is Locally Known as the "Exhibition." Some 2,500 Beds are Provided Here for Wounded Soldiers



TWO OF THE HOMELESS RACES HARRIED BY WAR



Homeless Jews from Lublin and Its Environs Seeking Shelter within Austrian Lines. In Retreating before the Germanic Allies, the Czar's Troops Destroyed Everything of Possible Value to the Enemy

Armenians, Intrenched Outside of Van, Repulsing a Turkish Attack Previous to the General Massacre of Their Countrymen

PHOTO COPYRIGHT UNDERWOOD & UNDERWOOD

WAR DEMONSTRATION IN RUSSIAN CAPITAL

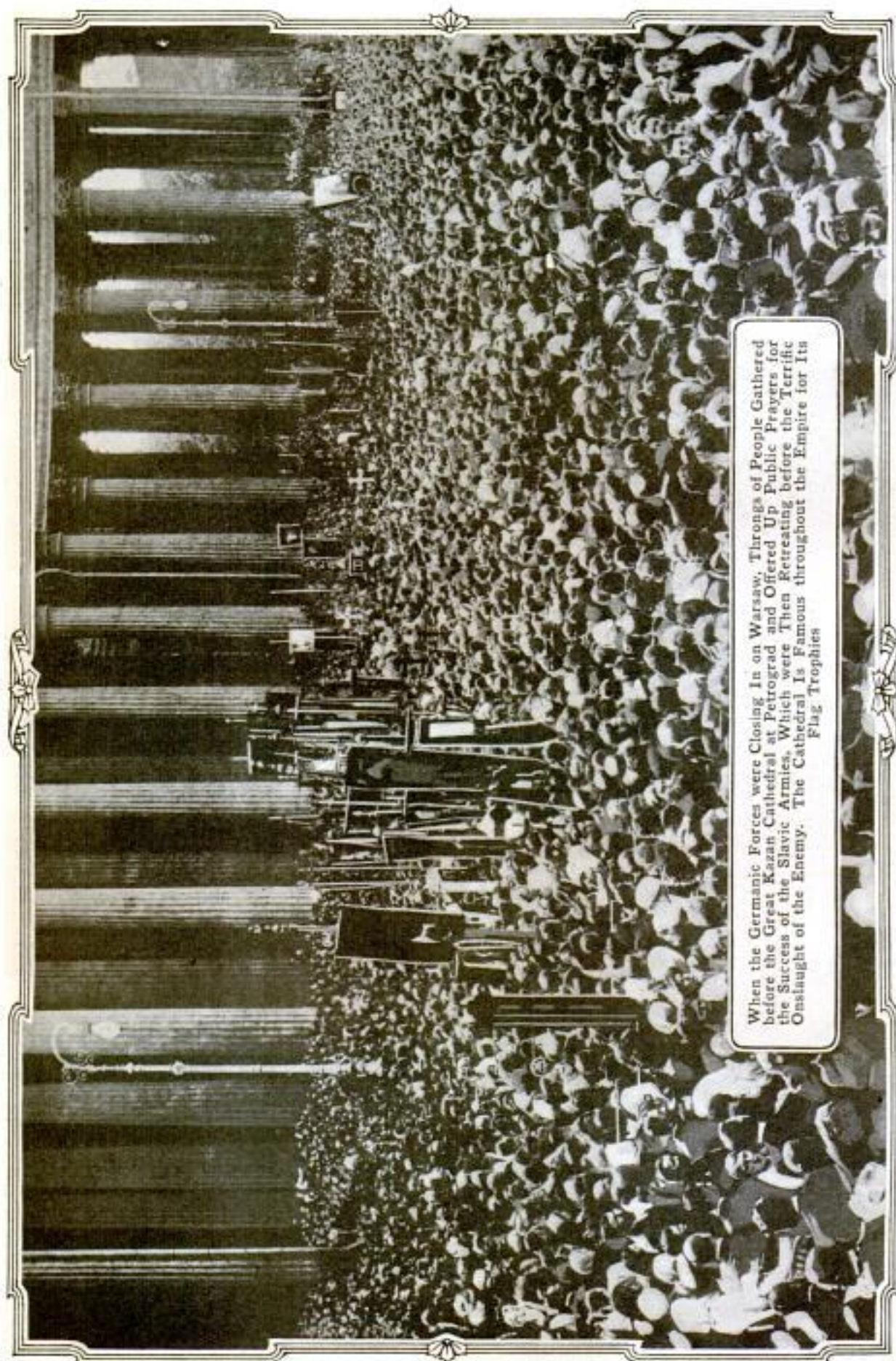

When the Germanic Forces were Closing In on Warsaw, Throngs of People Gathered before the Great Kazan Cathedral at Petrograd and Offered Up Public Prayers for the Success of the Slavic Armies, Which were Then Retreating before the Terrific Onslaught of the Enemy. The Cathedral Is Famous throughout the Empire for Its Flag Trophies

INTERESTING GLIMPSES BEHIND SLAVIC LINES



Priest Bestowing Individual Blessings upon Soldiers for Distinguished Service. To the Average Russian This Is a Greater Reward for Heroism than Any Military Decoration

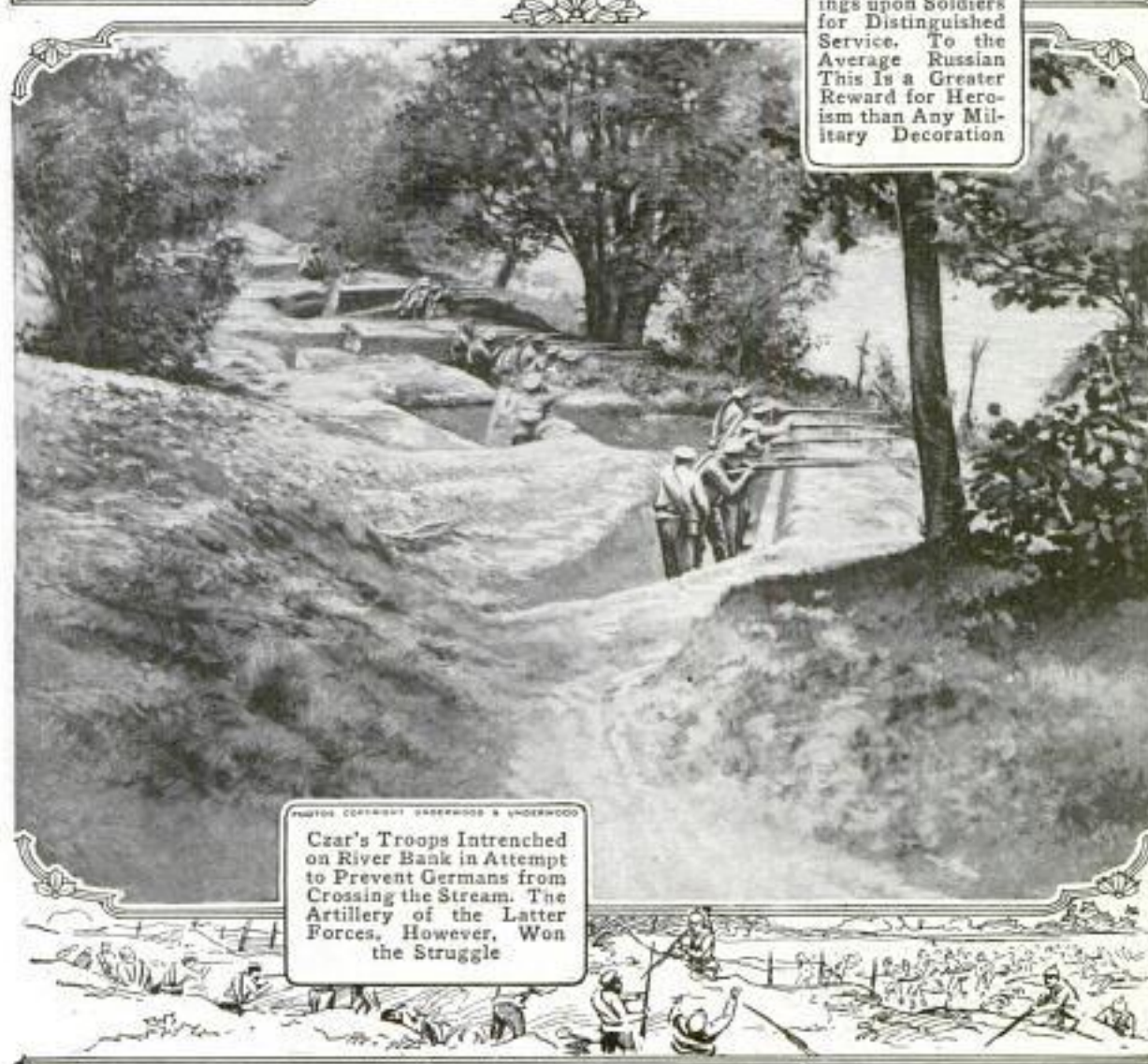

Czar's Troops Intrenched on River Bank in Attempt to Prevent Germans from Crossing the Stream. The Artillery of the Latter Forces, However, Won the Struggle

ABANDONED WINTER QUARTERS OF CZAR'S FORCES

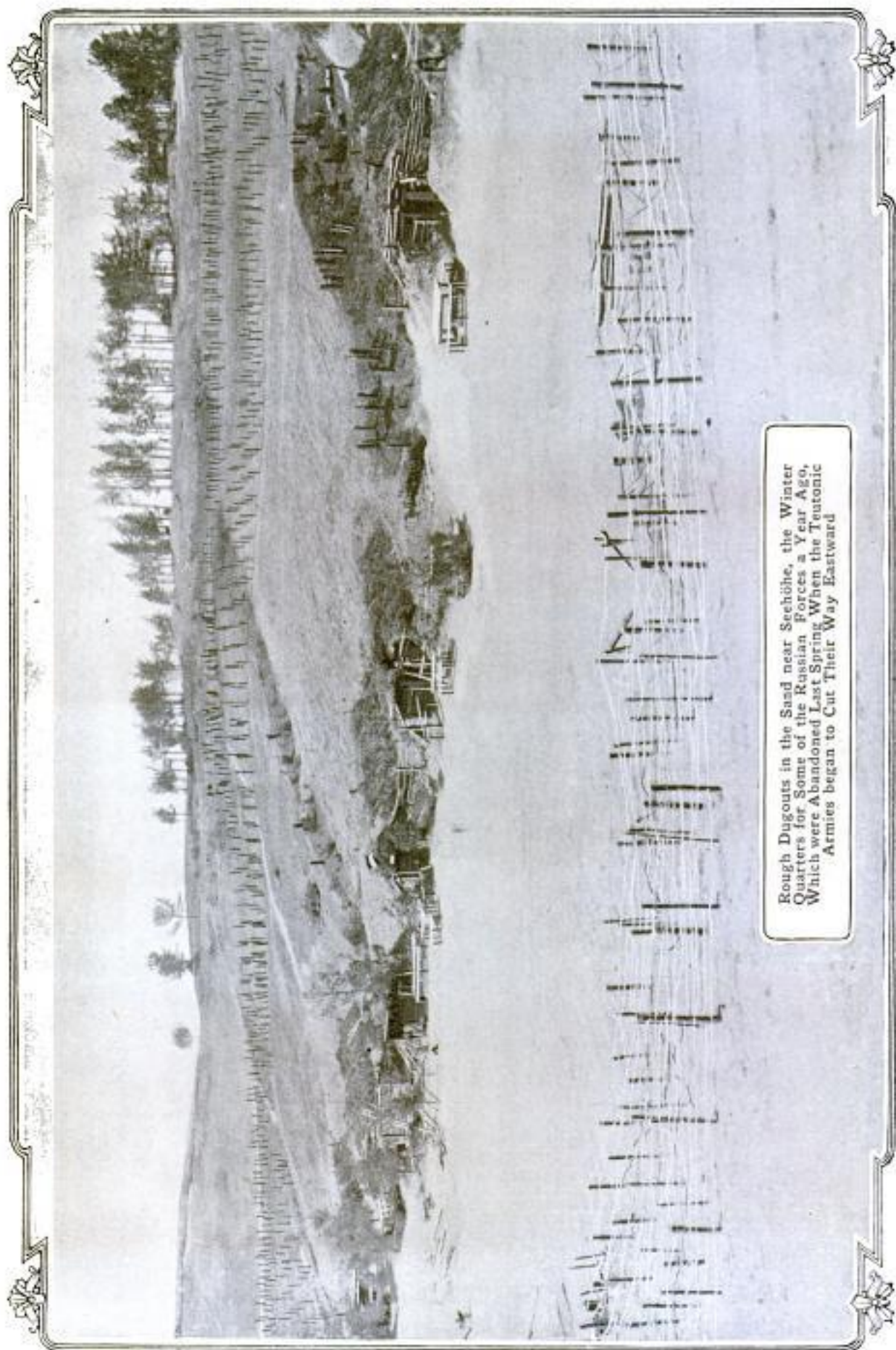

Rough Dugouts in the Sand near Seehöhe, the Winter Quarters for Some of the Russian Forces a Year Ago, Which were Abandoned Last Spring When the Teutonic Armies began to Cut Their Way Eastward

TEUTONS DURING THEIR FIERCE EASTERN DRIVE



Worn Austrian Soldiers on the Russian Frontier Washing and Refreshing Themselves at a Canal after a Long, Dusty March

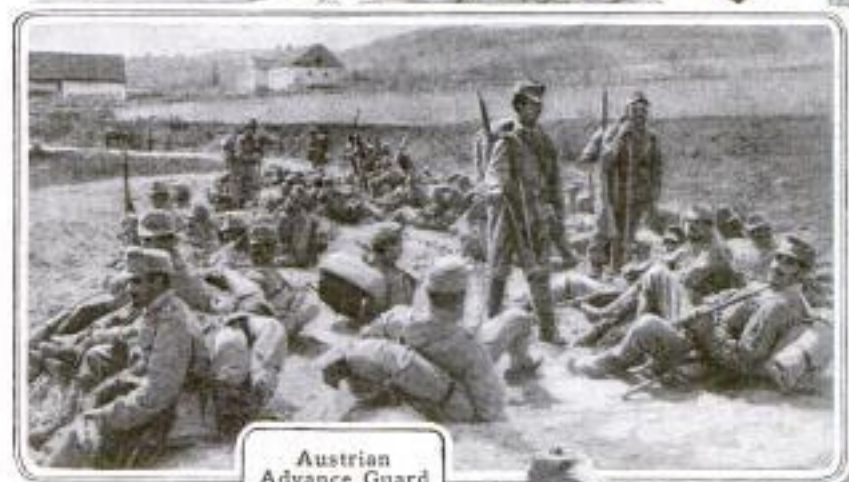

Austrian Advance Guard Resting during Forward Movement to Feel Out Slavs



The Bosnians Allied with the Teutons Are Fond of Pets: They Lead Goats, Ducks, and Even Lambs on Their Marches

PHOTOS COPYRIGHTED BY BROWN AND CAWSON

PRISONERS SEEN IN CAMPS OF THEIR ENEMIES

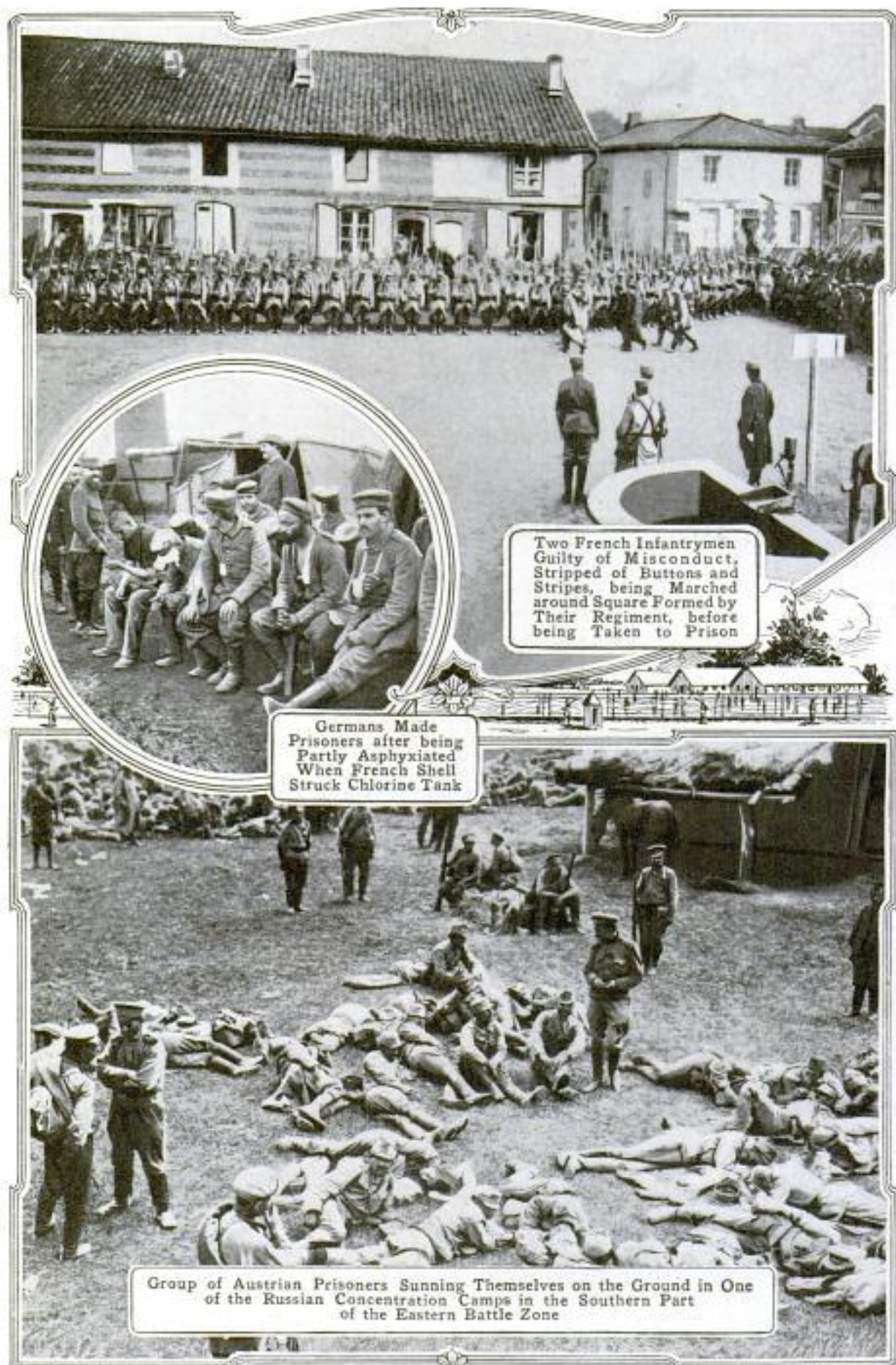

CURIOUS MAKESHIFTS OF WAR SEEN AT RANDOM

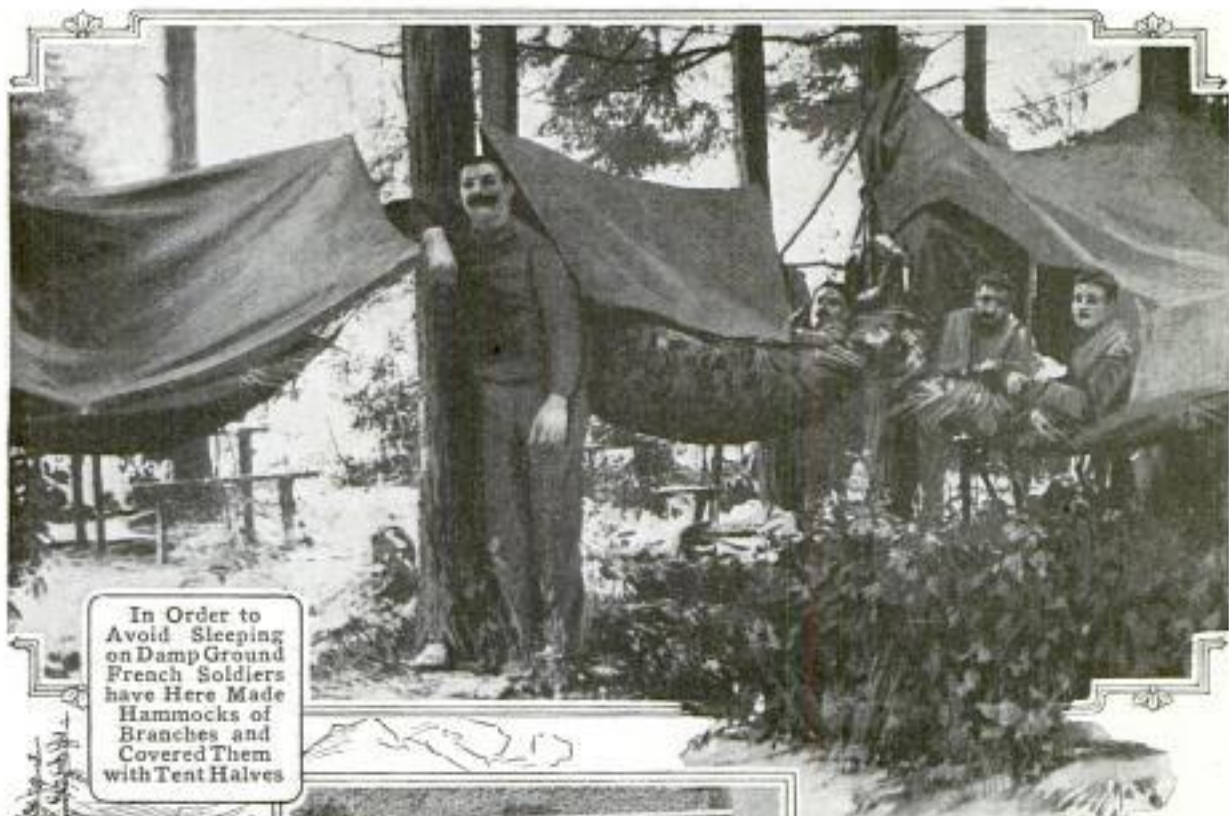

In Order to Avoid Sleeping on Damp Ground French Soldiers have Here Made Hammocks of Branches and Covered Them with Tent Halves

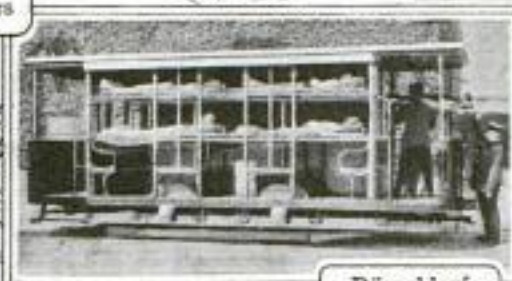

Düsseldorf Street Car Converted into Double-Decked Ambulance



COPYRIGHT, THE INTERNATIONAL PRESS EXCHANGE

Trainload of Manikins Used as Ruse by Russians



French Trench Equipped with Barbed-Wire Doors Placed 100 Yards Apart. If the Enemy Gets into the Trench the Doors are Locked to Impede Progress

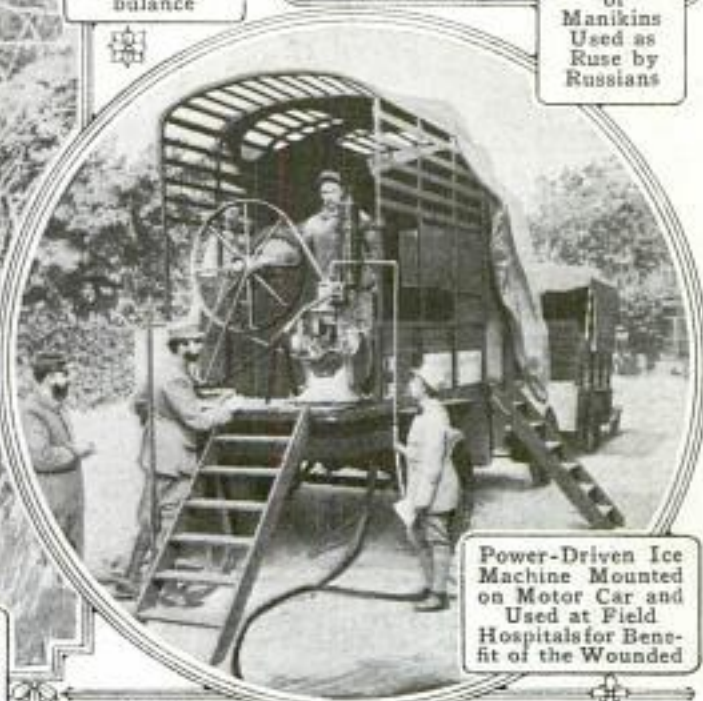

Power-Driven Ice Machine Mounted on Motor Car and Used at Field Hospitals for Benefit of the Wounded

COPYRIGHT, UNDERWOOD & UNDERWOOD

BURIAL GROUNDS OF EUROPE'S FALLEN SOLDIERS



Military Burial
at the Front,
Showing Deep
Trench Filled
with Dead after
Severe Battle

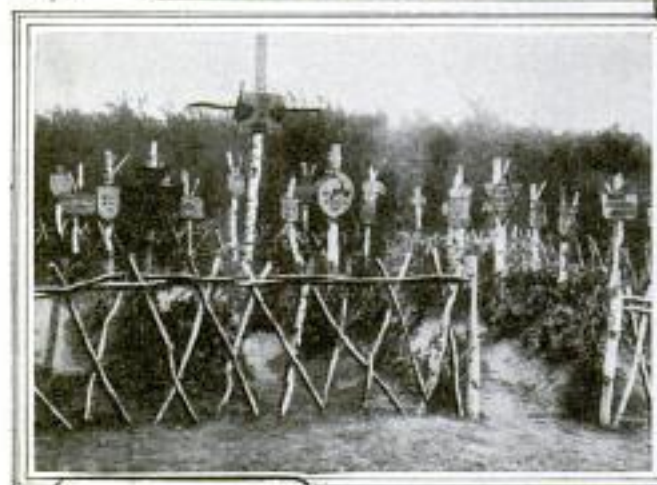

Germanic Cemetery
on Road between
Przemysl and Lem-
berg in Which Many
Soldiers Who Fell
in the Eastern
Struggle are Buried



This Aerial
Propeller
Marks the
Grave of a
Russian Air-
man Who
Fell in
Galicia



French Farmer Cultivating
Land Dotted with Graves
of Many Soldiers

Utility Sales Co.
Auto Power Co. La Porte, Ind.

Made by ~~La Porte Motor Mfg. Co.~~ POPULAR MECHANICS

863

DEVICE MAKES AUTOMOBILE
500 INTO POWER PLANT

For Ford Cars

Transforming an automobile into a power plant for operations about the farm, shop, or garage where belt drive is required, is quickly and easily accomplished by the use of a simple apparatus that has just been placed on the market. This apparatus consists of a frame which serves as a lifting jack, on the rear of which is mounted an axle carrying two bearing wheels and a belt wheel. In using, it is placed with the bearing wheels against the rear wheels of the car and with the jacks under the rear axle. The car wheels are then raised clear of the

ground with the jacks, and the levers are clamped, an operation that brings the bearing wheels firmly against the car wheels. In this position the power from the car is transmitted to the belt wheel and through this to the machine

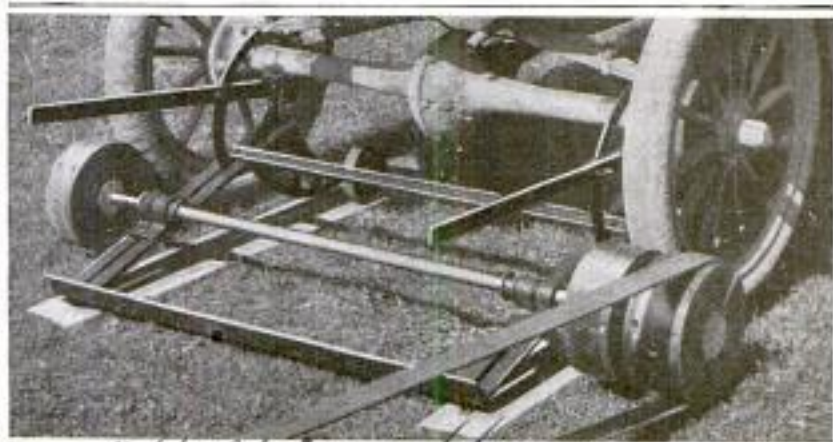

"Helping Henry"
With This Apparatus an Automobile is Quickly and Easily Transformed into a Power Plant for Operations Where Belt Drive is Required

car wheels are then raised clear of the

that is to be driven. The apparatus is quickly and easily placed in position.

67's GREAT SECTIONS OF AFRICA MADE DESERT
BY DRYING UP OF SURFACE WATERS

It has long been known that the two "dry continents," Asia and Africa, were gradually becoming drier, but the rapid rate at which the latter continent is losing its surface waters has only recently been revealed, through a report made public by the Smithsonian Institution. The alarming feature of this condition is that it is in no sense local, but affects practically the entire continent. Within a period of less than 50 years thousands of square miles of once fertile land in widely separated districts have been transformed into desert, the earth having apparently acted much like a gigantic sponge in absorbing the surface waters. So serious is the condition that now exists in Africa that it is enough to give some grounds for the belief held by a famous French astronomer that the continuous drying up of the earth will gradually result in the destruction of all life.

As a result of this increasing dryness some of the biggest bodies of

water in Africa have been seriously affected. Lake Ngami, for example, located about 1,000 miles northerly from Cape Town and once a lake of importance, is now a marsh threatened with speedy extinction, and there is every reason to believe that the surrounding country will soon become hopelessly sterile. About 2,000 miles northeast of Lake Ngami is Lake Rudolph, in British East Africa. This lake, the center of the drainage of the Abyssinian highlands and of a large part of the great equatorial plateau, is shrinking at an alarming rate.

The most serious case of the damage wrought by the increasing dryness of the African continent, however, is that of the Waterberg, a district comprising thousands of square miles in northern Transvaal. The name Waterberg was given this country for the reason that it was copiously watered by lakes, springs, and streams, and was dotted with marshes. It was an exceedingly fertile land and was the last stronghold

Smithsonian Institution
Oct. 2, 1915

of the big game of northern Transvaal. Today, after the culminating drought of 1913, it is practically a desert, with dried-up watercourses and springs, dead orange groves, some of which are over 50 years old, forests centuries old that are now lifeless, and desolate pasture lands that are devoid of cattle, or other animal life. There are few wild animals remaining in the Waterberg, and the fields where fine crops once grew are now parched and dead. Last year there was no running water in the entire Waterberg, while in the north of the district there is a tract comprising 4,000 square miles where not a drop of water, running or stagnant, could be found above the surface of the ground. The great Limpopo River is dry for its entire course through this district, and it is only by digging deep in its sandy bed that drinking water can be obtained.

Over everything in the Waterberg lies the silence of absolute lifelessness, the once fertile land having been taken over, apparently for all time, as a part of the desert. For four and a half hours every day the temperature is never less than 100° F. The heat combined with the absence of moisture has had a striking effect on the habits of such animals as remain. The nocturnal ant bear is forced to search for its food in broad daylight, since the ground has become so hard that the ants cannot be dug out in a single night. Most of the nocturnal beasts of prey hunt during the night as well as the day. Contrary to their habits, leopards on one occasion raided a camp in the early afternoon. Baboons, usually afraid of the dark, seem never to sleep, but prowl about day and night in search of food in any form. Animals not well equipped to dig for water, follow those more fortunate and use their water holes, the wart hogs particularly being followed all day long by a retinue of other animals awaiting an opportunity to slake their thirst. On account of the heat and drought the wild dogs that infest the country have become more savage than ever, driving in packs day and night and attacking all

animals. They are even credited with having caught and killed an ostrich, previously an unheard-of thing. A party of travelers digging for water in the bed of a dried-up stream unearthed a living crocodile, also in search of water, more than four feet below the surface. Certain species of white ants are apparently the only kind of animal life not affected by the extreme conditions. Vast numbers of these ants come out of their holes at midday, form in a compact ball and lie in the sun, although the ground is so hot that the bare hand cannot stand contact with it for more than two or three seconds.

One of the things for which the Waterberg was famous was its sweet grass. This is gone, and in its place has come a coarser sour grass that has peculiar drought-resisting qualities. The seed of the sour grass is one of the marvels of plant life, its actions under certain conditions being such as to raise a doubt as to whether it is really a seed or an insect. The body is shaped like a torpedo and is equipped with a long tapering tail. When magnified, the seed is seen to be studded all over with sharp, stiff bristles, set backward, while on the head is a horny spike, sharp as a needle, with a crown of harpoon points at its base. The seeds not only drift about with the wind but cling to the backs of animals, and even penetrate the skins of animals and human beings, causing both discomfort and danger. When water is sprinkled on a bunch of the seeds a curious phenomenon results. The seeds first disentangle themselves. The seed head is next lifted clear of the ground by the tail and the needle point is then thrust into the damp soil by a continuous pressure of the bent tail against the ground, this movement continuing until the seed is imbedded in the soil. The whole operation takes about 15 minutes. Here the seed lies dormant until a little rain falls, which insures the safe sprouting of the plant. Thus equipped, the sour grass thrives in spite of the severe drought against which the sweet grass is helpless.

383
CRUDE-OIL ENGINE WORKS AT LOW PRESSURE

A crude-oil engine that operates on a principle somewhat similar to that of the Diesel engine, but at a lower pressure, has recently been introduced, and is said to be giving satisfaction as a reliable and cheaply operated power plant. In this engine, which is of the four-cycle type, the crude oil is first taken into an auxiliary cylinder where it is agitated and where some of the lighter hydrocarbons are separated from the oil. These light hydrocarbons ignite at a considerably lower temperature than crude oil, and it is the utilization of this condition that forms one of the principal features of the engine. This cylinder has a connection with the main cylinder consisting of a hole about the size of the lead in a lead pencil. During the compression stroke of the piston of the main cylinder a small portion of the air contained in this cylinder is forced through this hole into the auxiliary cylinder, and owing to the resulting compression the light hydrocarbons are fired. The resulting explosion forces the oil, which constitutes the main charge, into the main cylinder where the air by this time is at a burning temperature, and the main explosion takes place. It is said that back-firing and preignition are impossible, and that

2 to 150 ft. - fuel 6 lb. per hour.
 cost about 1/2 cent per H.P. hour.
 weighs 350 lbs. in 75 H.P. size. 250 lbs. in smaller.

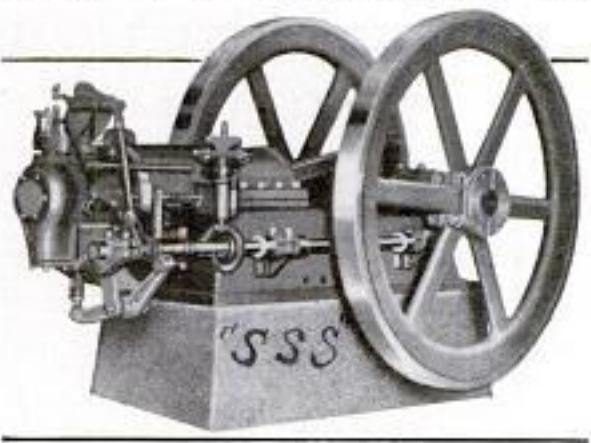

New Crude-Oil Engine in Which the Charge is Forced into the Main Cylinder by the Preliminary Explosion of Light Hydrocarbons

the engine can be operated at a cost of approximately one-half cent per horsepower-hour.

546
MARKSMAN TRIMS TALL TREE WITH HIGH-POWER RIFLE

It is approximately 120 feet from the ground to the lowest branches of a giant eucalyptus tree which stands alone, sentinellike in the Santa Clara Valley near San Jose, Cal. The total height of the tree is about 140 feet. Its present form is due to trimming, which was accomplished in a most unusual way. The owner of the ranch on which the eucalyptus stands is



Shooting Off the High Boughs of a Tall Tree

adept in handling a rifle, and this he used in stripping off the branches. A large number of shots were required to sever some of the big limbs, but the feat was ultimately accomplished, as the gaunt tree bears witness.

244
BACK FILLING PIPE TUNNEL THROUGH AUGER HOLES

Interesting engineering work was recently done in completing a section of the new Denver water conduit which connects the north tower of Marston Lake with the city piping system. At Loretto Heights, in order to keep the line at the required depth, it was necessary to place the 48-in. main at a depth of 36 ft. beneath the ground. A tunnel was bored for a distance of

Denver Union Water Co.
 Denver, Colo.

Fred W. Newman, 2618 Durant Ave., Berkeley, Calif.

850 ft., instead of making a cut. This subsequently had to be back filled. To obviate the necessity of drawing the dirt into the passage from the portals and shafts, 8-in. auger holes were bored from the tunnel to the surface of the ground at intervals of about 10 ft. These were then enlarged by workmen and loose dirt filled through them

GRAPE JUICE CONCENTRATED BY FREEZING METHOD

According to a report of the Department of Agriculture a unique method of concentrating grape juice has been discovered in the government laboratories. The process is considered a most important one for the wine industry, and among other things provides a way to improve vintages made from cheap, coarse varieties of grapes. In concentrating it by the new method the juice is first frozen, and the resulting ice crushed into fine pieces and placed in a machine, which by centrifugal force causes the sirup and sugar to be separated from the water. A gallon of liquid is in this way reduced to about a quart of thick sirup, which retains to a remarkable degree the original color of the grapes. The acidity of the juice is also lessened materially, for the cream of tartar is crystallized with the ice. Subsequent sterilization of the product enables it to be preserved indefinitely and used, if desired, for flavoring purposes.



This Shows a Row of the Craters Enlarged from the Auger Holes

into the underground cavity. To pack the earth about the pipe, water was turned into the craters thus formed.

quent sterilization of the product enables it to be preserved indefinitely and used, if desired, for flavoring purposes.

581

ACCURATE HEAT TREATMENT IN ROTARY FURNACE

To secure a dependable and uniformly tempered steel spring is a troublesome process, particularly with the older types of steel furnaces with their drafty doors and generally uncertain action. One of the chief difficulties, according to furnace men, is to keep the temperature controlled accurately, and to prevent undesired materials from the furnace itself from combining with the steel during the tempering

period. Then, too, the older types of furnaces, besides turning out a product of uncertain composition, present difficulties from a manual viewpoint—it is too hard to get materials into and out of the devices while in action, resulting in limited production.

A new furnace has recently been put in action at the plant of a Detroit company, which is expected to eliminate many of these defects and to turn

*Detroit Steel Products Co.
Detroit, Mich.*

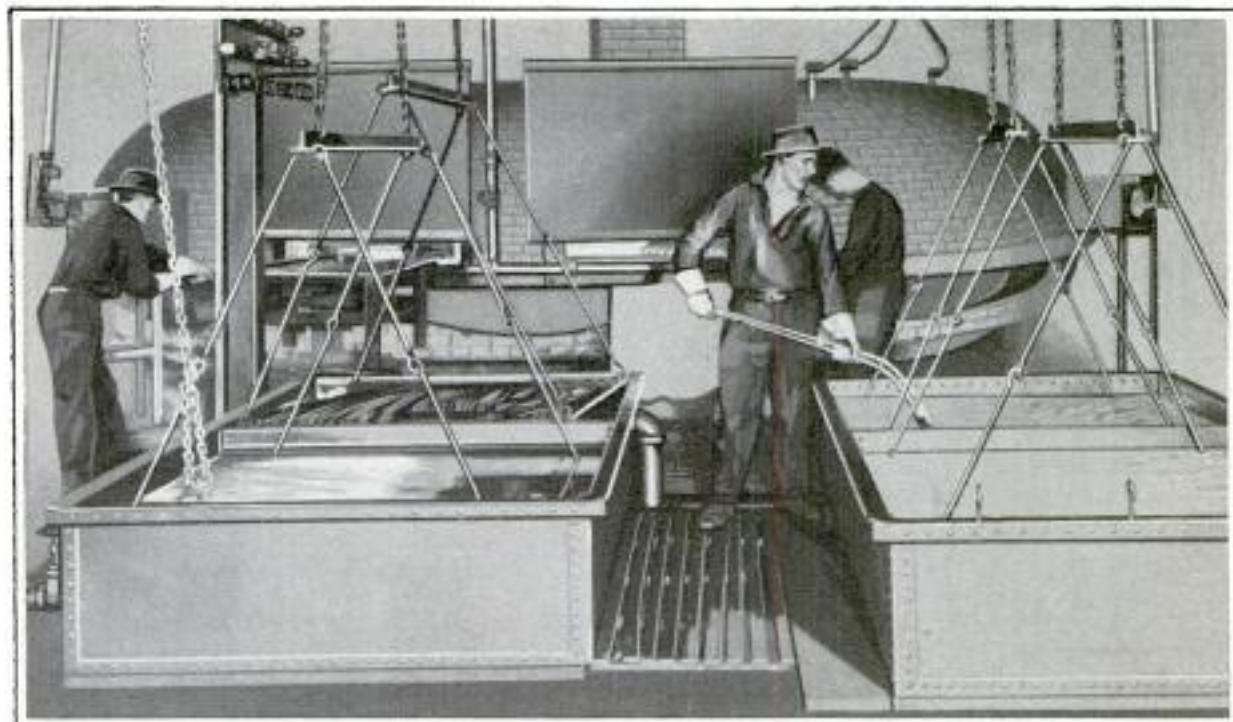

The Rotary Furnace in the Background Heats Automobile Springs Uniformly and Delivers Them at the Proper Temperature for the Oil-Tempering Baths

out products with an accuracy and speed never before obtained. Its specialty is the heat treating of automobile springs. Men place the leaves, or overlapping flat strips, of the typical automobile spring on the hearth at one point, and the whole apparatus turns about a central axis, delivering the leaves to another set of men farther on, hot oil fires within the furnace having in the meanwhile raised the leaves to a predetermined temperature. This usually ranges from 1,450 to 1,575° F., depending upon the particular requirements of a given kind of spring, and 10 electrical pyrometers—that is, thermometers capable of registering high temperatures with the aid of electricity—enable accurate check to be kept on the hotness of the springs at all times. Seven men are required to operate the furnace, and it can turn out 50,000 lb. of steel per day, said to be four times the capacity of the ordinary furnace of the kind. The hearth is 26 ft. in diameter, and revolves once every 20 or 30 minutes.

Approximately 3,000 volumes have been contributed toward the reconstruction of the Louvain University library.

79 MAKING NEW ANODES FROM SCRAP NICKEL

By using the oxyacetylene flame to weld together the pieces of worn-out nickel anodes, which have heretofore been scrapped and sold at less than half the cost of the new material, one company is now producing practically new anodes at a trifling cost. As the anodes are eaten away by the solution they are turned over to an oxyacetylene welder who "tacks" them together, using from two to four pieces, depending on the size and weight of the anode desired. The flame is also employed in removing the brass hooks used for supporting the anode while in the solution. No flux is necessary in the process, and the only new material used is a piece of nickel that serves as a filling rod.



The Prest-o-Lite Co. Inc.

Indianapolis, Ind.

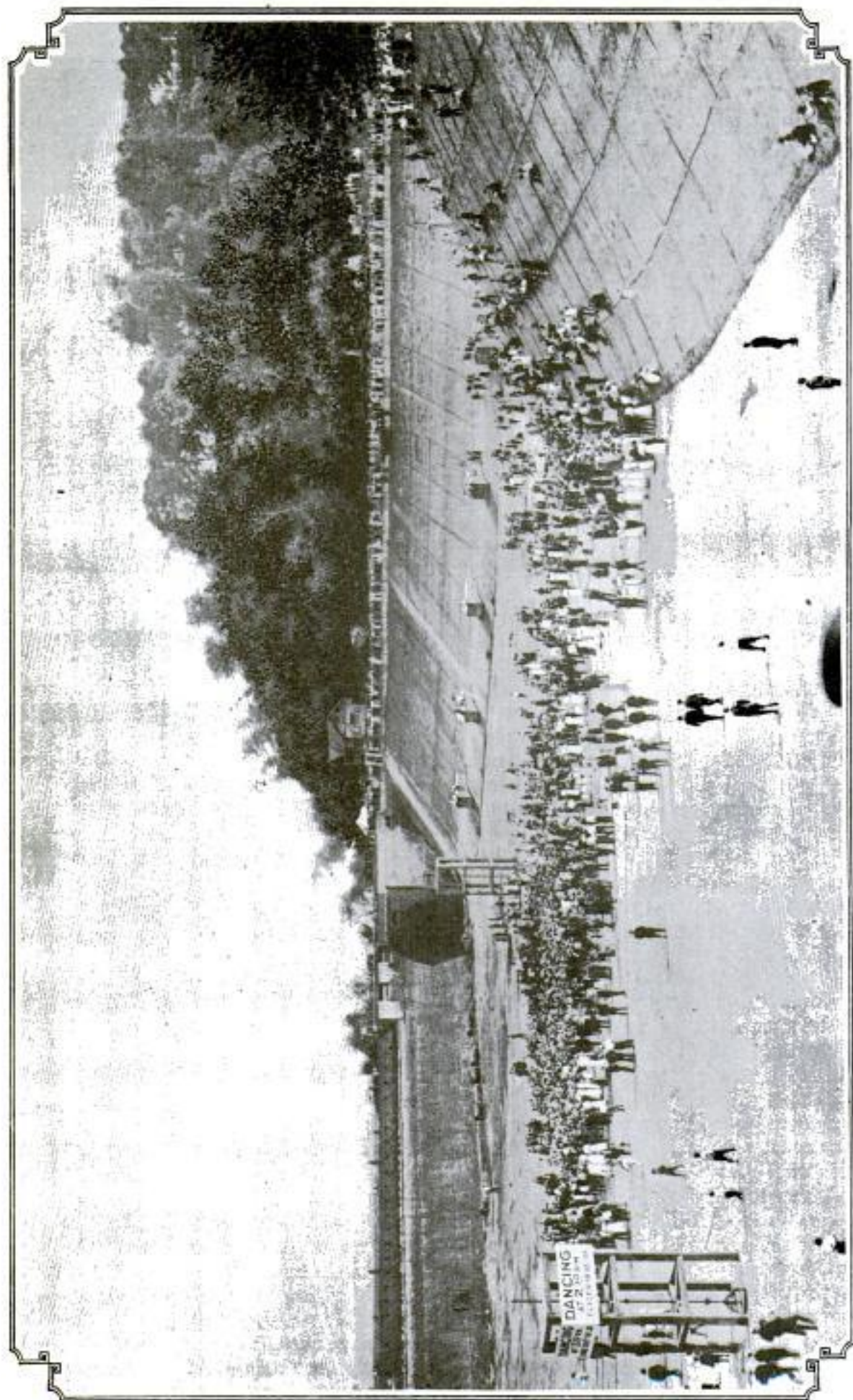

A Dance on the Concrete Floor of This Unused Reservoir Was the Novel Feature of a Municipal Picnic Recently Given in Ohio

**UNUSED RESERVOIR SERVES
555 AS DANCE HALL**

The leading feature of a municipal picnic given by a city in Ohio was a dance in which the basin of an unused water reservoir was pressed into service as a dance hall. The concrete floor served admirably for the purpose and furnished all the space needed by the hundreds of dancers who availed themselves of the novel privilege. The music was supplied by a brass band which occupied a temporary stand erected in the middle of the reservoir.

**LARGE TRIANGLES ARE USED
549 IN CANADIAN SURVEY**

G. A. Monitor 9-4-15
During the past summer triangles of uncommon size were employed by engineers in making a survey of the western Canadian boundary line between Queen Charlotte Sound and Prince Rupert. In one case a distance of 135 miles was measured by this method, the work being done at night with the aid of powerful lights which were used to identify the distant point to be sighted. The transit was placed on a mountain at a sufficient height to overcome the earth's curvature and escape intervening obstructions. The accomplishment is interesting, not because it is unique, but because it is unusual. The geodesist has worked with triangles having sides 200 miles in length. An instance of this was recorded some years ago when a survey was made across the Mediterranean between Spain and Africa.

**368 APPARATUS FOR FITTING
DOORS**

The elimination of the uncertainty and loss of time usually involved in fitting a door to its opening is the purpose of a new door-fitting apparatus that has made its appearance on the market. This apparatus consists of two parts, a frame and an electric cutting machine. The frame is made with sliding joints so that it can be adjusted to any size. It is simply placed in the

door opening, and when adjusted to a fit the joints are tightened. The frame is then laid and fastened over the door

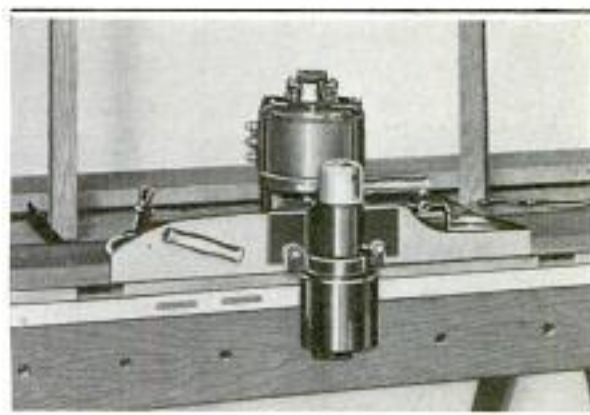

How the Cutting Machine is Used in Connection with the Adjustable Frame to Cut the Door to the Right Size to Fit the Door Opening

to be fitted and the cutting machine is brought into service. This machine is equipped with a guide that works against the edge of the frame so that the door is cut down the right amount to make it correspond to the frame. By means of an adjustment controlled by a lever, any desired bevel can be cut.

**588 BALLOONED MOTOR-CAR TUBE
RESEMBLES HUGE SAUSAGE**

For local advertising purposes a motor-car tire dealer at Morgantown, W. Va., recently ballooned an inner tube to quite an enormous size. The distortion was effected by stretching and weakening the walls of the tubing; a thing which required time and considerable patience. Subsequently a coat of red paint was applied, giving it the appearance of a great wiener wurst. This had an injurious effect upon the rubber, causing it to deteriorate and the tubing to burst after several days.



*B. F. Woodhick Co. Akron, Ohio.
Byman & Wheel, adv. Dept.*

*Brotherhood of Carpenters & Joiners Co., Inc.
51 Third St.
Milwaukee.*

603 **STREET SEMAPHORE HAS INTERLOCKING ACTION**

A new semaphore for the regulation of street traffic has recently been tried out in eastern cities. A policeman operates the device in lieu of his usual club and whistle.



Solid Comfort Provided Eastern Policemen Regulating Traffic Congestion at Street Corners

Inventor: E. H. Peck
of above company

In its ordinary form the contrivance is built on a pole, and consists principally of two pairs of semaphore arms at right angles to each other. These are controlled by interlocked levers on the lower part of the pole. Because of the interlocking, a policeman cannot give both streets at an intersection the clear signal at one time. A sheltering umbrella is provided for hot summer weather or rainy days, and a platform and seat conduce greatly to the officer's comfort. At night the machine shows a red and green light in addition to the "Stop" and "Proceed" positions of the semaphore arms. A gong automatically gives forth signals corresponding to the usual one or two blasts of a traffic policeman's whistle. Much superiority to the unaided policeman is claimed for the device, permitting crowds to be handled more promptly and with less chance of misunderstanding. The unmistakable character of the signals is one reason for this.

706 **ANCIENT PORCELAIN FACTORY REOPENED IN CHINA**

The famous King Teh Cheng porcelain factory, which from the year 1396 furnished all the fine porcelain for the royal palaces of China, is to be reopened immediately, according to a Chinese newspaper, and a grant of \$20,000 has already been made by the president of the republic for this purpose. This factory was partly destroyed during the revolution in which the republic was established and the various samples and patterns kept there were divided among the leading revolutionists. While the making of porcelain has been one of the leading Chinese industries for generations, this factory is said to be the only place in which the ancient ways of making porcelain, with the beautiful

ancient colors and designs, has been preserved. The factory will not only be employed in producing porcelain for the market, but will have a special department in which porcelain of the highest quality will be made for presentation to the rulers of other countries.

608

A BRIDGE WITHIN A BRIDGE SPANS WESTERN RIVER

The Arroyo Seco is a small California stream, but the valley through which it flows is wide and the surrounding hillsides are steep and difficult to climb. The main automobile roadway between Pasadena and Los Angeles had to cross the stream, but motorists objected to descending into the valley, only to be met after crossing the wide bottom of the basin, with a sharp ascent on the other side. So a large bridge was constructed, spanning the whole valley, and giving a level speedway over what was formerly

Chas. Alma Byers

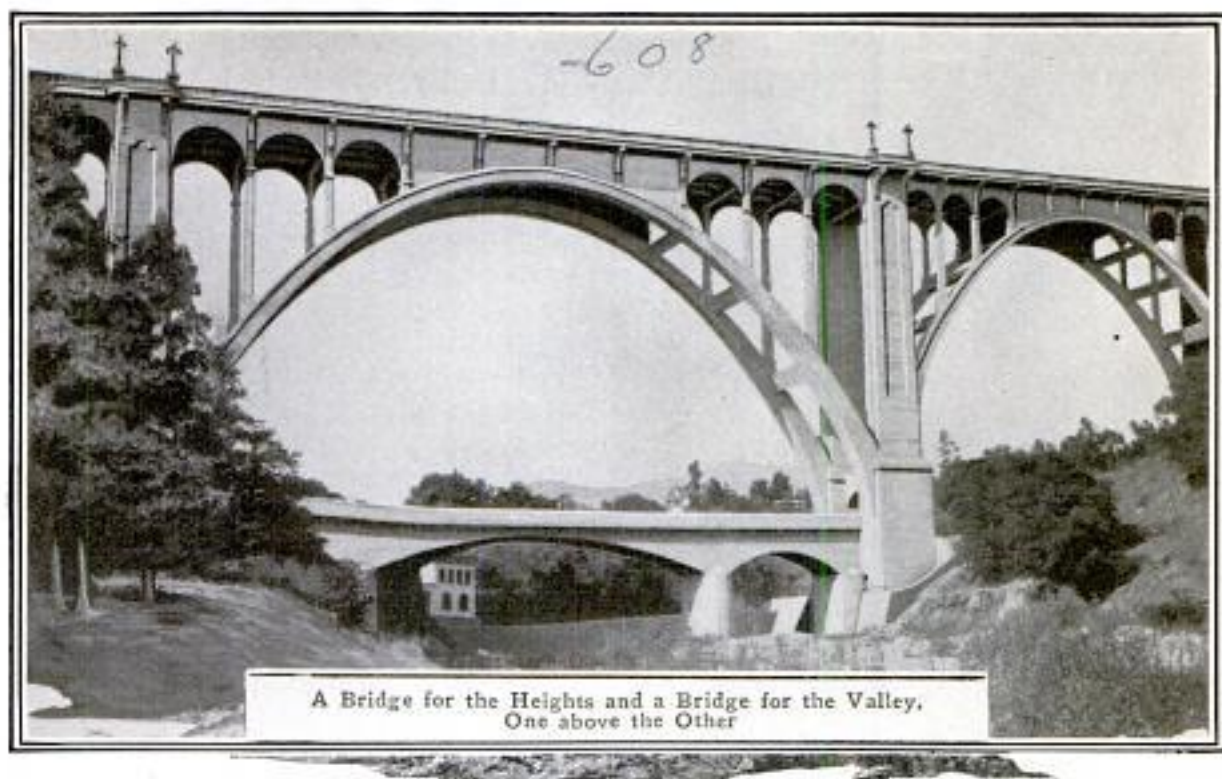

a difficult stretch of country. But this left the residents of the valley in an unusual predicament. To cross the river, they were confronted with the necessity of climbing the steep hills back of their homes in order to get onto the high bridge, and then, after getting to the other side, a corresponding descent had to be made. So, for their benefit, a second bridge was built directly under the first one, and even between its high piers. The result was a "bridge within a bridge," and neither of them very small structures. Both are of concrete, and together are said to have cost in the neighborhood of a quarter of a million dollars.

REFUSE COLLECTOR BUILT 451 IN KITCHEN SINK

Quite an interesting departure from the standard plan of kitchen-sink construction has been marked by the incorporation of a refuse trap as an integral part of the drain system. This idea has been developed by a western inventor who has provided a depression in which a strainer pail is counter-sunk. The waste pipe connects with this. The refuse collector is made of

white enamel and fits snugly in place, becoming a part of the sink. Dishes may be rinsed and cooking utensils scraped in the sink without danger of clogging it, for the sieve in this case is fine meshed. A bail is attached to the strainer to facilitate its removal when it is wished to empty its contents. Another convenient feature of the new sink is the presence of drawers and a roomy closet, which are provided beneath both ends of it.

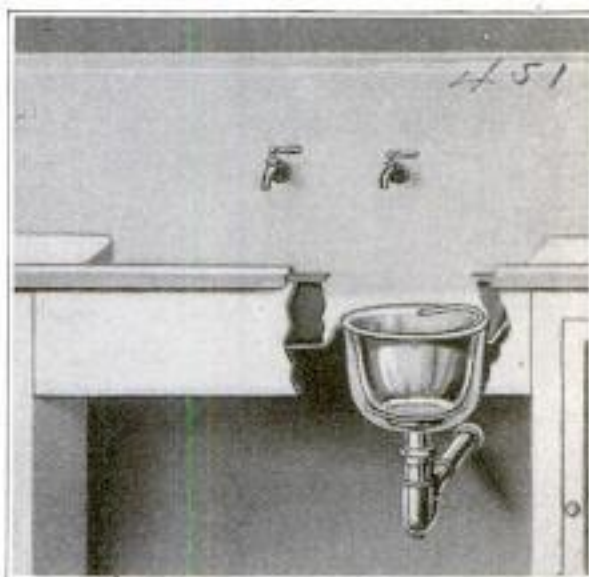

The Refuse Vessel Fits Snugly into the Depression and Becomes Part of the Sink

See Nov 15-757
Improved Sanitary Fixtures Co.
R. 612 Metropolitan Bldg.
(Parish Bazaar) Los Angeles, Calif.

**ELECTRIC SAND SIFTER THAT
617 OUTWORKS TEN MEN**

Many modern foundries are being equipped with electric sand sifters, or what foundrymen call "riddles." For



This Electric Sand Sifter is Suspended upon a Trolley and may be Moved Anywhere about a Plant

this innovation several advantages are claimed. Among these claims is the assertion that it will do the work of 10 men using older methods, and that the machine is much easier handled. The mechanism of the new riddle imparts to the sieve a gyratory motion, cleaning and sifting the sand as fast as it is poured in. Only a small motor is required to operate this new sifter, $\frac{1}{16}$ hp. being the usual size. A trolley permits its easy transportation.

**BOSTON'S NEW BALL PARK
507 HAS NOVEL FEATURES**

Permanency in construction and convenience in arrangement are two of the outstanding features of the Boston Braves' new home, which is credited as being the finest baseball park in America. The grand stand and main bleachers, providing seating space for about 37,000 persons, as well as the administration building and other appurtenances, are built of steel and reinforced concrete.

The field is depressed 17 ft. below the street level, and is provided with a complete drainage system. It is surrounded by a 10-ft. wall, and extends 520 ft. in a straight line from the home plate, which is 60 ft. from the central part of the grand stand. The foul lines running from this same point are carried out to a distance of 375 ft. on each side. The low level of the diamond has made it possible for two-thirds of the grand stand and bleacher structures to be built solidly on the ground, which materially lessens the climb from the outside to the top tier of seats. All of the 18,000 seats in the grand stand consist of comfortable armchairs. There are 37 rows of these, spaced to provide plenty of room for their occupants. On the roof of the grand stand, which is supported by steel columns and trusses, are located the press boxes, a writing room for correspondents, and a room for their telegraphers. The grand stand is of heavy construction and has been designed eventually to support a gallery, should the present capacity prove inadequate.

A tunnel gives access to the home bench behind third base. The clubhouses for the players are situated beneath the grand stand and are fitted with the usual accommodations. There is a total absence of stairways at the park, all of the elevations being reached by concrete ramps. Trackage for about 42 cars is provided within the grounds, and is reached by inclines from the various sections of seats. At the park entrance there is a row of 28 concrete

"The Coombe-Lyons atory. Foundry. Rivelle"

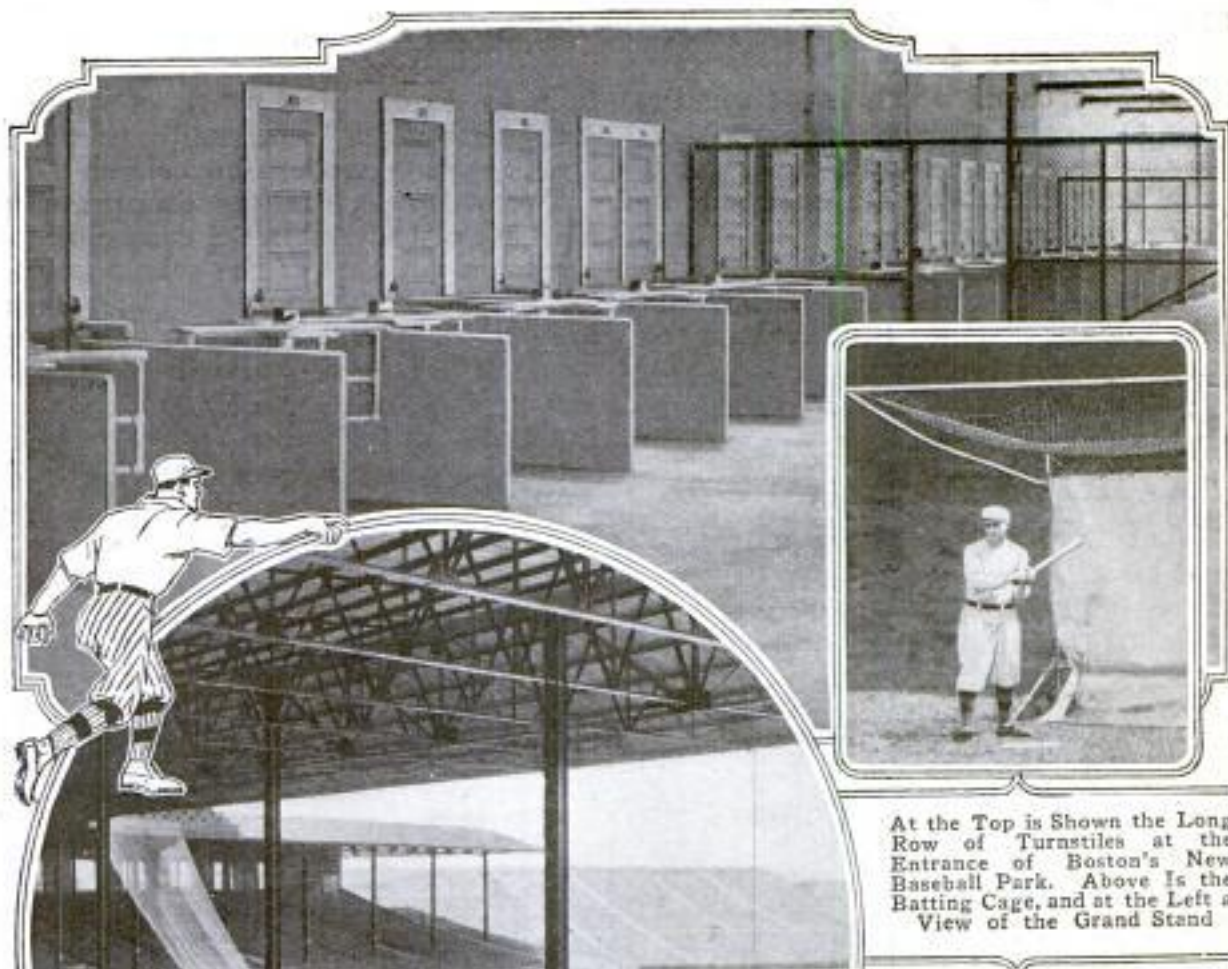

At the Top is Shown the Long Row of Turnstiles at the Entrance of Boston's New Baseball Park. Above is the Batting Cage, and at the Left a View of the Grand Stand

The Photograph at the Right Indicates How Gently Sloping Ramps Take the Place of Stairways, While Below is Shown a Front and Side View of the Administration Building at the Entrance to the Grounds



COPYRIGHT, BOSTON PHOTO NEWS CO.

→ 114 State St. Boston
Copyrighted material
Mass

stalls, in each of which is a turnstile. Past this point the passageways leading to the various sections of the grand stand and bleachers are inclosed by fences of iron netting. The ticket booths are situated within large concrete columns immediately back of the arcade extending along the front of the administration building.

374

HOUSEKEEPING MECHANICS TAUGHT IN MODEL SCHOOL

That the young women of Hollywood, Cal., may be instructed intelligently in various important branches of housekeeping which ordinarily re-



The Metal-Working Class at the Hollywood High School: Here the Young Women are being Shown the Inside of a Water Heater and Instructed in How to Repair It

ceive little or no attention in domestic-science classes, a high-school course has been inaugurated. The many mechanical devices which have been developed for lightening housework are dismantled and their principles explained. The purpose is not to make master plumbers of the girls, but so to equip them that if necessity demands it they may be able to fix a leaky faucet, repair a defective gas range, take proper care of a sewing machine or vacuum cleaner, and know instantly

how to do or direct work of similar character which continually presents itself in every modern household.

Every-day problems of almost every kind are considered in the course of instruction. A part of the school is finished off like a bungalow, and here each girl not only learns to cook and sew, but is taught to arrange furniture artistically, serve daintily a dinner or luncheon to a number of guests, and provide an evening's entertainment in accordance with her own ideas. Economical purchasing is an important feature of the training. Trips are made to the municipal market, where the art of getting good values is taught. In this the average wage-earner's income is taken as a basis.

362

TRAINS PROTECTED AGAINST BULLETS BY STEEL FENCE

Along a Canadian railroad that passes the end of a rifle range it has been found necessary to build a solid steel fence to protect the trains from stray bullets. The railroad is located near the top of a high and precipitous hill. Since it is about 150 ft. above the rifle range and is at a considerable distance from the firing station, there was thought at first to be no danger from bullets. When the railroad had been in operation a short time several bullets went through the windows of a train, narrowly missing some of the passengers, and the steel fence was then built. The fence is as long as the range is wide and extends well above the tops of the cars. It is supported on steel rails driven into the hill under the track.



Steel Fence Erected for the Protection of Trains on a Canadian Railroad That Crosses the End of a Rifle Range

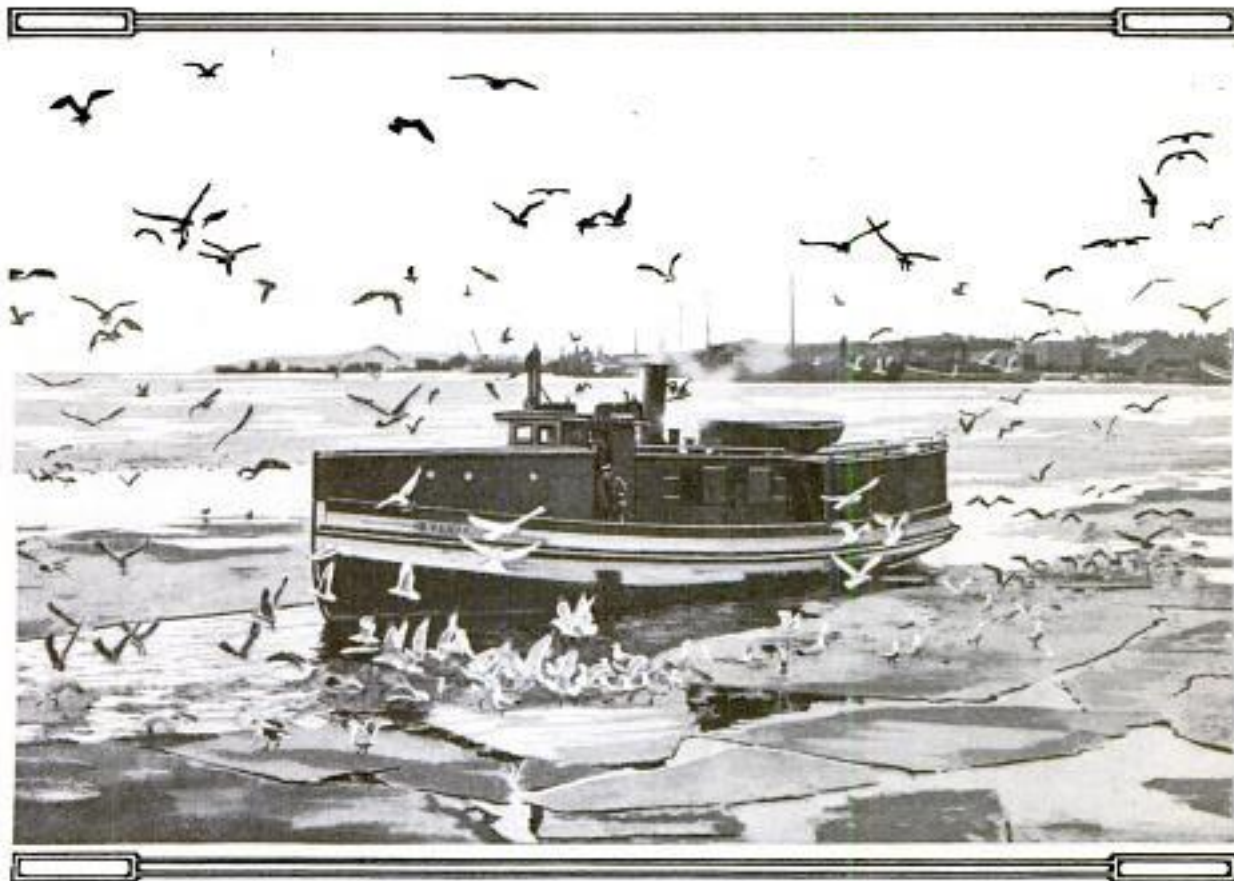

The Ice-Breaking Tug "Sylvia" Opening a Way through the Ice in Green Bay. The Gulls have been Attracted by the Opportunity for a Dip in the Channel Made by the Tug

POWERFUL TUG BREAKS ICE
9687 FOR FISHING FLEET

Connected with the fishing fleet that operates in Green Bay, on the western side of Lake Michigan, is the "Sylvia," an ice-breaking tug that is said to be the most powerful in the world of its size. This tug is the subject of a wager that has been open for years but has never been taken. The bet offered is \$100 to 50 cents that no tug of the same size afloat is able to equal the "Sylvia" in ice-breaking feats. The "Sylvia" is 60 ft. long and 15 ft. wide, and has succeeded in breaking up the ice in the bay winter after winter when other and larger boats have failed.

H31
MOTOR-CAR ROBE BRACKET
WITH LOCKING JAWS

For use in the tonneau of a motor car, a robe rail has been devised which has movable jaws between which coats and wraps may be locked securely and left unguarded without danger of being

stolen. These gripping members are faced with pyramid rubber so that they hold firmly and do not injure a garment. They are controlled separately by an individual key, a few turns of which serve to open or close them. The two outer, or stationary, jaws are designed so that they support the rod. When robes or articles of apparel are left in a car, locked in this manner, they cannot be taken away unless the thief steals machine and all.

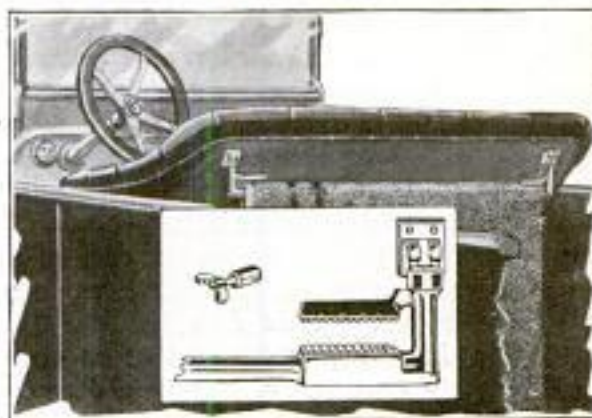

The Keys are Made in an Unlimited Number of Patterns, so That the Owner of One cannot Use It to Unlock a Rail in a Car Not Belonging to Him

Minnesota Motorob.
205 Temple Bldg, Duluth,
Minn.
(Philip G. Brown)
 Copyrighted material

*112-9379 - Philip Brown Brown 1/25/15
 Duluth Minn. Filed Dec 11, 1914, Ser. 876726
 Tel 45-137 Gopher 12-11-1075*

Bruce Daniels, 412 East 28th St.
Indianapolis, Ind.

Keystone Weekly 9-28-15

Submarine
War
876

POPULAR MECHANICS

ILLUMINE STEAMERS' SIDES WITH MOTOR-CAR LIGHTS

Neutral ships entering the so-called "war zone" carry their names and ports of registry displayed in large letters on their sides. In order that these signs may be distinguished at night by commanders of belligerent battleships and submarines, they are illuminated. Many of the small freight steamers at present engaged in the transatlantic

recent change to electric systems. These searchlights are mounted on arms, extended from the sides of the ships, and adjusted so that their shafts of light play over the banners.

684

PROPERTIES OF PLATINUM ARE STUDIED BY EXPERTS

Though more valuable than gold and greatly used in the arts and sciences, there have been many things about

platinum not fully known or understood. Particularly is this true of the metal's precise physical and chemical properties. The United States Bureau of Standards recently undertook to investigate these things, and some interesting developments were a result.

One accomplishment of the bureau was the invention of a delicate thermoelectric test for the purity of platinum. By its aid a rapid estimate of the amount of foreign matter in the metal, such as iridium or iron, may be made—and without injuring the metal in any way. Large purchasers of platinum ware are said to be using this test extensively. The bureau also obtained data by which it is now possible to predict accurately what will be the loss in weight of a platinum

crucible when heated, thus enabling certain tests in analytical chemistry to be made more exact than formerly.

For the 12 months ended August 31, 1915, the exports from the United States aggregated \$3,035,033,280, an increase of \$754,847,489 over the exports for the corresponding next-preceding period.

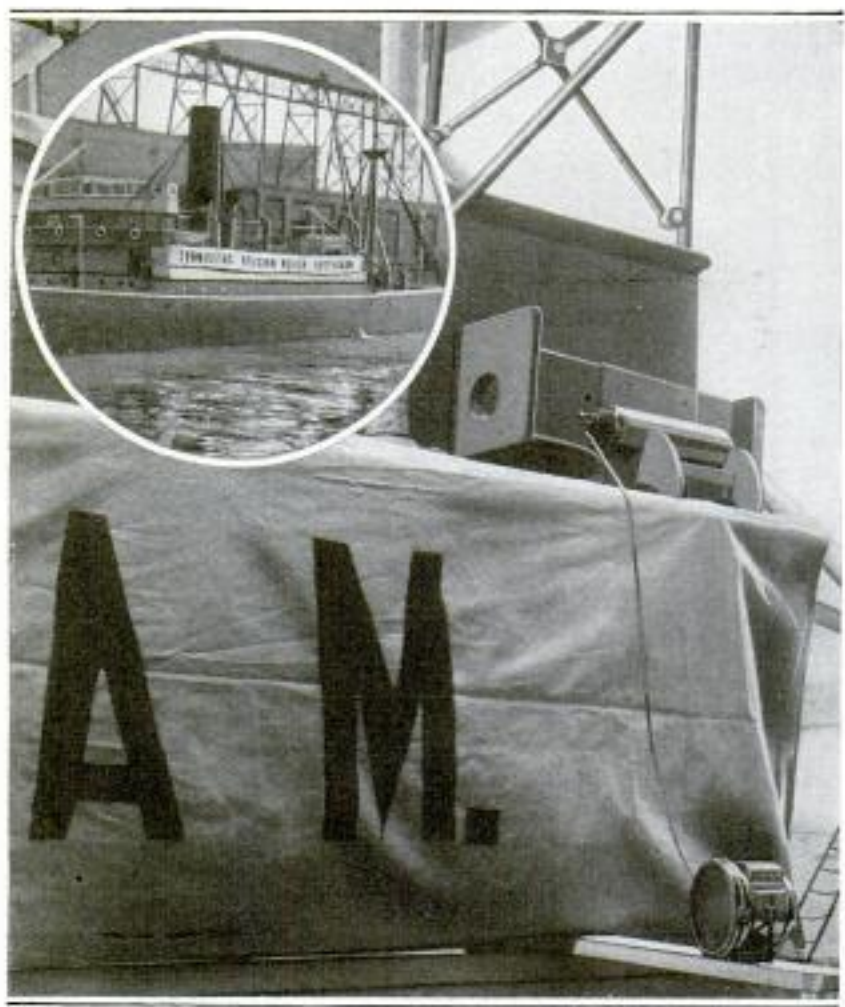

Freighter in the Service of the Belgium Relief Commission with Its Sides Marked by a Large Banner Which is Illuminated by Motor-Car Lamps Mounted at the Sides of the Ship as Shown in Lower View

service are not equipped with electric-lighting facilities, which has made it necessary for them to be provided with auxiliary systems for the illumination of their sides. This has led to the adoption in many instances of motor-car lighting equipment; powerful acetylene headlights supplied with gas from high-pressure tanks such as were almost exclusively used before the

E. M. Weaver, Long Island R. R. Co., Jamaica, N. Y.



The Arms Are Strong Enough to Stop a Motor Car if Its Driver Fails to See the Danger Warning

RAILWAY-CROSSING GATES

453 BARRICADE TRACKS

In an attempt to devise a crossing guard which will effectively hold back motor cars in cases of extreme emergency, an eastern railway company has made use of two 40-ft. spruce piles. These members, which serve as arms for the gate, are about a foot in diameter at the base and 8 in. thick at the tip. They are supported between posts by means of 1-in. bolts and are counterbalanced with 1,000-lb. weights. Fixed to the tip of each pole is a rope with which a gate is drawn down by a watchman, who then secures it by means of a large hook and chain. When the gate is lowered it is 3 ft. 6 in. from the crown of the roadway. At this height the poles are in a position to stop a motor car which has failed to heed the flagman's warning. The arms are painted with black and white spiral stripes.

MUSIC STILL PRINTED FROM PUNCHED PLATES

For more than a quarter of a century the method of making the original plates from which music is printed has remained practically unaltered. This is more or less interesting in view of the material changes which have marked the development of the general printing and engraving processes during the same period.

With the exception of the method ordinarily used in printing hymn books, in which each character is reproduced from a separate piece of type, the first step in the process entails the making of a "punched plate." This is the original negative, and is made today essentially the same as it was years ago. The plate itself is a composition of lead and zinc. The staff lines are cut into it with a ruling pen, after which the impressions of the various notes and marks are made by hand with punches.

When a large run is to be made by the publisher, a zinc etching is usu-



Making "Punched Plate" Negatives from Which Music is Printed

Walter Brinkman, 40 Limes St., Cincinnati, Ohio

*Infr: North Cross. Mfg. Co.
American St. & Lehigh Ave*

878.

*Phila.
Pa.*

POPULAR MECHANICS

Engineering News 9-9-15
**NOVEL RAILROAD BRIDGE FOR
678 RIVER IN JAVA**

ally made from this plate and the printing done from it in the regular manner. In other cases, however, the remaining part of the work is done by the lithographer, who makes a positive impression from the plate on sensitive paper and transfers this to a stone from which the printing is done.

170

SWIVEL VISE IS DESIGNED FOR BENCH AND MACHINE

Several advantages to the toolmaker and machinist are presented in a swivel

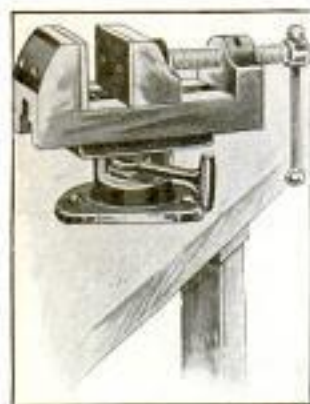

vise that has lately been brought out. This is so mounted that the upper section may be detached from the standard and used on a drill-press table, or in similar places.

At one side of the base is a lever, the adjustment of which locks or releases the device. On the under side of the mounting are three bosses that provide a level bearing on the bench.

8861

ACID-PROOF PUMP DESIGNED FOR USE IN MINES

For use in coal and mineral mines where the water is frequently of considerable acidity, a wooden pump has

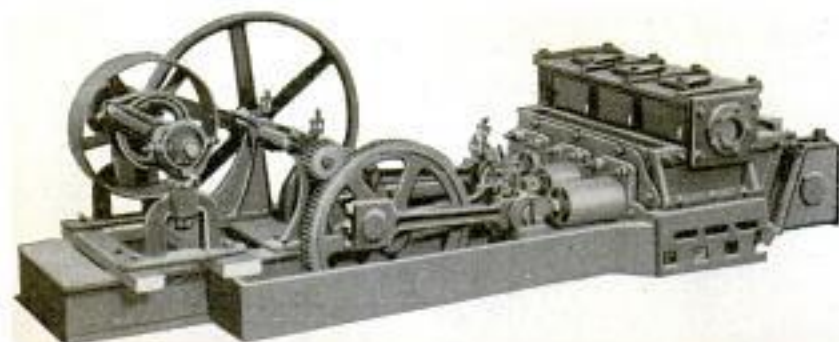

This Wooden Pump is Designed to Withstand the Corrosive Effects of Water Found in Mines

been invented to overcome the difficulty encountered by the corrosion of those built of metal. Practically the

only metal parts of this pump touched by water during its operation are the plungers, and these, by being kept well lubricated, may be protected from material deterioration. The cylinders, as well as the valve chests and plates, are made of wood and reinforced on the outside by metal castings. The valves are of the gravity type and do not require springs. An experimental pump of this kind has been in

use in an Ohio mine for approximately two years and is said to have required practically no repairing.

*N. E. Kuehner, Edit. Dept. Dispatch (X Dispatch)
Columbus, Ohio.*

Motor Ship + Motor Boat Oct 29-15

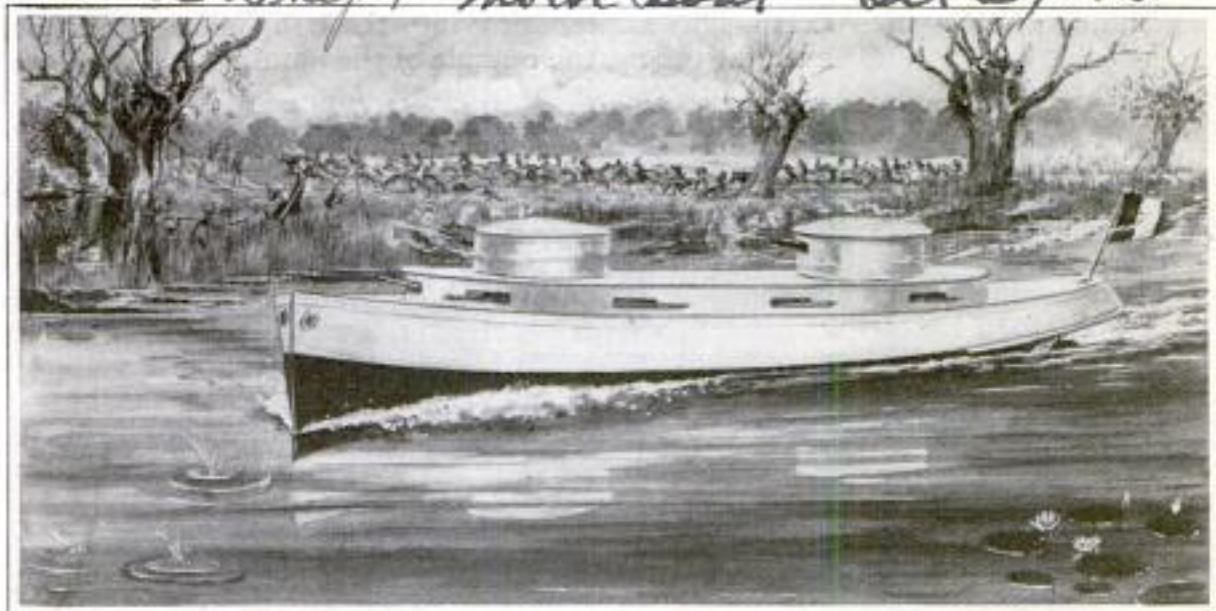

8936 Fast Armored Motor Craft Fitted with Revolving Turrets and Machine Guns

POSSIBLE WAR VALUE SEEN IN ARMORED MOTORBOAT

During the early part of the European war the Belgians made good use of a lightly armored motorboat on the River Dyle between Boom and Malines. The craft, having a length of about 35 feet, was protected by a double steel hull. The outer shell of this was about one-third inch in thickness, and the inner one approximately half that. The deck, carrying two revolving turrets, in which were mounted a pair of machine guns, was built over and provided with loop holes for military rifles. One officer, a helmsman, and 12 men constituted the crew. While cruising near Malines the boat was attacked by a relatively large body of German infantry and cavalry. The enemy failed to stop the vessel, was unable to kill any of its crew, and, moreover, suffered severely in the attempt, for the effect of the boat's machine guns was painfully apparent.

CA bulletin issued by the International Institute of Agriculture, at Rome, states that the crop of cereals grown in 1915 in the northern hemisphere exceeds the average crop of the past five years by more than 73,000,000,000 pounds.

FOUNTAIN SPONGE DEvised FOR VARIOUS USES

Fountain brushes both for painting and scrubbing purposes have been in use for some time, but a European inventor has recently adapted the same principle to a sponge. This is intended for washing surfaces from which sand or grit is to be removed. A nickeled pipe, which is shaped to fit the back of the operator's hand, is joined to the sponge and also connected to a piece



Water is Supplied to the Sponge through a Tubing
Connected with a Hydrant

*Julius Pintsch Co.
Frankfurt a/M.
Germany.*

of flexible tubing which extends to a water faucet or tank. The metal tube is held in place on the hand by a bracelet which fastens about the wrist.

CEILING BEAMS MADE OF VENEERED STRAWBOARD

Artistic ceiling effects are easily and cheaply obtained by the use of ceiling beams made of extra-heavy strawboard and covered with paper veneer to represent

"Patney Pat. Beamed Ceilings"

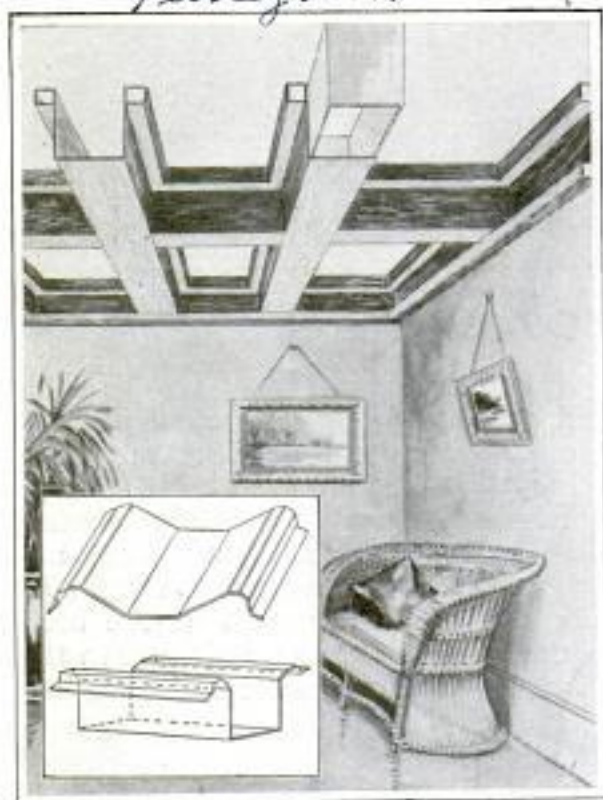

These Strawboard Ceiling Beams, When Covered with Paper Veneer, Have the Appearance of Wooden Beams; They are Attached to the Ceiling by Screws Driven into the Lath

resent some particular kind of wood. One of the advantages claimed for this material is that it can be put in place without difficulty by any paper hanger. The material comes flat, but is scored so that it is easily bent into the shape of a beam. When the beams are in place they are 4 in. square in section with a molding 1 in. square in the angles. The location of the beams is first laid out on the ceiling with chalk. The beams are bent into shape along the score marks and are then attached to the ceiling by means of screws driven through the top side of the

molding into the lath. Following this, the outside of the molding is bent down into position, and the lower part is pasted to the side of the beam, the parts being held together by wire loops while the paste is setting. For joining two sections, a core box, made of the same material and designed to fit accurately into the beam is used, while a junction with the side of another beam is made by cutting the material to an accurate fit. When the beams have been in place long enough for the paste to set they are covered with the paper veneer.

NEW SOLDER FOR WELDING ALUMINUM PARTS

There has just been placed on the market a new kind of aluminum solder that is likely to prove of the greatest value in connection with automobiles, aeroplanes, and other lines in which aluminum is used extensively, since it does away with the usual tedious processes of welding broken aluminum parts. No soldering iron is used with this material. It melts at a comparatively low temperature and all that is necessary for applying it is a gasoline torch. It can be used not only for straight welding but for building in lugs and broken-out aluminum sections from such parts as crank cases and manifold pipes. When in place it is said to stand the hammer test better than the original aluminum.

SEARCHLIGHTS FLASH MESSAGES ACROSS PANAMA

Although searchlight signaling between battleships was a means of communication at sea long before the introduction of wireless telegraphy, it is still utilized. The latest battleships of our navy have been equipped with projectors designed especially for this purpose, while the older vessels use their regular searchlights for which auxiliary shutters are supplied. Levers operate these latter members, flashing the lights on and off quickly so that messages may be spelled out

Alfred Pearl Co., 41 W. 14th St., New York City. Sole Distributor.

*800-
357790
9466*

J. R. Henderson, U. S. S. Michigan
U. S. Postmaster, New York City

9466

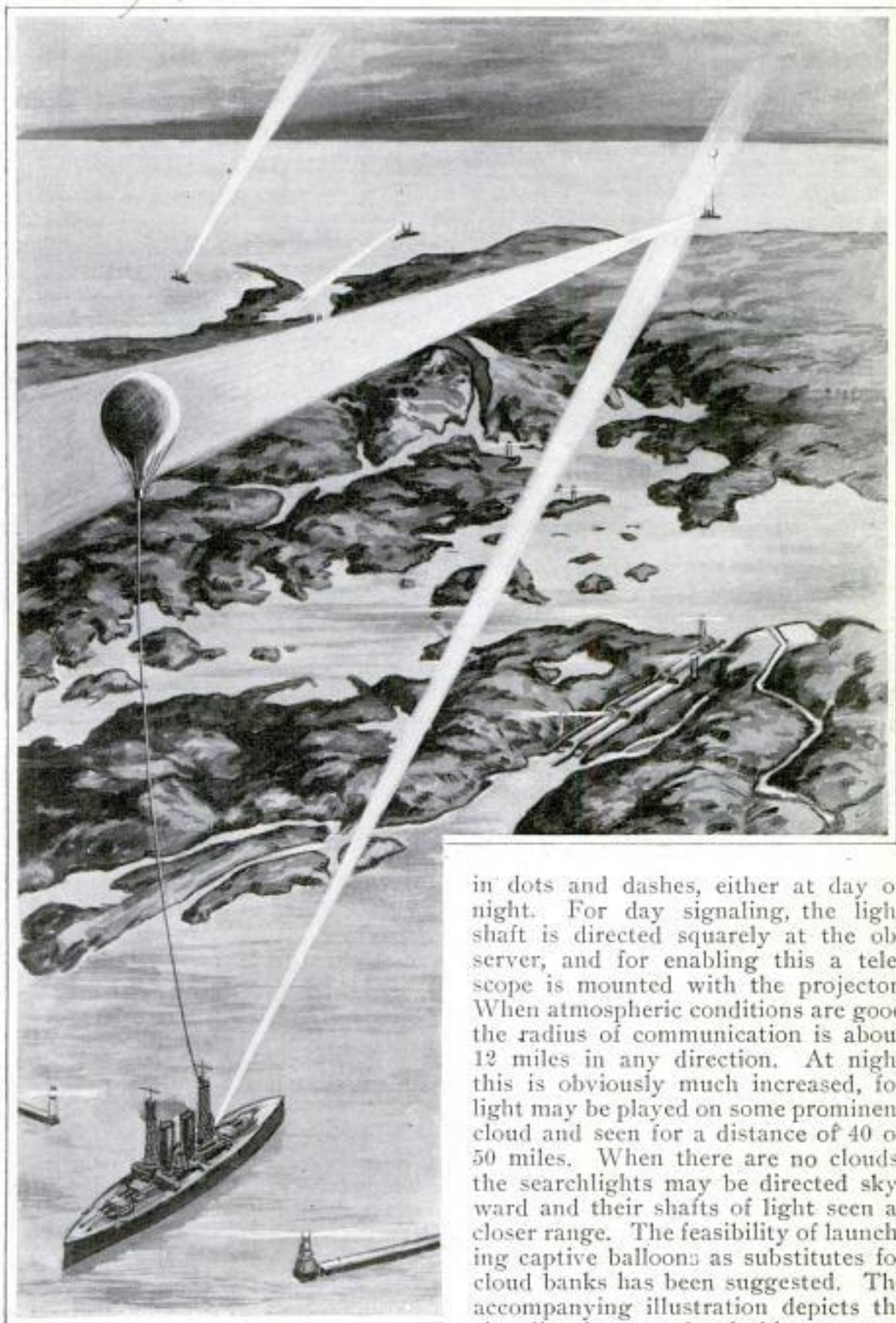

With Atmospheric Conditions Favorable, Messages may be Flashed in This Manner for Many Miles

in dots and dashes, either at day or night. For day signaling, the light shaft is directed squarely at the observer, and for enabling this a telescope is mounted with the projector. When atmospheric conditions are good the radius of communication is about 12 miles in any direction. At night this is obviously much increased, for light may be played on some prominent cloud and seen for a distance of 40 or 50 miles. When there are no clouds, the searchlights may be directed skyward and their shafts of light seen at closer range. The feasibility of launching captive balloons as substitutes for cloud banks has been suggested. The accompanying illustration depicts the signaling between battleships at opposite portals of the Panama Canal.

J. E. King, 202 S. Winnetka Ave. Dallas, Texas

MOVABLE QUICK-LUNCH CAFE OF BUNGALOW TYPE

In one of the largest Pacific-coast cities a dairy-lunch wagon of unusual proportions is driven to a favorable

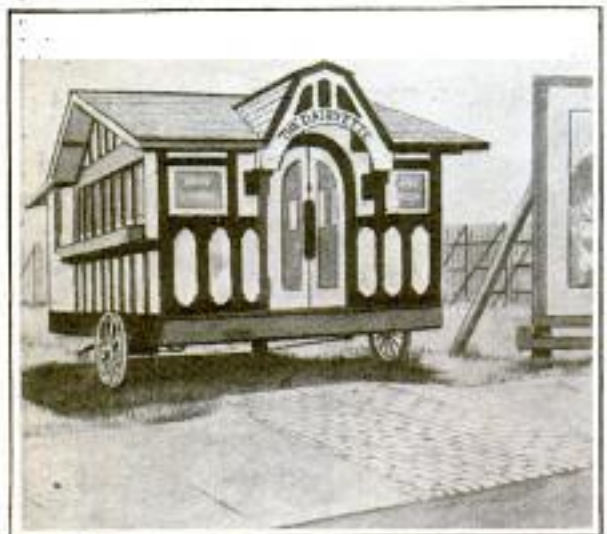

Large Dairy-Lunch Wagon Used in a California City

street location in the evenings, where it competes with the all-night restaurants. Virtually the caravan is a portable house. The superstructure, which is mounted on heavy wagon wheels, is designed much like a small bungalow and is about 12 feet by 15 feet in floor dimensions. During the daytime it is kept on a vacant lot in the middle of the business section of the city. It is neat and clean in appearance and provides sufficient room for the seating of more than a dozen patrons at one time.

565

MUNICIPAL MILK STATION PLANNED FOR NUREMBERG

In an attempt to deal with the milk situation at Nuremberg, Germany, the municipal authorities have approved the development of a permanent distributing station to be established as a limited-liability company. A trifle less than one-half of the capital is to be subscribed by the city, while dividends to stockholders are to be limited to a maximum of four per cent. This plan is to be undertaken so that milk may be obtained from a dependable source and at reasonable prices.

VALUABLE OIL IS TRAPPED 601 BY SIMPLE METHOD

The supply of crude oil coming from the Kansas and Oklahoma fields is said to be falling off, due, according to experts, to the gradual draining of great pools of the liquid which formerly underlaid those states, far beneath the prairie surface. Because of the diminishing supply, the amount available has had to be economized to a greater degree than formerly.

In other days oil from a newly bored well would generally be permitted to spurt out unchecked for a long period, flowing away on the surface of some near-by stream. Then, too, an occasional bursting oil tank would contribute its quota. As a means for saving this wasted oil, which of course floats on the surface of the water, oil men have taken to throwing out wooden booms over the surface, which shunt the oil off into pits dug in the banks of the stream. From the pits, the oil is pumped to storage tanks with gasoline engines. It is estimated that each of the traps so set up has caught, on an average, \$1,000 worth of oil per month. The oil is of inferior quality, however, due to the exposure and admixture of water.

MACHINE FOR SHARPENING 554 RAZOR BLADES

A slanting stroke that gives the razor the wedge-shaped edge so essential to satisfactory service, is the principal feature in the operation of a razor-sharpening machine that has just been brought out. This machine sharpens 12 blades at a time, the blades being carried in holders fixed to the ends of arms that are mounted on a horizontal floating hub. On each side of the space occupied by the holders is

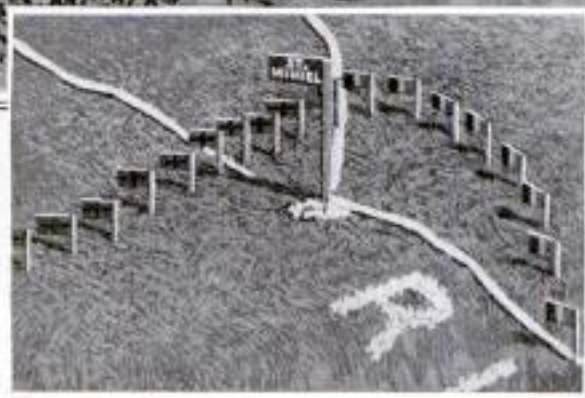
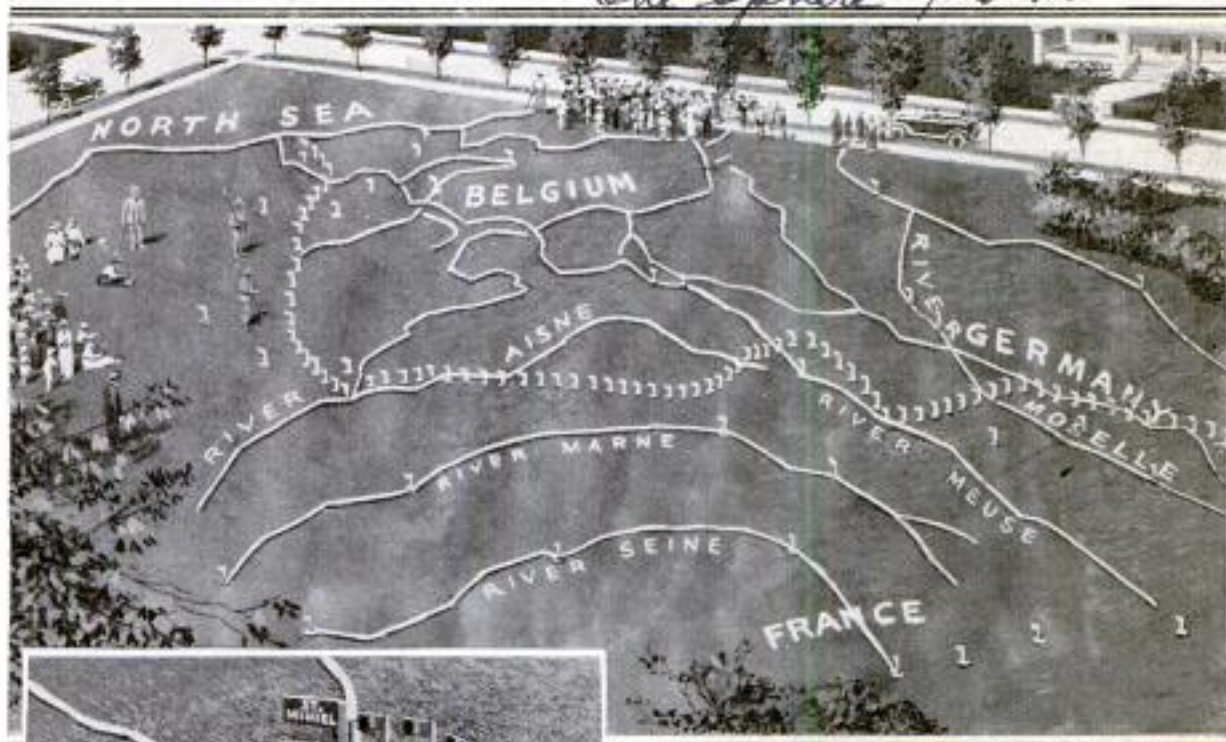

12/28/15 R. C. McCall & Co. Caswell Block 319 No Laramie av. Chicago.
James W. McCall

The Sphere 7-3-15

Large-Scale War Maps, Such as This, Accurately Laid Out on a Hillside, or Other Convenient Locality, Offer a Convenient Way for People to Follow European War Operations. The Small View Shows Detail of Map

WAR MAPS ON LARGE SCALE GIVE USEFUL INSTRUCTION

a vertical disk having a sharpening surface. Through the action of two cams that alternately engage the arms, the blades are made to bear against first one sharpening surface and then the other, the connection between the hub and arms being such that the angle of each blade is changed slightly at each of these changes so that the blade bears at the proper angle against each of the sharpening surfaces. During the first third of each stroke the blade passes over a soft honing surface and during the remainder of the stroke over a leather strop or finishing plate. The machine is run by a $\frac{1}{40}$ -hp. electric motor, and with it it is possible to sharpen ordinary razors as well as any kind of standard safety-razor blade.

CA new course for teaching farm boys how to operate an automobile has been established at a leading Iowa college.

It is often difficult to comprehend from a small map the significance of different movements and the strategic value of certain positions in the present European war, because of the vast territory involved. Seeking to get around this difficulty, several English lawns have been experimentally converted into large-scale, open-air maps. On these huge plats one can actually stroll up and down the "firing line," observe how close one's position is to that of the enemy, and, in general, gain a comprehensive idea of progress in warring operations. Small national flags mark the positions each country's armies occupy, and the towns are indicated by small posts, also appropriately flagged. Colored tape, staked down at intervals, shows the location of rivers, and small stones set in the sod spell out names of the various districts. It has been suggested that such large maps as these, installed in city parks of this country, might be useful in giving Americans short-cut knowledge as to progress in the war—especially in these

Arthur Chapman,
2612 E. Colfax St

884

Denver,
Colo

POPULAR MECHANICS

days when much of the war news is not read because of its confused character, and the concentrated attention which must be given it in order to gain an adequate comprehension.

610—

BURROS AID IN MARKETING HUGE TIMBER RESERVES

As a natural consequence of having acquired millions of acres of the finest timber lands in the world, the national government has necessarily had to go into the lumber business. The sales of timber from the national forests of Colorado have increased year by year, and supplying ties to railroads forms no small part of the government's lumber business, which is conducted

up in the mountains and hard to get to market.

Pack mules have had to be used in some cases in order to get the big sticks safely down the steep trails. A tie is strapped on either side of the little burros, and they march off in single file, dragging one end of the sticks on the ground. After reaching railroad or mill, the ties are piled up and each is marked by the watchful forest rangers, part of whose duties it is to see that the government stamp is on every tie that goes out of the forest.

587—

ICE-BREAKING CAR FERRY HAS PASSENGER QUARTERS

The "Prince Edward Island," an ice-breaking steamer recently built in England for service in the Straits of Northumberland, Canada, is a craft of unusual type, since it is designed not only to do the work of an ice breaker but that of a car ferry and a ferry for passenger, and other miscellaneous, traffic as well. The straits separate Prince Edward Island from the mainland of New Brunswick and Nova Scotia, and like most of the waterways in this latitude are icebound during the greater part of the long winter.



Top View: Forest Rangers Counting and Stamping Ties from Government Reserves before Turning Them Over to Purchasing Railroads

Lower View: Burros Trailing Railroad Ties down the Steep Mountain Sides of Colorado to Government Storage Yards

through the Forest Service. But much of the material available for ties is far

Infra: Armstrong, Whitworth & Co. Ltd.
Walker Shipyard 587 Newcastle upon Tyne,
England
885

POPULAR MECHANICS

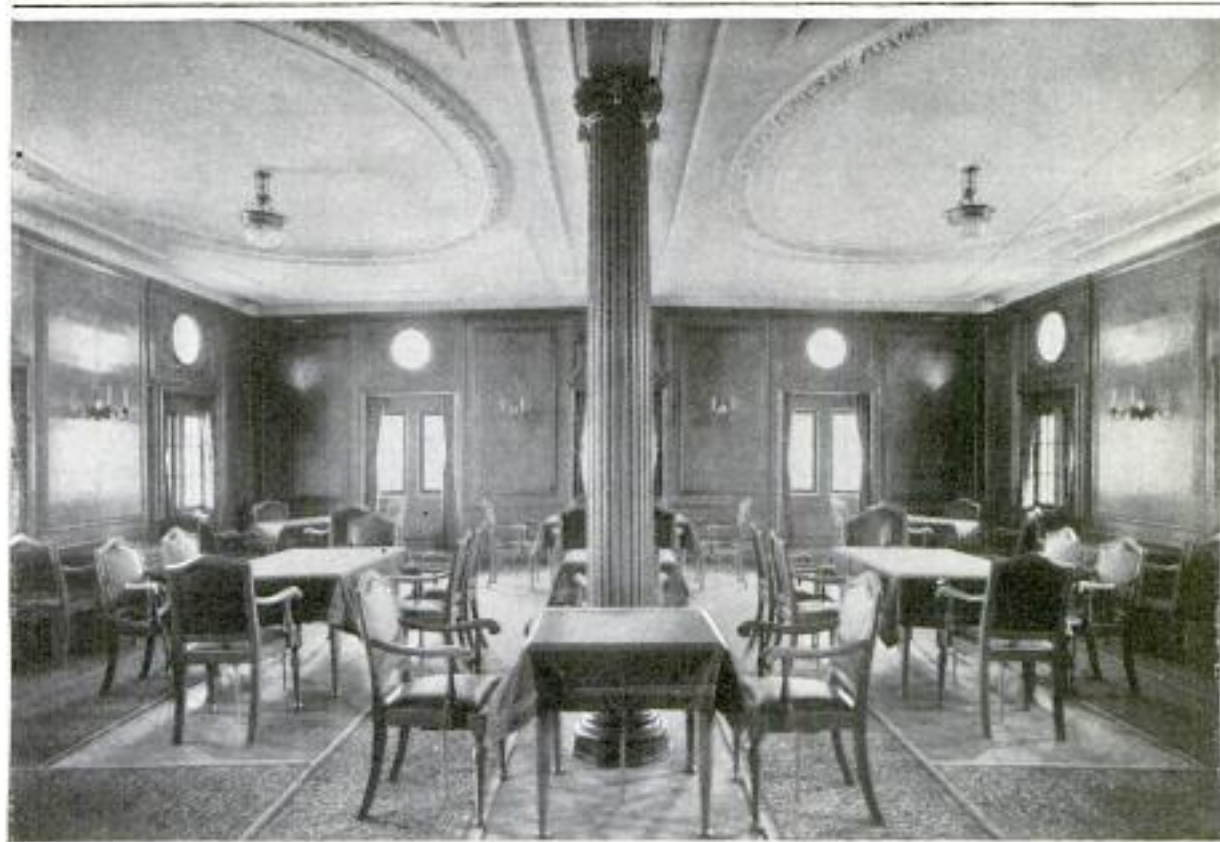

Ice-Breaking Car Ferry "Prince Edward Island," Built for Canadian Waters

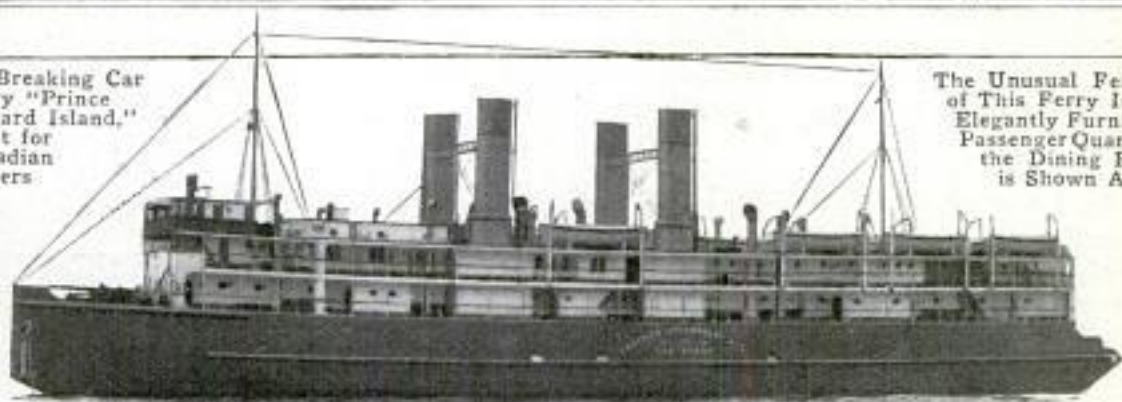

The Unusual Feature of This Ferry is the Elegantly Furnished Passenger Quarters; the Dining Room is Shown Above

At the narrow point in the straits, where the boat is to operate, the distance from the mainland to Prince Edward Island is about nine miles. With a clear channel the passage is made in about 40 minutes, but with the channel clogged with ice the passage may require several hours. On account of this the passenger quarters include a dining room and are comfortably and elegantly furnished throughout. The vessel is 285 ft. long, and has a mean draft of 18 ft., while the propelling ma-

chinery is capable of developing 7,000 hp. The load carried by the vessel, including coal, is about 650 tons. The bow is so shaped that it splits the ice and rides it down at the same time. One of the novel features of the craft is a propeller placed at the bow. This propeller is used not only in backing into the dock, but is a valuable aid in the work of breaking up the ice, since it draws some of the water from beneath the ice and thus weakens its support.

Pat. 1,142,233 June 8, 1916 Perry, D. Payson, Boston, Mass.
Assigned to Parier Wire Goods Co.
Worcester, Mass.

886 *Boyetts*
215-440

POPULAR MECHANICS

NEW SECTIONAL WIRE FENCE 297 EASILY ERECTED

A recently invented sectional fence designed for quick and easy erection is composed of U-shaped units, each



Fence Made Up of U-Shaped Wire Sections, Designed for Quick and Easy Erection

of which is made from a single piece of wire, the ends of the wires being driven into the ground in such a way that the units overlap and are securely bound together. One leg of each of the units is bent to form two loops, one located near the top of the fence and the other at the ground line. In erecting the fence the sections are driven into the ground successively, the straight leg of each section being first passed through the loops of the adjacent section.

675 —

AUTOMOBILES GET BUSINESS OF STEAMSHIP LINES

A steamship line in the excursion business on the northwestern coast found itself in an unusual predicament lately. The company started its season brilliantly by opening a number of resort places along the rivers and coast. For a time all went well. Then traffic

commenced to fall off, and stop after stop had to be abandoned.

An investigation revealed the cause. It was found that after the steamship company had popularized its resorts, most of the people who visited them came in automobiles. This was not at all satisfactory to the steamer people, as they had looked to passenger fares for their main returns. The company therefore concluded not to promote any places accessible to automobiles, and hereafter will plant all its summer colonies on islands, securely out of reach of four-wheeled rivals.

294 —

ROUGH BOULDERS ARE USED AS PUBLIC WATER BASINS

Municipal watering troughs for horses, and other animals, are most often constructed chiefly for utility, little of the esthetic entering into their designing. But at Grand Rapids, Mich., this is not the case. A large number of very plain, artistic basins have been installed at convenient places in different parts of the city. Instead of being made of iron according to a stereotyped pattern, they consist of large, rugged boulders, each weighing several thousand pounds. Bowls are

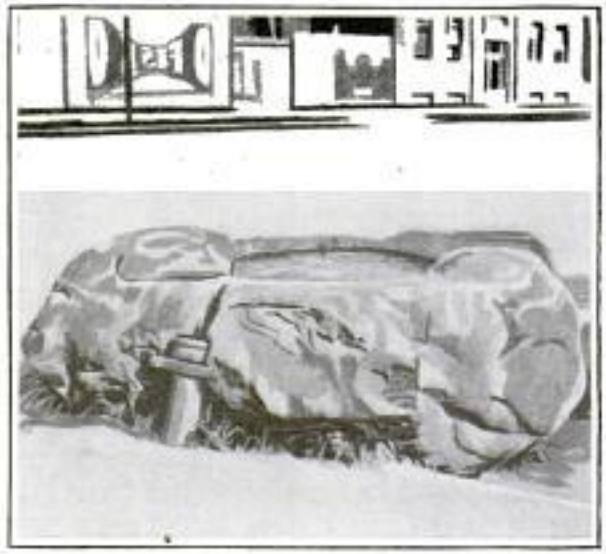

Many of These Rock Basins have been Installed at Different Points in a Michigan City

hollowed out in these, intake pipes laid to connect the water mains, and waste pipes joined with the sewer system.

*Superior Navigation Co
Seattle, Wash*

*Hester W. Shaper of News,
Grand Rapids, Mich.
Copyrighted material*

THE WAR'S INFLUENCE ON AMERICAN TOYS

695

By SEARLE HENDEE

POLITICAL conditions and social changes have for centuries reflected themselves in children's toys and games, just as they have influenced the dress, art, and literature of nations. It is not surprising therefore that this year the American boy's Christmas playthings bear conspicuously the stamp of Europe's conflict. A greater variety of military and naval toys is now afforded than ever before, both because of the status of affairs abroad and the striking changes in modern warfare and its instruments of destruction.

There is hardly a new war tool of importance which has not to some degree furnished a pattern for a child's bauble. A miniature battleship unequipped with wireless aerials or a complement of flying boats cannot be called modern. The air rifle which is without a blunted bayonet and a shoulder sling is obviously not designed for mimic hostilities. A cannon which fires only one wooden projectile at a time is at a disadvantage, for quick-fire and machine guns are now used in bombarding pasteboard forts and combating pigmy soldiers. These individuals have also undergone a radical change. They have developed into animated dolls fully attired in field uniforms and fitted with haversacks, cartridge belts, and rifles. They walk about with military pomp and clatter, instead of remaining quietly in the places they are set.

Thus the toy makers of both the old world and of America, who are the ordnance manufacturers for the youngsters' military forces, have kept astride with the Krupp, Schneider, and Bethlehem designers. Regardless of whether battles are fought from the bomb-proofed trenches in France, across a parlor floor, or in a bathtub, the exigencies of war are met with the latest implements. A few years ago a boy built his fort with blocks, inserted pencils in loopholes to serve as guns, and provided the "booms"

with his own lungs. The contrast between the war equipments of that lad and the boy of today is just as great as that of the fighting tools used in the Rebellion and those employed now. There are elaborate papier-mâché fortifications with disappearing guns that operate electrically and flash when they discharge. These may be fitted with toy radio plants and connected by electric railways over which troops and munitions can be transported from different parts of a room. If a boy's soldiers are attacking a fort, they have artillery batteries to cover their advance and siege guns to batter the stronghold.

One of the most ingenious toys of American manufacture inspired by the European war is a machine gun. This is mounted on a tripod, is 22 in. long, and has a businesslike appearance. The ammunition consists of wooden projectiles slightly less than two inches in length. Slots in these members allow them to be fitted onto a tape, which is passed over the barrel in front of a firing pin and attached to a reel. A crank at the rear controls the latter, and as it is turned the tape is wound, each revolution drawing a bullet into position and actuating a hammer which fires it. The gun may be shot in this manner a hundred times without reloading. As it is being fired, the barrel spitting out bullets in rapid succession, the gun may be sighted at different targets, or trained at a single object, as the operator deems expedient.

A play army equipped with a machine gun, but unprovided with fast artillery batteries, would be seriously handicapped. So a breech-loading, quick-fire gun has been developed. The mechanism of this is somewhat similar to that of the weapon just described, although its appearance is much different. It has a range of about 20 feet and may be fired at the rate of approximately 10 shots in three seconds. The ammunition, consisting of wooden projectiles, is held in a maga-

zine fixed at the top of a loading chamber. The bottom bullet rests in a slot at the rear of the barrel in firing position. A cylindrical block, fitted back of the loading chamber, is turned by a crank. Inside of it is a coil spring which is alternately compressed and released, forcing a firing pin against each shell in turn with considerable force.

The quick-fire gun is not of the mobile type, but instead is provided with a stationary mounting. A long-range field gun, however, which is similar in lines to some of the types used by the French and British artillery forces, has been produced. It is made entirely of metal, is mounted on wheels 6 in. in diameter, and has a barrel about a foot in length. With it is a mechanical soldier in uniform which lifts one end of the trail and draws the cannon along as he walks. The piece loads at the muzzle and fires wooden projectiles by means of a spring mechanism. It is fitted with a shield and is painted a war gray.

Another field gun, much smaller in size, is very similar in appearance to the famous French "75". It is provided with a slanting shield, while a recoil cylinder is attached beneath the barrel. Paper wads or rice kernels may be used as ammunition. For heavy work a wooden mortar which drops solid-rubber cannon balls on an enemy's fortifications is a part of the child's ordnance.

In the mind of a wide-awake child commander, a detachment of make-believe troops is no more immune to the effect of an enemy's fire than are flesh and blood men. The toy soldier now faces in the miniature many of the same engines of destruction as does his human prototype. If he is to make attacks against quick-fire and machine-gun batteries, he requires adequate defense. Therefore armored motor cars of different types have been placed at his service. Some of these resemble very closely the heavy, formidable vehicles of Europe's battle fields. One model, imported from England, looks much like an American-built car which

is being used by the allies. It is painted a war gray, has portholes for observation as well as rifle purposes, and mounts a light gun on a shield-protected turret. Inside of the car are two dolls, one a chauffeur sitting at the steering wheel, the other a gunner standing back of the turret. Metal doors in the sides of the body provide means of entrance and exit. An extra tire is carried at the rear, and the machine is propelled by clockwork.

For defense against aerial attacks an anti-aircraft gun has been designed. This is of the high-angle type and is mounted on the chassis of a toy motor car. It may be turned vertically or horizontally to any position. Ammunition is carried in a caisson immediately back of the driver's seat. The car is driven mechanically.

With all of these death-dealing implements, hospital and ambulance provisions are needed. So a motor-car ambulance for field service has been designed by an American maker. The power plant of this car, which consists of clockwork, is mounted under the hood, while a driving shaft extends to the rear axle. A small crank is used at the front in winding the motor. A stretcher of diminutive size is provided. Every army must have its field hospital, and, in addition to ambulances, surgeons and nurses, wounded soldiers, tents, and Red Cross flags are available so that proper care may be taken of those who fall in the bloodless parlor-floor battles.

During the winter months when it is not especially pleasant to play around a garden lagoon, naval battles must be waged indoors. This contingency has been looked after so that snow and ice need not interfere with an embryonic admiral's campaign plans. A large dark-blue rug forms a very good ocean for submarine attacks upon a dreadnaught, which is now provided. Both the ship and the toy undersea craft are made of wood and finished in war color. The latter has a hole in its bow which serves as a torpedo tube and allows a cylindrical wooden missile to be fired with considerable force by means of

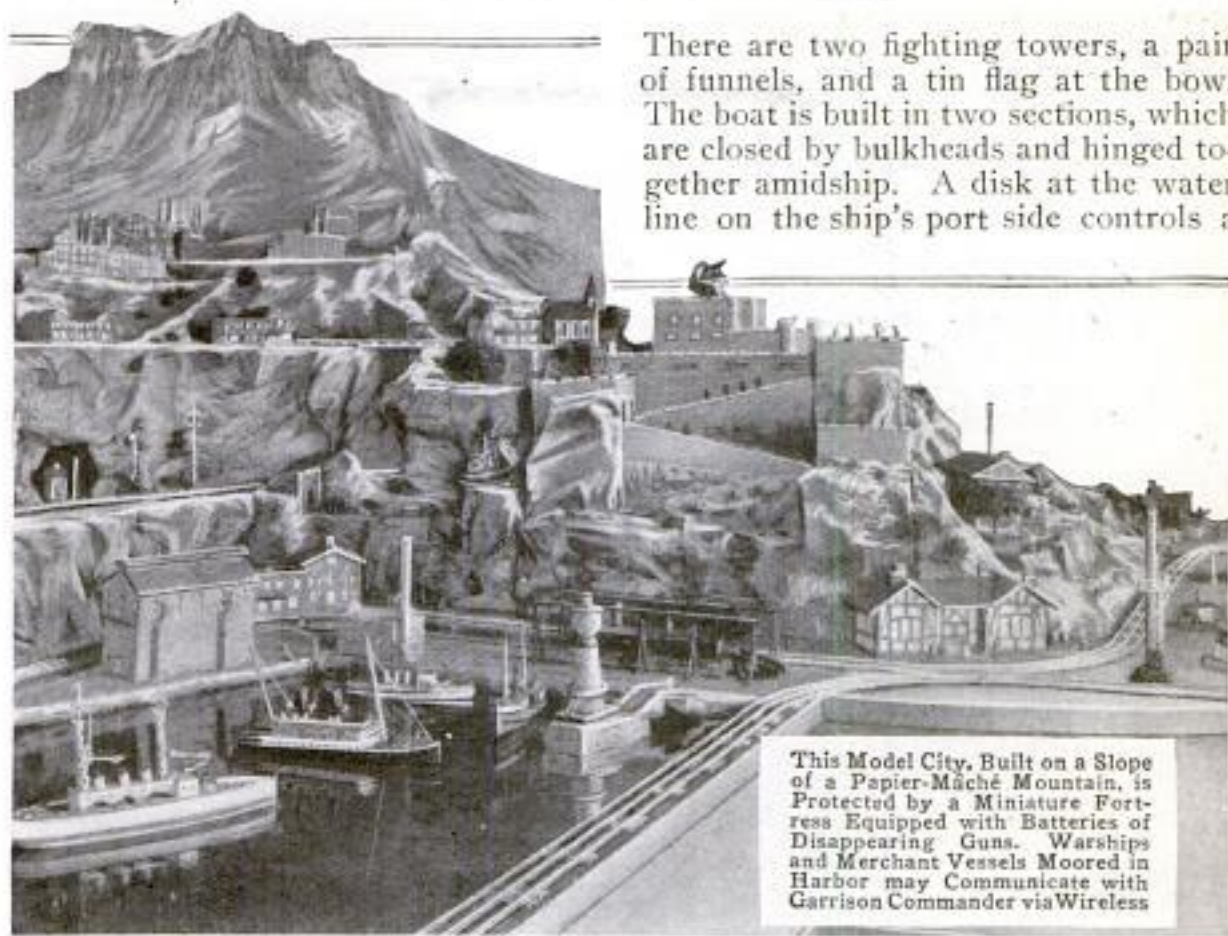

This Model City, Built on a Slope of a Papier-Mâché Mountain, is Protected by a Miniature Fortress Equipped with Batteries of Disappearing Guns. Warships and Merchant Vessels Moored in Harbor may Communicate with Garrison Commander via Wireless

a spring gun. The mechanism is contained inside of the craft and operated by a lever which extends through the conning tower. The dreadnaught is made with its deck, gun turrets, and funnels as separate pieces which fit in place. On the interior is a spring device similar to a mouse trap. When this is sprung, the dreadnaught is blown apart. A plunger, to which is attached a small red disk placed amidship on the starboard side, controls the spring. By launching a projectile from the submarine and striking this vital spot, the larger vessel is torpedoed and to all purposes destroyed.

For the young tar who spurns a blue-rug sea and insists upon fighting naval battles on real water, a similar game has been devised which is quite well adapted for either bathtub or swimming-tank purposes. It consists of a metal warship and a wooden torpedo, which when in action allow a child's imagination to carry him as far as he desires. The vessel has a complement of eight guns mounted in four turrets.

There are two fighting towers, a pair of funnels, and a tin flag at the bow. The boat is built in two sections, which are closed by bulkheads and hinged together amidship. A disk at the water line on the ship's port side controls a

catch, which when released allows the boat to collapse. Water then rushes into the two compartments through holes in the upper part of each bulkhead, while the air is forced out through portholes at both the bow and stern. After a few seconds the battleship sinks. The torpedo is of the usual shape and is provided with a band motor and propeller which carry it through the water quite rapidly. If the missile is accurately aimed, a large rudder fixed to it steers it straight for the ship's vital spot.

When the toy soldiers are cast aside and their commander becomes a mere private or petty officer in the neighborhood army, more mannish tools than these are required. A periscope is one of the instruments now available in the gewgaw world which has been directly inspired by the European war. Indian fighting, of course, doesn't require trenches and periscopes, but when the real war game is on, the average small boy has learned that bomb-proofed intrenchments are quite neces-

645

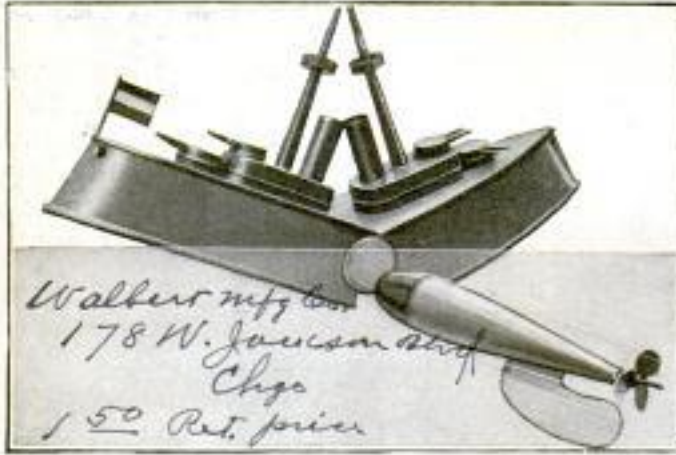

This Warship Buckles Amidship and Slowly Sinks to the Bottom of the Bathtub When Its Vital Spot is Struck by a Swift Toy Torpedo

② Rev. P. M. M. M.
Nov 16-196 adv.

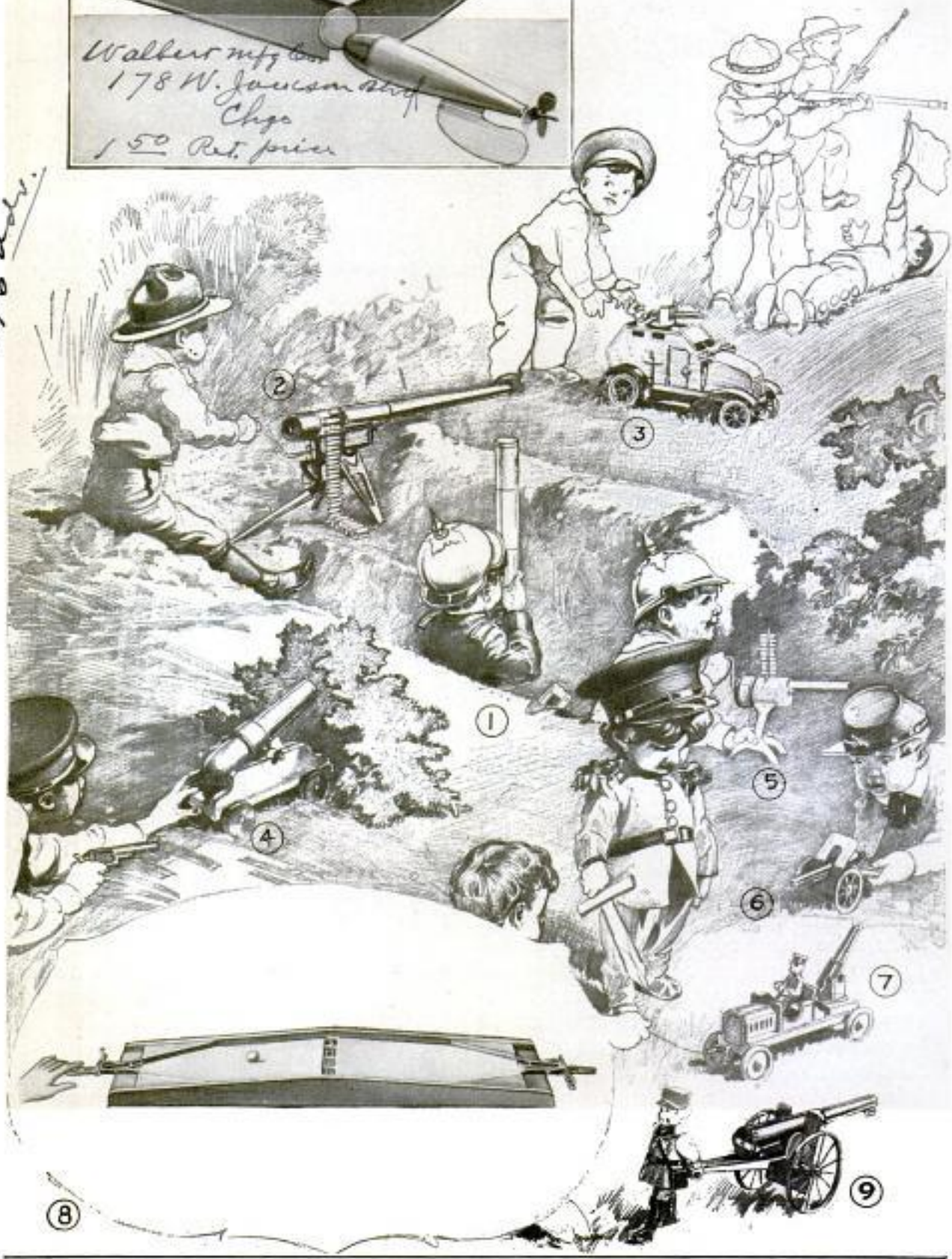



- ✓ 1. Boy Soldiers have Found the Periscope Indispensable in Mimic Trench Warfare
- ✓ 2. One Hundred Shots may be Fired without Reloading This Ingenious Machine Gun
3. The Armored Motor Car Holds Out against both Quick-Fire and Machine Guns
4. One of the Heavy Artillery Pieces: A Siege Mortar Firing Solid-Rubber Missiles
5. Quick-Fire Guns Spit Out Their Wooden Projectiles with Considerable Force and Speed
6. Small Field Piece Similar in Design to the French Artillery's "75" Gun
7. When There Are Toy Aeroplanes, High-Angle Aerial Guns are Much Needed for Defense
8. One of the Novel Artillery Games Lately Devised for the Nursery or Living Room
9. The Mechanical Artilleryman Pulls the Long-Range Gun after Him as He Marches
10. Miniature Submarines That Submerge are Patterned after the German Diving Craft
11. Even a Tiny Stretcher is Provided with This Diminutive Motor Field Ambulance
- 12. Air Rifles with Rubber-Tipped Bayonets are Now Made for America's Boy Soldiers
13. Substantial Wooden Submarines Electrically Propelled are Made in This Country
14. This Electric Destroyer is Capable of Maintaining a Speed of Four Miles an Hour
- ✓ 15. When the Dreadnaught is Torpedoed It is Blown Apart in a Realistic Manner

sary. And with these strongholds, periscopes made of tin and fitted with mirrors, are quite important accessories. They are made in tubular form and have angular reflectors at each end.

The latest gun for outdoor use is distinctly of a military type. It is an air rifle equipped with a rubber-tipped bayonet and web sling. It has an overall length of 38 in. and is comparatively light in weight, so that it is good for drilling purposes and skirmish work.

By far the most ingenious of the new war toys is a miniature replica of a German submarine, imported from that country. It is driven mechanically, and on the surface is capable of making a speed of four miles an hour. It is fitted with diving planes and, when set to do so, will submerge so that only the tip of its periscope is visible. The diving is controlled automatically and after the boat has proceeded for a certain distance it will rise to the surface and then disappear again after a short time. If its operator desires, the automatic control of the planes may be dispensed with and the craft sent either along the surface or beneath the water.

A domestic submarine has been modeled after the B-class boats of the United States Navy. It is 28 in. in length and is driven at a speed of about four miles an hour by an electric motor which is supplied with current by a dry cell carried within the craft. Diving planes are fixed near the stern, but these are purely ornamental, for the boat does not submerge past its normal water line. The propeller and rudder are made of aluminum, while the stuffing boxes, shafting, and deck rails are of bronze. A small gun is mounted in front of the conning tower.

Another unit for the child's navy, made in America, is a torpedo-boat destroyer patterned after the "Decatur," U. S. N. The upper works of this vessel are built low, while the armament consists of light guns mounted in two turrets, five rapid-fire guns, and two deck torpedo tubes. There are ventilator funnels, smokestacks, and

lifeboats on the deck. It is finished in war gray and driven electrically.

Both in this country and Europe a large number of war games have been developed during the last year. Abroad this industry has been materially stimulated by a great demand for amusement devices with which to entertain the wounded at various hospital bases. Many of these are patterned after chess, checkers, and pachisi, as well as other standard games, while some are quite new in all their details. An American game which represents artillery work, is especially pleasing to children. The board on which it is played is rectangular, 26 in. in length and inclined from both ends toward the middle, or crest, which is designated as a hilltop. A groove extending across the board at this point serves as a trench and is divided into five numbered sections. At the bottom of each incline there is a spring lever, or gun, that shoots a marble. The player's skill is determined by his ability to place the marble in the division he desires, as a score of exactly 500 is required to win.

War chess is a German game which has become very popular at the military hospitals. It is played on a chessboard with two sets of men, each 12 in number. The contending figures are distinguished by their color, but from the front side are otherwise identical in appearance. On the reverse side, however, each member bears a number representing its value. There are "aviators," "scouts," a "king," and others, and it is the capture of the "king" which ends the game. A good memory and an exercise of strategy are required in playing creditably. In designing toys and games the Europeans have not escaped displaying considerable venom and hatred for their enemies. This is true even in playthings for young children. A picture puzzle shows a soldier killing a child.

These are a few of the scores of new baubles and games for both children and adults. In practically every instance they have been inspired by the European war.

Dept. of Agriculture
RAPID SPREAD OF THE BOLL
671 WEEVIL

Owing to unusual conditions that prevailed in August, the most rapid movement ever made by the boll weevil when advancing into new country was made this year in the southeastern states. Ordinarily this insect advances at the rate of about 50 miles a year, but this year an advance of 100 miles was made in a period of only two weeks. This rapid movement carried the destructive insects for the first time into Georgia, where 25 counties became infested. During this period eight additional counties in Florida and 20 in Alabama were also invaded for the first time, the entire movement taking place between August 15 and August 31. One of the reasons for this rapid progress, as given by the Department of Agriculture, was the drought in Alabama, which deprived the insects of their usual food and forced them to seek a new district. The most important condition, however, was a series of extremely high winds that began on August 15 and blew continuously for several days toward the northeast, the insects being blown many times farther by the high winds than they could have traveled by natural flight, or with the aid of ordinary winds.

Surveys are to be made in the immediate future for the preparation of military maps of Long Island and other sections in the vicinity of New York harbor.

AUTOMOBILE WHEELS ROLL**580 TO THEIR CARS**

One of the large problems in factories is to handle raw material and parts with economy of time and labor. If this is not done, production costs rise. Many parts are quite unwieldy; not so in the case of wheels, however, as they may be rolled around far easier than carried. In a Detroit automobile plant wheels are unloaded from a truck into a narrow runway in the factory yard, down which they roll to an elevator on the outside of the building. Here fingers on an endless chain grip each wheel and lift it to the top of the building, where it rolls along another runway to the men who put the wheels on the axles.



Auto Wheels Roll into This Plant: The Elevator on the Right Lifts Them to the Top of the Building Where They Roll on Farther to Their Respective Autos

#8 Ward Sealey, 69 East 59th St. N.Y. City
 method used in the Detroit plant of the Sturtebaker Corp.

for sale by: Cecil McManimon Co.
San Jose, Calif.

894

POPULAR MECHANICS

463 FINGER-EXERCISING DEVICE
FOR PIANO BEGINNERS

For strengthening and limbering the fingers of pupils beginning the study of the piano, a device of very simple con-

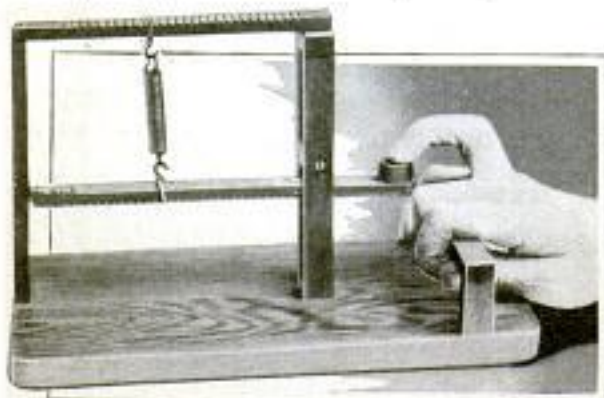

By Changing the Position of the Spring the Tension may be Varied to Suit the User

struction is made which may be adjusted to suit the requirements of different users. It consists of a lever held between two uprights and connected by a spring with a crossbar above. Notches cut in the under surface of the movable member and the top side of the crosspiece provide graduated spaces in which to place the

rings holding the spring, so that the tension may be varied as desired. The lever bar is secured to the rear upright by means of a hinge and moves in a groove extending through the front one. At the fore part of the apparatus is a rest which enables the wrist to be held in the correct position while different fingers are being exercised.

GARDEN AND TENNIS COURT
557 ON GARAGE ROOF

By taking advantage of a sidehill located at the rear of his residence, a builder of Salem, Mass., was able to build a garage the roof of which could be transformed into a garden and tennis court on the same level as the residence. The space for the garage was excavated out of the hill, which is about 18 ft. high. The structure is 38 by 27 ft., contains six compartments, and is built entirely of concrete. Part of the material excavated from the hill was placed on the roof and a garden and a tennis court of the regulation size were laid out. The tennis court has electric lights and is equipped with a wire netting that prevents the balls from going into the street below.



The Novel Features of This Garage Are a Garden and a Tennis Court Located on the Roof

J. Frank Reynolds, 1/2 Salem News
Salem, Mass.
Copyrighted material

Wm. B. Wallace 1102 Dean St. Brooklyn, N.Y.

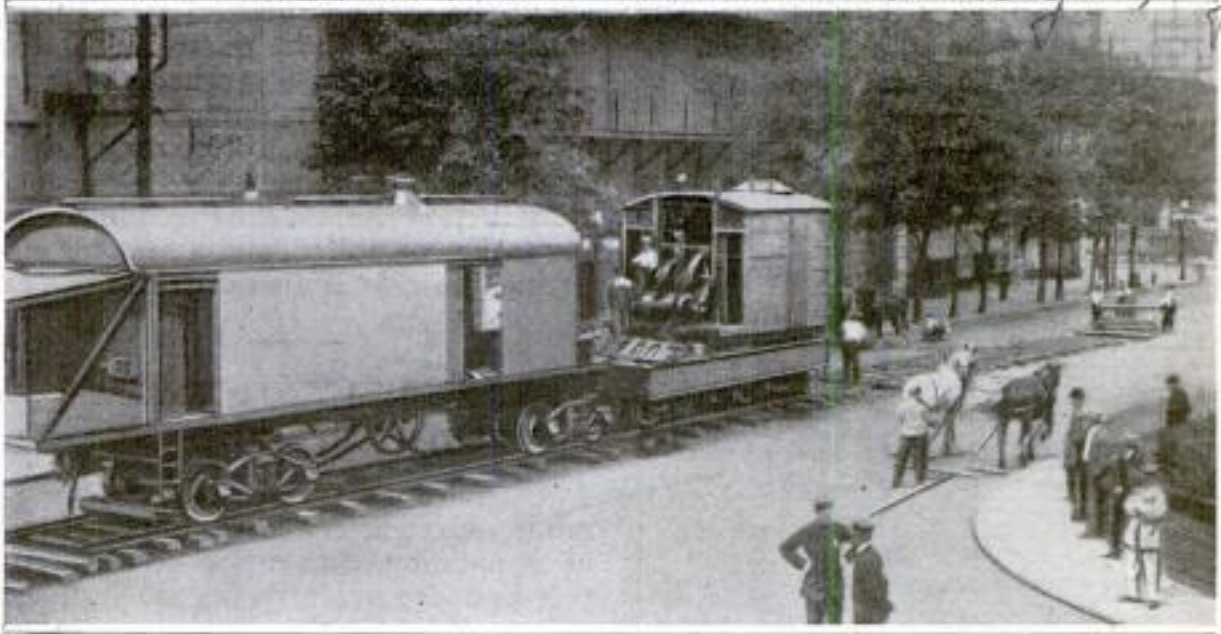

How a Steam Crane and Steam Winch were Taken for a Distance of Three Miles through the Streets of Brooklyn

501

TAKING SUBWAY MACHINERY THROUGH CITY STREETS

A steam crane and a steam winch that are being used in subway construction in Brooklyn, N. Y., were taken under their own power through the streets for a distance of about three miles over something like 150 feet of temporary track, which was taken up behind the machines and built ahead as the machines progressed. A force of 25 laborers, with two foremen and a superintendent, were required for handling the track, and even with this force the rate of travel under the best conditions was less than a mile a day.

207

INSTRUMENT FOR FINDING A SHIP'S POSITION

Finding the true bearing of objects at sea as well as the position of a ship with reference to a coast line, without resort to computation or plotting, is made possible by a new attachment designed to be mounted on the binnacle hood and operated in connection with the ship's compass. The instrument consists of a sight tube carried on a revolving standard, to the lower end of which is fixed a curved arm terminating in a pointer. The standard

must be mounted accurately over the center of the compass. The pointer hangs close to the compass card, and since it swings with the sight tube it shows instantly the bearing of any object on which a sight is taken. The instrument is also provided with two graduated scales by which the distance to any fixed object, such as a lighthouse, may be quickly and accurately found. This is accomplished by taking two bearings and noting the exact time that elapses between the two sights. The distance traveled by the ship during the interval is then estimated from



Taking a Bearing with the New Nautical Instrument. Left: How the Sight Tube and Pointer are Mounted on the Standard

its known speed. The scales are so mounted on the bushing of the standard that when this distance is set off

Capt. E. Y. Haskell, 31 Bellevue Place, New London Conn.
 May 5 - Nov 5 C. Steam Yacht "Viking" Station, Foot of E. 23rd St. New York

Complete 7.75
 Luggage Carrier 9" x 5 1/2" x 5" 40¢ extra
 " 12 x 7 x 6" 60¢ "
 Headlight 75¢ "

896

POPULAR MECHANICS

Roller in box 3 1/2" x 7" x 30" - 16¢

on one of the scales the distance from the course to the object is given by the other scale to the nearest tenth of a mile.

619

ROLLER SKATE AND TOY AUTO COMBINE IN NEW VEHICLE

There are dozens of curious vehicles that pass for children's autos and coast-

about the size and general mechanical construction of those on roller skates. The front pair can be turned about an axis by proper manipulation of the handlebars above, and thus the vehicle is steered. A foot brake of simple construction enables the speed in coasting to be controlled, and a seat for enjoying the ride is also provided.

553

ENORMOUS "NUTCRACKER" TESTS BUILDING TILE

A device that resembled an enormous nutcracker was the means used at a building convention in Iowa to test and demonstrate the strength of hollow building tile. The handles of this nutcracker were two 15-in. steel I-beams, each 25 ft. long and weighing 54 lb. to the foot. The lower beam was imbedded in the ground while the upper one was hinged at one end, as shown in the illustration. At the free end of the upper beam a tilting platform was constructed so that an automobile could be run upon it. The tile to be tested was placed between the beams, 3 ft. from the hinge, so that the pressure on the tile was about eight times the weight of the automobile with a portion of the weight of the beam added. The tile stood the test without being damaged.

Skate - Mobile Mfg. Co.
 18-74 Mc Microm. Av., Leanti, O.
 (Amman & Sanderson Assoc.)

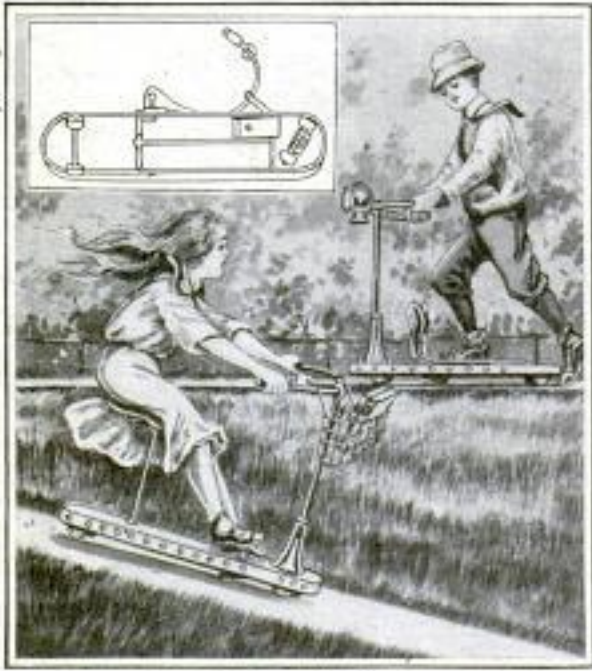

Toy Coaster is Built Like a Roller Skate, but Steers with Handlebars

ers, but it has remained for a Cincinnati firm to bring out a new variation. This contrivance has four small wheels

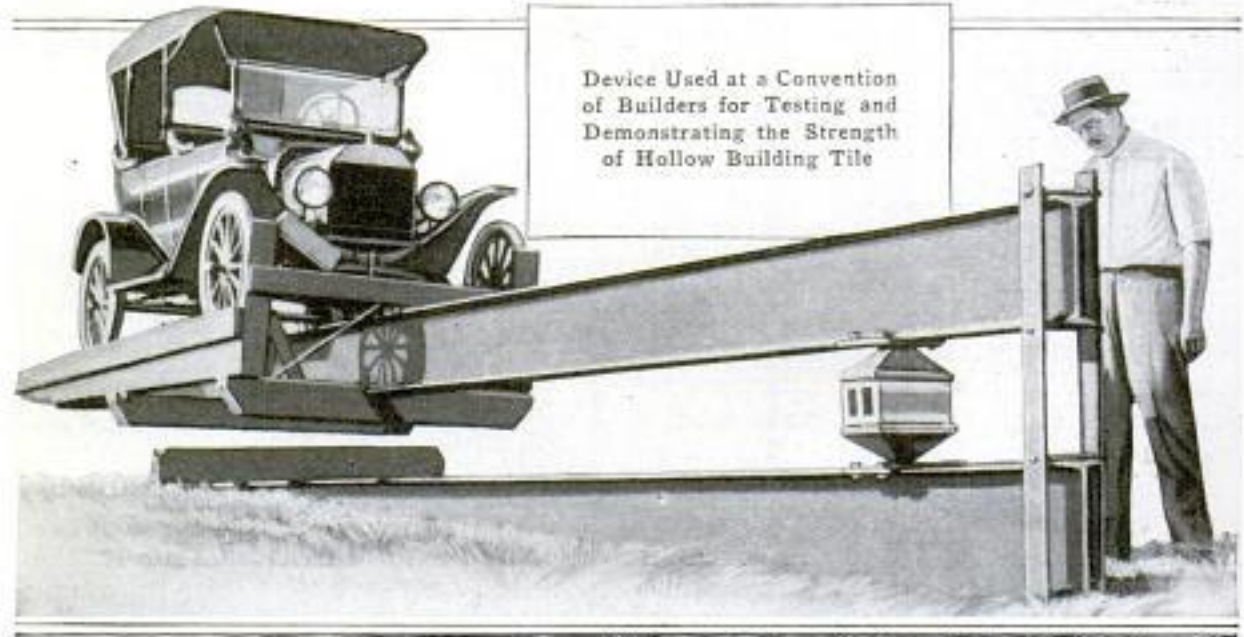

Device Used at a Convention of Builders for Testing and Demonstrating the Strength of Hollow Building Tile

Chas. Darlington, % Des Moines Capital, Des Moines, Iowa.
 Copyrighted material

DENVER FIRE STATION IS HOUSED IN BUNGALOW

One of the prettiest bungalows in Denver houses hose wagons and fire engines. When planning one of the newer stations, the board of safety decided to upset all prevailing ideas regarding fire-station architecture. Instead of conforming to time-honored plans and specifications, a building with a pergola and many of the embellishments of the modern bungalow was decided upon and built. The

firemen stationed in the unusual house have carried the idea farther by surrounding the station with well-arranged flower beds, shrubbery, and a well-kept lawn.



There is a Pleasing Contrast between This Denver Fire Station and the Type Usually Seen

MODEL LOCOMOTIVE BUILT BY BOY MECHANICS

As an illustration of what boys can do in the field of mechanics under the tutelage of skilled workmen, a group of apprentices in the shops of an eastern railway company recently built what is probably as complete a model of a Pacific-type locomotive as has ever been constructed by beginners.

This diminutive engine and tender, which are built on a scale of 3/4 in. to the foot, have together an over-all length of 57 in. and rest upon a stone-ballasted 3 5/8-in. gauge track. The work was done from 1/16-in. scale blueprints which were drawn by the boys and turned over to apprentice patternmakers as rapidly as they were completed. Before the work could progress very far, it was necessary for them to build much of their own machinery and equipment. This entailed the designing and construction of a lathe, shaper, and 1-hp. motor, besides the development of a machine shop, erecting plant, and foundry.

Needles were used in forming the pins for the valve gearing, for which hardened members were required, and rubber insulation stripped from copper wire was employed as air-brake hose. These and other ingenious substitutions were made by the boys, who frequently faced and solved perplexing



Complete Model of a Pacific-Type Locomotive Built by Boy Mechanics. Serving as Apprentices in the Shops of an Eastern Railway.

situations in finding fittings small enough in the railway shops to answer their needs.

FLEXIBLE OPERATING SHAFT FOR MOVIE CAMERA

By the invention of a new cranking device for motion-picture cameras a simple means has been provided for filming rapidly moving objects, such as birds in flight, aeronautical feats, and

H. E. Blackburn, Dunmore Apprentice School, Dunmore, Pa. made by apprentices above school

Mfd & sold only by Eberhard Schneider 219 Second St. No. 14th St. New York
(Mason of mine Vitas Nilson missing Moby)

similar things, which under ordinary circumstances are very difficult to catch. Movie cameras universally have to be used on tripods, and this makes it



The Operating Attachment Allows the Photographer to Follow His Subject with a Movie Camera in the Same Way that a Still Camera may be Used

exceedingly difficult for an operator to follow a speeding, or irregularly flying, subject. The new attachment consists of a flexible shaft connected at one end to a hand crank that may be turned by an assistant. This obviates the necessity of using a tripod, for the operation of cranking is done practically without affecting the steadiness of the camera. It enables an operator to hold a machine up with its finder before his eyes and follow his subject just as easily as if he were using a pair of field glasses. A small spring motor may be used instead of a hand crank, if desired. This instrument fits compactly into a small case worn suspended from the operator's shoulders.

Peru is experiencing hardships because of the shortage of small coins. Financial stringency in that country has caused individuals to hoard metal money, thus preventing its circulation.

NEW MECHANICAL PLANT FOR 585 HANDLING MAIL *Machinery*

For sorting and forwarding the enormous quantities of mail going into and out of that city daily, there has just been placed in service in New York what is said to be the largest and best equipped mail-handling plant in the world. This establishment is known as the Grand Central Terminal Post Office Building. Although mail matter of all kinds will be passed through the establishment, its principal function is that of sorting and forwarding bulky mail, its construction having been brought about mainly through the importance of New York as a center for the publication of periodicals and through the growth of the parcel-post service. The most interesting feature is the system of mechanical conveyors with which the mail is taken into the building and then sorted and distributed for forwarding, without the aid of porters or trucks and without being touched by anyone except the sorters. With this equipment the establishment is capable of handling about 400 tons of mail a day. It is expected that the success of this establishment will bring about the construction of similar plants in other large cities for the handling of third-class mail and parcel-post matter.

The building occupies an entire city block and was erected and equipped at a cost of over \$1,000,000. In spite of the apparent intricacy of the carrier system it is made up mainly of three simple devices—endless belts for transporting the mail on a level, bucket lifts for raising it, and chutes for transferring it to a lower level. Coupled with these devices is a series of trips, electrically controlled by an operator working at a central station, with which the mail is diverted at various points in accordance with the route it is to take. One of the endless belts runs beneath the platform at which the outgoing mail is received. When a truck load of mail is received, the bags are dumped through hatchways in the platform and are carried by this belt

E. Leslie Williams, 116 Waverly Place, N.Y. City
Inter. News Service

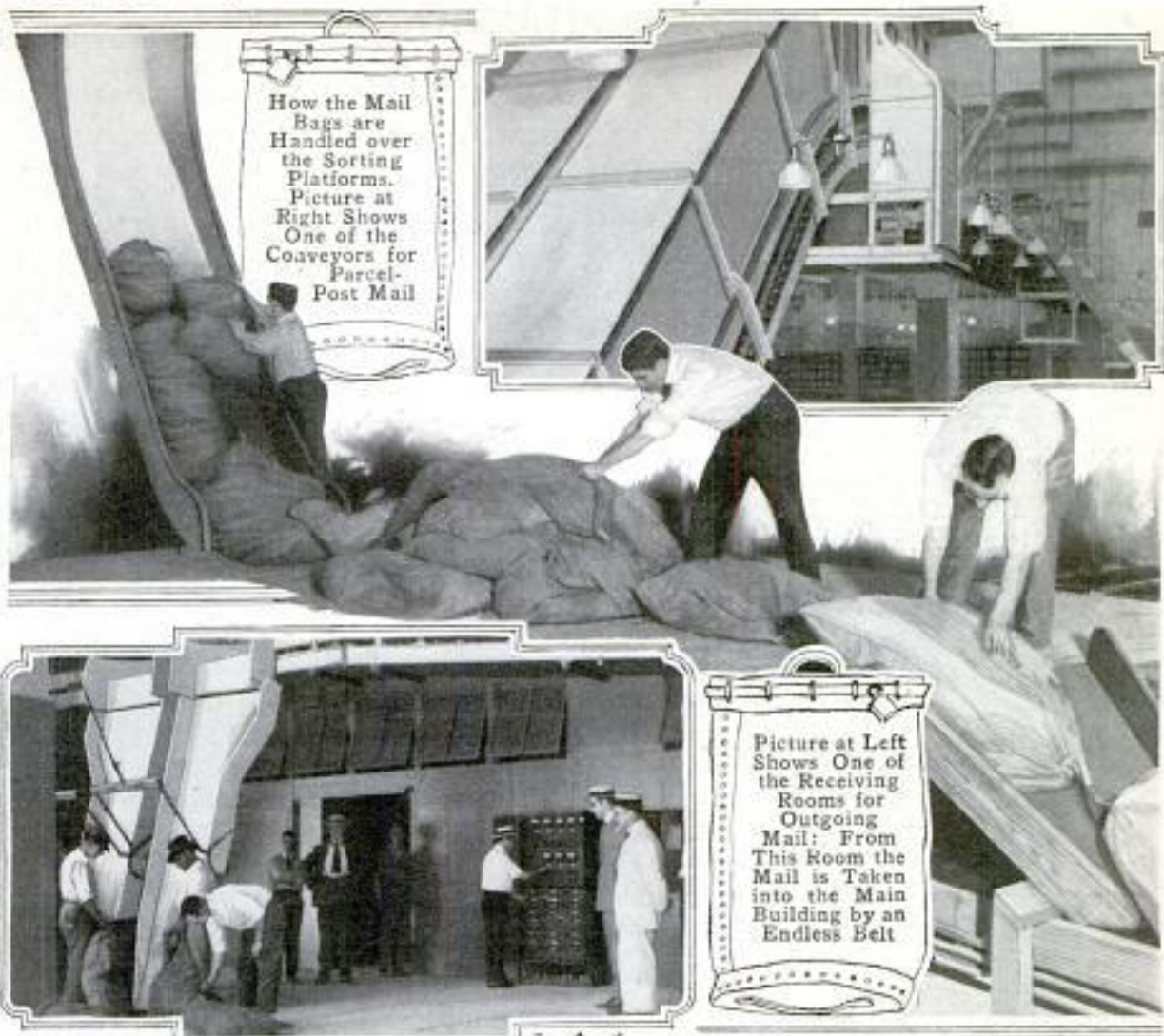

Williams

to a second belt that moves at right angles to it, and carries the mail into the building. From this point the mail that requires sorting is elevated by a bucket lift to the floor above and deposited on a third belt which runs the entire length of the big distributing room, while that which requires no sorting is diverted by trips and conveyed directly to doors of the mail cars. Two systems like this are provided for outgoing mail, one for handling second-class mail and the other for handling parcel-post matter. Underneath the building, located on each side of an island platform, are two tracks for mail cars, the two tracks together having a capacity of 33 cars. When the mail has been sorted and

repacked it is placed on an endless belt and conveyed to chutes, through which it drops to a belt that runs along this platform. From this belt the bags are again diverted at the proper points and finally dropped down chutes to the car doors. Incoming mail is handled by a system similar to this, the bags being dropped from the mail cars through chutes to a belt underneath the platform, and then raised to the distributing room by bucket lifts. The belts are made of canvas and rubber, and are 3 ft. wide. They work over rollers set close together in a steel frame and around drums at the ends, and travel at the rate of 150 ft. a minute. Electric power is used for operating the entire plant.

BRIDGE GIRDER OF UNUSUAL 545' LENGTH

A steel girder of such length that it was necessary to use four steel flat cars in shipping it was recently sent from the shops at Steelton, Pa., to Chicago, where it is to be used in a railroad bridge spanning a railroad and a street. This girder is 131 ft. 9 in. long and 10 ft. 6 in. high, and weighs 98 tons. The angles placed in the corners at the junction of the web and flanges form one of the unusual features of the girder. The legs of these angles are 8 in. wide and $1\frac{1}{8}$ in. thick, and each is made of one piece running the full length of the girder. They are said to be the longest angles of this size ever rolled. Particular attention was given in the shop to seeing that the girder was built with the right end

out having to be turned around. This girder is the longest of 15 required in the construction of the bridge.

691 MINERAL OILS SHOWN TO BE SUPERIOR FOR HARDENING

Experiments recently conducted on hardening oils show that those of mineral nature are superior to the kind originating from cottonseed, fish, or the like. Mineral oils were found to have a hardening effect of from .16 to .24, assuming water as unity, while cottonseed oil was found to be in the neighborhood of .16, with fish oil at .15. Rosin varied from .13 to .14. The kind of temper a piece of metal receives depends, for one thing, on its rate of cooling, as well as on the chemical composition of the medium in which it is placed. Thus different materials

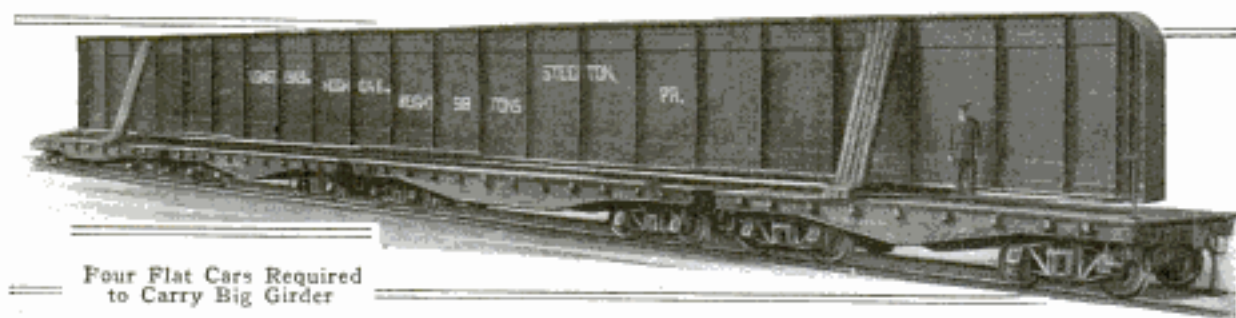

Four Flat Cars Required
to Carry Big Girder

forward so that it could be loaded, shipped, and used in the bridge with-

C. E. Drayer, 1801 E. 92d St.
Cleveland, Ohio.
Built at Steelton, Pa. for the Nickel
Plate road.

can have a vastly different effect on the metal in tempering.

machinery Sept 1915

Inventor: P. H. Lint, Los Gatos, Calif.

591

PRUNE-GATHERING MACHINE FOR LARGE ORCHARDS

In the prune belt of California the fruit is allowed to ripen on the trees and fall of its own weight. The gathering is then done by hand, which is a slow method that causes difficulty when there is a shortage of pickers. To facilitate this work by saving expense and time, a western inventor has developed a machine which picks the prunes from the ground as it is pushed along by an operator. The work is done by a large revolving drum, the circumference of which is covered with rows of sharp spikes. The prunes are pierced by these members and carried around to a point where they are automatically removed and deposited in a hopper at the rear. It is stated that the fruit is not injured by being perforated in this

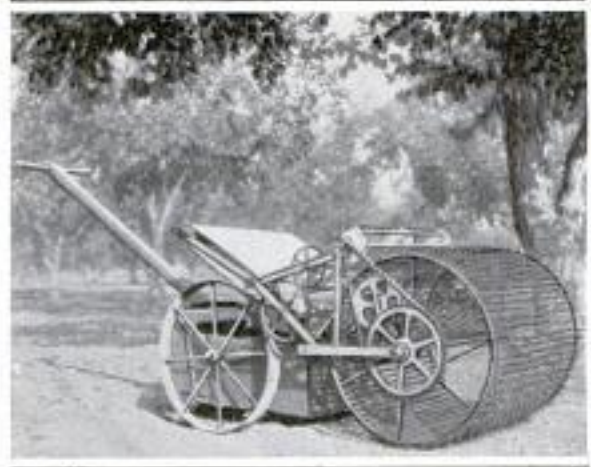

Prune-Gathering Machine Which Does the Work of Many Men

manner, because it is necessary to prick the skin of the prunes before they are dried.

583

A CUT-OUT BOX THAT CAN BE BUILT TO SIZE ON JOB

An eastern manufacturer of electrical goods has devised a cut-out box embodying the sectional idea. The box is not very different from the ordinary, except that it can be had in any number of duplicate units, which may be placed side by side to fit the demands of any kind of electrical installation. Thus it is unnecessary to order a special cut-

out box beforehand as at present, it being possible with this new type to construct one on the job by putting

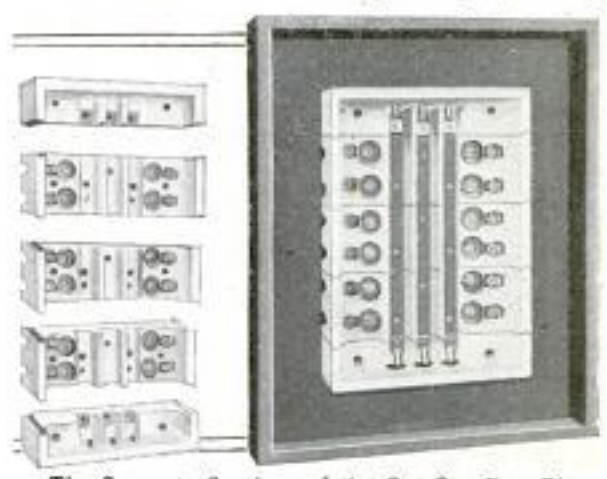

The Separate Sections of the Cut-Out Box Fit Together to Satisfy Any Capacity Desired

together a sufficient number of sections. The ordinary cut-out box is a familiar fixture in most any house or other structure. It is usually mounted on, or within, a wall, and serves to control electrical circuits to various parts of the building.

STEERING ATTACHMENT MADE FOR DIRECT-CONTROL CARS

For certain light motor cars which are not equipped with worm-and-sector steering gears, a spring device which eliminates the strain on the wheel and permits safer and easier driving has been devised. It is a small, neatly housed attachment which is intended to be clamped to the front axle and connected with the steering rod. Ex-



The Single-Acting Spring Makes Easy Driving of Direct-Control Cars Possible



"Hastings Stabilizer" expansion and contraction actuate the spring, which takes up the jolts ordi-

C. P. Electric Works
92 Hayden St.
Springfield, Mass.

602 of Hastings Mfg. Co., Hastings, Mich. Hastings Stabilizer

narily transmitted to the steering wheel of cars having direct control. Without some device of this character the steering gear is affected every time the front wheels of the machine strike

a rut, bump, or stretch of sand. The stabilizing attachment prevents swerving and relieves the driver from the constant physical strain which otherwise he is under.

HYDRAULIC STRETCHER MADE FOR HOSPITAL USES

For hospital purposes a stretcher has been built with a hydraulic lifting mechanism which enables it to be adjusted to various heights without subjecting a patient to jars and shocks which might be discomforting. The elevating device is mounted on a metal chassis, that is car-

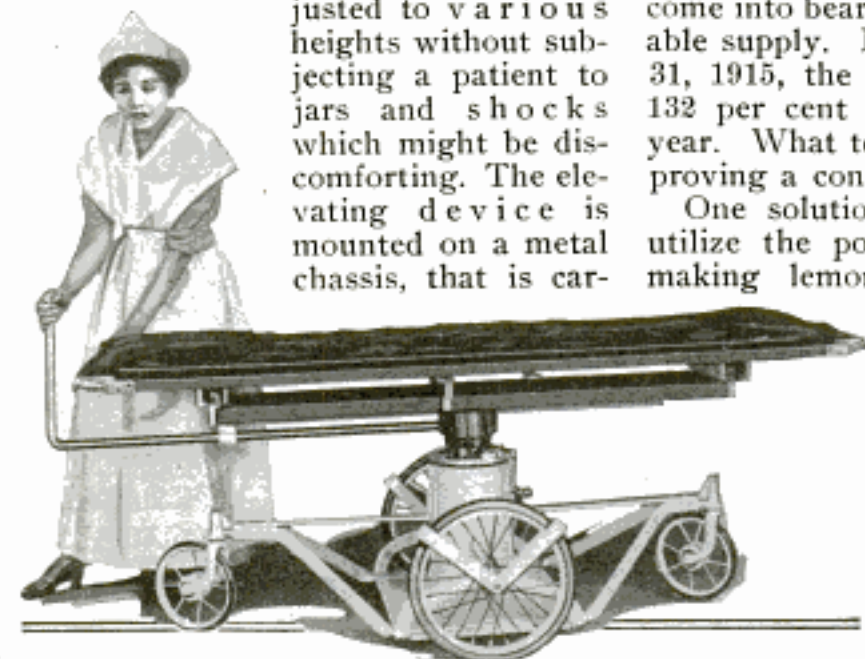

The Stretcher may be Lowered to the Same Level as a Bed, or Raised Even with an Operating Table

ried on rubber-tired wheels, and supports the stretcher above it. It may be lowered smoothly even with a bed, or raised to the same plane as an operating table, and without requiring exertion on the part of its operators. The stretcher itself may also be extended to one side or the other independently of the truck, so as to facilitate the work of moving a sick person onto or from it. The raising and lowering is done by regulating a flow of oil between two cylinders.

¶The "Independence," one of the oldest, and at one time the largest, of United States warships, was burned by its owners recently in order to recover the copper rivets which were used in its construction.

NEW CALIFORNIA PLANT WILL UTILIZE WASTE LEMON CROP

The Golden State is facing a problem in overproduction. Twenty thousand acres of young lemon trees will soon come into bearing and double the available supply. For the year ended Aug. 31, 1915, the crop was 6,667 cars, or 132 per cent more than the previous year. What to do with all this fruit is proving a considerable puzzle.

One solution offered is a plant to utilize the poorer grades of fruit in making lemon oil, citrate of lime, and similar products. This is now under construction, and will operate on a cooperative basis, the growers receiving full return for the by-products after paying the cost of production. By thus disposing of the poorer grades of fruit the growers hope to prevent demoralizing of

the market, as well as to get something from the part of the crop now going to waste.

NEW STEAM TRUCK USES COKE AS FUEL

The problem of devising a steam-driven road vehicle in which the firing is done with solid fuel without the necessity for an extra attendant to look after the fire, has apparently been solved in a coke-fired steam truck recently brought out by an English firm. Hills and other conditions bring about a continual variation in the power requirements of such a vehicle as it is driven over the road, and it has been found difficult to devise any kind of mechanical stoker that will meet these

inventor: National Steam Car Co. Ltd
W. Mansham Works,
Chelmsford
inventor: Chas. Clarkson

Inventor: Edward Taylor, Owensboro, Ky.

692
Bonniers Report 9/18/15
California Fruit Growers' Exchange
Los Angeles, Calif.

varying conditions satisfactorily. The semiautomatic feed which forms the essential feature of this truck and which enables the driver to control the steaming without leaving his seat, is apparently adapted as well to a passenger vehicle, in which the conditions are more unfavorable, owing to the frequent stops. The coke bunkers are built up the sides of the boiler and are filled through doors at the top. The grates slope from each side toward the center. At the bottom of each bunker is an opening of such size that the right amount of coke to take the place of that burned on the grates is fed through it by gravity. When a hotter fire is needed, as in climbing a hill, the driver simply works certain levers placed within his reach. These levers rock the grates, clearing them of ashes and clinkers, and also oscillate a set of bars that project into the bottom of each of the bunkers. Through the action of these bars the coke is loosened and made to flow to the grates more freely. In addition to these features there is provided a forced draft which is also operated from the driver's seat. This consists simply of a special nozzle which admits steam to the base of the chimney and thus accelerates the combustion.

GARDEN HOSE UTILIZED FOR MAKING RUBBER MATS

Considerable saving in the cost of rubber mats is brought about by a

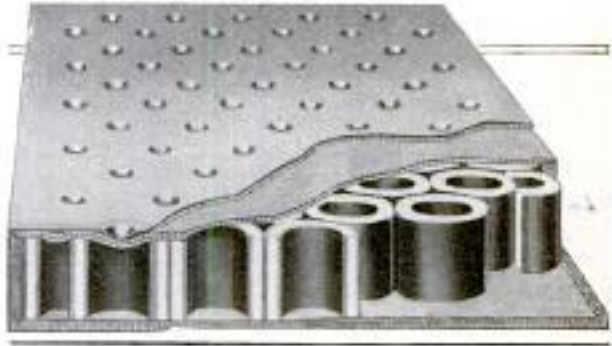

How Garden Hose Cut into Short Lengths is Used as a Filling for Rubber Mats

plan just invented for using scrap garden hose as an insert instead of making a solid rubber mat or using a



Two Views of Self-Dumping Steam Truck. Recently Brought Out in England, Which Uses Coke as Fuel

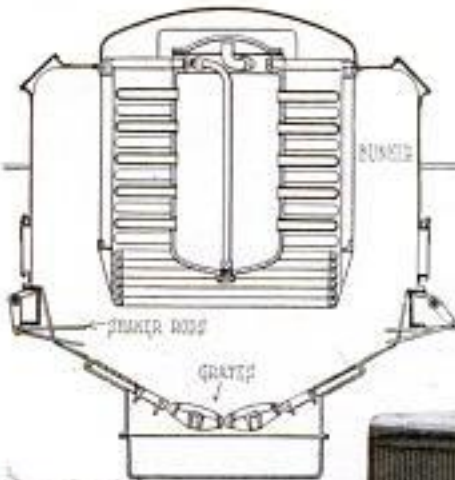

With the Arrangement Shown Above, the Coke Feeds Down Automatically Fast Enough for Ordinary Requirements; When a Hotter Fire is Required the Coke is Loosened by the Shaker Bars



*The Republic Rubber Co.
Youngstown, Ohio*

*inventor: web. Brown, adv. engr.
above firm*

354
361
361

cloth insert. The garden hose is cut into small pieces which are set on end, cemented together, and then impregnated with rubber. The filling thus formed is surfaced on each side with a sheet of rubber, an extra layer of fabric being placed under the upper surface in case the mat is to be sub-

jected to rough usage. The whole is then cured together, making a solid unit which gives an equal distribution of strain. Other kinds of material than garden hose can be used as a filler, the degree of resiliency depending on the kind of tubing employed. The mat can be made in any thickness from 1/2 in. up.

GOTHAM DEATH RATE SHOWN BY ELECTRIC CHART

In compiling vital statistics showing the mortality rate in New York City, the Department of Health investigated

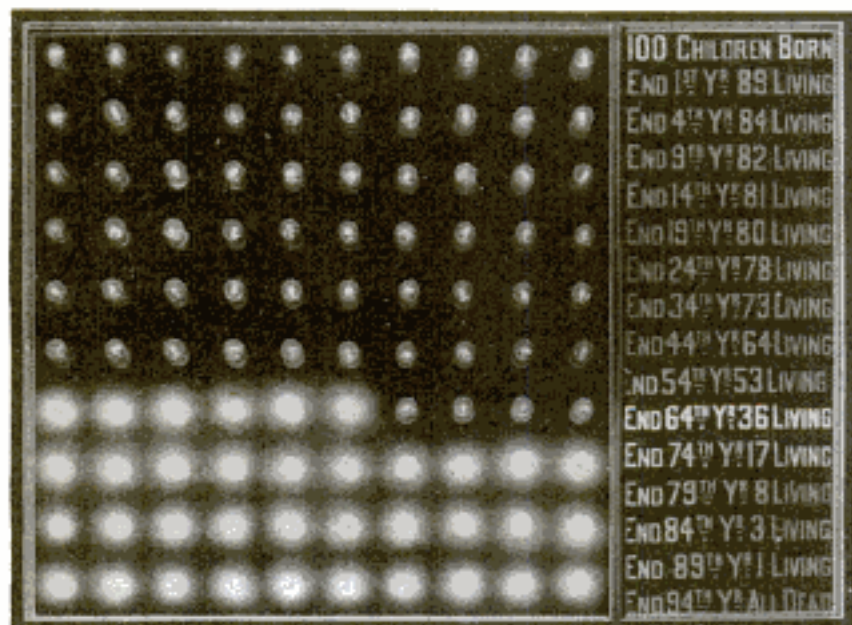

All of the Lamps are First Lighted and Then Successively Extinguished to Indicate the Rate of Mortality

more than 225,000 deaths. The findings are so significant that an electrically illuminated chart has been built to display the figures for an obvious purpose. The statistics given on the sign trace the length of life of the average New Yorker by starting with 100 infants and showing the rate at which they die. At 89 years only one out of the entire group survives, and at 94 years all are dead.

(Fishing lines now being made by the Japanese from wild-cocoon silk are said to be especially valuable in taking game fish, since they are invisible under water.

STEAM SHOVEL BEGINS WORK FOR GOVERNMENT BUILDING

In beginning the excavating work for the new home of the Department of the Interior at Washington, the formality of breaking the ground was carried out without the use of picks or shovels. Instead of a golden spade, or even an ordinary one, a large, modern steam shovel was employed for the first time in such a ceremony at the national capital. At the appointed time, the assistant secretary of the treasury, in the presence of a number of government officials, pulled a rope which opened the clam and dropped a load of earth into an awaiting wagon. The new

building, which will cost approximately \$2,000,000, will be constructed in accordance with the general plans laid out a number of years ago for the "ultimate Washington."

MAIL BOXES ROOST LIKE BIRDS IN COLONIES

Fifty-six mail boxes all nailed to the same rack is rather an unusual sight. It is stated that at one time there were as many as 70 boxes on this same rack. It is located in a suburb of a western city and was put up by the residents of a newly built-up section of

The Williams Service, 116 Waverly Place, N.Y. City

#2. D. Colburn, The Times, Wash. D.C.

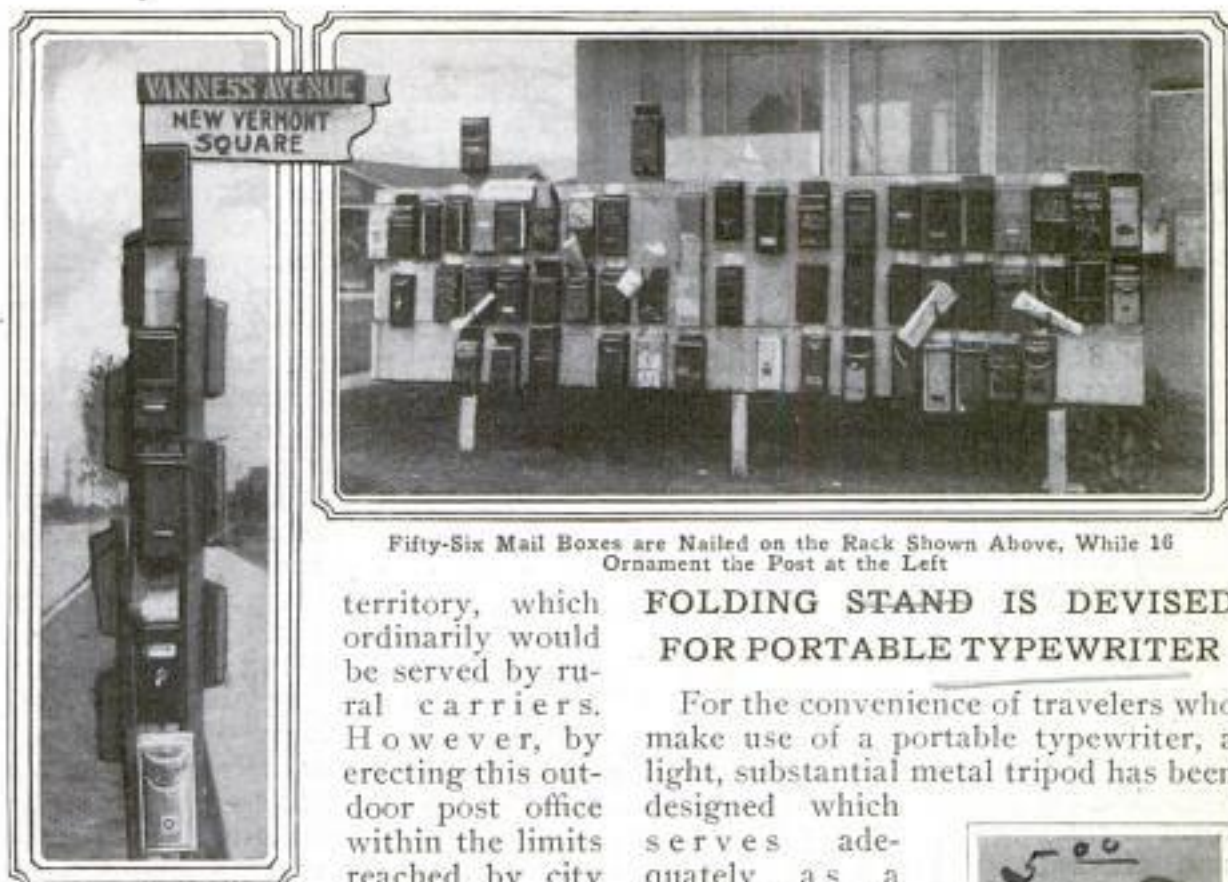

Fifty-Six Mail Boxes are Nailed on the Rack Shown Above, While 16 Ornament the Post at the Left

territory, which ordinarily would be served by rural carriers. However, by erecting this outdoor post office within the limits reached by city delivery, the residents of the district were enabled to receive mail more than once a day. In another instance a street signpost served the same purpose as the rack. In this case there were 16 boxes all on the one post.

HOW ALKALI AFFECTS CEMENT DRAIN TILE

As the result of a series of experiments conducted by the United States Bureau of Standards it has been found that the alkaline soils found in some sections of the West are destructive to cement drain tile unless the tile is of the best material and has been made with the greatest care. Well-made tile of a mixture as rich as one part cement to three parts sand and stone combined, is apparently not affected by the alkali, but tile made of a leaner mixture than this is likely to disintegrate within a short time when placed in a soil having a strong alkaline content. These conclusions are based on tests extending over a period of one year.

Book from Bureau of Standards

FOLDING STAND IS DEvised FOR PORTABLE TYPEWRITER

For the convenience of travelers who make use of a portable typewriter, a light, substantial metal tripod has been designed which serves adequately as a stand for the machine. It folds compactly and fits into a case, 10½ in. long, which has a maximum diameter of 2¾ in. When in use it is 24½ in. in height and supports a typewriter at the proper distance from the floor. By means of a bracket, which may be secured to one side of the stand, an arm is provided for supporting a notebook or loose leaves of copy. There are no screws or clamps to fasten when a machine is placed on the tripod, and the absence of reflecting surfaces tends to dissipate the sound waves arising from the operation of the typewriter, so that an operator may work on a train, in a hotel room, or in any public place, without making an objectionable noise.



Corona Typewriter Co., Inc., 141 W. 42nd St., New York

Engineering Record, June 5, 1915
"Information" P. R. R. employee magazine

NEW RAILWAY-SYSTEM TEST PLANT MODEL OF EFFICIENCY

PRACTICALLY all of the standardization tests incident to the acceptance of some \$80,000,000 worth of materials and equipment purchased annually by one of the eastern railways, are conducted in the laboratories of an inspection plant lately established at Altoona, Pa. The shop holds particular interest at this time when the demand for efficiency is gaining impetus; for it represents an institution in which figures and facts replace guesswork.

The test department of this railroad is maintained at an expense of approximately \$500,000 a year. Its major purpose is to pass upon the quality and fitness of the goods and supplies bought by the corporation. This gives a suggestion of the magnitude and variety of the tests performed at the plant, where a staff of 350 persons is engaged in examining thousands of articles ranging in character from soap and plush to pig iron, incandescent lamps, and locomotives. In the chemical laboratories alone more than 50,000 routine tests are made yearly. As a result of this system of scrutiny, an annual average of \$1,000,000 worth of goods is rejected.

Nearly all of the departmental branches are concentrated in one building, which affords 41,000 sq. ft. of floor space and was erected and equipped at a cost of about \$500,000. The structure is five stories in height and has a subbasement which provides space for a receiving room for materials, a machine shop where the laboratory apparatus may be repaired, vaults for the preservation of records, and a chemical-storage room. The equipment of the machine shop includes two 14-in. engine lathes, a 12-in. lathe, a 24-in. radial drill, a 24-in. shaper, milling machines, and other facilities for the preparation of metal specimens prior to their tests. All of the machinery in the plant is electrically operated.

The first floor of the building is devoted to the physical laboratory. Five machines are provided there for testing the tensile strength of materials. One

of these has a capacity of 1,000,000 lb. and is capable of gripping the ends of a piece of steel as large around as a fence post and stretching it out like rubber until it breaks. Laboratories for gas and water analyses, the examination of rubber goods and electrical instruments, bacteriological tests, and photometry occupy the third floor. Chemical experiments and tests are conducted in laboratories on the floor above. By extending the central bay of the building, a fifth floor has been provided which serves as a photographic laboratory. The roof of the structure is used also for photographic purposes and for testing the durability of paints.

The locomotive test shop is separated from the main plant, as are some other of the divisions. Instead of taking a passenger or freight engine out on the road and making it pull a string of cars over different grades in order to test its capacity, as was once done, it is driven into the shop onto a testing table. There it rests on a series of heavy wheels which form a sort of treadmill for it, enabling it to be worked out thoroughly, "run" at a high rate of speed, or made to pull enormous loads, without moving an inch.

Many of the tests are made as nearly similar to conditions met in service as is possible. The stay bolts of a locomotive, for instance, are subjected not merely to a pull, but also to a peculiar twisting strain such as is encountered in actual use. Car springs are tried out in a heavy apparatus which compresses and releases them alternately. After a spring has undergone thousands of compressions in this manner, it is taken out and measured to ascertain the amount of elasticity it has lost. In testing incandescent lamps, a large rack is used in which 1,000 bulbs are inserted at one time. This is done in determining the efficiency and probable life of various kinds of lamps. Currents ranging from far below normal to excessive strengths, are used for this purpose. Food products used in the dining service, the drinking water

Photographs supplied by J. W. Lee, Substantive Agent P. R. R. Broad St. St. Phila. Pa.

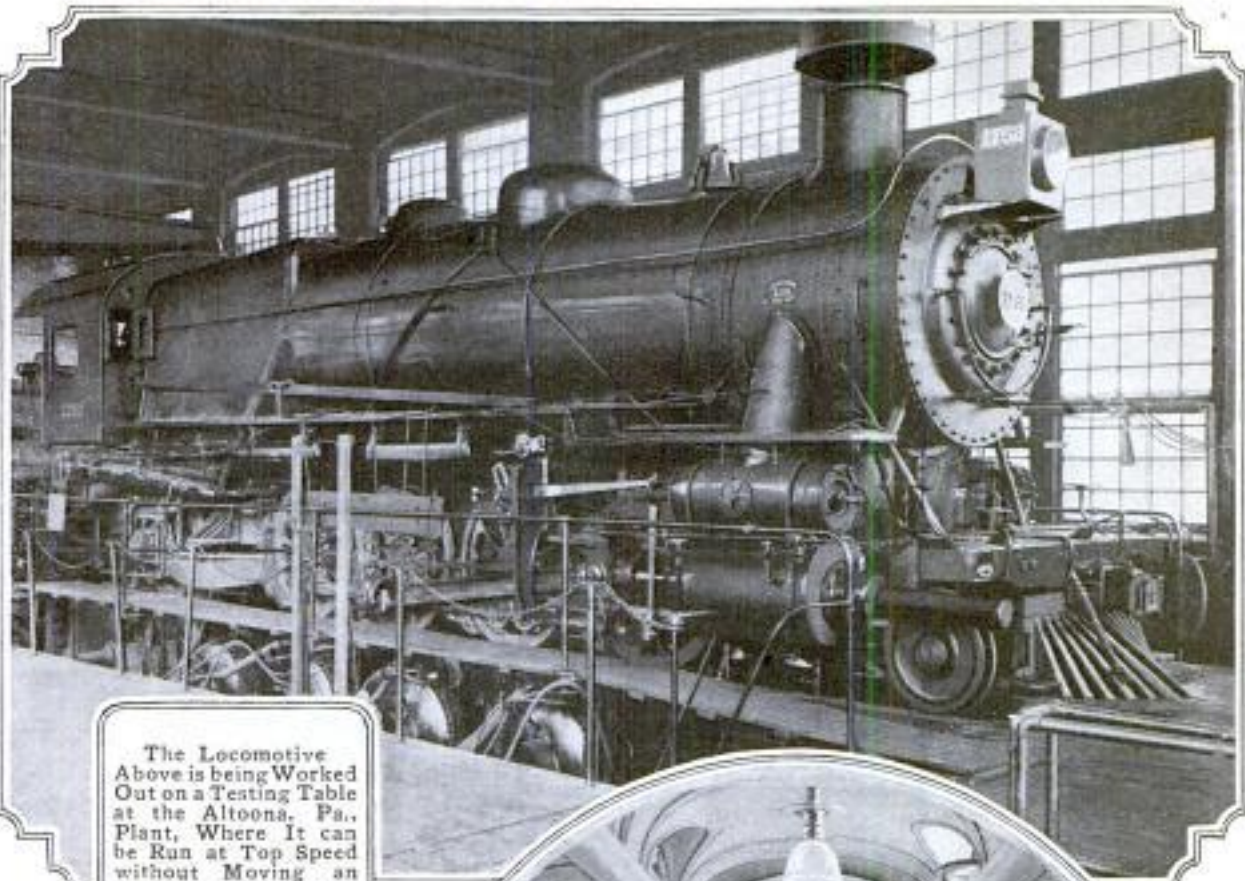

The Locomotive Above is being Worked Out on a Testing Table at the Altoona, Pa., Plant, Where It can be Run at Top Speed without Moving an Inch. At the Right is Shown the Interior of the Chemical Car for Testing Steel Rails at the Places of Their Manufacture, While the Photograph Below Shows the Racks Used in Trying Out Electric Lamps under Varied Conditions

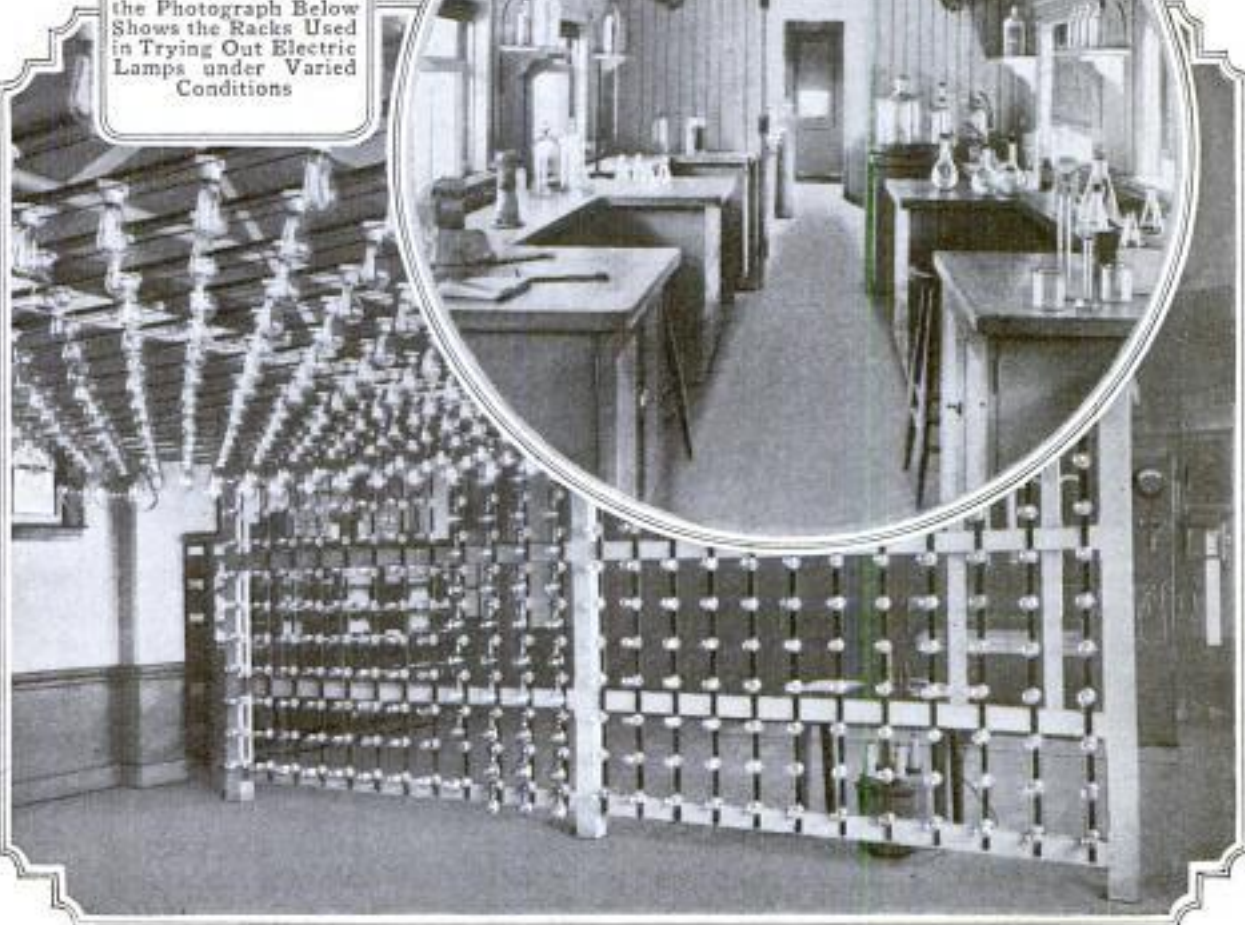

provided in stations and on trains, the condition of the atmosphere in various tunnels, and divers other things of similar character are tested regularly.

Much experimental work is done in order to devise means for lengthening the life of materials, as well as general equipment. For instance, some 286,800 cars periodically require painting. This is a big item of expense, and attempts are continually made to produce paints of greater durability. When a car is in the paint shop it represents a liability to the company instead of an asset. Therefore efforts are made to devise practical means for lessening the time required in painting

cars. A pronounced step in this direction was made not long ago. As a result of experiments, a great oven was built in which freshly painted cars are baked. This process reduces the length of the drying period 95 per cent and cuts in half the total time a car is kept out of service when being repainted.

To facilitate the work of testing steel rails, a car has very recently been fitted out as a chemical laboratory. This, when in use, will be sent to mills where rails are manufactured. Its attendants will thus be enabled to make their tests on the ground as the rolling is being done, which will save considerable time and delay.

586 OLD BRIDGES TRANSFORMED WITH CONCRETE

In one of the counties of southern Kansas novel work has been accomplished in reclaiming old dilapidated



This Bridge, Formerly an Old, Unsafe Steel Structure, was Made Serviceable by Coating It with Concrete

steel bridges which had been condemned. Instead of razing them and erecting new ones in their places, they have been converted into substantial, reinforced-concrete structures. This has been done by building wooden forms about the structural members and filling them with concrete. Thus the framework of the old bridges has been employed as reinforcements for the new ones. Metal bars and other pieces used in bracing the original structures provided reinforcement for the flooring.

666 THE "GROCETERIA," LATEST TYPE OF GROCERY STORE

The latest innovation in grocery stores is the "groceteria," which, as its name implies, is operated on the same plan as the cafeteria. In these institutions, three of which have already been opened in Santa Monica, Cal., there are no clerks, bundle wrappers, deliverymen, or bookkeepers, and, since they are run on a cash basis, there are no bad accounts. It is claimed that because of these conditions there is a saving of from 15 to 40 per cent for the consumer. Each customer simply helps himself to the articles he desires. As he departs the cashier checks over the goods and determines the bill. Package and canned goods take care of themselves without any attention, but it is necessary for the management to weigh and pack groceries that come in bulk. This is done in advance at times of the day when trade is not brisk.

Electric ovens are being used in German field hospitals for the treatment of bullet and shrapnel wounds.

Milton Axel Hagen, 2106 Magnolia Ave San Angeles, Calif.

435
MOTORCYCLIST IS SHIELDED FROM AIR BY DEFLECTOR

For motorcyclists, a simple deflector has been devised which, when attached to the handlebars of a machine, diverts the air currents over the head of the rider, leaving him in a comparatively still atmosphere while driving at almost any reasonable speed. It consists of a rectangular metal case containing a series of parabolical vanes, which form curved channels inside the case. When a motorcycle is speeding along with this apparatus fixed before its driver, the air enters the front of the deflector and is shot out of the top at a 45° angle. The air coming in the plane above the deflector strikes the upgoing current and is diverted by it so that it also takes an inclined course. This protects the upper part of the



rider's body from wind and dust. The device is supported a few inches above the handlebars so that it is about a foot below the rider's chin. In this position it does not obstruct the view or cause any inconvenience in driving. It is said that when the deflector is

used for the first time a rider has difficulty in estimating his speed, because of the stillness of the air about him. While traveling at a good clip it is possible for him to light a cigarette or cigar without trouble. These points tend to illustrate the effectiveness of the apparatus.

NEW MACHINE FOR SHOCKING 199 ALFALFA

An alfalfa shocker that picks up the hay just as it is left by the mower and places it in the shocks without the necessity for gathering it into windrows, is now being introduced in the alfalfa-growing sections of the coun-

try. This machine does away with the hay rake, which often incorporates considerable quantities of dirt in the freshly cut crop during the process of rak-

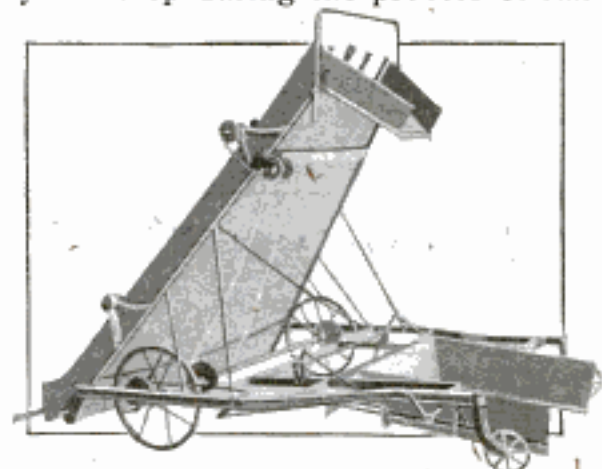

With This Shocker the Alfalfa is Placed Directly in the Shocks Instead of being First Gathered into Windrows

ing. The inventor claims that the machine acts as a saver of food value, since by placing the alfalfa crop in the shock as quickly as possible at least 90 per cent of the leaves can be saved. With this method of harvesting, the alfalfa is cured by the circulation of the air through the shock rather than by the action of the sun's rays.

NEW IRRIGATION SYSTEMS 686 IN HAWAII

Several large irrigation systems in the Hawaiian Islands, on which work has been in progress for some years, are now nearing completion. One of these systems, located on the island of Kauai, comprises several miles of ditches and about 10,000 feet of tunnel. Another large system, which is rapidly approaching completion, is located on the island of Oahu and passes under the Koolau range near Honolulu, by means of a tunnel seven miles long. This tunnel is to be used for carrying water from the Waiahole Valley to the lands of a sugar company located on the opposite side of the island.

The Japanese government is considering the advisability of transferring to private ownership all the factories now owned and operated by the government.

*Van Zile Ventilating Corporation
 39 Cortlandt Street
 New York*

*Inventor: Hugo H. Engelken
 923 Grant St. Beatrice, Neb.*

USING A CHEMICAL TO KILL WEEDS ALONG RAILROAD

A chemical spray for killing weeds and other vegetation on the roadbed, now being used on a number of railroads, is said not only to be highly efficient for this purpose but to provide an excellent preservative for the track structure. The chemical is car-



How the Chemical is Applied to the Roadbed for Killing Weeds and Other Vegetation

ried in one or more tank cars and is applied at a pressure of about 15 pounds through an extension arm consisting of a pipe perforated on the under side. This arm is hinged and can be quickly raised out of the way of obstructions. On a railroad in South Carolina it required 126 gal. of chemical, diluted with 3,024 gal. of water, to spray a width of 12 ft. over a mile of roadbed. One application of the chemical each season is usually enough to keep the roadbed sufficiently clear of vegetation.

SHIPS USING PANAMA CANAL SHOULD SIGNAL APPROACH

In order to expedite the passage of vessels through the Panama Canal, the authorities in charge are calling upon ship masters to announce their approach by wireless. A general rule governing this point was posted with other regulations when the waterway was first opened, but according to recent advices it has not been closely followed. More than half of the ships crossing the isthmus carry radio equipment, but only about a fourth of these have observed the practice of signaling their approach.

Unnecessary delays and more or less trouble frequently result when ships arrive at the portals unannounced. When their masters communicate with the canal authorities, on the other hand, sufficient time is allowed to prepare for meeting different problems and handling the traffic more smoothly than would otherwise be possible. There are few vessels equipped with wireless which would be unable to furnish advice of their probable time of arrival 24 hours in advance, if their masters were so disposed. Matter of this character is handled without charge at the government stations. At the present time 2,300 messages, most of them of this nature, are handled at the Colon plant and some 400 communications at Balboa.

The canal radio stations are performing quite an interesting service which is probably not generally known outside of commercial and shipping circles. Each afternoon at 3:30 o'clock the Colon station sends out general news bulletins which are picked up by vessels in various parts of both oceans. At noon weather predictions relating to the Caribbean, South Atlantic, and Gulf regions are also sent out broadcast. Information concerning the positions of dangerous derelicts, and other matters pertaining to the welfare of navigators, is filed at regular intervals.

Large deposits of potash salts have recently been discovered in Spain.

Atlas Concentration Co. of America, Inc.,
95 Liberty St., New York

8668

INSTRUMENT RECORDS EACH DAY'S SUN HEAT

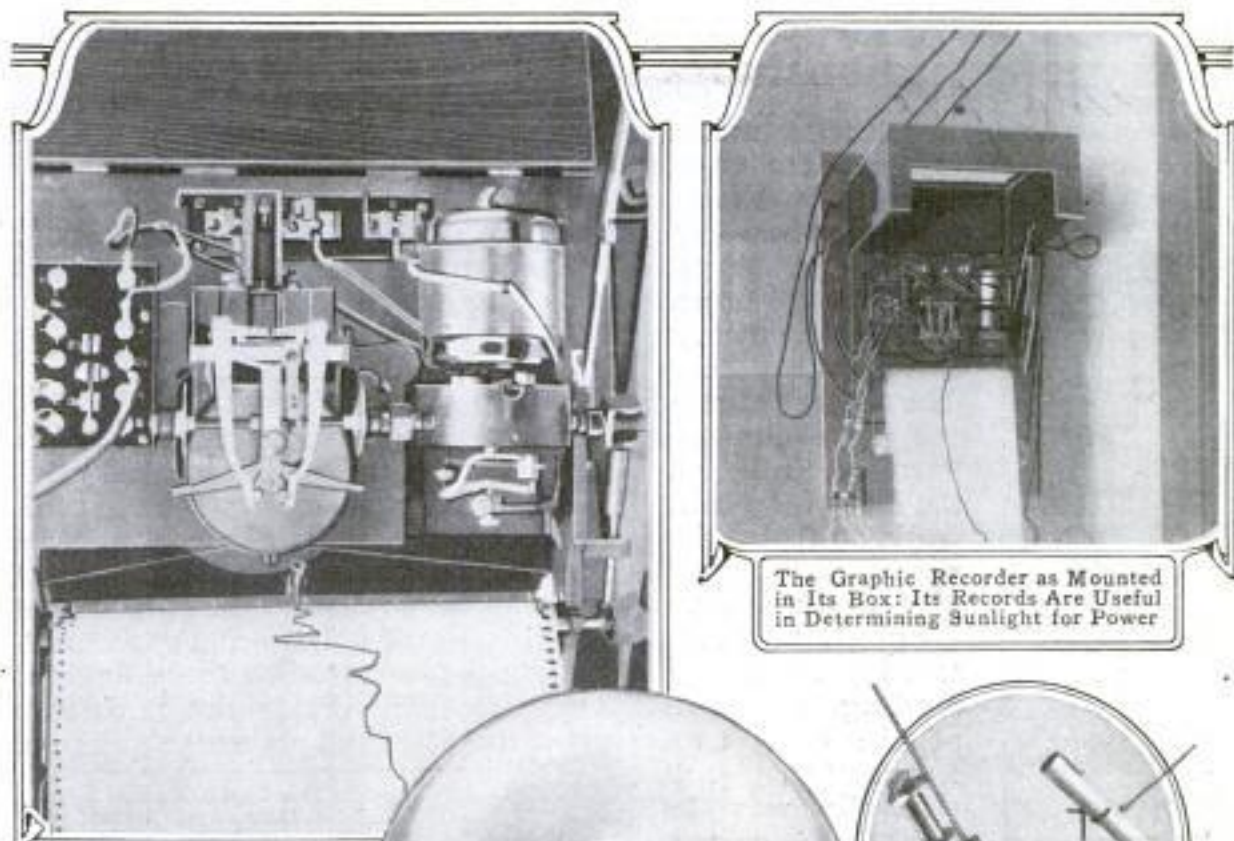

The Graphic Recorder as Mounted in Its Box: Its Records Are Useful in Determining Sunlight for Power

Above: Recording Galvanometer at University of Arizona Which Gives Chart of Amount Sun Shines in 24 Hours. At Right: Sunshine Receiver on Roof: Platinum Wires Change Resistance with Heat of Sun



Two Instruments for Measuring Direct Heating Effect of Sun's Rays

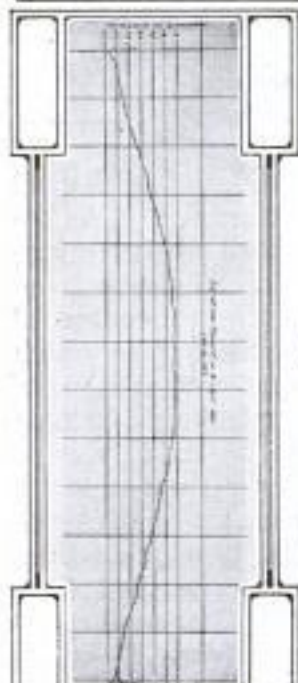

Smooth Record of a Clear Day

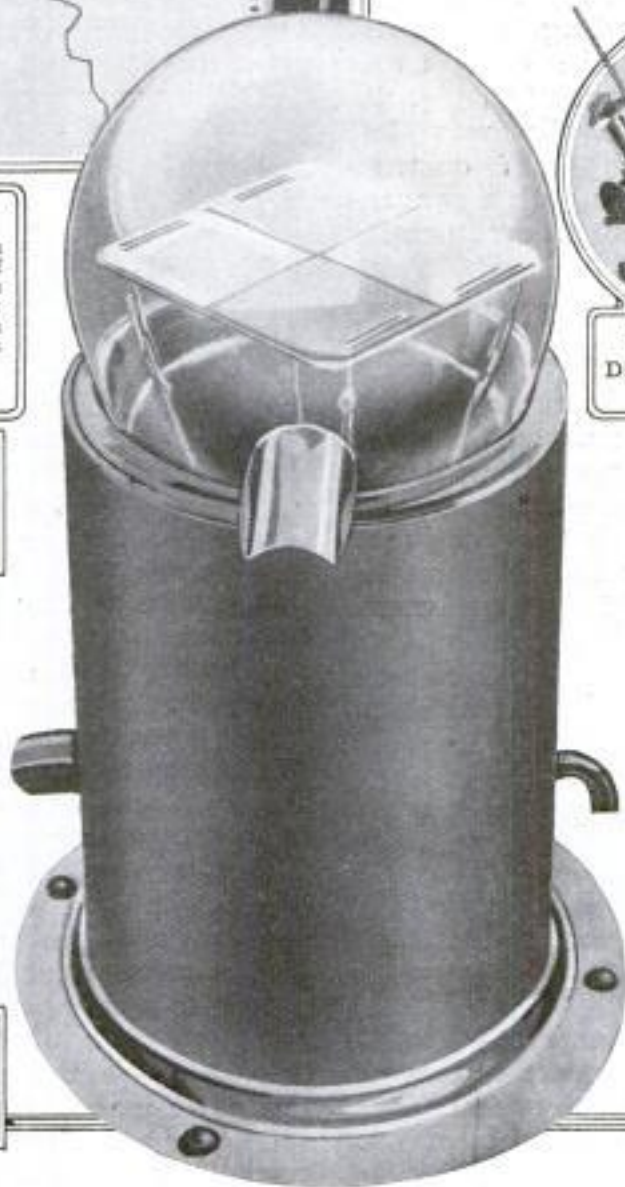

Clouds Cause Irregularities

WATER FOUNTAIN PROVIDED 41 IN FRONT OF BUILDING

Marple
In constructing a business building in a western city, a sanitary drinking fountain has been set in a niche provided in the front wall of the structure between two stores. The outer edge of the porcelain water bowl is flush with the face of the brickwork, so that it does not jut out in the way of pedestrians. By placing the fountain here, instead of erecting a pedestal at the curb, as is frequently done, the sidewalk was left free from obstructions.



The fountain is both a convenience to the public and an ornament.

406 — SIMPLE DEVICE FOR TIMING TELEPHONE TOLL CALLS

The time consumed in making a toll call is easily and accurately checked by the use of a simple timing device just placed on the market and designed for the convenience of telephone users. This device consists of a special clock



With This Special Clock the Time Consumed in Making a Telephone Call is Accurately Registered

having a single hand and a dial so divided that six minutes are registered with one revolution of the hand. The clock is started and stopped by means of a lever at the top of the case. The

hand is first set to zero and, with the completion of the toll connection, the clock is started by pushing the lever to the right. When the conversation is completed the clock is stopped by pushing the lever to the left. One winding of the clock is sufficient for 1,000 three-minute calls.

486 — INDEX CARDS KEPT CLEAN IN NEW FILING CASE

For sanitary reasons as well as for convenience and efficiency, a card-index filing system, arranged according to a new plan, has been introduced for office purposes. The chief points in its favor are that it offers a means of locating a card quickly and without allowing the record slips to be fingered or soiled. This keeps the cards in a clean condition and prevents them from

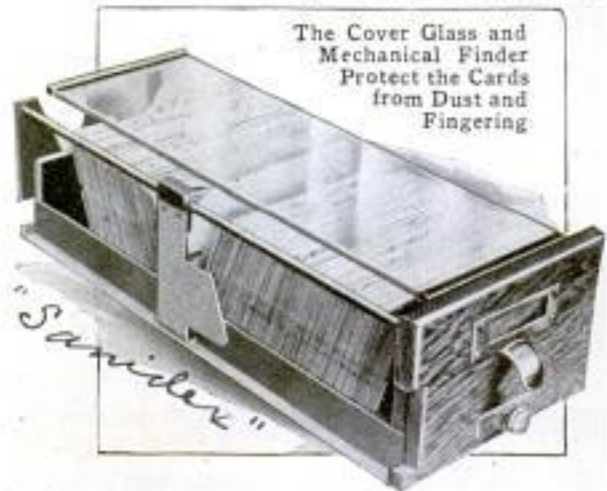

being worn or contaminated with filth because of frequent reference. The filing drawer is fitted with a plate-glass cover that protects its contents from dust. Passing through the center of it at the bottom is a small rod on which the perforated cards are threaded. On another rod extending along one side of the drawer is fitted a sliding device which acts as a finder. In locating a specific card, the operator makes use of this mechanical hand, which, when moved to and fro, turns the cards forward one at a time. The reading is done through the glass, which is intended to be removed only for the insertion of new cards or the removal or correction of old ones.

*C. N. Garrow Co.
Parsonage & Olive Sts.
Philadelphia, Pa.
"Phonometer"*

*G. W. Electric Co. Specially Co.
Chicago, Ill.
Chicago*

HOW A SHIP'S STABILITY IS DETERMINED

633

By JOSEPH R. OLDHAM, N. A.

2034 E. 81st St.
Cleveland, O.

(Since the appearance of the article on the "Eastland" disaster in the September number of Popular Mechanics Magazine we have received many requests for a more detailed explanation of the "metacenter" and the "metacentric height." The following article, written by an engineer and marine expert, makes this technical subject simple enough, we believe, for anyone to understand.—Editor.)

THE metacenter is a measure of the comparative stability of a ship. It is a fixed point, for one draft of water, through which the buoyancy may be assumed to act for all angles of inclination up to about 15° from the upright. It is also the point above which the center of gravity of a floating vessel cannot be raised compatibly with stable equilibrium.

In Fig. 1, the metacenter is marked M, the center of gravity is indicated by G, and the center of buoyancy is marked B. Though the altitude of the metacenter is measured from the center of buoyancy as its base, the actual power of the vessel to return to the upright position depends upon its height above the center of gravity of the ship, and not primarily upon its distance above the center of buoyancy. The metacenter may be compared to a pendulum having its point of suspension at M, and its weight concentrated in a bob at the center of gravity G. This distance is commonly called the G.M. So long as G is below M, the ship is in stable equilibrium. If G is above M, as indicated in Fig. 2, the ship is in unstable equilibrium. If G coincides with M, the ship is in neutral or indifferent equilibrium.

Consider a deep vessel, such as shown in section in Fig. 2, made still deeper by the addition of an upper deck, and then loaded with grain and no water

ballast carried, which was actually the case in the Atlantic trade a few years ago. This raised the center of gravity about three feet, moved that center slightly above the metacenter M, and produced a metacentric height of minus 5 in., and developed a heeling moment of nearly 3,000 tons, which caused the shifting of cargo and the capsizing of the vessel. The basic defect of this construction was excessive depth. Here it may be pertinent to state that when the depth of a bulk-cargo vessel, from the keel to the strength deck, materially exceeds 60 per cent of the extreme breadth, the structure may be considered as too deep. Though this vessel was deficient in statical stability, due to the low metacenter and the high center of gravity, it is, however, quite possible to have too great a metacentric height. If this height be excessive, due either to the high altitude of the metacenter, or to the low position of the center of gravity, or to a combination of these elements, the vessel will oppose too great a resistance to beam seas, thus setting up uneasy rolling and developing excessive vibration. This may be illustrated by Fig. 3, which shows a vessel with great metacentric height, due to small displacement, largely concentrated near to the load water plane, and to the great breadth of beam—the potent factor of a large moment of

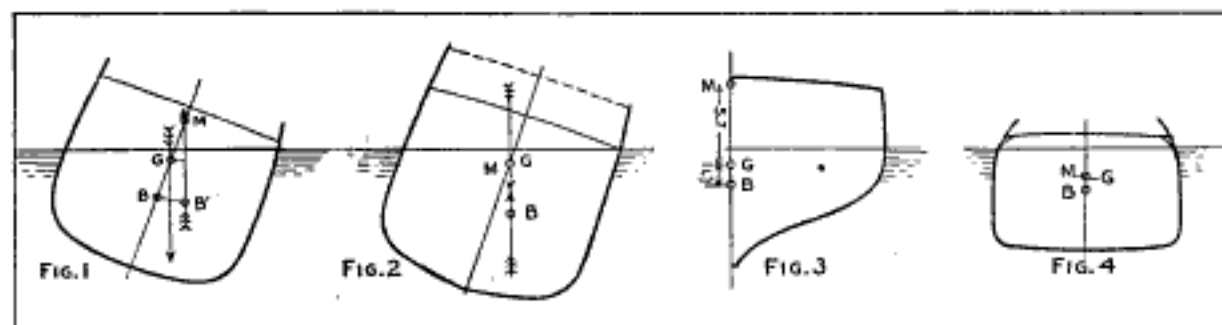

Fig. 1, Great Metacentric Height, Due to Fine Lines and Small Displacement; Fig. 2, High Center of Gravity Resulting from Excessive Depth, and Low Metacenter Due to Narrow Beam and Deep Immersion; Fig. 3, High Metacenter Due to Great Breadth of Load Water Plane, Small Displacement and Immersion; Fig. 4, Low Metacenter, Due to Large Displacement and Contracted Breadth of Load Water Plane

inertia. In this example the metacenter is 7.4 ft. above the center of buoyancy B, and as the center of gravity G is 1.7 ft. above the center of buoyancy, the metacentric height, or G.M., is thus 5.7 ft. The stiffness of a ship varies with the metacentric height. If it be doubled, the stiffness is doubled; if halved, the stiffness is reduced by one-half, and so on, in like proportion.

Though most of our lake steamers have an excessive metacentric height, due to the combination of a low center of gravity and a high metacenter, caused by the large moment of inertia of the load water plane and shallow draft of water, there are a few vessels afloat on these seas which exhibit a very moderate height when fully laden with a homogeneous cargo of low specific gravity. Some years ago, two large Atlantic liners were constructed resembling the outline section marked Fig. 4. These vessels had a "tumble home" of 7.5 ft. In other words, they were 7.5 ft. narrower at the deck than at their broadest point. Ships of somewhat modified design were constructed on the Great Lakes. Their architectural characteristics are a moderate moment of inertia, due to the diminishing breadths of the load water line, and large displacement with a low center of buoyancy, whose geometrical resultant is a low metacenter and

small metacentric height. This combination, however, can be readily counteracted by a judicious disposition of the weights carried, or by running some water ballast into the tanks, which would immediately lower the center of gravity and proportionately augment the metacentric height. They are, however, good sea boats and easy rollers, and they carry such cargoes safely, as their sides are strong and intact, with the exception of the small port aft, which is closed and made water-tight during severe weather.

Although the metacentric method is reliable primarily to demonstrate initial stiffness, or stability, it is susceptible of much broader application by shipbuilders of mature experience. Though a ship cannot capsize while she retains a metacentric height, it is equally true that certain types of ships, possessed of ample freeboard and unperforated top sides, may not capsize even though they have no metacentric height in the upright position. I have observed many such examples of similar vessels which were abandoned at sea. They heeled over toward an inclined position of stable equilibrium and there acquired a small metacentric height and a righting moment, continued to float, if the sea did not enter through the hatchways, and were finally salvaged.

8195

HINGELESS MOTOR-CAR DOOR DISAPPEARS WHEN OPENED

Instead of swinging outward into the path of passing traffic when opened,



This Motor-Car Door Disappears When Opened

a motor-car door, for which patent rights have just been issued, slides into the hollow space between the double walls of a vehicle body, disappearing from view. One of the advantages claimed for the device is that a lateral pressure upon it cannot cause it to open. It employs neither hinges nor locks and operates automatically by pressure on a release button. The door is hung on a pair of bars which are pivoted to the upper portion of it and to an angle plate fastened within the wall pocket. When in either an open or closed position it is held in place by its own weight and prevented from rattling by the tension of a spring.

Invention of Des Rovières, Detroit Mich.
 1,100,057 - June 16, 1914
 Filed 3-23-13 Dec. 7, 1910
 25 Hendrie Av.

LACE-CURTAIN STRETCHER NEEDS NO ADJUSTING

For stretching lace curtains and pieces of needlework after they have been washed, a new type of drying

BOW AND ARROW MADE SAFE TOY FOR CHILDREN

Among the toys recently invented for children is one which is modeled after the old crossbow of medieval

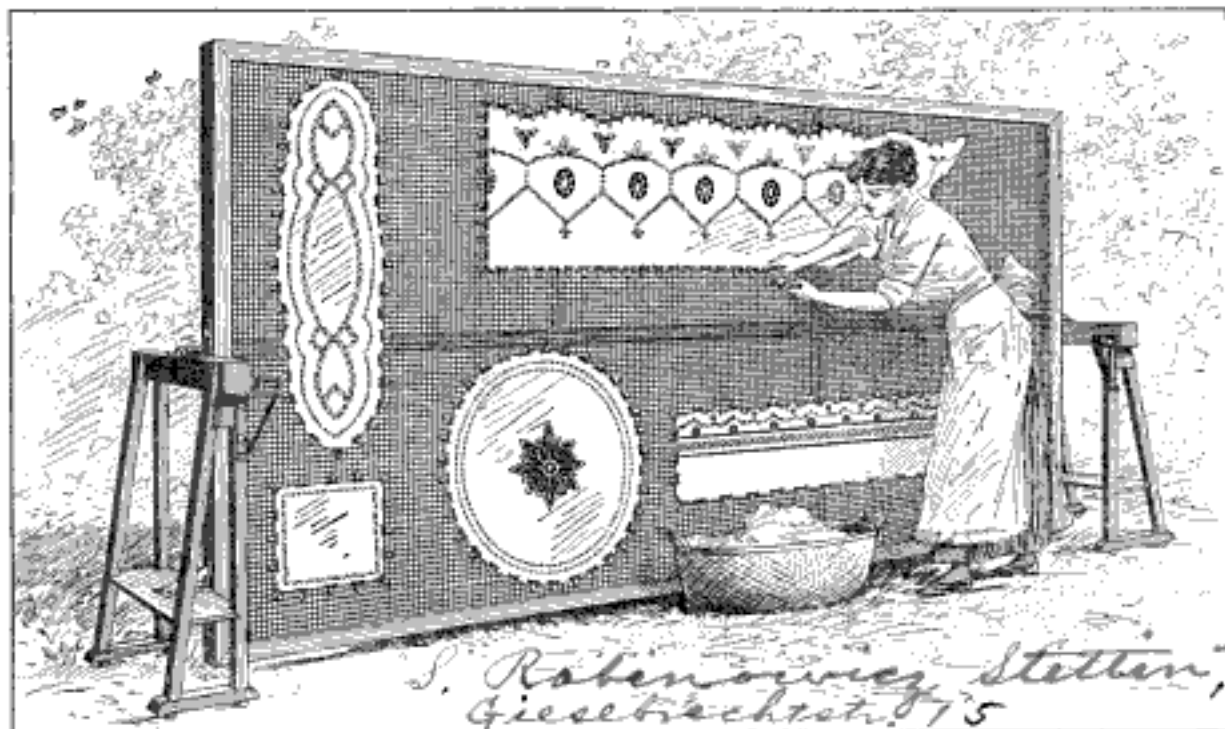

Curtains and Pieces of Lace are Secured to the Netting by Means of Specially Designed Clamps

frame has been brought out abroad which does away with the tedious task of adjusting forms such as are usually employed. The device consists of a wooden frame covered with a strong, large-meshed, nonmetallic netting. The articles to be dried are stretched to the surface of this by means of special spring clamps. Each of these is provided with a hook on one end which may be engaged in a mesh of the net. The clips are made in a number of styles with jaws of various patterns and sizes to suit the specific requirement of different articles. Besides its time and trouble-saving advantages, the frame prevents the distortion of the laces.

One thousand members of affiliated engineering societies in Scotland are being enlisted for week-end munition work in order to relieve those who have been so engaged since the war began.

days. The arrow used differs from that ordinarily seen in that it has a small parachute device attached to it which brings it slowly to the earth as it commences its downward fall, eliminating the danger of injuring bystanders. The arrow has the customary feathered end, and at the moment it leaves the bow its parachute is folded up, so that the flight of the missile is not seriously

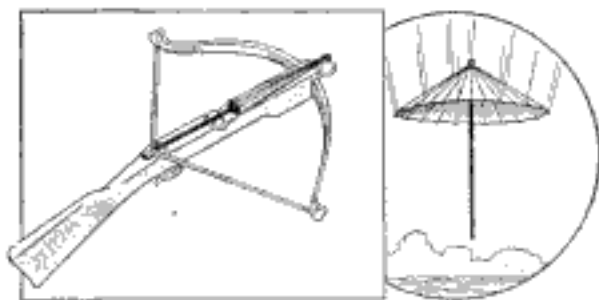

When This Arrow Falls a Parachute Device Opens, Making Its Downward Course Slow, to Eliminate Danger

impaired. As it reaches its limit of elevation and starts down, the device opens.

596
NOVEL AND PRACTICAL THINGS
FOR THE HOME

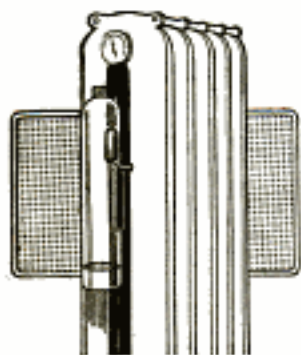

1 Glass Housing for Radiator Valve

An ingenious glass receptacle has been invented which serves a useful purpose. It is tubular in shape and has an aperture in its cylindrical wall which allows it

to be placed over a valve so as to catch the condensing steam and muffle the hissing noise.



2 Sanitary Toothbrush Has Removable Bristles

Designed for sanitary reasons, a tooth cleaner has been introduced which is so arranged that its brush may be renewed frequently. The brush and handle are separate members and joined by means of a small locking swivel. The former is made of bristles tightly gripped by twisted steel wire.

Near the upper end of the handle of a broom lately brought out there is a spring socket which is sunk flush with the surface. It is intended for suspending the broom, and for this purpose a button hanger is provided which may be screwed to a wall or kitchen tree. The socket slips over the ball readily and holds firmly.

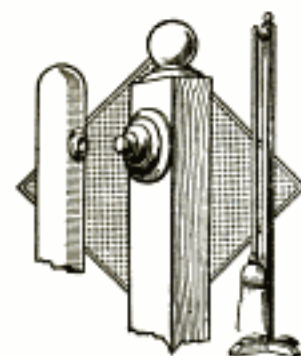

3 Hanging Device Provided in Broomstick

A novel hair-trimming instrument

has been introduced for men and boys which might be of particular service to those who reside in rural districts. Essentially it consists of a metal holder for a safety-razor blade and is designed to be clamped over a comb.

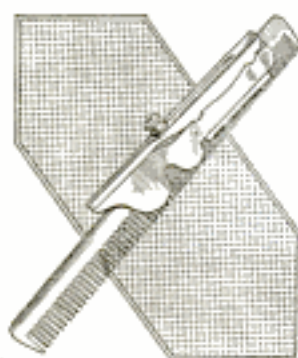

4 Simple Instrument for Trimming Hair

Convenience is found, by the woman who sews, in an ingeniously mounted magnifying glass intended to be used in threading fine needles.



5 Magnifying Glass Aid in Threading of Needles

A curved wire attached to the rim of the lens fits into a spool hole which serves as a standard. The glass magnifies the eye of a needle considerably and enables a woman to see what she is doing without straining her eyes.

For those who delight in popping corn at an open fireplace on winter evenings, a popper is made which has a sliding cover. A wire attached to it and also secured to a ring, encircling the handle, provides for its operation. This does away with



6 Corn Popper Fitted with Sliding Cover

the annoyance of spilled corn and burned fingers.

Baking dishes made of a special-process fireproof glass, which it is said will not chip or craze, are being introduced in many pleasing shapes and different forms. They are used both for cooking and serving, enabling food to be placed on a table piping hot, and also lessening the number of utensils needed in preparing a meal.

For domestic use, ball-bearing shears which cut smoothly and work easily, are a novelty now being advertised. The ball fits in an aperture drilled for it in one of the blades immediately back of the pivot screw. This reduces the friction somewhat and is intended to improve the action.

Sleeping caps which are also suited for outdoor wear in cold weather are being made of corduroy and lined through-



Warm Sleeping Cap Suited for Outdoor Wear

fit snugly about the neck and are well adapted for winter motoring, or skat-

ing, besides outdoor sleeping.

Several practical features are incorporated in a pot lately introduced which is fitted with a special cover. This is made in two parts, the inner of which is provided with a series of straining apertures and fastens in place securely. Over this sits another cover in which there is one large opening. By turning the knob at the top, the outer cover may be revolved and the strainers in the inner lid, which are of different mesh, exposed. A latch attached to the handle locks the top lid in place.

For the den, or as a companion piece for a smoking set, a combination cigar lighter and ash tray is made in an attractive design and finished in nickel-plate. It requires no batteries or wire connections, stands about six inches in height and weighs 9 oz. By pushing a small plunger, the flame is produced, and then extinguished by releasing the former.

To prevent the theft of groceries delivered at a residence, a receiving vault has been designed to be built in a kitchen wall. Its steel body is adjustable to different wall thicknesses and fitted with two cast-iron doors, the outer having a gravity lock.



Baking Dish Made of Fireproof Glass

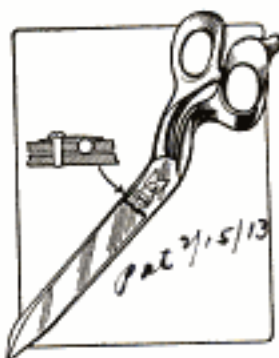

Ball-Bearing Shears for Household Use

out with a soft material. They are cut to permit various adjustments so that a person's face may be exposed entirely, only the nose and eyes left uncovered, or all but the tip of the former protected. They

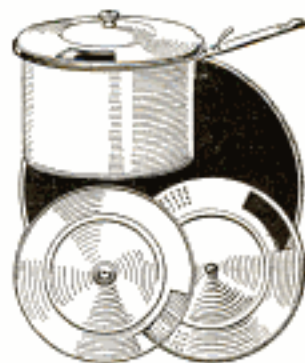

Water is Poured from Food through Strainers



Combination Cigar Lighter and Ash Tray



Built-In Receiving Vault for Packages

88 p. doz.
 7.50
 7.25
 918
 8433
 Lamie - Helices Complete
 Projectiles - Pellets
 100
 10
 Laminated Machine Co.
 40 N. 2nd St., New York
 Sales agents for U.S.

Kratz - Bouras
 Rue - Martel, 14, (10e) Paris

NEW FLYING TARGET MADE FOR TRAP SHOOTERS

To take the place of clay pigeons, glass balls, and similar flying targets used by sportsmen in gun practice, a small propeller-shaped device has been brought out in France. It is made of steel and is shot into the air by



This Propellerlike Flying Target has been introduced in France as a Substitute for Clay Pigeons

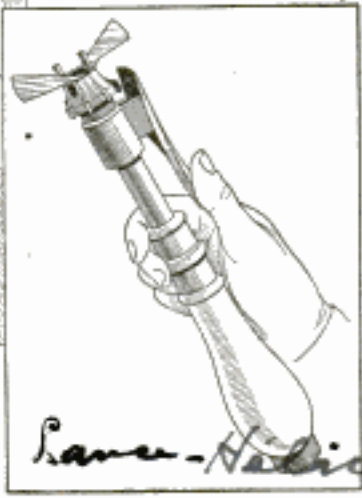

the strong spring action of an instrument which revolves it rapidly as it is released. The object can be made to ascend to a considerable height, and then planes for some distance before commencing to fall. As soon as it is struck by a shot, however, its rotary motion stops and it falls to the ground. Aside from the matter of cost, an advantage of the device is that it may be carried in a pocket.

NEW SHIM BLOCK IS MADE IN CONVENIENT FORM

Shimming brass is being made in solid blocks composed of thin layers



Shim Block Made of Thin Strips of Metal Held Together by a Metallic Binder

bound together by a metallic binder, so that in adjusting a bearing to take up wear it is only necessary to peel off

Laminated Shim Co. Inc.
 533-541 Canal St. New York
 (74707)

enough of the laminae to bring the strip down to the required thickness. This eliminates the laborious and exacting method of filing a bar to an accurate thickness, and offers greater convenience than the loose-leaf shim. The separate laminations are made in two thicknesses, .002 and .003 in., and by peeling off successive layers it is possible for an inexperienced workman to make a smooth, uniform shim of the required size.

FURNACE OF NEW DESIGN FOR STUMP BURNING

For clearing logged-off lands an Oregon man has patented a firing apparatus which is intended to facilitate the burning of stumps and do away with the necessity of grubbing and blasting. It is simple in design, and according to its inventor, is capable of destroying the upper portion as well as the root system.

It consists principally of a saddlelike hood with a flue and auxiliary apparatus for inducing a draft and stimulating the fire. In using it, a 2-in. hole

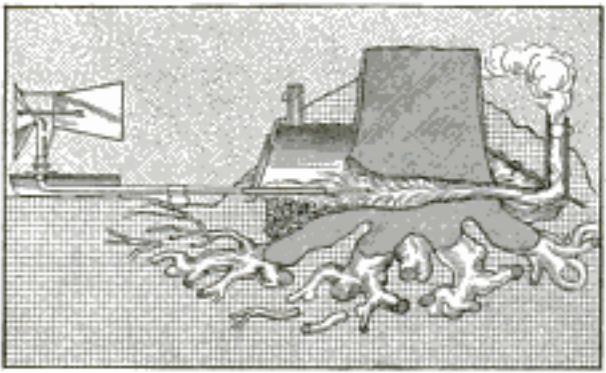

The Operation of the Apparatus is Inexpensive Because Fuel of Almost Any Character may be Used

is bored horizontally into the stump below the surface of the ground. This extends through the sapwood on a side from which the bark has been stripped. The ground adjacent to the hole is excavated so as to form a bed for the fuel. The furnace, which is made of metal with one end and its bottom open, is then set in place, while a pipe, less in diameter than the bore in the stump and provided at its far end with a wind funnel and vane, is set in close prox-

114 17 117 - June 1, 1914 - Danwell F. Zygote
 Thomas, Oregon. Filed Mar 12 - 1915
 Nov. 8 24 153. Dec 10 27 0: 803 12 15 10 233

imity to the auger hole. The latter member furnishes the air and promotes rapid combustion.

When a passage has been burned through a stump, a second hood provided with a smokestack and disk damper is set in place at the opposite side of the trunk and thoroughly banked with earth. After the burning has progressed a little farther, the first hood, and that section of the air pipe which holds the funnel and vane, are

1,141,747. APPARATUS FOR BURNING STUMPS. SAMUEL F. ZYSSEY, Thomas, Oreg. Filed Mar. 12, 1914. Serial No. 824,153. (Cl. 110-21.)



1. In a stump burner, the combination of a furnace provided with a combined draft and smoke outlet and open at its bottom and at one end to be located against one side of a stump, an air inlet pipe extending into the lower part of said furnace with its inner end in close proximity to the stump and movable progressively therethrough to supply air to the stump as a hole is burned therethrough and mechanism for directing a current of air into said air inlet pipe.

2. In a stump burner, the combination with a furnace adapted to be located against one side of a stump, an air pipe movably extending into the lower portion thereof with its inner end in close proximity to the stump, of a wind inlet funnel connected to said pipe, a supporting member carrying said wind funnel and movable bodily toward and away from the stump, and a wind controlled vane for shifting said funnel into position to receive the air and direct the same through the air inlet pipe into the furnace.

3. In a stump burner, the combination of a furnace to be located upon one side of a stump, a hood to be located upon the opposite side of said stump and provided with an outlet for the products of combustion, and a draft pipe extending into said furnace to facilitate the burning of a hole through the stump, and a wind funnel connected with said draft pipe and movable bodily therewith toward and from said stump.

4. In a stump burner, the combination of a furnace to be located upon one side of a stump, draft inducing mechanism comprising a hood to be located upon the opposite side of said stump and provided with an outlet for products of combustion, a draft pipe movably extending into the lower part of said furnace through the door thereof and movable bodily toward said stump, said draft pipe being admitted through an open end slot in said furnace door to facilitate the removal of said furnace and its replacement with a charge of earth after a hole is burned through said stump.

work.
pipe is
urning
rough
brown
e side.

SEAT

le has
hed to
to face

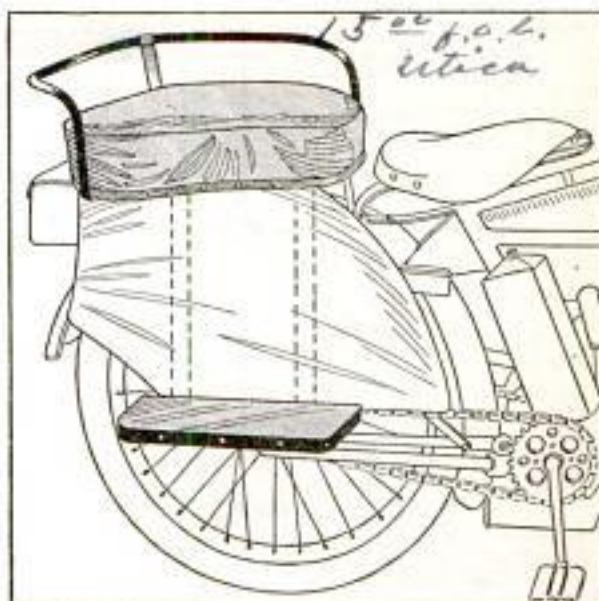

With This Seat a Person may Face Forward without Straddling the Rear Wheel When Riding Tandem on a Motorcycle

The seat is broad and roomy, and is intended to be attached by means of bolting clips to the frame of a luggage carrier. A canvas guard is provided to protect the skirt.

CA \$67,600 wire fence has been erected to inclose the Ashokan reservoir, which is a part of New York City's new water-supply system.

FEEDING DEVICE FOR POULTRY

alarm feeder will cause a bar, controlling the door catches, to rise, thus opening the doors.

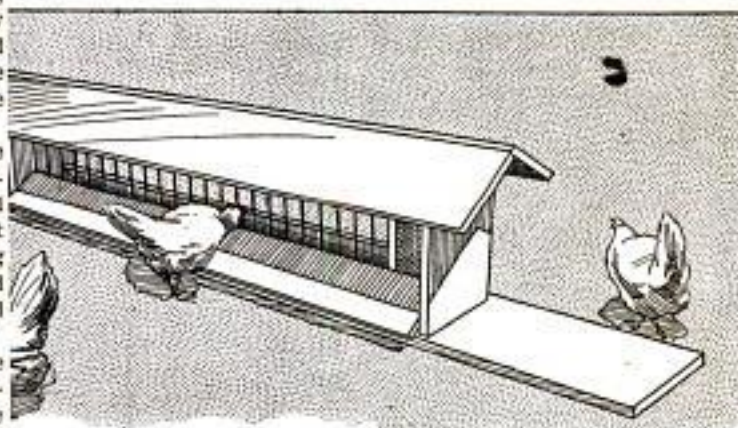

Chickens by a Mechanical Apparatus Operated by an Alarm Clock

ned by placed in key By setting the clock for a certain hour and filling the trough with grain, the chickens are fed without trouble.

John H. Allen, 150 1/2 Lincoln St. Utica, N.Y.
made for...
Copyrighted material
835 1913

H. H. Hinds Ltd. Young & Bridge Sts,
 Rabbit & Fox size 1 1/2 each
 posted anywhere 1/3 extra
 920
 also made for traps for mice, rats, etc.
 Sydney N. S. W.
POPULAR MECHANICS

**RABBIT TRAP MADE OF WIRE
 8957 NETTING**

A rabbit trap of a new type that is quickly and easily fixed in position for use consists simply of an inclosure
 "MORE-IN"

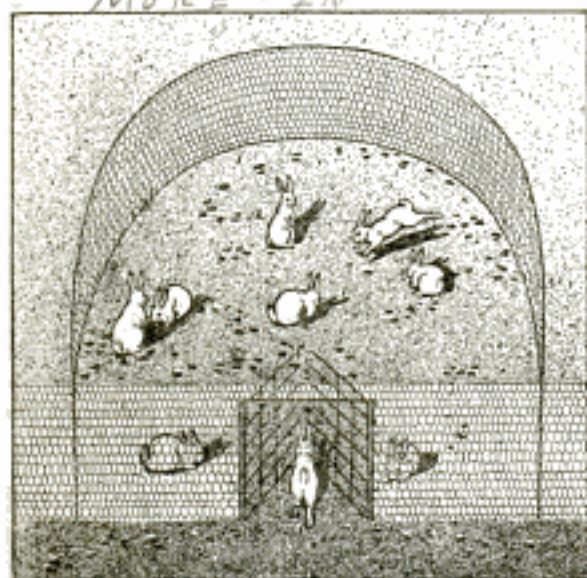

This Rabbit Trap, Made of Wire Netting, is Equipped with a Gate That Permits the Rabbits to Enter but Prevents Them from Getting Out

formed of wire netting and equipped with a gate of such form that it permits the rabbits to enter but prevents them from getting out. The trap is made up of two pieces, one straight and the other bent to a semicircle, and it is set up simply by joining these pieces together at the ends.

563
**LAND DRAINAGE IS PROBLEM
 OF EGYPTIAN FARMERS**

C. S. Monitor 9-7-15
 Agriculturists in Egypt are facing a peculiar situation which has been brought about by the promotion of irrigation. The financing of projects for supplying water to arid lands has not been attended with the difficulty met by drainage propositions. Because of this, certain districts once unproductive on account of the scarcity of water, are now suffering from an excess of moisture. Obviously much of the reclamation work has not been carried out as intelligently as it might have been, for conditions in some places have merely been changed from one extreme to another. The lack of

drainage facilities has caused fields to become soaked with water, ending with perfectly apparent results. Disastrous years have caused just as urgent a cry to be raised for drainage as was ever made for water, and eventually a normal balance will doubtless be established.

Egyptian cotton, which is of excellent quality, is grown almost entirely upon Nile land. A strip of soil reaching back about one mile on either side of the stream constitutes what at present is said to be the only area suited for cotton production. The country's part in this industry is governed by irrigation, and this in turn is controlled by the amount of water available in lean years. There has been a tendency to bring more land under cultivation, it is claimed by one authority, than could be maintained in years of minimum rise by the available irrigation facilities.

7658
**DEVICE KEEPS CABLE TAUT
 BY REMOVING SLACK**

Intended particularly for use on the control cables of an aeroplane, an instrument has been devised by an



English inventor for automatically taking up slack in a wire and keeping it taut. The check consists principally of a rod and piston fitted in a metal casing, with a strong spring so attached that it constantly tends to push them backward in the tube. A series of split spring rings fit around the rod between the heavy coil and the piston. In case a cable, to which the device is attached, stretches, the slack is taken up by the spring acting on the rod and piston. The same movement forces one or more of the spring rings into the piston chamber.

As soon as it enters this larger bore it expands and fills the space between the sliding member and the shoulder, preventing the former from moving forward.

Inventor: D. E. Turner
 2, King Henry's Road,
 Hampstead, Eng.
 Copyrighted material



Shop Notes

Washing Unopenable Windows

While using a special preparation for washing windows, apply the inside coat crosswise and the outside coat lengthwise; then, after the preparation has dried, the streaks will determine which side is not wiped clean. This is especially handy when washing windows that cannot be opened, as it will save many trips around to the outside when the streak is on the inside.

Portable Fan Outfit for Cooling Furnaces

In a large plant where there are many boilers having automatic-stoker furnaces, great delay was experienced in waiting for the hot brickwork to cool sufficiently to allow a workman to enter for the purpose of making repairs. The illustration shows how the delay was lessened. The fan cools

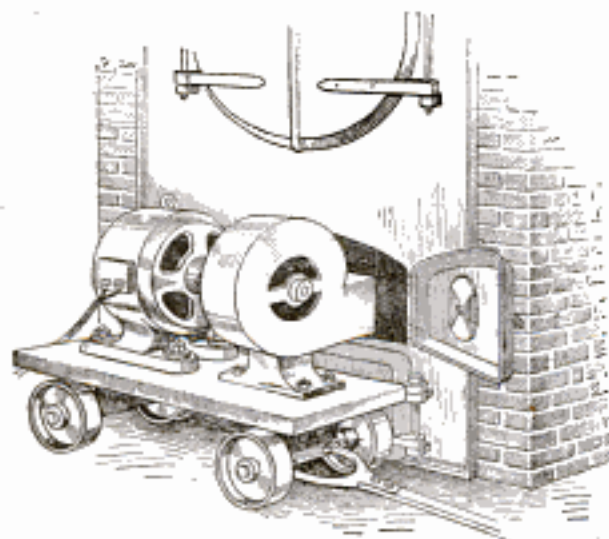

A Motor and Fan Placed on a Truck for Use in Cooling a Furnace for Making Repairs

the furnace to a workable temperature in a very small part of the time formerly required.—Contributed by J. J. O'Brien, Buffalo, N. Y.

Cover for a Drinking-Fountain Pipe

The drinking fountain in the playground in our city, when first erected, was merely a section of pipe with the cup attachment screwed into it. Recently a concrete base has been added, and a terra-cotta chimney top bedded

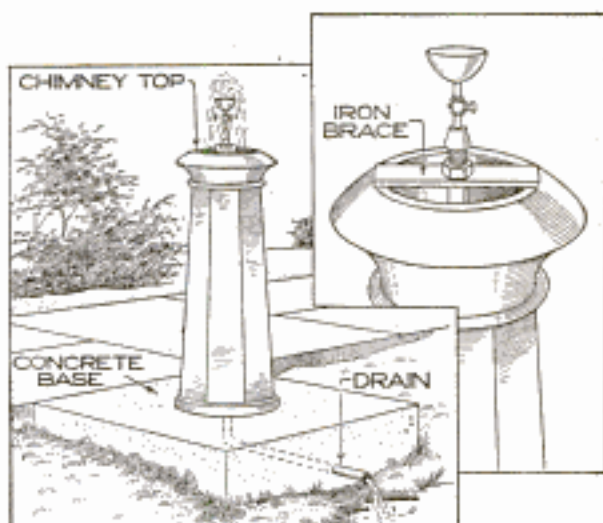

Terra-Cotta Chimney Top Used as a Protection and Ornament about a Drinking-Fountain Pipe

into it as shown. The concrete base is convenient for the youngsters to stand on, and the chimney top serves the double purpose of protecting the pipe and carrying the waste water down into a drain pipe running from the bottom of the chimney out into the gutter.—Contributed by James M. Kane, Doylestown, Pa.

Cutting Long Square Holes in Wood

It is often necessary to cut square holes through blocks of wood, and if the holes are of considerable length it is difficult to make them square and smooth. The tool illustrated is quite an aid for such work, and is simple enough for anyone to make.

An ordinary corner chisel is repre-

sented at A, into the angle of which is soldered a small block, B. To this block is fastened, by a small screw, a spring, C, of sufficient size to reach the opposite corner of the hole to be cut. The hole should be roughed out

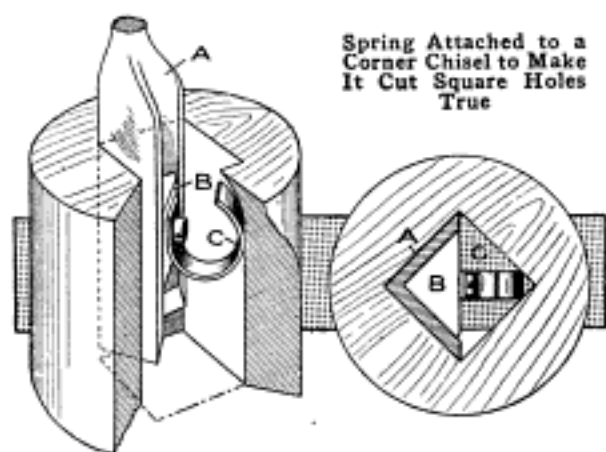

Spring Attached to a Corner Chisel to Make It Cut Square Holes True

first, after which it is easily finished with the corner chisel arranged as shown, since the spring C always forces the chisel down flat and holds it firmly in the corner as it is pushed through.—Contributed by J. A. Brearley, Washington, D. C.

A Portable Drawing Outfit

The illustration shows the construction of a self-contained drawing outfit, which is of value to engineers and students who find it necessary to carry drafting instruments to and from work. The size of the board is such

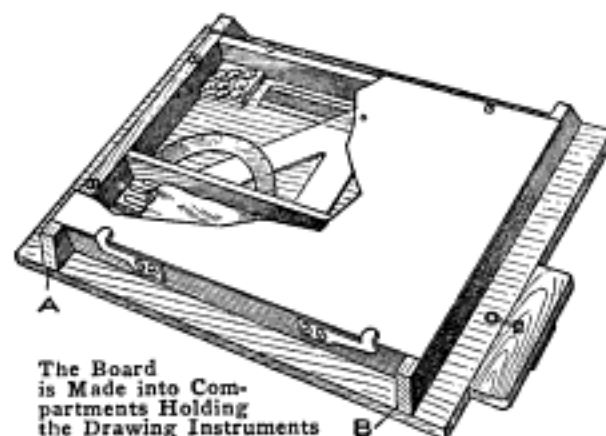

The Board is Made into Compartments Holding the Drawing Instruments

that it can be easily carried in a suitcase, and fair-sized drawings can be made upon it.

The drawing board is made of soft

pine, or poplar, $\frac{3}{8}$ in. thick by 14 in. long, and 12 in. wide. Three strips, with the grain of the wood running lengthwise of the board, are used for the board. The edges are made perfectly square and straight, for the use of the T-square.

The compartments for the instruments on the back of the board are made between two hardwood cleats, A and B, placed 1 in. from each end, and two similar cleats lengthwise, 1 in. from the sides. The cleats should be fastened to the board with wood screws.

The compartment formed within the cleats is divided in the center with another small cleat. A cover is made from a piece of sheet metal, aluminum preferred, and fastened in place by slots on one side which slip under round-head screws, and by two spring clips on the other side. The screws are driven almost down and filed flat.

In one compartment there is fitted a small chamois pouch, having pockets to receive the instruments, while in the other side there is room for a scale, protractor, triangles, pencils, etc. In one corner of one side, glue a small block of soft wood, to hold the thumb tacks. A T-square may be made to fasten across the face of the board by using small brass screw eyes and hooks. The blade of such a square should be about $1\frac{1}{2}$ in. wide, and just as long as the board.—Contributed by C. H. Van Fossen, Fayette, Ohio.

A Place for the Automobile Switch Key

If the key for the switch lock of an automobile is made of steel, it can be safely and conveniently kept in the car when not in use by attaching it to a small permanent magnet, concealed under the false dash, or elsewhere. Should the key be of brass, a steel duplicate can easily be made, or one may be made of tool steel, then hardened and magnetized so that it will adhere to any steel, or iron, part of the automobile. — Contributed by Carl F. Woodbury, Halifax, Nova Scotia.

Economy in Making Templates

A piece of work, shown at A, required holes drilled accurately, and quite a number of them were needed from time to time, making it necessary to have a template, as shown at B. The template was first made of machine steel and casehardened. The holes wore rapidly, and the template had to be discarded, and a new one made quite often.

To make a template that would stand the wear and not require a large amount of tool steel, one was turned up of machine steel, and the places for the holes were located and drilled for tapping with a $\frac{3}{8}$ -in. machine tap. Then the holes were tapped, and a piece of $\frac{3}{8}$ -in. tool steel was threaded and turned into each hole, and slightly peened over. The piece was then faced off, the places for the holes accurately marked on the tool-steel inserts, and drilled. The whole piece was heated, and the tool-steel pieces tempered. This formed a template as good as if

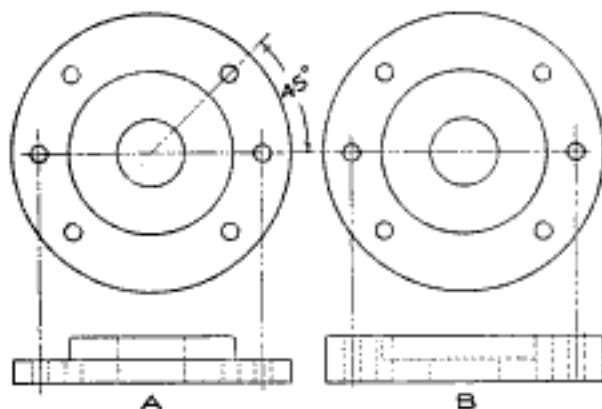

A Template Made of Machine Steel with Tool-Steel Inserts for the Holes

it had been made entirely of tool steel.—Contributed by Clarence H. Anderson, Worcester, Mass.

Cutting Threads on Foundation Bolts

In placing an engine on a foundation in a stone quarry, I found that some of the bolts had to be shortened about 3 in., and as these bolts were split on the lower end and an iron wedge inserted in the split it was impossible to remove them. The threads varied in

size owing to the bolt sizes, and by cutting off the necessary length from each bolt the threaded portion would

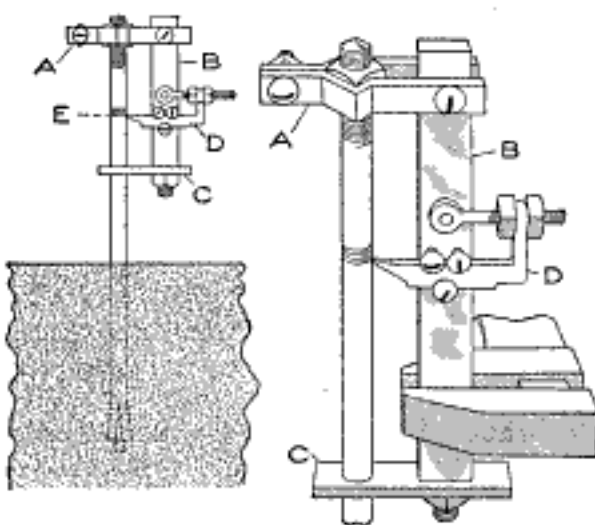

The Threaded End of the Bolt Provided a Means of Feed for Cutting Other Threads

be removed, thus making it necessary to cut new threads on the bolt ends. The bolts being located so close together, it was impossible to use ordinary stock and dies. It required a special threading tool, which was made as follows:

The nut was placed on the end of the bolt and turned to catch one thread. A clamp, A, was made of flat iron and screwed fast to the nut with screw-head bolts, as shown. A piece of flat iron, B, was drilled to fit the clamp A, the other end being provided with a thread and nut. An arm, C, was made of a piece of iron and bolted fast to the flat iron B. A thread-cutting tool, D, was made of flat tool steel, ground to the proper cutting point, and then clamped to the flat iron B with three screws. The device was placed on the bolt and the nut given a turn on one thread, then a wrench was applied to the bar B and by turning the nut, the tool cut the thread, the nut being used as a means for the feed. After cutting the thread the bolts were cut off at E.—Contributed by A. L. Kerbaugh, Allentown, Pa.

Turn the tailstock center of a lathe sufficient to take up the slack, and no more.

To Remove Burrs from Holes

The block shown is typical of many drilling jobs. Two holes, A and B, are to be drilled and one runs into the other. It makes no difference which hole is drilled first, the second hole throws up a burr in the first. The softer the metal the larger the burr, especially on brass. If one of the holes cuts only part way through, a small, thin shell of metal is left rather than a burr.

To take out the shell or burr, grind an ordinary twist drill flat on the end, and give the usual clearance to the flat edges. A drill so ground will do better and quicker work than one having a taper point. It will cut fast enough, and remove the proper amount of metal to please the most exacting production manager.

Another way in which this can be done is to insert a plug in the hole first drilled. If one or two pieces are to be drilled, this is a good way, but is too slow for quantity work. For a hole that only comes half through, a half round may be filed in the plug and it can be used over and over again.

Covering Paint in Pots Overnight

Paint in pots left overnight will harden on the surface sufficiently to make a scum that must be removed before starting work the next day. I avoid this by covering the surface of the paint in the pot with a disk of wax or paraffin. The disk is about $\frac{1}{4}$ in. thick, and should be of a size to fit snugly in the pot so that it will float on the surface of the paint. This covering prevents any scum from forming and



keeps the paint free from small bits of hard paint. When molding the disk a piece of wire should be put in so that a part of it will project from one surface, to make a handle for lifting the disk out of the pot.—James A. Hart, Philadelphia, Pa.

Dial to Locate Swing of Oil-Cock Control

The oil cock on the engine of an automobile was of the combination filling and drain type; that is, it could be opened one way to receive oil into the crank case, and the other way, to drain the lower half of the crank case of oil. The lever controlling the cock was made, as shown, without any provision for guiding it. The case was frequently drained by mistake when it was de-

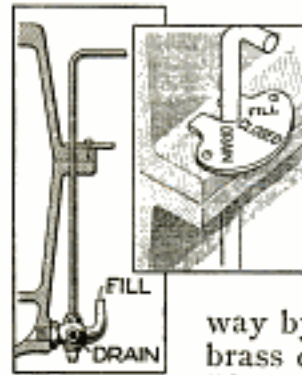

sired to open it for filling, causing the sod pan to drip continually from waste oil. A plan was finally devised to prevent the turning of the control the wrong way by making a piece of brass on which the words "fill," "closed," and "drain" were stamped, and then fastening it to the flange of the upper case by means of screws.

Making a Reamer Cut Oversize

When a smooth, round hole of small diameter is required, a hand reamer is used to produce it, and many times the reamer is from .001 to .004 under size. The reamer may be made to work effectively in the following manner: With a scraper made of a medium-size, half-round file, burnish the face of each flute with the oval side. This will raise an edge and cause the reamer to cut larger, the size depending on how long and hard the faces are burnished. This, of course, does not make a permanent edge, but it does very nicely in an emergency.

A Small-Farm Workshop

By FRANK L. RUSSELL

IT makes little difference whether a person owns a large farm or a truck garden, a place for small tools is not only convenient but almost a necessity. The house can be of a size proportionate to the requirements. The one illustrated is suitable for a small farm, and makes a place for the small hand tools, as well as provides a place where one can occupy spare time in making repairs and keeping the implements in proper shape.

The size of the house is 7 by 12 ft. and 7 ft. high at the eave. Lay out the ground selected for the size of the house and make a level place, digging into the earth from 4 to 6 in., on which to place a solid floor. A box or inclosure should be made of boards so that its inside dimensions are 7 ft. by 12 ft.

The height of this box may be from 6 to 8 in., depending on how high the floor is to be raised from the surface of the earth. The upper edge of these boards should be well leveled in all directions so that in making the filling of concrete the surface will be level.

Tamp in a solid bed of cinders so as to make the surface a trifle lower than the surrounding ground. Make a mixture of concrete, using 1 part cement, $2\frac{1}{2}$ parts sand, and 5 parts of broken stone or gravel, and fill into the space to within about 1 in. of the top, tamping it down firmly while putting in the mixture.

The space left at the top is filled in with what is called a neat mixture, 1 part cement and from 1 to 2 parts sand.

This is struck off level with the upper edges of the boards and troweled to make it smooth.

As this forms a perfectly level surface there is no way to fasten the wood structure on top of it. The fastening, however, may be made in one of two ways: by setting bolts in the concrete while it is soft, or by drilling holes in it after it has hardened and leading bolts in the concrete.

In setting the bolts, be sure to have them about $1\frac{3}{4}$ in. from the edge, and that about 2 in. of the threaded end projects above the surface of the concrete. Two or three $\frac{1}{2}$ -in. bolts are required for each end of the building, and four or five should be used on each side.

A plate made of studs, 2 by 4-in. material, is fastened with the

bolts so that its outer edge will be flush with the cement base. After these are securely fastened with the bolts, construct the end and side wall studs in the same way as building a house, cutting the studs to square the ends and making them with both top and bottom plates just 7 ft. over all. It will require four studs for each end and seven for each side. It is built up square on the ends as well as the sides, using two studs together at the corners. The upper plates are mitered at the corners so that the frame will be securely held together in a rectangle.

The rafters are cut to the pitch desired and fastened in position with a narrow board between their upper ends for a ridge. Ordinary siding can



A Place for Small Tools Is Not Only a Convenience but Is Almost a Necessity for the Farm, and a Workshop for Leisure Hours is Provided at the Same Time

be used, but since this is just a tool house and workshop, rough sheathing boards are put on, using halved joints

the pressure is sufficient to prevent the glass from turning. The tube was chucked and centered by running the

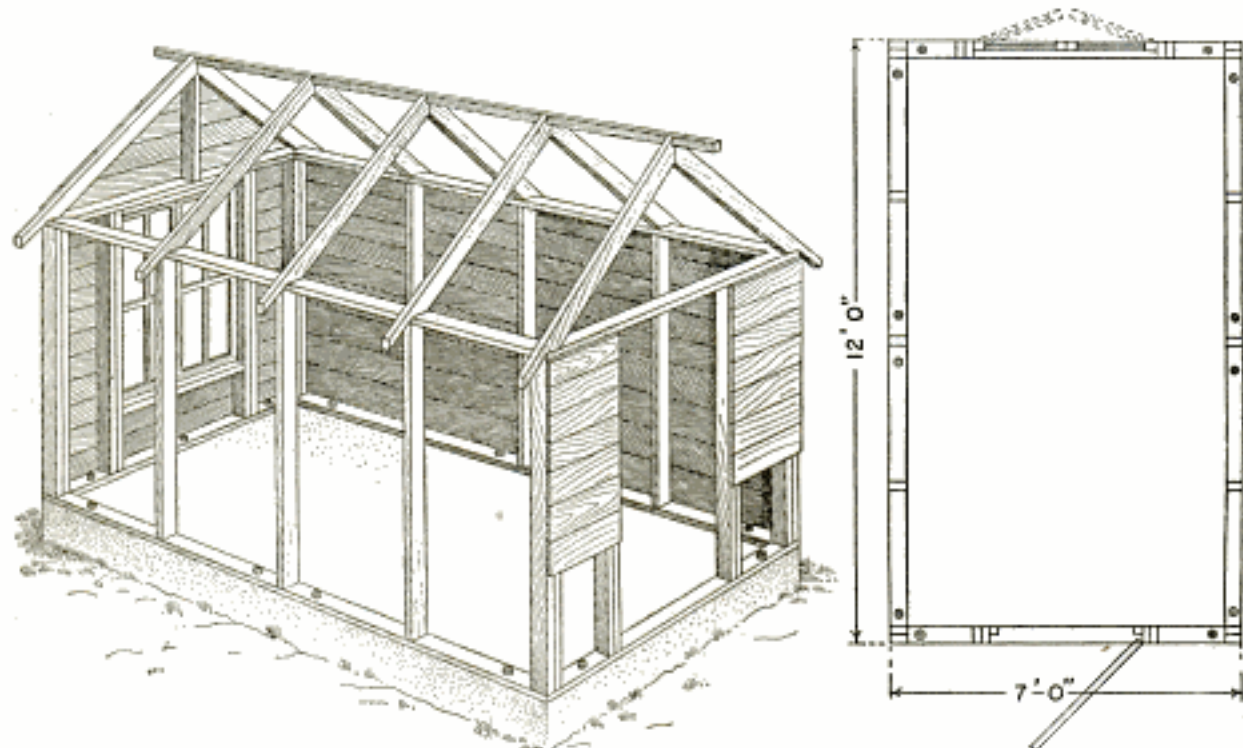

Ground Plan Showing the Location of the Studs and the Openings for the Door and Window, the Former a Regular Batten Door and the Latter Made Up of Two Casement Sash to Swing Outward

at the corners and allowing door and window spaces in the ends. Sheathing boards are put on the rafters and shingles laid.

The arrangement of the bench and hooks, or clips, for holding the tools can be made as desired and in the manner suiting the builder best.

Working Glass in Machines

At one time we had an order for a lot of glass tubes, inside diameter $\frac{1}{2}$ in., outside diameter $\frac{3}{4}$ in., and 10 in. long, to be threaded on each end with eight threads to the inch. The lathe was geared up for this thread, and a three-jaw universal chuck put on the spindle. The tubes were chucked with a piece of leather placed between the jaws and the glass. Near the other end of the glass tube the center rest was set, and a piece of leather was folded over each end of the center-rest jaws and wired in place.

This leather idea was to prevent scratching the glass surface. Very lit-

tle pressure is sufficient to prevent the glass from turning. The tube was chucked and centered by running the

tail center up and setting the jaws of the center rest. A 4-in. drum pulley was taken from the small tool grinder and put up over the lathe, and a tool-post grinder, carrying a beveled emery wheel, was set in the tool post instead of the threading tool. The tool-post grinder was belted to the 4-in. drum pulley, and the emery wheel set with a center gauge, whereupon the thread was cut as usual.

We found that by using hard wheels, dressed to suit the work, or by using a combination of wheels, glass can be worked as easily as cold-rolled steel. This would apply to planer work as well. Glass should be worked at high speeds, and a dull surface will be the result. The emery wheel must be kept wet, either by using a centrifugal pump or by means of the tin can with a hole punched in the bottom.—Contributed by J. B. Murphy, Plainfield, N. J.

☞ A little salt put in a forge fire will sometimes help wonderfully.

Homemade Magneto Coupling

In overhauling an automobile it was desired to change the ignition system from low to high tension. The high-tension system necessitated the installing of a magneto generator, and in addition a special type of adjustable coupling between the generator and the engine. The adjustment is necessary in order that the spark may be advanced or retarded at will. The magneto installed was a secondhand one, but to install a new coupling meant an expenditure of nearly twice that of the magneto. This being the case, it was decided to make one, with the result shown in the illustration.

A search of the junk heap in a nearby garage produced an old transmission spur gear and an old clutch ball-bearing housing. The gear was carefully cleaned up in a lathe and rebored to fit the magneto shaft, after which it was riveted in place, a piece of $\frac{3}{16}$ -in.

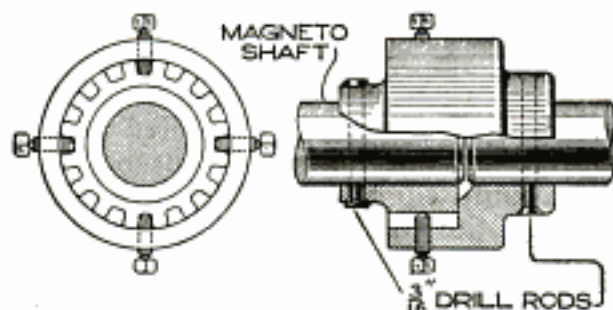

A Spur Gear Used as an Adjustment in the Coupling Driving a Magneto

drill rod being used as a rivet. The old ball-bearing housing was then rebored to fit the water-pump shaft, while the other inside diameter just happened to fit the outside diameter of the gear. Four holes were drilled, evenly spaced as shown, and tapped for four setscrews. The housing was then riveted to the shaft, the same as the spur gear. The setscrews serve as a connection between the two members of the coupling. The relative position of the two parts is varied by merely unscrewing the setscrews and turning the gear as desired. A small leather cover was provided for the complete coupling, to protect it from the grit and dust.—Contributed by Adolph Kline, New York City.

Stretching Window Screens on Frames

The screen wire is first fastened along one side with tacks, then this edge of the frame is placed against

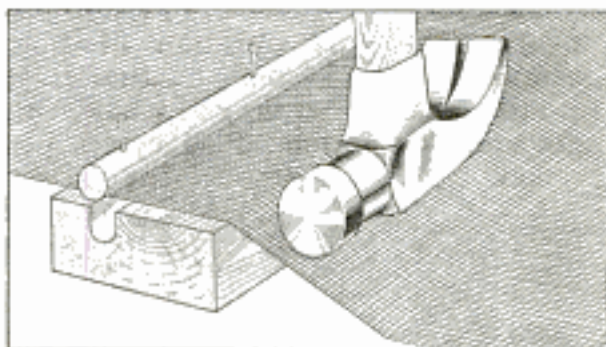

Stretching Window-Screen Wire on Frames with the Use of the Hammer Head

some support while it lies on the bench top or table. The screen is then stretched with the hammer head placed on the extending end of the screen and pressed down in the successive positions as shown. The screen will stay taut after removing the hammer, as the bend will hold it while the tacks are driven.—Contributed by E. K. Marshall, Oak Park, Ill.

A Faucet Lever

Upon a self-closing faucet I attached a piece of band iron, A, bent as shown and hooked over the faucet lever B and under the spout. The shape of the angle was such that if the lever was raised by taking hold of it at the end, it would pull down the faucet lever B, allowing the water to

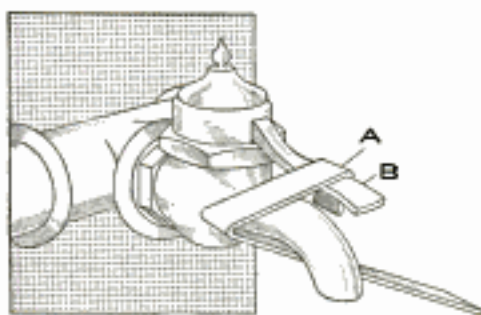

An Extra Lever Attachment for a Self-Closing Faucet to Hold It Open

run as long as desired. Pushing the iron back closed the faucet.—Contributed by R. F. Pohle, Lynn, Mass.

B buzzers without Contacts

How often a person sees the inscription "60 cycles" on alternating-current motors without stopping to think what it means. Nine people out of ten will underestimate the duration of time designated as a second, so that it is safe to presume that very few have any adequate conception of 60 cycles per second. The buzzers about to be

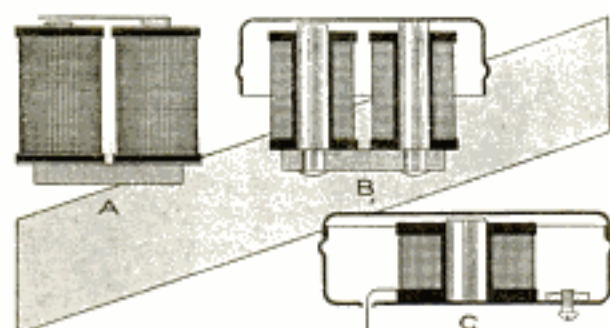

Three Types of Buzzers without Any Moving Parts for Use on Alternating-Current Lines

described will furnish direct and positive evidence to the ears, and will demonstrate, where an alternating current is available, that make-and-break contacts, with their liability to get out of adjustment and become corroded, are quite unnecessary. The small bell-ringing transformer, operating directly on the commercial lighting circuit, is largely replacing batteries as a source of power for bell and annunciator systems, and it is very natural that such should be the case, because the results are more positive, and the expense in the end less than that occasioned by the constant replacing of exhausted cells. While the small transformer greatly reduces the voltage, it does not, of course, affect the alternations or their frequency; hence, all that would appear necessary in order to make a buzzer, would be to provide a suitable armature and a coil with an iron core.

Simple though this may appear, in carrying out the idea in actual practice one is apt to learn several things about the subject of vibration. As a simple initial experiment, provide a coil with an iron core, and if the resistance is not 50 ohms or more, so that it may be connected directly across the 110-volt

circuit, connect it up in series with a small water rheostat. Clamp a strip of steel—an old hack-saw blade will do—in a vise and bring the coil near, having previously arranged a piece of board on which to place it. Vary the length of the spring projecting from the vise and note that there is just one length, about 2 in., for which the vibration will reach a maximum. It may also be noted that by shortening up the spring beyond this point, it may again be brought into phase by adding a small weight near the end. As 60 cycles means 60 reversals of the current per second it will cause 120 distinct magnetizations of the iron core, and when the spring is freely vibrating it is doing so at that rate. To furnish a comparison it may be stated that the middle "C" on the piano vibrates about 256 times per second.

This immediately suggests the simple form of buzzer indicated by the diagram A. Lay a piece of spring steel, or even tin, across the poles of a magnet and solder one end to one of the poles, which may be more easily done if a small hole is drilled in the spring at that point. With the edge of a knife slightly raise the other end barely the thickness of a sheet of paper, and the buzzer is complete. If the distance of the spring away from the pole is small enough, so as to cause it to hit the pole at each vibration, the tuning will be perfect.

In the buzzer B, the sound is considerably increased by replacing the spring with a small tin box, from 1½ to 2 in. in diameter. After the solder sets, be sure to do no more than just pry the tin loose from the other pole.

In the diagram C is shown a buzzer that has a decidedly commercial appearance, as it is completely self-contained within a small tin box, such as used for shoe polish. The soft-iron core in the center should be just long enough to reach from the bottom to the cover. File it off squarely and solder it to the bottom. Slip the coil on, and if it fits loosely, fasten it with shellac and paper packing. Ground one wire to the tin, and solder a small

battery nut on the inside so that a connection can be readily made. The other wire may be let out through a hole. Put on the top and adjust it until a good loud buzz is secured, and then fasten it with a drop of solder. Test it again, and add a second drop of solder, about one-third of the way around. If the buzz still remains loud and clear, the addition of a drop of solder at a third point will settle the matter. It will be evident that as the buzzer is dust-proof and has no moving parts to get out of order, it should last indefinitely.—Contributed by John D. Adams, Phoenix, Ariz.

Homemade Belts for a Cyclecar

The V-chains, or belts, on my cyclecar wore out, and I constructed two chains that gave good satisfaction, in the following manner:

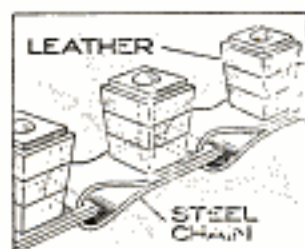

I procured enough galvanized-steel chain to extend around the pulleys, then from the nearest cobbler I procured enough scrap leather to make V-blocks for the links. The leather was put to soak, then cut into small pieces, and a hole was punched in the center of each piece for a rivet. The pieces were built up on a rivet to the desired thickness, and then they were cut to form a V-shape to fit the groove of the pulleys. For every link in the chain, a leather block was made and riveted to the link, as shown in the illustration.—Contributed by B. O. Bates, Campbellton, Can.

N. K.

A Center to Face and Polish in a Lathe

It often happens that amateurs, and sometimes even skilled workmen, have the troubles shown in the illustration when facing the ends of shafts in a lathe. In taking a roughing cut, more metal is removed than the depth of the center hole in the work, as shown at

A. At B is shown a tool set over at such an angle that it leaves tool marks, as exaggeratedly illustrated at

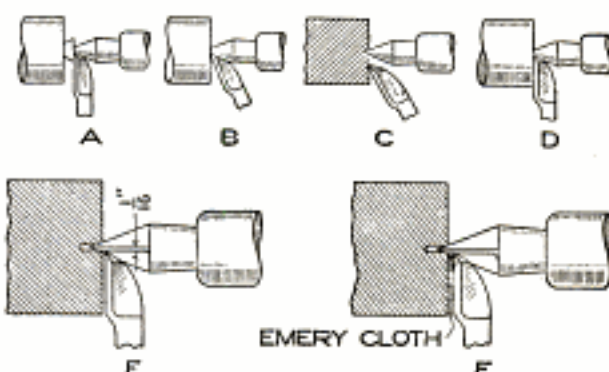

Center with a Cut-Out for the Tool in Facing and Polishing Work in a Lathe

C. If the tool is set as shown at D, the angle on the tool is too blunt at the point to fit into the space between the work and the lathe center, so that a burr is left similar to the one shown at A.

A good way to overcome or avoid these troubles is to use a center, as shown at E and F. A regular center is ground, or milled, to within about $\frac{1}{16}$ in. of the center point. This will allow the point of the tool to enter the center, and it will face the work smooth; besides, the work may be very easily polished by folding a piece of emery cloth, holding it between the tool and the work, and pressing it against the tooled face by means of the lathe carriage while the work is revolving.—Contributed by Geo. M. Jager, Irvington, N. J.

Repairing an Automobile Brake

The internal expanding brake on a certain automobile gave trouble, and finally the car had to be laid up while repairs were made. In action the brake did not respond as quickly as it should, and when it did take hold it was so suddenly and so hard that the wheels slipped. An examination revealed nothing very wrong except that two

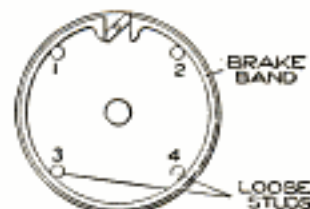

of the four studs, or posts, that spaced the brake band were loose. When new ones were made, driven in tightly, and riveted, the trouble ceased. These two loose studs let the band rise to the top when the cam was turned, and after considerable travel of the brake rod, the slack was taken up suddenly and so hard that it resulted in the slipping of the wheels.

An Aid in Drawing Fillet Lines

One of the most tedious operations in layout or detail work in a drawing room is the filling in of the lines of

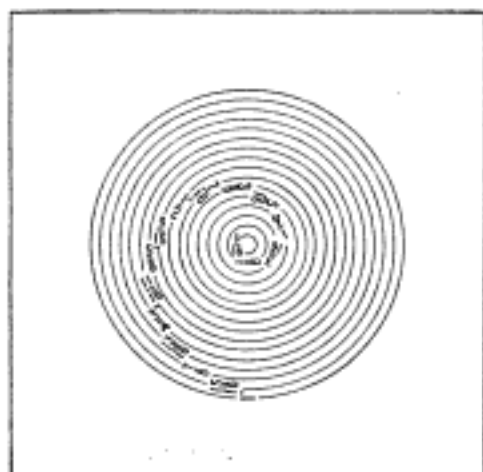

Any Circle Set on Two Intersecting Lines Locates the Center for Drawing Fillet Lines

fillets, or arcs, tangent to two or more lines. The usual way of measuring the distance between points of the compass and then trying to strike the right center is slow and tedious. A simple contrivance for finding this center can be made as follows:

Procure a piece of transparent celluloid, about 3 in. square. Set the points of a pair of dividers $\frac{1}{16}$ in. apart, and with one point as a center, set it as near the center of the celluloid as possible and strike a circle, scratching the celluloid so that the circle can be plainly seen. Then with a $\frac{1}{8}$ -in. radius and the same center strike another circle. Make similar circles, increasing the radius by $\frac{1}{16}$ in., up to 1 in., or larger, if required. Prick a hole through the celluloid with the divider point at the common center. Scratch the radius length in figures on each circle, as shown.

If, for instance, it is necessary to draw a full-size $\frac{7}{16}$ -in. arc between two intersecting lines, lay the celluloid on the drawing, placing the circle marked $\frac{7}{16}$ in. tangent to the two lines for the arc. Run the marker through the center hole until it pricks the paper sufficiently to be seen when the celluloid is removed. This point will be the exact center of the arc, and a compass, spaced to $\frac{7}{16}$ in., will draw the arc correctly. It is not necessary, however, to space the compass on the rule, as the center is found and the spacing can be done directly from the drawing.—Contributed by W. A. Scranton, Detroit, Mich.

How to Mix the Electrolyte for Lead Storage Batteries

The electrolyte used in the various types of lead batteries consists of a mixture of pure sulphuric acid and pure rain, or distilled, water. Sulphuric acid, when concentrated, is a liquid having a specific gravity of about 1.835; that is, it is about 1.835 times as heavy as water. It is customary to carry all gravity readings out to three decimal places, and the gravity of water, which is 1, is written 1,000 and read 1,000 rather than 1. Then, by this reading, pure sulphuric acid has a specific gravity of 1,835. A lead storage battery will not operate with acid of this strength, and it is necessary to dilute it with water. The electrolyte should be mixed, preferably, in a large jar, or lead-lined tank, and the acid must always be poured into the water while stirring the solution vigorously. In the operation of the storage battery the specific gravity of the electrolyte reaches a maximum of 1,250 to 1,300 when the cells are fully charged, and drops from 100 to 150 points when the cells are discharged. The lower and upper working limits of the gravity of the acid may then be assumed as 1,100 and 1,300, respectively. The following table may be used in determining the parts of water both by weight and volume, and the percentage of acid to

water to produce the different gravities. The results in this table are based on the sulphuric acid having a specific gravity of 1,835 at 70° Fahrenheit.

The electrolyte used in the storage battery expands when heated, and its specific gravity will change, although the actual strength of the solution will remain the same as before heating. The gravity of the electrolyte will change approximately one point for each 3° change in the temperature on the Fahrenheit scale. For example, if the electrolyte has a specific gravity of 1,250 at 70° F. and its temperature has changed to 85° F., the increase in temperature will cause the electrolyte to expand and its gravity will decrease one point for each 3° rise in temperature, or the total decrease in this case will be five points and the gravity at 85° will be 1,245. Similarly, a decrease in temperature will result in an increase in gravity. As a matter of convenience 70° F. is considered the normal temperature and all corrections in gravity due to a change in temperature are made so as to give the value of the gravity at 70° Fahrenheit.

Specific Gravity of Solution 70° F.	Parts of Water to One Part Acid		Percentage of Sulphuric Acid in Solution
	By Volume	By Weight	
1100	9.80	5.40	14.65
1110	8.80	4.84	16.00
1120	8.00	4.40	17.40
1130	7.28	3.98	18.80
1140	6.68	3.63	20.10
1150	6.15	3.35	21.40
1160	5.70	3.11	22.70
1170	5.30	2.90	24.00
1180	4.95	2.70	25.20
1190	4.62	2.52	26.50
1200	4.33	2.36	27.70
1210	4.07	2.22	29.00
1220	3.84	2.09	30.20
1230	3.60	1.97	31.40
1240	3.40	1.86	32.50
1250	3.22	1.76	33.70
1260	3.05	1.66	35.00
1270	2.90	1.57	36.10
1280	2.75	1.49	37.30
1290	2.60	1.41	38.50
1300	2.47	1.34	39.65

Parts of Water by Weight and Volume and the Percentage of Acid to Produce the Different Gravities

The temperature at which the electrolyte in the lead storage battery will freeze depends upon the specific gravity of the solution. The curve given in the sketch shows the approximate relation between specific gravity and

freezing temperature. This curve, as well as the other relations given, is used by one of the leading battery

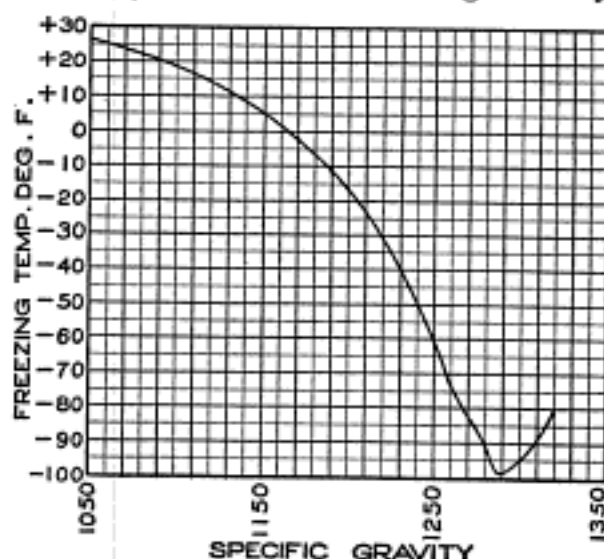

Curve Showing the Approximate Relation between Specific Gravity and Freezing Temperatures of the Electrolyte

manufacturers and may be considered, for practical purposes, fairly correct.

Attaching Casters to Angle-Iron Posts

The illustration shows a method of attaching casters to porch cots, or any equipment constructed of angle iron, that must be moved from time to time. Many persons use cots of this construction on their sun, or sleeping, porches, and have had finely finished floors scratched and marred by the moving of the bed. The complete equipment is made up of two loose pin butts, using only the side with the double lugs, and is sawed in halves and riveted to the angle iron with the caster in place.—Contributed by W. D. Smith, San Francisco, Cal.

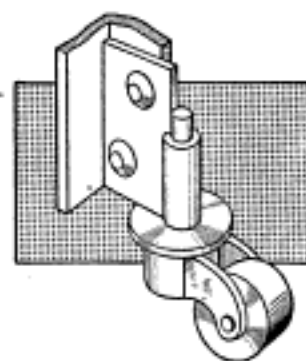

Use turpentine instead of oil when drilling hard steel, saw plate, and the like.

Automatic Draft Deflector for a Window

An office clerk working at a desk to the right of which was a large window, on many occasions found it impractical, or uncomfortable, to raise the lower section of the window on account of the cold draft and for the sake of the

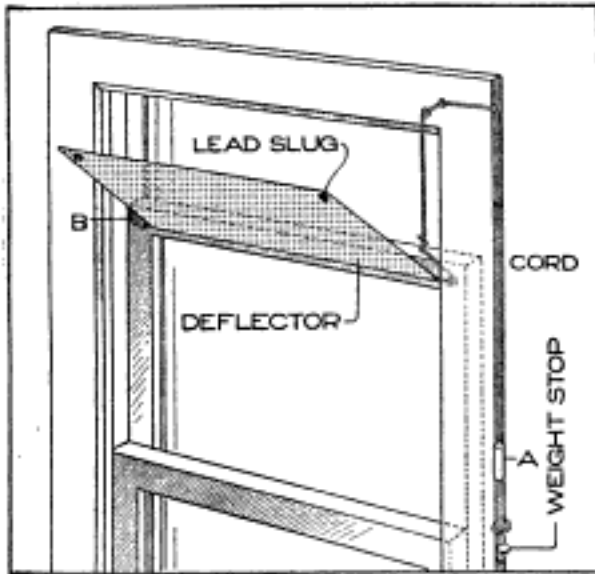

Deflector Attached to Upper Crosspiece of Top Sash and Operated by the Sash Movements

safety of the papers on the desk. It was also impractical to lower the upper section of the window, as the current of air was directed downward with almost the same results.

The sketch is descriptive of an automatic deflector applied to the upper crosspiece in the top sash, in such a manner that when the section is lowered, the deflector automatically rises to an angle of 45° , and the air rushing through the opening is deflected upward, ventilating the room perfectly without any inconvenience to the occupants.

The deflector is made of a piece of canvas, stretched over a wire frame. As the window section is lowered, the weight A pulls the deflector up to a point where it is held at 45° by a small lug, or stop, B. As the window is lowered farther, the weight A is only pulled a trifle more in serving its purpose. When the top section is again raised, the weight A falls until it rests on the small stop or shelf, and

the loose string then lets the deflector drop flat against the window. Two small lead billets in the corners of the deflector aid it in dropping when the raising weight is lowered to its shelf. The weight A is a small piece of lead, which is not conspicuous, since it runs along the thin side of the casing. The canvas deflector can be painted the same color as that of the casing and sash, and does not give any unsightly appearance to the room.—Contributed by F. W. Bentley, Missouri Valley, Iowa.

A Threading Tool for Taper Work

The sketch illustrates a very handy tool for cutting threads on short tapers, shoulders, and the like. While the tool was designed for work similar to that shown at A, it is also good for straight work.

The casing, or body, is a steel block, drilled and tapped for a plug at one end, the plug having a bearing for the tool-holder end. In boring the casing, a small shoulder is left at the end opposite the plug, to afford a seat for a ring on the tool holder. This ring also provides a seat for a helical spring,

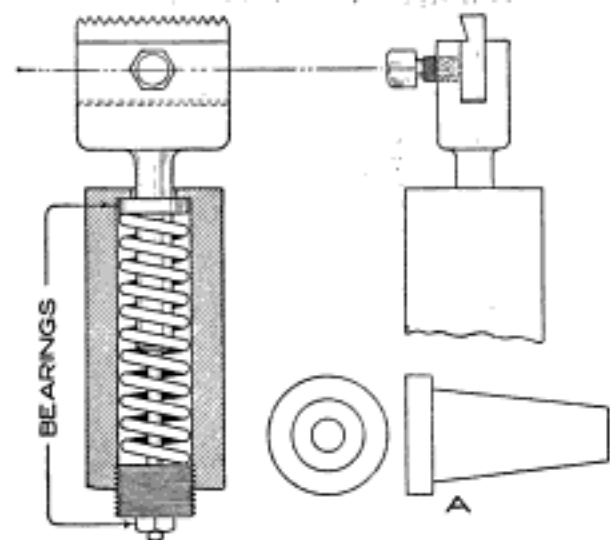

Tool for Use on a Lathe Not Provided with a Compound Rest, for Cutting Taper Threads

used to hold the cutting tool to the work, yet allows it to be forced away from the work when the pressure becomes too great, which occurs when the tool begins to remove more metal

than is necessary to produce the thread. The cutting tool is simply a standard "chaser," used in every shop of any size.

The pitch of the chaser, of course, must agree with the pitch of the thread to be cut, and the line of the teeth points must coincide with the taper of the work to be threaded, and, having been so set, it is only necessary to tighten the setscrew, set the tool for depth, and start the lathe just as in cutting any thread. The lathe, of course, must be geared for the same thread that the chaser is to cut, so that the feed of the lathe carriage may not conflict with the thread the chaser is cutting.

The work may be either chucked or carried on the centers, and the tool is clamped on the carriage, as it is too wide for the tool post. At the end of the cut, the feed is thrown off, and the tool quickly backed out by hand as usual. The spring arrangement takes the place of the compound rest in this class of thread-cutting.

Cutting Key Seats in Taper Holes

To cut key seats in magneto gears, or couplings on automobiles, which

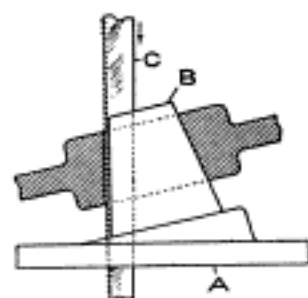

have a taper bore, is quite a task if not properly equipped for cutting them. The illustration shows a simple jig to use with a tool similar to a broach. The jig consists of a casting, A, with a steel plug, B, tapered to fit the work. One edge of B is set so that it will be perpendicular to the base, and a key seat is cut in it. A toothed drift, C, is made of tool steel to fit the key seat, and tapered along the teeth so that the upper ones extend far enough to give the proper depth to the keyway to be cut. It is only necessary to set the work on the plug B and drive the drift in the same as a broach. —Contributed by Allan J. Monahan.

Two-Way Switch for a Hall Light

A very handy contrivance for those using gas to illuminate a house is a small electric lamp to run on a battery, the lamp being operated with two switches, one placed just inside of the door and the other under the nearest gas light. This will allow a person to see the way clearly until the gas is lighted, when the electric lamp can be

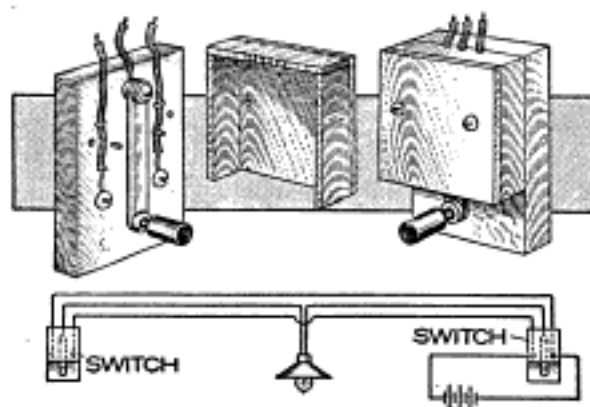

Operating an Electric Light in a Battery Circuit by Switches Located in Different Places

turned off without the trouble of returning to the door. For this purpose two-way switches must be used. They can be purchased cheaply, but are easily made by anyone at all handy with tools. The illustration shows the construction and scarcely needs a description. A small wood base, a piece of spring brass, a fiber, or wood, handle, and three screws are all that is necessary for one switch. The cover is in the form of a small box with one side removed, which can be fixed to the base with two screws. The wiring is shown in the diagram. The wires pass from the outside terminals of one switch to the outside terminals of the other. The center terminals connect directly to the lamp. The battery is connected to the two outside terminals of either switch. By this system of wiring, the lamp can be turned on or off at any time from either switch. The system is applicable to large rooms and basements where the gas light is some distance from the door.—Contributed by Morris G. Miller, New Rochelle, N. Y.

Reinforcing Hammer Handles

The illustration shows a method of bushing handles to prevent them from breaking at the eye of the hammer. The idea is one that will be appreciated by all machinists, toolmakers, and engineers that prefer tools of good ap-

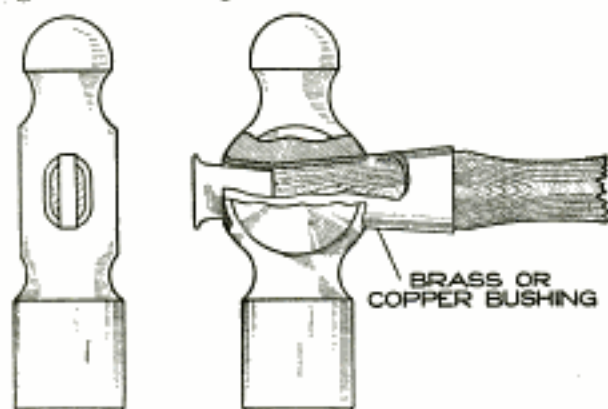

Bushing a Hammer Handle near the Head Where It Is Apt to Break Off

pearance and efficiency. Remove the handle from the head, and file the eye to the general shape shown, so that the bushing may be peened back to hold it in place. The front part of the eye is tapered uniform with the flat wedge, so that in driving the wedge into the end of the handle it also expands the bushing to the taper, and its sides force the wood of the handle and the soft bushing to the taper. This makes a neat and durable job, and adds much to the appearance of the hammer.

Hatrack for a Clothes Closet

Most clothes closets are built with a low ceiling, and do not provide sufficient space for hat hangers, so that the hats are apt to fall when taking out the clothes. In such a closet I made racks of a single piece of wire, bent as shown and nailed to the ceiling of the closet. Hats placed on these racks are more secure from falling, while within as easy reach.—Contributed by J. V. Loeffler, Evansville, Ind.

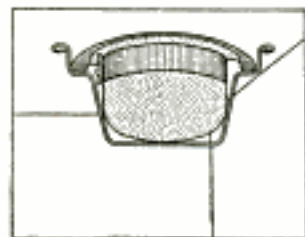

Cleaning Steel of Burnt Oil

The oil, coming in contact with the surface of steel when hardening, will burn in places, and is hard to remove. The cleaning can be accomplished easily by immersing the hardened tool in gasoline, and when exposed to the air, it will dry immediately. This will leave the part to be polished without the marks of burnt oil.

Shifting Continuous Flow of Liquid without Loss

It is practically impossible to change cans under a flow of liquid without spilling some of it or at least having it run down the sides of one or both cans. The sketch shows an arrangement of fittings which will positively eliminate this trouble. The flow of liquid from the vat, or tank, is through a pipe leading to the place for filling the cans. On the end of this pipe a tee is fitted and nipples, A and B, turned into the tee openings. It is only necessary to

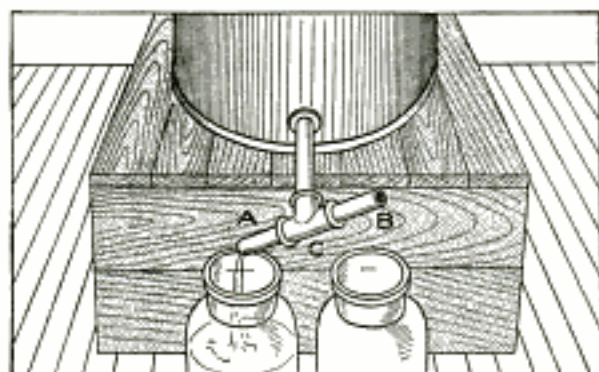

No Liquid can Escape in Turning the Tee from One Can to the Other

turn the tee C, to change the flow from one can to the other, and there will not be a drop of waste.—Contributed by Ralph E. Frizzell, Cleveland, Ohio.

Lathe-Center Lubricant

White lead and sperm oil, mixed together with just enough graphite to give it a dark color, make a good lubricant for lathe centers. This grease can be kept in a tin box, and oil added when necessary, to keep it from becoming too thick.

BUILDING A HOME

By Geo. M. Petersen



PART IX—Interior Decorations

NO matter how artistically the interior of a home may be designed, how expensive the woodwork and floors, or how excellent the workmanship, it will never look right unless the decorations are in strict keeping with the interior finish. Many houses, finished by the contractor in a first-class manner, when turned over to the owner are spoiled by the latter by poor decorations, which reflect on the workmanship of the contractor when it is not his fault. As a rule, keep the decorations light, and do not make the mistake of selecting dark stains and wall papers or freak color schemes, as they soon become tiresome to the eye.

The best way to obtain satisfactory results is to secure the services of some experienced decorator and have him make suggestions and submit figures. The cost may be too high, but the owner will benefit by the suggestions. If this course is not convenient, however, the builder might use the sugges-

tions given in the following table to good advantage, changing the proposed color schemes to suit personal taste.

Of course, the color schemes of the various rooms must be such that those adjoining each other will appear well, and have a tendency to blend together when the doors are opened between them. It will be well for the inexperienced decorator to bear in mind that direct and positive contrasts are much more desirable than are poorly selected "matches" or "near-blends" that do not harmonize.

Rooms with only a moderate number of windows should never be decorated with dark paper or stain, and bedrooms should always be light and airy. As mentioned in the table the wall paper should be in light tints of yellow, pink, green, blue, certain shades of brown, etc.; plain colors, with a small flower pattern or a narrow vertical stripe. If a border is wanted, it should be only a

COLOR COMBINATIONS

Room	Wood Finish	Wall Decoration
Vestibule	Natural Wood	Light Brown, or Tan
Hall	To Match Vestibule, or Living Room	Light Brown, Tan, or Living-Room Effect
Living Room	Light Weathered Oak	Tiffany Blends
Library	Mission	Leather Effect
Dining Room	Fumed Oak	Medium Brown Shades
Bathroom	White Enamel	Glazed-Tile Paper
Bedrooms	White Enamel, or Natural	Light Blue, Pink, or Green, with Small Figure
Kitchen	White Enamel, or Natural	Oatmeal Paper, or Tint Plaster
Pantry	Natural	Oatmeal Paper, or Tint Plaster
Upper Hall	White Enamel, or Natural	Medium-Light, Striped Paper

3 or 4-in. cut-out design, or a narrow band placed close to the ceiling. Any picture molding should be placed in the angle formed by the walls and ceiling. Dark colors in bedrooms are oppressive and for that reason should be avoided. Large, striking or peculiar figures should never be used in a bedroom.

Bathrooms are generally finished in white throughout. If a white tile floor is too expensive, the oak, or yellow-pine, floor may be finished natural, and the wainscot enameled white. The wall paper should be one of the glazed-tile designs with a plain white glazed ceiling.

While genuine tiffany blends are a little expensive, they not only set off the room in which they are used, but also do away with redecorating for several years. Like most high-grade materials, tiffany blends will stand up for a considerably longer time than wall papers costing a few cents less a roll. These blended effects also set off the furniture to advantage and harmonize well with any finish. Tiffany blends should be hung over a lining paper, which will protect the colors from the effect of any loose lime which may be in the plaster. Too much lime, or lime that is improperly slaked, will cause a multitude of little hair cracks on the surface of the finished plaster. Usually a coat of shellac varnish applied to the spot will protect the paper from becoming discolored, but the best method is to line the wall before putting on the paper, as the lime is very powerful and will work through the size which is put on the walls before any paper is hung.

Wall boards are being used quite extensively at the present time, and their use is practically unlimited. Wall boards are made of a wood fiber; not "trunk board," "press board," or so-called "waterproof" boards, which cannot be sized to take paint properly or are so permeated with grease that paint will not stick to them. Be sure to procure from the manufacturer or his agent a written guaranty that the board can be properly decorated, and

also samples of the board decorated as desired. These samples will not only show how the board takes the paint, but will serve as a guide in doing the work. The rich tones of flat colors, and the artistic "blended" and "stippled" effect, which may be obtained upon wall boards, are limited only by the decorator's artistic ability. Stenciled designs may be obtained at a very nominal cost, and are easily applied even by the inexperienced. There are a few points in connection with wall-board decoration, and the suggestions given, if carefully followed, will enable the owner easily to decorate his own wall board and save considerable expense.

See that the board is properly cut, does not buckle or bulge, and that at least $\frac{1}{8}$ in. is allowed between sheets. Apply a thin coat of wall-board primer, which is put up by all paint houses, using a little of the color selected for the finish. After the primer has set hard, the board may be painted in the usual manner, two coats being sufficient. If the board is to have a blended or stippled effect, the ground color is covered with a coat of blending color, applied before the ground color begins to dry. Blend the colors together, using a piece of cheesecloth, and giving it a circular motion. After the blending is completed and thoroughly dry, the stencils, if any are to be used, are put on in strict accordance with the accompanying instructions, care being taken to see that the panel strips, when applied, will not cut off part of the design. Leave plenty of edge around the stencil design so that it will show off to advantage and not appear crowded. The panel strips should be stained, shellacked, and varnished, and all panels decorated before putting the strips in place, as it is absolutely impossible to decorate a panel nicely with the strips fastened to the wall.

Finishing interior woodwork and floors is a very broad subject, and leaving out all "tricks" of the trade, a good job may be obtained if the work is done in accordance with the following suggestions: Upon the comple-

tion of the interior woodwork, and before any decorating is done, the surfaces of all wood parts to be stained, painted, or enameled, are lightly sanded, and all knots varnished with shellac. The surfaces are then given the priming coat, if paint is to be used. After the priming coat has hardened, any imperfections in the wood are filled with putty, using a wood spatula, as steel will mar the finished woodwork. The next step is to apply a second coat of paint mixed with turpentine and boiled linseed oil in equal quantities. The paint will dry out with a dull, or flat, surface, which will take the third coat properly. The third, or last, coat may be a regular ready-mixed "gloss" paint, or a prepared "flat" finish, as desired.

When enamel is to be used, the woodwork is usually given three coats of "flat white," the same as mentioned for the second coat in the preceding paragraph, and two coats of white enamel. The first coat of enamel should be lightly sanded before the second coat is applied. The finish coat may be left glossy, or may be rubbed with fine sandpaper or curled hair, to give it an "eggshell effect." Because of the great amount of work required to keep white-enameled woodwork clean, a number of first-class decorators are finishing the window sills, medicine-case doors, closet seats, and room doors in mahogany. White enamel and mahogany make a very pleasing and artistic combination, and the mahogany is naturally better adapted for places coming in contact frequently with the damp and soiled hands of children. The mahogany doors also set off the white-enamel trim to much better advantage than those having white surfaces.

Where interior woodwork is to be stained and varnished, the method of procedure is somewhat varied. If the material is oak, ash, chestnut, or any other open-grained wood, a coat of paste filler should be applied. Liquid fillers are often used, but are not, as a rule, satisfactory for the succeeding work. Paste fillers are applied with a

stiff brush and well rubbed in. After having set for about half an hour, the paste should be rubbed off with a handful of shavings, excelsior, or a rough cloth, rubbing across the grain and not with it. If the wood is to receive a stain, mix the filler with the stain. If the stain is applied to the wood and the filler afterward, it is very likely to produce small gray spots in the grain of the wood. Acid stains cannot be mixed with the filler. All putty work should be done after the filler has been wiped off and the work given a coat of shellac varnish. The putty is mixed with the color of the stain. Allow the shellac time to dry, and give the work a coat of good varnish. Do not use a cheap varnish, as it will dry with a too high gloss; will not cover as much surface or as well, and will not last as long. Never varnish in a damp room, as it will dry "tacky" or "sticky" and may never dry hard. The ideal place for drying varnish is a dry, warm room with plenty of sunlight. It may be well to mention that dark rooms should not be white-enameled, as the enamel will turn yellow in a short time. If a light stain will not do for the woodwork, it is better to use a cream, or old-ivory, color and paint it.

If it is possible to stand the expense, have the first coat of varnish hand-rubbed, and a second coat flowed over it. Sometimes as many as seven coats of varnish are applied, each coat being "flatted" before the others are put on, but one or two-coat work is sufficient for medium-priced houses. The woodwork may be finished with shellac, if preferred, but at least three coats are necessary.

The "eggshell" or "dull-gloss" finish, so popular at present, cannot be obtained in cans, but must be hand-rubbed from gloss varnish, although a fair imitation may be obtained by mixing dull-gloss varnish and gloss varnish about half and half, as a large percentage of dull-gloss varnishes are too dull, and are worthless unless used over a gloss varnish. The method of mixing the varnishes is very satisfactory.

Outside doors, window sills, and any

places exposed to direct and intense sunlight, should be protected with exterior, or spar, varnish, which will stand the effect of the rain and sun.

Close-grained woods, such as pine and whitewood, do not require any filler, the stain being thinned to the desired shade and put on like a wash. After the stain has had time to penetrate the pores of the wood, it is wiped off with a piece of waste, or a soft cloth. The grain will then show up much better than if the stain is allowed to dry in. The shellac and varnish are put on in the same manner as for open-grained woods.

The first thing to do in finishing floors is to have them properly scraped by the carpenter, or a regular floor scraper, preferably the latter, as they specialize in this kind of work and do it a great deal cheaper than the average carpenter. No matter how carefully, or how well, a floor is laid, there are sure to be little imperfections which all the finishing possible will not efface, or cover up, and, therefore, they must be scraped.

Floors are usually finished in natural oak, the lighter shades being the most popular, as they do not show the dust like the darker surfaces. After the floor has been properly scraped, it is filled, or stained, depending on the kind of wood, as mentioned for interior woodwork. The floor may then be shellacked, varnished, or waxed. If a semigloss finish is desired and shellac is used, the floor should be given about five coats of thin white, or orange, shellac. Shellac stains, or discolors, the wood less than any other varnish, and has the additional merit of drying quickly and refinishing cheaply. When varnished floors are wanted, the woodwork is first given a thin coat of shellac over the stain, and then as many coats of varnish as desired. From one to three coats of good floor varnish is sufficient.

To produce a wax-floor surface properly, apply two thin coats of shellac varnish and then five, or more, coats of wax, thoroughly rubbed down and polished with a weighted brush, made

especially for the purpose, between the coats. Each coat of wax should be allowed from five to seven days to harden before the following coat is applied.

Do not make the mistake of trying to save money on floor wax by using beeswax cut with turpentine or alcohol. Beeswax is not floor wax, and it is unfit for this purpose. Floor wax is a compound manufactured especially for this work.

In remodeling an old house, the interior woodwork may be cleaned by burning off the old varnish with a blowtorch and using a scraper, or it may be removed by the application of varnish removers and a stiff brush. While the latter method is a trifle slower and a little more costly, it is the best, as the fire hazard is removed entirely, and there is no chance to have any scorched woodwork. All varnish removers are volatile and highly inflammable, and should never be used in a room in which there is a fire of any kind. Varnish removers are used almost exclusively for cleaning out molding, which would be almost impossible to do with a blowtorch, and for cleaning floors.

For cleaning old wax floors, a 10-percent solution of carbonate of soda is the finest thing known. The soda is dissolved in hot water and applied with a brush, after which the solution is wiped up and the floor thoroughly rinsed with clean, cold water.

Locating Point on Planer Work to Set Pin Gauge

When pin gauges are used, mostly in large shops, on planer or boring-mill work, it is often a tedious job to find the point, exactly under the tool, where one wishes to face off the boss, or other elevation, to a certain height. To locate this point, squirt a few drops of oil on the tool, and where the oil drops will be the exact location for the lower end of the pin gauge. This appears to be very simple, but it saves a great deal of time.—Contributed by W. E. Butler, Wausaukee, Wis.

To Keep a Long Stencil from Sagging

Doing stencil work alone on walls and ceilings is a tedious job, especially when the stencil is 10 in. or more long. In brushing one end, the other end hangs down in the way, and there is also danger of smearing the work. A remedy for this is to tack a thin strip of wood to one side of the stencil—a yardstick is about the right size. This will hold the stencil flat to the wall and avoid all danger of smears. In making lines on ceilings, I alone have in this way handled stencils that were 3 ft. in length, and made a good job of it.—Contributed by Claude O. Soots, N. Salem, Ind.

Removable Spurs on Ladder Ends

Working as a beltman in a large manufacturing plant, I had considerable trouble in keeping the spurs on my ladder sharp. The floors were of wood, and a great many times the spurs would strike nails or pieces of metal on the floor, thus dulling the points. When dull, it was quite a task to remove and sharpen them. To overcome this difficulty I made the ends to hold a threaded spur, as shown. It is now very easy to remove the spur when it becomes dull, insert it in a holder, and grind a sharp point on it.—Contributed by William F. Gunn, Chicago, Ill.

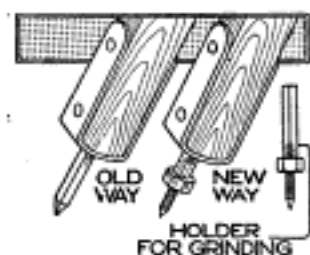

Stiffening Thin Wall Board

If thin wall board, the cheap kind that is weak and flexible, is given a coat of filler and a coat of oil paint on each side, it will not only be preserved against warping, but will become decidedly stiffer and stronger. Painting on one side only does not prevent warping, and only slightly increases the strength.

To Make a Stovepipe Elbow

In a mining camp, far from a supply station, we received a lot of stovepipe, but there was not one elbow

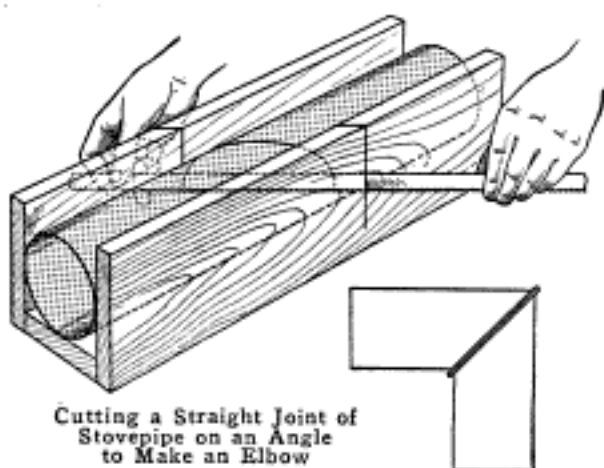

among them. To construct an elbow, which was badly needed, I made a box like a miter box, and cut a slot with a saw across the top, at a perfect 45-deg. angle. Then, with a hacksaw blade held in the hands, I sawed down through a straight length of pipe as shown. About $\frac{1}{4}$ in. of the stock on each slanting end was turned up like a flange. These flanged ends were set together to form the proper angle for the pipe, and then riveted, after which they were folded over to make the joint smoke-tight.—Contributed by W. A. Lane, El Paso, Tex.

Holding Threaded Studs in a Bolt Cutter

Short studs, or studs with only a small part left without threads, present a problem for the bolt cutter. In a certain machine-repair shop the usual scheme was to use a locknut, or to let a nut jam on the imperfect threads of the end first threaded. Both of these methods are crude and inefficient, as much time is lost in removing the stud. The following is an effective

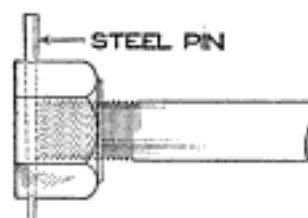

and simple solution of the difficulty. A hole, drilled through the base end of a nut as shown, is provided with a slightly tapered pin. The operation is evident. One end of the stud is threaded, the nut is placed in a vise, and the stud run up against the pin. After the threading, the pin is easily backed out by a slight rap and the stud removed with the fingers.

Flat Step for a Round-Rung Ladder

One who is not accustomed to painting, finds that the rungs of the ladder soon make the feet tired. This may

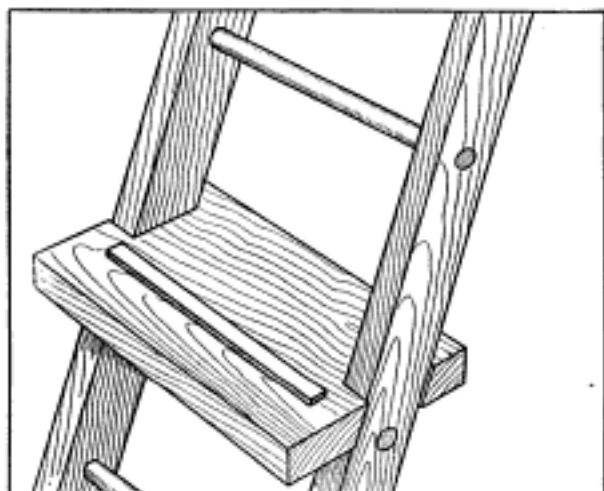

Flat Step to Fit on Ladder Rung, to Prevent the Feet from Becoming Tired

be prevented by procuring a plank, $1\frac{1}{2}$ in. thick, 8 in. wide, and as long as the width of the ladder, and cutting notches in the ends to fit the sides of the ladder, for a step. Nail a small strip on the step, as shown, to keep the feet from slipping. The plank can be changed from rung to rung as desired.—Contributed by W. S. Drace, Richmond, Mo.

Heating Tips of Tools for Hardening

When it is necessary to heat the tips of tools to harden or anneal them, use a raw potato to prevent any other part of the tool from heating, as follows: Stick the tool through the potato, leaving only the portion to be worked projecting, and the heat will reach only the exposed part.

Using a Large Planer for a Press

Sometime ago we had several steel tubes, about 5 in. in diameter and 4 ft. long, which had to be a press fit over the piston rods they were to cover. Not having a press large enough to handle the job, we were stuck until the following idea was hit upon. There was about .003 in. left for a force fit. Both ends of each tube were capped and live steam turned into them, which enlarged them about the amount mentioned.

The rods were bolted upon the platen of a 36 by 36-in. planer, and a solid back stop was erected just far enough away to allow for starting the tube. When all was ready, the steam was turned off, the caps removed, and the tube lifted in position and shoved on by hand for about 8 in., when it began to go hard; then the planer was started very slowly, which pushed the tube home without further trouble. The whole scheme worked out very nicely and without much trouble or outlay.—Contributed by A. Dane, Pottstown, Pa.

A Carpenter's Clamp

The clamp illustrated is quite handy, as it can be made adjustable for almost any size of work. The bar is of cold-rolled steel, 6 ft. long, 2 in. wide, and $\frac{1}{2}$ in. thick, with one end forged into a round shank and threaded. Two dogs are used on the bar, one adjustable for any position with the aid of holes through which a pin is inserted in the bar. The other dog travels only the

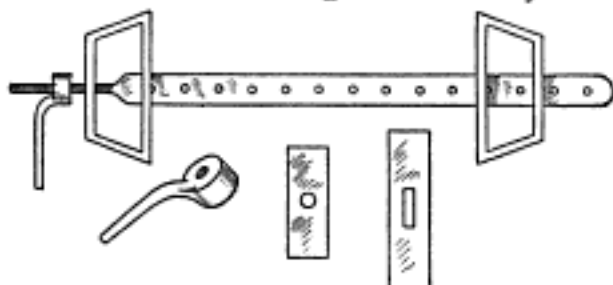

One Dog can be Set at Any Position within the Limits of the Bar, and the Other Used for Clamping

distance of the threads on the shank by the use of the handle.—Contributed by H. J. Olsen, Hibbing, Minn.



Measuring Resistance with a Lead Pencil

By JOHN D. ADAMS

THERE are very few electrical experimenters who can afford a Wheatstone bridge for measuring resistances, and yet, if one is to gain any knowledge from his experiments, it is very necessary to know what resistance is being used, particularly in handling 110 volts. The amateur will find the following method very useful.

There are several brands of lead pencils, the leads of which have a resistance of 200 to 300 ohms, while others have comparatively little resistance. Soak several pencils—preferably the large kind carpenters use—in water over night so that the leads may be removed without breaking. Connect up two 40-watt lamps in series and note how they burn. Then replace one lamp with a lead and note the relative intensity with which the remaining lamp burns. If the lead is of a sufficiently high resistance it will cut down the illumination about as much as the additional lamp.

Having selected a lead, mount it on a suitable board, holding it in place by clamping each end under a strip of brass held down with wood screws. Next screw in place two porcelain receptacles and place three binding posts in position, all as shown in the sketch. Connect up as indicated, and attach a short length of flexible cord, with a metal tip on the free end, to one terminal of the central receptacle. Procure a cheap 75-ohm receiver and connect it to the two ends of the pencil lead. Finally glue on a paper scale.

To operate, place a high-resistance lamp in the center receptacle—say, a 15-watt lamp—to prevent heating, and almost any lamp of known wattage in the other receptacle. From the rating

of this lamp the resistance may at once be determined by Ohm's law. Thus, at 110 volts, a 25-watt lamp will have a resistance of 484 ohms; a 40-watt

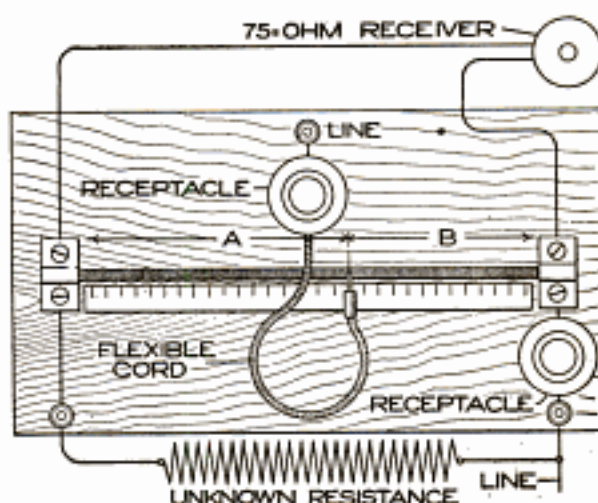

The Lead Taken from a Lead Pencil and Used as a Means of Measuring Resistance

lamp 300 ohms, and a 60-watt lamp, 200 ohms. Connect the unknown resistance, as shown in the drawing, and move the metal tip on the end of the flexible cord back and forth along the pencil lead until a point is reached where no sound is emitted by the receiver. This point will be very well defined, and as the connection is moved away from it in either direction the sound will increase rapidly. Note the reading on the scale, and then if a 40-watt lamp is used in the end receptacle, the unknown resistance will be $= \frac{300 A}{B}$.

The resistance of the center lamp does not enter into the computation, but by changing the lamp in the end receptacle, another set of figures may be obtained, and a means had to secure increased accuracy.

A High Chair

Where a high chair is not at hand or available, an ordinary solid-bottom kitchen chair can be used instead, if

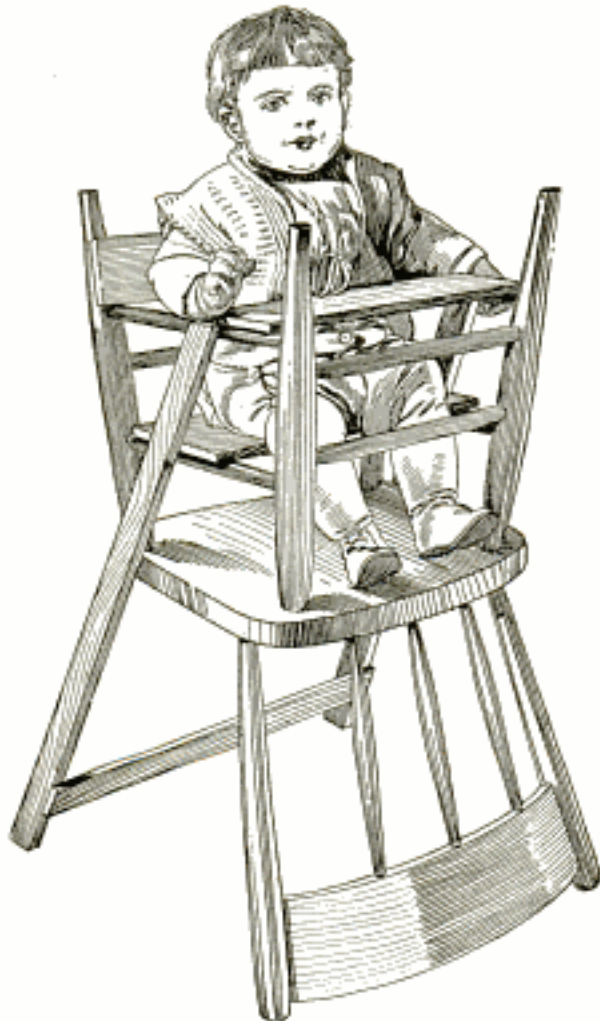

An Inverted Solid-Bottom Chair with Attachments Used for a Child's High Chair

rigged up as shown in the illustration. The chair is reversed, and the back is used as one support, while two pieces of wood fastened to the sides form the other. A seat board is fastened to the upper side rounds, and a table board to the two lower side rounds. A small piece is nailed to the two back posts for a back.—Contributed by J. S. Fritzen, Minneapolis, Minn.

Blower for a Fireplace

Having considerable trouble with a smoky fireplace when trying to start a coal fire in the basket grate, I decided to make a blower of sheet iron. A

blower covers the upper part of the fireplace and forces the draft through the basket grate until the fire gets a good start, then it can be removed. Before making the blower I again had trouble one morning when the chimney would not draw, and the whole room became filled with smoke; I then grabbed a newspaper and held it up against the upper part of the fireplace like a regular blower. To my surprise the suction of the chimney held the newspaper in place without any outside aid. In a few minutes the fire was roaring, and best of all, when it became hot, the newspaper caught fire and was sucked into the flames. This in reality became an automatic blower, as it removed itself when no longer needed.—Contributed by Charles F. Kopp, Amite, La.

An Ironing-Board Wall Fastening

One of the most useful and convenient articles for a household is an ironing board, one end of which is fastened to the wall by means of hinges to allow it to be folded up against the wall when not in use. Wood brackets are preferable to the metal hinges, as there must be some little space between the wall and the board to allow for the thickness of the covering. The brace which extends from near the end of the board to the base of the wall is best hinged with canvas strips, as they will last better than any other material for this joint. The hinges should be put in place when the board is in a vertical

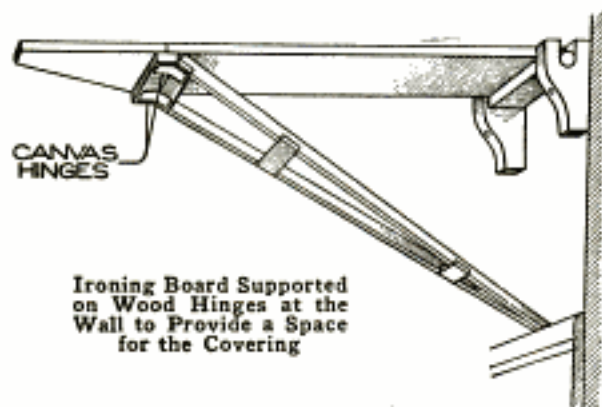

Ironing Board Supported on Wood Hinges at the Wall to Provide a Space for the Covering

position to allow the brace to go in position without straining.—Contributed by J. H. Beebee, Rochester, N. Y.

THE SHOTGUN

AND HOW TO USE IT

BY STILLMAN TAYLOR

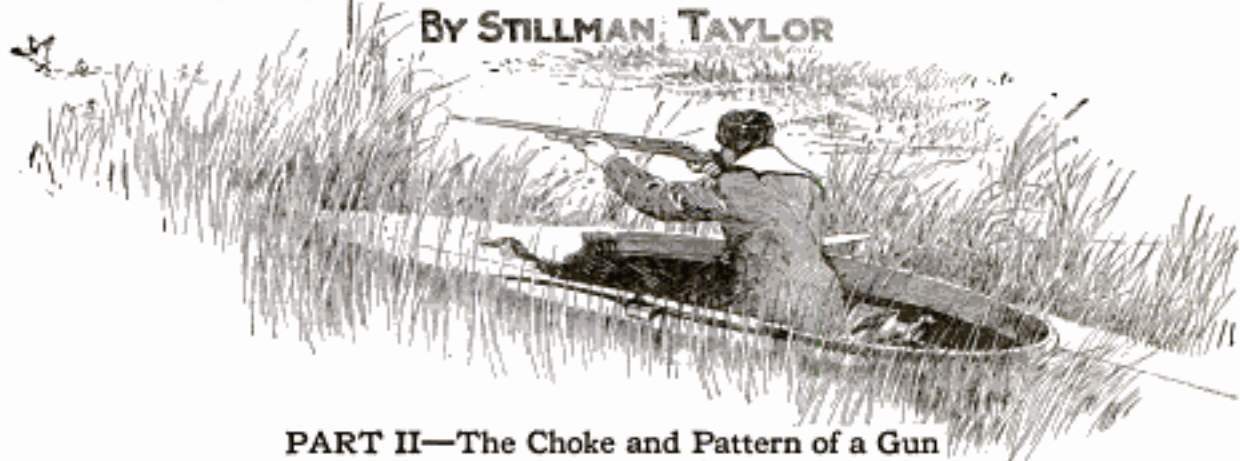

PART II—The Choke and Pattern of a Gun

HAVING picked out a gun that "fits the man," the matter of choke and pattern should be considered. For trap shooting and for wild fowling, the full-choke gun may be considered a necessity, since it will throw the charge of shot within a relatively small circle; in other words, make a denser pattern. Chokeboring is accomplished by constricting the barrel at the muzzle from $\frac{1}{25}$ to $\frac{1}{50}$ in., the amount of taper depending on the size of the bore and gauge. The narrowing of the muzzle forces the charge of shot together and prevents the pellets from scattering over a wide area. Guns are bored with varying degrees of choke, from the full to the plain cylinder, and the manufacturers compare them by recording the number of pellets which any given choke will shoot in a 30-in. circle at 30 yd., or any other range selected as the maximum distance. This gives the pattern from which we find that the full choke produces 70 per cent, the half choke 60 per cent, the quarter choke 50 per cent, and the cylinder 30 per cent.

For trap shooting and wild fowling the expert considers it essential that his 12-gauge should be capable of throwing not less than 300 pellets; hence he selects a full-choked gun with a pattern of 300 or better. As a full-choked 16-gauge will pattern about 275, it may be used for ducks with good success. For a general-purpose gun, a pattern from 250 to 275 will prove quite

satisfactory for ducks and upland game, and this may be had by picking out a half-choked 12-gauge, or selecting a full-choked 16-gauge. The 20-gauge gives a pattern of about 245 shot, and thus scatters its charge over too large a circle to prove effective on wild fowl, although it is very effective on upland game, which is flushed not over 35 yd. from the shooter. A gun patterning from 225 to 250 may be considered the ideal upland gun, and this may be had by choosing a quarter-choked 12-gauge, a half-choked 16-gauge, or a full-choked 20-gauge gun. These are known as "open-choked" guns, are the most effective at short ranges, up to 35 yd., and cannot be depended upon to kill clean when used at longer ranges.

Shooting with Both Eyes Open

To handle the weapon well is the desire of every sportsman, and this knack is not difficult to attain, providing the novice will make a good beginning. First of all, it is necessary to hold the gun correctly, and while the forward hand may grip the fore end at any convenient point, a well extended arm gives a better control of the gun when aiming, by giving free play to all the muscles of the arm; hence the gun should be held in a manner natural to the shooter, rather than in imitation of the style of another.

The old manner of aiming the shotgun by closing one eye and sighting

along the rib is fast becoming obsolete, for better shooting may be done by keeping both eyes open. Doctor Carter was the first great exponent of binocular shooting, and while but few men can hope to approach this famous gunner's skill, every one can learn to handle a shotgun more quickly and with greater accuracy by following his common-sense method. It may appear a bit strange at first to disregard the sights and keep both eyes open, and aim the gun by merely pointing it in the desired direction, but to sight along the rib and attempt to see the bead on the muzzle end can only make a slow and poky shot. This old-fashioned method may be good enough for making patterns on a stationary target, but it is not much of a success for wing shooting. For fine rifle shooting the left eye is invariably closed for target work, but for snap-shooting both eyes are kept open, the sights are disregarded, and the aim is taken by pointing the gun at the object to be hit. Of course, there are many good gunners who shoot with one eye closed, but the novice who is anxious to become a good wing shot should make it a point to practice with both eyes open. Vision is always clearer, and the objects more accurately judged with both eyes open than with one, and when this is done, and one eye controls the line of aim, the shooter is not so likely to make mistakes in estimating the distances and the rapidity of the flight of his game. In shooting, the right eye naturally governs the right shoulder, and vice versa, and this is so because habit has trained the eye to do this. To find which is the master eye, hold a pencil out at arm's length and point it at some small distant object with both eyes open, then close the left eye, and if the pencil still points to the object, the right eye controls the vision, and is the master eye. Should the closing of the left eye alter the aim, the right eye must be trained by practice until it becomes the master eye, or else the gun must be shot from the left shoulder, which is many times more difficult. The modern way of

mastering wing shooting is to point the gun where both eyes are looking, and after a little practice this may be done quickly, and the charge thrown more accurately at the object than by closing one eye, or sighting along the barrel in the old manner.

The Knack of Hitting a Flying Target

When shooting at clay targets, or at a flying bird, allowance must be made for the swiftness of flight and the distance from the shooter to the game, or in other words, the shooter must calculate the speed of the flying target and allow the probable time it will take for the shot to reach its mark. To make a quick snap shot at the flying target, the gun may be directly thrown at the mark and discharged as quickly as possible, or the gun may cover the mark and be quickly swung ahead and the charge sent at the point where the swiftly moving bird will be found when the shot gets there. Snap-shooting is only possible when the birds are flying straight away or quartering, and as the shooter fires point-blank at the rapidly moving bird, the shot must be delivered so rapidly that only a very quick and responsive trigger and a fast man back of it can hope to score even a fair percentage of hits. A more certain way of aiming a snap shot is to throw up the barrel below the bird, then rapidly swing it to the proper elevation ahead of the moving target, and throw the shot at the point where the line of the aim and the flight of the bird intersect. For shots at quail, woodcock, and partridge in the brush, the quick snap shot often must be taken, regardless of the chances of missing, for to delay even a second will lose the bird. When a bird rises near the shooter, no allowance of lead or elevation are required, and the charge is thrown directly at the bird.

The rapid swing, however, is the most accurate manner of using the shotgun, at all angles and at any distance within the killing zone of the weapon. To make this shot, the gun must be thrown up behind the bird and

then rapidly swung ahead of it, throwing the charge without checking the swing of the arm. In this style of snap-shooting, the elevation of the gun must be identical with the flight of the bird, inasmuch as the gun follows it, and if the gun is swung about three times as fast as the bird is traveling, plenty of allowance for the time necessary to press the trigger and deliver the shot at the determined point will be made.

To swing deliberately and cover the bird with the sight, then shove the gun ahead to give the proper lead, is all right for duck shooting where the game is usually seen approaching and thus remains within range for a longer time. But this deliberate style of handling the gun is far too slow for the uplands, and since the rapid swing is the only accurate manner of cutting down the fast bird, and usually useful for wild fowling, the novice should confine his practice to this practical style of wing shooting.

Stationary-Target Practice

The first great mistake the novice is likely to make is the natural one of supposing that he must take his gun to the field and learn how to handle it by practicing at flying game. This is by no means the best method, and there is scarcely a poorer way of becoming a wing shot, because the gunner is intent upon bagging the game and forgets to observe the many little points of gunnery, shooting high and low, and making the hundred and one mistakes of judgment he would not be guilty of when practicing at a stationary mark. Snap and wing shooting is the last word in shotgun handling, requiring quickness in throwing the gun, as well as a trained eye to calculate the distance from and the speed of the flying target. To acquire confidence in using the gun, begin by shooting at a fixed mark. A good target may be made by obtaining a dozen, or two, sheets of stout wrapping paper and

painting a 4-in. circle in the center of each sheet. Tack it up on a board fence, or on a board hung on a tree, measure off 60 ft., and try a shot. The shot will not



The Forward Hand may Grip the Fore End at Any Point, but a Well-Extended Arm Gives a Better Control of the Gun

spread very much at this short range, and it will be an easy matter to determine the result of your skill in holding a dead-on to the large mark. To avoid flinching and other movements of the head and body, caused by the recoil, begin your first practicing with a light powder-and-shot charge, say, about 2 dr. of bulk measure, or its equivalent in smokeless, and $\frac{7}{8}$ oz. of No. 8 or 9 shot. There is no advantage in using a heavier charge, and the recoil of the gun will appear much greater in deliberate shooting at a target than is likely to be felt during the excitement incidental to shooting in the field. A dozen shots at these targets will enable the gunner to make a good score by deliberate holding, and when this can be done without flinching, snap and wing shooting may begin.

Snap and Wing Shooting

The object which the gunner should now strive for is to train the eye, hand, and gun to work in unison, and to do this, bring the gun quickly to the shoulder, point it to the mark, and press the trigger without stopping the upward and even swing of the barrels. At the first few trials some difficulty may be encountered with the pressing

of the trigger at the proper moment, but a little practice will soon tell how to time the shots. Note the phrase, "press the trigger," for the trigger is not pulled by the forefinger alone, but rather pressed by clos-

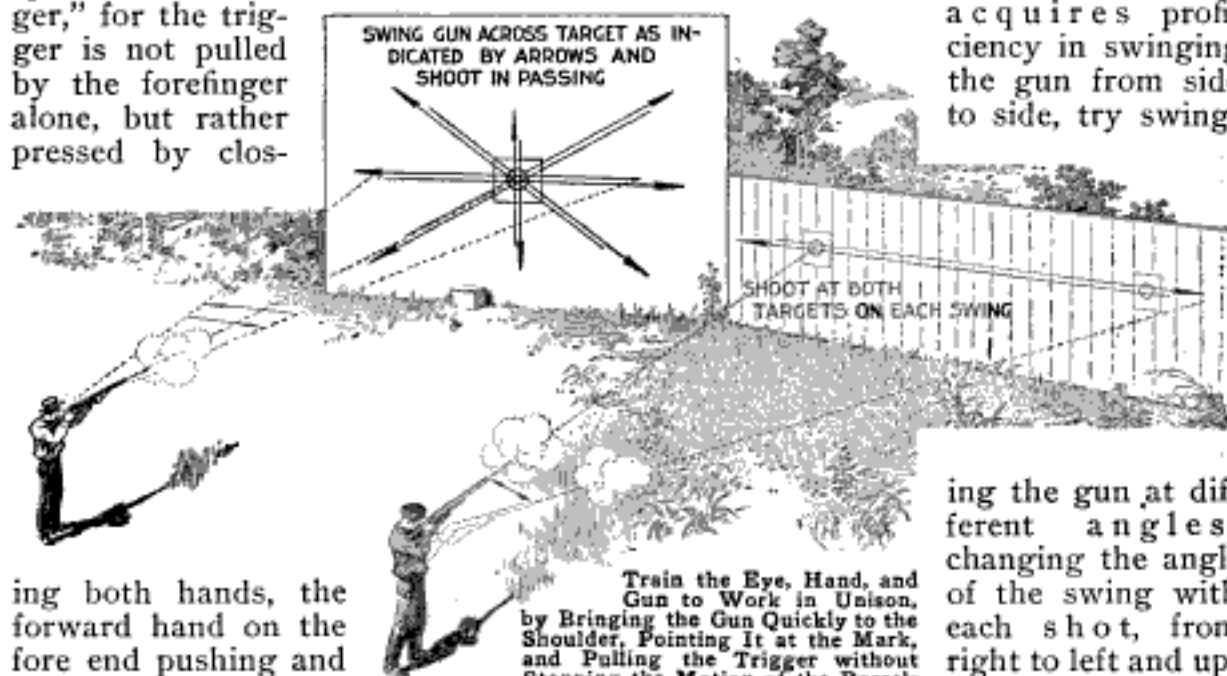

ing both hands, the forward hand on the fore end pushing and closing, and the hand grasping the stock being drawn back and squeezed at the same instant. This is easily done, but rather hard to picture. After a few trials with an empty gun, the novice will see the point, and also discover the fact that the recoil of the arm is much lessened by this proper grip of the weapon.

Confine the first practice in snap-shooting to throwing the gun to the shoulder, and when proficient in hitting the mark, try a snap shot by swinging the gun from the side, right to left and also left to right. Do not attempt to check the even swing of the gun, but rather let the barrels swing past the mark, concentrating the mind upon pressing the trigger the instant the line of aim covers the mark. Practice swinging slowly, and after being able to hit the mark with the center of the charge pretty regularly, increase the speed of the swing. In doing this, it will be discovered that the speed of pressing the trigger must also be increased to balance the speed of the moving barrel, and very likely it will be found that the natural tendency is to press the trigger a bit late. This is the common mistake which

practically every novice makes when in the field, although the error is likely to pass unnoticed when after game.

As the gunner acquires proficiency in swinging the gun from side to side, try swing-

ing the gun at different angles, changing the angle of the swing with each shot, from right to left and upward, at an oblique

angle upward, and so on, until it is possible to hit the mark with a fair certainty from a variety of angles. When trying out the several swings, one should always begin slowly and increase the speed of the swing as he becomes more expert, only making sure to shoot by calculation and not by guess. The manner of acquiring expertness sounds easy and is comparatively easy, and, as it is the backbone of snap-shooting, improvement will be rapid if the novice is willing to practice slowly and master each detail in turn. Do not make the mistake of overdoing the thing at the outset by shooting too long at a time. A box of 25 loads is ample for a day's practice, since it is not how much one shoots, but how well, that counts.

Snap-Shooting at Moving Targets

When the gunner has reached the point where he can hit the stationary target by swinging his gun both fast and slow, he has acquired better control of the weapon than many old shooters, and he is well prepared to take up snap-shooting at flying or moving targets. The access to a gun club

where clay birds may be shot at, will prove of much value, but this is not absolutely necessary, since tin cans, bits of brick, and bottles, thrown in the air at unknown angles by a companion, will afford the needed variety. Better than this is one of the inexpensive "hand traps" which project the regulation clay targets by means of a powerful spring worked by a trigger. One of the large powder manufacturers makes a trap of this kind, and a very good trap can be had for \$1.50. The standard clay targets cost about \$2.50 a barrel of 500. Practice of this sort may be made a very interesting and highly instructive sport, providing the targets are projected from different and unexpected angles, thus simulating the many-angled flight of the live bird.

Value of Second Barrel in Shooting

The use of the second barrel should not be overlooked in practicing with the idea of becoming an all-around wing shot, for the second shot is often needed to kill a cripple, or bring down a bird which has been missed with the first shot. Two-shot practice should begin by placing two paper targets about 20 ft. apart, then shooting at the first one and continuing to swing the gun to cover the second target. Practice swinging from various angles as directed for the initial practice, increasing the speed of the swing as proficiency is gained, and fail not to profit by the mistakes which must inevitably occur to all who try to master the shotgun. After a reasonable amount of practice, conducted along these lines, the gunner may venture afield, and if his acquaintance includes an old seasoned sportsman who will point out the mistakes made, much may be learned regarding the knack of handling the gun, as well as relating to the haunts and habits of our wild game birds.

Cleaning and Care of the Gun

A good shotgun is a thoroughly reliable and dependable weapon, but as with all tools of the sportsman's craft,

the best results can only be had when the arm is in good condition. It is gun wisdom always to clean the weapon after a day's shooting, and the amateur should make it a positive rule never to put his gun away until it is cleaned. The sooner firearms are cleaned after the firing the better, and if cleaned before the burnt powder has had time to corrode the steel, much future trouble is saved. In cleaning the barrels, never rest the muzzle against the floor. If a rest is needed, use an old piece of carpet or a bundle of rags. Clean from the breech end only, as any slight dust, or burr, at the muzzle will greatly impair the shooting qualities of any firearm. Never use a wire-wheel scratchbrush, as it will scratch the polished steel; a soft brass-wire cleaner is the only suitable implement for this work. There are several good cleaners to be had. For removing any rust deposits, a brass brush may be used, while for ordinary cleaning, plenty of cloth should be run through the barrels, taking care that it touches every part of the interior. This is easily done by rotating the cleaning rod as it is pushed through the barrel from the breech to the muzzle. When putting the gun away, the barrels should be stopped, at the breech and muzzle, with tightly fitting corks, or gun ropes may be run through the barrels after soaking them in some good oil. To prevent rusting, cover the metal, outside as well as inside the barrels, by smearing on a little heavy lubricating oil. Slip covers of chamois are often used to protect the stock and barrels before putting them in the leather case, but stout woolen covers are better, since chamois is likely to absorb more or less moisture.

The mechanism of a gun is not exactly complicated, but the novice had better leave well enough alone and not attempt to dismount the locks or tinker with the mechanism. The modern steel barrel is very hard and not easily dented, but if so injured, it is better to ship it to the factory for repairs than to trust it to the crude methods of the average gun repairman.

A gun should be given ordinary good care, and this is not forthcoming if one makes a practice of opening it and letting the barrels drop down with a bang. Snapping the triggers on an empty barrel is likewise foolish. If one desires to practice trigger pressing, put a couple of empty shells in the barrels.

If one owns a good-grade shotgun, the stock is probably finished in oil and hand-rubbed to a nice, durable polish. On cheap arms the varnish is usually employed to give an attractive finish in the store. Of course, this varnish will scratch, and otherwise come off,

and spoil the appearance of the arm. If a good finish is wanted, do not re-varnish the stock, but remove all the old varnish by using a little varnish remover, and rub down with oil. For an extra-fine polish, wet the wood to raise the grain; rub down with very fine sandpaper; wet the wood again, and sandpaper a second or a third time; then rub down with oil until the wood is saturated with it, and polish with a cloth, using plenty of pressure, and the stock will be as fine in appearance as if it had the "London oil finish" supplied with all high-grade guns.

Brass Machine Screws with Nuts

When small brass machine screws and threaded nuts to fit them are needed in small devices, or for experimental work, and the necessary taps and dies are not at hand, secure some old brass globe holders and cut out the threaded hole for the nut. The fastening-screw arrangement on these will answer every purpose very well. Enough metal can be left on each one to fasten it on wood, as shown at A, or they can be cut, as shown at B, if they are to be soldered to metal.

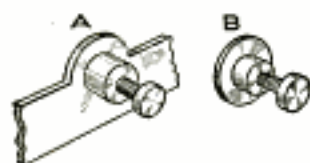

Snapper-Shell Ash Tray

An odd and unusual ash tray can be made from a snapping-turtle shell. Four brass, or wood, balls, or knobs, secured with screws, as shown, will keep it balanced. The exact points to place the supports under the tray will have to be determined by experiment, as no two shells are of exactly the same shape.



A Portable Fire Screen

The fire screen illustrated can be constructed at very small expense. In brief, the screen consists of a light metal frame surrounding three pieces of $\frac{1}{8}$ -in. sheet asbestos. The frames enclosing the asbestos pieces are hinged together, as shown in Fig. 1, with special hinges made to meet the requirements.

The asbestos comes in sheets 40 in. square, and this size determines the outside dimensions of the screen. The size of the different sections can, of course, be changed if such a change will better suit the existing needs. By making the screen in sections it may be folded up and thus occupy much less space, and when in use, the sections, by placing them at an angle to each other, serve the purpose of legs, which would be required if the screen were in one straight piece.

The dimensions and form of the outer portions of the frame are given in Fig. 2, and those of the inner portions, or edges, where the hinges are attached, are given in Fig. 3. The joining edges of the frames are made wider than the others for the reason that some of the metal is cut away where the hinges are attached. These frames may be made from heavy tin or galvanized iron, and it will be a simple matter for a tinner to bend them into shape. After all these pieces are

bent, fit them together at the corners, making sure that they clamp tightly on the asbestos sheets, as these help to hold the frame in shape. Drill a small hole in each of the corners and provide a small round-head rivet of proper length for each of the holes. The vertical portions of the frame should be placed inside of the horizontal, or end, pieces at the corners.

Make four pieces of brass having the form and dimensions given in Fig. 4. Two $\frac{1}{8}$ -in. holes are drilled in each of these pieces as indicated. Slots are cut in the inner edges of the frames of such dimensions as will accommodate these brass pieces. The location of these slots is given in Fig. 1. Obtain eight pieces of $\frac{1}{8}$ -in. steel rod, about 2 in. long. Place the ends of the brass pieces in the slots in the inner frame and then put the rods through the holes in the ends of them and solder the ends of the rods to the inside of the frames. Make sure that there is no solder run in between the rod and piece of brass, as this will prevent the hinge from operating freely. After the hinges are in place, the frames are riveted together. Notches are cut in the edges of the asbestos sheets at the location of the hinges to allow the lat-

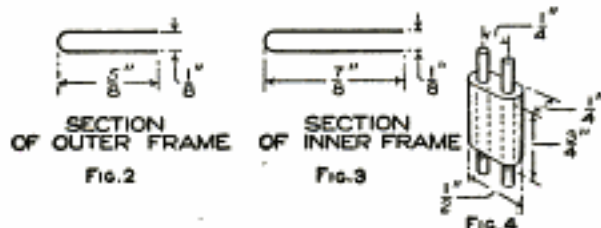
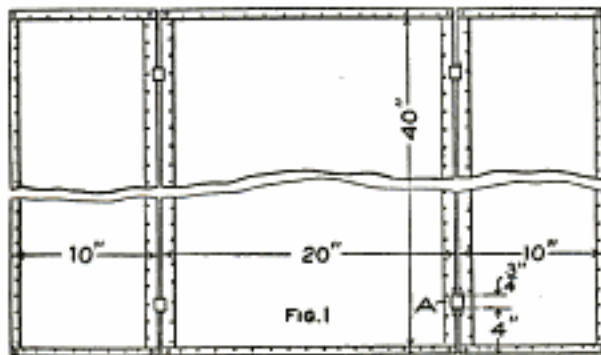

Fire Screen Made of Sheet Asbestos Inclosed in Thin Metal Frames Hinged Together

ter free movement. The sections of the screen may be made very rigid by placing a number of small rivets around the

inner edges of the frame to hold it tightly against the asbestos. The asbestos may be given a coat of bronze, or be otherwise decorated for appearance.

Tossing a Card at a Mark Accurately

There is an interesting old game that can be played instead of solitaire. It consists in trying to toss the great-

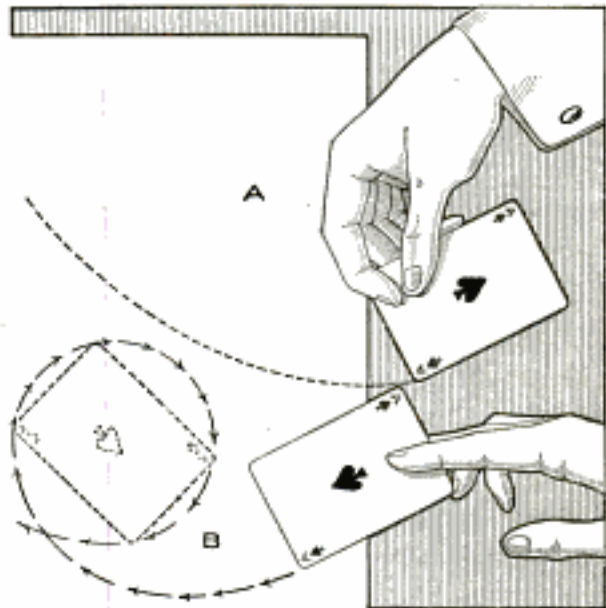

Tossing Cards Accurately so That They will Fall into a Receptacle Set at a Distance

est number of cards into a small basket or an upturned stiff hat, set at a distance. If the cards are held as shown at A, and tossed as at B, they may be thrown with surprising accuracy.—Contributed by James M. Kane, Doylestown, Pa.

A Sanitary Drinking Tube

To make this tube, procure a piece of $\frac{3}{4}$ -in. gauge glass, about 10 in. long, and bend it by heating the glass with a blow torch $2\frac{1}{2}$ in. from one end, as shown.

If this is done in a place where no air will strike the glass while it is heated and the tube is then allowed to cool slowly, it will not crack. It is used by putting the short end under the faucet and drawing on it as on a pipe.

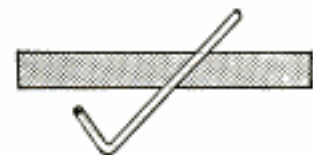

Combination Bookcase and Writing Desk

In planning a writing desk, much convenience can be added by providing

have this done by an experienced joiner, or in the mill. The back edges should be carefully planed, and rabbeted $\frac{3}{8}$ in. deep by $\frac{1}{2}$ in. wide for the $\frac{3}{8}$ -in. thick back. The bottom or foot piece of the

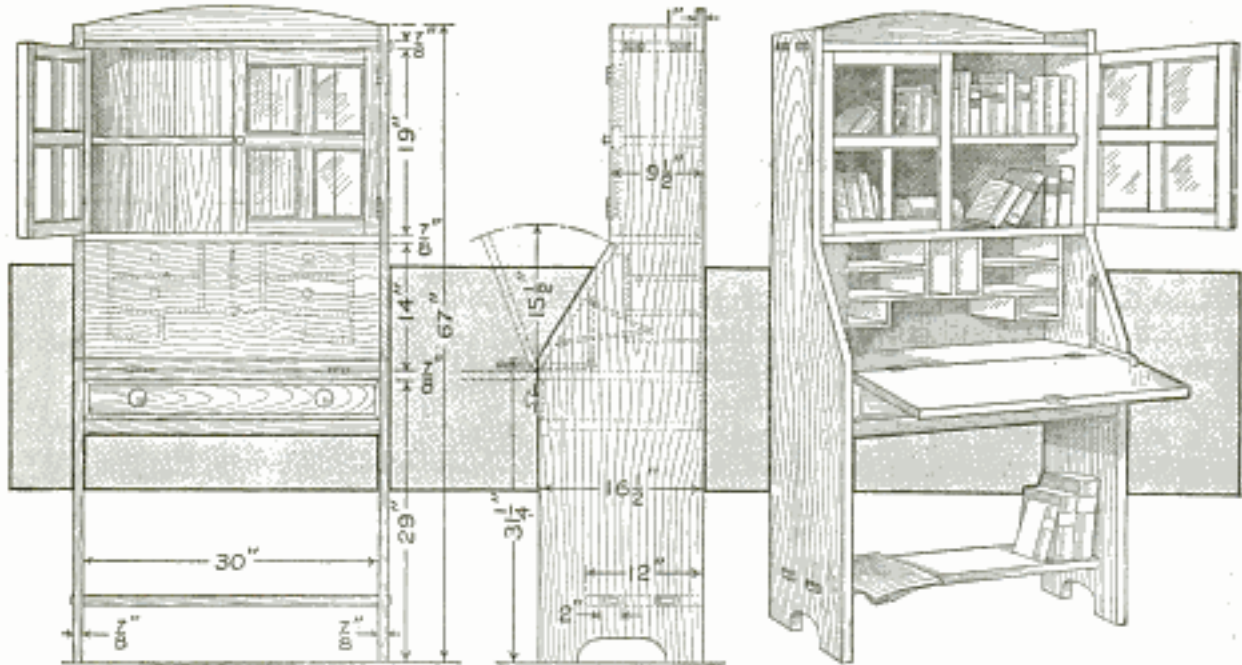

Combined Bookcase and Writing Desk Which can be Made Up in Golden Oak, Mission, or Mahoganyed Birch, and will Appear Well with Other Furniture of Like Construction

it with a bookcase, in which may be stored those reference works most frequently used. The design illustrated furnishes ample room as a drawing desk, besides providing sufficient space in an inclosed cabinet for books or letter-filing cases.

The material required, figuring exact sizes, is as follows:

- 2 sides, $\frac{3}{8}$ by $16\frac{1}{4}$ by 67 in.
- 1 bottom shelf, $\frac{3}{8}$ by 12 by $32\frac{1}{4}$ in.
- 1 top shelf, $\frac{3}{8}$ by $9\frac{1}{4}$ by $32\frac{1}{4}$ in.
- 1 back, $\frac{3}{8}$ by 40 by 31 in., made of pieces of convenient widths.
- 1 desk board, $\frac{3}{8}$ by $16\frac{1}{4}$ by 30 in.
- 1 lower bookcase shelf, $\frac{3}{8}$ by $9\frac{1}{4}$ by 30 in.
- 1 middle bookcase shelf, $\frac{3}{8}$ by $8\frac{3}{4}$ by 30 in.
- 1 desk cover, $\frac{3}{8}$ by $15\frac{1}{2}$ by 30 in.
- 1 upper back rail, $\frac{3}{8}$ by 5 by 30 in.
- Bookcase Doors**
- 4 stiles, $\frac{3}{4}$ by $1\frac{1}{4}$ by 19 in.
- 4 rails, $\frac{3}{4}$ by $1\frac{1}{4}$ by $13\frac{1}{2}$ in.
- 2 mullions, $\frac{3}{4}$ by 1 by $17\frac{1}{2}$ in.
- 2 mullions, $\frac{3}{4}$ by 1 by $13\frac{1}{2}$ in.
- 1 pigeon-hole stock, $\frac{3}{8}$ by 7 by 72 in.
- For Main Drawer**
- 1 front, $\frac{3}{4}$ by 4 by 30 in.
- 2 sides, $\frac{3}{8}$ by 4 by $15\frac{1}{2}$ in.
- 1 back, $\frac{3}{4}$ by $3\frac{1}{4}$ by $29\frac{1}{2}$ in.
- 1 bottom, $\frac{3}{8}$ by $15\frac{1}{4}$ by $29\frac{1}{2}$ in.
- 2 drawer slides, $\frac{3}{8}$ by $1\frac{1}{2}$ by 15 in.
- 1 lower rail, $\frac{3}{8}$ by $1\frac{1}{2}$ by 30 in.
- 1 molding strip, $\frac{3}{4}$ by $\frac{3}{8}$ by 120 in.

As the main sides are of considerable width, it would be best to make them of two pieces glued together and, in order to obtain a strong and neat joint, to

sides should be squared up with the back edges, or the completed desk is liable to be winding, or warped. The bottom and top shelves or main cross braces should be marked and cut out, and, to be in harmony with the shape of the sides, the lower-shelf tenons are made wider than those on the upper shelf. The top shelf should be rabbeted $\frac{1}{2}$ in. deep by $\frac{3}{8}$ in. wide, to fit the back boards which are nailed to it. The required mortises in the sidepieces are marked from the corresponding tenons of the shelves, and can then be cut out with a chisel. When finished, the four parts constituting the frame should be assembled, and may be held together with blind screws, or dowel pins, passed through the tenons.

The desk board and two library shelves should then be fitted, and fastened in place with blind screws through the sides, or with cleats from the inside. For a neat, finished appearance, the back boards should be carefully joined, exposing no cracks, and fastened with nails driven into the vari-

ous shelves. The upper rail, resting on the bookcase, and the lower rail, forming part of the drawer support, can then be fitted and secured to the sides with blind screws, either from the outside or diagonally through the rails from the inside. Drawer slides are fitted in place flush with the top edge of the lower rail, and fastened to the sides with screws.

In making the drawer, the usual construction should be followed. The front piece should be rabbeted near its lower edge to fit the drawer bottom, and notched $\frac{1}{2}$ in. at each end to fit the sides. The bottom and end pieces fit into grooves cut in the sides. Suitable drawer pulls or knobs should be provided.

For the doors of the bookcase, the best construction would be to tenon the rails into the stiles about $\frac{1}{2}$ in. The glass panel fits in a notch, $\frac{1}{2}$ in. deep and $\frac{1}{4}$ in. wide, cut around the inside edge of the door, and is held in position with molding strips. In order to give the door an appearance of being divided into four parts, mullions, or cross strips, are fitted on the outer side of the glass flush with the rails and stiles, and fastened to them with brads. The doors are attached with butt hinges.

In making the desk door, a specially selected board should be used, as the finished appearance of the desk will greatly depend on this. The ends and sides should be perfectly squared, and the lower or hinge end cut beveled corresponding to the edge of the desk board. Butt hinges are used to secure it in position, and hinged brackets or chains provided to support it when open. When closed, it rests against a strip fastened to the lower side of the bottom bookcase shelf.

In arranging the pigeonholes it is best to have the inside boards rest on the desk board, so that, when desired, the entire arrangement of the drawers and shelves may be withdrawn easily.

When thoroughly sandpapered and finished to taste, a serviceable, handy and attractive piece of furniture is obtained, suitable for either office or home.—Contributed by James Gaffney, Chicago.

Automatic Stop for Spring-Roller Curtains

It frequently occurs, in adjusting spring-roller curtains, that the cord slips through the hand and the curtain not only winds up to the top but continues until the spring has spent its force, and the curtain and cord are

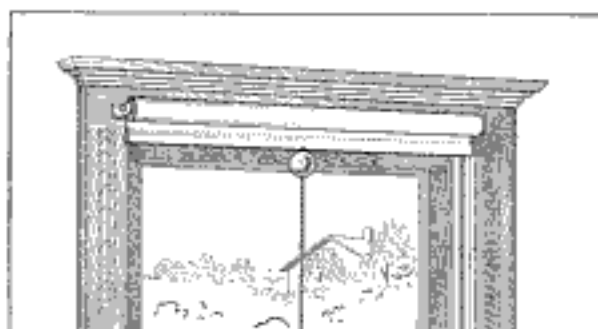

The Rubber Ball Fastened on the String at the Stick Prevents the Curtain from Winding Up

rolled up out of reach. It is then necessary to use a chair, or stepladder, to readjust it. All this trouble and annoyance can be avoided if a small hollow rubber ball is obtained, and holes punched through so it may be threaded on the curtain string, and tied close to the stick. Should the curtain slip away with this attachment, the ball will jam up against the window frame, preventing further winding up.—Contributed by T. B. Lambert, Chicago, Ill.

Spoon Attachment to Prevent Child from Using Left Hand

To discourage a child from using a spoon in the left hand, a projection was made of a piece of brass, filed into the shape shown in the illustration. After the projection was attached, the entire spoon was plated. This makes it impossible to use the spoon in the left hand, as the projection will prevent the



The Projection Keeps the Spoon from Entering the Mouth When Taken in the Left Hand

bowl from entering the mouth.—Contributed by W. H. Hutchinson, Hamilton, Ont.

A Comb Cleaner

A very handy device for cleaning combs can be made from a piece of spring sheet brass, $4\frac{1}{2}$ in. long and about 3 in. wide. Notches are cut in the ends of the brass with a hacksaw, making the projections as wide as the

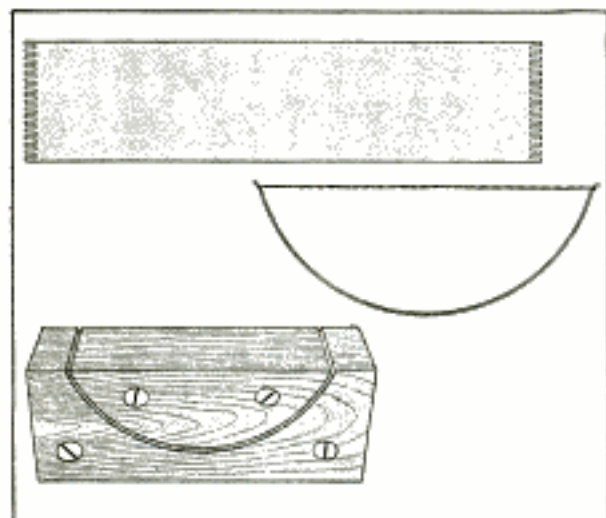

The Twisted Wires Form an Excellent Device for Cleaning a Comb

saw cut. The brass is then bent into shape with a special clamp made for the purpose, which consists of three pieces of wood, two being cut to form a curved slot, then fastened to the third piece. The brass is sprung into the slot, and then fine wire is stretched between the ends in the notches. The wire should be very fine and two strands twisted together and run through the notches.

Concealing the House Key

The time-honored custom of concealing the house key under the door mat, or in the letter box, when the family has not enough keys to go around, is so well known that an unauthorized person seeking to enter the house would look in these places first of all.

A simple and effective hiding place for the key can be quickly and easily made with the aid of an auger and two



pieces of tin. Pick out an obscure section of the porch railing, and in the edge of this bore a $\frac{3}{4}$ -in. hole, about $\frac{1}{4}$ in. deeper than the length of the key. Make a piece of tin into a cylinder, the same length as the key, so that the latter will slide easily into the hole. At one end of this cylinder solder a 1-in. disk of tin, which will make it appear as in the illustration.

If the key is placed in the cylinder and the latter pushed into the hole until it is flush with the surface, it will scarcely be noticed by anyone not in the secret, and by painting it the same color as the railing it will become still more inconspicuous.—Contributed by Frank L. Matter, Portland, Ore.

A Mysterious Watch

A very interesting experiment may be made with the ordinary dollar watch in illustrating the law of the



pendulum. A pendulum 39.1 in. long will make 60 one-way swings per minute, the number of swings varying inversely as the square root of the length. By actual count

it was found that the balance wheel of the watch in question made 240 one-way swings per minute, which is just 4 times as fast as the 39-in. pendulum. Therefore, according to the foregoing law, a pendulum $\frac{1}{16}$ as long, or about $2\frac{1}{2}$ in., would swing in unison with the wheel of the watch. The question then arises as to what would happen if the watch itself were suspended so as to swing as a pendulum of the latter length. The experiment was made as illustrated, with the result that the watch keeps on swinging continuously. The swing amounts to about $\frac{3}{8}$ in., and appears so vigorous that it is almost incomprehensible that the small spring in a watch should be able to maintain so much weight in continuous motion for 24 hours.

Surface Mining for Gold

By W. M. MILLS

PART III—Assaying

IN making a fire assay of gold, a more expensive and greater variety of tools is necessary than in the prospector's outfit or simple mining operations. Great accuracy must be used in weighing the small amount of gold found in a sample, or serious errors will result. It is, therefore, necessary to have a very delicate balance—capable of measuring $\frac{1}{20}$ milligram—for weighing tiny gold beads; a coarser set measuring to several ounces should be provided for weighing the crushed-ore sample and slag-forming ingredients. Besides these, there is needed a furnace, or forge, for melting the ore, and other equipment such as crucibles, cupels, ore grinder, and chemicals.

Weigh out approximately 30 grams—29.166 to be exact—or about one ounce of the ore. In the final weighing of the separated gold, every milligram weight will correspond to one ounce per ton of the ore. For example, if a bead of gold weighs 25 milligrams, then the ore value is 25 ounces troy of gold per ton of 2,000 lb. of ore. The amount of ore used in assaying (29.166 grams) is called an "assay ton"; it is the amount which corresponds to one ton of the actual ore; and the proportion of gold in one ton of ore would be the same as its proportion in the 29.166 grams used for the assay sample.

In order to form a proper composition with the gold-bearing ore, so it will readily fuse on the application of heat, certain chemicals and lead oxide, or litharge, must be added, which will combine with the ore, forming a molten slag. The lead oxide is reduced to lead, and forms an alloy with the gold and silver which sinks to the bottom of the crucible as soon as boiling of the slag ceases. The necessary composition of the flux varies with the character of the ore. A general lead flux may be made as follows: Sodium bicarbonate and potassium carbonate, both four parts by weight; powdered borax, two parts, and flour, one part. To this flux is added litharge in amounts depending on the character of the gangue, or soil surrounding the gold. If this contains sulphides or sulphur, several iron nails are added and the flour is reduced; if the gangue is siliceous and acid, the flour is increased. No one composition will work equally well for all ores.

If an assay ton of ore—29.166 grams—is to be used, a 20-gram crucible

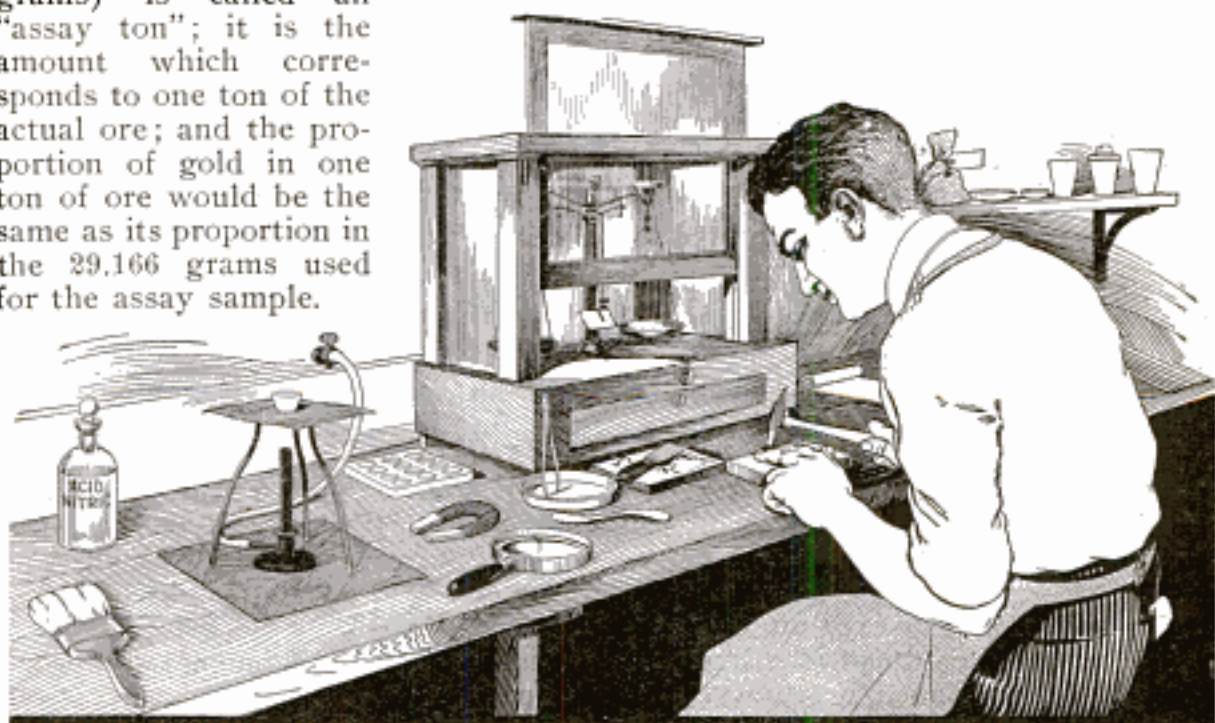

The Tools Necessary for Making a Fire Assay of Gold Are Greater in Variety Than Those Used by the Prospector or for Simple Mining Operations

must be provided for the fusion. In practice the amount of ore is usually cut down to one-half assay ton, making possible the use of a 10-gram crucible. Where assays are run in large

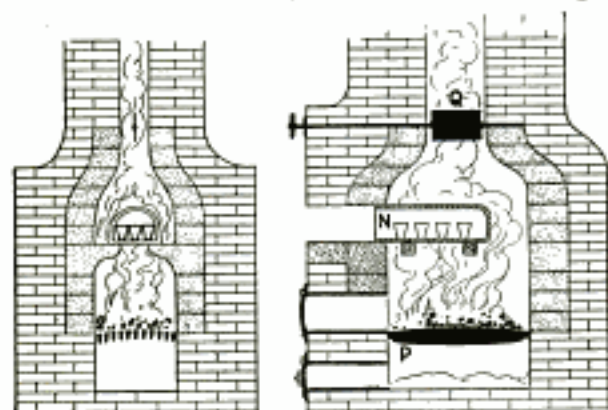

An Especially Large Furnace is Required for Fusing the Charge Where Assays Run in Large Batches

batches and one assay ton of ore is used in each, a specially large furnace would be required for fusing the charge.

When the mixture is made and combined with the finely ground ore, it is placed in a fire-clay crucible of suitable size, which is filled to about two-thirds of its capacity. The crucible and charge is now ready for the furnace. This may be either open or "muffled," but must produce an intense heat; coal is, therefore, generally used. For want of anything better, an ordinary blacksmith's forge may be used, in which case the crucible should be put well down in the coals. A muffle furnace, as illustrated, is one in which the crucibles are placed in an inclosed fire-clay muffle, or oven, having an opening at one end only; the heat of the fire can only affect the crucibles and charge. The muffle, or oven, N, is usually about 9 in. wide by 15 in. deep. Its open end may be closed up by a fire-clay door in order to increase the heat. The fire is built on grates, P, the ashes falling into an ash pit, whence they are removed through the door. The intensity of burning is regulated by a damper, Q. Furnaces using gasoline for fuel instead of coal or coke are coming into favor rapidly, due to their compactness, light weight, portability, and ease of heat regulation.

The muffle should be red-hot before

placing the crucibles in it. The fusion, or melting, will require from 20 to 30 minutes, after which another 15 minutes should be allowed to form a good, fluid slag. If the boiling is too violent, a small amount of common salt may be added. If a charge has boiled over, the assay is not reliable and should be repeated. When the fusion is completed, the crucibles should be removed from the furnace by means of a pair of long tongs, and the fused charge is then poured out on a piece of cold iron or metal mold, making sure that everything has been removed by tapping the crucible lightly. In cooling, the molten lead will settle to the bottom of the slag and may be easily separated from it when cold. This is now the lead button and contains all the gold and silver of the ore charge; it should be hammered into the shape of a cube and is then ready for the process of cupellation, which consists in evaporating and absorbing the lead in bone-ash cupels, the gold and silver remaining as a small bead.

Cupels are small shallow cups, usually about $1\frac{1}{4}$ in. diameter and $\frac{3}{4}$ in. high. They are made by mixing fine

Cupels Are Small Cups Made of Bone Ash and Water in a Mold

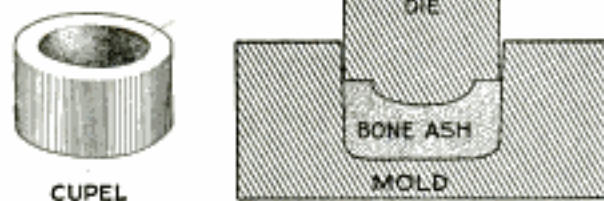

bone ash with water so it may be easily molded, then placed in a cupel mold and formed by several blows on the die. If a large number are to be made, cupel-stamping machines can be had which will turn out several hundred in an hour. The cupels should be dried for about a week before using.

The cupel should be heated red-hot before placing the button in it, after which they should be placed in the muffle with the opening closed un-

til cupellation begins, which is indicated by the fumes of lead oxide given off. The door is then opened to increase oxidation of the button. This gradually disappears as the lead oxidizes and is absorbed by the bone ash. Cupeling requires about 40 minutes.

When it is nearly finished, bright colors play over the surface of the button, which will suddenly darken and then brighten again with a flash; cupellation is then complete, and the cupel should be withdrawn from the muffle and allowed to cool slowly, to prevent spitting, or bursting, of the bead. It may even be necessary to cover a large bead with a hot cupel in order that cooling may be slower.

During cupeling it is very necessary to keep the temperature as uniform as possible. If the temperature should become too low, the button will "freeze," that is, become covered with a film of lead oxide which prevents further oxidation, and even though it may be thawed by placing it in a hotter part of the muffle or by placing a piece of charcoal on top of it, the final results are unreliable.

The cupel bead of gold and silver is then ready for weighing. It should be cleaned with a fine brush and carefully weighed on an accurate scale, registering to $\frac{1}{20}$ of a milligram, or less. This weight is the total of silver and gold, and should be recorded as such. The two must then be parted so the true weight of each can be determined. The bead is put in a small porcelain crucible and covered with a solution of one-third chemically pure nitric acid and two-thirds distilled, or pure, water, gently warmed on a hot plate. Bubbles will be given off as the silver passes into solution; parting is complete when these cease. The gold remains as a black bead; the acid should be drained off, and the bead washed in several changes of water, and finally dried on blotting paper, after which it may be brightened by heat. The gold may then be weighed very carefully and this final reading subtracted from the total weight, the difference being the amount of silver

in the ore. The weights are recorded in milligrams, each of which is representative of ounces in troy weight per ton of ore. If the original charge of ore in the crucible was less than one assay ton—or 29.166 milligrams—the determination can be made as follows:

Weight of button in milligrams
 \div weight of ore in assay ton or fraction thereof =



Parting the Silver from the Gold so That the Weight of Each may be Determined

troy ounces of gold per ton ore of 2,000 lb. For example: it frequently occurs that only one-half assay ton of ore is used in the crucible; then, supposing the weight of the gold bead to be 1.5 milligrams, the value would be $1.5 \div \frac{1}{2} = 3$ oz. per ton of ore; exactly the same as though one assay ton of ore had been used in the crucible and three milligrams of gold weighed in the balance. The money values of the gold and silver in ounces, as determined by weight, added together represent the value of the ore per ton, as assayed. If the gold assayed 1.5 milligrams per assay ton and its value were \$20 per ounce, it would mean a value of gold in the ore of 1.5×20 , or \$30. The value of the silver should be figured the same way, and the combined values would be the actual value of the ore per ton.

All assays and operations should be carefully recorded, not only for one's own benefit and habits of work but also for future reference. It is advisable to give all details of the assay, such as the owner, assay number, dates, values of all metals, and process followed.

A Table-Knife Sharpener

The knife sharpener shown can be easily made of two pieces of thin wood,

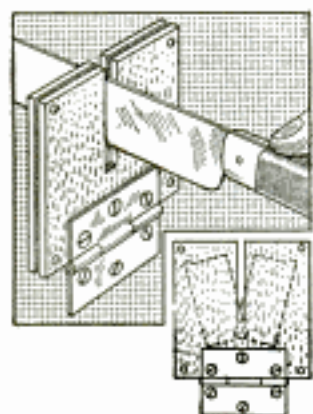

such as cigar-box covers, about 2 in. wide and 2½ in. long, and two discarded safety-razor blades of the heavier type. Lay the wood pieces together and saw a slot down the center for about 1¾ in. Lay the two

razor blades at an angle of about 2° on each side of the slot, as shown, fasten them to one of the boards, and securely attach the other board over them.

To sharpen a knife, run it through the slot two or three times. The sharpener can be fastened with a hinge so that it will swing inside of the drawer, or box, that the knives are kept in, and it will always be ready for use.—Contributed by Henry J. Marion, Pontiac, Mich.

Raising and Lowering Curtain at a Distance

To enable an invalid, or any other person, to easily raise and lower a cur-

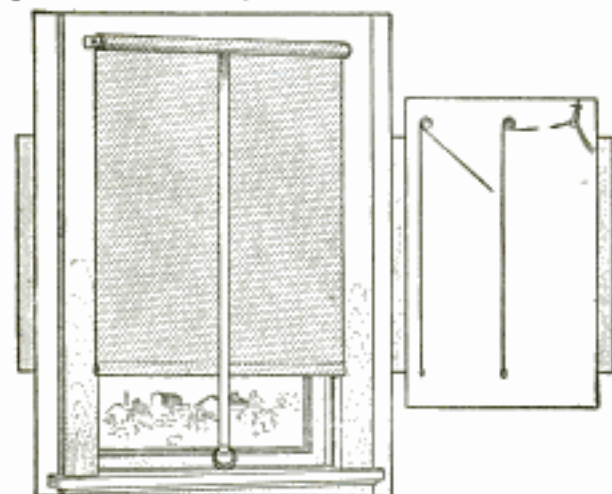

A Ribbon or Tape Attached to a Curtain Roller to Operate It at a Distance

tain from a position at a distance from the window, a ribbon can be attached to

the roller, at the center and on the inner side of the curtain. The ribbon may extend across the room in line with the window, and still operate the curtain as well as with the regular cord attached to the bottom. If desirable to operate the curtain by a vertical pull, a flat pulley may be conveniently fastened to the ceiling or wall, and the ribbon passed over it, or through a ring, as shown. This plan is especially adapted for show windows where the curtain string would otherwise mar the appearance, and be hard to get at.—Contributed by L. E. Turner, New York, N. Y.

The Mystic Climbing Ring

The performer hands out a wand for examination and borrows a finger ring.



He holds the wand in his hand, point upward, and drops the ring on it, then makes mesmeric passes over the wand with the other, and causes the ring to climb toward the top, stop at any place desired, pass

backward, and at last fall from the wand. The wand and ring are examined again by the audience.

To produce this little trick, the performer must first provide himself with a round, black stick, about 14 in. long, a piece of No. 60 black cotton thread, about 18 in. long, and a small bit of beeswax. Tie one end of the thread to the top button on the coat and to the free end stick the beeswax, which is stuck to the lower button until ready for the trick.

After the wand is returned, secretly stick the waxed end to the top of the wand, then drop the ring on it. Moving the wand slightly from oneself will cause the ring to move upward, and relaxing it causes the ring to fall. In the final stage remove the thread and hand out the wand for examination.

Dies for Cutting Cardboard

An inexpensive, yet very efficient, die for cutting quantities of tin foil, sheet lead, paper, and cardboard can be made from a steel rule such as used by printers. Procure a rule, two points or about $\frac{1}{32}$ in. thick, which comes in 2-ft. lengths. The rule can be readily bent without annealing. Bend it to the desired shape and solder, or weld, the ends together. To give it rigidity, fill in the space with melted lead to a depth of half the height of the die.

Place the material to be cut against the die and put both into a vise, or letter press. Apply pressure steadily until the die has cut through the last thickness of the material. As many as 25 pieces can be placed and cut at one time. When cutting designs for static machines, etc., from tin foil, this appliance does away with the tedious work of cutting one at a time, and then, too, they will all be uniform. In making the connection at the ends of the rule, be sure that they meet evenly and do not lap to make the joint.—Contributed by M. H. Granholt, Long Beach, Cal.

How to Make a Vacuum Pail

As a substitute for a vacuum bottle a very efficient pail can be made in the following manner: Procure a 1-gal. sirup pail for the outside and a $\frac{1}{2}$ -gal. size for the inside. Make a collar of tin, as shown, with projections; bend these down, inside and outside, then solder the collar to the inside of the larger pail, and the smaller pail to the inside of the collar. Be sure to make a perfectly air-tight joint in the soldering. This gives a double wall with an air-tight space all around the inner pail, or opening. To make vacuum covers for the pails, take two covers of each size and solder them together, as shown.

To produce a vacuum, make a small hole in the metal forming the collar, also one in each cover. Put a few drops of water in each vacuum compartment and set the parts on a heated

surface. When the steam escapes, solder the holes. This will produce a partial vacuum in the space around the

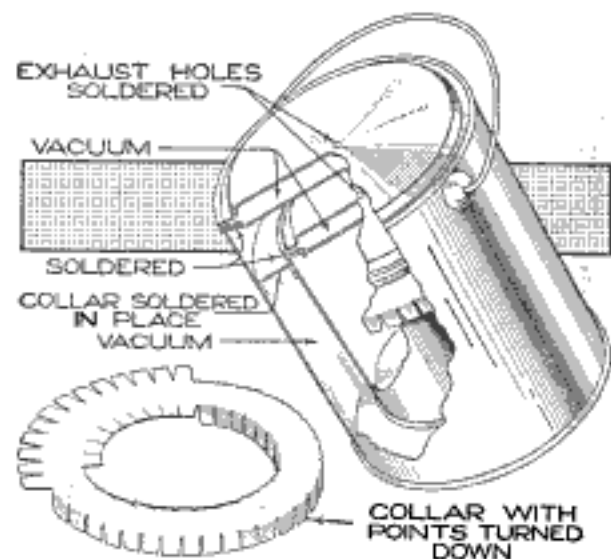

A Two-Wall Pail with Covers in Which a Partial Vacuum is Made

inner pail and in the covers. This will make a very efficient vacuum pail.—Contributed by John H. Spicer, Magnolia, Ark.

Ironing Board for Use on a Table

A handy ironing board for use on kitchen or dining-table top is made with a cleat to keep it from moving across the table top. The cleat, which is $1\frac{1}{2}$ or 2 in. wide, is fastened to the board with screws. If desired, the board can be made as immovable as the table top by putting another cleat at one end, so that the two cleats will

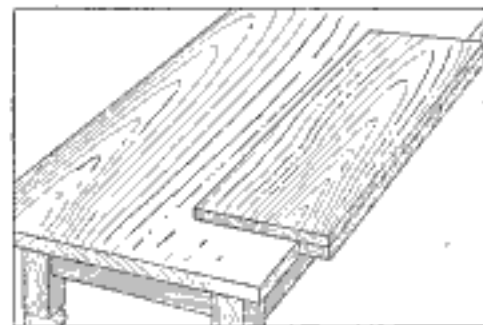

A Cleat Fastened to the Underside of an Ironing Board to Hold It on the Table Top

hold against one side and one edge of the table top.—Contributed by H. S. Craig, Rushford, Minn.

POPULAR MECHANICS

INTERESTING NEW PATENTS

COMBINED ELECTROLIER AND TELEPHONE COVER (Fig. 1)—The base of the electrolier is hollow and is made in the form of a receptacle for the telephone. It is equipped with two hinged doors, so that the telephone is easily removed, or is entirely concealed when it is in the receptacle and the doors are closed.



Fig. 1

METHOD OF REMOVING SNOW FROM CITY STREETS (Fig. 2)—The feature of this invention is the provision of ducts leading from the street to a sewer or other conduit, the snow being shoveled down the sloping ducts at the sides. As the snow is shoveled into the sewer it is flushed away with water forced into the sewer through the pipes in the vertical conduit at the center.

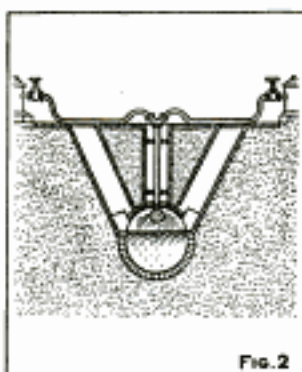

Fig. 2

DEFLECTOR AND DIMMER FOR AUTOMOBILE HEADLIGHT (Fig. 3)—This simple device consists of an oblong plate pivoted vertically in front of the headlight. When the edge is turned toward the lamp a full light is thrown ahead, and when it is turned with the side toward the lamp, the light is dimmed. The light is thrown to either side of the road by turning the plate at an angle.

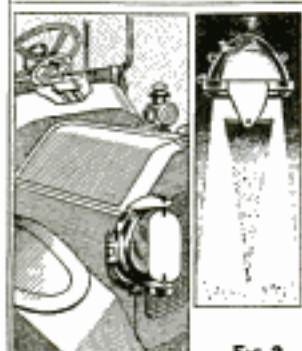

Fig. 3

COMBINED SHOE HORN AND BUTTON HOOK (Fig. 4)—The hook is hinged to the horn near one end so that it is easily folded back out of the way or extended for use. Clips are provided for holding the hook in either position.



Fig. 4

KNIFE SHARPENER (Fig. 5)—This device consists simply of a base, designed to be securely mounted on a table, on which is a standard split into two arms at the top. In recesses on the inner faces of the arms, near their junction, are mounted abrasive plates, and these are placed at such an angle that the proper angle is given to the edge of the blade when it is drawn between them.

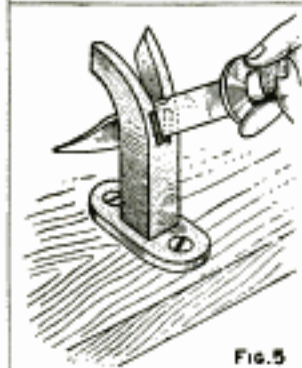

Fig. 5

FROST-PROOF BOX FOR WATER PIPES (Fig. 6)—The feature of this box is the arrangement by which the air is kept in constant circulation so that the cold air at the top is constantly displaced by the warmer air at the bottom. At one side of the box is a by-pass which opens into the box at top and bottom. As the warm air ascends through the by-pass the cold air is displaced and descends through the main chamber.

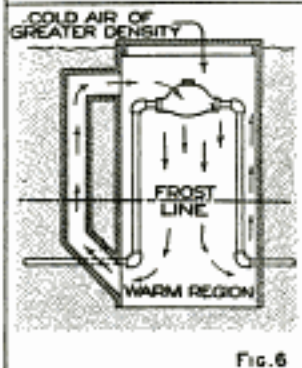

Fig. 6

DOOR HOLDER (Fig. 7)—One of the best features about this door holder is its simplicity. It consists simply of a plate pivoted to the door and controlled by a tension spring. One end of the plate is provided with a floor-engaging surface, while the other is formed into a prong that projects nearly at right angles to the door. The relation of the spring and pivot is such that when the holder is changed from one position to the other, the spring swings past the pivot and holds the plate in the new position. The prong is designed to engage the spring and prevent the upper end of the plate from being pulled against the floor when the holder is released.



Fig. 7

UNDERTOW INDICATOR (Fig. 8)—In this apparatus, which is evidently intended for use at bathing beaches, a gong is set ringing when an undertow is running. A submerged plate is set out from the shore far enough to be affected by the undertow. This plate is ordinarily held upright by a spring. When it is deflected outward it actuates mechanical and electrical connections that set the gong to ringing.

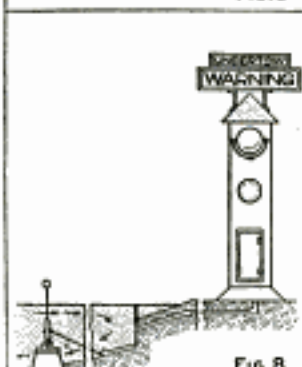

Fig. 8

FENCE POST (Fig. 9)—This post is made of steel and is tubular in form. The prongs at the bottom are for the purpose of anchoring it securely to the ground.

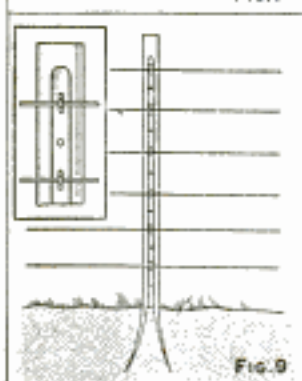

Fig. 9

MUZZLE SUPPORT FOR GUN (Fig. 10; American patent to Frenchmen)—This is a plan for using the bayonet scabbard for supporting the muzzle of the gun. For this purpose a leg is pivoted to the scabbard, and a lug and curved link are provided for attaching the scabbard to the gun barrel.

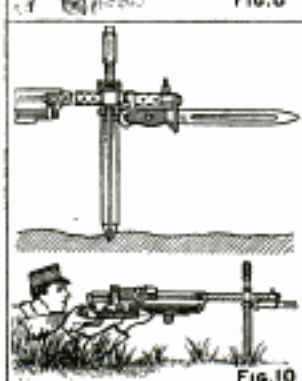

Fig. 10

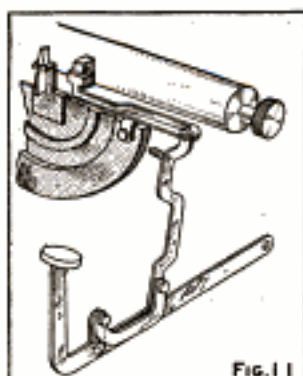

Fig. 11

ERASING ATTACHMENT FOR TYPEWRITER (Fig. 11)—With this attachment the eraser is permanently mounted on the typewriter and is operated by a key in an up-and-down direction. The eraser is carried on the end of a pivoted arm which is worked through a lever-and-link mechanism by a key lever mounted on the side of the typewriter.

SANITARY BREAD BOARD (Fig. 12)—The purpose of this invention is to provide a fresh surface of paper each time bread is kneaded. The paper is carried in a roll at the end of the board, where there is also means for clamping and tearing the paper. At the opposite end are clamps for holding the paper in place over the board.

MOTOR-DRIVEN SLED (Fig. 13; American patent to a German)—The feature of this invention is the plunger rods, having pointed ends for engaging the snow or ice, which are alternately thrust downward and rearward. These rods are operated by a crank shaft, which in turn is driven by the motor.

SILO WITH HINGED ROOF (Fig. 14)—The roof is hemispherical in form and consists of two sections carried on shafts that project from opposite sides of the silo, as shown. One section fits inside the other, so that a tight roof is provided when the sections are closed. When the sections are swung back and downward, unobstructed access to the interior of the silo is provided.

ATTACHMENT FOR PHONOGRAPH (Fig. 15)—In this attachment the jewel point that works in the groove of the record is mounted on a flexible arm, an arrangement designed to prevent wear on the record. By adjusting the counterweight carried at the opposite end of the attachment the pressure of the point on the record may be varied, with a corresponding variation in the intensity of the tone.

EXTENSIBLE SUITCASE (Fig. 16)—The bottom is hinged to both of the sides instead of being rigid, as is the usual practice. With this arrangement the suitcase lies flat when opened.

REPAIR ATTACHMENT FOR VEHICLE SPRINGS (Fig. 17)—This device consists of a rigid plate that can easily be secured to the spring to bridge the crack or break. It is fixed in place by means of bolts that extend down each side of the spring, as shown, and engage clamping plates placed under the spring.

BLOWGUN WITH AMMUNITION MAGAZINE (Fig. 18)—The blowgun is of an ordinary type and is equipped with a magazine, which is mounted on top of the barrel so that it can easily be slid back and forth. The barrel forms the bottom of the magazine. In the barrel is an opening just large enough to admit one of the projectiles, and a fresh charge is fed into the gun simply by sliding the magazine forward over this opening.

DEVICE FOR CHECKING MILEAGE OF AUTOMOBILE TIRES (Fig. 19)—This device has recently been invented for enabling a manufacturer to determine whether or not a tire has lived up to its guarantee. It consists of a metal tube which is imbedded in the bead when the tire is made. One end of the tube is closed, while the other is threaded to receive a gutta-percha plug. Inside the tube is a weight equipped with a pointed shank projecting toward the plug, while in the end opposite the plug is a metal ball. At each revolution of the wheel the ball first falls against the end of the tube and then against the weight, driving the pointed shank a slight distance into the plug. The mileage that the tire has traveled can be determined by the distance the point has penetrated into the plug.

LEMON SQUEEZER (Fig. 20)—The interesting feature of this device is the operation of the perforated hinged bottom. While the lemon is being squeezed, this bottom is drawn up close, permitting only the juice to escape. With the handle drawn back, the bottom drops so that the peeling can be thrust out.



Fig. 12

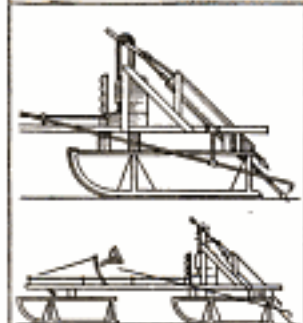

Fig. 13

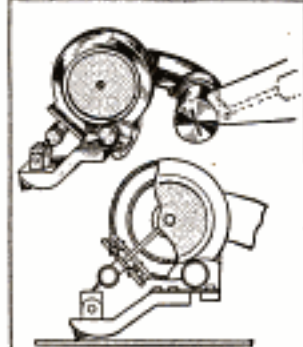

Fig. 15

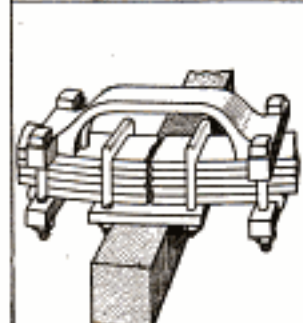

Fig. 17

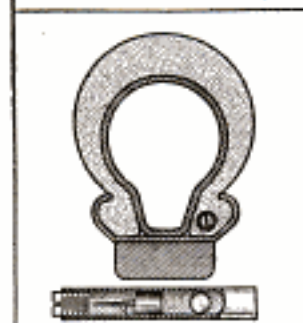

Fig. 19



Fig. 14



Fig. 16



Fig. 18

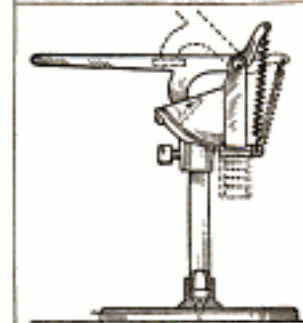
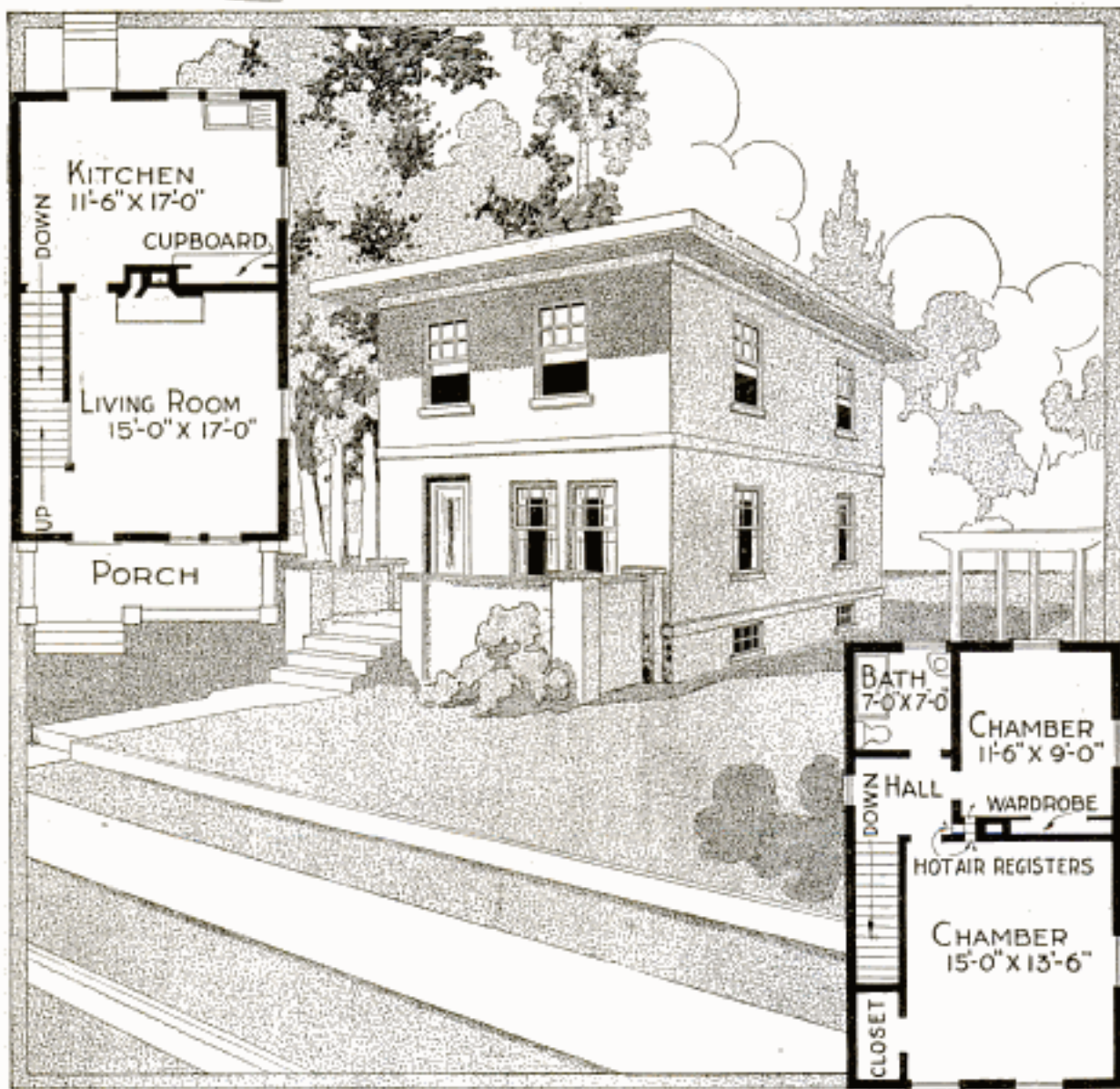

Fig. 20

CONCRETE RESIDENCE BUILT AT SMALL COST



J. A. POEHL, ARCHITECT, BUFFALO, N. Y.

DESIGNED originally as a cheaply built residence for workmen in the mining districts of Pennsylvania, this house is adapted as well to the needs of any owner of small means, especially for a suburban location, who desires to build a small home of permanent construction. The house is of poured concrete, a simple and quick method of construction, and is estimated to cost \$1,400. The exterior is what is known as "rough cast." In the interior, the walls and ceilings are of plaster laid on metal lath, the lath being so applied as to leave an air space for insulation against heat, cold, and moisture. The house is equipped with modern conveniences, and in spite of its small floor plan, the arrangement is convenient and the rooms are of sufficient size for comfort. An interesting feature that is made possible by the room arrangement is the heating system, there being only one hot-air duct. This is cast in the chimney and is provided with a register for each of the rooms except the bathroom, which must be heated from the hall. Built into the chimney at the side of the register in the living room is a fireplace. The kitchen is provided with a cupboard of ample size, while one of the bedrooms has a large closet and the other a built-in wardrobe. The front porch and steps, like the remainder of the house, are built of concrete.

IN accordance with the editorial policy of this magazine never to accept compensation in any form for what appears in our reading pages, and also to avoid all appearance of doing so, we are obliged to omit the name of the maker or the seller of any article described. This information, however, is kept on file and will be furnished free, by addressing Bureau of Information, Popular Mechanics Magazine, Chicago. [Editor.]

\$1151for this ALADDIN
Dunqlow the Ravenswood
**READI-CUT
HOUSES**
Save You the
Dealer's Profits

ALADDIN

**You Can
Build NOW
and Save Big Money**

Dodge the lumber trusts' profits. Save from \$200 to \$1200 on your new home. You can do it. Aladdin Read-Cut Houses are not made by a trust. You buy them direct from the producer and save middlemen's profits. You buy the material all cut to fit and save a third on erection. The old-fashioned method wastes 18% of the lumber. The Aladdin system saves this waste—you keep the money in your own pocket. Get the free Aladdin catalog—send the coupon. It shows you how thousands of Aladdin owners in every state have saved big money on their homes. It also pictures and describes over one hundred homes. Your copy of this book is ready. Will you send for it today?

Five Rooms \$298**\$797****\$683****Built Like a Skyscraper**

Aladdin Read-Cut Houses are built on the steel-skyscraper system of construction. All the work—sawing and fitting—is done in the Aladdin Mills. All you do is follow instructions and drive the nails. Thousands of Aladdin customers in every state have erected their Aladdins themselves and saved the cost of high priced labor.

ALADDIN Houses, Garages, Summer Cottages, \$134 to \$8000

There is an Aladdin owner near you—no matter where you live. Why not visit an Aladdin home? See the attractive design. Let the owner tell you his saving. This visit will mean much for you. Ask us for names of Aladdin owners near you.

**Price includes all material
—everything in one shipment**

Aladdin houses are complete. You get material as follows: Sills, Joists, Sudding, Building Paper, Sub-Floor, Rafters, Roof Sheathing, Sillies, Outside Finish, Flooring, Lath and Plaster or Plaster Board, Inside Finish, Doors, Casings, Base Board, Windows, Sash, Glass, Nails of all sizes, Locks, Hinges, Tin Flashing, Paints, Oil, Varnishes, Stairs, Putty and Shellac, with complete drawings, illustrations and instructions for erection—**The Complete House.**

\$1 for Every Knot

The Aladdin Dollar-a-Knot guarantee is the plainest and strongest guarantee ever offered to the home builder. It means that you get knotless siding, knotless outside finish, knotless shingles, knotless flooring, knotless inside finish. Where can you get as good material at twice Aladdin prices?

**Build Your
House and
Save Big
Money
in 1916**

Get the FREE
Catalog
NOW!

TEAR HERE
North American Construction Co., 292 Aladdin Ave., Bay City, Mich.
Send me your Catalog No. 180.

Name
Street
City
State



North American Construction Co.

Home Builders to the Nation. Mills in Michigan, Florida, Louisiana, Oregon, U. S. A. Toronto, Ottawa, Vancouver, Can.

292 Aladdin Avenue
Bay City, Michigan

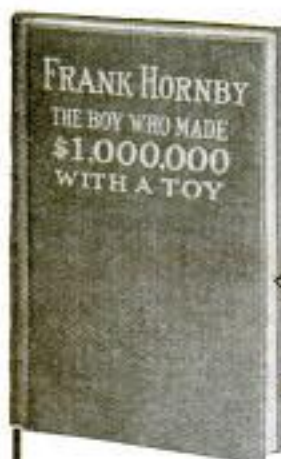

FREE—A Live-Wire

One of the greatest stories for boys ever written. A real story—not a catalogue. Tells all about how Frank Hornby invented the "Toy That Made A Million Dollars." Other boys say it's the finest story they ever read; you'll wish it were twice as long. It's just the book for boys who want to "start something." This fine story, with full information



MECCANO

Builds All Kinds of Models Easier, Quicker and Better

BOYS—you can build any kind of a model you want to with MECCANO. Small or large, simple or complicated ones; big, sturdy toys that it's **real** fun to play with. You can have more sport; you can build mechanically correct models easier, quicker and better, because MECCANO girders are ready to use; strong and rigid. Every part is inter-change-able; the equi-distant holes ($\frac{1}{2}$ " apart) in MECCANO parts allow unlimited inter-change-ability; you can use each part in any way you want to. MECCANO has more and better parts, too; flanged and sector plates, bent strips, flat strips, brass gears, wheels and pulleys, couplings and cranks. Lots of fine parts you won't find elsewhere. MECCANO is the original and leader of them all.

MECCANO is Sold by All Dealers

No. 0.....	\$1.00	No. 2x with Electric Motor	\$5.00
No. 1.....	2.00	No. 3.....	6.00
No. 1x with Electric Motor	3.00	No. 3x with Electric Motor	7.50
No. 2.....	4.00	No. 4 Spring Motor	Free 10.00
Young Inventor's Accessory Outfit		\$2.00	
Others at \$14.00, \$18.00 and \$36.00			



10,000 Models

were entered in the last prize contest; just think of all the different things MECCANO makes. Get an Entry Blank at any store that sells MECCANO and enter a model in our **\$1,000 Prize Contest NOW ON!**

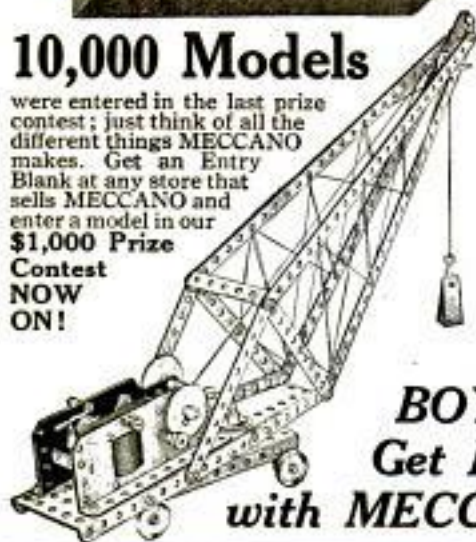

BOYS!
Get Busy
with MECCANO



Get

Story for Boys—FREE

about MECCANO (in a separate catalogue sheet) sent Free to you. Just send five (5) boys' names and addresses, with 4c in stamps to pay postage, and you get the book. Send names today.

Frank Hornby

MECCANO COMPANY
Room 15, 71 West 23rd St., New York City



MECCANO

Makes Fine Working Models The Ones You Like to Play With

BOYS—You can build real working models with MECCANO; high towers with electric elevators, derricks that hoist heavy loads, cranes that swing them around, bridges that open and close, steam shovels that you can dig with. You can work them all with the MECCANO Electric Motor.

See MECCANO at your dealer's. Look at the fine outfits. See all the new improvements and the dandy parts you get. Look at MECCANO now—but be sure it's MECCANO because there isn't anything just the same.

And say, Boys, if you want to read a **real** story send the coupon above and get Frank Hornby's book!

BOYS—This is the MECCANO Gear-and-Shaft Drive Electric Motor

The most powerful toy electric motor made; will lift 30 pounds. Connects direct to models, runs by gear wheels—no belt to slip. Motor shown here has starting, reversing and stopping control. Included in outfit No. 3x (\$7.50). Sold separate for \$3.00. Same motor, without control and with fewer gears, included in outfits No. 1x (\$3.00) and No. 2x (\$5.00). Sold separate for \$1.50.

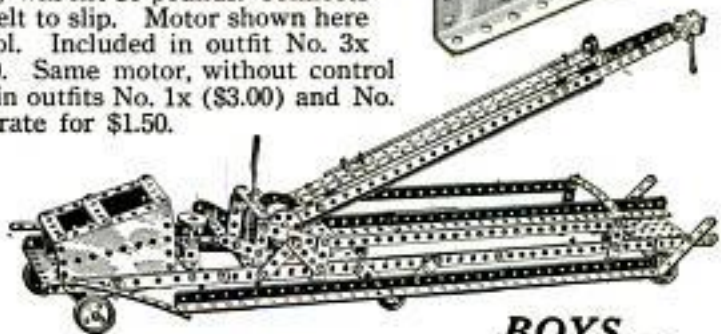
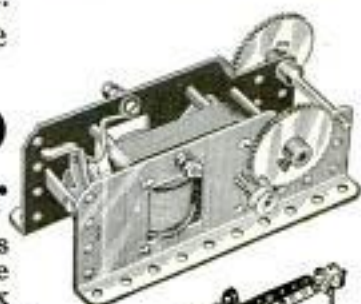

BOYS—
Build Models like
these and have
some real fun!



BOYS!
MECCANO for Christmas!

A Practical Christmas Gift

Christmas Eve will be a mighty good time to put a vacuum cleaner in your home. You know that no other present can ease home duties like it can. Vacuum cleaners are nowadays just as necessary as electric lights—no home is truly modern without one. Many types have been invented, but we believe our No. 11

Western Electric Vacuum Cleaner

is the most practical for general use. The convenient handle, on which to hang up the machine when not in use, the safety switch, the powerful Western Electric motor, the scientifically designed fan—all contribute to make this No. 11 vacuum cleaner most efficient. The fact that it bears the Western Electric name is absolute guarantee of mechanical excellence.

Price, \$32.50, including extension nozzle for cleaning under furniture. Write for booklet, "The Home Sanitary." Address our nearest house, asking for booklet No. 9-AW.

WESTERN ELECTRIC COMPANY

463 West Street, New York City

Houses in All Principal Cities of the U. S. and Canada

EQUIPMENT FOR EVERY ELECTRICAL NEED



Build It NOW

No use to wait till next season to build, when you can erect a permanent, substantial Home like this in 12 to 14 days.

Sterling System Homes

have reduced building costs 40%. And we give you 2 whole years to pay. Complete, modern Homes as low as \$296.00. Our prices include all materials—lumber, hardware, paints, plaster, nails, etc. Each board and timber comes cut-to-fit, which saves 1/2 usual labor cost. Send postal now for Catalog showing the "Famous Fifty" Designs.



International Mill & Timber Co.
Dept. Q12, Bay City, Mich.

EARTHQUAKE-PROOF HOSPITAL IN SAN SALVADOR—The violent earthquakes which are very common in San Salvador necessitate very substantial construction of public buildings. The new national hospital, which was designed to withstand the severest shocks, is built of pressed-steel plates bolted to a wrought-iron framework while the roof is of corrugated iron. A handsome church with two tall steeples follows the same general design with the addition of much cornice work.

THIS BUNGALOW \$900 CAN BE BUILT FOR

This and many others in my new book, Building Plans for Modern Homes, will save you hundreds of dollars. One of the most complete and comprehensive books of plans ever published by any architect. Fifth edition just off the press. Two hundred and fifty floor plans and photographs of bungalows, etc., costing from \$200 up; gives sizes and cost to build. Sent postpaid for \$1.00



FREDERICK H. GOWING
ARCHITECT
18 Tremont St., BOSTON, MASS.



HERE YOU ARE, BOYS

A medallion pin of Foxy Grandpa. Everyone will notice it on the lapel of your coat and try to get a closer look at it. All you have to do is press the bulb.—Foxy Grandpa will finish the job by squirting a fine stream of water over the inquisitive one. Will squirt 20 feet. Greatest joke out. Order one today and fool your friends. Price 15c. Foxy Grandpa and Hooligan both for 25c. 5 for 50c or 1 doz. for \$1.00. A beautiful fountain pen free with every \$1.00 order.

AMERICAN SUPPLY CO., 918 Union St., St. Paul, Minn.



Small Engines

Our 1/2, 1 and 1 1/2 H. P. Gasoline Engines for Farm and Shop are the best small engines.

SIEVERKROPP STARTER

\$15 SEAT STARTER FOR FORD CARS

Shipped on trial. Send stamp for Booklet and Special Offer
Sieverkropp Engine Co., 1224 18th St., Racine, Wis.



VIOLET-RAY TREATMENTS IN YOUR HOME

Best physicians now advise High-Frequency treatments to win health and strength. Newest and most efficient form of medical electric treatments. Promotes circulation. Eliminates all pains and aches. Write for our offer on the wonderful B-D VIOLETTA GENERATOR and thousands of testimonials. This instrument endorsed by physicians everywhere. Absolutely safe and guaranteed.

Write Now for Our 10 Day Free Trial Offer. Send your name and address on a letter or post card for particulars of our limited 10 day free trial offer. A single treatment proves the value of this instrument. No obligations. Write today. AGENTS: LIMITED TERRITORY STILL OPEN. BIG PROFITS. WRITE QUICK.

BLEADON-DUNN CO., 208 No. Fifth Ave., Dept. B, Chicago, Ill.



Business is booming!

Dayton, Ohio.

Merchants everywhere tell our 800 salesmen that business is booming.

Farmers have had two record crops, at big prices, with big demand at home and abroad.

Stocks of manufactured material are short, and labor is in great demand.

Exports largely exceed imports.

Factories are busy, many working overtime.

More freight cars are needed, and steamers are taxed to capacity.

People are living better, and spending their money more freely.

This country has the best money in the world, and more of it than ever before.

Such a combination of favorable circumstances never has occurred before, and probably will never occur again.

Billions of dollars are passing over the merchants' counters.

The people who spend this money want the best service.

They demand it in all kinds of stores, from the smallest to the largest.

They get it in stores which use our up-to-date Cash Registers, which quicken service, stop mistakes, satisfy customers, and increase profits.

Over a million merchants have proved our Cash Registers to be a business necessity.

[Signed]

Write for booklet to
The National Cash Register Co.
Dayton, Ohio.

John H. Patterson

THE Bausch and Lomb BALOPTICON

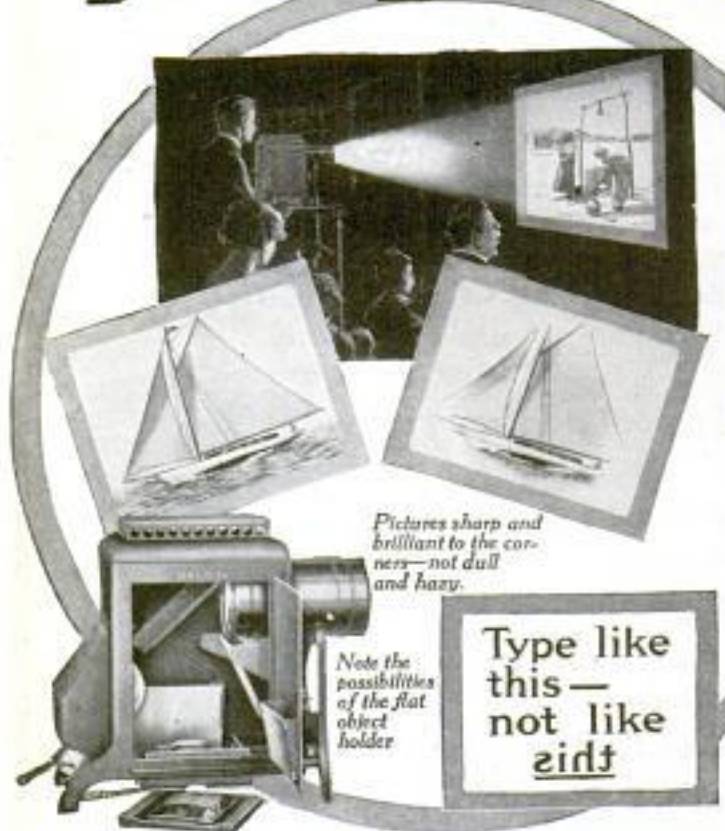

Pictures sharp and brilliant to the corners—not dull and hazy.

Note the possibilities of the flat object holder

Type like this —
not like this

The pleasure and instruction which the ear gets from the talking machine, the eye gets from pictures and other objects shown by the

HOME BALOPTICON

made primarily as a projector of post cards, photographs, and various objects. Special 400-watt, gas-filled Mazda lamp with optically corrected mirror gives an illumination superior to anything heretofore offered, attaching to ordinary lamp socket.

Automatic, perfectly safe and simple enough for any child to operate. Fitted with high-grade achromatic lens, giving well-defined pictures sharp to the corners. Ideal equipment for clubs and small classrooms, as well as the home — not a toy.

Price for Home Balopticon complete for the projection of post cards, including aluminum coated screen, only \$35. Sold by optical and photographic supply dealers. Other models to meet any requirement, \$20 and up.

Write for our booklet "Fun—and better"

Bausch & Lomb Optical Co.
576 ST. PAUL STREET ROCHESTER, N. Y.

Good Enlargements

Give you the best results from your kodak film.

We do only the very best work, using the best of materials and the most skillful workmen. Poor work is expensive at any price.

For \$1.00

We will make an eleven-inch enlargement, black and white or sepia, triple mounted and hand retouched. No extras of any kind. Postage prepaid. Send for price list. Films developed 10c per roll. Prints 3c, 4c and 5c.

JACKSON & SEMMELMEYER, 44 S. Wabash Ave., Chicago, Ill.
Milwaukee, Wis. Pasadena, Cal. Santa Barbara, Cal.

SEND TO OUR NEAREST STORE

Unique among cemeteries is that of L'Oud-el-Kebir, Algiers, in the graves of which are often found medicine bottles, usually partly filled. The natives of the territory bury with the deceased the medicine used in his last illness.

Runs on Alcohol

At Cost of Less than $\frac{1}{2}$ ¢ an Hour



anywhere without electricity, springs or batteries. Superb construction. 12-inch blades. Adjustable roller bearing. Reliable. A proved comfort. Prompt delivery. The original and only Lake Breeze Motor manufactured according to the design of the inventor and under his direct and personal supervision.

Keep Cool

\$15 Cash with Order

Lake Breeze Motor, 122 N. Jefferson St., Chicago

Funsten Pays Cash for FURS

Prices Higher This Year

Big Money in Trapping skunk, coon, mink, muskrat, fox, etc. You can trap furs—we teach you how.

Funsten Animal Baits guaranteed to increase your catch. \$1.00 a can postpaid. The Funsten Perfect Smoker "smokes 'em out." Price \$1.50; parcel post 30 cents extra. Both guaranteed satisfactory or money back. Traps at factory prices.



Largest in the World in Our Line

FREE 3 books in one (trapper's guide—game laws—supply catalog). Tells how, when, where to trap, how to remove, prepare and ship skins. Will send you fur market reports, shipping tags and big book **FREE**—Write today. We tan hides and furs for coats, robes and garments.

FUNSTEN BROS. & CO., 341 Funsten Bldg., ST. LOUIS, MO.

Please Mention Popular Mechanics

BOOK of BUNGALOWS

The pick of 1,000 practical and distinctive Bungalows, with plans, etc., actually built for from \$400.00 to \$4,000.00, all contained in my BUNGALOW BOOK De Luxe Edition

The largest exclusive Bungalow book ever published 100 Postpaid

I will send this to anyone anywhere for \$1.00 postpaid. This book contains 212 pages, showing exterior and interior views, floor plans, size of rooms, actual cost of construction, and valuable points and suggestions on Bungalow building written by an expert. Before you build, send for this book. Money back if not satisfactory. Send check, money order or stamps. A smaller book for 50 cents.

JUD YORO, The Bungalow Craftsman, 54 Bungalow Bldg., SEATTLE, WASH.

BEAUTY, SERVICE *and* ECONOMY IN THIS GARAGE



HAVE you ever seen a private garage in which were combined harmoniously the features of Beauty, Service and Economy? Here is one.

IT HAS *BEAUTY*, because it fits into the surroundings—it is a *part* of the home premises; because it has the graceful lines and “Homey” appearance that only a wood structure can have.

IT GIVES *SERVICE*, because, built of wood, it is *drier* and *warmer* in wet, cold weather than any metal, concrete, or brick structure possibly can be; and because the wood used—

Southern Yellow Pine

“*The Wood of Service*”

is the strongest, toughest and most durable wood adapted to such use—good for a lifetime.

IT IS *ECONOMICAL*, because a thoroughly satisfactory wood garage costs less than a similar structure—inferior for the purpose—of metal, concrete or brick; and because SOUTHERN YELLOW PINE, the best wood for such use, costs less than any other wood of anything like its high quality.

BUILD FOR SERVICE AND ECONOMY WITH SOUTHERN YELLOW PINE, and at the same time embellish, instead of disfigure, your home grounds.

We have the architect's working plans, lumber bill and cost estimate for this garage. They will be sent you FREE for the asking. Fill out and mail the coupon TODAY.



Southern Pine Association
NEW ORLEANS

SOUTHERN PINE ASSOCIATION

670 Interstate Bank Bldg., New Orleans

Send me your FREE plans, estimates, etc., for

 Garage No. 5

 Farm Building Plans

 House Plans

 Silo Book

Name.....

Street or R. R.

City..... State.....



Give your boy or girl a steering sled - but - be sure it's a

Flexible Flyer

The only sled with non-skid runners

They want to get *all* the fun out of coasting—and to get it they must have the swiftest, strongest, safest sled made—the Flexible Flyer. Easiest to steer and control. The new construction makes it easier and stronger than ever. All-steel front gives added safety, durability and ease in steering. Runners of chrome-nickel steel are tougher and stronger than usual—danger of snapping in cold is greatly reduced.

Junior Racer A new Flexible Flyer this year. Carries two children. Its low racy lines suggest the "go" there is in it. 4 feet long. Weighs but 10½ lbs. Express prepaid east of the Missouri River **\$3.50**

The Flexible Flyer is the only sled that completely satisfies every live boy or girl.

Outlasts 3 ordinary sleds

Nine sizes—3 to 8½ feet long. Sold by leading Hardware- and Department-Stores.

FREE Cardboard model showing how the Flexible Flyer steers. Also attractive booklet. Write for them today!

Insist on the genuine. It isn't a Flexible Flyer unless it bears this trade mark



S. L. ALLEN & CO.
Box 1101G PHILADELPHIA

Please Mention Popular Mechanics

"Little Guard" the new Torrey

gives a quick, smooth, clean shave

Here's a *real* safety guard razor, shaves in the only correct way, cuts close, doesn't rough the skin.

\$2

Like all

Torrey

razors, this new safety has the perfect shaving edge. Hold like any other *real* razor—it's two-thirds size. Has reversible safety guard.

If your dealer hasn't Torrey razors, write us; we'll tell you where to get them. Ask for Free Booklet, "How to Shave."

The new Torrey Honoring Strop has no equal

THE J. R. TORREY RAZOR COMPANY
Dept. P, Worcester, Mass.



VESSELS OF ELEVEN NATIONS IN PHILADELPHIA HARBOR—The ensigns of not less than 11 nations were represented one day recently in the fleet of merchant vessels lying in Philadelphia, a sight which old river men claim never to have seen before. Among the vessels were the "Teno," one of the few steamships that fly the flag of Chile. The other countries represented were Great Britain, Norway, Germany, Italy, France, Denmark, Austria, Argentina, Belgium, and the United States.

Nothing like a good lather to make the path of the razor smooth.

Colgate's Shaving Lather

STICK — POWDER — CREAM

Wonderfully softening and soothing in whichever form you use it. Send 4 cts. for a trial size of stick, powder or cream.

Colgate & Co., Dept. 81, 199 Fulton St., N. Y.

Something New!!

This unique and artistic design of a horse-shoe and horse-shoe nail makes a very handsome ring. The horse-shoe has a solid gold top, the nail is solid sterling silver set with a fine genuine garnet. The horse-shoe is considered an omen of good luck. The combination of the gold horse-shoe with a fine genuine garnet set in the bright silver nail makes a very pleasing and beautiful effect. This nobby ring will make a most appropriate and lasting holiday gift.

SPECIAL PRICE - - \$1.25

(Send string for size desired.)

Wear this ring for one week; show it to your jeweler; if not satisfied, we will refund money.

New Ready - New Catalog 147
Bennett Mfg. Co. 175 Broadway
NEW YORK
Est. 1878 References, any bank



All Sizes for Ladies and Gentlemen



Mobilizing for Fun!

Yes, an innocent call, "To Arms!"—and all the sharpshooters, little and big, file into the billiard room. Then the thrilling battle begins—moments of breathless suspense, jest and volleys of laughter.

Don't miss these happy home-spent hours at Carom and Pocket Billiards. They stir men's blood, and *put the sinews of manhood in the young.*

This Christmas—A Brunswick Home Billiard Table

Made of rare and beautiful woods in sizes to fit all homes. The "Grand," "Baby Grand" and "Convertibles" have long been conceded the finest and fastest home tables in the world.

Our new "Quick Demountable" is made by the same skilled men and methods. Yet here is the table that you can set up anywhere in a jiffy and put aside when not in use. Not a toy, but a scientific table with life! speed! and accuracy!

\$27 Up—Pay 10c a Day

Our prices are now the lowest in all our history because we are making these tables for thousands—\$27 upward. You can pay monthly till the table is paid for—as little as 10c a day!

30-Day Trial—Outfit FREE

Select the table you want. We let you try it 30 days. We also include Complete High Class Playing Outfit *free*—Balls, Cues, Markers, Cue-Clamps, Chalk, Expert Book of 33 games, etc.

Our interesting color-catalog shows all tables, prices and full details. This coupon or a postal brings this handsome book *free, postpaid!* Send at once—while they last.

Send This For Billiard Book FREE

The Brunswick-Balke-Collender Co. (485)

Dept. 22J 623-633 S. Wabash Ave., Chicago

Send free, postpaid, your color-catalog

"Billiards—The Home Magnet"

and tell about your home trial offer.

Name

Address

Please Mention Popular Mechanics



Trains Struktiron
Ives Toys
Make Happy Boys

His Christmas Question Answered

For weeks he has been hoping that his Christmas presents would include Ives Toys. And of course his dream is going to come true!

Watch how he "bubbles over" with happiness on Christmas morning when he sees his Ives Train and Ives Struktiron. They're gifts that enthuse any red-blooded youngster. They also give him practical training in mechanics and electricity.

Boys—with an Ives Railway you lay the track, arrange the switches, semaphores, stations and tunnels; couple the engine and cars, stop and start the trains and do everything else that is done on a real railroad.

With Ives Struktiron you build strong steel models of railroad bridges, elevated railways, signal towers, cranes and derricks operated by the powerful Ives electric motor. You can also construct hundreds of other realistic, practical models, such as aeroplanes, revolving shovels, battleships, "shoot the chutes."

Toy, hardware and department stores sell Ives Trains, (\$1 to \$25) and Ives Struktiron (\$1 to \$25). Ask to see them.

Write for Catalog and names of Ives dealers in your town.

Poster Stamps Free

Twelve of them—beautifully illustrated in colors. Six show the development of the locomotive from the famous "De Witt Clinton" of 1831 down to 1915. The other six show remarkable Struktiron models.

Absolutely free to any boy or parent. Write now (giving toy dealer's name) for complete set.

The Ives Manufacturing Corporation
202 Holland Ave. Bridgeport, Conn.

Boston Garter

Velvet Grip

Three Popular Styles:
NEVERBIND CORD and PAD

GEORGE FROST CO.
MAKERS
BOSTON



Silk 50¢
Lisle 25¢

3 YEARS TO PAY

Meister Piano 30 days free trial in your own home
\$1 A WEEK or \$5 A MONTH Price **\$175.00**

No cash payment down. No interest—no extras. Piano stool and scarf free

ROTHSCHILD & COMPANY
Dept. 16N CHICAGO, ILL.

VENTILATION OF THE NEW SUBWAY LINES IN NEW YORK—According to present plans ventilation will be by means of open gratings on the sidewalks. This plan is opposed, however, by the shop owners along the streets affected on the ground that the gratings are avoided by pedestrians, and they thus will look less into the store windows. Single tubes with the trains acting as pistons would secure a constant change of air.

10 Cents a Day

Pays for This Cornet An astounding offer! Only 10¢ a day buys this superb Triple Silver Plated Lyric Cornet. **FREE TRIAL** before you decide to buy. Write for our big offer.

WURLITZER Free Band Catalog

Write for our big new 256-page Band Catalog. Rock-bottom, direct-from-the-manufacturer's prices on all kinds of instruments. Pay for them at the rate of only a few cents a day. Generous allowance for old instruments. Free Trial. We supply the U.S. Govt. Write now

THE RUDOLPH WURLITZER CO., Dept. 1199
4th St., Cincinnati, Ohio 8. Wabash Ave., Chicago

1/3 SAVED Buy Direct From MANUFACTURER

J. Hardin Co., J. J. Lane, Pres.

No. 1 \$9.60 No. 2 \$15.50 No. 3 \$12.90

FREE BOOK

Install Your Own Plumbing and Heating

Get our catalog No. 69A—contains complete heating plants, heating goods of every description, bathroom outfits, sinks, roughing-in goods, pipe fittings, valves, etc., water pressure systems and lighting plants. In fact, absolutely everything in both grade plumbing and heating supplies, exclusively at wholesale prices. Any handy man can install our goods with our free easy installing plans. 400,000 plants behind our guarantee. **WRITE TODAY.**

No. 4826 00 00
J. HARDIN CO. 40 years at 4540-50 Cottage Grove Ave. **CHICAGO**

**Look for this Box
and Label**

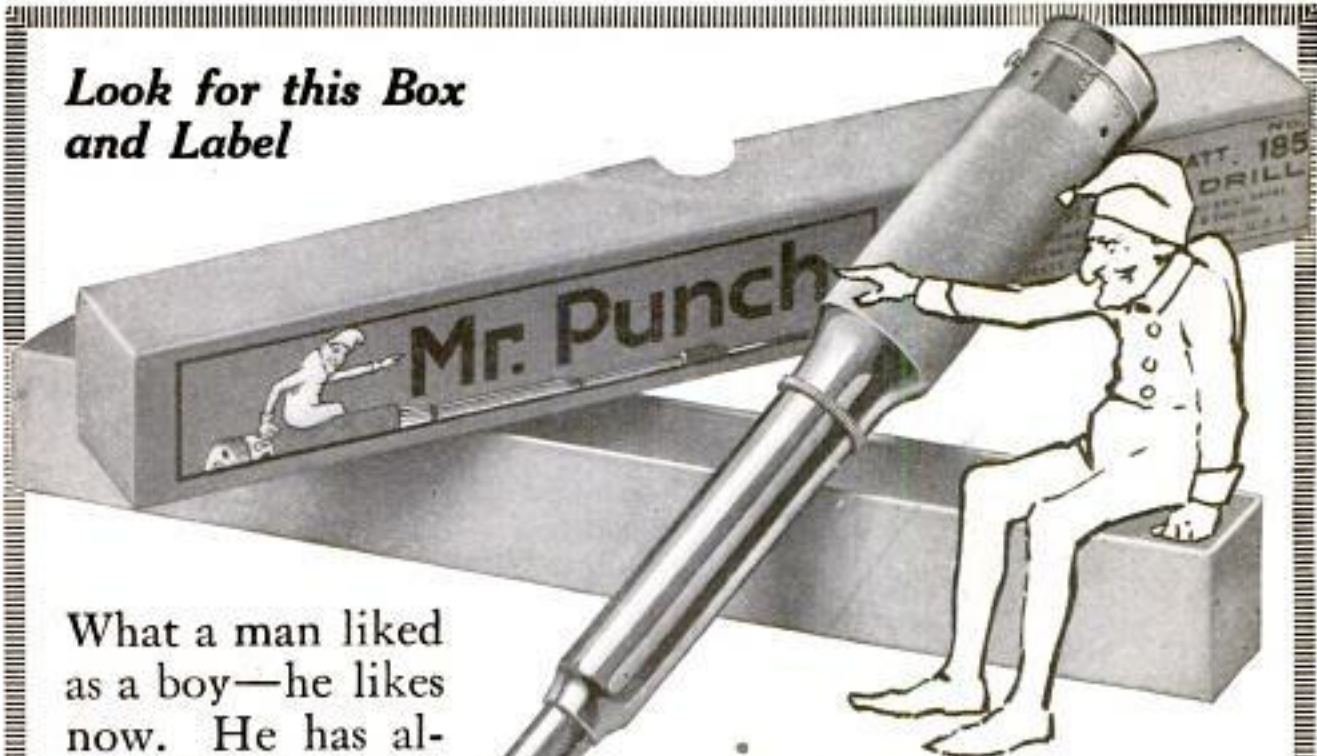

What a man liked as a boy—he likes now. He has always liked Good Tools. Give him what he likes.

A Dandy Gift

Mr. Punch is an Automatic Drill. You place the point of the drill and push. A spiral twist drives the drill. It will bite through an inch of solid oak in ten seconds.

The one great need in home tinkering is something to make a hole with. To drive a screw easily you must first make a hole.

You want a hole through broom and brush handles. To repair a chair, to put on screen or storm-door, to put up a hammock, to put up curtain or bathroom fixtures, to make a bookcase—you always have to make a hole.

Mr. Punch is the handiest tool in the home tool-chest.

In the handle are eight tool-steel drill points, seen through numbered holes of same size as drill points. Drills are released through a hole in the revolving cap.

Mr. Punch is solidly made of brass and has a high nickel finish. He sells for \$1.50 at

**GODELL
PRATT
1500 GOOD TOOLS**

Hack Saws
Micrometers
Saw Sets
Gauges
Grinders
Screw-drivers
Punches

Drills
Lathes
Levels
Vises
Bit Braces
Calipers
Squares

all hardware stores.

Send for our Christmas booklet, "What to Give the Boy," describing Mr. Punch and fifteen other Good Tools which every home needs.

Goodell-Pratt 1500 Good Tools are known all over the world by Good Mechanics. They combine exceptional quality with reasonable prices. Buy Mr. Punch for Christmas.

GODELL-PRATT COMPANY, Toolsmiths
Greenfield, Mass.



WIZARD

TRADE MARK

ELECTRIC PORTABLE LAMP

The Prize Winner of the
Panama-Pacific Exposition
Special Price, \$3.50



The Wizard Electric Portable Lamp, so named because it is almost magic in performance, gives you light just where you want it and just when you want it. It saves the eyes and is a wonderful convenience to every home. It sticks, hangs, clamps or stands anywhere. It has been named by those who have used it—

"The Lamp That Saves Its Cost."

A Wizard Lamp will make a much prized and a much appreciated Christmas Gift.

The Wizard must be seen and used to fully appreciate its many advantages. Send us \$3.50 for a "Wizard" today. Try it in your own home for 10 days and if you are not fully satisfied, return it and your money will be refunded.

The Wizard Lamp was awarded the highest award of any portable electric lamp at the Panama-Pacific International Exposition.

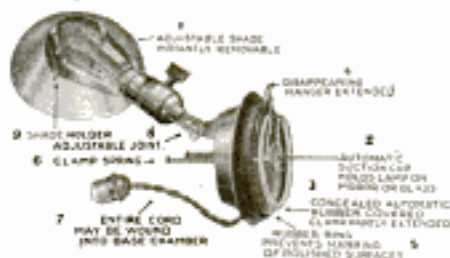

**Wizard
Electric Lamp Co.**
145 New Montgomery Street
San Francisco, Cal.

We have a very attractive agency opportunity. Write for it.



The Durham-Duplex Domino Razor with white American ivory handle, safety guard, stropping attachment, package of six of the famous Durham-Duplex double-edged, hollow ground blades in genuine red leather folding kit.

SOLVES YOUR CHRISTMAS PROBLEM

\$5 DURHAM-DUPLEX Domino RAZOR FOR \$1

We are requesting the owners of Durham-Duplex Demonstrator Razors to pass them along to friends, or at least to tell their friends about the shave it is possible to obtain with the wonderful Durham-Duplex Blade. This is good advertising for us, and we are paying for it by giving Demonstrator users an opportunity to obtain a Domino Razor for \$1.00, with twenty United Profit Sharing Coupons.

DURHAM-DUPLEX RAZOR CO., Jersey City, N. J.

Gentlemen:—Send me a \$5 Durham-Duplex Domino Kit Outfit as per illustration above for which find enclosed \$1.00.

Name

Street

City..... State.....

Any dealer will honor this coupon TA

Please Mention Popular Mechanics

For lack of copper, Germany, according to reports, uses the finer grades of sheet metal as a substitute for sheet brass in the manufacture of war material.

On railway lines between France and Belgium which intersect the trenches, and consequently cannot be used by regular trains, the Germans operate storage-battery cars to remove the wounded from the battle front, and to bring back supplies.

600 Shaves From 1 Blade



Yes, and more. That's the record of many men who shave themselves. Old blades made sharper than new—in ten seconds. Quick, velvety shaves for life with the wonderful, new

Rotastrop

For safety and old style razors, Dropblade in, turn handle, machine gives "heel to toe action", just like a barber strope a razor.

10 Days' Free Trial Write for free booklet. Send name of nearest dealer and state make of razor.
Burke Mfg. Co., Dept. 1199, Dayton, Ohio



LODGE and SOCIETY Emblems In MIDGET Size

have an added dignity thru their uniqueness of size, retaining with the detail of design of the regular-sized emblems. Inserted in point of lapel and tightly screwed

In Solid Gold only, 50c

- | | |
|------------------------|-----------------------|
| 1. Woodmen of World | 12. Elks |
| 2. Odd Fellows | 13. Men's Elks Class |
| 3. Redmen | 14. Dr. D. American |
| 4. Knights Columbus | 15. Knights Pythias |
| 5. Modern Woodmen | 16. Knights Templar |
| 6. Masonic | 17. Moose |
| 7. Bull & Cane Masonic | 18. F. O. Eagles |
| 8. Shrine | 19. Grotesque Masonic |
| 9. Travel Masonic | 20. Old Liberty |
| 10. Silver Masonic | 21. The Bell |
| 11. Keystone Masonic | |

Illustrations are actual size

Write us for those not listed

THE PHILADELPHIA BADGE CO.
174 N. Eighth St. Philadelphia, Pa.

GENUINE PERFECT CUT
DIAMONDS \$97.50
 Per Carat
 SPECIALLY SELECTED ARTICLES SUITABLE FOR CHRISTMAS GIFTS
 Send Now For One of These Wonderful Values!

You Save 35%

when you buy from L. Basch & Co. and here's the reason—We import diamonds direct from the European diamond cutters and sell direct to you. No middleman's profits included in our low import price of \$97.50 per carat. Retail value of these diamonds is \$150.00 per carat.

Send No Money—FREE Examination

Here's the popular Basch Plan. Select any article from our catalog or from this page. We ship your selection for your free inspection—entirely at our expense and risk—without it obligating you in any way. We invite you to examine and compare our goods without it costing you one cent. If you don't say that the article we send you is the greatest value you have ever seen, simply return it at our expense.

S01—This 14K solid gold ring, complete with 1/2 carat diamond, \$12.00
 1/2 carat diamond, \$21.25
 1 carat diamond, \$35.00
 1 1/2 carat diamond, \$48.75
 2 carat diamond, \$73.25
 3 carat diamond, \$101.25
 4 carat diamond, \$150.00
 5 carat diamond, \$198.75

S02—1/2-carat diamond. Compl. \$50.50

S03—1/2-carat diamond. Complete. \$22.00

S04—Solid gold. Pentoon 14-valliere 4 dia. Compl. \$27.50

S05—Solid gold. Valliere 3 dia. Complete. \$8.75

S06—Solid plat. Oval 1 dia. Complete. \$17.50

S07—1/2-carat diamond. Compl. \$19.75

S08—1/2-carat dia. each. Compl. \$65.50

S09—Coral Cameo ring. 3 diamonds. Compl. \$18.00

S10—Genuine cultured pearl. 1 diamond. Compl. \$15.00

S11—Man's cluster ring. 21 blue white dia. Special price compl. \$45.75

S12—Ladies' cluster ring. 7 blue white diamonds. Special price compl. \$17.50

S13—1/2 car. dia. Compl. \$27.50

S14—Solid gold. 14mm. set with links. Special price. \$1.75 per pair

S15—Solid gold dia. set tie clasp. Special price compl. \$1.00

S16—Solid gold. 14mm. diamond set. knife. 1 blade. 1 file. Guaranteed. Special price. complete. \$1.75

A Legal Money-Back Contract For You!
 It protects you against loss or disappointment. It is a written legal guarantee to refund in cash the full price paid less 10% should you for any reason wish to return your diamond any time within a year. Also allows full price in exchange at any time. Contains written statement of carat weight, quality and value of the diamond. "See that your diamond is Basch guaranteed." **Beautiful Basch De Luxe Diamond Book FREE!** We will forward you postpaid, a copy of this beautiful, costly book

THE POPULAR NEW FRIENDSHIP BRACELET

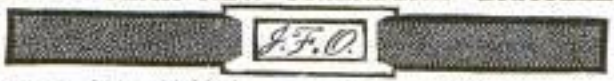

Start your sisters, girl friends, relatives, etc., with a friendship bracelet. Solid Sterling Silver links only 15c each. Retail value 25c. Black silk velvet band free with each link you buy for your different friends. The links are worn on the velvet band until you have enough links to encircle the wrist; then send us the complete set of links and we connect them with Sterling Silver Fasteners for 25 cents. The Friendship Bracelet is then complete and makes a very attractive permanent piece of jewelry. Mailing charges prepaid. Retail in any form convenient to you.



upon receipt of your name and address. It is complete, valuable and authoritative, and you will find it a helpful guide to select Christmas Gifts, and gifts for all other occasions. Contains facts written by life-long experts which enable you to buy your diamonds and jewelry safely and intelligently. Thousands of illustrations, of diamonds, watches, platinum and gold jewelry, silverware, cut glass, etc., all priced to you at remarkably low figures. See this book before making your purchase—you will appreciate our money-saving prices. Mail coupon or write us a letter or postcard for your free copy, now!

L. BASCH & CO.
 Dept. M2470
 State and Quincy Sts
CHICAGO, U. S. A.

FREE DIAMOND BOOK COUPON
 Please mail me FREE a full postpaid, without obligating me.
 Name _____ Address _____
L. BASCH & CO.
 Dept. M2470
 State and Quincy
 CHICAGO
 U. S. A.

Please Mention Popular Mechanics

BE A BIG MAN IN YOUR OWN TOWN

START A HAYWOOD
TIRE REPAIR PLANT



MAKE \$3000 A YEAR TO START

Sounds like a whole lot of money, and it is—looks pretty big from where you stand if you are earning just an ordinary salary at an ordinary job, but why continue the job? Why be on that side of the fence?

It is not every business that will permit you to start with a very small investment. Most manufacturing business require big capitalization. And rich men take the profits, while you the producer, get a salary and the small end. But here is a business that gives **big returns, quick returns,** and the demand for your product is ahead of the supply and increases every day in the year.

YOUR WONDERFUL OPPORTUNITY

The certainty of success in this business is about as sure as anything in the world can be. Automobile owners increase by the thousands each year and the tires are still the least durable part of the car. Every owner tries to cut down his tire expense—every owner tries to repair his tires as long as they will hold together. Make up your mind and send for our catalog TODAY. Learn of the wonderful money making possibilities in this fascinating new business. Make something—supply a want—become a manufacturer. This is your chance. **Send today for FREE catalog.**

The Haywood Tire & Equipment Co., 963 N. Capitol Avenue, Indianapolis, Ind.

— Steel Shoe Book Saves You \$20! —

1 Pair Outlasts 3 to 6 Pairs All-Leathers | FREE

If you are tired of wet, sore, calloused feet—Rheumatism and Galls—hard, twisted, leaky leather—Big Doctor and Shoe Bills—loss of time, money, health and comfort—TRY FREE my Latest Triumph—Leather-Tapped "Steels"
Light, Springy, Comfortable, Economical, Waterproof, Warm in winter—Cool in summer—Adjustable Leather Taps, instantly renewed. **FREE BOOK** tells how you can try "Steels" 10 days FREE and save \$10 to \$20 shoe money.



N. M. RUTHSTEIN—Steel Shoe Man—Dept. 132, Racine, Wis.



MONEY
IN
MUSHROOMS

FREE BIG BOOKLET TELLING
HOW TO GROW
MUSHROOMS

at home all the year. Big profits. Take advantage of this wonderful opportunity to become independent. With **Nat'l Spawn Co., Dept. 12, Boston, Mass.**

ART PIANOS From
and PLAYERS Factory
to You!

To introduce our wonderful Profit-Sharing Plan, we offer you on

30 Days Trial

this Handsome Art Piano. Our unlimited guarantee, backed by Three Million Dollar Capital, is your assurance of a Piano with Artistic Design, Exclusive Features, Wonderful Tonal Qualities and the Acme of Perfection. Write today for Catalog—it is yours for the asking.

Story & Clark Piano Co., Dept. A-18, Chicago

Please Mention Popular Mechanics



A large-capacity coal car for the Erie Railroad was exhibited at a recent convention of the Master Car Builders' Association. It is a hopper-bottom car with high sides and has a capacity of 70 tons.

The Grand Central Terminal in New York City has one of the largest, if not the largest, hot-water heating systems in the world. It comprises about 600,000 sq. ft. of radiating surface, and requires a water circulation of 10,500 gal. per minute.



Marlin Guns

Free Catalog—128 pages—full of valuable information about guns and ammunition. **THE MARLIN FIREARMS CO.** Send 3 stamps postage to 65 Willow St., New Haven, Conn.

Repeating Rifles in all popular calibers. Repeating Shotguns, 12 and 16 gauges, hammer and hammerless.

Champion Racer



MODEL AEROPLANES

Send 2c postage for Complete handbook of Models and Supplies.

Our set contains this and 9 other drawings, with instructions for building.....\$1.00

WADING RIVER MFG. CO.
WADING RIVER, N. Y.

Here's a New Business



Reproduce Photographs of persons and scenes upon watch caps, dials, china, etc. Work easily done. Knowledge of photography not necessary. **TRIAL OUTFIT** with directions, \$2 postpaid—Contains enough materials to make at least 15 reproductions that you should sell from \$2.00 to \$5.00 each.

START NOW—ORDER TODAY

AMERICAN ARTS & CRAFTS COMPANY, BOSTON, MASS.

AMERICAN MODEL BUILDER

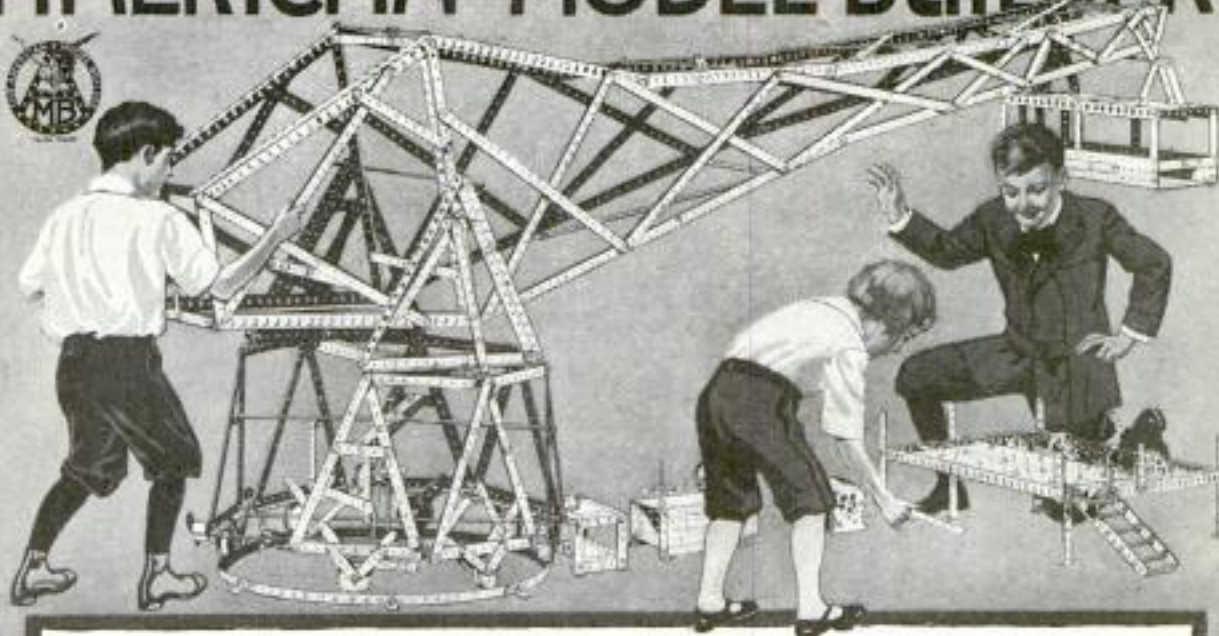

Say fellows! Here's the Boss of 'em all!

The American Model Builder! Gives you 15% more new and novel parts! Builds more practical working models! Builds models impossible with other outfits! Our big manual shows 370 models, and hundreds of others can be made. Every part made of finest brass and cold-rolled steel, double-plated. A real electric motor given free with most sets.

Boys, what do you think of that? Don't you say its many big improvements make the American Model Builder the "Boss of 'em all?"

Think what you can do with 15% more new and novel parts — such as real automobile wheels, car wheels, truck frames, bolster plates, "T" strips, ratchet pawls, new gears and angle irons!

Think of building a big grandfather's clock that will run for two hours; a stationary engine that will go like a real engine; traveling crane that will actually lift; derricks, windmills, automobiles, elevators, printing presses, trolley cars, pile drivers, warships, hoist bridges, and hundreds of other models that you can really operate!

This high-grade electric motor

Free! A real electric motor

This high-grade powerful electric motor is included with even the medium-priced sets of the American Model Builder. It has bronze bearings throughout, finest wiring, brushes, commutator, etc. Not a toy, but a real motor in miniature, capable of lifting ten pounds. Can be operated on dry cells or on city current through our inexpensive transformer.

Write for catalog

showing different outfits and hundreds of models you can build and details of big prize contest for new models. \$55 prizes. With it we will send you the "New Story of Steel," a mighty interesting romance of the steel industry. Write now. See it at your dealer's.

The American Mechanical Toy Co.
423 E. First Street Dayton, O.

given with most sets.



Write for

big free book

Please Mention Popular Mechanics

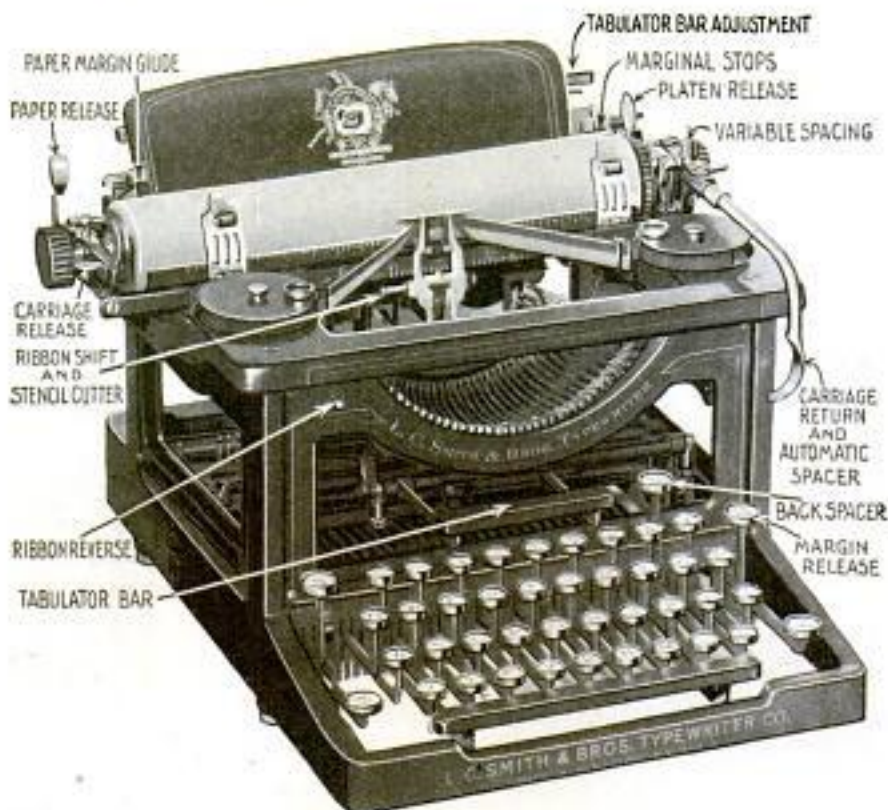

TYPEWRITER SENSATION

Free TRIAL—Use As You Pay
Only \$2.50 a month until the low total price of \$48.80
is paid, and the machine is yours

This is absolutely the most generous typewriter offer ever made. Do not rent a machine when you can pay \$2.50 a month and own one. Think of it—Buying a \$100.00 machine for \$48.80. Cash price, \$45.45. Never before has anything like this been attempted.

Standard Visible L. C. Smith

Perfect machines, not damaged or shop worn. Standard size, Keyboard of Standard Universal arrangement writing 84 characters — universally used in teaching the touch system. The entire line of writing completely visible at all times, has the tabulator, the two color ribbon with automatic reverse, the **Back Spacer**, Ball Bearing type bars, Ball Bearing shift action, the carriage runs on Ball Bearings, in fact every late style feature and modern operating convenience. Comes to you with everything complete, tools, cover, operating book and instructions, ribbon, practise paper — nothing extra to buy. You cannot imagine the perfection of this beautiful reconstructed Ball Bearing typewriter until you have seen it. I have sold several thousands of these perfect latest style Model No. 2 typewriters at this bargain price and every one of these thousands of satisfied customers had this beautiful, strictly up-to-date, visible machine on five days' free trial, before deciding to buy it. I will send it to you *f. o. b.* Chicago for five days' free trial on receipt of your request, without obligation of any kind on your part to purchase. It will sell itself, but if you are not satisfied this is the greatest typewriter bargain you ever saw, you can return it at my expense — but — you won't want to return it after you try it — you cannot equal this wonderful value anywhere.

H. A. SMITH
 510-231 N. Fifth Ave.
 CHICAGO, ILL.

Ship me a No. 2 L. C. Smith F. O. B. Chicago, as described in this advertisement. I will pay you the \$40.00 balance of the SPECIAL \$48.80 purchase price, at the rate of \$2.50 per month. The title to remain in you until fully paid for. It is understood that I have five days in which to examine and try the typewriter. If I choose not to keep it I will carefully repack it and return it to the express agent. It is understood that you give the standard guarantee for one year.

You Take No Risk—Put In Your Order Now

When the typewriter arrives deposit with the express agent \$8.80 and take the machine for five days' trial. If you are convinced that it is the best typewriter you ever saw, keep it and send me \$2.50 a month until our bargain price of \$48.80 is paid. If you don't want it, return it to the express agent, he will return your \$8.80 and return the typewriter to me. I will pay the return express charges. This machine is guaranteed just as if you paid \$100.00 for it. It is standard. Over one hundred thousand people own and use these typewriters and think them the best ever manufactured.

The supply at this price is very limited, the price will probably be raised when my next advertisement appears, so don't delay. Fill in the coupon today—mail to me—the typewriter will be shipped promptly. There is no red tape, I employ no solicitors—no collectors—no chattel mortgage, I deal direct with you — by mail only. It is simply understood that I retain title to the machine until the full \$48.80 is paid. You cannot lose. It is the greatest typewriter opportunity you will ever have.

Get the coupon in the mail today — sure

HARRY A. SMITH, 510-231 N. Fifth Ave., Chicago

Name

Address

..... Pop. Mech. Dec.



Only \$100

—and After Trial!

YES—the great New Edison with the new Diamond Stylus reproducer and your choice of all the brand new Diamond Amberol Records will be sent you on **free trial without a penny down**. The **finest**, the **best** that money can buy at very very much less than the price at which imitations of the genuine Edison are offered—a **rock-bottom offer direct from us**.

Mr. Edison's Own The Genuine New Edison Phonograph

Among all his wonderful inventions his phonograph is Mr. Edison's pet and hobby. He worked for years striving to produce the most perfect phonograph. At last he has produced this new model, and now it will be sent to you on a startling offer. **Read:**

Rock-Bottom Direct Offer

If you wish to keep Mr. Edison's superb new instrument, send us only \$1.00 after the free trial. Pay the balance on the easiest kind of monthly payments.

Think of it—a \$1.00 payment, and a few dollars a month to get this brand new style outfit—the Diamond Stylus reproducer, the musical quality—the same Diamond Amberol Records—all the musical results of the highest price outfits—yes, the greatest value for \$1.00 down, balance on easiest **monthly terms**. Convince yourself—a free trial first! No money down, no C. O. D., not one cent to pay us unless **you choose** to keep the instrument.

Our New Edison Catalog Sent Free

Your name and address on a postal or a letter (or just the coupon) is enough. No obligations in asking for the catalog. Get this offer—**while this offer lasts**. Fill out coupon today—right now.

F. K. BABSON, Edison Phonograph Distributors
1199 Edison Block, CHICAGO, ILL.
Canadian Office, 355 Portage Ave., Winnipeg, Manitoba

Entertain Your Friends

Hear all the latest up-to-date song hits of the big cities. Laugh until the tears stream down your face from laughing at the funniest of minstrel shows. Entertain your family and friends with everything from

Grand Opera to Comic Vaudeville—then if you choose, send it back.

To F. K. Babson
Edison Phonograph Distributors
1199 Edison Blk., Chicago

Gentlemen: Please send me your New Edison Catalog and full particulars of your free trial offer on the new model Edison Phonograph.

Name

Address



1916 MODELS NOW READY Any Watch You Want On CREDIT

**Waltham
Hamilton
Howard
Elgin
Illinois, Rockford**



ALL ARE 1916 MODELS

I SMASH THE TERMS!

And I am the first man in the country to offer the **New 1916 Models** of America's best known watches. I have them all, the latest products of the world's most famous factories, and watches are by no means all. You can get too, the very latest style mountings for **Diamonds**, and the most up-to-date pieces of exquisite **Jewelry**. Whether you buy for cash or credit, **THE PRICES ARE RIGHT.**

**Your Choice of
Inlaid Enamel Cases**

**30 Days Free Trial — No Money Down
Express Prepaid in Advance by Me**

That is the test that tells. Suppose you want a watch? Any make, any grade, any size, any case. I have it for you—just the watch that you want. **No Money Down, Express Prepaid.** You can try any one of America's best known timepieces for 30 Days. **A Free Trial, a Full Month to Carry It in Your Pocket.**

An Open Account—No References Demanded

The same kind of credit you get from your grocer liberally and cheerfully given. Arrangements are made for an Open Account as soon as you write. No red tape, publicity, notes or collectors. Every transaction is strictly confidential on terms made to suit you.

Send Coupon for Watch and Diamond Book

Why You Should Have This Book. It is the Encyclopedia of watches; a Dictionary explaining watch words; a History of Watch Making in America; the only Index Book of a **Good Watch** and an Absolute Authority on Watch Buying. Use a postcard, a letter or the convenient coupon. **Know Facts on All makes of watches before buying anywhere.** This book is a **Key to watch buying.** It tells you how to judge a good watch. Write for it today and get a letter from Square Deal Miller that makes you a friend for life.

Square Deal MILLER, Pres.

Miller-Hoefler Co., 577 Miller Bldg.

**Detroit,
Mich.**



**FREE
CATALOG COUPON**

Square Deal Miller, Pres.

577 Miller Bldg., Detroit, Mich.

Dear Sir: Please send me, without cost or obligation, your big book on all makes of High Grade Watches, the **1916 Models, Genuine Diamonds and Jewelry** and full information on your Easy Payment, No Money Down and 30 Day Trial Plan.

Name _____

Address _____

Please Mention Popular Mechanics

WHEE-E-E-E! A RIOT OF FUN FOR EVERYONE!



**EVERYBODY-
GOLFERS
AND SANE
PEOPLE**

PLAY GOLF WITH CARDS!

Whee-e-e-e! Father makes a 200 yard drive. Billy's next. Shucks! The ball's ditched. Watch Mother. Good for her! She "lofts" out of the sand on to the green. Poor Clara! She "slices" into the water. Hear them laugh!

That's the way it goes—real golf! Talk about fun—say, one hour on the card-table links with this game will crowd more merriment into sixty minutes than you've had in a coon's age.

"GOLF BUG" The GAME That's Biting 'em All!

The *only* game of golf with cards. You can slice, pull, top or fozzle the ball; you can drive for 200 yards, or make a nice mashie onto the green and hole out in bogey. You meet all the conditions experienced on an actual course.

Start A Golf Club! "GOLF BUG" clubs are all the rage. They are being organized for the winter everywhere. Be the one in your set to start the "GOLF BUG" parties rolling. Novel way to entertain. Solves the Winter evening question of "what to do." Try a Golf Tournament instead of a Euchre or Bridge Party and see which makes the bigger hit. Don't fail to have the game for your *next* gathering.

Get the "GOLF BUG" Today!

You'll avow that a dollar never did you a better turn than the one that buys your "GOLF BUG" game. The more you play the game the more you'll prize your investment. If your dealer hasn't got his supply as yet, just pin a dollar bill to the coupon or a letter and send it direct to us. If you don't say it's the most fascinating card game you ever played, return it and get your money back.

The game will be sent prepaid. Please give dealer's name when sending to us. *Today* is the day to get the "GOLF BUG."

CON. P. CURRAN PRINTING CO.
728 Walnut St., ST. LOUIS, MO.

What if you've never played golf! What if you don't know a mashie from a mutton-chop. Here's where you pick up the whole thing in one game right in your parlor in the king of indoor sports—"GOLF BUG!"

Note the youthful ring that comes back into Mother's voice when she plays it. And Father—what a kid it makes of him. And the young folks—they go wild about it. *Some* game, you'll articulate.

Not any more a matter of luck than the field game. "GOLF BUG" is a *scientific* game of absorbing interest to both those who play golf and those who don't. Keeps you "on edge" from start to finish. One game will make you a fan. It's the game that's "got" us!

Complete Outfit Only \$1

Eight golf sticks of 120 cards of highest quality; a golf links chart; book of golf terms and rules; score cards and markers—whole outfit packed in handsome durable box for only \$1. Makes a cracker-jack Xmas gift.

Ask for it at the stationers, sporting goods house or department store. If your dealer is not as yet supplied, send direct to us. Enclose only \$1.

Special \$1 Coupon

CON. P. CURRAN PRINTING CO.
728 Walnut St., St. Louis, Mo.

Enclosed is \$1 for which you will send me prepaid complete outfit of "GOLF BUG" game.

My Name

Address

Dealer's Name

The Next Great Business

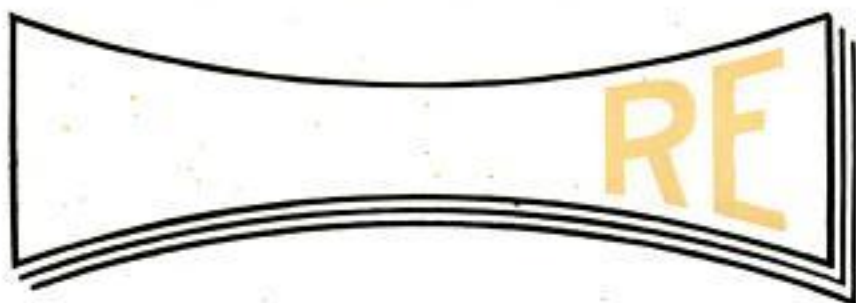

Domestic-Electric-Refrigerator

THE better living American public has been waiting to pass up the ice man and delivered ice. Are you the man who will control this demand in your territory? We will turn over an **exclusive** and **perpetual** sales contract to the financially responsible man who knows the present and future possibility of practical and economical electric refrigeration for the homes.

HERE IT IS— READY FOR DELIVERY

Not a laboratory experiment but a machine with two summers' proof of service behind it. Not a model but a manufactured product of interchangeable parts.

A silent, sturdy, electrically driven apparatus that keeps your present refrigerator at a uniformly low temperature night and day, without any attention or regulation.

Makes ice in cubes for table use from your favorite drinking water.

Maintains the safe and sanitary low temperatures insisted upon by the health experts—temperatures and dryness impossible with ice.

And the first new use of electric current that is cheaper than the service it supplants.

Don't write us if you are looking for a job, but if you want the most profitable business in your locality and have the ability or capital to finance a real monopoly, write for our proposition.

We have nothing to sell but machines and we have **opportunity** for the man who knows he can place domestic electric refrigeration in the good homes of your territory.

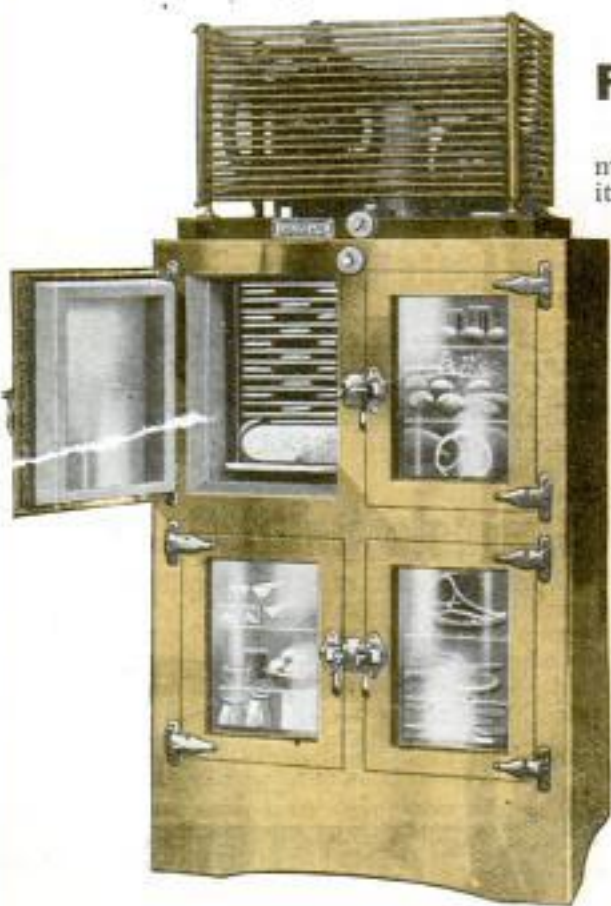

Cleaner, Colder, Cheaper than Ice

The Mechanical Refrigerator Company

718 Fisher Building, Chicago

FACTORY—CLYBOURN AVENUE AND WILLOW STREET, CHICAGO, ILL.

May 1-1916 to
The Ice Co 1735 Mt Elliott St. Detroit
See Sept 1915 p 412
Ice Co. of Chicago 343 S. Dearborn St. Chicago
Mich

7 CENTS A DAY Buys This Standard Visible Oliver Typewriter

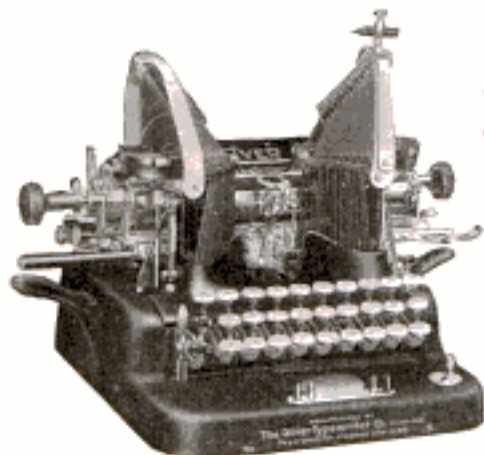

Much Less than Half Price FREE Trial—10-Year Guarantee

This is the best typewriter offer ever made. The typewriter is the genuine model No. 5 Standard Visible Oliver with complete, brand-new equipment. Perfect machines only. Not shop worn, not damaged, not inferior. Back spacer and tabulator—no features lacking. Warranted to be the equal in quality of any other \$100 typewriter.

This offer is not on some ancient style of blind typewriter, but on an up-to-date, standard, visible machine, the same kind of typewriter that many thousands of the world's best business firms are today using.

Oliver Points:

Nearly one-half million Olivers have been sold. Its record has never been equaled. It is easily "The Favorite."

Its simple efficiency, lightness and durability place it in a class ahead of all others; writing always in sight; writes in many different colors without changing the ribbon. Has the universal keyboard, back spacer, tabulator, ruling device, disappearing indicator. The type is beautiful; it is so hard that nothing can mar it. It outwears type found on other machines.

It is the lightest of all the standard typewriters. It is the only practical, portable typewriter. It has the lightest key action. Its speed is unlimited. It has the patented "U" shaped type bar which insures perfect alignment of the letters. One can write on ruled lines with it or it can be used to draw lines. It makes an efficient billing machine as well as correspondence machine.

The downward stroke of the type bar gives greater power. The Oliver is nearly always chosen for manifolding—some firms write as many as 20 copies at one writing. It does any practical thing which any typewriter can do.

It has the fewest parts. It requires the least adjustments. There is nothing to wear out. We guarantee it for 10 years.

While it is the choice of the experts, it is so simple in its design that anyone can learn to write on it in 10 minutes' time.

Sensational Reduction

Many thousands of purchasers paid \$100.00 for typewriters of this model. They were satisfied that at that price they were getting the best value that the market afforded.

Now, without any reduction in quality and with brand new standard equipment, our price to you is but \$39.80—a saving of over half, and we give you over a year in which to pay.

Our Offer Is This

Send the coupon and we will forward one of these typewriters with complete equipment on ten days' trial. We will ship it by express. When it arrives you leave \$3.80 with the express agent to be held while you try the typewriter.

If you do not find it to be the best typewriter that you ever examined, satisfactory in every respect, the best value offered anywhere, then you simply return it to the express agent, who will give you back the \$3.80 and return the typewriter to us at our expense.

If you decide to keep it, the express agent will forward the \$3.80 to us and it will be deducted from the \$39.80 price, leaving a balance of \$36.00, which you can pay at the rate of \$2.00 per month, the first monthly payment not being due until one month after date of delivery.

There are no interest charges, no red tape, no salesman, no collectors, no bother. The simple coupon is all we require.

Send the coupon today. Make sure of getting this bargain, as we will only supply 100 typewriters at this price.

United States Typewriter Exchange
Dept. 317, All Light Bldg., CHICAGO, ILL.

Trial Order Coupon

United States Typewriter Exchange

Dept. 317, All Light Bldg., CHICAGO, ILL.

You may send me a No. 5 Oliver Typewriter on approval. When it arrives I will leave with the express agent \$3.80 with the understanding that if I do not wish to keep the typewriter the \$3.80 will be returned to me by the express agent when I return the typewriter to him within ten days from the date I receive it.

Otherwise I will keep the typewriter and the \$3.80 will be forwarded to you to apply on your special purchase price of \$39.80, and I will pay the balance of \$36.00 in 18 consecutive monthly installments of \$2.00 each, commencing one month from date of delivery.

The title of the Oliver Typewriter remaining in you until it is totally paid for.

Name.....

Address.....

References.....

(127)

Grow Grapefruit and Oranges in Florida

WE FURNISH BOTH LAND AND TREES

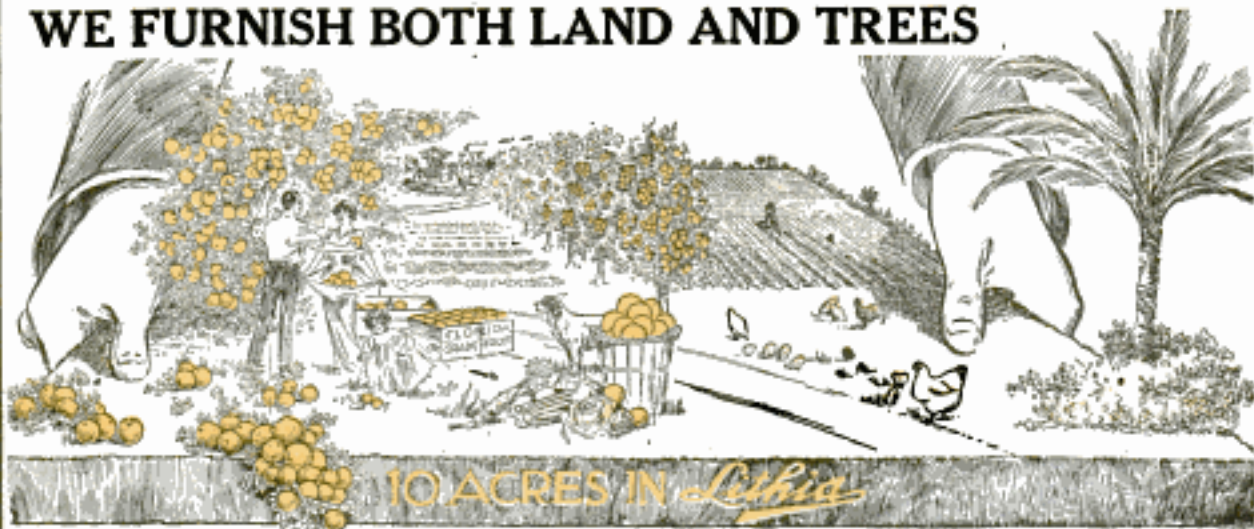

Get Away From City Drudgery

Live a real life in the bright health-giving sunshine. Enjoy your work in the open air the year 'round, in America's most delightful—most charming of all states. A few cents a day will pay for your land—also trees any time you want them—which opens the way to your independence and can be made to soon bring you a life income. No better land or location for fruit, truck, poultry and livestock can be found anywhere.

INVEST NOW IN OUR NEW LITHIA TRACT SUBURBAN TO TAMPA, the metropolis of South Florida. It is one of the few choice suburban farm tracts left in Hillsboro County, the recognized center of Florida's grapefruit and orange belt.

This is the third great Hillsboro County tract that has been opened to homeseekers and investors by our old established, responsible, thoroughly experienced organization. Over 2,500 families are now rejoicing because they bought at opening prices in our two former tracts. Every family can tell you they got a square and generous deal.

Our new Lithia Tract now offers you the same wonderful opportunity—and more, because of the rapid growth and development on all sides within the past five years.

The visible supply of select Hillsboro County grape fruit land is melting away very fast. Prosperous homes are scattered around the Lithia Tract—grapefruit and orange groves, truck gardens and poultry farms are flourishing on all sides. Already buyers are building homes on our new Lithia Tract, and values are due to rise soon.

Free—Absolutely Free—100 grapefruit and orange trees to each and every purchaser who reserves one of these farms NOW. These trees will be held in our Nurseries until you are ready to plant them. This will give you a splendid start in developing a grove which will bring you an ever increasing income and greatly increase the value of your entire farm.

The C. E. Thomas Nurseries are growing the finest varieties of grapefruit, orange, lime, fancy peach, plum and other semi-tropical and southern fruit trees, which we are selling to land owners throughout the south, as well as our land buyers. There are no better trees grown than the C. E. Thomas Nurseries Warranted Citrus Fruit trees. Every tree fully guaranteed to grow.

Get our big new Florida book and look at the map—read the many enthusiastic testimonial letters from settlers now living on the farms they bought from us. Four big railroads intersect these suburban tracts—all the comforts of modern life right at hand! The completion of the Panama Canal throws the spotlight on Tampa, the nearest deep water port, and the traffic of the whole maritime world will pause at Tampa's door.

Think of it—a 10-acre farm suburban to a city like this—a farm big enough to keep you in comfort all your lives, yet one you can pay for so easily that it will really surprise you.

Get the facts now. The coupon brings them to you without cost or obligation. Get this new wonderful opportunity clearly before you while prices on this newly opened tract are still low and terms easy. Today \$1 per acre per month buys you independence and a future. Tomorrow—who can say?

North Tampa Land Co., Pop. Mech. 12-15
837 Marquette Building, Chicago

Please send me, FREE, assortment blank for 100 grape fruit and orange trees, and your latest Illustrated Book on choice Citrus Fruit and Truck Farms suburban to Tampa, Florida.

Name

Street No.

City State

If you already own land and are in the market for high-grade fruit trees do not fail to write for our New Illustrated Nursery Catalog before buying trees elsewhere. It is free and gives much valuable information and instructions on planting and caring for trees. The coupon is for our land book only.

Honestly, now wouldn't you like to become the owner of a beautiful 10- or 20-acre farm in the heart of Florida's richest agricultural belt? You can easily do it if you will make the start. A few cents a day will pay for the land. You can improve it at your pleasure, or we can plant trees for you and have your grove taken care of for a term of years. Where else could you put aside a few odd dollars so safely, so securely, and with such surety of seeing your modest savings fund develop into a great big investment?

No use trying to make yourself believe that savings bank interest will ever make you independent, nor 6% loans make you rich. Your money isn't working when you tie it up in such ways—it's LOAFING. Make your money work for YOU; right here in these rich fruit lands is your opportunity—here where a few dollars put to work NOW will reap all the benefit of development work constantly being done by the fast increasing population.

If you do not wish to improve your farm, you can in a few years, cash in on it from the investment standpoint without a stroke of work on your part. Think of it—an investment of a very few dollars a month—and a magnificent grapefruit and orange grove is the result almost before you know it!

Tear off the coupon and mail it now and we will pay before you, by return mail, full and complete information showing how you can easily become the owner of one of these beautiful grapefruit and orange groves, and why it is sure to prove the shrewdest, most profitable investment you can possibly make.

NORTH TAMPA LAND CO.,
C. E. THOMAS, President
837 Marquette Building CHICAGO

Lower Power Cost Proves My Higher Engine Quality

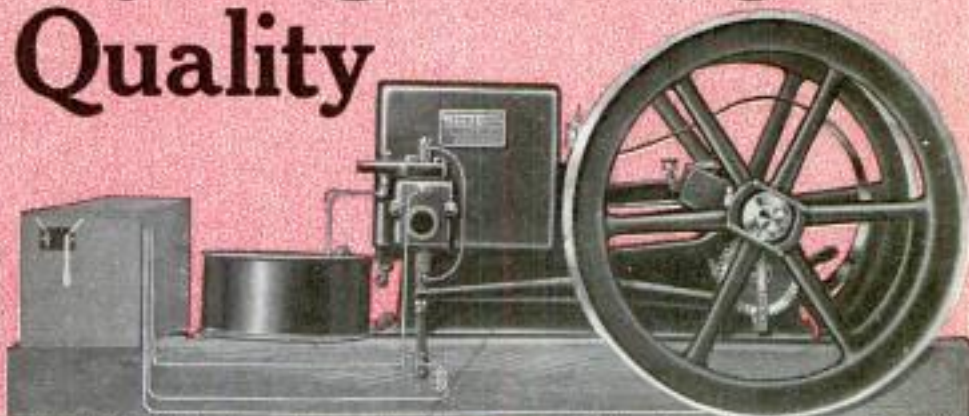

Latest WITTE Prices F. O. B. Factory STATIONARY

2 H-P.	\$ 34.95
4 H-P.	69.75
6 H-P.	97.75
8 H-P.	139.65
12 H-P.	197.00
16 H-P.	279.70
22 H-P.	359.80

PORTABLE

2 H-P.	\$ 39.95
4 H-P.	82.75
6 H-P.	127.75
8 H-P.	174.65
12 H-P.	237.00
16 H-P.	329.70
22 H-P.	412.30

SAW-RIG

6 H-P.	\$152.25
8 H-P.	202.15
12 H-P.	267.00

My engine H-P ratings have not been raised to make prices look low. My ratings are the same as in previous years—a 10% surplus of power in each size over the regular rating.

A WITTE Engine of any size is guaranteed to give its full rated horse-power with a liberal surplus. So, probably, will any other strictly high-grade engine. But the mere ability to deliver its rated horse-power is not all that is needed to prove engine quality. The big question to consider is this: "How much will it cost in fuel, lubricant, and upkeep expense to get that rated horse-power out of an engine?" Real engine quality is measured by the engine's ability to keep that cost down to the lowest possible notch. And, other things being equal—strength, durability, simplicity, ease of operation, smoothness of running—the engine which keeps its operating cost down to the lowest notch is the engine for you to buy.

WITTE ENGINES

Gasoline, Kerosene, Distillate and Gas

Thirty years ago when gasoline and other like fuels were cheap almost any type of engine that could pull its rated load, regardless of amount of fuel used, would answer the user's purpose. Those early engines were mostly over-heavy and a large part of their own power was consumed in overcoming excessive friction of their over-heavy parts.

Today fuel is a matter of first importance. I foresaw this years ago and began working toward a cheaper power cost. The result is the WITTE Engine of today which, measured by the cost of power put into the drive belt—its actual dollar-earning value—has set a new standard for engine efficiency. A saving of 25% of the fuel used by older type engines amounts, in a year, in many cases to more than enough to pay the entire first cost of a WITTE Engine.

Sent Direct From My Factory To User

CASH OR EASY TERMS

Five Year Guarantee On Efficiency And Durability

For 28 years the WITTE has maintained its lead in Engine Quality. Compare my prices with others and see how much you save on the first cost—to say nothing of the steady saving on fuel and upkeep.

FREE ENGINE BOOK. Tells why I use semi-steel castings; why I make cylinder and bed separable; vertical valves; four-ring pistons; automobile style ignition; safety spark shift for easy starting; and use other features without which no engine is of high grade quality. Mail coupon today.

ED. H. WITTE, Witte Engine Works
1745 Oakland Ave., Kansas City, Mo.
1745 Empire Bldg., Pittsburgh, Pa.

ED. H. WITTE, Witte Engine Works
1745 Oakland Ave., Kansas City, Mo.
1745 Empire Bldg., Pittsburgh, Pa.

Without cost to me, and with no obligation on my part, I should like to receive your latest and finest Engine Book, and to investigate your New Liberal Selling Plan.

Name.....

Address.....



WITTE Saw-Rig
Sizes: 6, 8 and 12 H-P. Kerosene and Gasoline engines furnished in this style.

Please Mention Popular Mechanics

The New Triumphs of Master Goldsmiths

The latest products of the craft. Exquisitely beautiful. Your own initials handsomely engraved on the superb gold strata case — guaranteed for 25 years. *The masterpiece of watch manufacture—19 jewels, adjusted to the second—adjusted to positions—adjusted to temperature—adjusted to isochronism. Open face or hunting case, ladies' or gentlemen's sizes.* Direct to you at the rock-bottom price.

The Movement

For the purpose of this sweeping *direct* offer the Burlington Watch Company selected its finest and highest grade watch. The 19 imported ruby and sapphire jewels represent maximum time keeping efficiency. The fact that 19 jewels gives the maximum, being known to every posted railroad man.

Adjusted to temperature and adjusted to isochronism and adjusted to positions—the Burlington watch is subjected to the most rigid tests—tests that require months after the watch is completed. Then after being fitted at the factory into its proper case, every Burlington watch is retimed so as to meet the ultimate standard of quality.

New Ideas In Watch Cases

Newest Ideas: Inlay Enamel Monograms, Block and Ribbon Monograms, Diamond Set, Lodge, French Art and Dragon Designs, Etc., Etc.

Open face or hunting case, ladies' or gentlemen's 12 and 16 sizes.

Imagine a beautiful hunting case with your own monogram on one side and the emblem of your lodge or any other emblem on the other side. Our catalog shows complete illustrations.

Every fighting vessel in the U.S. Navy has the Burlington Watch aboard



19 Jewel \$2.50 Burlington A Month

The Master Timepiece Now Sold Direct for Only

The Superb Burlington Watch—*adjusted* to positions, *adjusted* to temperature and *adjusted* to isochronism—now at the *direct* rock-bottom price—the same price that *even the wholesale* jeweler must pay—and in order to encourage everybody to secure this watch at once, pay this rock-bottom price, either for cash or \$2.50 a month on this great special offer. We send the watch on approval, **prepaid**. You risk absolutely nothing—you pay nothing, not one cent, unless you want this *exceptional* offer after seeing and thoroughly inspecting the watch.

Write for Special Offer!

Send us the coupon below—or a postcard for the great, sweeping *direct* offer on the genuine Burlington. We want you to see and examine the Burlington. Find out for yourself what a magnificent timepiece it is—and at a price which must surprise you. Write today for the book that shows you handsome illustrations in full color of the newest watch cases that you have to choose from. The latest triumphs of master goldsmiths are yours on this special offer.

Send the Coupon for New Watch Book

Learn the inside facts about watch prices, and the many superior points of the Burlington over double-priced products. Just put your name and address on the coupon, letter or postcard and get the Watch Book Free.

Burlington Watch Co.

19th Street and Marshall Boulevard, Dept. 1199, Chicago, Ill.

Burlington Watch Co.
19th Street and Marshall
Boulevard, Dept. 1199
Chicago, Ill.

Please send me (without obligations, prepaid), your free book on watches showing all the latest designs, with full explanation of your cash, or \$2.50 a month offer on the Burlington Watch.

Name.....

Address.....

LOOK! The Best You Ever Saw

The
Cheapest
Power
on
Earth

A
Marvelous
and
Practical
Combined
Tool

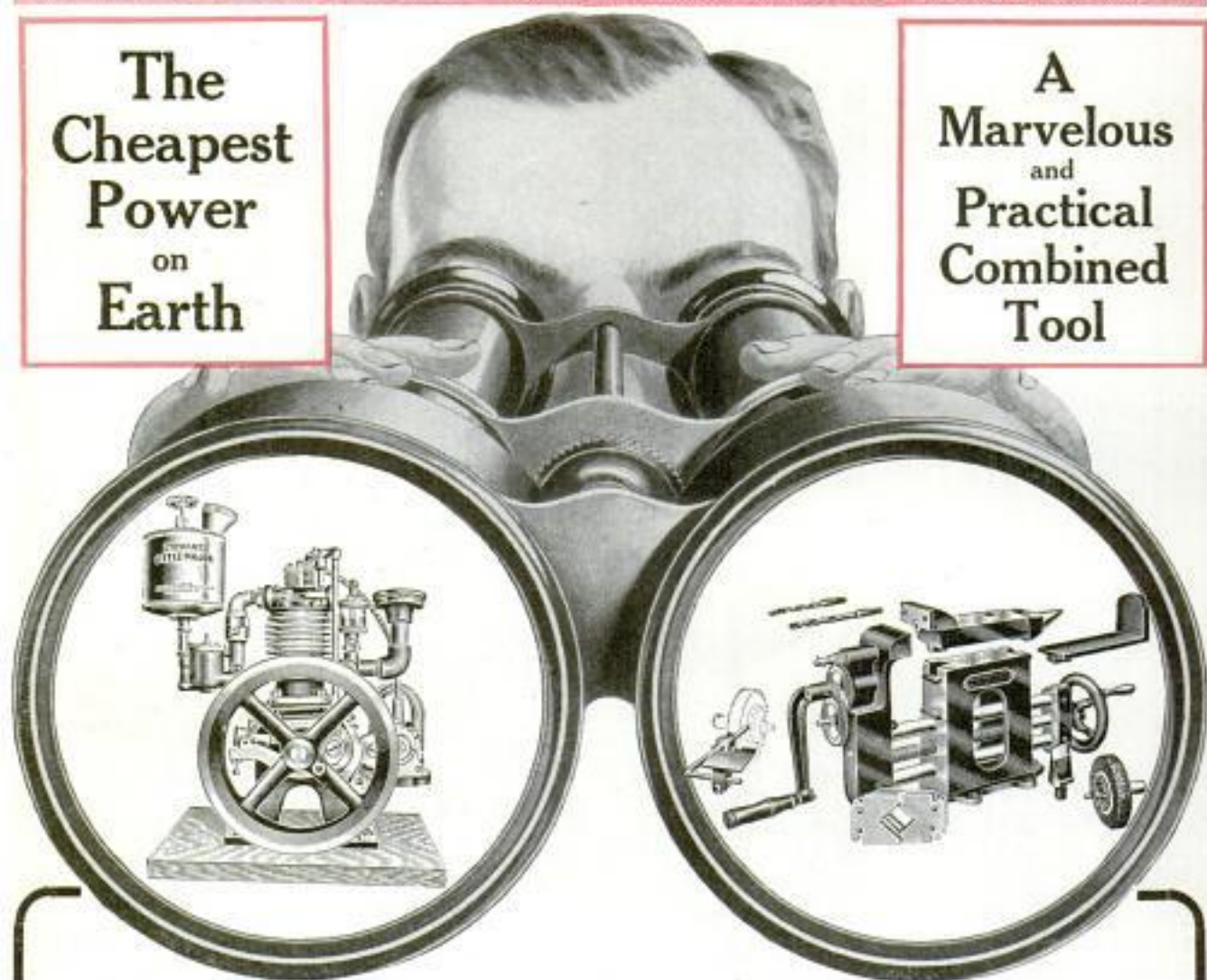

STEWART Marvelous Small Engines

are thoroughbreds. There is a vast difference between thoroughbred horses and scrubs. So it is with engines and Stewart Engines represent the last word in quality.

The Stewart Little Major

$\frac{1}{2}$ H. P. Engine shown above will operate any machine that can be run by hand and do it better and cheaper; uses less than a half gallon of gasoline for day of ten hours. Ideal for washing machine, small printing press, pump, fan, corn and feed cutters, ice-cream freezer, etc.

With battery **\$27.50**
with high tension magneto **\$37.50** and worth it.

Also 2 and 3 H. P. Engines of super quality and worth every cent asked for them. Send for catalog.

STEWART Handy Worker

THE HOME WORKSHOP

A big, strong, everlasting combined tool that will save many a quarter and half dollar. Enables one to make repairs at home. Valuable in the garage, small shop and about almost every home.

HERE'S WHAT IT COMPRISES:

A steel faced vise up to 4 $\frac{1}{2}$ inches. A steel pipe vise of marked superiority; takes pipe up to 1 $\frac{1}{2}$ inches. A strong and sturdy anvil. A cutting hardie. A corundum grinder, 5 inches by 1 inch; 3 speeds. A two-speed drill press, taking any standard drill.

Weight, boxed, 90 pounds. Price **\$12.50**
complete as shown

Send \$2.00 and pay balance when it arrives, or write for booklet.

CHICAGO FLEXIBLE SHAFT COMPANY, 105 N. La Salle Street, CHICAGO

Electric Light for Your Home

Have Electricity in your home this winter

No matter if you *do* live in the country or in a small town where direct city current is not obtainable, you can now have electric light and power in your home—at lower cost than ever before.

Think of having any room in your house instantly lighted at a snap of the switch. Think of the long winter evenings made bright as day by a steady, clear, non-flickering light.

The Uni-Lectric Lighting, Cooking and Power System

This wonderful invention, backed by a year's success in the hands of owners, is based on the fundamental principle of proper efficiency with utmost simplicity. Unlike all other private electric plants, the "Uni-Lectric" has no batteries, switchboards, rheostats, belts or chains. It consists simply of a high speed gasoline motor, generator and automatic governor, all complete in one small compact unit, occupying about two square feet of floor space. A complete "central station" plant in domestic size—easily operated and requiring no electrical knowledge at all. Better still, its first cost is much less than that of any other system, its operating cost still lower.

Generates standard 110-volt direct current and runs from one to 50 lights of different sizes and standard makes. Also operates electric motor, electric iron, vacuum cleaner, force pump, churn, washing machine, etc.

If you are still using kerosene or acetylene lamps, it's high time you changed to "Uni-Lectric"—the only light that does not consume the oxygen you ought to breathe. City people have been enjoying electric light and power for years—why shouldn't you have it this winter?

Write today for complete description, and let us demonstrate just how little it will cost to have your home electrically lighted this winter.

Waterman Motor Company

182 Mt. Elliott Avenue
DETROIT, MICH.

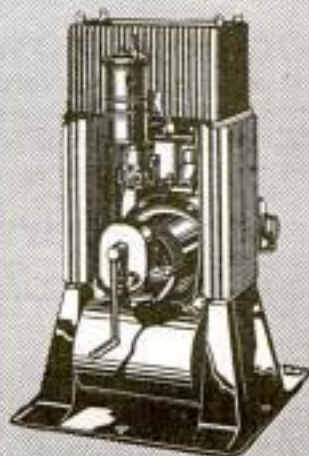

Uni-Lectric
GASOLINE-ELECTRIC UNIT
LIGHTING SYSTEM

Please Mention Popular Mechanics

Copyrighted material



Brand New REX Typewriters

On Our Agency Plan will cost you no more than an old-fashioned second hand rebuilt.

Monthly Payments if you like as low as
\$250

(ABOUT 7c A DAY)

No Money Down
10 Days' Free Trial
10 Years' Guarantee

1. Tilt back paper shelf.
2. Extra wide platen.
3. Line space lever.
4. Two color ribbon shift.
5. Shift lock.

6. Back spacer.
7. Right hand shift keys.
8. Universal keyboard.
9. Left hand shift keys.
10. Margin release key.

11. Tabulator key.
12. Two color ribbon.
13. Carriage release key.
14. Feed roll release lever.
15. Paper fingers.

16. Removable platen.
17. High writing line.
18. Tool steel center guide.
19. Line lock.
20. Stencil cutting.

Tie This Up—Quick!

for Your Town Write quick for our remarkable proposition to DEALERS. A wonderful opportunity to get the "exclusive" in your town for the greatest sensation ever sprung in the typewriter trade—the great new high-grade REX—the first perfect, faultless typewriter ever produced.

The New Typewriter Sensation

This is the new wonder that has staggered the typewriter industry and brought upon us a hail of criticism from our competitors for breaking the fixed \$100 price for standard machines. Here is the chance you have waited for, Mr. Dealer—an opportunity to line up with the livest typewriter organization in the world today. We are making the **DEALER** the foundation of our big business. We do not have, and will not have, any branch offices or salesrooms. By cutting out all the enormous expenses of branch offices and stores, rents, manager's and salesman's salaries and commissions, etc., and selling only through **dealers**, we are able to market a **better** typewriter—right from our factory to you—at an astounding low price. At last the typewriter field is open to you. Send coupon.

We guarantee the REX for 10 years and prove it to be superior to any other \$100.00 typewriter made, with every essential feature. Full standard size; visible writing; lightest touch; unlimited speed; extra wide platen; two-color ribbon; back spacer; line lock; tabulator; removable platen; perfect paper feed, etc., etc. A masterpiece of engineering skill—the first perfect typewriter.

Live Dealers Make Big Money We allow our dealers better profits than machines or second-hand (so-called "re-built") typewriters, and protect them fully. If you are the first to answer this ad from your town you can get the exclusive agency for the new REX. Don't wait. Write today for our dealer's proposition and the REX catalog. Don't miss this wonderful opportunity. Write now. You will never get another opportunity like this. The time to investigate is NOW. Write us immediately. Don't wait till your competitor, or some other hustler in your town, has seized this opportunity. Be the first to write us. No obligations whatsoever in sending for full details.

"Re-built" Dealers

Think of the advantages of selling the high-grade REX and building up for yourself a permanent, profitable business with the aid of our big organization—more sales and larger profits! Why not sell a new, guaranteed, satisfaction-giving machine and avoid the kicks of disappointed, "re-built" customers and the ruinous competition of "re-built" sellers. Get our proposition.

REX TYPEWRITER CO., Dept. 18, Steger Bldg., CHICAGO

BIG MONEY

in Taxidermy

**We teach you with complete success by mail!
Pleasant, fascinating work — quickly, easily learned!**

Professional Taxidermists earn from \$2000.00 to \$3000.00 a year, and there are not half enough Taxidermists to supply the demand. By giving only your *spare time* to this work you can easily earn from \$20.00 to \$50.00 per month without interfering with your regular business or occupation. Mounted specimens sell readily for big prices. Many birds and animals that are now killed and thrown away are *valuable* and can be turned into cash. Send the coupon today.

Sent FREE!

Our beautiful catalog, The Taxidermy Magazine, Sample Diploma, Pictures of Mounted Birds and Animals. Hundreds of letters from Sportsmen Students. All the above absolutely FREE for the asking. Mail coupon now.

We teach you **BY MAIL, IN YOUR OWN HOME**, to successfully

Mount Game Heads, Birds & Animals

also to **TAN** all kinds of hides and furs, and make them into beautiful **rugs** and **robes**. No other art is so fascinating, interesting. No other profession so profitable.

SPO

M

Mount Your Own Trophies!

Hunters, Anglers, Trappers, Nature Lovers—

Here is an opportunity you have long been waiting for! It's no longer necessary to lose the fine trophies you've secured during the hunting season, nor to pay the high prices asked by Taxidermists for stuffing them. *You can now learn* this great art for yourself during your spare time. You'll soon mount specimens as well as the most expert Taxidermist.

By taking our course of 40 lessons you will soon be able to do perfect mounting, and can *decorate your home, office or den* with the choicest of art. You will have a delightful diversion for your leisure time, and will *enjoy every moment* you give to the subject. Thousands of men and women of every vocation—bankers, lawyers and business men—are members of our school and highly endorse it.



Mounted by our student, F. Hawson, Kalamazoo, Mich.

This is the Original School of Taxidermy, and is endorsed by our thousands of students and all leading Museums, Naturalists and Taxidermists. We teach the **BEST STANDARD METHODS**, and positively **guarantee success**. Expert instructors in every department. Our Taxidermy work is widely known, having been awarded First Grand Prize and 9 Gold Medals at the Exposition. The Editor of any Sportsman's Magazine will tell you of the high standing of this school, which has taught Taxidermy successfully for many years.

Send for our printed matter today. It will interest you, and it's absolutely **Free**. We want every sportsman or nature lover in the country to become a member of the only school in the world "for sportsmen by sportsmen."

Our school and the success of our course are well known and highly endorsed by all highest authorities. Mail coupon or use postal card.

The Northwestern School of Taxidermy
1199 ELWOOD BLDG., OMAHA, NEB.

Sign and Mail Coupon Today
N. W. SCHOOL OF TAXIDERMY, 1199 Elwood Bldg., OMAHA, NEB.
Please send me sample Magazine, catalog, etc., FREE. I am interested in Taxidermy.

Name.....
P. O.....
Street.....
State.....
R. F. D.....

Please Mention Popular Mechanics

Here's Health and Power



Do you want them? Strength that is more than mere muscular strength. The strength of better health, abundant nerve force. The strength of keen relish. Write and find out what vibration will do for you. Nine out of ten people are only half alive. How about yourself? Do you feel just right? If you haven't that vigorous "go ahead" feeling all the time, don't fail to send the free coupon today for our big new book that will tell you all about

THE **WHITE CROSS**
ELECTRIC VIBRATOR

Our Combination Outfits give you three of the greatest curative agents—Vibration, Faradic and Galvanic electricity. We will send this wonderful machine to you on free trial. See it—try it—feel its health-giving vibrations for yourself.



Vibration Is Life!

In vibration there exists many of the secrets of life. The safest, surest and quickest way to recover normal health is by scientific manipulation of the organs affected and in this way stimulating them to perform their duties, whether it be those of digestion, respiration, circulation, or the nervous system. The rich, red blood will be sent coursing through every vein and artery. Write today—now—for our free book.



Lindstrom, Smith Co.

1100 S. Wabash Ave.
Dept. 1199, Chicago, Ill.

Please send me, absolutely free and prepaid, your new book, "Health and Beauty," and full particulars about the White Cross Electric Vibrator. I assume no obligations of any kind.

Send the Free Coupon

Just your name and address on the free coupon or a letter or a post card is enough. We will send you absolutely free and prepaid, our new book, "Health and Beauty." It's free. No obligations of any kind. Send the coupon today—at once.

Lindstrom, Smith Company

1100 S. Wabash Ave., Dept. 1199, Chicago, Ill.

We also manufacture White Cross Electric Stoves, Irons, Hair Dryers, Electric Lanterns, Electric Fans, Electric Automobile Horns, Electric Curling Irons, Heating Pads, Small Motors, etc., etc. Dealers write.

Name

Address

My Electrical Dealer's Name is

Please Mention Popular Mechanics

YOUR CREDIT IS GOOD WITH US!



"Distance is no barrier to fair dealing; it's no check upon human honesty, human sympathy or human needs."

Therefore, you should write for our Big Free Catalog at once, for no matter where you live, you are invited to open a charge account with HARRIS-GOAR CO. Whether it be Watches, Diamonds or Jewelry—Fine Cut Glass, Sterling or 1847 Rogers Bros. Silverware, Clothing, Musical Instruments, Sewing Machines, Leather Goods, Guns or Bicycles, you can get it here on easy payments and at money-saving prices.

Special For Early Gift Buyers \$12⁷⁵

Genuine 17 Jewel Elgin 25 YEAR GOLD-ENAMEL AND MONOGRAM CASES.

You'll want this wonderful bargain. It's made to prove to you that the great volume of our business in all parts of the country, enables us to do better by you than any other Watch or Diamond House in the world. We don't need the money. That's why we make such liberal terms and give you all the credit you want, and add this—the most marvelous watch offer ever made. Think of it! 17 Ruby and Sapphire Jewels—a genuine 17 Jewel Elgin. Standard of the World. Endorsed by Government and Railway Officials. Factory tested to the second. finely finished and fitted in a superb, plain polished or hand-engraved 25-year Gold case, and you'll never miss the money. We send this watch on the astounding terms of only **\$2 A Month**

Now Ready! NEW MODELS Exclusive Designs

Richly Enameled, Original, Exclusive Engravings, Just Out! In our New Catalog only, will you find the beautiful New Model "Classic," The New "Universal," The New "California," The New "Diamondett," The New "Satin," The New "Sunshine," The New "Double Circle"—all marvelously beautiful. And when you see the cases themselves, you'll agree that no illustration or printed page, can adequately convey the full splendor of these magnificent models. They are gorgeous in design and execution. They convey to the eye that degree of joy and satisfaction, made possible only by their richness of quality, gold shadings, enameleds, and the artist's touch. They have no lines that you would remove. They lack none that you would add. They instantly command your unstinted admiration. They carry their own evidence of superb quality and in the rigid gold assay test, stand in a class by themselves.

A Million Catalogs

: FOR YOU! :

Send Your Name on This Free Coupon

for the most interesting Catalog in America. A thousand fine illustrations, printed in four colors. Every page teems with quality and bargain prices. Every page tells a story of human interest. It shows you and you and everybody, everywhere, how to own a fine Watch or Diamond, or the things you want, without missing the money. You pay no interest—we ask no security—no red tape—just common everyday honesty among men—and you save nearly half. Your name and address on the Free Coupon or a postal will do. But do it now!

HARRIS-GOAR CO.

Dept. 1816 Kansas City, Mo.

The House That Sells More Elgin Watches Than Any Other Firm in the World.

Kansas City Bank Presidents Endorse HARRIS-GOAR CO.

We take very great pleasure in recommending the Harris-Goar Jewelry Co., to the business public. The company has large financial resources with patrons everywhere throughout the United States. Mr. Harris and Mr. Goar are well and favorably known as men of energy and business integrity, and we believe them worthy of the fullest confidence of the public. (Signed)

J. R. DOMINICK, Pres. Traders National Bank.
W. T. KEMPER, Pres. Commerce Trust Co.

HARRIS-GOAR CO.

Dept. 1816
KANSAS CITY, MO.

Please send me (without obligation and prepaid) your 1916 Catalog of Watches, Diamonds and other goods, together with the story of the Harris-Goar original easy credit plan.

Name

Town

State

R.F.D. or St.

Send No Money But Write For Catalog and Buy All Your Gifts On One Bill. EASY TERMS

Please Mention Popular Mechanics



FREE

\$15.00 Draftsman's Complete Working Outfit

Yes, sir. I will give you a complete draftsman's outfit absolutely free. It does not cost you a penny. Besides this set of Draftsman's Instruments shown here I also give you absolutely free a 20x25 inch drawing board, a 24 inch T square, 12 inch rule, supply of drawing paper, 2 triangles and French curve, pencils and eraser, drawing ink and thumb tacks, etc., etc. This is just the kind of an outfit I use myself. Genuine working instruments. You couldn't get this outfit anywhere for less than \$15.00. But you must hurry. I cannot give these outfits away to everyone that writes but will consider the names in the order in which they are received. Send the free coupon.

BE A DRAFTSMAN Pay As You Wish!

Earn \$125 to \$175 a Month at Once

Thousands of positions paying big money are open right along. All over, concerns are constantly wanting trained men. They pay big money. Hundreds of positions open paying from \$75.00 to \$100.00 weekly. A prominent Chief Draftsman will give you just the kind of training that you need, practical training, the kind demanded by firms that pay the biggest salaries. You can learn to become a draftsman in your own home — during your spare time — by mail. I will give you personal instruction until you are in a position drawing \$125 to \$175 a month. Write for full particulars.

What I want is the RIGHT KIND of men. Don't bother about expense. I will give you the working outfit free if you get in at once. I charge a very small fee for training you to be an experienced draftsman. You can pay the small cost as suits you best. My object is to develop experienced draftsmen.

CHIEF DRAFTSMAN Will Instruct You Personally

CHIEF
DRAFTSMAN
DOBE

Div. 9199

Engineer's Equipment Co.
CHICAGO, ILLINOIS

Please mail your book "Successful Draftsmanship" and also full particulars of your liberal "Personal Instruction" offer to a few students. It is understood that I am obligated in no way whatever.

For 20 years I have been doing the highest paid expert drafting work as Chief Draftsman of a large and a well known company. I will train you personally and give you just the kind of practical training that you need to hold one of the biggest paying positions. I know what the big firms demand and I will give you this kind of training so long as required during your spare time in your own home. Send me the free coupon at once. Do Not Delay. Write today — NOW.

SEND THE COUPON TODAY

For Free New Book

Just fill out the free coupon and mail it to me at once. I will send you absolutely free and prepaid, a new book, "SUCCESSFUL DRAFTSMANSHIP." Tells you all about the profession and the wonderful opportunities that are now open. Here is your chance to get into the big money class. The first step is to send the free coupon or a letter or a post card.

CHIEF DRAFTSMAN DOBE

Div. 9199, Engineer's Equipment Co., Chicago, Ill.

Name.....

Address.....

The Ceaseless Search that makes Homes Brighter

At our Research Laboratories in Schenectady scores of scientists are steadily at work in the far-reaching lamp investigations that MAZDA Service carries on.

Day after day the search goes on, studying, testing, experimenting—and little by little your home grows brighter and your light bills lighter.

For as each new idea in lighting, each new material and new method of construction is tested and approved, MAZDA Service transmits it immediately to our manufacturing centers at Cleveland and Harrison, and to the other manufacturers entitled to receive it. And thus the results of MAZDA Service come quickly to your home.

But the important thing to remember is that MAZDA, no matter whether you see it today, tomorrow, or years hence, is always the mark of this scientific Service to lamp manufacturers—always sign to you that the lamps so marked represent for the time being the sum of all that science knows of incandescent lighting.

GENERAL ELECTRIC
COMPANY

4629



MAZDA

"Not the name of a thing but the mark of a Service"



Wonderful New Kerosene Light

Burns Vapor
Saves Oil

Beats Electric
or Gasoline

Awarded
Gold Medal
at World's
Exposition
San
Francisco

Scientists
say its
White Light
is nearest
to daylight
in color

10-Days' Free Trial

SEND NO MONEY, WE PREPAY CHARGES

We don't ask you to pay us a cent until you have used this wonderful modern light in your own home ten days—we even prepay transportation charges. You may return it at our expense if not perfectly satisfied after putting it to every possible test for 10 nights. You can't possibly lose a cent. We want to prove to you that it makes an ordinary oil lamp look like a candle; beats electric, gasoline or acetylene. Lights and is put out like old oil lamp. Tests at 33 leading Universities and Government Bureau of Standards show that it

BURNS 50 HOURS ON 1 GALLON

common coal oil, (kerosene) and gives more than twice as much light as the best round wick open flame lamps. No odor, smoke or noise, simple, clean, no pressure, won't explode. Children run it. Several million people already enjoying this powerful, white steady light nearest to sunlight. Guaranteed.

\$1000.00 WILL BE GIVEN

to the person who shows us an oil lamp equal to the new Aladdin (details of offer given in our circular.) Would we dare make such a challenge if there were the slightest doubt as to the merits of the Aladdin?

Men Make \$50 to \$300 per Month With Rigs or Autos Delivering

the ALADDIN on our easy plan. No previous experience necessary. Practically every farm home and small town home will buy after trying. One farmer who had never sold anything in his life before writes: "I sold 61 lamps the first seven days." Another says: "I disposed of 24 lamps out of 31 calls." Thousands who are retiring money endorse the ALADDIN just as strongly.

No Money Required

We furnish capital to reliable men to get started. Ask for our distributor's plan, and learn how to make big money in unoccupied territory. Sample Lamp sent for 10 days' FREE Trial.

We want one user in each locality to whom we can refer customers. Be the first and get our special introductory offer, under which you get your own lamp free for showing it to a few neighbors and sending in their orders. Write quick for our 10-Day Absolutely Free Trial. Send coupon to nearest office.

MANTLE LAMP CO., 375 Aladdin Building

Largest Kerosene (Coal Oil) Mantle Lamp House in the World
Chicago, New York City, Portland, Ore., Montreal or Winnipeg, Can.

10-Day FREE TRIAL Coupon 375

I would like to know more about the Aladdin and your Easy Delivery Plan, under which inexperienced men with rigs make big money without capital. This in no way obligates me.

NAME.....
P. O.
ADDRESS..... STATE.....



The "BEST" LIGHT

A soft, luminous light, which casts no shadow. Brighter than electricity or acetylene. Makes and burns its own gas. Costs 2c a week. No dirt, smoke nor odor. Over 200 styles, ranging from 100 to 2000 candle power. Absolutely guaranteed. Write for illustrated catalog.

AGENTS WANTED EVERYWHERE
THE BEST LIGHT CO.
324 E. 5th St., Canton, O.

Sunshine Lamp 300 Candle Power FREE!

To Try in Your Own Home

Turns night into day. Gives better light than gas, electricity or 18 ordinary lamps at one tenth the cost. For Homes, Stores, Halls, Churches. A child can carry it. Makes its own light from common gasoline. Absolutely SAFE.

COSTS 1 CENT A NIGHT

We want one person in each locality to whom we can refer new customers. Take advantage of our SPECIAL FREE TRIAL OFFER. Agents Wanted.

SUNSHINE SAFETY LAMP CO.
616 Factory Bldg. Kansas City, Mo.



WHITE FLAME

BURNERS make your old kerosene lamps and lanterns give a brilliant white light better than electricity or gas. Doubles your light. Saves oil. NO MANTLE TO BREAK. Guaranteed Safe and Reliable. Delights every user. Send now for complete sample postpaid 35 cents, stamp or coin. 3 for \$1. MONEY BACK IF NOT SATISFACTORY. Live Representatives Wanted. Exclusive Territory.

WHITE FLAME LIGHT CO., 68 Clark Bldg., Grand Rapids, Mich.



ZINC USED FOR JOINTS IN CONCRETE BRIDGE—Zinc instead of mortar was used for joining the stones of two elliptical arches of the 82-ft. span of a reinforced-concrete bridge near Lyons, France. Previous experiments having proved that the molten zinc caused no fractures in dry stones, the zinc was melted



AGENTS WANTED

for our independent hollow-wire lighting systems for homes, stores, public buildings, etc. Use common gasoline. Best and cheapest illumination known.

AKRON LIGHTING SYSTEMS

are most improved, simplest and safest of all. Shed a clear, soft, bright light of high candle power. Also complete line of portable and street lamps and lanterns. Fully guaranteed. Our Agency Proposition cannot be best. Exclusive territory. Send quick for catalog and terms.

Akron Gas Lamp Co., 622 S. Main St., Akron, O.



BEACON BURNER FREE

FITS YOUR OLD LAMP

100 Candle Power Incandescent pure white light from (kerosene) coal oil. Beats either gas or electricity.

COSTS ONLY 1 CENT FOR 6 HOURS

We want one person in each locality to whom we can refer new customers. Take advantage of our Special Offer to secure a Beacon Burner FREE. Write today. AGENTS WANTED.

HOME SUPPLY CO., 111 Home Bldg., Kansas City, Mo.

Wear It a Week At Our Expense

We will send you a genuine Helion Jewel set in solid gold for a whole week's free trial. Compare it with a diamond, in brilliance, hardness and beauty. If you can tell the difference, send it back. Write today for New Jewelry Book. See illustrations of the exquisite gems. No obligations. The book is FREE.

John A. Sterling & Son
1199 Ward Building
CHICAGO, ILLINOIS



For 90c You Can Get the Ideal Gift for Every Man

A crystal glass humidor jar containing one pound of Tuxedo, the mildest, most fragrant tobacco.

The spirit of Christmas is the spirit of Cheerfulness and Good Will to Men—and *that* is the Tuxedo spirit.

Tuxedo is the mildest, pleasantest pipe tobacco in the world—made absolutely non-biting and delightfully mellow by the original "Tuxedo Process" that has never been successfully imitated.

Tuxedo is sold everywhere—but if by any chance you cannot obtain the Christmas Jar of Tuxedo at your store, send us your dealer's name and 90c, and we will send a jar to you or to any address in the United States you desire, all charges paid.

This Tuxedo Christmas Humidor Jar is beautifully decorated with holly, ribbon and Christmas card, and packed in a handsome carton, for sending by mail or messenger; price complete,

90c

Last Christmas the demand for Tuxedo humidor jars was so great that thousands of people were disappointed. The safe plan is to place your order with your dealer *now*.

SOLD IN MANY CONVENIENT SIZES

In Glass Humidors, 50c and 90c
In Tin Humidors, 40c and 80c
In Curved Pocket Tin, - 10c
In Moisture-Proof Cloth Pouch, - - - - - 5c

THE AMERICAN TOBACCO CO.
111 Fifth Avenue
New York

Illustration About One-Quarter Actual Size



Please Mention Popular Mechanics



300 Candle Power of Light AT A COST OF 1/8c PER HOUR

The Kerosene table lamp has one inverted mantle and **MAKES and BURNS ITS OWN GAS FROM COMMON KEROSENE or COAL OIL.** It gives a bright and steady white light **TEN TIMES as BRILLIANT** as an ordinary kerosene wick lamp

THE "QUICKLIT" Gasoline table lamp can be **LIT WITH AN ORDINARY MATCH, LIKE CITY GAS.**

Both styles equipped with automatic cleaning needle.

No smoke, no smell, no wicks to trim. A splendid proposition for dealers

LIVE AGENTS WANTED Write today for further particulars, also complete illustrated catalog describing the above kerosene and gasoline lamps and hollow wire systems.

THE NAGEL-CHASE MFG. CO., 152-160 East Erie St., CHICAGO, ILL., U.S.A.

The largest manufacturers of artificial lighting devices in the world.

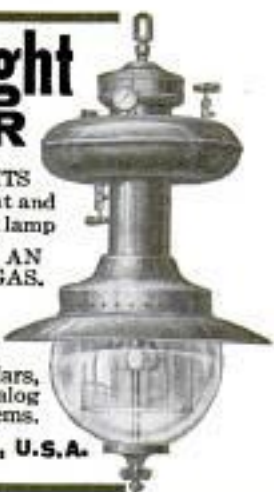

Write Today - See
**New Styles
1916 Prices**

GET the 1916
wholesale price

offer from
Kalamazoo

on 500 styles
and sizes of best quality
stoves and ranges. Mail
postal or letter today for

**New Catalog and
"Recipes FREE
in Rhyme"**

Cash or easy payments—30
days' trial—year's test. We
pay freight and ship within
24 hours. \$100,000 bank bond
guaranty. Write today.

Ask for Catalog 473

**Kalamazoo Stove Co., Mfrs.
Kalamazoo, Michigan**

Stoves, ranges, gas stoves
furnaces, white enameled
metal kitchen cabinets and
tables, 4 catalogs—please
say which you want.



**"A Kalamazoo
Direct to You"**

**BUY YOUR FURNACE
\$10 DOWN \$10 A MONTH**



Our monthly payment plan of selling direct
saves you the dealer's profits and charges
for installation. The

JAHANT FURNACE
with the patented "Down Draft System" is
best for residences, schools, hotels, churches,
etc., because it delivers plenty of heat wher-
ever and whenever desired at a saving of $\frac{1}{3}$ to
 $\frac{1}{2}$ in fuel bills. Install the Jahant yourself.
We send complete outfit, freight prepaid with
special plans, detailed instructions and all
necessary tools for installation. Satisfaction
guaranteed or money refunded.

WRITE FOR FREE ILLUSTRATED BOOK
THE JAHANT HEATING CO.

200 Steiner Avenue

AKRON, OHIO

Save $\frac{1}{3}$ to $\frac{1}{2}$ on Fuel Bills

Please Mention Popular Mechanics

OVER 70 YEARS'
EXPERIENCE

PATENTS

TRADE MARKS
DESIGNS
COPYRIGHTS, &c.

Anyone sending a sketch and description may quickly
ascertain our opinion whether an invention is probably
patentable. Communications strictly confidential. **HANDBOOK**
on Patents sent free. Oldest agency for securing patents.
Patents taken through Munn & Co. receive *special notice*,
without charge, in the

Scientific American.

A handsomely illustrated weekly. Largest circulation of any scientific
journal. Terms, \$3 a year; four months, \$1. Sold by all newsdealers.

**MUNN & CO. 672 Woolworth
Bldg., NEW YORK**
Washington Office, 625 F St., Washington, D. C.

and poured between the stones, forming metallic joints
 $\frac{3}{8}$ in. thick. Tests showed that zinc joints do not
weaken stones having a strength of about 14,000 lb. per
square inch. Cement joints, when as thick as $\frac{1}{25}$ in.,
or less, stood the tests equally well, but disintegration
gradually reduces the original strength of joints of
mortar.

JENKINS' VIOLINS

BIGGEST AND BEST VIOLIN VALUES

Easy payments—thousands to choose from. Complete out-
fits \$8.50 and up. Fifty-lesson certificate **FREE** with each
outfit. Send for our wonderful **FREE** descriptive catalogue today.

JENKINS MUSIC HOUSE

69 Jenkins Bldg.

KANSAS CITY, MO.



**Amazing Profits
In Mushrooms**

Anybody can add \$10 to \$40 per week
to their income, in spare time, entire
year growing mushrooms in cellars,
sheds, barns, boxes, etc. I tell you
where to sell, at highest prices.
Free Illustrated Instruction Booklet

HIRAM BARTON

Desk 2, 329 W. 48th St., New York

**A "BRIDAL" GIFT
WITH EVERY
IMPERIAL RANGE**

Simply send name and address. This re-
serves your delightful premium. Learn the facts
of Imperial Ranges—Heat retaining Stone
Oven Bottom, Odor Hood, Ash Sifter, all ex-
clusive features. Save \$30 to \$25. Direct from
factory. 30 days' Free Trial. Cash or Credit. Write
now for catalog and facts about YOUR premium.
THE IMPERIAL STEEL RANGE COMPANY
489 Detroit Street CLEVELAND, OHIO



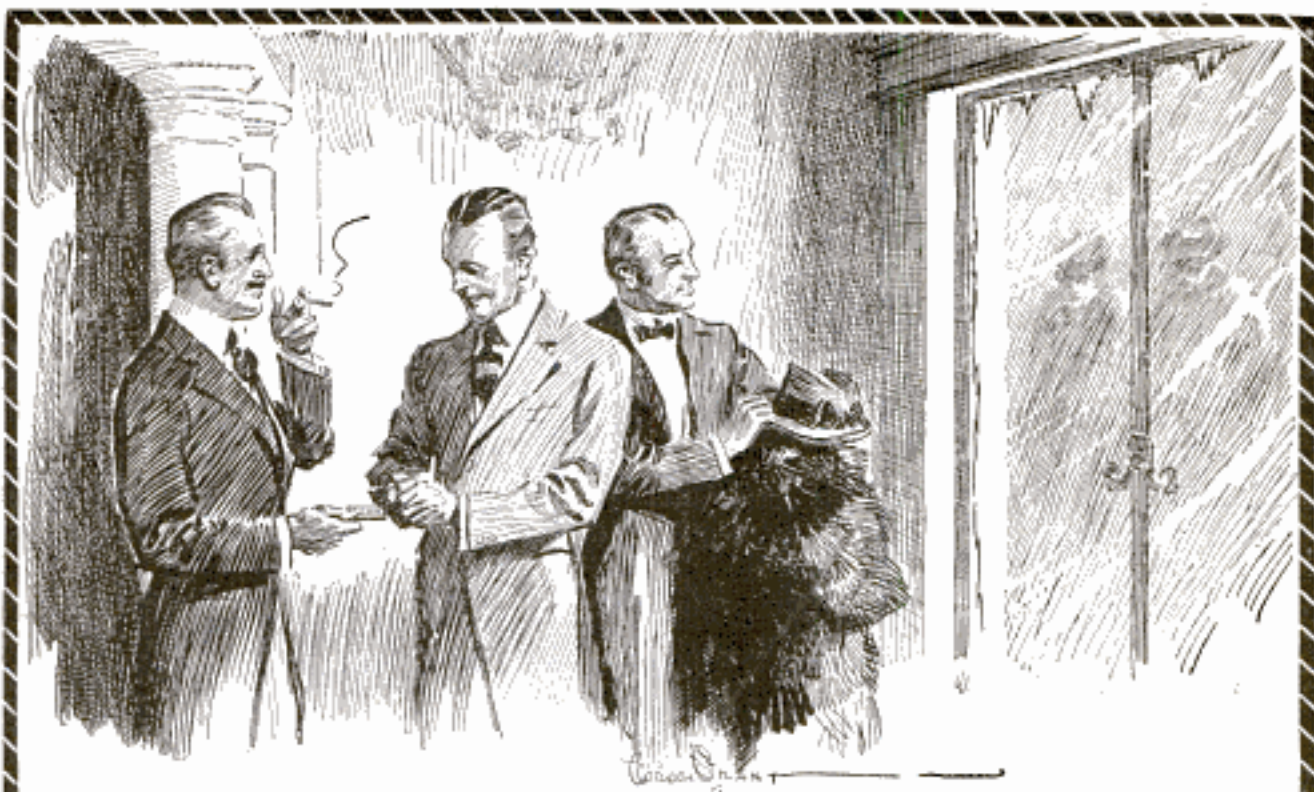

Always Welcome — Riz La Croix

The man who rolls his favorite tobacco in Riz La Croix takes pride in the fact that he uses the best cigarette "papers" the world produces. And his cigarettes have the fresh, mellow flavor and the rich fragrance of the tobacco, without a particle of "paper" taste or odor.

RIZ LA

(Pronounced: REE-LAH-KROY)

FAMOUS CIGARETTE PAPERS

5c

For a test—light two pieces of cigarette papers, Riz La Croix and some ordinary brand.

Note how much more freely and evenly Riz La Croix burns, with but a faint trace of gray ash—no charring, no odor.

It's far easier to roll your own cigarettes in Riz La Croix, because it's thin and light. And being made from pure flax linen, Riz La Croix is unusually strong and perfectly adhesive.

Cigarette paper is so small an item of expense that every man can afford the best. Try Riz La Croix.



FREE

Two interesting, illustrated Booklets — one about RIZ LA CROIX Cigarette Papers, the other showing how to "Roll Your Own" cigarettes — sent anywhere in U. S. on request. Address The American Tobacco Company, Room 1184, 434 Broome Street, N. Y.

Please Mention Popular Mechanics

Patents

**Trade Marks and
Copyrights Secured
or Fee Returned**

Special Offer—Free Search of Patent Office Records

Send us a model or sketch and description of your invention, and we will make a *Free Search* of the *Patent Office Records* to ascertain if it is patentable. If we report the invention patentable, we will guarantee to obtain a patent or return our fee, and furnish a certificate of patentability backed by a bonded contract to that effect. **This Certificate of Patentability will protect the inventor and serve as proof of the invention until the case can be filed in the U. S. Patent Office.**

Obtaining Assistance for Inventors

Our certificate is of great assistance to inventors who require financial aid to obtain patents.

Our Five Books Mailed Free

(SEE COUPON BELOW)

to any address. Send for these books—the finest publications ever issued for free distribution.

How to Obtain a Patent

Our illustrated eighty-page Guide Book is a book of reference for inventors, and contains 100 mechanical movements illustrated and described.

Money in Patents

Tells how to invent for profit, and gives history of successful inventions.

What to Invent

Contains a valuable **LIST OF INVENTIONS WANTED** and suggestions concerning profitable fields of invention; also information regarding prizes offered for inventions, among which is

Prize of One Million Dollars

offered for one invention, and \$10,000 for others.

Patents That Pay

Contains letters from our clients who have built up profitable enterprises founded upon patents procured by us; also endorsements from prominent inventors, manufacturers, Senators, Congressmen, Governors, etc.

We Advertise Our Clients'

Inventions Free

In a list of Sunday newspapers with two million circulation, in manufacturers' journals and in the *World's Progress*. Sample Copy Free. We save you time and money in securing patents. After the patent is granted we assist you **TO SELL YOUR PATENT.**

Foreign Patents

WE HAVE DIRECT AGENCIES IN ALL THE PRINCIPAL FOREIGN COUNTRIES and secure **FOREIGN PATENTS** in the shortest possible **TIME** and at the **LOWEST COST.** Write for our Illustrated Guide Book on Foreign Patents, sent free to any address.



VICTOR BUILDING

Our new \$200,000 building opposite U. S. Patent Office
SPECIALLY ERECTED by us for OUR own use

WANTED NEW IDEAS

Send for **LIST OF PATENT BUYERS** who consult us when purchasing patents. Contains requests from **MANUFACTURERS, MAIL ORDER HOUSES** and **PROMOTERS** for patents secured by us, and suggestions as to **New Ideas** they wish to purchase. We invite manufacturers and promoters to address our Sales Department regarding the purchase or leasing of a number of meritorious patents secured by us.

REFERENCES

Second National Bank, Washington, D. C.; Union Savings Bank, Washington, D. C.; Chamber of Commerce, Washington, D. C.; Pitner Gasoline Lighting Co., Chicago, Ill.; R. G. Dun & Co., Washington, D. C.; Smethport Glass Co., Smethport, Pa.; The Melvin Gauge and Signal Co., Scranton, Pa.; M. Winter Lumber Co., Sheboygan, Wis.; National Savings and Trust Co., Washington, D. C.

FREE COUPON!

VICTOR J. EVANS & CO., Patent Attorneys

NEW YORK OFFICES: 189-191 Broadway

PHILADELPHIA OFFICES: 1429 Chestnut St.

Main Offices: 765 Ninth St., N. W., WASHINGTON, D. C.

GENTLEMEN: Please send me **FREE OF CHARGE** your **FIVE** Books as described above.

NAME..... ADDRESS.....

WANTED IDEAS



Inquiries from Manufacturers and Other Buyers of Patents
Who Are Looking for Good Ideas

Protected by Owen Patents

Are constantly being received. Hundreds of ideas are wanted—a market exists for them to-day. YOURS may be one of them. Send for my free books and see for yourself—read the requests for inventions protected by me. Many are simple. You can help supply this demand.

As soon as my clients' rights are protected I aid in every practicable way, **without charge**, to sell. Their applications are advertised free—their patents are called to the attention of the proper prospective buyers—every necessary thing is done. Get my booklets and see.

THESE ARE FREE

You will incur no obligation by writing me. A simple request will bring them to you—the finest, most reliable and instructive patent books published. A postal will do.

"Successful Patents"—a 72 page guide book, tells how to proceed; describes my advantageous business methods; gives references, testimonials, etc.

"Stepping Stones"—gives hundreds of hints of inventions wanted; articles from interviews of noted authorities; tells the truth about prizes for inventions.

"Patent Promotion"—tells you how to sell; why some inventors fail; discusses the value of your idea; how I aid my clients; manufacturing aids furnished you; recent successful patents, etc.

You will also be sent from time to time, as new inventions are wanted, full information concerning them. Only in this way can you keep up to date.

Write for These To-day—Advice costs nothing. All communications confidential. I secure patents or receive no compensation. Your work will receive my personal supervision—but my fees are no higher than others.

Results Speak Loudest—But Here Are Some References

Columbia National Bank,
Washington, D. C.
National Locktile Co.,
Washington, D. C.
The Carnahan Press,
Washington, D. C.
Lightning Gun & Cycle Works,
Oklahoma City, Okla.
Antholene Mfg. Co.,
Hutchinson, Kans.

National Rack Co.,
61 Hannover St.,
Boston, Mass.
The C. J. Loftis Co.,
13 Spring Common,
Youngstown, Ohio
Whitehead Hosiery Mills,
Burlington, N. C.
Dickinson Mfg. Co.,
Des Moines, Iowa.

A LARGE NUMBER OF OTHERS IN MY BOOKLETS.

RICHARD B. OWEN 9-303 OWEN BLDG.
WASHINGTON, D. C.

Inventors submitting their inventions to me are protected in a tangible manner until their applications are filed.



Search of Records

Send sketch or model of your invention for free search of Patent Office Records and report on patentability.

PATENTS THAT PROTECT and PAY

Advice free. Terms reasonable. Highest references. Best results.
Send sketch or model for FREE examination and opinion.

BONDED and recommended Patent Lawyer in the Rand-McNally Directory of Bankers and Attorneys Published by Rand-McNally & Co., Chicago, Ill. Recommended Patent Attorney in the Bankers Register and special list of selected lawyers published by the Credit Company, Pontiac Building, Chicago, Sharp & Allen's Directory of Lawyers and Bankers of Philadelphia, Martindale's American Legal Directory of New York City, and the Con. P. Curran Directory of Bankers and Lawyers of St. Louis.

ALL BUSINESS GIVEN PROMPT AND PROPER ATTENTION

A large list of strong recommendations furnished free

WATSON E. COLEMAN, Patent Lawyer, 624 F St., Washington, D. C.



50c a Week

Send today for your free-for-examination set of the greatest electrical library ever published. The 1915 edition, just off the press, is recognized by big men in the electrical field as the most practical work of its kind. Covers completely the generation and use of electricity for power, light, transportation and communication, the construction and operation of dynamos and motors, central station engineering and telephone work, as well as wireless telegraphy and telephony and land and submarine telegraphy. Valuable alike to the beginner and expert.

Applied Electricity

Seven big volumes; 3500 7x10 inch pages; 3000 illustrations, full-page plates, diagrams, simple explanations, etc., with hundreds of valuable facts and figures. Handsomely bound in half red morocco, gold stamped.

Earn \$150 to \$250 Monthly Electrical Engineers earn from \$150 to \$250 a month. The work is pleasant—the hours short. These great books will fit you—in your spare time—to enter this fascinating, well-paid work. No previous experience necessary.

Examine These Books Free of Charge
The entire seven volumes, not a sample volume, will be sent, express prepaid, on receipt of the coupon below. Look these books over for a whole week free. Then decide whether or not you want them. If you do, send us \$2.00 within seven days and \$2.00 a month—50c a week—until the special advertising price of \$19.80 has been paid. Otherwise we'll take them back at our expense. In addition to this liberal discount from the regular price of \$55.50, we include with each set a \$12.00 Consulting Membership. This entitles you to the advice of a staff of experts for a whole year free!

AMERICAN TECHNICAL SOCIETY, CHICAGO, U. S. A.

American Technical Society, Chicago:

Please send Cyclopedia of Applied Electricity for 7 days' free examination. I will send \$2.00 within 7 days and \$2.00 a month until I have paid \$19.80; otherwise I will notify you and hold the books subject to your order. Title not to pass until fully paid. Pop. Mech. 12-16

NAME.....

ADDRESS.....

REFERENCE.....

PATENTS

C. L. PARKER
Formerly Member Examining Corps, U. S. Patent Office
PATENT LAWYER
210 MCGILL BLDG.
WASHINGTON, D. C.

Patents, Trade Marks, Copyrights, Patent Litigation
Handbook for Inventors, "Protecting, Exploiting and Selling Inventions" sent free upon request.

Let Our Factory Be YOUR Factory

We Can Make Your Metal Specialty Complete
or successfully do any part. We have pattern shop, foundry, machine shop and plating departments. Get our prices for the complete article, or for models, or parts for heavy and light machinery.

WESTERN PATTERN & MFG. CO.
MOLINE, ILL.

Please Mention Popular Mechanics

PATENTS AND TRADE MARKS

LANCASTER & ALLWINE

201 OURAY BLDG., WASHINGTON, D. C.

Book "Inventions—Patenting and Promoting" Free

Our co-operation with an inventor is, FIRST, to help him establish his rights before he discloses the idea to ANY attorney; SECOND, to give a frank opinion whether it will pay to patent his idea, based upon our extensive knowledge of manufacturers' wants and facilities; THIRD, to obtain for him a patent which is in reality a valuable monopoly; FOURTH, to advise and assist him in the profiting by outright sale, territorial grants, obtaining royalty, or independent manufacturing of the invention; and FIFTH, aiding him to so profit by conferring with manufacturers, investors or distributors of machinery.

Before sending a sketch to anyone, sign, witness, and deposit in our fireproof vault our document

EVIDENCE OF CONCEPTION
—AND ESTABLISH YOUR RIGHTS—

PECULIARITIES OF MONGOLIAN LIFE—Life in Mongolia, says the Japan Times, is so simple and primitive that Thomas Moore would have liked to give a picture of it in his Utopia. The people are not a whit

Send for **FREE BOOK** { **WHAT TO INVENT**
WHAT NOT TO INVENT
HOW TO SELL YOUR PATENT
Copies of nearest Patents and report in every case without charge
H. L. WOODWARD, 9th and G Sts., WASHINGTON, D. C.

Models and Gears **Experimenters—Inventors**
Developing inventions and making working models our specialty. Well equipped shop and staff of experts at your service. Carry complete stock of gears. Shipments same day order received. Send 4c stamps for booklet of Inventors' Supplies.
UNION MODEL WORKS, Est. 1882, 121 S. Clark St., CHICAGO

SETS OF CASTINGS OF MODEL ENGINES
FOR STUDY AND AL. CATALOGUE
STEEL WHEELS & PARTS OF MACHINES
WILHELM H. WERTHMAN & CO.

MECHANICAL SUPPLIES AND MATERIAL
of all kinds.
EXPERIMENTAL AND LIGHT MACHINE WORK
to order.
132 MILK STREET, BOSTON



BRASS GEARS

Cut by an entirely new process. The most accurate made and at prices that cannot be equalled by others. Every gear has a hub, center painted ebony black, edges turned trap, highest grade red brass, and much heavier than others. We carry the largest stock in the world and every gear listed is always shipped on date of order.

SEND FOR CATALOGUE
CHICAGO STOCK GEAR WORKS
16 S. Fifth Av. Chicago

Active Powers of Inventive Genius



INVENTORS

Our Brain Belongs to You. Our Ideas Are Free of Charge.

All we want in return is to build your model, special machinery, dies, tools and lugs to manufacture sheet metal goods, etc. We are expert mechanics, over thirty years' experience and have one of the best equipped shops in the country. Ask for Booklet No. 17. Consultation free. Experimental work strictly confidential.

A. Naecke & Son, J. Uhrman, A. Heidrich, Prop's
234-242 S. 9th St., Philadelphia, Pa.

Wanted—Ideas

Inventors! Send for these Remarkable FREE BOOKS, Today

Complete and full information about patents, everything the inventor or manufacturer should know, has been included in these books. Never before has such an inexhaustible fund of valuable information been at the inventor's disposal. Regardless of the fact that the compilation of this information cost us thousands of dollars, we will send to all interested persons, any or all of these books, entirely without charge or obligation.

"Millions In Patents"

This volume, 192 pages, tells the story of the romance of invention. The brain of the inventor is the magician that has made the ancient fairy tales come true. Millions have been paid for a hook, fortunes have come from a toy. Read "Millions in Patents," and you will realize that this country and all the nations of the world are ready to enrich you beyond your wildest dreams if you can contribute one useful or amusing thing.

"What Is a Trademark?"

It is not an exaggeration to say that billions of dollars have been made out of trademarks, labels and copyrights. He who can fashion a trademark or design a label which will make a product stand out above all similar products, is indisputably a genius for whose brains the world offers almost unlimited money.

"Foreign Patents"

A good invention is bought not by one country but by the world. "Foreign Patents" shows you how the inventor may be paid by other countries and other peoples, as well as by this nation, for his ideas and his inventions. It explains how we, through our representatives in the capitals of the world, maintain for your benefit an endless chain of opportunities which, if you take advantage of them, will girdle the earth and make of your product an agent that may bring back to you rich rewards.

"Inventions Needed"

This book, 256 pages, lays before you a description of the active and profitable field of invention. It tells you the inventions the world needs today, the devices manufacturers are seeking for their business, the ideas for which the public will pay big money. It gives great men's ideas of the most important things needed in inventions now. Science is the key to wealth, and this key can be turned best by the inventor. This book tells you why.

"How to Get Your Patent and Your Money"

The man who invents needs the co-operation of the man who invests. This book, 182 pages, is a guide to the inventor. It describes, according to the teachings of our experience and the lessons of men made rich by patents, how the inventor may secure money, the right amount of money, for the device which his brain has constructed. If you have invented something and desire to learn what it will cost you to get your patent and what you must do to find your market, read this book.

"Special Bulletin of Patent Buyers"

This bulletin, 64 pages, contains copies of hundreds of letters from wealthy men who are seeking to purchase patents. Next to the idea of the invention itself, the most valuable thing to the inventor is a hint of where there is a man ready to buy the invention or to finance the inventor so that his device can be readily marketed. We act as intermediary, without one cent of charge, between the man who invents and the man who invests.

We Secure Reliable Patents, Trade Marks,
Copyrights, On Most Liberal Terms
Ever Offered

Send Model or Sketch and Description of
your invention for Free Search of
the United States Patents

Rejected and Difficult Cases are Our Specialty

RANDOLPH & CO.
600 F St., N. W., Washington, D.C.

RANDOLPH & CO.,
WASHINGTON, D. C.

Gentlemen: Please send me, without obligation on my part, the books indicated on margin of this coupon. (Write on margin of coupon, names of books desired.)

NAME.....

STREET.....

CITY.....

STATE.....

PATENTS SECURED OR FEE RETURNED

Latest and Most Complete Patent Book Ever Published for Free Distribution

WRITE FOR IT

Compare My SERVICE and TERMS with Those of Any First Class Attorney

Send Sketch, Photograph, or Model of your invention for an ACTUAL SEARCH of the Records of the Patent Office and report as to patentability — FREE. I give every detail of every case my closest personal attention and do not entrust your interests to assistants. Impartial advice on your ideas. I help you sell your patent. Terms moderate. My 90-page book tells what inventors should know before they apply for a patent.

GEORGE P. KIMMEL, Patent Lawyer, 200 Barrister Bldg. Washington, D. C.

Agents! 500% Profit

\$25.00 to \$50.00 a week that's what our agents are making selling our new metallic sign letters for office windows, store windows and glass signs. For a quick, easy money making proposition for agents, salesmen and sign painters, there is nothing to equal the selling and putting up of our new metallic letters and numbers. There is no experience necessary to put up these signs. Anyone can succeed and make money right from the start. We will send you full particulars and you will see how easy it is to make money in this business. One agent says: "Have already put up 14 signs in this little burg and more in sight. Your letters are the best thing I have seen in years. Will soon be in a position to buy in 5000 lots." Another says: "I am getting all the work I can do and the letters have given entire satisfaction everywhere." We are daily receiving such letters from agents who have started in the sign letter business. This is the only field that is not overcrowded. There is a big demand for window and glass signs in every town. You can sell to nearby trade or travel from town to town all over the country as you please. We would be pleased to send you a free sample and full particulars.

WRITE TODAY. ADDRESS

The Metallic Sign Letter Co.

407 N. Clark Street, CHICAGO, U. S. A.



200 KINDS Iron, Wood, Wire & Steel

PUZZLES

Catalog and 2 wire leaders and trick card only 10c.

WESTERN PUZZLE WORKS ST. PAUL, MINN.

YOU CAN SELL THIS LINE

Just as easily and earn as much money as our hundreds of other agents who clean up—\$4, \$6, \$8, \$10 a day with our "ZANOL"

NON-ALCOHOLIC FLAVORS

In tubes, Soaps, Perfumes, Toilet Preparations, etc. Over 100 kinds. Fast sellers, steady repeaters. Every home a customer. Little or no capital required. 100 per cent profit. Light, neat sample case furnished. Write TODAY for full particulars — **FREE**

AMERICAN PRODUCTS CO. 3954 Third St. Cincinnati, O.



A Fortune to the Inventor

who reads and heeds it, is the possible worth of the book we send for 6 cents postage. Write us at once.

R. S. & A. B. LACEY, Dept. Y, WASHINGTON, D. C.

PATENTS THAT PAY. Protect Your Idea. **2 BOOKS FREE** \$600,000 MADE BY OUR CLIENTS
Send data (model) for Search
E. E. Vrooman & Co., 871 F St., Wash., D. C.

tainted by monetary calculations, for they are quite prepared to exchange a pint of milk for a spoonful of sugar, or to barter a cow for one dose of medicine. All the people except those in the districts near the frontier of China are simple-hearted and kind; they are also brave and have a strong sense of obedience. In fact, they have qualifications sufficient to form an independent country.

The Mongolians have the peculiar custom of playing

AGENTS—Make \$100 to \$300



per month easy selling our new **Triple Sauce Pan**. Cooking utensil for 3 different foods on one burner. **400 Specialties** — all **Whirlwind** sellers. Write quick for exclusive territory and large catalogue.

AMERICAN ALUMINUM MFG. CO. Div. 5 61 LEMONT, ILL.

Go Into MOVING PICTURE BUSINESS

Small Capital Starts You

on our easy payment plan. Begin now and get your share. We sell everything. Write TODAY.

Atlas Moving Picture Co. Dept. 40 525 S. Dearborn St., Chicago

Buy Him a Real Knife FOR HIS CHRISTMAS GIFT



Not the ordinary gift knife, but a genuine hand forged English razor steel knife that will cut and hold its edge—fully guaranteed. We will put any photo or lodge emblem on one side of the transparent handle, and any name and address on the other.

SPECIAL CHRISTMAS OFFER
No. 310—Governor Knife, 3 Blades, \$1.60. No. 320—Governor Knife, 2 Blades, \$1.25. CUT IS TWO-THIRDS ACTUAL SIZE.

FREE A Beautiful Pearl Handle Knife given absolutely free with a purchase of 3 Knives. Get your order in today, now.

Agents Wanted Everywhere. Write for Catalog and Terms.

GOLDEN RULE CUTLERY CO., 552 W. Lake St., Dept. 304, CHICAGO, ILL.

Please Mention Popular Mechanics

Manufacturers Calling for Over Two Hundred Inventions

Money Is Waiting to Back the Good Idea

(By a Washington Patent Attorney)

Never was there so good an opportunity for the inventor of something—*anything*—of merit as right now.

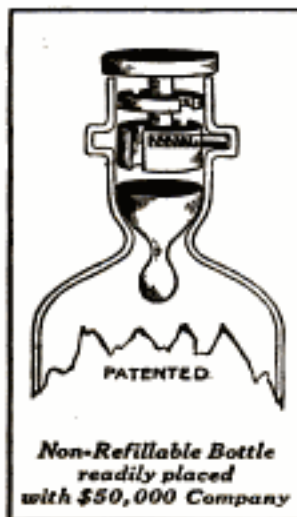

Manufacturers with money and facilities are asking for ideas—*calling* for them. The supply is not nearly equal to demand. Over 200 inventions are asked for in a list just given in a little book "What to Invent." The demand is not for anything extraordinary—just the common everyday things that make work easier or life more pleasant in the household, the shop or the field.

You might think the possibilities of the window screen had been exhausted, but I know of 28 concerns that are looking for a new screen, duly covered by patent, which they can manufacture. I know of 46 manufacturers and others who are ready to manufacture any good, patented household article such as can openers, baking pans, coffee pots, washing machines carpet sweepers and other devices.

Within the last few weeks I have received forty special requests for a dishwasher and drainer; seventeen others request an improvement in scissors. Manufacturers know that everyone must have a pair of scissors in the house, and they realize that a novelty in them would always sell in place of the old kind, and hence the demand. Among my letters are sixteen requests for a device to turn sheet music on a music stand or piano, and seventeen people are interested in the

purchase of a patent on a device for holding an electric light in any position. Besides these there are hundreds of manufacturers who do not specify any particular device but state that they would be interested in anything of merit



A Chicago man says: "I want something that can be sold to farmers by mail. There is practically no limit to the investment my associates would make in a good proposition." A man in Woodhaven, N.Y., says he is in the market for a small household article, light in weight, which can be sold somewhere around ten cents.

A prominent manufacturing company is interested in something to sell to hardware stores, but would also be interested in other things promising to be money-makers.

A man in Revere, Mass., says: "I am looking for something that can be manufactured, plant equipped, etc., and marketed for an outlay of not over twenty-five thousand dollars."

A big textile machinery company says they are interested in newly patented devices that can be

either bought outright or manufactured on royalty. They do not require machinery inventions alone, but anything of merit.

A company in Belvidere, Illinois, wants patents on small tools or metal novelties.

A Dayton, Ohio, concern writes for some machine or device that would have a general sale throughout the land.

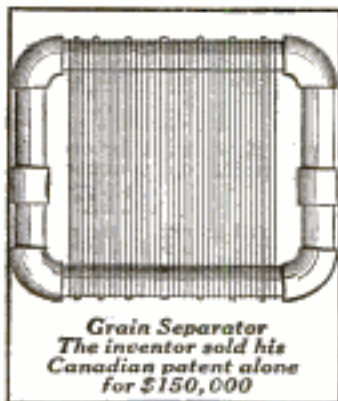

The names and addresses of these prospective purchasers are supplied absolutely without charge by Messrs. Chandlee & Chandlee to those who obtain patents through their firm. This firm has been in practice before the Patent Office for over twenty years, and its members are, consequently, familiar with every detail of patent work. They also issue a booklet entitled "How to Obtain a Patent," which tells in simple words just how to go about protecting an invention. The two books, "What to Invent" and "How to Obtain a Patent," are both free. Why don't you write for them and learn what manufacturers are looking for and how to protect your ideas? If you have an invention, send a sketch or model and description of it to Chandlee & Chandlee, 969 F Street, Washington, D.C. They will give you a free opinion as to whether or not it can be patented.



Creetings to Brush Dealers—Here's the long-haired, world-renowned gentleman who always suits brush users and builds up your business

The Largest Wholesale Dealers in Brushes in the United States buy Exclusively

WHITING-ADAMS BRUSHES

THE UNITED STATES NAVY has made its largest and most extensive purchases of Brushes several times of

WHITING-ADAMS BRUSHES

SEND FOR ILLUSTRATED LITERATURE

JOHN L. WHITING - J. J. ADAMS CO.

BOSTON, U. S. A.

Brush Manufacturers for Over One Hundred Years

Whiting-Adams Brushes Awarded Gold Medal, the Highest Award at Panama-Pacific Exposition, 1915

DO YOU HAVE KNIVES TO GRIND, SILVER TO POLISH, SMALL TOOLS TO OPERATE, WASHING MACHINES OR WRINGERS TO RUN? LET THE RED DEVIL

DO YOUR WORK

Attached to any water faucet will develop up to 3 Horse Power according to size of pipe and water pressure. Only perfect small motor made. Improved bucket wheel construction.

6 in. Motor for Mechanics and Tradesmen, Washing Machine, 1/2 H. P. on 3/4 in. pipe, 80 lbs. water pressure; 1 H. P. on 60 lbs. pressure, 2 in. pipe. Net price \$5, each with order.

No. 1492—4 in. Motor for grinding, polishing, fans, sewing machines; for Doctors, Dentists, Druggists, etc., with emery, buffing wheel, silver polish and pulley. \$3.

No. 1493—4 in. Motor and pulley only \$2.50, cash with order. Money back for any reason. Order your motor from dealer or from us. Send your water pressure and size of supply pipe. Active Agents wanted. Catalog free.

Only Motor to do this work



6 in. Motor

DIVINE WATER MOTOR CO.
DEPT P, UTICA, N.Y.



MOTOR DRIVEN BENCH SAW

Saws Wood and Soft Metals
Indispensable and most economical. For shop or private use. Full description and circular on request.

H. G. CRANE Cypress St., Brookline, Mass.

at wrestling after a meal. There is no prepared ring, and the player knocks down his opponent just as in jujutsu. Men and women are both good horse riders, and their skill in this art is shown in a charming manner at the time of a wedding.

They get married when they are fifteen or sixteen; but free marriage is never practiced. On the day of the wedding, the bride gets on horseback; and, after having ridden round her house several times, she runs away straight to her new home. She is then a real Amazon.

Water Pumps Water

with a Rife Ram. Plenty of it for every purpose about your farm and country home—day and night, winter and summer, without fuel, labor, freezing or repairs. The

RIFE RAM

is operated by any small stream having a fall of three feet or more and a supply of three or more gallons per minute. Fills high elevated tanks or operates air pressure system. Easy to install. First cost the only cost. Always on the job; over 11,000 in daily use. Tell us your water supply conditions. Ask for free estimate and catalog. Now is the time to install. Write today.

RIFE ENGINE CO., 3131 Trinity Building, NEW YORK

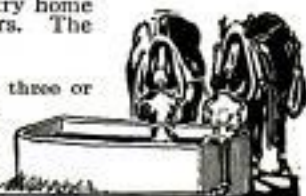

LATHES

9 to 18-inch Swing

List price \$75 and up according to size. When ready to buy send for Lathe Catalog and prices.

W. F. & John Barnes Co.
109 Ruby Street, ROCKFORD, ILL.



South Bend Lathes

For the Machine and Repair Shop

How to Run a Lathe
A 50 cent book for 10 cents. Postpaid, stamps accepted.

Straight or Gap Beds. Good for free catalog giving prices on entire line.

SOUTH BEND LATHE WORKS
423 Madison St., South Bend, Ind.

SEBASTIAN LATHES

HIGH QUALITY LOW PRICES

If you delight in good tools you will delight in Sebastian Lathes. For 25 years we have built lathes, and lathes only, employing skilled labor always, and improving equipment and machinery every year. Sebastian Lathes are

STANDARD FOR QUALITY—LOW IN PRICE

They are accurate, economical, simple and durable. Many re-orders and voluntary letters from users of Sebastian Lathes prove this. The Sebastian reputation is back of every Sebastian Lathe. You are judge and jury when you buy a lathe. We are not satisfied until you are. Look over the complete line in our new catalog. It shows Lathes for general repair work, garage and automobile work, etc.

When you buy a lathe, say "Sebastian"
ADDRESS (FOR THE CATALOG)

THE SEBASTIAN LATHE COMPANY, 107 Culvert St., Cincinnati, Ohio



Bright and Clean—Just Like New!



YOU can keep nearly everything in home, office or store always perfectly oiled, "clean as a whistle," polished bright as new and as free from rust and tarnish as the day it was bought.

Try **3 in One** for sewing machines, clocks, cameras, typewriters, furniture, bathroom fixtures, electric fans, lawn mowers, guns, fishing rods and reels, etc.

Three sizes—10 cts.—25 cts.—50 cts. Sold at all good stores.

FREE Write for generous sample and Dictionary—FREE!

3 IN ONE OIL CO.
42 CNW. Broadway, NEW YORK

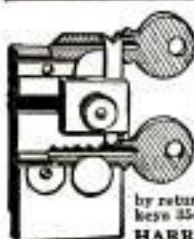

Duplicate Keys for all Pin Tumbler Locks can be made in a minute with **The Harrison M. L. P. Key Filing Machine**

Invaluable for Mechanists, Building Superintendents, Hardware and Repair Shops, Locksmiths, Carpenters, Electricians, Garages, etc. Anyone can make a perfect duplicate key without injuring the original. Every machine unconditionally guaranteed. Money refunded if not entirely satisfactory. Price \$3.00 net. Send us P. O. order or N. Y. draft and receive the complete machine by return Parcel Post. Special diamond shaped files for angular keys 35c each or 4 for \$1.00. Send for circular.

HARRISON & COMPANY, 81 NEW ST., NEW YORK



Tool Cases for Toolmakers and Machinists

Keep your tools orderly arranged in a Gerstner Portable Tool Case. There's a place for every tool in one of the felt lined drawers. Every up-to-date mechanic needs one and you'll find our Cases the best built, roughest and most practical on the market. We guarantee to please or refund all money. Write for our free booklet!

Gerstner & Sons

Mfrs. of Mechanics' High Grade Tool Cases -
808 Columbia St., DAYTON, OHIO

YOU NEED THIS TOOL

**GASOLINE
SOLDERING IRON
BLOW-TORCH**



Mfrs. Dep. I, Emmelmann Bros. Mfg. Co., Indianapolis, Ind., U.S.A.

For Your Boy for Xmas

**NOKORODE
SOLDERKIT**

\$1

with large illustrated instruction sheet never before published telling how to solder everything. Practical for experts—easy for amateurs, indispensable in homes. Includes practical Soldering Iron, length solder, 2 strips emery, 2 oz. can Nokorode Solder Paste, "best in the world," Roll Veriflex Friction Tape. Sent by parcel post prepaid in United States on receipt of \$1.00.

THE M. W. DUNTON CO., PROVIDENCE, R. I.



"A smile of satisfaction with every pair"

The Headlight coat is fuller cut, with larger armholes and wider sleeves, than any other made.

HEADLIGHT OVERALLS

(Union Made)

If your job's inside where it's warm, unbutton the top button and the collar rolls back comfortably.



The adjustable neckband, when buttoned close, gives a natty appearance and keeps out the grime and cold.

Look for this ticket

Guaranteed the best overalls you ever bought or money back after 30 days' wear.

Larned, Carter & Co., Detroit
World's Greatest Overall Makers
Factories: Detroit and Fort Huron, Mich., St. Louis, Mo., San Francisco, Cal., Canadian Factory, - Sarnia, Ont.



Give That Boy Who Likes Shop Work A Set of Good Tools

Here's the best way to encourage a student or apprentice taking up machine shop work. He will be proud of one of these sets; not playthings, but the same tools all expert mechanics use. The tools included are those essential to every young mechanic. Good mechanics know the trade mark insures quality.



BS

BS



Brown & Sharpe Sets of Standard Tools

are of two styles. The one shown is neatly arranged in folding leather case measuring 7" x 4 1/4" x 1 1/2" folded. It includes a tempered steel rule, combination square, centre gauge, centre punch and a pair each of dividers, outside calipers, inside calipers and hermaphrodite calipers. The other set, fitted in a wooden case, contains in addition to the above tools a very useful "Handbook for Apprenticed Machinists." Look over these sets at the leading hardware store or write us for a folder.

Brown & Sharpe Manfg. Co. Providence, R. I.

Our free catalog of Machinists' Tools shows a big line of micrometers, rules, squares, scales, verniers, protractors, indicators, calipers, dividers, gauges and other tools.

"Red Devil"
No. 542
6 in.



Most Powerful Nipper Made

One Pound Handle Pressure =
20 Pounds Cutting Pressure

Breaks the toughest wire with least strain. Honed and tested cutting edges. Scientifically shaped handles afford a grip like a vise. A handsome drop forged steel tool.

Sample postpaid for 85c.
Mechanics' Tool Booklet Free

Smith & Hemenway Co., Inc.
161 Chambers St., NEW YORK CITY

One-half part of iron in a million parts of water is detectable by taste, and more than four or five parts makes water unpalatable, as well as unusable for laundering purposes, according to the U. S. Geological Survey.

The elevators in the new Municipal Building in New York carry 35,000 persons a day. The daily travel of each elevator averages 15 miles.

THE AWL YOU WANT



Is the genuine MYERS \$1.00 "Lock Stitch" Sewing Awl with the exclusive feature. See thread reel in front of handle under the finger tips. Natural tension. Sews heavy or light material, diamond point, full grooved needles used to protect the thread when sewing.
C. A. MYERS COMPANY, 6339 University Ave., Chicago, Illinois

SLIDE

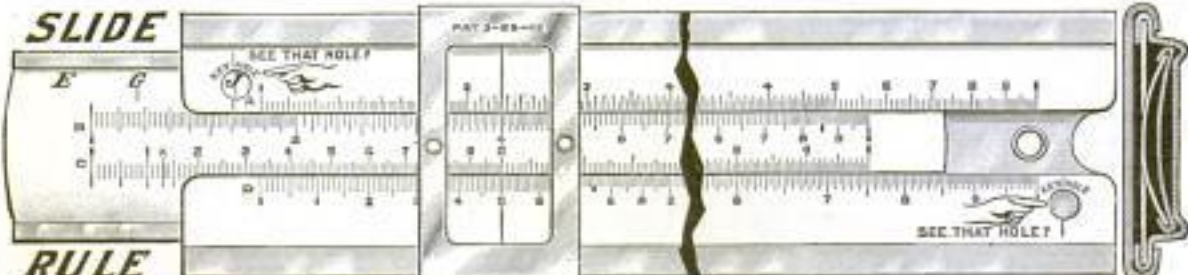

RULE

"MAID" IN AMERICA RICHARDSON'S DIRECT READING ALL METAL SLIDE RULE

The most wonderful calculating instrument ever offered to the public at a popular price. Frame made of solid Nickel, Scales Aluminum. No problems too intricate for its solution. Calculates interest and percentage, proportions, rule of three, will add and subtract numbers as well as multiply or divide them, square or cube numbers or extract the square or cube roots, etc.

Indispensable for merchants and cost estimators. For electricians it is a complete wire table in itself, for engineers it gives H. P. Engines, Pumps, capacity of tanks and cisterns, tensile strength of material, etc. The book, The Slide Rule Simplified, free, 64 pages, 100 illustrations, makes it easy for anybody to operate. Price in Aluminum, \$2.50, White Metal, \$4, German Silver, \$5, postpaid to any part of the world. Leather case fifty cents extra.

FOR CHRISTMAS PRESENT Nothing better could be selected, because the wide application of the instrument will find its use by any person. Bring your boy or girl up to learn the use of this valuable instrument, that life may be more easy for them in time to come. Space will not permit of telling all this wonderful instrument will accomplish.

Address GEO. W. RICHARDSON, Ex-Chief Electrician U. S. Navy, 4218 West 24th Place, CHICAGO, ILLINOIS



Give Him for Xmas The Simonds Prize Tool Cabinet

It is the handiest, most practical, and most satisfactory gift that can be made the boy or man of mechanical bent. It contains what the consensus of expert opinion has decided are the proper tools for general carpentry work about home, farm, or shop.

We are offering it as one of fifty-seven prizes to the boys who can make with carpenters' tools the most useful or ingenious thing at home or in school. In completeness and general excellence we consider it the best tool cabinet on the market, and we are offering it for sale as a splendid Xmas gift for man or boy. It includes

SIMONDS SAWS

which are favorably known everywhere for edge-holding and sharp-cutting qualities. All the tools are of standard makes and finest quality, conveniently and compactly arranged in the beautiful oak cabinet.

*"If you want saws that cut like diamonds
Ask for saws that are branded Simonds"*

Ask your dealer: if he hasn't it we will send it to you upon receipt of \$30. Write to Dept. 11 for our booklet, "The Professor and the Saw," which contains much valuable information for the amateur carpenter.

SIMONDS MANUFACTURING CO.

"THE SAW MAKERS"

5 Factories FITCHBURG, MASS. 11 Branches



KEEN KUTTER

Tools and Cutlery

Made by
Men Who
Know, for
Men Who
Know

The United States is the greatest paper-producing country in the world by a wide margin, the present yearly output being estimated to be worth well over \$300,000,000.

Drop Forged Snips \$1 to \$3.50 FOR HIS XMAS

Compound Lever. Made for hardest service. Highly tempered crucible steel, drop forged. Cuts keen. Holds the edge. Cuts 18-gauge metal at point easily—cutting power three times that of ordinary straight snip. For sale by dealers or sent post-paid in United States at these prices:

7-inch, - \$1.00	12-inch, - \$3.00
8-inch, - 1.50	14-inch, - 3.50
10-inch, - 2.25	

BARTLETT MFG. CO.
23 Lafayette Ave. E.
DETROIT, MICH.



CIRCULAR ON REQUEST

Sharp Tools All the Time Luther Hummer Tool Grinder

Puts keen cutting edge on all tools—easy and quick. No water needed. Won't draw temper. Enclosed dust-proof bearings and gears. Steel shaft drive. Perfect lubrication. Patented tool rest. 14 special attachments. Write for Big Free Book.

LUTHER GRINDER MFG. CO., 910 Point St., MILWAUKEE, WIS.



TOOL CASES

For Up-to-Date TOOLMAKERS and MACHINISTS

We carry the finest and most complete line of mechanics' toolcases and tools in the country. We guarantee to please you or refund money. Write for free catalogue.

J. M. WATERSTON

177 Jefferson Ave., E. Detroit, Mich.



THIS TOOL is well named, as with its use one can do all ordinary jobs with the addition of only a saw, a hammer and a plane.

It combines a Level, Plumb, Try Square, Mitre Square, Bevel, Scratch Awl, Depth Gauge, Marking Gauge, Mitre Gauge, Beam Compass and a One Foot Rule. The rule is graduated in sixteenths of inches. Just about the handiest and most convenient little tool you ever owned.

Price .75 Each

If you cannot procure this tool from your Hardware Dealer, we will send same postage prepaid to any part of the United States upon receipt of price mentioned above.

ADDRESS

STANLEY RULE & LEVEL CO.
NEW BRITAIN, CONN. U.S.A.

Don't blame the pipe —

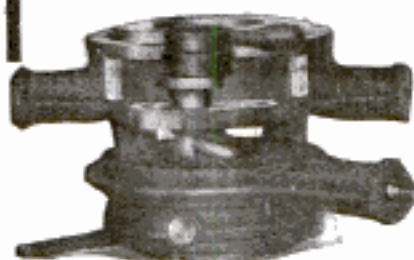

when a joint leaks. Blame the thread. And don't expect poor dies to cut good threads. The time and labor it takes to fix a leaky

OSTER BULLDOG RATCHET DIE-STOCK

joint cut by a poor stock costs more than the stock itself.

Now consider the Oster Bulldog Ratchet Die-Stock — it isn't cheap — there's not a cheap, flimsy part in it. It's strong, but light. The Ratchet feature makes it easy to pull. It has a range from four to six sizes of pipe. No backing over finished threads.

Ask for descriptive catalog giving prices for each size.

THE OSTER MFG. CO.
2100 E. 61st St.
CLEVELAND, O.

Please send Catalog

NAME _____
COMPANY _____
ADDRESS _____
CITY _____
STATE _____ (2100)

Please Mention Popular Mechanics

The Vise of Greatest Usefulness

Every tool maker, machinist, electrician, and user of high grade tools will appreciate this new "YANKEE" Vise. The new Swivel Base holds vise securely in any position. The special grooved Steel Plate enables operator to hold small work securely at any angle. Machined all over—can be used in any position as a jig for special work on drill press, or shaper.



JAWS $2\frac{1}{2}$ inches wide, $1\frac{1}{8}$ inches deep, open $3\frac{1}{2}$ inches. BODY $7\frac{1}{4}$ inches long

"YANKEE" Vise No. 1993 with Swivel Base

Your Dealer can supply you *Mechanics and Householders—write for "YANKEE" Tool Book.*
Automobilists—for "YANKEE" Tools in the Garage"—both free.

NORTH BROS. MFG. CO. OF PHILADELPHIA, PA.

"YANKEE" TOOLS *Make Better Mechanics*

The Pride of Many a Tool Kit is a Carborundum Sharpening Stone



THE carpenter, craftsman, mechanic, every man who uses edge tools, takes a pride in having a sharpening stone that really cuts—that really does put an edge on a tool quickly and easily.

¶ Carborundum is the most wonderful sharpening agent in existence—a hard, sharp, diamond-like product of the electric furnace.

¶ Every Carborundum stone cuts clean and fast—will not glaze if properly used—holds its shape, shows long life.

Send for Catalog and booklet
"The Romance of Carborundum"

Sample pocket stone by mail 15c. ¶ Ask your hardware dealer about the Carborundum stones for every edge tool.

The Carborundum Company
Niagara Falls, N. Y.

Please Mention Popular Mechanics

CARRY IT IN YOUR VEST POCKET



**BABY CRESCENT 4-INCH
ADJUSTABLE WRENCH**

Retails for 65 Cents

Small in Size. Large in Strength and Utility. Gets into many places where another Wrench can't go. ¶Fine for Automobilists, Electricians, Mechanics, Motorcyclists. ¶Crescent Wrenches are made in Seven Sizes, 4 to 18-inch.

[Get from your Hardware or Auto
Accessory Dealer, or sent postpaid
on receipt of regular retail price.]

CRESCENT TOOL CO.
JAMESTOWN, N. Y.



Portable Cases

**FOR TOOL MAKERS
AND MACHINISTS**

Twelve styles, felt lined drawers, solid brass trimmings, best of material, beautiful finish, low prices, satisfaction guaranteed. Ask for booklet of cases built for service.

The Pilliod Lumber Co.
SWANTON, OHIO

**BILLINGS & SPENCER
TOOLS**



When you "need
them bad," you
need them (good)

HARTFORD, CT.

**Wrenches
Pliers
Sc. Drivers
Hammers
Ratchets
Wrench Kits
Tool Kits**

1900 Motor Washer Electric or Water Power
on Free Trial to Readers of Popular Mechanics

Reduce household expenses by using this great laundry outfit. Cuts cost of washing to 2 cents per week. Write for Free Book, giving full details, to

1900 WASHER CO., 6217 Court St., Binghamton, N. Y.
Address Canadian 1900 Washer Co., 355 Yonge St., Toronto
if you live in Canada

3¹/₃¢ a Day

now buys a dazzling Lachman Gem. Their brilliance is eternal—they stand fire and acid tests and cut glass like diamonds. Cost but one-third as much. Set in solid gold. The newest design. Sold on Free Trial. See our new jewelry book.

Write for Big Jewelry Book Your name and address in enough. No obligations whatever. Write today—now.

HAROLD LACHMAN COMPANY
12 N. Michigan Avenue, Dept. 9129 Chicago, Ill.



**STARRETT
TOOLS**

Accuracy

INSPECTION in modern factories has become so rigid that the accuracy of workmanship is measured to the thousandth of an inch.

Every high-grade mechanic prizes his Starrett Tools because he knows they are standard throughout the world. He knows his skill aided by these instruments makes him an accurate workman and that Starrett Tools are almost an insurance against idleness, for manufacturers know that the best workmen use the best tools.

**Starrett
Tools**

include 2100 styles and sizes of fine instruments—steel rules, tapes, squares, levels, hack saws, calipers and dividers, micrometers, gauges, speed indicators and many others.

For sale at leading hardware stores. Send for Free Catalog No. 20 A. P.

THE L. S. STARRETT CO.
"The World's Greatest Tool Makers"
Athol • • Mass.
New York Chicago London

The L. S. Starrett Company
Manufactured in the United States
BY THE L. S. STARRETT COMPANY
MADE IN U.S.A.

Please Mention Popular Mechanics

"I've Read of Gold Mines" —

"I'VE read of gold mines, but yours is the first I have ever seen." That's what a patron said to J. J. Williams when he saw his Ten-Pinnet Alleys piling up profits. *You* can make a double profit from Ten-Pinnet, "world's greatest bowling game." Besides owning your own business, be our local representative and enjoy big commissions on sales in your territory.

Automatic Bowling—New and Fascinating!

Everybody plays Ten-Pinnet—men, women, children. Ingenious automatic feature makes your receipts nearly all net profit. No up-keep expense—no pin-boys—just someone to take in money. Alleys 38 to 50 feet long—easily installed in any room.



Valuable Premiums

to increase the interest of bowlers—we furnish coupons. An Ohio operator: "I am having great success. My place looks like a fair at times. Could use more alleys and may enlarge." *You* can start on small investment—easy terms. Write today for catalog and agent's prices.

The Ten-Pinnet Company

34 Van Buren Street,

Indianapolis, Ind.

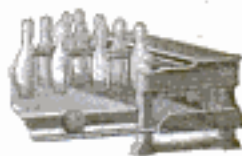

\$44⁵⁰

Cash
Price

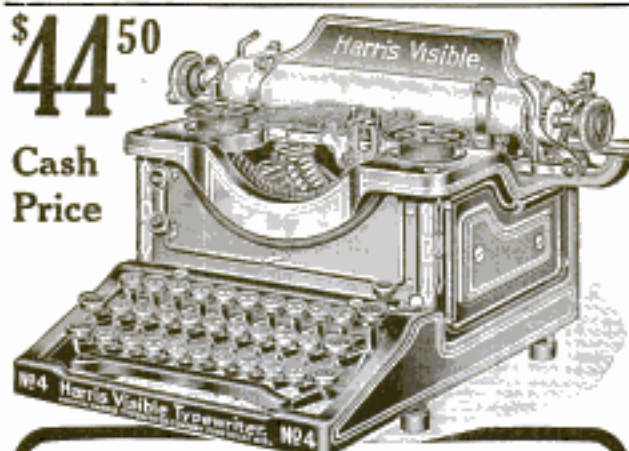

Easy Terms— 30 Days' Trial

The wonderful Harris Visible Typewriter, same as used by Sears, Roebuck and Co.—over 800 in daily service in our big Chicago store, and the best typewriter we have ever tested—now sold on easy monthly payments. The Harris is a guaranteed front strike visible writer with every valuable feature of most \$100.00 machines. Every one sold on thirty days' trial. Cash price \$44.50—monthly payment price only slightly higher—saving you about \$50.00 over other standard typewriters. Write today for free beautifully illustrated typewriter catalog, easy terms, full details. Don't delay—act now! Ask for Typewriter Catalog No. 801'00.

Sears, Roebuck and Co., Chicago

CHANGES IN KOREAN FEMALE ETIQUETTE—Korea has undergone a great change, a transformation in fact, since she was placed under Japanese control. Every custom, every usage in the community, has been more or less affected by it. Especially the cruel restrictions imposed upon women have been gradually thrown off, says the Japan Times.

It was an immemorial custom among the Koreans



Print Your Own Cards, circulars, book, paper. From \$5. Larger \$15. Rotary \$20. Save money. Profit for others, big profit. All easy, rules sent. Write factory today for catalogue of presses, TYPE, cards, paper, samples. It will pay you well. **THE PRESS CO., Meriden, Connecticut**

OWN A BUSINESS WE WILL HELP YOU



"I made \$88.16 first three days," writes Mr. Reed, of Ohio. Mr. Woodward earns \$170 a month. Mr. M. L. Smith turned out \$301 in two weeks. Rev. Crawford made \$7.00 first day. See what they have done, judge what you can do.

LET US START YOU

in Gold, Silver, Nickel and metal plating. Prof. Gray's new electro machine plates on watches, jewelry, tableware, and metal goods. Prof. Gray's New Royal Immersion Process latest method. Goods come out instantly with fine, brilliant, beautiful thick plate, guaranteed three to ten years. No polishing or grinding. Every family, hotel and restaurant want goods plated.

PLATERS HAVE ALL THEY CAN DO

People bring it. You can hire boys to do the plating as we do. Men and women gather work for small per cent. Work is fine—no way to do it better. No experience required, we teach you. Recipes, Formulas, Trade Secrets Free. Outfits ready for work when received. Materials cost about ten cents to do \$1.00 worth of plating. Our new plan, testimonials, circulars and SAMPLE FREE. Don't wait. Send us your address anyway.

GRAY & CO., PLATING WORKS
913 Gray Building CINCINNATI, OHIO

Please Mention Popular Mechanics

36184 \$100. 36043 36254 36080 36034 36071 36030 36043 \$25.

36055 \$100. \$50. \$100. \$45. \$55. \$25. \$60.

\$300. 36203 \$50. \$60. \$90.

\$25. 36226 \$15. 36935 \$15. 36175 \$50.

36198-\$25. 36237-\$125.

36231 \$75. 36278 \$150. 36180 \$75.

**EIGHT MONTHS TO PAY
BEAUTIFUL DIAMOND
SENT ON APPROVAL—NO MONEY DOWN**

No obligation; pay as you can. Order any diamond from our catalogue; when received, if not absolutely satisfactory, return it. Otherwise keep it and pay 20% of the price, and only 10% per month thereafter. Ten per cent. discount for all cash. A binding guarantee as to quality with each diamond. Exchangeable at any time at an increase of 7 1-2% more than you paid.

SEND FOR FREE CATALOGUE DELUXE No. 6
Contains over one thousand photographs of rings, pins, diamonds, and other precious stones.

L. W. SWEET & CO., Inc. 2 and 4 MAIDEN LANE
NEW YORK CITY

THE "VULCAN" INK PENCIL

Fully guaranteed. Made right to write right. Lasts a lifetime.



Highly polished rubber and safety lock cap. Absolutely non-leakable.
A useful gift. Red or black. Long or short. **\$1**
J. C. ULLRICH & CO., 27 Thames St., NEW YORK

**QUICK MONEY
Growing Mushrooms**

How to really make big money in mushrooms, is fully explained in the wonderful book, "The Truth About Mushrooms." Everything explained from A to Z, at first hand, from the greatest practical authority in America. Add \$10 to \$10 a week to your income. Demand exceeds supply. Grow in cellars, sheds, boxes, etc. Small capital to start. Profits bigger and quicker. Anyone can do it. Women and children, too. Now is the best time. Send for FREE book of information. Bureau of Mushroom Industry, Dept. 248, 1342 N. Clark St., Chicago

MAGAZINES

J. M. Hanson-Bennett Magazine Agency is the largest in the world. You can save money on the magazine you want by writing for

This Catalog FREE

Our New Catalog lists more than 9000 Periodicals and Club Offers. It's a big Money-Saver. Send us your name and address on post card today and get this big free catalog. **Do it Now.** Agents Wanted. Write for full particulars.

J. M. HANSON-BENNETT Magazine Agency
250 Brooks Building : : CHICAGO, ILLINOIS

CACHOO! Make the whole family "just sneeze their heads off" without knowing why. With Cachoo, the new long distance harmless snuff. Sent anywhere for 10c. 3 for 25c. 1 doz. and special premium for 90c. AMERICAN SUPPLY CO., St. Paul, Minn.

**100,000
"American Bankrolls"**

the 1916 MODEL—ready for your Christmas Gift-buying. Combination Billfold, Coin-purse, Photo & Cardcase of Finest, Genuine Black Seal Grain Leather with the show and elegance of a Dollar Article for only 50c postpaid (\$5.40 per dozen). Any name beautifully engraved in 23-Karat Genuine Gold FREE. Iron-strong, yet wonderfully limp and flexible. Closes with glove fastener to size 8 3/8 inches. Has secret bill-pocket, coin-purse, transparent photo or identification pocket and calendar, besides 2 hidden card pockets. Packed in handsome gift-box with Christmas card and tinsel cord ready for the TREE. If unable to get money order or bank draft, send postage stamps. 10th annual catalog of high grade GUARANTEED LEATHER GOODS and NOVELTIES free with orders for "Bankroll," or sent alone for 5c postage.

**50c**

Postpaid
Satisfaction
Guaranteed
Fits any Pocket
For Ladies
& Gentlemen

Copyright
USL&CO 1915

U. S. LEATHER GOODS CO., Dept. 2-B,
The Original Leather Goods Mail Order House.

Ravenswood, CHICAGO, U. S. A.
Established 1906. Incorporated 1910.

PREST-O-LITE

FOR MOTORCYCLES



The Light that Stands the Jolts

Prest-O-Lite is as sturdy as your motorcycle itself. Gives you constant service. Never needs any attention you yourself cannot give easily and quickly.

Furnishes ideal riding light.

Enables you to drive safely on any road—and never fails you in emergencies.

Yet Prest-O-Lite costs less to buy and less to use than any other system of brilliant light.

Sold on Money-Back Basis

Prove Prest-O-Lite on your machine. Use it for 30 days. Then if you are not satisfied, you get your money back.

Complete Equipment for Regular Service

You can have Prest-O-Lite on any make of motorcycle. The equipment combination most widely used by experienced riders is "Prest-O-Lite, a lamp, and a mechanical horn." Your dealer can make you this offer at an attractive price.

Your name and address on the margin of this page will bring complete information on motorcycle lighting. Get our valuable free book. Write today.

The Prest-O-Lite Co., Inc.

The World's Largest Makers of Dissolved Acetylene
265 Speedway Indianapolis, Indiana
Prest-O-Lite Exchange Agencies Everywhere

Please Mention Popular Mechanics

MAKE YOUR BIKE A MOTORCYCLE

at a small cost, by using our attachable outfit. Fits any Bicycle. Easily attached. No special tools required.

"Used His Four Years"

Harry A. Hyatt, of Boreas River, New York, writes: "About four years ago I received my motor attachment, and wish to say that I am satisfied with it in every way, for it has certainly given me good service. Anyone wanting a motorcycle or attachment, I would recommend them to the Shaw Manufacturing Co."

FREE BOOK Write today for bargain list and free booklet, fully describing the SHAW Bicycle Motor Attachment. Motorcycles all makes, new and second-hand, \$35.00 up.

SHAW MANUFACTURING CO.
Dept. 6 GALESBURG, KANSAS



Garage \$69.50

10x12feet "Steelcote" Edwards ready-to-use garage, \$69.50 complete. Factory price. Fireproof. Portable. Quickly set up. All styles and sizes of garages and portable buildings. Send postal for illustrated catalog.

THE EDWARDS MFG. CO.
320-370 Eggleston Ave., Cincinnati, O.



that the choice of a husband was absolutely left with the parents, and the daughter was not allowed to say even a word against it. And curiously enough husbands were younger than wives by four or five years, thus as a rule rendering the former henpecked.

The Tokyo Government decided to abolish this evil



Convert Your Bicycle into a Motor-Cycle Motor fits any wheel. BEST, MOST RELIABLE. Best hill climber. More STEFFEYS in use than all others. Stamp for circulars. STEFFEY MFG. CO., 5007 Brown Street, PHILA., PA.



"100 Miles for 10 cts."

Model 15, \$125
Model 16, \$140

SAFE, SILENT, CLEAN

WRITE FOR CATALOG

MIAMI CYCLE & MFG. CO., 120 Mobile Ave., Middletown, O.



Firestone CYCLE TIRES

Toughest, thickest, most resilient tread. Built like a motor-car tire. All sizes: Non-skid and corrugated tread.

Firestone Tire and Rubber Company
Akron, Ohio—Branches and Dealers Everywhere

5 H.P. 1915 Peerless Motorcycle



with Free Engine, Bosch Magneto, together with the best there is in Motorcycle construction, Power, Speed, Silence, Endurance, and those wearing qualities so essential for low cost of maintenance.
5 MILES FOR ONE CENT
Agents Wanted—Liberal Discount

PEERLESS MOTORCYCLE CO., 179 Huntington Ave., Boston, Mass.

BE A MANUFACTURER

OF HAYWOOD RETREADS MAKE \$3,000.00 A YEAR TO START

and more as you get accustomed to the business. The certainty of success is about as sure as anything in this world can be. You let down the DRAW BRIDGE for SUCCESS to enter into your career by getting into business for yourself. The business for you is the one where investment is small—the returns quick and for cash—where the margin of profit is large—the demand for your PRODUCT or SERVICE constant and ever on the increase. Each year adds thousands of new Automobile Owners—they need YOU to keep their tires in service.



MAKE
\$3,000.00
A YEAR

HERE IS YOUR OPPORTUNITY!

Put Yourself
Where
This Man
Is

He Is
Making
Money.



You might just as well be the first to enter this paying business in your town—open your shop and let the money roll in. Every automobile sold means more tires to mend. You start with one machine. The business grows fast. You need another and then another. Soon it gets to be a regular business of adding machine—after—machine until the first thing you know you are running a big shop—you are operating in a big way—you are a real business man and a factor in your community.

You know that punctures and blow-outs are common—tires need retreading and vulcanizing every day—something going wrong all the time—owner after owner forced to buy new tires because they cannot get the old ones fixed.

REPAIR TIRES AT HOME

Young men make money to attend college or start a garage and repair business. Automobile owners repair your own tires. Save money. Pay for your outfit in a short time. We have special outfits for home use. Mr. Ans. Man. It's worth while to invest. There is money in it. It's a field of wonderful possibilities. Make up your mind and send for our catalogue today. Learn of the wonderful money making possibilities in this fascinating new business. Make something—supply a want—become a manufacturer. This is your chance.

The Haywood Tire & Equipment Co.
904 Capital Ave. Indianapolis, Ind.

HAYWOOD
TIRE &
EQUIPMENT CO.
904 Capital Ave.
INDIANAPOLIS, IND.

Without any obligation upon my part please send me your complete FREE catalog of tire repair outfits.

Name

Address

1915 Harley-Davidson

Winner of the International Grand Prize Race at Venice, California, April 4th.

Complete description of various models can be obtained from any dealer or catalog will be mailed on request.

HARLEY-DAVIDSON MOTOR COMPANY
Producers of High Grade Motorcycles for Fourteen Years
431 B Street Milwaukee, Wisconsin



Indian Motorcycles

One, two and three speed Gears with cradle spring frame. Send for catalog.

HENDEE MFG. CO., 711 State Street, SPRINGFIELD, MASS.

Don't Worry About Your Radiator

No more burst radiators or jackets. No hard starting. No frozen fingers while trying to make repairs. It's always warm in your garage when you have the

Kanneberg
AUTO-HOT
GAS HEATER



It keeps a temperature of 50 to 70 degrees in your garage even in zero weather. Costs little, runs cheaply. No air from garage interior can get to the burner, so all danger of explosion from gasoline fumes is eliminated. Ice and frozen mud melts instead of remaining to damage car. You'll have a better car in spring than if you kept it in a cold garage. Write for free booklet.

THE KANNEBERG ROOFING & CEILING CO., 121 Robin Ct., CANTON, OHIO

MOTORCYCLES \$25 to \$175



All reliable makes. Some as good as new. Write today for full particulars and catalog. We repair and exchange motorcycles.

HARRY R. GEER CO., 888 McLaren Ave., St. Louis, Mo.

Don't Throw Away Your Worn Tires

You can get 5,000 miles MORE service out of them.

For over three years European motorists have been getting from 10,000 to 15,000 miles out of their tires by "half-soling" them with Steel-Studded Treads.

In eight months 20,000 American motorists have followed their example and are saving \$50 to \$200 a year in tire expense.

We Deliver Free Without a cent deposit, prepay the express and allow you to be the judge. **Durable Treads** double the life of your tires and are sold under a signed guarantee for 5,000 miles without puncture Applied in your own garage in thirty minutes.

Special Discount offered to motorists in new territory on first shipment direct from factory. Don't take any more chances with your tires. Mail the coupon today and find out how to get 5,000 more miles out of them.

—Tear off and Mail—Save the Discount—

Colorado Tire & Leather Company

1244 Tremont Bldg., Denver, Colo. Dept. L 44, Transportation Bldg., Chicago, Ill.
Suite 4412 Woolworth Bldg., New York, N. Y.

Gentlemen:— Please send me without obligation, sample, copy of 5,000 mile guarantee, special discount terms and book "10,000 Miles on One Set of Tires".

Name

Address

My Tire Sizes are

Please Mention Popular Mechanics



Cold?

THE warmth and easy fit of Hansen Gloves keep your hands cozy and blood circulating, and the strong horsehide protects perfectly and *looks right*.

Hansen Gloves

With or Without Lining

These gloves and mittens have plenty of style, with fit and the soft smoothness of the *outseam*.

**Write for New Free
Glove Book**

Describes many of the 500 styles—mittens too—for every occupation. All giving *most value for least cost*. Get Hansen Gloves from your dealer. If he is not supplied, write us. Anyway, write for book.

O. C. Hansen Mfg. Co.
291AK Milwaukee St.
Milwaukee, Wisconsin



All Steel Garage \$59²⁵

The Butler "Round Ruf" SIZE 10 x 14

Full protection and at least cost. Fire-proof. Corrugated. Easily put up. Attractive in appearance. Portable. Useful as a machinery, tool or storage building. Additional sections to increase length furnished at any time. If your dealer does not handle, write us for full information and prices on other sizes. Write nearest office.

BUTLER MFG. CO.
204 Butler Bldg., Kansas City, Mo.
911-6th Ave. S. E., Minneapolis, Minn.
Grain Bins, Tanks, Silos. Write for booklet on Stock, Poultry and Hog Furniture.



Please Mention Popular Mechanics



Smith & Wesson Automatic

Doubly safe

Protection against intruders. Safety against unintended discharge.



Get your dealer to show you the special features of the Smith & Wesson Automatic.

Booklet on request.

SMITH & WESSON
814 Stockbridge St., Springfield, Mass.

Every Smith & Wesson is the Best of its kind

custom and to elevate the women to a higher grade of enlightenment. For this purpose, a girls' high school was established at Seoul in 1908, and 54 girls, mostly daughters of noblemen, were admitted. The teachers were selected from among women at the special request of the parents. But the number of the students increased year after year, so that the necessity of efficient male instructors began to be keenly felt, and some new teachers were actually appointed. The community

BOYS! SEND FOR BOOKLET



The Lad's Car

Send 20c today for Booklet, telling how to build this automobile. Complete instructions and descriptions of parts and sizes, illustrated with diagrams, blue print, cuts made from photographs, and price list of parts.

Special Inducement to the Wide Awake Boy in Your Town.
NIAGARA MOTOR CAR CORP'N, Dept. A, NIAGARA FALLS, N.Y.



Mobil oils

A grade for each type of motor

Wins Big Trade!

Scores of drug, candy, fruit, cigar, news and department stores, picture theatres, etc., making \$25 to \$50 profits weekly with the famous **BUTTER-KIST Corn Popper**. Runs itself. Pops 1 bag in 40 seconds—\$1.75 per hour. Motion draws crowds. Police can't resist the *cracking fragrance*. **FREE**—handsome book "The Little Gold Mine"—gives photographs, proof of profits, easy terms, etc. Write today.

BULCOMB & HONE MFG. CO., 1794 Van Buren St., Indianapolis, Ind.



DIAMONDS-WATCHES ON CREDIT

Christmas Presents—Send for Catalog
Men's 12 Size Thin Model Watch, 17 Jewels, Adjusted
 Illinois, Elgin, Hampden or Waltham movement. Warranted accurate. Finest gold strata case, guaranteed 20 years; engraved, engine turned or plain polished. **Special Sale Price, \$18.95.** Eighty per cent of all men's Watches sold are these Thin Model. Give us your name and address, and we'll send you this splendid 17-Jewel Adjusted Watch, all charges prepaid.

ON APPROVAL—NO MONEY DOWN
\$2.00 A MONTH
 If you keep it, pay only \$2.00 a month.
 If you don't want to keep it, return at our expense.

These Diamond Rings are the famous Loftis "Perfection" 6-prong 14k solid gold mounting. Very fine brilliant diamonds. CREDIT TERMS: One-fifth down, balance divided into eight equal payments, pay also monthly. Write for Free Catalog, containing over 2,000 illustrations of Diamonds, Watches, Jewelry, etc. It tells all about our easy credit plan.

LOFTIS BROS. & CO., National Credit Jewelers
 Dept. G 894 — 100 to 108 North State Street, Chicago, Ill.
 Stores in: CHICAGO, PITTSBURGH, ST. LOUIS, OMAHA

The Best Gift of All

640 \$25
 641 \$50
 642 \$75
 643 \$100

No. N75

Typewriters

All Makes, Factory Rebuilt by the famous "Young Process"; look like new, guaranteed like new. Our big business insures "Square Deal" and permits lowest cash prices — \$10 and up; also machines rented — or sold on time. No matter what your requirements are, we can best serve you. Write and see — NOW.

YOUNG TYPEWRITER CO., Dept. 304 CHICAGO

No Money In Advance

This Marvelous Camera ON FREE TRIAL!

Only 10,000 of these marvelous, instantaneous picture-taking and making cameras to be sent out absolutely on approval without a penny in advance just to prove that it is the most wonderful invention—the camera sensation of the age. Just think of it—the Mandel-ette takes and makes finished pictures **INSTANTLY!**

You press the button, drop card in developer and in one minute take out a perfect finished post card photo 2 1/2 x 3 1/2 inches in size. Camera itself is about 4 1/2 x 3 1/2 x 7 inches. Loads in daylight. 16 to 30 post cards at one time. No Film—No Plates—No Dark Room. It is instantaneous photography. Universal focus lens produces sharp pictures at all distances. Pictures develop and print automatically. Can't overdevelop; results amazing.

We Trust You

We will send you the complete Mandel-ette outfit absolutely on approval, no references required, and give you 10 days to test it. If not satisfactory return at our expense. If you keep it simply pay \$1 when you get camera and \$1 per month until our special price of only \$5 is paid. No experience required. Plain instructions and everything complete with outfit so you can begin taking pictures the moment it arrives. We guarantee that even a child can operate it. Send coupon for camera.

MOVING PICTURE BUSINESS

Write For FREE Catalog

On Our Easy Payment Plan
Make \$20 to \$50 per night

With our Moving Picture Outfit We sell everything—Films, too.
Moving Picture Sales Co.
 Dept. P 548 Plymouth Place, Chicago, Ill.

Why Hens Stop Laying

E. J. REEFER, the poultry expert, is giving away, FREE, a valuable book explaining how every farm and backyard hen can be made to produce 200 eggs per year. The book contains scientific facts of vital interest to every poultry raiser. Write today for one of the valuable books—FREE.

E. J. REEFER (Dept. 1199) Greaser Bldg., Philadelphia, Pa. Nelson Bldg., Kansas City, Mo.

High Grade Violins 30 Days' Free Trial

Your choice from a large and carefully graded stock of representative instruments from the leading foreign violin makers. Strictly hand made and of superior tone. These violins are far superior to the average old violins sold at four times the price.

Write Today. Don't fail to send your name and address today for the superb Lewis catalog sent free and postpaid. Of value to everyone interested in high grade instruments. Learn how you can have your choice of these superb instruments on a free trial in your home. Write today.

Wm. Lewis & Son (Dept. 1199, 225 S. Wabash Ave. Chicago)
OUR SPECIALTIES: Imported wood-varnishes and tools for violin makers.

— THE CHICAGO FERROTYPE COMPANY —
 Desk 163 Ferrotype Bldg., Chicago, Ill.

Send me one complete Mandel-ette Camera outfit including supply of post cards and instructions. I agree to pay \$1 when I get the camera, and if satisfied keep it and pay you \$1 a month, until your special price of \$5 is paid. Otherwise I will return it at the end of 10 days.

Name.....
 Address.....



100 *Edwin's* **Havana Seconds \$1.90**
 GENUINE
 From Factory Direct To YOU By Ex. or Parcel Post Prepaid

Made of Imported Havana Picadura, from our own plantations in Cuba—leaves that are too short to roll into our high-priced cigars. They're not pretty, no bands or decorations, but you don't smoke looks. Customers call them "Diamonds in the Rough." All 4 1/2 inches long. Only 100 at this "Get Acquainted" price. Money cheerfully refunded if you don't receive at least double value. When ordering mention mild, medium or strong. Our references: Dan or Bradford's or any Bank.

To each purchaser of 100 Edwin's Genuine Havana Seconds, we will, for 60c extra, send Edwin's "Sample Case" containing one sample cigar each of our 12 Best Sellers — all Bargain Values — priced up to \$12.00 per 100. Include this in your order—it's the biggest sample value ever offered.

EDWIN CIGAR CO., Dept. N. 17 *Get Acquainted* **2338-2342 THIRD AVE. NEW YORK**
 Largest Mail Order Cigar House in the World
 When in New York **SAVE MONEY** by Patronizing any of the 100 EDWIN Retail Stores

ESTD 1843
TRADE MARK

7111 \$100

7106 \$50

7140 \$65

7269 \$35

7165 \$30

7169 \$75

7448 \$50

7123 \$250

7213 \$150

7264 \$85

DIAMONDS ON CREDIT

If for personal use, or as a gift, there is nothing to compare with a Diamond, if it be of good quality.

LYON DIAMONDS

are absolutely perfect and blue white. Nothing better as an investment, as our grade of Diamond is constantly advancing. Any honest person is offered our liberal terms of

20% Down 10% A Month

which allows eight months to complete payments

We furnish with our Diamonds a guarantee certificate attesting the quality and value, and providing for exchange at full purchase price. Write today for our latest Catalog No. 3, in which is shown a complete line of Diamonds, Watches, Jewelry and Silverware. Goods sent to any Bank or Express subject to approval. We allow a discount of 10% for cash.

**71-73 NASSAU ST.
NEW YORK**

J.M. LYON & CO., (Dept. B)

AGENTS \$10 to \$20 PER DAY!

New Pure Aluminum Hot Water Bottle — will outwear 100 Rubber ones. Lasts a lifetime. Low price makes quick sales. Write for sample and large catalog of 400 other Specials.

AMERICAN ALUMINUM MFG. CO.
Div. B. M. LEMONT, ILL.

BUY PLUMBING and HEATING SUPPLIES

at WHOLESALE Will Save You 30%

Don't pay retail prices. Full stock on hand for prompt shipment. Send for free catalog.

B. P. KAROL, 800-802 South Kedzie Ave., CHICAGO

4 Weeks' Trial

Choice of 38 Styles

Yes, we will ship you on four weeks' absolutely free trial, direct from our own factory, your choice of 38 new styles of the highest-grade Wing Piano or Player Piano. No obligations — no C.O.D. — no security.

No Money Down — Not a Cent of Freight

Use it and enjoy it four full weeks; then, if you wish, ship it back at our expense. You make the judge. You will be amazed at our rock-bottom, direct price on the superb Wing, guaranteed 40 years. Easy monthly payments or cash. **WRITE TODAY!**

Valuable Book—FREE "The Book of Complete Information About Pianos" sent free and post-paid. Valuable 100-page book. Tells how to judge pianos. Beautiful art catalog also sent and particulars of great Free Shipment Offer. Write today.

Wing & Son (Est. 1868), Wing Bldg., 9th Ave. & 13th St., Dept. 1199, New York

in general and the students' parents in particular were enraged at this radical innovation, alleging that it was an unpardonable crime for men to enter the gate of a girls' school in broad daylight, even if they were teachers. The school authorities, therefore, ruled that the male teachers should veil their faces when they passed the gate of the school. It is an absurd idea, but the students' parents were satisfied with it.

KEROSENE Gas Lamps

**BRIGHT AS THE SUN
Simple as a Candle**

A Flood of Shadowless Light for every purpose. If we are not represented in your town write for particulars in profit making deal for dealers and agents.

BRILLIANT GAS LAMP COMPANY, 1000X, S. Wabash Ave., Chicago, Ill.

A Real Auto For Boys

You Can Build It

Send a quarter for drawing, description, instructions and price list of parts. They make it easy.

THE MOTOR BOB, Dept. 1, BUFFALO, N. Y.

Please Mention Popular Mechanics

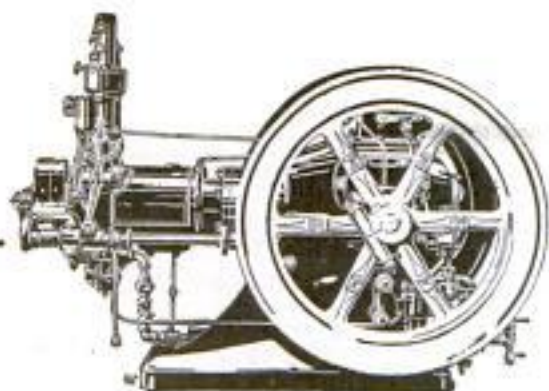

Be on the Safe Side

In your shop, your mill, your factory, or your power plant, where steady, dependable power is a necessity—you can have it at no extra cost except the time it takes to investigate International Harvester engines—Titan or Mogul. Or, you can profit by the experience of thousands and choose the vital point in your shop—your engine—from the thoroughly dependable, tried and tested, responsible line of

International Harvester Oil Engines

Buy the I H C engine exactly suited to your needs, whatever they are, give it a reasonable amount of care, and set it to work. Rest assured that your power needs will be satisfactorily supplied for years. For the emergency that may sometimes come, you will always have reliable I H C service back of the engine as long as it is in use.

International Harvester engines—Titan and Mogul—are made in all approved styles, for any purpose, in sizes from 1 to 50-horse power. They operate on both low and high grade oil fuels. Find out all there is to know about the I H C engine lines. Write us for catalogues and full information.

International Harvester Company of America

(Incorporated)

16 Harvester Building Chicago U S A

The municipal board of Manila has passed an ordinance providing that all buildings constructed in the city hereafter must be rat-proof. This measure is for safeguarding the public health against bubonic plague. Hollow walls and partitions are forbidden.

GET THIS CATALOG
FULL OF VALUABLE INFORMATION TO EVERY
BOAT OWNER ON
RACING PROPELLER WHEELS,
REVERSE GEARS AND
MARINE ACCESSORIES
LARGE CATALOG FREE. SEND TODAY
MICHIGAN WHEEL CO.
1139 MONROE AVE. GRAND RAPIDS, MICH.

Toledo MARINE MOTORS NONE BETTER

"Nothing Cheap but the Price"

3 H. P. 1 cyl. complete	\$ 65.00
6 H. P. 1 " "	84.00
6 H. P. 2 " "	125.00
12 H. P. 2 " "	160.00
18 H. P. 3 " "	250.00

Fully guaranteed by a responsible concern. 2 cycle, 2 part, 3 1/2 x 3 1/2 and 4 1/2 x 4 1/2. Send for free catalog "C."

THE UNIVERSAL MACHINE CO., Pike Ave., Bowling Green, O.

Hand Forged
Razor Steel
Blades. No. 57

This \$2 KNIFE 83¢
DIRECT AT FACTORY PRICE

HANDY SHAPED blade makes this knife best for mechanics, sportsmen and farmers; light but strong; resharpened easily. Stag handle, German silver finish; blades file tested, hand forged from razor steel and warrant ed. Sample 83c, 3 for \$2 postpaid. Cheapest post \$3 each.

Send for our 80 Page List and "How to use a Razor" FREE

MAHER & GROSH CO., 106 A. St., Toledo, Ohio.

Mail a
Postal
Today
for the
Brooks
Boat
Book

Especially Designed For Outboard Motor



New Brooks Model

New Semi-V-Bottom Type—Built with extra strength and buoyancy at stern to offset strain and weight of motor—seats 6 or 7 persons—light in weight—fast—seaworthy.

\$25.00 BUYS ALL MATERIALS
Shipped Knocked-Down

or boat built complete at factory—
shipped ready to use—only \$45.00

The Brooks Outboard Motor can be had with either plan. We will send you—1, boat in knocked-down form for \$25.00—2, knocked-down boat and motor \$70.00—3, completed boat, ready to use, \$45.00—4, completed boat and motor \$90.00. Boat is light, fast, seaworthy—sturdy frame—designed by experts—can be assembled by anyone in spare time.

Write for full description—also catalog showing complete line of boats. Write today.

Brooks Mfg. Co., Saginaw, Mich., U. S. A.
Largest concern of its kind in the world. Originators of the Pattern System of boat building.



WATKINS' SPECIAL MOTORS

3 H. P. Single Cylinder . . . 30 lbs.
6 H. P. Double Cylinder . . . 60 lbs.
12 H. P. Four Cylinder . . . 100 lbs.

A strictly HIGH GRADE Motor that will give CONSTANT and EFFICIENT service. Especially adapted for CANOES and LIGHT BOATS. Aluminum base, copper water jacket, steel shaft, bronze bearings.

THE WATKINS MOTOR CO.

837-839 West Sixth Street CINCINNATI, OHIO

FARM VIM MARINE ENGINES VIM ENGINES

Get a VIM Engine and save money. VIM Midget 1 1/2 H.P. Farm Motor shown below does all the chores—clearing, washing, pumping, separating, spraying, etc. Runs over easily. No over-heated parts. Weights only 20 lbs. Water cooled, automatic lubrication. Comes ready to run. Guaranteed. Full line marine engines 5 to 25 H.P.; 1, 2 and 3 cyl.; Speed, pressure and heavy duty types. Gasoline or kerosene.

Double ignition. Non-backfiring. Strong, simple, smooth. Absolutely dependable. Built for a lifetime. The best-builder's standard, the boat-owner's pride. When writing for catalogs, please mention whether interested in stationary or marine engines, or both. Ask for illustrative agency offer.

The Vim Motor Company, 812 Water St., Sandusky, Ohio

Please Mention Popular Mechanics

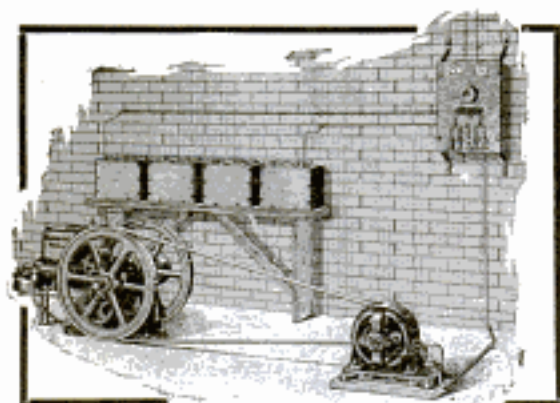

(440-4T)

Electric Lighting Plants for Farms and Country Homes

Simple—Compact—Easy to Operate
Give 24-hour service

Fairbanks, Morse & Co.

New York CHICAGO San Francisco
and other principal cities



Ask Your Dealer

for these new low engine prices.

Stationary: 2 H-P, \$35.10; 3 H-P, \$52.65;
4 H-P, \$70.20; 6 H-P, \$100; 8 H-P, \$140.40;
12 H-P, \$210.90. Portable Engines and Saw-
rig Outfits proportionately low.

Guaranteed 5 Years

Before you buy any engine for any price, investigate our engines. If your dealer cannot supply you, write us, giving dealer's name, and we will send full information and tell you how to get an engine for trial. *Catalog Free.*

MANUFACTURERS ENGINE CO.
1829 Crystal Ave. Kansas City, Mo

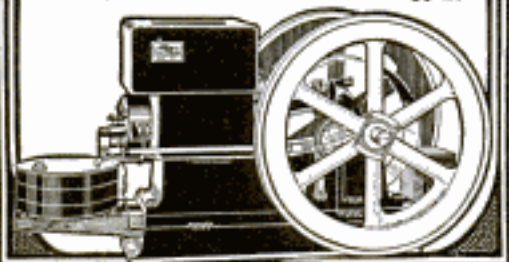

4 H.P. Cushman Weighs Only 190 lbs. 8 H.P. 2 Cylinder Only 320 lbs.

Discussing light-weight motors recently, the Scientific American said: "Efficiency means light weight, reduced friction, and above everything else, lowered operating cost." Cushman Light-weight engines are today recognized as the leading American light-weight, high efficiency, all-purpose motors, challenging comparison in minimum weight per horsepower, reduced friction, quality of material and workmanship and cost of operation.

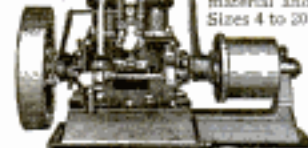

Sizes 4 to 20 H. P. Throttle Governor. Schebler Carburetor. Forced Water Cooling System. Moving parts enclosed and run in bath of oil. Not cheap engines, but cheap in the long run. ENGINE BOOK FREE.

Cushman Motor Works
882 N. 21st St., LINCOLN, NEB.

1c IS WORTH DOLLAR\$

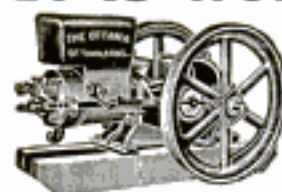

when you invest that 1c in a postal card to us. Here are a few of the good things in it for YOU—

1½ H.P., \$24.75	5 H.P., \$87.50
2 H.P., 28.75	6 H.P., 96.75
3 H.P., 53.90	8 H.P., 135.50
4 H.P., 68.90	10 H.P., 179.90
12½ H.P., \$214.90	

We guarantee against repairs forever
OTTAWA MFG. CO., 2033 King St., Ottawa, Kans.



RELIABLE POWER

Nearly 100,000 Galloway engines in daily use. Large bore, long stroke, heavy weight. Built for hard, continuous engine-use satisfaction. All sizes, prices, styles. Modern design, few parts. Best materials, skilled labor. Positively not overrated. Sold direct. Engine book free. Postal gets it. Invest-
you'll have no other. Address

Wm. Galloway Co., Box 965 Waterloo, Iowa

9875
7750
3950
3475
2675

BESSEMER KEROSENE ENGINE

30 DAYS FREE TRIAL

We say the Bessemer Kerosene Engine is cheapest in the long run—because of low running expense. We have a number of tests to prove this, which will be furnished you upon application. The Bessemer is built as a Kerosene Engine, and is not a converted gasoline type, therefore is freer from trouble and repairs. Sizes 2 to 10 H. P. Also direct connected to pumps, hoists, lighting plants, etc. Get a lot of real facts free by writing today.

BESSEMER OIL ENGINE

recommended where power from 15 to 200 H. P. is required. Burns crude and fuel oil and runs at about 1/3 to 1/4 cost of gasoline. Now being used in irrigation, flour mills, factories, lighting plants. This engine is revolutionizing the power question. Get the facts by writing for Catalog "O."

THE BESSEMER GAS ENGINE CO., 121 Lincoln Ave., Grove City, Pa.

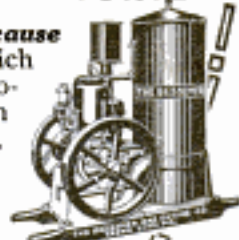

CREDIT to ALL!

Diamonds and Watches

at **LOWEST PRICES**

\$39.50 SPECIAL! Genuine Diamond Ring. Wonderful Value 14K Gold. Credit Terms, \$5 down, \$4.50 a month.

Lowest prices, greatest time-payment offer in U. S. on all famous Alfred Ware Guaranteed Diamond Rings. All Styles. Brilliant, perfect-cut diamonds. Money back 30 days if wanted. Sensation!

17 Jewel ELGIN, \$12.50

Regular \$18 value. Guaranteed Elgin Movement—25-year case. Engraving FREE. World's greatest watch bargain. Free Catalog—66 pages—astounding jewelry, silverware bargains on FREE TRIAL. Address: **ALFRED WARE CO., Dept 489 St. Louis, Mo.**



AGENTS

GET AUTO



This is no selling contest where only one person wins. Anybody can get this auto by introducing our **300 candle-power kerosene lantern** for farmers, teamsters, dairymen, hucksters, plumbers, campers, etc. Everybody needs it. Write for full particulars. **THOMAS MFG. CO., 8648 Rome St., DAYTON, OHIO**

FOR XMAS-A TYPEWRITER!

Look at these bargains! Typewriters Rebuilt in our own Factories, and guaranteed for one year.

Remingtons \$20 to \$55	Smiths \$18 to \$40
Underwoods \$35 to \$60	Royals \$25 to \$45
L. C. Smiths \$30 to \$50	Olivers \$20 to \$35

We have others, of course. Send for catalog describing them, and address of nearest branch office.

American Writing Machine Co., Inc., 345 Broadway, N. Y.



A Football Jersey

Be the First in Your Club



School, City or Town, to wear this pure, all wool sweater, double collar and cuffs. Your choice in colors. This jersey was selected by 10,000 of my customers for last season. Your chum will recommend it. My 1915-1916 catalogue is now ready. Write me and learn my offer for your club's order. Popular Prices. Best Grade Sporting Goods—Football, Basketball, Baseball, Tennis, Golf, etc. **WRITE ME NOW.**

JACK SHANNON CO., Dept. 46, 54 E. Monroe St., Chicago



TYPENWRITERS ALL MAKES

Prices \$15.00 up. SOLD or RENTED ANYWHERE at 1/2 to 1/3 MANUFACTURERS' PRICES, allowing RENTAL TO APPLY ON PRICE. Free Trial. Installment payments if desired. Write for Catalog L.

TYPENWRITER EMPORIUM, 34-36 W. Lake St., Chicago, Ill.

"The Colorado Gem," Newest Product of Our Gem Mines



A beautiful Genuine Topaz, of purest white color, finest Diamond cut, wonderful brilliancy and great hardness. Endorsed by leading experts. Far superior to the best imitation Diamond ever produced. Remember, we guarantee these stones to be genuine. Special price, \$2.00 each, 3 for \$5.00. Size, up to two carats. Free booklet. Address with remittance.

COLORADO JEWELRY MFG. CO.
1526 1/2 Champa St. Dept. 47 Denver, Colo.

Write

for This Free Washing Book



Great big book. Many pictures of actual washings. Tells how to save wear on clothes, how to save money, how to make washday easy—yes, really easy. Absolutely free for the asking. Send coupon today.

One Hour For a Wash!



Only an hour, Madam, to do a good-sized family washing. That's all, if you have a Thor Electric Home Washing Machine. Not a rub to wash finest laces or heaviest clothes. Does all the wringing, too. All you do is to press a button. Madam, learn all about this NEW washday marvel. Send coupon today.

The Thor

The machine which puts a wash-woman in your home each Monday at a cost of 2c. And your clothes are washed clean and white as snow. A special offer is on right now. We want to tell you all about it.

Mail This Free Coupon Special offer!

This coupon brings our 48-page book and all the good news about the better way of washing. Do not fail to mail the coupon for this book right now. It costs you nothing. We will tell you also about the big special offer we are making.

Hurley Machine Co.
29 S. Clinton St.
Dept. 1199
Chicago, Illinois
147 W. 42nd St.
New York, N.Y.

Name of Electric Dealer

Name.....





















Address.....

Hurley Machine Co.
29 So. Clinton Street
Dept. 1199 Chicago
147 W. 42nd St., New York

You may send the free washing book. Also full information about the special offer you are making now.

Please Mention Popular Mechanics

Boys! Here's your Xmas Present!

 2392 Boy Scout Knife, wt. 4 oz.	 2422 Hot Air Engine, wt. 2 lbs.	 3418 Nickel Pocket Light, wt. 4 oz.	 2421 Electric Bike Lamp, (no bat.) wt. 2 lbs.	 1088 1" Bull Dog Spark Coil, wt. 6 lbs.	 WIRELESS DETECTOR Real Wireless Detector, postpaid.
50c	95c	50c	\$1.15	\$4.00	10c
 6000 Wireless Outfit Complete, wt. 3 lbs.	 9000 3" Spark Static Machine, wt. 6 lbs.	 1331 6 volt, 6 amp. Dynamo, wt. 7 lbs.	 5602 Trailer Car Outfit with track, wt. 30 lbs.	 1024 Real Telephone Receiver, wt. 1 lb.	 7555 6 volt. Ema. Storage Battery.
\$1.25	\$3.75	\$3.70	\$5.65	40c	\$8.00
 2365 Rugby Football, guaranteed, wt. 2 lbs.	 1506 Wireless Receiving Outfit, wt. 4 lbs.	 9241 45 Plate Rotary Condenser, wt. 3 lbs.	 5707 18 ft. Xmas Tree Outfit, wt. 3 lbs.	 100 Little Hunter Motor, wt. 1 lb.	 7199 Revolver Flashlight, wt. 1 lb.
90c	\$3.75	\$3.75	\$4.05	85c	95c
 6717 Pedometer (Walk Meter), wt. 1 lb.	<p>When ordering any of the above, include postage, or goods must be sent by express collect. The goods shown here are only a fraction of our wonderful assortment, illustrated and described in our 275 page Cyclopaedia Catalog, containing 658 illustrations, Treatise on Wireless Telegraphy, List of all U. S. Wireless Call Letters, Code Chart and 20 Coupons for Free Wireless Course. Cyclopaedia sent free for 4 cents to cover postage only. Send for a copy today.</p> <h2>The Electro Importing Company</h2> <p>"Everything for the Experimenter"</p> <p>233A Fulton Street NEW YORK CITY, N. Y.</p>				 3356 New 3 volt Dry Battery, wt. 3 lbs.
85c					35c

ELECTRIC LIGHT PLANTS Complete gasoline engine, dynamo, switchboard and storage battery \$240. Agents wanted. American Battery Co., 1129 Fulton St., Chicago (Estab. 1880.)

ELECTRICITY

Ideal Xmas Gifts

Boys—this book is a mine of electrical knowledge, 128 pages full of cuts, complete description and prices of the latest electrical apparatus for experimental and practical work—Motors, Dynamos, Rheostats, Transformers, Induction Coils, Batteries, Bells, Telephone Sets, Telegraph Outfits. Greatest line of miniature **Electric Railways** and parts, Toys and Novelties.

This catalog with valuable coupon sent only for 6c in stamps. (No postals answered.)

VOLTAMP ELECTRIC MFG. CO. Voltamp Block Baltimore, Md.



VENTILATION OF BRITISH HOUSE OF COMMONS—It is an undeniable fact that a room filled with air, which, so far as chemical analysis can detect, is absolutely pure, may feel very stuffy; states a prominent British expert. For instance, in the House of Commons, on the ventilation of which he had experi-

GENERATORS

6 volts, 10 amperes, \$8.50. 8 volts, 10 amperes, \$10.00

For charging storage batteries, plating, operating wireless coils, lighting outfits, etc. Can be attached to automobile or motor head. Our smaller sizes of dynamo motors make ideal machines for experimenting, lighting, etc. As motors they will operate heavy models, emery wheels and other useful appliances.

18 watt dynamo-motor, \$3.00 24 watt dynamo-motor, \$3.85

40 watt dynamo-motor, \$5.25

Send 2 cent stamp for catalog of wireless apparatus, trains, electrical supplies, novelties, tools and books.

Laconia Electric Company, 1427 N. Artesian Ave., Chicago, Ill.

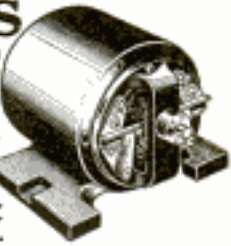

PLEASE THAT BOY

or, if you prefer, please yourself, by a gift of a pair of these

Murdock Wireless Receivers

Real, high-resistance, wireless 'phones, standard in every detail, and possessing exceptional sensitiveness.

Complete double set, 2000 ohms **\$4.00** Complete double set, 3000 ohms **\$5.00**

WM. J. MURDOCK CO.

10 Carter St., CHELSEA, MASS. 680 Howard St., SAN FRANCISCO



Boys—Here's Fun**FREE BIG CATALOG****Ask Dad
For This
TRAIN****Write Quickly for Catalog**

YOU'LL have barrels of fun with a Lionel electric locomotive; couple to it Pullmans or freight cars; get switches, semaphores, electric lights, track, etc. Make the trains scoot around with a touch of your finger. Run 'em on batteries or from electricity in your house with a Lionel transformer which saves batteries. (See illustration.)

250,000 Boys Own Them — Join us — this quarter million of happy boys.

Lionel Electric Trains

are safe — no shocks. They're Steel — not Cast Iron — and won't break. Are highest grade of material throughout, but not high priced. Unconditionally guaranteed. Finished handsomely in colors and gold. Models are faithful reproductions of originals seen on our prominent railroads.

WRITE QUICKLY FOR NEW BOY'S CATALOG — Written especially for YOU, crammed full of pictures. New photos tell you why you'll have such a dandy good time with Lionel Trains.

SECTION OF LIONEL RAIL FREE — Most toy dealers, electrical stores and department stores sell Lionel Toys. If you'll go to your toy dealer, find out if he sells Lionel Trains, and tell me when you write for catalog — I'll include a special section of rail — free.

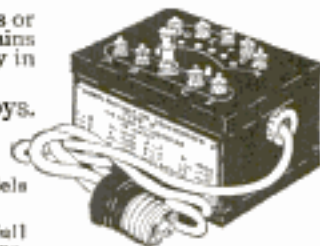

**If You Have Electricity
Be Sure to Get This
Transformer**

THE LIONEL MFG. CO.

486 E. 21st Street
NEW YORK CITY

J. LIONEL COWEN

A Friend of Boys
President

LIONEL TOYS ELECTRIC

mented for many months, the air in the debating chambers is, chemically, as pure as in any room in the world. Fresh air simply pours into it in extravagant volumes. In a moderately full house there are no less than 13,000

**Give Your Boy
A Merry Xmas**
by giving him a
**Thordarson
Improved Toy
Transformer**



Connects his toys directly to A. C. lighting circuit, yet with absolute safety. Arrow points to safety device which prevents all short-circuits. Handy. Portable. Runs a doz. toys at once. Write now for description and prices.
Thordarson Electric Mfg. Co., 518 S. Jefferson St., Chicago

Complete Wireless Sending and Receiving Station \$8.90

Receives hundreds of miles. Sends 8 to 20 miles.

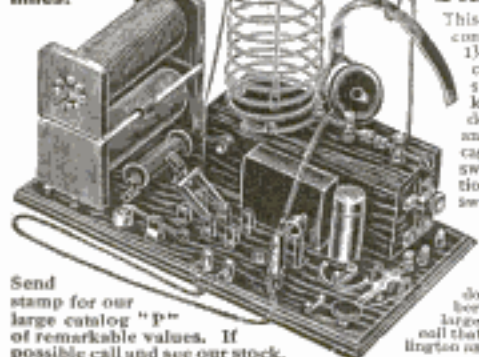

Send stamp for our large catalog "p" of remarkable values. If possible call and see our stock.

THE HANDEL ELECT. CO., 138-140 Centre St., NEW YORK

This remarkable station consists of a guaranteed 1½ in. spark coil, machine turned suted spark gap, our 1501 key, a flat plate condenser, assembled in an oak case, a large capacity bell, DPDT switch, 500 ohm potentiometer, buzzer and switch to tell if your 2 detectors are working, buzzer battery in nicked case, tubular condenser, bare wire wound double slide tuner, sum-ber 30 silk wire wound large capacity loading coil that allows you to get Arlington and long wave stations.

BOYS!*Here's a Man's Job***BUILDING REAL MODELS
OUT OF STRUCTO**

that work just like big machinery. Edison, Marconi and Fulton began when they were boys to build their dreams into inventions that have made them famous. They made models first.

If you're tired of playthings — give them to little sister. And build aeroplanes, battleships, coaling stations, fire trucks that will set Dad to puzzling.

There are more parts — more models in STRUCTO. The shafts are key seated, the gears are cast just like big machinery.

With every five dollar outfit we give you a

Powerful Electric Motor — Free

that will drive the machines you build. Write for our *Illustrated Book*. We will mail it free. It tells you all about STRUCTO. It contains illustrations taken from actual photographs of STRUCTO models. It will win Dad over in a minute when he sees it. Address Dept. G.

STRUCTO Manufacturing Co., Freeport, Ill.

Made in U. S. A.



(3)

DUCK'S NEW BIG No. 9 312-PAGE ELECTRICAL and WIRELESS CATALOG

More than ever justifies your verdict
that it is the *one* catalog worth while

Everything Electrical FOR THE BOY—HOME OR STORE

Only 8c in stamps will bring this unrivalled catalog to your home. The great cost of catalog and the exceptionally low prices (often times fully 25% below usual retail price) prohibits its distribution otherwise. You may deduct the 8c on first dollar purchase.

Our records, which have been verified by a representative of this magazine, show that 70% of our catalogs produce us patrons. Many of our competitors admit the waste of 90% of their catalogs. Who pays for them? This is the big, controlling reason why you should have our catalog, backed by a great selling and purchasing power, before even thinking of buying elsewhere.

Over 40 New Pages of Wireless Instruments and substantial reductions on many popular wireless instruments and standard electrical supplies.

A FEW OF THE ARTICLES IN OUR CATALOG:

129 pp. Wireless Instruments (129 pages) magnet wire of all kinds, raw material, storage batteries, telegraph instruments, battery motors, commercial motors and generators, sewing machine motors, telephones, step-down transformers, massage vibrators, bells, push buttons, auto accessories, flash lights, hand lanterns, auto and miniature lamps, Xmas tree outfits, voltmeters, ammeters, lighting plants, Victrolas, air rifles, electric aeroplanes, model builders, electric railways, electrical and mechanical books and general electrical supplies.

THE WILLIAM B. DUCK CO., 223-227 Superior St., TOLEDO, O.

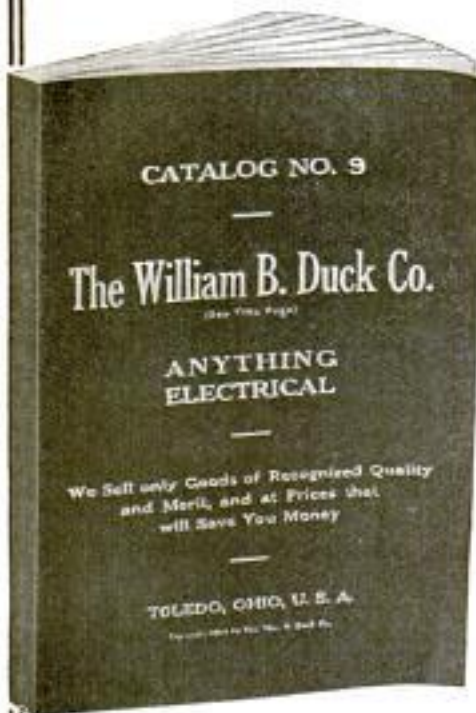

"The Electrical Experimenter"

The big electrical Magazine for those who dabble in electricity and Wireless. Chuck full of experiments. Intensely interesting. Monthly prices of \$5.00 for best experiments. Amateur Electric, Wireless News, Latest Patents 100 articles, 100 to 150 illus. Read the great serial: "Baron Münchhausen's New Scientific Adventures" \$1.00 a year.



Send 10¢ for 3 issues

Electrical Experimenter 234 Fulton Street, N. Y.
10c a copy at News-stands

cu. ft. of air supplied per head per hour. Yet it produces the effects which one is accustomed to think of as associated with defective ventilation—lassitude, sleepiness, infection, etc. A room may, on the contrary,

Old Stamps Wanted FOR CASH. We buy rare or old stamps of any country, also old or large stamp collections, old letter files (from 1848 to 1870) of private individuals or old business or banking firms. **PREMIUM LIST 10c.** Address **C. E. HUSSMAN STAMP COMPANY, Dept. M. O., St. Louis, Mo.**

250 "WIRELESS" TRANSFORMER \$9.00
WATT CLOSED-CORE TYPE 14000 VOLTS 3 DIFFERENT POWERS
SELF CONTAINED Shipping Weight 20 Lbs.
Send 2c stamp for catalogue of Wireless Supplies, folders, etc. Wisger's Telegraph Code Charts free with \$2 orders; otherwise 25c. each. Furnished in "station" or "pocket" size, Continental or Morse code; please state which, otherwise Continental "pocket" size will be sent. Wisger Electric & Mfg. Co., 711 So. Dearborn St., Chicago, Ill.

ELECTRIC HOME, FARM, THEATRE, STORE and TOWN LIGHTING PLANTS. \$18.00 Rectifier Charges Storage Batteries from Lamp Socket Lighting Your Auto Electrically for ONE CENT an hour. Lamps; Dynamos; Engines; Belts; Medical and Storage Batteries; Bells; Books; Sewing Machine and Power Motors; Railways; Bikes, Carriage, Fish, Hunting, Auto and Xmas Lights; Massage and Ozon Machines; Telephones. **MOTION** Picture Theatre Traveling and Permanent Equipments. Big Profits. Ten Cents an Hour Lights Theatre and M. P. Machine. Catalog 3c. **OHIO ELECTRIC WORKS, CLEVELAND, OHIO**

CHRISTMAS JOY

and permanent satisfaction are assured to those who select their purchases from our new catalog. Every reader will find something electrical to please, to lighten his duties, to mystify or to entertain. The best the world affords in motors, dynamos, lighting plants, meters, spark coils, electrical toys, heating and cooking devices, parts for building all sorts of electrical things, motion picture machines, phonographs and wireless telegraph apparatus, are shown in profusion.

Our catalog is invaluable not only to the experimenter or amateur mechanic, but to every wide-awake American.
CLAPP - EASTHAM CO., Manufacturers and Distributors
147 Main Street, CAMBRIDGE, MASS.

Send for your copy now, to-day, while you think of it.

IT'S FREE

Since 1907 our name has been linked only with apparatus which carries a feeling of pride and security.

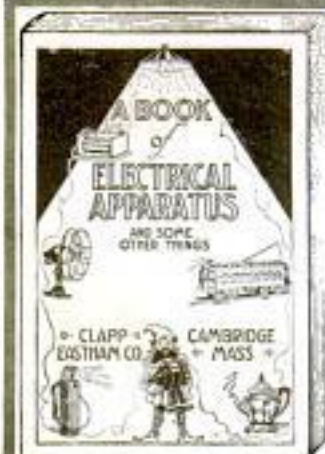

Perfectly Matched Tone



NEW booklet—our Catalog P—explains it. Tells why matched tone gives Brandes Wireless Receivers a sensitiveness that brings in the weak long-distance signals so clearly you sit up and take notice. Catalog P also contains full description and prices of Brandes Receivers. Send stamp for copy today.

C. BRANDES, Inc.
Room 817, 32 Union Square, New York

BRANDES WIRELESS RECEIVERS



Boy Electrician with 75 illustrations for making Batteries, Dynamos, Motors, Telegraph apparatus, Telephone, Lights, Bells, Alarms, Cols, "Wireless" Current Reverser, Electric Engine, Etc. By Electrical Experts so that anyone can understand it. With Cat. All 10c Ppd.

J. C. DORN, 705 So. Dearborn St., Dept. 100, Chicago, Ill.



Big Entertainer 320 Jokes and Riddles, 153 Parlor Games and Magic, 15 Tricks with Cards, 73 Toasts, 7 Comic Recitations, 3 Monologues, 22 Funny Readings, Also Checkers, Chess, Dominoes, Fox and Geese, 9 Men Morris. All 10c. postpaid.

J. C. DORN, 709 So. Dearborn Street, Dept. 17, Chicago, Ill.



Boys' Own Toy Maker

Tells how to make a Talking Machine, Camera, Electrical Motor, Bicycle Boat, Canoe, Boomerang, Bobbed, Wind Mill, Microscope, Water Wheel and Motor, Stills, Toboggan, Snow Coaster and Sail Boat, Telephone, Electric Bell, Railroad Wind Mobs, Paddle Raft, Traps, Kites, etc. All 10c. postpaid.

J. C. DORN, 707 So. Dearborn St., Dept. 80, Chicago, Ill.

Make Music Rolls

10c each. Inexpensive Lebarjan Perfoator makes player-piano rolls from any piece of music written. Music knowledge unnecessary. Pleasure or profit. Details free. LEABARJAN MFG. CO. DEPT. B HAMILTON, OHIO

feel fresh and sweet in which, judged by chemical standards, the air is very bad. There must be some combination of chemical or physical conditions which accounts for the effect—but nobody up to the present has ventured to specify what is that combination.

Ragtime Rastus

Pat'd March 16, 1915



An Automatic Dancing Doll For Disc Talking Machines
Ragtime Rastus is a Dancing Darky Doll, does One Hundred Different Steps to the music. The most amusing novelty you ever saw. Delights young and old.

Price (Postpaid in U.S.A.) \$1.00

NATIONAL TOY CO.

Manufacturers Toys and Specialties
30A Federal St., Boston, Mass., U.S.A.

Civil Engineers Earn \$1500 to \$5000 a Year

Don't take our word for it that these books will fit you to earn \$1500 to \$5000 a year as a Civil Engineer. Get them into your home—free—and determine their value for yourself. The books themselves, not what we say, must convince you that you need them, so send the coupon today—now—for your set of the 1915 edition Cyclopaedia of

Civil Engineering

9 volumes: 3900 7x10 inch pages; 3000 illustrations, photos, plates, maps, diagrams, etc.; hundreds of valuable tables and formulas. Handsomely bound in half red morocco, gold stamped. This great new work covers completely the entire field of Civil Engineering. Tells all about Surveying; Highway Construction; Railroad Engineering; Earth Work; Steel Construction; Specifications, Estimating and Contracts; Bridges Engineering; Masonry; Reinforced Concrete; Water Supply; Sewers and Drains; Water Power Development; River and Harbor Improvement; Irrigation Engineering—everything you need know to become a Civil Engineer.

50c a week if you keep them

The entire nine volumes, not a sample volume, will be sent, express prepaid, on receipt of the coupon below. Look these books over for a whole week free. Then decide whether or not you want them. If you do, send us \$2.00 within seven days and \$2.00 a month—50c a week—until the special advertising price of \$29.80 has been paid. Otherwise we'll take them back at our expense. In addition to this liberal discount from the regular price of \$45.00, we include with each set a \$12.00 Consulting Membership. This entitles you to the advice of a staff of experts for a whole year free!

AMERICAN TECHNICAL SOCIETY, CHICAGO, U. S. A.

FREE EXAMINATION COUPON

Please send me the Cyclopaedia of Civil Engineering for seven days' examination. I will send \$2.00 within seven days and \$2.00 a month until I have paid \$29.80, or notify you and hold books subject to your order. Title not to pass until fully paid.

Name.....
Address.....
As I have had no previous dealings with you, I refer you to.....

P. No. 12-16
A. T. S.

1/2 Saved

On Diamonds, Watches, Etc.
Our Customers Letters Continually Prove This
A firm of over 60 years of unquestioned integrity, backed by \$750,000, is offering diamonds of the finest grade—fully 50 per cent below normal price. Fully guaranteed. Write for bulletins.

Diamond Banking Lending money on diamonds enables us to quote amazing low prices.

Free Examination
We will send prepaid the gem or watch of your choice on approval. If not satisfied with article after seeing it, return at our expense.

Write Today for Latest Bulletin
Send your name and address for latest bulletin of diamond bargains. No obligations—write today—now.

Jos. DeRoy & Sons Only Opposite Post Office
199 DuRoy Bldg., Pittsburgh, Pa.
Reference by permission—Partners Deposit National Bank, Marine National Bank or any Pittsburgh daily Newspaper.

GOV'T JOBS OPEN

Railway Mail Clerks, City Carriers, Rural Carriers
City Postal Clerks, Panama Canal Clerks

\$800 TO \$2000 A YEAR, FOR LIFE

Rapid advancement to higher Government Positions. No "lay-offs" because of STRIKES, FINANCIAL FLURRIES or the WHIMS OF SOME PETTY BOSS. THE POSITION IS YOURS FOR LIFE. Country residents and city residents stand the same chance for immediate appointment. Common-sense education sufficient.

WE GIVE FREE SCHOLARSHIPS

Write immediately for schedule showing the places and dates of the Winter examination. Don't delay. Every day you lose means the loss of just so much coaching before the rapidly approaching examinations.

FRANKLIN INSTITUTE Dept. F-97, Rochester, N. Y.

FRANKLIN INSTITUTE The Pathway to Plenty

Dept. F-97, Rochester, N. Y.

This coupon, filled out as directed, entitles the sender to free sample questions; a free copy of our copyrighted book, "Government Positions and How to Get Them," a full list of positions now obtainable and to consideration for Free Coaching for examination here checked.

COUPON

- .. Railway Mail Clerk [\$800 to \$1800]
- .. Postoffice Clerk [\$800 to \$1200]
- .. Postoffice Carrier [\$800 to \$1200]
- .. Rural Mail Carrier [\$200 to \$1200]
- .. Bookkeeper [\$800 to \$1800]
- .. Customs Positions [\$800 to \$1500]
- .. Internal Revenue [\$700 to \$1500]
- .. Stenographer [\$800 to \$1500]
- .. Clerk in the Departments at Washington [\$800 to \$1500]
- .. Canadian Government Positions.

Name.....
Address..... F-97
Use this before you lose it. Write plainly.



LET your friends give you pretty trifles, but request that a *Bissell's Carpet Sweeper* head the family's gifts. If you already own this famous sweeper, tell them you want a *Bissell's Vacuum Sweeper*. Then you will be equipped with the most efficient cleaning apparatus that can be installed in any home—*Bissell's Carpet Sweeper* for daily sweeping and a *Bissell's Vacuum Machine* for suction cleaning and general renovation.

BISSELL'S

Carpet Sweeper or Vacuum Sweeper

sell at moderate prices and make a "*Bissell's*" an economical gift. *Bissell's Carpet Sweepers* are \$2.75 to \$5.75; the *Vacuum Cleaner* (without brush) \$7.50; the *Vacuum Sweeper* (with brush) \$9.00. Slightly higher in the West, South and Canada. Sold by dealers everywhere. Booklet on request.

BISSELL CARPET SWEEPER CO.

Largest Exclusive Manufacturers of Carpet Sweeping Devices in the World

Dept. 107 GRAND RAPIDS, MICH.
Made in Canada, too (240)



FORD RACERS

REBUILD YOUR FORD CAR
Sketches, specifications, and instructions. Prepaid for twenty-five cents. T. M. Co., Dept. A, Box 212, Woodford, Maine



ACORN UNI-LITE FREE

Turns night into day. 300 candle power. Carry as a lantern; use anywhere as a lamp. Weather proof. For house, barn, garage, camp and around the farm. Write for *big free offer*. *Special opportunity to farmers, stockmen and motorists. Agents make big money.*

WRITE TONIGHT
ACORN BRASS MFG. CO., 602 Acorn Bldg., Chicago



"AMERICAN" Key Cutter

ADD TO YOUR INCOME

The "AMERICAN" is the only machine on the market (barring none) that sharpens, hones, and strops razors, sharpens all kinds safety razor blades, scissors, clippers, pocket knives, surgical instruments, etc. No previous experience required. REMEMBER THE "AMERICAN" Key-Cutter is a little wonder. Cuts Square, Angular or Round slots.

AMERICAN SHARPENING MACHINE CO. (Inc.)
Dept. 12 184 W. Washington St. CHICAGO



"AMERICAN" Sharpener

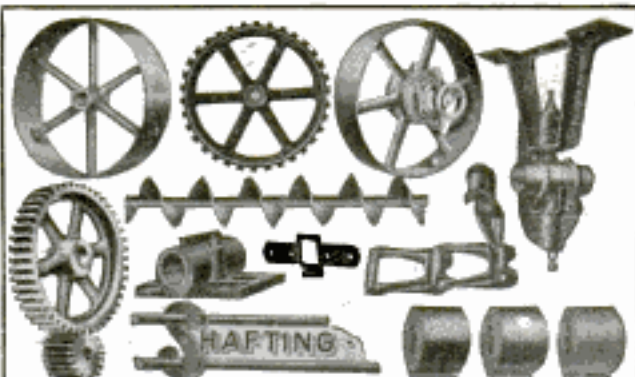

A complete line of appliances for the transmission of Power. Anything from a belt to a complete mill or factory outfit. Send for catalogue. Largest Manufacturers of Pulleys in the country. **W. A. Jones Foundry & Machine Co. CHICAGO**
1400 W. North Ave.

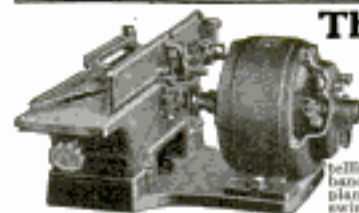

The CRESCENT BENCH JOINTER

is just the machine a lot of wood workers have been looking for. It is designed primarily for pattern makers and carpenters, but it will as well serve the purpose of the amateur wood worker.

Ask today for our 1915 catalog telling about this machine and our line of band saws, jointers, saw tables, planers, shapers, and routers, disk grinders, swing cut off saws, shapers, Universal wood workers, Variety wood workers.

THE CRESCENT MACHINE CO., 93 Columbia St., Leetonia, O.



GOOD AGENTS

Wide awake, energetic Men can secure protected Territory to sell our portable Lamps, Lighting Systems and our 250 C. P. Inc. Gasoline Lanterns, which are positively the simplest and most practical gasoline devices on the market. We challenge competition. **Your Chance.** Territory is being rapidly taken. If you want a good, steady income, write to us TODAY.

INTERNATIONAL LIGHT NOVELTY & SPECIALTY CO.
426 So. Clinton St., Dept. 78, CHICAGO, ILL.



The United States at present in time of peace expends over \$800,000 a day on the army and navy, of which more than \$10,000 a day is for smokeless powder alone.

The first directory of New York City, which was published in 1783, contained only 52 pages and had an introduction by Noah Webster. It listed 854 names, as against a million in the 1915 directory.



POWERLIGHT

Highest Award Inter. Exp. 335 C. P.—20 Hrs. 1 qt. Kerosene or Gasoline Equal Safety. Thousands of Satisfied users. Read and sew without spectacles—Saves eyes.

Daylight's GREATEST COMPETITOR

5 yr. Guarantee—20 styles—5 finishes. Everybody buys—Sure sale when seen. AGENTS—Contract exclusive territory. 100% Profit—Samples Loaned.

POWERLIGHT CO., 543 Broadway, NEW YORK



Hartman Will Trust You

Rock Bottom Prices

Furniture, Carpets, Rugs, Etc.
Easiest Terms
Hartman's credit terms easiest, most liberal ever offered. No security—no notes—no mortgages. Free from all objections. At the end of a month you may return anything unsatisfactory. Hartman refunds your money including freight.

FREE—Big Bargain Book Over 5,000 bargains. Write today for FREE copy.

HARTMAN FURNITURE AND CARPET CO.
3945-47 Wentworth Av., Chicago



Build an Aeroplane that *Flies*

Thousands of live boys, and grown-ups too, are racing model aeroplanes that they have built themselves. It's the great new American sport.

By means of our simple, easily understood directions and working plans (drawn to scale) we'll show you how to construct an

Exact 3-Ft. War Model

A real miniature flying machine with which you can have intensely fascinating and instructive sport.

In addition to plans and directions we supply Construction Outfits. These include all instructions and also all necessary parts in knock-down form that permits ready assembling. You can get "Ideal" Construction Outfits for all types of model aeroplanes. One of our most popular sets is that for the

"Ideal" 3-Ft. Curtiss Military Tractor

An exact scale reduction of the machines which are supplied to the U. S. Government and also being shipped in large numbers to Great Britain for use in the EUROPEAN WAR. Outfit includes stream-line aluminum disc wheels, carved 12 in. propeller, ball-bearing shaft, etc. *Guaranteed to rise from the ground by its own power and fly.* Complete, ready to assemble, with building and flying instructions - Price **\$5**

The Best Present of All for a Boy

Scale drawings and instructions *alone* for all 3 ft. models are offered at following prices:

Curtiss Military Tractor	25c	Bleriot Monoplane	15c
Curtiss Flying Boat	25c	Taube Monoplane	25c
Curtiss Hydroaeroplane	35c	Wright Biplane	25c
Nieuport Monoplane	25c	Cecil Peoh Racer	25c

SPECIAL:—Complete set of above 8 plans \$1.60

"Ideal" Flyers Fly from 100' to 500 ft. Being simpler in design, they cost less

than our regular war models. Prices are as follows:

"Ideal" 3 ft. Racer, assembled	\$3.50	Blue Bird Racing Aeroplane (22 in.)	\$1.25
"Ideal" 3 ft. Racer in knock-down form,		"Ideal" Speed-o-Plane (1 ft.)	.65
all parts and plan	2.50	"Ideal" Loop-the-Loop Glider	.30

There's a toy, game or department store near you at which you can get "Ideal" Model Aeroplanes and Flyers. If you can't find the store, write us. Write today for our 50-page Aeroplane Book, containing full information, prices for parts, complete models, etc., postpaid 5c.

IDEAL AEROPLANE & SUPPLY CO., 82-88 West Broadway, New York City



"Ideal" 3 ft. Nieuport Monoplane, complete outfit with all parts and plans, ready to assemble, **\$5**



"Ideal" 3 ft. Taube Monoplane, complete outfit with all parts and plans, ready to assemble, **\$4.25**



"Ideal" 3 ft. Bleriot Monoplane, complete outfit with all parts and plans, ready to assemble, **\$4.25**



PRIZE FOR MUSIC SETTING TO MUNICIPAL ANTHEM—The city of Baltimore, having adopted as its municipal anthem a poem entitled "Baltimore, Our Baltimore," which won the prize in a recent competition, now announces a contest, open to all citizens of the United States, for the best original musical setting to

BUILD YOUR OWN MOTOR For Bicycle or Motor-Bob

Send 25 cents (not stamps) for drawings and instructions and price list of finished parts. You can build it with few tools.

STEFFEY Motor, 5025 Brown St., Philadelphia, Pa.

TOOTH-ACHE STOP Stops the Pain; Stops the Tooth

Agents Wanted

TOOTH-ACHE STOP PRICE 25 CENTS 2 for 50 CENTS
ENOUGH TO STOP 30 TOOTHACHES Easy to use.
Squeeze a little of this paste into hollow in the tooth and the **ACHE STOPS INSTANTLY**, then the paste hardens, forming an antiseptic stoppage for the tooth, excluding the air and preventing a recurrence of the agony. **Guaranteed Absolutely Harmless**—will not spread and burn mouth. **Get** Have it ready for the next bad attack. A perfect evidence at two in the morning.
NATIONAL CHEMICAL CO., 7123 No. Clark Street, CHICAGO

Be The Auto Top Expert

IN YOUR TERRITORY

Earn \$10 AND MORE Per Day

Our copyrighted measurement system of making Auto Tops saves buyers nearly half the cost. Wherever introduced it controls the Auto Top business because low prices, perfect fit and high grade material get the orders. We will give live, hustling men exclusive territory to take orders and attach tops. You can learn how in a few hours and make \$10 per day at the start. Under our system you have no competition. Our low prices and samples get the order every time and we guarantee satisfaction. Our national advertising brings you customers. As your business grows live help and spend your time getting orders. Thousands of tops, worn by past season's use, must be replaced. This is your opportunity, the biggest offered any man where no capital is required. Necessary working tools furnished at cost when required. Write now, today for catalog, samples and full information free. We quote you for Seat Cover Business, too. Also have many interesting specialties.

AUTO SPECIALTY FACTORY

1011 Spring Street CINCINNATI, OHIO

A Profitable Vocation

STUDENTS ARE ENABLED TO CONTINUE THEIR STUDIES THROUGH THE COMPENSATION RECEIVED BY LETTING PRICE TICKETS and SHOW CARDS for the SMALLER MERCHANT, OUTSIDE of SCHOOL HOURS. Practical Lettering outfit consisting of 3 Marking and 3 Shading Pens, 2 colors of Lettering Ink, sample Show Card in colors, instructions, figures and alphabets. Prepaid, **\$1.**

PRACTICAL COMPENDIUM of COMMERCIAL PEN LETTERING AND DESIGNS, 100 PAGES, 8x11, containing 122 plates of Commercial Pen alphabets, finished Show Cards in colors, etc., also

large list of crisp business Advertising Phrases—a complete instructor for the Marking and Shading Pen. Prepaid, **\$1.00.**

TRADE MARK Address, **NEWTON AUTOMATIC SHADING PEN CO., Dept. A, PONTIAC, MICH., U.S.A.**

\$1⁰⁰ DOWN

Billiards and Pool are fine, clean, interesting games—games that fascinate with their close, exciting, constantly changing situations—games that test the skill of hand, eye and brain, and arouse the keenest sort of friendly rivalry—games that the whole family will enjoy.

Under our easy payment plan you will be surprised to find how easily you can own a handsome Burrowes Billiard and Pool Table. No special room is needed. The Table can be mounted on dining or library table or on its own legs or stand, and quickly set aside when not in use.

BURROWES

Billiard and Pool Table



is splendidly built, on scientific principles, and correct to the minutest detail. The rubber cushions used are the Burrowes Regis High-Speed Cushions—great experts say there is nothing better made. The most delicate shots, calling for skill of the highest order, can be executed with the utmost precision.

FREE TRIAL Prices are from \$15 up, on easy terms of \$1 or more down (according to size and style) and a small amount each month. You can play while you pay. Sizes of Tables range up to 4½ x 9 feet (standard). Cues, balls, etc., free with each Table.

WRITE FOR ILLUSTRATED CATALOG

Containing free trial offer, prices, terms, order blank, etc. Don't delay—write today!

THE E. T. BURROWES CO.
162 SPRING STREET
PORTLAND, ME.

*Mfrs. Burrowes Rustless Screens,
Burrowes Folding Card Tables,
Burrowes Cedar Chests.*

This Watch, Fob and Pin Set, \$14.75

Regular Price \$21.50

To introduce our high grade Sawcraft jewelry we offer these Watch, Fob and Pin sets for less than the price of the Watch alone. The movements are genuine Elgin or Waltham 15 ruby jewels, adjusted and regulated to close time. The case is heavy gold filled, warranted for 20 years. Fob and Pin monograms are made of heavy gold front and will wear like solid gold.

Regular price of this set \$21.50
Our special price \$14.75

Send your initials and \$2.00 to show you mean business, and we will make Fob and Pin to your special order and engrave watch case to match. If not as represented return and we will bear the loss; if satisfactory pay balance of \$12.75 and the set is yours.

Write for illustrations and prices

SAWCRAFT JEWELRY WORKS
Dept. 6, Box 843 Milwaukee, Wis.



this prize poem. The prize offered is \$250 in gold, and the competition closes Dec. 1, 1915. The rules governing the contest as well as a copy of the poem can be had by addressing The Municipal Song Contest, care of Frederick R. Huber, Peabody Institute, Baltimore, Maryland.

Do You Shoot? Send for Book—A New Chapter in an Old Story

—the history of projectile arms from primitive times to the most advanced sporting arms of today. Concise and interesting. Contains several full page game pictures in color. Send 50 cents (less than cost of production) to

REMINGTON ARMS-UNION METALLIC CARTRIDGE CO., 233 Broadway, New York City

30 Days FREE TRIAL

and freight prepaid on the new 1916 "RANGER" bicycle. Write at once and get our big catalog and special offers before buying.

Marvelous improvements. Extraordinary values in our 1916 price offers. You cannot afford to buy without getting our latest propositions. WRITE TODAY.

Boys, be a "Rider Agent" and make big money taking orders for bicycles and supplies. Get our liberal terms on a sample to introduce the new "RANGER."

Tires, equipment, sundries and everything in the bicycle line half usual prices. Auto. and Motorcycle Supplies.
MEAD CYCLE CO., DEPT. H108 CHICAGO



HERMAN'S US ARMY SHOES

"The New United States Army Shoe on the Munson last is the only perfect shoe made."—*Lieut. Townsend Whalen, U.S.A.*

It allows natural foot freedom while setting snug at the heel and will not chafe, bind, pinch or blister under severe tests of climate and service. Every U. S. Soldier, most militiamen and thousands of civilians wear it. Every Sportsman and outdoor worker ought to have a pair. Ask your dealer or send to us for catalog and testimonials.

The price is \$4.50 a pair, prepaid. A fine Christmas gift.

JOS. M. HERMAN SHOE CO.
160 Lincoln St., Dept. 56, Boston, Mass.



Earn Money Soldering

OUR NEW BOOK
SOLDERING KINKS

contains 32 pages of soldering instructions and suggestions selected from many hundreds of letters from every day users of **NOKORODE**—the perfect soldering flux.

Worded plainly—fully illustrated

Sent postpaid for 25c coin or stamps

150 Niagara St.



THE M. W. DUNTON CO. PROVIDENCE R. I.



Tobacco Habit BANISHED

in 48 to 72 Hours

No Desire After First Dose

Trying to quit the tobacco habit unaided is a losing fight against heavy odds, and means a serious shock to your nervous system. So don't try it! Make the tobacco habit quit you. It will quit you if you will just take Tobacco Redeemer according to directions.

It doesn't make a particle of difference whether you've been a user of tobacco for a single month or for 50 years, or how much you use, or in what form you use it. Whether you smoke cigars, cigarettes, pipe, chew plug or fine cut or use snuff Tobacco Redeemer will positively remove all craving for tobacco in any form in from 48 to 72 hours. Your tobacco craving will begin to decrease after the very first dose—there's no long waiting for results.

Tobacco Redeemer is absolutely harmless and contains no habit-forming drugs of any kind—the most marvelously quick and thoroughly reliable remedy for the tobacco habit the world has ever known.

Not a Substitute

Tobacco Redeemer is in no sense a substitute for tobacco, but is a radical, efficient treatment. After finishing the treatment you have absolutely no desire to use tobacco again or to continue the use of the remedy. It quiets the nerves, and will make you feel better in every way. If you really want to quit the tobacco habit—get rid of it so completely that when you see others using it, it will not awaken the slightest desire in you—you should at once begin a course of Tobacco Redeemer treatment for the habit.

Results Absolutely Guaranteed

A single trial will convince the most skeptical. Our legal, binding, money-back guarantee goes with each full treatment. If Tobacco Redeemer fails to banish the tobacco habit when taken according to the plain and easy directions, your money will be cheerfully refunded upon demand.

Let Us Send You Convincing Proof

If you're a slave of the tobacco habit and want to find a sure, quick way of quitting "for keeps" you owe it to yourself and to your family to mail the coupon below or send your name and address on a postal and receive our free booklet on the deadly effect of tobacco on the human system, and positive proof that Tobacco Redeemer will quickly free you from the habit.

Newell Pharmacal Company
Dept. 300, St. Louis, Mo.



**Mail Coupon NOW
for FREE Booklet**

NEWELL PHARMACAL CO.,
Dept. 300, St. Louis, Mo.

Please send, without obligating me in any way, your free booklet regarding the tobacco habit and proof that Tobacco Redeemer will positively free me from the tobacco habit.

Name

Street and No.

Town State

Please Mention Popular Mechanics

BARNEY & BERRY

SKATES

BOYS



What do you know about ice hockey?
How would you go about building an ice rink?

Send for the Barney & Berry catalog for 1915. It contains valuable information and illustrates the "American Club," the "International," the "All Clamp," the "Tubular Hockey," the "Canadian Hockey," the "Continental" skates and others of a complete line.

FOR FIFTY YEARS
BARNEY & BERRY

scientifically constructed skates have defied competition in all higher grades, and enjoyed the unqualified endorsement of professional ice skaters generally.

If your dealer cannot supply you with the style you select we will send prepaid upon receipt of price.

BARNEY & BERRY 137 Broad Street
SPRINGFIELD, MASS.

The Little Sho-Fur for FORD CARS

This little spring does the trick. Safety assured. No more tired wrists. Simplest, lightest, safest, and cheapest, perfect steering device on the market. Every Ford owner must have one. Write for full description. This is a gold mine for you. Ford Owners buy at sight. Dollar an hour profit. Sales guaranteed. Full details free.

Price **\$3**
Prepaid

Agents: White Mfg. Co., Dept. F, Cincinnati, O.

2 H.P. \$35 BEST ENGINE VALUE

Look at the Size, Power and the Price

Complete, no extras to buy. Four cycle, speed regulation constant. Power steady and smooth. Cheap to run. Free details.

The Self-contained Unit Power Plant

C. BENNINGHOFEN & SONS, Dept. 125, Hamilton, Ohio

FURS TRAPPERS

We can put many dollars in your pocket this season. Ship your furs direct to us and save commission and other charges. We have one million dollars to pay out in cash for furs.

We are the largest direct buyers of furs in the world and will pay you the most money for your furs at all times. Drop us a postal today and we will show you how and why we can make more money for you.

Most up-to-date Trapper's Guide FREE. Traps at factory prices, baits and other supplies. Write us today.

I. ABRAHAM
218 N. Main Street, St. Louis, Mo., U. S. A.

FURS

The American War Relief Clearing House for France and her allies, in a recent bulletin, states that there is great need at present at its Paris headquarters for bed sheets and other hospital linens, and appeals to the charitable public for contributions of funds for their purchase. Gifts in money should be forwarded to Clyde A. Pratt, executive secretary of the clearing house, 15 Broad Street, and supplies, which should be prepaid, to its warehouse, 150 Bank Street, New York City.

EVINRUDE

Detachable Rowboat and Canoe Motors attached in a few minutes to any kind of boat, make it a power boat. Can be carried anywhere. Automatic Reverse. Built-in Magneto, Maxim Silencer. Illustrated Catalog free.

EVINRUDE MOTOR CO.
31 Evinrude Block, Milwaukee, Wis., U. S. A.

STANWELD Cold Drawn Tubing

Seamless Steel Tubing made. Lightest, smoothest, strongest Steel Tubing made. World's largest manufacturers of bicycles, motorcycles and automobiles use it exclusively. Send for Folder "A."

THE STANDARD WELDING COMPANY
Main Office and Factory CLEVELAND, OHIO

THINK of a detachable bicycle Motor that you can attach to any bicycle in 5 minutes and ride at any speed up to 25 miles an hour—100 to 125 miles on one gallon of gasoline. Thoroughly practical—simple and economical. Full control from one small thumb lever attached to the handle bars of the bicycle. Descriptive literature on request.

A. O. SMITH COMPANY
Motorwheel Division 127
MILWAUKEE, WISCONSIN

Please Mention Popular Mechanics



SPORTING GOODS now sold on a value basis for the first time

For the first time, you are able to obtain quality such as only a specialty store can give and value which you can secure nowhere except from a mammoth organization like The Charles William Stores. Our Sporting Goods Store is but one of 43 stores, but it is an entirely separate specialty store in charge of experts.

New York's Best Merchandise Brought to You

The same high-grade merchandise which you would get from the most exclusive sporting goods store is brought to you in this book—and at a big saving. Although the prices you pay when you buy from a specialty sporting goods store are high, heretofore it has been necessary to pay them in order to get quality. But this book makes exorbitant prices no longer necessary. Specialty sporting goods stores must and do make large profits because they have heavy expenses, all of which you must pay when you buy from them. When you buy from us, you get the benefit of our tremendous cash buying power and our money-saving, direct selling system through which we save middlemen's profits and expenses. When you buy from us, you pay only our one small profit—you keep for yourself the money which would otherwise go to the middleman.

FREE New 1916 Book of 2000 Bargains

80 pages. Just off the press. Send no money! Merely a postal card brings you this free catalog of The Charles William Sporting Goods Store, fully prepaid. It quotes special offers on nearly 2000 articles—standard makes—for all sports. Nowhere else can you have so big a variety to choose from. This new book is free—write a postal card, simply say, "Send me your Sporting Goods Book Free." Address—

Charles William Stores 1052 Stores Building
New York

IF IT ISN'T
AN EASTMAN
IT ISN'T A KODAK

Agents \$60 WEEKLY

Robinson Folding Bath Tub. Big seller. Costs little, no plumbing, little water. Weight 15 pounds, folds into small roll. Full length baths, far better than tubs. Guaranteed 10 years. \$10 a day easily made. Write for free 16-color, Robinson Catalog Mfg. Co., 351 Factoria Bldg., Toledo, O.

Argo Standard

Standard tread, 4-cylinder motor; full streamline body; a wonder at the price.

Roadster
\$385

f.o.b. factory

Touring Car
\$435

f.o.b. factory

Electric lighting and starting system, \$60 additional

Not only the most but the best that such a price has ever bought.

ARGO MOTOR COMPANY, Inc.
614 Main St. JACKSON, MICHIGAN

All these are Regular **Pope** Made Bicycles

Columbia Tribune
Cleveland Crescent
Rambler Pope

Fitted with Coaster Brakes

That means that every one of them has behind it 38 years of experience in making bicycles that are known the world over for their superb workmanship—thoroughness of equipment—attractiveness of appearance.

The best present you can give yourself or anyone else is a Pope-made Bicycle. It's the modern necessity. It takes you to and from your work

—paying for itself in the saving of car-fares. And when work is over—it saves doctor's bills by giving you healthful exercise in the open.



Tell us the bicycle you want and we will send you a catalog.

Pope Motorcycles

Light-weight . \$150

Twin Motor
three-speed \$275
("Champion of the Hills")

Single Speed . \$225
("The Greyhound of the Road")

*Send for our
motorcycle catalog*

Dealers in every town

WESTFIELD MANUFACTURING COMPANY

Successors to Pope Manufacturing Company

15 Lozier Avenue, Westfield, Mass.

*Largest Manufacturers of High Grade
Bicycles in the World*



WE ARE HEADQUARTERS FOR

ELECTRICAL GOODS and WIRELESS APPARATUS

OUR 216 pp. CATALOG IS THE BEST ONE PUBLISHED



EXPERIMENTERS

THIS IS THE Experimenter's Reference Book

It's the latest edition of the famous Amco Catalogue, contains over 200 pages and is fully illustrated. Complete descriptions and prices of the latest electrical and experimental apparatus—Storage Batteries, Rectifiers, Transformers, Induction Coils, Wireless Apparatus, Lamps, Flashlights, Motors, X-Rays, Books, Tools, Electric Railways, Steam Engines, Water Motors, Dynamos, Motors, Telegraphs, Telephones, Electrical Supplies, Model Aeroplanes and Parts for building your own apparatus. 6c in stamps will bring you this wonderful book. Contains a complete list of Wireless Calls, gives Codes, Wiring Diagrams, tells how to put up an aerial and install apparatus, etc. Best catalog of Wireless and Electrical Apparatus, etc., published. Send for this catalog right away. Our prices will save you money. 6c in stamps brings it by return mail.



LOTS OF FUN FOR BOYS!

3 1/2 volt, 2 C. P. TUNGSTEN lamp, switch, socket, 20 ft. insulated wire and 3 rolls of dry battery all ready to install. May be used to light a dark closet or hall.
Price only 60c. Postage extra 15c



LITTLE GIANT MOTOR

Is nearly 4 in. high. Runs at high speed on a single cell of battery. Very powerful and may be used to run small toys, etc. Just the motor every boy has been looking for. Sent postpaid for only 50c

THE SIMPLEX TELEGRAPH OUTFIT

An opportunity for every boy to learn to telegraph and to get up a line with his chum. This is a full sized telegraph set, consisting of a fine key and receiver, mounted on a polished base. Will work any distance. An excellent Field Telegraph for Boy Scouts. Price, 90c. Postage Extra. Wt. 2 lbs.

UPRIGHT STEAM ENGINE

A fine engine of the best materials. 9 in. high. The Right Engine for Any Boy. Runs at high speed. Each engine tested at factory and fully warranted. Sent postpaid for only 50c

SIMPLEX WIRELESS OUTFIT

Every boy wants a wireless. Get in this interesting game and read the messages flying around you. This outfit is the greatest bargain ever offered. Consists of a large double slide tuner, a sensitive detector, condenser, telephone receiver and cord. Weight, 8 lbs. Special Price, Complete, \$2.25. Postage Extra.

Put an Electric Headlight on Your Bicycle

Every Boy wants a practical electric headlight for his bicycle. NO MATCHES—NO OIL—NO BOTHER. Shoots a powerful beam of light 200 ft. ahead. Burns 40 hours on one battery. Has powerful silver plated reflector and magnifying glass 4 inches in diameter. May be adjusted in any position. Comes complete with tungsten bulb, cord, battery case, etc.

PRICE ONLY \$1.75
A FINE CANOE LIGHT



FUN WITH ELECTRICITY

Here is a rare chance to get started right in your study of electricity. This wonderful outfit contains 46 page book of instructions and all the apparatus for performing 60 interesting and spectacular experiments which will give any boy a practical knowledge of electricity.
Price Only 50c. Postage 10c Extra



FUN WITH MAGNETISM

This outfit contains 32 page book of instructions and all the apparatus for performing 41 fascinating experiments. It will give you some new ideas about electricity and magnetism in such an interesting way you can't help remembering it. Price only 25c. Postage extra 5c

THE AMCO SPARK COIL

Here is a chance for every boy to get a powerful spark coil at a bargain price. It gives a crashing spark nearly 1/2 inch long and will send wireless messages over a mile. Price only \$2.25. Postage extra on 4 lbs.

VEST POCKET FLASHLIGHT

One of the handiest little flashlights on the market. Slips into the purse or vest pocket. Nickel plated case and tungsten bulb. Sent postpaid for only 60c.



ADAMS-MORGAN COMPANY "The Experimenter's Supply House"
25 Alvin Place UPPER MONTCLAIR, N. J.

WHY WELD

When you can do better work in one-fourth the time, at one-fourth the price, by using the latest great discovery.



No welding. No oxidization. No flux necessary. Runs at low temperature. Easily applied with gas-line torch, blowtorch or gas blower. Is twice as strong and much harder

than aluminum. Never breaks at soldered point. Convince Yourself by Trying It.

Used by Internat'l Motor, Locomobile, Packard, Stanley, Pierce Arrow, Brewster, Demarest, Studebaker, Simplex, Aeroplane manufacturers and U. S. Navy. Write for Booklet 1.

\$3.50 per lb. - Sample bar (1/2 lb.) \$1.50 net cash

SO-LUMINUM MFG. & ENGINEERING CO., Inc.
Sole Manufacturers and Distributors
United States Rubber Co. Bldg., 1790 Broadway, New York

DRINK PURE WATER

Disease lurks in unfiltered water. **BOHNER'S SELF-CLEANSING FILTER** insures health and sells on demonstration.

BOHNER MANUFACTURING CO.
1009 S. Wabash Ave., Chicago, Ill.



AGENTS WANTED

Easily attached to the faucet without tools.

SAFETY FIRST Yale Electric Lantern



and Combination Horse Lamp, Search and Flash Light. This is NOT a Toy. Turn a switch and you get a flood of light! The safest, handiest, most simple all-around light for motorists, campers, sportsmen, mountaineers, farmers, etc. Eliminates: Filling, matches, oil, grease, smoked chimneys, trimming of wicks and other troubles. Always ready when wanted. Introductory Price \$3.50. A sample will be sent by prepaid parcel post on receipt of remittance of introductory price. Order sample and agents' proposition now—be the first. Sold on money-back guarantee. A big money-maker for agents. Agents Wanted Everywhere. International Light, Novelty & Specialty Co., 424 S. Clinton St. Chicago, Ill.

HENDERSON 4-CYLINDER MOTORCYCLE

1916 Models

Single-Speed \$265 Two-Speed \$295

HENDERSON MOTORCYCLE CO.
1160 Cass Ave. DETROIT, MICH.

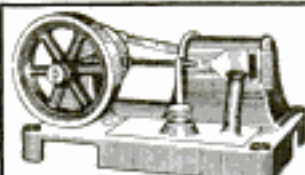

PUZZLE

What Makes It Go?

Many have tried, but few have solved it.

Pat. May 8, 1911

A perfect toy that "grown-ups" will enjoy, built of high grade steel and castings carefully machined.

A REAL ENGINE in Miniature

Has 1 inch cylinder, 1 1/4 inch stroke, speed 2000, exhausts like a motor boat. Has surprising amount of power. Useful for experiments. Ask your dealer for the SPEEDWAY or we will send C. O. D. prepaid. Price, \$3.50

Speedway Toy Mfg. Co. 219 Gibbons Arcade DAYTON, O.

Please Mention Popular Mechanics

SUPERIOR SINCE 1904

A limited number of slightly Trial-Worn and agents' demonstrating samples, will be sold, while they last, for

\$5 CASH WITH ORDER subject to refund after 10-day trial. Guaranteed to be in perfect operating condition for at least 1 year.

E. Geacher A.A.M. Co., 148 Duane St., New York

Golden Gem PORTABLE \$5 Adding Machine

Multiples - Subtracts

Rock Bottom Prices On Best Roofing

Grab This Bargain Before It Is Too Late

Far better than wood. Easier to lay. Lasts 5 times as long. Always tight. No after-trouble or expense. Present low prices run't last much longer. NOW is the time to take advantage of this wonderful rock-bottom offer on

"REO" Metal Shingles

On forever. Moisture proof, sun proof, rot proof, fire proof. That's because of the Edwards "Highcode" process and interlocking device. Every fraction of surface—top, bottom and sides—completely galvanized, each sheet dipped separately in molten zinc.

"Money-Back" Guarantee

A real guarantee fully protects you against trouble. And a further \$10,000 guarantee says "no loss from leaching." Easy to lay. Come in shingles in handy sheets 5 to 12 feet long. You can do it yourself with hammer and nails. Nail holes covered by upper layer.

Complete GARAGE Factory-to-You Set up easily anywhere. Fire proof and thief proof. Ask for free 64-page catalog, which gives all particulars. Tremendous output enables us to cut prices down. No in-between profits. We prepay freight. Ask for

Big Bargain Book on Edwards Roofing. Free. It will save you money & double before prices go up. WRITE NOW before prices go up. THE EDWARDS MFG. CO., 1200-1250 E. Lock Street, CINCINNATI, O. World's Largest Manufacturers of Sheet Metal Products

WHY IS A SHIP CALLED "SHE"?—Nothing is found in the naval archives to show why a ship is always spoken of as "she." In German the word ship, "Schiff," is neuter gender. In French "vaisseau"—ship—is masculine and is never spoken of but as "le vaisseau." They are given feminine names sometimes, however, says the Fleet Review, in reply to an inquiry. Calling a ship "she" must be set down to nautical and poetical license; it is used by both seamen and poets. No mention of a reason for the use of the term has been

"Interlox" SAVES TIME, TEMPER AND TROUBLE

MASTER SLIDE RULE
The Only Interlocking Rule made—and the Only one whereby inside measurements of doors, windows, etc., can be taken rapidly and accurately. Also superior to all others for outside measurements of walls, ceilings, etc. If your hardware dealer hasn't this Rule, send us his name and 10c per foot (in any length from 2 to 8 ft.) and it will be sent prepaid.

Liberal Proposition for Dealers and Agents

DAHL MFG. CO., 51P E. 42nd St., NEW YORK

When the "boys" spy the trim, dainty figure of alluring little Miss **SEPTEMBER MORN** so handsomely embossed on these WATCH Fobs, they go to them like hungry wolves. **ROSE GOLD FINISH**; twice the size shown here; genuine Leather strap. **A smashing big hit!**—get this classy fob and **BIG MONEY** agent's offer to-day, **25c. postpaid.** **BUFFALO EMBLEM JEWELRY CO.** 411 Morgan Building, Buffalo, N. Y.

Save the Dealer's Profit

Why pay fancy prices when you can buy any of our 6 models, 1 1/2 to 12 H. P., and save 20 to 25 per cent. Try 30 days at our risk before you buy. Every motor guaranteed for one year. Write for our catalog today. **LOCKWOOD-ASH MOTOR COMPANY** 1236 Horton Avenue, Jackson, Michigan



For the Workman

THE problem of the selection of the handsomest and most useful Christmas gift is happily solved by

THERMOS

For Thermos serves you right—
food or drink—hot or cold—
when, where, and as you like.

Every member of the family, every one on the list of friendship, from infancy to old age—either in the hours spent at or away from home—have innumerable daily uses for Thermos.

Thermos brings to them in the hot summer months all the comforts produced by ice, and in the cold winter season all the joys to be obtained by fire.

In buying Thermos for "him" or "her" as your Christmas gift, you are selecting the invention honored with the Grand Prize by the Panama-Pacific Exposition, and by like Expositions at Berlin, Paris, Antwerp, Madrid, Seattle, Vienna and London.

Thermos in great assortment awaits you at any one of 100,000 dealers. If you live in the country ask that it be sent postpaid. From \$1.00 up. Send for booklet.

American Thermos Bottle Co.
NORWICH, CONN.

MILLERS FALLS TOOLS
Braces Drills Hack Saws Mitre Boxes
Do Better Work and Last Longer
Write for catalog showing complete line
MILLERS FALLS CO., Millers Falls, Mass.

Howard Earl (sailor) writing "I have found that a ship is called 'she' because the rigging cost more than the hull." B "1/20/15"



EXCELSIOR LIGHT WEIGHT



\$135⁰⁰

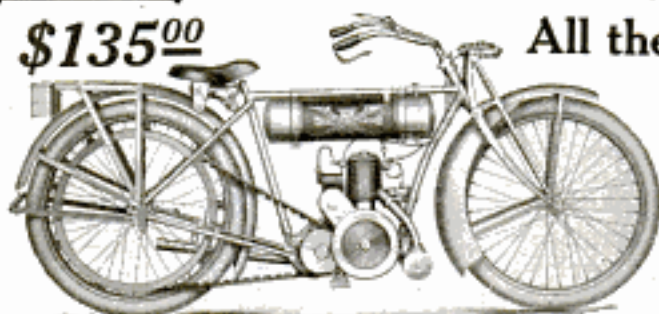

All the **SPEED** and **POWER**
You Need at Minimum
Cost and Maintenance

*All the Utility of a \$300 Motorcycle
at little more than the operating cost
of a bicycle.*

**A Strictly Man's Machine that
a boy can use in comfort and safety.**

In the EXCELSIOR LIGHT WEIGHT every detail is designed and constructed with the same care and of the same highest grade material used in the most expensive and elaborate models of "the GOOD OLD X."

The low price is attained through simplified design and the elimination of all dispensable complication.

The Valveless Two-Stroke Motor is Simple, Efficient and Economical.

The Two Speed Gear is the automobile type with annular ball bearings.

The Frame is Seamless Steel Tubing and Nickel Steel Drop Forgings throughout.

All other details are the same high class construction.

Write today for catalog fully describing this and five other models.

Excelsior Motor Manufacturing & Supply Co.
3702 Cortland St., CHICAGO



AETNA-IZE Protect yourself and your family in case of sickness or accident. \$50 a week, and as high as \$10,000 for death. Write for particulars.
AETNA LIFE INSURANCE COMPANY
Drawer 1341 Dept. PM. 12-15 Hartford, Conn.

INDOOR CLOSET

**More Comfortable, Healthful
and Convenient than the Out-Door Privy**

Eliminates the out-door privy, open vault and cesspool. They are breeding places for germs. Have a warm, sanitary, odorless toilet right in your house. No going out in cold weather. A boon to invalids. Endorsed by State Boards of Health.

W. M. Davis writes: "Your indoor closet is giving absolute satisfaction. It is certainly the thing for a home without sewerage."

**Absolutely Odorless
Put It Anywhere in the House**

The germs are killed by a chemical process in water in the container which you empty once a month. **Absolutely no odor.** No more trouble to empty than dishwater. Closet absolutely guaranteed. Write for full descriptions and price.

Agents Wanted — Big Profits Wonderful opportunities in every town, village and in the country. Best season just at hand. Every home is a good prospect. Sell eight out of every ten you call on. Ernest H. Smith writes, "Have ten orders." G. A. Dismas says: "Ship at once twenty closets and fifteen washstands. Sold them all in one community." Sell itself. Everybody takes the outdoor privy. Everybody wants a No-San Indoor Closet. Write quick for territory and full particulars.

ROWE SANITARY MFG. CO., 212P Sixth St., Detroit, Mich.

Ask about the No-San Washstand — Hot and Cold Running Water Without Plumbing

found in Hamersly's Naval Encyclopedia, in Smyth's Word Book, or in other dictionaries. But we do find a rather singular appellation for a ship broker: "Ship's husband."



ALORRA DIAMONDS
SPARKLE LIKE THE GENUINE — AT 1-40 THE COST
SOLID GOLD RINGS

—stand acid, fire and expert examination. See them before paying. Any style ring, ton or stud. Catalog FREE. The Alorra Co., Dept. A9, 140 S. Dearborn St., Chicago

1916 Model **RIDE a RANGER**

bicycle and know you have the best. Buy a machine you can prove before accepting.

DELIVERED FREE ON APPROVAL and 30 days' trial. No expense to you if you do not wish to keep it. **LOW FACTORY COST,** great improvements and values never before equalled in our 1916 models.

WRITE TODAY for our big catalog showing our complete line of 1916 bicycles, TIRES, sundries and parts, and learn the wonderful new offers and terms we will give you. Auto and Motorcycle Supplies at factory to user prices. Do not buy until you know what we can do for you.

MEAD CYCLE CO. DEPT. H108 CHICAGO

\$4.00 SEISS

**Powerful, Commanding,
Warning Signal.** Operated by touch of hand, either right or left — for short blast or long continuous sound, same as a Motor-Driven Horn.

**THE SEISS MFG. CO.
439 Dorr St., TOLEDO, O.**

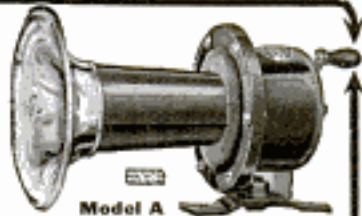

Model A

\$1 — This Stag Safety Blade Sharpener

Stop buying Blades. Sharpen your old ones, no skill required to make them better than new. A smooth, velvety shave always assured, if you will use our guaranteed Stag Sharpener.

Hones and Straps Too — The only sharpener that both hones and straps — guaranteeing perfect shaving qualities. Note wheel in holder sets blade always at proper angle — sharpens any safety razor blade. Will last a lifetime. Highest Awards at Panama-Pacific Exposition. Complete nickel-plated holder, barbers hone and strap in neat case, postpaid, \$1.00. You take no risk. Money refunded if not satisfied.

Dealers and Agents Be first to secure agency for your territory. Splendid chance to make money Write for our proposition. No delay, you can begin at once.

THE STAG COMPANY 80 South State Street CHICAGO, ILL.

IDEAL CHRISTMAS GIFT — Combining durability and sentiment with usefulness. A necessary and practical gift for every man.



**\$1
Post
Paid**

MODERN EXPLOSIVE MOTORS OF EVERY DESCRIPTION

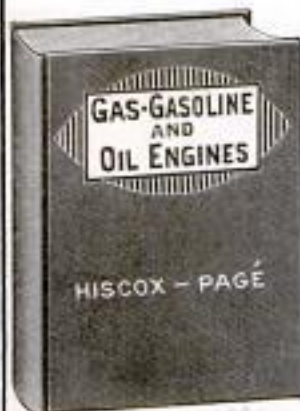

Stationary Motor Vehicle Marine and Aerial

are exhaustively treated in this standard, revised, enlarged, up-to-the-minute work

Gas, Gasoline AND Oil Engines

BY
G. D. HISCOX and V. W. PAGÉ

This is the age of gas power for all purposes. Understand the operating principles of the motive power that made the automobile, motorcycle, aeroplane and motor boat possible.

640 pp.—435 illus.—Cloth. Price \$2.50 Prepaid

This work is distinctive and valuable because it represents the experience of over 40 years with the design, construction and management of all types of explosive engines. Unlike the average treatise on the subject, it does not confine itself to but one type of power plant. The arrangement is such that after the basic and elementary principles of gas power plant action are outlined, the various standard designs of internal combustion motors for all purposes are shown. Many of the illustrations are direct reproductions of engineering and design drawings and are in correct proportions, forming a series of designs for reference of inestimable value to the engineer or draftsman. The practical man also will appreciate the many clear sectional views showing the relation of all engine parts. New tables, formulae and data have been added for those technically inclined, the information on installation, testing and management has been rewritten entirely and will have a special appeal for the practical mechanic.

POPULAR MECHANICS BOOK DEPT., 6 N. Michigan Ave., CHICAGO

A New 300 Page Book for Every Ford Owner, Dealer, Salesman and Repairman

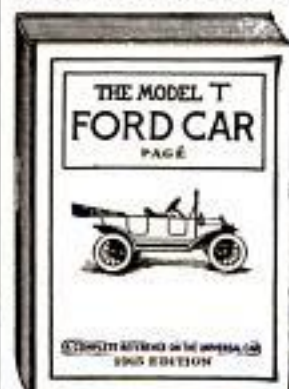

Deals Fully With Construction Operation Repair

Over 100 Special Engravings
Price \$1 Postpaid

This is the Most Complete and Practical Instruction Book ever published on the Ford Car. All parts of the Ford Model T Car are described and illustrated in a comprehensive manner—nothing is left for the reader to guess at. The construction is fully treated and Operating Principles made clear to everyone. Complete instructions for Driving and Repairing are given. Every detail is treated in a non-technical yet thorough manner. This book is written specially for Ford Drivers and Owners, by a recognized automobile engineering authority and an expert on the Ford, who has driven and repaired Ford Cars for a number of years. He writes for the average man in a practical way from actual knowledge. The illustrated chapter on Repairing and Overhauling alone, is worth many times the price of this book. Special description of book sent on request. Also

A NEW FORD ENGINE CHART

makes location and correction of engine troubles easy. Size 25x38 in. PRICE 25c POSTPAID. Your money back if not satisfied.

Popular Mechanics Book Dept.
6 N. Michigan Ave., CHICAGO



Technical High School, Salt Lake City, Utah, Fenestrated

Schools with "Built-In" Health and Cheerfulness

Plenty of fresh air and absolute control of ventilation at all seasons of the year are imperative if the health and cheerfulness of the pupils are to be conserved. Plenty of light, rightly distributed, is necessary if the students' eyes are to be saved from strain.

These two points conceded, listen to this:

"I am much pleased to say that

Fenestra
SOLID STEEL WINDOWS

"REG. U.S. PAT. OFF."
"The Best School Insurance"

give the best of satisfaction, both in amount of light and fresh air furnished. They are particularly pleasing in the method by which fresh air is supplied to the rooms."—L. M. GILLES, Salt Lake Technical High School, Salt Lake City, Utah.

Equally important is the protection against fire that Fenestra affords. That's not all—their use cuts down maintenance cost, reduces artificial light bills, enhances the beauty of the school building. Furthermore, when ordered in standard sizes, Fenestra Solid Steel Windows cost no more than good wood sash.

Build that school this winter—avoid the building rush next spring—and save money and time.

Write for our new pamphlet
"Better School Building."

Detroit Steel Products Co.
Dept. L6 Detroit, Mich.



Interior of Pennsylvania Training School, Morgantown, Pa., Fenestrated

WIRELESS XMAS SALE

Bargain Prices to prove the superiority of our goods. Our wonderfully low prices are made possible only by the enormous output for our tremendous trade.



"CRYSTALOI" The New Permanent WIRELESS DETECTOR

The most remarkable detector ever made—it will simply astonish you by its performance. Requires no battery or potentiometer and is ever ready to serve you under all conditions. Will stand all kinds of hard usage without being injured. This detector is a radical departure from all other types, inasmuch as it is constructed in such a way that a large surface of a very sensitive mineral is brought into contact with a very light, finely divided alloy. This arrangement renders the receiving apparatus free from static and other interferences. Price, Complete \$3.50

Complete \$14 Outfit

Sends up to 20 miles. Receives up to 2000 Miles

Mechanically and electrically perfect, ready for receiving and sending—including a 2000 Ohm headset, 1 1/2 inch spark coil, air cooler spark gap, collapsible helix, big two-slide tuner, fixed condenser, detector, wireless key, DPDT switch-buzzer with key.



Complete outfit ready to use at special price of **\$14.00** Regular Price \$20.00, for this month . . .

NEW NAVY TYPE LOOSE COUPLER

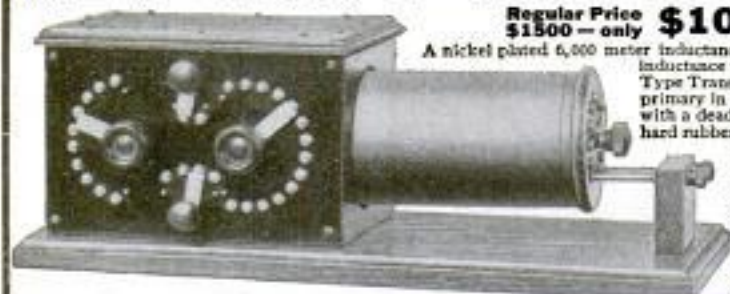

Regular Price \$15.00—only **\$10.00**

All finished parts of this coupler ready for assembling, **\$6.50**

A nickel plated 6,000 meter inductance tuner, perfect in every detail. Equipped with four point loading inductance which increases the wave length 4,000 meters over the average Navy Type Transformers. The primary winding has 24 taps—one switch controls the primary in groups of tens, the other controls one turn at a time—and is equipped with a dead end switch. Enclosed in a cabinet, the front of which is polished hard rubber. The secondary coil is wound with double silk covered wire and the inductance is varied by a ten point switch. With this coupler the very finest and most accurate tuning is easily and quickly secured. With a good sized aerial the reception of wave lengths up to 4,000 is possible. Send 4c postage for 152 p. Catalog A-10.

FREE—Big Electrical Toy Catalogue. Save Money—Send for it.

NICHOLS ELECTRIC CO.

1-3 West Broadway

NEW YORK

Complete Wireless Receiving Set

with 80 ohm double pole receiver, head band and cord
Receives 1500 Miles
With Suitable Aerial **\$4.45**

Beautifully finished and fully guaranteed. Equipped with two-slide loose coupler, primary wound with No. 26 bare wire, secondary wound with No. 30 silk covered wire and divided off into 10 taps which are brought out on the end piece, contact being made by a phosphor bronze rotary switch with hard rubber knob. Our new, specially designed detector affords an exceptionally fine adjustment. A fixed condenser of exact capacity, specially constructed for this loose coupler gives added efficiency. An extra pair of binding posts is provided to which a variable condenser may be attached. All parts are of solid oak and mounted on a solid oak base.



Send stamp for our big wireless catalog "P" and free code chart made of unbreakable fibre.

Universal Wireless Co. 19 E. 32 St. N. Y. City

All "Universal" sets are sold with 10 day trial privilege and money-back guarantee. Prompt shipments guaranteed.

Rural free mail delivery by motor cars is at present in operation on nearly 300 routes.

Does The Socket Chafe Your Stump?
If so, you are NOT wearing
BUCHSTEIN'S VULCANIZED FIBER LIMB which is soothing to your stump, cool, neat, light, walls not much thicker than a silver dollar, strong
Guaranteed 5 Years!

Sold on easy payments to good people. D. Buchstein
Co., 113 6th St. S., Minneapolis, Minn.

AGENTS Make \$100 to \$300 Month ALL OR SPARE TIME

Big profits selling famous "Car-van" steel scientifically tempered, pocket knives. Blades cut nails or hairs. Photos, emblems, name, address, etc., in handles clear as glass, tough as horn. Sell on sight. Please everybody—Knives, Razors, Fountain Pens, Scissors, Shaving Cut-throats, Kitchen Sets, etc. Attractive sample case. Easy selling plan. Don Wright, Ky., sold \$31.45 worth in 4 days. Write today for agency offer.

CANTON CUTLERY CO., Dept. 59, CANTON, OHIO

Run Your Ford, Overland or Chevrolet All Winter in Safety

Skidding, slipping, sidesway and stalling in bad spots will all be eliminated if you install the

BAILEY Gearless Differential

Gives positive drive to both rear wheels; all the advantage of a solid axle in straight going; power delivered only to wheel having traction in ruts or slush. Adds 50 per cent to comfort and safety; saves fuel, oil and tires. Thousands in use. Shipped ready to install on Money-back offer. See dealer or write for circular.

Gearless Differential Co., 892 Woodward Ave., Detroit, Mich.

BRAIN vs. BODY IN THE RACE FOR SUCCESS

All you fellows who are devoting every bit of your time and attention to the cultivation of mental efficiency, do you ever

STOP

and ask yourself what it will avail you if you neglect your body? You think the brain is the all important essential in the race for your goal. Is it?

Will your brain live longer than your body? Will your brain live up to its training and do good work if it has to be continually flushing messages from a neglected body, or registering protests from a disorganized stomach? Will the brain of a crooked, scrawny, dyspeptic, or weak, puny, undeveloped man justify the training it has had? Or will a brain weakened by youthful indiscretions be 100 per cent efficient?

My book, "Intelligence in Physical and Health Culture," will answer these questions in a way that will interest and surprise you. Send four cents in stamps to cover postage on a copy. Do it now!

LIONEL STRONGFORD, Health and Strength Institute
Dept. 5125 ATLANTIC CITY, N. J.

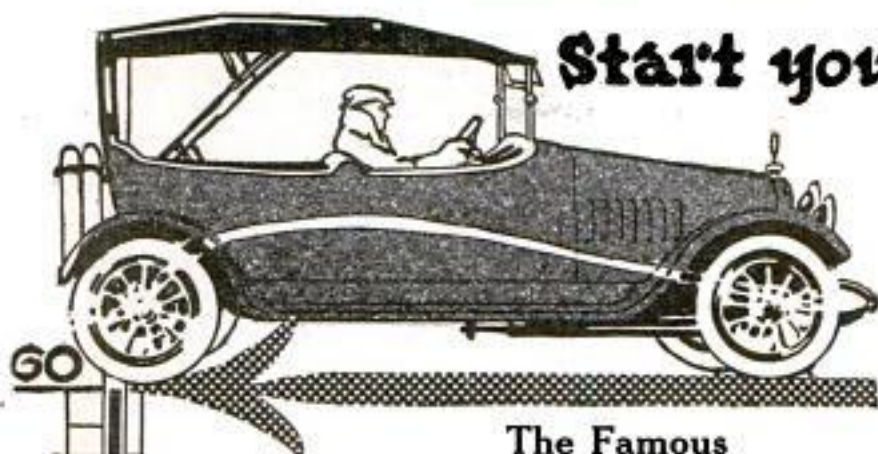

Start your Car at 60°

Send for "WINTER MOTORING"
—telling you all about
this remarkable heater—it's free.

The Famous Scientific Safety Garage Heater

enables you to always start your car at 60°—the starting point of efficiency. Install the Scientific Safety in your garage and Keep your car right by keeping cylinders, radiator, paint, etc., in prime condition.

Start your car right by starting it on the first turn of the engine.

EXPLOSION-PROOF—FOOL-PROOF

Operates on principle of miner's safety lamp—making it impossible to be affected by fumes or liquid gas. No exposed flame—Safety self-lighting device does away with matches.

Thermostatic Control insures uniform temperature automatically. Repeated service tests prove heater to be absolutely fool-proof—explosion-proof.

ZERO Only Garage Heater Listed by Fire Insurance Underwriters

It is compact—occupies but little space—easy to install—economical to operate. No more attention to run than gas jet.

Hot Water Coil—\$3.50 extra—insures plenty of hot water for washing car, etc.

THE SCIENTIFIC HEATER CO., 2900 Power Ave., Cleveland, Ohio



1916
Model
Scientific
Safety
Garage Heater

No. 750 Size comfortably
heats ordinary two car
garage during zero
weather. Price **\$25**

INVENTORS WANTING FOREIGN PATENTS

Invited to join new 3¢ rate plan. Get best patents obtainable. Installments, U. S. cases filed EX FEE (gov.) securing priority. Refer to clients with us 16 years and Invention League, U. S. BUREAU of Patents, 7 Broadway, New York.

WE SHOW HOW TO SELL YOUR PATENT

Of the 3,520 cheese factories in the United States, Wisconsin has one-half, while New York ranks second with a few less than a thousand.

You Can Make Big Money

C. F. Larsen has made over \$2000, selling Matchless Gas Lighters. E. C. Haines made \$17.10 in one day. You too can make big money.

The Matchless Gas Lighter lights gas or gasoline. Safer, cleaner, handier and cheaper than matches. Send 25¢ for agents' sample and big money making offer.

STEEL STAMPING CO., Dept. 29, 143 W. Austin Avenue, CHICAGO



\$5.00 Gillette Safety Razor \$3.95

Here is your opportunity to secure this celebrated \$5.00 Gillette Safety Razor for \$3.95. Not second-hand, but a new razor in a leather case (including one dozen blades), the kind your dealer would charge you \$5.00 for. Blades sold separately 85¢ a dozen.

Ideal Xmas Gift Order one today, now, before you forget it, as you may never have this opportunity again. Guaranteed Genuine. Money refunded if not satisfactory. AGENTS WANTED. RELIABLE SPECIALTY HOUSE, 1456 Ohio Street, CHICAGO, ILL.



Building a Launch? You Need This Book

It's the Callie Marine Motor Blue Book. It shows the most complete line of motors at the most economical prices in sizes ranging from 2 to 30 H.P. Every one is of highest grade, simple, sturdy, easy to operate, thoroughly guaranteed. This book has saved boat owners thousands of dollars. It will save you money. Get a copy. It's free.



8 H.P. \$150
The Callie
Perfection
Motor Co.,
1523 Cass St.,
Detroit,
Mich.

KERMATH Marine Engines

"America's Standard 4 Cycle Marine Motor"



4 Cycle, 4 Cylinder, 12 to 20 H.P. Highest quality. Silent operation. No vibration. Controls like the finest Motor Car engine. Extremely economical on fuel. Used as standard equipment by over 80 per cent. of the world's leading boat builders. Catalog on request. \$750 to \$300 depending on equipment.

KERMATH MFG. CO. Dept. P, Detroit, Mich.

LANDA "Prosperity" BILLFOLD

ELEGANT, Practical Xmas Gift—order one also for yourself. Combines currency fold, coin purse, card case, loose leaf memo pad, 1916 calendar, transparent identification card and photo holder. Made of finest soft, genuine black Seal Grain Leather. Any name beautifully engraved in 23-Kt. Gold—splendid, lasting gift. Size closed 2x3 1/4 inches, open 4x3 1/4. Compact, flexible—will fit any pocket. For ladies and gentlemen. Special price 50¢ postpaid—ordinarily \$1.00. Attractively packed in handsome gift box.

"DeLuxe," made of genuine Morocco Leather, \$1.00—worth \$2.50. Send M.O., draft or postage stamps. Order shipped day received. Satisfaction guaranteed. Write for Xmas Gifts catalog.

A. LANDA & SONS CO., Leather Goods Mfrs., Dept. C2 Chicago



Money Cheerfully Refunded

50c
Postpaid

Name Engraved Free in
23-kt Gold
For Ladies and
Gentlemen

MESCOLITE

consists of a japanned metal container with cover, fibre disc with battery contacts, polished metal reflector, clear glass lens, miniature battery lamp, lens cap or rim with three bayonet catches, a non-detachable bail or handle large enough to allow the arm to go through it, a RED SEAL Dry Battery.

SAFE—Anywhere— Everywhere—Always

in the hands of the old as well as the young; the careful and the careless; in the garage, barn, cellar or closet; on the motor boat or auto; in the factory or mill; on the dark forest trail or in camp; as a diagnostic lamp for the physician; for any emergency where a portable lamp can be used.

CHEAP INSURANCE NO FIRE WHERE USED

The RED SEAL Dry Battery will give about twenty-five hours of continuous service and from forty to fifty hours of intermittent service.

With the "Special" two cell dry battery, it will give you approximately sixty hours of continuous and one hundred twenty hours of intermittent service. If your dealer cannot supply you we will mail postpaid.



(Illustration shows container with cover removed and battery partly inserted)

No. 5343—MESCOLITE, complete with RED SEAL Dry Battery, 1½ volt lamp, \$1.50.

No. 5344—MESCOLITE, complete with "Special" two cell dry battery, 2.8 volt lamp, \$1.75.

Send for Our New Catalog P28

It is pocket size, 8 x 4½ inches, contains 248 pages, with over 1,100 illustrations, and describes in plain, clear language all about Bells, Push Buttons, Batteries, Telephone and Telegraph Material, Electric Toys, Burglar and Fire Alarm Contrivances, Electric Call Bells, Electric Alarm Clocks, Medical Batteries, Motor Boat Horns, Electrically Heated Apparatus, Battery Connectors, Switches, Battery Gauges, Wireless Telegraph Instruments, Ignition Supplies, etc.

There exist a thousand and one ways where electrical devices may be used, and to know what is best for your purpose you need this catalog. It costs you nothing.



Send for Our No. 2 Manual Wireless Telegraphy

You should have it even if only superficially interested. Around about you every day you read of some marvelous occurrence in which wireless played a distinguished part. It may not be entirely clear to you. The Manual will explain it. To the student of Wireless Telegraphy, the Manual contains much that is indispensable to a proper understanding of the art. A good portion of this is now published for the first time—and consists of formulas, tables, diagrams, Federal regulations, codes, diagrammatic instruction for installing, maintaining and operating wireless stations, together with a complete list of up-to-date wireless instruments and accessories. The Manual contains 120 pages, fully illustrated on high-grade paper stock with a two-color cover. We ask ten cents (\$0.10) for it—give you a coupon receipt which can be applied on any order amounting to One Dollar (\$1.00) or more. Do not wait until some other time, but act down now and send your name and address, and get one of the most complete, comprehensive and reliable wireless pamphlets published. IT MEANS MONEY SAVED TO YOU to have our Manual and our Catalog when you want to buy.



MANHATTAN ELECTRICAL SUPPLY CO.
NEW YORK: 17 Park Place
CHICAGO: 114 S. 5th Ave.
ST. LOUIS: 1106 Pine St.
SAN FRANCISCO: 604 Mission Street



PANAMA CANAL and GOLDEN GATE EXPOSITION

TO READ this matchless volume is like a real visit to the Canal and Exposition. Designed as a permanent souvenir edition this superb book by pen and camera portrays the eighth wonder of the world and the wonderful celebration of its completion.

Every American citizen, man, woman and child, should make a careful study of the World's Greatest Engineering Feat and beauties of the Exposition as recorded in this book. It was written by Ralph Emmett Avery and edited by William Haskins of the Canal Record, two men who have lived for years in Panama and watched the development of every stage of this gigantic undertaking.

It contains 400 large Quarto pages, 8x11 in., nearly 700 Photographic Illustrations, also 8 Full-Page Color Plates and a Statistical Map of the Canal and Canal Zone in colors.

Originally published to sell for \$5.00, the large editions made possible by its great popularity have reduced the cost so that we are able to offer for a limited time only this handsome souvenir edition, bound in fine cloth and emblematically stamped in colors for

ONLY \$2.50 FULLY PREPAID

A book well worth \$6.00. Your money back if not satisfied

POPULAR MECHANICS BOOK DEPT.
6 N. Michigan Ave., CHICAGO

No Better Christmas Present for \$1.50

than a year's subscription to

Popular Mechanics Magazine

containing nearly 4000 illustrations and 2000 pages of reading matter.

Much of it interests Everybody.

Most of it interests Anybody.

All of it interests Somebody.

Order through your newsdealer or address the publishers, POPULAR MECHANICS, CHICAGO

The Real Estate Educator

By F. M. PAYNE

A book for hustling Real Estate "Boosters," Promoters, Town Builders, and everyone who owns, sells, rents or leases real estate of any kind.

Containing inside information not generally known, "Don'ts" in Real Estate, "Pointers," Specific Legal Forms, For Sale, Exchange, Building and Swindler's Contracts, Bonds, Mortgages, Powers of Attorney, Leases, Landlord's Agreements, Notice to Quit, Deeds, Chattel Mortgages, etc. It gives, in the most condensed form, the essential knowledge of the Real Estate Business.

Apart from the agent, operator or contractor, there is much to be found in its contents that will prove of great value to all who wish to be posted on Valuation, Contracts, Mortgages, Leases, Evictions, etc. The cost might be saved five hundred times over in one transaction.

Cloth. 256 Pages. Price \$1.00 Postpaid

POPULAR MECHANICS BOOK DEPT., 6 N. Michigan Ave., Chicago



Private Weather Bureau**IN EVERY HOME**

Enables you to **PREDICT
THE WEATHER YOURSELF**

**A Reliable Barometer
An Accurate Thermometer**
Actual Size 13 Inches High

Indispensable to the farmer, business man, professional man, automobilist, in fact, to everybody who should know in advance what the weather will be. Will save you money and time.

**FORECASTS WEATHER
WEATHEROMETER**
HOURS IN ADVANCE

\$1.00 ONLY
REDUCED FROM \$3.00

Send us no money. Mail your order today and Weatherometer will be sent to you C. O. D. (10c extra). If you prefer you may enclose \$1.00 bill or money order with order. Satisfaction guaranteed.

WITHINGTON INSTRUMENT CO.
5 South Wabash Avenue, Dept. 24, CHICAGO

A Handsome Xmas Gift

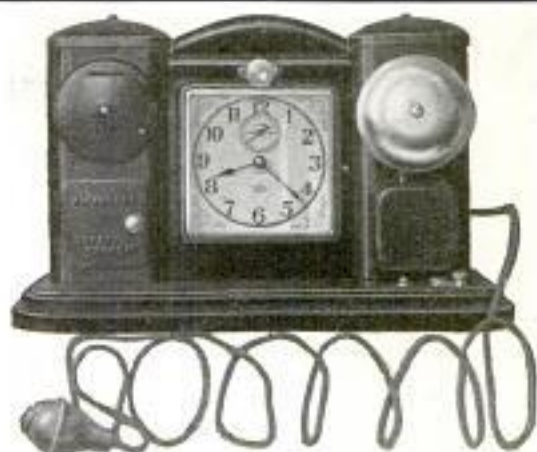
**The Appreciated Christmas Gift**

Send for this clock today — for your own home or for a friend's present. Our 30 years in business is your guarantee. It's the dependable

**Darche
Flashlight Electric Alarm Clock**

All ready for use — no connections to make. Operated by dry battery. By pressing button at end of cord (which is long enough to reach bed) a one candle power lamp illuminates clock dial and lights ordinary size room. Lamp is not a toy — as substantial as any electric light, only smaller — battery lasts one to two years, depending on use.

Combines Electric Alarm Clock — Electric Light — Savings Bank — Jewelry Safety Deposit. Made of stamped steel beautifully finished in gun metal.

Send Us \$5.50 and we will send this clock to you express prepaid. Money back if not satisfied. After you have it you will wonder how you did without it.
DARCHE MFG. CO., 13-17 No. Jefferson St., Chicago

When You Build

please bear in mind that there is still plenty of

WHITE PINE

Send for our free booklet, "WHITE PINE IN HOME BUILDING"

WHITE PINE BUREAU

1626 Merchants' Bank Bldg. ST. PAUL, MINN.

TRAPPERS!**Get More Money for Your Furs**

Don't ship anyone furs till you get Our **Free Bulletin** quoting cash prices we actually pay for **Coon, Mink, Skunk, Opossum** and other furs. We charge no commissions. Write today for **Free Bulletin** it will pay you big.
NATIONAL FUR AND WOOL CO., Dept. 413, ST. LOUIS, MO.

**FINE OLD VIOLINS**

**On Easy Payments
30 Days Free Trial**



allowed, no matter where you live. If not more than pleased with our values return violin **AT OUR EXPENSE**—and no harm done. Ability to play the violin brings social and financial success. Get a violin with a rich, mellow tone and it will create in you a desire to master it.

**Free! Magnificent
Album-Catalog**

containing portraits of the world's greatest violinists since Paganini's time, a half-tone of "Stradivarius in His Workshop," and the romantic story of The King of Musical Instruments. A postal brings all to you **FREE** — no obligations.

CREMONA VIOLIN SHOP
Dept. D541 CHICAGO

A Real Kerosene Engine

Here's the biggest engine value ever offered in a 1½ H. P. engine. Same cylinder capacity as many 2½ H. P. engines. Throttling governor adjustable while running; crankshaft extends on both sides. Runs either way. Starts without cranking. Equipped with Ellis Patent Fuel Device, guaranteeing successful operation on cheap oils. Beautifully finished in genuine engine enamel.

Runs on 9c a Day Just the engine for pumping, separating, churning, corn-shelling, sawing,

shop work, electric lighting and dozens of other light jobs. Sold on 30 days' trial. Guaranteed for 10 years. We make other sizes from 3 to 18 H. P., vertical and horizontal, single and double cylinders.

Ask for our free book, "ENGINE FACTS," telling how to judge and buy an engine.

ELLIS ENGINE CO., 2873 E. Grand Blvd., Detroit, Mich.

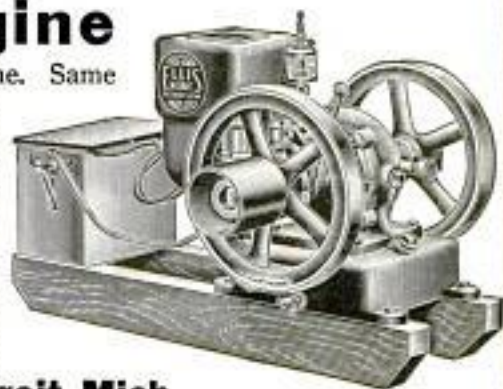

NOW for the BIG STRIKE

High Men Out Everywhere! Unless TIFCO Meets the Demands



Use This Freely, Men —
Score Every Point!

of bowlers everywhere — in all climates — unless they're satisfied in every particular the Company loses money. How can they afford to advertise their high grade "TIFCO" bowling ball extensively if it isn't absolutely correct in principle, design and manufacture?

TIFCO has Captured the Country!

Every Need, Every Demand, Every Wish and Whim of the professional bowler is fulfilled in this wonderful new Fibre Bowling Ball that is daily producing "high men." "TIFCO," the perfect, stays true. Will not warp, crack, split or nick around finger holes. Not an experiment — but a huge success. Five years on the market. Hundreds of satisfied bowlers everywhere. Recommended and used by Alley owners in every City. Own your own ball this season — have one that fits you in weight, hole and span. Get the big money. Win out! Be "High Man" in every game. Write today for our free book, "Head Pin Harry — the Pride of the Allies." It's a hit.

TOLEDO INTERLOCKED FIBRE CO., Dept. 10, TOLEDO, OHIO

"I Would Not Part with It for \$10,000"

So writes an enthusiastic, grateful customer. "Worth its weight in gold," says another. In like manner testify over 100,000 people who have worn it.

The Natural Body Brace

For MEN and WOMEN.

Develops erect, graceful figure, overcomes WEAKNESS and AILMENTS of Women & Men.

Brings womanly beauty and manly strength, restful relief, ability to work and enjoy life.

Banishes All These Troubles

Does away with the strain and pain of standing and walking; replaces and supports misplaced internal organs; reduces enlarged abdomen; straightens and strengthens the back; corrects stooping shoulders; develops lungs, chest and bust; relieves backache and nervousness. Comfortable and easy to wear.

Wear It 30 Days Free at Our Expense

Write today for illustrated booklet, measurement blank, etc., and read our very liberal proposition.

HOWARD C. RASH, Pres. Natural Body Brace Co.
223 Rash Building SALINA, KANSAS



Cut out this ad and mail it to us, with your name and address (no money), and we will send you our FAMOUS KARNAK RAZOR by return mail, postpaid. You may use the razor for 30 days FREE; then, if you like it, pay us \$1.85. If you don't like it send it back.

MORE COMPANY, 355 More Building, ST. LOUIS, MO.



Over One Million in Use.

Millions to be Sold.

This Instructive FREE Automobile Book

HELPFUL INFORMATION for the care of Automobiles

What Do You Know About Your Car?

Can you make the repairs that save little bills now, big bills later on? Can you get everything out of your car that the manufacturer put into it? Do you know how to cut your tire cost by taking care of your tires?

Learn Your Car!

Let us send you this book — "Helpful Information" — FREE. It tells you, in simple terms, all you need to know to take care of any emergency, make any repairs. Helps you know where trouble is, and to correct it. Covers every automobile problem. Complete in every detail. YOU cannot get a book like it for money. We give it to you FREE, with three months' subscription to *The American Chauffeur*. This offer is made for a limited time to introduce to you *The American Chauffeur*, one of the best magazines in the automobile field. Each issue contains valuable information. Send 25c in stamps or coin, and send it at once. The edition is limited, and offer will soon be withdrawn.

The American Chauffeur, 351 Butler Bldg., Cincinnati, Ohio



(2)

The "Chess-Board" of Motoring

McCULLOUGH'S Scientific and New AUTOMOBILE

Steering Instructor

Complete Automobile and Game-Board — with instructions in five languages. Prepaid, only \$1.25

P. J. McCullough & Co., 4240 McPherson Ave., St. Louis

AGENTS — The Million Dollar Hit!

New, wonderful home invention, just introduced, yet million sales already recorded. Tremendous, rapid sales stagger country. Agents happy — banking enormous profits daily. Mighty opportunity for you to get the mighty dollar. Failure impossible. Experience unnecessary. Money rolls in first hour — \$10 to \$30 daily. Amazing cash records made. Walters received

\$50.00 FOR 7 HOURS' WORK

Never sold goods before. Arnold sold 160 in 2 days; Hagen 100 same time; Webb 10 per hour; O'Connell 25 first day. Hundreds like these. You, too, can have money in abundance. Grab this Scientific Shoe Cleaner sells itself — you take orders — that's all. Every family wants one on their doorstep. Replaces unsightly, unsanitary, crude door mat. Automatically removes mud, dirt, snow from shoe in one operation. Cleans sole, sides, heel. Works like magic — sells like sixty. Saves drudgery, time, money, shoes — saves carpets, floors. Mechanical wonder. Has 7 new patented features not found in any other scraper — 10 steel blades — 10 dirt outlets — twin adjustable and removable brushes — compound springs. Rotates for sweeping. Can't clog — practically self-cleaning. Handsomely crumpled. Nothing else like it. Nothing so popular — so easy to sell. Selling price only \$1.00. You make half — 100 per cent. Satisfaction guaranteed. Write quick for free catalog — exclusive agency. Better still, send order, naming territory. Investigate anyhow.

SECURITY MFG. CO., Dept. 201, TOLEDO, OHIO

A BOOK OF NEW MISSION FURNITURE DESIGNS



Part 3—Mission Furniture HOW TO MAKE IT

A 128 page collection of 36 excellent new designs that have never before been published and that are entirely different from those in the books Parts One and Two previously issued.

Handsome Cloth Binding
Price 50c Postpaid

This new number has just been published and those already in possession of Parts One and Two will find this an even greater value in variety and excellence of the plans.

A feature of the New Book is a Complete Set of Dining-Room Furniture

Designed to Harmonize Perfectly

If you are at all handy with tools, you will find that the plainly written directions, dimension drawings and half-tone illustrations will enable you to

Make Your Own Furniture and Save Two-Thirds

The many who use tools for pleasure will find this book a working guide which will furnish many moments of delightful and profitable occupation while several of our readers have been able to devote their entire time to this work by disposing of what they have made at a nice profit. One man made and sold \$400 worth of one piece alone.

Parts One and Two in this series are also 50 cents each postpaid

Ask Your Book Dealer or Address the Publishers

POPULAR MECHANICS BOOK DEPT.
6 N. Michigan Ave. CHICAGO

YOUNG MAN! LEARN DRAFTING

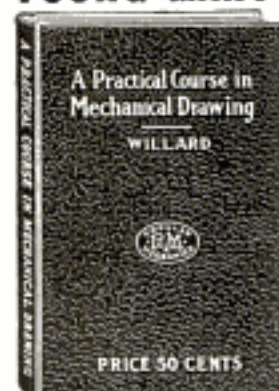

ONE of the most practical subjects of study today; an essential in most lines of engineering; indispensable in many occupations and often the secret of successful advancement; of no less importance to the farmer than the mechanic. There is bound to come a time when you will feel the need of the ability to "lay out" something in accordance with the rules and conventions used in the drafting profession.

Individual Study

may be successfully engaged in with the aid of our new enlarged edition of the book

A Practical Course in Mechanical Drawing

By WM. F. WILLARD

(For several years instructor in Mechanical Drawing at
Armour Institute of Technology, Chicago)

160 PAGES—SIZE 5x7—157 DRAWINGS—CLOTH COVER

Price 50 Cents, Postpaid

There has been a real need for a book of this kind, as it clinches each problem in the mind of the student by giving the practical application of that problem to every day practice in some phase of the world's work. It meets every modern requirement and is in advance of any other work on the subject. Excellent for use in shop classes, trade or high schools. A complete detailed description of the contents of this book sent free upon request.

Order of your Book Dealer or direct from the publishers
POPULAR MECHANICS BOOK DEPT.
6 N. Michigan Ave., CHICAGO



hampion
TOLEDO MADE FOR THE WHOLE WORLD TRADE

Dependable Spark Plugs

Our tremendous output—doubled this year as compared with last—enables us to go to extremes of engineering which lesser production would not warrant.

These extremes give you that dependable aid to ignition which Champions alone provide.

There is a Champion especially designed and constructed to meet the exact conditions imposed by your motor. Your dealer will tell you which one it is and supply your wants.

Be sure the name Champion is on the porcelain.

4 out of 5

American made gasoline motors are equipped with Champions. The men who build the big sellers—Ford, Overland, Studebaker, Maxwell and 85 others specify Champions.

Champion Priming Plugs Make Winter Starting Easy



It is not enough simply to enrich your mixture with the dash adjustment, or even merely to prime your cylinders, if the day is really cold.

Prime your plugs.

Then you have your rich mixture right at the ignition point—right where the first spark can fire it.

All-in-One Champion is the pet-cock type.

It is made in various sizes to serve efficiently the various styles and types of motors.

The Champion Guarantee

Complete satisfaction to the user—free repair, replacement or money back.

All-in-One
Champion
\$1.25

CHAMPION SPARK PLUG COMPANY
401 Avondale Avenue TOLEDO, OHIO

Get into a Paying Business

Here's an opportunity for a real hustler to start in business for himself. Or, it's a chance for some live motorcycle dealer to enlarge his present business.

The retail motorcycle business is a profitable line, and the local selling rights for the Harley-Davidson are generally hard to obtain. This is because they are valuable—ask any motorcycle dealer.

In a big city, widely known as a manufacturing center, and surrounded by rich farming territory, a dealer who has been conducting a profitable motorcycle business is compelled to sell out.

The conditions which compel this action have handicapped further expansion of his business, and now force him to dispose of his interests.

Harley-Davidson Motor Company, 444 B St., Milwaukee, Wis.



Here's a real opportunity to secure a business which is paying a good profit, and which can be made even more profitable to a man who is not handicapped as this dealer has been.

Only limited capital is necessary, but anyone interested must demonstrate that he has enthusiasm, good business ability, and plenty of push and energy before we can go into the matter in detail.

Write for particulars. All correspondence strictly confidential.

In a selling organization the size of ours, composed as it is, of thousands of dealers, some dealers are satisfied with one-third the profit they might make.

Each year at the opening of the new season we are compelled to replace some of the inactive ones. A number of splendid opportunities are open for the right men.

Possibly we have not closed a contract for your town. Find out.

TRAPPERS WE BUY FOR CASH



And pay highest prices for **Coon, Mink, Skunk, Possum, Muskrat,** and all other **Furs, Hides and Ginseng.** Best facilities in America. Send for Free Price List and Shipping Tags. No commission charged.

ROGERS FUR COMPANY, Dept. 452, St. Louis, Mo.

The Acetylene Blow Torch Prest-O-Torch

Costs less to buy than a good gasoline blow torch and costs less to use

In all soldering and brazing, the Prest-O-Torch avoids the delays and uncertainties of gasoline outfits. Provides a concentrated, intense flame that doesn't blow out even in a high wind. Needs no attention whatever. Used with handy sizes of Prest-O-Lite cylinders—ready-made gas. Style "A" sells for 75c (Canada 85c). Used with the small MS size Prest-O-Lite. Will braze up to 1/4 inch round rod. Can be fired with handle and hook for added convenience in bench and overhead work. Style "C" Prest-O-Torch, for use with the larger sizes of Prest-O-Lite, is recommended for large work. Will braze up to 1/2 inch round rod. Sells for \$2.25/Canada \$2.75.

Write for special literature and learn where you can see the Prest-O-Torch in operation.

THE PREST-O-LITE CO., Inc., 816 Speedway, Indianapolis, Ind.
Canadian Factory Branch, Merrifield, Ont. Exchange Agencies Everywhere

The total enrollment of students in all the educational institutions of the United States amounts to no less than 22,000,000.



WOULD YOU

show this standard high grade 42 key fully visible typewriter to your friends and let them see wherein it excels any other \$100 typewriter, if by doing this and rendering other small assistance, you could easily have one to keep as your own? Then by post card or letter to us simply say, "Mail Particulars."

GIVEN YOU

WOODSTOCK TYPEWRITER CO., Dept. D 204, Chicago, Ill.

THE TEMCO LOCK SWITCH

on your Ford Coil is a positive Guarantee against tampering or theft. You get genuine Corbin Cylinder Lock protection with the regular kick lever switch. The Temco is the only lock offering this combination.

PRICE \$3.25 ready to fit Quickly installed. Guaranteed. Ask your dealer—or sent direct on receipt of price.

THE TEMCO ELECTRIC MOTOR COMPANY
121 Sugar Street, LEIPSIC, OHIO



DIAMONDS ON CREDIT



THE JAMES BERGMAN Jewelry Book is Full of Bargains

It shows 4,000 illustrations: Jewelry and Gems, Watches and Diamonds, Gold and Silver Toilet Sets, Tableware, fine Leather Goods, and countless fascinating articles. Note the wonderful diamond values shown here. Compare these prices with others. Certified guarantee with every diamond. Credit terms, one-fifth down, balance divided into eight equal amounts, payable monthly. Sent prepaid on approval. Write for free 100-page Catalog No. 4. It tells about our easy credit plan.

JAMES BERGMAN, 37 and 39 Maiden Lane, Edts. 1035 New York City

WATCHES ON CREDIT



Oxy-Acetylene Welding and Cutting

Welding steel rings $1\frac{1}{2}$ by $\frac{1}{4}$ inch at a cost of 5 cents each

Make Added Profits by This Process

Manufacturers of metal furniture, racks, window sash, automobile parts, steel tanks, boilers, machine tools, laundry equipment, surgical apparatus and many other products have simplified construction and increased efficiency and profit through oxy-acetylene welding.

In some lines it has entirely displaced the rivet, resulting in higher quality at less cost.

Oxy-Acetylene welding makes added profits possible for you, by providing the best, quickest and cheapest method of metal joining.

The oxy-acetylene process is not limited to production work. It often more than pays for all needed equipment in time saved on repairs by repairing a single piece of broken or worn equipment, preventing tie-ups in production, delays and expense of replacement.

Necessary equipment is not expensive. We furnish high-grade apparatus for \$60 (Canada \$75); acetylene service at slight additional cost. Adaptable for oxy-acetylene cutting with the addition of special cutting apparatus. Thorough instructions are furnished free to every user of the Prest-O-Lite outfit. We will train your operators free if you desire.

Prest-O-Lite
PROCESS

Employs Prest-O-Lite Dissolved Acetylene (ready-made carbide gas) in portable cylinders—backed by Prest-O-Lite Service. Used as conveniently as cylinders of oxygen. Saves large initial outlay and heavy depreciation of making crude acetylene in carbide generators. Perfectly dried, cleaned and purified—makes better welds and is cheaper to use.

A Profitable Business of Your Own

Enterprising men looking for new and highly profitable fields should investigate the wonderful opportunities in doing Oxy-Acetylene repair work for others.

The many possible uses for Oxy-Acetylene welding in your shops today will surprise you. Write us for engineering data on any phase of welding work you are contemplating. Oxy-Acetylene literature, thoroughly illustrated, sent free.

The Prest-O-Lite Co., Inc.

The World's Largest Makers of Dissolved Acetylene
Main Office and Factory: 818 Speedway, Indianapolis, Ind.
Canadian Office and Factory: Merrithew, Ontario
53 Branches and Charging Plants

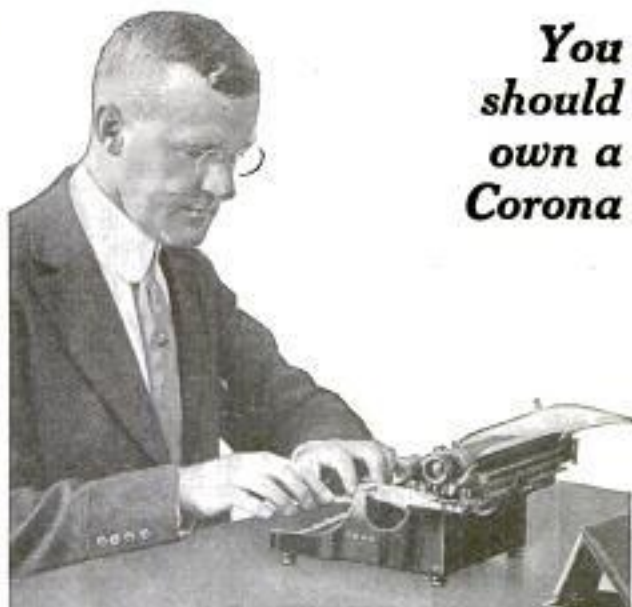

You
should
own a
Corona

A Six-Pound Typewriter for Your Own Use

Some people are judged by their appearance and others by the letters they write.

Your letter, personal or business, should be neat looking and legibly written to make as good an impression as you would like to make personally.

Whenever you have any writing to do, use a

CORONA

Folding Typewriter

At home, in the office, or when you travel you will find it a great aid in conducting your correspondence, writing reports or manuscripts.

Many progressive firms have equipped their salesmen with Coronas. Newspaper correspondents throughout the world use Coronas. Over 50,000 people in various vocations are enthusiastic owners of Coronas.

You, too, should own a Corona—use it in the office, at home, or take it with you when you travel. Weighs only 6 pounds. Costs only \$50.00.



Note these modern features

Visible writing, two-color ribbon, universal keyboard, back spacer, aluminum frame, double carriage release, mechanical type guide, ball bearing carriage, keyboards for all languages.

Send for this New Book

It contains the names of hundreds of firms and individuals who are now using Coronas. It proves what this machine does—not what we claim it will do. At the same time ask for Catalogue No. 13.

Corona Typewriter Co., Inc.
Groton, N. Y.

New York: 141 West 42nd Street
Chicago: 12 So. La Salle Street
Agencies in all principal cities



Please Mention Popular Mechanics

"Don't Shave Yourself"



Until you have tried a "BALIHONE," writes an enthusiastic user. He continues: "Eight months ago, after years of torture from imperfectly sharpened razors, a friend brought me a "BALIHONE," and asked me to try it. I knew no more about sharpening razors than a farmer would about cutting out a suit of clothes. My attempts at sharpening were successful from the first and shaving has been a pleasure ever since. I have not been shaved by a barber during this period; I have saved at least \$10.00 in money on sharpening and several times that amount in time and temper. I know that now I am master



of the situation; I can have a perfectly satisfactory shave when I want it and *no man living has or can have a sharper razor than I.* I have used *but one razor* since getting the

"BALIHONE" Dimensions: 1 1/4 in. high, 1 1/4 in. wide and 6 in. long. This is the *true* testimony of one and can furnish hundreds of others of like character. **Prove it yourself.** If dissatisfied, your money cheerfully refunded. Most appropriate for XMAS gift to Father, Son or Friend. No shaving outfit complete without a "BALIHONE." Applies to razors of any kind, safety blades, surgical instruments, cutlery, etc., etc.

Join our big band, You'll understand. They use a "BALIHONE."

Good live agents wanted. Attractive commission
 Price of Hone and Strop **\$1.00** Price of Safety Blade Holder..... **50c**
BAILEY RESILIENT HONE AND STROP CO., WILMETTE, ILLS.

You like to go HUNTING FISHING TRAPPING

Then surely you will enjoy the **National Sportsman Magazine** with its 160 richly illustrated pages, full to overflowing with interesting stories and valuable information about guns, fishing tackle, camp-outfits—the best places to go for fish and game, and a thousand and one valuable "How to" hints for Sportsmen. The **National Sportsman** is just like a big camp-fire in the woods where thousands of good fellows gather once a month and spin stirring yarns about their experiences with rod, dog, rifle and gun. All this for 15c a copy.

Special Offer
 We will send you **Free of Charge** one of our handsome Ormolu Gold watch fobs as here shown with Seal grain leather strap and gold plated buckle on receipt of \$1.00 for a year's subscription to the **National Sportsman**. Here's what you get for your money.

12 Copies National Sportsman at 15c each, value, \$1.80; Watch Fob, value, \$1.00. Total value, \$2.80. All to you for \$1.00, your money back if not satisfied.

NATIONAL SPORTSMAN, 269 Columbus Avenue, Boston, Mass.

RELIEF TO TRUSS USERS

If you must wear a truss, have one that fits and is comfortable. Our New Sponge Rubber Pad (pat'd) is velvety, soft to the skin, pliable, cannot slip, extremely comfortable, adapts itself to ruptured parts, is sanitary, long lived, holds ruptured parts in place with less pressure, allows blood circulation and produces many cures.

New Scrotal Pad Needs No Leg Strap
 Our new scrotal pad (pat'd) holds hernia perfectly without strap between legs in 8 out of 10 cases.

PAD FREE One Akron Sponge Rubber Truss Pad (pat'd) will be sent absolutely free upon request. Also booklet "Help to Truss Wearers." It's full of help. Send Now.

THE AKRON TRUSS CO., Dept. 112, AKRON, OHIO

AUTOMATIC CARD PRINTING IS EVER-LASTING-LY GOOD PAYING BUSINESS EVERYWHERE

WRITE TO DAY FOR FREE BOOKLET OF OUR AUTOMATIC SELF-FEEDING PRINTING PRESS
S. B. FEUERSTEIN & CO. MANUFACTURERS 542 W. JACKSON BLVD. CHICAGO ILL.

U. S. "Chain Tread" Motorcycle Tire

All the Strength of the "Chain Tread" Automobile Tire.
UNITED STATES TIRE CO., New York City

YOUR CREDIT IS GOOD — BUT — YOU CAN SAVE MORE THAN ONE-HALF BY PAYING CASH

That **WHY** we can offer this set of **HANDSOME GUARANTEED JEWELRY** Explains **WHY** for \$6.95, when you cannot duplicate it for \$15.00 on credit.

THIS HANDSOME SET OF JEWELRY CONSISTS OF THE FOLLOWING ARTICLES: —

- WATCH: —** Not much thicker than three five cent pieces. Case made of heavy 10 Kt. gold shell and guaranteed for 10 years of continuous wear. Registered trademark and address stamped in case as an imperishable guarantee of quality. Back and bezel screw on, making watch dust and moisture proof. Plain mirror finished back to permit monogramming. Movement has 7 selected garnet jewels and is of fine lever construction, adjusted to position, and guaranteed against mechanical defects for five years. You will find this watch accurate, reliable and durable and we back this statement by engraving our name and address on the movement as a guaranty.
- CHAIN: —** A very stylish and popular pattern, strongly made of gold shell and guaranteed for ten years of continuous wear.
- KNIFE: —** Cigar cutter style or regular knife (state which in order). Fine tool steel blades. Heavy Roman gold shell sides, guaranteed.

Each set is mounted in a handsome plush and satin lined jewel case.

Be skeptical — it will help you discover the many fine qualities of each article in this set of jewelry. — If you are in need of this jewelry, it will pay you to fill in the blank and mail it at once as you will not be out one cent if the jewelry does not meet your requirements. You cannot save seven or eight dollars every day. This set of jewelry makes an ideal Xmas gift.

WHY NOT DOUBLE THE VALUE OF YOUR CHRISTMAS MONEY?
BARCLAY WATCH MANUFACTURERS Woolworth Bldg. NEW YORK

Send me a Barclay Jewelry Set on approval. If in my judgment it comes up to your description I will accept it and pay \$6.95 at time of delivery. I am not to be put to any expense or obligation if the jewelry is unsatisfactory.

ALL FOR \$6.95

NAME..... OCCUPATION.....
 STREET..... CITY..... STATE.....

OXY-ACETYLENE

OXY-ACETYLENE
WELDING
AND CUTTING
SWINGLE

WELDING AND CUTTING

Including the Operation and Care of Acetylene Generating Plants and the Oxygen Process for Removal of Carbon

By C. F. SWINGLE, M. E.

200 Pages—76 Illustrations—Pocket Size Bound in Cloth, \$1.00

Full Leather—Round Corners—Red Edges
Stamped in Gold, \$1.50

Here is a brand new practical instruction book on the methods of welding and cutting by the oxy-acetylene process. The thirteen chapters cover the following general subjects:

Welding—Welding Flames—Oxygen Acetylene—Acetylene Gas Purification and Handling—Oxy-Acetylene Torches—Characteristics of Welding Torches—Welding Installations—Preheating and Annealing—Operating a Welding Installation—Metal Welding Practice—Oxy-Acetylene Cutting—Oxygen Carbon Removal—Index.

Sent postpaid upon receipt of price by

POPULAR MECHANICS BOOK DEPT.
6 N. Michigan Ave., CHICAGO

LITHOGRAPHIC MODELS

SIZE
10 x 14
INCHES

IN
COLORS

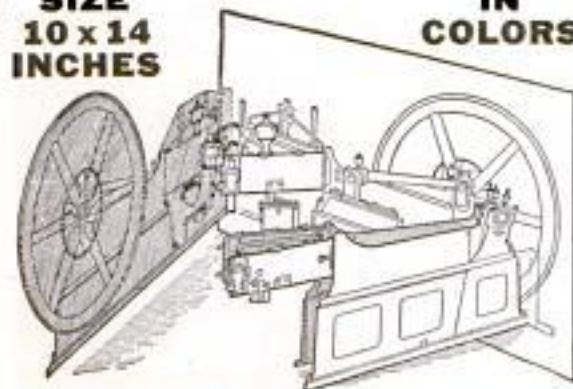

of the following: Mallet Compound Locomotive—Atlantic Type Locomotive—Automobile—Steamship—Steam Engine—Steam Turbine—Dynamo—Gas Engine—Wireless Telegraph.

As shown in the illustration these models are like a dissected chart of the human body, and open by means of a series of flaps which show every part of the machine for purposes of study. Each part is numbered and the name given. They are ingeniously made, accurate and show every detail; educational and worth many times their cost.

Price 50 Cents Each

or \$4.00 for complete set of nine subjects, prepaid

Popular Mechanics Book Dept.
6 N. Michigan Ave., CHICAGO



Number 21

AMERICAN SELF WINDING ELECTRIC CLOCK

"You Never Have to Wind It"

Dependable, Accurate, Key-Less Clock of Beautiful Appearance

Latest Mahogany Mantel Style, 13 inches wide, 10 inches high, with 5-inch silvered etched dial, gilt sash and convex glass. Self Winding Electric "Works," run by 2 standard dry batteries for a year to 18 months. New cells easily installed in the clock according to simple instructions with each clock. **\$12**
This number 21, complete and ready to run

Another very attractive self winding clock is this number 15 at **\$7**

It is 13 inches wide and 13 inches high, and you have your choice of golden oak, dark oak, or early English finishes.



Number 15



6" high
3½" wide
2½" deep

The Self Winding Works

used in our clocks can be purchased alone, without batteries or dial, for only **\$4**. You can use them for experimental purposes or to replace old-style key-wound works.

Remember, "You Never Have to Wind Them."

American Self Winding Clock Co.
Dept. P
136 West Lake Street, CHICAGO

Underwood Typewriters RENTED



or Sold at Half Regular Price
Easy Payments—No Interest

Rent a Nubilt Underwood—Buy it at half regular price on easy terms later if you decide to keep it. Rent you have paid will be applied on Purchase price. Liberal discount for cash.

Give a Nubilt Underwood for Christmas

This is the year for practical gifts—make someone happy with a Nubilt Underwood.

Our method of rebuilding typewriters is thorough and expert. Every machine leaves our factory thoroughly Rebuilt—not merely overhauled. **New Type, New Keys, New Platen (roller), New Ribbon, New Working Parts, Frame Newly Enameled, Newly Nickered, Newly Built Throughout**, so expertly, so thoroughly that it is difficult to tell which factory the machine came from,—ours or the manufacturer's,—and **You Save More Than Half.** Get a Nubilt Underwood



All typewriters we sell are completely rebuilt—rebuilt in our own Factory and are rigidly tested by experts before they are shipped. This thoroughness in rebuilding and testing makes it possible for us to guarantee our Nubilt Underwood for 5 years.

On 10 Days Free Trial

and convince yourself that here at last is a machine that completely fills your want. If for any reason you are disappointed, if you do not think it is as good as any hundred dollar machine you ever saw ship it back at our expense.

Guaranteed for 5 Years

We guarantee our Nubilt Underwood for 5 years against all imperfections in workmanship and materials.

TYPEWRITER EMPORIUM, Chicago

Please send me your Bargain List No. 49. Tell me all about your Nubilt Underwood Typewriters. This places me under no obligation to buy.

Name.....

Address.....

Town.....State.....

Book of Instructions FREE Standard-Visible Writing

Standard size, standard keyboard, standard in every particular—An Underwood Standard Typewriter at less than half. Writing visible at all times. For 23 years we have been rebuilding and selling standard typewriters. Ours is the largest and oldest business of its kind in the world. We have sold more than 100,000 machines of all known makes.

Before buying any typewriter investigate our wonderful offer. Get all the facts. Surely if we can save you more than half you want to know all about us.

Send Coupon for All the Facts

Get it off today. While the thought is topmost in your mind send the coupon for complete information. Send for Bargain List No. 49.

All Other Makes

at the same big saving. Remingtons, Oliviers, Smith-Premiers and so forth. Write for information on the kind you want.

TYPEWRITER EMPORIUM, CHICAGO

Marvelous New Valveless RADIOSENE Wickless Lamp

Burns vaporized kerosene by means of mantle—newly invented process—fast valveless, wickless kerosene lamp on the market. Gives more light than tungsten electric bulb, from cheaper, safest of fuels—10¢ worth of oil lasts an average week. Simple and reliable to use—perfectly safe, lighted or extinguished.

Radiozene rays called "scientific sun-light," next thing to nature's own—brilliant, steady and restful to the eyes. University professor asserts. "Tests proved Radiozene light to be free from red rays and to radiate 150 actual candle-power. The ideal light for any home."

AGENTS—Big Money for You

Best proposition for hustling agents. Demonstration makes sure sales—fine chance for the right man to build up profitable business of his own. Write at once for terms and exclusive territory.

**SUPERIOR
MANUFACTURING COMPANY**
294 Second St.
ANN ARBOR, MICHIGAN

\$750

150
CANDLE
POWER
OF WHITE
BRILLIANT
LIGHT



SEWS THIS DOLLAR AWL FOR ANYTHING



1916 MODEL
This Automatic Awl is superior to all others. It is of immense value for resewing all kinds of leather, harness, bags, booting, shoes, etc. **THREADED DIRECT FROM THE REEL.** So simple a child can use it. Regular price \$1. For a limited time only we will mail it anywhere, with express prepaid, two Diamond Point Needles (screwed and straight) and directions, for only 49¢ (postpaid 50¢). Extra Needle 1¢, Thread 10¢. **JACKSON SMITH & CO., Dept. 12, 715, South St., CHICAGO**

49¢

Add 4¢ for postage
AGENTS WANTED

Put Perrin "No Glares" On Your Car's Headlights

Avoid all danger from light-dazzled oncoming. Enjoy long, low, powerful light on both streets and country roads, with complete safety. Recommended by Police officials. Placed on lamp bulb permanently—always working—no buttons or levers. Over 100,000 in use.

\$1 per set of two. At your Dealer's or Garage or sent postpaid. Patented. Respect in-
PERRIN MFG. CO., Detroit, Mich.



Waterman PORTO

1916 Model leads the world in flexibility of speed control. The New Reversing Propeller permits perfect speed adjustment for any boat for racing or trolling. Original outboard motor—11th year—32,000 in use. Guaranteed for life. 3-h.p. Weighs 65 lbs. Automobile carburetor; high tension fly-wheel magnets with dual ignition; removable bearings; solid bronze skeg; 10 1/2 inch reversing propeller. Steers by rudder from any part of boat. Water-cooled exhaust manifold; noiseless under-water exhaust; spot copper water jacket. Demand these essentials, if you want your money's worth. Write us to-day for free book showing full line. Our prices will surprise you.

WATERMAN MOTOR CO., 230 Mt. Elliott Ave., Detroit, Mich.



Makes Any Boat A Motor Boat

No Money In Advance



I'll prepay the freight on an **Adler Piano** to your home to prove to you that my Celebrated **Adler Piano** is just the Piano you want. I invite you to use and play on any **Adler Piano** you select from my Piano Book, in your own home one month at my expense—I want you to test and compare it in any way you like. I prepay the freight and there's not a cent for you to pay in advance—no deposit—no obligation to purchase it. If after 30 days you are willing to part with it, return it to me, and I will pay return freight charges; your trial costs you nothing.

My Rock Bottom Factory Price Lowest Ever Made on Such Quality

My direct-to-you selling plan saves you from \$100.00 to \$150.00, because you keep the big profits of agent and middleman right in your own pocket. When you have decided to keep the instrument, you may pay cash if you wish; it is no cheaper, however, and I am quite satisfied to have you

Open a Charge Account with Me —No Collectors—No Interest to Pay

This makes it real easy for you to have sweet music in your home at once. Good music will do more to keep your family at home together than anything else I can think of. You can take from 2 to 3 years to pay and make payments so small you will never feel them and



I Sell Only
Direct from Factory
to Your Home. The Famous
\$1,000,000 Adler Factory—
Greatest in the World.

by my strictly confidential plan of dealing, nobody but you and me will know you didn't pay cash unless you tell. And remember, I prepay the freight to your station.

25-Year Guarantee

Biggest, best and strongest guarantee ever made and is backed by the **Adler** capital and resources of over \$1,000,000.

FREE My Big, Handsomely Illustrated PIANO BOOK

Coupon or postal brings my big, handsomely illustrated Piano Book and fairest, most convenient Piano Buying Proposition ever heard of.

CYRUS L. ADLER, Pres., ADLER MANUFACTURING CO.
4088 West Chestnut Street LOUISVILLE, KY.



Mail Coupon NOW

**CYRUS L. ADLER, President
Adler Manufacturing Company**
4088 W. Chestnut St., Louisville, Ky.

Without obligating me in any way, please send your Piano Book and Special Purchase Plans.

Name

Address

The Test



Musical history was made a short time ago at Orange, New Jersey. At the laboratories of the New Edison Diamond Disc Phonograph, 300 phonograph experts were witnesses to an epoch-making experiment. When the test was done, the entire gathering agreed as one — a modern miracle had been performed before their eyes!

Three factors predominated.

Alice Verlet, the famous Belgian prima donna, whom European musical critics have hailed as the "New Queen of Song."

The New Edison Diamond Disc Phonograph.

And Thomas A. Edison. He alone knew of the revelation to come; of the human voice with all its range, its sweetness, its mellowness, its sympathy and pathos coming from the instrument he had created.

Miss Verlet stood beside the New Edison Diamond Disc Phonograph. Mr. Edison sat with his head bowed upon his hand.

There came the clear notes of the beautiful song, "Caro Nome," from Rigoletto.

Which was singing, phonograph or lady? The ear could not distinguish. Only the eye could discern that Miss Verlet's lips were not moving. The Edison Diamond Disc was singing alone. Then—a greater volume—but *only* a greater volume—Miss Verlet joined her voice with the singing of the Edison Diamond Disc.

Two voices—exactly the same two—were singing together. No one among the 300 could tell which was the more clear or distinct, or more full of feeling.

The song volume decreased. The ear heard but one voice. The eye must tell again. *Miss Verlet's lips were moving.* It was she who was singing.

Faces were lit up with surprise—even with amazement—a modern miracle was happening just before them.

The phonograph and the lady continued their duet to the end. Enthusiasm, almost unbounded, ran through the audience.

Nearly 300 Phonograph Experts Held Spellbound By Unprecedented Re-creation of Music



Quickly these men realized that there had been given to the world a new instrument which years of endeavor had made so complete that even "perfect" failed as a descriptive word.

They could not describe the tone of the New Edison. It was not enough to call it "human, life-like, natural." No more could they describe a beautiful rose as "true to nature." This New Edison was *nature itself*. It was the artist in all but form.

The Edison has no tone of its own. It is a perfect vehicle for the re-creation of the artist's voice—or instrument.

New Edison Diamond Disc Phonograph

No Needles to Change

The reasons for the absolute perfection of the Diamond Disc Phonograph are manifold. The music passes through a real diamond, traversing a record so hard that human hands cannot break it. Edison records have been played 6,000 times, with the same sweetness and fidelity from the last rendition as from the first. Edison records are thicker than any ever made before.

By Mr. Edison's vertical system of recording, used only by him (as against the lateral system),

Unbreakable Records

there can be no wear on the record. The recorder makes a polished path which the smooth surface of the diamond stylus merely *floats over*.

The smooth diamond point in passing over the record is as an automobile running over a hill and then into a valley. There is no more wear on the top of the hill than at the bottom of the valley. This is in contra-distinction to the lateral system of recording, which is as a twisting river always wearing away its banks.

Edison dealers everywhere are ready to give you a demonstration of the new Diamond Disc. Ask to see the \$250 Diamond Disc Phonograph, which is the official laboratory model.

Special Edison Christmas Concerts are being given everywhere by Edison Dealers. You will be under no obligation if you ask to have your favorite records played for you. Make up your mind to hear a Christmas Concert early. If you would prefer, arrangements can be made to have a demonstration in your own home.

Or, write us for a catalog of records and Diamond Disc Phonographs

THOMAS A. EDISON, Inc. Dept. 1199, Orange, New Jersey



Weavers of Speech

Upon the magic looms of the Bell System, tens of millions of telephone messages are daily woven into a marvelous fabric, representing the countless activities of a busy people.

Day and night, invisible hands shift the shuttles to and fro, weaving the thoughts of men and women into a pattern which, if it could be seen as a tapestry, would tell a dramatic story of our business and social life.

In its warp and woof would mingle success and failure, triumph and tragedy, joy and sorrow, sentiment and shop-talk, heart emotions and million-dollar deals.

The weavers are the 70,000 Bell operators. Out of sight of the subscribers,

these weavers of speech sit silently at the switchboards, swiftly and skillfully interlacing the cords which guide the human voice over the country in all directions.

Whether a man wants his neighbor in town, or some one in a far-away state; whether the calls come one or ten a minute, the work of the operators is ever the same—making direct, instant communication everywhere possible.

This is Bell Service. Not only is it necessary to provide the facilities for the weaving of speech, but these facilities must be vitalized with the skill and intelligence which, in the Bell System, have made Universal Service the privilege of the millions.



AMERICAN TELEPHONE AND TELEGRAPH COMPANY
AND ASSOCIATED COMPANIES

One Policy

One System

Universal Service

Please Mention Popular Mechanics

Genuine Blue White
Perfect Cut

DIAMONDS

SMALL SIZES LOW AS \$50. A CARAT

\$ 88

Per
Carat

Sensational Bargains!

Think what this offer means to you! First we want to make it as emphatic

as we possibly can that every diamond we offer is guaranteed absolutely to be a *Blue White, Perfect Cut Genuine Diamond*. Secondly, our price, \$88 per carat is far less than others ask for diamonds of inferior quality. Beware of houses that advertise what they claim to be diamond bargains and don't dare to use the words **BLUE WHITE**. Why pay big prices for orange-white and other off-color stones? When you buy direct from us, you get FINE QUALITY and save the middlemen's tax, 35% and more.

JUST COMPARE THESE PRICES!



SPECIAL!

1-CARAT

Genuine Blue White perfect cut diamond, set in 14-karat solitaire Tiffany style ring, the perfect engagement setting. \$80 value. Our direct import price, **\$42.00**

Same ring with:
1-3 carat diamond \$ 9.00
1-4 carat diamond 17.25
1-5 carat diamond 30.75
1-6 carat diamond 67.15
1 carat diamond 90.88

14k. solid gold girl's, baby and child's ring. Set with Blue White perfect cut genuine dia. **\$2.88**

14k solid gold 6-tooth ring, the young men's favorite. Set with 1/2 carat genuine perfect cut Blue White Diamond. \$186 retail value. Our **\$47.75** import price only! For other size diamonds add our factory cost price of the mounting \$3.80 to price for diamonds given at right.



10 karat solid gold cuff links, patent stiffened posts, set with two dia. Roman finish. Exact size shown. \$5 value. Our price **\$1.88**

12 HOUR SERVICE on XMAS ORDERS!

Select your Xmas gifts from Barnard & Co.'s Diamond Book. 12 hour service guaranteed. Our stock is enormous. Mail your Xmas orders to us, you will avoid disappointment and be sure of the utmost satisfaction.

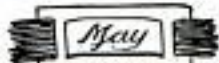

Showering silver friendship bracelet links, 1/2 size kind, engraved free for only **10c**

NO MONEY in Advance

Send no money, not even a deposit. No references, no waiting, red-tape or formalities. Our simple plan is the only safe way to buy your diamond. We actually show you the diamond and mounting you select from our Book or this ad. We'll ship to you for Free examination—entirely at our expense. We want you to see for yourself the tremendous value we give for the world's lowest price. Return or accept as you yourself decide. No obligation at all.

THE ONLY BANKABLE LEGAL MONEY BACK GUARANTEE

The only BANKABLE guarantee, the only safe Money Back contract. Here are its unique features: it allows you to return any diamond bought from us through any bank in America, or direct to us, and you'll get INSTANTLY cash refund; no quibbling, delay or red-tape. Where else can you get equal protection? And besides, our Guarantee allows you the full price in exchange at any time! And it legally certifies the true color, carat weight and money value. We can afford to stand back of our Diamonds with this amazing guarantee because we know the quality gives universal delight, and the money value can't be remotely equalled anywhere.

THE ONLY SAFE WAY TO BUY DIAMONDS!

SEND FOR THIS FREE BOOK

Our DeLuxe Book of Diamonds, especially the new 1916 Edition now ready, is the authoritative guide for the diamond buyer. A real bound book, full of expert's facts, profusely illustrated. First in the field with the new 1916 styles. Tells you how to judge, buy, tell value of diamonds. Comes to you free and without obligation. Mail coupon or write; or a postal will bring it. Write NOW!

BARNARD & CO.

Dept. 788C, S. W. Cor. Wabash & Monroe St. CHICAGO

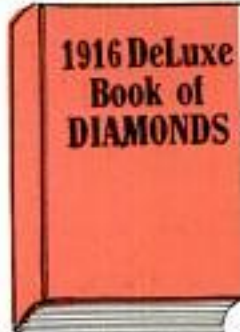

Roman finish, gold top knife, guaranteed quality, imported blade, set with genuine diamond. Is combination razor cutter. \$5 value. Our competition smashing price, **\$1.88**

Use This Coupon FOR FREE BOOK

BARNARD & CO. Dept. 788C, S. W. Cor. Wabash & Monroe St., CHICAGO

Without obligation on my part please send me free and postage paid by you, your 1916 DeLuxe Book of Diamonds.

Name

Address

ERECTOR

The Toy Like Structural Steel

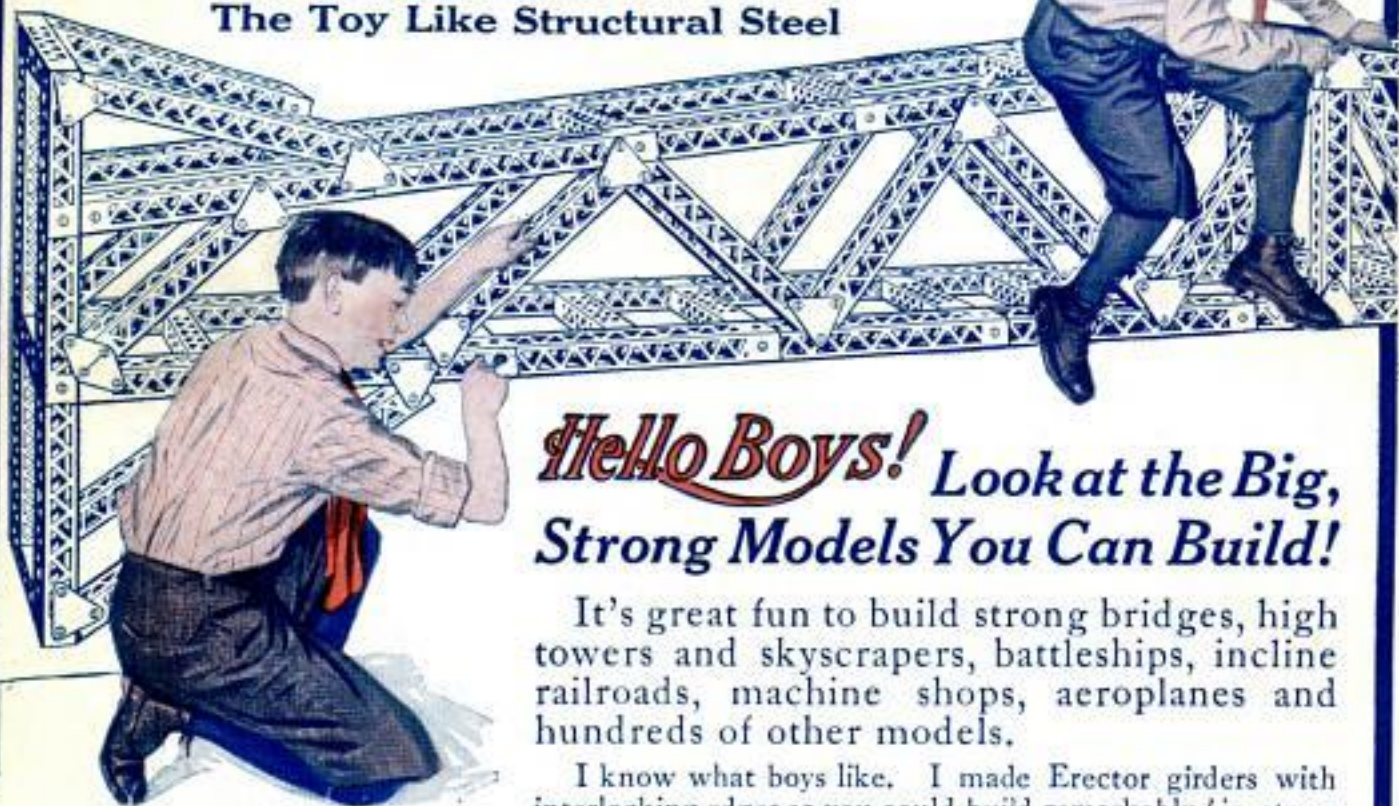

Hello Boys! Look at the Big, Strong Models You Can Build!

It's great fun to build strong bridges, high towers and skyscrapers, battleships, incline railroads, machine shops, aeroplanes and hundreds of other models.

I know what boys like. I made Erector girders with interlocking edges so you could build remarkably *big, strong*

models — some 21 feet long, some 8 feet high. Erector is the *only* construction toy with girders exactly like real structural steel. The electric motor (free with most sets) runs many of the models. It lifts 100 pounds and makes things hum!

Write for Free Book and 3 Free Issues of My Boys' Magazine

I want to give every boy, absolutely free, a three months' subscription to my boys' magazine, *Erector Tips*, including the big holiday issue in colors, brimful of stories and photographs.

Read the absorbing story, "How I Invented Erector" and the special articles telling my experiences as a World's Champion Athlete. These issues of *Tips* also explain how to do magic tricks; show photographs of the winners in last year's prize contest; give full details of this year's prize offer of automobile, motorcycles, tents, canoes, etc.

Send today for the three months' subscription — also a free copy of my new 24-page illustrated Book. Don't send any money or stamps. I want to present all this to you *absolutely free!*

Be sure you get Erector for Christmas. Dealers everywhere sell it, \$1 to \$25 per set. Look at Set No. 4 for \$5, has 571 parts and motor, builds 250 models and comes in handsome oak cabinet.

A. C. GILBERT, President

THE MYSTO MFG. CO., 104 Fox St., New Haven, Conn.

Five of Last Year's Prize Winners and Erector Motor

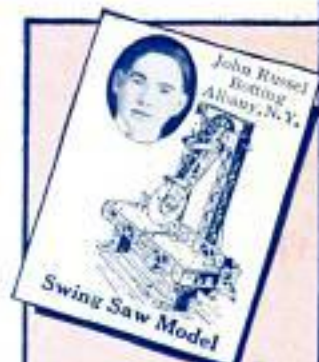

Swing Saw Model



Church Model



Derrick Model



Siege Gun Model



ERECTOR MOTOR

ERECTOR TIPS
\$3,000.00 Prize Contest
This Auto FREE

COUPON
Mr. A. C. Gilbert
The Mysto Mfg. Co.
104 Fox St.
New Haven, Conn.
Please send me a copy of your Free Book and 3 months' free subscription to your boys' magazine *Erector Tips*, which tells all about your big prize contest.

Name.....
Address.....
My toy dealer is.....