

THIS ISSUE 425,000 COPIES

# POPULAR MECHANICS MAGAZINE

WRITTEN SO YOU CAN UNDERSTAND IT

TRADE MARK





Harris Home Design No. 181

**\$769** Buys the Material

Sensibly  
Cut-  
to-  
fit

**"The Harris Way"**

The New  
Modern Way  
to Build  
Your Home

PLANS FREE

## Buy Now—Save 1/4 to 1/2—No Money Down

**Material** Our \$10,000,000 capital backs our absolute guarantee of every piece of sensibly cut-to-fit material, all carefully selected by experts. For the outside of this Harris Home we furnish clear knotless finishing lumber, Red Cedar or Cypress Shingles, No. 1 dimension lumber, Guaranteed Rawhide Roofing. Inside: clear modern Craftsman style thoroughly kiln-dried trim; clear, perfectly manufactured flooring, beautiful doors, satin finished hardware. Everything in perfect harmony with the design.

**Design** This charming Harris Home is a distinctive bungalow, elegant and striking in appearance. Any man would be proud to call it his home. It has a large living room across the front, then two big bed rooms, numerous closets, spacious dining room, pantry, ice box room and a large modern kitchen; but this is only one of the hundred or more homes to be found illustrated and described in our big free Book of Plans. Send for it! Take advantage of our money-saving building method.



Design 182

**\$564** Here is a bungalow suitable for any surroundings. Simple and elegant. Five rooms, bath, closets, pantry.

## We Manufacture and Ship Direct

Now is the time to buy from us when we have again reduced all prices because of our enormous new mill and manufacturing plant. Reap the benefit of our twenty-three years' experience in planning, designing and manufacturing. Keep all the in-between profits yourself. We manufacture and ship direct to you. Ours is the short cut to big savings. Our Plan Book tells you our clear, straight-forward proposition that every prospective house owner should know, and shows the letters of satisfied customers throughout the country.

## Sensibly Cut-to-Fit

We give you free the benefit of our powerful and accurate machinery. To you this means not only better material, but savings in labor and time as well, and you know that time is money in building operations. Our Sensibly Cut-to-Fit method absolutely results in better material for you, cut-to-fit the HARRIS WAY at less than the cost of material purchased the old-fashioned way. Send for our free Book of Plans. Know what the HARRIS WAY is and why it saves you money.

### Free Plan Offer

Would you like to see the Blue Prints? Send us a temporary deposit of \$2.00—as evidence of good faith—and we mail you complete Blue Prints, Specifications and Material List for any Harris home. They show and specify with illustrations the kinds of material furnished inside and outside, giving catalog numbers. If you are not satisfied with the plans, we will refund \$1.50.



Design 185

**\$867** Here is a stately home that has won favor in many states. Eight rooms, bath, large living rooms.

### Sent on Approval

Every house backed by our binding guarantee. Shipped on approval without the payment of one cent down. You have the privilege of inspecting your material before paying one cent. If it is not exactly as we say, send it back. We are not afraid of our material; that's why we can send it anywhere subject to your approval. We know that you will be more than satisfied.

### Free Book of Plans

We spent thousands of dollars to produce our big New Plan Book. We mail it to you free. It shows hundreds of Harris homes illustrated with floor plans, etc. It contains much valuable information. Mail the coupon below.

#### MAIL THIS COUPON NOW!

HARRIS BROS. CO., Dept. AW-7.

Send Books marked X  Free Book of Plans

Direct-to-You Lumber Prices  Plumbing and Heating Book

Name .....

Address .....

### Plumbing and Heating

You can easily install your own heating plant and plumbing material with the assistance of our free expert engineering service. We show you how to cut down expense and save money on material. Complete Bath Room Outfits as low as \$37.00. Warm Air Heating Plants \$67.00; Steam \$85; Hot Water \$95. Ask for our beautiful Plumbing and Heating Book which we mail free.

### Lumber and Millwork Savings

Our enormous facilities at our great new manufacturing plant enable us to ship direct to you any lumber or mill work at great savings. Ask in this coupon for our DIRECT-TO-YOU Lumber Prices. Great savings possible.



Design 193

**\$998** An imposing residence, architecturally superb. Seven rooms, bath, sun parlor, sleeping porch.

**HARRIS BROS. CO.** 35th & Iron Sts. CHICAGO

# Victrola

The instrument for  
the world's best music

The best music in the world is the music which is rendered by the *greatest* artists.

And there's just one way to enjoy all the world's best music in your own home—on the Victrola.

The world's greatest artists make records exclusively for the Victor—and only on the Victrola can you hear their superb renditions with all the distinctive personality and charm of interpretation which make them famous the world over.

Hearing is believing. Any Victor dealer in any city in the world will gladly play any music you wish to hear and demonstrate the various styles of the Victor and Victrola—\$10 to \$350.



Victrola XVI, \$200  
Victrola XVI, electric, \$250  
Mahogany or oak



CARUSO



MELBA



FERRUCIO



SCHUMANN-HEINK



MCDERMACK

CHAS. H. DEAN & CO. N. Y. N. Y.



Victor Talking Machine Co.  
Camden, N. J., U. S. A.

Beitner Gramophone Co., Montreal  
Canadian Distributors

Always use Victor Machines with Victor Records and Victor Needles—the combination. There is no other way to get the unequalled Victor tone.

New Victor Records demonstrated at all dealers on the 28th of each month

Please Mention Popular Mechanics

This One



BWTL-PFY-P8C9

Here's a "dandy" Free Text  
Book for Home Carpenters

12 WORKING  
VOL. 36  
**CYPRESS**  
POCKET LIBRARY  
"THE WOOD ETHERAL"

"SHORT CUTS" TO  
GOOD CARPENTRY

"Short Cuts to Good Carpentry"—  
(Vol. 36, Cypress Pocket Library)

48 pages of authoritative instruction (simple, clear and stimulating) fully illustrated and with big Supplement, 24 x 36 in. with detailed Working Drawings that show how to make twelve "hard jobs" easy, safe and economical of both labor and Lumber. Read what "Rural Life," (Rochester, N. Y.) says of

"SHORT CUTS to  
GOOD CARPENTRY"

"It is a *guide book* for the man or boy who can handle a saw or hammer and wants to know how to use them to the best advantage."

Ten topics pertaining to the house and 4 about barns. Sent *free* with our compliments.

WE TRUST YOUR  
OWN JUDGMENT  
and SELF-INTEREST to  
INSURE CYPRESS on YOUR job.  
"The Wood Eternal" keeps values  
going up by keeping the place from  
running down."

BOX SILL  
CONSTRUCTION

SELF  
SUPPORTING

JOIST

BARN  
FRAMING

ROOF TRUSS

CORNICE  
DETAIL

CYPRESS SHINGLES

When planning a Mansion, a Bungalow, a  
Farm, a Sleeping-Porch or just a Fence, remember  
WITH CYPRESS you BUILD TO LAST LONGER. TRY IT.

Let our "ALL ROUND HELPS DEPARTMENT" help YOU. Our resources are at your service with Reliable Counsel.

**SOUTHERN CYPRESS MFRS. ASSOCIATION**

1219 Heard Nat'l Bank Bldg., Jacksonville, Fla. or 1219 Hibernia Bank Bldg., New Orleans, La.

(Please address nearest office.)

INSIST ON CYPRESS AT YOUR LOCAL DEALER'S. IF HE HASN'T IT, LET US KNOW IMMEDIATELY.

Please Mention Popular Mechanics

# Popular Mechanics Magazine

6 N. Michigan Avenue, Chicago, U. S. A.

EDITED BY H. H. WINDSOR

England: The International News Co.,  
5 Breams Bldg., Chancery Lane, London, E. C.

Australia:  
The Australasian News Co.

ISSUED MONTHLY

SUBSCRIPTION:

SINGLE COPY, 15 CENTS

In United States, and its possessions, Cuba and Mexico, per year, postpaid . . . . . \$1.50  
To Canada . . . . . 1.75  
To all other countries in the Postal Union . . . . . 2.50

All subscriptions are discontinued at expiration. Please examine the date printed on your wrapper.  
Entered as Second Class Matter Sept. 15, 1903, at the Post Office at Chicago, Illinois, under Act of March 3rd, 1879.  
Entered as Second Class Matter at the Post Office Department, Canada.

Published monthly by POPULAR MECHANICS CO.

Copyright, 1915, by H. H. WINDSOR.  
Copyright, in France.

## Contents for November, 1915

Accountants, Calculating Instrument for.....	708
Adding Machine of Enormous Capacity.....	672
Air, Hot, Instead of Towel for Drying Hands....	693
Airship—Dirigible Balloon Made Rigid by Gas Pressure.....	658
Alloy, New, Strength and Lightness Found in....	742
Arcade, Display Cases in, Replace Show Win- dows.....	665
Army, Union, Remnant of in Review at Capital... 683	
Art Exhibit, Circulating, Is Educational Idea... 722	
Automobile, Adequate Space for Bags Supplied in Automobile Hearse Built as Limousine Also.... 684	
Automobile Springs, Simple Instrument Oils.... 759	
Barrel Drainer, Portable, of Convenient Form... 731	
Bell, Fire Alarm, Erected to Protect "Iron-sides" 706	
Bicycles, Side by Side, Driven by Motor..... 712	
Blind, Machine Enables to Read by Sound.... 694	
Boat, Combination, Made for Ice and Water Use 722	
Boat Drawn over Lake by Moccasined Dog Team 712	
Boat, New Method of Providing Air Cushion for 730	
Boat with Motor Housed in Keel.....	654
Bolt, New, with Folding Toggle.....	758
Boring Attachment for Mortising Machine..... 732	
Braking Apparatus for Logging Vehicles..... 740	
Bridge, Direct Lift, Built over Louisville Canal 642	
Bridge, Great Hell Gate, Nears Completion.... 730	
Building, Business, Odd Architectural Design in 717	
Building, Shiplike, Used as Fish Market..... 733	
Burn, Model Village to Amuse Crowds.....	738
Camera Tripod, Pocket Device Substitute for... 687	
Canal, Panama, First Year's Operation of..... 737	
Canal, Panama, Passing Battleship Fleet through 738	
Canal, Truckee, Discharge Chute for.....	715
Car, Light Chemical, Built for Small Town Use... 736	
Cars, Passenger, Auxiliary Platform Leaf for... 687	
Caucasus, Picturesque Customs of Peoples of... 750	
Chair, New Theater, with Folding Arms.....	755
Chimney, Man Marooned on, Saves Self in Odd Way.....	719
Chrysanthemums, Bush, Preparing for Exhibition 721	
Churn, Motor Driven, Built as Farm Creamery Plant.....	720
Concrete, Blowing Instead of Pouring It, by H. B. Kirkland.....	744
Concrete Mold, Adjustable, for Sewer Work.... 722	
Concrete Protection, Odd, Shields Motor from Sun.....	707
Concrete Roads, Motor Propelled Finisher for... 669	
Concrete Work, New Form Holder for.....	765
Drawings, Animated, Using to Illustrate Lec- tures.....	642
Drill, Rotary Oil Well, of New Type.....	753
Egg Testing Device Made for Large Consumers... 740	
Electric Plants in United States.....	705
Engine, New Two Cycle, Has Compression Chamber.....	662
Engine with Two Pistons for Each Cylinder.... 753	
Envelopes Sealed Quickly with New Device.... 661	
Explosion—New York Street Caved in by Sub- way Blast.....	681
Eyeglass Lenses, Instrument for Cleaning.... 733	
Forests, Government, Picking Men for Rangers of.....	734
Fruit, Method of Cleaning and Grading..... 731	
Gas Burner, Intense Heat Developed by..... 688	
Gas Plant Designed for Country Home.....	754
Gas, Water, New Apparatus for Making..... 751	
Geometric Figures, Instrument for Redrawing... 753	
Guns, New Naval, Have High Angle of Fire.... 705	
Hacksaws, Gauge for Limiting Cut of.....	760
Hand, Workman's, Recording Movements of... 724	
House, Kansas Town Builds for Touring Motor- ists.....	742
House Plan—Bungalow, Conveniently Arranged Frame.....	800
Hydroelectric Plants in the Pyrenees.....	706
Hydroelectric Power Development on Pacific Coast.....	651
Kiosks, Street, are Leased by City of Baltimore... 732	
Kitchen Cabinet Closes Like Roll Top Desk.... 665	
Ladle, Hot Metal, New Device for Tilting.... 759	
Lamp, Nitrogen, Powerful Light Produced by... 646	
Lamp with Folding Shade Easily Transported... 735	
Lawn, Large Dippers Employed in.....	741
Life Preserver and Traveling Bag, Combined... 679	
Lifeboats, Device Frees in Record Time..... 737	
Light, Mercury Vapor, Why Easy on Eye..... 746	
Lighting Plant for Movie Work on Motor Car... 660	
Lincoln Highway, Substantial and Artistic Marker for.....	752
Locomotives for Siberia Railway Built Here... 660	
Meters, Service, are Read with Special Camera... 685	
Milk Pail, Sanitary, Made after Curious Pattern... 704	
Mirror, Road, Danger at Hairpin Turn Lessened by.....	666
Motor Bus Side Fenders Guard Rear Wheels... 718	
Motorcycle, Novel, of Simple Construction.... 679	
Motor Trucks are Built in Iowa Prison.....	741

[Continued on Page 6]

Popular Mechanics offers no premiums; does not join in "clubbing offers," and employs no solicitors to secure subscriptions. It is for sale by nearly every newsdealer in the United States and Canada.

## [Contents—Continued]

Motors, Aerial, British Produce Starter for.....	642
Navy, Four Years in the, by Louis E. Browne: Part III—The Rewards of Naval Training.....	724
Novel and Practical Things for the Home.....	756
Oil, Sprinkling Country Roads with.....	743
Oven, Chimney, Waste Furnace Heat Used by.....	650
Oxyacetylene Flame, Enormous Weld Made with.....	742
Peat Used in Manufacture of Gas.....	733
Piano Transported up Mountain by Burros.....	641
Pictures, Making of Seeds Is New Art.....	714
Platforms, Portable, Used by Suffrage Speakers.....	649
Play String Instruments by Pressing Buttons.....	736
Police Boats, New York Harbor, Machine Guns for.....	686
Potato Race Is Fast Game When Played by Cowboys.....	704
Pump Set, Portable, for Draining Trenches.....	713
Pumping Plant, Odd, Built in Municipal Park.....	705
Push Buttons, Hitching Posts Equipped with.....	719
Radiator, Steam, Heated by Gas.....	649
Radiators, Steam, Heat Regulator Designed for.....	720
Railroad Cars Joined to Form Movie Theater.....	708
Railroad, Farm Demonstration Car Used by.....	707
Railroad Line, Busy Steam, Electrified.....	744
Raking Machine, Automatic, for Lawns.....	672
Road, Motor, to Summit of Pike's Peak.....	682
Sawmill, Odd, Operated by Wind Power.....	719
School, High, Duties of Womanhood Taught in.....	709
School, Large Technical, Built at Toronto.....	671
Screwdriver and Hammer, Combination.....	737
Setcrew, Headless, That Drives Flush.....	758
Ship—Destroyer Spreading Smoke Screen.....	693
Ship—Lake Steamer, Stability Test Is Given.....	752
Ships, Courses of in Fog Indicated by Signal.....	754
Shin's Vibrations, Instrument Reveals Cause of.....	680
Smokestack, High, Built through Hill.....	717
Snow Sweeper, New Type of for New York Streets.....	748
Soap, Shaving, Put Up in Wooden Bowls.....	760
Stairs Connect Streets on Different Levels.....	690
Store, Novel, within Walls of State Penitentiary.....	650
Street Cars, Express Service Is Tried on.....	741
Street Names Displayed by Curbstone Signs.....	658
Submarine "F-4," Raising of.....	677
Submarines, Coast Positions Attacked by.....	760
Sugar Factory Waste Used as Motor Car Fuel.....	672
Sundial, Quaint, Erected on Harvard Building.....	752
Sunset, Mid-Ocean, Not Seen by San Francisco Airman.....	680
Table, Serving, Is Wired for Electric Dishes.....	745
Table, Solid Appearing, Hides Many Drawers.....	668
Telephone Church Service on Island of Guernsey.....	714
Telephone Meter Is Made in Very Compact Form.....	669
Telephone, Novel Sanitation Device for.....	733
Tent Studio, Winter Landscape Artist Has.....	730
Thunderbolt, Single, Electric Service Tied Up by.....	684
Timber, Lifting over Arrowrock Dam.....	692
Tires, Motor, Fiber Fabric Is Employed in Re- making.....	716
Tool Holder, New, Has Cam for Setting Tool.....	760
Tower, Novel Collapsible, for Fire Fighters.....	646
Town Attracts Motorists in Novel Manner.....	671
Transformer for Electrical Toys.....	687
Tree, Old, Grafting New Roots on.....	746
Typewriter, New Form of Copy Holder for.....	723
Vacuum Cleaner for Teeth New Dental Appliance.....	759
Valves, Twelve Foot, Built for Power Station.....	747
Vehicle, Curious Pleasure, Designed for Children.....	717
Ventilate Factory Plant through Columns.....	718
War, European: Battle Fields, Grim Phases of War Seen on.....	703
Balloon, Captive, Making Observations from.....	695
Britain's Defenders at Practice and Play.....	701
Camps, Modern Army, Behind Firing Lines in.....	696
Crown Prince Reviews Victorious Troops.....	690
Desert Sands, On, with Expeditionary Forces.....	698
Eastern Battle Front, Striking Scenes on.....	691
Europe, Battle Ridden, Random Glimpses of.....	702
German Viewpoint, Side Lights on War from.....	700
Hospital, Crude, for Wounded Russian Soldiers.....	692
Italians, With, on Alpine Battle Front.....	699
Przemysl, The Crumbled Masonry That Was.....	689
Russians, Retreating, in the Wake of.....	694
Wounded and Crippled Soldiers, Treating.....	697
War's Emergencies, Meeting with Ingenious In- ventions, by Searle Hendee.....	673
Water Main, Submarine, Flexible Tubing Used for.....	713

Wells, Michigan's Flowing, Unfailing Water Source.....	663
Wireless Antenna, Ground Resistance in.....	732
Women to Promote National Preparedness.....	747

## SHOP NOTES

Automobile Crank Handle, To Prevent Rattle of.....	778
Automobile Engine Case Breather, Covering to Prevent Dust from Entering.....	770
Automobile Engines, Keeping Cable Tube Clean on.....	769
Automobile Hub Cap, Preventing Loss of.....	778
Automobile Steering Post, Loose, Reinforcing.....	779
Automobile, To Prevent Squeaking Noises on.....	777
Beeswax, Uses for.....	771
Bench Hook, Shoot Board and Miter Mox.....	777
Blower for Small Forge.....	770
Boat, Double Deck, One-Man Control for.....	767
Boiler Tubes, Reflecting Light Into for Inspec- tion.....	777
Buggy Spindle Straightener.....	769
Coating Solution for Laying Out Work.....	776
Concrete Form Bolts, Puller for.....	772
Concrete Sidewalk Material, Broken, Making Use of.....	766
Dowel Holes, Renewing in Old Wood Patterns.....	772
Drill, Broken, Removing.....	778
Drill, Motor, Base for.....	768
Drills, Flat, Guard Holder for.....	764
Eave Trough, Water Guide for.....	778
Eyeglass Cleaner.....	770
Eyeglass Lens, Loose, Remedy for.....	778
Garage, The Private.....	761
Gear Box Filler Cover, Holding Spring for.....	763
Gold Leaf, Method of Applying Economically.....	763
Greasing Crosshead Pins.....	772
Guy Line, Makeshift Tightener for.....	762
Home, Building a: Part VIII—Interior Woodwork.....	773
Ice Creepers.....	764
Lathe, Wood, Compound Rest for.....	768
Light, Disappearing Desk.....	767
Mandrel, Removing Milled Work from.....	772
Motor Truck, Number Plate Bracket for.....	770
Motorcycle, Repairing Pedal Crank on.....	766
Pen, Ruling, Calibrating Thumbscrew on.....	764
Railroad Repair Tracks, Alarm Signal for.....	769
Road Roller Made of Old Boiler.....	762
Shock Produces Greater Strain than Pressure.....	780
Steel, Appearance of Casehardening Given to.....	767
Stenciled Initials or Monograms on Automobiles.....	765
Tire Tool, Convenient Demountable Rim.....	771
Tires, Using Skid Chains, Care of.....	780
Tool Setting and Lining Bar.....	780
Tools, Holding in Their Handles.....	772
Torch, Emergency.....	770
T-Square, Carrying on Drawing Board.....	771
Violin, Softening Harsh Tone of.....	764
Wire, Live, Detector.....	772

## AMATEUR MECHANICS

Ammonia Carrying Case for Insect Bites.....	791
Blowtorch, Alcohol, for Difficult Soldering.....	797
Candlestick, Mission.....	783
Candlesticks, Sectional Spun Metal, Repairing.....	797
Cartridge, Brass, Bearing Made of.....	797
Cleaning Mixture, Dry.....	790
Fish Bait, Luminous Minnow.....	789
Fish Scaler.....	791
Flowers, Cut, How to Preserve.....	786
Gluing Press, Inexpensive.....	781
Gold, Surface Mining for: Part II—Recovering Gold from River Beds.....	793
Lights in Basement, Lighted, Signal for.....	783
Match, Lighting in Wind.....	797
Minnows, Catching for Bait.....	792
Putty, To Prevent Sticking to Hands.....	782
Rope, Sheepshank Knot Used to Recover.....	792
Sewing Machine Thread, Preventing from Tan- gling.....	797
Shotgun and How to Use It: Part I—How a Shotgun Is Made.....	783
Tenpins, Home, Pin Setter for.....	789

[Contents Continued on Page 8]

**Now the  
Most Used  
Engineers'  
Library in  
Existence**

**Including**  
Mathematics  
Boilers  
Engine  
Running  
Valve Setting  
Piping  
Pumps  
Electricity  
Shafting  
Belting  
Governors  
Steam  
Turbines  
Refrigeration



Actual Size of Each Book  $5\frac{1}{2} \times 8\frac{1}{2}$  Inches

# POWER PLANT PRACTICE COMPLETE

**ON  
APPROVAL**

**NO  
MONEY  
DOWN**

**The Power Plant Library Has Revolutionized All Former Methods  
of Teaching the Principles of Power Plant Engineering**

**\$  
1  
P  
E  
R  
M  
O  
N  
T  
H**

## CONTENTS

**Practical Mathematics, Four Parts.** By Claude Irwin Palmer, Assistant Professor of Mathematics, Armour Institute of Technology. 650 pages. 3000 drill exercises and problems.

**Power Catechism (Engine Running).** By Fred R. Low, Editor of Power. 226 pages, 131 illustrations. Nearly 1000 answers to direct questions.

**Valve Setting.** By Hubert E. Collins, Consulting Engineer. 209 pages, 1230 illustrations. Diagrams, Tables.

**Boilers, Piping, Pumps.** By Hubert E. Collins. Three Parts, 435 pages, 250 illustrations. Diagrams, Tables.

**Shafting, Belting, Governors.** By Hubert E. Collins. Two parts, 286 pages, 185 illustrations. Diagrams, Tables.

**Electrical Catechism.** By George D. Shepardson, Professor of Electrical Engineering, University of Minnesota. 422 pages, 325 illustrations. Diagrams, Tables. 1520 questions answered.

**Steam Turbines (Practical Turbine Running).** By Hubert E. Collins. 186 pages, 103 illustrations. Diagrams, Tables.

**Mechanical Refrigeration.** By Fred E. Matthews, of the American Society of Refrigerating Engineers. 172 pages, 75 illustrations. Tables, Diagrams.

**I**F you are interested in power plant work—if you are an engineer or expect to become one, you cannot be too careful in the purchase of your instruction books. Only books written from **PRACTICE BY PRACTICING ENGINEERS** should be considered.

The McGraw-Hill Company has studied the problems of the power plant engineer for nearly forty years, and the **POWER PLANT LIBRARY** is the culmination of these years of experience and effort.

Written entirely from the practical man's viewpoint and in his own language, these books are just as valuable to the beginner as to the \$5,000-a-year chief engineer—because there is no theory and no high mathematics—**ONLY FACTS AND FIGURES THAT YOU REQUIRE IN ORDER TO REACH THE TOP IN THE ENGINEERING PROFESSION.**

**The Power Plant Library Supplies the Essentials of a Complete Technical Education**

It is accurate, thorough and up-to-date. In a word, it is standard. With sure strokes every item of information is driven home. No words are wasted. From the first of the nearly three thousand pages to the end there is something of educational and technical value.

Upon receipt of the coupon below we will send you by express or parcel post, prepaid, the entire eight volumes, durably and beautifully bound in cloth of the tough H pattern. The titles are in gold, and the set weighs about fourteen pounds.

## FREE EXAMINATION COUPON

McGraw-Hill Book Co., Inc., 239 W. 39th St., New York

Gentlemen:— Ship the Power Plant Library, eight volumes, for my inspection. If satisfactory after examination, I will send you \$1 in ten days and the balance at the rate of \$1 per month until I have paid the price of the books, \$12. If not satisfactory I will write for shipping instructions.

Signature .....

Residence Address .....

City and State .....

Name of Employer .....

Reference .....

Address.....PM-NOV

**McGraw-Hill Book Co., Inc.**

PUBLISHERS OF BOOKS FOR  
ENGINEERS SINCE 1876

239 West 39th Street  
NEW YORK

# FREE

We Assist Students Getting Actual Driving Experience



## A. L. DYKE'S 32-Page Booklet

about his New Idea a Working Model Course of Automobile Instruction, testimonials and proofs.

### JUST MAIL THE COUPON BELOW

This booklet is interesting and instructive in itself. Learn how you can get all this training for only \$15. Fill out coupon below or write a postal — but do it now. Hundreds have learned the

## AUTOMOBILE BUSINESS

AT HOME during their spare time by mail with DYKE'S NEW IDEA WORKING MODEL METHOD.

### WHY NOT YOU?

If we prove to you that we have started hundreds of others into the repair business and as chauffeurs — who had no previous experience and who knew no more about an auto than you do right now — you must admit we can do the same for you. Write me today — now — and let me prove it.

The Automobile Business is growing — more help needed and big pay. No other business offers such opportunities. It's easy to learn. An Auto Repairman is not a machinist — his work consists of adjustments and re-fitting worn parts, "knowing the principle," that's the thing. One of our students writes: "Before I started with your course I was a clerk at \$50 per month. After finishing I followed your instructions, started a repair shop and cleared \$122 the first month — pretty good for the first month." Let us show you this and many other letters.



Our book of testimonials, showing photos of students and their shops — free.

We will show you the way to start a repair shop of your own — or drive a car and make more than you are making now — we can give you this training during your spare time — with **DYKE'S NEW IDEA OF TEACHING BY MAIL WITH WORKING MODELS**

On these models you get actual practice, see the actual operation and learn more than you could from the auto itself — it's easy and quick. You don't have to study hard with this system — we teach through the eye — a new idea. Mr. Dyke is the originator of the system of teaching by mail with models — therefore beware of imitators.

**Our Employment Plan for Students** represents years of work to provide something that no other school had, namely, a way for the student to get started in the practical line of work.

Mr. Dyke has been identified as a pioneer inventor, supply man, etc. with the auto industry since its beginning. He originated the first auto supply co. and published the first book on autos in America. No other man with such experience is today teaching others.

**Dyke's Correspondence School of Motoring**  
Box 196, Roe Bldg., St. Louis, Mo.

Send me your free 32-page booklet about your New Idea Working Model Course and testimonials and proofs. It is understood I am under no obligations in sending for this.

Name.....  
Town.....  
Street..... State.....



This school is a department of the firm A. L. Dyke, Publisher and Importer. Dyke's system is endorsed by leading motor authorities of the world.  
**SPECIAL INSTRUCTION on Six, Eight, Twelve Cylinder Engines. 1915 Electric Starting and Generating Systems.**

Please Mention Popular Mechanics

### (Contents—Continued from page 6)

Towel, Disappearing .....	791
Trick—Card Deception, Simple.....	792
Trick—Magically Naming Written Card.....	799
Typewriter, Plain Ribbon, Writing Two Colors on .....	792
Window Sash, Locking.....	790

### PATENTS

Automobile, Sliding Door for.....	799
Automobiles, Theft Indicator for.....	798
Bathtub Attachment, New.....	798
"Beauty Mark," New Type of.....	798
Belt, Elastic.....	798
Bench Grip, Automatic.....	799
Billiard Cue, Guide for.....	798
Clothesline Hanger.....	798
Cork Extractor.....	798
Egg Boiler.....	799
Flagstaff and Torpedo Holder, Combined.....	798
Igniter.....	798
Kitchen Utensil—Lifter for Plates and Pans.....	799
Ladder, Portable Orchard.....	799
Ladder, Scaffolding.....	798
Mouse Trap.....	798
Railroad Track, Instrument for Measuring.....	798
Street Car, Fender for.....	799
Telephones, Party Line, Selective Signal for.....	799
Umbrella Equipped with Electric Fan.....	799



### THIS COURSE MEANS MORE MONEY FOR YOU

Increase your income writing show cards. Big opportunity for ambitious men and women. Experience unnecessary. Our practical course teaches you quickly and explains the remarkable results obtained with Litholia Colors. Whatever your position, write for FREE BOOKLET now.

LITHOLIA COLOR CO.

1040 Flatiron Building NEW YORK

SHOW CARD WRITERS  
EARN FROM  
\$2 to \$50 PER WEEK

### FEAR STAMMERS!

Consult Foote, the trained expert Psychologist. If you have tried many other methods and failed know that you cannot fail if you place yourself in my hands — either for personal treatment or by correspondence. I have studied psychology in the greatest Universities in the World. It is now recognized that the trained Psychologist is the only one who can successfully treat stammering. Mine is the only scientific method of treatment which will permanently eradicate your "FEAR." Write for booklet, "The Cure of Stammering."  
Prof. F. B. Foote, Michigan Boulevard Building, Chicago, Illinois

### J-M ASBESTOS ROOFINGS

Sometimes called "The Everlasting Roof." Investigate J-M Roof Registration always mindful of J-M Roofing Responsibility.  
**H. W. JOHNS-MANVILLE COMPANY**  
3192 New York and Every Large City



### Every Boy His Own Toymaker

Greatest boys' book ever written. Tells how to make a Steam Engine, Telephone, Magic Lantern, Bats, Kites, Balloons, electrical and mechanical toys, traps, fishing tackle, 200 illustrations, also catalog of 150 puzzles, puzzle picture card and "Doubtful Times" wren and bird call all for only 10c. WESTERN PUZZLE CO., ST. PAUL, MINN.



### \$2.50 A Month

The masterpiece of watch manufacture—adjusted to the second, position's, temperature and isochronism. Encased at the factory into your choice of the exquisite new watch cases.

### 19 Jewel Burlington

All sizes for both men and women. The great Burlington Watch sent on simple request. Pay at the rate of \$2.50 a month. You get the watch at the same price even the wholesale jeweler must pay. Write Today for Free Watch Book. See handsome color illustrations of all the newest designs in watches that you have to choose from. Your name and address on a postcard is enough. Get this offer while it lasts. Burlington Watch Company, 19th St. & Marshall Bldg., Dept. 9193, Chicago



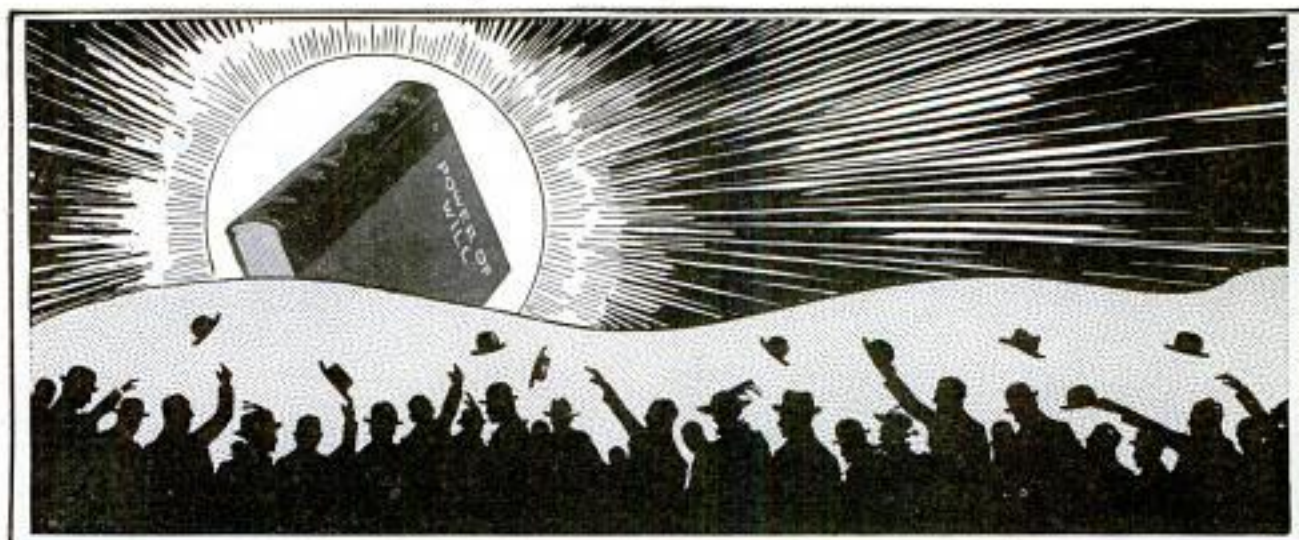

### Some "Power of Will" Owners

Among those who read, use and praise "Power of Will" are such men as Judge Ben B. Lindsey; Supreme Court Justice Parker; Wu Ting Fang, Ex-Chinese Ambassador; Asst. Postmaster General Britt; General Manager Christeson of Wells-Fargo Express Co.; E. St. Elmo Lewis, now Vice-President Art Metal Construction Co.; Ernest Knaebel, Asst. Atty. Gen'l of the U.S., etc., etc. These are but a few. We can name hundreds of others almost equally prominent, and thousands more whose names you know.

"I hand you \$3 in payment; from what I have already seen I believe I can get \$500 to \$30,000 worth of good out of it."—C. D. Van Vechten, General Agent No. West Life Ins. Co., Cedar Rapids, Ia.

"Will Power" is a compilation of mighty force. My first week's benefit in dollars is \$900.00—cost \$3.00; profit \$897.00.—J. W. Heistand, 916 Tribune Bldg., Chicago, Ill.

"The character of 'Power of Will' is such that he who reads and puts forth effort will soon find himself out of the common herd."—F. A. Good, President of Nebraska Lumber Dealers' Assn., Cowles, Neb.

"I have carefully gone over 'Power of Will' and find it admirable."—Chas. Olin, Editorial Rooms, Boston Evening Transcript, Boston, Mass.

"I am unable to do this book justice with the pen. It is a lifelong study, known and prized by those who are fortunate enough to select it out of the many."—Sam'l Rose, Jefferson Loan Society, Inc., Norfolk, Va.

"After carefully looking it over I am fully convinced that it is everything which has been claimed for it—and a great deal more. It is a wonderful book on a wonderful subject."—Gus A. Olson, Cashier, Shermerville State Bank, Shermerville, Ill.

"I specialized on psychology—and I consider 'Power of Will' the greatest book on the subject ever written. I will make it an important factor in my scheme of life."—J. H. Leventhal, Butler Hebrew Inst., Butler, Pa.

We have hundreds of such testimonials on file.

# "Power of Will"

## —THE BOOK THAT STARTLED THE WORLD

Let Me Lend It to You for 5 Days Free—Send No Money

Rarely, if ever, has a book been published which has created such a sensation. In the last few months over 75,000 thinking men and women have become owners of "Power of Will" and unless every sign fails this number will be doubled almost before this announcement goes to press.

Wherever one goes, people are discussing the wonderful discoveries and new-found secrets of achievement laid bare for the first time in this great work—by Frank Channing Haddock, the famous scientist—secrets which enable any man or woman to train his or her will into a faculty of almost magical health and money-winning power.

### How to Strengthen the Will

Everyone knows what can be accomplished by exercising the brain. Our whole educational system is founded upon the theory that brain can be developed in proportion to the amount of intelligent exercise and use to which it is put.

For years scientists have known that the same is true of the will—that the will can be made indomitable by intelligent exercise and use.

The trouble has been that until now no one has ever devoted their attention to the cultivation of the will.

And since we have never been taught to use it, most of us don't know how. We float along carrying out other people's wills simply because our own will has become scotched and dormant from lack of use.

### A Complete Course

"Power of Will," while bound in book form, is in reality a complete course in Will Training—the first ever conceived. The author, Dr. Haddock, has devoted years to the most profound analysis of the will in human beings. Yet every step in the 28 fascinating lessons is written so simply that anyone can understand them and apply the principles, methods and rules set down with noticeable results almost from the very start.

### A Veritable Godsend

"Power of Will" has pulled men out of the gutter and put them on the road to self-respect and success—it has enabled men to overcome drink and other vices almost overnight—it has helped overcome sickness and nervousness—making thousands of sick people well—it has transformed unhappy, envious, discontented people into dominating personalities suffused with the joy of living—it has enabled people who had sunk deep into the grooves of a rut to pull themselves out and become masters instead of the blind tool of circumstance—it has reawakened ambition in men and women who had been turned from their life purpose and given them the courage and confidence to build anew—it has converted failures in business into spectacular successes—it has enabled successful men to undertake even bigger projects by showing them how to use the power they already possess with even more telling force.

### Send No Money—Examine Book First

Although "Power of Will" is a 400-page, leather bound book containing more material than any \$25 correspondence course the price is only \$3. The publishers will gladly send a copy free, for five days' inspection. Send no money now. Merely mail the coupon on the right, enclosing your business card, or giving a reference. If you decide to keep the book, send the money. If not, mail the book back. Tear out and fill in the coupon now, before you turn this page.

**A. L. PELTON,**  
511 Pelton Bldg., Meriden, Conn.

### Partial Contents

The Law of Great Thinking.  
The Four Factors on which it depends.

How to develop analytical power.

How to think "all around" any subject.

How to throw the mind into deliberate, controlled, productive thinking.

Detailed directions for Perfect Mind Concentration.

How to acquire the power of Consecutive Thinking, Reasoning, Analysis.

How to acquire the skill of Creative Writing.

How to guard against errors in Thought.

How to drive from the mind all unwelcome thoughts.

How to follow lines of thought with keen, concentrated Power.

How to develop Reasoning Power.

How to handle the Mind in Creative Thinking.

The secret of Building Mind Power.

How the Will is made to act.

How to test your Will.

How a Strong Will is Master of Body.

What creates Human Power.

The Six Principles of Will training.

Definite Methods for developing Will.

The NINETY-NINE METHODS for using Will-Power in the Conduct of Life.

Seven Principles of drill in Mental, Physical, Personal power.

FIFTY-ONE MAXIMS for applied power of Perception, Memory, Imagination, Self-Analysis, Control.

How to develop a strong, keen gaze.

How to concentrate the eye upon what is before you—object, person, printed page, work.

How to become aware of Nerve Action.

How to keep the body well-poised.

A complete list of contents would almost fill this page.

A. L. Pelton,

President,

Pelton Pub. Co.,

511 Pelton Bldg.,

Meriden, Conn.

Gentlemen:—Please send

me a copy of "Power of Will"

without charge. I agree to remit

\$3.00 or, return the book in five days

Name .....

Address .....

Please Mention Popular Mechanics

# Become An EXPERT ACCOUNTANT!



## \$3,000 to \$10,000 Yearly!

If you remain a clerk or bookkeeper, salary increases are improbable—an independent future impossible. You can't demand a raise—there are thousands awaiting your job. There is one sure way to overcome your handicap: become an **EXPERT ACCOUNTANT** by our modern home-training method—**be sought—don't seek.**

There are 500,000 big firms today requiring annual or semi-annual audits—and there are only **1,500 certified public accountants in the U. S.** This proves the tremendous, unlimited opportunities for you—the independence—the assured future—the big salary. These firms are willing to pay **Expert Accountants** \$3,000 to \$10,000 yearly. But they pay clerical workers and bookkeepers only \$12 to \$20 weekly. Become an **Expert Accountant** and your rise in the business world will be practically unlimited—many of our graduates are now managers of big firms. Remain a clerk or bookkeeper and you will always be bossed.

## WE TRAIN YOU BY MAIL

In your own home, during your spare time, no matter where you live. You don't give up your present position and income—you don't deny yourself pleasures or sacrifice duties. Devote a little spare time evenings preparing for independence and a big income and you will soon master this lucrative profession. You can readily master our modern method in your own home—you can complete it in less time than any other. In many particulars it offers more advantages than a college course in Higher Accountancy—you are not held back by professors.

The La Salle Extension University course in Higher Accountancy was prepared by some of the world's most noted accounting experts. It is under the direct supervision of William Arthur Chase, a nationally recognized leader, who is Ex-President of the American Association of C. P. A. Examiners, and Ex-Secretary of Illinois State Board of Examiners in Accountancy.

Our course is thorough—advanced—covering the Theory of Accounts, Practical Accounting, Cost Accounting, Auditing, Business Law, etc., and prepares you for C. P. A. Examinations in any State.

**Valuable Book FREE** Write at once for a free copy of "What Every Bookkeeper Should Know"—a valuable special book which gives exactly the information you require to become an Expert Accountant, studies, kind of examinations, State regulations, salaries paid, positions to be had.

## SPECIAL REDUCED RATE

**SCHOLARSHIP—Limited Special Offer.** Write quick and learn how, for a limited time, we are able to offer a special reduced rate scholarship.

**We Show RESULTS!** This institution is a strong, conservative organization—with thousands of students and as many letters from successful graduates. There is no other home-study course so thorough—endorsed by America's greatest Accounting Experts. We want you to know facts about the successes of our students and the unlimited opportunities that confront you today by our method of home-training.

La Salle Extension University,

Dept. H. 873, Chicago

Send at once, without cost or obligation to me, your valuable book of **Accounting Facts**, and full details of your Course in **Higher Accountancy**; also advise me about Special Time-Limited Reduced Rate Scholarship.

Name.....

Street No.....

City.....

## Mail Coupon NOW!

Secure valuable book free, and learn how you can advance from a small job with a small salary to distinction, independence, a future. Earn \$3,000 to \$10,000 yearly. Act NOW!

LA SALLE  
EXTENSION  
UNIVERSITY,  
CHICAGO

Please Mention Popular Mechanics

# YOU CAN EARN THIS MAGNIFICENT BUSH MOTOR CAR

And the Agency for Your Territory



5-Pass. 28-H. P.

Write quick for full particulars of this wonderful offer! Send your name **before some other man gets your territory.** You can earn a Car and at the same time qualify yourself to

## MAKE \$3,000 TO \$5,000 A YEAR AND UP

in the Automobile business—Driving, Repairing, Garage and Selling. Close to a **billion dollars** will be spent this year in the United States for automobiles and supplies. I'll show you how to get **your share** of this vast fortune.

## Full Information FREE—Write Quick

Costs you nothing to get full details of this remarkable **AUTO Offer.** Unequaled opportunity for ambitious men and boys. Don't delay.



Write **NOW—before you turn this page.** A postal will do. Just say, "Send me your auto offer." Address **J. H. Bush, President.**

**BUSH MOTOR COLLEGE, Inc.**

DEPT. 1117, BUSH BUILDING

NORTH CLARK STREET AND CHICAGO AVENUE, CHICAGO, ILLINOIS

## COPY THIS SKETCH

and let me see what you can do with it. Illustrators and cartoonists earn from \$20 to \$120 a week or more. My practical system of personal individual lessons by mail will develop your talent. Fifteen years' successful work for newspapers and magazines qualifies me to teach you. Send me your sketch of President Wilson with 6c in stamps and I will send you a test lesson plate, also collection of drawings showing possibilities for you.

**The Landon School of Illustrating and Cartooning**  
1438 Schottel Building, CLEVELAND, O.



## GOVERNMENT POSITIONS

offer employment for life at a salary ranging from \$800 to \$1800 per year, with short hours under pleasant conditions and no fear of "lay-offs" or strikes. American citizens 18 or over are eligible. Our 64-page booklet contains list of positions, requirements, etc., and tells how you can prepare for "Exams" under the personal supervision of a former U. S. Civil Service Secretary-Examiner. Booklet is **FREE**, without obligation. **Write today.**

**PATERSON CIVIL SERVICE SCHOOL**  
111 Irving Place ROCHESTER, N. Y.



## BE A BANKER

Splendid opportunities. Pleasant work, short hours, all holidays off, yearly vacation with pay, good salary. Learn at home. Diploma in six months. Catalog free. **EDGAR G. ALCORN, Pres.**  
**AMERICAN SCHOOL OF BANKING, 419 E. State Street, COLUMBUS, OHIO**



## IF YOU STAMMER

attend non-stammering school till you get my large **FREE** book and special rate. Largest and best school in the world curing by natural method. Write today.  
**Lee Wells Millard, Pres., North-Western School, Inc.**  
2317 Grand Avenue Milwaukee, Wis.

## JEWELRY ENGRAVING

We teach you, by our new and original method of instruction, this clean, fascinating and profitable business **right at your home**, and furnish you all tools needed absolutely **free.** Write for free book to the **WISCONSIN SCHOOL OF ENGRAVING, 37th Bldg., MILWAUKEE, WIS.**

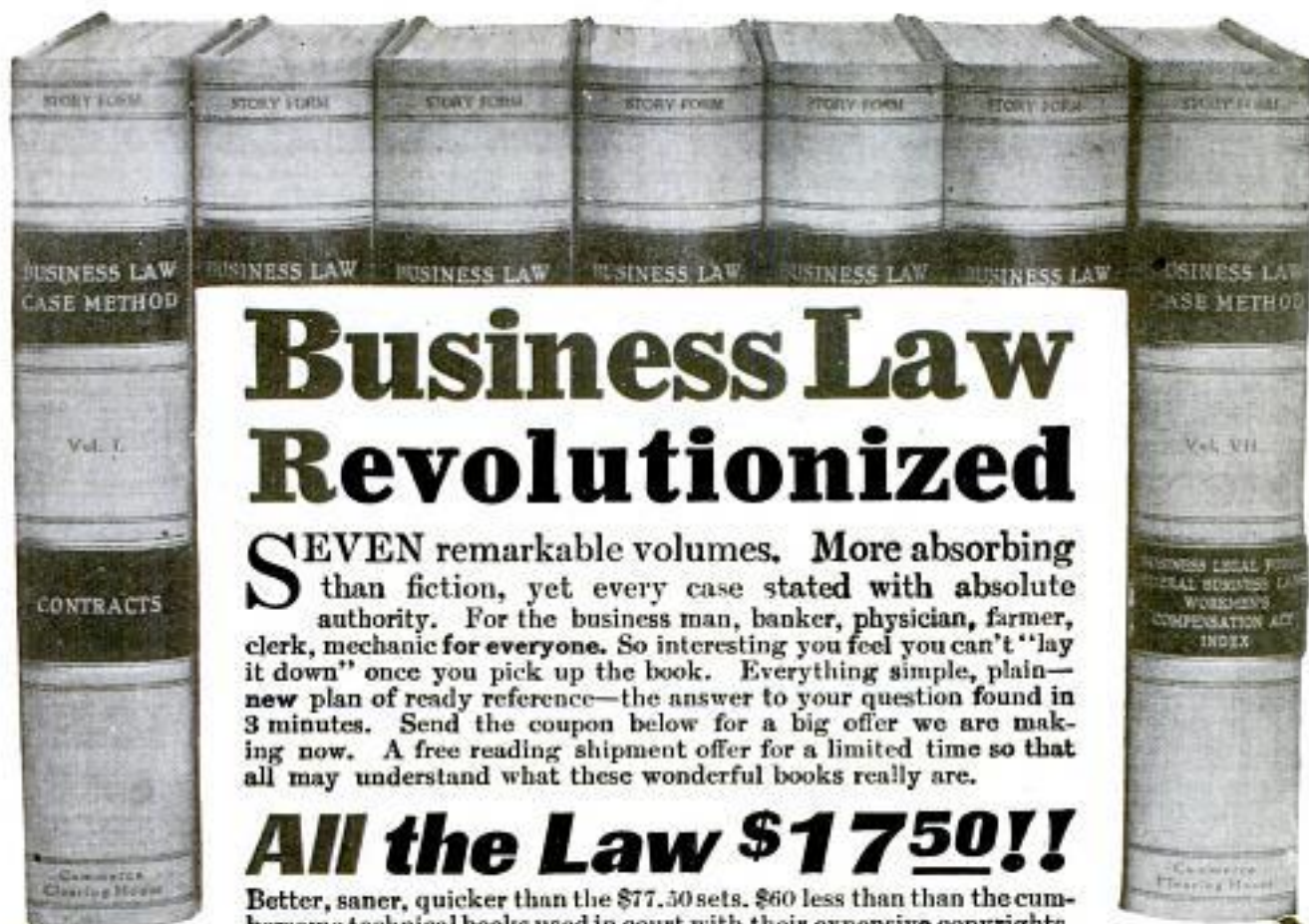

# Business Law Revolutionized

**S**EVEN remarkable volumes. More absorbing than fiction, yet every case stated with absolute authority. For the business man, banker, physician, farmer, clerk, mechanic for everyone. So interesting you feel you can't "lay it down" once you pick up the book. Everything simple, plain—new plan of ready reference—the answer to your question found in 3 minutes. Send the coupon below for a big offer we are making now. A free reading shipment offer for a limited time so that all may understand what these wonderful books really are.

## All the Law \$17.50!!

Better, saner, quicker than the \$77.50 sets, \$60 less than the cumbersome technical books used in court with their expensive copyrights.

## One of the Law Stories

### A Negotiable Instrument Must Be Signed

**Story Case**  
George Bishop dictated the following note to his stenographer who copied it on a typewriter:

January 1, 1918.  
I promise to pay to Finson Lang's order the sum of fifty dollars in three months from date.  
(Signed) G. B.  
This note, which was entirely typewritten, including the signature, "G. B.," was delivered to Lang in payment for merchandise. Lang endorsed and delivered it to Ernestus Bishopham. On April 15, 1918, Bishopham brought suit upon the note as a negotiable instrument. The merchandise delivered by Lang was not as he represented, and Bishopham desired to be released from the obligation. He maintained that the instrument was not a negotiable note, since it did not contain his signature. Is this correct?

**Ruling Court Case**  
Block vs. Bell, Volume 1, Moore and Robinson Reports, page 149. This action was brought by Block against Bell on a note in the following form:

"On demand, I promise to pay A. Block, or bearer, the sum of \$15.00, for value received."  
This instrument was not in the hand writing of Bell, and was not signed by him at the bottom. But it was addressed to him in the margin and he had written under the address, "accepted, J. Bell." Bell contended that he was not liable upon this because it was not properly signed by him.

**Decision:** Before a note becomes operative it must be signed by the maker. However, it is not necessary that the signature should follow the words of promise. Although in the form of an acceptance, this signature was sufficient to secure the adoption of this promise. \* \* \* Judgment was given for Block.

**Ruling Law**  
**Story Case Answer**  
It is necessary that a negotiable instrument be signed, a bill of exchange by the drawer, a note by the maker. It is not necessary, however, that the signature should follow the words of the promise; a signature placed in any part of the instrument with an intent to sign is sufficient. The name may be printed or typewritten, although it is preferable that it be in the handwriting of the maker, since it will not then be difficult to prove the document. The name should be written in full, although this is not indispensable. The initials or any mark which the party uses to indicate his intention to bind himself will be effectual. \* \* \*

Bishopham is liable on the negotiable note in the Story Case.

## All Business Law

is covered with authority. As interesting as the above. You can positively get a working knowledge of the entire subject of business law. W. H. Niblack, Vice Pres. Chicago Title and Trust Company says, "You have done a great service to those who have no legal training."

Send the coupon now and see the books themselves. Or write for further information. Write now.

## Every Man in Business

—every man who works! You know what a value a knowledge of business law is, and you know how hard it has been to get it. How terribly tedious it has been to read dry, uninteresting stuff. But now you sit down and read a series of charming stories. Each brings out a particular law point. You cannot fail to understand. And you remember. Won't you have these books shipped to you so that you may judge? You need send no money. Just see for yourself.

## Send Only This FREE Coupon

Merely mail the coupon. It brings this astounding set of books. Seven volumes—splendidly bound in law buckram—compiled and endorsed by Harvard, Chicago, Stanford experts. Send no money. The Commerce Clearing House wants you to see the books. Or, if you wish, simply send your name and address on a letter or postcard and ask for more information. No obligation whatever. Address—

**COMMERCE  
CLEARING  
HOUSE**

Dept. 1198  
6 N. Michigan Ave.  
Chicago,  
Ill.

**Commerce  
Clearing House**

6 N. Michigan Ave.  
Dept. 1198 Chicago, Ill.

Gentlemen:—You may send me for 5 days' examination, "Story Case—Business Law," 7 volumes. At the end of a week, I will return the volumes, express collect, if they are not satisfactory. If I keep them I will remit 50 cents in a week and \$2.00 per month—until \$17.50, the complete price of books, has been paid.

Name .....

Address .....

Occupation .....



**Earn \$125 to \$250 a Month**

in the Steam Engineering field. Prepare in your spare time for a Stationary or Marine Engineer's license, or position as Locomotive Engineer. These great books, written by 27 experts, contain all the information necessary to take up this well-paid work.

## Steam Engineering

7 volumes; 3300 pages, 7x10 inches; 2500 illustrations, full page plates, diagrams, etc.; hundreds of valuable tables and formulas. Handsomely bound in half red morocco, gold stamped. Covers the construction and operation of stationary, locomotive and marine engines and boilers; the use of gas and gasoline engines for power and locomotion; the transformation of steam and gas power into electricity; and the application of steam and gas power to refrigeration, compressed air, etc.

### Examine These Books Free of Charge

The entire nine volumes, not a sample volume, will be sent, express prepaid, on receipt of the coupon below. Look these books over for a whole week free. Then decide whether or not you want them. If you do, send us \$1.00 within seven days and \$2.00 a month - 50c a week - until the special advertising price of \$19.50 has been paid. Otherwise we'll take them back of our expense. In addition to this liberal discount from the regular price of \$35.00, we include with each set a \$12.00 Consulting Membership. This entitles you to the advice of a staff of experts for a whole year free.

### American Technical Society, Chicago:

Please send *Cyclopedia of Steam Engineering* for 7 days' free examination. I will send \$2.00 within 7 days and \$2.00 a month until I have paid \$19.50; otherwise I will notify you and hold the books subject to your order. Title not to pass until fully paid. Pop. Mech. 11-15

NAME.....  
ADDRESS.....  
REFERENCE.....

## Ridpath's History of the World At a Bargain



**Free**  
We will mail free a beautiful 46-page booklet of sample pages to all who mail coupon.

4000 Pages  
2000 Pictures

We will name our special low price and easy terms only in direct letters to those mailing us the Coupon below. Tear off Coupon, write name and address plainly, and mail now before you forget it. The 46 Free Sample Pages will give you some idea of the splendid illustrations and wonderfully beautiful style in which the work is written. Thousands have already availed themselves of our offer and every purchaser is more than satisfied. Mail Coupon Now.

### FREE COUPON

WESTERN NEWSPAPER ASSOCIATION 11-15  
140 So. Dearborn St., Chicago, Ill.

Please mail your 46-page free sample booklet of Ridpath's History of the World, containing photographs of Napoleon, Socrates, Caesar and other great characters in history, and write me full particulars of your special offer to Popular Mechanics readers.

NAME.....  
ADDRESS.....

Please Mention Popular Mechanics

## SHORTHAND IN 30 DAYS

We absolutely guarantee to teach shorthand complete in only thirty days. You can learn in spare time in your own home, no matter where you live. No need to spend months as with old systems. Boyd's Syllabic System is easy to learn—easy to write—easy to read, simple, practical, speedy, sure. No ruled lines—no positions—no shading as in other systems. No long lists of word signs to confuse. Only nine characters to learn and you have the entire English language at your absolute command. The best system for stenographers, private secretaries, newspaper reporters and railroad men. Lawyers, ministers, teachers, physicians, literary folk and business men and women may now learn shorthand for their own use. Does not take continual daily practice as with other systems. Our graduates hold high grade positions everywhere. Send today for booklets, testimonials, etc.

Chicago Correspondence Schools  
969 Unity Bldg., CHICAGO, ILL.

## Learn How to WRESTLE



In Your Own Home  
By Mail

Yes, learn to become an expert wrestler right in your own home, by mail, from the greatest wrestler the world has ever known. Be an athlete, be strong, be healthy. Learn how to throw and handle big men with ease. Learn to defend yourself. All taught in our course of lessons, and illustrated with hundreds of charts and actual photographs by

### Farmer Burns and Frank Gotch

Farmer Burns, "the grand old man of the mat," taught Frank Gotch, the present World's Champion, all he knows about wrestling, so Gotch says. He will now teach you Scientific Wrestling—Physical Culture—Jiu-Jitsu—Self Defense. Every man and boy in America, no difference what age, needs this wonderful course of lessons. Write today—your name, age and address on a postcard or letter brings you our fine book absolutely free—no obligation of any kind. A splendid book on wrestling and physical culture. Write today stating your age.

Farmer Burns School of Wrestling 1198 Range Bldg., Omaha

This Wrestling Book FREE

## "THE LAW-TRAINED MAN"

is a remarkable book, showing how Big Business picks law-trained men for its leaders. It also shows how men unable to leave home or business can, for the first time, secure a Course including the comprehensive features of the best Resident Law Schools. 80 eminent legal authorities prepared the Modern American Law Course and Service of BLACKSTONE INSTITUTE. This 151-page book is inspiring, practical and free. Write for your copy today.



### BLACKSTONE INSTITUTE

20 W. Jackson Blvd., Dept. 1358, Chicago, Ill.



## For Artists and Art Students

Publishes Cash Art Assignments, lessons and articles on Cartooning, Illustrating, Lettering, Designing and Chalk-Talking. Critiques amateurs' work. Interesting, helpful, artistic, UNIQUE. It will please you. Money back if not satisfactory.

Clare Briggs, Ryan Walker, and other noted artists contributors.

Send Now \$1 for 12 Issues

STUDENTS ART MAGAZINE  
Dept. 52, Kalamazoo, Mich.

### BE AN ILLUSTRATOR

by mail how to draw for magazines and newspapers  
Send for Catalog

Learn to draw.

We will teach you  
School of Illustration  
112 Page 1151g,  
Chicago, Ill.



## MUSIC TAUGHT FREE AT YOUR HOME

Write Today for our booklet. It tells how to learn to play Piano, Organ, Violin, Mandolin, etc. Beginners or advanced pupils.

AMERICAN SCHOOL OF MUSIC, 50 Lakeside Bldg., Chicago, Ill.

## Learn Watchmaking At Home



You can learn by our modern and original system of instruction every part of the Watchmaker's Trade at home as good or better than at a shop. You can earn money while learning and secure a well paying position or start in business after completing our course of instruction. Good watchmakers are always in demand and earn from \$20 to \$35 per week. For particulars apply to the Wisconsin School of Watchmaking, Strub Bldg., Milwaukee, Wis.

# Do It Electrically



The applications of electricity are increasing every day. The man who has an exact knowledge of electrical science has ever growing opportunity for profit. Ten years ago practically all machines in use were run by steam engine and countershaft. Statistics now show that most of the machines used are now operated by the electric drive. A generation ago gas was the only known means for lighting and cooking. Now almost every modern house is lighted by electricity, and electric cooking utensils are coming more and more in use. Even the steam locomotive, that great achievement of the twentieth century, is being gradually replaced by electric power. Whether it be for driving machines, for railway transportation, for lighting, for heating, for cooking, for a thousand daily necessities, the watchword of the age is "Do It Electrically."

## Hawkins Electrical Guides Will Show You How

Electrical knowledge means money to you and these books will show you how to get it. Hawkins Electrical Guides are the standard works on Electricity. They cover every single phase of the subject and they are written in a way you can understand. The text matter is arranged in questions and answers, and contains several thousand illustrations. No more groping for a solution of your electrical problem. You find the answer at once, clearly and concisely.

## A Most Complete Library of Electricity at the Lowest Cost

Look at the titles and convince yourself that Hawkins Electrical Guides tell you everything you want to know in Electricity. They are a complete course in Electrical engineering, written especially for the ambitious man who is training himself for advancement, for the wide awake man who is likely to be called in for work outside of his regular line, for the man who needs at his elbow, for ready reference, an accurate up-to-date work on electricity. An examination of these books will convince you of their value instantly. They cost \$1 per volume. They are a wonderful buy at this price, and they are the best electrical books at any price. Don't take our word for their merits. Fill out the coupon today and the books will be sent you absolutely FREE for your own examination. You have seven days full use before you pay a cent.

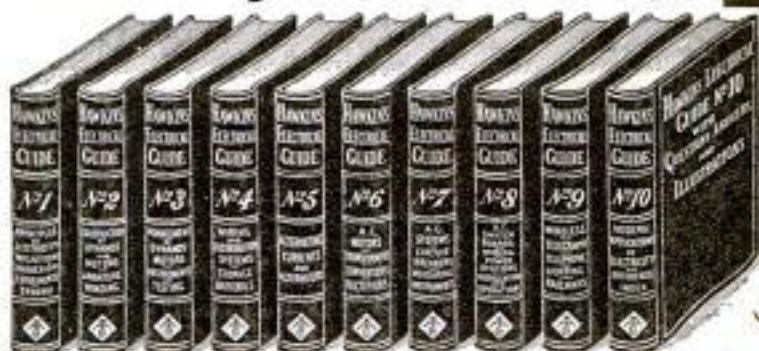

**In Handy Separate Volumes** The binding is in flexible black leather with gold edges—very durable and attractive. The books are easy to handle and easy to read. They fit your pocket and your pocket-book as well.

## Shipped to You FREE

Send no money. Examine the books first. Decide for yourself that they are the most complete library of electricity ever published, and that you cannot afford to be without them. Every book is complete in itself. The price is only \$1 per copy, but the complete set is the best bargain. Settlement can be made at only \$1 per month. EIGHT NUMBERS ARE READY.

### A FEW OF THE SUBJECTS

Magnetism—Induction—Experiments—Dynamo—Electric Machinery—Motors—Armatures—Armature Windings—Installing of Dynamos—Electrical Instrument Testing—Practical Management of Dynamos and Motors—Distribution Systems—Wiring—Wiring Diagrams—Sign Flashers—Storage Batteries—Principles of Alternating Currents and Alternators—Alternating Current Motors—Transformers—Overhead Lines—Rectifiers—Alternating Current Systems—Circuit Breakers—Measuring Instruments—Switch Boards—Wiring—Power Stations—Installing—Telegraph—Telegraph—Wireless—Bells—Lighting—Railways. Also many Modern Practical Applications of Electricity and Handy Reference Index of the 10 numbers.

## Easy Payments

Accept this great offer now—today. Each page—every illustration will convince you of the big value we are offering. See the books first, then decide. If you decide to keep them you can make settlement at only \$1 monthly until paid for.

## Mail Coupon Today

THEO. AUDEL & CO. 72 FIFTH AVENUE NEW YORK, N.Y.

**FREE COUPON**

**Theo. Audel & Co.**  
72 Fifth Avenue  
NEW YORK

Please submit me for examination Hawkins Electrical Guides (Price \$1 each). Ship at once, prepaid, the first eight numbers; if satisfactory I agree to send you \$1.00 each month until paid.

Signature .....

Occupation .....

Business Address .....

Residence .....

Reference ..... Nov. P.M.

Please Mention Popular Mechanics



## "The Power of Law Training"

SEND the coupon now for our new 171-page free book "The Power of Law Training." It carries a vital and inspiring message to every ambitious man—to the man who is already successful—to the young man just starting out in life—to the man who has already made his start but has not yet hit his stride—to all men who realize the need of more power. "The Power of Law Training" will give you a remarkable insight into the vital relation of law to business. Write for your copy today—now. It's FREE.



## If You Know Law—

The power of the man with law training is apparent all about you. Look to the men of your own acquaintance who have achieved the most—look to the men who stand high in the affairs of the nation. Almost without exception you will find them Law trained. The man with the Law training is the man of power—the leader.

## Learn from Masters of the Law!

Through the Course and Service of the American Correspondence School of Law—the oldest and largest institution of its kind in the world, you read law right in your own home—directed by men who stand prominent in the profession. You may become law trained or prepare for the practice of law. More than 40,000 men have utilized this Course and Service to their advantage and recommend it highly.

With this Course and Service is included a complete and comprehensive encyclopedia of the law without extra charge. Special reduced price offer now being made in many localities.

## Send the Coupon!



Put your name and address in the coupon or on a letter or post card now and get the big 171-page free book, "The Power of Law Training." It's free. No obligations of any kind. Write today.

American Correspondence School of Law  
1198 Manhattan Building Chicago

American Correspondence School of Law  
1198 Manhattan Bldg., Chicago

Gentlemen:—Please send me free and prepaid your 171-page book, "The Power of Law Training" and particulars of your special reduced price offer.

Name.....

Address.....

Please Mention Popular Mechanics



## Learn a Paying Profession

that assures you a good income and position for life. For twenty years we have successfully taught

## PHOTOGRAPHY

Photo-Engraving and Three-Color Work

Our graduates earn \$20 to \$50 a week. We assist them to secure these positions. Learn how you can become successful. Terms easy—living inexpensive. Write for catalogue—NOW!  
ILLINOIS COLLEGE OF PHOTOGRAPHY, 999 Wabash Avenue, Effingham, Ill.

## New York ELECTRICAL School

Gives you a complete training by actual practice. You get the knack of "HOW" together with the theory of "WHY" and the best business methods used in the World of Electrical Activity.

The N. Y. Electrical School is the pioneer and premier school of the "Learn by Doing" method. When you have completed this Course you shall be fully qualified to handle ALL branches of Electrical industry.

The equipment of this School is unequalled and up-to-the-minute. No preparation needed to become a "learner" in this school. You can start to learn on any day of any week throughout the whole year.

Visitors heartily welcomed. Send for catalogue.

44 West 17th St. New York City  
N. Y. ELECTRICAL SCHOOL

## Practical Electrical Education

Our practical course in Electrical Science and Engineering trains you to get and keep the big-pay jobs. Enter at any time, no matter what your education. Advance as fast as you can master what we teach. Course combines theory with actual practice in all branches of electrical work. Individual instruction. Positions paying \$1,500 a year up, waiting for graduates. Write for FREE ILLUSTRATED CATALOG. Eleventh school year now open.

School of Engineering of Milwaukee, 224 1/2 St. Bldg., Milwaukee, Wis.



## LEARN THE JEWELRY TRADE

Splendid opportunities in the jewelry business. Good money, pleasant work. Learn this trade in the shortest, most direct, easiest way by the Broxler Extension System Correspondence Course. Practical instruction in simple, easily understood form makes you proficient and opens the way to a money-making business. Write today for free booklet which shows you how and why

The Drexler School, Sentinel Building, Milwaukee, Wis.

## LEARN TELEGRAPH

Morse and Wireless—R. R. Accounting (Station Agency) taught. Splendid opportunities. Positions secured. Marconi Co. takes our wireless graduates. We own and exclusively occupy two large modern buildings equipped with R. R. and Western Union wires and complete \$5,000 Marconi Wireless Station. Largest School—established 52 years. Investment \$25,000. Endorsed by Railroad, Marconi and Western Union Officials. Expert practical teachers. Low living expenses; easily earned if desired. Tuition low. Easy payments. Correspondence course also. Catalogs Free.  
Dodge's Telegraph, Ry. & Wireless Institute  
224 1/2 St. Bldg., Milwaukee, Wis.



## DON'T TRY TO BE A CHAUFFEUR

or go to ANY SCHOOL to learn, or part with your hard earned dollars until you have read our valuable guide FIRST. It tells what you should PAY and what you should GET. Do not be deceived by schools which claim everything and give you nothing. YOU CAN'T AFFORD TO SPEND ONE CENT TILL YOU GET OUR GUIDE. It costs nothing and may save you many dollars. Write now for this FREE BOOK.

PRACTICAL AUTO SCHOOL, 68 Beaver St., New York



# The Only Grand Prize (Highest Award) given to Dictionaries at the Panama- Pacific International Exposition was granted to **WEBSTER'S NEW INTERNATIONAL**



and the Merriam Series for  
**Superiority of Educational Merit.**

The new work is more scholarly, accurate, convenient, and authoritative than any other English Dictionary. It contains a clear, concise, final answer to those thousands of puzzling questions on all kinds of subjects. A farmer, lawyer, clergyman, banker, teacher, builder, doctor, sportsman, student, each will find his department treated by a master. Why not make this universal-question answerer a part of your home library, your office furniture, your school equipment?

- Salient Features :**
- 400,000 Vocabulary Terms.
  - 30,000 Geographical Subjects.
  - 12,000 Biographical Entries.
  - Thousands of other References.
  - Hundreds of NEW Words not given in any other dictionary.
  - 6,000 Illustrations. 2,700 Pages.
  - The only dictionary with the new divided page, characterized "A Stroke of Genius." Type matter is equivalent to that of a 15-volume encyclopedia.

WRITE for specimen pages of both Regular and India-Paper Editions.  
**G. & C. MERRIAM COMPANY, SPRINGFIELD, MASS., U.S.A.**

## The One Supreme Authority :

It is the *standard* of the Federal and State Courts. The *standard* of the Government Printing Office. The *standard* of nearly all the schoolbooks. *Indorsed* by State School Superintendents. *Universally recommended* by Statesmen, College Presidents, Educators, and Authors. Adhered to as *standard* by over 99% of the newspapers. *All States* (30 in number) that have taken official action regarding the adoption of dictionaries recognize the Merriam Series as authoritative. *The above cannot be said of any other dictionary.*

**GET THE BEST.**

Similar Highest Awards given to WEBSTER'S DICTIONARIES at other Expositions

Centennial 1876 Philadelphia **Highest**

Columbian 1893 Chicago **Highest**

Universal Exposition Paris 1900 **Gold Medal**

Louisiana Purchase St. Louis 1904 **Grand Prize**

Lewis & Clarke Portland 1905 **Gold Medal**

Jamestown Tercentennial Norfolk 1907 **Gold Medal**

Alaska-Yukon-Pacific Seattle 1909 **Grand Prize**

and other awards in this Country, Europe, and Australia

**A Unique Record**



G. & C. MERRIAM CO., SPRINGFIELD, MASS.

Please send me specimen: of the New Divided Page, Illustrations, Regular and India Paper, etc.

Name.....

Address.....

**FREE** a useful set of pocket maps if you mention Pop. Mec.

## WANTED

**Railway Mail Clerks  
\$900 to \$1800 a Year  
(\$75 to \$150 a month)**

Rapid advancement to higher Government Positions. "No lay-offs" because of STRIKES, WARS, FINANCIAL FLURRIES or the WHIMS OF SOME PETTY BOSS. THE POSITION IS YOURS FOR LIFE.

Country residents and city residents stand the same chance for immediate appointment. Common-sense education sufficient. Political influence NOT REQUIRED.

Write immediately for schedule showing the places and dates of THE COMING GOVT. examinations. Don't delay. Every day you lose means the loss of just so much coaching before the rapidly approaching examinations.

**FRANKLIN INSTITUTE, Dept. E104, Rochester, N. Y.**



Pleasant Work - Continually Traveling

**FRANKLIN INSTITUTE (The Pathway to Plenty), Dept. E104, ROCHESTER, N. Y.**

This coupon, filled out as directed, entitles the sender to free specimen questions; a free copy of our book, "Government Positions and How to Get Them," a list of Government positions now obtainable, and to consideration for Free Coaching for the examination here checked.

**COUPON**

- ..Railway Mail Clerk..(\$900 to \$1800)
- ..Bookkeeper.....(\$900 to \$1800)
- ..Postoffice Clerk....(\$900 to \$1200)
- ..Postoffice Carrier..(\$800 to \$1200)
- ..Rural Mail Carrier..(\$500 to \$1200)
- ..Auto Chauffeur.....
- ..Customs Positions...(\$800 to \$1500)
- ..Steographer.....(\$800 to \$1500)
- ..Internal Revenue...(\$700 to \$1800)
- ..Clerk in the Department at Washington.....(\$800 to \$1500)
- ..Canadian Gov't Positions.....

Name..... Address..... E104

Use this before you lose it. Write plainly.

Please Mention Popular Mechanics

# Become a TRAFFIC EXPERT

## Learn at Home



### NEW JOBS OPEN, <sup>BIG</sup> PAY

Thousands of large shippers and all Railroads need trained Traffic experts and Managers—newly created positions are open everywhere with salaries of \$35 to \$200 weekly. The demand for trained men is greater than the supply. Recently enacted railroad rate laws and interstate commerce regulations have produced new conditions that necessitate trained specialists—men who know how to **route shipments**, to obtain **shortest mileage, quickest deliveries—lowest rates**. With such knowledge you can qualify for an important, big-salaried position with a future—**quick**.

### WE TRAIN YOU BY MAIL

at home, in spare time, without giving up your position or income. The cost is small—we make the payments to suit you. All you need, to get into this powerful, big paying occupation is our training. No matter where you live, what you work at now, how small your pay, how long your hours—no matter what your age or education—if you can read and write—our Interstate Commerce Course will train you expertly to handle proficiently a big Traffic Manager's job—to merit and retain influence, respect, power and \$35 to \$200 weekly.

### MOST THOROUGH METHOD KNOWN

The LaSalle method is simple, practical, logical—anybody can readily master it. It is the work of some of the greatest Traffic Experts in America. It covers thoroughly every feature of the profession you will ever need to know—it is different and more complete than any other method of home-training in Interstate Commerce ever known. This is the largest home-study Extension University in the world—our graduates are recognized as real experts—they are trained to do the kind of work that commands big positions.

### NEW, UNCROWDED OCCUPATION

This is a new, uncrowded occupation—there's room for you if you prepare at once. Let us train you now for a big future, with power, dignity, respect and a big income, with almost unlimited opportunities. All you need is a desire and our home training to become a big man with independence and a big income. Don't remain in a small job that thousands of men are constantly after—let us make you the master—the big man—a successful leader among men.

### FREE—Wonderful Book

Send the coupon below now and receive free copy of our much-talked-of book "10 Years Promotion in One"—learn more about the opportunities afforded Traffic Experts with our training—learn about the big positions now open—learn how easy it is for us to make you a traffic specialist. Remember only trained men can secure the big positions now open—remember that big employers are seeking our graduates because of their efficiency. Send the coupon—no money.

La Salle Extension University, Chicago

La Salle Extension University, Dept. 6875 Chicago, Ill.

Send at once, without expense to me, FREE copy of your famous book "10 Years Promotion in One"; also book telling how I may, without interfering with my present position, prepare myself as Traffic Expert.

Name .....

Address .....

Occupation .....

Please Mention Popular Mechanics

### LEARN IN 3 MONTHS TO EARN \$1300 TO \$4000 A YEAR

MECHANICAL DENTISTS DO IT—the demand is years ahead of the supply. Any man or woman can learn, no previous schooling or entrance examinations required. PROF. BODEE, the most ingenious and thorough mechanical dentist in America, instructs each student personally.

ESTAB. 1892

BODEE  
TRADE



DENTAL  
SCHOOL

15-17 W 44th St

NEW YORK CITY

The first and only school recognized by the Dental Profession. Not a correspondence school, Practical individual instruction on actual cases in our large laboratory; no book study. Tuition payable in moderate monthly installments; we assist you to positions. Students received at any date.  
WRITE TODAY FOR CATALOG P

## ELECTRICITY

CONDENSED COURSE IN  
ELECTRICAL ENGINEERING

Complete in One Year  
Bliss Electrical School



Studies restricted to theoretical and practical electricity, mechanical drawing and necessary engineering knowledge. Actual construction of apparatus, installation and testing right in the school. Teaches concentration and hard work. 23rd year opens Sept. 22nd. Write for new catalog E. Special 6 months Evening Course in

"Wire and Wireless Operating"

opens November 15th, 1915. An

Exceptional Opportunity

to qualify as a

First Class Commercial Operator.

Write for Catalog W.

136 Takoma Avenue,

WASHINGTON, D. C.

### The University of Chicago

HOME  
STUDY

in addition to resident  
work, offers also instruction  
by correspondence.

For detailed in-  
formation address

24th Year

U. of C. (Div. 20) Chicago, Ill.



Michael Tamm

### LEARN WATCH REPAIRING

Be a watchmaker—you can learn this profitable trade by correspondence in a few weeks in your own home by the DeSels Chart System. After you complete the course you will know a watch from A to Z. You will know just what the matter is and how to repair it. When you graduate you will be a practical watchmaker and repairer and competent to fill any position. Positions for our graduates.

Ask for our Free Book. It explains our system and terms.  
THE DeSELMS WATCH SCHOOL  
23 Perry Street ATTICA, INDIANA



## DRAWING

Caricature, Cartoon, Comic, Commercial, Fashion, Newspaper and Magazine illustrating taught by mail. Illustrated book 6c in stamps. THE BOSTON SCHOOL OF DRAWING,  
755M Boylston St. BOSTON, MASS.



### Only Practical Auto School on the Pacific Coast

Fully equipped. Most modern methods. Expert instructors. Our course includes everything worth knowing about the auto business. No time limit. Hundreds of successful graduates. Room and board while learning. Assist graduates to positions. We guarantee satisfaction.

SPECIAL EXPOSITION RATES CATALOG FREE  
NATIONAL SCHOOL OF ENGINEERING  
2111 West 7th St. (Est. 1905) Los Angeles, California





## Can You Accept a Position Paying \$125 to \$300 a Month?

**A**RE your services in demand today? Have you the the training that equips you to hold a position paying \$125 to \$300 a month? Have you the same knowledge as the man who gets the fat pay envelope? If you are ambitious—send the coupon below and find out about the opportunities that await you in the profession of Signal Engineering. Salaries are paid to men who know. You can get just the kind of training you need to accept one of the big jobs, right in your own home—during your spare time. We need men. Send the coupon for the book that tells you all about it. Do not delay—send today—now.

### Be a Signal Engineer

Be the man who gets the fat pay envelope. The profession of Signal Engineering is only in its infancy. There are thousands of miles of block signals to be installed. Signal Engineers, supervisors, inspectors and foremen are required to superintend the installation. Hundreds of maintainers and battery men are needed to maintain the systems already in use.

Your duties may take you from coast to coast. Railroad men are always in a fortunate position to travel and see the world because free transportation is liberally awarded. You can accept a position where you will be located steadily at one place, if you prefer—the position of authority—the high place and the fat pay envelope may be yours. Send the coupon for the free Signal Book.

### \$12500 to \$30000 a Month

That is an ordinary salary for Signalmen—many Signal Engineers make much more. In the Signal Department, supervisors, inspectors, maintainers, battery men, positions of authority paying from \$125 a month up, all open to the men who have had the kind of training you can get right in your own home. Even while you are learning you may hold one of the positions in the Signal Department under a Signal Engineer. Send the coupon for the Free Signal Book.

### Send Coupon for Big New Book

Put your name and address on the coupon or on a letter or a post card now, and send it to us. Absolutely no obligations of any kind. We will send you our big new book absolutely free, and prepaid. Read about this fascinating profession. Read about the opportunities that await you. The book is free. Send the coupon for it now—it's the first step toward the realization of your ambition. Get your name and address in at once.

Department of Signaling

Room 1198, 1810 Wilson Ave., Ravenswood Station, Chicago

### We Need Men

The profession of Signal Engineering is calling to ambitious men. Our ranks are not over-crowded. There are opportunities—golden ones, awaiting the men who answer the call. Block signal systems are no longer in the experimental stage. All over the country they are being installed. Some States have legislated to compel the railroads to install systems immediately. In our profession you will have the chance you have been looking for.

We are calling you. Don't fail to send the coupon today for our big free Signal Book and full particulars.

#### Two Big Outfits FREE

Complete Signal Engineer's Outfit and Complete Professional's Outfit given away absolutely free to our students.

#### Department of Signaling

Room 1198, 1810 Wilson Ave., Ravenswood Station, Chicago

Gentlemen:—Please send me absolutely free and prepaid your big new book on Signal Engineering. Also full particulars about your great special free outfit offer. It is distinctly understood that I assume no obligations of any kind.

Name.....

Address.....

Age..... Occupation.....

Please Mention Popular Mechanics



## Because

I want every man who gets my practical Drafting Room Training to be qualified for the highest paid position, I will give you

Free  
Yes,

Free

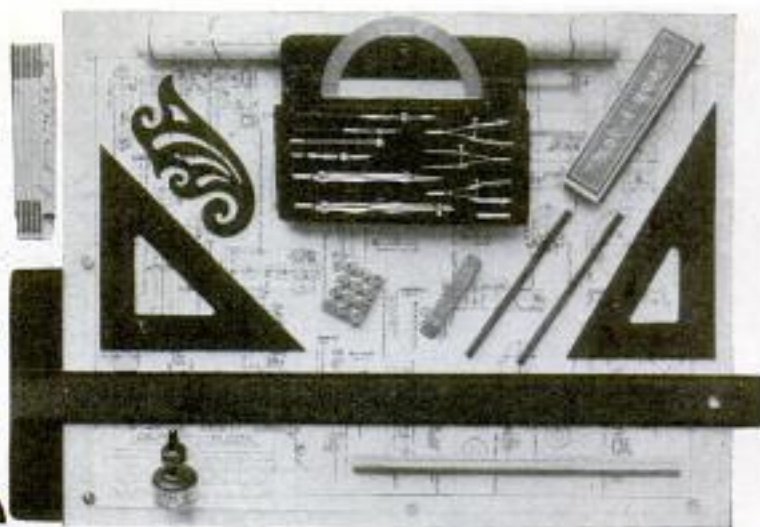

# \$15<sup>00</sup> Draftsman's Outfit

IT does not cost you a cent. This splendid, complete Draftsman's Outfit is first class in every particular and is just the kind of an outfit used by highest salaried draftsmen in practical work. It will last you a life time. After you have had my practical training, you will use this same outfit in first class draftsman's work, when you earn \$200.00 a month. Read what my students say about it. Then put your name and address on the coupon today and get my free book. A golden opportunity awaits you.

## Chief Draftsman Will Instruct You Personally

As chief draftsman of a large and well known company, I know just exactly the kind of training that the men must have who get the highest salaries. This is just the kind of training that I give you. I have trained hundreds of men. With my personal training in a very short time you can get just the knowledge and practical experience that will qualify you to hold a good paying permanent position. **\$125 to \$200 a month straight salary is ordinary pay for a good draftsman.** Many of my students earn more than that. Read what they say. You can do as well, or better. You can be the man who gets \$200 to \$300 a month. But you must hurry. I accept and train only a limited number—they are the men who make good. You can be one of them. The first step is to put your name and address in the coupon now.

## Start For That \$200 Job Today

There is a demand for draftsmen all over the country. Permanent positions paying good salaries are offered to men who have the kind of practical training I will give you. Opportunity is calling you. But do not delay. You cannot afford to put off sending the coupon another minute. Give your ambition a chance. Send the coupon and start for that \$200 job today.

## Send the Coupon for Big Book

### Chief Draftsman Dobe

Engineer's Equipment Co.  
Division 1198, CHICAGO, ILL.

Without any obligation to me whatsoever, please mail your book "Successful Draftsmanship" and full particulars of your liberal "Personal Instruction" offer to a few students. It is understood that I am obligated in no way whatever.



Put your name and address in the coupon, or a letter or a post card and send to me at once. You will be under no obligations. I will send you my big new book "Successful Draftsmanship" and tell you all about the special offers I am making. Do not delay. Opportunity calls. Remember—just your name and address on the coupon is enough.

**Chief Draftsman Dobe**  
Division 1198  
Engineer's Equipment Company  
CHICAGO, ILL.

### Excerpts From Letters

Am at present employed at a salary of \$1800.00 per year.

I have been earning from \$125.00 to \$160.00 per month.

I have made more than \$400.00 per month.

I designed special Automatic machinery getting \$150.00 per month. I have always given you credit for this.

I am employed at a straight salary of \$2500.00 per year.

I am employed and have been with this company for the last five years due to your training and help.

I have a position in the Drafting room and am well satisfied with the position. Thank you for the aid you have given me.

Have been working as a Draftsman and I must say that I derived all of my Drafting knowledge from your course.

I would not take ten times the cost of my correspondence course.

I am holding a position in the U. S. Government service for the last five years.

I have made plans and estimates for the government. Have worked for an increase of \$200.00 salary per year.

After finishing your course was employed by the New York State Railway Company and later became foreman over the Drafting department.

I hold a position as Draftsman and Superintendent. Have worked for the leading Architects of this city.

I have been working at Drafting, designing automatic machines. At present I am working designing tools.

For the past years I have been designing complete manufacturing plants.

I have designed a great many buildings and most of them were built under my supervision.

Name.....

Address.....

# CLASSIFIED ADVERTISEMENTS

We have records to prove that a classified ad in these columns will find a buyer for almost anything which can be sold. Doubtless you have some article of value to some one else which you no longer need. Why not turn it into money?

Advertisements in this section, 15 cents per word, each insertion, minimum 10 words, payable in advance. To insure ads being inserted under proper classified head in the December issue, copy must reach this office not later than November 1st.

Popular, Month, Sept. 30, 1915.

Popular Mechanics Magazine, Chicago.

Gentlemen:—I am enclosed \$4.50 for which insert the following attached classified advertisement in your November number.

We have filled orders for our "Deerskin Vests" from Scotland and South Africa, which business was created by the one small ad we carried in your magazine, which shows that your magazine is right there in covering the country.

Yours truly,  
INDIAN BEADWORK CO.

## AUTOMOBILES

AUTO Gasoline 3c a gallon. Sounds wonderful, but it's a fact, and what is better, your motor car will have "pop," "snap," power and speed as never before. Carbon evil eliminated. All these good things and more come when "Gas-Tonic" is added to ordinary Gasoline. Mileage increased 46%. Scientifically right. Gas-Tonic can treat 260 gallons of gasoline. \$2 prepaid. Results guaranteed. Motorists enthusiastic wherever "Gas-Tonic" is tried. Circular and convincing details free. Great opportunity for live dealers and agents. White Mfg. Co., Dept. 112A, Cincinnati, Ohio.

AUTO owners double tread your own old tires; two in one; it's easy; 50c per tire per 1,000 miles; repair men make big money at this business. Agents Wanted. Tire Trading Co., Newark, N. J.

FOR Sale. Argo Electric Brougham, 108% in wheel base, run only enough to keep batteries in order. \$1,250. T. P. Plumridge, 904 Holland Bldg., St. Louis, Mo.

A WRITTEN guarantee for 5,000 miles without puncture. European Motorists are getting 19,000 miles out of their tires by increasing them about one-half inch in size. In eight months 29,000 American Motorists have followed their example. It's so easy that you can do it in your own garage in thirty minutes, no matter what condition your tires are in. Send for free catalog, sample and copy of guarantee. Colorado Tire & Leather Co., 1115 Tread Bldg., Denver, Colo.

FOR Sale—Hupmobile Touring Car, \$250. Roger Side-Car, \$35. C. J. Fischer, West Burlington, Iowa.

CYLINDER Regrinding—First-class equipment, fifteen years' experience, and specializing in this work enables us to do high grade work at lowest prices. We manufacture the "Neverless" individual cast piston rings. Prices will interest you. Bridgeport Piston Ring Co., 346 Connecticut ave., Bridgeport, Conn.

PUNCTURES can be avoided by using "Sure-Tite" in your tubes. \$1.25 per wheel. Agents wanted. Exclusive territory. George H. Monroe Co., Jamestown, N. Y.

AUTOMOBILE Instruction—\$55.25. Four weeks' course, best-equipped school in the country. Men enrolled from all parts of the U. S. Booklet P. M. on request. West Side Y. M. C. A., 318 West 57th Street, New York.

PAINT Your Car Yourself—Save \$25 to \$75 by doing the work at home with the Arsenal system. Our big free booklet "The Car Beautiful" tells how. Send for it today. Arsenal Varnish Co., Dept. P, Rock Island, Ill.

## AUTOMOBILE SUPPLIES

1 CHALMERS Roadster, \$375; 1 Monitor Truck—1 ton, \$400; 1 2-cyl. Model F Buick Truck, \$250; 1 Ford chassis, less power plant, \$60; 1 2-cyl. Pope chassis, less radiator, \$85; 1 2-cyl. Model F Buick car, \$125; 1 2-cyl. Maxwell Runabout, \$175; 1 Coupe body, \$60; 1 Limousine Body, \$100; 1 Peerless Truck, \$190; 1 E. M. F. 5-Pass. Rebuilt, \$400. Mitchell parts, Ford roadster bodies, Touring bodies, racing seats, motors, transmissions, magneto, fenders, tanks, radiators, and welding. L. & M. Manufacturing Co., 319 So. Jefferson St., Chicago.

ANY magneto, coil, lighting and starting system repaired. Work guaranteed. Estimates cheerfully given. Pellet's Magneto Exchange, 1604 Michigan Avenue, Chicago, Illinois.

SEND \$2.50 to Primm & Emmerson, Manufacturers, Lincoln, Illinois, for new device with which one person can easily raise or lower auto top (not one man). Simple, easily adjusted, selling everywhere. Mailed postpaid on receipt of price. Agents also wanted.

INTERSTATE Puncture Proof will stop all punctures and slow leaks immediately. Not a filler, or chemical in action, and cannot injure tire or tube. Costs only \$1.25 per tire—only a little more than one puncture would cost you. Endorsed by thousands of motorists. Send in your order today—we absolutely guarantee to refund your money if you're not satisfied. Interstate Puncture Proof Co., Denver, Colo.

AUTOMOBILE tires, tubes or any mechanical part for any car at cut prices. Specializing on parts for Ford and Maxwell cars. Write for prices to Grossman Auto Parts Co., White Plains, N. Y.

1,900 AGENTS Wanted: Exclusive Territory: Repeat Proposition. "Glix"—Fuel for Increasing Efficiency of Gasoline Engines. Registered U. S. Patent Office No. 105,513. One Cent per Gallon. Eliminates Carbon Trouble, Increases Power and Mileage. Easy Starting. Absolutely Non-Injurious. Highly Indorsed. 100 Tablets One Dollar. Fred M. Giddings, Mfr., 63 E. Simmons St., Galesburg, Illinois.

OUR Double-Tread Tires are Guaranteed (written) for 3,500 miles. Two tires in one. Big, strong, extra heavy, 30x3 1/2, \$7.00; 34x4, \$9.25; 36x4 1/2, \$12.00; 37x5, \$13.00. Big saving on other sizes also. Send for list now! State size and type rim. Max Libben & Company, 205B West 48th, New York.

FOUR Cylinder Ford, Engine Model 8., \$50; Two-cylinder Meta, with Magneto, \$30; 1,700 lb. Lathe, 13 in., \$100. Sisson, Marshall, Ill.

EXPLOSION Whistle. Fits priming cup. Most powerful signal made. Rapid seller owing to real value. Buell Manufacturing Co., 1141 E. 46th St., Chicago.

FOR Sale—3 Buick motors, Model "M," 4-cylinder. Completely overhauled. Suitable for pleasure car or light truck. \$95.00 each. Harvey Motor Truck Works, Harvey, Ill.

RECTIFIERS for garages. All sizes. Charge one to eight batteries, \$12 upwards. American Battery Company, 1129 Fulton St., Chicago.

BATTERY Charging Dynamos earn 60% profit. Write us. Hobart Bros., Troy, Ohio.

"THE How and Why of the Automobile"—A 200-page book of practical information for seekers after the fundamental facts regarding the gasoline engine and its application to the motor car. Interesting and instructive to both the beginner and the expert. Bound in full cloth—250 illustrations. Price \$1 postpaid. Popular Mechanics Book Dept., 6 N. Michigan Ave., Chicago.

TIRES—Special sale this month only. Cap-top tires, guaranteed 4,000 miles in writing. 30x3, \$6.95; 30x3 1/2, \$8.95; 32x3 1/2, \$9.95; 33x4, \$11.95; 34x4, \$15.50; 36x4 1/2, \$21.95; 37x5, \$25.00. Wolke Rubber Company, Louisville, Ky.

WANTED—Secondhand automobile motor, 40 to 60 h. p. J. W. Edgar, McLaughlin, S. D.

VULCANIZER for shop. Bargain. Vanderpool's, Springfield, Ohio

## FORD ACCESSORIES

DIFFERENTIAL ring gear, \$3.60, and any and all other parts for Ford cars at equally astonishing low prices. Write for bargain sheet. Grossman Auto Parts Company, White Plains, N. Y.

FORD Owners should have a Safety Ford Starter on their car. Write at once for particulars. Safety Ford Starter Corporation, 701 Seventh Ave., New York.

"STEER Red" for Fords. Guaranteed Best Made. Want Agents. Sample \$3.00; prepaid. C. B. Post, New London, Ohio.

NEW 300-page book on the Ford car for every Ford owner, dealer and repairman. Deals fully with construction, operation and repair. 100 engravings. Best and most complete Ford book ever published. Price, \$1 postpaid. Also Ford Engine Chart—25x38 in. Location of engine troubles made easy. Price, 25c postpaid. Your money back if not satisfied. Popular Mechanics Book Dept., 6 N. Michigan Ave., Chicago.

## WELDING

\$1.00 BRINGS the correct answer to any practical or scientific question on problem on electric welding, or money refunded. We also give lessons by correspondence. General Welding Supplies Co., Westfield, N. J.

OXY-ACETYLENE Welding and Cutting is the title of a brand new practical instruction book on the methods of doing this work. It includes the operation and care of Acetylene Generating Plants and the Oxygen Process for removal of carbon. 200 pages, 76 illustrations, pocket size, cloth, \$1.00; leather, \$1.50 postpaid. Popular Mechanics Book Dept., 6 N. Michigan Ave., Chicago.

PREST-O-LITE welding outfit, cost \$100, for \$75; practically new; tank, instruction-books. Denver Brass Works, Denver, Colo. Castings, Machining, Manufacturing.

WELDING Plants, \$25 to \$250. Liberal terms. Write Berne Co., Omaha, Neb., U. S. A.

## MOTORCYCLES, BICYCLES & SUPPLIES

SEND for latest Bulletin of real Motorcycle Bargains, used and slightly used, all makes, models and prices; if you have \$25 and really want a powerful Motorcycle, send for this Bulletin; hundreds of machines at all prices, new ones on easy payments; tell us what you want and how much you can pay; we can fix you up. Peerless Motorcycle Co., Dorchester, Mass.

WRITE today for our list of Motorcycle Bargains. The greatest values in the country. Every machine fully warranted in perfect running order. David Stern Co., 1047 W. Madison St., Chicago, Ill.

CLOSING Out Sale of high-grade slightly used motorcycles. This time of year we close out all our used motorcycles. All standard makes, twins and singles, belt and chain drives. Prices \$25 and up. Write for complete list. Gotham Sporting Goods Company, 37 Warren St., New York City.

\$35.00 TAKES 1914 Rogers Side Car, little used; \$200 for Harley-Davidson 1915 Three-Speed; lamp, horn. Cost \$300; new condition. Earl S. Collier, Shelbyville, Missouri.

FOR Sale—1914 Indian twin. David Potheringham, Emington, Ill.

A 1914 7 HP. Excelsior, equipped, Al condition. Cheap for cash, or will trade on lathe or Ford Shoemaker, E's, Kan.

1915 MODEL C-3 Dayton, never uncrated, \$215. First deposit gets it. R. N. Mathews, Newportville, Pa.

BIG bargains in good motorcycles we have taken in exchange on new ones. Send for special bargain list. Shaw Mfg. Co., Galesburg, Kansas.

FOR Sale: Good-paying sporting goods, Motorcycle and bicycle business cheap. Guy W. Campbell & Co., Waterloo, Iowa.

100 MOTORCYCLES; new and second-hand; all makes; \$25 and up. Write for complete list and prices. Machines sent on approval. Guy W. Campbell Co., Waterloo, Iowa.

LARGE stock of second-hand motorcycles—Harley-Davidson, Indian, Dayton, Reading Standard, and others. Write for prices. John G. Nuebling, Reading, Pa.

\$245.00—INDIAN motorcycle and side car. Electric lights, horn, speedometer, two-speed, 1915 Kickstarter. Dr. A. J. Vanwinkle, Phillipsburg, Kansas.

1915 TWO-SPEED Thor twelve; perfect condition, very fast, \$290. H. A. Denbroeder, 132 Pond St., South Braintree, Mass.

BARGAINS—Two 11 two-speed Indians Elec. Equipped \$165 each, perfect condition. Other real bargains in Readings, Harleys, Merhels and Thors. Write for our list. Don't delay. W. Edw. MacDougal Co., Paterson, N. J.

TWIN Excelsior 1913. Completely equipped, guaranteed good condition. Sacrifice at \$110. A. A. Archbold, 110 N. Morgan St., Chicago.

NEW Heitger Carburators, \$4.75. Motorcycle Clothing. Coats, \$1.50. Pants, 75 cents. Exhaust whistles, \$2.75. Spark Plugs, 15 cents. 28% Goodgear tubes, 28 cents. Fauber crank hangers complete, \$1.25. Pulley rims, 50 cents. Wandersee Company, 129 Gratiot Ave., Detroit, Mich.

EXCEPTIONAL Bargains—1914 Twin Excelsior; 1913 Twin Harley-Davidson. Address Postoffice Box 251, Waterloo, Iowa.

BARGAINS in used motorcycles and side cars. Waggoner Brothers, Boststeel, S. Dak.

USED Motorcycles from \$25 to \$250. Small deposit required. Money refunded if machine not satisfactory. Write for list today. C. H. Lang, 1701 Michigan Avenue, Chicago.

\$5 STEWART-Warner Signals \$2.49. \$5 Auto or motorcycle Headlights, brass or nickel \$2.98. \$4 motorcycle saddles, large size, now \$2.48, 75, \$1 and \$1.25 spark plugs, any size, 15c. 75-cent motorcycle grips, long or short, 20c. \$15 speedometers for any motorcycle, \$7.50. We specialize on motorcycle parts for all machines. Send for free catalog and bargain sheet. Largest motorcycle dealer in the state. Wandersee Co., 129 Gratiot Ave., Branch 2996 Woodward, Detroit, Mich.

THOR 4 H. P., good shape, fully equipped, lamp, horn, tandem, seat, etc., \$85. Harley-Davidson, fully equipped, lamp, horn, carrier. In fine running shape, \$39. Merkel 8 H. P. twin magnets, clutch, lamp, horn, rear seat and cushion. A snap, \$45. Dayton 1913 model. Demonstrator, 9 H. P., new spring fork. Fully equipped, spring tandem, lamp, horn, tire, motor enamel, in practically new condition. \$125. 1915 Harley-Davidson, 11 H. P., electric model, fully equipped. Like new, for only \$175. Write for free catalog and bargain sheet. Wandersee Co., 129 Gratiot Ave., Branch, 2996 Woodward, Detroit, Mich. Largest motorcycle and accessory dealer in the state.

\$50 TO \$150 buys the best motorcycles; every make and model in our large stock must be cleared. Half price. Send for list today. Brown Music Co., 9119 Commercial Ave., Chicago, Ill.

MOTORCYCLE cylinders reground, fitted with new piston and rings \$5.00, guaranteed. Muncie Piston Co., Muncie, Ind.

RARE Bargain, Harley-Davidson, 4 HP, excellent condition, \$45. Williams, 4308 Indiana Ave., Chicago.

BARGAIN—1914 Harley-Davidson, 2 speed, single, perfect condition, good tires. Henry Ross, Manchester Depot, Vermont.

HELP!! Help!! Bring our 1915 Season to a close. All Models listed in our Circular No. 49, reduced 5% from list. Do not delay your reply, but write at once. All makes and models at \$10 to \$200. Trucks, Side Cars, Side Vans and Bicycles. Mueller Cycle & Supply Co., 726 National Ave., Milwaukee, Wis., Oldest and Largest Dealers in the Northwest.

1915—12-HORSE, two-speed Thor, Split-dorf Mag. Dynamo. Cost \$315, sell for \$230. Aug. Schierholz, LaSalle, Ill.

FAST 1914 Twin Excelsior Motorcycle, finest equipment, \$115. Enoch Easler, Brownsville, Pa.

FOR Sale, cheap, Harley-Davidson motorcycle, single, fine condition. DeVere Spencer, 413 N. Central Park Blvd., Chicago.

USED Motorcycles cheap. Guaranteed. Childster & Company, Ottumwa, Iowa.

GENUINE Bargains in New and Used Motorcycles. Boyd P. Blakeman, Creighton, Neb.

FOR Sale—Pierce Arrow Motorcycle, 4-cylinders, 2 speeds, Excellent Condition. Write for specifications. Paul Pitts, Roseto No. 1, Brunswick, Ga.

NEW Motorcycle Book—Just Published—Motorcycles, Side Cars and Cyclecars, Their Construction, Management and Repair—559 pages, cloth, 350 illustrations. The Dealer, Mechanic and Rider will find this treatise a work of reference without an equal. Price \$1.50 postpaid. Popular Mechanics Book Dept., 6 N. Michigan Ave., Chicago.

MOTORCYCLES; Indians, Harleys, Thors, Excelsiors, Emblems, Flanders, \$20 up. Many others. Write for list. Hall & Gravatt, Atlantic City, N. J.

DON'T buy a Bicycle Motor Attachment until you get our catalogue and prices. Shaw Mfg. Co., Dept. 27, Galesburg, Ia. 505.

WANT to sell your motorcycle? I have a method which has sold many. Write me today for free information. F. W. Johnson, Room 306, 78 E. Madison St., Chicago.

Big bargains in second-hand motorcycles, \$25 up. Indians, Harleys, Thors, Excelsiors and Merhels. Write for descriptions, Howard A. French & Co., Baltimore, Md.

SUPPLIES—Our big catalogue with prices lower than usual sent free to motorcycle owners. Mecca, Hammondport, N. Y.

#### AERONAUTICS

BUILD a 3-foot Monoplane Racing Model that will fly 2,600 feet. Complete Plan drawn to scale and careful instructions how to build and fly this record Model. 25c. Philip T. McCutchen, Model Designer, 2943 West Toga Street, Philadelphia, Pa.

AVIATION Motors, all makes, up to 150 H.P., \$250 up. Complete aeroplanes, all types, \$500 up. State your needs. Aero Exchange, 28 Park Row, N. Y. C.

CLEMENT-Bayard 30 H.P., two cylinder motor, Magneto, carburetor, water pump, 168 pounds, Brand new, \$275. C. H. Wetzel, Wayne, Pa.

BICYCLE Monoplane easy to build, drawings easy to understand, 25c coin; complete material, \$10. Elmer Hammet, Rasputing, Md.

WILL sacrifice Gray Eagle equipped Curtiss Biplane \$290. Also \$1,200 Flying boat \$775. Both ready to fly. Heath Aerial Vehicle Co., Chicago.

HOW to Make a Biplane Glider—Our book "Amateur Mechanics No. 2" contains a complete detailed description of how to make one. Price of book, 25c postpaid. Popular Mechanics Book Dept., 6 N. Michigan Ave., Chicago.

BUILDING and Flying an Aeroplane—109-page handbook covering the building of small models and full sized gliders and machines. In both biplane and monoplane models the well-known Curtiss and Bleriot types are followed. Fully illustrated with detail drawings. Price, \$1 postpaid. Popular Mechanics Book Dept., 6 N. Michigan Ave., Chicago.

BEST and lowest priced aeroplanes, motors and propellers. Bates, 104 Oak, Chicago.

CATALOG "H" off the press, most complete aeronautical catalog ever published, sent for 6 red stamps. Motor Catalog, 8c; propeller catalog, 6c. Heath Aerial Vehicle Co., Chicago.

COMPLETE Plan, drawn to scale, with precise instructions for building 2-foot Model War Aeroplanes at the following prices: Bleriot, 15c; Nieuport, 25c; Taube, 25c; Curtiss Flying Boat, 25c; Curtiss Military Tractor, 25c; Wright, 25c; "Pencil," 25c; 48-pp. Model Supply Catalog, 5c. Ideal Aeroplane Co., 82½ West Broadway, N. Y.

TURNBUCKLES: National Aero Varnish. National Aeroplane Company, Machinery Hall, Chicago.

FOR Sale—Two used aeroplane motors, 14 and 60 H. P. Prices right. Lock Box 173, Harlan, Iowa.

LIGHT Weight, Gasoline Engines, 2½ lbs. Guaranteed ½ H. P. The Weiss Co., Torrington, Conn.

#### CHRISTMAS SUGGESTIONS

A CHRISTMAS Gift that is sure to please the schoolboy, schoolgirl and grown-up. Their name stamped in gold letters on beautiful red, green, blue or white enameled, high-grade, rubber-tipped lead pencils. 3 pencils in Christmas box, 25c; 6 pencils, 50c. Stamps or coin. Write name plainly. Rochelle Pencil Co., Dept. D, New Rochelle, N. Y.

#### BOOKS AND PERIODICALS

"COMPARATIVE Cancellation"—Solves all Arithmetical and Geometrical Calculations with ease, accuracy and large saving of figures, 150 pages, Cloth bound, \$1 postpaid. Money back if dissatisfied. Herrick & Horton, Publishers, Princeton, Ill.

BOYS—10c brings large 9x12 boys' magazine one year. Canada, 20c. Dandy stories, mechanics, stamps, electric. Youths' Magazine, 2122 Mallers Bldg., Chicago.

CORRESPONDENCE Courses, technical books, cameras, typewriters, automatic gas water heaters bought, sold. Cut rates. Clarence Bulb, Detroit, Michigan.

SMALLEST newspaper, note size, 2c stamp. Busy Print Shop, Asheville, N. C.

FREE Catalog of Mechanical Books—Our 98-page catalog of 500 books on 100 different subjects will show you where to find that particular information you are in need of on any mechanical subject. Send for it today. Popular Mechanics Book Dept., 6 N. Michigan Ave., Chicago.

BINDER for Popular Mechanics magazines. Best adjustable magazine binder on the market made especially to hold any number from one to six copies of this magazine with name "Popular Mechanics" in gold letters on front cover. No laces or cutting or perforating of pages necessary. Simple, unique adjustment; handsome, durable and neat. We buy in quantities and can offer our readers this regular \$1.50 binder for \$1.25, all shipping charges prepaid. Address Popular Mechanics Book Dept., 6 N. Michigan Avenue, Chicago.

CAESAR Lessons are prepared better and more easily by users of my "Consecutive Vocabulary"—lists and defines the words as they come, 116 pages, cloth, 60c postpaid. T. H. Winters, 1739 N. 4th Street, Columbus, O.

VOLUMES and sets on all technical subjects bought, sold, exchanged, rented. Correspondence-school books specialty. Boston Book Exchange, 36 Bromfield St., Boston, Mass.

BOOKS worth while; instructive and entertaining. Puzzles, Tricks, Novelties. Illustrated catalogue, free. Auburn Supply Co., Dept. 11B, 7817 Florita St., Chicago.

SHOE Repairing, Self Taught. It's easy. Fascinating. Profitable. Price 50 cents. W. J. Shuman, North Second Street, Chambersburg, Pa. Write for contents.

PRODUCTS Or Dividends is a calculator book that beats any other means or machine. Standard of western railroad since 1907. Indorsed by technical and office men. Instruction Chart 10c, stamps accepted. Advertiser Company, 116M Alpine Street, San Francisco.

SPANISH Books—Every kind. Catalog free. Bernardo Lopez, Kansas City, Mo.

MAGAZINE readers, write now for my catalog. Mederie Gaultin, 103 Brook Street, Woonsocket, R. I.

READ these great books about the War: 1. Germany and the Next War, by Gen. F. Von Bernhardi (discusses Germany's war plans for crushing England and France. Price 85 cents). 2. Secrets of the German War Office (by A. K. Graves, for twelve years a spy in the Kaiser's service. Price \$1.50). 3. Germany's Fighting Machine (by E. F. Henderson. Divided into three parts. The War, The Army and The Navy. Price \$1.35). 4. Men Around the Kaiser (by F. W. Wile. Tells about those men who figure most prominently in the affairs of Germany at the present time. Price \$1.35). 5. The Germans (by I. A. R. Wylie. A graphic picture of the German people on the eve of the great conflict. Price \$2.15). 6. The War and America (by Hugo Munsterberg, the great German-American. Price \$1.10). 7. War's Aftermath (a study of the deterioration of the quality of stock occasioned by the lamentable waste of war. Price 85 cents). Popular Mechanics Book Dept., 6 N. Michigan Ave., Chicago.

MENTAL Work and Etching—A 90-page hand book for art metal workers telling how to make a great variety of useful and ornamental objects, such as desk sets, artifacts, jewelry, etc. Price, 50c postpaid. Popular Mechanics Book Dept., 6 N. Michigan Ave., Chicago.

AUTOMOBILE Troubles and how to remedy them. Cloth, \$1; leather, \$1.50. Many other practical and reliable mechanical books. Send for circular. Chas. C. Thompson Co., Dept. C, 501-509 Plymouth Ct., Chicago.

MY Book Cement contains directions for building beautiful homes, and for manufacturing many valuable articles from reinforced stone and woodfiber concrete. Price fifty cents postpaid. Peter De Lunde, Zion City, Ill.

**CHAUFFEUR'S** Blue Book of Practical Questions and Answers. 50c postpaid. W. E. Moody, Box 473, Rochester, N. Y.

**LESLIA** Harmonica (mouth-organ). Complete self-instructor, 15c. G. Elser, Owosso, Mich.

**USED** Books. All kinds. Bargains. Catalogue. Higens's, A-2441 Post, San Francisco.

**SEND** ten cents for the liveliest outdoor magazine published. Hunter-Trapper, Box 39, Columbus, Ohio.

**ENGINEERS'** questions and answers for license. By Hobson, for twenty-five cents, postpaid. Send stamps. Reilly's Book Store, Philadelphia, Pa.

#### EDUCATIONAL AND INSTRUCTION

**NEW**, easy shorthand. Students write business letters after fourth lesson. Touch Typewriting. English. Personal correction of work. Investigate. Home Study School, 409 Caesar Misch Building, Providence, R. I.

**YOU** get fifty-nine lessons in business writing, six pens and oblique penholder for one dollar. F. B. Courtney, Box 492, Detroit, Mich.

**CARRY** a Gilson Pocket Slide Rule (Patented). It is indestructible and solves any mathematical problem accurately and rapidly. Price, with complete instructions, 5c. Circulars Free. Gilson Slide Rule Company, Niles, Michigan.

**MOULDS** and models for ornamental casting of novelties, statuary, garden furniture, in cement, plaster, Italian marble, etc. Free illustrated catalogue displaying large assortment. Roth, A-4, Frost St., Brooklyn, N. Y.

**EXPERIMENTS.** A new 256 page book that gives practical information for building simple, efficient apparatus at small cost, conducting tests and experiments, establishing a laboratory and applying the best experimental methods. Shows you what you can do with your own brains and hands. Both amateur and commercial work is covered. Send for complete description free or book itself sent postpaid upon receipt of price, \$1.50. Popular Mechanics Book Dept., 6 N. Michigan Ave., Chicago, Ill.

**SHOW-CARD** Writing taught by mail, personal instruction. Complete Course, \$5. A. Greenwald, Chippewa Falls, Wis.

**RAISED** letter signs. Send 25c for complete instructions. Eastern Exchange, Bridgton, Maine.

**STUDY** Bacteriology, Public Health, and Sanitation. Positions pay \$3,000 to \$5,000. Interesting home study course. Previous experience unnecessary. Degree granted. We help secure positions. Write for prospectus. Amer. Can. College of Bacteriology, Dept. 29, Chicago.

**LEARN** to be a good correspondent. Sample letters and copy of magazine upon request. Book Publishing Co., Evanston, Ill.

**WANT** to secure a marine or steam engineers' license? For that great class of ambitious and hard working men, the officers, coal-passers, watertenders, firemen or anyone who wants real practical and useful information regarding the every-day operation of a steam plant, Chief McAllister of the U. S. Revenue Cutter Service has written an engineering story called "McAndrew's Floating School," that makes it possible for those who have not had previous training to absorb the necessary information. Cloth, 256 pages and 37 diagrams. Price, \$2. Popular Mechanics Book Dept., 6 N. Michigan Ave., Chicago.

**BRIEFHAND** enables you to write as fast as the average scribe, using longhand letters. Easy to learn, write, read. Simple, speedy, sure, clear, concise. Many testimonials. Complete self-teaching Manual containing 3,000 illustrations and many short-cuts, \$1.00. No other expense. Home Study. Sample lesson free. Premier Briefhand School, Dept. 14, Washington, D. C.

**MECHANICAL** Expert Teaching Drafting, modern machine work and die making. Lessons 50 cents, 12 lessons \$5. Boma Co., 2077 E. 77 St., Cleveland, Ohio.

**EIGHTEEN** Ways to Make Money! Interesting, isn't it? If you are mechanically or electrically inclined don't fail to write for our free book. Efficiency Company, 104-A, East 16th St., New York.

**DETROIT** Technical Institute offers courses university grade in Automobile, Chemical, Electrical, and Mechanical Engineering, Law, Accountancy, Business Administration, Pharmacy, Salesmanship, Advertising, Real Estate, Credits, and Watchmaking. Bulletin free. Address Director of Education, Room 311, Y. M. C. A., Detroit, Mich.

**ARTIFICIAL** Marble, Sanitary flooring, ornamental casting, concrete, plaster, papier-mache, interior decorations, garden furniture, statuary, life casting, elastic moulds, electro bronze depositing (immensely profitable work), complete instructions \$1; particulars, 270 illustrations free. Mahler, D-117 Russell St., Brooklyn, N. Y.

**POOR** handwriting easily and quickly changed to good. Particulars free. Address D. B. Jones, Florence Station, Ky.

#### TELEGRAPHY

**TELEGRAPHY**—Morse and Wireless—taught at home in half usual time. The Omnigraph Automatic Transmitter combined with sounder or buzzer sends you messages, any speed, just as expert operator would. Used by U. S. Gov't to examine all applicants for licenses. Trifling cost. Catalog free. Omnigraph Mfg. Co., 41-G Corlandt St., New York.

**TELEGRAPHY**—Morse and Wireless—also Station Agency taught. R. R. and Western Union wires and complete Marconi Wireless Station in school. Graduates assisted. Marconi Co. employs our wireless graduates. Low living expense—easily earned. Largest school—established 40 years. Investment \$25,000. Correspondence courses also. Catalog Free. Dodge's Institute, 13th St., Valparaiso, Ind.

#### TRADE SCHOOLS

**ELECTRICITY.** Plumbing, Bricklaying, Mechanical and Architectural Drafting taught by practical instruction. This is largest and best equipped practical school in America. Short time required and small expense. Positions secured. Earn expenses while learning. Write for big illustrated book. It's free. Coyne Trade School, Dept. 3198, Chicago.

**EARN** \$30 to \$75 weekly—Learn Sign Painting and Card Writing in Practical School in short time. Earn expenses while learning. Sign Card School, Dept. A., 131 N. 5th Ave., Chicago.

**LEARN** Theatrical Scenepainting at your own home. Indispensable to Painters and Decorators. Anybody can learn. Start your own Mail Order Business. Catalog and particulars free. Natl. Comm. Art School, 649 Omaha Natl., Omaha, Neb.

**ENTER** the Plumb Trade. Learn the plumbing and heating trade from practical work on jobs with business methods. The Only School in America where get this training. Litchfield Trade School, Libertyville, Ill.

**PAINTING,** Decorating, Paper Hanging taught by actual practice. Free catalogue. Chicago School of Painting, 159 West Austin Ave., Chicago.

**AUTOMOBILE** instruction. A complete home study course that shows you exactly what you want to know about the automobile. 229-page book, giving definite, thorough, authentic and practical detailed information about every part of the automobile as well as thorough instruction in regard to driving, repairing and general care of the complete car. 190 illustrations, \$1.50 postpaid. Popular Mechanics Book Dept., 6 N. Michigan Ave., Chicago.

#### WIRELESS

**\$9** WIRELESS receivers, \$4.50 pair. Variable Condensers \$2.75. Circulars. Imperial Electric Co., 89 Wallabout St., Brooklyn, N. Y.

**WIRELESS** Set. How to Make—36-page book telling how to construct at small cost an outfit suitable for transmitting four or five miles. Price, 50 cents, postpaid. Popular Mechanics Book Dept., 6 N. Michigan Ave., Chicago.

**WIRELESS** telegraphy taught by mail. High-grade instruction. Complete. Catalog explains. New York Wireless School, 342 West 56th St., New York.

**WE** teach Wireless by Mail. Catalog tells how. National Radio School, 1401 You St., Washington, D. C.

#### PICTURES, POSTCARDS, PENNANTS

**MEMBERSHIP** printed immediately, 10c. Pacific Card Exchange, Bryn Mawr, Wash.

**TEN** Beautiful Asbury Park Postcards, 10c. Richard Lavery, Asbury Park, N. J.

**BOOKS** and Pictures. Stamp brings Catalogue. Duff, 2713 Mozart, Chicago.

**200** ILLUSTRATIONS Free. Beautiful art casts. Mahler, K-117 Russell St., Brooklyn, N. Y.

**10** ELEGANT Postcards and catalogue, 10c. Stewart Co., Providence, R. I.

**IF** you really want to exchange postcards, try our splendid club. Lists circulate in many countries. Membership, 10c. Halcyon Club, Box 153, Erie, Pa.

**3,000** SELECTED Cartoons for \$3. A Panorama of World Events, Political, Industrial—Social—Humorous—Tragic—all of intense human interest. A wonderful collection of 3,000 cartoons reproduced from the newspapers of the United States, Canada, Mexico, Cuba and the cities of the Old World, has been made by Cartoons Magazine from more than one hundred and fifty thousand published cartoons, and, bound in an artistic and durable cover, are now ready for your library table. Vol. I, Jan.-June, 1912—\$1. Vol. II, July-Dec., 1912—\$1. Vol. III, Jan.-May, 1913—\$1. Cartoons, 78 E. Madison St., Chicago.

**CROSS-SECTIONAL** view of ocean liner "Britannic," showing interior arrangement of ship in colors, size, 14x20 inches, on heavy plate paper for framing or hanging. Very interesting. Reproduced from front cover design of July issue Popular Mechanics. Will be sent postpaid to any address in the world on receipt of 4 cents in stamps to cover packing and mailing. Popular Mechanics Magazine, 6 N. Michigan Ave., Chicago.

**COLLEGE** and State Pennants, 9½x26 inches, 15 assorted, 50c; 6 assorted, 25c. Postpaid. Lunch Specialty Co., Joplin, Mo.

#### CAMERAS AND PHOTO SUPPLIES

**REAL** help for every Photographer. "Practical Photography" series of handbooks of everyday problems—clear, concise, comprehensive. Now ready: "The Secret of Exposure"; "Beginners' Troubles"; "How to Choose and Use a Lens"; "How to Make Prints in Color." Clothbound 50c each, paper 25c—at photo-supply dealers or Practical Photography, 452 Pope Bldg., Boston.

**IF** you have a High-grade Camera, Lens, Kodak, or Motion-Picture Camera, and want to turn it into cash, write us today. State particulars, price, etc. We buy and trade, sell or exchange everything in Cameras from Vest Pocket to Graflex, Prompt, satisfactory service and a square deal to all. David Stern Co., 1947M W. Madison St., Chicago, Ill. In business since 1835.

**KODAK** Films Developed, 10c per roll, any size. Prompt attention given mail orders. Prints, 2½x3¼ to 3½x4½, 3c. 4x5 to 3½x5½, 4c. J. M. Manning, Box B, 1062 Third Ave., New York City.

**CAMERA** and Lens Bargains. Cut Rate Photo Bargain List just off the press. Send stamp. Willoughby, 810 Broadway, New York.

**ROLL** Film developed, 10c a roll. Packs 20c each; Prints, Brownies, 2c; 14, 3x4, 3x5, and Post Cards, 3c each. Work returned next day. Postage paid. Kodak Film Finishing Co., 112 Merchants Station, St. Louis.

**FILMS** developed 5c, prints 3c, all sizes. Johnson's Studio, Oswego, N. Y.

**SECOND-HAND** Lenses. All makes and sizes. Work just as well as new ones. Send for our bargain list. Hyatt's Photo Supply House, St. Louis, Mo.

**HAVE** you a Camera? Write for samples of my magazines, American Photography and Popular Photography, which tell you how to make better pictures and earn money. F. R. Frapelle, 141 Pope Bldg., Boston.

**8x10** TRIPLE mounted enlargement of your favorite negative for the next 30 days introducing our Art Copy Deluxe for 25c. National Photo Service, 143 No. Dearborn St., Chicago, Ill.

**INSTRUCTIONS** and formulas for Phosphorescent Photos, Disappearing Photos, Photos on Apples, Cloth, Chinaware, etc. Simple Enlarger, Trick Pictures, 25 in all, for 25c. Disappearing Photo Free with each order. Money-Back Basis. P. Benson, Stewartville, Minn.

**FILMS** developed, ten cents per roll. Velox post card prints, four cents, smaller sizes three cents. Guy Hall, Chagman, Kansas.

**EXTRAORDINARY** Offer. Your next kodak film roll developed, five cents. Prints from same, two cents each. Only one roll developed at this price for each customer, to show quality of our work. Moser & Son, A 29 Arcade, Cincinnati, O.

**PHOTO** Finishing. Reduction in cost of developing and printing. Roll films developed 8 cents. Film packs 12 cents per pack. Plates developed 2½ cents. Printing prints or post cards 2½ cents. Give me a trial, you will be pleased; samples and complete price list mailed upon request. R. A. Orman, Sac City, Iowa.

**BIG Money Saved on Photographic Lenses and Apparatus**—goods exchanged; repairing done. Ralph J. Golsen, 5125 Kenmore Ave., Chicago, Department F.

**WE buy, sell and exchange** Bargains in Microscopes, Telescopes, Binoculars, Cameras, etc. Bargain list sent. Kahn & Son, Opticians, No. 54 John St., New York. Established 62 years.

**DEVELOPING and Printing.** For people who want quality. 12c roll, 12 exposure rolls 25c. Prints 2 1/2 x 3 1/4 or smaller, 1c. Larger sizes, 3c. Full enlargements \$1. 11x14, \$1.50. If you have been disappointed with cheap local work, give me a trial. A. E. Andrews, South Haven, Mich.

**THE Camera** is the magazine you need in photography. Beautifully illustrated; contains the information you want. Prices for beginners and advanced workers. Five months' trial 50 cents. 220 North 13th St., Philadelphia.

**LET me finish your next roll of Kodak Film.** Send 10c for trial order, 80c for 100. 406 Main, Peoria, Ill.

**TWELVE prints, colored.** \$1. Negative, stamp, brings sample. A. (Shut-in) Gibson, 11 Sheldon, Chicago.

**FILMS developed, 10c;** prints, 3c to 5c. A reputable incorporated company conducting largest existing plant. Price list and special offer. Enlargements our specialty. Chicago Photo Engraving Co., 51 W. Lake St., Dept. A, Chicago.

**KODAK developing 10c,** by professional experts. Enlarging, hand painting, very cheap. Mellen Photo Works, Times Bldg., Chicago.

**KRUXO paper, 3x5, 35c gross;** 5x7, \$1.65, postpaid. Vindex Anastigmat Lens, 3x5, speed f-6.8, in barrel or Regio Shutter, \$16.95. A. E. Andrews, South Haven, Mich.

**ENLARGEMENTS—8x10, 25c.** Film developed, 10c. Prints, 2c to 7c. A. A. Kuback, 101 Cooper St., Brooklyn, N. Y.

**CAMERAS—Anastigmat lenses,** \$40 Colinear, \$21; \$62 Cooke, \$10; \$85 Zeiss, \$40; \$32 Ernemann Camera, \$15; \$115 Reflex, Goetz Lens, \$9; \$20 Kodak, \$11. Get lists. Newark Photo Supply Co., Newark, New Jersey.

**UNUSUAL trial offer for 10c.** Send one roll of film, any size, 6 or 12 exposure (or film pack); we will develop film or pack and make a total of 6 pictures from the best negatives for 10c (slaps). Beautiful 10-inch mounted enlargements 25c. Price list and sample print free upon request. Roanoke Cycle Company, Roanoke, Va.

**FILMS developed 10c,** all sizes. Prints 2 1/2 x 3 1/4, 3c; 2 1/2 x 3 1/4, 3 1/2 x 3 1/4, 3 3/4 x 4 1/4, 4c; Post Cards, 50c doz. Work guaranteed and returned 24 hours after receiving. Postpaid. Send negatives for samples. Girard's Commercial Photo Shop, Holyoke, Mass.

**SAVE 40% on Photo Paper from factory.** Prepaid. "Instanto" has a sparkling quality no other gaslight paper possesses, quick printing develops easy. Money back guarantee. Send 25c for 3 dozen postals or 4x6 size, price list and full directions. Photo Products Co., Dept. J, 6108 La Salle St., Chicago.

#### MOTION PICTURES

**\$35 PROFIT Nightly—Moving Picture Business—small capital starts you,** no experience needed. Teach you—furnish everything. Ralph J. Golsen, 5125 Kenmore Ave., Chicago, Dept. M.

**SPOT cash paid for second-hand high-grade Motion-Picture Cameras, Lenses, etc.** Write us today. David Stern Co., 1047 W. Madison St., Chicago, Ill.

**WRITE Moving Picture Plays;** constant demand; big prices paid; past experience or literary ability unnecessary; details free. Giese Co., 215 Whitman St., Cincinnati, Ohio.

**MAKE big money writing moving picture plays.** Previous experience, literary talent or correspondence course unnecessary. Free details and special offer. E-Z Scenario Co., 609 West 125th St., New York.

**BIG Money Writing Moving-Picture Plays.** Constant demand. Correspondence course; literary ability unnecessary. Write for free booklet, "How to Write Moving-Picture Plays." Universal Publishing Co., 291 Fergus Falls, Minnesota.

**MAKE \$50.00 clear nightly.** We start you in the moving-picture business on the installment plan. No experience necessary. Write for free catalog. Monarch Film Service, Dept. P, Memphis, Tenn.

**PHOTO-Plays Wanted.** Big prices paid. We show you how. Details free. Rex Publishers, Box 175H, Chicago.

**MAKE a complete Motion Picture Camera and Projector from instructions** given in our book *Amateur Mechanics No. 4*. Full details given. Not hard to construct. Worlds of enjoyment taking and exhibiting subjects dear to the heart. Price of book only 25c postpaid. Popular Mechanics Book Dept., 6 N. Michigan Ave., Chicago.

**MOTION Picture Work—A large 618-page book** covering every phase of the moving picture, its production and its theatre. Indispensable for reference and instruction to the thousands of workers in the motion picture field. Price \$3, postpaid. Popular Mechanics Book Dept., 6 N. Michigan Ave., Chicago.

**WRITE Photoplays—Earn a big income.** Our book tells how. Details free. Enterprise Co., PM-3518 Loma Ave., Chicago.

**WRITE Moving-Picture Plays.** Good prices. Devote all or spare time. No correspondence school. Details free. Atlas Publishing Co., 394, Cincinnati.

#### BUSINESS OPPORTUNITIES

**INDEPENDENCE and fortune quickly** attained in the Manufacturing Mail Order business. I furnish Formulas, Manufacturing Processes and Trade Secrets in all lines. Sold under positive guarantee; 18 years' practical experience. Revision and improvement of Formulas and Processes—reduction of manufacturing cost—utilization of waste materials, etc., a specialty. Booklet, Formula List, and Valuable Information Free. W. L. Cummings, Ph. D., 127 Standard St., Syracuse, N. Y.

**OWN a business.** Co-operate with me earnings at home. Everything furnished. Don't worry about capital. Boyd H. Brown, Dept. K-11, Omaha, Neb.

**THE story of Fred Taylor's success,** who laid the foundation of a fortune in one year, through our unique Co-operative Realty plan, will be sent on request. If you desire to make big money and to your own boss, write today. Previous experience unnecessary. McDonnell, Dept. 317, 1426 You St., Washington, D. C.

**LEARN the real estate business.** Our complete instruction book teaches: listing, appraising, management, salesmanship, insurance, brokerage, advertising, renting agency, forms, etc. 121 subjects. Exceeds \$20.00 correspondence course. Buckeye cover 75c; silk cloth \$1.00, postpaid. Catalogue free. Realty Book Company, 5982 Euclid Ave., Cleveland, Ohio.

**LET the parcels post help you.** Add (\$15 to \$25 weekly) to your present salary or income. Start during spare time and build up a permanent mail-order business of your own. We show you how and help you make good. No canvassing. Experience unnecessary. The Parcels Post makes success doubly sure. Our new ideas and up-to-date plans bring the money. No so-called "Course of Instruction" to sell. We give that free. Write today. Address Pease Mfg. Co., Inc., Dept. A, 79 Broadway, Buffalo, N. Y.

**STOP! Here!** Let me start you in a home-business that will bring you money every day. Experience unnecessary. Spare time. No canvassing. I furnish everything. Send for proofs. Voorhies, Desk C. R., Omaha, Neb.

**SPOT cash paid for second-hand high-grade Cameras, Lenses, Kodaks, Motion-Picture Cameras, Microscopes, Binoculars, etc.** David Stern Co., 1047 W. Madison St., Chicago, Ill.

**ADVERTISERS, Mail Dealers.** Our 1915 Rate Book lists 2,000 Principal Publications, rates, circulation. Includes 30 Mail-Order Plans. Price 10c. Dearborn Advertising Agency, 210 Franklin Bldg., Chicago.

**MANUFACTURERS, Promoters and Patent Buyers** are invited to write us stating the line of invention in which they are interested, as we can supply their wants in any class of patents. Victor J. Isaacs & Co., 162 Ninth St., Washington, D. C.

**MAKE Money Repairing.** Particulars, stamp. Houlgate, 1019 Cypress, Pasadena, Calif.

**MONEY for everybody,** young, old. No soliciting. Not work, but fun. Endless chain. Gets the money just like finding it. Beautiful and useful premiums too. Some make \$20.00 weekly. Send no money. Just write. Dept. D, Box 12, Station C, Toledo, Ohio.

**50 FIRMS that buy names,** 10c. Aurora Mail Service Company, Dept. C3, Aurora, Illinois.

**20,000 FORMULAS,** 500p, \$1, 3,000 valuable formulas, 368p, 40c, 1,000 selected formulas, 110p, 25c. All three, \$1.50. Satisfaction guaranteed. "Ideal," 3311-P, Belleplaine Ave., Chicago.

**I NEED Branch Managers** for my worldwide mail-order business; operate from your own home in spare time; no canvassing or peddling; experience unnecessary; you should make \$30 weekly. Butler, 474 Factoris, Toledo, Ohio.

**WE will start you in the cleaning and dyeing business.** Big profits, little capital needed. Write for booklet. Ben-Voerde System, Dept. C, Charlotte, N. C.

**CAN handle good proposition.** What have you? Farrelhorn, Yonkers, N. Y.

**WE will show you without charge how** to start a profitable business. Send addressed envelope for instructions. Norman Co., 157 E. 47th St., New York.

**WE show men and women how to make** \$30 to \$100 weekly, year around. Amazing opportunity for large income. Why waste time working for others? Use your spare time at home and gain financial independence. No canvassing. Be your own master. Universal Success Co., Dept. 150, No. 70 Fifth Ave., New York City.

**JUST what you have been looking for** (Liquid Celluloid). Simply d.p. article and have genuine celluloid finish. Sample can 25c. Elk C. P. Co., Inc., P. O. Box 53, Bergen Station, Jersey City, N. J.

**CONDUCT a "Handy Kitchen"**—Clear \$10 daily; practically no capital required; booklet free. The Kennon School, 142 W. Ontario St., Dept. A, Chicago.

**FREE Book** telling how to obtain Government Positions, Contracts, Patents; also reliable and official information on Congressional and Departmental Matters, or any subject, as aid to men of every profession or occupation. Send today. Washington Bureau of Information, 612 14th St., Washington, D. C.

**MONEY in making barley crisp.** Fine confection, 5c package cost 1c. Machine, instructions complete, \$7.50 prepaid. Samples 10c. Particulars free. Mohler, Monon Bldg., Chicago.

**ADD our leaders—receive benefits** from advertising National Advertisers. Everything furnished. Two 20c samples, 10c. Particulars free. Stanford Company, Sebring, Ohio.

**WE start you in business, furnishing** everything; men and women, \$20.00 to \$200.00 weekly operating our "New System Specialty Candy Factories" home or small room anywhere; no canvassing. Opportunity lifetime; booklet free. W. Ragsdale Co., East Orange, N. J.

**RESILVERING Mirrors;** guaranteed process; 150 formulas, 20c. "Ideal," 3311-P, Belleplaine Ave., Chicago.

**OPERATE Mail-Order Book Business.** Easiest, best paying line in Mail Order Field; everything furnished; folders, wholesale price lists, free. Rollins, Box 5272, Boston.

**LEARN to collect money.** Good income; quick results. Send for free booklet, "Skillful Collecting." Collectors' Association, Long Street, Newark, Ohio.

**"HIRE Yourself as Boss."** Big corporation will back you in Money-Making Mail-Order Business selling guaranteed Goods. Start spare time. Small capital. No canvassing. Wm. J. Dick, Mgr., Dept. C-10, 20 W. Lake St., Chicago.

**MAKE More Money—24 valuable formulas** and 100 business opportunities sent for 25c. Badger Sales Co., Box 305-A, Wausau, Wis.

**"GOOD Results"**—Greatest Mail Order Agents' Magazine. Published—Bar None! Helps others make money in Mail Order business—can and should help you, too! 2 Big Issues 10c. Good Results, 156M Washington, Chicago.

**I PUBLISH a wonderful magazine** of money making plans, ideas, suggestions and inspiration! It will show you how to make more money. Sample, 10c. Editor, Booster Magazine, Northwestern Bldg., Chicago.

**GET rich profits in business of your own.** Big Kansas company offers fast selling Mail Order line; factory prices. Brand new unique Selling Plans free to workers. Start spare time in your own home if desired. No capital. No canvassing. Legitimate, honorable, big paying business. Copyrighted Prospectus free. Write Eystone, 111 W. 7th, Pittsburg, Kans.

**\$500 WEEKLY** my income from Collection Business (by mail), started two years ago. Independent managers, district managers and collectors wanted everywhere. Booklet "My System" free. Geo. Macomber, Box 189, Washington, D. C.

USE your spare time to build up a mail order business of your own. We help you start for a share in profits. 27 opportunities. Particulars free. Opportunities Exchange, Buffalo, N. Y.

BIG money made installing alarm clock apparatus to control drafts on steam, hot water, hot air and natural gas heating outfits. Warm house in the morning. Use your own clock. Price, \$2.90. Altray Mfg. Co., 1234 Harvard, Washington, D. C.

WONDERFUL Investment Opportunities in Texas. The Lone Star Magazine gives the facts. Write for free sample copy. E. O. Glenn, publisher, Union Bank Bldg., Houston, Texas.

YOU can earn \$10 per hour cutting silhouettes. Our system teaches you quickly. Graduates travel, see the world and make enormous profits. Postal helps information. The Thomsen System, Chicago, Ill.

CANDY making a profitable and pleasing trade. Be your own employer. Our Candy Book tells how. 25c. Auburn Supply Co., Dept. 11C, 1817 Peoria St., Chicago.

BRYAN Plastographed—plasterography instructions with formulas enable you to make life busts of your friends, portraying more delicate lines and shadows than photos or paintings. With it free mold of President Wilson, Lincoln or Victor Emmanuel. Very profitable work, easily learned. Price, \$1. School Plaques made to order. P. P. Spahr, York, Pa.

MARKET your spare time; commercial information wanted; high grade opportunity; confidential; good pay. Free particulars. "Cleo," Pmc, Evansville, Indiana.

CONNECT Land Buyers and Sellers by mail. Dunning System easily operated. Highly profitable. Complete, \$2. Particulars free. Dunning Co., Windsor, N. C.

"DOLLARS" yearly in your back yard. No ginseng, mushroom dope. New ideas never before published, particulars free. Metz, M. 313 East 89th St., New York.

RESILVER Mirrors. Full instructions, 25c. H. E. Allen, Garden Grove, Ia.

MIRROR resilvering is a paying trade. We have best instructions 25c. Auburn Supply Co., Dept. 11K, 1817 Peoria St., Chicago.

TWELVE years ago I started a small mail order business at home in spare time with a few dollars capital. I wanted to make \$30 or \$40 a month, evenings. The net profits the first year averaged \$200 a week. Five years' work netted me \$50,000. I will show you how to start a small mail order business. Send today for my proposition. It's interesting. No canvassing. Heacock, Box 867, Lockport, N. Y.

INCREASE Your Income—Operate a Mail-Order Business; we show you how. 12 New Plans Free. Bamberg's Supply House, 2231 South Albany, Chicago.

Men and women for easy business. No interference with present position. Good money. Free information. F. Leonard Eager, Waterbury, Conn.

PHOTO-Plays Wanted. Big prices paid. We show you how. Details free. Rex Publishers, Box 1753, Chicago.

\$25,000—I MADE it in mail-order business. Had \$3 to start. I'll loan you \$3. Free Booklet tells how. Alb Scott, Cohoes, N. Y.

100 BUSINESS-BUILDING Ideas, Plans, Trade Secrets, Formulas, etc., only 10c. Coyne Supply Co., 2841 Warren Ave., Chicago.

DISTRICT Managers Wanted to handle territory. Must finance orders—Kor-Ker Puncture Cure. The Standard adds 50% to tire mileage. Not a filler. Preserves the tire. Highest testimonials furnished. Proposition unusually good. Secure territory at once. Alamo Mfg. Co., 14 Bridge St., Newark, N. J.

LEARN Lettering and Show-Card Writing at home. Pays well. Write for particulars. Milwaukee School of Lettering, Milwaukee, Wis.

I WILL start you earning \$4 daily at home, silvering mirrors; free instructive booklet. G. F. Redmond, Dept. 306, Boston, Mass.

BARGAINS! Bargains! Send for free magazine, 1,200 bargains, Farm lands, business chances; any kind, anywhere. Our services free to buyers. Western Sales Agency, Menapoli's, Minn.

MEN—A business of your own; no canvassing, experience or capital needed. Information free. Address, The A. & S. Repair Shop, 149 Norman Ave., Desk K, Brooklyn, N. Y.

RUBBER Stamps—Make them yourself, new process, twenty-five cents coin. Be independent, large profits. Guy Sears, Ashland, Ohio.

BIG Money in Extracts. Send \$1 for oil and formula which will make 27 ounces Orange Extract. W. N. Durant, Orange Grower, Covina, California.

MISTAKES are expensive—We have indispensable information for anyone in or about to start in the Mail Order Business. Be sure to investigate this before taking up any Mail Order Proposition. Premium Sales Co., 4890 Lincoln Ave., Chicago.

OPERATE Hahn's Premium Machine. The best seller for cigars and candy. J. Hahn, 1016 Germantown Ave., Phila.

MEN—If you want to make more money send 50c for plans. Thos. Morrow, Tyrone, Pa.

WANT Big Profits? Learn Tartaric Mirror Silvering. New process opens enormously profitable business. Particulars free. H. Barstow, 514 23rd Street, Oakland, Calif.

INVENTORS: We develop and perfect inventions, make models, dies, tools, Metal stamping and special manufacturing. Gerding Bros., Lion Bldg., Cincinnati, O.

START in the Carpet or Clothes Cleaning Business Now. Thurman Vacuum Process unequalled for commercial cleaning. We show you how. Easily learned. Only \$125 capital needed to earn good income in towns of 2,000 and over. Write today. Thurman Vacuum Cleaner Co., manufacturers all types Vacuum Cleaners, Dept. H, St. Louis, U. S. A.

SAN-O-TEX, sanitary, fireproof floors for kitchens, pantries, theatres, hospitals, etc. Learn how to mix and spread and have an income of \$150 to \$300 monthly from kitchen floors alone. Instructions \$3. San-o-tex Company, Mechanic Street, Washington, Indiana.

MAKE Big Money Opening Safes and Setting Combinations. Wayne Strong, Box 1430, Los Angeles, Cal.

WOULD you like to own a good-paying Mail-Order Business? We have a line that gets repeat orders all the time. You can start in spare time; invest a dollar or two a week and soon own a nice business of your own. Particulars free. Nadico, 4313 Lincoln Ave., Chicago.

PATENTABLE Ideas wanted—Send for 3 free books. R. B. Owen, 30 Owen Bldg., Washington, D. C.

WRITE Moving-Picture Plays. Good prices. Devote all or spare time. No correspondence school. Details free. Atlas Publishing Co., 3046, Cincinnati.

HOW to Operate a Mail Order Business. 30 Big Profit Plans and year's Mailing service sent for 10c. Mail Dealers' Wholesale House, 521 Franklin Bldg., Chicago.

BE Wise. Don't experiment in mail order. I can tell you how to succeed. B. Newham, Waukegan, Ill.

I WANT to send you proof of the wonderful pulling power of Popular Mechanics classified pages. What's your proposition? Write me today. F. W. Johnson, Classified Dept., Popular Mechanics Magazine, 6 N. Michigan Ave., Chicago.

#### INVESTMENTS

10 CENTS buys \$100 mortgage. Part of first mortgage on real estate in San Francisco or country, California, paying 6% per annum interest. Guaranteed by oldest, largest mortgage and guaranty company on Pacific Coast. Payments of only 10 cents day. Your interest begins with first payment of \$3. For interesting particulars, Howard H. Hogan, 785 Market St., San Francisco.

#### BUSINESS FOR SALE

EQUIPPED brass foundry for sale—equipped brass foundry located at 145 Chandler Street, Buffalo, New York. Former Black Rock Brass & Bronze Company. For further particulars, address, M. L. Donner, 145 Chandler Street, Buffalo, New York.

#### TO MANUFACTURERS

MANUFACTURERS. We want specialties to sell through agents. Useful articles. Give price, terms, details. Mohler, Monon Bldg., Chicago.

WANTED—Some one to manufacture Ford feature on royalty. G. Duffoth, Onaka, S. Dak.

#### MAIL ORDER SUPPLIES

INCREASE your sales. Place your proposition before the readers of "Cartoons Magazine." 20,000 copies guaranteed every month. Classified rate 2c per word. Mail to a trial ad today. Cartoons Classified Dept., 78 E. Madison St., Chicago.

#### FOR ADVERTISERS

YOUR fifteen-word adv. in our 9x12 magazine reaching 20,000 boys for 25c. Extra words 1c each. Youths' Magazine, 2180 Mailers Bldg., Chicago.

ADVERTISE! Twenty words in 100 monthlies, \$1. Sample Magazine Free. Stanford Agency, Sebring, Ohio.

BARGAIN—20-word ad, one insertion, 35,000 circulation and one year subscription, 25c; extra words, 1c. Digest, Grand Rapids, Mich.

YOUR advertisements placed in 36 different magazines for 3c per word; displayed, \$1.80 per inch; three times for price of two. List, particulars free. King's Magazine, Box 13-P, Little Silver, N. J.

#### LETTER SPECIALISTS

"LETTERS That Landed Orders"—10 cents. What was said and why—a full campaign, illustrations and all. How you can do it. A new book by Van. Introductory offer. Costs \$2 a year. Send a dime to "Van" today, 160 Jackson Blvd., Chicago.

#### AGENTS WANTED

LOOKING for just a job, or a large income? We have all the essentials for success; 1st, a monopoly; 2nd, a necessity to 95 in every 100 men, women and children; excites curiosity, creates desire; 3rd, you can sell wholesale and retail. The poor shoe string used today will never be used again. People will demand the Wonder Lace, your income will increase by leaps and bounds. Wholesalers, individuals won't require urging; they want it on sight and know it. Endorsed by leading shoe dealers. Slight delay owing to shortage skilled mechanics but machines will be completed in a few days. So get in quick for big money. Twenty-five cents for sample set. Address The Wonder Shoe Lace Co., 181 50 Church St., N. Y. City.

\$1,000 PER Man per County. Strange invention startles world—agents amazed. Ten inexperienced men divide \$40,000. Korstad, a farmer, did \$2,200 in 14 days. Schleicher, a minister, \$195 first 12 hours. \$1,200 cold cash made, paid, banked by Stoneman in 39 days; \$15,000 to date. A hot or cold running water bath equipment for any home at only \$6.50. Self-heating. No plumbing or waterworks required. Investigate. Exclusive sale. Credit given. Send no money. Write letter or postal today. Allen Mfg. Co., 4137 Allen Bldg., Toledo, Ohio.

AGENTS Wanted—No matter who you are, or where you live, or what you do, right now before you turn the page, before you do another thing, send us your name and address so we can send you free our beautiful, heavy sample book, crowded with wonderful bargains in men's made to measure clothes, all the latest fables, advance styles, inside prices, measuring chart and everything needed to make \$5.00 to \$10.00 an hour in your spare time. Special offer on your own suit to advertise us. Don't miss this. We pay express and guarantee satisfaction. Send a postal now. American Woolen Mills Co., Dept. 1114, Chicago.

YOU can make \$888 as our general or local agent. Household necessity; saves 89 per cent; permanent business; exclusive territory; salary or commission; free sample; credit. J. Pitkin, 113 Redd St., Newark, N. Y.

FIND out how easy it is to make big money taking orders for brushes needed in every home. Our representatives are averaging \$15 to \$50 a week. We have a few open territories. Write, naming county wanted. J. I. Holcomb Brush Mfg. Co., 5119 Draper, Indianapolis.

MEDALLIONS—300% profit. Make up your own goods and be independent. Catalogue free. Resag Co., 1265 Randolph St., Chicago.

WANTED—A live man in every locality to sell the best and most widely used, nationally advertised Shock Absorber—the C-C. Has everything in its favor, even the price. Every car owner needs them—every one can afford them, and you get good commission on each sale. Cox Brass Mfg. Co., Albany, N. Y.

**MEN and Women Agents:** Money talks—how much are you making? If you are earning less than \$200 a month, no matter what your locality, you will positively be delighted with our Sentinel Buglar Alarm proposition. Many agents easily earn \$15.00 daily. Brand new invention. Sells quickly on sight to homes, offices. Patented. No competition. Free exclusive territory. Instantly attached any door knob. Impossible turn knob without ringing bell. No batteries, screws, nails. Handsomely nickel-plated. Retail \$1.00. Provides cheap burglar insurance. It's a big money maker. Let us prove why. If you mean business write today for liberal terms to agents. Marshall Dotbbs & Co., Manufacturers, 1422 Marquette Bldg., Chicago.

**TAILORING Agents Wanted.** If \$10 to \$50 a week for your spare time interests you, write us quick for beautiful new sample outfit, 60 lofty fabrics, 32 swell styles, wholesale prices, measuring chart, tape line, etc., all free to you by return parcel post. We pay express charges and guarantee satisfaction on all our clothes. Your own suit special to show your friends, made to your measure and the finest you ever saw; new, lofty, stylish and first-class in every way. Write us quick. Even if you can't be our agent, get our proposition on a suit for yourself. Paragon Tailoring Company, Box 1113, Chicago.

**50% PROFIT** selling our wonderful sign letters for office windows, store fronts and glass signs; resembles finest gold leaf; easily applied; samples free. Metallic Letter Co., 106 N. Clark St., Chicago.

**GET** into your own business. Cut loose from lay-offs, short hours and wage-slavery. Our catchy soap and toilet combinations have put thousands on Prosperity Road. Tremendous saving to consumer—20% profit for you. Send postal quick for details. E. M. Davis Co., 264 Davis Bldg., Chicago.

**THE Wife's Friend—Portable Oil Gas Stove.** No valves, wicks, wood, coal or ashes. Steady, intense heat; will boil, bake, fry, roast, cook anything; heat rooms, stores, etc. Simple, durable, saves time, labor, money. "Much cheaper, quicker, cleaner than wood or coal."—S. Ludwig, Ill. "Safe and clean as a lamp."—Mrs. A. R. McClellan, Ill. "Baked pies, cakes and bread; never saw nicer baking done."—Mrs. O. Thompson, O. Agents making money. R. L. Heusted, Mich.: "Out one day, sold 11 stoves." R. P. Adams, Ia., ordered 2 stoves, then 12. C. P. Schroeder, Conn., 40 stoves one order. Price, \$3.25 up. Not sold in stores. Show cylinder making gas—people stop, look, get interested—buy. Send postal. World Mfg. Co., 6397 World Bldg., Cincinnati, O.

**AGENTS** make \$100 monthly selling our 300 handy household articles. Catalogue free. Scheff Company, DesPlaines, Ill.

**YOU** can be your own boss with our Key Check Outfit. Good for \$5 a day stamping names on pocket key checks, fobs, etc. Sample check with your name and address, 15 cents. Pease Die Works, Dept. M, Winchester, N. H.

**PORTRAIT Agents:** Our goods will make you big profits. Delivery guaranteed. Receipts credited. Prompt shipments. Low prices. Send for latest catalogue and prices. Adam J. Kroll & Co., 692 Blue Island Ave., Chicago, Ill.

**AGENTS** make big money. The best line of food flavors, perfumes, soaps and toilet preparations, etc., ever offered. Over 250 light-weight, popular-priced, quick-selling necessities—in big demand—well advertised—easy sellers—big repeaters—100% profit. Complete outfits furnished free to workers. Just a postal today. American Products Co., 3133 American Bldg., Cincinnati, O.

**WE** Will Pay Expenses and Salary or Commission—introducing King Hunter Separator. Produces finest butter from cream or milk, sweet or sour, in 5 minutes. Retail \$5 up. Write for free sample and salary proposition. De King Mfg. Co., Dept. 13R, Chicago, Ill.

**AGENTS—\$50.00 weekly.** The only knife-sharpener made on correct principles. Wonderful seller, 120 to 300% profit. Simply demonstrate. No talking. General agents, \$150.00 week. Particulars free. 30c sample by mail, 25c. Thiele Co., 5 Austin Ave., Chicago.

**SOMETHING** New, sanitary shirt buttons, scarfpins, samples and particulars, 15c. Jordan, 117 E. Ohio, Chicago, Ill.

**WE** want agents in the small towns and surrounding territories to introduce our gasoline lamps and mantles. Big money for the man who can sell. For catalogue and full particulars, address: Grand Rapids Novelty Co., 538 Woodlawn St., Grand Rapids, Mich.

**AGENTS: New, Mighty, Money-Making Marvel;** strange; scientific discovery; world startled; all clothes-washing ideas revolutionized. Positively abolishes drudgery, rubbing, wash-boards, washing machines, etc. \$1,000 guarantee absolutely harmless; \$50,000 corporation inventors and Mfrs. Nature's mighty elements work wonders; women astounded; wild over it, Franklin, Idaho, realized \$345 in 30 days; exclusive territory; no experience necessary; credit granted; own a fascinating repeat-order business; pocket big profits; hurry! Write today, get overwhelming proof; all free. Equitable Corporation, Dept. 331, 215 W. Superior, Chicago.

**STOP** Here! Let me start you in a home business that will bring you money every day. Experience unnecessary. Spare time. No canvassing. I furnish everything. Send for proofs. Voorhies, Desk C. R., Omaha, Neb.

**I** NEED Branch Managers for my world-wide mail-order business; operate from your own home in spare time; no canvassing or peddling; experience unnecessary; you should make \$50 weekly. Butler, 773 Factories, Toledo, Ohio.

**AGENTS:** Here's a live one. A real live household necessity. Easy to sell. Offers splendid profit. Every customer satisfied—experience not necessary. Don't wait—write us at once for our attractive proposition. O. K. Mfg. Co., 1519 Sedgwick St., Chicago.

**POSTCARDS** 90c per 1,000 up. Our sample line 300 High-Grade Art. Birthday, Greetings, Lovers, Hallowsen, Thanksgiving, Christmas, New Year's, delivered, \$1.00. Particulars free. Green Onard Co., 2147 Arthur Ave., New York.

**AGENTS** Coin Money selling Repeat tube flavoring extracts and toilet preparations. Quick sales. You give premiums Free with every purchase. Outfit Free. Kittredge Co., 19 South, Tunkhannock, Penna.

**AGENTS** are coining money selling our big 10c Packages of 20 Assorted Postal Cards, "5,000 Varieties." "Big Profits." Sell everywhere at sight. Sample Packages 10c. Particulars Free. Sullivan Card Co., 1234 Van Buren St., Chicago, Ill.

**KEROSENE** Gas Burners in Cook Stoves or Ranges stop use of wood or coal. Recently patented. Money-Maker for Agents. The Vapor-Gas Burner Co., Desk 8, Columbus, Ohio.

**AGENTS:** Every woman buys our Triplex Hand Bag. They can't resist. \$50 weekly easily. Aikman, 106 N. La Salle St., Chicago.

**AGENTS—\$10** daily and more earned by everybody undertaking an easy agency as an extra; expert knowledge unnecessary. Write Mr. Brouwers, 43 Welmarstr, Den Haag, Netherlands. (Postage 5c.)

**SELL** Dry Goods Remnants. Greatest bargains on earth. Remnant Store Co., Cincinnati, Ohio.

**GOVERNMENT** Clerks—Men and Women—wanted, \$75 month. Many positions obtainable. Write immediately for list. Franklin Institute, Dept. C-22, Rochester, N. Y.

**AGENTS—Just** out. New Dollar Winner. "Wilson" One Hand Speed Wrench. Machinists, autoists, farmers, everybody, buys at sight. 100% profit. Make \$30 to \$50 weekly. Toledo Speed Wrench Co., Dept. 11, Toledo, Ohio.

**\$61.50 WEEKLY** introducing and selling a new gas light burner for kerosene lamps. Beautiful light. No chimney. No mantle. Perfectly safe. Simple in construction. Nothing to get broken or out of order. Will not burn out. Durable. Will last for years. Low price. Easy to sell. 200 per cent profit. Experience not necessary. Sample free. Why not try one on your lamp? Beware of imitations. No branch offices. Luther Manufacturing Co., Dept. 110, Cincinnati, Ohio.

**WANTED—Sales** Agent every state. Call on factories and machine shops. Big seller. Write for proposition. Waterbury Pressed Metal Co., Waterbury, Conn.

**AGENTS,** slide line men—investigate our new specialty. Sells on sight to merchants. Weights 2 oz.; costs \$2.00. Fine repeater. Build permanent business at home or travel. Sample free to producers. Specialty Sales Co., 833 Real Estate Trust Bldg., Philadelphia.

**AGENTS.** Money making, useful, fast selling goods. If you want to make money ask for free sample. Mohler, Monon Bldg., Chicago.

**AGENTS:** Make \$50 weekly selling \$10 Starter and \$1.75 E. Z. Steerer for Ford Cars. Write Geo. H. Wilson, 1400 Northwestern Bldg., Minneapolis, Minn.

**AGENTS: Kleanol Sanitary Wire Twisted** Brushes pay big profits; new low prices; freight paid and delivery guaranteed; quick service; exclusive territory; profit-sharing; full line fast sellers; oldest, largest wire brush makers. Kleanol Brush Company, Inc., Dept. J, Springfield, Mass.

**I** HAVE a money maker for responsible agents. Address Carl Milstead, Chatsworth, Ill.

**YOU** can make big profits selling our Pure Aluminum Kitchen Utensils—Guaranteed for 20 years. Our specialties are not sold in stores, and they get the business for you. \$200,000 firm and liberal credit plan backs you. We have an attractive General Agency offer. Wm. J. Dick, Manager, Dept. C-21, 20 W. Lake St., Chicago.

**AGENT** Wanted in each county to handle our line of quick-selling household specialties. Exclusive territory. Huenfeldt Mosler Co., 4224 Normandy Ave., Madisonville, O.

**DON'T** be an Agent—You take the money; be your own master. Doro Crawford, W. Va., writes: "Made \$42.75 first week." Smith, Pa., writes: "301 in two weeks." Bostwick, N. Y.: "Make an average of \$10 a day." We have started hundreds of others. Gray's outfits \$15 and up. Plate Gold, Silver, Nickel, Metal, etc. We furnish recipes, formulas, trade secrets and teach you the art; work easy. Royal new dipping process. Every family, hotel, restaurant, shop has tableware, jewelry, metal goods of all kinds to be replated. Every other business overcrowded, few plating shops. Send postal, free sample plating. Gray & Co. Plating Works, 213 Gray Bldg., Cincinnati, O.

**AGENTS—Newest,** Patented, most legitimate article marketed. Ideal for agents, mail-order dealers; enormous profits, unusual opportunity. Sample prepaid 15c. Free Particulars. Dorsa Novelty Co., 560 2nd Ave., N. Y.

**AGENTS—Air** Cell Washing Machine. New, marvelous invention. Exceeds work of washers costing \$25.00 and up. Sells only \$1.00. No wonder every home buys. Exclusive territory free. Nearly 200% profit. Write today. Air Cell Washer Co., 3037 Detroit Ave., Toledo, Ohio.

**NEW** Novel Invention. Sells on sight. \$18 a day. Act quick. The Kitchen Specialty Mfg. Co., Reading, Pa.

**AGENTS—Best** selling household article. Large demand. Profit \$25—\$50 weekly. Write today. M. H. Specialty Co., Bayonne, N. J.

**DON'T** hesitate—Get our new catalogue; contains Six Corking Propositions. Each a winner. Berg & Beard, Inc., 61 Fleet Place, Brooklyn, N. Y.

**\$60 WEEKLY** to deliver "KeroSafe" Lamp. Burns common coal oil. (Kerosene.) 300 candle power—low priced. Portable light. Costs one-third cent per hour to operate. Every home needs one. Big profits for agents. No experience needed. No capital required. Credit given. Hinkson sold 28 first week, West, 3 first night. Write today for terms of free sample. Thomas Mfg. Co., 1162 West St., Dayton, O.

**BIGGEST** money-maker out. Newly invented "Linefinder and Copy Holder" for stenographers. Greatest time saver. Exclusive territory. Linguist Mfg. Co., 160 N. 5th Ave., Chicago.

**FREE** samples of Delbare's Naphtha Washing Tablets sent to men and women agents. Make 100% profit. Easiest seller out. Sure repeater. Naphtha Washing Tablet Co., 714 So. Dearborn, Chicago, Ill.

**AGENTS!** Earn big commissions selling \$20 value all-wool made-to-measure suits for \$10 retail. No experience necessary. Chicago Woolen Mills, Dept. 100, 833 Jackson Blvd., Chicago.

**200% PROFIT.** You can't beat it. Sells everywhere. Free pocket sample. Our goods get the orders. Wm. J. Dick, Mgr., Dept. C-4, 20 W. Lake St., Chicago.

**AGENTS** Wanted—Agents make 500 per cent profit selling "Novelty Sign Cards." Merchants buy 10 to 100 on sight. 800 varieties. Catalogue free. Sullivan Co., 1234 Van Buren St., Chicago, Ill.

**CANVASSERS** Magazine, monthly; live, progressive, interesting Agents' Magazine; illustrates newly patented specialties, exposes "fakes," tells how to buy direct from manufacturers, and hundred other things canvassers should know. Yearly subscription, \$1.00; special rate, 3 months, 15c. (None free.) Canvassers Magazine, Dept. D-1, South Whitley, Ind.

**AGENTS:** \$50 weekly, selling our Automobile Specialties. New, live, quick sellers. Every car owner needs them. Get busy. Write now. Progressive Mfg. Co., Dept. P, Reading, Pa.



**AGENTS**—Average \$5 to \$12 daily selling astonishing Astec massage machine. New, just patented. Different. No electricity or water power required. Nothing complicated. Affects exhilarating massage without cent expense. Lowest priced, but best outfit. Retail \$2.50 allowing you big end of the profit. Particulars and "beauty" folder free. Astec Remedy Co., Dept. 132, Toledo, Ohio.

**AGENTS**—Make Money Quick—Sure—Easy. Brand New, Low-Priced Self-Heating Iron, 100% profit. Every home a possible customer. Sell only two a day—your profit \$27 a week. Send Postal today for money-making plans and full particulars. Address C. Brown Mfg. Co., 4797 Brown Bldg., Cincinnati, O.

**PLASTER**—One-Minute-Puncture-Repair Device, Patented, Guaranteed. Great demand. Derrick, Monroe Bldg., Chicago.

**PHOTO** Pillow Tops, Portraits, Frames, Sheet Pictures, Photo Plates, Pennants, Rejects credited. Prompt Shipments; samples and catalogue free to agents. 30 days' credit. Jas. C. Bailey Co., Desk R-3, Chicago.

**AGENTS**—Get particulars of one of the best paying propositions ever put on the market. Something no one else sells. Make \$4,000 yearly. Address E. M. Feltman, Sales Mgr., 3134 Third St., Cincinnati, O.

**AGENTS** make \$30 weekly selling household specialties. McPheters, Inc., took 62 orders in one hour. Send 42c for samples. Western Specialty Co., 1360 14th St., San Diego, Cal.

**AGENTS**—Make \$30 to \$50 weekly selling our 300 c.c. power gasoline table and hanging lamp for homes, stores, halls, churches; no wick, no chimney, no mantle trouble; cost 1c per night; exclusive territory; we loan you sample. Sunshine Safety Lamp Company, 125 Factory Bldg., Kansas City, Mo.

**OWN** your own business. Make \$500 monthly, carry no stock, just sample. S. O. S. Electric Pliers, new, powerful, making agents rich. Write quick for big special proposition. Commonwealth Mfg. Co., 460 Illinois, St. Louis, Mo.

**AGENTS**—Coin money selling self-filling fountain pens for \$1; 15% profit; sell on sight. Sample 25 cents, coin. W. Hurley, Inc., 312, L. Supoc, Cal. Gen. A.

**AGENTS**—Best Plate Pictures. Sell on sight for \$1. 5% commission. Send photograph and 5c for agents' sample. The H. H. Mfg. Co., Grayville, Ill.

**LISTEN!** Can you sell gasoline at one cent per gallon? If so, sell "Gasotone." Gives 40% more gasoline mileage; eliminates carbon. Auto owners grabbing for it, \$10 a day easy. Heats made \$25 first day. Act quick, man. Details free. White Mfg. Co., Dept. 112-B, Cincinnati, O.

**WINTER** Till Christmas. Everlasting Plants in Brass Jardinières. Sample 2c, prepaid. Redolph, Manufacturer, 403 Northwestern Building, Chicago.

**GET** rich profits in business of your own. Big Kansas company offers fast selling Mail Order line; factory prices. Brand new, unique Selling Plans free to workers. Start spare time in your own home if desired. No capital. No commission. Legitimate, honorable, big paying business. Copyrighted Prospectus free. Write Eye-stone, 110 W. 7th, Pittsburg, Kans.

**AGENTS** make big money taking orders for business and calling cards; outfit and agent's instructions free. Welfer, Co., Jackson, Mich.

**AGENTS**—Can make \$108 per week selling a new device called Help-a-Phone; every telephone user needs one; information free. Echo Supply Co., Echo, Minn.

**AGENTS**—Send for sample "Fretnot"—the wash day wonder. Be convinced you can do a whirlwind business. You can clear at least \$20 to \$100 weekly, according to spare or whole time. You don't have to talk, if she doesn't buy at sight, leave sample, she will be looking for you long before you are able to make the rounds again. Samples furnished free. Frem uns for your customers. Exclusive territory granted to agents who can produce. Credit given. Don't call. P. M. Motter & Sons, 3713 Warren Ave., Chicago.

**DEPARTMENT** stores, jobber agents making money selling our high-grade magnifying glasses. Send for circular. Christian Schleker Mfg. Co., 12 Bloomingdale Street, Rochester, N. Y.

**AGENTS**—Men and women, newest invention. Wing Self Heating Flat Iron; guaranteed, sells everywhere. Women delighted. Write for particulars. Wing Mfg. Co., 1698 Fulton St., Chicago.

**YOU** can make more money employing agents than by being one yourself. We show you how. We only make money when you make money. Write for particulars. Mumford & Larson, 336 Walker Building, Salt Lake City, Utah.

**WONDERFUL** invention—cooking and heating stove burner. Gas from coal oil and air. Free territory. Big profits. Illustrated catalogue. Economy Manufacturing Co., St. Louis, Mo.

**\$30 WEEKLY.** Slot machine substitutes. Unlimited possibilities. Sample 50c. Particulars free. Mann Company, 1107A Independence Blvd., Chicago.

**"STEAM-NO-MORE"** for eye glasses. Everyone who wears glasses buys. Live agents 20% profit. Send 10 cents for 25c sample. Gray's Sales Agency, Port Huron, Mich.

**WARD** off poverty. Send 25c for How to Get Rich and 20 other books, postpaid straight to you. Ward Pub. Co., Box 433, Chicago.

**AGENTS**—Hard soldering made easy. Easily sold to jewelers, braziers, manufacturers, etc. Big profits. Special offer, N. R. Moore, Vander B, Pa.

**MAKE** \$5 to \$10 daily selling hosiery, underwear, sweaters. Everybody needs them. Many years our incomparable goods have pleased thousands. Permanent business. Exclusive territory. Agents wanted Iowa, Nebraska, Colorado. Write quick. Hunt, 123 10th Street, Denver.

**SELL** Christmas Packages! Everybody buys them. 20% profit. \$10 day easy. Send dime for samples and particulars. Get busy now. International Distributing House, 5338 Laffin, Chicago.

**NEWEST** wonder of the age! Silveron, the polish that silver-plates. Actually rubs on sterling silver. Used everywhere. Sells on sight. Repeat orders. Big profits. Protection. Send 10c for sample and introductory offer. Carisa, 137 Cedar, New York, Dept. C.

**AGENTS** wanted to sell Non-Alcoholic Food Flavors, Perfumes, Toilet Articles, Soaps, Soft Drink Extracts, Household Necessities. 8% saving to consumer. Big Profits to Agent. Sample free. Credit given. Arthur N. Christy & Co., Dept. 8, Newark, New York.

**AGENTS**—Here's a brand new article, just ready for market. Make over 100% profit, with satisfied customers. Every mechanic needs one, sells quickly on sight; no competition. Our proposition is a winner. Don't wait. Write for it now. The Security Aluminum Rule Pocket Co., Irwin, Calif.

**AGENTS**—We've had 100% sales on "Midget" American Flags—1/16 inch size. Enamelled in colors. Made in screw-barks. Sold Gold, \$4 dozen; \$36 gross. Sells for 50c. Gold-Plated, \$1.50 dozen; \$15 gross. Sells for 25c. Sample 10c. Philadelphia Badge Co., 172 N. 8th St., Philadelphia, Pa.

**WANTED**—Reliable Men and Women to place our Egg-ne in stores and appoint sub-agents. Takes the place of eggs in baking and cooking at less than 9c a dozen. Chas. Morrissy Co., 4402-5 Madison St., Chicago.

**ACCEPT** no agency until getting offer on Ho-Ho-Co Skin and Scalp Soap and Toilet Articles. Our plan new and different. Territory limited; write today. Roche, 299 N. 2nd, St. Louis.

**AGENTS**—Both sexes; brand new household article, 100% profit. Clark, Illinois, made \$11.50 clear profit first 2 days out. Sample Free. Vivaco Co., 3179 Broadway, Chicago.

**"RITE-TONE"** Attachments for Talking Machines. Making sensational hit. Men or women agents. Exclusive town, county or state rights. Combination Attachment Co., Grant Park Bldg., Chicago.

**AGENTS** make money selling Art Calendars and novelties. Samples and terms, 10 cents. 109 Artistic Christmas Post Cards, assorted, 50 cents. H. W. Rankin, Plainfield, N. J.

**BIG** income. Sell our rare, fragrant toilet preparation, etc. Steady profits and permanent business for energetic men and women. The Hamilton Co., Washington, D. C.

**WILL** pay reliable agents \$25 to distribute 100 free packages of Lice Powder among poultry owners. No money required. Poultry Remedy Co., St. Paul, Minn.

**AGENTS**—Biggest seller. Just out. Rite-Tone Attachment plays Edison records on Victrolas. Circular free. Pitts, Wilmette, Ill.

**30% PROFIT**—10c household specialty; free samples and information. Rath Mfg. Co., Bricksburg, Philadelphia, Penn.

**WONDERFUL** Rosary. Beads shine in darkness. Frank C. Perkins, Prospect Ave., Buffalo, N. Y.

**HERCULES** Carpet Remover—Best article on market. Big profits for agents. Sample 50c, prepaid. "Hercules," 108 Security Bldg., Davenport, Iowa.

**AGENTS**—Send for prices on our quality Photographic Portraits. Myland, 2125 Front St., Philadelphia, Pa.

**NEW** \$2.50 pocket addy. Sell 10 daily easy. Excellent profit. Everyone buys. No competition. L. Bassett, 5021 Indiana Ave., Chicago.

**AGENTS**—100% profit; write. Summer Specialty Company, E-5446 Augusta St., Chicago.

**SLICKEST** Needle Threader you ever saw. 10c. Stovers, Millersburg, Pa.

**SELL** Luminous Crucifix. "Shines all Night," to Catholic institutions and families. Old Paducah Co., Paducah, Ky.

**AGENTS**—Free—My new working plan will show you how to earn \$50 to \$75 weekly. Clow Co., Argyle, N. Y.

**I PROMISE** any man or woman who will go out tomorrow and call at ten houses, at least two sales, which net \$1.80 apiece. Ten calls—\$3.60 for your day's work. It's that aluminum combination set that you are to offer—aluminum the women are crazy for, at a price they go wild over. Experience in selling or not—doesn't matter. Drop a card and let me post you on my \$3.60 a day offer. Manager, Perfection Products, 1423 Westmoreland St., Philadelphia.

**NEW** Field for Agents—Clothes washer that fits set of ordinary tubs. Won medal Panama-Pacific Exposition. Retail \$10. Big profits. Great for apartments. Stores in tub. Write for agents' terms and booklet. Home Devices Corp., 212 Bush Terminal, Brooklyn, N. Y.

**LADY** or gentleman, fair education, to travel for old-established firm. No canvassing. Salary, \$9.6 per year, payable weekly, pursuant to contract. Expenses advanced. Address G. M. Nichols, Philadelphia, Pa., Pepper Bldg.

**DRUNK, Sick or Crazy**—Not us, but our plan lets you collect the money and keep it all. We get ours later. U. S. Mfg. Co., Dept. P, Columbus, Ohio.

**STAIRBRITE** gold letters make the best window signs. Easily applied. Big profits. Steady income. Sample free. Stairbrite Co., Dept. P, Long Island City, New York.

**GENERAL** Representatives with little capital for Jap 80K nonbreakable Gas Mantle; America's latest invention; throws greater light; outlives others; substantial income assured handling sub-agents and trade. Jules, 209 W. 48th, N. Y.

**BIG** Money easily made selling Jules Folding Portable Electric Lamps, containing 10 ft. concealed extension cord automatically lengthened or shortened. Other features. Demonstration insures sales, Homes, Offices, Factories, Hospitals, Students. Rose-Strauss Co., 215 W. 48th, N. Y.

**BRANCH** Manager Wanted. Everywhere costly marble is ruined for lack of proper cleansers. Marbletone cleanses, enriches, granite, onyx, porcelain, enamel, metal, woodwork. Big cleansing contracts easily made. Write for full particulars. A. Ryan, 138 E. 38th St., New York.

**SELF** Hair Drying Comb just patented (not electrical). Most wonderful article ever invented for women. Dries the hair in a few minutes. 100% profit, biggest thing in years. Metropolitan Sales Co., Tacoma Bldg., Chicago.

**EVERY** household on farm, in small town or suburbs, where oil lamps are used, needs and will buy the wonderful Aladdin Mantle Lamp. Burns common coal oil (Kerosene); gives a light five times as bright as electric. Awarded gold medal at San Francisco Exposition. One farmer cleared over \$500.00 in six weeks; hundreds with rigs earning \$100.00 to \$300.00 per month. No cash required. We furnish capital to reliable men. Write quick for wholesale prices, territory and sample lamp for free trial. Address nearest office. Mantle Lamp Co., 517 Aladdin Bldg., Chicago, Ill. Mantle Lamp Co., 517 Thermo Bldg., New York City.

**BIG** Textile Mills will employ everywhere reliable people to take orders for dress fabrics, hosiery, underwear, sweaters, waists and skirts from samples. Factory prices. Spare or all time. No experience. Permanent. Many making over \$30.00 weekly. Steamfast Mills, 20 Remsen St., Cohoes, N. Y.

**MAKE** and sell your own goods. Formulas by expert chemists. Manufacturing processes and trade secrets. Formula Catalog for stamp. B. Mystic Company, Washington, D. C.

**BIG** money made installing alarm clock supports to control drafts on steam, hot water, hot air and natural gas heating outfits. Warm house in the morning. Use your own clock. Price, \$2.90. Alroy Mfg. Co., 1234 Harvard, Washington, D. C.

**MAKE** your own Extracts and Perfumes. H. Lake Co., Adair, Ill.

**AGENTS**—Here is an article of merit. A patented ventilator for home, office and public buildings. Instantly installed without tools and adjusts to fit any window. Unlimited market. The Chapman Brothers Co., Box 20, Saybrook, Conn.

**VACUUM** Cleaner Men: You all know Hugro. Biggest Vacuum factory in world. Best and latest models. All styles. Blue bird indoor and outdoor clothes racks. Lowest factory prices. Hugro Mfg. Co., Warsaw, Indiana.

**YOU** can make big money selling electrical diamonds for the holidays. Send 10 cents for samples of scarf pin or ring. Our catalogue is a winner. Send for it. Leon Wilder & Sons, 530 Broadway, New York.

**AGENTS**—Large Manufacturer wants reliable men, women, to sell guaranteed Hosiery, Underwear, Shirts, direct to homes. Write for free samples. Madison Mills, 588 Broadway, New York.

**AGENTS**—Steady Income. Large manufacturer of Handkerchiefs and Dress Goods, etc., wishes representative in each locality. Factory to consumer. Big profits, honest goods. Whole or spare time. Credit given. Send for particulars. Froepert Mfg. Co., 59 Main St., Brooklyn, N. Y.

**AGENTS**—Salary or commission. Greatest seller yet. Every user pen and ink buys on sight. 200 to 500 per cent profit. One agent's sales \$620 in six days; another \$32 in two hours. Monroe Mfg. Co., X-6, La Crosse, Wis.

**"GOLDLINE"** Sign Letters—1,000% profit. Sample free. Johnston Co., Quincy, Ill.

**AGENTS**—Brand new specialty Aluminum Triplicate Sauce Pan with detachable handle. Cooks 2 different foods on one burner. Saves gas. Lasts lifetime. \$100 to \$300 per month easy. Send for our catalogue of 400 other specialties. American Aluminum Mfg. Co., Div. J. 10, Lemont, Ill.

**MAN** to advertise and solicit for Rogers' Guaranteed Silverware. Good salary and commission. A. A. Cline, 31 Copeland Building, Philadelphia, Pa.

**SOAP** Agents—Our Vegetable Soap, Toilet Goods, Remedies, Flavorings, Excel—Outsell. Sample Free. F. A. Buchanan & Co., Dept. 54, St. Louis, Mo.

**AGENTS**—Biggest hit ever! Eleven-piece Toilet Article Set, selling like blazes at \$1; with \$1 Carving Set Free! Enormous profits! Tremendous sensation! Experience unnecessary. Engle made \$51.00 first week. Write quick! Pierce Co., Dept. P, 906 Lake St., Chicago.

**OUR** line of brushes is a winner. So is our proposition. We want live brush agents everywhere. United Brush Company, 622 W. Lake St., Chicago.

**AGENTS** who can make \$3,000 and more yearly. No others apply. Fuchs-Kelly Co., 38 Park Row, N. Y.

**SIGN** Letter Agents and Painters; 500% Profit Gold and Silver Sign Letters for Stores and Office Windows. Anyone can put on. Big demand. Free samples. Metallic Letter Co., 104 N. Clark St., Chicago.

**ENDLESS** Neckties—Something new, twelve ties in one; costs no more than old style; man made \$70 three days; woman made \$92 week; write for special agents' offer. Endless Necktie Mfg. Co., Dept. 10, Kansas City, Mo.

**AGENTS**—\$5 daily selling our Handy Tool, 12 articles in one. Lightning seller. Sample free. Thomas Mfg. Company, 702 North St., Dayton, Ohio.

**JUST** show them—The new adjustable floor and wall mops, dustless dusters and sanitary brushes sell themselves. Big line, big profits. Agents write Silver-Chamberlin Co., Dept. M, Clayton, N. J.

**EASY**, pleasant work for Mechanics, Shop Men, Clerks, during spare hours, will add many dollars to their salaries. Also want persons who can give full time. Big wages assured. Novelty Cutlery Co., 67 Bar St., Canton, Ohio.

**\$15.00** MADE first day by 13-year-old boy with Shomescope. Woman made \$8.00 first hour. Particulars free. Shomescope Mfg. Co., 523 W. 13th St., Kansas City, Mo.

**YOUNG** Man, would you accept a tailor-made suit just for showing it to your friends? If you live in a town smaller than 10,000, write Banner Tailoring Co., Dept. 120, Chicago, and get beautiful samples, styles and a wonderful offer.

**AGENTS**—Here's a winner. The Midget Vest Pocket Garment Hanger—sells on sight. The most attractive proposition ever offered. 150% profit. No competition as article is fully protected by U. S. and foreign patents. Address: Dept. "M," The Silver Company, 171 Madison Ave., New York.

**MEN** and women earn up to \$3,000.00 yearly distributing Guaranteed Hosiery from mill to wearer. All or part time. Repeat orders insure permanent increasing business. No capital or experience needed. 1) Parker Mills, 2733 No. 12th St., Philadelphia, Pa.

**YOU** are looking for more long green. You doubtless deserve it, and willing to work for it. Our soap and toilet article combinations have every ear-mark of being real coin getters, we can prove that they are. Write for convincing proofs. Davis Soap Works, M 64 Davis Bldg., Chicago.

**WE** are the largest manufacturers of twisted Wire Brushes in America. Highest grade goods, best service, largest profits. Our new Auto Specials are winners. Send for catalog. Fuller Brush Company, Hartford, Conn.; Rock Island, Ill.

**NEW** 1915 Model—Send no money, just your name on a postal card, and learn by return mail how to get the best Vacuum Cleaner made, without costing you one cent. Shipped direct from factory, guaranteed for 5 years. Reliable. Live agents wanted. The Warner Company, Dept. Z, Muncie, Indiana.

**AGENTS**—Sell the Primus, genuine Swedish wickless, coal-oil stoves. Smokeless, odorless. Twice the heat of gasoline at one-eighth the cost. No danger of explosion. Big profits. James Anderson & Sons, Sidney, Ohio. American distributors.

**AGENTS** make big money and become sales managers for our goods. Fast office sellers. Fine profits. Particulars and samples free. One Dip Pen Company, Dept. 2, Baltimore, Md.

**READ** the Agents Magazine and make more money. 2 issues 10c. Agent's Magazine, Chicago.

**AGENTS**—Sell rich-looking imported 35c 68 Rugs, \$1 each. Carter, Tenn., sold 115 in 4 days. Profit, \$57. You can do same. Write for sample offer selling plan; exclusive territory. Sample rug by parcel post prepaid, 98c. Condon, Importer, Stonington, Maine.

**AGENTS** make \$5 to \$10 a day on the start. Atkinson writes: "The best proposition I have found in my forty years' canvassing." Permanent work. Household necessity. Saving 80%. Write today for General or Local Agents terms. Free sample. C. H. Stuart & Co., 16 Union St., Newark, New York.

**AGENTS**—Stamping names on Pocket Key Protectors; sample Check with your name and address, 12c. Stamping Outfits, Emblem Checks, Check Pads, Name Plates, Hart Mfg. Co., Desk 2, 303 Degraw St., Brooklyn, N. Y.

**BIG** Profits for You! Manufacture Barley Crisp. New Confection, 5c package costs you 1c. Machine, instructions complete \$7.50 prepaid. Send 10c for samples. Harley Crisp Co., 1205 Broadway, San Francisco.

**MAIL-ORDER** Opportunities: 25 new Propositions. No competition! Make 25c profit on dollar order; complete outfit 19c. Mail Dealers Wholesale House, 521 Franklin Bldg., Chicago.

**AGENTS** of ability and high character wanted on a new household article. Over 100 per cent profit. Special selling plan that pulls results. Address Merritt & Brock, 59 to 63 Temple Place, Boston, Mass.

#### SALESMEN WANTED

**ADVERTISING** Salesmen who wish to make a very profitable connection for 1915 should write us at once. Entirely new ideas to submit prospective customers. Competition eliminated. Exclusive designs, protected territory and liberal commission. The Hayes Lithographing Co., Lakeview Ave., Buffalo, N. Y.

**SIDELINE** Men and General Agents Everywhere—Flashing electric advertising signs for store windows, banks and theatres. Our men are clearing \$40 to \$100 weekly; no samples necessary; a clean-cut proposition. Write today for full particulars. The Telesign Co., 8 N. Clark St., Chicago.

**\$7.50** COMMISSION each sale. Weekly settlements. Few minutes' time among hardware-impliment, lumber and wire-fence trade; every state. Pocket sample. No competition. Toledo Cable Co., Dept. 41, Toledo, O.

**PERMANENT** Income from sale of Transo (Transparent face) envelopes. Every business house a possible customer; commission basis; local or traveling salesmen. Transo Envelope Company, Chicago.

**SPECIALTY** Salesmen—Large Eastern organization manufacturing patented, popular-priced office efficiency devices wants representatives in unoccupied territory. Splendid proposition. Small capital. Cash or credit. Fine line "repeaters." Full protection. Ask for "Folder A5." Chelsea Mfg. Company, 111 Broadway, New York.

**\$150** HAS been earned in 3 days by our representatives, some even better, introducing our new advertising method which solves the advertising problem for merchants in smaller cities and towns. If you are or want to be a salesman I will show you how to build up a big profitable repeat business quick. Whole or part time. Big money if you set now. Write Salesmanager, Winslow Cabot Company, 67 Congress Bldg., Boston, Mass.

**EXCLUSIVE** county rights. Sell Tankik; new auto fuel. Profitable. Tankik Chemical Co., Cleveland, Ohio.

**AGENTS**—Your photo on pillowtop 50c. On pennants \$1. Agents wanted. H. C. Lingle, Box 115-E, Anua, Ill.

**SIDELINE** Salesmen will profit by selling our new idea Price Tickets, Samples. Trade-Bright Co., Syracuse, N. Y.

**HIGHEST** Class Salesmen only to call on telephone users. Attractive offer. Goodwin Co., Dept. 49, Newport News, Va.

**\$4 TO \$8** daily selling easily demonstrated device to business men under our original plan. Over 300 men earning big incomes; territories still open. Write for money-making plan and leads to prospects. Mr. Neumann, Mgr., 450 Fourth Ave., New York.

**EVERYBODY** needs our Little Wizard Combination Vest Pocket Clothes Hanger, made of steel, heavily nicked; fits in vest pocket. Over one hundred thousand sold first week. Sent by parcels post prepaid upon receipt of price, 35c each; 3 for \$1 (stamps or currency). Agents wanted. Farquhar-Moon Mfg. Co., Box 92, 140 W. Van Buren St., Chicago, Ill.

**ADVERTISING** Novelties—Side Line. Salesmen, brokers, write us your references. Territory covered; if satisfactory, will send our pocket sample case full of good sellers. Crown Throat & Opener Co., 703-711 Fulton St., Chicago.

**FORD** Owners can make more money selling Safety Ford Starters than any starter on the market. Write at once for particulars. Safety Ford Starter Corporation, 701 Seventh Ave., New York.

**WANTED**—Representatives everywhere. Exclusive territory. Gold sign letters for stores and office windows. Any one can put on. Write today for free sample. Metallic Letter Co., 463 N. Clark St., Chicago.

**SALESMEN**: Pocket side line; new, live proposition; all merchants in towns of 100-500 and under want it. Pays \$5.00 commission on each sale. No collecting, no risk to merchant. We take back unsold goods. Easiest, biggest paying side line ever offered. Canfield Mfg. Co., 208 Sigel St., Chicago.

**SALESMAN**. Sell beautiful 28x38 Artz-kraft felt rugs for \$13.50 per doz. Your profit, \$3 per doz. Kelso, Battle Creek, Mich., sold 50 doz. last week. His profit, \$90. Write for exclusive territory and selling plan. Prepaid sample, \$1.50, refunded on first order. H. Condon, Mgr., Stonington, Maine.

**WANTED**—Side line salesmen calling upon hardware and general stores. National Production Co., 180-190 No. Market St., Chicago, Ill.

**HELP-A-PHONE**. Salesmen make \$100 weekly. Write Edward, 415 Belden Ave., Chicago.

**SALESMEN**—Get our plan for Monogramming Automobiles and Motorcycles by transfer method. Very large profits. Motorists' Accessories Co., Ashland, O.

**SALESMEN**—Make Big Money on our Couvex Portraits 35c, Frames 35c, Glass 20c. Largest house in America. Est. 15 years. Samples Free. The Culver Co., Box 101, Westerville, O.

**SALESMEN**: Acquainted with merchants. Large demand. Lib. comm. Pocket samples. Write Salesbook Co., Chicago.

## HELP WANTED

**RARE** opportunity for good man to handle fastest selling auto necessity on the market. Will net anyone \$25 weekly—hustlers earning \$50. Middle-west motorists enthusiastic about it. First demonstration brings order. Easy to carry—easy to sell. No experience necessary. Write at once for details. Lightning Mfg. Co., Perin Bldg., Cincinnati, O.

**GOVERNMENT** Examinations. Most thorough preparation, \$5; returned if not appointed; particulars free. American Civil Service School, Washington, D. C.

**BE** a traffic inspector—we teach you. A new profession. \$4 a day to start. Unlimited opportunities for travel and advancement. Positions now open. Frontier Prep. School, Dept. A2, Buffalo, N. Y.

**WANTED**—Men and Women, 18 or over, for U. S. Government Jobs, \$75 month. Steady work. Common education sufficient. Write immediately for list positions now obtainable. Franklin Institute, Dept. C-21, Rochester, N. Y.

**STOP** Here! Let me start you in a home business that will bring you money every day. Experience unnecessary. Spare time. No canvassing. I furnish everything. Send for proofs. Voorhis, Desk C. R., Omaha, Neb.

**WANTED**—An Idea! Who can think of a simple thing to patent? Protect your ideas; they may bring you wealth. Write for "Needed Inventions" and "How to Get Your Patent and Your Money." Randolph & Co., Patent Attorneys, Dept. 144, Washington, D. C.

**WANTED**—Circular distributors. Send 10c for contract, magazine. Oliver A. Barkley, Mount Pleasant, Pennsylvania.

**\$20 TO \$25** per month extra money to any employed persons without interfering with regular work. No selling. No canvassing. Positively no investment. Unemployed need not apply. Address The Silver Mirror Co., Inc., 119 W. Madison Street, Chicago, Ill.

**\$7.50 COMMISSION** each sale. Weekly settlements. Few minutes' time among hardware-impliment, lumber and wire-fence trade, every state. Pocket sample. No competition. Toledo Cable Co., Dept. 45, Toledo, O.

**A MAN** making \$12 a week needed \$30. Let us tell you how he made it. Lock Box 116, South Bend, Ind.

**RAILWAY** Mail Clerks Wanted, \$75 month. Many government positions obtainable. Write for list. Franklin Institute, Dept. C-21, Rochester, N. Y.

**GOVERNMENT** Jobs coming everywhere. Apply at once. Instructions free. For particulars write Civil Service, Prof. Ingram, now at Higden, Ark.

**PLEASANT** spare-time work; mailing circulars. Good pay. No scheme. Details free. Home Pub. Society, 46 N. 12th, Philadelphia.

**I NEED** Branch Managers for my worldwide mail-order business; operate from your own home in spare time; no canvassing or peddling; experience unnecessary; you should make \$50 weekly. Butler, 475, Factories, Toledo, Ohio.

**OWN** a business. Co-operate with me evenings at home. Everything furnished. Don't worry about capital. Boyd H. Brown, Dept. K-11, Omaha, Neb.

**BECOME** Railway Mail Clerks, \$75 month. Common education sufficient. Write immediately. Franklin Institute, Dept. C-21, Rochester, N. Y.

**GET** a Government Job! See ad on page 16. Write now—today! Patterson Civil Service School, Rochester, N. Y.

**MEN** wanted to make Toy Soldiers. Germany's great toy industry. War stopped importation. Greatest demand. Good paying home work on small scale. Enormous business for industrious people. We buy soldiers the whole year. Tools, experience unnecessary. Casting-form outfit \$2 up. Interesting booklet, patterns, sheet, pay list free. Toy Soldier Manufacturing, 33 Union Square, New York.

**FIREMEN** and Brakemen: \$160 monthly. Experience unnecessary; hundreds needed for the best railroads everywhere. Particulars free. \$10 Railway Bureau, East St. Louis, Ill.

**BIG** money for employed persons and others. Both sexes; new, unique, fascinating plan; no canvassing; no capital. Vulcan Co., Dept. 1, 101 S. Fifth Ave., Chicago, Ill.

**MARKET** your spare time; commercial information wanted; high grade opportunity; confidential; good pay. Free particulars. "Cico," Pmc, Evansville, Indiana.

**USE** your spare time to build up a mail order business of your own. We help you start for a share in profits. 27 opportunities. Particulars free. Opportunities Exchange, Buffalo, N. Y.

**QUIT** working for others. Start a cleaning and dyeing business. No experience and but small capital needed. Tremendous money-maker. Greatest re-order business known. Send for free booklet 17 today. Full details. White Wonder Co., 270 Guardian Trust Bldg., Denver Colo.

**MEN** Wanted for detective work. Also instructed by former U. S. Govt. Detective. Write, J. Ganor, 2309 Calumet, Chicago.

**LEARN** Auto Driving and repairing. Earn while learning. Sample lessons free. Franklin Institute, Dept. C-802, Rochester, N. Y.

**MEN**—Women—18 or over, wanted as U. S. Government Clerks, \$70 month. Vacations. List of positions now obtainable free. Franklin Institute, Dept. C-21, Rochester, N. Y.

**EARN** \$25 to \$75 weekly. Own a business. Complete set of illustrated lessons, "Be a Tree Expert," mailed for \$2. Money refunded should you fail to learn. Those desiring correspondence course with personal instructions, write immediately for free booklet. Willmette School of Tree Dentistry, Willmette, Ill.

**PHOTO**—Plays Wanted. Big prices paid. We show you how. Details free. Rex Publishers, Box 173K, Chicago.

**GOVERNMENT** Clerks—Men and Women—wanted, \$75 month. Many positions obtainable. Write immediately for list. Franklin Institute, Dept. C-21, Rochester, N. Y.

**\$150.00 SALARY** for 60 days' work paid man or woman in each town to distribute free circulars and take orders for White Ribbon Concentrated Flavoring. J. S. Ziegler Co., 7 P. East Harrison, Chicago.

**INVENTORS** Wanted. Your ideas may mean fortune. Send Sketch. Patents secured through new credit system. Book and advice free. Waters & Co., 4102 Warder Bldg., Wash., D. C.

**FIREMEN**, Brakemen Wanted, all railroads; \$120 monthly. Experience unnecessary. Railway Association, Dept. 298, Brooklyn, N. Y.

**WANTED**—Men to get members and establish lodges on commission basis for the Owls, South Bend, Indiana.

**BECOME** Detectives. Large salaries; easy work. Write Chief Wagner, 1243 Lexington Avenue, New York.

**YOUR** services are needed as Topographic Draftsman at excellent salary. You can learn from us soon. Get particulars. Columbia School of Drafting, McClachlen Bldg., Washington, D. C.

**DISTRIBUTORS** Wanted—Good pay; steady work; giving away packages Perfumed Borax Soap Powder with Soaps, etc. No capital or experience needed. S. Ward & Co., 218 Institute Pl., Chicago.

**WRITE** Moving-Picture Plays. Good prices. Devote all or spare time. No correspondence school. Details free. Atlas Publishing Co., 3945, Cincinnati.

**MEN** to refinish lighting fixtures, brass beds, etc. All or spare time. No capital or canvassing. Experience unnecessary. Information free. Gunmetal Co., Dept. G, Decatur, Ill.

**BE** a Detective—Earn from \$150.00 to \$300.00 per month. Travel over the world. Write C. T. Ludwig, 540 Westover Building, Kansas City, Mo.

**GO** on the Stage. Vaudeville career offered you. Experience unnecessary. Managers endorse my method. Instructive vaudeville book free. Write today. Frederic LaBelle, 8th, 10, Jackson, Mich.

## FOR SALE

**"BARDOU"** Astronomer's Telescope and Tripod. Cost \$175. Our price \$60. Write for further information. David Stern Co., 1047 W. Madison St., Chicago, Ill.

**FOR** Sale—One new \$45 drawing board with sliding rule and high revolving stool and large drawer cabinet for drawings; all complete; very cheap. Geo. J. Baker, Lafayette, Indiana.

**PHOTOGRAPHS**—Less than half price. I have purchased a large lot of salesmen's samples. Will sell this \$30 late model for \$10. Check Protection is a necessity. Do not delay until it's too late. E. G. Snow, Lafayette Bldg., Philadelphia.

**FOR** Sale—Heavy Canton portable floor crane, new and cheap. Geo. J. Baker, Lafayette, Indiana.

**TYPE** and Printing Material at bargain prices. Now is the time to buy. All sizes rebuilt Job Presses very cheap. Catalogue free. Philadelphia Printers' Supply Co., 14 So. Fifth St., Philadelphia.

**"SWIFT & Sons, London,"** microscope, oil immersion objective, and two low powers, Abbe condenser, etc. Price \$42. Other bargains. Write us today. David Stern Co., 1047 W. Madison St., Chicago, Ill.

**FURNITURE** Manufacturers: Investigate Seat Connection Patent, \$2,500. Lock Box 1146, Manila, Philippine Islands.

**SLOT** machines. Mills Operator Bells, \$10. Floor Venders \$15, each to close out quick. Send for price list. Auto Vending Company, Minneapolis, Minnesota.

**FIELD** and Marine, Day and Night Glasses, with beautiful case. 25-mile adjustment; \$50 value, only \$7.50. Money back if not satisfied. Well's Curiosity Shop, 20 S. Second St., Philadelphia, Pa.

**FIELD** Glasses, 9 power, case, strap, \$6.25 postpaid. Zehrbach & Cruikshank, Leipzig, Ohio.

## SALE OR EXCHANGE

**ELECTRIC** Barber Sign, Encyclopedia, Player Piano, Regina Music Box, Sewing machines, Snare or bass Drum, Camera, Typewriter, Safe, Dynamo, Watch, Vibrator, Indian Baskets, Waxed Dried Fruits, Nuts, Merchandise, Cash Register, Scales, Coffee Mill, Late Phonograph, Diamond, Motorcycle, Adding Machine, or Automobile. What have you? Syd Evans, Klamath Falls, Oregon.

**LIVE** prospects to sell or trade anything anywhere. Write for plan. Mathews Rauch Publicity, 305 Mallers Bldg., Chicago.

**COMMERCIAL** printing traded for anything. Tracey Printing Company, Tuppercase City, Ohio.

## FLOUR &amp; FEED MILLING MACHINERY

**SPECIAL** bargains in second hand Attrition mills, burr mills, crushers, corn shellers, bran dusters, dust collectors, purifiers, reels, double, single, 2 and 3-pair high roller mills, sieve bolters, receiving separators, scrouers, etc. Write for description and prices. Sprout, Waldron & Co., P. O. Box 429, Muncy, Pa.

## ENGINE CASTINGS AND BLUE PRINTS

**SMALL** Gasoline Engines and Castings. Crown Motor Works, Elgin, Ill.

**GASOLINE** Engine Castings, with drawings. Cheap. Catalog for stamp. Novelty Manufacturing Co., 853 West 6th St., Cincinnati, Ohio.

## MACHINERY, TOOLS AND SUPPLIES

**MACHINERY**—For Sale, 2,000 feet 5/8 Elevator cable, one 1/10 and one 1/4 H. P. motors 110 V.-D. C., lot new bottles, corbs, etc. T. P. Plumridge, Manager Holland Bldg., St. Louis, Mo.

**VISES** for Sale. Have a limited stock of stationary-type blacksmith, pipe and machinists' vises. Below cost while they last. Puritan Machine Company, 55 Tenth Street, Detroit, Mich.

**FOR** Sale—2 lathes and 2 planers. W. J. Ferrell, Barborton, Ohio.

**LATHE**—Footpower, screwcutting, 10 in. by 25 in. Bargain, \$48. Box 152, Marlon, Ohio.

**GLASS** Cutter, improved type; cuts any thickness. Saves labor, time, money. Saves the hands. 10c. Smith & Hemenway Co., 1611 Chambers Street, New York City.

**PULLEYS**, Gears, Sprockets, Shafting, Hangers; see page 140. W. A. Jones Foundry & Machine Co., Chicago.

**FOR** Sale—New Power Hack Saw, capacity 4 in. by 4 in., \$15. New 10-inch Sensitive Bench Drill Press, drilling capacity 3/16 inch, \$15. Passman Bros., 28 So. Green Street, Chicago, Ill.

**VACUUM** Pumps and Cleaners, all sizes; complete outfits. Thurman Vacuum Cleaner Co., manufacturers, Dept. O, St. Louis, U. S. A.

**HAVE** for sale several sizes of lathes, milling machines, drill presses, punch presses, shapers, planers, boilers, steam engines, oil, gas and gasoline engines and wood-working machinery. Finmer, 122 Water St., New York, N. Y.

**ENGINE** Lathe, swings 9 1/2 in., takes 26 in. between centers. Complete set gears cutting all size threads 3 in. to 40 in. \$43.50. Grammes & Sons, Allentown, Pa.

## ENGINES, MOTORS AND DYNAMOS

**REBUILT Engines**—We have on hand a number of rebuilt "Buffalo" engines, guaranteed, at greatly reduced prices. Write for bargain list. Buffalo Gasoline Motor Co., 1293-1305 Niagara Street, Buffalo, N. Y.

**GUARANTEED** single and three phase alternating, and direct current motor bargains. Complete stock. Tell us your needs. Motors bought, repaired, exchanged. Send for illustrated bargain list supplies and motors. Satisfaction guaranteed or money refunded. Hyre Electric Co., 613P South Dearborn St., Chicago.

**1/2 H. P. MOTORS** and Generators. Alternating and Direct. Bargains. Geo. Black, 601 Lorenz Ave., Pittsburgh, Pa.

**MOTORS DC. 1-2-3 HP.** Easy payments. Hobart Bros., Troy, Ohio.

**1/2 H. P. TAKES** new General Electric 5 H. P. 3 phase motor. Heath Aerial Vehicle Co., Chicago.

**LIGHTING** dynamo sold on easy payments. Hobart Bros., Troy, Ohio.

**JUST ISSUED**—Amateur Mechanics No. 6. Another great book of 293 articles for those who like to make things. Similar in style to the other numbers in the series. 128 pages. 261 illustrations. Paper. Price 25 cents postpaid. Popular Mechanics Book Dept., 6 N. Michigan Ave., Chicago.

**STORAGE** Sale—Small motors and dynamo, all new, 110 volts, 1/2 H. P.—A. C., \$10.50; 1/2 H. P.—A. C., \$18.50; 1/2 H. P.—D. C., \$6.50; 8 light dynamo, \$12.00; motor generator sets, \$35.00. Other sizes, all voltages less than half price. Johnston, E-ans Ave., Ingram, Pa.

**GOVERNORS**, fans, jack shafts, etc., for motor engines when used as stationary. Circulars, Box 56, Taft, Calif.

## BOATS, LAUNCHES, ETC.

**MOTORCRAFT** Encyclopedia—A 159-page book that tells 1361 things every motor boatman should know. How to overcome engine troubles. Price \$1, postpaid. Popular Mechanics Book Dept., 6 N. Michigan Ave., Chicago.

## CEMENT

**CONCRETE** Building Block Machines and moulds. Free catalogue. 5 Market St., St. Louis, Mo.

## GUNS, SPORTING GOODS, ETC.

**PEERLESS** famous combination spring exercisers with patented grip handles. Just the thing for athletes, business men, women, boys or girls. All the gymnast advantages in your own home. Prices \$36 to \$4.00. Five styles, three tensions. Send for complete manufacturer's catalogue. Peerless Athletic Supply Co., 333 Pearl St., Brooklyn, N. Y.

**FIREARMS**—Old-time and modern. Buy, sell, exchange all sorts. Stephen Van Rensselaer, West Orange, New Jersey.

## BLACKSMITHS

**SHOP** Notes—Many valuable hints for blacksmiths are contained in our series of Shop Notes books, 10 volumes, 50c each, postpaid, or \$5 per set prepaid. Popular Mechanics Book Dept., 6 N. Michigan Ave., Chicago.

**BLACKSMITHS**, Listen: Wear the smile that won't come off, by doing hard jobs easy with Toy's Modern Methods on blacksmithing. Making all welds solid, tempering all tools to a standard with colored tempering charts. All for one dollar. Samples free. W. M. Toy, Sidney, Ohio.

## WANTED

**WANTED**—Absolutely new articles: must be manufactured, ready to sell. H. R. Nicol, 1258 John St., Seattle, Wash.

## FOR THE SHOP

**FOR** That Boy—He will appreciate a copy of the great boy's book "The Boy Mechanic" that tells about 700 different things for boys to do and has 800 pictures. 480 (7x10) pages, cloth, big, handsome book for the price, \$1.50 postpaid. Popular Mechanics Book Dept., 6 N. Michigan Ave., Chicago.

## ELECTRICAL

**LATEST**—Wonder—Flashlight: Guaranteed to burn three years. Greatest value—very useful. Price, 50c postpaid. Columbia Sales Agency, Columbia, Pa.

**"AMATEUR** Electrician" make Batteries, Motors, Engines. 75 illustrations. 10c. Renew Dry Batteries, 3 guaranteed processes, 20c. Both 25c. "Ideal." 3511-P Belleplaine Ave., Chicago.

**ILLUSTRATED** bargain list supplies, flashlights, motors. Buy your supplies at wholesale prices. Hyre Electric Co., 613-P South Dearborn St., Chicago.

**TATTOOING** Outfits, Electric and Hand, \$1 up. Roberts Company, 635 West Ave., Buffalo, N. Y.

## STAMP COLLECTING

**STAMP** Album with 538 Genuine Stamps, incl. Old Mexico, Malay (tiger), China (dragon), Tasmania (landscape), Jamaica (waterfalls) etc., 10c. 190 diff. Jap. N. Zid., etc., 5c. Big List, Coupons etc. Free! We buy stamps. Husman Stamp Co., St. Louis, Mo.

**PACKET** of 25 stamps; no two countries alike, 500 hinges. Set of \$1 and \$2 U. S. Rev., all for 5c. Mention paper. Miami Stamp Co., Toledo, Ohio.

**TEST** Philatelic Fellowship. Join Philately's only order. Philatelic Brotherhood, Logansport, Indiana, Dept. 119.

**STAMP** collectors try our net priced approvals. Our sheets contain only stamps in best condition. Prices from 1c upwards. References essential. South-Western Stamp Co., Box 1946, Los Angeles, Calif.

**FREE**—Ten different Canada, to approval applicants. Reference. Little, Rock Island, Illinois.

**STAMPS** sent on approval at 75% discount. Foreign Revenues, 1/2c each. Reference required. Emory Bernal, Hanover, Penna.

**FREE**. Choose one! Sixty different Japanese, 101 United States, 201 foreign, fifty Sweden, fifty Norway-Denmark. Remit 25c. Six month's subscription. McKel's Stamp Weekly, Boston, Mass.

**I WANT** to buy a good collection. Sholley, Linden Hills, Minneapolis, Minn.

**STAMPS** on approval, 1c and 50c selections for beginners. Better stamps at net. Premium—7 Bulgaria. Reference necessary. Mrs. L. Kellough, West Hartford, Conn.

**PORTUGUESE** Colonies, 18 different "Republica" stamps, unused, 15 cents. Fine Approvals, 50% commission. Easy sellers. Agents wanted. C. Nammack, Box 55 X, Brooklyn, N. Y.

**STAMPS** Free—3 different Nyassa (giraffes, camels), or 5 different Japanese-China, or 1916 Hungarian War Stamp, big price lists, bargain lists, \$2 premium coupon, etc., free for 2c postage. W. C. Phillips & Co., Glastonbury, Conn.

**FREE**. Choose one, Sixty different Japanese, fifty Sweden, 101 United States, 20c foreign, 50c article; remit 25c, six month's subscription, McKel's Stamp Weekly, Boston, Mass.

**MONSTER** American Packet Tree, old issues, commemoratives galore. Dues, Revenues, etc. 2c postage. Midland Stamp Co., Midland, Ontario.

**24 VARIETIES** Cuban stamps, 10 cents. List of 6,000 low-priced stamps free. Chambers Stamp Co., 111 P. Nassau St., New York City.

**BARGAIN** list, premium for 2c stamp. F. Biedell, Schenectady, N. Y.

**STAMPS**—12 different from warring nations, 10c; 10 different foreign coins, 15c; 20 Belgium stamps, 10c. Lists free. Toledo Stamp Co., Toledo, Ohio.

**FOREIGN** Stamps Free: 52 different foreign, including China and Venezuela, to all who apply for our high grade approval selections. Send two-cent stamp for return postage. Edgewood Stamp Co., Dept. H, Milford, Conn.

**25 DIFFERENT** British Colonials to applicants for stamps on approval who send 2c postage. Nickles, 122 Florida Ave., Washington, D. C.

**STAMPS**—145 China, etc., stamp dictionary and list, 2c. Bullard, Sta. A, Boston.

**STAMPS**, 100, all different, free. Postage 2c. Mention paper. Quaker Stamp Co., Toledo, Ohio.

## RARE COINS

**OLD** Coins Bought and Sold. Full catalogue list of coins for sale, free to collectors only. Buying catalogue quoting prices I pay for coins, 10 cents. Wm. Hessein, 101 Tremont St., Boston, Mass.

**\$50.00 PAID** for Dollar 1873 S. Mini; \$2.00 for 1904 Dollar, proof; \$7.00 for 1853 quarter, no arrows, etc. Many valuable coins in circulation. Watch your change. Look up your old money; you may have or get coins of premium value. Don't let a valuable coin slip away from you. Get Posted. Send only 4c. Get our Large Illustrated Coin Circular. It may mean large profits to you. You certainly have nothing to lose. Send Now to Numismatic Bank, Dept. H, Fort Worth, Texas.

**MEXICAN** war currency; genuine Villa dollars (Un Peso) 10c each, three for 25c. Excelsior Exchange, Box 571 Albuquerque, New Mexico.

**BUFFALO** Nickels, certain kinds. Original buyer has Coin Catalog, quoting highest prices. Send 10c at once for this catalog and full particulars. Means \$3 to you. National Co., Dept. 5, Olney, Ill.

**DID** you know that the Exposition California gold tokens of 1915 are out, \$1.00, 50c, 25c sizes, and Alaska has New Gold tokens called one P. inch, 1/2 P. inch, 1/4 P. inch. Booklet for stamp. Coin Exchange, New Rochelle, N. Y.

**ALL** for 30c. A California 25c gold token, a Columbia Nickel Coin Book and Lucky Seed. Selling list for stamp. C. J. Carey, New Rochelle, N. Y.

**\$1.25 EACH** Paid for U. S. Flying Eagle Cents dated 1856. We pay cash premiums on hundreds of Old Coins. Send ten cents at once for New Illustrated Coin Value Book 4x7. It may mean your fortune. Clarke & Co., Coin Dealers, Box 15, Le Roy, N. Y.

## FOR MEN

**DEERSKIN** Vests. Made to measure. Lined throughout with silk finish. Neat, comfortable and attractive in appearance. Outwears dozen cloth vests, \$1. Particulars free. Write now, Indian Beadwork Co., Poplar, Mont.

**FOR** Sale—10,000 pounds best leaf tobacco. Mail stamps for samples. Anton Warrin, Franklin, Ky.

## SAFETY BLADES SHARPENED

**SAFETY** razors sharpened; two cents each. Guaranteed. Blade box free. Electro Stropping Co., 134 Shelby St., Detroit, Mich.

## FOR BOYS

**BIG** New Book for Boys—The Boy Mechanic, Vol. II.—Just Out—A sequel to, but containing nothing found in Vol. I. Tells all about 1,000 interesting things to make and do. 480 Pages; 985 illus. Cloth. Price, \$1.50 Postpaid. Send for descriptive circular. Popular Mechanics Book Dept., 6 N. Michigan Ave., Chicago.

## FOR THE HOME

**ARTISTIC** Lamps and Shades in metal and art glass easily made by the amateur craftsman from instructions given in our book of 18 designs ranging from ordinary reading lamps to pretentious chandeliers. Expense only slight. Price of book 50c postpaid. Popular Mechanics Book Dept., 6 N. Michigan Ave., Chicago.

**BEAUTIFUL** arts-crafts lamps—Anyone can make them out of paper, cardboard and wood. 16 designs. Inexpensive yet artistic. Complete book of instructions. Price, 50c postpaid. Popular Mechanics Book Dept., 6 N. Michigan Ave., Chicago.

## BUSINESS SERVICE

**ESTIMATING** and Contracting by Radford—A 200-page manual of up-to-date methods for rapid, systematic and accurate calculation of costs of all types and details of building construction, with quotation of ordinary prices for labor and materials, standard schedules and forms, labor-saving tables and other data useful to the building trades. Flexible leather illustrated—\$2 per copy postpaid. Popular Mechanics Book Dept., 6 N. Michigan Ave., Chicago.

# YOU ARE WANTED

at a **BIG SALARY!** GET READY FOR PROSPEROUS TIMES



**CHARLES W. MOREY**  
President of the College  
Head of the firm of  
Charles W. Morey & Co.,  
Consulting Engineers.



**WM. T. HOOPER**  
Architect, Vice-Pres.  
of College, Head of  
Dept. Architecture.



**E. OTTOMANN, Jr.**  
Consulting Engineer  
Secretary of College



**M. M. CASE**  
Consulting Engineer  
Head of Mechanical and  
Electrical Depts.

Prosperous times are coming—they're here now. Far-seeing men are getting ready for boom times. You can—you must—share in this prosperity. You will if you are ready. Training is the key.

**Here are men who can help you** The men at the head of this school are doing real work—big work—every day. They are in active touch with big contractors where trained help is needed. They conduct their own offices and are in charge of important construction work at all times. They are the men you get to know personally. Let them help you to

## Earn from \$3000 to \$5000 a Year.

You can do it. There is such a position for you if you have the training. All branches of **DRAFTING, ENGINEERING** (Civil, Electrical, Mechanical, Architectural) are calling for trained men. We can't fill all the applications we get. If you will put in your spare hours in study for a short time we will help you.

**HERE'S  
YOUR  
CHANCE  
TO LEARN**

# DRAFTING

Hundreds of men are in daily attendance in the day and evening schools of the College. In your own home you can do the same work these men are doing and the same experts that teach them will teach you. These well known architects and engineers know exactly the practical training you need, and they train you—they prepare your instruction matter—your work is examined and approved by them.

**STUDY AT HOME** Your Spare Time is Enough

It will cost you nothing to get full information; an inquiry will not obligate you in any way. It is up to you and you alone whether you fit yourself for the big job—whether you draw the big pay. Let us make you a big earner. Prosperity and opportunity are here NOW. Fit yourself to grasp big things. Sign, tear and mail the coupon now.



Complete \$15 Drawing Outfit FREE

**MAIL COUPON TODAY!**

A few readers of this magazine—only a few—who are prompt in making application will secure a

**\$45 Scholarship Free**  
In Mechanical Drawing.

This offer will be withdrawn as soon as the limited number of scholarships have been awarded.

## BIG SALARY COUPON

CHICAGO TECHNICAL COLLEGE  
1050 Lake View Building

Without any obligation on me, please send me full particulars about your **FREE SCHOLARSHIP.**

I have marked subject in which I am interested.

- Machine Drafting
- Electrical Drafting
- Architectural Drafting
- Structural Steel Drafting
- Builders' Course
- Plan Reading
- Estimating
- Sheet Metal Drafting
- Civil Engineering
- Surveying

Name .....

Address .....

Town..... State .....

College or Home Study?.....

**CHICAGO TECHNICAL COLLEGE**  
1050 Lake View Building, Chicago, Ill.

Please Mention Popular Mechanics

# MAKE FURNITURE LIKE THIS



## Shown in the Photograph

ONE of our readers, who is strictly an amateur with tools, experienced no difficulty in making and finishing every piece of furniture, with the exception of the piano, shown in the accompanying picture. It is impossible in a small space to display all the different designs in Mission Furniture which we have published, but this picture shows something of the variety of pieces and how well they go together. The

## MISSION FURNITURE SERIES of 3 Volumes

Comprises 93 Attractive Designs, all different

**MISSION FURNITURE, Part 1**  
New Enlarged Edition 128 Pages, 30 Designs  
**MISSION FURNITURE, Part 2**  
Recently Issued 128 Pages, 32 Designs  
**MISSION FURNITURE, Part 3**  
New Book—Just Out 128 Pages, 36 Designs

Cloth, Size 5x7 inches **Price 50 Cents** Per Vol., Postpaid

THESE books describe how to make furniture for every room in the house as well as swings for porch and lawn. Whether you need a complete set or only some special article to fill in with here and there, you will find full directions, dimensions and working drawings for making it in these books. The instructions are easy to follow and even the amateur can obtain most satisfactory results as related above. A complete list of the designs in each book will be furnished free upon request.

ASK YOUR BOOK DEALER or address the publishers  
**POPULAR MECHANICS BOOK DEPARTMENT, 6 N. Michigan Ave., CHICAGO**

## OXY-ACETYLENE

OXY-ACETYLENE  
WELDING  
AND CUTTING  
SWINGLE

## WELDING AND CUTTING

Including the Operation and Care of Acetylene Generating Plants and the Oxygen Process for Removal of Carbon

By C. F. SWINGLE, M. E.

200 Pages—76 Illustrations—Pocket Size Bound in Cloth, \$1.00

Full Leather—Round Corners—Red Edges Stamped in Gold, \$1.50

Here is a brand new practical instruction book on the methods of welding and cutting by the oxy-acetylene process. The thirteen chapters cover the following general subjects:

Welding—Welding Flumes—Oxygen Acetylene—Acetylene Gas Purification and Handling—Oxy-Acetylene Torches—Characteristics of Welding Torches—Welding Installations—Preheating and Annealing—Operating a Welding Installation—Metal Welding Practice—Oxy-Acetylene Cutting—Oxygen Carbon Removal—Index.

Sent postpaid upon receipt of price by

**POPULAR MECHANICS BOOK DEPT.**  
6 N. Michigan Ave., CHICAGO

## LITHOGRAPHIC MODELS

SIZE  
10 x 14  
INCHES

IN  
COLORS

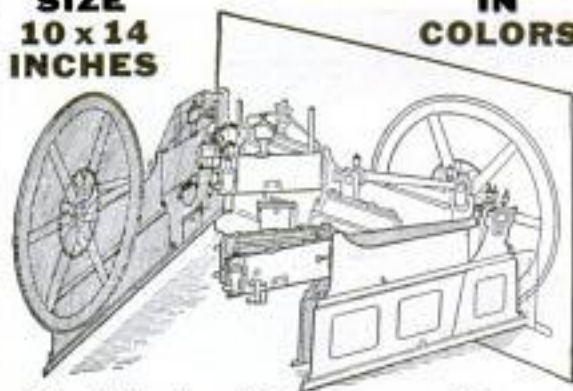

of the following: Mallet Compound Locomotive—Atlantic Type Locomotive—Automobile—Steamship—Steam Engine—Steam Turbine—Dynamo—Gas Engine—Wireless Telegraph.

As shown in the illustration these models are like a dissected chart of the human body, and open by means of a series of flaps which show every part of the machine for purposes of study. Each part is numbered and the name given. They are ingeniously made, accurate and show every detail; educational and worth many times their cost.

**Price 50 Cents Each**  
or \$4.00 for complete set of nine subjects, prepaid

**Popular Mechanics Book Dept.**  
6 N. Michigan Ave., CHICAGO

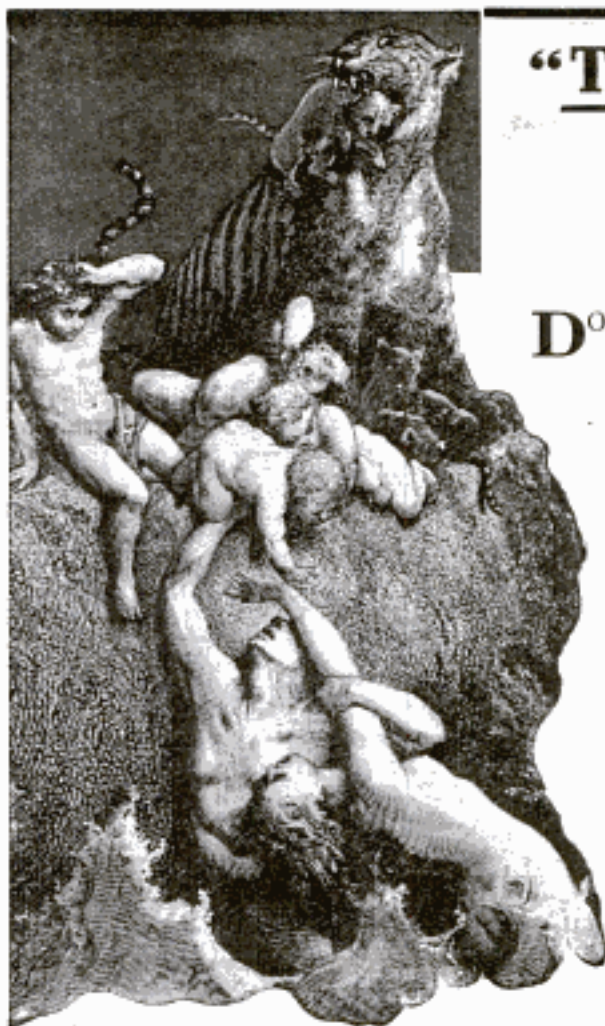

## "The Chaldean Story of the Flood"

**Dug Up From the Ruins  
of Ancient Chaldea**

**DO YOU KNOW** that there has been dug up from the ruins of old Chaldea a complete story of the Flood—the same in every detail as Moses' account in Genesis—and that it was written thousands of years before his version appeared? Hardly one in a million has ever had an opportunity of seeing this startling story—**HAVE YOU?** But it is one of the many thousand curiously interesting accounts in

## The Library of Original Sources

now for the first time available to the general public. Up to the present this remarkable Library has only been sold by subscription, but by taking over the *entire unsold edition* from the publishers we secured it at an *absolutely unheard of bargain*. Therefore we are able to offer the few remaining sets to POPULAR MECHANICS readers at an

## EXTRAORDINARY BARGAIN

### **FREE BOOK**

— thousands have written for our interesting **FREE** book of sample pages and list of curious "original records." Mail the coupon **NOW** and this book will be sent to **YOU**.

Send us the attached coupon **AT ONCE**, and we will tell you how to get the Library on **EASY MONTHLY PAYMENTS**, and mail you **FREE** a book of rare documents. Remember there are only a limited number of sets, so act quickly. Mail the coupon **NOW**. You assume no obligation. No salesman will call. The book is **FREE**.

**THIS MARVELOUS WORK** is revolutionizing modern thought. It's turning upside down old notions and ideas. It gives the authoritative, rock-bottom sources of our knowledge on **ALL SUBJECTS OF HUMAN INTEREST** from the earliest civilization down to today—the inside facts which the average person has never even heard of.

**OVER 100 RESEARCH SPECIALISTS** spent ten years gathering the contents of this great work. Ancient and remote and forgotten civilizations in all parts of the globe were uncovered, and age-buried hieroglyphics on monuments, tablets, sun-baked bricks and papyrus scrolls yielded their secrets; untiring workers ransacked the hidden literature of every age, ancient, medieval and modern, to find the "original documents" that shaped the civilizations and influenced the thought and life of the world. Nothing like it has ever been attempted or thought of before. You'll be amazed at the wealth of information this unique library contains.

**DO YOU KNOW** that the old Egyptians 5000 years B. C. had a Bible?  
Do you know the Assyrian literature gives the story of the Creation?  
Do you know that books and newspapers were printed in Asia thousands of years before printing was invented by Gutenberg?  
Did **YOU** ever read Columbus' *personal log* of his great voyage?  
Do you know that there occurred in Medieval England the first great Socialist protest? Do you know by what unique process Harvey demonstrated the circulation of the blood?  
Do you know who Machiavelli was or what world famous treatise he wrote?

**YOU'LL FIND THEM ALL**—and thousands of others equally as curious and important—in The Library of Original Sources. Every document is in the exact words of the original, translated; every contribution is from the actual eye-witness or person who took part; every idea is in the words of the thinker, investigator, discoverer or inventor.

**JACK LONDON SAYS:** "It is a whole library in itself. I certainly never could spare these books from my shelves."

10 sumptuous, massive volumes, bound in rich, black imported sheepskin; full-page illustrations, pure silk headbands, printed in large, clear type on hand-made paper, gold tops—a veritable triumph of the bookmaker's art.



**MAIL THIS COUPON FOR FREE BOOK**

Name.....  
Address.....

University  
Research  
Dept. G  
Milwaukee, Wis.

Send me the **FREE** book of rare documents, showing curious inscriptions of the Ancients, and tell me of your easy payment offer. I assume no obligation, the book and all you send me is to be *free*, and no salesman is to call.

11  
15  
P. M.

A New, Complete Book for Every Ford Owner, Dealer, Salesman and Repairman

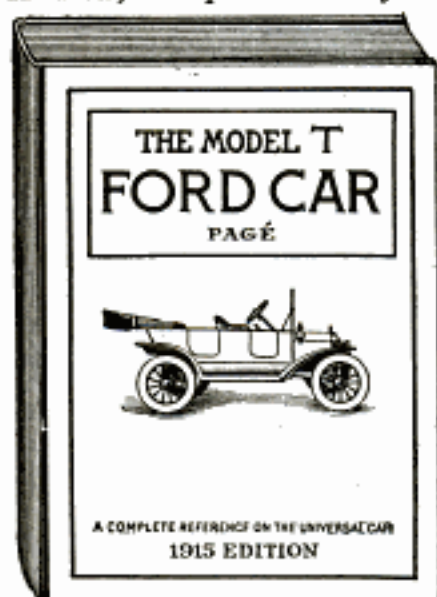

## The Model T Ford Car

### Its Construction, Operation and Repair

By VICTOR W. PAGE

Author of "The Modern Gasoline Automobile," etc.

300 (5x7) Pages. Over 100 Specially Made Engravings and Two Large Folding Plates.

This is the MOST COMPLETE and PRACTICAL instruction book ever published on the FORD CAR. A high-grade cloth-bound book printed on the best paper, illustrated by specially made drawings and photographs. All parts of the Ford Model T Car are described and illustrated in a comprehensive manner—nothing is left for the reader to guess at. The construction is fully treated and OPERATING PRINCIPLES MADE CLEAR TO EVERYONE. Complete instructions for driving and repairing are given. Every detail is treated in a non-technical yet thorough manner.

This book is written specially for FORD DRIVERS AND OWNERS, by a recognized automobile engineering authority and an expert on the FORD, who has driven and repaired Ford Cars for a number of years. He writes for the average man in a practical way from actual knowledge. All parts of the Ford Model T Car are described.

The illustrated chapter on repairing and overhauling alone is worth many times the price of this book. Special description of book sent on request.

**PRICE \$1.00 POSTPAID**  
Your money back if not satisfied

**Popular Mechanics Book Department**  
6 N. MICHIGAN AVENUE, CHICAGO, ILL.

JUST PUBLISHED

**Location of Ford Engine  
Troubles Made Easy**  
A NEW FORD ENGINE CHART

By VICTOR W. PAGE

Size 25x38 inches. Printed on heavy bond paper, Price 25 Cents, Postpaid

## YOUNG MAN! LEARN DRAFTING!

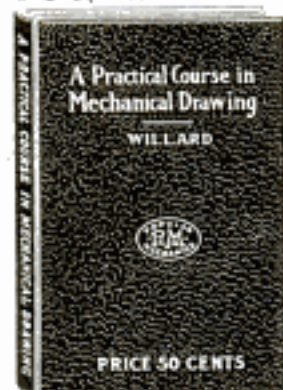

ONE of the most practical subjects of study today; an essential in most lines of engineering; indispensable in many occupations and often the secret of successful advancement; of no less importance to the farmer than the mechanic. There is bound to come a time when you will feel the need of the ability to "lay out" something in accordance with the rules and conventions used in the drafting profession.

**Individual Study**

may be successfully engaged in with the aid of our new enlarged edition of the book

## A Practical Course in Mechanical Drawing

By WM. F. WILLARD

(For several years instructor in Mechanical Drawing at Armour Institute of Technology, Chicago)

160 PAGES—SIZE 5x7—157 DRAWINGS—CLOTH COVER

**Price 50 Cents, Postpaid**

There has been a real need for a book of this kind, as it clinches each problem in the mind of the student by giving the practical application of that problem to every day practice in some phase of the world's work. It meets every modern requirement and is in advance of any other work on the subject. Excellent for use in shop classes, trade or high schools. A complete detailed description of the contents of this book sent free upon request.

Order of your Book Dealer or direct from the publishers

**POPULAR MECHANICS BOOK DEPT.**  
6 N. Michigan Ave., CHICAGO



Ready—Vol. XI  
**SHOP NOTES**  
FOR 1915

**626 Easy Ways To Do Hard Things**

"Written So You Can Understand It"  
224 Pages 517 Illustrations

Paper, 50 Cents; Cloth, \$1.00 Postpaid

A BOOK that is indispensable to everyone who uses tools, either for pleasure or as an occupation. This is Vol. XI in our remarkable series of Shop Notes Annuals and, in addition to the many hundreds of practical time and labor-saving kinks each of these books gives, this volume contains the following articles which are of special value:

Home Garage—Gate for Stock Farm—Concrete Wall—Lawn Sweeper—Glass Cutter for Circular Work—Segment Work in Pattern Making—Simple Level—Locomotive Parade Float—Paving and Pavements—Concrete Garbage Furnace—Portable Boat Landing—Camper's Sleeping Outfit—Water-Power Vacuum Cleaner—Foot-Power Hammer—Automobile Turntable—Reversed Action of Oars—Hammock Swing—Engineer's Kerosene Torch—Elbow Pattern—Power-Driven Catamaran—Air Circulation in Furnace Heating—Windmill—Open-Air Swinging Bed—Self-Contained Gasoline Soldering Torch—Disk Cutter—Electric Cigar Lighter—Simple Resistance Thermometer—Oxyacetylene Welding Torch—Water-Heating Attachment for Furnace—Basement Hothead—Heating an Automobile—Portable Cottage—Bed Desk for Invalid.

Complete sets of Shop Notes consisting of 11 volumes and case \$5.50 prepaid, or any of the single volumes sent postpaid at 50c per copy.

**Popular Mechanics Book Dept.**  
6 N. Michigan Ave., Chicago





# Eat to Live 100 Years

## Synopsis of Course

1. Three great laws that govern life.
2. What food is and its true purpose.
3. Digestion, assimilation and metabolism.
4. Chemistry of the body and the chemistry of food.
5. How wrong eating causes disease.
6. How foods establish health by removing causes of disease.
7. Scientific eating explained, sample menus.
8. Harmonious combinations of food tables.
9. How to select, combine and proportion your food according to age, sample menus.
10. How to select, combine and proportion your food according to occupation and season of year, sample menus.
11. Obesity, cause and cure, sample menus.
12. Emaciation, cause and cure, sample menus.
13. The business man—right and wrong ways of living, sample menus.
14. The new Vieno System of Food Measurement.
15. Food and morality.
16. Tea, coffee, liquor, tobacco, etc.
17. Supercidity, fermentation, gastric catarrh and ulcer, intestinal gas and auto-intoxication. Causes, sample menus.
18. Devoted to same subjects as Lesson XVII, with remedy and sample menus.
19. What to eat and omit for all stomach and intestinal disorders. Read reference lesson.
20. Intestinal congestion (constipation), cause and cure, sample menus for the four seasons of year.
21. Appendicitis—cause, sample menus.
22. Nervousness—cause and cure, sample menus.
23. Curative menus; for each season of year for manual laborers and sedentary workers.
24. Diagnosis simplified and made practical.

## Health, Efficiency and Length of Life Depend on the Foods You Eat

Many authorities agree that over 90% of all sickness originates in the stomach due to wrong eating. Yet not one person in a hundred has any knowledge of how to properly select, combine or proportion his food, which is the fuel of the human system, so as to get any power out of it.

If your stomach only had a window in it so that you could look in and see what happens down there after almost any meal, you would be amazed. Many foods, harmless in themselves, when eaten in combination with other harmless foods produce a chemical reaction and literally explode.

No wonder most people are below par physically most of the time—no wonder the average life of man is only 39 years when it should be three times as great.

Yet the improper combination of foods is only part of the great wrongs we do our systems. Few people know anything about selecting or proportioning their food. We try to run the human system on fuel as unfitness as mud, wet leaves, soggy wood and dynamite would be for a furnace.

## 24 Lessons in Scientific Eating

By EUGENE CHRISTIAN, F.S.D.

No Money in Advance

Only \$3 if You Keep Them

Eugene Christian has long been recognized as a world authority on food and its relation to the human system. Over 23,000 people have come under his care and the results of his work have bordered on the miraculous. Without drugs or medicines of any kind—simply by teaching the proper selection, combination and proportion of foods under given conditions (and they vary according to age, climate, occupation, etc.), he has cured nearly every known non-organic ailment by removing the cause and has doubled the personal efficiency of his patients almost times without number.

### 24 BOILED DOWN LESSONS

Scientific Eating contains the boiled down essence of Dr. Christian's twenty years' experience in actual practice. Every step is logically explained. Reasons are given for each statement which anyone can easily understand and it is a simple matter to follow the simple directions. And the beauty of Dr. Christian's methods is that you get results with the very first meal. No special foods are required. You don't have to upset your table to follow Dr. Christian's directions. Neither do you have to eat things you don't enjoy—nature never intended that you should.

### AN AID TO SUCCESS

You can't do good work unless you feel full of "pop" and ginger. The best ideas, plans and methods—the biggest business deals—are put over when you are bubbling over with vitality. It is impossible to be really fit unless your food is scientifically chosen to supply the nutritive elements your mind and body demand. Man is made up of the sum total of what he eats. You can't add up to a very high state of efficiency if you don't know how to select your food, for the wrong foods counteract the good in right foods—and very often two right foods in combination make a wrong food. Dr. Christian has time and again turned sluggish, slow, unsuccessful men and women into very dynamo of success—achieving efficiency and greatly prolonged the lives of thousands by merely teaching them food values.

### Send No Money

The price of Eugene Christian's course, complete in 24 lessons, is only \$3 and it contains rules, methods and menus that are literally priceless. But we do not ask you to pay a single penny until you have examined this great work in your own home. Merely fill out and mail the coupon enclosing your business card or giving a reference, or write a letter and the entire course of 24 lessons will be sent, all charges paid, the day we hear from you. Keep it five days. Study it at your leisure. Then if you feel you can afford not to be master of the invaluable information it contains, send it back and you owe us nothing. Mail the coupon now, however, as this offer may never again be repeated.

CORRECTIVE EATING SOCIETY, INC.

511 Hunter Avenue,

Maywood, N. J.

## What People Say

"I am feeling fine again, thanks to you and your course of lessons on Scientific Eating. There ought to be 100,000 men practicing Scientific Eating in America."—F. A. Fulby, Niagara Falls, South Ont., Canada.

"I am delighted beyond expression with the lessons. They have proved invaluable to me and have revolutionized both my diet and my health."—Olive M. Sees, 725 East Tipton St., Huntington, Ind.

"Your work on Scientific Eating is invaluable. It is with much pleasure that I recommend your course to prospective students everywhere."—Chas. A. Ivel, 1212 Termon Avenue, North Side, Pittsburgh, Pa.

"Your Course in Scientific Eating is wonderful because it has simplified both the chemistry of the body and the chemistry of the food and teaches one how to unite these two branches of science so as to make our food prevent and cure disease."—Eugene A. Ayers, Harrington Park, N. J.

"I think the Almighty sends men on the earth at different periods with independence and fearless minds to rectify the wrongs that have been taught and reveal the truth in all its simplicity."—Edward Brook, 10 No. 10th W. St., Salt Lake City, Utah.

"I have read of you for years and I have recently looked over some of your work. You are doing much for humanity. I congratulate you on your latest contribution to the health and happiness of man."—Dr. V. M. George, 2305 N. High St., Columbus, Ohio.

SEND NO MONEY—MAIL THIS COUPON TODAY

Corrective Eating Society, Inc.  
511 Hunter Ave.,  
Maywood, N. J.

Send me the "Christian Course in Scientific Eating." I will either return it within five days, and owe you nothing, or send you \$3.

Name.....  
Address.....  
City..... State.....

Please Mention Popular Mechanics

# Get Into a Business that Pays Big Money

**Driving \$80 to \$125 a Month — Repairmen and Salesmen \$300 and Up!**

Lots of driving and touring jobs now open in all large cities and good chances (if you are ambitious) to start a garage, do repairing, sell cars, etc. 400,000 more automobiles this year than last. Every small town in the country needs a Real Expert Auto Repairman. We teach you—and we do it right—the way you would like to learn. We put you to work into overalls, with tools, on all kinds of automobiles, in a real shop and garage. Plenty of actual driving and repairing. Our method is down-in-the-grease—and out-on-the-road. No time limit—you stay till you learn thoroughly and are perfectly satisfied. Here is a chance to "Double Your Pay." If you are out of work or dissatisfied with your present job, change now—Get into

**THE COMING BUSINESS**  
**NATIONAL AUTO SCHOOL** 2625 Reading Rd.,  
 CINCINNATI, O.



Write your name and address on margin of this page, tear out and mail to us—we'll send you our catalog and full information.

**AUTOMOBILE DRIVERS AND REPAIRERS EARN \$75 TO \$150 A MONTH**

The demand for automobile drivers and repairers exceeds the supply. Decide now to fit yourself for one of these well-paying jobs. You can do it—easily—in your spare time. These brand new books—the most practical ever written on automobile engineering—will quickly make you an expert driver or repairer.

**AUTO ENGINEERING**

**\$25.00 Set Now \$14.80—50c a Week**

This auto library contains 2,000 pages, with 1,800 illustrations that make technical points as simple as A-B-C; full-page plates that literally pick the mechanism to pieces before your very eyes; drawings and diagrams that show the working of all the principles employed in the various types of motors. Bound in half red morocco, gold stamped. These five volumes are a most remarkable value at the regular price. Yet we offer a limited number of sets at a special introductory price of \$14.80—payable \$2 a month.

**SHIPPED FREE** Test these books before you buy. You wouldn't buy a car until you had tried it out. Buy books the same way. We send the full 5 volumes to you, express prepaid, for 7 days' free examination. Look them over for a whole week free. See if they don't contain everything a driver or repairer should know. If the books are what you want, send us \$2. Otherwise we'll take them back, paying the express both ways ourselves. In addition to this liberal discount from the regular price of \$25.00, we include with each set a \$2.00 Covering Membership. This entitles you to the advice of a staff of experts for a whole year free.

American Technical Society, Chicago:

Please send Cyclopedia of Automobile Engineering for 7 days' free examination. I will send \$2.00 within 7 days and \$2.00 a month until I have paid \$14.80, otherwise I will notify you and hold the books subject to your order. Title not to pass until fully paid. Pop. Mech. 11-15

NAME.....

ADDRESS.....

REFERENCE.....

## Huge Bargains In Books—New Plan

Special sale by Library Press of good books—fiction, juvenile, history, science—at rock-bottom prices direct: Same price we quote to biggest libraries now to you while this offer lasts. ½ to ¼ publishers' prices. \$1.50 books only 43 cents; similar savings on large sets. Write for bargains today.

**Library Prices to You**

Write for our library catalog with net prices to libraries plainly quoted. Send now.

The Library Press, 1198 Tower Bldg., Chicago, Ill.

## FREE Send for large Catalogue of Practical Mechanical Books FOR HOME STUDY

Best Books for Electricians, Telephone Men, Motion Picture Operators, Engineers, Railroad Men, Motormen, Draftsmen, Automobile Mechanics, Plumbers, Carpenters, Builders, Sign and Card Writers, also Bookkeepers and Civil Service Applicants.

**F. J. DRAKE & CO., Dept. 8**  
 1325 Michigan Ave., CHICAGO



This New Book Sent Prepaid  
 Cloth Binding \$1.00  
 Leather " 1.50

## Learn Typewriting and Stenography at Home

On a Standard, High Grade, 42-key Visible, Silent Woodstock Typewriter. Machine and instructions 10c a day, payable \$3 per month. By showing the machine to friends and acquaintances to let them see wherein it excels any other high grade typewriter, and rendering other small assistance, you can easily earn one, including instructions, to keep as your own. WRITE FOR PARTICULARS.

WOODSTOCK TYPEWRITER CO., Box L 1, WOODSTOCK, ILL.

## EARN FROM \$55 to \$175 A MONTH Learn Telegraphy

In the best equipped COMMERCIAL and RAILWAY TELEGRAPH SCHOOL in the west. Dispatchers' wires of the Union Pacific and K. C. Southern Railroads in school room. Our home instruction course is the most thorough, systematic and satisfactory covering the entire field of telegraphy. Write for catalog.

Armstrong Telegraph & Railroad School, 913 Walnut St., Kansas City, Mo.

## PRACTICAL ART

Invest your spare time. Learn card and sign writing, and lettering. Big growth of advertising makes constant demand for our graduates. I prove there is a big field. Earn a good salary or start in business. Earn while you learn. Cartoonists—learn to letter. It will help you. Course self-paying. Work easy, pleasant. I personally correct all lessons. Write for free booklet, testimonials, etc. Rising School of Lettering and Design, 731 Union Bldg., Cleveland, Ohio

Please Mention Popular Mechanics

# FREE!

Yes, I mean just exactly what I say—that I will give you this magnificent set of Draftsman's Drawing Instruments positively and absolutely free. And besides the instruments in this beautiful plush lined leather case, I will also give you absolutely free a 20x25 inch drawing board, a 24 inch T square, a 12 inch rule, two triangles, a French curve, two bottles of drawing ink, a supply of paper, pencils, erasers, thumb tacks, etc., etc.—a complete draftsman's working outfit, the very same kind that I use myself.

This superb set is valued at \$17.50. It goes absolutely free to those who get my personal instructions in Draftsmanship.

## Become A Draftsman

The need now is for draftsmen! Companies everywhere are looking for skilled draftsmen to fill positions paying from \$125.00 to \$175.00 per month. The work is light, pleasant and profitable. Look at the want ads of our metropolitan newspapers and see for yourself what an urgent demand there is for draftsmen. This is the "Construction Age"—the epoch of a new pace in every field of industrial endeavor. The services of the draftsman are needed more than ever before. Give me a few minutes of your spare time for a few months and I will qualify you for a big salary and a real future.

## Take Your Time To Pay Me

Let me count on you as an earnest student and you won't have to bother about the money question. I'll help you take care of that. To secure the quick enrollment of a few more ambitious men I'll cut my tuition price to an extremely small figure and give the privilege of paying this small cost on terms so easy that you'll scarcely miss the money. Remember you get the draftsman's outfit free, so that you can start in right away. Send the coupon for my amazing free book and full particulars of my special offer.

### CHIEF ENGINEER COOKE

Chicago Engineering Works, Dept. 1X, 455 Cass St., CHICAGO, ILL.

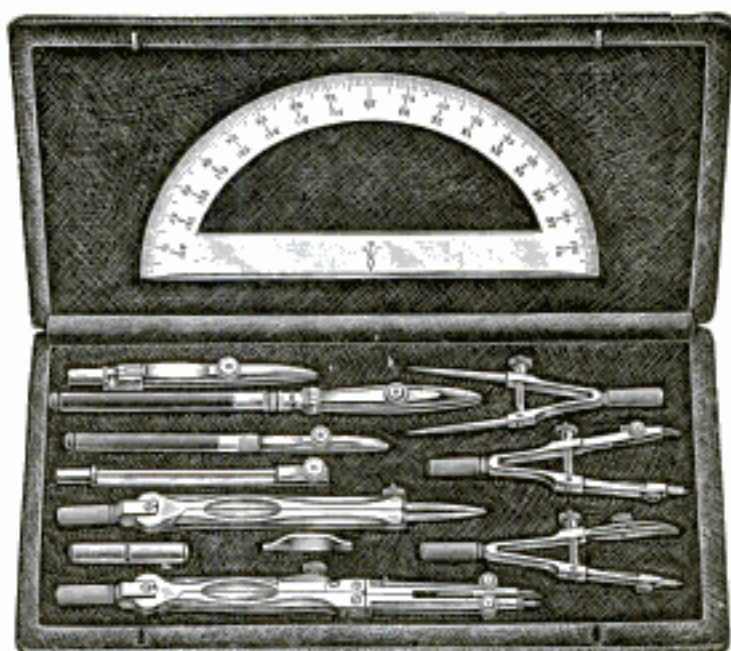

## I Will Train You By Mail

I am Chief Engineer of a large firm. Draftsmanship brought me to my position. I know just the kind of training you need to get a big salary. I will give you personal instruction by mail—instruction based on my own every day practical experience. You need no special talent or requirements. You do not have to take a minute from your regular work. No matter who you are or where you live, if you can read and write and are ambitious I will take you in hand and make a real draftsman out of you. Write for my free book and see what I have done for others. Send the coupon or postcard.

## MAIL COUPON TODAY

### CHIEF ENGINEER COOKE

Dept. 1X, 455 Cass St., Chicago, Ill.

Without obligation or cost to me send prepaid your free book "The Road to Success" and particulars of your very extra special offer.

NAME .....

ADDRESS .....

Please Mention Popular Mechanics

# 95000

Positions Like This  
Are Waiting For  
Trained Men At  
\$1800 to \$4000  
a Year



Why not fill one of them yourself? We're talking facts now—not theories. There's no vivid imagination behind these words. You can prove them before you answer this advertisement if you wish.

## Trained Traffic Men in Demand Everywhere

Here's the proof. There are 500,000 shippers in the United States. 100,000 of them are big enough to employ individual traffic managers. There are now 3000 to 5000 traffic managers in the country. That leaves 95,000 shippers without a traffic manager to fill one of the most important positions in their entire organization; a man they need; a man that can save them money.

### PREPARE NOW TO FILL ONE OF THESE SPLENDID POSITIONS

Thousands of shippers are coming to realize their need of an expert, trained traffic manager.

But the supply of trained men who know all the ropes doesn't begin to meet the demand.

Thousands upon thousands of men in America are in the wrong job; right perhaps, as far as the work is concerned, but wrong where the pay comes in. Few men can be contented in a job that doesn't pay well or offer a good chance for steady and sure advancement.

This is the day when far sighted ambitious men climb out of ruts and seek opportunities where the going is good.

To become a successful and highly paid traffic manager, just three things are essential. A common school

**INTERSTATE TRAFFIC SCHOOL**

education, intelligence and training. You don't have to have "special talent". It's a simple proposition of figures and knowledge. When you have mastered tariffs and freight rates you can land in a job paying at least \$1800 and if you get in with a big firm, where your services will save lots of money, you can earn as high as \$10,000.

This isn't theory—it's facts—cold facts. Ask any shipper you know if the trained traffic manager isn't one of the most important and well paid men in the shipper's service. Ask him if it wouldn't be a good thing for you to get into.

Then send for our free catalog. It tells who we are, what we teach and how we do it. We'll train you to earn \$1800 to \$4000 a year as a Traffic Manager.

Dept. 171 FT. WAYNE, INDIANA

**CACHOO!** Make the whole family and all your friends "just sneeze their heads off" without knowing why, with **Cachoo**, the new long distance harmless snuff. Sent anywhere for 10c. 3 for 25c. 1 doz. and special premium for 90c. **AMERICAN SUPPLY CO., St. Paul, Minn.**



### SPEAK A FOREIGN LANGUAGE!!!

The European war has created a great demand and unlimited opportunities for those who know Spanish, French, German or Italian. Now is the time to better your position or increase your business. You can learn quickly and easily, at home, during spare moments, by the

#### LANGUAGE-PHONE METHOD And ROSENTHAL'S PRACTICAL LINGUISTRY

You listen to the living voice of a native professor pronounce the foreign language, over and over, until you know it. Our records do all talking machines. Write for booklet, particulars of Free Trial. Easy payments.

The Language-Phone Method, 941 Putnam Bldg., 2 W. 45th St., N. Y.



## BE A DETECTIVE

Earn from \$150.00 to \$300.00 per month; travel over the world. Write

C. T. LUDWIG, 133 Westover Bldg., Kansas City, Mo.

### Chicago Correspondence School of Law

Prepares Students at Home for the Bar. Four Courses of Study: College, Post-Graduate, Business Law and Bar Examination Review. Actual Daily Lessons by a recognized School that is approved by Bench and Bar.

Write today for FREE Catalog and Rules for Admission to the Bar.

520 Reaper Block, Chicago



### SHOW CARD WRITERS

EARN \$80 TO \$200 A MONTH  
**LEARN FREE!**

We will furnish a thorough course in Show Card Writing and Lettering absolutely free to introduce our colors if you will purchase an assortment of Alpha Colors to use while practicing. Particulars for stamp.

ALPHA COLOR COMPANY, Inc., Dept. K, 81 East 125th St., N. Y. City



## Be an Artist AND DRAW for Magazines, Newspapers, Etc. Earn Big Money

All Branches of Art Taught BY MAIL or Local Classes. Write for illustrated booklet, terms and list of successful pupils. ASSOCIATED ART STUDIOS, 2122 Flatiron Bldg., NEW YORK

## LEARNED BY ALMOST ANYONE AT HOME SMALL COST

Send today 2c stamp for particulars and proof. O. A. SMITH, Room D 130, 823 Bigelow St., PEORIA, ILL.

## ARITHMETIC SELF-TAUGHT

A plain, easily-understood volume for all who have not had the opportunity of learning this subject thoroughly, or who have forgotten what they once learned. 257 Pages. Requires no teacher. This great little book sent postpaid for 60 CENTS. Stamps accepted.

GEO. A. ZELLER BOOK CO. Est. 1878, 4472 W. Belle Place ST. LOUIS, MO.

SPANGENBERG'S PRACTICAL ARITHMETIC Self-Taught

Learn to Write

BEGIN TODAY WRITE FOR MY FREE BOOK

I can make a good penman of you at home during spare time. Write for my free book, "How to Become a Good Penman."

It contains specimens and tells how others mastered penmanship by the Tambllyn System.

Your name will be elegantly written on a card if you enclose stamp to pay postage.

F. W. Tambllyn, 418 Meyer Bldg. Kansas City, Mo.

Write for it Today

BOOK



# SENT FREE

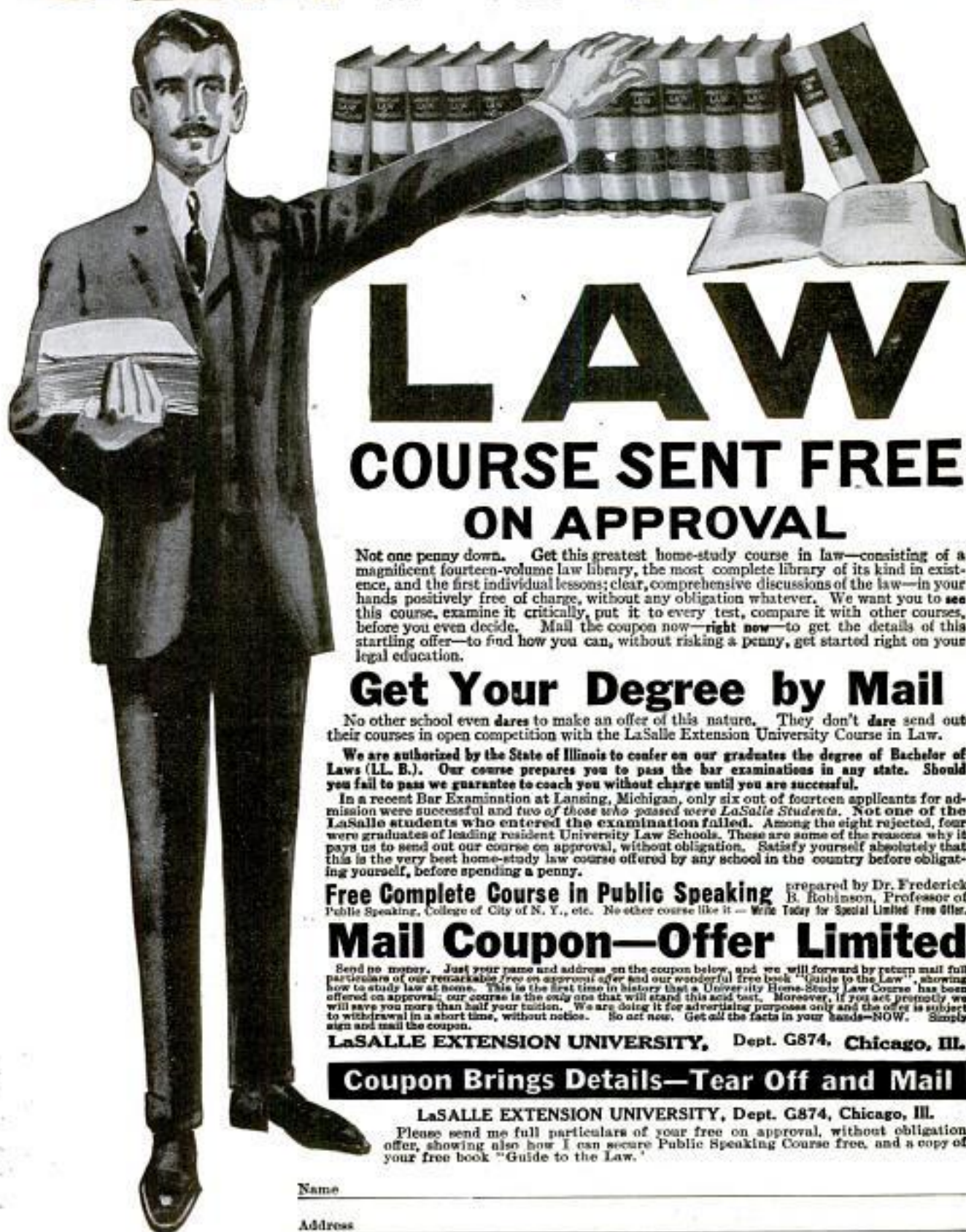

## LAW

### COURSE SENT FREE ON APPROVAL

Not one penny down. Get this greatest home-study course in law—consisting of a magnificent fourteen-volume law library, the most complete library of its kind in existence, and the first individual lessons; clear, comprehensive discussions of the law—in your hands positively free of charge, without any obligation whatever. We want you to see this course, examine it critically, put it to every test, compare it with other courses, before you even decide. Mail the coupon now—right now—to get the details of this startling offer—to find how you can, without risking a penny, get started right on your legal education.

### Get Your Degree by Mail

No other school even dares to make an offer of this nature. They don't dare send out their courses in open competition with the LaSalle Extension University Course in Law.

We are authorized by the State of Illinois to confer on our graduates the degree of Bachelor of Laws (LL. B.). Our course prepares you to pass the bar examinations in any state. Should you fail to pass we guarantee to coach you without charge until you are successful.

In a recent Bar Examination at Lansing, Michigan, only six out of fourteen applicants for admission were successful and two of those who passed were LaSalle Students. Not one of the LaSalle students who entered the examination failed. Among the eight rejected, four were graduates of leading resident University Law Schools. These are some of the reasons why it pays us to send out our course on approval, without obligation. Satisfy yourself absolutely that this is the very best home-study law course offered by any school in the country before obligating yourself, before spending a penny.

**Free Complete Course in Public Speaking** prepared by Dr. Frederick B. Robinson, Professor of Public Speaking, College of City of N. Y., etc. No other course like it—Write Today for Special Limited Free Offer.

### Mail Coupon—Offer Limited

Send no money. Just your name and address on the coupon below, and we will forward by return mail full particulars of our remarkable free on approval offer and our wonderful free book "Guide to the Law", showing how to study law at home. This is the first time in history that a University Home-Study Law Course has been offered on approval; our course is the only one that will stand this acid test. Moreover, if you act promptly we will save you more than half your tuition. We are doing it for advertising purposes only and the offer is subject to withdrawal in a short time, without notice. So act now. Get all the facts in your hands—NOW. Simply sign and mail the coupon.

**LaSALLE EXTENSION UNIVERSITY, Dept. G874, Chicago, Ill.**

### Coupon Brings Details—Tear Off and Mail

LaSALLE EXTENSION UNIVERSITY, Dept. G874, Chicago, Ill.

Please send me full particulars of your free on approval, without obligation offer, showing also how I can secure Public Speaking Course free, and a copy of your free book "Guide to the Law."

Name \_\_\_\_\_

Address \_\_\_\_\_

Please Mention Popular Mechanics



# Power for YOU!

Power from within! Strength that is *more* than mere muscular strength—the strength of better health, abundant nerve force. Write—

find out what vibration will do for you. Nine people out of every ten are only *half alive!* Are you? If you haven't that vigorous, "go-ahead" feeling all the time, send the coupon for our big new book.

## The Exhilarating Vigor of Life—Strength—Youth

may be returned to you through *Vibration*. For *Vibration is Life itself*. In *Vibration* there exists many of the secrets of life. The safest, surest and quickest way to recover normal health is by scientific manipulation of the organs affected and in this way stimulating them to perform their duties, whether it be those of digestion, respira-



tion, circulation or nervous system. Your blood is sent humming along through every vein, artery and tiny capillary. Our combination outfits give you three of the greatest curative agents—Vibration, Faradic and Galvanic electricity. We will send this wonderful machine to you on free trial. See it—try it. Feel its health-giving vibrations for yourself. You can enjoy its wonder-working powers right at home, right in the privacy of your own room. Find out what vibration will do for you.

### The White Cross Electric Vibrator

is the result of years of work and experiment. It is absolutely perfect. If you have your house wired for electricity, you can connect it up as easily as an electric lamp; if not, it will run perfectly on its own batteries.

### Special Offer for a Limited Time

For a short time only we are making a remarkable Special Introductory Offer on the White Cross Electric Vibrator—amazing discounts—actual rock-bottom prices direct if you act at once.

**FREE BOOK** Sign the coupon and mail it to us today. Get our splendid big FREE book telling you all about the marvels of *Vibration*. Read what scientists say about it. Post yourself on what it will do for you. Learn all about the White Cross Electric Vibrator and our limited offer. You are under no obligations at all—all you need to do is to send the coupon today—

you can send a postal card or a letter, but the coupon will do just as well.

**Lindstrom-Smith Co.**  
1100-1110 S. Wabash Ave.  
Dept. 1198, CHICAGO, ILL.  
We also manufacture White Cross Electric Stoves, Irons, Hair Dryers, Electric Lanters, Electric Fans, Electric Automobile Horns, Electric Carding Irons, Heating Pads, Sewing Motors, etc., etc. Dealers write.

**Lindstrom-Smith Co.**  
1100-1110 S. Wabash Ave.  
Dept. 1198  
Chicago, Illinois

Without any obligations on my part, please send me, free and prepaid, your free book on *Vibration*, full particulars of the White Cross Vibrator and your Special 60-Day Offer.

NAME.....

ADDRESS.....

My Electrical Dealer's name is

.....

## Home-Made Toys for Girls and Boys

Wooden Toys, Cardboard Toys, Spool Toys, Mechanical and Electrical Toys

By A. NEELY HALL

*Profusely illustrated with photographs and working-drawings by the author and Norman P. Hall. Net, \$1.25*

Home-made toys have an increased value over purchased ones in the pleasure and practical experience gained in producing them.

It is not a lack of playthings that makes toy-construction so attractive, but rather the love of doing something interesting, and afterward being able to say of each toy, "I made it all myself."

At all bookstores. Send for Free Catalog.

LOTHROP, LEE & SHEPARD CO., BOSTON



## DO YOUR OWN SOLDERING

—and Save Money

Send 55 cents for "Simple Soldering"

A BOOK of Instructions

(Illustrated)

SPON & CHAMBERLAIN  
123 P. M. Liberty St., N. Y.



SEND  
FOR  
FREE  
BOOKS

## DO YOU WANT TO KNOW HOW TO DEVELOP VITALITY, ENERGY, ENDURANCE, NERVE STRENGTH, MUSCULAR STRENGTH PERFECT PHYSIQUE?

My FREE BOOKS, "The 'Whys' of Exercise" and "The First and Last Law of Physical Culture," tell you, if you are weak or underdeveloped, how to grow strong; if strong, how to grow stronger. They explain how to develop lungs and muscle, the strong heart and vigorous digestion—in short, how to improve health and strength internally as well as externally. Send TO-DAY—NOW—for these FREE BOOKS. Enclose 4c in stamps to cover postage.

PROF. H. W. TITUS, Department 133  
55-56 Cooper Square, New York City

MAGIC

TRICKS

Let us send you two clever card tricks—puzzling to your audience, yet easy to do. Also booklets illustrating THE MAGIC SHOP

numerous Magic and Card Tricks All For 10¢  
We have a selected assortment of new Card Tricks Sent for \$1.00 postpaid  
52 N. 13th St. Phila., Pa.

**BOY ELECTRICIAN** with 75 illustrations for making Batteries, Dynamos, Motors, Telegraph Apparatus, Telephone, Lights, Bells, Alarms, Cords, "Wireless" Current Reverser, Electric Engine, etc. By Electrical Experts, so that anyone can understand it. With Cat. All 10c Postpaid. NATIONAL CO., Dept. 34, 3422 Lyndale St., CHICAGO

FREE

"Linene" COLLAR

State size on postal and whether you want collar like cut or low turnover style.  
REVERSIBLE COLLAR CO., Dept. U, Boston, Mass.

Please Mention Popular Mechanics

**SALESMEN  
GET THE  
BIG PAY**



**WHEN YOU BRING IN A BIG  
SALES RECORD YOU CAN  
TALK TO THE BOSS  
ABOUT A BIG SALARY  
AND HE'LL LISTEN**

# BE A TRAVELING MAN

## EARN \$2,500 TO \$10,000 A YEAR

See the wonders of America; live at the best hotels; wear the latest clothes; interview successful merchants; earn the best salary; save money, be independent.

Everywhere there is an unlimited demand for Trained Salesmen. You can be one. You can learn at home in your spare time and have an opportunity to earn Big Pay while you learn. My easy, practical Course of Instruction in Scientific Salesmanship requires only a very little of your time—an hour or so each day—for a surprisingly short period, to prepare you to fill a position as a Salesman—and my big Free Employment Bureau will assist you to secure a position where you should easily earn from \$2,000 to \$10,000 and more per year.

My Big Free Illustrated Book, "A Knight of the Grip" tells the whole story. Send for it today. Learn first-hand, and now, just how easy it is for you to fit yourself at your home in spare time, to become a successful, prosperous Salesman. Learn how my easy, practical Course fits you to earn more money, and earn it easier, in a single week than most men earn in a whole month. Thousands of men everywhere (like those testimonials we publish herewith) have accepted this invitation to "Learn How To Sell," and as a result are today holding permanent, pleasant, big-paying positions as Salesmen, representing the biggest firms in America.

I have received requests from more than 15,000 of the biggest and best firms in America for Trained Salesmen—men whom I could personally recommend as competent, and capable of filling good paying positions as Traveling Salesmen. These firms employ thousands of Salesmen every year and are always in the

market for good ones. I merely mention this to emphasize the unlimited demand of the business world for

Trained Salesmen, and the fact, too, that good Salesmen are always the sought instead of the seekers; always the makers of terms and the dictators of salaries. They are the most independent, best paid body of men in the world.

There is a position as a Salesman ready for you—a good position where your Earning Power will be unlimited—when you are ready for it. Prepare yourself now.



**I Have Earned  
\$1,500 a Month**

I was formerly a printer, since taking your Course four years ago I have earned from \$200.00 to \$1,500.00 a month as a Salesman. Your Course is worth fifty times what you charge for it.

JAS. SEVICK,  
4415 N. Avera  
Avenue  
Chicago, Ill.

**I am in the  
\$2,500 to  
\$10,000 Class**

I was a carpenter, am now a Salesman and can proudly say I am in the \$2,500.00 to \$10,000.00 a year class. Wish I could invest more dollars that would bring me the big returns I have invested in your Course.

J. E. WOOD,  
Rosen 352-54  
Pacific Bldg.  
San Francisco,  
California

**I Made \$280  
and Expenses  
the First Month**

Any ambitious man can become a Salesman and increase his earning power by taking your Course. Your Employment Bureau is a dandy. I had no trouble in securing a good position and will be delighted to boost for the N. S. T. A.

J. ED. WHITE,  
622 1/2th Av. S. W.  
Great Falls,  
Mont.

**I Earned \$6500  
This Year**

Last year I only earned \$800.00 as a clerk. This year I have earned \$6500.00 and have been promoted to Salesmanager and done it by studying your Course during spare time. Your Employment Bureau offers me many good positions.

C. W.  
Firming base,  
2015 W. 25th St.  
Denton, Ohio

**Increased Earn-  
ings \$300 First  
Month**

Have derived great benefit from your Course already. Before I enrolled I only earned \$20.00 a month. Your instructions have enabled me to earn over \$700 this month. They will help an old Salesman as well as a beginner.

Max H. Yucht,  
67 E. 114th St.,  
New York, N. Y.

**I Lead the  
"Saxodent"  
Sales Force**

I had been a machinist but on joining your School in 1909 you secured for me my present position with Hall & Buckel, the makers of "Saxodent." I have led the selling force continuously and my success is due to your training.

H. A. Raynor,  
48 Prospect St.,  
Dover, N. J.

*W. Dugheerty*

**SEND FOR THIS  
BIG FREE BOOK  
NOW**



THIS  
FREE  
BOOK  
TELLS  
THE WHOLE  
STORY

## BE A WINNER — START TO-DAY

You can't give one single, sane reason why you should not be able to earn more money—several times more—than you are now earning, unless it is that you have failed to prepare yourself. This is true, and you know it. You know, too, that no profession offers such wonderful money-making possibilities as does that of Salesmanship. In no profession can one earn so much money, be so independent, or broaden so rapidly as in Salesmanship. It's training that counts—just such a Training as you can get from my Easy, Common Sense, Thorough, Practical Course of Instruction in Salesmanship that has enabled thousands of other men to make a success.

The reason for the tremendous demand for our graduates is that they are Trained Salesmen—the kind that make good and that every firm wants and that there is an unlimited demand for, and that get the Big Pay. You can become one of them. Learn how by filling out the coupon and mailing it Today. Our free book, "A Knight of the Grip," tells the whole story; it also contains a large number of testimonials from our Students and a big list of the different lines of business in which there are now good openings for Salesmen—Send for it—NOW.

**NATIONAL SALESMEN'S TRAINING ASSOCIATION**  
DEPARTMENT 507  
CHICAGO • NEW YORK • SAN FRANCISCO

**MAIL THIS COUPON NOW**

National Salesmen's Training Association,  
Chicago, San Francisco  
(Send your request to the office nearest your home.)  
With no obligation on my part, please send me your FREE Illustrated Book—"A Knight of the Grip."

Name.....

Street No.....

Town.....State.....



H. J. RAHE, President  
Automobile Training School  
Kansas City, Mo.

## Men Wanted

To Fill Positions Paying  
**\$75 TO \$300**  
PER MONTH

Six weeks from the day you commence your studies in this great practical school, you will be able to repair any make of automobile and to drive any car on the market.

Prepare yourself to earn a salary of from \$75.00 to \$300.00 per month; or to go into business for yourself as a garage owner or automobile agent and make from \$2,000.00 to \$5,000.00 a year.

Graduates of this school are in demand. Many of our graduates are to be found in high-salaried positions in some of the largest automobile factories in the country. Many are in business for themselves and are making big money. Ask us to prove that the Automobile Training School of Kansas City, Mo., has more graduates holding responsible positions than all other automobile schools in the West combined.



**No Books Used**  
**No Tools to Buy**

The Automobile Training School has no illustrated books and offers no charts or correspondence courses. Our students receive individual practical instruction under practical conditions on up-to-date automobiles and motors from the best instructors that we can secure. This school, we claim, is the largest in the world, occupying three big buildings, operating two of the principal garages and repair shops in Kansas City. We claim to have more floor space, more instructors, more equipment than any other Automobile School in the United States.

## \$50 Scholarship Free

As a very special inducement to enroll the full capacity of our school without delay, we are including with our regular automobile course, absolutely free of any charge, our big new combination in Tractor and Stationary Engineering. We will only offer a limited number of these free scholarships. If you wish to take advantage of this special offer, write today. We will send you free and postpaid, copy of our big sixty-page book, "How To Make Money In The Automobile Business"—filled with scores of illustrations from our school, and letters from successful graduates all over the world. Sign your name and address on the coupon below, and mail it now.

HENRY J. RAHE, President

**Automobile Training School**  
1058 Locust St. KANSAS CITY, MO.

### FREE SCHOLARSHIP AND BOOK COUPON.

Henry J. Rahe, Pres., AUTOMOBILE TRAINING SCHOOL, 1058 Locust St., Kansas City, Mo. Send me, free and postpaid, your big, 60-page illustrated book, also the free \$50.00 Scholarship Certificate covering Course in Tractor and Stationary Gas Engineering and Electric Starting and Lighting, as offered in your advertisement. This request does not obligate me in any way.

Name.....R. F. D.....  
Postoffice.....County.....State.....

Please Mention Popular Mechanics

## Young Man!

### Your greatest opportunity



Write  
for  
Book  
Today  
It's  
FREE

To the man who wants to improve his condition in life—to increase his earning capacity—to get away from the monotony, grind, and low wages of ordinary occupations—to elevate his social standing, the new profession of Tree Surgery, which is not overcrowded, offers the young man of today his greatest opportunity. The Extension Course given by The Davey Institute of Tree Surgery will fit you to practice this profitable profession.

### LEARN TREE SURGERY AND FRUIT GROWING BY MAIL

You can become proficient in this work without interfering with your present occupation. An hour or so a day will give you a training that will make your future bright and prosperous. The work of a Tree Surgeon is healthful, fascinating and remunerative. The call for men in this profession is far greater than the supply, and the demand is growing. There are positions open at good salary and opportunities everywhere to establish a paying business of your own. Why work for others at small pay when you can be your own boss? Write today for our book, "Adventures in Success." Read what others have done, and learn how easily and quickly you can improve your condition in life.

**THE DAVEY INSTITUTE  
OF TREE SURGERY**  
363 Oak St., Kent, Ohio

## DRAWING

Learn by mail in your own home. Cartooning, Newspaper, Magazine and Commercial Illustrating, also

**Water-Color and Oil Painting**

Learn Drawing or Painting for profit and pleasure. We can develop your talent. This school has taught thousands. Free Scholarship Award—special limited offer. Your name and address brings you full explanation and our handsome Illustrated Art Annual by return mail. Don't delay. Write today.

**FINE ARTS INSTITUTE, Studio 218, Omaha, Neb.**

VIOLIN  
MANDOLIN  
GUITAR

**FREE FINE TONE**

or

CORNET

To introduce our wonderful new system of teaching note music by mail, Violin, Guitar, Mandolin, Piano, Organ or Brass Band, will give you a dandy instrument absolutely FREE and guarantee to make you a player or no charge. Complete outfit FREE. Special offer to first pupil. Write at once. SLINGERLAND'S CORRESPONDENCE SCHOOL OF MUSIC, Dept. 9, Chicago, Ill.

### LEARN WATCHMAKING AND ENGRAVING

Earn while learning. Most practical watch school. Individual instructions. Graduates in great demand. Book free. Chicago School of Watchmaking, 63 E. Van Buren St., Chicago

## Public Speaking Taught at Home

Write for our special public speaking offer. 15 minutes a day, spare time, will make you a powerful, convincing speaker. You can be at ease before any audience—enrich your vocabulary—increase your earning power—become more popular. We have trained hundreds of successful speakers by mail at home.

**Special Offer—Write Now** Send quick for detailed offer. No obligation. But you must hurry. Write now.

**Public Speaking Department**

American Correspondence School of Law, 1198 Manhattan Bldg., Chicago, Ill.



# Learn Electricity! Plumbing—Bricklaying

## Earn \$125 to \$250 a Month

That's what many of our graduates earn right from the start. That's what YOU can earn if you become a COYNE trained man. All of these trades offer exceptional opportunities for starting a business of your own, on very small capital, and becoming entirely independent.

Any man between the ages of 15 and 50 who is ambitious, can learn one of these big paying trades thoroughly in a short time and at small expense. No special education necessary.

16 Years of Success



## COYNE TRADE SCHOOLS

### Largest, Best Equipped Trades School in America

For fifteen years we have sent hundreds of men out annually as skilled mechanics to help supply the rapidly increasing demand. Let us train you for one of these big jobs. Our employment bureau assists graduates to big paying positions free of charge.

We teach all these big paying trades under actual working conditions. We do not have classes, do not use books, do not teach by correspondence. Each man is instructed individually right in our big shops. Drafting, Estimating and Plan Reading included in ALL courses.

We charge a small tuition fee which can be made in easy payments if desired. All tools, equipment and material is furnished by the school FREE. Our institution is open Day and Evening. Many of our students earn a part or all of their expenses while attending. Our employment bureau is always ready to assist a man to earn expenses, without charge.

### Motion Picture Operating Drafting Courses

Also PRACTICALLY TAUGHT  
These new big paying trades are demanding more and more trained men everywhere and our graduates are sought after by theatre managers and Engineering firms throughout the country.

## Send for Free Book of Trades



MAIN BUILDING

Fill in this coupon and mail today. We'll send you our Book of Trades and full particulars. Free and Prepaid.

Address, B. W. COOKE, Director  
**COYNE NATIONAL  
TRADE SCHOOLS**  
Dept. 1198  
39-51 E. Illinois St., Chicago

SEND THIS  
COUPON

### FREE BOOK COUPON

B. W. COOKE, Director  
**COYNE NATIONAL TRADE SCHOOLS**  
Dept. 1198, 39-51 E. Illinois St., Chicago

Dear Sir:— Without any obligations on me whatsoever please send me your book of trades and full particulars— ALL FREE.

Name.....

Address.....

Please Mention Popular Mechanics



Prof. F. W. Foote  
Psychologist

Do You Know  
the LAWS which  
CONTROL Your  
Brain?

and  
Personal  
Power Can  
Be Obtained as  
an Absolute Result  
from a Knowledge of  
**MENTAL LAWS**

You know that your Brain plays tricks with you and that you are conscious of **Constant Mental Leakage**; **Constant Loss of Mental Power and Energy**; **Constant Worry, Anxiety and Muddle**.

Now, **Why work in the Dark?** Realize that you can **Train Your Brain to Think**

just as you can train YOUR MUSCLES TO ACT. It is useless for you to attempt any kind of study unless you can so master your Brain so as to obtain instant **Obedience**. Brain control is the first requisite for **Success**.

**A TRAINED BRAIN**

will give you ability to bring all the facts of any problem into the focus of your **MENTAL** machine when needed. It is not only mental activity, but control and use of that activity so that the greatest results may be obtained. Let me teach you these laws which will give you this **MASTER POWER**. The "systematic study of Mental Laws" which is the

Science of  
Psychology

will give you  
**Positive Success**

Your

**Personality** will be expressed in all your actions; and you will have the conscious knowledge and use of your own **Trained Will Power**

Nothing will be able to throw you down, for you will have a **Mental Equipment** which will be able to penetrate and **Master every Circumstance**. Your struggles will be opportunities for **Success**. You will thus **Master Your Destiny** by using your powers to the full.

My scientific training in the great Universities of the world is at your disposal. It will be my pleasure to personally train you to increase your **Mental Powers**. My knowledge will enable me to know which is the law for you to use and master. You cannot afford to ignore the opportunity which this course of study offers. It is based on the fact of law. **YOUR SUCCESS IS POSITIVE and ASSURED**. You will send for this Free Book and obtain the information which will mean **POWER and MONEY for YOU**.

Send for this **FREE BOOK** at Once

**FREE BOOK COUPON**

**PROF. FREDERICK W. FOOTE**  
President Frederick Academy of Correspondence  
30 No. Michigan Blvd., CHICAGO, ILL.

Send me Free Book "Mental Mastery" and all particulars of your Mental Training Course.

NAME.....

ADDRESS.....



11-15

**New Positions Ready**

\$25 to \$45 Weekly



New profession just being created—only uncrowded field. Big positions with lucrative salaries to start for **men and women**. You are needed now—learn at our risk—be a **CONFIDENTIAL SECRETARY**

— the new executive position — right-hand aid to the big boss. Learn his secret methods—step into official position. Thousands now needed in large and small towns. You can qualify through the remarkable new discovery—the salary-raising **Botsford NEW METHOD IN TOUCH** — the speed system that amazed employ-  
Typewriting. New idea—write 150 per cent faster without looking. Stenographers everywhere will soon discard slow, old-time sight systems.

**Big Position While Learning**

by mail, in spare time. W. F. Gousser, 1123 Drummond Pl., Chicago, writes: "An only half through course and I secured high-salary position as Confidential Secretary to Gen. Mgr. of largest firm of its kind in the world. Know nothing before about Typewriting." Write for other letters like this. No matter what your present work, we qualify you easily—quickly. Stenographic or office experience unnecessary. If already a stenographer, double your salary.

**SUCCESS OR MONEY BACK** — you risk no money — entire course on trial. Write for bank proof. Don't hesitate—tuition payments to suit you. One of these big positions is possible for you. Begin now while the need is great.

**START FREE SEND NO MONEY** — No obligation — simply write for complete first lesson — **FREE**.

Special limited offer — act NOW! Write for proof of graduation needed and letters of success. Learn how we loan \$100.00 Typewriter while learning. **Shorthand — FREE** first lesson. If you wish to learn Short Hand only, write for special offer on Botsford Classified Course—used by world experts. Address: **Jessie Parrish Hays, Botsford Institute, 1102 Botsford Building, CHICAGO**

**\$100.00 Typewriter FREE** While Learning

**GOOD MEN WANTED**

at once to learn the auto business. Big future for you or anyone who makes himself an auto expert. You learn here by doing the work yourself. Lifetime opportunity to learn the highest and most expensive auto work ever given. Omaha's **NEW Auto Training College**, one of the largest in the west, conducted by experienced Automobile men of Omaha, giving the highest and finest practical auto training work to be found anywhere.

**AUTO** Experienced repairmen come and take exactly same course. We teach expert higher training here regular auto repairment that they don't who teach you shouldn't even know.

**\$900 to \$3,000 a Year, Salary or Bus. Profits** in Repairshop or Garage, or as Salesmen, Factory Testers, Chauffeurs, Repairmen, Starter Experts or Garage Manager. If ever you are going to make a change to get into a higher paying and more pleasant line of work, **DO IT NOW**, the opportunities are the best now that they have ever been. Take our wonderful training course now until you are competent, and then go right into the automobile business from here. Positions now open needing capable men, and we want some good men at once to take up this work. Special \$50 course in Elec. Starting and Tractioning **FREE** with regular course. Learn here in 6 wks. or more. Tuition small. Life scholarship. Work easy and interesting. Many make expenses while learning. Free catalog at once.

**AMERICAN AUTO COLLEGE, 483 Auto Bldg., Omaha, Neb.**

**DO YOU WANT MORE MONEY?**

Learn the art of Sign & Showcard Writing. Branch of Advertising. Men and women make big money. Personal instruction and original methods (copyright) make you expert.

**\$6.00 Per Day or More**

is the union scale in Chicago and other towns. You can make even more on job work. Have a big business of your own. We show you how, and help you pay for your course. Particulars and booklets free. Contains everything. Write today. The School with a **METHOD**.

**ILLINOIS SCHOOL OF LETTERING & DESIGN**  
Dept. B, 157 N. Clark Street Chicago, Illinois



OSCAR A. PORE  
PRESIDENT

**Cartooning** Taught by Mail in  
Your Own Home

Learn while holding present position. Cartoonists make good money. No matter where you live, our course will fit you in spare time to earn larger salary. Work congenial, independent, interesting. Don't delay. Write today for full information.

**NATIONAL SCHOOL OF CARTOONING**  
780 Terminal Building INDIANAPOLIS, U. S. A.



# Direct from Class-Room to Student

is the way we teach law. We are the only school doing this. Our system of teaching is interesting; not dry and dull like the average law course. Our system of conducting examinations is the most thorough, complete and expensive (to us) of any examinations ever given. A student can if he chooses, take part of our course by mail and finish in our resident school where he will receive full credit for all work done by mail.



Our Degree Bachelor of Laws, LL.B.  
NOT a Diploma or Certificate

## Study at Home Become an LL.B.

We confer this Degree of Bachelor of Laws—LL.B.—only when the student has completed our full course with the necessary credits, to the satisfaction of the Faculty, exactly the same as in our resident school. This College is no "degree mill." Passing Bar Examination is not our standard for conferring this degree. Our degree stands for accomplishment, honor and distinction. It is worth working for, and a treasure to its possessor.

## Written Bar Guarantee

We give an absolute written guarantee to prepare our students to pass bar examinations.

The Hamilton College of Law is a regular, thoroughly recognized, bona-fide College of Law and NOT an "institute," "correspondence school," or a corporation selling sets of law books under the guise of teaching law.

This College occupies the entire third floor of the New Advertising Building where its large and commodious Class-rooms, Extensive Library and executive offices are located. School and Course Highly Endorsed and recommended by Government Officials, Business Men, Noted Lawyers, Graduates and Students.

## FREE Complete Course in Oratory and Public Speaking

This course has been prepared and written by Prof. Oscar G. Christgau, LL. M. (Master of Laws), the regular resident school professor in charge of this work. Knowing law, from a lawyer's standpoint, he has prepared this series of 36 lectures to meet all the requirements of the practicing attorney. This Course in Oratory and Public Speaking sells, individually, for \$30.00, but it is absolutely free to Hamilton College students.

Partial View of One of Resident Class Rooms of Hamilton College of Law.



**ONLY  
LAW  
SCHOOL  
of its Kind in  
AMERICA**

ONLY recognized resident law school in the United States conferring Degree of Bachelor of Laws, LL.B.—by correspondence, strictly on the merits of its course. ONLY law school in U. S. conducting standard resident school and giving same instruction by mail. Only law school giving over 500 class-room lectures to its extension students. Only law school giving a full 3-Year, University Law Course, by mail, having an actual faculty of over 30 prominent lawyers in active practice. Only law school in existence giving a Complete Course in Oratory and Public Speaking, in conjunction with its law course.

## Our Law Library

consists of 24 volumes of Students' Standard Text Books, two volumes bound together under one cover, making a total of 12 books. These books were prepared at an enormous cost especially for the students of the Hamilton College of Law, by one of the largest and best law book publishers in America. This is the only set of text books ever prepared exclusively for students' use. We would be glad to have you submit these books to any lawyer or judge in the country and get his opinion regarding them.



These 12 Volumes are Free to Students

## Mail Coupon Today

and get our Handsomely Illustrated Prospectus. Gives you a clear understanding of the Profession of Law, and how we are successfully teaching it by correspondence. It may mean the turning point in YOUR career.

**HAMILTON COLLEGE OF LAW**  
901 Advertising Building, Chicago, Ill.

Gentlemen:—Kindly send me your Illustrated Prospectus and full particulars regarding your successful and exclusive method of teaching law by mail.

Name.....

Address.....

# Crippled Children

ARTHUR FURNISS, 13 years old, son of Mr. A. J. Furniss, 647 So. 21st St., Louisville, Ky., was afflicted with a deformed foot, due to paralysis. He came to us December 12, 1914. These photographs convince you beyond the shadow of a doubt that his foot was made straight and strong here. Read also this evidence in black and white:

"Both Mrs. Furniss and myself are more than pleased with Arthur's condition on his arrival home after 5 months' treatment at the McLain Sanitarium. He is continuing to improve. Whenever we can say a good word for your institution we will certainly do it."  
A. J. FURNISS.



## DEFORMITIES

For thirty years this private institution has been devoted exclusively to the treatment of Club Feet, Spinal Diseases and Curvature, Infantile Paralysis, Hip Disease, Bow Legs, Knock Knees, Wry Neck, etc., especially as found in children and young adults. Complete modern equipment.

Write for information and our book, "Deformities and Paralysis"—also book of references. Both free.

The McLain Orthopedic Sanitarium  
902 Aubert Avenue ST. LOUIS, Mo.

## NO JOKE TO BE DEAF

—Every Deaf Person Knows That.



I made myself hear after being deaf for 25 years with these Artificial Ear Drums. I wear them day and night. They are perfectly comfortable. No one sees them. Write me and I will tell you a true story, how I got deaf and how I make myself hear. Address



Medicated Ear Drum  
Pat. Nov. 3, 1908

Geo. P. Way, Artificial Ear Drum Co. (Inc.), 11 Adelaide St., Detroit, Mich.

Erickson Artificial Limb Co., 36 Wash. Av. No., Minneapolis, Minn.  
Light Bristle  
Does Not Chafe Overheat or Draw End of Stump



Each Over 25 Cts.  
Information or Catalog Given

PATENTED

We are  
Under  
Govt.  
Bond

## The Natural Body Brace

overcomes WEAKNESS and AILMENTS of Women and Men. Develops erect, graceful figure.

Wear It 30 DAYS FREE at Our Expense

Write for booklet, measurement blank and our liberal offer.  
NATURAL BODY BRACE COMPANY, Dept. C, SALINA, KAN.

I will send my 25c book

## Improve Your Eyes

For 10c stamps or coin

A high-grade exercise and massage method that quickly strengthens and beautifies the eyes.

Also a most beneficial system of exercises that will improve the muscles of the temples and sides of face, thereby facilitating mastication and vocal pronunciation. Completely illustrated. Entirely without apparatus.

## MUSCLE BUILDER

A steel spring exerciser and chest expander, with a complete course of twenty-four selected exercises for developing all the muscles of the body. It is equal to any \$3.00 exerciser. My price for a short time only, \$1.00.

PROF. ANTHONY BARKER  
4644 Barker Bldg., 110 W. 42d St., New York



# STOP USING A TRUSS

Do Away With Steel And Rubber Bands

**FREE TRIAL**

TRADE MARK

STUART'S ADHESIVE

PLAPAO-PAD

Inner surface is made adhesive to secure the FLAPAO-PAD firmly to the body, keeping the PLAPAO continually applied and the pad from slipping. No straps, buckles or springs attached. Soft as velvet—easy to apply.

PATD APRIL 6 1909

It's the Non-Slipping, yet Non-Rigid Pad and What is Within It That Counts

## FREE to 5,000 Truss Sufferers

To the first 5,000 Sufferers who write, I will send, ABSOLUTELY FREE, a sufficient quantity of the Flapao to positively convince them that this is the only logical, common-sense way of treating rupture. Flapao is a highly astringent medication placed within the Flapao-Pad and being absorbed through the skin, creates a wonderful feeling of relief and at the same time tends to strengthen the weakened muscles and thus permanently close the rupture opening. The process of recovery is natural, so you'll have no use for a truss—you can throw it away forever! Old and young have testified under oath that the Flapao-Pads cured their rupture—many of them long-standing, aggravated cases—without delay from work. Patent allowed in U. S. and foreign countries. Awarded Gold Medal at Rome and Grand Prix at Paris.

Send No Money—for a sufficient quantity of the Flapao is sent without charge to enable you to give it a thorough test; you pay nothing for this trial now or ever. Write for it and full information today. Address Flapao Laboratories, Block 1427 St. Louis, Mo.

AMERICAN CHEESE EXPORT GROWING—The domestic cheese production ranges from 320,000,000 to 330,000,000 lb. annually, and is five to six times as much as the annual import of foreign cheese. The export, on the other hand, which in 1881 amounted to nearly 150,000,000 lb., gradually declined from that time on until the first half of 1914 when an upgrade movement began, which still continues and gives promise of soon reaching respectable proportions.



## BOW LEGS AND KNOCK-KNEES CORRECTED

Free booklet showing photos of men with and without the "Perfect Leg Forms" for Bow Legs and Knock-Knees. Manufacturers of Braces, Trusses, Abdominal Belts, Elastic Stockings, and Artificial Limbs. Please state your needs. PERFECT SALES CO., Dept. S 140 No. Mayfield Ave., Austin, Chicago, Ill.

## Mammoth Jubilee Book Free

Picturing 5152 Home Things  
Get your book while the edition lasts.  
SPIEGEL, MAY, STERN CO., 1401 W. 35th St., Chicago

# NO MORE BALD HEADS



When our VACUUM CAP is used a few minutes daily. We accept no pay until you have tried the Cap 60 days and are satisfied. The Vacuum Cap is an appliance that draws the blood to the Hair Roots and starts a new healthy crop of hair. It stops Dandruff, stops the hair from falling out. Bought by Doctors and men who

know that it is the only reasonable HAIR GROWER known to science. No Drugs Used. Write for application blank, testimonials, and booklet on "HAIR," sent sealed in plain envelope, FREE.

## THE MODERN VACUUM CAP CO.

X. 559 BARCLAY, DENVER, COLO.

Please Mention Popular Mechanics



## THE MAN WHO KNOWS TRAFFIC

Easily Earns \$50 to \$100 Weekly

*The Traffic Fields Calling for Trained Men. The Demand Is Increasing Each Year*

The railroads are the arteries of commerce. Modern commerce is absolutely dependent on Transportation—TRAFFIC. It makes or breaks. Ignorance of classifications and correct routings permits profits to slip away. Shippers are realizing this more each day. They are eager for trained traffic men who can prevent such losses. Right now many thousands of high-salaried, efficient traffic men are needed. And there is no fixed salary limit. YOU will be paid what you are worth. Thousands of Traffic Managers receive \$50 to \$100 weekly. Many a great deal more. It is no longer difficult to gain Traffic Knowledge. You can have the active cooperation of many of America's noted Traffic Experts. They will help you, guide you—TEACH YOU.

Endorsed by  
Traffic Authorities

Mr. A. T. Waterfall, Traffic Commissioner, Detroit, Mich.: "You are to be congratulated on this splendid and important work." Mr. C. C. McCain, Chairman of the Trunk Line Committee, representing fourteen Eastern railroads, says: "The American Commerce Association has provided a training service which appears to be the broadest, most complete tariff rate, and traffic training yet devised." Mr. H. G. Wilson, President of The National Industrial Traffic League, writes: "Your Association is better equipped to advance the efficiency of traffic men than any other."

### American Commerce Association

This is an organization of Traffic Men by Traffic Men for Traffic Men to promote American Commerce, Export and Import Trade. Our methods are thorough and practical. The work is fascinating. It is really easy to learn—easy to become an efficient traffic man. *And You Can Study During Your Spare Hours in The Evenings.* In a short time you can acquire the same valuable knowledge gained by numerous traffic experts only after a life-time of hard work and tedious study. Traffic Knowledge, so easily gained in so short a time, will become your permanent asset—YOU can always "cash" it. It is Your Big Opportunity. Investigate! Let us tell you all the facts.

American Commerce Association  
Dept. 23, The Rookery, Chicago, Illinois

Ask Us for a FREE Copy



of one of these valuable books. "Opportunities Along the Trails of Traffic" by H. G. Wilson. Straightforward and informative. "Traffic Efficiency," 92 pages. Tells the need of high salaried efficient Traffic Men. "Millions Wanted in Traffic." Gives actual cases. Intensely interesting. Tells of Traffic Savings Opportunities.

MAIL THIS TODAY

AMERICAN COMMERCE ASS'N.

Dept. No. 23, "The Rookery," Chicago. Please send me, entirely without charge or obligations, book as checked. "Opportunities Along the Trails of Traffic." "Traffic Efficiency." "Millions Wanted in Traffic." Also explain how your course in Traffic Efficiency will train me to become a traffic expert.

Name.....

Address.....



16:

### LEARN TO BE A Show Card Writer

Unlimited Demand. \$18 to \$45 a Week

Pleasant, Fascinating, Profitable Work. Earn money after first few lessons. Expert teaches personally by mail. \$1 per lesson.

EASY SHOW CARD SYSTEM

Dept. G, 105 Chambers St., NEW YORK

### Do You Like to Draw? Cartoonists Are Well Paid

We will not give you any grand prize if you answer this ad. Nor will we claim to make you rich in a week. But if you are anxious to develop your talent with a successful cartoonist, you can make money, send a copy of this picture, with 5c in stamps for portfolio of cartoons and sample lesson plate, and let us explain.

The W. L. Evans School of Cartooning  
821 Leader Bldg., Cleveland, O.



# LAW BOOK FREE



Be Sure to Get This 80-page Free Book Before You Enroll for Any Law Course: No matter which school or which course you may be considering—no matter which method of instruction you may favor—be sure to read "How to Acquire a Legal Training" before you enroll. One of the greatest free books on law ever offered. Tells how to weigh and judge the claims of correspondence schools. Tells just what a law course should contain to give you the training absolutely necessary to succeed in the legal profession. Tells the easiest and best way to become a lawyer by studying at home, and explains all about the American School's simple method of home law instruction. Prepared by 56 of America's greatest legal authorities—25 more subjects and 30 more authors than any other correspondence law course.

## FREE 13 Volume Law Library and 60 Text Books

With each course we furnish 60 new pocket size Text Books, 36 Case Books, and our big 13 volume Law Library. Written in plain, simple, easily understood language especially for correspondence instruction. Don't fail to investigate this wonderfully complete and practical course before taking up the study of law—send for your free book today. Just drop us a postal—there is no obligation—it is absolutely free for the coupon.

American School  
of Correspondence, Chicago, U.S.A.

Pop. Mech. 11-15  
A. S. of C.  
Gentlemen: Please send me your FREE Law Book, "How To Acquire a Legal Training," and fill particulars regarding your wonderful new system of correspondence law instruction.

NAME.....  
ADDRESS.....

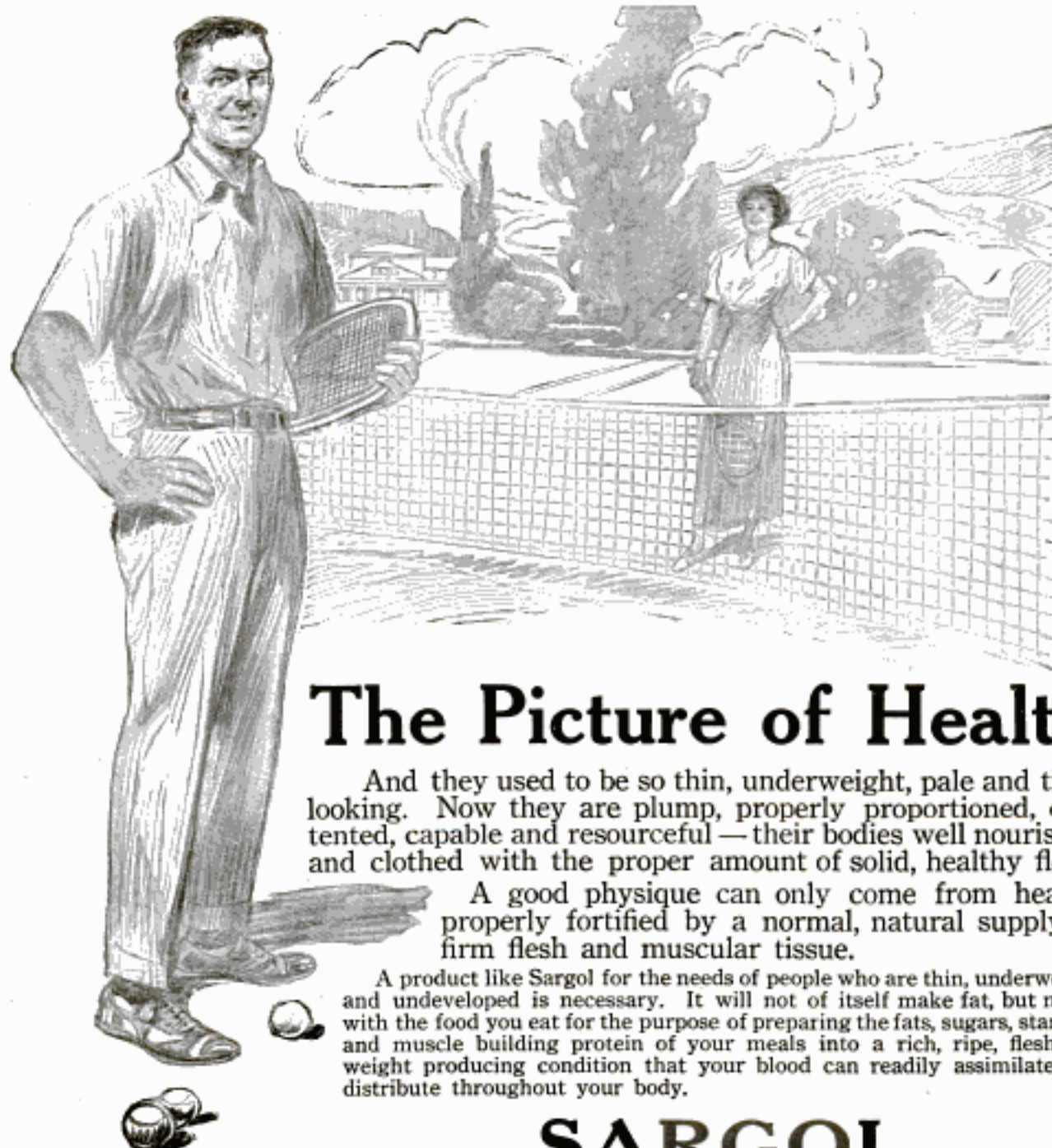

## The Picture of Health

And they used to be so thin, underweight, pale and tired looking. Now they are plump, properly proportioned, contented, capable and resourceful — their bodies well nourished and clothed with the proper amount of solid, healthy flesh.

A good physique can only come from health, properly fortified by a normal, natural supply of firm flesh and muscular tissue.

A product like Sargol for the needs of people who are thin, underweight and undeveloped is necessary. It will not of itself make fat, but mixes with the food you eat for the purpose of preparing the fats, sugars, starches and muscle building protein of your meals into a rich, ripe, flesh and weight producing condition that your blood can readily assimilate and distribute throughout your body.

## SARGOL

works on the theory that most of the fat and tissue building elements of food pass through the thin person's body as waste. That to stop this waste and encourage proper food assimilation means the creation of millions of new flesh-forming cells and the rounding out and developing of the body to proper, normal weight and proportions.

Sargol either will or will not increase *your* weight and the only way you can ever know is to try it.

### Let Us Prove What Sargol Can Do For You

Let us send you a regular 50-cent package of Sargol free for your own use. Take one tiny tablet with every meal and watch results. With the package we will send you valuable information on the nutrition and assimilation of food and the testimony of many who report successful use of Sargol. Address

#### THE SARGOL COMPANY

849-L HERALD BUILDING

BINGHAMTON, N. Y.

#### WHAT YOU SHOULD WEIGH

The following table of Normal Weights for both men and women will enable you to decide how badly you fall beneath the average that proper development demands.

Height	Men	Women
5 ft. 0 in.	121	113
5 ft. 1 in.	124	116
5 ft. 2 in.	129	121
5 ft. 3 in.	135	127
5 ft. 4 in.	139	131
5 ft. 5 in.	145	138
5 ft. 6 in.	149	141
5 ft. 7 in.	156	148
5 ft. 8 in.	161	153
5 ft. 9 in.	166	158
5 ft. 10 in.	171	163
5 ft. 11 in.	176	168
6 ft.	182	174

LEARN THE AUTOMOBILE BUSINESS BY ←

# THE SWEENEY SYSTEM

OF PRACTICAL EXPERIENCE IN EIGHT WEEKS

The Sweeney System is now universally recognized as the most thorough, practical and interesting course of automobile, gas engine instruction leading to certain and profitable employment. It embraces every point worth knowing, including vulcanizing, brazing, oxy-acetylene welding, lathe work, machine shop practice, testing, driving, truck repairing, and operating, etc. And you learn by doing the work on Real Cars under the watchful eyes of skilled instructors.

I started seven years ago teaching a couple of young men in a little shop. I had one BIG IDEA. That was to teach them by practical experience. Not merely to TELL them how, but to SHOW them how and then have them do the work with their own hands, over and over until they could do it perfectly. And that is the EASIEST

WAY to learn—because the right way is always the easiest. I taught my young men how to do everything that any mechanic is ever called on to do about a car. Not merely to drive but to repair. Not merely to repair but if necessary to make his own tools. Everything from blacksmithing up. And then over and above that I taught them how to manage for themselves—how to make money in the business—how to run a garage, and so on.

Today I point to thousands of men who have made good under my system of practical instruction. I can point to what I claim is the biggest school of its kind in the world. The School with the most complete and best equipment obtainable. The school with 19 instructors. The school with pupils from almost every state in the Union and some from foreign countries. We teach by "Practical Experience," you see what makes the wheels go round. We don't use books, we furnish free tools to the men and they learn by doing the work with their own hands under skilled instructors. I qualify them for a trade that's good for \$50 to \$150 a month or an independent business of their own.

### New Silent Knight Motor

The Sweeney School claims the most complete equipment of any school in the world; it claims to have more pupils, more successful graduates, to afford better practical instruction. We want every young man to investigate these claims and to see for himself before he pays down one cent of

tuition. To show you how we keep up to date—we have just ordered the new 12 Cylinder Packard, and will have the first delivered in Kansas City. Have just purchased a Willys-Knight car with Silent Knight Motor. Learn about the Sleeve-Valve Motor, there will be 10,000 manufactured this year. To be a real automobile expert you must understand this motor. We own 5 tractors and in our own factory are building the famous Sweeney Tractor (3885), thus giving students a wonderful advantage in factory experience. This feature alone offers a unique opportunity to young men who wish to become experts in the tractor field. We have spent thousands of dollars on new equipment. For instance, we have put in a new 8 cylinder Buda Motor, a Fellowes Gear Shaper, 18-inch American Quick-Change Lathe, and a 24-inch Planer. In our machine shop, we make our own gears, in a word the very latest developments are put in the hands of our students, as we know our success depends on making you competent to handle any mechanical proposition and of being strictly abreast of the very latest developments.

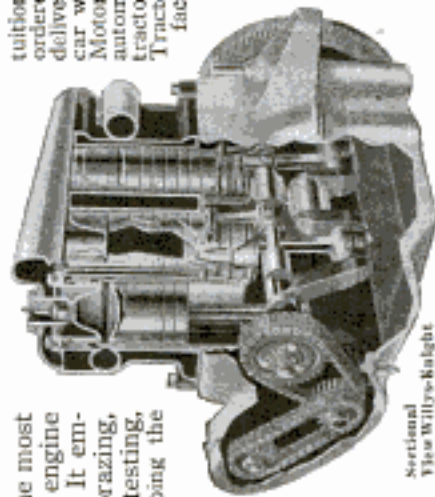

Sectional  
View Willys-Knight  
Sleeve-Valve Motor

### Save \$50

To advertise the school and also to give special training in a branch that is getting more important all the time, I will give a complete \$50 scholarship in Traction Engineering free with an enrollment for the regular automobile school course. Now, as you know, we not only have 5 tractors here but I have a big factory where we build the famous Sweeney Iron Horse. You are taught by men that know how.

### Do It Now

Sign and mail the coupon attached or write me a post card, I will send you my big free book and full details of this scholarship offer. The certificate will entitle you to the \$50 saving in case you enroll this fall. It will not obligate you in any way. As a matter of fact I won't take a cent of a man's money until he has personally inspected the school and has satisfied himself.

The book pictures the wonderful equipment of the Sweeney School. It shows how you are taught, shows the class of men you will associate with, portrays various phases of the automobile industry, explains how, when and where you begin to earn money, in a word is a complete encyclopedia of the subject. I don't urge you to send for it unless you really want it, but to every young man mechanically inclined I will be very glad indeed to mail it free, together with my regular magazine. Simply send name and address.

CATALOG

**Sweeney**  
AUTOMOBILE  
SCHOOL

KANSAS CITY  
MISSOURI

THE WORLD

Send free and without obligation your Catalog and tractor scholarship certificate.

Name \_\_\_\_\_

Address \_\_\_\_\_

SWEENEY AUTO SCHOOL, 1166 E. 15th St., Kansas City, Mo.

**SWEENEY Auto School** 1166 E. Kansas City, Mo.  
15th St.

# BOYS! BUILD THINGS!

THIS BIG NEW BOOK

Vol. II — **THE BOY MECHANIC** — Vol. II

Tells All About 1000 Interesting Things To Make and Do

A SEQUEL TO, BUT CONTAINING NOTHING FOUND IN VOLUME I

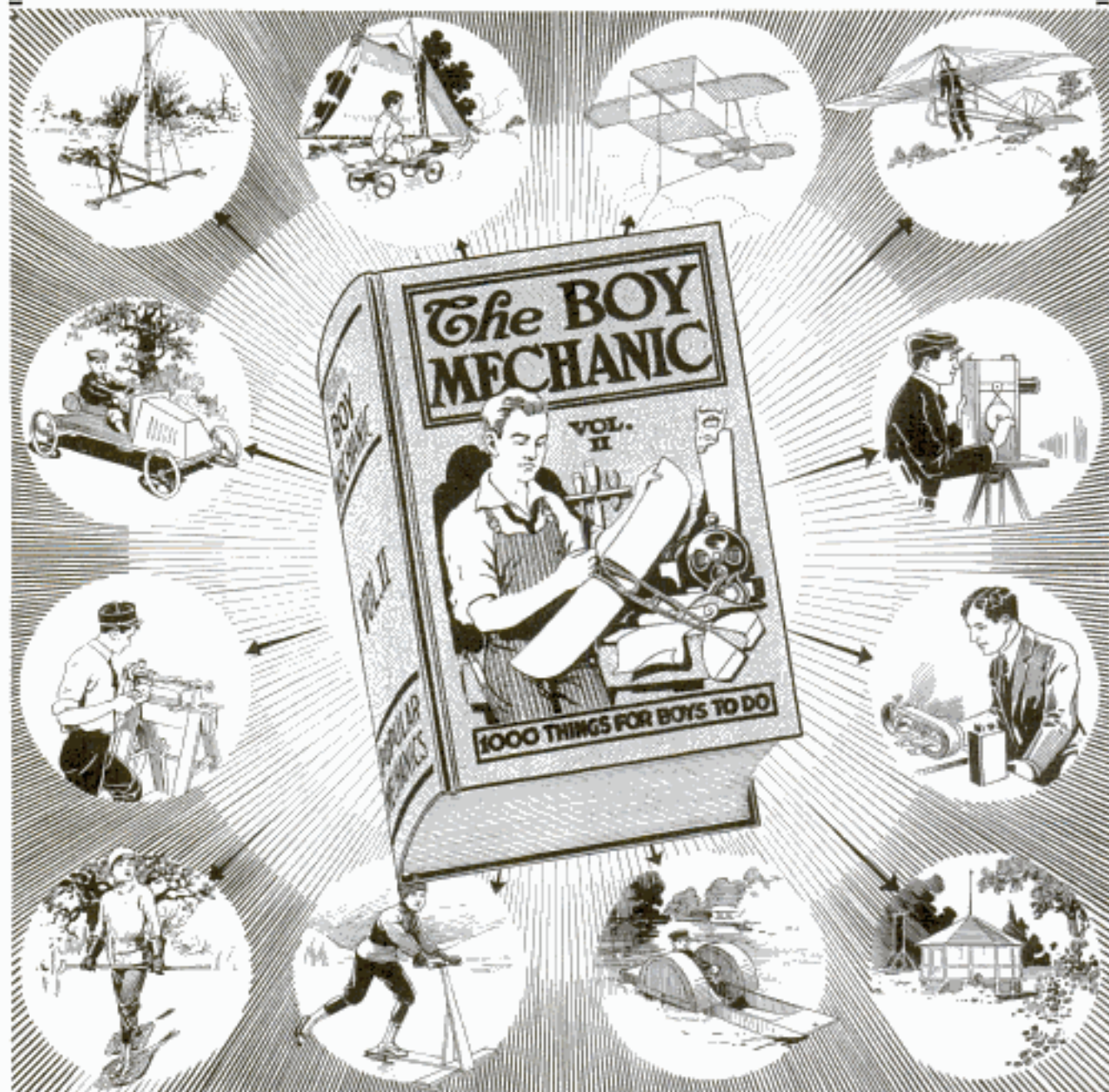

**480 PAGES (6¾x9¾ in.)—995 ILLS.—CLOTH—PRICE \$1.50**

#### HOW TO MAKE

Bobsleds—Snowshoes—Ice Boats—Ice Gliders—Boats—Camps—Fishing Tackle—Houses of Poles—Kites—Aerial Gliders—Motion-Picture Camera—Spot-Light Lantern—Mile-O-View Camera—Photographic Appliances—Indoor Games—Tricks—Cyclemobile—Pushmobile—Flymobile—Roller Coaster—Ferris Wheel—Sunlight Flasher—Reed Furniture—Electrical Devices—Mechanical Contrivances—Art-Craft Work and hundreds of equally interesting things.

SENT POSTPAID UPON RECEIPT OF PRICE BY PUBLISHERS

**POPULAR MECHANICS BOOK DEPT., 6 NORTH MICHIGAN AVE., CHICAGO**



# A \$2,000,000 Sale—

## —Made Possible by a

# Trained Memory



When Carl F. Schader, real estate operator, miner, banker, public-spirited citizen and all-around good fellow, returned to Los Angeles a few weeks ago, after a mysterious absence of fifteen days, with the announcement that he had put across the sale of the \$2,000,000 Palos Verdes ranch, his friends exulted with him over what was unquestionably the greatest achievement of the year in realty circles.

**S**UPPOSE you had a contract to purchase a 16,000-acre ranch with a year to pay—that the greatest legal talent of Southern California had fought you to a frazzle and all you had was an interlocutory decree of the court—to pay or lose—that adverse business conditions had swept away your financial backing—that with only two weeks remaining you saw your only hope to be the sale of the property—and that after making the rounds of the money kings in vain—that the President of New York's biggest bank offered you just five short minutes to present your proposition. What would you do? What Carl F. Schader did is only partly told in the above clipping from the Los Angeles Times. Mr. Schader boiled down his arguments—rehearsed them in his hotel room—and then presented the salient features of his property so clearly—so earnestly—so completely—that the interview was extended and the sale finally made.

## Schader Succeeded Because He Had the Ability to Concentrate—to Remember

Mr. Schader's experience is typical of thousands of America's men of power. Trained memory, concentration, the development of self-control—is the sure road to a better position—bigger pay—social and business success—**THE EFFICIENT LIFE.**

## The Dickson Method of Memory Training

The Dickson method of Memory Training is a simple series of brain exercises so graded and arranged that they will bring your memory to a state of perfection in the shortest time possible with the least effort.

### 50,000 Students

Dickson Memory Training has helped thousands. Men in every walk of life—men with exceptionally poor memories who have developed them to amazing perfection—men with remarkably good memories who have made them better. What Dickson Training has done for these men

it will do for you—will teach you to think and talk connectedly—will increase your earning power.

### Special Offer "How to Speak in Public" FREE

This deluxe edition handsomely illustrated book, regularly priced at \$2.00, for a limited time will be presented to every student enrolling in the course in Memory Training absolutely FREE. The book will train you to think on your feet—to express yourself clearly, logically and convincingly whether talking to one person or a thousand. Get full particulars of this liberal offer at once.

**Carl F. Schader**  
"One of California's  
Biggest Men"

## —What He Says About Dickson Memory Training

"Words cannot express my appreciation of the many courtesies you have extended in the matter of assisting me in my work.

"Although I finished your course of memory training and public speaking a few years ago, I continue to study it and I find each time I go over the course I gain new knowledge.

"The psychoscope taught me concentration. The special exercises greatly improved my general condition. Your desk book has given me a wonderful vocabulary. I find when delivering an address that unconsciously I use better English and have better command of my audience.

"My voice has improved to such an extent that I now talk with ease and make myself heard to an audience of several thousand.

"To sum it up, I have been improved physically and mentally beyond my own expectations by the continued studying of your course.

"Every business man, especially those called upon to talk at Chambers of Commerce, Realty Boards, Advertising Clubs and other meetings, should take your course. I unhesitatingly recommend it to those who desire to increase their **POWER OF PERSONALITY.**"



### FREE Wonderful Book on "How to Remember"

Simply send your name and address on the coupon, or a postal for this remarkable book. No charge—no obligation. Together with the book I will send my celebrated Memory Test, a test which has a direct bearing on your business success. Get this Free book—this Memory Test—and the facts on how Memory Training will guarantee your Future Success—NOW.



**Prof. Henry Dickson**  
America's foremost Authority on Memory Training, Public Speaking, Self Expression, Lecturer and Principal of the Dickson Memory School, Hearst Building, Chicago.

## Book — FREE

**Prof. Henry Dickson, Dickson School of Memory,**  
705 Hearst Building, Chicago, Illinois

Please send me your free booklet "How to Remember" and your remarkable copyrighted Memory Test. Give me facts on your special short time FREE offer of your book "How to Speak in Public" and particulars on the Dickson Course in Memory Training.

Name \_\_\_\_\_

Address \_\_\_\_\_

*Carl F. Schader*

# YOU are needed NOW

**YES, there's a good position waiting for you—will you get ready for it?**

Yes, sir—you are needed to fill a good job. But you're not ready—you're not trained. You can't fill it now. But you can in six months if you study. Will you do it? **Will you get ready?** Big salaries don't grow on trees. They don't just happen. They go to men who get ready for them—who can fill to a T the jobs that pay big salaries. Do you know anything about electricity? Are you inclined that way? If not inclined, would a good salary make it interesting? We'll prepare you during your spare time.

## Earn \$1,200 to \$3,000 a Year

as an Electrical Meter Engineer. When you're ready to fill a job—a job is ready for you. Listen! There are over 7,000,000 meters now in use. Another half million will be installed this year. Think of the men needed to install and keep them in order. Think of the engineers needed—who know meters and can direct the work. Meters are delicate—need constant adjusting.

Electric light companies lose thousands yearly on slow running and out-of-order meters. Can't get enough good men to keep them right. Fort Wayne Trained men quickly get good jobs—are quickly advanced—always ready for the bigger job of meter engineer. Our course teaches the theory of electricity; design, construction, operation, calibration, care, and maintenance of all makes and types of electrical measuring instruments and meters. You'll know meters from A to Z—all kinds. No problem will stump you. Our students are successful. E. D. Henley, Ala. writes: "When I commenced your course was making \$65.00 a month testing meters. Soon I was able to take care of standardizing instruments and salary was raised to \$90. Special work brought it up to \$125." Martin Erinarud, Minn. wrote: "My salary is now three times what I got when I started your course." Will you begin now? Will you get ready for a good steady position? We are ready to prepare you. Read our guarantee.

**Write today for free booklet, "Electrical Meter Engineering". Address**

**FORT WAYNE CORRESPONDENCE SCHOOL**  
Dept. 191  
FT. WAYNE, INDIANA

**OUR GUARANTEE**

We guarantee to furnish you with our complete course of instruction in Electrical Meter Engineering and train you without charge, other than tuition as specified in our Enrollment Blank, until you are qualified to accept a position paying from \$75 to \$300 a month. Furthermore, we guarantee to assist you in securing a high grade position after you receive your Diploma. We also guarantee to answer any questions regarding your school work, or daily work as well.

## CIVIL SERVICE

positions are in all parts of the country. Good pay, steady work, life positions, congenial surroundings, promotions on merit, short hours, annual vacation and sick leave with pay. Many thousands appointed yearly. Both sexes. No political pull. Nearly 300,000 classified positions. Common school education sufficient. Full information and questions used by the Civil Service Commission free.

**COLUMBIAN CORRESP. COLLEGE, Washington, D. C.**

## LEARN RAG TIME

Let me teach you Rag-Time Piano Playing by Mail. You learn easily—in just a few lessons, at home. My system is so simple you'll play a real ragtime piece at your 5th lesson. Whether you can play now, or not, I'll teach you to play anything in happy ragtime. "Money Back Guarantee." Write at once for special low terms and testimonials.

**AXEL CHRISTENSEN, "Czar of Ragtime,"**  
Room 15, 526 So. Western Ave., Chicago, Ill.



## Learn to PAINT SIGNS and SHOW CARDS

I'll teach you personally by mail. 16 years' successful teaching. Big field for men and women. You can **Earn \$18.00 to \$45.00 a Week**

Scherer (Chicago) writes: "Your instruction is great. Highly pleased." Fall details promptly on request

**DETROIT SCHOOL OF LETTERING**  
Chas. J. Strong, Founder Dept. 211, Detroit, Mich.



## A GOOD POSITION

with **UNCLE SAM** is most desirable. Life positions, pleasant surroundings, good pay, steady work, short hours, promotions on merit. Both sexes. No political pull. Thousands of appointments yearly. Most thorough preparation \$5. Returned if not appointed. Full information and questions used by the Civil Service Commission free.

**AMERICAN CIVIL SERVICE SCHOOL WASHINGTON, D. C.**

# HELP WANTED

## \$65 TO \$150 A MONTH

**Railway Mail Clerks—City Mail Carriers—Postoffice Clerks**  
—Rural Carriers—Panama Canal Clerks

Steady Work—Vacations with Full Pay—Rapid Promotion—  
"Pull" Unnecessary—Common Sense Education Sufficient.

**MANY POSITIONS FOR WOMEN**

Write today—before you forget—for list and description of positions now open to you; and free sample examination questions. It will cost a 2c stamp—it may bring you thousands of dollars.

**FRANKLIN INSTITUTE, Department E106, ROCHESTER, N. Y.**

NAME.....

ADDRESS.....

**FRANKLIN INSTITUTE**  
Dept. E 106, Rochester, N. Y.

This coupon, filled out as directed, entitles the sender to free specimen questions; a free copy of our book, "Government Positions and How to Get Them," a list of Government positions now obtainable, and to consideration for Free Coaching for the examination here checked.

.. Railway Mail Clerk .. (\$900 to \$1800)  
.. Bookkeeper .. (\$800 to \$1800)  
.. Postoffice Clerk .. (\$800 to \$1200)  
.. Postoffice Carrier .. (\$800 to \$1200)  
.. Rural Mail Carrier .. (\$500 to \$1200)  
.. Auto Chauffeur .. (\$800 to \$1500)  
.. Customs Positions .. (\$800 to \$1500)  
.. Stenographer .. (\$800 to \$1500)  
.. Internal Revenue .. (\$700 to \$1000)  
.. Clerk at Panama Canal .. (\$1200 to \$1800)  
.. Canadian Gov't Positions ..

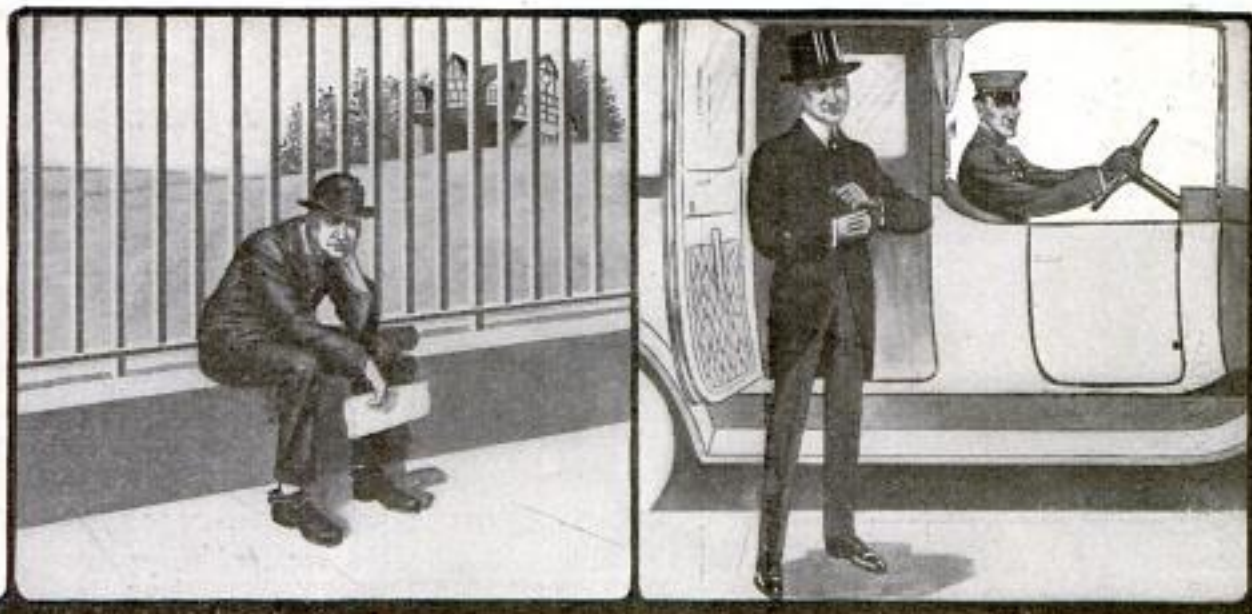

## 7 Years a Failure—Then Sudden Success!

*"Culture of Courage," a Work That Is Performing Miracles. Let Me Lend You a Copy.*

"For seven years I worked unsuccessfully on a project and had about given it up until I got a copy of 'Culture of Courage'. By applying the principles set forth in this great book, I was able to put the proposition over in less than two months, and it wasn't so hard after all."

These are the words of a man who recently became an owner of "Culture of Courage," and they reflect the experience of thousands of other men and women in all walks of life who are following the fear destroying, success achieving secrets laid bare for the first time in this great course—secrets which show how to win life's battles by cultivating the courage to succeed.

### Fear is Man's Greatest Enemy

The poisonous dragon of fear does more to hinder the world's progress each year than all the European war's ravages since the struggle began. Fear of things, fear of people, lack of self-confidence and worry are the dragon's claws which pin millions of good men down when they could and should be successful in all that they undertake.

### Courage Wins

Courage is the indispensable weapon in man's fight for success. The courageous man wins because he doesn't know the failure slogans "I dare not," "I haven't the ability." Instead, he is sure of himself—he succeeds because he never contemplates failure and thus he often accomplishes the "impossible."

### "Culture of Courage"

is by Frank Channing Haddock, Ph. D.—the famous author of "Power of Will"—a scientist

whose name ranks with James, Bergson and Royce. It is not an inspirational book which merely admonishes you to "destroy your fears" and "be courageous." Instead, it is a practical course in how to overcome each particular kind of human fear, physical as well as mental, to which we are all subjected. It contains actual principles, rules, methods and exercises which anyone can easily follow and become ten times bigger—ten times more successful—ten times happier than you have ever dared hope.

### Will Help YOU

Never, we believe, has a book of more practical help been written. One man tells us how he had been out of a position for months and had absolutely lost confidence in himself until after reading "Culture of Courage" he went out and secured an excellent position the very same day.

That is only one example. Some say that it has made them self-confident and able to demand what they want, instead of whining for it hat in hand. Others say that for the first time are they able to talk to men they had always held in awe—others, that it has given them courage to take risks they dared not and they have won out—others, that they have banished superstition and fear of things formerly beyond their control—some say that they now have courage to say "no," the hardest word in the English language—and hundreds say

it has given them a new grip on life.

What "Culture of Courage" has done for thousands of users, among them many prominent in all fields of endeavor, it will do for you by forever eliminating fear in all its diabolical disguises and putting in its place a brand of courage that will make you well nigh invincible.

### No Money in Advance

So confident are we that once you examine this great book in your own home, you would never give it up, that we offer to send it on five days' free trial without a cent in advance. Keep it five days—look it over carefully—then if you feel you can afford to be without it, mail it back and you owe us nothing, otherwise remit \$3.00, the small price of this big 460 page leather bound book. Remember, no money in advance. Merely mail the coupon enclosing business card or giving a reference today.

A. L. PELTON  
5111 Pelton Bldg.  
Mexico, Conn.

Gentlemen: Please send me a copy of "Culture of Courage" on approval. I agree to remit \$3.00 or return the book in 5 days.

Name .....

Address .....



460 pp.  
Half Leather  
Gold Top  
Leaves

\$1

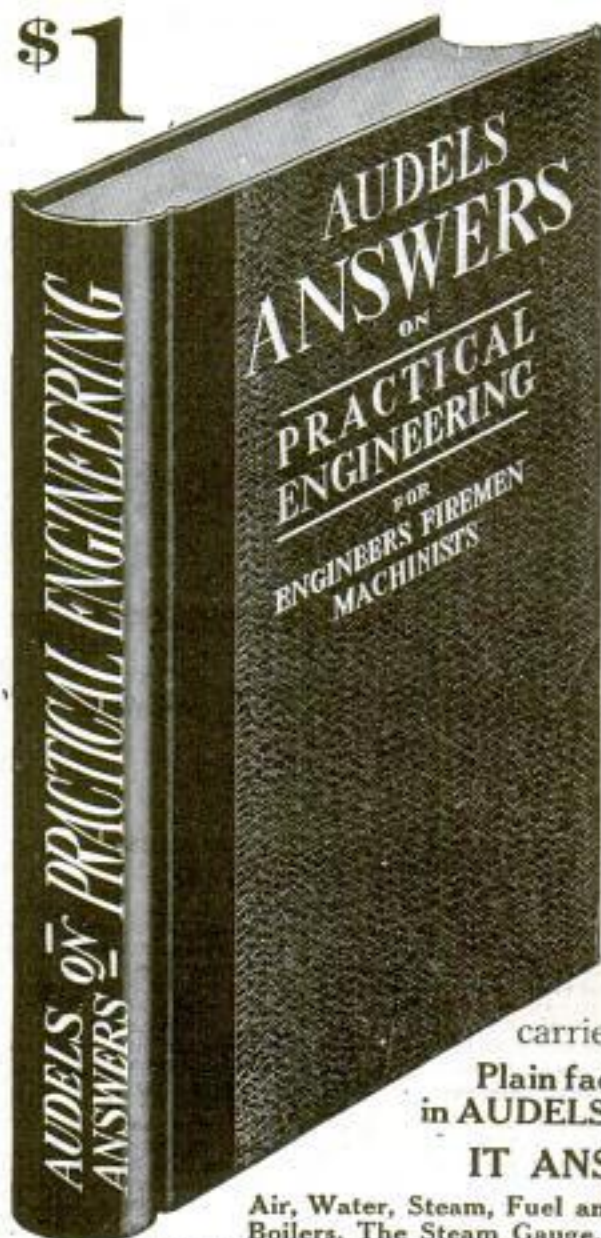

# ENGINEERS

This Book Will Help You

## Audels Answers on Practical Engineering

*When you spend your good hard earned money for books, always make sure that you are going to receive something that will assist you in bettering your position*

**T**HIS book deals largely with the foundation principles which govern the practice of steam engineering. Nothing so soon condemns the applicant as want of knowledge of the every day practice and simple laws relating to the care and management of a steam plant.

No one is expected to know everything, but all are required to be familiar with certain facts which may be called "the beginning of things."

The lack of knowledge of the small things carries conviction of the same lack in the larger.

**Plain facts, that you should know, are plainly explained in AUDELS ANSWERS ON PRACTICAL ENGINEERING.**

### IT ANSWERS YOUR QUESTIONS ON

Air, Water, Steam, Fuel and Heat, Steam Boilers, Boiler Construction, Water Tube Boilers, The Steam Gauge, The Safety Valve, Properties of Steam, Installation of Boilers, Management of Boilers, Engineers' Law, Firemen's Law, Steam Engines, The Valve and Valve Gear, The Corliss Engine, Engine Arithmetic, Lubricators, Installation and Operation of Engines, Steam Pumps, Injectors, Feed Water Heaters, Steam Heating, Steam Traps, Belts, Gears and Pulleys, Steam Turbines, Refrigeration, Practical Electricity, Elevators.

Understand the framework of which your work is but a cross bar. Know something of the cause of which your work is but an effect. Know something of the effect of which your work is the cause. And, above all, know why it is done one way and not another.

**LEARN THE THEORY UNDERLYING THE WORK.** Practical Engineering contains 288 pages fully illustrated, handsomely bound and printed and is in every way a first class book.

Please send me for examination one copy

**\$1** Audels Answers on Practical Engineering

If I keep the book, I promise to send you within 7 days after receiving it ONE DOLLAR, in full payment; if I do not keep it, I will mail it back to you within 7 days.

## Examination Offer

**If You Are Interested** sign and mail the coupon, and it will bring to your plant a book of sterling merit, for free examination. You can have one week in which to dig out the mine of valuable information contained in its 200 or more pages.

### Carry It in Your Pocket for One Week

and at the end of the time, if you do not think the book is worth one dollar, mail it back to us. If it is, you can mail us \$1.00 in payment for your copy. If you fail to consider this liberal offer you are not dealing fairly with yourself. We take all risk that "Audels Answers on Practical Engineering" is a book you should own. Act now before you forget it.

Signature.....

Occupation.....

Address.....P.M. Nov. '15

**THEO. AUDEL & CO., 72 5th Ave., NEW YORK**

# Learn Agriculture at Home

No matter how little or how much land you may own—a garden, an acre, or 1000-acres—you can make the most out of it if you know scientific farming. Learn the best methods for making the soil produce big profits. Take advantage of the work done by the investigators of the U. S. Department of Agriculture. This information is ready for you now, at a cost that is merely trifling. It is offered to you in the great library described here—which gives you in complete but handy form the experience of thousands of successful farmers—which tells you what to do and what not to do to make more money from the soil. Sent, express prepaid, for ten days' free examination, if you will simply mail the coupon.

## Farmer's Cyclopedias



(Abridged Records, U. S. Dept. Agriculture)

7 big volumes, over 5000 pages, 3,000,000 words, give you in condensed, yet complete and practical form, the results of work which cost the government over four million dollars—work to which the experts gave years that every known method might be investigated and every fact verified. The best ways to make money from grain growing, fruit growing, cattle and sheep breeding, dairy farming, hog raising, poultry, bees, market gardening—hundreds of tested methods—are placed at your fingers' ends, ready to help you to make every foot of ground profitable. All this you can have in these 7 great volumes, for less than 7 cents a day.

### A Few Things the Cyclopedias Teach

#### Feed and Care of Dairy Cows

(This alone worth the price.)

#### Feeds and Feeding for Beef

(A wonderful work.)

#### Diseases and Insect Pests

(How to protect cattle and crops against them.)

#### Profitable Hog Raising

(A complete library on the hog.)

#### Success with Sheep

(Every question answered.)

#### Poultry Problems Solved

(No other books on poultry ever need be read.)

#### Soils and Fertilization

(Make your land yield more.)

#### Latest Facts and Investigation on

#### Every Farm Product

(Insures bigger, better crops with less labor.)

#### Every Phase of Farm Management

(From Government Experiments and Researches.)

#### Farm Buildings

(How to plan and build on the farm.)

#### Domestic Science

(Comfortable, economical farm house-keeping.)

(Lightens the work of the house-keepers.)

And thousands of other subjects of vital interest and value.

# FREE

## This Valuable Book

Hon. F. D. Coburn, America's most famous farming expert, has written a valuable book to use in connection with the Cyclopedias.

Full of suggestions on how to direct your reading and get the most benefit out of it. You really study under the direction of this master farmer. Mr. Coburn says of the Cyclopedias: "It contains the most valuable agricultural information ever gathered together." Let Mr. Coburn help you. His book comes absolutely free with the Cyclopedias.



Doubleday, Page & Co.  
Dept. 1198  
Garden City New York

## Send Coupon Without Money

We will send the books and the Coburn Manual prepaid, for 10 days' free examination. Inspect them carefully. See what a vast store house of money-making information you can have at your disposal at merely a trifling cost. If you keep them, send us only 50 cents as first payment—then \$2.00 monthly for a year. Otherwise write to us and we will arrange for their return. Grasp this opportunity to secure the information which it has taken 10 years of earnest research by the government experts to secure. It costs you nothing, remember, to examine the Cyclopedias before you decide to buy. And the Coburn Manual is free with the 7 big volumes. Mail the coupon now.

Doubleday, Page & Company Dept. 1198  
Garden City, New York

Send me, all charges prepaid, the complete set of Farmer's Cyclopedias (Abridged Records of U. S. Dept. of Agriculture) in 7 big, thick volumes—bound in strong buckram. If not satisfactory, I will tell you so in 10 days and you will tell me where to return the books at your expense. Otherwise I will send 50c down and then \$2.00 monthly for 12 months.

Name.....

Address.....

## GRASP THIS OPPORTUNITY TO LEARN THE AUTO BUSINESS

Earn a Splendid Salary or Have a Business of Your Own

RIGHT NOW is the time to start. Over 2 million cars are now in use; nearly a million more next year; and practically no limit for the future. That means wonderful opportunities for properly trained men. Over 3000 graduates are making good money as Chauffeurs, Testers, Mechanical Experts, Repairmen, Shop Foremen, Demonstrators, Dealers, etc., etc. We have constant calls for more and more men; our graduates get jobs quickly because our School has an established reputation for practical and up-to-date training.



## CLEVELAND AUTOMOBILE SCHOOL

12 Years of Success — Oldest and Best Established

Latest Equipment — Individual Instruction

UP-TO-DATE Training in 4 Weeks, including repairing and driving high powered cars; careful painstaking and individual instruction; latest types lighting and starting equipment; Knight and all other type motors; new 8-cyl. car here, Twin-Six on the way; every type of every part of auto—most completely equipped auto school in America—the most practical, experienced and helpful teachers. COME AND JOIN US.



A corner in our repair shop

C. H. Pratt, Chief Instructor

**Tuition and Board Low** right near the school, with congenial company and surroundings. We help you get located and feel at home.

*New Classes Forming; Write at Once for Catalog and Terms.*

**Cleveland Automobile School**  
Clyde H. Pratt, President  
2338 Euclid Ave., Cleveland, Ohio



### WE TEACH YOU TO DRAW A GOOD SALARY

Most Art Schools merely teach you how to draw pictures—we teach you how to draw a good salary as well. **PRACTICAL and PERSONAL INSTRUCTION** Study during your spare time and learn *How to Make Pictures That Will Sell*. Artists earn from \$25 to \$100 a week. Send copy of picture on left for free criticism and 6 cents in stamps for illustrated catalog. Correspondence and local school.

WASHINGTON SCHOOL OF ART 823 F Street N. W.  
WASHINGTON, D. C.

### GOOD PENMANSHIP PAYS I CAN TEACH YOU BY MAIL

Complete Course in Business Writing \$2, Ornate Writing \$4. Both for \$5. All pen written copies. Personal criticisms. Booklet on Graphology 10c. BEAUTIFUL PEN ART CATALOG FREE. Address

L. H. HAUSAM, Box 744P, BLACKWELL, OKLAHOMA

## You're a Human Dynamo

full of undeveloped power, capable of mastering the forces about you. If you are not getting full mental and physical efficiency from your mind and body, the wires are crossed somewhere. LEAVITT SCIENCE tells how to develop your dynamic forces, get perfect adjustment. Its vital message has helped others to complete self-mastery—why not you? 24c in stamps brings this handsome 48-page de luxe book. Write to-day to

C. Franklin Leavitt, M. D., Suite 946, 14 W. Washington St., Chicago



### Learn Piano

### Better and Faster

at 1-4 usual cost, in your own home, by Dr. Quinn's famous WRITTEN METHOD. Enforced by leading musicians. Play chords in first lesson, complete piece within a few lessons. Successful for 25 years. Graduates everywhere. Diplomas granted. Reduced terms this month. Send for FREE book.

M. L. QUINN CONSERVATORY, Box 650 K.L., CHICAGO

## OHIO AUTO SCHOOL

Before enrolling with any school, get our proposition. It will interest and please you. Learn the auto business, the opportunity of the 20th Century. Write us. 111, 1521 Prospect Ave., CLEVELAND, OHIO



### Delivered to You Free

A sample 1916 model "Ranger" bicycle, on approval and 30 DAYS TRIAL and free riding test.

Write at once for large illustrated catalog showing complete line of bicycles, tires and supplies, and the most marvelous offer ever made on a bicycle. You will be astonished at our low prices and remarkable terms.

**RIDER AGENTS Wanted**—Boys, make money taking orders for Bicycles, Tires and Sundries from our big catalog. Do Business direct with the leading bicycle house in America. Do not buy until you know what we can do for you. WRITE TO US.

MEAD CYCLE CO., DEPT. H108, CHICAGO

## AUTOMOBILE WATCH FOB

The neatest and most novel Fob ever designed. Has a leather strap and nickel buckle. Wheel is made of Rubber and is an exact reproduction of an automobile wheel with a quick detachable tire which can be removed and put on in a "jiffy." We will mail you this neat watch fob

### ABSOLUTELY FREE

If you will send us 25c in coin or stamps for a three months' trial subscription to the AMERICAN CHAUFFEUR AND AUTOMOBILE DIGEST, the new illustrated technical Automobile magazine, which is full of valuable, interesting, helpful Automobile information.

Send today, as our supply of Watch Fobs is limited. Address

THE AMERICAN CHAUFFEUR  
261 Butler Bldg. CINCINNATI, OHIO



Please Mention Popular Mechanics

**\$ 800**  
to  
**\$ 2400**  
in 3  
**Years**



## We Guarantee You More Pay

### SALARY GUARANTEE

THE AMERICAN SCHOOL OF CORRESPONDENCE GUARANTEES that you will receive an increase of fifty per cent over your present salary within three years from the date of your enrollment; or, failing in this, the School guarantees to refund to you the full amount paid for your course.

Salary advanced from \$800 to \$2400 in three years! That's what the right training did for Rudolph F. Koops, Dorchester, Mass., who enrolled with the American School for a course in Electrical Engineering.

He didn't have to neglect his regular work, either. We trained him at home—in his spare time. Result—salary trebled in three years. You can win in your chosen line of work just as easily. The American School guarantees it. And it costs you nothing to find out how.

## How You Can Make More Money

If you're really ambitious to earn more money and win advancement in the occupation of your choice, mark and mail the coupon.

Then the American School will send you some mighty interesting facts regarding a guaranteed increase in salary. You'll be glad you wrote. It will be your first step out of the rut.

For over eighteen years this school has been preparing men for bigger jobs and better pay. It has trained thousands for success in **Engineering, Business and Law**. The American School will give you the training you need to make more money, no matter where you live or what you do. Remember—you don't have to give up your work—we train you at home, in your spare time.

Mark and mail the coupon today—now!

**American School**  
of Correspondence. Chicago. U.S.A.

### Your Opportunity Coupon

Mark the position you want  
and mail the coupon now

- |                                |                          |
|--------------------------------|--------------------------|
| .... Electrical Engineer       | ... Lawyer               |
| .... Elec. Light & Power Supt. | ... Business Law         |
| .... Hydroelectric Engineer    | ... Business Manager     |
| .... Telephone Engineer        | ... Auditor              |
| .... Architect                 | ... Accountant           |
| .... Architectural Draftsman   | .... Cert'd Public Acc't |
| .... Building Contractor       | .... Private Secretary   |
| .... Building Superintendent   | .... Stenographer        |
| .... Structural Engineer       | .... Bookkeeper          |
| .... Structural Draftsman      | .... Fire Ins. Inspector |
| .... Mechanical Engineer       | .... Fire Ins. Adjuster  |
| .... Mechanical Draftsman      | .... Fire Ins. Expert    |
| .... Civil Engineer            | .... Sanitary Engineer   |
| .... Steam Engineer            | .... Plumber             |
| .... Shop Foreman              | .... Reclamation Eng.    |
| .... Shop Superintendent       | .... Textile Eng.        |
| .... Sheet Metal Draftsman     | .... College Preparatory |
- We also prepare for civil service examinations in all engineering subjects

NAME .....

ADDRESS .....

Pop. Mech. 11-15



**MICHIGAN STATE AUTO SCHOOL**

## Come to Detroit the automobile center and

# LEARN THE AUTOMOBILE BUSINESS

Detroit trained men get preference over all others, get jobs quick as soon as ready. *The reason*—study the heart in lower corner. Realize its tremendous power. No other city, no other school can give you what Detroit offers. Factories shown are not all. Think what it means to learn at Detroit. Every factory knows us, endorses our school, glad to get our graduates. You're right in the middle of great auto activity. Men are needed everywhere as testers, repairmen, chauffeurs. Splendid chance to start in business. Hundreds of our graduates are doing it.

## Earn \$75 to \$300 a Month

We teach you to handle any auto proposition. Our equipment is complete. Students actually build new cars from start to finish, getting regular factory training in assembling, block-testing, road-testing, etc. **That's the Detroit Way.** All leading types of starting, lighting and ignition systems in operation. Learn to time motors, adjust carburetors, magnetos, valves, bearings, etc. Six-cylinder Lozier touring car is used for road instruction. We have a new 8-cylinder King chassis, the latest thing out. Only school having Delco equipment and endorsement.

### Detroit is the Place to Learn, Start Any Time

There are 44 auto factories in Detroit. Our students have the privilege of going through any or all of them, including Detroit electric service department, while taking our course. You can't get these advantages and opportunities anywhere else. **Detroit is the automobile center.** You make faster time here and you get practical instruction. Come to Detroit and learn the business right. Enter classes any time.

**GUARANTEE**  
We guarantee to qualify you for a position as chauffeur, repairman, tester, salesman, demonstrator or garage man paying from \$75.00 to \$300.00 in a short time or refund your money. We have constantly more requests for men, at \$100 salaries, than we can supply.

**Write for full particulars. Ask for "Auto School News."**  
It's free. Or, better still, jump on train and come to Detroit.

**Great Demand for Detroit Trained Men**

Garages throughout the country write us for men. Why not fit yourself for one of these good paying positions?

**Demand Greater Than Supply for Competent Men. Following Clipped from Daily Papers—All Parts of U. S.**

Experienced motor mechanics, bearing scrapers, assemblers, repairmen; good wages. Henderson Motorcycle Co., 1158 Cass.

10 road testers, 20 garage repairmen, final assemblers. Maxwell Motor Co., Inc., Oakland Ave. Plant.

## DETROIT

THE HEART OF THE AUTOMOBILE INDUSTRY



THE AUTOMOBILE CENTER OF THE WORLD

**Michigan State Auto School** Dept. P. M., 10 Selden Ave.  
DETROIT, MICH., U. S. A.

**DON'T TAKE A COURSE IN MACHINE DRAFTING** till you've read my proposition. Practical, experienced Draftsman, regularly employed in large modern works, will teach a few men by mail. Best way to become a well-paid Draftsman. Special courses in Mathematics also. Instruments furnished. Rates very reasonable. **Pay a part after in position.** Draftsman, 252 S. Corona St., Denver, Colo.

### If You Are a Shallow Breather

*You most certainly are in need of Conscious Evolution to become fully alive and have the benefit of living in full. Why live an inferior life when you can become superior to yourself through Conscious Evolution?*

**MY NEW BOOK** explains the human body as it has never been explained before. It tells of the dangers and after effects of exercise and conscious deep breathing. My free book will prove of great value to you. If you desire to be more successful, to have greater will power and the successful powers, physical, physiological and mental, you cannot afford to be without my free book. Write for it today.

**ALOIS P. SWOBODA**  
1313 Aeolian Hall NEW YORK CITY

*Please Mention Popular Mechanics*

### LEARN WATCHMAKING

and become independent. Good-paying positions secured. Easy to learn. Send for FREE CATALOG.

**ST. LOUIS WATCHMAKING SCHOOL, Dept. 5, ST. LOUIS, MO.**

### LEARN TO WRITE EARN \$25 to \$100 A WEEK ADVERTISEMENTS

We can positively show you by mail How to increase your salary. **BOOK MAILED FREE.**

PAGE-DAVIS CO., 112 Page Building Chicago, Ill., or 150 Nassau St., New York

### LEARN PIANO TUNING AT HOME

My Patented Tune-a-Phone method makes it easy. Eliminates guess work. Anyone can learn. A. D. Pope, Texas, made \$82 first ten days. Course guaranteed as represented. Diploma granted. Write for free booklet, graduates' records, etc.

Niles Bryant School of Piano Tuning, 451 1st. Bldg. Battle Creek, Michigan

### MEN WANTED

Prepare as Firemen, Brakemen, Electric Motormen, and colored Train Porters. First Class Standard Roads. Hundreds put to work—\$65 to \$150 a month without any experience. **500 more wanted.** Uniforms and passes arranged for when necessary. Enclose stamp for Application Blank. Name position you want.

**I. RAILWAY C. I., Dept. 35, Indianapolis, Ind.**





BOAT DRILL AT NAVY TRAINING STATION

## An Attractive Career

**T**HE U. S. NAVY offers many attractions as a career for young men. The instruction which apprentice seamen receive at the Training Stations is full of interest, consisting as it does of boat drills, infantry and artillery practice, sham battles, signalling, swimming and the like. Plenty of time is allowed for sports, baseball, football; gymnasium exercises, "movies," etc.; and the recruits usually find their time too much taken up to get into mischief. They associate with healthy, clean-minded young men, and every incentive is offered them to strive for advancement.

After six months at the Training Station, the apprentice seamen are promoted to a sea-going rating, and they are assigned to a ship, where they can put into practice the instruction they have gained ashore. They find their superiors willing to aid them in mastering their profession, and if they apply themselves to their duties they are certain to win promotion.

The Navy has many opportunities for bright young men, and these opportunities are increasing year by year. Promotion is open through the various petty officer ratings to warrant officer and eventually for the exceptional men, to Commission.

Write for full particulars, and for address of Navy recruiting station nearest you. You'll be interested in the Navy's offer.

ADDRESS BOX 67

# BUREAU OF NAVIGATION

NAVY DEPARTMENT

WASHINGTON, D. C.



## The Finish Is Important

After spending many hours making a beautiful piece of furniture—you don't want to spoil it with a poor finish. Surely the "finish" is a subject which should be given its share of attention. Our Instruction Book tells all about finishing furniture, basketry, woodwork, floors, etc. It is chock-full of valuable ideas on home beautifying.

## JOHNSON'S WOOD DYE

is just the preparation for dyeing wood, reed, etc. It makes inexpensive soft woods look as beautiful and artistic as hardwood. It is very easy to use—penetrates deeply—is economical and dries ready

for the finish in fifteen minutes. Made in seventeen shades including *Mahogany*, *Mission*, *Early English*, *Fumed*, etc. Ask your dealer to show you panels of wood finished with it.

## JOHNSON'S PREPARED WAX

is the proper finish to use over the Dye. It imparts that soft, artistic polish so appropriate to Craftsman furniture. It is impervious to water, dust, scratches, finger-prints, etc. Furniture

finished with it can easily be kept in perfect condition. Every family has dozens of uses for Johnson's Prepared Wax—it is just as necessary around the house as soap. Keep a can always on hand for cleaning and polishing your

S. C. JOHNSON & SON, Racine, Wis. PA11

I enclose 10c for a can of Johnson's Prepared Wax—sufficient for polishing several pieces of furniture, a small floor or an automobile. Also send Instruction Book on Wood Finishing free.

Name .....

Address .....

City and State .....

*Piano*  
*Linoleum*  
*Woodwork*  
*Automobiles*

*Desks*  
*Floors*  
*Furniture*  
*Leather Goods*

Use coupon for trial can—enough for polishing several pieces of furniture, a small floor or an automobile.

**S. C. JOHNSON & SON**  
"The Wood Finishing Authorities"  
RACINE, WIS.

# Popular Mechanics Magazine

REGISTERED IN U. S. PATENT OFFICE

WRITTEN SO YOU CAN UNDERSTAND IT

Vol. 24

386 H

NOVEMBER, 1915

No. 5

## Piano Transported up Mountain by Burros

NOT long ago the proprietor of a mountain resort in southern California decided to purchase a piano for the entertainment of his guests. Access to his alpine place is gained only by following a long and exceedingly narrow trail which hugs the sides of the mountains and occasionally overlooks an uninviting precipice. Freight is always carried up the trail on the backs of pack animals, and these, most often, are sure-footed burros. It devolved upon two of these little beasts to transport the pi-

ano up the mountain, which they did with the assistance of several moun-



Pushing up a Mountain Trail with a Heavy Piano. Below: Fording a Mountain Stream with the Piano Strapped to the Small Burros

taineers. The heavy instrument was securely strapped to a pair of long timbers, the burros were placed at either end, and the planks lashed to

the packsaddles. The men guided the animals and steadied the load. The burros negotiated the mountain safely and delivered the piano uninjured.

527  
 X BRITISH PRODUCE STARTER  
 FOR AERIAL MOTORS

One of the most interesting developments that has been made recently in improving aeroplane equipment has

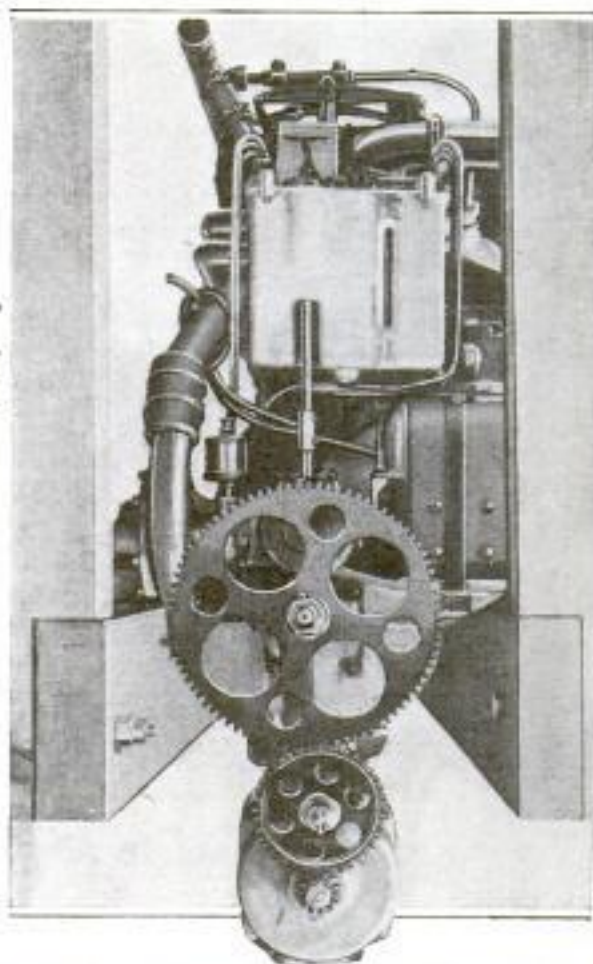

A 90-Horsepower Aerial Motor Fitted with One of the New Electric Starters, Which is Built as an Integral Part of the Crank Case

been announced in England, where an apparently practical self-starter for aerial motors has been constructed. The importance of this invention, especially from the standpoint of the military flier, is most obvious. The utter necessity for reasonable compactness and lightness in such mechanism has been the principal stumblingblock to be overcome in meeting aeronautical requirements. The device complete

weighs only 84 lb. and is capable of turning over a 90-hp. motor continuously for two minutes at a speed of 50 revolutions a minute. The motor develops 1.4 hp. with 38 to 1 gearing and is provided with a 12-volt battery of 66 ampere-hour capacity. The apparatus is made as an integral part of the crank case.

X  
 499 DIRECT-LIFT BRIDGE BUILT  
 OVER LOUISVILLE CANAL

Across the widened Louisville and Portland Canal at Louisville, Ky., an interesting type of vertical-lift bridge has recently been opened to traffic. This is at Eighteenth Street and replaces an old swing structure of much smaller proportions which was erected years ago over the then narrow channel.

The main span of the new direct-lift bridge is 210 ft. in length, while the approaches are 75 and 85 ft. in length. The boats navigating the river at this point require a vertical clearance of about 55 feet at high-water level. This, and the length of the span, were two of the determining factors leading to the adoption of the present type of structure, which has a 40-ft. lift. The bridge is meant for vehicle traffic and has a 16-ft. roadway capable of carrying a live load of 100 lb. to the square foot.

Weighted trusses pivoted to uprights fixed to the approach spans provide for the raising and lowering of the main span, which they counterbalance. The lower ends of the hangers are connected by pins to the ends of the lift span and the center points are pivoted to the vertical posts. The trusses are also connected at their outer extremities to the counterweight links, joining the weights. These latter members are connected to the trusses in such a way that the lift span and the centers

C. A. Vandervell & Co.  
 Warple way, Acton Vale, W.  
 London

Steel - Penn Bridge Co., Beaver Falls, Pa.  
 Erected by - Middle States Construction Co.,  
 Columbus, O.

POPULAR MECHANICS

643

Plans & Spec. - Strauss Bascule Bridge Co.  
 under direction of 1011 So. Michigan St., Chicago,  
 Major J. C. Baker  
 U. S. Engr at Louisville

Contract awarded  
 July 14 -  
 Completed &  
 first operated  
 6-23-1915

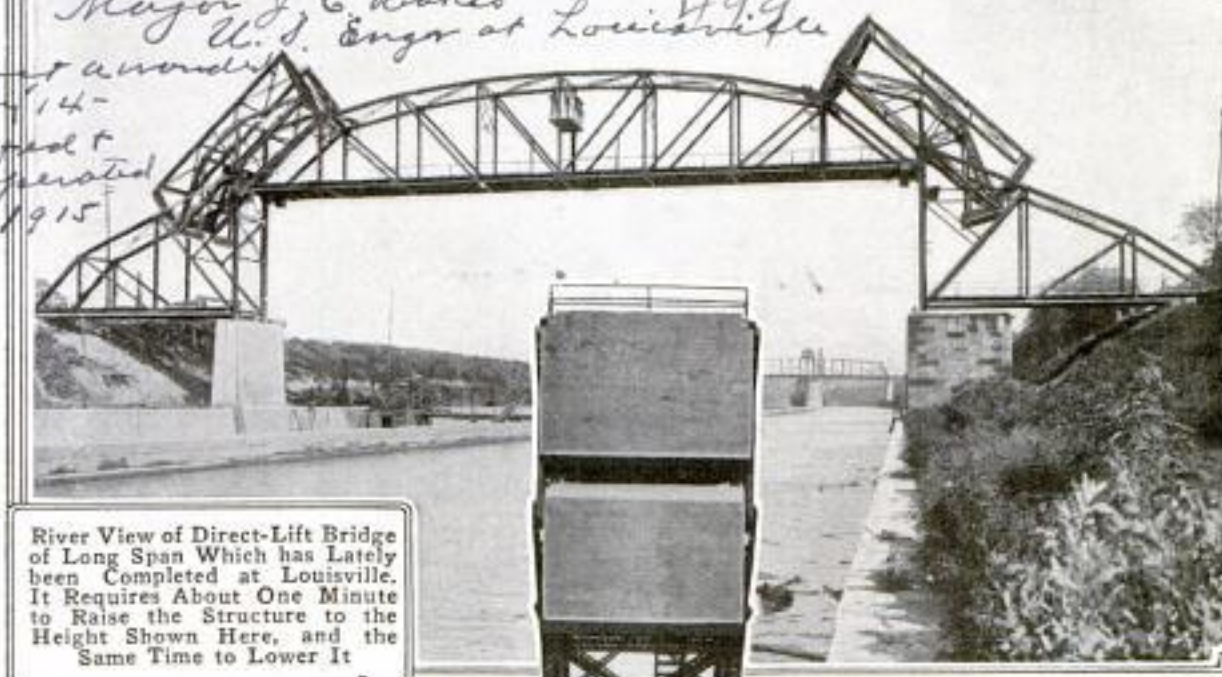

River View of Direct-Lift Bridge of Long Span Which has Lately been Completed at Louisville. It Requires About One Minute to Raise the Structure to the Height Shown Here, and the Same Time to Lower It

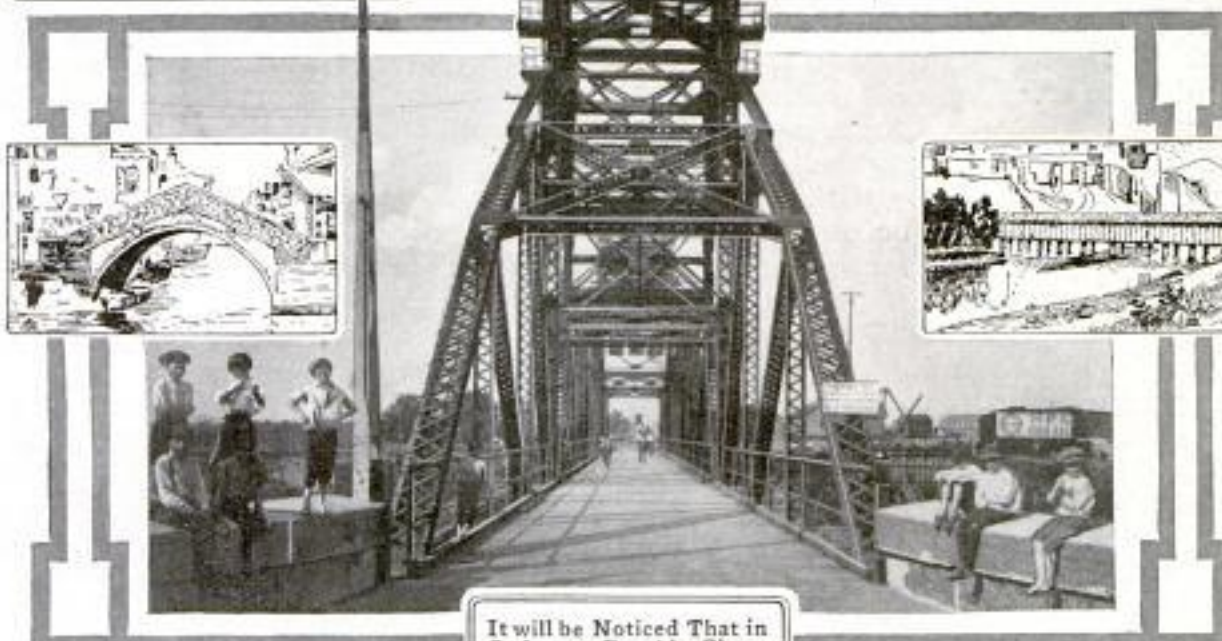

It will be Noticed That in Order to Provide Clearance for the Counterweights, the Top Struts are Offset

This Shows the Bridge in Normal Position: It is Controlled from the Cabin Suspended in the Middle of the Span

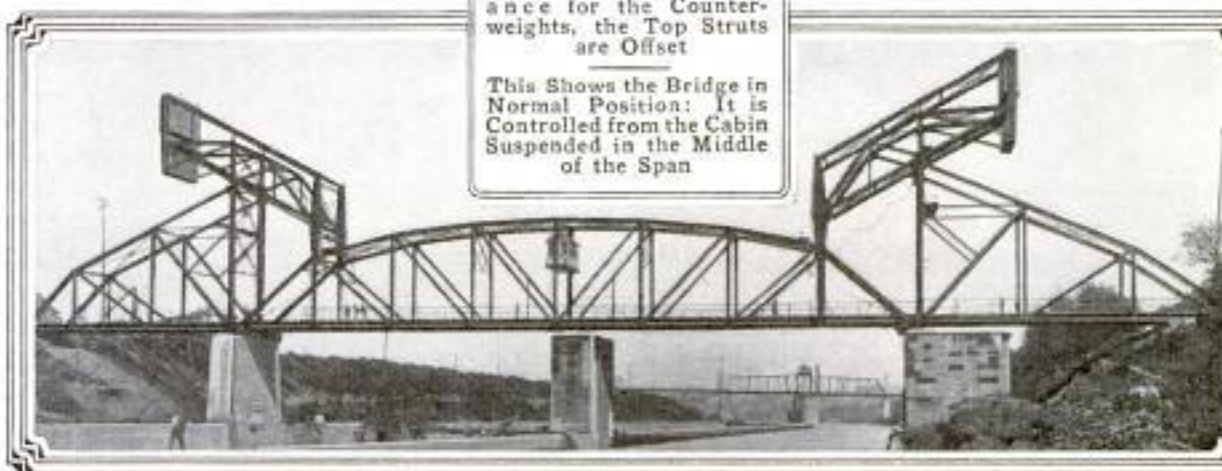

of gravity of its counterweights may be raised and lowered vertically.

The bridge is operated electrically and controlled from a small cabin situated in the middle of the bridge. There are four operating pinions fixed

beneath the flooring, where they engage with racks attached to the inner side of the vertical posts at the four corners of the main span. One minute is required either to raise or lower the structure.

## MACHINE ENABLES BLIND TO READ BY SOUND

*"The Phonopticon"*

380  
BY the invention of an electrical "eye" through the medium of which sound waves may be developed from printed letters, a means has apparently been discovered for enabling the blind to read. A professor at the University of Iowa has built an apparatus which literally reads print. It is called a phonopticon, and in the course of experiments has shown itself capable of pronouncing various letters of the alphabet, as well as figures and other characters, by sounding different combinations of musical notes. By learning the particular sounds representative of each letter, a person unable to see is made able to read. It is even considered likely that the apparatus may ultimately be developed so that an impression of a painting or photograph may be conveyed to those deprived of sight.

The "eye," when in use, is moved along a line of text to be read. It is by means of this that other mechanism, which develops and carries the sound waves to the ears of the user, is actuated. Crystalline selenium, a peculiar element that is sensitive to light and a conductor of electricity, is the all-important part of the artificial optic. It is the effect which light has upon this substance that renders it valuable for this purpose. The conductivity of the crystal varies according to the intensity of its illumination, since the resistance of the material is reduced by exposure to luminous rays.

Three separated crystals are placed above an aperture in the reading device and so connected as to form arms of a Wheatstone bridge, which in brief is a device for measuring electrical resistance. When the "eye" is passed over blank paper the instrument

is neutral. A bright band of light from an outside source moves with the "eye," illuminating each letter in turn. As the black outline of part of a character is reached its image is thrown through a lens upon one of the crystals. This shadow reduces the illuminated area of the crystal, increasing its resistance. In turn this unbalances the current and deflects a part of it into one of a series of three branch circuits. In each of these is an interrupter which produces a current of definite frequency. These impulses are converted into sound waves of a specific pitch by a resonator provided in each receiver.

In this way, it may be seen, each part of a printed letter, as the upper, lower, and middle sections, acts upon a certain crystal and through it upon a separate interrupter and resonator. The frequency given the currents by the interrupters is governed by the number of segments of the latter and their respective speeds in revolving. The entrance of the successive parts of a letter into the illuminated area is instantly announced by a change in the pitch of the note.

In this particular instrument three telephone receivers are used. The number corresponds to the number of crystals employed, which it is possible to vary from one to four. In order to enable the use of more than two receivers, a pair is incorporated in one holder. These instruments replace the galvanometer of the Wheatstone bridge.

At its present state of development the apparatus weighs approximately 35 lb. and the electrical "eye" 2 lb. These weights are greater than will be required in a finished machine. The

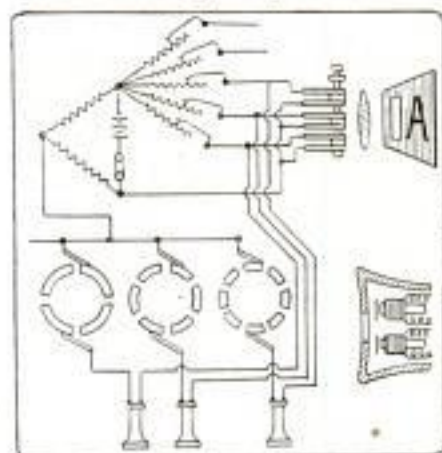

Cross Section of Instrument

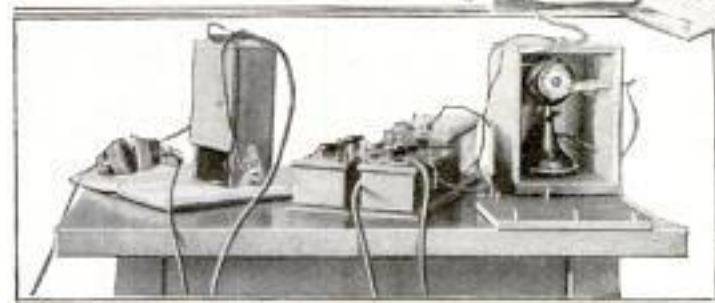

Electric Eye being Passed over a Printed Page



The Diagram Illustrates the Plan of the Phonopticon and the Relative Positions of Crystals, Lens, and Light Band as the Letter is Approaching "A." The Arrangement of Circuits is Also Shown. The Drawing at the Right Explains the Grouping of Receivers in Pairs. Photograph Exhibits Experimental Apparatus Which will Ultimately be Made Lighter and More Compact

Objections to the Present System of Touch Reading are Made Obvious by This Photograph, Which Shows Six Large Volumes of Raised-Letter Books, the Blind Man's Edition of David Copperfield

"eye" itself, which for convenience needs to be lightened considerably, can be made very compact and not more than a small fraction of a pound in weight.

The apparatus was recently tried out at a California institution for the blind and also at a convention of those engaged in promoting the welfare of blind persons. After a number of subjects had acquainted themselves with the different combinations of sounds peculiar to individual letters, they were able to distinguish letters and words more or less readily. Some of these tones are given in sequence, the letter "V," for instance, being rendered something like G, E, C, E, G, in the key of C major. The notes of charac-

ters having upright lines such as "L," "I," and "E," are rendered simultaneously, since the upper, middle, and lower portions act upon the selenium members at the same time.

It is the purpose of the inventor to perfect the machine so that it will be practical for use in any home where it may be needed. It is considered that it will be of value to persons with weak eyes whose businesses necessitate voluminous reading, and that it may also enable many blind persons to become self-supporting.

Inventor: *Albert Audelet,*  
*Salem, Mass.*

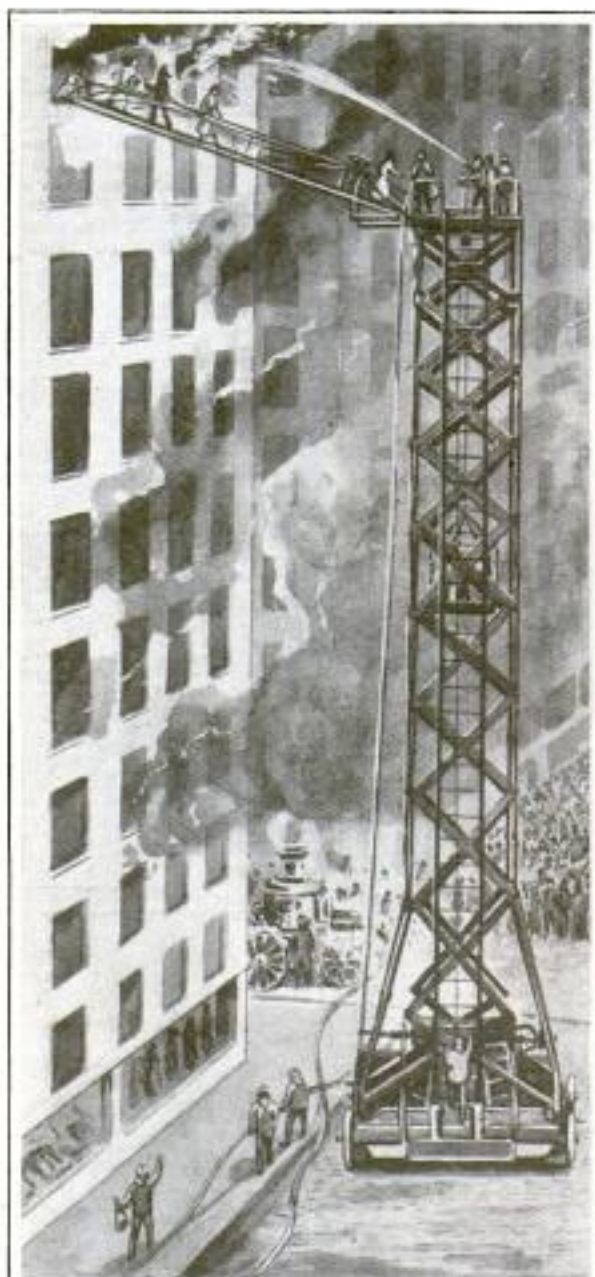

4  
426  
**NOVEL COLLAPSIBLE TOWER  
FOR FIRE FIGHTERS**

For life-saving and fire-fighting purposes, a Salem, Mass., inventor has designed a collapsible tower which may be extended to a height of 100 ft. in approximately one minute. Its plan of construction is not greatly unlike that of some of the folding observation structures employed in the field by European armies. At the top it supports a working platform for the fire fighters, on one end of which is fixed a short extension ladder which may be adjusted to various angles. In addition to this there is a jointed steel ladder reaching from the ground to the apex of the structure, which is raised into position with the rest of the apparatus. Fixed in the middle of the shaft is a basket elevator that is intended to be used for lowering persons rescued from burning buildings. Two leads of fire hose secured to the "fighting top" are carried up with the tower as it is raised. The device is intended to be mounted on a motor truck and operated by the machine's power plant. When collapsed it fills the space back of the driver's seat.



4  
540  
**POWERFUL LIGHT PRODUCED  
WITH NITROGEN LAMP**

Through the development of a specially designed reflector and projector-type housing for an incandescent lamp, a young western electrician has brought out a lantern which when fitted with a 1,000-watt nitrogen-filled globe produces a penetrating light rated at approximately 500,000 candle-power.

The lamp is suited for various indoor purposes and is also well adapted for brilliant exterior illumination. Simplicity, efficiency, and economy in operation make its use more convenient in many places than the more expensive and complex searchlight. It is because of these attributes that it is of especial value for night construction work in the open as well as for emergency and general purposes.

The Tower may be Elevated to a Height of 100 Feet in One Minute's Time. Its Appearance When Collapsed is Shown Below



American Lighting Co.

747 Railway Exchange Bldg.

POPULAR MECHANICS

647

"Electric Sunlight" Chgo.

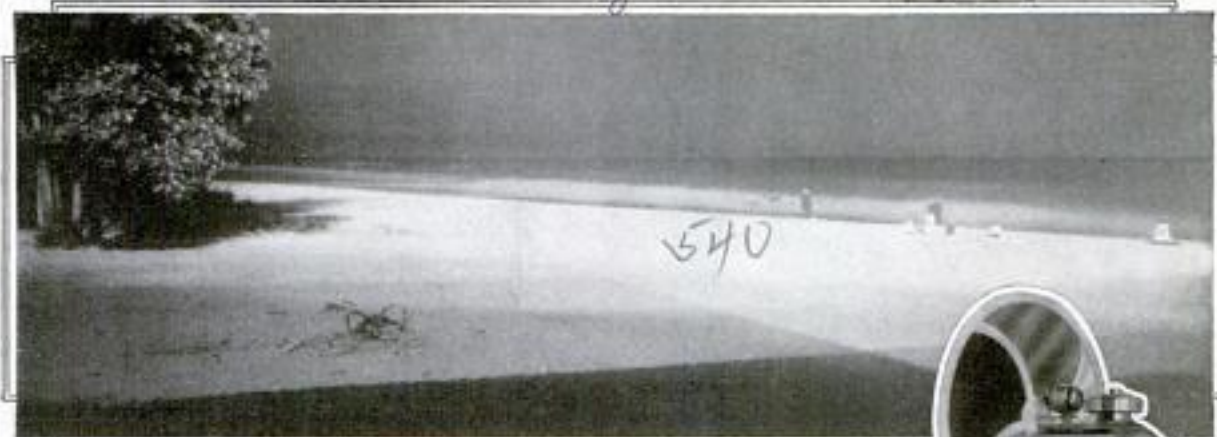

A Battery of the Lamps, Equipped with Color Wheels, is Hidden above the Silk Hangings Draping the Ceiling of This Restaurant

Clarendon Beach at Chicago Illuminated by 10 of the Powerful Incandescent Lights. Insert Shows Lamp Housing Equipped with Color Wheel

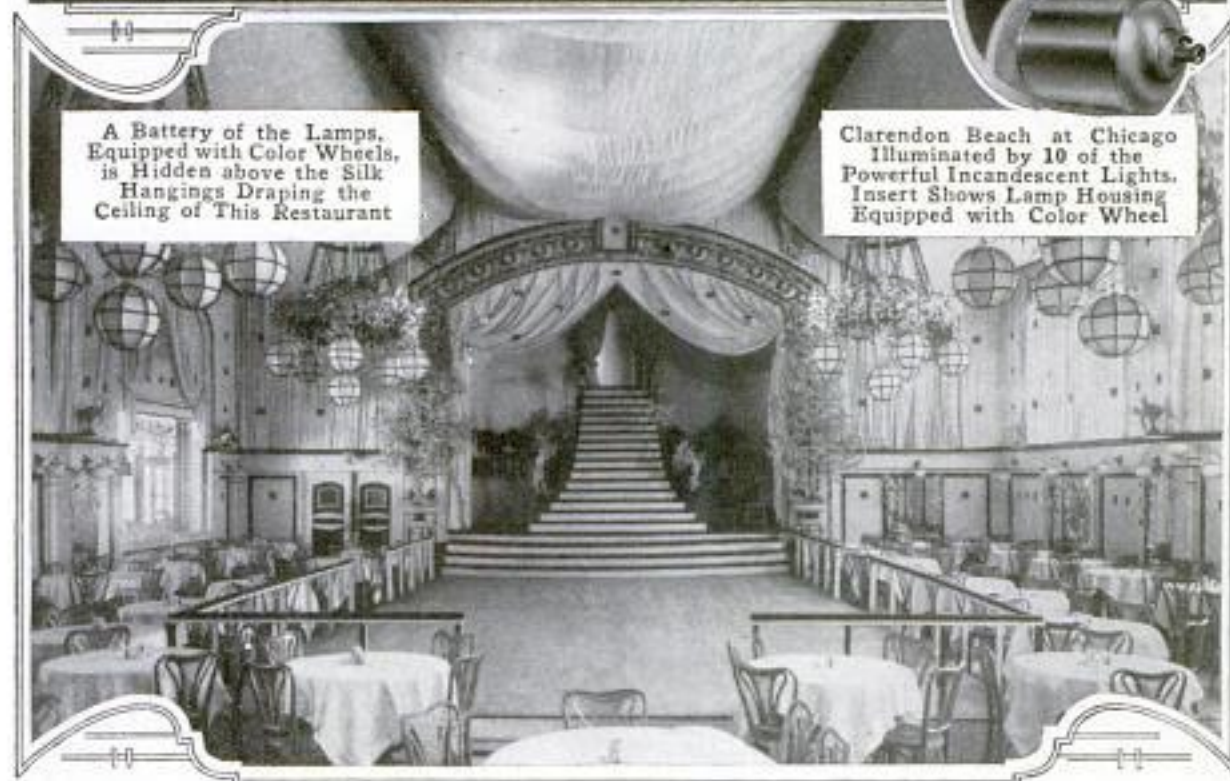

Batteries of these lights were used to assist the night rescue work at the time of the "Eastland" tragedy and proved very adequate. It was following this rather spectacular demonstration of their power that they were adopted for illuminating one of the municipal bathing beaches at Chicago where a number of accidents had occurred. It was desired to light the surf and shore both as a measure of safety and convenience to the bathers. Ten lights were used in this capacity with a result which may be partly appreciated by glancing at one of the accompanying illustrations. The several units, having an aggregate of about 5,000,000 cp., lighted the water

for a considerable distance out into the lake.

A battery of four of the lamps equipped with motor-driven color wheels has been utilized in carrying out an interesting illuminating scheme at a Chicago restaurant. The ceiling has been draped with silk hangings, above which the lamps are installed. The color wheels are not operated in synchronism, so constantly changing and blending hues are cast upon the translucent silk and through it upon the diners.

A silverplated reflector is used with the lamp. At the back of it is a regulating device which enables it to be focused for use as a spot light, if desired.

548

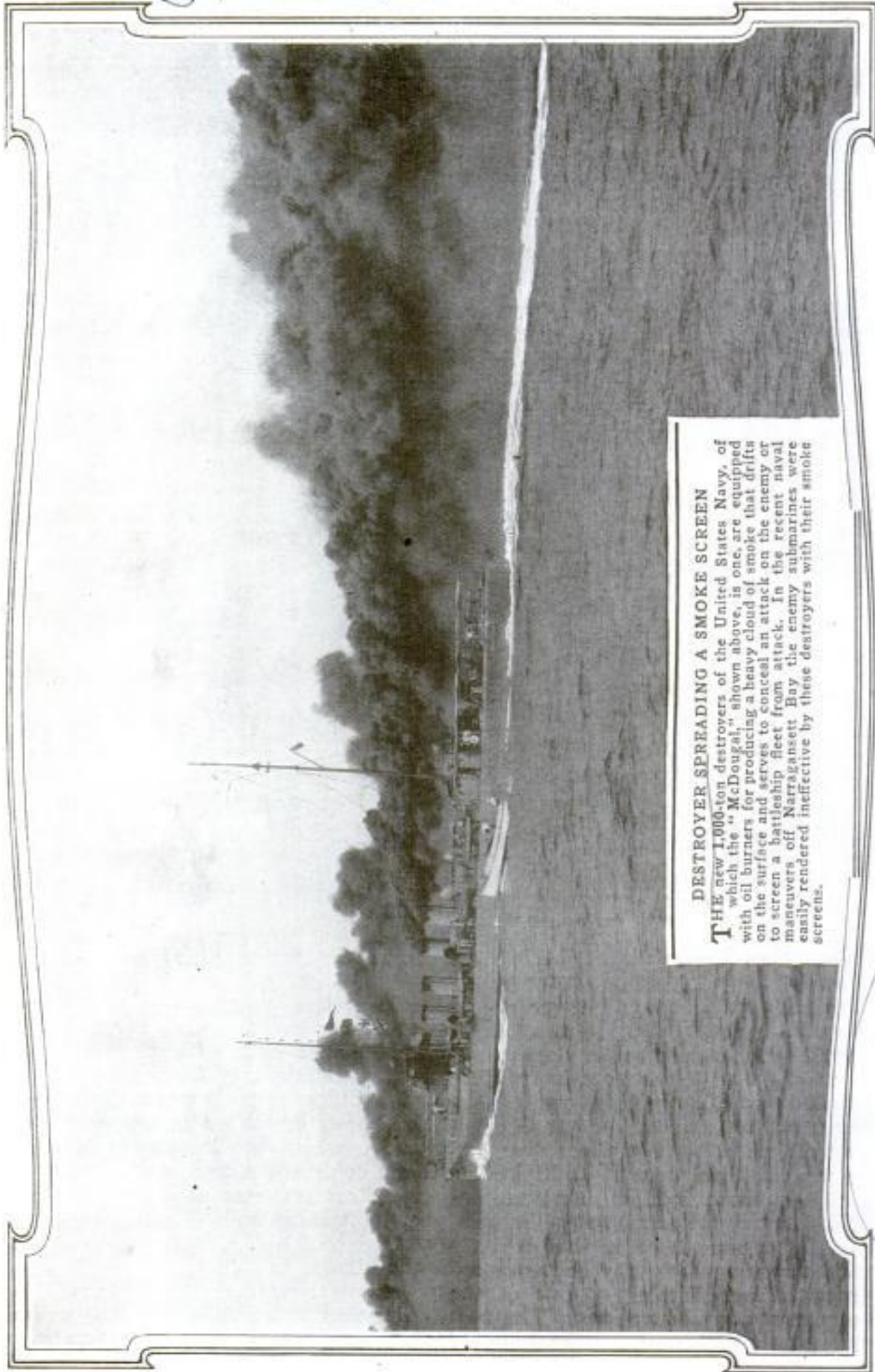

**DESTROYER SPREADING A SMOKE SCREEN**

**T**HE new 1,000-ton destroyers of the United States Navy, of which the "McDougal," shown above, is one, are equipped with oil burners for producing a heavy cloud of smoke that drifts on the surface and serves to conceal an attack on the enemy or to screen a battleship fleet from attack. In the recent naval maneuvers off Narragansett Bay the enemy submarines were easily rendered ineffective by these destroyers with their smoke screens.

Copyrighted 1915 by Enrique Muller

P.O. Box 774  
N.Y. City

*Educational*

*Garwood Gas Lamp & Heater Co.  
Canton, O.*

**USING ANIMATED DRAWINGS  
TO ILLUSTRATE LECTURES**

*Machinery Sept-1915*

In illustrating a lecture in which armor plate and armor-piercing projectiles were discussed not long ago at the British Institution of Mechanical Engineers, an interesting employment was made of motion pictures. A number of drawings in which a shell was shown leaving a gun, hitting a plate of armor, the cap then breaking into pieces, the projectile passing through the metal protection and subsequently detonating, were filmed. The pictures when projected on a screen showed graphically what original photographs could not have portrayed. The drawings had been carefully executed and the resulting effect was good.

**PORTABLE PLATFORMS USED  
BY SUFFRAGE SPEAKERS**

When making open-air talks in various parts of the city, Philadelphia suffragists, who are carrying on a vigorous campaign for enfranchisement, employ portable speaking platforms which may be pushed from point to point. Fixed to the front legs of the wood framework is a pair of wheels. When a speaker finishes a talk she steps down from the elevation and tilts the stand so that the weight is carried on the wheels. Then, by using the platform railing as a handle, she pushes the contrivance along trucklike. Although somewhat cumbersome, it is not too heavy for a woman to handle. When erect, it forms a substantial platform.



*# Wm. H. Watson, Morton, Pa.*

**STEAM RADIATOR HEATED  
BY GAS**

One of the new features in heating equipment is a steam radiator in which the heat is supplied by means of gas,

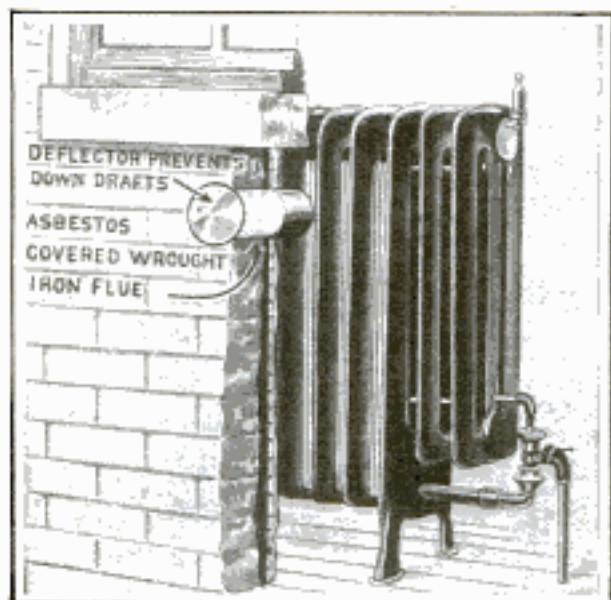

Steam Radiator in Which the Heat is Supplied by Gas: Each Radiator Forms a Unit and No Piping is Required

which may be either natural or artificial. Each radiator forms a unit, and no piping is required, as the water and steam simply circulate through the coils of the radiator. The gas burner is placed at the bottom under the center of the radiator. It is provided with a thermostat that controls the flow of the gas and keeps the steam at any required temperature. The products of the combustion of the gas pass through a pipe to the outside of the building so that the air in the room is not polluted. In operation, the water is heated and formed into steam at the bottom of the center coils and then passes upward and across the top to the overhanging coils at the ends. In these coils the steam is cooled and condensed, and the resulting water passes over the burner, where it is again formed into steam. In this way a constant circulation of water and steam is kept up. All that is necessary for placing the radiator in service is to pour about a gallon of water into the water-filling plug at the side and light the burner.

**WASTE FURNACE HEAT USED  
BY CHIMNEY OVEN**

To make it possible to utilize the waste heat of a furnace for cooking purposes, thus effecting a saving in gas

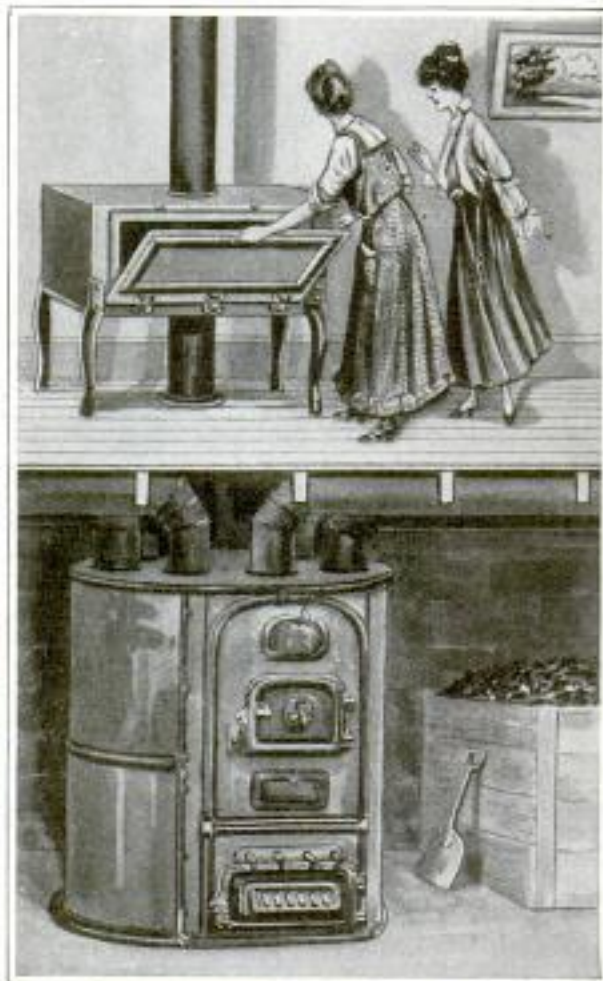

The Operation of the Chimney Oven Shown Above Costs Nothing, Since It Utilizes the Heat Given Off by the Smoke and Hot Gases Passing Up from the Furnace Beneath.

consumption, an oven has been designed which bakes by means of the smoke and hot gases that ordinarily pass out of a chimney. It is intended to be installed either in a kitchen or basement adjacent to a flue. The outer jacket is made of range steel and the inner compartment of black iron. A pipe leading from the furnace is passed through the floor and connected with the bottom of this, while the outlet is fixed at the top and leads into a chimney. A hollow space between the walls of the oven provides for the free circulation of the smoke and gases, so that all sides are heated uniformly. This does not increase the fuel consumption

of the furnace, so there is no cost whatever attending the use of the oven. It is especially economical in homes where much baking is done.

**NOVEL STORE WITHIN WALLS  
OF STATE PENITENTIARY**

Practically all of the provisions, personal articles, and permitted luxuries required by some 2,000 inmates of the Illinois penitentiary at Joliet are carried in stock at the prison store. To those who are unfamiliar with the ways of prison life, this supply house is probably a curious institution. Particularly is it interesting when one considers that it monopolizes the trade of a community which in the outside world would be supplied by a score of stores of various kinds.

Although it carries on a considerable volume of business, cash is not accepted as a medium of exchange at its counters. Money in hand will buy nothing at the store, where every purchase is charged to the account of the inmate buying it. If a prisoner wants a lead pencil and nothing else, a requisition is signed for the article, which is then charged against his balance in the penal bank, providing, of course, that he is fortunate enough to have a deposit there. Another particular in which this store differs greatly from the customary shop is that the goods are not displayed and no attempt is made to increase the business or show a profit at the end of the year.

It is a practice to give each inmate in good standing his choice between a plug and a small package of smoking tobacco each week. Those who desire more tobacco than this, or who wish cigarettes, cigars, snuff, or other articles, such as playing cards, pencils, paper, underwear, handkerchiefs, and similar things, are permitted to order them. For this purpose four men make the rounds of the cells each week listing the individual wants of the inmates. These requisitions are subsequently filled and delivered the following week. Orders for candy and fruit are taken in the same manner monthly.

*Joliet Prison Post*  
7-1-1915

## HYDROELECTRIC - POWER DEVELOPMENT ON THE PACIFIC COAST

520  
m

How the Tremendous Water-Power Resources of the Sierras are Utilized for the Production of Electrical Energy

**T**HE hydroelectric systems of the West, the greater part of which have been built in a period of about 12 years, constitute in the aggregate one of the biggest industrial developments this country has ever known. This development is due not only to the demands for power, but to the fact that because of its topography this section of the country is particularly favorable for the generation of electric current on an extensive scale by means of hydroelectric plants. It is estimated by government experts that out of a total of about 26,000,000 hp. which it is possible to develop in this way in the entire country, nearly 19,000,000 hp. lies west of the Rocky Mountains. Conditions for hydroelectric development are particularly favorable in the three states of the Pacific coast where the waters from the melting snows, discharged down the precipitous slopes of the high sierras, provide one of the greatest natural resources in the world for the production of electrical energy.

Electrically, the Pacific coast may be divided into distinct zones centering about the five principal cities. In the

section about Spokane, Wash., power is chiefly supplied by one company, which has four water-power developments, all located on the Spokane River. The most important of these is the Long Lake development, the dam and power house for which are shown in one of the illustrations. The transmission system operated by this company consists of 600 miles of 60,000-volt lines. Power is supplied to a district within a radius of 100 miles of Spokane, the most important load center being in the Coeur d'Alene mining district in Idaho. In the Puget Sound country, Seattle is the electrical center. The needs of this section are also met for the most part by one company, which has approximately 75,000 hp. in hydroelectric developments and 35,000 hp. in steam stations. Farther south is a large electrical district having Portland, Ore., for its center. Here, out of a total of 85,000 hp. required for supplying the district, 54,000 hp. is produced by hydroelectric stations. San Francisco is the most important electrical center of the coast. Current for this and the adjacent cities is sup-

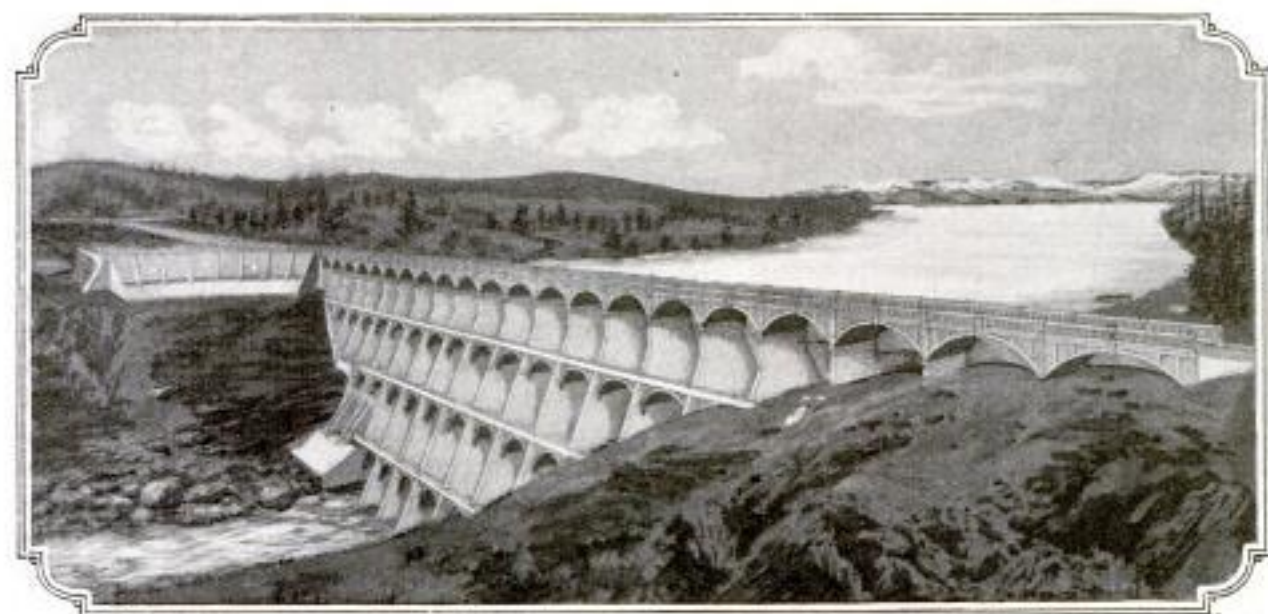

The Big Meadows Dam: When This Dam, 150 Feet in Height, is Completed, It will Store Up More Water than Any Other in the World with the Exception of the Assuan Dam in Egypt

The Picture at the Right Shows the Spaulding Dam Completed to a Height of 275 Feet, with the Stone-Crusher House, Aerial Cableways, and Other Construction Equipment Still in Place. Below Is a View of the Fore-Bay Reservoir and, within the Oval, a Typical Section of the "High-Line" Canal Which Conveys the Water from the Reservoir to the Penstocks.

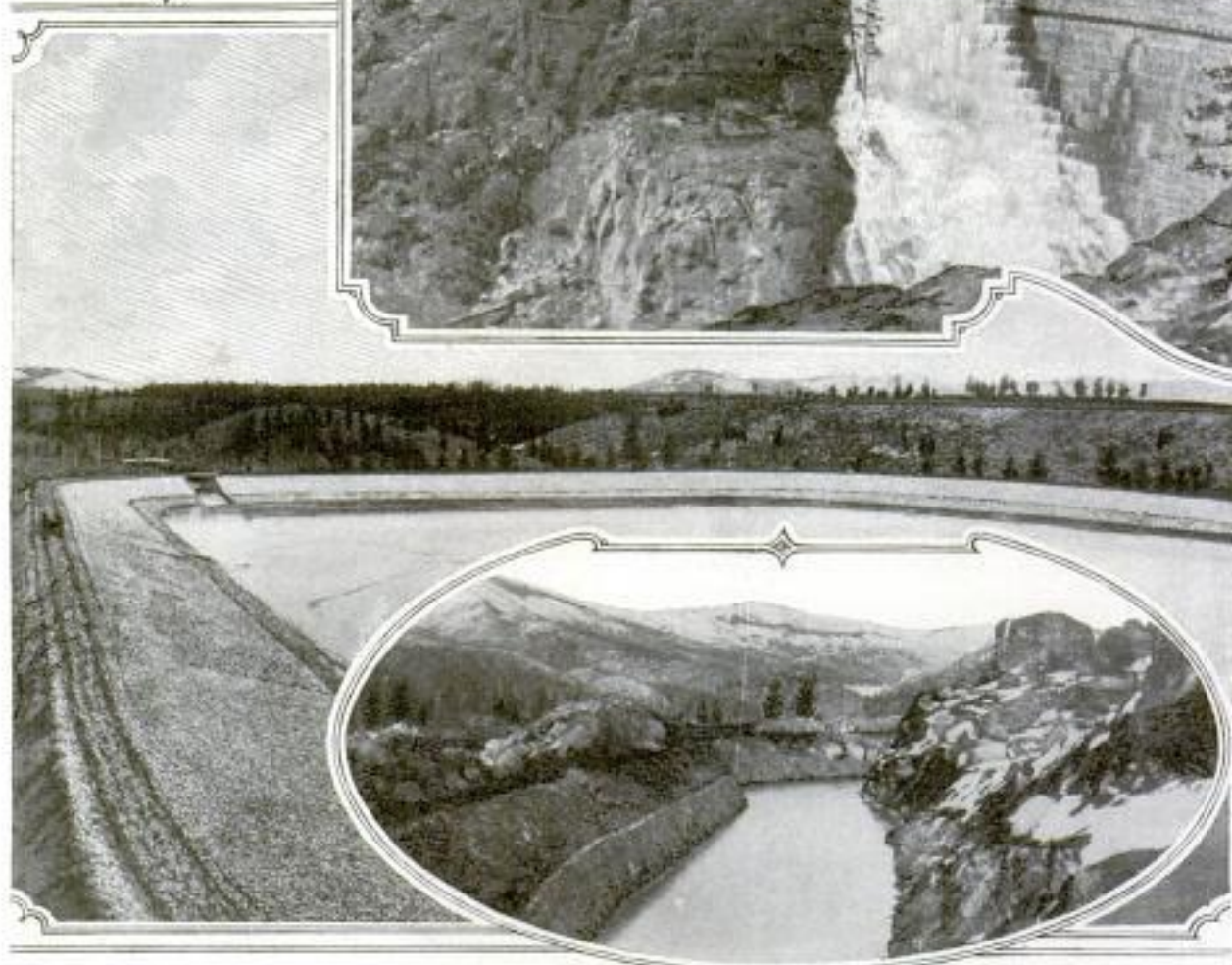

plied by three companies, each of which brings in hydroelectric power from long distances. In the district centering in Los Angeles there are a number of large hydroelectric stations, the most important, the Big Creek project, now being under construction. This project will ultimately be provided with four power houses through which the water will be used successively. The power will be carried 241 miles over three lines operat-

ing at a voltage of 150,000. With the completion of this system, the company operating in Los Angeles and vicinity will be able to supply 405,000 hp. In addition to these five electrical districts there are others of less importance. In California alone there are 110 reservoirs for hydroelectric purposes with a total storage capacity of 235,780,000,000 gallons.

It is the tremendous and precipitous fall of the water as it passes from the

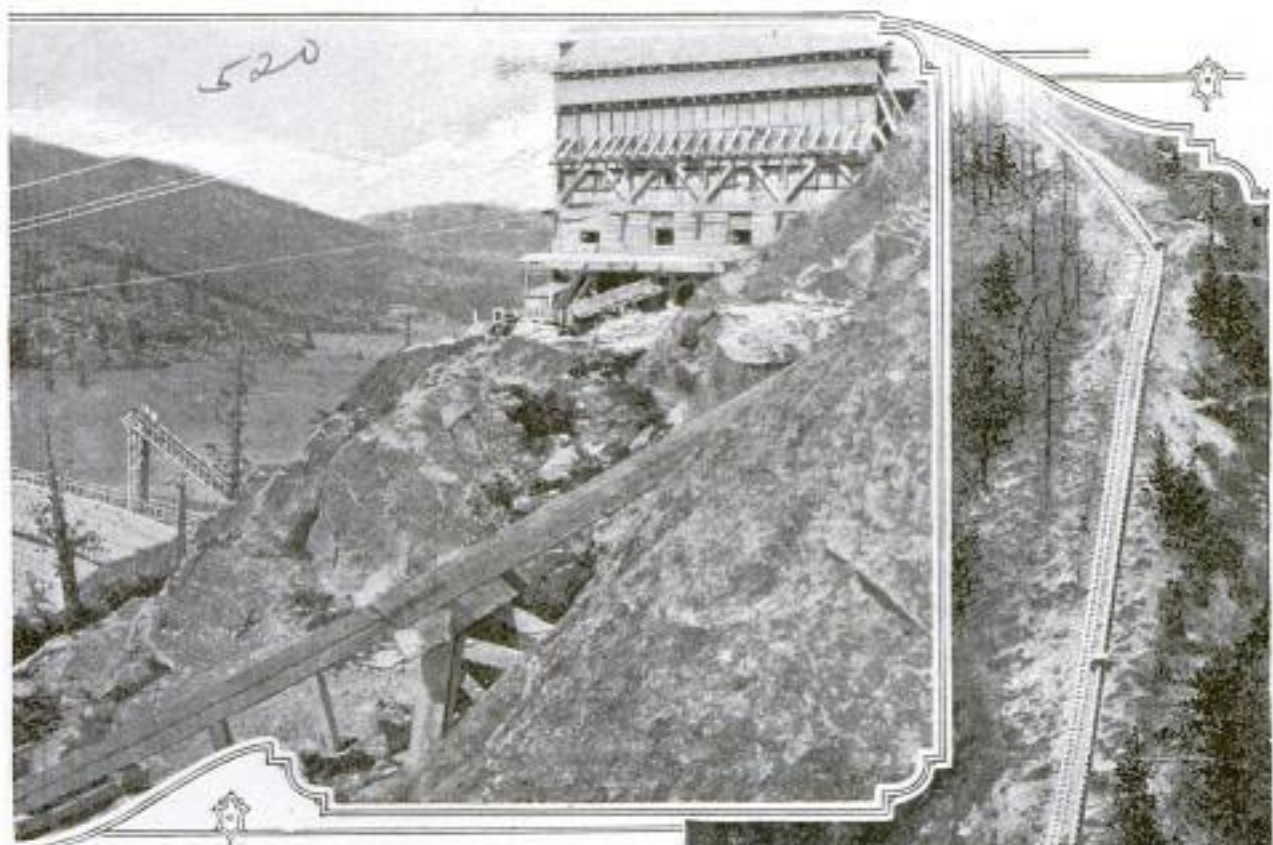

high sierras to the valleys, a feature characteristic of the coast belt, that makes hydroelectric development on such a scale possible. Ordinarily the water goes tumbling down the cañons, the fall being so broken up that the water is practically useless as a source of power. The usual method of hydroelectric development consists in building a dam high up in the mountains near the source of power, and in conducting the water from the reservoir thus formed through a canal that has

The Drum Power House and the Penstock through Which the Water from Spaulding Lake Drops down the Mountain Side to the Turbines: The Penstock Is 72 Inches in Diameter, and, if Laid Out Flat, an Automobile could Easily Pass through It. The Water Issuing from the Pipes at the Lower Side of the Power House is Conducted down the Valley and Used for Irrigation

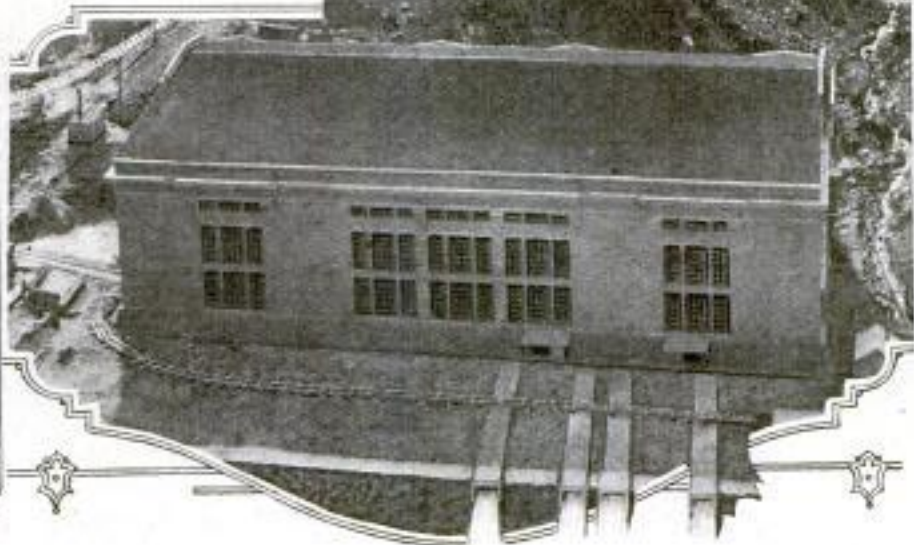

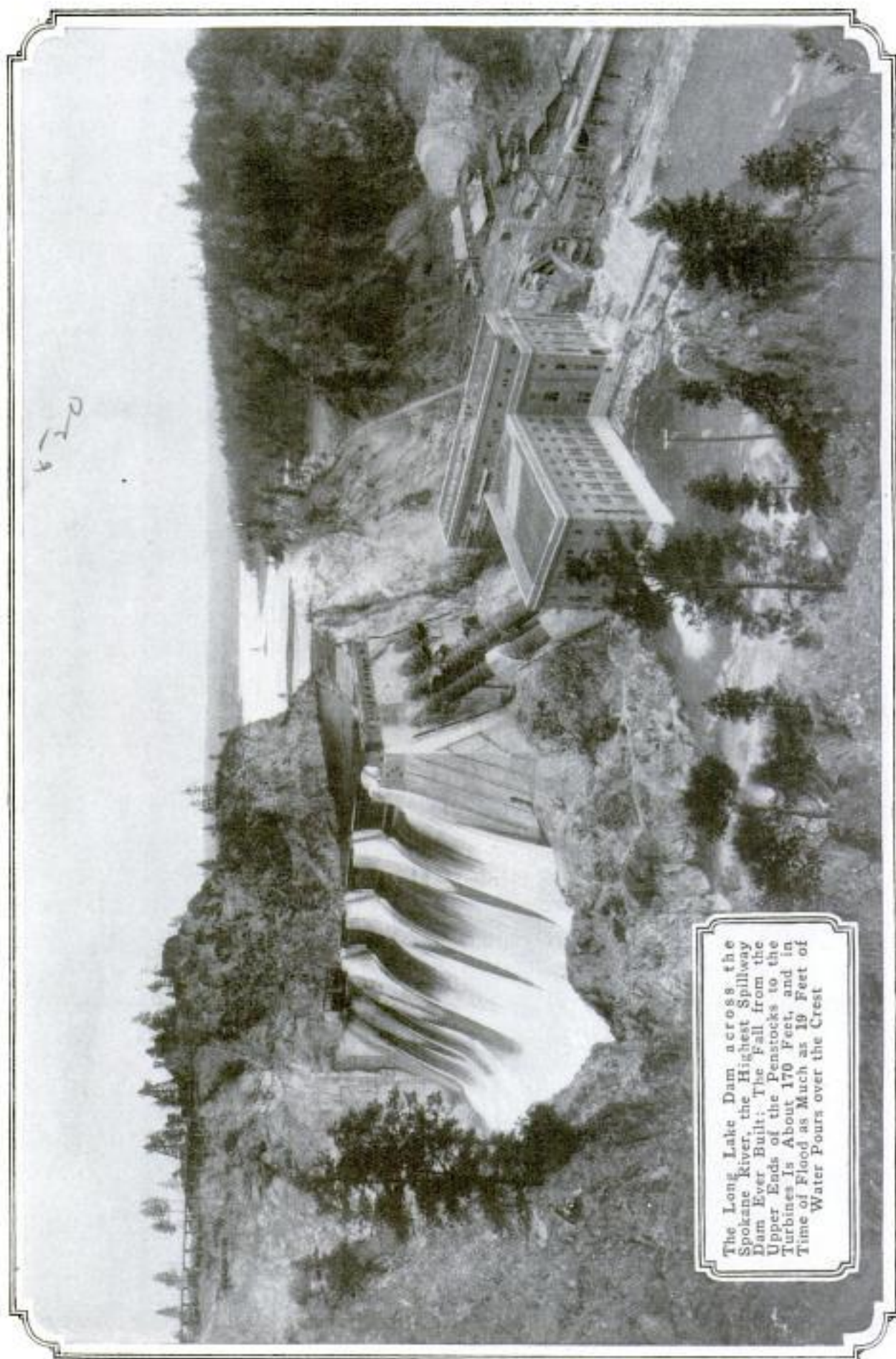

The Long Lake Dam across the Spokane River, the Highest Spillway Dam Ever Built: The Fall from the Upper Ends of the Penstocks to the Turbines is About 170 Feet, and in Time of Flood as Much as 19 Feet of Water Pours over the Crest

COURTESY OF THE ELECTRICAL WORLD



just enough fall to cause the requisite amount of flow, to a point where the entire fall can be concentrated in one tremendous drop. Such a canal must necessarily wind in and out for miles along the mountain sides, and its construction is usually a thing involving many difficult engineering problems. At the lower end of the canal are the penstocks through which the water drops down the mountain side through the turbines that drive the electric generators. Many of the plants operate on a vertical fall, or head, of a few hundred feet, while there are a number that operate on heads of from 1,000 to 2,000 ft. Under such heads as the latter the water strikes the turbines at an enormous velocity, the pressure being so great that no attempt is ever made to shut off the water at the lower end, owing to the danger that the entire plant would be wrecked by the resulting water hammer. With plants that operate under a head of 100 or 200 ft. the "high-line" canal is usually dispensed with, the penstocks taking the water direct from the reservoir and delivering it to the power house located below the dam. From the generators the current is sent to the distributing centers over transmission lines which carry voltages of from 60,000 to 150,000. One company supplying power to San Francisco operates more than 2,500 miles of high-voltage transmission lines. The electrical network of this company supplies current to more than 1,000,000 people, serving 30 of the 56 counties of California. This district comprises 32,431 square miles, an area one-half as great as that of all the New England states combined. Current for the Panama-Pacific Exposition is supplied by this company.

One of the best examples of hydroelectric development on a large scale is the Spaulding Lake system in California. Spaulding Lake is a reservoir located high in the mountains near Lake Tahoe and formed by one of the highest dams in the West. This dam is now 275 ft. high, and when fully completed is to be 350 ft. in height. The

depth of water when the dam is built to the latter height will be such that if the Call Building in San Francisco



Map Showing Principal Transmission Lines and Hydroelectric Plants on the Pacific Coast

could be set just above the dam, it would lack 50 ft. of reaching to the surface. This dam serves the purpose of catching and storing the water that comes from the melting of the snow on the mountain peaks. The "high-

line" canal that transports the water from the reservoir to the power house is 16 miles long. At the lower end of this canal is the fore-bay reservoir, designed to hold a reserve supply of water for meeting sudden demands for extra power from the distributing centers. This reservoir is hollowed out of the top of the hill from which the penstock starts. Although it looks small in the illustration, the penstock has a diameter of 72 in., and if it were laid level it would be possible for an automobile to drive through it. After doing its work in the production of electrical energy the water issuing from the turbines is conducted down the valley and used for irrigation purposes.

One of the most remarkable dams yet built is the Long Lake dam across the Spokane River, 24 miles northwest of Spokane. This dam has the distinction of being the highest spillway dam ever erected. In time of flood it carries about 19 ft. of water over the crest. Here the power house is located directly below the dam, the fall from the upper ends of the penstocks to the turbines being about 170 ft. The power obtained in this way is sufficient for driving four 22,500-hp. turbines. Roller dams will eventually be mounted on the crest of the dam to keep the level of the lake the same during low and high water. It will not be necessary to employ the total head at this station for several years to come, and the roller dams will therefore not be installed until needed. The biggest of these reservoirs is the one to be formed by the Big Meadows dam, now under way. When this dam is completed it will store up more water than any other dam in the world, with the exception of the Assuan dam in Egypt. With a crest only 150 ft. above the bottom of the cañon, this dam will form an artificial lake having an area of 40 square miles and containing enough water to cover 1,325,000 acres of land to a depth of one foot.

As interesting and as difficult in an engineering way as the construction of the hydroelectric stations is that of some of the high-voltage transmission

lines. This is particularly the case with the lines centering in San Francisco, which is located at the northern end of a long, narrow peninsula. Power from Spaulding Lake is taken across the Carquinez Straits and around the southern end of San Francisco Bay. It is this line that supplies San Jose. The other two companies avoid this long and circuitous route by crossing the bay, one with a submarine cable and the other with aerial cables. The submarine cable crosses under the bay from Oakland. It is about three and one-half miles in length and carries a voltage of 12,000. This is said to be the longest submarine cable in the world transmitting current at as high a voltage as this. The aerial cables across the bay were installed by a company that supplies most of the current for the traction system of San Francisco. The hydroelectric plant of this company is located on the Stanislaus River about 125 miles from San Francisco, and the transmission line encounters the bay several miles south of Oakland. A narrowing of the bay known as Dunbarton Narrows was selected for the crossing. The transmission lines are carried across the bay on steel towers built high enough to provide ample clearance for the navigation using this part of the bay.

One of the most striking features in transmission-line construction is the crossing of the Carquinez Straits, where the longest wire spans in the world are in operation. The valleys of central California are drained by two rivers, the San Joaquin and the Sacramento. These two rivers come together to form San Pablo Bay, which in turn empties into San Francisco Bay. The problem of transmitting to San Francisco the power from Spaulding Lake was therefore a serious one, owing to the obstacle interposed by this body of water. About midway between the east and west ends of the bay the shores come comparatively close together and form the Carquinez Straits, and at this point the crossing was made. Owing to the depth of the water the placing of towers in the

The North End of the Carquinez Crossing, with the Leaning Tower at Left. At the Right in the Picture Below are Shown the Houses for the Anchorages That Take the Tension of the 4,420-Foot Wire Spans

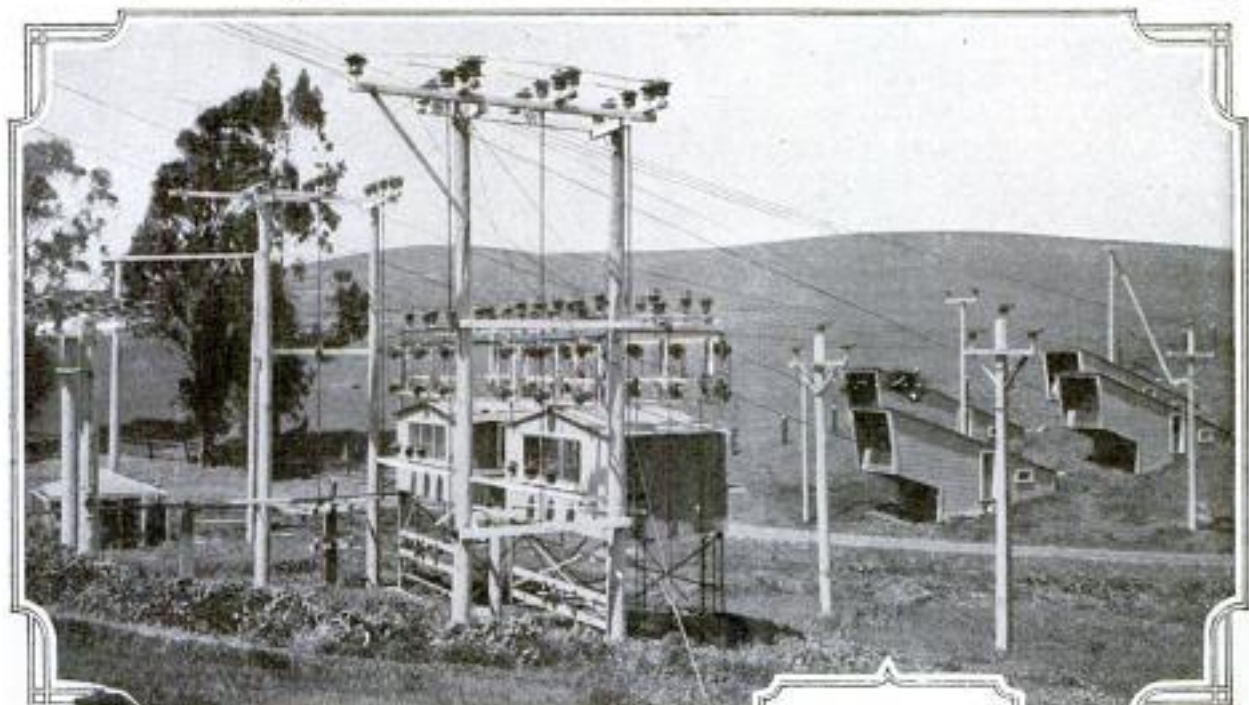

At Left are Shown the Four Wires, Each Carrying 15,000 Volts, Spanning the Carquinez Straits. The Picture Below Shows the Steel Towers and Aerial Cables That Transmit Hydroelectric Power across San Francisco Bay

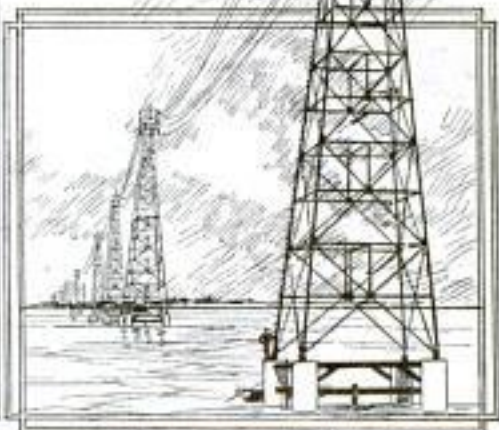

straits was out of the question. At the same time it was necessary to keep overhead wires at such a height as to clear navigation. Between towers erected on the high land on each side of the straits near Benicia, four wires are stretched, so that at the lowest point they clear the water 206 ft. The distance between towers is 4,420 ft. With the tension resulting from such a span as this, some delicate and difficult problems in design were involved. Strong anchorages for the wires were required, and, since each wire carries 15,000 volts, careful work was necessary in designing and constructing these anchorages in such a way as to

prevent danger of grounding. The anchorages are placed in specially designed houses. In addition to the anchorage on the north shore, it was found necessary to construct a leaning tower, which is shown in one of the illustrations. Some time after the wires were stretched it became necessary to paint them, and this work furnished a very good test of the strength of the installation. A trolley device was suspended from one of the wires, and on this an attendant worked his way across the straits, painting the wires as he went and completing the work without placing excessive strain on the wires or their anchorages.

X  
369  
**STREET NAMES DISPLAYED  
BY CURBSTONE SIGNS**

At an intersection of two thoroughfares in the business district of San Francisco an experiment is being made



Besides Showing the Street Name, the Sign Lights the Curbstone for Pedestrians

with a novel plan for displaying street names. Electrically illuminated signs bearing the street titles have been imbedded in the vertical sides of the curbs. These consist of waterproof cast-iron boxes, 40 in. long and 8 in.

deep, perforated with the street names and illuminated by means of tubular electric lamps which are connected with the city lighting system. Two of these signs are installed at each of the four corners at the intersection.

M  
981  
**DIRIGIBLE BALLOON MADE  
RIGID BY GAS PRESSURE**

What appears to be one of the most important inventions of recent years in the way of air craft is a dirigible balloon, recently patented by a prominent American scientist and inventor, in which no interior framing is used, the envelope being held to its proper shape by the pressure of the contained gas. This dirigible is designed to fly at speeds of 60 miles an hour or more without danger that the envelope will be deformed in the least by the pressure of the air. The secret of this accomplishment lies in the shape of the envelope and the maintenance of the right gas pressure. Instead of the rounded ends characteristic of Zeppelins and most other dirigibles, the envelope of this dirigible has the shape of two cones placed together base to base with the points projecting to the front and rear. With this shape the head pressure of the air is evenly distributed over the forward half of the envelope. The displaced air, instead of

# M. A. Hagen  
2106 Magnolia Av.  
Los Angeles Calif.

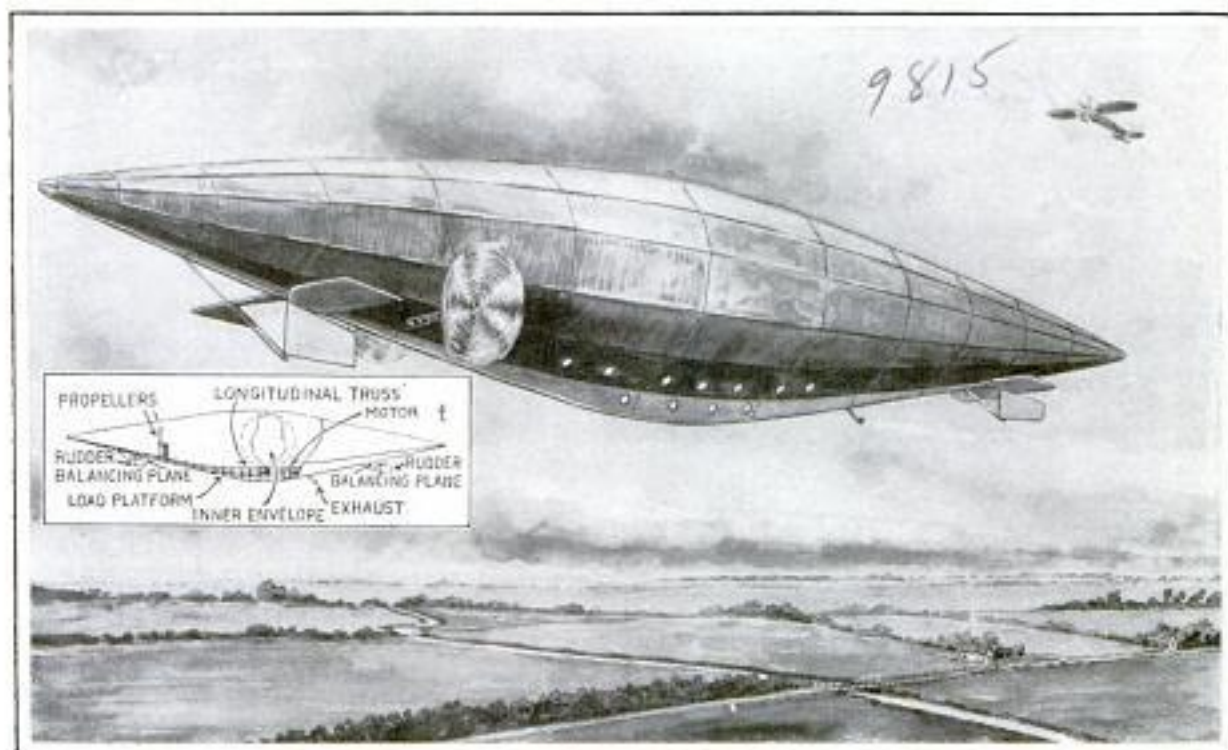

New Dirigible, Recently Invented, of the Type in Which Interior Framing is Replaced by the Pressure of the Gas Contained in the Envelope

eddy behind the envelope, presses in radially against the rear half of the envelope with a pressure about equal to the head pressure with friction not taken into account. In this way the gas is made to act practically as a compression member running longitudinally of the envelope. The maintenance of the proper gas pressure is a matter of vital importance. This is accomplished, and the inevitable leakage of gas is overcome, by means of a ballonet placed within the main envelope and designed to be expanded, as required, with compressed air, the air being pumped in through a valve that connects with a blower by means of a pipe passing through the bottom of the envelope. When the gas is at the required pressure this ballonet is empty and flat. As the pressure decreases air is pumped in and the expansion of the ballonet from this cause restores the pressure, this process being continued as often as may be necessary until the full capacity of the ballonet has been utilized.

While apparently this arrangement will enable the envelope to resist deformation from the pressure of the air, it is necessary to provide some rigid

means of distributing the load carried to prevent the envelope from being drawn downward and out of shape at the points where the loads are attached. This is accomplished by means of a truss, curved to correspond to the underside of the envelope, and running from the nose to the stern. The truss is suspended from the sides of the envelope without the use of a net, and on it are carried the car, engine, propellers, and other accessories. Two propellers are used. These are located one on each side of the envelope about midway between the center of the craft and the nose. They are supported on the truss at such a height that their axles are about level with or a little below the longitudinal center line of the envelope. With this arrangement there is little of "bucking" at high speeds, and the craft is in effect drawn through the air instead of being driven through it. The propellers are connected by a differential gear, a feature designed to insure an equal pressure under varying air conditions. Ease of handling is provided for by equipping the dirigible both fore and aft with horizontal and vertical rudders.

### STAIRS CONNECT STREETS ON DIFFERENT LEVELS

*Marple*  
In some hilly cities it is not unusual for a more or less important street to end abruptly at the crest of a high

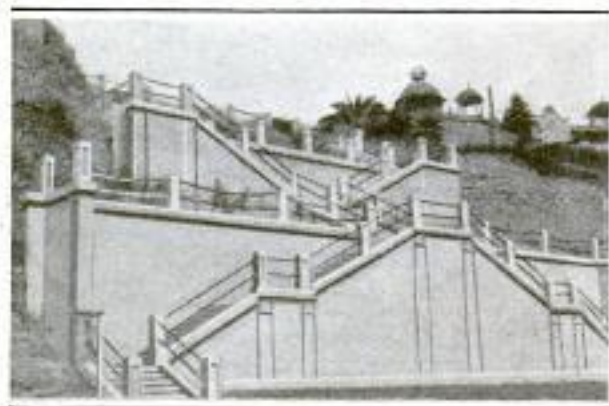

The Staircase Provides Communication between the Two Highways for Pedestrians

embankment or cliff, many feet above what would be an intersecting artery were the two built on the same level. This is the condition of a well-known street in Los Angeles. The annoyance of having it end some 50 ft. above Lake Shore Avenue, preventing communication between the two traffic lanes, has been partially overcome by the construction of a large reinforced-concrete stairway which provides access for pedestrians.

### LOCOMOTIVES FOR SIBERIA RAILWAY BUILT HERE

*504*  
Twenty locomotives are being constructed at the New York plant of a large domestic company for the use of the Russian government on the Trans-Siberian Railway. As rapidly as they are assembled and tested they are

taken down and shipped to the coast, from where they are transported to Vladivostok via Panama Canal and Japan. Each has a weight of approximately 316,000 lb. when in working condition and a wheel arrangement known in railroad parlance as "2-10-0." The cylinders are 25 by 28 in. in dimension, and the driving wheels 52 in. in diameter. Following the receipt of a rush order for these locomotives, work was commenced upon them June 26. The first of the number was completed August 13, a performance which came near being a record at the plant.

### LIGHTING PLANT FOR MOVIE WORK ON MOTOR CAR

*420*  
One of the large motion-picture producing companies has recently put in service a portable, high-power lighting plant which is being used in making photographs in caverns of the Grand Cañon and for night film work. The equipment is a new departure in the movie world and will allow the use of settings which otherwise would be impracticable from a photographic standpoint.

The plant is mounted on the chassis of a motor car and consists essentially of a 35-hp. engine, of the motor-car type, and a dynamo. A 12-in. navy searchlight of the projector type, capable of developing 4,500,000 cp., is fixed at one side of the driver's seat where it may be operated while the machine is in motion, if desired. At the front of the car is a battery of five power lamps.

With a 2,000-ft. cable it is possible



Type of Locomotives being Built in America for the Russian Government

*American Locomotive Co.  
30 Church St., New York  
Built at Schenectady Loco. Works of A. L. Co.*

Lubin Mfg Co.,  
Indiana and 20th St., Philadelphia.

POPULAR MECHANICS 661  
Romaine Fielding, Director Arizona Lubin Co.  
Phoenix, Ariz.  
Mitchell car 470

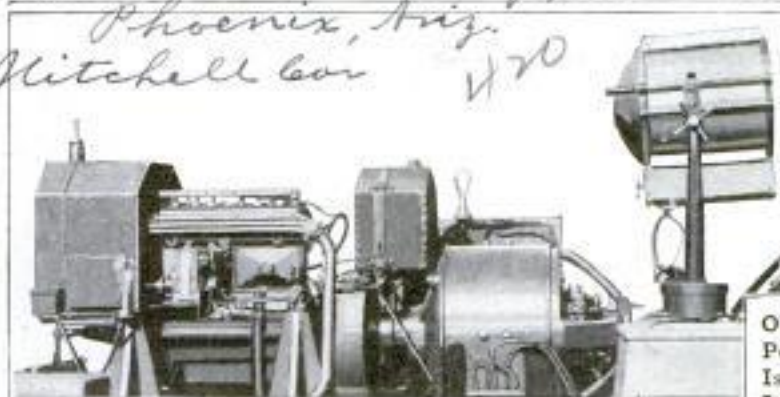

One of the Interesting Points of the Plant Is the Compactness of Its Arrangement, as Shown Above

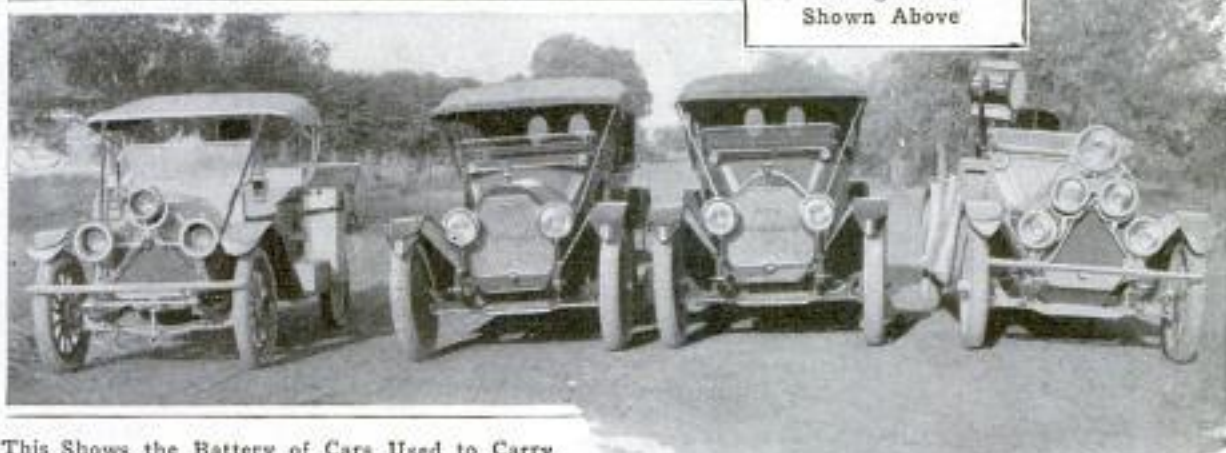

This Shows the Battery of Cars Used to Carry Lighting Equipment, Photographic Paraphernalia, and Actors into the Grand Cañon

to reach and adequately light places where it would be entirely impracticable to extend special transmission lines. A switchboard is installed so that wires may be extended to various points where lighting may be needed. Another car is provided which is fitted with compartments for carrying reels of film, cameras, and other equipment.

#### ENVELOPES SEALED QUICKLY WITH NEW DEVICE

491 H  
Simplicity in both construction and operation is the outstanding feature of a new envelope-moistening appliance which has been introduced as an office accessory. With the assistance of this device, which is quite compact and may be used on the top of a desk, it is possible to seal between 3,000 and 4,000 letters an hour. It receives both large and small envelopes, irrespective of the bulkiness of their contents. The device consists of a neatly finished

wooden case in which the envelopes are placed with their flaps extended. The letters are pressed forward by a spring fixed to a follower at the back of the device. As an envelope is removed at the front by a quick downward movement of the right hand, the glue-faced surface of the flap is passed across a moistening wick which is supplied with water by a reservoir mounted at the top of the case. The letter is then sealed by placing it face up in the left hand between the thumb and fingers.



Sealing Device Which Has No Machine Parts to Become Worn or Broken by Hard Usage

John H. Barrow & Co.,  
501 Tacoma Bldg.,  
520 N. Dearborn St., Chicago.  
Copyrighted material

*Inventor: Clayton E. Frederickson, San Francisco, Cal.  
 Assignor of 1/2 to Grace B. Stenger, Peoria, Ill.  
 World's Motor Co.  
 333-6 Hippodrome Bldg., Peoria, Ill.  
 POPULAR MECHANICS  
 Frederickson Patents Co., 2231 Prairie av., Chicago, Ill.*

662

**NEW TWO-CYCLE ENGINE HAS COMPRESSION CHAMBER**

An important innovation in gas-engine design that forms the principal feature of a two-cycle engine just invented and patented is an arrangement by which the gas is compressed in the inner end of the cylinder instead of

mitted through the hollow shaft into the crank case, from which, without being compressed, it is admitted intermittently into the inner end of the cylinder through the action of a rocking valve that comprises the most essential detail of the invention. The valve consists in effect of two diverging plates joined together at one end to form a

*Pat. 1,088,017 Feb 24, 1914  
 Filed 1-31-13*

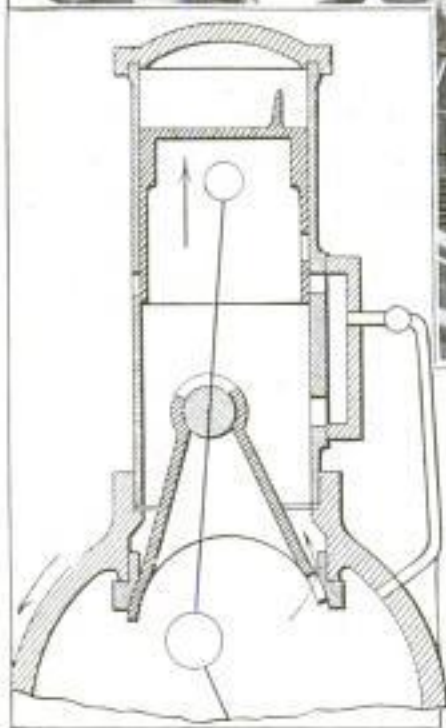
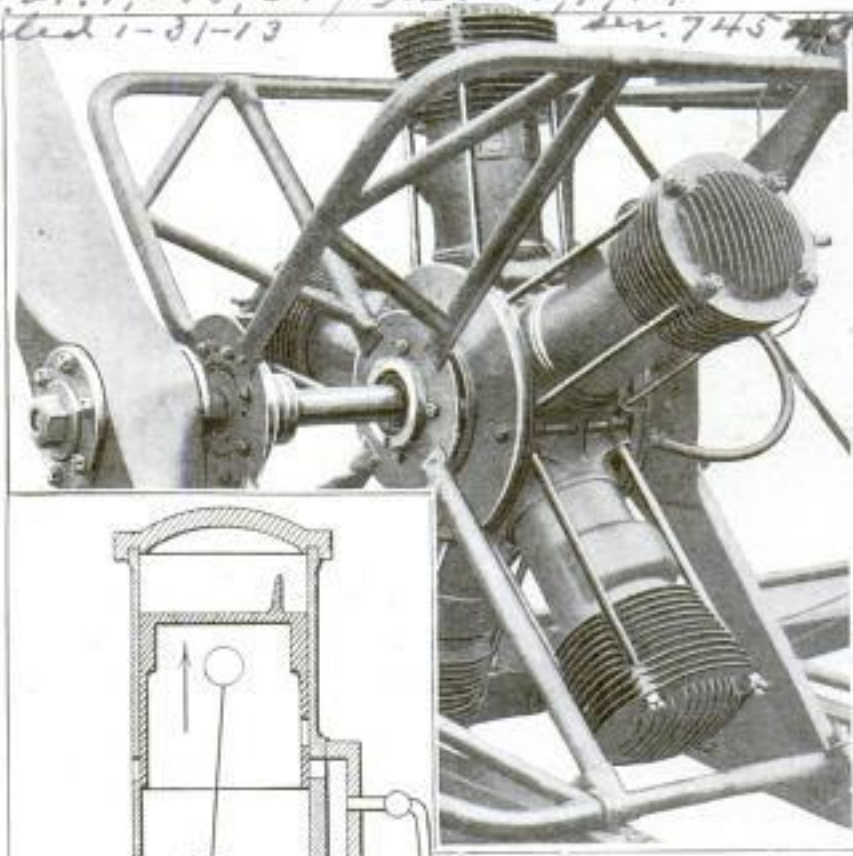

In This Two-Cycle Gas Engine the Gas is Compressed in the Inner End of the Cylinder Instead of in the Crank Case. The Rocking Valve for Admitting the Gas to the Cylinder is Shown in the Diagram at Left

sliding bearing. It is so mounted that the junction of the plates is within the cylinder, while the free ends slide against opposite sides of the opening between the cylinder and crank case, one of the plates acting as a sliding valve and the other simply as a bearing. The piston rod works through the sliding bearing formed at the junction of the plates. This bearing is free to oscillate, so that the valve as a whole simply rocks back and forth with the piston rod. In the illustration the direction in which the crank case revolves is indicated by the arrow. To understand the action of the valve

being compressed in the crank case, as is the usual practice. Although adapted as well to making engines in which the cylinders are stationary, this novel feature is particularly intended for an aeroplane engine of the type in which the crank case and cylinders revolve about a stationary shaft. The gas, under atmospheric pressure, is ad-

mitted through the hollow shaft into the crank case, from which, without being compressed, it is admitted intermittently into the inner end of the cylinder through the action of a rocking valve that comprises the most essential detail of the invention. The valve consists in effect of two diverging plates joined together at one end to form a sliding bearing. It is so mounted that the junction of the plates is within the cylinder, while the free ends slide against opposite sides of the opening between the cylinder and crank case, one of the plates acting as a sliding valve and the other simply as a bearing. The piston rod works through the sliding bearing formed at the junction of the plates. This bearing is free to oscillate, so that the valve as a whole simply rocks back and forth with the piston rod. In the illustration the direction in which the crank case revolves is indicated by the arrow. To understand the action of the valve it is best to consider the crank case and cylinders as stationary and the shaft as revolving in the opposite direction to that indicated by the arrow. With the piston at the end of the downward stroke the piston rod stands on the center line of the cylinder, and in this position the valve is closed. As the crank arm swings to the left the top of the valve also swings to the left, with the result that the sliding valve portion at the end of the right-hand plate opens and remains open until the piston has nearly completed the upward stroke. In the meantime the gas is being sucked into the cylinder by the upward movement of the piston. When the piston reaches the end of the upward stroke the piston is again



see  
Bay, Calif.



Artesian Wells Are Common throughout a Northeastern Michigan District: Nearly Every Farmer Has One or More of These Never-Failing Fountains on His Place

on the center line of the cylinder and the valve is closed. On the downward stroke the imprisoned gas is compressed, the valve being oscillated to the right and therefore remaining closed until the piston has started on the next upward stroke. As it reaches the extreme low position the piston uncovers the exhaust port, and, through the registering of the ports in the piston and cylinder, the gas is admitted through a by-pass into the working end of the cylinder. The engine is to be manufactured with three, five, or ten cylinders.

**MICHIGAN'S FLOWING WELLS UNFAILING WATER SOURCE**

In the yard before a rough log schoolhouse in a sparsely settled district in northeastern Michigan is an artesian well which supplies a constant flow of clear, cold water. The well is 101 ft. deep, and the water spouts to a height of about eight feet above the

ground. This is typical of what may be found almost anywhere in this section of the state. Little difficulty is experienced in obtaining an adequate supply of water in the region. Many of the farmers have several artesian wells on their places, while in the various villages the community systems are supplied in the same way. Water is usually available at depths varying from 25 ft. to 200 ft. and in some places the pressure is sufficiently great to carry the water to the second story of buildings without the use of pumps. The water evidently comes from the rainfall over the great watershed, which practically insures its permanency. The steady increase in the drilling of wells has not had any noticeable effect upon the force of the respective flows, but attention is now being turned to the advisability of requiring that all bores be capped in order to conserve the supply to meet the demands which will be made when the country becomes more thickly settled.

# Charles S. Thomas,  
90 Bay City Terms, Mich.  
Bay City,

**HOT AIR INSTEAD OF TOWEL  
USED FOR DRYING HANDS**

As an improvement upon the long-condemned roller towel, an electric toilet apparatus of novel form has been designed for installation in business and public buildings. The purpose of it is to obviate entirely the use of towels of any kind in such places and serve as a hygienic medium for drying the face and hands of its user. The general appearance of the device, which is finished in white enamel and surmounted by a mirror, is not materially different from many vending machines. A pedal at the base of the standard provides for the operation of the instrument, which throws out through an adjustable funnel at the front a steady draft of hot, perfumed air. Pressure exerted upon the pedal not only starts the machine but also adjusts the funnel to whatever angle is desired. The



*Notowal Mfg Co. Inc.  
302 W. Water St.  
Syacuse, N. Y.*

hands may be thoroughly dried in this manner in about 20 or 30 seconds. By bending close to the funnel, the face may be dried similarly.

**MOTOR-CAR HEARSE BUILT  
AS LIMOUSINE ALSO**

In order that his motor car might be made to serve two purposes, an eastern undertaker recently had a body designed which is convertible into either a hearse or limousine. Its lines are such that it may be used for either of these purposes without attracting particular attention or looking especially inappropriate. Instead of the long body appearing out of proportion when the car is used for pleasure purposes, it looks very roomy and comfortable. It is fitted with both side and rear doors, which obviously are employed according to the use to which the machine is being put. All of the hearse furnishings and fittings are so arranged that they may be easily removed, allowing rugs and upholstered chairs to be placed in the body of the car when it is desired as a limousine. The machine weighs 5,000 lb., has a wheel base of 134 in., and is equipped with a 4-cyl. 50-hp. motor. The body is built on a standard chassis.



This Car can be Quickly Transformed from a Hearse to a Pleasure Vehicle

*Cherry D. Washburn*

*Springfield, Mass.*

*Store of - Burrows Bros Co., Bondsmen & Stationers*



The Arcade, Which Extends along the Entire Front of the Building, is Kept Well Lighted

*"New England Building" 13 stories*

**DISPLAY CASES IN ARCADE  
REPLACE SHOW WINDOWS**

487  
H

During the alteration of a large building at Cleveland, O., a retail company which occupies the ground floor of the structure has continued business. The remodeling includes the construction of a new front, and, as is customary, a wooden inclosure has been erected over the sidewalk for the protection of pedestrians. In this instance, however, the structure has been built in the form of an airy arcade instead of a dark passage with solid walls on either side. In order to counteract the effect of losing its display windows during the building operations, the company has placed a series of shallow show cases along the inner wall of the temporary structure. These are well lighted, serving as good substitutes for the regular windows and relieving the store of what otherwise would be a boarded-up appearance.

into three general compartments, each of which is screened by a wooden curtain that may be rolled entirely out of the way when access to one of the spaces is desired. This likewise does away with the use of glass, which is always subject to breakage, especially when moving is undertaken. A small ironing board, a composition top, and special glass receptacles for sugar, coffee, salt, and spices are other serviceable features of the cabinet.

**KITCHEN CABINET CLOSES  
LIKE ROLL-TOP DESK**

419  
H

In constructing an adjustable kitchen cabinet, the work table of which may be raised or lowered to suit the convenience of its user, the sliding curtain of the roll-top desk has been employed in an interesting way. By using this means of inclosing the case, the possible objection to swinging doors has been overcome. It is divided



Kitchen Cabinet with Adjustable Table and Roll Doors

*Greencastle Cabinet Co.  
Greencastle, Ind.*

Inventor, mfr. & dealer:  
Mr. Eberhard Schneider  
219 Second Ave. N.Y. City

666

## POPULAR MECHANICS

### DANGER AT HAIRPIN TURN LESSENER BY ROAD GLASS

*H.H.O.*  
In several foreign countries the use of road mirrors has proved very helpful to motorists and has apparent-



The Mirror Serves Just as Effectively at Night as It Does in the Daytime

ly done much to avert accidents at view-obstructed crossings and dangerous turns. This same idea has been employed to lessen the danger at a hairpin turn in a much-traveled road in western Pennsylvania. An automobile club has erected a large mirror at the crest of a ridge where this road has a bad turn and a steep grade on both approaches. The glass has been mounted in such a manner that it gives a motorist a view around the curve, regardless of his direction of travel. It is as effective at night when the

glare from the headlights of approaching cars is reflected, giving warning and showing the relative positions of the machines.

### LIFTING TIMBER OVER THE ARROWROCK DAM

*b 3 b*  
In the basin of the Boise River, above the Arrowrock dam in Idaho, there is approximately 3,000,000,000 feet of merchantable timber, estimated to be worth about \$36,000,000 when made into lumber, all of which eventually will be cut and taken down the river to sawmills near Boise. The river furnishes the only practicable means of getting the timber out. This involves taking the logs around or over the Arrowrock dam, and delivering them in good condition in the river below. In this requirement a knotty problem was presented, as it is necessary to handle the logs not only economically but without the possibility of damage to the dam. This problem has been solved by the construction of an apparatus that is capable of handling 60,000,000 ft. during the 60 days of each summer when the water is 45 ft. or less below the top of the dam. At this rate it will require 50 years to transport the entire 3,000,000,000 ft. past the dam if this method alone is used, and since the equipment will doubtless be in service for a great many years in any event, it is being built of the best of concrete and steel. This equipment is located at the extreme south end of the dam. With it the logs will first be taken out of the reservoir by means of a cable lift and deposited on a concrete deck on the top of the dam. From this deck they will be fed, one at a time, by a stop and loader to power-driven spiked rolls which will take them across the dam and deliver them to a bull chain which is provided with spurs or teeth to prevent the logs from sliding. This chain will take the logs at a speed of 85 ft. a minute down a slope having a fall of 62½ ft. to 100 ft. and will finally deposit them in a gravity chute through which they will slide into the river be-

*See dam*

low. Power for operating the equipment is to be supplied for the present from a diversion dam located 12 miles downstream, but a power plant for this purpose is eventually to be built immediately below the Arrowrock dam.

*Claw*  
**POCKET DEVICE SUBSTITUTE  
 356 FOR CAMERA TRIPOD**

When he is without a tripod or an adequate substitute for one, an amateur photographer often experiences difficulty in finding a means of holding a camera while making a time or bulb exposure. To obviate this and also do away with the trouble of carrying a tripod, a New York inventor has designed a folding device, small enough to be slipped into a vest pocket, which may be secured to a tree, or some other convenient object, to support a camera. It has two sharp prongs which, when pressure is applied against a small lever, fasten themselves in the bark of a tree or in other wooden objects against which they are set. A friction clamp attached to this holds the camera. By folding back the prongs and



By Pressing a Small Lever the Prongs Fasten Themselves into Any Wooden Object

employing another fastening medium which is provided, the same device may be fixed to a stone or metal surface or to polished furniture.

*Inventor*  
 R. H. Denman  
 124 Maple Av.  
 Ithaca, N. Y.

*Railroad*  
**AUXILIARY PLATFORM LEAF  
 287 FOR PASSENGER CARS**

*Penn. R. Co.*  
 One of the eastern railway companies has equipped a steel vestibule car with extensible trapdoors for experi-

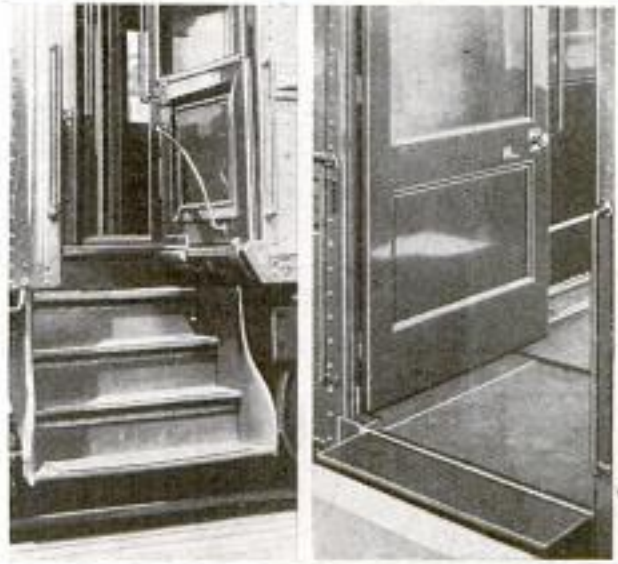

When Extended by Opening the Vestibule Door, the Auxiliary Leaf Bridges the Gap between the Car and a Station Platform. A Means is Also Provided for Opening the Door without Actuating This Mechanism, So That the Steps may be Used

mental purposes. At a number of its terminals it has constructed high station platforms. The convenience and object of these are obvious, but a difficulty arises in using them when it is necessary that they be constructed on a curve, for in such instances a gap occurs between the flooring and the cars. It is frequently impossible, because of the physical conditions at many of the stations, to build a raised platform on a tangent. The extensible trap which is now being tested is designed to overcome this objectionable situation by bridging the open space between the car and the platform when the outline of the latter is curved. This is arranged so that the sliding member is moved into position by the opening of the vestibule door. When the door is closed, preparatory to the departure of a train, the leaf is simultaneously withdrawn. A control handle in the vestibule permits the disengagement of a gear which makes it possible to open the door without actuating the leaf, when this is desired.

Inventor: *Ernest Hagberg*  
30 Winchester St.  
Medford

668

Mass. POPULAR MECHANICS

7<sup>th</sup> Aug 1917-2

Inventor: *Henry V. Deemar*  
137 1/2 Union Av. St. Louis  
or 2/0 Aluminimum Ore Co., E. St. L.

391 **SOLID-APPEARING TABLE  
HIDES MANY DRAWERS**

After 10 years of planning and painstaking work, a Medford, Mass., carpenter has constructed a small table

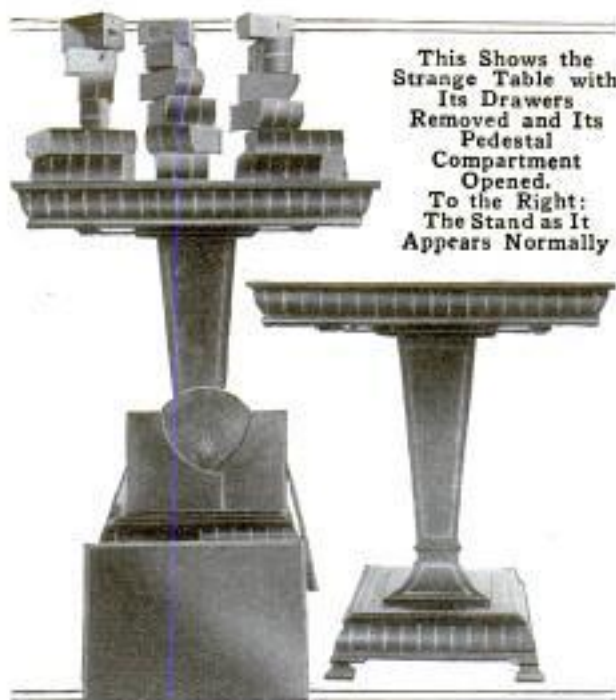

which contains some 29 secret drawers. It is built of mahogany inlaid with walnut, ebony, and boxwood, and, as far as its outward appearances are concerned, is intended as a game board for cards, chess, and checkers. A series of hidden buttons set beneath the top provides access to the various compartments. These are so ingeniously concealed that a scrutinizing observer would in all probability miss the significance of the table unless he discovered the operating buttons. Beneath the checkerboard top are a number of compact drawers in which cards, chessmen, and chips may be kept. Each of these is reached by pressing a separate button which releases a spring and opens the desired compartment. Drawers are secluded in all sides of the table, in the top and the pedestal. Besides the 29 of these there are two shelves, five covers, and one door. The available storage space amounts to 1,288 cu. in. The stand is 2 ft. 2 in. square and of normal height. It offers a good hiding place for household valuables.

9965 **INTENSE HEAT DEVELOPED  
BY NEW GAS BURNER**

Very high temperatures have been attained with a gas burner lately designed by a St. Louis inventor, in which combustion takes place, as it does in the cylinders of gasoline engines, within an air-tight chamber. The flame is not subjected to the cooling effect of a surrounding atmosphere of secondary air and the heat units are thus conserved. The burner is made in the form of a cylinder having an upper and a lower chamber, the latter of which consists of an air mixer. The mixture ascends into the chamber above, passing through a perforated disk, or burner, which divides the compartment horizontally. A shutter, provided in the combustion chamber, is opened only when it is necessary to ignite the gas. As is true of any such burner, the heat is regulated by the flow of gas and the amount of primary air entering into the mixture. The burner is especially adapted for domestic water-heating apparatus. The



The Various Parts of the Device are Shown and Identified at the Left, While at the Right Is the Burner Assembled

supply pipe leading to a tank is encased in a 2 1/2-in. tube into which the flame of the burner is directed.

CA submarine base for the United States Navy is probably to be established at New London, Connecticut.

*Inventor: R. D. Baser*  
*R. D. Baser Co. 705 W. Whitney Bldg.*  
*Paving Contractors. Detroit Mich. 669*  
*also 14 Thomas St. Hamtramck, Detroit*

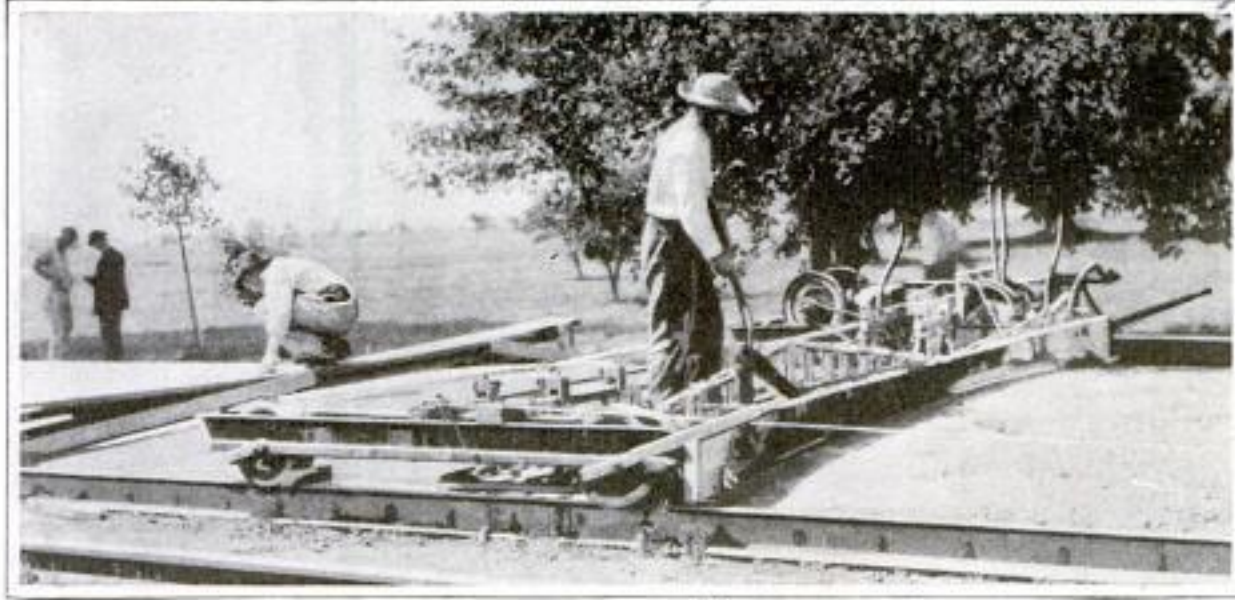

The Apparatus Works Rapidly and Effects a Saving in Labor

**MOTOR-PROPELLED FINISHER  
 FOR CONCRETE ROADS**

367

For saving labor in the construction of concrete roads and bases for street pavements, a motor-driven template has been invented which is capable of working approximately 500 feet of 16-ft. roadway a day. The apparatus is carried on car wheels which roll along the tops of steel forms used to hold the mixture in place. At one side is mounted a gasoline engine which provides the propelling power and also imparts to the template a reciprocating motion which expedites its work. At the rear the contrivance is designed to serve as a smoothing tool. Only two persons are required in operating it. One rides the machine, watching the template plank and also filling in low places, while the other follows up the work, mending small defects in the surface of the concrete.

side of the latter, is pressed, the meter is wound and started. Until this is done communication over a line is prevented. At the expiration of a specified period, the meter automatically cuts off a conversation, making it



Part of the Special Telephone Receiver is Disconnected Here to Show the Position of the Meter

necessary to again push the button, and thus reset the timer, if further use of a line is desired.

**TELEPHONE METER IS MADE  
 IN VERY COMPACT FORM**

9766

By making use of an ordinary watch movement, a telephone meter has been invented which is intended to perform much the same function as does an electric-light or gas meter. The device is fitted inside of a receiving instrument. When a button, fixed in the

An American neurologist, recently returned from Europe's battle fields, asserts that thousands of soldiers are being made incurable idiots by the rupture of their nerve trunks and centers. This is due to the terrific explosions of large shells.

*Inventor:*  
*E. H. Martin, Webster City, Ia.*

Dr. McKay, Prin. of Technical School, Toronto, Can

670

POPULAR MECHANICS

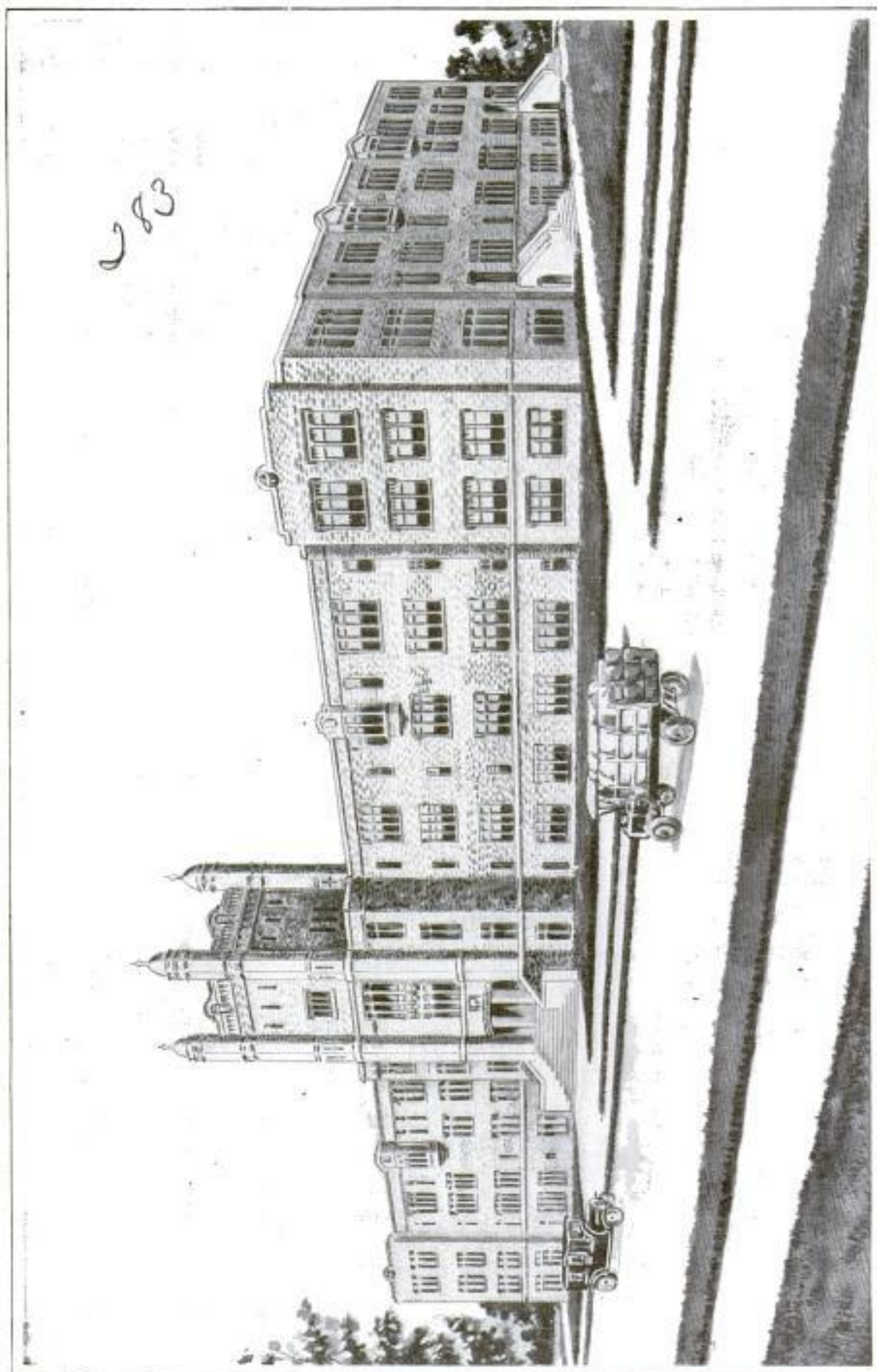

The New Central Technical School of Toronto, Canada, Which When Fully Equipped will Represent an Investment of Nearly \$2,000,000



**LARGE TECHNICAL SCHOOL****BUILT AT TORONTO**

983 On account of the constantly increasing demand by young men and women of Toronto, Canada, for elementary technical training as well as vocational and domestic instruction, the city has expended nearly \$2,000,000 in erecting and equipping one of the largest and best appointed industrial schools in North America. This institution, which is known as the Central Technical School, is now practically completed and will be able to accommodate approximately 2,500 day pupils and 5,000 night attendants.

The building is constructed of stone, is four stories in height, and has seven acres of available floor space. Its 320 rooms are divided principally into shops, laboratories, study and recitation rooms, and lecture halls. It is provided with a large gymnasium, a natatorium, adequate locker rooms, and an auditorium with individual seats for 1,300 persons.

A staff of 150 instructors has been engaged to carry out the educational work. These men and women will have charge of courses which will include everything from lace making, cooking, and art work to bricklaying, steam fitting, and architecture. Aside from ordinary high-school subjects, metallurgical work, casting, forging, electrical construction, painting and decorating, printing, carpentering, wood carving, machine and topographical drawing, sewing, millinery, and a myriad of other things will be taught.

For day pupils, four-year courses in industrial subjects for boys, and three-year courses for girls, are to be given. One-half of the time in the last two years of each course will be spent in actual shop work. There will be courses in applied science and household science, to which only pupils qualified to enter high school will be matriculated. In addition to these there will be special short courses in theoretical and practical technology as well as instruction in fine and applied arts adapted to different industries.

Every possible means of extending help to the night and part-time pupils is to be used. Practical demonstrations will be given by skilled workmen in industrial courses, to which only those who are engaged in that occupation will be admitted.

The new school is the central one of a group of similar, but smaller, schools.

**TOWN ATTRACTS MOTORISTS  
IN NOVEL MANNER**

316 Laconner, a little town in Washington, is situated some distance from one of the state highways used by many motor tourists. It boasts, however, a lone hill which commands the best view obtainable of Skagit Valley, one of the rich farming districts of that section. In order to draw the passing tourists from their beaten path and attract them to Laconner for the advantage of local business, the community has constructed a winding road to the summit of the hill and there built an observation stand. To advertise the lookout point, the words "Auto View"

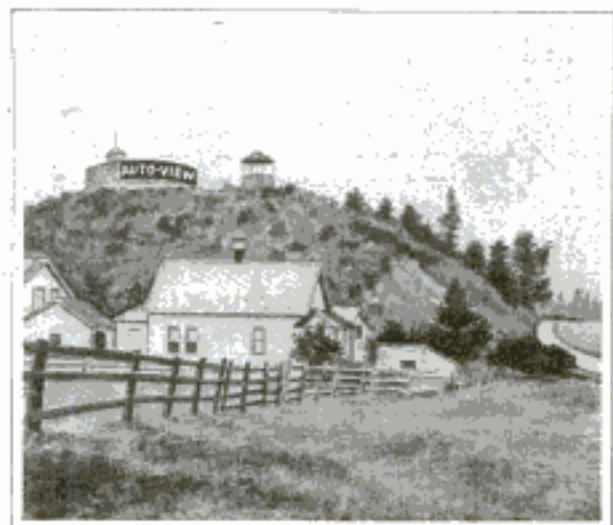

By Providing a Lookout Point for Motorists,  
Laconner has Commercialized Its  
Only Hill

have been painted in letters 8 ft. high, on the wall of a water reservoir at the hill's crest. This sign is sufficiently large to be seen for a long distance.

CPromoters of the San Francisco fair have announced that the enterprise is now free from debt.

**AUTOMATIC RAKING MACHINE FOR LAWNS**

Everything, from small leaves to newspapers, may be picked up from the lawn rapidly by means of a self-



Patented *mech 30, 1915*  
cleaning lawn rake that has just been invented and patented. This machine looks much like a lawn mower. The teeth extend from the front to the rear and are mounted in a sloping position so that their curved forward ends touch the ground. As the material is picked up it is drawn backward along

the teeth and deposited in a carrier at the rear by an endless belt which runs on rollers mounted at the front and rear of the machine. The rear roller, and through it the belt, is operated by a pinion worked by one of the wheels.

**SUGAR-FACTORY WASTE USED AS MOTOR-CAR FUEL**

*54* **THE GAS ENGINE SEPT. 1911**  
Experiments are being conducted in Great Britain with a new fuel for motor cars which apparently gives greater power than gasoline. It is an alcoholic mixture obtained from the waste products resulting in the refining of sugar and has a specific gravity of .800. The liquid was recently tried in an aerial motor of 100 hp., which it turned over at a speed of 1,450 revolutions a minute. Gasoline drives the same engine at only 1,250 revolutions a minute. Alcoholic mixtures have a common fault in that they are prone to cause corrosion in the cylinders should combustion be incomplete. To offset this an alkaline ingredient is introduced which neutralizes the acid properties of the new fuel. For six months the product has been used exclusively in a testing car with satisfaction.

*360* **ADDING MACHINE OF ENORMOUS CAPACITY**

What is undoubtedly the most remarkable calculating machine in existence has recently been constructed

its ever being used to more than a millionth of its capacity, it is also capable of subtracting, dividing, and multiplying in duodecillions. In other words, the machine is able to handle 40 columns of figures at one time. A practical use for it comes in its ability to add several different sets of figures simultaneously without confusing their totals. This allows it to accomplish what otherwise would require the

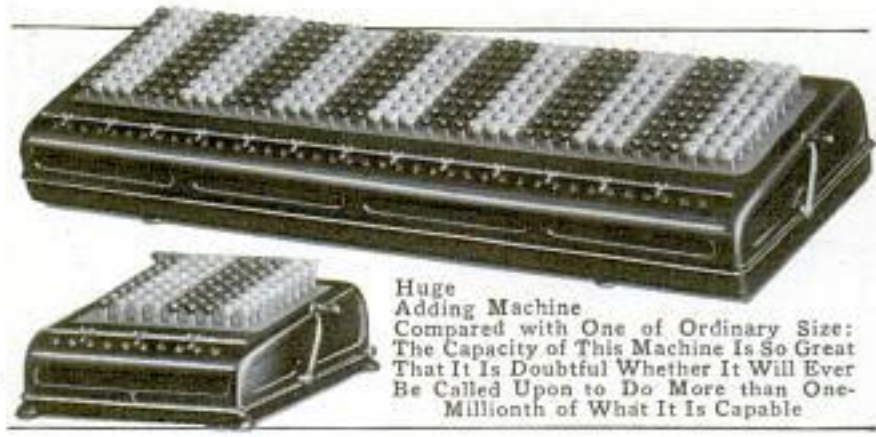

Huge Adding Machine Compared with One of Ordinary Size: The Capacity of This Machine Is So Great That It Is Doubtful Whether It Will Ever Be Called Upon to Do More than One-Millionth of What It Is Capable

and is capable of adding figures totaling within one unit of ten duodecillions. While it is hard to conceive

services of from six to ten instruments of ordinary capacity. The machine is 33 in. wide, but weighs only 35 pounds.

*Surronge Adding Machine Co*  
*Detroit, Mich.*

# MEETING WAR'S EMERGENCIES WITH INGENIOUS INVENTIONS

599 H

By SEARLE HENDEE

SINCE Europe has been merged in hostilities, scarcely a month has passed unmarked either by the development of some new agent of destruction, or the introduction of some new medium of defense. The creative genius of half the world has been concentrated in an effort to make war more terrible on the one hand, and safer on the other. And first one belligerent and then the other has met crucial emergencies by ingenious, not to say startling, inventions.

The apparent deadlock on the western frontier has presented a perplexing situation. For months the armies have fought battles more sanguinary than Waterloo without making progress except in terms of yards. Trench warfare has been responsible for this. Any kind of an offensive movement has meant heavy losses.

To make the trench less secure for the enemy is an object which each of the belligerents is striving to accomplish. A step in this direction is found in the work of a British inventor who has developed a wheeled body shield that affords immunity from rifle bullets and shrapnel when advancing upon fortified positions. The body of this is constructed of tempered-steel plates, the front so rounded and tempered that bullets strike the surface at an angle and glance off without doing harm. The rear is open, while the interior is just large enough to accommodate one soldier, who rests on his hands and knees. The device is propelled forward by pushing against the ground with one foot. A long slit in the front part terminating in a porthole forms a lookout for the soldier and also a loophole through which to fire. When

within a few yards of an objective point the fighter leaves the armored shell and charges in the usual way.

It was inventive skill applied in a different channel that made possible the construction of a gigantic steel network across the Narrows in the Dardanelles to check the operations of the allies' submarines in the Sea of Marmora. The barrier extends some 75 ft. beneath the water and is long enough to block the entire channel from Chanak Kalessi in Asia Minor to Namazieh on the European side. It is composed of a number of great nets, each approximately 600 feet long, moored end to end by means of buoys and anchors. The middle portions of the units consist of torpedo nets from German and Turkish battleships, while the buoys were taken from the Sea of Marmora and the Black Sea where they had been used to aid navigators. Attached to both ends of these members are heavy nets of 5-ft. tri-



The Wheeled Body Shield in Use: This British Invention Is the Latest Scheme Developed for Protecting Infantrymen during Offensive Operations against Enemy Trenches

angular mesh, made of  $\frac{1}{8}$ -in. iron wire. Interlaced over the whole of the latter sections are reinforcing skeletons of Manila and wire cables, woven in 30-ft. squares. The units are bound by heavy cables fixed at the top and bottom, and to these the anchor and buoy chains are secured. The former are placed at intervals of 120 ft., while the buoys are but a short

Daily News, Scientific American  
Illus. London News.

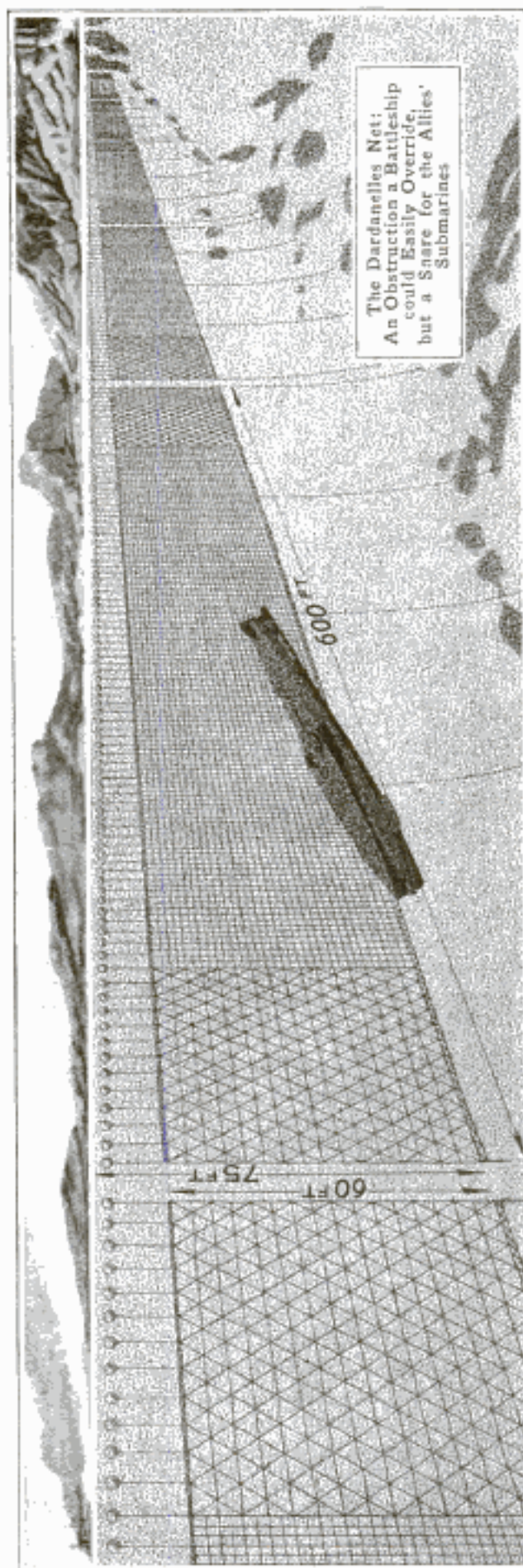

distance apart. The nets are suspended perpendicularly and reach within 100 ft. of each shore line, or to water too shallow to float a submarine. The open spaces intervening between the nets are not sufficiently great to permit the passage of a submersible.

The British submarines have not been entirely blocked by the net, although their activities have been hampered. The French submarine "Mariotte," however, was caught in the trap early in August while attempting to dive beneath it. Most American undersea boats are capable of submersion to a much greater depth than 80 ft.—which is necessary to pass beneath the barrier—but the rumor is current that the British and the French crafts leak badly when the feat is undertaken. When the "Mariotte" attempted the dive it took water so fast that its commander was forced to rise, and in so doing the starboard diving plane fouled the net, entrapping the vessel, which was almost immediately captured by a Turkish patrol boat.

At the beginning of the war there was a deep-rooted belief that the submarine was destined to banish dreadnaughts and battleships from the seas. Except for the attacks upon merchant vessels by German undersea craft, which have been negligible so far as real military value is concerned, the submersible has done very little of especial importance. This represents a striking case in which inventive genius has met one of war's serious emergencies. The submarine has become as vulnerable a boat as any afloat. Inventions, of which the Dardanelles net is but one example, have been responsible for this changed condition.

The net across the Narrows has been a practical means of defense because there is little tide in the eastern Mediterranean to disturb it. This condition is not true in the waters about England, where a different scheme has been used by the British admiralty with remarkable results. It has been repeatedly stated in press reports that in a period of about two months following the first week in May, Ger-

many lost more than 60 submarines, among which were listed the "U" boats Nos. 2, 4, 5, 7, 9, 15, 16, 18, 22, 23, and 24. This, it is claimed, has been accomplished by literally seining the

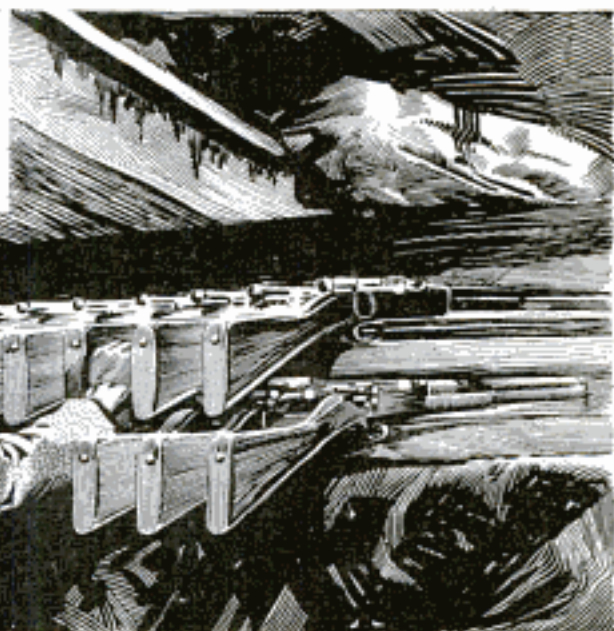

Batteries of Rifles Mounted on the Trench Parapets are Fired by Pulling a Rod Extending through the Trigger Guards. This Is France's Ingenious Substitute for Machine Guns

boats. The nets used for this are made in lengths of about 170 ft. with heavy iron wire. They are usually about 27 ft. in width and of 15-ft. mesh. When in use they are stretched between the bows of two oil-burning destroyers and buoyed by means of large blocks of wood attached to the binding cables along the top. When an enemy submarine is sighted, the fast destroyers cut ahead of the vessel and moor the net directly in the path it is pursuing.

The rough condition of the water in the North Sea greatly restricts the range of a periscope, making it effective for a distance of only about a mile. This permits the destroyers to set the trap, after observing the course a submarine is taking, and escape unnoticed. The result is that the submersible proceeds, ignorant of danger, and drives its nose into the netting, the top of which is about eight or ten feet beneath the surface.

More surprises in the way of new death-dealing and defensive machines have been introduced on the battle fields, however, than at sea. Machine guns have played a more important part in this war than ever before. These implements are very expensive and in no case is any of the armies supplied with as many of them as it could use. The French, however, have overcome their shortage by a most clever makeshift. By utilizing the rifles of dead and wounded soldiers, they have constructed a very ingenious and quite satisfactory type of "machine gun." The weapons are set in rows in wooden frames mounted on the parapets of the trenches. Frequently as many as 20 guns are grouped in one of these batteries. By pulling a rod placed through the trigger guards of the rifles in each tier, all of the pieces are discharged at one time. By using the magazine fire,

about 40 bullets can be shot from a modern army rifle in one minute. This explains how such a battery of guns can discharge from 600 to 800 shots a minute, which is equivalent to the work of a machine gun. The loading requires more time than that of a machine gun, but the firing itself is just as rapid.

When the Germans commenced fighting with poisonous gases in the western war zone it required only a short time for the allies to equip their soldiers with respirators, and install warning signals in the trenches. These agents practically neutralized the effectiveness of this means of fighting. A further defense against asphyxiation has been suggested, however, which shows how truly the war is a conflict of wits. The use of gas depends upon there being a gentle breeze to carry the fumes to the enemy's positions. A strong wind is as useless for this purpose as is a calm. The new plan is to combat the gas clouds with counter air currents, just as our western pioneers once fought prairie fires with fire. This it is proposed to do by installing a series of fan blowers in the advanced trenches to create updrafts and raise the vapor clear of the lines.

These, when operated by hand, would be placed at intervals of 10 or 12 feet, and connected with large pipes extending through the base to the front of the earthwork. The spaces between the units would be increased when large, motor-propelled fans were installed. Anyone who is familiar with the blowing force of an aerial propeller, will readily appreciate how effectively a scheme of this kind might be worked out.

Ingenuity of a much different character has been shown by the Germans in connection with their aerial activities. Before hostilities commenced, night aeroplane flying was not practiced to any extent. A few months of war showed, however, that the flying machine could accomplish much under the cover of darkness that it could not attempt without extreme hazard in the daytime. One of the greatest problems encountered by a pilot at night is that of landing safely. To ameliorate this condition the Germans have devised lighting systems for their army aerodromes which assist airmen in alighting after nocturnal voyages. A powerful white light is installed in a large pit dug in the middle of a field and covered with heavy



Rotary Blowers, Operated by Hand, Installed in an Advance Trench to Lift the Clouds of Deadly Gases Used by the Germans. This Plan has Recently been Proposed by the British

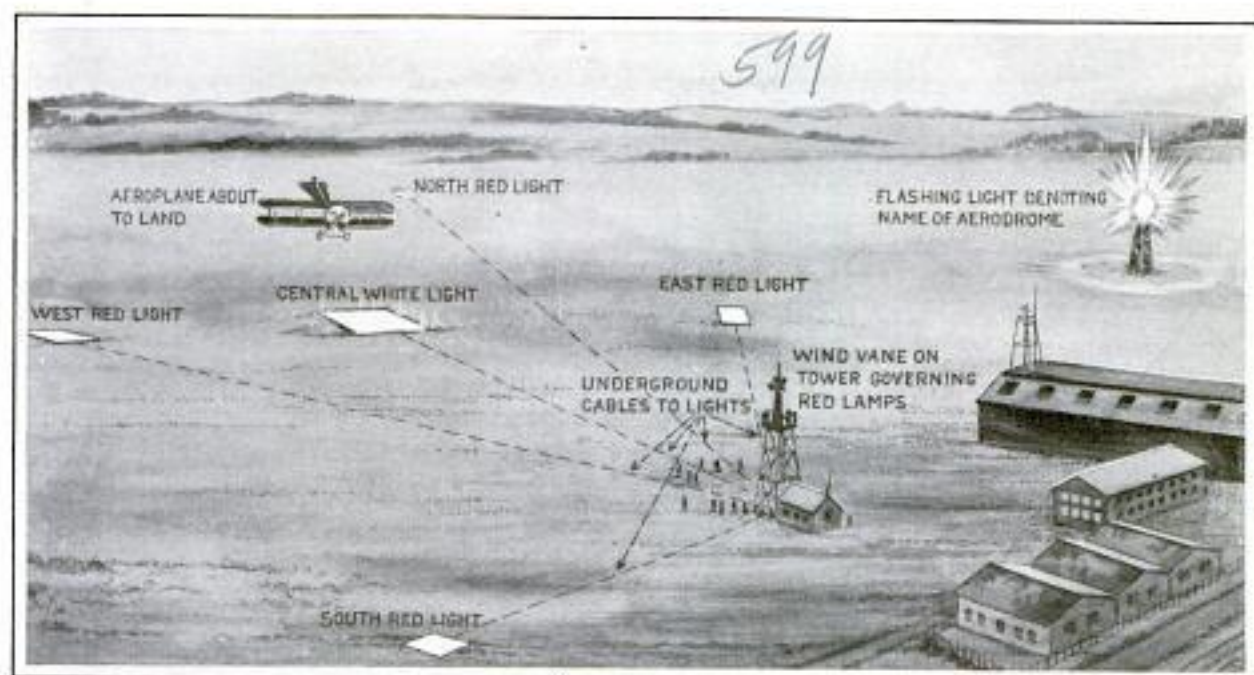

This Shows Graphically the Lighting Arrangement Employed at German Military Aerodromes to Assist Airmen in Landing without Accident after Terminating a Reconnaissance Flight, or Aerial Raid, at Night

plate glass. Surrounding this central light, at distances of about 250 ft. from each corner of the pit, and corresponding to the cardinal points of the compass, are four red lights similarly fixed in the ground. These are controlled by a switch working in connection with a wind vane. When a red light shows at the east of the field, the aviator knows that the wind is blowing in that direction. As he approaches an aerodrome he signals the attendants by flashing a revolver. The lights are then turned on, the big white glow indicating where to land and the relative distance to the ground,

while the red patches announce the direction of the wind. He turns the nose of his machine toward the white light and glides to the earth, avoiding the dangers of being caught by a side wind or misjudging the distance.

These illustrate a few of the numerous ways in which the war's emergencies are being met. For every new instrument of destruction introduced, some means is promptly developed to counteract its effect or nullify its efficiency. And for every fresh obstacle encountered in the ever-changing methods of war, some scheme is devised for surmounting it.

## HOW THE SUNKEN SUBMARINE "F-4" WAS RAISED

616 <sup>m</sup> After five months of practically continuous work under extremely trying conditions, the submarine "F-4," which with a crew of 22 men on board had failed to rise following a dive in water 300 ft. deep outside the harbor of Honolulu, was raised to the surface and on August 30 was placed in dry dock. The raising of this vessel is by far the most remarkable feat in ship raising ever accomplished. In the early stages of the work all records in deep-sea diving were broken, five descents being

made to a depth of 306 ft., and eight to a depth of 275 ft. The first efforts made toward the recovery of the submarine consisted in grappling with looped steel cables in an attempt to drag the vessel into shallow water. When, however, the snapping of line after line proved that the submarine was completely waterlogged, this method was abandoned for that of lifting with cables suspended from mud scows, the dragging operations having definitely indicated the location of the

Andrew Farrell / of the Advertiser, Honolulu, T.H.  
Harriet

sunken vessel. The scows, of which two were used, were 134 ft. long, with a beam of 36 ft. and a depth of 13 ft., and were equipped with vertical wells. Through these wells the steel lifting cables, each  $2\frac{1}{2}$  in. in diameter, were operated by means of shafts, 16 in. in diameter, mounted on horizontal bearings. To rotate the shafts, spools having a diameter of between four and five feet were fitted to the ends, and cables wound around these were unwound by steam power as required. The dead weight to be lifted was about 250 tons. Four slings were used, the loop of each sling being swept under the hull and the ends led up to the surface and fixed to the shaft. When the actual work of lifting began, a new trouble developed, the chafing under the keel of the submarine causing line after line to break. Chains,  $2\frac{1}{2}$  in. in diameter, were then spliced into the loops of the slings to take the chafe of the keel and the work of lifting proceeded without further mishap. At the end of each day's work the scows were towed in-shore until the submarine grounded, and by this method the vessel was finally grounded close to shore in water only 50 ft. deep. Inspection by divers showed the condition of the vessel to

be such that it would be unsafe to lift it to the surface by the chains, and pontoons were therefore substituted. These pontoons, of which there were six, consisted of steel cylinders which were sunk alongside the submarine and slung to it by means of chains. While being sunk, the cylinders were filled with water, the water being later forced out by compressed air. After the vessel had been docked, an examination showed two large holes, one at the bow and the other at the stern, while the bottom and starboard were found to be filled with sand, mud, battery plates, and other debris. At that time no definite cause for the disaster to the vessel could be discovered. There were indications, however, that the crew had been asphyxiated by chlorine gas generated by the leakage of sea water into the cells of the storage batteries, and that the holes in the hull had been caused, after the death of the crew, by the pounding of the vessel on the sea bottom.

While making more than 16 miles an hour the battleship "Wyoming" recently took on oil from the collier "Cyclops" by means of a pipe extended between the two vessels.

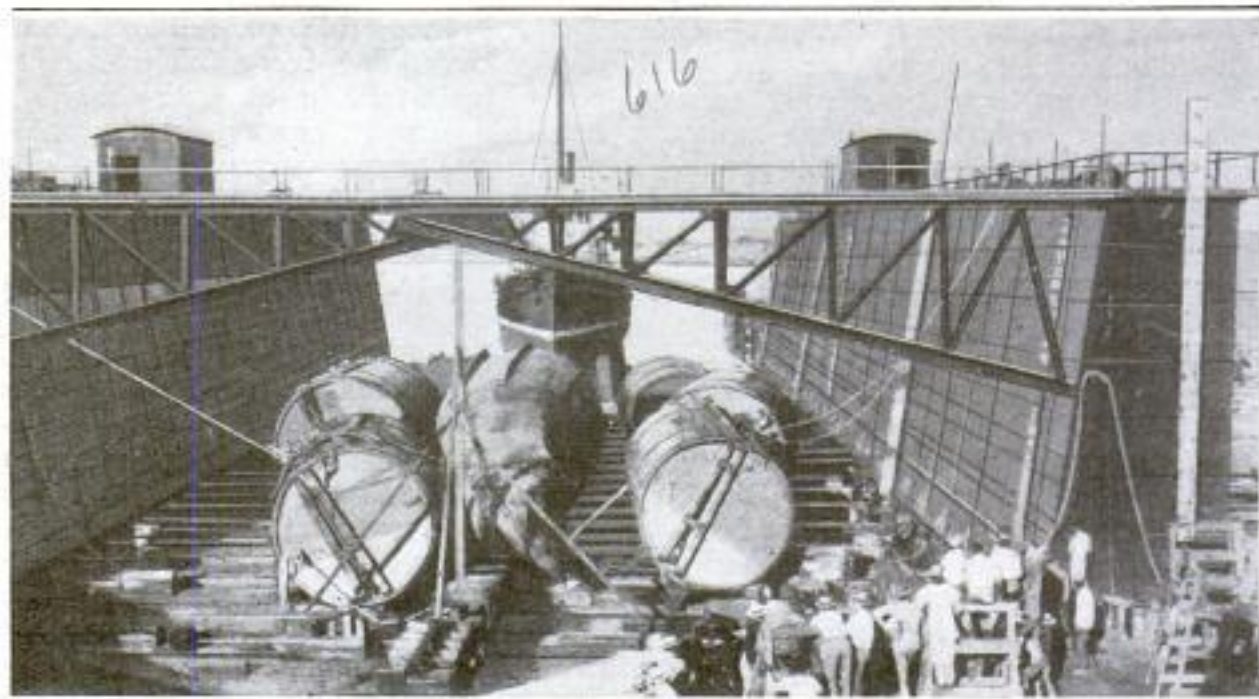

The Submarine "F-4" as It Appeared after being Raised and Placed in Dry Dock: The Steel Cylinders alongside the Vessel Are the Ones Used for Making the Final Lift to the Surface

COPYRIGHT, INTERNATIONAL NEWS SERVICE



*Inventor. J. L. Edlund,  
Blauesholm, Alta.*

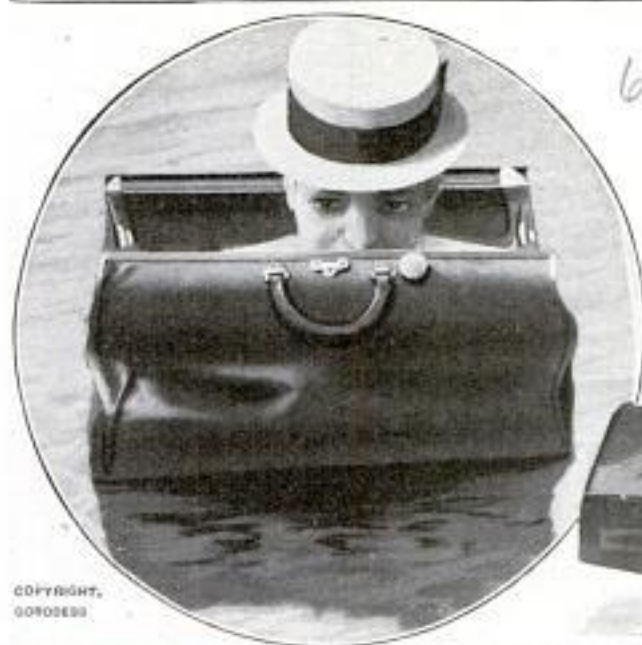

COPYRIGHT,  
GORDON



This Traveling Bag Has a False Bottom Which is Removed to Convert the Bag into a Life Preserver

The Top Floats Well above the Water and It Is Safe to Open It in a Calm Sea

**COMBINED LIFE PRESERVER AND TRAVELING BAG**

609m Designed not only to look like an ordinary traveling bag but to be used as one under ordinary conditions, a life preserver that has just been invented apparently provides a sensible solution of the problem of safety at sea in time of sudden emergency. The bag is equipped with a false bottom that serves to hold in folded position a water-tight union suit which is attached in such a way that the bag and suit act as a water-tight unit. In an emergency all that is necessary is to dump out the contents of the bag, remove the false bottom to let the suit unfold, and get inside. The user then closes and locks the top over his head and jumps into the water, the required buoyancy being supplied by the bag. The body of the bag is equipped with a window and with valves that admit air but not water. Inside, there is space for storing food and water sufficient to last several days. To prevent disaster in case the water-tight suit is punctured, an air-tight bag that is easily inflated is installed inside the traveling bag. Since the top floats well above the water it is safe to open the bag in a calm sea.

**NOVEL POWER-DRIVEN CYCLE OF SIMPLE CONSTRUCTION**

598  
# Several interesting features are embodied in a light-weight, power-driven bicycle which was introduced at the recent Chicago motorcycle show. It is built especially for the person who needs an efficient and comparatively inexpensive conveyance of very simple construction. The power plant consists of a 1½-hp. motor mounted in the front wheel, which is made of pressed steel. A gas tank of 1-gal.

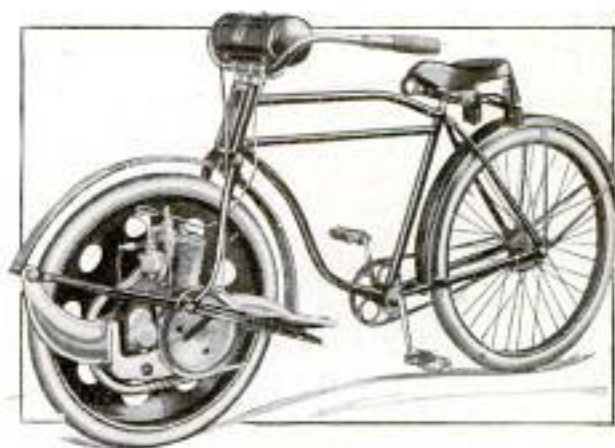

The Weight is Distributed Equally, since the Front Wheel Carries the Motor and the Rear One Supports the Rider

*Davis Sewing Machine Co.,  
Cyclists Dept., Dayton, O.*

capacity, sufficient for 100 miles, is clamped to the handlebars. The front wheel is flexibly attached to a three-stem fork and directly connected with the motor by means of a compensator. The advantages cited for the driving arrangement are that the weight of both the rider and engine is equally distributed, and the vibrations of the

motor are not communicated through the frame. The mounting of the motor within the wheel is worked out as it was in the auxiliary power wheel for bicycles brought out some time ago. A speed range of from 5 to 25 miles an hour is provided. The cycle has a wheel base of 43 in. and weighs 115 pounds.

### INSTRUMENT REVEALS CAUSE OF SHIP'S VIBRATIONS

A new instrument for the investigation of vibration in ships has just been brought to such a stage of development that it is being installed at the model basin, Washington, D. C., for the use of the engineers of the United States Navy. This instrument is known as the pallograph. It records both vertical and horizontal vibrations, and while intended mainly for

recording the vibrations of the ship, it indicates the revolutions of the ship's shafts. The record is made on a paper strip which is moved at a constant speed by a small motor, means being provided for regulating the speed from  $\frac{5}{8}$  in. to  $1\frac{1}{2}$  in. per second. The instrument weighs only 90 lb., and is 24 in. long, 14 in. wide, and 20 in. high.

### MID-OCEAN SUNSET NOT SEEN BY SAN FRANCISCO-AIRMAN

On page 598 of the October number of Popular Mechanics Magazine appeared an article claiming that an airman at San Francisco had viewed a mid-Pacific sunset from an elevation of 6,000 ft. Through some mischance this statement, obviously in error, escaped editorial vigilance, and was printed before it was observed. A calculation of the angular distance to the horizon from an altitude of 6,000 ft.—assuming the earth's radius to be 4,000 miles, and its circumference on any great circle, 25,000 miles—shows it to be approximately  $1\frac{1}{3}$  degrees, which corresponds to a little over 92 miles. What the airman took for a sunset must therefore have been some afterglow or reflection against a cloud of light far below his horizon.

By painting periscope tubes with parallel stripes representing the colors of the spectrum, it is reported the Navy Department hopes to make these members of submarine craft invisible to an enemy. It is thought that when refracted the colors will appear as a white ray, practically indistinguishable at a distance.

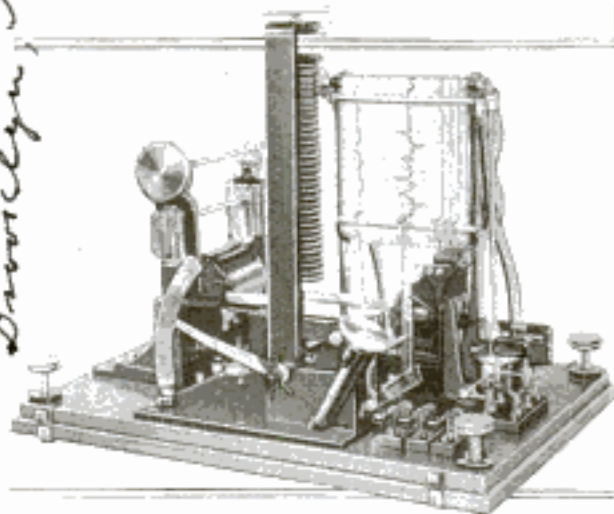

New Instrument with Which the Smallest Vibrations of a Ship are Recorded and Traced to Their Source

use on board ship, it may be used to trace vibrations of any character to their source. The first pallograph was invented shortly before the ill-fated "Lusitania" was launched and was used successfully in discovering the cause of excessive vibrations in that vessel. The instrument just brought out is so made that it is not affected by any regular or periodic motions of the ship such as rolling and pitching. It is equipped with a time marker indicating seconds, and in addition to

Only one in U. S.

.. two or three  
in existence

Dr. Schliek, Hamburg, Ger. - 1st practical one.

Sperdy, Synoscope Co.,  
26 Nassau St.,  
Brooklyn, N. Y.

614  
NEW YORK STREET CAVED IN BY SUBWAY BLAST



PHOTO COPYRIGHT INTERNATIONAL NEWS SERVICE  
**A DYNAMITE** blast at Twenty-Fifth Street in the Seventh Avenue subway, under construction at New York, recently caused an entire block of the thoroughfare to collapse. The timbers supporting the roadway were dislodged by the explosion, and a crowded street car, a motor truck, and many pedestrians were precipitated into the 30-foot excavation beneath. Seven persons were killed and about 100 others injured. The photographs show the rescue work in progress.

577

## MOTOR ROAD TO THE SUMMIT OF PIKE'S PEAK

**M**OTORING into and above the clouds is a novel and fascinating feat made possible for the tourist by the completion of the new motor road to the summit of Pike's Peak. In the operation of the road the trip to the summit will ordinarily be made from Colorado Springs, the route leading through the Garden of the Gods, through Manitou, and up Ute Pass to Cascade, which is on the edge of the Pike National Forest and is the point where the new road begins. Cascade is located about 12 miles west from Colorado Springs. From this point the road passes through some of the finest scenery in the West, and after 17 miles of winding and doubling through the cañons and along the mountain sides, it reaches the summit of the mountain 14,109 ft.

above sea level. The road skirts many of the best-known scenic features of this section of the Rockies, such as Crystal Creek Valley, perched 10,000 ft. above sea level, and Lover's Leap, a precipice having a sheer drop of 2,000 ft. It is estimated that from the summit something like 30,000 square

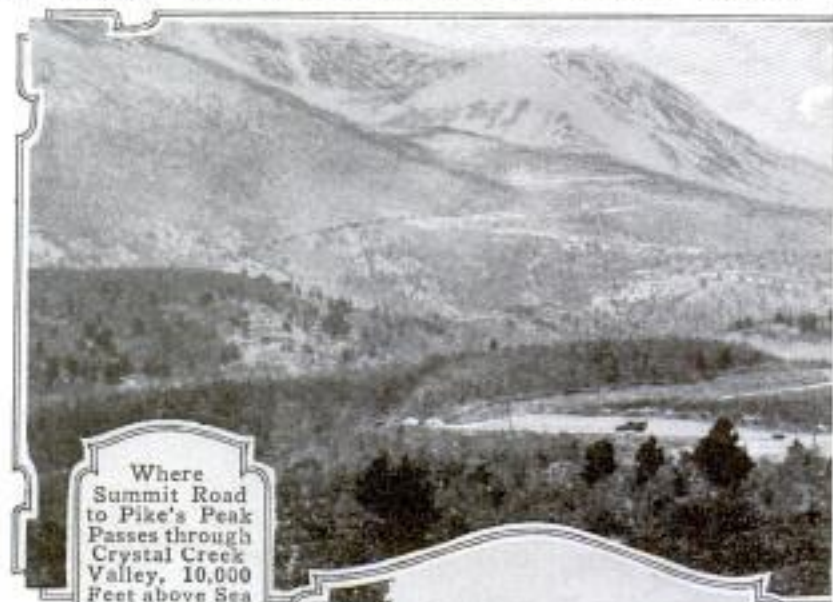

Where Summit Road to Pike's Peak Passes through Crystal Creek Valley, 10,000 Feet above Sea Level



At This Observation Point, Elevation 9,000 Feet, the First Hint is Given of the Magnificent View That Greet the Traveler at the Summit

Lower Slopes of the Mountains: At This Point the Elevation is 8,100 Feet above Sea Level



Toll Gate at Cascade, 7,400 Feet above Sea Level, Where the Real Climb Begins

miles of the earth's surface is visible, the view extending over a hundred miles to the east, and including to the west scores of peaks that are covered with perpetual snow.

The road is built according to the best engineering practice with the question of safety constantly in view. The grade at no point exceeds 10 ft. in 100 ft., and reaches this maximum at only three or four places. The roadway is 20 ft. wide except on curves, where it is from 35 to 40 ft. wide. It is surfaced throughout with disinte-

grated granite. There are turnouts and view stations, as well as supply stations for the motor cars, at frequent intervals along the route. In some places the road consists simply of a ledge blasted from the solid rock of a precipice, and at these and other

This Car has Climbed to an Elevation of 11,500 Feet, a Few Hundred Feet below Timber Line



Construction Gang Excavating a Ledge for the Roadway at a Curve 1,100 Feet below the Summit

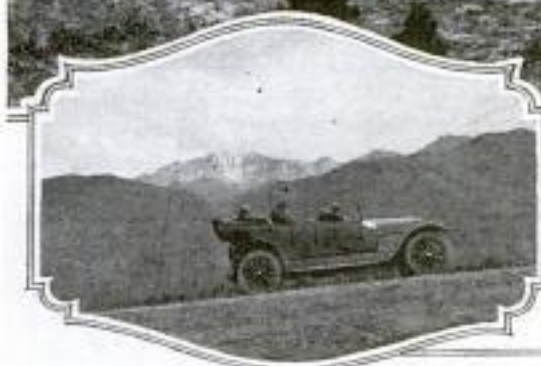

Halfway Up to the Summit: One of the Peaks of the Rampart Range in the Distance

points where there is an element of danger, a low wall has been built to prevent any car not under proper control from running over the edge. At the frequent passing places there is a wall in the middle of the road that separates the up-bound from the down-bound traffic. This is a new feature in mountain-road construction in this country, although it has been in use in the Alps for a number of years.

The cost of the Pike's Peak automobile road was originally estimated at about \$175,000. It is the highest motor road on the western hemisphere with the exception of one in Bolivia, which crosses the Andes at a height of 17,000 ft. above sea level. The road

is to be used not only by the motor busses and touring cars operated by the company that built it, but by private motor vehicles as well. The round trip can be completed in about five hours by any car possessing the power necessary for making the climb. Some idea of the popularity of the trip to the summit of this mountain is given by the fact that since 1896 a total of about 1,500,000 persons have gone to the summit over the Cog

Railway, on burro back, or on foot. In addition to the regular day schedules there will be a service consisting of motor cars reaching the summit in time for sunrise, sunset, and moonlight views from the peak.

#### COUNTY DERIVES REVENUE FROM OIL WELLS

Oil was struck some time ago on a poor farm in one of the northern counties of Ohio. A number of wells that were subsequently drilled are now producing a steady flow of petroleum which gives the county a revenue of about \$1,000 a month. In addition to this, about \$25 a day is being derived from a small well which was struck only recently.

*C. S. Monitor*

### ELECTRIC SERVICE TIED UP BY SINGLE THUNDERBOLT

631  
7/21  
When the guy wire of a pole carrying the trunk-line feeders of the electric light and power service of Knoxville, Tenn., was struck by lightning, the falling pole carried with it 19 other poles and did a most thorough job of tying up the electric service of the city. As a result of this thunderbolt, which was the only one that did any damage in a storm of moderate intensity, the entire city with the exception of a small section served by auxiliary power was without current for two days and two nights. In residences not supplied with gas, primitive methods of lighting were resorted to and candles immediately jumped into the greatest demand. Social events had to be called off, lodge meetings were postponed, moving-picture shows were closed, and business generally was

carried on under the greatest difficulties, until the linemen, working day and night, were able to restore the service.

### BOAT WITH MOTOR HOUSED 612 m IN KEEL

A hollow fin that serves not only as a keel but as a housing for the motor and propelling and steering mechanism, is the interesting feature of a new type of boat which is said to have proved so efficient that it has been recommended by government authorities for use in the United States life-saving service. One of the distinctive qualities of this boat is that it can make a turn at high speed in a distance less than its own length, a quality due partly to the action of the fin as a keel, but mainly to the lowering of the center of gravity that results from placing the motor well below the water line. Other qualities claimed for this boat are that it responds to its steering apparatus instantly, and that it can turn with equal facility into or away from the wind when moving at any speed ahead or astern. Its accurate steering qual-

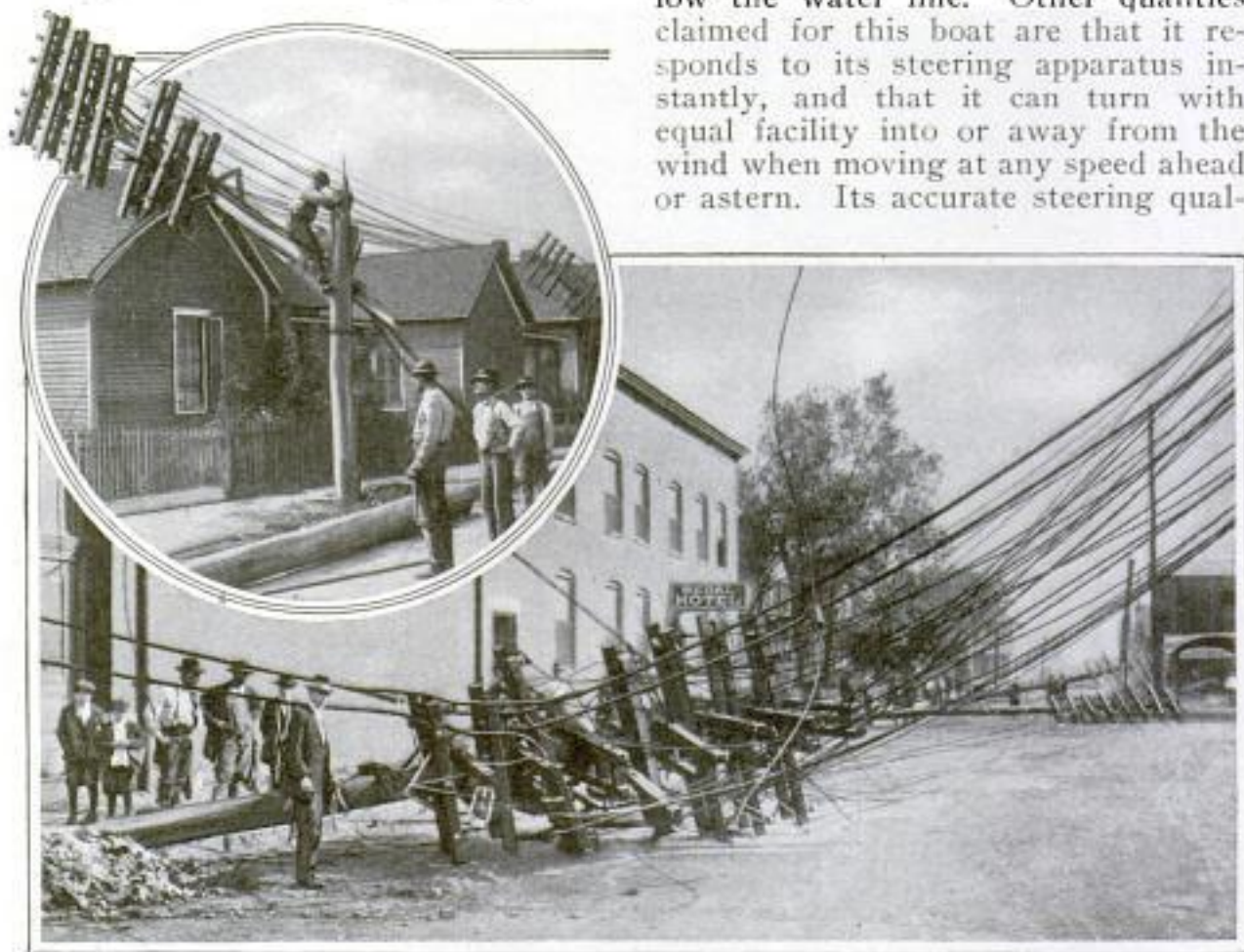

The Pole That Started the Trouble after being Hit by a Thunderbolt. The Upper Picture Shows How a Row of Poles were Pulled Down on the Roofs of Adjacent Houses

Inventor: Captain Samuel Golden  
 Union Dry Dock & Repair Co.  
 Weehawken, N. J.



This New Boat can be Run at High Speed Either Forward or Backward. The Picture Shows It Running Full Speed Astern

Boat Hoisted Clear to Show the Fin in Which the Motor, with Propelling and Steering Mechanism, is Housed

COPYRIGHT, UNDERWOOD & UNDERWOOD

ities may be judged from a test in which a boat of this type having a length of 35 ft. and a beam of 7 ft. was run into a 60-ft. slip at a speed of 11 miles an hour, and was then turned around and run out again without shutting off the power. The fin is about half the length of the main hull, is shaped much like a fish of the mackerel type, and is just wide enough to accommodate the motor and shaft so that they will be easily accessible from the cockpit. The draft of this boat is said to be no greater than that of a boat of the ordinary type.

posure to be varied from one-fifth to one-half second, according to working conditions. Four miniature tungsten lamps, each of 3.8 volts, supplied with current from a storage battery carried inside of the camera case, provide sufficient light for photographing meter dials. Roll films permitting 75 exposures are used in the device, while a chamber for carrying two additional spools is provided. A small drawer in

503 SERVICE METERS ARE READ WITH SPECIAL CAMERA

Photographic reading of electric, gas, and water meters has been made possible through the development of a special camera recently introduced for the use of public-utility companies. The reason for making meter readings in this manner is to obviate errors and disputes as well as to save time and labor. The apparatus is made in the form of an oblong box, provided with a high-grade lens and a simple automatic shutter which permits the time of ex-



Factograf  
 Using the Camera in Taking the Reading of a Gas Meter

the front of the box also permits the storage of a half dozen extra lamps. In making readings with the instru-

Eastman Kodak Co.  
 Rochester, N. Y.

Reserved to users for 22.50 each.  
 Licensed only for Eastman films.

ment, the front opening of the camera is pressed against a meter dial and a small lever moved. This action automatically turns on the light, opens and closes the shutter, and finally extin-

guishes the lamps. After each exposure the operating lever locks automatically against movement until the film has been wound preparatory for another photograph.

## MACHINE GUNS FOR NEW YORK HARBOR POLICE BOATS

By HENRY JAY CASE

*Under & Under  
N. Y. City*

**S**OMEHOW a policeman afloat appeals to the popular humor, the public apparently having the idea that a cop is a landlubber raised to the n'th power, and that no one could possibly cut a more ridiculous figure aboard ship. Still, New York City has police sailormen, and boasts a fleet of eight launches, two dories, and a flagship of 235 tons—an organization small, to be sure, but a skeleton one so constructed that at short notice in an emergency it can be increased to a force of several hundred fighting men, equipped with rifles, one-pounders, and machine guns. Moreover, the New York harbor cops are a hardy, fine-looking lot of watermen, inured to exposure and perfectly at home aboard ship.

There are 435 miles of waterways inside the greater city on which ride ships carrying a world's commerce—everything from giant transatlantic liners to barge-canal boats, coasters, freighters, tramp steamers, sailing ships, tankers, coast and deep-sea fishermen, excursion boats, ferryboats, and palatial yachts flying the burgees of racing clubs known across the seven seas. This means big business down the harbor and bay, up and down East and North rivers, into the Harlem and the ship canal, and out into the entrance of Long Island Sound. And where there is business there must needs be the cop to watch and patrol, to regulate traffic, chase river pirates, safeguard life and property, and recover bodies of the drowned.

There are miles upon miles of piers and slips with rich ware and storehouses, and with the big war now on,

at no previous time in the history of the harbor have there been so many treasure ships passing in and out, nor such a bulk of shipping on the piers! All this requires careful watching day and night with constant vigilance against plots and conspiracies. This, in brief, covers the job of the harbor police.

The "Patrol," flagship of the police fleet, is a twin-screw steamer, armed with two one-pound guns, fore and aft, and with a rapid-firing, or machine, gun mounted on the upper deck, capable of firing 400 shots a minute. Each of the swift launches, for night and day patrol, is armed with machine guns, and both the "Patrol" and the eight launches are equipped with powerful searchlights, which sweep every nook and corner of the wharves along the river and harbor front. The crews are drilled in gun and rifle fire, and each has a signal detail which has daily instruction and practice in the wigwag system of communication. The guns aboard ship are so mounted that they may be detached and used ashore on small carriages provided for them in case of riot or insurrection, thus making a powerful addition to the land force.

This armament, though light, is necessary. When the "Patrol" runs alongside a 40,000-ton ship to assert the authority of the municipality she must have armed power to back up her flag and station, and when a howling mob of aliens comes piling out of a pier shed to wreck a cargo, it must be met with something more forcible than a white-gloved hand or a gold badge of authority.



New York City's police department is preparing for any eventuality in the way of strike, riot, or war, and that the Federal government is in sympathy with this spirit of preparation is shown by the fact that the city police force, horse, foot, and marine, is receiving daily instruction from army and navy officers. The United States Navy, it may be assumed, is watching all entrances to the port of New York from the sea, but to the city's police is left the task of looking after the trouble on the inside stretches of New York's waterways. And to keep the harbor police in communication with the Federal and municipal authorities on land and water, and to speak to the bridge of the ships that come and go, the wig-wag system of communication has been installed. This, indeed, is also being practiced from the roofs of high buildings up and down each borough of the city in preparation for an emergency,

should telephone and telegraph communication be broken or destroyed by earthquake, conflagration, riot, or war.

In case of trouble on a large scale, the New York police department should be in condition to give a good account of itself as a supplementary force to both the army and navy.

**TRANSFORMER FOR RUNNING ELECTRICAL TOYS**

593 m

The use of small transformers connected with electric-lighting circuits and designed to transform the current into one suitable for operating electrical toys is becoming increasingly common. A new transformer made for this purpose apparently eliminates all danger from short circuits, and other troubles that may arise from accident or from the carelessness or ignorance of the user. When this transformer is overloaded from any cause, a device with which it is equipped automatically opens the circuit and cuts the transformer out of service. The circuit is then closed by pressure on a push button, but this can only be done after the trouble has been corrected. An additional feature is a regulating device with which the voltage can be varied in steps from one volt up to the maximum of which the transformer is capable.

*Invt: E. W. Thorsen  
Thorsen Electric Co., 501 So. Jefferson, Chicago*

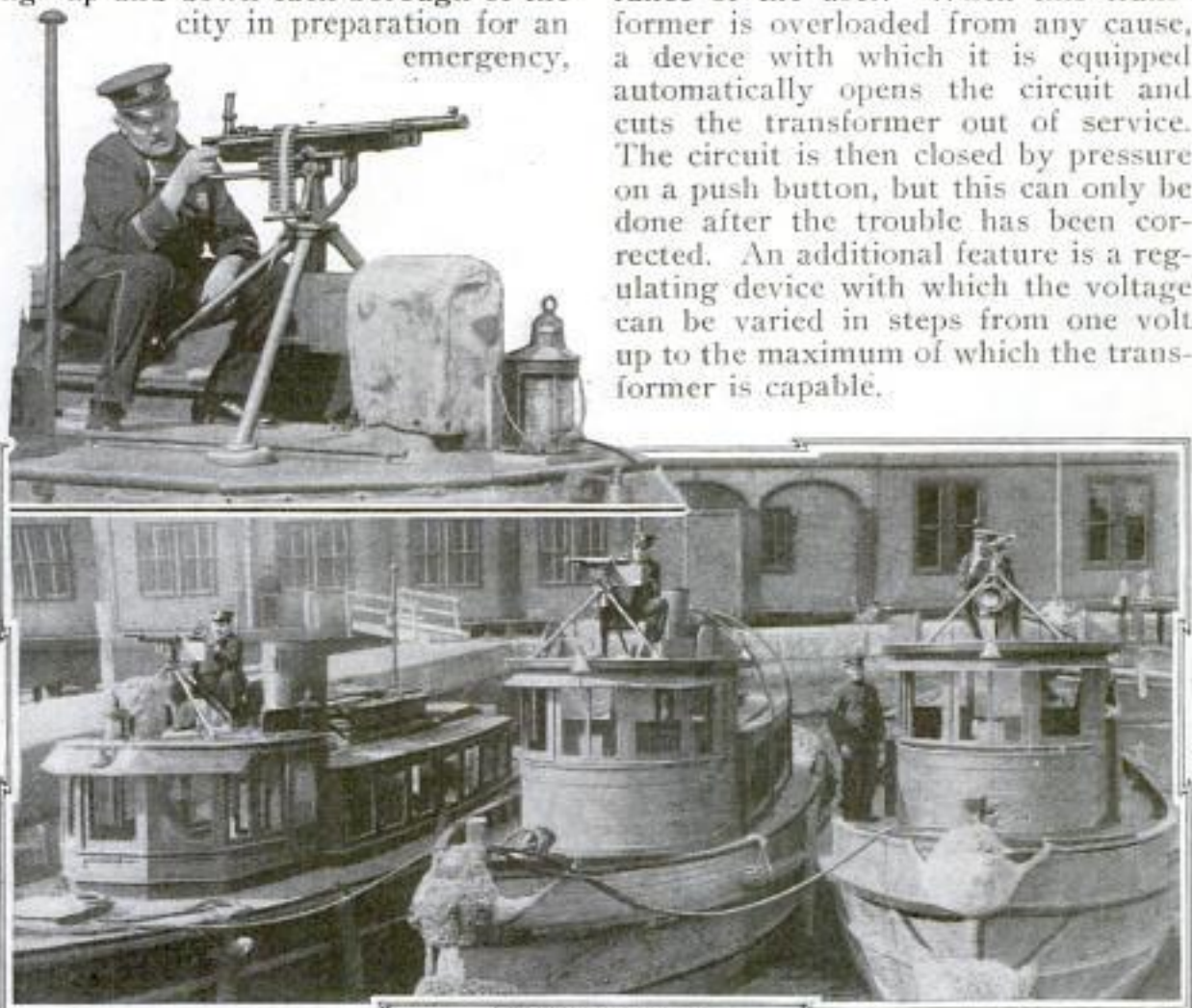

How New York has Increased the Efficiency of Her Harbor Police: These Machine Guns Are Capable of Firing 400 Shots a Minute

## REMNAANT OF UNION ARMY IN REVIEW AT CAPITAL

As the crowning feature of the forty-ninth annual encampment of the G. A. R., 8,000 veterans of the Civil War marched down Pennsylvania Avenue at Washington on September 29 and saluted President Wilson, just as they saluted President Johnson half a century ago upon their triumphant return from the battle fields.

The review was one of the most impressive that the capital has ever witnessed. In the place of the broad, even lines of youthful fighters who once filled the same thoroughfare, there were time-thinned regiments of old men. Some of them had

to be supported by attendants, several were blind, and many marched with the aid of canes.

As they passed the stand, which was at the point where Johnson reviewed them years ago, they cheered President Wilson, a southerner. The hatred once fostered after the bitterness of a harrowing campaign was gone. The president stood with bowed head for four hours while the faltering line of men passed.

There was not a single man in the parade who commanded an army during the war. In the ranks, however, marched John Durst, the only man now living who fought on the "Monitor" during its memorable encounter with the "Merrimac."



John Durst, the Only Man Now Living Who Fought on the "Monitor"

Eight Thousand G. A. R. Veterans Marching in a Grand Review through Washington after Half a Century. The Flag Is One of the Largest in the World

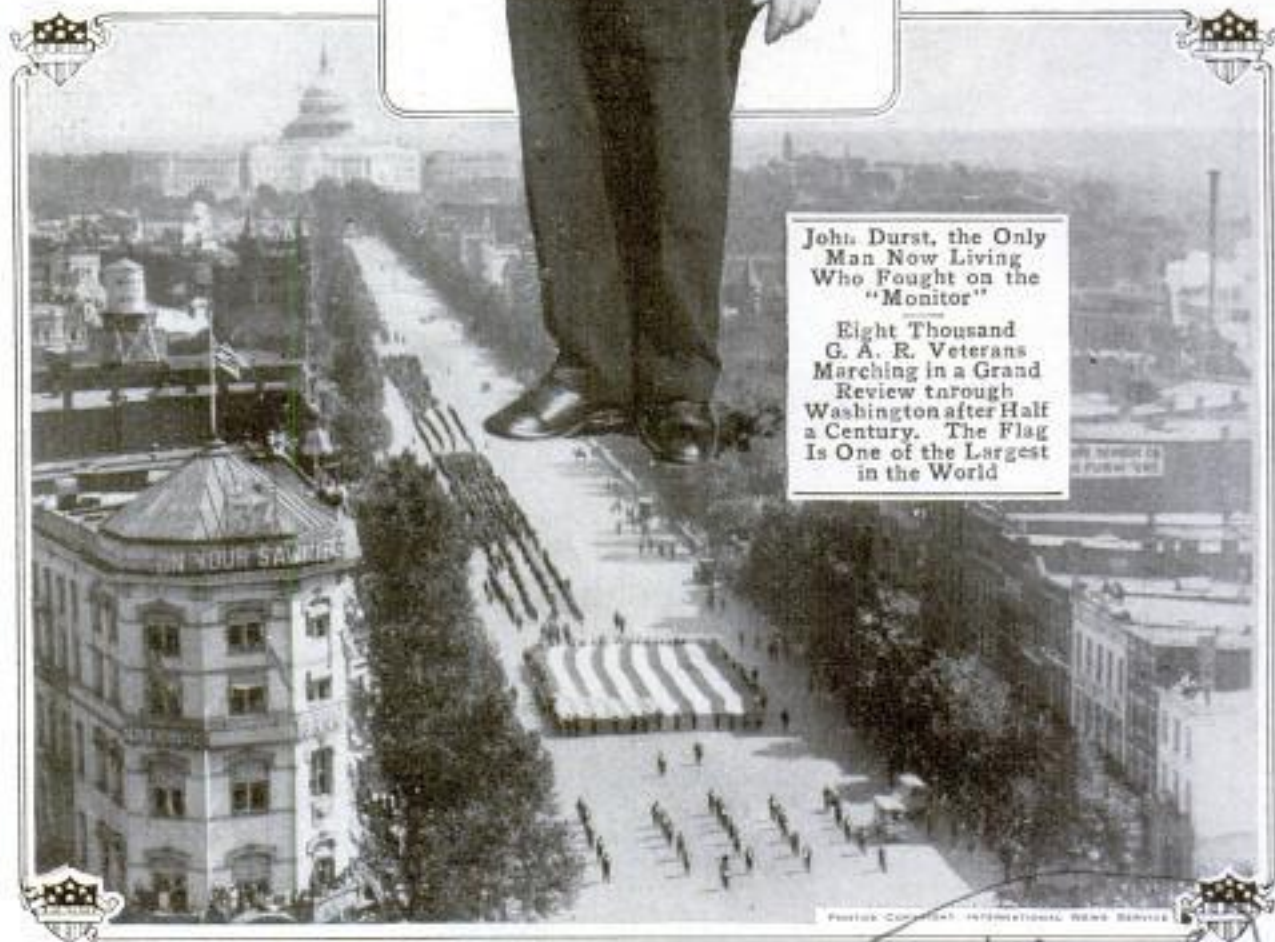

PHOTO COURTESY INTERNATIONAL NEWS SERVICE

258 William St.  
N. Y. C.

# THE CRUMBLED MASONRY THAT WAS PRZEMYSL



German Sentry at Fort No. 9, Przemyśl, after Its Capture



Przemyśl was Shelled by Russians, Blown Up by Austrians, and Again Battered by Germans



Guns and Cupolas of Fort No. 11 which Show Przemyśl's Condition

PHOTOS COPYRIGHTED BY SHOWN & DAWSON.

## CROWN PRINCE REVIEWS VICTORIOUS TROOPS



WÜRTTEMBERG REGIMENTS IN TRIUMPHANT PROCESSION BEFORE THE CROWN PRINCE AND HIS STAFF IN THE ARGONNE FOREST FOLLOWING A VICTORY: THE FLAGS ARE THOSE OF THE REGIMENTS WHICH PARTICIPATED IN THE ENGAGEMENT, AND LEAD THE PARADE. EACH REGIMENTAL BAND WITHDRAWS FROM THE COLUMN UPON REACHING THIS POINT, MASSES AT THE LEFT OF THE ROAD, AND FORMS ONE LARGE BODY OPPOSITE THE CROWN PRINCE, WHO STANDS AT THE RIGHT IN ADVANCE OF THE OFFICERS

# STRIKING SCENES ON EASTERN BATTLE FRONT



PHOTO COPYRIGHT,  
UNDERWOOD UNDERWOOD  
Russian  
Cavalry Divi-  
sion Making  
Orderly  
Retreat before  
the Advancing  
Germans

COPYRIGHT, PRESS  
ILLUSTRATING CO.  
A Ruin in the  
Eastern War Zone  
Which Illustrates  
the Efficiency of  
German Guns



Throughout Galicia and  
Poland Many Century-  
Old Bridges have been  
Destroyed by the Czar's  
Retreating Forces



## STRAW-COVERED FLOOR OF CRUDE HOSPITAL

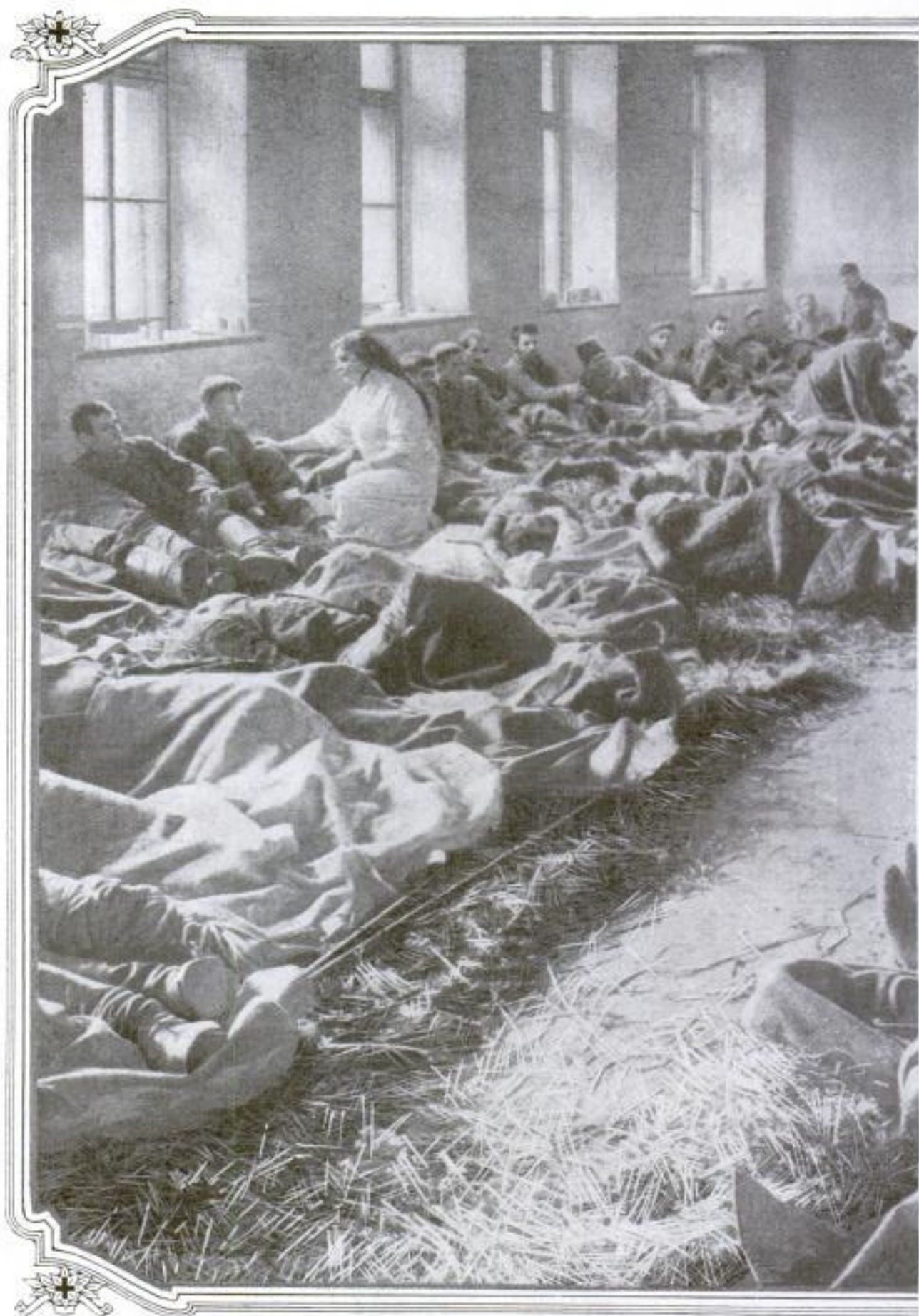

COPYRIGHT, INTERNATIONAL NEWS SERVICE

**T**HE grim, human side of war as the men in the fields and trenches find it, is pictured realistically here, where military hospital, where the suffering and privations of the sick, crippled soldiers, and the totally other parts of the war zone. The priest in the background attempts to cheer the men, and is frequently called

## FOR SCORES OF WOUNDED RUSSIAN SOLDIERS

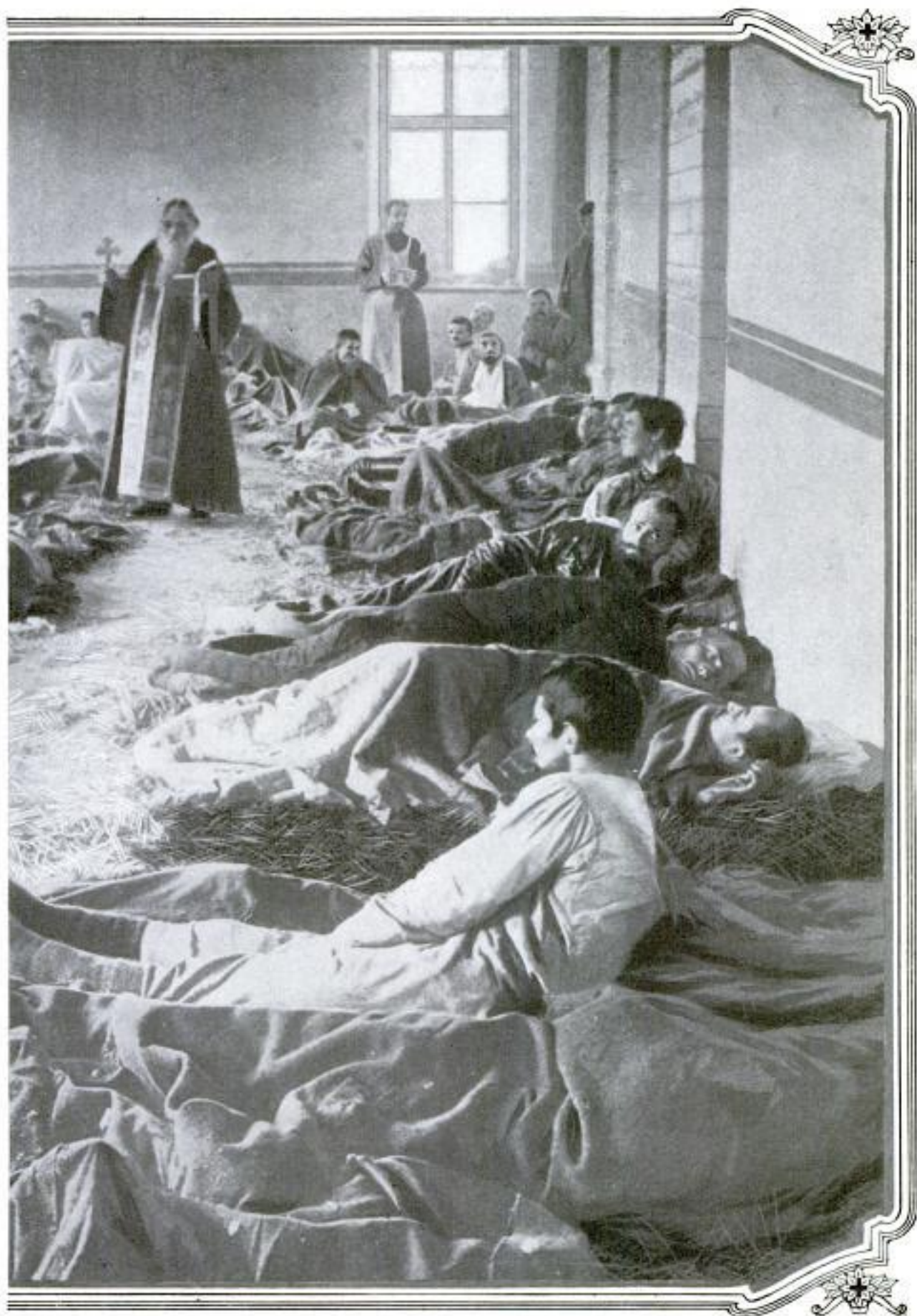

the glamor and glory of battle are far removed. The photograph shows the interior of an improvised Russian inadequate provision for their care are strikingly manifest. There are many of these places in Russia, as in upon to perform the last rites over their bodies.

## IN THE WAKE OF THE RETREATING RUSSIANS



One of the Ironies of War: Russian Prisoners Pulling Their Machine Guns behind Them at the Command of Their Captors



Russian Cannon Struck Squarely in the Muzzle by a German Shell during Lemberg Battle



Guns Captured from Russians being Loaded into Trains



Germans Searching Abandoned Trenches for Waste Metal



# MAKING OBSERVATIONS FROM CAPTIVE BALLOON

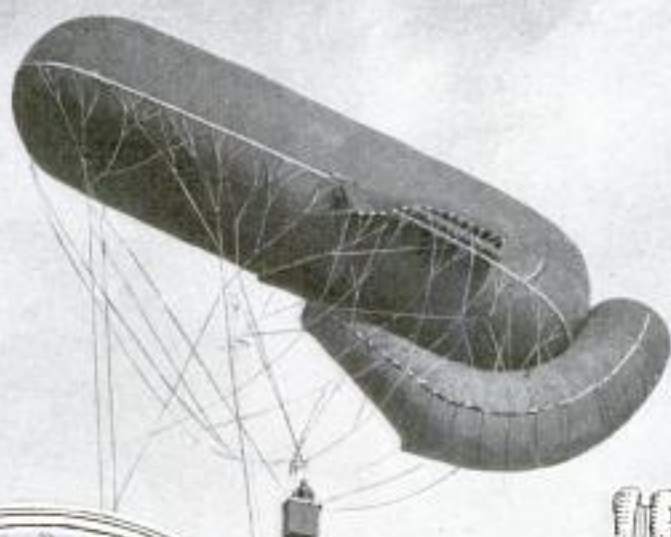

Directing Artillery Fire from Captive Balloon of German Signal Corps: The Observer Is About 300 Feet from the Ground



Removing the Heavy Felt Boots Worn by Observer, Who has Just been Relieved



Launching a Captive Balloon: The Observer Has a Telephone Strapped to His Body, Enabling Him to Communicate with His Superiors



The Pulley at the Left Moves along an Anchoring Cable and by Drawing upon Ropes the Balloon is Pulled to Earth

# BEHIND FIRING LINES IN MODERN ARMY CAMPS

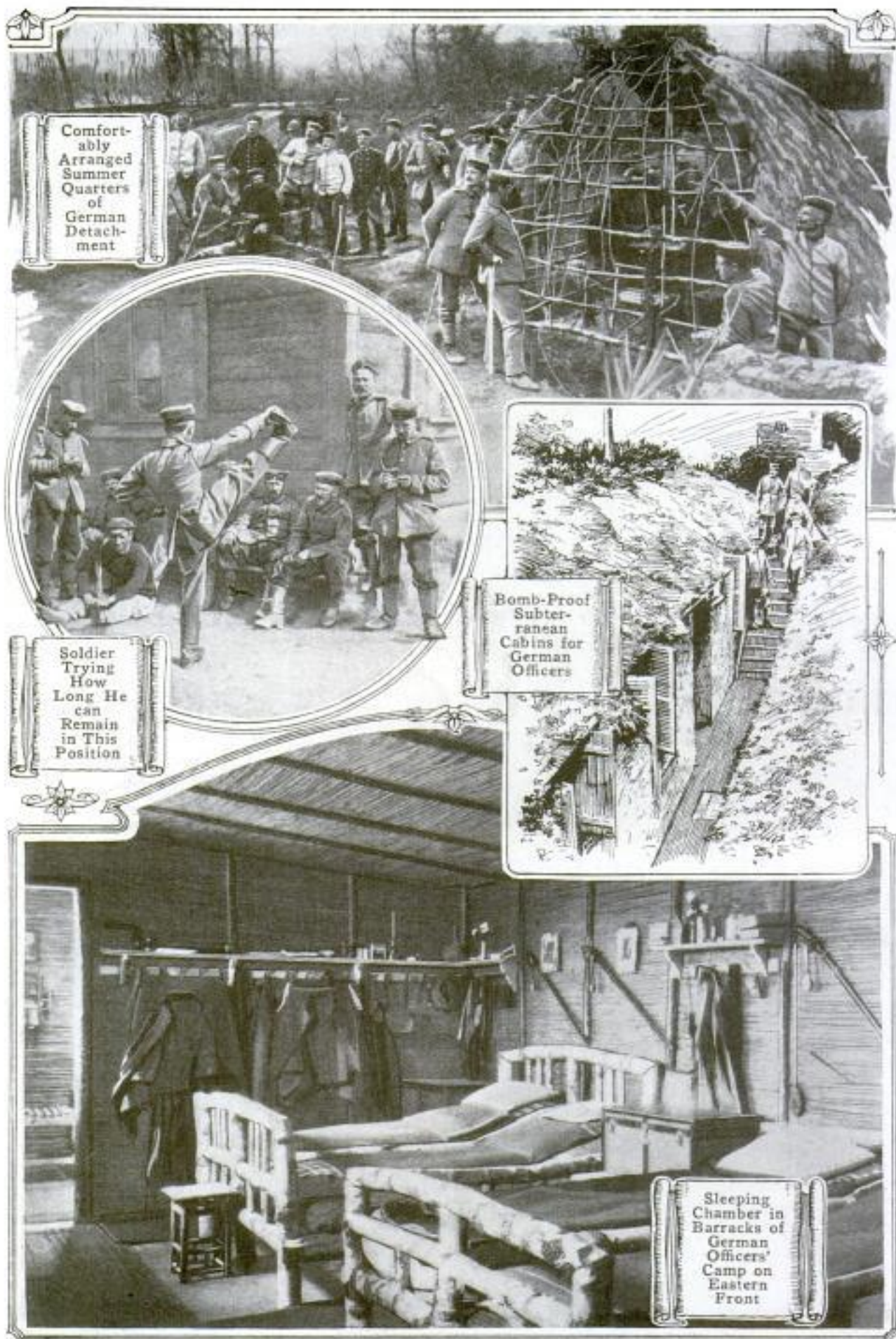

## TREATING WOUNDED AND CRIPPLED SOLDIERS



German Soldiers  
Accustoming  
Themselves to  
the Use of  
Their Artificial  
Hands



Using an Electro-  
magnet  
to Remove  
Splinters  
from a Sol-  
dier's Eyes



One of the  
Means  
of Teaching  
the Maimed  
to Overcome  
Awkwardness



Orthopedic  
Apparatus  
being Employed  
to Assist in Re-  
gaining Use of  
Hands and Feet

# ON DESERT SANDS WITH EXPEDITIONARY FORCES



British Compound at Alexandria for the Disciplining of Soldiers



Turkish Military Caravan Procuring Water at Oasis Well

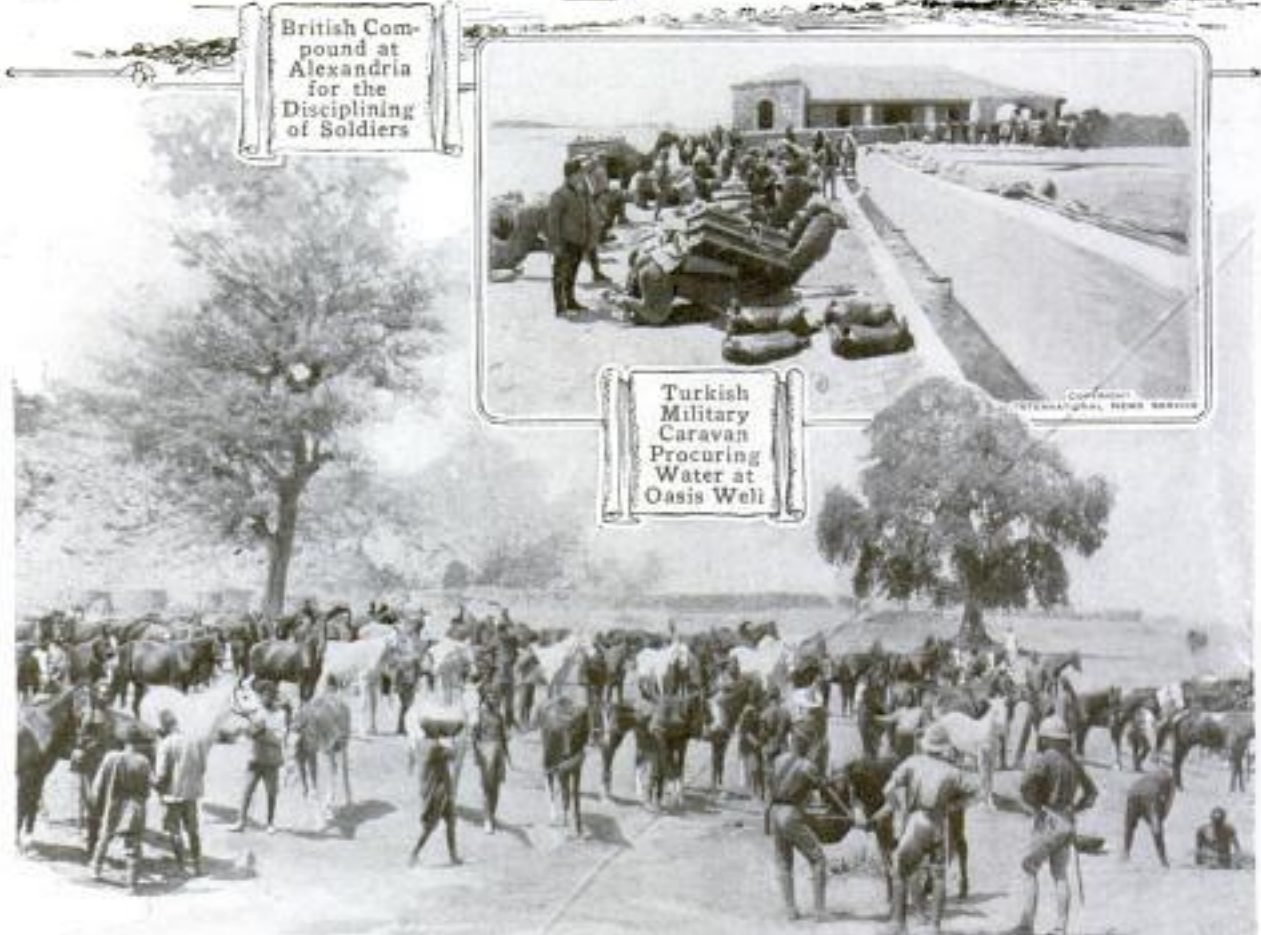

Palm Leaves Stuck in the Hot Sand Shade This Crude Field Kitchen in a Singalese Camp in Egypt



British Cavalcade, Worn and Baked after Long Desert March, Bivouacking at First Water Hole

# WITH THE ITALIANS ON ALPINE BATTLE FRONT



COPYRIGHT, UNDERWOOD & UNDERWOOD  
Outpost  
Tele-  
phoning  
Head-  
quarters



Italian Scouting  
Party in the  
Mountains  
around Trieste



Heavy Siege Gun  
Used in Dislodg-  
ing Austrians from  
Concrete  
Trenches in Alps

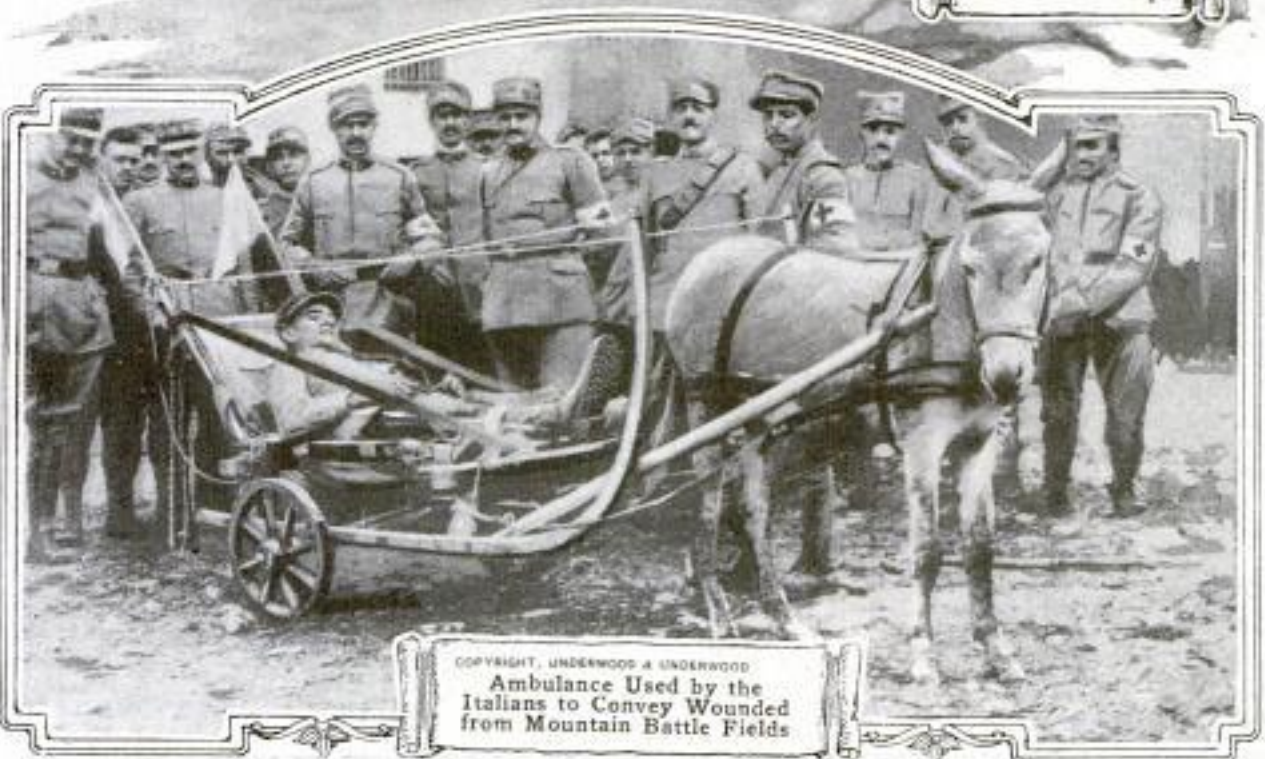

COPYRIGHT, UNDERWOOD & UNDERWOOD  
Ambulance Used by the  
Italians to Convey Wounded  
from Mountain Battle Fields

# SIDE LIGHTS ON WAR FROM GERMAN VIEWPOINT



Sanitary Corps Disinfecting Soldiers' Clothing

Bathing in an Improvised Tub Fed by a Stream of Water



Vermin-Infested Soldiers are Sprayed with a Specific

Army Dentist Treating Polish Peasants

Portable Sausage Factory of German Commissary Department

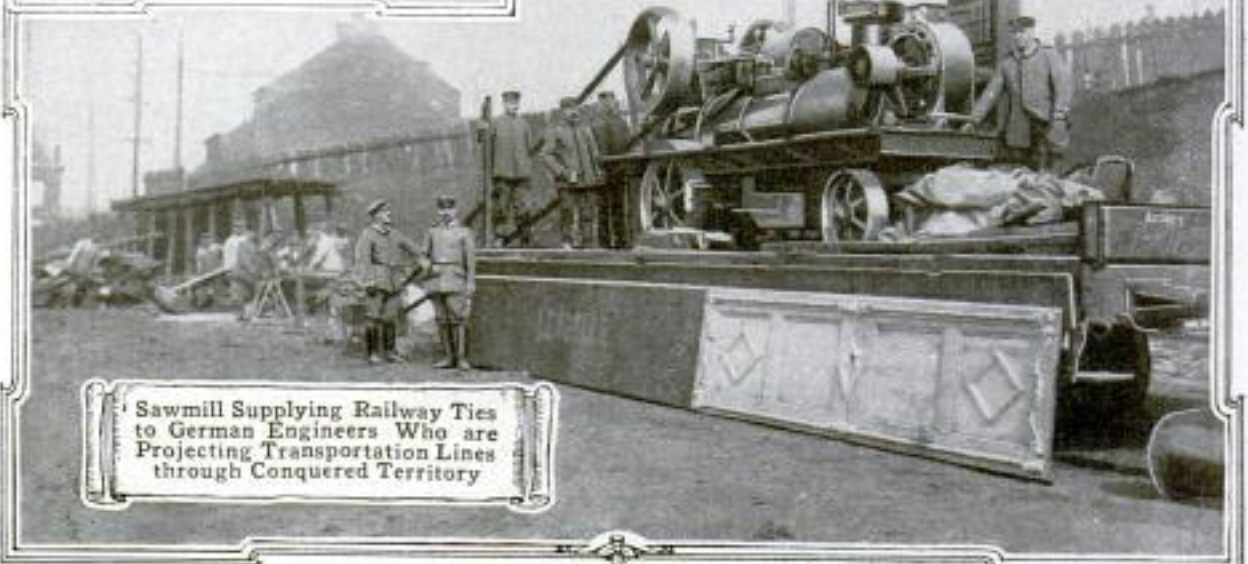

Sawmill Supplying Railway Ties to German Engineers Who are Projecting Transportation Lines through Conquered Territory

## BRITAIN'S DEFENDERS AT PRACTICE AND PLAY



Drilling Recruits  
in Use of Hand  
Grenades for Of-  
fensive Actions in  
Modern Trench  
Warfare

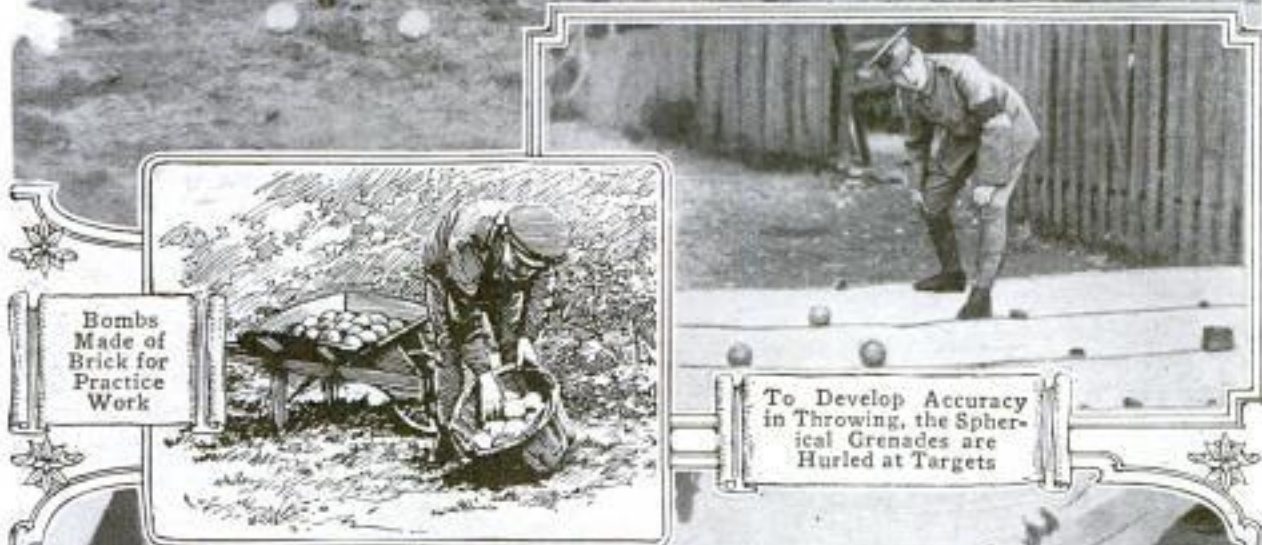

To Develop Accuracy  
in Throwing, the Spher-  
ical Grenades are  
Hurled at Targets



Bombs  
Made of  
Brick for  
Practice  
Work



One of the Battleships Oper-  
ating in the Dardanelles Re-  
cently Put into a Friendly  
Port Where the Seamen  
Played Cricket in a Dry Dock

# RANDOM GLIMPSES OF BATTLE-RIDDEN EUROPE



Shortage in Uniforms has Forced New Dutch Soldiers to Don White Suits



Thousands of Geese Left Behind by Fleeing Russian Peasants Are Food for Germans



Pathetic Scene in Galician Village Showing Exodus of Jews upon Approach of Germans



# GRIM PHASES OF WAR SEEN ON BATTLE FIELDS

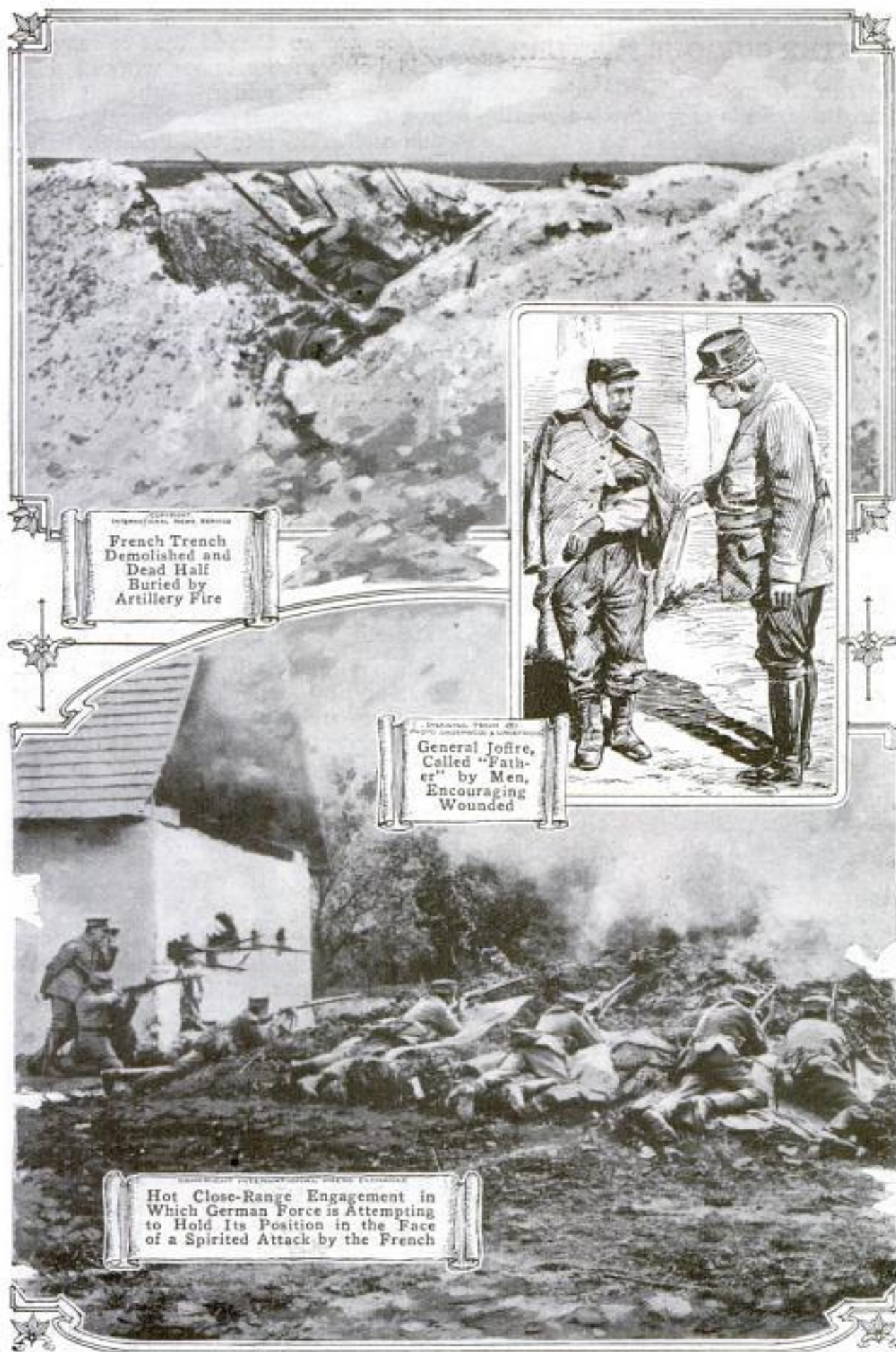

French Trench Demolished and Dead Half Buried by Artillery Fire

General Joffre, Called "Father" by Men, Encouraging Wounded

Hot Close-Range Engagement in Which German Force is Attempting to Hold Its Position in the Face of a Spirited Attack by the French

1135 848 Nov 13, 1915  
 Albert O. Row Grand Island, Neb.  
 Filed 7/6/14 - Ser. 849141 [cl 31-75]  
 204 Gazette  
 V 213-668

POPULAR MECHANICS

**SANITARY MILK PAIL MADE AFTER CURIOUS PATTERN**

979x  
 X

A sanitary milk pail which cannot be kicked over by a cow during the milk-



The Milking is Done Directly into the Strainer. While the Milker Sits upon the Bucket

ing process has been invented by a Nebraskan. Fastened in the lid of the bucket is a flexible tube that terminates

in a straining funnel. The sides of this device are so shaped that it may be held between the knees without difficulty by the milker. When it is in use, the dairyman seats himself on the pail and milks into the strainer. This promotes cleanliness, tends to prevent the milk being spilled, and makes it unnecessary for a man to carry a stool with him while doing his work.

**POTATO RACE IS FAST GAME WHEN PLAYED BY COWBOYS**  
 L.M. EDITHO L.M.

332  
 X

Although lacking in that science which makes polo the game it is, a sport indulged in this year by the cowboys of the Southwest at their annual meet is one which demands an exercise of much skill in horsemanship. It is played by eight mounted men; four on each side. At each goal is a small square box. In the middle of the field is a third case, which is filled with potatoes. The riders are provided with long, lancelike, sharp-pointed poles. At a signal they dash at the potato box, certain of them attempting to spear potatoes and plunge back to their goal boxes with them. At the same time the guards of one side endeavor to prevent the scoring of the other by blocking their opponents, preventing them from spearing a potato in the first place and—if one succeeds in doing so—by knocking the tuber from the lance. At the end of eight minutes the game is stopped, and the side having the greatest number of potatoes in its goal box wins.



Lower View: The Start of the Game: The Riders are Dashing Toward the Potato Box. Top View: The Rider on the White Horse has Scored a Point by Dropping a Potato in His Goal Box

# J. H. Berry, Waterloo Water-works, Waterloo, Iowa

*Avant navy jour. 8-28-15*  
**NEW NAVAL GUNS HAVE HIGH ANGLE OF FIRE**

*528 m*  
An elevation of 30°, an angle that is just double that of the older ships, is to be given the guns of the new United States battleships. Apparently the upper part of the arc is intended mainly to facilitate the handling of the gun in rough weather, as, even with the present angle of fire, the guns of battleships of the type of the "Arkansas" have a range of 11 sea miles, or about 22,000 yd. Official reports show that the British battle cruisers engaged in the fights of the North Sea and off the Falkland Islands inflicted severe damage on the German ships at ranges of about 18,000 yd. Owing to the curvature of the path traveled by projectiles fired at such a range, a plunging fire results, the projectile usually striking the deck or the upper part of the ship instead of the side. In view of this, plans are being considered for protecting the decks of the new battleships with armor considerably thicker than that heretofore used for this purpose. This additional armor will add considerably to the weight of the ships.

*Power*  
**ELECTRIC PLANTS IN THE UNITED STATES**

Of the 4,992 electric plants in the United States 3,199, approximately 64 per cent, are able to supply light, heat, and power during the day as well as during the night, the remainder supplying current only during the night. Central-station service is provided for a total of 6,775 cities, of which 4,336 have full day and night service.

*Amer. machinest*

*H 185*  
**ODD PUMPING PLANT BUILT IN MUNICIPAL PARK**

At Waterloo, Ia., a pumping station over an artesian well which supplies the town with water, is situated in

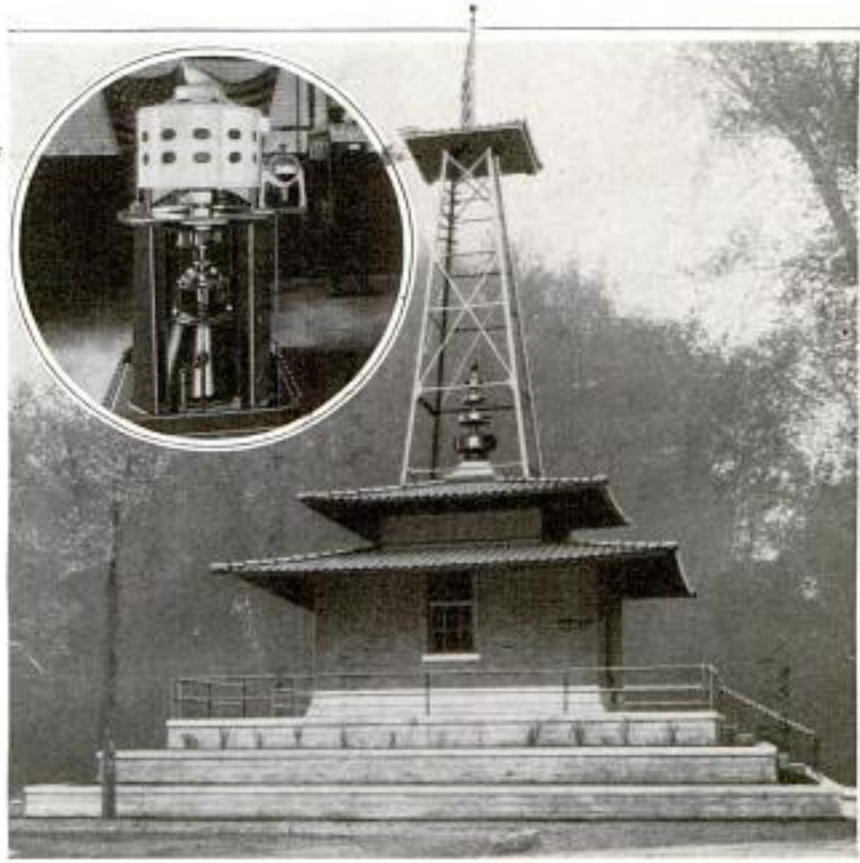

The Terraces Raise the Building above the High-Water Mark. Insert Shows the Type of Pump Employed in This Novel Station

one of the local parks on ground which is inundated when an adjacent creek overflows. In designing the structure it was necessary, because of this, that its floor level be placed above the high-water mark and that this height be attained in such a manner as not to make the building unsightly in appearance. An 8-ft. foundation was constructed and three pyramid terraces, bound by concrete retaining walls, built about it. That the structure itself might be in harmony with its stepped elevation, the plant was built after the lines of a pagoda.

ⒸThe only state in which tolls are charged for using the Lincoln Highway is Pennsylvania, and a strong movement is now on foot for abolishing these charges.

**FIRE ALARM BELL ERECTED  
TO PROTECT "IRONSIDES"**

As a means of helping to safeguard  
the "Constitution"—"Old Ironsides"—

**HYDROELECTRIC PLANTS IN  
THE PYRENEES**

To provide hydroelectric power for  
Barcelona, Spain, the fourth largest

concrete dam in the world is now in process of construction at Talarn, on the edge of the Pyrenees. This dam, which is now nearing completion, will stand 269 ft. above the bed-rock of the river and over 328 ft. above the lowest point of its foundation. It will raise the level of the water 243 ft. and will form a reservoir containing nearly 230,000,000 cu. yd. of water. This plant will produce 50,000 hp. The water, after having done its work in the turbines, will be returned to the river and farther downstream will be captured anew and forced to turn the wheels of the Barcelona plant, where 56,000 hp. will be generated. The electrical energy produced at Talarn will be transmitted at 110,000 volts for a distance of 130 miles to Barcelona and the surrounding

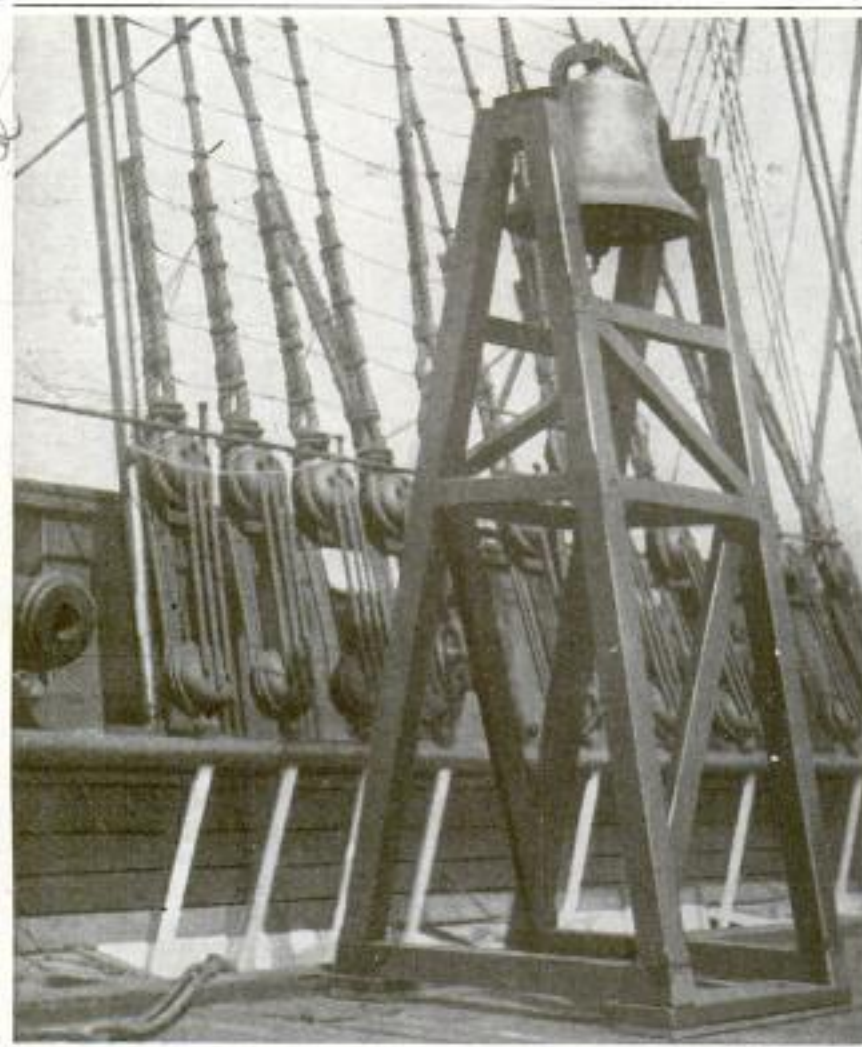

Alarm Bell Which would Summon Assistance Should Fire Break Out Aboard the "Constitution"

which distinguished itself during the early part of the nineteenth century and especially in the War of 1812, from being destroyed by fire, a large alarm bell has been mounted at the pier where the aged naval relic is moored in the Charleston Navy Yard. This is supported by a heavy wooden framework which stands close to one side of the ship. A cord extends from the bell over the ship's railing in ready reach of the watchman. Hundreds of visitors inspect the vessel daily and for a long time it has been recognized that precautions must be taken to protect it against fire.

district and then transformed to suitable voltages for distribution. This plant is only one of a number of important water-power projects now being developed in the Pyrenees. In these projects, irrigation as well as the production of power forms an important part.

¶The value of scrap metal, exclusive of platinum, gold, silver, steel, and iron, salvaged during 1914 amounted to \$57,039,706. About 127,882 tons of copper, 61,062 tons of lead, 71,642 tons of zinc, and 4,522 tons of aluminum were recovered.

Ship  
Historical

534m

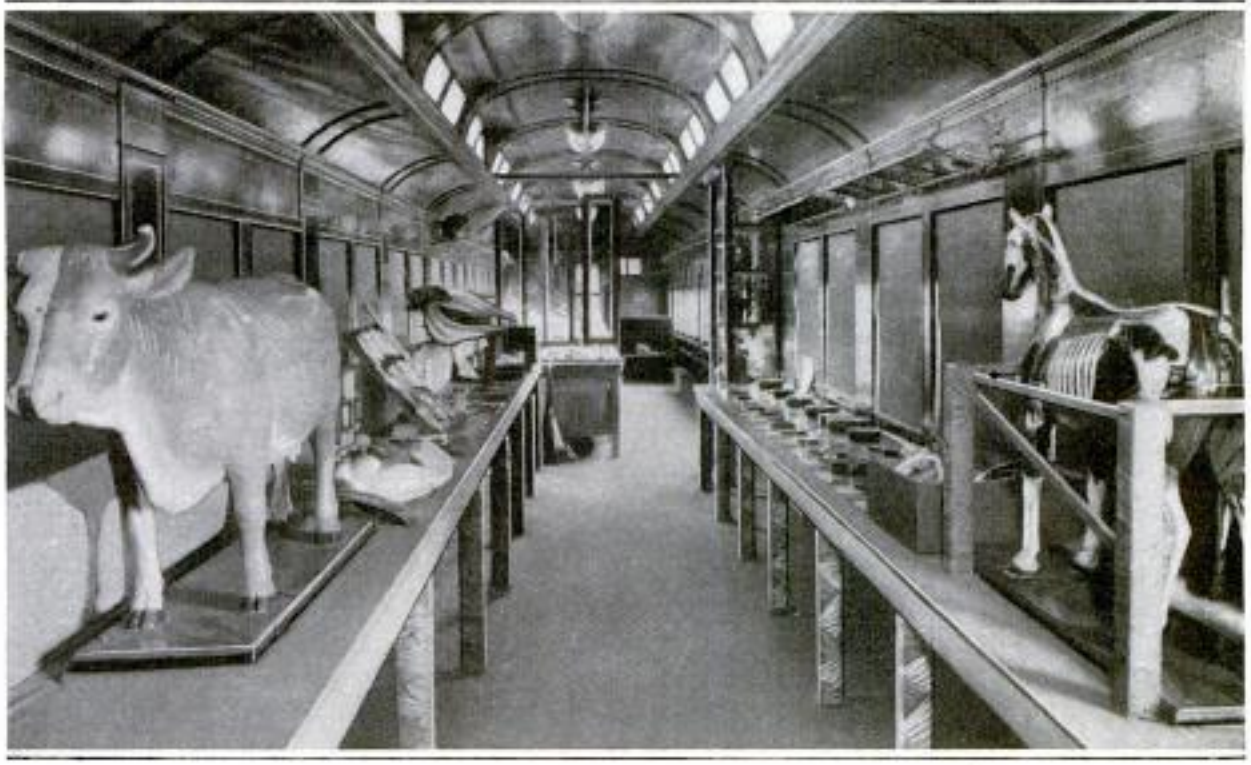

Interior of a Western Railway's Agricultural Demonstration Car

**FARM DEMONSTRATION CAR  
 USED BY RAILWAY**

495 H

Some of the agricultural demonstration trains which are sent through various western states by different railway companies are carrying elaborate exhibits intended for the education and help of the farmer. A number of roads have expended thousands of dollars in attempting to teach settlers along their routes how to raise better and bigger crops, how to handle live stock and poultry, and moreover, how to become successful agriculturists. The accompanying illustration shows the interior of a car which carries an exhibit devoted to live stock. It includes papier-mâché models of cows and horses, plaster molds showing the physiology of these and other farm animals, and various things of value in giving a farmer an insight into approved ways of caring for his live stock. A car of this kind is attended by a competent authority on animal husbandry who unravels many of the perplexing problems which confront farmers, especially those who are comparatively inexperienced in the industry.

**ODD CONCRETE PROTECTION  
 SHIELDS MOTOR FROM SUN**

Auto  
 433

In one of the Chicago cemeteries a reinforced-concrete structure of interesting design has been erected as a motor-car shelter. It is a canopy that extends out over a driveway and is supported by three heavy pillars, set in a row along one side. There is no counterweight to balance the slightly tilted roof, as the foundation serves as the anchor for the overhanging leaf. This naturally gives it a top-heavy appearance, although it is adequately supported.



The Canopy Is of Rigid Construction and Requires No Counterweight to Balance the Roof

Graceland

9805 **RAILWAY CARS JOINED TO FORM MOVIE THEATER**

As a part of its display at the Panama-Pacific Exposition an eastern railway company maintains a motion-picture theater, consisting of two all-steel coaches joined side by side, in which films showing scenery at various points of interest along its lines are exhibited. The character of this little parlor is interesting. In building it the adjacent sides of the cars, set parallel with each other, were removed and the space bridged and roofed, forming one spacious, fireproof room. The interior is fitted with four rows of plush seats. The windows bear the pictures of typical scenery to be found along this company's route, as well as the seals of the various states traversed by

the road. The cars are set on standard track and will ultimately be returned to service.

209 **CALCULATING INSTRUMENT FOR ACCOUNTANTS**

Designed to meet the requirements of bookkeepers and clerical workers, a comparatively inexpensive rapid-calculating device has been introduced which is capable of adding, subtracting, and multiplying quickly and accurately. The instrument is about 10½ in. long, 2¼ in. wide, and ½ in. thick. It is provided with a series of seven dials which are revolved by a stylus when making calculations. A single turn of one of the wheels adds a figure to a previous register and simultaneously shows a total. The device may be used on a ledger page and moved downward as the work proceeds. In order to clear the machine it is only necessary to place a stylus in the large opening of each disk and turn it toward

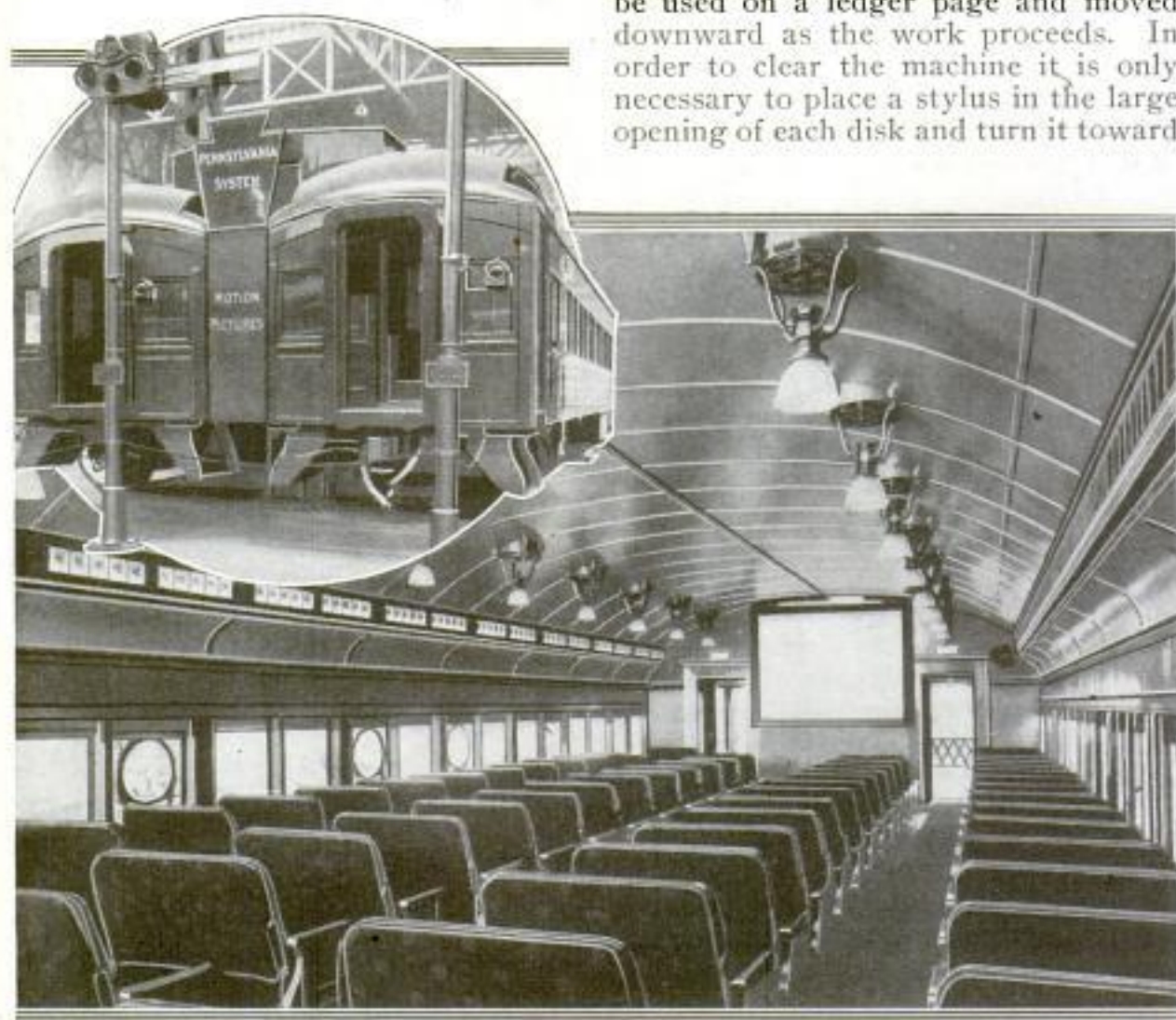

Above: Exterior of Railway Motion-Picture Theater. Lower View Shows the Interior and Finishing of the Unusually Built Auditorium

Made by Calculator Sales Co., Grand Rapids, Mich.  
 Oxidizing Metal 75%  
 Gold Plated  
 POPULAR MECHANICS  
 Sent Postpaid to any point in U. S.

709



The Instrument Adds, Subtracts, and Multiplies with Accuracy and Quickness

the left until zero is reached. To correct an error the operator merely turns

the proper dial backward the required number of spaces.

## DUTIES OF WOMANHOOD TAUGHT IN HIGH SCHOOL

*8920 m*  
*facts not furnished*  
**A**BOUT ten years ago, when a high school for girls was opened in a ramshackle building located on the border of the East Side, in New York City, the first step was taken in the development of educational ideals and methods which at that time were nothing less than revolutionary. In the meantime this institution, because it meets a real educational need, has grown wonderfully. It is now known as the Washington Irving High School. It is housed in its own school building, which is one of the largest and best equipped in the world. It is a true high school, with the usual curricula, but it has one feature that distinguishes it from most institutions of its kind. Its special work is that of training girls to take their proper place in life as women, and all other features, academic and otherwise, are subordinated to this.

Although the school now has more than 6,000 pupils, the organization is such that the individual needs of every girl, as well as her prospective position in life, are given constant consideration from the time she enters the school until she graduates. Thousands of the pupils live within walking distance of the school and most of them come from the homes of wage earners. The majority of these girls will eventually marry and have homes of their own, and in most cases this home will be a city flat. For this reason home management, particularly the management of a little home, forms one of the

most important features of the training. This training is given in a practical and effective way. A city flat is included in the institution, and the girls are not only told how to take care of it but each is given her turn in actual management. Since many of the girls will be compelled to work for their livelihood, at least for a time, a great variety of vocational courses is provided. Training in the duties of motherhood is given by the "laboratory" method. Babies are brought to the school regularly and the pupils are given instruction and practice in dressing and undressing the babies and in caring for them generally. The babies used in this work are usually the little brothers or sisters of some of the pupils.

During the first year the pupil is given a chance to find out where her real interests lie. With the beginning of the second year the elective system comes into play, and at this time most of the pupils begin to specialize. The usual academic work is given, but in such a way as to show the relation of the studies to real life. In vocational work the pupil has the choice of courses that will fit her for business and office work, for dressmaking, book-binding, or some other trade that a woman can follow; or she can take courses that will fit her for teaching or for an artistic career. More than five-sixths of the pupils avail themselves of the vocational training provided by the school. There is a group of about

*Mechanics Magazine May 1913*  
*World's Work May 1913*  
*St Nicholas Feb. 1911*  
*Review of Reviews August 1914*



The Roof Playground, Where Outdoor Sports are Kept Up Almost without Intermission throughout School Year

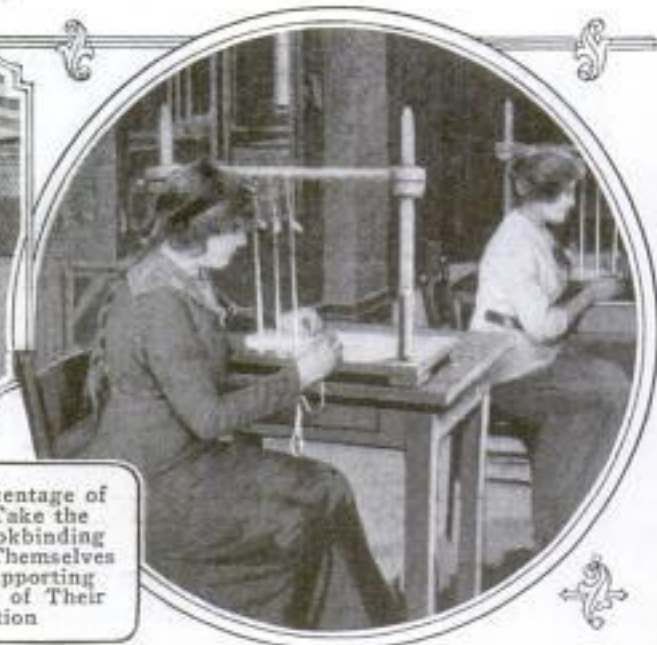

A Large Percentage of the Pupils Take the Course in Bookbinding and Thus Fit Themselves to be Self-Supporting from the Day of Their Graduation



800 each year who confine themselves to high-school work without reference to any particular calling in after life.

The work of the school does not stop with teaching the girls how to do useful things. Each is given every opportunity to acquire poise and dignity. In the Girls' Assembly the pupils are trained to speak in public and to preside at a meeting. Dancing and training in the social graces are a part of the regular instruction. The school has its theater, and in it plays written by pupils are enacted by other



Dressmaking is Taught as Thoroughly as in a Dressmaking Establishment: One of the So-Called "Fads" of the Pupils is the Making of Graduation Gowns Complete at an Expense of One Dollar, or Less

The School Laundry: Instruction in This Kind of Work is Given All the Pupils and Forms Part of the Training in the Management of a Little Home





Potting Plants in the Greenhouse of the School: Instruction in this Department Is Such That the Pupils are Competent Florists by the Time They Graduate

pupils. Healthful play forms as much a part of the day's routine as work at the school desk, and outdoor sports on the roof playground with which the school building is equipped are kept up almost without intermission throughout the school year. The school has become one of the important social centers of the city. During the school year there is a succession of social, dramatic, and musical entertainments, and exhibitions of works of art.



In the School Kitchen the Pupils are Not Only Taught How to Cook, but are Made to Realize the Importance of Such Details as Washing Dishes and Checking Weight of Purchases



Training in the Duties of Motherhood is Given by the "Laboratory" Method. Real Babies being Regularly Brought in for This Purpose

**SIDE-BY-SIDE BICYCLES**

1934 **DRIVEN BY MOTOR**

By coupling two bicycles side by side and attaching a small power wheel at



Curious Vehicle Used for Pleasure Riding by a Florida Cyclist

the rear, a cyclist at Miami, Fla., has devised a novel motor-driven vehicle. Steel rods extend from steering head to steering head of the wheels and

from one seat post to the other, and with auxiliary bracing members hold the machines together. By means of the handlebar connection the bicycles are easily steered in unison. On good roads the light contrivance drives smoothly and is able to maintain a fair speed.

9819 **BOAT DRAWN OVER LAKE BY MOCCASINED DOG TEAM**

After the first heavy freeze at the beginning of winter a party of prospectors working in northern Canada found themselves on the wrong side of a lake over a hundred miles wide, on the opposite side of which was the winter headquarters. They were without any means of transportation other than a boat in which were stored all their belongings and provisions. Hiring a half-breed with his dog team, they put runners under the boat and made their way easily and safely across the smooth expanse of ice, the efforts of the dog team being aided by a sail erected on the boat. To protect the feet of the animals from the hard surface of the ice each dog was fitted out with miniature moccasins made of padded buckskin.

# Francis J. Dickie  
18 Harbour Street,  
Edmonton,  
Alta.

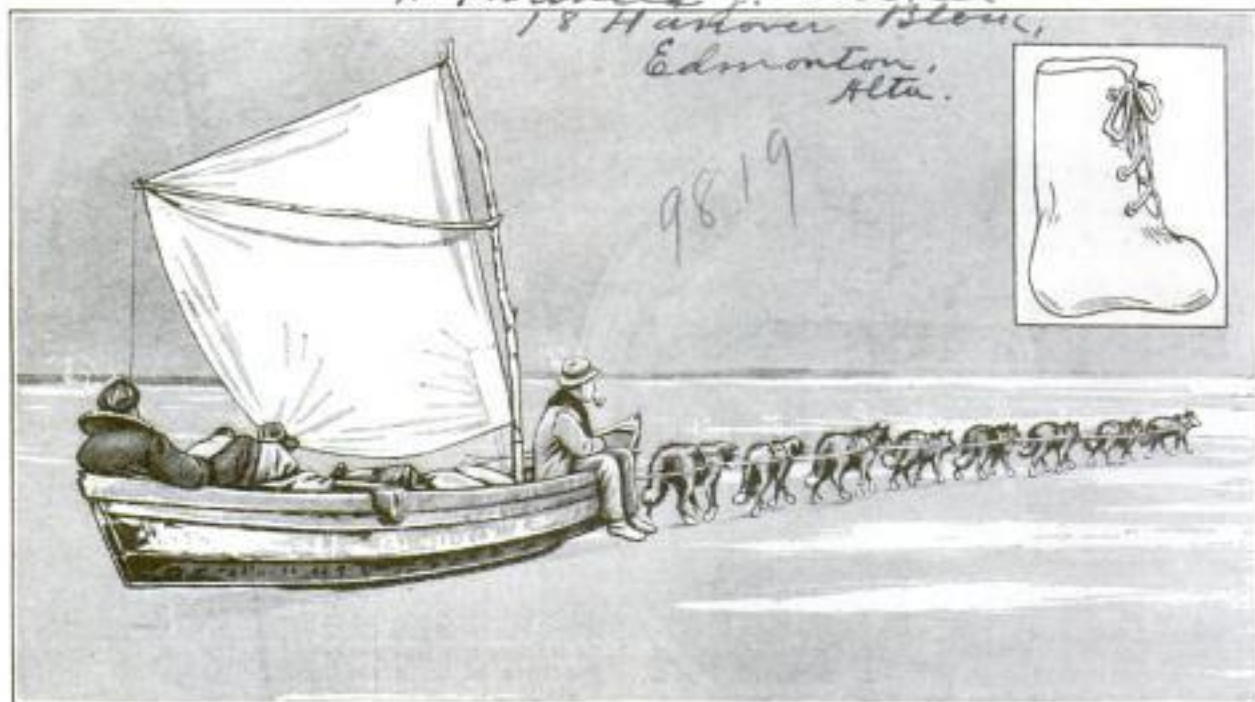

How a Party of Prospectors Working in Northern Canada Reached Winter Headquarters After being Caught on the Wrong Side of a Lake by a Heavy Freeze

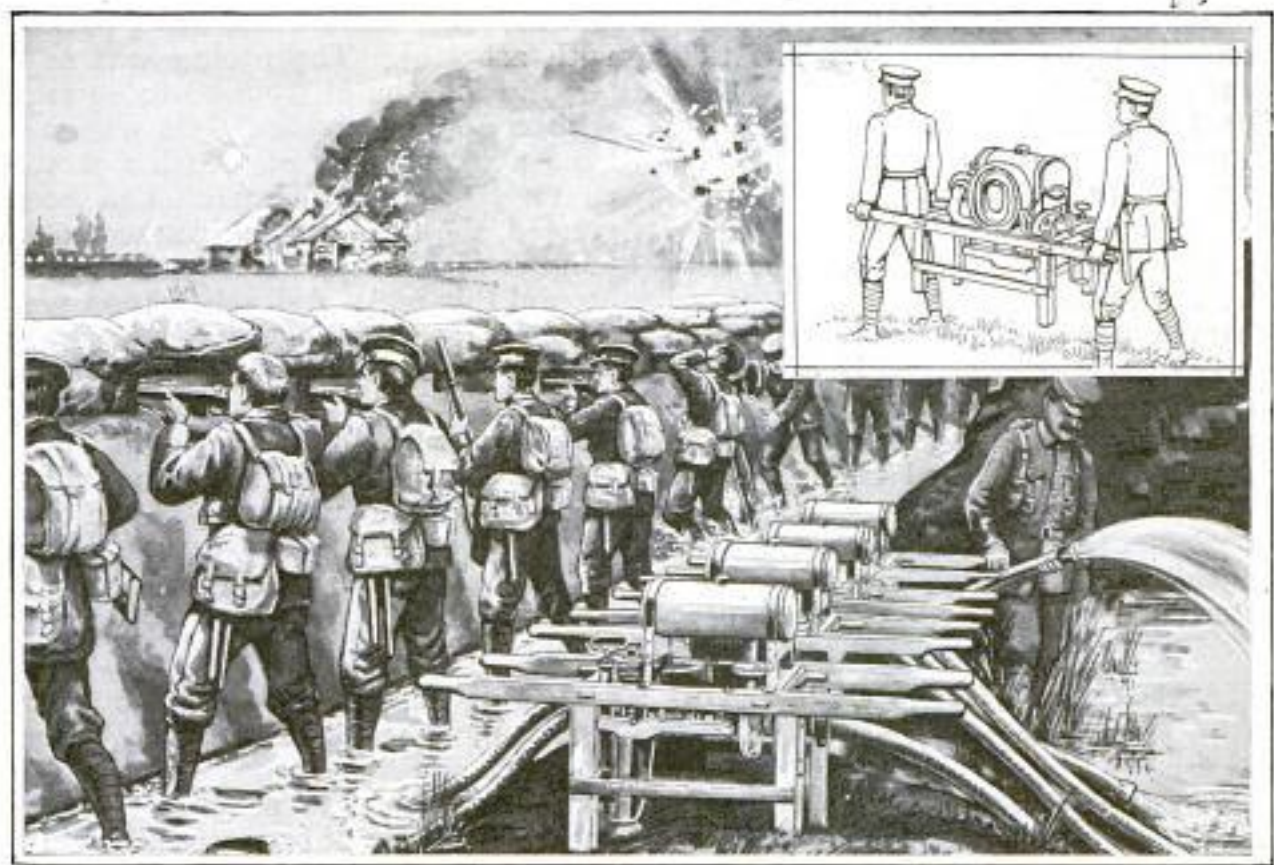

A Battery of Four Gasoline Pumps in Action Draining a British Trench in Belgium. The Picture at Top Shows How the Pumps are Transported from Trench to Trench

**PORTABLE PUMP SET FOR DRAINING TRENCHES**

377 *m*  
 A portable gasoline-driven pump set that is capable of discharging 30 gal. of water a minute against a head of 16 ft. is being used by the British for draining their trenches in Belgium. The entire set weighs only 120 lb., is mounted on a wooden frame that is provided with handles, and is easily carried about by two men. The pump is driven by a 1-hp. single-cylinder engine. Through the action of a knife working within the pump all fibrous material such as cotton waste and rags, as well as sand and mud, is cut to pieces, a feature that makes the pump particularly suited to trench work. The set, when fully charged with fuel and oil, will run continuously for from 10 to 12 hours. The pump is equipped with a suction hose, 8 ft. long, and a discharge hose, 50 ft. long, so that the water can be discharged at such a distance that there is little danger of its running back into the trench. When the set is to be started, the suction hose

is placed in the water and the air is first exhausted by a small hand pump mounted on the frame, the discharge hose being closed by means of a throttling clip during this process.

**FLEXIBLE TUBING USED FOR SUBMARINE WATER MAIN**

71-350  
 By using flexible bronze tubing 4 in. in diameter, the problem of supplying water to Partridge Island, which lies 3,250 ft. off the mainland at St. John,

Flexible Bronze Tubing Used for a Water Main under the Harbor at St. John, New Brunswick: The Picture Shows How the Tubing can be Bent without Danger of Injury

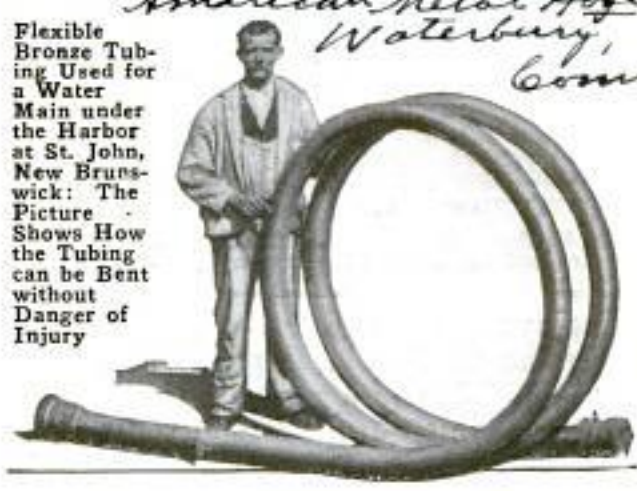

N. B., has apparently been solved satisfactorily and permanently. The tidal range at this point is about 28 feet, there is usually a current of from two to three miles an hour, and the channel is therefore a difficult place in which to lay pipe without damaging it. A 6-in. galvanized wrought-iron pipe with ball-and-socket joints, laid several years ago, soon developed leaks, and an exposed portion was finally caught by an anchor and seriously damaged. Recourse was then had to flexible tubing, which could be reeled from a barge without danger of injury. This tubing consists of a strip of bronze wound helically, each winding overlapping and interlocking with the one preceding it,

and the joint thus formed being packed with asbestos. The tubing was supplied in lengths of from 30 to 40 feet, with couplings attached. It was laid from a steam scow on which a wooden reel, 12 ft. in diameter, had been erected, the tubing being connected in lengths of about 200 feet and wound around this reel. As each section was prepared for laying, it was securely jointed to the one preceding it. The entire line was laid in a trench which was dredged as the pipe laying proceeded. In most cases the trench filled in quickly from the action of the current, and only at a few points was it necessary to dump in material for back filling.

### MAKING PICTURES OF SEEDS

#### 150 # IS NEW ART

Seeds of various kinds were used instead of pigments in making an interesting barnyard picture which is



To Produce the Soft White Effect, Seed Corn was Crushed into a Paste Which was Used as a Paint

displayed at one of the exhibits of the Panama California Exposition at San Diego. This is a portrait of a white rooster which from a short distance might easily be mistaken for an oil

canvas or pastel. In truth, however, it is a most painstaking arrangement of seeds. Kaffir-corn seed, for instance, was used to produce the predominating tone of brown, while white Egyptian corn gives the picture another shade of the same color. For part of the background the seed of the Eucalyptus was used, and black onion seed for the jet field. Some of the white was made by crushing seed corn into a paste and applying it to the picture. The tones are wonderfully soft, the lines good, considering the materials used, and the effect of the whole quite striking. This method of picture making was originated in the West, where it has become quite a fad.

### TELEPHONE CHURCH SERVICE ON ISLAND OF GUERNSEY

Residents on the island of Guernsey, in the English Channel, are enabled to listen to church service in their homes any Sunday evening at a charge of about 10 cents. Policemen and firemen, as well as lighthouse keepers and other government employes who are prevented by their occupation from going to church, are furnished the telephone service free of charge. At Platte Fougère lighthouse station sometimes as many as eight persons sit down together to hear the telephone service from a church five miles away.

Telephony 8-28-15

# D. W. Cole, U. S. Reclamation

POPULAR MECHANICS Service, 715

Gallon, Nevada

# DISCHARGE CHUTE FOR THE TRUCKEE CANAL

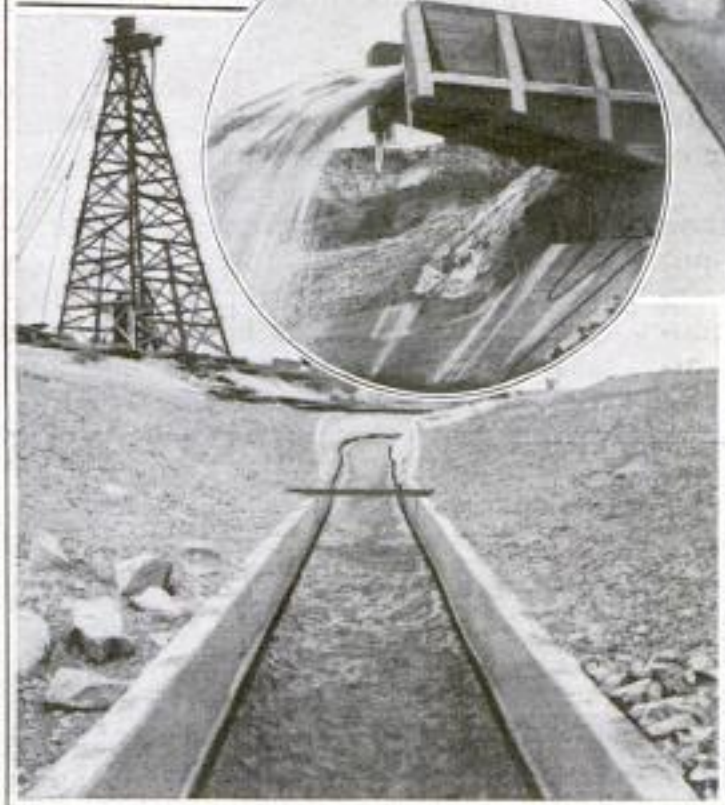
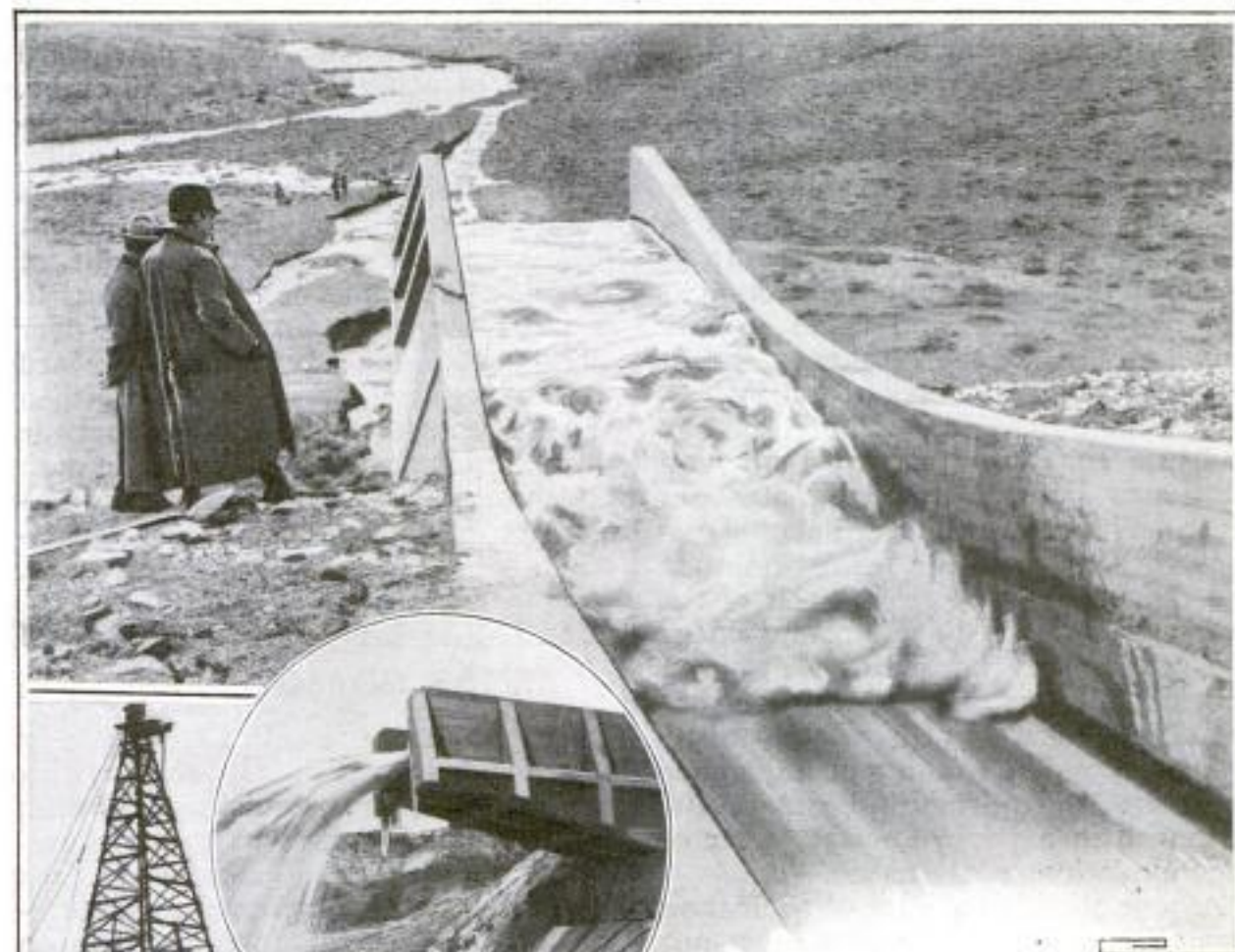

The Back-Water Wave That Forms at the Nozzle When a Small Volume of Water is being Discharged

An Intermediate Section of the Chute, Showing How the Rounded Section is Changed to a Rectangular Section. Insert Shows How the Water is Thrown Upward and Outward by the Concrete Nozzle

Where the Truckee main canal empties into the reservoir formed by the earth dam, 124 ft. high, that has been built across the Carson River, a novel type of chute has been installed for conducting the water past

the sand and gravel slopes and discharging it into the reservoir without danger of erosion or other damage. The canal is 31 miles long and at its lower end the water surface of the full canal is 130 ft. above the bed of the river and about 20 ft. above the full reservoir level. The total length of the structure connecting the canal with the river is 1,122 ft., of which 681 ft. consists of the chute proper. The total drop in the structure is 52 ft. Leading from the canal is an approach section 300 ft. long, terminating in a rectangular fore bay, the two sides of which form weirs. Along each side of the fore bay is a concrete channel, and these two channels, or tail-races, converge into a single channel

through a funnel-shaped section located just below the fore bay. It is at this point that the chute proper begins. With this arrangement of fore bay and tailraces the water is maintained at the required level in the canal, while the volume of water that flows over the weirs into the tailraces is easily regulated by the controlling works. At this point the chute is rounded in section, but the section is gradually changed and made slightly smaller until, at the discharge end, it has a rectangular section and is 9 ft. wide and 6 ft. deep. The discharge end is a concrete structure built as a cantilever with an overhang of about 18 ft. The end of the cantilever structure is 2 ft. above the lowest point in the chute, which is 18 ft. back of the discharge end. With this arrangement the water is discharged as if from an enormous nozzle, being thrown upward and outward at a velocity of 34 ft. per second and falling at a distance of about 50 ft. from the end of the structure in a pool of water, clear of the foundations of the chute.

A curious hydraulic phenomenon was observed when the chute was put in operation. A small volume of water was first let in, and this was gradually increased until the maximum al-

lowable flow was reached. For some time the water was pocketed in the low section just back of the nozzle, and the discharge was vertically downward instead of being in a parabolic curve. As the flow was increased a back-water wave was formed at this point, which finally rose nearly to the tops of the side walls, and it was thought necessary to increase the height of these walls by means of sand bags to prevent the water from flowing over the sides. The flow was then increased to the regular service volume, when the stream suddenly shot out from the nozzle in the calculated parabolic path and the back wave disappeared instantly. The phenomenon was repeated each time the water was turned in.

### FIBER FABRIC IS EMPLOYED IN REMAKING MOTOR TIRES

By making use of a remarkably tough fabric which is woven with thread and fiber strands, a California inventor has devised a means of rebuilding dilapidated motor-car tires and making them, moreover, puncture-proof. This fabric is incorporated into the tire during the process of retreading it. The cloth, it is claimed, is a nonconductor of heat. As a demon-

*Inventor: Frank W. Simons*

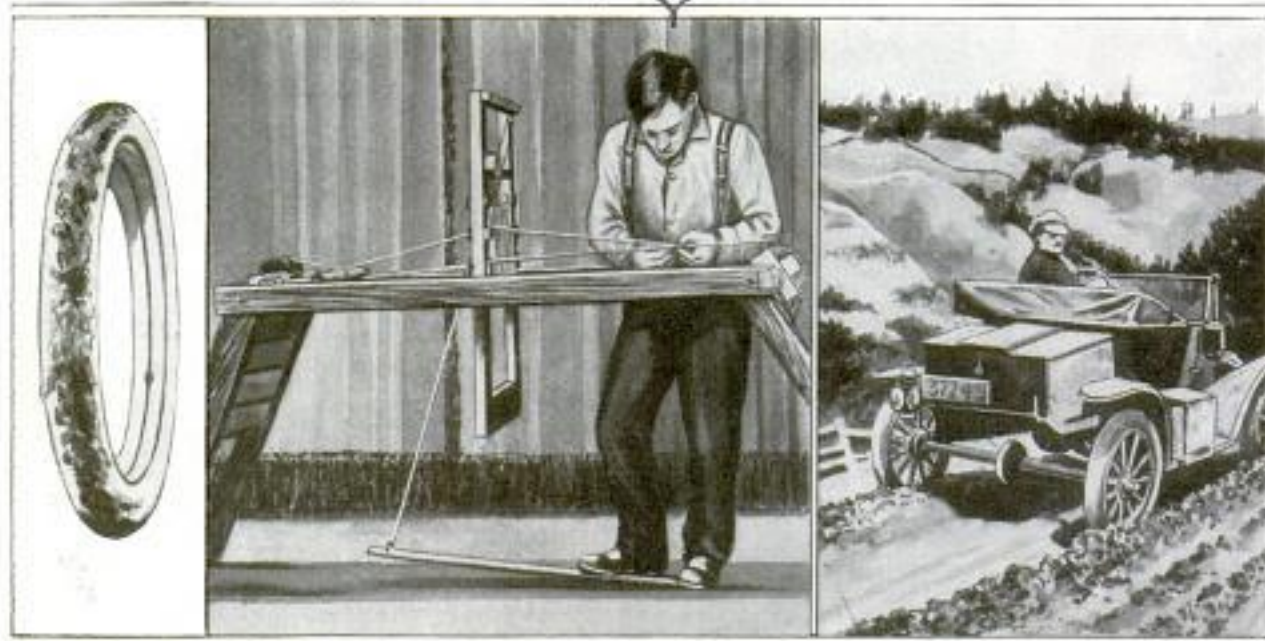

At the Left is Pictured a Worn-Out Tire Which was Reconstructed and Again Put in Service, as is Indicated at the Right. The Man in the Middle is Weaving the Puncture-Proof Fabric by Hand

*Simons' Mfg Co.  
Vallejo, Calif.*

station of the resisting qualities of one of these reconstructed tires, a car was recently dropped from a platform, 18 in. high, onto a plank, holding the upturned points of a number of large nails and spikes. The tire struck these, bending them over without injury to itself. This specific casing had been recovered from a roadside where it had been abandoned with a hole in it as large as a brick, and the fabric badly cut and worn around the entire circumference.

**CURIOUS PLEASURE VEHICLE  
DESIGNED FOR CHILDREN**

Built entirely of metal in a light but apparently substantial form, a five-wheeled velocipede has been devised as a pastime vehicle for children. The fifth wheel, which is the driving member, is mounted in the

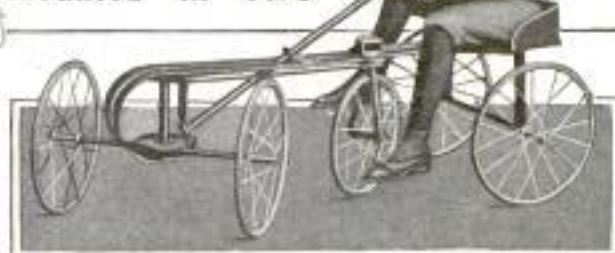

The Velocipede is Lightly and Substantially Built and may be Pedaled Easily by a Small Child

middle and supplied with foot pedals similar to those of a tricycle. A fixed-gear steering column, which allows the conveyance to be guided in the same manner as a motor car, is employed. It is easily operated and is capable of good speed.

**ODD ARCHITECTURAL DESIGN  
IN BUSINESS BUILDING**

Quite an odd effect has been attained in a bank building erected at Grinnell, Ia., in which the architect has striven to create an atmosphere of age. Except for two broad panel windows, set on either side of an elaborately carved stone entrance, which is sur-

mounted by a rose window, the front of the structure has no openings. The roof of the building is made almost

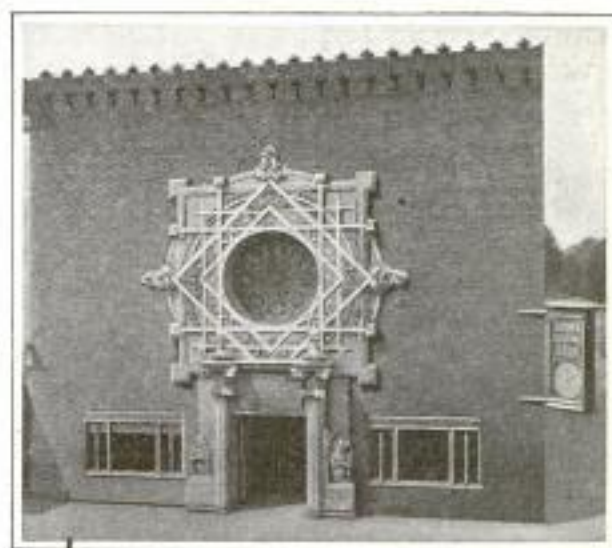

A Glass Roof Covers the Building, so That the Interior is Lighted Adequately

entirely of glass, so that the interior lighting is not impaired by a lack of apertures in this wall. Except for the parapet and the ornate decorative work about the rose window and entrance, the brick façade is perfectly plain. The inside is finished in natural brick and trimmed with oak.

**HIGH SMOKESTACK BUILT  
THROUGH HILL**

In erecting a tall smokestack at an Arizona smelter a simple method of construction was adopted. Adjacent

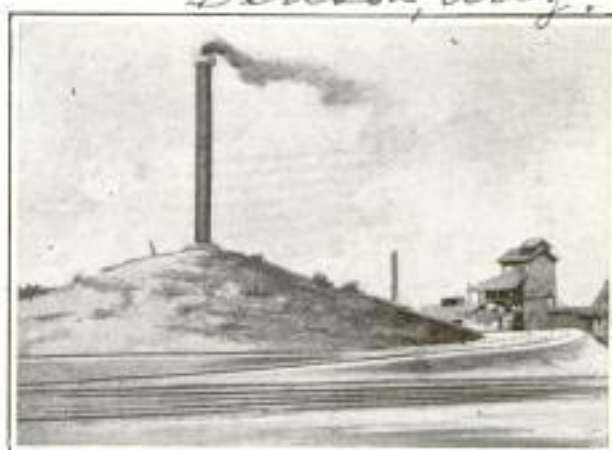

Tunnel Extends from the Smelter to the Middle of the Hill

to the plant is a small knoll. A tunnel was excavated to the middle of this

*Am. S. fabricke (inventor)  
2423 No Fairfax St  
Chgo. Ill. 1888*

*Date rec'd  
found*

*99574*

*# C. F. Stoddard  
Grinnell Ia.  
1-8-16 - 424 Stoddard St. G.I. N.W.  
Washington, D.C. (D)*

and a shaft sunk from the top of the hill to connect with it. This passage was then lined and a steel stack built at the summit. This provided a very substantial stack requiring little or no bracing and one with only two-thirds as much metal construction as would have been necessary had it been built on the level.

*34* **MOTOR-BUS SIDE FENDERS**  
**GUARD REAR WHEELS**

Longitudinal fenders designed to prevent pedestrians from being caught by the rear wheels have been installed on a large number of motor busses operating in New York City. The guards are made of wooden slats mounted at the sides of a car below the body, so as to span the greatest part of the distance between the front and rear wheels. At first sight the purpose of a fender of this character might not be apparent. The reason for it is that an analysis of the statistics covering motor-bus accidents in New York and

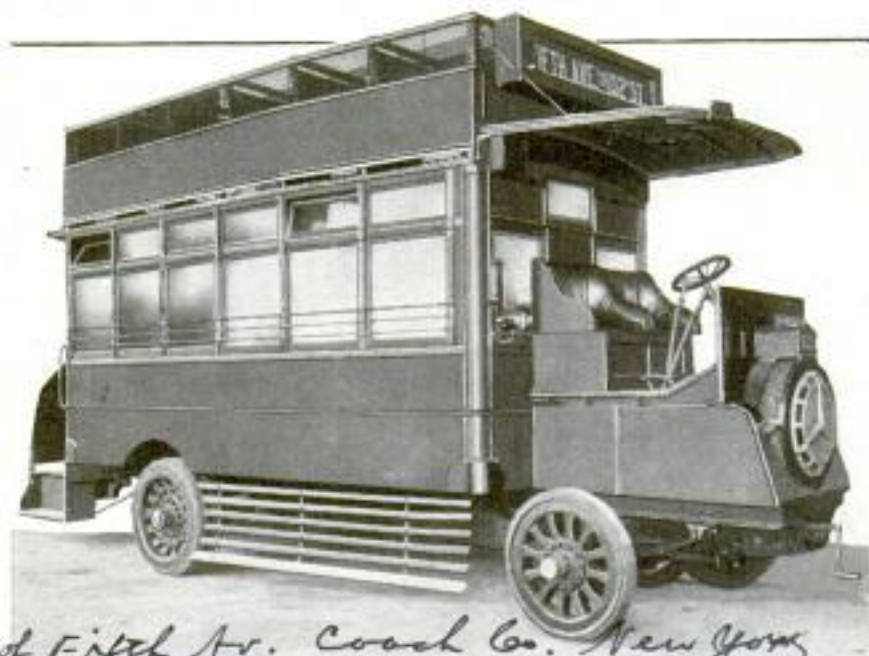

*Bus of Fifth Av. Coach Co., New York*  
Fenders of This Type have been Fitted to Motor Busses Operating in New York City to Prevent Pedestrians from Stepping in the Path of the Rear Wheels

London showed that in the majority of cases pedestrians heedlessly walked against the sides of the cars, with the result that their feet or legs were caught by the rear wheels.

*W 537* **HITCHING POSTS EQUIPPED WITH PUSH BUTTONS**

As a convenience for its customers, many of whom are farmers, a grocery company in Lexington, Ky., has equipped each of the iron hitching posts in front of its establishment with an electric push button. Before these push buttons were installed, country customers driving up to the establishment with nervous horses which they were afraid to leave, were sometimes compelled to wait a considerable time before attracting the attention of a salesman. All the buttons are on the same line, and when any one of them is pressed it sounds a buzzer which can be heard all over the store and which attracts immediate attention. Current is supplied by dry batteries.

*434* **VENTILATE FACTORY PLANT THROUGH COLUMNS**

In a new factory building recently constructed for a Baltimore company, the distributing ducts of the ventilating system have been placed in the hollow steel-concrete supporting columns. The operating units are installed in a penthouse on the top of the structure, and leading from this across the roof are the main supply pipes which carry air to the column ducts. Because of the double purpose they were to perform, the interior columns were not made after the usual pattern, but formed by placing two built channels together and concreting them. The hollow spaces thus provided permitted the installation of galvanized-iron pipes which were subsequently incased in concrete. The ducts decrease in circumference downwardly so that they are proportioned to the



volume of air they are expected to carry at the various vents, which are provided at each story. The taper form of the ducts also provides for the increasing of the concrete area as the load becomes greater.

**ODD SAWMILL OPERATED  
BY WIND POWER**

On the shore of San Francisco Bay there is a curious, homemade sawmill which is owned by an aged man who collects the driftwood tossed up by the surf, cuts it into stove lengths, and makes his livelihood by disposing of it. It is a wind plant and has been built by its owner solely from odds and ends salvaged from near-by dumps. It consists of an upright wooden frame supporting a medium-sized windmill wheel that may be adjusted to suit the various changes in the breeze and which operates the blade of an old bucksaw mounted in a vertical position. The wind blows almost constantly from across the bay and furnishes enough power to keep the little plant working.



The Wind Sweeps In from the Bay, Providing Plenty of Power to Operate the Crude Sawmill

**MAN MAROONED ON CHIMNEY  
SAVES SELF IN ODD WAY**

While four workmen were engaged in making repairs at the top of a 125-ft. brick chimney adjacent to a power



Marooned at the Top of This Chimney, a Workman Saved Himself by Removing the Bricks and Cutting His Way Ten Feet to the Iron Ladder

plant, an accident occurred which tore away the staging on which they were standing and precipitated three of them into the shaft. By very quick action one of the men managed to obtain a grip on the top bricks of the stack and draw himself on the wall, which he then straddled. The fire department was called upon to rescue him from his perilous position, but it was without a ladder which would reach to the required height. About eight feet below the top of the stack was the first step of an iron ladder which extended down the chimney. Seeing the rescue party fail in its attempts to save him, the marooned man commenced to remove the bricks from the chimney and cut a hole down the wall to this ladder. When he reached the first step he found that it was so loosely set in the bricks that it would not bear his weight, so he worked downward to the second one.

*Chelsea, Naval Hospital*

*Man employed by  
New River Construction Co. (?)  
(?) Maine Chimney Co. 30 Church Street*

# A. F. Waiiac, 1114 E. 19th St.  
So. Oakland, Cal.

430 **MOTOR-DRIVEN CHURN BUILT  
AS FARM CREAMERY PLANT**

For farm and dairy purposes a small, power-propelled churn has been introduced which is a complete butter-mak-

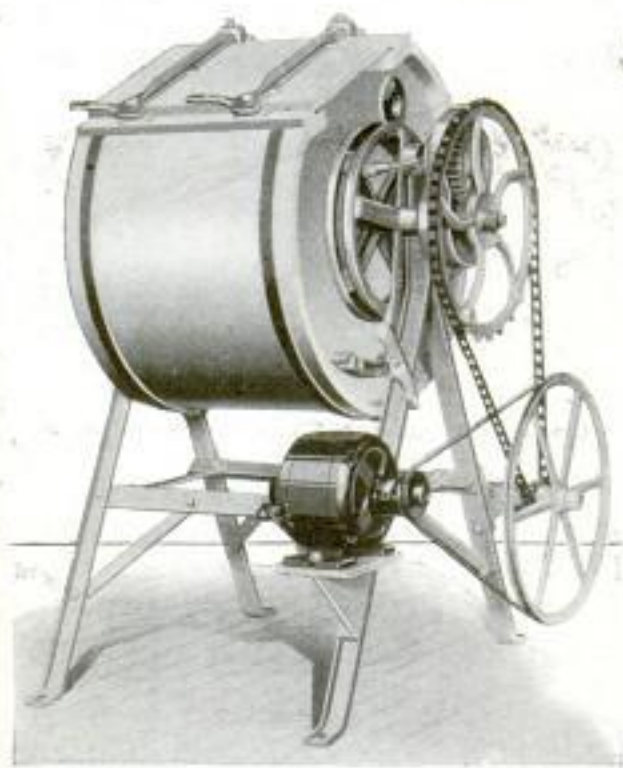

The Machine may be Operated Either by a Gasoline Engine or an Electric Motor

ing plant in itself. It is intended to provide the average farmer with an efficient, quick, and economical facility for manufacturing butter on a small scale without the time consumption and hard labor which attended the old hand methods of churning. In this instance the cream is poured into the machine and the motor started. The rest of the operation is mechanical. The cream is ripened and churned into butter, the latter worked, the proper amounts of moisture and salt incorporated in it, and the process completed in less than a half hour. When the churning operation is ended the milk is drained through a strainer, which retains the butter fat. The motor is then changed into low gear, starting the rollers. These are contained in a basket arrangement inside of the barrel and may be adjusted to handle different amounts of butter.

When the work is finished the product lies in a collected mass in the basket, from which it may be readily removed and packed.

378 **HEAT REGULATOR DESIGNED  
FOR STEAM RADIATORS**

By the invention of an adjustable thermostatic controller which is intended to be attached to a steam or hot-water radiator, a simple means of maintaining a room at a nearly constant temperature has been devised. The plan of the instrument is such as to make it possible to keep separate rooms in a house at different temperatures when illness or other conditions make this desirable. The device is only a few inches in height and is not objectionable in appearance. The thermostat consists of two corrugated silver disks which are hermetically joined. The hollow space provided between these drums is filled with a gas, the expansion and contraction of which turns on and off the steam when the heat in a room drops below or rises

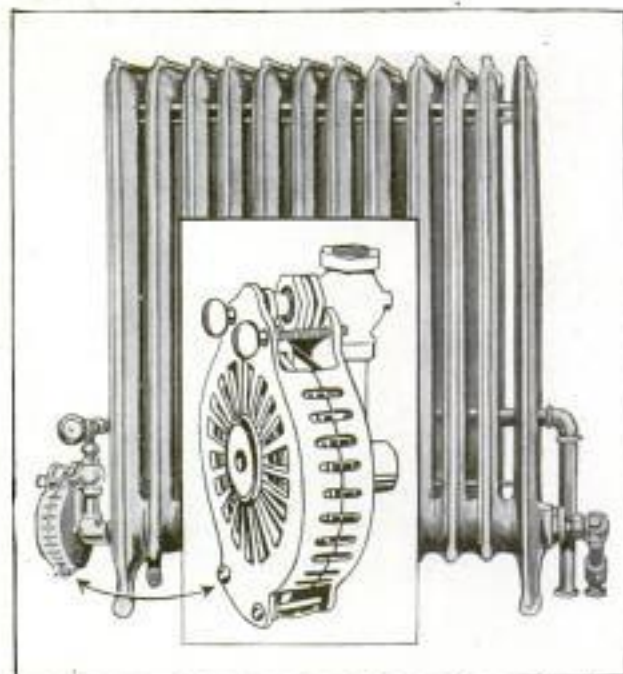

By Installing a Controller on Each Radiator, Various Rooms may be Kept at Different Temperatures

above predetermined points. A shield is provided which protects the thermostat against the effect of heat given off from the radiator.

346H

PREPARING BUSH CHRYSANTHEMUMS FOR EXHIBITION

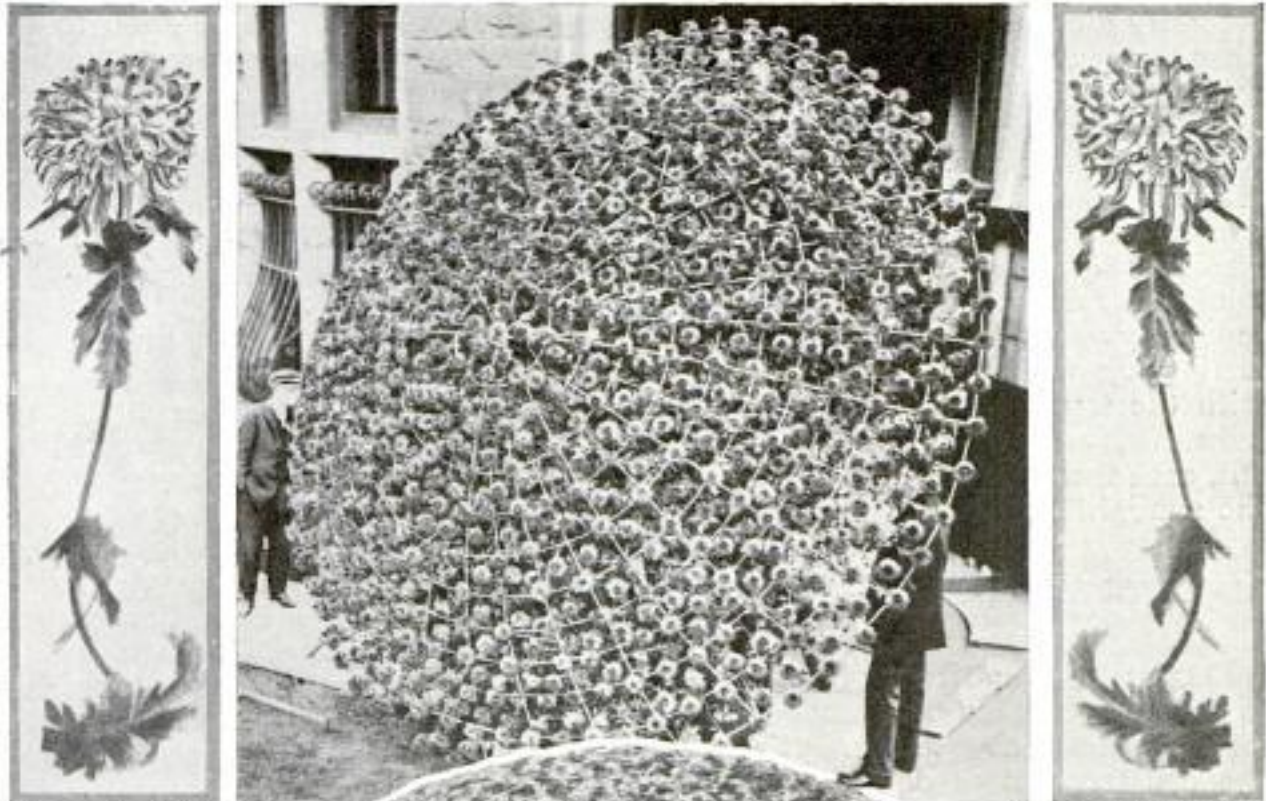

Above: One of the Largest Bush Chrysanthemums Grown in This Country

The Moving of One of These Big Plants Presents a Real Problem



never fail to win unstinted admiration. These extravagant specimens of skillful plant culture are sometimes more than 14 ft. in diameter and present as many as 1,400 blossoms. Weeks of care and daily work are required for their training and final preparation for exhibition. In doing this one of the most successful growers selects three of the most uniform plants available and places them in a 24-in. tub, in which the soil has been fertilized and specially prepared. A wooden stake is driven into the center of the pot and

cut off about four feet above the soil. Four round iron rods approximately 10 ft. in length, their centers crossed, are then laid

over the tub and their ends fastened to the rim. A ring of heavy wire is subsequently made to encircle the frame formed by the bars. This forms the foundation for the elaborate framework which is gradually built up to support the myriad of blooms. As the work goes on, the plants are taken down all around and the longest growths tied evenly to the wiring on all sides. The short stems are held up toward the center by cords attached to the middle stake. As these latter growths develop they are tied down, the frame

*Grown by John Canning, Ardsley, N.Y.*

*Florist's Review 7/15/15 p 9  
Variety not stated*

being expanded in circumference by the addition of encircling wires as necessity dictates, as well as closed toward the center. The ribs of the frame consist of pieces of heavy wire passed from one edge of the circle to the other, resting on the stake, to which they are secured. Longitudinal wires of smaller size are fastened to these supporting members, eventually giving the frame the form of a hemisphere, which is subsequently painted a foliage green. The final tying is done in the bud stage with the tops 2 in. above the wiring. When this is done and the flowers open out, each turns its head upward toward the sunlight.

### ADJUSTABLE CONCRETE MOLD FOR SEWER WORK

Designed so that it may be expanded to various sizes, or collapsed, a metal form has been invented for facilitating the construction of concrete culverts and sewage mains. It is made in cylindrical form, is about 10 feet in length, and may be readily adjusted to any diameter between 18 and 60 in. The drum is made of a lapped piece of sheet metal held in shape by a series of arms that may be extended or contracted by revolving a crank provided at one end of the device. When the form is to be used it is set at a certain diameter and the concrete then poured about it. When the latter has had adequate time to set, the diameter of the drum is decreased and the form

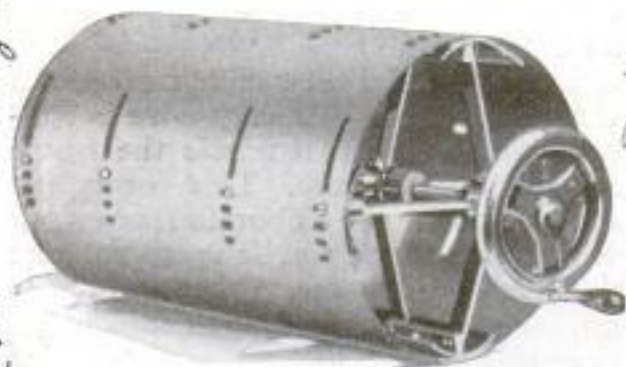

The Cylinder may be Expanded to Various Sizes  
by Operating the Crank at the Right

withdrawn. A conduit of any length may be constructed by building it segment by segment, each time leaving

just enough of the cylinder in the mouth of the previously laid section to provide for a joint. In addition to its convenience, the device saves the time of wood-form construction.

### CIRCULATING ART EXHIBIT IS EDUCATIONAL IDEA

In the hope of raising existing standards and stimulating a deeper appreciation of art within their state, the club women of Wisconsin are promoting a noteworthy educational scheme. By applying the plan of the circulating library and university extension course to an exhibit of paintings, they are making it possible for every community in the commonwealth to enjoy the collection, which is composed of some 75 paintings representing the work of about 40 native artists. For the reasonable fee of \$5, plus transportation charges, any individual or municipality may procure the paintings and display them for one week. As is true in every state, there are many villages in Wisconsin which hold groups of individuals who have never been afforded an opportunity to see original canvases of merit, and it is this class of people that the women particularly desire to reach. The idea also furnishes a means of helping state artists by making their works known and enlarging their coterie of admirers. Approximately 35 cities and towns have already applied for the loan of the exhibit.

### COMBINATION BOAT IS MADE FOR ICE AND WATER USE

In order to navigate Lake Pend Oreille during the winter months when its upper part is frozen and the southern half open, an Idaho boat builder has constructed a craft which is designed for both water and ice. It is driven by an aerial propeller and is capable of gliding rapidly over smooth ice, taking to open water at full speed and then running back onto the ice when making the return trip to the northern part of the lake. The

Inventor: J. W. Chambers, Mich.  
 (Not on Mer yet - Jan 26-15)

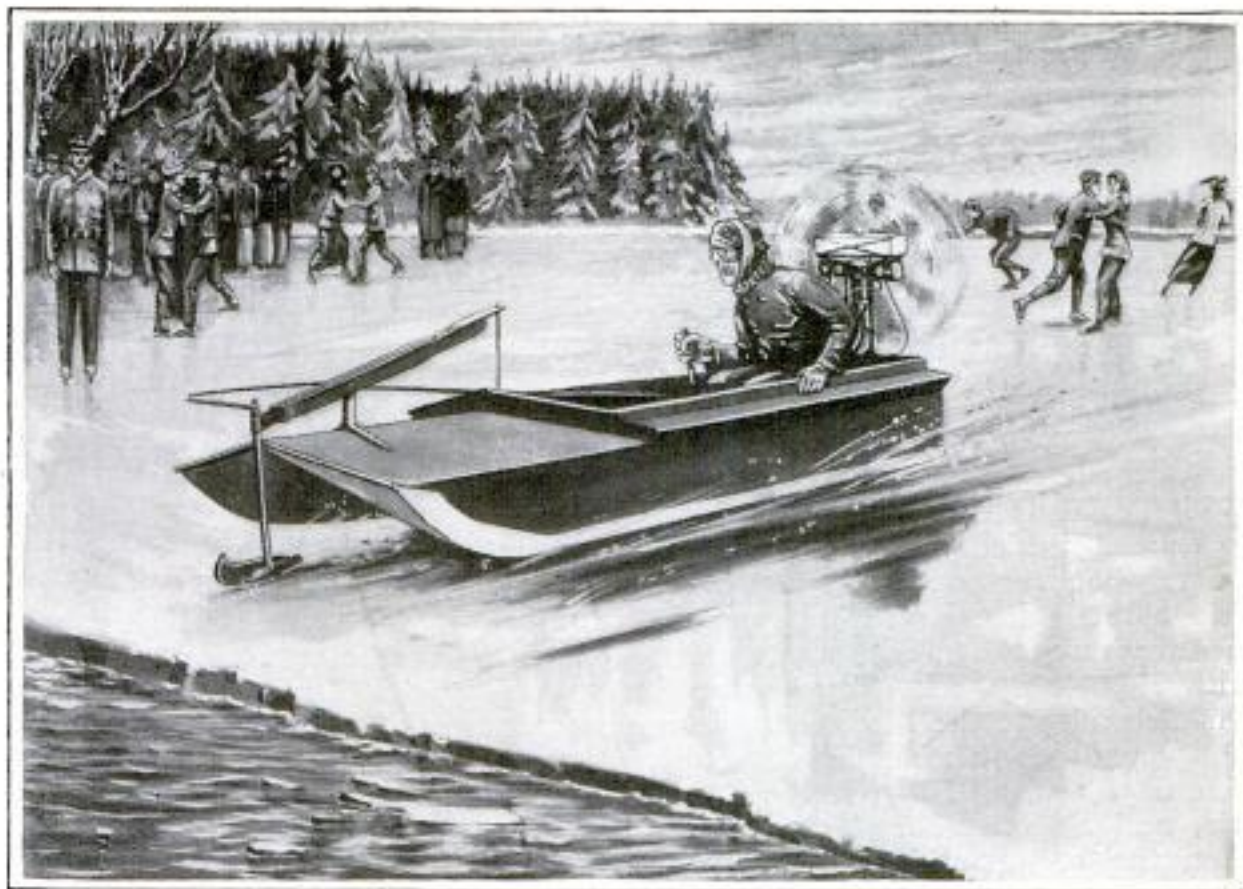

Peculiar Craft Adapted to Navigate over Both Water and Ice, Built for Use on Lake Pend Oreille during the Winter Months

boat is 14 ft. in length and approximately 4 ft. wide. Its bottom is shaped like an inverted V, quite similar to that of the average hydroplane, which allows it to ride high in the water. At its stern are two skatelike runners and at the bow a single one to which a control lever is attached for guiding the craft when it is used as an ice boat.

**NEW FORM OF COPY HOLDER**

114 H **FOR TYPEWRITER**

Several convenient features are incorporated in a copy holder which has been introduced as a typewriter attachment. It is designed to be mounted securely at the back of a machine and consists essentially of a substantial frame that supports a platen and gauge. A key, which when struck spaces the roller, is fixed to a lever that extends along the right side of the machine. Copy of any character may be placed in the device, which obviously is in front of the operator. This is one of

the especially convenient points, for the copy is thus supported in the logical place, in the line of direct vision, so that the strain of keeping the neck craned to one side hour in and hour out, as is usually necessary, is eliminated. Another feature is that the device makes it nearly impossible to miss a



The Copy is Held Directly in Front of the Typist

line when transcribing and, furthermore, does not make it necessary for a typist to look twice to locate his place.

*M. A. Leach (M. M. Leach) Monarch Building, 124 N. Van St. S. F. Cal.*

*Grove Sales Corporation,  
 M. A. Leach, Pres. 243 Monarch Building,  
 Eric S. Scudder, Sec. San Francisco.*

# FOUR YEARS *in the* NAVY-



## PART III THE REWARDS OF NAVAL TRAINING

BY LOUIS E. BROWNE

**T**RAVEL is an advantage of the naval service. The Navy Department, whenever possible, sends every ship abroad once a year to give the men from five to ten days' shore leave, with about six weeks' pay to spend. On the cruise to the Mediterranean in 1913 hundreds of bluejackets spent nine days touring Italy, France, Austria, and Switzerland. The Atlantic fleet, the organization of all of the active battleships of the United States, spends the winter at Guantanamo, Cuba; Colon, Panama; and Pensacola, Florida. In April it comes north for target practice off the Chesapeake capes and battle maneuvers off Newport, Rhode Island.

In port, when practicable, one-half of the crew may go ashore after three o'clock in the afternoon to return aboard before eight the next morning. Forty-eight and 72-hour furloughs are granted frequently. Ships are usually in their home ports at Thanksgiving and Christmas. Ten days' leave is granted during the latter holidays. Civilian clothing is forbidden, but when ships are in port for any length of time, many men rent rooms and keep "cits" in them, which they wear during shore leave.

There are fully equipped sick quarters, operating rooms, and a corps of surgeons and nurses on each warship. Men report at 8:30 and 5:00 (sick call) for treatment. Every ship has a government savings bank. The sailor has a pass book and is allowed four per cent interest on money deposited. On request, a portion of the sailor's pay will

be sent home or to a private bank by the paymaster-general through the navy allotment office on shore. The canteen supplies the bluejacket with tobacco, sweetmeats, toilet articles, souvenirs, etc. Divine service is held on Sunday mornings when the weather permits. The chaplain conducts the service of the church of which he is a member. Attendance is not compulsory. The Naval Y. M. C. A. has buildings at all of the navy yards and naval stations and frequent meetings are held in the crew's space on shipboard.

Officers have living quarters (the wardroom) in the extreme bow of the dreadnaughts and far aft in the old ships. The bluejacket is not permitted to loiter on the deck above the wardroom; likewise officers are supposed to keep out of the men's part of the ship. Men must salute commissioned officers on shore but not on shipboard unless they wish to address them, when remarks must be prefaced by "sir." Chief petty officers have quarters and a mess of their own, but are entitled to neither a salute nor a "sir." At sea regulations are relaxed.

In bad weather hatches are battened down and the air below decks gets unbearably foul, but officers and men must endure it for days at a time. All bluejackets wish to be members of a boat's crew, for at sea they may sleep in their boats; which insures plenty of fresh air and eliminates the bother of lashing and swinging hammocks. Rough weather endangers the boats, and then the men are ordered below.

Naval discipline is rigid. The captain is judge and jury; his court is called "mast." Desertion, disobedience, overstaying leave, and the use of intoxicants are the most numerous service offenses. Misdemeanors, such as smoking out of hours, wearing dirty clothes, or out of uniform, are disposed of with loss of liberty, extra duty, and a warning. Constant offenders are punished by confinement in the brig—a ship's cell—on bread and water for a week or more, with full rations once every third day. More serious offenses, such as desertion, theft, insolence, and assault, mean a court martial which can sentence the offender to prison; to the disciplinary barracks;

deprive him of rank and several months' pay; or give him a "kick out"—that is, a dishonorable discharge from the service.

The disciplinary barracks are at Port Royal, S. C., and Puget Sound, Wash. They aim to take old offenders and, through many months at hard labor, never-ending drills, no liberty, and no pay, turn them back into the service wiser men who have had a taste of prison life, without the stigma attached to a prison sentence. Men discharged from the barracks rarely again give trouble. Many of them reenlist. Conviction after a term in the disciplinary barracks for a serious offense, means a prison sentence. During the past

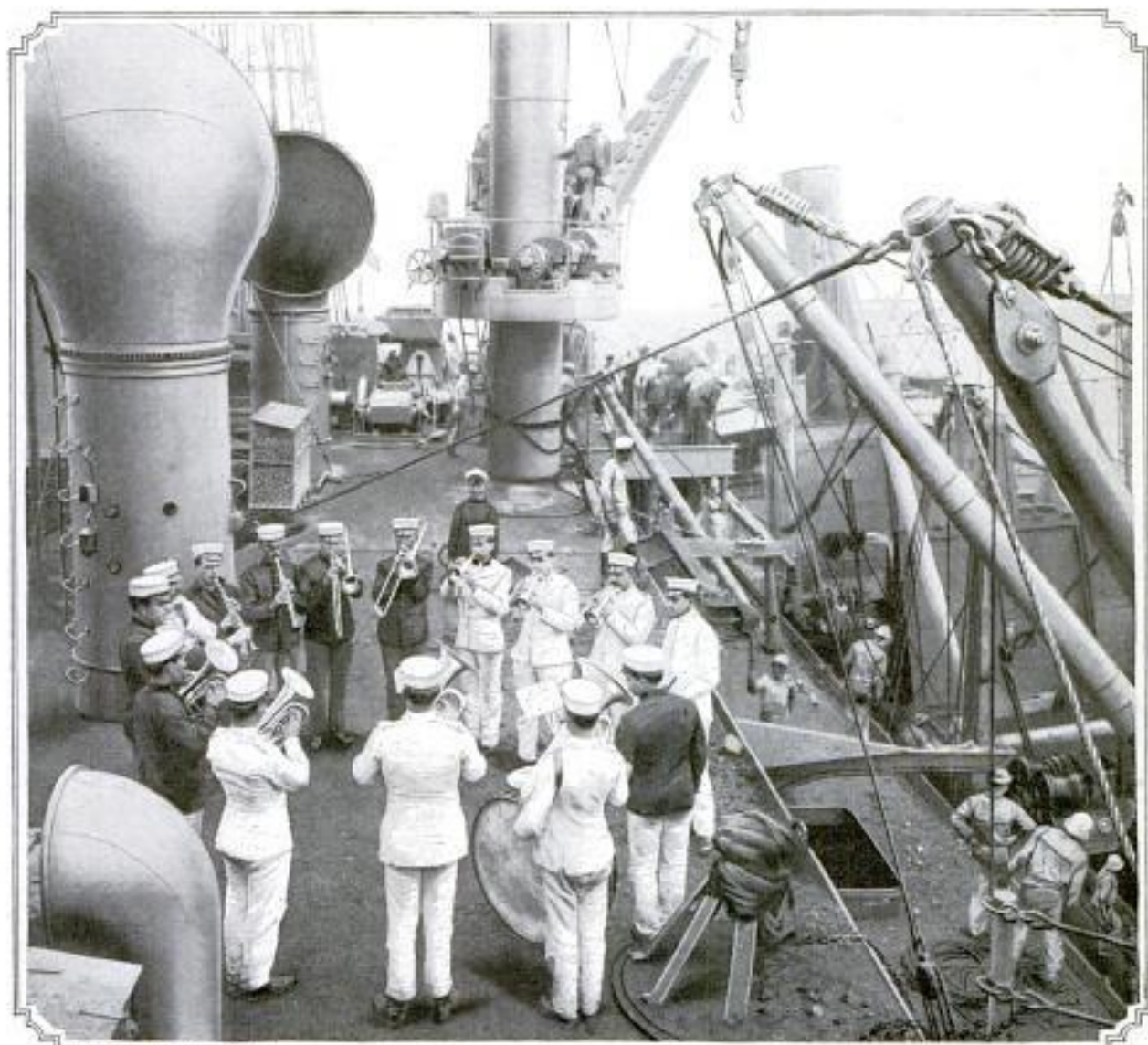

PHOTO COPYRIGHT BY E. MULLER

Coaling Ship Is a Strenuous Proceeding, But is Made a Sort of Gala Occasion by the Bluejackets. It Is Customary in the Navy to Accompany This Work with a Band Concert

year the plan of substituting disciplinary ships for disciplinary barracks has been tried, and it is likely that this arrangement will be made permanent as a means for disciplining and reforming the men, especially the younger bluejackets, whose offenses have not been of a serious nature. The "Topeka," stationed at the Portsmouth, N. H., Navy Yard, is now being used for this purpose. The men sentenced to this ship are known as detentioners. They are subjected to constant drill and instruction, but not to hard labor, or other prison conditions.

"Short-timers" are detached from the fleet and sent to destroyers, submarines, and cruisers to complete their enlistment. Life on these craft is vastly different from that of a battleship. Discipline is much more free; the men sleep in bunks; the quarters are extremely cramped; and it is nearly impossible for men to keep their uniforms clean. Duty on submarines means increased hours, but also increased pay. During the last year of enlistment a bluejacket is often given short duty if he signifies intention of reënlisting. Second-enlistment men are often ordered to the Philippines, Hawaiian Islands, or the China coast. These billets are widely sought. Duty in the Canal Zone and on gunboats doing tropical duty is not attractive to the bluejacket.

A chief petty officer who has been in the service seven years may obtain warrant rank if he passes the required examination. This grade pays from \$1,500 to \$2,400 a year. Any bright man, who will study, can reach this grade. From warrant officer the enlisted man may be promoted through the various ranks of commissioned officers—but these promotions are rare. Unless a man becomes a petty officer before the expiration of his first enlistment, he is advised to remain in civil life. Out of 51,000 men in the service, 16,000 are petty officers.

Promotion is made easy for the deserving man. When a bluejacket completes his first enlistment he is given four months in which to reënlist, with

continuous pay. A reënlisted petty officer, under thirty years of age, with a good conduct record, may attend the Seaman Gunners' Schools, at Washington, D. C., or Newport, R. I.; or the Machinists' School, at Charleston, S. C., if he passes the examination. The courses are six months long. At the former schools the sailor learns to assemble guns and breech mechanism; the manufacture of shells and powder; the construction of storage batteries; deep-sea diving; he takes a course in metallography. In Washington the bluejacket works several hours a day in the great naval-gun factory; in Newport he learns all about torpedoes and mines; at Charleston he has instruction in bench work; working with machine tools, marine engines, etc. Besides technical subjects, many hours a week are spent in the class rooms with academic subjects. The routine is rigid. Reveille is at 5 A. M., and during the day, except on Wednesday and Saturday, there is a two-hour infantry and field-artillery drill. These schools put the man in line for promotion.

After 20 years' service, a sailor physically disqualified may retire on one-half pay; after 30 years' service, he may voluntarily retire on three-quarters pay, plus \$15.75 in lieu of rations, clothing, and quarters. Service in the army and marine corps is counted; war service counts double time.

A "big ticket" is an honorable discharge at the end of an enlistment with a recommendation for reënlistment; a "small ticket" is a discharge without the recommendation, or a bad-conduct discharge; and a "kick-out" is a discharge for the "good of the service." In the last case the man is brought to the quarter-deck, and his hatband and the white stripes from the blouse of the uniform are ripped off by a master-at-arms in the presence of the officer of the deck.

Upon the death of an enlisted man, from wounds or disease incurred in the line of duty, an amount equal to six months' pay is forwarded to his widow, or other previously designated beneficiary.



## FOREIGN TRAVEL A FEATURE OF LIFE IN NAVY

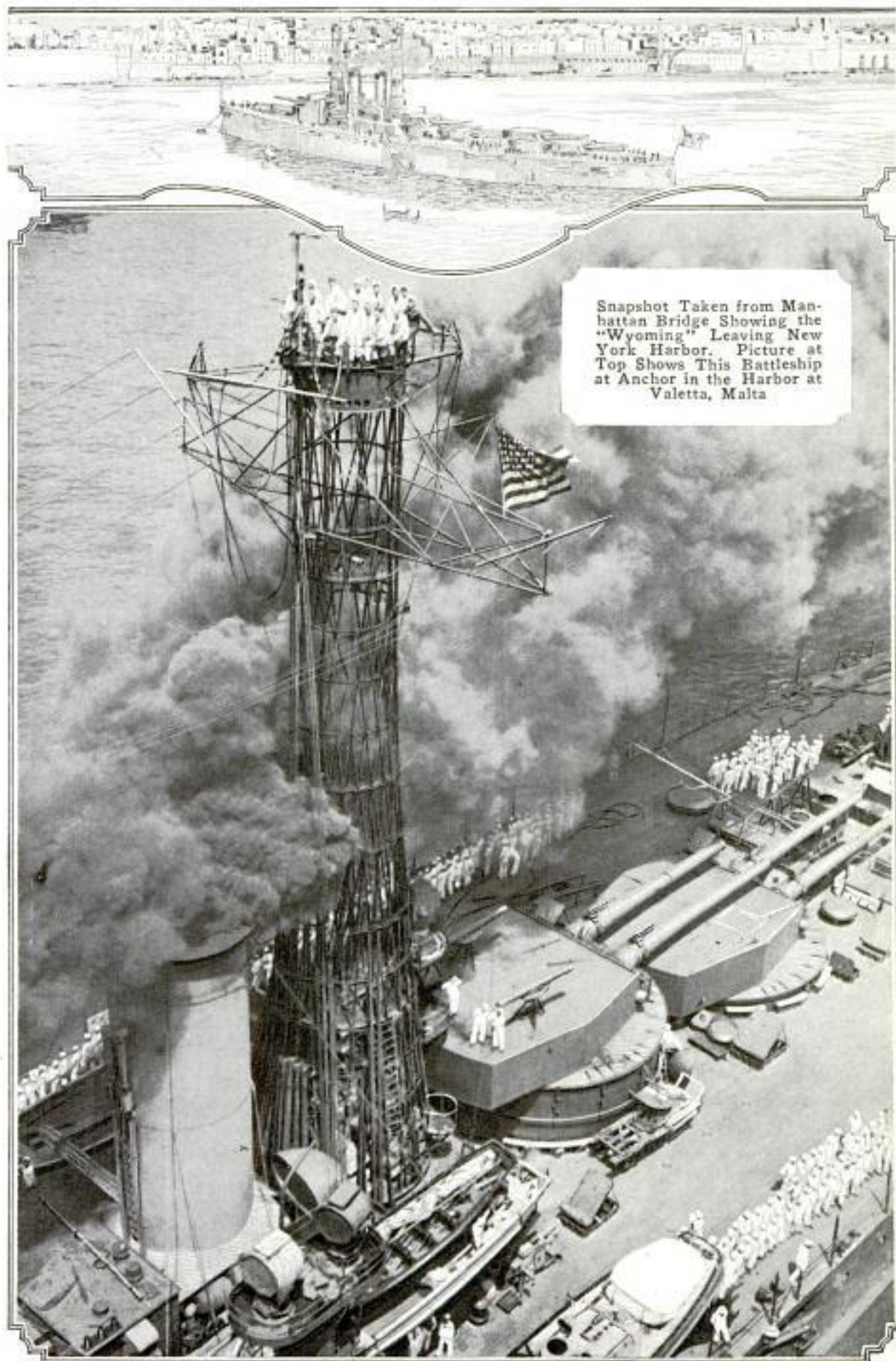

# ONE OF THE REWARDS OF THE SERVICE IS THE



## OPPORTUNITY FOR ACQUIRING A USEFUL TRADE



Some of the Trades Fit the Men for Profitable Employment in Civil Life, While Others Lead Only to Promotion in the Naval Service. This Picture Shows an Award of \$20, \$10, and \$5 Gold Pieces to Gunners of the "Georgia," for Excellence in Target Practice

COPYRIGHT, INTERNATIONAL NEWS SERVICE



WINTER-LANDSCAPE ARTIST HAS PORTABLE STUDIO

A Minnesota artist who devotes much attention to winter landscapes in the North, has devised a portable studio

which enables him to carry on his work during very severe weather. The outfit consists of a miner's tent which is provided with a large window in one side and a wooden flooring to which the ends of the canvas are secured. This small shelter, which affords only enough room for an easel and chair, in addition to a small oil stove and provision bag, is sometimes packed on a sled and at other times rolled into a bundle which he straps to his back in much the same manner as a haversack. With this and his snowshoes, or skis, when they are necessary, he starts out for his day's work.



The Tent Studio Ready for Use by the Artist

NEW METHOD OF PROVIDING AIR CUSHION FOR BOAT

A novel feature in boat construction, just invented and patented by a Canadian, consists of air passages so placed that air is drawn from inside the boat and discharged below the water line along the sides of the hull and at the stern, the purpose being to do away with skin friction and with suction at the stern. The passages along the sides consist of pipes leading downward and backward from the cockpit and cabin. Each of these pipes is fitted with a valve which is closed when the boat is at rest and is opened by the suction of the water and the air pressure when the boat is in motion. The stern is fitted with a set

of rectangular conduits which extend vertically downward from the deck to the lower part of the hull, where each makes a right-angle turn sternward. Through openings well above water level, air is drawn into the con-

1,005,698-Oct 10 '11 - filed April 1 '10 - Serial 552920

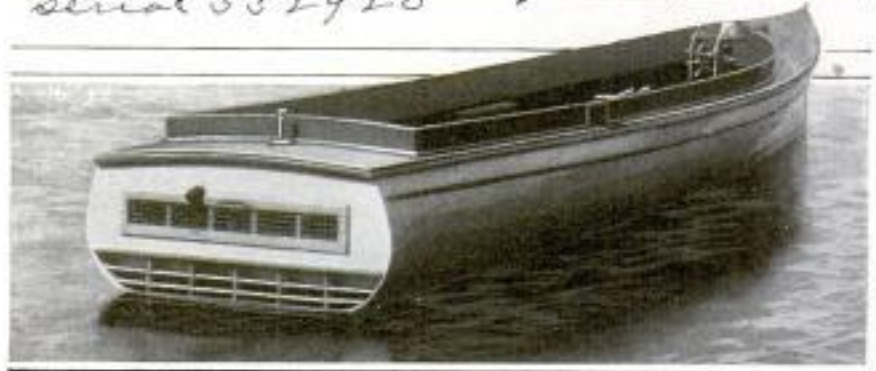

Boat Arranged for Discharging Air under the Sides and from the Stern

duits and is discharged below the water line, the idea being to overcome suction by preventing the water from being drawn in behind the boat, and thus avoid the drag caused by suction.

Arthur Allie  
191  
St. Paul, Minn.

Inventor: Francis Dillon, Dillon Port, Or  
address on his letter:  
Parry Harbor, Dist. of Parry Sound, Ont.

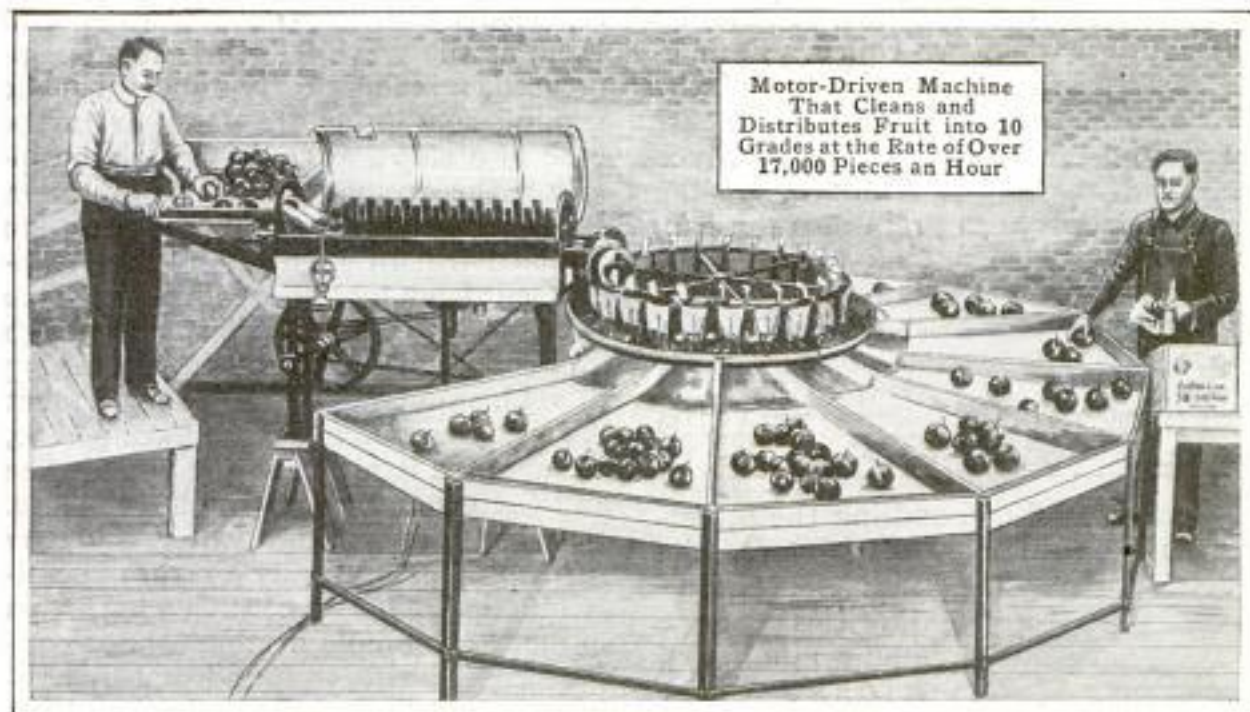

9560m **MACHINE FOR CLEANING AND GRADING FRUIT**

A motor-driven machine for cleaning and grading fruit, that has just been brought out in Oregon, is capable of handling apples, peaches, pears, oranges, and lemons, and of distributing them into 10 grades at the rate of over 17,000 pieces an hour. The fruit is first fed into the cleaner where it is thoroughly cleaned by revolving brushes made of hog bristles, and from this machine it passes automatically to the grader. The grader is built in circular form and occupies a space about 13 feet in diameter, the outer part consisting of a sloping table which is divided radially into bins for receiving the different sizes of fruit as it is graded. The center of the machine is occupied by a revolving plate on which are 24 cups, each of which, as it passes under the discharge apron of the cleaner, receives one piece of the fruit. At the point where the fruit is received the cup is practically closed at the bottom. The opening at the bottom of the cup is controlled by two cam rails in such a way that it gradually widens as the cup swings round the circle, and at a point over the proper bin this opening becomes large enough to al-

low the fruit to drop. The cups and other parts of the machine with which the fruit comes in contact are lined with felt so that there is no danger that the fruit will be bruised during either the cleaning or grading process. The machine is intended to be driven by an electric motor or a gasoline engine.

9543 **PORTABLE BARREL DRAINER OF CONVENIENT FORM**

To make easier the work of draining oil barrels, a special apparatus has been brought out which facilitates the handling of large casks and tends to eliminate waste. The drain is constructed of galvanized steel and is



The Drain Pan Fits in a Frame and may be Removed Readily if Desired

fitted in an iron frame which is mounted on casters. Extending to the front

Wayne Oil Tank & Pump Co.  
Fort Wayne, Ind.  
Copyrighted material

of this is a notched incline, or skid, up which the barrels are rolled. Four 6-in. casters attached at the top of the frame form a bed for a barrel to rest upon and enable it to be revolved easily. The bung is removed and the contents allowed to drain into the pan, which feeds into a tank beneath. A curved apron at the back prevents splashing.

### STREET KIOSKS ARE LEASED BY CITY OF BALTIMORE

As a method of handling the street-vending question at Baltimore, the



municipal authorities have had a number of kiosks constructed at the intersections of different business thoroughfares and have rented them to the highest bidders. These little booths, which are not much larger than the ticket offices of small motion-

picture theaters, are set near the curb lines on the sidewalks. They are used as newspaper, candy, tobacco, and fruit stands. Two of them were opened July 1. One of these, erected at the corner of Holliday and Baltimore streets, was rented for \$35 a month. The structures are neatly and substantially built.

### GROUND RESISTANCE IN WIRELESS ANTENNA

Ground resistance in the antenna is one of the vagaries of wireless operation for which no satisfactory explanation has yet been found. The total resistance, which includes the ohmic resistance of the wires, the radiation resistance, and the ground resistance, falls rapidly as a short wave length is

replaced by longer wave lengths, and then, as the wave length is further increased, remains nearly constant if the ground conditions are good, as in the case of a ship's antenna, but rises rapidly if the ground conditions are poor. In one case this resistance more than doubled when the wave length was increased from about one-half mile to one and one-fourth miles. Although great difficulty is found in explaining this phenomenon, it is believed that the antenna system acts as a condenser, the antenna itself being the upper plate and the ground water the lower plate. Between the ground water and the surface there is usually a layer of semi-conducting material of such a nature as to make the whole system a poor condenser. It has been found that by covering the ground under and around the antenna with a wire net, thus making the wire net the lower plate of the condenser, the ground losses nearly disappear.

### BORING ATTACHMENT FOR MORTISING MACHINE

An arrangement for using a chisel-boring device with a foot-power mortising machine has recently been invented and patented. The device used is the ordinary hollow chisel bit. It is driven by a 1/4-hp. electric motor that makes 2,600 revolutions a minute.



In the latest annual report of the Sanitary District of Chicago an expenditure of nearly \$5,000,000 for bridges is reported, this expenditure covering 13 bridges over the Chicago River and 15 bridges over the main drainage canal.

*Journal of Franklin Institute*  
Sept 1915  
from U. S. Bureau of Standards  
Inventor: Fred Brackett  
Lancaster, Wis.  
(are made by W. F. Johnson  
Warren Co. Copyrighted material)

# Walter B. Ward, 1300 American Bldg. Baltimore, Md.

3707

2087

*order*

533

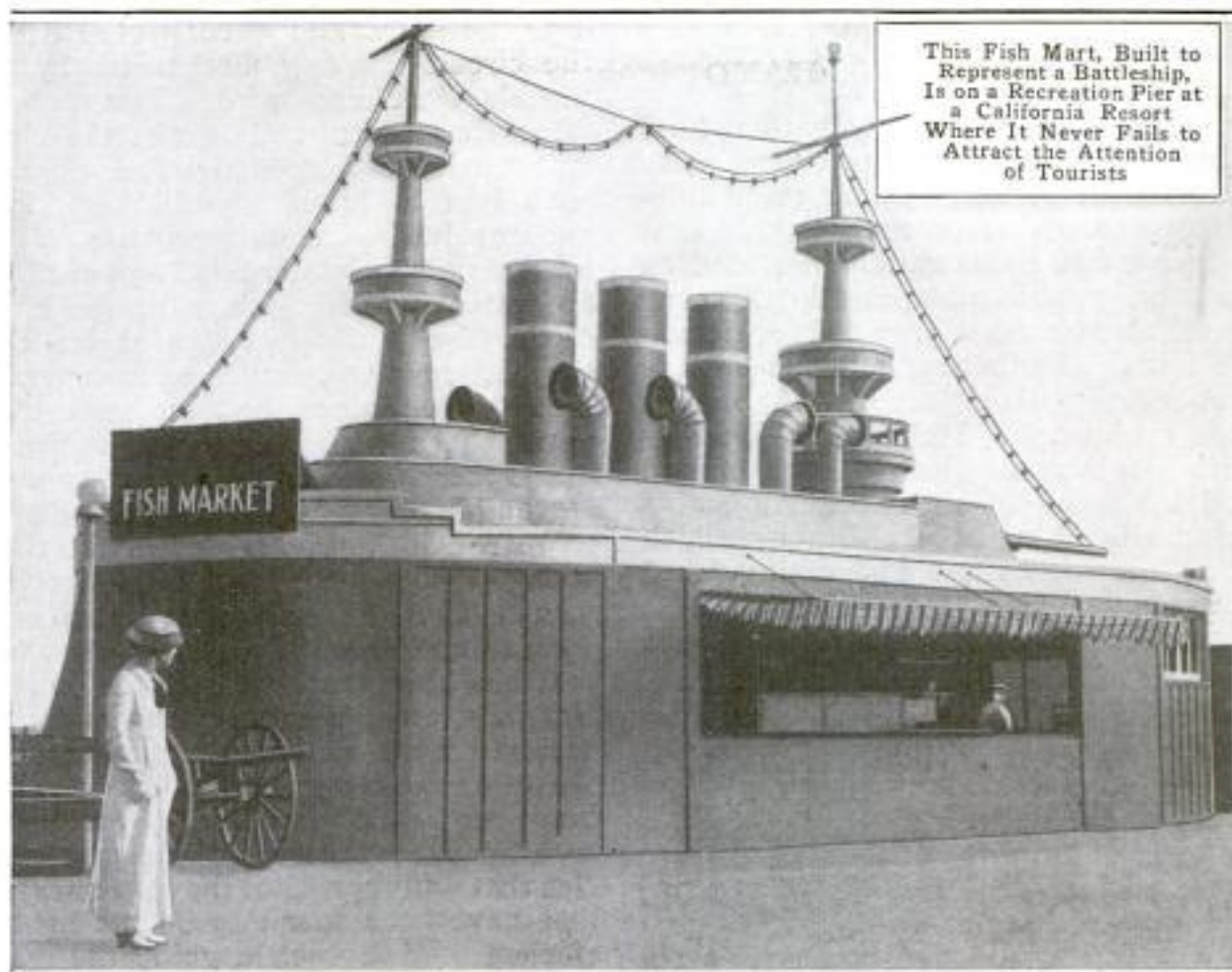

This Fish Mart, Built to Represent a Battleship, Is on a Recreation Pier at a California Resort Where It Never Fails to Attract the Attention of Tourists

### SHIPLIKE BUILDING USED

#### 9966 H AS FISH MARKET

On the principal recreation pier at Venice, an ocean resort in California, is a curious fish market roughly built to represent a battleship. It is fitted with fighting tops, funnels, and ventilators, and at the bow and stern mounts long, realistic-looking rifles. On the promenade side is a shaded opening, across which a counter is extended, while on the ocean front are portholes which furnish sunlight for the interior during the daytime. Instead of being decked with flags, the "boat" is decorated with a string of colored electric lights which identify it from both the water and pier sides when illuminated at night.

☛Firing a set of blasts simultaneously is estimated to be about 25 per cent more effective in breaking rock than firing the blasts one at a time.

### INSTRUMENT FOR CLEANING

#### 290 H <sup>Spectacles</sup> EYEGGLASS LENSES

For cleaning eyeglasses easily and quickly, a convenient device has been perfected. It is a folding instrument that is provided with two tweezerlike blades which mount disk-shaped chamois buffers at the ends. A lens is slipped between these two members, which are pressed firmly against both sides of a glass by a slight pressure of the thumb and forefinger, and readily freed from oil and dirt. The prongs fold into a receiving space, provided in the handle of the instrument, much the same as a blade folds into the handle of a penknife.



Inventor:  
Joseph T. Leonard,  
St. Joseph, Mo.

### RECORDING THE MOVEMENTS OF A WORKMAN'S HAND

9559  
m  
With a new apparatus that has been developed by an efficiency expert every movement of the hand as it manipulates a machine or tool, or performs other work, is accurately recorded on a photographic plate, and in this way a reliable means is provided for detecting and eliminating all unnecessary motions. This apparatus is known as the cyclegraph. Its essential features are a miniature electric lamp carried on the hand of the workman and a circuit-breaking mechanism by which this lamp is lighted and extinguished at regular intervals. The lamp is mounted on a ring which is slipped



over the finger and is connected with the circuit-breaking mechanism by a flexible, insulated wire. The apparatus that makes and breaks the circuit consists of a wooden disk equipped with half a dozen dry-cell batteries and revolved at a uniform rate by a motor, which is started and stopped by an ordinary switch. Crossing the face of the disk is a copper strip which, as the disk revolves, serves to make and break the circuit of the lamp, with the result that a series of flashes are produced that are recorded as short dashes on the photographic plate. Each dash represents an interval of time, and the string of dashes the trail of the workman's hand. Usually the resulting record looks much like a skein of yarn that has been dropped from the hand. Not only can unnecessary motions be detected by this method, but the inventor is convinced that work of any kind can be standardized by making, with the aid of such records, a wire device that will reproduce the movements that have been found to be the most efficient. With such a guide the apprentice workman would learn the proper motions, not by instruction from another workman, but by following the movements indicated by the wire.

### PICKING MEN FOR RANGERS OF GOVERNMENT FORESTS

9938  
X  
One of the several accomplishments an applicant for a position as government forest ranger must possess before he can enter the service is an understanding of how to pack a horse. Un-



Record Made by the Cyclegraph: The Tangled String of Dashes Shows the Trail of the Workman's Hand as He Manipulates the Machine





One must Know How to Pack a Horse Correctly Before He can Pass the Civil-Service Examinations of a Forest Ranger

less he can throw a squaw hitch over a pack, balanced so that it won't injure the animal bearing it, or can execute the diamond hitch, his preliminary training is too limited to allow him to pass successfully the examinations. Civil-service tests for forest rangers include many such pioneering tricks as these, and unless a man can assemble a bed, a week's provisions, and various tools, needed for fighting fires and doing other work in the forests, on a horse rightly, his other capabilities are of little help. There are some 2,500 men in the service who know the timber-cutting and grazing regulations, who are hunters of predatory animals, capable fire fighters, woodsmen fundamentally, and of good character.

be packed compactly for storing, or easily carried in a trunk and taken to a summer bungalow or cottage at the opening of the summer season.



"India" collapsible Electric Lamp



The Lamp Stand is Made Substantially of Brass, While the Shade may be Folded Like an Umbrella

# LAMP WITH FOLDING SHADE EASILY TRANSPORTED

96x2

An electric lamp which is suited for the drawing room, a den or a dressing chamber, is being made with a collapsible shade which may be used while opened wide, partly closed, or folded pear-shape. It is covered with figured cretonne or heavy silk, giving soft, harmonious color effects, and has a frame which opens and closes the same as an umbrella. The advantage of this, in addition to the various effects which may be produced with it, is that it can

Ross Bros & Co.  
Lancaster, Pa.

*me sign*

### LIGHT CHEMICAL CAR BUILT FOR SMALL-TOWN USE

9733

Intended particularly to meet the needs in suburban districts and small towns where the village fire-fighting

ment mounted on the chassis of a light, standard motor car, is being built. The outfit, in comparison with the large motor-chemical cars ordinarily used in cities, is moderately priced and if properly cared for should have a low maintenance expense. It is provided with a 35-gal. chemical tank and soda canister, 200 ft. of hose, two 3-gal. hand fire extinguishers and a small extension ladder, as well as pikes and axes. It also mounts a 9-in.

*Ford First Aid Chemical Apparatus*

*pat. applied for*

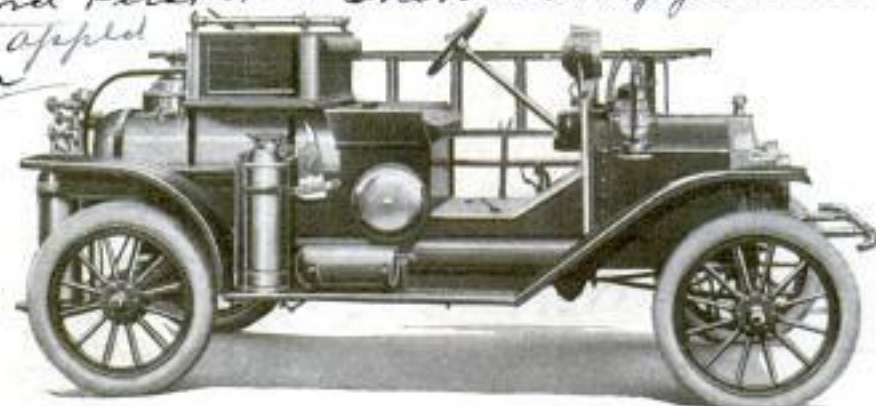

Light Chemical Car Designed for Emergency Purposes in Suburban and Country Towns

paraphernalia is more or less inadequate, an emergency apparatus, consisting of chemical and auxiliary equip-

gas searchlight. The car itself is equipped with electric lights, oversize tires, and other accessories.

*7111111111*

### PLAY STRING INSTRUMENTS BY PRESSING BUTTONS

9432

An electrically operated tremolo attachment for banjos has recently been invented which enables a musician to play this and similar stringed instruments by pressing a series of push buttons instead of doing the customary

pick work. The apparatus is mounted on a table and is supplied with a rack in which the banjo is held firmly. The tremolo device, which is partly incased in an aluminum housing, consists of a series of small shafts, at the end of each of which are fixed three

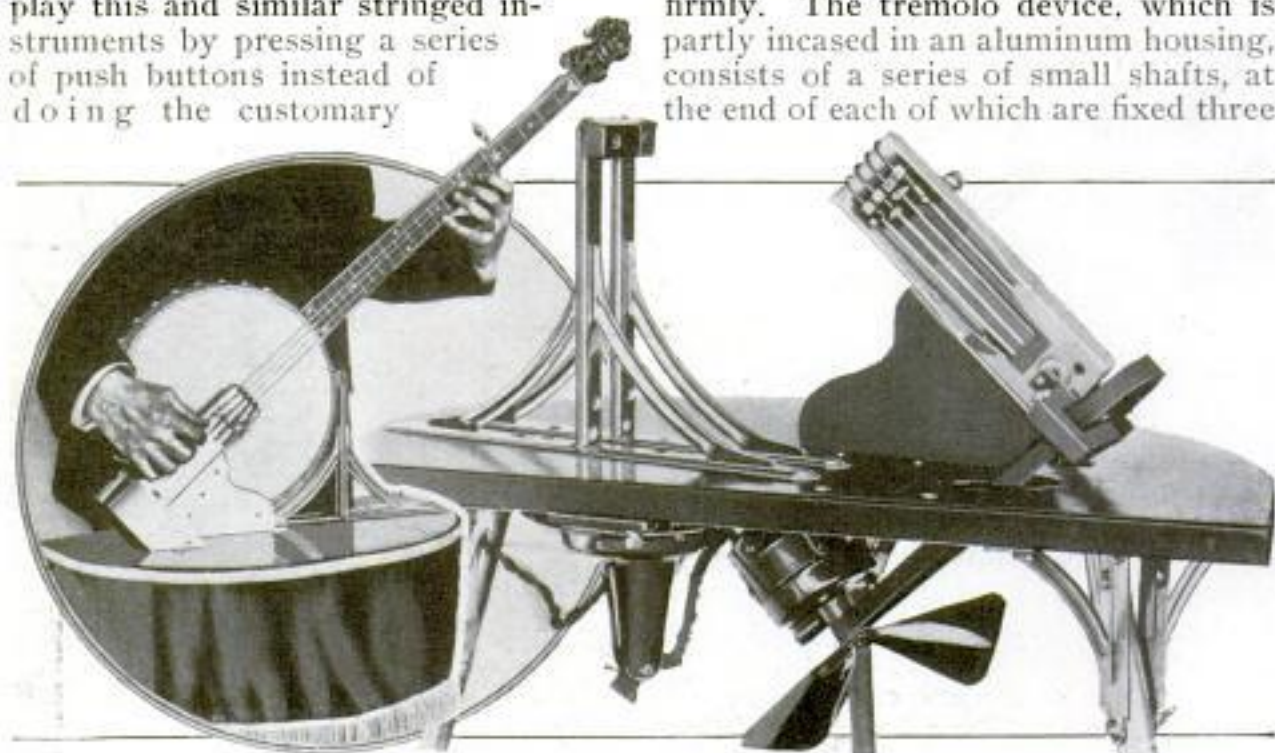

At the Left the Apparatus is Shown with a Banjo in Place Ready for Playing, While at the Right the Instrument is Removed, Displaying the Mechanism of the Device

*Inv. R. S. Russell*

*# J. T. Sturgeon  
620, So. Broad St.*

fiber picks. These rods, corresponding in number to the strings which they parallel, are actuated by a motor and controlled by buttons fitted in the front side of the case, which when pressed move the picks in contact with the strings, heavily or lightly as the player desires. The speed of the rods is regulated by a rheostat which allows a variation of from 600 to 2,000 picks a minute.

### FIRST YEAR'S OPERATION OF PANAMA CANAL

*530 m Canal Record 8-18-15*  
 During the first year of the commercial operation of the Panama Canal, which ended on August 14, 1915, a total of 1,317 seagoing vessels, in commercial or naval service and including yachts, passed through the canal. The gross tonnage of these vessels was 6,494,673. The eastbound and westbound traffic were practically equal, the eastbound traffic comprising 661 vessels with a gross tonnage of 3,227,757, and the westbound traffic comprising 656 vessels with a gross tonnage of 3,266,916. All tonnages were estimated on the basis of the Panama Canal measurement. The tolls earned during the year, including a little over \$114,000 levied on United States government vessels but not collected, was \$5,216,149.26.

### DEVICE FREES LIFEBOATS IN RECORD TIME

*403*  
 To facilitate the work of releasing lifeboats from their leashes on a steamer, so that they may be swung out on their davits and lowered in the shortest possible time when an emergency arises, a new type of fastener has been invented. This device, which enables one man to free a score of boats in about a minute's time, has lately been adopted by an eastern company whose steamships ply between New York and Boston. It consists of a steel triangle and hook. The former is fixed to a rope fastened to the deck of the ship, while the latter is attached to the line that passes over the boat and

*Inventor F. A. Jones, Gen. Mgr.,*

*Eastern Steamship Corporation  
 268 Atlantic Av., Boston, Mass.*

is held in place by a link that fits over its upturned end. This ring protrudes over the rest of the fastening so that

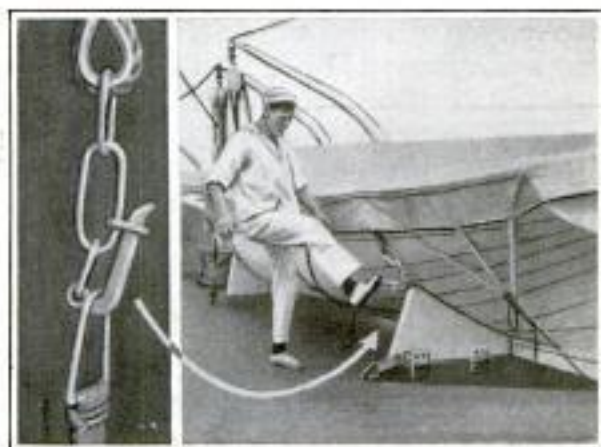

A Sailor Runs along the Line of Lifeboats, Kicking Each of the Rings and Releasing the Boats

a slight upward stroke disengages it and releases the leash. A sailor is able to run along the line of boats, kicking each locking ring in turn and simultaneously freeing the various craft.

### COMBINATION SCREWDRIVER AND HAMMER

*102 m*  
 A new tool designed for carpenters and other woodworkers, and particularly convenient when a screw is to be hammered into the wood far enough for the threads to catch, is a combination screwdriver and hammer just placed on the market. The hammer head is pivoted at the center to the handle end of the screwdriver, and when folded into line with the tool, it forms part of the handle. When turned at right angles, it serves either as a hammer head or as a means for applying a greatly increased leverage to the screwdriver.



*Greenleaf Tool Co., Jamestown, N.Y.*

**ADEQUATE SPACE FOR BAGS  
SUPPLIED IN MOTOR CAR**

329

Luggage compartments of sufficient capacity to accommodate four suitcases are provided beneath the tonneau

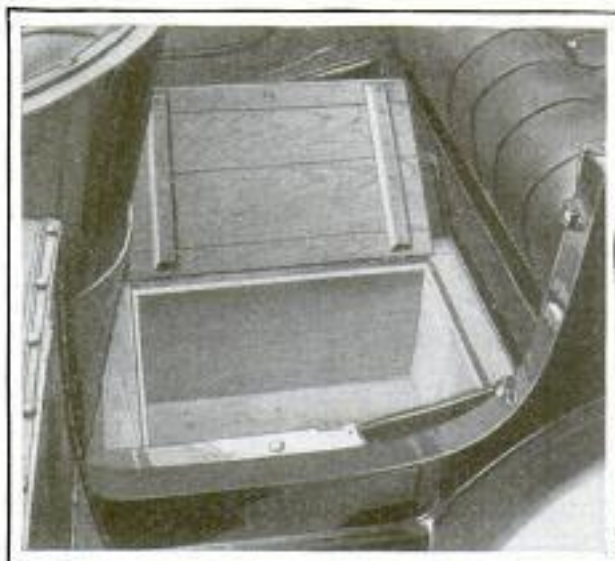

Each of the Compartments Is Large Enough to Receive Two Suitcases

floor of a western-built motor car. This facility, which is a very convenient one when touring is to be done has only recently been introduced. The carrying space is divided into two separate holds, enabling access to be gained to either one of them without necessitating the occupants of the tonneau to leave the car. By furnishing the storage room, the need of strapping paraphernalia to the fenders and runboards of the machine is escaped, while the baggage is also protected from dust and rain.

**PASSING BATTLESHIP FLEET  
THROUGH PANAMA CANAL**

529

That the main battleship fleet of the United States Navy, comprising 21 vessels, could be passed through the Panama Canal in one day is the opinion of the commander of the fleet composed of the "Missouri," "Ohio," and "Wisconsin," which were the first of the big warships to go through the canal recently. At the Pedro Miguel and Miraflores locks the "Missouri" and "Ohio" were locked through side by side, one in each of the duplicate

Canal Record 8/25/15

locks, with the "Wisconsin" occupying the lock with one of the other ships. By this method four battleships could have been put through as easily and in the same length of time. In the case of dreadnaughts only one ship could be placed in a lock at one time, but even ships of this size could be sent through in pairs.

**PEAT USED IN MANUFACTURE  
OF GAS**

Gas that is declared to be of excellent quality is being extracted from a mixture of coal and peat, at a municipal plant in Friesland, in the northern part of Holland. No attempt is made to use the peat alone, because of the excessive heating of the retorts by the steam that comes from the moisture in the peat. The retorts are filled with two parts in weight of coal to one part of peat. The peat is entirely consumed in the process so that there are no by-products as with coal. Since most of the coal used in Holland must now be imported from a great distance at heavy cost, the process is resulting in a great saving in the cost of gas, especially in Friesland, where peat is plentiful and can usually be dug in the vicinity of the gas works.

**NOVEL SANITATION DEVICE  
FOR THE TELEPHONE**

As a sanitary protector for a telephone transmitter an ingenious attachment which covers the mouth-



piece of an instrument, and prevents the accumulation of filth within it, has recently been brought out. The device is made of nickelled steel and

consists of a compact case, at the top of which a small roll of thin paper is supported. A strip of the latter is held in place over the transmitter and may be changed whenever desired.

The Norman Co.  
Box 387 Atlantic City  
Copyrighted material

Handwritten notes on the right side of the page, including "329" and "529" written vertically, and other illegible scribbles.

456

# GREAT HELL GATE BRIDGE NEARS COMPLETION



Bird's-Eye View of Enormous Structure Taken from One of Its Towers Shows Progress of Work

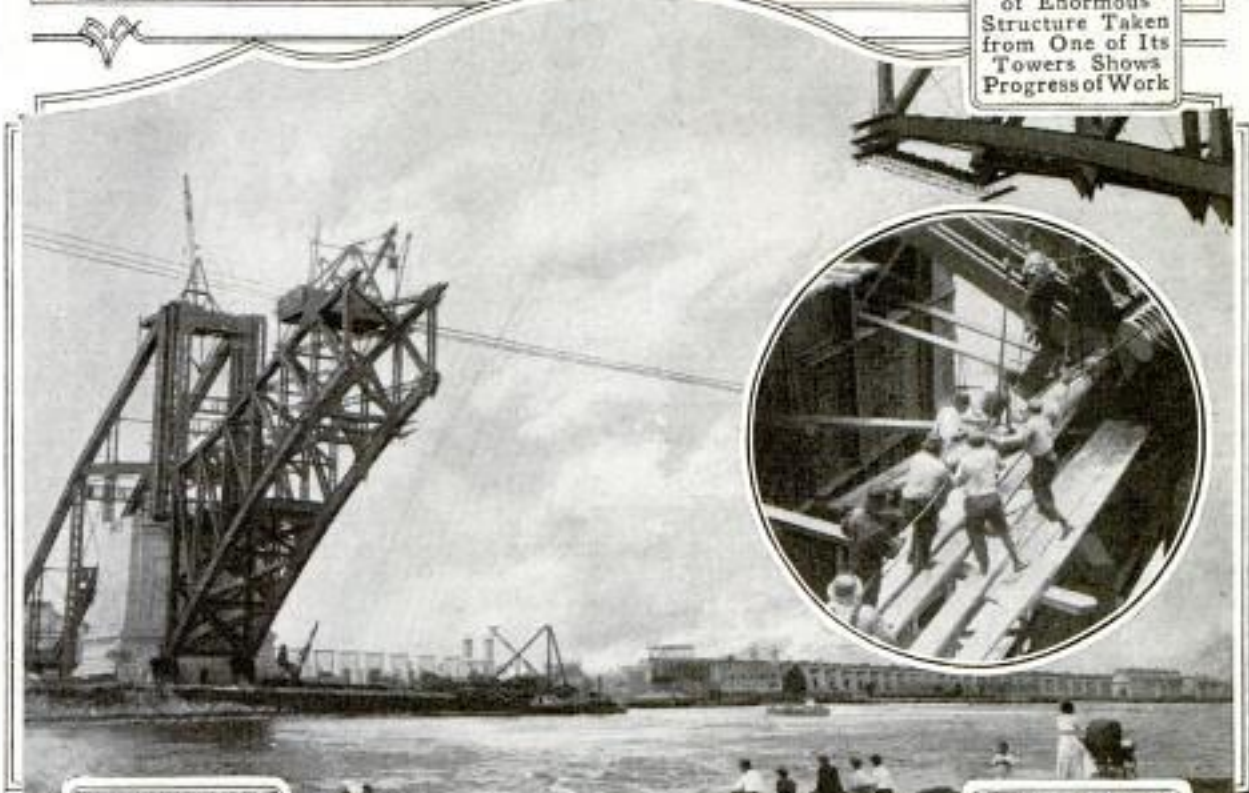

Part of Steel Arch over East River Which will be Longest in the World When It is Finished

Above: Setting a Pin 400 Feet from Earth. Below: One of the Smaller Bridges in the System



PHOTOS COPYRIGHT, UNDERWOOD & UNDERWOOD

417 - 5th Ave  
N.Y. City

Wm. Rigling Egg Tester  
+ Mfg. Co.  
Hamilton, O.

# M. T. Puzley,  
~~1230 Amsterdam~~  
New York.

740

POPULAR MECHANICS

**EGG-TESTING DEVICE MADE FOR LARGE CONSUMERS**

For testing eggs in hotels, restaurants, and similar places, an electrically operated device is being made which

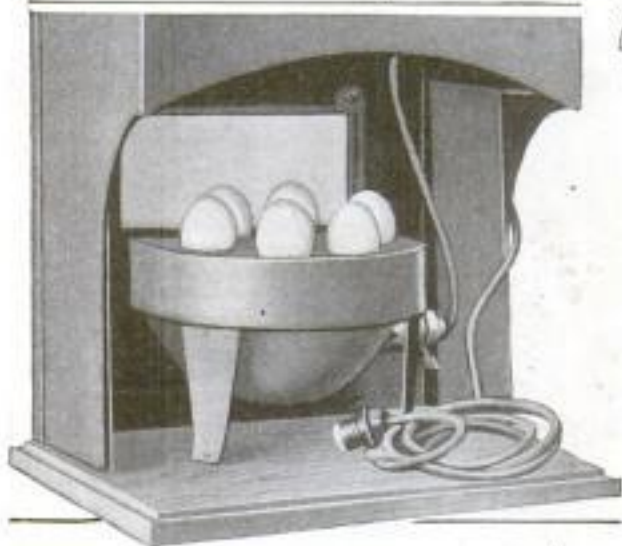

With This Tester a Case of Eggs may be Inspected and the Unfit Ones Separated from the Others Rapidly

enables the quality of such produce to be determined quickly. The tester is made in several sizes and styles, but the general principle is the same in each case. A circular receiver with felt-cushioned spaces for the eggs is mounted over a strong electric light. In some instances the holes are backed by mirrors, enabling all sides of a shell to be seen without turning an egg. It requires only a few minutes to inspect

carefully the contents of a case. This permits the return of poor eggs and also insures against their being served to patrons.

**BRAKING APPARATUS FOR LOGGING VEHICLES**

Heavy loads may be safely let down the steepest grades by the use of a new braking device that is particularly designed for logging operations in hilly or mountainous country. This device consists of four sheaves mounted on a solid frame that is anchored to the top of the hill and is equipped with hardwood blocks for braking each of the sheaves. Around these sheaves runs a cable so arranged that while one end of the cable is being taken downhill the other is being drawn in. The braking blocks are controlled by two levers by which two or four of the sheaves may be braked, as may be necessary. The down-going wagon or sled is hitched to one end of the cable. On a winding road, roller posts are set at each curve. On reaching the bottom of the hill the driver unhooks the cable and notifies the man at the top by means of an electric bell. The device is



With This Braking Device, Which is Particularly Designed for Logging Operations, It is Possible to Let Loaded Sleds or Wagons Down the Steepest Grades Safely. As One End of the Cable is Taken Down the Hill by the Vehicle the Other End is Drawn to the Top in Readiness for the Next Load

then ready for instant use by the next wagon or sled.

Ryther & Pringle Co., Carthage, N. Y.  
Copyrighted material

without cleaving at all  
complete with

9685

**MOTOR TRUCKS ARE BUILT**

9781 H **IN IOWA PRISON**

Following the abolition of the contract-labor system in the state penal institutions of Iowa, it devolved upon the prison authorities to direct the energies of the convicts more or less into new channels in order to keep them occupied. While a re-adjustment was being made to suit the changed conditions, a number of prisoners at the Fort Madison penitentiary who are skilled mechanics, were put to work making a motor truck. This was done principally as an experiment. The result, however, was that the men turned out a machine sufficiently good to cause an

order to be given for the manufacture of 14 similar ones to be used at the different state institutions. It is now believed by the warden that it is feasible to establish a motor-truck plant as

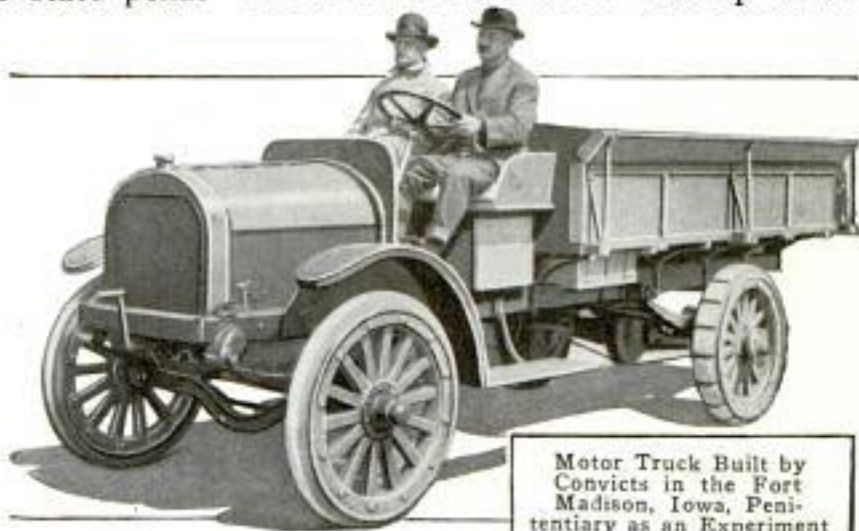

Motor Truck Built by Convicts in the Fort Madison, Iowa, Penitentiary as an Experiment

a part of the prison factory and keep a certain number of convicts engaged in building machines, which it is assumed could be disposed of readily.

Street Car  
**EXPRESS SERVICE IS TRIED**

315 H **ON SURFACE LINES**

In an attempt to increase the traffic capacity and lessen the schedule running time on surface-traction lines at Chicago, a "skip-stop" operating system has been inaugurated experimentally on several routes. The plan abolishes the custom of stopping cars at all street intersections, in a specific zone, and designates regular points at which passengers are to be received and discharged. The average distance between these points is 687 ft., while in the past the average has been 407 ft. Thus more than a third of the stops are eliminated and the maintenance of a much faster schedule made possible. If the test proves successful, it is intended to make the plan general.

289 **LARGE DIPPERS EMPLOYED IN WATERING LAWN**

Tin pans secured to the ends of poles, forming long-handled dippers,



With Dippers of This Kind the Terrace is Watered without the Use of a Hose

are used in watering the grass-covered terraces along the banks of a river at San Antonio, Texas. The stream meets the edge of the grass, making it easy for a keeper to walk along the shore line and dish up plenty of water.

# Barry Scobee, 108 Lewis St.  
San Antonio, Texas.

*American Metal Prod  
3009-3021 Lisbon Av.  
Milwaukee,  
Wis.*

*70  
5-5*  
**ENORMOUS WELD MADE WITH  
OXYACETYLENE FLAME**

In repairing the cracked and broken hub of the spider for a gyratory stone crusher, one of the biggest jobs

*406*  
**STRENGTH AND LIGHTNESS**

**FOUND IN NEW ALLOY  
"AMPCO BRONZE"**

Bronze, made by a secret process, is being used in manufacturing die-cast machine parts which are claimed

to be more durable than steel. The new alloy, which has a copper content varying from 75 to 97 per cent, is not in combination with tin, zinc, lead, or phosphorus. It has a tensile strength as great as 100,000 lb. to the square inch, a specific gravity of 7.35, is an electrical conductor and nonmagnetic. It can be either cast in sand or die-cast, eliminating the necessity of much machine and handwork in finishing. The most peculiar characteristic claimed for it is that it cannot be softened by any known annealing method. Castings made of the alloy are said to be twice as strong as

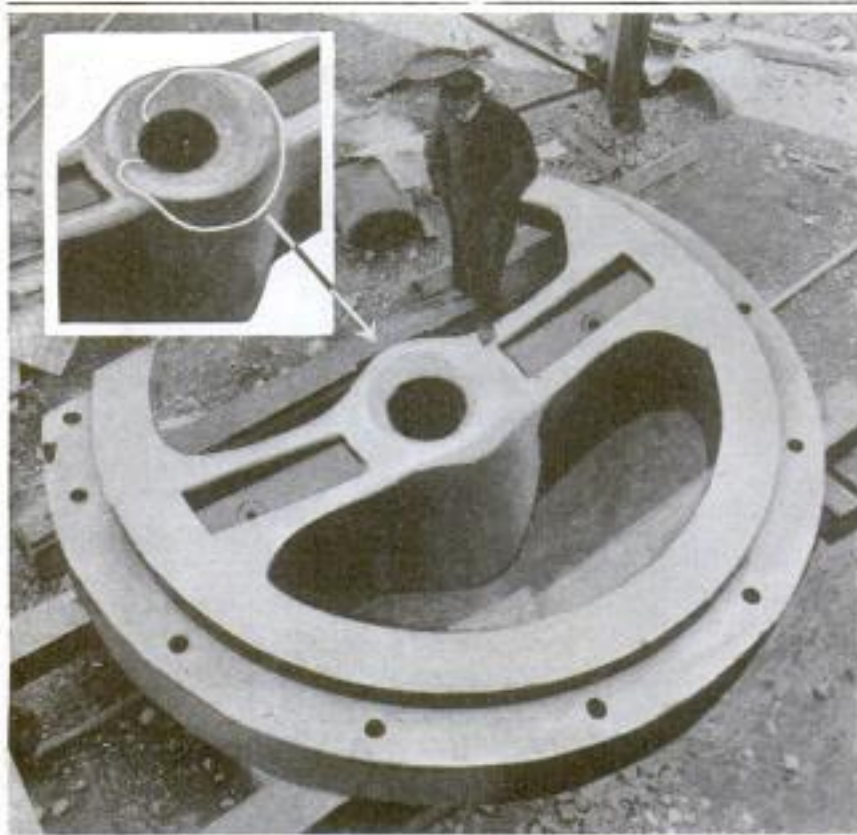

In Repairing the Hub of This 30-Ton Spider, More than 900 Pounds of Metal was Welded into Place with the Oxyacetylene Flame

of oxyacetylene welding ever attempted was recently carried out successfully in Chicago. The section of the spider that included the hub, shown in the illustration, weighed 60,000 lb., while with the segment not shown the spider weighed 80,000 lb. After the crack and break in the hub had been chipped out it was necessary to weld in more than 900 lb. of metal. The actual welding required more than 60 hours of continuous work, the fractured hub being buried in a charcoal fire during the process to prevent local expansion or contraction.

CA journal devoted to the interests of publishers estimates that the number of persons in the United States who buy books is about 16,000,000. Of these, 500,000 are classed as regular book buyers.

steel and will not rust or corrode, or be affected by hydrochloric or sulphuric acids. Small chisels made of the alloy for advertising purposes are capable of cutting iron or soft steel. Lightness and strength are two of the outstanding points advanced in favor of the bronze, which may be machined or forged readily.

*405*  
**KANSAS TOWN BUILDS HOUSE  
FOR TOURING MOTORISTS**

Motorists who tour the old Santa Fe trail through Kansas are given a real example of hospitality when they reach the little town of Delavan, where a municipal "camp house" has been erected for their reception. This is a neat, white frame structure which provides separate spaces for two motor cars and accommodations for several

*# O. R. Leyer, 1429 W. 9th  
Des Moines, Iowa*

*Oxweld Acetylene Co  
36th & Gaspar Plank, Chgo.*



Unusual Signboard  
Erected a Short  
Distance Outside  
of Delavan, Kansas

The Town Supports  
This Building for  
the Accommodation  
of Its Tourist  
Guests



guests. The living quarters are plainly, but comfortably, furnished and equipped with cooking utensils, a stove, toilet articles, road maps, a telephone, and other little things convenient for travelers. Daily newspapers are kept on file with magazines and a few books. The building offers a clean place to spend the night, or obtain shelter during a storm. The garages also give chauffeurs an opportunity to tune the engines of their cars and make minor repairs during the stop. Two miles west of the place is a large signboard which points the way to Herington, the next town, and bears a picture of the "Old Santa Fe Trail in the Forties."

### SPRINKLING COUNTRY ROADS

9924 m WITH OIL. Sargent

In some sections of the country oil is being extensively used in place of water for sprinkling country roads. It has been found that the oil not only lays the dust as effectively as water and as cheaply, but that after a dozen applications it covers a macadam road with an asphalt surface that is dustless and practically permanent. A typical sprinkler, used in California, consists of a truck on which is carried a tank for the oil supply, with a smaller tank, carried on the rear of the truck, in

which the oil is heated almost to the boiling point. The heating is done by an oil burner. The oil is applied at the rate of about 100 gal. to the mile and is distributed by a turbine capable of throwing a spray a distance of about 18 ft. The power for driving the turbine is obtained through a roller that engages one of the wheels of the truck,

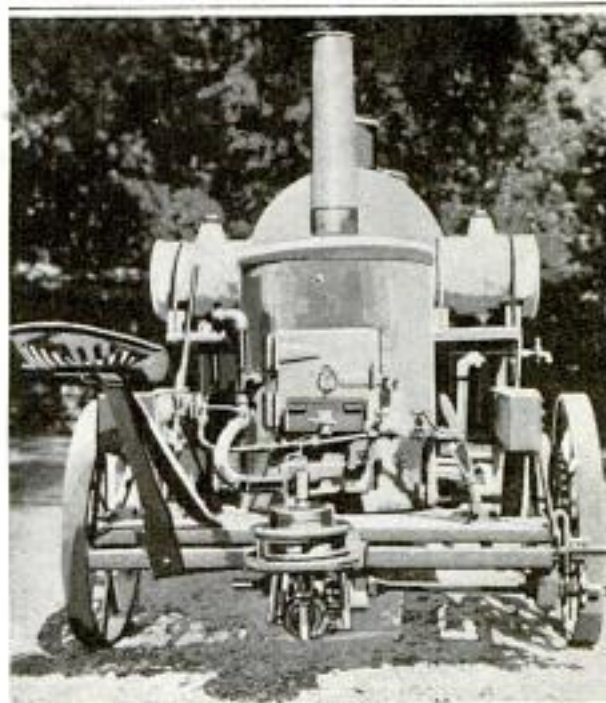

Machine Used in California for Sprinkling Country Roads with Oil

and the spray is regulated by a valve that controls the admission of oil to a chamber in the center of the turbine.

At a recent national convention of jewelers a publicity campaign was started for the purpose of inducing the people of the United States to wear jewelry by seasons.

1138489 - Henry B. Knief, Napa Calif May 4-15  
filed Nov 28 1913, Serial No. 803487. [El 137-64]  
Patent Gazette V. 214 p 270.

B 11/5/15

Copyrighted material

## BUSY STEAM-RAILWAY LINE ELECTRIFIED

536m  
The electrification of 20 miles of heavy-traffic railway line is now being completed between Paoli, Pa., and the Broad Street station of the Pennsylvania Railroad in Philadelphia. In spite of the fact that over one section of this line no less than 2,295 train movements occur daily, this work has been accomplished without accident of any kind and without interference with traffic. Current is transmitted to the cars by means of overhead wires, the type of construction being what is known as the "catenary" system. A heavy wire, which necessarily has some

sag in it, was first stretched between supports, and from this the trolley wire is suspended by vertical wires of varying length, so that it hangs level and straight. This construction is used as a means of keeping the sag out of the trolley wire and thus preventing sparking at the supporting points when a train is running at high speed. The work was done at a cost of about \$4,000,000.

¶The severe and prolonged headaches caused by inhaling the fumes of nitroglycerin, or by handling dynamite with bare hands in hot weather, are due to the fact that nitroglycerin is a powerful heart stimulant.

## BLOWING CONCRETE INSTEAD OF POURING IT

2x2  
By H. B. KIRKLAND

THE art of making masonry of a wet mixture of cement and stone poured into molds has developed many methods and machines. The latest of these is that of blowing concrete through a steel pipe from a central mixing plant to the forms, or molds. This method is particularly advantageous for building the walls and arched roofs of railroad tunnels and other smaller tunnels. Although the government patent has only recently been issued, the method has been adopted on practically all tunnel work in the United States, and is also finding a place in the construction of other large concrete work.

Besides the actual conveying of the concrete through the steel pipe, it is also mixed by the blowing process. The cement, sand, and stone are simply dumped into the machine, which is then sealed by an air-tight door at the top, whereupon the materials are mixed and discharged by passing air at high pressure through the machine and out through the pipe at the bottom. The materials travel through the pipe like dust in a hurricane, and the speed is estimated to be about 150 miles per hour. The pressure required to dis-

charge each batch is equivalent to about three tons.

Tunnels are lined by blowing the concrete into the molds, at the top, with great velocity and allowing the material to flow over into the side walls until the whole space to the top of the arch is filled solidly. After the concrete has become set sufficiently hard to remove the molds, they are drawn forward on wheels to the next position, and the operation is repeated.

Before this method was adopted for tunnel work, 40 or 50 men were required to place the concrete. The concrete was mixed in a mechanical mixer and discharged in the cars, which were pulled by small locomotives to the forms in the tunnel; the cars were then elevated to a platform and dumped onto a shoveling board, and from here the concrete was shoveled into the forms. The method was slow and expensive.

With the pneumatic method, a single steel pipe takes the place of expensive equipment and of two-thirds the labor formerly used. The average gang of men required for this method is about ten and a great amount of the danger of tunnel work is obviated.

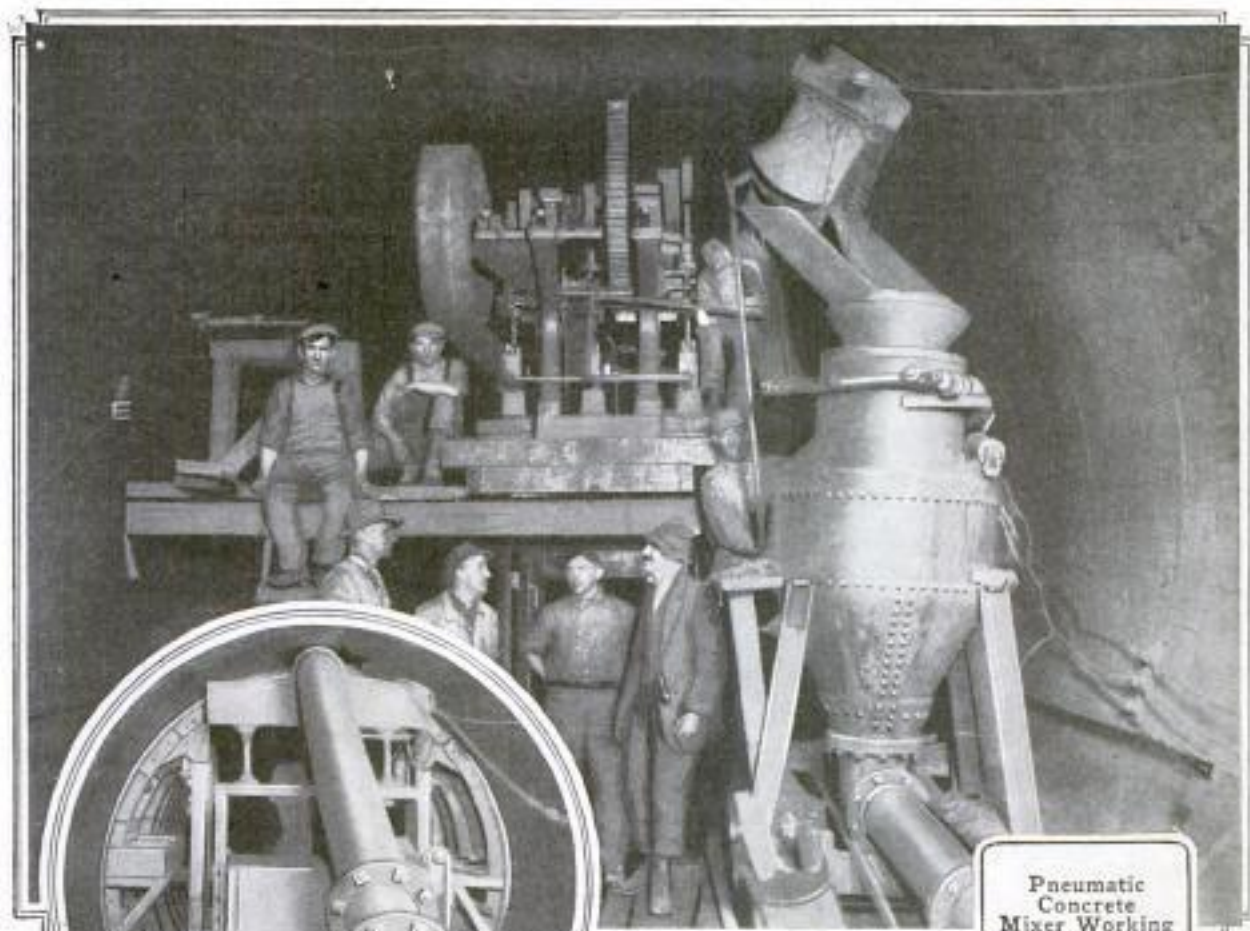

Pneumatic  
 Concrete  
 Mixer Working  
 in a Memphis  
 Tunnel

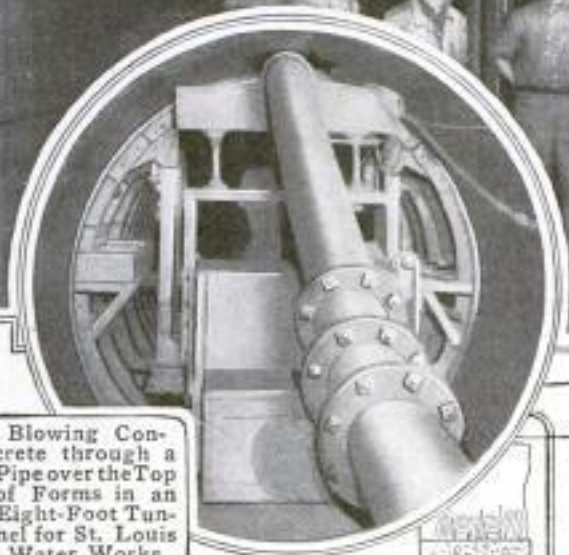

Blowing Con-  
 crete through a  
 Pipe over the Top  
 of Forms in an  
 Eight-Foot Tun-  
 nel for St. Louis  
 Water Works

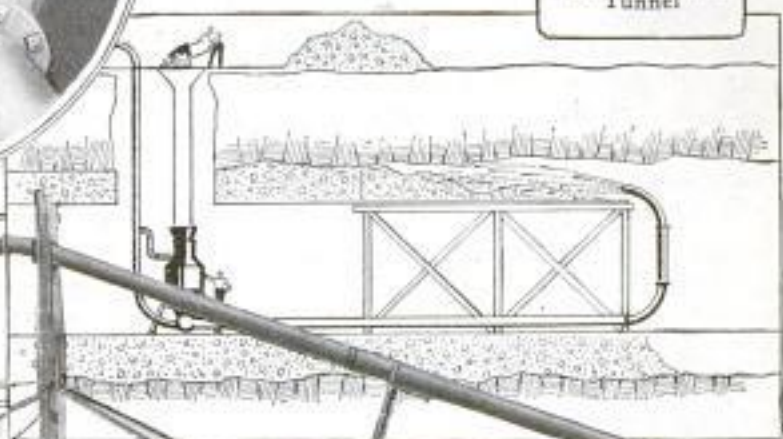
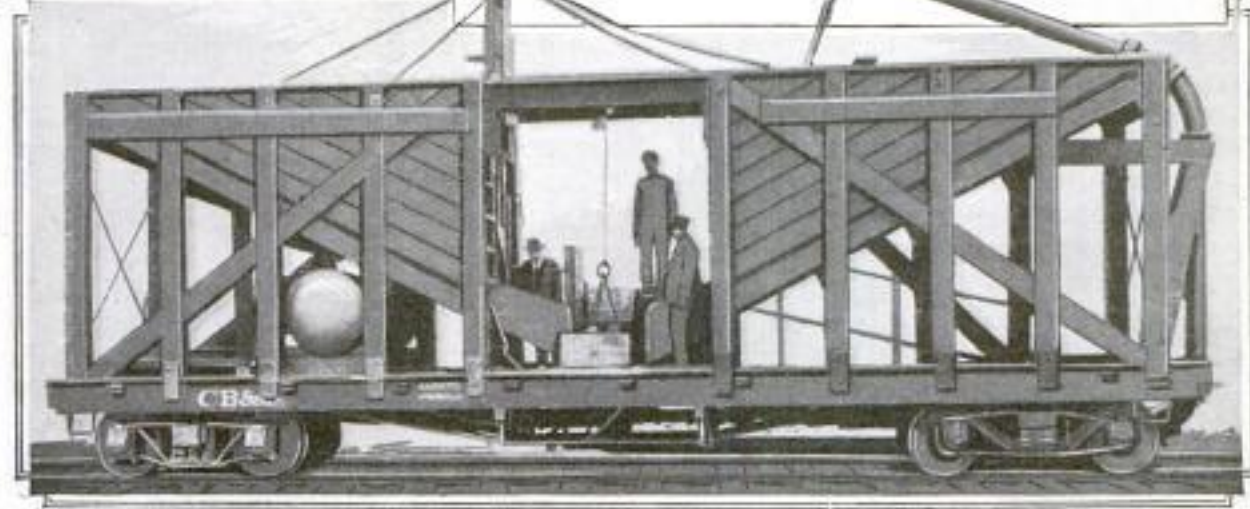

Diagram Shows How the Concrete  
 Blowing Apparatus is Installed and  
 Operated in a Tunnel.  
 Lower View: Portable Plant  
 Used by a Railroad System  
 for Its Tunnels



### GRAFTING NEW ROOTS ON AN OLD TREE

9648 m  
Supplying new roots for an old tree is the feat accomplished by a California fruit grower whose orchard had been



Healthy Shoots Planted around a Diseased Tree and Grafted to the Trunk to Serve as New Roots

attacked by pear blight. To stop this disease it is often necessary to cut away affected portions of the tree and roots, and a tree is sometimes killed by the means used to cure it. To save a pear tree that had been deprived of the greater portion of its roots in this way, the plan was tried of planting young and healthy shoots all around the trunk and grafting these to the old tree after they had grown to a sufficient height. The plan proved successful, the sustenance of the tree was provided for after the severe cutting, and a valuable producer was saved.

Belgians between the ages of 16 and 40 are forbidden, by the German governor-general of Belgium, to leave that country without written permission.

### WHY MERCURY-VAPOR LIGHT IS EASY ON THE EYE

519 m  
One of the greatest advantages in the mercury-vapor arc is the color of its light, experience having shown that less eye strain is caused by light produced in this way than by any other artificial means of illumination. This condition is easily explained on scientific grounds. The mercury-vapor arc is produced by a device consisting essentially of a vacuum tube in which mercury is vaporized sufficiently to serve as a conductor for an electrical current passing from one end of the tube to the other. The result is an electric arc of great brilliancy. Unlike the light given off by a solid conductor, that given off by a gas contains only a few of the colors of the spectrum, nearly 60 per cent of the light emitted by the mercury-vapor arc being green or yellowish green. White light is a composite of the rays of all colors, and these different colors are brought to a focus at different points in the eye. The red elements, for example, come to a focus farther from the lens than the blue and violet rays, while the yellow and green rays come to a focus at a point intermediate between these extremes. As it cannot adjust itself for all the colors at once, the eye automatically focuses for the green rays, letting the red focus behind the retina and the blue and violet in front of it. In addition to this, the retina is more sensitive to the green, since this color has the middle position in the range of colors which the eye can distinguish. Green and yellowish green are therefore the colors that cause the least eye strain. Owing to the sensitiveness of the eye to these colors only about one-half the illumination for obtaining equal results is required with a mercury-vapor lamp as is required with an incandescent lamp of the tungsten type. Aside from the effect on the eye, the economy resulting from transforming current into light of such efficiency is therefore a matter of importance, especially where much illumination is required.

9945 **TWELVE-FOOT VALVES BUILT FOR POWER STATION**

Water valves 12 ft. in diameter and so designed that they are capable of closing automatically in the event of a break occurring in the pipe line are

*Johnson Valves*

515 **WOMEN TO PROMOTE NATIONAL PREPAREDNESS**

The enlistment of millions of American women in a nation-wide organization to promote national preparedness is the purpose of a society recently

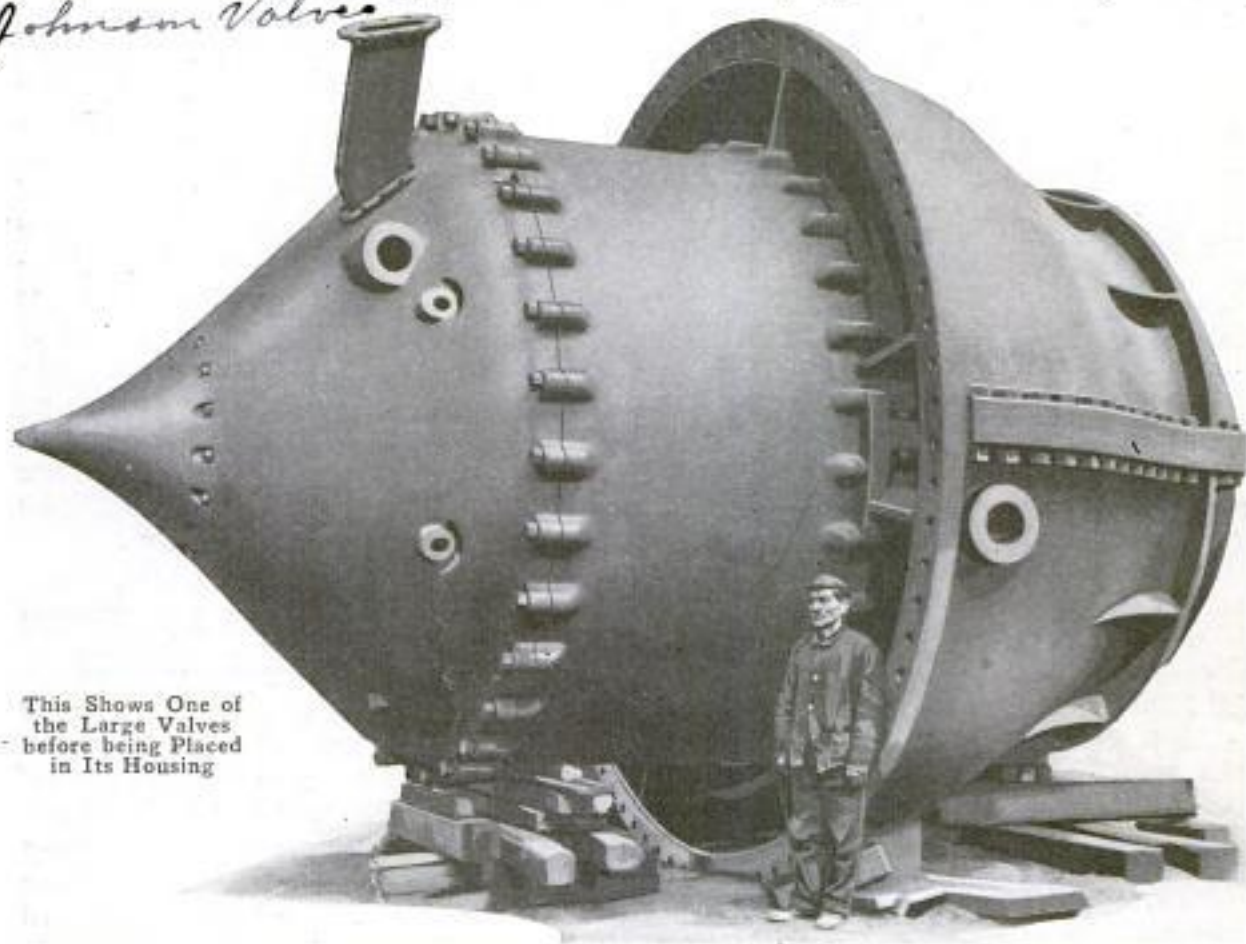

This Shows One of the Large Valves before being Placed in Its Housing

being installed at a Utah hydroelectric plant. They are made alike, each with a bulblike shell, or housing, which in reality is an enlarged section of the pipe. Each valve consists essentially of two large cones, one of which acts as a sliding plunger and regulates the flow. The nose of this and the form of its companion piece are both shaped to guide the water through the gate without materially lessening its pressure. The operating mechanism is arranged so that the pressure of the water in the conduit is utilized in opening and closing the valve, in the former instance forcing the plunger back so that it nests inside of the larger section and allows the water to pass freely.

formed in New York. Immediate action by Congress is to be urged by this society, but other work of as great importance is to be undertaken on a big scale, and has in fact already been begun. Lists are being prepared of women who are willing to offer their summer homes for use as hospitals in case of war, and specimen kits for the regular and volunteer army, as well as kits for hospital purposes and for convalescents, have been made up. The compilation of lists of sewing clubs which may be called on for the preparation of garments needed in the field is also being made. The society has undertaken to keep a register of nurses and others who would volunteer their services in connection with war relief

*Special Relief Society*  
597 Fifth Ave.  
N. Y. City

in this country, and of possible contributors of materials and funds, the idea being to have all relief work thoroughly and permanently organized and ready for quick action in case of emergency.

### MODEL VILLAGE IS BURNED TO AMUSE CROWDS

475 About the middle of summer the fire departments of St. Paul and Minneapolis, Minn., staged a spectacular as well as novel entertainment at the state fair grounds before a crowd of approximately 30,000 persons. The event was a fire-fighting exhibition which was produced in a most realistic and thrilling manner. A long line of frame buildings, one a four-story hotel, and all of them typical small-town

structures, had previously been erected before a grand stand. Nearly a hundred men and women were placed in the "guest rooms" and roof garden of the hostelry before the buildings were set afire. As smoke commenced to roll out of the windows and streaks of flame shot from the roof of the hotel, policemen patrolling the "street" turned in an alarm summoning the awaiting fire departments. The rest of the exhibition was fraught with real work. While a half dozen streams of water were being played on the roaring blaze, the "rescue" work was undertaken. Some of the players were carried down ladders on the backs of firemen, others jumped from the upper windows into nets held for them, and many were lowered to the ground with ropes. The buildings, which are said to have cost approximately \$12,000 to erect, burned to the ground.

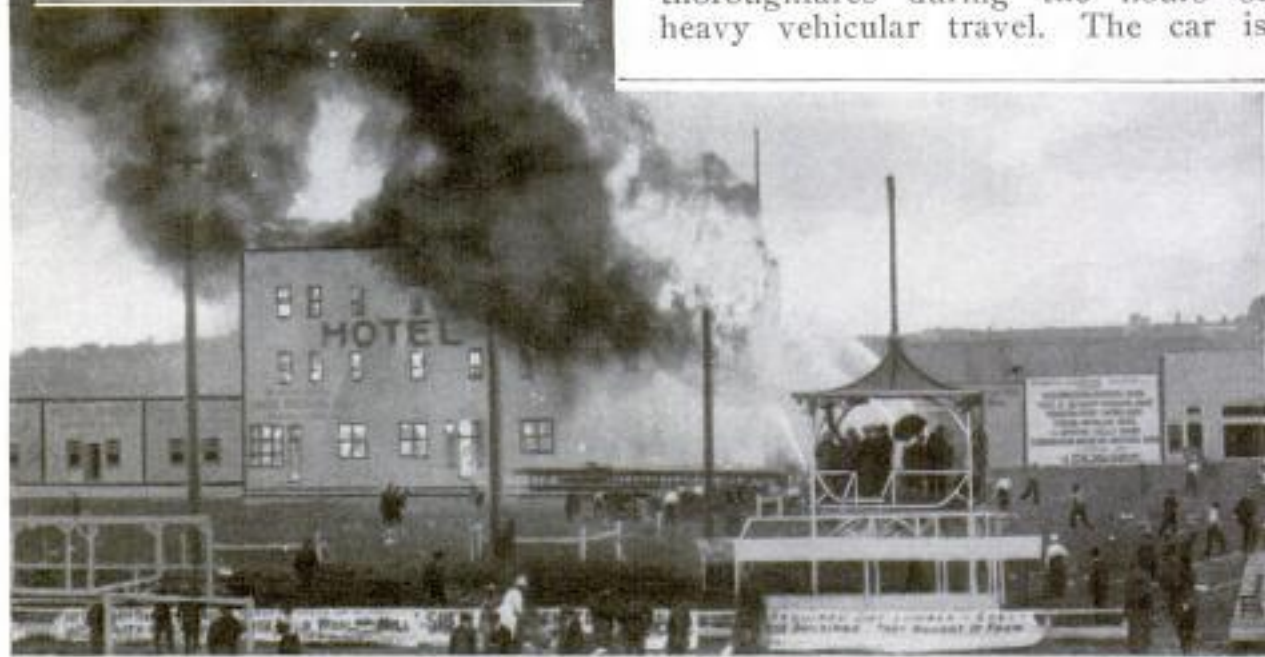

Above: Section of the Buildings of the Model Town Before the Fire was Started. Below: The Buildings in Flames and the Fire Fighters Carrying Out Their "Rescue" Work

### NEW TYPE OF SNOW SWEEPER FOR NEW YORK STREETS

9630 To prevent the congestion of traffic during snowstorms in New York, a street-railway sweeper has been constructed which is designed particularly to meet the difficulties encountered heretofore in clearing the snow from thoroughfares during the hours of heavy vehicular travel. The car is

# R. D. Beard, 57 W. Street, N. W. Wash. D. C.

provided with a large, outboard rotary brush which is so mounted that it may be moved freely back on the tracks when vehicles are encountered. It is

capable of sweeping a path 12 ft. in width, or narrower, while the car is going at a normal speed, without hindering the progress of passenger cars

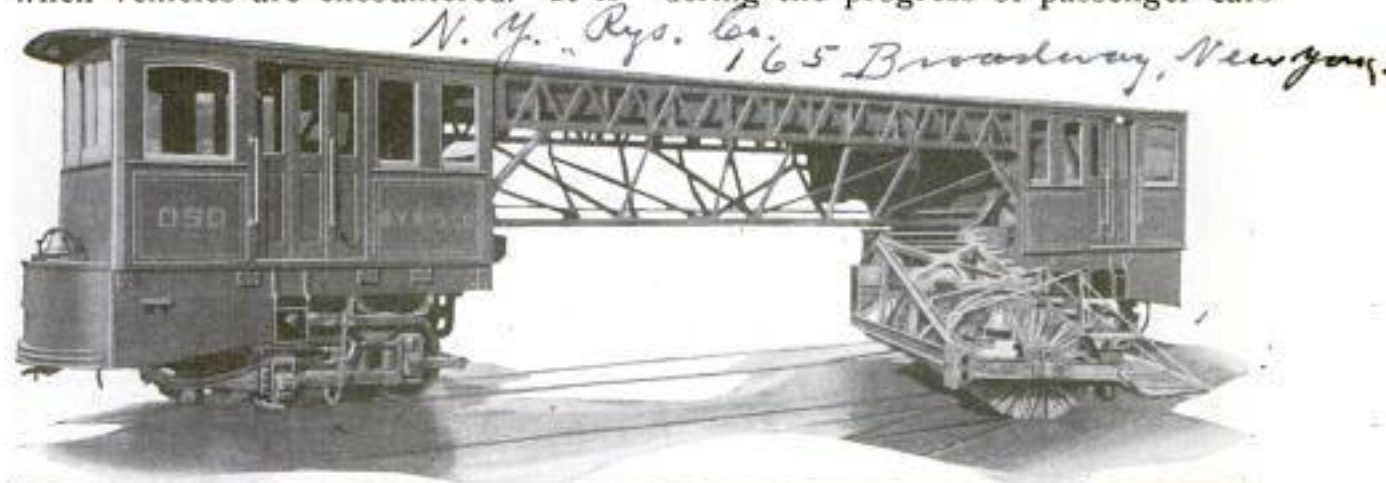

This Snow Sweeper is Adapted Particularly for Clearing Streets on Which There Is Heavy Vehicular Traffic also arranged so that it may be swung from one side of the street to the other at any angle, when it is desired to reverse the direction of the car. It is behind. A fender is provided in front of the broom. This equipment is expected to expedite greatly the work of the street department.

455 **SERVING TABLE IS WIRED FOR ELECTRIC DISHES**

As a convenient appointment for a breakfast room, a tea wagon, wired and fitted with connecting sockets for the accommodation of a coffee percolator, a toaster, and a chafing dish, has been introduced. Except for the wiring it is not different from an ordinary serving cart. In homes where electric table appliances are utilized freely, it makes a very attractive and serviceable accessory, for it may be used for almost any informal occasion and in any room, or sun porch, where a lighting socket is available. By having the various electric appliances on a tea wagon the work of both setting and clearing a table is simplified, while the latter is also left unincumbered by serving and warming dishes during a meal.

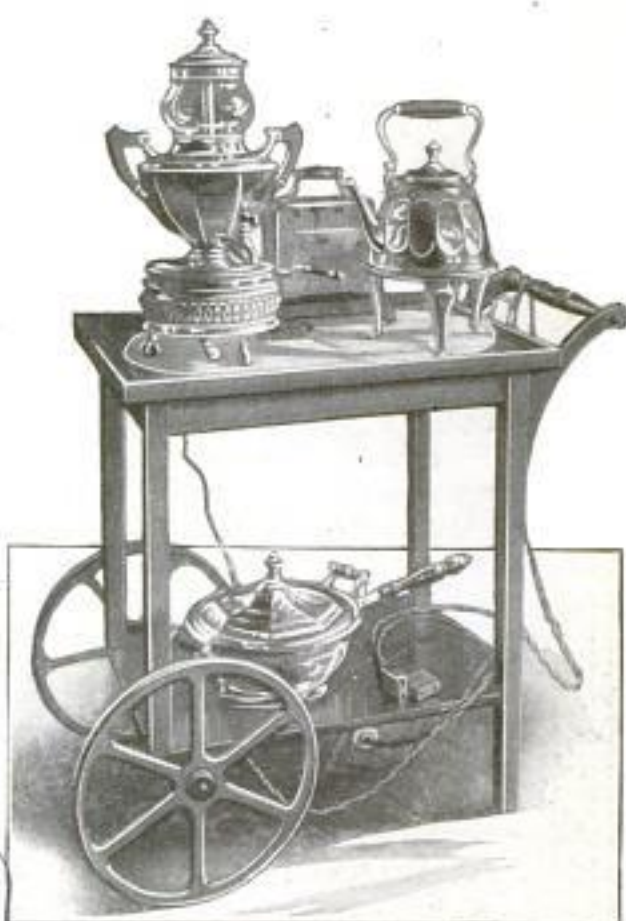

COPYRIGHT, BILL SMITH  
An Electric Serving Table Is Very Convenient When Electric Table Appliances are Used

“California’s Magazine” is a new quarterly journal made up of information relating to the industrial, agricultural, commercial, and social activities of the state of California.

California Publishers Cooperative Assn.

Edited by E. J. Wickson, Prof. of Hort., Univ. of Calif., Berkeley, Calif.

High & Development Co., (W. A. Smith, U.P.) St. Louis, Mo.

Copy-righted material

202  
**PICTURESQUE CUSTOMS OF ROMANTIC PEOPLES**

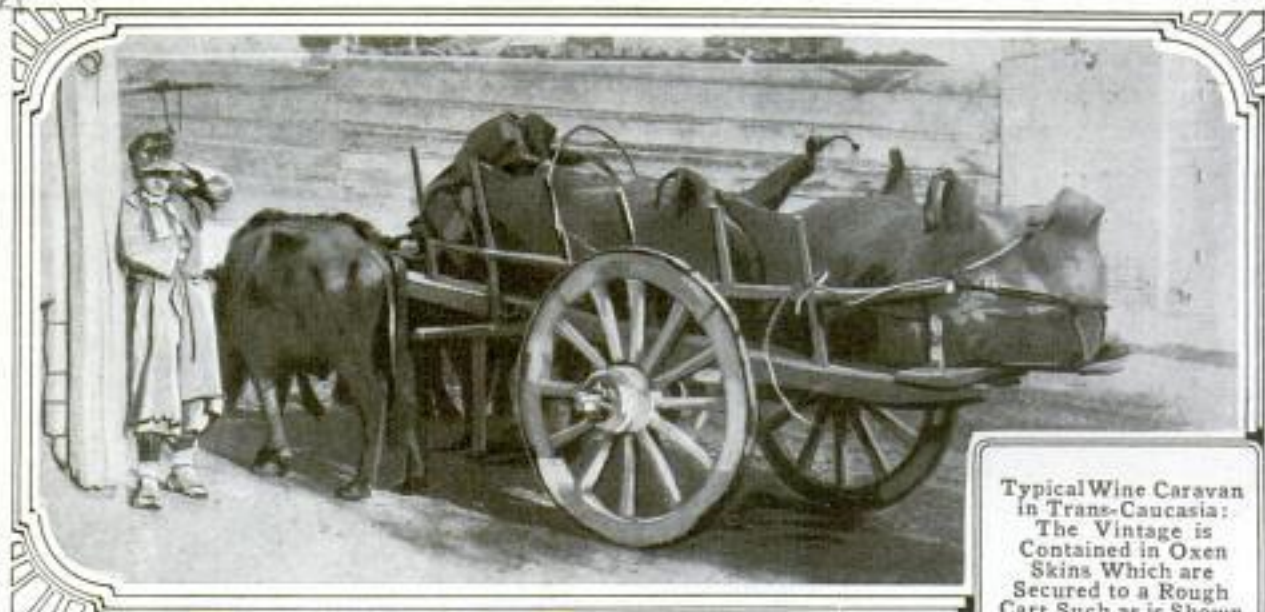

Typical Wine Caravan  
 in Trans-Caucasia:  
 The Vintage is  
 Contained in Oxen  
 Skins Which are  
 Secured to a Rough  
 Cart Such as is Shown  
 Above. This Driver  
 was Seen in the  
 City of Tiflis



Armenian  
 Patrolman on  
 the Lookout  
 for Robbers,  
 Many Bands  
 of Which Hide in  
 the Mountains



Firewood  
 Packed on  
 Backs of  
 Donkeys  
 is Sold in  
 the Streets

Water Seller in  
 One of the Villages:  
 Water is Carried  
 in Earthen Urns  
 Fitted in a Heavy  
 Framework Packed on  
 the Back of a Donkey.  
 It is Only  
 in Certain  
 Localities  
 That  
 These  
 Peddlers  
 are to be  
 Found



PHOTO BY HENRY RUSCHKIS



OF THE CAUCASUS SHOWN IN CAMERA GLIMPSES

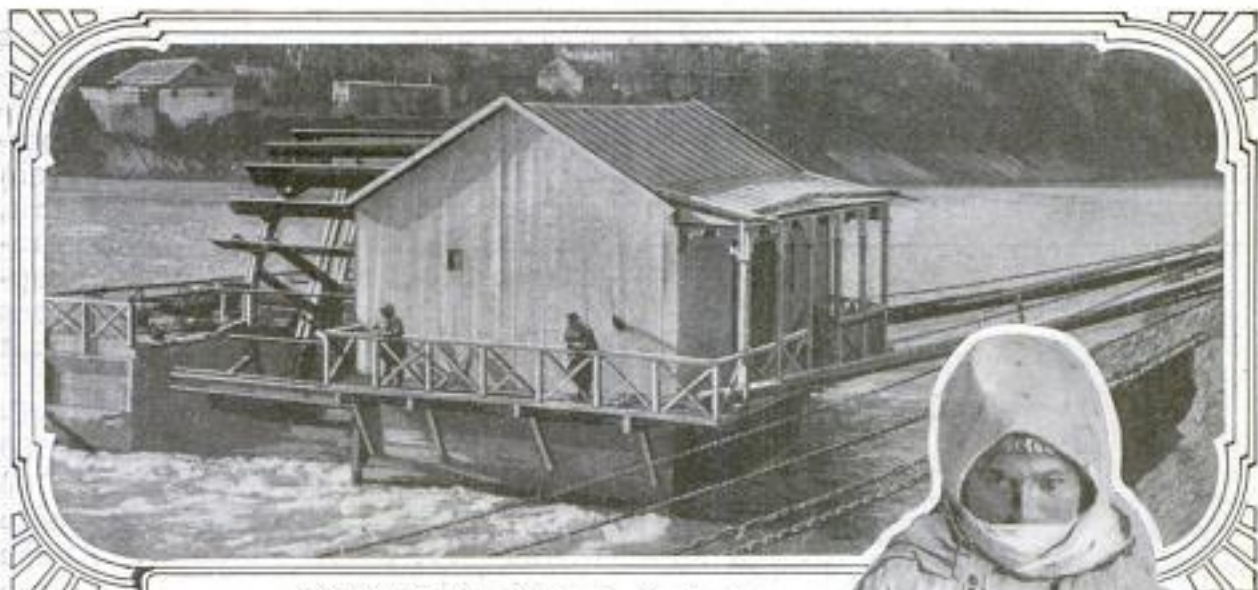

Mill on the River Kur in the Southeastern Part of Trans-Caucasia: This Structure is Built on pontoons and Worked Up and Down the Stream, Grinding First at One Place and Then Another



Bird Dealer, of Which there are Many: The Birds are Carried in Large Baskets Divided into Compartments and Fastened to the Sides of an Ass. With This Outfit the Young Armenian Lad Travels from Village to Village Buying and Selling



Linen is Much Used for Summer Garments throughout Russia. This Shows how Flax is Woven

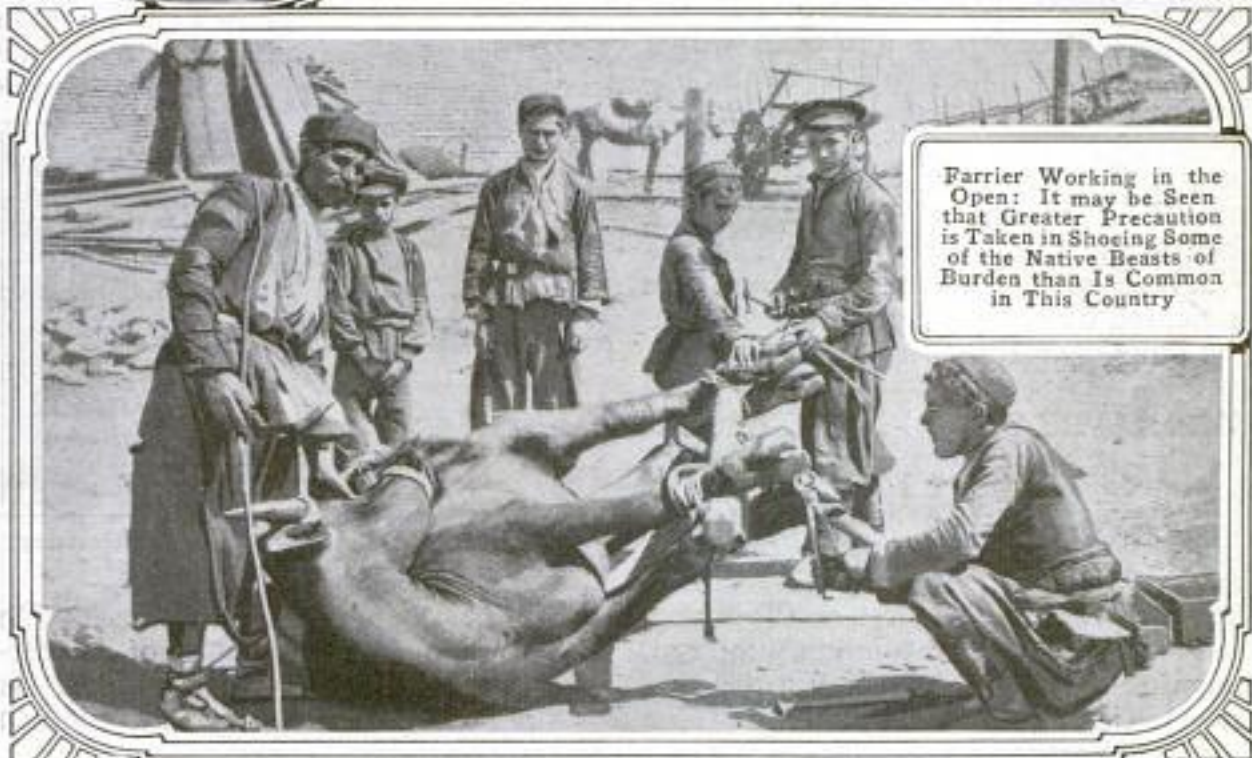

Farrier Working in the Open: It may be Seen that Greater Precaution is Taken in Shoeing Some of the Native Beasts of Burden than is Common in This Country

## QUAINT SUNDIAL ERECTED ON HARVARD BUILDING

Near the top of the south wall of Smith Hall, one of the new dormitory buildings at Harvard University, is an



Sundial of Pleasing Appearance Built in Dormitory Wall at Harvard

artistic sundial. Its design is an expression of simplicity and taste. The dial itself is square in shape and marked with Roman numerals which start with the figure "VIII" in the upper left-hand corner and proceed in regular order in a "U" fashion around to the opposite corner, where the figure "VII" appears. At the top of the face is the single word, "Veritas," the Harvard motto. The half hours are indicated by separating marks between the hour characters.

## STABILITY TEST IS GIVEN OLD LAKE STEAMER

Following the "Eastland" tragedy at Chicago, many of the excursion boats in the lake service were subjected to stability tests. The first of these was the "Christopher Columbus," an old, ungainly whaleback which plies between Chicago and Milwaukee. This vessel successfully underwent what

*Clippings from Chicago  
Dailies*

was regarded as a severe experiment in demonstrating its seaworthiness.

The federal inspectors allow this ship to carry a maximum of 3,736 persons, including the crew, under certain restrictions. When put to the test, the vessel showed that in a comparatively smooth sea it is capable of supporting approximately 5,000 persons on one side of its center line without capsizing.

With a crew of 250 men and 50 officials and guests aboard, some 7,500 bags of sand, each weighing about 100 lb., were piled along the starboard side of the three passenger decks. At the time this was done the ship was practically stationary and its water-ballast tanks were empty. The steamer listed about 12 degrees.

## SUBSTANTIAL AND ARTISTIC MARKER FOR HIGHWAY

Few country-wide undertakings have met with more genuine cooperation on the part of the public than has the construction of the Lincoln Highway. As a single evidence of this is a marker that was erected recently by an Iowan on one corner of his property at a junction of the national artery and a county road near Boone. It is a concrete structure several feet in height which identifies the intersecting roads for motorists and shows the respective



The Concrete Marker Identifies the Intersecting Routes and Stands on a Corner of the Builder's Property

routes to Boone and Des Moines. On one surface it bears the date of its erection and the initials of its builder. It is sufficiently heavy in construction to withstand years of weathering.

*# L. R. W. Allison, 170 Roseville Ave  
Newark, N. J.*

Wm. D. Rees, Columbus, O.  
 Inv. & Mfr. - Patents Pending - Sealers

**POPULAR MECHANICS** 753  
 Price, with Descriptive Text, postage & prepaid, 30c  
**INSTRUMENT FOR REDRAWING**  
 321 **GEOMETRIC FIGURES**

Designed especially for assisting students of mathematics in the study of the conic sections, a simple, moderately priced instrument is made which may be used to facilitate the work of reproducing and enlarging complicated figures presented in textbooks. Drawings of this kind, encountered in geometry of position and similar subjects, are often small, which makes their resketching in large proportions difficult for the novice. This instrument makes the task of plotting and sketching ellipses an easy operation and allows a beginner to produce neat, quick work.

It is provided with two arms, one of which is movable, and both of which are threaded with a fine cord, a reserve of which is held on a reel. In using the instrument, it is placed with its arms extending forward and its points adjusted so as to span the foci of the major axis

of the proposed ellipse. The amount of tape needed is determined by the length of the greater axis. The former is made taut around a pencil, or pen, point placed at one end of the major axis. A line is then drawn with the

"The Zodiac Elliptograph."

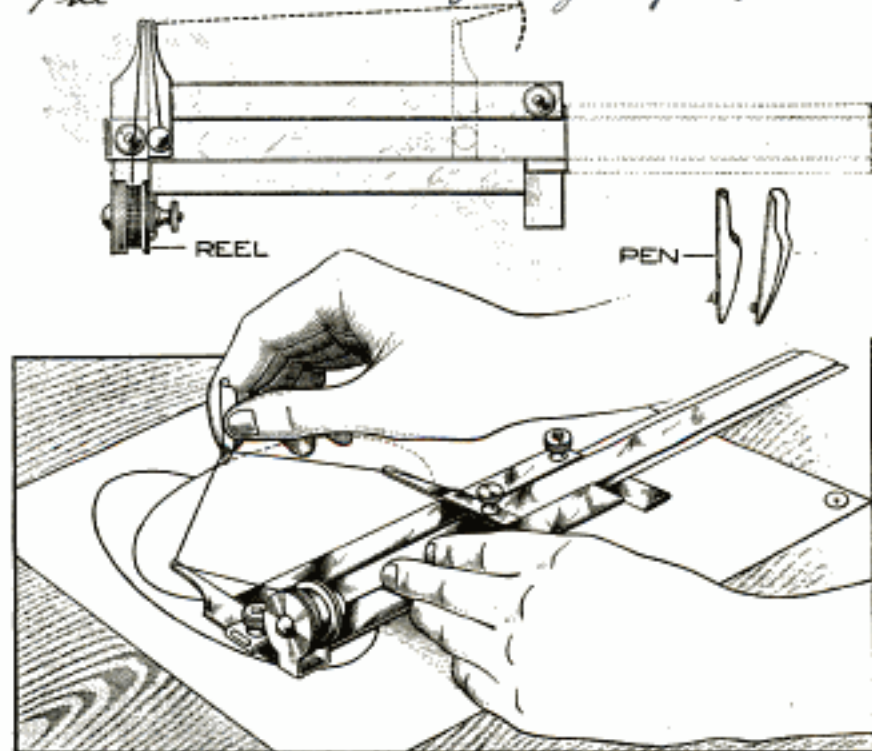

Enlargements of Complicated Figures may be Made Easily with This Instrument. The Special Pen Point Provided with the Instrument may be Used in an Ordinary Holder if More Convenient

marker to pass through one end of the minor and the opposite end of the major. By then reversing the position of the instrument the ellipse may be completed.

**ROTARY OIL-WELL DRILL**

8549 **OF A NEW TYPE**

A submersible electric motor that grips the side of the casing, but can easily be released for raising or lowering, forms one of the principal features of a new type of rotary oil-well drill that has recently been developed. When in operation the motor is held stationary at the bottom of the casing by automatic clutches and drives the drill bit through a short shaft. A 10-hp. induction motor is used. The bit is made up of two cones, each of which has a plurality of serrated cutting edges, and is of an expansible

type so that it drills a hole large enough for the casing to follow. Both the motor and bit are provided with waterways, and through these the drillings,

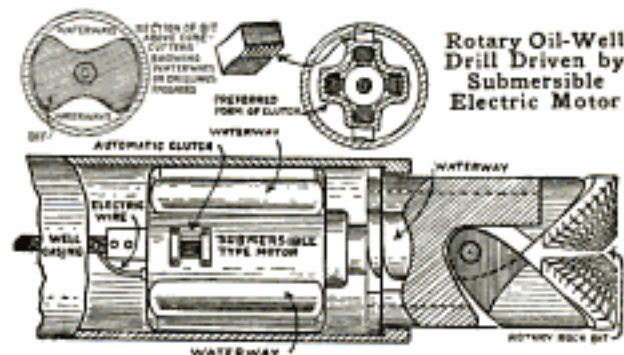

Rotary Oil-Well Drill Driven by Submersible Electric Motor

finely pulverized by the bit, float to the surface of the water, where they

Universal Drilling Machine Co.

3/27/18 Sullivan, Attol. Indiana  
 Electric Rotary Well Drilling Co.  
 321 to Vermilion St. Danville, Ill.

are removed by a bailer. Power is supplied to the motor through electric wires that are inclosed in the hoisting cable and are thoroughly protected from the water. The clutches that hold the motor to the casing are released simply by reversing the direction of rotation, and the motor and bit can then be easily raised to the surface. With this apparatus the power is the same no matter how deep the drilling may go and the weight of the casing may be used for applying pressure to the bit if required. The apparatus is rapid in its action, being capable of drilling 3 in. a minute in compact limestone, and 2 in. a minute in red granite.

### GAS PLANT DESIGNED FOR THE COUNTRY HOME

One of the latest conveniences for the country home, where as a rule gas cannot be obtained from a commercial plant, is an apparatus for converting line into gas and

storing it so that it can be piped about the premises as needed. An important feature of this

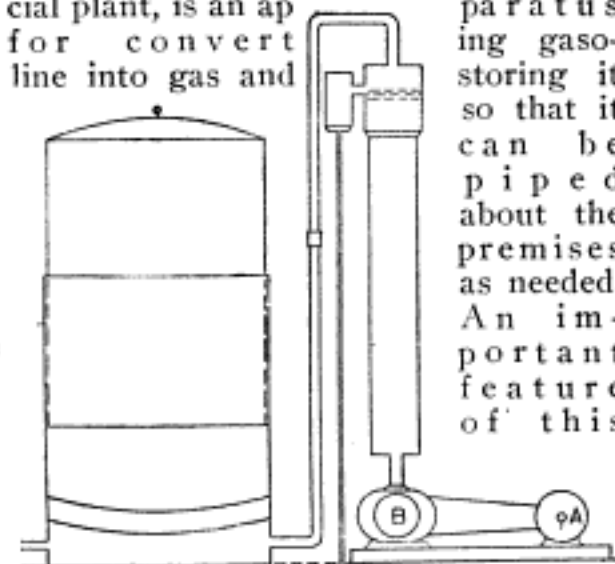

Apparatus for Converting Gasoline into Gas; Air is Forced into the Upright Cylinder by the Blower B, Which is Driven by the Motor A; the Air and Gasoline, After being Mixed in the Enlarged Upper End of the Cylinder, Pass through the Pipe into the Storage Tank at the Left

apparatus is that it does away with the necessity for having the liquid gasoline near a flame. The only power needed is a small motor for running the blower that forces the air through the generator and into the storage tank. The generator consists simply of a vertical cylinder with an enlarged top in which are baffle plates. Adjacent

to the cylinder is a carburetor to which the liquid gasoline is fed either by gravity or by a force pump. The carburetor discharges the gasoline on the baffle plates in exactly the right quantities to form the required mixture of air and gasoline, which permanently retains the form of a vapor. From the generator the mixture of air and gasoline passes through a pipe to the storage tank. The top of this tank consists of a bell that rises and falls with the varying content of gas and is equipped with a water seal exactly like that of one of the big tanks used by commercial companies. When power is furnished by an electric motor or water wheel, the plant can easily be rigged for automatic operation by the bell. With this arrangement, when the tank has been pumped full of gas, the power is automatically shut off, and the bell lowers gradually as the gas is used. When the supply is almost exhausted the apparatus is again started automatically and another installment of gas is made. The gas is said to be practically odorless and safe, there being no danger to animal or plant life when a burner is left open by mistake. It is claimed that the cost of the gas is less than half that of producer gas.

### COURSES OF SHIPS IN FOG INDICATED BY SIGNAL

There are few things more trying to a mariner than the uncertainty which accompanies the sounding of a foghorn, for while he knows that another ship or dangerous water is near, it is very difficult for him to determine with any degree of certainty the direction of the sound source, because of puzzling echoes. To overcome this and lessen the danger of vessels colliding under such conditions, a new signaling apparatus has recently been invented. It consists partly of a steam-operated sounder making a loud hissing noise which is echoed very faintly, if at all. A special receiving instrument is used to detect the sound and indicate the direction of its source. This con-

D. W. Smith  
 212 St. Vincent St.  
 Glasgow, Scotland.

POPULAR MECHANICS

"Smith's Patent Localizable Fog Sound Signal"

sists of a concave reflector, at the focus point of which is a receiver provided with ear tubes. The device is placed on deck and so mounted that it may be turned to the various points of the compass. Unless it is pointed almost directly at the source, however, the signal cannot be heard. The hissing blast is blown following the use of the ordinary whistle. When the whistle is heard the operator of the receiving instrument on some adjacent ship turns the reflector until the hissing sound is audible to him. A pointer arm which moves over a compass dial and is actuated by the turning of the reflector then shows almost exactly the direction from which the signal has come. Repeated observations of this kind will

crete or a little below it, and the form is secured to the rod by means of the bolt. After the concrete is placed, the form is removed by unscrewing the

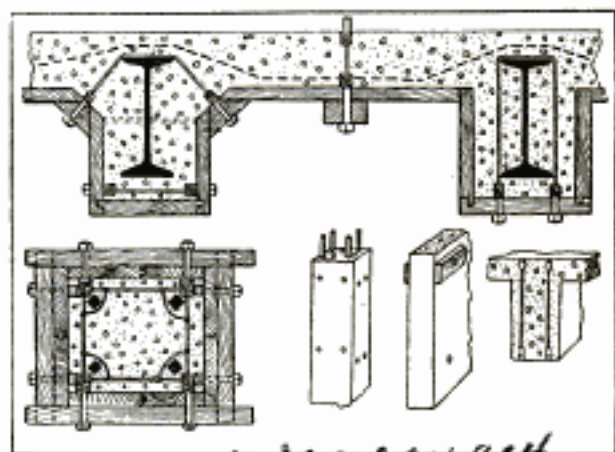

The Rod Not Only Serves as Reinforcing After the Concreting is Completed but Provides Sockets with Which Attachments are Easily Made

Sound Producer and Receiving Apparatus of the New Marine-Signaling System

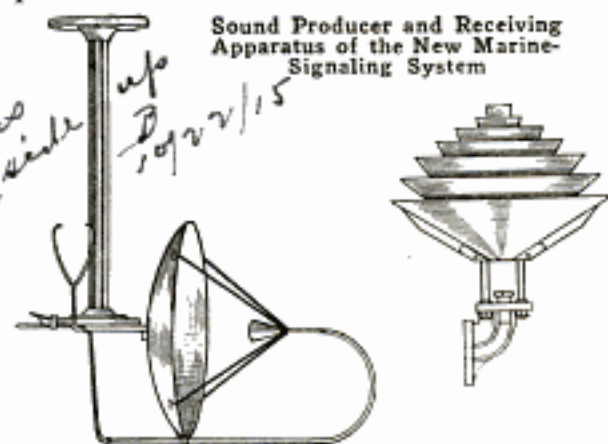

show whether the signaling ship is stationary, or what general course it is pursuing.

NEW FORM HOLDER FOR CONCRETE WORK

A new form holder for concrete construction consists simply of a specially made rod that is left permanently in the wall after the work is finished, and not only serves as reinforcing but provides sockets by which attachments or future construction may be connected, if desired. It can be used to bind the two sides of a wall form together, or can be placed with one end imbedded in the concrete, to suit the conditions. Each end of the rod is closely coiled so that the coils serve as threads for specially made bolts. The rod is placed so that the end of the coil comes flush with the surface of the con-

bolt, and the coil is pointed over, if it is not to be used as a connection. The rod serves as a spreader as well as a tie.

NEW THEATER CHAIR WITH FOLDING ARMS

A new type of chair designed for use in theaters, and other public places, is so made that when not in use both the arms and seat fold up against the back and are out of the way. This chair is intended as either a fixed or portable seat. It is equipped with rubber floor

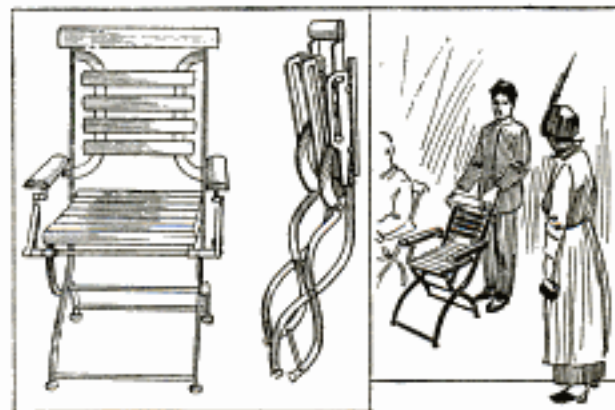

In This Theater Chair Both the Seat and Arms Fold Up against the Back

tips which are attached to the iron feet by screws. With the tips removed the screw holes are used in attaching the chair rigidly to the floor.

Unit-Hall Construction Co., Inc.  
 132-8 Broadway  
 New York

Invention of New Rubber Floor  
 St. Louis, Mo.

## NOVEL AND PRACTICAL THINGS FOR THE HOME



1 Folding Shoe-Tree for Travelers

It is made compactly of metal in three sections. These nest together when the device is not in use, allowing it to be carried in a suitcase or bag, taking up but little space.

As an attachment for an ordinary broom, an ingenious bellows device has been invented which is intended to collect the dust when sweeping is done. A trap placed on the suction apparatus receives the fine particles of dirt as they are collected before the broom. A flexible connection between the handle and the broom provides for the operation of the bellows.

2 Dust-Collecting Attachment for Broom

One of the latest step-saving conveniences for the kitchen is a built-in garbage receptacle. This has a steel body which contains a garbage can. It is set in an outside wall so that access to it is given both from the inside and exterior of the house. On the outside is a hinged door that enables the removal of the receiver by a collector.



3 Built-In Garbage Receptacle

Several practical functions are performed by a can opener lately devised.

It is designed to cut the tops of round, oval, and square cans; remove milk-bottle caps, lift the metal tops sealing bottled goods, and do other similar things. It is provided with a disk knife which cuts a circular hole.



4 General-Utility Can Opener

Incorporated in the handle of a folding umbrella, which will fit into a suitcase, is a small electric flash light. The battery is contained in the stock, entirely out of sight but readily accessible. When it is raining it may be used to illuminate a sidewalk, while at other times it may be employed in the same capacity as a pocket lamp.



5 Flash Light Fixed in Umbrella Handle

A specially designed top has been invented for earthen jars and metal cans. The cover is fitted with crossed arms which grip the rim of a receptacle. The cover may be clamped in place tightly, so that the utensil to which it is applied is made air-tight, by the use of thumbscrews.

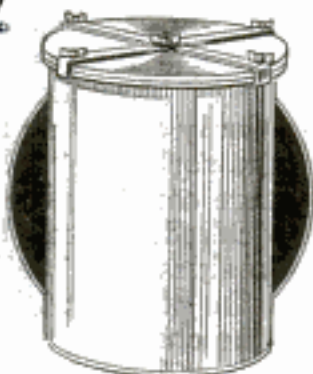

6 Air-Tight Cover for Cooking Utensils

Fixed in a weather-proof case, a clothesline reel is made which protects a rope from rotting, or being soiled by exposure, and also lessens the trouble of removing and subsequently re-stretching it. The device is attached to a post or building. When a line is wanted, the desired amount of rope is drawn out and one end fastened in place. The reel winds automatically, and holds sufficient rope for ordinary purposes.

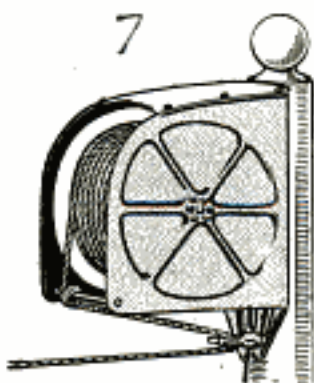

Serviceable Reel for Clothesline

For kitchen purposes a signal clock has been devised which embodies convenient features for a cook. The circumference of the dial is marked in minute periods and after each of these characters is the name of some dish requiring the indicated number of minutes for cooking. The call hand is set when a dish is placed in the oven or on the stove. At the proper time the alarm rings, indicating that at-



Alarm Clock Designed for Kitchen



Electrically Heated Baking Oven

tention should be given the food. Suitable for general baking purposes in a small family, a neat electric oven is made after the pattern of a roasting pan. It is constructed entirely of pressed steel and is intended to be connected to a lamp socket. An auxiliary section,

which fits in the middle, increases its size sufficiently to receive large roasts or chickens.

To prevent the clogging of the drain pipe of a kitchen sink, a refuse pan now made is provided with a grease trap. This permits only water to pass through the strainer when parings and meat scraps are scraped from dishes and cooking utensils.



Sink Pan with Grease Trap

An adjustable swinging gate for porches and staircases in homes where there are small children, has been invented. It is made of hard wood, and in one size is capable of being extended 3 1/2 ft. This feature makes it especially useful for persons whose residence is temporary. When not in use it may be stored in a small space.



Adjustable Gate for Porches

In a self-heating flatiron that has lately been invented, the fuel, consisting of gasoline under air pressure, is carried in a tubular handle. This eliminates the customary tank, characteristic of similar devices. Six ounces of gasoline is sufficient to operate the iron for approximately four hours. The heat is regulated by a small knob at the rear. It is especially convenient for outdoor work, and for use in homes which are not supplied with electric current.

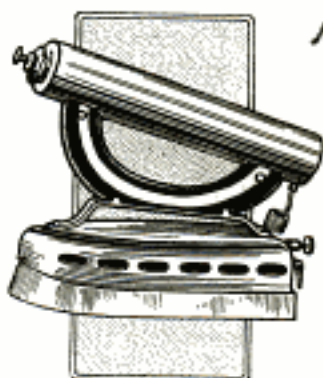

Cylindrical Handle Holds Fuel

*Fullagar Engine, Limited*  
*South Shore-road, Gateshead-on-Tyne*  
*England*

*See also V. Engineer (London) 7-10-14 p 50*  
*also Engineering " " 7-17-14 p 103*  
*" " 7-25-14 p 164*

758

**POPULAR MECHANICS**

**ENGINE WITH TWO PISTONS FOR EACH CYLINDER**

A simple and practical solution of the problem of making an internal-combustion engine in which the pistons are forced apart by the explosion of the gas between them has been worked out in England. This engine necessarily has two cylinders with piston rods working side by side on one shaft. The cylinders have open ends and the top piston in each cylinder is connected by a diagonal rod with the bottom piston in the other cylinder. With this arrangement the cylinders work alternately and the power is transmitted equally to both crank arms when the pistons in either cylinder are thrust apart by an explosion. The obliquity of the diagonal rods is small, being less than the maximum obliquity of the rods that connect the piston rods with the crank arms. The engine is of the two-cycle type, and each crank arm therefore receives two impulses to each revolution of the shaft.

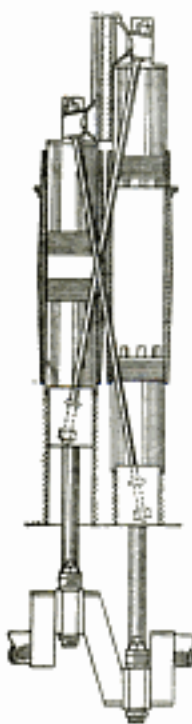

*Invent or H.F. Fullagar*

*was built by W. H. Allen & Sons Ltd Bedford Eng. &*  
*given Arnold's Chamber Westminster London*  
 dovetail slots, while the special wrench used in handling the screw has six flukes that fit into these slots. The dovetails are of such shape that when the screw is being driven hard, the special wrench gives it a true rotary motion without any tendency to expand and crack the hollow portion of the screw.

**NEW BOLT WITH FOLDING TOGGLE**

A recently invented bolt, designed for working in close quarters, is equipped with a double spring toggle which folds against the sides while the bolt is being slipped through the hole, and springs outward and furnishes a wide and solid bearing as soon as it is released. This bolt can be used with a nut or as a screw bolt. The toggle is arranged to work on the screw threads when it is used as a screw bolt.



**NEW APPARATUS FOR MAKING WATER GAS**

Plants for producing water gas are as a rule operated on the intermittent principle, about 60 per cent of the time being given to actual gas making and the remaining 40 per cent to heat regeneration and clinkering. The greatest difficulty with plants designed for continuous operation has usually been that they were too wasteful to be operated economically. A continuous plant that works along entirely new lines has recently been invented, and it is claimed that this plant satisfies all the requirements of economical operation. In this plant the large installation of steam boilers usually employed with a water-gas plant is omitted, and the steam is obtained from a water tank placed beneath the fuel bed, and arranged in such a way that the water is evaporated by radiation from the

**HEADLESS SETSCREW THAT DRIVES FLUSH**

A new headless setscrew is designed to be driven flush with the surface, and is particularly adapted to use where frequent adjustment is necessary. The



**New Headless Setscrew: The Dovetail Slots are so Shaped That the Special Wrench does Not Expand and Crack the Screw**

upper end of the screw is hollow, and the inner face is provided with six

*Bristol Co.*  
*Waterbury, Conn.*  
*mfg under Goodwin Patent of 10-14-1913*

*Pacific Company*  
*1218 Marquette Bldg.*  
*Chicago*

*London Tyne Engineering Co.*



heated water gas as it leaves the plant. One of the essential features of the apparatus is an arrangement for the admission of superheated air to the fuel bed.

**SIMPLE INSTRUMENT OILS  
MOTOR-CAR SPRINGS**

For oiling motor-car springs properly, distributing grease where it is needed and not over the outside, a lubricating instrument has been invented which separates the leaves of a spring easily and inserts oil or grease between them. The device consists of an eccentrically mounted wedge supplied with a grease cup which forces its contents through an orifice in the tool into the space between the leaves. In use, the instrument is placed over a spring, and by pulling its handle, the wedge is drawn between the metal layers, parting them sufficiently so that

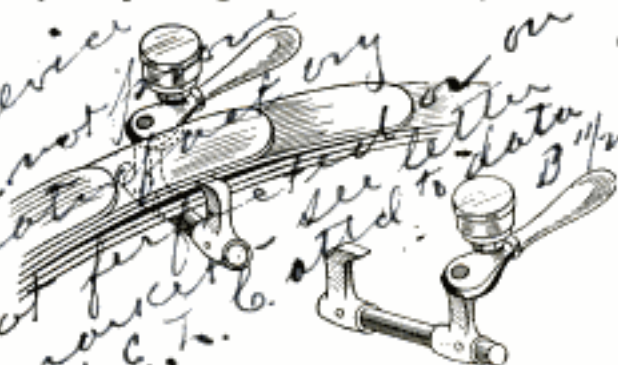

Motor-Car Springs may be Oiled with This Instrument in a Few Minutes

a turn of the cap on the grease cup pushes the lubricating compound into the proper place.

**NEW DEVICE FOR TILTING  
HOT-METAL LADLE**

Tilting a ladle so that the molten metal will be poured in an even and smooth stream is an operation requiring much skill when done by the usual method. An ingenious device recently patented is designed to do this mechanically. The ladle rotates on fixed bearings, as shown, and is tilted by a cable attached to the back. The feature of the invention is that the cable passes over a cam which rotates at a uniform

speed. As the cable is wound on the cam the speed of tilting gradually increases so that the rate of flow from

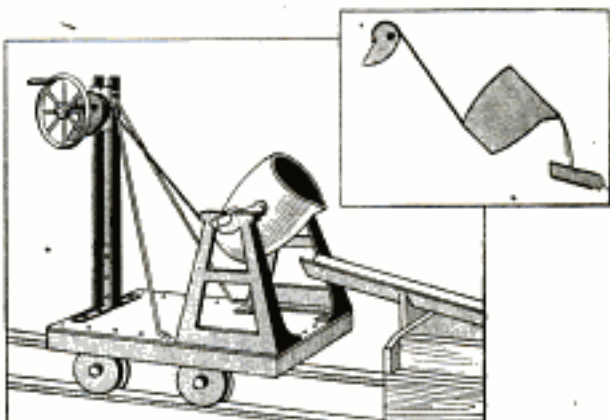

Molten Metal is Poured from the Ladle in a Uniform Stream

the spout of the ladle is exactly the same at all stages of the process of emptying.

**VACUUM CLEANER FOR TEETH  
NEW DENTAL APPLIANCE**

Among the recently invented dental appliances which are being introduced, is a vacuum cleaner for the teeth. This is intended to furnish a method for removing small particles of foreign matter which cannot be reached easily by other processes, and also to stimulate blood circulation in the gums. The device consists of a three-cylinder exhaust pump which is operated by an electric motor. A mouth cup which fits

This Vacuum Cleaner is Intended to Renovate the Teeth and Massage the Gums

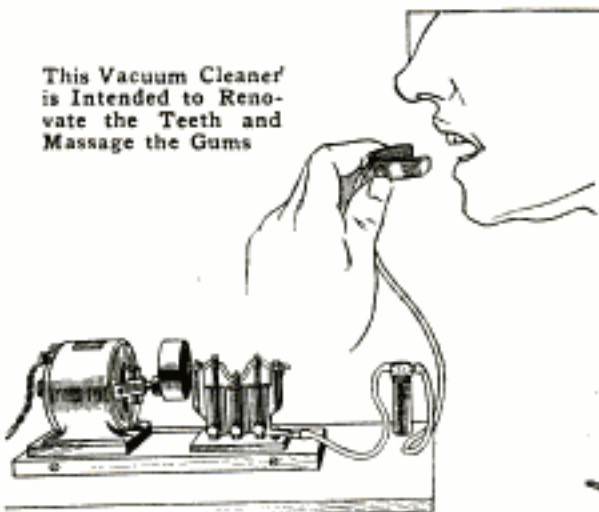

over the teeth and gums is connected to this by a rubber tube, and between these two members is placed a re-

I deal Brass Works, Toledo, O. & B. Inc. 12/20/15

Device did not work on Not for sale see letter of E.T. B 11/23/15

Deutsche Maschinenfabrik, A. S.  
Duisburg Germany.

Sanitor Co. 549 W. Washington St. Chicago

ceptacle in which the matter removed during the renovation process is collected.

### SHAVING SOAP PUT UP IN WOODEN BOWLS

A London firm of perfumers has brought out a novel shaving-soap package that does away with the necessity

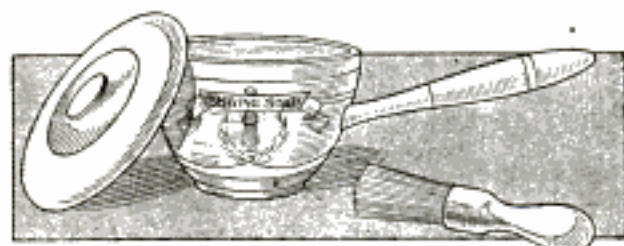

Wooden Bowl Used in Place of a Shaving Mug

for using a shaving mug. The soap is packed in a wooden bowl with which are provided a wooden handle that screws in at one side, and a wooden cover. The bowl answers the purpose of an ordinary shaving mug, and when the soap has been used can be thrown away.

### GAUGE FOR LIMITING CUT OF HACKSAWS

A new depth gauge for hacksaws consists simply of a metal strip made of pressed steel and attached to the

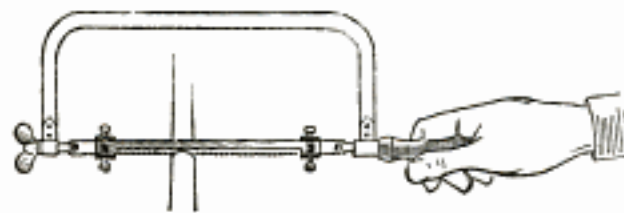

This Gauge Attached to the Hacksaw Limits the Cut to Any Desired Depth

saw at the ends by setscrews. It is easily set to limit the cut to any depth. This gauge is adapted to a great many uses and is designed particularly for such work as cutting into flexible electric-wire conduits, where, without such a gauge, there would be danger of injuring the interior insulation.

From 1909 to 1914 the estimated amount of concrete pavement in the United States increased from 364,000 sq. yd. to 19,200,000 square yards.

### NEW TOOL HOLDER HAS CAM FOR SETTING TOOL

A tool holder just placed on the market and designed for lathe and planer work is equipped with a cam which is used in place of the usual setscrew for holding the tool in position. A number of important advantages are claimed for this arrangement. The holding efficiency of the cam is said to be greatly superior to that of the setscrew, while the greatest disadvantage of the setscrew, the breaking of the head with the trouble that results from such an accident, is entirely done away with. With the new holder the tool is quickly and easily secured by turning the cam



through an angle of about 30°. The cam has a hexagonal end and the equipment includes a special wrench for setting.

### COAST POSITIONS ATTACKED BY SUBMARINES

Bombardment of coast cities and of military works ashore has been successfully carried out on several occasions during the present war by submarines operating at short range. The first of these attacks occurred early in August, when a British submarine bombarded the Zeitunlik powder mills on the eastern side of the Bosphorus, near Constantinople. Several weeks later a German submarine bombarded the towns of Whitehaven, Harrington, and Parton at the entrance to the Solway Firth on the west coast of England. Submarines carry guns of small caliber, but they are able to approach a coast unobserved, especially at night, and can then rise to the surface and open an effective fire at short range.

Army & Navy Jour. 8/21/15



## The Private Garage

By JAMES STANTON

**S**INCE private garages are usually built as ground-floor or one-story structures, with practically no space under the floor, a convenience like a pit appears a luxury, for the expense of digging and properly lining and protecting the walls is out of proportion to the benefits derived from it. But such buildings, if set on sloping ground, offer all the possibilities of a pit with but few shortcomings, as will be detailed.

When, as is often the case in suburban localities, the lot on which the garage is to be built slopes from 4 to 10 ft. in the length of a building, substantial supports must be provided for the elevated side. It may be that a basement, or cellar, is excavated to the lower level and a floor put down, or the ground may be left in its natural slope, but in any case the expense of inclosing the space below the main floor is not large, and the future will prove it worth while. A garage so

built may have a trapdoor in the floor, and a man standing below can work at the under side of a motor without stooping. An inspection lamp will only supplement the natural light that will come from below, and a dropped object can be located with ease.

Such a pit does away with crawling on the floor, lying on a creeper and holding a light in one hand while assembling two or three pieces with the other; with the grease and litter of the average floor, and the discomfort of having to work in a strained position. Moreover, inspections and adjustments of hard-to-get-at parts are often neglected when there is no pit.

An excellent example of a private garage embodying some of the features mentioned was found in a barn built on a hillside, which was converted into a garage. It was a single-story affair and had at one side of the large room a stairway leading to the cellar, or basement. It was decided to utilize

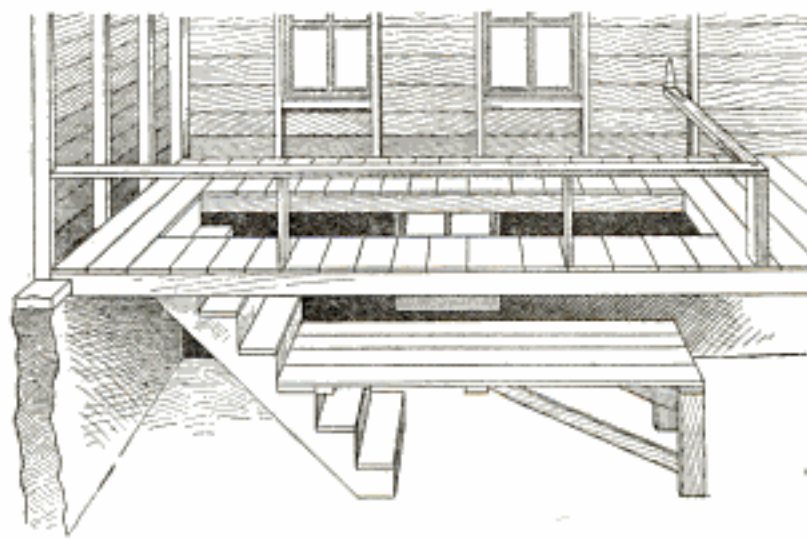

A Stairway in the Corner of a Large Barn Floor Makes an Excellent Place to Get at the Under Side of an Automobile for Adjustment or Making Repairs

the stairs for work under the car. To that end two windows were cut through the wall near them, which gave an abundance of light, and a platform was built that formed a floor at a convenient level. This platform was strongly constructed, one end resting upon the stairs, and made wide enough to prevent articles from falling off. It did not require any fastening and could be easily moved out of the way when not wanted.

The trapdoor over the stairs was removed, and a substantial railing built around the opening. A hinged bar, lifted to permit a car to run over the hole and dropped back into place when the car is moved away, made the opening perfectly safe. A construction such as this is feasible also for a public garage wherever state regulations permit any floor opening at all. It is cleaner and lighter than a pit, and more comfortable for the workmen. The addition of a trapdoor, working auto-

matically with the removal of the car, would overcome the only objection.

Experience with automobiles has taught that rainwater is the best to use in radiators. Yet few use it, although it is as easy to get as to attach a hose to the faucet. Provide a gutter on one side of the garage roof and a short length of pipe leading from it, together with a substantial barrel, or half barrel. That is all the initial investment and there is no upkeep cost, for no meter need be applied. A spillway, or drain, will naturally be laid to carry off the water from the roof, and the barrel will stand on this and overflow into it. A more elaborate arrangement would be to set the barrel with the top at the height of the eaves, in which case the water may be piped to suit the requirements. A few drops of kerosene on the water every 10 days will prevent the breeding of insects. This will provide a good supply of the softest water obtainable.

### Road Roller Made of an Old Boiler

One of the old-style boilers without an attached fire box, or an upright one, makes a fine road roller. In building

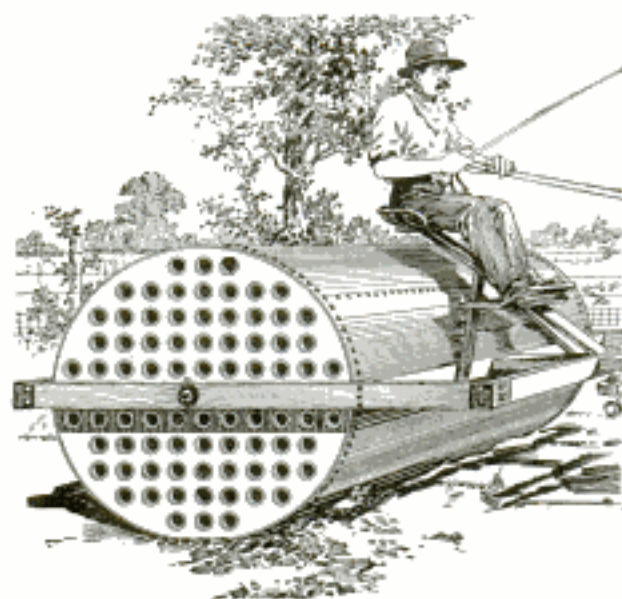

An Old Boiler with Frame Attachment for Use in Rolling Soil for a Roadway

roads in a southern state, one of these boilers was used. A hole was drilled through the center of each head, and a

shaft run through them, the ends being used for hauling it over the roadway by means of a special-built frame and tongue for a team of horses. The left of the boiler was sufficient to pack very loose soil to make a solid roadbed.

### Makeshift Tightener for a Guy Line

One day while working for a mining company, I was sent alone up an incline to tighten the guy line on a sheave-pulley frame. The only tool I had was a small monkey wrench, and when I arrived on the job I had to think of some easy way to do a hard thing. I thought of a way and returned to the shop for some cable clamps and two long bolts with nuts and washers. I run more threads on the bolts to make them 8 in. long. On my way back along the railroad track I found four fishplates and bolts, used to join the ends of rails. With these parts assembled, I soon had a tightener ready to work as shown in the illustration.

The fishplates are shown at A, with

the bolts in place, drawn just close enough so that the bolts B move freely. Four wood blocks were fitted and placed in at C, to keep the bolts B close up to the center bolts of the fishplates and to keep them in line with the cable. The cable clamp was placed on the loose end of the cable, at D; then the fishplates were spread apart as far as possible, and another clamp fastened to the cable, at E. It was only necessary to turn the nuts on the bolts B to take up the slack in the guy line. When the end of the threads was reached, the line was still slack and needed more tightening. A clamp was then placed on both lines just ahead of

face. The illustration shows the gold leaf on a sheet of the paper and how it appears when the gold has been re-



Handling Gold Leaf with Paraffin Paper to Prevent Waste and for Covering Only Necessary Surface

moved to cover the surface of a letter.—Contributed by James M. Kane, Doylestown, Pa.

#### Holding Spring for a Gear-Box Filler Cover

The small cover closing a hole through which the grease was poured into a gear-box case was held in position by means of two studs with ordinary wing nuts. The nuts would become loose and drop out, and the studs, being made of very soft material, wore badly. It was finally decided to discard the stud-and-nut method of holding the cover, and the arrangement shown was substituted in its place. The studs were first removed from the case and the holes left by them filled with lead. A piece of flat spring steel was bent into the proper shape and

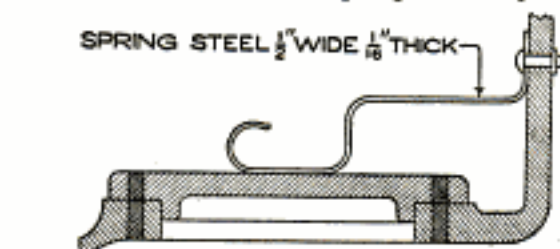

A Stout Spring Makes a Better Holding Device for a Gear-Box Cover than Bolts

bolted in such a position that its end pressed at the center of the cap. In this manner the troublesome nuts were eliminated, and the advantage of having a cover device that could be quickly operated was gained.

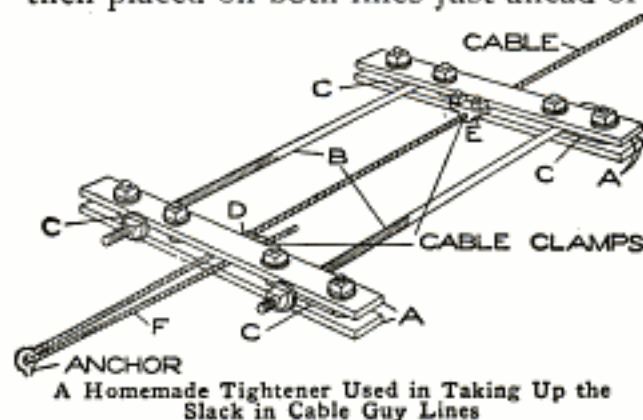

A Homemade Tightener Used in Taking Up the Slack in Cable Guy Lines

the anchor bolt, at F, to hold the slack taken up. The tightener was then reset and used as before.—Contributed by E. C. Lane, El Paso, Texas.

#### A Method of Applying Gold Leaf Economically

Recently I had quite a lot of gold leaf to apply and was assisted very materially by a stunt I found in an old English sign painter's manual. The directions called for a paper prepared in a certain way, but I used ordinary paraffin wrapping paper as a substitute.

Taking the pieces of paraffin paper, I placed them carefully over the gold leaf in the book and rubbed them with my fingers. The gold adhered to the paper and could be handled without danger of its blowing away. When placed against the sized surface and rubbed with a piece of cotton, the paraffin paper allowed just enough gold to be released to cover the sized sur-

### Ice Creepers

In crossing a pond in winter where the ice would carry my weight, I found it difficult to travel when a very light snow or frost had fallen. To save time in traveling and to

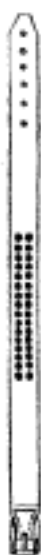

prevent slipping, I purchased two skate straps and made creepers of them. They were cut to a length to reach over the ball of the foot, as shown. The portion of the strap under the shoe sole was filled with tacks so that their points would enter the ice. I can now walk over the ice without fear of falling.—Contributed by W. A. Potter, Lexington, Mass.

### Guard Holder for Flat Drills

The common flat drill, used for drilling preliminary boring holes in chucked work on the lathe, is held in various ways to suit the convenience of the lathe operator.

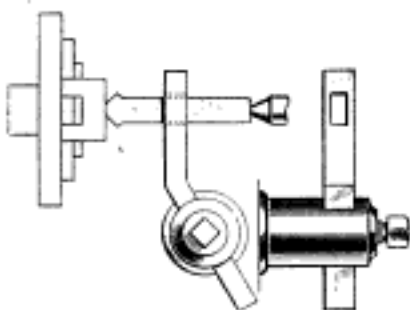

It is, of course, not only necessary to hold the drill rigidly so that it will not turn, but the center of the tailstock, holding the end of the flat drill, must be operated so as to act as a feed for the drill. It being impossible to do two things at once, an accident is often the result of trying to perform such an operation, as a wrench cannot be relied upon to keep the drill from turning.

The sketch shows a jig, held by the tool post and provided with a slot, through which the flat drill passes. The only attention required of the operator is to feed the drill by the cen-

ter of the tailstock. The jig can be easily and quickly centered for the drill. It is also an excellent safety device, for it is impossible for anything to get caught, or fly around and injure the operator of the machine, since the common flat drill, when ground correctly, will not dig or drag into the work in the chuck, cutting only when it is forced by the pressure applied to the center of the tailstock.—Contributed by F. W. Bentley, Missouri Valley, Ia.

### Calibrating Thumbscrew on a Ruling Pen

It is quite difficult for the beginner in a drafting room to set the nibs of



the pen each time to draw uniform lines. This can be done accurately if the thumbscrew is calibrated and a mark made on the nib of the pen as shown. It is an easy matter to turn the screw a certain number of times to a mark that will set the nibs the same distance apart each setting.—Contributed by A. Jaminet, Denver, Col.

### Softening the Harsh Tone of a Violin

All violins of the inexpensive kind, and many high-priced ones, have a loud, harsh, and unmusical tone.

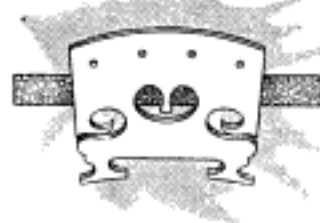

A good remedy for this is to purchase a new bridge, and instead of cutting it down, drill holes just large enough for the strings as shown. If the sound is too much muffled, trim a little off from the top of the bridge until the proper tone is secured.—Contributed by C. E. Wurth, New York Mills.

# Stenciled Initials or Monograms on Automobiles

By JAMES M. KANE

THE practice of placing the owner's initials, or monogram, on some portion—usually the doors or side panels—of the automobile is becoming more common, and with a good reason. Possibly it was unnecessary some years ago when cars were few and not many alike, but with the rapid increase in the output of cars, especially of the lower-grade cars, there are considerably more cars alike, and since the majority of car owners probably could not remember their license numbers if put to it, there is need for some identifying mark that can be distinguished at a glance.

I find that the use of a carefully cut stencil insures clear, quick work, as it can be placed on the exact spot without resorting to the preliminary outlining, trial marks, and spacing lines necessary when working in the usual way. As the high gloss on the varnished surface of an automobile will show the least scratch, the fewer preliminary marks the better, hence the stencil for safety. In addition to this, it can be put away for future use, insuring the car owner of an exact duplicate of the letters when the car is repainted, or when another car is purchased.

Ordinary stencil paper is not so

blank spaces left by the ties in the stencil are afterward filled in so as to form a complete letter, these ties can



HOLDING STENCIL ON THE WORK



REMOVING STENCIL

Applying and Holding the Stencil in Position, and Removing It after Painting the Surface

be left at portions of the letters that are most likely to curl up. Ordinary stencil work requires that the ties be placed with due regard for the general appearance of the finished work, as the



LAYING ON THE LEAF



REMOVING THE LEAF WITH COTTON

Applying Metal Leaf with a Camel's-Hair Brush and Removing the Surplus Leaf

tie spaces are not filled in. The stencil described must lie flat at all points, and the ties are designed with this object in view. The ties should not be too heavy.

As the stencil will lie closely to the varnished surface, the finger nail would seem to be the most natural thing to use in removing it, but as this would be likely to result in a scratch as well as in smudging the letters, the best plan is to turn up two corners of the stencil, either of which can be easily grasped and the stencil lifted off without trouble. The color used should be almost dry so that it will not slip beyond the outlines of the letters. After the stencil has been removed, the color can be used more freely in going over the letters and filling in the spaces left blank by the ties.

While color gives very satisfactory



The Stencil as It is Cut; after Applying; Completed Letters; Sized and Pounced

good for the work as heavy, smooth-surfaced writing paper, or bond paper thinly coated with shellac. As the

results, metal leaf is much better, as it insures an even surface, wears better, and shows no brush marks. Gold or silver leaf may be difficult for the amateur letterer to handle, but aluminum leaf is stout enough to be applied by the inexperienced person. Gold



leaf is now put up on prepared paper that can be laid over the work and gently rubbed, causing only the gold that comes in contact with the

painted or sized surface to adhere, the balance of the leaf remaining on the paper.

The work should be pounced if metal leaf is applied, as the least tackiness of the varnish will cause the leaf to stick where it is not wanted. The pounce is merely a small bag made of fine cheesecloth, filled loosely with whiting. This is dabbed on the surface and forms a resist against the leaf. It does not prevent the paint or size from adhering,

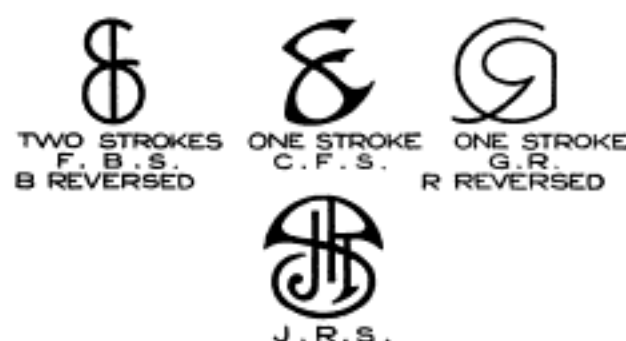

Original Monograms, Showing How Three Letters may be Combined to Make an Individual Mark

however. A wet sponge removes the whiting after the letters are dry.

While letters are sufficiently distinctive, the use of a monogram adds an air of exclusiveness and individuality to the job and removes it from the commonplace.

☞ In taking pipe apart when the joints are stuck so that they will not turn, heat the coupling or fitting; or hammer it, not the pipe, and the pipe can be easily unscrewed.

### Making Use of Broken Concrete-Sidewalk Material

Through a mistake there was delivered to my house a load of defective concrete-sidewalk material that had been torn up by the contractor for replacement. Not caring to pay for hauling it away, I sought some use for it, and found such a satisfactory one that I am going to get another load, which can be had for the hauling, as usually the contractor must haul it a long distance to dispose of it.

I squared up the concrete into flags with a cold chisel, and with the various sizes matched up on the edges, it made an excellent 2-ft. walk through the poultry yard. The ground was excavated about 5 in. deep, and filled in 1 in. with heavy soil. Then water was turned into the trench, making a slush, and while in this condition, the flags were set in and forced into the slush, which ran up between them. The soil, when dried out and hardened, made a firm base conforming to the uneven bottom surface of the flags.

With the odd broken pieces and chips, I constructed four drains directly under the drain spouts from the house, carrying the water well into the soil and into the garden bed, where it can be used to better advantage than on the lawn. This also avoided the gullies on the lawn that heavy flows from the drain pipes are apt to create.—Contributed by Victor Labadie, Dallas, Texas.

### Repairing Pedal Crank on a Motorcycle

The weakest point on the crank hanger of a motorcycle is the threaded projection on the end, and this usually is broken in case of a spill. The usual remedy is a new crank, but this expense can be avoided by the simple repair shown. The end of the broken part is filed, or ground down, level with the shoul-





der, and a hole drilled and tapped for a machine screw. This will not only hold as well as before, but it will make possible a quick repair on the road in case it is damaged in a like manner.—Contributed by E. K. Marshall, Oak Park, Ill.

### A Disappearing Desk Light

On high desks, such as bookkeepers use, the ordinary standing lamp is in the way, not only during the day, but also when in use among large books. This condition led me to contrive a light which could be pushed into one of the pigeonholes when not in use. A thin board was cut as long as the pigeonholes are deep and just wide enough to slide freely in and out. The front piece was then nailed on, and a small brass knob placed in the center. A lamp receptacle was then screwed on, and a piece of bright tin bent into a semicircular shape to serve as a reflector. Tack this to the board and then fasten in a thin strip of wood on each side of the pigeonhole near the top for the board to slide on. Screw in the lamp and connect up with a flexible cord, which should be run out through a hole in the back of the desk, leaving the cord sufficiently loose to permit the lamp to be drawn out.

A light arranged in this manner leaves the bed of the desk perfectly free,

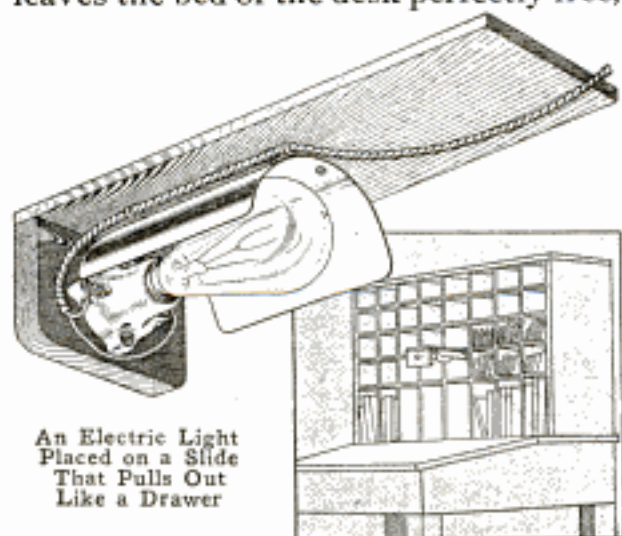

An Electric Light Placed on a Slide That Pulls Out Like a Drawer

shades the eyes, and illuminates the work in a very satisfactory manner.—Contributed by John D. Adams, Phoenix, Ariz.

### One-Man Control for a Double-Deck Boat

In my seagoing yacht I installed a one-man control after building an upper deck so that the boat could be

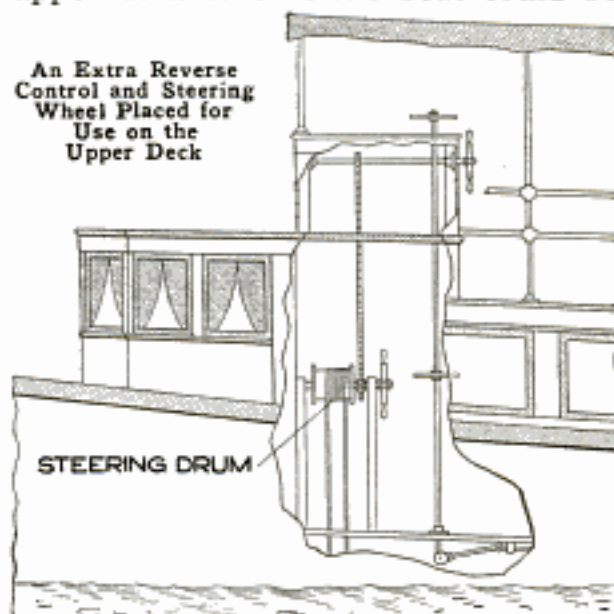

handled from either deck. The added control and steering device was practically the same as used in the wheelhouse. The rod controlling the reverse was simply extended to the deck above, and a handwheel attached to it. The wheel used was one purchased from an automobile dealer, taken from a steering post of an automobile. A sort of countershaft was installed, carrying the extra steering wheel on the rear end and a sprocket from which a chain was run to the steering-drum shaft.—Contributed by W. F. Quackenbush, New York City.

### The Appearance of Casehardening Given to Steel

A solution of 1 part nitric acid to 20 parts of water will produce a surface on polished or ground steel to give it the appearance of casehardening. Immerse the object about 20 seconds, then rinse in cold water.

Most drills are broken by unfair usage, such as crowding too hard before the drill has entered its full cut, or after the point has come through the work.

## Base for a Motor Drill

A decided improvement on motor drills, as shown in the illustration, is to replace the handle on the head with

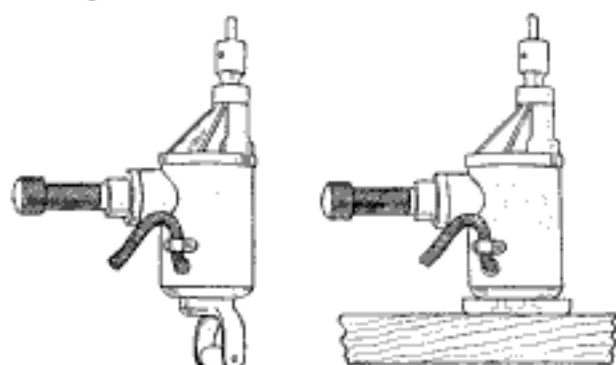

The Attached Base to the Motor Drill Makes a Flat Surface for Setting It on a Bench

a flat, round wood base, about  $1\frac{1}{4}$  in. thick, with a diameter equal to the body of the motor. This will allow the motor to stand on end, which makes it most convenient for the insertion of drills.

It is also a safety attachment, as in taking hold of the motor by the chuck end, it can be placed almost anywhere on a machine with safety and without danger of rolling off. It makes a better breast pressing surface, and once used, will never be discarded. It also makes it possible to use the motor as a speed lathe for dressing up the ends of taper pins, and the like.—Contributed by Russell Hollis, Chicago.

Do not put up cleats on electric wiring with nails.

## A Compound Rest for a Wood Lathe

Metal turning is rarely done on a wood lathe, and, if attempted at all, the hand tools used give poor results. By adding a compound rest to a wood-lathe equipment, its scope is broadened, and even steel and cast iron can be turned if the diameter is not too large. It is also very useful in wood turning, especially so on accurate taper work and patterns.

The base is made of oak, or maple, wood, as shown, the lower piece being slotted to admit a clamping bolt. The shears and carriage body are made of cold-rolled steel,  $3\frac{1}{4}$  in. long by  $\frac{1}{4}$  in. thick, and the shear for the cross slide, 2 in. long and  $\frac{1}{4}$  in. thick. The general dimensions given in the sketch are for a rest to fit on a lathe of  $9\frac{1}{2}$ -in. swing. In fitting the angle pieces, care should be taken in drilling the screw holes and in fitting the screws. The main, flat shear is fastened to the base wood member by means of six large wood screws. The two wood pieces are clamped together on a glued joint with four  $\frac{1}{4}$ -in. carriage bolts.

The cross slide is fastened to the carriage plate with four  $\frac{1}{4}$ -in. flat-head machine screws, and is supported by four pieces of  $\frac{1}{4}$ -in. pipe of equal lengths. The cross-slide tool block has a  $\frac{1}{4}$ -in. tapped hole in the rear, and this is counterbored to  $\frac{5}{16}$  in. in front, to provide clearance for the feed screw. This block has a  $\frac{3}{4}$ -in. tapped hole in

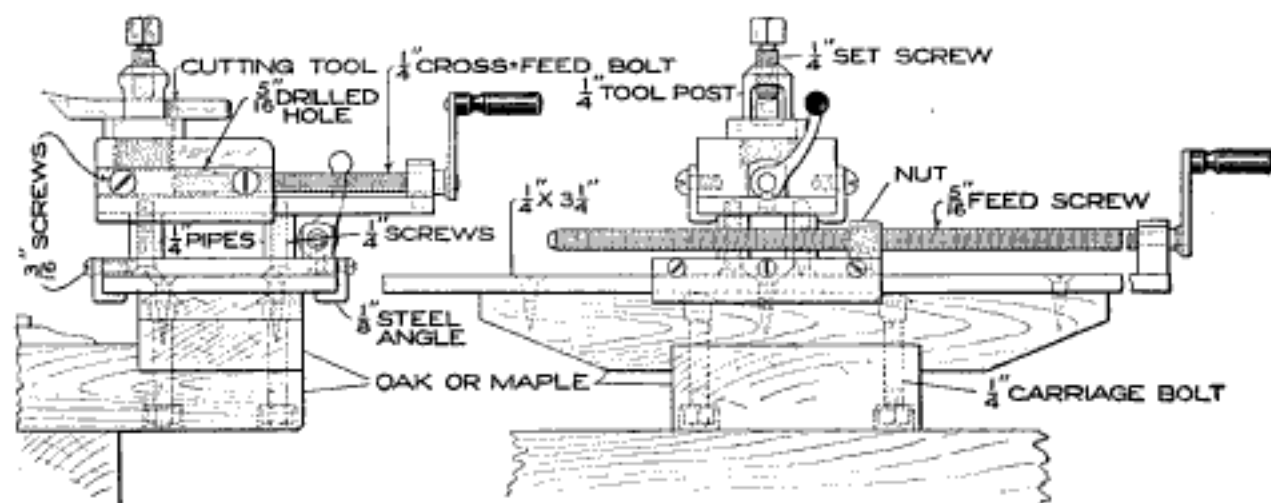

A Compound Rest Adds Greatly to the Equipment of a Wood Lathe, Which Makes It Possible to Turn Accurate Tapers as Well as to Turn Small Diameters in Metals

its upper surface for the tool post. Tools made of  $\frac{3}{8}$ -in. steel are ideal for all purposes. Small boring bars can be made of the same material and a hole drilled in one end to hold  $\frac{3}{16}$ -in. round steel tools. The end of the bar is then split, and a  $\frac{3}{16}$ -in. setscrew used to clamp the tool tightly.—Contributed by Joe V. Romig, Allentown, Pa.

### Buggy-Spindle Straightener

Any blacksmith can add, by using a little spare time, a very useful tool to his shop, to straighten buggy axles quickly. The one shown is made up as follows: The arm A is made of a 1-in. square steel bar, bent as shown, and the shorter end grooved to fit the axle, a ring, B, being used to hold them together while in use. The other end of the bar is slotted to receive the threaded end of a  $\frac{1}{2}$ -in. rod, C, that is 2 ft. long. A piece, D, is forged to fit over the other spindle, close to the

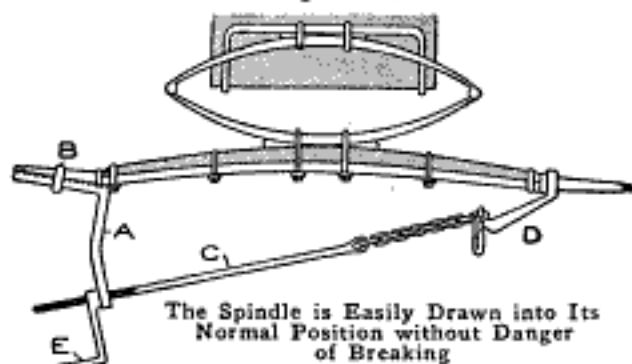

back, or larger, end, with a hook on the opposite end for attaching a chain that connects the two pieces. A crank, E, threaded to fit the  $\frac{1}{2}$ -in. rod, is used to draw the bent spindle straight.—Contributed by D. C. Goff, Knoxville, Tennessee.

### An Alarm Signal for Repair Tracks

In freight-car repair yards men are subjected to a great deal of danger, and many accidents have resulted in pulling cars from the running repair tracks. In order to prevent accidents and give men warning that the switch leading to such a track is open, and to keep from under the cars, the device illustrated was put into service. Air is always piped along

these tracks for use in testing out air brakes, and the air pipe from the device is coupled to the air line. When the switch on the repair track is opened it opens up the cut-out cock, allowing the

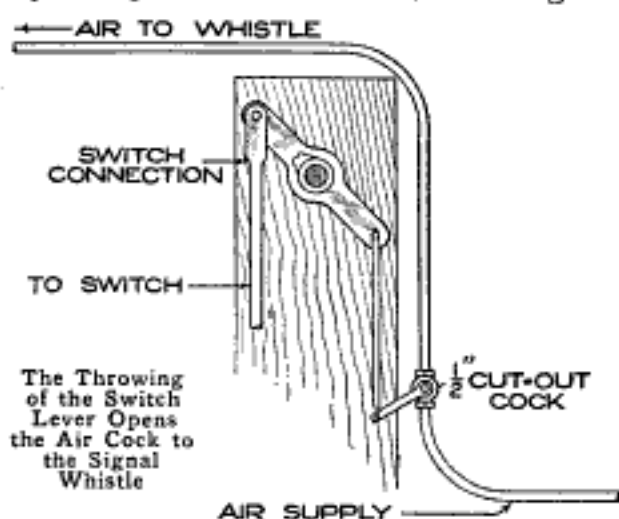

air to pass through a whistle until the switch is again closed. When the whistle stops blowing, this indicates that it is safe to go under the cars. The air pipe is  $\frac{1}{2}$  in. and fitted with a  $\frac{1}{2}$ -in. cut-out cock. The length of the arm that works the cock lever is optional and is made to suit the conditions.—Contributed by J. R. Minter, Washington, Ind.

### Keeping Cable Tube Clean on Automobile Engines

In overhauling an automobile engine recently we noticed that the tube carrying the spark-plug cables was so clogged with grit and dust that it was impossible to remove the cables. This trouble can be easily avoided if both ends of the tube are plugged in some manner, preferably with a piece of hard, red fiber, as this forms a very good insulator between the copper tube

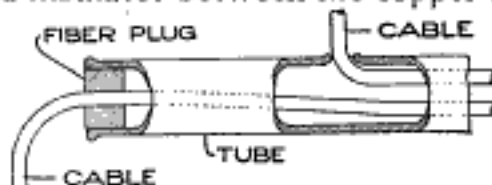

A Fiber Plug Inserted in the End of a Cable Tube to Keep Out Dirt

and the wire cable. The illustration shows the end of one of these tubes with a fiber plug inserted.—Contributed by Adolph Kline, New York City.

### Number-Plate Bracket for a Motor Truck

A quickly made bracket for a truck number plate can be constructed from two pieces of  $\frac{3}{8}$ -in. by  $1\frac{1}{2}$ -in. cold-rolled steel, hammered in the form of the letter "C" and riveted in the position shown. It is best to rivet the bracket to the vehicle frame, but it can be fastened by means of small machine screws. To give the plate a neat appearance, flat-head screws should be used with the heads facing the plate.

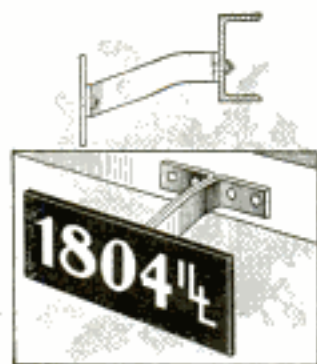

To give the plate a neat appearance, flat-head screws should be used with the heads facing the plate.

### Blower for a Small Forge

Having constructed a light forge, I had no way to furnish the blast unless a fan was made, and not wanting to take the time for making one, I used our vacuum cleaner as follows: The hose attachment to the cleaner was fitted to the discharge pipe and run to the forge tuyère; thus obtaining as good a blast as could be desired for the forge fire.—Contributed by Luther Turner, Beardstown, Ill.

### An Emergency Torch

Procure a piece of pipe of any metal, about 6 in. long and  $\frac{3}{4}$  in. in diameter, with both ends open, and fill it with absorbent cotton, or if this is not at hand, ordinary cotton, or even common waste, will answer the purpose, but it is not so good as the absorbent cotton. A very small part of the cotton is allowed to project at one end. Pour several tablespoonfuls of gasoline or benzine on the cotton to saturate it, but not enough to make it drip. This torch will burn with an



even, steady light for about 30 minutes on one filling. It will burn lying or standing, and is absolutely safe.

An ordinary case, such as used for putting up shaving sticks, makes a good torch to carry around, as it will not let the gasoline evaporate when the top is screwed in place. To extinguish such a torch place the lighted end against any flat surface.—Contributed by James E. Noble, Toronto, Can.

### Covering Engine-Case Breather to Prevent Dust from Entering

The breather on a gasoline engine of an automobile serves the purpose of allowing any excess pressure in the

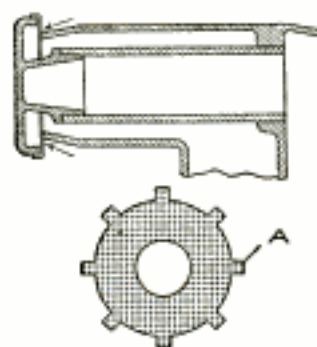

crank case to escape, and also provides an opening to pour in the lubricating oil. The breather construction, as shown in the illustration, will allow considerable

grit and dust to enter and cause havoc with all the bearings. While it is necessary to have some opening at the top, it also is a problem to keep out the dirt and dust. A piece of very fine mesh and comparatively thin brass-wire screen, cut to the shape and necessary dimensions to fit the breather cap, will eliminate the trouble. The projections A are bent over the side of the cap for the purpose of holding it in place.

### An Eyeglass Cleaner

The most common cleaner for eyeglasses is a silk pocket handkerchief which is rubbed for a considerable length of time over the glass surface before they are clear. Tissue paper is an excellent cleaner but is not always on hand, and instead an old dollar bill can be used. It cleans the glasses as clear as crystal without "breathing on them." An old, worn bill is preferable to a new one.

### A Convenient Demountable-Rim Tire Tool

The motorist living in a large city is not troubled with tire changes, as the service man takes care of the work. In smaller places the person who drives must make his own tire changes. The introduction of the demountable rim enables the driver to carry an extra tire and make emergency changes on the road.

Although the demountable rim is split transversely, and at first glance, the tire would seem to be easily removed, such is not the case. In fact, it is about as difficult to get the tire off the rim as it is to remove it from the old-style clincher-rim wheel. If the ends of the rim where it is transversely split could be lapped and the rim contracted, the tire would fall off of its own accord.

The removing may be easily accomplished by means of a turnbuckle, as shown in the illustration. Two holes must be drilled in the rim, one close to the split and the other about 10 in. from it. A turnbuckle, 12 in. long, can be purchased from any hardware dealer. The ends should be heated and turned at an angle, to hold securely in the holes drilled in the rim. It will be found that the stiffest rim may be contracted and the old casing removed

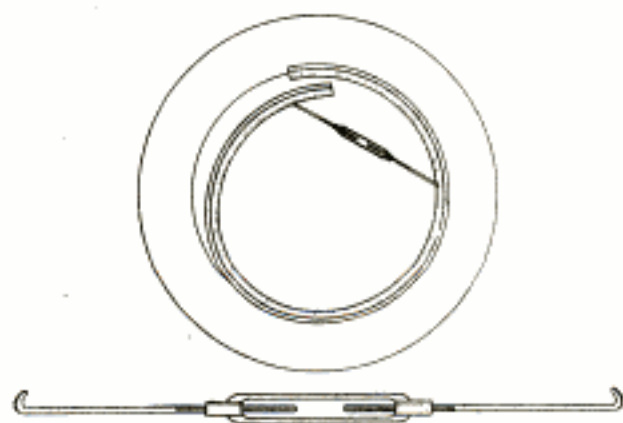

Rim-Contracting Tool for Demountable Rims, for Quickly Removing Tires in Making Repairs

with little effort, and replaced while the rim is contracted. New tires may be put on the rim in a like manner.—Contributed by James F. Gwinner, Memphis, Tenn.

### Carrying T-Square on a Drawing Board

Most drawing boards have battens on the back to keep them straight. To provide a place for the T-square it is

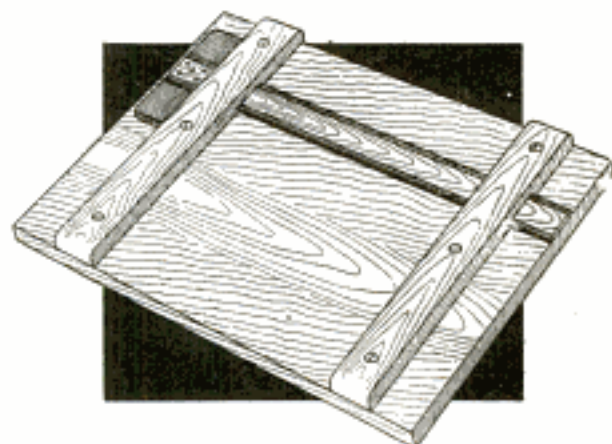

Notches Cut in the Battens of a Drawing Board to Admit the Blade of the T-Square

only necessary to cut out a notch in each batten on a line with each other and of a size to admit the blade. This makes a convenient way to safely carry the T-square.

### Uses for Beeswax

Beeswax has been used to advantage to take the impression of a door key, but there are several other places where it comes in handy as well. When filing a key and using another key for a pattern a very small amount of the wax placed between the two and squeezed in a vise will keep them together until finished. The wax also makes a first-class fillet in pattern work, by putting it on in little pieces and then going over it with an iron just a little hotter than is necessary to melt it. It makes an excellent composition for filling holes and little imperfections in wood, where it is superior to putty, as it does not shrink and leave a depression. A small leak in a pan, or other receptacle for liquids, may be made tight for the time being by pressing a very small piece over the holes, or melt a few drops with a hot iron and let them fall on the place to be plugged.—Contributed by A. Dane, Pottstown, Pa.

### Removing Milled Work from a Mandrel

Often in turning up milled edges, or fancy hand nuts, of medium thickness, it is necessary to tap the nut to the required size and screw it on a mandrel,

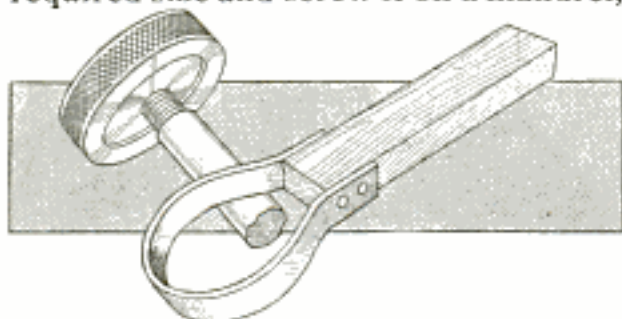

A Wrench Made of a Stick and a Piece of Leather to Remove Finished Parts from Arbors

or arbor, previously turned down and threaded and held in a lathe chuck, while finishing one side of the nut, then take it off and replace it to get at the other, or opposite, side. In turning, the lathe tool tightens the nut on the arbor so that it is necessary to use a vise and wrench to remove it, thus damaging the finished part.

To prevent marring the partly finished piece, I simply screw the arbor in the vise, then remove the piece with a wrench made as follows: A piece of leather belting, any convenient width, is nailed on a strip of wood to form a loop, which is placed around the finished part and used in the same manner as a chain pipe wrench.—Contributed by W. E. Day, Pittsfield, Mass.

### Live-Wire Detector

It is not generally known that if one terminal only of the ordinary telephone receiver is placed in contact with a wire carrying the usual 110-volt commercial lighting current, a faint buzzing sound will be heard. This static effect not only shows the extreme sensitivity of the telephone receiver, but affords a

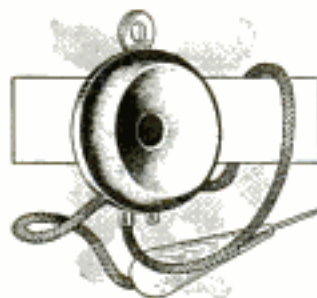

convenient and absolutely safe means of identifying live wires without endangering the fuses or disconnecting. For work among covered wires, the end of the single conductor from the receiver may be connected with a darning needle firmly set in a small awl handle, which will readily penetrate the insulation.

### Greasing Crosshead Pins

Considerable trouble was experienced in lubricating crosshead pins with oil, which resulted in adopting other means of lubrication. Pin grease was used successfully on the side and main rods of the locomotives for lubricating the brass and crank pin, and the idea embodied in the sketch was worked out, which clearly illustrates the method. The grease is put into the cavity, and

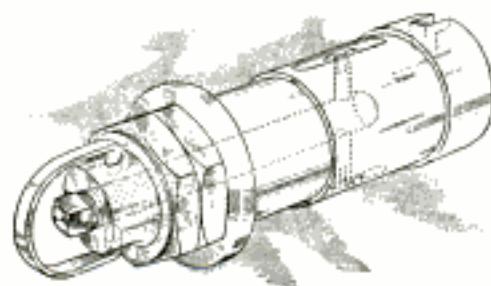

A Method of Lubricating Crosshead Pins with Grease, and a Substitute for Taper Pins

the plug forces the grease into the slots, cut in the bearing surface of the pin.

In order to overcome delays in removing bent taper pins, which were used to prevent the nuts from working off the crosshead pin, a spring ring was devised. The sketch shows the method of its application. To remove the device, insert a chisel and pry the ends out of the holes.—Contributed by J. R. Minter, Washington, Ind.

### Holding Tools in Their Handles

A good adhesive for holding tools in their handles is rosin and a small quantity of rottenstone. The hole in the handle is filled with the powdered rosin to which has been added a little rottenstone. The tang of the tool is heated and pushed into place. When cold, it will stick firmly in the handle.

# BUILDING A HOME

By Geo. M. Petersen



## PART VIII—Interior Woodwork

THESE are probably very few persons outside of the building profession who fully realize the effect of the interior finish on the general appearance, sale of the property, and the amount of a mortgage loan. Most people build for themselves, but it is well to bear in mind the fact that emergencies may arise necessitating the sale of the property to tide over a temporary financial depression, or the owner may be forced to change location from one state to another and therefore must dispose of his real estate. He may outgrow the home and want the money invested to build again and on a larger scale; he may desire to move to a new and better neighborhood, or have any other of the numerous reasons for selling his property. On this account it is well for the prospective home builder to consider his house from the practical side as well as from the ownership ideas of what is right. Keep away from "freak" notions, unless money is no object, and then think twice before incorporating them into a home. Keep the cost of the house as low as possible with the use of first-class material and workmanship. If this is done, it will be an easy task to unload it at a small profit any time it may be necessary or convenient to do so, but a house poorly finished on the interior is sometimes a hard thing to sell.

The bank, or individual, to whom a person applies for a first-mortgage loan

will first learn the cost of the lot; the cost of the buildings and improvements, such as sewer, city water, pavements, gas, electric lights, etc.; amount of loan desired; the amount the builder can pay back each year, and the rate of interest. If, with these facts before him, the prospective mortgagee thinks it a good risk he sends out an appraiser to check up and see whether the information given is correct. The appraiser generally secures land values from the recent sales in that vicinity, but when it comes to the building he is his own judge as to the value. As

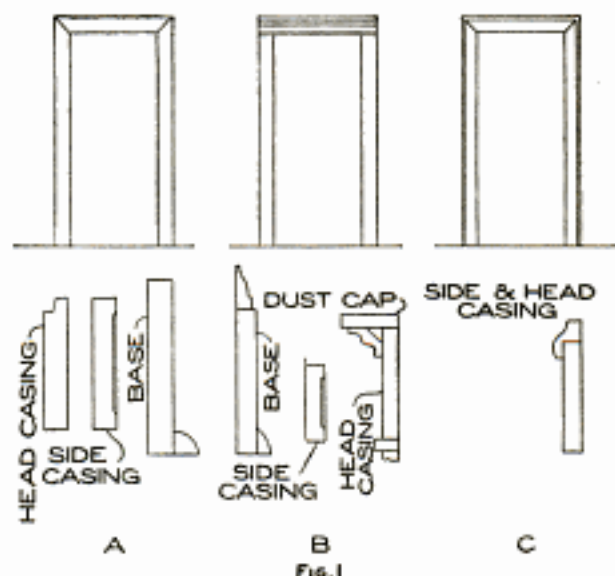

Fig. 1  
Three Styles of Finish Most Commonly Used: The Mitered, the Cabinet-Head, and the Back-Band

these appraisers are sometimes real-estate men, and often contractors and builders, it is almost certain they will

value the building at its actual cost. Nothing depreciates a building as rapidly as poor interior finish. A large

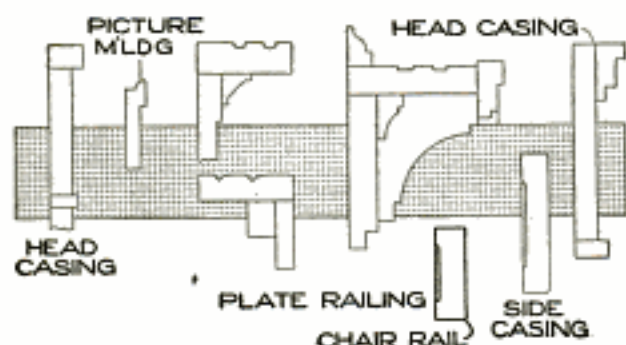

Fig. 2

The Mission and Near-Mission Styles of Interior Trim That are Sometimes Used

number of builders and contractors make up an artistic exterior, but fall down on the inside work.

To have good interior finish does not necessarily mean that the material must be expensive, but rather to have the best of its kind and properly worked. At one time I appraised two houses of approximately the same size and almost the same design, where I disapproved the loan on one which was really the more expensive, as it was finished in oak and birch, but approved the other and cheaper one that was finished in yellow pine. This was due to the fact that the yellow-pine trim was clear and free from imperfections and put up in a thoroughly workmanlike manner so that it would stand the test for years to come.

The more expensive house, while finished in fairly expensive woods, did not pass inspection because of defects

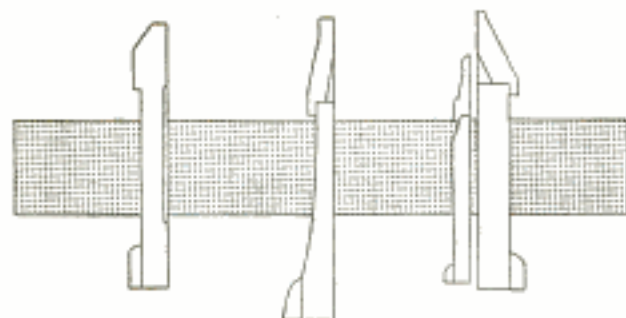

Fig. 3

Three Styles of Baseboards Used in Connection with the Trim for the Door and Window Casings

which the carpenter had not taken the time to cut out, and also because of the workmanship being very poor. In

a short time the owner could not get half the cost for it. Putty, stain, and varnish cover a multitude of carpenter's errors, but even the inexperienced eye soon learns to observe that something is wrong. One or two defects will cause a look for others, and in a short time he will become dissatisfied, and the once cherished home will not have its pleasures as anticipated.

What is said in the foregoing paragraph applies to prospective purchasers as well. Houses in which the joints in the woodwork have started to "pull," or open up; where the putty is leaving the edges of the wood, and where the surface of the varnish is dulled by the oil from the putty used to cover some imperfection; in which defective material or workmanship is apparent, are almost impossible to sell, and few real-estate men will waste their time in trying to dispose of them.

#### Kinds of Material

White pine is used where a good but inexpensive wood is desired. In certain localities it is only used where the surface is to be painted, as the wood is too soft to stain nicely, but it may be dyed with good results. White pine is used almost exclusively in the eastern states for outside doors which are exposed to the weather; for door and window frames, exterior trim and moldings, and occasionally for interior trim. It is probably the best wood known for gluing purposes, and almost all veneered work is glued over a white-pine core.

Yellow pine is a general favorite for interior trim and certain localities. This wood is hard, heavy, and strong, and has a marked grain which roughly resembles oak. It makes an excellent flooring and takes a very nice finish. This wood is liable to crack, or check, in places subjected to extremes of atmosphere, but will give very satisfactory results for ordinary use. It is sometimes known as "southern" or "Carolina" pine. Georgia pine is similar to yellow pine but superior to it.

Cypress is undoubtedly gaining in popularity for interior trim, as it is the



one wood which can be used to advantage throughout a building, at a nominal expense, and is very beautiful when

Birch is used extensively for imitation mahogany, as it has very little grain, is fine-textured, and can be used



Designs for Wood and Burlap Panels: Where Wood is Used for the Panel It must be Made of Three-Ply Veneer to Prevent Warping by the Changes in Weather

stained and finished. The wood comes from the southern part of America and Europe and closely resembles cedar in color and ease of working, but has a grain that is not obtained in cedar. Great care must be exercised in the seasoning, as it will check and become "shaky" if the drying is forced. It is sometimes difficult to work this wood into interior trim without raising the grain, and for this reason some mills and builders will not make it up.

Oak is really the best wood for interior finish, but it is a little more expensive than some of the ones mentioned. It is more expensive to work, as the wood is extremely hard, heavy, and cross-grained. The American white oak is a light, yellowish-brown color, while the red oak is darker and redder, coarser-grained, and more brittle. Both red and white oak are used extensively for floors and trim, and quartered white oak is used for veneer on a core of white pine or chestnut.

for interior trim and cabinetwork. It is hard and very durable.

Chestnut is a comparatively soft, close-grained wood and very brittle. It has become a popular interior-finishing wood on account of its peculiar and attractive graining and its adaptability to the various finishes.

Poplar, or white wood, is light, brittle, and soft, and is frequently used as a base for white-enamel work. It shrinks and warps badly in slight changes of atmosphere. Its color changes from white to a pale yellow.

Basswood bears a close resemblance to white pine, but is much more flexible. The main fault of this wood is its tendency to warp, as it shrinks parallel with and across the grain. It is used to some extent for interior finish, but principally for curved panels.

In addition to the woods mentioned there are mahogany, red gum, rosewood, ebony, black walnut, cherry, curly maple, curly birch, cedar, and

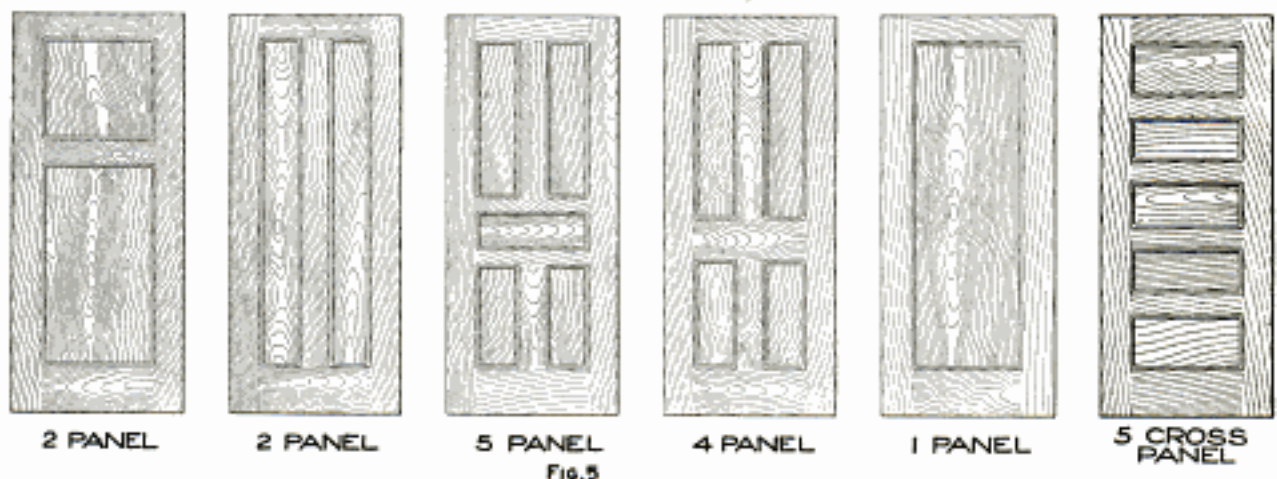

Several Designs of Stock Interior Doors Carried by Lumber Dealers, Each Door Having a Different Paneling and the Cost Being Practically the Same for All Styles

many other woods, but those mentioned are the ones generally used for moderate-priced work.

If possible, use different woods in

Baseboards may be of the styles shown in Fig. 3. Some suggestions for paneling are shown in Fig. 4. If oak panels are used they should be three-ply

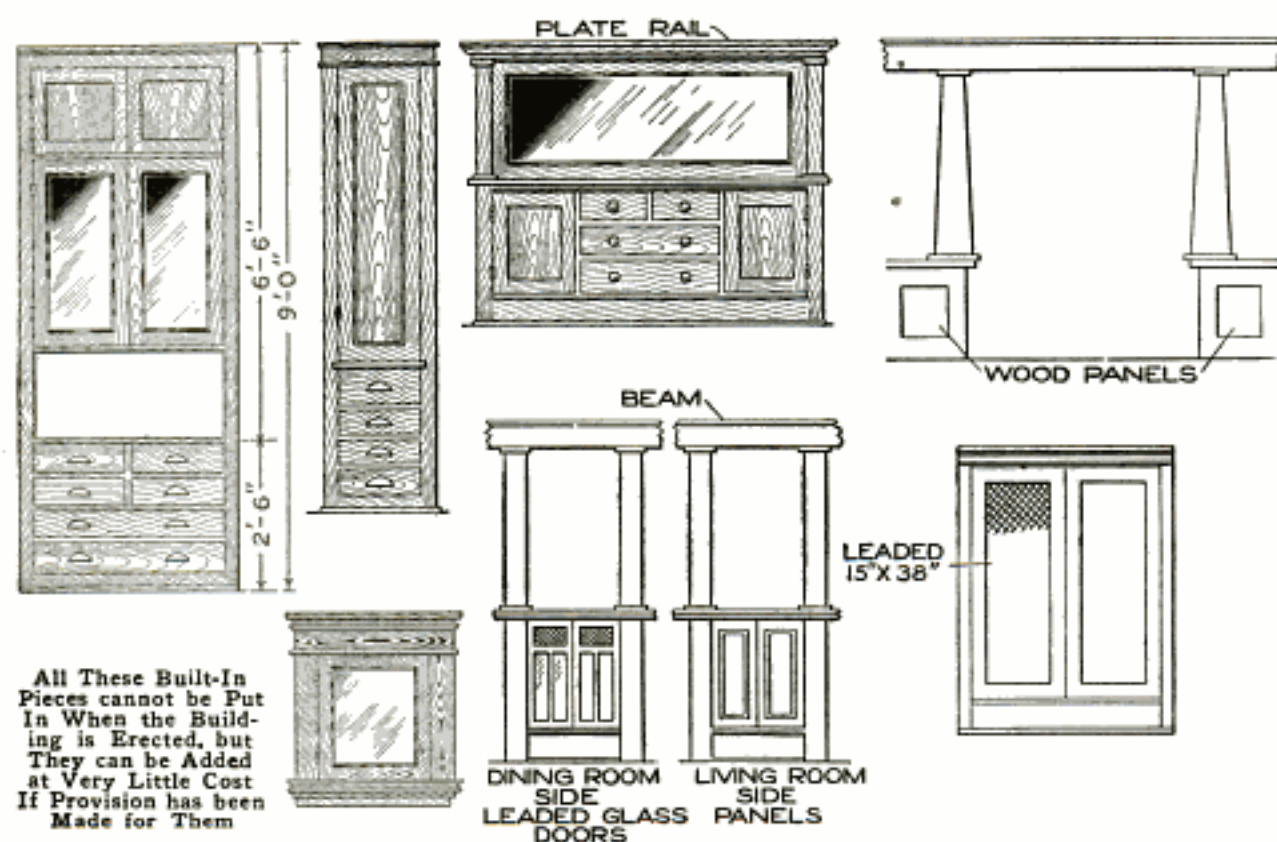

Fig. 6

the different rooms in a house to break up the monotony. As a suggestion, use cypress for the living room; red oak for the dining room and hall; yellow pine for the kitchen and upper hall; white wood for the bathroom, and finish the bedrooms in birch, chestnut, or white wood.

This combination requires doors made with different woods on the two sides, but for the small difference in cost it will pay for the satisfaction derived. Work out the color schemes and then select the wood best adapted for it.

There are various standard styles of interior finish, the three principal ones being the mitered trim, A, cabinet-head trim, B, and back-band trim, C, Fig. 1. In addition to these are "mission," and "near-mission" trim, a few styles of which are shown in Fig. 2.

All trim should be sprung into place, fitted tightly and securely nailed to the studs with eight-penny finishing nails.

vener to prevent warping. A few designs of stock interior doors are shown in Fig. 5, the price on all being practically the same.

While it is not always necessary to have built-in furniture, yet sometimes a few things may be wanted, and it will not come amiss to illustrate them. These are shown in Fig. 6. All the things shown cannot be put in when the building is erected, but they can be installed afterward at little additional cost, if provision has been made for them.

#### Coating Solution for Laying Out Work

A solution made up of  $\frac{1}{2}$  doz. drops of copper sulphate placed in a spoonful of dissolved zinc chloride is a very good preparation for making a coat of copper on iron or steel for laying out work. This will be found a better material to use than the ordinary blue-vitriol solution.

### Combined Bench Hook, Shoot Board, and Miter Box

This handy accessory to the workbench should be made of hard wood, preferably maple, and all parts accurately finished before assembling. The amount of stock required is as follows, the dimensions being in finished sizes: One piece, 12 in. long, 8 in. wide, and  $\frac{3}{4}$  in. thick; one piece,  $8\frac{1}{2}$  in. long,  $5\frac{3}{4}$  in. wide, and  $\frac{5}{8}$  in. thick; two pieces,  $5\frac{3}{4}$  in. long,  $1\frac{7}{8}$  in. wide, and  $\frac{3}{4}$  in. thick; one piece,  $5\frac{3}{4}$  in. long, 2 in. wide, and  $\frac{7}{8}$  in. thick, and one piece, 8 in. long, 1 in. wide, and  $\frac{3}{4}$  in. thick.

The various parts are assembled by gluing and screwing them to the larger piece that forms the base. The screws are put in from the bottom so that no heads will show when the box is in place on the bench. Care should be taken to keep the screws away from the places where the miter cuts are made.

As a shoot board, it is used with a 14-in. iron plane. The plane lies on its side and is pushed back and forth on the  $2\frac{1}{4}$ -in. ledge. For planing miters, a piece with one end cut to a  $45^\circ$  angle is placed against the forward

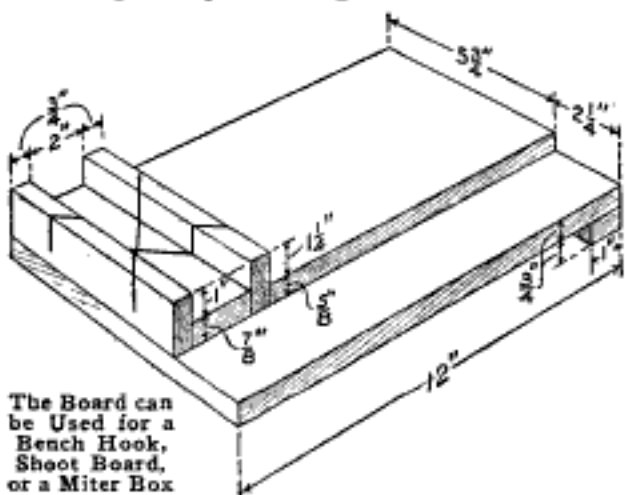

The Board can be Used for a Bench Hook, Shoot Board, or a Miter Box

stop. This holds the piece to be planed at the correct angle, and perfect joints will be the result.—Contributed by J. A. Shelly, Brooklyn, N. Y.

ⒸIn raising a shaper knee do not loosen the screws too much, as this will allow chips to drop behind it.

### Reflecting Light into Boiler Tubes for Inspection

An inspector finds it very difficult to detect any flaw, or other imperfection, in boiler tubes, superheater tubes, and

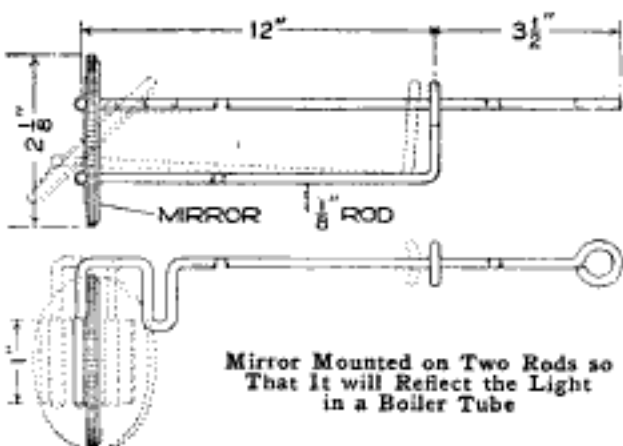

arch pipes at the front, or near where they are kneaded or welded to the flue sheet. This is due to the small amount of light to be had in these places. The illustration shows a very simple device that will reflect the rays of light on the parts that require the most attention.

The device is very simple. The mirror used is similar to those given out for advertising purposes, on the back of which is soldered a strip of tin bent around the two rods, the ends of the rods being slightly riveted to hold the glass in place. Either of the rods may be pulled to turn the mirror at an angle in directing the light rays. The small bend in one rod is to prevent the glass from being pulled too far over the proper angle.—Contributed by Joseph K. Long, Renovo, Pa.

### To Prevent Squeaking Noises on an Automobile

One frequently hears a series of squeaking noises when driving a car, and upon careful examination the trouble cannot be found. Nearly always the squeaks are caused by the body bolts and nuts loosening up a little. The body, being an extremely heavy part of the car, has a natural tendency to work loose from the chassis frame, and for this reason, secure locking means should always be provided on the various nuts.

### Preventing the Loss of a Hub Cap

Quite frequently one of the hub caps of an automobile is lost, especially where no locking means is provided. Such a loss can be prevented by using a locking device as illustrated. A comparatively stiff helical spring is inserted in the cap and over the nut, as shown in the sketch, so that the cap is screwed down against the action of the spring. This spring being constantly compressed, it has a tendency to push the cap outward against the sides of the threads, and in this manner a secure locking means is obtained.

### To Prevent the Rattle of an Automobile Crank Handle

Counterbore the handle end so that a short piece of coil spring can be inserted over the handle pin. This will keep the handle tightly against the crank and prevent it from rattling, yet allow sufficient free action to turn in cranking.—Contributed by Thomas M. Ritchie, Waterloo, Iowa.

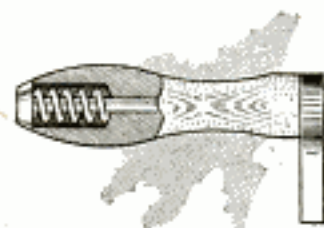

### Removing a Broken Drill

In using center drills it happens quite often that the part A breaks off and remains firmly imbedded in the work being centered. In such cases grind the body, or more properly, the countersink part remaining as shown. The center drill is then rechucked and run down in the hole. This cuts a clearance around the drill and allows it to be removed with

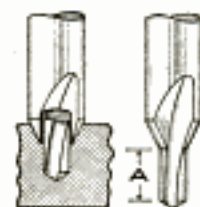

a pair of pliers. The only result in bad cases is that it makes the center a little deeper than intended. This idea, of course, cannot be applied to standard twist drills or to taps, but is thoroughly efficient for the work mentioned.

### Water Guide for an Eave Trough

Having trouble in setting a barrel beneath the eave trough to catch the water during rainstorms on account of the varying volumes of water, one owner nailed a stick to the end of the trough, as shown in the illustration, and his troubles were over. The water would follow down the stick and into the barrel, no matter how much or little water was running. The stick should project above the bottom of the trough to catch the water.—Contributed by H. V. Olson, Hibbing, Minn.



### Remedy for Loose Eyeglass Lens

Eyeglasses generally have an annoying way of becoming loose at the screws which hold the lenses in place. This can sometimes be remedied by the insertion of a piece of cotton thread in one of the two places indicated in the sketch. If there is a space between the inner edge of the glass and the shoulder of the clip, or if the hole in the lens is too near the edge, the glass will swing slightly about the screw every time the glasses are cleaned, and this naturally loosens the screw. By removing the lens and placing a piece of thread at A, this movement is prevented, or at least greatly minimized. In addition, this makes the inside of the hole in the lens bear on the side of the screw, thus keeping it in place tightly. If the jaws



of the clip are slightly open at the edge of the lens, as shown in the lower sketch, thus making the lens wobble as indicated, it can be remedied by inserting a piece of thread, B, around the screw, crossing the ends while tightening the screw, then cutting them off, and the job is finished. The "give" in the cotton provides a sort of spring-washer effect.—Contributed by Morris G. Miller, New Rochelle, N. Y.

### Puller for Concrete-Form Bolts

The action of the puller is the same as that of the lever jack. The holding device is made of a steel plate, 3 in. square and  $\frac{1}{2}$  in. thick. A hole is drilled near the center on an angle of  $60^\circ$  to the surface. It is only for use with headless bolts such as are com-

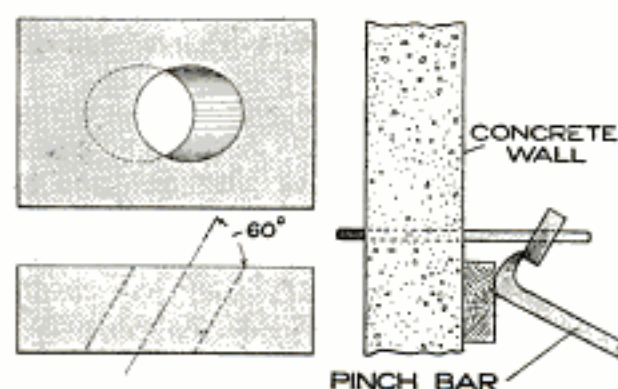

The Oblique Hole in the Steel Block Forms a Grip Like a Lever Jack

monly used for concrete-wall forms. With this style of bolt a collar and setscrew takes the place of the head. A pinch bar is used in connection with the piece of steel, as shown.—Contributed by J. J. O'Brien, Buffalo, N. Y.

### Renewing Dowel Holes in Old Wood Patterns

This is usually a job disliked by the patternmaker, as the holes must be plugged and new holes bored. In boring the holes the bits will be damaged by striking nails or old molding sand. It is much more satisfactory to make a cut with a  $\frac{1}{2}$ -in. chisel, or the size suitable for the dowel, on each side of the dowel hole, running with the

grain of the wood, then drive in wedges until the wood is forced to reduce the

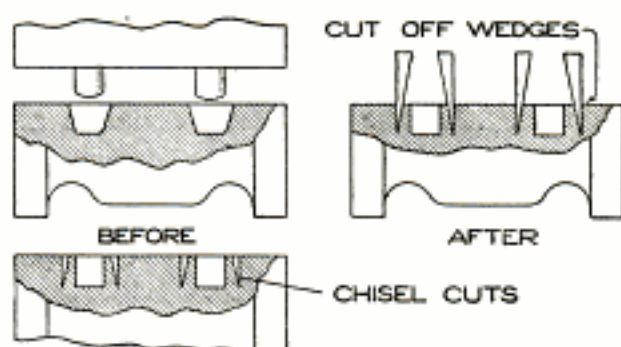

Wedges are Driven in Chisel Cuts on Each Side to Reduce the Dowel-Hole Size

dowel hole to the proper size.—Contributed by J. C. Hansen, Maywood, Illinois.

### Reinforcing a Loose Steering Post

A loose steering post on an old automobile truck was reinforced in the following manner: A piece of flat steel stock,  $1\frac{1}{2}$  in. by  $\frac{3}{8}$  in. in cross section, was annealed and then forged into the proper shape and dimensions, as shown. This was slipped over the steering post and clamped to it by means of a  $\frac{3}{8}$ -in. screw and nut. The base in turn was fastened to the steel dash with suitable

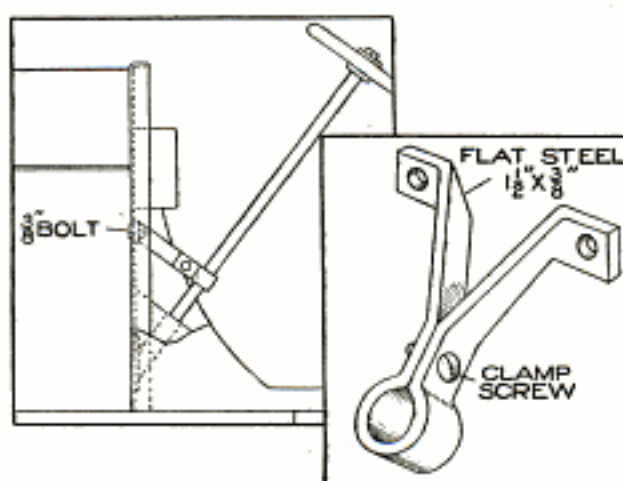

An Extra Brace to Support a Loose Steering Post of Very Old Construction

screws. This supported the steering post at two points and consequently made it very rigid.

CA forge shop should never be made too light, as the workman cannot see the heats well in a brightly illuminated shop.

### A Lining and Tool-Setting Bar

The sketch shows a simple gauge for lining up various machine tools and for setting them to cut different depths. As the indicator consists al-

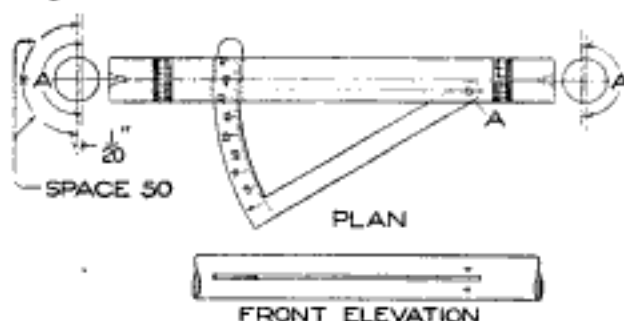

#### A LENGTH OF GRADUATION

A Lathing and Tool-Setting Bar for Making Accurate Adjustment of the Tailstock

most of one solid piece, it is practically accident-proof and there is nothing to get out of order. The bar, or body, of the tool is first turned true, the slot for the protractor arm is cut, and the hole for the pin A drilled. The bar is then chucked, and both centers are faced off almost entirely, leaving just enough of the original centers for a marker. From this marker lay off new centers, each toward the same side of the bar and  $\frac{1}{20}$  in. from the original centers, as shown. On the full side of the bar mark off the graduations, spacing them for one-quarter of the circumference with 50 graduations in each space, each graduation representing .001 in. The shaping and fitting of the protractor arm and its hub require no explanation, save to state that no locking screw is provided, the protractor arm being merely a tight fit. Caseharden the bar and grind-finish all over.

To use the instrument, set it freely on the lathe centers, move a square-point tool to almost touching the "low" side of the bar, and carefully turn it. Supposing the bar touches the tool at  $20 + 3$ , or 23 thousandths of an inch, without changing the tool, let the bar swing clear, and run the carriage up to the other end, and carefully turn the test bar again. If it touches the tool indicating  $15 + 1$ , then the lathe is out of line .007 in., and since the greater number was found at the tail-

stock end, the tailstock must be moved forward .007 in. The use of the protractor needs no further explanation. —Contributed by J. B. Murphy, Plainfield, N. J.

### Care of Tires Using Skid Chains

The cutting of tires with skid chains can be eliminated to great extent by using just a little care in applying the brakes, thereby increasing the mileage considerably. When the brakes are jammed on hard and quickly, instead of easily and slowly, one or both rear wheels will cease to revolve, and the section of the skid chain that happens to be between the tire and the road heats up quickly, at times becoming almost red-hot, and burns into the rubber tread. Dirt and water then get between the rubber and fabric, and loosen the tread, which wears off quickly.

The chain burning is many times called a chain cut. Although chain burning and chain cutting amount to the same thing, they are actually two very distinct damages, and by bearing in mind that rubber will burn under the conditions mentioned, much expense can be saved.—Contributed by L. E. Turner, New York City.

### Shock Produces Greater Strain than Pressure

Why does a hammer blow start a "stuck" shaft when a screw pressure will not? Assuming, for example, that the pressure applied is 1,000 lb. in each case. It is a law in mechanics, known and observed by all machine designers, that a force suddenly applied produces twice the stress of one gradually applied. A blow is twice as powerful as a static pressure. In designing machine parts this must always be kept in mind, for a part built to carry a ton weight would fail under a ton blow from a power hammer.

Use plenty of good lard oil when cutting threads on steel.



## An Inexpensive Gluing Press

By N. E. STUDEBAKER

**T**HE floor space in our high-school shop is somewhat limited, leaving no room on the floor for the gluing press, and during a large part of the year the temperature on the floor is too low for gluing. We met these conditions with the gluing press illustrated.

Three pairs, or sets, of steps, A, were made of pine, 2 in. thick, and fastened in a series by strips B, so that they all would move forward or backward between the guides C, which are nailed to the floor above the shop. On one of the steps—the corresponding one in each pair—rests a piece of wood, D, 4 in. wide and 2 in. thick, through which, near its ends, are bored holes to receive lengths of 1-in. gas pipe, E. Over these holes and screwed to the wood piece are 1-in. floor flanges, F. The pipes E are threaded at one end so that they will screw through the floor flanges about 3 in. On the other

ends of the gas pipes are fitted pieces of material, 4 in. wide and 2 in. thick, G, resting on washers, which in turn rest on the locknuts H. The locknuts H prevent the tees J from unscrewing in operating the press. A rod is used through the tees as a handle for screwing the pipes E on or out of the floor flanges F. On top of the pieces G rests the floor K, on which are placed the pieces to be glued. On the under side of the ceiling joists, and directly over the floor K, is spiked the 2-in. piece L, between which piece and the floor K the material is pressed. For the sake of stiffness and lightness the floor K is built up of 1-in. material, as shown in the detail. This floor may be raised or lowered by the windlass M. The windlass is simply a  $\frac{3}{4}$ -in. gas pipe turning in bearings fastened to the under side of the ceiling joists.

Supposing the press to be standing

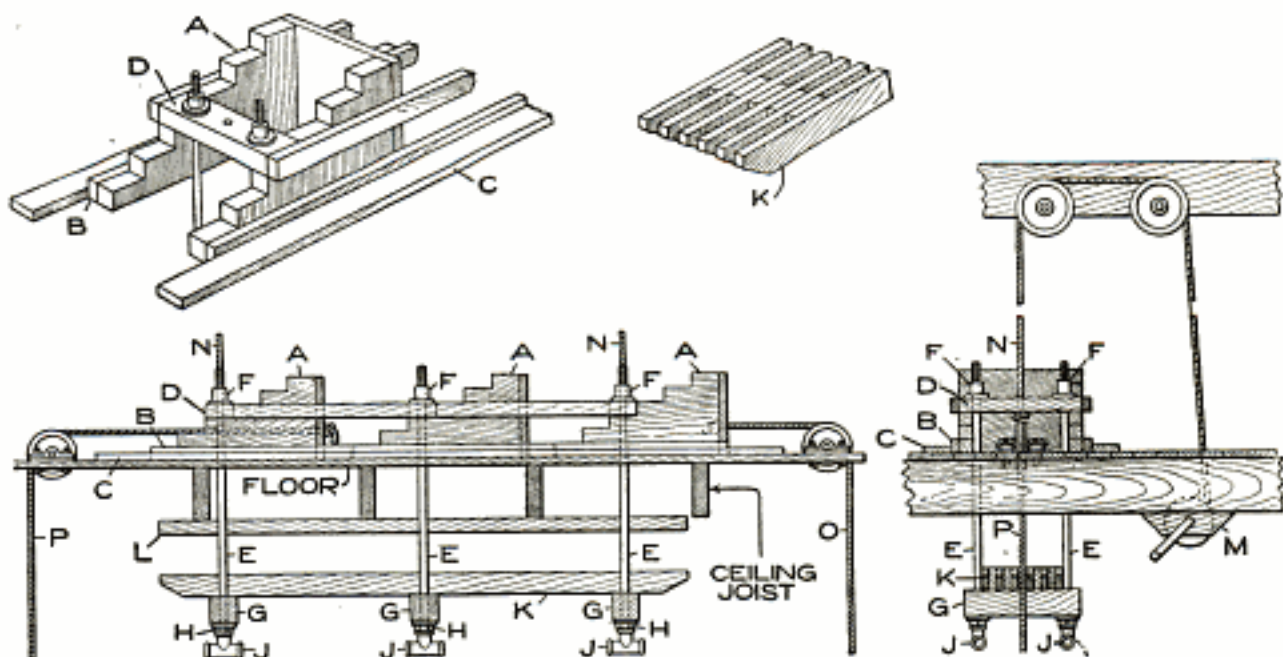

The Gluing Press is Attached to the Ceiling Where It Is Out of the Way and Where the Temperature Is More Correct for Making a Strong-Holding Joint

as shown in the drawings, it is operated as follows: The pipes E are unscrewed so that their upper ends are flush with the top surface of the floor flanges F. The ropes N are wound up a trifle on the windlass M, thus raising the pieces D, the pipes E, and the floor K. Lifting D clear of the steps releases the latter so that the entire series may be moved to the right by pulling the rope O. In unwinding the ropes from the windlass, D is let down on the lowest step, which has just been drawn directly under it. This operation lowers the floor K to its lowest limit and the pieces to be glued are placed, one on the other, on this floor. If the total thickness of the material

to be glued is sufficient to nearly fill the space between the floor and the piece L, a rod is thrust through J, and the pipes are screwed up, thus pressing the material between the floor K and the piece L. If, however, the material does not fill the space well, then the ropes N are wound up on the windlass M, thus raising the floor and its contents as far as possible, and by pulling the rope P the steps are drawn as far to the left as possible and D rests on a higher step, thus lessening the space to be taken up by the screws. The pipes are then screwed up tightly as in the first operation. Our press is operated from a mezzanine floor where all the gluing is done.

### A Luminous-Minnow Fish Bait

Make a plug of light wood, preferably cedar or white pine,  $1\frac{3}{4}$  in. long and  $\frac{3}{4}$  in. in diameter at the large end,

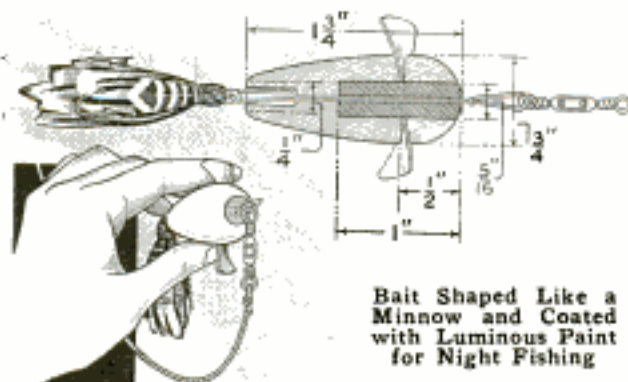

tapering to  $\frac{1}{4}$  in. at the small end. Finish it to the shape of a minnow and bore a  $\frac{5}{16}$ -in. hole, 1 in. deep, in the large end. Make a lead plug, with a hole through the center, to drive tightly into the hole in the head of the minnow, and finish the front end smooth and even with the wood. Run a wire through the minnow and form an eye at the tail for hooks, and another at the head for the swivel. A three-cornered piece of tin inserted  $\frac{1}{2}$  in. back of the head on each side and bent so that the water will cause it to turn gives motion to the lure.

Two coats of luminous paint will be sufficient for the illumination. Expose the minnow to the light for sev-

eral hours, and it will give a luminous glow in the dark that makes it easily seen by the fish as it is drawn through the water. As most game fish are night feeders, it makes a very effective lure.—Contributed by Charles Carrol, Saint Cloud, Fla.

### To Prevent Putty Sticking to the Hands

When purchasing putty buy a little whiting. This is one of the ingredients of the putty. Mix enough of it with the putty to absorb the excess oil. This will prevent it from sticking to the hands. It also gives the putty more body and makes it much easier to handle.

### Signal for Lighted Lights in Basement

To avoid the loss of electric current by forgetting to turn out the light in the basement, I placed a 3-cp. lamp in the circuit near the switch at the head of the stairs. The small light is a sig-

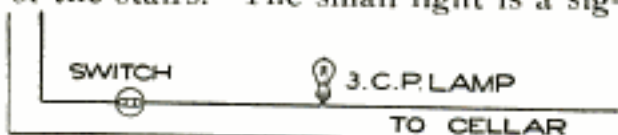

The Small Lamp near the Switch in Circuit Glows When Lights Are On in the Basement

nal that the light is still turned on in the basement.—Contributed by A. MacCunn, Toronto, Can.



# The Shotgun and How to Use It

By STILLMAN TAYLOR

## PART I—How a Shotgun is Made

**H**UNTING and fishing have always held the most important places in the field of sport. Primitive man was an expert hunter and a skilled fisherman. He had to be in order to secure food and skins, and while but few men are now dependent upon this method of getting a living, the call of the outdoor world is still heard by millions of men and women. This, then, may be reckoned the inheritance which our primitive ancestors have bequeathed to every man, and every man will find health and recreation through it. It would be interesting to begin this chapter at the start and set down the history of weapons, trace the evolution of the hunting arm all the way from the bow down to the modern hammerless shotgun, but as this is a practical article on how to pick out a good gun and the knack of using it, only modern weapons will be discussed. While the novice need not know the detailed process of constructing a shotgun, he will find it an advantage to know something of the way in which a serviceable weapon is manufactured, for with this knowledge he is better qualified to pick out a suitable arm for his own particular use.

The frame of a shotgun—that is, the part to one end of which the barrels are affixed, the stock being bolted to the other—contains the lock mechanism, and that the weapon may give the

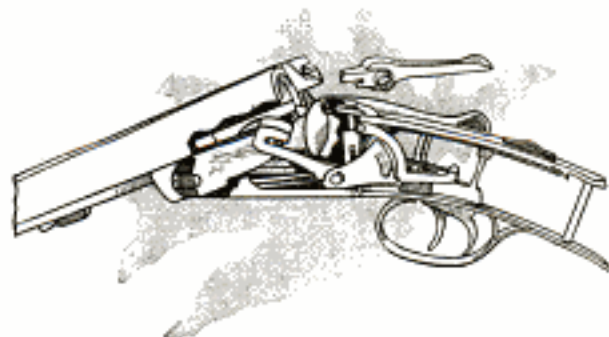

The Side-Plate Lock Is a Development of the Old Hammer Lock with the Striker Inside

utmost satisfaction for many years, the lock must be of good quality, of the requisite temper, and the bolting

mechanism—securing the barrels to the frame—must be simple, yet strong

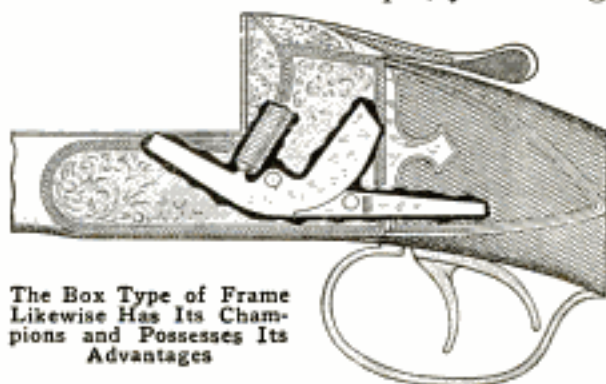

The Box Type of Frame Likewise Has Its Champions and Possesses Its Advantages

and serviceable. For the frame, a solid drop forging is milled to make a shell into which the working mechanism is fitted, and two types of frames are used in making the modern shotguns. The side-plate lock is really a development of the old hammer lock, with the striker inside. This lock is preferred



The Cocking Hook Is an Ingenious Device, with Variations Used on Different Makes of Arms

by some shooters because of its neat and graceful lines, and some manufacturers use this type because it enables them to make use of a lighter frame.

The box type of frame likewise has its champions and possesses certain advantages. Certainly it makes a strong and rigid frame, and for inexpensive weapons it would be difficult to improve upon. While its square, boxlike form is not graceful in line, it enables the maker to use a spiral, or coil, spring instead of a flat spring for operating the locks, which is an advantage. In brief, the merits of both types may be summed up in this fashion: The use of the box type of lock enables the maker to turn out a better quality of

gun at a low price, but in the case of a well-made gun, selling for a reasonable figure, there is very little choice between them so far as dependability



A Hammerless Gun with Roller Bearings to Overcome the Short Leverage and Make It Open and Close Easily

and long service are concerned. Both are much used by manufacturers of the finest weapons, hence the shooter may pick out the one which best suits his fancy.

#### The Cocking Mechanism of the Hammerless

The locks of the hammerless shotgun work inside of the frame or lock, and are cocked by an ingenious little mechanism operated by the movement of the barrels when they are opened. The Anson & Deely cocking mechanism is one of the oldest and best of these devices, and is still used on many American as well as European arms. The levers of this mechanism are hung with pivots in the end of the frame—one end

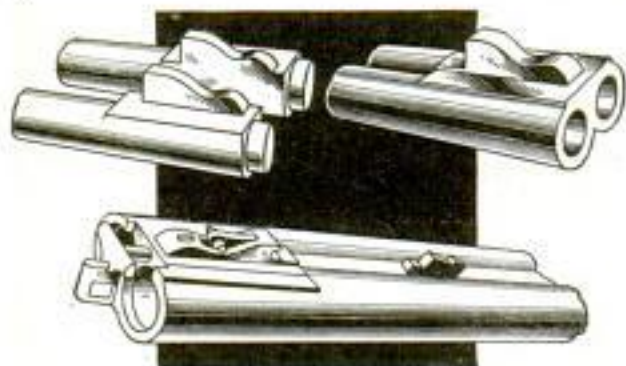

A Lug is Forged on the End of Each Barrel, and When Fitted Together They are Brazed

projecting into the fore end and the opposite end resting beneath the hammer toe. As the gun is "broken," or opened, it presses down the forward end of the cocking lever, and the other end rises and pushes the ham-

mers into the cocked position. This is the principle upon which all cocking devices are constructed, and while it works smoothly and is so simple that it is not likely to get out of order, it is mechanically weak, owing to the short frame required to secure adequate leverage. Perhaps one of the best variations of the Anson & Deely device is one employed by an American manufacturer who makes use of a rod running through the frame from the fore end to the hammer. To each end of this rod is attached a crank, so hung that as one crank is depressed the other rises and pushes the hammer to the cock position as the barrels are swung to open the gun.

The cocking hook is an ingenious device found on American shotguns and many variations of it are, of course, used on the different makes of arms. The Parker gun is provided with a hook, working a slide, thus pulling the hammers to cock. In the Baker, a bent arm is pivoted to the breech to serve the same purpose. Another example of American ingenuity may be noted in the lug-cocking devices used on the Ithaca and Fox guns. This simple arrangement is made by connecting the toe of the hammer directly with the lug, which is an integral part of the barrel. The hammer is thus made to act as its own lever, for as the toe portion rises when the barrel is opened, the striker falls back until it is caught in the notch of the sear.

To guard against the possibility of accidental discharge of the hammerless gun, in which type of gun the hammer must be always at full cock, a safety trigger bolt is utilized. This bolt is affixed in the frame in a vertical position by pivoting it, and to the upper part of the lever is attached a slide, placed on top of the tang immediately back of the top lever which opens the barrels. As this safety slide is pushed, the lower end of the lever is brought close up against the triggers, blocking them, and thus prevents them from moving while the safety is in the "on" position. To discharge the gun, the slide must be pushed forward to the

"off" position, which moves the lower end away from the triggers. This type of safety is of the nonautomatic variety and can only block the triggers when the slide is operated by the shooter.

The automatic type of safety consists of a block, or bar, fitted in the frame and extending from the safety bolt to the post of the top lever. When the top lever is pushed to one side to open the barrels, this block, or bar, pushes the safety bolt over the triggers, automatically blocking them and preventing accidental discharge. The

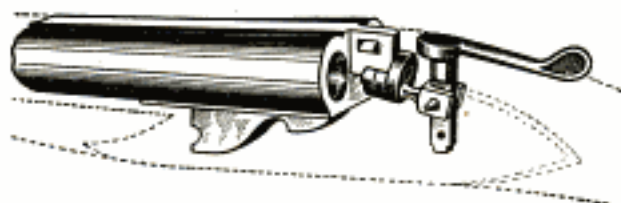

The Rotary Bolt, an American Invention, Is Strongest Device Known for Locking the Barrels to the Frame

triggers must be pressed to withdraw the automatic safety bar.

To make the shotgun less likely to go off in the hands of the careless gunner, the tumbler safety has been incorporated into the mechanism of a few American weapons. The tumbler safety is a bar, automatically operated by the triggers, and interposed between the strikers and their firing pins. This device makes it impossible for the arm to be discharged by the hammer jarring off when dropped, for the tumbler bar occupies its position between the strikers and firing pins until the triggers are pulled.

The practical value of both the automatic safety and the tumbler type of bolt is questioned by practically all experienced gunners. Its presence is designed to make the arm less dangerous

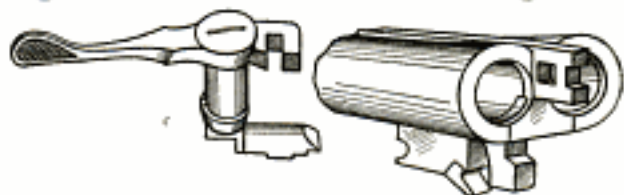

The Three-Bolt Mechanism Is One Form of the Rotary-Bolting Principle Used by Many Gun Builders

in the hands of careless and ignorant sportsmen. This it may serve to do, but since there should be no excuse for

tolerating the latter, most handlers of the scatter gun fail to see the utility of the former. The novice should lose no time in acquiring the knack of han-



The Fore End Is an Extension of the Stock beyond the Triggers and the Frame

dling his chosen weapon, and if he will but exercise a little care, he will find the hand-operated safety quite sufficient, for he will not be troubled through accidental discharge of his gun. By far the larger portion of accidents occur through careless handling of the gun and by the untimely pulling of the trigger, either by dragging the gun through the brush or by nervousness, and it is impossible to make use of a safety device to prevent the accidental discharge.

#### The Barrels of a Shotgun

Between 15 and 20 years ago shotgun barrels were made by combining bars of iron and steel and welding them



The Comparative Sizes of a 20-Gauge and a 12-Gauge Repeating Shotgun

together to form barrels of the proper diameter or bore. When these strips of metal were twisted to make a spiral tube they were welded together to make the familiar "twist," "laminated," and "Damascus" barrels. Sometimes three, four, and five strips of iron and steel were twisted together to make the "three-stripe," "four-stripe," and "five-stripe" Damascus barrels. This old type of a barrel was strong and flexible, but being comparatively soft, it was easily damaged by denting.

The modern compressed-steel barrels are fashioned from solid drawn steel, are very hard, will stand much higher pressure than the Damascus type, and since the process of manufacture is simpler, a first-class steel

barrel may be produced at one-quarter the cost of the old type. The several manufacturers have adopted trade names to distinguish the various grades of steel barrels. Various trade names come from abroad, and those of American manufacture are labeled "nitro-steel," "armor steel," "high-pressure steel," etc. While differences very likely exist in the quality of the different barrels sold under the several names, all the barrels used by reputable gun builders will be found amply strong to resist any pressure exerted by ordinary charges of powder, hence the cheaper guns are perfectly safe and will stand many years of hard shooting.

#### Locking the Barrels to the Frame

In the early models of the breech-loader the barrels were locked to the frame with a bolt operated by a lever placed under the fore end. All modern guns have the top-lever action. In this device a "lump" is fastened to the under side of the barrels near the breech, forming a hinged joint to which the fore end is attached when fitting the barrel and stock together. When closed, the breech end of the barrels is held down to the action and tight up against the breech by a slide, or bolt, which fits into the "lump" attached underneath the barrels. Different makers use various forms of top-lever bolting devices, as the "hook rib" or "extension rib," otherwise known as the "doll's head," and the cross bolt first used by Greener, the celebrated English gun builder. All of these devices are satisfactory on a good grade of gun, but the strongest mechanism is an American invention, known as the Smith rotary bolt. This rotary bolt is tapered and is pushed through an opening in the rib by means of a strong spring. Mechanically this locking device is all that can be desired, and it cannot loosen through manipulation, because of its compensating feature, that is, the spring forces the bolt farther in as the bearings become worn through much service. Many of our well-known builders use this splendid fastening.

#### Shotgun Stocks

Walnut is exclusively used for gun-stocks, and the several grades are termed plain American walnut, fine American walnut, English walnut, selected English walnut, fine English walnut, Italian walnut, and Circassian walnut. The plain American walnut is simply a common quality of black walnut, oiled and varnished, and fitted on the cheaper guns. Fine American walnut is of better quality, darker in color, and of better grain. It is strong and durable, and when well oiled and polished by hand, it makes a neat stock for the inexpensive gun. The selected English walnut is of good color and with good grain. When oiled and hand-polished it makes an attractive stock for the knockabout gun. Fine English walnut is usually fitted to guns selling at a higher price, and is generally made to order. Italian walnut is a dark wood with a fine grain and is usually supplied to order on the finest guns. Circassian walnut is the finest wood obtainable, of a rich dark color and a fine curly grain. It is therefore expensive and only finished to order and fitted to the most expensive guns.

#### The Fore End

The fore end is an extension of the stock beyond the triggers and frame and affords a grip for the extended hand—protecting it from the hot barrel—serves to lock the barrel to the frame, and likewise holds the ejector mechanism. The Deely & Edge, and Snal fore ends are both used on American guns, and they are so well designed and made that it is practically impossible for the modern types to loosen even when the arm has been subjected to long, hard service. Hence this detail of the shotgun need not be considered when selecting an arm.

#### Self-Ejector Mechanism

Although a great many shooters do not use the self-ejector, this handy device will many times prove of great value in the field, for when the birds are coming fast and the shooter happens to score a miss, the self-ejector throws out

the empty shell and enables him to shove in a fresh load to bring down the following bird. The nonejecting arm is plenty good and quick enough for trap use, for when shooting "clays," plenty of time is given each man to reload between shots, but for upland-bird and for duck shooting, the automatic ejector is a desirable addition to the double-barreled gun.

#### Repeating and Automatic Shotguns

While a good double-barreled gun in the hands of the average shot will very likely bag as many birds as the shooter is entitled to—and it may be depended on to do this when fitted with a good automatic ejector—many shooters prefer the repeating gun. The hand-operated, sliding fore arm, trombone-action, or pump gun is so well-known that no recommendation is needed. It will suffice to mention that it will do everything that a double-barreled gun can perform, and considering that every pump gun is self-ejecting, and its cost less than an equal grade of double gun equipped with an ejecting device, it is not difficult to understand its popularity. So far as accuracy is concerned, the repeater will shoot rather more steadily than the double-barreled gun in the hands of the average man, and after two shots have been fired, there remain four more in the magazine. Rapid firing is not always an advantage, of course, but when after ducks, the third shot is often wanted in the interval that is required to load the double-barreled gun.

The automatic, or self-loading, shot-



The Shells are Started About One-Quarter Inch in the Regular Way Before the Ejector Kicks Them Out

gun is the logical development of the repeater, and while its mechanism is necessarily more complicated, it has some merits peculiarly its own. The devotee of the double barrel is inclined to believe that the repeater and the automatic shotgun do not balance so well

as his favorite weapon, and the man who swears by the pump gun is inclined to think that the automatic arm is balanced like a club and prone to get out of order. Both factions can put

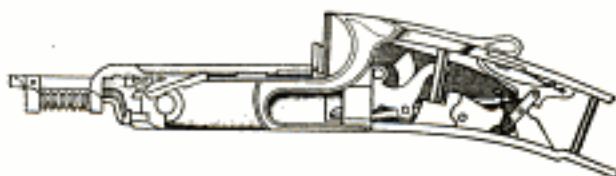

The Automatic Ejector Mechanism Enables the Gunner to Shove in a Fresh Load for the Following Bird

up plenty of argument to support their opinions, but to the unprejudiced gunner, both the repeater and the self-loader will prove very fine guns after the shooter has become familiar in handling them. The double-barrel is a mighty fine gun, so is the repeater and

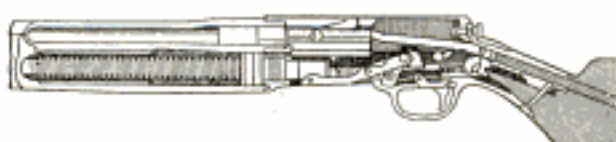

A Self-Loading Shotgun in the Positions of the Action Open and Closed

again the automatic; so let the gunner pick out the type he likes best.

#### How to Select a Shotgun

That the shooter may not be handicapped by using a misfit gun, it is well to make a selection at one of the larger dealers' where guns of various sizes, weights and lengths, as well as drops in stocks, may be tried until one is found that fits the gunner the best. A good shot can pick up almost any gun and do fairly accurate shooting with it, but he can do better work with a gun fitting him properly. The chief measurements of a gunstock are the length and drop of the stock, and the drop and shape of the comb. The ordinary thickness of the grip will suit the average hand, but in the case of unusually large or small hands, this must be taken into consideration. For the average man these measurements will prob-

ably be about right: Length of stock, from forward trigger to center of butt plate, A-A, 14 to 14½ in., drop at comb, B-B, 1½ to 1⅞ in., which will give cor-

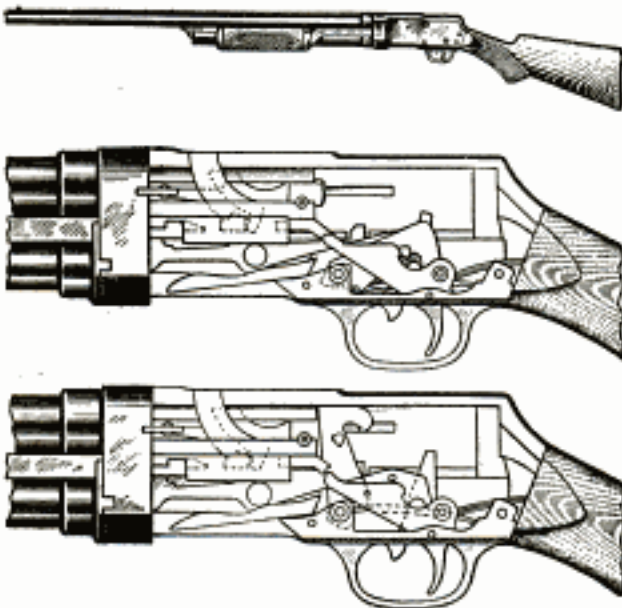

A Repeating Shotgun and the Position of Its Different Parts When Cocked and after Firing

responding drop at the heel, C-C, from 2½ to 3 in. A fairly straight stock of good length may be reckoned an advantage for trap shooting, but for use in the field, a somewhat crooked stock with more drop at the comb, say, 1⅝ in. with 2⅝-in. drop at the heel, will more fully meet the average shooter's idea of a well-balanced gun. However, as men differ, and there are as many faces and eyes as there are men, every shooter must decide this question for himself. So far as the circumference of the grip is concerned, the size of the shooter's hand and the length of his fingers will decide this detail. For a



The Measurements are Taken of the Drop at the Comb and Heel, and of the Stock from the Butt to the Forward Trigger

small hand, a 7-in. grip is about right, while a grip of 7½ in. will probably fit the large hand well. The question of straight or pistol grip is purely a matter of personal taste, for one is as good as the other so far as accurate handling of the gun is concerned.

#### The Gauge, or Size of Bore

The 10-gauge may be occasionally useful for long-range duck and goose shooting, but for ordinary duck and upland use the 12-gauge is plenty large enough. The larger the gauge the greater will be the killing zone, and up to their ranges the small bores may, for all practical purposes, be regarded as shooting quite as accurately and with as much power as the heavier gauges, that is, the small bores will shoot to kill if held correctly. The standard 12-gauge gun is fitted with 30-in. barrels, weighs 7 to 8 lb., and the standard load for the field is 3 dr. of powder and 1⅛ oz. of shot. This gives a killing range up to 40 yd. The standard 16-gauge, with 30-in. barrels, weighs from 6½ to 7¼ lb., and the standard load is 2½ dr. of powder and 1 oz. of shot, with a killing range up to 35 yd. The standard 20-gauge, with 28-in. barrels, weighs from 5 to 6½ lb. and the standard load is 2¼ dr. of powder and ⅞ oz. of shot. Best killing range up to 30 yards.

For an all-purpose gun, suitable for wild fowling as well as upland shooting, the 12-gauge is the best choice, although the 16-gauge will be found a hard-hitting weapon. For the good shot, the 20-gauge will prove a fine little arm for upland work, only the gunner must shoot well with the small bore to kill his bird clean. Contrary to the notion, the large bore, not the small gauge, will bring the most game to the novice's bag.

#### Mission Candlestick

Even though a candlestick is one of the simplest of the smaller household furnishings, it nevertheless can be made a very attractive feature.

For the illustrated mission design, a base, 4 by 4 by ⅞ in., should be provided. This is cut, with the grain, for a ½-in.-wide groove, ¼ in. deep and extending from one side to within ½ in. of the opposite side. In this groove is to fit the handle, which is made from a piece of ½ by 2¼ by 3¾-in. stock. It

is provided with a finger-grip hole  $\frac{3}{4}$  by  $1\frac{1}{4}$  in. at one end. Its upper edge should be marked off from the center pedestal and fitted to it. The pedestal can be made from stock  $1\frac{7}{8}$  by  $1\frac{7}{8}$  by 5 in. A tenon,  $\frac{1}{4}$  in. long by  $1\frac{1}{4}$  in. square, is formed on the lower end. This tenon is to fit a mortise in the center of the base. A slot  $\frac{1}{2}$  in. wide is cut centrally in the pedestal, and 2 in. above the lower end, to fit the handle. The upper end of the pedestal is cut straight for  $\frac{1}{4}$  in. and squared off to  $1\frac{1}{8}$  in. This is to serve as a tenon to fit a corresponding mortise in the  $\frac{1}{2}$  by 2-in. square top. The sides of the pedestal are evenly tapered off from the  $1\frac{7}{8}$ -in. square base to the lower end of the  $1\frac{1}{8}$ -in. square tenon, at the top.

The parts, before assembling, should be thoroughly sandpapered, as considerable difficulty would otherwise be experienced. No nails or screws need be used, as good glue will keep the parts together equally well. When completely assembled, a hole should be drilled through the top and into the pedestal, to fit the size of candle to be

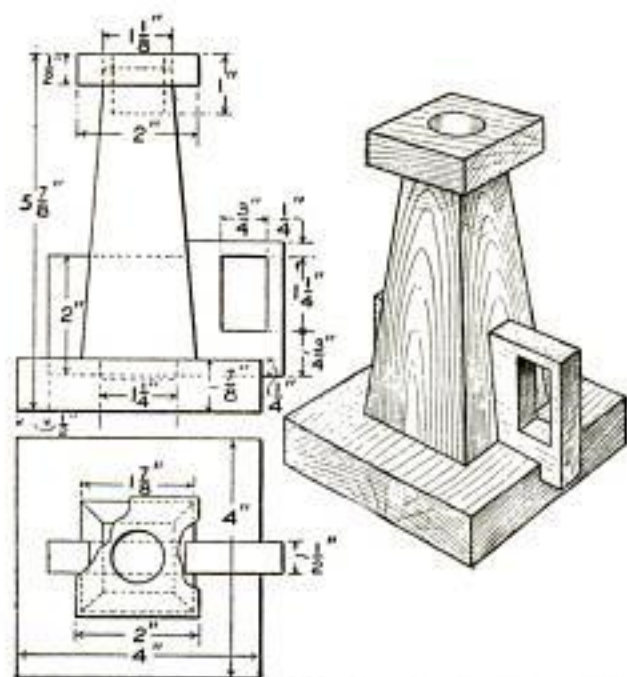

Mission Candlestick of Pleasing Design, That will Appear Well with Other Furniture of This Class

used. A carefully applied mission stain and varnish will give a proper finish to the candlestick.—Contributed by G. Crossley, Erie, Pa.

## Pin Setter for the Home Tenpins

Bowling with a set of small tenpins, which can be purchased at a department store, is a very interesting game. The chief drawback, however, is the setting of the pins. With a little rack like the one shown in the illustration, the

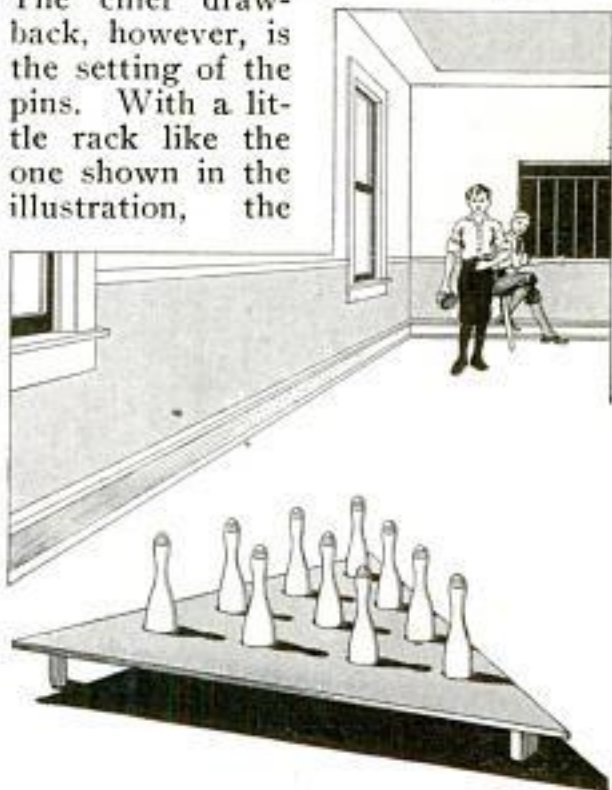

All the Tenpins are Quickly Set, and Each in Its Proper Place

interest in the game may be increased considerably. It not only helps in setting the pins rapidly, but insures a good setting with the proper spacing between the pins. It is very simple to make, as it consists of a triangular piece of wood with ten holes bored into it at the proper places, the dimensions of which will be governed by the size of the pins, and three supports. The pins are dropped in the holes and the rack lifted from them.—Contributed by F. K. Howard, Los Angeles, California.

## Magically Naming a Written Card

This experiment consists in requesting anyone of a company of spectators to name a card and write it on a piece of paper, whereupon the performer instantly names the card written.

Two persons are necessary, the performer and his assistant. The per-

former leaves the room while the spectator writes the name of the card on the paper, the assistant supplying the

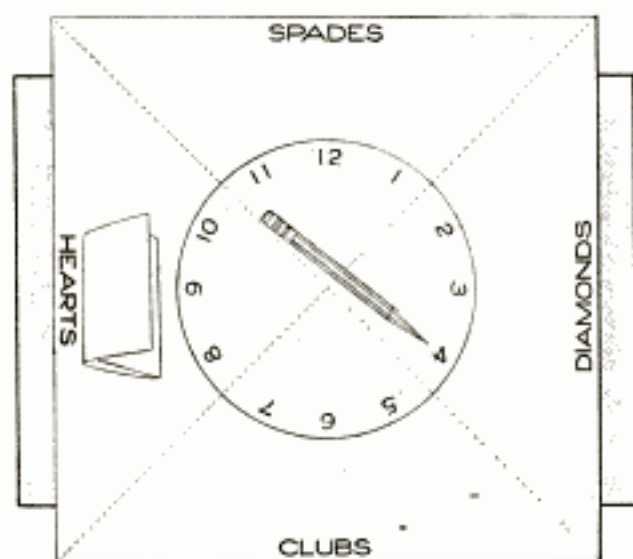

The Markings are Memorized so That Only Positions of Pencil and Paper will be Seen

paper and pencil. When the name of the card is written, the paper is folded by the spectator and handed to the assistant with the pen or pencil. The assistant lays the pencil and paper on a table in certain positions to designate the name of the card. Previous to this test, the performer and the assistant must have the positions of the paper and pencil mentally fixed in their minds. Referring to the sketch, the four sides of the table represent the card suits, viz., spades, hearts, clubs, and diamonds; and an imaginary circle divided into twelve parts indicates the number of the card, 1 standing for ace, 2 for deuce, and so on.

The assistant, knowing what has been written on the paper, places the paper to indicate the suit, and the pencil is laid so that it points to the number on the imaginary circle, or dial. The one shown in the sketch is designating the four of hearts.

#### Dry-Cleaning Mixture

An emulsion of gasoline and water is much used by dry cleaners for removing grease, tar, and paint spots from clothing. It is in the form of a thick, white sirup, which evaporates entirely and is not injurious to any

fabric or color. The directions for preparing this emulsion should be followed out carefully.

Dissolve, in 1 qt. of boiling water,  $\frac{1}{2}$  oz. of pure castile soap, and  $\frac{1}{4}$  oz. of gum arabic. Allow this to cool, and then add 1 oz. glycerin, 1 oz. strong aqua ammonia,  $1\frac{1}{2}$  oz. chloroform, and 2 oz. sulphuric ether. Shake well, and pour enough of the mixture into a quart bottle to fill it for  $\frac{3}{4}$  in. On top of this, pour not more than  $\frac{1}{4}$  in. of gasoline, and shake until creamy. Repeat the addition of gasoline, shaking each time, until full. The cleaning mixture will then be ready for use, and may be applied with a rag, or small brush.

If, on adding the first lot of gasoline and shaking, the mixture does not become emulsified, it proves that too much gasoline has been added. In this case, allow it to stand for a few minutes, and pour off the excess gasoline which comes to the top. Shake well, and add a smaller quantity of gasoline. When the bottle is half full, larger quantities of gasoline may be added at a time.

It is interesting to note that the more gasoline is added, the thicker the emulsion becomes, and if the addition of gasoline and shaking is prolonged, a semisolid jelly is formed, which will not run from a bottle.—Contributed by H. E. Zschiegner, Wellsville, N. Y.

#### Locking Window Sash

An excellent lock for window sash is to use two small, but strong, hinges, one fastened on each side of the top sash close to the upper edge of the lower sash. This allows one wing of each hinge to swing freely, which permits it



to be swung over the upper edge of the lower sash, locking both securely. In placing the hinges in this position, they are out of sight and not in the way.



### A Fish Scaler

All kinds of devices, both simple and complex, have been made and patented for use in scaling fish, but for a novelty I found the following, which necessity compelled me to improvise on an outing trip, to be as efficient as any of them. As usual, the commissary, in making up the outfit, neglected to take the curry comb to clean the fish, and at the same time remembered to take a plentiful supply of bottled goods. Long before it became necessary to scale any fish enough bottles had been opened to provide the basis of a tool for the purpose, which I constructed by using the small tin bottle caps, a few being nailed on a block of wood, about 3 in. wide by 4 in. long, making a splendid fish scaler, as good and efficient at home as in the camp, and both

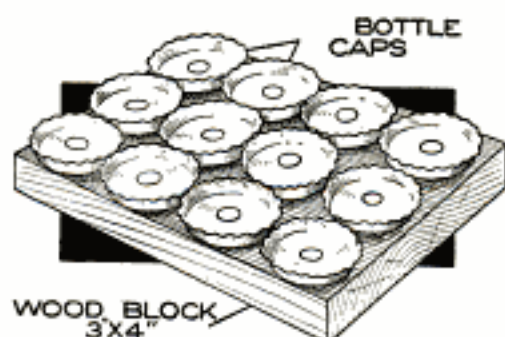

Bottle Caps Nailed to a Wood Block for Removing Scales from a Fish

inexpensive and easily made. The sketch shows the general appearance.—Contributed by T. B. Lambert, Chicago.

### A Disappearing Towel

Nothing is more unsightly to a stranger entering a home than a dirty towel in either the bathroom or the kitchenette. To keep the towel out of sight I made a hanger as shown in the illustration. A wire was bent into shape similar to a clothes hanger and a sliding clip made to hold the towel in place. A cabinet was made to accommodate the towel, and the hanger was attached to a cord run over a pulley fastened at the top, through a weight pulley, and then tied to a screw

eye at the top. The weight draws the towel into the cabinet. Near the bottom edge a slot was cut and a small

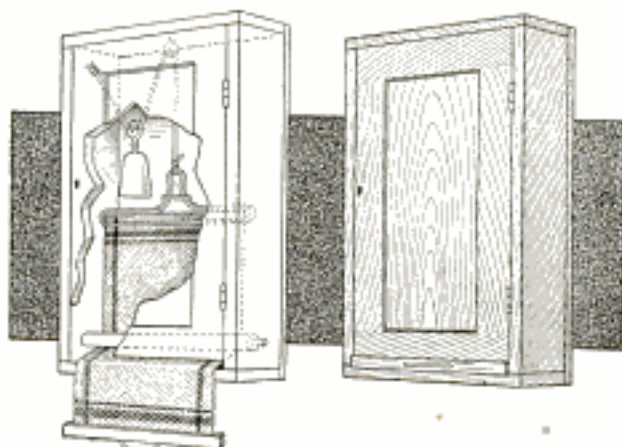

The Weight Draws the Towel into the Case Out of Sight When Not in Use

panel fitted in it. This small panel is fastened to the lower end of the towel. It is only necessary to pull out the small panel to get at the towel. When through with the towel, let loose of it and the weight will draw it into the opening.—Contributed by Chas. C. Bradley, W. Toledo, O.

### Ammonia-Carrying Case for Insect Bites

An old clinical-thermometer case can be easily turned into a vial in which to carry ammonia for insect bites. Fit a small rubber stopper in the case, then push a darning needle into the stopper so that its end will be a little more than midway in the case. Cut or break off the needle end projecting on the outside and attach a small wad of cotton to the inside end. The case is then filled with ammonia. For bee stings this works fine, as the ammonia completely neutralizes the formic acid which the bee deposits.—Contributed by E. Everett Buchanan, Elmira, N. Y.



ⒸThe contact points of a firm-joint caliper should never be struck on hard surfaces to adjust them.

### Sheepshank Knot Used to Recover Rope

The knot shown has a peculiar characteristic which enables a person to recover the rope after letting himself

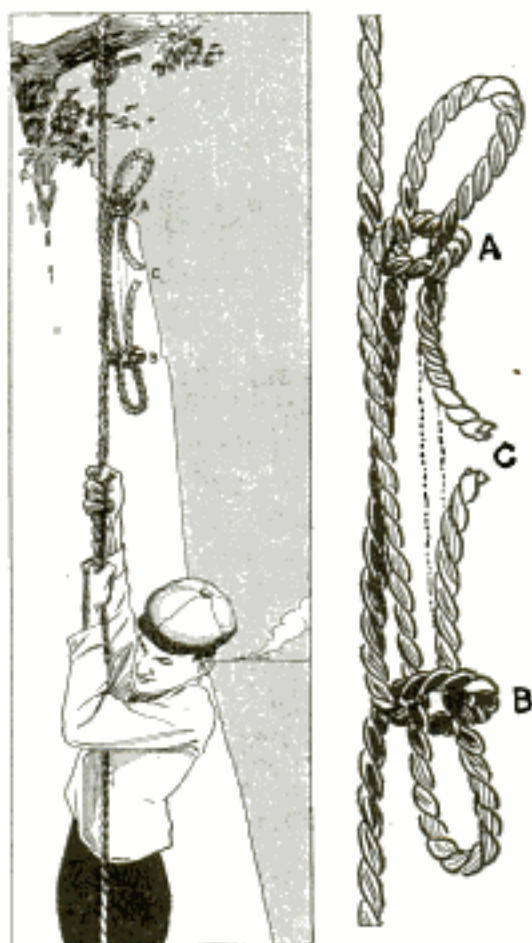

Only a Small Portion of the Rope will be Left on the Projection

down from some elevated position. After the rope has been tied firmly to some support, as a limb of a tree, tie this knot, or "sheepshank," as high up as possible. Close inspection will show that one of the three sections of the knot holds no part of the weight below. This section is identified as the portion which projects through the loops A and B at both ends. The other sections project through at one end only. When the knot has been arranged, slide down carefully to a position just below it and cut the rope at C; then descend to the ground. By shaking the rope the knot may be loosened, and only a short piece will be left attached to the support.—Contributed by F. R. Gorton, Ypsilanti, Michigan.

### Writing Two Colors on a Plain-Ribbon Typewriter

To write red, or any other color, on a one-color ribbon typewriter place a long enough piece of red carbon paper, or the color desired, between the ribbon and the paper. It will hold its place quite well, does the work as well as a two-color ribbon used on expensive machines, and does not cost very much.—Contributed by Leslie E. Turner, New York City.

### A Simple Card Deception

The effect of this trick is not new, but the method is a new one. A card is selected by a spectator and noted, then returned to the pack, which is shuffled by the one drawing the card. Despite the thorough mixing the correct card is located by cutting the pack. The secret is this: When the card is chosen, the chooser is allowed to remove it from the pack. The performer then takes it and holds it up and asks the audience to fix it in their minds. While doing this, allow the thumb nail of the index finger to slightly graze the edge of the card. This will not show, nor can it be detected by the holder, and he suspects nothing of the kind. When returned to the deck and shuffled the pack is evened up for cutting. A glance at the edges will show a small white spot distinctly, as the scraped edge will contrast with the other soiled cards. It is simple to cut the pack from this key.—Contributed by John C. Moorehead, Minneapolis, Minn.

### Catching Minnows for Bait

Instead of chasing the little fish up and down the stream to catch enough for bait, try putting a clean bit of shell in a wide-mouth jar and holding it in the water. The minnows will be attracted in great numbers, and it is an easy matter to dip them up. A bit of shell can be used also in a net. The white, shining shell seems to be a good lure for the little fellows.—Contributed by Miriam Colchester, Amherst, Can.

# Surface Mining for Gold

By W. M. MILLS

## PART II—Recovering Gold from River Beds

A VERY ancient but still popular and good way of recovering gold from river beds is to use a "cradle" or "rocker" instead of the sluice box. An assembled view of this is shown in one of the illustrations. It consists mainly of three parts: a hopper, A; an apron, or inclined riffle, B, and the cradle, or sluice box, C. Proportions and methods of construction may differ to suit various conditions. The cradle box C consists of a bottom board, D,  $\frac{1}{2}$  by 15 by 30 in., with the long edges planed to a slight bevel, so the sides E will tilt inward, thereby preventing excessive slopping of the water when rocking the cradle. The sides E are cut to 3 in. at one end and  $1\frac{1}{2}$  in. at the

other, and run to a point 4 in. high about 15 in. from the 3-in. end. The low-end piece F is slightly curved from end to end to produce a more uniform flow when rocking. The hopper A consists of a rectangular frame, 3 in. high, strongly braced in the corners. On the bottom side is fastened a plate of sheet metal punched with  $\frac{1}{2}$ -in. holes; or, better still, it may be covered with No. 5 mesh screen. The hopper rests on the high portion of the sides E, being held in place by the extensions of the corner braces which fit up against the sides. The side handle G is used to do the rocking.

Underneath the hopper—when this is in position on the cradle—is the in-

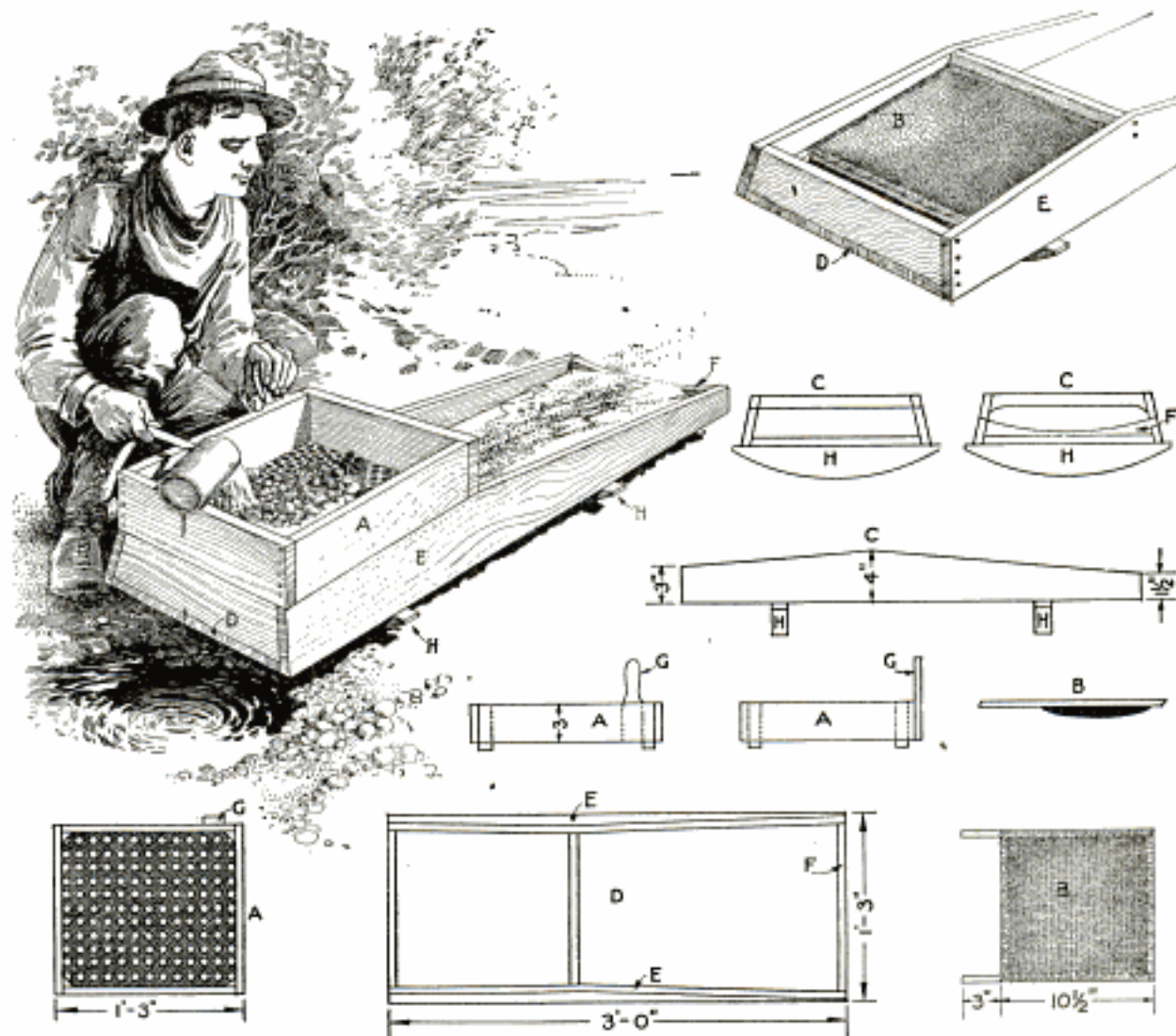

The Cradle or Rocker is Used Instead of the Sluice Box for Recovering Gold in River Beds. It Consists Mainly of Three Parts: the Hopper, Cradle, and Apron, or Inclined Riffle

clined apron, or riffle, B, which consists of a frame,  $13\frac{1}{2}$  in. long, loosely covered with canvas for about  $\frac{3}{4}$  of its length, the remainder being open. It is supported on the high, or canvas, end by a crosspiece extending from one side to the other; the lower, or open end, rests on the bottom board of the cradle. Rockers, H, are provided to produce the necessary rocking motion. When used, the cradle should be set so as to have a slight incline of about 1 in. toward the low end.

The gold-bearing gravel or sand is placed in the hopper and water is added, at the same time rocking the cradle. This causes the sand, silt and fine gravel to be washed out, flowing down over the apron and out at the lower end. After removing the worthless pebbles and large stones from the hopper, any gold nuggets, too large to pass the screen, may be seen.

The apron, directly underneath, catches any smaller gold particles which have passed through the hopper screen. If the gold be of a very fine size, riffles, or pockets, may be formed in the apron by supporting the canvas with several crosspieces. These riffles tend to retard the flow momentarily and cause the gold particles to drop. A surer method of getting the fine gold is to put mercury in the pockets, or riffles, and produce an amalgam, which can easily be separated by means of the iron retort, as explained in the previous chapter.

Mining in a desert would hardly appeal to the average person, but even in such regions, rich deposits of gold have been found. A different method of recovering gold must be used there. Placer mining has been used in the "arroyos," or dry washes, but changes must be allowed for, from that previously described, which applies only to places where water is plentiful. The cradling must be done without water, or with very little, as water is a scarce

article in the desert and may even be more valuable than the gold. The desert gold is usually found as fine flour and must be carefully collected. Its separation from the dirt can best be accomplished in a jig, or churn. This may consist of a water-tight box open at the top. Another loose-fitting box must be provided. Its top also is open, but the bottom consists of a very fine screen. In operation, the dirt is placed in the inner box with water all around in the larger one, and the loose box—being provided

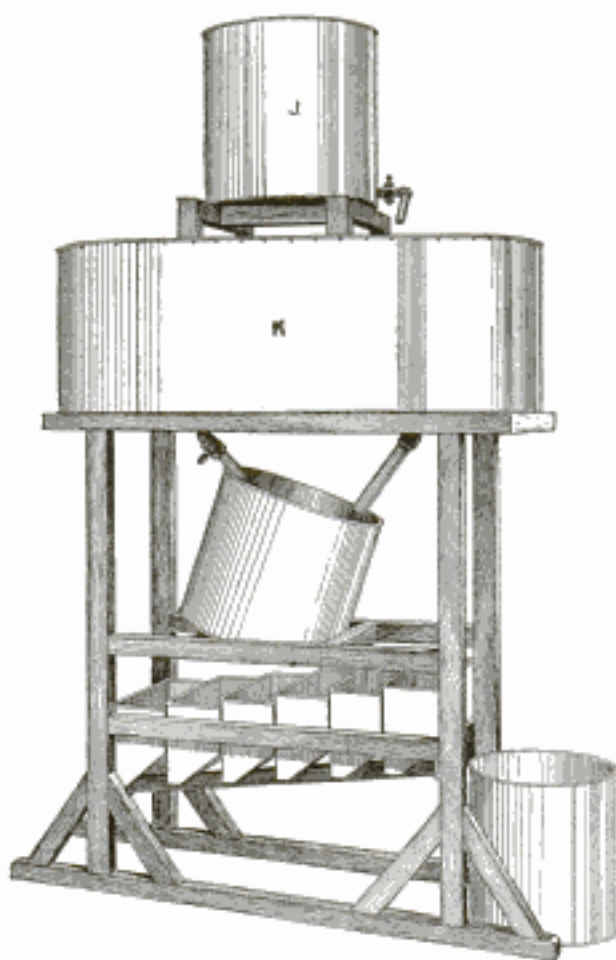

The Cyaniding Process is Especially Recommended for Desert Gold, Which Occurs in a Fine-Grained Condition

with a handle—is then moved up and down rapidly in the water. This jiggling action tends to arrange the dirt and the gold in separate layers, due to their weights differing considerably. After the jiggling has been continued for some time, the contents of the loose box may be examined for gold; this will be found in the bottom layer, due to its weight being greater than the dirt. Where power is available, power-driven jigs may be used, the reciprocating

ing action being obtained by means of eccentric cams, or cranks.

The cyaniding process for obtaining gold is one of the recent methods, especially recommended for desert gold, which occurs in a fine-grained condition. The illustration represents a cyanide plant of small proportions. The finely ground ore is placed in a vat, J, where it is covered with a weak solution of potassium cyanide and allowed to stand for four or five days. The gold passes into solution and this is then drawn off into a settling vat, K, where zinc shavings are added. This will cause the gold to drop to the bottom as a black powder, which may then be collected, placed in a crucible or retort, and, after mixing it with a small amount of borax, heated in a furnace, which will cause the gold to appear in its bright metallic condition. The cyanide process is especially adapted to low-grade ores of the right condition. In its operation, special precaution must be taken not to inhale the cyanide fumes nor have any of the solution mix with drinking water, even after having passed through the soil, as it is extremely poisonous and a very small dose of it may prove fatal.

The determination of the exact value of the ore per ton is called its assay. It is the process of separating the gold from a very small sample of ore and finding its proportion to waste matter in a definite weight of sample, thereby determining the relative value of the gold per ton of ore, and of the mine, as a business proposition. The separa-



A Conical Pile is Made of the Ore, Then It is Divided into Quarters

tion of gold from ore in large quantities must be carried on in specially equipped mills or smelters. Assaying

may be either by the "wet" or "dry" process; the chemical analysis corresponds to the wet method, and the fire assay to the dry process; the latter

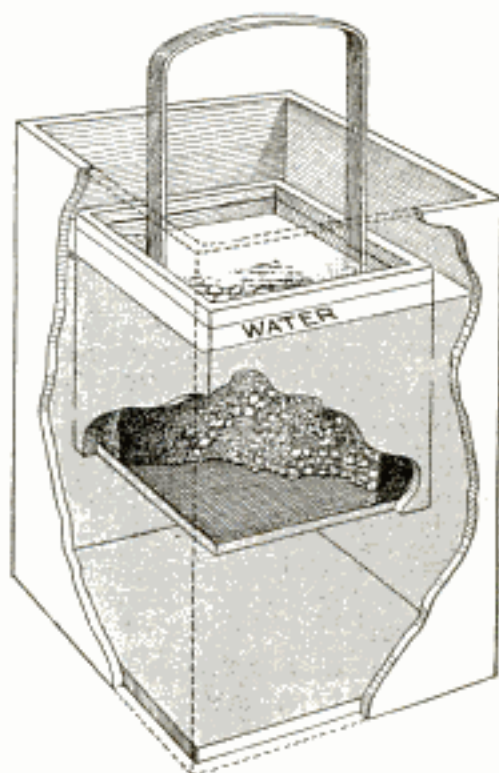

A Jig or Churn Used to Separate the Desert Gold with Very Little Water

method is the one mostly used for gold, due to its comparative simplicity and accuracy. It consists, in a general way, in heating the ore in the presence of a lead ore; the gold and silver will combine with the lead, from which it may be readily separated; the refuse of the ore will form a slag which may be thrown away.

One of the most important operations preliminary to the actual assay of the ore—whether this assay be done by oneself or by a regular assayer—is that of taking the sample. If a batch of ore is taken from one spot and sent to the assayer, it may show a value very much too high or too low. A representative sample should be made by taking portions from various parts of the mine. "Salting" a mine sample consists in increasing its value by the addition of fine gold, or chemicals containing gold. In selling gold-mining properties, unscrupulous salting is often resorted to, and the purchaser should be on his guard against any

such practices. As an assayer's sample is usually small, a very little gold added to it would increase the valuation of the assay immensely.

An assayer's sample may consist of one or more bags of ore. This may as well be reduced to a smaller amount in the following manner: The ore should first be crushed until it will pass through about a  $\frac{1}{2}$ -in. screen. Then a conical pile should be made and this divided into quarters, as shown in the illustration. Remove the two opposite quarters, leaving the others, then form another conical pile and again quarter and remove as before. The process should be continued until about 1 lb. is left, which should be crushed to about  $\frac{1}{4}$  in., or less, when the quartering process is again repeated until about 4 oz. are left. This amount is used in the assaying. It should be pulverized so as to pass a very fine screen of about 100 mesh to the inch, after which it is ready for the actual assaying.

#### How to Preserve Cut Flowers

Cut flowers remain fresh for such a very brief time that any means of prolonging their life is eagerly welcomed by the flower lover. Many experiments have been tried along this line by modifying the water in which the flowers are placed. Thus, roses, carnations, and orchids have been found to keep three times as long if a small quantity of sugar is added to the water. This is taken up and helps to keep the cells of the flower from collapsing, and thus wilting. A small lump of starch has also been found beneficial. Other flowers begin to bleed as soon as they are cut, and the precious sap running out of the stem causes the cells to collapse immediately. To prevent this, the end of the stem must be quickly closed, and this is best done by searing in a flame, or by placing directly in hot water. For corsage bouquets the searing process is best, although a little tedious, as each stem must be so treated.

When flowers are placed in hot water, the water will immediately become discolored and unsightly, but a

pottery vase overcomes this difficulty, and also prevents accidents, likely to occur were the hot water placed in a glass vase. There are many flowers which can be successfully treated by this process, namely, dahlias, heliotrope, Shirley poppies, nasturtiums, and maidenhair fern. The florists of California go so far as to boil the stems of the brilliant Poinsettias, or Christmas flowers, for which they are so famous. The stem is first stuck through a large sheet of paper to prevent the steam from rising directly into the flower and injuring it.

Carnations and chrysanthemums will keep almost twice as long if placed in fresh water daily and a small piece is clipped from the ends of the stems each time. While cutting this piece off, keep the stem under water so that no air bubbles are allowed to enter the stalk and thus retard the upward flow of water.

Violets often lose their fragrance after being picked, especially the larger varieties. If they are placed under a glass globe immediately and no air is allowed to reach them, they will retain their fragrance until wanted for use. To keep a quantity of violets to send away or to use later, tie them in bunches, sprinkle with water, wrap in a wet newspaper and place in a cool spot.

If large-headed flowers, such as chrysanthemums or peonies, are to be sent some distance, insure their arriving in good condition by wrapping each blossom separately in waxed paper. This is best done with a sheet of paper about 12 in. square. In the center of one side make a slit to the center of the paper. Pull the flower stem to the center of this slit so that the blossom rests in the very center and above the paper. Draw the four corners together over the flower and twist them well.

The main thing to be remembered about cutting flowers is to wait until the sun has left them, either in the evening, or, preferably, in the early morning while they are still wet with dew.—Contributed by Mabel H. Wharton, Oakland, Cal.

### Repairing Sectional Spun-Metal Candlesticks

In repairing hollow, spun-brass candlesticks I find that frequently the metal rod holding the sections together becomes loosened from the pitch composition designed to hold it in the base. By tinning the outer edges of the sections that fit into the other portions, which are also tinned on the inner surfaces, and then using an iron, or an alcohol torch, to run the solder together at these points, I secure a very firm job. Paper can be placed at points necessary to keep the solder from running out of bounds. When the rod is firm and the nut only gives trouble, solder can be used to fasten the nut permanently to the grease cup at the top.—Contributed by James M. Kane, Doylestown, Pa.

### Alcohol Blowtorch for Difficult Soldering

To solder in close places, I have found the device illustrated quite convenient, as it leaves both hands free to handle the object being soldered. Two pieces of spring brass, about 3 in. long and  $\frac{1}{4}$  in. wide, are bent to the shape shown at A and clamped together with a screw taken from a dry cell, as shown at B. This device clamped to the blowpipe end and fitted with a tube, such as used for holding pencil leads, filled with a wick saturated in alcohol, completes the blowtorch. It makes an ex-

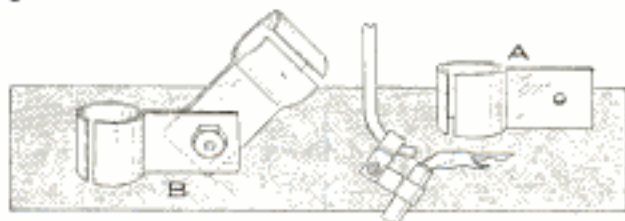

Clamps for Holding the Alcohol Receptacle on the End of the Blowpipe

cellent tool for small work, as the hands are free to hold the parts to be soldered in place.—Contributed by J. A. Tandy, Ghent, Ky.

ⓈElectric wires should never be run crooked.

### Preventing Sewing-Machine Thread from Tangling

The highly enameled surface of a sewing-machine arm offers so little resistance to the bottom of the spool that the thread will unwind faster than it is used, thereby causing a tangle. A piece of paper slipped over the spool post will cause enough friction to prevent the spool from revolving beyond the proper speed.

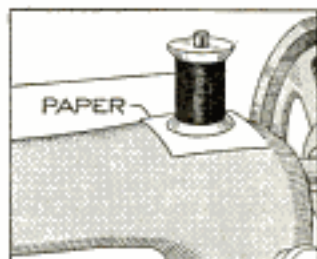

### Bearing Made of a Brass Cartridge

A brass cartridge makes a good bearing to fit in a wood driving rod used to run a small piece of foot-power machinery. It prevents wear on the wood and admits more lubrication than the bare wood. Cut the cartridge to the proper length, and ream out the cap hole even with the diameter of the bore of the shell.

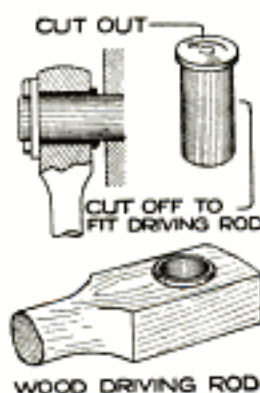

diameter of the bore of the shell.

### Lighting a Match in the Wind

To light a match in a stiff wind is very easy if the wood part back of the prepared end is cut and turned up about it before striking the match. The curled-up shavings about the striker will catch fire easily and hold a flame, where in the ordinary way it is easily blown out when the composition of the striker has burned up.—Contributed by E. K. Marshall, Oak Park, Ill.



## INTERESTING NEW PATENTS



Fig. 1



Fig. 2

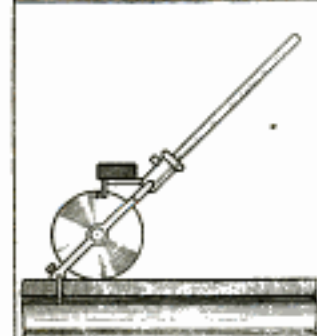

Fig. 3



Fig. 4



Fig. 5

**THEFT INDICATOR FOR AUTOMOBILES** (Fig. 1)—This device consists simply of a plate which is designed to be locked over the license number and on which the words "Stolen Car" are conspicuously displayed, the idea being to attach this plate whenever the car is left standing at the curb or elsewhere. The plate is made to hook over the top of the license plate and is locked in place with a padlock.

**LADDER SCAFFOLDING** (Fig. 2)—The purpose of this invention is to provide a means of securely mounting a scaffold plank on two ladders set against a wall, and the device is so made that it can be attached either to the inside or the outside of the ladders as required. It consists of a bracket which is easily attached to the rungs, as shown.

**INSTRUMENT FOR MEASURING RAILROAD TRACK** (Fig. 3)—With this instrument the tedious work of measuring track with a surveyor's tape line is entirely done away with. The instrument is simply placed on the rail with the two guides at the forward end engaging the sides, and is then pushed along the section of track to be measured. The distance that the wheel travels is shown on a distance recorder carried on the frame.

**NEW TYPE OF "BEAUTY MARK"** (Fig. 4)—This invention is intended to provide an improvement over the ordinary patch of court-plaster sometimes used by members of the fair sex for enhancing the effects of their good looks. The new "beauty mark" consists of a sparkling stone cemented to a piece of court-plaster which may be cut in any shape to serve as a sort of border for the stone.

**GUIDE FOR BILLIARD CUE** (Fig. 5)—The guide is made of metal and is curved to fit over the index finger. Projecting from the outer side is a curved tongue in which the cue slides. The guide is attached to the hand with a strap passed around the fingers.

**NEW BATHTUB ATTACHMENT** (Fig. 6)—Through this attachment the water is carried from the faucet to the floor of the bathtub and is there discharged, so that the usual noise connected with filling the tub with water is eliminated. Inside the grating through which the water is discharged is a valve connecting with the drain pipe leading to the sewer. This valve is used for emptying the tub, and is operated by the rod that projects upward from the discharge head.

**CLOTHESLINE HANGER** (Fig. 7)—Evidently intended to be used with small articles such as handkerchiefs, this device consists simply of a rod which is suspended transversely to the clothesline by means of a specially designed hanger. The hanger is made of elastic metal and is so shaped that it grips the clothesline.

**COMBINED FLAGSTAFF AND TORPEDO HOLDER** (Fig. 8)—This flagstaff is designed for the convenience of railway flagmen, who are compelled to carry torpedoes while doing their work. The flag is secured to the staff by a rod passing through the hem, while the torpedoes are carried in the slot formed at the back by bending over the sides of the staff, which is of metal. The torpedoes are inserted and removed at the handle end of the slot, this end being opened and closed by a pivoted bar, as shown. The opposite end of the slot is permanently closed.

**CORK EXTRACTOR** (Fig. 9)—This extractor has a pointed shank, on one side of which is a slot. Mounted in this slot is a pivoted bar which lies flush with the shank when it is being thrust into the cork, but swings outward and engages the cork when the shank is pulled upward.

**MOUSETRAP** (Fig. 10)—In its attempt to reach the bait the mouse must walk out on a pivoted plate. The weight of the mouse tilts the plate sharply and the mouse is precipitated into a self-closing receptacle, or one filled with water.

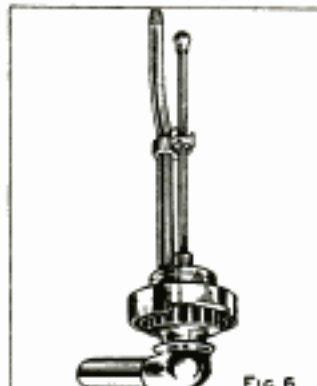

Fig. 6

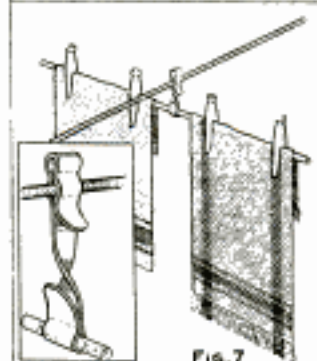

Fig. 7

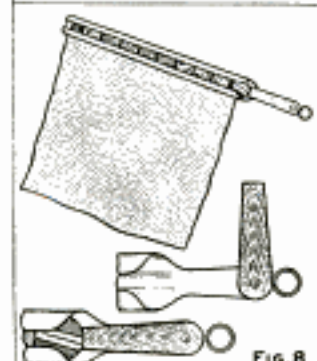

Fig. 8



Fig. 9

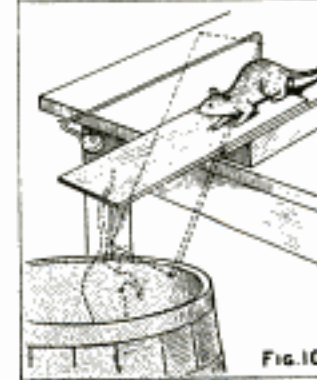

Fig. 10





Fig. 11

**UMBRELLA EQUIPPED WITH ELECTRIC FAN** (Fig. 11)—The umbrella has a tubular rod in which is a small electric motor and a shaft for driving the fan. The fan is placed inside the umbrella and near the top so that it throws a breeze downward on the user. It is arranged in such manner that it does not interfere with the closing of the umbrella.

**SELECTIVE SIGNAL FOR PARTY-LINE TELEPHONES** (Fig. 12)—This signal consists of a dial indicator and is designed for single-wire party-line circuits. In using, the pointer is set to the number of the telephone called. All the bells on the circuit will then ring, but only the indicator on the telephone called will drop to position. In case the subscriber is not within hearing of the bell, the indicator shows him that he has been called. In answering the call, he leaves the indicator as it is, and none of the indicators on the other telephones are affected.



Fig. 12

**EGG BOILER** (Fig. 13)—The holder in which the eggs are placed is attached to the lid by two pivots, and is raised and lowered by the lid. With the eggs in place, the lid is closed and locked so that the eggs are lowered into the boiling water contained in the receptacle. The lock is provided with a timing device that releases the lock at a predetermined time and allows the lid to rise under the action of a spring.

**ELASTIC BELT** (Fig. 14)—This belt differs from other elastic belts in that no rubber is used, the elasticity being supplied by a flattened coil spring placed in a pocket at the back. This spring is shaped around two flat metal tongues, one attached to each half of the belt. The free end of each tongue is turned up to form a stop against which the spring bears. The spring is compressed as the belt is stretched.

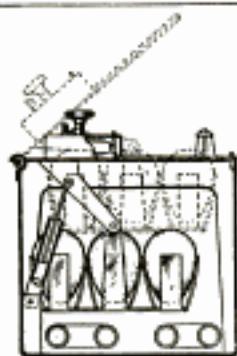

Fig. 13

**SLIDING DOOR FOR AUTOMOBILE** (Fig. 15)—The door is operated by a toggle lever, one end of which is pivoted to the door and the other to the side of the car body. The door opens when the lever is made to buckle, and closes when it is straightened out. Through the action of a spring the toggle is held in either of its extreme positions.

**PORTABLE ORCHARD LADDER** (Fig. 16)—The frame on which the ladder is mounted is a vehicle having wheels at the forward end and feet at the rear end, the latter holding the vehicle stationary when in use. The ladder is pivoted near its center to standards placed just behind the wheels. It is held at any desired slope by a bar that engages one of the rungs.

**FENDER FOR STREET CAR** (Fig. 17)—The feature of this device is an endless belt, faced with a cleaning material, that projects to the front of the car and revolves in such a way as to pick up anything that may be struck. The belt works on two rollers, of which the rear one is driven by a rod geared to the car axle.

**LIFTER FOR PLATES AND PANS** (Fig. 18)—This device is made up of two elements, both of which are equipped with claws for engaging the plate or pan. One of these elements is made entirely of wire, which is twisted at one end to form a handle and is shaped, near its center, into a slot, or guide, for the sliding bar that forms part of the second element. Claws are fixed to this bar, and the device is adjusted to any size of plate, or pan, simply by sliding the bar in the guide.

**IGNITER** (Fig. 19)—This device is used for producing a spark by friction, and differs from other igniters of this class in that it works like a pair of shears. The curved end of the longer arm is roughened to supply the necessary friction, and against this works the igniting material, which is carried in a casing on the shorter arm.

**AUTOMATIC BENCH GRIP** (Fig. 20)—This device consists of two removable jaws, with the nose ends cut away so that they overlap when free, and provided with steel pins on the lower sides with which the jaws are set in spaced holes in a bed plate. When a board is to be worked it is placed on edge and slid between the jaws, where it is held securely. The bedplate is countersunk in the workbench and is secured with screws.

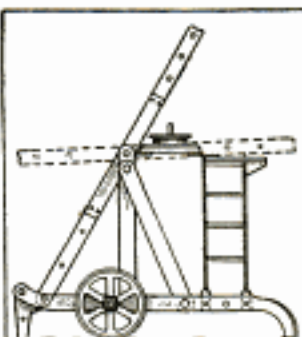

Fig. 16

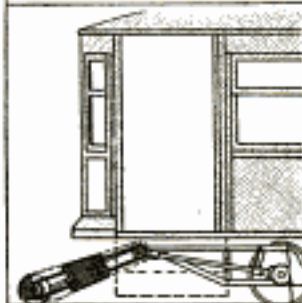

Fig. 17



Fig. 18



Fig. 19

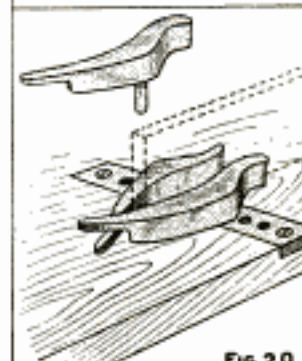

Fig. 20



Fig. 14

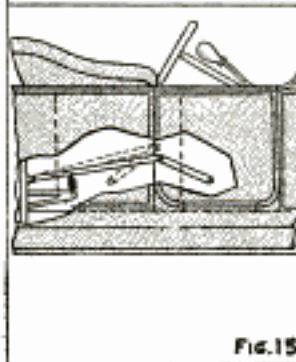
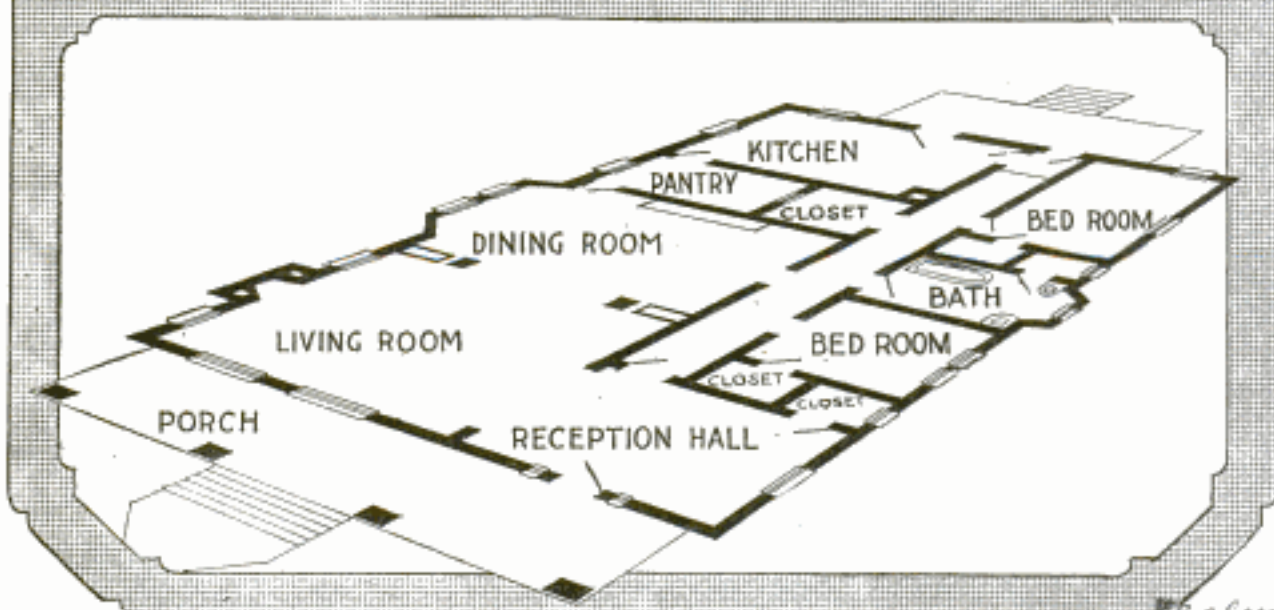
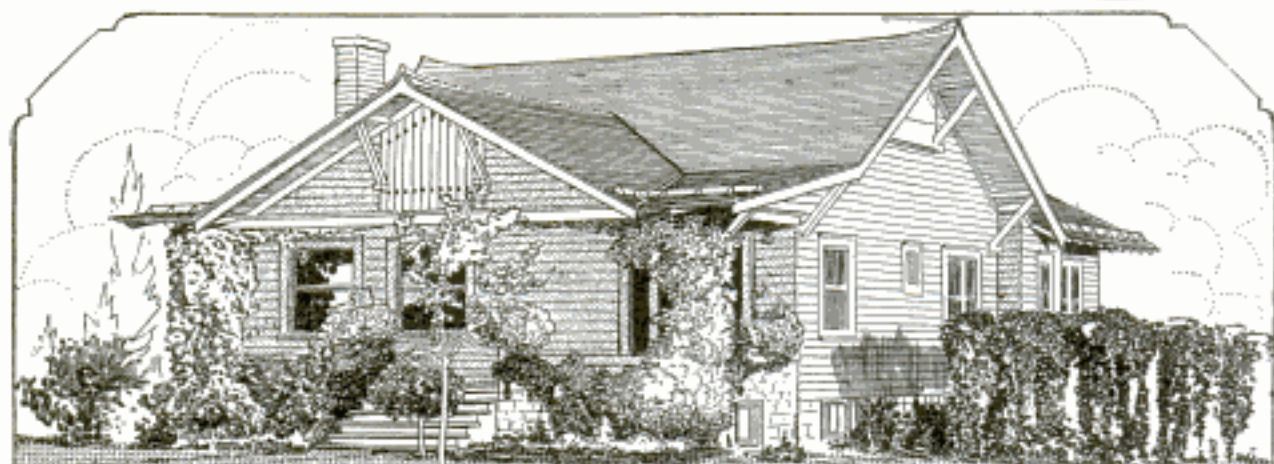

Fig. 15

## A CONVENIENTLY ARRANGED FRAME BUNGALOW



DESIGNED BY MRS. R. L. WOOD, WAVERLY, MO.

THE feature about this house that distinguishes it from bungalows of the usual type is the hallway extending from the reception hall to the screened porch at the rear, and the arrangement by which every room, including the bathroom, is made to open on this hallway. The living room and dining room form practically one large room, being separated only by an archway, which is flanked by bookcases. By means of the sliding doors leading to the reception hall both these rooms can be entirely shut off from the remainder of the rooms, a feature that is often exceedingly convenient when there are guests in the house. At the rear of the hallway are two stairways, one leading to the attic and the other to the basement. An ingenious arrangement made possible by the roof gable at the rear is the sleeping porch built as a second story above the screened porch, the sleeping porch being reached by the stairway that leads to the attic. Access from the kitchen to the dining room is through the butler's pantry. This bungalow was designed with particular reference to the convenience of the housewife and is therefore well equipped with closets. The house is of frame construction. It is estimated to cost \$2,250 when faced with shingles, and \$2,500 when faced with stucco.

IN accordance with the editorial policy of this magazine never to accept compensation in any form for what appears in our reading pages, and also to avoid all appearance of doing so, we are obliged to omit the name of the maker or the seller of any article described. This information, however, is kept on file and will be furnished free, by addressing Bureau of Information, Popular Mechanics Magazine, Chicago. [Editor]

# Costs Less Than a Stove

**A FURNACE** complete, ready to install, for less than a stove! Have you ever heard of a real bargain like this before? The price—**\$47.50**—for the furnace complete would not buy a first-class base-burner or hard coal stove. Think of the time, trouble and money you can save. First: the Aladdin furnace *requires no more fuel* to heat your entire house than you would use in a stove that heats only a few rooms. Second: the furnace is installed in the basement. It is out

**\$47.50**  
Aladdin  
Furnace  
Complete

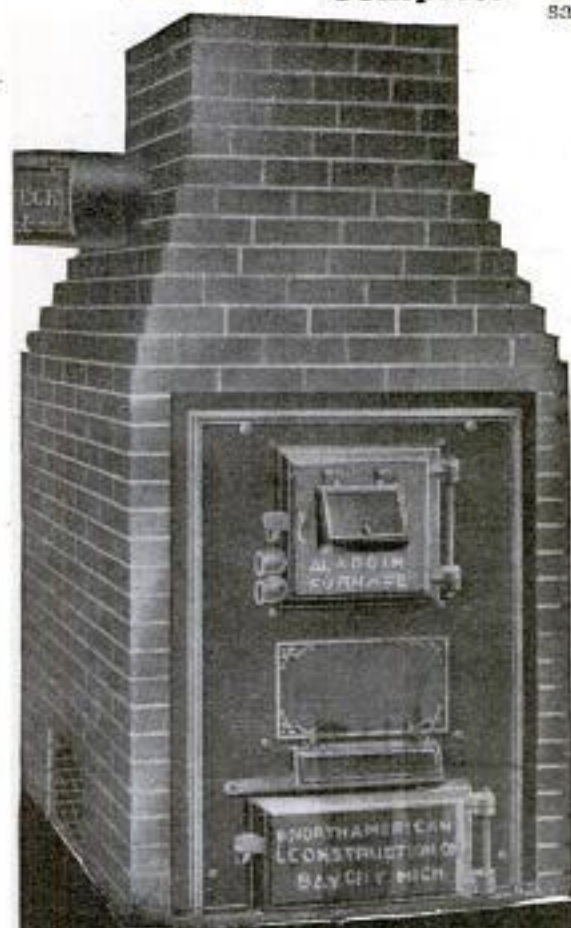

## ALADDIN FURNACE

To Buy "Costs Less than a Stove"  
To Use

of the way and does not occupy valuable space in the home. No dirt or dust carried from the living rooms. Third: It is installed permanently. You don't have to bother taking down and setting it up each season.

If you are doubtful, send for the guaranty. You cannot lose. If the furnace doesn't heat your home to satisfaction, your money is refunded. In other words, we know this furnace will satisfy you and we guarantee it to you, so that you cannot lose.

## No Pipes, Install It Yourself

There are no pipes on the Aladdin furnace to obstruct passage in the basement, and furthermore, the principle of this great heating system is so simple that you can install it yourself in your own home within twenty-four hours and have it ready for use. It is easy to operate. You will have no trouble at all to run this furnace, as any one who can run a stove can operate it.

## Read What Users Say

Shall we send you letters from some of last year's users? Thousands of home owners have installed this furnace, some near you wherever you live. Why not visit an owner, feel the comfortable temperature of his home, find the low cost of operating, see how easy it is to work? "Burns less fuel." "Heats house easier." "Heats entire house, both floors." "Burned three tons less coal this winter." And thousands of other statements are sent to us each day from users of this furnace.

## Guaranteed to Heat Your House

With each furnace you get an absolute guaranty that the furnace will heat your home to an even temperature with a variation of less than three degrees over your entire house, and that the Aladdin furnace will heat your house for less than any other furnace or your money will be refunded. Could we be any fairer to you? Can you secure a better bargain?

## Quick Shipment —Installed in 24 Hours

Our furnace factories are turning out thousands of these furnaces. Your furnace will be shipped quickly and shipped complete. After you receive it, it can be installed in twenty-four hours, ready for use. Then you start saving money on your winter's fuel. Send the coupon below to us today. We will send you complete information. We will also send you a copy of the guaranty. Why not send the coupon now?

North American  
Construction Co.

Manufacturers of  
ALADDIN Houses  
969 Aladdin Avenue  
Bay City, Michigan

Send Coupon  
NOW

North  
American  
Construction  
Co.

969 Aladdin Ave.  
Bay City, Mich.

Send me your Merchandise Catalog No. 130 with full information on the Aladdin Pipeless Furnace.

Name.....

Street.....

City.....

State.....

Please Mention Popular Mechanics

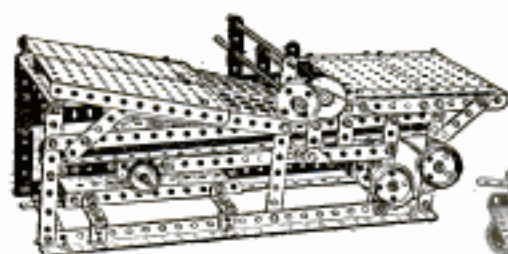

**Boys!** This printing press runs just like a real one.

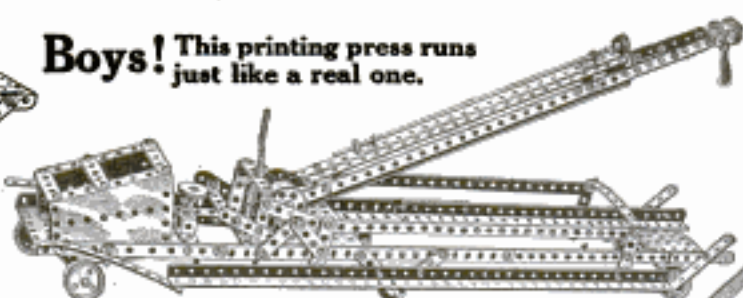

**Boys!** This electric crane works. Build one and have real sport.

**Boys!** Isn't this a dandy automobile? Build one like it.

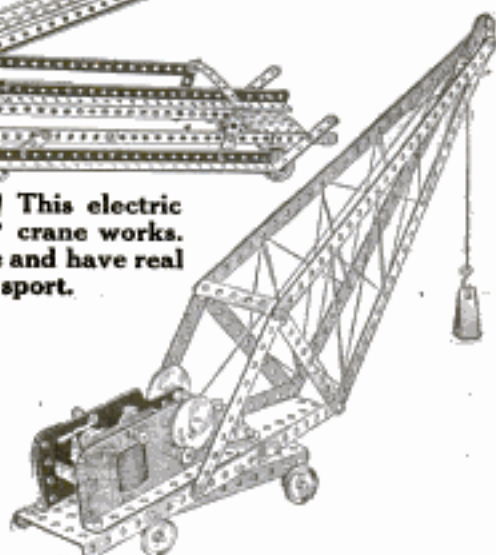

### Here's the New MECCANO Girder Strip

It builds big models like the tower above, quicker, easier and better. Is interchangeable with all other MECCANO parts. Made in two sizes: 5 1/2" long, 35c per half dozen; 12 1/2" long, 50c per half dozen. Both included in the Inventors' Accessory Outfit.

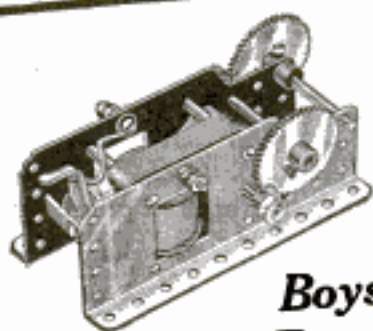

### Boys Here's the Boss of All Electric Motors

It operates models like real machinery. Direct shaft and interchangeable gear wheel drive—positive and powerful. 2 or 3 dry batteries run it. It's a real little electric engine—the most powerful toy electric motor made. Above MECCANO motor, with starting, stopping and reversing lever, included in outfit No. 3x (\$7.50); sold separately for \$3.00. Same motor, without control lever and with fewer gears, included in outfits No. 1x (\$3.00) and No. 2x (\$5.00); sold separately for \$1.50. Get a motor and double your MECCANO fun!

# BOYS— You Can Build More Toys With MECCANO

A new toy every day; bridges, towers, locomotives, cranes and derricks, steam shovels, fire engines, automobiles, clocks, submarines and thousands of others. Small, complicated ones, or large, strong ones; anything real engineers build! It's the greatest fun you ever had—you'll never want to stop.

You build like a big engineer; and you can make your models work just like real machines. It's easy, too; you don't have to learn. You can start right away. Each outfit has everything you need—girders, beams, plates, rods, couplings, cranks; wheels, pulleys, gears, nuts, bolts—lots of things you won't find elsewhere.

### MECCANO With Electric Motor As Low As \$3.00

Sold in Toy Departments

Get MECCANO-wise! See the outfits and new parts now.

Outfit No. 0	\$1.00
Outfit No. 1	2.00
Outfit No. 1x With Electric Motor	3.00
Outfit No. 2	4.00
Outfit No. 2x With Electric Motor	5.00
Outfit No. 3	6.00
Outfit No. 3x With Electric Motor	7.50
Outfit No. 4 With Spring Motor	FREE 10.00
Other Outfits at \$14.00, \$18.00 and \$36.00	

### This is What You Want If You Have MECCANO

This Inventors' Accessory Outfit contains all this year's new parts. Girderstrips; Sprocket Wheels and Chain; 1/2" and 2" Pulleys; Large Gear Wheels; Heads for Weaving Machines; and other parts. Can be used with any MECCANO Outfit.



Sold for  
\$2.00  
in Toy  
Departments.

Please Mention Popular Mechanics

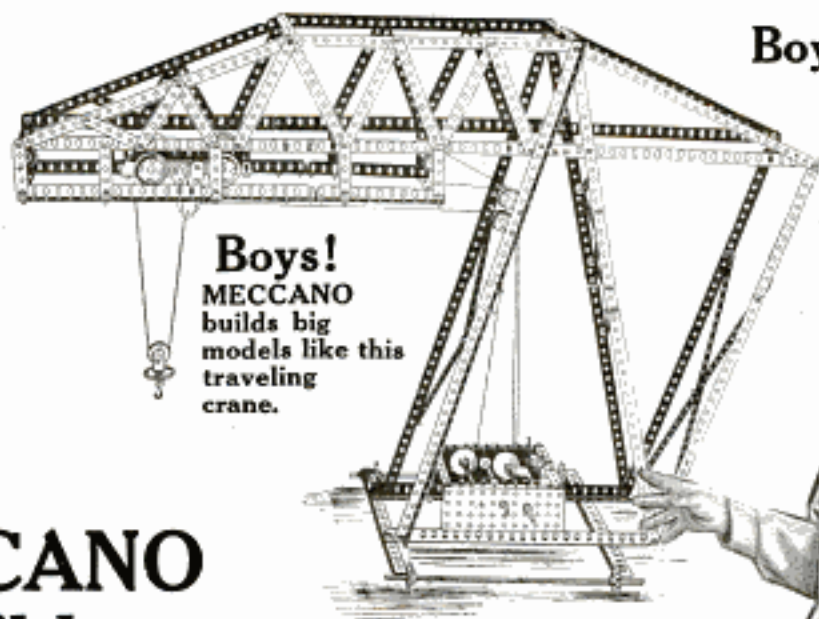

**Boys!** Look what I made with MECCANO. It's great fun.

**Boys!**  
MECCANO  
builds big  
models like this  
traveling  
crane.

## MECCANO Builds 10,000 Models

10,000 were entered in our last contest—just think of all the things you can build! MECCANO builds the most models because it has the most inter-change-able parts, as well as greater inter-change-ability of every part. MECCANO is mechanically correct; you need fewer parts to make your models and can make them better, easier and quicker. That's why MECCANO Toy Engineering is more fun.



## Big \$1,000.00 Prize Contest

Get into the 1915-1916 Prize Contest. Be an inventor! Build a good model and win a fine prize. Get an Entry Blank at the Toy Department and start now.

**BOYS**—Get MECCANO-wise! See the outfits in the Toy Department. Each one is complete, nothing extra to buy. Pick the one you're going to get. See the new 1915 Improvements. Get MECCANO-wise!

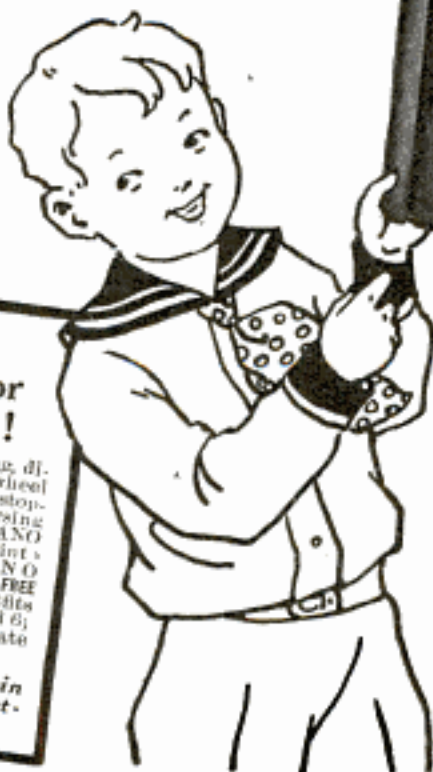

**BOYS—**  
This Spring Motor  
Makes 'Em Whiz!

Has a strong spring, direct shaft and gear wheel drive, starting and stopping brake and reversing lever. It's a MECCANO motor—builds into any MECCANO model. Given FREE with outfits Nos. 4, 5 and 6; sold separately for \$2.00.

Ask for one in the Toy Department.

**Hey—  
Fellows—  
Here's a Real Story!**

Tells how a hustler got an idea, made his first model, got a shop and finally won success and fortune. Tells all about how he did it. It's a live-wire story, boys; you'll want to read it twice. It's FREE, too. Just tell 5 other boys about MECCANO; send their names and addresses, with 4c in stamps for postage, and the book is yours. Better do it today!

*Frank Hornby*  
President

MECCANO CO., Inc.  
Room 15, 71 W. 23rd St., New York City

Please Mention Popular Mechanics



# 100,865,000 Piston Strokes per Year

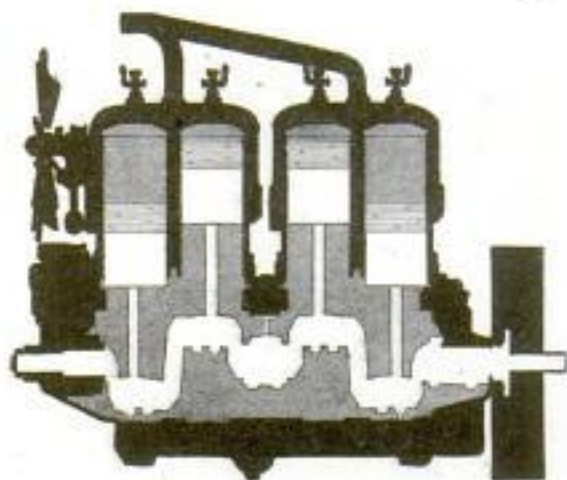

*Protected by an oil film thinner than this line* \_\_\_\_\_

**E**VERY power stroke pays some toll to friction. But few motorists realize how high friction-toll may mount. The following remarkable figures make this clear.

The average of three of the most popular 4-cylinder cars shows that during each mile on high gear, there are 20,173 piston strokes—20,173 rubs within the cylinders,—the pistons and cylinder walls separated only by about  $3/1000$  of one inch of oil—seldom more.

On low gear the piston strokes total over 60,500 per mile.

At the end of the season, assuming that the car has traveled

5000 miles on high gear, *the pistons have made 100,865,000 strokes.*

Each of the 100,865,000 piston strokes is only made possible by the wearing quality of this protective oil film.

It is easy to see then, the vital importance to the motorist of this thin film of oil.

It is now well known that the lubricating efficiency of different oils differs widely.

In engineering circles the Vacuum Oil Company's lubricants have commanded a higher price per gallon. This higher per-gallon price is willingly paid—in view of the ultimate reduced



cost of lubrication and the longer life of the car.

The ability of Gargoyle Mobiloils to stand up under the heat of service results in low consumption per mile. This superior "wear" is important to the motorist who wishes to protect the moving parts of his motor.

Motorists of experience, therefore, are rapidly coming to the use of the grade of Gargoyle Mobiloils specified for their cars in the Chart of Recommendations printed in part on the right.

For several years this chart has been the standard guide to correct automobile lubrication.



Mobiloils

A grade for each type of motor

The four grades of Gargoyle Mobiloils for gasoline motor lubrication, purified to remove free carbon, are:

- Gargoyle Mobiloil "A"
Gargoyle Mobiloil "B"
Gargoyle Mobiloil "E"
Gargoyle Mobiloil "Arctic"

For Electric Vehicles use Gargoyle Mobiloil "A" for motor and enclosed chains. For open chains and differential use Gargoyle Mobiloil "C."

In buying Gargoyle Mobiloils from your dealer, it is safest to purchase in original packages. Look for the red Gargoyle on the container. For information, kindly address any inquiry to our nearest office.

VACUUM OIL COMPANY
Rochester, N. Y., U. S. A.

Specialists in the manufacture of high grade lubricants for every class of machinery. Obtainable everywhere in the world.

Domestic Branches: Detroit, Boston, New York, Chicago, Pittsburgh, Philadelphia, Indianapolis, Minneapolis

Correct Automobile Lubrication

Explanation: In the Chart below, the letter opposite the car indicates the grade of Gargoyle Mobiloils that should be used. For example, "A" means Gargoyle Mobiloil "A," "Arc" means Gargoyle Mobiloil "Arctic," etc. The recommendations cover all models of both pleasure and commercial vehicles unless otherwise noted.

Table with columns for Model of Car and years 1911, 1912, 1913, 1914, 1915. Rows list various car models and their corresponding recommended lubrication grade (A, B, E, Arc, etc.).

# Build A Career With the Frantz Premier

## Opportunities Already Developed for Ambitious Men

If you have selling ability, or *think* you have, it will pay you to ask for particulars of the Frantz way—by which successful salesmen are promoted to important positions as Branch Managers in the big cities, while others become department heads at our home office in Cleveland.

### Frantz Premier Men Who Have Won

Mr. B came into our Chicago office on the 1st of December, 1914 looking for a job. Working under exactly the same sales plan that has been developed by the Frantz Premier Company with a very little coaching, he sold his fiftieth Frantz Premier at retail on Christmas Eve. In the month of January Mr. B. again sold fifty Cleaners at retail. It was noticed at this time that Mr. B. had not only the ability to sell machines himself but that he had taught several others how it was done, and February 1st he was appointed temporarily as City Manager of the Chicago Branch—a position he filled so successfully that he was appointed permanently on March 1st. Mr. B. says that owing to business conditions he had a great deal of difficulty in earning a living in any of the lines to which he had been accustomed. He had no previous experience in selling electrical specialties for the home. Mr. B's income while a retail salesman averaged better than \$350.00 a month.

Mr. F. H. last December was employed as a cigar clerk in a tobacco shop in Chicago, earning \$15.00 a week. This tobacco shop happened to be in the lobby of the building where the Frantz Premier offices are in Chicago and Mr. H. was induced to try selling the Frantz Premier. His income since January 1st has averaged better than \$160 a month and in some months he has made as high as \$325.

Mr. H's brother, Mr. W. B. H. was also working for a salary averaging less than \$18.00 a week in a clerical position and has since February 1st averaged better than \$175.00 per month.

Mr. A. H. B. who, on Aug. 1st was appointed Frantz Premier Branch Manager at Indianapolis, earned his position through his good work as a retail salesman, and later as a wholesale salesman at the Company's Chicago office. Mr. B. came with us as a salesman on Feb. 15th.

Names Given on Request

Already over 100,000 Frantz Premier Electric Cleaners have been sold in the United States. Yet at that the surface hasn't been scratched.

For here is today's finality in cleaners—a handy, all 'round electric cleaner that weighs only nine pounds—does all the most complex vacuum cleaner can do—gets under beds and low furniture—works in the corners—cleans everything from a Brussels carpet to a suit of clothes.

And—the

## Frantz Premier Electric Cleaner

### Is Heavily Advertised

Full pages and other liberal size advertisements in leading magazines and newspapers will continue to tell the great story of the Frantz way of cleaning house, and of the new low price of \$25 which puts the Frantz Premier within easy reach of every average home. This advertising works for YOU.

## Promotion Ahead

And, remember—we are the world's largest makers of Electric Cleaners. We can guarantee quality. We can sell at lowest prices. And, what is more, we will promote successful salesmen to important positions as Branch Managers and Department Heads.

Write for the plan today. It will surely interest you. It more than promises opportunity—it offers a career with a large, successful, growing concern.

Read to the left what others are doing. Get in line to join them. Ask for free book "A Career with the Frantz Premier." Tell something about yourself, and what you've done.

Address, Sales Dept.

**The Frantz Premier Company**  
1122 Power Avenue Cleveland, O., U. S. A.

Principal Canadian Headquarters  
The Premier Vacuum Cleaner Co., Ltd., Toronto, Ont.





House of Daniel W. Nye, Esq., Kew Gardens, Long Island, N. Y. Aymar Embury II, Architect, New York, N. Y.

FIGURING value in terms of service, the most economical wood for home-building is

## WHITE PINE

Lumber men, architects and carpenters have for generations agreed that no other wood gives such long and satisfactory service, when exposed to the weather, as White Pine.

It does not shrink, swell, crack, twist, warp or rot—and once in place it “stays put,” after years of exposure, even in the closest fitting mitres and in delicate mouldings and carvings.

These are not mere claims—every one has been proved by three centuries of building experience in America.

If your lumber dealer is unable to supply White Pine, we would appreciate the opportunity of being helpful to you in securing it.

Address, *WHITE PINE BUREAU,*  
2126 Merchants Bank Building, St. Paul, Minn.



“White Pine in Home-Building” is beautifully illustrated with old Colonial and Modern homes, full of valuable information and suggestions on home-building, and gives a short, concise statement of the merits of White Pine. Send for it now. There is no charge for it to prospective home-builders.

Representing  
The Northern Pine Manufacturers' Association of Minnesota, Wisconsin and Michigan, and The Associated White Pine Manufacturers of Idaho



## Buy Your New House Wholesale Save \$200 to \$500

LET us ship you an \$1100 home complete for \$886—a \$900 home for \$682—a \$1400 home for \$1066—a \$1600 home for \$1271. Stately mansions, cosy bungalows—all at a saving of from 25% to 50%. Carefully thought-out floor plans and first class material for substantial, permanent homes. We supply complete plans, blue prints and specifications. Our estimates are "Guaranteed Right."

### Quality, Safe Delivery Anywhere and Absolute Satisfaction Guaranteed or Money Back

Three strong banks vouch for us. Over 100,000 delighted customers stand back of our legal binding guarantee. We guarantee quality to be the highest. We guarantee safe, prompt delivery to you anywhere—no matter where you live and we guarantee absolute satisfaction in every respect or refund your money. You are the judge. Test this guarantee. Try us. We save

you dollars for every nickle in freight, allow generous leeway on all measurements and protect you against "Extras" and "comebacks." Prices tell you to build or remodel now. Get our \$10,000 Plan Book. Also write for our 5,000 Bargain Catalog of Building Materials—Free. Crammed full of money savers. A veritable Builders' Encyclopedia. Big savings possible now. Estimates free.

### GORDON-VAN TINE COMPANY

783 Federal Street, Davenport, Iowa  
Established 1883—In Business over half a century



### This is the Book of 100 "Quality" Home Plans

Send for it. It cost us \$10,000 to prepare but we send it free on receipt of 10 cents for postage. Contains photographs, plans, figures, color schemes. Full details. Every house in it has been built hundreds of times. Can be varied to give individuality. Thousands of home builders throughout the world praise these plans. Thousands have saved money on them. Give us an opportunity to save for you. That will cost you nothing. Get this Plan Book—today—now.

### Use the Coupon

#### GORDON-VAN TINE CO., 783 Federal St., DAVENPORT, IA.

Gentlemen—Please send the books checked below.

Building Material } Lumber, Millwork, Hardware, Paints, etc.  Plan Book

Name .....

Address .....

Occupation .....

In sending for Plan Book, enclose 10 cents for postage and mailing. You will receive the books by return mail.

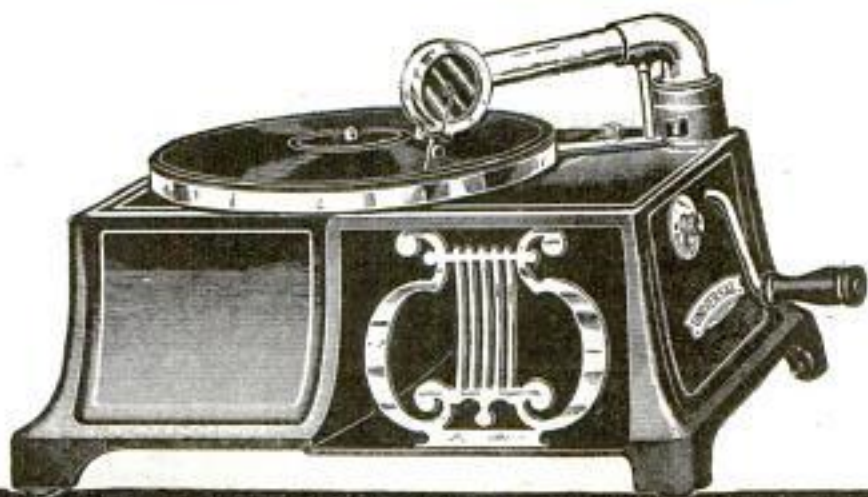

# No Money In Advance

## Sensational Phonograph Offer

We offer you the most sensational, the most astoundingly liberal offer ever made in the history of the Phonograph business. We will send to you without one penny in advance, without one bit of obligation on your part whatsoever, this remarkable Universal Phonograph—this startling new invention—this marvelous all metal machine which is revolutionizing the talking machine world. Just 10,000 of these wonderful Phonographs have been set aside to be sent out on this amazing advertising offer which is made in order to get a machine in each locality of the United States immediately.

Never before—and without doubt never

again—will an offer so liberal be made. Not one cent in advance—no references asked—no C. O. D.—no delay—no red tape—not even your promise to keep the machine. The coupon below is all that is necessary. And with this remarkable machine will be sent eight splendid selections—the regular 65c double disc Columbia records. Play this grand Universal in your home with the superb selections sent with it—give the Universal a thorough ten days' test and then, if after a thorough test and examination you believe it to be the most remarkable, the most wonderful phonograph you ever heard, simply

# Pay Only \$1.00 In Ten Days

and pay balance of our Special Limited Introductory Bargain price of \$16.50 in small monthly payments of \$1.55 each. If for any reason you do not want to keep the phonograph and records simply return to us within ten days after receipt at our expense and you owe us nothing—without the records the Phonograph furnished for only \$13.90.

Think what a remarkable Phonograph this one must be in order to stand such a critical test as this. Songs, Speeches, Instrumental Music, Band and Orchestra Selections, each voice, male or female, each instrument brought out in an actual reproduction exactly as the original, not one sound or syllable blurred or indistinct

—no screeching or buzzing. Gorgeous Harp frontispiece and all trimming beautiful silver effect, not one particle of tin or wood in its entire construction; base 15 inches wide by 6 inches high, 11½ inches deep; weight 17 lbs.; has exclusive automatic start and stop. Plays ALL makes and sizes of disk records.

Eight beautiful selections—the regular 65 cent double disc Columbia records—will be sent to you on this offer. A complete list of hundreds of the most famous selections will be sent along with the machine and records. You have the privilege of exchanging immediately any or all of the 8 selections sent to you for those of your own choice.

## No Reference Asked

Remember, no reference asked. On receipt of the coupon we simply ship the phonograph and records right out to you. If you decide that you want to keep the Phonograph and records send us only \$1 within ten days and pay the balance at \$1.55 a month until you have paid us our Special Introductory Bargain Price of only \$16.50. Otherwise return them at our expense. Do not delay in this matter. Send coupon today, then examine and test this beautiful, perfect, new Universal Phonograph in your home on this liberal No Money In Advance offer. This offer is limited—immediate action is necessary—mail the coupon today.

**UNIVERSAL PHONOGRAPH COMPANY,**  
133-37 West 39th Street, Chicago, Ill.

## Send No Money!

**Universal Phonograph Co.,**  
133-37 West 39th St., Chicago, Ill.

Send at once your wonderful new Universal Phonograph and 8 selections of the regular 65c Double Disc Columbia Records. If satisfactory after examination, and I decide to keep them, I will send you \$1 in ten days after arrival. I then agree to pay the balance of \$15.50 in monthly payments of \$1.55 each until paid. Otherwise I will return Phonograph and records at your expense.

Name.....  
Address.....

P-M

Please Mention Popular Mechanics

# SAXON ROADSTER

## \$395

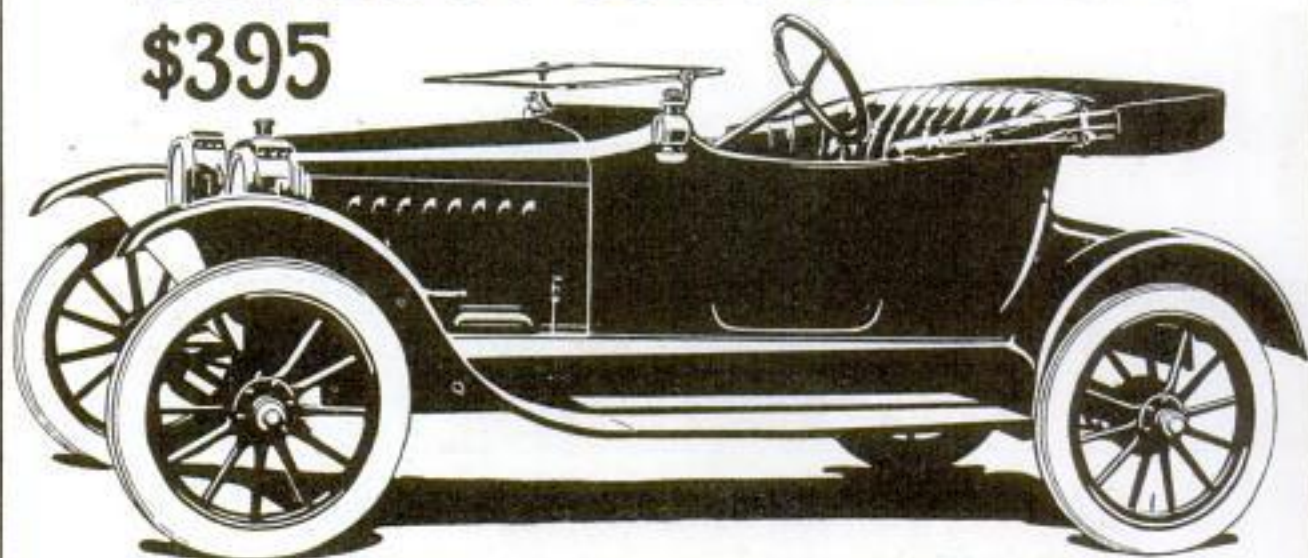

## The only car under \$400 with these modern features

**3-Speed sliding gear transmission**  
—used on all high priced automobiles.

**Modern high speed motor**  
—provides flexibility, quietness and power to go anywhere.

**Honeycomb radiator**  
—assures perfect cooling; finest type of radiator made.

**Timken axles**  
—we know of no other axles so good.

**Graceful, roomy, streamline body**  
—distinctive, stylish, classy.

**Dry plate clutch**  
—\$2000 cars use the same type.

**Vanadium steel cantilever springs**  
—easiest riding type of spring suspension.

Saxon is the only car selling at less than \$400 that is absolutely modern

in design. Yet it contains no experimental features. There is nothing freakish about it. Saxon is a proved car. It has been tried in the hands of many thousands of users, in engineer's tests, in public contests. Everywhere it has made good.

Because Saxon is light in weight and so well built, it gets *over* the roads—not *through* them. It goes anywhere any car can go and lots of places where big cars sink down in mud and sand, or have to turn back.

And don't overlook the Saxon virtue of economy. Saxon costs least to run of any car yet produced. It takes you long distances without filling up again on gasoline and oil. Half a cent a mile is the Saxon average for car operation—one-fourth of a cent per passenger.

Saxon dealers are everywhere. See one nearest you and have a Saxon ride. Dealer's name on request. Also copy of "Saxon Days" with information about the New Series Saxon Cars. Address Dept. J.



"Four" Roadster	\$395	"Six" Touring Car	\$785
With detachable Coupe top	455	With detachable Limousine top	935
Delivery Car	395	"Six" Roadster	785

**Saxon Motor Company, Detroit**

(172)

# Now a Brunswick HOME BILLIARD TABLE at ~

**\$27**  
Upward

**"Quick  
Demountable"**

With the New, Genuine

## Astralite Billiard Bed

Light Weight—Ever-Level

The Brunswick "Grand," "Baby Grand" and "Convertible," made of rare and beautiful woods, have long been conceded the fastest and finest home tables in the world. And now comes the Brunswick "Quick Demountable," that you can set up anywhere and take down in a jiffy. It is made by the same skilled men and methods.

### No Toy—A Scientific Table

The "Quick Demountable" is not a toy. It's an expert carom or pocket billiard table. A real man's table with life! speed! and accuracy of angle!—worthy of sharing the Brunswick name and glory.

Yet our price is the lowest in all our history, because we are making this "Quick Demountable" for thousands.

### No Home Too Small

Now the cottage, like larger homes, can have its billiard table. For we furnish a range of sizes. And this "Quick Demountable" comes without stand for use on top of any table you may have; or with folding stand or detachable legs if you wish. Thus you can easily put it away when not in use.

The cabinet work is superb. The slights are genuine ivory.

### Famous Monarch Cushions

The cushions and bed are the most vital parts of a perfect carom or pocket billiard table.

And Brunswicks alone have Monarch rubber cushions, famed in all lands for their life and lightning-action.

### New Astralite Bed

We use fine Vermont slate beds in all other Brunswick tables. But slate is too heavy for a "Quick Demountable" table, made to take down with ease.

So our experts, with the aid of science, developed this new bed—called Astralite. It is built like a bowling alley—many seasoned strips compressed into an inseparable unit. After that we give it the Astralite process that makes it impervious to water. So this bed won't warp or "buckle" like ordinary wood. Yet it has the ever-level playing qualities of slate, without its weight.

We control the Astralite construction. And the Brunswick "Quick Demountable" is the only table that has it.

### 10c a Day—Outfit FREE!

Despite our new low price, we've decided to include a high-class Playing Outfit Free with all our tables—Balls, Cues, Rack, Markers, Spirit Level, Cue-Clamps, expert book of 49 games, etc., etc.

Our plan lets you try any Brunswick 30 days right in your own home free! Then pay a small amount monthly—terms as low as 10 cents a day!

Get full details and see these handsome tables in our de luxe book—"Billiards—The Home Magnet." The coupon or a postal brings it by return mail, free, postpaid. Send today, without fail. (475)

### Mail This For Billiard Book FREE!

The Brunswick-Balke-Collender Co.  
Dept. 31B, 623-633 S. Wabash Ave., Chicago  
Send free, postpaid, your book in colors—

**"Billiards—The Home Magnet"**  
and tell about your home trial offer.

Name .....

Address .....

Please Mention Popular Mechanics

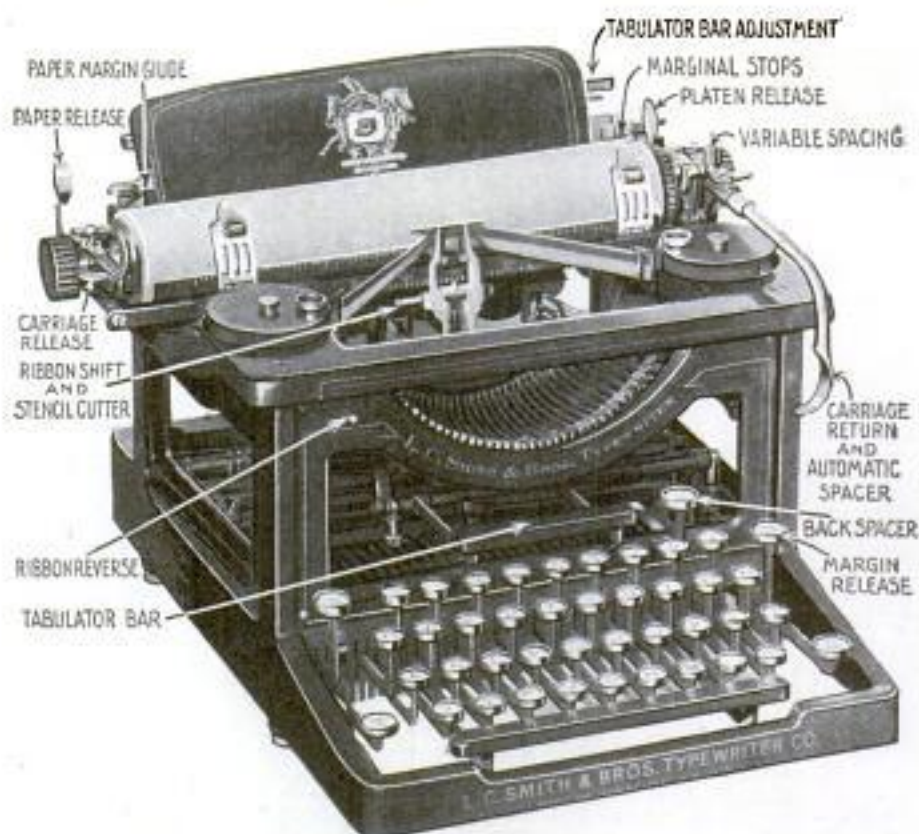

# TYPEWRITER SENSATION

Free TRIAL—Use As You Pay

Only \$2.50 a month until the low total price of \$48.80 is paid, and the machine is yours

This is absolutely the most generous typewriter offer ever made. Do not rent a machine when you can pay \$2.50 a month and own one. Think of it—Buying a \$100.00 machine for \$48.80. Cash price, \$45.45. Never before has anything like this been attempted.

Standard Visible **L. C. Smith**

Perfect machines, not damaged or shop worn. Standard size, Keyboard of Standard Universal arrangement writing 84 characters — universally used in teaching the touch system. The entire line of writing completely visible at all times, has the tabulator, the two color ribbon with automatic reverse, the Back Spacer, Ball Bearing type bars, Ball Bearing shift action, the carriage runs on Ball Bearings, in fact every late style feature and modern operating convenience. Comes to you with ever thing complete, tools, cover, operating book and instructions, ribbon, practice paper—nothing extra to buy. You cannot imagine the perfection of this beautiful reconstructed Ball Bearing typewriter until you have seen it. I have sold

several thousands of these perfect latest style Model No. 2 typewriters at this bargain price and every one of these thousands of satisfied customers had this beautiful, strictly up-to-date, visible machine on five days' free trial, before deciding to buy it. I will send it to you f. o. b. Chicago for five days' free trial on receipt of your request, without obligation of any kind on your part to purchase. It will sell itself, but if you are not satisfied this is the greatest typewriter bargain you ever saw, you can return it at my expense — but — you won't want to return it after you try it — you cannot equal this wonderful value anywhere.

**H. A. SMITH**  
231 N. Fifth Ave.  
CHICAGO, ILL.

Ship me a No. 2 L. C. Smith F. O. B. Chicago, as described in this advertisement. I will pay you the \$40.00 balance of the SPECIAL \$48.80 purchase price, at the rate of \$2.50 per month. The title to remain in you until fully paid for. It is understood that I have five days in which to examine and try the typewriter. If I choose not to keep it I will carefully repack it and return it to the express agent. It is understood that you give the standard guarantee for one year.

**You Take No Risk—Put In Your Order Now**

When the typewriter arrives deposit with the express agent \$8.80 and take the machine for five days' trial. If you are convinced that it is the best typewriter you ever saw, keep it and send me \$2.50 a month until our bargain price of \$48.80 is paid. If you don't want it, return it to the express agent, he will return your \$8.80 and return the typewriter to me. I will pay the return express charges. This machine is guaranteed just as if you paid \$100.00 for it. It is standard. Over one hundred thousand people own and use these typewriters and think them the best ever manufactured.

The supply at this price is very limited, the price will probably be raised when my next advertisement appears, so don't delay. Fill in the coupon today—mail to me—the typewriter will be shipped promptly. There is no red tape. I employ no solicitors—no collectors—no chattel mortgage. I deal direct with you — by mail only. It is simply understood that I retain title to the machine until the full \$48.80 is paid. You cannot lose. It is the greatest typewriter opportunity you will ever have.

Get the coupon in the mail today — sure

**HARRY A. SMITH, 231 N. Fifth Ave., CHICAGO**

Name .....

Address .....

# Will it be You?

*One of these seven  
will be killed  
or hurt this year*

One of these seven will be killed or hurt this year. That is what accident does each year. When the accident is coming, or how, you cannot tell. It may be only a scratch from a rusty nail, or it may be a wrecked train. But when it does come, what will you do? What will your wife do? Be prepared—

## AETNA-IZE

3 cents a day is all it need cost you if you are in a "Preferred" occupation. 3 cents a day brings \$1,250 to \$3,250 in case of death by accident; \$5 to \$10 weekly income for disability due to accidental injuries plus \$1,000 to \$3,000 for loss of two limbs or eyes; or the income plus \$500 to \$1,500 for loss of one hand, foot or eye, or \$250 for death from any cause. You can make these amounts as much bigger as you like by paying more than three cents daily. (\$50 added to above payments for death if you insure while under 40 years of age.)

**Send the coupon now and be safe in time.**

Send this coupon and find out how to protect yourself, your wife and your children from the accident that lurks around the corner; from the expense that may use up your income. It costs you nothing to send it and it may be the most important thing you ever did in your life. **Send it today.**

### AETNA LIFE INSURANCE COMPANY

Drawer 1341 HARTFORD, CONN.

*The largest company in the world writing Life,  
Accident, Health and Liability Insurance.*



Agency opportunities for all  
Casualty and Bonding lines.

An Aetna agent has a national advertising campaign working for him all the time.

Name..... P.M. 11-15  
Occupation.....  
Bus. Address.....  
AETNA LIFE INSURANCE CO.  
Drawer 1341 HARTFORD, CONN.  
I have marked the kinds of insurance  
I wish to know about: Accident ( )  
Health ( ) Disability ( ) \$500  
Life Certificate ( ) My age  
is..... years. I am in  
good health. 5

Please Mention Popular Mechanics

# A Good Bookcase for the price of a good book!

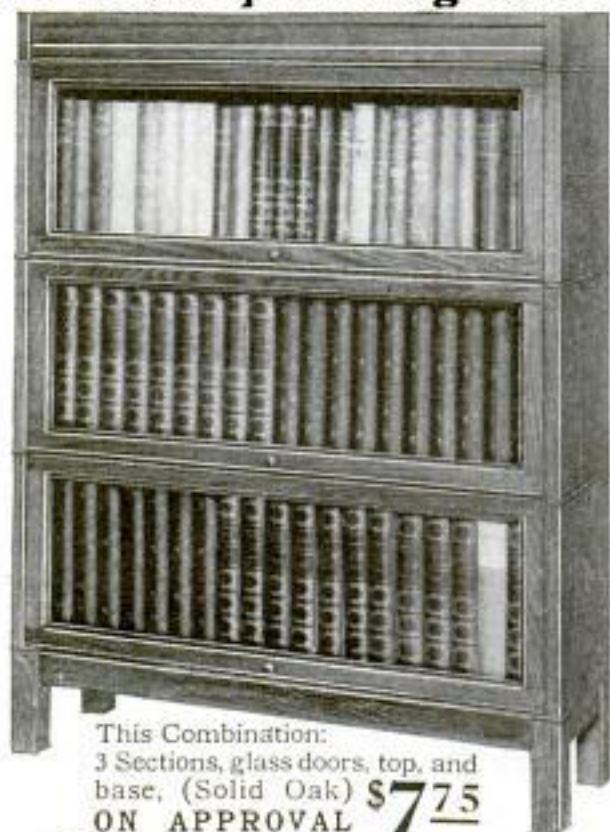

This Combination:  
3 Sections, glass doors, top, and  
base, (Solid Oak) \$7.75  
ON APPROVAL

## Lundstrom IT GROWS WITH YOUR LIBRARY SECTIONAL BOOKCASE

Our new "Universal Style" combines a pleasing, enduring design with latest practical improvements. Adapted for home or office library; beautifully finished in SOLID OAK with non-binding, disappearing glass doors, at \$1.75 per section; top and base \$1.25 each. Greatest value we have ever offered. On orders amounting to \$10.00 and over we pay freight; freight equalized to extreme Western States. Other styles and grades at correspondingly low prices. Sold only direct from our factory at a considerable saving to you. Hardly a village in the country left where there are no Lundstrom Bookcases. Endorsed the best by over 75,000 users—many prominent citizens, governors, senators, doctors, lawyers and clergymen. Lundstrom Bookcases have been made for 15 years and have always given full satisfaction. Write for our new catalog No. 21-N.

PER SECTION  
\$1.75

THE C. J. LUNDSTROM MFG. CO.  
LITTLE FALLS, N. Y.  
Mfrs. of Sectional Bookcases and Filing Cabinets  
Branch Office: Flatiron Bldg., N. Y. City.

## 30 DAYS FREE TRIAL

Total cost only

\$7.50

By Our

7 MONTHS TIME  
Purchase Plan

to prove to you that this magnificent Royal has the SWEETEST, PUREST, LOUDEST and CLEAREST TONE—

to prove to you that it is as large and handsome as the trust machines that sell at \$25.00—

to prove to you that it has the strongest motor, the best reproducer and tone arm and the most ingenious devices to start, stop and control the music.

Shipped with a supply of 10-inch double-disc records of your selection, so you can enjoy the finest entertainments for one whole month. Return the outfit **AT OUR EXPENSE** if for any reason you do not wish to keep it. Drop a postal for our big list of unsolicited testimonials, record book and other literature—all Free.

Central Distributing House  
Dept. G 41 6101-11 May St., CHICAGO

# Electric Light for Your Home

This newly invented system enables every rural home to make their own electric current; operates from one to fifty lights; and will drive small electric motor, electric iron, toaster, etc. Everything complete in one compact unit; no batteries or switchboard. Uses standard lamps and fixtures that any dealer can supply. Nothing to watch but the small, high-speed gasoline motor, which requires slight attention once a week.

The ideal electric lighting system for country homes. Nothing like it ever sold before. Costs less than other systems to buy and to operate. Will last for years.

**WATERMAN MOTOR COMPANY**  
182 Mt. Elliott Ave. DETROIT, MICH.

Write today for  
descriptive literature  
and prices.

**Uni-Lectric**  
GASOLINE-ELECTRIC UNIT  
LIGHTING SYSTEM



The number of fuel-briquetting plants in the United States in 1914 was sixteen. Of these, five used anthracite culm as a raw material; two, semianthracite; two, bituminous slack; two, a mixture of anthracite culm and bituminous slack; two, petroleum residuum; two, semibituminous slack; and one, a mixture of anthracite culm, bituminous slack, coke and lignite.



THINK of a detachable bicycle Motor that you can attach to any bicycle in 5 minutes and ride at any speed up to 25 miles an hour—100 to 125 miles on one gallon of gasoline. Thoroughly practical—simple and economical. Full control from one small thumb lever attached to the handle bars of the bicycle. Descriptive literature on request.

**A. O. SMITH COMPANY**  
Motorwheel Division 127  
MILWAUKEE, WISCONSIN

## EVINRUDE

Detachable Rowboat and Canoe Motors attached in a few minutes to any kind of boat, make it a power boat. Can be carried anywhere. Automatic Reverse, Built-in Magneto, Maxim Silencer. Illustrated Catalog free.

**EVINRUDE MOTOR CO.**  
31 Evinrud's Block, Milwaukee, Wis., U. S. A.



## POWERLIGHT HOME LAMP

Highest Award Inter. Exp. of Safety. Useful ornament in any parlor. 335 C. P., 20 hrs. one filling—1 qt. Burns Kerosene or Gasoline equal safety without wick. Can't spill or explode.

**SIMPLE-CLASSY-GUARANTEED**  
Revolutionizing Lighting. Thousands sold N.Y. and other cities. Greatest competitor to Electricity. Sure sale when seen. AGENTS—100% profit—Contract exclusive territory. Samples loaned.  
**Powerlight Co., 543 Broadway, New York**



# No Money In Advance



## \$1 Per Month Hartman's Big Heater Bargain

No. MJ141. "Regent" Hot Blast Heater, made of cold rolled steel plate with cast iron fire pot; strong base. The nicked parts are swing cover, reflector, side columns, urn, foot rails, screw drafts, front base strip and front base legs. Body 16 in. diameter, 66 in. high. Price .....\$12.65

## Velvet Rug

No. MJ140. Medallion center, conventional border. Woven of best yarns that give great service. Tan, green, brown and red colorings. A wonderful bargain. 6 x 9 ft. ....\$9.69 **75c Per Month**  
8 ft. 8 in. x 10 ft. 6 in. **\$1 Per Month**  
\$14.35; 9 x 12 **\$16.75 Per Month**  
11 ft. 3 in. x 12 ft. ....\$22.95 **\$1.75 Per Month**



# Bargains Worth While

Bargains that mean astounding savings on goods of the highest quality. Bargains that you can pay for in small monthly payments to suit your own convenience. Our \$10,000,000 buying power enables us to make prices lower than you ever thought possible. And back of your purchase stands our broad, binding, legal Guarantee. Keep what you order for 30 days, if you are then not perfectly satisfied that we have proven our low price and high quality contention, simply send it back at our expense and you won't be out one cent.

# No Reference Required

No embarrassing questions. No red tape. Everything strictly confidential. No interest to pay! No security of any kind required. Everything sent on 30 days' approval. Take advantage of this remarkable offer right now and learn what it means to deal with this great House.

## Our Catalog FREE

A mammoth volume of amazing bargains—largest and most beautiful ever published. Everything in House Furnishings. Write for catalog No. 86

**HARTMAN FURNITURE & CARPET CO.,**  
3945 Wentworth Ave., Chicago

# Your Credit Is Good

## Solid Oak Rocker

No. MJ145. Large roomy rocker, made of solid oak—genuine quarter-sawn arms, has rich golden finish. Upholstered with "Imperial" Spanish brown leather on seat and back. Slip seat has six springs and is stuffed with tow and cotton. Posts are elegantly curved. Seat front is button tufted, also upper panel of back. Has strong posts and runners. Height 39 in., seat is 18 x 19 1/2 in. between arms. A real bargain at...\$3.58



**50c Per Month**

## 5-Piece, 2-Inch Post, Steel Bed Outfit

No. MJ148. Continuous post, 3/4-in. fillers in artistic design; height head end 32 in.; link fabric; steel frame spring; cotton top, fibre filled mattress, two 4 1/2-lb. hen feather pillows covered with striped ticking, 18 x 26 in. All sizes, 3 ft., 3 ft. 6 in., 4 ft., or 4 ft. 6 in. Colors White, Pea Green or Verma Martin. Price **59.89 75c Per Month**



## "Regent" Steel Range Bargain

No. MJ146. Complete with high warming closet. Leg base, large oven 18x18 in. Duplex grates, 6 hole top, oven thermometer, improved fire system, steel high closet with nicked shelves. Steel base. With or without contact type reservoir. With silver-nickel trimmings as shown in illustration.



Without reservoir, **\$24.75 1.75 Per Month**  
With res., **\$28.65 2.00 Per Month**

## Solid Oak Dining Table

No. MJ142. Solid oak, Colonial style, 9 in. round pedestal fitted to Colonial scroll platform base, extreme width 24 in.; scroll legs are 1/2 in. thick; top 45 in. in diam., opens to 6 ft.; deep box rim. Price. **\$10.95 75c Per Month**



## Solid Oak Kitchen Cabinet

No. MJ149. Sanitary "Comfort" Kitchen Cabinet of Solid Oak. Base has smooth, white wood table, handy bread board; cutlery and utility drawers; roomy cupboard; top has large china cupboard with 2 art glass doors; metal flour bin, 65 lb. capacity, removable sifter; 67 in. high over all. **\$10.95 75c Per Month**



## Three-Piece Solid Oak Library Set

No. MJ144. Elegant solid oak, turned finish, three-piece library set made in newest style, upholstered with "Imperial" Spanish brown leather. Table is solidly constructed, square edge top 34x24 in. Book shelf at either end and strong lower shelf. Arm chair and rocker have center panel and seats upholstered, arms are quartered oak. Price **\$11.89 75c Per Month**



# Grow Grapefruit and Oranges in Florida

## WE FURNISH BOTH LAND AND TREES

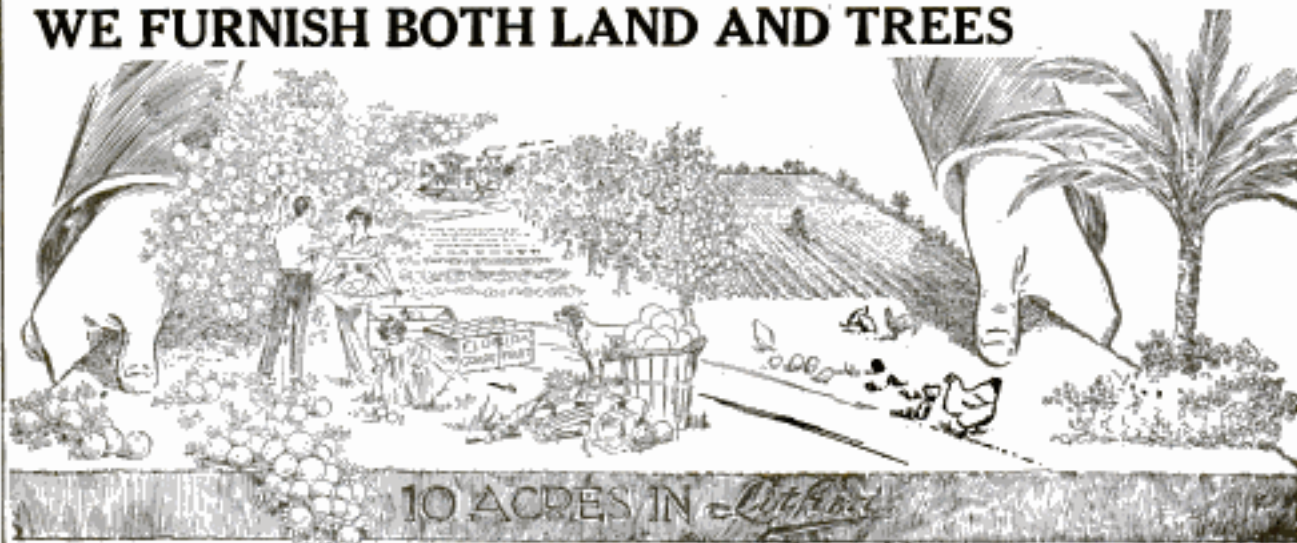

## Get Away From City Drudgery

Live a real life in the bright health-giving sunshine. Enjoy your work in the open air the year 'round, in America's most delightful—most charming of all states. A few cents a day will pay for your land—also trees any time you want them—which opens the way to your independence and can be made to soon bring you a life income. No better land or location for fruit, truck, poultry and livestock can be found anywhere.

**INVEST NOW IN OUR NEW LITHIA TRACT SUBURBAN TO TAMPA, the metropolis of South Florida.** It is one of the few choice suburban farm tracts left in Hillsboro County, the recognized center of Florida's grapefruit and orange belt.

This is the third great Hillsboro County tract that has been opened to homeseekers and investors by our old established, responsible, thoroughly experienced organization. Over 2,500 families are now rejoicing because they bought at opening prices in our two former tracts. Every family can tell you they got a square and generous deal.

Our new Lithia Tract now offers you the same wonderful opportunity—and more, because of the rapid growth and development on all sides within the past five years.

The visible supply of select Hillsboro County grapefruit land is melting away very fast. Prosperous homes are scattered around the Lithia Tract—grapefruit and orange groves, truck gardens and poultry farms are flourishing on all sides. Already buyers are building homes on our new Lithia Tract, and values are due to rise soon.

**Free—Absolutely Free—100 grapefruit and orange trees to each and every purchaser who reserves one of these farms NOW.** These trees will be held in our Nurseries until you are ready to plant them. This will give you a splendid start in developing a grove which will bring you an ever increasing income and greatly increase the value of your entire farm.

The C. E. Thomas Nurseries are growing the finest varieties of grapefruit, orange, lime, fancy peach, plum and other semi-tropical and southern fruit trees, which we are selling to land owners throughout the south, as well as our land buyers. There are no better trees grown than the C. E. Thomas Nurseries Warranted Citrus Fruit trees. Every tree fully guaranteed to grow.

Get our big new Florida book and look at the map—read the many enthusiastic testimonial letters from settlers now living on the farms they bought from us. Four big railroads intersect these suburban tracts—all the comforts of modern life right at hand! The completion of the Panama Canal throws the spotlight on Tampa, the nearest deep water port, and the traffic of the whole maritime world will pause at Tampa's door.

Think of it—a 10-acre farm suburban to a city like this—a farm big enough to keep you in comfort all your lives, yet one you can pay for so easily that it will really surprise you.

Get the facts now. The coupon brings them to you without cost or obligation. Get this new wonderful opportunity

If you already own land and are in the market for high-grade fruit trees do not fail to write for our New Illustrated Nursery Catalog before buying trees elsewhere. It is free and gives much valuable information and instructions on planting and caring for trees. The coupon is for our land book only.

Honestly, now wouldn't you like to become the owner of a beautiful 10- or 20-acre farm in the heart of Florida's richest agricultural belt? You can easily do it if you will make the start. A few cents a day will pay for the land. You can improve it at your pleasure, or we can plant trees for you and have your grove taken care of for a term of years. Where else could you put aside a few odd dollars so safely, so securely, and with such surety of seeing your modest savings fund develop into a great big investment?

No use trying to make yourself believe that savings bank interest will ever make you independent, nor 6% loans make you rich. Your money isn't working when you tie it up in such ways—it's LOAFING. Make your money work for YOU; right here in these rich fruit lands is your opportunity—here where a few dollars put to work NOW will reap all the benefit of development work constantly being done by the fast increasing population.

If you do not wish to improve your farm, you can in a few years, cash in on it from the investment standpoint without a stroke of work on your part. Think of it—an investment of a very few dollars a month—and a magnificent grapefruit and orange grove is the result almost before you know it!

clearly before you while prices on this newly opened tract are still low and terms easy. Today 51 per acre per month buys you independence and a future. Tomorrow—who can say?

Tear off the coupon and mail it now and we will lay before you, by return mail, full and complete information showing how you can easily become the owner of one of these beautiful grapefruit and orange groves, and why it is sure to prove the shrewdest, most profitable investment you can possibly make.

**NORTH TAMPA LAND CO.**  
C. E. THOMAS, President  
837 Marquette Building CHICAGO

North Tampa Land Co., Pop. Mech. 11-15  
837 Marquette Building, Chicago

Please send me, FREE, assortment blank for 100 grapefruit and orange trees, and your latest Illustrated Book on choice Citrus Fruit and Truck Farms suburban to Tampa, Florida.

Name .....

Street No. ....

City..... State.....

# GENUINE PERFECT CUT DIAMONDS \$97.50 Per Carat

SEND NOW FOR ONE OF THESE WONDERFUL VALUES!



B2  
1 ct. dia.  
Compl. \$104.50



B3  
1/2 ct. dia.  
Compl. \$50.50



B1  
14k Mtg.  
Compl. with  
1/8 c. dia. \$12.00  
1/4 c. dia. 21.25  
3/8 c. dia. 35.00  
1/2 c. dia. 48.75  
3/4 c. dia. 71.25  
1 c. dia. 101.25



B4  
1/3 ct. dia.  
Compl. \$27.50



B5  
1/8 ct. dia.  
Compl. \$12.25



B13  
1/8 ct. dia.  
Compl. \$12.50



B14  
7 dias.  
Compl. \$17.50

## WE SAVE YOU 35%

We import diamonds direct from the European cutters and thus eliminate middlemen's profits; our tremendous sales justify smallest profits and this enables you to buy genuine perfect cut diamonds at the lowest price ever offered—\$97.50 PER CARAT. These diamonds are full \$150.00 per carat retail value.

## WE SHIP FOR YOUR FREE EXAMINATION

Never mind the money! YOU PROVE OUR CLAIMS YOURSELF AT OUR EXPENSE. Just select one or more articles from our catalogue or from this page. We ship for your free examination—entirely at our expense—without obligating you to buy—without it costing you one cent. If you don't say the article we send you is the greatest value you have ever seen, simply return it at our expense.

## A WRITTEN LEGAL MONEY-BACK GUARANTEE

It protects you against disappointment or loss. A written legal contract to refund in cash full price less 10% should you for any reason wish to return your diamond any time within a year. Also allows full price in exchange at any time. Contains written statement of carat weight, quality and value of the diamond. "See that your diamond is Basch guaranteed."

## BEAUTIFUL BASCH DE LUXE DIAMOND BOOK FREE

We will forward you postpaid, a copy of this beautiful book upon receipt of your name and address. It is complete, valuable and authoritative. Contains facts written by life-long experts which enable you to buy your diamonds and jewelry safely. A helpful guide to select Christmas gifts and gifts for all other occasions. Thousands of illustrations of diamonds, watches, platinum and gold jewelry, silverware, cut glass, etc.—all priced to you at remarkably low figures. See this book before making your purchase—you will appreciate our money-saving prices. Mail coupon or write us a letter or postcard for your free copy, NOW!



State birth-stone desired.

Compl. \$2.45



B11 Birth-stone Laval- liere.

B12 3 dias.

Compl. \$8.75



B6  
Solid gold filled dia. set knife  
Compl. \$1.75



B7  
Coral Cameo  
2 dias.  
Compl. \$17.50



B8  
3/8 ct. dia.  
Compl. \$33.50



B9  
Onyx, 1 dia.  
Compl. \$22.50



B10  
3/8 ct. dia. each  
Compl. \$66.50



B15  
Dia. set  
\$1.75 per pair



B16 Platinum 1 dia.  
Compl. \$15.00



B17  
Dia set tie clasp  
\$1.00

\$97.50 Per Carat DIAMONDS  
**BASCH**  
CHICAGO MONEYBACK GUARANTEE

**L. BASCH & CO.**  
Dept. L2470, State and Quincy Sts.  
**CHICAGO, U. S. A.**

**FREE DIAMOND BOOK COUPON**  
Please mail me FREE, without obligating me, Basch De Luxe Diamond Book.

Name.....  
Address.....

**L. BASCH & CO.**  
Dept. L2470  
State & Quincy Sts.  
**CHICAGO, U. S. A.**

Please Mention Popular Mechanics



## The Goal of Cigarette Perfection

for men who prefer to roll their own cigarettes, can only be attained with Riz La Croix "papers." Because the supreme *Quality* of these world-famous cigarette papers insures absolute smoke-satisfaction at all times and on all occasions.

# RIZ LA

(Pronounced: REE-LAH-KROY)

FAMOUS CIGARETTE PAPERS

5<sup>c</sup>

Give the best results with any tobacco. Smooth, round, firm cigarettes that hold their shape—rolled in a few seconds without bother or fuss.

The extreme thinness and lightness of Riz La Croix make cigarette rolling easy—a real pleasure. You get the pure flavor of the tobacco—no "paper taste" in the smoke—because combustion is perfect.

Naturally adhesive, because made of best flax-linen—a pure vegetable product.

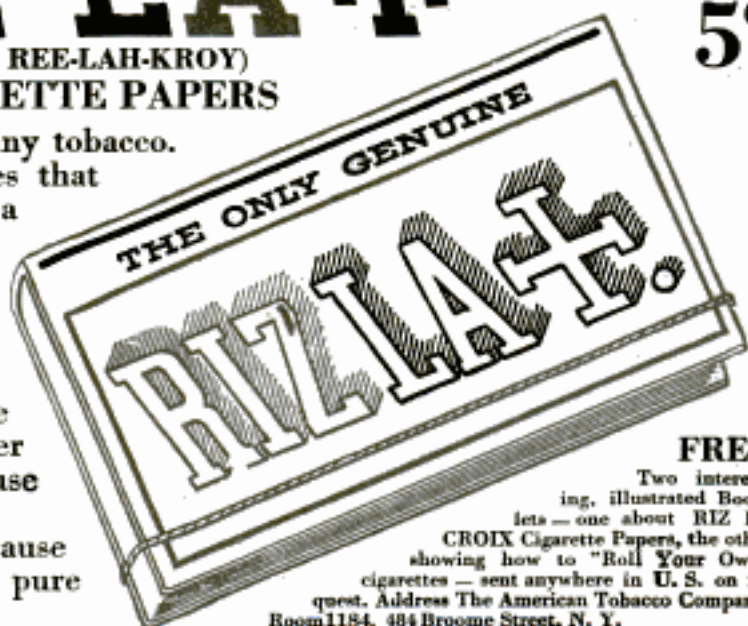

FREE

Two interesting, illustrated Booklets— one about RIZ LA CROIX Cigarette Papers, the other showing how to "Roll Your Own" cigarettes— sent anywhere in U. S. on request. Address The American Tobacco Company, Room 1184, 484 Broome Street, N. Y.

Please Mention Popular Mechanics

# New

## Ideas in High-Grade Watches

The masterpiece of watch manufacture — the Burlington — 19 jewels, adjusted to the second — adjusted to positions — adjusted to temperatures — adjusted to isochronism.

Write for the Burlington Catalog and handsome art color illustrations of the latest ideas in watch cases: *Inlay Enamel Monograms, Block and Ribbon Monograms, Diamond Set, Lodge, French Art, Dragon Designs.* Open face or hunting case, ladies' or gentlemen's 12 and 16 sizes. Imagine a beautiful hunting case with your own monogram on one side and the emblem of your lodge or any other emblem on the other side.

Send coupon today for Free Watch Book

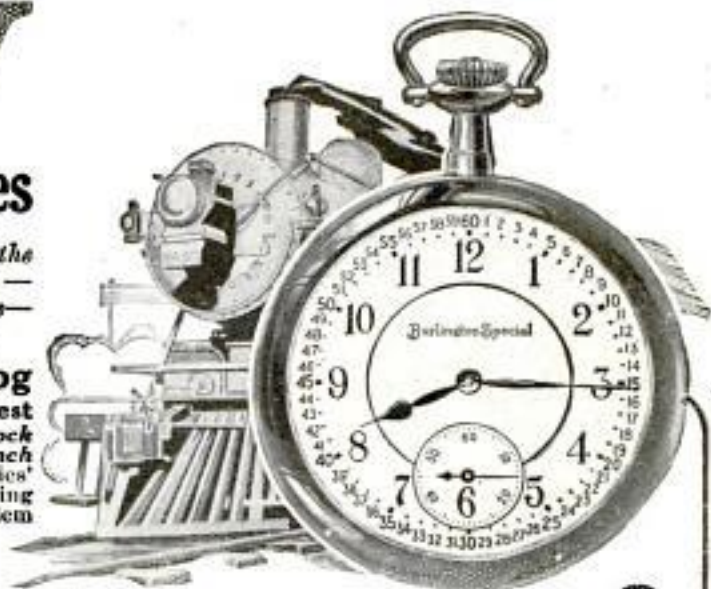

# Extra!

## No Money Down!

We will send the genuine Burlington without a penny down. See this master timepiece for yourself. Note its many points of superiority. Satisfy yourself that the experts are right when they say "The Burlington is the greatest of them all." Select one of the newest cases. We will even engrave your own monogram on the case if you wish it. Then if you are not absolutely satisfied send it back at our expense. If you decide to buy you pay only the *direct* rock-bottom price — the same price that even the wholesale jeweler must pay — and in order to encourage everybody to secure this watch at once, pay this rock-bottom price, either for cash or \$2.50 a month on this great special offer! Don't delay —

## Send This Coupon For New Book on Watches

Learn the inside facts about watch prices, and the many superior points of the Burlington over double-priced products. Just send the coupon or a letter or a postal. Get this offer while it lasts.

**Burlington Watch Co.**

19th St. & Marshall Blvd.—Dept. 1198  
Chicago, Ills.

Burlington Watch Company  
19th Street & Marshall Blvd., Dept. 1198, Chicago

Please send me (without obligation and prepaid) your free book on watches, with full explanation of your cash or \$2.50 a month offer on the Burlington Watch.

Name.....

Address.....

Please Mention Popular Mechanics

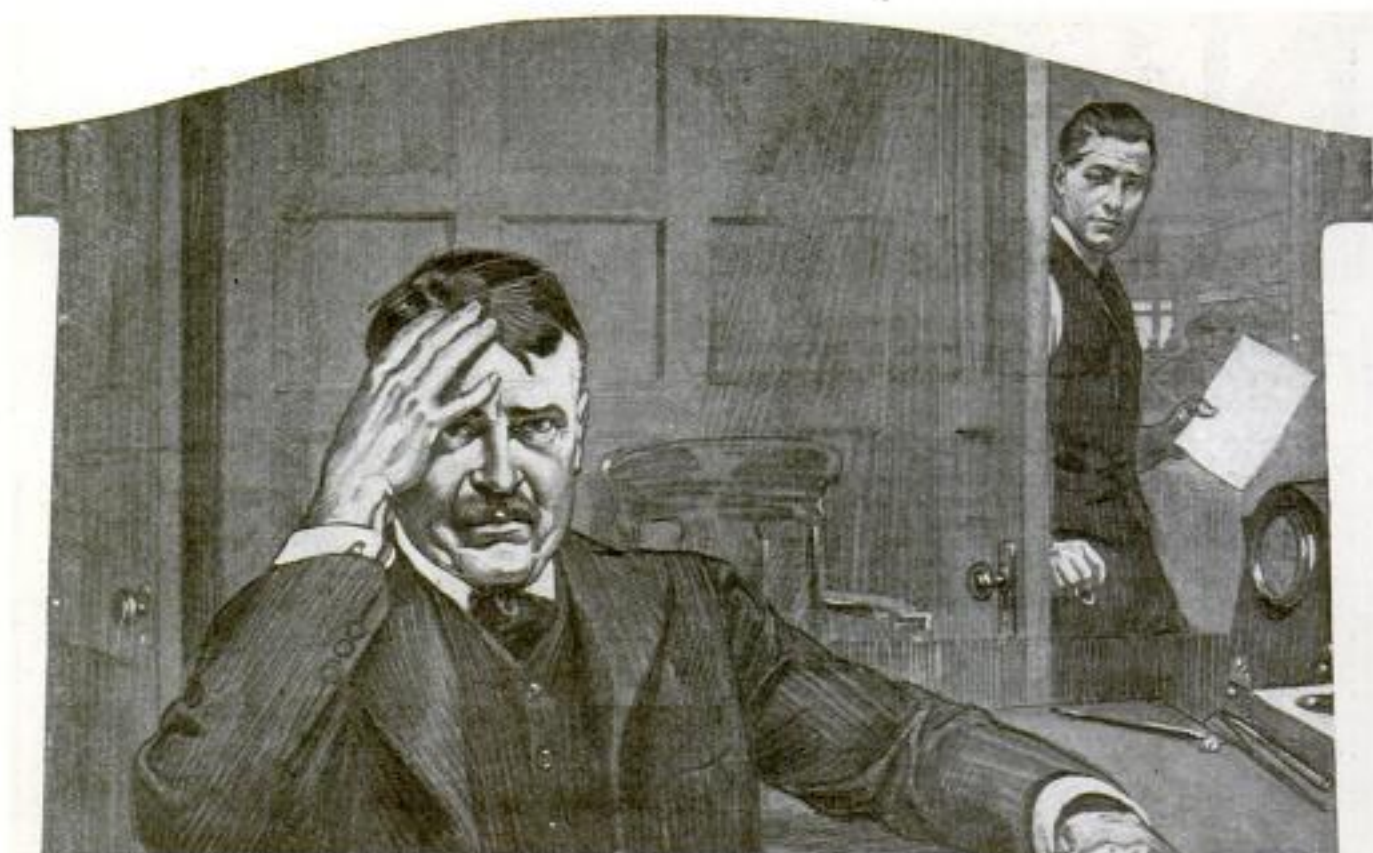

## No-You're Not Losing Your Grip

Those days or times in the day when you lack "punch" in your work don't mean that you're slipping back. The condition isn't mental at all—it's as purely physical as is a "foggy" brain after loss of sleep.

And you're not in any "alarming" physical condition—yet for efficiency's sake it needs a remedy—proper nourishment is the remedy. You don't take enough exercise to get away with the heavy meals which would give you the nourishment you need. What you should take is

### ANHEUSER-BUSCH'S *Malt-Nutrine* REG. U.S. PAT. OFF. TRADE MARK Liquid-Food-Tonic



A real aid to digestion—therefore enabling you to get fuller nourishment from what you eat. Itself nourishing. These qualities giving you just what you need to replace the strength and energy you're burning up so fast in your daily brain-taxing and nerve-straining work. A genuine strengthening tonic. Taken before retiring, a splendid aid to sound sleep. Recommended for the over-worked, the anæmic—all who are over-wrought or under-nourished.

All Druggists—Most Grocers

Malt-Nutrine declared by U. S. Internal Revenue Department to be a pure malt product, not an alcoholic beverage. Contains 14.50 per cent malt solids—1.9 per cent alcohol.

Interesting Booklet on Request

ANHEUSER-BUSCH,

St. Louis, U. S. A.



Please Mention Popular Mechanics



## Smith & Wesson Automatic

*Doubly safe*

A safe pistol for the home  
—two real safety devices.



Get your dealer to show you the special features of the Smith & Wesson Automatic.

Booklet on request.

**SMITH & WESSON**  
814 Stockbridge St., Springfield, Mass.

*Every Smith & Wesson is the Best of its kind*

WEAR

Trade Mark  
Registered

**B.V.D.** U. S. Patent Office  
and Foreign Countries

UNDERWEAR

## Drink Pure Water

Perfect health demands it. Disease lurks in impure water. Insure purity by installing a

### Bohner Self-Cleansing Filter

Gives you constant supply of crystal water, pure as ozone. Inexpensive. Anyone can install with out tools. Lasts a lifetime. Full particulars on request.

Bohner Mfg. Co. 1009X, So. Wabash Av. CHICAGO, ILL.



AGENTS WANTED

Guaranteed to give satisfaction or money back if returned in 15 days.

## 4 Weeks' Trial

Choice of 38 Styles

Yes, we will ship you on four weeks' absolutely free trial, direct from our own factory, your choice of 38 new styles of the highest-grade Wing Piano or Player Piano. No obligations — no C.O.D. — no security.



*One of 38 Styles.*

**No Money Down — Not a Cent of Freight**

Use it and enjoy it four full weeks; then, if you wish, ship it back at our expense. You alone are the judge. You will be amazed at our rock-bottom, direct price on the superb Wing, guaranteed 99 years. Easy monthly payments or cash. **WRITE TODAY.**

**Valuable Book—FREE** "The Book of Complete Information About Pianos" sent free and post-paid. Valuable 134-page book. Tells how to judge pianos. Beautiful art catalog also sent and particulars of great Free Shipment Offer. Write today. Wing & Son (Est. 1868), Wing Bldg., 9th Ave. & 13th St., Dept. 1198, New York



*The Sign of the Nurse Points Out the SAN \* TOX Druggists*

# Supreme Satisfaction

A thick, creamy lather that needs no mussing rubbing in with the fingers to so soften the beard that your keen blade goes over your face without a scratch or a pull—

A lotion that soothes and cools and instantly banishes the last trace of "razor sting" from the most sensitive skin—

A talcum of unquestioned purity and exceeding fineness for the finishing touches—

That, gentlemen, is supreme shaving comfort such as you can only experience by using

# SanTox

## The Public Service Line

No matter what SAN \* TOX preparations you test — shaving cream, lotion or powder, tooth paste, hair tonic or any of the more than 125 toilet specialties and household remedials which comprise the line — you will secure the utmost in quality and economy.

The SAN \* TOX druggist in your locality has been selected because of his established reputation for honesty and progressiveness. For his part he has rigidly investigated the entire SAN \* TOX line and personally guarantees your complete satisfaction. He will

cheerfully refund your money if you are not pleased. You will know his store by the sign of the Nurse in the window.

**THE DEPREE CHEMICAL CO.**  
Chicago, Illinois



# AMERICAN MODEL BUILDER

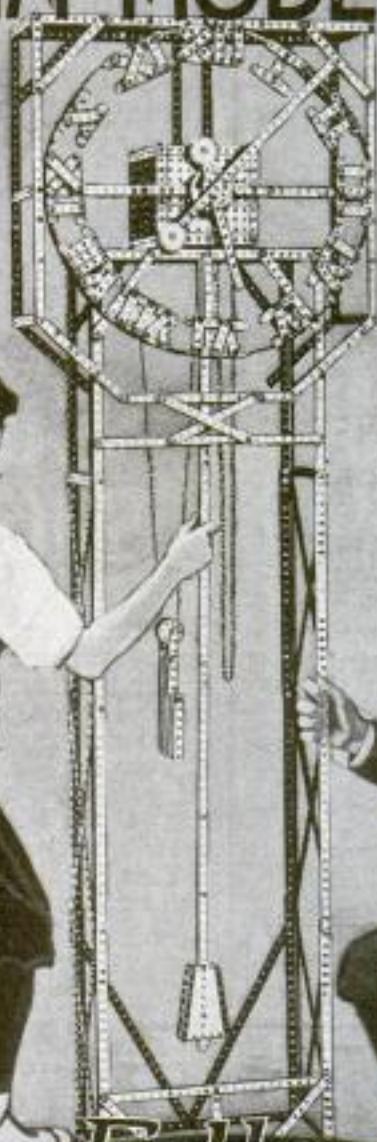

Write for  
big free  
book!



## Say Fellows!

### Here's the *only one* for YOU!

The American Model Builder is the new construction toy you'll say has got 'em all beat!

—because it gives you 15% more new and novel parts.

—because you can build *more* practical working models, models that you can really operate.

—because you can build lots of models possible with

no other outfit. Our 1916 manual shows 370 models, a new toy for every day in the year—and hundreds of others can be built.

**A real electric motor given FREE**

—with even the medium-priced sets. Not a toy, but the *real thing*—has bronze bearings, finest wiring

throughout, brushes, commutator, etc. Will lift ten pounds.

Write for the "New Story of Steel"—a gripping romance of the steel industry, and catalog showing different outfits and hundreds of models you can build, such as clocks that run, automobiles, warships, derricks, etc. With it we will send details of big prize contest for new models, with 155 prizes valued up to \$100 each. Write now.

The American Mechanical Toy Co., 413 E. First St., Dayton, Ohio

See the American Model Builder at your dealer's



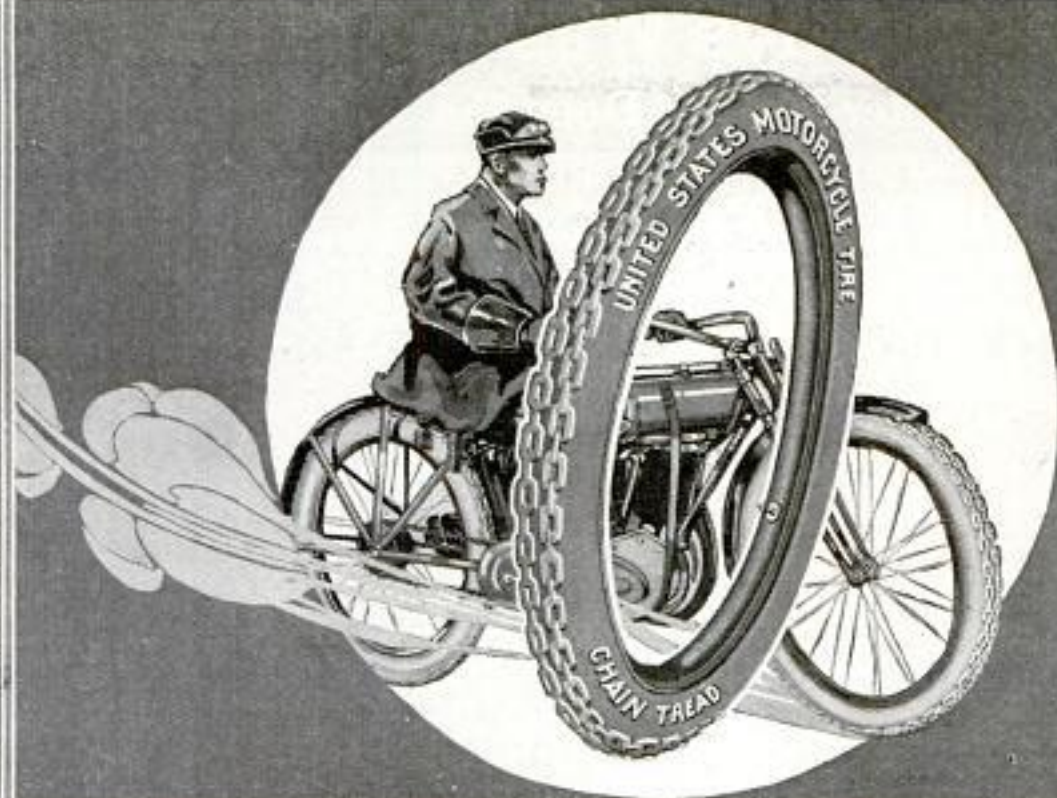

## A Motorcycle Tire Triumph

THE "Chain Tread" Motorcycle Tire was welcomed with enthusiasm by motorcyclists. From the date of its introduction, the popularity of the "Chain Tread" Motorcycle Tire has steadily increased. Built strong enough for automobile service, this famous tire gives phenomenal mileage on the speedy, lighter weight, motorcycle.

The "Chain Tread" Tire for motorcycles has the same heavy service construction, the same wear-resisting rubber and fabric, and the same practical anti-skid tread, as the famous "Chain Tread" automobile tire which is the sensation of the automobile world.

Profit by the experience of the keen automobile and motorcycle manufacturers, who are increasing the prestige of their products by equipping the machines they make with "Chain Tread" Tires. You can buy "Chain Tread" Tires from good dealers everywhere.



# United States Tires

Made by the Largest Rubber Company  
in the World



Please Mention Popular Mechanics

# 2c a Week Pays Wash Bill!

Write for  
FREE Book

## Electricity or Water-Power Does the Work

### Just a "Twist of the Wrist" Starts or Stops the Machine!

The 1900 Motor Washers are now at work in thousands of homes. They are doing the work formerly done by women, at a cost of 2c a week for power! Saving thousands upon thousands of dollars in wash bills. Saving worlds of wash-day troubles. Leaving the women free to do other work while the machines are doing the washing.

## The 1900 Motor Washer



Doing the wringing with  
1900 Electric Motor Washer

1900 Water Motor Washer  
Can be connected with  
any water tap instantly

### Washes a Tubful in Six Minutes!

#### Handles Heavy Blankets or Dainty Laces

The outfit consists of the famous 1900 Washer with either Electric Motor or Water Motor. You turn on the power as easily as you turn on the light, and back and forth goes the tub, washing the clothes for dear life. Then, turn a lever, and the washer does the wringing. All so simple and easy that it is mere child's play.

### A Self-Working Wringer Sent With Every Washer!

The motor runs Washer and Wringer. We guarantee the perfect working of both. No extra charge for Wringer, which is one of the finest made. **Write for FREE BOOK and 30 Days' FREE TRIAL OFFER!** Don't doubt! Don't say it can't be done. The free book proves that it can. But we do not ask you to take our word for it. We offer to send a 1900 Motor Washer on absolute Free Trial for an entire month to any responsible person. Not a cent of security—nor a promise to buy. Just your word that you will give it a test. We even agree to pay the freight, and will take it back if it fails to do all we claim for it. A postal card with your name and address sent to us today will bring you the book free by return mail. All correspondence should be addressed to



**1900 WASHER CO., 6201 Court St., BINGHAMTON, N. Y.**  
OR, IF YOU LIVE IN CANADA, WRITE TO THE CANADIAN WASHER CO., 355 YONGE ST., TORONTO, CANADA. (23)

**If you shoot** you need the **Ideal Hand Book**. Tells all about powders, bullets, primers, reloading tools for rifle, pistol and shotgun ammunition. Shows how to cut your ammunition expense in half. **160 pages**—sent free to shooters for 3 stamps postage by The Marlin Firearms Co., 65 W. St., New Haven, Conn.

## Are Your Private Papers Safe?

Keep your Notes, Receipts, Insurance Policies and valuable Papers in a Barler New Document File.

Made of Steel, covered with "Chase Leather." 18 Manila Pockets—4 1/4 x 10 1/2 in. with metal eyelets.

**\$1.25 Delivered**  
Guaranteed satisfactory or money back.



**A. C. BARLER MFG. CO., 343 East Ohio St., CHICAGO**



All Sizes for Ladies and Gentlemen

## Something New!!

This unique and artistic design of a horse-shoe and horse-shoe nail makes a very handsome ring. The horse-shoe has a solid gold top, the nail is solid sterling silver set with a fine genuine garnet. The horse-shoe is considered an omen of good luck. The combination of the gold horse-shoe with a fine genuine garnet set in the bright silver nail makes a very pleasing and beautiful effect. This nobby ring will make a most appropriate and lasting holiday gift.

**SPECIAL PRICE - - \$1.25**

(Send string for size desired.)

Wear this ring for one week; show it to your jeweler; if not satisfied, we will refund money.

**Now Ready - New Catalog 146**  
**Bennett Mfg. Co. 175 Broadway NEW YORK**  
Est. 1879

References, any bank

## MAKING POULTRY PAY

depends more on the knowledge you have of Poultry Culture than on expensive equipment or extensive space.

Let Director Quisenberry teach you how to raise poultry successfully and make a good living and a nice profit from a flock of thrifty hens.

If you want to save money and make money in the poultry business write us today for our large illustrated **Free Book**, "Dollars and Sense in the Poultry Business." It points the way to success.

**American School of Poultry Husbandry**  
Box 75 Mountain Grove, Missouri



## 600 Shaves From 1 Blade



Yes, and more. That's the record of many men who shave themselves. Old blades made sharper than new—in ten seconds. Quick, velvety shaves for life with the wonderful, new

### Rotastrop

For safety and old style razors. Drop blade in, turn handle, machine gives "heel to toe action", just like a barber strops a razor.

**10 Days Free Trial**—write for free booklet today. Send name of nearest druggist or hardware dealer.  
**Burke Mfg. Co., Dept. 1198 Dayton, Ohio**

## Save Your Wife



the hard labor of the weekly ironing. Save her time, her health and money by getting her a

### SIMPLEX IRONER

THE BEST IRONER

It will do better ironing in 1/2 the time it now takes. Operates by hand or power. Heated at nominal expense. 8 sizes. Low prices. Easy payments. Write for catalog, **FREE Ironing Hints Booklet**, and **30 days' FREE Trial Offer**.

**AMERICAN IRONING MACHINE CO., 532 - 168 N. Michigan Ave., CHICAGO**

# Free!

## Complete Set of Drawing Instruments

Yes, I will give you this complete set of drawing instruments absolutely free. They are regular working instruments—the kind I use myself and they do not cost you a penny. And besides the instruments in this exquisite plush lined leather case, I will give you absolutely free a 20x25 inch drawing board, a 24 inch T-square, a 12 inch rule, a supply of drawing paper, two triangles and a French curve, pencils, erasers, thumb tacks, etc., etc. A complete draftsman's working outfit. And I give it to the men who get my personal instruction absolutely free.

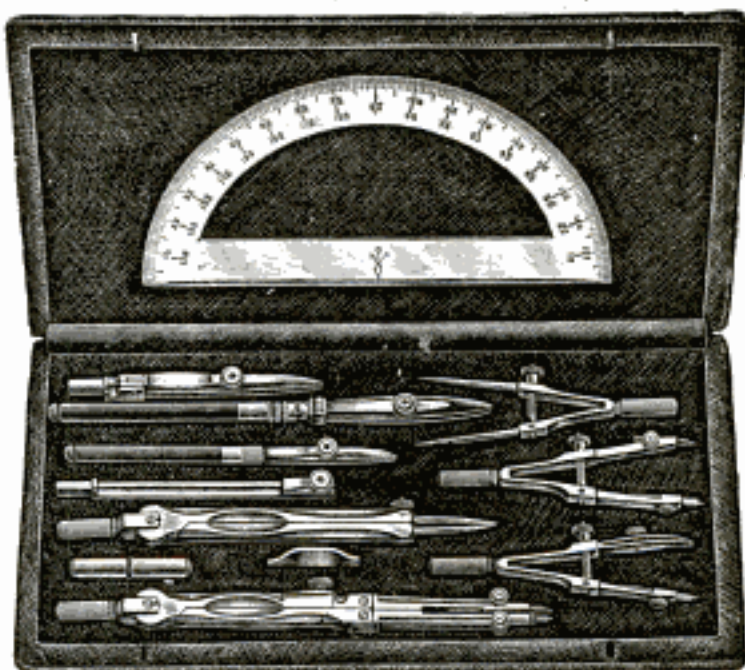

# Be a Draftsman!

## Draw \$125 to \$175 Per Month

There is an urgent demand for skilled draftsmen. Companies are issuing calls every day for men to fill positions paying from \$125.00 to \$175.00 per month. Work is light, pleasant and profitable.

## Chief Draftsman Will Instruct You Personally

I am Chief Draftsman of a large and well known firm. I have been doing the highest paying expert drafting work for a quarter of a century and I know just the kind of training that is demanded from men who get the big salaries. I will give you personal instruction, deal individually with you and give you up-to-date, practical working plans just as your ability and advancement require. I train you by giving you actual work—practical work, the kind that you must be able to do in order to hold permanent, big paying positions. I give you my individual instruction. If your work is right, I will advance you rapidly. If it is wrong, I will show you where, and make you do it right, and do all I can to make you an expert draftsman and designer in a short time. **Write today without fail**

**Pay as You Wish!** What I want is the RIGHT KIND of men. Don't bother about expense. I will give you the working outfit free if you get in at once. I charge a very small fee for training you to be an experienced draftsman. You can pay the small cost as suits you best. My object is to develop experienced draftsmen.

## Send the Coupon for My Big New Book

Put your name and address on the free coupon or a letter or a post card and send it to me today. I will send you absolutely free and postpaid my new book "Successful Draftsmanship," and the great special offer that I am now making on which you get the \$15.00 Draftsman's Working Outfit absolutely free. You assume no obligations of any kind in sending in the coupon. Get in line now for a big paying position. Getting the book and full particulars of the special offer is the first step. Write today—now.

**Chief Draftsman Dobe**

Engineer's Equipment Co., Inc., Div. 9198, CHICAGO, ILL.



**Chief Draftsman Dobe**  
Engineer's Equipment Co.  
Div. 9198 Chicago, Ill.

Without any obligations on me whatsoever, please mail your book "Successful Draftsmanship" and full particulars of your liberal "Personal Instruction" offer to a few students. It is understood that I am obligated in no way whatever.

NAME.....

ADDRESS.....

# Take the Hard Work out of Wash Day

Sit down and rest, while electricity does it quicker and better and **ALMOST WITHOUT COST**. Have a whole lineful washed, rinsed, wrung and hung out in a jiffy—to be ironed the same day. **Swiftest and safest method**. Write for full information about our **FREE TRIAL PLAN** that enables you to try out the wonderful

## Western Electric Washer and Wringer

in your own home. This is the washer that cleans the clothes by forcing hot suds through them. No rubbing—no tearing. Runs automatically. Attaches to any electric light socket. Guaranteed by the world's largest distributors of electrical supplies. An investment that will soon pay for itself in any home.

Send post card to nearest house below for "Booklet No. 88-AW."

### WESTERN ELECTRIC COMPANY

New York	Atlanta	Chicago	Kansas City	San Francisco
Buffalo	Richmond	Milwaukee	Omaha	Oakland
Newark	Savannah	Indianapolis	Oklahoma City	Los Angeles
Philadelphia	New Orleans	Detroit	Minneapolis	Seattle
Boston	Houston	Cleveland	St. Paul	Portland
Pittsburgh	St. Louis	Cincinnati	Dallas	Denver
				Salt Lake City

EQUIPMENT FOR EVERY ELECTRICAL NEED



### BUY PLUMBING and HEATING SUPPLIES



at **WHOLESALE**

Will Save  
You 30%

Don't pay retail prices. Full stock on hand for prompt shipment. Send for free catalog.

B. P. KAROL, 800-802 South Kedzie Ave., CHICAGO

### Save Half ON PLAYER PIANO ROLLS

Enjoy the best, full-score music, yet save 45c to 50c on the dollar, get quicker delivery and choice of **OVER 2000 SELECTIONS** (classic, popular, etc.) Arrangement of our rolls celebrated. Materials of highest quality.

**90-Page Catalog FREE**

Shows convincingly how to get truly desirable (\$8-note) player-music at **GENUINE** half prices.

S. H. CONSUMERS MUSIC CO., Sta. H., BUFFALO, N. Y.

**FIND FISH A PAYING FARM CROP**—A new method of livelihood, as well as a new method of living, is afforded by fish farming, which is a rapidly growing industry. It may be a lazy man's job, says the Fishing Gazette, but for development beyond an addition to the family living, of course, it takes time and attention. A running stream or an acre of pond can be made to earn more money than a well-tilled five-acre farm. Farmers all over the country are coming to recognize that a private fish pond is a splendid source of food supply. It



### QUICK MONEY

Growing Mushrooms

How to really make big money in mushrooms, is fully explained in the wonderful book, "The Truth About Mushrooms." Everything explained from A to Z, at first hand, from the greatest practical authority in America. Add \$10 to \$10 a week to your income. Demand exceeds supply. Grow in cellars, sheds, boxes, etc. Small capital to start. Profits bigger and quicker. Anyone can do it. Women and children, too. Now

is the best time. Send for **FREE** book of information. Bureau of Mushroom Industry, Dept. 735, 1342 N. Clark St., Chicago

### DIAMONDS ON CREDIT

Whether for personal use, or as a gift, nothing can compare with a Diamond, if it be of pure quality.

**Lyon Diamonds** are absolutely free from flaws or imperfections and of the rich Blue-white color. Every honest person is offered our liberal terms of

**20% Down and 10% A Month**

With every Diamond we furnish a Guarantee Certificate attesting the quality and value, and providing for exchange at full purchase price. Send for Catalog No. 3, showing splendid line of Watches, Jewelry and Silverware. Goods sent prepaid for inspection, subject to approval. **10% Discount Allowed for Cash.**

**J. M. LYON & CO.,** Est'd. 1843 71-73 NASSAU STREET  
NEW YORK CITY, U. S. A.



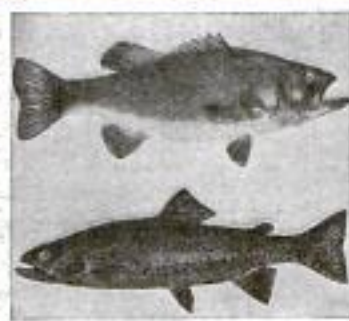

## Learn to Mount Specimens Like These

This advertisement is for every *sportsman* and *nature lover*, everywhere. *Write to-day. Send the coupon* for our *free books*. They contain something of great value to hunters, trappers and all people who love the out-of-doors. *You should have this book. Write for it today.*

## Do You Shoot or Fish?

If so, you should be able to save your beautiful and valuable trophies. *We can teach you how.* We have taught over 35,000 of the best sportsmen of the country, and they are now doing their own taxidermy work with wonderful success. They save taxidermists' bills and enjoy their spare time as never before. Taxidermy is the most fascinating of all professions. *We can teach you to mount all kinds of game specimens* absolutely true to life, by the latest and best methods. Easily, quickly and perfectly learned, in your own home *during your spare time.* No need of leaving your present employment. You can decorate your home with Nature's best art; you can double your interest in sportsmanship. Let your gun and rod pay for your vacation.

**BIG PROFITS** You can easily make from \$25 to \$50 a month during your *spare time*, practicing Taxidermy, or if you go into the work as a profession you can make \$5,000 or more per year. You can sell your own mounted specimens for big profit. You can make big money doing mounting for others. You should investigate this remarkable offer.

## This Taxidermy Book FREE

We will send you this book on taxidermy absolutely free. It tells you all about our school and the most fascinating profession of Taxidermy. It will tell you how you can learn to become an expert taxidermist in a few months—*by mail—in your own home*—during your spare time. You need this book and it costs you *absolutely nothing.* Merely send in the *free coupon.* Write for it today—it is free—we will also send you the famous *Taxidermy Magazine* and hundreds of letters from our delighted graduates. Write today—*now—immediately—before you lay aside the paper.*

**NORTHWESTERN  
SCHOOL OF TAXIDERMISTRY**  
1198 Elwood Building  
OMAHA, NEB.

"A school for sportsmen  
by sportsmen."



**FREE  
COUPON**

Northwestern School  
of Taxidermy  
1198 Elwood Bldg.  
Omaha, Neb.

Gentlemen:—Please send me your new book on Taxidermy and the Taxidermy Magazine, also full particulars of your special offer. All Free and prepaid. No obligations on me whatsoever.

Name.....

Address.....

Please Mention Popular Mechanics

## Order This High Grade Xmas Gift for "Him" Now

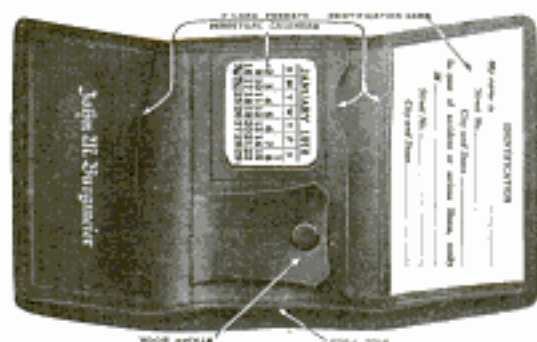

### The Biggest Bargain Ever Offered for the Money

A Genuine Leather Combination Card Case and Bill Fold, 5x3 inches folded; 5x8 inches open (4 times size of illustration). Has many useful pockets. Perpetual Calendar, Stamp Book, Identification Card, etc.

Made in 3 grades at the following prices, postpaid:

In Genuine Seal Grain Leather \$1.00  
In Genuine Morocco Leather 1.50  
In Genuine Seal Goat Leather 2.00

"His" Name Engraved in Gold FREE

(Write name to be engraved plainly.)

Packed in fancy Christmas Box, 10c extra. Sent by Insured Parcel Post, 5c extra. Money refunded if not satisfactory. All orders filled promptly. Remit by Bank Draft or Money Order only to

Northwestern Leather Goods House, 1913 North Ave., Chicago

## Typewriters



-- All Makes, Factory Rebuilt by the famous "Young Process"; look like new, guaranteed like new. Our big business insures "Square Deal" and permits lowest cash prices -- \$10 and up; also machines rented -- or sold on time. No matter what your requirements are, we can best serve you. Write and see -- NOW.

YOUNG TYPEWRITER CO., Dept. 222 CHICAGO

## "E-Z" Coin Safety Self-Filler Pen

A USEFUL MODERATE PRICED GIFT



A new safety self-filler for every man, at any man's price. To fill merely insert coin or other article in slot and press once. Safety Cap prevents leakage if carried point down. Holder of Diamond Chased Vauclain Rubber. 14 Kt. Gold Pen. Every part guaranteed. No. 215 Vase-Pocket size \$1.75. No. 216 Regular size \$2.00. Free Catalogue. Agents Wanted.

J. C. ULLRICH & CO., 27 Thames St., NEW YORK

# Rapid

## AUTO PEN

The Perfect SINGLE STROKE medium for Lettering Price Tickets, Show Cards, Etc.

SPEED and UNIFORM LETTERING GUARANTEED

Manufactured in 76 sizes and styles. Special introductory offer--6 pens and 2 shades Lettering Ink, with complete instructions, prepaid \$1.00. Catalog free.

THE NEWTON AUTOMATIC LETTERING PEN CO.  
Dept. A, PONTIAC, MICH., U. S. A.

Please Mention Popular Mechanics

## Oliver Standard



### Visible No. 5

We can sell you this typewriter at this price if you act quick. We guarantee the machine for life, but we guarantee the price for only a few days. The return of good business conditions stimulates the full-price typewriter market and cuts down our supply so that we are sure of only a limited number of machines. If you write at once that you are in the market for a Standard Oliver at our low price we will reserve a machine for you, to be shipped subject to your approval after you get our literature with details of offer. Your letter will obligate you in no way--no salesman will call. Our terms are nothing down, free trial and a year to pay if you wish. The machine has all the quality, improvements and equipment that you would have to pay full price for anywhere else. Write at once. Offer may be withdrawn any day.

TYPEWRITERS DISTRIBUTING SYNDICATE, 1510-73J Wabash Ave., Chicago

Price for a \$56 Short Time

## MONEY IN MUSHROOMS

Make \$20 a Week and Over Growing Mushrooms at Home

Quickly and easily raised in cellars, stables, sheds, caves, boxes, etc., all the year. Crop sells for \$0.50 to \$1.00 a lb. Only small space needed. Previous experience or capital not necessary. Costs little to start, large profits; markets waiting. We can show you how, by using our spawn and simple directions, to make big money at this fascinating occupation. We are an old and reliable concern; spawn from our spawn and help our customers to success. We teach you our methods free and tell you how and where to sell your crop. SEND TODAY for our large illustrated, 32 page Free booklet and learn this great business.

NAT'L SPAWN & MUSHROOM CO., Dept. 17, BOSTON, MASS.

was no long time ago when such a thing had not been thought of. Now generally there is a comprehension that such a private pond costs little to maintain and is almost sure to furnish far more fish than any one family can



## TYPEWRITERS ALL MAKES

Prices \$15.00 up. SOLD or RENTED ANYWHERE at 1/4 to 1/2 MANUFACTURERS' PRICES, allowing RENTAL TO APPLY ON PRICE. Free Trial. Installment payments if desired. Write for Catalog L.

TYPEWRITER EMPORIUM, 24-26 W. Lake St., Chicago, Ill.

## TYPEWRITERS BARGAIN PRICES

Look at these bargains! Typewriters Rebuilt in our own factories, and guaranteed for one year.

Remingtons \$20 to \$55 Smiths \$18 to \$40  
Underwoods \$35 to \$60 Royals \$25 to \$45  
L. C. Smiths \$30 to \$50 Oliverts \$20 to \$35

We have others, of course. Send for catalog describing them, and address of nearest branch office.

American Writing Machine Co., Inc., 345 Broadway, N. Y.



## 10c a Day Now buys This Superb Baader Violin

An exquisite instrument. Made by the great Violin Maker, J. A. Baader. Pay for it at the rate of 10 cents a day--10 days free trial. We supply the **WURLITZER** *Viola Cello* *Double Bass* *per year at instrument making* *the* *U. S. Gort.* Thousands of superb instruments to choose from. You get the benefit of our mammoth facilities by buying in large quantities. **Write Today** for Special Circular. No obligations. See full particulars of our great special offer and handsome illustrations of the superb instruments that you have to choose from. Read our direct money saving offer. Write today. **THE RUDOLPH WURLITZER COMPANY** Dept. 1155 E. 4th St., Cincinnati, Ohio 50, Wabash Ave., Chicago, Ill.



## OVER 100,000 IN USE Golden Gem 10

Mostly sold through recommendation. For Personal Desk or General Office. It checks mental calculations. Buy through your stationer. Write for 10-Day Trial Offer. E. Gacher & A. M. Co., 148 Dasse St., New York

Agents Wanted

Multiplicates - Subtracts

# Not A Cent For 3 Months

Think of it! Not one cent to pay for three months on any size or mounting of a Majestic Engine! How absolutely perfect this engine must be in every particular—how positive we must be that it will make good under all conditions—when we offer to send it to you without a cent in advance—without your making a deposit with a bank or anybody—without any restrictions of any kind whatever—and tell you to subject it to the severest test you can think of on any and all kinds of work for three whole months before you pay out a single penny.

We want you to be absolutely sure from your own experience with it, that the Majestic is exactly the engine you want above all others before you even think of buying it. In fact, we won't sell you a Majestic unless you are positive that it will do your work better and more economically than any other engine you can buy regardless of price. If after using it 30 days you are not convinced—if for any reason at all you don't wish to keep it—send it back at our expense. If you decide to keep it, you can make the first payment three months after you receive it and the balance in 6, 9 and 12 months, giving you

## A Year To Pay WITHOUT INTEREST

Only the great House of Hartman with its enormous \$10,000,000 capital can afford to sell an engine at the remarkable bargain price of the Majestic, back it up with a strong guarantee and extend such liberal credit terms—the most liberal ever conceived.

### NO MONEY IN ADVANCE

If you need power, no matter where you live, this offer is for you. Remember, you don't have to send a penny in advance. No bank deposit—no references—no mortgage—no embarrassing questions—no collectors—no red tape. You may pay all cash if you prefer, but it costs you not one penny extra to take advantage of Hartman's most liberal credit terms.

## The Great Majestic Engine

### Gasoline, Kerosene, Naptha, Gas

Has fewer number of parts—a marvel of simplicity. Perfectly balanced—just the right weight for the power it is designed to develop—no excessive friction. It must not be confused with old-style, over-heavy type of gasoline engines which consume enormous amounts of fuel and are, therefore, expensive to operate. Neither is it the opposite extreme, so light they literally jerk themselves to pieces when running at high speed or under a heavy load. It is the "happy medium" engine—not too heavy nor too light.

The Majestic is the simplest, most durable, most powerful for its H. P. rating and most economical-to-operate gasoline engine ever made. Big improvements in all vital parts—and the most wonderful automatic mixer ever put on a gasoline engine. All Majestics are horizontal, 4-cycle type, open jacket, hopper cooled. No over-heating of parts or sticking of valves. Very little water needed for cooling. Convenient, compact, easy to run.

### Free Engine Book

Most valuable engine book ever published. Tells how to pick out size and style engine best suited for your needs and explains the famous Hartman selling plan. Send for Engine Catalog No. 86-E

**FREE  
Engine  
Book  
Coupon**

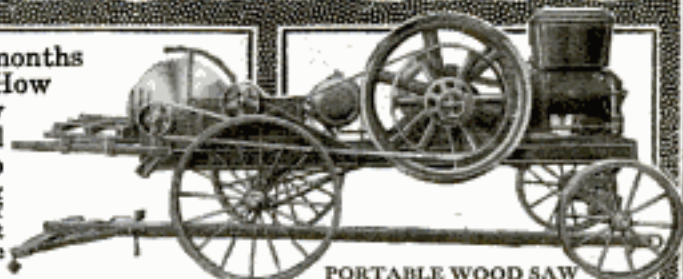

**PORTABLE WOOD SAW**  
With Friction Clutch Pulley

Table slides on wheels; cannot sag or get out of alignment. Outfit shipped complete, ready for work. 5, 7, 9 and 14 H. P., mounted this style.



**HORSE PORTABLE**

With Friction  
Clutch Pulley

All-Steel truck, wide-tired wheels, heavy hubs, staggered spokes. Front axle is swivel type so made that wheels, passing over obstructions, do not disturb level of engine. 5, 7, 9 and 14 H. P., mounted this style.

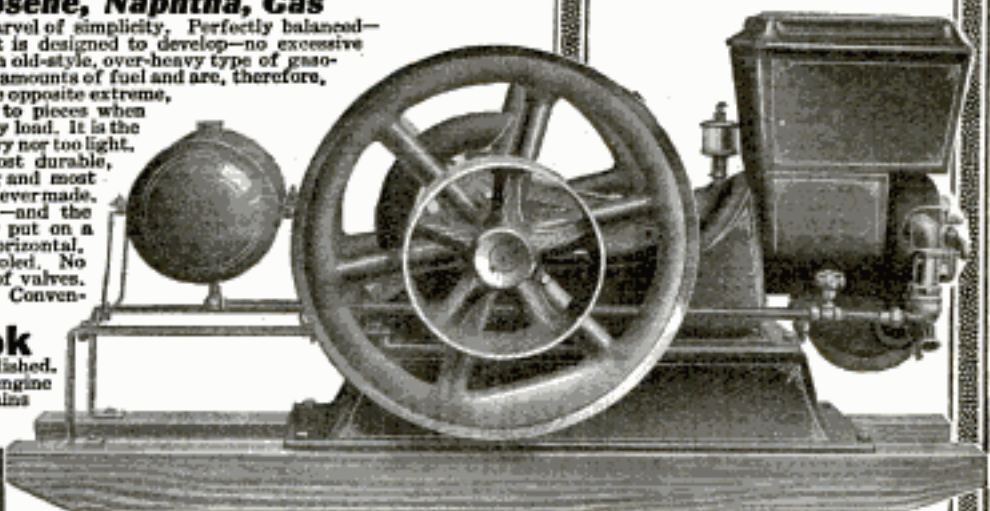

**MAJESTIC STATIONARY ENGINE—Sizes 2, 3, 5, 7, 9 and 14 Horsepower**

**The Hartman Company, 3945 La Salle St., Chicago**

Without obligating me, send your Engine Catalog No. 86-E illustrated in colors, and full particulars of your original plan, whereby you agree to send me any size Majestic Engine I want without a cent in advance, without a deposit or references and, if I decide to keep it, give me a full year to pay without interest.

Name.....

Address.....

P. O. Box or R. F. D.....Town.....State.....

# 10 Days' Free Trial Charges Prepaid Send No Money

TWICE THE  
LIGHT

HALF THE  
OIL

## NEW KEROSENE LIGHT BEATS ELECTRIC OR GASOLINE



We don't ask you to pay us a cent until you have used this wonderful modern light in your own home ten days—we even prepay transportation charges. You may return it at our expense if not perfectly satisfied after putting it to every possible test for 10 nights. You can't possibly lose a cent. We want to prove to you that it makes an ordinary oil lamp look like a candle; beats electric, gasoline or acetylene. Lights and is put out like old oil lamp. Tests at 33 leading Universities and Government Bureau of Standards show it

### Burns 50 Hours on One Gallon

common coal oil, and gives more than twice as much light as the best round wick open flame lamps. No odor, smoke or noise, simple, clean, no pressure, won't explode. Several million people already enjoying this powerful, white, steady light, nearest to sunlight. Guaranteed.

### Men Make \$50 to \$300.00 Per Month With Rigs or Autos

delivering the ALADDIN on our easy trial plan. No previous experience necessary.

Practically every farm home and small town home will buy after trying. One farmer who had never sold anything in his life before writes: "I sold 51 jumps the first seven days." Another says: "I disposed of 27 jumps out of 31 calls." Thousands who are coming money endorse the Aladdin just as strongly.

### NO MONEY Required

We furnish capital to reliable men to get started. Ask for our distributor's plan, and learn how to make big money in unoccupied territory. Sample sent for 10 days' FREE TRIAL.

Awarded  
**GOLD MEDAL**  
at World's  
Exposition  
San  
Francisco

### \$1000 WILL BE GIVEN

to the person who shows us an oil lamp equal to the new Aladdin (details of offer given in our circular). Would we dare make such a challenge if there were the slightest doubt as to merits of the Aladdin? We want one user in each locality to whom we can refer customers. Be the first and get our special introductory offer under which you get your own lamp free for showing it to a few neighbors and sending in their orders. Write quick for 10-Day Absolutely

Free Trial. Just say, "Show me how I can get a strong white light from kerosene oil, without risking a cent." Address our nearest office.

**MANTLE LAMP COMPANY, 374 Aladdin Building**  
CHICAGO, ILL. NEW YORK CITY PORTLAND, ORE.

Largest Kerosene (Coal Oil) Mantle Lamp  
House in the World.  
MONTREAL or WINNIPEG, CAN.

## KEROSENE Gas Lamps

**BRIGHT AS THE SUN**  
Simple as a Candle

A Flood of Shadowless Light for every purpose. If we are not represented in your town write for particulars in profit making deal for dealers and agents.

BRILLIANT GAS LAMP COMPANY, 1009X, S. Wabash Ave., Chicago, Ill.

## WHITE FLAME

BURNERS make your old kerosene lamps and lanterns give a brilliant white light better than electricity or gas. Doubles your light. Saves oil. **NO MANTLE TO BREAK.** Guaranteed Safe and Reliable. Delights every user. Send now for complete sample postpaid 35 cts. stamps or coin. 3 for \$1. **MONEY BACK IF NOT SATISFACTORY.** Live Representatives Wanted. Exclusive Territory.

WHITE FLAME LIGHT CO., 68 Clark Bldg., Grand Rapids, Mich.

## The "BEST" LIGHT

A soft, luminous light, which casts no shadow. Brighter than electricity or acetylene. Makes and burns its own gas. Costs 2c a week. No dirt, smoke nor odor. Over 200 styles, ranging from 100 to 2000 candle power. Absolutely guaranteed. Write for illustrated catalog.

AGENTS WANTED EVERYWHERE  
**THE BEST LIGHT CO.**  
324 E. 5th St., Canton, O.

eat. The demand for fish adapted to this kind of pond culture is greater than the supply, and farmers enterprising enough to have ponds have no difficulty in selling the product.

## AGENTS WANTED

for independent hollow-wire lighting systems for homes, stores, etc.; also complete line of lanterns and portable and street lamps. Use common gasoline.

### AKRON GAS LAMPS

are most improved, simplest and safest of all. Best and cheapest illumination known. Shed a clear, soft, bright, white light of high candle power. Fully Guaranteed. Handy demonstration outfit. Our Agency Proposition cannot be best. Exclusive territory.

Write quick for Catalog and Terms  
Akron Gas Lamp Co., 622 So. Main St., Akron, O.

## Sunshine Lamp FREE! 300 Candle Power

To Try in Your Own Home

Turns night into day. Gives better light than gas, electricity or 18 ordinary lamps at one tenth the cost. For Homes, Stores, Halls, Churches. A child can carry it. Makes its own light from common gasoline. Absolutely SAFE.

### COSTS 1 CENT A NIGHT

We want one person in each locality to whom we can refer new customers. Take advantage of our SPECIAL FREE TRIAL OFFER. Agents Wanted.

**SUNSHINE SAFETY LAMP CO.**  
616 Factory Bldg. Kansas City, Mo.

## BEACON BURNER FREE

FITS YOUR OLD LAMP

100 Candle Power Incandescent pure white light from (kerosene) coal oil. Beats either gas or electricity.

### COSTS ONLY 1 CENT FOR 6 HOURS

We want one person in each locality to whom we can refer new customers. Take advantage of our Special Offer to secure a Beacon Burner FREE. Write today. AGENTS WANTED.

HOME SUPPLY CO., 111 Home Bldg., Kansas City, Mo.



**BURROWES****\$1 DOWN****Billiard and Pool Table**

enables the whole family to enjoy these fine, clean, wholesome, interesting games — games that fascinate with their close, exciting, constantly changing situations — games that test the skill of hand, eye, and brain, and arouse the keenest sort of friendly rivalry.

Under our easy payment plan you will be surprised to find that a few cents a day (payable monthly) will pay for a fine Burrowes Home Billiard and Pool Table. No special room is needed—Table can be mounted on dining or library table or on its own legs or folding stand, and quickly set aside when not in use.

Burrowes Tables are splendidly built, on scientific principles, and are correct to the minutest detail. Great experts pronounce the Burrowes Regis High-Speed Cushions to be the best made. The most delicate shots, calling for skill of the highest order can be executed on a Burrowes Table with the utmost precision.

**FREE TRIAL**

Prices are from \$15 up, on easy terms of \$1 or more down (according to size and style) and a small amount each month. You can play while you pay. Sizes of Tables range up to 4 1/2 x 9 ft. (standard). Cues, balls, and full playing equipment free with each Table.

**NO RED TAPE** On receipt of first payment we will ship Table, Play on it one week. If unsatisfactory return it, and on its receipt we will refund your deposit. This insures you a free trial. Write for illus. catalog containing prices, terms, order blank, etc.

**THE E. T. BURROWES CO.** 161 Spring Street  
PORTLAND, ME.

Mrs. Burrowes Rustless Screens, Folding  
Card Tables, Cedar Chests

**South Bend Lathes**  
For the Machine and Repair Shop

**How to Run a Lathe**  
A 50 cent book for 10 cents.  
Postpaid, stamps accepted.

Straight or Gap Beds. Send for free  
catalog giving prices on entire line.  
**SOUTH BEND LATHE WORKS**  
423 Madison St., South Bend, Ind.

**Give Him a Pair of SEARIGHT Compound Lever  
Mechanics' Snips for Christmas**

The cutting power of these snips is three  
times that of the common straight snip.  
They are forged from  
Crucible Tool Steel.

No. 7  
No. 10-12-14

Sizes: 7, 8, 10, 12 & 14 in. long  
Prices: \$1.00, \$1.50, \$2.25  
\$3.00, \$3.50 Prepaid

**BARTLETT MANUFACTURING CO.**

21 East Lafayette Ave., DETROIT, MICH.

**Tool Sharpening Made Easy with  
Luther Hummer Tool Grinder**

**Dimo-Grit** (artificial diamond) wheels sharpen  
every tool in jigtime with light touch. No water  
needed. **Won't draw temper.** Steel shaft drive like  
auto. Dust-proof bearings and gears. Patented tool  
rest. Perfect lubrication. Many special attachments.

Shall We Send You Big Free Book?  
**LUTHER GRINDER MFG. CO.**, 301 First St., MILWAUKEE, WIS.

**Auto Gasoline 3¢ a Gallon**

Sounds wonderful, but it's a fact; and what is better, your motor car  
will have "pop," "snap," power and speed as never before. Carbon  
evil eliminated. All these good things and more come when  
**GASO-TONIC** is added to ordinary Gasoline. Mileage increased 40%.  
Scientifically right. Quart can treats 30¢ gallons of gasoline. \$2 prepaid.  
Results guaranteed. Motorists enthusiastic wherever **GASO-TONIC** is  
tried. Circular and convincing details free. Great opportunity for  
live dealers and agents.

**WHITE MFG. CO., Dept. 112, CINCINNATI, OHIO**

**Civil Engineers Earn  
\$1500 to \$5000 a Year**

Don't take our word for it that these books will fit you to earn \$1500 to  
\$5000 a year as a Civil Engineer. Get them into your home—free—and  
determine their value for yourself. The books themselves, not what we  
say, must convince you that you need them, so send the coupon today—  
now—for your set of the 1916 edition Cyclopaedia of

**Civil Engineering**

9 volumes; 3900 7x10 inch pages; 3000 illustrations, photos,  
plates, maps, diagrams, etc.; hundreds of valuable tables and  
formulas. Handsomely bound in half red morocco, gold stamped.

This great new work covers completely the entire field of Civil Engi-  
neering: Tells all about Surveying; Highway Construction; Railroad Engi-  
neering; Earth Work; Steel Construction; Specifications, Estimating and  
Contracts; Bridge Engineering; Masonry; Reinforced Concrete; Water  
Supply; Sewers and Drains; Water Power Development; River and Harbor  
Improvement; Irrigation Engineering—everything you need know to  
become a Civil Engineer.

**50c a week if you keep them**

The entire nine volumes, not a single volume, will be sent, express  
prepaid, on receipt of the coupon below. Look these books over for a whole  
week free. Then decide whether or not you want them. If you do, send us  
\$1.00 within seven days and \$2.00 a month—50c a week—until the special  
advertising price of \$29.80 has been paid. Otherwise we'll take them back  
at our expense. In addition to this liberal discount from the regular price  
of \$45.00, we include with each set a \$15.00 Consulting Membership.  
This entitles you to the advice of a staff of experts for a whole year free!

**AMERICAN TECHNICAL SOCIETY, CHICAGO, U. S. A.**



P. No.  
11-15

**A. T. S.**

Please send

Cyclopaedia of

Civil Engineering

for seven days' exam-

ination. I will send \$2.00

within seven days and \$2.00

a month until I have paid \$29.80,

or notify you and hold books sub-

ject to your order. Title not to pass

until fully paid.

Name .....

Address .....

As I have had no previous dealings with you, I refer you to

Please Mention Popular Mechanics

# "I've Read of Gold Mines" —

"I'VE read of gold mines, but yours is the first I have ever seen." That's what a patron said to J. J. Williams when he saw his Ten-Pinnet Alleys piling up profits. You can make a double profit from Ten-Pinnet, "world's greatest bowling game." Besides owning your own business, be our local representative and enjoy big commissions on sales in your territory.

## Automatic Bowling—New and Fascinating!

Everybody plays Ten-Pinnet—men, women, children. Ingenious automatic feature makes your receipts nearly all net profit. No up-keep expense—no pin-boys—just someone to take in money. Alleys 38 to 50 feet long—easily installed in any room.

### Valuable Premiums



to increase the interest of bowlers—we furnish coupons. An Ohio operator: "I am having great success. My place looks like a fair at times. Could use more alleys and may enlarge." You can start on small investment—easy terms. Write today for catalog and agent's prices.

### The Ten-Pinnet Company

34 Van Buren Street,

Indianapolis, Ind.

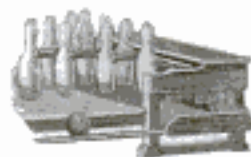

## BIG CHANCE FOR AGENTS



### You can earn BIG MONEY

Selling the most complete line of guaranteed transparent handle Knives and Razors with Photo, Name and Lodge Emblem—also full line of cutlery. Write today for catalogue and terms. Golden Rule Cutlery Co., 554 W. Lake St., Dept. 210, Chicago, Ill.



### Amazing Profits In Mushrooms

Anybody can add \$10 to \$40 per week to their income, in spare time, entire year growing mushrooms in cellars, sheds, barns, boxes, etc. I sell you where to sell, at highest prices.

Free Illustrated Instruction Booklet

**HIRAM BARTON**

Desk 2, 329 W. 48th St., New York

## AGENTS: \$6 PER DAY AND UP

### MEN AND WOMEN

Out of work? Got a lot of spare time? Handling a poor line now? We want an active man or woman in each town to open an agency for our famous

### NON-ALCOHOLIC FOOD FLAVORS

Colors, Soups, Perfumes, Toilet Preparations, etc. Over 100 different varieties. Flavors put up in tubes, not bottles. Fast sellers, steady repeaters. Every home a customer. Commissions paid in real money—\$4, \$6, \$8, \$10 a day. Little or no capital required. Experience unnecessary. Full instructions for beginners. Fine light sample case furnished. Write for full particulars



**FREE**

ACT  
QUICK  
WRITE  
TODAY

AMERICAN PRODUCTS CO., 3953 Third St., CINCINNATI, O.

A "famine" of hosiery needles is seriously crippling the stocking-making industry of England. About 50,000,000 of these are needed yearly, most of which before the war were supplied by Germany.

Go into **MOVING PICTURE BUSINESS**  
**Small Capital Starts You**  
 on our easy payment plan. Begin now and get your share. We sell everything. Write TODAY.  
**Atlas Moving Picture Co.**  
 Dept. 40 5255 Dearborn St., Chicago

GO INTO THE **MOVING PICTURE BUSINESS**  
 Write For **FREE Catalog**  
**On Our Easy Payment Plan**  
**Make \$20 to \$50 per night**  
 With our Moving Picture Outfit We sell everything—Films, too.  
**Moving Picture Sales Co.**  
 Dept. 2 540 Plymouth Place, Chicago, Ill.

**AGENTS \$10 to \$20 PER DAY!**  
**New Pure Aluminum Hot Water Bottle—will outwear 100 Rubber ones.** Lasts a lifetime. Low price makes quick sales. Write for sample and large catalog of 400 other Specials.  
**AMERICAN ALUMINUM MFG. CO.**  
 Div. B. M. LEMONT, ILL.

**Pay as You Wish**  
 We'll send you a genuine Lachnite for you to wear for 10 full days. If you can tell it from a real diamond send it back at our expense. Costs but 1-30th as much. If you decide to keep it pay only a few cents a month. Write for catalog.  
**Genuine Lachnite Gems** keep their dazzling fire forever. Set in solid gold. Out by world renowned diamond cutters. Will stand fire and acid tests. All kinds of jewelry at astounding low prices. Easy payments. **WRITE TODAY.**  
**H. Lachnite Co., 12 N. Michigan Av., Chicago Dept. 1198**

# PATENTS

IF YOU HAVE AN INVENTION which you wish to patent you can write fully and freely to Munn & Co. for advice in regard to the best way of obtaining protection. Please send sketches or a model of your invention and a description of the device, explaining its operation.

All communications are strictly confidential. Our vast practice, extending over a period of seventy years, enables us in many cases to advise in regard to patentability without any expense to the client. Our Hand-Book on Patents is sent free on request. This explains our methods, terms, etc., in regard to *Patents, Trade Marks, Foreign Patents, etc.*

All patents secured through us are described without cost to the patentee in the *SCIENTIFIC AMERICAN*.

**MUNN & CO.**  
SOLICITORS OF PATENTS  
672 WOOLWORTH BLDG., NEW YORK  
and 625 F STREET, WASHINGTON, D. C.

## YOU NEED THIS TOOL

GASOLINE  
SOLDERING IRON  
BLOW-TORCH



Address Dept. 1, Emmelmann Bros. Mfg. Co., Indianapolis, Ind., U.S.A.



**KEEN KUTTER**  
Tools and Cutlery

Made by  
Men Who  
Know, for  
Men Who  
Know

## High Grade Violins 30 Days' Free Trial



Your choice from a large and carefully graded stock of representative instruments from the leading foreign violin makers. Strictly hand made and of superior type, these violins are far superior to the average old violins sold at four times the price.  
**Write Today.** Don't fail to send your name and address today for the superb Lewis catalog sent free and postpaid. Of value to everyone interested in high grade instruments. Learn how you can have your choice of these superb instruments on a free trial in your home. Write today.  
Wm. Lewis & Son, Dept. 1198, 225 S. Wabash Ave. Chicago  
**OUR SPECIALTIES:** Imported good-varnishes and tools for violin makers.

A Football Jersey



## Be the First in Your Club

School, City or Town, to wear this pure, all wool sweater, double collar and cuffs. Your choice in colors. This jersey was selected by 10,000 of my customers for last season. Your club will recommend it. My 1915-1916 catalogue is now ready. Write me and learn my offer for your club's order. Popular Prices. Best Grade Sporting Goods—Football, Basketball, Baseball, Tennis, Golf, etc. **WRITE ME NOW.**

JACK SHANNON CO., Dept. 46, 54 E. Monroe St., Chicago

## Here's a New Business



Reproduce Photographs of persons and scenes upon watch caps, dials, china, etc. Work easily done. Knowledge of photography not necessary. **TRIAL OUTFIT with directions, \$2 postpaid.**—Contains enough materials to make at least 15 reproductions that you should sell from \$2.50 to \$5.00 each.  
**START NOW—ORDER TODAY**

AMERICAN ARTS & CRAFTS COMPANY, BOSTON, MASS.

# Here's Health and Power— Vim and Vigor



Do you want them?

Strength that is more than mere muscular strength. The strength of better health, abundant nerve force. The strength of keen relish. Write and find out what vibration will do for you. Nine out of ten people are only half alive. How about yourself? Do you feel just right? If you haven't that vigorous "go-ahead" feeling all the time,

don't fail to send the free coupon today for our big new book that will tell you all about

## THE WHITE CROSS ELECTRIC VIBRATOR



### Our Combination

Outfits give you three of the greatest curative agents—Vibration, Faradic and Galvanic electricity. We will send this wonderful machine to you on free trial. See it—try it—feel its health-giving vibrations for yourself.

## Vibration Is Life

In vibration there exists many of the secrets of life. The safest, surest and quickest way to recover normal health is by scientific manipulation of the organs affected and in this way stimulating them to perform their duties, whether it be those of digestion, respiration, circulation, or the nervous system. The rich, red blood will be sent coursing through every vein and artery. Write today—now—for our free book.



## Send the Free Coupon

Just your name and address on the free coupon or a letter or a post card is enough. We will send you absolutely free and prepaid, our new book, "Health and Beauty." It's free. No obligations of any kind. Write today—at once.

Lindstrom, Smith Company  
1150-1110 South Wabash Avenue  
Dept. 9898 Chicago, Illinois

We also manufacture White Cross Electric Stoves, Irons, Hair Dryers, Electric Lamps, Electric Fans, Electric Automobile Horns, Electric Curling Irons, Heating Pads, Small Motors, etc., etc. Dealers write.

Name.....

Address.....

My Electrical Dealer's Name is.....

Lindstrom,  
Smith Co.

1160 S. Wabash Ave.  
Dept. 9198 Chicago

Please send me, absolutely free and prepaid, your new book, "Health and Beauty" and full particulars about the White Cross Electric Vibrator. I assume no obligation of any kind.



## 300 Candle Power of Light AT A COST OF 1/8c PER HOUR

The Kerosene table lamp has one inverted mantle and **MAKES** and **BURNS** ITS OWN GAS FROM COMMON KEROSENE or COAL OIL. It gives a bright and steady white light **TEN TIMES** as **BRILLIANT** as an ordinary kerosene wick lamp

**THE "QUICKLIT"** Gasoline table lamp can be **LIT** WITH AN ORDINARY MATCH, LIKE CITY GAS.

*Both styles equipped with automatic cleaning needle.*

**No smoke, no smell, no wicks to trim. A splendid proposition for dealers**

**LIVE AGENTS WANTED** Write today for further particulars, also complete illustrated catalog describing the above kerosene and gasoline lamps and hollow wire systems.

**THE NAGEL-CHASE MFG. CO., 152-160 East Erie St., CHICAGO, ILL., U.S.A.**  
The largest manufacturers of artificial lighting devices in the world.

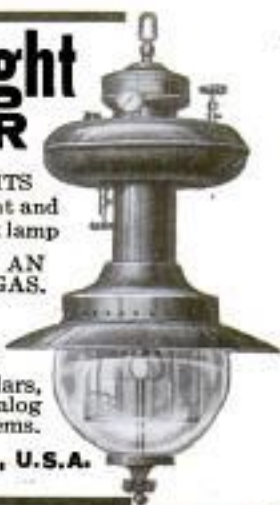

Write Today - See  
**New Styles  
1916 Prices**

**GET** the 1916  
wholesale price  
offer from  
Kalamazoo

and sizes of best quality  
stoves and ranges. Mail  
postal or letter today for

**New Catalog and  
"Recipes in Rhyme" FREE**

Cash or easy payments—30  
days' trial—year's test. We  
pay freight and ship within  
24 hours. \$100,000 bank bond  
guaranty. Write today.

Ask for Catalog 473

**Kalamazoo Stove Co., Mfrs.  
Kalamazoo, Michigan**

Stoves, ranges, gas stoves  
furnaces, white enameled  
metal kitchen cabinets and  
tables. 4 catalogs—please  
say which you want.



**A Kalamazoo**  
Trade Mark Registered.  
**Direct to You**

**BUY YOUR FURNACE  
\$10 DOWN \$10 A MONTH**



Our monthly payment plan of selling direct  
saves you the dealer's profits and charges  
for installation. The

**JAHANT FURNACE**

with the patented "Down Draft System" is  
best for residences, schools, hotels, churches,  
etc., because it delivers plenty of heat where-  
ever and whenever desired at a saving of 1/3 to  
1/2 in fuel bills. Install the Jahant yourself.  
We send complete outfit, freight prepaid with  
special plans, detailed instructions and all  
necessary tools for installation. Satisfaction  
guaranteed or money refunded.

WRITE FOR FREE ILLUSTRATED BOOK  
THE JAHANT HEATING CO.

300 Steiner Avenue AKRON, OHIO

**Save 1/3 to 1/2 on Fuel Bills**

**ART PIANOS** From  
and **PLAYERS** Factory  
to You!

To introduce our wonder-  
ful Profit-Sharing Plan,  
we offer you on

**30 Days Trial**

this Handsome Art Piano. Our  
unlimited guarantee, backed by  
Three Million Dollar Capital, is  
your assurance of a Piano with  
Artistic Design, Exclusive Feat-  
ures, Wonderful Tonal Qualities  
and the Acme of Perfection.

Write today for Catalog—it is yours for the asking.

**Story & Clark Piano Co., Dept. A-18, Chicago**



**A "BRIDAL" GIFT**  
WITH EVERY  
**IMPERIAL RANGE**

Simply send name and address. This re-  
serves your delightful premium. Learn the facts of  
Imperial Ranges—Heat retaining Stone  
Oven Bottom, Odor Hood, Ash Sifter, all ex-  
clusive features. Save \$10 to \$25. Direct from  
factory. 30 days' Free Trial. Cash or Credit. Write  
now for catalog and facts about YOUR premium.  
**THE IMPERIAL STEEL RANGE COMPANY**  
369 Detroit Street CLEVELAND, OHIO



**3 YEARS TO PAY**

**Meister Piano** 30 days free trial  
in your own home

**\$1 A WEEK or Price \$175.00**  
**\$5 A MONTH**

No cash payment down. No interest  
—no extras. Piano stool and scarf free.

**ROTHSCHILD & COMPANY**  
Dept. 16M CHICAGO, ILL.

**1/3 SAVED** Buy Direct From  
MANUFACTURER  
**J. Hardin Co., J. J. Lavin, Pres.**



No. 1 \$9.60

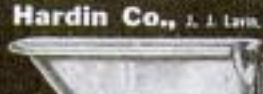

No. 2 \$15.50



No. 3  
\$12.90

**FREE BOOK**

**Install Your Own  
Plumbing and Heating**

Get our catalog No. 69A—contains com-  
plete heating plants, heating goods of every de-  
scription, bathroom outfits, sinks, roughing-in goods,  
pipe fittings, valves, etc., water pressure systems  
and heating plants. In fact, absolutely everything in  
both grade plumbing and heating supplies exclusively at  
wholesale prices. Any handy man can install our goods  
with our free easy installing plans. \$450,000 plants behind  
our guarantee. **WRITE TODAY.**



No. 4226 60 up

**J. HARDIN CO.** 40 years at 4533-43 CHICAGO  
Cottage Grove Ave.

# Diamonds Watches

## on Credit

**DO YOUR CHRISTMAS SHOPPING EARLY**

This special selection of Diamond-set jewelry shows the most popular of the season's new mountings. Gorgeous beautiful Diamonds, of fiery brilliancy, set in solid gold or platinum. As an inducement to do your Christmas shopping early, we have cut prices almost to cost. It's your opportunity to save money. Watch No. 886 is an extra special bargain—men's 12 Size, or ladies' O Size, 17 jewels, choice of Illinois, Elgin, Waltham, or Hampden movement. Any selection sent on approval, delivery charges prepaid. If satisfied, send one-fifth of the price as first payment, balance divided into eight equal amounts, payable monthly. If not just what you wish, return at our expense. **Send for Our Handsome 116-Page Illustrated Catalog.** Over 2,000 suggestions for gifts for any occasion, or for personal wear. All the new styles in jewelry—rings, studs, scarf pins, ear screws, brooches, bracelets, watches, chains, watch bracelets, silverware, etc. Liberal credit terms on anything desired. Christmas is not far off. **Send for free Catalog and do your shopping NOW.**

**SEND FOR JEWELRY CATALOG—FREE**



No. 885  
12 Size  
\$20  
17 Jewels  
25-Year

**LOFTIS BROS. & CO.,**  
The National Credit Jewelers  
Dept. FB94 108 N. State St.,  
Chicago, Ill.  
Stores in Pittsburgh,  
St. Louis, Omaha

**We Save You \$8.00**

## FALL SUITS & OVERCOATS \$10 to \$22

Our plan enables you to be well dressed and save money in the bargain.

**We refund your money if you are not satisfied**



Every garment is guaranteed not only to fit perfectly, but to keep its perfect shape permanently. Glen Rock garments are noted for the excellence of cloth, trimmings, cutting and tailoring. Signed guarantee attached to every made-to-order garment.

**FREE** Send today for Style Book and 40 Cloth Samples.

**GLEN ROCK WOOLEN CO.**  
J. E. Griggs, Treas. & Gen. Mgr.  
219 Main St., SOMERVILLE, N. J.

**FREE SHOE BOOK SAVES \$20**

*"The Sole of Steel"* describes my light, springy, comfortable, economical, waterproof, all-season, general purpose shoe that saves your feet, health and money. 1 pair of "Steels" outwears 3 to 4 pairs leather workshoes. Investigate before buying shoes again. Address, "The Steel Shoe Man,"

**N. M. RUTHSTEIN, Dept. 132, RACINE, WIS.**

## Runs on Alcohol

**At Cost of Less than 1/2¢ an Hour**

anywhere without electricity, springs or batteries. Superb construction. 12-inch blades. Adjustable roller bearing. Reliable. A proved comfort. Prompt delivery. The original and only Lake Breeze Motor manufactured according to the design of the inventor and under his direct and personal supervision.

**Keep Cool**  
\$15 Cash with Order

Lake Breeze Motor, 122 N. Jefferson St., Chicago

## 100,000 "American Bankrolls"

the 1916 MODEL—ready for your Christmas Gift-buying. Combination Billfold, Coin-purse, Photo & Cardcase of Finest, Genuine Black Seal Grain Leather with the show and elegance of a Dollar Article for only 50c postpaid (\$5.40 per dozen). Any name beautifully engraved in 23-Karat Genuine Gold FREE. Iron-strong, yet wonderfully limp and flexible. Closes with glove fastener to size 3x3 1/2 inches. Has secret bill-pocket, coin-purse, transparent photo or identification pocket and calendar, besides 2 hidden card pockets. Packed in handsome giftbox with Christmas card and tinsel cord ready for the TREE. If unable to get money order or bank draft, send postage stamps. 10th annual catalog of high grade GUARANTEED LEATHER GOODS and NOVELTIES free with orders for "Bankroll," or sent alone for 5c postage.

# No Money In Advance

## This Marvelous Camera ON FREE TRIAL!

Only 10,000 of these marvelous, instantaneous picture-taking and making cameras to be sent out absolutely on approval without a penny in advance just to prove that it is the most wonderful invention—the camera sensation of the age—the camera sensation of the age—takes and makes finished pictures **INSTANTLY!**

You press the button, drop card in developer and in one minute take out a perfect, finished post card photo 2 1/2 x 3 1/2 inches in size. Camera, itself, is about 4 1/2 x 7 inches. Loads in daylight, 16 to 50 post cards at one time. No Films—No Plates—No Dark Room. It is instantaneous photography. Universal focus lens produces sharp pictures at all distances. Pictures develop and print automatically. Can't overdevelop; results amazing.

**We Trust You**

We will send you the complete Mandel-ette outfit absolutely on approval, no references required, and give you 10 days to test it. If not satisfactory return at our expense. If you keep it simply pay \$1 when you get camera and \$1 per month until our special price of only \$5 is paid. No experience required. Plain instructions and everything complete with outfit so you can begin taking pictures the moment it arrives. We guarantee that even a child can operate it. Send coupon for camera.

**— THE CHICAGO FERROTYPE COMPANY —**  
Desk 163 Ferrotypic Bldg., Chicago, Ill.

Send me one complete Mandel-ette Camera outfit including supply of post cards and instructions. I agree to pay \$1 when I get the camera, and if satisfied keep it and pay you \$1 a month until your special price of \$5 is paid. Otherwise I will return it at the end of 10 days.

Name.....

Address.....

**U. S. LEATHER GOODS CO., Dept. 2-A,**  
*The Original Leather Goods Mail Order House.*
**Ravenswood, CHICAGO, U. S. A.**  
*Established 1906. Incorporated 1919.*

# Patents

Trade Marks and  
Copyrights Secured  
or Fee Returned

## Special Offer—Free Search of Patent Office Records

Send us a model or sketch and description of your invention, and we will make a *Free Search* of the *Patent Office Records* to ascertain if it is patentable. If we report the invention patentable, we will guarantee to obtain a patent or return our fee, and furnish a certificate of patentability backed by a bonded contract to that effect. **This Certificate of Patentability will protect the inventor and serve as proof of the invention until the case can be filed in the U. S. Patent Office.**

### Obtaining Assistance for Inventors

Our certificate is of great assistance to inventors who require financial aid to obtain patents.

### Our Five Books Mailed Free

(SEE COUPON BELOW)

to any address. Send for these books—the finest publications ever issued for free distribution.

#### How to Obtain a Patent

Our illustrated eighty-page Guide Book is a book of reference for inventors, and contains 100 mechanical movements illustrated and described.

#### Money in Patents

Tells how to invent for profit, and gives history of successful inventions.

#### What to Invent

Contains a valuable **LIST OF INVENTIONS WANTED** and suggestions concerning profitable fields of invention; also information regarding prizes offered for inventions, among which is

#### Prize of One Million Dollars

offered for one invention, and \$10,000 for others.

#### Patents That Pay

Contains letters from our clients who have built up profitable enterprises founded upon patents procured by us; also endorsements from prominent inventors, manufacturers, Senators, Congressmen, Governors, etc.

#### We Advertise Our Clients'

#### Inventions Free

In a list of Sunday newspapers with two million circulation, in manufacturers' journals and in the *World's Progress*. Sample Copy Free. We save you time and money in securing patents. After the patent is granted we assist you **TO SELL YOUR PATENT.**

#### Foreign Patents

**WE HAVE DIRECT AGENCIES IN ALL THE PRINCIPAL FOREIGN COUNTRIES** and secure **FOREIGN PATENTS** in the shortest possible **TIME** and at the **LOWEST COST.** Write for our Illustrated Guide Book on Foreign Patents, sent free to any address.



**VICTOR BUILDING**  
Our new \$200,000 building opposite U. S. Patent Office  
SPECIALLY ERECTED by us for OUR own use

## WANTED NEW IDEAS

Send for **LIST OF PATENT BUYERS** who consult us when purchasing patents. Contains requests from **MANUFACTURERS, MAIL ORDER HOUSES** and **PROMOTERS** for patents secured by us, and suggestions as to **New Ideas** they wish to purchase. We invite manufacturers and promoters to address our Sales Department regarding the purchase or leasing of a number of meritorious patents secured by us.

### REFERENCES

Second National Bank, Washington, D. C.; Union Savings Bank, Washington, D. C.; Chamber of Commerce, Washington, D. C.; Pitner Gasoline Lighting Co., Chicago, Ill.; R. G. Dun & Co., Washington, D. C.; Smethport Glass Co., Smethport, Pa.; The Mevin Gauge and Signal Co., Scranton, Pa.; M. Winter Lumber Co., Sheboygan, Wis.; National Savings and Trust Co., Washington, D. C.

### FREE COUPON!

## VICTOR J. EVANS & CO., Patent Attorneys

NEW YORK OFFICES: 189-191 Broadway

PHILADELPHIA OFFICES: 1429 Chestnut St.

Main Offices: 765 Ninth St., N. W., WASHINGTON, D. C.

GENTLEMEN: Please send me **FREE OF CHARGE** your **FIVE** Books as described above.

NAME..... ADDRESS.....

# WANTED IDEAS



Inquiries from Manufacturers and Other Buyers of Patents  
Who Are Looking for Good Ideas

## Protected by Owen Patents

Are constantly being received. Hundreds of ideas are wanted—a market exists for them to-day. YOURS may be one of them. Send for my free books and see for yourself—read the requests for inventions protected by me. Many are simple. You can help supply this demand.

As soon as my clients' rights are protected I aid in every practicable way, **without charge**, to sell. Their **applications** are advertised free—their patents are called to the attention of the proper prospective buyers—every necessary thing is done. Get my booklets and see.

## THESE ARE FREE

You will incur no obligation by writing me. A simple request will bring them to you—the finest, most reliable and instructive patent books published. A postal will do.

**"Successful Patents"**—a 72 page guide book, tells how to proceed; describes my advantageous business methods; gives references, testimonials, etc.

**"Stepping Stones"**—gives hundreds of hints of inventions wanted; articles from interviews of noted authorities; tells the truth about prizes for inventions.

**"Patent Promotion"**—tells you how to sell; why some inventors fail; discusses the value of your idea; how I aid my clients; manufacturing aids furnished you; recent successful patents, etc.

You will also be sent from time to time, as new inventions are wanted, full information concerning them. Only in this way can you keep up to date.

**Write for These To-day**—Advice costs nothing. All communications confidential. I secure patents or receive no compensation. Your work will receive my personal supervision—but my fees are no higher than others.

## Results Speak Loudest—But Here Are Some References

Columbia National Bank,  
Washington, D. C.

National Locktile Co.,  
Washington, D. C.

The Carnahan Press,  
Washington, D. C.

Lightning Gun & Cycle Works,  
Oklahoma City, Okla.

Antholene Mfg. Co.,  
Hutchinson, Kans.

National Rack Co.,  
61 Hannover St.,  
Boston, Mass.

The C. J. Loftus Co.,  
13 Spring Common,  
Youngstown, Ohio

Whitehead Hosiery Mills,  
Burlington, N. C.

Dickinson Mfg. Co.,  
Des Moines, Iowa.

A LARGE NUMBER OF OTHERS IN MY BOOKLETS.

### Search of Records

Send sketch or model of your invention for free search of Patent Office Records and report on patentability.

**RICHARD B. OWEN** 9-303 OWEN BLDG.  
WASHINGTON, D. C.

Inventors submitting their inventions to me are protected in a tangible manner until their applications are filed.



# PATENTS THAT PROTECT and PAY

Advice free. Terms reasonable. Highest references. Best results.  
Send sketch or model for FREE examination and opinion.

BONDED and recommended Patent Lawyer in the Rand-McNally Directory of Bankers and Attorneys Published by Rand-McNally & Co., Chicago, Ill. Recommended Patent Attorney in the Bankers Register and special list of selected lawyers published by the Credit Company, Pontiac Building, Chicago, Sharp & Allen's Directory of Lawyers and Bankers of Philadelphia, Martindale's American Legal Directory of New York City, and the Con. P. Curran Directory of Bankers and Lawyers of St. Louis.

**ALL BUSINESS GIVEN PROMPT AND PROPER ATTENTION**

A large list of strong recommendations furnished free

**WATSON E. COLEMAN, Patent Lawyer, 624 F St., N.W., Washington, D.C.**

## Money in Patents

Manufacturers are always looking for inventions. All patentable ideas should be protected by a patent. (By a Registered United States Patent Attorney.)

The great majority of money making inventions are thought of by persons, I will term amateur inventors, and nearly always are some very small or simple thing, for the reason that a large invention takes too much time and money for the average person to produce. I have inquiries from all over the country, in which manufacturers and business houses are looking for patents in every line of industry. Owing to these inquiries I am about to put inventors in direct touch with manufacturers who want patents, and thereby find a ready sale for their invention, which, for results, is far more practicable than any other mode of assistance to inventors.

A book "How to get your patent and make your profits thereon," which contains general patent information, is free and I would be very glad to have you write me for a copy of it.

**MANSSELL F. MILLS**

Registered United States Patent Attorney

244 Commercial National Bank Building, WASHINGTON, D. C.

### A Fortune to the Inventor

who reads and hears it, is the possible worth of the book we send for 6 cents postage. Write us at once.  
E. S. & A. B. LACEY, Dept. Y, WASHINGTON, D. C.

## PATENTS

**C. L. PARKER**  
Formerly Member Examining  
Corps, U. S. Patent Office  
**PATENT LAWYER**  
210 MCGILL BLDG.  
WASHINGTON, D. C.

Patents, Trade Marks, Copyrights, Patent Litigation

Handbook for Inventors, "Protecting, Exploiting and Selling Inventions" sent free upon request.

## PATENTS THAT PAY. 2 BOOKS

Protect Your Idea

FREE

\$600,000  
MADE BY  
OUR CLIENTS

Send data (model) for Search

E. E. Vrooman & Co., 871 F St., Wash., D. C.

Send for FREE BOOK { WHAT TO INVENT  
WHAT NOT TO INVENT  
HOW TO SELL YOUR PATENT

Copies of nearest Patents and report in every case without charge  
H. L. WOODWARD, 9th and G Sts., WASHINGTON, D. C.



## Models and Supplies

We make working models of any description and material, also dies, tools and sheet metal stampings. Send your drawing or sample for estimate. Write for catalog of gears and model supplies.

The Pierce Model Works, 3405 Pierce Ave., Chicago, Ill.

# PATENTS SECURED OR FEE RETURNED

Compare My SERVICE and TERMS with Those of Any First Class Attorney

Send Sketch, Photograph, or Model of your invention for an ACTUAL SEARCH of the Records of the Patent Office and report as to patentability — FREE. I give every detail of every case my closest personal attention and do not entrust your interests to assistants. Impartial advice on your ideas. I help you sell your patent. Terms moderate. My 90-page book tells what inventors should know before they apply for a patent.

**GEORGE P. KIMMEL, Patent Lawyer**, 200 Barrister Bldg. Washington, D. C.

Latest and Most Complete Patent Book Ever Published for Free Distribution

WRITE FOR IT



# Wanted—Ideas Inventors! Send for these Remarkable FREE BOOKS, Today

Complete and full information about patents, everything the inventor or manufacturer should know, has been included in these books. Never before has such an inexhaustible fund of valuable information been at the inventor's disposal. Regardless of the fact that the compilation of this information cost us thousands of dollars, we will send to all interested persons, any or all of these books, entirely without charge or obligation.

## “Millions In Patents”

This volume, 192 pages, tells the story of the romance of invention. The brain of the inventor is the magician that has made the ancient fairy tales come true. Millions have been paid for a hook, fortunes have come from a toy. Read “Millions in Patents,” and you will realize that this country and all the nations of the world are ready to enrich you beyond your wildest dreams if you can contribute one useful or amusing thing.

## “What Is a Trademark?”

It is not an exaggeration to say that billions of dollars have been made out of trademarks, labels and copyrights. He who can fashion a trademark or design a label which will make a product stand out above all similar products, is indisputably a genius for whose brains the world offers almost unlimited money.

## “Foreign Patents”

A good invention is bought not by one country but by the world. “Foreign Patents” shows you how the inventor may be paid by other countries and other peoples, as well as by this nation, for his ideas and his inventions. It explains how we, through our representatives in the capitals of the world, maintain for your benefit an endless chain of opportunities which, if you take advantage of them, will girdle the earth and make of your product an agent that may bring back to you rich rewards.

## “Inventions Needed”

This book, 256 pages, lays before you a description of the active and profitable field of invention. It tells you the inventions the world needs today, the devices manufacturers are seeking for their business, the ideas for which the public will pay big money. It gives great men's ideas of the most important things needed in inventions now. Science is the key to wealth, and this key can be turned best by the inventor. This book tells you why.

## “How to Get Your Patent and Your Money”

The man who invents needs the co-operation of the man who invests. This book, 132 pages, is a guide to the inventor. It describes, according to the teachings of our experience and the lessons of men made rich by patents, how the inventor may secure money; the right amount of money, for the device which his brain has constructed. If you have invented something and desire to learn what it will cost you to get your patent and what you must do to find your market, read this book.

## “Special Bulletin of Patent Buyers”

This bulletin, 64 pages, contains copies of hundreds of letters from wealthy men who are seeking to purchase patents. Next to the idea of the invention itself, the most valuable thing to the inventor is a hint of where there is a man ready to buy the invention or to finance the inventor so that his device can be readily marketed. We act as intermediary, without one cent of charge, between the man who invents and the man who invests.

We Secure Reliable Patents, Trade Marks,  
Copyrights, On Most Liberal Terms  
Ever Offered

Send Model or Sketch and Description of  
your invention for Free Search of  
the United States Patents

Rejected and Difficult Cases are Our Specialty

**RANDOLPH & CO.**  
600 F St., N. W., Washington, D.C.

**RANDOLPH & CO.,**  
WASHINGTON, D. C.

Gentlemen: Please send me, without obligation  
on my part, the books indicated on margin of this  
coupon. (Write on margin of coupon, names of  
books desired.)

NAME.....

STREET.....

CITY.....

STATE.....

# WAR INCREASES DEMAND FOR INVENTIONS

*Foreign Factories Closing—America Becoming Factory for the World. Manufacturers Must Have New Inventions*

**T**HE tide is on for American-made goods. War conditions are closing factories in Europe. Our manufacturers must not only continue to manufacture the goods they have been making in the past, but they must now manufacture articles to take the place of the thousands of things that have been made by foreign manufacturers in the past, for sale both here and abroad. They must have new inventions because they cannot manufacture articles that are covered by patents held by foreigners.

American manufacturers appeal to American inventors to get busy. Nothing hard or specially unusual is wanted—just everyday things—new things to be used here and abroad and improvements in old things. Improvements that will do the work better or that will cost less are in demand.

We are advertising in newspapers for manufacturers to consult us if they wish to buy patents. Letters are constantly coming in from all over the country requesting patents of all kinds. Some say just what they want and others want any good invention. These names and addresses are conveniently arranged and are given to our clients free of charge. The inventions that are wanted are given in our book, "What to Invent." Send for it and also our book, "How to Obtain a Patent," both FREE. Send us a rough sketch of



**Jewelry Box Sold Immediately After Filing Application**

any invention you have in mind. It may be just what is wanted. We will send our free opinion regarding patentability.

A New York company wants U. S. or foreign patents on inventions for automobiles and

mail-order articles. A Lockport company wants household and office articles and assures a splendid outlet. An Indiana company just asked for wood inventions, as ironing boards and other household articles, farm gate and window screens. A New York



**Gas Stove Air Mixer. Patented Throughout World and Capitalized \$300,000**

man wants dish washer, odorless garbage can and mail-order articles.

These are only a few of the thousands of requests for the hundreds of things given in our lists. Why don't you write for our free books and learn what manufacturers are asking us for and how to protect your ideas.



**Improved Clothes Horse Has Ready Sale**

**Chandlee & Chandlee**  
969 F St., Washington, D. C.

PATENTS AND TRADE MARKS

**LANCASTER & ALLWINE**

201 OURAY BLDG., WASHINGTON, D. C.  
BOOK INVENTIONS—PATENTING & PROMOTING FREE

Our co-operation with an inventor is, FIRST, to help him establish his rights before he discloses the idea to ANY attorney; SECOND, to give a frank opinion whether it will pay to patent his idea, based upon our extensive knowledge of manufacturers' wants and facilities; THIRD, to obtain for him a patent which is in reality a valuable monopoly; FOURTH, to advise and assist him in the profiting by outright sale, territorial grants, obtaining royalty, or independent manufacturing of the invention; and FIFTH, aiding him to so profit by conferring with manufacturers, investors or distributors of machinery.

Before sending a sketch to anyone, sign, witness, and deposit in our fireproof vault our document.

**EVIDENCE OF CONCEPTION**  
AND ESTABLISH YOUR RIGHTS

**Models and Gears**

**Experimenters—Inventors**

Developing inventions and making working models our specialty. Well equipped shop and staff of experts at your service. Carry complete stock of gears. Shipments same day order received. Send 4c stamps for booklet of Investors' Supplies.

UNION MODEL WORKS, Est. 1882, 121 S. Clark St., CHICAGO

**INVENTORS!—"Let Us Be Your Factory"**



We manufacture Special Machinery, Patented Metal Specialties of all kinds, Electric Articles, Hardware, Contract Manufacturing, Development, Sample Work. You get the advantage of our splendid equipment, up-to-date methods and wide experience. **We Do It All.** Tools, Dies, Stampings, Lathe, Screw Machine Work, Milling Machine Work, Metal Spinnings, Metal Drawings, Castings, Plating of all kinds, Enameling, Japanning, Tinning, Galvanizing, Wood and Metal Patterns, Drafting, Designing, Blue-print Work. Send sample for expert advice. **Our 25c book free**, containing tables and valuable information. **Write for it today.** Address:

**THE EAGLE MFG. CO., 1604 Blue Rock St., CINCINNATI, O.**

Please Mention Popular Mechanics

**PATENTS SECURED THROUGH CREDIT SYSTEM**  
Free search. Send sketch. Booklet and "How To Sell Your Patent" FREE. **WATERS & CO., 4281 Warder Bldg., Washington, D. C.**



**MECHANICAL SUPPLIES AND MATERIAL** of all kinds. EXPERIMENTAL AND LIGHT MACHINE WORK to order. 132 MILK STREET, BOSTON



**BRASS GEARS**

Cut by an entirely new process. The most accurate made and at prices that cannot be equalled by others. Every gear has a hub, center painted ebony black, edges turned true, highest grade rod brass, and much heavier than others. We carry the largest stock in the world and every gear listed is always shipped on date of order.

SEND FOR CATALOGUE  
**CHICAGO STOCK GEAR WORKS**  
16 S. Fifth Av. Chicago

**Sharpen Your Safety Blades With a Stag Sharpener \$1 POST PAID**

The only one of its kind. Note wheel in holder; Sets blade always at proper angle. Simple, Easy to use; Sharpens any safety razor blade. **GUARANTEED.** Will last a lifetime. Highest Awards at Panama-Pacific Exposition. Complete nickel plated holder, barber's hone and strap in neat case, \$1.00. Money back if dissatisfied.

The Stag Co., 54 S. State St., Chicago, Ill.

**Agents and Dealers Wanted**

**3 1/3c a Day**

now buys a dazzling Lachnite Gem. Their brilliance is eternal—they stand fire and acid tests and cut glass like diamonds. Cost but one-third as much. Set in solid gold. The newest designs. Sold on Free Trial. See our new jewelry book. **Write for Big Jewelry Book** Your name and address is enough. No obligations whatever. Write today—now. **HAROLD LACHMAN COMPANY**  
12 N. Michigan Avenue, Dept. 9198 Chicago, Ill.



## Agents! 500% Profit

\$25.00 to \$50.00 a week that's what our agents are making selling our new metallic sign letters for office windows, store windows and glass signs. For a quick, easy money making proposition for agents, salesmen and sign painters, there is nothing to equal the selling and putting up of our new metallic letters and numbers. There is no experience necessary to put up these signs. Anyone can succeed and make money right from the start. We will send you full particulars and you will see how easy it is to make money in this business. One agent says: "Have already put up 14 signs in this little burg and more in sight. Your letters are the best thing I have seen in years. Will soon be in a position to buy in 5000 lots." Another says: "I am getting all the work I can do and the letters have given entire satisfaction everywhere." We are daily receiving such letters from agents who have started in the sign letter business. This is the only field that is not overcrowded. There is a big demand for window and glass signs in every town. You can sell to nearby trade or travel from town to town all over the country as you please. We would be pleased to send you a free sample and full particulars.

WRITE TODAY. ADDRESS

### The Metallic Sign Letter Co.

407 N. Clark Street, CHICAGO, U. S. A.

## AGENTS—Make \$100 to \$300



per month easy selling our new Triplicate Sauce Pan. Cooking utensil for 3 different foods on one burner. 400 Specialties—all whirlwind sellers. Write quick for exclusive territory and large catalogue.

AMERICAN ALUMINUM MFG. CO.  
Div. 5 61 LEMONT, ILL.

**Do You Shoot?** Send for Book—**A New Chapter in an Old Story**—the history of projectile arms from primitive times to the most advanced sporting arms of today. Concise and interesting. Contains several full page game pictures in color. Send 50 cents (less than cost of production) to  
REMINGTON ARMS-UNION METALLIC CARTRIDGE CO., 233 Broadway, New York City

## OWN A BUSINESS WE WILL HELP YOU.



"I made \$88.16 first three days," writes Mr. Reed, of Ohio. Mr. Woodward earns \$170 a month. Mr. M. L. Smith turned out \$301 in two weeks. Rev. Crawford made \$7.00 first day. See what they have done, judge what you can do.

### LET US START YOU

in Gold, Silver, Nickel and metal plating. Prof. Gray's new electro machine plates on watches, jewelry, tableware, and metal goods. Prof. Gray's New Royal Immersion Process latest method. Goods come out instantly with fine, brilliant, beautiful thick plate, guaranteed three to ten years. No polishing or grinding. Every family, hotel and restaurant want goods plated.

**PLATERS HAVE ALL  
THEY CAN DO**

People bring it. You can hire boys to do the plating as we do. Men and women gather work for small per cent. Work is fine—no way to do it better. No experience required, we teach you. Recipes, Formulas, Trade Secrets Free. Outfits ready for work when received. Materials cost about ten cents to do \$1.00 worth of plating. Our new plan, testimonials, circulars and **SAMPLE FREE.** Don't wait. Send us your Address anyway.

**GRAY & CO., PLATING WORKS**  
912 Gray Building CINCINNATI, OHIO

# Save 1/2 on Diamonds

Watches  Jewelry

Our Customers' letters continually prove this.

**A FIRM of over 60 years of unquestioned integrity is offering special diamond bargains right now. Exquisite gems which you can secure at prices you should not overlook. Read below the indisputable reasons that make these attractive prices possible. Then write for latest bulletin. Just issued.**

**We are diamond bankers. We loaned money to the former owners of the fine diamonds we now offer. The loans have not been paid. So we must sell the diamonds at a fraction of their proper value. You get the benefit.**

**Diamonds of the finest grade—beautiful, scintillating blue white gems—fully 50% below the normal figure. And fully guaranteed. Don't miss these great bargains. Write—write today for the latest bulletin.**

## Diamond Banking

Our business as diamond bankers enables us not only to quote you amazing low prices, but it also enables us to get hold of the very choicest gems—diamonds which were selected originally by purchasers only after long study and investigation. We have often offered stones which cost originally more than \$100 for \$25 or less. You should write at once for the bulletin with complete descriptions and prices—now ready to mail.

Under No. 362549 is a beautiful guaranteed perfect cut quality blue white gem, 3/4-3/8, 1/64 kt. in a lady's ring for only \$108.00, with a further loan of \$50 guaranteed. Try to match for \$200.

No. 256322 is a handsome 14 kt. tooth setting with 3/8-1/16 kt. blue white perfect cut diamond gem. Try to match it at \$100. We guarantee a \$50 loan. We'll let you have it at Unpaid Loan Price, \$49.

Then this cluster under No. 254689—it's offered at \$31.65 only because they are unpaid loan diamonds. It looks like a solitaire of full 1 1/2 kt. Try to match it at \$65. Hundreds of startling unpaid loan bargains are illustrated in our latest bulletin. Write for it now.

## Free Examination

### The DeRoy Money-Back Guarantee

provide for Everything as offered; Exact weight to smallest fraction; Quality, color, etc. Exchange at full price; Exact cash loans.

We will send prepaid the gem or the watch of your choice on approval. See it and approve it for yourself. Compare it with any other you ever have seen—satisfy yourself that the price we are making you represents a most remarkable achievement even for a 50 year old house as large as ours—over \$100,000 behind us. If not satisfied with article after examining it, return at our expense.



## Send the Coupon

For Latest Bargain Bulletin

Fill out the coupon and mail

it now—or send letter or post card

and get our big new bargain bulletin

absolutely free. No obligations of

any kind. Read our prices—then

decide yourself. See the exquisite

illustrations of the superb dia-

monds, watches, etc., you have

to select from. Write now.

**Jos. DeRoy & Sons**

Only opposite Post Office

198 DeRoy Building,

Pittsburgh, Pa.

Reference by permis-

sion—Farmers Dep.

Nat. Bank, Marine

Nat. Bank or any

Pittsburgh daily

Newspaper.

Name.....

Address.....

**Jos. DeRoy  
& Sons  
198 DeRoy Bldg.  
Pittsburgh, Pa.**

Gentlemen—Please send me absolutely free and prepaid your new Bargain Bulletin of diamonds, watches and other jewelry. It is distinctly understood that I assume no obligations of any kind.

Please Mention Popular Mechanics

# SEBASTIAN LATHES HIGH QUALITY LOW PRICES

If you delight in good tools you will delight in Sebastian Lathes. For 25 years we have built lathes, and lathes only, employing skilled labor always, and improving equipment and machinery every year. Sebastian Lathes are

## STANDARD FOR QUALITY—LOW IN PRICE

They are accurate, economical, simple and durable. Many re-orders and voluntary letters from users of Sebastian Lathes prove this. The Sebastian reputation is back of every Sebastian Lathe. You are judge and jury when you buy a lathe. We are not satisfied until you are. Look over the complete line in our new catalog. It shows Lathes for general repair work, garage and automobile work, etc.

When you buy a lathe, say "Sebastian"

ADDRESS (FOR THE CATALOG)

THE SEBASTIAN LATHE COMPANY, 107 Culvert St., Cincinnati, Ohio

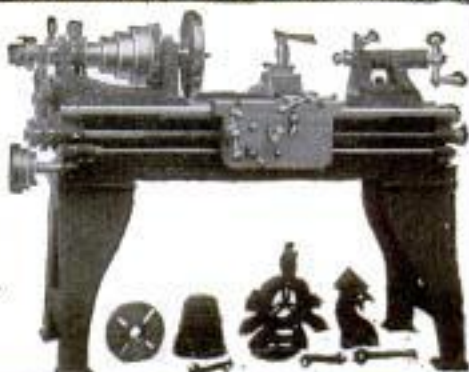

## A Constant Water Supply For Your Farm Home

Don't depend on a windmill or the back-breaking hand pump to fill your water tank. It's more reliable and economical to install a

## RIFE RAM

and be sure of a constant supply of fresh water, without fuel or attention. The Rife Ram operates by the flow of any stream having a fall of 3 feet or more and a supply of 3 gallons or more per minute. Will maintain air pressure system. Simple to install. Over 11,000 in use. Satisfaction guaranteed.

Write today for catalog and free estimate

**RIFE ENGINE CO.**  
3131 Trinity Building NEW YORK



DO YOU HAVE KNIVES TO GRIND, SILVER TO POLISH, SMALL TOOLS TO OPERATE, WASHING MACHINES OR WRINGERS TO RUN? LET THE RED DEVIL

DO YOUR WORK

Attached to any water faucet will develop up to 3 Horse Power according to size of pipe and water pressure. Only perfect small motor made. Improved bucket wheel construction.

6 in. Motor for Mechanics and Tradesmen, Washing Machines, 3/4 H. P., on 1/2 in. pipe, 80 lbs. water pressure; 1 H. P., on 3/4 in. pipe, 100 lbs. pressure, 2 in. pipe. Net price \$5, cash with order.

No. 1482—4 in. Motor for grinding, polishing, fans, sewing machines; for Doctors, Dentists, Druggists, etc., with emery, buffing wheel, silver polish and pulley, \$3.

No. 1483—4 in. Motor and pulley only \$2.50, cash with order.

Money back for any reason. Order your motor from dealer or from us. Send your water pressure and size of supply pipe. Active Agents wanted. Catalog free.

Only Motor to do this work



**DIVINE WATER MOTOR CO.**  
DEPT P. UTICA, N. Y.



## MOTOR DRIVEN BENCH SAW

Saws Wood and Soft Metals Indispensable and most economical. For shop or private use. Full description and circular on request.

**H. G. CRANE** Cypress St., Brockton, Mass.

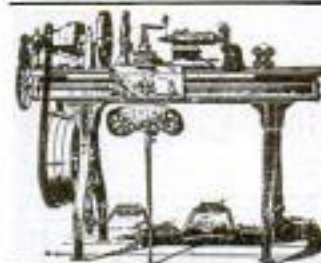

## LATHES

9 to 18-inch Swing

List price \$75 and up according to size. When ready to buy send for Lathe Catalog and prices.

**W. F. & John Barnes Co.**  
100 Ruby Street, ROCKFORD, ILL.

**A MEAN MOVIE MAN**—In the down-town district of Chicago, a certain man has a movie theater which had been in the habit of opening up at 9 a. m. and running continuously until midnight. It was profitable, but the owner is an alert manager and up to date. Recently he discovered that the difference between the cost of keeping open all night and what he was paying for watchmen was very little. And so he blossomed forth with an all-night movie which only shut down for an hour

## CRESCENT WOOD WORKING MACHINERY

is making money for a steadily increasing number of users who are satisfied with the excellent performance of these splendid tools. Send today for your Crescent catalog just off the press telling about our line of band saws, jointers, saw tables, planers, planers and matchers, swing cut off saws, disk grinders, shapers, universal wood workers, variety wood workers, hollow chisel mortisers, bench jointers.

**The Crescent Machine Co.**  
92 Columbia St., LEONIA, OHIO

## Small Engines

Our little guaranteed engines are unequalled for operating small machinery, washing machines, grinders, etc.

### SIEVERKROPP STARTER

\$15 SEAT STARTER FOR FORD CARS  
Shipped on trial. Send stamp for Booklet and Special Offer  
**Sieverkropp Engine Co., 1224 18th St., Racine, Wis.**

## JENKINS' BRASS BAND AND ORCHESTRA INSTRUMENTS

We save you money and give easy payments  
Biggest line of Band and Orchestra Instruments: Cornets, Trombones, Clarinets, Drums, Saxophones, Violins, Guitars and all wind and stringed instruments. Send for free catalog of instruments you want. We give a fifty lesson FREE certificate with each instrument. Tell us the instrument you wish to play.

**JENKINS MUSIC CO., 55 Jenkins Bldg., Kansas City, Mo.**

## The Deaf Hear!

Write for our big Introductory Offer on the latest scientific hearing instrument—the perfected, new

## 1915 Thin Receiver Model

**Mears Ear Phone** MANY times as efficient and powerful as the old model. 50 degrees of ear in 8 adjustments, instantly changed by a touch of the finger.

**Free Trial** Sold only direct from our New York office on trial at our expense. Test it for 15 days. It costs nothing if you do not want to keep it. Easy monthly payments if you wish, at the lowest net laboratory prices direct to you. Send for the Mears Booklet—FREE. Drop a postal for this booklet today.

**Mears Ear Phone Co., 45 West 34th Street, Dept. 1198, New York**



The A-1 carpenter,  
craftsman or  
mechanic



Is the man who has good tools, knows how to use them and how to take care of them.

### Carborundum Sharpening Stones

are found in the tool kits and on the work benches of thousands of just such workmen.

Carborundum Stones cut quick and clean—they hold their shape, they last and they do not fill or glaze—there is a Carborundum stone for every sharpening need.

*From your hardware dealer.*

*Let us send you complete catalog and  
"The Romance of Carborundum"*

The  
Carborundum Company  
Niagara Falls, N. Y.

Boston New York Philadelphia Pittsburgh  
Cleveland Cincinnati Grand Rapids Chicago  
Milwaukee Manchester, Eng. Reisholz, Ger.

## The Knurled Washer Gets Them

Those dinky little screws, so hard to set, are quickly and accurately started with this

### "Yankee" Ratchet Screw-driver

No. 15

The Knurled Washer turns the blade and starts the wobbly little screws, the hand meanwhile steadies the driver and holds the screw straight.

Then a Ratchet movement quickly drives the screw home.

A big time and trouble saver, for cabinet makers, electricians and all workers who use tiny screws.

### "Yankee" Ratchet Screw-driver

No. 15

Blade  $\frac{1}{8}$  in. diameter. Six lengths:

2 in. blade . . .	40c	5 in. blade . . .	55c
3 in. blade . . .	45c	6 in. blade . . .	60c
4 in. blade . . .	50c	8 in. blade . . .	70c

Your dealer can supply you

Mechanics and householders—write for  
"Yankee Tool Book." Automobilists—for  
"Yankee Tools in the Garage"—both Free.

NORTH BROS. MFG. CO., Philadelphia

**"YANKEE" TOOLS**  
Make Better Mechanics



**A Kit of Good Tools  
is the Mark of  
a Careful  
Work-  
man**



**B. & S. Tools are  
the Kind You Need  
for Precision Work**

You can be proud of your kit, if it contains B. & S. Tools, because they are so carefully made and thoroughly finished. They have built a reputation for long life and accuracy. Ask your hardware dealer about them. If he cannot give you our Catalog No. 26, drop us a postal for a copy.



**BROWN & SHARPE MFG. CO.  
PROVIDENCE, R. I.**



**10 CENTS  
worth of  
common  
ordinary  
KEROSENE**

or **Coal Oil** will keep this lamp in operation for **60 HOURS** and will produce **300 Candle Power**

of the finest, whitest and most efficient light ever known. Nothing to wear out or get out of order. **ABSOLUTE SATISFACTION** guaranteed.

**AGENTS MAKE \$25**

per week in their spare time. You can do the same. Send for our offer while your territory is open.

**KNIGHT LIGHT CO., 360 Knight Bldg., CHICAGO**

**NO WICKS  
to trim  
NO SMOKE  
NO SMELL**

or so, about daylight, for cleaning-up purposes.

To the surprise of some incredulous people, the venture proved a good one and the after-midnight attendance was actually profitable. It is a five-cent house and ere long the jobless and hard-ups, and others who hadn't the price or wanted to save the cost of going to a hotel, found in the warm room and comfortable chairs of the all-night movie a welcome refuge from the chill night wind, and only five cents to pay. Rapidly this class of patronage increased until the house was in danger



**Portable Cases  
FOR TOOL MAKERS  
AND MACHINISTS**

Twelve styles, felt lined drawers, solid brass trimmings, best of material, beautiful finish, low prices, satisfaction guaranteed. Ask for booklet of cases built for service.

**The Pilliod Lumber Co.  
SWANTON, OHIO**

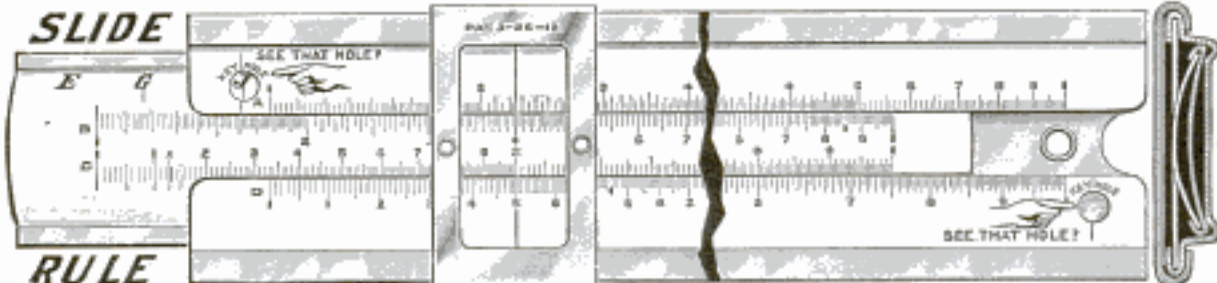

**"MAID" IN AMERICA RICHARDSON'S DIRECT READING ALL METAL SLIDE RULE**

The most wonderful calculating instrument ever offered to the public at a popular price. Frame made of solid Nickel, Scales Aluminum, no problem too intricate for its solution. Calculates interest and percentage, proportion, rule of three, will add and subtract numbers as well as multiply or divide them, square or cube numbers or extract the square or cube roots, etc.

Indispensable for merchants and cost estimators. For electricians it is a complete wire table in itself, for engineers it gives H. P. Engines, Pumps, capacity of tanks and cisterns, tensile strength of material, etc. The book, *The Slide Rule Simplified*, free, 64 pages, 100 illustrations, makes it easy for anybody to operate. Price \$2.50, \$4.00 and \$5.00 postpaid to any part of the world. Leather case fifty cents extra.

**FOR CHRISTMAS PRESENT** nothing better could be selected, because the wide application of the instrument will find its use by any person. Bring your boy or girl up to learn the use of this valuable instrument, that life may be more easy for them in time to come. Space will not permit of telling all this wonderful instrument will accomplish.

Address **GEO. W. RICHARDSON, Ex-Chief Electrician U. S. Navy, 4218 West 24th Place, CHICAGO, ILLINOIS**

## Build An Ice Boat This Fall

EVERY young man would like to own an ice boat. There is nothing better for healthful winter sport, and you will get great satisfaction and add much to your knowledge of tools and skill in carpentry by building one. An ice boat can be built inexpensively and simply, and our booklet, "The Professor and the Saw," gives full directions with plans and specifications. It also tells how to build other useful things and is full of valuable information for the amateur carpenter.

# SIMONDS SAWS

are ideal for all uses, and are used by professional and amateur carpenters everywhere. They run easily, hold their edge and set, cut fast and clean with least muscular exertion, and don't bind or scrape. They are the product of the finest material and most expert workmanship, are backed by over eighty years' experience in making cutting edge tools, and are absolutely guaranteed.

*"If you want saws that cut like diamonds,  
Ask for saws that are branded Simonds."*

We make a saw for every use and will supply you if your dealer can't. Write for Booklet No. 11.

**Simonds Manufacturing Co.**

*"THE SAW MAKERS"*

5 Factories Fitchburg, Mass. 11 Branches

## THE AWL YOU WANT

See That Reel



In the genuine MYERS \$1.00 "Look Stitch" Sewing Awl with the exclusive feature. See thread reel in front of handle under the finger tip. Natural tension. Sews heavy or light material, diamond point, full grooved needles used to protect the thread when sewing. C. A. MYERS COMPANY, 6339 University Ave., Chicago, Illinois

## TOOL CASES

For Up-to-Date TOOLMAKERS and MACHINISTS

We carry the finest and most complete line of mechanics' toolcases and tools in the country. We guarantee to please you or refund money. Write for free catalogue.

**J. M. WATERSTON**

177 Jefferson Ave., E. Detroit, Mich.

## Cuts Glass Circles



### "Red Devil" Circular Glass Cutter

makes it easy to cut glass in neat curves and circles for mirrors, headlights, reflectors. Has 2 extra hand-honed cutting wheels in head. Sample No. 263 sent for \$1.25. Booklet free.

**SMITH & HEMENWAY CO., Inc.**

161 Chambers Street

New York City

# GOODELL PRATT

1500 GOOD TOOLS



**Stuck!**

Screw half sunk in hard wood and stuck. Not if Mr. Punch first sinks a hole.

## You Push He Twists

Zip! and there's your hole. Through solid oak as you'd push a pencil into cheese. Never splits the wood like a gimlet. Starts a screw straight. Great for putting up curtain or bathroom fixtures. A joy to man or boy and makes women good carpenters.

# Mr. Punch

Known to mechanics as our Automatic Drill No. 185. You place the drill-point and push—handle rebounds at each stroke. Made solidly of nickel-plated brass. In handle are eight tool-steel drill-points, seen through numbered holes. A turn of cap releases any drill. We make 1500 good tools, of which these are a few:

Lathes	Punches
Hack-saws	Drills
Micrometers	Vises
Saw Sets	Levels
Gauges	Bit Braces
Grinders	Calipers
Screwdrivers	Squares

Send for a book listing 15 tools useful in the home

Buy Mr. Punch at Hardware Stores. If your dealer can't supply, send \$1.50 to us.

**GOODELL-PRATT COMPANY**

*Technique*

Greenfield Mass.



Please Mention Popular Mechanics



## What is "Standard?"

A standard is that which is established and fixed as the measure of quantity, weight extent, value or quality.

Starrett Tools are Standard Tools. That means there is no slightest variation from the standard measures.

Oneten-thousandth of an inch measured by a Starrett instrument is exactly one ten-thousandth of an inch the world over.

# Starrett Tools

on account of their accuracy proclaim the good workman. Modern methods of manufacture and inspection require the utmost accuracy and workmen are obliged to have the instruments for such work and skill in their use.

Starrett Tools are recognized by every superintendent in the land as tools of standard accuracy.

Starrett Tools include 2100 styles and sizes of fine instruments—steel rules, tapes, squares, levels, calipers and dividers, hack saws, micrometers, gages, speed indicators and many others.

For sale at leading hardware stores. Send for Free Catalog No. 20-A. P.

## THE L. S. STARRETT CO.

"The World's Greatest  
Tool Makers"  
Athol, Mass.

New York Chicago London  
Chicago

The L. S. Starrett Company

Member of the American Society  
of Mechanical Engineers  
MEMBER OF



Please Mention Popular Mechanics

## BOY SCOUTS—ALL BOYS —TRY 3 IN ONE FREE

"Attention!" We want every Boy Scout and every other boy in America to give 3-in-One a good hard test, *absolutely free*.

Write *today* for a generous free sample and the valuable free 3-in-One Dictionary. 3-in-One has been for over 17 years the leading bicycle oil. It makes all bearings run much easier and prevents wear—cuts out all dirt and never gums or clogs. It cleans and polishes, prevents rust on all metal parts.

3-in-One is also the best gun oil. It oils exactly right trigger, hammer, break joint—cleans and polishes barrels, inside and out; polishes the stock like new, too.

Always use 3-in-One on your ice and roller skates, fishing reels, scroll saws, golf clubs, cameras and every tool you own. A few drops does the work. 3-in-One will keep your catcher's gloves soft and lasting, also prevents rust on your catcher's mask.

3-size bottles at all good stores: 10c, 25c and 50c. (The 50c size is the *economical* size.)

Write for the free sample *today*.

**3-in-One Oil Co.**  
42 CNG. Broadway, NEW YORK



of getting a bad name. Evidently something must be done or the all-night sign taken down.

The manager was equal to the occasion, however. He went out and purchased the fiercest, most blood-curdling horn known to automobile row, which goes into action every 10 minutes, producing a veritable explosion of noise. The report is that no sleeper's nerves have thus far been able to endure more than the fourth blast. As for the patrons who do not come to sleep, they are expecting the call to life and find additional entertain-



## Tool Cases for Toolmakers and Machinists

Keep your tools orderly arranged in a Gerstner Portable Tool Case. There's a place for every tool in one of the felt lined drawers. Every up-to-date mechanic needs one and you'll find our Cases the best built, neatest and most practical on the market. We guarantee to please or refund all money. Write for our free booklet.

*Gerstner & Sons*

Mfrs. of Mechanics' High Grade Tool Cases  
808 Columbia St., DAYTON, OHIO

## Rent This Level 9 Months — Then It's Yours

### BUILDERS and CONTRACTORS

High price and cash payments are eliminated. For the first time it is possible to obtain a high grade Level on terms so easy that you can not afford to be without one.

#### Convertible Level

Besides its use as a Level, it can also be used for running straight lines, getting angles, taking vertical sights, etc., for which ordinarily a Transit is required.



For more than fifty years Aloe's surveying instruments have been recognized as standard instruments. This Level is offered to you with an absolute guarantee that is backed by a **ten day free trial offer.**

#### FULL PARTICULARS

and details of our extraordinary selling plan will be sent on request

**A. S. Aloe Co., 515 Olive St., St. Louis, Mo.**



# WHITING-ADAMS BRUSHES

Panama-Pacific  
International Exposition 1915  
Awarded Gold Medal  
**THE HIGHEST AWARD**

FOR SALE BY  
**Dealers Everywhere**  
Send for illustrated literature telling about  
WHITING-ADAMS BRUSHES

MANUFACTURED ONLY BY  
**John L. Whiting-J. J. Adams Co.**  
690 to 710 Harrison Avenue  
BOSTON, U. S. A.

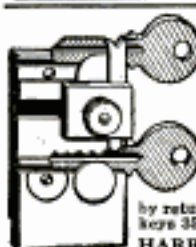

Duplicate Keys for all Pin Tumbler  
Locks can be made in a minute with  
The Harrison M. L. P. Key Filing Machine

Invaluable for Machinists, Building Superintendents,  
Hardware and Repair Shops, Locksmiths, Carpenters,  
Electricians, Garages, etc. Anyone can make a perfect  
duplicate key without injuring the original. Every machine  
unconditionally guaranteed. Money refunded if  
not entirely satisfactory. Price \$3.00 net. Send us P.  
O. order or N. Y. draft and receive the complete machine  
by return Parcel Post. Special diamond shaped files for angular  
keys 35c each or 4 for \$1.00. Send for circular.

HARRISON & COMPANY, 81 NEW ST., NEW YORK

**BILLINGS & SPENCER**

**TOOLS**



In a tight place  
the best is not  
too good.

HARTFORD, CT.

Wrenches  
Pliers  
Sc. Drivers  
Hammers  
Ratchets  
Wrench Kits  
Tool Kits

**UNION  
Tool Chests**

Over 15 Different  
Styles and Sizes

Plain or Quartered Oak  
or Leatherette covered.

Design, material and workmanship of the best.

**Let Us Save Your Tools and Money**

If dealer does not carry, we have a special offer that will  
interest you. You cannot afford to go without a Union.  
Chest guaranteed to meet your entire approval or money back.

WRITE TODAY—CATALOG FREE

**UNION TOOL CHEST WORKS**  
22 Railroad St. Rochester, N. Y.



**Stanley  
Tools**  
"ODD  
JOBS"  
No. 1

**T**HIS TOOL is well named, as with its use one can  
do all ordinary jobs with the addition of only a  
saw, a hammer and a plane.

It combines a Level, Plumb, Try Square, Mitre  
Square, Bevel, Scratch Awl, Depth Gauge, Marking  
Gauge, Mitre Gauge, Beam Compass and a One Foot  
Rule. The rule is graduated in sixteenths of inches.  
Just about the handiest and most convenient little tool  
you ever owned.

**Price .75 Each**

If you cannot procure this tool from your Hard-  
ware Dealer, we will send same postage prepaid to  
any part of the United States upon receipt of price  
mentioned above.

—ADDRESS—

**STANLEY RULE & LEVEL CO.**  
NEW BRITAIN, CONN. U.S.A.

**Quick Drilling  
Where You Want It  
—by Electricity**



Saves time  
and labor.  
It doubles  
efficiency.

Attaches to any  
Electric Light Socket.

**A Portable  
Machine Shop**

Handiest device ever  
known for drilling, tapping, grind-  
ing valves, sharpening tools, etc.—  
quickly and easily. Does away with  
tiring hand work.

**TEMCO**  
**Electric Portable Drill**

Weights only 11 pounds. Perfect balance between  
handles makes it seem doubly light and free to  
place and hold. Has famous Temco motor. Con-  
nect with any lamp socket (A. C. or D. C.)  
Costs only 1 cent per hour to run. Reverses in-  
stantly on full speed. Changes tap to drill in one  
minute. Has multitude of uses. Saves cost quickly  
in time and hard work. Guaranteed not to burn out.

**Ten Days' FREE Trial**

Mail postal or letter quick—get descriptive CATA-  
LOG FREE. Address

**The Temco Electric Motor Co.**  
120 Sugar St., Leipsic, Ohio

Special Designers and Mfrs. of 1-50 to 1-6 H.P. Motors

Please Mention Popular Mechanics

# PREST-O-LITE

for  
**MOTORCYCLES**



## Economical Efficient and Brilliant Light

Prest-O-Lite gives perfect riding light— is as sturdy as your motorcycle itself. It stands the jolts, needs no attention you yourself cannot give. Practical, simple, and trouble-proof.

Considering its simplicity and freedom from trouble, it is at once the most convenient and the most economical lighting system for motorcycles.

### Complete Equipment for Regular Service

Nearly all dealers make this typical equipment combination: "Prest-O-Lite, a lamp, and a mechanical horn." Costs less to buy and less to use.

Your name and address on the margin of this page will bring complete information on motorcycle lighting. Get our valuable free book. Write today.

### The Prest-O-Lite Co., Inc.

The World's Largest Makers of Dissolved Acetylene  
265 Speedway Indianapolis, Indiana  
*Prest O-Lite Exchange Agencies Everywhere*

## MAKE YOUR BIKE A MOTORCYCLE

at a small cost, by using our attachable outfit. Fits any Bicycle. Easily attached. No special tools required.

### "Used His Four Years"

*Harry A. Hyatt, of Boreas River, New York, writes: "About four years ago I received my motor attachment, and wish to say that I am satisfied with it in every way, for it has certainly given me good service. Anyone wanting a motorcycle or attachment, I would recommend them to the Shaw Manufacturing Co."*

**FREE BOOK** Write today for bargain list and free booklet, fully describing the SHAW Bicycle Motor Attachment. Motorcycles all makes, new and second-hand, \$35.00 up.

**SHAW MANUFACTURING CO.**  
Dept. 6 GALESBURG, KANSAS



## THE MOTOR-BOB

Dept. 1, BUFFALO, N. Y.

**BOYS,  
YOU  
CAN  
BUILD  
A  
REAL  
LITTLE  
AUTO  
LIKE  
THIS!**



Send a quarter for a set of our plans and instructions, with a large working drawing and price list of parts. They make it easy for you.

ment and fiendish satisfaction in watching the frantic actions of the sleepers. In fact, the horn is a distinct novelty and a positive attraction.



### Convert Your Bicycle into a Motor-Cycle

Motor fits any wheel. BEST, MOST RELIABLE. Best hill climber. More STEFFEYS in use than all others. Stamp for circulars. STEFFEY MFG. CO., 5007 Brown Street, PHILA., PA.



### MOTORCYCLES \$25 to \$175

All reliable makes. Some as good as new. Write today for full particulars and catalog. We repair and exchange motorcycles.

HARRY R. DEER CO., 888 McLaren Ave., St. Louis, Mo.

**Miami** Reg. U.S. Pat. Off.  
**Power Bicycle**

"100 Miles for 10 cts."  
Model 15, \$125  
Model 16, \$140  
SAFE, SILENT, CLEAN  
WRITE FOR CATALOG  
MIAMI CYCLE & MFG. CO., 180 Noble Ave., Middletown, O.

## Garage \$69.50

10x12feet "Steelcote" Edwards ready-to-use garage, \$69.50 complete. Factory price. Fireproof. Portable. Quickly set up. All styles and sizes of garages and portable buildings. Send postal for illustrated catalog.

THE EDWARDS MFG. CO.  
320-370 Eggleston Ave., Cincinnati, O.



Please Mention Popular Mechanics

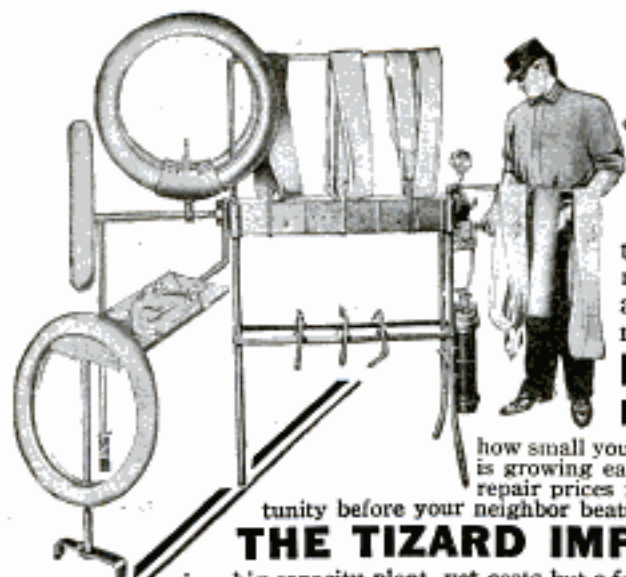

## Be a Tizard Tire Doctor

Enter the best-paying trade—tire repairing, 10,000,000 tires in service—thousands being sold each day. Demand for tire doctors growing—some one must look after the tires in YOUR locality—will YOU be the man to reap the enormous profits?

**MAKE \$40 TO \$70 A WEEK BEGIN NOW**

Get out of the wage class—OWN your business—make BIG money. No matter how small you start, a vast opportunity awaits you. The automobile industry is growing each day—demand for tire repairmen far exceeds the supply—so repair prices remain HIGH. Make \$2,500 to \$4,000 a year—grasp the opportunity before your neighbor beats you to it.

### THE TIZARD IMPROVED STEAM VULCANIZER

is a big-capacity plant, yet costs but a few cents a day to run. It vulcanizes SIX inner tubes and THREE casings at one time. Is equipped with work-bench, two tire racks, tools, etc.—it's complete, ready to produce the minute installed and the price is low.

#### Our Help-You-Plan Assures Success

When you buy a Tizard Vulcanizer, you get business insurance. With the machine, we give you, FREE, business letterheads and envelopes printed with your firm name, merchandising plans, service data, co-operation, which will insure you SUCCESS. We furnish also for starting you out, business cards, follow-up system, price list folders—a system of advertising to bring you the business. In short, we co-operate with you and stand back of you.

#### WRITE FOR OUR BEAUTIFULLY ILLUSTRATED BOOKLET

and learn about this wonderful business. This handsome book reads like a story—it's an education itself. Tells how rubber is gathered in the Brazilian jungles, how manufactured and made into tires. It describes and pictures various tire injuries and best methods of repair. Let us tell you about our new help-you-plan—nothing like it elsewhere. Send the coupon—a letter or postal will do as well—and DO IT NOW while the opportunity in your territory is waiting.

Tizard Manufacturing Company, Dept. 208, Omaha, Neb.

Tizard  
Mfg. Co.,  
Dept. 208,  
Omaha,  
Nebraska

Please send free  
and prepaid your il-  
lustrated book and de-  
tails of your HELP-ME  
plan.

**Send This Coupon Today**

Lead pencils were first made in England in the Elizabethan era. As a matter of fact, they were not lead pencils at all, but graphite pencils, like those now in use.

### Indian Motorcycles

One, two and three speed Gears with cradle spring frame. Send for catalog.

HENDEE MFG. CO., 711 State Street, SPRINGFIELD, MASS.

### \$4.00 SEISS

Powerful, Commanding, Warning Signal. Operated by touch of hand, either right or left—for short blast or long, continuous sound, same as a Motor-Driven Horn.

THE SEISS MFG. CO.  
439 Dorr St., TOLEDO, O.

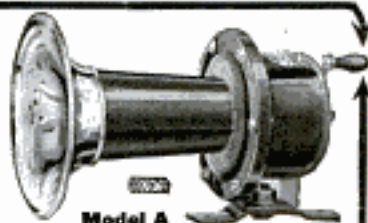

Model A

## HENDERSON 4-CYLINDER MOTORCYCLE

1916 Models

Single-Speed **\$265** Two-Speed **\$295**

HENDERSON MOTORCYCLE CO.

1160 Cass Ave.

DETROIT, MICH.

5 H.P.

### 1915 Peerless Motorcycle

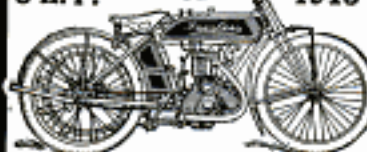

with Free Engine, Bosch Magneto, together with the best there is in Motorcycle construction, Power, Speed, Silence, Endurance, and those wearing qualities so essential for low cost of maintenance.

8 MILES FOR ONE CENT

Agents Wanted—Liberal Discount

PEERLESS MOTORCYCLE CO., 179 Huntington Ave., Boston, Mass.



## Don't Throw Away Your Worn Tires

For over three years European motorists have been getting from 10,000 to 15,000 miles out of their tires by "half-selling" them with Steel Stud Treads. In eight months 20,000 American motorists have followed their example and are saving \$50 to \$200 a year in tire expense.

**We ship on Approval** without a cent deposit and allow you to be the judge.

**Durable Treads** double the life of your tires and are sold under a signed guarantee for 5,000 miles without puncture. Applied in your own garage in thirty minutes.

**Special Discount** offered to motorists in new territory on first shipment direct from factory. A postal will get full information and sample within a week. Size of tires. Don't wait—write today. Address nearest factory office.

**THE COLORADO TIRE & LEATHER CO.**

1144 Tread Bldg., Denver, Colo.

Dept. K 44, Box 228, Chicago, Ill.

Suite 4411 Woolworth Bldg., New York, N. Y.

**All Steel Garage \$59<sup>25</sup>**

**The Butler "Round Ruf" SIZE 10 x 14**

Full protection and at least cost. Fire-proof. Corrugated. Easily put up. Attractive in appearance. Portable. Useful as a machinery, tool or storage building. Additional sections to increase length furnished at any time. If your dealer does not handle, write us for full information and prices on other sizes.

**BUTLER MFG. CO.**  
204 Butler Bldg.

KANSAS CITY, MO.

Grows Bins, Tanks, Silos. Write for booklet on Street Fronts and Box Furniture.



# Build Your Own Cabin Cruiser

You Save Over Two-Thirds the Cost

We furnish all materials, cut to shape and fitted. We do all the difficult part of the work. Thousands of amateurs have erected and finished our knocked-down boats. Full illustrated instructions cover every step of the work. You may finish and fit out the boat as simply or elaborately as you wish. Start your cruiser this fall. We furnish any length from 25 to 41 feet, knocked-down cruiser frames from \$90 to \$195.00. Complete knocked-down cruisers, all materials and fittings, everything (except the paint) from \$180.00 to \$395.00.

There's pleasure, profit and education in boat building. Send for our free boat catalog of canoes, rowboats, launches, sailboats and cabin cruisers, sold either knocked-down or finished ready to run.

## BROOKS MFG. CO.

Largest and oldest concern of its kind in the world  
8211 Brooks Ave., SAGINAW, MICH., U. S. A.

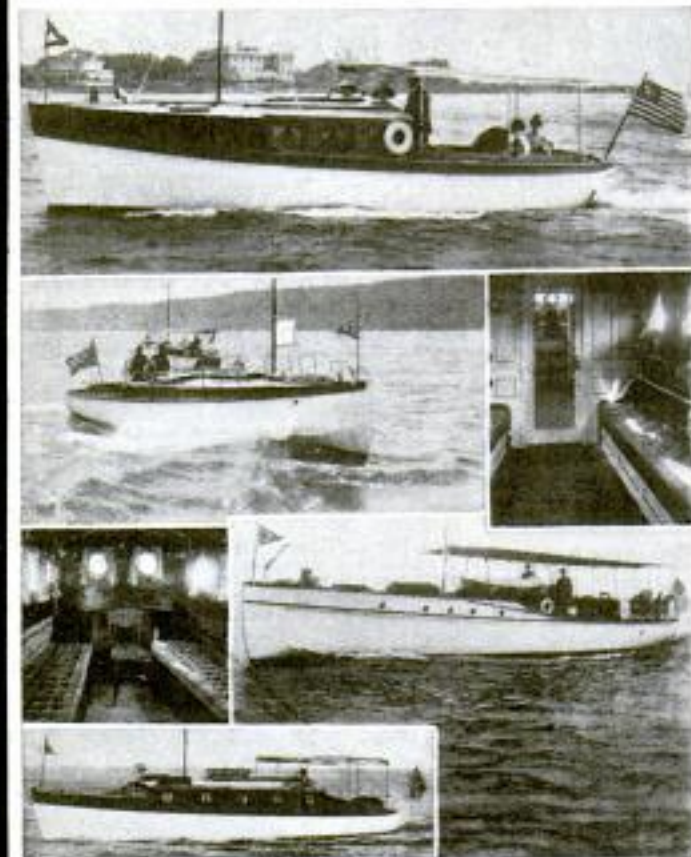

## Cushman Light Weight Engines

Easy to move around from job to job, or may be attached to other machines (moving or stationary) to drive all or part of the machinery. 4 H.P. weighs only 190 lbs.; 8 H.P. only 320 lbs. and 20 H.P. only 1200 lbs. No heavy bases or large fly-wheels. Steady and quiet, because of sensitive Throttle Governor and perfect balance.

Double Cylinder  
8 H.P.  
Weight  
320 lbs.

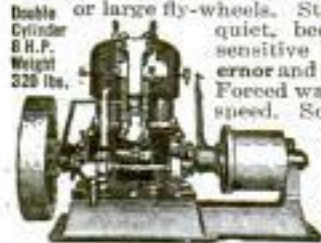

Forced water cooling system. Run at any speed. Schebler Carburetor and Friction Clutch Pulley. Not a cheap engine, but cheap in the long run.

Ask for Engine Book  
Cushman Motor Works  
882 N. 21st St., LINCOLN, NEB.



Handy Truck

4 H.P.



## RELIABLE POWER

Nearly 100,000 Galloway engines in daily use. Large bore, long stroke, heavy weight. Built for hard, continuous motor-users' satisfaction. All sizes, prices, styles. Modern design, few parts. Best materials, skilled labor. Positively not overrated. Sold direct. Engine book free. Postal gets it. Investigate before you buy, compare value we give and you'll have no other. Address:

Wm. Galloway Co., Box 965 Waterloo, Iowa

9875

7750

3950

3475

2675



## WATKINS' SPECIAL MOTORS

3 H. P. Single Cylinder . . . 30 lbs.  
4 H. P. Double Cylinder . . . 46 lbs.  
12 H. P. Four Cylinder . . . 100 lbs.

A strictly HIGH GRADE Motor that will give CONSTANT and EFFICIENT service. Especially adapted for CANOES and LIGHT BOATS. Aluminum base, copper water jacket, steel shaft, bronze bearings.

THE WATKINS MOTOR CO.

837-839 West Sixth Street CINCINNATI, OHIO

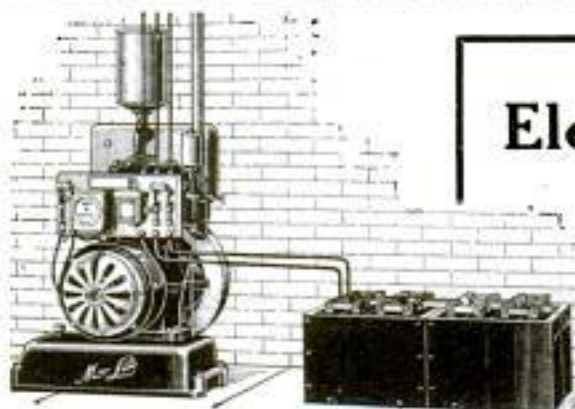

(449-4R)

*Mor-Lite*

## Electric Lighting Plant

For Farms and Country Homes

Semi-Automatic Self Contained

Fairbanks, Morse & Co.

New York CHICAGO San Francisco

and other principal cities



Buy  
Reliable  
Power

People who are familiar with the construction and the reliable operation of International Harvester engines—Titan or Mogul—often grow enthusiastic and declare that you would have to take all the good points on all other engines and combine them, in order to get the equal of the engine with the I H C mark.

Strictly speaking they are wrong. Such a composite would still not equal any engine in the I H C lines for it could not include the famous individual features that you find on no other engine made.

### International Harvester Engines

long ago outstripped every other brand or make or manufacture, in sales and in popularity.

Whatever your use for engine power, you cannot afford not to consider International Harvester oil engines—Titan and Mogul. Made in all styles—built for all power purposes—in sizes from 1 to 50 H.P. They run on the cheapest or most convenient fuel.

Ask us to do these two things—send you an interesting catalogue showing the I H C engine features, and tell you the name of the nearest I H C dealer.

**International Harvester Company of America**  
(Incorporated)  
16 Harvester Building Chicago U S A

## FARM VIM MARINE ENGINES

Get a VIM Engine and save money. VIM Midget 1 1/2 H.P. Farm Motor shown below does all the chores—churning, washing, pumping, separating, spraying, etc. Works over easily. No complicated parts. Weighs only 15 lbs. Water cooled, automatic lubrication. Comes ready to run. Guaranteed. Full line marine engines 5 to 27 H.P., 1, 2 and 3 cyl., 1 speed, planetary and heavy duty types. Gasoline or kerosene. Double ignition. Non-backfiring. Strong, simple, accessible—absolutely dependable. Built for a lifetime. The boat-builder's stand-by, the boat-owner's pride. When writing for catalogue, please mention whether interested in stationary or marine engines, or both. Ask for attractive agency offer.

The Vim Motor Company, 211 Water St., Sandusky, Ohio

## KERMATH Marine Engines

"America's Standard 4 Cycle Marine Motor"  
4 Cycle, 4 Cylinder, 12 to 30 H.P. Highest quality. Silent operation. No vibration. Controls like the finest Motor Car engine. Extremely economical on fuel. Used as standard equipment by over 80 per cent. of the world's leading boat builders. Catalog on request. \$150 to \$350 depending on equipment.

KERMATH MFG. CO. Dept. P, Detroit, Mich.

# BESSEMER

## KEROSENE ENGINE

**30 DAYS FREE TRIAL**

The Bessemer costs just what a good engine should cost.

It is a real Kerosene Engine and not a converted gasoline type, therefore will run perfectly on kerosene, alcohol, or gasoline. This is due to the wonderful Universal Fuel Feeder, controlled exclusively by us. Sizes 2, 4, 6, 8 and 10 H.P. Also direct connected to pumps, hoists, air compressors, electric lighting plants, saws, farm machinery. If you would like to try a Bessemer Kerosene Engine 30 days before you decide to buy, write us and we will arrange a trial for you. Catalog "K" is free.

**Bessemer Oil Engine**

recommended where power from 15 to 200 H.P. is required. Burn crude and fuel oil and run at about 1/3 to 1/4 cost of gasoline. Now being used in irrigation, flour mills, factories, lighting plants. This engine is revolutionizing the power question. Get facts by writing for Catalog "O."

**THE BESSEMER GAS ENGINE CO.**  
121 Lincoln Ave., GROVE CITY, PA.

**LOWEST FUEL COST**

STATEMENT OF THE OWNERSHIP, MANAGEMENT, CIRCULATION, ETC., REQUIRED BY THE ACT OF AUGUST 24, 1912, of Popular Mechanics Magazine, published monthly at Chicago, for October, 1915. Editor, H. H. Windsor, 6 No. Michigan Ave., Chicago. Managing Editor, J. L. Peabody, 6 No. Michigan Ave., Chicago. Business Manager and Publisher, H. H. Windsor, 6 No. Michigan Ave., Chicago.

### Toledo MARINE MOTORS

Nothing Cheap but the Price

3 H.P. 1 cyl. complete	\$ 65.00
6 H.P. 1 " "	84.00
6 H.P. 2 " "	125.00
12 H.P. 2 " "	180.00
18 H.P. 3 " "	250.00

Fully guaranteed by a responsible concern. 2 cycle, 2 port, 3 1/2 x 3 1/2 and 4 1/2 x 4 1/2. Send for free catalog "G."

**THE UNIVERSAL MACHINE CO., Pike Ave., Bowling Green, O.**

**NONE BETTER**

### 1c IS WORTH DOLLARS

when you invest that 1c in a postal card to us. Here are a few of the good things in it for YOU—

1 1/2 H.P.,	\$24.75	5 H.P.,	\$87.50
2 H.P.,	28.75	6 H.P.,	96.75
3 H.P.,	53.90	8 H.P.,	135.50
4 H.P.,	68.90	10 H.P.,	179.90
		12 1/2 H.P.,	\$214.90

We guarantee against repairs forever

**OTTAWA MFG. CO., 2033 King St., Ottawa, Kans.**

## This \$2 KNIFE 83¢

DIRECT AT FACTORY PRICE

Handy shaped blade makes this knife best for mechanics, sportsmen and farmers; light but strong; resharpened easily. Stag handle, German silver finish; blades file tested, hand forged from razor steel and warrant ed. Sample \$3c, 3 for \$2 postpaid. Cheapest post \$2 each.

Send for our 80 Page List and "How to use a Razor" **FREE**

**MAUER & GROSH CO., 106 A. St., Toledo, Ohio.**

# TAILOR MADE TO ORDER 6 MONTHS TO PAY



Be the swellest dresser in your set. Wear clothes that virtually breathe class. Take six months to pay for them. Get acquainted with America's greatest price-smashing tailoring house. See how our tremendous buying power gives us the pick of the world's finest fabrics at lowest prices known. Our catalog will astound you. Write for it.

## Save Half!

Think of it! \$25 tailored-to-your-order Suits and Overcoats only \$13 from us; \$35 values only \$18, etc. Don't buy ready-mades and pay double our price. Don't pay other tailors two or three times as much as we charge. Don't buy clothes that can't be guaranteed to the limit. We must make good clothes to uphold our reputation.

### Only \$2.30 Per Month!

No need to sacrifice the advantage of made-to-order clothes. So easy to pay our way that you won't miss the money. We trust you. No references required. No red tape. No delay. No collectors. No extra charge for the credit. Absolutely rock-bottom prices.

### BEWARE

of the houses advertising "made-to-measure" clothes who don't dare to back up their claims. Don't be fooled into accepting altered-to-fit ready-mades as made-to-order clothes. Deal with the house that believes in quality and fairness.

**\$1,000 Reward** To anyone who proves that we do not make all our garments absolutely tailor-made to your own individual order and measurements. There's our sensational offer. Don't confuse us with the ordinary run of so-called tailoring houses. We're different. See our money-back guarantee in our catalog.

### DeLuxe Book of Style FREE!

Just off the press—our wonderful Book of 1915 Fall and Winter Fashions. Most advanced and exclusive styles—the choicest designs from the world's greatest style centers. The cream of the greatest mills. Write for it today. Post cards brings it free together with full particulars of the most sensational offer ever made in the history of high class tailoring. Write now!

STANLEY-ROGERS CO., 544 S. Clark St., Chicago, Ill.

## The REAL Triumph of WATCH MANUFACTURING—the "Santa Fe Special"

17 or 21 Jewels, thin model, 16 size  
YOU CAN NOW SAVE from \$15 to \$25 on a STANDARD RAILROAD WATCH  
"Direct from Factory to You"  
Saves ONE-THIRD of Your Money

The Famous "Santa Fe Special" is the one watch that's guaranteed to last you all your life. Accurately adjusted to the second, adjusted to positions, adjusted to temperature, adjusted to isochronism. Guaranteed to pass railroad inspection

### EXTRA SPECIAL OFFER

We will send you the "Santa Fe Special" watch without One Cent Down. Examine it carefully. Wear it 30 Days. Send it Back if you don't want it. You risk nothing.

Our "Direct to You," easy payment plan is explained fully in the Santa Fe Special catalog. Payments are so small you will not miss the money, only \$3.50 a month and you wear the watch right from the start.

#### NEW CASE DESIGNS

The new watch book shows all the very latest designs of the world's most talented engravers, each case illustrated in beautiful color combinations, showing three color inlay monograms, engraved monograms, fraternal emblems, French art and special designs.

A postal brings the new watch book. Address Dept. M-102

**SANTA FE WATCH CO.**  
Topeka, Kan.



Please Mention Popular Mechanics

# TORREY Razors

make  
smooth  
shaving  
a daily  
delight

With a  
**Torrey**  
you always  
shave clean  
and smooth,  
because it has  
the perfect shaving  
edge. Adjusted  
to glide over the face  
at the right angle. Cuts  
close, without pulling,  
without roughing the skin.

### A Real Man's Razor—

this beautiful razor is one of the finest examples of Torrey skill in razor making. It guarantees comfortable shaving.

If your dealer hasn't Torrey razors, write to us; we'll tell you where to get them, and send you FREE booklet, "How to Shave."

The Torrey Honing Strop has no equal

**The J. R. Torrey Razor Company**  
Dept. P, Worcester, Mass.

Owner, Popular Mechanics Co.; Stockholder, H. H. Windsor, 6 North Michigan Ave., Chicago. Known bondholders, mortgagees, and other security holders, holding 1 per cent or more of total amount of bonds, mortgages, or other securities: None.

H. H. WINDSOR.

Sworn to and subscribed before me this 14th day of Sept., 1915.

J. GRAHAM.

(My commission expires June 17, 1916.)

GET THIS CATALOG  
FULL OF VALUABLE INFORMATION TO EVERY  
BOAT OWNER ON  
RACING PROPELLER WHEELS,  
REVERSE GEARS AND  
MARINE ACCESSORIES  
LARGE CATALOG FREE. SEND TODAY  
MICHIGAN WHEEL CO.  
1138 MONROE AVE. GRAND RAPIDS, MICH.

**INVENTORS** Our Brain Belongs to You. Our Ideas Are Free of Charge.  
All we want in return is to build your model, special machinery, dies, tools and rigs to manufacture sheet metal goods, etc. We are expert mechanics, over thirty years' experience and have one of the best equipped shops in the country. Ask for Booklet No. 17. Consultation free. Experimental work strictly confidential.  
A. Naecke & Son, J. Urmann, A. Helrich, Prop'rs  
236-242 S. 4th St., Philadelphia, Pa.

## Wear It a Week At Our Expense

We will send you a genuine Helion Jewel set in solid gold for a whole week's free trial. Compare it with a diamond, in brilliance, hardness and beauty. If you can tell the difference, send it back. Write today for New Jewelry Book. See illustrations of the exquisite gems. No obligations. The book is FREE.  
**John A. Sterling & Son** 1198 Ward Building  
CHICAGO, ILLINOIS



## You Can Win a King Prize

They're crackerjack prizes, too. Just the things that red-blooded boys want most—things for the camp, for the stream, for the woods and for the athletic field.

If you haven't an air rifle buy or borrow one and get into training for the Grand National King Marksmanship Contest—Nov. 8-13 inclusive.

Ask your dealer—the man in your town who sells air rifles—about this great shooting contest. If he can't give you full information and free targets send us his name and address and we will supply him with all data. There is an interesting illustrated booklet A we'd like to send you. Write for it.

**The Markham Air Rifle Company**  
Plymouth, Mich.

Pacific Coast Office  
Phil B. Bekeart, 717 Market St., San Francisco, Cal.  
Southern Representatives  
Sand & Hulfish, 11 Hanna Haus, Baltimore, Md.

(11)

**KING**  
AIR  
RIFLES

### IT WRITES WITH WATER! THE INKLESS PEN

Only  
**10**  
CENTS  
3 for 25c  
postpaid

Writes 500 words with one dip in water. It is a real pleasure to write with the Inkless Pen, as you have simply to dip the pen in plain water. The nib is of special construction and of a peculiar metal. It resists corrosion and lasts very much longer than ordinary pens. The writing is copyable and is marvellously neat and legible. Better than a Fountain Pen. May be carried in any pocket.

Or with very handsome Silver-plated Holder, 25c.

Extra Nibs (will fit any holder) 50c per doz.

Obtainable Only From

INKLESS PEN CO., 7121 N. Clark Street, CHICAGO



## CLASS PINS

FACTORY TO YOU

M3249 Made to your special order, any style or material. Write to-day for free catalog of 1915 designs. Special offer, either style of pins here illustrated with any equal number of letters and figures, with one or two colors of best hard enamel. SILVER PLATE, \$1.15 each, \$1.50 per dozen; STERLING SILVER, \$1.30 each, \$3.00 per dozen; GOLD PLATE, \$1.35 each, \$3.50 per dozen; SOLID GOLD, \$1.50 each, \$15.00 per dozen.  
BASTIAN BROS. CO. 225 BASTIAN BLDG., ROCHESTER, N. Y.



## Made-to-Measure EXPRESS PREPAID \$2.75

Pants cut in the latest style. Made to your individual measure. Fit, workmanship and wear guaranteed.

### No Extra Charge

for peg tops, no matter how extreme you order them.

**Agents** A good live hustler in every town to take orders for our **Wanted** celebrated made-to-measure clothes. Samples of all latest materials FREE.

### We Pay Big Money

to our agents everywhere. Turn your spare time into cash by taking orders for our stylish clothes. Write today for beautiful FREE outfit.

**THE PROGRESS TAILORING CO.**  
Dept. 107, CHICAGO, ILL.

# Write

## for This Free Washing Book



Great big book.

Many pictures of actual washings. Tells how to save wear on clothes, how to save money, how to make washday easy—yes, really easy. Absolutely free for the asking. Send coupon today.

## One Hour For a Wash!



Only an hour, Madam, to do a good-sized family washing. That's all, if you have a Thor Electric Home Washing Machine. Not a rub to wash finest laces or heaviest clothes. Does all the wringing, too. All you do is to press a button. Madam, learn all about this NEW washday marvel. Send coupon today.

# The Thor

The machine which puts a wash-woman in your home each Monday at a cost of 2c. And your clothes are washed clean and white as snow. A special offer is on right now. We want to tell you all about it.

## Mail This Free Coupon Special Offer!

This coupon brings our 48-page book and all the good news about the better way of washing. Do not fail to mail the coupon for this book right now. It costs you nothing. We will tell you also about the big special offer we are making.

Hurley Machine Co.  
29 S. Clinton St.  
Dept. 1198  
Chicago, Illinois  
147 W. 42nd St.  
New York, N.Y.

Name.....

Address.....

Name of Electric Dealer

Hurley Machine Co.  
29 S. Clinton Street  
Dept. 1198 Chicago  
147 W. 42nd St. New York

You may send the free washing book. Also full information about the special offer you are making now.

Please Mention Popular Mechanics

## A Handy Tool for the Handy Man



Fits any Hand

Send for pocket catalog showing complete line

## Has Exclusive Time-and-Labor-Saving Features

Work in close quarters, full stroke and perfect control—these are the points that will interest you in this

## MILLERS FALLS STAR HACK SAW No. 1027

Quality just "sticks out" all over this tool. Grip fits any hand without crowding. Thumb screw for tightening blades is at inner end of saw, offering no obstruction and permitting maximum stroke at all times. Frames may be adjusted to blades from 8 to 12 inches—the strong sheath at back keeping it rigid at all lengths. Blades may be faced in four directions. Depth between frame and blade is  $3\frac{1}{2}$  inches.

### Let Your Dealer Show You

You will also be interested in Millers Falls Hand Drill 306 and Bit Brace 772—new tools with improved features that wide-awake mechanics will recognize at once.

**MILLERS FALLS  
TOOLS**



**Millers Falls Co.**  
Millers Falls,  
Mass.

NEW YORK OFFICE, 28 Warren Street

Don't fail to visit our exhibit in Block 26, Avenue D, Manufacturers' Building, while at the Panama-Pacific Exposition.

Please Mention Popular Mechanics

## Build an Aeroplane

We'll show you how

By means of our simple, easily understood instructions and scale drawings you can build an



Ideal Taube Monoplane, 3 ft. Model, complete ready to assemble, \$4.25

## Exact 3-ft. War Model

Guaranteed to Fly

Not a toy, but a wonderfully interesting real miniature flying machine with which you can have delightfully fascinating and instructive sport. Scale drawings, building and flying instructions, carefully prepared, are supplied at following prices:—

Curtiss Flying Boat	25c	Bleriot Monoplane	15c
Military Tractor	25c	Taube Monoplane	25c
Hydroaeroplane	35c	Wright Biplane	25c
Nieuport Monoplane	25c	Cecil Peoli Racer	25c

## Build a Fleet

Get a complete set of above 8 plans for **\$1.60**

In addition to plans you can get all knocked down parts necessary for building complete aeroplanes. An especially popular knocked down model is the



IDEAL BLERIOT

## "Ideal" 3-ft. Bleriot Monoplane

Duplicating exactly the man-carrying aeroplanes used in the European War. Complete plans, simple directions and all parts, including silk for planes, nickel plated pneumatic tired wheels, substantial fittings. Marvel of beauty and scientific value. Delivered ready to assemble, all charges pd. **\$4.25**

There's a dealer near you who sells parts and plans for "Ideal" Aeroplanes. If you can't find him, write us and we'll see that you are supplied.

Write today for our 50-page Aeroplane Book with full information, prices for parts, complete models, etc., postpaid, 5c.

**IDEAL AEROPLANE & SUPPLY CO.**  
82-88 West Broadway NEW YORK CITY

Cotton exported from this country from Aug. 1, 1914, to May 1, this year, amounted to 7,321,420 bales, or half of last year's crop.



## ALORRA DIAMONDS

SPARKLE LIKE THE GENUINE — AT 1-40 THE COST

**SOLID GOLD RINGS**

—stand acid, fire and expert examination. See them before paying. Any style ring, pin or stud. Catalog FREE.

The Alorra Co., Dept. AT, 140 S. Dearborn St., Chicago



## SELF-SHARPENER FOR SAFETY RAZORS

Insert safety blade (any but Durham Duplex), turn handle few times. Honed and sharpens one operation; keen cutting edge like new. Sent anywhere for \$3. Money-back guarantee. **AGENTS WANTED.**

CIRCULAR P ON REQUEST.

**IN. MFG. CO., 1 W. Broadway, New York**

## Funsten Pays Cash for FURS

**Prices Higher This Year**

**Big Money in Trapping** skunk, coon, mink, muskrat, fox, etc. You can trap furs—we teach you how.

**Funsten Animal Baits** guaranteed to increase your catch. \$1.00 a can postpaid. The **Funsten Perfect Smoker** "smokes 'em out." Price \$1.50; parcel post 30 cents extra. Both guaranteed satisfactory or money back. **Traps at factory prices.**

**FREE** 3 books in one (trapper's guide—

game laws—supply catalog). Tells how, when, where to trap, how to remove, prepare and ship skins. Will send you fur market reports, shipping tags and big book **FREE**—Write today.

**We tan hides and furs for coats, robes and garments.**

**FUNSTEN BROS. & CO., 340 Funsten Bldg., ST. LOUIS, MO.**

Largest in the World in Our Line



Line



# CREDIT to ALL!

## Diamonds and Watches

at **LOWEST PRICES**

**\$39.50 SPECIAL!** Genuine Diamond Ring. Wonderful Value 14K Gold. Credit Terms, \$5 down, \$4.50 a month. **Easy Terms**

Lowest prices, greatest time-payment offer in U. S. on all famous Alfred Ware Guaranteed Diamond Rings. All Styles. Brilliant, perfect-cut diamonds. Money back 30 days if wanted. Sensation!

**17 Jewel ELGIN, \$12.50**

Regular \$18 value. Guaranteed Elgin Movement—25-year case, Engraving FREE. World's greatest watch bargain. Free Catalog—64-pages—astounding jewelry, silverware bargains on FREE TRIAL. Address: **ALFRED WARE CO., Dept 488 St. Louis, Mo.**



## Don't Grope for the Light

This wonderful luminous bulb locates your light in the dark. It is just the thing for the bath room, pantry and bed room. No more swinging your arms around in a circle to find the chain.

### Eradium Pull Chain Bulbs

attach easily to any gas or electric light pull chain. Obtain this bulb from your dealer, or write us direct. Price 35 cents—three for \$1.

Agents are earning big commissions on this easy seller. Write today.

**Pioneer P. & P. F. Co., Luminous Dept.**  
1249 W. 63rd Street, CHICAGO, ILL.



## FORD RACERS

**REBUILD YOUR FORD CAR**  
Sketches, specifications, and instructions. Prepaid for twenty-five cents. T. M. Co. Dept. A, Box 212, Woodford, Maine



## KEYLESS PADLOCK

No knobs to turn—no clicks to count. Press the buttons and it flies open—40,000 combinations possible on each lock. Operated as easily in the dark as in light. Solid brass. **AGENTS making 100% profit.** Sell on sight—no competition. Write for terms of free sample. A postal will do.

**American Keyless Lock Co., 633 Jackson Blvd., Chicago**



## GOOD AGENTS

Wide awake, energetic Men can secure protected Territory to sell our portable Lamps, Lighting Systems and our 250 C. P. Inc. Gasoline Lanterns, which are positively the simplest and most practical gasoline devices on the market. We challenge competition. **Your Chance.** Territory is being rapidly taken. If you want a good, steady income, write us TODAY.

**INTERNATIONAL LIGHT NOVELTY & SPECIALTY CO.**  
426 So. Clinton St., Dept. 77, CHICAGO, ILL.



## GO INTO THE MOVING PICTURE BUSINESS

**Make Money Fast! Be Your Own Boss!**  
\$30 to \$50 PER NIGHT CLEAR  
**No Experience Needed**  
We furnish you with machine, film, curtain and complete outfit ready to go to work with on our Easy Payment Plan. Write Now for Our **LARGE FREE CATALOGUE**

**MONARCH FILM SERVICE**  
228 Union Ave., Dept. N, Memphis, Tenn.



# 50c a Week

Send today for your free-for-examination set of the greatest electrical library ever published. The 1915 edition, just off the press, is recognized by big men in the electrical field as the most practical work of its kind. Covers completely the generation and use of electricity for power, light, transportation and communication, the construction and operation of dynamos and motors, central station engineering and telephone work, as well as wireless telegraphy and land and submarine telegraphy. Valuable alike to the beginner and expert.

## Applied Electricity

Seven big volumes; 3500 7x10 inch pages; 3000 illustrations, full-page plates, diagrams, simple explanations, etc., with hundreds of valuable facts and figures. Handsomely bound in half red morocco, gold stamped.

**Earn \$150 to \$250 Monthly** Electrical Engineers earn from \$150 to \$250 a month. The work is pleasant—the hours short. These great books will fit you—in your spare time—to enter this fascinating, well-paid work. No previous experience necessary.

### Examine These Books Free of Charge

The entire seven volumes, not a sample volume, will be sent, express prepaid, on receipt of the coupon below. Lock these books over for a whole week free. Then decide whether or not you want them. If you do, send us \$2.50 within seven days and \$2.00 a month—50c a week—until the special advertising price of \$19.50 has been paid. Otherwise we'll take them back at our expense. In addition to this liberal discount from the regular price of \$55.00, we include with each set a \$12.50 Consulting Membership. This entitles you to the advice of a staff of experts for a whole year free!

**AMERICAN TECHNICAL SOCIETY, CHICAGO, U. S. A.**

**American Technical Society, Chicago:**  
Please send Cyclopaedia of Applied Electricity for 7 days' free examination. I will send \$2.50 within 7 days and \$2.00 a month until I have paid \$19.50; otherwise I will notify you and hold the books subject to your order. Title not to pass until fully paid. Pop. Mech. 11-15

NAME.....  
ADDRESS.....  
REFERENCE.....

# OSTER

## Pipe - Threading TOOLS

For quick, easy, clean-cut pipe-threading, get a quick-action Bulldog Die Stock with adjustable dies and self-locking guides—no loose bushings or small parts. No running back over finished threads. Bulldog No. 82, shown here (the "baby" of the line), threads all pipe from 1/4 to 3/4 on one set of dies. Write for catalog.



**THE OSTER MFG. CO.**  
2100 East 61st Street  
Cleveland Ohio U.S.A.

Please send me by return mail the free Oster catalog.

Name.....  
Business.....  
Address.....  
City..... State..... (2100)

Please Mention Popular Mechanics



"A smile of satisfaction with every pair."

## HEADLIGHT OVERALLS

(Union Made)

There's roominess and comfort in Headlights that you don't get in other overalls.

Better materials—fuller cut—better workmanship. Will outwear two pairs of the ordinary kind.

Guaranteed the best overalls you ever bought or money back after 30 days' wear.

Look for this ticket

Larned, Carter & Co.

Detroit

World's Greatest Overall Makers

Factories: Detroit and Fort  
Hare, Mich., St. Louis,  
Mo., San Francisco, Cal.,  
Canadian Factory,  
Sarnia, Ont.



Please Mention Popular Mechanics

# BOYS!

Here's Real Rainy-Day Sport  
Build Machines that Work  
With **STRUCTO**

You can build fortresses, battleships, aeroplanes, derricks, bridges, with a **STRUCTO** outfit—not toys, but real models that work.

You can put one over on Dad. Build a machine that will make him get down on his knees to see how it works.

You won't get tired of **STRUCTO**. We furnish 145 models, and you can invent a thousand of your own. The shafts are key seated and the gears cast, to make your models run like big machinery.

With every five dollar set we furnish a

**Powerful Electric Motor—Free**

that will drive the machines you build. Write for our *Illustrated Book* that we send you free. It tells you about Die Cast Gears and **STRUCTO MODELS**—illustrated from actual photographs. Get a copy of this book for nothing. Show it to your Dad. Then he'll get you a **STRUCTO** Outfit.

Address Dept. F.

**STRUCTO Manufacturing Co., Freeport, Ill.**  
Made in U. S. A.

(7)

The United States' annual production of petroleum is about 238,000,000 bbl., or 63 per cent of the world production.

IF IT ISN'T  
**AN EASTMAN**  
IT ISN'T A KODAK

**MAZDA** Always etched on electric lamps to which **MAZDA** Service has been applied.

**Agents \$60 WEEKLY**

Robinson Folding Bath Tub. Big seller. Costs little, no plumbing, little water. Weight 15 pounds, folds into small roll. Full length baths, far better than tin tubs. Guaranteed 10 years. \$10 a day easily made. Write for free tub offer. Robinson Cabinet Mfg. Co., 231 Factory Bldg., Toledo, O.

# Deafness



Perfect hearing is now being restored in every condition of deafness or defective hearing from causes such as

Relaxed or Sunken Drums, Roaring or Hissing Sounds, Perforated, Partially Destroyed Drums, etc.

**Wilson Common-Sense Ear Drums**

"Little Wireless Phones for the Ears"—require no medicine but effectively replace what is lacking or defective in the natural drums. They are simple devices, which the wearer easily fits into the ears where they are invisible. Soft, safe and comfortable to wear at all times.

Write today for our 168 page FREE book on DEAFNESS, giving you full particulars and plenty of testimonials.

**WILSON EAR DRUM CO., Incorporated**  
250 Inter-Southern Building LOUISVILLE, KY.

**SPECIAL!**



**1c. Genuine Blue White perfect cut diamond set in 14-karat solitaire Tiffany-style ring, the perfect engagement setting. \$42.00 import price.**  
 Same ring with:  
 1-2 carat diamond \$ 8.00  
 1-4 carat diamond 17.25  
 1-6 carat diamond 30.75  
 1-8 carat diamond 67.13  
 1 carat diamond 90.88

**14k. Solitaire**

6-tooth ring, the young men's favorite. Set with 1/2 carat genuine perfect cut Blue White Diamond. \$110 retail value. **\$68.75** import price only.  
 For other size diamonds add our factory cost price of the mounting \$4.00 to prices for diamonds given at right.

**GIRL'S DIAMOND RING**

14k. solid gold girl's, baby and child's ring. Set with Blue White perfect cut genuine diamond. **\$288**



**May**  
 Friendship bracelet. Links. Sterling silver, initials or same engraved free. 10c  
 25c quality. Our price



**SEND FOR THIS BOOK, FREE!**

Our DeLuxe Book of Diamonds, especially the new 1916 Edition now ready, is the authoritative guide for the diamond buyer. A real bound book, full of expert's facts, profusely illustrated. First in the field with the new 1916 styles. Tells you how to judge, buy, sell value of diamonds. Comes to you free and without obligation. Mail coupon or write; or a postal will bring it. Write NOW!

**BARNARD & CO., Dept. 6C, Mail Coupon, Post Card or Write Today!**  
 N.W. Cor. Michigan Ave. & Adams St., Chicago

**GENUINE BLUE WHITE Perfect Cut**

**DIAMONDS**

**\$88**

**SMALL SIZES AS LOW AS \$50. A CARAT**

**The Lowest Prices in the World!**

Nowhere else can you get fine diamonds guaranteed Blue White, Perfect Cut and Genuine for only \$88 per carat, small sizes down to \$50 per carat! Expert comparison proves their value fully \$150 per carat. Our direct importing price less even than established jewelers must pay wholesale! You save over 35% by going to Barnard & Co. the direct Importers!

**Per Carat**

- 1 Carat \$88
- 3/4 Carat \$64.25
- 1/2 Carat \$40.25
- 1/4 Carat \$15.50
- 1/8 Carat \$8.25

**ABSOLUTELY NO MONEY IN ADVANCE**

Send no money, not even a deposit. No references, no waiting, red-tape or formalities. Our simple plan is the only safe way to buy your diamond. We actually show you the diamond and mounting you select from our Book or this ad. We'll ship to you for Free examination—entirely at our expense. We want you to see for yourself the tremendous value we give for the world's lowest price. Return or accept as you yourself decide. No obligation at all.

**The Only Bankable Money Back Guarantee!**

Here are its unique features: it allows you to return any diamond bought from us through any bank in America, or direct to us, and you'll get INSTANTLY cash refund; no quibbling, delay or red-tape. Where else can you get equal protection? And besides, our Guarantee allows you the full price in exchange at any time! And it legally certifies the true color, carat weight and money value. We can afford to stand back of our Diamonds with this amazing guarantee because we know the quality gives universal delight, and the money value can't be remotely equalled anywhere.



Without obligation on my part please send me free and postage paid by you, your 1916 DeLuxe Book of Diamonds.  
 (Write name and address in margin below)

**BARNARD & CO., Dept. 6C, N.W. Cor. Michigan Ave. & Adams St., CHICAGO**



**HERE YOU ARE, BOYS**

A medallion pin of Foxy Grandpa. Everyone will notice it on the lapel of your coat and try to get a closer look at it. All you have to do is press the bulb.—Foxy Grandpa will finish the job by squirting a fine stream of water over the inquisitive one. Will squirt 20 feet. Greatest joke out. Order one today and fool your friends. Price 15c. Foxy Grandpa and Hoogan both for 25c, 5 for 50c or 1 doz. for \$1.00. A beautiful fountain pen free with every \$1.00 order.

**AMERICAN SUPPLY CO., 918 Union St., St. Paul, Minn.**

**A MARVELOUSLY PRACTICAL COMBINED Tool is this Stewart Handy Worker**

Comprises on one base a vice up to 4 1/2 inches; width of jaw, 4 inches; powerful pipe vice up to 1 1/2 inch pipe; a strong, sturdy anvil; cutting handle; drill press with two speeds; conatum grinding wheel, 5 inches x 1 inch, operated at 3 speeds, etc. Weighs, boxed, 90 pounds; complete, f. o. b. Chicago, **\$12.50** only.  
 A complete workshop. Order one or write for booklet.



**Chicago Flexible Shaft Company**  
 105 N. La Salle St. Chicago, Illinois

**THIS BUNGALOW \$900 CAN BE BUILT FOR**

This and many others in my new book, Building Plans for Modern Homes, will save you hundreds of dollars. One of the most complete and comprehensive books of plans ever published by any architect. Fifth edition just off the press. Two hundred and fifty floor plans and photographs of bungalows, etc., costing from \$200 up; gives sizes and cost to build. Sent postpaid for \$1.00



**FREDERICK H. GOWING ARCHITECT**  
 18 Tremont St., BOSTON, MASS.

**GOV'T JOBS OPEN**

**Railway Mail Clerks, City Carriers, Rural Carriers**  
**City Postal Clerks, Panama Canal Clerks**  
**\$300 TO \$2000 A YEAR, FOR LIFE**

Rapid advancement to higher Government Positions. No "lay-offs" because of STRIKES, FINANCIAL FLURRIES or the WHIMS OF SOME PETTY BOSS. THE POSITION IS YOURS FOR LIFE.

Country residents and city residents stand the same chance for immediate appointment. Common-sense education sufficient. Political influence NOT REQUIRED.

Write immediately for schedule showing the places and dates of the Winter examination. Don't delay. Every day you lose means the loss of just so much coaching before the rapidly approaching examinations.

**FRANKLIN INSTITUTE Dept. E-97, Rochester, N. Y.**

**FRANKLIN INSTITUTE The Pathway to Plenty Dept. E-97, Rochester, N. Y.**

This coupon, filled out as directed, entitles the sender to free sample questions; a free copy of our copyrighted book, "Government Positions and How to Get Them," a full list of positions now obtainable and to be considered for Free Coaching for examination here checked.

**COUPON**

.. Railway Mail Clerk	(\$300 to \$1800)	.. Customs Positions	(\$800 to \$1500)
.. Postoffice Clerk	(\$400 to \$1200)	.. Internal Revenue	(\$700 to \$1800)
.. Postoffice Carrier	(\$800 to \$1200)	.. Stenographer	(\$400 to \$1500)
.. Rural Mail Carrier	(\$500 to \$1200)	.. Clerk in the Departments	at Washington
.. Bookkeeper	(\$500 to \$1800)	.. Canadian Government Positions.	(\$500 to \$1500)

Name.....  
 Address.....  
 Use this before you lose it. Write plainly.

# REIBOX

GUARANTEED QUALITY

REIBOX guarantees purity of every ingredient. You can eat all you want. You will want to eat all you can. So pure they cannot be other than healthful.

REIBOX always sold direct to consumer, therefore always fresh. Money cheerfully refunded if not satisfied. Creamed fruit, nut and combination centers that melt in your mouth. Covered with REIBOX Special Blend Chocolate that lingers. A dollar bill brings you 2 pounds of these delicious chocolates which makes you one of our many satisfied customers.

**FREE** one REIBOX certificate with each \$1.00 REIBOX purchase. 15 certificates entitles holder to one regular \$1.00 REIBOX purchase free, postpaid.

REIBOX COMPANY, 1614 Wilson Ave., CHICAGO, U. S. A.

75c per pound guaranteed  
Quality Chocolates No. A-335  
2 lbs. for \$1 POST PAID

REIBOX \$1.00 SALES

No. A-331—Old-Fashioned Pure Sugar Hard and Nut Filled Candies. Price \$1.00 for 2 lbs., postpaid.

No. A-332—Caramel, Nougat, Caramel and Butter Special combinations. Price \$1.00 for 2 lbs., postpaid.

No. A-333—Brazil Nut Bars combined with transparent Pure Sugar are just right. Price \$1.00 for 2 lbs., postpaid.

No. A-334—Dessert Chocolate Mints, something new. Especially adapted for parties. Each piece packed in a dainty crimped container ready to serve. Price \$1.00 for 2 lbs., postpaid.

No. A-335—Reibox 75c per lb., Guaranteed Quality Chocolates, 2 lbs. for \$1.00, postpaid. To avoid errors order by number. Each number packed only in 2 lb. boxes.

Each number is a Reibox guaranteed quality.



## Good Enlargements

Give you the best results from your kodak film.

We do only the very best work, using the best of materials and the most skillful workmen. Poor work is expensive at any price.

For \$1.00

We will make an eleven-inch enlargement, black and white or sepia, triple mounted and hand retouched. No extras of any kind. Postage prepaid. Send for price list. Films developed 10c per roll. Prints 3c, 4c and 5c.

JACKSON & SEMMELMEYER, 41 S. Wabash Ave., Chicago, Ill. Milwaukee, Wis. Pasadena, Cal. Santa Barbara, Cal.

SEND TO OUR NEAREST STORE

# Build It NOW

No use to wait till next season to build, when you can erect a permanent, substantial Home like this in 12 to 14 days.

## Sterling System Built Homes

have reduced building costs 40%. And we give you 2 whole years to pay. Complete, modern Homes as low as \$296.88. Our prices include all materials—lumber, hardware, paints, plaster, nails, etc. Each board and timber comes cut-to-fit, which saves a usual labor cost. Send postal note for Catalog showing the "Famous Fifty" Designs.



International Mill & Timber Co. Dept. Q11, Bay City, Mich.

## Private Weather Bureau

IN EVERY HOME

A Reliable Barometer  
An Accurate Thermometer  
Actual Size 13 Inches High

Indispensable to the farmer, business man, professional man, automobilist, in fact, to everybody who should know in advance what the weather will be. Will save you money and time.

FORECASTS WEATHER

# WEATHEROMETER

HOURS IN ADVANCE

\$1.00 ONLY — Reduced from \$3.00

Send us no money. Mail your order today and Weatherometer will be sent to you C. O. D. (10c extra). If you prefer you may enclose \$1.00 bill or money order with order. Satisfaction guaranteed.

WITHINGTON INSTRUMENT CO.

5 South Wabash Avenue, Dept. 24, CHICAGO



## Rider Agents Wanted



in each town to ride and show a new 1916 model

"RANGER" bicycle. Write for our liberal terms.

DELIVERED FREE on approval and 30 days' trial. Send for big free catalog and particulars of most marvellous offer ever made on a bicycle. You will be astonished at our low prices and remarkable terms.

FACTORY CLEARING SALE—a limited number of old models of various makes, \$7 to \$12. A few good second-hand wheels \$3 to \$5. Write if you want a bargain.

Tires, lamps, wheels, sundries, parts, motorcycle supplies of all kinds at half usual prices. Write us before buying.

MEAD CYCLE CO., DEPT. H108, CHICAGO

## Save the Dealer's Profit



Why pay fancy prices when you can buy any of our 6 models, 1 1/2 to 12 H. P., and save 20 to 25 per cent. Try 30 days at our risk before you buy. Every motor guaranteed for one year. Write for our catalog today.

LOCKWOOD-ASH MOTOR COMPANY  
1176 Horton Avenue, Jackson, Michigan



WIN HER WITH A **DIAMOND** ON EASY TERMS AT CASH PRICES

FREE ILLUSTRATED WATCH & DIAMOND CATALOG



These are Samples of the Diamond Bargains we offer

51—Tiffany Ring \$ 50 | 54—7 Diamond Cluster \$75  
52—Tiffany Ring 1.3 | 55—6 Prong Tooth Ring 60  
53—Tiffany Ear Screws 65 | 56—Belcher Stud 40

Our prices save money for you on every purchase, and our liberal terms will please you. The Diamonds we offer are pure white, perfectly cut stones, the pick of the mines, set in 14 kt. solid gold hand-made mountings. Every one a bargain—and it requires only a small payment of one-fifth down for you to possess it. Write today—now—before you forget.

WALKER EDMUND CO. Dept. C, 143 W. 36th St., New York  
Diamond Importers or Dept. C., State & Madison St., Chicago



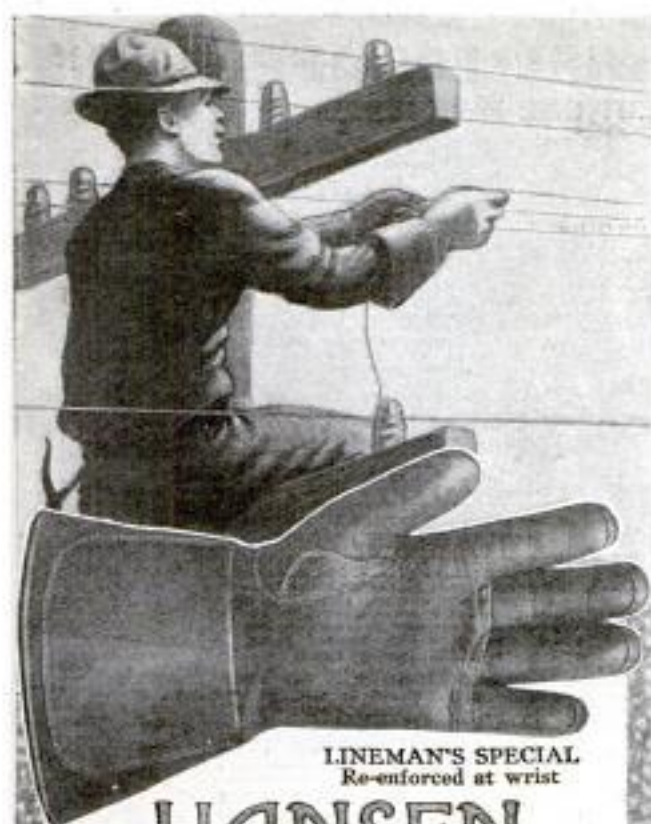

LINEMAN'S SPECIAL  
Re-enforced at wrist

## HANSEN GLOVES

are generally used by electrical workers and linemen everywhere because they are built exactly to suit their particular needs. "Built Like a Hand."

Note strong re-enforcement where the wrist rubs pole. And extra tips on fingers protect without hindering. Hansen leather stands up longest against the three glove enemies—water, wear and weather. Washing in gasoline leaves it soft and shapely.

Write for free book describing your glove and everybody else's, too. If your dealer is not supplied, write us.

O. C. Hansen Mfg. Co.

291 A. J. Milwaukee St. Milwaukee, Wis.

## The Cheapest Power on Earth



for any machine capable of being run by hand, is this **Stewart Little Major Engine, 1/2 horse power.** With battery, \$27.50; with high tension magneto, \$37.50.

The simplest, strongest and most practical big little engine ever offered.

It operates for a full ten-hour week day on less than a half gallon of gasoline.

Just the thing to run a small press, washing machine, bone cutter, lathe, drills, small saw, cream separator, ice cream freezer, spraying outfit, pump, feed mill, etc. Stewart Engines in 1/2, 2 or 3 horse power sizes.

Order today or write for catalogue.  
**CHICAGO FLEXIBLE SHAFT CO.**  
105 N. La Salle St., Chicago, Ill.



## Send Your Name For This Electric Stove

A **REMARKABLE** value in a combination electric stove and grill. It can be operated on a table, in buffet, dining room or living room, with no more effort than turning on the electric light. And on a remarkable special offer we will send it to you, **express prepaid**, without a penny down. If you don't like it, send it back at our expense.

## White Cross Electric Stove

A *practical combination of Toaster, Griddle, Broiler and Stove.* It will make delicious toast—four pieces at a time—tea, coffee—it will fry steak, eggs, ham and bacon, besides supplying just the heat you need to operate the chafing dish properly. It is handsomely finished in nickel and stands upon a beautiful nickel-plated tray.

## For Christmas—

What woman would not glory in the possession of a genuine White Cross Electric Stove? You want one yourself—and your friends will like it as well as you do. Just turn the switch and in a jiffy there's a glowing red heat that will toast your bread, fry the eggs and bacon—and do a hundred other things. It will bring a joy Christmas morning that you'll not forget.

## Send the Coupon for Our Special Offer

Just put your name and address

on the coupon, or a letter or post-card now, and get our special circular. It tells you more about the White Cross Electric Stove—and how you can get one express prepaid, by sending your name and address. Besides the Electric Stove it illustrates and describes a host of other electrical conveniences and accessories. No obligations. Send coupon.

**Lindstrom-Smith Co.**  
1100 So. Wabash Ave.  
Dept. 8198 Chicago, Ill.

Gentlemen—Please send me without obligation full particulars of special offer on White Cross Electric Stove.

**Lindstrom-Smith Co.**

Dept. 8198  
1100 S. Wabash Ave., Chicago

We also manufacture White Cross Electric Vibrators, Irons, Hair Dryers, Electric Lamps, Electric Automobile Horns, Electric Carling Irons, Heating Pads, Small Motors, etc., etc. Dealers write.

Name.....

Address.....

My Electrical Dealer's Name is.....

Please Mention Popular Mechanics

# WE ARE HEADQUARTERS FOR ELECTRICAL GOODS and WIRELESS APPARATUS

OUR 216 pp. CATALOG IS THE BEST ONE PUBLISHED

## EXPERIMENTERS

THIS IS THE Experimenter's Reference Book



It's the latest edition of the famous Amco Catalogue, contains over 200 pages and is fully illustrated. Complete description and prices of the latest electrical and experimental apparatus—Storage Batteries, Rectifiers, Transformers, Induction Coils, Wireless Apparatus, Lamps, Flashlights, Motors, X-Rays, Books, Tools, Electric Railways, Steam Engines, Water Motors, Dynamos, Motors, Telegraphs, Telephones, Electrical Surpluses, Model Aeroplanes and Parts for building your own apparatus. 6c in stamps will bring you this wonderful book. Contains a complete list of Wireless Calls giving experiments, Wiring Diagrams, tells how to put up an aerial and install apparatus, etc. Best catalog of Wireless and Electrical Apparatus, etc., published. Send for this catalog right away. Our prices will save you money. 6c in stamps brings it by return mail.



### FUN WITH ELECTRICITY

Here is a rare chance to get started right in your study of electricity. This wonderful outfit contains 55 page book of instructions and all the apparatus for performing 60 interesting and spectacular experiments which will give any boy a practical knowledge of electricity.

Price Only 50c. Postage 10c Extra



### FUN WITH MAGNETISM

This outfit contains 32 page book of instructions and all the apparatus for performing 61 fascinating experiments. It will give you some new ideas about electricity and magnetism in such an interesting way you can't help remembering it.

Price only 25c. Postage extra 5c



### THE AMCO SPARK COIL

Here is a chance for every boy to get a powerful spark coil at a bargain price. It gives a flashing spark nearly 1/2 inch long and will send wireless messages over a mile. Price Only \$2.25. Postage extra on 4 lbs.

### VEST POCKET FLASHLIGHT

One of the handiest little flashlights on the market. Slips into the purse or vest pocket. Nickel plated case and tungsten bulb. Sent postpaid for only 75c.



### LOTS OF FUN FOR BOYS!

2 1/2 volt, 2 C. P. TUNGSTEN lamp, w/1 ch. socket, 20 ft. insulated wire and 3 cells of dry battery all ready to install. May be used to light a dark closet or hall.

Price only 60c. Postage extra 15c

### LITTLE GIANT MOTOR

Is nearly 3 in. high. Runs at high speed on a single cell of battery. Very powerful and may be used to run small toys, etc. Just the motor every boy has been looking for. Sent postpaid for only 50c

### THE SIMPLEX TELEGRAPH OUTFIT

An opportunity for every boy to learn to telegraph and to put up a line with his chum. This is a full sized telegraph set, consisting of a fine key and receiver, mounted on a polished base. Will work any distance. An excellent Field Telegraph for Boy Scouts. Price, 95c. Postage Extra. Wt. 2 lbs.



### UPRIGHT STEAM ENGINE

A fine engine of the best materials. 9 in. high. The Right Engine for Any Boy. Runs at high speed. Each engine tested at factory and fully warranted. Sent postpaid for only 50c



### SIMPLEX WIRELESS OUTFIT

Every boy wants a wireless. Get in this interesting game and read the messages flying around you. This outfit is the greatest bargain ever offered. Consists of a large double slide tuner, a sensitive detector, condenser, telephone receiver and cord. Weight 3 lbs. Special Price, Complete, \$2.25. Postage Extra.



### Put an Electric Headlight on Your Bicycle

Every Boy wants a practical electric headlight for his bicycle. NO MATCHES—NO OIL—NO BOTHER. Shoots a powerful beam of light 200 ft. ahead. Burns 40 hours on one battery. Has powerful silver plated reflector and magnifying glass 4 inches in diameter. May be adjusted in any position. Comes complete with tungsten bulb, cord, battery case, etc.



PRICE ONLY

\$1.75

A FINE CANOE LIGHT



ADAMS-MORGAN COMPANY "The Experimenter's Supply House"  
25 Alvin Place UPPER MONTCLAIR, N. J.



## DUCK'S NEW No. 9—325 PAGE Electrical and Wireless Catalog

Ready on October 20th

40 more pages of wireless instruments at more attractive prices than ever.

Also many new items in electrical supplies at substantial reductions in price.

This unrivaled catalog mailed to anyone upon receipt of 8c in stamps or coin, which may be deducted on first dollar purchase. Great cost of catalog and low prices prohibit distribution otherwise.

### What This Big Catalog Contains:

- |   |  |
|---|--|
| 160 pp. Wireless Apparatus for Commercial and Experimental use; | 5 pp. Lighting Plants;   |
| 10 pp. Raw Material;  | 10 pp. Ammeters and Voltmeters;  |
| 5 pp. Transformers;   | 25 pp. Electrical and Mechanical Books;                                |
| 8 pp. Storage Batteries;  | 12 pp. Telephone Equipment;  |
| 15 pp. Telegraph Insts.;  | 10 pp. Auto Accessories;   |
| 42 pp. Motors and Dynamos;                                      | 13 pp. Victrolas, on our Easy Payment Purchase Plan; (No Down Payment) |
| 10 pp. Miniature Lamps;   | 30 pp. General Electrical Supplies.                                    |
| 8 pp. Flashlights;  |  |
| 5 pp. Massage Vibrators;  |  |
| 10 pp. Miniature Railways;                                      |  |

THE WILLIAM B. DUCK CO.  
223-227 Superior St., TOLEDO, OHIO

BRITISH LANDING IN GALLIPOLI RECALLS STORY OF ANCIENT TROY—In getting their first landing party ashore on the Gallipoli Peninsula the British resorted to a ruse as ingenious as that of the wooden

## Complete Instruction Booklet on Aviation 10c

Explains fully: Essential parts of an aeroplane; operation; control; inspection; training; laws governing flight; starting, rising and landing; air structure; air currents and cloud formation; cross country flying; speed-variations; radius of vision from heights 500 ft. to 1 mile; radius of glides; altitude and barometer reading; pleasure and exhibition flying. A thoroughly practical instruction by one of America's foremost aviators and flying machine manufacturers. Sent prepaid upon receipt of 10c.

THOMAS BROS. AEROPLANE CO.  
156 State Street, ITHACA, N. Y.



### "The Electrical Experimenter"

The big electrical Magazine for those who dabble in electricity and Wireless. Chuck full of experiments. Intensely interesting. Monthly prices of \$5.00 for best experiments. Amateur Electric, Wireless News, Latest Patents 100 articles, 100 to 150 illus. Read the great serial: "Baron Munchhausen's New Scientific Adventures" \$1.00 a year.

Send 10¢ for 3 issues







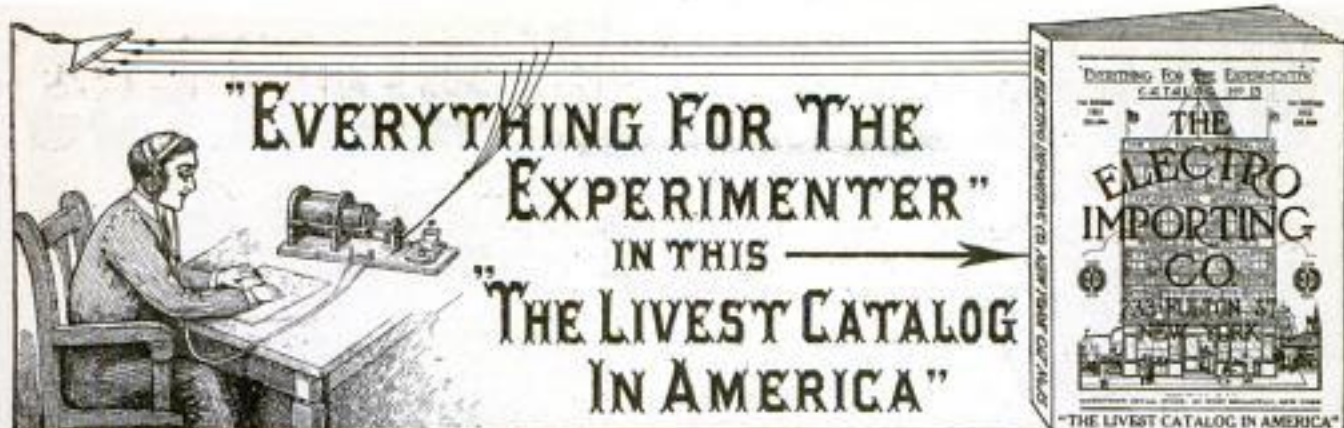

















Electrical Experimenter 234 Fulton Street, N. Y.

10c a copy at News-stands

**"EVERYTHING FOR THE EXPERIMENTER"**  
IN THIS  
**"THE LIVEST CATALOG IN AMERICA"**



**THE ELECTRO IMPORTING CO.**  
"THE LIVEST CATALOG IN AMERICA"

2392 	2422 	3418 	1119 	1550 	WIRELESS DETECTOR 
<b>Boy Scout Knife.</b> 2 Steel Blade, stag handle, detachable chain. Sh. wt. 4 oz. Size 2 $\frac{3}{4}$ ". Price <b>\$5.50.</b>	<b>Caloric Engine.</b> Runs by hot air, no steam or water used, very durable. Size 9 $\frac{1}{2}$ x 4 $\frac{1}{2}$ ". Wt. 2 lbs. Price <b>\$9.95.</b>	<b>Smallest Flashlight Made.</b> Gives powerful light. Fits in vest pocket. Size 2 $\frac{1}{2}$ x 1 $\frac{1}{4}$ ". Wt. 4 oz. Price <b>\$5.50.</b>	<b>Telegraph Key.</b> Double circuit, rubber comp. base, knob and 3 binding posts. Size 2 $\frac{1}{2}$ x 3 $\frac{1}{2}$ ". Wt. 1 lb. Price <b>\$3.35.</b>	<b>Inter-Ocean Wireless Receiving Outfit.</b> Has coupler, detector, condenser, loading coil, all connected and mounted. Size 10x12". Wt. 10 lb. Price <b>\$8.00.</b>	<b>Wireless Detector.</b> Guaranteed to receive long distance messages or money back. Our Cyclopaedia sent FREE with it. Price prepaid, <b>\$1.10.</b>
6050 	9000 	1331 	WIRELESS COURSE 	1024 	1547 
<b>Wireless Experimenting Receiving Outfit</b> contains detector, receiver, cord, serial and connecting wire, insulators, ground clamp directions. Sh. wt. 3 lbs. Price <b>\$1.25.</b>	<b>Static Machine.</b> Turning crank gives powerful 3" spark. No battery required, made of steel and hard rubber. Size 8x5x10". Wt. 6 lbs. Price <b>\$3.75.</b>	<b>Dynamo.</b> Gives 6 volts, 6 amps., lights lamps, charges batteries, etc. No toy. Size 6x6x6". Wt. 7 lbs. Price <b>\$3.70.</b>	<b>Wireless Course Free.</b> 20 lessons, 100 pages. Size 7x10 $\frac{1}{2}$ ". Coupons for this FREE Wireless Course in our Cyclopaedia Catalog.	<b>Telephone Receiver.</b> 75 Ohms, rubber shells, powerful magnet with two phones, no battery. You can talk 500 ft. Size 2 $\frac{1}{2}$ x 1 $\frac{1}{4}$ ". Wt. 1 lb. Price <b>\$4.40.</b>	<b>"Presto" Hand Lamp.</b> Fits any dry cell, burns 50 hours, no danger, reflector adjustable. Wt. 1 lb. Price <b>\$7.75.</b>
2420 	5602 	4300 	2421 	1088 	3352 
<b>Upright Steam Engine.</b> Has water gauge, whistle, balance wheel, operates on kerosene. 11" high. Wt. 3 lbs. Price <b>\$9.95.</b>	<b>Trolley Car Outfit.</b> Runs on dry cells, outfit includes car, controller, headlight and 15 $\frac{1}{2}$ ft. of track. Wt. 10 lbs. Price <b>\$5.65.</b>	<b>Pocket Ammeter.</b> 0-30 amps., pocket size, nickel plated, accurate, dependable. Size 2 $\frac{1}{2}$ ". Price <b>\$6.80.</b>	<b>"Presto" Bicycle Lamp.</b> (Electric) Operates on one dry cell, reflector adjustable; with battery container, no battery included. Wt. 2 lbs. Price <b>\$1.15.</b>	<b>Bull Dog Spark Coil.</b> Gives hot 1 in. spark, performs 1000 experiments, great for Wireless. Wt. 6 lbs. Price <b>\$4.00.</b>	<b>Printing Press.</b> (Self Inking). All type, ink, etc., included. No toy. Size 14x7 $\frac{1}{2}$ x 5 $\frac{1}{2}$ ". Price <b>\$3.00.</b>
2365 	810 	5000 	5707 	100 	7199 
<b>Rugby Football.</b> Excellent leather, lined with duck. Bladder guaranteed against everything for one year. Reg. size. Wt. 2 lbs. Price <b>\$9.00.</b>	<b>Dynamo.</b> 8 volts, 10 amps., heavily built for charging batteries, etc. Made to last. Size 8x5 $\frac{1}{2}$ x 4 $\frac{1}{2}$ ". Wt. 20 lbs. Price <b>\$9.00.</b>	<b>Rheostat.</b> Porcelain base, resistances 10 ohms, capacity 3 amps. Great for lamps, motors, etc. Size 4 in. Wt. 2 lbs. Price <b>\$6.60.</b>	<b>Xmas Tree Lighting Outfits.</b> For 110 volts current, has 8 lamps, colored socket and cord, absolutely safe. Wt. 3 lbs. Price <b>\$1.95.</b>	<b>Hustler Motor.</b> Runs on one dry cell. Size 3x3x4". Wonderful value. Wt. 1 lb. Price <b>\$85.</b>	<b>Revolver Flashlight.</b> Shoots brilliant light, looks like automatic revolver. Takes reg. flash batteries. Wt. 1 lb. Price <b>\$9.95.</b>

When ordering any of the above, include postage, or goods must be sent by express collect. The goods shown here are only a fraction of our wonderful assortment, illustrated and described in our 275 page Cyclopaedia Catalog, containing 658 illustrations. Treatise on Wireless Telegraphy, List of all U. S. Wireless Call letters, Code Chart and 20 Coupons for Free Wireless Course. Cyclopaedia sent free for 4 cents to cover postage only. Send for a copy.

**THE ELECTRO IMPORTING COMPANY**  
"Everything for the Experimenter" 233A Fulton Street, NEW YORK CITY, N. Y.

Write your name and address in the margin below.

Please Mention Popular Mechanics

# WIRELESS READ THESE Special Offers for November WIRELESS



## Free, Complete Gem Station

Receives up to 500 miles. We will give absolutely free a Gem Outfit to every one who sends us the cost of the necessary

equipment for it. This equipment consists of

2000 Ohm Headset.....	\$3.95	30 Ft. of Rubber Cable	
16 Insulators.....	.48	for lead in .....	\$ .90
1 Ground Clamp.....	.10		
500 Ft. of Al. Wire.....	1.20		\$6.63

Send \$6.63 at once and we will include the Gem Receiving Station Free. A splendid outfit for beginners.

## Complete Outfit \$14.00

Sends up to 20 miles. Receives up to 2000

Mechanically and electrically perfect, ready for receiving and sending — including a 2000 Ohm headset, 1 1/2 inch spark coil, air cooler spark gap, collapsible helix, big two-slide tuner, fixed condenser, detector, wireless key, DPDT switch-buzzer with key. Complete outfit ready to use at special price of \$14.00.



# NEW NAVY TYPE LOOSE COUPLER

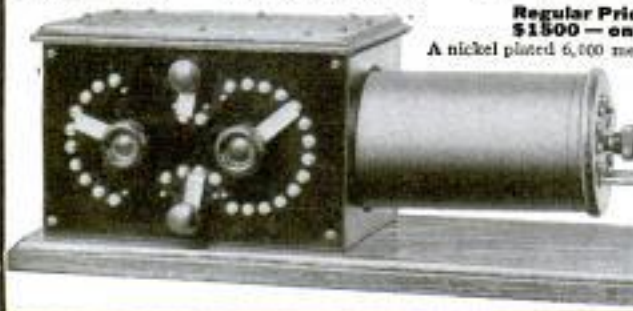

Regular Price \$15.00 — only \$10.00

A nickel plated 6,000 meter

All finished parts of this coupler ready for assembling, \$6.50

inductance tuner, perfect in every detail. Equipped with four point loading inductance which increases the wave length 4,000 meters over the average Navy Type Transformers. The primary winding has 24 taps—one switch controls the primary in groups of tens, the other controls one turn at a time—and is equipped with a dead end switch. Enclosed in a cabinet, the front of which is polished hard rubber. The secondary coil is wound with double silk covered wire and the inductance is varied by a ten point switch. With this coupler the very best and most accurate tuning is easily and quickly secured. With a good sized aerial the reception of wave lengths up to 6,000 is possible. Send 4c postage for 152 p. Catalog D-40.

NICHOLS ELECTRIC CO., Inc.  
1 and 3 West Broadway NEW YORK



**200 KINDS** Iron, Wood, Wire & Steel  
**PUZZLES**  
Catalog and 2 wire leaders and track card only 10c.  
**WESTERN PUZZLE WORKS**  
ST. PAUL, MINN.



## FUN

and electrical knowledge galore — Get a

## Thordarson Improved Toy Transformer

Largest size, 3x2x4 in. Runs a doc. electrical toys at once. Handiest, Safest. Arrow points to protective device—no other transformer has this. Absolutely prevents short-circuits and burning. A fine Xmas gift. Write NOW for description and price. Thordarson Electric Mfg. Co., 501 S. Jefferson St., Chicago

horse recorded by Homer in the story of the siege of Troy. A huge collier was set drifting toward the shoals lining the shores near the plains of Troy. The Turkish



**Boy Electrician** with 78 illustrations for making Batteries, Dynamos, Motors, Telegraph apparatus, Telephone, Lights, Bells, Alarms, Coils, "Wireless" Current Reverser, Electric Engine, Etc. By Electrical Experts so that anyone can understand it. With Cat. All 10c Ppd.

J. C. DORN, 705 So. Dearborn St., Dept. 100, Chicago, Ill.



**Big Entertainer** 320 Jokes and Riddles, 153 Parlor Games and Magic, 15 Tricks with Cards, 73 Toasts, 7 Comic Recitations, 3 Monologues, 22 Funny Readings. Also Checkers, Chess, Dominoes, Fox and Geese, 9 Men Morris. All 10c. postpaid.

J. C. DORN, 709 So. Dearborn Street, Dept. 17, Chicago, Ill.



## Boys' Own Toy Maker

Tells how to make a Talking Machine, Camera, Electrical Motor, Bicycle Boat, Canoe, Boomerang, Bobbed, Wind Mill, Microscope, Water Wheel and Motor, Stilt, Toboggan, Snow Coaster and Sail Boat, Telephone, Electric Bell, Railroad Wind Mobile, Paddle Raft, Traps, Kites, etc. All 10c. postpaid.

J. C. DORN, 707 So. Dearborn St., Dept. 80, Chicago, Ill.

## \$2500 A YEAR

Easy for high grade men selling this motor car device every car owner needs—and will buy the minute he knows what it will do. The **Hart-Bell Carbon Remover** is a simple, ingenious device for removing carbon—safe, sure, certain. Note the illustration, which shows how simple and practical this device is. No mechanical knowledge required to sell it. Hundreds in use, and every one in use has won an unqualified endorsement. "Perfect satisfaction . . . one of the best means for removing carbon brought to my notice in all of my twelve years' experience." "It is so simple and works so splendidly that we will be very glad to recommend it to anyone."

## CAR OWNERS! "Write for Book 'Causes and Effect'"

If you can sell anything you can sell this. We have some good territory still to be allotted. Are you big enough to handle it? If you are, write

Utility Products Co., INC.  
1408 Times Bldg., NEW YORK



## 1915 Harley-Davidson



Winner of the International Grand Prize Race at Venice, California, April 4th.

Complete description of various models can be obtained from any dealer or catalog will be mailed on request.

HARLEY-DAVIDSON MOTOR COMPANY  
Producers of High Grade Motorcycles for Fourteen Years  
431 B Street Milwaukee, Wisconsin

## "Interlox" SAVES TIME, TEMPER AND TROUBLE

**MASTER SLIDE RULE**  
The Only Interlocking Rule made—and the Only one whereby inside measurements of door, windows, etc., can be taken rapidly and accurately. Also superior to all others for outside measurements of walls, ceilings, etc. If your hardware dealer hasn't this Rule, send us his name and 15c per foot (in any length from 2 to 8 ft.) and it will be sent prepaid.

Liberal Proposition for Dealers and Agents

DAHL MFG. CO., 51P E. 42nd St., NEW YORK



# Boys—Here's Fun

**FREE BIG CATALOG**

## Ask Dad For This TRAIN

**STOP  
LOOK  
LISTEN**

**Write Quickly for Catalog**

**YOU'LL** have barrels of fun with a Lionel electric locomotive; couple to it Pullmans or freight cars; get switches, semaphores, electric lights, track, etc. Make the trains scoot around with a touch of your finger. Run 'em on batteries or from electricity in your house with a Lionel transformer which saves batteries. (See illustration.)

**250,000 Boys Own Them** — Join us — this quarter million of happy boys.

### Lionel Electric Trains

are safe — no shocks. They're Steel — not Cast Iron — and won't break. Are highest grade of material throughout, but not high priced. Unconditionally guaranteed. Finished handsomely in colors and gold. Models are faithful reproductions of originals seen on our prominent railroads.

**WRITE QUICKLY FOR NEW BOY'S CATALOG** — Written especially for YOU, crammed full of pictures. New photos tell you why you'll have such a dandy good time with Lionel Trains.

**SECTION OF LIONEL RAIL FREE** — Most toy dealers, electrical stores and department stores sell Lionel Toys. If you'll go to your toy dealer, find out if he sells Lionel Trains, and tell me when you write for catalog — I'll include a special section of rail — free.

**THE LIONEL MFG. CO.**

DEPT. 46  
48-52 E. 21st Street  
NEW YORK CITY

**J. LIONEL COWEN**

A Friend of Boys  
President

# LIONEL TOYS ELECTRIC



If You Have Electricity  
Be Sure to Get This  
Transformer

patrols noticed it, but its apparent helplessness deceived them entirely and when, toward night, the big boat struck bottom and the crew was seen taking to their boats and rowing hastily toward the sea, the Turks felt

**ELECTRIC HOME, FARM, THEATRE, STORE and TOWN LIGHTING PLANTS.** \$18.00 Rectifier Charges Storage Batteries from Lamp Socket Lighting Your Auto Electrically for ONE CENT an hour. Lamps; Dynamos; Engines; Belts; Medical and Storage Batteries; Belts; Books; Sewing Machine and Power Motors; Railways; Bikes, Carriage, Fish, Hunting, Auto and Xmas Lights; Massage and Ozon Machines; Telephones.

**MOTION Picture Theatre Traveling and Permanent Equipments.** Big Profit. Ten Cents an Hour Lights Theatre and M. P. Machine. Catalog 3 etc.

**OHIO ELECTRIC WORKS, CLEVELAND, OHIO**

## GENERATORS

6 volts, 10 amperes, \$8.50. 8 volts, 10 amperes, \$10.00

For charging storage batteries, plating, operating wireless coils, lighting outfits, etc. Can be attached to automobile or motor boat. Our smaller sizes of dynamo motors make ideal machines for experimenting, lighting, etc. As motors they will operate heavy models, ensaw wheels and other useful appliances.

18 watt dynamo-motor, \$3.00 24 watt dynamo-motor, \$3.85

40 watt dynamo-motor, \$5.25

Send 2 cent stamp for catalog of wireless apparatus, trains, electrical supplies, novelties, tools and books. Loomis Electric Company, 1427 N. Artesian Ave., Chicago, Ill.

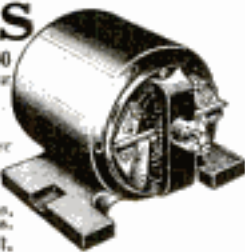

**Complete Wireless Sending and Receiving Station \$10<sup>10</sup>**

Receives hundreds of miles.

Sends 8 to 20 miles.

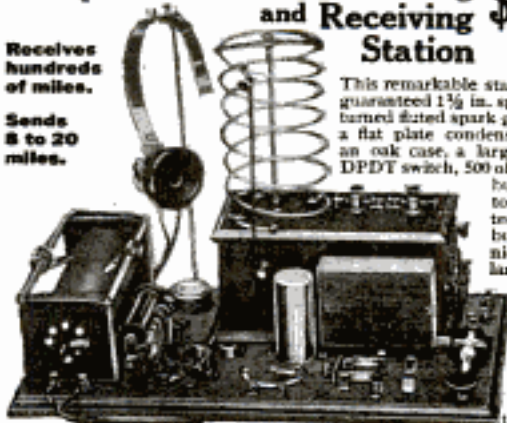

This remarkable station consists of a guaranteed 1 1/2 in. spark coil, machine turned fluted spark gap, our 1501 key, a flat plate condenser, assembled in an oak case, a large capacity helix, DPDT switch, 500 ohm potentiometer, buzzer and switch to tell if your 2 detectors are working, buzzer battery in nicked case, tubular condenser, bare wire wound double slide tuner, number 30 silk wire wound large 6 capacity loading coil that allows you to get Arlington and long wave stations.

Send stamp for our large catalog "P" of remarkable values. If possible call and see our stock. **THE HANDEL ELECT. CO., 138-140 Centre St., NEW YORK**

## Murdock Wireless Receivers

Complete double set, 2000 ohms, \$4.00

Complete double set, 3000 ohms, \$5.00



Handsome, sturdy, sensitive instruments, perfect in every detail of materials and construction, they will positively equal the best performance of phones selling for many times the prices and completely surpass in total efficiency any offered at similar prices.

We will allow fourteen days' trial for any tests you may care to make and will refund the purchase price if the set proves unsatisfactory in any way. Order a set today. Try them. They will prove the best investment you can make if you want really good receivers.

Our 48-page catalog describing these sets and other good apparatus, will be sent on request.

**WM. J. MURDOCK CO.**

10 Carter St. CHELSEA, MASS.

680 Howard St., San Francisco

Please Mention Popular Mechanics

# Friends—Americans—Countrymen LEND US YOUR EARS

Our new catalog is brimful of new things,—mostly electrical; motors, dynamos, lighting plants, meters, spark coils, electrical toys, electrical heating and cooking devices, parts for building all sorts of electrical things, Motion Picture machines, Phonographs, and hundreds of other things, besides the highest grade wireless instruments made in America. It has an appeal for every wide-awake man, woman, girl, or boy. The holiday season is nearly here and it will help solve many a perplexing problem of "what to give" or "what you want."

CLAPP-EASTHAM CO., Manufacturers and Distributors, 147 Main St., Cambridge, Mass.

Send for your copy now, to-day, while you think of it.

## IT'S FREE

Since 1907 our name has been linked only with apparatus which carries a feeling of pride and security.

## JUST OUT! PERMANON DETECTOR

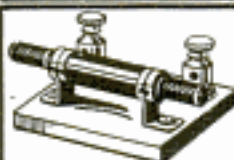

AT LAST—a permanent detector at a low price.

A little marvel, within the reach of every wireless amateur. Increase the range and pleasure of your station with this wonderfully sensitive and easily adjusted detector. **\$2.25**  
Send today—price postpaid only . . . .

### Have You Our New Catalog?

It's chock full of new electrical and experimental specialties that are right in price and quality. Everything illustrated, fully described and exactly as represented. Save money and get a square deal. Send 4 cents in stamps for catalog—J.

THE ELECTRO-SET CO., SIXTH ST., CLEVELAND

## Valuable Wireless Information—New

THIS brand new booklet, Catalog P, just off the press, is full of descriptions and methods that will help you. Gives Construction of Antennae; Theory of Wireless; Diagrams of Connections, etc. Also full description of our high grade receiving apparatus. *Send 4c (stamps) today—Now.*

Room 817 C. BRANDES, Inc. 32 Union Square NEW YORK

## BRANDES Wireless Receivers



## Firestone CYCLE TIRES

Toughest, thickest, most resilient tread. Built like a motor-car tire. All sizes: Non-skid and corrugated tread.

Firestone Tire and Rubber Company  
Akron, Ohio—Branches and Dealers Everywhere



The Green Automatic

## ADD TO YOUR INCOME

With little effort you can make **\$5 to \$10** a day

"AMERICAN" Sharpener

The "AMERICAN" is the only machine on the market (barring none) that sharpens, hones, and strops razors, sharpens all kinds safety razor blades, scissors, clippers, pocket knives, surgical instruments, etc. No previous experience required. REMEMBER THE GREEN AUTOMATIC is one of our latest conceptions, it Sharpens, Hones, and Stropps each and every blade, all in one operation; it finishes from four to six blades per minute. Write for free booklet.

AMERICAN SHARPENING MACHINE CO., (Inc.) Dept. 11, 184 W. Washington St., CHICAGO



## AGENTS!

Here is Your Chance to make money by saving money for others. Our new discovery, **EGGINE** Powder, takes the place of Eggs in baking and cooking at less than 9c a doz. A 25c package equals 3 doz. An absolutely Pure Food Product fully guaranteed. Derived principally from milk and corn. Convenient, economical and always fresh. Satisfaction certain, thus steady customers. Send 10c for trial package and terms postpaid.

CHAS. T. MORRISSEY & CO.  
4414 Madison St. CHICAGO, ILL.

FREE



TRIAL

Cut out this ad and mail it to us, with your name and address (no money), and we will send you our **FAMOUS KARNAK RAZOR** by return mail, postpaid. You may use the razor for 30 days **FREE**; then, if you like it, pay us \$1.85. If you don't like it send it back.

**MORE COMPANY, 182 More Building, ST. LOUIS, MO.**

certain that the stranded vessel would be safe for the night and made no attempt to board her. In the morning, however, when they returned they were met by a sharp fire from British troops, which had landed during the night from the apparent derelict.

**ELECTRIC LIGHT PLANTS** Complete gasoline engine, dynamo, switchboard and storage battery \$340.  
Agents wanted. American Battery Co., 1129 Fulton St. Chicago (Estab. 1889.)

**Old Stamps Wanted FOR CASH.** We buy rare or old stamps of any country, also old or large stamp collections, old letter files (from 1843 to 1870) of private individuals or old business or banking firms. **PREMIUM LIST 10c.** Address **C. E. HUSSMAN STAMP COMPANY, Dept. M. O., St. Louis, Mo.**



## ELECTRICITY

**BOYS**—Send today for our new 128-page catalog of everything electrical. Motors, Dynamos, Flashlights, Lamps, Coils, Batteries, Transformers, Magnet and Resistance Wires, Telegraph Outfits, Miniature Electrical Railways and Parts. Catalog with coupon sent only for 6c in stamps or coin. No postals answered.  
**VOLTAMP ELECTRIC MFG. CO. Voltamp Block, BALTIMORE, MD.**

**AUTOMATIC CARD PRINTING IS**  
**EVER-LASTING-LY GOOD PAYING BUSINESS EVERYWHERE**  
WRITE TO DAY FOR FREE BOOKLET OF OUR AUTOMATIC SELF-FEEDING PRINTING PRESS  
**S. B. FEUERSTEIN & CO. MANUFACTURERS 542 W. JACKSON BLVD. CHICAGO, ILL.**

# HERMAN'S U.S. ARMY SHOES



**"The New United States Army Shoe on the Munson last is the only perfect shoe made."**—*Lieut. Townsend Whelen, U.S.A.*

It allows natural foot freedom while setting snug at the heel and will not chafe, bind, pinch or blister under severe tests of climate and service. Every U. S. Soldier, most militiamen and thousands of civilians wear it. Every Sportsman and outdoor worker ought to have a pair. Ask your dealer or send to us for catalog and testimonials. The price is **4.50 a pair**, prepaid. A fine Christmas gift.



**JOS. M. HERMAN SHOE CO.**  
160 Lincoln St., Dept. 56, Boston, Mass.

## AGENTS \$60 A WEEK



We want Special Agents to travel by automobile selling our **300 Candle Power Outdoor Lamp and Safety Lantern**

Burns Kerosene. Can't explode. Can't set fire to anything. Burns in all kinds of weather. Rain proof, wind proof, bug proof. For farmers, teamsters, hucksters, plumbers, dairymen, campers—everybody needs it.

## This Auto Given



Write for plan how we furnish each representative with an automobile. This is no selling contest, where only one person wins. Anybody can earn this auto.

**THOMAS MFG. CO., 1048 East St., DAYTON, OHIO**

## Argo Standard

Standard tread, 4-cylinder motor; full streamline body; a wonder at the price.

Roadster  
**\$385**

f.o.b. factory

Touring Car  
**\$435**

f.o.b. factory

Electric lighting and starting system, \$60 additional

Not only the most but the best that such a price has ever bought.

**ARGO MOTOR COMPANY, Inc.**  
614 Main St. JACKSON, MICHIGAN

## A "MIDGET" Emblem of Your Order

has an added dignity thru its uniqueness of size, retaining without its individuality in detail of design. Inserted at point of lapel and tightly screwed.

In Solid Gold only, 50c

- |                        |                       |
|------------------------|-----------------------|
| 1. Woodmen of World    | 11. Korston Masonic   |
| 2. Odd Fellows         | 12. Elks              |
| 3. Redmen              | 13. Men's Bible Class |
| 4. Knights Columbus    | 14. Jr. O. American   |
| 5. Modern Woodmen      | 15. Merchants         |
| 6. Masonic             | 16. Knights Pythias   |
| 7. Hill & Cane Masonic | 17. Knights Templar   |
| 8. Shrines             | 18. Moose             |
| 9. Trained Masonic     | 19. F. O. Eagles      |
| 10. Slipper Masonic    | 20. Grocers Masonic   |

20-21 Old Glory and the Bell

**PHILADELPHIA BADGE CO.**  
174 N. Eighth St. Philadelphia, Pa.



Square Deal  
Miller  
Says—



**1916 Models Now Ready!**

**Any Watch You Want On Credit**



**Waltham  
Hamilton  
Howard  
Elgin  
Illinois, Rockford**

## All Are 1916 Models.

And I am the first man in the country to offer the **NEW 1916 MODELS** of America's best known watches. I have them all, the latest products of the world's most famous factories, and watches are by no means all. You can get too, the very latest style mountings for **Diamonds**, and the most up-to-date pieces of exquisite **Jewelry**. Whether you buy for cash or credit, the prices are right.

**\$2.75 A MONTH**  
NO MONEY DOWN  
GIFT SPECIAL NO. 1

## I Smash the Terms!

My Square Deal methods—my high grade, well known merchandise, my liberal policies, right prices, lowest terms, have earned me my title—"Terms Smashing Miller." No catalog published offers such remarkable values, such smashing terms, as our brand new **1916 Free Book**.

## 30 Day Free Trial

**No Money Down Express Paid in Advance By Me**

That is the test that tells. Suppose you want a watch? Any make, any grade, any size, any case. I have it for you—just the watch that you want—a **1916 Model**—NO MONEY DOWN, Express Prepaid. You can try any one of America's best known timepieces for 30 days. **A Free Trial, a Full Month to Carry it in Your Pocket.**

## No References Demanded—An Open Account

The same credit you get from your grocer liberally and cheerfully given. Arrangements are made for an Open Account as soon as you write. No red tape, no publicity, notes, nor collectors. Every transaction strictly confidential.

## Send This Today For Watch & Diamond Book

Send me your name and address at once so I can mail you, Free and postpaid, the most beautiful catalog of its kind ever printed. I want you to see the **New 1916 Models** of America's best known watches. The book is a gem. It illustrates all makes of valuable **Watches, Elegant Genuine Diamonds**, and a vast assortment of **Beautiful Jewelry**, all on the easiest and most liberal terms.

Write today and get a letter from me that will make you a friend of mine from the start.

**SQUARE DEAL Miller, Pres., Miller-Hoefel Co.**  
552 MILLER BUILDING  
DETROIT, MICH.

**SQUARE DEAL MILLER, Pres.**  
552 MILLER BLDG.  
DETROIT, MICH.

Dear Sir: Please send me, without cost or obligation, your Big Book on all makes of High Grade Watches, the **1916 Models**, Genuine Diamonds and Jewelry and full information on your Easy Payment, No Money Down, and 30 Day Trial Plan.

Name \_\_\_\_\_  
Address \_\_\_\_\_

Please Mention Popular Mechanics



## GET ACQUAINTED WITH US ON THE NEWS-STANDS

**I**F you are a Man of Affairs, and would like to know what the world is thinking—if your time is limited, and you want a “Cook’s Tour” through the realm of world thought—if a Monthly Review in Cartoon and Comment of Current Events appeals to you—if you want the viewpoint of other nations—if you would like to read history in the making in its most attractive form

GET A COPY OF

# CARTOONS MAGAZINE

(Published by H. H. WINDSOR, Publisher of Popular Mechanics Magazine)

It is the only magazine in the field mobilizing the pen-and-ink satirists from the four corners of the world, men who are fighting silent battles on their drawing boards.

So great has been the demand for back numbers of this periodical that several issues published early in the war have been exhausted. The file of *Cartoons Magazine* will be almost priceless a few years hence. It is a magazine for your library and reading table.

**25c A COPY**

**\$3.00 A YEAR**

**This Coupon** and \$3 brings it to you for a **Year**.

CARTOONS MAGAZINE

6 N. Michigan Avenue, Chicago

Enclosed please find \$3.00, for which enter me for a year's subscription to your magazine.

Name.....

Street .....

City .....

# \$100 And You Keep This Superb NEW EDISON

The great New Edison with the new Diamond Stylus reproducer and your choice of all the brand new Diamond Amberol Records will be sent to you on free trial without a penny down.

## Entertain Your Friends

Hear all the latest up-to-date song hits of the big cities. Laugh until the tears stream down your face from laughing at the funniest of minstrel shows. Entertain your family and your friends with everything from Grand Opera to Comic Vaudeville—then if you choose, send the outfit back to us at our expense.

## Rock-Bottom Direct Offer

Think of it — a \$1.00 payment, and a few dollars a month to get this brand new style outfit — the Diamond Stylus reproducer, the musical quality — the same Diamond Amberol Records — all the musical results of the highest price outfits — yes, the greatest value for \$1.00 down, balance on **easiest monthly terms**. Convince yourself — a free trial first! No money down, no C. O. D., not one cent to pay us unless you choose to keep the instrument.

## Our New Edison Catalog Sent Free

Your name and address on a postal or a letter (or just the coupon) is enough. No obligations in asking for the catalog. Get this offer — while this offer lasts. Fill out coupon today.

**F. K. Babson, Edison Phonograph Distributors**  
1198 Edison Bldg., Chicago, Ill.  
Canadian Office: 355 Portage Ave., Winnipeg, Manitoba

Name .....

Address .....

To **F. K. BABSON,**  
Edison Phonograph Distributors,  
1198 Edison Bldg., Chicago, Ill.

Gentlemen: Please send me your New Edison Catalog and full particulars of your free trial offer on the new model Edison Phonograph.

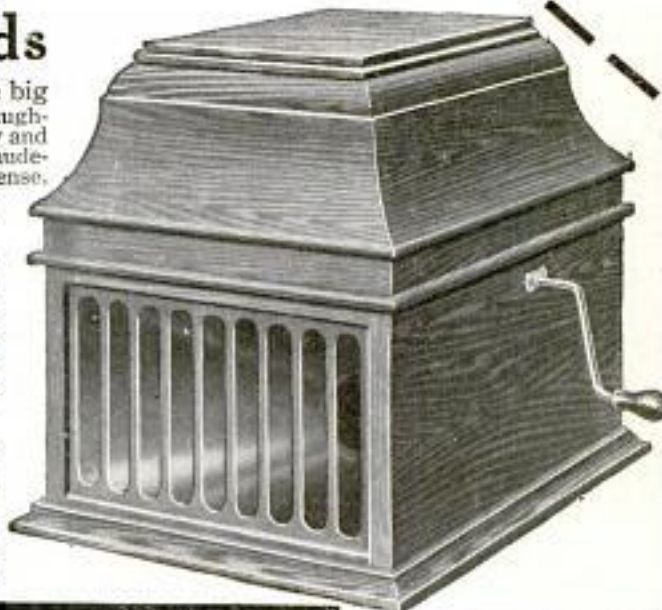

## Take Better Pictures

### THE TRILUX EXPOSURE METER

tells *instantly, accurately and easily* the correct time for all exposures indoors and out

All timing guesswork is eliminated. Shows instantly, on plainly marked scale, time for exposure; used with any film or shutter. Can't get out of order. No sensitive paper. No larger than a roll of film — weighs less than three ounces. Neatly finished in gruzmetal and nickel. Use the Trilux and never lose a film. At your dealer's or postpaid, \$2.00. Money back if not satisfied. Send for booklet. **Trilux Photo Co., 1401D Marquette Bldg., Chicago, Ill.**

**1,800 MILES IN A DORY**—After a voyage of 1,800 miles from Unga, Alaska, in a 16-ft. fishing dory, two Alaska fishermen recently sailed into San Francisco Harbor. The trip had taken 45 days.

## The Acetylene Blow Torch Prest-O-Torch

Costs less to buy than a good gasoline blow torch and costs less to use.

In all soldering and brazing, the Prest-O-Torch avoids the delays and uncertainties of gasoline outfits. Provides a concentrated, intense flame that doesn't blow out even in a high wind. Needs no attention whatever. Used with handy sizes of Prest-O-Lite cylinders—ready-made gas, instantly available.

Style "A" sells for 75c. Used with the small MC size Prest-O-Lite. Will braze up to 1/4 inch round rod. This outfit can be fitted with handle and hook for added convenience in bench and overhead work. Style "C" Prest-O-Torch is recommended for large work. Will braze up to 3/4 inch round rod. Sells for \$2.25. For use with the larger sizes of Prest-O-Lites.

Write for special literature and learn where you can see the Prest-O-Torch in operation.

**The Prest-O-Lite Co., Inc., 216 Speedway, Indianapolis, Ind.**  
Exchange Agencies Everywhere

36278 \$150.	36034 \$45.	<b>20% = 10%</b> DOWN MONTHLY <b>DIAMONDS ON CREDIT</b>	36030 \$25.	36184 \$100.
36043 \$100.	36254 \$50.	<b>SAVE</b> money on your diamonds, watches and jewelry by buying from our new Catalogue de luxe, which explains our easy payment system. We are Importers and guarantee you every advantage in price and quality. <b>20% DOWN and 10% MONTHLY.</b> Guarantee certificate with each diamond. Full credit allowed on exchange. Transactions strictly confidential. Write today for Catalogue Number 6	36055 \$300.	36211 \$90.
36226 \$25.	36071 \$55.	<b>L. W. SWEET &amp; CO.</b> 2 and 4 MAIDEN LANE NEW YORK CITY	36080 \$100.	

Please Mention Popular Mechanics

## (CONTINUED FROM PAGE 28 FRONT ADVERTISING SECTION)

## MUSIC

"FIGHT for the American Flag," latest patriotic song, and professional copy of "You Were, You Are, You'll Be," most wonderful love song ever written, for 15c. Bauer Music Co., 133 East 34th St., New York.

SHEET Music 5 cents a copy. Postal brings 1st. Knorr & Co., Spring Valley, N. Y.

SONG Melody free. Piano part \$2.00. Send poem. L. M. Clark, Composer, D 27, Thomaston, Me.

RECORDS for Victrola, Columbia and Edison (disc or cylinder) Talking Machines. Edison Standard, 9c; Blue Amberol, 25c; Victrola, 15c; bought, sold and exchanged. Permanent Jewel Needle, \$1; Jewel point attachment for Victrola or Grafonola to play Edison disc records, \$2. Send for record list. Well's Curiosity Shop, 20 S. 2nd St., Philadelphia, Pa.

"DREAMS," the greatest waltz ballad in years. For sale everywhere or direct from us, 10 cents. Marks-Goldsmith Co., Dept. 91, Washington, D. C.

## DIAMONDS, WATCHES AND JEWELRY

GENUINE Perfect Cut Diamonds, \$97.50 per carat! Direct from the importer to you. We eliminate middlemen's profits and thus save you 35%. Any select on shipped for free examination without obligating you to buy. Written Money-Back Contract with every diamond. In this we certify carat weight and value; allows full price in exchange any time; allows 90% cash refund any time within one year. Write for our big valuable Basch De Luxe Diamond Book free! Beautiful illustrations of thousands of articles of jewelry. Shows how to buy diamonds intelligently. Write to L. Basch & Co., Dept. L-2400, State and Quincy Streets, Chicago.

## FORMULAS AND TRADE SECRETS

100 MONEY-MAKING Formulas, 10c. Process Company, 415 E. Dearborn Building, Chicago.

25 USES for salt; also two excellent cake recipes. All for 10c. John Stockburger, 1702 Royal Ave., Canton, Ohio.

10,000 SELECTED scientific, chemical, technological, and practical recipes and processes, including hundreds of so-called trade secrets for every business, alphabetically arranged in one large volume of 800 pages. Price \$3 prepaid. Popular Mechanics Book Dept., 6 N. Michigan Ave., Chicago.

3,000 FORMULAS 40c; 100 plans, schemes, 25c. 75 Manufacturing secrets, 10c. Reeliver Mirrors, 20c. All 50c. Catalogue free. "Ideal," 2311-P, Belleplaine Ave., Chicago.

HIGH Grade Guaranteed Formulas for almost any occasion. Prices reasonable. Cole Chemical Co., Chicago.

SILVERING mirror formula (Guaranteed); complete working instructions, 2c. Scientific Bureau, W. Lynn, Mass.

29,000 FORMULAS—Price \$1, prepaid; complete list 4c stamps. Edm. Bromley, Waterliet, N. Y.

## GAMES AND ENTERTAINMENTS

FREE Catalogues of Magic Illusions, Escapes, Mind Reading and Money Making Secrets. W. Albert Tripp (Dept. C), New Bedford, Mass.

ONLY 10c—250 Magic Tricks with cards, coins, handkerchief, egg, ring, glass—simple, illustrated—all for only 10c to introduce catalogs, books, novelties. Muntean Specialties, 4310 Broadway, Galveston, Texas.

MAGIC, Sleight of Hand, Secrets of 24 excellent tricks for home entertainments, 50c. Stratman, 4224 Parker, Omaha, Nebr.

BARGAIN Catalogue and Secret Free. New Magic Tricks. Eagle Magical Co., Minneapolis, Minn.

JUST out—the Nut Puzzle; best ever made. Tricks, large assortment of new puzzles, jokers' goods and pocket novelties. Shooting cigarettes, cigars, matches, 500 others. Send 2c for our large new catalogue. J. Grandefeld, 1238 Theriot Ave., Bronx, New York.

UNCLE Joe's Initiation—Very humorous reading. Lodge hit. Everybody laughs. Copy 25c. E. A. Crowl, Peekin, Ill.

TRICKS, Puzzles, Jokes, Magic Goods, Sensational Escapes, and Illusions. B.g. catalogue free. Oaks Magic Co., Dept. 254, Oshkosh, Wis.

FUNABOUT Fords—The book that contains the funny Ford stories that the whole nation has laughed over. The greatest book novelty of the year. A collection of nearly one hundred of the very latest and best current "Ford stories" in book form. 64 pages, 6½x11½ in. Heavy boards. Price 25 cents postpaid. Send for your copy now. Popular Mechanics Book Dept., 6 N. Michigan Ave., Chicago.

PLAYS, Vaudeville Sketches, Monologues, Dialogues, Speakers, Minstrel Material, Jokes, Recitations, Tableaux, Drills, Musical Pieces, Entertainments for all occasions. Make-up Goods. Large Catalog Free. T. S. Denison & Co., Dept. 11, Chicago.

MAGIC Pocket Trick, including professional catalog, 6c. Magic Co., Sta. 10, 249 West 38th St., New York.

MAGIC: We teach you to perform Tricks at home as good as the great professionals. Feature Acts in Mind Reading, Spiritualistic Work, Rope Ties, Escape Acts. Send for New Thumb Tie for stage work—7 illustrations; complete directions, 50c. Catalogue 100 pages, greatest on earth, 10c. Chicago Magic Co., Dept. B, 72 W. Adams St., Chicago, Ill.

## TYPEWRITERS AND SUPPLIES

TYPEWRITERS, all makes factory-rebuilt by famous "Young Process." Look like new, wear like new, guaranteed like new. Our big business insures "Square Deal" and permits lowest cash prices—\$10 and up. Also, machines rented or sold on time. No matter what your needs are, we can best serve you. Write and see—now. Young Typewriter Company, Dept. 221, Chicago.

ABSOLUTELY Best Typewriter Bargains, \$7.50 to \$45.00. Guaranteed five years. 15 days free trial. Send for Illustrated and Descriptive catalogue. Typewriter Manufacturers Exchange, 3121 Broadway, New York, N. Y.

LARGEST Stock of Typewriters in America—All makes; Underwoods, Oliviers, Remingtons, etc., one-fourth to one-half manufacturers' prices, \$15 up, rented anywhere, applying rent on price; free trial; installment payments if desired. Write for catalogue 70. Typewriter Emporium (Established 1892), 34-36 West Lake Street, Chicago, Illinois.

## DUPLICATORS AND DEVICES

MALALANE Duplicators excel all. 100-150 copies on writing, 10x12" size \$2.50. Ask booklet. Malalane, 1765 Southern Blvd., New York.

MULTIGRAPH (rebuild). Perfect. ¼ cost. Guaranteed. Ship on approval. John Paul, Bourne Bldg., Philadelphia, Pa.

DUPLICATORS, 9x12, price \$1. Make 50 copies from pen or typewritten original. Booklet Free. Scientek Laboratories, Dept. 1, Madison, Maine.

OUR "Modern" Dupliator—Yours for \$2.40. No Glue or Gelatin. Always ready. All sizes. Free trial. 34,000 users. Standard for 15 years. Booklet free. Sole mfrs., J. E. Durkin & Reeves Co., 339 Fifth Ave., Pittsburgh, Pa.

## MAILING LISTS

FARMERS, Guaranteed, Circulars mailed 500 for \$2.50. The Letter Shop, 517 Main St., Davenport, Iowa.

5,000 NAMES Motorcycle owners Southern States, \$6.00. Clifton Byrd, P. O. Box 89, Durham, N. C.

FREE to business men, copy of our comprehensive "Silent Salesman." Contains over 2,000 different classifications of mailing lists with number and price of each list, and information every business man needs. Accept this free offer. Trade Circular Addressing Co., G 164½ W. Adams, Chicago.

## PRINTING, ENGRAVING AND MULTIGRAPHING

IMITATION typewritten letters, heading black, body purple, \$1.80; 6x9 circulars, 9c; letterheads, \$1.20; envelopes, \$1.16; statements, \$1; tags and ad slips, 60c. All in 5,000 lots. Elegant sample free. Good's Printery, Harrisonburg, Va.

100 TWO color Letterheads and 100 Envelopes, bond; Postpaid, \$1. Satisfaction guaranteed. Catalogue, 2c red stamp. Swift Printery, Worcester, Mass.

1,000 3½x8 Circulars postpaid, \$1.00. International Trading Agency, 218-D Jefferson Ave., Rochester, N. Y.

PROPER Printing. Not cheaper but better. 1,000 envelopes, letterheads, bill-headers circulars, \$2.50 per 1,000. Samples. Robbison Printery, Curwensville, Pa.

AUTOMATIC Card Printing press, little used with stock complete, \$250. A splendid outfit for either mail-order or store business. Write The Sterling Print, Sterling, Mass.

500 3-PLY Business Cards, 75c. Tracey, Tippencanoe City, Ohio.

ENVELOPES, Billheads, Noteheads, 1,000, \$1.50. 1,000 Linen-finish letterheads or envelopes, \$2.50; 500, \$1.50. Samples free. Specialties, Circulars, booklets, Jukes, 129 Fifth, Philadelphia.

PRINTING Outfits—Presses, type, supplies, type novelties. Send stamp for catalogue. Model Press, York, Penna.

4,000 GUMMED Labels printed in two colors, 1¼x2¼, \$1. Star Press, Clintonville, Conn.

GOOD Business Cards, regular \$3 value, printed to order, 1,000, \$2; 500, \$1.15. Sent prepaid. Lyons Co., 262 S. Ebert St., Columbus, Ohio.

BOYS—Earn Christmas money. Presses and printing outfits \$5 and upward. Catalogue free. Excelsior Press Co., 14 So. Fifth St., Philadelphia.

100 NEATLY printed calling cards, with nice card case, 25c. Gem Co., Box 467, Marion, Ind.

IMITATION typewritten letters that look real. Prices reasonable. Free samples. Write. Miss Emma Fuerst, Moon Building, Chicago.

250 BOND letter heads and 250 envelopes, printed, \$1.40 prepaid; samples. Rose Co., Culberson, N. C.

25 BUSINESS Cards, your copy, 10c. Chas. Walter, Lancaster, Oh. o.

QUALITY Printing Prepaid—500 either envelopes, noteheads, cards, statements, \$1.25. 1,000 \$1.85; 1,000 envelope slips, \$1. 1,000 6x9 circulars, \$1.75. 500 linen-finish letterheads or envelopes, \$1.75; 1,000, \$3. Printing prepaid. Imitation typewritten letters. Stamp brings samples. Model Company, Manchester, Iowa.

150 HAMMERMILL Bond Letterheads and 150 envelopes printed to order, \$1 prepaid. Samples free. Andrew Grems, Corona, N. Y.

1,000 BOND Letterheads, 8½x11, \$1.00. Samples free. Burton Bros., Louisville, Ky.

MULTIGRAPHED Letters, complete—heading black, body purple, 25 lines copy, 1,000, \$3.50; 500, \$2.35; 250, \$1.75. Quick delivery, perfect work. Samples free. Franklin Letter Press, Waukegan, Ill.

250 BOND Letterheads and 250 Envelopes neatly printed, \$1.75, prepaid. Elegant samples free. Wolverine Press, 37 Harrison, Detroit, Mich.

HAMMERMILL Bond Letterheads and Envelopes, 100 of each, and 100 white wove return envelopes, \$1.00 postpaid. Samples Free. Toledo Press, Box 184C, Toledo, Ohio.

MULTIGRAPH Letters, Letterheads—1,000 complete, \$3. Letters purple, heads black. Samples for stamp. Perfection Letter Company, Muncie, Indiana.

ADVERTISERS—Here's your opportunity. 25 word classified ad inserted in "Cartoons Magazine" for 50c; one inch display ad \$1.25. 20,000 copies guaranteed. Send in your ad for the next issue. Cartoons Classified Dept., 78 E. Madison St., Chicago.

GOOD Printing at low prices. 1,000 good letterheads, envelopes, cards, billheads, labels, circulars, \$2.50. Samples free. Catalogues, booklets, and circulars our specialty. Ernest L. Fantus Co., 323 S. Dearborn St., Chicago.

## PATENT ATTORNEYS

PATENT Applications bring results when addressed to Snow Church Co. and Percy Metzger, Washington, D. C.

PATENTS secured through Credit System. Free Search; Send Sketch. Booklet Free. Waters & Company, 4280 Warder Building, Washington, D. C.

**WANTED—New Ideas.** Write for List of Inventions Wanted. \$1,000,000 in prizes offered for inventions. Our Four Books sent free upon request. Victor J. Evans & Co., 166 Ninth St., Washington, D. C.

**PATENTS** obtained through D. Swift being promptly sold to manufacturers. Write today for free books of "Inventions Needed," and surpassing references. D. Swift, 319 Seventh St., Washington, D. C.

**DON'T** lose your rights to patent protection. Before proceeding further send for our blank form Evidence of Conception to be signed and witnessed. Book, suggestions and advice free. Lancaster and Allwine, 221 Ouray Bldg., Washington, D. C.

**PATENTS** procured. Drawings, searches, advice free. Richardson & Co., 918 F, Washington.

**PATENTS;** Established 1849. Twelve Years Member Examining Corps United States Patent Office. Fourteen Years' Shop Experience. Electrical and Mechanical Experts. D. C. Reinohl & Sons, 604 Ouray Building, Washington, D. C.

**INVENTIONS** Wanted—Patents pay. Send sketches for free search. Lester Sargent, 700 9th St., Washington, D. C.

**PATENT** specification and drawing prepared \$10.00. Thirty day special offer. Seyer Company, 1100 New York Avenue, Washington.

**PATENTS** are valuable; protect your invention. Attorney's fee payable when patent allowed. No misleading inducements to file applications. Correspondence solicited; advice free. Jaynes & Jaynes, 655 Keillogg, Washington, D. C.

**PATENTS** secured promptly. Personal attention. Edward W. Kibbey, Patent Attorney, 503 Victor Bldg., Washington, D. C.

**PATENT** your invention. \$10,000 offered for inventions wanted. Booklet and Opinion free. M. J. B. Stevens & Co., Established 1864, 685 F St., Washington; 353 Monadnock Block, Chicago.

**PATENT** what you invent. It may be valuable. Write me. No attorney's fee until patent is allowed. Estab. 1882. "Inventor's Guide" free. Franklin H. Hough, 522 Loan & Trust Bldg., Washington, D. C.

**THE** Patentome is free. An education in obtaining patents. Established 1863. Anderson & Son, Attorneys, 707 7th St., Washington, D. C.

**INVENTORS** will receive prompt attention and advice from Edwin S. Clarkson, Patent Lawyer, 545 Victor Bldg., Washington, D. C. Established 1899.

**PATENTS** secured or fee returned. Send sketch for free search. Latest and most complete patent book ever published for free distribution. George P. Kimmel, attorney, 212 Barrister Bldg., Washington, D. C.

**PATENTS—100** mechanical movements, 50 perpetual motions. Free. Send 10 cents postage for mailing. F. G. Dieterich & Co., 60 Ouray Bldg., Washington, D. C.

**PATENTABLE** Ideas Wanted—Send for 3 free books. R. B. Owen, 30 Owen Bldg., Wash., D. C.

**PATENTS** Secured—Take advantage of my personal experience; send sketch or model. Get my free book containing 200 mechanical movements. W. N. Roach, Jr., 930 McGill Bldg., Washington, D. C.

**PATENTS—Trade-Marks.** Send for my free book, "How To Get Them." It's full of information you should know. Joshua R. H. Potts, 8 Dearborn St., Chicago; 929 Chestnut St., Philadelphia; 805 G. St., Washington.

**PATENTS** explained in my free books, telling what you should know—what to invent—what not to invent—how to sell your patent, etc. Write today. H. L. Woodward, 902 G St., Washington, D. C.

**PROTECTIVE** patents procured promptly. 112 page blue book on patents sent on request. Trade-marks registered. Robb & Robb, 211-215 Southern Bldg., Washington, D. C.

**PATENTS—Herbert Jenner,** patent attorney and mechanical expert, 606 F St., Washington, D. C. I report free of charge if a patent can be had and its exact cost. Send for circular.

**PATENTS—Send** sketch for free search and report. Books on patents and book of reference letters sent free. John S. Duffie & Co., 610 F St., Washington, D. C.

**PATENTS** That Pay. Proof given. Two wonderful guide books free. E. E. Vrooman & Co., 871 F St., Washington, D. C.

**Attorney** fees until patent allowed. Send sketch for free report. Books free. Frank Fuller, Washington, D. C.

**C. L. PARKER,** Ex-member Examining Corps, Patent Office, Patent Attorney, 919 G St., Washington, D. C. Inventor's handbook, "Protecting, Exploiting and Selling Inventions," sent free upon request.

**PATENTS** that protect and pay. Advice and books free. Rates reasonable—highest references; best results. Watson E. Coleman, Patent Lawyer, 624 F St., N. W., Washington, D. C.

#### TRADE MARKS, COPYRIGHTS, ETC.

**TRADEMARKS** registered; all countries; protect your trade name or symbol. It is your business reputation; terms low; literature free. Sanders, 7 Webster Building, Chicago, Ill.

**COPYRIGHTS** procured; all countries; protect your literary, dramatic, musical, etc., works; terms low. Sanders, 7 Webster Building, Chicago, Ill.

#### FOR INVENTORS

**PATENT** Office drawings \$4. Complete set drawings of latest inventions on your subject, \$5. List Patent Buyers Free. Engineering Company, 808 Sixth St., N. W., Washington, D. C.

**MECHANICAL** Engineers. Specialist in designing and perfecting inventions. 15 years experience. Send details for free estimate of cost. Albert S. Kux, 105 W. Monroe St., Chicago.

**EXPERT** draughtsman—inventions developed. Drawings, tracings, blue prints. U. S. and Canadian patent drawings and specifications. Arthur Haar, Suite 611, 500 Fifth Ave., New York.

**DRAWINGS** from rough sketch or model. Special machinery and tools designed. Inventions put in practical shape. R. C. Nevin, Indianapolis, Ind.

**DEVELOP** Your Ideas—Profit in them. Particulars 2 cents. Kemik Reference Co., Box 46, Phila., Pa.

**WANTED—An Idea!** Who can think of some simple thing to patent? Protect your ideas; they may bring you wealth. Write for "Needed Inventions" and "How to Get Your Patent and Your Money." Randolph & Co., Patent Attorneys, 629 F St., Washington, D. C.

**HAVE** You an Idea? If so, you should protect it by a patent. Send us a model or sketch for free opinion as to patentability. Write for our Four Books sent free to any address. Victor J. Evans & Co., 157 Ninth St., Washington, D. C.

**COMMERCIALIZE** Your Patents and get your income. We make it easy for you to interest capital or to exploit your invention yourself. Write for particulars. DeCamp & Sloan Mfg. Co., 423 Ogden St., Newark, N. J.

**PATENTS** and Patentable Ideas sold. Best location and facilities. Fuller Company, 500 5th Avenue, New York.

**INVENTIONS—Patenting** and Promoting. A book containing practical advice and directions for inventors and manufacturers. Book, suggestions and advice free. Lancaster and Allwine, 221 Ouray Bldg., Washington, D. C.

**DRAWINGS** for patents, inventions, exhibits, illustrations, machine designing, blueprints. Goethals Engineering Co., 1651 Monadnock Block, Chicago, Ill.

**DRAWINGS** made for inventors. Consulting Engineer, PMS340 Seminary Ave., Chicago.

**SECRETS** and original ideas safely developed. We advise, plan, develop and execute original ideas in strict confidence. We are specialists in appliances and apparatus for reducing operating costs. We design, build or improve experimental machinery, dies, tools, etc., for manufacturers and inventors. Confide in us and we will respect your rights. Farrand Engineering Company, 44 No. 4th Street, Philadelphia, Pa.

**INVENTOR'S** Guide. One of the best books printed. Illustrated. Sent Free. E. B. McBath, 737 8th St., Washington, D. C.

**WANTED—Models, Tools** and Light Special Machinery to build. We have the Experienced Mechanics and Facilities to build perfect Working Models. Accurate, reliable and confidential work of every description. Regal Model & Tool Works, Chicago.

**MECHANICAL** engineer expert on manufacturing methods and designer of special machinery, will develop your ideas and inventions into commercially practical form. Albert S. Kux, 105 W. Monroe St., Chicago.

**PATENTABLE** Ideas Wanted—Send for 3 free books. R. B. Owen, 30 Owen Bldg., Wash., D. C.

**INVENTORS!** Send to postage for Handsome Book on Patents and List of Inventions Wanted. Sanders, 7 Webster Building, Chicago.

**PATENTS, Trade-Marks** and Copyrights. Our handbook on patents will be sent free on request. All patents secured through us are described without cost to the patentee in the Scientific American. Munn & Co., Patent Attorneys, 672 Woolworth Bldg., N. Y. Washington, D. C., office, 625 F St.

**WIRE** goods all kinds made to order. Cooley, 553 W. Monroe, Chicago.

**HAVE** you a Patent to sell? You'll be interested in my proposition. Write now for free particulars. F. W. Johnson, 6 N. Michigan Ave., Chicago.

**INVENTORS:** My patent made a fortune. Particulars free. Let me sell yours. Eugene Pearl, 323 Union Square, New York.

**PATENTS** without advance attorney's fees. Send sketch for free report. Books free. Frank Fuller, Washington, D. C.

#### INVENTIONS MARKETED

**INVENTIONS** Marketed. This company's principal business is to develop for the market original and patented products of its own Laboratories. Its Sales Department will consider outside patented inventions. Send copy of patent with stamps for return. McCormick Laboratories, McCormick Manufacturing Company, Dayton, Ohio.

#### PATENTS FOR SALE

**WOVEN** Wire Stretcher. Works perfectly and with ease. Will sell patent right and patterns for reasonable price. Detailed information free. A. L. Stamp, 1330 13th St., Moline, Ill.

**FOR** Sale—On royalty basis—Patented Cabinet Bed with compartment sections. Saves space, time and labor. A convenience in any room. P. O. Box 434, San Antonio, Texas.

**PATENT** Buyers are invited to address our sales department for information on any class of Patents they wish to purchase or lease on a royalty. We have secured a number of valuable patents in all lines of invention. Mail Order, Department Store and Household Novelties a specialty. Victor J. Evans & Co., 160 Ninth St., Washington, D. C.

**AUTO** Headlight Dimmer, outright or royalty. Wilson, 2419 East Aloha, Seattle, Wash.

**FOR** Sale—U. S. and Canadian Patent, Cylinder Phonograph Record Cabinet. Can be manufactured cheaply. Will sell outright. T. Howard, Box 15, Steveston, B. C., Canada.

**SAFETY** Door Catch. Holds door securely. A patent of merit offering money-making opportunity. Inspection invited. Outright or royalty. Capt. W. P. Blackwell, 3871 Tennesson St., Denver, Colo.

**PATENT** Door Slide, cash or trade for auto. E. H. Lindenmeier, 21, Peru, Ill.

**JUST** allowed. A device to cut the fuel bill in half—on all kind of pressing. Jones, 1106 Poplar St., Phila.

**FOR** Sale—Patent on Receptacle Enclosure (see article on page 756). For particulars, address A. Drewitz, 422 Tully St., Syracuse, N. Y.

**FOR** Sale or Royalty, Pat. 1,192,122, Canadian, same Pat., 162,545—"Lateral Grip" reinforcement (concrete construction) in territorial sections. For printed particulars apply to Wm. Appleley, Napa P. O., Calif.

**FOR** Sale—U. S. Patent 1,103,917. Value indicator, patented July 14, 1914. Can be stamped out of sheet metal. I will sell right. Give offer. Jasper C. Lawson, Box 52, San Francisco, Calif.

**AUTOMOBILES,** etc., with Combined Seat and Storage Cabinet. Patent for sale or exchange for good automobile. Chas. J. Vlasak, St. Louis, Mo.

**SMALL,** cheap, needed, efficient, profitable invention. Bart Jennings, Marshall, Texas.

**LATE** date patent on little machine that doubles quantity of butter. Big winner. One thousand dollars or value in land or automobile. L. A. Brown, Clay Center, Neb.

**PATENT;** Handy Carpenter's pocket tool, U. S. and other countries. Cheap to make, great demand. Herman Komeska, Hutchinson, Kansas.

**THE** New Adjustable cover fits the different sizes of kettles, skillets, basins, etc. The entire U. S. rights of this patent for sale. Address J. C. Allen, Burlington, Vt.

**PATENT** on amusement apparatus for parks, resorts, playgrounds, etc. Reasonable. Investigation invited. A. Lott, Sellersburg, Indiana.

\$1,500 **BUYS** the patent rights, tools and dies for making the "Edge Orr" skate sharpener. For particulars address Thomas Elsom, 243 Belleville Ave., Newark, N. J.

**FOR** Sale or royalty, window cleaner, clean both sides simultaneously. Child can operate. Cost about 25 cents to manufacture. Also miniature bowling game, same terms. B. F. Hoffman, 457 E. 182nd St., Bronx, N. Y.

**MECHANICAL** Dictionary for Children. Defines with crank. Price, model. W. H. Robtson, 1721 New York St., Paris, Ky.

**THE** only practical Non-refillable Bottle. Patent allowed. Make offer. Write G. R. Hoagland, 318 S. 11th St., Easton, Pa.

**PATENT** Fence-Repairing Machine. A boon to farmers, ranchmen and railroads. A money-maker for some one. Strachan, 318 Board of Trade, Kansas City, Mo.

**NEW** Trap—Can be made for any size animals, this should have a universal sale. C. A. Trull, Waco, Texas.

#### MODELS AND MODEL SUPPLIES

**CHICAGO** Model Works. Established 1867. Chicago, Ill. Cast wheels, model supplies, working models. Write for catalogue of model supplies.

**MODEL** and Experimental work. Inventions developed. Wm. Doffert, Tatamy, Pa.

**FREE** catalogue of model supplies. Castings, metal specialties on contract. North Chicago Tool Works, 15 Grove Ave., North Chicago, Ill.

**PRODUCERS** of Results: Inventions developed, Models, Experimental Work, anything special in metal to order, novelties, spinning, forging, castings in any material, electrical devices, patterns of all kinds, plating, general manufacturing, designing, special tools, punches and dies, stampings. Send drawings or sample. Expert information free. John's Machine & Stamping Works, Dept. C, Cleveland, Ohio.

**WE** make models dies, metal novelties, stamping, etc., reasonable. Star Novelty Co., 4 Nicholson Place, St. Louis, Mo.

**WE** develop and perfect working models for inventors. Light machinery building, scientific experiment work. Dies made and stamped done. Modern Die & Tool Company, 79 Ship St., Providence, R. I.

**MODELS**, dies, and manufacturing for inventors, by builders of "Tools That Work." La Creux Tool Co., 214 N. 21st St., St. Louis, Mo.

**MODELS** made for inventors; general machine work; designing and perfecting; developing automatic devices and machinery. In a position to do all kinds of light tool and machine work. Prices reasonable; estimates cheerfully given. Ideal Machine Works, 62 Ann Street, New York City.

**WE** make working models for inventors; also dies and stamping of specialties, and carry a complete stock of brass gears and model supplies. Send for catalogue. The Pierce Model Works, 3405 Pierce Ave., Chicago, Ill.

**SPECIAL** Electrical and Mechanical devices built to order. Models, Tools, Dies. Benj. Lev, 357 West Broadway, N. Y. City.

#### MANUFACTURING

**WANTED**—To manufacture: Good new metal specialty. We have enormous mfg. and selling organization. What have you? Hugro Mfg. Co., Warsaw, Ind.

**WIRE** Goods, all kinds, made to order. Cooler Mfg. Co., 553 W. Monroe St., Chicago.

**LET** Our factory be Your factory. Metal specialties developed and correctly manufactured. L. R. Nelson Mfg. Co., Peoria, Ill.

**STAMPINGS**, dies, manufacturing, sometimes selling. Emco, 523 Monroe St., Chicago.

#### GINSENG

**GINSENG** Culture, 10c. Golden Seal estimate \$4,000 an acre. Booklet giving my experience, 10c. W. N. Long, Florence, Ky.

#### REAL ESTATE AND FARM LANDS

**CALIFORNIA**—San Joaquin Valley calls you. Come see the country and people who are making good there. They'll tell you what they're doing—you could do as well. Healthful climate, good schools, churches, roads, quick transportation to big cities and eager markets. Write for free booklet and make plans to investigate this winter. C. L. Seagraves, Gen. Colonization Agent, AT&SF P.O., 1882 Ry. Exch., Chicago.

**BURLINGTON** County, New Jersey. Farms our specialty. List free. Established 1878. Albert Warren Dresser, Dept. P, Burlington, New Jersey.

**FLORIDA** Opportunity—During the past year, which has been one of financial depression, panics, hard times and scarce money, we have sold to bankers, doctors, brokers, investment experts, lawyers and the choicest class of business men, about 17,000 acres of first-class orange, grapefruit and Natal hay land in Lake County, Fla.; this in spite of the fact that other companies in Florida have been doing little or nothing in the selling line. There is a reason why we have been able to do this and the reason is—the land. Let us show you as those who have bought have already been shown. Lake County Land Owners' Association, No. 93 Lake Ave., Fruitland Park, Florida.

**ORCHARDS** in Famous Fruit Belt of Virginia. Low price—easy terms—On railroad, near market. Write for list. Farm lands \$15.00 per acre up. Mild summers, short winters, good markets. If you will send names of two friends interested in Virginia or North Carolina will enter your name for year's subscription free to Southern Home-seeker. Write P. H. LaBaume, Agri. Agt., Norfolk & Western Ry., Room 250, N. & W. Bldg., Roanoke, Va.

**CALIFORNIA** Land, \$1 acre cash, balance entire purchase, 90 cents a month per acre; immediate possession given; no taxes; no interest; Merced County; 5-acre tracts up; clear; ready to plow; gravity irrigation \$1 acre per annum. Particulars, maps free. Sterinson Colony, 785 Market St., San Francisco.

**DIXIE** farms for sale, reasonable. J. F. Fiberts, Cabot, Ark.

**SALE**, rent or exchange; farms, ranches and city property. J. C. Murphy, O'Neill, Neb.

**SELL** your property quickly for cash, no matter where located. Don't pay big commissions. Particulars free. Real Estate Salesman Co., Desk B, Lincoln, Neb.

**REALTY** Owners! My maps will sell your land quickly; mineral land, farms, quarries, oil land. Viersen, Webster Building, Chicago.

**FREE** Map of Florida, showing South Florida Combination Citrus and Vegetable lands on the Gulf Coast, also counties, townships, all cities and towns, railroads, etc. Sarasota-Venice Co., Box 57, Sarasota, Fla.

**1798 DOLLARS**—each \$3.19. Coin Premium Book 15c. Moore Coin Company, Commerce, Texas.

**SOUTHERN** land: are low in price but high in productive value, make two to four crops a year and give largest profits in grain, vegetables, fruits, live stock and dairying. Unsurpassed climate, good markets. Southern Progress is on the Southern Railway. Publications on request. M. V. Richards, Commissioner, Room 64, Southern Railway, Washington, D. C.

**MONEY-MAKING** Farms throughout 15 Eastern States; one acre to 1,000 acres, \$10 per acre up; many with live stock and tools included; big illustrated catalogue free. E. A. Strout Farm Agency, Station 3943, 47 W. 34th St., New York.

**I** HAVE a successful way of selling farms and farm lands. Write me for free particulars. No obligation whatever. E. J. Zimmer, 925 Tower Bldg., Chicago.

**FARMS** for Sale or exchange anywhere in the U. S. or Canada, direct from the owners. State where you want to locate. Information free. American Investment Association, 37 Palace Bldg., Minneapolis, Minn.

#### DOGS, BIRDS, POULTRY, PETS

**BILL** of Fare for Hens, 10 cents. A well defined system of feeding hens daily, causing larger production of eggs in cold weather. Morr's F. Koenig, Hazleton, Pa.

**PETS**—Pets—Pets—Pets—If interested in pets, send for our "Special Offer." Circular free. The Original Cugley's, 52 N. 9th St., Philadelphia.

**DESIRABLE** dogs, also other pets. Descriptive list, 2c. Graham, 4938 State, Chicago, Ill.

**FOR** Sale—Fine Pedigreed Collie puppies, Edward Podhaski, Monticello, Iowa.

**RAISE** Belgian Hares for us, big profits. We furnish stock and pay you \$2 each, also Gavis, Mink, Skunk, Fox, Squabs, Frogs, etc. Two booklets and contract for dime. Particulars Free. The Belgian Hare, Box 43, Holmes Park, Mo.

**GOLDFISH**—Rare specimens, artistic aquariums, wa erplants. Circular free. Pioneer Goldfish Hatchery, Racine, Wis.

**BEAGLES**—Balt's, Fox Hounds, Setters, Pointers, Coon, Skunk, Squirrel, Bear, Deer, Wolf Hounds, Ferrets. Catalogue 10c. Brown's Kennels, York, Pa.

#### PERSONAL

**HAVE** cured myself of a filthy and expensive tobacco habit in one week. For \$1 I will send same amount that cured me. H. Dalton, 328 Johnson Ave., Trinidad, Colo.

**BROTHER**—Accidentally discovered root cures tobacco habit. Gladly send particulars. F. Stokes, Mohawk, Florida.

**FREE**—Stop using Tobacco. Free. We will give free information how to conquer the habit easily and permanently. Results Guaranteed. A Tobacco League, 618 Paxton Block, Omaha, Neb.

#### MISCELLANEOUS

**ERADIUM** (Luminous) Pull Chain Bulb for Electric or Gas Light, pull chain or key. Shines at night. Locates your chair in a "jiffy." Sample 35c. Auburn Supply Co., 7817 Peoria St., Chicago.

**BIG** Mail Free. Your name listed once, 25,000 circulation and magazine one year 10c. Digest, Grand Rapids, Mich.

**LOCK** Picks—10, \$1.50; 50, \$5. McDougald, 5322 Windsor Ave., Chicago, Ill.

**MEXICAN** Constitutional Money, all denominations, at 5c per peso, or combination sets including \$1 to \$100 bills for \$5. These bills are genuine and make excellent advertising with your name stamped thereon. Willing Circulating Agency, El Paso, Texas.

**FOR** a 50c Postal Order I will send you a formula for the best Paint and Varnish Remover in existence; removes paint and varnish clean to the wood instantly with one application. Easy to make, 200% profit. Bruce Cody, 91 Hiawatha Ave., Toronto, Ont., Canada.

**RUBBER** Stamps, photo type, egg daters, sign markers, steel dies, metal badges, milk checks, burning brands, seals, stencils, Catalogue 10c. Buckeye Stamp Works, Market, Dayton, Ohio.

**150** SELECTED formulas and big catalog, 10c. "Ideal," 3311-P, Belleplaine Av., Chicago.

**EGYPTIAN** Scarab Tie Pin (Beautiful Fortune Bug); also French Tie Form (saves time, temper, tying neckties); also Catalog and Extra Sample, 25c postpaid, Carroll Novelty Company, Vancouver, British Columbia.

**"ART** of Cut-Making." Simple, etching process. Guaranteed. Regular price, \$1. Now 25c. "Ideal," 3311-P, Belleplaine Ave., Chicago.

**VIEW** Card see-ers' membership, 10c. Pacific Exchange, Bryn Mawr, Wash.

**GREYGO** Hair Tonic positively restores Gray Hair to its natural color, prevents dandruff and falling hair. Gives needed nourishment to the hair-cells, insuring a healthy growth. Absolutely Not a Dye and guaranteed harmless. Testimonials, 50c and \$1.00 bottle postpaid in plain wrapper. Liberal sample bottle 25c. Vanco Laboratories, 823 N. 5th St., Camden, N. J.

**SKELETON** Keys, open most common door locks, 15 cents prepaid. Larger set, 50 cents. Secret of opening Pin Tumbler Cylinders without picks or key, \$1.00. Lorenzo Stottler, Stamford, Conn.

**\$2.50** POCKET Adder. Send for circular. Bassett, 5921-K, Indiana Ave., Chicago.

**INDIAN** Baskets, Ropes, Price free. G. Gilham, Highland Springs, Cal.

**CUTS** anybody can make. Simple Etching Process, \$1. Particulars, specimens, for stamp. M. Day, Windfall, Ind.

**GRANDFATHER'S** Clock Works, \$5. Slightly shop-worn, quantity limited, others with chimes, all prices; also several nice Grandfather's Clock cases, exceptional bargains. Clock Company, 1673 Ruffner St., Philadelphia, Pa.





**No  
Money  
in  
Advance**

# Remarkable Watch Sale

**Elgin-Waltham-Rockford**  
ALL STYLES—ALL SIZES

Here is the grandest opportunity ever offered you to secure one of these famous makes of watches which have long been recognized as the world's leaders. Any style, any size, (ladies' or gentlemen's) or any number of jewels you want, at

Hartman's sensational bargain prices and on most liberal terms.

## Guaranteed for Life

How absolutely perfect these must be, and how sure we must be of the perfect satisfaction any one of them will give when we dare give them the backing of our unlimited life time guarantee! Moreover, we will keep any watch purchased of us in repair for all time.

## Sent On Approval

Any watch shown, either on this page or in our big watch catalog will be sent, all charges prepaid, without one cent in advance. Carry it for 30 days. If not satisfied that it is the watch you've long wanted, return at our expense. In fact, unless you are absolutely sure that it is exactly the watch you want, we would much rather not sell it to you. We prize your friendship and good will far more than we do your order for a watch.

It is the Hartman policy never to have a dissatisfied customer.

These offers will prove to you that it pays big to deal with Hartman the house of sensational bargains and easiest credit terms.

**As  
Low as  
50c  
Per Month**

Just think of it! You can now own a magnificent genuine Elgin, Waltham or Rockford Watch on payments as low as 50 cents a month—less than 2 cents a day! Never in your life before have you had the opportunity to buy just the watch you want for as little money and on such easy terms. Of course, you may pay all cash if you prefer, but it costs not one cent more to take advantage of Hartman's long-time, open account credit terms. Our prices are so extremely low that we cannot afford to sell a bit cheaper even for all cash. We ask no references, no embarrassing questions, no mortgage, no security, no interest. Only the Mammoth House of Hartman with its enormous purchasing power of more than ten million dollars can afford to offer such sensational watch bargains.

## FREE—Hartman's Beautiful Watch Bargain Catalog

Contains the most complete selection of dependable watches ever shown. Handsome, full size illustrations in rich colors. Shows newest 10, 20, 25-year and permanent guaranteed cases, also solid gold cases with Inlay Enamel Monograms, Block and Ribbon Monograms, Lodge Emblems Diamond Set and French Art Designs, open face or hunting cases, ladies' and gentlemen's sizes. Get your copy of this free book. Ask for Special Watch Catalog No. 401-J



**Your  
Credit  
Good**

**Mail  
Coupon  
Now**

**HARTMAN'S Jewelry Dept., 123-25 W. 39th St., Chicago, Ill.**

Without obligating me to purchase, please send your Watch Catalog No 401-J

Name.....

Street and No.....

Town..... State.....

Please Mention Popular Mechanics



## IVES STRUKTIRON

Ives Toys give your boy all the material needed to construct and operate a complete railroad. He is the construction crew, the train dispatcher, the engineer — everything from "section hand to president." And while he plays, he is learning the practical principles of mechanics and electrical engineering.

With an Ives Railway your boy lays the track; arranges the switches, semaphores, stations and tunnels; couples the engine and cars; stops and starts the train, and does everything else that is done on a real railroad.

## Ives Toys

Make Happy Boys

With Ives Struktiron he builds strong steel models of railroad bridges, elevated railways, signal towers, cranes and derricks operated by the powerful Ives electric motor. He can also construct hundreds of other realistic, practical models, such as aeroplanes, revolving shovels, battleships, "shoot the chutes."

Toy, hardware and department stores sell Ives Trains (\$1 to \$30) and Ives Struktiron (\$2 to \$25). Ask to see them.

Write for Catalog and names of Ives dealers.

### Free Poster Stamps

Beautifully illustrated in colors. Six stamps show the development of the locomotive from the famous "De Witt Clinton" of 1831 down to 1915. The other six show interesting Struktiron models.

Absolutely free to any boy or parent. Write now (giving toy dealer's name) for complete set.



## IVES TRAINS

The IVES  
Manufacturing  
Corporation  
202 Holland Ave.  
Bridgeport, Conn.



Please Mention Popular Mechanics

## The Truth About Poultry

Get the Facts by  
Reading

## The One- Man Poultry Plant



Successful Methods of Men on Farms or Small Acreage.  
Complete in twelve parts; printed in one volume.

By DR. N. W. SANBORN

REAL work, with real poultry, on a real New England Farm. This is a simple story of what has been done by a man, at forty-five years of age, town bred and city educated, getting out of practice of medicine, buying a small farm in the hill country, and making a success of the venture. Not only is the rearing of chicks and the management of adult fowl completely covered, but the interesting side issues of fruit growing, grain raising and the production of milk, that cannot be escaped on a real farm. You get rugged facts—rarely found in print. The truth about poultry as found in actual life on a one-man poultry farm.

### You Can Do the Same, Book Tells How

OUR SPECIAL OFFER—The One-Man Poultry Plant, in twelve parts (book form), and the American Poultry Advocate, one year, for only 50 cts., book and Advocate, three years, for only \$1.00, if order is sent at once.

Our paper is handsomely illustrated, practical, progressive and up-to-date on poultry matters. Established 1892. 44 to 132 pages monthly. 50 cents a year. 3 months' trial 10 cents. Sample copy free. Catalogue of poultry literature free. *Adms*

AMERICAN POULTRY ADVOCATE, 523 Hodgkins Bldg., Syracuse, N.Y.

The per-capita consumption of cheese in the United States is 3.8 pounds.

## SOME CAR! BOYS! Send for Booklet Today



### The Lad's Car

Send 20c today for Booklet, telling how to build this automobile. Complete instructions and descriptions of parts and sizes, illustrated with diagrams, blue print, cuts made from photographs, and price list of parts.

SPECIAL INDUCEMENT to first boy in your town  
Niagara Motor Car Corp'n, Dept. A, Niagara Falls, N. Y.

## FINE OLD VIOLINS

On Easy Payments  
30 Days Free Trial



allowed, no matter where you live. If not more than pleased with our values return violin AT OUR EXPENSE—and no harm done. Ability to play the violin brings social and financial success. Get a violin with a rich, mellow tone and it will create in you a desire to master it.

### Free! Magnificent Album-Catalog

containing portraits of the world's greatest violinists since Paganini's time, a half-tone of "Stradivarius in His Workshop," and the romantic story of The King of Musical Instruments. A postal brings all to you FREE—no obligations.

CREMONA VIOLIN SHOP  
Dept. C541 CHICAGO



I Built this  
Plant With  
My Profits



# I Want to Start Energetic Men

## In A Permanent Profitable Business

### A Business Like Mine—All of Your Own Repair and Retread Auto Tires—No Experience Needed

Listen to this if you want **success, wealth and power**—if you have nerve, ambition and energy and are waiting for your opportunity to get into a big paying business of your own. I started in the tire repair business about six years ago. There were mighty few automobiles then as compared to today. The automobile industry just about got under way. **Your chances to win now are ten to one better than mine.** This is the biggest year in the automobile business. Stop working for others. Get into business for yourself. Get the big end of the money instead of the small. I will show you how to gain independence, happiness, riches, if you will write me at once.

## Make \$3,000 This Year to Start

**One Million New Autos to be Made. This Gives You the Chance**

Think of it. **One million new automobiles will be made in this country this year.** One concern alone plans to make over half the entire country's production. There are now nearly 900,000 Fords alone in use and they are being turned out at the rate of over 1,000 a day. **Think what a chance this gives you in the tire repair business.**

#### Punctures and Blow Outs Are Common

Every automobile means four tires to mend. **Over 4,000,000 tires will need repairing besides the millions already in use.** There is no business under the sun that offers such wonderful opportunities. **And now you can get into it easy.** Yes Sir. You can make \$3,000 a year to start. Many men with Haywood equipments are averaging that the year round. Many are making more. **Johnson, Texas, writes: "I have made as high as \$18 a day in this business."** I will gladly send you more proof of success when you write. The demand for tire repairing and retreading is already ahead of the supply, and 4,000,000 more tires will be added to that demand this year. **Be the first in your town with a new Haywood equipment.** Mends tires the best and quickest. Does the work

at the biggest net profits to you. **Retreading, vulcanizing and repairing of tires saves motorists money,** so business comes easy. Old autoists and the one million new autoists will be eager to give you their business.

#### Tires to Mend the Whole Year Round

Autos are used both winter and summer. **No seasons to tide over, without any work.** Money comes in from one year's end to another, continually growing bigger and better, making you rich, prosperous and contented.

#### Haywood Tire Repair Plants

are all complete in the finest detail. Nothing omitted to make them a winner. **Experience is absolutely unnecessary.** Just a little mechanical turn and follow directions is all that's required. The investment is small. **One machine will give you the start.** That's the way I did it. Business grows fast from this beginning. You will soon need another machine and then another. The first thing you know, you will be running a big shop—**You're a Real Manufacturer—and a Success.**

## This Is Your Opportunity

There was never a better one for any man anywhere. Why not make the most of it while the chance is before you? **Why keep tied down,** shackled to the whims and purse strings of bosses? Why don't you hold the bag and make the big money? I built the business you see at the top of this page, the business I want to start you in. It's well worth your while to investigate. This coupon or post card will bring you complete information.

MAIL THE  
COUPON TODAY



### Get All the Facts From This FREE BOOK

The biggest year in the automobile business has just started. Learn all the secrets of this proposition. **The Free book gives all details.** Tells all about tires and how to repair them. Shows outfits in use. Tells stories of successes from men who grasped their opportunity. It's really an important message that every ambitious man should read. Just send your name and address only.

Use the coupon, a letter or postcard, but do it at once.

M. E. HAYWOOD, Pres.  
HAYWOOD TIRE &  
EQUIPMENT COMPANY  
980 Capitol Ave.  
INDIANAPOLIS, IND.

FREE  
COUPON

M. E. HAYWOOD, Pres.  
HAYWOOD TIRE & EQUIPMENT CO.  
980 Capitol Ave., Indianapolis, Ind.

Dear Sir:— You can send me your book and full particulars about your tire repairing device. This, of course, without any obligation on my part.

NAME.....

ADDRESS.....

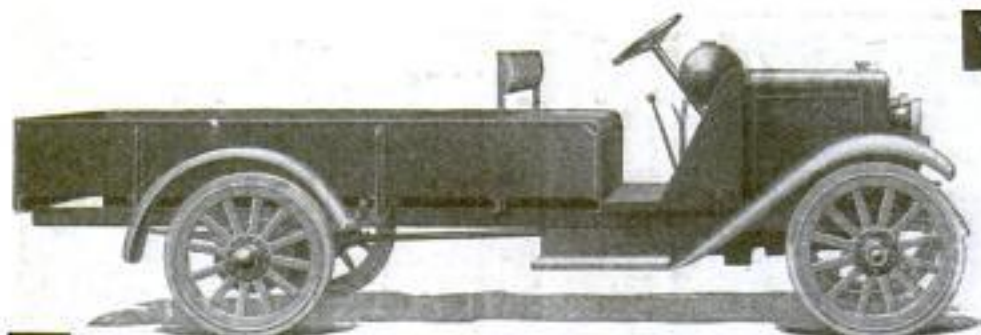

*With body as shown. Top, panel body, starting and lighting system or pneumatic tires, if desired, at moderate extra expense.*

## Yes! You Can Make This Truck Pay!

Here's a truck designed and built from the ground up for light-delivery duty. Yet it possesses all the mechanical features of superiority that have made the larger Denby models famous.

You will be interested, for instance, in the Denby internal-gear drive. Study it—and you'll agree with the engineers who say that this form of axle will speedily make all others obsolete.

Unit power plant, extra large springs, sturdy frame—no truck could be better built. And the service that goes with it solves the problem of "making it pay."

### Three Larger Denby Units

Each supreme in its class; each capable of chassis and body modification which enables it to be fitted accurately to any business.

**Prices (chassis only):** Type B 1 ton \$1,475  
Type D 1½ tons 1,685  
Type E 2 tons 1,985

*Write for full descriptive literature on the model you're interested in*

**Denby Motor Truck Company** 403 Holbrook Avenue  
DETROIT, MICHIGAN

# DENBY

$\frac{3}{4}$  ton  
**TRUCK**  
**\$890**

*Ask about the  
DENBY  
Business-Building and  
Sales Efficiency  
Service*

A correspondence course of thirty-six lessons, taking up every branch of retail salesmanship. Every truck-owner may nominate one person to take the course, free of charge. Prepared by experts; adds one thoroughly equipped salesman to the force of every owner.

**\$3,000 in rewards to  
proficient students**

## Oxy-Acetylene Welding and Cutting

# Prest-O-Lite

### PROCESS



Welding branch into 3-in double extra heavy pipe for hydraulic service, 3,800 lbs. to the sq. in., eliminating "T" fitting with threaded joints and consequent possibility of leakage. Welding cost, 75 cents. "T" fitting cost \$7.50.

Write today for valuable engineering data on oxy-acetylene welding and cutting—how others have saved time and money in repair and manufacturing operations. Large profits for job welders. Write about it. Thoroughly illustrated book free on request.

**The Prest-O-Lite Co., Inc.** 816 Speedway, Indianapolis, Ind.  
53 Branches and Charging Plants  
*The World's Largest Makers of Dissolved Acetylene*

## Did for 75c what would have cost \$7.50

Every manufacturer of metal work, and every repair shop, should know the boundless possibilities of economy through uniting metal parts by oxy-acetylene welding instead of by older methods.

One railroad shop saved \$5,000.00 in a single month on repair work alone.

In *your* factory, in *your* repair shop, there is a profitable place for this remarkable, low-cost process. If you cannot find that place, give us a chance to find it.

Necessary equipment is not expensive. We furnish high grade apparatus for \$60; acetylene service extra. Adaptable for oxy-acetylene cutting with the addition of special cutting apparatus.

### Prest-O-Lite Acetylene Service

Furnishes the highest grade of Dissolved Acetylene (ready-made carbide gas) in portable cylinders. Used as conveniently as cylinders of oxygen. Saves large initial outlay and heavy depreciation of making crude acetylene in carbide generators. Perfectly dried, cleaned and purified—makes better welds and is cheaper to use.



# Modern Power Appliances

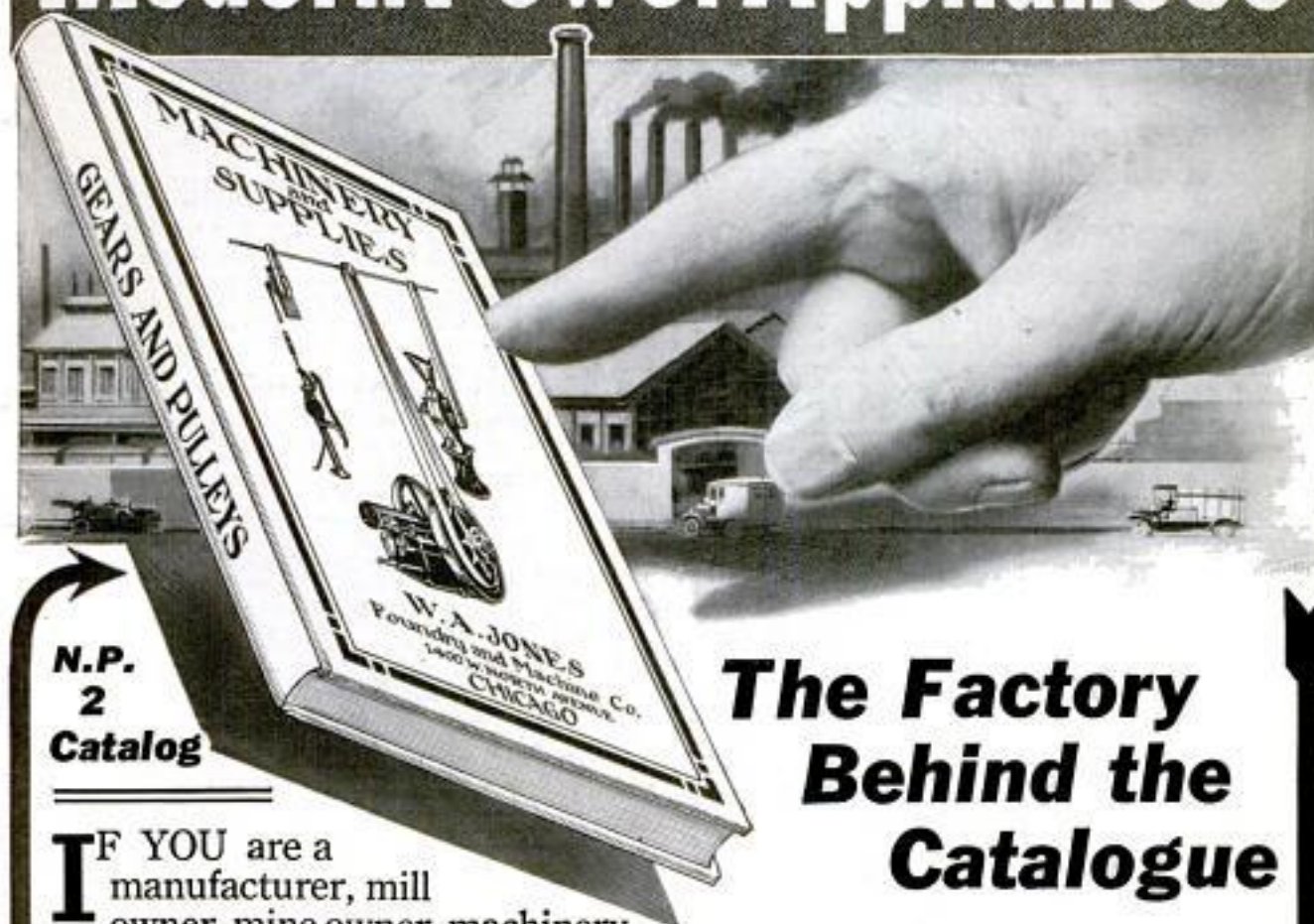

**N.P.  
2  
Catalog**

## The Factory Behind the Catalogue

**I**F YOU are a manufacturer, mill owner, mine owner, machinery dealer, purchasing agent, master mechanic, engineer, superintendent or foreman — you should have this catalogue before you. Every user of Electric, Steam or Gasoline Engine Power should have a copy of it. Thousands are using it as a guide to their purchases. It contains a complete line of approved, modern, up to date Power Transmission Appliances such as machine moulded pulleys and gears, friction clutches, sprocket wheels, chain belting, shafting, couplings, hangers, boxes, collars, leather, cotton, canvas, rubber belting, elevating and conveying appliances, mill and factory supplies.

This catalogue will put you in touch with the manufacturers who can save you time and money. Send for it and be convinced. Every order, no matter how small or how large, receives special attention in a large factory equipped with modern machinery. This with the reputation of the W. A. Jones Foundry & Machine Co. assures you of receiving reliable goods at prices within the reach of all.

**The name JONES on machinery is a  
Guarantee of Quality.**

FILL IN, TEAR OUT, MAIL TODAY

**FREE CATALOGUE COUPON**  
W. A. JONES FOUNDRY & MACHINE CO.  
1400 W. North Avenue, CHICAGO

Gentlemen: Please send me your new illustrated 1916 Catalogue, N. P. 2.

Name .....

Town..... State.....

Business.....



## No More Starting Troubles This Winter

Winter starting troubles never bother the motorist who equips his engine with



### Primings Plugs

A few drops of gasoline inserted in these plugs puts a rich, volatile mixture right at the igniting point. Instantly you get the maximum explosion.

No matter how cold your motor may be this simple priming treatment is instantly effective. And besides the advantage of the priming device you have also the dependability provided only by **Champion Spark Plugs**—the most highly efficient aid to perfect ignition.

The new Champion Priming Plug has a key lock attached to the needle valve. All you have to do is open the needle valve, prime and then close tightly.

The "All-in-One" Champion Priming Plug is for those who desire the pet cock type. This plug is exceedingly simple and effective.



Price, \$1.25

Price, \$1.25

**Champion Spark Plug Co.**  
407 Avondale Ave. TOLEDO, OHIO

Please Mention Popular Mechanics



# STOP!

*The Law Says:*  
**You must not have glaring headlights**

Any man that permits his headlights to "glare" into the eyes of other drivers invites accidents and hard feelings. Why class yourself among the "road hogs". Comply with the law and observe the ordinary courtesies of the road. You can have *all* the driving light you now have—without any of the glare.

### Use the Perrin No Glare on your Car's Headlights

Gives a long, low, powerful driving light. Made of aluminum and slips around the light bulb. Held on with springs—can't damage bulb. Use on any car—with or without a dimming switch. No buttons or levers. Drive from city to country without change. Does not dim the light. Recommended by leading motorists and police authorities. Insist on having the genuine Perrin No Glare—it's the best.

At Your Dealer's or Garage, or Sent Postpaid by Mail



Perrin Mfg. Co.  
Detroit, Mich.

Price \$1 Per Set

Patented June 9th 1914

**MUNICIPAL WASTE IN LONDON**—A recent statement in the London Times is to the effect that "it costs 18s. (\$4.38) more per head of the population to administer London than to administer any one of the largest provincial cities."



**Print Your Own** Cards, circulars, book, paper. For 50¢ \$5. Larger \$18. Rotary \$60. Save money. Print for others, big profit. All easy, rules sent. Write factory today for catalogue of presses, TYPE, cards, paper, samples. It will pay you well. **THE PRESS CO., Meriden, Connecticut**



## WOULD YOU

show this standard high grade fully visible typewriter to your friends and let them see wherein it **excels** any other \$100 typewriter, if by doing this and rendering other small assistance, you could easily earn one to keep as your own. Then by post card or letter to us simply say, "Mail Particulars."

**WOODSTOCK TYPEWRITER CO., Box N 204, Woodstock, Ill.**



## A BROKEN COG

will stop a machine; a worn or defective part will tie up a plant. So it is with your body. You can't go on and expect to do good work unless every part of your body is capable of doing its share.

The body is no stronger than its weakest part, and without a strong, vigorous, virile development you cannot have a clear, quick-thinking brain, particularly if your health is undermined by the effects of youthful habits.

If you want to get the most out of life, drop me a line, telling me your ailment or ailments, and I will come right back at you with some interesting advice on your particular trouble. Four cents in stamps to cover postage will bring my book, "INTELLIGENCE IN PHYSICAL AND HEALTH CULTURE." It will show you just where you now stand, and where you OUGHT TO STAND.

**LIONEL STRONGFORT**

Health and Strength Institute  
Dept. S 115 ATLANTIC CITY, N. J.



# Tobacco Habit BANISHED

## in 48 to 72 Hours



### No Desire After First Dose

Trying to quit the tobacco habit unaided is a losing fight against heavy odds, and means a serious shock to your nervous system. So don't try it! Make the tobacco habit quit you. It will quit you if you will just take Tobacco Redeemer according to directions.

It doesn't make a particle of difference whether you've been a user of tobacco for a single month or for 50 years, or how much you use, or in what form you use it. Whether you smoke cigars, cigarettes, pipe, chew plug or fine cut or use snuff Tobacco Redeemer will positively remove all craving for tobacco in any form in from 48 to 72 hours. Your tobacco craving will begin to decrease after the very first dose—there's no long waiting for results.

Tobacco Redeemer is absolutely harmless and contains no habit-forming drugs of any kind—the most marvelously quick and thoroughly reliable remedy for the tobacco habit the world has ever known.

### Not a Substitute

Tobacco Redeemer is in no sense a substitute for tobacco, but is a radical, efficient treatment. After finishing the treatment you have absolutely no desire to use tobacco again or to continue the use of the remedy. It quiets the nerves, and will make you feel better in every way. If you really want to quit the tobacco habit—get rid of it so completely that when you see others using it, it will not awaken the slightest desire in you—you should at once begin a course of Tobacco Redeemer treatment for the habit.

### Results Absolutely Guaranteed

A single trial will convince the most skeptical. Our legal, binding, money-back guarantee goes with each full treatment. If Tobacco Redeemer fails to banish the tobacco habit when taken according to the plain and easy directions, your money will be cheerfully refunded upon demand.

### Let Us Send You Convincing Proof

If you're a slave of the tobacco habit and want to find a sure, quick way of quitting "for keeps" you owe it to yourself and to your family to mail the coupon below or send your name and address on a postal and receive our free booklet on the deadly effect of tobacco on the human system, and positive proof that Tobacco Redeemer will quickly free you from the habit.

**Newell Pharmacal Company**  
Dept. 300, St. Louis, Mo.



**Mail Coupon NOW  
for FREE Booklet**

**NEWELL PHARMACAL CO.,**  
Dept. 300, St. Louis, Mo.

Please send, without obligating me in any way, your free booklet regarding the tobacco habit and proof that Tobacco Redeemer will positively free me from the tobacco habit.

Name .....

Street and No. ....

Town..... State.....

Please Mention Popular Mechanics



## When You Work

in your garage, work-shop, garden, cellar or do anything that is apt to soil your good clothes **DON'T FAIL** to wear a suit of

## FINCK'S "Detroit Special" Work Clothes

They are made of the finest materials on the market, and they will give you the best service you have ever had. This is because they are cut to give a lot of comfort and fit. Feel comfortable and clean in the garments which

### "WEAR LIKE A PIG'S NOSE"

If by chance, your dealer hasn't them, send us his name with this ad, and the necessary amount of money, and we will send your garment parcel post prepaid.

High Back Overalls . .	\$1.00
Suspender Overalls . .	1.00
Jacket . . . . .	1.00
Vest High Back Overalls	1.25
Combination Suits . . .	2.00

Light or dark Blue Denim— or Khaki

**W. M. Finck & Company**  
1154 Gratiot Ave. DETROIT, MICH.

## Be a Diamond Expert Free Diamonds to Students

Write today for our free book, "Paying Diamond Knowledge." It's creating a stir in the diamond game. Get the most important book on diamonds ever published. By return mail free. UNIVERSAL SCHOOL OF CORRESPONDENCE, 73 East Seventh Street, CHICAGO, ILL.

## 100 TYPEWRITERS AT 40 PER CENT DISCOUNT

**EASIEST PAYMENTS**

10 year guarantee — 10 days' free trial

BRAND NEW 1915

## REX VISIBLE TYPEWRITER

The REX is America's finest typewriter priced at \$100.00. Typewriters lacking any of the following REX features cannot be classed as standard. Full visible writing—two-color ribbon—back spacer—tabulator—automatic line space—automatic line lock—unlimited speed—perfect printing—card writer—stencil cutter—eleven inch carriage—universal keyboard of 84 characters, right and left hand shift key—special models for doctors, ministers, lumbermen, real estate dealers. Foreign languages.

**Send No Money**—just send your name and address for catalog and full particulars of our great special offer, the greatest typewriter opportunity. Full information free. No salesman—no red tape.

**REX TYPEWRITER COMPANY**

Dept. No. 8, 28 East Jackson Blvd.

CHICAGO, ILLINOIS



Wisconsin leads all the states in the country in cheese production, with an output of close to 150,000,000 lb. New York is next with over 100,000,000 lb. and the nearest competitors, Michigan, Pennsylvania, and Ohio, far behind with some 13,000,000 lb. each.

## Waterman PORTO

1915 Model has reversing propeller, high tension magneto and a restricted speed control. 3 H. P. W.L. 65 lbs. Sold direct from factory to you, freight paid. Original outboard motor—1915 year—20,000 in use. Guaranteed for life. Fits any shape stern. Has automobile carriage, removable bearings, solid bronze slip protecting 10x14 in. propeller. Steers by rudder from any part of the boat. Water cooled exhaust manifold; noiseless underwater exhaust; span copper water jacket. Demand these essentials if you want your money's worth. Write today for free book showing both outboard and inboard engines. Our prices will surprise you.

**WATERMAN MOTOR CO.**  
229 Mt. Elliott Ave., Detroit, Mich.



Makes Any Boat A Motor Boat

## LANDA "Prosperity" BILLFOLD

**ELEGANT, Practical Xmas Gift**—order one also for yourself. Combines currency fold, coin purse, card case, loose leaf memo pad, 1916 calendar, transparent identification card and photo holder. Made of finest soft, genuine black Seal Grain Leather. Any name beautifully engraved in 23-kt. Gold—splendid, lasting gift. Size closed 8x3 1/2 inches, open 8x3 1/2. Compact, flexible—will fit any pocket. For ladies and gentlemen. Special price 50c postpaid—ordinarily \$1.00. Attractively packed in handsome gift box.

"DeLuxe," made of genuine Morocco Leather, \$1.00—worth \$2.50. Send M.O., draft or postage stamps. Order shipped day received. Satisfaction guaranteed. Write for Xmas Gifts catalog.

A. LANDA & SONS CO., Leather Goods Mfrs., Dept. A2 Chicago



Money Cheerfully Refunded

**50c**  
Postpaid

Name Engraved Free in  
23-kt Gold  
For Ladies and  
Gentlemen



# WHY WELD

When you can do better work in one-fourth the time—at one-fourth the price—by using the latest great discovery

**So-Luminum**  
The Aluminum Solder

No welding. No oxidization. No flux necessary. Runs at extremely low temperature. Easily applied with gasoline torch, blowtorch or gasblower; twice as strong and much harder than aluminum. Never breaks at soldered point.

### Convince Yourself by Trying It

Used by Internat'l Motor, Locomobile, Packard, Stanley, Pierce Arrow, Brewster, Demarest, Studebaker, Simplex, Sperry Gyroscope Co., Aeroplane Mfgs., and U. S. Navy.

Write for booklet 1

\$3.50 per lb. Sample stick (1/8 pound) \$1.50 net cash.

So-Luminum Mfg. & Engineering Co., Inc.

Sole Manufacturers and Distributors

UNITED STATES RUBBER CO. BLDG., 1790 Broadway, NEW YORK



## FREE

### New 1916 Book of Sporting Goods

64 pages! Just off the press

Send no money! Merely a postal card brings you this latest, greatest, free catalog of the Charles William Sporting Goods Store, fully prepaid. It tells you how to make a big saving on your sporting goods. Gives rock-bottom prices on

Standard Guns and Rifles

Quality Basket Balls

Real Grain Leather Foot Balls

Latest Model Revolvers

Best Hunting Clothing

Clareview and Scout Cameras

Sweaters, Gloves, etc.

and nearly 2,000 other articles—standard makes—for all sports. Don't buy any article for Hunting, Trapping, Foot Ball, Basket Ball, Skating, Photography or other sport until you have this new, up-to-the-minute book to help you. We have millions of dollars' worth of merchandise in stock. Nowhere can you have so big a variety to choose from; no one else can offer you the convenience, safety and saving in purchasing. This new book is free—write a postal now; simply say, "Send the Free Sporting Goods Book" Address

**Charles William Stores** 1051 Stores Building  
New York

## Call Up The "Light" Reserves To Re-enforce Your Workers



Raise the "standard" of efficiency! Fortify employes against the dangers of mistakes, accidents and ill health. Put darkness and poor ventilation to rout. In short, win the fight for Better Humanity and Bigger Business, by installing

**Fenestra**  
SOLID STEEL WINDOWS  
"REG. U.S. PAT. OFF."

## Walls of Daylight

Their growing use in loft buildings and industrial buildings is special proof of the added light, air and temperature-control assured by Fenestra sash and partitions.

Fenestra reduces insurance rates. Lowers lighting bills. Maintenance cost negligible. Standard sizes supplied on short notice. Price no greater than that asked for good wood sash. A postal card will bring an estimate.

**Detroit Steel Products Company**  
Department K6 Detroit, Michigan



Fenestra steel partitions for factories, warehouses, loft buildings, etc.—interchangeable, fire-resisting.

# MESCOLITE

## WILL MAKE YOUR WAY SAFE and BRIGHT



(Illustration shows container with cover removed and battery partly inserted)

in garage, barn, cellar, closet; in camp; on the motor boat; for the dark country road or any other situation where a lantern, lamp or candle is used, besides many places when an open flame would mean fire, explosion, danger and disaster. The MESCOLITE consists of a japanned metal container with cover, fibre disc with battery contacts, polished metal reflector, clear glass lens, miniature battery lamp, lens cap or rim with three bayonet catches, a non-detachable bail or handle large enough to allow the arm to go through it, a RED SEAL Dry Battery or a special two cell dry battery. It is the simplest battery lantern made. Battery cannot be inserted in the container in any other way than the **RIGHT WAY**.

The RED SEAL Dry Battery will give about twenty-five hours of continuous service and from forty to fifty hours of intermittent service. Always use the RED SEAL Dry Battery in preference to any other. It does not deteriorate when not in use. If the RED SEAL Dry Battery cannot be had any other standard size dry cell can be used.

With the "Special" two cell dry battery, it will give you approximately sixty hours of continuous and one hundred twenty hours of intermittent service. If your dealer cannot supply you we will mail postpaid.

No. 5343—MESCOLITE, complete with RED SEAL Dry Battery, 1½ volt lamp, in U. S., \$1.50; in Canada, \$2.25.

No. 5344—MESCOLITE, complete with "Special" two cell dry battery, in U. S., \$1.75; in Canada, \$2.50.

### Send for Our New Catalog P28

It is pocket size, 8 x 4½ inches, contains 248 pages, with over 1,100 illustrations, and describes in plain, clear language all about Bells, Push Buttons, Batteries, Telephone and Telegraph Material, Electric Toys, Burglar and Fire Alarm Contrivances, Electric Call Bells, Electric Alarm Clocks, Medical Batteries, Motor Boat Horns, Electrically Heated Apparatus, Battery Connectors, Switches, Battery Gauges, Wireless Telegraph Instruments, Ignition Supplies, etc.

There exist a thousand and one ways where electrical devices may be used, and to know what is best for your purpose you need this catalog. It costs you nothing.



### Send for Our No. 2 Manual Wireless Telegraphy

You should have it even if only superficially interested. Around about you every day you read of some marvelous occurrence in which wireless played a distinguished part. It may not be entirely clear to you. The Manual will explain it. To the student of Wireless Telegraphy, the Manual contains much that is indispensable to a proper understanding of the art. A good portion of this is now published for the first time—and consists of

formulas, tables, diagrams, Federal regulations, codes, diagrammatic instruction for installing, maintaining and operating wireless stations, together with a complete list of up-to-date wireless instruments and accessories. The Manual contains 120 pages, fully illustrated on high-grade paper stock with a two-color cover.

We ask ten cents (\$0.10) for it—give you a coupon receipt which can be applied on any order amounting to One Dollar (\$1.00) or more. Do not wait until some other time, but sit down now and send your name and address, and get one of the most complete, comprehensive and reliable wireless pamphlets published. **IT MEANS MONEY SAVED TO YOU** to have our Manual and our Catalog when you want to buy.

**MANHATTAN ELECTRICAL SUPPLY CO.**  
**NEW YORK:** 17 Park Place  
**CHICAGO:** 114 S. 5th Ave.  
**ST. LOUIS:** 1106 Pine St.  
**SAN FRANCISCO:** 604 Mission Street



# DEAF?

## "I Now Hear Clearly"

Mr. Garrett Brown (photo above) is but one of the 200,000 deaf people whom the Acousticon has enabled to hear clearly and usefully. This makes us feel so certain of its efficiency, that we will gladly send to every deaf person, simply on request, our new

## 1916 ACOUSTICON FOR FREE TRIAL

No Deposit—No Expense

Just say that you are deaf and will try the Acousticon, and the trial will not cost you one cent, as we even pay delivery charges.

**WARNING!** There is no good reason why every one should not make as liberal a trial offer as we do, so do not send money for any instrument for the deaf until you have tried it.

We most sincerely state that we do not want one cent of your money if you cannot hear; that's the reason we want you to try the Acousticon first and convince yourself—**you alone to decide. Just write today for your absolutely free trial and interesting particulars.**

**GENERAL ACOUSTIC CO., 1307 Cedar Bldg., NEW YORK**  
**Toronto, Ont., Royal Bank Bldg.**

## A Wonderful Fountain Pen

SPECIAL REDUCTION TO READERS OF POPULAR MECHANICS



### De LUXE TAB-FIL FOUNTAIN PEN

Makes its own ink—always ready—can't leak—carries ink supply in the cap—never without ink.

Fill pen barrel with water, drop in one De Luxe Ink Tablet—close pen and write. A "Modern" sensible innovation. Low in price for the school girl or boy—high in quality for the particular pen user—made to educate the use of De Luxe Ink Tablets.

All 14K. Gold Iridium pointed pens expertly ground—pure hard rubber hand turned barrel representing the highest grade of workmanship and material—nothing better can be made—**FULLY GUARANTEED.**

One year supply of De Luxe Ink Tablets **FREE** with each pen. Pen-point sizes (14K. Gold) No. 2 No. 3 No. 4 No. 5 No. 6

Regular (Slip cap) \$2.00 \$2.50 \$3.00 \$4.00 \$4.50 \$5.00

Special (Screw cap safety) 2.50 3.00 3.50 4.50 5.00

**GOLD MOUNTINGS IN MANY VARIETIES**

**TELESCOPE FOUNTAIN PEN** short barrel for L. dy's purse or Gentleman's vest pocket No. 2 point screw cap (safety).

Special price.....\$2.50

**DE LUXE MFG. CO., 234 Manhattan Bldg., Chicago, Ill.**



## Building a Launch? You Need This Book

It's the **Callie Marine Motor Blue Book**. It shows the most complete line of motors at the most reasonable prices in sizes ranging from 2 to 30 H.P. Every one is of highest grade, simple, sturdy, easy to operate, thoroughly guaranteed. This book has saved boat owners thousands of dollars.

**S. H. P. \$150** It will save you money. Get a copy, it's free.



The Callie Perfection Motor Co.  
 1523 Callie St.  
 Detroit, Mich.

# EDWARDS METAL ROOF

Get the roof that stays and pays—"any roof" won't do. The Edwards is the one roof that is absolutely fire-proof, rust-proof, and rot-proof. The Edwards Interlocking Device and the Edwards "Tightcote" process settle those questions once for all. No raw edges. No spots. One man with a hammer can lay it.

## Cheaper and Better

Cheaper in the first place; cheaper in the long run. The Edwards costs less and lasts longer than any other roofing material. When you put on this "one-piece" roof, it's on for good. All sizes and styles. Comes in big sheets. Handy to handle.

## Free Lightning Insurance

Write for our Bargain Catalog No. 1150. Give size of roof and we send complete cost estimate.

Get our figures NOW before prices go up. Write today—right now.

The Edwards Manufacturing Co., 1100-1150 Lock St., Cincinnati, Ohio

Stays  
"PUT".

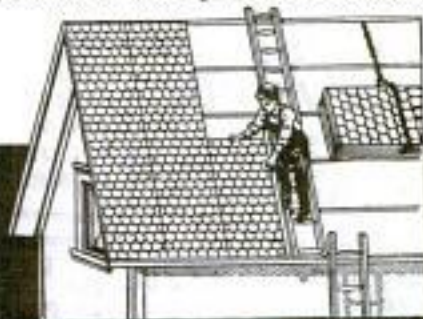

## ACORN UNI-LITE FREE

Turns night into day. 300 candle power. Carry as a lantern; use anywhere as a lamp. Weather proof. For house, barn, garage, camp and around the farm. Write for big free offer. Special opportunity to farmers, stockmen and motorists. Agents make big money.

WRITE TONIGHT

ACORN BRASS MFG. CO., 601 Acorn Bldg., Chicago

## STANWELD Cold Drawn Seamless Steel TUBING

Lightest, smoothest, strongest Steel Tubing made. World's largest manufacturers of bicycles, motorcycles and automobiles use it exclusively. Send for Folder "A."

THE STANDARD WELDING COMPANY  
Main Office and Factory CLEVELAND, OHIO

## THE DESTRUCTIVE WORK OF A SUBMARINE

can be best understood by studying our Chart of a Modern Submarine, size 14x28 inches; printed on plate paper and showing and naming over 200 parts. This chart is a cross-sectional view (lengthwise) and shows the entire construction and operation; is really an encyclopedia of a submarine; educational and worth many times its cost.

PRICE 25 CENTS POSTPAID  
POPULAR MECHANICS BOOK DEPT.  
6 N. Michigan Ave., CHICAGO

STUCK!



## Send for this FREE BOOK

It tells about the most important improvement in Automobile construction since the adoption of the self starter.

# M & S DIFFERENTIAL

"Pulls both wheels"—Does away with wheel spinning—saves wear on rear tires—Gives you ALL your engine power ALL the time—Enables a car to go through deep mud, sand or snow if EVEN one wheel ONLY has traction.

## FORD OWNERS

can now get the M. & S. for replacing the old style bevel gear differential in their present Ford cars. Send in the coupon and keep up with automobile progress. Big money making opportunity for garage and supply men.



M. & S. GEAR CO.  
1037 David  
Whitney Bldg.  
DETROIT

M. & S.  
GEAR CO.,  
1037 David Whitney Bldg.  
DETROIT

Please send me your booklet

"Stuck"—I drive a..... car.

Name.....

Address.....

## One Man and This Machine Will Earn \$50 to \$100 Daily Profit



Not a dream—not a myth—but a reality. If you are honest-earnest, and anxious to go in business for yourself, I will help you. I have helped lots of men to make from \$500.00

to \$1500.00 per month. It's an honorable business—can be started most anywhere, in any town of over 500 population.

## A GOOD BUSINESS PROPOSITION

You want a business of your own. Go into the Popcorn Crispette business and make \$2000.00 to \$7000.00 a year. All you need is a machine, a few dollars and a good location. You can learn to make Crispettes in a day. They sell everywhere for a nickel a package. You make almost four cents profit.

## SEND FOR FREE BOOK

It tells the whole story—how and where to start, how to succeed, gives experiences of others, etc. It's worth reading, even if you don't start. If you're looking for a good thing and easy money, write today for the FREE BOOK.

Eakin made \$1500.00 in one month with a Long Crispette Machine, in a store window.

You can do equally as well, or even better.

W. Z. LONG CO.  
1112 High St.,  
SPRINGFIELD, OHIO

Name.....

Address.....



**"Please hand me the Corona, Jack—"**

"I have to give that new salesman Russell a little friendly sermon on the way he handled the Acme deal and don't exactly like to dictate it to Miss Lester. By the way—why not give Russell one of these machines? It's all I can do to read his reports and I hate to think of the impression his letters must be making on our customers."

The Corona surely is a practical little machine—never in the way and always ready for work. Light enough to be carried in one hand and small enough to be packed in a grip. Even if you have never operated a typewriter you'll soon speed up on the



## CORONA FOLDING TYPEWRITER

Has two color ribbon, back spacer, full width keyboard and—well, it's a complete typewriter and will stand up under any kind of service. For assurance on this point, write for "Proof of the Pudding"—it tells what the Corona has done, not what we claim it does. Also ask for Booklet No. 13 and name of nearest Corona dealer.

**Corona Typewriter Co., Inc., Groton, N. Y.**  
 New York: 141 W. 42d St. Chicago: 12 S. La Salle St.  
 Agencies in all principal cities

SEND FOR this Booklet. It is the proof, and will interest any business man.

PROOF-  
OF THE  
PUDDING

### This Watch, Fob and Pin Set \$14.75

Regular Price \$21.50

To introduce our high grade Sawcraft jewelry we offer these Watch, Fob and Pin sets for less than the price of the Watch alone. The movements are genuine Elgin or Waltham 15 ruby jewels, adjusted and regulated to close time. The case is heavy gold filled warranted for 20 years. Fob and Pin monograms are made of heavy gold front and will wear like solid gold.

Regular price of this set \$21.50  
 Our special price \$14.75

Send your initials and \$2.00 to show you mean business and we will make Fob and Pin to your special order and engrave watch case to match. If not as represented return and we will bear the loss, if satisfactory pay balance of \$12.75 and the set is yours.

**Sawcraft Jewelry Works**  
 Dept. 6 Box 843, Milwaukee, Wis.



## REDEMOTORS

GREATEST SMALL GAS ENGINES

These small engines are now accepted as the logical power for light machinery. For running Washing Machines, Cream Separators, Churns, Pumps, Coffee Mills, Railway Velocipedes, Boys' Autos, Bouts, Electric Dynamos, etc., they have no rival. Thousands in use in all parts of the world. Run on gasoline, kerosene, alcohol or on city gas, natural gas or blue gas. 1 hp., 1/2 hp. and 3/4 hp. Get Catalog J.

ELGIN WHEEL & ENGINE CO., ELGIN, ILLINOIS



WORK FOR US—\$50 to \$75 EVERY WEEK

START NOW



Experience not necessary. Honesty and willingness to work is all we ask, selling **The Easy Wringer Mop**; make \$5000 a year.

LISTEN! One man's orders \$2600

one month—profit \$1650. Mess boy in Pa. made \$9.00 in 2 1/2 hours. **It sells itself.** No investment required. Sample free with first order. Valuable booklet **FREE.** Write Today.



THE U. S. MOP CO., 317 Main Street, Toledo, O.

## AGENTS—The Million Dollar Hit!

New, wonderful home invention, just introduced, yet million sales already recorded. Tremendous, rapid sales stagger country. Agents happy—banking enormous profits daily. Mighty opportunity for you to get the mighty dollar. Failure impossible. Experience unnecessary. Money rolls in first hour—\$10 to \$30 daily. Amazing cash records made. Walters received

**\$50.00 FOR 7 HOURS' WORK**

Never sold goods before. Arnold sold 160 in 2 days; Hagen 100 same time; Webb 10 per hour; O'Connell 25 first day. Hundreds like these. You, too, can have money in abundance. Grab's Scientific Shoe Cleaner sells itself—you take orders—that's all. Every family wants one on their doorstep. Replaces unsightly, unsanitary, crude door mat. **Automatically removes mud, dirt, snow from shoe in one operation.** Cleans sole, sides, heel. Works like magic—sells like sixty. Saves drudgery, time, money, shoes—saves carpets, floors. Mechanical wonder. Has 7 new patented features not found in any other scraper—10 steel blades—10 dirt outlets—twin adjustable and removable brushes—compound springs. Rotates for sweeping. Can't clog—practically self-cleaning. Handsomely enamelled. Nothing else like it. Nothing so popular—so easy to sell. Selling price only \$1.00. You make half—100 per cent. Satisfaction guaranteed. Write quick for free catalog—exclusive agency. Better still, send order, naming territory. Investigate anyhow.

**SECURITY MFG. CO., Dept. 191, TOLEDO, OHIO**

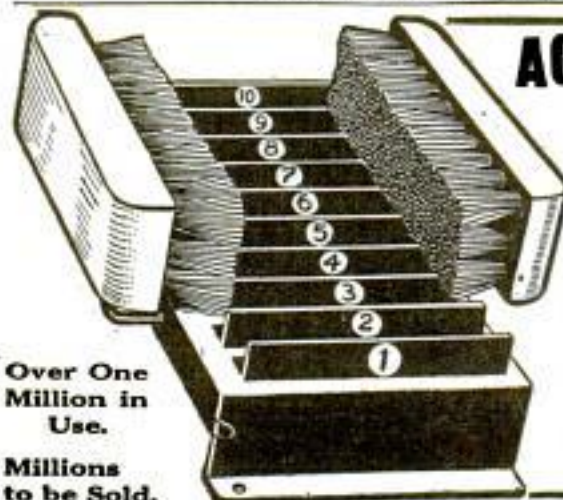

Over One Million in Use.

Millions to be Sold.

## Free Try-On of the Aluminum Soled Shoes

with  
Solid Rubber or  
Leather Heels  
and Rocker Bars

Think of aluminum protection and lightness with the easy walking comfort of rubber or leather! No other metal soled shoe has these features!



You can now get our 1916 *improved* Water-proof—rain-proof—snow-proof—puncture-proof. Save \$50 worth of ordinary shoes—protect you from colds, rheumatism, lumbago, pneumonia.

### Racine Aluminum Shoes

Keep your feet warm and dry *anywhere*. Positively the most comfortable shoe you ever wore. *No metal can touch you.* Made in every height from 6 to 16 inches. Every size from 1 to 13. Boys' shoes as well as men's. Prices surprisingly low.

Get our try-on, money-back proposition. Money cheerfully refunded if you are not entirely satisfied.

Write today for illustrated free book, "Aluminum the Sole of Health." Address

Racine Aluminum Shoe Co.  
73 12th Street, RACINE, WIS.



## FACTORY REBUILT Indian Motorcycles at Exceptionally Low Prices

WE have purchased from the Hendee Mfg. Company 100 factory rebuilt machines—models ranging from 1911 to 1914—Single and twin cylinders—Multi speeds—prices \$50 to \$160.

These machines are not to be compared with the average second-hand machines, as they have been completely overhauled, re-enameled and re-nickled by the Indian factory itself. They are practically new machines.

Write today for complete specifications and prices

THE MOTOR SALES COMPANY  
705 Main Street Worcester, Mass.

## Heat Your Garage

\$24<sup>00</sup>



To 70 degrees in coldest winter. Makes easy starting. Prevents ice, snow and frozen mud from spoiling your car. Safe. Low in cost; cheap to run. The

KANNEBERG  
**AUTO-HOT**  
GAS HEATER

eliminates danger of burst radiators or jackets. Clean your car or make repairs comfortably even in coldest weather. You enjoy your ride because you're warm when you start. Anyone can install. Booklet FREE.

The Kanneberg Roofing & Ceiling Co.  
122 Robin Ct. CANTON, O.

## Extra Money For Storekeepers!

### \$3,120 Yearly

Every smart man who runs a confectionery, cigar, drug, grocery or department store, theatre, restaurant, news stand or concession is going to answer this ad if he sees it, or lose from \$5 to \$16 daily. Send no money—but mail the coupon today, and see the actual evidence from men like you who are getting rich from this famous Butter-Kist Corn Popper.

See how eager folks crowd around and watch this remarkable corn popper *run itself!* How one installed last winter earned \$2,085.65 the first five months! How many men are making \$25 to \$60 weekly above expenses! How this machine can earn from 70c to \$4 per hour!

Not only that—but win more trade for everything you sell—put new blood in your whole concern.

## BUTTER-KIST Corn Popper

turns out big, white, fluffy Butter-Kist Pop Corn with a *cooking fragrance* that makes folks hungry to buy. Not a sticky, smeary confection—but crisp, crackling pop corn, evenly, *automatically* buttered with pure creamery butter—piping hot, untouched by hands. Yes, genuine Butter-Kist Pop Corn, advertised to 43,000,000 readers. The tempting, tantalizing national treat that folks walk blocks to buy.

### Superbly Built

Occupies only 26 by 32 inches of floor space—earns five times as much profit per square foot as anything else in your place. Gleaming plate glass sides—handsome mahogany, oak or white enameled cabinet, metal parts highly polished and nickled.

### Pay From Its Earnings

\$150 starts it popping you profits right in your store! Then the machine pays balance itself.

Photographs, figures that *prove profits*, and full details all shown in our handsome color book, "The Little Gold Mine."

Valuable, inspiring! Sent free, postpaid. Mail the coupon or a postal *NOW!*—and gain from \$5 to \$16 daily.

Holcomb & Hoke Mfg. Co.  
1759 Van Buren St.  
Indianapolis, Ind.



Fitted for  
the  
Finest  
Store

Send for "Little Gold Mine" FREE

HOLCOMB & HOKE MFG. CO. (112)

1759 Van Buren St., Indianapolis, Ind.

Send, free, your color book, "The Little Gold Mine," that tells all about the Butter-Kist Corn Popper.

Name.....

Business.....

Address.....

Please Mention Popular Mechanics

# THE Bausch and Lomb BALOPTICON

The pleasure and instruction which the ear gets from the talking machine, the eye gets from pictures and other objects shown by the

## HOME BALOPTICON

made primarily as a projector of post cards, photographs, and various objects. Special 400-watt, gas-filled Mazda lamp with optically corrected mirror gives an illumination superior to anything heretofore offered, attaching to ordinary lamp socket.

Automatic, perfectly safe and simple enough for any child to operate. Fitted with high-grade achromatic lens, giving well-defined pictures sharp to the corners. Ideal equipment for clubs and small classrooms, as well as the home — not a toy.

Price for Home Balopticon complete for the projection of post cards, including aluminum coated screen, only \$35. Sold by optical and photographic supply dealers. Other models to meet any requirement, \$22 and up.

Write for our booklet "Fun—and better"

**Bausch & Lomb Optical Co.**  
576 ST. PAUL STREET ROCHESTER, N. Y.

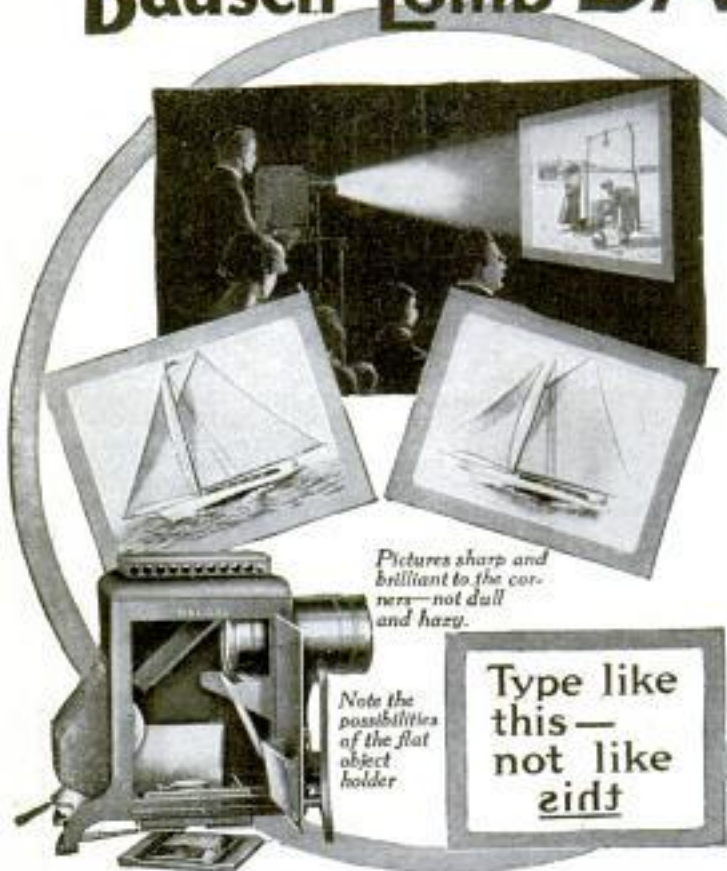

Pictures sharp and brilliant to the corners—not dull and hazy.

Note the possibilities of the flat object holder

Type like this — not like zidz

### 2 H.P. \$35 BEST ENGINE VALUE



Look at the Size, Power and the Price Complete, no extras to buy. Four cycle, speed regulation constant. Power steady and smooth. Cheap to run. Free details.

The Self-contained Unit Power Plant

C. BENNINGHOFFEN & SONS, Dept. 125, Hamilton, Ohio

The value of the gold, silver, and copper production of Alaska for 1914 aggregated \$18,835,520.

### The Wrench of a Thousand Sizes



Universal Adjustable Wrench—dozen wrenches in one. Instantly adjusted to grip objects of all sizes and shapes. Indispensable for the MECHANIC, CHAUFFEUR and for HOUSEHOLD purposes. From your dealer, or direct from us, \$1.00 postpaid. LIVE AGENTS Wanted

THE COLYTT LABORATORIES, 567 West Washington, CHICAGO, ILL.

### Valuable Poultry Book

IF you raise chickens and want them to produce real profits, write E. J. Reefer, the poultry expert, for one of his fascinating books which tells how to make the average hen lay 200 eggs every year. It contains scientific facts of vital interest to every poultry raiser. Send name and address on a post card or a letter and the book is yours absolutely free.

**E. J. REEFER** (Dept. 1198) Grocer Building, PHILADELPHIA, PA. Nelson Building, KANSAS CITY, MO.

## Boston Garter

Velvet Grip

Three Popular Styles:

NEVERBIND  
CORD and  
PAD

GEO. FROST CO.  
MAKERS  
BOSTON



Silk 50¢  
Lisle 25¢



### Run Your Ford or Overland All Winter in Safety

Skidding, slipping, sideways and stalling in bad spots will all be eliminated if you install the

### BAILEY Gearless Differential

Gives positive drive to both rear wheels; all the advantage of a solid axle in straight going; power delivered only to wheel having traction in ruts or slush. Adds 50 per cent to comfort and safety; saves fuel, oil and tires. Thousands in use. Shipped ready to install on Money-back offer. See dealer or write for circular.

Gearless Differential Co., 892 Woodward Ave., Detroit, Mich.

10811  
From W. Reed  
Filed Apr 24 1915  
City 63277  
81-703  
Aug 09 7-674



# ENGINE QUALITY HIGHER — PRICES LOWER

Engine quality means *earning capacity*. High earning capacity means *high quality*. Low *first cost* (engine price) and low *after cost* (cost of fuel and up-keep) — both of these factors together, when they give you steady, dependable, continuous operation at fuel load — these things mean *high earning capacity* — high quality. Add to this low money-cost (price and operating cost), the matter of convenience — engine easy to understand and manage, easy and quick to start without cranking — and you come to the highest point of high engine quality.

It is just this kind of high quality, that has made successful, for over 28 years (almost ever since there have been any gasoline engines), my well-known, fuel saving

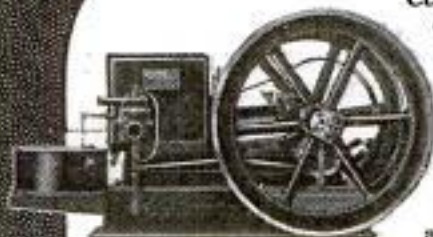

Gasoline and Naphtha Engine — Stationary Sizes: 2, 3, 4, 6, 8, 12, 16 and 22 H-P. Shown mounted on iron sub-base.

## WITTE ENGINES

GASOLINE, GAS, KEROSENE, AND DISTILLATE

WITTE Engines — On Skids  
Sizes: 2, 3, 4, 6, 8 and 12 H-P.  
Kerosene or Gasoline.

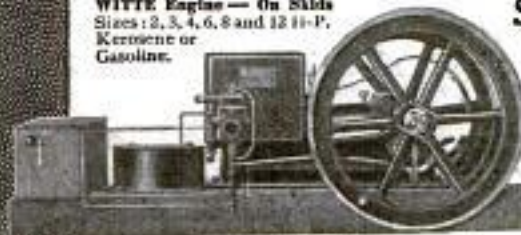

Sold Direct from Maker to User

If you knew my engine quality, as well as many thousands of my old customers, you would believe, just as they believe and freely say, "You can't buy any better engines for any price, and none as good for the low WITTE price." My engines are now made to deliver 30% to 50% surplus power, according to size, over the regular rating, and to operate on 15% to 30% less fuel per H-P. delivered in the belt or at the brake. Yet with these important advantages, the price is lower than ever, averaging for stationary engines

Steel mounted portables now average less than \$22.00 per H-P. and complete engine value, you should send at once for my new

**EASY-TO-UNDERSTAND ENGINE BOOK — FREE**

This book shows in detail, how to judge engines, as to construction, low cost and easy operation, and which sizes are most suitable for the various kinds of work for which any kind of engine can be used to advantage. Until you read my book, you will not fully know just how much quality your engine money can and should buy. Let me show you my offer before you arrange to try any engine. Write to-day, to my office nearest to you.

**ED. H. WITTE, WITTE ENGINE WORKS**

1749 Oakland Ave., KANSAS CITY, MO.

1749 Empire Bldg., PITTSBURGH, PA.



WITTE Saw-rig  
Sizes: 4, 6, 8 and 12 H-P. Kerosene and Gasoline engines furnished in this style.

### Latest WITTE Prices

5-Year Guarantee on Efficiency and Durability

CASH OR EASY TERMS (F. O. B. Factory)

#### Stationary

2 H-P., \$34.95  
3 H-P., 52.45  
4 H-P., 69.75  
6 H-P., 97.75  
8 H-P., 139.65  
12 H-P., 197.00  
16 H-P., 279.70  
22 H-P., 359.80

#### Portable

2 H-P., \$39.95  
3 H-P., 60.50  
4 H-P., 82.75  
6 H-P., 127.75  
8 H-P., 174.65  
12 H-P., 237.00  
16 H-P., 329.70  
22 H-P., 412.30

#### Saw-Rigs

4 H-P., \$124.25  
6 H-P., 152.25  
8 H-P., 202.15  
12 H-P., 267.00



ED. H. WITTE, WITTE ENGINE WORKS,  
1749 Oakland Ave., Kansas City, Mo.  
1749 Empire Bldg., Pittsburgh, Pa.

Without cost to me, and with no obligation on my part, I should like to receive your interest and finest Engine Book, and to investigate your New Liberal Selling Plan.

Name .....

Address .....

Please Mention Popular Mechanics



# EXCELSIOR LIGHT WEIGHT



**\$135<sup>00</sup>**



**A Motorcycle for Everybody**

*The Triumph of Economy,  
Reliability, Simplicity,  
Convenience and Comfort*

**Takes Anybody Anywhere  
at the Lowest Possible Cost**

**A Rational Motorcycle for Sensible People**

The Excelsior Lightweight is not a new untried experiment, but is a machine that has been thoroughly tried on all kinds of roads and is a type that throughout Europe, has practically supplanted the big heavy twins on account of Simplicity, Economy and Convenience.

**NOTE THESE DETAILS:** Two Stroke Motor, Light and Powerful; Sliding Clutch Transmission, Simple and Efficient; Ignition by High Tension Magneto; Carburetor Schebler, specially designed for this motor; Frame, Seamless Steel Tubing and Nickel Steel Drop Forgings throughout; Folding Foot Rests; Steel Luggage Carrier; Waterproof Tool Box; Complete Grip Control.

**EXCELSIOR QUALITY THROUGHOUT**

Write today for our new catalog fully describing the EXCELSIOR LIGHTWEIGHT and five models of the new series "16", the Most Powerful and Fastest motorcycle ever built.

**Prices \$135.00 to \$280.00**

**Excelsior Motor Manufacturing & Supply Co.**  
3702 Cortland St., CHICAGO

## Ideal Christmas Gift

FOR boys and girls from 3 to 12. Wonderful new mechanical principle. Speed without labor. Rider propelled by his own weight. No pushing.



### Skudder Car

It develops the lungs, shoulders and legs. Children never tire of it. Ball bearing, unbreakable steel frame.

Write for Free Circular.

**SKUDDER CO.**

Straus Bldg. CHICAGO

## 250 "WIRELESS" TRANSFORMER \$9.00

**CLOSED-CORE TYPE 14000 VOLTS 3 DIFFERENT POWERS SELF CONTAINED** Shipping Weight 20 lbs. Send 2¢ stamp for catalogue of Wireless Supplies, folders, etc. Winger's Telegraph Code Charts free with \$1 order; otherwise 20c ea. Furnished in "station" or "pocket" sizes, Continental or Morse code; please state which, otherwise Continental "pocket" size will be sent. Winger Electric & Mfg. Co., 711 So. Dearborn St., Chicago, Ill.

In the first year of the European war seven vessels flying the American flag entered the port of Lisbon, Portugal. Prior to August 1, 1914, only one vessel of American registry had entered that port in 15 years.

## BARODA DIAMONDS

**FLASH LIKE THE GENUINE - AT 1-50 THE COST**  
**SOLID GOLD MOUNTINGS** Stand acid test and expert examination. See them first, then pay. Catalog FREE. Patent Ring Gauge included for 5 two-cent stamps. The Baroda Co., Dept. E5, 1458 Grand Ave., Chicago



## YOUR CREDIT IS GOOD — BUT — YOU CAN SAVE MORE THAN ONE-HALF BY PAYING CASH

The set of jewelry illustrated herewith would cost you about fifteen dollars in the average retail store, with every chance that you could not duplicate the quality we offer you. **Prove this at our expense.**

The watch is not much thicker than three five cent pieces and has surpassed well known, highly advertised watches in extensive time and pressure tests. That is why we guarantee each movement for five years and engrave our name and address on every movement as an irrefragable guarantee of quality. This proves our willingness to make good the slightest defect that is not the result of accident, abuse or amateur repair work.

The 10 Kt. gold stack case is made with a dust and moisture proof screw back and bezel, and is guaranteed

**NO MONEY IN ADVANCE**  
This Handsome Set of Guaranteed Jewelry Delivered to Your Address for... **\$6.95** Complete Inspection at Our Risk

for ten years of continuous wear or for a longer period in proportion to daily use. Our registered United States trade-mark, name, address and guarantee is stamped in the back of every case. Don't you think that is far more convincing than a pretty bond-like, legal looking document that you may lose or mislay?

The chain is a beautiful pattern, very popular and stylish. It is made of the same stock as the watch case and guaranteed accordingly.

You have the choice of a cigar cutter knife like illustration or a regular two bladed pen knife; both have fine tool steel blades and heavy rolled gold sides that are guaranteed to give satisfactory wear. **State your choice in ordering.**

This set is designed for the use of the working man because the watch is durable, reliable, accurate and so thin that a blow that would crush a thick watch in your pocket, would strike your body before it could exert enough force on this watch.

Every gentleman will admire this beautiful set of jewelry because it is useful alike for business and formal affairs.

If you actually want to buy a watch and secure the rest of the jewelry, all for the one price, write on a letter or postal giving your name and an address at which the express company could present the jewelry set for inspection during their business hours, and we will do the rest. **You do not obligate yourself in any way.** If you buy the set, our invoice will clearly state your money will be refunded upon return of the set in good condition if it does not prove all that we say. If you desire to send cash in advance we can give the very best of references.

**BARCLAY WATCH CO., 233 Broadway, Woolworth Bldg., New York**

Write us for further particulars if there is no express company in your town, or if you are under any other difficulty—but write by return mail.

Please Mention Popular Mechanics



# YOUR CREDIT IS GOOD WITH US!

*"Distance is no barrier to fair dealing; it's no check upon human honesty, human sympathy or human needs."*

Therefore, you should write for our Big Free Catalog at once, for no matter where you live, you are invited to open a charge account with HARRIS-GOAR CO. Whether it be Watches, Diamonds or Jewelry—Fine Cut Glass, Sterling or 1547 Rogers Bros. Silverware, Clothing, Musical Instruments, Sewing Machines, Leather Goods, Guns or Bicycles, you can get it here on easy payments and at money-saving prices.

**Special For Early Buyers** *Gift* **\$12<sup>75</sup>**

**Genuine 17 Jewel Elgin** 25 YEAR GOLD-ENAMEL AND MONOGRAM CASES.

You'll want this wonderful bargain. It's made to prove to you that the great volume of our business in all parts of the country, enables us to do better by you than any other Watch or Diamond House in the world. We don't need the money. That's why we make such liberal terms and give you all the credit you want, and add this—the most marvelous watch offer ever made. Think of it! 17 Ruby and Sapphire Jewels—a genuine 17 Jewel Elgin. Standard of the World.

Endorsed by Government and Railway Officials. Factory tested to the second. finely finished and fitted in a superb, plain polished or hand-engraved 25-year Gold case, and you'll never miss the money. We send this watch on the astounding terms of only **\$2 A Month**

## Now Ready! NEW MODELS Exclusive Designs

**Richly Enameled, Original, Exclusive Engravings, Just Out!** In our New Catalog only, will you find the beautiful New Model "Classic," The New "Universal," The New "California," The New "Diamonett," The New "Satin," The New "Sunshine," The New "Double Circle"—all marvelously beautiful. And when you see the cases themselves, you'll agree that no illustration or printed page, can adequately convey the full splendor of these magnificent models. They are gorgeous in design and execution. They convey to the eye that degree of joy and satisfaction, made possible only by their richness of quality, gold shadings, enamels, and the artist's touch. They have no lines that you would remove. They lack none that you would add. They instantly command your unstinted admiration. They carry their own evidence of superb quality and in the rigid gold assay test, stand in a class by themselves.

## A Million Catalogs

FOR YOU!

### Send Your Name on This Free Coupon

for the most interesting Catalog in America. A thousand fine illustrations, printed in four colors. Every page teems with quality and bargain prices. Every page tells a story of human interest. It shows you and you and everybody, everywhere, how to own a fine Watch or Diamond, or the things you want, without missing the money. You pay no interest—we ask no security—no red tape—just common everyday honesty among men—and you save nearly half. Your name and address on the Free Coupon or a postal will do. But do it now!

**HARRIS-GOAR CO.**

Dept. 1764 Kansas City, Mo.

The House That Sells More  
Elgin Watches Than  
Any Other Firm  
in the World.

**Kansas City Bank  
Presidents Endorse  
HARRIS-GOAR CO.**

We take very great pleasure in recommending the Harris-Goar Jewelry Co., to the business public. The company has large financial resources with patronage everywhere throughout the United States. Mr. Harris and Mr. Goar are well and favorably known as men of energy and business integrity, and we believe them worthy of the fullest confidence of the public. (Signed)

J. R. DOMINICK, Pres.  
Traders National Bank.  
W. T. KEMPER, Pres.  
Commerce Trust Co.

**HARRIS-GOAR CO.**

Dept. 1764

**KANSAS CITY, MO.**

Please send me (without obligation and prepaid) your 1916 Catalog of Watches, Diamonds and other goods, together with the story of the Harris-Goar original easy credit plan.

Name .....

Town .....

State .....

R F D. or St. ....

Please Mention Popular Mechanics

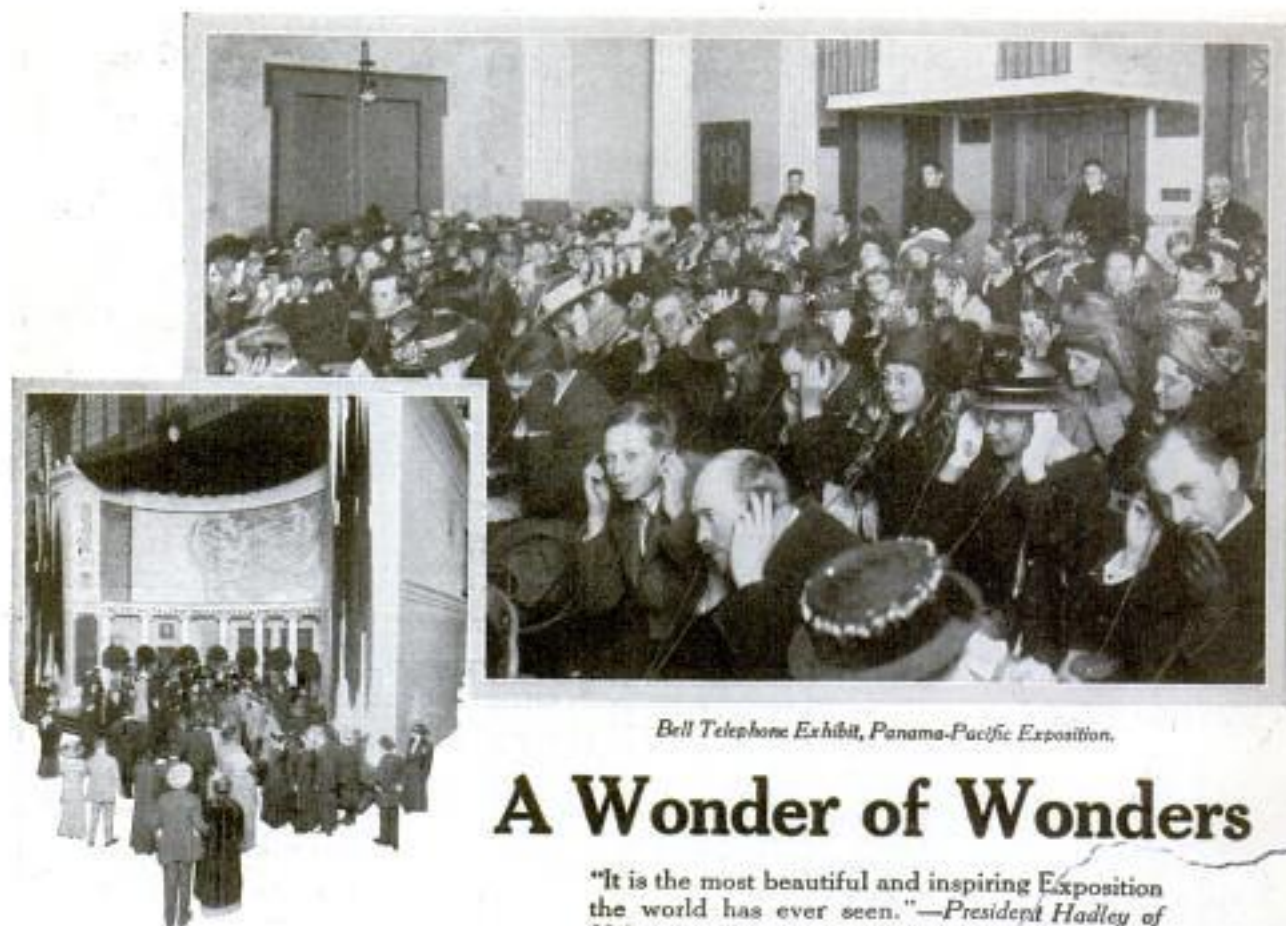

*Bell Telephone Exhibit, Panama-Pacific Exposition.*

## A Wonder of Wonders

*"It is the most beautiful and inspiring Exposition the world has ever seen."—President Hadley of Yale, in speaking of the Panama-Pacific Exposition.*

**E**VERY American should feel it a duty as well as a privilege to visit the Panama-Pacific Exposition and view its never-equaled exhibits of achievements in Art, Science and Industry.

In all this assemblage of wonders, combining the highest accomplishments of creative genius and mechanical skill, there is none more wonderful than the exhibit of the Bell Telephone System.

Here, in a theatre de luxe, the welcome visitors sit at ease while the marvel of speech transmission is

pictorially revealed and told in story. They listen to talk in New York, three thousand miles away; they hear the roar of the surf on the far-off Atlantic Coast; they witness a demonstration of Transcontinental telephony which has been awarded the Grand Prize of Electrical Methods of Communication.

This Transcontinental Line has taken the thought, labor and ingenuity of some of the greatest minds in the scientific world. Yet it is but a small part of the more wonderful universal service of the Bell System, which makes possible instant communication between all the people of the country.



**AMERICAN TELEPHONE AND TELEGRAPH COMPANY  
AND ASSOCIATED COMPANIES**

***One Policy***

***One System***

***Universal Service***

*Please Mention Popular Mechanics*

# ERECTOR

The Toy Like Structural Steel

Here is the famous Erector girder

Erector is the *only* construction toy with girders exactly like real structural steel. The patented interlocking edges (an exclusive Erector feature) enable boys to build *big, strong* models of bridges, skyscrapers, inclined railroads, elevators, workshops with machinery of all kinds, battleships, aeroplanes

and hundreds of others. The powerful Erector motor, free with most sets, runs many of the models. It's great fun for boys!



**FREE**

I want to give every boy, absolutely free, a three months' subscription to my boys' magazine, *Erector Tips*. Including the big holiday issue in color, brimful of stories and photographs.

Be sure to get this interesting magazine and read the absorbing story, "How I Invented Erector" and the special articles telling how I became a World's Champion Athlete. *Tips* also contains full details of the \$3000 Prize Offer of automobile, motorcycles, bicycles, camping outfits, canoes and other valuable prizes.

Write today for the three months' subscription—also a free copy of my new 24-page Book telling all about construction toys. Don't send any money or stamps; I want to present all this to you absolutely free.



**Erector Sets Sold Everywhere, \$1 to \$25**

Be sure to see Set No. 4 for \$5 which contains 571 parts and motor, builds 250 models and is packed in handsome oak cabinet.

A. C. GILBERT, President

The Mysto Manufacturing Co. 104 Fox Street  
New Haven, Conn.

Name.....  
Address.....  
My dealer is.....  
Send this coupon to  
Mysto Mfg. Co., 104  
Fox St., New  
Haven, Conn.

# COLGATE'S SHAVING STICK

SEPTEMBER



OCTOBER



wonder  
NOVEMBER

most men use  
COLGATE'S  
SHAVING  
STICK  
-it lasts  
so long



Softens wiry beards without irritating tender skins.

Needs no mussy "rubbing in" with the fingers. Trying is believing!

Colgate's Rapid-Shave Powder and Shaving Cream give the same perfect lather as the Stick. Many men say they get four or five months shaving from a single Colgate Stick. The Powder can be used to the last grain without waste. One user writes about the Cream, "After the tube was apparently squeezed out I split it open and got enough soap for a splendid shave by passing the moistened brush over the inner surface. Which was economy *plus*."

Send 4c in stamps for Trial Size of Shaving Stick or Powder or Cream—3 styles, one result.

COLGATE & CO.  
Dept. 81 199 Fulton Street New York

Makers of Cashmere Bouquet Soap—luxurious, lasting, refined



#### Economy With Colgate's Stick

When the one you now have is nearly used up, wet it and press it firmly on the end of the new stick. It stays—and you use every bit instead of having to throw away the last half inch (or so) as usual.