

April

15 Cents

POPULAR MECHANICS MAGAZINE

WRITTEN SO YOU CAN UNDERSTAND IT

TRADE MARK



HUMAN SPIDERS
OF THE
BROOKLYN BRIDGE

\$699

BUYS THE MATERIAL To Build This Harris Home

THIS IS OUR WELL KNOWN
HARRIS HOME No. 161

Why Pay Rent?

A home is within your reach—no matter how limited your income.

4

Big Lumber
Shipping Points

The material to build this or any of the more than a hundred modern Harris Homes in our free \$10,000 Book of Plans, can be shipped "direct to you" from our main lumber yards at Chicago or St. Louis, also from our stocks at Washington and Mississippi for quick delivery and lowest freight expense.

A true bungalow design easily built under our guaranteed no shortage no extras system, and positive accurate plans.

No Money Down
Save 1/3 to 1/2

Send Us Your Lumber Bill

We will name you freight pre-paid prices on everything—Lumber, Millwork, Hardware, Plumbing, Heating, etc., that will mean a saving of from 1-3 to 1-2. Upwards of 20,000,000 feet of brand new lumber is in our mammoth stock at all times. We would not dare ship this material without one cent down if we were not certain that you would be pleased.



BUILD THE HOME YOU HAVE BEEN DREAMING OF FOR YEARS—AT THE PRICE YOU OUGHT TO PAY

Our Guarantee
Protects You

Greatest of all is this Harris Home Building Plan. A truly wonderful offer—clean and straightforward. This was the first real helpful home building plan. We placed the opening wedge and made it possible for the many thousands of satisfied Harris home owners to realize their dream of years. In dealing with us you reap the benefits of these vital essentials—22 years of expert planning, designing and close study of economy in material and labor. Through all these years we have maintained, with ease, our lead, never finding it necessary to recognize competition. Make us prove this to your satisfaction. It won't cost you a penny to get our offer now—today. Our binding guarantee, backed by every cent of our \$10,000,000 capital stock and surplus, gives you an iron clad protection. You can't possibly go wrong for we take all of the risk.

THE DESIGN The Harris Home No. 161, above, is a perfect combination of comfort, convenience and economy; modern in every respect. Six rooms, bath, large closets, pantry and modern stairway. This is but one of the many splendid designs which can be carefully studied from our **Free Plan Book** in your own home during your leisure hours. Mail the coupon below for your copy of our Plan Book today.

THE MATERIAL The above price includes all first class lumber. Clear Mission Georgia Pine Interior Trim, Clear Flooring and clear Cedar Shingles. No. 1 Dimension Lumber; up-to-date Hardware. Ready-cut door and window frames, inside door jamba; outside door and window casings. All glass in and back puttied—saves time and labor. All Harris homes are of sound construction and are architecturally correct in every detail.

Mail Coupon
Below Today

PLANS FREE We will send you a complete set of blue print plans of above house, such as would cost you from \$25 to \$100 if drawn up by any reputable architect, upon receipt of the coupon below and \$1. We will also include along with the plans, free of charge, Specifications, Material List and a guaranteed delivered price to your station. If you decide to purchase, you will be credited with this remittance of \$1 on your bill, so you see this service is absolutely free. If the plans did not suit and you are not ready to buy, return them, and \$1 will be refunded. We also make plans to order after your own ideas—prices way down. Write us.

Plumbing and Heating

You can easily install your own heating plant and plumbing material with the assistance of our free expert engineering service. We show you how to eliminate much of the biggest expense. Mail the coupon for your copy of our new plumbing and heating book. Complete bathroom outfits, \$37.50. Enamelled bath-tubs as low as \$13. Warm air heating plants, \$67. Steam heating plants, \$85. Hot water heat, plants, \$95.

Quality Roofing Building Material

Our new roofing book is full of practical information. Tells you the correct grade and style of material adapted to your particular purpose. Everything explained by diagrams. Biggest values ever offered, in ready roofing, metal roofing, siding, ceilings, etc. Prices represent savings of from 1-3 to 1-2 in every instance. Mail coupon for FREE copy today.

Mail the coupon today for our 200-page building material book, replete with bargains in lumber, doors, windows, millwork, paint, roofing, plumbing, hardware, lighting fixtures, mantles, grates, colonnades—in fact, everything in structural materials for the construction of any building. Substantial savings evident in every instance.

Dept. E-7
Harris Bros. Co.

Send me your Free \$10,000 Plan Book I am also interested in

Name _____

Address _____

The Chicago House Wrecking Co. has been favorably known to the public everywhere for more than 20 years as "The Great Price Wreckers." The four Harris Brothers who have been the owners and executive officers through all these years have decided that their best interests require more prominent use of the owners' names and will now advertise and sell their goods under the name of

HARRIS BROTHERS CO. 35th & Iron Sts. CHICAGO

Victor Record
of "Habanera"
sung by
Farrar



Farrar in the
title role of
Carmen



Both are Farrar

The Victor Record of Farrar's voice is just as truly Farrar as Farrar herself.

The same singularly beautiful voice, with all the personal charm and individuality of the artist.

To hear the new Carmen records by Farrar is to be stirred with enthusiasm, just as were the vast audiences—the largest ever assembled in the Metropolitan Opera House—which greeted her performance of Carmen, and acclaimed it the supreme triumph of this great artist's career.

The proof is in the hearing. Any Victor dealer in any city in the world will gladly play for you any of the sixty-two Farrar records, or Victor Records by any other of the world's greatest artists.

There are Victors and Victrolas in great variety of styles from \$10 to \$250.



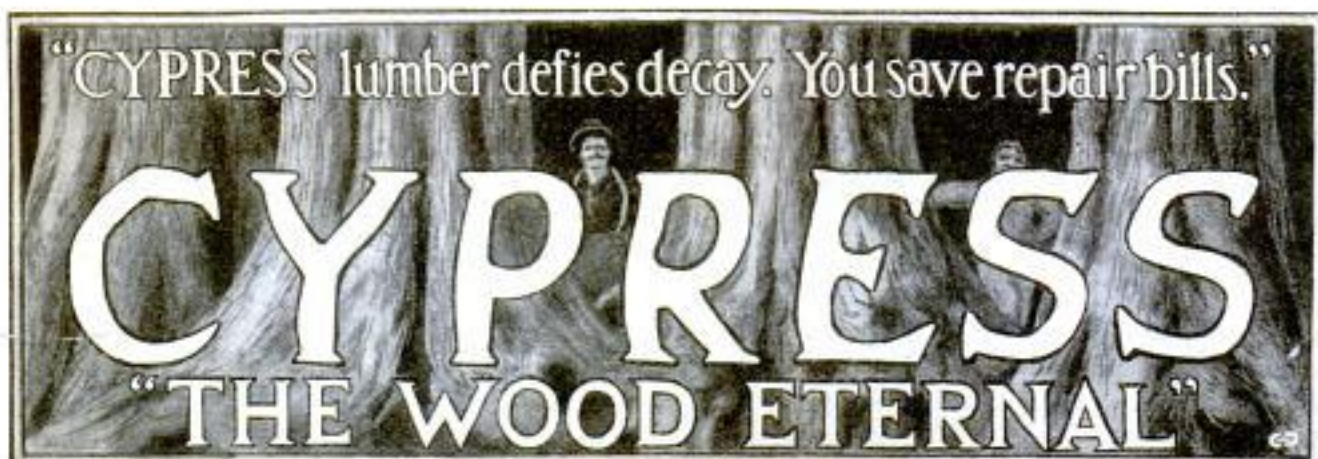
Always use Victor Machines with Victor Records and Victor Needles—the combination. There is no other way to get the unequalled Victor tone.

Photo copy't Dupont

Victor Talking Machine Co., Camden, N. J., U. S. A.

Berliner Gramophone Co., Montreal, Canadian Distributors

New Victor Records demonstrated at all dealers on the 28th of each month



IS A \$1000. 3-ROOM CYPRESS COTTAGE ABOUT RIGHT? WELL, HERE IT IS!

And a joy and a blessing it will be to anyone with a little plot of earth to put it on.

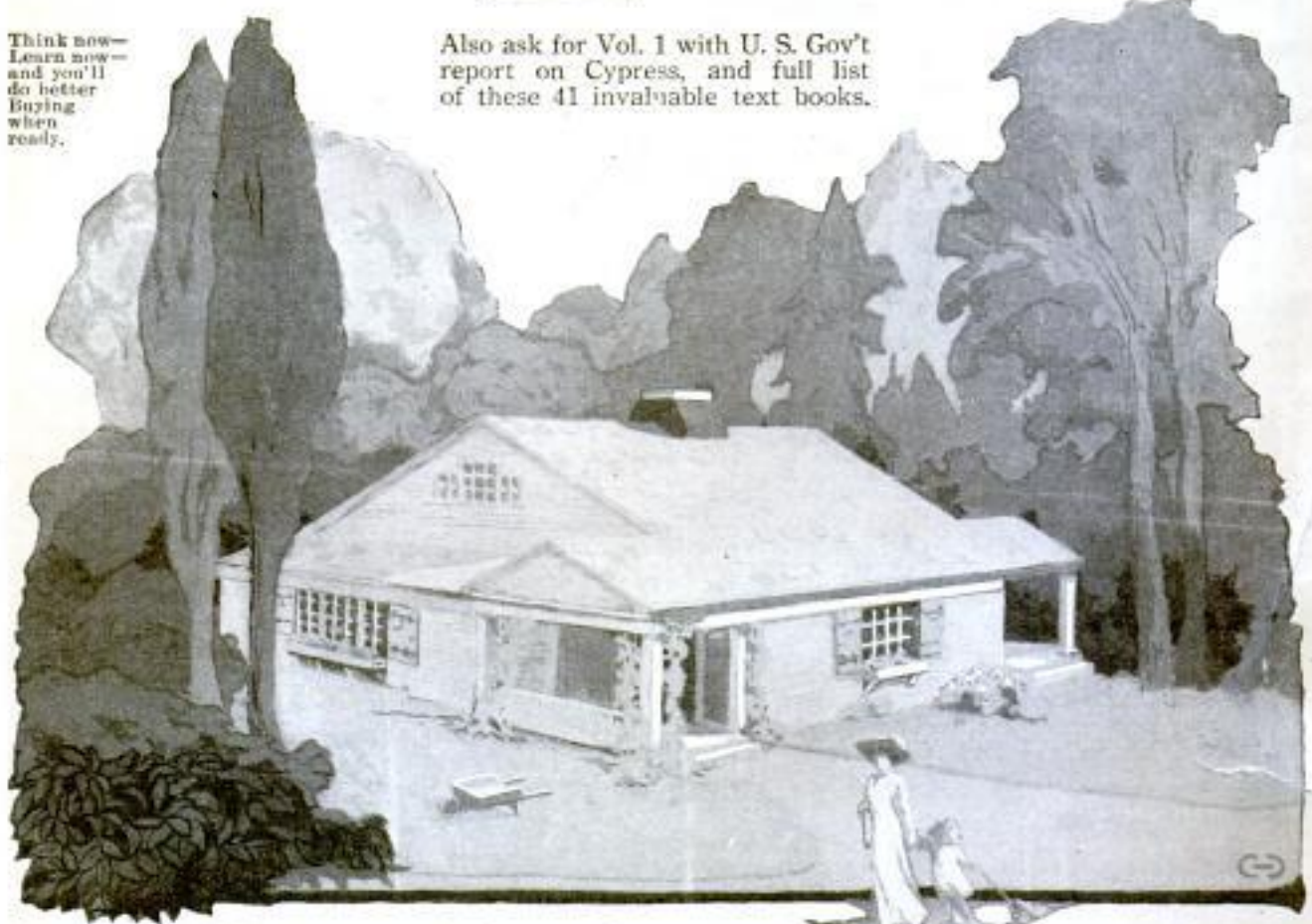
FULL PLANS & SPECIFICATIONS FREE TO ALL PEOPLE WHO LOVE LITTLE HOMES

Ample for any competent carpenter to build from. Above estimate of cost is a fair average figure the country over.

WRITE RIGHT NOW for VOL. 32, of the CYPRESS POCKET LIBRARY

Think now—
Learn now—
and you'll
do better
Buying
when
ready.

Also ask for Vol. 1 with U. S. Gov't report on Cypress, and full list of these 41 invaluable text books.



Remember—We recommend Cypress Lumber only where it is your *one best buy*.

Let our "ALL-'ROUND HELPS DEPARTMENT" help YOU. Our entire resources are at your service.

SOUTHERN CYPRESS MANUFACTURERS' ASSN.,

1219 Heard Nat'l Bank Bldg., JACKSONVILLE, FLA., and 1219 Hibernia Bank Bldg., NEW ORLEANS, LA.

INSIST ON CYPRESS at YOUR LOCAL DEALER'S. IF HE HASN'T IT, LET US KNOW QUICK.

Popular Mechanics Magazine

6 N. Michigan Avenue, Chicago, U. S. A.

EDITED BY H. H. WINDSOR

England: The International News Co.,
5 Becons Bldg., Chancery Lane, London, E. C.

Australia:
The Australasian News Co.

ISSUED MONTHLY

SUBSCRIPTION:

SINGLE COPY, 15 CENTS

In United States, and its possessions, Cuba and Mexico, per year, postpaid	\$1.50
To Canada	1.75
To all other countries in the Postal Union	2.50

All subscriptions are discontinued at expiration. Please examine the date printed on your wrapper.

Entered as Second Class Matter Sept. 15, 1903, at the Post Office at Chicago, Illinois, under Act of March 3rd, 1879.
Entered as Second Class Matter at the Post Office Department, Canada.

Published monthly by POPULAR MECHANICS CO.

Copyright, 1915, by H. H. WINDSOR.
Copyright, in France.

Contents for April, 1915

Aeroplane Mail Service, may Establish.....	542	Drinks Illuminated by New Mixer.....	548
Aeroplanes, Safest Place for Soldier is in.....	518	Dyes, Sulphur, To Replace Aniline.....	546
"Aeroscope" Like Enormous Inverted Pendulum.....	515	Earthquakes, "Wobbling" of North Pole Possible Cause of.....	487
Apple Cars, Unloading with Water.....	540	Electric Light Fixture, Adjustable.....	597
Automobile Converted into Railroad Car.....	492	Fire Escape, Descending Head First to Test.....	546
Automobiles, Economical Speed for.....	497	Flag, College Class, Novel Method of Raising.....	554
Automobiles, New Rear Signal for.....	574	Flags Made of Home Grown Cotton.....	498
Aviation—Cup Trophy for Army Fliers.....	498	Flash Light, Fountain Pen.....	596
Barge, President's, for Panama Canal Opening.....	498	Flash Lights, Use Made of, by Visiting Doctors.....	598
Barge Run and Steered by an Aerial Propeller.....	588	Flatiron Heated by Gasoline.....	575
Baseball Game, Reproduce on Electric Board.....	498	Flower Boxes, Ornamental, for Bungalow Roofs.....	555
Belt, Conveyor, Large.....	539	Flying Boats, New, for the United States Navy.....	508
Belt, New Type of, for Radiator Fan.....	546	Footbridge, Hanging, in Japan.....	591
Bichloride of Mercury, New Devices for Marking.....	568	Fountain Pen, Calendar Clip for.....	597
Birds, Feeding Device Provides Shelter for.....	585	Fruit, Real, Imitation, Picture Made of.....	545
Blackboards, School, Made of Plate Glass.....	484	Game, New Mechanical, Skill Needed in Playing Garage in Basement of Residence.....	520 494
Boots, Cossack, Latest in Feminine Footwear.....	553	Garage, Suburban, Cobblestone Walls for.....	544
Boring Machines, Electric, for Timber Working.....	577	Gasoline, New Process will Make Cheaper.....	516
Bowling Alleys, Electric Pin Setter for.....	581	Grain, Brazilian Natives Grind in Crude Mortar.....	567
Brake, Differential Hand, for Street Cars.....	541	Guard, Spur, Protects Trousers from Mud.....	599
Breeches Buoy Saves Crew of Beached Ship.....	516	Gun, Big, for Defense of Panama Canal.....	576
Bridge, Brooklyn, Painting, Task for Human Spiders.....	502	Guns, Big, Change War Tactics.....	549
Building, Highest Reinforced Concrete.....	547	Guns—Howitzers, Twelve Inch, for the British Army.....	523
Building, Keeping Warm with Stored Heat.....	504	Hair, Child's, Guide for Trimming.....	596
Building—Latest Addition to New York's Sky- scrapers.....	513	Hammocks, Infant, Carried by Palestine Mothers.....	556
Bulletin Board for Train Crew Assignments.....	539	Handkerchief with Coin Purse.....	596
Burglar Alarm, New, Fires Blank Cartridge.....	541	Heliograph, Uses to Sell Groceries.....	577
Cable, New Steel, Strength Record Broken by.....	586	Hillside, Steep, Made into Residence Section.....	486
Cables, Subterranean, Used by German Spies.....	598	Hook, New, for Holding Live Minnows.....	555
Calculating Device Used by the Japanese.....	594	House, Fireproof, Furniture Burned in Test of.....	578
Canes, Collection of, at the National Museum.....	557	Irrigation Made Possible by Utilizing Motor Car "Jitney Bus" a New Rival of the Street Car.....	580 500
Car, Gasoline Interurban, with Friction Drive.....	587	Ladders, Two, Combined in One.....	539
Caster Wheel, Ingenious Mounting for.....	593	Life Preservers Made of Kapok Fiber.....	542
Censor, Deleted by, Illustrated.....	522	Lights, Road, in Germany Burn for Month.....	595
Chain, Noiseless, Uses Wedge Principle.....	595	Mail Box, Rural, Pumpkin is Made to Serve as.....	571
Clock, New Plan to Set Ahead during Summer.....	540	Microscope and Telescope Combined.....	518
Columns for Lincoln Memorial, Cutting.....	494	Mine, Big Metal, Changing Shift in.....	569
Comment and Review, by H. H. Windsor:		Mining, Coal, Electric Machines in.....	496
Child Labor Law.....	511	Monument, Fighting Top, to "Maine" Victims.....	501
Income Tax, The.....	509	Monument in Memory of Dead Miners.....	564
Insurance Law, Sensible.....	510	Monument, Last, Set on Canada Boundary.....	505
Meat Supply, Future.....	509	Monument, Mount Mitchell, Destroyed.....	497
Spring and Hope.....	512	Motorcycle Driven by Electric Motor.....	493
Copper and Cartridges, by Edward C. Crossman.....	581	Motorcycle Sidecar, Riot Gun Mounted.....	514
Costumes, Picturesque, Worn in Hungary.....	589	Moving Pictures, Carrying into Rural Districts.....	587
Cottage, Four Room, Built at Small Cost.....	649	Moving Pictures, Freight Crews Called by.....	492
Cuff Buttons, Convenient, for Shirt.....	596	Moving Pictures Used by Germans to Show Army Work.....	539
Cuff, Reversible Shirt.....	572	Multiplication Table, Device Aids in Learning.....	599
Decks, Roller Top, Made for Schoolrooms.....	585		
Diving, Deep Sea, New Records in.....	546		
Drinking Fountain, Paraffin Paper Tube for.....	592		

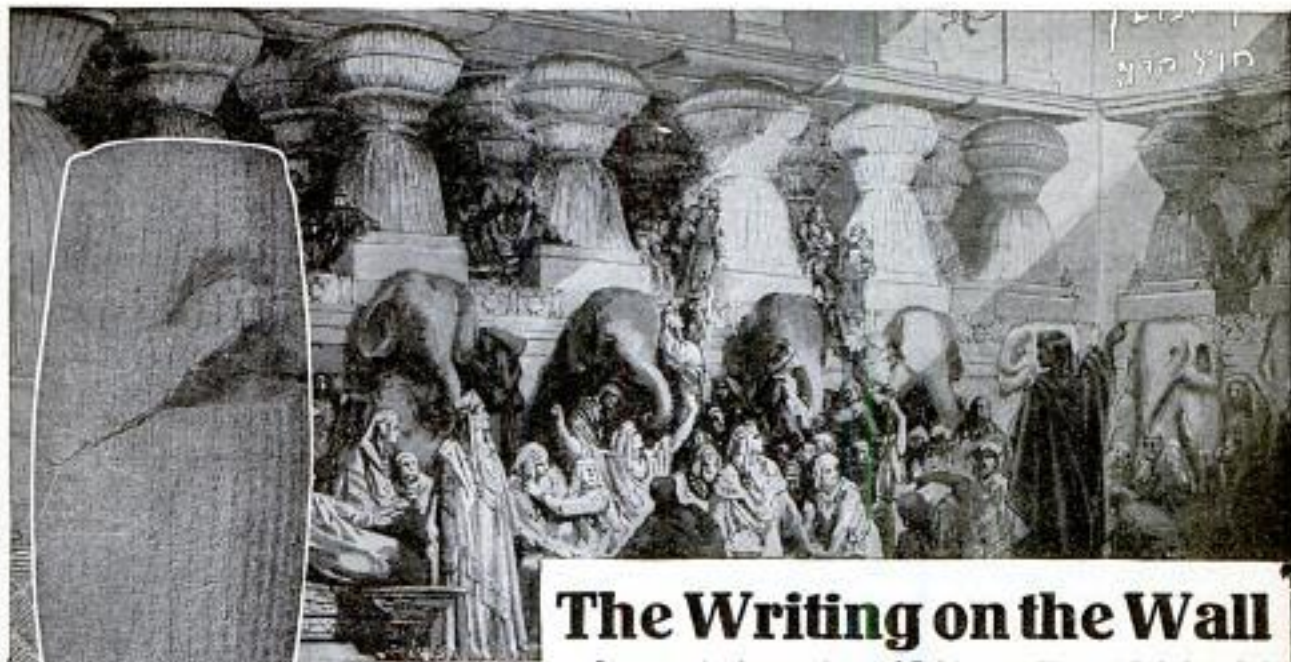
[Continued on Page 6]

Popular Mechanics offers no premiums; does not join in "clubbing offers," and employs no solicitors to secure subscriptions. It is for sale by nearly every newsdealer in the United States and Canada.

This One



28TH-UQH-DZLJ



Terra-cotta cylinder containing Cyrus' own story of the "Fall of Babylon"

The Writing on the Wall

It was at the famous feast of Belshazzar, King of Babylon, that the prophet Daniel read the awful dictum—"Mene, Mene, Tekel Upharsin." That night Cyrus and his army captured the city, but not until thousands of years later was unearthed the inscribed cylinder that told the real story of the "Fall of Babylon." This curious account is but one of many thousand "original documents" contained in the marvelous work

The Library of Original Sources

now for the first time available to the general public. This remarkable Library had previously been sold by subscription, but by purchasing the *entire unsold edition* from the publishers we secured it at an *absolutely unheard of reduction*. Therefore we are able to offer a few sets to POPULAR MECHANICS readers at

AN EXTRAORDINARY BARGAIN

Send us the attached coupon AT ONCE, and we will tell you how to get the Library on EASY MONTHLY PAYMENTS, and mail you FREE a book of rare documents showing curious inscriptions of the Ancients. Remember there are only a limited number of sets, so act quickly. Mail the coupon NOW. You assume no obligation. No salesman will call. The book is FREE.

THIS MARVELOUS WORK is revolutionizing modern thought. It gives the authoritative, rock-bottom sources of our knowledge on ALL SUBJECTS OF HUMAN INTEREST from the earliest civilization down to today—the inside facts which the average person has never even heard of.

OVER 100 RESEARCH SPECIALISTS spent 10 years gathering the contents of this great work. Ancient and remote and forgotten civilizations in all parts of the globe were uncovered, and age-buried hieroglyphics on monuments, tablets, sun-baked bricks and palimpsests yielded their secrets; untiring workers ransacked the hidden literature of every age, ancient, mediæval and modern, to find these "original documents." Nothing like it has ever been attempted or thought of before. You'll be amazed at the wealth of information this unique library contains.

DO YOU KNOW that the old Egyptians 5000 years B. C., had a Bible? Do you know that the Assyrian sacred literature gives the story of the Creation? Do you know that books and newspapers were printed in Asia thousands of years before printing was invented by Gutenberg? Did YOU ever read Columbus' personal log of his great voyage—filled with strange happenings and ominous forebodings? Do you know that there occurred in Mediæval England a great Socialistic protest? Do you know by what unique process Harvey demonstrated the circulation of the blood? Do you know who Machiavelli was, or what world famous treatise he wrote?

YOU'LL FIND THEM ALL—and thousands of others equally as curious and important—in The Library of Original Sources. Every document is in the exact words of the original, translated; every contribution is from the actual eye-witness or person who took part; every idea is in the words of the thinker, discoverer or inventor.



MAIL THIS COUPON FOR FREE BOOK

University
Research
Dept. G
Milwaukee, Wis.

Send me the FREE book of rare documents, showing inscriptions of the Ancients and tell me of your easy payment offer. I assume no obligation, the book and all you send me is to be free, and no salesman is to call.

Name.....

Address.....

We Assist Students Getting Actual Driving Experience



YOU CAN LEARN the AUTOMOBILE TRADE

WITH DYKE'S NEW IDEA WORKING MODEL METHOD

IF OTHERS CAN, YOU CAN
 Bert Tippey, De Soto, Ill., writes us that he knew nothing about autos when he started with us, but is now doing repair work, owns his own car, and owes his success to Dyke's Course. In a recent letter he states he began repair work before completing course and paid for course out of first job. He started in a small way, but is now doing general repair work. He grinds valves, cleans carbon, greases cars, times valves, sets magnetos, adjusts carburetors, etc., etc., and sells supplies. We started him. *We first taught him the principle of all parts and then helped him get his start, just as we can do for you if you have any hustling ability.*

If we prove to you that we have started hundreds of others into the repair business and as chauffeurs—who had no previous experience and who knew no more about an auto than you do right now—you must admit we can do the same for you. Write me today—now—and let me prove it.

- A. M. Atkie, Repairing, Overhauling and Supplies, Leno Tree, Iowa, R. D. No. 1, in a recent letter says: "I have a lot of repairing to do; have been called upon several times to inspect second-hand cars."
- Harry J. Hepbin, Jamestown, Kans., was a farmer, but has doubled his income repairing and selling autos.
- Mr. G. Strickland, Westport, Ont., Canada, writes us: "I am glad I took your course. Have just overhauled a car; timed the valves and set the magnetos. Owner says engine has more power. This is my first job. Thanks to your course."
- Donald Stewart, Oakland City, Ind., became a chauffeur at \$25 a week.
- H. M. Fawcett and S. T. Shybock, both graduates, are now running a Garage and Repair Shop at Woodbine, Iowa.

And we could continue until we had filled this and several more pages.



Our book of testimonials, showing photos of students and their shops—free.

All the Result of the Dyke System

We can thoroughly train you during spare time. Open a repair shop or drive a car and make many times more than you are making now. Don't forget, we help you get your start with our *Employment Plan*, if you want it.

DYKE'S NEW IDEA OF TEACHING BY MAIL WITH WORKING MODELS

is something new. We use *real* working models—not just one, but *five*. On these models you get actual practice, see the actual operation and learn more than you could from the auto itself—it's easy and quick. You don't have to study hard with this system—*we teach through the car—a new idea*. We are the originators of the system of teaching by mail with models. We also use charts—268 of them and a 16 page manual. Our 40 instructions and Repairman's Instructions are simplicity itself—simple as A B C.

Our Employment Plan for Students

This represents years of work to provide something that no other school had, namely, a way for our students to get started in the practical line of work.

Mr. Dyke has been identified as a pioneer inventor, supply man, etc., with the auto industry since its beginning. He originated the first auto supply co. and published the first book on autos in America. No other man with such experience is to-day teaching others. And all the experience and inside information of the auto business he has thus gained, is embodied in this *Employment Plan*.

WRITE TO-DAY FOR THIS FREE BOOK

It is instructive and interesting—does not cost you a cent and places you under no obligations whatever—You need it for your own sake, not mine. Don't wait—there's no profit in waiting—**WRITE NOW** and learn how you can obtain all this training for only \$15, if you act immediately.



DYKE'S CORRESPONDENCE SCHOOL OF MOTORING
 Box 189, Roe Bldg. ST. LOUIS, MO.

NOTE—Beware of Imitators—Deal with the Originator
SPECIAL INSTRUCTION on Six and Eight Cylinder Engines 1915 Electric Starting and Generating Systems

Please Mention Popular Mechanics

(Contents—Continued from page 6)

Talking Machines, Needle Box for.....	631
Trick of Taking Dollar Bill from Apple.....	631
Washing Board, Rubbing Slats for.....	631
Wire Wound on a Spool, Measuring the Length of.....	632
Workbench, Back Stop for.....	637

INTERESTING NEW PATENTS

Automobiles, Variable Speed Transmission for..	639
Boat Propelling Device, Novel.....	639
Cap Equipped with Mirror.....	639
Chair and Bed, Combination.....	639
Chair and Walking Stick Combined.....	638
Cigars, Mouthpiece for.....	638
Concrete Work, Movable Form and Platform for.....	638
Cotton, Device for Picking.....	638
Fruit Picker.....	639
Headlight, Dirigible, for Trolley Car.....	638
Car, Double Action.....	639
Pipes, Drain, Device for Preventing Freezing of.....	639
Propeller, Novel, for Boat.....	638
Refrigerator Drip Pan, Overflow Alarm for....	638
Ship, Landing Ladder for.....	639
Sled, Wheel Attachment for.....	639
Tire, Pneumatic, Detachable Cover for.....	638
Toothbrush, Fountain.....	638
Umbrellas and Canes, Locking Attachment for..	639
Window Shade and Curtain Pole, Support for....	638



LETTERING AND DESIGN

Will pay you a good salary or establish you in the business world. Fit yourself through home study to become a Card or Sign Writer, Letter Artist and Designer in the Lithographic or Printing Fields. Lessons simple, fascinating and thorough. My students become competent—we can see. Personal guidance makes the Course Self-Paying. Prepare now for a better future and send for Free Booklet No. 20 and full information.

The Rosing School of Lettering & Design
 The 1900 Euclid Building CLEVELAND, OHIO

A GOOD POSITION

with **UNCLE SAM** is most desirable. Life positions, pleasant surroundings, good pay, steady work, short hours, promotions on merit. Both sexes. No political pull. Thousands of appointments yearly. Most thorough preparation \$5. Returned if not appointed. Full information and questions used by the Civil Service Commission free.

AMERICAN CIVIL SERVICE SCHOOL WASHINGTON, D. C.

DRAWING

Cartoons, Cartoon, Comic, Commercial, Fashion, Newspaper and Magazine Illustrating taught by mail. Illustrated book 6c in stamps. **THE BOSTON SCHOOL OF DRAWING, 755M Boylston St. BOSTON, MASS.**

BE AN ILLUSTRATOR Learn to draw. We will teach you by mail how to draw for magazines and newspapers. **School of Illustration 112 Page Bldg. Chicago, Ill.**

Send for Catalog 

Be an Auctioneer Travel over the country and make big money. No other profession can be learned so quickly, that will pay as big wages. Write today for big free catalogue of Home Study Course, as well as the Actual Practice School. **Missouri Auction School Largest in the world. W. B. Carpenter, Pres. 330 HALL BLDG. KANSAS CITY, MO.**

LEARN WATCHMAKING AND ENGRAVING

Earn while learning. Most practical watch school. Individual instructions. Graduates in great demand. Book free. **Chicago School of Watchmaking, 63 E. Van Buren St., Chicago**

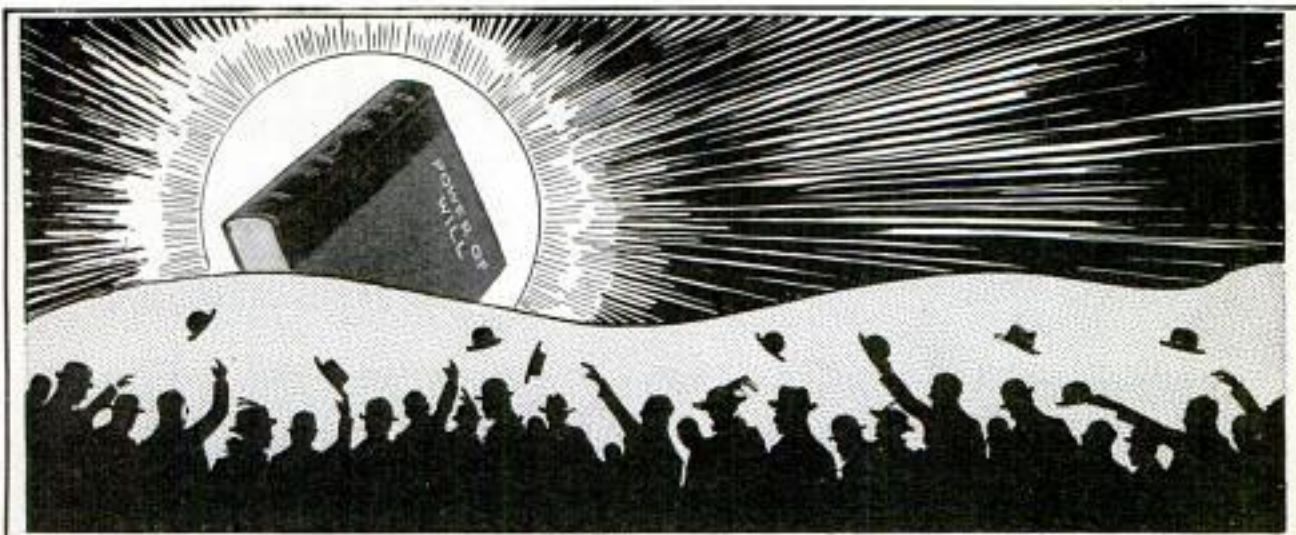
Rider Agents Wanted

in each town to ride and show a new 1915 model "RANGER" bicycle. Write for our liberal terms. **DELIVERED FREE on approval and 30 days' trial.** Send for big free catalog and particulars of most marvelous offer ever made on a bicycle. You will be astonished at our low prices and remarkable terms. **FACTORY CLEARING SALE—a limited number of old models of various makes, \$7 to \$12. A few good second-hand wheels \$3 to \$5. Write if you want a bargain.** Tires, lamps, wheels, candies, parts, motorcycle supplies of all kinds at half usual prices. **Write us before buying.**

MEAD CYCLE CO., DEPT. D108 CHICAGO



CLEAR A CHILD CAN UNDERSTAND EXPLANATIONS SO STARTING AND LIGHTING SYSTEMS



Some "Power of Will" Owners

Among those who read, use and praise "Power of Will" are such men as Judge Ben B. Lindsey; Supreme Court Justice Parker; Wu Ting Fang, Ex-Chinese Ambassador; Asst. Postmaster General Britt; General Manager Christeson of Wells-Fargo Express Co.; E. St. Elmo Lewis, now Vice-President Art Metal Construction Co.; Ernest Knaebel, Asst. Atty. Gen'l of the U. S., etc., etc. These are but a few. We can name hundreds of others almost equally prominent, and thousands more whose names you know.

"I hand you \$3 in payment; from what I have already seen I believe I can get \$300 to \$50,000 worth of good out of it."—C. D. Van Vechten, General Agent No. West Life Ins. Co., Cedar Rapids, Ia.

"'Will Power' is a compilation of mighty force. My first week's benefit in dollars is \$900.00—cost \$3.00; profit \$897.00."—J. W. Heistand, 916 Tribune Bldg., Chicago, Ill.

"The character of 'Power of Will' is such that he who reads and puts forth effort will soon find himself out of the common herd."—F. A. Good, President of Nebraska Lumber Dealers' Assn., Cowles, Neb.

"I have carefully gone over 'Power of Will' and find it admirable."—Chas. Olin, Editorial Rooms, Boston Evening Transcript, Boston, Mass.

"I am unable to do this book justice with the pen. It is a lifelong study, known and prized by those who are fortunate enough to select it out of the many."—Sam'l Rose, Jefferson Loan Society, Inc., Norfolk, Va.

"After carefully looking it over I am fully convinced that it is everything which has been claimed for it—and a great deal more. It is a wonderful book on a wonderful subject."—Gus A. Olson, Cashier, Shermerville State Bank, Shermerville, Ill.

"I specialized on psychology—and I consider 'Power of Will' the greatest book on the subject ever written. I will make it an important factor in my scheme of life."—J. H. Leventhal, Butler Hebrew Inst., Butler, Pa.

We have hundreds of such testimonials on file.

"Power of Will"

—THE BOOK THAT STARTLED THE WORLD

Let Me Lend It to You for 5 Days Free—Send No Money

Rarely, if ever, has a book been published which has created such a sensation. In the last few months over 50,000 thinking men and women have become owners of "Power of Will" and unless every sign fails this number will be doubled almost before this announcement goes to press.

Wherever one goes, people are discussing the wonderful discoveries and new-found secrets of achievement laid bare for the first time in this great work—by Frank Channing Haddock, the famous scientist—secrets which enable any man or woman to train his or her will into a faculty of almost magical health and money-winning power.

How to Strengthen the Will

Everyone knows what can be accomplished by exercising the brain. Our whole educational system is founded upon the theory that brain can be developed in proportion to the amount of intelligent exercise and use to which it is put.

For years scientists have known that the same is true of the will—that the will can be made indomitable by intelligent exercise and use.

The trouble has been that until now no one has ever devoted their attention to the cultivation of the will.

And since we have never been taught to use it, most of us don't know how. We float along carrying out other people's wills simply because our own will has become scotched and dormant from lack of use.

A Complete Course

"Power of Will," while bound in book form, is in reality a complete course in Will Training—the first ever conceived. The author, Dr. Haddock, has devoted years to the most profound analysis of the will in human beings. Yet every step in the 28 fascinating lessons is written so simply that anyone can understand them and apply the principles, methods and rules set down with noticeable results almost from the very start.

A Veritable Godsend

"Power of Will" has pulled men out of the gutter and put them on the road to self-respect and success—it has enabled men to overcome drink and other vices almost overnight—it has helped overcome sickness and nervousness—making thousands of sick people well—it has transformed unhappy, envious, discontented people into dominating personalities suffused with the joy of living—it has enabled people who had sunk deep into the grooves of a rut to pull themselves out and become masters instead of the blind tool of circumstance—it has reawakened ambition in men and women who had been turned from their life purpose and given them the courage and confidence to build anew—it has converted failures in business into spectacular successes—it has enabled successful men to undertake even bigger projects by showing them how to use the power they already possess with even more telling force.

Send No Money—Examine Book First

Although "Power of Will" is a 400-page, leather bound book containing more material than any \$25 correspondence course the price is only \$3. The publishers will gladly send a copy free, for five days' inspection. Send no money now. Merely mail the coupon on the right, enclosing your business card, or giving a reference. If you decide to keep the book, send the money. If not, mail the book back. Tear out and fill in the coupon now, before you turn this page.

A. L. PELTON,
54 Pelton Bldg., Meriden, Conn.

Partial Contents

The Law of Great Thinking.
The Four Factors on which it depends.

How to develop analytical power.

How to think "all around" any subject.

How to throw the mind into deliberate, controlled, productive thinking.

Detailed directions for Perfect Mind Concentration.

How to acquire the power of Consecutive Thinking, Reasoning, Analysis.

How to acquire the skill of Creative Writing.

How to guard against errors in Thought.

How to drive from the mind all unwelcome thoughts.

How to follow lines of thought with keen, concentrated Power.

How to develop Reasoning Power.

How to handle the Mind in Creative Thinking. The secret of Building Mind Power.

How the Will is made to act.

How to test your Will.

How a Strong Will is Master of Body.

What creates Human Power. The Six Principles of Will training.

Definite Methods for developing Will.

The NINE TV-NINE METHODS for using Will-Power in the Conduct of Life.

Seven Principles of drill in Mental, Physical, Personal power.

FIFTY-ONE MAXIMS for applied power of Perception, Memory, Imagination, Self-Analysis, Control.

How to develop a strong, keep gaze.

How to concentrate the eye upon what is before you—object, person, printed page, work.

How to become aware of Nerve Action.

How to keep the body well-poised.

A complete list of contents would almost fill this page.

A. L. Pelton,
President.

Pelton Pub. Co.,
54 Pelton Bldg.
Meriden, Conn.

Gentlemen:—Please send me a copy of "Power of Will" without charge. I agree to remit \$3.00 or, remail the book in five days

Name

Address

Please Mention Popular Mechanics

HUNDREDS OF GOOD JOBS OPEN

YOU have read about the wonderful rise and spread of the jitney service in Kansas City that is competing with the street railway, taking in \$2500 per day and carrying thousands of passengers and giving employment to hundreds of chauffeurs, repairmen, garagemen, etc. This opens up new avenues of quick and profitable employment and also offers a wonderful chance to go into business for yourself. Lots of former motormen and conductors are learning the automobile business. This is a good time to learn the auto business and a good place to learn. Write today and learn what is going on in Kansas City and the opportunity afforded young men at the

Sweeney Automobile School

LEARN IN 6 WEEKS—EARN \$100 A MONTH

We are not a Chauffeur school. We are a mechanical school. We do not guarantee you positions or guarantee to learn you the business. We can teach you, but we cannot make you learn. We guarantee our school to be exactly as we represent it, and if you have a back-bone instead of a wish-bone and come here to school, knowing that you cannot get gold out of a gold mine unless you dig, you can qualify yourself in six weeks' time to earn from \$75.00 to \$150.00 a month, as an automobile repairman, driver, garage manager, salesman, demonstrator, truck driver, Gas Traction Engineer or any branch of the gas engine business that you may wish to follow.

Free Catalog We have just issued one of the finest and the largest photographic catalogs ever issued by any automobile school in this country. This valuable book contains 115 illustrations, actual photographs, showing the students here in the school at every phase of repair work on automobiles and traction engines. It is practically a moving picture show, demonstrating the unique advantages of the Sweeney System of Practical Experience. How men are taught in six weeks' time every detail of the automobile business and are fitted to earn \$75.00 to \$150.00 a month as skilled mechanics, garage owners, etc.

It tells you how we teach the business, the opportunities there are for the skilled man and shows hundreds of letters from our graduates who are making good. If you are mechanically inclined you should get this catalog. It costs us 50 cents apiece to publish it, but we will send it to you absolutely free, also one of our papers which gives a full description of the new Cadillac eight-cylinder car. The Sweeney School uses in teaching its students the new eight-cylinder Cadillac car. We have also just purchased 2 more complete Delco systems, making 3 in all.

Simply send name today, if you are interested, and you will receive what hundreds of men have said to be the most complete catalog ever issued and it is absolutely FREE to you. It is the only book we use. When you arrive in school you use tools instead of books.

SWEENEY AUTO SCHOOL

1160 E. 15th St.

KANSAS CITY, MO.

Sweeney
Auto
School

1160 E. 15th St.
Kansas City, Mo.

Send catalog and free
certificate.

Name

Address

MAIL COUPON TODAY!

Ridpath's History of the World At a Bargain



FREE
We will mail
free a beautiful
46-page book-
let of sample
pages from
Ridpath's history
to all who
mail this coupon

2000 Pages
4000 Pictures

We will name our price only in direct letters to those sending us the Coupon below. Tear off the Coupon, write name and address plainly, and mail to us now before you forget it. Dr. Ridpath is dead, his work is done, but his widow derives her income from his history, and to print our price broadcast for the sake of quickly selling these few sets would cause great injury to future sales.

FREE BOOKLET COUPON

WESTERN NEWSPAPER ASSOCIATION 4-15
140 So. Dearborn St., Chicago, Ill.

GENTLEMEN—Please mail your 46-page free sample booklet of Ridpath's History of the World, containing photogravures of Napoleon, Caesar and other great characters in history, and write me full particulars of your special offer to Popular Mechanics readers.

NAME

ADDRESS



PRIZE PACKAGE FREE

We will send you FREE a big package of Magic Tricks, Puzzles, Cards, Jokes, Riddles, Money Making Secrets, Splendid Games, Yonats, Card Tricks, Feats in Harter Magic, all FREE. Just send us 1c to pay for postage and adv. and we

will send this trick package free. NATIONAL CO., Dept. 32, 3422 Lyndale St., CHICAGO



FREE "Linene" COLLAR

State size on postal and whether you want collar like cut or low turnover style.

REVERSIBLE COLLAR CO., Dept. U, Boston, Mass.



Delivered to You Free

A sample 1915 model "Ranger" bicycle, on approval and 30 DAYS TRIAL and free riding test.

Write at once for large illustrated catalog showing complete line of bicycles, tires and supplies, and the most marvelous offer ever made on a bicycle. You will be astonished at our low prices and remarkable terms.

RIDER AGENTS Wanted—Boys, make money taking orders for Bicycles, Tires and Sundries from our big catalog. Do Business direct with the leading bicycle house in America. Do not buy until you know what we can do for you. WRITE TO US.

MEAD CYCLE CO., DEPT. D108 CHICAGO



SEND
FOR
FREE
BOOK

DO YOU WANT TO KNOW HOW TO DEVELOP VITALITY, ENERGY, ENDURANCE, NERVE STRENGTH, MUSCULAR STRENGTH, PERFECT PHYSIQUE?

My FREE BOOKS, "The 'Whys' of Exercise" and "The First and Last Law of Physical Culture," tell you, if you are weak or underdeveloped, how to grow strong; if strong, how to grow stronger. They explain how to develop lungs and muscle, the strong heart and vigorous digestion—in short, how to improve health and strength internally as well as externally. Send TO-DAY—NOW—for these FREE BOOKS. Enclose 4c in stamps to cover postage.

PROF. H. W. TITUS, Department 132
56-58 Cooper Square, New York City

Please Mention Popular Mechanics

FOLLOW THIS LEAD TO SUCCESS.

LAW.

What a word to conjure with! How it stirs the imagination of the ambitious! What an inspiration it has been to thousands of people and how it has spurred them on to achievement!

Law! Since the days of Moses the laws of nations have been graven on stone and bark and parchment and inscribed in ponderous tomes; and among the brightest, greatest men of all times are numbered those who sharpened their intellects, achieved their greatness and left their names carved deep on the scroll of fame through their enactment and interpretation of those laws.

Today law is more insistent in its appeal and offers greater inducements and opportunities for a successful career than ever before. It is the profession that is in constant and intimate touch with every phase of human activity—social, political, ethical and commercial. It is a profession which, as a profession, leads more directly than any other to positions of power and wealth and fame in the world of politics.

Yes, the thought of entering the legal profession does make a powerful impression upon the mind of the really ambitious man of today.

And what a wonderfully vivid picture film this thought flashes upon the screen of his imagination.

He sees himself pleading for his client before judge and jury, moving them and spectators alike with the force of his eloquence and logic. As a newly elected district attorney he sees himself winning his way to the front through his exposure and conviction of bands of bribers and political grafters. Riper in years and experience but with his legal knowledge and training ever as his sure foundation, there comes a day when he

takes his seat in the halls of Congress, or in the Governor's chair, or some other position of National or State government.

Air castles? Idle day dreams?

No! All human achievement worthy of note has been rocked in the cradle of inspiration. There never was a great battle won, or great discovery made in the realms of science, or great book written or picture painted; nor has any man ever climbed the heights which law has made it possible for him to climb, without the inspiration of just such "day dreaming." Who shall say that the great Lincoln, poring over his borrowed law books by feeble candle light, did not, himself, dream of the day when he would be the acknowledged leader of men?

The study of Law is no longer complicated or difficult, and it is unnecessary to attend a resident college or pay a large tuition fee.

In this age of home study, Law can be easily learned at home during the student's spare time at a trifling cost. Anyone with average intelligence and the ability to read and write English can easily master and learn this remarkable profession by the simplified, home study Law course of the LaSalle Extension University. The LaSalle method of training has revolutionized the study of Law, making it easier and really interesting.

The LaSalle has shown, by the remarkable success of its many students, that its course in Law is the most desirable for home study and to assure success in bar examinations.

If you are ambitious for success, you will think seriously of this advice and make it a point immediately to investigate the LaSalle Extension University Law Course as described below.

Become a LAWYER



If you are ambitious for a future of success and prosperity, we can show you the way. We want to prove to you that your opportunity faces you right now in LAW. We want to tell you how the LaSalle has opened the way to success for others like yourself. The need today for competent Lawyers is far greater than ever before. Large firms and corporations need Lawyers on their regular staffs at handsome salaries.

Success—Prosperity

Lawyers enjoy incomes of \$5,000 to \$10,000 and more yearly. To insure a successful career, choose a profession that is broad enough in scope to afford you the opportunities of success. Such famous men as Abraham Lincoln, James Garfield, Wm. H. Taft, Patrick Henry, John W. Wainwright, E. H. Harriman, etc., each had legal training. President Wilson and every member of his cabinet, with but one exception, learned law.

We Train You By MAIL

No need now to give up your position. We have simplified the study of Law. If you can read and write English intelligently we can train you at home, in spare time, no matter where you live, who you are, what your present occupation or wages. (We make terms to suit you). The LaSalle simplified Home Study Law Course uses the same methods as residential colleges. The LaSalle law text is written in plain language by some of America's foremost legal experts, such as James Parker Hall, Dean of University

of Chicago Law School, James DeWitt Andrews, former member faculty Northwestern University, and other noted authorities and professors in such colleges as Harvard, Leland Stanford, University of California, University of Michigan, University of Wisconsin, Tulane University, etc. Recognized as foremost Home Study Law Course. We are the largest Home Study Law School in America and enroll more students than any other.

The State of Illinois authorizes us to confer on our graduates the degree of Bachelor of Laws (LL.B.). Our course prepares you to pass all subjects covered by bar examinations. We guarantee to coach free and until successful, any student failing to pass bar examinations.

Become an LL.B. FREE Complete Course in PUBLIC SPEAKING Most remarkable offer with any Law Course. Prepared by Dr. Frederick B. Robinson, A. B., A. M., Ph. D., Professor Public Speaking at College of City of New York, Editor Public Speaking Review, etc. Complete, authoritative. Write now for facts of how, for a short time, we give this course free.

MONEY-BACK GUARANTEE BOND So thorough is the LaSalle Home Study Course—so exceptional has been the success of LaSalle students—that we issue with each LaSalle Course a legal, binding guarantee to refund the entire tuition fee if after you complete the Course you are not perfectly satisfied. This guarantee is backed by our entire capital and resources of more than one million dollars, which assures your absolute success.

Special Course for Business Men Business men recognize the necessity of legal training. Many are studying our special course for business men. Write for facts and explanation of our simplified methods.

ACT TODAY Let us prove that Law offers you greatest possibilities and we can easily qualify you.

LaSalle Extension University, Dept. F-533 Chicago, Ill. City.....State.....

Name.....

Street and No.....

City.....State.....

City.....State.....

City.....State.....

City.....State.....

City.....State.....

City.....State.....

City.....State.....

City.....State.....

City.....State.....

City.....State.....

City.....State.....

City.....State.....

BECOME A DRAFTSMAN



Big buildings, machines and structural work are being planned everywhere and high-salaried positions are open for Draftsmen always. Let us prove free that if you become a Draftsman you need never be out of a good paying position.

\$2400 a Year

If you could see the great possibilities offered Draftsmen I know that you would make up your

mind to make Draftsmanship your life's work. How would you like to step into a position at \$2,400.00 a year or more? How would you like to build a future of independence and prosperity? You can! Let me prove how I take men out of the lowest paying positions and personally train them to become Expert Draftsmen.

MEN WANTED

Draftsmen are needed now—positions must be filled. This is your opportunity. There is much work to be done—many of my students are making big money on the side long before graduating. Let me prove quick how my students succeed—how Draftsmen can advance to big positions as Chief Draftsmen, Chief Engineer or Superintendent at handsome salaries.

I SHOW YOU

I give you my personal training by mail in your own home, in spare time—I teach you all you must know about Draftsmanship—I know what big American employers of Draftsmen demand. I give you the benefit of my years of practical experience as Expert Draftsman and Designer. My students are successful because I train them personally until they secure a good paying position. Let me send you free the most complete book ever published on Draftsmanship. No previous experience is needed. I show you everything from the ground up.

FREE \$17.50 DRAFTSMAN'S
OUTFIT Enroll now and I will give you absolutely free a magnificent set of Draftsman's Drawing Instruments, valued at \$17.50—same as I use. Every Draftsman needs these—they last a lifetime.

Smallest Easiest Payments

SPECIAL TUITION OFFER

To a few more students I offer my personal instruction at such small, easy payments that no matter how small your present salary you can now become a Draftsman. I can give my personal attention to only a few more students and as an inducement for you to enroll at once I make an extra special offer of a free \$25.00 TUITION CREDIT. I am the only Draftsman giving personal instruction on such small payments. Send free coupon now. Now is the time to start—you are now needed.

Chief Engineer

Chicago Engineering Works 457 Cass St., Chicago, Ill.



CHIEF ENGINEER, 457 Cass St., CHICAGO

Without obligation or cost to me send prepaid your free book, "The Road to Success," and particulars of your limited offer.

Name.....

Address.....

Please Mention Popular Mechanics

3000 PRICELESS RECIPES

Hundreds of Profitable Trade Secrets
 Money-Making Wrinkles About Every Trade and Manufacture
 Valuable Formulae for Many
 Processes Hitherto Jealously Withheld

Establish yourself in business. Become independent. Whether you are a man, woman, boy or girl, you may secure a **Constant Income** and a **Respectable Business**, without hard work or worry. **Make at your own home** in spare time some of the hundreds of articles which find ready sale everywhere, the manufacture of which is clearly described in this valuable book. A single recipe properly employed may be the foundation of a fortune. Pear's Soap, Beecham's Pills, Holloway's Ointment, hundreds of similar things, from which huge incomes are derived, may be equalled or even surpassed by some of the articles described among the **3000 Priceless Recipes**. This valuable work of 388 pages is the result of the life-work of the famous Scientist, **Dr. N. Y. Oliver**, who has selected and published only the best of the many formulae submitted to him, having thoroughly tested every recipe, many of which cost large sums to acquire. Not a cookery book. It is a book of **recipes**, and **NOTHING BUT RECIPES**, of inestimable value to Farmers, Housekeepers, Mechanics, Manufacturers, Chemists, Confectioners, Metal Workers, to Everybody. Write at once for this valuable book. Sent by post to any address for only 35 cents.



Johnson Smith & Co., Dept. 3, 713 S. Dearborn St., Chicago

DO YOUR OWN Soldering —and Save Money



Send 55c for cloth bound Book "Simple Soldering"—and learn how to join metals, both hard and soft.

CONTENTS—Soldering. The Uniting of Metals. Soft Soldering. The Flux. Hard Soldering or Brazing. Soft Soldering. Heating the Work. Flux for Soldering. Etc. Methods of Holding Work. Wiring Work. Silver Solder. Soldering Copper. Etc. Cleaning Up Work. Polishing. Scraping Down. Honing. Etc. Standard Apparatus. The Blow-Pipe. Foot Bellows. Etc. Home Made Apparatus.

SPON & CHAMBERLAIN
 123 P. M. Liberty St. NEW YORK

DON'T TRY TO BE A CHAUFFEUR



or go to ANY SCHOOL to learn, or part with your hard earned dollars until you have read our valuable guide FIRST. It tells what you should PAY and what you should GET. Do not be deceived by schools which claim everything and give you nothing. **YOU CAN'T AFFORD TO SPEND ONE CENT TILL YOU GET OUR GUIDE.** It costs nothing and may save you many dollars. Write now for this FREE BOOK.

PRACTICAL AUTO SCHOOL, 68 Beaver St., New York

123 Place the 9 figures so the 2nd row is twice as much as top row and bottom row as much as top and 2nd row added together. All correct replies will receive 25 cents' worth of our iron puzzles with catalog postpaid. Answers not correct will receive solution. Catalog of 200 puzzles and one of our leading 15c. products. All answers to enclose 10c. in stamps or coin to cover mailing, packing, etc.

456

789

WESTERN PUZZLE WORKS, St. Paul, Minn.

THE IRON CROSS 10c
 Latest War Novelty. All ages. Fun for everybody. Wear one. Decorate your front door porches, etc. Dull finish as original. Nearly 3-inch diameter. Order now. Price 10c, 4 for 30c, 12 for 60c. Postpaid. Address nearest house.
ANTHONY LEMCK & CO., Dept. 70, KANSAS CITY, MO., or 141-149 West 36th St., NEW YORK CITY

3 1/3c a Day

now buys a dazzling Lachnite Gem. Their brilliance is eternal—they stand fire and acid tests and cut glass like diamonds. Cost but one-third as much. Set in solid gold. The newest designs. Sold on Free Trial. See our new jewelry book.

Write for Big Jewelry Book Your name and address on a separate card. No obligations whatever. Write today—now.

HAROLD LACHMAN COMPANY
 12 N. Michigan Avenue, Dept. 1194 Chicago, Ill.



This Splendid LIBRARY of ELECTRICITY

Sent Free for Examination

\$1 Per Volume—Pocket Size—Leather Bound

Why You Should Own Hawkins Electrical Guide

It is a work of education, explanation and encouragement.

It is a royal road to a practical knowledge of Electricity.

It answers your electrical questions in concise, practical and easily understood language.

It covers thoroughly the elementary principles as well as the most approved practice.

All important points are fully illustrated by drawing or a full descriptive illustration, which adds greatly to the clearness and value of the work.

It contains the correct and most up-to-date safety rules for installing Modern Electric Machinery and Appliances.

It gives complete explanation on Electrical Construction. It is a practical, authoritative, comprehensive guide for all desiring a working knowledge of Electricity.

No catalogue description can do justice to the work; it contains too many thousand points; only the important headings are shown in the list of contents.

*Sign the Coupon
now and get this
practical Education in
Electricity "Written so
you can understand
it"*

Endorsement of Satisfied Users

"After a thorough examination we find they are the best that have ever been published on this particular subject. I am thoroughly convinced that after examination these books can sell themselves."—Triumph Electric Co. (H. H. Panschar), Cincinnati, O.

"I wish to say that I have been doing Electrical Work for 15 years, and have upwards of \$100 worth of Electrical books, but I consider the Hawkins Electrical Guides the best ever for the practical electrician."—O. A. Armfield, Mulberry, Fla.

"They are the most complete set of books on the subject for that price that I have ever seen. Perfectly satisfactory; they cover the subjects in a way that can easily be understood by anyone."—J. W. Gledhill, Vineland, N. J.

"The Hawkins Electrical Guides seem to me to be the best and most complete set of Electrical books that I have ever had the opportunity to find."—T. J. Messinger, Columbus, Pa.



"That's Just What I Need"

HERE is a set of books that no man in the ELECTRICAL FIELD should do without. This is the ELECTRICAL AGE in which we live; ELECTRICITY now controls more trades, directs more men, offers more opportunities than any other power that man has yet discovered. Do you wish to know the underlying principles of Modern Electrical Practice?

If so, HAWKINS ELECTRICAL GUIDES will give you the information. In reality they are a school within themselves, containing a complete study course with QUESTIONS, ANSWERS AND ILLUSTRATIONS, written in plain everyday language so that a practical man can understand.

The How, When and Why of Electricity

Read over the titles shown on the back of each volume, and note the scope of each book. They are handsomely bound in flexible black leather with gold edges and will readily go in the pocket. They are not only the best, but the cheapest works published on Electricity.

Each book is complete in itself and will be supplied \$1.00 per copy, but we believe that the complete set is the best bargain. The books can speak for themselves and a careful examination, page by page, and illustration by illustration, will convince you of their big value. If you will fill out the following coupon giving all the information requested, we will submit the six volumes for examination on conditions named.

Apr. 15
Pop. Mech.

Please submit me for examination HAWKINS ELECTRICAL GUIDES (Price \$1 each).
Ship at once prepaid the 6 numbers; if satisfactory I agree to send you \$1 within seven days and to further mail you \$1 each month until paid.

THEO. AUDEL CO., 72 5th Ave., New York—Free Examination Offer

SIGNATURE

OCCUPATION

BUSINESS ADDRESS

RESIDENCE

REFERENCE

Come to Detroit
the automobile center
and

LEARN THE AUTOMOBILE BUSINESS

Big Opportunities Everywhere for Detroit Trained Automobile Men

Interesting, pleasant, and money making business. Ambitious men needed to start garage and repair shops in down town and residence districts everywhere.

Learn now, be ready for the spring automobile boom—when opportunities are greatest. Chauffeurs, garage and repair men, testers, etc., have more than they can do. Plenty of room for you.

Earn \$75.00 to \$300.00 Per Month

Get into biggest and best business of the 20th century. The business of big profit and sure progress. We teach you to handle any auto—our equipment is complete. Students actually have experience of building new cars from start to finish—regular factory training in block testing, road testing, etc.—all leading types of starting, lighting and ignition systems in operation. You learn how to read motors, adjust carburetors, valves, bearings, etc. New 6 cyl. Lozier Touring Car used for road instruction. Just purchased—New 8 cyl. King Chassis. Latest thing out. Used solely for students' instruction. Part of our regular equipment.

10,000 Square Feet of Floor Space Just Added

The popularity of our school has demanded extensive additions to our equipment. Dormitory space for nearly 75 students on the premises. Large, new, rooey, light, airy lecture and instruction room, study room in connection. Broad new lounge room. Ambitious, cheerful companions.

Detroit is the Place to Learn Detroit Electric Service Department. Impossible to get these advantages elsewhere.

Detroit is the Automobile Center You make faster progress here, and get practical instruction. Come to Detroit and learn the business right. Our students are successful. W. C. Garden, Tennessee, is Chauffeur, \$25.00 per week and expenses. E. Livingston is head of The Government Garage at Toronto. Dozens of others are holding good positions or running businesses of their own. Remember, ours is the Old Reliable School, in the heart of the Automobile Industry. Anyone can learn by our method. Practical from the ground up. Write us for full particulars. Ask for Copy of "Auto School News," it's free. Or better, jump on the train and come to Detroit. Take Woodward Ave. Car from the Depot and get off at Selden Ave., and our building is right there. **Learn the automobile business in Detroit and learn it right.**

Michigan State Auto School, Department P4, 11-17 Selden Ave., Detroit, Michigan

Our Guarantee

We guarantee to qualify you for a position as chauffeur, repair man, tester, salesman or demonstrator in a short time, or we will refund your money.

And don't forget, we furnish positions, too

On account of being in the auto center, we can furnish positions that cannot be obtained elsewhere

The Most Important Boys' Book in Years THE BOY ELECTRICIAN

Practical Plans for Electrical Toys and Apparatus, with an Explanation of the Principles of Every-Day Electricity.

By **ALFRED P. MORGAN**

With full-page illustrations, and 324 working drawings and diagrams by the Author. 8vo. Cloth.

Price, Net, \$2.00 Postpaid, \$2.25

This is the most complete, the best illustrated, the most correct and the most entertaining work on the subject of electricity, its uses, and the economical making at home of practically all kinds of electrical appliances that has ever been produced. It also tells very clearly how electrical matters are handled on a large scale.

All Bookdealers. Send for Free Catalog.

LOTHROP, LEE & SHEPARD CO., BOSTON



Practical Electrical Education

Our practical course in Electrical Science and Engineering trains you to get and keep the big-pay jobs. Enter at any time, no matter what your education. Advance as fast as you can master the work. Course combines theory with actual practice in all branches of Electrical Science. Individual instruction. Only practical training school of its kind in U. S. Endorsed by leading electrical employers past 16 years. Our trained students always in demand and well paid. Write for FREE ILLUSTRATED CATALOG. Spring Term Now Open.

SCHOOL OF ENGINEERING OF MILWAUKEE, 152 Stroh Bldg., MILWAUKEE, WIS.



BE A TRAVELING SALESMAN

Hundreds of good positions now open. No experience required to get one of them. Write today for list of openings offering opportunities to earn big money while you learn and train on the job. Thousands of our students who are earning \$100 to \$500 a month. Address nearest office, Dept. 517 NATIONAL SALESMEN'S TRAINING ASSOCIATION Chicago, New York, San Francisco

Get A Government Civil Service Position

A job with Uncle Sam under Civil Service protection means employment for life with good pay, short hours, pleasant work, annual vacations and the assurance that you will get your pay regularly in spite of panics or hard times.

Post Office, Railway Mail, Rural Carrier, Custom - Internal Revenue and other examinations are being held all the time.

If you're an American citizen 18 or over, we can help you secure one of these good jobs. Our 64 page booklet tells how you can prepare for "exams" under personal supervision of a former U. S. Civil Service Secretary-Examiner—a man who knows and whose knowledge is at your disposal.

Write today for booklet. It's free, without obligation.

PATTERSON CIVIL SERVICE SCHOOL
304 Irving Place
ROCHESTER, N. Y.



Be an Artist. We Buy Our Students' Drawings

All Branches of Art Taught BY MAIL or Local Classes. Write for illustrated booklet, terms and list of successful pupils. ASSOCIATED ART STUDIOS, 2122 Flatiron Bldg., NEW YORK

IF YOU STAMMER

attend no stammering school till you get my large FREE book and special rate. Largest and best school in the world curing by natural method. Write today.

Leo Walls Millard, Pres., North-Western School, Inc. 2317 Grand Avenue Milwaukee, Wis.

Every Boy His Own Toymaker

Greatest boys' book ever written. Tells how to make a Steam Engine, Telephone, Magic Lantern, Boats, Kites, Balloons, electrical and mechanical toys, traps, fishing tackle. 200 illustrations; also catalog of 150 puzzles, Kellie's Magic Ace Trick Card and "Double Tinker" warbler and bird call all for only 10c. WESTERN PUZZLE CO., ST. PAUL, MINN.



"Weighs only 7 lbs."

The INDIA-PAPER Edition of **WEBSTER'S** **NEW INTERNATIONAL** The *Merriam* Webster



It is a real pleasure to use *The Supreme Authority* in this new and convenient edition. A delighted purchaser writes: "*The volume is so flexible, so portable, so agreeable, so readable that looking up a word has lost all its terror.*"

2½ inches of shelf room hold this wonderfully compact storehouse of authentic information. Only half as *thick*, only half as *heavy* as the Regular Edition. Printed on expensive, thin, strong, opaque, India Paper.

PUZZLING WAR WORDS

as *Landsturm, Contraband, Belligerent, Batum, Blockade, Flanders, Moratorium, Transylvania*, and thousands of others are clearly defined or located in the Webster's New International.

THE ONE STANDARD AUTHORITY

It is the *standard* of the Federal and State Courts. The *standard* of the Government Printing Office. The *standard* of nearly all the schoolbooks. *Indorsed* by every State School Superintendent. *Universally recommended* by Statesmen, College Presidents, Educators, and Authors. Adhered to as *standard* by over 99% of the newspapers. *The above cannot be said of any other dictionary.*

G. & C.
MERRIAM
CO., SPRING-
FIELD, MASS.

Please send me specimens of the NEW DIVIDED PAGE, Illustrations, India and Regular Papers, etc.

400,000 Vocabulary Terms.
30,000 Geographical Subjects.
12,000 Biographical Entries.
Thousands of other References.
Hundreds of NEW Words not given in any other dictionary.
6,000 Illustrations, 2,700 Pages.

Colored Plates and Half-Tone Engravings,

The only dictionary with the new divided page, characterized "A Stroke of Genius." Type matter is equivalent to that of a 15-volume encyclopedia.

More Scholarly, Accurate, Convenient, and Authoritative than any other English Dictionary. Critical comparison with all other dictionaries is invited.

WRITE for specimen pages of both India-Paper and Regular Editions.

G. & C. MERRIAM COMPANY, SPRINGFIELD, MASS., U. S. A.

For over 70 years publishers of the Genuine-Webster Dictionaries.

Name.....

Address.....

FREE a useful set of pocket P. Mech. maps if you mention

WANTED

RAILWAY MAIL CLERKS

\$75 to \$150 a month for life

OVER 230,000 U. S. GOVERNMENT POSITIONS ARE OPEN TO COMPETITORS

Many appointments are made each month
WAR-PROOF - PANIC-PROOF - SURE-PAY JOBS

Country residents and city residents stand the same chance for immediate appointment. Common-sense education sufficient.

Write immediately for schedule showing the places and dates of the Spring examinations in your neighborhood. Don't delay. Every day you lose means the loss of just so much coaching before the rapidly approaching examinations.

FRANKLIN INSTITUTE, Dept. T 104, Rochester, N. Y.



COUPON

This coupon, filled out as directed, entitles the sender to free specimen questions; a free copy of our copyrighted book, "Government Positions and How to Obtain Them," a list of positions now obtainable, and to consideration for Free Coaching for the examination here checked.

... Railway Mail Clerk (\$900 to \$1200) ... Customs or Int. Rev. Pos. (\$700 to \$1800)
... Bookkeeper (\$800 to \$1200) ... Stenographer (\$800 to \$1200)
... City P. O. C. or Car. (\$800 to \$1200) ... Clerk in the Departments at Washington (\$900 to \$1500)
... Rural Mail Carrier (\$600 to \$1200) ... Canadian Government Positions.
... Panama Canal Clerk (\$1200 to \$1800)

COUPON

Name..... Address..... T104

Please Mention Popular Mechanics

Make This Easy Jump to Success!



Become
A

Traffic Expert

What is your salary now—what opportunities does your present position offer? Those are the problems you face. If you are following the wrong vocation, get out of it now. Begin preparation now for future success, big income and independence.

Right now the opportunity of a lifetime confronts you. A new, uncrowded field for success awaits you if you act quick. Positions of power, wealth and independence are newly created.

WAR Has Created New Opportunities for You

The gigantic world-war has opened the rich, extensive markets of South America for American Manufacturers and Shippers. American houses are in great need of trained men who know how to handle Ocean traffic and trade. Your choice of these big positions is possible for you if you let us train you now to become A TRAFFIC EXPERT.

Earn \$35 to \$125 Weekly

Begin now and secure one of these remarkable positions—advance into a big executive chair—make a place for yourself that will not be taken from you by competition or reverses. Traffic Managers earn \$35 to \$125 weekly and more. You can qualify, no matter who you are. We help you as we are now helping others.

We Train You by MAIL

at home, in spare time, no matter where you live. Past experience unnecessary. Makes no difference what you work at now, if you can read and write English you can master the LaSalle simplified, complete Interstate Commerce course. The LaSalle course was prepared especially for home study by some of America's greatest Traffic authorities. LaSalle graduates are exceptionally successful. The LaSalle is a powerful, reliable institution.

NOW

Don't let lack of money keep you down—we make payments to suit you. Prepare now for a big position. Mail coupon for facts, proof that we can qualify you, and remarkable book—

"10 Years' Promotion in One." Send free proof about opportunities for Traffic Experts, copy of "Ten Years' Promotion in One" and Money Refund Bond.

LaSalle Extension University Dept. C-531 Chicago, Ill.

Name.....

Address.....

LEARN TO PAINT SIGNS and SHOW CARDS

THERE'S MONEY IN IT

I'll teach you personally by mail. 16 years' successful teaching. Five courses: (1) Complete Lettering, Sign and Card Writing; (2) Show Card and Ticket Writing; (3) Lettering; (4) Advanced Show Card and Ticket Writing; (5) Advanced Sign Painting and Show Card Writing. You can succeed—big. No limit to the window cards, sale cards, banners, and signs used. Gold lettering on glass and wood valuable feature of course. Teaches everything you need. This knowledge will help you wherever you are. Pay good, work fascinating, hours short.

Neal (Ohio) says, "Lessons easy to understand—anyone can easily learn." Schwartz (Del.) writes to say, "Yours is the only school that really teaches," and Tarbell (Ill.), "Price of course too cheap—best in existence." Get in on this big thing too. Your name and address brings full particulars.

THE DETROIT SCHOOL OF LETTERING
Chas. J. Strong, Founder, Dept. 2040, Detroit, Mich.

Guarantee—
I guarantee to place my graduates in positions paying \$85.00 to \$175.00 when they have graduated and are competent. We have constantly more requests for men at good salaries than we can supply.

Learn to Write

I can make a good penman of you at home during spare time. Write for my free book, "How to Become a Good Penman." It contains specimens and tells how others mastered penmanship by the Tamblin System. Your name will be elegantly written on a card if you enclose stamp to pay postage.

FREE BOOK Write for it Today

F. W. Tamblin, 428 Meyer Bldg. Kansas City, Mo.

Learn the Auto Business

Earn a Splendid Salary

By practical experience we train you for a good position as automobile mechanic, salesman or chauffeur. Over 3,000 graduates are earning big salaries. Complete training in 4 weeks, including extensive practice in repairing and driving high powered cars. Tuition and board reasonable.

Send today for free catalog and list of graduates

Cleveland Automobile School
2338 Euclid Ave., CLEVELAND, OHIO

LEARN PIANO TUNING AT HOME

My Patented Tune-a-Phone method makes it easy. Eliminates guess work. Anyone can learn. A. D. Pope, Texas, made \$52 first ten days. Course guaranteed as represented. Diploma granted. Write for free booklet, graduate's records, etc.

Miles Bryant School of Piano Tuning, 444 East Bldg. Battle Creek, Michigan

ARITHMETIC SELF-TAUGHT

A plain, easily-understood volume for all who have not had the opportunity of learning this subject thoroughly, or who have forgotten what they once learned. 257 Pages. Requires no teacher. This great little book sent postpaid for 60 CENTS. Stamps accepted.

GEO. A. ZELLER BOOK CO.
Est. 1878, 4472 W. Belle Place ST. LOUIS, MO.

SPANGENBERG'S PRACTICAL ARITHMETIC Self-Taught

Please Mention Popular Mechanics

Will Your Memory Meet This Test?

IS your memory the kind that builds big business success? Do you have the facts, figures, names, faces and arguments—on which your business success depends—at your instant command? For your own sake you should know how much your memory is to be depended upon. Send at once for my copyrighted memory test. No charge. No obligation. Get this test into your hands and apply it at once.

Stop Forgetting!

Your memory can be developed. I have helped thousands of men. I can help you. No matter how poor or how good your memory may be, I can make it better—I can make it *sure*. I can give you an exact memory for figures and details which you never dreamed possible. My course will enable you to concentrate, develop self-control, overcome self-consciousness, bashfulness, think on your feet intelligently, address an audience without notes. Any day you may be called upon to speak before a board of directors or a gathering of business men, or give an after-dinner speech. Be prepared. Send at once for my copyrighted memory test—and booklet "How to Remember."

Prof. Henry Dickson, Principal
Dickson School of Memory
705 Auditorium Building, CHICAGO, ILL.



Prof. Henry Dickson, Principal, Dickson School of Memory

Memory Test FREE

Prof. Henry Dickson, Principal,
Dickson School of Memory,
705 Auditorium Bldg., Chicago, Ill.

Please send me, free of charge and without obligation, your copyrighted memory test—also your booklet, "How to Remember," and also how to obtain a Free Copy of the Deluxe book—"How to Speak in Public."

Name _____

Address _____

FREE—Increase Your Income

IN AN UNDEVELOPED, PROFITABLE FIELD



Learn Show Card-Writing and Lettering. We furnish a reliable and thorough course, absolutely free, to introduce ALPHA colors, if you purchase an assortment to use while practicing. Particulars for stamp. Alpha Color Co., Inc., Dept. K, 1960 Broadway, N.Y. City

DON'T TAKE A COURSE IN Mechanical Drawing

until you have read my proposition. Practical draftsman, regularly employed by the most progressive company in the West, with long experience also as teacher of Mathematics and Drawing, will instruct a few men by mail. **Positively the best way to become a practical well-paid draftsman.** Instruments furnished. Rates reasonable. **Pay a part after in position.** For information write.

DRAFTSMAN, 252 South Corona Street, Denver, Col.

LAW STUDY AT HOME BECOME AN LL.B.

Only recognized resident law school in U. S. Conferring Degree of Bachelor of Laws—LL. B.—by correspondence. Only law school in U. S. conducting standard resident school and giving same instruction, by mail. Over 450 class-room lectures. Faculty of over 30 prominent lawyers. Guarantees to prepare graduates to pass bar examination. Only law school giving Complete Course in Oratory and Public Speaking. School highly endorsed and recommended by Gov. Officials, Business Men, Noted Lawyers and Students. Send today for Large Handsomely Illustrated Prospectus. Special Course for Business Men and Bankers. HAMILTON COLLEGE OF LAW, 405 Advertising Bldg., CHICAGO, ILL.

LEARN WATCHMAKING

and become independent. Good-paying positions secured. Easy to learn. Send for FREE CATALOG.

ST. LOUIS WATCHMAKING SCHOOL, Dept. 5, ST. LOUIS, MO.



LEARNED BY ALMOST ANYONE AT HOME VENTRILOQUISM SMALL COST

Send today 2c stamp for particulars and proof. O. A. SMITH, Room D 123, 823 Bigelow St., PEORIA, ILL.

"HELP WANTED" Uncle Sam.



Railway Mail Clerks
Postoffice Clerks
City Mail Carriers
Clerks in the Government
Offices at Washington

Thousands of Appointments Coming
Spring Examinations Everywhere

\$900⁰⁰ to \$1800⁰⁰ a Year
for LIFE

No "layoffs" without pay, because of strikes, wars, financial flurries or the whims of some petty boss. Excellent opportunities for quick advancement to Higher Government Positions. If you want immediate appointment, send TODAY for our schedule showing locations and dates of all Spring examinations. Any delay means the loss of just so much time in preparing yourself for examination.

We give 25 free scholarships

This coupon, filled out as directed, entitles the sender to free sample questions; a free copy of our book, "Government Positions and How to Obtain Them," free list of positions now obtainable; and to consideration for Free Coaching for the examination here checked.

SEND COUPON BELOW

FRANKLIN INSTITUTE

Dept. T106, ROCHESTER, N. Y.

COUPON

..... Railway Mail Clerk (\$900 to \$1800) Customs Positions (\$800 to \$1500)
..... Postoffice Clerk (\$800 to \$1200) Internal Revenue (\$700 to \$1800)
..... Postoffice Carrier (\$800 to \$1200) Stenographer (\$800 to \$1500)
..... Rural Mail Carrier (\$800 to \$1200) Clerk in the Departments at Washington (\$800 to \$1500)
..... Bookkeeper (\$800 to \$1800) Canadian Government Positions

Name.....
Address..... T 106
Use this before you lose it. Write plainly.

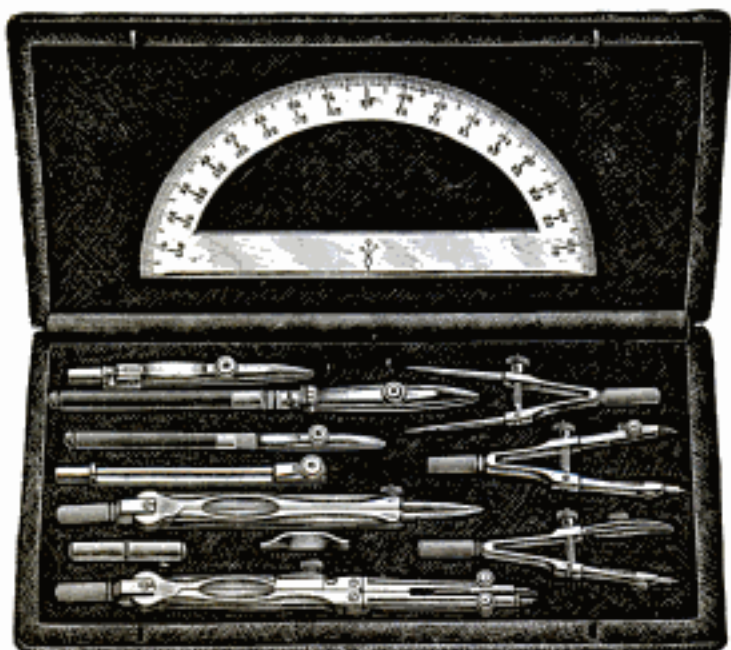
Please Mention Popular Mechanics

Copyrighted material

Free!

Complete Set of Drawing Instruments

Yes, I will give you this complete set of drawing instruments absolutely free. They are regular working instruments—the kind I use myself and they do not cost you a penny. And besides the instruments in this exquisite plush lined leather case, I will give you absolutely free a 20x25 inch drawing board, a 24 inch T-square, a 12 inch rule, a supply of drawing paper, two triangles and a French curve, pencils, erasers, thumb tacks, etc., etc. A complete draftsman's working outfit. And I give it to the men who get my personal instruction absolutely free.



Be a Draftsman!

Draw \$125 to \$175 Per Month

There is an urgent demand for skilled draftsmen. Companies are issuing calls every day for men to fill positions paying from \$125.00 to \$175.00 per month. Work is light, pleasant and profitable.

Chief Draftsman Will Instruct You Personally

I am Chief Draftsman of a large and well known firm. I have been doing the highest paying expert drafting work for a quarter of a century and I know just the kind of training that is demanded from men who get the big salaries. I will give you personal instruction, deal individually with you and give you up-to-date, practical working plans just as your ability and advancement require. I train you by giving you actual work—practical work, the kind that you must be able to do in order to hold permanent, big paying positions. I give you my individual instruction. If your work is right, I will advance you rapidly. If it is wrong, I will show you where, and make you do it right, and do all I can to make you an expert draftsman and designer in a short time. **Write today without fail**

Pay as You Wish! What I want is the RIGHT KIND of men. Don't bother about expense. I will give you the working outfit free if you get in at once. I charge a very small fee for training you to be an experienced draftsman. You can pay the small cost as suits you best. My object is to develop experienced draftsmen.

Chief Draftsman Dobe
Engineer's Equipment Co.
Div. 1194 Chicago, Ill.

Without any obligation on me whatsoever, please mail your book "Successful Draftsmanship" and full particulars of your liberal "Personal Instruction" offer to a few students. It is understood that I am obligated in no way whatever.



Send the Coupon for My Big New Book

Put your name and address on the free coupon or a letter or a post card and send it to me today. I will send you absolutely free and postpaid my new book "Successful Draftsmanship," and the great special offer that I am now making on which you get the \$15.00 Draftsman's Working Outfit absolutely free. You assume no obligations of any kind in sending in the coupon. Get in line now for a big paying position. Getting the book and full particulars of the special offer is the first step. Write today—now.

Chief Draftsman Dobe

Engineer's Equipment Co., Inc., Div. 1194, CHICAGO, ILL.

NAME.....

ADDRESS.....

CLASSIFIED ADVERTISEMENTS

We have records to prove that a classified ad in these columns will find a buyer for almost anything which can be sold. Doubtless you have some article of value to some one else which you no longer need. Why not turn it into money?

Advertisements in this section, 15 cents per word, each insertion, minimum 10 words, payable in advance. To insure ads being inserted under proper classified head in the May issue, copy must reach this office not later than April 1st.

Popular Mechanics Magazine, Chicago, Illinois.

December 11, 1914

Gentlemen: Replying to your letter of December 8th in regard to the success we have had with classified advertising in your magazine, would say that the results have been far beyond our best expectations. We have had considerable experience in running classified advertisements in newspapers and other publications, but would say that as far as results are concerned, we would not exchange our ad in Popular Mechanics, amounting to \$4.00 or \$5.00 a month, for \$400.00 or \$500.00 worth of advertising in other mediums.

Very truly yours,

THE SILVEX COMPANY.

AUTOMOBILES

YOU can earn an auto by my new, easy plan; anyone over 16 years old can get a brand-new Ford Touring Car for a little cash, respectable work among neighbors. Free Book tells all about it. Postal brings it. Send Auto Tom, 617 S. 16th St., Omaha, Neb.

OAKLAND 40 Parts. Three speed and reverse transmissions, multiple disk clutch, shaft drive, rear axle, complete, \$65. Front axle with knuckles, complete, \$15. Set of four wheels, 34x4, demountable rims, \$19. Steering gears, \$19. Oakland frames, \$19, and a lot of other parts. Complete Oakland chassis, less motor, \$85. Harley-Davidson twin 1913, \$140. E. J. Gustafson, 1462 N. Hickory St., Joliet, Ill.

ELECTRIC Automobile, fine condition, \$295. Roy Harvey, 1214 Farmers Building, Pittsburgh, Pa.

FORD cylinders rebored, fitted with 4 oversize pistons, 12 rings, 4 wrist pins, 8 bushings. Cost of complete job \$15. Delivery in 24 hours. Every job guaranteed. Everts Machine Company, 14 Hicks Street, Hartford, Conn.

CYLINDER Boregrinding or Boreing. New oversize pistons and rings fitted. Accuracy guaranteed. Prompt delivery. Worn or broken parts duplicated. Everts Machine Company, 14 Hicks Street, Hartford, Conn.

FOR Sale Cheap—Latest Model White Steam car, excellent running order. Box 98, Ft. Wayne, Ind.

AUTOMOBILE tire puncture proofing \$1. motorcycle 50c. Establishes profitable business anywhere. See Kelp Laboratories, Colongrove, California.

1913 REO touring car, almost new condition, \$360.00. Box 1139, Pittsburgh, Pa.

USED Cars. Look out! Avoid costly mistakes in buying a used car by knowing positively the vital points to look for—and know how to locate the "snaps" you hear about. Send no money—just say—"Show me." L. E. Smith, Fort Atkinson, Wisconsin.

\$390.00 SAVED on 1915 Chalmers Master Six. This car is the latest model, absolutely new and completely equipped, just as advertised, and has not yet left the factory. Urgent need of funds compels me to sacrifice it for \$2,100. f. o. b. Detroit. H. P. Allen, Box 76, Fort Wayne, Indiana.

AUTOMOBILE owners, do your own vulcanizing and save tire expenses. My instant vulcanizer is so simple that a child can operate it. Price \$3. Send for booklet. Winsor Sales Co., cor. 124th St. and Lexington Ave., New York.

AUTOMOBILE Flexible Metal Tubing for carburetors, wire covering, exhaust pipe, tire inflating and speedometers. Flexible metal hose, all kinds. Get catalogue. Herge, Newark, N. J.

MAXWELL "Special" automobile for sale. Five passenger. "26" horsepower. Good condition. Kelly-Springfield tires. Starter. Allen Neel, Marshall, Va.

AUTOMOBILES at rock bottom prices; write for Bargain Bulletin. Eureka Auto Co., Rebuilders, Beavertown, Pa.

AUTO owners: oxygen carbon remover; not \$40, only \$7.50. Cleans four cylinders, total cost 67c. Absolute guarantee of money back if not satisfied. Peerless Supply Co., Box 44, Millburg, Pa.

USED automobiles \$750 to \$350; send for free list. Brown Music Company, 9119 Commercial Ave., Chicago, Ill.

\$1,000 CASH takes a real bargain in my Abbot-Detroit car, including 2 bodies, 5-passenger open body for summer use and 4-passenger coupe for winter use. Easy to change bodies as the season warrants. Car is fully equipped. Late 1913 model or really a 1914 model. No change was made in 1914 or 1913. Electric lighted and electric starter. Just overhauled and running in perfect condition. Continental enclosed valve T head motor. Absolutely noiseless and has never given any trouble. My open body is almost like new, as I had a set of \$85 seat covers made for it last summer, also new carpet for tonneau. Timken axles and Timken bearings. Nickel finish throughout. Tire irons, large storage battery, tool chest on running board and numerous other accessories that would cost you money to buy and that are not included in the standard equipment of a new car. Coupe cost \$800 alone last winter. All steel body. Electric lighted throughout and lined with beautiful green whipcord cloth. Silk window roller curtains and all that goes with a luxurious coupe for winter use. Just the car for a doctor. Original cost for car without coupe, \$1,825. Coupe made to order, \$800. Cost complete without any accessories that I am throwing in, \$2,625, so you can see that it is a bargain at \$1,000. Act quick. Write C. F. Minor, 946 Almslie St., Chicago.

SAVE Cylinder retooling, use Triple rings, 99 cents each; Regular rings, 25 cents; Radiators, \$11; Steering gear complete, \$10; Motor 4 1/2"x5" L-Head, \$150. Grossman Auto Parts Company, White Plains, N. Y.

NICKEL Plate your Automobile Trim-mings with Nickel Powder. Prevents brass from tarnishing, steel from rusting. \$1 per can, prepaid. Gunmetal Co., Decatur, Ill.

PAINT Your Car Yourself—Save \$25 to \$75 by doing the work at home with the Arsenal system. Our big free booklet "The Car Beautiful" tells how. Send for it today. Arsenal Varnish Co., Dept. P, Rock Island, Ill.

"THE How and Why of the Automobile"—A 200-page book of practical information for seekers after the fundamental facts regarding the gasoline engine and its application to the motor car. Interesting and instructive to both the beginner and the expert. Bound in full cloth—250 illustrations. Price \$1 postpaid. Popular Mechanics Book Dept., 6 N. Michigan Ave., Chicago.

THE Last Word in Automobile Literature—New Book. "The Modern Gasoline Automobile," 740 6x9 in. pages, 500 illustrations, is superior to any treatise heretofore published. Deals with every modern improvement. Price, \$2.50 postpaid. Popular Mechanics Book Dept., 6 N. Michigan Ave., Chicago.

STUDEBAKER 30, late "1912" fore-door touring, looks and runs like new, \$250. Also Studebaker "20" runabout \$150. Others from \$75 up. Automobile Buyers Association, 2407 Walton Ave., New York City.

CYLINDERS scored by piston pin, restored to original shape; use same piston. No welding. Cobb Machine Shop, 2935 Detroit Ave., Cleveland, Ohio.

IF your car hasn't the compression and power it once had, you'll probably find that your cylinders are worn or scored and need regrounding. We've reground thousands of cylinders in our six years' experience and can refer to pleased customers everywhere. Advise make of car and bore diameter, so we may quote. Do it now before you forget. Waterbury Welding Corporation, Waterbury, Conn.

PISTON Rings—Use Peerless Positive Leak proof, when overhauling your motor, more power on less fuel guaranteed. Peerless Piston Ring Co., 31 Lafayette, Newark, N. J.

BUILD your own small car and save \$150.00. Anyone who can use a wrench can do this, as we furnish parts completely machined and ready to assemble. This is a well known car and all parts are sold on a money back offer. Deferred payments. Catalog four cents in stamps. Layout of cars twenty-five cents. Triumph Company, Export Dept., Oswego, Tioga County, N. Y.

AUTOMOBILE SUPPLIES

NEW Text Book on Oxy-acetylene welding and cutting. Experts say, "best ever published for practical men." Third edition, cloth bound, 150 pages, fully illustrated. Price \$1.50. Star welding and carbon-burning apparatus complete, including automatic regulators, high and low pressure gauges, welding materials, new text book, and special torch, which will pay for plant by saving in gas. Best outfit ever sold for less than \$100, now \$75. Write today. Vulcan Process Co., Minneapolis, Minn.

\$3.95 AUTO or Motorcycle Hand Horns; no wires or batteries; delivered in the United States; money refunded if unsatisfactory upon examination. Spark Plugs 35 cents, delivered; Cementless Patches 50 cents, delivered; Ammeters 75 cents, delivered; Tires, new fresh stock, 30x3, \$7.50; 30x3 1/2, \$9, not delivered. Norton Tire Co., 1613 Grand Ave., Kansas City, Mo.

4 Cyl. Mason motor, 2 Cyl. Autocar Motor. Planetary Transmission cheap. Lambertson, Hadley, Mich.

AUTOMOBILE sheet-metal parts made new and duplicated. Tanks, fenders, Ford racing seats and bodies. Welding of all kinds. L. & M. Manufacturing Company, 319 S. Jefferson St., Chicago, Ill.

AUTOMOBILE Seat Covers at half price. Our direct-to-owner plan will save you money. Write for particulars. Satisfaction guaranteed. Globe Seat Cover Co., Box 75, Dept. P, Racine, Wis.

WANTED—Second-hand Bosch magnetos; we pay cash. Expert magneto repairing. Emels Manufacturing Co., 217-221 Iowa St., Davenport, Iowa.

AUTOMOBILE Rims—State make and size or describe and we will quote. Shock Absorbers for Ford, \$1.75 set four prepaid. Sandberg Bros. Supply Co., Minneapolis, Minn.

ENGINES and Parts for Sale. 35 H. P. Continental \$100; 45 H. P. Stoddard Dayton \$100; Studebaker 35 H. P. \$85; 25 H. P. Oswald \$80; 6-cyl. Stevens Duray with transmission \$140; Bucket seats \$18 pair. Presto tanks, B size, \$10. Model T Ford Eng. \$100. Axles, wheels, springs, magnetos, connecting rods, crank shafts, pistons and Buick 10 parts. Auto Salvage & Parts House, 1436 Wabash Ave., Chicago, Ill.

ANY make of magneto and coil sold and repaired. Work guaranteed. Write for our prices. Pellet's Magneto Exchange, 1606 Michigan Avenue, Chicago.

AUTOMOBILE wheels for any car or truck. Ford wheels with 3/4x3 1/2 inch clincher rims \$2.75 each; 10% off to dealers. Millar Wheel Works, 2213 S. Michigan Ave., Chicago.

CARBURETORS—Slightly used Strombergs, Rayfields and Model L, Scheblers, 1-inch, 1 1/4-inch and 1 3/4-inch, \$8 each. Condition guaranteed. Henry A. Currier, Auburn, Mass.

16 H. P. OPPOSED Engine with coil \$35; Metz with magneto \$35; Quinlan 10 upright, two cylinder, \$59; Prentice Lathe \$150; Pittsburgh Shaper \$150; Drill Press \$30. List for stamp, Sisson Machine Works, Marshall, Ill.

ELECTRIC Hand Lantern, uses standard dry cell, Great, \$1.25 postpaid. Agents wanted. Skelton Sales Co., Auburn, Mich.

USE an Air-Friction Carburetor, 1915 Improved Model C or D, increases power and economy of motor one-half. Absolutely impossible to load or choke. Starts easy warm or cold weather. Uses either light or low grade fuels with finest results. We fit all motors and guarantee definite results or refund money if returned within thirty days. Liberal exchange allowance on other carburetors or old model air-frictions. We also make and absolutely guarantee the Air-Friction Spark Plug. Sold in sets of five only at \$3 per set. The Air-Friction Carburetor Co., Dayton, Ohio.

AUTO Parts—Build or repair your own car, as we can furnish parts for any make of car at cut prices and discounts. State your wants to Grossman Auto Parts Company, White Plains, N. Y.

RACING equipments, seats, tanks, cowls, bodies, etc. Latest types, classy designs. On Ford and other chassis. Standard Auto Sheet Metal Works, 532 S. Canal St., Chicago.

SHOP Vulcanizer, Bargain. Tires at cut prices. Vanderpoels, Springfield, Ohio.

MOUNT power vacuum cleaner on your auto. Buy parts, assemble. \$50 cost—earn \$15 daily. Vacuum Supply Co., Ann Arbor, Mich.

WELDING

WE weld all metals. Charges reasonable. Work guaranteed. We rebores cylinders and fit pistons. Berischky Kan-Fix It, Omaha, Neb.

EARN \$1900 a month. The Admiral Welding Equipment, with Decarbonizer, Supplies and Instruction Book outfits you for conducting a general welding business. You can't buy a better outfit. Handles any class of work. Many of our customers have earned the cost the first week. We conduct the largest Job Welding Shop in Kansas City, and use this Equipment exclusively. Booklet Free. Admiral Welding Machine Company, 1322 Walnut St., Kansas City, Mo.

WELDING Plants, \$25 to \$250. Liberal terms. Write Berno Co., Omaha, Neb., V. S. A.

"OXY-ACETYLENE Flame and Its Uses"—The most complete instruction book upon welding show practice ever published, \$1 prepaid. Admiral Welding Machine Co., Kansas City, Mo.

OXY-ACETYLENE Welding and Cutting is the title of a brand new practical instruction book on the methods of doing this work. It includes the operation and care of Acetylene Generating Plants and the Oxygen Process for removal of carbon. 290 pages, 76 illustrations, pocket size, cloth, \$1.00; leather, \$1.50 postpaid. Popular Mechanics Book Dept., 6 N. Michigan Ave., Chicago.

FORD ACCESSORIES

EQUIP your Ford with a self-starter. Easily attached. Fully guaranteed. Write for particulars. Agents wanted. Western Motor & Supply Co., Lincoln, Neb.

FORD Shock Absorbers—\$8.50 set of four—Touring—Roadster. Guaranteed. Fasco, 203 Bulck Building, N. Y.

PISTON Rings for Ford Cars ten cents, piston gear one dollar, differential drive gear three dollars, set of 14 Model T gaskets thirty-five cents. Grossman Auto Parts Company, White Plains, N. Y.

MOTORCYCLES, BICYCLES & SUPPLIES

MOTORCYCLES: Indian Twin \$45. Snap, Pope Twin Demonstrator, fully equipped, \$85; Yale single \$37.50, Grips 15c, Spark Plugs 15c, Casings \$4.75, Electric Horns \$1.50, Pedals 75c, Long Leather Leggings 75c, Fauber Motorcycle Crankhangers \$1.75. W. E. Wandersee Company, 129 Gratiot Avenue, Detroit, Mich.

WELDING—We repair broken castings, any shape. Cylinders, crank cases, frames, handle bars, etc. C. M. Anderson, Batavia, Ill.

BARGAINS in new and slightly used motorcycles. Some new, others demonstration models, and balance in slightly used ones in all well-known makes. We now have all told over 75 in stock. We own these motorcycles at prices less than one-third their value. This month we are offering them at prices that will move them quickly. Write for our free list giving descriptions and prices. You will save from 25 to 50 per cent. Gotham Sporting Goods Co., 37 Warren St., New York City.

BARGAINS in used machines, \$20 and up. Ernst Bros., Marcus, Ia.

A FEW brand-new 1914 Harley-Davidson motorcycles, still in the original crates, at the following reduced prices, F. O. B. Portland, Oregon: One single cylinder two-speed \$160, one twin cylinder single-speed \$175, one twin cylinder two-speed \$200. Davenport Motor Co., Portland, Oregon.

FOR Sale—1914 Yale Twin Two-Speed, completely equipped, \$290. Jas. J. Belland, Bayne City, Mich.

NOW is the time to buy Bargains in Used Motorcycles—All makes, \$25 and up. 75 Harley-Davidsons, all models, all overhauled, some like new, guaranteed in best condition, good tires. Write for bargain list and get first pick. Mueller Cycle Co., Milwaukee, Wis.

1913 TWIN Indian. Fine condition, \$160. J. M. Chism, Kraus, Texas.

GOOD Two-speed, 1914 Indian, Address Wm. G. Lauterbach, Mendota, Ill.

DON'T buy a Bicycle Motor Attachment until you get our catalogue and prices. Shaw Mfg. Co., Dept. 27, Galesburg, Kansas.

YOUR Motorcycle delivered free! Send for big list, with over one hundred machines, \$25 to \$50 below others. Write today. Western Supplies Co., 1432 Larimer St., Denver, Colo.

SEND for big list of bargains in second-hand motorcycles at wholesale prices. Howard Cycle Co., 152 N. Broad St., Trenton, N. J.

1913 INDIAN, racing carburetor, \$109. Tom Johnston, Collins, Ohio.

INDIAN 5 twin, fine condition, \$83. Ralph Leffer, Tiffin, Ohio.

SAVE Money on Tires—We have all makes at reduced prices. Some bargains in Prest-O-Tanks and lamps. Anderson's Motorcycle Garage, Batavia, Ill.

BARGAIN—Indian twin \$185, single \$85. Fred Dahl, Lake Benton, Minn.

YALE 1913 twin \$160; sidecar \$45. Thomas Dunham, Aurora, Ill.

FOR Sale—N. S. V. 5 h. p. twin; looks like new. A real bargain for someone; \$125. Edward Janke, Monticello, Minn.

FOR Sale—1914 Harley Davidson Twin, equipped with 2 speed, Auto Tires, Speedometer, Prestolite and big lamps. Fast, powerful and like new, \$185. Otto Merker, 2021 S. Central Park Ave., Chicago, Ill.

1910 HUPP Runabout in fine condition, \$275. 1915 Indian Twin, two-speed, \$135. Shipped on approval. Unused Indians. E. F. Caranah, Sibley, Ill.

REAL bargains in used machines. Harley single \$69; Excelsior single \$40; Flaudes single, \$55; Thor single, \$75; Emblem twin, \$90. Guaranteed in serviceable condition. Will ship \$10 cash, balance C. O. D. Vesely Bros., 3839 Ogden Ave., Chicago, Ill.

1912 INDIAN Twin Cyl., best condition. Sell or trade for good engine lathe. E. L. Rankin, Wellsville, O.

LIVE agents wanted for the new 1915 Eagle motorcycles. Write quick and make good money as our local representative. Sterling Motor Company, 720 Center Street, Brockton, Mass.

\$5,000 WORTH of used Motorcycles, all makes; Harley-Davidsons, Indians, Excelsiors, Hendersons, etc. Twins, \$75 and up; Singles, \$25 and up. Send for our list at once. C. H. Lang, 1704 Michigan Ave., Chicago.

MOTORCYCLES and Bicycles, New and Used, all guaranteed. At lowest prices. Send for our lists. Seelzer & Hofheins, Buffalo, N. Y.

HARLEY-DAVIDSON 1913 twin, magneto, mechanically perfect, like new, \$140. E. J. Gustafson, 1492 N. Hickory St., Joliet, Ill.

BARGAINS in all makes of used motorcycles. Victor H. Roos, Omaha, Neb.

200 REBUILT Motorcycles, Standard makes, new list. Chicago Motorcycle Works, 2911 Clarendon Ave., Chicago.

BICYCLES cheap for cash. Send for catalog. Ted Manthel, \$500 No. Clark, Chicago.

NEARLY new motorcycle to exchange for camera. Roly, Fowler, Ind.

EAGLE—Two-speed, twelve and sixteen horsepower, Arrow—Light weight, five-horsepower single, ten-horsepower twin. Parts and accessories for all makes. Get list 37 rebuilt machines. Agents wanted. Motorcycle Paris Manufacturing Works, 4713 Cottage Grove, Chicago.

ALL makes at low prices. Two-speed Indians, Harleys, and Excelsiors, \$35 up. Walter Goerke, 823 Washington St., Newark, N. J.

SPECIAL Piston Rings, Unbreakable. Guaranteed to increase compression, power and speed. 50c each postpaid. Anderson's Motorcycle Garage, Batavia, Ill.

LOWEST prices on New and Used Motorcycles. Ask for list M. Prices \$20 up. Rebuilt Motorcycle Dept., 801 Center Street, Brockton, Mass.

POPE \$35; 1911 and 1912 Harley-Davidsons \$45 and \$65. Twin Indian \$65. Lister Motorcycle Co., Cleveland, O.

TWO speed twin Thor and side car, like new, bargain, \$225. Zell, 1423 Westmoreland St., Philadelphia, Pa.

FIRST check for \$130 takes my 1915 Harley-Davidson, all equipped, new tires, all overhauled. M. A. Hendricks, 11 No. Main St., Brockton, Mass.

\$50 TO \$150 buys the best motorcycles; every make and model in our large stock must be cleared. Half price. Send for list today. Brown Music Co., 7119 Commercial Ave., Chicago, Ill.

BIG bargains in second-hand motorcycles. \$25 up. Indians, Harleys, Thors, Excelsiors and Merbels. Write for descriptions. Howard A. French & Co., Baltimore, Md.

SEND for latest Bulletin of real Motorcycle Bargains, used and slightly used, all makes, models and prices; if you have \$25 and really want a powerful Motorcycle, send for this Bulletin; hundreds of machines at all prices, new ones on easy payments; tell us what you want and how much you can pay; we can fix you up. Peerless Motorcycle Co., Dorchester, Mass.

RELIABLE place to buy dependable used motorcycles, all makes, \$25 up. Guaranteed as represented or money refunded. Write for winter lists and terms. Few brand-new 1914 Thor twins, greatly reduced prices. Thor Motorcycle Co., 356 Columbus Ave., Boston, Mass.

BIG bargains in good motorcycles we have taken in exchange on new ones. Send for special bargain list. Shaw Mfg. Co., Galesburg, Kansas.

SUPPLIES—Our big catalogue with prices lower than usual sent free to motorcycle owners. Mecc, Hammondsport, N. Y.

NEW Motorcycle Book—Just Published—Motorcycles, Side Cars and Cyclecars, Their Construction, Management and Repair—550 pages, cloth, 350 illustrations. The Dealer, Mechanic and Rider will find this treatise a work of reference without an equal. Price \$1.50 postpaid. Popular Mechanics Book Dept., 6 N. Michigan Ave., Chicago.

BICYCLISTS—We'll pay you for using and advertising wonderful Houghton "Nail-Proof" Tires. Drive nails, tacks—no leaks. Same air pressure. Light weight. Double guarantee. Nothing like it. Get limited offer quick. Houghton, Marion, Ohio.

CYCLECARS

CYCLECARS: New Scripps-Booth \$250, Demonstrator \$175, Metal Bodies \$15, 28x3 Casings \$5.50, Electric Horns \$1.50. W. E. Wandersee Company, 129 Gratiot Avenue, Detroit, Mich.

FOR Sale—New Pioneer Cyclecar \$200. Completely equipped; guaranteed first-class. H. S. Williams, Watseka, Ill.

CYCLECAR MATERIAL

CYCLECAR parts; busted prices. Write for circular. Act at once. Address Motor-ette, Hartford, Conn., U. S. A.

COMPLETE Plans and instructions for building a Cyclecar. \$1. Shelton Sales Co., Auburn, Mich.

CYCLE Car wheels. All sizes. Send for Bulletin. Heath Aerial Vehicle Co., Chicago.

CYCLECAR Friction Transmissions. Aluminum disc, tarred fiber wheel. Roller bearings. Guaranteed. Cogswell Manufacturing Co., Hall St., Springfield, Mass.

AERONAUTICS

FOR Sale: 6 cylinder, 75 h.p. Roberts aviation motor in good condition with propeller and radiators, \$475 cash. National Aeroplane Company, Machinery Hall, Chicago.

AERO Propellers. Odd Stock. High Class Designs for boats, etc. \$2 per foot. American Propeller Company, Baltimore, Md.

FOR Sale, genuine Blériot with fifty horse power Gnome Motor. Louis Horn, 3128 Mozart Ave., Cheriot, Ohio.

BEST and lowest priced aeroplanes, motors and propellers. Bates, 194 Oak, Chicago.

BLERIOT two-seater, complete except cloth and motor, \$250 cash. T. H. Simpson, Round Hill, Va.

WILL sacrifice fully equipped 30 h.p. water-cooled Curtiss Motor, \$275. Heath Aerial Vehicle Co., Chicago.

ONE 30-40 HP. two-cyl. opposed "Detroit" aeroplane motor complete, \$86. Cost over \$300. Practically new. Badger Motor Company, Milwaukee, Wis.

FOR Sale—50 H. P. Maxmotor with radiator. Price \$380. Jas. McCall, Norwich, Conn.

ONE Roberts 65-horsepower aviation motor, with two radiators, magneto and crate; \$400. 1801 Young St., Dallas, Texas.

BIPLANE wings, struts and extra Spence \$50. Griffith, 120 E. Jacob St., Louisville, Ky.

LEARN to drive a flying machine and fill a good position. Many aviators making good money filling exhibition dates. Our school is equipped for teaching to fly and construct, because we build machines. Course costs you \$360. Send for information. German, French and English spoken. Pallissard & Co., School of Aviation, Cicero Flying Field, Chicago, Ill.

GET world's largest aeronautical catalogue, 6 red stamps, or our aeronautical motor catalogue just off the press, 4 red stamps. Blue prints \$1.75, all standard aeroplanes and aerial driven cycle car. The latest fad, "Heath" Propellers for air, water and land represent the survival of the fittest. Six years propeller production proves perfection. 3 red stamps for propeller catalogue. Heath Aerial Vehicle Co., Chicago.

FOR Sale—Two Curtiss Biplanes. One Blériot Monoplane. All complete. Bargains. Lorain Hydro and Aero Co., Lorain, Ohio.

MODEL Aeroplanes—7c brings greatest handbook and catalog. Cheapest supplies. Walter Phipps, 503 5th Ave., New York.

WILL sacrifice latest flying boat, \$775. Completely equipped. Heath Aerial Vehicle Co., Chicago.

LIGHT Weight, Gasoline Engines, 2½ lbs. Guaranteed ½ H. P. The Weiss Co., Torrington, Conn.

COMPLETE Plan, drawn to scale, with precise instructions for building a Curtiss 2-foot Model Flying Boat, 25c. Other plans: Blériot, 15c; Wright, 25c; Nieuport, 25c; Curtiss Hydro, 35c; "Peoli" Racer, 25c. Set of six, \$1.25. 48-pp. Model Supply catalogue, 5c. Ideal Aeroplane Co., 824 West Broadway, N. Y.

HOW to Make a Biplane Glider—Our book "Amateur Mechanic No. 2" contains a complete detailed description of how to make one. Price of book, 25c postpaid. Popular Mechanics Book Dept., 6 N. Michigan Ave., Chicago.

BUILDING and Flying an Aeroplane—160-page handbook covering the building of small models and full sized gliders and machines. In both biplane and monoplane models the well-known Curtiss and Blériot types are followed. Fully illustrated with detail drawings. Price, \$1 postpaid. Popular Mechanics Book Dept., 6 N. Michigan Ave., Chicago.

BOOKS AND PERIODICALS

STARTLING 1915 Prophecies—Redding's dollar book foretold war; America becoming involved; existing institutions destroyed; sensational disclosures; fascinating; convincing. Agents wanted. Circulars, Loomis, 339 Fifth Avenue, New York.

THE Black Fox Magazine, the trade journal of the Canadian fox industry. Free sample copy. Dr. Randall, Truro, Nova Scotia, Canada.

WORLD'S Best Self-Educational Books (and Periodicals): Electrical, Mechanical, Agricultural, Sciences, Chemistry, Business, Art, Literature, Languages. Any subject. Lists 6c. Explain subject thoroughly. C. Hignee Co., 2441-F Post St., San Francisco.

FROM Dance Hall to White Slavery. 400-page, cloth book, illustrated, \$1. Immense sale. Experience unnecessary. Liberal terms. Big money quick. Charles C. Thompson Co., Manufacturing Publishers, 1125 Wabash Ave., Chicago.

WONDERFUL handbook 20c postpaid. Boyce & Boyce, 654 Central Ave., Brooklyn, N. Y.

SET "New Standard Encyclopedias," 12 vols.; cost \$42, sell \$28. C. Barnhart, Sherman, N. Y.

READ these great books about the War: 1. Germany and the New War, by Gen. F. Von Bernhard (discloses Germany's war plans for crushing England and France. Price 85 cents). 2. Secrets of the German War Office (by A. K. Graves, for twelve years a spy in the Kaiser's service. Price \$1.60). 3. Germany's Fighting Machine (by E. P. Henderson. Divided into three parts, The War, The Army and The Navy. Price \$1.25). 4. Men Around the Kaiser (by P. W. Wile. Tells about those men who figure most prominently in the affairs of Germany at the present time. Price \$1.25). 5. The Germans (by L. A. R. Wylie. A graphic picture of the German people on the eve of the great conflict. Price \$2.15). 6. The War and America (by Hugo Munsterberg, the great German-American. Price \$1.10). 7. War's Aftermath (a study of the deterioration of the quality of stock occasioned by the lamentable waste of war. Price 85 cents). Popular Mechanics Book Dept., 6 N. Michigan Ave., Chicago.

3,000 SELECTED Cartoons for \$5. A Panorama of World Events. Political, Industrial—Social—Humorous—Tragic—all of intense human interest. A wonderful collection of 3,000 cartoons reproduced from the newspapers of the United States, Canada, Mexico, Cuba and the cities of the Old World, has been made by Cartoons Magazine from more than one hundred and fifty thousand published cartoons, and bound in an artistic and durable cover, are now ready for your library table. Vol. I, Jan.-June, 1915—\$1. Vol. II, July-Dec., 1915—\$1. Vol. III, Jan.-May, 1915—\$1. Cartoons, 78 E. Madison St., Chicago.

COMPLEXITIES Conquered—All Arithmetical and Geometrical Calculations solved with ease, accuracy and large saving of figures by Comparative Cancellation, 145 pages, \$1.00 postpaid. Money returned if dissatisfied. Herrick & Horton, Publishers, Princeton, Ill.

"SOMETHING-TO-DO." Interesting magazine for children who like to draw, paint, read and make small useful articles. You'll like it. Send postal card for free sample copy. Something-To-Do, 120M Boylston St., Boston, Mass.

CORRESPONDENCE Courses and Technical Books. Bought; sold; cut rates. C. A. Bubb, Detroit, Michigan.

IF you like "Real Fascinating" books, pictures, novelties, etc., send dime for "Nifty" samples (kind that will make you want more), with attractively illustrated catalogue (sent sealed). Dime back if not pleased. Williams Publishing Co., 721-B North Dearborn, Chicago.

LEARN Harmonica (mouth-organ). Complete self-instructor, 12c. G. Elser, Owosso, Mich.

BINDER for Popular Mechanics magazines. Best adjustable magazine binder on the market made especially to hold any number from one to six copies of this magazine with name "Popular Mechanics" in gold letters on front cover. No laces or cutting or perforating of pages necessary. Simple, unique adjustment; handsome, durable and neat. We buy in quantities and can offer our readers this regular \$1.50 binder for \$1.25, all shipping charges prepaid. Address: Popular Mechanics Book Dept., 6 N. Michigan Avenue, Chicago.

"SUCCESSFUL Brains," a \$1 book reduced one half. Limited number of orders taken. Price, 50c postpaid, Box 127, Evans-ton, Ill.

IMMORTALITY Certain. Swedenborg's "Heaven and Hell," 400 pages, 15 cents postpaid. Pastor Landenberger, Windsor Place, St. Louis, Mo.

RARE Books and first editions collected and arranged for people who are too busy to attend to the forming of libraries. Address Downing, Box 1396, Boston, Mass.

ENGINEERS' questions and answers for license, by Hobson, for twenty-five cents, postpaid. Send stamps. Reilly's Book Store, Philadelphia, Pa.

METAL Work and Etching—A 96-page hand book for art metal workers telling how to make a great variety of useful and ornamental objects, such as desk sets, art-crafts, jewelry, etc. Price, 50c postpaid. Popular Mechanics Book Dept., 6 N. Michigan Ave., Chicago.

"SHE," dandy book, 25c. Catalogue, 2c. Duff, 2713 Mozart, Chicago.

INSTRUCTION Books, Automobile, Inventors' Electricity, Engineers', Jewelers', Machinists', Plumbers' (best published). Lamont Co., Beacon, New York.

SEND stamp for our book "How to Make Patents Profitable." Benjamin & Bassett, 141 S. Dearborn St., Chicago, Ill.

WAR Books—A careful selection of all the most vital and trustworthy books on the great European War situation. Send for complete descriptive list free. Popular Mechanics Book Dept., 6 N. Michigan Ave., Chicago.

FREE Catalog of Mechanical Books—Our 96-page catalog of 500 books on 100 different subjects will show you where to find that particular information you are in need of on any mechanical subject. Send for it today. Popular Mechanics Book Dept., 6 N. Michigan Ave., Chicago.

EDUCATIONAL AND INSTRUCTION

ARTIFICIAL Marble, sanitary flooring, ornamental casting, concrete, plaster, papier-mâché, interior decorations, garden furniture, statuary, life casting, elastic moulds, electro bronze depositing (immensely profitable work), complete instructions \$1; particulars, 200 illustrations free. Mahler, D-117 Russell St., Brooklyn, N. Y.

PARAGON Shorthand. Learned in 7 days. Valuable invention by expert—not by mere theorist. Speed capacity beyond reach of hand. Is being used in service of United States Government. Request names of writers and fee, Paragon Institute, 125 Coliseum St., New Orleans, La.

BE a Draftsman—I'll teach you. Free outfit. Many big-paying positions open. Learn in spare time. British wage drudgery. Draftsman, E. H. Rousseau, 935 No. Solomon St., New Orleans, La.

CRAYON Portraits—How to make at home, simple and book instructions postpaid, 25 cents. Roy Dallas, Dept. 4, Cambridge, Ohio.

BE Successful! Develop Magnetic Force. Send for "Why Men Succeed." It's free. H. M. Otto, 57 E. Vanuren, Chicago.

MECHANICAL Drawing Students—Expedients and short-cuts of practical drafting. Instruction \$1.00. T. Farris, 632 Penna Ave., Elmira, N. Y.

LEARN Lettering. Best book for home study. Full instructions, 25c stamps. Stevens Company, 7 Cooper Union, New York City.

AMBITIOUS Men and Women wanted by Government as Clerks, \$70 month. Vacations. Spring examinations everywhere. Sample questions free. Write immediately. Franklin Institute, Dep't R-22, Rochester, New York.

STENOGRAPHERS become most rapid when they use "The Stenographer's Word-Book" (15c) and "Word-Book Dictation Sheets" (50c). Sample "Word-Book" and four "Dictation Sheets," 10c. Word-Line Co., A-888, Omaha, Neb.

BUSINESS Courses—Lowest tuition. Success guaranteed. Atlanta Normal, Colby, Kansas.

EXPERIMENTS. A new 256 page book that gives practical information for building simple, efficient apparatus at small cost, conducting tests and experiments, establishing a laboratory and applying the best experimental methods. Shows you what you can do with your own brains and hands. Both amateur and commercial work is covered. Send for complete description free or book itself sent postpaid upon receipt of price, \$1.50. Popular Mechanics Book Dept., 6 N. Michigan Ave., Chicago, Ill.

FREE Tuition by Mail—Civil Service, Normal, Academic, business, agricultural, English, drawing, engineering, real estate, and law courses thoroughly taught by mail. For "Free Tuition Plan," address Carnegie College, Rogers, Ohio.

\$25.00 REALTY Brokerage Course, \$1.00. Money back unless delighted. Prospectus free. Healy, Box 348-U, Joplin, Mo.

SUCCESS! How? Study at home; fit yourself for a better paying position through one of our 60 courses, including Business, Normal, Kindergarten, Agriculture, Engineering, and Law. Thousands of successful graduates. Chartered 1903. Write for free 50-page catalog, stating instruction wanted. The Modern School of Correspondence, San Francisco, Cal., Dept. C.

EIGHTEEN Ways to Make Money! Interesting isn't it? If you are mechanically or electrically inclined don't fail to write for our free book. Efficiency Company, 101-A, East 16th St., New York.

WANT to secure a marine or steam engineers' license? For that great class of ambitious and hard working men, the oilers, coal-passers, watertenders, firemen of anyone who wants real practical and useful information regarding the every-day operation of a steam plant, Chief McAlistair of the U. S. Revenue Cutter Service has written an engineering story called "McAndrew's Floating School," that makes it possible for those who have not had previous training to absorb the necessary information. Cloth, 250 pages and 37 diagrams. Price, \$2. Popular Mechanics Book Dept., 6 N. Michigan Ave., Chicago.

IRREGULAR handwriting changed to a rapid business style by mail. Journal free. F. B. Courtney, Box A 492, Detroit, Mich.

ARTISTS' MATERIAL

FOLDING Drawing Board Support, patented Jan., 1915. For Card and Sign Writers, and all Artists for Home and Studio work (spring clamp to any table). \$2.00 postpaid to all parts of the United States. Handy, Strong, Rigid as an Anvil. Money-back Basis. Daly & Neubert, 1345 Wells St., Chicago, Ill.

TRADE SCHOOLS

I WILL teach you the automobile business or how to be an aviator in 60 days with my practical correspondence course. Capt. John Berry, Licensed Pilot 24, Champion Aviator of America, Dept. 11, St. Louis, Mo.

MAKE \$5 to \$8 a day as skilled Electrician, Plumber, Draftsman, Bricklayer, Moving Picture Operator. We teach you in short time at small expense, profitable trades. Free employment bureau places graduates in good jobs. Special limited offer now. Write at once for catalogue and full particulars—no obligations. Dept. 8194 Coyne National Trade School, 51 E. Illinois St., Chicago, Ill.

YOUNG MAN—Learn the plumbing, heating, ventilating trade from practical work on jobs. Good position for students. Write for particulars. Litchfield Trade School, Libertyville, Ill.

PAINTING, Decorating, Paper Hanging taught by actual practice. Free catalogue. Chicago School of Painting, 150 West 40th Ave., Chicago.

AUTOMOBILE Instruction. A complete home study course that shows you exactly what you want to know about the automobile, 220-page book, giving definite, thorough, authentic and practical detailed information about every part of the automobile as well as thorough instruction in regard to driving, repairing and general care of the complete car. 100 illustrations, \$1.50 postpaid. Popular Mechanics Book Dept., 6 N. Michigan Ave., Chicago.

TELEGRAPHY

TELEGRAPHY—Morse and Wireless—also Station Agency taught. R. R. and Western Union wires and complete Marconi Wireless Station in school. Graduates assisted. Marconi Co. employs our wireless graduates. Low living expense—easily earned. Largest school—established 40 years. Investment \$25.00. Correspondence courses also. Catalog Free. Dodge's Institute, 15th St., Valparaiso, Ind.

TELEGRAPHY taught in the shortest possible time. The Omnigraph Automatic Transmitter combined with standard key and sounder. Sends you telegraph messages at any speed just as an expert operator would. Five styles. \$2 up, circular free. Omnigraph Mfg. Co., 41 G, Cortland St., New York.

WIRELESS

WIRELESS Set. How to Make—96-page book telling how to construct at small cost an outfit suitable for transmitting four or five miles. Price, 50 cents, postpaid. Popular Mechanics Book Dept., 6 N. Michigan Ave., Chicago.

PICTURES, POSTCARDS, PENNANTS

SPIRIT Photos: Genuine permanent pictures made instantly without camera. Never before considered possible. Marvelous results. Entertains and astonishes. Satisfaction or money back. Sample outfit, 25c; enough for 24 pictures. Alpharis Company, 134 Brook Ave., New York.

15 PHOTOS of Beauties taken from life for 10c. Kay I Co., Box 67, Ottawa, Ill.

PHOTO Postcards made from any size Film or Photo. 50 for \$1.00, or 100 for \$1.50. Film or Photo returned. D. J. Du Saar, Holland, Mich.

RECEIVE Post Cards from everywhere. Join our jolly club. Send 10c. H. J. Teeple, Decatur, Indiana.

RARE fascinating beauties in attractive poses. Sent in sealed wrapper. Complete set postpaid, 15c. M. Reissler, 134 Brook Ave., New York.

12 FINE postcards, copied from any good photograph, 50 cents. Expert copying of all kinds. Good work, low prices. Myland, 2125 N. Front, Philadelphia.

BEWITCHING Female Beauty Poses, rare imported models, taken from life, exquisitely hand-tinted, "true to nature." Send dime for good samples that will make you want more, with attractively illustrated catalogue of "Real Fascinating" books, pictures, novelties, etc. (sent sealed). Dime back if not pleased. Williams Publishing Co., 721-C North Dearborn, Chicago.

POSTCARDS—Charming Women in attractive poses. Imported; no trade. Catalog and one sample, 10c. Hitz Publishing Co. (Not Inc.), Dept. 53, Chicago.

10 BEAUTIFUL postcards from the Great Inland Empire, the land of the Big Baked Potato, depicting scenes from the orchards, farms, mountains and lakes. 25c coin or stamps. E. C. Dent, Justin Hotel, Spokane, Wash.

ART Photos: girls bathing. Splendid samples (postcards), 25c. "Real" goods. G. Olive, Willmar, Minn.

REAL Art Studies. Samples and prices. 10c. Thiberg, Proctor, Vt.

EXCHANGE pretty postcards with our members far and near. Best card club. Membership, 10c. Jolly Card Exchange, Box 126, Decatur, Indiana.

BETTER than "September Morn." Two new pictures by same painter. These two and "September Morn" 25c. Box 592, Minneapolis, Minn.

GIRLS in rare poses. Something new. One postcard and 50 poses in folder, 25 cts., 10 postcards, \$1.00 prepaid. Den Photo Works, 460 Times Bldg., Chicago.

THREE Cabinet Photographs Sioux Indians, 25c. Jennings Studio, Valentine, Nebraska.

PHOTOS, Handsome Models, Stunning poses, Samples 10c. Box 32-P, Randolph, Mass.

BOOKS and Art Photos, Sample of either, 10c; both, 15c. Globe Co., Box 52, Augusta, Mich.

3,000 SELECTED Cartoons for \$3. A Panorama of World Events, Political, Industrial—Social—Humorous—Tragic—all of intense human interest. A wonderful collection of 3,000 cartoons reproduced from the newspapers of the United States, Canada, Mexico, Cuba and the cities of the Old World, has been made by Cartoons Magazine from more than one hundred and fifty thousand published cartoons, and bound in an artistic and durable cover, are now ready for your library table. Vol. I, Jan.-June, 1912-\$1. Vol. II, July-Dec., 1912-\$1. Vol. III, Jan.-May, 1913-\$1. Cartoons, 78 E. Madison St., Chicago.

20 BEAUTIFUL College Pennants, all different, 9x18 1/2, 30 cents. Herlman Supply Co., Box 121, Williamsport, Pa.

BOYS! Girls! Exchange cards for fun. Trial membership and five cards, 10c. Six months, 35c. Illinois Exchange, 3441 Michigan Ave., Chicago.

REAL photos of pretty girls; samples and catalogue, 10c. H. H. Sun Co., Harrison, Mich.

20 BEAUTIFUL, high grade, assorted view cards, membership in our Post Card and Correspondence Club, monthly magazine containing instructions "How to Read Character from Handwriting," all for 25c. Gentlemen's membership in club including 6 fine cards, 10c. Ladies, 5c. All Write Club, 4971 Seventh Ave., Newark, N. J.

ART Poses, Rare Imported Models, samples and catalog, 10c. Girard Novelty Co., Pautucket, R. I.

IF you really want to exchange postcards, try our splendid club. Lists circulate in many countries. Membership, 10c. Halcyon Club, Box 133, Erie, Pa.

EIGHT photo postcards Panama-California Exposition, 25c. P. S. Daniels, 1268-1310 St. San Diego, Cal.

MEMBERSHIP in press immediately, 10c. Pacific Card Exchange, Bryn Mawr, Wash.

PHOTOS—Fascinating subjects, 10 for 25c. Duff, 2713 Mozart, Chicago.

STUNNING Photos of pretty girls. Real "Beauties." Very clear. 8ct, 25c. Rembrandt, Stone St., Newark, N. J.

CROSS-SECTIONAL view of ocean liner "Britannic," showing interior arrangement of ship in colors, size, 14x20 inches, on heavy plate paper for framing or hanging. Very interesting. Reproduced from front cover design of July issue Popular Mechanics. Will be sent postpaid to any address in the world on receipt of 4 cents in stamps to cover packing and mailing. Popular Mechanics Magazine, 6 N. Michigan Ave., Chicago.

EXCHANGE pretty postcards with our members in far-off lands. Membership, 10c. Elite Exchange, R32, 3684 Milwaukee Ave., Chicago.

CAMERAS AND PHOTO SUPPLIES

SEND us six of your kodak negatives, any size; will print one picture from each negative for a total of 10c (stamps). Or will develop any size roll of film (or film pack) and furnish a total of six prints for 10c. 8x10 mounted enlargements, 25c. Send only the negative. Mention this ad. Roanoke Cycle Company, Roanoke, Va.

VEST pocket exposure meter and detailed description of the best German genuine Anastigmat Lenses made, and sold at way-down prices—all for a two-cent stamp. Five seven double Anastigmat in Ibsco shutter only \$28. Lafayette Co., 305 North Fifth Ave., Chicago.

HAVE you been disappointed with promises of the "best work?" Do you want "Real Prints," snappy and clear, and the kind that will not turn yellow and fade? "We Finish your Kodak Pictures Better." This is not merely a promise—Let us "show you." Films developed, 5c per roll. Prints, 3c each. Colonial Art Company, Box 566, St. Louis, Mo.

PHOTOCARDS—Many hundred thousand photograph postcards we make in one year for merchants, corporations, battle ships, societies and individuals. Send for free sample card, "Kodak Hits" and price list. Send four negatives (4) and \$1.50 for "one hundred" finished postcards. Send 25c and one roll film—we will develop and make you six postcards or prints. Calkins Photo Works, Oneonta, N. Y. This advertisement will appear again in May issue.

PHOTOGRAPHIC Retouching Taught; cheap course; learn at home. Y. & M. Retouching Co., Dept. M, Marshall, Mich.

FILMS Developed ten cents per roll, all sizes. Prints 2 1/4x3 1/4, to 3 1/4x4 1/4, three cents, 4x5 to 5x5 1/2, four cents. Prompt service. Excellent work. C. C. Smith, 1634 Grand Central Terminal, New York City.

DRAWINGS and specifications for making electric shutter-trip, forty cents. Ke-lo Company, 4034 Charlotte, Kansas City, Mo.

FOR Sale. A kodak, Tessar lens, Volute shutter, rack and piston for focusing. Complete outfit cost \$151. Perfect condition, little used, \$85 cash. Dr. Jay Tuttle, Astoria, Ore.

TRANSFER photographs to china, etc. Particulars. Film, 280 West 142nd St., New York City.

FILMS developed 10c, prints 3c to 5c. A reputable incorporated company, conducting largest existing plant. Price list and special offer. Enlargements our specialty. Chicago Photo Finishing Co., 51 W. Lake St., Dept. A, Chicago.

TIPAX, attractive corners that do not pierce pictures, hold in wood or plaster; nickel or black rubber finish; 24 mailed for 10 cents. Frank F. Austin Company, 501 South La Salle Street, Chicago.

BEAUTIFY your photos with our artist tints. Complete assortment of ten colors, brush and materials with full instructions how to apply them, and the colors to use. Send 50 cents (coin). P. M. Greene Art Co., 25 Third Ave., N. Y.

25 FORMULAS for latest fads in photography, 25c. Includes disappearing photos, Phosphorescent photos, Trick pictures; simple enlarging apparatus. Transferring to cloth, chinaware, etc. Satisfaction or money back. P. Benson, Stewartville, Minn.

AMATEURS with focusing cameras learn new plateless process worked without special apparatus or material. Stamp brings photo and particulars. Koch & Co., Chamita, New Mexico.

DEVELOPING 10c, prints 2c up, returned in 24 hours. Individual service. Write for free sample prints and enlargements. H. Coff. Shaw, 118 Bowdoin St., Boston, Mass.

ONE roll film developed and printed for dime, as sample. V. Paddock, Ashton, Ill.

SPOT Cash paid for high-grade Kodaks, Leases and Cameras. Send full description stating lowest price. Camera exchanged. In business since 1885. David Stern Co., 1047M W. Madison St., Chicago.

HAVE You a Camera? Write for samples of my magazines, American Photography and Popular Photography, which tell you how to make better pictures and earn money. F. R. Fraprie, 698 Pope Bldg., Boston.

NEW 3A Film Pack Premo Kodak, with R. R. Lens, autotime exposure scale, tripod carrying case, ruby lamp and printing frame, \$10.00. John A. Betthausen, Coloma, Wis.

TRANSFER printed pictures to china, paper or glass. Process, 10c. Service Bureau, 3311-D, Belleplaine Ave., Chicago.

KODAKS, Cameras, all makes, all sizes. Motion picture cameras, hundreds of anti-stigmat lenses and speed shutters of all makes at about half regular prices at New York's largest photographic store. Send for largest bargain book. Koshler's Camera Exchange, Inc., 7 East 14th Street, New York.

PRINTING 2 1/2 x 3 1/4, 2c; 3 1/2 x 5 1/4 and postcards, 2c. Developing, 10c. Neat, prompt work. Pay S. Lincoln, Box 210, Greensburg, Pa.

CHROSS Photographic Co., 3317 Delmar, St. Louis. Finest equipment in America. Prints 2 1/2 x 4 1/4, 2c each; 3 1/2 x 4 1/4 to 3 1/2 x 5 1/4, 3c each. Roll films developed, 10c. Send for prices and free coupon.

ACTINO Cartridge Holder, the best, safest, most convenient means of supporting flashlight cartridges. Will send postpaid with free copy illustrated booklet "Flashlight Photography" for 50c. J. H. Smith & Sons Co., 3548 Cottage Grove Ave., Chicago, Ill.

WE buy, sell and exchange. Bargains in Microscopes, Telescopes, Binoculars, Cameras, etc. Bargain list sent. Kahn & Son, Opticians, No. 54 John St., New York. Established 62 years.

FILMS developed 10c, all sizes. Prints 2 1/2 x 3 1/4, 3c; 2 1/2 x 4 1/4, 3 1/2 x 3 1/4, 4c; Post Cards, 50c doz. Work guaranteed and returned 24 hours after receiving. Postpaid. Send negatives for samples. Girard's Commercial Photo Shop, Holyoke, Mass.

BIG Money Saved on Photographic Lenses and Apparatus—goods exchanged; repairing done. Ralph J. Golsen, 65 East 40th St., Chicago, Department P.

SAVE 40% on Photo Paper from factory, prepaid. "Instanto" has a sparkling quality no other gaslight paper possesses, quick printing develops easy. Money back guarantee. Send 25c for 3 dozen postals or 4x6 size, price list and full directions. Photo Products Co., Dept. J, 6100 La Salle St., Chicago.

HOLL Film developed, 10c a roll. Packs 20c each; Prints, Brownies, 2c; 1a, 3x4, 3x3, and Post Cards, 3c each. Week returned next day. Postage paid. Kodak Film Finishing Co., 112 Merchants Station, St. Louis.

KODAK Films Developed, 10c per roll, any size. Prompt attention given mail orders. Prints, 2 1/2 x 3 1/4 to 3 1/2 x 4 1/4, 3c; 4x5 to 3 1/2 x 5 1/4, 4c. J. M. Manning, Box B, 1052 Third Ave., New York City.

ANY 6-exposure Roll Film developed and printed for 25c. 12-exposure roll, 50c. 24 hour service. Wolff—3109 N. Grand, St. Louis, Mo.

MOTION PICTURES

WE can show you how to sell your photoplays, stories and ideas. Quick, profitable sales. Model photoplays and criticisms free. No courses or revision. Proof free. Manuscript Sales Co., Box 399, Hazelhurst, Pa.

BIG Money Writing Moving-Picture Plays. \$75 each. Literary talent or experience unnecessary. Write for free booklet "How to Write Moving-Picture Plays." Lundeen Publishing Company, 221 Fergus Falls, Minn.

\$500 CASH for new ideas for photoplays. We show you how to write them. No correspondence course necessary. Address Movie Magazine, Van Ness Bldg., Los Angeles, Cal. Special Photoplaywrights' edition 10c.

A BARGAIN, 1,000 stereopticon lantern slides, beautifully hand-colored, brand-new, 10c each; also slides of European War, Passion Play, Battle of Gettysburg, others. Modern stereopticon cheap. Novelty, 67 West 23rd Street, New York.

WRITE Moving-Picture Plays, \$30 each. Correspondence course unnecessary. Details free. Atlas Publishing Co., 394, Cincinnati.

WRITE motion picture plays; \$50 to \$100 Paid. Correspondence course unnecessary; details free. New Writers, 1213 Victoria Bldg., St. Louis.

WRITE Moving Picture Plays—\$100 for each Photoplay; experience unnecessary. Particulars Free. Palmer-Cherney, 2819 Franklin, St. Louis, Mo.

WRITE stories for moving pictures in spare time; producers pay \$25—\$150; experience not necessary; literature free. Photoplay Writers' Syndicate, Dept. P, Providence, R. I.

\$50 to \$100 weekly writing moving picture plays. Send for free booklet, valuable information, and special prize offer. Chicago Photoplaywright College, Box 278 T. D., Chicago.

DYNAMO special for arc in moving picture show, \$75; payments \$5 per month. Box M. Troy Ohio.

WE accept manuscripts in any form; criticism free; sell on commission. Quick sales; big prices. Don't waste money on "Instructions," etc. Write us, Story Revision Co., Box 69, Smethport, Pa.

LOOK! \$50 each writing moving-picture plays. We have special offer for complete, easy instructions. Experience or correspondence course unnecessary. Details free. E-Z Scenario Co., 311 W. 93 St., New York.

I GUARANTEE \$10 for first photoplay you write by my method. As former scenario editor, I speak with authority. Send for free booklet, "How to Write Photoplays." Elbert Moser, Box 772 P. P. Chicago.

CASH for Moving Picture Plays, stories, poems. Write Photoplay Pub. Co., Desk FA, St. Louis, Mo.

MAKE money writing motion picture plays, \$25 to \$100 each. You can write them. No literary experience necessary. Big demand. Free illustrated booklet tells how. American Authors Ass'n, R 25, 1535 Broadway, New York.

\$25 PROFIT Nightly—Moving Picture Business—small capital starts you, no experience needed. Teach you—furnish everything. Ralph J. Golsen, 65 E. 40th St., Chicago, Dept. M.

MAKE a complete Motion Picture Camera and Projector from instructions given in our book Amateur Mechanics No. 1. Full details given. Not hard to construct. Worlds of enjoyment taking and exhibiting subjects dear to the heart. Price of book only 25c postpaid. Popular Mechanics Book Dept., 6 N. Michigan Ave., Chicago.

MOTION Picture Work—A large 618-page book covering every phase of the moving picture, its production and its theatre. Indispensable for reference and instruction to the thousands of workers in the motion picture field. Price \$3, postpaid. Popular Mechanics Book Dept., 6 N. Michigan Ave., Chicago.

MANUFACTURERS AND EXPORT COMMISSION HOUSES, INDUSTRIAL PROMOTERS, ETC.

MANUFACTURERS and Export Commission Houses represented in the ABC Republics, S. A.; franchises, water powers, etc. procured; bids tendered for securing contracts, supplying materials, etc.; reports on establishing manufactories and industries, promoting new enterprises, etc. Terms equitable. Ample and satisfactory references offered. Address: T. Dennis Locking, P. O. Box 1301, Santiago, Chile.

PAN-AMERICAN INVESTMENTS, A. B. C. REPUBLICS, SOUTH AMERICA

CAPITALISTS desiring to investigate with the view to investing in Coal, Iron, Petroleum, Nitrate or Borax deposits, etc.; Mining Properties (Copper, Tin, Silver, Gold, etc.); Real Estate (large land tracts, Government or private, all forest, grazing or agricultural), located in the "ABC" and adjoining South American Republics, are invited to write for information, enclosing 20c in stamps, to T. Dennis Locking (Pan-American Real Estate Dealer), P. O. Box 1301, Santiago, Chile.

BUSINESS OPPORTUNITIES

SPLENDID General Agency Proposition now open (City, District or State) on remarkable Vacuum Cleaner—the "Hydra"—operated simply by attaching to any water-faucet. None other anything like the "Hydra"—at any price. The only thoroughly efficient, light, portable, sanitary home Vacuum Cleaner on the market; and retails at only \$12.50. Every woman who sees it, wants it; universal satisfaction. A bonanza for live General Agency men, who can finance themselves; no salary or "drawing account" men wanted. If interested, write at once—stating full particulars, references, and territory desired. General Sales Manager, The Vulcan Metals Co., Inc., 1485 West 23rd Street, New York.

RESILVERING Mirrors, Renewing Dry Batteries, 150 selected formulas 25c. Formula Service, 3311-D, Belleplaine Ave., Chicago.

OWN a line of Vending Machines in your town. They cost you nothing, and provide a steady income. Write for proposition. Illinois Vending Co., 503 So. Jefferson St., Chicago, Illinois.

OPERATE profitable mail-order book business. 700% profit each sale; small outlay, everything furnished. Spare time. Particulars free. Rollins, Box 5272, Boston.

OPPORTUNITY is knocking at your door. Owing to the war, many common weeds are now of great value. Dandelion has doubled. Our treatise on roots, herbs, barks—collecting, curing, selling. Thirty cents, postpaid. L. J. Brown & Co., Muskegon, Mich.

MAKE More Money—Operate a Mail-Order Business in spare time. Our magazine will show you how. Four months' trial subscription and five money-making plans, 10c. Popular Advertiser, 834 Barry Ave., Chicago.

QUIT working for others. Start a Cleaning and Dyeing Business. No experience necessary. Tremendous money-maker. Greatest no-order business known. Send for free booklet No. 11 today. Full details. White Wonder Co., 210 National Safety Vault Bldg., Denver, Colo.

MAKE Extra Money during evenings. Get 100-page book "1,000 Ways to Get Rich," money-making discoveries, formulas, recipes, etc. Price 25c. Bohman, 5 Water St., New York.

MAKE Big Money mailing circulars. Particulars free. Stanford, Canonburg, Pa.

HOW to Operate a Mail Order Business. 20 Big Profit Plans and year's Mailing service sent for 10c. Mail Dealers' Wholesale House, 521 Franklin Bldg., Chicago.

OWN a business. Co-operate with no evenings at home. Everything furnished. Don't worry about capital. Boyd H. Brown, Dept. K-4, Omaha, Nebr.

DISTRICT Managers Wanted to handle territory. Must finance orders—Kee-Kee Puncture Cure, The Standard adds 50% to tire mileage. Not a filler. Preserves the tire. Highest testimonials furnished. Proposition unusually good. Secure territory at once. Aleemo Mfg. Co., 14 Bridge St., Newark, N. J.

I NEED branch managers for my world wide mail-order business. Operate from your own home in spare time. No canvassing or peddling. Experience unnecessary. You should make \$50 weekly. Butler, 244 Factories Bldg., Toledo, O.

"DOLLARS" yearly in your back yard. No ginseng, mushroom dope. New ideas never before published, particulars free. Metz, M. 132 W. 34th St., New York.

YOU can operate a profitable mail-order business. Complete plans 25c. Flaster, 588, Nevada, Mo.

START Profitable Mail Order Book Business. Further information and sample catalogue sent for stamp. Sheridan Co., 417 E. 151st St., New York.

\$5,000 YEARLY Business Proposition. Particulars, 2c. Manager, 324 S. Third, Rockford, Ill.

\$25 WEEKLY easily made; sells like wildfire; no experience necessary; particulars free. Address Ward, Box 298, Lakeview, Mich.

\$5 DAILY easily earned at home, spare time, silvering mirrors; no capital. Free instructive booklet tells how. Patterson & Co., Dept. 3, Brookville, Ky.

HOW to conduct a mail order business successfully. For particulars address Eureka T. & N. Co., 87 Warren St., New York.

EVERY dollar invested brings six dollars return. Make 500% profit with our Premium Trust Scheme handling high grade Perfume and Sachet Powders. Write for free sample and particulars. Superior Perfume Company, 501 Unity Building, Chicago.

BIG Kansas Company will start ambitious man or woman in fast growing business; any locality; \$3,000 yearly; spare time; no canvassing; no experience. We furnish everything. Write for unique selling plan. C. W. Eyestone, President, 174 E. 5th, Pittsburg, Kansas.

WRITE Moving-Picture Plays; \$50 each. Correspondence course unnecessary. Details free. Atlas Publishing Co., 3016 Cincinnati.

A PROMINENT and highly successful automobile accessory house desires to extend its branches into uncovered territory and is willing to place exclusive agency in the hands of a capable live-wire business man, able to avail himself of opportunities which will be brought forcibly to his attention. This proposition involves an expenditure of around \$300, and our agent will not only be protected by the manufacturer, but will have the benefit of their hearty and earnest co-operation. We shall be glad to acquaint you with this proposition which should pay you \$50 a week or more. Write today and we will let you know if your particular territory is open. Address 13 N. 20th Street, Philadelphia, Pa.

"HIRE Yourself as Boss." Big corporation will back you in money-making Mail-Order Business selling Guaranteed Goods. Start spare time at home. Ambition and honesty more essential than capital. Wm. J. Dick, Mgr., Dept. H-10, 20 W. Lake St., Chicago.

WE want to send you some interesting mail-order literature. This is free. If you enclose twenty-five cents we will include one plan which can be operated during your spare time, and tell you where to obtain all necessary printed matter free. Monarch Book House, Broadway, Waukesha, Wisconsin.

READ "Booster" and make more money! Operate Mail Order business during your spare time. We'll show you how! Special: Two issues, 10c. Booster Magazine, Northwestern Bldg., Chicago.

THREE Questions! Can you answer them? Do you know: How to put Punch in your Sales Letters? Attraction and Appeal in your Booklets? And Life in your Mailing List? These questions are vital to your business. We will answer them. Send your present literature. Address Business Department, Martin & Miller, Advertising Counselors, 239 Fourth Avenue, New York.

IT Pays to Investigate Our Mail Dealers' Proposition. \$500 reward offered. Merford Company, Incorporated, Dept. P, Chicago.

MAKE More Money! Sell "Northern" Specialties by mail. Particulars, two samples, 10c. Guaranteed Formula for renews old dry batteries, 25c. Northern, 154P, West Randolph, Chicago.

MONEY in contracting. Spread San-1-tite floors; sanitary; fire-proof. \$150 to \$300 made monthly contracting kitchen floors alone. Instructions telling how to make and spread sold outside this district for \$3. San-1-tite, Saint Petersburg, Florida.

CANDY Making Taught by Expert. Make Delicious Goodies at 1/2 regular prices. Big Prices Operating Candy Kitchen. \$15 Course for \$1. Particulars free. Trade Secrets, Box I 161, Brooklyn, N. Y.

START Profitable Business of Your Own. Make big money placing Premium Punch Board Deals. \$100 investment required. Washington Sales Co., Dept. P M, Chicago.

WE analyze everything. Guaranteed formulas by experts. D. Laboratories, 092 Tinton Avenue, New York.

MAIL-Order Supplies! We start you in the M. O. business. Furnish everything. Circulars, \$1 per thousand. Ideal Novelty Co., Palmyra, Pa.

"PROTECTING Inventions Before Patent Without Cost." next issue Inventor's Advocate, Advocate Building, 14, Washington, D. C., one year, 25c; three months, 10c.

PATENT Application fully prepared, \$10. Why pay \$65? Particulars free. Patent News, Dept. 20, Washington, D. C.

WE will start you in the cleaning and dyeing business; little capital needed, big profits. Write for booklet, Ben-Vonde Systems, Dept. 4, Charlotte, N. C.

USE your spare time to build up a mail-order business of your own. We help you start for a share in profits. 27 opportunities. Particulars free. Opportunities Exch., Buffalo, N. Y.

FAST sellers. Best opportunity. Send red stamp for samples and particulars. Ralfstanger Laboratory, Ridgefield, Conn.

INSTRUCTIONS for manufacturing six big Sellers and 100 business opportunities, 10c. The Rils Sales Co., New Brunswick, N. J.

NEW Way to Paint Signs without experience. Our life-size patterns do the work. Samples, 10c. Butts Advertising Co., 15 W. 10th St., Kansas City, Mo.

LEARN to make Metallic Sign Letters. \$30 to \$50 per week profit. Experience and capital unnecessary. Particulars free. Cushing, 4816 South Vermont, Los Angeles, Cal.

RESILVER Mirrors and make money. Others are doing it. The best formula 25c. Auburn Supply Co., Dept. B4, 7745 Peoria St., Chicago.

FOUR years ago I started a local business with less than \$50 capital. To-day I occupy an entire building (four floors), carry \$5,000 in stock, and would not sell the business for \$10,000. You can do the same in Your locality. Write for information. Address, Arthur Harrison, Poughkeepsie, N. Y.

PAYS Well Making Transparent Window Display Signs with Stencil Cutouts. Specimens, 10c. F. Murphy Mfg., 27 1/2 York St., Jersey City, N. J.

TWELVE years ago I started a small mail-order business at home in spare time with a few dollars capital. I wanted to make \$30 or \$40 a month, evenings. The net profits the first year averaged \$200 a week. Five years work netted me \$50,000. I will show you how to start a small mail-order business. Send today for my proposition. It's interesting. No canvassing. Hancock, Box 867, Lockport, N. Y.

WOOD Stains, complete instructions, \$1. Mahogany, birch, maple, ebony, mission, early English, walnut, oak, etc., etc. Roth, A-45 Frost St., Brooklyn, N. Y.

MY proposition: Fifteen to thirty dollars per day, rain or shine. Four red stamps brings convincing evidence. "Distributor," 612 Seventh Street, Parkersburg, W. Va.

OPERATE Hahn's Premium Machines, the best seller for cigars and candles. J. Hahn, 1016 Germantown Ave., Philadelphia.

VALUABLE to M. O. Dealers. Agents—Herb Doctor Recipe Book and herb catalogue, 10c, worth dollars. Teaches how to make herb medicines for all diseases. Ind. Herb Gardens, Dept. 41, Hammond, Ind.

MEN and Women! Make real money in spare time, opportunity free to all. Write today and reap the harvest in your locality. Don't delay. The Sign Co., 26 Main St., Silver Creek, N. Y.

MAKE Money Easy and Quick. Stop slaving. Be your own master; capital unnecessary. Be wise like others, Particulars free. Skolmepo Polish Co., P. O. Box 1028, New Haven, Conn.

AGENTS—Mail Order Merchants—18 attractive circulars of quick-selling specialties, bearing your imprint, hundred 20c. All money-makers. Orders filled direct to customers. No stock to carry. Write quick. Mail Order Corporation, Newburgh, N. Y.

EXHUME, as the name implies, not only exterminates bugs and insects, but it fumigates your home, factory, etc., in a thorough manner. Spray your horses or cattle and a fly will not touch them. Can be used on silk or anywhere without soiling. Will sell formula. Sample 25c. S. L. Kerr, 3 Hazen Ave., St. John, N. B., Canada.

1,000% PROFIT manufacturing job. Start at home during spare time. Capital and experience unnecessary. Enormous and endless demand. Our secret formulas and sure selling plans insure you a lucrative, steadily increasing business. Investigate immediately. Particulars free. A. Cobert, Secretary, 6935-6939 Kenwood Ave., Chicago, Ill.

WANTED—General Agent. Exclusive territory. Small capital—secured. Mackinnon-Cobleigh Co., Box 532, Templeton, Mass.

START in the Carpet or Clothes Cleaning Business now. Thurman Vacuum Process unequalled for commercial cleaning. We show you how. Easily learned. Only \$125 capital needed to earn good income in towns of 2,000 and over. Write today. Thurman Vacuum Cleaner Co., Manufacturers all types Vacuum Cleaners, Dept. H, St. Louis, U. S. A.

\$130 HAS been earned in 3 days by our representatives, some even better, introducing our new advertising method which solves the advertising problem for merchants in smaller cities and towns. If you are or want to be a salesman I will show you how to build up a big profitable repeat business quick. Whole or part time. Big money if you act now. Write Salesmanager, Winslow Cabot Company, 69 Congress Bldg., Boston, Mass.

LEARN the Real Estate Business. Our complete instruction book teaches: Listing, Appraising, Management, Salesmanship, Insurance, Brokerage, Advertising, Renting Agency, Forms, etc., 121 subjects. Exceeds \$20.00 correspondence course. Buckeye cover, 75c. 80k cloth \$1.00 postpaid. Healthy Book Company, 5982 Euclid Ave., Cleveland, Ohio.

CONDUCT a "Candy Kitchen." Clear \$5 to \$25 daily. Small capital required. Particulars free. The Kennon School, 142 W. Ontario St., Dept. A, Chicago.

LET me show you the way to success! Postal brings wonderful opportunities. Thos. Singer, Hancock, Wis.

ADVERTISE in 133 different magazines, special price 5c word. Send copy now. Lists free. King's Magazine, Box 1370, Little Silver, N. J.

RAISE Frogs—"French Frog Farming" tells how, 50c. Weybret-Lee Co., Monterey, Cal.

MEN wanted to manufacture and sell Concrete articles, costs three dollars, sells for eighteen dollars anywhere. Write for particulars. Eureka Concrete Co., Meridian, Miss.

GET Wise! Make \$25 weekly. Superior Sign Co., 1839 Linden St., Brooklyn, N. Y.

BE a Merchandise Broker. Earn \$2,000 to \$5,000 a year. Our system insures success. Write for free information. National Brokerage Company, Davenport, Iowa.

FORMULAS and instructions for manufacturing six big sellers, and 100 business opportunities, for 10c. H. B. Essex, Box 476, Baltimore, Md.

LET the parcels post help you. Add (\$15 to \$25 weekly) to your present salary or income. Start during spare time and build up a permanent mail-order business of your own. We show you how and help you make good. No canvassing. Experience unnecessary. The Parcels Post makes success doubly sure. Our new ideas and up-to-date plans bring the money. No so-called "Course of Instruction" to sell. We give that free. Write today. Address Parcels Post Co., Inc., Dept. A, 79 Broadway, Buffalo, N. Y.

I GUARANTEE \$10 for first photoplay you write by my method. As former scenario editor, I speak with authority. Send for free booklet, "How to Write Photoplays." Elbert Moore, Box 772 P.G., Chicago.

BE Wise. Don't experiment in mail order. I can tell you how to succeed. B. Nounham, Waukegan, Ill.

MANUFACTURERS, Promoters and Patent Buyers are invited to write us stating the line of invention in which they are interested, as we can supply their wants in any class of patents. Victor J. Evans & Co., 162 Ninth St., Washington, D. C.

WOULD You Like to Own a good-paying mail-order business? We have a line that gets repeat orders all the time. You can start in spare time; invest a dollar or two a week and soon own a nice business of your own. Particulars free. Nadico, 1604 Belmont Ave., Chicago, Ill.

INDEPENDENCE and fortune quickly obtained in the Manufacturing Mail Order business. I furnish Formulas, Manufacturing Processes and Trade Secrets in all lines. Sold under positive guarantee; 18 years' practical experience. Revision and improvement of Formulas and Processes—reduction of manufacturing cost—utilization of waste materials, etc., a specialty. Booklet, Formula List, and Valuable Information Free. W. L. Cummins, Ph. D., 127 Standard St., Syracuse, N. Y.

STOP Here! Let me start you in a home business that will bring you money every day. Experience unnecessary. Spare time. No canvassing. I furnish everything. Send for proofs. Voorhes, Desk C. R., Omaha, Neb.

ADVERTISERS, Mail Dealers: Our 1915 Rate Book lists 2,000 Principal Publications, rates, circulation. Includes 30 Mail-Order Plans. Price 10c. Dearborn Advertising Agency, 210 Franklin Bldg., Chicago.

PATENTABLE ideas wanted—Send for 3 free books, R. B. Owen, 30 Owen Bldg., Wash., D. C.

IF you want facts instead of fancies about Patents, address Benjamin & Bassett, 140 S. Dearborn St., Chicago.

LEARN to collect money. Good income; quick results. Send for free booklet, "Skillful Collecting," Collectors' Association, Long Street, Newark, Ohio.

I WANT to send you proof of the wonderful pulling power of Popular Mechanics classified pages. What's your proposition? Write me today. F. W. Johnson, Classified Dept., Popular Mechanics Magazine, 6 N. Michigan Ave., Chicago.

BE Independent; own a Wallpaper-Cleaning Business; whole or spare time; \$150-\$200 a month easy; big profits; no experience required; my booklet shows you how; write today. Milliken Co., Gayport, Iowa.

ONE beginner makes \$200 per week operating an original mail business we planned. You can. Small capital—spare time—experience unnecessary. No "quiffs" or "Instructions." Proof free. Success Mint, 400 Main, Smithport, Pa.

MAIL ORDER SUPPLIES

SELL Joker's Novelties! 16 samples 10c. Chambers Works, Plainwell, Mich.

INCREASE your sales. Place your proposition before the readers of "Cartoons Magazine." 30,000 copies guaranteed every month. Classified rate 2c per word. Mail in a trial ad today. Cartoons Classified Dept., 78 E. Madison St., Chicago.

TO MANUFACTURERS

WE desire to correspond with manufacturers seeking the best locations. We have a railroad about to be constructed through a territory where steam coal can be had at 75 cts. per ton, gas from 5 to 7 cts. per 1,000 cubic feet. This road touching or crossing ten railroads and seven systems, without paralleling any, offers exceptional opportunities for manufacturers of all kinds. Territory rich in pottery, brick and tile clays; fine quality of sand, limestone, and cement rock. Splendid farming and dairying country entire length of the line. Good factory sites in thirty towns. Address B. F., 9th floor, 78 E. Madison St., Chicago.

WANTED—Foundries to manufacture small machine, finished, in quantities. Knight and Baker, Gunter, Tex.

FURNITURE Manufacturer could make fortune with my new Refrigerator. Has more selling points than others. Royalty basis. Dr. Young, Thomson, Georgia.

WANTED—Address of manufacturers of low-voltage generators, switchboard supplies and storage batteries. Box 487, Ludl, Wis.

DUPLICATORS AND DEVICES

\$2.40—THE "Modern" Duplicator. 30 days' free trial—32,846 firms use it to make 50 to 75 duplicate ("Made in U. S. A.") copies of each letter, or anything written with pen, pencil or typewriter. Booklet free. Main office, J. E. Durkin & Reeves Co., 329 Fifth Ave., Pittsburgh, Pa.

A DUPLICATOR \$1.00. Letter size. Make over 50 copies from pen or typewritten original. Send for circulars. Selenetek Laboratories, Dept. 1, Madison, Maine.

FOR ADVERTISERS

ADVERTISERS! Your 40-word ad in the enlarged 32-page Boys' Companion, reaching 24,000 boys, 50 cents. Boys' Companion, Chicago.

25-WORD advertisement in 100 magazines, \$1; special newspaper rates; 2c brings lists. Gem Advertising Agency, 302 Appel Bldg., Denver, Colo.

50 WORDS display in 18,000 copies Northern Star, \$1.00. Stanford, Canonsburg, Penna.

10,000 BOYS read our large 9x12 magazine. Display 6c line. Minimum 7 lines. Classified, 1c word. Minimum, 25c. Two insertions, 15% discount. Youths' Magazine, Chicago.

ADVERTISE in 133 different magazines, special price 5c word. Send copy now. Lists free. King's magazine, Box 15-P, Little Silver, N. J.

YOUR 30-word ad in our big postcard magazine, 25c. Inch display, 50c. Elite Exchange, 3684 Milwaukee Ave., Chicago.

ADVERTISERS—Here's your opportunity. Your proposition placed before the readers of "Cartoons Magazine" for only 2c per word. Circulation 30,000 copies guaranteed. Send a trial ad for our next issue. Cartoons Classified Dept., 78 E. Madison St., Chicago, Ill.

ADVERTISING SERVICE

INQUIRIES—but no orders! Is that your trouble? Send me your free criticisms. Let me write you a strong, pulling follow-up that will turn those prospects into customers. C. T. Anderson, 1933 Waverly Ave., Duluth, Minn.

PERSONAL

FREE! Stop Using Tobacco. Free. We will give you free information how to conquer the habit easily and permanently. Results Guaranteed. Anti Tobacco League, Paxton Block, Omaha, Neb.

GET valuable mail whole year, thirty cents. P. Crenish, Scrabbleville, N. Y.

CORNS! Relief Assured. 25c Safety Corn Shaver postpaid only two dimes. Ideal Mfg. Co., Fall River, Mass.

BROTHER—Accidentally discovered root cures tobacco habit. Gladly send particulars. F. Stokes, Mohawk, Florida.

GET Success—Read "H. E." Thousands helped. Marvellous results. Particulars free. Winslow D. Chase, Washington, D. C.

STAMMERING and Stuttering cured in your own home by my mental training course. Particulars free. R. Arnaud, Keene, N. H.

AGENTS WANTED

AGENTS—Would \$35 to \$50 per week in practically any locality interest you? In more populous sections, hustling agents easily make \$75 to \$175 per week, selling our Sentinel Burglar Alarm. Actual sales tests prove this. Amazing new invention—just out—retail price one dollar. Sells quickly at sight to homes, offices, stores, hotels. Handsomely nickel plated—mechanically perfect—weight, 7 ounces. It provides perfect and cheap burglar insurance. Every home needs and wants one or more. Instantly attached to any door knob. Impossible to turn knob or open door without ringing bell. No batteries, wires, screws or nails are used. Just turn thumb screw and it is ready for instant action. Patented. No competition. For one dollar we will send you postpaid with our descriptive circular. If not entirely satisfactory, return it and we cheerfully refund your dollar. Write for our most liberal terms to agents. We want only live, aggressive workers who will actively push sales. Marshall Dobbins & Company, Manufacturers Household and Office Specialties, 1422 Marquette Bldg., Chicago, Illinois.

AGENTS Wanted—Right here is the one big chance of your life. If you want to make good money—\$10 a day or more, as easy as rolling off a log, and get your swell clothes free besides, you can do it by acting as our agent. We are the biggest people in the business and want our agents to make big money and be nifty, stylish dressers. Send a postal today for free \$10 outfit, including a big book of nobly suiting samples to select your swell agent's suit from. Then take orders from people who admire your nifty clothes. They come to you—not you to them. This is the way to get rich—the sure, easy way. Remember, you need no money—everything is furnished by us free. We pay express on everything. Just send a postal, but do it today. You can't get started too quick, making this big money and wearing these stylish clothes. Address card to Paragon Tailoring Co., Dept. 414, Chicago, Ill.

AGENTS actually making a week's wages every day selling the new Air Cell Washer. Amazing invention. Washes clothes thoroughly without rubbing. Banishes hardship and drudgery. Sells for only \$1. Curry (Okla.) writes, "Have been in the agency business for years, but this beats them all." Dodds (Miss.) made \$65 first week, without any previous selling experience. Let us give you the same opportunity. No trick at all—simply get busy. Nearly 200% profit. Be first—get exclusive territory. Write today. Air Cell Washer Co., 3026 Detroit Ave., Toledo, Ohio.

\$20 WEEKLY and more easily earned! taking orders for our guaranteed trees, shrubs and roses; part or full time; no delivering; no collecting. Chariton Nursery Company, Dept. J, Rochester, N. Y.

MAKE money operating profitable Mail Order Book business. 700% profit; everything furnished. Small outlay; particulars free. Rollins, Tremont Row, Boston.

BIG Textile Mills will employ everywhere reliable people to take orders for dress fabrics, hosiery, underwear and neckwear from samples. Factory prices. Spare or all time. No experience. Permanent. Many making over \$30 weekly. Steadfast Mills, 20 Remsen St., Cohoes, N. Y.

LADIES—Splendid New Article for home. See Tiptax under "Cameras."

OUR Agents are coling money selling the latest household specialty just out. The Star clothes line Reel, 70 feet of line. Fully guaranteed. Sells at sight. Every lady wants one. Big demand. Make \$15 to \$25 daily. Write for proposition. Utility Mfg. Co., Cedar Rapids, Iowa.

IF interested in mail order business at home, write Roberts, Valley Junction, Iowa.

400% PROFIT. No competition or mail order proposition. Free sample. Southern Co., Muncie, Ind.

400% PROFIT—Evergrip Gliders—No rollers; pocket sample free; anyone can attach; cost 2c, sell 15c; homes buy dozens, hotels hundreds; save floors and carpets. S. Mfg. Co., 418, Warren St., N. Y.

\$1,000 PER Man per County. Strange invention startles world—agents amazed. Ten inexperienced men divide \$40,000. Korstad, a farmer, did \$2,200 in 14 days. Schlicher, a minister, \$195 first 12 hours. \$1,200 cold cash made, paid, banked by Stouman in 30 days; \$15,000 to date. A hot or cold running water bath equipment for any home at only \$6.50. Self-heating. No plumbing or waterworks required. Investigate. Exclusive sale. Credit given. Send no money. Write letter or postal today. Allen Mfg. Co., 4069 Allen Bldg., Toledo, Ohio.

AGENTS—\$10 daily and more earned by everybody undertaking an easy agency as an extra; expert knowledge unnecessary. Write Mr. Brouwers, 29 Stationsplein, Den Haag, Netherlands. (Postage 5c.)

SURPRISING Profits: General Agents wanted in every city to handle our sanitary "Ray-Ice" Cloth. Reduces ice bills half by preventing useless melting in refrigerators. Exclusive rights. Harsh Mfg. Co., Indianapolis, Ind.

AGENTS make \$10 per day selling our cigar-shape pipes in every town. Sample 10c, mailed. Big profit. C. O. Orquhart, 624 W. 131st St., New York.

SOAP Agents—For profitable side line fitting into your regular work write Leilman Mfg. Co., Richmond Hill, N. Y.

AGENTS—Make \$12 daily introducing the Kirke Lawn Fertilizer Cartridge. Now is the season. Simply attach to garden hose and fertilize while watering. No odor, refuse or labor as with other methods. Big commission. Sells for \$3.00 to every home, florist and dealer. Carry full size sample in pocket. Write today for proposition and literature. Hustlers wanted everywhere. Chemical Sales Co., Box 30, North Wales, Pennsylvania.

\$15 MADE first day by 15-year-old boy with Shomescope. Woman made \$8 first hour. Particulars free. Shomescope Mfg. Co., 523 W. 13th St., Kansas City, Mo.

AGENTS Wanted—An opportunity to get into big business. We want motor truck agents in several territories to handle our well known motor trucks in three sizes—half-ton, one-ton and two-ton capacities. Must be financially capable of paying for demonstrator and contract for a number of trucks to be sold during 1915. Our agents have tremendous leverage for obtaining business through being able to sell on time payments. A rare opening for the man who wants to enter a permanent business in which there is an unlimited future with the pioneers of the motor truck industry. Address Motor Trucks, Box 655, Waterloo, Iowa.

PHOTO Pillow Tops, Portraits, Frames, Sheet Pictures, Photo Plates, Pennants, objects credited. Prompt shipments; samples and Cat. free to agents. 30 days' credit. Jas. C. Bailey Co., Desk A-4, Chicago.

AGENTS Wanted—If you know a chance when you see it you'll see this one now. Big money—stylish, nifty clothes—little work—no experience or capital needed—can you beat that? We want agents everywhere to take care of our business in their localities and to advertise our nifty suits by wearing them. We furnish everything complete and charge nothing for agent's outfit. The swiftest dressers everywhere are our agents and all we ask is that you tell people who inquire about your fine clothes where and how they can get them. You make big money—\$10 a day—without trouble. Just a postal brings you full outfit free. Big, new sample book of up-to-the-minute suitings sent so you can pick out your first suit; also measuring blanks and everything you need. We pay express on everything—not a penny for you to pay. Send quick before some one else gets the agency there—mail postal today to the American Woolen Mills Co., Dept. 414, Chicago, Ill.

BEGINNERS, agents, two best pullers ever offered. Particulars quarter; sample only 10c. Sure repeater. Rural Supply, Sallenville, Ohio.

AGENTS all agree we have the world's greatest money-makers. New startling offer. Great demand. Factory running overtime. Ask us. American Aluminum Bread Board Co., Cambridge, Ohio.

PERFECTION Ford Starters for Ford Cars, 8,500 sold. Guaranteed to start any Ford Car that is in running condition. Splendid proposition and inducement for state and county agents. Only \$25, 50¢ to agents. Send \$12.50 for sample and get agency contract. The Perfection Auto Starter Co., 234 14th St., Denver, Colo.

AGENTS—Snappiest household line on earth. Red-hot sellers, steady repeaters—100% profit. 250 light-weight, fast-selling, popular-priced necessities. Agents' outfit free. Get busy—quick. Write today—postal will do. American Products Co., 563 American Bldg., Cincinnati, Ohio.

"JIFFY" Ironing Board Cover and Clamps is the biggest red-hot seller ever invented, 150% profit. No competition. Lake Shore Manufacturing Company, Michigan City, Ind.

AGENTS, write quick for big free sample case proposition—Maximol Toilet Accessories, Restroom Plants, Arizona Diamonds, etc. New line; exclusive territory; no competition. Big chance for hustlers. Lester Company, Box ET, Mesilla Park, N. M.

I NEED branch managers for my world-wide mail-order business. Operate from your own home in spare time. No canvassing or peddling. Experience unnecessary. You should make \$50 weekly. Butler, 343 Factorie Bldg., Toledo, Ohio.

MAKE \$21 next Saturday. Brand new proposition, patented last January. Amazing invention, compressed air washing machine, weighs but two pounds; excels work of high-priced machines. Customers excited; agents coining money. A sale at every house. Price only \$1.50; 200% profit. Cleans tub of clothes in three minutes; works like magic. F. Hughes made \$21 first eight hours. No charge for territory. Investigate. Write now. Wendell Co., 735 Oak St., Leipsic, O.

AGENTS, make \$5,000 this year. Be your own boss—Independent—abundant money—your time your own. All or spare time—at home or traveling. Write today for full particulars. E. M. Feltman, Sales Mgr., 560 Third St., Cincinnati, Ohio.

AGENTS—Sell Fibersilk specialties—ties, jabots, scarfs and shawls. Made by new process on patented machines in many rich beautiful colors. Brilliant silky lustre—washable. Ties sell quickly at 35c and 50c—and sell for 25c and still net you 100% profit. Scarfs and shawls sell for \$1 each. Exceptional proposition for spare time and agents. Send 15c for sample tie (guaranteed). Fisher Knitting Company, Oak St., Urica, N. Y.

NEW 1915 Model—Send no money, just your name on a postal card, and learn by return mail how to get the best Vacuum Cleaner made, without costing you one cent, shipped direct from factory, guaranteed for 5 years. Reliable agents wanted. The Warner Company, Dept. Z, Muncie, Indiana.

MAIL-ORDER instructions complete and 27 propositions to begin with. Literature free. Write I. Hale, Box 192 E. College View, Neb.

MILLIONS Postcards, \$1 thousand; big lunch samples, proposition 10c. Hancus Co., 715 Washington St., Boston, Mass.

AGENTS: A free course in General Salesmanship is given to every man of our Sales Organization. This organization is a body of successful men selling the Handy Light; that unique electrical device which cuts the cost of electric lighting in half. Sells for \$3.50, is used in home, office, store, factory; weighs only one pound. Sold by demonstration. All agents furnished with well-planned methods for gaining interviews. A high-grade business for a man of ability and standing in his community. General Agents preferred. Inquire for our full proposition by addressing The Handy Light Co., 1191 Handy Light Block, Cincinnati, Ohio.

\$61.50 WEEKLY introducing and selling a new gas light burner for kerosene lamps. Beautiful light. No chimney. No mantle. Perfectly safe. Simple in construction. Nothing to get broken or out of order. Will not burn out. Durable. Will last for years. Low price. Easy to sell. 200 per cent profit. Experience not necessary. Sample free. Why not try one on your lamp? Beware of imitations. No branch offices. Luther Manufacturing Co., Dept. 491, Cincinnati, Ohio.

AGENTS Wanted—Agents make 500 per cent profit selling "Novelty Sign Cards." Merchants buy 10 to 100 on sight, 800 varieties. Catalogue free. Sullivan Co., 1234 Van Buren St., Chicago, Ill.

AGENTS make \$10 a day selling rugs at \$1 each; cost agents 55 cents; sizes 36x48; sell from one to six at every house; something every housewife wants; full size rug for sample, 95 cents by parcel post. Commerce Specialty Co., Commerce, Tex.

AGENTS—To sell Heiman Electric Flash Signs. Interchangeable letters. Most effective, practical and economical advertising window sign. Fully guaranteed. Price within means of every merchant. Live agents sell several a day easily. Liberal commissions and exclusive territory. Permanent, profitable business. Heiman Novelty Mfg. Co., 4418 Langley Ave., Chicago, Ill.

YOU Can Sell Kleenol Sanitary Brushes to every housekeeper. Buy direct from the largest manufacturers of wire frame brushes in America, at lowest prices. Several fine localities still open—exclusive sale granted if you open agency now. We furnish everything—no capital required. Kleenol Brush Co., 71 Taylor St., Springfield, Mass.

NOVELTY At Last, A 1c Pencil Sharpener, does work of \$10 article. Get sample. Salesmanship Book, proposition and quantity prices for a quarter. Show sample—sell dozens. Deposit Co., Majestic Building, Detroit.

AGENTS: New Adjustable Fountain Percolator. Fits any coffee pot. Rapid seller. Big profits. Write today for catalogue. H. B. Burham Mfg. Co., Muncie, Ind.

AGENTS—Make \$50.00 week Selling our Specialties. Send 25c for samples, get wholesale price of Money makers, The Electric Appliance Co., Inc, 1891, Burlington, Kansas.

\$25.00 TO \$30.00 Weekly to hustling men and women—anywhere. Rudolf, Northwestern Building, Chicago.

AGENTS wanted everywhere to sell our 2 articles used in almost every house and office. Never previously sold by agents or mail-order firms. They sell on sight. Send for circular. Swedesford Specialty Co., Norristown, Pa.

BIG Kansas Company will start ambitious man or woman in fast growing business; any locality; \$3,600 yearly; spare time; no canvassing; no experience. We furnish everything. Write for unique selling plan. C. W. Prestone, President, 108 E. 5th, Pittsburg, Kansas.

READ the Agents Magazine and make more money. 2 Issues 10c. Agent's Magazine, Chicago.

SELL Dry Goods Remnants, Greatest bargains on earth. Remnant Store Co., Cincinnati, Ohio.

AGENTS Wanted—Women and Men—for Gloria Cream; new, quick seller. Good profit. No experience necessary. Some make \$50 first week. Write for full particulars. E. J. Husted, Dept. 1104, Grand Rapids, Mich.

AGENTS Wanted to sell Non-alcoholic food flavors, perfumes, toilet articles, soaps, household necessities; 80% saving to consumer. Big profits to agent, premiums to customers. Free sample. Apply immediately. Dept. 8, Arthur N. Christy & Co., Newark, New York.

AGENTS in every city and county. Splendid paying national business. Legitimate; new; exclusive territory. Crystella Co., 325 Washington St., Brooklyn, N. Y.

WANTED—Live Agents for Specialty selling to every Wholesale and Retail Shoe Dealer, Repair Shops and Notion Stores. Big money for hustler. Gilliam Mfg. Co., Box 474, Canton, Ohio.

AGENTS—\$15 profit, two sales. Machine for saloons. Free sample, salesmanship course. Mohler, 1059 North California Ave., Chicago, Ill.

AGENTS for Ho-Bo-Co Skin and Scalp soap, perfumes, toilet articles. Our prices are lower, quality of products better, orders repeat. Botcho, 212 N. Second St., St. Louis, Mo.

AGENTS make big money taking orders for business and calling cards; outfit and agent's instructions free. Wolverine Co., Jackson, Mich.

80% PROFIT, Selling Art Show Cards. Every merchant buys. Send 10c. samples worth 50c. Catalogue free. Merchants Specialty House, Chicago.

SAFETY first! New quick-selling household article for agents. Retail 50c. Over 100% profit. Write or send 25c for sample. Hayes Sales Co., 4132 Keomore, Chicago.

YOU double your money on the popular Hygienic Milk Bottle Holder. Sample, 15c. prepaid. Catalog free. Weymouth Household Supply Co., Box 387, Springfield, Massachusetts.

"PROTECTING Inventions Before Patent Without Cost." next issue Inventor's Advocate. Advocate Building, 12, Washington, D. C. one year 25c; three months 10c.

AGENTS for Whirlwind Traffic Officer Automaton metal automobile novelty. Fits all radiator caps. \$10 a day profit. Welch Novelty Co., 4540 Papin St., St. Louis, Mo.

INVISIBLE Ink can't be seen until heated; write your letters with it, draw funny pictures. Bottle by mail 10c. Agents wanted. Nutley Sales Co., Department 5, Nutley, N. J.

USE your spare time to build up a mail-order business of your own. We help you start for a share in profits. 27 opportunities. Particulars free. Opportunities Exch., Buffalo, N. Y.

THE Wise Agent is interested in two things, a new commodity and a liberal commission. We furnish both. Kirkham Mfg. Co., Washington Blvd., Stamford, Conn.

WANTED—Agents and salesmen, Simplified Klox Lye Arm. Sells in every household for \$1.00, 100% profit. Write for particulars and folder. Klox Lye Arm Company, Stapleton, N. Y.

YOU can make big profits selling our order getting line of guaranteed goods. \$300,000 firm and liberal credit plan backs you. We have an attractive general agency offer. Valuable premiums. Wm. J. Dick, Mgr., Dept H21, 20 W. Lake St., Chicago.

AGENTS: Our newly patented knife sharpeners sell rapidly. Big money maker. Write quick for territory. C. Hecht, 1062 Argyle St., Chicago.

GENERAL Agents—Capable of calling on the big trade themselves and handling canvassers for the house to house and office to office business, to sell the newest electric specialty on the market; sold everywhere there is electricity, in the home, office, factory, store, hotel; liberal profits; sales-driving sample, weighs a pound, no experience or knowledge of electricity required; shows how to use one light instead of two and get the same results; sells for \$2.50, \$3.50, \$5.00, and saves the purchaser an investment of \$25.00. Write for particulars. The Handy Light Company, 153 Handy Light Block, Cincinnati, Ohio.

AGENTS are meeting with wonderful success because we start them by trusting to \$2.60 worth Starr's Powdered Enamel. Repairs chipped and rusty spots on granite. Stops all leaky metalware without heat, soldering iron or tools. Old table-linoleum does the trick after mixing with water. Sample and particulars 10c stamps. Starr, 1910 Monroe St., Toledo, O.

WAR books, white star books, show cards, post cards, tricks, novelties. Interesting literature free. Ward Publishing Co., Box 433, Chicago.

\$2.50 PER day salary paid one man or woman in each town to distribute free circulars and take orders for concentrated flavorings in tubes. Permanent position. J. S. Ziegler Co., 7P East Harrison, Chicago.

AGENTS, sell "Kant Leak" Rain Coats—\$5.00 kind for \$3.95. Cooper cleared \$40 in 5 days. We deliver direct to customer. Write for terms and Free Samples. Corner Mfg. Co., 50 Broad St., Dayton, O.

WINDOW Lettering Business. We start you free. Everette Co., Dept. P., Long Island City, New York.

AGENTS Wanted. New proposition. Big demand. Every demonstration produces sales. Exclusive territory. Manufacturer, 2811 Woodland, Kansas City, Mo.

SELLS like hot cakes. New ironing wax holder and asbestos rest. Perfumes clothes; nothing like it. Working outfit 5c. M. B. R. Manufacturer, 9 Water Street, New York.

WANTED—Agents in every county in the United States to sell our Automatic Fire Alarm and Extinguisher combined. Hardt Gay & Co., Canastota, N. Y.

HURRAH for the Unicycle Hoop for Boys to ride in. Write Thomas B. Bemis, Indianapolis, Indiana.

AGENTS and Ford Owners—Get particulars of best-selling proposition, latest Auto-Specialties, no trash, big profits. Valerius Distributing Co., 140 West 83rd St., New York.

AGENTS—For automobile specialties. Man with automobile preferred. Sales manager, 650 Woodward Ave., Detroit, Michigan.

NICE income easily earned with quick, sure sellers. Permanent position. Free samples. Will Sales Co., Syracuse, N. Y.

AGENTS—Salary or commission. Greatest seller yet. Every user pays and ink lasts on sight. 200 to 500 per cent profit. One agent's sales \$620 in six days; another \$32 in two hours. Monroe Mfg. Co., X6, La Crosse, Wis.

HUNDREDS of agents are making money with our "No-Burn" Kettle Bottom and Bread Toaster. Sample free. Enclose 20c for mailing expenses. Oatrich Sales Co., Two Rivers, Wis.

LOCAL and State Agents. Big Money. Phone-Arm. Symes Bldg., Denver, Colo.

PORTRAIT Agents—Deal direct with a good, reliable artist and get your work at first hand. Guaranteed work. A. Jensen, 222 N. State St., Chicago.

AGENTS—Buy from the manufacturer. Make 233% profit selling our new improved Glove Mender and Stocking Darner. Entirely new. Every housewife buys on sight. Send 10c for sample. Also good line of household novelties selling for 10 and 15 cents. The Boett Specialty Co., Putnam, Conn.

AGENTS to take orders for Visiting and Business Cards. Large Profits. Output Free; 2c postage required. Forman Printery, Waterbury, Conn.

AGENTS make big money with our premium plan. Write today. Advance Agency, Box 3792, Boston, Mass.

AMERICA'S daily necessity.—Free sample. Wm. E. Spunnon Co., Hicksville, Ohio.

AGENTS to sell honest goods for good, honest profits. The Kelson Co., A, Southbridge, Mass.

WONDERFUL New \$10.00 Washing Machine. Generates own power, forcing twenty streams boiling suds through clothes. Brute made \$170.00 first Seven Days. You can, too. Geyser Washing Machine Works, Chicago.

AGENTS—If you make less than \$1.00 per hour, write us; we manufacture new household necessity; patented; low price; wonderful seller; not sold in stores. Tyler Co., 2210 Main St., Muncie, Indiana.

AGENTS—Latest patent check-protector, paper weight. Big money-maker. Sells on sight. Sample 25c. Valmars, 261 Broadway, New York.

LIBERAL Commission. High-class Toilet and Household Articles, repeat orders. Dept. B, The Hamilton Company, Mfg., Washington, D. C.

GOOD money showing new time-saving help. Merit and popular prices insure steady, pleasant work, whole or spare time. Business comes to you when introduced. Sterling Sales, Morgan Park, Ill.

AGENTS are making money selling our big 10c Packages of 20 Assorted Postal Cards, "5,000 Varieties." "Big Profits." Sell everywhere at sight. Sample Packages 10c. Particulars Free. Sullivan Card Co., 1234 Van Buren St., Chicago, Ill.

200% PROFIT. You can't beat it. Sells everywhere. Free pocket sample. Our goods get the orders. Wm. J. Dick, Mgr., Dept. H-4, 20 W. Lake St., Chicago.

AGENTS—To sell the newest electric appliance on the market; sold everywhere there is electricity, in the home and office; liberal profits; sales-driving sample, weighs a pound, no experience or knowledge of electricity required; it shows how to use one light instead of two and get the same results; sells for \$3.50 and saves the purchaser an investment of \$25; write for particulars. The Handy Light Co., 15 Hainy Light Block, Cincinnati, Ohio.

GREAT \$2 Clothes-Drying Contrivance. Agents write Jay New Mfg. Co., Box 355-R, Hagerst wn, Maryland.

I WILL start you in the Mail-Order Business, furnish everything, if you will handle my goods. Crest Co., 50, Atlantic City, N. J.

AGENTS—Sell "Attacho Electric Lights," make \$4 to \$15 daily; enormous demand; send now for terms, territory. Attacho Light & Novelty Co., St. Louis, Missouri.

SELL New Bake Pans; sides let down; cakes don't break; every woman buys; send quarter for sample and take orders. Self-Sellers Company, Box 113, Chelsea, Mass.

AGENTS and Auto owners, the greatest Spark Gaps on earth; no car complete without them. G. E. Clark, Ottawa, Canada.

AGENTS, our "Boston Pencil Pointer" sells rapidly. Offers big profit. Get next to this money-maker. Circulars free. B. D. Hall, Gran, N. Y.

IT will pay you to write me before you take an agency for Guaranteed Aluminum Utensils. I have an attractive general agency offer. Wm. J. Dick, Mgr., Dept. H-12, 20 W. Lake St., Chicago.

AGENTS—Sell the Everlasting Garter for men; new, patented. Send 25c for sample. Make \$4 per day. Address The Complete Supply Co., M., 1230 W. Lehigh Ave., Philadelphia, Pa.

WAR posters, largest variety, lowest price. Salesman Album with 100 good sellers, 50c. Vondraun, 552 West 149th St., New York.

AGENTS—Both sexes, city, town, country, for "Aladdin" 2 in 1 metal and furniture polishing cloth; enormous demand everywhere; 200 per cent profit; sample free. Thomas G. Dougherty, 257 East 80th St., New York.

MAGIC Ink Eraser. No blade, no acid. Removes ink like magic. Sells like bread in a famine. Sample 10c. Sells 25c to 35c. S. Mfg. Co., 41X, Warren St., N. Y.

INTRODUCE Jap-81K unbreakable gas mantle. New in America; lasts longer; throws greater light; fits standard inverted burners; rapid seller. Sample 25c. Particulars upon request. Jules, 209 W. 48th St., New York.

BE a demonstrator. Learn this wonderful new profession. Earn \$1,800 to \$2,500 a year. We place you in a position, free, that pays from \$3 to \$10 a day while you are learning. Free instructions so you can start in a few days. Madam Bendit, 2204 Orchard St., Chicago.

HOUSEHOLD necessity, mends any metal article except aluminum; price twenty-five cents; to prospective agents, ten cents. Sample of carpet cleaning soap same price; with formula, fifty cents. Ask for circular on massage beautifier. Clifton Specialty Co., Buffalo, N. Y.

MAKE and sell your own goods. Formulas by expert chemists. Manufacturing processes and trade secrets. Formula catalog for stamp. B. Mystic Company, Washington, D. C.

GUARANTEED hosiery manufacturer selling direct to consumer wishes agent in every county. Permanent, big paying business. Protected territory. Credit. D. Parker Mills, 2733 No. 12th St., Phila., Pa.

YOU can sell our Raincoats. Anyone will buy. We give you one. Output free. Tempie Raincoat Co., Box 201, Templeton, Mass.

AGENTS—Father sex. Big profits. Quick seller. Several needed in every family. Unusual merit. Pleasure to handle. Write quickly. Hudson Co., Box 969, Leominster, Mass.

YOUNG Man, would you accept a tailor-made suit just for showing it to your friends? If you live in a town smaller than 10,000, write Banner Tailoring Co., Dept. 875, Chicago, and get beautiful samples, styles and a wonderful offer.

AGENTS. Cost, 3c, sell 25c. Gold window letters. Any one can apply. Samples free. Chicago Letter Co., 2513 Lincoln Ave., Chicago.

500% PROFIT selling our wonderful sign letters for office windows, store fronts and glass signs; resembles finest gold leaf; easily applied; samples free. Metallic Letter Co., 400 N. Clark St., Chicago.

IDEAL Lamp Filler saves bother filling lamps. Men and women canvassers and agents. Good opportunity to make money. Samples A & B 25c. Harry Otis Mayo, Box A2298, Boston, Mass.

AGENTS—Stamping names on Pocket Key Protectors; sample Check with your name and address, 12c. Stamping Outfits, Emblem Checks, Check Fobs, Name Plates, Hart Mfg. Co., Desk 2, 393 Degraw St., Brooklyn, N. Y.

AGENTS—200% profit. Wonderful little article. Sells like wildfire. Can be carried in pocket. Write at once for free sample. H. Mathews, 1062 Third St., Dayton, Ohio.

30 TO 40% Profit to Agents selling our guaranteed U. S. Fire Extinguishers. Tremendous demand. Orders repeat. Exclusive territory to county and district managers. United Mfg. Co., 1508 Oakwood, Toledo, Ohio.

AGENTS, biggest line, biggest profit, extractors, perfumes, medicines, sprays, jelly powder. Premiums for your customers. Western Laboratories, 1923 Van Buren St., Chicago.

WE need one active, reliable person in every community to take orders for our popular mechanical books. You don't have to be a book agent. These books do their own talking. Simply show them. They contain just that sort of information about how to do and make things that every mechanically inclined person is looking for. And they are reasonable in price. We allow you a liberal commission for this pleasant work which you can do during spare time without interfering with your regular occupation. Don't neglect this real opportunity, but write now for full details to Manager Book Dept., Popular Mechanics Magazine, 6 N. Michigan Ave., Chicago.

AGENTS Wanted—To advertise our goods by distributing free sample to consumer. 90 cents an hour. Write for full particulars. The Farvel Company, 1062 West St., Dayton, O.

FITS-UR-POT aluminum coffee percolator fits any coffee pot. Agents wanted quick. Big profits. Write today for circulars. Standard Spinning & Stamping Co., 2249 Smud Ave., Toledo, O.

AGENTS—Graham's Self-Gartered Socks. Patented. Price no higher. Guaranteed never creep down. Don't pinch leg. Fine gauge, wear-forever quality. Send 25c for samples. State size. Graham Company, 558-P Forest Ave., Oak Park, Ill.

1,000% PROFIT manufacturing inks. Start at home during spare time. Capital and experience unnecessary. Enormous and endless demand. Our secret formulas and sure selling plans insure you a lucrative, steadily increasing business. Investigate immediately. Particulars free. A. Cotter, Secretary, 6055-6059 Kenwood Ave., Chicago, Ill.

AGENTS—Earn \$30 weekly selling my household and office specialty. R. F. Maddox, Brownsville, Tenn.

AGENTS—Sell rich-looking imported 35c 68 Bags. \$1 each. Carter, Tenn., sold 115 in 4 days. Profit, \$57. You can do same. Write for sample offer selling plan; exclusive territory. Sample rug by parcel post prepaid, 98c. Condon, Importer, Stonington, Maine.

ENDLESS Neckties—Something new, twelve ties in one; costs no more than old style; man made \$70, three days; woman made \$92, week; write for special agents' offer. Endless Necktie Mfg. Co., Dept. 10, Kansas City, Mo., or Universal Products Co., Toronto, Canada.

AGENTS—Quit hard-work-no-pay-cantasting. Wonderful French Process opens enormously profitable business. No capital; no selling; no stock to buy. Start anywhere. Barstow, 514 23rd Street, Oakland, Calif.

YOU can make from \$25 to \$100 per week operating Aerial "Ads" in big cities. Don't delay. Get on the job. Conyne-Kite, 3598 McLean Ave., Chicago.

A LIVE, ambitious man, well acquainted with railroad men or in large factory, to sell town lots on monthly payments in new, fast-growing railroad shop town in sunny South Texas. Experience not necessary. Good commissions. Earnings should run \$50 to \$250 per week. Townsite Company, North Pleasanton, Texas.

"YANKEE" Tie Forms: Tremendous seller—Enormous profit. Made of pure German silver, \$2.50 per gr. (144), including circular, silk braid ties, 75 cts. per dz.—\$6 per dz. Sample Form and Tie, with full particulars, and best "Spiel" ever written, sent postpaid for 10 cts. in stamps or coin. The Yankee Novelty Co., 94 E. 10th St., N. Y.

SELL Our Attractive Brass Easel Poster Frames to picture theatres, also changeable letter signs for every store; big demand; easy sales; liberal commissions. Newman Manufacturing Company, Cincinnati, Ohio.

JUST show them—The new adjustable floor and wall mops, dustless dusters and sanitary brushes sell themselves. Big line. Big profits. Agents write Silver-Chamberlain Co., Dept. M, Clayton, N. J.

AGENTS: Here's \$50 a week easy! Brand new device! Every housewife enthusiastic. \$1.25 profit on \$2 sale. Wonderful selling plans. Parvin Mfg. Co., Fond du Lac, Wis.

ADVERTISE—20 words in 100 monthlies, \$1; 3 months, \$2. Sample magazine free. Copo Agency, St. Louis.

SAFETY First! Sell our line of Sanitary Twisted Wire Brushes. Big income assured. Exclusive territory given. Goods sell themselves. Households, Offices. Catalogue free. 3 in 1 Brush Co., 105 Beckman Street, New York.

LET me start you Manufacturing and Selling Extracts. H. Lake Co., Adair, Ill.

1,000% PROFIT—Prepared Sign Letters. Share co-operative business free. Johnston Co., Quincy, Ill.

AGENTS—Average \$5 to \$12 daily selling astonishing Aztec massage machine. New. Just patented. Different. No electricity or water power required. Nothing complicated. Affords exhilarating massage without cost expense. Lowest priced, but best outfit. Retail \$2.50 allowing you big end of the profit. Particulars and "beauty" folder free. Aztec Remedy Co., Dept. 132, Toledo, Ohio.

YOU can be your own boss with our Key Check Outfit. Good for \$5 a day stamping names on pocket key checks, fobs, etc. Sample check with your name and address, 15 cents. Pease Die Works, Dept. M, Winchester, N. H.

OUR national advertising helps you sell Fuller Sanitary Brushes and Dustless Mops and Dusters—full line—easy sellers. We tell you how. Biggest factory for twisted wire brushes in U. S.—reliable, strong concern. Your territory is valuable. Write at once. Fuller Brush Co., 53 Hoadley Place, Hartford, Conn. Western Branch, Rock Island, Ill.

STOP Here! Let me start you in a home business that will bring you money every day. Experience unnecessary. Spare time. No canvassing. I furnish everything. Send for proofs. Voorhies, Desk C. R., Omaha, Neb.

BIG Profits for You! Manufacture Barley Crisp. New Confection. 5c package costs you 1c. Machine, instructions complete \$7.50 prepaid. Send 10c for samples. Barley Crisp Co., 1295 Broadway, San Francisco.

EASY pleasant work for Mechanics. Shop Men, Clerks, during spare hours, will add many dollars to their salaries. Also want persons who can give full time. Big wages assured. Novelty Cutlery Co., 67 Bar St., Canton, Ohio.

AGENTS make big money and become sales managers for our goods. Fast office sellers. Fine profits. Particulars and samples free. One Dip Pen Company, Dept. 2, Baltimore, Md.

AGENTS make \$100 monthly selling our 500 handy household articles. Catalogue free. Scheff Company, Desplains, Ill.

OUTFIT Free to Agents. Best selling Handkerchiefs, Dress Goods and Fancy Goods on the market. Quick sellers, big profits. Deal direct with a large manufacturer. Send stamp for particulars. Freeport Mfg. Co., 59 Main St., Brooklyn, New York.

MEDALLIONS—80% profit. Make up your own goods and be independent. Catalogue free. Resag Co., 1265 Randolph St., Chicago.

MAIL-ORDER Opportunities: 25 new Propositions. No competition! Make 35c profit on dollar order; complete outfit 10c. Mail Dealers Wholesale House, 521 Franklin Bldg., Chicago.

AGENTS make \$5 to \$10 a day on the start. Atkinson writes: "The best proposition I have found in my forty years' canvassing." Permanent work. Household necessity. Saving 80%. Write today for General or Local Agents terms. Free sample. C. H. Stuart & Co., 14 Union St., Newark, New York.

AGENTS—Great opportunity to be permanent representative largest manufacturers high-grade soaps and toilet goods. \$25-\$75 weekly. Write for immediate appointment. E. M. Davis Co., R. 64, Davis Bldg., Chicago.

AGENTS—\$5 daily selling our Handy Tool, 12 articles in one. Lightning seller. Sample free. Thomas Mfg. Company, 462 Third St., Dayton, Ohio.

AGENTS—\$50 weekly. We manufacture the best needle case made; a wonderful seller; 200% to 500% profit; talking unnecessary; our "Trust Scheme" envelopes do the work; general agents can make \$100 weekly; particulars free; 25c sample outfit for 10c; buy direct from the factory. Paty Needle Co., 102 Davis St., W. Somerville, Mass.

YOU can make \$888 as our general or local agent. Household necessity; saves 80 per cent; permanent business; exclusive territory; salary or commission; free sample; credit. J. Pitkin, 113 Redd St., Newark, N. Y.

AGENTS of ability and high character wanted on a new household article. Over 100 per cent profit. Special selling plan that pulls results. Address Merritt & Brock, 59 to 69 Temple Place, Boston, Mass.

AGENTS: \$1,000 to \$3,000 yearly selling over eighty everyday articles to farmers. Pleasant, permanent business. Full instructions. Big chance. Write quick. Duoform Factories, North Java, N. Y.

PORTRAIT Agents make big money selling our goods. Our quality is tight. Prices low. Delivery guaranteed. Credit for rejects. Ask for our latest catalog. Adam J. Kroll & Co., 692 Blue Island Ave., Chicago, Ill.

AGENTS Wanted for a new Duplicator. Sells to every business man. Fisher Company, 113 Amsterdam Avenue, New York City.

MANUFACTURER requires general agents for patented demand of centuries. Three minute demonstration convinces. A financial independence to acceptable parties. Samuel C. Osborn, Masonic Temple, Chicago.

AGENCIES WANTED

WANT two more household articles with exclusive rights. Address Manager, 4152 Kenmore, Chicago.

NEW YORK organization, live wires, responsible, will represent manufacturers, new meritorious articles. Valmars, 261 Broadway, New York.

SALESMEN WANTED

TRAVELING Salesmen Wanted—Experience unnecessary. Earn big pay while you learn by mail during spare time; only eight weeks' time required, one or two hours a day. Steady position, easy work, hundreds of good positions to select from. Write today for free book, "A Knight of the Grip," containing full particulars and testimonials from hundreds of students we have recently placed in good positions and who are earning \$100 to \$500 per month. Address Dept. B-16, National Salesmen Training Association, Chicago, New York, Kansas City, San Francisco.

EXCLUSIVE Rights. Permanent, pleasant connection, representing Mills direct. Business long established, many customers. Position worth \$1,500 up to energetic person, good character. Give reference, experience. Winona Mills, Wallace Street, New Haven, Conn.

SALESMEN with ability to get a hearing with engineers and purchasing agents; splendid opportunity and territory open to big producers. Box 190, Station C, Cleveland, Ohio.

SALESMEN—Agents: Competition killed. Electric Flashing sign; over 50 different display arrangements possible with 210 three and six inch letter combinations—in colors. 30-inch model \$10. Sample to producers. Multifarm, 397 Manhattan Bldg., Chicago.

GREAT opportunity for general Agents selling New Specialty to Merchants. Retail \$5, \$10, \$15 each. Your profit 200%. No competition. Exclusive territory. Free samples. Sayers Co., 408 Olive St., St. Louis, Mo.

ONE salesman in each locality for new patented automobile shoes; better than chains; price low; big profits. Adjustable Auto Shoe Co., Indianapolis, Ind.

WANTED—Representatives everywhere. Exclusive territory. Gold sign letters for stores and office windows. Any one can put on. Write today for free sample. Metallic Letter Co., 403 N. Clark St., Chicago.

SALESMEN are clearing \$50 weekly and up, selling our changeable electric flashing window signs; get our proposition now, with valuable exclusive territory. Telesign Company, 8 North Clark Street, Chicago.

POCKET side line. Splendid new article. See Tiptax under "Cameras."

SALESMEN, something real new. Every lady buys. R. Supply Co., Maplebay, Minn.

SALESMEN—We have some excellent territory open to salesmen of ability. This is a proposition that appeals to the best class of concerns. Sales are easy and your profits large. Write us today for catalogue P. M., covering the Schick All-Steel Paper Baker, Davenport Mfg. Company, Davenport, Iowa.

SALESMEN—Get our plan for Monogramming Automobiles and Motorcycles by transfer method. Very large profits. Motorists' Accessories Co., Ashland, O.

HELP WANTED

CANVASSERS—Make from \$5.00 to \$10.00 a day selling our guaranteed line of Flavors, Soaps, and Toilet Articles. Permanent occupation. J. M. Hampton, S. C., says: "Made repeat sales of \$3.95 to one family, \$3.85 to another; profit \$1.10. Time, 1 hour." Active agents make big money. National Company, Newark, New York.

GOVERNMENT Wants Clerks. \$70 month. Spring examinations everywhere. Sample questions free. Write immediately. Franklin Institute, Dept. R-21, Rochester, N. Y.

WANTED—Names of Ford owners. We pay \$5.00 per 100. Send 25 cents for contract blanks, particulars, instructions and outfit. Universal Syndicate, 1123 13th Ave., Moline, Ill.

OWN a business. Co-operate with me evenings at home. Everything furnished. Don't worry about capital. Boyd H. Brown, Dept. K-1, Omaha, Neb.

AMBITIOUS Men and Women wanted by Government as Clerks. \$70 month. Vacations. Spring examinations everywhere. Sample questions free. Write immediately. Franklin Institute, Dept. R-21, Rochester, N. Y.

A MONEY Proposition—Co-operate with me in a profit-sharing mail-order business. Will place trial advertisement, furnish printed matter, goods to fill orders and divide the profits. Particulars, Desk 133, Hazen A. Horton, Tekonsha, Mich.

I NEED branch managers for my worldwide mail-order business. Operate from your own home in spare time. No canvassing or peddling. Experience unnecessary. You should make \$50 weekly. Butler, 315 Factories, Toledo, O.

FREE Illustrated Book tells of about 200,000 protected positions in U. S. service. Thousands of vacancies every year. There is a big chance here for you, sure and generous pay, lifetime employment. Just ask for booklet 8-29. No obligation. Earl Hopkins, Washington, D. C.

DETECTIVES earn from \$25 to \$100 per week and traveling expenses. We show you how. Write National School of Detectives, Room 536, 489 Fifth Avenue, New York.

GOVERNMENT Wants Clerks. \$70 month. Spring examinations everywhere. Sample questions free. Franklin Institute, Dept. R-21, Rochester, N. Y.

GET a civil service appointment. Work for Uncle Sam. Liberal pay. Steady job. We teach you how to secure appointment by mail. Write for free book, "The Easy Way"—It's free. Commercial Correspondence Schools, 204 Schools Building, Rochester, N. Y.

DISTRIBUTORS Wanted—Good pay; steady work; giving away packages Perfumed Borax Soap Powder with our Soaps, etc. No capital or experience needed. S. Ward & Co., 218 Institute Place, Chicago.

GET a Government Job! See ad on page 14. Write now—today! Patterson Civil Service School, Rochester, N. Y.

BECOME Chauffeurs. \$18.00 week. Learn while earning. Sample lessons free. Franklin Institute, Dept. R-802, Rochester, N. Y.

SALESMEN: Crackerjack, \$5 check protectors; also useful advertising and self-selling specialties; liberal commissions. Dorling, 61 Weehauken, N. J.

USE your spare time to build up a mail-order business of your own. We help you start for a share in profits, 27 opportunities. Particulars free. Opportunities Exch., Buffalo, N. Y.

CASH for Names, Ideas, Formulas. Turn what you know, see, hear, into money. Booklet for stamp. Information System, 228, Marietta, Ohio.

\$15 WEEK Salary paid person each town selling non-alcoholic beverages. Lifton Co., Kansas City, Mo.

GET Government Jobs, Spring Examinations, Schedule free. Franklin Institute, Dept. B-21, Rochester, N. Y.

WRITE Moving-Picture Plays: \$50 each. Correspondence course unnecessary. Details free. Atlas Publishing Co., 2015, Cincinnati.

MEN and Women Wanted for U. S. Government Life Jobs, \$65 to \$150 month. Common education sufficient. Write immediately for list of positions open to you. Franklin Institute, Dept. R-21, Rochester, New York.

CASH paid for butterflies, inserts, summer work. Instruction book. Send stamp. Sinclair, Box 244 D. G., Los Angeles, Cal.

SALESMEN, agents, everywhere; New auto fuel; permanent, profitable. Tankki Chemical Sales Co., Cleveland, Ohio.

SILVERING mirrors, Patent tableware, auto-brass. Home booklet, plans free. Clarence Sprinkle, Dept. 28, Marion, Ind.

WANTED—Distributors of advertising matter everywhere; send dime for Application Contract; Sample Magazine (none free). Barkley's Distributing Agency, 105A, Blairsville, Pennsylvania.

WANTED—Men, Women, Government Jobs, \$70 month. Write immediately for list of positions now obtainable. Franklin Institute, Dept. R-21, Rochester, N. Y.

FIREMEN, Brakemen, good wages on all railroads. Experience unnecessary. Surely state age. Railway Association, Dept. 208, Brooklyn, N. Y.

GOOD Opportunities for Veterinarians, Send for catalogue. Grand Rapids Veterinary College, Dept. Z, Grand Rapids, Mich.

UNEMPLOYED men and women can make good wages selling our new original package; no talking necessary; as high as 9c profit on each 10c sale; 25c up starts you. Mr. Pantus, 525 So. Dearborn St., Chicago.

LEARN Tartaric Mirror Silvering—New process. Barstow, 513 23rd Street, Oakland, Calif.

MEN to refinish lighting fixtures, brass beds, etc. All or spare time. No capital or canvassing. Experience unnecessary. Write for information. Gunmetal Co., Detroit, Ill.

LEARN Automobile Repairing, driving on up-to-date cars; electrical, civil engineering; surveying; methods most practical; room and board while learning; many positions secured; satisfaction guaranteed; catalog free. National School of Engineering, 2110 W. 7th, Los Angeles.

BECOME detectives—Large salaries; nice work; experience unnecessary; write Superintendent Wagner, 1243 Lexington Avenue, New York.

I GUARANTEE \$10 for first photoplay you write by my method. As former scenario editor, I speak with authority. Send for free booklet, "How to Write Photoplays." Elbert Moore, Box 772, P. F., Chicago.

BE a Detective—Earn from \$150.00 to \$300.00 per month. Travel over the world. Write C. T. Ladsig, 310 Westover Building, Kansas City, Mo.

STOP Here! Let me start you in a home business that will bring you money every day. Experience unnecessary. Spare time. No canvassing. I furnish everything. Send for profits. Voorhies, Desk C. R., Omaha, Neb.

WANTED—An Idea! Who can think of some simple thing to patent? Protect your ideas; they may bring you wealth. Write for "Needed Inventions" and "How to Get Your Patent and Your Money." Randolph & Co., Patent Attorneys, Dept. 144, Washington, D. C.

GO on the Stage, Vanderbilt career offered you. Experience unnecessary. Managers endorse my method. Instructive vanderbilt book free. Write today. Frederic LaDelle, Sta. 10, Jackson, Mich.

GOVERNMENT Examinations. Most thorough preparation, \$5; returned if not appointed; particulars free. American Civil Service School, Washington, D. C.

BE a detective. Earn big money. Write John J. Gilles, Licensed and Bonded N. Y. State Detective. Retired Member N. Y. Police Dept., 22 years Experience, 234 Huguenot St., New Rochelle, N. Y. Investigation solicited.

POSITIONS—High as \$1,500 and \$1,800 open to persons trained by us in special Lettering and Map Drafting; real opportunity. Particulars and booklet, "Topographic Drafting," on request. Columbia School of Drafting, Tooth and G, Washington.

BE a Detective. Earn \$150 to \$200 monthly. Travel over the world. Write American School of Criminology, Dept. F, Detroit, Michigan.

FOR SALE

THREE Talking Machine accessories—the Well permanent needle, great convenience. Improves the tone, \$1. The Well Attachment for playing Edison Discs on Victrolas, \$2 complete. The Well Automatic Stop—for disc machines; easily installed; very simple; saves the records, \$1 each. Well's Curiosity Shop, 20 S. Second St., Phila., Pa.

GENERATORS—Magneto 50 cents, for shocking machines, ringing bells, etc. Experimental supplies. Columbia Telephone Co., Columbia, Pa.

FOR Sale—New Long's Crispette Machine, cheap. Max Wilbur, Edgerton, Wis.

FIELD, Marine, Day and Night Glasses with beautiful case, 25-mile adjustment, \$30 value, only \$6.50. Money back if not satisfied. Well's Curiosity Shop, 20 S. Second St., Philadelphia, Pa.

PEANUT Pareher—One hundred dollars f. o. b. Lumberton; bargain. C. Moody, Lumberton, Miss.

GAS outfit for cooking or lighting, \$100. Six horsepower Detroit Kerosene or Gasoline engine, \$75. Both used but a very short time. Howard B. Rand, Haverhill, Mass.

MCCREERY Vacuum Machine and all tools, good as new; no truck. Used on automobile. A bargain. Address, John Preslar, 121 E. Jefferson Ave., Dallas, Tex.

HARNESSEMAKERS: For Sale—Landis lock-stitch sewing machine, gasoline heat. Kemp Lre. Co., Hagerman, N. M.

VACUUM cleaner pumps and parts for assembling, save 75%. Vacuum Supply Co., Ann Arbor, Mich.

SALE OR EXCHANGE

1913 MODEL L Pope, Twin Cylinder Motorcycle, for Oxy-Acetylene Welding Plant or Machine Tools, Talcott Bros., Sherwood, Ohio.

ELECTRIC Piano, Air Brush, Cash or trade. H. Tucker, Centerburg, Ohio.

TRADE, twin belt, magneto, motorcycle for chain single, pool table or runabout; also \$50 magneto for side-car. A. F. Seymour, 1641 E. 84th St., Cleveland, Ohio.

EXCHANGE—30 Auto-Rifle for Electric Motor. H. D. Hutchinson, Magnolia, Ark.

TO Buy, Sell or Exchange, Farms, Business, Patent, etc., anywhere. Write, Black's Business Agency, Desk D, Chippewa Falls, Wis.

WANTED

WE want to buy an article of merit that we can manufacture and sell to the automobile trade. The Crum Manufacturing Co., Ottawa, Kansas.

PARTNERS WANTED

WANTED—Partner to furnish money to patent new sliding valve gasoline motor. Write Ray Liddle, Springfield, Wash.

GUNS, SPORTING GOODS, ETC.

FIREARMS—Old-time and modern. Buy, sell, exchange all sorts. Stephen Van Rensselaer, West Orange, New Jersey.

FLOUR & FEED MILLING MACHINERY

SPECIAL bargains in second hand Attrition mills, burr mills, crushers, corn shellers, bean dusters, dust collectors, purifiers, reels, double, single, 2 and 3-pale high roller mills, slate bolters, receiving separators, scourers, etc. Write for description and prices. Sproust, Waldron & Co., P. O. Box 429, Muncie, Pa.

MACHINERY, TOOLS AND SUPPLIES

REBUILT Leather Belting, Half price—new—equal quality; less stretch, equal service. Less price, cheap, new, better service. All sizes, guaranteed. New leather, rubber, canvas, factory prices. Agents wanted. Friedrich Belting Co., Manufacturer, St. Louis, Mo.

MARK your tools. Your name on a steel stamp \$1. Three initials, 50c. Gideon Pike, Attleboro, Mass.

PULLEYS, Gears, Sprockets, Shafting, Hangers; see page 140. W. A. Jones Foundry & Machine Co., Chicago.

SECOND Hand Lathes, 13 inch and 15 inch for sale. Bargain; both good condition; were taken in exchange. South Bend Machine Co., 627 E. Madison St., South Bend, Ind.

WANTED—Two $\frac{1}{2}$ -1 ton chain hoist. Box 205, Saugerties, N. Y.

WANTED—Foot-power lathe. "Star" preferred. Geo. Snyder, Odessa, Mo.

VACUUM Pumps and Cleaners, all size, complete outfits. Thurman Vacuum Cleaner Co., Manufacturers, Dept. O, St. Louis, Mo., U. S. A.

5,000 FEET good 2" leather belt, 10c a foot. Lucas & Son, Bridgeport, Ct.

FOR Sale—All sizes new and second-hand Pulleys, Belting, Shafting, Hangers, Couplings, Pillow Blocks, Collars, etc. Passman Bros., 28 and 30 So. Green Street, Chicago, Ill.

VACUUM cleaner pumps, tools, etc., for stationary house or wagon outfit. Vacuum Supply Co., Ann Arbor, Mich.

FOR Sale—25 Lincoln milling machines, \$25 to \$100 each. Lucas & Son, Bridgeport, Conn.

HAVE for sale several sizes of lathes, milling machines, drill presses, punch presses, shapers, planers, boilers, steam engines, oil, gas and gasoline engines and wood-working machinery. Pinner, 122 Water St., New York, N. Y.

ENGINE Lathe, swings 10 $\frac{1}{2}$ in., takes 25 in. between centers. Complete set gears cutting all size threads 3 in. to 40 in., \$43.50. Grammes & Sons, Allentown, Pa.

FOR Sale: 5 good Engine lathes, 16" to 32"; state size wanted. Lucas & Son, Bridgeport, Conn.

JUST Published—Popular Mechanics Shop Notes for 1915—628 Easy Ways to do Hard Things. This is Vol. XI and is similar in style to the other numbers in the series, 224 pages, 517 illustrations. Paper 50 cents, Cloth, \$1, postpaid. Popular Mechanics Book Dept., 6 N. Michigan Ave., Chicago.

ENGINES, MOTORS AND DYNAMOS

ALTERNATING current, single-phase motors, \$4 to \$95. Direct current and three-phase bargains. Motors bought, sold, repaired. Satisfaction guaranteed or money refunded. Send for electrical supply bargain list. Hyre Electric Co., 613-W., So. Dearborn St., Chicago.

FOR Sale—20 H. P. White steam engine and generator complete \$75. 1 $\frac{1}{2}$ H. P. Locomobile steam engine \$10. Also 2, 4 and 6-cylinder gasoline engines at bargains. Also 4 3/4 by 5 Michelin clincher tires \$30 per set. 1143 North Ave., Bridgeport, Conn.

FOR Sale—3 hp. steam engine and boiler. Frank Damsel, Barnesville, O.

ELECTRIC Motor, 1 $\frac{1}{2}$ h. p., 500 volts d. c.; also Singer Shoe Patch Sewing Machine. Glaser, Sistersville, W. Va.

FOR Sale: Elbridge engine, 27 hp., 5-cylinder, 2-circle (almost outfit), complete outfit. Stubbs, 818 Granite Building, Rochester, N. Y.

FOR Sale—Second-hand 1912 Sterling Engine, 18-25, 4-cylinder, fully equipped, first-class condition. Stubbs, 818 Granite Bldg., Rochester, N. Y.

TWO-cylinder motor, 20, New, Salineville Model & Machine Works, Salineville, Ohio.

QUICK Sale Storage Consignment Small Generators: 10 lights—110 volts—\$12.50; 20 lights—\$32.50; 60 lights—50 volts—\$35.00; 80 lights—60 volts—\$40.00; others larger. Write for special list. Johnston, Evans Ave., Ingram, Pa.

MARINE Motors. A new motor at wonderful price. Am producing 3,000 motors of one type and size, consequently this price. Motor, 4 cylinder, 4 cycle, 15 h. p. Price, \$97.50. Money back if not satisfied. Catalog, 4c. Triumph Company, Marine Dept., Oregon, Tioga County, N. Y.

FOR Sale—Used Wagner two-horse electric motor. Otto Zeen, Troy Grove, Ill.

HEAVY Duty gasoline engine, 4 cyl. 6x5, \$350. 12 H. P. marine \$90; 11 H. P. marine \$95. N. Box 263, Moline, Ill.

BARGAINS in Rebuilt Stationary Gasoline Engines. These are our own engines taken in exchange and rebuilt good as new, 1 1/2 to 12 H. P. \$20 up. Write for description. State size wanted. Sta-Rite Engine Co., La Crosse, Wis.

FOR Sale—Gasoline engines, automobiles, marine and stationary, also castings. Second-hand ones taken in exchange and for sale. Apply with stamps, B. W. Richardson, R. No. 36, Peoria, Ill.

REBUILT Engines—We have on hand a number of rebuilt "Buffalo" engines, guaranteed, at greatly reduced prices. Write for bargain list, Buffalo Gasoline Motor Co., 1293-1295 Niagara Street, Buffalo, N. Y.

JUST Issued—Amateur Mechanics No. 6. Another great book of 293 articles for those who like to make things. Similar in style to the other numbers in the series. 128 pages, 261 illustrations. Paper. Price 25 cents postpaid. Popular Mechanics Book Dept., 6 N. Michigan Ave., Chicago.

ENGINE CASTINGS AND BLUE PRINTS

SMALL Gasoline Engines and Castings with drawings. Stamp for circular. Crown Motor Works, Elgin, Ill.

FOR Sale—Castings for two-cycle engines. Richards Iron Works, Manitowish, Wis.

GASOLINE Engine Castings, with drawings. Cheap. Catalog for stamp. Novelty Manufacturing Co., 853 West 6th St., Cincinnati, Ohio.

BOATS, LAUNCHES, ACCESSORIES

PALMER Motors and Launches, two to fifty horsepower, two and four cycle. Get our 1915 reduced prices. Catalog free. Palmer Bros., Cos Cob, Conn.

FOR Sale—Semi-speed launch, 27 ft. by 4 ft. 6 in. Trelbert, 40 hp., fully equipped, splendid condition, speed twenty-two miles. Stubbs, 818 Granite Bldg., Rochester, N. Y.

MOTORCRAFT Encyclopedia—A 150-page book that tells 1091 things every motor boatman should know. How to overcome engine troubles. Price \$1. postpaid. Popular Mechanics Book Dept., 6 N. Michigan Ave., Chicago.

FOR THE SHOP

FOR That Boy—He will appreciate a copy of the great boy's book "The Boy Mechanic" that tells about 760 different things for boys to do and has 300 pictures, 480 (7x10) pages, cloth, big, handsome book for the price, \$1.50 postpaid. Popular Mechanics Book Dept., 6 N. Michigan Ave., Chicago.

BLACKSMITHS

BLACKSMITHS, get out of the rut; be progressive. Get Toy's modern methods of doing hard jobs easy. Make solid welds. Temper all tools to a standard with Toy's Colored Tempering Charts. Do the job the other smith can't do. All for \$1. Send for free samples, W. M. Toy, Sidney, Ohio.

SHOP Notes—Many valuable hints for blacksmiths are contained in our series of Shop Notes books. 10 volumes, 50c each, postpaid, or \$5 per set prepaid. Popular Mechanics Book Dept., 6 N. Michigan Ave., Chicago.

BLACKSMITHS — Learn hand-wrought ornamental blackwork. Our 200-page book "Hand Forging" points out clearly all the guiding principles and methods which underlie all forge work. Written by a practical authority. 122 illustrations, cloth, \$1 postpaid. Popular Mechanics Book Dept., 6 N. Michigan Ave., Chicago.

CEMENT

IF you want the best information on cement and concrete construction, subscribe for Concrete-Cement Age, leading cement and concrete monthly. Sample copy, 10 cents. Yearly subscription, \$1.50. Concrete-Cement Age, 135 Newberry Bldg., Detroit, Mich.

ELECTRICAL

50-LIGHT Dynamo \$55; 100 light dynamo \$75, in payments \$5 per month. Hobart Bros. Co., Troy, Ohio.

GENERATOR, Direct Current, 25 volts, 20 amperes. Almost new; selling price, \$20. Drigo Sales Company, Bath, Maine.

TRANSFORMERS 110-110 volts, \$5c; 1,000 volt, \$3.75. Stamp for circulars. Daniel Russell, 134 Glenwood Ave., Jersey City, New Jersey.

"AMATEUR Electrician." Make Batteries, Dynamos, Motors, Electric Engine, Telephone, etc. 75 illustrations. 10c. Renew Dry Batteries, 3 guaranteed processes. 20c. Both, 25c. Novelty Shop, 3311-D, Belleguaine Ave., Chicago.

EIGHT inch new Western Electric Fans with ten feet cord and plug, direct current, only \$3. Only few left. Magueto Generators, \$1. Edgar Phillip, 197 Field Ave., Detroit, Mich., for bargains.

FOR Sale: 25 K. W. 125 V 200 A. D. C. generator, \$250.00; 1 H.P. D. C. motor direct connected to 3 K. W. 50 V. generator. This is a storage battery booster, price \$140.00. Lucas & Son, Bridgeport, Conn.

STAMP COLLECTING

CUT the "High Cost" of your Stamp Collection by purchasing from my net priced selections. Bargains galore. Roberts Scyces, Quakertown, Pa. Re. Honduras, No. 15, used. Cat. 75; net \$3.

20 VARIETIES Asia and Africa free to approval applicants enclosing 2c postage. Leon Case, Quakertown, Pa.

WATERMARK Detector and fifty different stamps, ten cents. Bert McCann, Kirksville, Missouri.

FREE packet for Canada, Newfoundland, Turkey, China, etc., with request for our 50% sheets. Enclose 2c for postage. Liberty Stamp Co., 170A Tremont St., Boston.

NICARAGUA, 145 varieties, catalogue value, \$12.70, for \$1.25. Want list solicited; fine approvals. Alfred Nielsen, 272 Union St., Brooklyn, N. Y.

FORTY West Indies, twenty cents; Twenty Chile, ten cents. Pierce Company, Manchester, Michigan.

YOU save money when buying from my 1, 2 and 3c approvals. References please. Wm. Haase, 971 East 39th St., Los Angeles, Cal.

FOREIGN Stamps Free: 52 different foreign, including China and Venezuela, to all who apply for our high grade approval selections. Send two cent stamp for return postage. Edgewood Stamp Co., Dept. H, Millford, Conn.

STAMP Collectors—\$2 premium coupon, big 1915 price list, Monthly Bargain Lists, etc., free. No unsolicited approvals. W. C. Phillips & Co., Glastonbury, Conn.

OLD Canada Packet Free—Early issues, Maps, Jubilees, Tercentenary, Dues, Maple Leaves, etc. Postage 2c. Superb 50% Approvals. Midland Stamp Company, Midland, Ontario.

FREE—295 foreign, 101 United States, 50 Sweden, 50 Asiatic, 50 Norway-Denmark, all different, with McKel's Stamp Weekly, Boston, Mass., six months. Remit 25c. Choose one.

FREE, 100 different stamps, perforation gauge and lists, Postage 2c. Payn Stamp Co., Los Angeles, Calif.

8 ROUMANIA or 6 Greece, 1901, free with trial approvals. References. Sawyer Stamp Co., Onset, Mass.

1,000 STAMPS from 30 countries, 12c. Edward Lubbery, Wallingford, Conn.

BOYS! Stamps 66% discount and premiums. M. D. Place, Wrentham, Mass.

STAMPS, 1,000 mixed 12c. 500 var. Foreign 60c. Approvals. Western Stamp Co., Omaha, Neb.

104 DIFFERENT stamps, including United States 1861 Civil War, Japan, Argentina, etc. Large price list and sample New England Stamp Monthly, only 5c. Finest approval sheets, 50% discount. New England Stamp Company, 19 Washington Bldg., Boston.

FINE low-priced approvals. Mention paper and receive good premium free. S. E. Colman, 634 Keefer Place, Washington, D. C.

STAMPS, 100, all different, free. Postage 2c. Mention paper. Quaker Stamp Co., Toledo, Ohio.

STAMPS—12 different from warring nations, 10c; 10 different foreign coins, 15c; 25 Belgium stamps, 10c. Lists free. Toledo Stamp Co., Toledo, Ohio.

STAMP Album with 338 Genuine Stamps, incl. Rhodesia, Congo (tiger), China (dragon), Tasmania (landscape), Jamaica (waterfalls), etc., 10c. 100 diff. Jap., N. Zed., etc., 5c. Big list; coupons, etc. Free. We buy stamps. Hussman Stamp Co., St. Louis, Mo.

STAMPS sent on approval at 70% discount. Reference required. 1000 Peckleback Hinges 8c. Emory Renoll, Hanover, Pa.

24 VARIETIES Cuban stamps, 10 cents. List of 6,000 low-priced stamps free. Chambers Stamp Co., 111 P. Nassau St., New York City.

PACKET of 23 stamps; no two countries alike, 500 hinges, Set of \$1 and \$2 U. S. Rev., all for 5c. Mention paper. Miami Stamp Co., Toledo, Ohio.

25 DIFFERENT British Colonials to applicants for stamps on approval who send 2c postage. Nickles, 125 Florida Ave., Washington, D. C.

RARE COINS

25c EACH paid for 1913 Buffalo Nickels, and Lincoln pennies. We also buy all old coins, and are willing to compare our prices with any dealer in United States. Send 10c for Coin Catalog. Jones, Coin Dealer, Dept. 38, Newton, Ill.

COINS, Antique Relics—Five curious, rare coins with catalog, 10c. Ray Chapin, New Berlin, N. Y.

OLD Coins Bought and Sold. Spring catalogue list of coins for sale, free to collectors only. Buying catalogue quoting prices I pay for coins, 10 cents. Wm. Hesslein, 191 Tremont St., Boston, Mass.

TEN different coins from warring nations, 25c. Leo Mardonough, Toledo, Ohio.

WE pay big prices for Lincoln Pennies. Send dime for elegant catalog and information. Independent Coin Brokers, 92, Olney, Illinois.

COINS—Coins, Coin value book 15c; 5 foreign 10c. List 2c. Moore Coin Co., Commerce, Texas.

10 COINS from Warring Nations 25c; 10 United States large cents 60c; 150 different stamps 10c. Stamps on approval. Burgess Co., 572B Beaton, Toledo, Ohio.

HOW to earn a 25c and 50c California gold coin. Send stamp. Coin Exchange, New Rochelle, N. Y.

\$50 PAID for Half Dol. 1853, no arrows; \$5 for 1878 Half, 8c Mint, \$100 for 1894 Dime, 8c Mint. Many valuable coins circulating. Get posted. Send 4c. Get our Illus. Coin Circular. It may mean large profits to you. Send now. You have nothing to lose. Numismatic Bank, Dept. 8, Fort Worth, Texas.

\$4.25 EACH Paid for U. S. Flying Eagle Cents dated 1856. We pay cash premiums on hundreds of Old Coins. Send ten cents at once for New Illustrated Coin Value Book 4x7. It may mean your fortune. Clarke & Co., Coin Dealers, Box 15, Le Roy, N. Y.

ALL for 30c. A 25c California gold piece, a Premium Coin Catalog, a selling list, a Colombia nickel and a lucky seed. C. J. Carey, New Rochelle, N. Y.

FOR MEN

SELF Shavers—Long Sharing Bibbs protect clothing, 25c. Fred Huffer, Lewisville, Texas.

MEN, buy your hats direct from the manufacturer. Save money. Send for catalogue. Orange Hat Mfg. Co., Dept. E, Orange, N. J.

MANILA cigars. Direct from factory to smoker, at wholesale price, 100 cigars, best grade, \$5 by registered mail, all duties paid. Write for free catalogue. Satisfaction or money returned. Patingell, Martin & Co., Lucena, P. I.

SAVE money on shoes! Factory to feet. You save retailer's profit and get better shoes. Fit and entire satisfaction guaranteed or money back. Style book free. Pathfinder Shoe Co., Dept. P, Webster, Mass.

SAFETY BLADES SHARPENED

SAFETY Razor Blades resharpened keen as new, 2 1/2c up. Pay after you try blades. American Tool Co., Springfield, Ohio.

ANY blade ground, honed, 2c. Keenedge, Oshkosh, Wis.

SAFETY razors sharpened; two cents each. Guaranteed. Blade box free. Electro Shoothing Co., 184 Shelby St., Detroit, Mich.

FOR THE HOME

NEW Burglar-Proof Lock—Prevents rattling, also raising by burglars or children, even if window partly raised for ventilation. Easily attached, never wear out; no home safe without them. Send 5 cents in stamps for sample lock to try in your own home. The Warner Company, Dept. 30, Muncie, Ind.

BEAUTIFUL arts-crafts lamps—Anyone can make them out of paper, cardboard and wood. 16 designs. Inexpensive yet artistic. Complete book of instructions. Price, 50c postpaid. Popular Mechanics Book Dept., 6 N. Michigan Ave., Chicago.

MAKE your own mission furniture at the minimum of expense. Out 3 books "Mission Furniture. How to Make It." Parts 1, 2 and 3, tell in plain, simple language just how to make 98 different pieces. Full dimensions, working drawings and half tones of finished articles. Price, 50 cents each or \$1.50 for the three volumes, postpaid. Popular Mechanics Book Dept., 6 N. Michigan Ave., Chicago.

ARTISTIC Lamps and Shades in metal and art glass easily made by the amateur craftsman from instructions given in our book of 18 designs ranging from ordinary reading lamps to pretentious chandeliers. Expense only slight. Price of book 50c postpaid. Popular Mechanics Book Dept., 6 N. Michigan Ave., Chicago.

INVALID FURNITURE

ROLLING Chairs. We make 70 styles, carrying chairs, invalids' lifts, beds, tables, bed trays, back rests, commodes, etc. Catalog "B" illustrates—describes free. Send for it. Geo. F. Sargent Co., 284 Fourth Ave., New York.

DIAMONDS, WATCHES AND JEWELRY

I will give you one of the finest 17 jewel Elgin, Waltham, or Illinois Movements, fitted in a superb Double Strain Gold Case, guaranteed to wear 25 years, for \$12.50. Examination free. Satisfaction or money back. Write for biggest bargains ever offered in World Standard Watches. Sutton, The Watch Man, 207 Keller Building, Louisville, Ky.

PIANOS AND MUSICAL INSTRUMENTS

TALKING Machines—Columbia Grafonola complete with 25 records, only \$12.00. Edison Standard, 2 minute, complete, horn, stand, 25 records, only \$6.00. Edison Standard and Amberol records, 9c up. Victor records, 15c up. Player-Piano rolls, 5c, 6c, 8c-note, 15c up. We buy and exchange. Large selection. Weil's Curiosity Shop, 20 S. Second St., Philadelphia, Pa.

TALKING Machine Records at cut prices. 100,000 10-inch records for Victor and Columbia Talkers, 60c kind, our price, 20c. Send for catalogue. Deninger, the Price-Cutter, Rochester, N. Y.

BRAND New Columbia Grafonola. "Regent," solid mahogany. Cost \$225. To sell quick, \$115. Other Victrola bargains. David Stern Co., 1047 M W. Madison St., Chicago.

USED talking machines, all makes, \$5 and up. Send for free list. Brown Music Company, 9119 Commercial Ave., Chicago, Ill.

MUSIC

"DREAMS," the greatest waltz ballad in years. For sale everywhere or direct from us. 10 cents. Marks-Goldsmith Co., Dept. 91, Washington, D. C.

BUSINESS SERVICE

ADDRESSES and special papers prepared; dinner talks and commencement work; commercial translations. The Writers' Bureau, Tiffin, Ohio.

INCORPORATE. Our lawyers do the work, saving you time, annoyance and money in incorporating under the most liberal laws of Arizona. Laws and forms free. Southwestern Securities & Investment Co., Box 1488, Phoenix, Ariz.

ESTIMATING and Contracting by Radford—A 990-page manual of up-to-date methods for rapid, systematic and accurate calculation of costs of all types and details of building construction, with quotations of ordinary prices for labor and materials, standard schedules and forms, labor-saving tables and other data useful to the building trades. Flexible leather illustrated—\$2 per copy postpaid. Popular Mechanics Book Dept., 6 N. Michigan Ave., Chicago.

FORMULAS AND TRADE SECRETS

PLUMBERS and Pipefitters: I haven't a formula for everything, but one dollar gets formula for best pipe joint dope on market. Can buy necessary ingredients in your own town for 3c pound. Sample 6c. Leo Symmes, Eau Claire, Wis.

MAKE your own dry batteries. Guaranteed instructions and blueprint, 10c. Dirigo Sales Company, Bath, Maine.

1,650 **FORMULAS** 40c, 100 plans, schemes 20c, 75 manufacturing secrets 10c, resistor mirrors 10c. All 50c prepaid. Service Bureau, 3311-D Bellgrade Ave., Chicago.

HIGH Grade Perfumes 17 cents ounce. Formula for 12 odors \$1. Dubreuil, Chemist, 341B Plessis, Montreal, Canada.

FARMERS: Make your own fertilizer, \$15 per ton. Formula, \$1. M. S. Bacon, 8 Slocum St., Providence, R. I.

RELIABLE Formulas on anything, 25c each. Rose Information Bureau, 87 W. Cedar St., Boston.

A HIGH grade, guaranteed formula for almost any occasion. Prices reasonable. Correspondence confidential. Cole Chemical Company, Chicago.

20,000 **FORMULAS**—Price, \$1, postpaid; complete list 4c stamps. Edm. Bromley, Watervliet, N. Y.

10,000 **SELECTED** scientific, chemical technological, and practical recipes and processes, including hundreds of so-called trade secrets for every business, alphabetically arranged in one large volume of 800 pages. Price \$2 prepaid. Popular Mechanics Book Dept., 6 N. Michigan Ave., Chicago.

GAMES AND ENTERTAINMENTS

MAGICIANS, Amateur and Professional, we can save you money in the magic line; send for our illustrated catalogue. Northwestern Supply Co., 2215 4th Ave., N., Minneapolis, Minn.

470 **TRICKS, Jokes, Riddles, Fortune-telling Secrets** and big catalog 10c. Novelty Shop, 3311-D Bellgrade Ave., Chicago.

BOYS: Latest trick out, only twelve cents. Holt Sales Company, Atlanta, Ga.

TRICKS, Puzzles, Jokes, Magic Goods, Ventriloquist Figures, Sensational Escapes and Illusions. Big catalogue free. Oaks Magic Co., Dept. 170, Oshkosh, Wis.

WONDERFUL Magic Trick Cards Free! To introduce our catalogue. Walwen Company, 150 Nassau St., New York.

TRICK Joker articles, novelties. Wholesale, Retail. Useful and entertaining books of every description. Catalog with Revenue letter 6 cents. Japanese Novelties, 451 84th Ave., New York.

MAGIC trick cards and catalog 5c. McGuinness, 109 Weirfield St., Brooklyn, N. Y.

MAGICIANS! Save money! Buy your Magic Tricks from factory at lowest prices on earth. We retail at wholesale prices. Bargain Catalogue free. Eagle Magic Co., 1211 Nicollet, Minneapolis, Minn.

\$1,000.00 **WORTH** used magic tricks cheap. Twenty-six page list and catalog 2c. Fake money, flashy reel, real-looking maxima, our own make. With catalog 10c. Gilmore, Morgan Park, Illinois.

SPIRIT Photos: Genuine permanent pictures made instantly without camera. Never before considered possible. Marvelous results. Entertains and astonishes. Satisfaction or money back. Sample outfit 25c; enough for 24 pictures. Alpha Company, 134 Brook Ave., New York.

FUN, Magic and Mystery, a big collection of Parlor Magic, Tricks with Cards, Toasts, funny readings, flirtations, amusing experiments, money-making secrets, 25c new jokes, riddles, parlor amusements, puzzles, problems, parlor games, etc., all for 10c. The Isis Sales Co., New Brunswick, N. J.

NOVELTIES, Books, Tricks, Games, Etc. Illustrated Catalogue free, Sample 25c Card trick, 10c. Autumn Supply Co. Specialty Dept., 7745 Peoria St., Chicago.

MAGIC disappearing coin and ring trick, Mystical amuses. Send 10c in coin. Catalog. Powell Sales Company, Dept. E, Ossining, N. Y.

MAGIC Plate Lifter free with instructions how to get other tricks free. Box 308-P, Waco, Texas.

62 **TRICKS, 58 Puzzles, 57 Games,** and 224 Jokes, 10c. H. J. Sun Co., Harrison, Michigan.

SEND 6c to Home of Magic, Albany, N. Y. Get trick complete and two catalogues.

MAGICIANS' tricks, Handcuffs, Escapes, Ventriloquist and Punch figures. Prices low. Catalog free. Sample trick, 2c. Magic Parlors, 192 Clifford, Providence, R. I.

FREE Magic Pocket Trick. Worth 25c. Illustrated catalog included. Send 6c stamps. Everything for stage and parlor entertainment. Buy direct from a professional manufacturer. Magic Co., Sta. 10, 247 West 38th Street, New York.

P-L-A-Y-S. Speakers, Dialogues, Drills, Joke Books, Wags and Beards. Catalogue free. Amos Publishing Co., Dept. 49, Clyde, Ohio.

BE a handcuff king. We teach you. Escape from handcuffs, boxes, ropes, etc. Secrets of 20 sensational escapes \$1. Particulars free. The Magcraft Co., Dept. A, Box 251, Detroit, Mich.

PLAYS, Vaudeville Sketches, Monologues, Dialogues, Speakers, Minstrel Material, Jokes, Recitations, Tableaux, Drills, Musical Pieces, Entertainments for all occasions. Make-up Goods. Large Catalog Free. T. S. Denison & Co., Dept. 11, Chicago.

MAGIC Catalogue, 100 pages, greatest on earth, ten cents. Learn magic at home. We teach you to do these tricks as good as the great professionals—escape acts, rope ties, mind reading, handcuff secrets. Satisfaction guaranteed. Chicago Magic Co., Dept. B, 72 W. Adams St., Chicago, Ill.

NIFTY Joke. September Morn squint ring, 10c. Stovers, Millersburg, Pa.

MAILING LISTS

AGENTS' Names—We will furnish carefully selected names and addresses of live, active agents at \$1 per hundred. Collected through recent high-class magazine advertising at cost of about 25c per name. Names gathered from all parts of the country and sure to give results. How many do you want? Fisher Knitting Company, Utica, N. Y.

THE Mailing List. Just compiled. 500 rural, 500 women small towns, 500 heads of families, 250 machinists, 250 stenographers. 2,000 names in all. \$1. No checks or stamps accepted. The F-W Pub. Co., Commercial Information Dept., Winona, Minnesota.

FARMERS' Names, Auto Owners; also all businesses in Texas and surrounding states. Texas Name Listing Association, Dallas, Texas.

20,000 **MALE inhabitants** in rural sections of Western North Carolina. All over twenty-one years of age. Correct name and address. Only recently compiled, splendid list. Printed and neatly bound, \$2.00 per thousand. Lock Drawer 612, Asheville, North Carolina.

2,000 N. Y. **FARMERS' names,** 50c. Miller, 1951 Germantown Ave., Philadelphia.

2,000 **NEW YORK** state rural names \$1.50; 1,000 for \$1.00. Rodgers, Box 302K, Fall River, Mass.

BONA Fide rural addresses, 600 at 50c a hundred. Satisfaction guaranteed. Post-office News Co., Hicksville, Ohio.

FREE to business men, copy of our comprehensive "Silent Salesman." Contains over 2,000 different classifications of Mailing lists with number and price of each list, and information every business man needs. Accept this free offer. Trade Circular Addressing Co., G 164 1/2 W. Adams, Chicago.

TYPEWRITERS AND SUPPLIES

ALL standard makes of typewriters. Big saving. Liberal guarantee. Catalogue, bargain list and valuable typewriter information free. The leading mail order typewriter house, A. E. Atchison, 110-112 No. LaSalle St., Chicago.

1915 MODELS, \$100 machines, \$80, payable \$5 monthly. Old machines exchanged for new models. Catalog free. Edward Biele, Woodridge, New Jersey.

WRITE for free trial and cut rate prices. Remingtons \$10. Officers \$15. Smiths \$12. 500 Machines \$5 to \$35. Everyone perfect; guaranteed 5 years. Arme Typewriter Exchange, 162 North Dearborn, Chicago.

TYPEWRITER Ribbons, best quality. 50 cents each; \$5 doz. postpaid. Standard Ribbon Co., Mfrs., Natick, Mass.

ALL Typewriters \$10 up. Catalogue free. National Typewriter Exchange, 355 Broadway, New York.

TYPEWRITERS, all makes, factory-rebuilt by famous "Young Process." Look like new, wear like new, guaranteed like new. Our big business insures "Square Deal" and permits lowest cash prices—\$10 and up. Also, machines rented—or sold on time. No matter what your needs are, we can best serve you. Write and see—now. Young Typewriter Company, Dept. 145, Chicago.

\$2 A MONTH for Rebuilt Oliver Visible Typewriters, Free Trial, 10-Year Guarantee. United States Typewriter Exchange, Dept. 289, Federal Life Bldg., Chicago.

WANTED—Used Corona Typewriter. Must be in A1 condition. Write, giving lowest price, etc. O. H. Stivers, 10 East Pearson St., Chicago.

GOOD, serviceable typewriters \$7.50 and up. Post card brings list. Hub Typewriter Co., 286 Deronshire St., Boston.

TYPEWRITERS—Rare bargains from \$5 to \$50; all guaranteed; shipped with privilege of 15 days' free trial; get our proposition before purchasing a writing machine. We can save you dollars. Coast Typewriter Exchange, Atlantic City, N. J.

CIRCULAR MAILING

CIRCULARS honestly mailed, 6x9 or smaller, 1,000, \$2. Earle Fowler, Clintonville, Conn.

PRINTING, ENGRAVING AND MULTIGRAPHING

PRINTING—500 either noteheds, envelopes, statements, cards, \$1; 1,000, \$1.50; 1,000 linen finish letterheads or envelopes, \$2.50; 1,000 typewriter letters, \$2. Samples. Model Company, Manchester, Iowa.

1,000 **IMITATION** Typewritten Letters, heading black, body purple, bond paper, \$1, 1,000 Art Advertising Slips, 150 words, \$1, postpaid. Send for price list. McCartney, Box 207, Harrisonburg, Va.

125 **LETTERHEADS** and 125 Envelopes, printed, \$1 postpaid. Patterson, Printer, Beaver Falls, Pa.

PRINTING Outfits—Presses, 1,500, 800-plies. Catalogue free. The Model Press, York, Pa. In business forty years.

100 **EACH** Bond Noteheds and Envelopes, 60c postpaid. Also Kodak developing. Coleman, Henry, Va.

125 **WHITE** Bond Letterheads and 125 Envelopes, printed, \$1, prepaid. B. Lutz Printing Co., York, Pa.

1,000 **ENVELOPES**, Letterheads, cards, or 6x9 circulars, \$2.25. Imitation typewritten letters—perfect reproduction. Samples. Franklin Press, Waukegan, Illinois. 6x3 foot-power press, outfit and typewriter for sale.

\$2.00 **FOR** 250 either linen finish or plain bond letterheads and 250 envelopes, 5,000 20 pound bond letterheads for \$7.50. Multigraphed letters of quality. Direct Advertising Co., Akron, Ohio.

IMITATION Typewritten letters, letterheads, envelopes, circulars, \$1.50 thousand. Elegant set samples free, including Art and DeLuxe Slip, \$1 thousand prepaid. Good's Printery, Harrisonburg, Va.

YOUR Name on 200 gummed stickers, 10c; with address, 15c. Star Press, Clintonville, Conn.

GUMMED labels, 3,000 \$1. Catalogue 2c. MacTaggart, 1235 Arch, Philadelphia, Pa.

150 **LETTERHEADS** and 150 envelopes, white, blue, pink or canary, neatly printed to order, \$1 postpaid. Guaranteed. Samples. Union Publishing Co., Dept. M, Uniondale, Indiana.

1,000 **LETTERHEADS** Envelopes, Bill Heads, Cards, \$2.50. The National Print Shop, Edwin J. Robb, Proprietor, PM39, 59 L Street N. E., Washington, D. C.

ARISTOCRAT, the new stationery adopted by leading concerns. Most practical size. Special offer—1,000 letterheads and 1,000 envelopes (printed), prepaid, for \$5. Send for portfolio of fine samples—free. L. S. Frank, Adv. Mfg. Co., 704 Locust St., St. Louis.

TWO-COLOR printed Stationery; inexpensive, attractive. Send copy for samples. Satisfaction guaranteed. Westall Printery, 11 South Vine Street, Worcester, Mass.

POSTPAID—1,000 Envelope Slips 75c; 500 Noteheds, Statements, Cards, 50c; Envelopes, 50c; Bond Letterheads, \$1. Samples. Ryder, Barnerville, N. Y.

POSTPAID—100 Linen Letterheads or Envelopes 50c. A. J. Sturm, Stratford, Wis.

30 **CALLING** Cards, 10c, prepaid. F. Shengard, Rome, N. Y.

PREPAID, 200 gummed labels 10c; 1,000 circulars \$26, 85c; 500 bond letterheads and envelopes \$2.85. The Majestic Printing Co., 3044 Leeward Ave., Los Angeles, Calif.

HIGH-CLASS Developing and Printing. Valuable booklet free, W. W. Sweetman, Box 602, Portland, Me.

EMBOSSED Letterheads—Envelopes, price of common printing. Samples. Turner & Dunlap, Wilkes-Barre, Pa.

BILL Heads, Letter Heads, Cards, Envelopes, Circulars, 1,000 for \$2.25. Burrill Printing Co., 178 East Court, Kankakee, Illinois.

1,000 **TWO-COLOR** Circulars, 3½x5½, best grade enamel paper, 100 words, postpaid \$1.20. Same in one color 35c. The Conger Printing Co., Portsmouth, Ohio.

500 **LETTERHEADS**, 500 envelopes on bond (watermarked), \$4. Circular letters \$2 per 500. The Sun Publishing Co., Jackson, Ohio.

CUTS easily made by anyone. Instructions 25c. Joe Bek, 118 Gazette Ave., Lexington, Ky.

CUT-PRICE Multigraph Letters, Letterheads, Schwartz Bros., Congress, Detroit, Michigan.

RUBBER stamp; name and address 15c. Hecker, 1174 Stout, Denver, Colo.

FREE—How to make your Letterhead attractive; send me one. D. Frechurn, Hicksville, Ohio.

250 **ENVELOPES** and letterheads, \$1.50. Souldard Printing Co., 1033d Souldard, St. Louis. Samples, 2c stamp.

ADVERTISERS—Here's your opportunity, 25 word classified ad inserted in "Cartoons Magazine" for 50c; one inch display ad \$1.25. 30,000 copies guaranteed. Send in your ad for the next issue. Cartoons Classified Dept., 73 E. Madison St., Chicago.

PRINTING Presses, Type and Supplies. Big bargain sheet for stamp. Popular Bargains, Richmond, Pa.

PRINTING Presses, type, supplies. Catalogue free. L. M. Carroll & Co., 326 Madison St., Chicago.

GUMMED Labels, 3,000—\$1, 1x2 inches, printed to order. Catalogue 2c. Helmers Co., Hoboken, N. J.

GOOD Printing at low prices. 1,000 good letterheads, envelopes, cards, billheads, labels, circulars, \$2.50. Samples free. Catalogues, booklets, and circulars our specialty. Ernest L. Fantes Co., 513 S. Dearborn St., Chicago.

PAN-AM. PATENTS AND TRADE MARKS

T. DENNIS LOCKLING, C. E. (Pan-American Patent Attorney), P. O. Box 1801, Santiago, Chile. Patent and trademark protection procured in the "ABC" and adjoining South American Republics; workings effected; prosecution of legal defenses; industrial representation; reports, translations; charges and powers forwarded patent attorneys on request.

PATENT ATTORNEYS

PATENTS secured in quick time. We save you \$20. Send sketch for Free Patentability Report and Financial Possibility Diploma. Fuller & Stoyton, Engineers and Patent Attorneys, 500 Fifth Avenue, New York.

PATENTS—U. S., foreign, obtained by us, sold on commission. International Bureau of Patents, Inc., Park Row Building, New York.

OFFICIAL Drawings Free. Patents procured or fee refunded. Expert services. Send sketch for Free search. The Patent Exchange, Washington, D. C.

PATENTS secured promptly. Trademarks, Designs and Copyrights. Personal attention. Edward W. Kibbey, Patent Attorney, 503 Victor Bldg., Washington, D. C.

EQUITABLE Plan enables you to file application for patent at moderate cost. Particulars on request. Geo. R. Hamlin, 800 H Street, N. W., Washington, D. C.

PATENTS \$50.50, payable by easy installments. Wm. C. Dashiell, 300 H St., Washington, D. C.

PATENT your invention. \$10,000 offered for inventions wanted. Booklet and opinion free. Milo B. Stevens & Co., established 1864, 485 F St., Washington; 353 Menadnock Block, Chicago.

THE Patentome is free. An education in obtaining patents. Established 1885. Anderson & Son, Attorneys, 707 7th St., Washington, D. C.

"PATENTS and Patent Possibilities" is a 72-page treatise which tells all about patents, what to invent and where to sell it. It gives honest advice to inventors, and is full of valuable and interesting information. Write for it today! It is free. H. S. Hill, 905 McLachlen Bldg., Washington, D. C.

PATENT what you invent. It may be valuable. Write me. No attorney's fee until patent is allowed. Estab. 1882. "Inventor's Guide" free. Franklin H. Hoag, 322 Loan & Trust Bldg., Washington, D. C.

FOR dependable advice about Patents, address Benjamin & Bassett, 140 S. Dearborn St., Chicago, Ill.

PATENTS—Herbert Jenner, patent attorney and mechanical expert, 606 F St., Washington, D. C. I report free of charge if a patent can be had and its exact cost. Send for circular.

C. L. PARKER, Ex-member Examining Corps Patent Office, Patent Attorney, 919 G St., Washington, D. C. Inventor's handbook, "Protecting, Exploiting and Selling Inventions," sent free upon request.

PATENTS build fortunes for you. Our free booklets tell how; what to invent, how to choose an attorney. Write today. D. Swift, 317 Seventh St., Washington, D. C. Established 1889.

WANTED—New Ideas. Write for List of Inventions Wanted. \$1,000,000 in prizes offered for inventions. Our Four Books sent free upon request. Victor J. Evans & Co., 160 Ninth St., Washington, D. C.

PATENTS explained in my free books, telling what you should know—what to invent—what not to invent—how to sell your patent, etc. Write today, H. L. Woodward, 902 G St., Washington, D. C.

PATENTS that protect and pay. Advice and books free. Rates reasonable—highest references; best results. Watson E. Coleman, Patent Lawyer, 622 F St., N. W., Washington, D. C.

PATENTS That Pay. Proof given. Two wonderful guide books free. K. E. Vrooman & Co., 871 F St., Washington, D. C.

PATENTS—Send sketch for free search and report. Books on patents and book of reference letters sent free. John S. Duffie & Co., 610 F Street, Washington, D. C.

PATENTS—Trade-Marks. Send for my free book "How To Get Them." It's full of information you should know. Joshua R. H. Potts, 8 Dearborn St., Chicago; 929 Chestnut St., Philadelphia; 305 G St., Washington.

INVENTIONS Worth Thousands—Their value is governed by the strength of the patent. Get the advantage of our 39 years' experience in procuring your patent. Clients in your state. Write and send sketch. Louis Bagger & Co., 609 Barrister Bldg., Washington, D. C.

PATENTABLE Ideas Wanted—Send for 3 free books. R. B. Owen, 30 Owen Bldg., Wash., D. C.

PATENTS secured or fee returned. Send sketch for free search. Latest and most complete patent book ever published for free distribution. George P. Kimmel, attorney, 212 Barrister Building, Washington, D. C.

C. W. GERARD, formerly Patent Office Examiner, Scarritt Building, Kansas City, Mo.

NO Attorney fees until patent allowed. Send sketch for free report. Books free. Frank Fuller, Washington, D. C.

PATENTS secured through credit system. Patentability search free. Booklet free. John Louis Waters & Co., Hutchins Bldg., Washington, D. C.

PROTECTIVE patents procured promptly. 112 page blue book on patents sent on request. Trade-marks registered. Robb & Robb, 211-215 Southern Bldg., Washington, D. C.

PATENTS Secured—Take advantage of my personal experience; send sketch or model. Get my free book containing 209 mechanical movements. W. N. Roach, Jr., 950 McGill Bldg., Washington, D. C.

FOR INVENTORS

PATENTS, Trade-Marks and Copyrights. Our handbook on patents will be sent free on request. All patents secured through us are described without cost to the patentee in the Scientific American. Munn & Co., Patent Attorneys, 672 Woolworth Bldg., New York City, Washington, D. C., office, 383 F Street.

It cost One Dollar in 1893

It was then the Wonder Watch of the day. Here in 1915—a thinner watch, a better keeper of time, simpler and more durable, the price is still One Dollar.

It is today the greatest monument in industry to the old adage about doing one thing and doing it well.

Twenty-two years have brought more than a thousand improvements and the fine perfection that goes with long practice.

He who is without an Ingersoll, in this day, is a rare individual.

60,000 dealers in all parts of the United States sell these watches. If your dealer does not, a dollar will bring one prepaid.



1893



1915

Ingersoll
**the Dollar
 Watch**

Robt. H. Ingersoll & Bro., 315 Fourth Avenue, New York, N. Y.

YOUR OPPORTUNITY



Prof. F.W. Foote
Psychologist

Tells you of
**YOUR
NECESSITY**
of
MY COURSE
in Scientific
**MENTAL
TRAINING**

THE RESULT: Your
possession of

CONCENTRATION
*The Master
Power*

which
Makes
Failure Impossible

Frequently you have failed because your Brain has played tricks with you, and you accomplish nothing compared with what you know you have power to accomplish. No matter how well equipped mentally you may be, you must have power to Concentrate—to dictate to the Brain its task, and demand obedience.

Your Brain Machine is governed by law—I will personally teach you these laws through the **Science of Psychology** and when you are in possession of this knowledge you will be able to Master your Destiny. No matter what vocation you may follow, this is a necessary and fundamental study.

If you desire Will-Power, Poise, or a fully developed Personality, you must first have the control over your Brain so that you have **Power to Concentrate**

Without that power nothing can be accomplished. Do not lumber your Brain with a system that you have to remember. My method of training will make the scientific knowledge part of yourself. The Course is simply and plainly written, and from your study of the first lesson you will be conscious of new power. Mr. Thomas Woods writes under date of February 24, 1915. "I have received my first lesson, and am already conscious of definite improvement."

I have a personal and individual method of Teaching and Training every student. My scientific training in the great Universities of the world is at your disposal. It will be my pleasure to personally train you to increase your Mental Powers. My knowledge will enable me to know which is the law for you to use and master. You cannot afford to ignore the opportunity which this course of study offers. It is based on the fact of law. **YOUR SUCCESS IS POSITIVE AND ASSURED.** You will send for my free book now and also learn how to secure

Two Vocational Courses Free



THE SIGN OF MENTAL VICTORY

PROF. FREDERICK W. FOOTE P. M. 4-15
Principal Chicago Institute of Menti-Culture
(A School of Applied Psychology)
30 No. Michigan Blvd., CHICAGO, ILL.

Send me Free Book "Masters of Destiny" and all particulars of your Mental Training Course and special offer of Two Vocational Courses FREE.

Name

Address

Please Mention Popular Mechanics



Learn a Paying Profession

that assures you a good income and position for life.
For twenty years we have successfully taught

PHOTOGRAPHY

Photo-Engraving and Three-Color Work

Our graduates earn \$20 to \$50 a week. We assist them to secure these positions. Learn how you can become successful. Terms easy—living inexpensive. Write for catalogue—NOW!
ILLINOIS COLLEGE OF PHOTOGRAPHY, 999 Wabash Avenue, Effingham, Ill.

ELECTRICAL men with training are always in demand. Having trained over 2000 young men in the past 22 years in the fundamentals of Applied Electricity, The **Bliss Electrical School**, with its well-equipped shops and laboratories, is peculiarly well qualified to give a condensed course in Electrical

ENGINEERING



including Mathematics, Steam and Gas Engines, Mechanical Drawing, Shop Work, and Theoretical and Practical Electricity, in all branches. Students construct dynamos, install wiring and test efficiency of electrical machinery. Course, with diploma, complete

IN ONE YEAR

For practical young men with limited time. 23rd year opens Sept. 22nd. Catalogue on request. 105 Takoma Ave., Washington, D. C.

TRADE SCHOOL COURSES

give just the practical training needed to qualify for good paying jobs. Save a year's time. Automobile, Machinist and Manual Training Courses, 48 weeks. Chauffeur Course complete in 12 weeks—general knowledge of the auto—how to drive and locate trouble in car. Special 6 weeks' driving course. Engineering. Low fees and living costs. For catalog address
Geo. P. Magill, Pres., Highland Park College, Des Moines, Ia.

The University of Chicago

**HOME
STUDY**

in addition to resident work, offers also instruction by correspondence.

For detailed information address

23rd Year U. of C. (Div. 20) Chicago, Ill.



Drafting Will Promote You!

These courses will give you the knowledge that means promotion and big salary. Architectural, Mechanical and Structural Drafting and Design, Estimating and Contracting, Builders' Courses and Plan Reading.

DRAFTING

Complete \$15.00
Outfit and all Blue
Print Plans FREE.

Day, Evening, Home-Study Courses. Write today.
CHICAGO TECHNICAL COLLEGE
1050 Lake View Building CHICAGO, ILL.

MUSIC TAUGHT FREE AT YOUR HOME

Write Today for our booklet. It tells how to learn to play Piano, Organ, Violin, Mandolin, etc. Beginners or advanced pupils.
AMERICAN SCHOOL OF MUSIC, 50 Lakeside Bldg., Chicago, Ill.

LEARN TELEGRAPH

Morse and Wireless—R. R. Accounting (Station Agency) taught. Splendid opportunities. Positions secured. Marconi Co. takes our wireless graduates. We own and exclusively occupy two large modern buildings equipped with R. R. and Western Union wires and complete \$5,000 Marconi Wireless Station. Largest School—established 47 years. Investment \$25,000. Endorsed by Railroad, Marconi and Western Union Officials. Expert, practical teachers. Low living expenses; easily earned if desired. Tuition low. Easy payment. Correspondence courses also. Catalogue Free.
Dodge's Telegraph, Ry. & Wireless Institute
8th Street, Valparaiso, Ind.

You
Can
Make
This
Jump
Easy!



Become an EXPERT ACCOUNTANT

\$3,000 to \$10,000 Yearly Right now railroads, corporations and other big firms need Expert Accountants at salaries of \$3,000 to \$10,000 yearly. The need for experts is greater than the supply, and possibilities for advancement into big, powerful executive positions of prosperity are excellent everywhere. Become an Expert Accountant and name your own salary—be your own boss—build a future of prosperity and independence. Be a big man—an important factor.

We Train You By MAIL!

You can become an Expert Accountant—we make it easy, no matter what you work at now, your wages or education. If you can read and write English, the LaSalle Extension University can qualify you for this remarkable vocation at home, in spare time. It is not necessary that you already understand bookkeeping. For those who need elementary training, we have devised a general Course in Bookkeeping that prepares you from the ground up for more advanced work in Higher Accountancy. The LaSalle Course is thorough, advanced, comprehensive. Prepared by some of the world's most noted Expert Accountants and covers Theory of Accounts, Practical Accounting, Cost Accounting, Auditing, Business Organization and Management, Business Law, etc. Administered under the supervision of William Arthur Chase, a nationally recognized leader, Ex-President American Association C. P. A. Examiners and Ex-Sec'y Ill. State Board Examiners in Accountancy. Prepares you for C. P. A. examinations in any state.

Remarkable Book FREE—What Every Bookkeeper Should Know—tells information you need to be had, etc. Send coupon now for free copy.

Special Reduced Rate Let us tell you how, for a limited time only, to secure Special Extra Reduced Rate Scholarship. This offer is limited and might be withdrawn any day, so do not delay. Send NOW for facts.

ACT

today. Let us tell you about the success of LaSalle students and the success possible now for Expert Accountants with LaSalle training. Let us prove that we can qualify you for one of these opportunities. Don't let money worry you—we make terms to suit you. Mail coupon now. Send no money—all free.

LaSalle Extension University Dept. H-532 Chicago, Ill.

LaSalle Extension University
Dept. H-532 Chicago, Ill.

Send free book, How to Become an Expert Accountant, and details of your Course in Higher Accountancy; also facts about Reduced Rate. I am obligated in no way.

Name

Address

MONEY-BACK GUARANTEE BOND

So thorough is the LaSalle Home Study Course—so exceptional has been the success of LaSalle students—that we issue with each LaSalle Course a bond, binding ourselves to refund the entire tuition fee if after you complete the Course you are not perfectly satisfied. This guarantee is backed by our entire capital and resources of more than one million dollars, which assures your absolute success.

Learn to PAINT SIGNS and SHOW CARDS

I'll teach you personally by mail, 16 years' successful teaching. Big field for men and women. You can Earn \$18.00 to \$45.00 a Week. Shaw (Ky.) says, "Your personal criticism worth price of course." Write me for outlines of courses.

DETROIT SCHOOL OF LETTERING
Chas. J. Strong, Founder Dept. 304, Detroit, Mich.



Would You Like to Write 100 Words a Minute Without Knowing Shorthand? If So, Learn

BRIEFHAND

The modern substitute for stenography, using longhand characters. Easy to learn, write and read. Invaluable to business and professional men and women, ministers, teachers, secretaries, clerks, students, boys, girls—EVERYBODY. Recommended by many responsible persons. Complete self-teaching Manual, containing full instructions, 2900 illustrations and many "short cuts," \$1.00.

PREMIER BRIEFHAND SCHOOL, Dept. B, WASHINGTON, D. C.

Learn Watchmaking At Home



You can learn by our modern and original system of instruction every part of the Watchmaker's Trade at home as good or better than at a shop. You can earn money while learning and secure a well paying position after completing our course of instruction. Good watchmakers are always in demand and earn from \$20 to \$35 per week. For particulars apply to the Wisconsin School of Watchmaking, Stroh Bldg., Milwaukee, Wis.

SPEAK A FOREIGN LANGUAGE!!!



The European war has created a great demand and unlimited opportunities for those who know Spanish, French, German or Italian. Now is the time to better your position or increase your business. You can learn quickly and easily, at home, during spare moments, by the

LANGUAGE-PHONE METHOD

And ROSENTHAL'S PRACTICAL LINGUISTRY You listen to the living voice of a native professor pronounce the foreign language, over and over, until you know it. Write today for Booklet, particulars of Free Trial. Easy payments.

The Language-Phone Method, 961 Putnam Bldg., 2 W. 45th St., N. Y.

SELF MASTERY

Stop and Think

Do you realize what this means to you? It means freedom from physical aches and pains, a strong and healthy body, happiness, success in whatever you may undertake.

Leavitt Science

will show you the way. It accomplishes this result easily and quickly. It gives you courage for despair, strength for fear, direction for aimlessness.

Power of Concentration, Self-Control and Self-Confidence

of influence to attract to you those you desire, those that can help you. It means freedom from servitude and bondage. C. Franklin Leavitt's Wonderful Book, which will show you how to become "Master of Your Fate" and "Captain of Your Soul," will be sent for twelve two-cent stamps. Send for it today and begin to live.



C. Franklin Leavitt, M. D.
Suite 948
14 W. Washington St.
Chicago, Ill.

Enclosed find 24c in stamps, for which please send me your wonderful book on How to Become Your Own Master.

Name

Address

Please Mention Popular Mechanics

Learn Electricity!



Earn \$150⁰⁰
TO
\$300⁰⁰
a Month

Electricity is today the great motive power of the world. Its use has extended to every phase of life and industry.

Thos. A. Edison says that the field of electricity is in its infancy—that electrical workers of the future will discover uses for this great force now undreamed of.

Right now there are not enough electrical engineers to fill the big paying positions open. Every month our Free Employment Bureau has calls for Electrical Engineers greater than we can fill. Therefore, we are making a very special offer to students.

Write today! Send the free coupon for our catalog and free information.

**We Teach You in a Short Time—
—at Small Expense**

In order to supply more electrical engineers we are charging a small tuition fee. Your tools and equipment of all kinds are furnished FREE by the School. You may have easy payments if desired. Our course of instruction is clear, simple and thorough. Our Graduates demand handsome salaries. Don't pass up this opportunity.

FREE TOOLS

We will furnish all the material and tools you use in taking our course—ABSOLUTELY FREE. All we charge is a very small amount for tuition. Many of our students earn their expenses while taking the course.

**Men Wanted
for These Trades**
Electricity Plumbing
Bricklaying
Moving Picture Operating
Mechanical Drawing

We also teach the trades mentioned above. There are unlimited possibilities in any one of these trades. When you have completed our course you will be in a position to demand from \$5.00 to \$8.00 a day right at the start. Or go in business for yourself and make from \$3,000 to \$7,500 a year.

**Send the FREE COUPON for
Catalog and Particulars**

FREE COUPON

L. L. COOKE,
Director

Coyne National
Trade Schools

39-51 E. Illinois St.
Dept. 1194, CHICAGO, ILL.

GENTLEMEN: Without any obligations on me whatsoever, please send me your school catalog and full particulars of this offer to men—ALL FREE

L. L. COOKE, Director

Coyne National
Trade Schools

39-51 E. Illinois St.
Dept. 1194
Chicago,
Ill.

NAME.....

ADDRESS.....

Please Mention Popular Mechanics



The biggest money making field in the Automobile Industry today is in repairing tires. It is an enormous field and growing larger every year. Locations for good tire repair shops are open in every city and town in the country. You can make

\$1500 TO \$5000 A YEAR

If you learn by our system of instruction. We teach you every phase of TIRE REPAIRING and TIRE CONSTRUCTION by practical demonstration, in a school equipped with every necessary appliance. This is not a correspondence course. You get your training by actually using equipment and repair material. That's the only way.

WE TEACH YOU BUSINESS METHODS

Instruct you how to open your shop. How to take care of sales. How to retain your trade. How to make your shop pay.

WHAT OUR STUDENTS SAY

O. E. Bonnell writes, "I did a \$15,000 business last season." A. A. Robinson, "Have been in business 30 days. More than doubling expenses. Did not know money could be made so easily." C. E. Kartz says, "We are crowded with work." G. M. Marsh, "Business coming too strong, and I have not advertised a bit." Hundreds of others tell of similar successes.

SEND FOR OUR FREE BOOKLET A

It tells all about our school, about our methods of teaching, what our students have accomplished. Be first to enter into this big paying business in your town.

CLOUSE TIRE REPAIR SCHOOL
EUCLID AVENUE AND 90th ST., CLEVELAND, OHIO

Big Profits IN THE Auto Business

400,000 more cars this year than last. Thousands of new jobs as drivers, repair men, garage managers, etc.

NATIONAL AUTO SCHOOL

prepares for these jobs. Splendidly equipped workshops. Teaches its students everything about the automobile. For complete information and catalogue address

NATIONAL AUTO SCHOOL
2625 Reading Rd. Cincinnati, Ohio



DO YOU LIKE TO DRAW?

That's all we want to know

Now we will not give you any grand prize—or a lot of free stuff if you answer this ad. Nor do we claim to make you rich in a week. But if you are anxious to develop your talent with a successful cartoonist, so you can make money, send a copy of this picture with 6c. in stamps for postage of cartoons and sample lesson plate, and let us explain.

The W. L. Evans School of Cartooning
821 Leader Bldg., Cleveland, O.



LEARN TO WRITE ADVERTISEMENTS EARN \$25 to \$100 A WEEK

We can positively show you by mail How to increase your salary. BOOK MAILED FREE. PAGE-DAVIS CO., 112 Page Building Chicago Ill., or 159 Nassau St., New York



DO NOT STAMMER

My book, "How to Stop Stammering"—a treatise on "Scientific Talking and Psychic Training." School and circular literature FREE. M. L. MATFIELD, Prin. of The Pacific School for Stammerers, 1918 Grove St., OAKLAND, CAL.

LEARN WATCH REPAIRING

Be a watchmaker—you can learn this profitable trade by correspondence in a few weeks in your own home by the DeSelms Chart System. After you complete the course you will know a watch from A to Z. You will know just what the matter is and how to repair one. When you graduate you will be a practical watchmaker and repairer and competent to fill any position. Positions for our graduates.

Ask for our Free Book. It explains our system and terms.
THE DeSELMS WATCH SCHOOL
23 Ferry Street ATTICA, INDIANA





Johns-Manville Service and Responsibility have been my greatest asset in assuring roofing satisfaction

S. W. Gundlach
of the Gundlach Machinery Co.
Belleville, Ill.

Everyone around Belleville, Illinois, knows this contractor and knows that a Johns-Manville roof is a roof you can depend on because of

J-M ROOFING Responsibility

J-M Transite Asbestos Shingles

Fire- and weather-proof, last forever
Highly artistic.

J-M Asbestos Ready Roofing

Weather-proof, fire retardant, needs no coating. First cost only cost.

J-M Asbestos Built-up Roofing

Permanent, fire resistant. Lightweight, smooth surfaced, needs no paint. The imperishable flat roof.

J-M Regal Ready Roofing

"Rubber-Type" ready roofing for general roofing purposes.

J-M Roofings for Every Requirement



When you put a J-M Roof on your building and register it with us, its long life and efficient service become *our* responsibility.

Every J-M Registered Roof, no matter where it may be located, is systematically kept under our care.

The tremendous size of the Johns-Manville field force, with its representatives everywhere, enables us to give this

unique service and in the fullest practical sense to live up to our idea of J-M Responsibility.

J-M Asbestos Roofings are more than weather-proof. They give fire protection also. Sparks and flying brands will not ignite them.

J-M Asbestos Roofings are examined by Underwriters' Laboratories (under the direction of the National Board of Fire Underwriters).

We want every J-M Roof Owner to register his roof with us so we can see that it gives him the real J-M Roofing Service we know it ought to give. Tell us what kind of building you have to roof and we will send you Roofing Literature that will solve your roofing problem.

H. W. JOHNS-MANVILLE CO.

Akron	Buffalo	Dayton	Houghton	Louisville	New Orleans	Portland, Ore.	Seattle
Albany	Chicago	Denver	Houston	Memphis	New York	Rochester	Syracuse
Atlanta	Cincinnati	Detroit	Indianapolis	Milwaukee	Ottawa	St. Louis	Toledo
Baltimore	Cleveland	Dubuque	Kansas City	Minneapolis	Philadelphia	St. Paul	Washington
Birmingham	Columbus	Galveston	Los Angeles	Newark, N. J.	Pittsburg	Salt Lake City	Wilkes-Barre
Boston	Dallas					San Francisco	Youngstown

THE CANADIAN H. W. JOHNS-MANVILLE CO., LTD., Toronto, Winnipeg, Montreal, Vancouver

2012



"The Power of Law Training"

SEND the coupon now for our new 171-page free book "The Power of Law Training." It carries a vital and inspiring message to every ambitious man—to the man who is already successful—to the young man just starting out in life—to the man who has already made his start but has not yet hit his stride—to all men who realize the need of more power. "The Power of Law Training" will give you a remarkable insight into the vital relation of law to business. Write for your copy today—now. It's FREE.



If You Know Law—

The power of the man with law training is apparent all about you. Look to the men of your own acquaintance who have achieved the most—look to the men who stand high in the affairs of the nation. Almost without exception you will find them Law trained. The man with the Law training is the man of power—the leader.

Learn from Masters of the Law!

Through the Course and Service of the American Correspondence School of Law—the oldest and largest institution of its kind in the world, you read law right in your own home—directed by men who stand prominent in the profession. You may become law trained or prepare for the practice of law. More than 40,000 men have utilized this Course and Service to their advantage and recommend it highly.

With this Course and Service is included a complete and comprehensive cyclopedia of the law without extra charge. Special reduced price offer now being made in many localities.

Send the Coupon!



Put your name and address in the coupon or on a letter or post card now and get the big 171-page free book, "The Power of Law Training." It's free. No obligations of any kind. Write today.

American Correspondence School of Law
1194 Manhattan Building Chicago

American Correspondence School of Law
1194 Manhattan Bldg., Chicago

Gentlemen:—Please send me free and prepaid your 171-page book, "The Power of Law Training" and particulars of your special reduced price offer.

Name.....

Address.....

Please Mention Popular Mechanics

New York ELECTRICAL School

Gives you a complete training by actual practice. You get the knack of "HOW" together with the theory of "WHY" and the best business methods used in the World of Electrical Activity.

The N. Y. Electrical School is the pioneer and premier school of the "Learn by Doing" method. When you have completed this Course you shall be fully qualified to handle ALL branches of Electrical industry.

The equipment of this School is unequalled and up-to-the-minute. No preparation needed to become a "learner" in this school. You can start to learn on any day of any week throughout the whole year.

Visitors heartily welcomed. Send for catalogue.

44 West 17th St. New York City
N. Y. ELECTRICAL SCHOOL

SHORTHAND IN 30 DAYS

We absolutely guarantee to teach shorthand complete in only thirty days. You can learn in spare time in your own home, no matter where you live. No need to spend months as with old systems. Boyd's Syllabic System is easy to learn—easy to write—easy to read. Simple. Practical. Speedy. Sure. No ruled lines—no positions—no shading as in other systems. No long lists of word signs to confuse. Only nine characters to learn and you have the entire English language at your absolute command. The best system for stenographers, private secretaries, newspaper reporters and railroad men. Lawyers, ministers, teachers, physicians, literary folk and business men and women may now learn shorthand for their own use. Does not take continual daily practice as with other systems. Our graduates hold high grade positions everywhere. Send today for booklets, testimonials, etc.

Chicago Correspondence Schools
969 Unity Bldg., CHICAGO, ILL.

CIVIL SERVICE

positions are in all parts of the country. Good pay steady work, life positions, congenial surroundings, promotions on merit, short hours, annual vacation and sick leave with pay. Many thousands appointed yearly. Both sexes. No political pull. Nearly 300,000 classified positions. Common school education sufficient. Full information and questions used by the Civil Service Commission free.

COLUMBIAN CORRESP. COLLEGE, Washington, D. C.

LANGUAGES

Quickly Learned AT HOME by the Original Phonographic Method

German—French—English—Italian—Spanish or any other language learned quickly and easily by the Cortina Method at home with Disk Cortina-Records. Write for free booklet today; easy payment plan.

CORTINA ACADEMY of LANGUAGES
1286 Heena Bldg., 1600 Broadway,
Corner 48th Street, New York

CORTINA-PHONE

CORNET FREE!

We guarantee to teach you to play by mail and will give you a Beautiful Cornet or any Band Instrument absolutely FREE. You pay weekly as lessons are taken. Instrument is sent with first lesson. Write today for our booklet and wonderful tuition offer.

INTERNATIONAL CORNET SCHOOL
45 Federal St., Boston, Mass.

BE A BANKER

Splendid opportunities. Pleasant work, short hours, all holidays off, yearly vacation with pay, good salary. Learn at home. Diploma in six months. Catalog free. EDGAR G. ALCORN, Pres.

AMERICAN SCHOOL OF BANKING, 119 McLENE Bldg., COLUMBUS, OHIO

JEWELRY ENGRAVING

We teach you, by our new and original method of instruction, this clean, fascinating and profitable business right at your home, and furnish you all tools needed absolutely free. Write for free book to the

WISCONSIN SCHOOL OF ENGRAVING, 5th Bldg., MILWAUKEE, WIS.

THE AGE OF SKILLED LABOR

THIS is the age of skilled labor. It becomes more difficult each year for unskilled men to obtain steady work. And when times are dull, the unskilled workmen are the first to be laid off. It is a problem for many young men to acquire the necessary training in a lucrative trade, without expense beyond their limited means.

☐ This problem has been solved *in the Navy* for thousands of unskilled youths. The Naval service offers the opportunity to obtain practical training, and the chance to learn a useful trade.

☐ The men are paid meanwhile, and furnished with an ample supply of wholesome food, an outfit of clothing, and are cared for at Government expense when sick or injured. When they have become useful to the Navy they are advanced in rating, and their pay is increased. The Navy needs men of mechanical ability, and a young man who is "handy" with tools will find plenty of opportunities to become skilled in the trade of his choice.

☐ If you are over 17 and under 25, an American citizen of good health and habits, it will pay you to look into the Navy's offer.

Men between 25 and 30 are accepted in certain specified trades, provided they are competent to work at their trades, without preliminary instruction. Write for pamphlets, and for the location of the nearest *Navy Recruiting Station*.

ADDRESS BOX 68

BUREAU OF NAVIGATION

NAVY DEPARTMENT

WASHINGTON, D. C.



We Will Send Postpaid a Can of JOHNSON'S PREPARED WAX

—enough for polishing a small floor, a piano, several pieces of furniture or an automobile.

Johnson's Prepared Wax is a complete finish and polish for all finished surfaces. It gives perfect results over varnish, shellac, oil, etc. You will find it splendid as a polish for

<i>Floors</i>	<i>Pianos</i>
<i>Linoleum</i>	<i>Furniture</i>
<i>Woodwork</i>	<i>Automobiles</i>

Johnson's Prepared Wax is clean and easy to use and economical. It imparts a perfectly hard, dry, artistic finish of great beauty and durability. It is impervious

to water, scratches, heel-marks, finger prints, dust, etc. and can easily be kept in perfect condition.



Every Housewife

who takes pride in keeping her home sanitary and in a high state of repair needs Johnson's Prepared Wax. It is just as necessary around the house as soap.

JOHNSON'S WOOD DYE

for the artistic coloring of all wood. With it inexpensive soft woods may be finished so they are as beautiful as hard wood. Made in seventeen shades including *Mahogany*, *Mission*, *Early English*, etc.

Johnson's Wood Dye penetrates deeply—is economical—dries quickly and is very easy to use. It is unequalled for finishing new furniture, woodwork and floors and for doing over old work of this character—for staining basketry, etc. Your dealer can show you panels of wood finished with Johnson's Wood Dye.

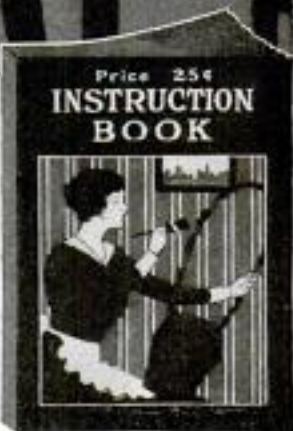
Free Instruction Book

Ask your paint or hardware dealer for a free copy of our 25c color book "The Proper Treatment for Floors, Woodwork and Furniture." This book is the work of famous experts—it is full of valuable ideas

on home beautifying—beautifully illustrated in colors.

For 10c we will send you postpaid a can of Johnson's Prepared Wax—sufficient for polishing a small floor, a piano, several pieces of furniture, or an automobile.

S. C. JOHNSON & SON
"The Wood Finishing Authorities"
RACINE, WIS., U. S. A.



PA4

I enclose 10c for a can of Johnson's Prepared Wax—enough for polishing a small floor, an automobile, a piano or several pieces of furniture, also Instruction Book on home beautifying.

Name

Address

City and State

Please Mention Popular Mechanics

Popular Mechanics Magazine

REGISTERED IN U. S. PATENT OFFICE

WRITTEN SO YOU CAN UNDERSTAND IT

Vol. 23

APRIL, 1915

No. 4

9271m British Troops Using Handmade Grenades

GRENADES made in the trenches by the soldiers themselves and thrown at the enemy's trenches either by hand or by a crude device that suggests the Roman catapult, form one of the curious features in the desperate fighting that goes on almost continually along the battle lines of Flanders, and illustrate a surprising development of the present war in Europe—the reversion to methods of fighting that a year ago were thought to be forever discarded. In the early stages of the war most of the fighting was done at such long range that only modern

equipment and ammunition could be used effectively, as was to be expected in a twentieth-century war. Since then the opposing forces have settled down in trenches that are in many places only 30 to 100 yd. apart.



British Soldiers in the Trenches are Using Hand Grenades Made from Tin Cans and Thrown by Primitive Catapults

Sniping at close range, mining and sapping, and the use of hand grenades are common features of the fighting.

It is in the British trenches that the handmade grenades are being used. Each of these consists simply of a tin can, or a "jam tin," as the British call it, filled with small pieces of iron and a charge of guncotton, and equipped with a fuse. This is frequently thrown by hand, but more often by a crude device consisting of a heavy timber with an automobile spring fixed vertically in the upper side. When a grenade is to be thrown, the top of the spring is

drawn back and is held by a notch in a wooden trigger that is also fixed to the timber. The grenade is placed in a tin holder attached to the spring, and the fuse is lighted. Then the trigger is pulled back and the grenade is thrown upward and forward by the force of the spring, the idea being to throw the grenade high so that it will drop behind the breastworks of the enemy. The device is adjusted for range, which must evidently be short, simply by placing the timber on a greater or less incline or by varying the amount that the spring is drawn back.

SALVAGE WORK ON SUNKEN "EMPRESS OF IRELAND"

9243 All the bodies that could possibly be reached, as well as the mail and silver bullion on board the sunken "Empress of Ireland," have been recovered, as the result of one of the most remarkable feats of deep-water salvage ever attempted. When the ship was sunk near the mouth of the St. Lawrence it settled in the soft mud at the bottom of the river, which is 138 ft. deep at low tide, and heeled over at a sharp angle. Because of these conditions the divers were compelled to work at times at the unusual depth of 160 ft. In spite of the extremely dangerous character of the work only one accident occurred, but this, unfortunately, resulted in the death of one of the divers.

To familiarize the divers with the arrangement of the ship and the location of the strong box, pasteboard models were made, and the divers were thoroughly schooled with these before being permitted to undertake the work. As a further precaution the first work that was done by the divers after a hole had been cut in the side of the ship was that of bulkheading all flanking doorways and passageways along the route to be followed inside the ship, so that no diver could go astray or get his hose, life line, or telephone connections tangled. Because of the dangers involved the divers worked always in pairs, and as soon as one couple came to the surface two

~~more men were ready to descend and carry on the work.~~ To furnish as much protection as possible against the cold water each diver was equipped with rubber gloves, which were made thin enough to enable the diver to guide himself where necessary by the sense of touch alone. The salvage vessel was equipped with a compressed-air system, and the divers received their air supply from storage tanks instead of from pumps, as is the common custom.

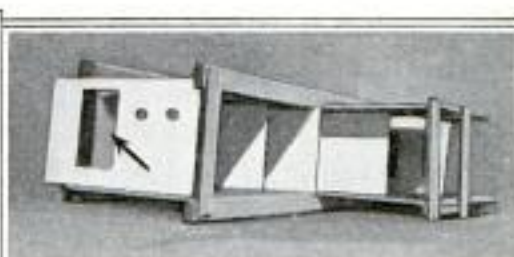
The one man who lost his life slipped from the side of the sunken liner and fell into considerably deeper water. The sudden application of hydrostatic pressure apparently confused him, and in his excitement, instead of opening his air valve, he screwed it close. After this fatality every valve seat was notched so that air would reach a diver in distress and keep him alive until aid could be sent to him. In addition to the work of recovering the bodies of the victims, and the mail and bullion, the steel masts of the "Empress of Ireland" were cut away with air drills, thus removing a serious menace to navigation.

☞Nine billion stamped envelopes and newspaper wrappers in one order were recently bought by the Post Office Department.

Photos from Robt. B. Skerrett
15 Williams St.,
N. Y. City



Two Divers Going Overboard from Tender



Model of Section of "Empress of Ireland"; Arrow Indicates Cut in Side of Ship



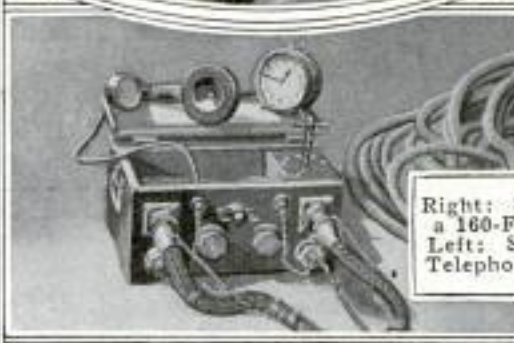
Drilling Outfit for Piercing Side of Ship



Working the Surface Apparatus with Divers Below. The Steel Cylinder is the Hospital Lock



Bringing Up an Ingot of Silver



Right: Starting on a 160-Foot Dive. Left: Submarine-Telephone Central

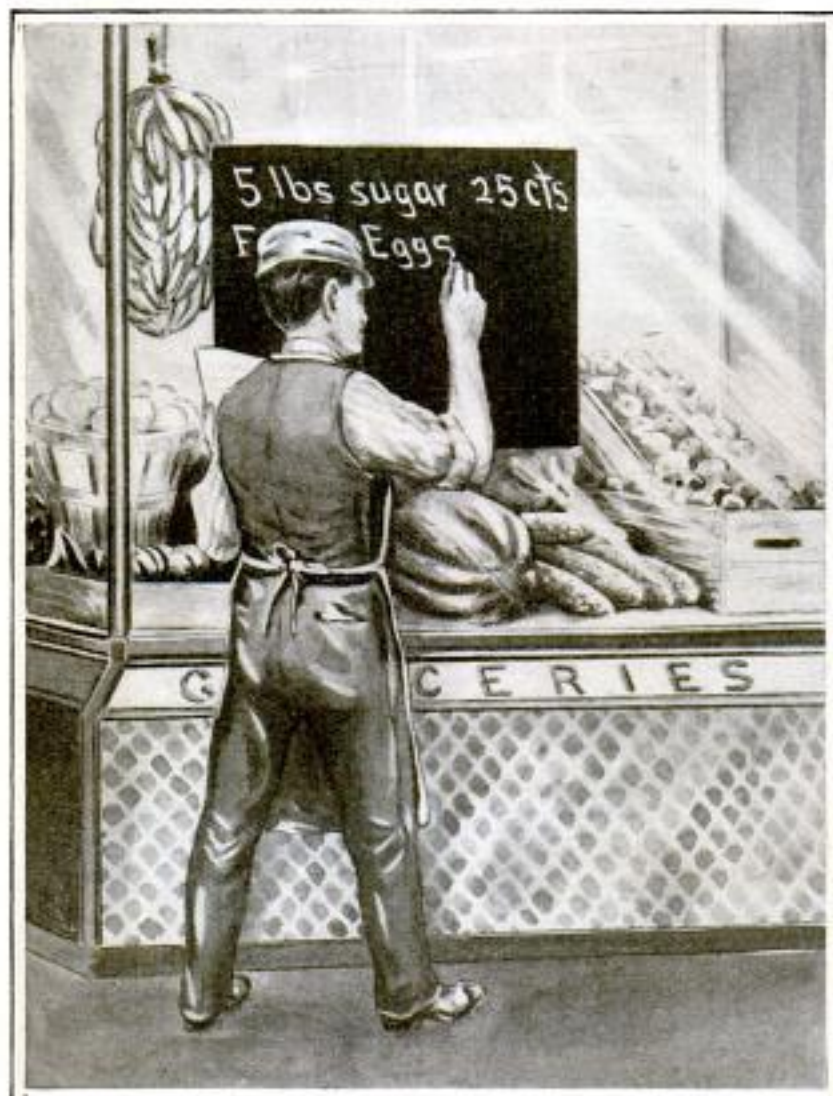


mfr: *Pittsburgh Plate Glass Co.,
Pittsburgh, Pa.*

**SCHOOL BLACKBOARDS-MADE
914 H OF PLATE GLASS**

Blackboards made of an especially ground plate glass have been installed

floor, if desired, enabling both beginning and advanced pupils to use the same board without difficulty to either because of its height. Since the paint is applied on the reverse side, such a board may be used indefinitely without its requiring any attention other than an occasional washing, while it cannot become slick in spots, as is frequently the case with some boards. The same process can be applied to plate-glass store windows, providing a permanent blackboard for advertising announcements.



Blackboard Made by Grinding the Surface of Plate Glass and Painting the Back Black

**NEW PROCESS FOR
TREATING LOW-
GRADE RUBBER** ⁹²⁴⁶

For treating low-grade rubber and making it suitable for rolling, and other processes of manufacturing, a new method has been invented, the principal purpose of which is to extract the resin and thus do away with the sticky quality of the rubber. The rubber gum is first made into a stiff solution with naphtha, or some other light solvent material.

This solution is then placed in a receptacle in which a partial vacuum is created by an ordinary exhauster. With the pressure of the air removed, the naphtha quickly expands the rubber into a spongy mass consisting of thin-walled cells and passages, which affords a multitude of cell walls to be acted on and is easily permeated by the fluids used in the subsequent treatment. The resin can then be removed easily by caustic soda or some other resin solvent, and the rubber is ready for vulcanizing.

Inventor: S. C. Stanton,

Durham, N. C.

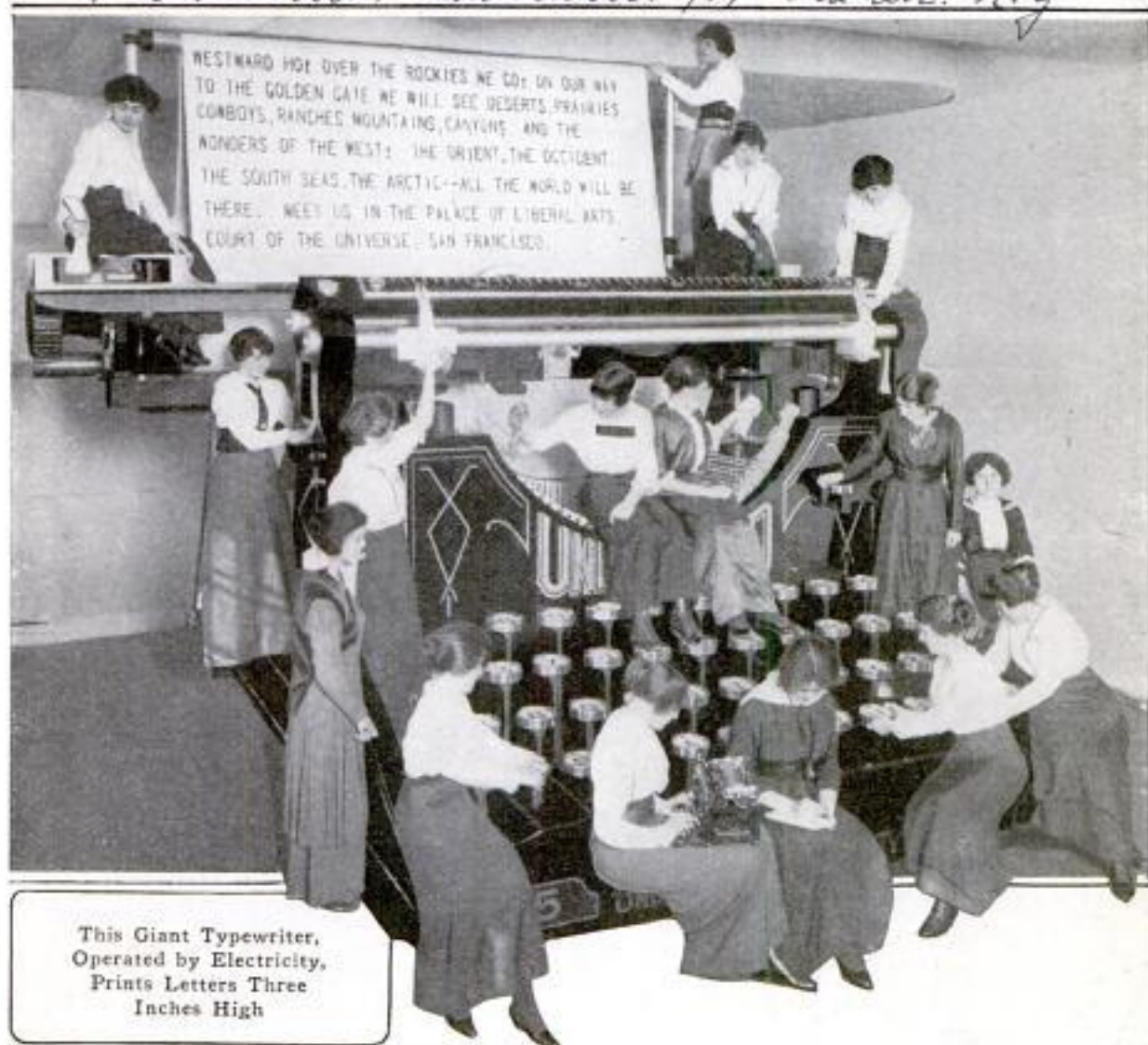
Copyrighted material

Public Schools - about 1,000,000 sq. ft.

9211 m

THE BIGGEST TYPEWRITER IN THE WORLD

Underwood + Underwood 417 - 5th Ave. N. Y.



A typewriter that is nearly 2,000 times the size of the ordinary machine is one of the novel exhibits at the Panama-Pacific Exposition. While installed principally as an advertisement, this enormous machine also serves another purpose of as great importance, since it is used for writing newspaper bulletins that can be read a block away. This machine, which is 21 ft. wide and 15 ft. high, is reported to have cost \$100,000. The type are 3 in. in height and print letters which are spaced 2 in. apart from center to center. The weight of the carriage is 3,500 lb., the diameter of the key cup, which is the part of the machine ordinarily pressed by the fin-

ger, is 7 in., while the hollow cylinder is large enough for a man to crawl through. For using the machine, paper 9 ft. wide is required. The operator sits at an ordinary typewriter which is electrically connected with the large machine so that when a key on the small machine is struck the corresponding key on the large machine is struck through the action of the electrical apparatus. This typewriter has been under construction for about two years, and requires four electric motors in its operation.

ⒸTorpedo nets that can be placed in position in three minutes have been adopted for British warships.

NEW REFRIGERATOR MADE IN
DETACHABLE SECTIONS

One of the interesting features in a new refrigerator is that it can easily



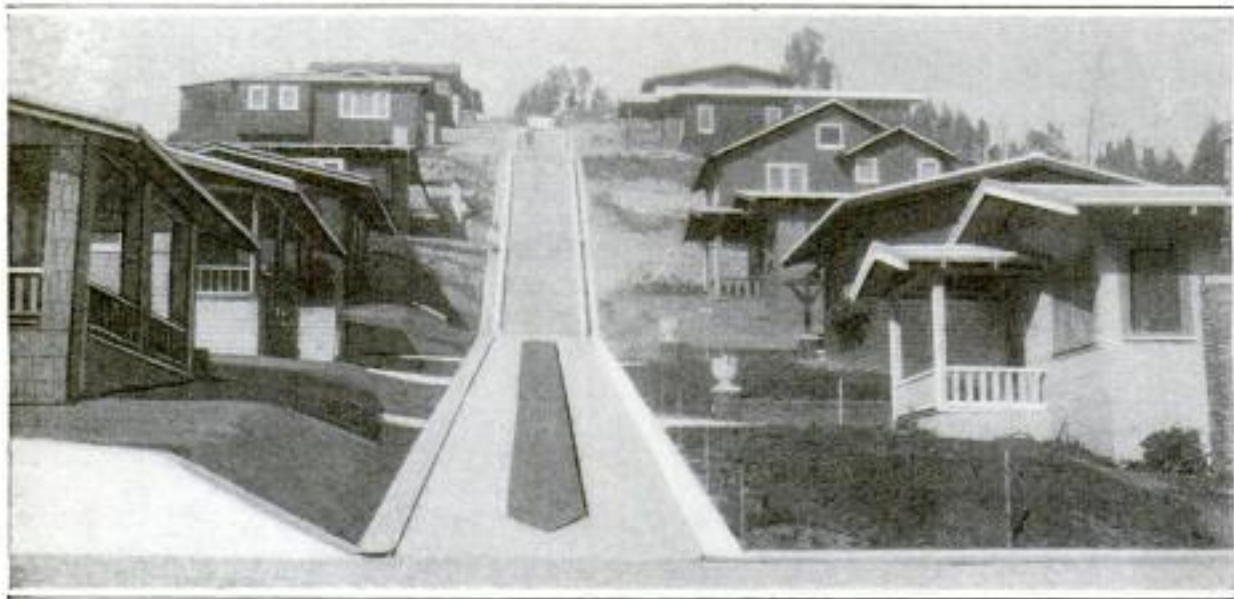
This Refrigerator can be Taken Apart for Cleaning and Then Put Together in a Few Minutes without Tools of Any Kind

be taken apart for transportation or for cleaning, and then put together in

a few minutes without the use of tools of any kind. The base, sides, front, back, and top form separate sections. These are connected by locking bars, having slots in the ends, which fit over pins projecting from the parts to be connected and are so arranged that when the refrigerator is set up, these parts are held rigidly together. Other features of this refrigerator, such as that of circulating the water formed by the melting ice through pipes under the shelves, have been described in this magazine.

STEEP HILLSIDE MADE INTO
RESIDENCE SECTION

A hillside, so steep that it was generally thought to be worthless and had been given over for years to sagebrush and weeds, has been transformed into an attractive residential section by an enterprising California builder. The hill was graded into terraces, and on these attractive bungalows were built. Running straight up the hill is a concrete construction consisting of four sections of steps and three stretches of incline walks, and having a total length of 700 ft. The steps are 12 ft. wide, while the incline is made up of two strips of concrete, each 4 ft. wide, between which runs a strip of lawn of the same width.



This Group of Residences Occupies a California Hillside That was Formerly Considered Worthless and was Given Over for Years to Sagebrush and Weeds

Albert Marple
322 Boynton St.,
Tropico, Calif.

Mrs Stuart Mosby-Coleman
1223 - 15th St. N.W., Wash. D.C.

THE "WOBBLING" OF THE NORTH POLE A POSSIBLE CAUSE OF EARTHQUAKES

9258A

THAT the "wobbling" of the north pole may be responsible for the earthquake that devastated central Italy, obliterating many of its towns, killing approximately 40,000 of its inhabitants, and doing damage to property in excess of \$60,000,000, on January 13, is the latest theory tentatively advanced by scientists for such an upheaval of the earth's surface. It is generally agreed by investigators that many quakes are caused by volcanic action. Many of them are also due, according to generally accepted theories, to "slips" or sudden readjustments of the deep-lying rock strata which form the foundations of the earth. There are, however, many earthquakes that cannot be attributed to either of these causes, so far as scientific investigators have been able to demonstrate. That these quakes, or some of them, are in some way connected with the variation of the earth's axis from its normal position, has been suggested by some excellent authorities.

Recent study of these polar aberrations has demonstrated that the axis is constantly moving about in a spiral course, in much the same manner as a top travels when it is spinning on a slightly uneven surface. By astronomical observations this path has been traced and the discovery made that the axis returns to about a normal position approximately every seven years. It has been found that when the axis makes a sharp turn in its very irregular course, seismic activity is materially increased. From this it is reasoned that the movement of the

pole probably sets up stresses in the crust of the earth which result in violent upheavals along faults and ridges.

Differing conclusions have been formulated regarding the relationship of the two phenomena. One of these holds that it can hardly be assumed that there is any direct connection between earthquake frequency and polar changes, other than that both effects may quite probably be caused by a common force. It has been suggested that this energy may be developed by the redistribution of surface material by either the currents of the ocean or by meteorological causes.

In support of the belief, however,

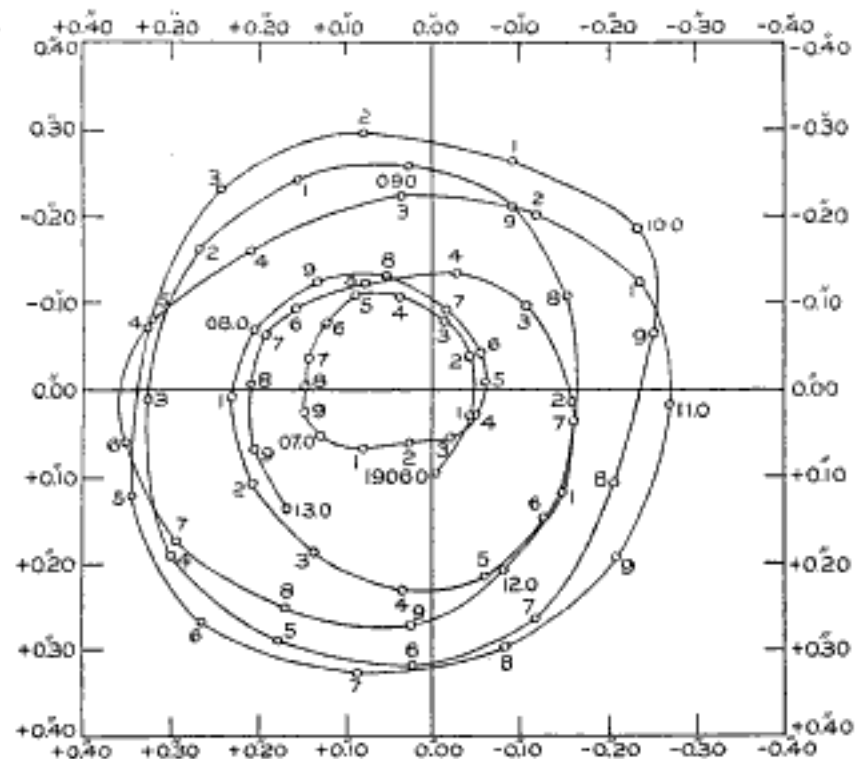


Diagram Showing the Variations of the North Pole from 1906 to 1913 in Fractions of a Second of Latitude

that seismic disturbances often may be traced directly to the polar aberrations it is worthy of notice that during 1906 and 1907, when repeated upheavals of a violent character occurred in different parts of the world, including the disasters at San Francisco and Valparaiso, the movement of the pole was very irregular. A sharp turn in



Above Is the Crumbled Heap of Brick and Stone Which Now Buries What Before Was the Main Street of the Medieval Town of Avezzano, a Place of 12,000 Inhabitants, Less Than a Thousand of Whom Survived the Catastrophe

Remains of Torlonia Castle Outside of Rome, and One of Avezzano's Streets



Group of Survivors at Avezzano Transporting a Few Pieces of Household Furniture to an Improvised Shelter outside the Zone of Tottering Walls. The Ruins at the Right Are Typical of Those of Thousands of Buildings throughout Central Italy, East of Rome and South toward Naples.



A Little Handful of Survivors Huddled Together in One of the Few Open Spaces Left in the City after the Upheaval

its course may also be found in the tracings of the last part of 1908, at which time the Messina disaster claimed thousands of victims. The same is true of the years 1892 and 1893, which include the time of the great Persian earthquake in which 12,000 persons lost their lives.

A somewhat different view of the significance attached to the "wobbling" axis is suggested by studies made at the United States Naval Observatory, where it has been noticed that violent seismic disturbances and the widening of the spiral curve followed by the earth's axis are occurrences which take place simultaneously. The erratic circuit made by the pole, which is confined to a range of from 40 to 60 ft., causes the latitude of the earth to vary constantly. Three and a half years are consumed in the outward swing and the same length of time in the inward course, so that the spiral is recommenced about every seven years. At the present time the pole is in the second year of its outward swing, and in accordance with the theory that upheavals increase as the spiral widens, next year should be one of frequent ruptures.

Another very interesting observation which has recently come to popular attention is the fact that a great percentage of the earthquake zones where the shocks are the most violent, lie on a belt encircling the globe, touching north of Panama, the Azores, France, Spain, Southern Asia, and the Indian Ocean. Thus the quake areas of Europe, Central America, the West Indies, the Azores, the Caucasus, the Himalayas, as well as of western Polynesia, all appear in this belt. In this connection also it is pointed out that the areas of submarine disturbances, both in the Indian Ocean and the Atlantic south of the Azores, are coincident with submerged ridges of land. In the former case no less than 23 submarine disturbances have been recorded in the vicinity of the submerged strip.

The recent upheaval in Italy centered its force in the mountainous

province of Abruzzi. The shock lasted 34 seconds, but in that brief time the whole countryside was changed into a burial ground of cities and a region of famine and suffering. There was a succession of lesser shocks following the quake which were felt from the southernmost part of the peninsula into certain parts of France and Switzerland, causing serious avalanches to occur in the Swiss Alps which isolated villages and destroyed large forests. These disturbances, in the opinion of some, indicated that the quake was not of volcanic origin.

Avezzano, a town of 12,000 inhabitants, lying less than 70 miles east of Rome, is now a dust-laden heap of crumbled stone, with here and there a tottering wall. In all, there were nearly a score of towns which were wiped out completely, and more than 100 where severe tolls of both life and property were reported. Sora, Arpino, Celano, Lipari, Aielli, Marsi, and numerous other towns, were among those which suffered most. Rome, long considered immune from serious seismic disturbances, and its suburbs, Tivoli and Frascati, were shaken severely. The district which suffered the most from the visitation was not a thickly populated one and most of its towns were hill places, off the beaten paths of tourists, which have been little affected by modern influences and still retained a charming atmosphere of the medieval.

The earthquake came almost with the unexpected suddenness of a flash of lightning. A confused murmuring sound swept across the peninsula and south past Naples. Simultaneously loose objects commenced to tremble, the murmur growing into a roar. What at first seemed to be a quiver became a violent shaking which caused the ground to heave and sink like the surf, and buildings to toss about like boats. Then a double twisting, shaking motion of the earth, and walls commenced to fall, roofs to drop, and the streets to fill with debris. As the movement of the earth became more violent, the ground opened in long cracks along

the crests of the troughs and then crashed together again, sending clouds of dust and particles of earth into the air. Entire buildings seemed to be swallowed up by the earth, and above the deafening, crashing, rumbling noise, were heard the shrill screams of the injured and dying. After the ground had returned to an even, swinging motion, the shaking ceased almost as suddenly as it had commenced. Then, where there had been cities a few seconds before, only clouds of dust and smoke were to be seen.

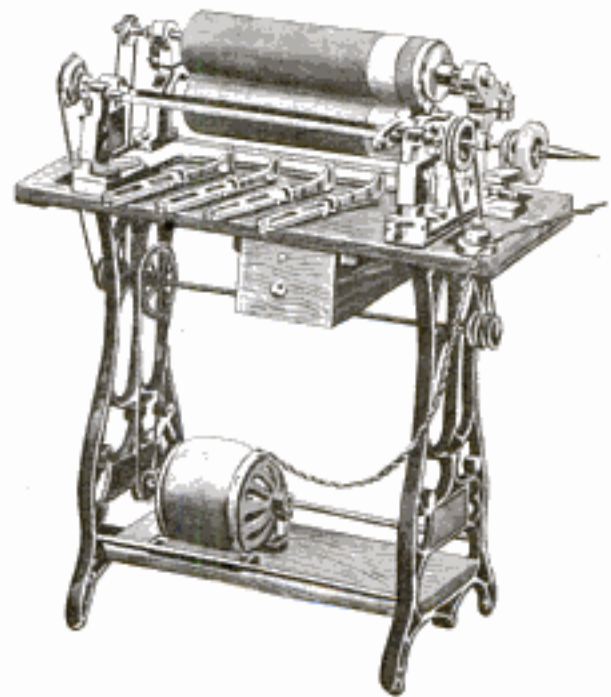
Rome itself failed to escape entirely from the upheaval. A survey of the city after the first terrible shock had passed, showed that many of its architectural monuments had suffered

greatly. More than fifty palaces and churches within the walls of the city were badly shaken and damaged. The famous gateway designed by Michelangelo at the Porta del Popolo was shaken until it had to be braced to prevent its falling. The Claudian aqueduct was injured, the great tower at Arpino which commemorated the birthplace of Cicero was toppled over and the obelisk in St. Peter's Square was damaged. It is reported that the tunnel draining Lake Fucino was caved in by the earth vibrations. Damage to this subterranean work presents a problem, for Lake Fucino since medieval times has been a source of great difficulty to the government, owing to its lack of a natural outlet.

MACHINE FOR SHARPENING SAFETY-RAZOR BLADES

9088_m
A new and interesting machine for sharpening safety-razor blades has recently been brought out and is now being placed on the market. With this machine the work is all done automatically, the only thing necessary in operating it being to place the blades in holders, attach the holders to an oscillating rod at the front of the machine, and then remove the holders after the work is finished. One end of the holder is attached to this rod, while the free end, on which the blade is carried, projects into the recess between two rollers that bear against each other and revolve in opposite directions. As the rod oscillates the edge of the blade is brought in contact in rapid succession with first one roller and then the other, the blade taking the proper angle with reference to each of the rollers through the action of a flexible clamp in which it is held. In this way the edge of the blade is ground, honed, and stropped evenly on both sides. The blade travels the full length of the rollers from right to left. The first work on the blade is the grinding, which is done by a short section of stone on each of the rollers. Then comes a section covered with

honing material. Both of these sections revolve so that they work toward the blade. The last operation is that of stropping, which is done by a pair



New Electrically Driven Machine That Sharpens Safety-Razor Blades Rapidly and Automatically

of rollers covered with leather. These rollers revolve in the opposite direction, or away from the blade. The machine is operated by a small electric motor.

American Sharpening Machine Co., Inc.,
184 W. Washington St.,
Chicago, Ill.

*C. Hastings Contributor
The Railway Specialty Co.,
Atchison, Kans.*

*Auto equipped by above Company &
Commissioner of Dept. of the Santa Fe Ry.*

492

POPULAR MECHANICS

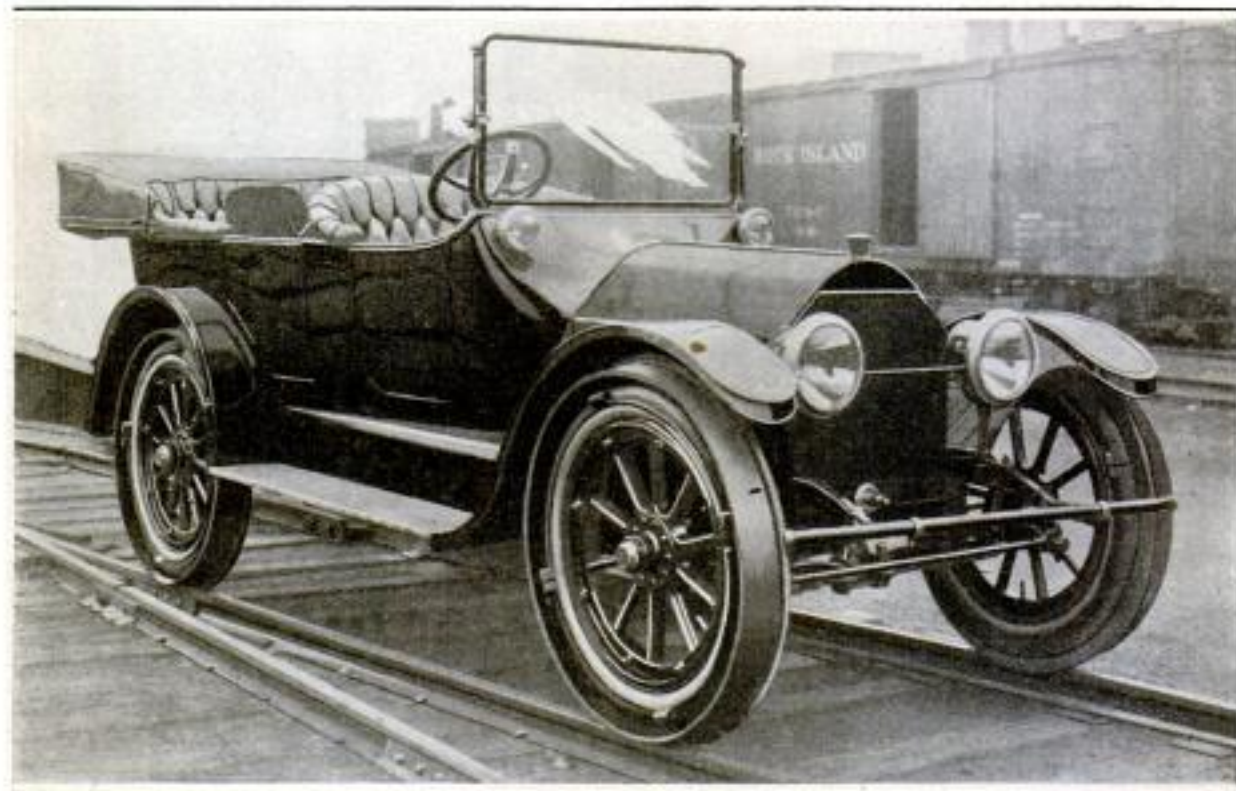
Railway Review 1-16-15 FREIGHT CREWS CALLED BY 9215 *m* MOVIE SCREENS

Through an arrangement between the railroad authorities and the motion-picture theaters at Sayre, Pa., freight crews are regularly called for their runs by brief notices flashed on the screens at the theaters. When a given crew is wanted, this fact is simply telephoned to all the theaters, and the notice is flashed on the screen in some such form as "James Brown, Thomas Jones, William Black, and John White boarded for 10 p. m." This means that the men are scheduled to take out a freight train at the time given, but other details, of course, must be found out by the men from the regular train board at the railroad offices. The plan was originated with the idea of permitting the men off duty to seek recreation about the town without running the risk of being missed by the call boy when wanted.

By milling rails while they are still hot, "seaming," which causes many breakages, is eliminated.

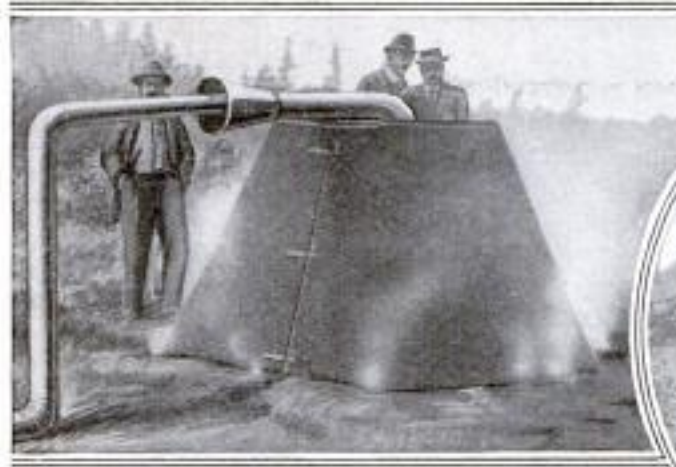
9285 *m* INTO RAILROAD CAR

The latest feature in railroad inspection cars is a flanged steel tire that can be fitted securely over a pneumatic tire, thus making an ordinary automobile suitable for running on a railroad track, and a seven-passenger touring car equipped in this way is already in use on one of the leading American railroads. The steel tire has the tread and flange of a standard railroad tire, but is provided with a deep groove on the inner surface into which the pneumatic tire fits. The pneumatic tire is first partly deflated and the steel tire is slipped over it, after which the pneumatic tire is inflated until it comes to a firm bearing in the groove of the steel tire. With this arrangement, the pneumatic tire serves its original purpose of absorbing the shock and vibration. When operating on the railroad track the steering gear is locked by clamping the steering knuckle, with the wheels lined up for going straight ahead. A set of four tires for application to 36 by 4½-in. pneumatic tires weighs



Seven-Passenger Touring Car Equipped with Steel Tires for Running on Railroad Track. These Tires are Easily Put On or Removed, So That the Car can be Used Either for Railroad or Highway Service

see sec 15
p 918



New Type of Stump Burner Which Leaves Only Ashes Behind

1,000 lb. As this additional weight is not carried on the springs, but merely rolls along the track, it has no detrimental effect on the running of the car, but aids in holding it to the rails when running at high speed.

NEW STUMP BURNER—USED FOR CLEARING LAND

To facilitate the work of clearing logged-off lands for agricultural purposes, a stump burner has been invented which eliminates much of the expense involved in the grubbing process and does not disturb the top soil, as in the case of dynamiting. The apparatus consists of an iron hood, which incloses the stump to be destroyed, and a motor-driven blower that is connected to it by a 4-in. air pipe. When a stump is to be removed, an auger hole is bored into it and a stick of dynamite employed to split it apart. Following this, the hood is placed over the stump and banked with earth at the bottom so as to prevent the heat from escaping. The wood is then ignited and the blower started, which throws a heavy down draft into the inclosure, fanning the blaze and hastening the consumption of the stump. During the operation the heat becomes so intense within the chamber that burning is completed within a comparatively short time. The device was recently used at Gladstone, Ore., on an old, damp stump,

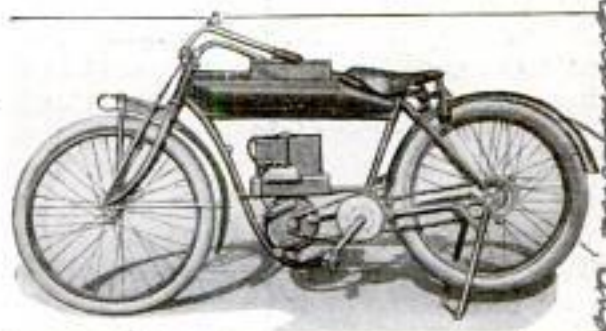


This Stump was Completely Destroyed in Six Hours by the New Burner

4 ft. in height and 20 ft. in circumference at the base. In six hours' time the operation was finished at an expense of \$1.15. Five hoods may be attached to the blower at one time, and when this is done the expense of clearing land is correspondingly decreased. When a stump is consumed, the hood is removed and what fire remains covered with dirt, which allows the roots to burn out without the assistance of the blower.

MOTORCYCLE DRIVEN BY ELECTRIC MOTOR

An electrically driven motorcycle recently brought out in California is built exactly like an ordinary motorcycle, but has an electric motor in place of the usual gasoline engine. A stor



This Motorcycle is Driven by an Electric Motor, Power being Supplied by a Compact Storage Battery

Made by: Marshall Starlinger, 370 W. 7th St., San Jose, Calif.

Copyrighted in Calif

see sec 15
p 918
Lumber & Equipment Co., Inc.,
Lumber Exchange Bldg.,
Portland, Oregon.
L. H. Black (One Northwest Oil
Reservoir) 519
Lumber Exchange Bldg.,
Portland, Oregon.
Le Roy W. Allison
170 Roseville Ave.,
Newark, N. J.

Paul J. Bailey
456 West 29th St
San Francisco, Calif.

age battery of compact design, which carries a large reserve of electric power in proportion to its size, is clamped above the motor and furnishes the current for operation. The power is trans-

mitted to the rear wheel in the usual way by chain and sprocket. It is reported that this novel machine is capable of making a speed of about 25 miles an hour.

GARAGE IN BASEMENT OF RESIDENCE

8808 m

By constructing a driveway leading down from the street to the basement of his residence, an automobilist pro-



Entrance to Garage Located in Basement of Residence



With the Car Stowed Away in the Garage There Is Plenty of Room for Cleaning and Repairing

vided himself with a garage that is both convenient and economical. One advantage in this garage is that it is heated by the same furnace that supplies heat for the residence. The floor is sloped to drain into a catch basin in the corner so that when the car is washed the water drains into the sewer. The entrance is 16 ft. long and has a drop of 3½ ft. in this distance. This slope runs to the door of the garage, which is of such height as to give the top of the car sufficient clearance when

entering or leaving. Outside the entrance is a concrete floor on which the car is washed in case there is more mud than the driver cares to take into the basement. This floor is also provided with a catch basin connecting with the sewer.

CUTTING MARBLE COLUMNS FOR LINCOLN MEMORIAL

8899 H

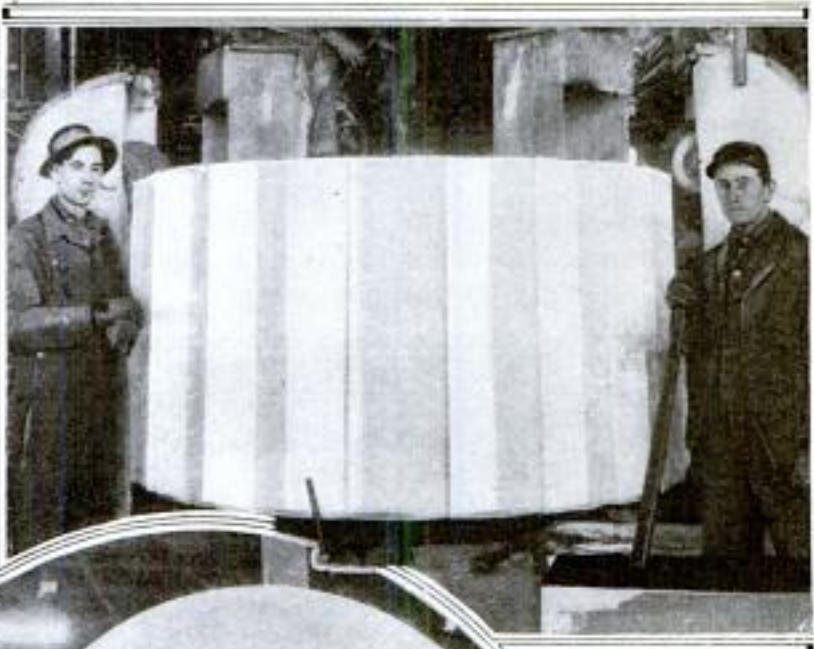
The columns for the classic portico of the Lincoln Memorial at Washington, for which Congress some time ago appropriated \$2,000,000, are being made in Colorado from white marble taken from the quarries in the Sopris National Forest Reserve. Thirty-eight columns, each of which will be 46 ft. in height and weigh approximately 192 tons, are being made in 12 sections, or drums, crated and shipped to the capital. In making these drums, which themselves weigh about 16 tons, the blocks of marble are lined in a row and cut into uniform thicknesses. This is done with a wire saw which extends along a line of blocks and cuts them into equal sizes in a single operation. After this sizing is completed the blocks are placed beneath an instrument known as a "barrel," where they are cut into cylindrical form. This "barrel" is a hollow drum which cuts its way into the marble as it is revolved rapidly, sawing out the cylindrical piece. When this operation is finished, the marble is placed in a large lathe, where it is turned and trimmed so that its two ends will join evenly with the surfaces of the sections placed below and above it in the column. The fluting is done by means of carborundum wheels, hand rubbing and polishing. The memorial monument is to be erected on the Mall, near Maryland Avenue, and close to the banks of the Potomac.

#Jacob C. Kirsch
Marble, Colo.

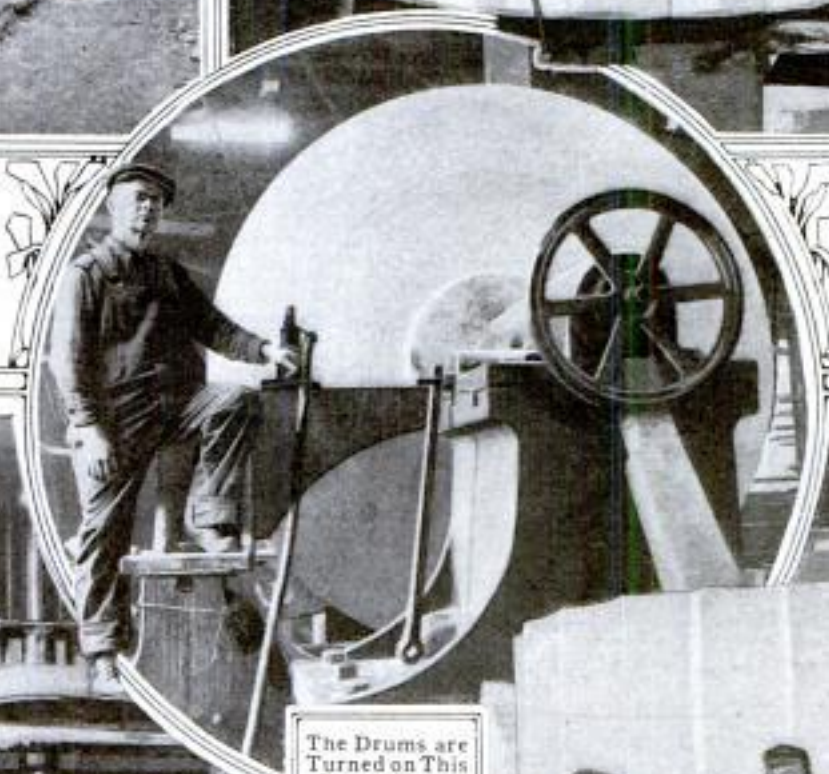
#Louie S. Warner, Fort Clinton, Ohio.
Garage owned by Antoine Bahnsen of Fort Clinton, Ohio.



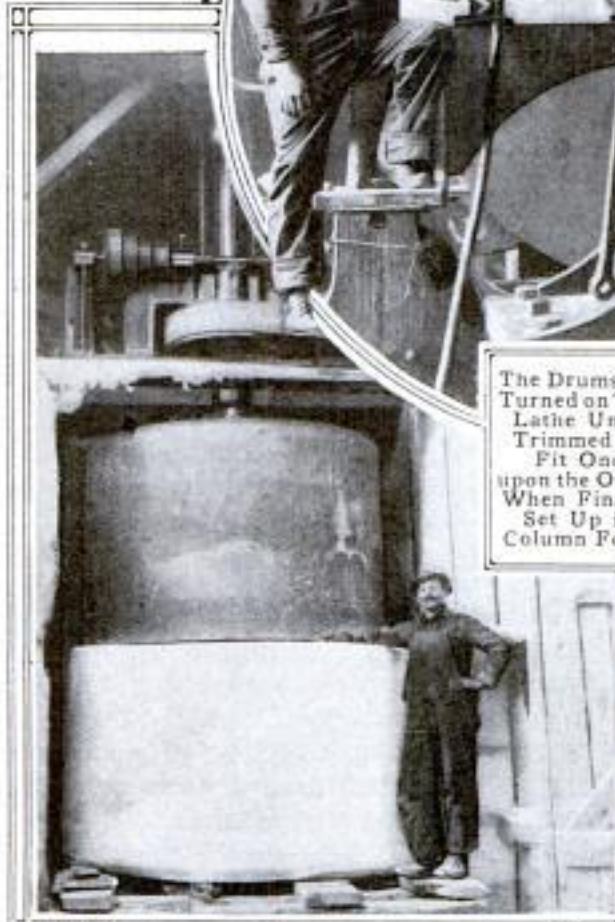
Marble Blocks being Cut into Uniform Sizes by Means of a Wire Saw Which Passes through the Entire Line of Stone



Large Carborundum Wheels are Used to Flute the Drums of Marble and Get Them Ready for the Hand Polishers to Complete the Work



The Drums are Turned on This Lathe Until Trimmed to Fit One upon the Other When Finally Set Up in Column Form



After being Sized, the Marble is Cut by a "Barrel" into Large Cylinders Which are Later Fluted and Polished



This Shows the Last Stage in the Work. The Two Drums Shown Here are being Polished and Fitted

J. Crosby Mc Carthy
Evening Star,

496 Wash. D. C. POPULAR MECHANICS

FLAGS MADE OF HOME-GROWN 9300 m COTTON

As a result of experiments now being conducted on board the revenue cutters "Apache" and "Seminole" home-grown cotton may be adopted instead of imported wool for making the flags used not only by the new coast-

C. E. Drayer, 1801 East 93d St.,
Cleveland, Ohio

Jeffrey Mfg. Co., Columbus, Ohio ELECTRIC MACHINES IN COAL 8609 MINING

Electric power is becoming a more important factor every day in the operation of up-to-date coal mines, this class of power being used not only for transportation but for the actual mining as well. One of the latest of electrical machines for mining is the overcutting machine, in service in some of the mines of Pennsylvania for cutting horizontal grooves several feet



Using the Drum and Cable to Haul Loaded Car Out of a Room



Overcutting Machine in Operation

guard service, but by the navy as well. Cotton has not been used in the past for making flags employed in the government service, because of the tendency of the fabric to stiffen after wetting and the difficulty in obtaining colors that are "fast" and will not fade under continual exposure to the sun and rain. The present experiments are being carried out to test the qualities of cotton made by a new process of carding and weaving designed to overcome these disadvantages. One of the advantages claimed for cotton flags made by this process is that they will not fray out as quickly as those made of wool bunting. If the new fabric meets the expectations of the maker, it will constitute a big step in the "Made in America" movement.



This 25-Ton Electric Locomotive Handles the Entire Output of the Mine against a Grade of 132 Feet to the Mile

deep in the face of the vein preparatory to blasting out the coal. The cutting is done by tools carried on an endless chain which works in a metal frame supported on the machine. This frame, with its cutters, can be raised and lowered, or swung, to cut in any direction, as required. Transportation of the coal within the mine is practically all by electric power. The electric locomotive for this work is equipped with a drum and cable used mainly for hauling cars out of rooms to a point where a coupling with the locomotive can be made. Electric locomotives of another type are used for transporting the coal from the mine tippie to the railroad in cases where, on account of excessive grades or curvature, a railroad spur cannot be built to the mine.

A motion-picture laboratory for producing educational films is maintained by the United States Department of Agriculture.



Mount Mitchell Monument After Dynamiters had Destroyed It

MOUNT MITCHELL MONUMENT DESTROYED

9269 m

An act of vandalism committed for no apparent reason was the destruction by dynamite on the night of Dec. 28, 1914, of the monument erected 26 years ago, on the summit of Mt. Mitchell, North Carolina, to mark the grave of Dr. Elisha Mitchell, who lost his life while exploring the mountain. This mountain stands 6,711 ft. above sea level and is the highest peak east of the Rocky Mountains. The monument was 12 ft. high with a base 30 in. square. It was made of a composition of lead and zinc, and was carried in sections on mule back over the mountains from Asheville to be erected over the grave of the explorer. Near the summit of the mountain is a cabin occupied by a caretaker. On the night the act was committed, a charge of dynamite was first exploded in the yard in front of the cabin, evidently for the purpose of terrorizing the caretaker. A few minutes later a heavier explosion was heard on the summit and on the following morning the monument was found to have been destroyed. A movement is now under way for replacing the old monument with a new one built of granite.



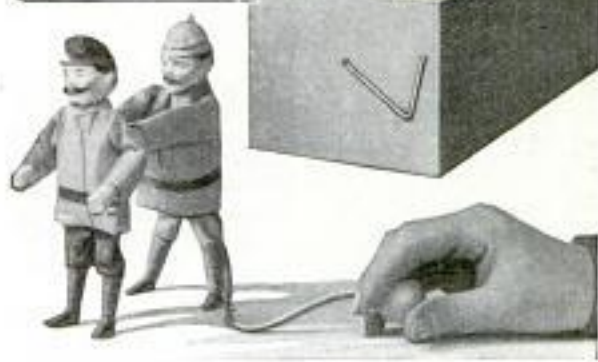
Monument on Mount Mitchell, the Highest Peak East of the Rockies

eral types of cars have shown that a speed of 20 miles an hour results in the greatest economy in fuel, and that an increase of about 16 per cent in fuel consumption per mile may be expected when this speed is either increased or diminished by eight or nine miles an hour.

GERMAN TOYS FOR WAR TIME

9208 m.

THESE pictures show two war toys now popular in Germany. The one at the right represents a Russian going through the process of being hung, while the other, worked by a bulb and tube, represents a German soldier bringing in a French prisoner.



THE ECONOMICAL SPEED FOR AUTOMOBILES

9309 m

That a speed of about 20 miles an hour is the most advantageous seems to have been shown by a close study of the economics of automobile operation. This speed is a safe one for driving on ordinary roads, and for touring, or distance driving, is about the least that the average motorist will care to employ. Actual tests with sev-

Ohio Motorist Jan. 1915

Curt E. Engelbrecht
332 Main St.
Springfield, Mass.

Henry L. Sweinhart
1706 S. St. N. W.,

498 Wash. D. C. POPULAR MECHANICS

CUP TROPHY FOR ARMY

9051 *m* FLIERS



THE third annual contest of army airmen, consisting of a flight from Los Angeles to San Diego made under conditions as much as possible like those of actual warfare, took place in December, 1914. The Mackay army aviation cup is the trophy, and the names of the winning team for each year are inscribed in one of the spaces at the base.

PRESIDENT'S BARGE FOR

9276 PANAMA CANAL OPENING

m The power-driven barge in which President Wilson will lead the procession of ships that is to pass through the Panama Canal at the formal opening in May has been completed and by this time is probably on board a battleship on its way to the Canal Zone. The barge was built at the Kittery Navy Yard at Portsmouth, N. H., and although built with the utmost care and richly finished, its construction was completed in the record time of six

weeks. It is 40 ft. long, and the metal finishings throughout are of coin silver, while the pit in which the president will travel is covered with a bullet-proof shield of steel. On its trial trip the barge made a speed of $24\frac{3}{4}$ miles an hour.

REPRODUCE BASEBALL GAME

8518 *H* ON ELECTRIC BOARD

An electrical baseball board which indicates each play as it is enacted on a field during the course of a game, has been built by an Omaha, Neb., inventor and shown in one of the local theaters. The outline of the diamond is represented by rows of white lights and each baseman by a white and blue light, while the other positions are designated similarly. At the right and left of the catcher's position are two "foul" lamps, one of which ignites when the batter knocks a foul ball. When the game is started the pitcher's light glows until the ball leaves his hand. The lamp at the catcher's position lights when the ball is received there. When it is batted to the right field, for instance, the fact is shown by the lighting of that fielder's lights; a white one appearing if the ball is caught, and a blue one showing in case of an error in play. The runner is followed around the bases by a succession of advancing flashes along the rows of lamps reaching between the different points on the diamond. At one side of the board strikes, balls, outs, and runs are shown



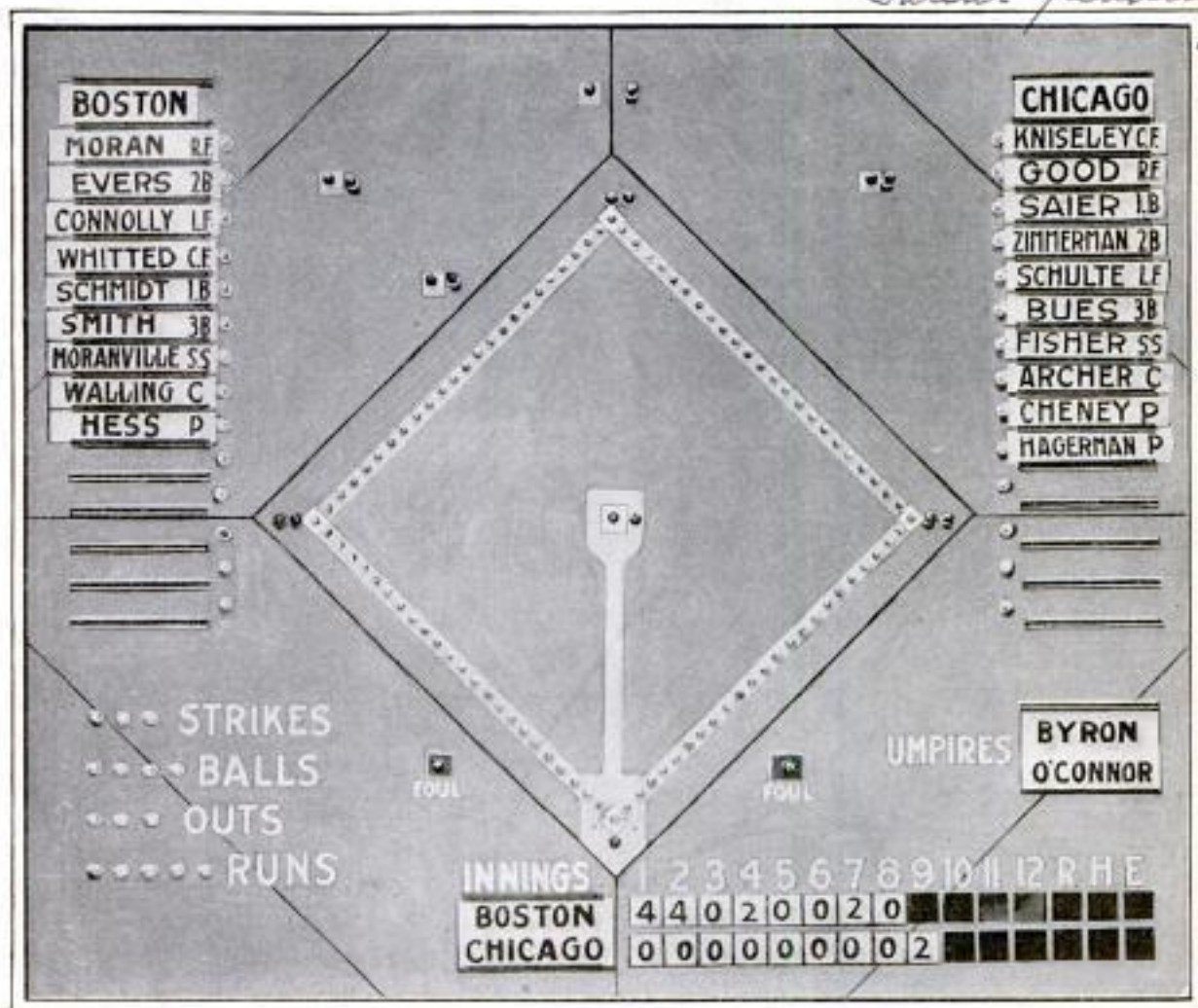
Forty-Foot Mahogany Barge with Coin-Silver Trimmings and Bullet-Proof Cockpit, for President Wilson's Use in Opening the Panama Canal

Geo. A. Walton
3 Lenny's Court,
Newbury, Mass.

A. E. Long, Omaha Bee, Omaha, Neb.

Inventor: Chas. Franke, 2912 Harney St., Omaha, Neb.

Patent pending



Electric Baseball Board upon Which Every Move in the Course of a Game is Faithfully Reproduced

by electric lights, while the line-up of players, and other details, are shown as on an ordinary score board. The spectators follow a game without needing a word of explanation, knowing all the time who is at bat, who are playing the various positions, and what is taking place. When a batter knocks the ball to shortstop and starts for first base, the shortstop's light ignites, and the base-line bulbs flash rapidly one after the other. If the runner is put out, a light appears at the base he is approaching before he reaches it. When a man takes a base on balls, the lights ignite slowly, one after the other, to indicate a walk. Even all the moves of base stealing are reproduced.

Telephone lines are to be extended to Tromsø, Norway, 200 miles north of the arctic circle.

NEW VEHICLE DRIVEN BY
8939^m AERIAL PROPELLER

A new vehicle capable of making 25 miles an hour, which is driven by an aerial propeller and is designated by the maker as a "wind wagon," is made up almost entirely of motorcycle and cyclecar parts. The frame of the car is of ash, and on the rear of this frame is mounted a 4-hp. motorcycle engine.

This "Wind Wagon," Made Up of Motorcycle and Cyclecar Parts, is Capable of Making 25 Miles an Hour



Clare Vance
322 Spear St,
Logansport, Ind.

The wheels are of the cyclecar type, and the brake is a hardwood block which works in a V-belt pulley on the rear wheels. The aerial propeller is 40 in. in diameter and is driven by a V-belt. The car has an 80-in. wheel base and a tread of 36 inches.

"JITNEY BUS" A NEW RIVAL OF THE STREET CAR

Although a new feature in city transportation, the "jitney bus" has come into such popularity, particularly in cities of the Pacific coast, that it is proving a serious rival to the service of the street-car companies and is fur-



nishing some knotty problems for the municipalities themselves. The "jitney bus" is simply an automobile that carries passengers for five cents. "Jitney" is a slang term of uncertain origin used for years on the Bowery in New York, and meaning a five-cent nickel coin. In Portland, Seattle, Los Angeles, and the cities of San Francisco Bay, there were nearly 3,000 automobiles engaged in this service in January, 1915, with the number constantly increasing, and the minimum daily earnings of these cars aggregated about \$19,000. As a result of this competition, the street railways of Los An-

geles are cutting down some of the runs and taking off cars. Now the "jitney bus" has been introduced in Denver, Kansas City, Mo., and Des Moines, Ia., and is rapidly making its way eastward.

While the popularity of this means of transportation is doubtless due in some degree to its novelty, it is to be accounted for mainly by the fact that the "jitney bus" takes on and discharges passengers at the curb, can thread its way through the traffic and thus avoid delays and blockades, and can even go off its regular route for the accommodation of its passengers. The "jitney bus" has therefore apparently come to stay, but it has brought some problems with it. The congestion of street traffic is increased enormously. In Los Angeles it is not an uncommon thing, when the crossing whistle blows, for a string of from 20 to 40 "jitney busses" to start over a crossing, blocking everything until they pass. Many of the cars are operated by persons who have no financial resources, other than the ownership of the car, so that pedestrians or passengers injured have practically no redress. Suitable indemnity bonds as a condition for the issuance of a license are now being considered in San Francisco and Los Angeles. Automobiles of every size and description, ranging from the big bus capable of seating 56 persons to the little machine with a seating capacity of five, are used in this service. During the rush hours the cars are operated at much more than their seating capacity, with passengers standing on the running boards, and it is estimated that in Los Angeles many of the owners of little cars, bought at secondhand for a few hundred dollars, are making a clear profit of more than \$10 a day.

At an electric dinner given in Toledo, each guest was provided with an electric grill, electric chafing dish and electric coffee percolator, and cooked his own food at the table. Baked potatoes were supplied from an electric oven, and cigars lighted with individual electric lighters.

Lou Strohm
Dept. 15, Hall of Records
Los Angeles, Cal

9288 *Brusher Breakwater Co.,*
1207 141 Broadway, N.Y.C.

FIGHTING TOP A MEMORIAL

(9288) *Scientific American 1/30/15*
combating the ocean waves with compressed air.

9303 *m* TO "MAINE" VICTIMS

The fighting top of the battleship "Maine," recovered from the sunken vessel when it was raised from the bottom of Havana Harbor, has been erected and dedicated in Arlington cemetery, Washington, D. C., as a memorial to the officers and men who lost their lives with the sinking of the battleship. The fighting top is exactly the same as it was at the time of the disaster, but a new turret has been built at the base of the mast.

The idea consists of the construction of a virtual "air breakwater" which will dissipate the breakers by setting up a flow of air bubbles at right angles to the wave undulations. This would be accomplished by laying a 4-in. perforated pipe a short distance from the shore along the stretch of beach to be protected. It would be placed on the bottom at right angles to the sweep of the breakers with a connecting line running to an air compressor on the beach. The plan is not a totally untried one. Actual tests of it have been conducted at Crotch Island, Maine, where an experimental plant was constructed some time ago. According to reports the waves were running so high that the spray from them was breaking over the tops of the trees along the shore when the air was turned into the pipes. Within a very few minutes the water between the shore line and the

Inventor: Philip Brusher

Benjamin Franklin Co.

COMBATING OCEAN WAVES WITH COMPRESSED AIR

For the protection of the Atlantic coast against the severe storms which are annually battering its beaches and working incalculable damage to towns and resorts from New England to North Carolina, an eastern engineer has evolved a plan for

See Aug 1907 Scientific American p. 878



PHOTO BY G. V. BUCK

Fighting Top of the "Maine" Erected in Arlington Cemetery, Washington, D. C., as a Memorial to the Officers and Men Who Lost Their Lives with the Sinking of the Battleship in Havana Harbor

Underwood + Underwood
(9303) 417 Fifth Ave., N.Y.C.

air breakwater was calm, while the sea beyond was as turbulent as ever. The plan is one which seems to be feasible where the expense of maintenance is not an important item for consideration.

NOVEL SIGN ADVERTISES

8992 LAND SALE

Of the many methods of advertising resorted to by real-estate men in southern California, where the sale of land and homes forms one of the biggest features in business, the sign



Novel Sign Used in Southern California for Advertising Sale of Home Sites

shown in the illustration is one of the latest and most ingenious. The little bungalow that surmounts the sign looks very much like part of a modern "full-grown" bungalow. It is 3 ft. in width, 2 ft. in height, and about 12 in. in thickness, and is painted gray. The eaves have extensions of 6 in., and the chimney is of modern design. This tiny bungalow rests on a light wooden framework. On each side is a blackboard on which are listed prices and other features of the tract of land that the sign advertises.

PAINTING BROOKLYN BRIDGE TASK FOR HUMAN SPIDERS.

8991 Every three or four years it becomes necessary to paint the Brooklyn bridge in order to prevent the corrosion and deterioration of its structural members. This is a task which requires the services of a small army of "human spiders," who climb about over the web of cables and stringers with almost as much composure and agility as if they were insects instead of men.

With buckets and brushes they cling in the network, swinging in the wind as the constant stream of traffic surges across the East River. Between them and the river beneath there is more than 200 ft. of space, and the cables.

Every exposed strand and spot of the whole structure must be painted, so the men scramble over the cables until they reach the topmost point of the great towers, which extend 272 ft. above the water, and finally end up on the scaffolds suspended beneath the structure where the mastheads of passing vessels scrape under the plankings, sometimes missing them by a margin of only a few inches. This work continues usually for six or eight months before it is completed, and costs approximately \$50,000.

Approximately 117,000 lb. of paint are used in covering the structure. In the past the painting was carried on almost continuously because the work was undertaken by a smaller staff. Recently, however, the bridge-painting force has been consolidated for economic and efficiency reasons, so the work may be done now in less time and at a greater saving than heretofore. More precautions for the safety of the men are now being taken than in the past, and during the recent repainting of the bridge not a single accident occurred, a record never before made.

The bridge was opened in 1883, and from then until 1904 it was the only means of transportation over the East River between Manhattan and Brooklyn, aside from the ferries. For years



Above Is a Group of Human Spiders Climbing Unconcernedly over the Great Web of Steel Stringers Which They are Painting

Below: The Men are Suspended on Narrow Scaffolds with Nothing Else between Them and East River Far Beneath

it was the largest suspension bridge in the world, but it is now surpassed by the Williamsburg bridge, a mile or so farther north, in both total length and clear span. Its length is 6,016 ft. against 7,308 ft. of the newer structure. It has four supporting cables, each of which is $15\frac{3}{4}$ in. in diameter and is

composed of 5,296 galvanized, oil-coated wires. These are laid parallel with each other and wrapped with steel wire into a solid cylinder. The total length of the wire contained in them is 14,361 miles, while their weight amounts to 3,600 tons. The trains, cars, vehicles, and passengers passing

H. Lionel Greaves
 40 J. V. Beverhoudt, Box 340
 Cristobal, C. Z.

over the four East River bridges, Brooklyn, Manhattan, Williamsburg, and Queens Borough, every 24 hours weigh approximately 721,000 tons; while the whole United States army could march across Brooklyn bridge in one hour and 33 minutes.

KEEPING BUILDING WARM WITH STORED HEAT

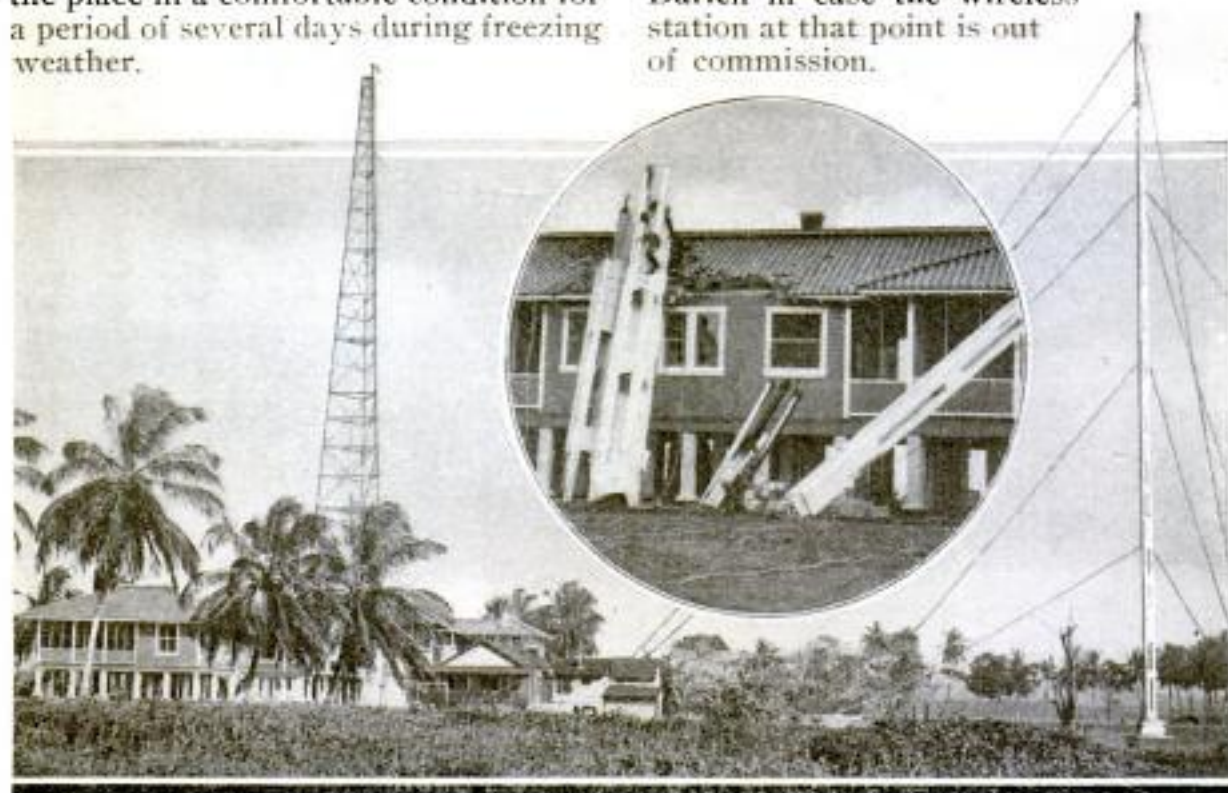
German engineers, confronted with the problem of warming an old castle in which there was no heating equipment, found a novel method of accomplishing the object sought. The building was to be used for a state dinner, and it was stipulated that no part of the heating system should be visible. For several days previous to the occasion, the floor of the banquet hall was thickly covered with steam pipes, which were connected to a temporary boiler. The heat was allowed to reach a high degree until a short time before the dinner, when all the steam pipes were removed. The heat which had been absorbed by the heavy walls of the building proved sufficient to keep the place in a comfortable condition for a period of several days during freezing weather.

Power
 11/17/14

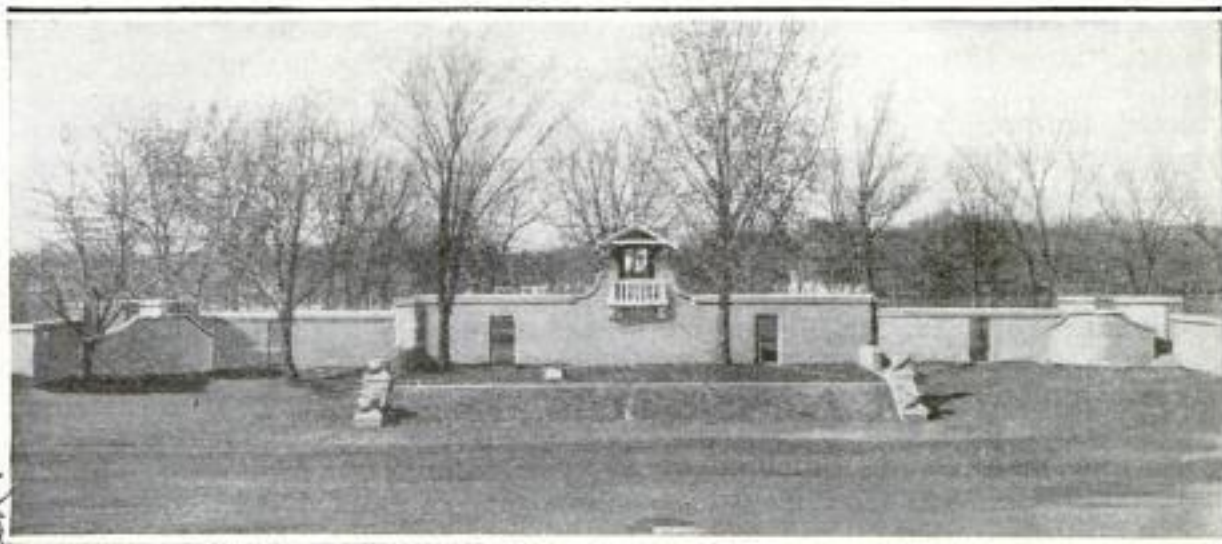
WRECK OF WIRELESS MAST

9205 m AT COLON

During a storm that occurred in March, 1914, one of the wooden wireless masts at Colon, Canal Zone, was struck by lightning and considerably damaged. Temporary repairs were made, and the mast was kept in service for several months until arrangements could be made for building two steel towers, one of which was to occupy the site of the damaged wooden tower. While the old mast was being taken down it buckled at the center and collapsed, killing two men who were working at a distance of about 125 ft. above the ground. The old masts, three in number, were erected about nine years ago and were 212 ft. high, while the plant had a range of 1,000 miles. The new towers are each 300 ft. high, and are connected with apparatus for local and long-distance transmission. With the long-distance apparatus in operation these towers will have a range of over 3,000 miles. This station will be able to handle all the work now done at Darien in case the wireless station at that point is out of commission.



New Steel Tower for Wireless Station at Colon and Wreckage of Wooden Mast That Collapsed While being Taken Down



The Open-Air Theater Partially Completed: The Stage Consists of a Blue-Grass Lawn That is Illuminated by Footlights Set in a Concrete Trench

**LAWN MADE INTO OPEN-AIR
8796 m THEATER**

Novel features are to be included in an open-air theater that is being built for a northern college. The stage is a blue-grass lawn, 75 by 150 ft., set with elm trees and illuminated by footlights placed in a concrete trench. The amphitheater, which is to be equipped with temporary benches, will accommodate 3,000 persons. Extensive electrical effects are provided for in the plans. Decorative shrubbery is to be set out on the stage, and a box hedge will serve to mark the outline of the raised amphitheater. Drainage is to be provided for by cesspools. This theater is intended principally for open-air productions of Shakespeare's plays.

**CUTLERY STEEL THAT WILL
9307 m NOT TARNISH**

Steel made by a new process and said to be nonrusting, unstainable and untarnishable, has been brought out by an English firm. It is especially adapted to use in making table cutlery, the claim being made that it retains its polish indefinitely with use, even when brought in contact with acid foods. The cost of this steel is about double that of ordinary steel.

**LAST MONUMENT SET ON
9277 m CANADA BOUNDARY**

The last of the permanent monuments marking the boundary between the United States and Canada from Lake of the Woods to the Pacific Ocean was set in January, 1915, and with the setting of this monument a work that has been going on intermittently for nearly 100 years was brought to a close. As early as 1818, a joint commission was appointed to establish the line between the two countries, but it was not until 1874 that the last post was set. These posts were of wood, and in 1908 it was arranged to re-mark the boundary with permanent monuments and to place them sufficiently close together to provide a clear view from one monument to the next.



Each of the new monuments consists of an aluminum-bronze post,

*Thos. Firth & Sons Ltd., Sheffield, Eng.
Firth - Sterling Steel Co., Mc Keesport, Penna.
Harry A. Johnson, Vermillion, S. Dak.*

*Daily Consular & Trade Reports
Reported by Council
John M. Savage,
Sheffield, Eng.*

*#W. Mc D. Lait
Singer Creek, Alberta,
Can. Cardston*

Copyrighted material

made in three sections to facilitate transportation through the mountains. Each section weighs 65 lb., and when erected, the sections are held together by a steel rod passing through the center. The monuments are set in heavy concrete foundations. On the west faces of each monument in raised letters are the words "Canada" and "Convention of 1818," and on the east faces the words "United States" and "Treaty of 1908."

Great difficulty was experienced in setting many of the monuments. In some places the monuments and

the engineers had to be lowered with a rope down the face of a cliff, and it was frequently necessary to blast out holes in the solid rock to make a foundation for the post. The monument on the continental divide is 5,600 ft. above sea level, while there is one that stands 8,100 ft. above sea level. Monument No. 1 is on an island in the Pacific, monument No. 272 is on the continental divide, while monument No. 925 is on the shore of Lake of the Woods, which lies on the boundary line between Manitoba, Minnesota, and the province of Ontario.

SUBMARINE FOR RECOVERY OF SUNKEN TREASURE

A spherical submarine, now being built, apparently solves the problem of recovering treasure from ships sunk at great depths. This is the apparatus described and illustrated in an article entitled "Gathering Gold from the Ocean's Floor," that appeared in the June, 1913, number of this magazine, with which it was expected that depths as great as 1,000 ft. might be reached. At that time the submarine was simply an invention. Now it is not only being built, but is practically completed, and it is likely that before the end of the year this curious diving apparatus will be in actual use.

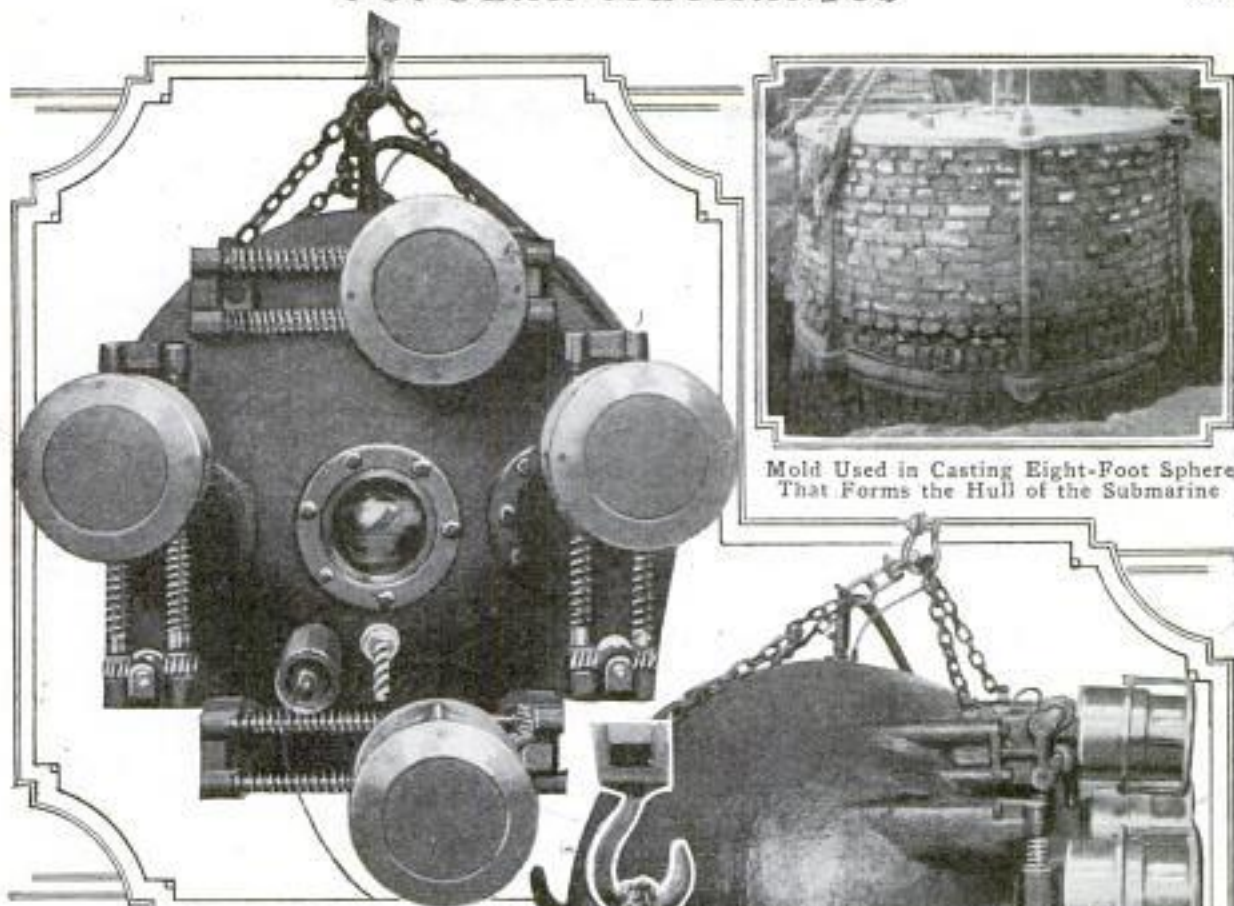
The new submarine consists of a steel sphere, 8 ft. in diameter and capable of carrying two workmen. It is designed to be lowered into the water from a tender, but is provided with electrically driven propellers by which it can be moved about in the water as it hangs at the end of the cable. One of its essential features is a set of four electromagnets which, when energized by current from the motors within the sphere, serve to hold it securely to the steel hull of a sunken ship. Current for operation is supplied through a cable running down from the tender. In addition to this equipment it will be provided with electric drills for piercing the side of a ship and with a powerful searchlight, for working purposes and for exploring the bed of the

ocean when the exact location of a sunken ship is not known.

In operation the submarine will be conveyed by a tender to a point above the sunken ship, and will then be lowered to the required depth at the end of a cable. By means of the propellers it will be possible for the observers within the submarine to drive it for a considerable distance, and with the aid of the searchlight the exact location of the hulk can be found. The next step will be to lower a large steel cylinder filled with sea water, but provided with a motor-driven pump for expelling the water after the cylinder has been attached to the hulk. The submarine is then moved in against the hull by means of the propellers and is secured to the side by the simple process of energizing the electromagnets. The apparatus is then in position for drilling. A hole is drilled through the steel plates of the sunken ship and into this a hook which is attached to a steel cable fixed to the cylinder is inserted. The submarine is shifted as required and additional holes are drilled until all the hooks hanging from the pontoon are made fast. This process is continued until a sufficient number of cylinders for raising the vessel have been attached. With this completed, the water is pumped out of the cylinders and the resulting buoyancy raises the vessel.

C. L. Edholm, 1353 W 36th Pl. Los Angeles, Cal.

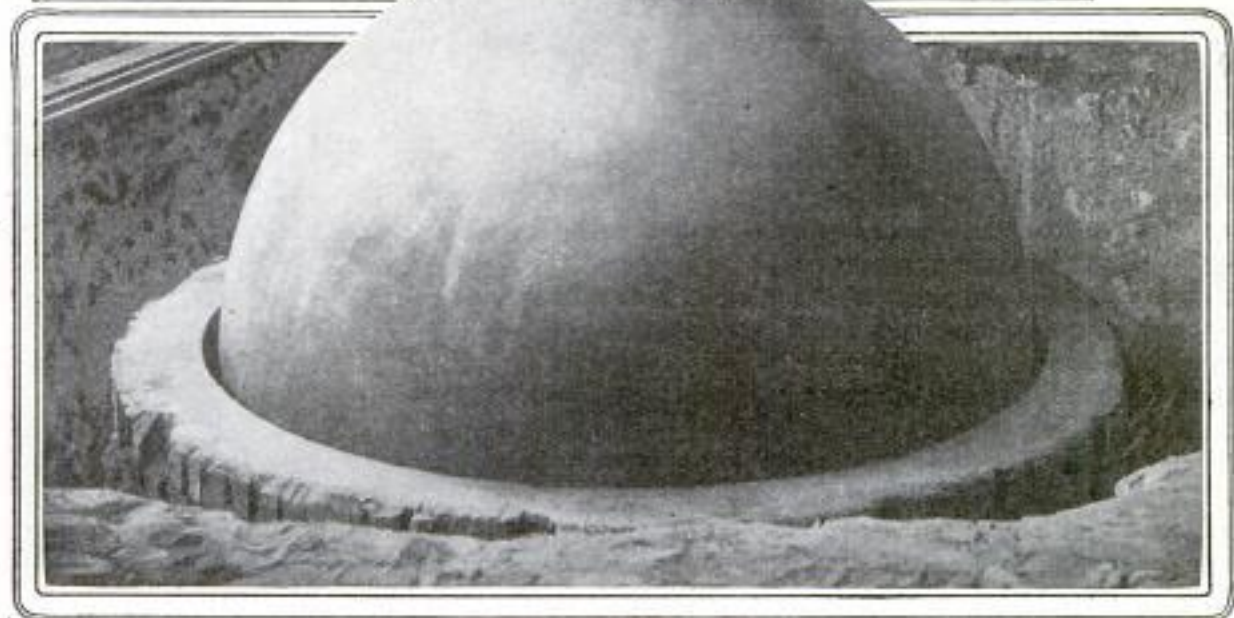
American Salvage Co.
224 W. 42nd St., New York
Sub-salvage (4021)



Mold Used in Casting Eight-Foot Sphere That Forms the Hull of the Submarine

Front and Side Views of the Submarine for Deep-Sea Salvage: The Four Projecting Cylinders Are the Magnets Which, When Energized by Electric Current, Hold the Sphere Securely to the Side of a Steel Ship; These are Provided with Screw Adjustments, as Shown, so That the Sphere can be Shifted a Short Distance along the Side of the Ship without Releasing the Hold of the Magnets

Below: Lifting the Sphere from the Mold After the Work of Casting had been Finished

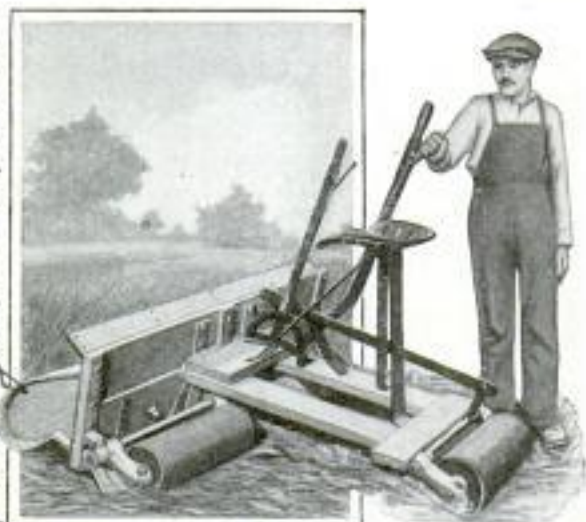


V.W. Killick, 1521 Oak St.,
Glendale, Calif.

NEW TYPE OF ROLLER

9026m **SCRAPER**

A roller scraper recently brought out in California has a wooden scraper board mounted on rollers in such a



The Scraper Board is Controlled by the Levers and can be Made to Dig into the Ground or to Deposit Earth as Required

way that it can be raised or lowered by controlling levers, placed in convenient reach of the operator's seat. This scraper is drawn by horses, and as the operator rides he can dig into the ground, or deposit earth as required, simply by manipulating the levers. The trailing rollers not only smooth down the earth, but make the pulling easier for the horses.

NEW FLYING BOATS FOR THE UNITED STATES NAVY

9330m In a call recently made by the Navy Department for bids for the construction of six flying boats, the specifications consisted only of an outline of the service requirements that the machines would be expected to meet, leaving the question of the type of machine and all details of construction to the inventive genius of the bidders. The general requirements are for a machine capable of carrying a pilot

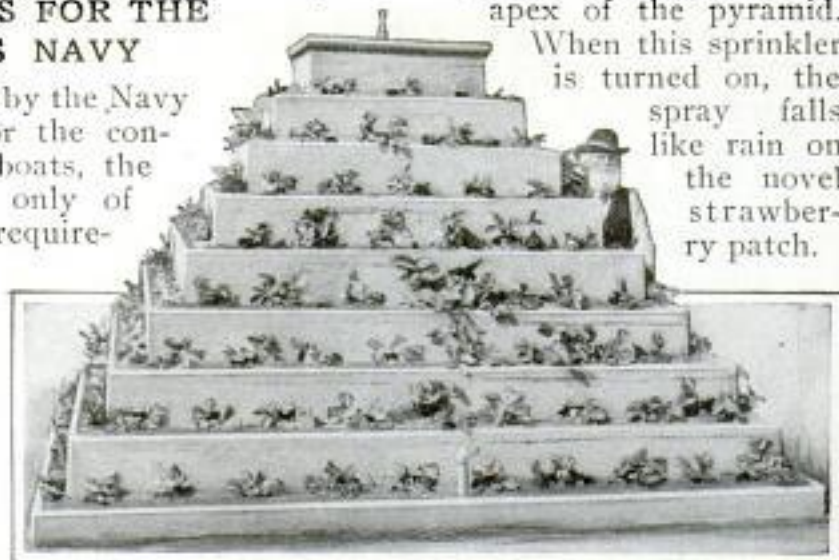
Army & Navy Jour.

and observer and having a weight allowance for a gun and ammunition, protective armor, and all necessary tools. The machine must have a range of speed of from 50 to at least 80 miles an hour, must be capable of sustained flight at full speed for four hours, and must be able to climb at the rate of 250 ft. a minute for the first 10 minutes, and to glide at an angle of 6 to 1, while control and stability must be such that flying in a wind of 35 miles an hour will be practicable and safe. In addition to these requirements, the machine must have a turning radius of 40 yd., must be able to get off the water and to alight safely under ordinary conditions on the open sea, and to ride at anchor or adrift without danger of capsizing.

9185m **GROWING STRAWBERRIES IN A CONCRETE PYRAMID**

In a hollow pyramid built of concrete a western farmer grows a large crop of strawberries on a comparatively small area. The pyramid built up in eight tiers, or steps, is hollow and filled with earth. About a foot apart in each step are small holes out of which the strawberry plants grow, the foliage and berries covering the sun-heated surface and maturing quickly. Irrigation is accomplished by a sprinkler at the apex of the pyramid.

When this sprinkler is turned on, the spray falls like rain on the novel strawberry patch.



Novel Concrete Pyramid Used by a Western Farmer for Growing Strawberries

C. L. Edholm, 1353 W. 36th Pl.,
Los Angeles, Calif.

Inventor: S. E. Kennedy, San Jacinto, Cal.
Mfr: Brennan Mfg. Co. Exnard, Calif.
Made in 5 and 19 ft. lengths + sells at \$30 + \$70

COMMENT AND REVIEW

FROM very earliest Bible times down to the present day, the human race have been meat eaters, when they could get it. Vegetarians have propounded their theories, and pointed to long life as a reward for abstaining from flesh, but the red-corporuscle, hungry man will not forsake his meat to any perceptible extent. On the contrary, modern methods of canning and cold storage have brought the shipment of meats to such a high degree of certainty and perfection, its consumption has greatly increased. City dwellers are large consumers, and our cities have doubled in population in the past generation, while our export trade has grown from almost nothing to immense proportions during the period named.

Future Meat Supply

While this demand has been increasing, the system under which our beef was produced has largely vanished. Twenty years ago millions of acres of western range were as free to use as the air, and ranchers and cattle companies by the hundreds grazed their stock by the tens of thousands. These vast herds, advancing leisurely, slowly grazed their way from one good feeding ground to another; and, after a herd was once started, the comparatively trifling cost of herding was all it cost, while the production and shipping went on year after year. Now conditions are radically changed. The vast ranges have been surveyed, sold, fenced, and passed from government ownership to individuals. It is no longer possible to drive the herds from one feeding place to another, both on account of obstructions and inability to graze while on the way.

The evident readjustment must come through a reversal of the former system. Instead of one man marketing 5,000 head a year, there will be 5,000 owners producing each one beef per year. Some farmers, of course, will market more, but the great, reliable, steady flow of beef production will ultimately go to the packing houses in a vast stream made up of innumerable small branches. Under these conditions one or two beeves will live on what is now practically going to waste, and with the extra care which usually is given small units the weight and quality will profit. There will still be some cattle kings in each of the western states, but a great abundance can be maintained indefinitely through a million small producers.



THE man with an income of more than \$4,000 has been going through his annual attack of income-tax report; like the influenza it grows worse each year. Contrary to a somewhat general belief, the small percentage of citizens thus honored do not whine and fuss so much about the tax itself—most of them pay it even cheerfully—but they do fume and blow up at the complications, exasperations, and impossibilities imposed. As an exhibit of crude, inconsistent, and amateurish complexities this latest report is a "masterpiece of incompetence," as a leading daily expresses it. A well-known lawyer, after trying to fathom the law,

The Income Tax

gave it up in despair with the remark, "It is impossible to understand its meaning save by consulting a palmist."

As interpreted by the department it is a case, for the government, of heads I win, tails you lose. For instance, a man in moderate circumstances sells a piece of land at a profit. That profit must be declared as a part of his income for the year. That's all right. But, should he through necessity be compelled to sell that same land, and, in order to raise money, be forced to sell at an actual loss, then he cannot deduct from his net income for the year that loss, *unless* he is a recognized real-estate dealer, speculating in property as well as making sales for other people. In other words, he practically pays a tax on his loss. The same ruling applies to sales of all other things in which the seller is not a recognized dealer, be it stocks, bonds, hay, grain, or whatever it may.

The government also imposes an unfair burden in making its collections. Thousands of small investors and widows who do not pay any tax, but cash the interest coupon at a bank, cause a lot of work which the bank must do at its own expense. The holder of a \$5 interest coupon wants to cash it. Stores will not take it as money. The holder goes to a bank. In order to comply, the bank must first get a signed statement that the client has or has not an income in excess of \$3,000. The bank makes no charge for cashing the coupon, but must do a lot of bookkeeping for the government. One bank in Chicago alone spent \$6,500 last year for clerks to do this work.

The foregoing is not a discussion of the justice or merits of the tax, but offers only a suggestion of the numerous inconsistencies in the government's method of applying and collecting the tax. No time should be lost in revising the law, which was passed hastily and without suitable consideration, and providing in its stead one which shall be as definite and consistent as the regulations governing the payment of customs, tobacco, and spirits taxes.



IT would take a large book to contain the insurance laws of all the states, for legislation of this character has been varied and prolific. The courts are constantly used in the settlement of fire losses, and

*Sensible
Insurance
Law*

the adjusters wax fat on both the companies and the insured. It has apparently remained for the State of Florida to enact a fire-insurance law that is based on sound principles and at one stroke cuts out litigation and leaves no room for dispute; and as for adjusters, professional or otherwise, why, there is little they can do. All this sounds too good to be true, but it is, and the scheme is so simple the wonder is that every state does not have one just like it.

The Florida fire-insurance law reads that when a policyholder has a fire loss, the company must pay. If, for instance, you own a building worth only \$5,000 and you can get an agent to issue a policy for \$10,000, and the building burns, you recover your \$10,000, providing, of course, the company cannot prove you are guilty of arson. The total

destruction of an insured property must be paid for at whatever amount your policy calls for. And there is probably less arson in Florida than in any other state.

The whole procedure is logical. The companies cannot take chances in appointing careless, dishonest, or irresponsible agents. The agent, in order to hold his agency, does not sell policies as a dealer hands out cigars over a counter. He exercises a lot of caution. He will not issue a policy unless he knows something of the party insured, and he personally examines the building or goods and satisfies himself the property is worth the amount the insured desires. Thus, policies for fictitious amounts are not written, for what is written must be paid. On the other hand, the insured is not allowed or induced to pay premiums on amounts which could not be recovered in other states.

This maximum liability tends to decrease fires, for the agent must keep his record up to a certain standard or the company gets another in his place. The local agent becomes a sort of inspector. He has to be constantly watchful; and when he discovers a client is becoming careless and taking chances which might lead to a fire, the agent cautions such a party and threatens to cancel his policy. This eternal vigilance at both ends of the insurance policy is automatically maintained, for both the company and its agents are anxious to stay in the business. And as for the honest policyholder, he knows at all times exactly what his protection is, and, should he burn, just what he will receive.



MANY of the states have enacted laws governing child labor, and the evils of child life in factories have been largely corrected. In the cotton mills of the South the evil still exists to a considerable

*Child-
Labor
Law*

extent, with small prospect of relief from state legislatures. Child-welfare workers finally hit on a plan which at this writing seems likely to carry, having already passed the House and being in the hands of a Senate committee. The bill provides that no manufactured goods made in part or whole by child labor shall be received for transportation by interstate commerce lines. This practically puts an embargo on the use of child labor, as none of the southern mills could exist with sales confined to its own state.

In the factory towns where child labor has been employed, one does not have to be an expert to pick out the young men and women who began factory work too young. The pale face, anaemic condition, stooping shoulders, and weak physique stamp unmistakably those who were robbed of their right to become strong and healthy during those growing years when the foundations must be laid for a lifetime, be that long or short. In many cases, parents, who wanted the earnings, have been as much or more to blame as the factory management, but, whatever the reason or excuse, the practice is all wrong and it is to be hoped the pending bill will effectually remedy the evil for all time.

*Spring
and
Hope*

AS children and adults, we look forward to the coming of Spring with renewed hope. Even though the Autumn means the gathering of harvests, the fulfillment of hopes, a something accomplished, it does not afford that renewed action and awakening to effort that the softening breezes, gentle showers and mild skies of Spring call to life. A great planting is in progress. In the South much of it has already been done, and like a vast wave is sweeping from Gulf to Lakes. Probably never in our history have so many acres been plowed and planted as this year, for we have not only ourselves but other lands to feed. We look and hope for an unprecedented yield. That's encouraging.

The railroads, having secured the rate increase so long withheld, are striving to float loans and secure the money necessary to repair their roads and rolling stock, long neglected. Already a total of \$40,000,000 to be spent in this way is announced, and the result is car shops are opening their long-closed doors and many a small plant which has been idle for months is getting ready to resume and furnish the specialties they manufacture. That's hopeful.

The steel mills have sent out the welcome news, and thousands of workmen who have been idle all Winter now hasten each morning toward the goal of their dependence. Not all are needed yet, by any means, but the number is increasing every week. That helps.

The shelves of the country dealer are as nearly empty as possible; so are the storage rooms of the wholesaler and jobber. Yet they have been able to weather the gale, for the failures have been remarkably few in number; there is no inflation in merchandising, and once the tide turns, as it must inevitably do one of these days, the wires will almost melt with the frantic appeals to hurry up orders and shipments. The factories will be working night and day and the wheels of commerce will merrily turn again. All this is no dream, but the inevitable. Some unforeseen cog may slip and occasion some delay, but signs surely do point to a splendid resumption of business from now on. That's promising.

What's the matter with us, anyway? Big crops for two years and now wartime prices for grain and the money piling up in the banks. The deposits in Chicago banks alone increased \$90,000,000 the first six weeks of 1915. We are better off than we know, stronger than we realize. We have not lost our skill, nor initiative, nor vitality. We're scared. We are like a lot of people at a funeral: the service is over, it's time to go, everybody wants to leave, and each hesitates to be the first to start. The "buy it now" and the "build it now" and a lot of "do it nows" are all right. While our sympathies for others in distress naturally depress us, it is time to rise above our fears, and with firm hands and brave hearts march confidently out into our future and our destiny. And do things.

H. H. WINDSOR

February 27, 1915.

LATEST ADDITION TO NEW YORK'S SKYSCRAPERS

93237M



Photo Copyright UNDERWOOD & UNDERWOOD

THE new 40-story building erected on the site of the old Equitable building, destroyed by fire in 1912, is so enormous that it forms one of the most impressive features of lower New York, even though it has some of the biggest skyscrapers in the world for its neighbors. This building covers a ground area of 50,000 sq. ft. and has 1,200,000 sq. ft. of available floor space. In spite of its enormous size, the work of erecting the building took only a year. It is located in an interesting neighborhood, as will be seen from the illustration. In the foreground of the picture, at the left, is the historic steeple of Trinity church; opposite this is the beginning of Wall Street, and in the background at the extreme left is the tower of the 49-story Singer building.

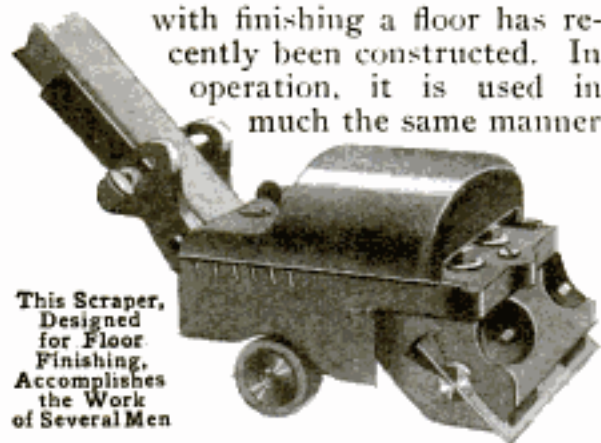
Underwood + U. 417 - 5th Ave.

N. Y. City

WEIGHTED SCRAPER BUILT FOR FLOOR FINISHING

2725 H

Capable of being used on either hard or soft wood, a weighted scraper which eliminates much of the labor connected with finishing a floor has recently been constructed. In operation, it is used in much the same manner



This Scraper,
Designed
for Floor
Finishing,
Accomplishes
the Work
of Several Men

as a polishing brush, doing away with the necessity of handwork and allow-

ing a workman to stand in a natural position instead of getting down on his knees. An 8-in. blade is employed, and this may be adjusted to any angle, vertical or lateral, which may be necessary under varying conditions. The weight is so arranged that by sliding it forward or backward the pressure on the scraper is increased or decreased as desired.

The device is mounted on rubber-tired wheels, so that it is not difficult to use, while its weight of 140 lb. provides it with sufficient bearing power to give a floor a smooth, uniform surface without waves or chatter marks.

CA double-decked concrete viaduct, half a mile long, across 32 railroad tracks, has been built in Kansas City.

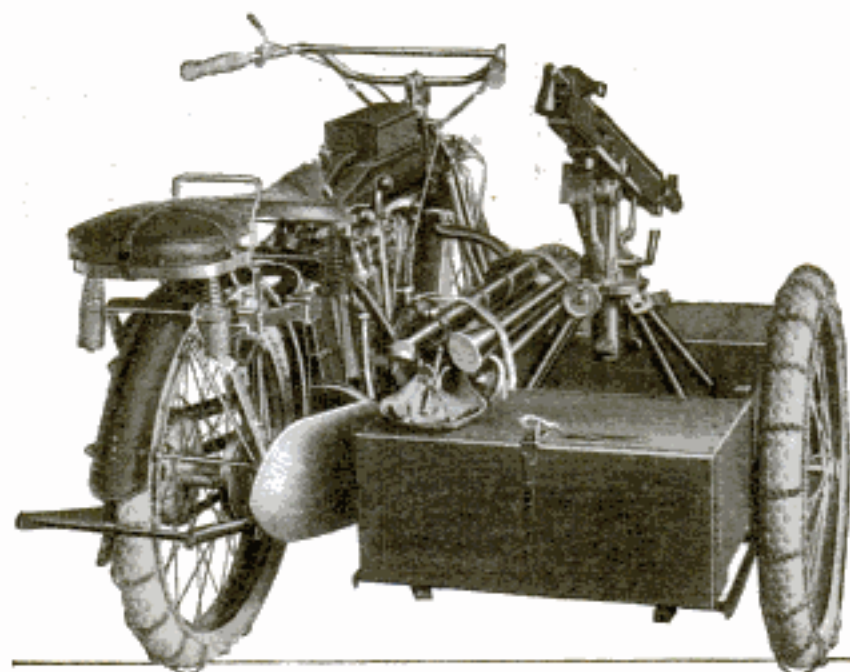
RIOT GUN MOUNTED ON MOTORCYCLE SIDECAR

9164 m

A motorcycle with sidecar chassis on which is mounted a machine gun of rifle caliber for riot service, has recently been brought out in this coun-

try, and some of the Canadian military forces have been equipped with it. The machine has a two-speed gear, is

capable of making a speed of 40 miles an hour, and can cover a distance of about 75 miles on one tankful of gasoline. It is made for carrying two passengers, so that the gun can be operated while the machine is in operation. The gun, which has a firing capacity of 450 shots a minute, is carried on a special mounting and can be operated on the machine or detached and mounted on a collapsible tripod. Four feed boxes, each having a capacity of 250 rounds of ammunition, are carried on the chassis. The gun has an effective range of $2\frac{1}{2}$ miles and is so designed that after the first shot is fired, the loading, firing, and ejection of the shells is



Motorcycle Sidecar Equipped with Rapid-Fire Gun for Riot Service

performed automatically by the force of the powder gases as long as the operator presses the trigger.

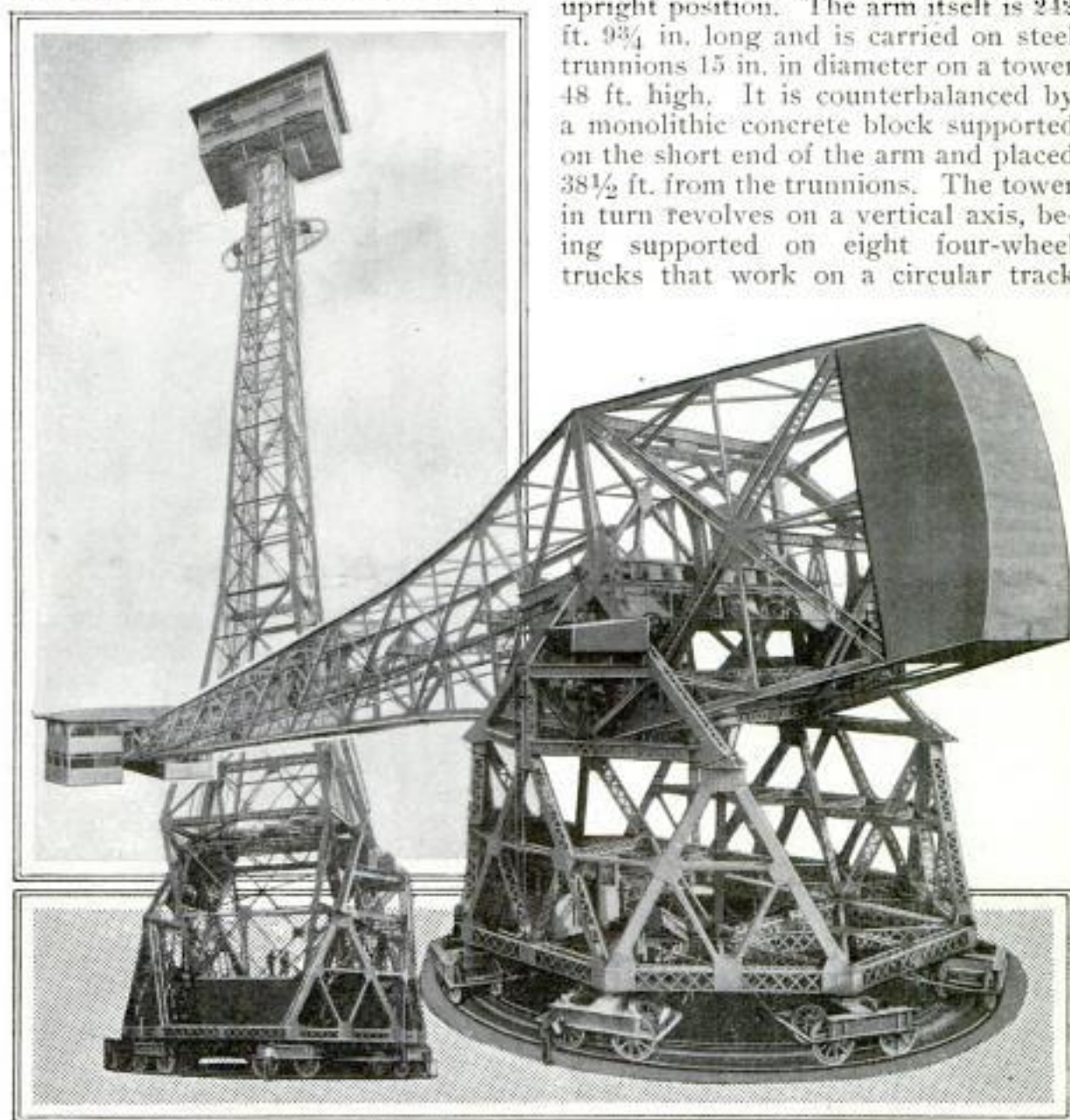
C. Swayne, 76 Merchants Station, St. Louis, Mo.

Indian machine - Hendee Infr. Co. - Springfield, Mass.

"AEROSCOPE" LIKE ENORMOUS INVERTED PENDULUM

One of the striking amusement devices at the Panama-Pacific Exposition is the "aeroscope," an enormous inverted pendulum built much like a bascule bridge and having suspended at its free end a car in which passengers are lifted to a height of 250 ft. above the exposition grounds. One of the most novel features of this device is that the arm is lifted to a vertical position by two aerial propellers placed 27 ft. from the swinging end and operated by elec-

tric motors. After lifting to a point where it will clear the neighboring structures, the arm swings horizontally around the supporting tower as it lifts, so that the sensation is much like that of ascending an enormous spiral stairway that has a constantly narrowing diameter as the top is approached. The car is capable of carrying 118 passengers and two attendants, and is so connected with the arm that it is impossible for it to take any but an upright position. The arm itself is 242 ft. 9 $\frac{3}{4}$ in. long and is carried on steel trunnions 15 in. in diameter on a tower 48 ft. high. It is counterbalanced by a monolithic concrete block supported on the short end of the arm and placed 38 $\frac{1}{2}$ ft. from the trunnions. The tower in turn revolves on a vertical axis, being supported on eight four-wheel trucks that work on a circular track



The "Aeroscope" at the Panama-Pacific Exposition: In the Car at the End of the Lifting Arm 120 Persons at a Time are Raised to a Height of 250 Feet. The Arm is Lifted to an Upright Position by Two Aerial Propellers Placed 27 Feet Down the Arm from the Car

having a diameter of 61 ft. These trucks are driven electrically through gear trains. The entire operation of the aeroscope is controlled from an operator's cabin at the base of the tower.

9048m **TOWN MENACED BY BURNING OIL-TANK WAGON**

While discharging gasoline at a garage in Uniontown, Pa., an oil-tank wagon was set on fire by a boy who



This Oil-Tank Wagon was Set on Fire by a Match Applied to the Gasoline Drippings

applied a lighted match to the drippings from the wagon. The result was a fire which threatened for a time to spread to the surrounding buildings, but which finally burned itself out without damage other than the destruction of the wagon. Although partly filled with gasoline the tank did not explode, and it was this that prevented the fire from being thrown broadcast.

NEW PROCESS WILL MAKE

9436 **GASOLINE CHEAPER**

see June 15 - 1915
A process by which three times as much gasoline can be extracted from a given quantity of petroleum as by the methods generally used has been invented by Dr. Walter F. Rittman, chemical engineer of the U. S. Bureau

of Mines. The patents on the new process are to be dedicated to the public, so that any refiner may use them. It is believed by the officials of the Department of the Interior that this will result in greatly reducing the cost of gasoline to the consumer.

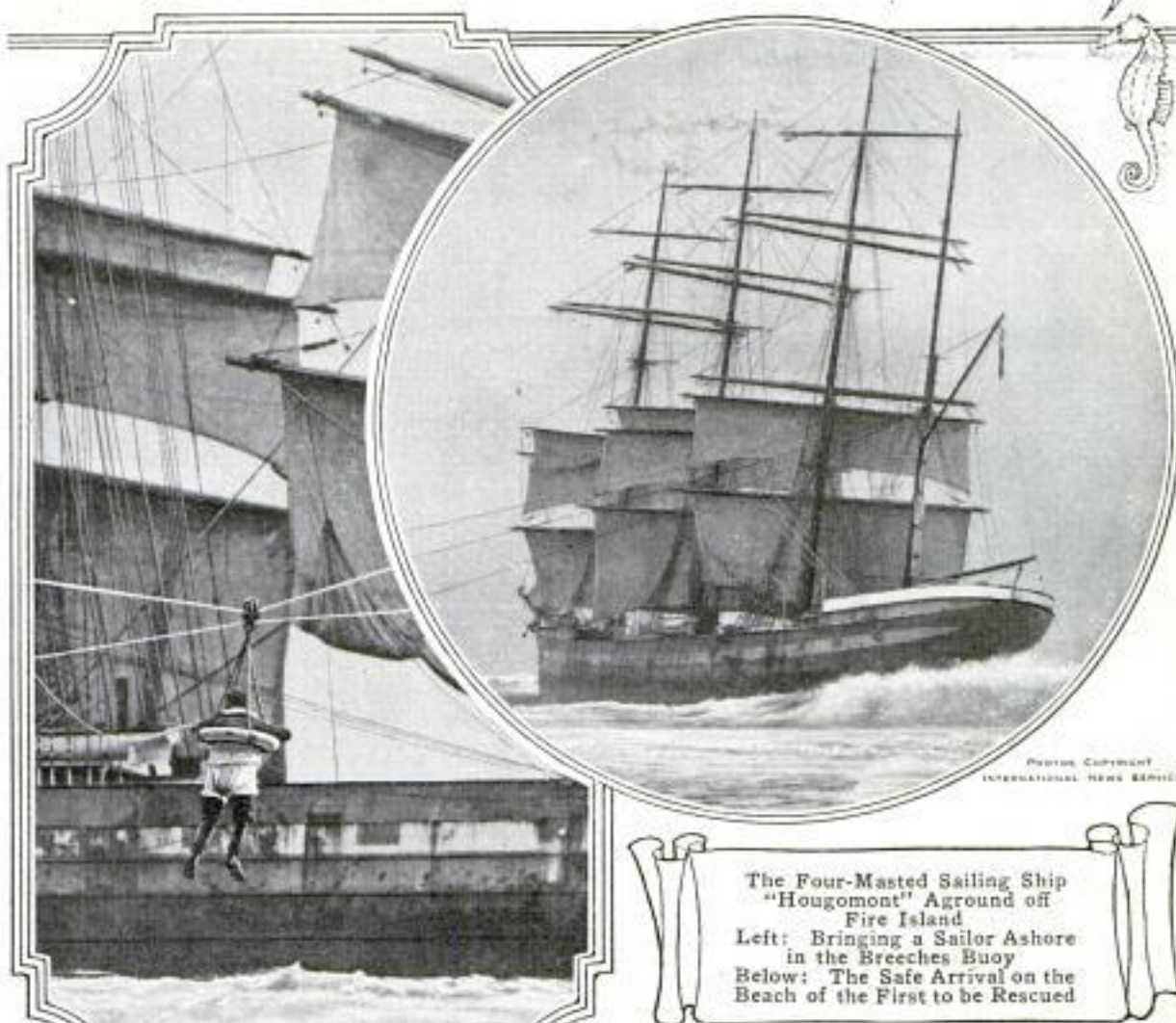
Another invention which is also to be given to the public is a means of obtaining toluol and benzol from crude petroleum. These products, which are the bases of many modern explosives as well as of the most generally used dyestuffs have heretofore been produced in Germany from coal tar.

BREECHES BUOY SAVES CREW
9339m **OF BEACHED SHIP**

During a severe storm which recently swept the Atlantic, rolling up heavy breakers which battered the shore for miles along the east coast, the four-masted barkentine "Hougomont" was beached off Fire Island, New York. This narrow island forms a margin along the south shore of Long Island and tapers into a sandbar which extends out beneath the water for hundreds of yards at some points. The shoal reaches so far from the beach that a vessel may be sailing in what to all appearances is deep water and suddenly run aground, unless her pilot knows the coast well. This makes navigation particularly difficult for small craft, especially sailing vessels, when they are caught in a squall, or hurricane, which drives them inshore at this point. This is what happened to the "Hougomont." The wreck fortunately occurred within easy reach of the Fire Island life-saving station. It was only a very short time after the doomed vessel had been sighted until the rescue party was on the beach with mortars and life lines. After a short time a line was shot across the vessel's beam and its crew brought ashore by aid of the breeches buoy.

CA dictating phonograph by which an airman may record his observations while flying and still have his hands free is a new idea in military aviation.

From associated Press dispatch in Monday morning paper - Mar. 1 confirmed by J. C. McCarthy, Sec. Star see June 1915 - 867 Wash. D. C.



PHOTOGRAPH BY
INTERNATIONAL NEWS SERVICE

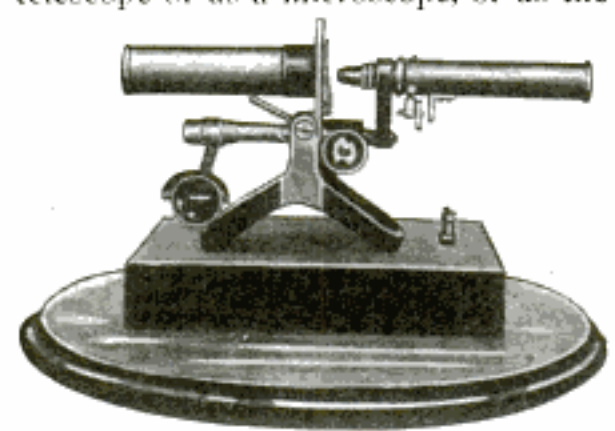
The Four-Masted Sailing Ship
"Hougomont" Aground off
Fire Island
Left: Bringing a Sailor Ashore
in the Breeches Buoy
Below: The Safe Arrival on the
Beach of the First to be Rescued



#2 J. Leah, 605 Mutual Life Bldg., Buffalo, N.Y. Buffalo,

518 POPULAR MECHANICS
English inventor: A. Cornell
COMBINED MICROSCOPE AND
6798 TELESCOPE *Cambridge, Kent*

A small and compact instrument that is capable of being used either as a telescope or as a microscope, or as the



Combined Microscope and Telescope Mounted and Ready for Use

two combined, has been developed by an English inventor. With this instrument it is possible to make a microscopic examination of minute objects or observe the moons of Jupiter with equal facility. Its most important use is apparently that of making microscopic examinations of objects placed

several yards from the instrument, an arrangement that overcomes the usual requirement in microscopic work that objects examined must be flat. Although many experiments of a scientific nature were required in developing it, the instrument is simple in construction. It consists of a microscope, in front of which is mounted a tube containing a telescopic objective and provided with the usual "pin hole," as well as with a number of diaphragms for stopping down the light. The telescope produces an inverted image which is magnified and transformed into an upright image by the microscope. Any degree of magnification from 20 to 48 diameters may be obtained by adjustment of the draw tube and eyepiece. For convenience in observing stars and other objects at an elevation, a mirror provided with a universal joint may be attached to the object end of the instrument.

☐ Fatalities in coal mines in the United States in 1914 numbered 2,451, a decrease of 334 as compared with 1913.

9385 SAFEST PLACE FOR SOLDIER
IN AN AEROPLANE

Is an aeroplane the safest place for a soldier in war?

The English newspapers recently reported that an officer of the Royal Flying Corps had applied to be allowed to rejoin his regiment in his former capacity. When inquiry was made as to his reasons he replied that he could not bear to see his brother officers running all the risks of the trenches while he himself was in safety flying in the air above them. Similar remarks by other British military airmen, all of whom seem to regard their work as much less hazardous than that of the fighting man on the ground, have lent interest to reports of the surprisingly small number of casualties suffered by fliers since the war began.

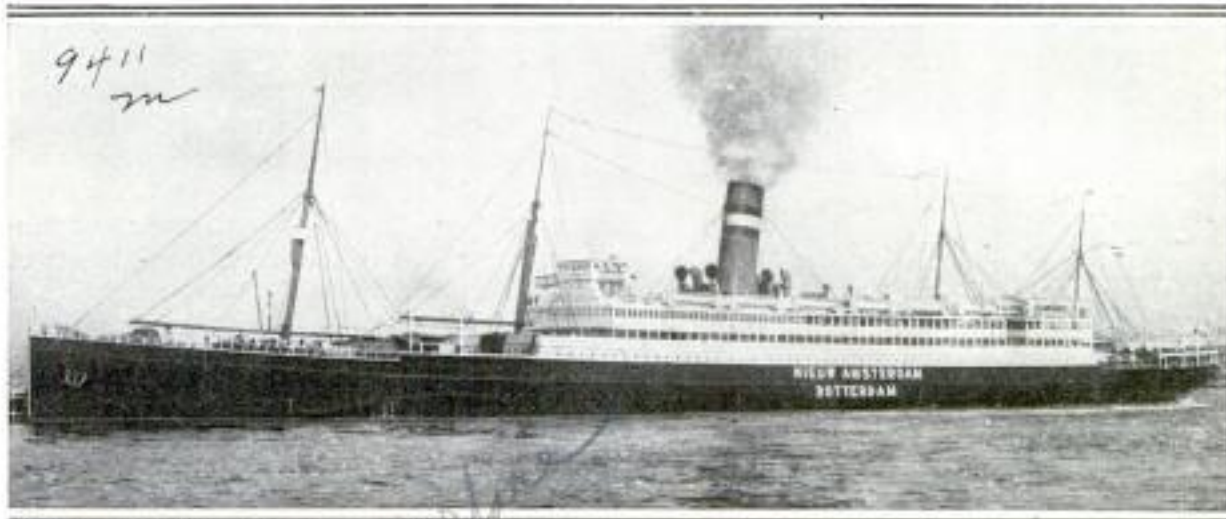
When the Royal Flying Corps was organized, in 1912, it was estimated

that in case of war the entire personnel would have to be renewed every six months—that that period would represent the average life of an airman in active service. In the first five months of the present war, however, during which the entire corps was almost continuously engaged in scouting and raiding expeditions, the total loss was six airmen killed by the enemy, five killed accidentally, five wounded, and five missing or prisoners: a total disablement of less than three per cent of the airmen in active service. While no exact figures, either of losses or of the number of troops engaged in the field, have been made public by any of the powers engaged in the war, it is certain that the percentage of losses in land fighting, both of officers and enlisted men, has been very much larger than this in each of the armies.

All of which seems to answer in the affirmative the question with which this article began.

The Engineer + The Aeroplane
2/3/15

PROCLAIMING NEUTRALITY IN WAR-ZONE WATERS



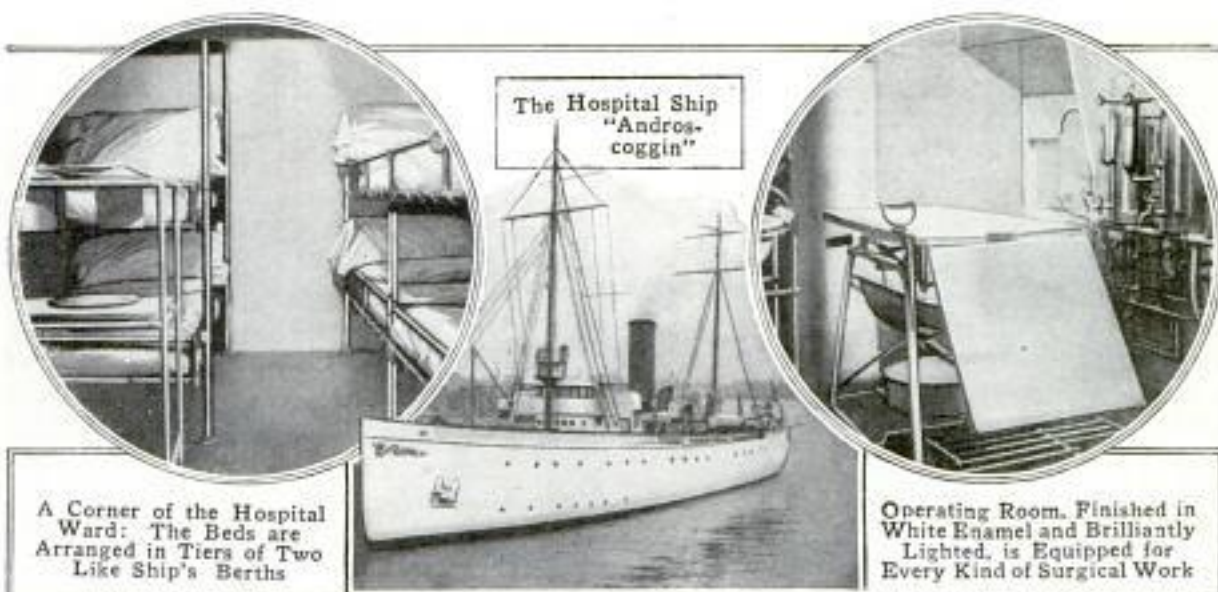
COPYRIGHT, UNDERWOOD & UNDERWOOD

FOR protection against submarines in the war zone, neutral shipowners have adopted the plan of painting on the sides of each vessel the name of the ship and that of its home port. This picture shows how the "Nieuw Amsterdam," the largest of Dutch ships, looked as it left New York on its first voyage to Rotterdam after the war-zone decree went into effect.

9024 m HOSPITAL SHIP TO WORK WITH FISHING FLEET

Equipped with the most modern facilities for the care of the sick and wounded, the United States revenue cutter "Androscoggin" is now in service as a hospital ship and will operate among the fishermen working on the Grand Banks of Newfoundland. This is said to be the first hospital ship ever outfitted by the United States government for service with a fishing fleet, although the plan is not a new one with other countries. The hospital equip-

ment of the vessel consists of a tiny operating room finished in white enamel and brilliantly lighted, a ward room containing a large number of beds, and a bathroom. A doctor and three assistants will have charge of the hospital facilities, which, though compact, are as complete as those of many shore hospitals. During the fishing season the hospital ship will be stationed on the Grand Banks, where fishermen live and work for weeks and



A Corner of the Hospital Ward: The Beds are Arranged in Tiers of Two Like Ship's Berths

Operating Room. Finished in White Enamel and Brilliantly Lighted, is Equipped for Every Kind of Surgical Work

Geo. A. Walton & Tenny's Court, Newbury, Mass

where there has often been great suffering in the past because of the lack of medical and surgical attendance.

SKILL NEEDED IN PLAYING NEW MECHANICAL GAME

Among the recently introduced mechanical games, designed for amusement parks, is one which taxes both the strength and skill of a player. The apparatus upon which it is played consists of a series of vertical tubes through which a steel ball weighing 1 lb. is knocked by pressure ex-

pocket at the bottom of that bore. Similarly, a pressure of 200 lb. will put the sphere into the second return pipe, while a 500-lb. blow will send it completely around the outside tube, dropping it at the extreme right. The game is played by knocking the ball in turn into each of the baskets, which requires the player to estimate, within less than 100 lb., the striking force of his blows.

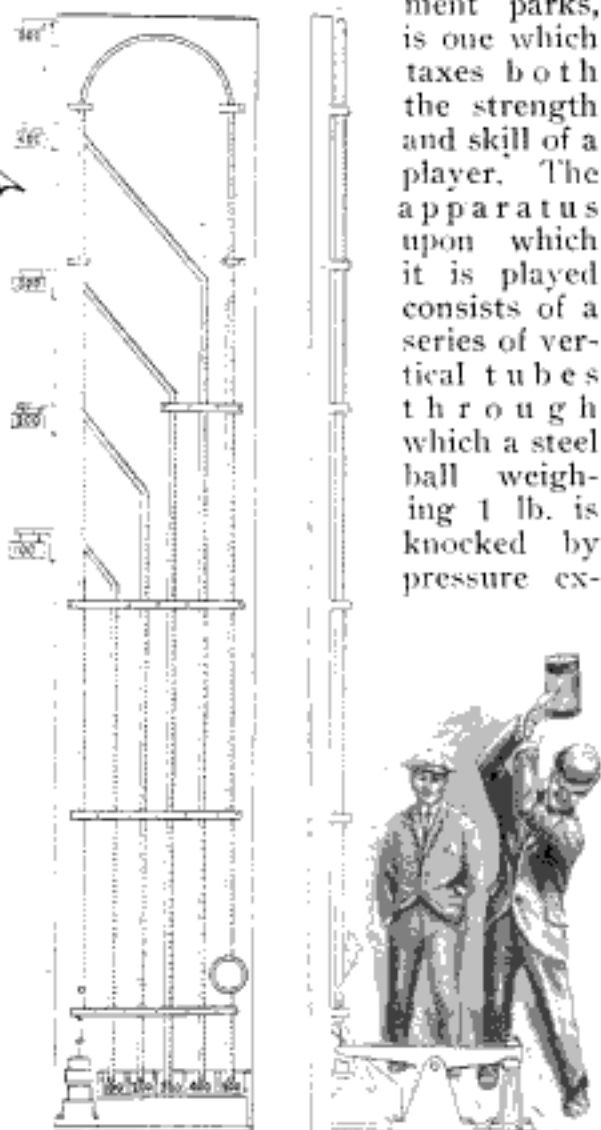
"AUDACIOUS" IN SERVICE AFTER STRIKING MINE

The "Audacious," the 25,000-ton British dreadnaught which struck a mine off the coast of Ireland during the latter part of last October and was reported to have sunk, has rejoined its squadron with decks stripped for action and the Union Jack astern. Photographs taken from aboard the transatlantic liner "Olympic," which went to the rescue of the wrecked battleship, towing it for a considerable distance, showed it to be in a sinking condition with its decks all but awash. One of these photographs appeared in this magazine.

What really happened, instead of the ship going to the bottom, was that it was taken in charge by naval vessels, after apparently being abandoned by the "Olympic," and towed to Belfast, where it was placed in dry dock and repaired. The dreadnaught has a remarkable system of bulkheads, and it is to this that credit largely falls for keeping it afloat. As soon as the location of the rent was reported, collision mats were used to cover the hole beneath the water line, and sand bags put in place about it on the interior of the hull. Experts from a shipbuilding company at Belfast were summoned by wireless and joined the ship while it was being towed into port, making the necessary survey preliminary to the repairs, so that no time was lost after the ship was once placed in dry dock.

Army & Navy Journal

☞ Fires in national forests in 1914 destroyed timber worth \$307,303.



The Harder the Blow the Higher the Steel Ball will Go

erted upon a lever by a sledge. The sphere is inserted in the apparatus, shown in the accompanying illustration, through an aperture in the pipe at the extreme left. If a pressure of 100 lb. is exerted upon the lever, the ball will be elevated just high enough to trip a valve and enter into the first tube to the right, falling into a receiving

Inventor & Contributor: John H. Steinmetz Jr.,
109 Cleveland St., Corona, L. I., N. Y.

D. S. Rockwell, Berkeley, Cal.

THE MIDNIGHT GLORY BY THE GOLDEN GATE

9372



When the Battery of Huge Searchlights at the Panama-Pacific Exposition is Turned On in Full Force the Aurora-Like Effect is a Marvel of Gorgeous Splendor

The Illumination of the Tower of Jewels, the Central Feature of the San Francisco Fair, is So Complete That Every Detail is as Visible by Night as by Day

Reported by Commercial agent
Larrard Harris, Belize,
British Honduras.

Daily Consular & Trade Reports - page 1523

"DELETED BY THE CENSOR"
887⁵m ILLUSTRATED

OIL FROM THE COHUNE-PALM
NUT A VALUABLE PRODUCT

In France, as in the other countries engaged in the European war, the censorship is so rigid that little, if any,

⁹²²⁰A product the commercial value of which has only recently become recognized is the oil extracted from the nut of the cohune palm.



LE GÉNÉRAL [REDACTED] DOURS DE L'INTENDANCE
Sur le fameux cours de l'Intendance déjà si animé d'habitude, et qui depuis quelques semaines est devenu un lieu très parisien, on croise les personnalités les plus en vue. Voici le général [REDACTED] DOURS du [REDACTED] entretenant avec un autre officier supérieur.

This Reproduction from a Page of a French Publication Shows How Thoroughly the Censor Works

information that might be of value to the enemy is allowed to appear in any publication. How thoroughly the censor works is indicated in the reproduction of part of a page from a French illustrated journal. From this report the reader gets the news of a meeting of military officers, with the name of the commanding general and the place of the meeting carefully obliterated, to keep this information from the enemy.

This species of palm grows in British Honduras, Guatemala, and the southern part of Mexico, and comprises from 20 to 30 per cent of the vegetation in many sections of these countries, so that the supply of nuts is believed to be practically inexhaustible. The oil, extracted by a crude process, has been in use by the natives in some sections for years as a dressing for foods, and recent experiments have proved that it comprises a fat that is valuable for many purposes. Just before the war it was reported that the Germans had found a way of using it as a substitute for glycerin in high explosives, while a dairy company in Liverpool is said to employ it regularly in the manufacture of oleomargarine, finding it superior to any other fat that can be obtained. The nut of the cohune palm is usually from 2 to 2 3/4 in. long, the outer covering consisting of a hard, woody substance that is exceedingly difficult to break. A new process now being used makes this and the extraction of the oil a comparatively easy matter. The nuts are given a preliminary roasting which causes the kernels to shrink and become detached from the hull. The hulls are then broken in a crusher and hulls and kernels are dumped into a

solution of salt water. The kernels float while the hulls sink to the bottom. The salt water appears to have no effect on the kernels other than to act as a preservative against rancidity in the oil. The oil is finally extracted from the kernels by pressing.

Armed Navy Journal
**TWELVE-INCH HOWITZERS
 FOR THE BRITISH ARMY**

9331

The report that the English are prepared to put 12-in. howitzers in the field this spring is apparently confirmed by the fact that a large order has recently been placed in the United States for 12-in. shells. The projectiles are of the high-explosive, thin-



Some of the Debris Left along the Shore at Redondo Beach



One of the Cottages Washed from the Shore by the Waves and Caught in the Wreckage of the Bulkhead

shell type and are evidently intended for driving the Germans out of their trenches in France and Belgium. Nothing is known as to the character of the guns or carriages, but it is thought that the English ordnance experts have developed a carriage capable of taking these heavy guns across country.

**HEAVY STORM SWEEPS COAST
 LINE OF CALIFORNIA**

9365H

Heavy waves swept California's coast line several weeks ago, battering and cutting its beaches and working considerable damage to shore property at many of its resorts. At different places bulkheads that had held back the Pacific during other of its severe storms, this time gave away under the incessant pounding of the great breakers. Many cities along the coast

Wreckage of the Board Walk on the Bulkhead which Gave Away, Allowing the Breakers to Sweep the Beach



suffered severely, but southern California points faced without protection the full fury of the sea, which raged and tossed, washing out the foundations of cottages and, in some cases, lifting hotels and carrying them into the ocean. Redondo Beach was greatly damaged. Almost before residents were aware of the severity of the storm the enormous waves carried away the greater portion of the bulkhead which held a 15-ft. board walk. This gave the sea an opportunity to attack the beach, which it did, washing residences and hotels one after the other into the breakers and then pounding them to pieces. At this one resort it is estimated that more than \$300,000 damage was done to property.

#Albert Marple 322 Boynton St., Tropico, Calif.

GERMANY'S GREAT WAR MACHINE IN ACTION



Taking Turns
Snatching a Few
Minutes of Sleep in a
Snow-Lined Rifle Pit
in East Prussia during
a Short Recess in a
Hard, Stubborn Fight
in Freezing Weather



COPYRIGHT BY
UNDERWOOD & UNDERWOOD

German Regiment
Charging
against a French
Line, Crossing
an Open Field in
the Face of
Machine-Gun
and Shrapnel Fire



Group of the
Kaiser's
Artillerymen
before a Typical
Dugout Back of
the Lines in the
Western Theater
of War

AND PERSONAL GLIMPSES OF ITS SOLDIERS



This Remarkable Picture was Taken a Few Minutes after the One Opposite It, in the Same Spot. It Shows War as It Is. Almost at the Instant the Shutter Snapped, Four Soldiers were Struck by Bullets



At an Observatory Post of a Heavy-Artillery Battery Where the Effect of the Fire against the Russian Trenches is being Watched



Christmas Day in a German Trench after the Men had Received Boxes and Letters from Home. Wherever It Was Possible, the Soldiers Decorated a Tree, Even in the Rifle Pits

SOME CURIOUS DEVICES DEVELOPED BY WAR



This Odd Pyramid, Marked on Its Four Sides with the Cross, has been Erected at Budapest to the Memory of Fallen Hungarian Soldiers



This Armored Motorcycle and Sidecar, One of the New Types of War Vehicles in Use in Europe, Carries Two Riflemen and a Driver, and Travels at High Speed



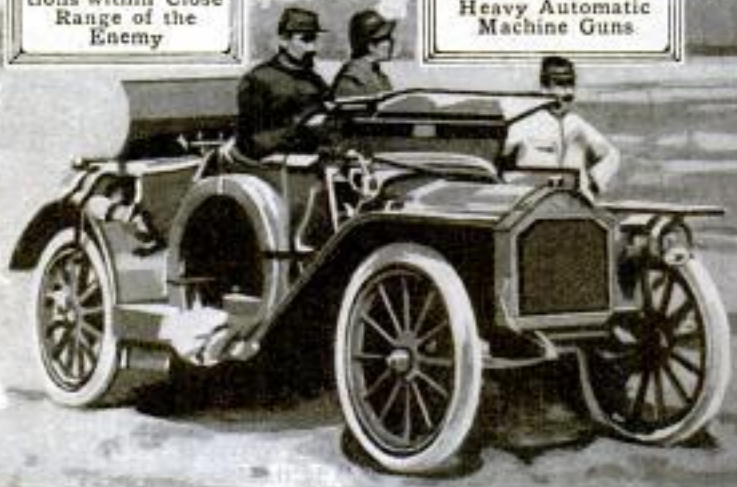
Steel Helmet and Cuirass Worn When Taking Open Observations within Close Range of the Enemy



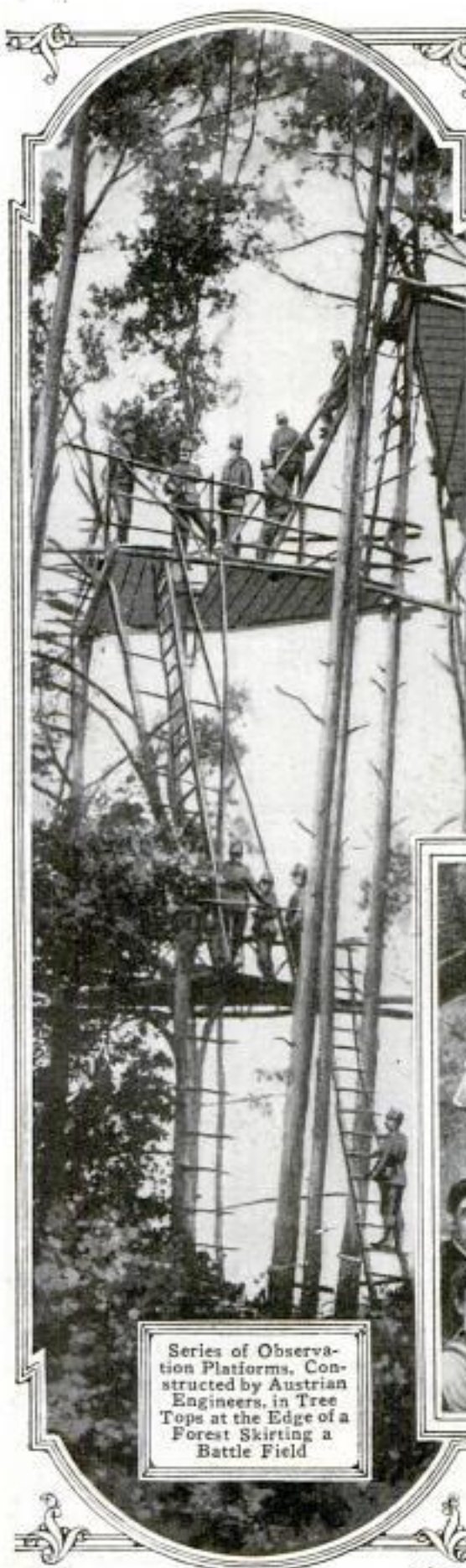
This Shows How an Infantryman, When It Is Necessary, Carries One of the Heavy Automatic Machine Guns



Ladder-Tripod Mounting for Searchlight. The Motor Car Carries an Electric Plant Supplying Current to the Arc



WAR SEEN FROM THREE NOVEL VIEWPOINTS



Series of Observation Platforms, Constructed by Austrian Engineers, in Tree Tops at the Edge of a Forest Skirting a Battle Field



Heavy French Artillery Battery, Mounted on Flat Cars, Operating along Trackage Previously Held by the Enemy. The First Gun Is About to be Fired and Its Crew are Holding Their Hands to Their Ears



During the Drawn-Out Shelling of Soissons by the Germans, the Inhabitants Sought Refuge in the Cellars beneath Their Wrecked Homes, This Being the Only Means of Protection Open to Them

APR 1918. COURTESY: UNDERWOOD & UNDERWOOD

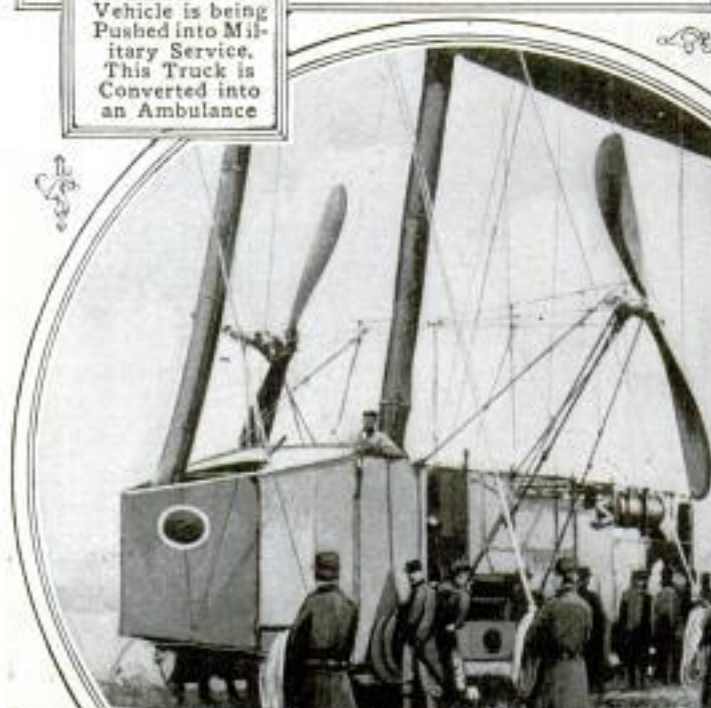
BEHIND BATTLE LINES ON FRANCE'S FRONTIER



Almost Every Available Motor Vehicle is being Pushed into Military Service. This Truck is Converted into an Ambulance



Copyright International Home Service
French Dirigible Leaving Its Hangar at Paris and Heading Eastward with Aerial Scouts on Reconnaissance Duty



Copyright International Home Service
One of the Late Types of Military Dirigibles, a French Craft with an Armored Nacelle for the Protection of Its Crew



Experience in Europe has Taught That the Machine Gun is as Effective against Air Craft as Any Weapon So Far Developed

MAKING ANOTHER ARMY FOR KITCHENER



"Winnipeg Rifles,"
Recruited from
Canada, being Put
through Bayonet
Drills on Salisbury
Plain, Where They
Wintered in England



Bayonet Practice
against Straw
Bags Scattered
on Ground,
Another Step
in Training



Group of Raw
Recruits Tak-
ing a Hurdle
in the Course of
a Rigorous Cross-
Country Run,
One of the Hard-
ening Processes



Coaching the Volun-
teers in the Fine Art
of Trench Digging, a
Menial and Tiresome
Task, but a Welcome
Knowledge When
Bullets are Whistling

PHOTO COURTESY UNDERWOOD & UNDERWOOD

GRIPPING SCENES OF FRENCH TROOPS



IN ACTION DURING HEATED FIGHTING



No Form of Fighting Is More Thrilling Than That against an Enemy Air Craft Which is Returning Bombs for Bullets. Here a Squad of Zouaves is Firing at a Mere Speck in the Sky—a German Taube Flying over the Lines

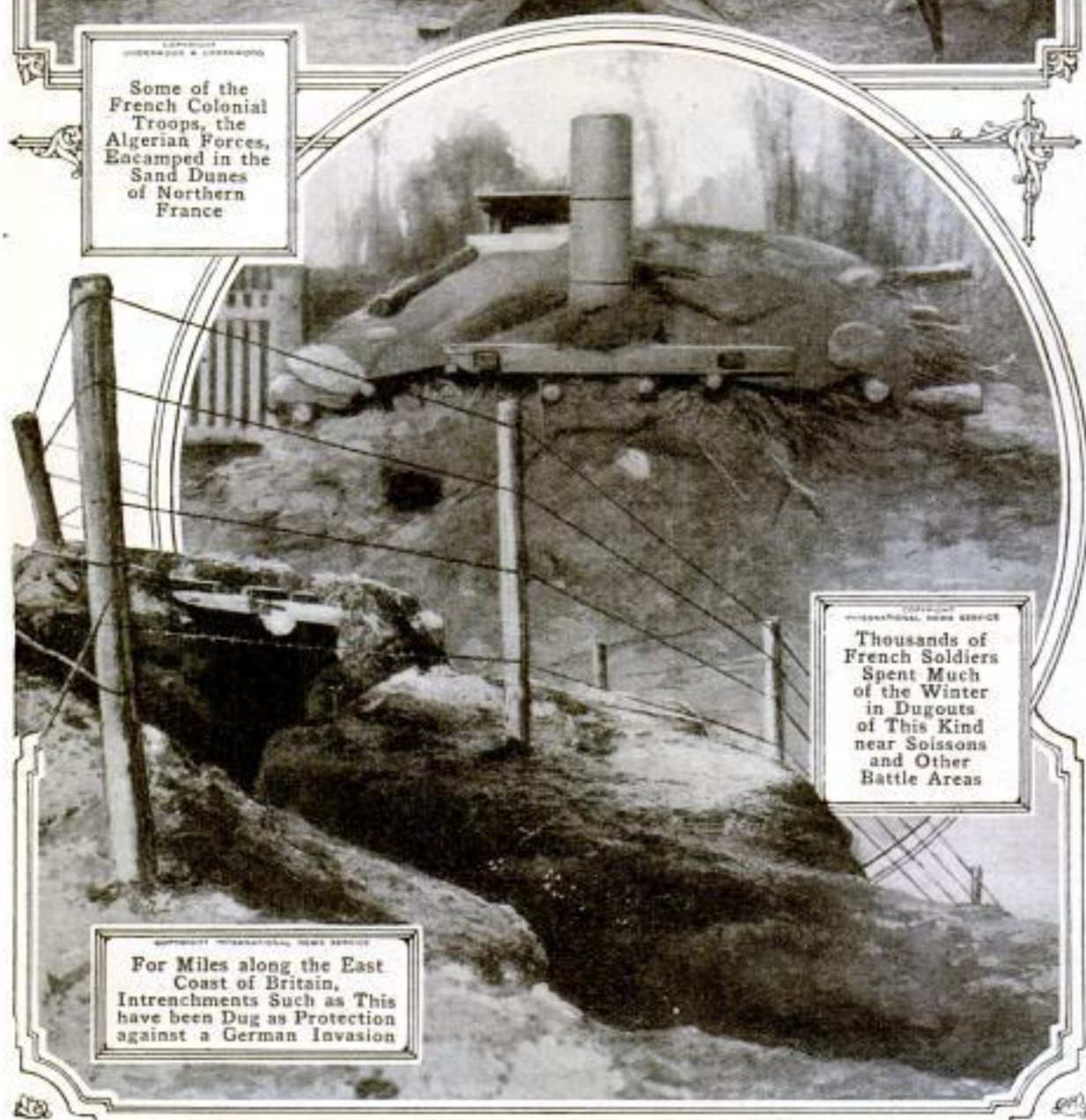
Detachment of French Troops in the Midst of a Hot Skirmish in the Flooded Section of the Northwestern Frontier of France, Where Soldiers have Weathered Heavy Rains

Beginning of a Charge against German Lines by French Infantrymen: The Order has Just been Given, Following Shelling of the Enemy's Position, and the Soldiers are Climbing from the Trenches to Advance

WINTER CAMPS IN BRITAIN AND FRANCE



Some of the French Colonial Troops, the Algerian Forces, Encamped in the Sand Dunes of Northern France



Thousands of French Soldiers Spent Much of the Winter in Dugouts of This Kind near Soissons and Other Battle Areas

For Miles along the East Coast of Britain, Intrenchments Such as This have been Dug as Protection against a German Invasion

PARTS PLAYED BY DOGS IN ARENA OF WAR

COPYRIGHT INTERNATIONAL NEWS SERVICE
Belgian Troopers Taking
Light Artillery Dogs
from Their Kennels and
Putting Them in Harness
Preparatory for Military
Operations



COPYRIGHT UNDERWOOD & UNDERWOOD
Here Two Dogs
and a Donkey
are Drawing a
Cart Holding
the Belongings
of a Family of
Refugees
Fleeing with
Many Others
from Lille



COPYRIGHT INTERNATIONAL NEWS SERVICE
The War Dog in Foreground was Wounded in Battle
and is being Led through a Street of Louvain

RESCUING SURVIVORS AFTER A NAVAL BATTLE

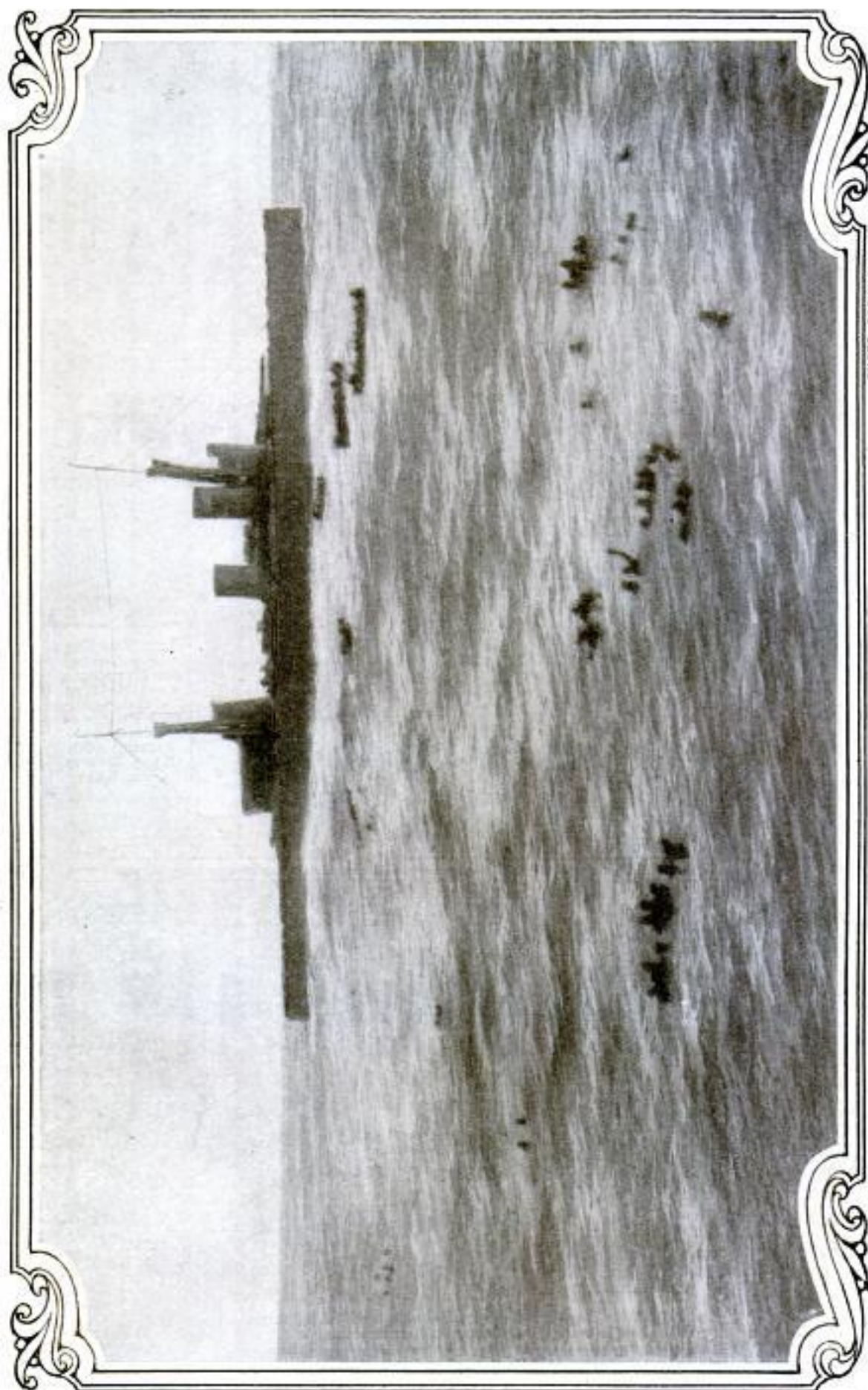


PHOTO COPYRIGHT, INTERNATIONAL NEWS SERVICE
Final Scene in the Five-Hour Battle between the German and British Fleets near the Falkland Islands, off South America, December 8, 1914. When the German Battle Cruisers "Scharnhorst," "Gneisenau," "Leipzig," and "Nürnberg" were Sunk: This Photograph, Made from the Crow's Nest of the British Ship "Invincible," Shows the Boats Putting Off from the British "Inflexible" to Pick Up German Survivors Swimming in the Sea

HOW AN ARMY BLAZES ITS PATH IN WAR



Tangled
Wreckage
of a Steel Bridge
at Lagny, Less
Than a Half
Hour by Rail
from Paris

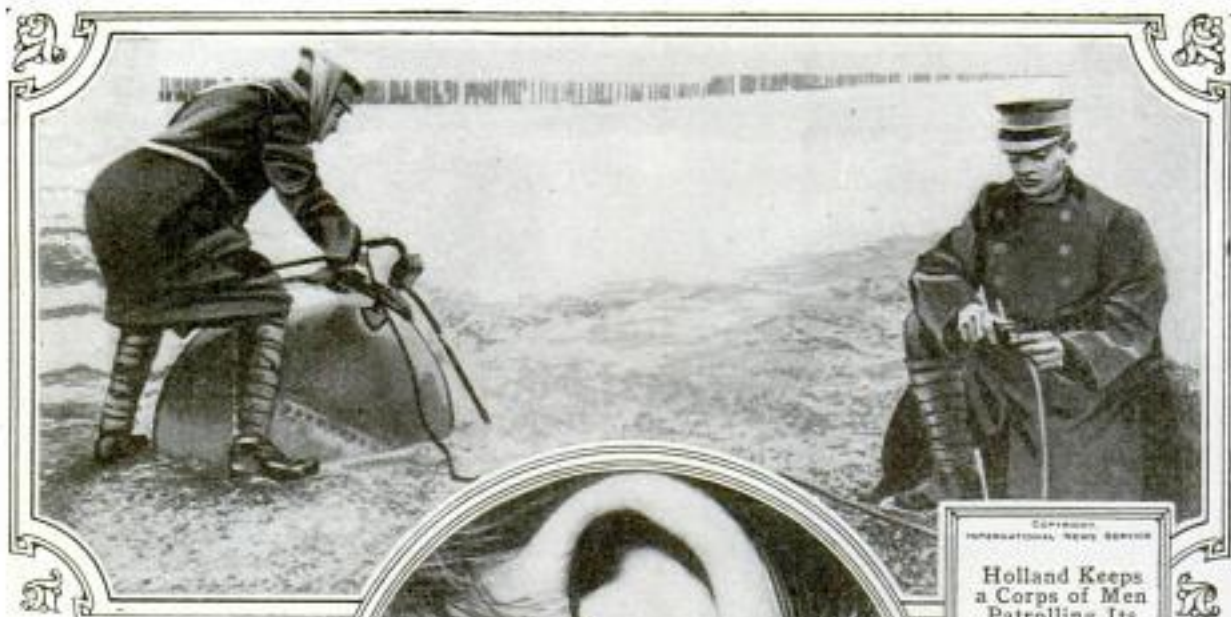


One of the Many
Bridges Destroyed
by the Germans
in Poland, Which
It Is Now Necessary
for Them to Rebuild



This Structure near Lizy-sur-Ourcq
on the Road to Paris was Blown Up,
Causing a Train to Drop into the River,
during the Battle of Meaux

CURIOUS THINGS SEEN IN THE WAR ZONE



COPYRIGHT
INTERNATIONAL NEWS SERVICE
Holland Keeps
a Corps of Men
Patrolling Its
Coast to Find
and Explode the
Mines Washed
Up onto the
Beaches from
the North Sea



PHOTO
UNDERWOOD & UNDERWOOD
Wearers of This
Ear Protector
Hear Ordinary
Sounds,
but are
Protected from
Vibrations
of Big-Gun Fire

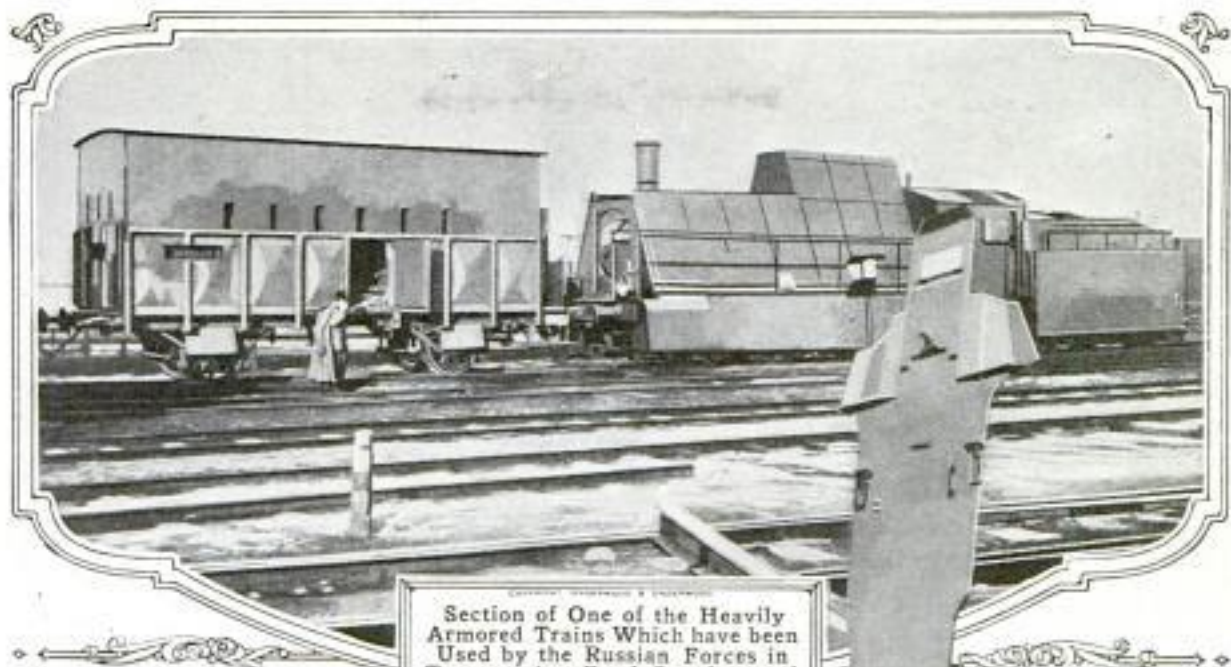


In Time of War the Life of a
Man Represents No More
Than That of a Horse, and
Often Not so Much. This
Shows the Body of a German
Scout Caught in the Crotch of
a Tree and Left There

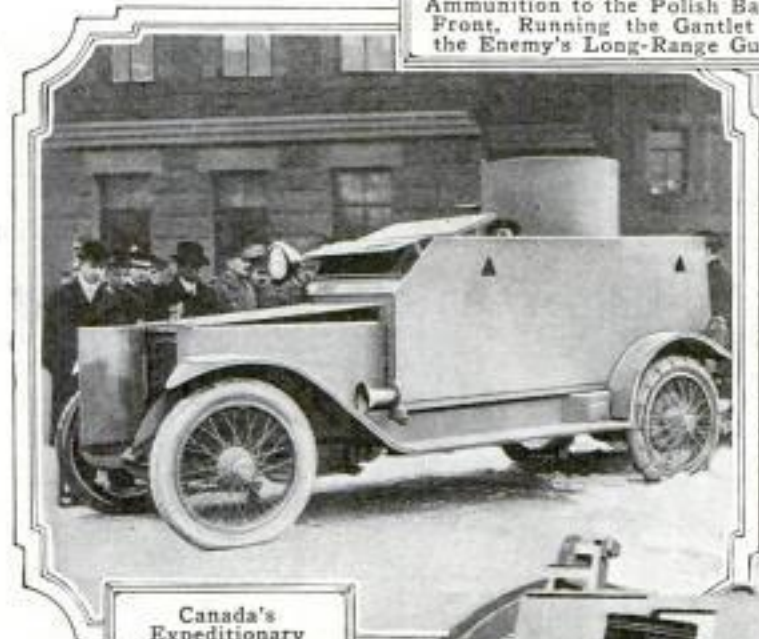


PHOTO
UNDERWOOD & UNDERWOOD
Latest Product
of the Krupp Gun
Works: A New
Type of Weapon
for Defensive
Operations against
Enemy Air Craft

ARMORED VEHICLES USED IN EUROPE'S WAR



Section of One of the Heavily Armored Trains Which have been Used by the Russian Forces in Transporting Food Supplies and Ammunition to the Polish Battle Front, Running the Gantlet of the Enemy's Long-Range Guns



Canada's Expeditionary Forces have been Supplied with Modern Fighting Tools. This Shows the Dominion's First Armored Car

Observation Ladder, Fitted with Steel Shield, Such as is Used by the French Artillery with the Batteries of Famous "75" Guns. The Shield Protects Every Part of Lookout's Body



SCOUTS AND LOOKOUTS WATCHING THE ENEMY



PHOTO COPYRIGHT
INTERNATIONAL NEWS SERVICE
Belgian Motor-
cycle Scout Doing
Reconnaissance
Work under
Difficulty in the
Sand Dunes
South of Ostend



PHOTO COPYRIGHT
UNDERWOOD & UNDERWOOD
This "Rustic
Pavilion"
Represents One
of the Austrian
Tree-Top Obser-
vatories, Fitted
with Machine
Guns, Telescopes
and Telephones

PHOTO COPYRIGHT, INTERNATIONAL NEWS SERVICE
Perched on Top of a Peasant's
Dwelling in Poland, This Rus-
sian Outpost Is Able to Scan
the Country for Miles Around

*Mfg. Boston Belting Co.,
84 Linden Park St.,
Boston, Mass 539*

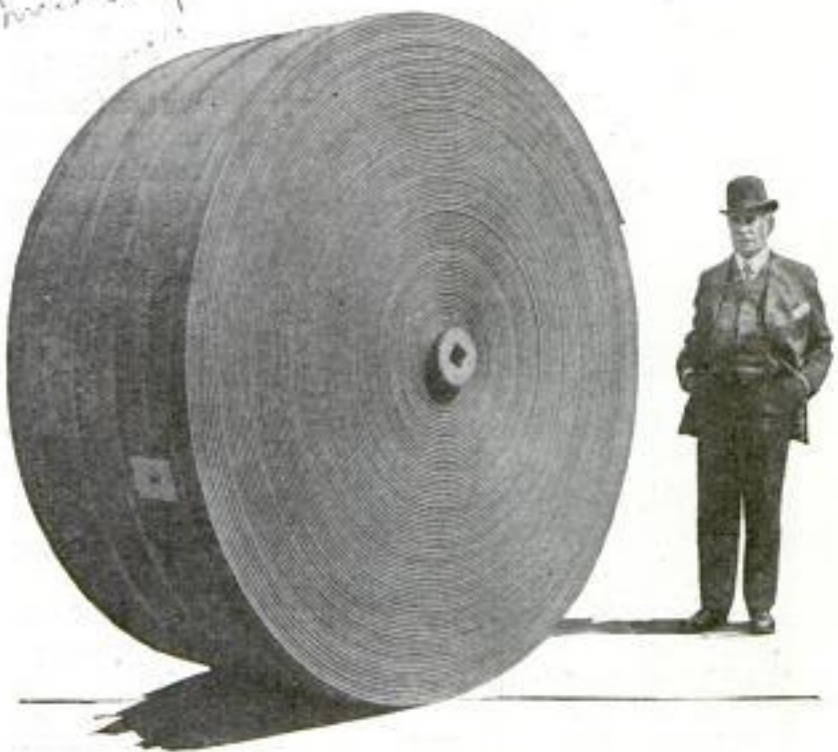
POPULAR MECHANICS

Army & Navy Journal 10/2/14
**FILMS USED BY GERMANS TO
SHOW ARMY WORK**
8717m

**ONE OF LARGEST CONVEYOR
BELTS EVER MADE**
8555m

For a year or more preceding the outbreak of the war, the German government made extensive use of motion-picture films both for instructing recruits and for making the military service popular with the public. Recruits were instructed in such matters as mounting guard, tent erecting, bayonet drill, and acting as vedette, through the medium of films. Films were also used for giving instruction in the "scientific" branches of military work, such as bridge building, railway destruction, throwing up earthworks, the erection of barricades for street fighting, mine springing, and pontoon work. Special films showing military maneuvers were supplied to motion-picture operators without charge, and were exhibited to the public throughout the empire.

A conveyor belt that weighs 12,000 lb. and is valued at nearly \$6,000, recently completed for a stone quarry in



This Conveyor Belt, Made for a Stone Quarry in Ohio, Is 893 Feet Long Weighs 12,000 Pounds, and is Valued at Nearly \$6,000

Ohio, is probably the largest belt of the kind ever made. It is 893 ft. long and 36 in. wide, and is all in one piece. The body of the belt is made of eight-ply duck, which alone weighs 5,000 lb., and this is coated with a thick cushion of rubber. It is estimated that the belt will last for several years under the heavy service to which it will be subjected.

**TWO LADDERS COMBINED
IN ONE**
8479m

A new type of ladder is designed to be used either as a step-ladder or as an extension ladder. The two parts of this ladder are pivoted together at one end, and hooks and clamps are provided for holding the parts securely. One part has steps; the other has rungs.



*Inventor
Philip F. Swart
8184 Peach Dr.
Rochester, N.Y.*

**BULLETIN BOARD FOR TRAIN-
CREW ASSIGNMENTS**
8621H

Bulletin boards are maintained at railway division points so that various members of the personnel may be informed regarding the assignments of crews to trains. At large points, however, where many trains are constantly arriving and departing, considerable difficulty has often been experienced in attempting to post this information so that it may be found quickly and with-

Railroad Employees

*Fred Telford, 605 S. Douglas
Springfield, Ill.*

*# Mrs. Avis Gordon Vestal
4243 N. Foster Ave.,
Chicago, Ill.*

*Ogden & Messersmith, Inc.,
1542 Ellicott Square Bldg.,
Buffalo, N.Y.*

#J. L. Greff, 84 W. South Water St.
Chicago, Ills.

Used by a Grand Traverse Co.,
Cider manufacturer

out confusion. At Bloomington, Ill., the Chicago & Alton Railway has installed an octagonal board which has



Much Difficulty in Posting Assignments at a Railway Division Point has been Eliminated by the Use of This Bulletin Board

eliminated the trouble formerly suffered. The assignment of crews for passenger trains is shown on one plane with each division separated, while passenger-train enginemen, freight crews, and others, have their individual spaces which they may find readily by turning the board until the proper side appears.

OXYGEN MADE BY ELECTRIC 9332 m PROCESS

Owing to its widespread use as an agent in cutting and welding operations, oxygen gas has become an important commercial product and is now being produced from water in large quantities by an electrolytic process in a number of factories in this country. The electrolyte used is a 10 or 15-percent solution in water of caustic soda or of caustic potash. A direct current is passed through this electrolyte with the result that oxygen is given off at

*Electrical World & The
Engineer*

one of the electrodes and hydrogen at the other. The oxygen is collected and compressed while the hydrogen is allowed to escape.

UNLOADING APPLE CARS

9031 m WITH WATER

A Michigan cider manufacturer uses water for unloading the apples shipped in by rail, and the method is said to result not only in economy in the work of unloading, but in such a thorough cleansing of the apples that they can be conveyed direct to the grinders without the necessity for further cleaning. As soon as the car is set in position, a 10 by 12-in. hole is cut out of the lower door boards. Through this the apples are washed out under the impact of a stream of water thrown from a hose having a 2-in. nozzle, a beginning being made with the apples near the door. As the apples are washed out, they fall through a hopper into a channel that leads to a concrete pit, receiving the side wash from a stream that falls into the channel about



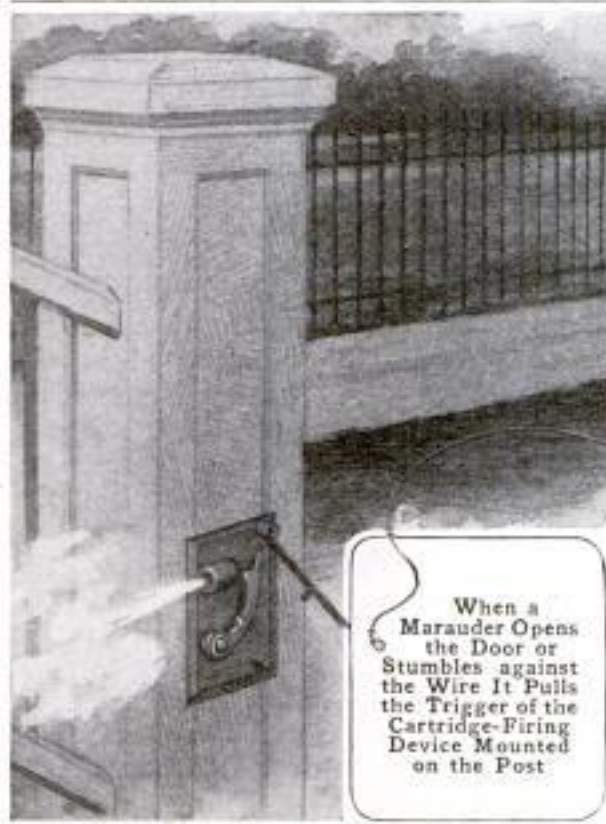
Apples are Washed Out of the Car by a Stream Thrown from a Hose, and Float Down a Channel to Conveyors That Lift Them to the Cider Machines

midway of its length. At the end of the pit the apples fall into a conveyor that lifts them to the grinders.

**NEW BURGLAR ALARM FIRES
BLANK CARTRIDGE**

8517m

A burglar alarm designed for the protection of garages, barns, chicken



coops, and outbuildings generally, consists simply of a wire that fires a blank cartridge when pulled or stumbled over. For installing, a hole is bored in the rear wall of the building to be protected. The wire is passed through the hole and attached to the door by a hook. The other end of the wire is then attached to the trigger of the firing device, which is mounted on a tree or post. In case the door is opened or the wire is stumbled over by a marauder, the trigger is pulled outward and the cartridge is fired by a spring-actuated hammer. The device is also intended to be used in protecting orchards and gardens.

ⒸMixing the dry cement thoroughly with the sand and gravel before any water is used makes a stronger and more uniform concrete.



**DIFFERENTIAL HAND BRAKE
FOR STREET CARS**

7854H

Particularly intended for use on surface-traction cars, a shaftless, differential hand brake has been devised which is both compact and powerful. The differentials are cast in one unit and keyed to the shaft of the handwheel on the control, one turn of which applies the brake. To this latter member a pawl is fixed which automatically engages with a ratchet and locks the endless chain against a backward movement after power has been applied. In releasing the brake the operator steps on a floor pin which disengages the pawl. A check is provided so that the chain cannot become too slack when the tension is removed. The device complete weighs less than 100 pounds and can be installed on any car to replace hand-operated brakes of old types.



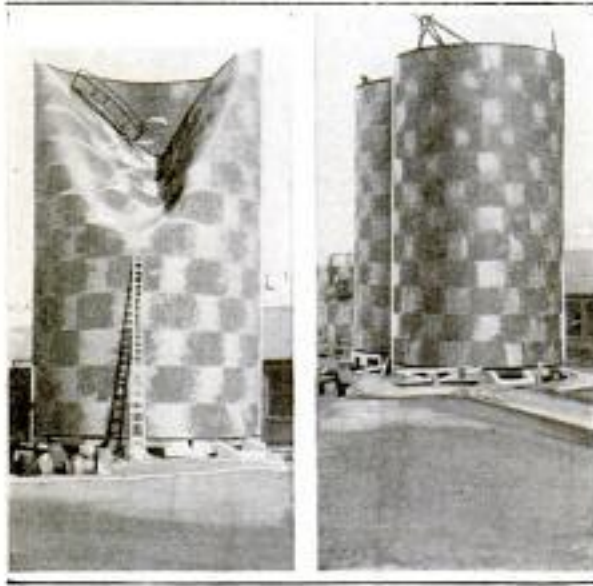
*For sale M.T. Dr. Co. 130 Broadway, N.Y.
87 34th St. Busch Terminal*

Electric Traction, June 1914

J. A. Steel, 595 Fargo Ave.,
Buffalo, N. Y.

STRAIGHTENING A CAVED-IN STEEL SILO

8400 m
A silo made up of steel plates had been completed to a height of 75 ft.



Condition of a Steel Silo After being Hit by a Storm, and How It Looked After It had been Straightened Out with Steel Cable and Pulleys

when it was hit by a severe wind-storm, with the result that the upper third of the structure was caved in,

as shown in the illustration. Serious as the damage looked, it was easily repaired. A steel cable was attached to the top of the bent plates and passed through pulleys anchored to the ground. A steady pull by six men was sufficient to straighten out the damaged section in about 15 minutes.

9308 m
Scientific American 11/23/15
MAY ESTABLISH AEROPLANE MAIL SERVICE

The establishment of an aeroplane mail service is reported to be one of the innovations now being considered by the U. S. Post Office Department. The section of the country where this means of carrying the mails would be of the greatest value is in the Rocky Mountains, where communication between some towns, a short distance apart on an air line, requires a trip of a hundred miles or more by the only available surface routes. One advantage in the aeroplane service is that the going would be practically as good in winter as in summer, since the present-day aeroplane can be operated in any but the stormiest weather.

9213 m
LIFE PRESERVERS MADE OF KAPOK FIBER

As a result of experiments made with kapok by the Navy Department it is likely that this little-known material will soon come into general use as a filling for life preservers and for buoyant cushions and mattresses. It has been discovered that there is a great difference in buoyancy in the kapok grown in different parts of the world, though it all looks pretty much alike. The failure of life preservers made of kapok having a small degree of buoyancy is doubtless responsible for the setback which the use of this material received following the "General Slocum" disaster in New York Harbor, in 1904.

The best kapok for life-saving purposes is grown in the East Indies, particularly in Java, and in the Philippine Islands. This material is a silky vegetable fiber which grows in pods, five or

six inches long. It contains an oil that prevents it from absorbing water easily, while the fibers are so fine and so closely packed together that the water is held out of the mass by the surface tension of the water itself. An unconfined mass placed in the water will support 20 times its own weight for hours, and if inclosed in leather, or a semi-waterproof fabric, it will support this weight for three months. There seems to be no exaggeration, therefore, in the statement that a mattress made so that it will not double up, and stuffed with this material, will support a shipwreck victim until rescued or until the passenger dies of hunger or thirst. Life preservers made of this material are lighter than those made of cork, and although somewhat bulky, can be compressed into small compass for storage without losing their resiliency.

J. C. Coburn, Naval Constructor U. S. Navy yard
Boston, Mass.

Inventor Lieut. A. P. Edmonds (Retired)
c/o R. R. Co. sup 543.

Robinson & Rodler Co.
 "Universal Slaveholder"
 27-33 New Jersey Railroad Ave
 Newark, N. J.



Beating
 the Seeds
 Out of
 the
 Fluffy
 Fiber

Javanese Women and
 Children Opening
 Kapok Pods;
 Typical Kapok Tree
 Shown at Left

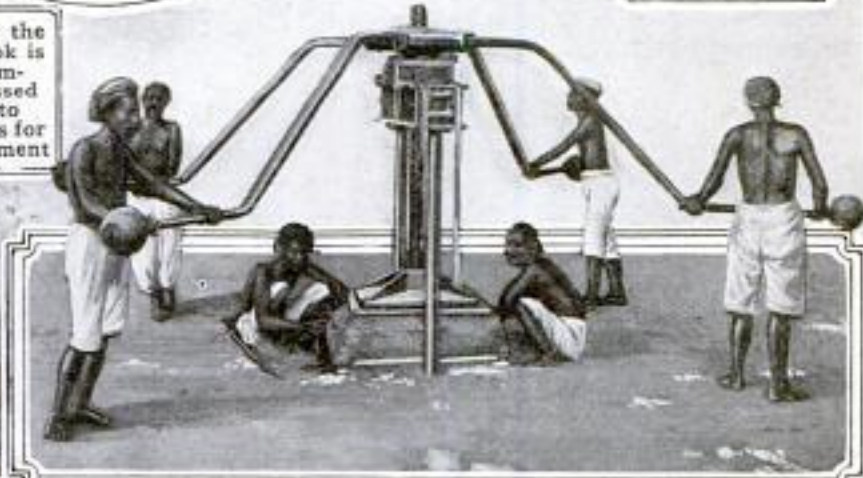
9213



Testing Kapok-
 Filled Mattress,
 Pillow, and Life
 Preserver



How the
 Kapok is
 Com-
 pressed
 into
 Bales for
 Shipment



United States Collapsible Steel
Container Co., ^{INC.} ~~125 East 22nd St.~~

Albert Marple 322 Baynton St.,
Tropico, Calif.

544 N. York City POPULAR MECHANICS
Whitehall Bldg 17 Battery Place.
COLLAPSIBLE SHIPPING BOX

8669 H MADE OF METAL

Collapsible sheet-metal boxes which
may be used indefinitely are being
made as shipping cases for merchan-

A. P. Cochrane (Inv)



332 E. 16th St.
Flatbush, Brooklyn N.Y.

Collapsible Shipping Case Made of Sheet Metal

dise and other products. They are
manufactured in various sizes suitable
for all ordinary purposes and are ca-
pable of withstanding the effects of
hard usage. When constructed of No.
24 gauge sheet steel, the weight of a
case is only one-half that of a box of
the same cubical capacity made of
7/8-in. lumber. Besides lessening
freight charges for a shipper, these
containers offer a certain insurance
against the loss or injury of their con-
tents, since, if properly packed, goods

are less liable to damage in transit.
The cases are provided with stanch
locks, eliminating entirely the neces-
sity of using nails, rope, or wire in
preparing a box for shipment, a thing
which represents a considerable sav-
ing of time in the packing room. It
requires only a few minutes to either
set up or knock down one of the con-
tainers. When collapsed, one may be
stored in a space 4 in. in height.

COBBLESTONE WALLS FOR
SUBURBAN GARAGE

By picking up and using the cobble-
stones scattered about his suburban
place, one automobile owner has built
an attractive and practical garage with
what would otherwise have been waste
material. This garage is 12 by 15 ft.
and has a ceiling height of 9 ft. The
walls are about 2 ft. in thickness, and
the floor is of cement. Arranged
around the wall in the interior are cup-
boards, benches, and drawers for the
storage of tools and of oil, gasoline,
and other supplies. The mixture used
in laying up the cobblestone walls was
made in the proportion of one-eighth
sack of lime to one sack of pure cement
and four sacks of sand.

8989 m
Cobblestone
wall



This Attractive Garage is Built of Cobblestones Picked Up about the Owner's Suburban Place

See Dec 1916 p 899

J. J. Sturgeon, 620 So. Breed St.
Los Angeles, Calif.

Picture drawn from window of
Chicago grocery store.

POPULAR MECHANICS

SILVER A BY-PRODUCT OF

MOTION PICTURES

9282m

Recovery of silver from the worn-out fixing bath used in making motion-picture films has become a profitable industry for the one plant engaged in it in Los Angeles, Cal., where thousands of feet of negatives and positives are developed every day in the many "movie" studios located in and around the city. The chief ingredient of the composition used on a photographic plate or film is silver bromide. Under the action of the light much of this is changed chemically and is rendered practically insoluble, but a considerable portion is left in a free state, and this is removed by the hyposulphite of soda used as a fixing bath. Owing partly to chemical changes, but mainly to the accumulation of the silver bromide held in solution, the fixing solution eventually becomes inactive. Formerly it was thrown away, but now it is sold, and the silver is recovered. The average tank, where the rack system of development is used, holds from 165 to 200 gal. of the solution, and the price usually paid for a tankful is \$30. The solution is collected in a tank wagon which is equipped with a pump and hose for pumping from the laboratory tanks. It is then placed in a precipitating tank and treated with some chemical, such as sodium sulphide, with the result that a residue consisting of sulphide of silver is precipitated. This is then subjected to chemical treatment which extracts the pure metallic silver in quantities sufficient to make the business of recovering it profitable to the operators.

IMITATION PICTURE MADE

OF REAL FRUIT

A picture that was realistic in the strictest sense was employed by a Chicago grocer recently for attracting



How a Chicago Grocer Made an Attractive Picture of Real Fruit

attention to his establishment. This was simply an imitation picture consisting of an attractive display of fruit with a background of draperies arranged behind a large frame to look like a real picture.

Spectacle

USE SOLDER TO ATTACH LENS TO NOSE-GLASS STRAP

9090H

By employing a solder made of a sand composition, rimless lenses are being attached to the metal parts of eyeglasses without the use of screws. This mounting process eliminates the hole in the lens and thereby gives it strength at the point where breakage most often occurs. The metal frame has a lead lining with which the solder fluxes readily, as it does with glass. The solder contains hydrofluoric acid, lime, barium, and carbonate of lead.

? # William Wallace Ferris
92 Wheeler Ave., Providence, R.I.
made by Martin Copeland Co.
298 Madison, Chicago.

Chemical Economy Co. Inc.
1217-1218 No. Main St.
Los Angeles, Calif.

A. A. Abernethy
401 N. Salisbury St.,
546 W. Lafayette, Ind.

POPULAR MECHANICS
DESCENDING HEAD FIRST TO TEST FIRE ESCAPE

To demonstrate the safety of a new fire escape, which consists only of a slender steel ribbon paid out from a reel in much the same manner as a tape measure, the inventor let himself down, head first, from the second floor of a building, landing so gently that he was able to shield his head thoroughly by the use of the hands alone. In using this device, which has been described in a past number of this magazine, the free end of the steel ribbon is made fast to any solid object, and the user is supported by a strap attached to the reel, the speed of descent being controlled by a clutch device on the reel.



See April 13-496-2340

any solid object, and the user is supported by a strap attached to the reel, the speed of descent being controlled by a clutch device on the reel.

NEW RECORDS IN DEEP-SEA

9237m DIVING

That deep diving is a practical procedure not accompanied by great danger when the proper precautions are taken seems to have been demonstrated by tests carried out by the Navy Department during the fall of 1914 off the coast of New England. In these tests only such apparatus as is supplied with the diving outfits of all naval vessels was used. About 100 dives were made, and although great depths were reached, no mishaps or difficulties were experienced. One diver went to a depth of 274 ft., and it is believed by the officers in charge that a depth of 300 ft., or more, can be reached without serious danger.

Army & Navy Journal
11-9-15

Daily Consular & Trade Reports
1328-1914
Bureau of Inv. & Dom. Commerce
Franklin D. Hite Hale (U.S. Cons.)
SULPHUR DYES TO REPLACE ANILINE
Huddersfield, Eng.
9225m

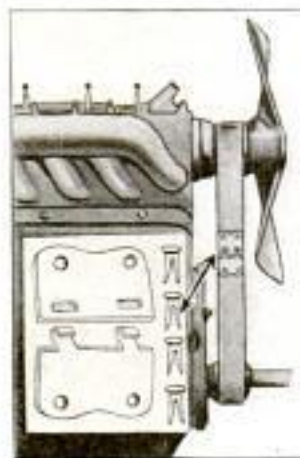
A discovery that is likely to revolutionize the dyeing industry is that of a process for using sulphur dyes for fabrics other than cotton, for which sulphur dyes have heretofore been exclusively used. The new process was developed in an English laboratory and is the result of experiments made for finding a substitute for the German aniline dyes which have been practically shut out of the market by the war. Aside from the fact that sulphur can be obtained from many sources, one of the principal advantages claimed for the process is that wool, silk, artificial silk, and hemp can be dyed together in one bath, thereby saving the cost of separate dyeing and that of dyeing by the present two-bath process. The process is said to be so simple that any competent dyer can learn it with less than half a day's instruction.

Auto Access

NEW TYPE OF BELT FOR

9199m RADIATOR FAN

A new fan belt just placed on the market is designed to overcome one of the annoyances of motoring, that of



the tearing out of the lacing in the belt that connects the radiator fan with the engine. It is equipped with a clasp consisting of a plate with hooks, fixed to one end of the belt, and a similar plate with receptacles for these hooks, fixed to the other end. These plates are so attached that the belt is noiseless in operation. The belt is made of the right length for the individual car, and is stretched in advance so that there is no stretching after it is placed in service.

E. J. Mitchell, Sales Mgr.,
The Belting Co. of Ohio.
Cleveland, Ohio

Pat. of Huddersfield Technical College.

Pat. of Huddersfield Technical College.

Good material

Edwin Levick, 108 Fulton St., N. Y. City

HIGHEST REINFORCED-CONCRETE BUILDING



THIS structure is the highest reinforced-concrete building ever constructed. It has recently been completed on the Brooklyn water front, between the terminals of the Brooklyn and Manhattan bridges. It has 17 stories and measures 275 feet from curb to roof. Twelve of the floors are 125 by 200 feet in dimension, while the remaining five, which are carried in the tower, are 50 feet square. The building is one of a group of similar, but smaller, structures that have been erected during the last few years, and each of which is typical of a period in the history of reinforced-concrete construction.

**DRINKS ILLUMINATED BY
9193_m NEW MIXER**

A new drink mixer designed to be used with a soda fountain is equipped with an electrically driven agitator and an electric light so placed that it illuminates the drink while it is being mixed. The motor for driving the agitator is mounted on a standard directly above the glass, and the current is turned



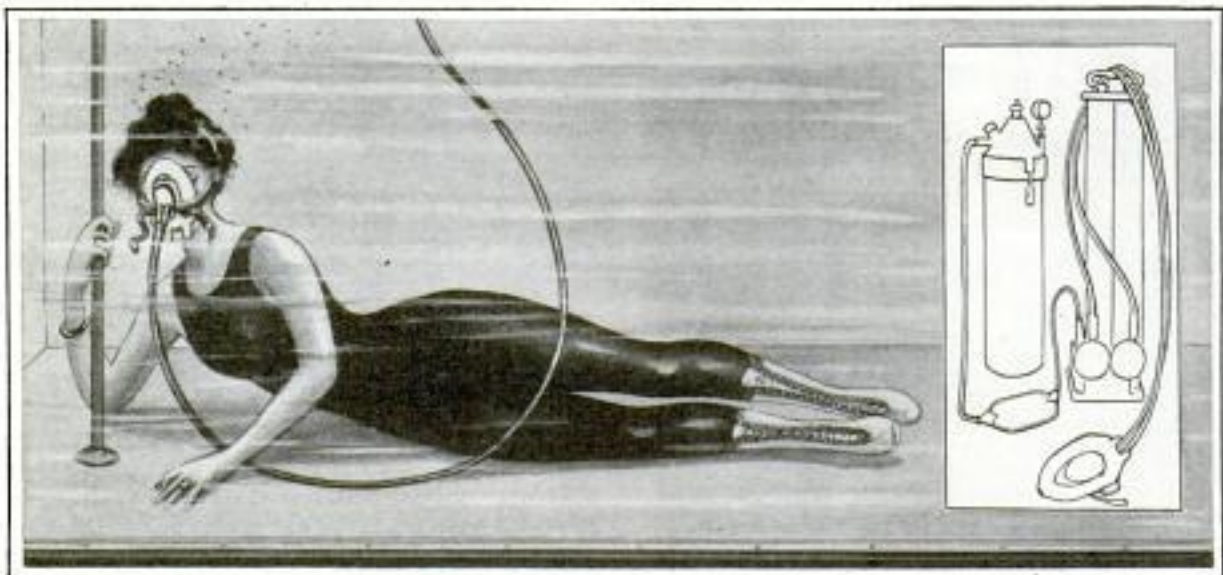
on and off by a switch knob and button on the agitator shaft.

**MACHINE KEEPS GIRL ALIVE
9065_H UNDER WATER FOR HOUR**

During the recent Safety and Sanitation Exposition at New York, a young woman was kept alive under water for one hour and 10 minutes by means of a resuscitating machine such as is used by the government in mine-rescue work. The test was performed for the purpose of illustrating the ef-

iciency of mechanical respiration and was conducted under the direction of a former surgeon of the United States Bureau of Mines. The breathing mask, which has a double rubber tube extending to a hand-operated lung apparatus, was strapped over the girl's nose and mouth, and she was then placed in a large glass-front tank. Throughout the period she was submerged she did no breathing of her own accord. The function ordinarily performed by the human lungs, that of inhaling and exhaling air, was accomplished by the machine, each downward stroke of one piston in the two-action pump sending a proper amount of air, or in other words, a normal breath, into her lungs, and the upward stroke of the companion plunger withdrawing it. Because of the fact that the machine is so constructed that only a normal pressure is exerted by it, the girl was under no material strain while submerged. When taken from the tank she is said to have showed no especial indications of fatigue other than would be natural after remaining for a long period in water.

CA glass which gives the same intensity of color values as daylight when used with a gas or tungsten light has been developed.



By Means of Mechanical Respiration This Young Woman Was Able to Remain under Water for More Than an Hour

Arthur Miller, The New York Press Club,
21 Spruce St., N.Y. City

BIG GUNS CHANGE WAR TACTICS

How Europe has Come to Realize for the First Time
the True Importance of Powerful Artillery

8859K
SEVEN months of the most terrific fighting the world has ever known has upset many previously accepted military theories, caused others to be modified, placed the individual soldier in the background, and made artillery preëminent in war.

War, as it is fought today, is largely a matter of pitting one death-dealing machine against another. This means that, more than ever before, the army with the strongest artillery is the superior force. It is the long-range field gun, heavy howitzer, and high-explosive projectile which weaken the enemy's resistance, more than rifle fire from the trenches.

At the beginning of the war Germany's heavy artillery was wheeled onto the battle field for the first time. The enormous power of its big howitzers constituted the one real surprise of the war. The introduction of a 16.5-in. siege piece to batter down fortifications was just as radical an innovation as was the "Monitor" when it made its appearance at Hampton Roads during the Civil War. So at the opening of the world-wide struggle Germany's enemies were in one particular unprepared: the forts in Belgium were not built to withstand anything heavier than a 9-in. shell, and even the 11.2-in. Krupp howitzers were too much for any fortification in their path.

Napoleon placed his chief reliance upon his artillery. His remarkable military achievements were largely due to his superior tactics, as he admitted when he asserted, "When once the mêlée is begun, the man who is clever enough to bring up an unexpected force of artillery without the enemy knowing it, is sure to carry the day." These words have continued to live in France, the result being that the Tricolor has always had the strongest field artillery in Europe and the most thoroughly trained gunners. In other words, France appreciated, probably earlier than any other nation, the im-

portance of having a strong artillery, for it has developed this arm of its military service beyond that of any other, with the possible exception of the aerial division.

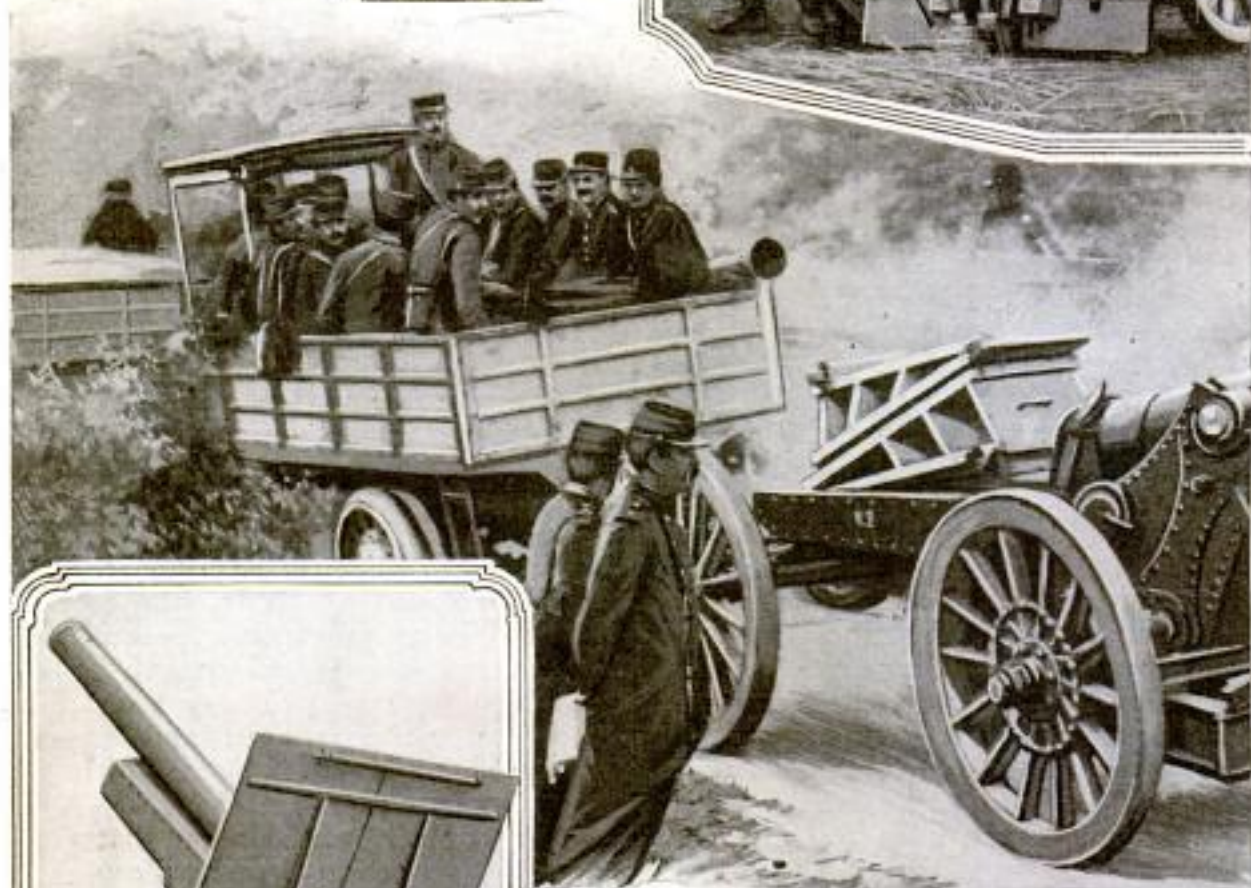
Germany, so far as it is known, has only two of the great 16.5-in. howitzers. And now it is reported, probably correctly, that Great Britain has developed an even greater engine of death which will be brought out when the first chance comes. This new ordinance is supposed to be modeled after the master Krupp piece and to have a 17-in. bore. There is little doubt that in a number of instances the Germans have been credited with using much larger siege mortars than were actually fired, as for instance at Namur, where it is now declared that the 11.2-in. howitzer was employed. This weapon has frequently been mistaken for the larger one and pictured as it. Its existence was not unknown prior to the opening of hostilities. In fact, it was so well known that France, in 1911, also developed a 11.2-in. howitzer of equal destructive capacity as a rejoinder. This is a Schneider gun and is provided with a stationary mounting, concrete anchor weight and ground plates, when in action, instead of being fired from its carriage.

From this it would seem that Germany's strength in siege artillery is no greater now than that of her enemies. The reason that so much has been heard of the heavy Krupp guns and so little about the Schneider howitzers of the French, is obvious. So far Germany has been fighting largely on the offensive in the territory of her enemies, breaking through solid fortifications and storming cities. The allies, on the other hand, have been resisting invasion. If the coming of spring brings with it an invasion of Germany, which will mean the storming of the fortifications along the Rhine, the Schneider siege howitzers—and possibly the new British piece—will be

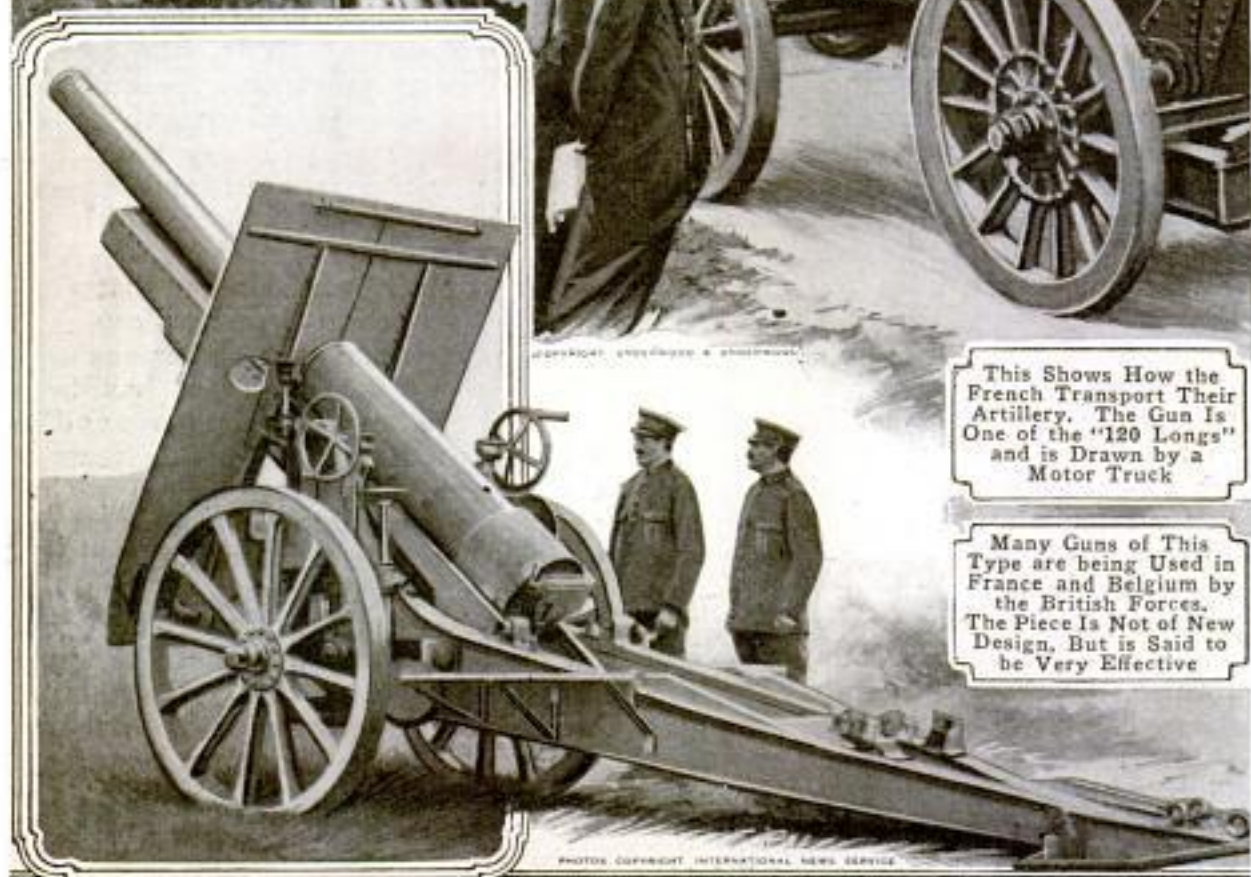
The Illustrated London News 11-21-14.



After the 11-Inch Howitzers. This 6-Inch Piece Is the Most Formidable French Weapon



This Shows How the French Transport Their Artillery. The Gun Is One of the "120 Longs" and is Drawn by a Motor Truck



Many Guns of This Type are being Used in France and Belgium by the British Forces. The Piece is Not of New Design, But is Said to be Very Effective

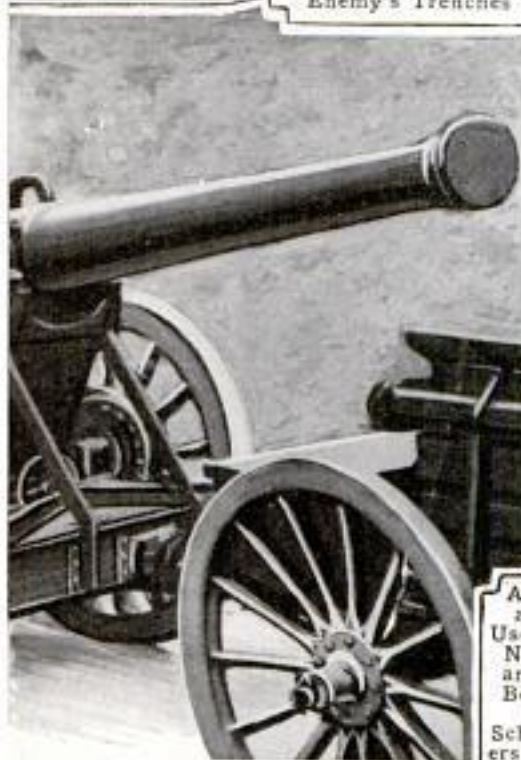
PHOTOS COPYRIGHT INTERNATIONAL NEWS SERVICE



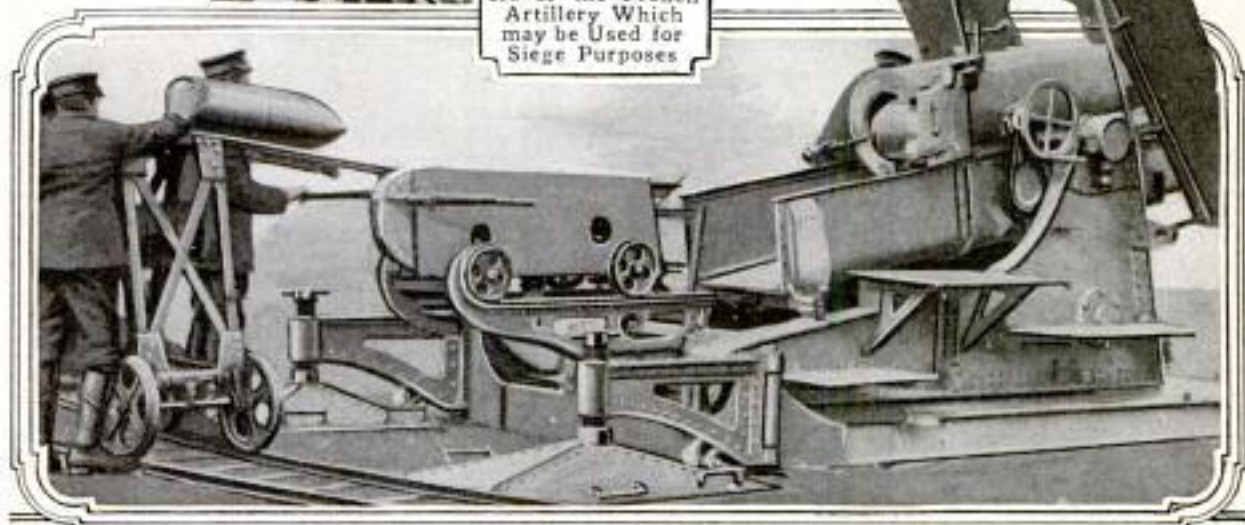
This Is One of the Famous "75" Guns Which the French have Used with Telling Effect against the Enemy's Trenches



One of the Heavy "Longs" of the French Forces, Fitted with Detachable Treads, being Tuned for Action



Above is Shown a Type of Gun Used by the French North of Rheims and at Soissons. Below Is One of the 11-Inch Schneider Howitzers of the French Artillery Which may be Used for Siege Purposes



brought out for action. Until such a time, however, there is little or no opportunity to use them.

Very little actual information has filtered through the German lines regarding the 16.5-in. siege howitzer, or mortar. The measurements of the 11.2-in. howitzer, however, are known, and military authorities, using these as a basis for their calculations, have compiled figures for the larger weapon which approximate accuracy. These estimates place the weight of ordnance with the breechblock at 21.3 tons; the weight of the piece in action, 50 tons; the heaviest load to be transported, including transport wagon, 31.3 tons; the weight of the shell used, 2,565 lb.; recoil energy, 1,530 tons.

The actual number of these large siege guns and howitzers is comparatively small and by far the greatest part of the fighting has been carried on with field guns of enormous power but not extreme size. Britain's 6-in. howitzer, used on a field carriage, has won the admiration of its allies and the respect of its enemies. The same is true of the French 6.20-in. piece, while France's favorite "75," a 3-in. gun, has been used with very telling effect. France has another field gun, a 4.20-in. weapon, which is a large edition of the "75."

In the past, artillery has been used more for its moral effect than actually to destroy the enemy. This is no longer true. Today it is the real reliance of the army. With the aid of the reconnaissance aeroplane the enemy's trenches may be located and obstructions sighted. When the range is found, the shells rightly timed, and the firing commenced, whole intrenchments may be blown away and great areas swept clean of entanglements and other blockades. It is extremely difficult to conceal the position of trenches from aerial observers, and equally hard for soldiers to survive the fire of massed artillery. Never before have such careful precautions been taken in the construction of intrenchments as in the present struggle. Bomb-proof, covered, and undercut

trenches are practically new to warfare, as is the British trench with individual stalls which furnish protection on the sides from bursting shells and shrapnel. The gunner today occupies a place of far greater importance than at any time since the organization of artillery units. This is equally true of the field, siege, and garrison gunners. Upon them rests the task of keeping up an incessant rain of shells so accurately aimed that they wipe away the infantry trenches or demolish the gun turrets of a fortification miles away.

The French, in concentrating their artillery batteries against the enemy's lines, have placed great faith in the "75" gun, which, so far as caliber is concerned, is nothing at all uncommon. It is the rapidity with which this gun may be fired, the ease with which it may be handled, and, moreover, its high-explosive projectile which make it valuable. It is capable of being fired 25 times a minute, has a flat trajectory, and uses either shell or shrapnel. The fuse may be timed to explode the shell at any point of its trajectory, or left unset, which will cause the missile to explode by contact. The first shot fired by the gun drives the spade trail into the ground and sets the carriage so that the barrel alone is moved by the recoil. The gun is pivoted to the axle so that it may be turned to the right or left and fired without moving the carriage. Its effective range with a 15-lb. shell is slightly more than three miles.

The larger size of the same type of weapon, a 4.20-in. piece, known as the "105 millimeter," fires a 60-lb. shell at the rate of 15 shots a minute, and has an effective range of about 7 miles. The 6.2-in. siege gun of the French is a different type of piece and weighs approximately $4\frac{1}{2}$ tons. The weight of its shell is about 94 lb. This is a very formidable gun and is one which is much used in dislocating hostile artillery batteries. It has an effective range of more than four miles. A field gun with a flat trajectory, an equal caliber but a greater range than this,

is also used by the French. The British 6-in. howitzer is the chief rival of this ordnance. It weighs less than a ton and a half and fires a 100-lb. shell, either high-explosive or shrapnel. While in action it is held in place by a "hold-fast" anchor. It recoils in its cradle, is checked by a hydraulic buffer, and by means of a spring mechanism is returned to its firing position. The effective range is about 8,000 yards.

The Schneider 11.2-in. howitzer has a very novel mounting and one which it is reasonable to believe the British have followed in building their 17-in. monster, for it is much more satisfactory, so far as ease of handling is concerned, than that of the Krupp piece. In setting the gun for action a large hole is dug in the ground for it. Gallows are erected about this and a heavy steel platform of the "tank" type lowered in place. The hollowed-out part of this is then filled with concrete, which gives the gun a solid base. Eight or ten days are required for the concrete foundation of a Krupp gun to set sufficiently to be used, while with the Schneider gun this is not required, as the concrete acts more as a steadying weight, or anchor, for the metal base, making it immaterial

whether it is fully set or not. To prevent the rear end of the platform from sinking, additional bearing surface is furnished by two ground plates.

British engineers, previous to the announcement of England's new gun, computed that a 17-in. howitzer of Krupp type with the Schneider system of transportation and mounting could be made which would have a gross weight of only 27 tons. In the vicinity of fortifications in Germany the roads are in such good condition that even on hills three 22-ton traction engines would be sufficient, with the aid of winding gears, to move ordnance of this weight.

The "120 long" is a heavy artillery piece much used by the French, which closely resembles many coast-defense guns. Its caliber is 4.8 in. Great Britain and Belgium have also been using guns very similar to this in bore and range. The piece is used for dislodging the enemy's artillery, but may also be employed effectively against the trenches. Another gun, known as the "120 short," is of the same size but fitted with a shorter barrel. The unusual length of the "long's" barrel gives it its popular name. Neither this gun, nor the one used by England, however, is new.

COSSACK BOOTS THE LATEST IN FEMININE FOOTWEAR

9128 *m* Military boots, made to imitate the boots worn by Russian Cossacks, are now being introduced in New York City, and furnish the latest surprise in feminine footwear. These boots are made of suede, with vamps, heels, and trimmings of patent leather, and are to be worn with a tailored suit of a military type. They come in all colors to match the costume, but are invariably trimmed in patent leather.

Tests of wood preservatives applied to ties, timbers, poles, piling, and paving blocks are being made by 54 companies and cities.



These Boots are Made of Suede to Match the Costume, with Vamps, Heels, and Trimmings of Patent Leather

Underwood & Co. 417 Fifth Ave. N. Y. City.

NOVEL METHOD OF RAISING COLLEGE-CLASS FLAG

904' m
During the annual college-class scrap at a western university the members of the sophomore class adopted



an ingenious means of fixing their colors at the top of a 90-ft. steel flagpole so that the members of the opposing class could not get them down. The banner was first fastened, top and bottom, to the endless rope that runs through pulleys at the top and base of the flagpole. About four feet below the banner the rope was cut,

and the end tied in a slip noose around the other half of the rope. A short rope was looped around the pole, and the ends attached to the lower corner of the banner. The last operation was to cut the rope nearly through about ten

feet above the banner and soak that portion with molasses and glue. When the banner was drawn to the top of the pole the sticky rope jammed in the pulley. A strong pull broke the rope where it had been partly cut, and the banner hung securely at the top of the pole with only about four feet of rope dangling from the lower corner.

PANAMA CANAL WATERS BECOMING SALT

8923 m
As the result of a curious and unexpected hydraulic action in connection with the operation of the locks, it is now more than probable that the entire Panama Canal, including Gatun and Miraflores lakes, will in the course of time become salt, this action having already progressed so far that Miraflores Lake has been rendered brackish and unfit for the water supply planned in connection with it. In addition to this, the currents caused by the mixing of the fresh and salt water have brought about a rather difficult problem in the passage of ships through the locks.

The double flight of locks at Miraflores is located about eight miles inland from the Pacific, while the surface of the lake is 55 ft. above mean sea level. As a ship enters the lower lock

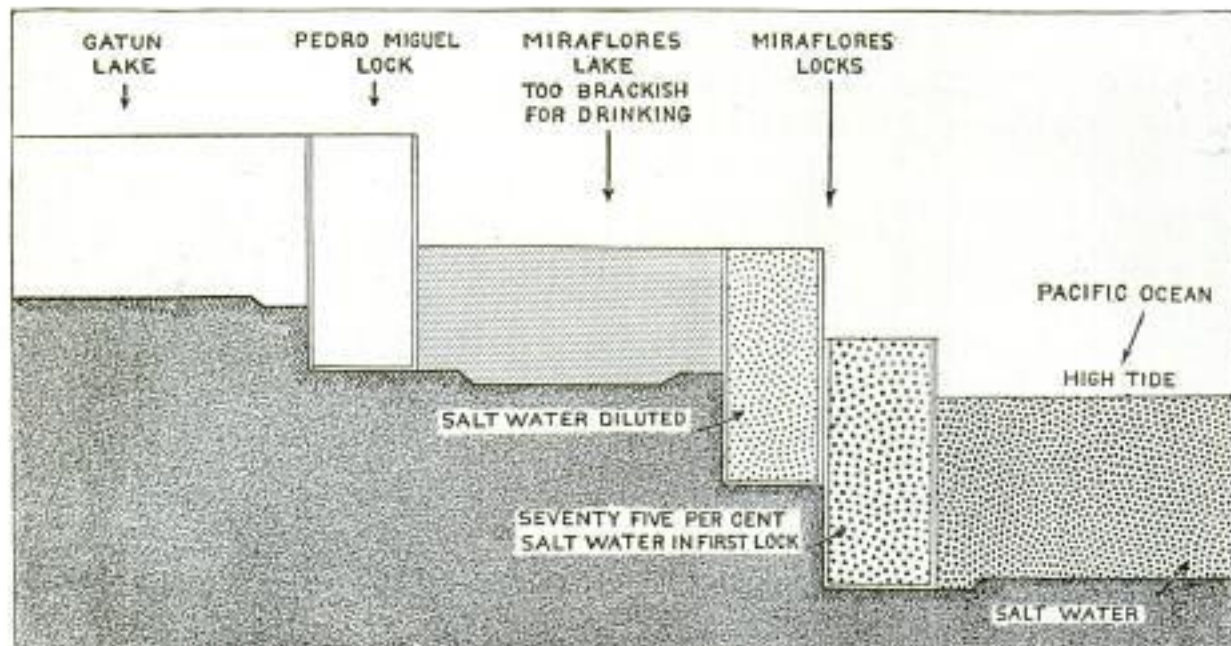


Diagram Showing How the Salt Water of the Ocean is Gradually Ascending into the Lakes at Panama, through the Locks

Engineering News 11-26-14



Ornamental Flower Boxes Placed on the Roof are Becoming a Popular Feature in Southern California

from the Pacific there is a mingling of the fresh and salt water, so that after the gates are closed the water in the lock chamber is about 75 per cent salt water. Fresh water is then let into the chamber through the culverts to raise the ship to the next higher level. Owing to the difference in density of the fresh and salt water the resulting mixing sets up currents that often make it difficult to handle ships passing through the locks. The same process, with the salt water greatly diluted, takes place when the ship enters the upper lock, and when the upper gates are finally opened a small quantity of salt water finds its way into the lake. This process has doubtless been going on in the same way at the Gatun locks, but it has not yet advanced far enough to cause any noticeable proportion of salt in the water of Gatun Lake.

ORNAMENTAL FLOWER BOXES FOR BUNGALOW ROOFS

Ornamental flower boxes placed in conspicuous places on the roof form a feature that is fast coming into favor among bungalow owners in southern California. In shape and finish these boxes are made to harmonize with the architectural treatment of the building,

and when filled with plants produce a striking effect. The general use of these boxes is made possible through the fact that most of the bungalows in this section of California have flat roofs.

NEW HOOK FOR HOLDING LIVE MINNOWS

A minnow hook that holds the live minnow in a natural swimming position and permits it to move freely is one of the latest features in fishing equipment. The minnow is held securely, but without being injured, in a snap holder which grips the back fin. The fishhooks, three in number, are attached to the holder in such a way as to be partly concealed by the minnow's body.



A new tungsten electric lamp has a 3-ft. filament coiled in a spiral.

Detroit Glass Minnow
Lure Co., Detroit, Mich.
73 Lafayette Blvd. W.

Albert Marble
322 Boynton St.,
Tropico, Cal.

The Graphic
**INFANT HAMMOCKS CARRIED
 BY PALESTINE MOTHERS**

When going into the cities or to marketing places, the country women of Palestine have the custom of carrying



COURTESY OF THE GRAPHIC
 Baby of a Palestine Woman Hanging in a Hammock
 at a Market Place

their babies in small hammocks which they suspend over their shoulders and support on their backs. Often these tiny beds are very elaborately decorated with tassels of bright colors, while as often they are very plain, and designed merely for comfort and service. At the markets there are usually racks supplied with hooks from which the hammocks are suspended while the mothers transact their trading. The sight of these small cradles hanging in rows, their young occupants peacefully reclining and often slumbering, is one of the things which always attract tourists.

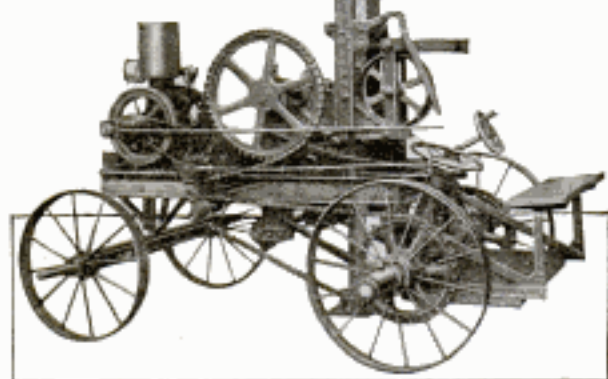
Osage-orange wood is being used in dyeing textiles, furnishing a permanent yellow.

The Aeroplane
**GERMAN PAPER PRINTED IN
 FRENCH LANGUAGE**

It is reported that German military airmen have recently been flying over the French lines in different places and dropping a newspaper called the "Gazette des Ardennes," which is intended for the public in some of the districts controlled by the kaiser's forces. The publication is ostensibly one containing information from the outside world of interest to the French and Belgians, and is said to be well printed in good French. The text, it is asserted, is taken principally from the official dispatches of the German headquarters. When the papers have been thrown behind the French lines, which has been done principally in a spirit of bravado, they have been wrapped in German flags.

Road
**NEW TRACTION TAMPING
 MACHINE**

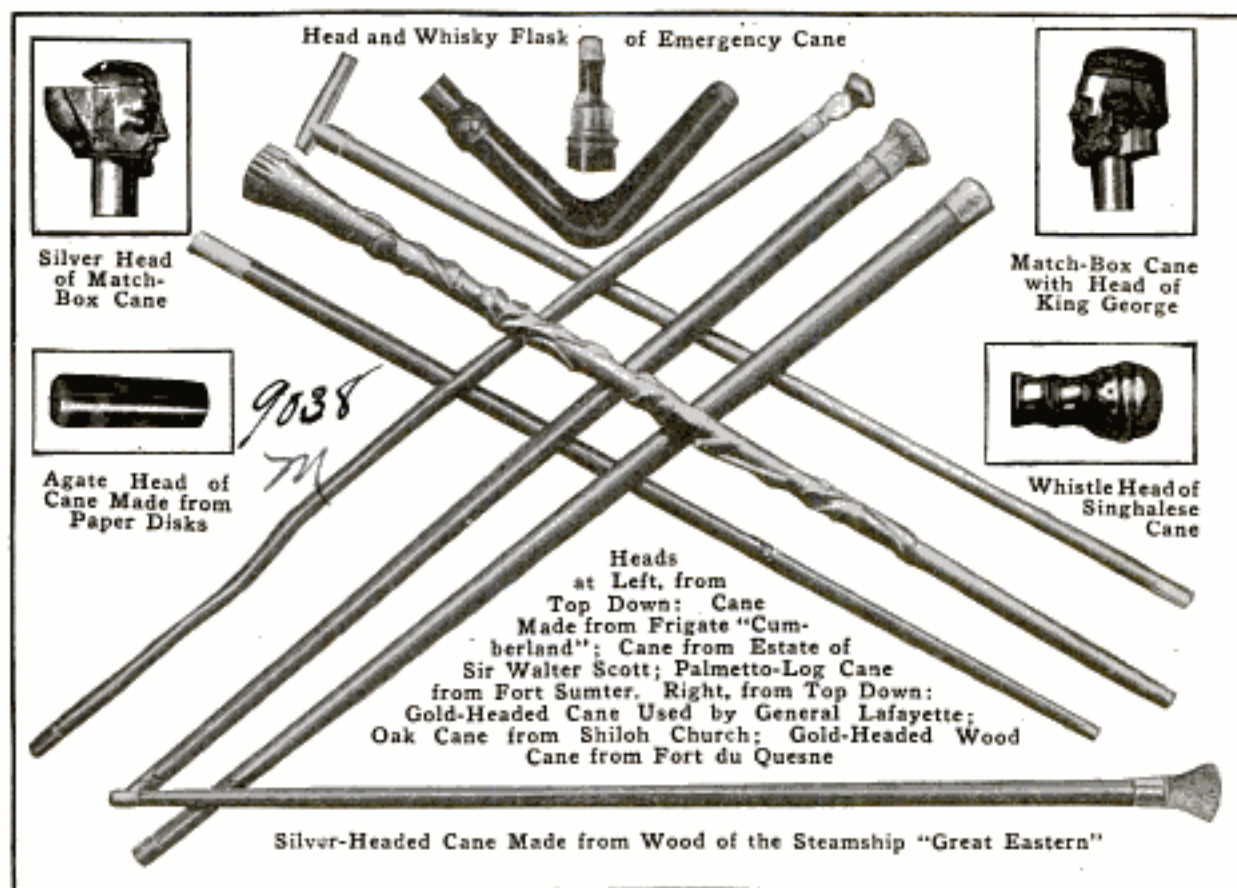
A new machine for tamping, and for cutting and breaking asphalt, concrete, macadam, and other road materials, is equipped with a gasoline engine which furnishes the power not only for the machine but for the tamping apparatus and the drive wheels which are connected with the engine, and are controlled from the



This Tamping Machine is Operated and Propelled
 by Its Own Power

operator's seat. Only one man is required for handling the machine.

*Pauling & Harnischfeger Co.,
 Milwaukee, Wis.*



COLLECTION OF CANES AT THE NATIONAL MUSEUM

A collection of canes made of practically every kind of suitable material and representing 45 foreign countries as well as 21 states of the union forms one of the interesting exhibits at the National Museum at Washington, D. C. Forty different kinds of wooden canes are on exhibition, as well as canes made of ivory, bone, horn, skin, paper, tin, wire, and other substances. In this collection are many canes that are artistic and others that are merely curious in shape, as well as some made for emergency uses. Among the latter are one containing a whisky flask, a sketching cane with drawing materials stored in the handle, a number equipped with match safes, mountain-climbing canes with sharp-spiked ferules, an officer's "swagger stick," and sword and gun canes of various types. The most interesting feature of the exhibit, perhaps, is the historical element. There are canes that have been carried by various presidents and by prominent naval and military officers, while

a considerable portion of the exhibit is composed of canes of wood taken from historical spots or historical objects. There is one cane, for example, made from wood taken from the U. S. frigate "Cumberland," and another made from the Confederate ram "Merrimac." One gold-headed cane is made from a log that was used in the defenses of Fort Sumter. A curious cane in point of construction is one made of disks cut from newspapers thoroughly compacted and held together by an iron rod passing through the center. The body of this cane has the appearance of rawhide and is finished with an agate handle. The history of canes is an interesting one, consisting of periods of popularity alternating with periods when their use was prohibited or when they were confined to the use of specified classes, these restrictions usually being brought about by the amiable habit that the users often fell into of employing their canes in the settlement of personal disputes.

J. C. McCarthy, Evening Star, Wash. D. C.
J. W. Dorsey, Smithsonian Institution, Wash. D. C.

G. L. Edholm, 1353 W. 36th Place
Los Angeles, Cal.

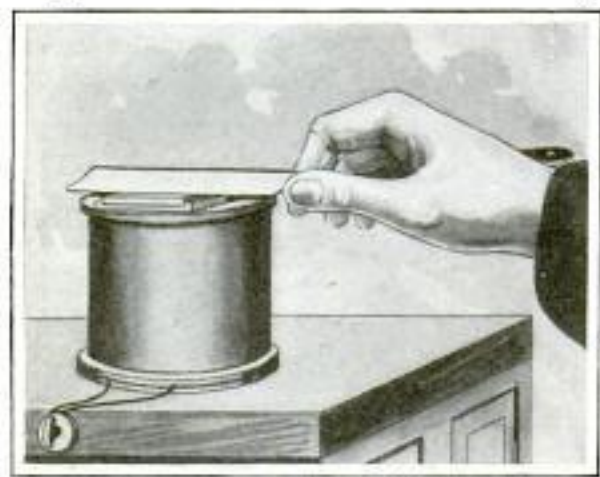
Barber: E. J. R. Smith, Oak Barber Shop
558/06 N. Spring St., Los Angeles, Cal.

POPULAR MECHANICS

ELECTRICITY AIDS IN HONING

8947m **RAZORS**

By placing an electromagnet in a base made to support his hone, a Los Angeles barber has devised a means by



With This Device the Razor Blade is Held Flat on the Hone by Magnetic Attraction

which the razor is held firmly against the stone while it is being honed. The magnetic attraction keeps the blade flat so that it is honed at the proper angle, and permits the work to be done faster than with the ordinary hone. The device is attached to the electric lighting system used in the shop, so that a turn of the switch energizes the magnet or cuts off the current.

RADIO USED IN GREAT WAR

8408A **FOR FIRST TIME**

Wireless telegraphy is now, for the first time since its development, play-



Hidden in the Lava Rocks of Ascension Island, in the South Atlantic, is a British Radio Station Which Links Great Britain with Its South African Possessions

ing a big part in a really great conflict. Aside from the function it serves on the battle field it is the one means of quick communication indispensable to any nation in time of hostility, for it is the most difficult for an enemy to interrupt. The cutting of a submarine cable is comparatively as simple an operation as it is effective, and were it not for high-power radio plants a country embroiled in war would constantly be in imminent danger of being isolated from the rest of the world.

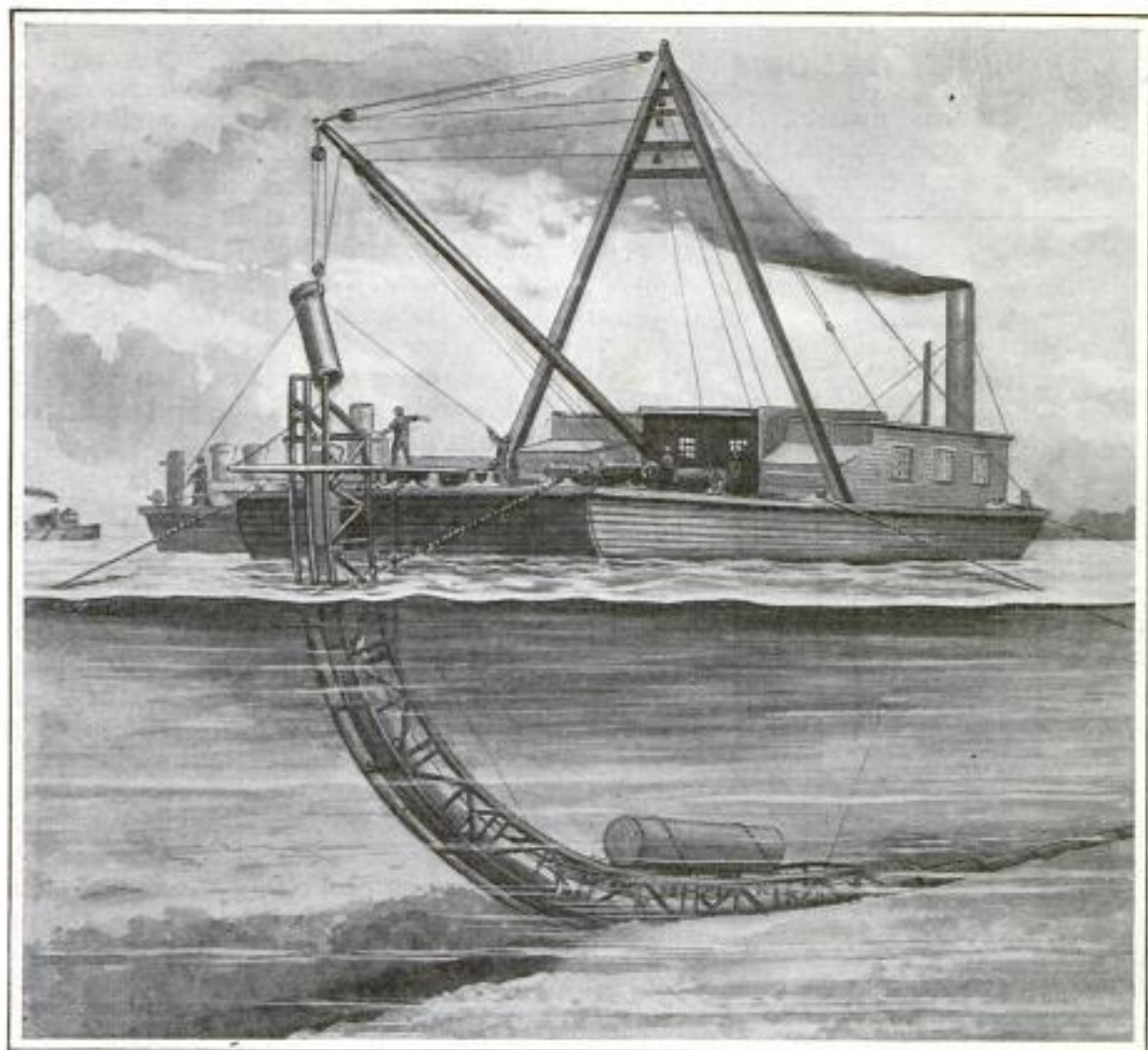
The accompanying photograph, which was taken since the outbreak of the European war, shows one of the wireless stations that links Great Britain with its colonial possessions in South Africa. The plant is situated on Ascension Island, the base of the British African squadron in the Atlantic Ocean, 800 miles northwest of St. Helena. A part of the garrison of the island is grouped about the entrance of the radio station, which is so completely hidden among the blocks of volcanic stone, of which the island is composed, that it is indistinguishable from a distance. The antenna is concealed in the mountains so that the destruction of the plant would be extremely difficult to accomplish, and would require much time to find even if the island were overrun by an enemy. Until the arrival of Napoleon at St. Helena, the island had been uninhabited, but it was then garrisoned by the British government. Today it is under the rule of the admiralty, is governed by a naval captain, is a depot for navy stores, and is used chiefly as a sanatorium.

SUBMERGED PIPE LINE WITH

9082m **FLEXIBLE JOINTS**

Novel methods and equipment are being used in laying a submerged pipe line across the Narrows to convey water from Brooklyn to Staten Island. The distance from shore to shore is about 10,000 ft. and the line extends across the busiest lanes of traffic to and from the port of New York. In some places the depth of water is as great as 74 ft. The pipe line is made

Engineering Record Dec. 19, '14



By the Ingenious Use of Flexible Joints the Pipes Connecting Staten Island with the New Catskill Aqueduct are Laid on the Bed of New York Harbor at the Narrows

up of 36-in. cast-iron pipe in 12-ft. lengths and provided with flexible joints. It is laid in a trench dredged out of the bottom of the channel and is to be covered over as soon as completed. The most novel feature of the work is the method of laying the pipe. A steel launching cradle, having the appearance of being curved, has its lower end resting in the pipe trench and its upper end supported by the scow used in laying the pipe. This cradle is made up of 12-ft. sections, each straight, with an angle of 5° between adjacent sections. On this cradle the pipe sections are supported as they are connected together, the joints in the pipe line being of a bell-and-spigot type that can be bent 5° out of

line without damage. Each 12-ft. length in succession is placed on the top pipe resting on the cradle and the joint made secure. The scow is then pulled forward 12 ft. by its forward anchors, power drums being used for pulling the anchor ropes. In this process the pipe line slides down on the cradle, and the lower pipe goes into position in the trench while room is made at the top for placing the next pipe. The average time required for making a joint and lowering a 12-ft. length complete is three hours. Both the dredging and the laying of the pipe are difficult and require the greatest care, owing to the strong tidal currents that run alternately up and down the Narrows.

Alan D. Withowsky, 542 1/2 East
View Park, Chicago, Ill.

Security

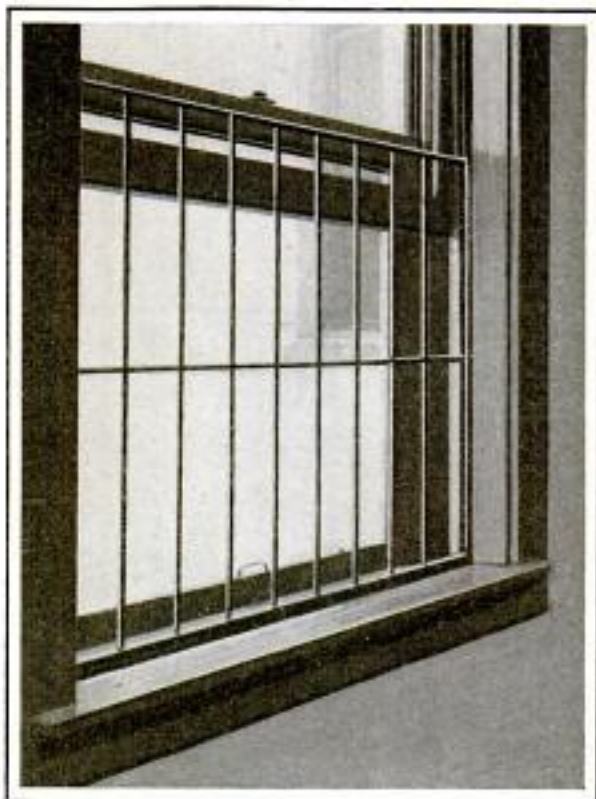
POPULAR MECHANICS

DETACHABLE STEEL GUARDS FOR WINDOWS

8344 H

Steel window guards, designed to furnish adequate protection against robbers, have recently been invented

Security Window Guard Co.,
30 East Randolph St., Chicago



Steel Guards Make Windows Proof against Entrance from the Outside

which may be attached to or detached from a casing at will. They may be fitted to a window almost in a moment's time without difficulty, or danger of marring the woodwork. The bars are so arranged that they fit into the inner sill of a window and into grooves along the sash. The grating cannot be removed when the window is open.

Daylight Saving

NEW PLAN TO SET CLOCK AHEAD DURING SUMMER

9132 m

The plan of setting the clock ahead an hour so that it will correspond to eastern time, has been agitated in a number of middle-western cities, and has been adopted in some of the cities near the border between the time zones, with the idea of saving as much daylight as possible for recreation pur-

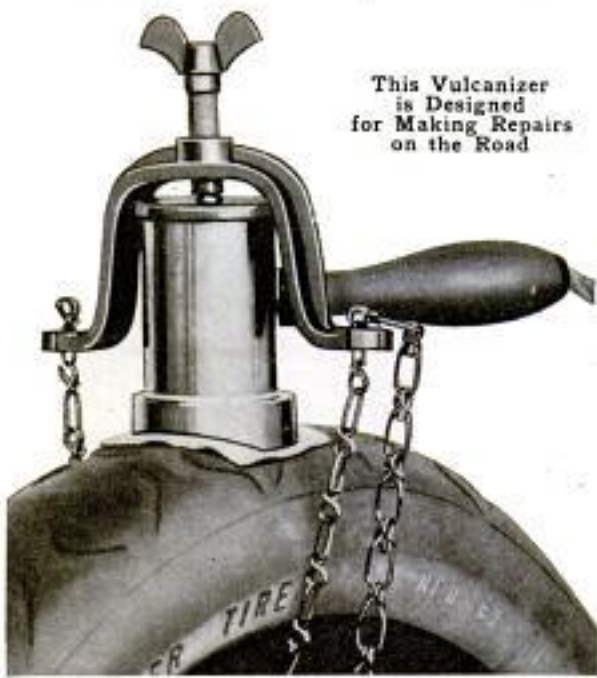
The Nation's Business
12-15-14

poses. It is now proposed to bring about an international agreement by which the clocks in all countries in the northern hemisphere will each year be set forward an hour on May 1 and then set back the same amount on October 1. It is estimated that in the latitude of London a saving of 154 hours of daylight a year would be effected by this plan. In connection with this better utilization of daylight there would also be an enormous saving in artificial lighting in commercial and industrial establishments.

PORTABLE VULCANIZER FOR AUTOMOBILE TIRES

By means of a new portable vulcanizer that is designed to be carried on the automobile, it is now possible to repair a tear, break, or sand blister in the tire immediately and before it has time to cause a blow-out. This vulcanizer operates either from its own six-volt battery or by plugging into the lamp sockets of an electrically equipped automobile, or connecting with the ignition battery. It uses about

This Vulcanizer is Designed for Making Repairs on the Road



8 1/2 amperes, so that the current consumption is an unimportant feature. It can be connected and made ready for use in five minutes or less.

Henry J. Adams & Co.
6823 So. Chicago Ave.,
Chicago, Ill.

COPPER AND CARTRIDGES

9278 S BY EDWARD C. CROSSMAN

HOW long will five billion cartridges last in a war of the size of the present one? How much copper has Germany on hand from which to make new cartridges for the infantry rifles and machine guns, new ammunition cases for the field guns, and driving bands for the shells of all sizes? Great Britain has declared copper contraband of war, and is trying to stop its going to any port whence it might reach Germany. Other things might end the war more speedily, but when the supply of copper quits, then the war quits likewise. The Germans were reported to have had nearly five billion rifle cartridges on hand when war broke out. They probably have four million men under arms, possibly more. They have thousands of machine guns, each of which eats up cartridges as fast as a whole infantry battalion. Twelve hundred and fifty rounds per soldier, excluding the machine guns, and the 5,000,000,000 cartridges are gone. Without doubt the Germans are reduced already to picking up the fired cases when it is feasible to do so. Trench fighting is particularly well adapted to this purpose, while from a machine gun the ejected cases are thrown so uniformly that a basket would catch practically all of them.

The German cartridge cases are not well adapted to being reloaded. The American government reloads the fired rifle cartridges, and the requirements specify that each case must stand 20 such reloadings without splitting or giving way at any spot. Hundreds of thousands of fired cartridges are reloaded by the United States Army each year, and the economy thereof is great because while the complete loaded cartridges cost $2\frac{1}{2}$ cents, the case itself costs nearly $1\frac{1}{2}$ cents, a saving of 60 per cent through reloading.

Both the German authorities and Sir Charles Ross, the designer of the Canadian army rifle, have experimented with the manufacture of steel cartridge cases. Ross produced them,

but they were too costly to be commercially practicable.

The start of the brass cartridge case is a flat disk of copper-zinc alloy. It goes through a battery of draw presses until it has been drawn out to a brass cylinder, about the length of the complete shell. Then the head is formed from the thick brass left in the base. During these drawing operations the case has to be frequently annealed, the process making the brass very brittle. In American cartridges the final operation is to "neck down" the cylinder to the proper bottle-neck form for that particular rifle. In the British service, where the cordite powder is loaded in the form of tubular strips, the powder is inserted before the case is necked down. Every shell has to be gauged to make sure it will chamber in the rifle, for a bad one might jam a rifle or tie up a machine gun for a day.

Brass instead of pure copper is used, because copper, while tough, has not resiliency to spring back to form after being thrust against the chamber walls in the rifle by the terrific gas pressure. If the case does not do this, it cannot be extracted. So the temper of the finished shell is very important. If it is too brittle, it will split at the neck or break off at the base, disabling the weapon. If it is too soft, it will upset or swell into the chamber's most minute rough spots, and cannot be extracted.

The chamber pressure of the rifles used in the war ranges from 40,000 lb. to 55,000 lb. per square inch of chamber area. The actual thrust on the head of the bolt holding the shell in the Mauser rifle is 9,000 lb. With the high pressures, brass has not always proved entirely sufficient to stand the strain. The cartridge case is the weak point of the modern rifle. The first sign that the chamber pressure is too high is the "flowing" of the head of the cartridge out into the unsupported space around the extractor cut, and over the head of the bolt. In very high pressures the case is literally

"smeared" all over the head of the bolt, flowing back like butter. The steel case is not open to the objections pertaining to brass cases, but steel refuses to be jammed at high speed through a series of draw presses.

Military bullets are made in much the same fashion as the cartridge. Disks of the jacket metal are stamped out of sheets and then run through presses to make the jacket. In American and British arsenals this metal is a copper-nickel alloy, about 75 per cent copper, and 25 per cent nickel, making, roughly, German silver. In the German service the jacket is sheet steel, plated to guard against rust. The presses finally turn out the complete jacket, just the shape of the finished

bullet, but of course hollow. Then lead or lead alloy, in the form of wire on great reels, the wire about the diameter of the finished bullet, is fed into a machine that cuts it off to the right length and pushes the slug down into the jacket.

The German sheet-steel jacket is supposed to wear out the rifle barrel faster than cupro-nickel, but it is easier to obtain in uniform quality and sufficient quantity, and it does not "metal foul" the rifle barrel. Cupro-nickel, on the other hand, when pushed up a barrel by the very hot cordite of the British service, or at the high speed of the American rifle, melts from the heat and friction, and leaves copper in the rifle grooves.

SALT IMITATES SNOW IN TOY BATTLE FIELDS

9245
m

IN all the warring countries of Europe war toys have to a great extent taken the place of dolls. In England particularly means for enabling the children to play at the war game have been worked out in elaborate fashion, and toy soldiers capable of holding toy guns and arranged in battle array on battle fields made of salt to imitate snow are a common nursery feature.

These photographs show how the English children play at winter fighting. In the picture on this page a column of soldiers is seen descending a mountain pass, dragging their artillery after them. At the top of the next page a small body of troops is holding a mountain pass against Germans, while the picture at the bottom of the page shows grenadier guards fighting in snow-covered trenches.

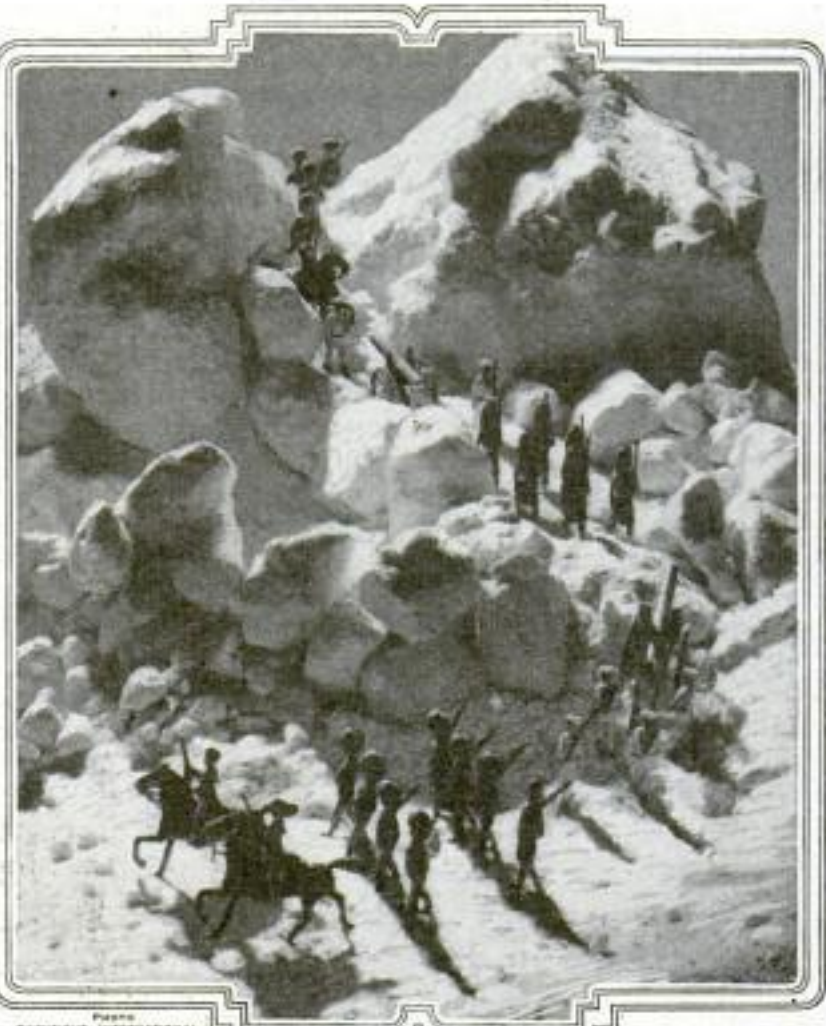
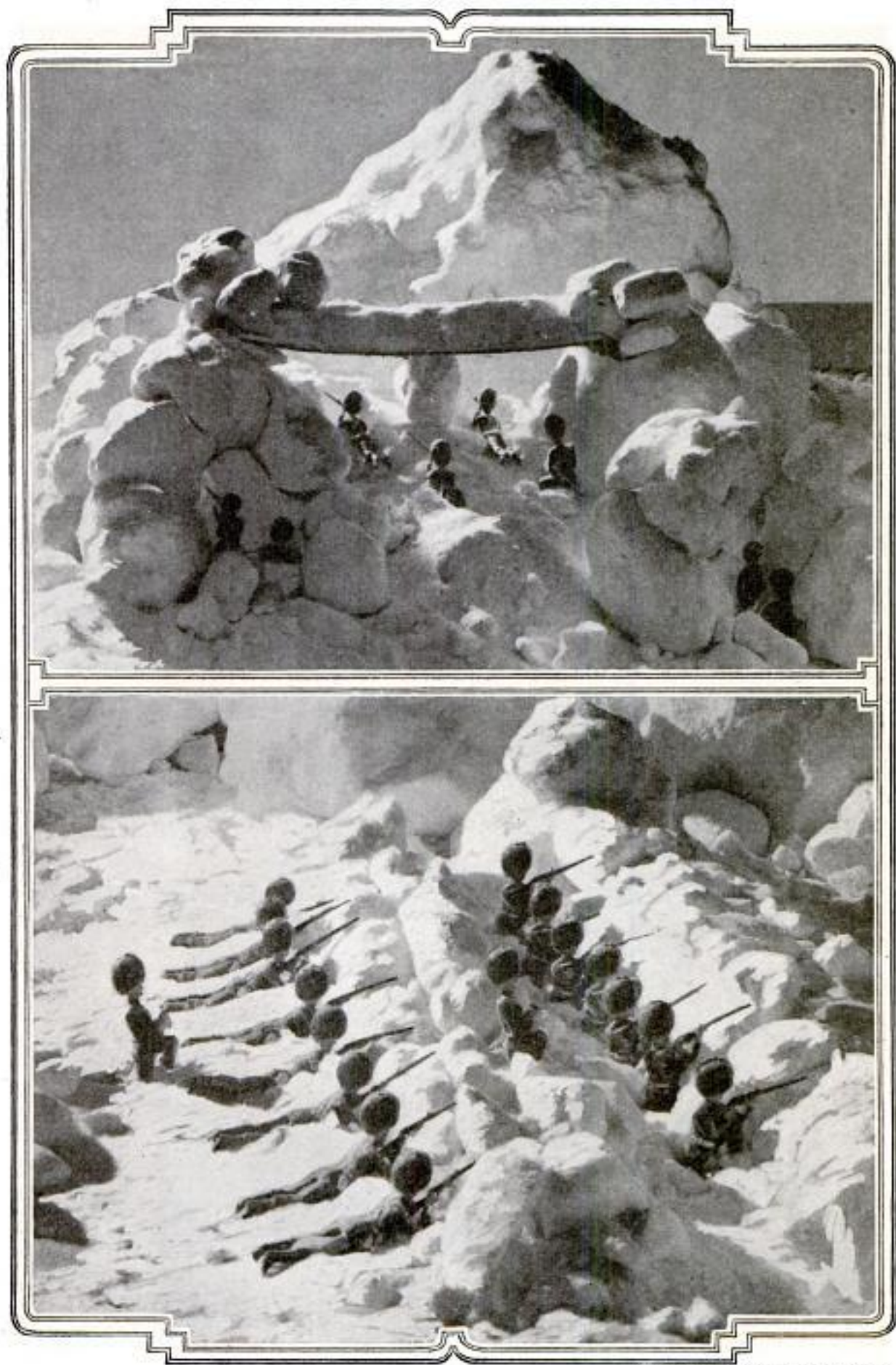
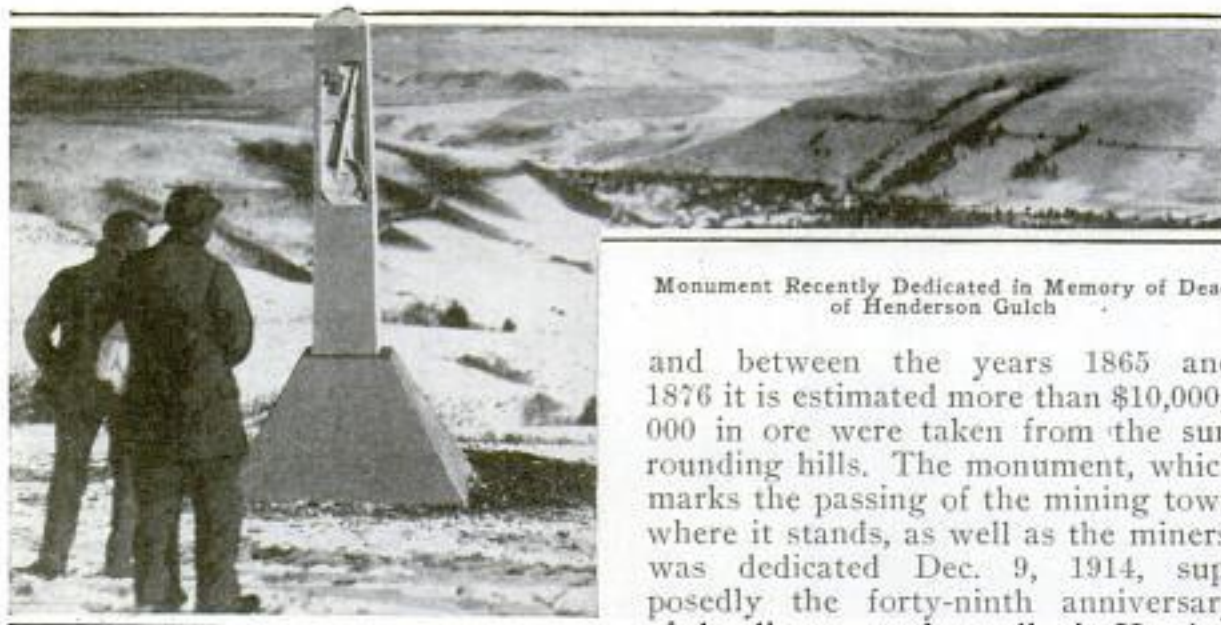


PHOTO
COPYRIGHT, INTERNATIONAL
NEWS SERVICE

International News Service
238 Williams St. N.Y. City



PHOTOS COURTESY INTERNATIONAL NEWS SERVICE



Monument Recently Dedicated in Memory of Dead
of Henderson Gulch

**SHAFT RAISED IN MEMORY
OF DEAD MINERS**

9197H

In memory of the known and unknown dead of Henderson Gulch, an old-time placer-mining district in Montana, a monument has been raised on the side of a hill above the once lively town of Emmetsburg. A lone log cabin, now in a condition of decay and neglect, marks the site of the town, which like the gold seekers has passed. The region was once a flourishing one,

and between the years 1865 and 1876 it is estimated more than \$10,000,000 in ore were taken from the surrounding hills. The monument, which marks the passing of the mining town where it stands, as well as the miners, was dedicated Dec. 9, 1914, supposedly the forty-ninth anniversary of the discovery of pay dirt in Henderson Gulch. The shaft is of white marble and beneath the symbolic pick and shovel, cut in one side, are the names of those who are known to have died. On another side is the inscription, "God Sent You Here to Make a Wilderness a State. This Done He Called You Home but Left Your Work for Inspiration."

More than 100 entombed miners have been rescued by the life-savers of the U. S. Bureau of Mines.

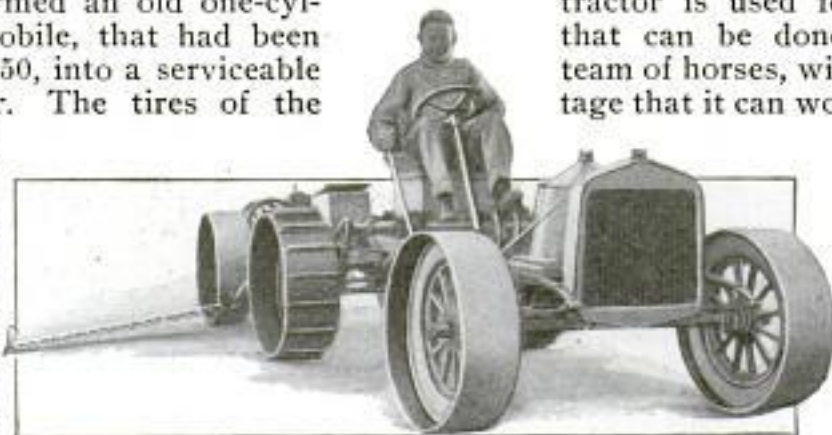
Wm. J. Gardner

FARM TRACTOR MADE FROM OLD AUTOMOBILE

9108

By replacing worn-out parts and making minor changes in the machine, the blacksmith on a southern plantation transformed an old one-cylinder automobile, that had been bought for \$50, into a serviceable farm tractor. The tires of the automobile were removed and the grooved rims of the wheels were replaced with wide tires made of sheet steel.

The body of the car was then taken off, and a seat for the driver was placed over the battery and tool box. This tractor is used for any work that can be done by a light team of horses, with the advantage that it can work on ground



This Light Farm Tractor, Shown Hauling a Mower, was Made from an Old One-Cylinder Automobile

too soft to support a team. Sheet-steel traction lugs are riveted to the shoes fitted to the rear wheels.

*Kent S. Hewes
Bonchartrain Grove
La.*

*J. Gardner Bennett,
New Orleans Lake Shore Land Co.,
1003 Hibernia Bank Bldg,
New Orleans, La.*

Will Branan
P. O. Box 722,
New Orleans, La.

Contributor & Inscr.
A. C. Andrews,
Hunterville, Texas. 565

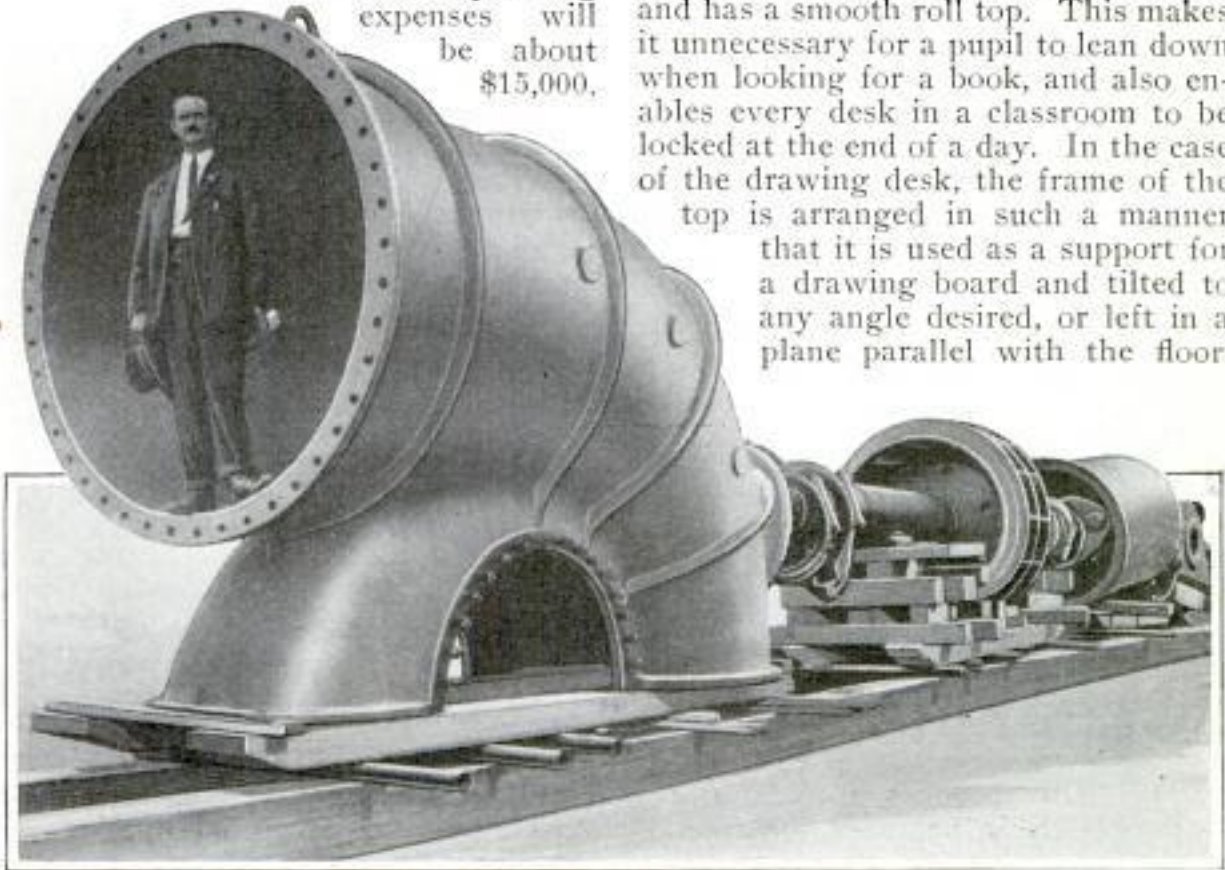
POPULAR MECHANICS

BIG PUMPS FOR DRAINING

8-567m LOUISIANA LAND.

Five centrifugal pumps each having a diameter of 76 in., with a suction opening of 9 ft. and a discharge opening of 12 ft., have been built and are to be installed for draining a 37,000-acre tract of lowland in Louisiana. This pumping plant, which is said to be the largest yet built for drainage purposes, has a guaranteed capacity of 1,000,000 gal. a minute. The drainage district is practically an island, being surrounded on three sides by the Mississippi River, and on the fourth by a canal and the lower part of the Bayou Barataria.

The particular work of the plant will be to keep the waters of the canal and bayou at a low level so that the farms of the district can be drained into them. The plant has a foundation of piles, driven to a depth of 60 ft. and capped with concrete. The cost of the plant was about \$246,000, and it is expected that the annual operating expenses will be about \$15,000.



One of the Five Enormous Pumps Built for Draining a 37,000-Acre Tract of Lowland in Louisiana

ROLLER-TOP DESKS MADE

74164 FOR SCHOOLROOMS

Roller-top desks designed for common school and mechanical-drawing purposes represent a new type of class-

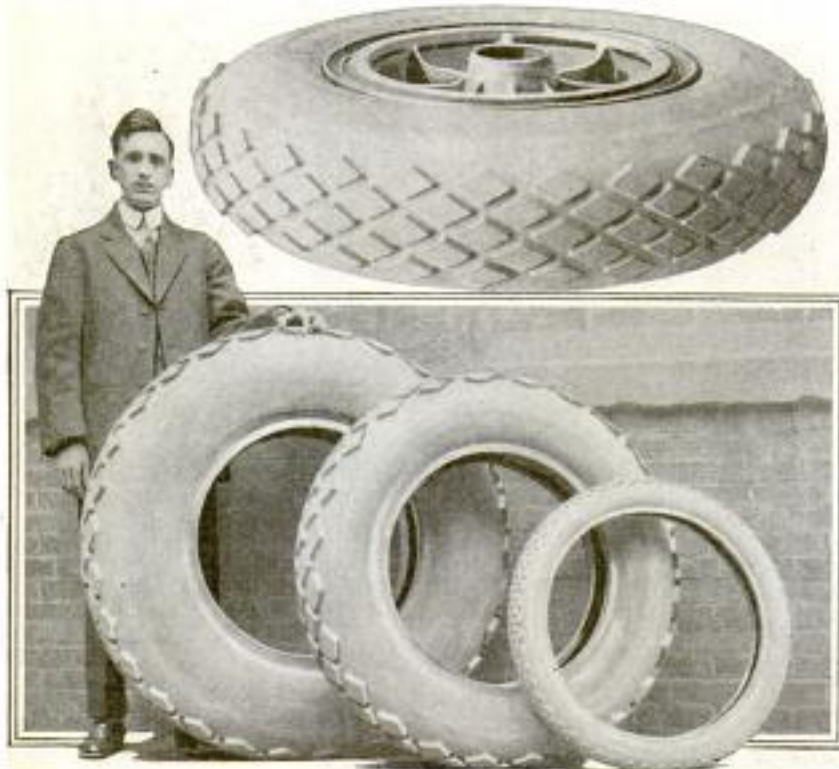


Roller-Top Desk Built for School Purposes

room equipment which has recently been introduced. The fixture intended for use in grammar schools is of the same general form as those ordinarily used except that it is entirely inclosed and has a smooth roll top. This makes it unnecessary for a pupil to lean down when looking for a book, and also enables every desk in a classroom to be locked at the end of a day. In the case of the drawing desk, the frame of the top is arranged in such a manner that it is used as a support for a drawing board and tilted to any angle desired, or left in a plane parallel with the floor.

ENORMOUS TIRES FOR MOTOR TRUCKS

What are probably the largest pneumatic tires ever made have just been placed on the market for use on motor



How the New Tires for Motor Trucks Look in Comparison with an Ordinary Pneumatic Tire; the Largest of the Tires Is 48 Inches in Diameter with a Tube 12 Inches in Diameter

trucks of the heaviest type. These enormous tires are made in two sizes for different classes of service, one being 48 by 12 in., and the other, 42 by 9 in. Some idea of their size is given by the comparison with an ordinary tire shown in the illustration.

STRENGTH RECORD BROKEN BY NEW STEEL CABLE

All records for cable strength are said to have been surpassed when a 3-in. steel cable withstood a pulling test of 751,600 lb., or practically 376 tons. This cable is to form part of the longest and strongest hoisting cable in the world, and is to be used in a mine in Cuba. It weighs 15.7 lb. to the foot and is made in lengths of 8,000 ft. This cable has a hemp center around which are wound six strands consisting of 19 steel wires each.

GERMANY ENCOMPASSED BY WIRELESS

Before the outbreak of the war the Germans were engaged in the construction of a series of wireless stations, which have since probably been completed, forming a ring entirely around the German frontier. These stations are thought to have been planned particularly with the idea of increasing the efficiency and safety of operation of the Zeppelins and other military air craft, as with the aid of these stations an airship is not only enabled to keep in constant touch with a German base during an expedition, but can determine its own location when the land is obscured by clouds or mist. In addition to these wireless stations, all the large aerodromes in Germany are

equipped with powerful wireless so that no air craft, apparently, need be beyond the range of wireless communication with the military authorities when flying over any part of Germany. All the newer military and naval air craft are equipped with wireless apparatus having a minimum range of 120 miles, and capable of encompassing wave lengths of from 300 to 1,200 meters. The apparatus weighs only 270 lb. with its dynamo, and is so designed, according to reports, that all danger from sparks is eliminated.

BIG TENT COVERS BUILDING DURING CONSTRUCTION

Erecting a building inside of a tent is the novel method which was employed during recent cold weather at Cleveland, Ohio, in rushing work on a factory building under contract to be

C. E. Drayer 1801 E. 93d St.,
Cleveland, Ohio.

A. G. Morlock
Lansford, Pa.

completed within 30 days. In constructing the building, which is 90 ft. wide and 202 ft. in length, the outer brick walls were raised to a height of several feet and the tent then set in place so that it inclosed everything. Steam pipes were laid along the inside

crushing mimona beans, in making an oil which is used for illuminating purposes.



To Facilitate the Construction of This Building during Cold Weather It was Inclosed by a Large Tent and Its Walls were Kept Warm by Steam Pipes

of the walls to hasten the setting of the mortar and safeguard also against its freezing.

The tent used is much larger than the building itself, so that it provided plenty of working room, allowing all the materials which might have been damaged by dampness if left unprotected to be kept under cover, and also affording protection to the workmen. Work on the structure was commenced January 10 and the building turned over to its owners ready for occupancy on January 21.

BRAZILIAN NATIVES GRIND GRAIN IN CRUDE MORTAR

8381/H

There are few, if any, grist mills in the interior of Brazil, and the cereals consumed by the natives are ground by hand. To do this they use wooden mortars and pestles, crude implements borrowed from some of the Indian tribes inhabiting the sparsely settled regions. Outside of nearly every hut occupied by members of the poorer class may be found one of these primitive devices which is used not only for making meal from maize, but also for pulverizing coffee berries and



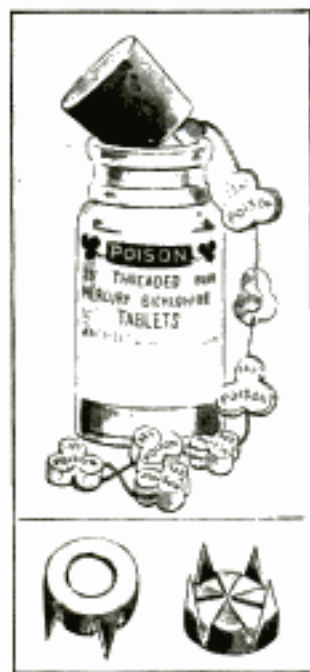
Grinding Coffee Berries in the Interior of Brazil

Robt. H. Becker
Field Museum of Natural History
Chicago, Illa

**NEW DEVICES FOR MARKING
BICHLORIDE OF MERCURY**

8819 m

Various methods designed to prevent the mistaking of bichloride of mercury for medicine, or some other harmless substance, have been proposed with the idea of making it possible to use this deadly poison as an antiseptic without incurring any danger. Two of the latest of these are extremely simple but evidently effective. One method consists in stringing the tablets together and then bottling them in the usual manner. A



tablet can only be detached by cutting the string, and this apparently does away with all possibility of mistake. The other method is to incase the tablets in metal guards having sharp prongs, so that it is impossible to swallow them. The tablet can be dissolved with the guard in place or can easily be removed from the guard.

**THE IMPACT OF FLAT SPOTS
ON CAR WHEELS**

9281 m

The impact resulting from flat spots on railroad wheels under different loads and at different speeds is being studied at a western university by means of an instrument that records the force of the blow photographically. In these tests, which cover flat spots of various lengths, it has been found that a wheel with a flat spot 3 in. long strikes a blow of 104,000 lb. with the car going at 16 miles an hour and carrying a load of 20,000 lb. Under similar conditions a flat spot 1 1/2 in. long produces a blow of 20,000 lb., and a flat spot 2 in. long, a blow of 25,000 lb.

The Engineer

**LIGHTS TAKE PLACE OF
THEATER USHERS**

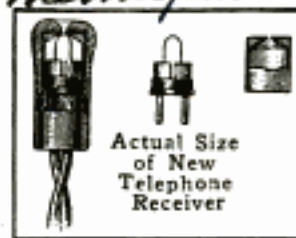
9216 m

A simple plan that practically does away with the necessity for ushers has been adopted in some of the theaters in Vienna. This consists in placing in the back of each seat a small electric light which illuminates the seat number and is countersunk so that it cannot be brushed against and damaged. So long as the seat is turned up, as it usually is when not occupied, the light is burning, but is shut off the instant the seat is turned down. With this arrangement all the theatergoer needs when entering the theater is general directions as to the location of the seat, since the number is illuminated and therefore easy to find. All the lights are controlled by a master switch by which the current can be turned on at the opening of the theater and turned off at the close of the performance.

**TELEPHONE RECEIVER TO BE
PLACED IN THE EAR**

9224 m

The latest thing in telephone receivers is one that is no larger than half an inch of lead pencil and is designed to be placed in the ear instead of being held against it. The electromagnet and diaphragm of the ordinary receiver are eliminated and are replaced by a very fine platinum wire housed within a small cover which is pierced by a minute opening. As the currents pass through the wire



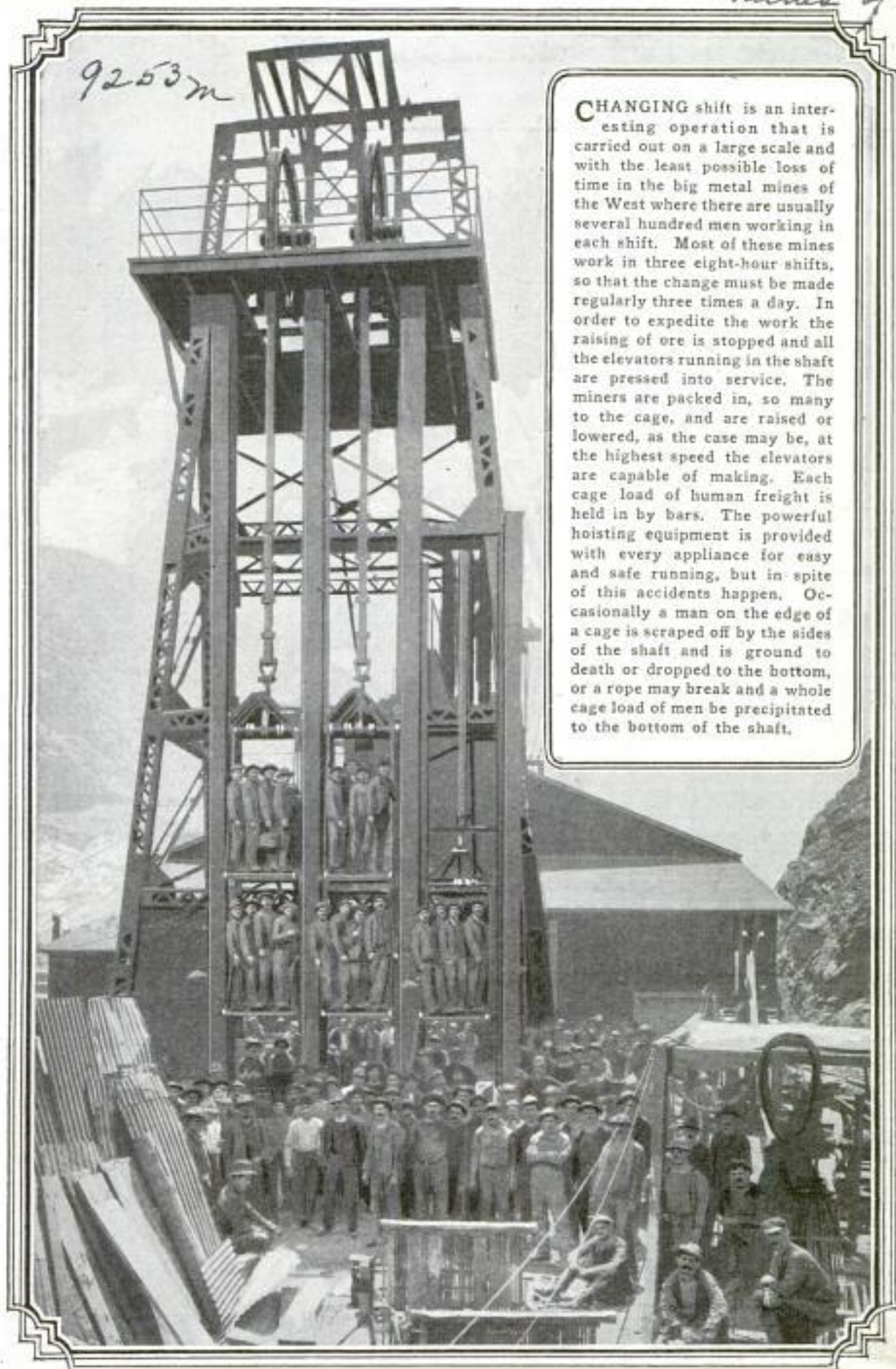
they cause small increases and decreases of heat and the resulting expansions and contractions of the surrounding air are transformed into sound. The sounds produced by this receiver are not so loud as those produced by the ordinary receiver, but have the advantage of being pure in tone and are sufficiently loud for all practical purposes when the receiver is placed in the ear.

Inventor: Dr. P. de Lange
read paper Utrecht
before Royal Soc. Holland
London Dec 3-14

Mechanical Engineering Dept. Purdue University Lafayette, Ind. Infr: C. J. Dawson, Miles, Whose

A. S. Kellogg, Grantwood, N. J.

Elevator in use at the United Verde mine, one of the big
CHANGING SHIFT IN A BIG METAL MINE *copper*
mines of Ariz.



CHANGING shift is an interesting operation that is carried out on a large scale and with the least possible loss of time in the big metal mines of the West where there are usually several hundred men working in each shift. Most of these mines work in three eight-hour shifts, so that the change must be made regularly three times a day. In order to expedite the work the raising of ore is stopped and all the elevators running in the shaft are pressed into service. The miners are packed in, so many to the cage, and are raised or lowered, as the case may be, at the highest speed the elevators are capable of making. Each cage load of human freight is held in by bars. The powerful hoisting equipment is provided with every appliance for easy and safe running, but in spite of this accidents happen. Occasionally a man on the edge of a cage is scraped off by the sides of the shaft and is ground to death or dropped to the bottom, or a rope may break and a whole cage load of men be precipitated to the bottom of the shaft.

**SEARCHLIGHTS AID LINEMEN
IN NIGHT REPAIR WORK**

8959
H

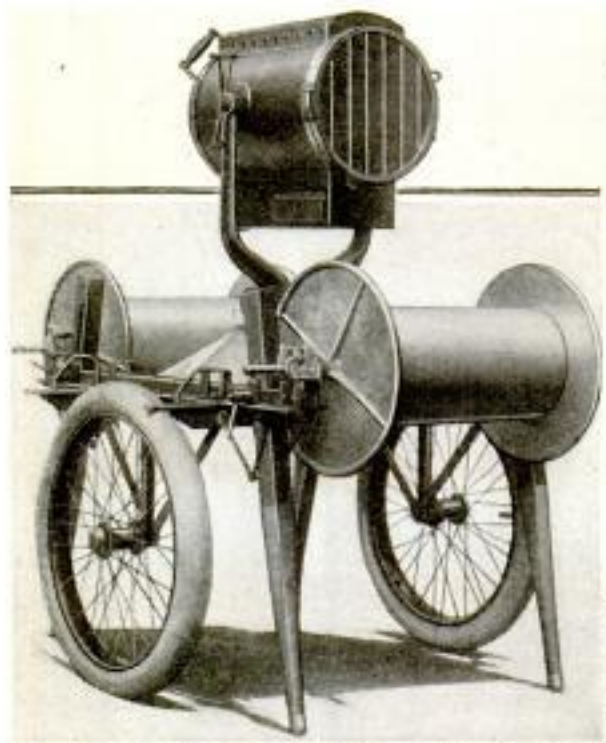
During a storm at Philadelphia extensive damage was done to overhead electric-light lines, putting much of the city in darkness and making it necessary for linemen to work in night shifts until the system could be repaired. To facilitate this an armored searchlight car, which had been constructed for military purposes, was placed in service to provide illumination for the workmen. The machine is

equipped with two 5,000-cp. searchlights mounted on rubber-tired sulky. On each of these carriages are two large reels of heavily insulated wire connecting the arcs with the generating unit built on the motor car. This makes it possible to wheel the searchlights for a half mile in any direction from the machine. The apparatus proved valuable in lighting long lines of poles and thus enabling the work to be carried on without material difficulty.

**ELEVATED PLAYGROUND FOR
NEW YORK SLUMS**

8693
H

In order to provide a public recreation place in New York's densely populated East Side, an elevated playground has been constructed at the west end of the Williamsburg bridge. It is of street width, 480 ft. in length, and affords a breathing space for several thousand persons during the sultry days and nights of summer. In its center is an open-air pavilion where dancing and band concerts are held, while at convenient intervals seating accommodations are provided beneath awnings for the benefit of those who



This Military Searchlight Battery was Employed Recently at Philadelphia When It Became Necessary to Repair Electric-Light Lines at Night

Geo. F. Wrote, 405 W. 118th St. N.Y. City



This Elevated Structure, Which Provides a Recreation Place for Several Thousands of Persons in New York's East-Side District, is Situated at the West End of the Williamsburg Bridge

frequent the place during the heat of the day. Basket weaving and sewing are taught the neighborhood children by instructors, while folk dances, roller skating, and various other forms of diversion may be indulged in by them. In this way children who otherwise would be forced to seek their recreation in the streets are given a clean and much cooler playground under city supervision, and their parents also afforded a place where they may occasionally listen to music and escape much of the heat.

PUMPKIN IS MADE TO SERVE 8487 HAS RURAL MAIL BOX

The employment of a large jack-o'-lantern as a roadside post box is the uncommon use made of a pumpkin by a farmer near Skowhegan, Me. In making the receptacle, the inside of the rind was scraped, burned with a hot iron, thoroughly dried, and shellacked. The exterior was varnished in order to withstand the effect of the weather, and the receiver was then fastened to the top of a post near the road. Mail is inserted in the box through the

mouth-shaped opening in the face of the lantern, and removed by lifting the



Jack-o'-Lantern Which is Made Use of as a Post Box by a Maine Farmer

cover by the natural stem of the pumpkin.

¶The Nobel prizes for 1914 will be awarded in the autumn of 1915 and, beginning with 1916, July 1 will be the date for the annual awards.

John E. Taylor, Skowhegan, Maine
maker of mail box, George Hayes, Skowhegan, Maine

ask Mr. Windsor
**DECORATED TIRE TELLS OF
 WEDDING BELLS**

9040 m
 Following a marriage in Chicago, the enterprising friends of the bride and groom adopted a novel and very



As Indicated by the Decorations, This Couple had Just Been Married

effective means of giving notice to the public that the couple had just been married. The extra tire carried on the limousine in which the couple started on their wedding trip was decorated with ribbons, while painted in large letters on the face of the tire drum were the words "Just Married; War Has Begun."

**EXTRACTING SALT FROM THE
 PACIFIC OCEAN**

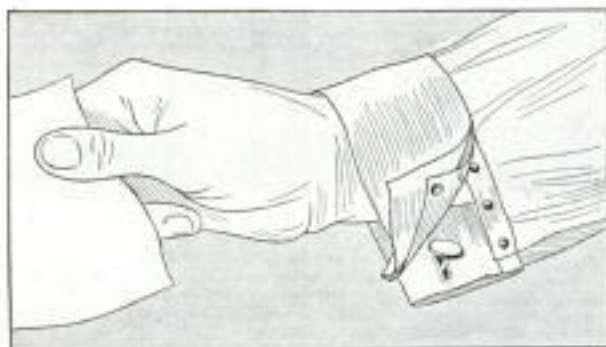
9131 m
 Because the distance from other sources of supply makes the process an economical one, salt is now being extracted in large quantities from sea water at San Diego, Cal. During the very high tides that occur about twice a month the sea water flows into a large storage pond from which it is pumped into a succession of smaller and shallower ponds until the evaporation by the sun's heat has reduced it to a brine consisting of about 60 per cent salt and 40 per cent water. In this process the gypsum, magnesium, and other foreign

Marine Jour. 1-9-15

substances are deposited so that when the brine is drawn off into the crystallizing vats it is rid of most of its impurities. In the crystallizing vats the salt is allowed to settle, the water being drawn off and fresh brine let in until there is a deposit about 10 in. thick. The salt is then broken up and passed through a series of washers which convert it into "commercial" salt, good for such uses as tanning and pickling, but not fit for table use. To convert it into table salt, it must be dissolved in absolutely pure water and crystallized repeatedly until all trace of impurities has been removed.

NEW REVERSIBLE SHIRT CUFF

9798 m
 A detachable cuff that can be readily folded in a reverse direction so the soiled side is hid and a fresh surface is presented to view, has recently been patented. This cuff is particularly intended for wear with shirts of soft material, and when in use, it has the appearance of a permanently attached cuff of the folding type usually worn with such shirts. It is attached to the wristband by means of spring studs and sockets, as shown, the studs being fastened to the wristband in such a way that they do not project through and bear against the wrist. When one side is soiled, the cuff is detached, turned and folded in the opposite direction,



When One Side of the Cuff is Soiled It is Simply Detached and Folded in the Opposite Direction and Again Attached by Means of the Studs and Sockets

sockets for this purpose being spaced along both sides of one of the edges. The fold is so arranged that the folded part hides the sockets from view.

*Inventor & Contrib.: E. M. Steinmetz
 1945 Baltimore St., Wash. D. C.*

Geo. F. Werts, 3084 Broadway, N. Y. City
Inventor: Frederick Eugene Ives, 1205 Race St., Phila., Pa.

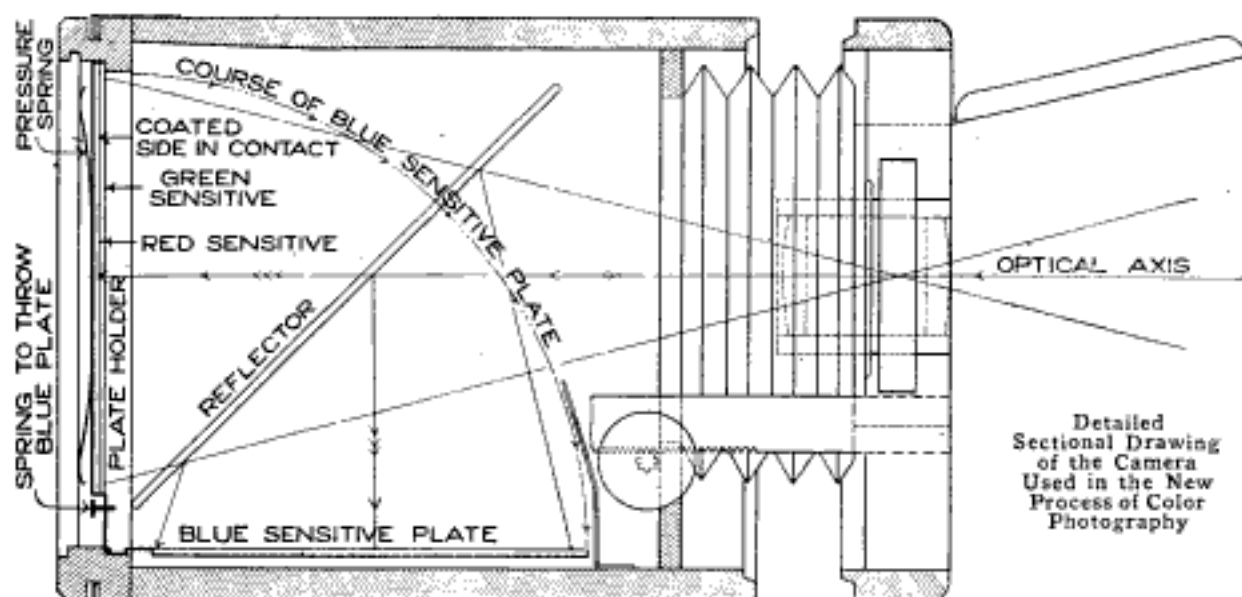
PHOTOGRAPHS IN NATURAL COLORS

New Process Makes Reproduction of Unlimited Number of

9299 Prints Practicable for the First Time "Tripak Process"

THE reproduction on paper of an unlimited number of photographic prints in the true colors of the original subject, which has been the dream of every inventor in the photographic field, is now possible by a process which is stated to be so simple

taneously, by a single exposure, and from these, positives of different colors are printed. Two of the positives are on celluloid; the third, or bottom layer, is on paper. Each of the three negative plates separates out from the various colors of the object photographed



Detailed
Sectional Drawing
of the Camera
Used in the New
Process of Color
Photography

that any intelligent amateur can master it. Frederick Eugene Ives, the American inventor of the half-tone process of printing and the three-color half-tone process, as well as of many devices in the field of applied optics, has taken out patents on this new photographic method.

Color photography on transparent slides has been in use for several years, but only one transparency could be made from a single negative. No reproduction in colors on paper has heretofore been possible by any simple and dependable process. The new "Tripak" process has been reduced to so uniform a basis that color prints can be accurately duplicated. Tests already made indicate that the prints will retain the brilliance of their original colors in spite of constant exposure to light.

The new process is based on the same principle as the three-color half-tone. Three negatives are made simul-

one of the three colors of red, green, and blue. The negatives themselves are colorless, but one records in black and white the red rays of light reflected from the object photographed, one the blue rays, and the other the green rays. In the finished prints, one of the celluloid films is dyed red, and the other yellow, both being superposed upon a paper print of peacock blue. The print from the negative that recorded the green rays is on the red film, and the resultant image of the green portions of the subject is transparent and colorless. When this film is seen through the layer of yellow celluloid and the blue paper is also visible through it, the greens of the picture are the same color as in the original subject, since blue and yellow make green. By applying the same principle to the other positives, every object photographed will, when the prints are cemented together by a transparent varnish, appear in its nat-

ural colors. Intermediate shades, which are made up of various combinations of the three basic colors, are registered on more than one plate, so that in the finished print the correct blend is obtained.

The camera used in this new color photography resembles in outward appearance the well-known type of folding camera, and may be used for ordinary photography, with either plates or film pack. When a color photograph is desired, a set of three plates, arranged in a thin metal carrier in a special plate holder, is inserted. When the opaque slide in the front of the plate holder is lifted, a spring pushes the blue-sensitive plate forward on a hinge to the bottom, or "floor," of the camera. The plates for recording the red and green rays are held firmly upright, film surface against film surface. After the blue plate has fallen into position, a sheet of yellow glass is dropped to form an angle of 45° with the plate on the bottom.

When the shutter is opened, the light, after passing through the lens, is filtered through a small compensating glass. It next strikes the yellow glass, which reflects a part of it down to the plate in the bottom of the camera which is sensitive to blue rays only. The remainder of the light passes on through the reflector glass and first

impinges upon the emulsion of the green-sensitive plate, then passing through a red, transparent coating on the film of the same plate, and registering on the red-sensitive plate. The length of exposure required is ordinarily a trifle less than one second, in sunlight, with a rapid rectilinear lens. After the exposure, the pressure of a lever restores the yellow screen to its former position and the blue-sensitive plate into the carrier. The plates are developed in the usual photographic solutions with the aid of a holder which makes it unnecessary to remove them from the carrier.

The prints from the three negatives are made at one time in a single printing frame. That made from the red-sensitive plate is on a paper which gives a print in peacock blue. After printing, the celluloid film bearing the image from the green negative is dyed magenta pink, and that from the blue negative, yellow. The resulting yellow and red films are placed upon the blue print so that the images exactly coincide, and the picture which results has all the colors of the original.

Transparencies may be made in the same way except that the blue print is also on a celluloid film. Experiments in the application of the process to moving-picture films are said to be very satisfactory.

NEW REAR SIGNAL FOR

8817m AUTOMOBILES

A new rear signal for automobiles consists of a semicylindrical lamp di-



vided into three compartments, in each of which is a small tungsten lamp. The rear face of the lamp is of glass,

and over the compartments are painted hands pointing right and left and the word "Stop." The proper signal is

given to a following car simply by turning on the light in the corresponding compartment, which is done by means of a lever carried on the dash. The faces of the three compartments are in different colors, the one at the left being red; the one at the middle, black, and the one at the right, green. With this arrangement a driver is able to make out the intentions of the driver ahead even when he is too far away to read the sign.

At the British embassy in Washington wool is being distributed to those who wish to knit it into bandages for wounded soldiers of the allies.

*Standard Signal Lamp Co.,
1 Sanford Bldg.,
Bridgeport, Conn.*

P. S. Daniells, 1268 -
13th St., San Diego, Cal.
575

POPULAR MECHANICS

Electrical World 12-26-14
ELECTRIC METHOD OF

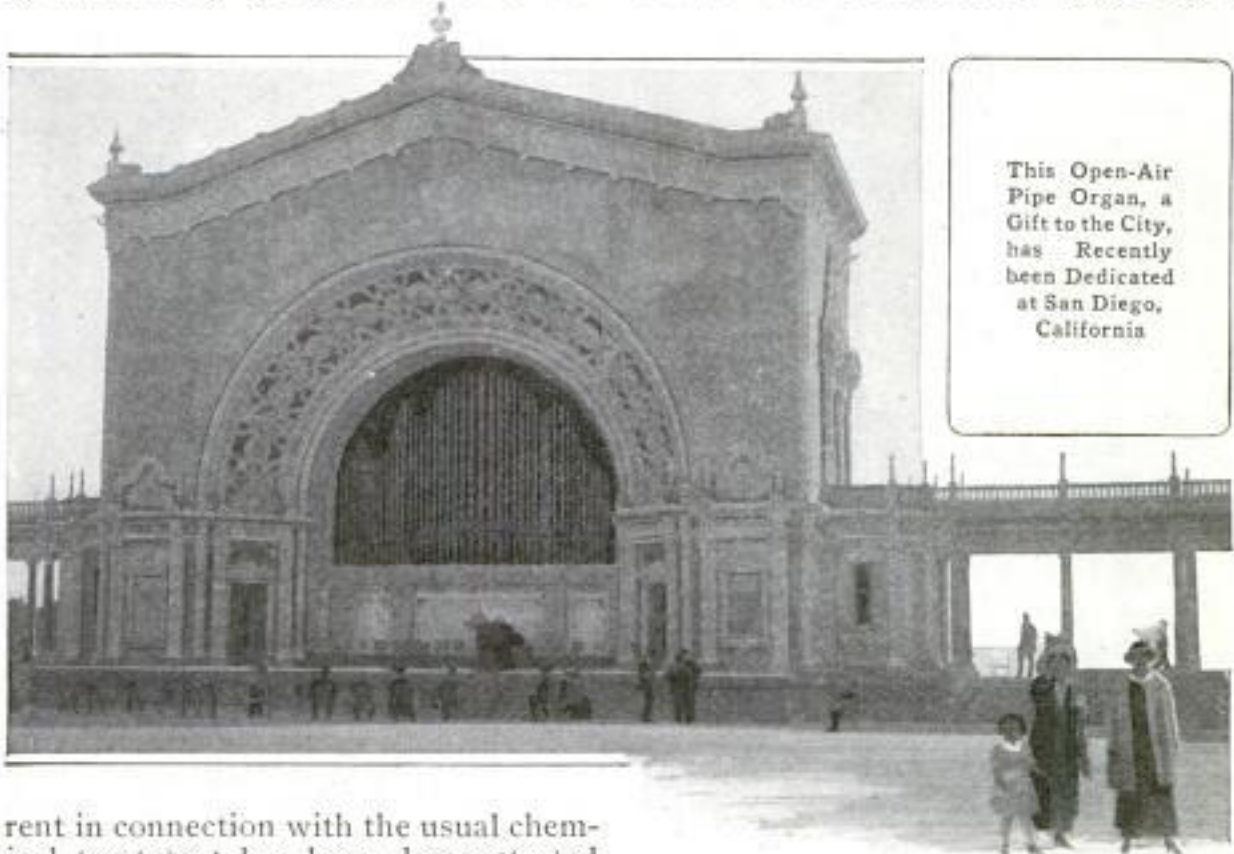
9223 SOFTENING WATER

That the process of softening water for steam-power purposes can be greatly hastened by the use of electric cur-

OPEN-AIR PIPE ORGAN AT

9168m SAN DIEGO

What is believed to be the only open-air pipe organ in the United States was dedicated at San Diego,



This Open-Air Pipe Organ, a Gift to the City, has Recently been Dedicated at San Diego, California

rent in connection with the usual chemical treatment has been demonstrated by recent service tests. In using this method the water is first analyzed and the chemical treatment necessary for precipitating the scale-forming compounds is determined. After the chemical compound has been added, the water is circulated between parallel electrodes which are placed close together in order that as much of the water as possible may be brought in contact with the plates. Because of its ionizing property, the electric current hastens the action of the chemical in separating the scale-forming compound into its component parts, and in forming precipitates which coagulate and can be removed without difficulty. A surprisingly small amount of current is required for the purpose, it being stated that 10,000,000 gal. of water have been treated daily with a continuous power requirement of only 480 watts per 1,000,000 gallons.

Cal., on New Year's Eve, 1914, and forms one of the novel and attractive features of the Panama-California Exposition. This organ was a gift to the city and is of enormous size and power. The pavilion and flanking colonnade are of concrete.

FLATIRON HEATED BY

8308m GASOLINE

In a self-heating gasoline flatiron recently placed on the market, the tank is so designed that the danger of explosion is entirely eliminated. The tank is air-tight and has only one opening, which is at the top. The gasoline is forced out through this opening and through the pipe to the burner by air pressure which is applied and regulated by means of the screw projecting above the tank. It is impossible to fill the tank while it is attached to the iron,

Electrolytic Purification Co.,
5th & Wallace,
Phila., Penna.

The Frank E. Wilson Mfg. Co.,
Lancaster, Ohio.

1000 copies of Am. Soc. of Refrigerating Engineers at N. Y. C. - 1914
by C. J. Landerth & Phila. 8th & Wallace Sts.
Rev. - 4917 Abnerment Rd.

while the slightest movement of the screw connection by which the tank is held in place shuts off the air pressure,



Self-Heating Iron That Uses Gasoline as Fuel: The Gasoline Tank is So Made That All Danger of Explosion is Eliminated. When Inverted and Attached as Shown in the Lower View, the Same Tank Furnishes Fuel to a Portable Camp Stove

and the fire goes out. The tank is so made that it is readily attached or detached, and may be used interchangeably with a portable camp stove.

Key Stone 1-15-14
CURIOUS EFFECT OF RADIUM

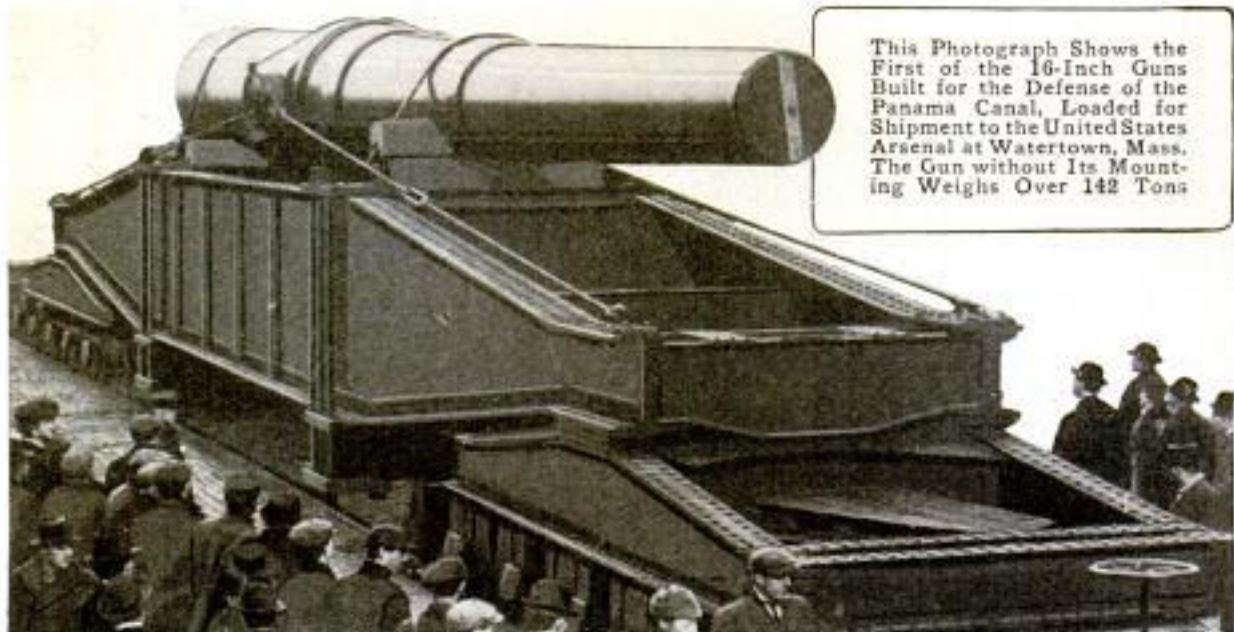
9214 m
ON DIAMONDS

Diamonds exposed to the action of radium become highly radioactive and remain so for years with apparently undiminished force, according to a statement made by a British scientist. In one case a diamond was exposed to radium for several months about 12 years ago, becoming sufficiently radioactive to affect a photographic plate. It has never been near radium since and is now practically as active as ever in spite of the fact that it has been carried about continuously and has been subject to the drastic treatment of being boiled in strong acids.

9257 m
BIG GUN FOR DEFENSE OF

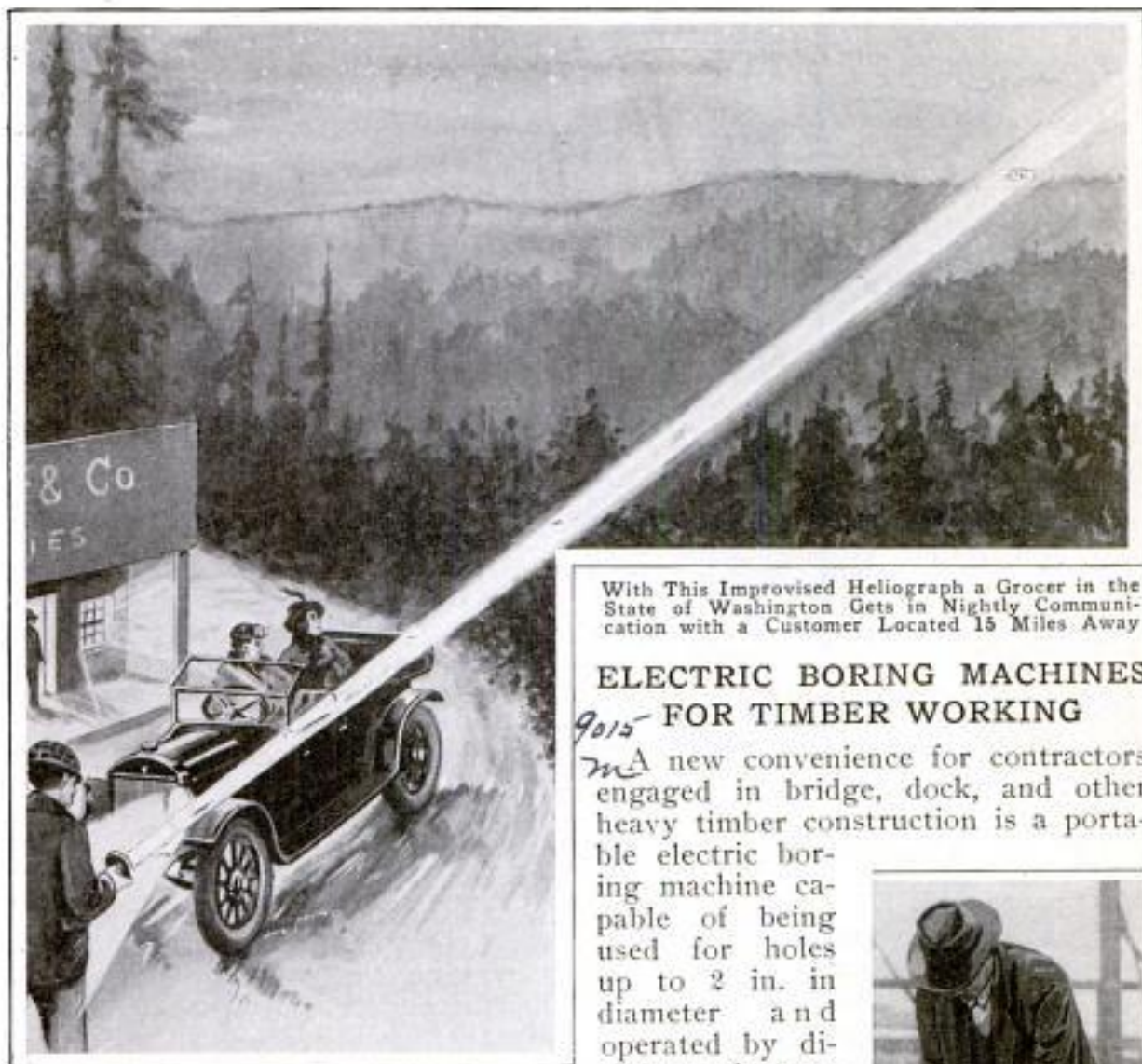
PANAMA CANAL

The first of the 16-in. guns for the defense of the Panama Canal has just passed its final tests and is now being mounted preparatory to shipment to the Canal Zone. This gun weighs 284,800 lb. It is the biggest gun ever made in this country and one of the biggest ever made in the world. For shipping it from the factory to the U. S. arsenal at Watertown, Mass., it was necessary to use a specially constructed steel-bridge car which alone tips the scale at 192,420 pounds.



This Photograph Shows the First of the 16-Inch Guns Built for the Defense of the Panama Canal, Loaded for Shipment to the United States Arsenal at Watertown, Mass. The Gun without Its Mounting Weighs Over 142 Tons

*Underwood + U. 417 Fifth Ave.,
 N. Y. City*



With This Improved Heliograph a Grocer in the State of Washington Gets in Nightly Communication with a Customer Located 15 Miles Away

ELECTRIC BORING MACHINES FOR TIMBER WORKING

A new convenience for contractors engaged in bridge, dock, and other heavy timber construction is a portable electric boring machine capable of being used for holes up to 2 in. in diameter and operated by direct or alternating current taken from an ordinary electric-lighting circuit. This machine has much the weight and appearance of a pneumatic machine and is handled in the same manner. A larger machine of the same type, which requires considerably heavier power, and is made to use only one kind of current, is used for boring holes up to 3 in. in diameter, and larger. One of the big points claimed for these machines is that of economy, power being used only while the machines are in actual operation.



USES THE HELIOGRAPH TO SELL GROCERIES

Perhaps the most novel of all methods of selling goods is that devised by a grocer in Tonasket, Wash., who uses the heliograph for signaling inquiries and quotations to a forest-service station located 15 miles away across the mountains, and receives orders flashed back by the same method. The grocer's heliograph is an improvised instrument consisting only of a mirror held in front of an automobile headlight. With this he flashes his messages in the code used by the Forest Service.

In a recent test 14 electric automobiles made an average mileage of 100.1 on a single battery charge.

Suppl: W. Montelius Price Co.,
530 First Ave. South
Seattle, Wash.

*Directing Mfg. Co. Inc.
72-78 South St.
Rochester, N. Y.*

AUTOMATIC COPY HOLDER

9175m **FOR TYPISTS**

One of the latest conveniences for typists is a copy holder that automatically shifts the notebook, or copy, past



The Notebook is Raised or Lowered One Line at a Time by Means of the Lever at the Right of the Operator

a line finder, one line at a time, through the operation of a lever placed at the side of the typewriter. This holder is mounted on the desk just back of the typewriter so that the copy is held vertically within easy range of the eye. The line finder is stationary, while the portion of the device that supports the copy is raised one line when the lever is pressed down, or lowered one line when the lever is raised. The device is easily adjusted to any spacing from $\frac{1}{32}$ in. to $1\frac{3}{8}$ inches.

WHERE THE MEXICAN PEARLS

8627m **COME FROM**

Pearls having an average total value of \$2,000,000 are exported annually from La Paz, a seaport located on the Gulf of California, near the southern end of Lower California. This city is the greatest pearl-fishing center on the Pacific coast of America, and the third greatest in the world. The shells, which often are 15 in. across and are valuable for their mother-of-pearl alone, are never found in beds, but must be

sought singly by the divers. The pearls usually range in value from \$100 to \$1,000, but most of the highly valuable pearls possessed by the European dynasties are said to have come from the coast around La Paz. Diving for pearls is about as injurious as any occupation could well be, resulting in deafness first and then in nervous prostration. Few of the divers are able to follow the work for more than five years.

FURNITURE BURNED TO SHOW

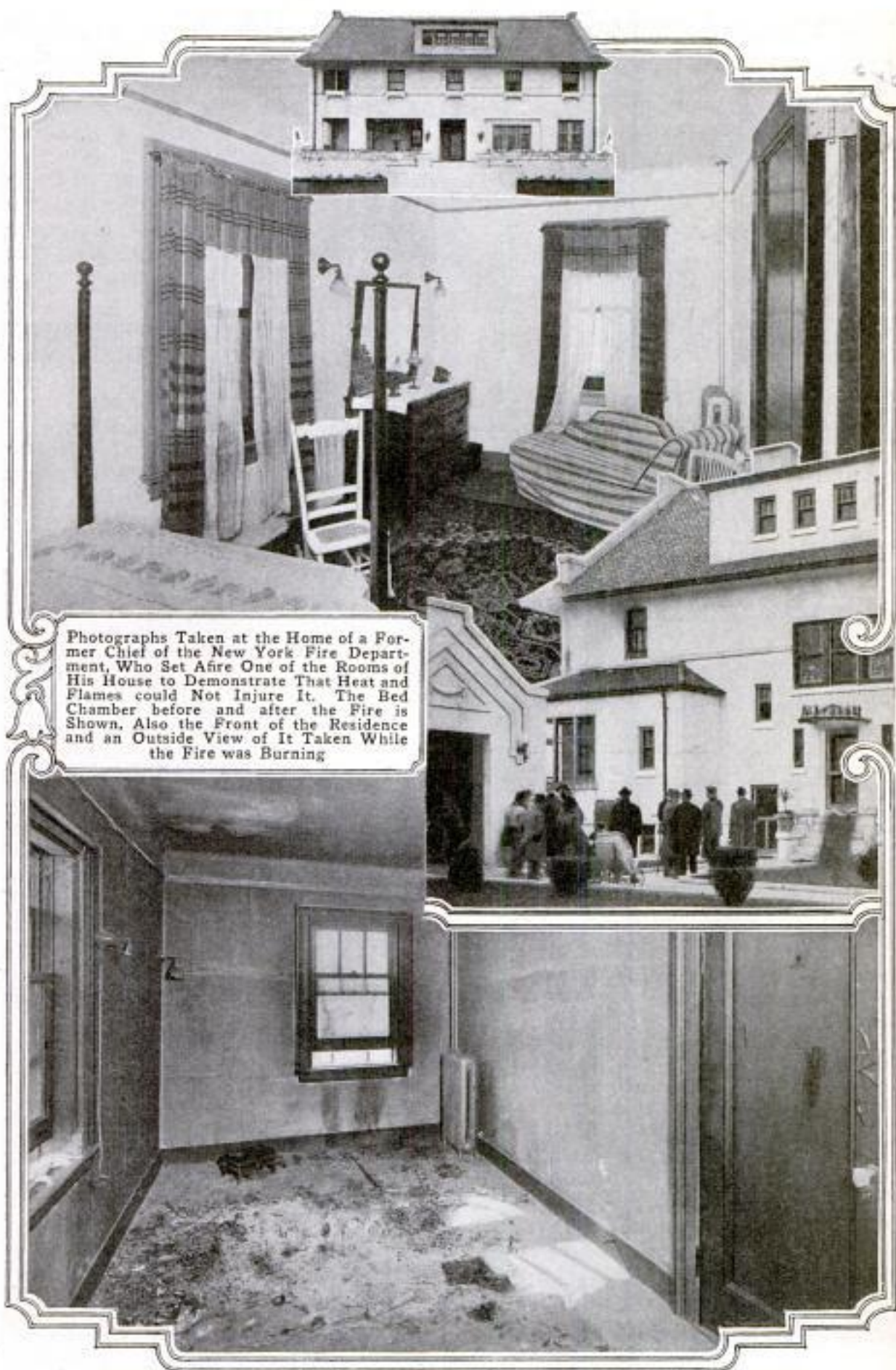
9155m **HOUSE FIREPROOF**

In order to demonstrate the fireproof qualities of his new residence on Long Island, a former chief of the New York fire department recently started a fire in one of its rooms and allowed it to burn unwatched. The chamber was thoroughly sprinkled with kerosene before it was ignited. In an adjoining room dinner was served to a party of guests, some time after which the family retired for the night without examining the blazing room. At nine o'clock on the following morning the door was opened, disclosing that everything that had been in the room had been entirely consumed, but the chamber itself, aside from its decorations, was uninjured. The building is constructed of reinforced concrete, hollow tile, asbestos, steel finishings, and wire-glass windows. The only combustible thing used in it is a wood molding, which was uninjured by the fire because of a protective coating of fireproof paint. Each room in the residence is supplied with a fire-detecting device which indicates on an annunciator in another part of the building the exact location of a fire within a half minute after it starts. An asbestos stucco is one of the materials used in the structure. This has no sand content, but instead is composed of ground asbestos fiber mixed with cement. The plastering likewise has an asbestos base so that it is capable of resisting fire. The plumbing and wiring are all incased in cement. The building is valued at \$40,000 and is uninsured.

*See June '08 - 394
See White card = Pearls, Cultivation of
for full info.
Marine Journal
610. Criadbra Bonchay y Perlas,
La Paz, Lower Calif.
Mexico
See of Espiritu Santo*
*Geo. F. Werts, 3089 Broadway
N. Y. C.
House owned by ex-Fire Chief
Croker of New York.*

*See June '08 - 394
See White card = Pearls, Cultivation of
for full info.*

See of Espiritu Santo



R. W. Mattox, 503 Consoli-
dated Bldg., Jacksonville, Fla

580

POPULAR MECHANICS

SEMAPHORE FOR CONTROL- LING STREET TRAFFIC

7545
Mr

After years spent in unraveling traf-
fic tangles, a crossing policeman in



Semaphore That Takes the Place of the Crossing
Policeman's Whistle

Jacksonville, Fla., has devised a sema-
phore that controls not only the traffic

that goes straight ahead, but vehicles
that are to turn the corner as well.
This device consists of two pairs of
signboards set at right angles to each
other, one pair being red with the
warning "Stop" displayed in large let-
ters, and the other pair white, with the
word "Open." These boards are
mounted on a vertical shaft which is
turned back and forth with a handle.
Screened lights illuminate the sema-
phore arms at night. These are sup-
plied with current by a storage battery,
which also operates the bell that gives
warning when the semaphore is being
turned. The rule in using this sema-
phore is that the center line of the inter-
secting street cannot be crossed if the
red is set against the vehicle. A driver
coming up to either the red or white
signal is free to turn to the right, but
can only turn to the left when given the
white signal, as this involves crossing
the center line of the cross street.

Two pounds of wood has the fuel
value of one pound of coal, according
to calculations by the Forest Service.

CRUDE VEHICLES EMPLOYED THROUGHOUT CHINA

8342 H



How Meats and Produce are Brought to the Markets in China

One of the
vehicles most
commonly
seen in China is
the wheelbar-
row, which is

used by farmers and merchants alike
for hauling purposes. This type of
conveyance is almost universally em-
ployed in transporting agricultural
products to the city markets in those
sections of the country where the

roads are of a character
that will permit pas-
sage. They are usually
very crudely con-
structed and exceed-
ingly heavy. The
greater part of the
weight is supported by
the shoulders of the
pusher, over which a
canvas strap, attached
to the handles of the
vehicle, passes like a
yoke. Not only horses
but other draft animals
are almost unknown
in rural China.

Janet M. Cummings; 316 E. 112th St. N. Y. City

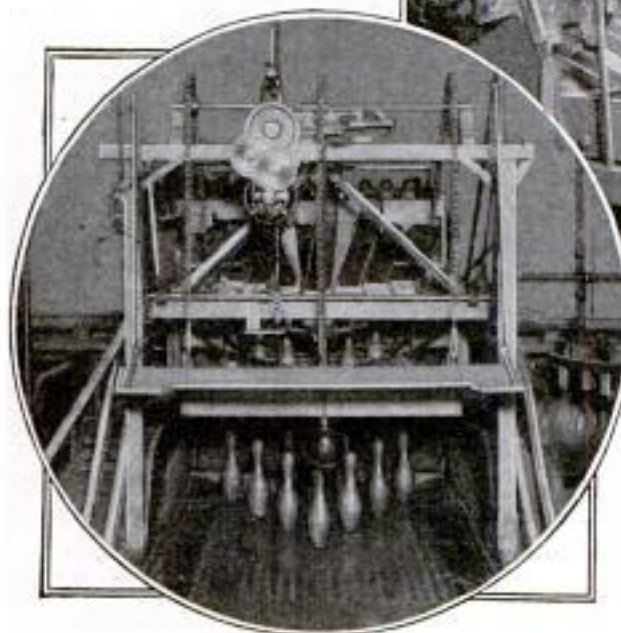
Ernest Hedenskoog, inventor of machine, the model of which is at the Bensinger Alleys, 29 W. Randolph St.,
POPULAR MECHANICS Chicago 581

ELECTRIC PIN SETTER FOR BOWLING ALLEYS

8465 H. Brunswick - Balke - Collender Co.,
623 So Wabash av. Chgo.

Performing its various operations with exactness and speed, an electrical apparatus has been invented to replace pin boys in bowling alleys and do the work more cheaply and with greater efficiency than is possible by

white button on the control board, a sweeper arm at the front of the ma-

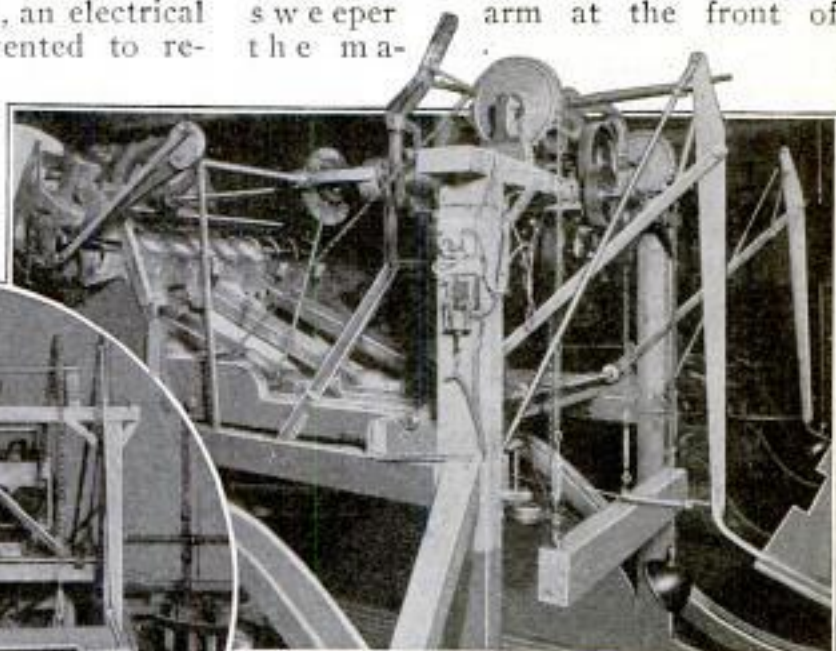


Electric Pin Setter as It Looks to Bowlers

manual labor. One serious obstacle that has always stood in the way of the practical development of such a machine was the problem of removing the fallen pins, or "dead wood," from an alley without disturbing those still standing. This difficulty has been overcome by the employment of electromagnets.

Every action of the electric pin setter is controlled through the electric push buttons of a control board on a post at the player's end of the alley. On the top of it are two buttons, one white, the other black, while a leaf forming one side, like the lid of a cigar box, carries 10 numbered buttons arranged in pyramid form similar to a "set up" of tenpins.

Assuming that the pins are set ready for play, a bowler, for illustration, rolls a ball and scores a "strike," knocking down all the pins. By pushing the



Some of the Machinery That Operates the Electric Pin Setter

chine descends to the floor and moves backward, clearing the alley of any pins which may have remained on it. As it rises, a rack drops, setting 10 pins on the spots and then returning to its position. The second bowler scores a "spare," one pin remaining standing with "dead wood" about it. By pushing the black button the pin rack descends. On the under side of it is a series of 10 electromagnetic disks. One of these comes in contact with the top of the standing pin, in which there is a steel plug. The rack then rises automatically, lifting the standing pin with it, while the sweeper arm descends and clears away the "dead wood." As the latter goes back to its normal position the rack once more drops, placing the standing pin in exactly the same position it was in originally, the disks at the same instant being demagnetized and releasing it.

If by a mistake the bowler had pressed the white button instead of the black, the result would have been that an entirely new set of pins would have been set. Instead of losing his

play, however, the bowler raises the side leaf of the control board and presses the buttons corresponding to the numbers of those he wishes to have replaced, as for example, those numbered three and eight. These buttons form a contact with the two magnets immediately above the respective pins which it is wished to reach. The rack is lowered, the two pins selected are lifted while the sweeper arm removes the rest from the alley. The rack then descends and replaces the two pins. The diameters of the magnetic disks are such, that should a pin be jarred an inch or two from its spot, it will be replaced exactly in that same position after being lifted for the removal of "dead wood."

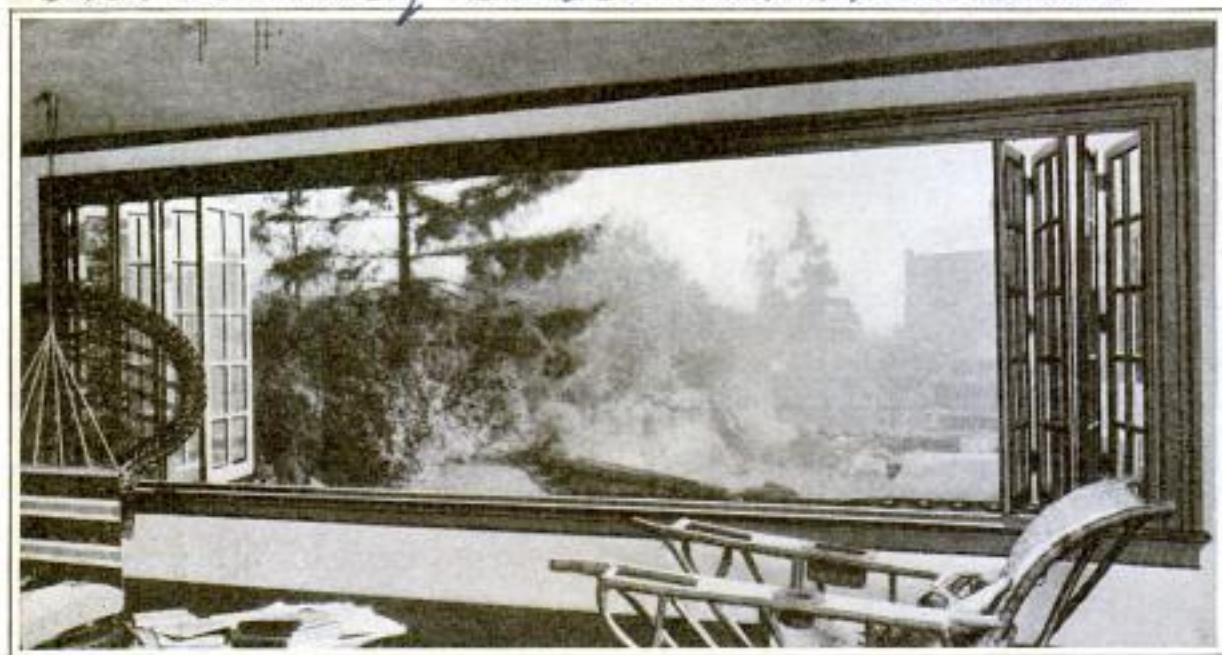
Instead of having the customary flat-bottomed pit at the end of the alley, there is a cylindrical hopper. Moving through this is an endless-chain bucket conveyor into which the pins and balls fall as they are knocked from the alley. As the balls are carried up this conveyor they are dropped out on a returning track, down which they roll to the bowler. The pins, however, are elevated to the top of the machine and dropped one by one into a channel, bottom first, falling to a horizontal distributing rack into which

they are fed by a worm. When this rack is full, a catch is released which allows the pins to drop by gravity through distributing chutes to the cupped holders in the pin rack. Twenty-nine pins are used in the operation of the machine, in order that the rack may always be full. In performing any one of its several functions, the apparatus consumes only a few seconds, thus shortening considerably the length of the average game.

CASEMENT SASH CONTROLLED BY NEW METHOD

Artistic effects for both the interior and outside of a house or building may be obtained with a recently invented casement window. An opening in the wall of any desired length can be treated as a single window, or group of windows, by means of this device. The window sash may be used either singly or in pairs. In the latter instance adjacent sides are hinged together, while the outer edge of each sash is mounted at the head of the casing on a roller bearing that moves in a track, and at the sill with a roller and flange device. The windows open outward, folding together, and since their pivotal points are not fixed they may be readily

"The Whitney Casement Hardware"



Very Pleasing Effects may be Had with This Style of Window

*Mrs. H. E. Holbrook Co., 444-5-6 John Hancock Bldg.
Boston, Mass.
W. L. Van Damm, sales agent
183 N. Wabash Av., Chicago.*

moved to either side. As many pairs as are needed to cover an opening may be used together. In no case is there any hinged connection between one pair and another, or between them and the sides of the casing.

Die Unmechan
THE REVOLUTION OF SPIRAL
9222 m **NEBULÆ**

That spiral nebulae have a rotary motion similar to that of a planet is said to have been proved by recent spectrum observations made at the Lowell observatory at Flagstaff, Ariz. This theory has long been held by astronomers but has never before been verified by actual observation. The proof was found in a curvature of the lines in the spectrum of the nebula corresponding to the curvature in the lines of the spectrum of a planet and known to be caused by the rotation of the planet on its axis.

8406 m
NEW STEEL WHEEL HAS
PRESSED-STEEL CENTER

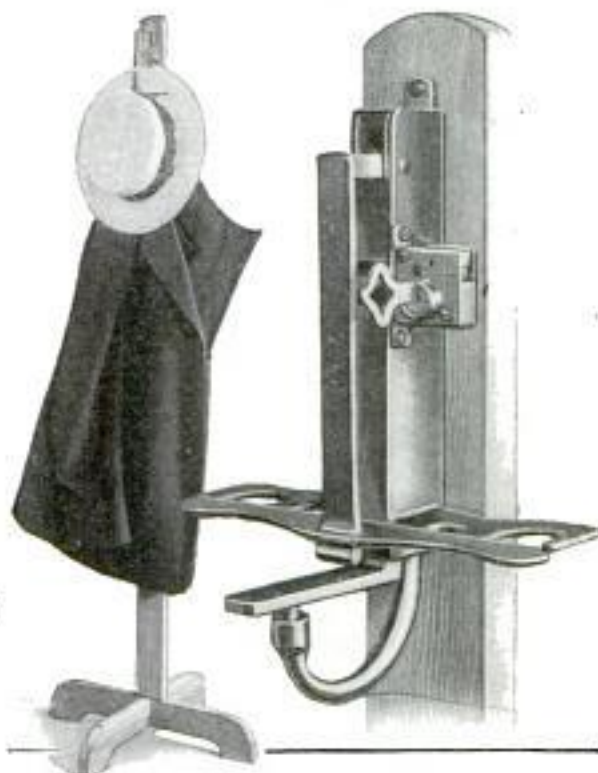
A pressed-steel disk, stamped with alternate ridges and depressions that radiate from the center like spokes, is the feature in a new steel wheel that is now being introduced in the motor-car trade. This disk is made with an opening for the hub at the center, is rigidly bolted, or riveted, in between the hub and rim of the wheel, and can be fitted to any standard hub and rim when it is desired to substitute it for the wooden spokes in an automobile wheel. Not only automobile wheels but wheels for other kinds of vehicles, ranging from motor trucks to wheelbarrows, are now being made in this manner.



C. L. Edholm, 1353 W. 36th St.,
Los Angeles, Cal.

LOCKING HOLDER FOR HAT,
8563 COAT, AND UMBRELLA

MA A new holder for coat, hat, and umbrella is equipped with a locking mechanism by which these articles,



Coat Hook That Locks Garments in Place

though out in the open, may be secured under lock and key. It is therefore particularly adapted to shops and offices as well as to barber shops, restaurants, and similar places. In using, the mechanism is first unlocked and opened, the arrangement being such that the key cannot be removed until the mechanism is again closed. The coat is placed on the hook projecting from the bottom, the umbrella in the hole in the horizontal bar that best suits its size, and the hat on the smaller bar projecting from the front. When the holder is closed, these articles are held securely and cannot be removed except by unlocking the mechanism with the key.

Tests of rubber-capped wood paving blocks in London showed no perceptible wear in a period in which all-wood blocks on the same street wore down from 1/8 to 1/4 inch.

WHITE-LEAD PAINT BANISHED BY LAW

9305 France has Forbidden Its Use and Other European Nations have Prescribed Drastic Rules for Painters

COMPREHENSIVE national laws prohibiting all working painters from using white lead or products containing it in any form, have recently become effective throughout France. This legislation, aimed at the commonest source of lead poisoning, is the most drastic step yet taken in the attempt to check the ravages of this industrial disease.

Plumbism, as this malady is known, is a subject which has commanded much scientific study and provoked almost continuous discussion in Europe during the last decade. Extensive inquiries into its causes and effects have resulted in the enactment of severe laws in Great Britain, Germany, and other countries. Although similar investigations have been made in the United States, Illinois alone has passed laws intended to lessen the dangers to which painters are subjected.

Lead poisoning is caused by the absorption of the mineral into the system through the respiratory organs, the alimentary canal, or the skin. Its victim may have been exposed to its dangers for only a few days, or for years. The disease manifests itself in many different ways. The victim may become blind, be seized with paralysis in the form of "wrist drop" or "ankle drop," lose his mind, develop heart trouble, or Bright's disease, or die in a few hours from a combination of disorders.

Carelessness, ignorance, and uncleanliness are listed as the causes of lead poisoning among painters. Such common practices as holding the paintbrush between the teeth, placing putty and white lead in the palms of the hands, eating before thoroughly washing the hands and removing the working clothes, using tobacco while working, and other similar customs, that bring the lead into contact with the skin or into the mouth are strictly forbidden by European laws. One of the most dangerous occupations, according to European investigations, is that

of sandpapering a lead-painted surface. Fine particles of lead dust are given off which the worker cannot avoid breathing. Another fruitful source of plumbism is in burning off old paint, while the dust given off by the clothes worn by painters is almost equally dangerous.

The new French law, which was enacted some five years ago but is only just now in full effect, rules that "the use of white lead, of linseed oil mixed with lead, and of all specialized products containing white lead is forbidden in all painting, no matter what its nature, carried out by working painters either on the outside or on the inside of buildings." As in England, Germany, Austria, Belgium, and the Netherlands, there are numerous laws which regulate the work in the various branches of the lead industry, requiring medical examination, prompt report of all cases of the disease, and stipulating even the kind of clothes worn by workers, what they must do before eating, and what provisions must be made at workshops for their personal cleanliness. Austria has prohibited the use of white lead for all interior work. The International Congress of Industrial Hygiene has considered the advisability of entirely prohibiting the use of it in all of the countries represented. A study of hospital reports in New York City has shown that out of 60 deaths resulting from lead poisoning in two years, 40 of the victims were painters. Out of 100 apparently able-bodied painters who were examined, 59 had chronic lead poisoning. Of 1,000 Chicago painters who answered questions asked by the Department of Labor, more than a third exhibited symptoms of plumbism.

All of the foregoing facts together with much additional information on the subject are contained in official reports of the U. S. Department of Labor, which has compiled the results of investigations in Europe and America.



German Soldiers Shooting at Floating Targets Painted to Represent Human Heads

GERMANS DRILLED IN EVERY PHASE OF WARFARE

8815 *m*

Long before the war, the German army had been thoroughly drilled in every phase of attack and defense that might occur in actual fighting. One of these drills was that of repelling an attack in which the enemy would be compelled to wade a canal or river. For this purpose targets painted to represent human heads and provided with military caps were set floating in the water to be shot at by the defenders. This drill is now of particular interest on account of the fighting over the lowlands of the Belgian coast.

¶ Six mine-rescue stations, eight rescue cars, and one rescue motor truck are maintained by the Bureau of Mines.

Chicago Record Herald 11-18-14

FEEDING DEVICE PROVIDES SHELTER FOR BIRDS

8967 *m*

Bird lovers will be interested in a new homemade feeding device that has just been placed in service in an Ohio city. This device consists mainly of two pudding pans of enameled ware, one of which is 1 ft. and the other 1½ ft. in diameter. The smaller pan is placed right side up and in the center is mounted a spool support for the larger pan, which is inverted. A space of several inches for the passage of the



Made by Dr. R. D. Woodmansee, Columbus, Ohio

Dr. R. A. Donoran, Columbus, Ohio

birds in and out is left between the rims of the pans. The food is placed in the lower pan and the upper pan serves as a shelter in wet or snowy weather. The whole device is mounted on a wooden base, to the bottom of which is fixed a piece of gas pipe used for attaching to a tree, roof, or other suitable support.

PURIFYING DRINKING WATER

8457H FOR U. S. SOLDIERS

In an endeavor to lessen the danger from drinking impure water, the War Department has inaugurated a new method of providing the soldiers with water. A 40-gal. hemp water bag, designed to be suspended from a tripod or the limb of a tree, and fitted at the bottom with a series of faucets, has been adopted. When this is filled, a small quantity of calcium hypochlorite is mixed with the water, which is then

allowed to stand for about 10 minutes. The chemical in that time will kill all injurious germs, rendering the water safe for drinking without making it unpalatable. Each bag holds enough water to fill 157 canteens, and every company is being provided with one.

Another step which has been taken for health preservation relates to dish washing. In the past, soldiers for the most part have washed their eating utensils in cold water, and usually at some stream. Three buckets of boiling water are now provided in which the various articles may be thoroughly sterilized. Two of the containers are filled with soapy water and the other with plain water, and all of them suspended over a fire. By dipping the dishes, first into the stronger soapsuds, then into the weaker suds, and finally into the clear water, they are cleaned and sterilized.

ⒸElectrical energy amounting to 772,587,049 kw.-hr., developed by Canadian water powers, is imported into the United States annually.



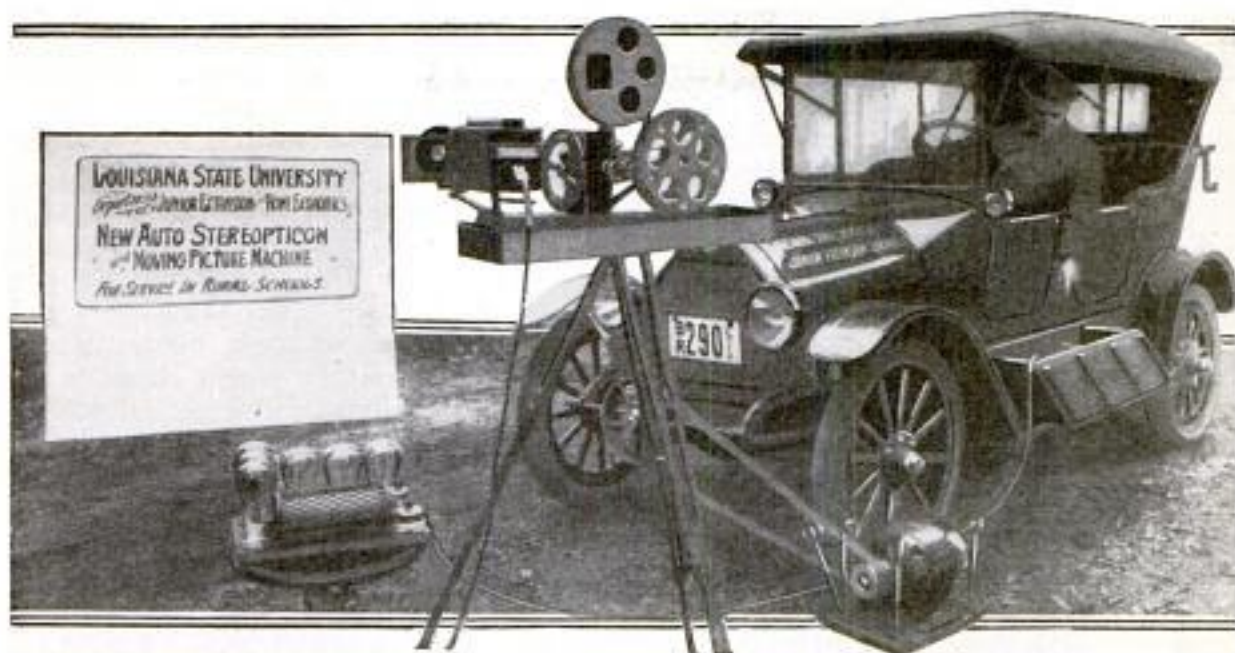
How United States Soldiers
Now Wash Dishes

Right: This Bag Holds 40
Gallons of Water Which
is Chemically Treated to
Destroy Possible Germs
Before It is Used



J. R. Schmidt, 3557 St. Charles Place, Hyde Park,
Cincinnati, Ohio

Invention or discovery of Major W. J. Lyster, U. S. A.



This Motor Car Which Carries a Portable Motion-Picture Apparatus is Used in the Rural Districts of Louisiana by the Extension Department of the State University for General Educational Purposes

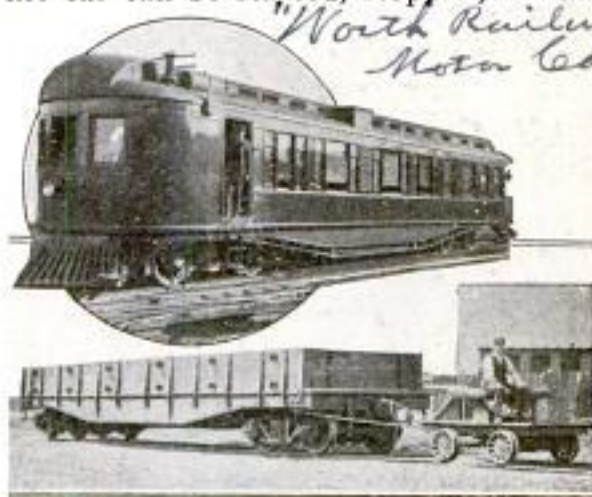
**CARRYING MOTION PICTURES
 INTO RURAL DISTRICTS**

Through the medium of the motor car, motion pictures of an educational nature are being shown through the rural districts of Louisiana. The project is promoted by the extension department of the state university in the interest of general and agricultural development. The machine carries a portable movie projector, and is taken by field lecturers into the out-of-the-way districts which for the most part are inaccessible by rail and therefore, partially at least, isolated from outside influences. Country schoolhouses, churches, and meeting places, which may even be located at some cross-roads, are visited by the party, the community gathered and the pictures shown. In this way people in some of the most unfrequented parts of the state are reached and benefited. The films, when the weather permits, are sometimes shown out of doors, and frequently to people who are attracted from miles around to see motion pictures for the first time. The motor car is equipped with an electric generating plant which is driven by the engine and furnishes a sufficient amount of current for the operation of the pro-

jector. When taken down for transportation the movie equipment is packed in two compact cases carried on one running board and at the rear of the car.

**GASOLINE INTERURBAN CAR
 8802 WITH FRICTION DRIVE**

A new application of the friction drive forms the special feature of an interurban car recently brought out. The engine runs at a constant speed, being controlled by a governor, while the car can be started, stopped, or run



New Interurban Car Driven by Gasoline Motors with Friction Transmission. The Original Model Used in Developing the System of Transmission Was About the Size of a Handcar, and Was Capable of Hauling a Steel Coal Car without Difficulty

O. C. Ballard, Marion, Ind.
 Railway Motor Car Co.
 Marion, Ind.

at any speed forward or reverse by the use of a speed valve and reverse valve. An additional important feature is that the power is applied to each of the wheels independently. A shaft driven by the engine runs lengthwise of the car. Mounted on this shaft are eight disks arranged in pairs, one pair being provided for each pair of traction wheels, while working between each pair of disks are two friction wheels through which the power is transmitted to the traction wheels. The friction wheels are mounted on separate axles, on opposite sides of the disk centers, and are arranged to slide on their axles. They are so connected by a system of levers that they can be made to slide simultaneously toward the center line of the disks, or toward the outer edges, as may be required, and in this way variations in speed are obtained. The friction wheels have a play of about $\frac{1}{8}$ in. between the

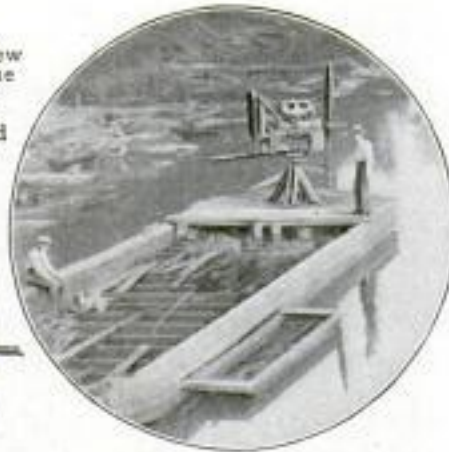
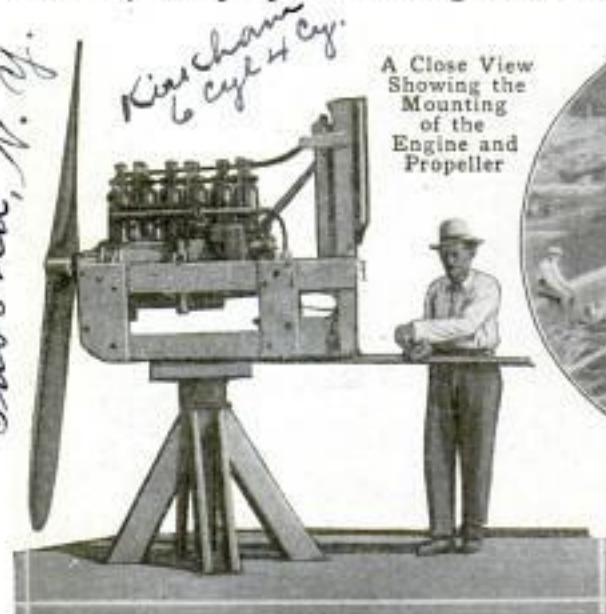
disks, and are mounted on a pivoted frame, so that when one wheel bears against one disk, the other wheel bears against the opposite disk. With this arrangement, all that is necessary for reversing the car is to reverse the bearing of the friction wheels against the disks. In the intermediate position, when the friction wheels do not bear against either disk, no motion is imparted to the car. These movements are all controlled by the action of two air valves located in the operator's compartment. The axles of the friction wheels are journaled in such a way that they allow the slight movement required for these adjustments. The car is equipped with two 6-cyl. 150-hp. motors, which may be used independently or as a combined power plant. Each traction wheel runs on roller bearings on a dead axle, and is driven from the axle of the corresponding friction wheel.

BARGE RUN AND STEERED BY AN AERIAL PROPELLER

8488
The owner of a barge operating on one of the small rivers of Missouri has worked out a scheme that enables him not only to propel the barge but to

-56' x 14' beam
bow of the barge so that the power may be applied in any direction by the simple expedient of turning the shaft. This feature is said to have proved

particularly valuable in getting the barge off sand bars and snags, and in making short turns. A minor feature of considerable importance in hot weather is that the propeller can be used, at reduced speed, as a fan for the workmen loading or unloading the barge.



This Barge is Propelled and Steered by an Aerial Propeller, Which can be Swung Horizontally to Apply the Power in Any Direction

steer it with an aerial propeller and without the aid of a rudder. This is accomplished by mounting the engine and propeller on a vertical shaft at the

The propeller is 9 ft. in diameter with a pitch of 3 ft., and is capable of pulling the loaded barge at the rate of about 15 miles an hour.

J. S. Smith, 1013 L-2 Oakland Ave. Milwaukee, Wis.

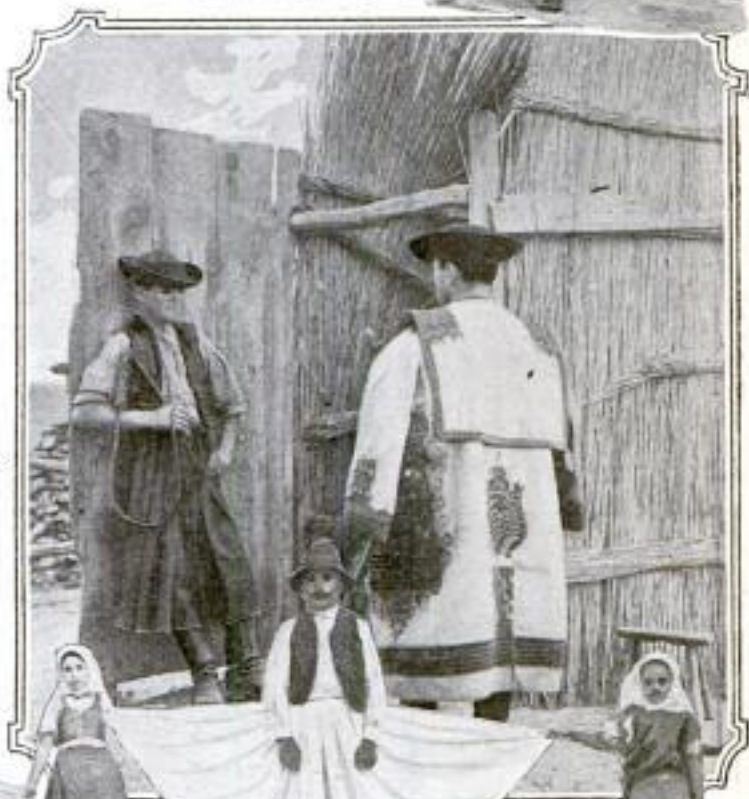
Owner: Victor Groves, Callao, Mo.



This Is the Customary Sunday Attire of Young Men in the Villages and Rural Districts of Hungary



Typical Group of Gypsies Such as may be Seen Almost Anywhere in Hungary: These Roving Bands Go from Place to Place through the Country Mending Pots and Pans, and Doing Other Work of Similar Nature



Hungarian Cowboys on the Plains before One of the Grass Shelters Where Their Meals are Cooked and Usually Eaten. They Wear Baggy Trousers Which Bear Almost the Appearance of being Skirts

Old Pillory at Postyen to Which Thieves were Once Locked on Sundays

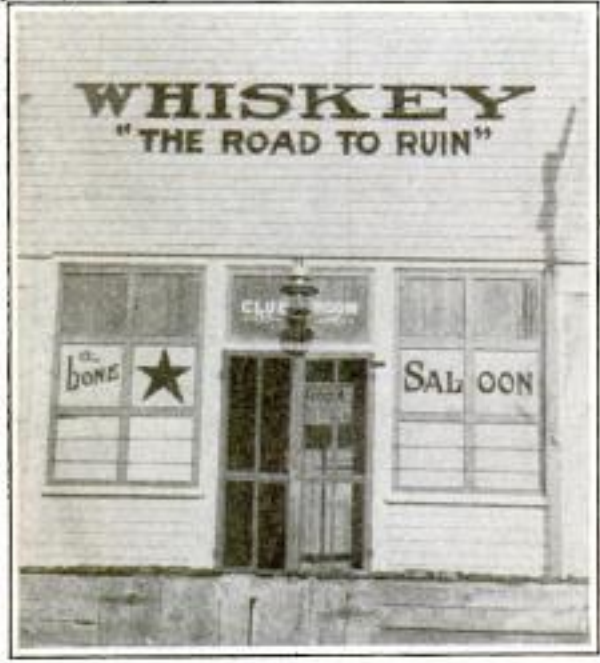


Father and Son Wearing the Wide, Baggy Trousers Characteristic of the Peasant Dress

H. E. Zimmerman
Mt. Morris, Ill.

A UNIQUE AND TRUTHFUL
SALOON SIGN

8591 m



These Frank Words, "The Road to Ruin," Form a Part of a Sign Painted across the Front of a Saloon in Corona, New Mexico

principal features of the exhibit will be a demonstration of methods of profitably utilizing the blood, bones, and hides in the manufacture of by-products.

IRRIGATION MADE POSSIBLE
BY UTILIZING MOTOR CAR

8248

An Iowa truck farmer who recognized the necessity of finding some method for irrigating his land, solved the problem of obtaining water by harnessing his motor car and utilizing its power for pumping purposes. A large pump was operated by the engine and water drawn from an artesian well. By using wooden troughs, the flow was directed wherever irrigation was needed, the water spreading over a large area as it was poured between the rows of vegetables. In this manner it was possible for the man to keep his gardens in good condition at small expense during the dry part of the season.

Warren D. Schreurs,
Highland Park, Ill.
Ill.

MODEL SLAUGHTER HOUSE AT
SAN FRANCISCO FAIR

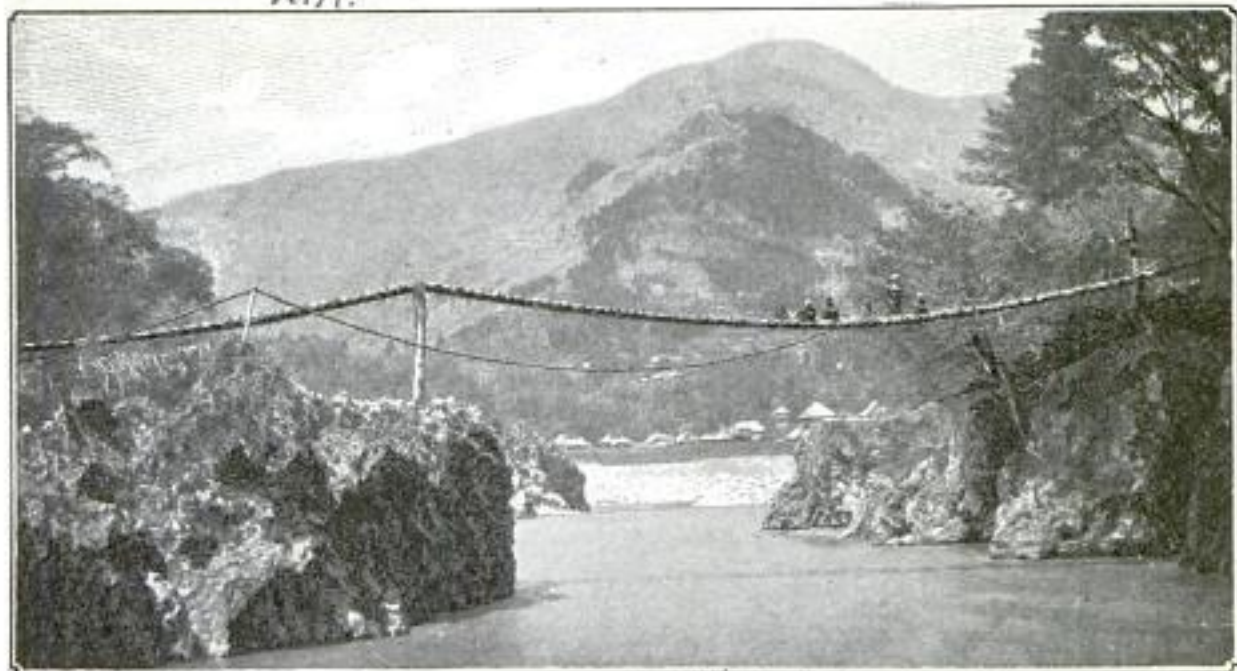
9228 m

A model slaughter house, built on a scale of 1 to 16 and planned by the best specialists available with special reference to sanitary and economic features, is to be one of the exhibits of the United States Department of Agriculture at the Panama-Pacific Exposition. The estimated cost of the full-sized slaughter house is \$22,500, if built of wood, and \$33,500, if built of concrete as is the model. One of the



Irrigating a Celery Field by Pumping Water from the Ground with a Motor Car

Information Sheet
sent out by Dept. of Agriculture



Hanging Bridge over the Fuji Kawa in Japan

A HANGING FOOTBRIDGE

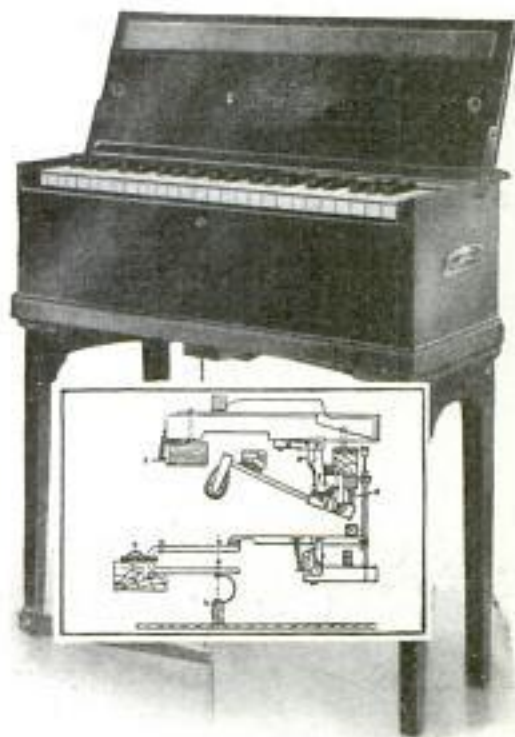
9791 m IN JAPAN

A primitive type of bridge found in some sections of Japan is the hanging footbridge, of which there are many similar to the one shown in the illustration. This bridge is made entirely of wood and rope, and consists of two spans of equal length, one of which spans the mountain gorge and the other the rocky approach at one side.

TUNING FORKS SUBSTITUTED FOR PIANO STRINGS

8309 m
A type of musical instrument that is fast gaining in popularity, especially where the feature of portability is important, is the dulcitone, an instrument which is played like a piano, but in which the tones are produced by a series of tuned steel forks which are struck by hammers operated by the keys. With these tuned forks substituted for the usual strings, it is claimed that the instrument never needs tuning, and that it will stand a great deal of moving about without getting out of order. The mechanism is much simpler than that of a piano. The steel forks are U-shaped and are held edge-wise with the prongs projecting toward

the front of the instrument. When a key is struck, the damper, which normally rests on the fork, is lifted and the key strikes the upper prong, and with the release of the key the damper comes back into position. Through a semi-



In Appearance, This Instrument Is Like a Miniature Piano. The Diagram Shows the Simple Mechanism for Striking the Steel Fork and for Damping the Tone

circular steel spring attached to the lower prong, the tone is transmitted to

Thomas Macchell & Sons
45 Great Western Road
Glasgow, Scotland



Every Part of This Open-Air Tea Room, Including the Table, is Made of Concrete

the sounding board. The whole series of forks may be controlled by a pedal which is used for the same purpose as a piano pedal. The dulcitone is said to be especially suited to tropical countries, where piano strings at high tension are subject to rapid deterioration.

AN OPEN-AIR TEA ROOM IN SOUTHERN CALIFORNIA

m 8990 Owing to the mildness of the climate, open-air tea rooms are becoming an established institution in southern California, and some of these are now being built of concrete. One of the latest of these tea rooms, shown in the illustration, is a three-sided inclosure with walls about 3½ ft. in height, and a seat running around the three sides. The walls, floor, seat, and table located at the center are all made of concrete. Each wall is 4 in. thick, and is surmounted by a cap, 2 in. thick and 10 in. wide.

PARAFFIN-PAPER TUBE FOR DRINKING FOUNTAIN

m 8800 A new paraffin-paper drinking cup, made to be used with a drinking fountain of any type, is designed not only for sanitary purposes but as a means of preventing water waste as well. It is inserted in an opening of the fountain, as shown, and each tube is intended to be used only once and to be handled only by the person using it.



Operated by the tube is a simple mechanism attached to the fountain which turns on the water under the slight pressure required for getting a drink, and then turns it off as soon as this pressure is removed. The plan is to keep the tubes in a closed receptacle, from which they are released singly by a push button.

J. M. Stewart, Mayville, N. Dak.
Invented by J. M. Engberg,
Mayville, N. Dak.

HOW SOUP IS SERVED HOT IN RUSSIAN TRENCHES

m 9219 Portable soup kettles that are in effect enormous vacuum bottles are one of the interesting features in the commissary equipment of the Russian army. After the soup has been prepared at a field kitchen in the rear of the army it is put into these kettles, transported to the front and served hot to the men in the trenches, the kettles being so thoroughly insulated against the escape of the heat that the soup will keep hot for hours. Each kettle holds rations sufficient for about 1,500 men.

Die Unschau

La Nature 2-14-14
INGENIOUS MOUNTING FOR

7176 *m* CASTER WHEEL

An ingenious mounting for the wheel is embodied in a furniture caster recently invented. The caster holder re-



This Caster Wheel Slides to One Side While being Moved, But Takes the Central Position When at Rest

volves on a pin inserted in the furniture leg in the usual manner, while each end of the axle of the wheel works in flat inverted-V-shaped slots in the sides of the holder, so that the wheel slides from one side to the other when the furniture is being moved and trails readily without requiring the holder to reverse. When the furniture is at rest, the axle takes its place at the middle or high part of the slot, and the caster wheel is therefore central under the furniture leg.

ANIMAL TRAP THAT APPLIES
7375 *m* ELECTROCUTION

An animal trap that has just been invented and patented is designed first to catch the animal, then to electrocute it, and finally to drop it into a barrel or other receptacle. At the top of this trap is a sort of vestibule with the front half of each end open, and into the front side of this vestibule the rat or other animal enters by means of

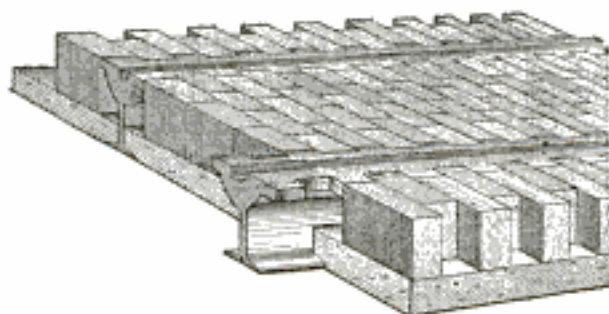
Chas. E. Beach
259 Ainslie St.,
Brooklyn, N. Y.
Copyrighted material

NEW SKYLIGHT GLASS DOES
9218 *m* AWAY WITH DRIP

The problem of eliminating the drip that forms on skylights from the condensation of the moisture in the air has apparently been solved in a new type of glass that has just been placed on the market. In this glass the under surface is formed in webs or channels running with the pitch of the roof and so shaped as to give the greatest degree of capillary attraction. The result is that all condensation is held and is gradually conducted to a gutter at the lower edge of the glass sheet. This glass is said to be effective in preventing drip on a pitch as low as 10 degrees.

7162 *H* FRENCH GROOVED RAIL PRESERVES PAVEMENTS

Serious injury to pavements along street-car lines, where heavy teaming works much damage to the roadway in the immediate vicinity of the tracks, is minimized by a grooved rail in experimental use at Paris. Instead of being of the ordinary type of construction, the rail is made with wings which form recesses interlocking with the paving material. These are so arranged as to receive bricks, creosoted wood blocks, or asphalt, and form an even surface. In all the large cities of the United States preservation of pavement along street railways has been a problem. To a greater or less

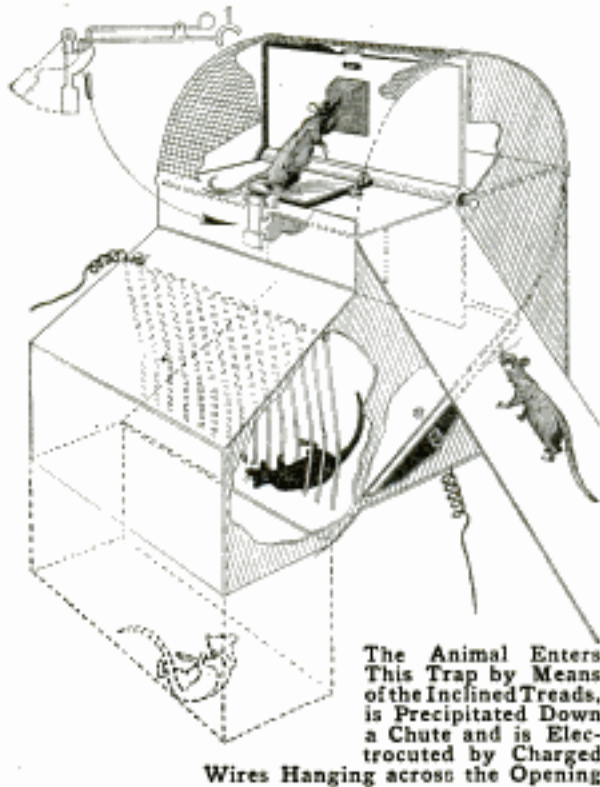


An Interlocking Rail Which Reduces Damage to Pavement

degree the same trouble has been encountered with both grooved and T-rails, and so far has not been remedied successfully.

La Technique Moderne
4/1/14

one or two inclined treads, or runways. Arranged radially around a longitudinal axle within the vestibule and spaced at intervals of 90° are four plat-



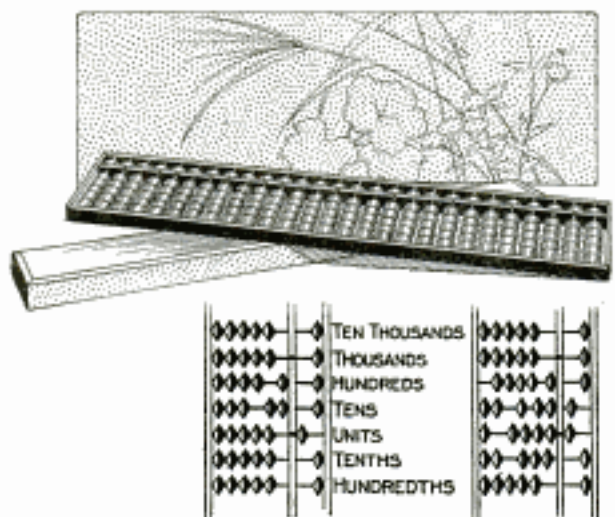
The Animal Enters This Trap by Means of the Inclined Treads, is Precipitated Down a Chute and is Electrocutted by Charged Wires Hanging across the Opening

forms. At each quarter turn of the axle one of these platforms comes into position as the floor of the vestibule and is held in that position by a latch. In order to reach for the bait, which it never gets, the animal must step on a flat plate that trips the latch. The weight of the animal causes the axle to make a quarter turn, the animal is precipitated down a chute, and the following plate comes into position and latches. Near the mouth of the chute is a row of electrically charged wires which hang to within an inch or two of the bottom of the chute, which at this point consists of an electrically grounded false bottom. As the animal slides down the chute it comes in contact with these wires and the full electric charge passes through its body to the false bottom. A barrel placed under the mouth of the chute receives the bodies of the rodents.

Tests of coal from the Matanuska fields in Alaska prove it to be of better quality than that of the Bering fields.

7684
The Japanese seldom use a pencil and pad in making calculations of any kind, but employ instead a calculating device which they call the "soroban," and which they have developed and perfected from the "abacus" in use among the Chinese. In the hands of an expert, the soroban can be used for making almost any kind of commercial calculation, while the operations of addition and subtraction can be performed readily by a novice with only slight instruction. The soroban consists of a shallow box in which is a series of transverse crosspieces, each of which carries six beads or counters. Five of the counters carried on each crosspiece are at the left of a longitudinal partition and represent units, while the remaining counter is at the right of the partition and represents five units, the term unit being used in this connection to mean any multiple or fraction of one when 10 is used as a factor. For example, any row of counters may be chosen to represent ones. The next row above will then represent tens, the next row hundreds, and so on, while the decimal fractions will be in the successive rows below.

forms. At each quarter turn of the axle one of these platforms comes into position as the floor of the vestibule and is held in that position by a latch. In order to reach for the bait, which it never gets, the animal must step on a flat plate that trips the latch. The weight of the animal causes the axle to make a quarter turn, the animal is precipitated down a chute, and the following plate comes into position and latches. Near the mouth of the chute is a row of electrically charged wires which hang to within an inch or two of the bottom of the chute, which at this point consists of an electrically grounded false bottom. As the animal slides down the chute it comes in contact with these wires and the full electric charge passes through its body to the false bottom. A barrel placed under the mouth of the chute receives the bodies of the rodents.



The Soroban, a Device Universally Used by the Japanese in Making Commercial Calculations

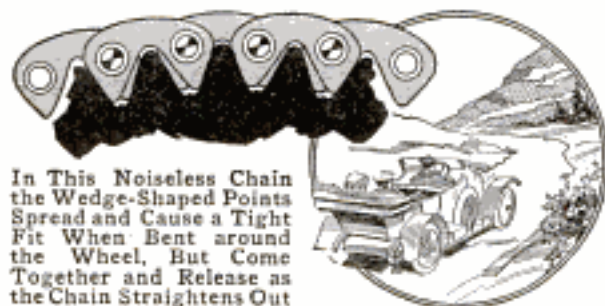
Any figure is represented simply by sliding the proper counters against the partition, the use of the five-unit

counter making this a quick and convenient operation. When the second number is to be added, the counters that represent this number are then moved, and the sum is read at a glance. The process may be continued indefinitely. Carrying to the next higher denomination is a matter of the simplest mental calculation, and soon comes to be a mechanical process.

NOISELESS CHAIN USES

7185m WEDGE PRINCIPLE

A new noiseless chain for the transmission of power works over a wheel having V-shaped openings into which points on the chain fit closely and in such a way as to prevent rattling. The links of the chain are made with a wedge-shaped point at each end, and



In This Noiseless Chain the Wedge-Shaped Points Spread and Cause a Tight Fit When Bent around the Wheel, But Come Together and Release as the Chain Straightens Out

the points at adjacent ends of two links fit over each other, as shown, when the links are pivoted together. When the chain is bent around the wheel the tips of the points pass beyond each other and make a tight fit in the opening on the wheel, but when the chain straightens out as it leaves the wheel these points come together, and the links release easily and noiselessly.

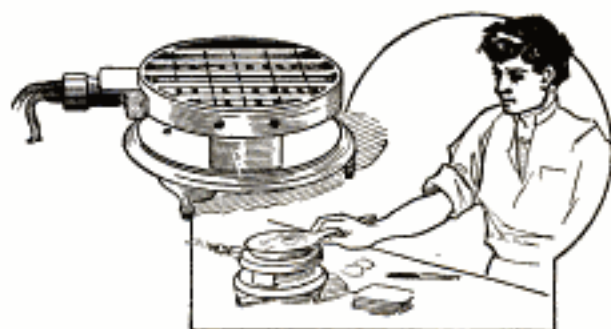
NEW TYPE OF PORTABLE

7357m ELECTRIC STOVE

A portable electric stove that has just appeared on the market has a space between the base and the electric coils which may be used for toasting at the same time that the grating above the coils is being used for other cooking operations. This stove is light and compact and is intended to be set on a table, the grating being just large

Ask Smison
Amer. Electric Heater Co.,
Detroit, Mich.

enough to take a flat-bottomed cooking utensil 6 in. in diameter. The coils are insulated from the frame of the



This Electric Stove Has a Clear Space beneath Coils That may be Used for Toasting While Grating is being Used for Other Cooking Operations

stove by mica rings and glass beads, while the electric terminals to which the cords are attached are protected by a steel plate that prevents damage to the connections from spilled liquids.

4 ROAD LIGHTS IN GERMANY 7622 BURN FOR MONTH

Roadside beacons at crossings and dangerous places along country turnpikes are being provided motorists in Germany and certain parts of England. Electric feed lines in rural districts are the exception, and not the rule, so development of a system of illumination which does not require daily attention has



had to be along other lines. The solution of the problem was found in a dissolved-acetylene outfit capable of burning for nearly a month without needing adjustment. The signposts are provided with automatic flashing devices which attract the attention of approaching motorists. Directions and distances to near-by cities also are shown by the posts.

Compressed peat is used as a sound-insulating material in Berlin.

The Illuminating Engine
see June 1914

NOVEL AND PRACTICAL THINGS

9171 4 FOR DAILY USE



Fountain-Pen Flash Light

carried in a vest pocket as conveniently as a pen or pencil. So far as external appearance is concerned it consists of a barrel, cap, and clip. In the end of

MADE compactly in the form of a fountain pen, a miniature electric flash light has been devised which may be carried in a vest pocket as conveniently as a pen or pencil. So far as external appearance is concerned it consists of a barrel, cap, and clip. In the end of the tube there is a small electric bulb, and in the cap, a battery. The clip serves the double purpose of holding the device in a pocket and acting as the contact point.



Suited for Coal and Gas Stoves

embodied in a combination two-fuel kitchen stove which has been introduced. When used for coal, its internal

appearance practically corresponds with that of many ordinary stoves, but by sliding a bolt and turning a crank, the front lining is dropped and the gas burners raised into a normal position. By then pressing down



Sand-Filled Cloth Rabbit

on a valve stem, the stove is ready to be used as a gas range.

Quite a lifelike cloth rabbit, which is intended for children playing on a beach, is made so that it may be filled with sand and its sides rounded out plumply. When playtime is over, the

sand may be released and the cover washed so that it will be clean and presentable when next used. It has pink glass eyes, long ears, and a fur tail.



Convenient Cuff Buttons for Shirt

buttons are fitted to the extended arms of a coil spring to which a small clamp



Handkerchief with Coin Purse

the spring effect holds them in place.

A woman's handkerchief which is provided with a small pocket in one corner, suitable for carrying street-car tickets or several silver coins, is fastened by a washable cloth-covered button. It is made of white hemstitched linen, daintily em-

Cuff buttons which allow a shirt sleeve to be held in any position on the forearm, thus making it unnecessary to turn the cuffs back, are being introduced. Instead of being made in the form of ordinary links, the buttons are fitted to the extended arms of a coil spring to which a small clamp is attached. They are inserted in the buttonholes in the regular manner, and the extended part is fastened to the sleeve by means of the clamp. The flexibility of the links allows the sleeves to be pulled up as far as desired, while

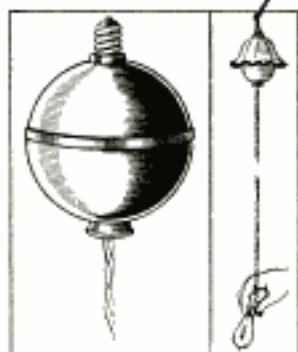


Guide for Trimming Child's Hair

broidered, and may be used conveniently when it is not desired to carry a purse.

To make it possible for children's hair to be cut at home by their parents, or nurses, instead of by a barber and at the same time have the work done neatly, a trimming gauge has been devised. This fits about the head and provides a guide which may be followed in cutting bangs or boxing the hair.

Intended to fill various functions in either home or office, an adjustable electric-light fixture has been invented which enables a lamp to be carried to almost any point in a room. Its principal feature is a ball reel which allows the wire to be extended as needed and then wound up automatically, so that it is entirely out of sight when not in use. A small bracket is provided which enables the bulb to be clamped to a mirror, the



Adjustable Electric-Light Fixture



Shelves Suspended from Picture Molding



Portable Gasoline Stove

head of a bed, the back of a chair, or in almost any position.

Wall shelves which may be used in a room without disfiguring the paper or plaster with screw or nail holes have been invented. Brackets are placed on parallel, perpendicular

rods, at the upper ends of which are

metal hooks that fit over a picture molding.

Fitted with a standard-sized burner, a small, portable gasoline stove is being made which is suited for several uses in the home, and also serves conveniently when carried on a camping or motor trip. It holds a quart of gasoline under pressure, and gives about the same amount of heat as a single burner on many larger stoves. It weighs 3 1/2 pounds.

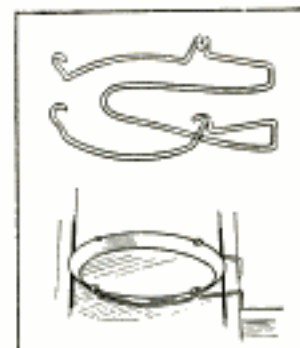
A pencil and fountain-pen clip has been devised which, in a transparent celluloid pocket on its front side, carries a miniature calendar. This consists of a number of small, but legible, leaves, each representing a certain month of the year.

For the purpose of securely holding a child's plate on the tray of a high chair, so that it cannot be accidentally tipped and its contents spilled, a wire clamp has been invented. This is provided with four fingers which grip the rim of a dish firmly.

A soap-scraping device which may be attached to a wash boiler, or other receptacle, is made with a concave surface and supplied with three rectangular holes set diagonally. When a bar of soap is rubbed over the apertures it is cut into thin shavings.



Calendar Clip for Fountain Pen



Clamp Holds Plate on High Chair



Device for Slicing Soap

USE MADE OF FLASH LIGHTS BY VISITING DOCTORS

Among the varied purposes to which electric flash lights are being put is the somewhat novel use that is made of



How a Physician Makes Valuable Use of a Pocket Flash Light in Examining a Patient's Throat

them by many visiting physicians. It is becoming a more or less common thing for a doctor to carry one of these small hand lamps in his medicine case, the reason being that such an instrument is of material value when it is necessary to examine the throat or mouth of a patient. In his office the physician is usually equipped with suitable lighting apparatus for work of this nature, but in the average residence it is frequently difficult to make such a diagnosis quickly on account of poor lighting. With a flash light in his case, this trouble is completely eliminated.

SUBTERRANEAN CABLES USED BY GERMAN SPIES

Accurate information concerning the Russian positions and strength continually leaking through to the kaiser's forces from some point near Insterburg, some 40 miles from Koenigsberg, East Prussia, proved puzzling to the Russian commanders. Since neither overhead telephone nor telegraph wires were, at that time, available in this locality, it was concluded that

The Engineer

secret agents of the German war office were using subterranean cables which had been laid before the opening of hostilities in this district, if not before the outbreak of the war. To support this theory and at the same time illustrate the remarkable organization and scope of Germany's system of espionage, private cables of this kind have been found by the allies on several occasions. A few weeks ago the disclosure was made that an instructor in a school at Marggrabowa was in reality a German spy who by means of a concealed telephone was furnishing information to the Germans. The telephone instrument was hidden in a hatbox in a wardrobe and was connected to an underground cable which extended to a point where German soldiers were stationed. When this discovery was made, false information was telephoned to the troops, the teacher was arrested, and the wires were cut.

ADJUSTABLE BARREL TRUCK 6950 W SAVES HANDLING

A strong, compact truck for moving barrels and kegs up to 600 lb. in weight has been marketed recently. Formed of steel bars, the truck is equipped with a sliding hook on the handle, which fits over the top rim of the barrel, and may be adjusted to any height made necessary by the size of the barrel to be moved. The truck is run up to the barrel and raised to a vertical position, when



Convenient Truck for Handling Barrels

the hook engages the rim, and two steel prongs at the bottom of the frame lift the barrel and support it.

Distributor:
R. B. Webster, 418 E. 31st St.,
Chicago, Ill.

*La Nature - For sale by
Kratz, Boussac, 14 Rue
Marcel, Paris, France*

POPULAR MECHANICS

599

Keystone - 1-15-15
**WATCH CRYSTALS TO BE
MADE IN AMERICA**

On account of the deficiency resulting from the war in Europe, where practically all watch crystals have heretofore been made, one of the leading optical companies in this country has gone into the business on an extensive scale and will attempt to supply the American trade with watch crystals. This is said to be the first time in the history of this branch of the optical trade that an American company has been able to compete on a large scale with the European manufacturers. One of the features about these American-made crystals is that they will be produced to absolute standards of measurement, a goal that has not yet been reached by the foreign manufacturers.

**NEW SPUR GUARD PROTECTS
TROUSERS FROM MUD**

Mudguards in the form of spurs to be fastened to the heel of the shoe is a Parisian novelty. A thin metal shield,



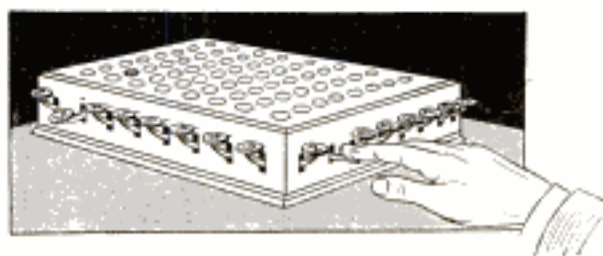
COURTESY OF LA NATURE

having a prong on the inside curve, is inserted in the heel or between the heel and the upper leather of the shoe. A band or leather strap drawn through eyelets in the ends of the metal shield passes over the instep and holds the device in place. This contrivance is designed to prevent mud from splattering or coming in contact with the lower edge of the trouser leg in walking on muddy streets.

**DEVICE AIDS IN LEARNING
MULTIPLICATION TABLE**

An ingenious apparatus has been developed by a French teacher for helping young students in learning the multiplication table. The mechanism is inclosed in a flat box and is operated

by two series of levers, a series of eight being placed along each of two adjacent sides of the box. The top of

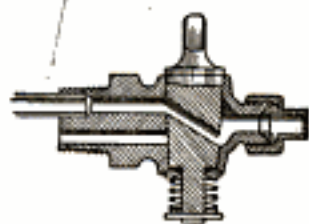


Automatic Multiplier Designed to Help Students in Learning the Multiplication Table

the box has 64 perforations, each of which is located at the intersection of a lever of one series with that of the other series. The levers of each series are numbered from 2 to 9, the 1 being omitted as superfluous. When a multiplication is to be made, the lever corresponding to one of the numbers is pressed. Then when the lever in the other series corresponding to the other number is pressed, the product appears in the perforation at the intersection of the levers. In the illustration the product of 3 times 3 is shown.

**EMERGENCY TANK COCK FOR
MOTORBOATS**

A device designed to reserve a certain amount of gasoline for use after the supply tank is almost exhausted offers to motorboat owners and operators an assurance against being left far from a source of supply when cruising. The cock communicating with the gasoline supply has two openings, only one of which can be used at one time. When the gasoline gets as low as the top pipe from the tank, no more gasoline is fed to the engine, which of course stops. A turn of the handle brings the outlet in the cock opposite the lower pipe, and the reserve gasoline in the tank is drawn upon. This warning gives the motorboat engineer ample opportunity to make a direct run for another supply of fuel.



*La Nature 12/13/13 Maker:
M. Severe Jutas, Rue de la
Rapine, Lille, France*

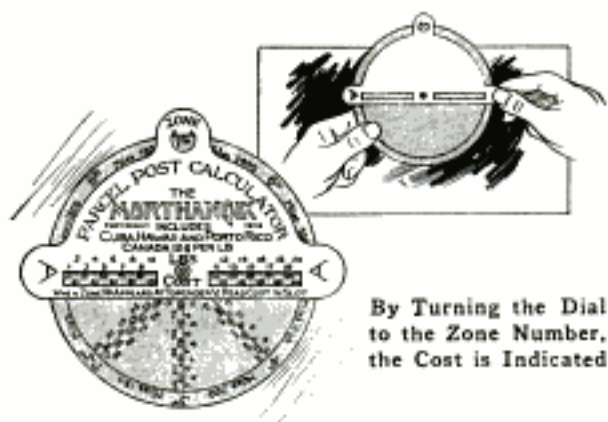
*Mfrs: The Lunkenheimer Co.
Cincinnati, Ohio*

Copyrighted material.

DIAL POINTS OUT PARCEL-

POST RATES

For the convenience of parcel-post users, a rate calculator which shows instantly the cost of sending almost



By Turning the Dial to the Zone Number, the Cost is Indicated

any package anywhere in the United States, its holdings, or Canada, has been made. The scale is shown on a dial which carries the charge in relation to pounds for each zone. By turn-

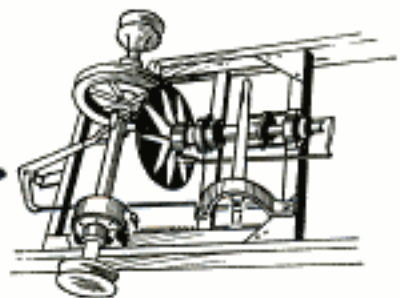
ing the indicator to the proper zone number, the rate on the package desired to be shipped may be read.

9062 PELTON WHEEL BUILT FOR MILE FALL OF WATER

A Pelton wheel able to withstand the terrific pressure of a 5,412-ft. fall of water has been constructed for the new hydroelectric power plant, previously described in this magazine, which is being built near Martigny, Switzerland. It has a diameter of 11 1/2 ft., and at 500 revolutions a minute will be capable of developing approximately 3,000 hp., with a jet of only 1 1/2-in. diameter. In constructing the pipe lines to carry the water, it was necessary to give the lower portions of them sufficient strength to resist a pressure of 2,425 lb. to the square inch, which gives some idea of the great head pressure under which this horizontal-shaft wheel must operate.

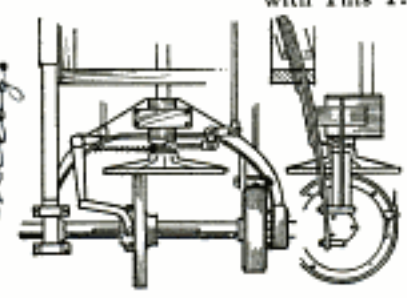
FRICITION TRANSMISSION IS POPULAR IN CYCLECARS

Application of friction-drive transmission to many of the recently introduced cyclecars has been made on account of the simplicity of its principle. Use of such a transmission system does away with the difficulties

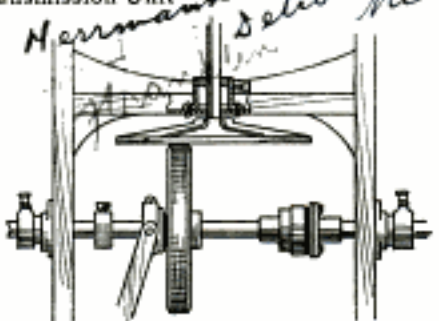


A True Rolling Surface on Fourth Speed and an Automatic Spring Tension at All Speeds are Given with This Transmission Unit

attending the use of spur gears, planetary gear sets and clutches, and because of this, it has been deemed by several manufacturers as the ideal system for the small car. The main reason for this came in the realization that the average cyclecar owner would do his own repair work, making a simple form of construction necessary. Several friction-transmission sets suitable for use on almost any cyclecar have been brought out by different factories. Most of these follow the same general plan but bear their own characteristics.



This Rear-Axle Transmission Set Is One of the Simplest Forms of Friction Drive That has been Applied to Cyclecars



The Collar on the Shaft at the Left of the Driven Wheel Prevents It from Sliding Past the Disk

In one of the sets a true rolling surface is given on the fourth speed, with automatic spring tension at different speeds. Another set with its differential on the jackshaft is intended for chain-drive cars, while a third is designed to be fitted to the rear axle of a machine.

The American Cyclecar May 1914

H.C. Roth
2922 Cent. Geo. W. Chgo. Ill.
C. A. Ostermaier
Chicago



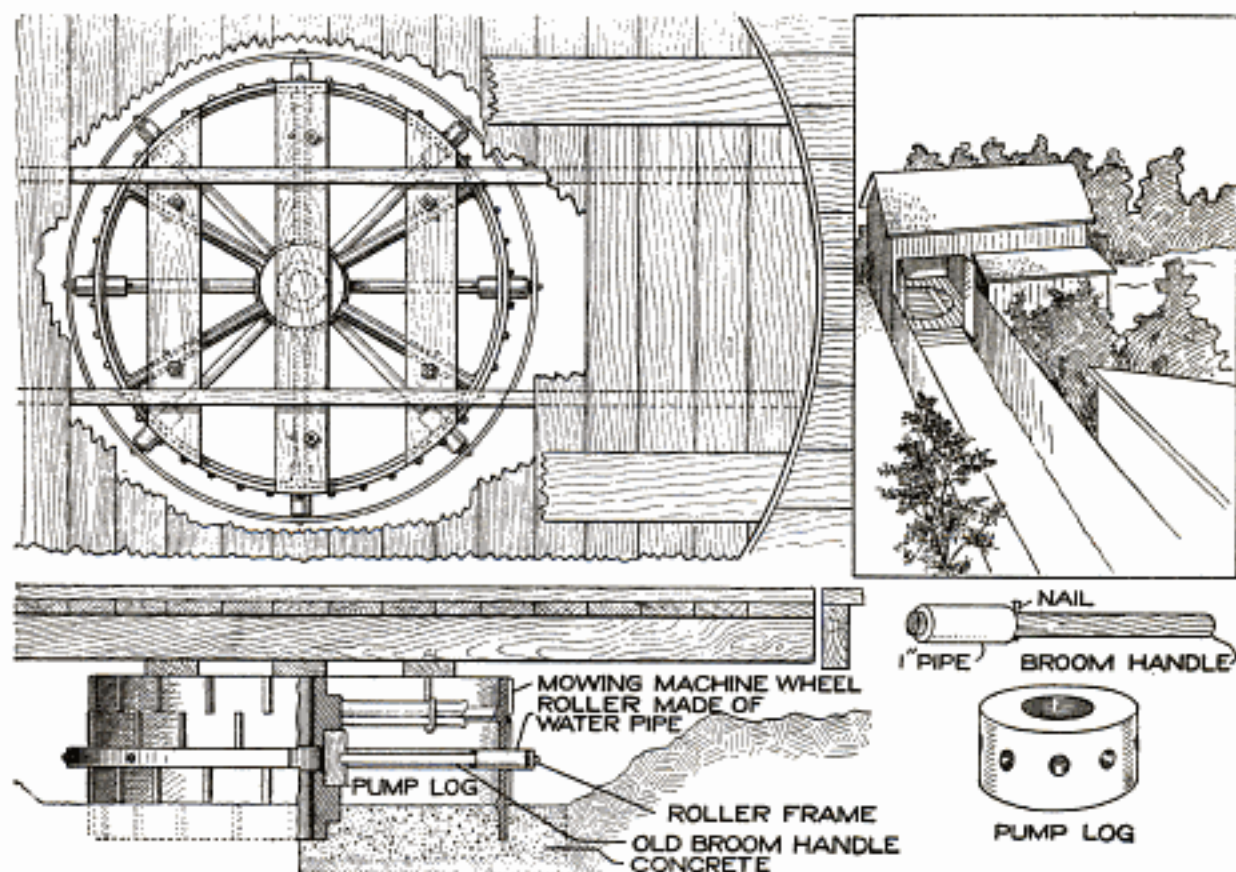
A Homemade Automobile Turntable

By FRANK G. SWARTZ

THE location of a home garage made it necessary to back the automobile about 200 ft. either in entering or going out, and for this reason it was desirable to construct some kind of an inexpensive turntable in the garage floor. The floor being made of boards, a circle was drawn upon them having a diameter equal to the length of the automobile, and a little more for convenience. The boards were numbered, cut, and laid aside, and the earth was removed from the center; then an old mowing-machine wheel with an un-

broken rim was bedded in concrete so that the center of the hub was in the center of the circle cut out of the floor. The concrete was built up halfway on the spokes and rim.

A piece of wood pump log was procured, and eight holes bored in it in the manner of constructing a hub for a wheel, and eight spokes were cut from discarded broom handles and inserted in the holes. The lengths of the spokes should be such that the periphery of the ends extend over the rim of the mowing-machine wheel 1 in., or more.



Two Old Mowing-Machine Wheels with a Center Wheel Carrying Rollers Make the Turning Part of the Table, on Which a Floor is Laid Level with the Garage Floor

These ends were evened up to fit in a band made of an old buggy tire. A roller was made for the end of each spoke by cutting a piece of 1-in. pipe 4 in. long, all rollers being held in position with pins run through holes in the spokes at their inner ends and in the rim at the outer ends of the spokes.

This wheellike arrangement was placed on the mowing-machine wheel set in the concrete so that the rollers rested on the rim. Another mowing-machine wheel was set on top of the built-up wheel, and the three were kept in line by a shaft run through the hubs.

On the upper surface of the top wheel, two timbers, about 7 ft. long, 4 in. wide, and 2 in. thick, were secured with bolts having a hook on the head end to engage the spokes near the rim. A center timber of the same size, and as long as the diameter of the circle cut in the floor, was secured to the center of the upper wheel in the same manner. On these timbers joists were placed, and the floor boards securely nailed to them. About $\frac{3}{4}$ in. of the boards were sawed off all the way around, to make a clearance. Two boards, 12 in. wide, were laid crossways on top of the flooring to take the tread of the automobile. A support was placed under the edge of the turntable where the automobile is driven on, but low enough so that when the machine is standing on the platform the weight will rest entirely on the rollers.

Wire Cutter Made of Old Files

A simple and powerful wire cutter can be made of two old flat files. The



ends should be annealed and drilled for a bolt. In one piece, near the bolt hole, to produce a large leverage, must be drilled a hole to fit the wire to be cut. If several sizes of wire are to be cut, holes of corresponding diameters must be provided, the largest one nearest the bolt hole, in order to

obtain the best leverage in cutting them. The narrow edges of the cutting file should be ground sharp, and when one becomes dull, the file can be turned over and the other side used.—Contributed by D. C. Goff, Knoxville, Tennessee.

Replacing Parts Properly in Assembling an Engine

When reassembling the engine of an automobile after an overhauling, extreme care should be taken to replace the various valves, valve springs, spring washers, tappets, etc., with their respective cylinders. A good plan is to number each set by means of steel figure punches, and in this manner the engine can be reassembled properly.

Cement-Floor Covering to Prevent Dust

If it is desired to make a concrete floor in a factory or mill that will not sand off or make dust, a coating for the purpose can be prepared when making the floor. This coating consists of one part cement to two parts crushed rock or hard gravel, which will pass through a $\frac{1}{2}$ -in. sieve, and from which the fine dust has been removed. This is thoroughly mixed in a mixing box, or by a machine mixer, with a sufficient amount of water to produce a plastic but not sloppy consistence, and spread on the under concrete before either the finish or the under concrete has had time to set. It is floated with a wood float to a true level, and then slightly troweled with a steel trowel, to bring it to a proper level and to smooth the top slightly. This will give a finish which is pebbly, and not dead smooth or slick like a sand finish. After the finish has been troweled and has set sufficiently so that the covering will not mar the surface, it should be covered with sawdust, sand, cloths, or any other material which will hold water continuously. The finish should be kept soaking wet for at least a week, or, better, for 10 days.

Range Finder to Locate Points of Interest

Tourists stopping at points of interest seldom have the chance, or take the time, to travel the surrounding country to see some spot that would take hours to reach. For this reason the general viewpoint, in some places, is provided with a device to point out, or locate, the most interesting bits of scenery so that the traveler can use his field glasses to a good advantage.

The device consists of a standard, solidly set in the earth and provided with a round top, about 1 ft. in diameter, on which is mounted a revolving finder. The standard is

tically. The weight of the pipe, if it freely slips into the standard, will be sufficient to keep it in one position, and a pin run through a hole drilled in the pipe at the proper place will prevent it from dropping too low.

A yoke, shaped from a piece of metal, is fastened into the upper end of the smaller pipe, which provides the support for the "telescope," or range finder. This range



To Locate a Place of Interest Turn the Pipe "Telescope" and Set It in the Proper Notch, Then Look through the Opening

made of a $1\frac{1}{4}$ -in. pipe, and the top, which is of hard wood, is fastened to a flange screwed to the pipe end. A hole is bored through the center of the wood disk in which a $\frac{3}{4}$ -in. pipe is fitted, projecting down into the standard so that it will revolve freely without changing its position ver-

finder consists of a piece of 1-in. pipe, about 18 in. long, and is hung in the yoke on pins centrally located and fastened in the walls of the pipe.

Around the circumference of the disk, and properly located, are pieces of sheet metal with their upper ends cut out to receive the circular form of the pipe. If a certain point of interest is higher than the view point, the piece of sheet metal for that point must be of such height that the range-finder pipe will point to it when placed in the notch. The pieces of metal must, therefore, be made separately for each point of interest, and if a point is at a lower altitude, a portion of the board top can be cut out to receive the pipe end in place of the metal standard.

When the pipe "telescope" is turned on its swivel and set into a notch labeled "Bears Head," etc., the observer looks through the opening, and the field

of view is narrowed down so that the point of interest, which may be a good many miles away, can be easily located. The field glasses are then brought into use and the object viewed without having to make a long trip to see it.

The same device would be of interest on a country estate, located where most of the surrounding country can be seen. In this instance the device can be so constructed that a moderate-priced telescope can be placed in the yoke and standards around the wood-disk edge, permitting the things to be seen enlarged without the use of a field glass. The yoke is made in the same manner, but, instead of pins for fastenings, the inside of the metal is lined with rubber, or felt, and a thumbscrew fitted in the upper end of one arm, to use as a clamp to fasten the telescope in place. In this manner the telescope can be removed to prevent loss by theft.

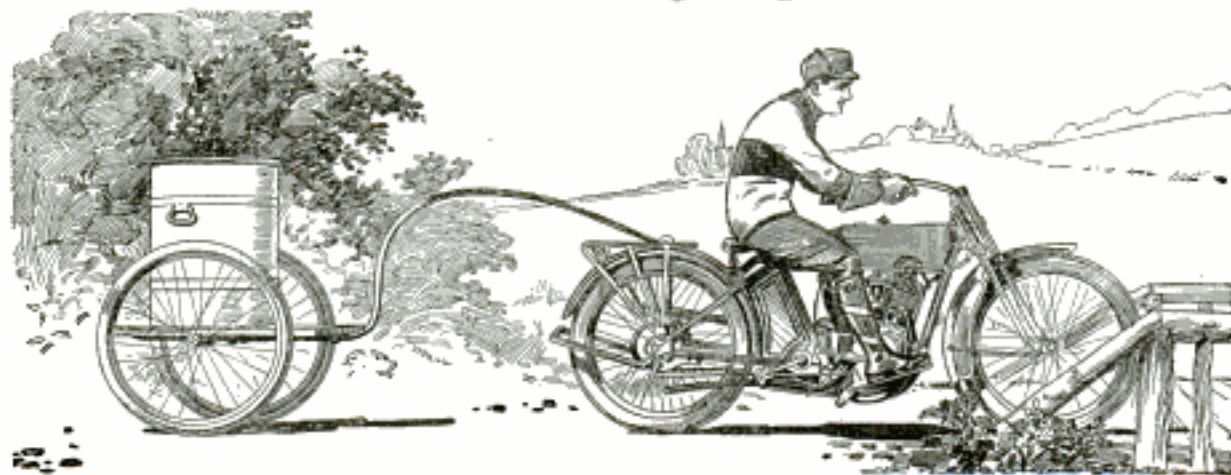
Motorcycle Trailer for Ice-Cream Kegs

To make quick delivery of bulk ice cream one druggist made a trailer for his motorcycle as shown in the illustration. Two ordinary bicycle wheels were fitted on a straight axle, and on top of it a platform of boards was fastened. The surface of this platform was made large enough to carry one extra-large ice-cream keg, or four small ones. To the front end of the cart a curved rod was attached, so that it could be fastened to the brace on the

rear mud guard of the motorcycle. The connection was made flexible so that turns could be accomplished without trouble or tipping of the trailer.

Hat Hook Used as a Switch in a Bell Circuit

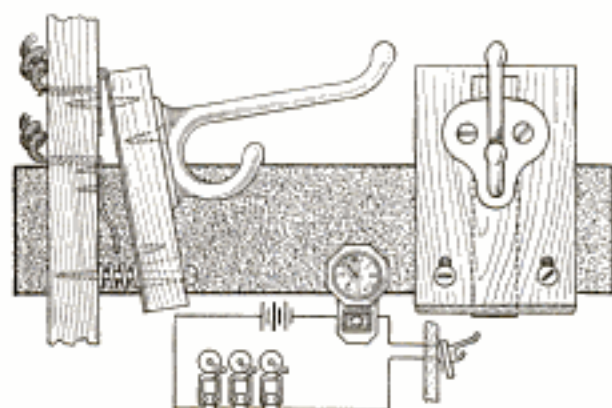
Where a set of electric bells were installed in a high-school building to be rung from the school clock, it was necessary to place a cut-out switch in the line, to prevent the bells from ringing at night and when the school was



A Trailer Serving the Purpose of Delivering Ice-Cream Kegs, but Which could be Used for Many Other Kinds of Light Delivery If Provided with a Covering

closed, thus avoiding unnecessary use of the batteries. Knowing that an ordinary switch would be frequently forgotten, the scheme illustrated, which is positive and as good as automatic, was adopted.

On the face of a block, about $\frac{1}{2}$ in. thick, 3 in. long, and 2 in. wide, is fastened an ordinary coat or hat hook. On the back at the upper end is fastened a brass hinge, and in electric contact with this is a brass strip that runs down the center. The hinge is then secured to the wall and connected to one terminal. A second contact strip, connected to the other terminal, is fastened to the wall directly behind the brass strip on the back of the block. Near each lower corner of the block an oblong hole is made, and through these brass screws are driven into the wall, around each of which a short piece of coiled spring is placed to keep the contacts apart.



The Weight of a Hat Closes the Contact Points and Makes the System Operative

When the head master hangs his hat on the hook the springs are compressed, the break in the circuit is closed, and the controller in the clock is connected to the system and becomes operative. The removal of the hat opens the circuit, and there is no chance of the bells operating out of school hours unless the head master goes home bareheaded.—Contributed by J. A. Bannister, Chesley, Ont.

It is well to know that rapid cooling of a liquid produces fine crystals; the slower it changes form, the larger the crystals.

Display Board for Moving-Picture Show Posters

An enterprising owner of a moving-picture theater uses a bill or poster board as shown. As the program is

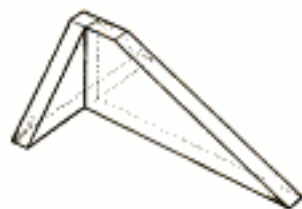


The Outer Surface of the Board Has a Hinged Skeleton Door to Hold the Poster

changed nightly, the posters must be removed and new ones put in daily. The skeleton door frame on the board holds the poster in place without the use of paste. The panel shape of the upper part of the door automatically frames the headline. The door is fastened with a small hook and eye. This method is far handier and much less messy than where paste is used.

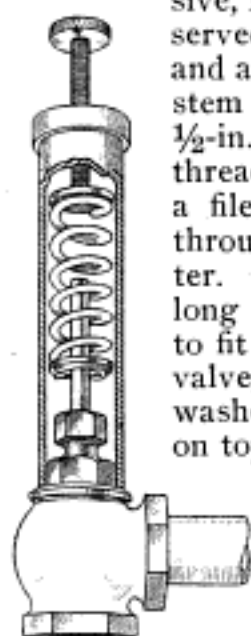
A Doorstop

A simple and effective doorstop can be made in a short time by nailing together two pieces of pine board, cut as shown in the sketch. In use, the long wedge-shaped piece is shoved under the bottom of the door, which, when released, holds the doorstop firmly in place, making it impossible for the door to close. If desired, a strip of rubber, or felt, can be glued to the bottom of the doorstop.—Contributed by A. J. Stover, Corvallis, Ore.



Homemade Safety Valve

On my oxyacetylene-welding outfit there were needed several relief and safety valves. As these are quite expensive, I constructed some that

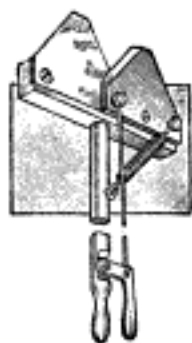


served the purpose from pipe and angle valves. The valve stem was removed from a $\frac{1}{2}$ -in. angle valve, and the threads were removed with a file. A hole was drilled through the stem for a cotter. A piece of pipe, 5 in. long and of the proper size to fit over the bonnet of the valve, was procured. A washer was put on the stem on top of the cotter, then an open coil spring.

The upper end of the pipe was fitted with a cap, drilled centrally and tapped for a $\frac{1}{4}$ -in. rod. A rod, $\frac{1}{4}$ in. in diameter and about $2\frac{1}{2}$ in. long, was threaded for its entire length, and a disk fastened to its lower end. The upper end was fitted with a knurled head. The pressure can be set at any number of pounds desired by this adjustment.—Contributed by A. H. Waychoff, Koenig, Col.

Berry-Bush Trimmers

The essential parts necessary to make the illustrated berry-bush trimmer are two mower-



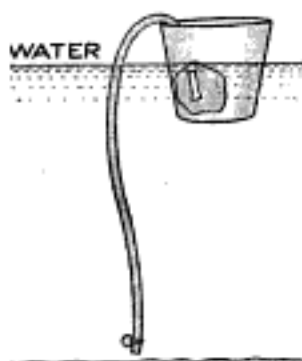
sickle sections, a spiral spring, some wire, screws, and a wooden frame. The frame is made T-shaped with a handle, about 3 ft. long, and a crosspiece, about 6 in. in length, securely fastened at the top. Should this work loose, it can be strongly braced

with triangular blocks fitted in the junction of the two pieces, and fastened to each. One of the sickle sections is rigidly connected to the frame. The other is drilled for a center hole in line

with the regular rivet holes at opposite corners. The corners are bent up slightly, to provide an easier rocking motion. The section can then be fastened to the crosspiece with a round-head screw, a washer being placed next to the wood to line up the two sections. One end of the spiral spring is connected at the outer end of the sickle blade, and the other end to the handle, as shown. An operating wire connects with the opposite corner of the blade, and leads to a hand lever conveniently hinged near the end of the handle. When the hand lever is pulled down, the rocking section swings across the stationary piece, thereby cutting off the dead limbs, twigs, etc., caught between them. When the handle is released, the spring returns the rocking section to its original position, preparatory for another cut.—Chas. J. Donahue, Crete, Indiana.

Procuring Clean Water from a River or Lake

To obtain clean water from a stream, or lake, for a camp, it must be taken



from below the surface. This can be done with a large bottle by covering the hole in the neck and dipping it in the water deeply, then removing the covering and allowing the bottle to fill. The

trouble of this method is that campers never have a large bottle at hand.

Cool, clear water can be taken from a depth of 15 ft. with the use of a small rubber tube. The illustration clearly shows how this may be accomplished. Place the tube in the water and in the bucket as a siphon, then push the bucket into the water as far as possible without letting any of the surface scum run in. Start the water flowing into the bucket as in starting a siphon.—Contributed by Geo. Goodwin, Ottawa, Ont.

BUILDING A HOME

By Geo. M. Petersen



PART I—What It Means to Own a Home

ALMOST every person has in mind to have a home of his own at some future time, and usually sacrifices many luxuries to lay aside systematically sums of money to gain that end. When that time comes, and the little hoard has grown to such proportions that, with a loan, one thinks a home can be started, then, also, is the time to do a great deal of figuring before starting the construction work. However, in one's haste to begin building, he usually forgets to incorporate in the house his own ideas, and it is erected in accordance with the idea of some architect, with the not uncommon result that it is entirely too costly for the income of the one who intends to own it.

If a person starts to build before enough money is on hand to complete it entirely, the interest on loaned money must be taken into consideration together with taxes, insurance, and depreciation. By way of illustration, suppose a house costing \$4,000 is built on a lot worth \$875 and, when complete, would bring a rental of \$25 or \$30 a month; then, to figure this on a cash basis, the yearly charges would be:

Interest on \$4,875 at 6 per cent.....	\$292.50
Taxes on assessed valuation of \$3,000...	60.00
Water	10.00
Insurance	10.00
Depreciation, 5 per cent of \$4,000.....	200.00
	\$572.50

This represents a gross carrying charge of \$572.50 a year, or \$47.70 per month. If a rental of \$25 per month can be derived from such a house, \$300

per year may be deducted from the above amount, making the net carrying charge \$272.50 per year, or an outlay of \$22.70 each month for the pleasure of living in one's own home. The items mentioned above do not include heat, light, and other household expenses which must be taken in consideration under any condition of living. The \$292.50 interest is not money paid out, but represents what the money would earn at a reasonable rate of interest and which is lost in the investment.

As another example, consider that cash is paid for the lot and that a first mortgage is given for \$3,000 at 5½ per cent, and a second mortgage for \$1,000 at 6 per cent. The second mortgage is usually figured to be cleared off in three years by making certain yearly or half-yearly payments. In this case the carrying charge would be approximately as follows during the life of the second mortgage:

Interest lost at 6 per cent on \$875.....	\$ 52.50
Interest on first mortgage of \$3,000 at 5½ per cent.....	165.00
Principal and interest on second mortgage at 6 per cent.....	396.00
Taxes on assessed valuation of \$3,000...	60.00
Water and insurance.....	20.00
Depreciation of 5 per cent on \$4,000....	200.00
	\$803.50

Thus the total carrying charge for a year would be \$893.50, or \$74.46 a month, and if credit is given for a monthly rental of \$25, or \$300 a year, the net carrying charge would be \$593.50, or \$49.46 a month, which will be reduced to \$41.46 gross and \$16.45

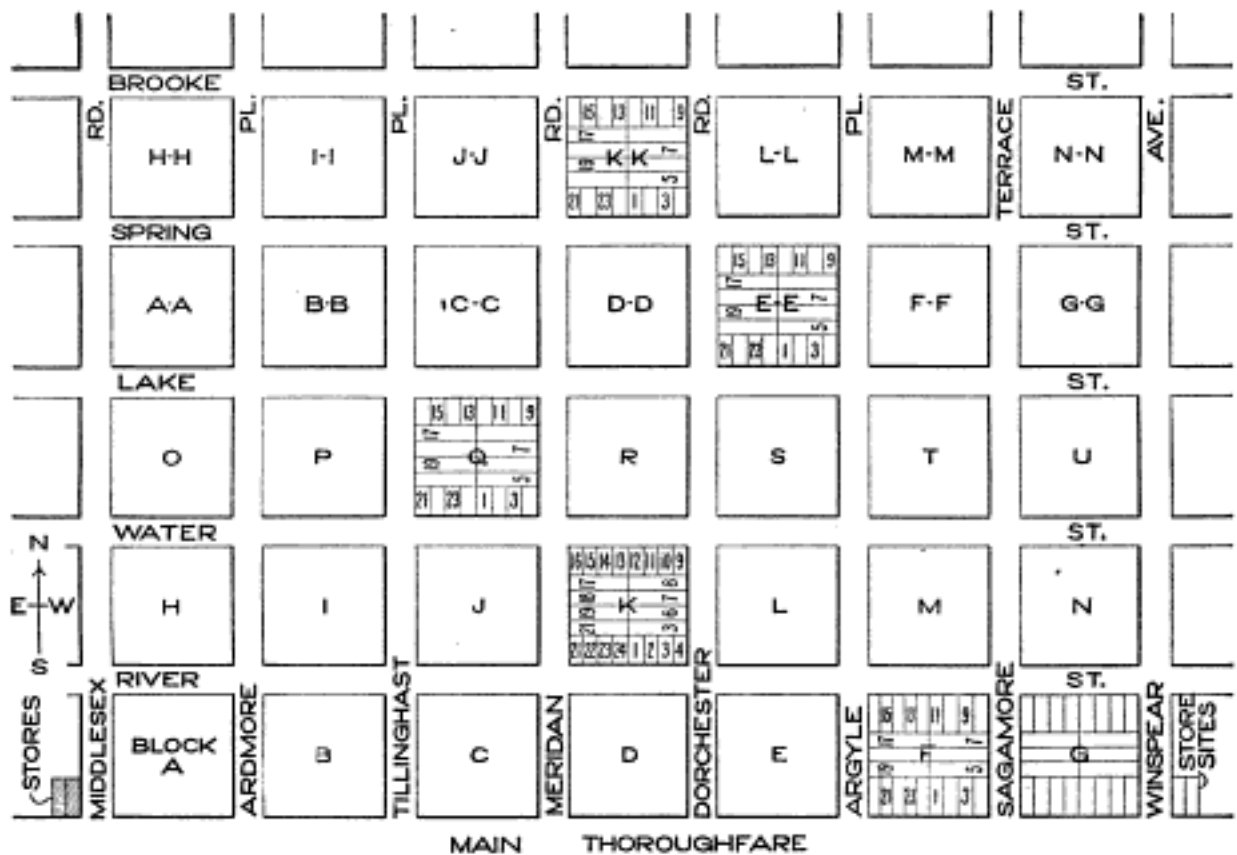
net at the end of three years when the second mortgage is paid up.

The item of depreciation may not be an actual one during the life of the second mortgage, but experience has shown that the life of the average present-day frame dwelling is only about 20 years, which is due to light construction and poor materials. Of course, the land might increase in value fast enough to make up for the depreciation in the building, but this land increase cannot be taken in consideration. As a business proposition, a depreciation fund should be started in a savings bank, and into this account five per cent of the value of the building should be placed each year. This fund could be used for making needed repairs, which would

extend the life of the building, and at a time when it is too old for further use there would be sufficient capital to build a new one.

These notes are not intended to discourage anyone who is contemplating the construction of a home on the first and second-mortgage plan, but to call attention to the numerous items, which are seldom mentioned by the installment builders when they are closing up a deal. Too many people start to build a home and lose it just because they forgot to figure the interest on the first mortgage, the taxes, or something else that would have caused them to wait a little longer and saved their money and home.

After counting the cost, and making

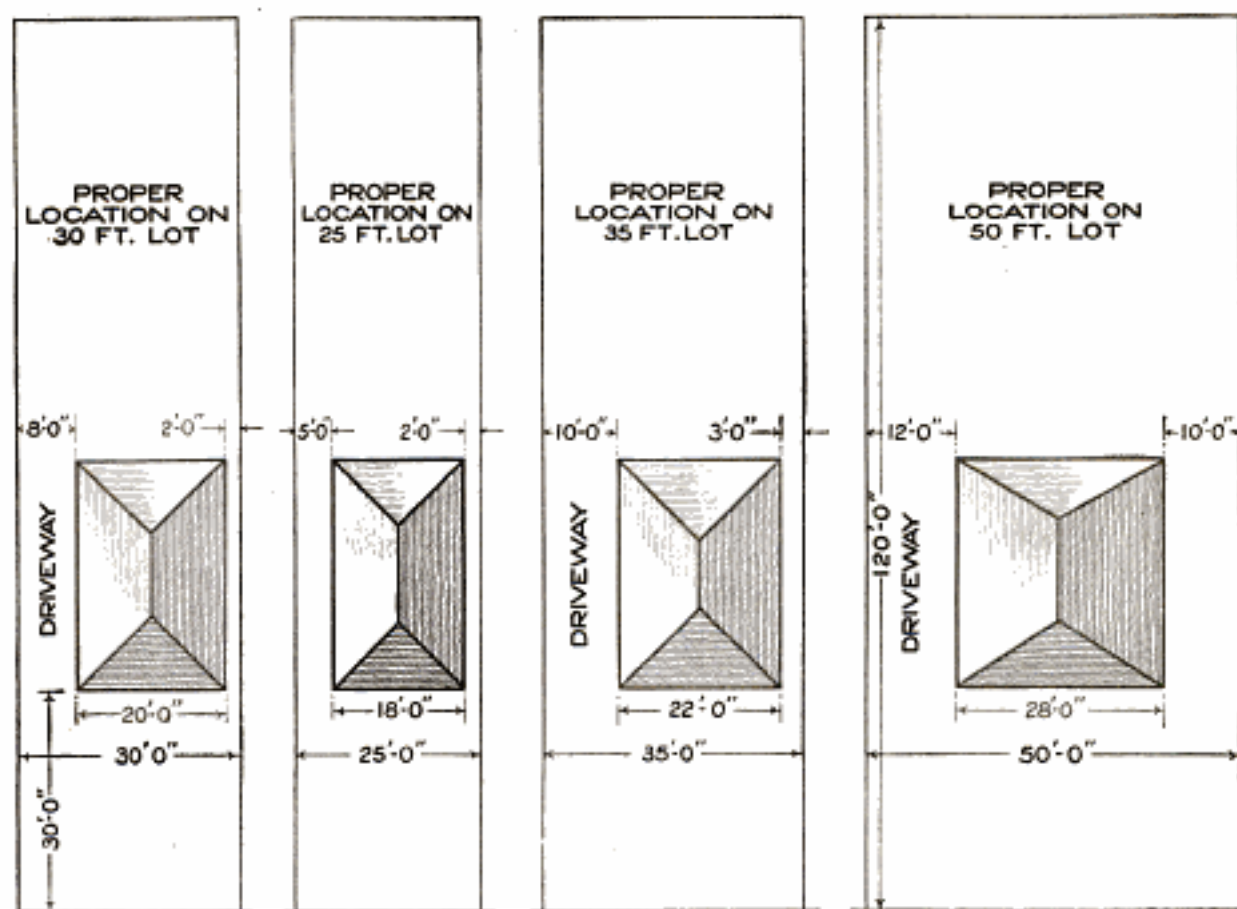


SUBDIVISION OF ELMWOOD HEIGHTS PARK

STORE SITES, PARKS, ETC., DESIGNATED BY BLOCK A, LOT 21., ETC.

NORTH & SOUTH OF BLOCKS	A TO N INC.,	2-STY. SINGLE HOUSES	TO COST NOT LESS THAN \$10,000
	O " U	" " " " " " " "	" " " " " " " "
EAST & WEST OF BLOCKS	AA " GG	" " " " BUNGALOWS	" " " " " " " "
	HH " NN	" " " " FLATS	" " " " " " " "
	A " N	" " " " SINGLE HOUSES	" " " " " " " "
	O " U	" " " " " " " "	" " " " " " " "
EAST & WEST OF BLOCKS	AA " GG	1 " BUNGALOWS	" " " " " " " "
	HH " NN	2 " FLATS	" " " " " " " "

A Small Subdivision Layout Showing How the Blocks are Divided for Single Houses, Bungalows, and Flat Buildings Where There Are Restrictions as to Location and Kind of Buildings.



All Houses on the Street should be Built to Front on a Line Some Distance from the Sidewalk and to be Well Located Sideways, Much Depending on the Width of the Lot

sure that the income will be sufficient to carry the project of building a home, it is advisable to get in touch with some first-class contractor whose advice can be depended upon in regard to the selection of a lot, the location of the house on the lot, style of house, etc. The modern contractor usually has an architect, or first-class draftsman, who will make plans and specifications for the building free of charge, if given the contract for building the home. The contractor, having practical experience, usually knows how to cut the expense without it showing in the quality of the building.

If the contractor has not such a man, procure the services of a good architect and have a complete set of plans and specifications made, so that when the house is finished, the material and workmanship can be checked.

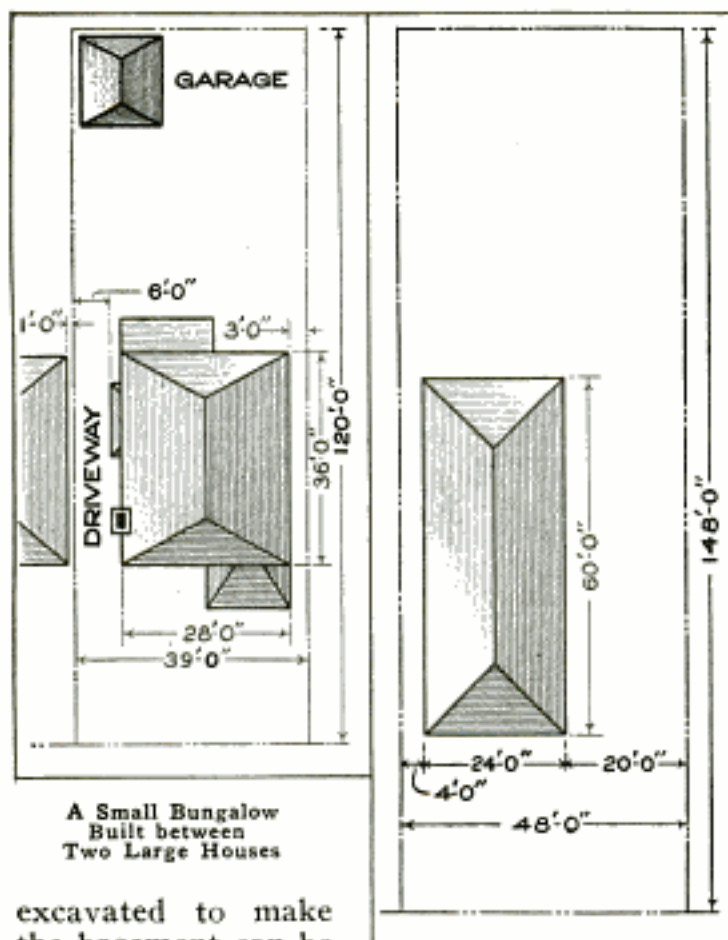
Selecting a Lot

When selecting a lot, make sure that the location is exactly what is wanted,

and then get the price of a number of lots in the immediate vicinity from persons other than the one who has the lot for sale, to ascertain if the price is right. Also be sure to take into consideration the present conditions of the surrounding property, and learn whether the property value is going up or down. Select a location that has good chances for an increase in value.

If it is necessary to use some conveyance to and from business, transportation facilities must be considered. Also ascertain whether sewer and water connections are in, and if the street is paved, that all assessments are paid. When selecting a lot and planning a house, build in a locality and construct a house that will appeal to others, so that, if forced to sell, it can be done without loss.

When placing the valuation on a lot, take into consideration its formation. That the lot is a little low compared with the surrounding land is no drawback, but an advantage, as the material



A Small Bungalow
Built between
Two Large Houses

A Ground
Layout for
a Large
Two-Family
Flat
Building

excavated to make the basement can be used for filling in, and thus considerable money saved by not having to haul the soil away. The character of the earth must be determined, as a lot composed of stone will make excavating expensive. Sandy-loam soil is best, soft clay next, then hard clay, shales, and stone.

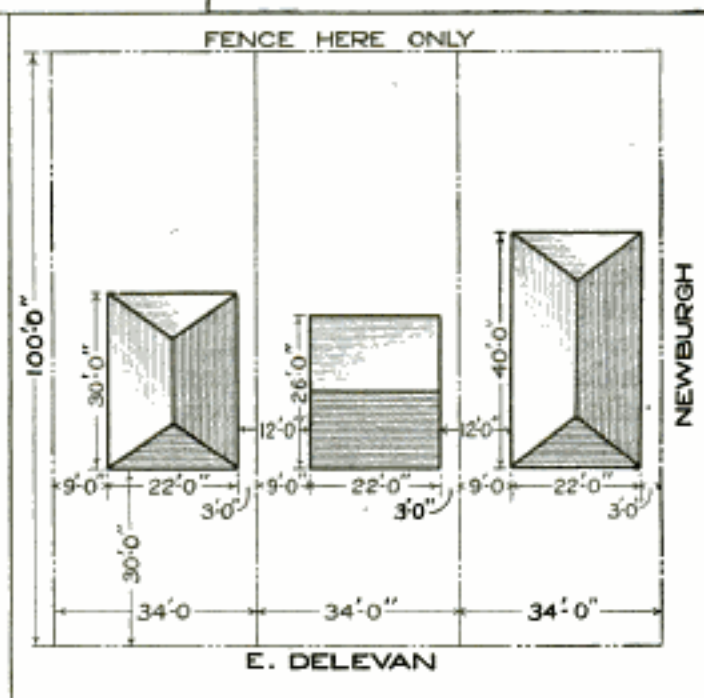
Usually a corner lot is selected, but it is not always advantageous, since assessments are always higher, and if pavements are to be placed or are in, the assessments are levied for two streets instead of one. The water bill will also be much higher, as the sprinkling charge is based on the frontage and a corner lot fronts on two streets. There is also a great deal more sidewalk to clear in the winter and more grass to cut in summer. However, it is best to get a lot that one is absolutely satisfied with, since,

no matter how fine the house may be, he is apt to dislike the home on account of the lot.

It is always best to keep away from factories, mills, saloons, street-car barns, shops, medical colleges, public institutions, hospitals, sanitariums, cemeteries, etc., as such property is not desirable for residences.

The most important thing to look into when buying a piece of vacant, or improved, property, is to carefully examine the title and see that it is clear. An expert abstract man should always do this part of the work. A loan cannot be had on an imperfect title, and to effect a sale is very difficult in such a case, not to mention that it is likely to throw the property into litigation.

Do not become too enthusiastic over a certain lot or location. Take time to think over



A Ground Plan of a Bungalow, a Semi-Bungalow, and a Two-Family Flat, Erected on Adjoining Lots, Each Having a 34-Foot Front, and All the Lots being Terraced

the objections that may be raised against the property. Have these answered by the owner or the agent, then consider their arguments.

Almost all modern subdivision lots are sold with restrictions, which are mentioned in the deed to the property, stating what style and class of house can be built on each particular lot. A restricted subdivision is a very good proposition, as one knows that all lot owners must build houses of similar size and class. One of the illustrations shows a small subdivision layout.

Of course, these lots are sometimes purchased by people who will try to evade the restrictions and build a store building on a residence site, or a flat building in a block of single houses. In most communities these buildings may be stopped any time before completion by any one property owner applying for and getting an injunction from the court. If the restrictions cover the entire street or neighborhood, and the company selling the lots is reliable, such structures can be removed from the premises. While on the subject of subdivision lots it may be well to state that it is more desirable, in many instances, to purchase a lot from a subdivision company than from an individual, as the company will have a number of lots and all must be protected, while the average individual owner simply desires to sell.

While a building can be started at almost any time, it is best to begin in the spring. The winter can then be given to a study of the conditions of the lot and to sum up the defects before making the purchase. The one great advantage of spring building is that the lumber dealer lays in a stock of framing lumber in the fall to carry him through the winter. This material is piled in the yard in such a way that it will be well dried in the spring. The lumber sold in the summer usually is taken direct from the boats, or cars, and is somewhat green.

Locating the House

After selecting the lot, which should not be less than 35 ft. wide, if room is desired for a driveway, it is well to draw a little plan of it on paper and lay out the location of the house. Building plans are drawn to scale, usually $\frac{1}{4}$ in.

to the foot, 1 in. on the drawing equaling 4 ft. on the lot.

Figure on keeping the front porch in line with those of the adjoining houses. Allow at least 2 ft., and more if possible, on the side of the lot opposite the walk or driveway. Various sizes of houses on different widths of lots are shown in the illustration, together with dimensions. In locating the house and laying out the grounds, be sure to arrange the building properly. If there is a large two-family flat building on either side, do not try to build a little bungalow, as it will not only make the house look squatty, but will seriously interfere with the draft in the chimney. A bungalow will appear best if the ground is terraced up to about 2 or 3 ft. and has plenty of room around it. All houses should be kept back from the street as far as possible, as they present a more pleasing appearance when so located, than when set out near the sidewalk.

A Safety Bill Holder

The illustration shows a clip that will prevent the loss of paper money when it is carried loose in the pocket. It is made of a piece of flat spring, bent into the shape of the letter W. The bills are slipped into the space A, and the extending ends B and C are used to release the hold on the money. It would be a difficult matter for anyone to remove the clip and money without attracting the attention of the owner, as the ends B and C must be pressed together before it could be removed, especially if it is carried in the small upper pocket made for a watch.



Ⓞ Plumbago, graphite, or black lead will sometimes prevent a shaft from running hot when oil fails.

Sawhorse Attachment for Short Sticks

When it is necessary to saw a few short pieces, the ordinary sawhorse is an unhandy place to hold the wood.



Sawhorse Attachment That Provides a Way of Holding Any Short Length of Wood

As I had a great many short pieces to cut for a small round stove, I made an attachment, as shown in the illustration, that would hold a stick regardless of its length.

The attachment consists of four pieces of board, two of which are joined together in the same manner as the crossed pieces for the sawhorse ends, but in such a position that they will hang over the center crossbar and make the depth of the yoke the same as that of the sawhorse. The end of one piece bears against a board that is fastened to the front pieces of the sawhorse.

Another piece, hinged to the lower end of the opposite center-yoke piece, is provided with notches, or a rack made of nails, to engage the upper edge of the board, as shown. The manner of using the device is obvious.—Contributed by A. S. Thomas, Amherstburg, Can.

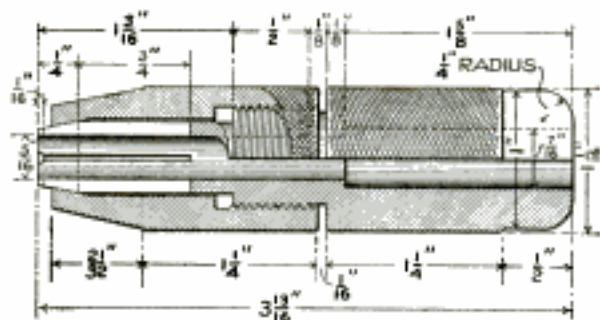
☞ Worn ball bearings can be repaired by truing up the ball races and using larger balls.

Disposing of Fumes from a Gas Stove

Where natural or artificial gas is used, the cost of building a chimney can be saved in the following manner: A 3-in. vent pipe is run from the vent of any gas stove, or heater, through the walls and up into the hood used over the kitchen range, about 6 in. from the bottom of the hood. Where the pipe passes through a wall, use asbestos wrapping as a precaution against fires. This will carry off the disagreeable odors of the burnt gases from the heater. The application of the heat in the hood creates a draft and will make the hood twice as effective.—Contributed by D. B. Koenig, Los Angeles, California.

Tool Holder for Round Shanks

In most tool holders using round stock, difficulty is frequently experienced in fastening or unfastening the tools, due to the short grip usually made on the nut or lower part of the holder. This trouble can be overcome by making an equal length of grip on both parts, as shown in the illustration, thereby increasing the force with which the parts may be screwed together, or separated, and the tool gripped in place, or unloosened, as the case may be. This holder calls for $\frac{5}{16}$ -in. stock. The grip jaws are provided with a slot, into which can



The Knurled Part on the Chuck and Handle are the Same Length to Provide an Equal Grip

be placed a pin fastened to the shank of the tool, thus preventing its slipping when under strain, as when using a screwdriver.—Contributed by J. R. Jarvis, New Haven, Conn.

Rocking Base for Shaking Down Contents of Barrels and Boxes

When it becomes necessary to ship nuts, washers, or other small articles of a similar nature, a saving can be effected in the number of barrels or boxes used for shipment, if these articles are thoroughly shaken down by rocking the containers back and forth. To decrease the labor and time required in this operation, a simple arrangement can be made as illustrated. A cover of wood or iron, larger than the barrel bottom, should be obtained and fastened to a piece of pipe, or round rod. This should be secured to the floor with staples, or nails, driven on each side, permitting the device to rock back and forth. In use the barrel or box is placed on the platform



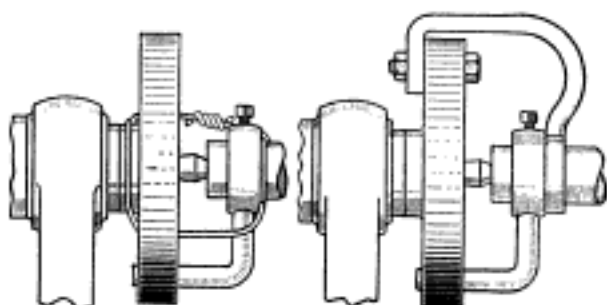
A Tipping Base for Use in Jostling Down Small Parts in Barrels and Boxes for Shipment

and its contents are shaken down by a rocking motion simplified by the roller bearing.—Contributed by John J. Kolar, Maywood, Ill.

Spring to Hold Work against Lathe Center

It frequently is necessary to turn work in a lathe where one end is held to the faceplate center and the other supported in a center rest. To keep the work in place, it usually is tied to the faceplate with a cord, or wire, wound around the lathe dog. With this method it is necessary to have the work drawn tightly to the lathe center, and to do so, the faceplate must be unscrewed several turns when binding the work to the dog, after which the faceplate is turned to its usual position, thereby tightening the connection. To avoid this difficulty, a flat spring can be substituted for the cord. This is bent to clamp against the back side of the faceplate, at one end, while the

other end is fork-shaped, to straddle the work, and is clamped against the dog, forcing it and the work against the



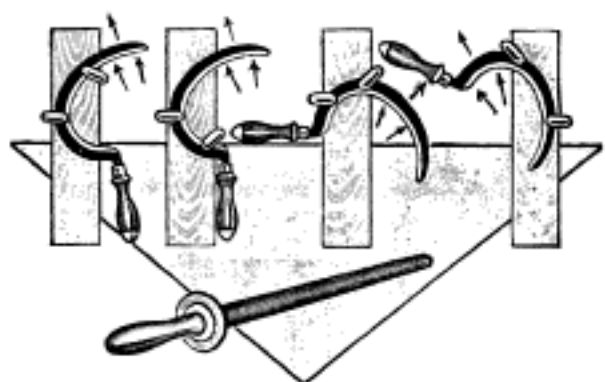
The Old Method of Wiring Work to a Lathe Center, and Spring That Takes Its Place

center. The spring is held in place on the faceplate with a bolt and nut.

Sharpening a Sickle

Where a grindstone is not convenient, a good cutting edge can be put on the ordinary sickle with the aid of a file. The sickle is clamped securely to a piece of board—old wringer clamps will answer the purpose—and shifted around in the various positions shown, so that a new surface is presented to the file. The arrows show the directions in which to file.

A tin disk, with a thick piece of leather as a face, makes a good guard for the hand. The leather will not spoil the edge of the sickle, should the file slip, and the tin prevents the sickle from cutting the hand, if filing is done with more vigor than care. A vise is



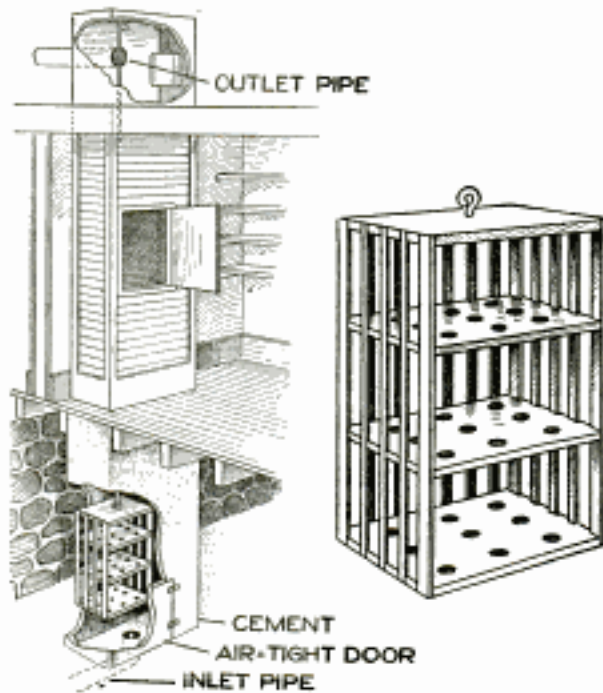
Various Positions for Clamping a Sickle to a Board for Filing Its Edge Sharp

not essential, as the board holding the sickle can be nailed to any convenient wood surface.—Contributed by James M. Kane, Doylestown, Pa.

See June 08 - 409 - S. N. V. (09) 911
" July 13 - 128 - " XI (15) 2098

An Iceless Refrigerator

In order to build the iceless refrigerator shown in the illustration, a shaft of suitable dimensions must be provided, having its bottom several feet



Dumb-Waiter Used to Lower Edibles in a Shaft Where They will be Kept Cool

below the surface of the ground, and the upper end extended above the receiving floor up to the ceiling or, better still, up into the attic. The lower part of the shaft, for a distance of several feet—or up to the receiving floor if possible—should be built of cement, the walls being several inches thick; the remaining portion, up to the top of the shaft, can be made of matched lumber. At a convenient distance above the floor, a door should be provided in order to give access to the lift. This door may be attached with hinges or made to slide in grooves, as preferred.

To conveniently get into the shaft at the bottom, an opening can be made which should be provided with a heavy air-tight cover, to be closed when using the refrigerator. An air-circulating pipe, leading from the outside, should be connected to the shaft at the bottom; another pipe should connect the upper end of the shaft with the chimney, thereby forming a complete and continuous air circulation which, to-

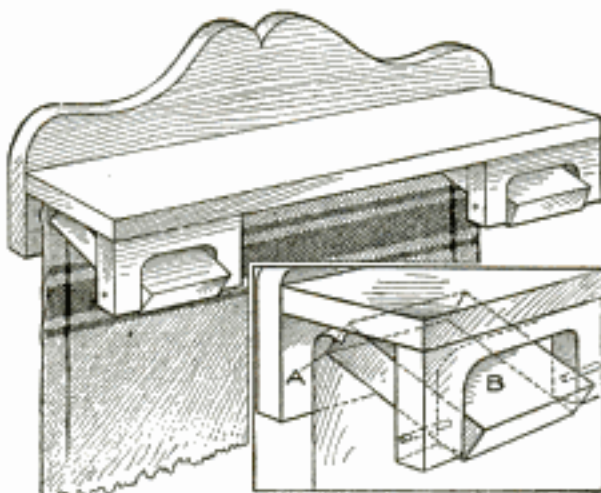
gether with the heat insulation provided by the cement walls, produces a temperature sufficiently low to keep almost any food.

A lift, or dumb-waiter, must be made, with its shelves perforated, as shown. One of its vertical sides is left open for placing the food; the other three consist of strips with spaces between. The air in its upward course is thus enabled to freely circulate through the lift.

The lift is suspended by a rope, which is passed over a pulley attached to the top of the shaft. A weight attached to the rope is used to counterbalance the lift. Provision for an outside suspension of the counterweight must be made, if the shaft is so short that the weight and lift come together before the lift can be brought to its proper position before the shaft door. For this purpose, a second pulley should be provided and conveniently suspended on one of the outside walls of the shaft; a hole must be bored for the lift rope, and the counterweight fastened to the loose end.—Contributed by H. R. Goodwin, Marblehead, Mass.

A Handy Towel Holder

Hand towels hung on a rail often drop to the floor for the reason that they are hastily hung up and no care



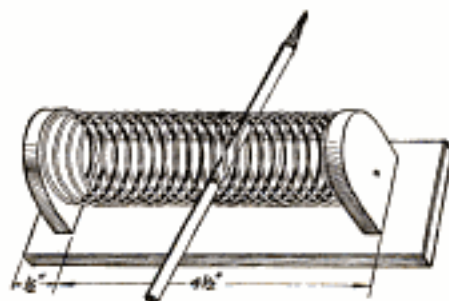
The Towel is Gripped at One End, Leaving Its Entire Length Hanging for Use

is taken to even the lengths of the ends. The hanger illustrated, the holding device being shown in the small sketch,

grips one end of the towel, which cannot come out until the grips are released. Any person handy with tools can cut out the holder from any suitable wood. The edge A of the hinged block B holds the corner of the towel against the back piece.

Penholder and Pencil Rack

A simple rack, made as illustrated and conveniently suspended on a wall or at a desk, will serve to keep penholders and pencils in a place where they may always be found. The parts necessary for its construction are a wooden frame and a coiled compression spring. The frame consists of two end blocks, fastened to a back piece which is drilled at one end for suspending it from a nail or hook. In selecting or making the spring, a No. 20 gauge brass spring wire, or one about $\frac{1}{32}$ in. in diam-



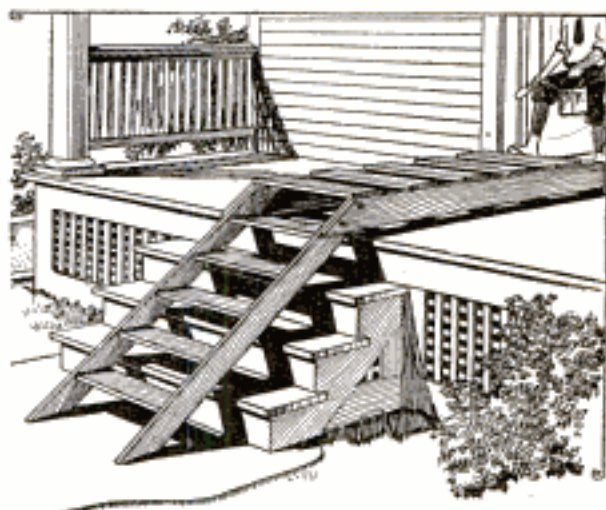
A Coil of Wire, Fastened between Two Supports on a Base, Makes a Good Pen and Pencil Rack

eter, should be used. The length of spring, when free, should be such that a pressure will be required to force it between the end pieces of the frame. In securing it in position holes should be provided in the frame so the ends of the spring may be passed through and bent down, to prevent them from pulling back. The completed holder should be stained and varnished to match the desk or wall it is fastened to.

Emergency Steps

New fresh paint on steps compels the occupants of a house not to use them until the coating becomes dry. In some places it is almost impossible to discontinue the use of the steps for any length of time. To provide a means of

using an entrance where steps are freshly coated with paint, I made the arrangement shown in the illustration.

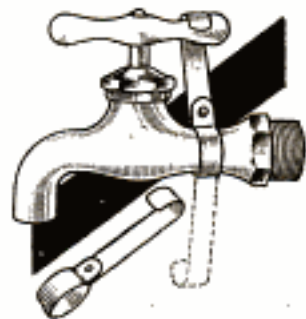


Temporary Steps Made of a Few Boards, to Provide a Way for Entering over Fresh Paint

It is constructed of a few boards in step form, and is bolted together so that it can be adjusted to different heights, or taken apart and stored.—F. Ibbotson, Toronto, Can.

Holding a Self-Closing Faucet Open

When a large quantity of boiling water is drawn from a self-closing faucet, the handle becomes too hot to be held unless it is covered with a cloth, or kept open in some other manner. A simple way to overcome the difficulty is to use an iron band, bent, at one end, to form a loose loop around the faucet which is held together with a rivet, or bolt and nut. The other end is made to fit the handle when it is in its open position. When not in use, the hook may be swung out of the way, as indicated by its dotted position.—Contributed by G. Jaques, Chicago, Ill.

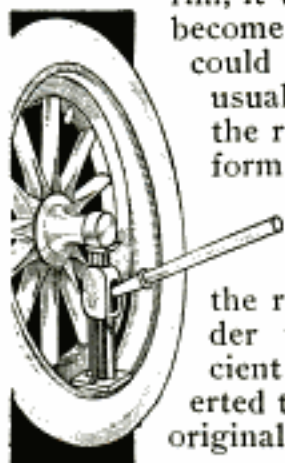


Ⓒ Warm high-speed tools, especially the lubricant, before using them.

Replacing Oval-Shaped Automobile-Wheel Rims

In trying to replace a demountable rim, it was found that it had become oval-shaped, and could not be put on in the usual manner. To force the rim back to a circular form a jack was used, as shown in the illustration. It was set with the base on the rim and the head under the hub, and sufficient pressure was exerted to force the rim to its original form, after which it was easily driven into place;

the entire operation requiring less than two minutes.



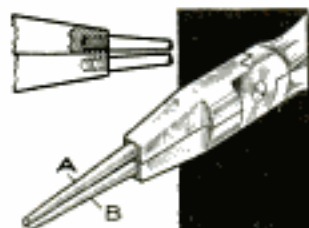
An Electric-Light Socket Hook

A hook by the aid of which an electric light can be attached to any particular place, is made as shown in the sketch. A band of sheet-spring stock is formed so that it will act as a clip on the lamp socket. The clip and hook can be made of one piece. The clip is slipped on and off the socket very easily, and proves a handy device for holding a light in a certain place temporarily.



Round-Nose Attachment for Pliers

An attachment consisting of two tapered rods threaded at one end, by means of which ordinary pliers can be quickly transformed into the round-nose type, is here shown. Two pins, A and B, of suitable size, are tapered and the larger ends, which are turned down slightly to form a shoulder, are threaded. The



ends of the plier jaws are ground on a slight angle, so that when they are drilled and tapped for the rods A and B, they will take the same angle, allowing them to close flush. Other attachments suited to special work can be made to fit threaded jaws, and prove of value to the mechanic without in any way interfering with the pliers being used in their original form.

A Pencil-Point Protector

To avoid breaking the pencil point every time the pencil is dropped, make an attachment as follows: Cut



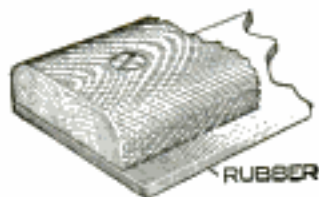
a piece of rubber, that is about $\frac{1}{8}$ in. thick, into

a square, a little wider each way than the diameter of the pencil. Make a hole exactly in the center and force it on the pencil point, as shown.

The rubber can be used as an eraser and it will also prevent the pencil from rolling off the desk. If the pencil is dropped the rubber will prevent the point from striking the floor.

Inexpensive Weather Strips

In cold climates weather strips on the door casings of houses are a necessity. The house owner who is also an automobilist can make for himself weather strips of the very best kind at very little expense. Such a one is illustrated. It



consists of a flat strip of rubber, fastened under a molding strip so that the yielding edge of the rubber will effectively seal the joint.

An old inner tube is cut into strips, 1 in. wide, which are fastened beneath strips of molding, about $\frac{1}{4}$ by $\frac{3}{4}$ in. in size. The strips are screwed to the door casing in such a position that the edge of the rubber will strike the door just before it strikes the door stop.

To Locate and Correct Troubles in Direct-Current Dynamos

By A. E. ANDREWS

PART II—Heating and Noise

Heating of the Armature

THE heating of an armature may be caused by an overload, or by its not being centrally located between the poles; by a short circuit, a broken circuit, or a cross connection, the remedies of which were given in the preceding chapter. Another cause is moisture in the armature coils. The remedy for the latter is to dry out the coils with a slow heat. This may be done by sending through the armature a current regulated not to exceed the proper value. If it is not so bad as to cause a short circuit, cross connection, or too much heat, the moisture may be dried out by the heat of the armature current itself while running.

Eddy currents in the armature core will cause heating. This results from a faulty armature core, which becomes hotter than the coils after a short run. The core should be finely laminated and the laminæ insulated. There is no other remedy than to rebuild the armature. Hot commutator bars and hot journals may affect the armature temperature. These troubles may be eliminated as described.

Heating of the Field Coils

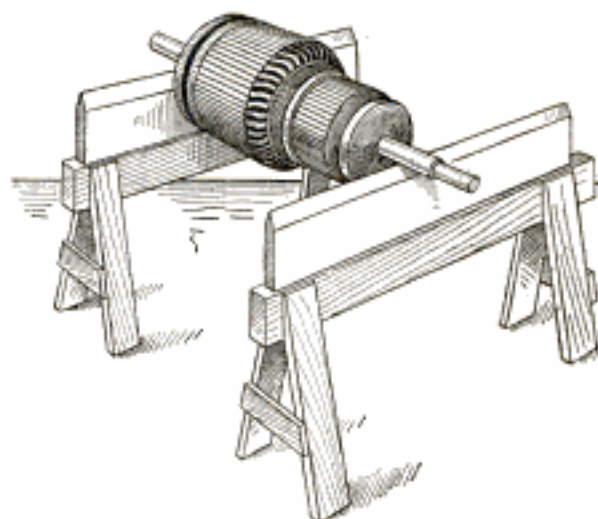
An excessive current in the field circuit will cause the heating of the field coils. If it is a shunt machine, decrease the voltage at the terminals by reducing the speed or by increasing the resistance of the field coils. The latter may be accomplished by winding more wire on the coils, by rewinding with finer wire, or by putting a resistance in series with the field.

In series-wound machines shunt a portion of the current, or take off one or more layers of wire, or rewind the fields with coarser wire. An excessive current may be due to a short circuit or to moisture in the coils acting as a short circuit.

Eddy currents in the pole pieces will cause the heating of the field coils. The

pole pieces may be hotter than the field coils after a short run, due to a faulty construction, or to a fluctuating current in the latter. Regulate and steady the current.

The coils may show a resistance lower than normal, which may be caused by a short circuit, or contact



Knife-Edge Leveling Bars Used for Locating the Heavy Side of an Armature

with the iron of the dynamo, or by a short circuit resulting from moisture in the coils. Use the same remedy as in drying out the armature coils.

Heating of Bearings

Among the main things to do is to supply plenty of good, clean oil and see that it feeds into the bearings properly. The best quality of mineral oil, free from grit, should be used. Be careful not to flood the bearings so as to force oil on the commutator, or into the insulation of the brush holders, as the oil will gradually char, gather copper dust and form a short circuit. Vaseline, cylinder oil, or other heavy lubricant, may be used if ordinary oil fails to remedy the hot box. Use it until the run is over, then clean up and adjust the bearings.

If the bearings have collected dirt, grit, or other foreign matter, wash it out by flooding with clean oil until

the run is over. Be very careful not to flood the commutator or brush holders. After the run is over, remove the cap and clean the journals and bearings, and when again assembled, lubricate them well. If it is necessary to remove the bearings completely, allow them to cool naturally, then polish and free them from grit, and reassemble. If a journal is rough, smooth and polish it in a lathe, to remove all burrs, cuts, scratches, and tool marks, then make new bearings of babbitt, or other metal, to properly fit the shaft.

If the journals are too tight in the bearings, slacken the bolts in the cap and put in packing pieces until the run is over; then fit them to smooth bearings and easy rotation by hand if the machine is small. Turn down the journal smooth, and repolish, or scrape, the bearings until they fit properly.

A bent, or sprung, shaft, if small, should be straightened by springing it while set between the centers of a lathe.

When bearings are out of line, loosen the base of the bearings, and shift them until the armature turns freely by hand with the belt off, while at the same time it is in the center of the polar space. Remount and, when fastened in place, fit new dowels, to allow the new position to be kept when the bolts are drawn up tightly. If the shaft needs to be raised or lowered, shim up or trim down the foot of the bearing to allow the proper setting.

The end pressure of the pulley hub or shaft collars against the bearings will cause heat. See that the foundation is level, and that the armature moves freely with a small amount of end motion. If there is no end motion, turn off the shoulders on the shaft, or remove a portion of the bearing ends with a file, until the necessary end motion is obtained. Line up the shaft so that the pulley and belt will cause no end thrust on the shaft, allowing the armature to have free end play while in motion.

Too great a load, or strain, on the belt will cause the bearings to heat.

Slacken the belt to reduce the strain. If possible, do not drive a dynamo with a vertical belt. The vibration or flapping of a belt will cause the lamps to flicker. If a belt slips when running slightly slack, use a larger pulley with a wider and longer belt. The slack side of a belt should be run on top so as to increase the adhesion and pull without excessive tightening.

If the armature is not centrally located between the poles, it will cause the bearings to heat, also the wear to come on one side. Center the armature in the polar space, and adjust the bearings to the new position. If the bearings have become worn from this cause, replace them with new ones. The polar space may not be exactly true, and in that case, file it out so that there will be an equal clearance all around the armature. Sometimes it is possible to spring the pole away from the armature enough to right the trouble, and then fasten it in the new position. This, however, is very difficult to do in large and rigid machines.

Noise

When an armature, or pulley, is not properly balanced, it will cause considerable noise. The only way to remedy this is to remove the armature and place it on balancing edges, to determine the heavy side. Weight is added to the light side to make the armature properly balanced. If the armature strikes, or rubs against, the pole pieces, file out the pole where the armature strikes; and should a coil strike, press it down and secure any projecting wires with proper tie bands of strong wire.

The collars, or shoulders, of a shaft, hub, or web of a pulley may strike or rattle against the bearing. The bearing may be loose or worn out and cause a noise. New bearings may be required, or portions may be cut off to prevent their striking moving parts. Tighten up all screws, bolts and connections to make a bearing firm, and keep them so by daily attention. The jar and moving of dynamos tend to work screwed connections loose.

If the brushes sing or hiss, apply a little mineral oil, or, better still, vaseline, or hold a piece of stearic acid to the commutator and then wipe off, just leaving a faint trace of the oil, or grease. Lengthen or shorten the brushes in the holder until a firm, yet gentle, pressure is maintained, free from any hum or vibration.

A laced belt will cause the flapping, or pounding, noise. If possible, use an endless belt. Where a laced belt must be used, have the square joints

properly laced. The slipping of a belt, caused by an overload, may be overcome by making the changes described previously.

Humming caused by the armature lugs, or teeth, passing the pole pieces may be overcome by sloping the ends of the pole pieces so that the armature teeth will not pass the edges all at once. This humming also can be greatly reduced by decreasing the magnetism of the fields, or by increasing the magnetic capacity of the teeth.

Forcing Oil into a Bearing

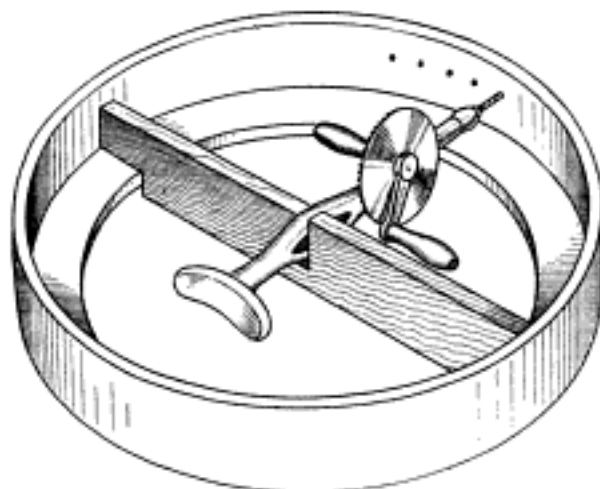
Sometimes when a bearing becomes heated and requires oil it will be found that the oil will not flow down in the oil hole. Either the hole is clogged with dirt or the heat may cause the air to rise and prevent the oil from entering. Where a wire cannot be used effectively, the following remedy, although it is not infallible, is almost sure to make the oil reach the bearing. Fill the hole with oil and quickly place the thumb over it to prevent the air from escaping, and if the oil cup does not leak, the heated air inside will rise above the oil, and in two or three minutes it will be forced into the bearing, even if it has to pass considerable dirt. When a bearing cannot be reached in this way, and when light oils, such as kerosene, are ineffective, try placing a little mercury in the oil hole and allow it to remain a few minutes, then use oil.—Contributed by J. B. Murphy, Plainfield, N. J.

Show-Case Match Box to Prevent Waste of Matches

To reduce the waste of matches placed on a cigar case, one dealer used the following device: The cover on a shallow cigar box was removed and nails were driven into the bottom from the under side so that they projected into the box and about 1 in. apart. Only the thumb and forefinger can be introduced between the nails, and two or three matches at most can be taken.

Drilling the Inside of a Ring

A ring of cast iron, 42 in. in diameter and having a flange on one edge, was designed to have a row of holes on the inside, spaced to given dimensions,



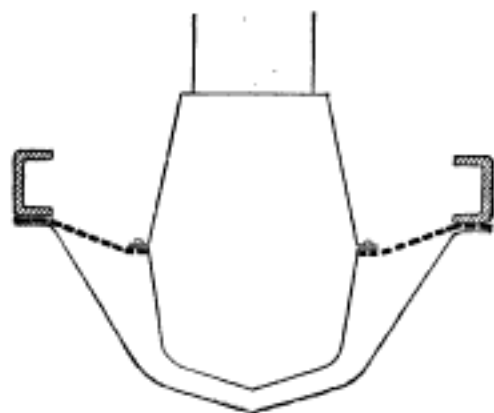
Drilling Holes Accurately and Quickly on the Inside Surface of a Large Ring

drilled in the same horizontal plane of the ring, and accurately radial. The holes were spaced out correctly with dividers and marked with a prick punch. To drill them did not appear so easy, as the holes were on the inside only and small in size. To drill them in a machine meant a lot of rigging up for a small amount of work.

The drilling was accomplished quickly as shown. The block of wood was so cut that it would hold the breast drill perfectly radial when the drill was set in the punch mark. A man stood inside of the ring and drilled the holes in a short time.—Contributed by Donald A. Hampson.

Improved Type of Automobile Sod Pan

The usual type of sod pan used in automobile construction is fastened to the frame side members of the car, and

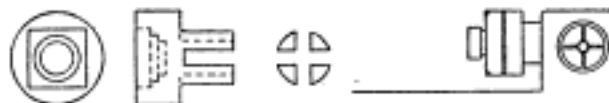


Sod-Pan Construction That Makes the Lower Part of the Crank Case Easily Accessible

passes under the engine crank case, as shown by the full line in the sketch. This is not only a very heavy and expensive construction, but the pan often jars loose, and must be removed from the chassis when being cleaned. The sod pan substituted is shown by the dotted lines, and simply consists of metal sheets, fastened on one side to the flange of the lower crank case, and on the other to the frame side members of the chassis. This construction is cheap, very light, and can easily be cleaned. The lower part of the crank case is exposed, but the dirt collected on it can be easily removed without disturbing the sod pan.—Contributed by Adolph Kline, Newark, N. J.

Jig to Thread Pipes in a Bolt-Cutting Machine

Machine shops are frequently equipped with bolt threaders but have no provision for threading pipe in any



The Jig as It is Attached in the Chuck of the Bolt-Cutting Machine to Thread Pipes

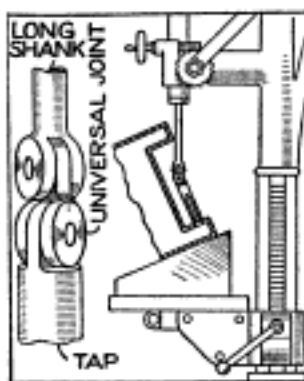
other way than by hand. The simple jig shown can be easily made and will do the work with but little special preparation. It consists of a metal

block provided with a square opening at one end, to fit the pipe dies, and countersunk so that the pipe can enter far enough for the standard length of thread. The back end of the block is turned to fit the inside of the regular bolt-cutter chuck, and slotted to match the dies, any size answering the purpose.

In using the jig, it is put into the chuck with the slots slipped over the dies. It is best to protect these with strips of copper placed in the slots. The required pipe die is put in place in the square opening at the front end. The pipe is held with the vise, and threaded in the same way as a bolt. In backing off, either the machine may be reversed or the die withdrawn and unscrewed with a wrench.—Contributed by F. W. Bentley, Milwaukee, Wisconsin.

Universal Joint on Drills and Taps

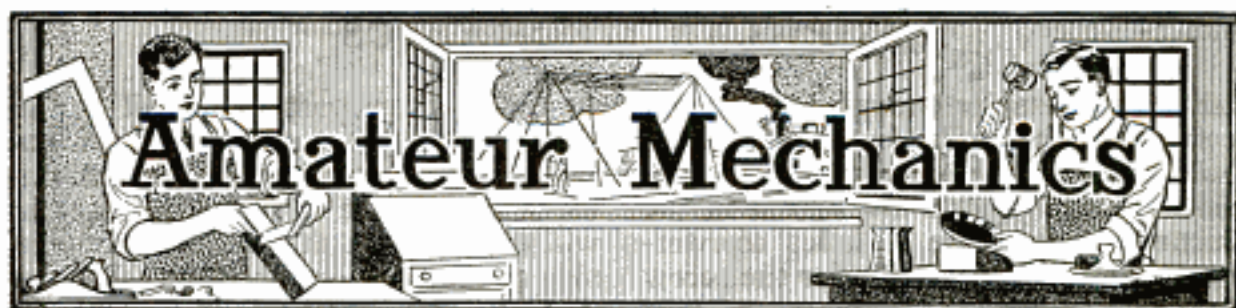
Castings are frequently designed for holes under overhanging portions,



which makes it impossible to do direct machine drilling in a drill press unless some special arrangement is provided. If the cutting tools are constructed with universal joints, as shown in the illustration, the

drilling and tapping can be easily accomplished. One end of the joint is fastened to the tool and the other to an arbor. The arbor end is gripped in the chuck of a drill press. In drilling such a hole, it is best to provide a special guide block which can be clamped in position on the casting.

Iridium is used principally for the hard points on gold pens, for making platinum hard and springy, and for making a black glaze on glass or porcelain.



A Small Shocking Machine

AN amusing as well as instructive shocking machine, usually called

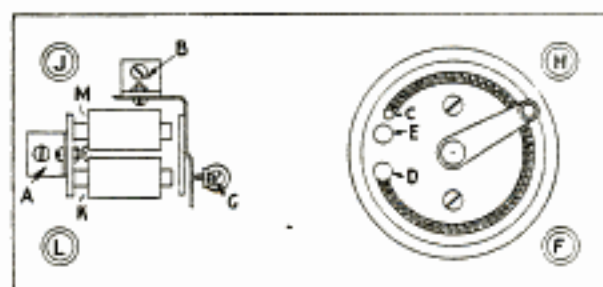


FIG. 1

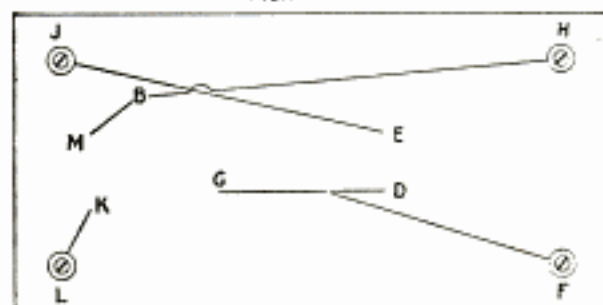


FIG. 2

The Base upon Which the Buzzer and Rheostat are Fastened, and the Electrical Connections

a medical coil, can be easily constructed from a discarded buzzer or electric bell, four binding posts, some pieces of insulated wire, two carbon rods, and a rheostat.

A base for attaching the parts is made of a piece of poplar, 10 in. long, 5 in. wide, and $\frac{1}{2}$ in. thick, which can be finished as desired, but a good method is to shape the edge like molding and give it a mahogany stain, and when dry apply a coat of white shellac, which should be allowed to dry a day, whereupon the

surface is rubbed with prepared wax. When the base is ready, mount the buzzer at one end. This can be easily done by making an L-shaped piece of metal, A, which is fastened to the base with a screw, and to the yoke of the magnet coil with a small bolt. If the armature and its connections are also used from the buzzer, the height of the coils must be taken in consideration. These parts are fastened in position as shown, using an L-shaped piece of metal, B, for the spring end. The screw holding the armature spring to the base, as well as the vibrator screw, should be of such a length that it will



The Shocking Coil as It is Used for Amusement, or in the Manner a Current is Given a Patient

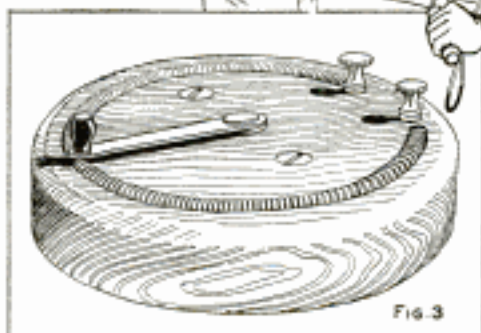


FIG. 3

Left: The Rheostat That is Used to Regulate the Flow of Current in the Carbon Hand Pieces

enter the base far enough to permit a connection for a wire in a countersunk hole bored in the base from the under side. Binding posts are placed in the corners of the base in holes countersunk from the under side for the screw heads.

The rheostat is of the miniature-battery type, which has a round base and a coil of resistance wire with a lever passing over the coil. Such a rheostat can be purchased from an electrical store, but if the person constructing the shocking machine desires to make one, it is not difficult if a lathe is at hand.

To make the rheostat, turn up a disk, about 3 in. in diameter, from a piece of hard wood, such as oak, maple, or walnut, and form a circular groove in the upper surface, about $\frac{3}{8}$ in. inside of the circumference. The groove is to admit a circular coil of resistance wire, and in making it, be sure to have it the proper size to take the coil snugly. The coil can be of any size, and to make it, resistance wire is wound around a piece of wire used as a mandrel. If the coil is $\frac{1}{4}$ in., or a trifle smaller, in diameter, it will make a good size. Be sure that the depth of the groove is such that it will allow a part of the coils of the resistance wire to project above the surface of the wood disk. The coil of wire should be just long enough to fit in the groove and allow a 1-in. space between the ends, one of which is anchored to the base, at C, the other being attached

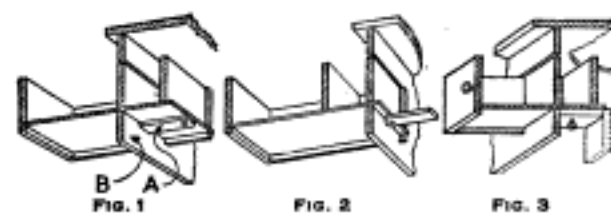
to the binding post D. Drill a hole through the center of the disk and fasten a lever, taken from a switch, or one made of a piece of sheet brass, that will extend from the center to the outside of the disk, or over the resistance-wire coil. A small handle is attached to the outer end. A connection is made from the center support of the lever to the binding post E.

The connections for the buzzer and rheostat are made on the under side of the base, where grooves are cut to run the wires in, so that they will be below the surface of the wood. In the diagram, the binding post F is connected to the binding post D of the rheostat, which in turn is connected to the screw of the make-and-break point G. The other binding post H is connected to the bracket B supporting the armature spring. The binding post E of the rheostat is connected to the base binding post J. The magnet coils are connected, as shown, from K to L, and from M to B.

The two pieces of carbon, which are used for the hand pieces, are connected with silk-insulated wire. These connections are made to the binding posts F and H. The other two binding posts, J and L, are connected to a battery. The carbons used may be purchased, or taken from an old battery. Two or more dry cells are used for the current. The rheostat controls the amount of current passing through the hand pieces.—Contributed by Gilbert Crossley, Erie, Pa.

Secret Compartment in Ordinary Table Drawer

It is frequently desired to have some handy place for storing valuables where



Two Positions of the Strip for Holding, or Giving Access to, the Secret Part, and a Hinged Strip

there is but little chance of discovering them. Secret drawers in tables usually require special and expensive changes, but with only a few simple changes on a regular drawer of any ordinary table, a secret compartment can be made which is as secure as can ordinarily be figured on, outside of a steel safe. Having chosen the desired table, a partition should be placed across the entire back part of the drawer, allowing for necessary space in the secret compartment. This partition should resemble the real back of the drawer as closely as it is

possible to make it. The compartment must not be too wide, for the resulting small width of the front part of the drawer might then arouse suspicion. On the lower side of the secret compartment a strip of wood, A, should be attached with a screw, as shown in Fig. 1, allowing sufficient looseness so the strip may be turned end for end when necessary. With the strip set as shown, it will strike the front side B of the table when the drawer is pulled out, leaving the secret compartment still hidden. In order to expose this, it will be necessary to turn the strip, as shown in Fig. 2, when the drawer can be pulled out to its full length.

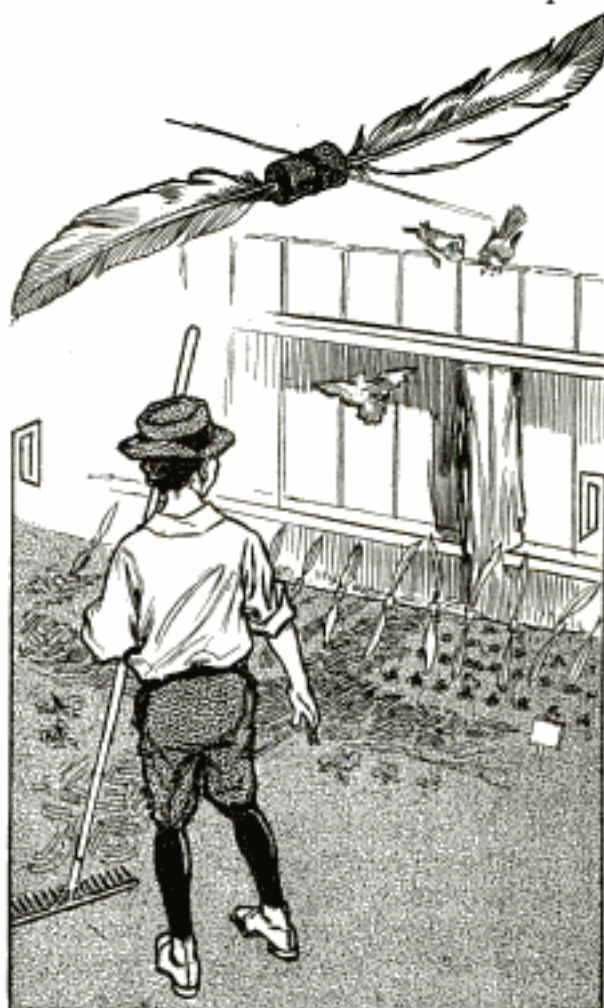
It being necessary that the strip A be as long as the secret compartment is wide, to fully expose this, there may be cases where the drawer is not wide enough to allow the strip A to turn around. In that case the strip can be hinged to the back of the drawer as shown in Fig. 3. When it is hanging down, as shown by the dotted outline, the drawer may be pulled out to its full extent. When it is desired to lock the secret compartment, the hinged strip must be swung up in position, and fastened. An ordinary thumbscrew or eye can be used which, by a turn or two, will either release it or fasten it in place.—Contributed by Paul Durst, Detroit, Mich.

Inflating Handballs

When handballs become "dead," or no longer bounce freely, they may frequently be restored by inflating them with air. This can be done by means of a bulb attached to a hypodermic needle. The needle must be inserted through the soft plug which every inflated ball has, and which can be discovered by pressure. After the ball is inflated and the needle extracted, the soft rubber closes around the fine hole, preventing the escape of the air. If a leak is found, which allows the air to escape too rapidly, a repair can be made with a single-tube tire outfit.—Contributed by A. B. Wegener, Camden, N. J.

A Garden-Bed Scarecrow

A very neat and successful scarecrow for garden beds can be made as follows: A number of corks are pro-



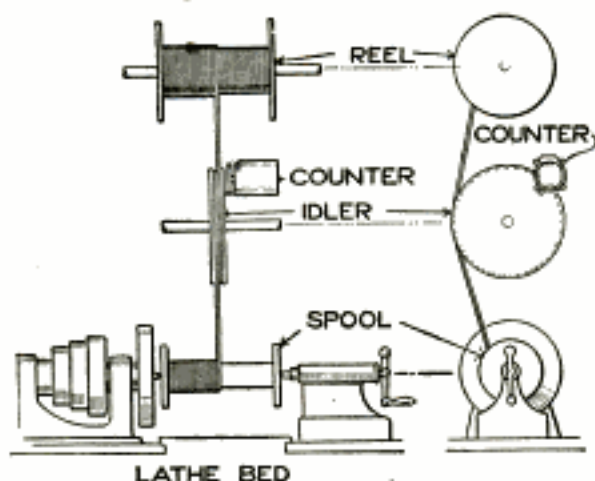
The Fluttering Feathers Attached to the String with Corks Scare the Birds Away

cured, and a feather is stuck in each end of them, as shown. These are tied to a string, spacing them from 1 to 2 ft. apart, and the string is hung over the beds. The slightest breeze will keep them fluttering, and no bird will come to rest on the beds.—Contributed by M. T. Canary, Chicago.

Measuring the Length of Wire Wound on a Spool

When winding magnet spools on a lathe, the exact amount of wire used can be easily determined by means of the device shown in the illustration. The large reel from which the wire is obtained is conveniently placed on a

loose mandrel, or rod, near the lathe, and in line with the spool which is to be wound. A grooved idler wheel, the ex-

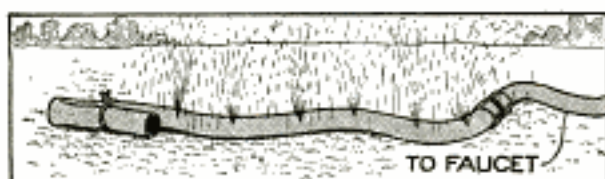


Measuring the Length of Wire on a Spool with the Use of an Idler and Counter

act diameter of which is known, is supported between the spool and wire reel so it may freely revolve; the number of its revolutions should be obtained, automatically, by a revolution counter. When using the device, the wire from the reel is placed once around the idler to insure the necessary grip to prevent it from sliding; then it is led to the spool. The exact diameter of the idler being known and the number of revolutions indicated, the true length of the wire wound on the spools can be easily determined by the following formula: Length of wire on spool in feet equals circumference of idler in feet times number of revolutions of idler.—Contributed by C. Swayne, St. Louis, Mo.

Homemade Lawn Sprinkler

With a short length of old hose, a serviceable lawn sprinkler can be quickly and easily made. One end is provided with a regular coupling for connecting it to the line of good hose. The other end is turned up for several inches, and securely wired to the main

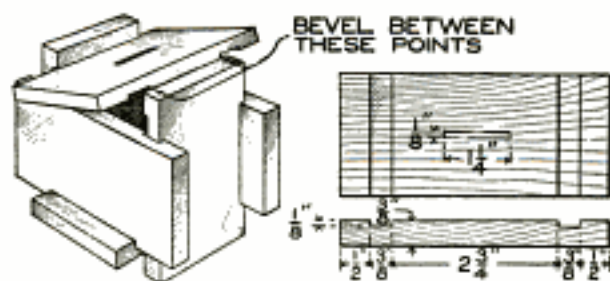


The Slots Cut in the Hose will Produce a Very Fine Spray of Water

part, thereby shutting off any flow through it. Several cuts are made into it, about halfway across and 6 in. apart. If the water is forced in, the only means of escape will be through the slots, which will produce fine sprays, giving as good service as a manufactured sprinkler.—Contributed by A. B. Shaw, N. Dartmouth, Mass.

Homemade Toy Bank

The little bank illustrated is not exactly burglar-proof, but once put together it cannot be opened except by the destruction of one of the units of which it is composed. It requires but little skill to make, and would be a good problem for manual training, as it offers an excellent opportunity for teaching certain rudiments of wood-working by the application method.



Six Pieces of Wood as They are Put Together to Form a Toy Bank

In its construction, six pieces of hard wood, of the dimensions shown in the sketch, are required. White wood will do if there is no hard wood at hand. The coin slot is $\frac{1}{8}$ in. wide by $1\frac{1}{4}$ in. long, and is cut in only one piece.

No difficulty will be experienced in putting the first five pieces together, but the sixth, or top, piece, shown in the sketch, will not go in, because the bottom edge of the raised side will strike the inside of the piece to the right. By beveling this edge with a chisel from top to bottom between the dadoes, or grooves, it can be forced down quite a distance and sprung in place by placing a block of wood on the high side and striking it a sharp blow with a heavy hammer.—Contributed by J. A. Shelly, Brooklyn, New York.

Reed Furniture

By Chas. M. Miller

A Reed Basket

See May 16-793 - July 16-153

INASMUCH as there is a great demand for reed furniture and since good weavers are comparatively few in number, it would be well to learn the process of reed weaving. The weaving operations can be learned much better through the construction of some small article, such as a basket or jardinière cover. The center is the most difficult part of the basket making, and it is best to begin with wood bottoms, as the whole basket can be kept in a much better form due to the stiffness furnished by such a bottom. It is also an approach to the reed furniture which is woven on framework. The objectionable feature of the wood bottoms is the unfinished appearance of the wood edge showing through, but this can be overcome by the use of the roll shown in the illustration.

While the wood bottoms have been

used for this class of work for a number of years, the roll is new and is very popular with those who have seen and used it. The roll can be placed in many ways on different-shaped baskets, and other reed pieces, so that it is best to master this piece of work thoroughly before attempting the other, or larger, pieces that will be described later, in other articles.

The description is for a basket 5 in. in diameter and 3 in. high, as shown in the illustration. A disk of wood, $\frac{1}{4}$ in. thick and 5 in. in diameter, is required. Basswood makes the best bottom, but pine, or cedar, will do. Cut a board about 6 in. square, and draw diagonal lines on it intersecting at the center, then draw a circle, 5 in. in diameter, as shown in Fig. 1; also another circle, using the same center, $4\frac{3}{4}$ in. in diameter. Set compass points about $\frac{5}{8}$ in. apart, and step off spaces on the inner

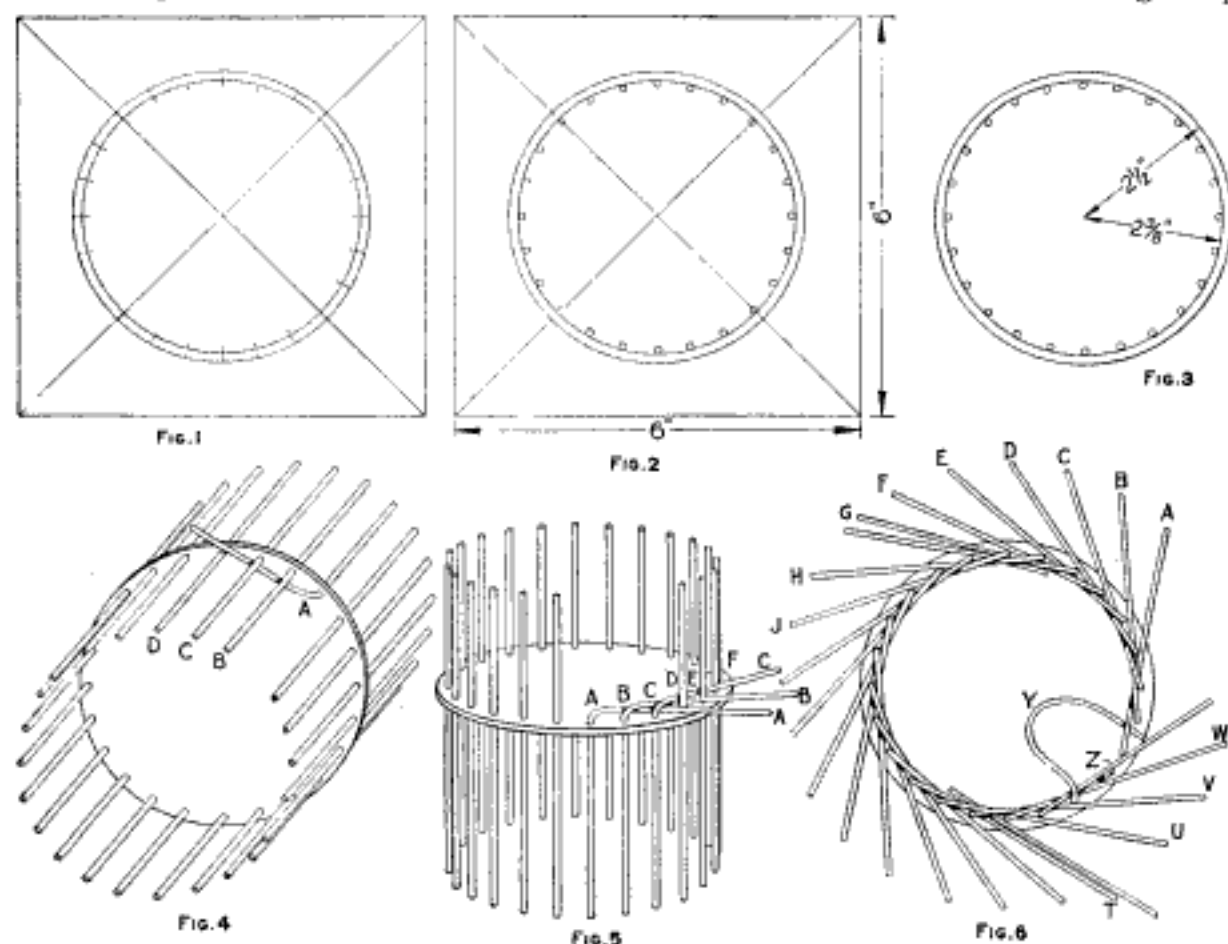


circle to make 24 points. This will have to be tried out more than once, to get the spaces to come out evenly and just have the right number of points. Holes are bored with a $\frac{1}{8}$ -in. bit, just inside of the inner circle, back of the places marked by the compass points, as shown in Fig. 2. Cut the board on the outside circle with a coping, or turn, saw, to make the circle, as in Fig. 3. Do not saw out the circle before boring the holes, as otherwise the disk might split in places.

The reeds placed vertically are called spokes, and the horizontal ones are the weavers. For the spokes, what is called a No. 4 reed is used. Do not wet the spokes before putting them through the wood. Allow the ends to project about $5\frac{1}{2}$ in. below the bottom, as shown in Fig. 4. Place the bottom, with the spokes, in water, and soak them thoroughly, especially the part below the bottom. About 15 minutes of soaking will be sufficient to make

them pliable enough to bend over at right angles. It will not injure the wood bottom to soak it with the reeds. As shown at A, Figs. 4 and 5, each spoke below the wood bottom is bent down and back of the two nearest spokes, B and C, then out between the third and fourth spokes, C and D, and so on. The last two spokes, Y and Z, Fig. 6, are forced under the spokes A and B, respectively. In this illustration the spoke Y is shown as it is being inserted under the spoke A. When this operation is completed, the bottom will have the appearance of a fireworks pinwheel.

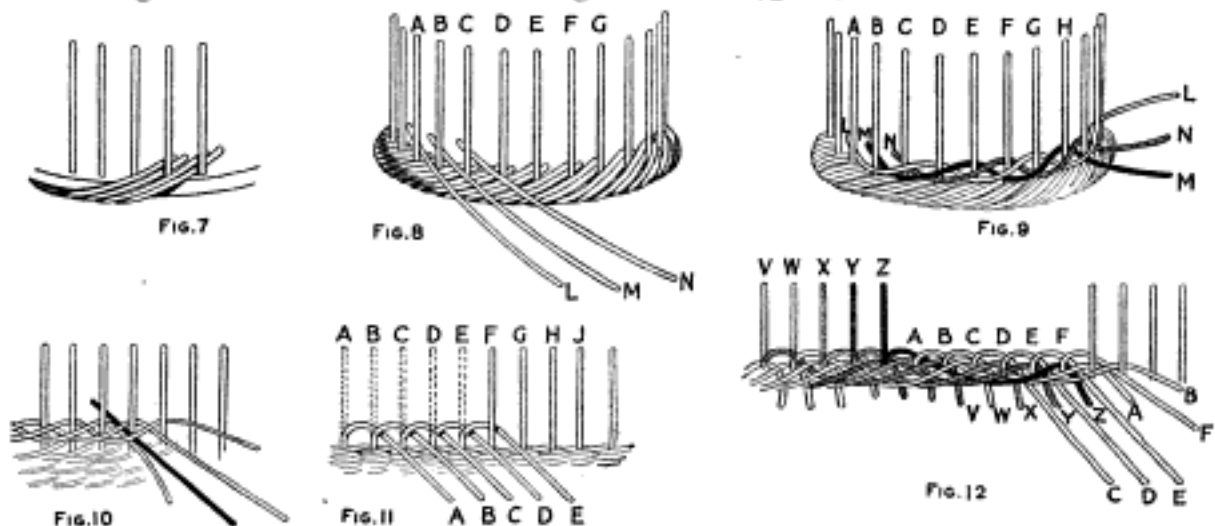
Continue the bending of the spokes, in the same direction, up and across the thickness of the wood in front of three other spokes and behind the fourth, as shown in Fig. 7. This would not cover the edge of the wood entirely, and, for this reason, other short spokes must be inserted in front of each of the first ones before it is brought up



The Bottom is Cut from a Piece of Wood to Give Strength and to Avoid the Most Difficult Part of the Weaving; the Reeds are Attached to the Bottom and Their Lower Ends Bent as Shown

across the edge of the wood. These supplementary spokes should be about 4 in. long. The manner of inserting

a weaver is used up, press it back to the side a little, push in a new reed about 1½ in., and continue the weav-



The Lower Ends of the Spokes are Turned to Cover the Edge of the Bottom, Then the Reeds are Woven into the Upright Spokes to the Right Height, Where They are Broken Down and Woven into a Top Border

these spokes before making the bend is shown at G and T, Fig. 6. The double spokes must be pressed down flat, when brought up in place, without riding one on the other. If the ends are too long and interfere with the next pair, they can be cut off a little with a flat chisel, or knife, being careful not to make them too short, or the pieces will not stay in place. If there is still an open space, an extra, short spoke can be inserted to crowd the pieces together and fill up the space.

When the roll is completed, insert three weavers, of No. 3 reed that has been soaked about 15 minutes, placing them between the spokes A and B, B and C, and C and D, as shown in Fig. 8. Pass weaver L in front of the spokes B and C, then back of D and out between D and E. Weaver M is passed in front of C and D, back of E and out in front of E and F. These operations are clearly shown in Fig. 9. The weaver N is placed in front of D and E, back of F and then in front of G and H. At this point the weaver L is used again. The weaver farthest behind each time is brought in front of the two spokes nearest to it, then behind the third and out in front of the next two spokes. Do not try to use weavers longer than 8 ft., which is about half the length of a reed. When

ing. This is clearly shown in Fig. 10. This weaving is known as the triple weave, which cinches down well and holds tightly. The first round should be carefully worked, so as to get the ends of the roll properly pressed down flat in place. Each throw of the weaver should be well pressed down.

The break-down-tight border is used for the finish at the top. The first operation in making this border is shown in Fig. 11. The spoke A is bent over back of spoke B and out between spokes B and C. The spoke B is bent over back of the spoke C and out between C and D, and so on, until the spoke E is turned down. Then take the end of the spoke A, Fig. 12, and lay it over B, C, D, and E, in front of F, back of G, and out between G and H. The end of spoke F is then brought down, also between G and H, but back of the end of A. The end of B takes a similar leap, passes behind H and out between H and J; then G is brought down behind the end of B, in the same manner as F was brought down back of A. The last four or five spokes are the most difficult to handle, as they must be forced through the first ones to correspond with those already in place. It is best not to pull the ends of A, B, C, and D down too tightly at first, keeping in mind that the last ones

must be inserted under the first ones. The last standing spokes are represented by the full and shaded lines.

If the roll illustrated in Figs. 11 and 12 is too difficult, a simple break-down can be used, such as shown in Fig. 13. To make this finish, spoke A is turned back of spoke B, in front of spoke C and back of spoke D, but not out again. Spoke B is bent back of C, in front of D, and back of E. The others are turned down the same way. The manner in which the two last spokes are turned down and inserted is shown by the double dotted lines.

The remainder of the illustrations show the method of forming a roll between the first and second spokes, where only three spokes are turned down before the throwing-across process begins. The first three spokes turned down are shown in Fig. 14, and the throwing over, in Fig. 15. The second beginning is shown in Fig. 16. The finishing of this top is shown in Figs. 17 and 18. The full, heavy lines represent the final insertions, and the reed must be in quite a sharp loop to make the end enter the right place. It is then drawn down and forced in front of the other reed that passes out between the same spokes.

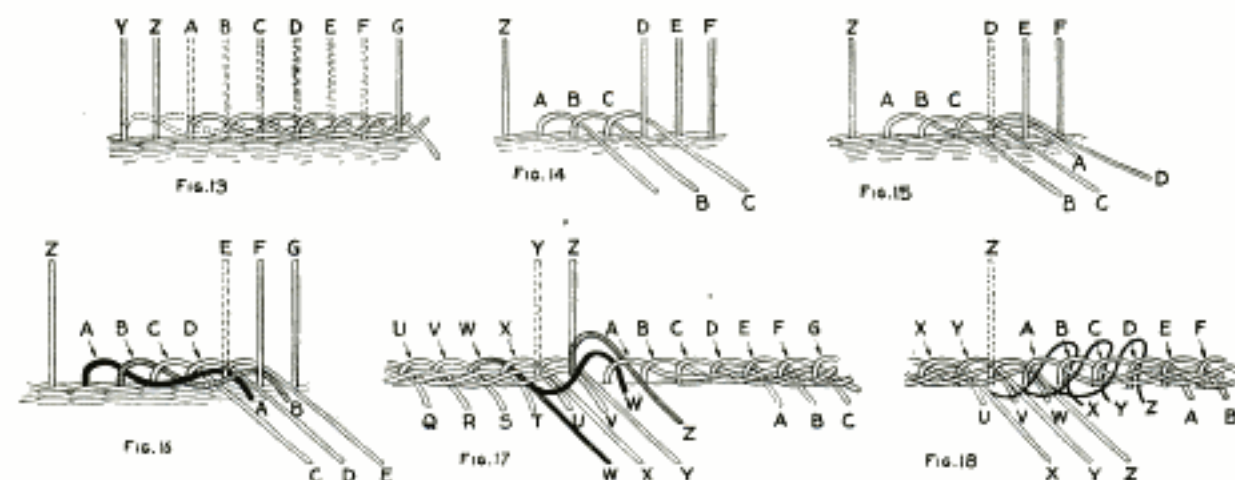
When the basket is dry, the long ends can be cut off close up with a

other, flame that will not smut. If it requires bleaching, brush some chloride of lime, mixed in a little water, over the reeds and set in the sunlight for a short time. It is better to leave the finish a little dark rather than use too much bleaching, as the latter will give an objectionable whitish appearance that looks like a poor job of painting.

In working the reeds, do not leave them in the water longer than necessary, as this will turn them dark. A bleached reed will stand the water much longer than in the natural state. Dampen the reed frequently while weaving it, as the weavers pack down much closer when wet. The dampening process is also required to remedy the drying out caused by whisking the reeds through the air in weaving operations. A great variety of baskets can be made from this form, viz., low, tall, tapering vase forms, bowl shapes, etc., in plain or dark weaves.

Wireless-Lighted Lamp Deception

Window displays of puzzling nature usually draw crowds. A lighted globe lying on its side in full view, yet apparently not connected to any source of electricity, could easily be arranged as a window display, deceiving the closest observer. A mirror, or window glass,

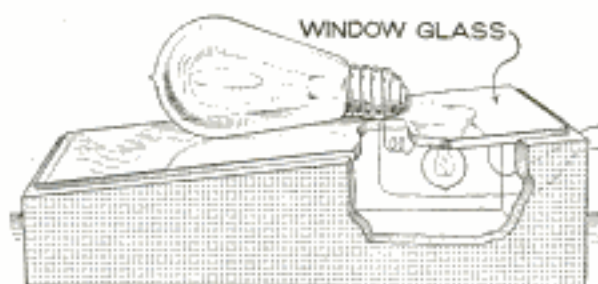


A Simple Break-Down Roll for the Top. Also a Method of Forming a Roll between the First and Second Spokes Where Only Three Spokes are Turned Down Before the Throwing-Across Process Begins

knife, being careful not to cut a weaver. If there are hairy fibers sticking out they can be singed off over a gas, or

backed with some opaque material, should be used for the foundation of the device. For the display lamp, it is

best to use a 25 or 40-watt tungsten, as these will lie flatter on the glass than the larger sizes, and the deception will not be as easily discovered. The place where the brass cap of the lamp touches the glass should be marked and a small hole drilled through to the wire connecting the tungsten filament to the plug on the top of the lamp. At any suitable place, a hole should be drilled in the glass plate, no larger than is necessary, to permit two small cotton-covered magnet wires to pass through. One of the wires should be looped, passed through the hole in the cap and hooked onto the bare wire connecting with the plug on top of lamp. The other wire should be fastened to the brass cap, near the drilled hole, after which the lamp may be placed in position and the two wires connected to a source of electricity. If proper care has been taken and no crosses oc-



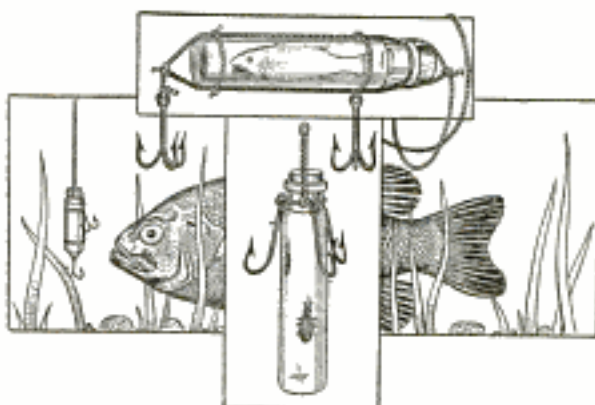
An Electric Globe Lighted on a Piece of Glass Makes a Good Window Attraction

cur, the lamp will light, and if the display is placed in the proper surroundings, it will prove very deceiving. To protect against a fuse blow-out from a short circuit, it is advisable to run another lamp in series with the display lamp, as shown.—Contributed by Clyde W. Epps, Mineola, Tex.

Live Bait Used in Fishing

With the simple device illustrated, no fisherman need worry over running short of bait or even regarding the usual repeated baiting of the hook. A small clear-glass bottle should be procured, and several hooks wired to it about the neck, or at each end, as desired or found best after several trials. After filling the bottle with water a live minnow is placed in it, and the bottle is sealed with a cork, which is

notched around the edge to permit water to enter or leave the bottle without losing the bait. If live grasshoppers,



The Bait is Kept Alive and Unharmed in a Bottle Surrounded with Hooks

or similar bait, is desired the cork can be used unnotched to form a water-tight stopper. As illuminated bait for night fishing, several fireflies can be put in the bottle.—Contributed by L. Wahrer, Tiffin, Ohio.

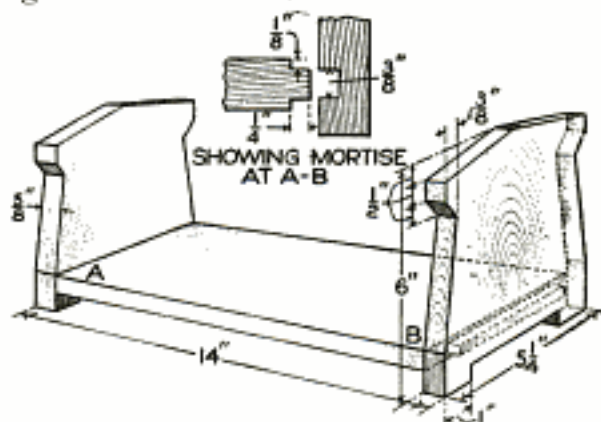
Bookrack

The material necessary for the illustrated bookrack is as follows:

- 2 end pieces, $\frac{5}{8}$ by $5\frac{1}{4}$ by 6 in.
- 1 shelf, $\frac{5}{8}$ by $5\frac{1}{4}$ by 13 in.

The shelf is cut rectangular, $5\frac{1}{4}$ in. wide by $14\frac{1}{2}$ in. long. Its two ends should then be provided with tenons $\frac{3}{8}$ in. thick by $4\frac{1}{4}$ in. wide, and extending out $\frac{1}{4}$ inch.

The end pieces, after being cut to the given dimensions, are marked off and



A Bookrack That can be Made in Any Wood to Match Other Furniture

cut out for mortises to fit the shelf tenons.

In assembling the parts, they are

glued in place, and clamped with hand screws until the glue has set. Any of the good mission stains, properly applied, will give a finished appearance to the bookrack.

A Paper Gas Pipe

When one fits up an attic or a back room as a workshop, it is seldom that a gas connection is available on about



CROSS SECTION OF JOINT

The Tube is Run Out Horizontally from the Chandelier to the Wall Where the Drop is Connected

the same level as the workbench so that a Bunsen burner and soldering apparatus may be operated. To install the standard gas pipe, it would be necessary either to alter the chandelier connection or to tear up some of the plaster, the former plan resulting in a rather conspicuous display of pipe and the latter in considerable expense. The following method permits the rolling of a pipe, about the size of a lead pencil, from paper that becomes so stiff that it is almost impossible to crush it between the thumb and fingers. This small inconspicuous pipe may be run directly from the side of the valve on the chandelier to the wall, as shown in the sketch, thence down some corner

formed by a door jamb or window frame, which protects it and renders it almost unnoticeable.

A good grade of tough Manila paper should be procured and cut into strips, about 18 in. long and wide enough to build up a tube at least $\frac{1}{2}$ in. in thickness. This will require from 4 to 6 in., according to the thickness of the paper. A piece of $\frac{1}{4}$ -in. round iron or hard wood, 20 in. long, is procured and carefully oiled or greased. Apply a coat of strong fish glue to one of these pieces of paper, omitting a strip along one edge, about 1 in. wide. Using the outspread fingers of each hand, begin with the unglued edge and roll the paper around the wood. As it is impossible to get the paper uniformly tight with the fingers, select a smooth place on the table and then roll the newly formed tube forward by means of a piece of board, as shown in the illustration. On the return stroke lift the board. In this way it is possible to get a tight, smooth tube. Immediately withdraw the core, twisting it slightly in a reverse direction if it tends to stick. Before using the core again, make sure it is free from glue and regrease it. When a sufficient number of tubes have been made and hardened, neatly trim the ends off squarely, and then form an equal number of short tubes, about 2 in. long, by winding a strip of glued paper on a large wire nail until a diameter is reached that will fit snugly into the pipes already made. The joints may then be set up with strong glue and finally wrapped with two thicknesses of paper on the outside. The construction of these joints is shown in the cross section.

The connection with the chandelier can be made by means of a metal tube soldered in at a point where the regular valve will cut off all connection with the paper piping when it is not in use. This metal tube should be coated with thick shellac, and the paper tube slipped over it for 1 in. or more, after which the joint should be given several additional coats on the outside. A small regulating gas cock can be

attached to the lower end of the piping, and if this is rigidly fastened to the wall, or casing, the connecting and disconnecting of the rubber tubing will not disturb the piping in any way.—Contributed by John D. Adams.

Rubbing Slats for a Washing Board

In an emergency, and to substitute something for a broken glass rubbing plate on an ordinary washing board, I fitted a series of $\frac{3}{8}$ -in. dowels horizontally across the board, closely together. This proved to be better than glass or zinc, as fabrics adhered to the wood dowels and caused them to revolve, making a more desirable rubbing surface and accomplishing the work of loosening the dirt in the fabric with far less effort than that necessary on the metal or glass board.—Contributed by H. M. Spamer, Vineland, N. J.

Catching Bugs Attracted by Light

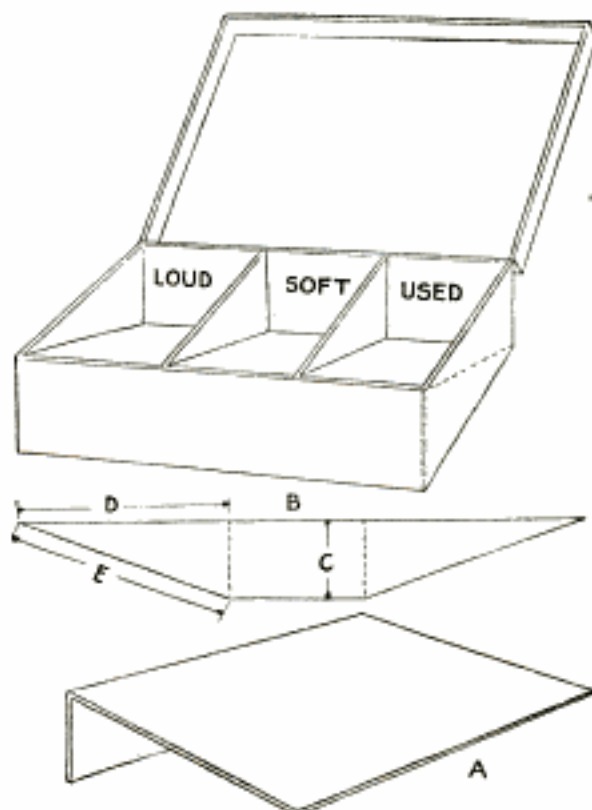
Bugs, moths, and insects attracted by lights on summer evenings can be caught by means of sticky fly paper, suspended as shades around the lamps. Cuts in the shade allow the greater portion of the light to pass through and attract the bugs, which will surely be caught as they travel about the light onto

the sticky paper. It is advisable to make two shades at the same time from a double sheet of the sticky paper, pasted, as when bought, with the sticky faces together so that the shades may be cut and handled easier.—Contributed by John J. Kolar, Maywood, Illinois.

Oilcans should be marked to indicate the kind of oil in them.

Needle Box for Talking Machines

An empty cigarette box can be easily changed to a useful container for talking-machine needles, as shown in the



Three Compartments are Provided with Sloping Bottoms in a Neat Box for the Needles

sketch. Take a fairly heavy card, trim it to the same length as the box, then bend and crease it, as shown at A, and glue the short, upright side to the inside of the box. Cut another card to the shape B, so that the depth C equals the inside depth of the box, and the side D is as long as its width. The side E should equal the inclined length of the card A, and is glued upon it when B is in position. The three compartments may be suitably labeled as indicated.—Contributed by V. A. Rettich, New York, N. Y.

Trick of Taking Dollar Bill from Apple

A rather pleasing, yet puzzling, deception is to pass a dollar bill into the interior of an examined lemon or apple. This can be accomplished in several ways, either mechanically or purely by sleight of hand. The mechanical

method, of course, is the easier and really just as effective. In performing, a plate with three apples is first ex-



The Dollar Bill is Hidden in the Knife Handle That Cuts the Apple

hibited, and the audience is given choice of any one for use in the experiment. The selected one is tossed out for examination and then returned to the performer, who places it in full view of the spectators while he makes the dollar bill vanish. Taking the knife he cuts the apple into two pieces, requesting the audience to select one of them. Squeezing this piece he extracts the dollar bill therefrom. The entire secret is in the unsuspected article—the table knife.

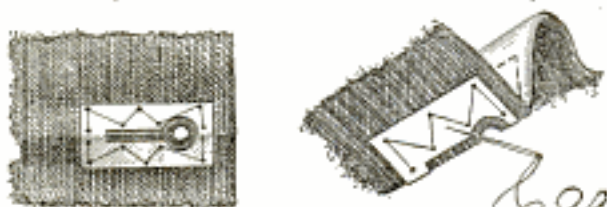
The knife is prepared by boring out the wooden handle to make it hollow. Enough space must be made to hold a dollar bill. The knife lies on the plate with the fruit, the open end facing the performer. After the bill has been made to vanish and the examined apple returned to the entertainer, he takes it and cuts it in half. One of the halves is chosen, the performer impaling it on the end of the knife blade and holding it out to view. While still holding the knife he turns the blade downward and

grasps the half apple and crushes it with a slight pass toward the knife-handle end where the bill is grasped along with the apple, which makes a perfect illusion of taking the bill out of the apple.

As to the disappearance of the dollar bill, there are many ways in which this may be accomplished. Perhaps the method requiring the least practice is to place the bill in the trousers pocket, and then show the audience that the latter is empty. This can be done by rolling the bill to small compass, and pushing it into the extreme upper corner of the pocket where it will remain undetected while the pocket is pulled out for inspection. Other combinations can be arranged with the use of the knife, which is simple to make and very inexpensive.

Guide for Making Buttonholes

It is almost impossible to make a perfect buttonhole in the ordinary manner by hand without a guide. The illustration shows a very simple guide that can be easily made by anyone. Procure two pieces of tin, or sheet brass, cut them as shown, and drill holes in them large enough for a needle, so that it will be easy to fasten them to the cloth with basting thread. Cut the buttonhole slot, then punch a hole at the end with an ordinary belt punch. Such a punch can be purchased from a local hardware dealer in any size. In making the buttonhole stitch, keep the



The Form of the Buttonhole is Cut in the Edges of the Two Pieces of Metal

needle close against the metal edge of the guide, as shown.—Contributed by A. L. Kerbaugh, Allentown, Pa.

ⒸAn easy way to put varnish in the grooves of a tennis racket is to use a medicine dropper.

Fishing-Rod Making and Angling

BY STILLMAN TAYLOR

Am. M. 8-813

PART II—Various Two and Three-Piece Rods

WHILE the action of the one-piece rod is undeniably better than when the rod is made in two or three pieces, it is less compact to carry. To make a 5-ft. two-piece bait-casting rod, the same dimensions as given for the one-piece rod will make a very fine fishing tool. It is well to make two tips in view of a possible breakage. The rod may consist of two pieces of equal length, but a rod of better action is secured by making the butt section somewhat shorter with a relatively longer tip. By making the butt section about 23 in. long, exclusive of ferrule and butt cap, and the



tip section $32\frac{1}{2}$ in. long, a splendid little rod is obtained which will fit any of the regulation rod cases of 35-in. length. To make a $6\frac{1}{2}$ -oz. rod of this kind with a cork hand grasp, caliper it in the same manner as the one-piece rod, making the butt section $32\frac{1}{2}$ in. long, tapering from $\frac{15}{32}$ in. at the upper end of the hand grasp to $\frac{19}{64}$ in. at the ferrule. The tip is made 33 in. long, tapering from $\frac{17}{64}$ in. to $\frac{7}{64}$ in. By making the tip and butt to these lengths, both parts will be of equal length when the ferrules and the tops

are added. The material list is as follows, the attachments being made of german silver: Dagame or greenheart butt, $\frac{5}{8}$ in. by 3 ft. long; two tips $\frac{3}{8}$ in. by 3 ft. long; one $\frac{3}{4}$ -in. reel seat with straight hood; one 1-in. butt cap; one taper, $\frac{15}{32}$ in. at the small end; two $\frac{3}{32}$ -in. offset agate tops; two $\frac{1}{2}$ -in. narrow agate guides; two No. 1 size one-

ring casting guides; one $\frac{17}{64}$ -in. welted and shouldered ferrule, with two closed-end centers, one for each tip; two dozen cork washers, $1\frac{1}{4}$ in. in diameter, and two spools of winding silk.

The three-piece rod should be made up to 6 ft. in length to secure the best action, but even if so made, the use of

The Making of a Rod Not Only Affords Much Pleasure, but the Rod can be Constructed as Desired

the extra ferrules makes the rod less resilient and elastic than the rod of one or two-piece construction. The best action is obtained only when the rod bends to a uniform curve, and since the ferrules cannot conform to this curve, or arc, the more joints incorporated in a rod, the less satisfactory it will be from an angling standpoint.

Convenience in packing and carrying are the sole merits which the many-jointed rod possesses. Complete specifications for making a three-piece bait-casting rod, together with a material list, is as follows: A rod, about 5½ ft. long with a single or double hand grasp made of cork, will weigh about 7 oz. Caliper the butt so that it will taper from 15/32 in. to 11/32 in. at the cap of the ferrule, making it 21½ in. long. The middle joint is tapered from 21/64 in. to 15/64 in., and is 21¾ in. long. The tips are 21 in. long and are tapered from 13/64 in. to 7/64 in. Dagame or greenheart is used for the butt, joint, and tips, and german silver for the fittings. All pieces are 2 ft. long, the butt is 5/8 in., the joint and tips, 3/8 in. One ¾-in. reel seat with straight hood; one 1-in. butt cap; one taper, small end 15/32 in.; one 21/64-in. welted and shouldered ferrule; one 15/64-in. welted and shouldered ferrule with two closed centers, one for each tip; two 3/32-in. offset agate tops; two ½-in. narrow agate guides; two No. 1 size one-ring casting guides; two dozen cork washers, and winding silk, size 00 or 0.

Fly Rods for Trout and Bass

Having made a good bait-casting rod, the amateur will find little trouble in making a rod with a number of joints, and no special instructions need be given, since the work of planing and smoothing up the wood, and finishing and mounting the rod, is the same as has been described in detail before. For fly fishing for trout, accuracy and delicacy are of more importance than length of cast, and the rod best suited to this phase of angling differs greatly from that used in bait casting. A stiff, heavy rod is entirely unsuited for fly casting, and while it is, of course, possible to make a rod too willowy for the sport, the amateur, working by rule of thumb, is more likely to err on the other side and make the fly rods of too stout a caliber. The idea is simply to help the amateur over the hard part by giving a list of dimensions of a representative trout and a bass fly rod. To make a 9-ft. trout fly rod, with a

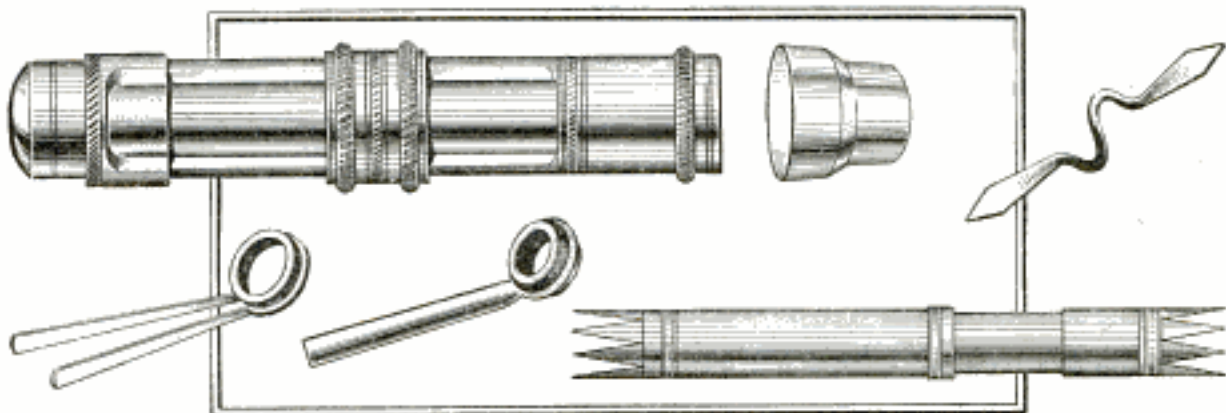
cork grasp having a length of 9 in. above the reel seat, caliper the material as follows: The butt is tapered from 7/16 in. to 25/64 in. at 1 ft. from the butt end; 1½ ft., 11/32 in.; 2 ft., 21/64 in.; 2½ ft., 5/16 in., and 3 ft., 19/64 in. The first 6 in. of the middle joint is calipered to 3/32 in.; 1 ft., 17/64 in.; 1½ ft., 15/64 in.; 2 ft., 7/32 in.; 2½ ft., 13/64 in., and 3 ft., 3/16 in. The first 6 in. of the tips are calipered to 11/64 in.; 1 ft., 5/32 in.; 1½ ft., 1/8 in.; 2 ft., 7/64 in.; 2½ ft., 3/32 in., and 3 ft., 5/64 in. All joints are made 36½ in. long. The material used is dagame, or greenheart, the butt being 5/8 in. by 4 ft., the joint 3/8 in. by 4 ft., and the tips 3/8 in. by 4 ft. The attachments, of german silver, are: One ¾-in. reel seat, fly-rod type with butt cap; one taper, 33/64 in. at the small end; one 9/32-in. welted and shouldered ferrule; one 11/64-in. welted and shouldered ferrule with two closed-end centers, one for each tip; two No. 4 snake guides for the butt joint; three No. 3 snake guides for the middle joint, and six No. 2 snake guides, three for each tip section; two No. 7 agate angle fly tops, the kind to wind on; one dozen cork washers, and two 10-yd. spools of winding silk, 00 size.

A bass fly rod 9½ ft. long, weighing 7½ oz., with a cork grasp, 9½ in. above the reel seat, is calipered as follows: The butt is tapered from 13/32 in. to 25/64 in. 1 ft. from the end; 1½ ft. from butt, 23/64 in.; 2 ft., 11/32 in.; 2½ ft., 21/64 in., and 3 ft., 19/64 in. The first 6 in. of the middle joint is 19/64 in.; 1 ft., 9/32 in.; 1½ ft., 17/64 in.; 2 ft., 15/64 in.; 2½ ft., 7/32 in., and 3 ft., 13/64 in. The first 6 in. of the tips, 11/64 in.; 1 ft., 5/32 in.; 1½ ft., 7/64 in.; 2 ft., 1/8 in.; 2½ ft., 7/64 in., and 3 ft., 5/64 in. The joints are 36½ in. long. The mountings are the same as for the trout fly rod. Dagame, or greenheart, wood is used, the butt being 5/8 in. by 4 ft., the joint 3/8 in. by 4 ft. and the tips 3/8 in. by 4 feet.

The two-piece salt-water rod with an 18-in. double cork hand grasp, the whole being 6½ ft. long, is made to weigh about 13 oz., with the following caliperings: A uniform taper of 35/64 in. to 29/64 in., from the cork grasp to

the ferrule, is given to the butt. The first 6 in. of the tip is $1\frac{3}{32}$ in.; 1 ft., $2\frac{5}{64}$ in.; $1\frac{1}{2}$ ft., $1\frac{1}{32}$ in.; 2 ft., $2\frac{1}{64}$ in.; $2\frac{1}{2}$ ft., $\frac{9}{32}$ in., and to tip, $1\frac{5}{64}$ in. The

etted in place, and a soft-pine sleeve is fitted over the wood core and the ferrule. The forward end of the sleeve is, of course, tapered to fit the taper



The Mountings for a Fly Rod Consist of a Reel Seat with a Straight Hood, a Taper, Snake Guide, Agate Angle Top, and Serrated Ferrule. The Toothed Ends are Wound with Silk to Afford Additional Strength

joints are made $36\frac{3}{4}$ in. long. Dagame, or greenheart, is used with german-silver mountings. Both pieces of wood are 4 ft. long, the butt being of $\frac{3}{4}$ -in. and the tip of $\frac{1}{2}$ -in. material. One $\frac{7}{8}$ -in. reel seat with straight hood, one 1-in. butt cap, one $\frac{7}{16}$ -in. ferrule, one taper with small end $\frac{35}{64}$ in.; one $1\frac{10}{32}$ -in. stirrup-tube agate top; two No. 3 bell guides; two dozen cork washers, and two spools, size A, winding silk.

The Independent-Butt Rod

The independent-butt rod, in which the hand grasp contains the ferrule and the tip is made in one piece, is a favorite type with many of the best fishermen. This mode of construction may be used with all classes of rods, the light fly and bait-casting rods, and the heavier caliber rods used in salt-water angling. In rods of this type, it is only necessary to use the same size ferrule to make as many tips as desired to fit the one butt. Tips of several calibers and weights may thus be fashioned to fit the one butt, and if the single-piece tip is too long for some special use, one tip may be made a jointed one for ease in carrying.

The independent butt, or hand grasp, is made by fitting the ferrule directly on a length of dagame, or greenheart, which has been rounded so that the seated ferrule will not touch the wood. The ferrule is then cemented and riv-

etted in place, and when properly fitted, its lower end will project about $\frac{1}{4}$ in. beyond the pine sleeve. Glue the sleeve on this wood core, cement the reel seat to the sleeve, and rivet the reel seat in place.

The cork washers are glued in position, working the first one into the metal edge of the reel seat, to make a nice, tight joint at this point. The other corks are then glued in place until the hand grasp is of the desired length. The projecting end of the wood core is then cut off flush with the last cork, and the rod is mounted in the usual manner.

In making a double hand grasp, the forward grasp may be fitted over the wood core in the fashion already described in making the hand grasp for the one-piece bait-casting rod, or the forward grasp may be fitted to the tip, just above the ferrule, as preferred. Both methods are commonly used, the only difference being in the manner of finishing up the forward grasp. If the forward grip is affixed to the ferruled end of the tip, two tapered thimbles will be required to make a nice finish.

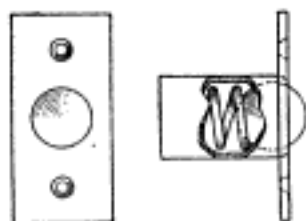
The heavy-surf, or tarpon, rod is made up of an independent, detachable butt, 20 in. long, having a solid-cork or cord-wound hand grasp, and a one-piece tip, $5\frac{1}{2}$ ft. long, altogether weighing $23\frac{1}{2}$ oz. It is uniformly calibered to taper from $2\frac{9}{32}$ in. to $\frac{5}{16}$ in. One

piece of dagame, or greenheart, 1 in. by 6½ ft., will be required. One 1-in. reel seat for detachable butt, including one ¾-in. male ferrule; one 1½-in. butt cap; two No. 11 wide, raised agate guides; two No. 1 trumpet guides; one ⅜-in. agate stirrup top; two spools of winding silk, A-size, and two dozen cork washers, or sufficient fishline to

cord the butt. The guides are whipped on double, the first set spaced 10 in. from the top, and the second, 26 in. from the reel. The core of the independent, or detachable, butt is constructed of the same material as the rod, which makes the hand grasp somewhat elastic and very much superior to a stiff and rigid butt.

Homemade Ball Catch for Cabinet Doors

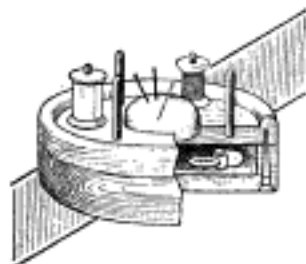
To make a ball catch, procure a piece of brass, 1 in. long, ½ in. wide, and about ⅛ in. thick, and an old gas burner having a diameter of ⅜ in. As described by Work, London, the threaded part of the burner is cut off,



which forms a contracted end that will hold a steel ball ⅜ in. in diameter and allow it to project ⅛ in. A hole is drilled in the center of the brass plate, and the barrel soldered in place. A piece of spiral spring is inserted behind the ball. The stiffness of the spring will depend on the use of the catch. The barrel is cut to length and plugged. Another plate of brass is fitted with screw holes and a hole in the center to receive the projecting ball part, for the strike.

Combination Needle and Thread Tray

When any attempt is made to keep sewing material, such as needles, spools, or buttons, separate, each of the articles is usually kept in some special drawer, or by itself, and when necessary to use one, the others must be found, frequently necessitating many extra steps or much lost time in hunting up the various articles. The



illustrated combination tray avoids this difficulty. It consists of two round trays fastened together near one edge with a wood screw, which is loosely fitted in the lower tray but screwed into the upper to permit them being swung apart. Extra thickness and weight should be given the bottom piece so no tipping will result when the top is swung out to expose the buttons in the lower section. The thread spools are placed on pegs set in the upper tray, and the cushion in the center is provided for the pins and needles.—Contributed by J. Harger, Honolulu, Hawaiian Islands.

Repairing Worn Escapement Wheel of a Clock

When the ordinary clock has served its usefulness and is apparently worn out, the jeweler's price to overhaul it frequently amounts to almost as much as the original purchase price. One weak place in the clock is the escapement wheel. The points soon wear down, thereby producing a greater escapement and pendulum movement, resulting in an increased strain and wear of the clock. If the tips of the teeth on the wheel are bent up slightly with a pair of pliers, the swing of the pendulum will be reduced, thereby increasing the life of the clock. Many of the grandfather's clocks can be put in order in this manner so as to serve as a timepiece as well as a cherished ornament.—Contributed by C. F. Spaulding, Chicago, Ill.

ⒸA piece of work should never be fingered while filing it in a lathe.

An Old-Oak Stain

To make old oak of ash, elm, box alder, chestnut, maple, yew, and sycamore wood use a solution of copper acetate, or iron acetate. Either of these can be made by allowing a strong acid to come in contact with copper or iron. Acetic acid, or vinegar, will do for the acid. The chemical can be obtained from a local druggist if it is not desired to make the stain. By varying the strength of the solution, several shades may be obtained. A weak solution of iron acetate gives various brown hues. As the strength of the salt increases by concentration, the shades of brown darken.

Tablespoon End Used as Lemon Squeezer

In an emergency, the ordinary tablespoon can be used as a lemon squeezer by turning the lemon around the end



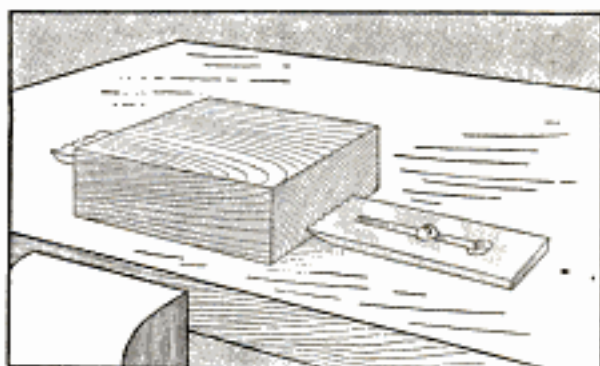
The Shape of the Spoon Bowl Produces the Same Effect as the Lemon Squeezer

of the spoon. This produces the same result as obtained with the regular squeezers, which act on the principle of extracting the juice by turning and crushing the lemon over a rough projection which approximately matches the shape of a half lemon.—Contributed by L. E. Turner, New York, N. Y.

A Back Stop for a Workbench

In planing small pieces on a bench, they usually have a tendency to tip up or slide around. This difficulty can be easily overcome by providing the bench with an extra back stop. For this purpose a discarded plane iron will do very

well. Its edge should be notched so that it will easily enter the wood. The edges of its central slot should be



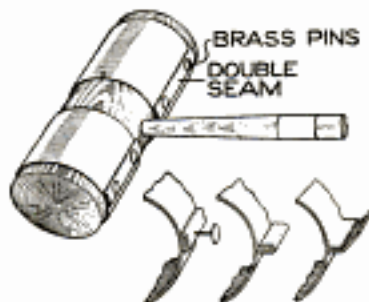
A Plane Bit Fastened to the Top of a Bench to Hold Blocks While Planing Them

beveled off, if an ordinary wood screw is used to fasten it to the bench. A series of holes, several inches apart and in line with the regular back stop, should be bored in the bench so the screw and iron can be readily changed, to fit varying lengths.—Contributed by C. S. Rice, Washington, D. C.

Croquet Mallets Protected by Metal Rings

Due to the severe service they are subjected to, croquet mallets very frequently split off at the ends, which spoils them for further use in accurate driving.

To prevent this, metal bands may be placed around the ends of the mallets. Thin sheet iron, or tin, can be used for this purpose. One end is bent up at right angles, the opposite end is provided with a loop to fit over the upright portion of the first end, and then the loop is closed up and hammered down to draw the metal tightly around the mallet. The ring is secured in place with several tacks, or short nails, driven through the seam.—Contributed by H. E. Stratmeyer, Rockville, Md.



BRASS PINS
DOUBLE SEAM



9167
m

INTERESTING NEW PATENTS

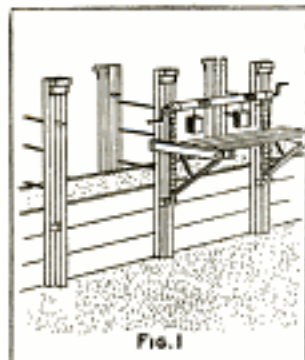


Fig. 1



Fig. 3



Fig. 5



Fig. 7



Fig. 9

MOVABLE FORM AND PLATFORM FOR CONCRETE WORK (Fig. 1)—The idea of this invention is to use the same form material repeatedly as well as to provide a working platform that can be raised as required. The studs for holding the planks in place are faced with toothed metal strips on which the brace of the movable platform rests, the inner side of the platform being suspended by ropes from the windlass and attached to the strips that slide on the sides of the studs. The platform is gradually raised to the tops of the studs as the work progresses, when the studs and planks are moved to a higher level. This process is repeated until the work is finished.

DIRIGIBLE HEADLIGHT FOR TROLLEY CAR (Fig. 2)—The headlight is supported on a vertical pivot and is connected with the front of the car truck by a series of levers. With this arrangement the headlight points straight ahead on straight track, but turns on its pivot and illuminates the track when the car is rounding a curve.

DETACHABLE COVER FOR PNEUMATIC TIRE (Fig. 3)—This cover consists of a leather tread strip equipped with tongues, on the ends of which are fasteners, as shown. The tongues are simply wrapped around the tire and fastened on the inner side, holding the tread securely in place.

OVERFLOW ALARM FOR REFRIGERATOR DRIP PAN (Fig. 4)—This device consists of an electric bell actuated by a float. When the water reaches a level near the top of the pan the electric circuit is closed and the bell is set ringing.

COMBINED CHAIR AND WALKING STICK (Fig. 5; British patent to a German)—This walking stick consists of a hollow staff with a collar to which are attached pivoted arms. Ordinarily these arms are folded compactly against the staff. When they are opened out, one arm serves as a chair leg, while between the other arm and the staff is supported a belt which may be used as a seat. The staff is made hollow so as to form a receptacle for an umbrella.

SUPPORT FOR WINDOW SHADE AND CURTAIN POLE (Fig. 6)—The feature about this device, which has attachments for carrying a window-shade roller and a curtain pole, is that it is simply suspended by hooks from the top of the window casing. The lower end of the device has two buffers which bear against the face of the window casing.

DEVICE FOR PICKING COTTON (Fig. 7)—This receptacle is made to fit closely around the wrist, but flares outward around the hand to form a pocket into which the cotton is thrust by the fingers as it is picked. The upper portion is cut away to permit free movement of the hand.

FOUNTAIN TOOTHBRUSH (Fig. 8)—The handle of this brush consists of an elliptical frame in which a bulb containing a cleansing liquid is mounted. Pressure on the bulb forces the liquid through an aperture into the brush. The handle portion is unscrewed from the brush when the bulb is to be filled.

MOUTHPIECE FOR CIGARS (Fig. 9)—This device consists of a pair of hinged jaws which are shaped to conform to the contour of the tip of the cigar. The portion adjacent to the hinge is so shaped that the device is easily and securely held between the teeth.

NOVEL PROPELLER FOR BOAT (Fig. 10)—The propelling blade is eccentrically mounted on a wheel so that it is submerged on the outward stroke and is lifted clear of the water as it is drawn toward the boat. The wheel is chain-driven, and the working of the blade is controlled by a system of levers, as shown.

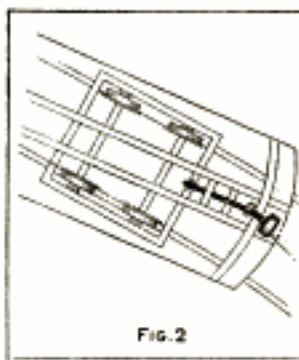


Fig. 2

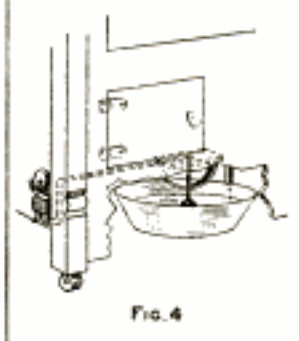


Fig. 4

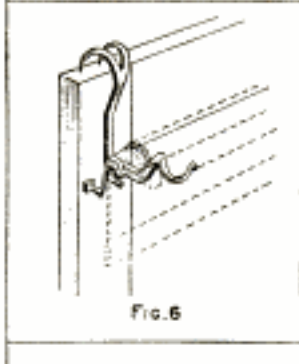


Fig. 6



Fig. 8

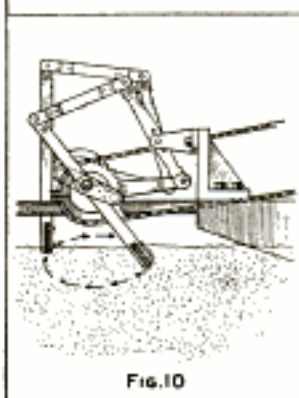


Fig. 10

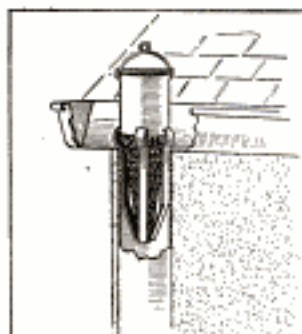


Fig. 11



Fig. 13



Fig. 15

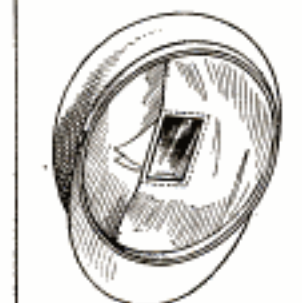


Fig. 17

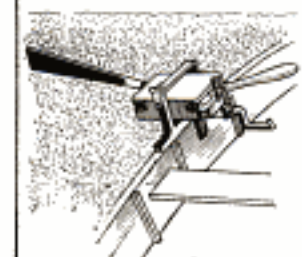


Fig. 19

DEVICE FOR PREVENTING FREEZING OF DRAIN PIPES (Fig. 11)—This device consists of a container made of open work and placed in the top of a vertical pipe. The container is filled with rock salt, which prevents the water from freezing as it passes through. Ordinarily the container requires filling only at the beginning of the winter.

FRUIT PICKER (Fig. 12)—With this picker the fruit is detached by the movable jaws and then dropped automatically through the tube into the basket. The jaws are normally held apart by a spring and are brought together to engage the fruit by means of a cord, the lower end of which is held in the user's hand. The jaws are made of flexible material to prevent injury to the fruit.

LOCKING ATTACHMENT FOR UMBRELLAS AND CANES (Fig. 13)—The handle of the umbrella, or cane, contains a cavity in which a chain and lock can be housed, one end of the chain being attached to a pin within the handle. When the cavity is closed by the pivoted disk, the handle has the appearance of an ordinary handle. With the disk turned out of the way, the free end of the chain can be drawn out and the handle securely locked to any convenient object.

VARIABLE-SPEED TRANSMISSION FOR MOTOR CARS (Fig. 14)—The driven member consists of a disk, on the face of which are three concentric rows of teeth. The oscillating shaft may be shifted from one row of teeth to the other for varying the speed, or may be shifted to the opposite side of the disk for reversing the car. The oscillation of the shaft is made possible by the pivoted arrangement of beveled gears.

COMBINATION CHAIR AND BED (Fig. 15; American patent to a Canadian)—The sides of the chair consist of diagonal side bars, pivotally connected as shown, and so arranged that the chair may be drawn out to form a bed. The seat is supported by longitudinal bars which slide on each other when the chair is drawn out to the extended position.

WHEEL ATTACHMENT FOR SLED (Fig. 16)—The rear wheels are rigidly attached to the runners, while the front wheels are mounted in pivoted yokes to permit of steering. Each of the front wheels is connected by a rod with the steering apparatus.

CAP EQUIPPED WITH MIRROR (Fig. 17)—This curious invention consists of a cap, mirror and receptacle for small articles, combined in one. The mirror is attached to the lining, while the pocket between the mirror and the crown is utilized as a receptacle.

LANDING LADDER FOR SHIP (Fig. 18)—This device is evidently intended to provide a safe means for boarding, or leaving, a ship lying alongside a wharf. A ladder reaching to the wharf is suspended from the outer ends of the horizontal arms, while the space between the arms is floored to provide access between the ladder and the ship.

DOUBLE-ACTION OAR (Fig. 19)—With this device the oarsman faces toward the bow of the boat. The principal feature is the pedal by which the foot as well as the hand is used in operating the oar and propelling the boat. The casing containing the mechanism is pivoted to its supports and swings to lift the oar clear of the water at each return stroke.

NOVEL BOAT-PROPELLING DEVICE (Fig. 20)—This device is designed to produce a high rate of flow through Venturi tubes carried in a submerged position at the sides of the boat, and to use the force of the flow for propelling the boat. It consists of a pipe ring placed around the restricted part of the tube and provided with orifices that project into the tube and point in a rearward direction. Through the pipe ring any gaseous medium is pumped, with the result that the water is forcibly ejected from the Venturi tube. The impact of this stream against the supporting body of water propels the boat forward.



Fig. 12



Fig. 14



Fig. 16

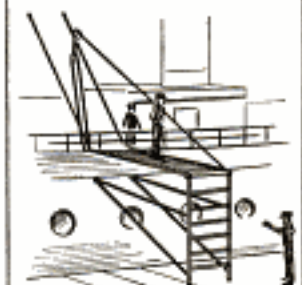


Fig. 18

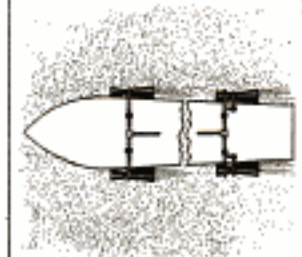
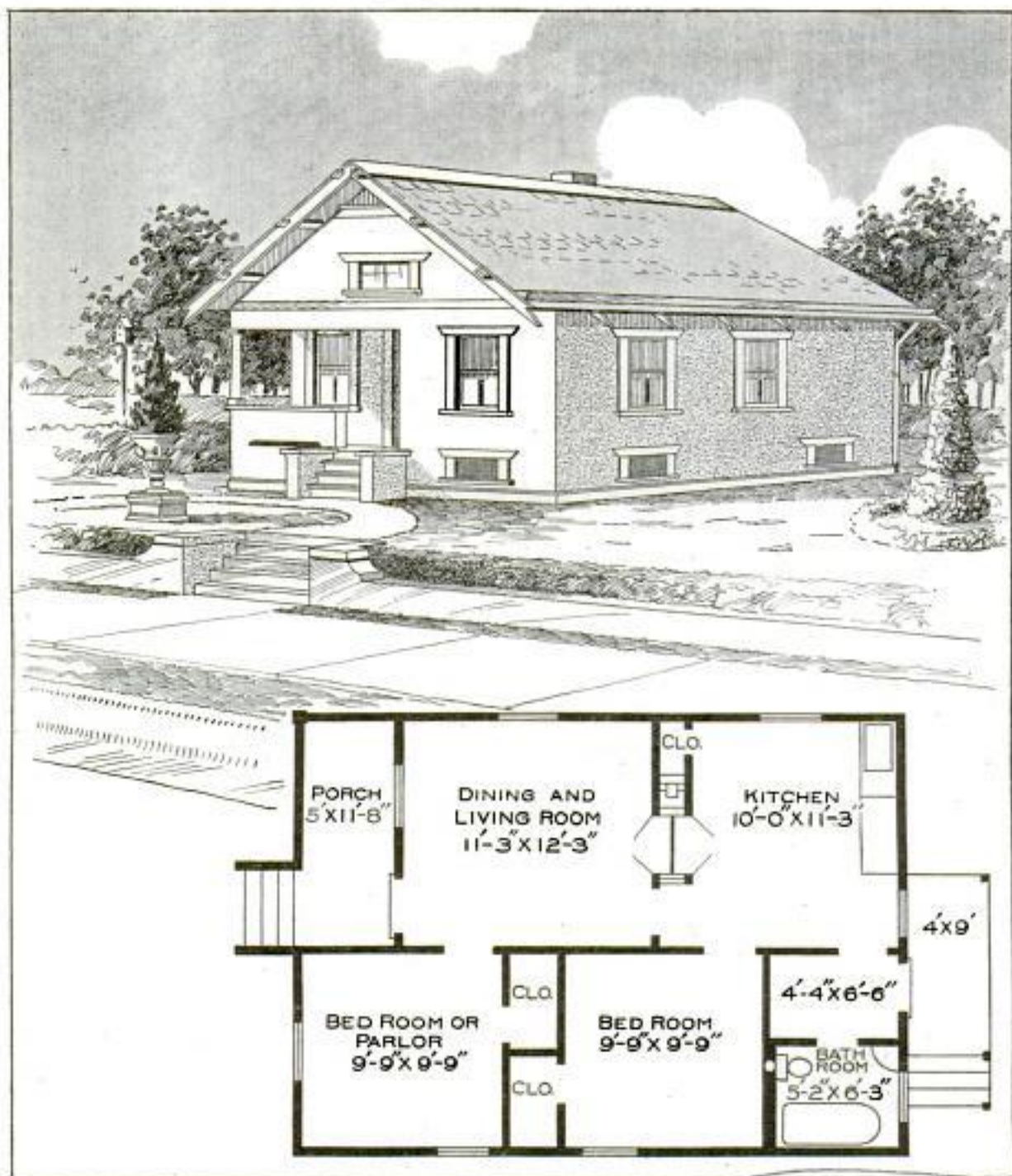


Fig. 20

FOUR-ROOM COTTAGE BUILT AT SMALL COST



F. M. SHIELDS, DESIGNER, SACRAMENTO, CAL.

THIS compact cottage, containing four rooms and bath, is estimated to cost only \$1,000, and has been designed with the idea of providing, at the least possible cost, a well arranged and practical cottage, equipped with modern conveniences. It is especially adapted to use as a tenant's cottage on a farm, or for construction on a suburban lot where the owner is compelled to build as cheaply as possible. The house is of wood construction with plastered walls, either shiplap or clapboards being used for exterior covering. The space is so carefully utilized that in spite of the small ground plan, 22 by 30 ft., each of the rooms is of ample size. There is a fairly large closet for each of the bedrooms, while the space adjacent to the single chimney is skillfully used for a built-in china closet in the dining room, and a built-in cupboard in the kitchen. The location of the bathroom is such that it is easily heated from the kitchen. The estimated cost includes standard plumbing equipment.

411 Tullar Ave.

ALADDIN KNOTLESS

Here's What
You Get

With Every ALADDIN House

Sills, cut to fit
Joists, cut to fit
Studding, cut to fit
Rafters, cut to fit
Ceiling Joists, cut to fit
Subfloor, cut to fit
KNOTLESS Flooring, cut to fit
Building Paper
Sheathing, cut to fit
KNOTLESS Shingles
Roof Sheathing, cut to fit
KNOTLESS Siding
KNOTLESS Outside Finish
KNOTLESS Plancer
KNOTLESS Frieze
KNOTLESS Faciers
Lath and Plaster or Plaster
Board, as you wish
KNOTLESS Interior Baseboard
KNOTLESS Inside Doors
KNOTLESS Outside Doors
KNOTLESS Window Casings
KNOTLESS Door Casings
Window Glass, in place
Front and Back Steps
Nails in all sizes, guaranteed
to be enough for house
Hinges for all Doors
Lock Sets for all Doors
Sash Lifts for all Windows
Stains and Varnishes
Paints for two coats inside
and outside
Putty, Oils, etc.
Complete working plans, In-
structions and Illustrations
for Erection

Ask About the 5-
Room House at \$298

North American Construction Co.

Mills in Michigan, Florida, Louisiana and Oregon

962 Aladdin Ave. Bay City, Mich.

for this ALADDIN
Complete

\$797



ALADDIN Houses Are Not Made by a Trust

ALADDIN Quality has set a new standard for lumber quality — is raising the old-time lumber standards of quality to a new plane. The ALADDIN Dollar-a-Knot guarantee is the plainest and strongest guarantee ever offered the home builder. ALADDIN Houses are not made by a trust or combine—we do not ask you to buy lumber according to any mysterious Association grading rules. A guarantee of simply a Dollar a Knot — anyone knows what a knot looks like. No other lumberman in the world has had the courage to equal the ALADDIN Dollar-a-Knot Guarantee. But you can secure knotless lumber — at a distinct saving in price, too — in an ALADDIN House.

Mills in Michigan, Florida, Louisiana and Oregon

Over one thousand ALADDIN Houses are here carried in stock, ready for instant shipment. Your order is received and loaded immediately. Our mills are located in Michigan, Florida, Louisiana and Oregon. Shipment is made from the nearest mill. No matter where you live, your house comes in a straight line from forest to you. Long distance and excessive freight rates are cut out. No hold-up on the way. In a short time after shipment is received, you move into your own home. You can build your own ALADDIN. Complete instructions and illustrations are furnished with every ALADDIN House. All you do is to follow the working plans and drive the nails. Thousands of ALADDIN customers in every state have enjoyed the simple work of erecting their ALADDINS. You can do this also and save the cost of skilled labor.

Complete Furnace \$45

ALADDIN products include high grade heating plants of all kinds, plumbing, lighting fixtures, hardware, furniture, rugs and carpets — in fact, everything for the home. Ask for the Merchandise Catalog, too, if interested in these products.

Send Now

Your First Step
Toward a
\$500.00
Saving

North American Construction Co., 962 Aladdin Ave., Bay City, Mich.
Send me your House Catalog No. 180.
Send me your Merchandise Catalog No. 180.

Name

Street

City

State

SAXON \$395



"Sweet Land of Liberty"

To the Saxon owner, America becomes, in a new sense, the "sweet land of liberty." The region "just beyond the hills" or the show places of the continent are alike within your reach. You can go anywhere you want, in your daily business rounds or out on pleasure tours, in this sturdy, willing car. No roads are too rough and rugged for it; no mountain climb too difficult.

Ideal Car for Everyday Motoring Needs

Two Saxon owners, G. W. and J. W. Logan recently drove from their home city, Tiffin, Ohio, to Los Angeles, California, over every possible condition of road—at a total cost for car operation of \$38.60.

Letters from all parts of the country tell of the stylish Saxon's never-failing and economical performance.

Mrs. E. J. Parenteau of Pittsburg says: "I have driven my Saxon about 5,500 miles and have found it ideal for country driving as well as city use—at an exceedingly small upkeep. On a recent trip from Pittsburg to Monongahela, we took the wrong road, covering a route where no automobile had ever gone before. So we feel quite proud of our Saxon."

From Paul E. Reiff, Saxon owner in New Cumberland, Pa., comes this evidence: "The car does the work to my entire satisfaction and can climb hills on high gear that lots of machines are obliged to take on second."

Extravagance and False Pride Not Popular

No one apologizes any longer for riding in a low priced car. We no longer have any sense of false pride. It used to be fashionable to be extravagant. Now it is fashionable to be economical—to get the most service for your dollar.

Saxon is a big car for the price—wide and roomy enough for two large people to sit in perfect comfort. It is sturdily built, smooth riding with light but powerful and flexible motor.

The 1915 Saxon has many improvements which make it even more desirable than before. Saxon is the modern car—distinctive, graceful—a car you'll be proud of. Electric lights and starter, specially built for the Saxon, furnished when desired, as extra equipment.

We sell the Saxon car with the absolute confidence that on the average, year in and year out, under all kinds of conditions, it will carry its owner whatever number of miles he wishes to go at less expense than any other automobile.

Saxon "Six" \$785

This is a big, handsome five-passenger car—of exceptional value. It is fully equipped, including Gray & Davis electric starting and lighting system, and has features usually found only in cars of much higher prices. 112-inch wheelbase, roomy, comfortable streamline body, cantilever springs, 32x5½" tires, demountable rims, one-man top, speedometer.

"Saxon Days," our interesting magazine, contains more proof of Saxon superiority in construction and performance. We will gladly send you a copy upon request. Saxon dealers are everywhere—get in touch with one located nearest you, or write us for his name. Address Department J.

Saxon Motor Company
Detroit

THE greatest amount of paid-for life insurance ever secured in a single year by any company in the world—

\$518,963,821

was obtained during 1914 at the lowest expense-rate in its history by

The Prudential



Payments to policyholders were larger than ever before, \$39,273,810.05

THE PRUDENTIAL INSURANCE COMPANY OF AMERICA

Incorporated under the laws of the State of New Jersey

FORREST F. DRYDEN, *President*

HOME OFFICE, NEWARK, NEW JERSEY

Everybody is invited to visit the Prudential Exhibit on Life Insurance and Public Welfare, Panama-Pacific Exposition, San Francisco.

Please Mention Popular Mechanics



The Agency of a United People

A striking comparison between a homogeneous country and a heterogeneous group of countries is obtained by placing over the map of the United States the map of Europe. These represent the same area—about 3,000,000 square miles—if a few of the remote provinces of Russia are omitted.

Europe has the advantage in population, with more than four times as many people as the United States; in the number of large cities, with two and a half times as many cities of over 100,000 population.

Yet the United States, a comparatively young country, has outstripped Europe in the diffusion of civilization, because of its wonderfully greater means of communication between all parts of its area. The United States not only excels in transportation facilities, but it has nearly three times as many telephones as Europe, or about eleven times as many in relation to population.

By the completion of the Transcontinental Line we now talk from one end of this country to the other, while in Europe the longest conversation is no farther than from New York to Atlanta, and even that depends on the imperfect co-operation of unrelated systems.

Europe, with twenty-five countries and many different languages, serves as an illuminating contrast to the United States, with one language and a homogeneous people, despite the fact that our population has been derived from all parts of the world.

During the last forty years the steadily extending lines of the Bell System have contributed in no small measure to this amalgamating of different races. The latest achievement—the linking of coast to coast—has given greater force to the national motto, "E Pluribus Unum."

**AMERICAN TELEPHONE AND TELEGRAPH COMPANY
AND ASSOCIATED COMPANIES**

One Policy

One System

Universal Service

Please Mention Popular Mechanics

"The stock ain't
fed yet, Hiram!"



"Third Call
for Dinner" —



"Teaching
Young America
to Shoot!"



"That tense
moment" —



Enchanted Homes Transformed by Billiards

This grand old game was once the sport of royalty alone. Yet these are days when Carom or Pocket Billiards reigns supreme in mansion or cottage alike.

Each evening in the billiard room a round

of gayety ensues. Men's cares are lost amid the thrilling rivalry. Here girls develop gracefulness and charm. And billiards keeps boys home, quickens their wits and makes them *great big-hearted little men!*

SUPERB BRUNSWICK

Home Billiard Tables

Real Brunswick Regulation tables, modified only in size and design to harmonize with home surroundings. The "GRAND" and "BABY GRAND" are cabinet masterpieces in mahogany, richly inlaid.

Other styles include "Convertible" models that also serve as perfect Library and Dining tables.

All Brunswick tables have quick-acting Monarch cushions, genuine Vermont slate bed, fast imported billiard cloth—the most scientific playing qualities.

20 Cents a Day!

Our popular purchase plan—terms as low as 20c a day—lets you pay monthly as you play.

And you are privileged to try any table 30 days right in your own home.

Playing Outfit FREE!

Balls, Cues, Rack, Markers, Spirit Level, expert book on "How to Play," etc.—all included without extra cost. Handsome new book, "Billiards—The Home Magnet," shows all tables in actual colors, gives low factory prices and full details.

Sent free, postpaid! Mail the coupon.

This Brings Billiard Book FREE

The Brunswick-Balke-Collender Co.

Dept. 15-A, 623-633 S. Wabash Ave., Chicago

Send me, free, your book in colors, "Billiards—The Home Magnet," and details of 30-day trial offer.

Name

Address..... (434)

Please Mention Popular Mechanics

HARTMAN Will Trust You

Remarkable Bargains Never Before Equaled

More than ever before you owe it to yourself and family to get acquainted with the startling Hartman values in Furniture, Carpets, Rugs, Silverware, Draperies, Clocks, Stoves, Refrigerators, Sewing Machines, Jewelry, Washing Machines, Bedding, Curtains, etc., which as the largest homefurnishing concern in the world our \$10,000,000 purchasing power enables us to buy in such immense quantities that we secure the best the market affords, at absolutely rock bottom prices.

Your Credit Good Pay A Little At A Time

We ship dependable homefurnishing goods to more than a million customers year after year, in every part of this country. The plan has proven so satisfactory that we say to you—"Your credit is good, no matter where you live, no matter how small your income; order what you need, pay a little every month. We require no references, ask no embarrassing questions, charge no interest, ask no security." Most liberal and satisfactory credit plan ever devised.

Don't Miss These Wonderful Get-Acquainted Bargains

The Hartman Company alone has such unbounded confidence in its goods that it offers to send to any reader of this publication any one of the remarkable get-acquainted bargains in this advertisement—and that without asking you to send any money in advance. But at these prices we can afford to send but one to each family. Order any one you wish from this advertisement; when you get our mammoth catalog, order any amount you desire.

Every Hartman Bargain Sells On Its Merits

Read our guarantee: "We guarantee to ship each and every article on approval and if within thirty days from receipt of the goods anything is not perfectly satisfactory, for any reason whatever, we will accept their return and when the goods are returned to us, we will refund all moneys paid on them, including payment of freight both ways."

FREE HARTMAN'S MAMMOTH CATALOG

This is the most interesting Homefurnishing Catalog you have ever seen. Hundreds of pages done in beautiful colors. You need a copy. Send your name and address on apostal today and receive a copy absolutely free, prepaid.

HARTMAN

Furniture & Carpet Co.,
3945 Wentworth Ave., Chicago, Ill.

No Reference Is Required

Comfortable Rocker Bargain No. MH110.

Large, comfortable Rocker at bargain price. Solid oak, golden finish, choice design. Is upholstered with "Imperial" Spanish brown leather seat and back. Seat has 4 springs, stuffed with tow and cotton. Front and back posts handsomely carved. Seat front plaited and back is button tufted. Strong posts and runners. The best rocker value ever offered at the low price of

\$3.45



50c Per Month
Collapsible Go-Cart

No. MH122. One motion collapsible Go-cart, equipped with large convenient automobile hood with roll-up side curtains, large foot well, padded seat, two position reclining back, 10-inch wheels with 1/2 inch rubber tires, nickel fenders, heavy push rods and cross handle. Covering is of "Imperial" leather. Cart is of all steel construction and can be ordered with Black, Green or Brown covering. Price.....

\$8.38 75c Per Month



No. MH 108. Washing Machine

8 shirt capacity, made of Louisiana red cypress, corrugated on inside. Finished natural color. Four pronged 10 in. cypress dasher block, cannot slip or crack. Gearing is durable; roller bearings, easy to run. Tub supported by 3 legs which bolt into iron sockets. Don't tear clothes. Price

\$4.50 50c Per Month

Lawn Swing Bargain

No. MH127. This delightful hardwood Lawn Swing holds four passengers and is exceptionally well made and durable. Posts are painted red and swing operates freely and noiselessly. Remarkable bargain at our price.

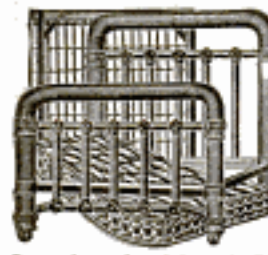
\$4.65 50c Per Month



2-Inch Post Steel Bed Outfit

No. MH123. Complete bed outfit bargain, consisting of elegant 2-inch continuous post steel bed with heavy fillers in artistic design. 58 inches high; link fabric steel frame bed spring, and cotton top fibre filled mattress. Outfit comes in all sizes: 3 ft. 3 in. 4 ft. or 4 ft. 6 in. (full size). Colors: White, Pea Green or Vernis Martin.

Our price only **\$9.77 75c Per Month**



Three-Piece Mission Set Bargain

No. MH109. Solid oak, fumed finish, 3-piece Mission Set. Table 28x34 inches, strongly built; convenient book shelf at either end. Rocker and Arm Chair made to match; upper and outside panels upholstered with "Imperial" Spanish leather; seat set on 4 springs, expertly filled and upholstered. Price.....

\$11.78 75c Per Month

No Money In Advance

Brussels Rug Bargain

No. MH125 Beautiful Brussels Rug in 4 sizes. Design is very charming; neat medallion center; conventional border. Colors: Tan, Green, Brown, Red and light colorings. This is a great opportunity to get a magnificent rug for little money. Size, 6 ft. 9 in. x 9 ft. Price.....**\$6.25**
Size, 8 ft. 3 in. x 10 ft. 6 in. Price.....**\$8.95**
Size, 9x12 ft. Price.....**\$10.75**



75c Per Month
Size, 10 ft. 6 in. x 13 ft. 6 in. Price...**\$18.50**

\$1.25 Per Month



Astounding Offer to Homebuilders

Two Years to Pay!

THE most beautiful and modern Homes ever designed!
The lowest prices ever quoted! Sold on wide open
credit—**TWO YEARS TO PAY!**

This in brief, is the Sterling World-beating offer to
Home Builders of America. Think what it means! The home
you've long wanted—yours on monthly payments so low that
now no family can afford to pay rent.

Send for the latest Sterling Catalog and learn all about this
astounding Offer.

Sterling System Built Homes

Sterling direct-from-the-forest prices speak for themselves.
All you need do is compare them to others. And remember—
the Sterling price includes everything from the ground up—
lumber, plaster, hardware, glass, paint, etc. And don't forget
this—all Sterling lumber comes Measured and CUT-TO-FIT
no hand-measuring, no hand-sawing, no trial fitting! We
save you as much Carpenter Expense as Material Expense.

All due to modern, machine-methods. To the wonderful
Sterling Factory which last season built a thousand HOMES;
which now has a capacity of one complete home per hour!

As to quality of Sterling Materials and Workmanship,
what further proof could anyone want than the fact that we
sell ON CREDIT TERMS? Men may sell second rate ma-
terials where the buyer must part with Cash, before he sees
the goods, but no man who sells on credit dares ship poor
materials. Buyers would justly refuse to meet their payments
if the goods were not as represented.

Homes not "Houses"

Sterling Homes are permanent, lasting structures—NOT portable af-
fairs. They mark a new era in architecture. Richly handsome in de-
sign, practical to the last detail in arrangement, they bring a world of
comfort and happiness to their occupants; to the wife they bring count-
less work-saving conveniences and sunny home surroundings; to the
husband, luxurious ease; to the children, robust health and happy lives.
What more could any home, at any price GIVE?

Get Our Latest Book Instead of cataloging a vast and
confusing multitude of Houses, the
"The Famous Fifty" Sterling 1915 Book pictures and de-
scribes—just Fifty! Sterling archi-
tects selected the Fifty from more than TWO THOUSAND Designs.
Each is a masterpiece—a model Home. Each is so perfectly pictured,
diagrammed and described that one almost sees the actual Home, both
inside and out.

Don't miss this Sterling Book. It is by long odds the finest and most
complete ever published. Whether you choose to pay \$300, \$400, \$500,
\$800 or \$1000 or any other price up to \$3000, you'll find the Home you
want, shown in this Sterling Book. And by the Sterling Plan, you
have TWO YEARS to pay.

Send postal today and receive the latest Sterling Book and com-
plete Explanation of our Two-Years-To-Pay Plan by return mail.

INTERNATIONAL MILL & TIMBER CO.
Dept. Q-4 Bay City, Michigan

Be sure to address Dept. Q-4



41c Per Day
Brings This Home

THE "MANOR"

One of the most beautiful Homes ever de-
signed—the "MANOR"—modern in every
particular—built of unsurpassable material—
seven rooms with bath. Can be erected in 12
to 16 days, yet as permanent as can be. The
Materials would ordinarily cost you close to
\$1200. Our price is \$730 and all lumber comes
cut-to-fit.

Instead of demanding cash in full, we ask
only \$441 down, balance payable in monthly
installments of \$12.25. That's only 41c per day.



39c Per Day

THE "MIRACLE"

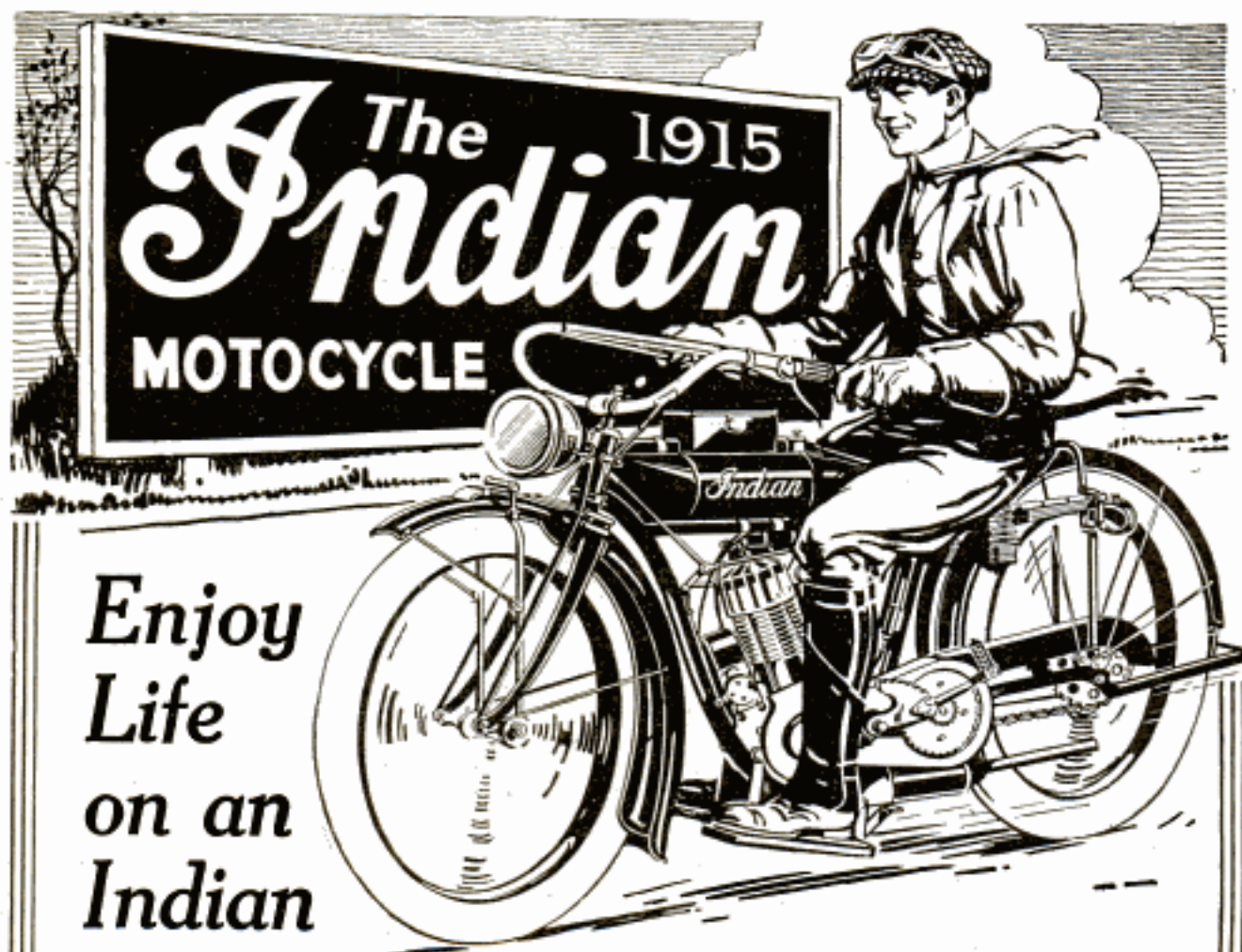
This Thousand Dollar Bungalow, the "Mir-
acle," we offer for \$691. Can be built in 12
to 14 days. Our Terms, \$414 down and
\$21.52 per month—or 39c per day.



18c Per Day

THE "MARTINDALE"

This handsome 5-Room Cottage, the "Mar-
tindale," worth \$600. Can be erected in 6 to
9 days. Our Terms, \$187 down and \$6.20
per month—or 18c per day.



*Enjoy
Life
on an
Indian*

ON the long stretches of the country road, over the hills and through the valleys—on the streets of the big town—every mile is a happy mile to the man who rides an

Indian Motorcycle

Ten sensational, *exclusive* devices maintain the 1915 superiority of the Indian. These features—found only on the Indian—are: Starter—starting from standstill; Dual Clutch Control; Cradle

Spring Frame; Vanadium Steel Construction; Indian Carburetor; Light and Horn Control Buttons in Switchboard; Magneto - Generator; Cam System; Double Brake Mechanism; Neutral Countershaft.

Each of these features means added value, best explained in detail in the big, new, 1915 Indian Catalog. They tell you why established Indian domination remains unshaken.

Hendee Manufacturing Company, 711 State Street, Springfield, Mass.

(Largest Motorcycle Manufacturers in the World)

Branches and Service Stations:

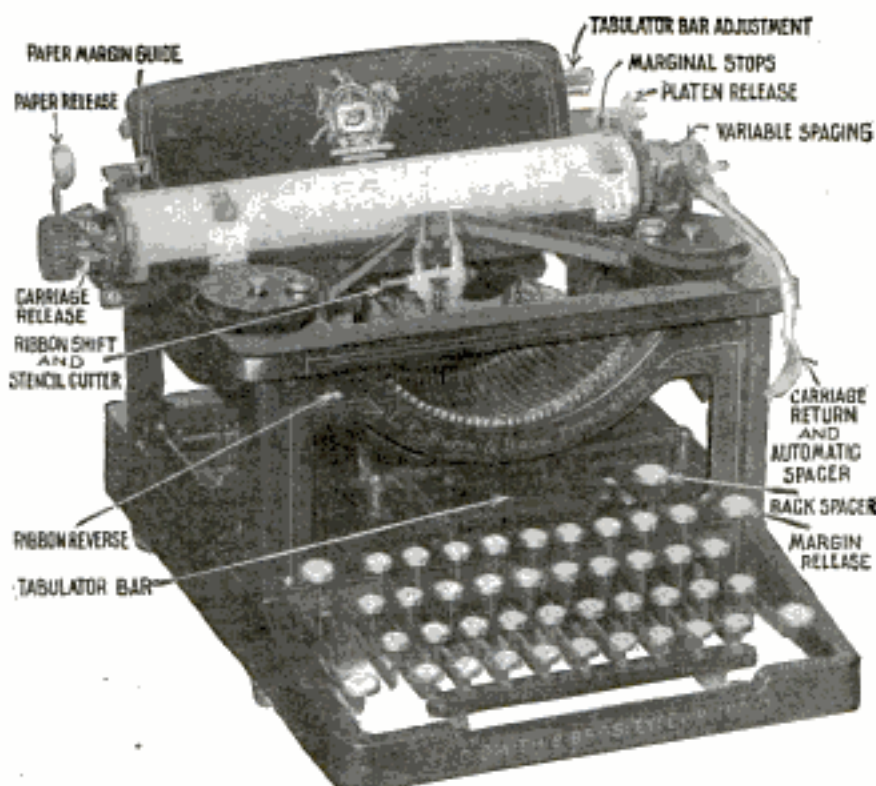
Chicago
San Francisco

Dallas
Atlanta

Kansas City
Toronto
Melbourne

Minneapolis
London

Please Mention Popular Mechanics



TYPEWRITER SENSATION

Free TRIAL—Use As You Pay

Only \$3.00 a month until the low total price of \$48.30 is paid, and the machine is yours

This is absolutely the most generous typewriter offer ever made. Do not rent a machine when you can pay \$3.00 a month and own one. Think of it—Buying a \$100.00 machine for \$48.30. Cash price, \$45.45. Never before has anything like this been attempted.

Standard Visible **L. C. Smith**

Perfect machines, Standard size, Keyboard of Standard Universal arrangement writing 76 characters—universally used in teaching the touch system. (Keyboard writing 84 characters \$1.00 extra.) The entire line of writing completely visible at all times, has the tabulator, the two color ribbon with automatic reverse, the Back Spacer, in fact every late style feature and modern operating convenience. Comes to you with everything complete, tools, cover, operating book and instructions, ribbon, practise paper—nothing extra to buy. You cannot imagine the perfection of this beautiful typewriter until you have seen it. I will send it to you F. O. B. Chicago for five days' free trial. It will sell itself, but if you are not satisfied that this is the greatest typewriter you ever saw, you can return it at my expense. You won't want to return it after you try it—you cannot equal this wonderful value anywhere.

You Take No Risk—Put In Your Order Now

When the typewriter arrives deposit with the express agent \$9.30 and take the machine for five days' trial. If you are convinced that it is the best typewriter you ever saw, keep it and send me \$3.00 a month until our bargain price of \$48.30 is paid. If you don't want it, return it to the express agent, receive your \$9.30 and return the machine to me. I will pay the return express charges. This machine is guaranteed just as if you paid \$100.00 for it. It is standard. Over one hundred thousand people own and use these typewriters and think them the best ever manufactured.

The supply at this price is very limited, the price will probably be raised when my next advertisement appears, so don't delay. Fill in the coupon today—mail to me—the typewriter will be shipped promptly. There is no red tape. I employ no solicitors—no collectors—no chattel mortgage. It is simply understood that I retain title to the machine until the full \$48.30 is paid. You cannot lose. It is the greatest typewriter opportunity you will ever have. Do not send me one cent. Get the coupon in the mails today—sure.

HARRY A. SMITH, 231 N. Fifth Ave., CHICAGO

H. A. SMITH
231 N. Fifth Ave.
CHICAGO, ILL.

Ship me a No. 2 L. C. Smith F. O. B. Chicago, as described in this advertisement. I will pay you the \$30.00 balance of the SPECIAL \$48.30 purchase price, at the rate of \$3.00 per month. The title to remain in you until fully paid for. It is understood that I have five days in which to examine and try the typewriter. If I choose not to keep it I will carefully repack it and return it to the express agent. It is understood that you give the standard guarantee for one year.

Name

Address

Pop. Mech. April

How Many Hides Has a Cow?

For shoe soles, one. But a cow's hide, being too thick and stiff for upholstery, is split into at least three sheets, only the top one of which is natural leather. The lower, fleshy splits, after being coated and embossed to look like leather, and which make up 75% of all so-called leather upholstery, are really artificial leather of quality inferior to

**Motor Quality
For Automobiles**



**Craftsman Quality
For Furniture**

GUARANTEED SUPERIOR TO COATED SPLITS

America's leading automobile manufacturers have adopted Motor Quality Fabrikoid for upholstery in place of coated splits. America's leading furniture manufacturer says: "The cheap split leathers should be entirely eliminated in furniture manufacturing." He uses first-grade leather and Fabrikoid.

Specify for automobile upholstery, Motor Quality Fabrikoid, and for tops and curtains, Barytite Fabrikoid, guaranteed one year. Specify Craftsman Quality Fabrikoid on new furniture and for recovering. Its appearance and service will please you. **Small sample free, or a piece 18" x 25" postpaid, 50c.**

DU PONT FABRIKOID COMPANY, Wilmington, Del.
CANADIAN BRANCH, TORONTO, ONTARIO

Craftsman Quality Fabrikoid is on sale by Palais Royal, Washington, D. C.; John Wannemaker, Philadelphia; McCreery & Co., Pittsburgh; J. & H. Phillips, Pittsburgh; John Shillito Co., Cincinnati; Stutz-Baer-Fuller Co., St. Louis; Du Pont Fabrikoid Co., 90 West St., New York; Stewart & Co., Baltimore, Md.; T. Eaton & Co., Ltd., Toronto and Winnipeg; Davison-Faxon-Stokes Co., Atlanta, Ga.; D. N. & E. Walter & Co., San Francisco, Los Angeles, Seattle, Portland, and most upholstery dealers.

A good shave is a "running start" on a good day. Good lather means *real* comfort.

Colgate's Shaving Lather Stick—Powder—Cream

Plentiful—luxurious—lasting. Softening—soothing—sanitary.
Send 4 cts. for trial size of your favorite method.

COLGATE & CO., Dept. 81, 199 FULTON ST., N. Y.

Small Engines

Our 3/4, 1 and 1 1/2 H. P. Gasoline Engines for Farm and Shop are the best small engines.

FORD AUTO SEAT STARTER

Shipped on trial. Send stamp for Booklet and Special Offer.

Sieverkropp Engine Co., 1224 18th St., Racine, Wis.

UNDERGROUND MAIL RAILWAY FOR LONDON—A tunnel for the conveyance of mail, 9 ft. in diameter, will be constructed in London. It will contain two tracks with island platforms at the eight stations from Paddington to Whitechapel, inclusive. The trains will be run without operators from distant control stations at an average speed of 25 miles an hour. Electric elevators will transfer the mails to the sorting offices at the island platforms.

Famous Line of Paper Balers

\$22 AND UP



Send Today For Circulars

Desk E

Famous Mfg. Co., East Chicago, Ind.

A Bookful of Beautiful Rooms Free

When you build a new home or an addition, remodel one or two rooms, or alter an office or store, try crack-proof BEAVER BOARD instead of lath and plaster.

Write at once for a free sample and this interesting book. All about our free design and decoration service. Absolutely no obligation. Address,

The Beaver Board Companies 158 Beaver Road Buffalo, N. Y.

BRANCH OFFICES in Baltimore, Boston, Chicago, Cleveland, Detroit, Indianapolis, Kansas City, Mo., Minneapolis, New York City, Omaha, Philadelphia, San Francisco

BEAVER BOARD

WALLS & CEILINGS





"That's The Man!"

THE delicate child, who must be kept toned up with something. How much better, for you and for him, to give him something that you don't have to coax him to take—something that tastes so good there'll be no fighting against it—and, best of all, something that's not drug or medicine but just a wholesome, nourishing, liquid-food-tonic.

ANHEUSER-BUSCH'S *Malt-Nutrine*

REG. U. S. PAT. OFF.

TRADE MARK

Liquid-Food-Tonic

A wine glassful at each meal and before going to bed will soon make another child of that delicate, anaemic boy or girl of yours. You'll see the appetite pick up, the cheeks fill out—yes! and there'll be more noise about the house—the noise of a healthy child. A genuine food and tonic for all who are weak, anaemic or run down.

ALL DRUGGISTS—MOST GROCERS

Malt-Nutrine declared by U. S. Internal Revenue Department a pure malt product, not an alcoholic beverage. Contains 10½ per cent malt solids—1.9 per cent alcohol.

Interesting Booklet on Request

ANHEUSER-BUSCH

St. Louis, U. S. A.



Please Mention Popular Mechanics



Have You Any Idea How Little It Costs to Own

a

BURROWES

Billiard and Pool Table



\$100 DOWN

Terms are very easy—\$1 or more down (depending upon size and style selected), and a small amount each month. Prices from \$15 up. Cues, balls, etc., free. Sizes range up to 4½x10 ft. (standard.)

No Special Room Needed

The Burrowes Billiard and Pool Table is built particularly for homes where space is limited. Can be set up in a few moments on dining or living room table or on its own legs or folding stand. It is light, easy to handle. Occupies practically no space when not in use.

The expense is so little and so gradual that you will scarcely notice it. In fact, if you have been accustomed to play in a public poolroom, the same cost or less will let you have a Table of your own, playing on it while paying for it. No games are more fascinating. A Burrowes Table will prove a constant source of entertainment for you and your friends. Burrowes Tables are splendidly made and scientifically accurate. Some of the leading experts use them for home practice.

FREE TRIAL—NO RED TAPE

On receipt of first installment we will ship Table. Play on it one week. If unsatisfactory return it, and on its receipt we will refund your deposit. This insures you a free trial. Write today for illustrated catalog giving prices, terms, etc.

THE E. T. BURROWES CO., 166 Spring St., Portland, Me.

Manufacturers of Burrowes Rustless Insect Screens and Burrowes Folding Card Tables



Alcohol Motive Power

Runs anywhere with no electricity, wiring, springs or batteries. Quiet, delicious, satisfying. No home or office complete without one. Price, **\$15.00** cash with order only.

THE LAKE BREEZE MOTOR CHICAGO
P. O. Box 505

An ingenious railway flagman in Kansas recently changed his oil lantern into a modern electric lamp. To avoid purchasing batteries, however, he has connected the lantern through a long flexible cord to one of the lamp sockets used ordinarily for lighting the coach platform. He employs the lantern only for signaling the engineer from the rear platform of the train, says the Electrical World, and hence, in actual use, does not need to take the lantern far from the car.

1900 Motor Washer Electric or Water Power on Free Trial to Readers of Popular Mechanics

Reduce household expenses by using this great laundry outfit. Cuts cost of washing to **2 cents per week**. Write for Free Book, giving full details, to

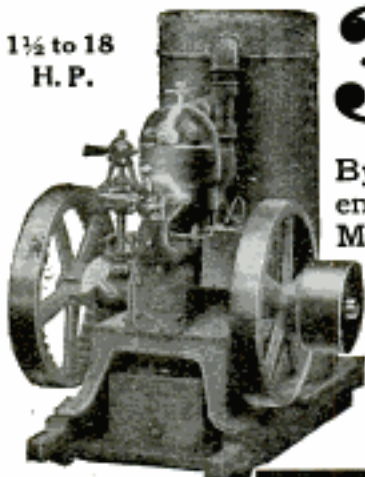
1900 WASHER CO., 6176 Court St., Binghamton, N. Y.
Address Canadian 1900 Washer Co., 355 Yonge St., Toronto
if you live in Canada

KEROSENE Gas Lamps

Perfect 300 to 1000 Candle Power Light for all purposes from common Coal Oil. Simpler, safer, more reliable and economical than any self-making gas lamps or systems made. Nothing complicated. Children can light and operate.

Write for particulars.
BRILLIANT GAS LAMP COMPANY
10095 So. Washburn Ave. CHICAGO, ILL.

1½ to 18
H. P.



34c

Runs this 6 H. P. Engine for a 10 hour day on KEROSENE

By means of the patent throttle you can run it as a 4 H. P. engine for 23 cents a day, or as a 2 H. P. for 12 cents a day. Many other strong points; force-feed lubrication; uniform speed; sight-feed fuel supply; automobile muffler; no cranking; runs either way; uses any fuel oil satisfactorily. And it's **Guaranteed for 10 Years**. Write for catalogue and 30 days' free trial.

WE PAY THE FREIGHT

ELLIS ENGINE CO., 2871 East Grand Blvd., Detroit, Mich.



Men Who Roll Their Own Cigarettes

know the importance of using the best "papers" obtainable. They know that Riz La Croix cigarette papers *are* the best that money can buy—famous the world over for superior *quality* that never fails to give the greatest satisfaction.

RIZ LA C.

(Pronounced: REE-LAH-KROY)

FAMOUS CIGARETTE PAPERS

Your favorite tobacco is easily rolled into round, firm cigarettes with Riz La Croix papers. Cigarettes that hold their shape, draw well and give you a fine flavor, free from the slightest paper-taste. The lightness, thinness, natural adhesiveness and perfect combustion of Riz La Croix guarantee these desirable properties. Made from the best flax-linen—a pure vegetable product—Riz La Croix insures *healthful* enjoyment.



FREE
Two interesting, illustrated Booklets—one about RIZ LA CROIX Cigarette Papers, the other showing how to "Roll Your Own" cigarettes—sent anywhere in U.S. on request. Address The American Tobacco Co., Room 1184, 111 Fifth Avenue, N.Y.

TO EVERYMAN
EVERYWHERE



YOU CAN DRESS \$
ALWAYS for

10

Good Clothes
Always \$10.00 Suit or Overcoat

72 SAMPLES & BOOKLET
FREE

Sounds impossible, doesn't it?—smacks of exaggerated advertising—looks like imagination run riot—but IT ISN'T. We are the largest manufacturers of men's clothing in the world, doing business DIRECT with the wearer. The entire output of our factory—just suits, overcoats and top coats—is sold by mail or from our six stores. Price always \$10. We specialize—make clothes at one price only. Everything going into them—the pure wool cloth—the linen canvas—

linings—hair cloth—all are of a standard quality bought in immense quantities. We sell thousands of garments, instead of hundreds—make hundreds of a model instead of a few, all of which reduces the cost on each item and makes possible, always \$10.00.

Big Business Men Wear 'Em—The Men Who Make Money and Keep It—wear these suits. They know Richman Clothes are worth a great deal more than \$10. They prefer several clean suits to one shabby one. In Cleveland, home of our factory and largest store for 35 years every sixth man of its 650,000 inhabitants buys a suit or overcoat of us once a year. Men in every walk of life are wearing them—they are the clothes for YOU—whichever you are, wherever you are. A ten dollar bill and postage will bring you Richman clothes right to your door—parcel post. Satisfaction guaranteed or money back.

STYLE BOOK FREE—write for Spring catalog of latest styles—and 75 newest fabrics.



The largest exclusive clothing store in America where nothing but clothes of our own make are sold

THE RICHMAN BROTHERS CO., Dept. 26, CLEVELAND, O.
Milwaukee, Wis.; Cincinnati, O.; St. Paul, Minn.; Minneapolis, Minn.; Duluth, Minn.



HIWAIAN DIAMONDS ARE THE BEST

imitation of real diamonds. Fine cut. Full of fire. They fool experts.



SPECIAL OFFER

Just to Advertise
Send \$2 paper money or P. O. order for Lion's head with ruby eyes—Hiwaian diamond in mouth, or cluster ring, ruby or emerald center, with 16 selected

Hiwaian Diamonds. Money refunded if not satisfied. Send for catalogue.

KRAUTH & REED, Dept. M, Masonic Temple, Chicago, Ill.



Father, Mother, Brother, Sister—

You will find many uses for SKAT, after work or play—or for cleaning utensils, tools, and things around the house generally. Great for removing dirt, grime and grease from the hands, quickly and thoroughly—leaving them white, smooth and soft. Injures nothing. A little goes a long way—most economical soap made.

10 cents at dealer's. If yours hasn't it, send us his name with 10c and we'll see you are supplied. SALESMEN WANTED.

THE SKAT COMPANY, HARTFORD, CONN.

The total expenditures of the United States on behalf of education now approximate \$500,000,000 a year.

BUY PLUMBING and HEATING SUPPLIES



at WHOLESALE Will Save You 30%

Don't pay retail prices. Full stock on hand for prompt shipment. Send for free catalog.

B. P. KAROL, 768 to 772 W. Harrison St., CHICAGO



Amazing Profits In Mushrooms

Anybody can add \$1 to \$40 per week to their income. In spare time, entire year growing mushrooms in cellars, shrubs, barns, boxes, etc. I tell you where to sell, at highest prices.

Free Illustrated Instruction Booklet

HIRAM BARTON

Desk 2, 329 W. 48th St., New York



MODEL AEROPLANES

Send 2c postage for Complete handbook of Models and Supplies.

Our set contains this and 9 other drawings, with instructions for building \$1.00

WADING RIVER MFG. CO.
WADING RIVER, N. Y.

\$27⁷⁵ in 5 hours

Profit made by L. C. Loce of Sioux Falls. Big money made easy at home, traveling, at fairs, etc., with a plateless

DAYDARK POST CARD MACHINE

making photos 3 a minute. No experience needed. Write for particulars and FREE TRIAL.

Daydark Specialty Co., Dept. 2, St. Louis, Mo.



New DAYDARK sent 10 days FREE TRIAL

No Money Down

Elgin, Waltham Rockford All Styles All Sizes

There is no longer any need to buy a worthless watch just because it's cheap, or to pay a fancy price for a top-notch time-piece. If you want a highest grade watch, either ladies' or gentlemen's, or if you ever expect to own such a watch you should write today for Hartman's Free Watch Book which shows all the different styles and explains fully the details of the most startling price reducing offers ever made on highest grade, absolutely dependable watches in guaranteed cases. Adjusted to positions, adjusted isochronism and absolute accuracy to the fraction of a second. Open Face or Hunting Cases. Our ten million dollar purchasing power enables us, alone, to make such startling offers. Our wholesale prices on Elgin, Rockford or Waltham watches are the lowest ever made.

Free 30 Days Approval Test

We ship any watch shown in our big catalog on approval, all charges prepaid. You risk absolutely nothing—you pay nothing—unless you accept the watch after thorough inspection. Carry it a month. If you are not satisfied that it is the rarest watch bargain you ever heard of, return the watch at our expense.

NO REFERENCES ASKED

If you want to pay cash, you may, but it costs you absolutely not one penny extra to take advantage of Hartman's long time open account credit terms. No references asked, no embarrassing questions, no mortgage, no security, no interest, no collectors. Most liberal, satisfactory credit plan ever devised.

Remarkable Bargains

No. 9. G. 1141. Ladies' Bracelet Watch. 20-year guarantee gold-filled thin model case, expansion bracelet. 15 jewel lever high-grade movement. Elgin, Waltham or Swiss, 00 size. Only **\$1.00 Per Month**

No. 9. G. 1204. Celebrated genuine Elgin, newest model, 7 jewel movement, in thin, moisture, dust and wear-proof 16 size silver case. Only **50c Per Month**

No. 9. G. 1178. 17 Jewel Elgin, Waltham or Rockford movement. Thin model, 12 size, Hunting Case, permanent guarantee gold-filled case, bright cut in yellow and natural gold to contrast on rich red gold. Only **\$2 Per Month**

No. 9. G. 1197. 15 Jewel Elgin, Waltham or Rockford movement in guaranteed 16 size, thin model, 25-yr. guarantee gold-filled Hunting Case. Inlaid enameled border and monogram; any two or three letters you select in red, blue and white enamel. Only **\$2 Per Month**

No. 9. G. 1164. Elgin, Waltham or Rockford Ladies' watch. 14K solid gold 9 size Hunting Case Bassi model set with genuine diamond of excellent color and brilliancy. Only **\$3.50 Per Month**

No. 9. G. 593. Gentlemen's Gilt Case, 12 size newest thin model 25 year guarantee gold-filled case, 15 Jewel Elgin Pride movement. Fine gold gold Waldemar chain, 13½ in. long, and 2 blade gold stiffened Solid Gold Handle Knife in handsome black Morocco case. Remarkable bargain, only **\$2 Per Month**

FREE Hartman's Beautiful Watch and Jewelry Catalog Send your name and address on a postal today—get your free copy. Learn our astonishingly low prices on famous Watches, Jewelry of every kind, Diamonds, etc., and easiest terms ever made. Address

HARTMAN'S Jewelry Dept.
123-25 W. 39th St.,
Chicago, Ill.

Your Credit Good

Please Mention Popular Mechanics



Boston Garter
Velvet Grip

Holds Your Sock Smooth as Your Skin

Men who dress well prefer the silk Boston Garter for personal satisfaction

GEORGE FROST CO., MAKERS, • • BOSTON



SEND \$1.00 FOR THIS REAL BUNGALOW BOOK

Design No. 534 by Fred Yoho. Est'd Cost \$2000.

1915 DeLuxe Edition, 112 Pages
The largest exclusive bungalow book published

Shows cream of 1000 practical and distinctive bungalows actually built for \$400 to \$4000, suited to any climate, with exterior and interior views, plans, size of rooms, cost, etc.

Contains valuable suggestions on bungalow building written by experts. Worth many **\$1.00 Post** times its cost to any builder. Sent anywhere **— Paid**

A smaller book 50c. Send check, money order or stamps. Money back if not satisfied.

JUD YOH0, The Bungalow Craftsman, 50 Bungalow Bldg., Seattle, Wash.

BUY YOUR FURNACE \$10 DOWN \$10 A MONTH



Our monthly payment plan of selling direct saves you the dealer's profits and charges for installation. The

JAHANT FURNACE

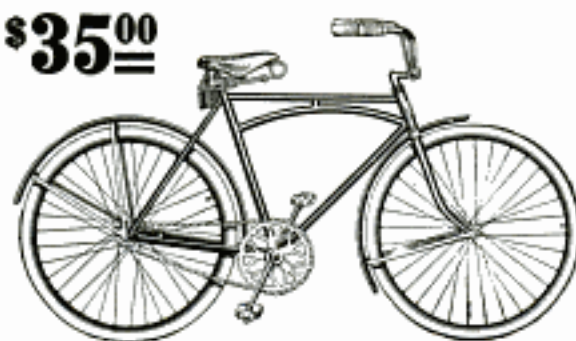
with the patented "Down Draft System" is best for residences, schools, hotels, churches, etc., because it delivers plenty of heat wherever and whenever desired at a saving of $\frac{1}{3}$ to $\frac{1}{2}$ in fuel bills. Install the Jahant yourself. We send complete outfit, freight prepaid with special plans, detailed instructions and all necessary tools for installation. Satisfaction guaranteed or money refunded.

WRITE FOR FREE ILLUSTRATED BOOK
THE JAHANT HEATING CO.

168 Mill Street AKRON, OHIO

Save $\frac{1}{3}$ to $\frac{1}{2}$ on Fuel Bills

\$35⁰⁰



Pope Go to Your Dealer Today and See This
Defiance Model Bicycle

It is great value at \$35. A high grade, light weight chain wheel, splendidly built for hard riding. The special "true rib" arch gives unusual frame strength without additional weight. Beautifully finished—perfectly adjusted—good for years of service. Complete with Coaster Brake, Heavy Service Tires, Large Sprocket and Pope Mud Guards. The Pope trade mark guarantees the quality. It has identified the best in bicycles for 37 years.

POPE BICYCLES are made in 92 models. A full line of chainless and chain-driven wheels for every purpose.

MOTOR CYCLES—Six Models. Single cylinder, twins and two speeds.

Send for either catalog you wish.

THE POPE MFG. CO.

16 Cycle Street Westfield, Mass.

STANDARD BARREL FOR DRY COMMODITIES ESTABLISHED BY CONGRESS—By a recently passed bill, Congress has established a standard barrel for fruits, vegetables, and other dry commodities. The bill provides for a barrel with 28½-in. staves and 17¼-in. heads made of material not thicker than four-tenths of an inch. However, any barrel having a capacity of 7,056 cu. in. will be considered standard. A separate standard is fixed for cranberry barrels.

10c OFFER KEITH'S



To introduce Keith's Magazine on Home Building, a beautiful House Building number of 80 pages, together with a copy of a book of 20 Wonder

Homes, will be mailed postpaid for 10c, silver or stamps.

M. L. KEITH, 742 McKnight Building, MINNEAPOLIS, MINN.

QUICK ROAD TO HEALTH

Boys and girls from 4 to 15 years of age can now have fun out of doors while they build up strong bodies. Speed without labor. The rider's own weight keeps the car whizzing along. No pushing. Perfect control and safety. Induce the child to spend long hours out of doors in the wind and sun. The



Skudder Car

will develop the lungs, shoulders and legs. Ball bearing, unbreakable steel frame. Let us send you one and show you how it will make your child happy and healthy.

Write for free circular

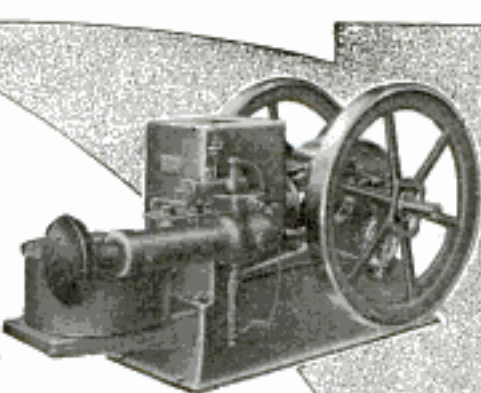
SKUDDER CO.

Room 516 Straus Bldg., CHICAGO

Please Mention Popular Mechanics



Why I Can Make Lower Engine Prices



Buy From An Engine Specialist

With my own hands, 27 years ago, I made my own first engine, and gave it my own name. Ever since, I have personally supervised my own factory. I know every WITTE engine, inside and out, that leaves my factory.

I am the only man in the United States who makes his own engines, in his own debt-free factory, from his own designs, using his own special machinery and selling his entire output under his own name—direct from factory to user only.

I have built the WITTE engine of fewer parts and so have made it longer lasting; more easily understood, and more easily managed; and last but not least, it takes less fuel per horsepower hour, on account of its fewer and simpler moving parts.

ED. H. WITTE

WITTE Gasoline and Naphtha Engine—Stationary

Shown mounted on iron sub-base, which makes a permanent foundation where it is impractical to use masonry construction.

My latest prices are for the best engines I ever made. And for over 27 years, WITTE engines, in all parts of the world, at all kinds of work, have proven themselves of the highest quality.

Recently I have expended many thousands of dollars in enlarging my factory to more than double its former capacity, and for specially designed machinery of the latest types to reduce my cost of production while still maintaining the high standard WITTE quality. Then, too, I have my own natural gas well which furnishes me free power, light and heat. I share these advantages with every customer by making the **lowest** prices possible for strictly high-standard engines.

WITTE ENGINES

Kerosene, Distillate, Gasoline & Gas

Sold only Direct from my Factory Doors to the User's Hands!

No matter what kind of work nor how much of it there is to be done there is a WITTE Engine, **stationary, portable, skidded, or special saw rig**, of just the size and style that is best suited for that particular work.

Whatever size or style you select, it is guaranteed to stand up under years of hard wear and deliver steady power for the lowest fuel cost. So simple in construction that you can easily understand, start and run it, whether you are experienced with an engine or not.

Get My Complete New Offer and Copy of My New Book FREE

You should have a copy of my new Book — **HOW TO JUDGE ENGINES**. Explains how to start and keep an engine running—how little it

costs, and how easy it is, under my liberal easy terms and sales plan, for any WITTE engine to earn its own cost while it is being paid for. Mail coupon today and I will send you the whole WITTE story by return mail.

ED. H. WITTE
WITTE IRON WORKS CO.
1748 Oakland Avenue
Kansas City, Mo.

WITTE Kerosene Engine—Stationary
Burns Kerosene, Distillate, Solar Oil, Toppings and all fuels of like grades. Also Gasoline, Naphtha and Gas.

Latest WITTE Engine Prices:

(On account of war conditions, subject to change without notice.)

2 H-P \$34.95
4 H-P 69.75
6 H-P 97.75
8 H-P 139.65
12 H-P 219.90
16 H-P 298.80
22 H-P 399.65

Portable and Saw-rig Outfits proportionally low

WITTE prices make you a good profit right on the first cost and give you the satisfaction and protection of dealing direct with the maker. I give a liberal **5-Year Guaranty** on the efficiency and durability of every engine I ship.



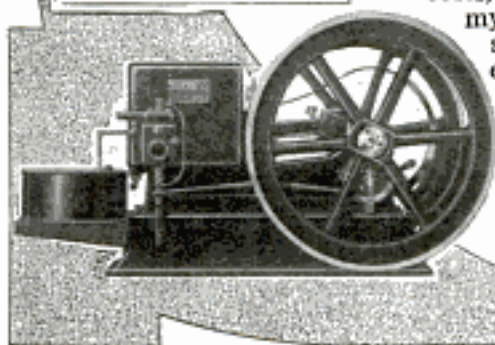
MAIL THIS COUPON TODAY

ED. H. WITTE, Witte Iron Works Co.
1748 Oakland Ave., Kansas City, Mo.

With no obligation on my part I should like to receive your latest and finest Engine Book, with your new liberal Selling Plan.

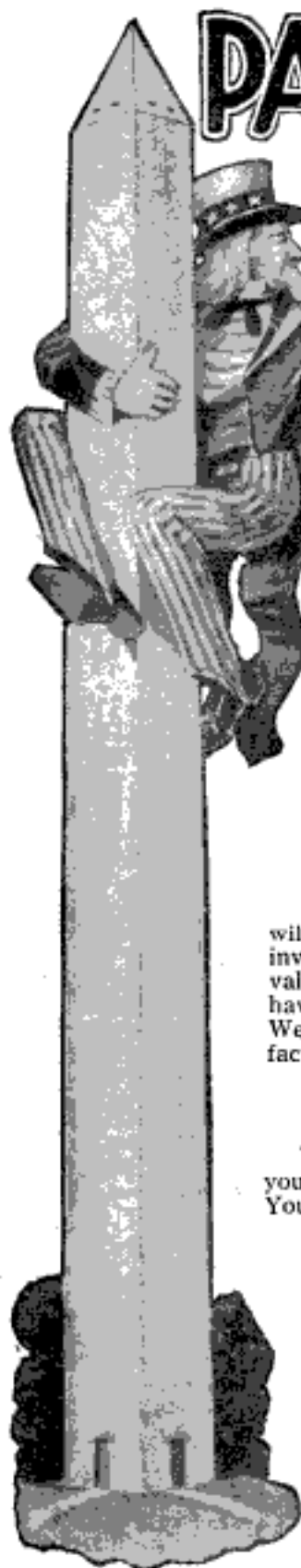
Name

Address



Please Mention Popular Mechanics

PATENT YOUR IDEAS



*—There is a Constant Demand
for Good Inventions*

Thousands of the biggest money-making inventions have been the "little" things that have made people wonder why they were never thought of before.

"WHAT TO INVENT"

and

"HOW TO OBTAIN A PATENT"

These Books Sent Free

If you have an invention send us a sketch, photograph or model of it. We will give you a report as to its patentability absolutely free. If you have no invention send for our book, "What to Invent." It contains hundreds of valuable suggestions. We are recognized authorities on patent matters and have helped hundreds to find a ready and profitable market for their ideas. We can prove it. If you wish to sell your patent we will advertise it in manufacturers' journals at our expense.

Don't Wait—Find Out NOW!

Your idea will never do you any good if some one else patents it ahead of you. Act quick! Let the other fellow say "he thought of it a long time ago." You reap the profit. Let the others wish they had.

Advice Free—All Matters Confidential

We have secured patents for thousands of inventors and have many letters proving the value of our services. Write us. Send rough drawing or model of your invention for our opinion. We will guard it carefully and report quickly. You are under no obligations to proceed further. Our plan is simply a square deal to all. Our books, "What to Invent" and "How to Obtain a Patent" are the best publications written for the man who has an idea to patent, or who is of an inventive turn of mind. They show just how to proceed with your idea and tell of hundreds of things to invent. We gladly send these books free. The sooner you write for them the sooner you will know all about patents and the many different lines in which new inventions or improvements may be made.

If you have an invention send us a sketch of it for report and ask for the books at the same time.

CHANDLEE & CHANDLEE, 953 F Street, Washington, D. C.

REGISTERED ATTORNEYS

WANTED IDEAS



Inquiries from Manufacturers and Other Buyers of Patents
Who Are Looking for Good Ideas

Protected by Owen Patents

Are constantly being received. Hundreds of ideas are wanted—a market exists for them to-day. YOURS may be one of them. Send for my free books and see for yourself—read the requests for inventions protected by me. Many are simple. You can help supply this demand.

As soon as my clients' rights are protected I aid in every practicable way, without charge, to sell. Their applications are advertised free—their patents are called to the attention of the proper prospective buyers—every necessary thing is done. Get my booklets and see.

THESE ARE FREE

You will incur no obligation by writing me. A simple request will bring them to you—the finest, most reliable and instructive patent books published. A postal will do.

"Successful Patents"—a 72 page guide book, tells how to proceed; describes my advantageous business methods; gives references, testimonials, etc.

"Stepping Stones"—gives hundreds of hints of inventions wanted; articles from interviews of noted authorities; tells the truth about prizes for inventions.

"Patent Promotion"—tells you how to sell; why some inventors fail; discusses the value of your idea; how I aid my clients; manufacturing aids furnished you; recent successful patents, etc.

You will also be sent from time to time, as new inventions are wanted, full information concerning them. Only in this way can you keep up to date.

Write for These To-day—Advice costs nothing. All communications confidential. I secure patents or receive no compensation. Your work will receive my personal supervision—but my fees are no higher than others.

Results Speak Loudest—But Here Are Some References

Columbia National Bank,
Washington, D. C.
National Locktile Co.,
Washington, D. C.
The Carnahan Press,
Washington, D. C.
Lightning Gun & Cycle Works,
Oklahoma City, Okla.
Antholene Mfg. Co.,
Hutchinson, Kans.

National Back Co.,
61 Hannover St.,
Boston, Mass.
The G. J. Loftus Co.,
13 Spring Common,
Youngstown, Ohio
Whitehead Hosiery Mills,
Burlington, N. C.
Dickinson Mfg. Co.,
Des Moines, Iowa.

A LARGE NUMBER OF OTHERS IN MY BOOKLETS.

RICHARD B. OWEN 9-303 OWEN BLDG.
WASHINGTON, D. C.

Inventors submitting their inventions to me are protected in a tangible manner until their applications are filed.



Search of Records

Send sketch or model of your invention for free search of Patent Office Records and report on patentability.

PATENTS THAT PROTECT and PAY

Advice free. Terms reasonable. Highest references. Best results.
Send sketch or model for FREE examination and opinion.

Recommended Patent Lawyer in the Bankers' Register and special list of selected lawyers. Also in Martindale's Law Directory, Sharp and Alleman's Directory of Lawyers, The Con. P. Curran Directory of Lawyers and Bankers, and bonded and recommended Patent Lawyer in Rand-McNally's Directory of Lawyers and Bankers.

ALL BUSINESS GIVEN PROMPT AND PROPER ATTENTION

A large list of strong recommendations furnished free

WATSON E. COLEMAN, Patent Lawyer, 622 F St., N.W., Washington, D.C.

Money in Patents

Manufacturers are always looking for inventions.

All patentable ideas should be protected by a patent. (By a Registered United States Patent Attorney.)

The great majority of money making inventions are thought of by persons, I will term amateur inventors, and nearly always are some very small or simple thing, for the reason that a large invention takes too much time and money for the average person to produce. I have inquiries from all over the country, in which manufacturers and business houses are looking for patents in every line of industry. Owing to these inquiries I am about to put inventors in direct touch with manufacturers who want patents, and thereby find a ready sale for their invention, which, for results, is far more practicable than any other mode of assistance to inventors.

A book "How to get your patent and make your profits thereon," which contains general patent information, is free and I would be very glad to have you write me for a copy of it.

MANSSELL F. MILLS

Registered United States Patent Attorney

244 Commercial National Bank Building, WASHINGTON, D. C.

A Fortune to the Inventor

who reads and keeps it, is the possible worth of the book we send for 6 cents postage. Write us at once.

E. S. & A. E. LACEY, Dept. Y, WASHINGTON, D. C.

PATENTS C. L. PARKER

Formerly Member Examining Corps, U. S. Patent Office
PATENT LAWYER
210 MCGILL BLDG.
WASHINGTON, D. C.

Patents, Trade Marks, Copyrights, Patent Litigation

Handbook for Inventors, "Protecting, Exploiting and Selling Inventions" sent free upon request.

WARNING AGAINST SLAUGHTER OF WALRUS
—That the walrus is rapidly nearing extinction is the

PATENTS

MASON, FENWICK & LAWRENCE
Established 1861. — 610 F St., Washington, D. C., New York City and Chicago. Manufacturers buy good patented ideas. Booklet Free.

Send for **FREE BOOK** { **WHAT TO INVENT**
WHAT NOT TO INVENT
HOW TO SELL YOUR PATENT
Copies of nearest Patents and report in every case without charge

H. L. WOODWARD, 9th and G Sts., WASHINGTON, D. C.



MECHANICAL SUPPLIES AND MATERIAL of all kinds.
EXPERIMENTAL AND LIGHT MACHINE WORK to order.
132 MILK STREET, BOSTON

PATENTS THAT PAY

OUR TRADE-MARK

OVER \$600,000.00 MADE BY CLIENTS

PATENTABILITY REPORT

Send sketch or model of your invention for free search of the Patent Office Records and report as to patentability.

2 WONDERFUL BOOKS

entitled (1) "Inventor's Guide" and (2) 127-Page "What and How to Invent—Proof of Fortunes in Patents" which every inventor should have, and can have, FREE.

Highest References, including 100 manufacturers we serve
Promptness Assured

Across the Street from the U. S. Patent Office
E. E. VROOMAN & CO., 871 F STREET, N. W., WASHINGTON, D. C.



Active Powers of Invention Center

INVENTORS

Our Brain Belongs to You. Our Ideas Are Free of Charge.

All we want in return is to build your model, special machinery, dies, tools and lugs to manufacture sheet metal goods, etc. We are expert mechanics, over thirty years' experience and have one of the best equipped shops in the country. Ask for Booklet No. 17. Consultation free. Experimental work strictly confidential.

A. Nacks & Son, J. Urmann, A. Heldrich, Prop's
236-242 S. 9th St., Philadelphia, Pa.



BRASS GEARS

Cut by an entirely new process. The most accurate made and at prices that cannot be equalled by others. Every gear has a hub, center painted ebony black, edges turned true, highest grade red brass, and much heavier than others. We carry the largest stock in the world and every gear listed is always shipped on date of order.

SEND FOR CATALOGUE
CHICAGO STOCK GEAR WORKS
16 S. Fifth Av. Chicago

Patents

Trade Marks and
Copyrights Secured
or Fee Returned

Special Offer—Free Search of Patent Office Records

Send us a model or sketch and description of your invention, and we will make a *Free Search* of the *Patent Office Records* to ascertain if it is patentable. If we report the invention patentable, we will guarantee to obtain a patent or return our fee, and furnish a certificate of patentability backed by a bonded contract to that effect. **This Certificate of Patentability will protect the inventor and serve as proof of the invention until the case can be filed in the U. S. Patent Office.**

Obtaining Assistance for Inventors

Our certificate is of great assistance to inventors who require financial aid to obtain patents.

Our Five Books Mailed Free

(SEE COUPON BELOW)

to any address. Send for these books—the finest publications ever issued for free distribution.

How to Obtain a Patent

Our illustrated eighty-page Guide Book is a book of reference for inventors, and contains 100 mechanical movements illustrated and described.

Money in Patents

Tells how to invent for profit, and gives history of successful inventions.

What to Invent

Contains a valuable **LIST OF INVENTIONS WANTED** and suggestions concerning profitable fields of invention; also information regarding prizes offered for inventions, among which is

Prize of One Million Dollars

offered for one invention, and \$10,000 for others.

Patents That Pay

Contains letters from our clients who have built up profitable enterprises founded upon patents procured by us; also endorsements from prominent inventors, manufacturers, Senators, Congressmen, Governors, etc.

We Advertise Our Clients'

Inventions Free

In a list of Sunday newspapers with two million circulation, in manufacturers' journals and in the *World's Progress*. Sample Copy Free. We save you time and money in securing patents. After the patent is granted we assist you **TO SELL YOUR PATENT**.

Foreign Patents

WE HAVE DIRECT AGENCIES IN ALL THE PRINCIPAL FOREIGN COUNTRIES and secure FOREIGN PATENTS in the shortest possible TIME and at the LOWEST COST. Write for our Illustrated Guide Book on Foreign Patents, sent free to any address.



VICTOR BUILDING

Our new \$200,000 building opposite U. S. Patent Office
SPECIALLY ERECTED by us for OUR own use

WANTED NEW IDEAS

Send for **LIST OF PATENT BUYERS** who consult us when purchasing patents. Contains requests from **MANUFACTURERS, MAIL ORDER HOUSES** and **PROMOTERS** for patents secured by us, and suggestions as to **New Ideas** they wish to purchase. We invite manufacturers and promoters to address our Sales Department regarding the purchase or leasing of a number of meritorious patents secured by us.

REFERENCES

Second National Bank, Washington, D. C.; Union Savings Bank, Washington, D. C.; Chamber of Commerce, Washington, D. C.; Pitner Gasoline Lighting Co., Chicago, Ill.; R. G. Dun & Co., Washington, D. C.; Smethport Glass Co., Smethport, Pa.; The Melvin Gauge and Signal Co., Scranton, Pa.; M. Winter Lumber Co., Sheboygan, Wis.; National Savings and Trust Co., Washington, D. C.

FREE COUPON!

VICTOR J. EVANS & CO., Patent Attorneys

NEW YORK OFFICES: 189-191 Broadway

PHILADELPHIA OFFICES: 1429 Chestnut St.

Main Offices: 765 Ninth St., N. W., WASHINGTON, D. C.

GENTLEMEN: Please send me FREE OF CHARGE your FIVE Books as described above.

NAME..... ADDRESS.....

DIAMONDS

ON EASY TERMS



1926	\$25
1927	\$50
1928	\$75
1929	\$100

Better Than a Savings Bank!

Start Right. Start Now. Buy a Diamond. Beats a Savings Bank four to one, besides daily dividends in pleasure while wearing it.

Big Special Sale!

Greatest Diamond values ever offered in \$25, \$50, \$75 and \$100 sizes. Pure white, perfectly cut, sent on approval, **no money down.**

FREE CATALOG. Write for it quick. Make your selection and when the diamond comes, if you like it and want to keep it, pay for it on our Liberal Club Plan—payments so easy, you'll never miss the money. No red tape, no security—just common honesty among men. Postal will do.

HARRIS-GOAR CO. Dept. 1575
Kansas City, Mo.

WE TRUST You

\$ 4 A MONTH

Oliver Typewriter

Nothing Down—Free Trial. Less than Agents' Prices. Shipped on approval. If you want to keep it, send us \$4 a month. Send for famous FREE typewriter book. Tells how to save \$48.00. Write today.

TYPEWRITERS DISTRIBUTING SYNDICATE
166-480 N. Michigan Blvd., CHICAGO (270)



"Vulcan" Ink Pencils

RED OR BLACK

Inexpensive and Durable. Unequaled for general writing

ONLY Non-Leakable moderate price INK PENCIL made

EXTRA SIZE BOWL \$1.25
2 SIZES AND 5/8 IN. \$1.00

J.C. ULLRICH & CO. AGENTS TERRITORY OPEN
27 TRINITY ST. NEW YORK



A Book Form Business Card

carried in a leather case and detached as needed will appeal to your old customers and get new ones. To the trade we supply the blank scored cards for

PEERLESS PATENT BOOK FORM CARDS

Appearance of Our Neat Cards in Case

and furnish a patent lever binder case, so you can print and bind them in your own shop. There is nothing that surpasses them, and your trade will appreciate it if you call their attention to the convenience and economy of using them.

Write for samples and our plan for supplying you. Write today.

THE JOHN B. WIGGINS CO. (Established 1857)
Engravers, Plate Printers, Die Embossers
62-64 East Adams Street CHICAGO



Please Mention Popular Mechanics

KEROSENE AND GASOLINE LANTERNS

Absolutely bug and wind proof and give 300 candle power of light, at a cost of 1/5c per hour. Suitable for use on farms, watchmen, side shows, circuses, street carnivals, garages, livery barns, summer resorts, warehouses, boat landings, etc.

For complete catalog and agency proposition address

THE NAGEL-CHASE MFG. CO.
150 East Erie St. CHICAGO



SAFETY FIRST "Yale Electric" Lantern

Combination House Lamp, Search and Flash Light. Full size, regular shape. Just turn the switch and get a flood of light, twice as much as the old. The simplest, safest, handy light for autoists, campers, merchants, farmers and the home. No matches, no oil, no wick trimming, no smoky chimneys, no danger of fire. Always ready.

\$3.50 Sent postpaid on receipt of price, on Money-Back guaranteed. Big money for agents. Get our agent's proposition. Start today. Be the first.

YALE MANUFACTURING CO., Dept. B, 22-30 So. Clinton St., CHICAGO



TYPEWRITERS ALL MAKES

Prices \$15.00 up. **SOLD or RENTED ANYWHERE** at 1/4 to 1/2 MANUFACTURERS' PRICES, allowing RENTAL TO APPLY ON PRICE. Free Trial. Installment payments if desired. Write for Catalog 1.

TYPEWRITER EMPORIUM, 24-26 W. Lake St., Chicago, Ill.




warning sounded by all observers. Proof is supplied by the slaughter caused by one crew in a single season.

POULTRY PAPER

44-124 PAGE periodical, up-to-date; tells all you want to know about care and management of poultry for pleasure or profit. Four months for 10 cents.

POULTRY ADVOCATE, Dept. 98, SYRACUSE, N. Y.



Greider's Fine Catalogue

and calendar of pure bred poultry; 70 varieties illustrated and described, many in natural colors. A perfect guide to poultry raising—full of facts. Low prices on stock and eggs for hatching. Incubators and brooders. 22 years in business. You need this noted book. Send 10c for it—today.

B. H. GREIDER, Box 19, Rheems, Pa.



SHOEMAKER'S BOOK ON POULTRY

and Almanac for 1915 has over 200 pages with many colored plates of fowls true to life. It tells all about chickens, their prices, their care, diseases and remedies. All about incubators, their prices and their operation. All about poultry houses and how to build them. It's an encyclopedia of chickendom. You need it. Only 15c.

C. C. SHOEMAKER, Box 1107, Freeport, Ill.



\$7.16 PROFIT PER HEN

That's what Director Tom Quisenberry does at the Missouri State Experiment Station. He does not claim you can do that, but

HE WILL SHOW YOU HOW to succeed "The Quisenberry Way." Only exclusive poultry school in the world. \$1 starts you. Write for illustrated free book that tells the story.

The AMERICAN SCHOOL OF POULTRY HUSBANDRY
BOX 75, MOUNTAIN GROVE, MO.



Values Ripped Wide Open

Big Money in Poultry My 1915 values are creating a SENSATION. I have the largest incubator factory in the world. My tremendous output is enabling me to rip values wide open. The same high-grade world-beating quality that has made RELIABLE INCUBATORS AND BROODERS the standard of experienced poultrymen all over the world. Don't buy until you get my 1915 prices and book of facts. You'll regret IF YOU DON'T. Write now.

J. W. BYERS, Pres., RELIABLE INCUBATOR & BROODER COMPANY, Box 251, Quincy, Ill.





LET OUR EXPERTS Draw Up Your **FREE** Heating Plans

TAKE advantage of our trained experts—be sure of heating every room. Keep down coal bills. Deal direct with manufacturer—save \$25 to \$75 by buying at **Low Wholesale Factory Price**



We grant year's test—back guarantee with bank bond—cash or long time credit—easy payments. *We pay freight. Blue prints free, whether you order or not—no obligations. Write today for*

Catalog No. 936.

Kalamazoo Stove Co., Mfr.
KALAMAZOO, MICH.

**"A Kalamazoo
Trade Mark
Registered Direct to You"**

30 Days FREE TRIAL
and freight prepaid on the new 1915 "RANGER" bicycle. Write at once and get our big catalog and special offers before buying.

Marvelous improvements. Extraordinary values in our 1915 price offers. You cannot afford to buy without getting our latest propositions. **WRITE TODAY.**

Boys, be a "Rider Agent" and make big money taking orders for bicycles and supplies. Get our liberal terms on a sample to introduce the new "RANGER."

Tires, equipment, sundries and everything in the bicycle line at half usual prices. Auto. and Motorcycle Supplies.

MEAD CYCLE CO., DEPT. D108 CHICAGO

ABOUT MUSHROOMS

How to really make big money in mushrooms is fully explained in the wonderful book, "The Truth About Mushrooms," a great revolutionary improvement, things many growers never knew before. Everything explained from A to Z, at fast hand, from the greatest practical authority in America. Add \$10 to \$20 a week to your income. Demand exceeds supply. Grow in cellars, sheds, boxes, etc. Small capital to start. Prints larger and quicker. Anyone can do it. Women and children too. *Now is best time. Send for free book.*

BUREAU OF MUSHROOM INDUSTRY, Dept. 191, 1342 N. Clark St., CHICAGO

YOU SAVE \$8

Spring Styles Suits and Overcoats

\$10 to \$22

Our 1915 Style Book is ready. It contains 29 full-length illustrations. Shows what style suits and light-weight overcoats well-dressed men will wear this Spring. Also 40 samples of the most pleasing cloth patterns. You take no chances. You see the styles and the cloth. Just fill out the measurement blank and send to us. Cloth is strong and durable. You are doubly protected by our legal guarantee and our "Money Refunded If Not Satisfied" policy. A safe and easy plan to get a new suit **Made to Order** and still save \$8.

Send today for Style Book and Cloth Samples. It's **FREE**

GLEN ROCK WOOLEN CO.
219 Main St., Somerville, N.J.



\$375

Cash or Payments

Playable with
music rolls or
by hand without
previous practice

"One Can't Tell It From Hand Playing"

Before you play the first selection on your Symphonic Player Piano ask the other members of your family to step out of the room. Put in a roll of music and play. Then, nine chances out of ten, they will exclaim as did Miss Zimmerman of Michigan, "One can't tell it from hand playing!" Many customers have so expressed themselves. This perfect imitation of hand playing is the result of the Symphonic's wonderfully sensitive and instantly responsive "expression controls." These, as you play, accurately interpret your feelings and emotions.

Symphonic Pianos
Symphonic Player Pianos
Sold with Larkin Groceries and Supplies

Our Plans of Sale permit you to cut your family's Grocery bills and to secure in the Symphonic a piano or player of the highest quality at a price surprisingly low. Flour, Sugar, Coffee, Tea, Canned Goods, Soaps, Toilet Articles, in all 900 every day necessities make up our list.

SYMPHONICALS

Do you like vocal as well as instrumental music? You may have the best of both with a Symphonic in your home which plays Victor and Columbia records. Also sold at rock bottom Factory-to-Family prices with Larkin Groceries and Home Supplies.

**1 to 4 Years' Time
NO INTEREST OR RENT**

Symphonics and Symphonicas are shipped after we receive your first Grocery and Home Supply order. The balance you pay in one to four years, time depending upon instrument purchased.

**Send for FREE
INSTRUMENT CATALOG**

This book shows these instruments in beautiful Pined, Golden, and Early English Oak, in Circassian Walnut and Fluted Mahogany. It also explains in detail how we save you so much money by direct Factory-to-Family dealing. Ask for it today.

SEND THIS COUPON

\$60
Cash or
Payments

LARKIN CO., Buffalo, N. Y.
Dept. PM-415

Send me the Instrument Catalog and all details of your offer on the instrument here checked.

Piano Player-Piano Symphonic

Name

Town

R. D. or St. Address



CLASS PINS

**FACTORY TO YOU
FOR COLLEGE, SCHOOL OR SOCIETY**

Catalog with attractive prices mailed free upon request. Special offer, either style of pins here illustrated with any three letters and figures, one or two colors of enamel. **STERLING SILVER, 30c each; \$3.00 dozen; SILVER PLATE, 15c each; \$1.50 dozen.**

BASTIAN BROS. CO.



551 BASTIAN BLDG., ROCHESTER, N. Y.

5¢ A DAY BUYS A GIBSON

Terms as low as \$1.00 down and \$1.50 per month. Mandolin or Guitar sent on approval. The wonderful new Gibson Violin construction has set the whole Mandolin and Guitar world talking. Get our new FREE BOOK—100 pages—90 illustrations, a valuable fund of information for player and teacher. Also FREE treatise on "How to Practice." Here are some of the exclusive features embodied in every Gibson that make Gibson instruments unequalled:

Stradivarius arching—scientific graduation from thick center to thin which secures strength—eliminates free vibration of entire sounding board. **Tilted neck** permits high bridge with extension string holder securing increased string pressure and bigness of tone never before realized. **Reinforced non-warpable neck—elevated guard-plate and finger rest.** Easy action. **Adjustable string-bearing** at bridge overcomes sharpening of heavier strings in upper positions.

BIG MONEY TEACHING AND SELLING THE GIBSON

Becomes a teacher—we show you how. Splendid opportunities for Mandolin and Guitar teachers—either sex, in every locality, for private and class instruction, and the sale of Gibsons. The Gibson has "made" many a teacher, professionally and financially. G. A. Templeton, Sioux City, Iowa, writes: "If it were not for the Gibson I would not be in the teaching business. I consider that the Gibson Company has set me up in business." F. Marshall Dell, Flint, Mich., writes: "I find by my books that I have sold \$1300 worth of your goods since last year." The Gibson is used and endorsed by Wm. Pacer, Jr., Providence, R. I., Star Soloist for Victor Talking Machine Co., and a virtuoso of note.

Write To-Day If a teacher, become our agent, do business on our capital. Stock furnished. We help sell. Agents' territory protected. You make the profits. We pay the advertising. You pay for our goods when sold; return goods not sold. Try our "Still Hunt." Catalog and Thematic list free.

GIBSON MANDOLIN GUITAR COMPANY, 193 Harrison Court, Kalamazoo, Mich.

Open: A splendid, permanent teaching and business opportunity to the right teacher. Either sex. Write promptly. Other positions pending.



3 CUSTOM SHIRTS FOR \$5.00

I make shirts that fit you, because I make your shirts from your measurements and guarantee to take them back if they do not satisfy you.

I send you 100 samples to select from.

I send you measurement blank with rules. I send you the finished shirts express prepaid. No ready-made shirts in my shop, but facilities for quick delivery of the highest grade of custom work. Write for my samples. (High-priced fabrics, too.) Spring and Summer samples now ready. No agents.

CLARENCE E. HEAD (Master of Shirts), 110 Cayuga Street, ITRACA, N. Y.

An Attractive Bungalow Can Be Built for \$900.00

Plan of this bungalow and 117 other plans of bungalows, cottages and other houses in my new book, "Building Plans for Modern Homes," just off the press. One of the most complete and comprehensive books of plans ever published by any Architect. Nearly 300 illustrations of floor plans and elevations, costing from \$250.00 up, gives ideas and cost to build. Sent postpaid for \$1.00.



FREDERICK H. GOWING, Architect, 18 Tremont St., Boston, Mass.

The catch amounted to 723, of which 420 were cows and calves. Many were fatally wounded or shot dead, but not caught. A full-grown bull walrus weighs a ton. The walrus is a tempting bait to the hunter because of the amount of wealth found in the skin, the oil, and the rich ivory in the tusks. The disappearance of the walrus means the extinction of the Eskimos, who depend largely on this animal for food supply, fuel, lights, boats, and leather.



TYPEWRITERS ALL MAKES

Underwoods, Remingtons, Oliverts, Smiths, from \$10 to \$60. Guaranteed 5 years. 500 Typewriters at \$12.50, every one perfect. Write for liberal FREE trial offer at once. All Makes Typewriter Exchange Co., 168 N. Dearborn St., Chicago, Ill.

Try My *Rapid* FIRELESS COOKER

30 Days In Your Home At My Risk

A big saving in food bills, fuel, work—and food tastes better. I am making

Special Price on 10,000

to introduce cooker into new neighborhoods quick. Cooker is aluminum lined throughout. Complete outfit aluminum utensils free.

Write for Free Book and Bargain Prices direct from factory.

WM. CAMPBELL CO. Dept. 64 DETROIT, MICH.



LONGACRE

NEW YORK CITY HOTEL
Broadway and 47th St.

EXCLUSIVELY BACHELOR

Convenient to Everything. The refined air and good service of a club

RATES PER DAY

50 rooms with lavatory \$1.00

150 rooms with private bath 1.50

50 rooms with private bath 2.00

Two-room Suites, \$3.00 to \$4.00

Special Weekly Rates

Restaurant a la carte.

Club Breakfasts

DINING ROOM OPEN TO LADIES

The best value in New York City

both in rooms and restaurant.

'Phone, 7790 Bryant

J. G. BOGGS

Hand Forged
Razor Steel
Blades. No. 57



This \$2 KNIFE 83¢
DIRECT AT FACTORY PRICE

Handy shaped blade makes this knife best for mechanics, sportsmen and farmers; light but strong; resharpened easily. Stag handle, German silver finish; blades file tested, hand forged from razor steel and warranted. Sample \$30, 3 for \$2 postpaid. Cheapest pearl \$2 each.

Send for our 80 Page List FREE and "How to use a Razor"

MAHER & GROSH CO., 106 A. St., Toledo, Ohio.

"IDEAL" Lawn Mower Grinder

Grinds all makes of Mowers perfectly in 15 minutes without removing wheels, ratchets or reel-knife. Ball-bearing; operated by either hand or power. Skate Sharpener Attachment for sharpening skates.



"You Grind It As You Find It"

Write Today for full information of this great labor-saver and money-maker. Will do the work so much better, quicker and easier you cannot afford to do without it. The only practical machine for sharpening Lawn Mowers on the market. Over 6000 in use. Fully warranted. Sold on easy-payment terms. Write today. Don't delay.

THE ROOT-HEATH MFG. CO., Plymouth, O.

YOU CAN DRILL WHERE YOU CAN'T DIG

There is a big opportunity in every community for a capable man to establish himself in the well drilling business and make money. The right kind of a man with the right kind of equipment can be independent. Let your equipment be

★ DRILLING MACHINES

Equipped with either steam or gasoline power. Thousands of STARS are now in use. The demand for drilled wells is increasing. You can drill where you can't dig. It is a well known fact that there are but few places where water cannot be obtained by drilling. Write us today for catalogue (enclose 5c for postage) and let us show you the superiority of STARS. Furnished on payments, if desired.

THE STAR DRILLING MACHINE CO.

506 Washington Street

Akron, Ohio



DO YOU HAVE KNIVES TO GRIND, SILVER TO POLISH, SMALL TOOLS TO OPERATE, WASHING MACHINES OR WRINGERS TO RUN? LET THE RED DEVIL

DO YOUR WORK

Attached to any water faucet will develop up to 3 Horse Power according to size of pipe and water pressure. Only perfect small motor made. Improved bucket wheel construction.

6 in. Motor for Mechanics and Tradesmen, Washing Machines, 3 H. P. on 1/2 in. pipe, 80 lbs. water pressure; 1 H. P. on 3/4 in. pipe, 2 in. pipe. Net price \$5, cash with order.

No. 1492—4 in. Motor for grinding, polishing, face, sewing machines; for Doctors, Dentists, Druggists, etc., with emery, buffing wheel, silver polish and pulley, \$3.

No. 1493—4 in. Motor and pulley only \$2.50, cash with order.

Motor back for any reason. Order your motor from dealer or from us. Send your water pressure and size of supply line. Active Agents wanted. Catalog free.

Only Motor to do this work



6 in. Motor

DIVINE WATER MOTOR CO. DEPT P. UTICA, N. Y.

27 Below Zero Winter's Coal Bill Only \$20



1/2 to 2/3 Saving in Coal Bills Guaranteed with the New-Feed UNDERFEED.

"Our house was new, we had to maintain a greater heat, the winter was very severe—thermometer registering 27 below zero in the coldest weather. My UNDERFEED coal bill has been about \$20 for this winter—from a third to one-half less than with any overfeed furnace."

That's what Mr. Charles Petts writes from Warsaw, Mo. And we can send you thousands of just such others telling of more heat and better heat, at a saving in coal bills of from one-half to two-thirds with a Williamson UNDERFEED Furnace or Boiler.

This year brings the New-Feed UNDERFEED—the perfected UNDERFEED. Even less trouble. A twelve-year-old boy can operate it to perfection. Operated from a standing position. Ashes have to be removed but twice a week.

WILLIAMSON NEW-FEED UNDERFEED Furnaces and Boilers

Cut Coal Bills 1/2 to 2/3 FEEDS COAL FROM BELOW.

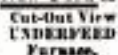
In the New-Feed UNDERFEED, coal is fed from below. The clean, live fire is always on top, in direct contact with the most effective radiating surfaces. All smoke, soot and gas converted into clean, live, usable heat. Ashes clean and white—and fewer of them.

And the New-Feed UNDERFEED burns any size of coal, from soft coal slack and pea or buckwheat anthracite up. Right there is a great saving you can actually see before you spend a penny. Larger sizes may be used if desired.

Adapted to warm air, steam or hot water. Get a New-Feed UNDERFEED for that new home or other building, or to replace that wasteful, unsatisfactory stove, grate or "overfed" furnace.

50% Saving in Coal Bills Guaranteed.

Not mere "say-so," but an actual guarantee where the New-Feed is properly installed and operated. This guarantee is



Cut-Out View UNDERFEED Furnace.

bona fide—backed by a million-dollar concern. Learn more about it. Use the attached coupon.

It describes the simple yet wonderful operation of the New-Feed UNDERFEED, and also brings the great, free, interesting book, "From Overfed to UNDERFEED."

Sending the coupon involves no charges or obligation. Send it to-day—NOW!



The Williamson Heater Co.

(Formerly The Peck-Williamson Co.)

45 Fifth Avenue, CINCINNATI, OHIO

COUPON

THE WILLIAMSON HEATER CO., 45 Fifth Avenue, Cincinnati, Ohio.

Tell me how to cut my coal bills from 1/2 to 2/3 with a Williamson New-Feed UNDERFEED. Warm Air..... Steam or Hot Water..... (Mark an X after System interested in)

NAME

ADDRESS

My Dealer's Name is.....

Fresh Water for Stock without effort or expense

It's mighty pleasant to know there's plenty of water for your stock with no tiresome hand pumping or engine troubles ahead of you. That's exactly the situation when you



INSTALL A RIFE RAM ON YOUR FARM

—Any stream having a fall of 3 feet or more and a supply of 3 gallons or more a minute will operate it. Insures a constant, automatic, permanent water supply. No skilled labor required to install. Used with either overhead or air pressure tank. Over 11,000 in daily use. No freezing. No attention. Satisfaction guaranteed.

Tell Us Your Water Supply Conditions and we will send free estimate on a Ram for your requirements. Write today for catalog and particulars.

RIFE ENGINE COMPANY, 3131 Trinity Building, NEW YORK CITY

Williams' Junior "Ford" Set "B"



A combination of thoroughly high-class tools and assured great utility. Each tool class tried out for service upon a model T "Ford" Car. Maximum service in a minimum number of Wrenches.

Send for pamphlet or go to your dealer

List prices, \$1.71, \$2.54, \$3.79 per set.
Roll lists 45c extra.

J. H. WILLIAMS & CO.
47 Richards St., BROOKLYN, N. Y. CITY
Chicago Warehouse, 36 So. Clinton St.



Crescent Woodworking Machines

are intended only for those particular users of wood working machinery who want the best.

Ask today for catalog of band saws, jointers, saw tables, planers, planers and matchers, disk grinders, swing cut-off saws, shapers, borers, variety wood workers, Universal wood workers.

The Crescent Machine Co., 93 Columbus St., Leontonia, Ohio



South Bend Lathes

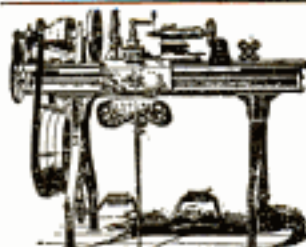
For the Machine and Repair Shop

11 inch Lathe Complete, \$100.00
12 inch Lathe Complete, 125.00
13 inch Lathe Complete, 165.00
14 inch Lathe Complete, 200.00
16 inch Lathe Complete, 250.00
18 inch Lathe Complete, 300.00

How to Run a Lathe

A 50 cent book for 10 cents. Postpaid, stamps accepted

Straight or Gap Beds. Send for free catalog giving prices on entire line.
SOUTH BEND MACHINE TOOL CO., 423 Madison St., South Bend, Ind.

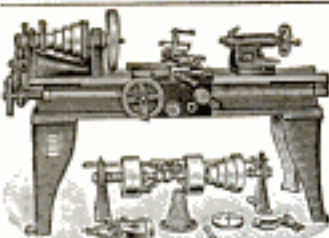


LATHES

9 to 18-inch Swing

List price \$75 and up according to size. When ready to buy send for Lathe Catalog and prices.

W. F. & John Barnes Co.
100 Ruby Street, ROCKFORD, ILL.



OUR BIGGEST LATHE VALUE

16-inch Lathe with 6-foot bed, \$252.00; other sizes at proportionately low prices. Every lathe guaranteed. Buy your lathe from us and save \$50.00 or more. Machinery Catalog No. 80P139 sent free on request.

SEARS, ROEBUCK AND CO.
CHICAGO

SEBASTIAN LATHES HIGH QUALITY LOW PRICES

If you delight in good tools you will delight in Sebastian Lathes. For 25 years we have built lathes, and lathes only, employing skilled labor always, and improving equipment and machinery every year. Sebastian Lathes are

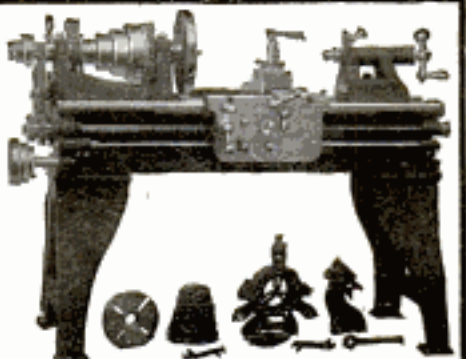
STANDARD FOR QUALITY—LOW IN PRICE

They are accurate, economical, simple and durable. Many re-orders and voluntary letters from users of Sebastian Lathes prove this. The Sebastian reputation is back of every Sebastian Lathe. You are judge and jury when you buy a lathe. We are not satisfied until you are. Look over the complete line in our new catalog. It shows Lathes for general repair work, garage and automobile work, etc.

When you buy a lathe, say "Sebastian"

ADDRESS (FOR THE CATALOG)

THE SEBASTIAN LATHE COMPANY, 107 Culvert St., Cincinnati, Ohio





As necessary as a saw or a hammer in your tool kit

Carborundum Sharpening Stones

Quick, clean-cutting stones, that bring the edge to the tool with just a few strokes.

And they cut the edge on the tool—They don't merely rub it on.

Every stone positively uniform in grit and hardness, holds its shape, shows long life.

The round Carborundum Combination Bench Stones for general tool sharpening, the beveled edge slips for touching up gouges, carving bits, etc.—the extra hard extra fine Carborundum stones for that finer edge for your finer tools.

EVERY STONE IS GUARANTEED

Ask your hardware dealer

The
Carborundum
Company

Niagara Falls, N. Y.



Please Mention Popular Mechanics

The Convenient and Rapid **YANKEE** Chain-drill
Chain Tightened by Friction-feed
Bit Fed Automatically by
Ratchet-feed



You Need this— No. 1500 "YANKEE" Chain Drill

It's the only Chain Drill with Automatic Ratchet - and - Friction Feed. It saves drill points, it cuts down time of working, it does away with nuisances of hand-fed drills. Chain is quickly tightened and drill set, with a few turns on Friction Feed

—move the little lever and the drill is on the Automatic Ratchet Feed—feeding uniformly, and under exactly the right pressure for large and small drills, until the job's finished, when a few turns of Friction Feed draws drill from work. Appreciated by the "good man" are all

"YANKEE" TOOLS *Make Better Mechanics*

No. 500—Made with 2-jaw chuck, holds square shanks up to 1/2 in. diam.

No. 1500—As illustrated—3-jaw chuck, holds round shanks only, up to 1/2 in. diam. Jaws of tool steel, square thread, steel feed screw. Length 9 1/4 in.; weight 3 1/4 lbs.

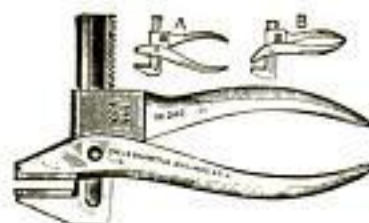
Yankee Chain Drill No. 1500. Price \$3.00

Your dealer can supply you

Write for "'Yankee' Tool Book" FREE, for mechanics and householders, or "'Yankee' Tools in the Garage" for Motorists.

NORTH BROS. MFG. CO., Philadelphia, U. S. A.

Are You Making Something?



Have you invented some device or machine that you are anxious to have just right? Are you making a model that you wish to be particularly proud of? Are you experimenting with some delicate apparatus, the success of which depends on your workmanship? Then insure the accuracy of your measurements and speed up your work by using

Starrett Tools

The measuring tools — rules, gages, caliper-squares, micrometers, vernier calipers, etc., are the last word in accuracy. Work measured with them is right — the other tools for general purposes, such as the expansion pliers, cut nippers, screw drivers, etc., are made to give a wide range of service and to last a lifetime. An advertisement can't do Starrett tools justice.

Let us send you our free catalog 20 AP which describes the full line and gives prices. Do not forget that Starrett Tools are sold at all good hardware stores.

The L. S. Starrett Co.

WORLD'S GREATEST TOOL-MAKERS

Athol, Mass.

42-182

**First Drill
a Hole**



Most men would rather sleep with mosquitoes than put on a screen door. Mr. Punch makes it so easy! He sinks a hole for each screw in exactly the right spot. Screw goes in without effort and the hinge is straight.

Mr. Punch

You Push—He Twists

Mr. Punch is known to mechanics the world over as Goodell-Pratt Automatic Drill No. 185. It works by a spiral twist and the handle automatically rebounds after each stroke. You just place the drill-point and push.

There are eight tool-steel drill-points of different sizes in the handle, seen through numbered holes. Drills are released through hole in revolving cap.

Send for a book on household tools that any man would like to own—it's free. Hardware stores sell Mr. Punch for \$1.50—or we will ship direct if you have any trouble finding it.

GOODSELL-PRATT CO. *Toolsmiths* Greenfield, Mass.

Actual Size of Holes



Please Mention Popular Mechanics

MILL TAILINGS FOR ROAD MATERIAL—In Missouri a considerable amount of road material is obtained from the tailings of the concentrating mills at the zinc mines. This material, which is put on the market

SOLDERING MADE EASY

**GASOLINE
SOLDERING IRON
BLOW-TORCH**



Address Dept. 1, ENNEMANN BROS. MFG. CO., INDIANAPOLIS, IND., U.S.A.



Portable Cases

**FOR TOOL MAKERS
AND MACHINISTS**

Twelve styles, felt lined drawers, solid brass trimmings, best of material, beautiful finish, low prices, satisfaction guaranteed. Ask for booklet of cases built for service.

The Pilliod Lumber Co.
SWANTON, OHIO

**A Bench like
this is just the
thing for the
home.**



OHIO TOOLS



REGISTERED

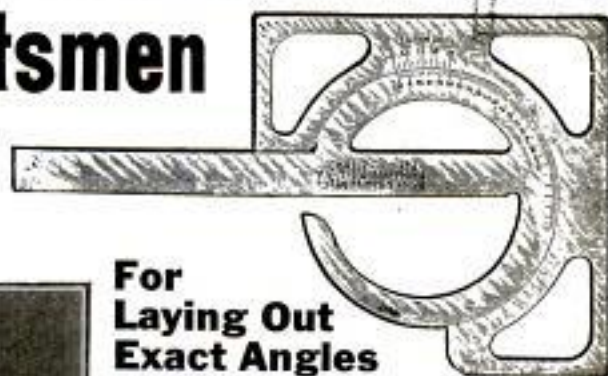
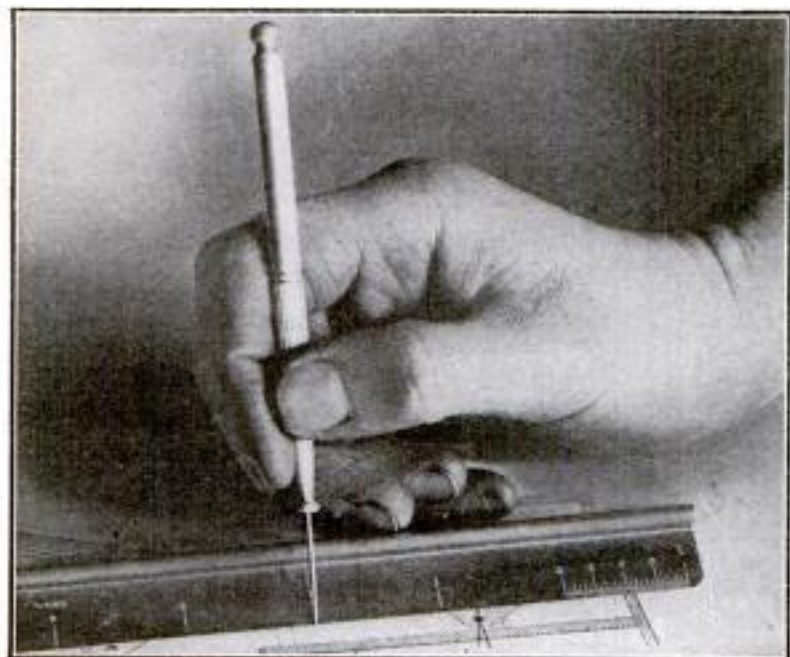
Planes, Chisels, Auger Bits, etc.
It will pay you to insist upon getting tools of this brand.

CATALOG FREE

OHIO TOOL CO.
Dept. 3 Charleston, W. Va.

A Kink for Draughtsmen

It's easy to lay off exact dimensions on a drawing with one of these light, nickel-plated steel scales. Just let the needle point slip down the correct groove in the scale as below. The graduations are close to the paper and the rib on top makes it easy to pick up.



For Laying Out Exact Angles

And this Protractor is another good tool that should be on your draughting table. It is nickel finished and can be used either side up. The graduations read to five minutes. Use it to lay off or transfer angles, divide circles, etc.

Ask to look at BROWN & SHARPE Improved Draughtsmen's Scales and Protractors at the leading hardware or supply store.

Our free catalogue of Small Tools shows our entire line. WRITE FOR ONE.

**BROWN & SHARPE
MFG. CO.
PROVIDENCE, R. I.**

as "chats," consists of small angular fragments of chert and limestone. The zinc companies are very glad to get rid of this waste material, which is loaded on the cars by railroads of the district at a cost of about six or eight

Learn How to Solder 10¢
Solder at home—save money. Solder for others—make money. Send 10¢ in stamps for complete instructions; fully illustrated. Money back if not satisfied.
THE M. W. DUNTON COMPANY, SO. PROVIDENCE, R. I.

Duplicate Keys for all Pin Tumbler Locks can be made in a minute with The Harrison M. I. P. Key Filing Machine
Invaluable for Machinists, Building Superintendents, Hardware and Repair Shops, Locksmiths, Carpenters, Electricians, Garages, etc. Anyone can make a perfect duplicate key without injuring the original. Every machine unconditionally guaranteed. Money refunded if not entirely satisfactory. Price \$3.00 net. Send us P. O. order or N. Y. draft and receive the complete machine by return Parcel Post. Special diamond shaped files for angular keys 35¢ each or 4 for \$1.00. Send for circular.
HARRISON & COMPANY, 81 NEW ST., NEW YORK

THE AWL YOU WANT

See That Reel



Is the genuine MYERS \$1.00 "Lock Stitch" Sewing Awl with the exclusive feature. See thread reel in front of handle under the finger tips. Natural tension. Sews heavy or light material, diamond point, full grooved needles used to protect the thread when sewing.
C. A. MYERS COMPANY, 6339 University Ave., Chicago, Illinois

ToolCases for Toolmakers and Machinists
Keep your tools neatly arranged in a Gerstner Portable Tool Case. There's a place for every tool in one of the fast lined drawers. Every up-to-date mechanic needs one and you'll find our Cases the best built, neatest and most practical on the market. We guarantee to please or refund all money. Write for our free booklet.
Gerstner & Sons
Mfrs. of Mechanics' High Grade Tool Cases
808 Columbia St., DAYTON, OHIO



True, Tight Pipe-joints with,—

OSTER-CUT THREADS

WHATEVER sort of pipe-threading you have to do, there is a tool in the Oster line exactly suited to it. And you may be sure that your work will be quicker, easier and better with an Oster die-stock than any other. If you haven't the Oster catalog, here is a coupon that will bring it to you free by return mail. It is complete with illustrations, descriptions and prices.

THE OSTER MFG. CO.

2100 East 61st St.
CLEVELAND, OHIO



Please send me by return mail the free Oster catalog.

Name.....

BUSINESS.....

Address.....

City.....

State.....(2100)

Please Mention Popular Mechanics

Stanley Tools



No. 200

Stanley Cutter and Chisel Grinder

A device for holding Plane Irons, Chisels and other similar cutting tools that they may be ground or honed to any desired angle or bevel, insuring an accuracy that is very difficult to obtain when tool is held in the hand.

Price, Each, 90c

If you cannot procure this tool from your hardware dealer, we will send same, postage prepaid, on receipt of the price mentioned above.

— ADDRESS —

STANLEY RULE & LEVEL CO.
NEW BRITAIN, CONN. U.S.A.

Style A 6 Others



Are Your Tools Good Enough to Keep Well?

Then why not one of the

UNION TOOL CHESTS

Made in 15 Different Styles and Sizes. Plain or Quartered Oak or Leatherette Cover. All hardware heavy Extra Nickel Plate. Drawers strong and perfectly fitted and some lined with felt. Made by skilled workmen for skilled workmen. Prices low because of our big output.

Why Every Mechanic Should Buy

Every place in a UNION designed for use. You keep your tools clean, safe, free from bangs, knocks, moisture. You save motions, save time, save tools. You check up borrowed tools and lock them up.

Write Now for Catalog and Prices

UNION TOOL CHEST WORKS
22 Railroad St. Rochester, N. Y.

Prize Contest



SEW. CO. N.Y. 12-4 RED DEVIL

Prizes from \$1 to \$10

for boys under seventeen, for work done with "Red Devil" Glass Cutters, mailed for 10c, with enrollment blank and complete instructions. Lots of fun. Enroll in time. Write today.

Smith & Hemenway Co., Inc.
161a Chambers St. NEW YORK CITY

IRWIN BITS

Forged from a single piece of special crucible steel. This steel and IRWIN workmanship are found only in bits made by

THE IRWIN AUGER BIT CO., Wilmington, Ohio

cents a ton. It makes more than ordinarily good roads and is widely distributed all through the Middle West, says Mining and Engineering World. It is used for railroad ballast as well as road making. The annual output amounts to about 1,900,000 tons.

YOU OUGHT TO HAVE ONE OF OUR Insured "Vandor" Hammers

— Drop forged from Vanadium Steel, tempered in oil and Warranted for a Lifetime. Best Postpaid anywhere on receipt of \$1 and Dealer's Name.



Made in four sizes. No. 21½, weight 16 oz. Standard Size. No. 22, weight 13 oz. Gen'l Purpose. No. 22½, weight 10 oz. Finishing Size. No. 72½, weight 16 oz. Ripping Style.

VAN DOREN MFG. CO., Dept. 104, CHICAGO HEIGHTS, ILL.

SIMONDS NO-SET HAND SAW

Cuts Smooth Like a Plane

This new Simonds Saw gives a cut which is almost as smooth as if sand-papered—the sides of the cut are finished by the saw.

It runs with more freedom and ease than the ordinary saw—with great speed and trueness.

For finishing almost any kind of work, for quick cutting any kind of

dry wood, you need this saw, no matter how many saws you now own.

It is a most beautiful and workmanlike tool, with a Simonds special crucible steel blade, straight back, four brass screws and large hand hole in a carved and polished apple-wood handle. Price, \$3 each. If your dealer doesn't have it in stock, we will send it charges prepaid on receipt of price.



Simonds Mfg. Co.
"The Saw Makers"
Fitchburg, Mass.
(Founded 1857)



A Splendid Oil in a Handy Can

The handiest thing a man can have within hands' reach is a Handy Oil Can of 3-in-One. With it he can "ease" a tight bearing, clean and polish steel or wood, and "slip one over" on rust and tarnish anywhere.

3-in-One oil

makes everything go easier and look better. All housefurnishing stores, drug stores, grocery, hardware and general stores keep it. 10c for 1 oz. bottle; 25c for 3 oz.; 50c for 8 oz. ($\frac{1}{2}$ pt.). The Handy Oil Can shown above holds 3 $\frac{1}{4}$ oz. and sells for 25c. If your dealer hasn't it, we'll send one by parcel post, full of good 3-in-One for 30c.

A Library Slip with every bottle. **FREE**—A generous sample and the 3-in-One Dictionary by mail.

THREE-IN-ONE OIL CO.

42CNG, Broadway New York

3
IN ONE

Nineteen million children were enrolled in public schools and about 200,000 students in colleges, and other higher institutions of learning, during the year 1914.

THE SPEEDY STITCHER

SEWS LEATHER LIKE A MACHINE

Price \$1.00

Send for terms to Agents

Automatic Awl Co., 26 Benson St., Worcester, Mass.



THE MASTER SLIDE RULE



the only RULE in the world whereby inside measurements of doors and windows, etc., can be taken rapidly and accurately. Also superior to any other rule for outside measurements of walls and ceilings, etc., as it can be extended and closed instantly. **MECHANICS, BUILDERS, AND ARCHITECTS, TRY ONE TODAY! DON'T WAIT.** Ask hardware dealer for it.

On receipt of 15 cents per lineal foot, a 4, 6, 8 or 8 foot rule will be sent to you prepaid. Large profits to agents. Write for circulars and particulars.

DAHL MFG. CO. 51-A East 42nd St. NEW YORK CITY

Tool Sharpening Made Easy with Luther Hummer Tool Grinder

Dimo-Crit (artificial diamond) wheels sharpen every tool in jigtime with light touch. No water needed. **Won't draw temper.** Steel shaft drive like auto. Dust-proof bearings and gears. Patented tool rest. Perfect lubrication. Many special attachments.

Shall We Send You Big Free Book?

LUTHER GRINDER MFG. CO., 250 Pelet St., Milwaukee, Wis.



MILLERS FALLS TOOLS

Braces
Drills

Hack Saws
Mitre Boxes

Do Better Work and Last Longer

Write for catalog showing complete line

MILLERS FALLS CO., Millers Falls, Mass.



Smith & Wesson Automatic

Doubly safe

Two safety devices
—can't be fired
unintentionally.



Get your dealer to show you the special features of the Smith & Wesson Automatic. Booklet on request.

SMITH & WESSON
814 Stockbridge St.
Springfield, Mass.

Every Smith & Wesson is the Best of its kind



AETNA ACCUMULATIVE ACCIDENT

POLICIES cost little, and pay \$50 a week for disability. \$10,000 for accidental death. Investigate.

AETNA LIFE INSURANCE COMPANY

Drawer 1841

Dept. PM. 4-15

Hartford, Conn.

SEARIGHT Compound Lever Mechanics' Snips

cut 16 gauge metal at the point with one hand. The cutting power of these snips is three times that of the common straight snip. They are Drop Forged from Crucible Tool Steel.



BARTLETT MANUFACTURING CO.
DETROIT, MICH., U. S. A.

"DON'T BUY BLADES"

\$1.00

Postpaid

Our Newly patented Safety Razor Blade Sharpener! It hones and strops all make blades. Make one blade last you two year round. Puts an edge on a blade in 10 seconds. Save 35c on each dozen! Pays for itself in a hurry. Combination Hone and Strop, with blade grip, packed in plush lined case.

THE ALMORE CO.

856 Belmont

Chicago, Ill.

Agents
Wanted



Large Profits from Small Capital

A Business of your own bringing you an income of at least \$10.00 per day with practically no experience or overhead expense.

The Green AUTOMATIC MACHINE

sharpens, hones, and strops all kinds of safety razor blades, all in one operation, at the rate of 150 to 250 blades per hour, you can readily figure your profits. Let us send you our free booklet explaining everything.

Am. Sharpening Machine Co. (Inc.)
Dept. 4, 184 W. Washington St., Chicago



SATIN LINING FREE

In This Handsome Blue Serge Suit



Our system of selling fine tailoring direct—through no stores, agents or dealers, saves you big money and enables you to dress better. We want you to become one of our regular customers—that's why we will make one of our regular all-wool worsted blue serge suits

Tailored-to-Your-Measure (\$25.00 VALUE) \$15

and line it with guaranteed \$4 satin lining free—also pay shipping charges. Read the guarantee—we take all the risk—you take none. Send for our NEW SPRING CATALOGUE.

BIG BOOK—70 Samples—Mailed FREE Contains generous samples of our plain and fancy suitings (prices \$15 to \$27)—explains our tailoring system—quotes lowest prices on men's furnishings, hats and shoes, also boys' clothes. Send for your copy today to

Bernard-Hewitt Co. Desk D24 564 W. Monroe St. Chicago

Our Guarantee

We guarantee to please you in style, fit, fabric, and workmanship or you don't pay us one cent



Taking out the Broken Blade

Length of Knife 3 1/2 inches

BANG!

Out Goes the Broken Blade

CLICK! and the new one is inserted

QUICK, easy, no tools required, because it's a Nagle ReBlade Knife—"The Pocket Knife with Replaceable Blades." Look at this handsome, sturdy, jack knife. Costs no more than a regular knife. Same quality—same looks—same strength. **But you can reblade this knife and keep it always new, always 100 per cent efficient.** Blades can't come out accidentally. Every man and boy wants a pen knife because it will do things a pen knife is not meant for. You can tackle any job with this Nagle ReBlade Knife. If a blade breaks, we'll send you a brand new Sheffield steel blade for only 25c. Here's our introductory offer for quick action. **Send us a dollar bill for money order!** right now for the best Jack Knife you ever saw, and an extra blade for reblading. Every Nagle ReBlade Knife is fully guaranteed.

Extra Blade - Same driver construction

Agents or Dealers Wanted
NAGLE ReBlade KNIFE Co.
72 Parker Ave., Poughkeepsie, N. Y.
Ref: First Nat. Bank, Poughkeepsie, N. Y.

OVER 65 YEARS' EXPERIENCE

PATENTS

TRADE MARKS
DESIGNS
COPYRIGHTS, &c.

Anyone sending a sketch and description may quickly ascertain our opinion free whether an invention is probably patentable. Communications strictly confidential. **HANDBOOK** on Patents sent free. Oldest agency for securing patents. Patents taken through Munn & Co. receive special notice, without charge, in the

Scientific American.

A handsomely illustrated weekly. Largest circulation of any scientific journal. Terms, \$3 a year; four months, \$1. Sold by all newsdealers.

MUNN & CO. 672 Woolworth Bldg. New York

Washington Office, 625 F St., Washington, D. C.

ELECTRICAL ENERGY EXPORTED FROM CANADA—Of the hydroelectric energy generated along the international boundary in Canada more is exported to the United States than is used in Canada, according to a report issued by the Dominion government. The total production of electrical energy, in 1913, by Canadian companies with transmission lines extending into the

BIG CHANCE FOR AGENTS



C. C. Coy.

You can earn BIG MONEY

selling the most complete line of guaranteed transparent handle Knives and Razors with Photo, Name and Lodge Emblem—also full line of cutlery. Write today for catalogue and terms. **Golden Rule Cutlery Co., 554 W. Lake St., Dept. 203, Chicago, Ill.**

AGENTS \$6 A DAY

Should be easily made selling our Concentrated Non-Alcoholic Food Flavors, Soaps, Perfumes and Toilet Preparations. Over 100 kinds, put up in collapsible tubes. Ten times the strength of bottle extracts. Every home in city or country is a possible customer. Entirely new. Quick sellers. Good repeaters. Not sold in stores. No competition. 100 per cent profit to agents. Little or no capital required. Elegant sample case for workers. Start now while it's new. Write today—a post card will do—for full particulars **FREE**



AMERICAN PRODUCTS CO., 174 Third St., CINCINNATI, OHIO

PRINCE ALBERT

the national joy smoke

AMUSEMENT MEN, HERE'S THE WINNER!



The very latest and most novel amusement attraction for Parks, Resorts, Carnivals, etc.

A BIG Money Maker.

THE CIRCLING WAVE GETS THE CROWD

and keeps them spending their nickels. The most successful fun and profit-maker ever invented. Some operators have made \$400 in ONE day. More up-to-date and costs 50 per cent less than the old-fashioned Carousel. Easily moved in two wagons. Operated by one man with gasoline or kerosene motor. Can be erected in four hours. Seats 80 people. Price includes complete machine with gasoline motor and either piano or organ. Write for details—a postal will do.

ARMITAGE & GUINN, Mill St., SPRINGVILLE, N. Y.



Does Work of Four Women

Four strong women doing your ironing without pay is what you in reality accomplish when you iron with a

SIMPLEX IRONER

For City and Country Homes

"THE BEST IRONER"



Your ironing done with a beautiful finish in one-fourth the time and effort and at a few cents expense. No tired feet, head or back.

30 Days' FREE Trial

The Simplex ironer is operated by hand, gasoline or electric power. Heated by gas, gasoline or electricity. Made in eight sizes, \$25 and up. Easy payments.

Write for FREE Booklet on Ironing.

American Ironing Machine Co.
(Established 19 Years.)

593, 168 N. Michigan Ave. CHICAGO, ILL.

See our Exhibit at the Panama-Pacific Exposition, San Francisco

NEED BRANCH MANAGERS

for my world-wide mail-order business. Operate from your home. Spare time. You should make \$50 weekly. Experience unnecessary.

C. A. BUTLER, 346 Factory, TOLEDO, OHIO

BARODA DIAMONDS

FLASH LIKE THE GENUINE - AT 1-50 THE COST

SOLID GOLD MOUNTINGS

Standard acid test and expert examination. See them first, then pay. Catalog FREE. Patent Ring Gauge included for 2-cent stamps.

The Baroda Co., Dept. W, 1455 LaSalle St., Chicago



MAKE BIG INCOME



Men and Women grow mushrooms all the year at home in cellars, stables, sheds, boxes, etc. Sell as high as \$1.00 a lb. Great demand, markets waiting. Start Now. Big Booklet telling how to do it Free. Nat'l Spawn Co., Dept. 12, Boston, Mass.

GO INTO THE MOVING PICTURE BUSINESS

Write For FREE Catalog



ON OUR Easy Payment Plan Make \$20 to \$50 PER NIGHT

With our moving picture outfit. We sell everything—Films, etc.

DEARBORN NOVELTY CO.
Dept. P, 537 S. Dearborn St., Chicago, Ill.

Southern Office: MONARCH FILM SERVICE, Dept. P, 228 Union Avenue, MEMPHIS, TENN.

OVER 100,000 IN USE

Mostly sold through recommendation. For Personal Desk or General Office. It checks mental calculations. Day through your stationer.

Write for 10-Day Trial Offer
E. Gancher & A. M. Co., 148 Duane St., New York

Agents Wanted

Golden Gem PORTABLE Adding Machine



Multiples - Subtracts

ON CREDIT DIAMONDS WATCHES

JUST SEND US \$10

Immediately on receipt of your remittance we will send you our famous No. 1267, Loftis "Perfection" \$50 Diamond Ring. **WEAR IT FOR THIRTY DAYS**

and if you are then entirely satisfied, send us \$5 a month for eight months, making a total of \$50, and the ring is yours. If, on the other hand, you are not absolutely satisfied with it after wearing it for 30 days, or if you do not believe it to be the biggest bargain and the most beautiful diamond you ever saw for \$50, return it to us and we will immediately refund your ten dollars. If you prefer, we will send the ring for your examination and you can make the first payment of \$10 to your express agent.

Each Diamond is specially selected by our experts, and is perfect in cut and full of fiery brilliancy. The large illustration gives a perfect idea of the graceful 14 karat solid gold Loftis "Perfection" ring mounting. Can you imagine an easier way to secure a fine Diamond Ring for personal wear, or for a gift to a friend or loved one?

Write for our Free Catalog containing over 2,000 photographs of illustrations of Diamonds, Watches, Jewelry, Silverware, Cut Glass, Novelties, etc. It tells all about our easy credit plan. Write today.

LOFTIS BROS. & CO.

The National Credit Jewelers
Established 1858

Dept. 1111 108 N. State St., Chicago, Ill.
Stores in: Chicago; Pittsburgh; St. Louis; Omaha

TYPEWRITERS

BUY DIRECT

All makes \$10 up Underwoods, Remingtons, Olivettis, Paces, etc. Tremendous savings. Guaranteed 2 years - 15 days' free trial. Money refunded if unsatisfactory. Catalogue free. AGENTS WANTED.

NATIONAL TYPEWRITER EXCHANGE, Dept. 55 353-357 Broadway, New York.



This Catalog FREE

Write for It

J. M. Hanson-Bennett Magazine Agency is the largest in the world.

Save Magazine Money Our 1935 catalog lists more than 3000 Periodicals and Club Offers. It's a Big Money-Saver. Send us your name and address today.

AGENTS WANTED Write for full particulars.

J. M. HANSON-BENNETT Magazine Agency 223 W. Jackson Blvd., CHICAGO, ILL.



I Will Send You My Valuable Book on HOW to DEVELOP PERFECT HEALTH AND STRENGTH For 10 Cents in Stamps or Coin

Contains valuable information that is worth hundreds of dollars. How to develop and gain great muscular strength, in a very short time, without medicine or apparatus. Also how to gain and govern perfect health. Explaining how to develop and improve your eyes. No other book like it to be had anywhere at this unknown price. Take advantage of this offer today - this minute - and you will never regret doing so. You have nothing to lose, but everything to gain.



PROF. F. BLETZINGER, 607 Marquette Bldg., Chicago, Ill.

My \$3.00 Exerciser Reduced to \$1.00

Until further notice I will send one complete

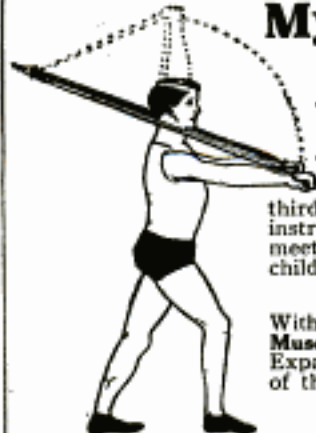

MUSCLE BUILDER OUTFIT

to any reader of Popular Mechanics upon receipt of \$1.00—just one-third the regular price. I will also include a complete body-building course of instructions containing 24 selected exercises. The Muscle Builder will meet the requirements of any person—weak or strong—man, woman or child. Can be used to exercise any muscle in the body.

A CHEST EXPANDER ALSO

With each outfit, I will give an extra handle, without charge, by which the Muscle Builder can instantly be converted into a most effective Chest Expander to be used for developing the chest and lungs. Take advantage of this opportunity while it lasts. Send your order to-day.

PROF. ANTHONY BARKER
Studio 6, 110 W. 42d St. NEW YORK CITY

Scientific Device That Does Away With TRUSS-FREE TRIAL



Inner surface is made adhesive to secure the PLAPAO-PAD firmly to the body, keeping the PLAPAO continually applied and the pad from slipping. No straps, buckles or springs attached. Soft as velvet—easy to apply.

TRADE MARK

STUART'S ADHESIVE

PLAPAO-PAD

PATD APRIL 6 1909

It's the Non-Slip- ping, Yet Non-Rigid Pad and What is Within It That Counts

Over 250,000 Now In Use

We have proved to hundreds of thousands of sufferers from hernia (rupture) that to obtain lasting relief and develop a natural process for betterment comes by wearing a Plapao-Pad. This patented mechanico-chemico device can do the same for you. The wearing of an improper support aggravates rather than improves the condition. The Plapao-Pad can and does aid the muscles in giving proper support, thereby rendering efficient aid to Nature in restoring strength to the weakened muscles. Being self-adhesive there is no slipping and shifting of pad with resultant irritation and chafing. No discomfort whatsoever—no delay from work. Awarded Gold Medal at Home and Grand Prix at Paris.

Send No Money. We will send you a trial of Plapao absolutely FREE, you pay nothing for this trial now or later. Write for it today, also full information.

PLAPAO LABORATORIES, Block 70 St. Louis, Mo.

Deafness



Perfect hearing is now being restored in every condition of deafness or defective hearing from causes such as

Relaxed or Sunken Drums, Roaring or Hissing Sounds, Perforated, Partially Destroyed Drums, etc.

Wilson Common-Sense Ear Drums

"Little Wireless Phones for the Ears"—

require no medicine but effectively replace what is lacking or defective in the natural drums. They are simple devices, which the wearer easily fits into the ears where they are invisible. Soft, safe and comfortable to wear at all times.

Write today for our 168 page FREE book on DEAFNESS, giving you full particulars and plenty of testimonials.

WILSON EAR DRUM CO., Incorporated
639 Inter-Southern Building LOUISVILLE, KY.

Please Mention Popular Mechanics

Put Your Body in Tune

The Flynn System of Health Culture makes you clear-eyed, erect, vigorous, ambitious, buoyant, vibrant. It vitalizes and energizes every organ; develops a reserve force of body, brain and nerve—puts your whole being in tune. A rational and simple system that brings you health and gives vigor, happiness and success.

For thirty-six years I have taught this system from lecture platform and in class, reaching a yearly average of 287,000 persons. My correspondence course enlarges the work and makes it more effective. Cost small, no extras to buy; investment returned many times a year in savings and increased efficiency. For men and women. Write for free literature.

W. EARL FLYNN Dept. 16, Lincoln, Nebraska

United States was 1,543,464,097 kw.-hr., of which 772,507,049 kw.-hr. was exported and 770,867,048 kw.-hr. was used in Canada.



Bow Legs and Knock-Knees Unsightly Send for our booklet showing photos of men with and without the **PERFECT LEG FORMS. ARTIFICIAL LEGS \$49.50. Guaranteed.** Manufacturers of Braces, Trusses, Abdominal Supporters, and Elastic Stockings.

Perfect Sales Co., 140 N. Mayfield Ave., Dept. 5, AUSTIN, CHICAGO, ILL.

SEPTEMBER MORN

WATCH FOB. ROSE GOLD Finish. Just like illustration. The bewitching little figure of Miss "September Morn" handsomely embossed on heavy metal. Size of Fob 1 1/4 x 1 1/4. Genuine black leather strap. Boys, a real work of art. Classy, alluring. **Makes 'em all take notice.** Agents wanted everywhere. Dandy sample fob and our great easy money proposition to hustlers sent **postpaid 25 cents.** Address **BUFFALO ENIGMA JEWELRY CO., 481 Morgan Building, BUFFALO, N. Y.**

NO MORE BALD HEADS



When our VACUUM CAP is used a few minutes daily. We accept no pay until you have tried the Cap 60 days and are satisfied. The Vacuum Cap is an appliance that draws the blood to the Hair Roots and starts a new healthy crop of hair. It stops Dandruff, stops the hair from falling out. Bought by Doctors and men who

know that it is the only reasonable HAIR GROWER known to science. No Drugs Used. Write for application blank, testimonials, and booklet on "HAIR" sent sealed in plain envelope, FREE.

THE MODERN VACUUM CAP CO.
Q. 559 BARCLAY, DENVER, COLO.

Is Your Refrigerator Poisoning Your Food?

A leading medical authority says: "A poor refrigerator means not only wasted ice, but often wasted lives from spoiled food." Read what physicians and others say about wonderful ice-saving and health protection the Monroe affords.



Approved by Good Housekeeping Institute

The "Monroe"

Established 1868

The Monroe food compartments are Genuine Solid Porcelain ware—in one piece—over an inch thick—every corner rounded. Not cheap porcelain-enamel on metal base—but one piece of white unbreakable porcelain ware which can be easily kept free of germs—no cracks, joints, or corners—nothing to break or chip.

30 Days' Trial—Cash or Credit

Sold direct from factory at factory price. Freight paid and all money back if not absolutely satisfactory.

Monroe Refrigerator Co. (Established 1868), Sta. 28C, Lockland, O.

"Using about one-third the ice the others did."—T. G. Mackie, New Orleans.

"Out ice bills from \$36 to \$8."—T. W. Williams, Milwaukee

"Reduced ice bills nearly 40 per cent."—Dr. B. H. Wells, Southport, Conn.

"Much more economical than any other of several I have had."—Dr. O. B. Shreve, Salem, Mass.

"Saved about 50 lbs. of ice per day over another make of same size."—W. M. Riecke, Paducah, Ky.

"An ice saver, a germ preventer, hence a health preserver to any family."—Dr. Chas. Hups, Lafayette, Ind.

"Economical in use of ice; and preserving in best manner articles placed in it."—Dr. R. E. Starkweather, Easton, Ill.

Send a **FREE BOOK** once for **about refrigerators**

It tells you how to select the home refrigerator—how to keep food longer without spoiling—how to cut down ice bills—how to guard against sickness—doctor's bills.

**Waltham
Hamilton
Howard
Elgin
Illinois
Seth-Thomas
Rockford
Watches**

Any One You Want On Credit

30 Days FREE Trial Express Prepaid in Advance by Me

You take no chances with me. I am "Square Deal" Miller and I trust the people. That is why I am doing the greatest Credit Watch, Diamond and Jewelry business in the country.

No Money Down

Suppose you want any one of the country's best makes of watches? Name any one. I have it for you, No Money Down, Express Prepaid. A Full Month to Carry It in Your Pocket and the easiest of Long Time Payments. That's the best that tells. All these watches **Guaranteed for 25 Years**

I Smash the Terms No References Demanded

My terms are made to suit you. You get unlimited credit with no red tape, notes or collectors, no unnecessary details.

An "Open Charge" Account

The same kind of credit you get from your grocer. No matter where you live or what your income is, you can now own the finest watch, a beautiful diamond or any rare piece jewelry and never miss the money.

COSTLY CATALOG FREE

Send me your name and address on the coupon, a post card or letter, so I can mail you, Free and Postpaid, the most beautiful catalog of its kind ever printed. I want you to have this book. It's a gem. It illustrates all makes of valuable Watches, Elegant Genuine Diamonds and a vast assortment of Beautiful Jewelry, all on the easiest and most liberal terms. Write for book today and get a letter from me that will make you a friend of mine from the start.

Square Deal Miller, Pres.
Miller-Hoefer Co., 465 Miller Bldg., Detroit, Mich.

Dear Sir: Please send me without cost or obligation your Big Book on all makes of High Grade Watches, Genuine Diamonds and Jewelry and full information on your Easy Payment, No Money Down and 30 Day Trial Plan.

Name _____
Address _____

WHITE VALLEY GEMS LOOK LIKE DIAMONDS

Stand acid and fire diamond test. So hard they easily scratch a file and will cut glass. Brilliance guaranteed 25 years. Mounted in 14k solid gold diamond mountings. See them before paying. Will send you any style ring, pin or stud for examination—all charges prepaid. No money in advance. Money refunded if not satisfactory. Write today for free catalog.

WHITE VALLEY GEM CO., 701 Wulsin Bldg., Indianapolis

3 YEARS TO PAY

Meister Piano 30 days free trial in your own home

\$1 A WEEK or \$5 A MONTH Price \$175.00

No cash payment down. No interest—no extras. Piano stool and scarf free.

ROTHSCHILD & COMPANY
Dept. 16D CHICAGO, ILL.

Furniture On Credit

Write for Mammoth Bargain Book picturing 4,918 articles
SPIEGEL, MAY, STERN CO.
1089 West 35th Street, Chicago

TYPEWRITERS BARGAIN PRICES

Look at these bargains! Typewriters Rebuilt in our own factories, and guaranteed for one year.

Remingtons \$20 to \$35 Smiths \$15 to \$40
Underwoods \$30 to \$40 Royals \$25 to \$40
L. C. Smiths \$30 to \$50 Oliviers \$20 to \$30

We have others, of course. Send for catalog describing them, and address of nearest branch office.

American Writing Machine Co., Inc., 345 Broadway, N. Y.



Please Mention Popular Mechanics

6 MONTHS TO PAY



Made To Order

Again we lead in lowest prices and save you over half! Our nation-wide reputation as America's greatest price smashers is retained. Our tremendous buying power enabled us to buy world's finest fabrics at lowest prices known.

Save Half

Can you equal these prices? Regular \$35 tailored-to-your-measure suits and overcoats only \$15 from us; \$45 values only \$18, etc. These are only examples. Don't buy ready-mades and pay double our price. Don't pay other tailors four times as much as we charge.

Just Off the Press

This season Stanley-Rogers styles and fabrics are more nifty, more handsome than ever before. Send now for gorgeous 1915 Spring and Summer Fashion Book—just off the press—24 latest, handsomest, exclusive styles.

\$2.00 Monthly

Our remarkable credit plan beats every plan known. No security—no references—no red tape—no delay. Our terms and long credit make it easy for every man to dress up-to-date at lowest prices, no matter where he lives.

Don't Be Deceived

"made-to-measure" clothes. Don't let them fool you into believing that they are making your clothes tailor-made-to-your-measure. They send you hand-me-downs. They merely alter them here and there and charge you twice their value. That's why you're dissatisfied—no style, no fit, no class, no wear.

\$1,000 Reward to anyone who proves that we do not make all our garments, no matter how low the price, absolutely tailor-made to your individual measurements. We do not sell ready-made garments—would not have them in the place. We give a local guarantee of money back if you are not surprised, delighted with Stanley-Rogers garments. We treat our customers right.

FREE 1915 Spring and Summer Fashion Book

Over 70 Magnificent New Styles. Best all past designs in beauty and class. The cream of the greatest mills. Styles are exclusive—cannot be duplicated. Write for free copy. Don't be without one.

WRITE Now for Special Offer Save big money—dress smart—get better fit, better wear, better service. Write us now for most startling clothes facts, proof that we save you over half and free style catalog. Don't buy clothes until you hear from us. Send no money—all is free.

STANLEY-ROGERS COMPANY,
544 South Clark Street, Chicago, Ill.

Regular Price \$1.25 **THE RAPID VACUUM WASHER**



Sold on 30 days' trial.

The only Washer with Automatic Suction

Washes everything from blankets to fine laces. Tub of clothes washed in 5 to 10 minutes. A child can operate it.

AGENTS WANTED. Special price on sample postpaid. Write for terms and trial offer.
STEWART-SKINNER CO., 26 Cherry St., Worcester, Mass.

The 1915 **ARROW** Electric Light



New Motorcycle

Type Write for New Catalog. The biggest bicycle value ever built.

Read the wonderful new 1915 improvements.

1915 Features

Electric Light
Reinforced motorcycle frame. Large, easy motorcycle saddle. New Departure coaster brake. Long, rubber-grip motorcycle handlebars. Special motorcycle pedals. Motorcycle mudguards, stand and parcel rack. Flat tire tread clincher tires.

Nothing like this ever offered before. The New 1915 Arrow—a positive wonder for beauty, speed, easy riding and comfort. A perfect motorcycle type. Built to last a lifetime. All sizes for men, boys, women. Write today for new catalog.

Special!

Pay as You Ride

Write today for our special, 30 day, reduced price offer. Just a very small amount down and we will ship you this sensational 1915 Arrow. Start riding and enjoying this bicycle wonder right away—and pay for it while you ride. Write for full details.

Write Today Send for free catalog of this wonderful motorcycle type, 1915 Arrow. Also particulars of our special 30 day, reduced price offer. No obligations. Don't delay. Just send a postal today.

Arrow Cycle Co. 12th St. and California Avenue Dept. 3194 Chicago

According to a recently issued government pamphlet, "Statistical Record of the Progress of the United States, 1800-1914," foreign commerce in that period has grown from \$318,000,000 to \$4,250,000,000, and the per capita value of exports from \$18.96 to \$23.27.

BUILD

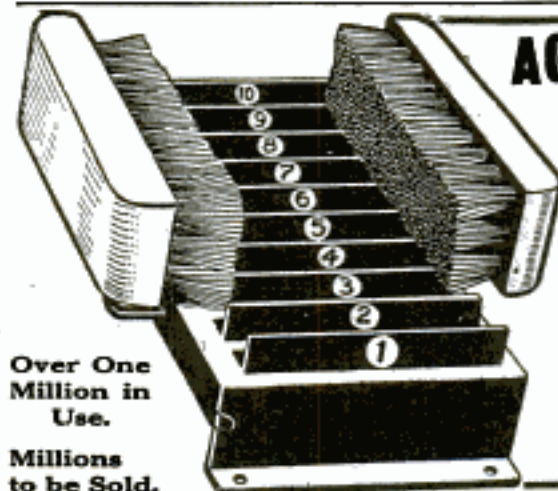


We have accurate scale drawings and knock-down parts of all man-carrying aeroplanes for class-room demonstrations, exhibition purposes, etc. Students of aeronautics, everyone with an inquiring turn of mind, should construct one of these fascinating models.

PRICES OF F.F.I. MODEL SCALE DRAWINGS—Curtiss Flying Boat, 25¢; Newport Monoplane, 25¢; Bleriot Monoplane, 15¢; Wright Biplane, 25¢; Curtiss Compressible Hydroaeroplane, 35¢; Cecil Paul Champion Racer, 25¢.

SFT. CURTISS FLYING BOAT

Complete Set of Six \$1.25 Postpaid
50 pp. Ideal Model Aeroplane Supply Catalog 5¢
IDEAL AEROPLANE & SUPPLY CO., 82-88 West 87th St., N.Y.



Over One Million in Use.
Millions to be Sold.

AGENTS—The Million Dollar Hit!

New, wonderful home invention, just introduced, yet milk on sales already recorded. Tremendous, rapid sales stagger country. Agents happy—banking enormous profits daily. Mighty opportunity for you to get the mighty dollar. Failure impossible. Experience unnecessary. Money rolls in first hour—\$10 to \$30 daily. Amazing cash records made. Walters received

\$50.00 FOR 7 HOURS' WORK

Never sold goods before. Arnold sold 160 in 2 days; Hagen 100 same time; Webb 10 per hour; O'Connell 25 first day. Hundreds like these. You, too, can have money in abundance. Grab's Scientific Shoe Cleaner sells itself—you take orders—that's all. Every family wants one on their doorstep. Replaces unsightly, unsanitary, crude door mat. **Automatically removes mud, dirt, snow from shoe in one operation.** Cleans sole, sides, heel. Works like magic—sells like sixty. Saves drudgery, time, money, shoes—saves carpets, floors. Mechanical wonder. Has 7 now patented features not found in any other scraper—10 steel blades—10 dirt outlets—twin adjustable and removable brushes—compound springs. Rotates for sweeping. Can't clog—practically self-cleaning. Handsome enameled. Nothing else like it. Nothing so popular—so easy to sell. Selling price only \$1.00. You make half—100 per cent. Satisfaction guaranteed. Write quick for free catalog—exclusive agency. Better still, send order, name territory. Investigate anyhow.

SECURITY MFG. CO., Dept. 137, TOLEDO, OHIO

Please Mention Popular Mechanics



10 Days Free Trial

YES we will send you the violin of your choice for the full ten days' trial. Play on it—test it in every way before you decide whether you wish to buy or not—then if you are not more than satisfied send it back at our expense. Write today for special new violin circular.

Your Choice

The products of the leading violin makers of the world are yours to choose from—Farny, Baader, Glier, Heberlien, Fiedler, Wurlitzer and many others. Violins of the highest grade as well as those of moderate prices—all special values. Priced from \$2.79 to \$50 and from \$50 to \$250.

WURLITZER

200 years of instrument making

Our collection of rare old violins is one of the largest in America. Write for special art catalog.

Get the benefit of our mammoth facilities for buying in large quantities. The house that supplies the U. S. Government now makes a startling money-saving offer direct to you. Write for circular.

Pay As You Wish

If you decide to keep the violin after you have tested it out for ten full days, pay only the rock-bottom price at the rate of only a few cents a day.

Write for Special Circular

Put your name and address on a letter or a postcard today and get the special circular that describes this remarkable assortment of violins. No obligations. Write today, now!

The Rudolph Wurlitzer Co., Dept. 1194
E. 4th Street, Cicero St. Wabash Ave., Chicago

10c a Day



Now buy this superb Lyric Cornet. Exquisite triple silver-plated long model Lyric Cornet direct to you on a startling offer. 10 days free trial before you decide to buy. Liberal allowance for old instruments. Write today for 25-page catalog—a free will give 250 instruments that you have to choose from.



Print Your Own

Cards, circulars, menus, newspaper, book, etc. PHS \$3. Larger \$15. Rotary \$65. Save money. Big money printing for others. All easy, rules sent. Write factory for illustrated press catalog, TYPE, cards, paper, samples, etc. THE PRESS CO., Meriden, Conn.

2 1/2 oz.



The perfected combination lubricating oil, powder solvent and rust preventative. Cannot gum. For guns, typewriters, razors, etc. Write for folder. Compounded and guaranteed by Remington Arms-Union Metallic Cartridge Co., New York.

I HELP INVENTORS SUCCEED

BY OBTAINING Protecting Patents
My new book "How to Patent Your Invention and 100 Things to Invent" gives a new light on the Patent, Copyright and Trade Mark business. I give a binding guarantee—"No Patent, No Pay." Send sketch of your ideas for free search.
CARL H. CRAWFORD
610 Jenifer Bldg., Washington, D. C.

You have it
The **Line-O-graph**
The Drawing Attraction of the Drawing World
Patented Dec. 12-24. Home use only.
Jr. \$1.25 25c Draftsman \$2.50
Your dealer should have it

Pay as You Wish
We'll send you a genuine Lachnite for you to wear for 10 full days. If you can tell it from a real diamond send it back at our expense. Costs but 10-cents a month. If you decide to keep it pay only a few cents a month. Write for catalog.
Genuine Lachnite Gems
Keep their dazzling fire forever. Set in solid gold. Cut by world renowned diamond cutters. Will stand fire and acid tests. All kinds of jewelry at astonishing low prices. Easy payments. **WRITE TODAY.**
H. Lachman Co., 12 N. Michigan Av., Chicago Dept. 9194



Power for YOU!

Power from within! Strength that is more than mere muscular strength—the strength of perfect health, abundant nerve force—now within

your own reach through *Vibration!* Nine people out of every ten are only *half alive!* Are you? Listen—

The Exhilarating Vigor of Life-Strength-Youth

may be returned to you through *Vibration.* For *Vibration is Life itself.* It will chase away the years like magic. Every nerve, every fibre in your whole body will fairly tingle with the force of your own *awakened power!* Stagnation simply cannot exist. You are made over new from head to foot. Your blood is sent humming along through every vein, artery and tiny



capillary. All the poisonous matters in your system are washed away. Every organ is put in *perfect working order.* Your self-confidence—your self-respect are increased a hundred fold. Yes, *Vibration* will do all this, and more, much more. And it is within your reach. You can enjoy its wonder-working powers right at home, right in the privacy of your own room. You can give yourself the same treatments which you would receive in the offices of the world's most famous specialists—all without extra charge.

The White Cross Electric Vibrator

is the result of years of work and experiment. It is absolutely perfect. If you have your house wired for electricity, you can connect it up as easily as an electric lamp; if not, it will run perfectly on its own batteries.

FREE BOOK

Sign the coupon and mail it to us today. Get our splendid big FREE book telling you all about the marvels of *Vibration.* Read what scientists say about it. Post yourself on what it will do for you. Learn all about the White Cross Electric Vibrator and our limited offer. You are under no obligations at all—all you need to do is to send the coupon today—or you can send a postal card or a letter, but the coupon will do just as well.

Lindstrom-Smith Co.
1100 S. Wabash Ave.
Dept. 1194
CHICAGO, ILL.

SEND FOR THIS BOOK

Without any obligations on my part, please send me, free and prepaid, your free book on *Vibration.* Full particulars of the White Cross Vibrator and your Special 60-Day Offer.

NAME.....
ADDRESS.....
My Electrical Dealer's name is.....

Please Mention Popular Mechanics



"Another blow-out—I'm through with cheap tires"

A blow-out isn't a question of luck. There's always a cause; usually a weak fabric and adulterated rubber. A cheap tire is built so it cannot stand heavy strains, and when put to the test it bursts. Vitalic Bicycle Tires can't burst. That sounds strong, but it's true. We believe a rim would break before a Vitalic Bicycle Tire would blow out. We have at last found a way of

VITALIC Bicycle Tires

compound-
ing pure
rubber so that it has all the toughness and wear-resisting qualities formerly secured by introducing a lot of foreign materials. At the same time we preserve the elasticity and life of the pure rubber.

Vitalic Tires are as wear-resisting as an elephant's hide. Send for test sample and prove it. Also the story, "The Man Who Rode On His Rims." It's good reading.

CONTINENTAL RUBBER WORKS

840 Liberty St.

Erie, Pa.



You get double the fun out of bicycling when you equip your wheel with a

ORBIN

DUPLEX COASTER BRAKE

You coast as often as you please—keep your feet at rest on the pedals and go sailing along. Yet, by slight pressure with your feet, you bring the wheel to a gradual or instant stop. The wheel is under your control at all times.

"CORBIN CONTROL MEANS SAFETY ASSURED"

Have your dealer attach a Corbin Brake to your old wheel. Be sure one is on the new wheel you buy. Write today for catalog.

THE CORBIN SCREW CORPORATION
The Am. Hardware Corp., Successor
New Britain, Conn.

Don't Throw Away Your Worn Tires

For over three years European motorists have been getting from 10,000 to 15,000 miles out of their tires by "half-soiling" them with 84ee-18 Studied Treads. In eight months 20,000 American motorists have followed their example and are saving \$50 to \$200 a year in tire expense.

We ship on Approval without a cent deposit, prepay the express and allow you to be the judge.

Durable Treads double the life of your tires and are sold under a signed guarantee for 5,000 miles without puncture. Applied in your own garage in thirty minutes.

Special Discount offered to motorists in new territory on first shipment direct from factory. A postal will get full information and sample within a week. Size of tire. Don't wait—write today. Address usual factory office.

THE COLORADO TIRE & LEATHER CO.

344 Gault Bldg., West 44th Ave., CHICAGO, ILL.

194 Tread Bldg., DENVER, COLO.

The total production of cotton in the United States for the season 1914-15, according to a government estimate, will amount to 7,437,113,000 lb., equivalent to 15,963,000 bales of 500 pounds.

RIDERS FREE THIS CATALOG

Write for it to the largest supply house in U.S.

WE SAVE YOU \$\$\$\$

Our 1915 catalog lists 3015 accessories you should know about. You can't be an up-to-date rider without one. It is the one others try to copy. You need it so send us your name and address today.



SOME CAR! BOYS! Send for Booklet Today



The Lad's Car

Send 20c today for Booklet, telling how to build this automobile. Complete instructions and descriptions of parts and sizes, illustrated with diagrams, blue print, cuts made from photographs, and price list of parts.

SPECIAL INDUCEMENT to first boy in your town
Niagara Motor Car Corp'n, Dept. A, Niagara Falls, N. Y.

The Acetylene Blow Torch Prest-O-Torch

Costs less to buy than a good gasoline blow torch and costs less to use.

In all soldering and brazing, the Prest-O-Torch avoids the delays and uncertainties of gasoline outfits. Provides a concentrated, intense flame that doesn't blow out even in a high wind. Needs no attention whatever. Used with handy sizes of Prest-O-Lite cylinders—ready-made gas, instantly available.

Style "A" sells for 75c. Used with the small MC size Prest-O-Lite. Will braze up to 3/8 inch round rod. This outfit can be fitted with handle and hook for added convenience in bench and overhead work. Style "C" Prest-O-Torch is recommended for large work. Will braze up to 1/2 inch round rod. Sells for \$2.25. For use with the larger sizes of Prest-O-Lites.

Write for special literature and learn where you can see the Prest-O-Torch in operation.

The Prest-O-Lite Co., Inc. 216 Speedway, Indianapolis, Ind.
Exchange Agents Everywhere



Perfection in Every Detail



"One swallow does not make a summer," nor does one or two good points make a really satisfactory motorcycle; it must be **RIGHT** in every detail.

In considering the 15 Models of the

EXCELSIOR AUTOCYCLE

do not stop your inspection, no matter how well satisfied, at one feature of superiority.

Note the powerful and speedy "Big X" motor, the only motorcycle engine that has ever attained a speed of 100 miles per hour, with oversize enclosed valves, large exhaust pipes and positive delivery lubricating system.

Automobile type, Three Speed Transmission with oversize annular ball bearings and heavy nickel steel gears.

Oversize, automatically oiled Multiple Disc Clutch.

Nickel Steel Neutral Shaft with heavy sliding jaw clutch and automatically oiled annular ball bearings.

Model 15-3, Three Speed, \$275.00.

Oversize, knock-out axle, hubs with tools, steel cups and cones.

Powerful double brakes, hand and foot operated.

The powerful EXCELSIOR Frame with nickel steel forgings throughout, low saddle position and permanent side car lugs.

Beautiful round cornered tank with anti-leak needle valve fittings.

Long, double hinged Foot Boards, Non-splash Fenders and heavy unbreakable armless stand.

Model 15-1, Single Speed, \$225.00

See them, get a demonstration and be convinced. Our new catalog fully describes these and four other models. A postal card will get it. Do it now.

Excelsior Motor Manufacturing & Supply Co.

3702 Cortland St., CHICAGO

\$40



MOTORCYCLES!

New and Rebuilt Motorcycles. Largest stock in the world. Lowest Prices. We guarantee to save you from \$25 to \$50. We repair any make of motorcycle. Send us your motorcycle for repairs. Motorcycle tires \$4, best Belts, \$5. Buy direct; save dealer's profit. Send for Catalogue.

DENINGER CYCLE CO., ROCHESTER, N. Y.



Morgan Gas Lighter

Factory Representatives wanted everywhere to handle our Auto and Hardware Necessities. Unusual Contract. Large Profits. Increasing Demand. Write today, letter - no postals - Exclusive Territory. Samples. **FREE SALES-PLANS!**

Morgan Rolling Wedge Spring Leaf Opener
Only instantaneous spreader on market. For fabricating Wagon, Axles, or any springs. Best Opportunity for Mechanics. Immense field. Popular Prices. Millions will be sold. All our Specialties carry Money-Back Guarantee. Write Now to

MORGAN MFG. CO., Bellevue St., Newport, R. I.



RIDE a RANGER

1915 Model bicycle and know you have the best. Buy a machine you can prove before accepting.

DELIVERED FREE ON APPROVAL and 30 days' trial. No expense to you if you do not wish to keep it. **LOW FACTORY COST**, great improvements and values never before equaled in our 1915 models.

WRITE TODAY for our big catalog showing our complete line of 1915 bicycles, TIRES, sundries and parts, and learn the wonderful new offers and terms we will give you. Auto and Motorcycle Supplies at factory to user prices. Do not buy until you know what we can do for you.

MEAD CYCLE CO. DEPT. B108 CHICAGO

Garage \$69.50

10x12feet "Steelcote" Edwards ready-to-use garage, \$69.50 complete. Factory price. Fireproof. Portable. Quickly set up. All styles and sizes of garages and portable buildings. Send postal for illustrated catalog.

THE EDWARDS MFG. CO.
370-370 Eggleston Ave., Cincinnati, O.



The Henderson


is the greatest single development in the motorcycle industry. The changes in design and in materials used make the 1915 Henderson the most reliable, the most efficient and the most economical motorcycle in the market.

Have you met "Henderson Bill"?
Write for an introduction.

HENDERSON



The Henderson Motorcycle Company
1160 Cass Ave.
Detroit, U.S.A.



THOUSANDS OF DOLLARS MADE REPAIRING TIRES

The amount you can make in dollars repairing tires is measured by your own energy. You can make anywhere from \$1500 to \$3000 a year above expenses. Your investment to start in business is small, returns are quick and your income cash. Profits are large on every job you turn out. The tire repair business is in its infancy. It's growing every year, because more tires are being used every year. In almost every city and town there is a crying need for a good tire repair man. That means opportunity for you. Start in your home town if you want to. This is a new money making business. Don't delay getting busy. But, above all be prepared with an equipment that means satisfactory work for your customers. Buy only an

AKRON WILLIAMS TIRE REPAIR EQUIPMENT

The better your equipment, the better your work and the greater your volume of business. Let us start you in business right. Use an equipment which is

ENDORSED BY 30 LEADING TIRE MANUFACTURERS

It takes you but a short time to become an expert tire repair man. We help you here. We are making an unusual offer to everybody who buys our equipment. You can become an expert by our plan.

SEND FOR OUR 30 DAY SCHOOL PLAN

It means when you start in business, you start right. You are prepared to make money from the jump. No experimenting. No Failures. You become a practical, first class repair man.

WRITE FOR CATALOGUE NO. 244.

WILLIAMS FOUNDRY & MACHINE CO. Main Street AKRON, OHIO



HOWARD BICYCLE

Something new in a bicycle; you cannot afford to buy until you get our 1915 catalogue. Make some extra money, be a rider agent; send for our free proposition. Write to-day.

HOWARD CYCLE CO.
Dept. P. M. Trenton, N. J.



\$40 Motorcycle

We have the largest line of new and used Motorcycles in the country at the lowest prices. We also have a thoroughly equipped repair department and are in position to furnish repairs for any machine. Send us your machine to be overhauled. We pay cash for second hand motorcycles. Send for Catalog.

HARRY R. GEER CO., 888 McLaren Ave., ST. LOUIS, MO.

Ride While You Pay



The New "ARROW" Free Catalog

Shipped to you at our risk, without a penny down. If you keep the wonderful 1915 Arrow, pay just a small amount each month while you ride. Write now for free catalog.

1915 Arrow

Electric Light — New Motorcycle Type

Easy motorcycle saddle—New coaster brake—motorcycle m.d. guards, stand and parcel rack—motorcycle pedals—long rubber grip motorcycle handle bars—complete tool kit and tire pump—informed motorcycle frame. Flak Red Tread Glueher Tires—beautiful finish. Write TODAY.

Many remarkable new features. A splendid value. Just what bicycle riders wish for. All sizes, boys, men, women.

Write Today for free catalog and our rack-bottom pay-as-you-ride offer. **SEND AT ONCE.**

ARROW CYCLE CO., Dept. 1194
California Ave. & 19th St., Chicago

Two chronometers for use of the Panama Canal have been placed in the offices of the captains of the port of Cristobal, and will be used in furnishing ships passing through the canal with standard time for the 75th meridian west.



5 H.P. 1915 Peerless Motorcycle

with Free Engine, Bosch Magneto, together with the best there is in Motorcycle construction, Power, Speed, Silence, Endurance, and those wearing qualities so essential for low cost of maintenance.

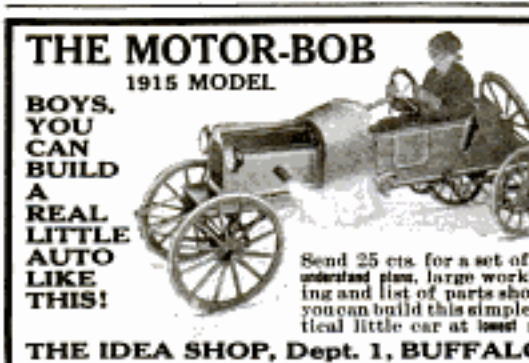
2 MILES FOR ONE CENT
Agents Wanted—Liberal Discount!

PEERLESS MOTORCYCLE CO., 179 Hunting Ave., BOSTON, MASS.



Mobil oils

A grade for each type of motor



THE MOTOR-BOB

1915 MODEL

BOYS, YOU CAN BUILD A REAL LITTLE AUTO LIKE THIS!

Send 25 cts. for a set of our easy to understand plan, large working drawing and list of parts showing how you can build this simple and practical little car at lowest possible cost.

THE IDEA SHOP, Dept. 1, BUFFALO, N. Y.



Make Your "Bike" a Motorcycle

Yes, thousands of **others** have turned their old-fashioned bicycles into up-to-date, swift, sure, easy riding, high power motorcycles with the easily attached, inexpensive *Shaw motorcycle attachment!*

Fits bicycles of any make or size. Everything is complete and we send it to you all ready to attach to your bicycle in just a few minutes without the aid of an expert mechanic and without any special tools—just an ordinary wrench and screwdriver.

Built of highest grade, most serviceable materials; every part guaranteed; plain, easily understood directions sent with each equipment. Thousands of enthusiastic owners everywhere. Here is your chance to get a powerful, dependable, durable, fine looking and speedy motorcycle at a price so small you will wonder how you ever got along with the old-fashioned "leg power" machine!

Read What These Users Say of the Shaw Motorcycle Attachment

"IT'S THERE—RUNS FINE"

Moose Lake, Minn., December 7, 1914.
Shaw Manufacturing Co., Galesburg, Kansas.
Gentlemen: The Motor Attachment that you sent to me is a dandy. It runs fine. It brighs there, Johnnie on the spot, all kinds of roads and hills. The boys here think it is a little dandy. There are quite a few of the boys thinking of buying an Attachment in the spring. As our winter is settling in now they could not make use of it any more this fall.
WALTER J. EHR.

"HAS ENOUGH POWER FOR TWO"

Rockville, Mo., December 8, 1914.
Shaw Manufacturing Co., Galesburg, Kansas.
Gentlemen: I got the engine and put it on Friday night. I towed two bikes with riders on to Rockville, a distance of five miles, and brought one back. The engine has power for two bicycles.
JOSEPH HIRN.

"TAKES ME OVER ALL KINDS OF ROADS"

Shaw Manufacturing Co., Galesburg, Kansas.
Dear Sirs: In reference to your 2½ H. P. Shaw Bicycle Attachment, must call it a very reliable attachment for bicycles which does away with all foot propelling, giving one the sense of coasting down hills all the time. As to power it will take me over all ordinary roads and hills. Have run my machine in the dead of winter while 50 degrees below zero as well as towing two bicycles and riders in ordinary weather. A "Shaw" makes all roads look alike. The joy of bicycle riding without pumping.
GILBERT SEARIGHT, Milled, Sask., Canada.

Write For FREE BOOK!

We want to send you, free and postpaid, a copy of our booklet illustrating and fully describing the SHAW Motorcycle Attachment. When you read about the simplicity and the low cost of the SHAW attachment you will no longer be satisfied with your old-fashioned, slow-going, tiresome bicycle, but will want to send and join forces with the thousands of other go-getters who are now hitting the high speed trail with a SHAW!

Send name on the coupon or postal card for the free booklet today

Shaw Manufacturing Co.
Department 94 Galesburg, Kans.

"I AM MUCH PLEASED"

Richmond, Va., August 12, 1914.
Shaw Mfg. Co., Galesburg, Kansas.
Gentlemen: I am much pleased with the little attachment. I have seen two of them in action since writing you. They were working very nicely. I enclose my order and part payment. Please ship this order soon as possible by express, balance C. O. D.
W. R. COLEMAN,
3011 W. Clay St., Richmond, Va.

"GIVES PERFECT SATISFACTION"

Shaw Manufacturing Co., Galesburg, Kansas.
Dear Sirs: The Motor that I purchased from you is giving perfect satisfaction and has plenty of power for all ordinary hill sand. As for speed there is no other make of motorcycle around here that has anything on it. Wishing you many sales, I remain
HERMAN R. KEIFFER, Georgetown, Ohio

CONVERT YOUR
BIKE INTO A
MOTORCYCLE



Just What You Need
When Looking for It

Shaw Manufacturing
Company
Galesburg, Kansas

Thousands in Use
in America and
Foreign
Countries

SHAW
Manufacturing Co.
Dept. 94, GALESBURG, KANSAS

Please send me, free and postpaid, copy of your book illustrating and describing the SHAW Motorcycle Attachment as advertised in the April issue of POPULAR MECHANICS. Quote me your lowest net cash, factory price.

NAME

ADDRESS

DUCK'S NEW 325 Page Electrical No. 8 and Wireless Catalog

Is a TREATISE on ELECTRICITY and WIRELESS. With prices a little lower than the lowest. Bound in imitation leatherette with bronze lettering.

THE WM. B. DUCK
COMPANY
WHYRELESS ELECTRICAL
OR
WIRELESS
TOLEDO OHIO

This unrivalled catalog mailed to anyone upon receipt of 8c in stamps or coin which may be deducted on first dollar purchase. Great cost of catalog and low prices prohibit distribution otherwise.

WHY WASTE TIME AND POSTAGE IN SENDING FOR A DOZEN CATALOGS

ELECTRIC HAND LAMP

For use with the ordinary dry cell battery. Throws a brilliant light over 100 feet. Gives a concentrated light of 85 c. p.



The hand lamp that blazed the way; that initiated many inferior types but no rivals.

In tests conducted in one of the biggest laboratories in America our lantern was found not only to give a greater concentrated light than any other, but an increase of approximately 100 per cent over another widely advertised lamp for which great claims are made. The difference is in the reflector and the lamp. This hand lamp will last sixty hours on continuous burning and longer if used intermittently. Indispensable to plumbers, automobile, delivery men, switchmen, housekeepers.

Complete, less battery, in burnished brass finish, \$1.50.
Complete, less battery, in pressed rolled steel with hard rubber finish \$1.50.
Postage extra. Shipping weight 2 lbs. Postmaster will inform you some rate from Toledo.

when this catalog contains practically everything worth while in wireless and electrical goods, advertised in this and all other magazines, — and in most cases at more attractive prices.

What This Big Catalog Contains

125 pp. Wireless Apparatus for Commercial and Experimental use;	8 pp. Flashlights;	2 pp. Fans;
10 pp. Raw Material;	5 pp. Massage Vibrators;	12 pp. Telephone Equipment;
5 pp. Transformers;	10 pp. Miniature Railways;	6 pp. Heating Appliances;
8 pp. Storage Batteries;	5 pp. Lighting Plants;	10 pp. Auto Accessories;
15 pp. Telegraph Insts.;	10 pp. Ammeters and Voltmeters;	13 pp. Victrolas, on our Easy Payment Purchase Plan; (No Down Payment);
42 pp. Motors and Dynamos;	25 pp. Electrical and Mechanical Books;	30 pp. General Electrical Supplies.
10 pp. Miniature Lamps;		

SEND 8c for THIS CATALOG TODAY

(Reasons for requesting 8c mentioned above)

The most elaborate, comprehensive, educational and artistic catalog in its line published. Glance through the contents. Note the amazingly low prices of products representative of the best in the field of electrics. Then you will know why the overwhelming mass of users of electrical and wireless supplies have for so many years adopted the slogan:

**"IF DUCK SELLS IT, IT MUST BE GOOD;
IF DUCK DOES NOT SELL IT, THERE'S A REASON"**

THE WM. B. DUCK CO. ARCADE BLDG., TOLEDO, OHIO
(Our Former Name "THE J. J. DUCK COMPANY")

250 "WIRELESS" TRANSFORMER \$9.00

CLOSED-CIRCUIT TYPE SELF-CONTAINED 14000 VOLTS 3 DIFFERENT POWERS Shipping Weight 20 Lbs.
Send 8c stamp for catalogue of Wireless Supplies, folders, etc. Winger's Telegraph Code Charts free with \$2 orders; otherwise 20 cts. each. Furnished in "station" or "pocket" sizes, Continental or Morse code; please state which, otherwise Continental "pocket" size will be sent. Winger Electric & Mfg. Co., 711 So. Dearborn St., Chicago, Ill.



ELECTRICITY

BOYS—Send today for our new 128-page catalog of everything electrical. Motors, Dynamos, Flashlights, Lamps, Coils, Batteries, Transformers, Magnet and Resistance Wires, Telegraph Outfits, Miniature Electrical Railways and Parts. Catalog with coupon sent only for 6c in stamps or coin. No postals answered.
VOLTAMP ELECTRIC MFG. CO. Voltsamp Block, BALTIMORE, MD.

"Let There Be More Light"

Goodbye Old Oil Lantern

METEOR
ELECTRIC LANTERN
COSTS LESS THAN OIL



Price only
75c
(postpaid)

Add 10c for postage. This price does not include Dry Battery.

Batteries can be obtained at any hardware store throughout the country, or direct from us, for 25 cents, postage extra and can be attached in a few seconds.

USES ANY NO. 6 DRY BATTERY. ABSOLUTELY SAFE AROUND GAS, GASOLINE OR OIL.

1 BATTERY LASTS FROM 6 TO 8 MONTHS

The Meteor Electric Lantern is furnished with high power and improved Tungsten bulb which will stand any jar or rough usage. Simple—Convenient—Safe—Economical. Light is clear, bright and steady. Unaffected by weather—absolutely reliable. Practical—not a toy. Not simply a flashlight, but can be used for continuous burning. Simply press the switch with thumb, and you have a most brilliant white light for over 60 feet ahead.

The Ideal Light for automobiles, bicycles, and vehicles. So designed that it can be hung on a buggy dashboard and serve as a BRILLIANT HEAD LIGHT.

Don't be without one another day. Agents wanted

Johnson Smith & Co., Dept. 3, 713 S. Dearborn St., Chicago

It is estimated that 4,708,000,000 wood screws are used in the United States each year.



"THE ELECTRICAL EXPERIMENTER"

The big electrical Magazine for those who dabble in electricity and Wireless. Chuck full of experiments. Intensely interesting. Monthly prices of \$5.00 for best experiments. Amateur Electric, wireless news, Complete Electric Course etc. 50 to 100 illustrations. Only 50c a year in U. S. and Canada. On all News-stands. Send for free sample.

Electrical Experimenter 234 Fulton St., N. Y.

DYNAMO-MOTOR

As a dynamo it will operate induction coils, light lamps, charge storage batteries, electroplate, etc., makes an ideal machine for experimenting. As a motor they will operate heavy models, amey wheels, and other useful appliances.

18 watt dynamo-motor \$3.00
24 " " " 3.85
40 " " " 5.25

Send 2 cent stamp for catalog of wireless apparatus, trains, electrical supplies, novelties, tools and books.

LOOMIS ELECTRIC COMPANY
1427 N. Artesian Ave. Chicago, Ill.



Boy Electrician

with 75 illustrations for making Batteries, Dynamos, Motors, Telegraph apparatus, Telephone, Lights, Bells, Alarms, Coils, "Wireless" Current Reverser, Electric Engine, Etc. By Electrical Experts so that anyone can understand it. With Cat. All 10c Ppd.

J. C. DORN, 705 So. Dearborn St., Dept. 21, Chicago, Ill.



Big Entertainer

320 Jokes and Riddles, 153 Parlor Games and Magic, 15 Tricks with Cards, 73 Toasts, 7 Comic Recitations, 3 Monologues, 22 Funny Readings. Also Checkers, Chess, Dominoes, Fox and Geese, 9 Men Morris. All 10c. postpaid.

J. C. DORN, 709 So. Dearborn Street, Dept. 17, Chicago, Ill.



Boys' Own Toy Maker

Tells how to make a Talking Machine, Camera, Electrical Motor, Bicycle Boat, Cannon, Boomerang, Bobbed, Wind Mill, Microscope, Water Wheel and Motor, Sifts, Toboggan, Snow Coaster and Sail Boat, Telephone, Electric Bell, Railroad Wind Motive, Paddle Boat, Traps, Etc., etc. All 10c. postpaid.

J. C. DORN, 707 So. Dearborn St., Dept. 38, Chicago, Ill.

Brandes WIRELESS RECEIVERS



You cannot get the best out of your receiving set without a pair of Brandes Receivers

"Ask the man who has them"

Prices \$1.65 each up to \$13 per pair

SEND STAMP FOR CATALOGUE TO

C. BRANDES, Inc., 11 Liberty St., New York

BOYS 10¢

A REAL WIRELESS DETECTOR FOR 10 CENTS

We want to acquaint you with "Wireless." Read this astounding and hitherto unattempted offer. For 10c. we will mail you prepaid a complete wireless detector exactly as illustrated, also 25¢ 1/2 x 1/2 1/2. In connection with any telephone receiver and a wire on your roof, this detector is guaranteed to receive messages from 100 to 500 miles. Complete instructions furnished. This detector is not only easy to use, but does exactly the same work.

FREE with detector. A copy of our famous Electrical Encyclopedia, No. 14, containing 400 illustrations and 200 articles. "Treatise on Wireless Telegraphy" and "The Electrical Experimenter." If detector is not wanted send 2c. for other books.

Electro Importing Co., 233A Fulton St., N.Y. City
"Everything for the Experimenter"

BOYS 10¢

Over 22,000 newspapers and periodicals were published in the United States in the year 1914.

AGENTS—A BIG SELLER SCREEN DOOR CHECK

Splendid summer seller. Stops the bang. Easy Sales. Big Profits and saves the door. Big demand. A sale in every home. Dozen can be carried in pocket. Demonstrating sample free to workers.

THOMAS MFG. CO., 1448 Rome St., Dayton, Ohio



LOW-PRICED

Send for a Copy of Our New Manual No. 2



Its pages give simple formulas for calculating the natural period of an antenna; capacity of a receiving or transmitting condenser; spark frequency of rotary spark gaps; tables for calculating the correct amount of wire for the construction of magnets and tuning coils; tables for ascertaining the spark lengths of different voltages; the Federal regulations regarding the restrictions of wave lengths for amateur stations; instructions for the installation, maintenance and operation of wireless stations; directions for learning the code, working diagrams and a complete list of up-to-date wireless instruments and accessories, together with other features of interest to the amateur or professional wireless enthusiast.

Containing as it does a fund of valuable information not generally contained in a catalogue, it approaches nearer a text book in the fascinating field of wireless telegraphy. It is printed on good stock with a heavy paper cover in two colors. No expense has been spared to make it accurate and reliable. We make a charge of 10c for it which amount will be allowed on an order amounting to \$1 or more.

No Wireless Experimenter Should be Without the *Mesco Wireless Manual*

Send for Our Pocket Catalog P.28 It will contain over 200 pages, with over 1,000 illustrations, describing in plain, clear language all about Bells, Push Buttons, Batteries, Telephone and Telegraph Material, Electric Toys, Burglar and Fire Alarm Contrivances, Electric Call Bells, Electric Alarm Clocks, Medical Batteries, Motor Boat Horns, Electrically Heated Apparatus, Battery Gauges, Wireless Telegraph Instruments, Ignition Supplies, Etc.

It Means Money Saved to You to Have Our Manual and Our Catalog When You Want to Buy

Manhattan Electrical Supply Co. New York 17 Park Place Chicago 114 So. 5th Av. St. Louis 1106 Pine St. San Francisco 604 Mission St.

WONDER LIGHT OUTFIT



Lots of Fun for Boys
Consists of 3 1/2 volt, 2 C. P. lamp, switch, socket, 20 ft. insulated wire and 3 cells of dry battery all ready to install.
May be used to light a dark closet or hall.

PRICE ONLY 60c. Post. Extra 15c

SEND NOW

LITTLE GIANT MOTOR

Is nearly 3 in. high. Runs at high speed on a single cell of battery. Very powerful and may be used to run small toys, etc. Just the motor every boy has been looking for.

Sent postpaid for only 50 cents

THE SIMPLEX TELEGRAPH



An opportunity for every boy to learn to telegraph and to put up a line with his chum. This is a full sized telegraph set consisting of a fine key and sounder mounted on a polished base. Will work any distance. An excellent Field Telegraph for Boy Scouts. Price 98 cents. Postage extra. Wt. 2 lbs.

UPRIGHT STEAM ENGINE

A fine engine, made of the best materials, 9 in. high. The right engine for any boy. Runs at high speed on low pressure. Each engine tested at the factory and fully warranted. Sent postpaid for only 50 cents

SIMPLEX WIRELESS OUTFIT



Every boy wants a wireless outfit. Get in this interesting game and read the messages flying around you. This outfit is the greatest bargain ever offered. Consists of a large double slide tuner, a sensitive cat whisker detector, condenser, telephone receiver and cord. Size 8x6x4 inches. Wt. 3 lbs.

Special price, complete, \$1.95. Postage extra.



EXPERIMENTERS

THIS IS THE Experimenter's Reference Book EVERY BOY NEEDS IT

It's the latest edition of the famous **AMCO Catalog**, nearly 200 pages, fully illustrated. Complete description and prices of the latest Electrical and Experimental Apparatus—Storage Batteries, Rectifiers, Transformers, Induction Coils, Wireless Apparatus, Lamps, Flashlights, Meters, X-Rays, Books, Tools, Electric Railways, Steam Engines, Water Motors, Dynamos, Motors, Telegraphs, Telephones, Electrical Supplies, Model Aeroplanes and parts for building your own apparatus. A treatise on Wireless Telegraphy telling how to put up an aerial, connect apparatus, etc., together with a Call List and Wiring Diagrams, FREE with every catalog. 6c in stamps will bring you this wonderful book. The best catalog of wireless apparatus, etc., published.

ADAMS-MORGAN CO., "THE EXPERIMENTER'S SUPPLY HOUSE"
Dept. M, Upper Montclair, N.J.

ELECTRIC LIGHT PLANTS

Complete gasoline engine, dynamo, switchboard and storage battery \$240.

Agents wanted. American Battery Co., 1129 Fulton St. Chicago (Estab. 1889.)

ELECTRIC HOME, FARM AND STORE LIGHT PLANTS.

LIGHTS, DYNAMOS, MOTORS, ENGINES.

Belts, Books, Rectifiers, Storage & Medical Batteries, Railways.

Bicycles, Carriage & Xmas Lights, Massage, Ozon & M.P. Machine.

MOTION PICTURE THEATRE Permanent and Travelling

Equipments. Big Opportunity. Catalog 3 cts.

OHIO ELECTRIC WORKS, CLEVELAND, OHIO



ELGIN
WATCHES
ON-
CREDIT

17 Jewel

Now, during this Special 30-day Sale, is the time to buy this elegant 17-Jewel Elgin. Factory tested and fitted in a 25-year Gold-Filled Case.

NO MONEY DOWN—\$2 A MONTH

Because we want to prove to you that the great volume of our business enables us to save you nearly half on this \$30.00 Elgin. **Special \$12⁷⁵**

3 Fine Books FREE! Mr. Harris wants to send you his three latest books free—one the story of "The Diamond," its discovery, where and how mined, cut and marketed; the other, "Facts vs. Funs," or all about the Watch Business, both at home and abroad, also our Big Free Watch and Diamond Book.

You do not pay a cent until we have placed the Watch or Diamond in your own hands for approval—no security—no interest—no red tape. **Big Catalog Free.**

HARRIS-GOAR CO. Dept. 1572
KANSAS CITY, MO.



140,000 Gears
IN STOCK FOR
IMMEDIATE SHIPMENT

This does not include our large stock of pinion wheels, racks, chains, ball bearings, universal joints and gear gauges. See our Catalog K8.

BOSTON GEARWORKS
Norfolk Downs (Inn), Mass.

AGENTS \$50 to \$90 Per Week
Men or Women



NEW INVENTION—Just Out 20th Century YOUTHIFIER!
Nature's remedy for beauty ills. Lowest price massage machine on the market. Marvelous outfit without a peer. Puts massage facilities within reach of all.

No Electricity or Water Power Needed. Nature's laws utilized. Slight pressure of the thumb gives an exhilarating, fascinating massage. Brings back the energy, buoyancy and beauty of youth. Produces natural glow of health. Pleases, delights, satisfies. Enormous business everywhere. Women attracted, interested, fascinated—buy at sight, without urging.

BEAUTY FOLDER FREE

GET OUR PROPOSITION

Fortunes will be made by live agents who answer this ad. We furnish you help that absolutely prevents failure. Act on our liberal proposition. No charge for territory. Circular and advertising matter furnished free. Excellent territory still open. Be the first in your locality. Hurry. Send no money. Simply write a postal for free particulars.

Aztec Remedy Co., Dept. 145, Toledo, Ohio



Canoeing!

How can you spend the summer without a canoe? There's nothing quite like canoeing—so exhilarating—so satisfying; nothing that will bring you quite so close to nature and force the daily grind of yesterday so far into the background.

MULLINS CANOES

possess every refinement that you will want in your canoe. Exquisite workmanship—beauty, grace and lightness, carefully matched cedar, canvas cover rubbed and polished to perfection—and the price will please you, too. Big, interesting, illustrated catalog on request. Wherever canoes are sold you will find a Mullins.

THE W. H. MULLINS COMPANY
73 Franklin Street, Salem, Ohio
World's largest manufacturers of steel and wooden boats

COTTON STANDARDS PROMULGATED—New official cotton standards of the United States were promulgated Dec. 15, 1914, by the Department of Agriculture. The new standards replace the old official grades heretofore issued by the department and must be used after Feb. 18, 1915. Copies of the standards are being prepared as rapidly as possible and are sold at cost.

Rémoh Gems



Look and wear like diamonds. Brilliance guaranteed forever. Stand file, acid and fire like diamonds. Have no paste, foil or backing. Set only in 14 karat solid gold mountings. About 1-30th the price of diamonds. A marvelous synthetic gem—will cut glass. Guaranteed not an imitation and to contain no glass.

Sent C. O. D. subject to examination. Write today for our 4-color catalog DeLuxe, it's free.

Rensch Jewelry Co., 622 Washington Ave., St. Louis



We Teach You the Business FREE!

400% to 800% Profit in Popcorn-Crispette and Candy Business

Crowds swarm to buy our Kettle-Popped Popcorn—topped under glass—seasoned while popping!—GREAT BIG-CRISP-PLUFFY KERNELS! Corn pops 25 per cent bigger with the Delzenbarger machine and 100 per cent better product. Our delicious CRISPETTES melt in your mouth. Wonderful new Automatic Crispette Press is a regular money-maker! Big extra money in candy!

Course in Candy Making FREE with Every Outfit
Write AT ONCE for FREE Catalog, new money-making plans, special prices and sensational easy payment offer. NOW is the time to start. No experience necessary and very little money. Write

C. E. DELZENBARGER CO., 64 Bissel St., JOLIET, ILL.

Please Mention Popular Mechanics



Tobacco Habit BANISHED

in 48 to 72 Hours

No Desire After First Dose

Trying to quit the tobacco habit unaided is a losing fight against heavy odds, and means a serious shock to your nervous system. So don't try it! Make the tobacco habit quit you. It will quit you if you will just take Tobacco Redeemer according to directions.

It doesn't make a particle of difference whether you've been a user of tobacco for a single month or for 50 years, or how much you use, or in what form you use it. Whether you smoke cigars, cigarettes, pipe, chew plug or fine cut or use snuff Tobacco Redeemer will positively remove all craving for tobacco in any form in from 48 to 72 hours. Your tobacco craving will begin to decrease after the very first dose—there's no long waiting for results.

Tobacco Redeemer is absolutely harmless and contains no habit-forming drugs of any kind—the most marvelously quick and thoroughly reliable remedy for the tobacco habit the world has ever known.

Not a Substitute

Tobacco Redeemer is in no sense a substitute for tobacco, but is a radical, efficient treatment. After finishing the treatment you have absolutely no desire to use tobacco again or to continue the use of the remedy. It quiets the nerves, and will make you feel better in every way. If you really want to quit the tobacco habit—get rid of it so completely that when you see others using it, it will not awaken the slightest desire in you—you should at once begin a course of Tobacco Redeemer treatment for the habit.

Results Absolutely Guaranteed

A single trial will convince the most skeptical. Our legal, binding, money-back guarantee goes with each full treatment. If Tobacco Redeemer fails to banish the tobacco habit when taken according to the plain and easy directions, your money will be cheerfully refunded upon demand.

Let Us Send You Convincing Proof

If you're a slave of the tobacco habit and want to find a sure, quick way of quitting "for keeps" you owe it to yourself and to your family to mail the coupon below or send your name and address on a postal and receive our free booklet on the deadly effect of tobacco on the human system, and positive proof that Tobacco Redeemer will quickly free you from the habit.

Newell Pharmacal Company
Dept. 300, St. Louis, Mo.



Mail Coupon NOW for FREE Booklet

NEWELL PHARMACAL CO.,
Dept. 300, St. Louis, Mo.

Please send, without obligating me in any way, your free booklet regarding the tobacco habit and proof that Tobacco Redeemer will positively free me from the tobacco habit.

Name

Street and No.

Town State

Please Mention Popular Mechanics

A Real Kerosene Engine

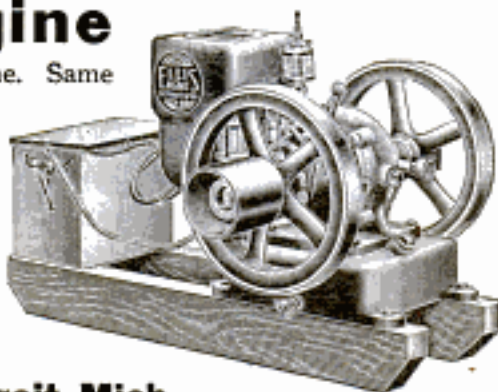
Here's the biggest engine value ever offered in a 1½ H. P. engine. Same cylinder capacity as many 2½ H. P. engines. Throttling governor adjustable while running; crankshaft extends on both sides. Runs either way. Starts without cranking. Equipped with Ellis Patent Fuel Device, guaranteeing successful operation on cheap oils. Beautifully finished in genuine engine enamel.

Runs on 9c a Day Just the engine for pump-

ing, separating, churning, corn - shelling, sawing, shop work, electric lighting and dozens of other light jobs. Sold on 30 days' trial. Guaranteed for 10 years. We make other sizes from 3 to 18 H. P., vertical and horizontal, single and double cylinders.

Ask for our free book, "ENGINE FACTS," telling how to judge and buy an engine.

ELLIS ENGINE CO., 2873 E. Grand Blvd., Detroit, Mich.



FREE TRIAL 30 DAYS BESSEMER NON CRANKING KEROSENE ENGINE

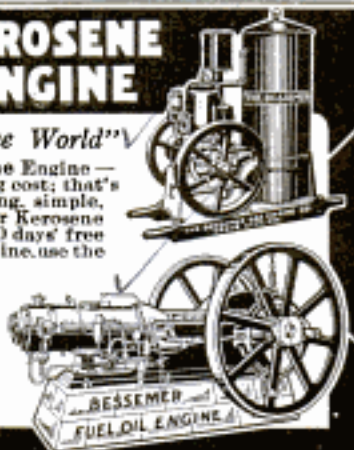
"The Masterpiece of the Largest Manufacturers of 2-Cycle Engines in the World"

"Pays for itself in fuel saved!" That is the proud achievement of the Bessemer Kerosene Engine — and that's what interests you! Built to give years of steady service on the lowest operating cost; that's why the Bessemer is displacing other types of engines everywhere. Non-cranking, simple, only three moving parts — a boy or woman can run it. Thousands of Bessemer Kerosene Engines are giving daily service on farms all over the world. 2 to 10 H. P. — 30 days' free trial. Immediate shipment. Write for Catalog "K." If you require a larger engine, use the

BESSEMER FUEL OIL ENGINE

Lower picture shows the famous Bessemer Fuel Oil Engine. Widely used in irrigation, flour mills, factories, electric light plants, etc. Runs on cheap fuel and crude oils. No batteries or magnetos require; ignition is automatic after starting. 15 to 165 H. P. Special Catalog "O" free.

THE BESSEMER GAS ENGINE COMPANY
121 LINCOLN AVE. GROVE CITY, PA.



CAILLE 5 Speed
5 Motor
Push-Button Control

Gives two forward, a neutral and two reverse speeds, by simply pressing a button. Magneto enclosed in fly-wheel. Dual ignition. Silencer on exhaust. Water-tight gear housing and six other exclusive features. Send for catalog. We also build marine motors from 2 to 30 h. p. Details on request.

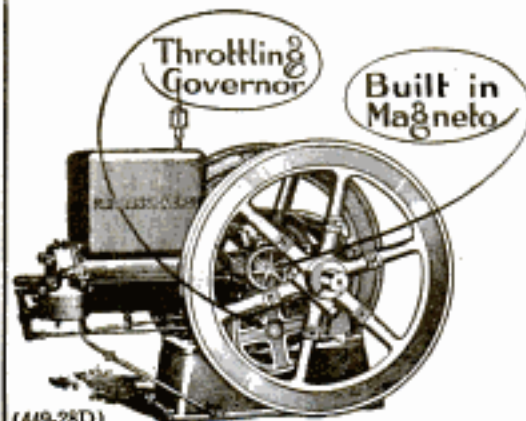
The Caille Perfection Motor Co.
1323 Caille St.
Detroit, Michigan

MANGROVE BARK FOR TANNING—Not long before the outbreak of hostilities in Europe a firm of tanners in England conducted some experiment with the bark of the common mangrove and reported excellent results. The content of tannin is relatively much higher, it was asserted, than in oak bark of the choicest sort. The bark is thin, all of it is heavily impregnated with tannin, and there is no waste. Mangrove is common in the tropics, along the shores, the mouths of rivers, and in swamps and water districts.

"VIM" ENGINE **\$25 COMPLETE**

Save money by using a **VIM 1½ HP. Farm Motor** for churning, washing, pumping, separating, spraying, etc. Women operate easily. No valves, cams, gears or complicated parts. Water Cooled, automatic positive lubrication, sensitive governor. Weighs only 75 lbs. Comes ready to run. Fully guaranteed. Get catalog and special agency offer.

THE VIM MOTOR CO., 804 Water St., SANDUSKY, OHIO



(449-28D)

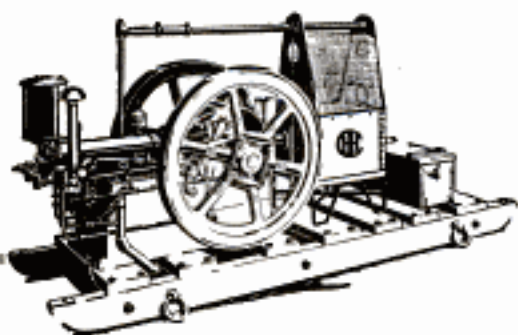
Two Special Features

put Fairbanks-Morse Multi-fuel Oil Engines in the lead for hard, heavy, everyday work of shop and farm. Insure absolute reliability with cheap fuel at all times—saving money the year around.

ASK FOR DETAILS

Fairbanks, Morse & Co.

Chicago New York San Francisco



Join the Titan Users

No other single mechanical force has taken so much of the hard, disagreeable labor off the shoulders of human beings in this country as has the power of International Harvester Oil Engines. When you realize that more than a quarter of a million engines have been put into use in the towns and on the farms of the continent by the makers of

I H C Titan Engines

you will consider with interest the "why" of this great popularity and success.

The man who looks longest for the right engine, who studies most carefully all details of engines on the market, inevitably buys a Titan. No engines last longer, run more steadily, deliver more power—are more uniformly satisfactory, than Titan engines. They are built in all styles, sizes 1 to 50 H. P., run on any one of a half-dozen different fuels, built for any particular need—your need.

Titan engines are sold by local dealers only. Write for a catalogue, showing an interesting array of special features, and we will tell you where you can see the engine.

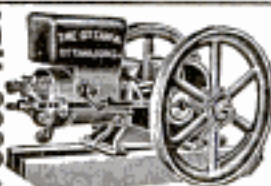
International Harvester Company of America

(Incorporated)

16 Harvester Building Chicago U S A

6 H. P. \$96⁷⁵

1½ H. P. \$24.75 5 H. P. \$ 87.50
2 H. P. 28.75 8 H. P. 135.50
3 H. P. 53.90 10 H. P. 179.90
4 H. P. 68.90 12½ H. P. 214.90



Many other sizes—all sold direct and fully guaranteed. BIG 32-PAGE CATALOG FREE. Write today.

OTTAWA MFG. CO., 252 King St., OTTAWA, KANS.

HILDEBRANDT BAITS

HOOK AND LAND 'EM

240 sizes and kinds for all kinds of game fish. 3 shapes, 6 finishes, any color fly, reversible blades. Send for

1915 TACKLE CATALOGUE—Colored Insert

J. J. HILDEBRANDT CO., 1324 High St., Logansport, Ind.

Toledo MARINE MOTORS NONE BETTER

"Nothing Cheap but the Price"

3 H. P. 1 cyl. complete	\$ 65.00
6 H. P. 1 " " "	84.00
6 H. P. 2 " " "	125.00
12 H. P. 2 " " "	160.00
18 H. P. 3 " " "	250.00

Fully guaranteed by a responsible concern. 2 cycle, 2 post, 3½x3½ and 4½x4½. Send for free catalog "C."

THE UNIVERSAL MACHINE CO., Pike Ave., Bowling Green, O.

WATKINS' SPECIAL MOTORS

3 H. P. Single Cylinder	30 lbs.
6 H. P. Double Cylinder	60 lbs.
12 H. P. Four Cylinder	100 lbs.

A strictly HIGH GRADE Motor that will give CONSTANT and EFFICIENT service. Especially adapted for CARGES and LIGHT BOATS. Aluminum base, copper water jacket, steel shaft, bronze bearings.

THE WATKINS MOTOR CO.
837-839 West Sixth Street CINCINNATI, OHIO

SPECIAL

\$4.75

Size 7 x 7 ft.
Genuine Full Weight
8 oz. Duck



Boys' Special Offer Genuine Wall Tent Complete

Just think of it. This 7x7 foot genuine eight-ounce duck wall tent for only \$4.75 Everything complete. Poles, ropes and pins. Big enough for four boys. Strong enough to stand blizzards or storms. You can have lots of fun this winter. Don't stay in the house. Take your boy friends out in the tent. You cannot possibly get wet. It's nice and warm too. Great to sleep in. Start to save today. Sign your name to the coupon and tear it off and send it to us. We will mail you at once a beautiful book telling you many things you ought to know about outdoor life. This book is absolutely free and prepaid.

Army Shelter Tents

Commonly Called "Dog Tents" — Made up in 2 Sections, Complete with Poles and Pins

Special White Cloth

Special Khaki Cloth

\$2²⁵

\$3



Just like the regular soldiers use. Boy Scouts all over the country are using them. Can be set up and taken down in a minute. When not in use can be easily carried on your back. Absolutely waterproof. This tent is 5 ft. 8 in. long by 8 ft. 6 in. wide by 5 ft. 9 in. high. The poles are spliced. Every boy ought to have one of these tents. Send your order in today. They are going like hot cakes.

Send FREE Coupon for New Camp Guide

Just put your name and address on free coupon and mail it at once. We will send you our new 1915 Camp Guide. Gives a hundred pointers on camping boys should know. Tells how, when and where to camp out. We also send a list of supplies you need and where you can get them cheapest. Book is sent free and prepaid. No obligations of any kind. Mail coupon now. Do it now as the supply of these books is limited.

**H. Channon
Company**

Dept. 1194
150 North
Market Street
Chicago
Illinois

**FREE
Camp Guide
Coupon**

H. Channon Company

Dept. 1194

150 North

Market St., Chicago

Gentlemen: Please send me, absolutely free and prepaid your new 1915 Camp Guide. Also full particulars of bargains you are offering on tents and other supplies. (Canadians must enclose 10c because of duty.)

Name

Address

Please Mention Popular Mechanics

Go Camping with an "Old Town Canoe"



It is made for the man who wants a craft rigid enough to withstand the shock of hidden obstructions; one with the speed that comes from perfect balance and proportion; a canoe that's as buoyant as a cork and as steady as a rowboat; one that's as responsive to the paddle as a good horse to his bit; that doesn't leak and cares as much for a boat-house as a duck does for shelter from the rain.

In short, "Old Town Canoes" are made for sportsmen who are experts in canoe lore and have the connoisseur's pride of possession.

Made in many styles for many purposes. There is one for you in the 4000 ready for shipment—all low-priced. Write for catalog and name of dealer in your town.

OLD TOWN CANOE CO., 1464 Middle St., Old Town, Maine, U.S.A.

Cat-
alog
Free

The Outings You
Look Forward To

Make them real, all-play-and-no-work outings—with a stout, dependable Wisconsin Row Boat Motor to swing you over lake and stream, swiftly and tirelessly. Be sure it's a Wisconsin motor—perhaps the new "Wisconsin Junior" shown here. Then you won't have to tinker with your little power plant to keep it on the job. You can always bank on a

WISCONSIN DETACHABLE Row Boat Motor

The motor shown here, the "Wisconsin Junior," is the latest addition to our line. It meets the demand for a thoroughly reliable row boat motor at a low price. The distinct features of the higher priced Wisconsin Motors are clearly visible in the "Junior":

Same power plant—2 horse power—same ignition, Battery or Magneto—same wide range of adjustments, Vertical and Horizontal. The Independent Rudder is replaced by a swinging propeller with self-locking tiller. A twist of your wrist locks the propeller in the desired position—no more tired arms from holding the tiller against the natural propeller thrust—no more of the constant watch of the tiller to maintain a straight line course. Write today for our Free Catalog U, showing full line of 7 models.

DEALERS—Here's a Wisconsin you need in your store. There's a big demand for a GOOD motor at a low price. Cash is an ill!

WISCONSIN MACHINERY & MFG. CO.
Minor St., Milwaukee, Wis.



Any **ONLY \$5 DOWN**—One Year to Pay

\$38 buys the reliable U. S. Engine (size 1 1/2 H. P.) direct from our factory on easy payments of only \$5 down and \$3 a month. Free Catalog Folder shows nine larger sizes all sold at similar low prices and on very easy terms. All guaranteed 5 years and backed by 62 years manufacturing experience; all shipped on 30 days' trial.

U.S. ENGINES

Burn Gasoline, Kerosene or Distillate

—have double the power of other engines of equal weight—are easiest to move—easy to get at—take up least space—run smoothest—start easy—burn less fuel and last longer. Free Catalog Folder gives 18 reasons for U. S. superiority and quotes low easy-to-pay factory prices. Write now.

(1) U. S. ENGINE WORKS, 3712 Ogden Ave., CHICAGO

The street-railway company of Manila, Philippine Islands, recently installed five waiting stations for the public at various points throughout the city. More stations will be built later, as required.

GET THIS CATALOG
FULL OF VALUABLE INFORMATION TO EVERY BOAT OWNER ON

RACING PROPELLER WHEELS, REVERSE GEARS AND MARINE ACCESSORIES

LARGE CATALOG FREE. SEND TODAY
MICHIGAN WHEEL CO.
1139 MONROE AVE., GRAND RAPIDS, MICH.



Let Us Save You The Price
Of a Row Boat on Your
Outboard Motor!

Our Price Only **\$44.95**

Others Ask \$70

Why pay \$70 or \$80 for a motor not one whit better than the American at \$44.95? It embodies just as good materials, workmanship and design. We sell cheaper because of big production and the fact that

American Motors Are Sold Direct saving you dealers' profits. The American gives 2 1/2 h. p. Runs 4 to 9 miles an hour. Adjustable for stern. Reversible. Weighs about 50 lbs. Steers with propeller. Also has rudder steered model. Magneto ignition at small cost. Ask for catalog B.

American Engine Company, 605 Boston St., Detroit, Mich.




VIM MOTORS

5 to 27 h. p.
1, 2 and 3 cylinder Gasoline or Kerosene

Speed, regular, or heavy duty. Strong, simple, accessible—absolutely dependable. Built for a lifetime. The boat-builder's stand-by, the boat-owner's pride. Double ignition. Non-backfiring. Heavy brass fittings.

"Only fault with my Vim is that I did not get it sooner. It runs and sounds like an electric fan. Ran it steady last Sunday on 6 gal. gasoline—that's a right good for a 10 H. P. engine. My friend says his motor is a gasoline 'rater' and if he can sell it, a Vim goes in his boat." This from Rex N. Pratt, Warren, Pa.

VIM MOTOR CO.
104 Water St., Sandusky, Ohio



NORTHWESTERN MARINE ENGINES

2 to 18 H. P.

The most compact, powerful and silent running motors for their size in existence. Sold at moderate prices and sent on thirty days trial before buying. Pay if satisfied, otherwise return at our expense. 2 H. P. with complete boat equipment \$50. Other sizes in proportion. Send for 1915 Catalog.

NORTHWESTERN MOTOR COMPANY, 1101 Spring St., Eau Claire, Wis.



NORTHWESTERN ROWBOAT MOTOR

Strictly high grade—nothing better made at any price. Finished in polished brass and aluminum, nickel-plated fly wheel, Battery or Bosch Magneto. Rudder swings separate from engine, and all other modern improvements. Complete with electrical equipment, \$50. Send for 1915 Catalog.

\$50



Joymotor

For Rowboats and Canoes



Joymotor will fit any boat ever made—square stern, pointed stern or decked stern—without additional attachments. Just hook it on or off in a jiffy. Joymotor's unusual bracket takes care of everything. No matter where you take Joymotor you know it will fit the boat you have to use. For Canoes Joymotor special bracket sets motor low down—safety first.

Marine Engine Dealers Write for Agency Proposition

REVERSING PROPELLER

The exclusive patented feature of Joymotor that makes it the safest, most convenient, easiest to handle motor in the world. No more danger of accidents. No drifting or paddling to dock or shore. No more awkward, hurried cranking to reverse the motor. Just move the steering tiller to right or left and Joymotor almost instantly—**Stops your boat and backs it up without reversing the engine**

"Joymotor is rightly named"—"A joy to own"—"evidently built to enjoy"—that's what owners tell us. Easily

portable. Weighs 52 lbs. Runs your boat 7 to 9 miles per hour—canoes 10 to 12. Has real high tension magnets and real carburetor, efficient timing system and does not have weights, tangled up pump hose. Write postal now for catalog and life size picture of Joymotor giving full details of the finest, most satisfying portable motor to be had. Write postal now to



This picture shows how Joymotor steering tiller swings and reverses position of propeller. Compare this position with large picture.

JOY ENGINEERING COMPANY
430 Tribune Bldg., CHICAGO

TOY BALLOONS TRAVEL NINETY MILES—

Three toy balloons, about 24 in. in diameter, released at Chillicothe, Ohio, were found in a field about 90 miles from their starting point. A post card which had the return address of the sender on it was attached to the balloons so that a message from the finder would advise their location. The balloons were not in any way damaged, and only because of escaping gas at the neck did they descend.

KERMATH BOAT MOTORS \$180.00 up

4 Cycle, 4 Cylinder, 12 to 20 H. P.
Highest quality. Silent operation. No vibration. Controls like the finest Motor Car engine. Extremely economical on fuel. Used as standard equipment by over 60% of the world's leading boat builders. Catalogue on request. \$180 to \$360 depending on equipment. **KERMATH MFG. CO., Dept. P., Detroit, Mich.**

More Power For Less Money 6 H.P. \$98.75

The New Galloway Masterpiece "Six" is the most down-to-the-minute engine that mechanical ingenuity can produce. It is perfectly adapted to furnish power to the shop, the mill, the contractor anywhere and where ready, steady, reliable, efficient and economical power is needed.

My New 1915 Proposition
is the greatest offer ever made by any manufacturer and is the first time in the history of engine building that an A 1 high-grade engine of this h. p. could be bought for so low a price. Write for particulars and price-reducing sliding scale schedule.
Wm. Galloway, Pres. The Wm. Galloway Co. 965 Galloway Station, Waterloo, Iowa



DAYLIGHT BY NIGHT "SEARCH-LIGHT" BICYCLE LAMP

For Your Protection At Night Ruts seem deep—Stones are big—Automobiles run fast. A brilliant gas light is necessary. A "Search-Light" Bicycle Lamp makes its own gas. Will not jar out. Handsomely nickel-plated. Get a "Bridgeport" Pump for your wheel. Send for new booklet describing lamps and pumps.
BRIDGEPORT BRASS COMPANY
P. O. Station K
BRIDGEPORT, CONNECTICUT

HAFTING

A complete line of appliances for the transmission of Power. Anything from a bolt to a complete mill or factory outfit. Send for catalogue. Our prices challenge the world.
W. A. Jones Foundry & Machine Co. CHICAGO

Unmatched Speed No Vibration

Speed that runs away from all other rowboat motors. Double the power—no vibration. It does not shake the boat.

2-Cylinder 3 H.P. KOBAN ROWBOAT MOTOR

Last season's record proved its mettle. Absolutely dependable—easy to start—reverses by pressing button.

TROPHY WINNING RACER TYPE
The Koban has 2 opposed cylinders— that's what removes vibration—3 H. P.—nearly double that of other motors—speed propeller. Best constructed rowboat motor on the market. Write for 1915 catalog. Active Agents Wanted.
Koban Mfg. Co., 291 So. Water St., Milwaukee, Wis.

On a Summer Sea—or Lake or River—

with your Mullins boat you will find miles and miles—hours and hours of invigorating, healthful, business-forgetting pleasure. Sweet, cool air, fresh from fields and mountains—nature's laboratory—will make your heart beat faster from the sheer joy of living. Sixty thousand owners of



MULLINS BOATS



are now planning a glorious summer to be spent, for the most part on the water. Mullins boats of either wood or steel, are designed by America's foremost Naval Architects, built in the largest boat factory in the world—powered with 2 and 4-cycle motors. Speedy—beautiful—distinctive. Send for interesting, free Catalog and learn where you can see a Mullins Boat.

The W. H. Mullins Company ⁹² Franklin St., Salem, O.
World's largest builders of pleasure boats



THE NEW STYLE

Edison Phonograph



and your choice of over 1500 records now shipped direct to you for a full free trial in your own home. Yes, try it out right in your own home. Entertain your family and friends. Send it back at our expense if you don't want to keep it. A few dollars a month now pays for a genuine Edison at the Rock-Bottom Price and without interest on monthly payments.

Write Today for Our Free Edison Book

Tells about the wonderful entertainers. Shows you all the machines and records you have to choose from. No obligations in asking for our FREE EDISON BOOK. Write Today—NOW.
F. K. BABSON, Edison Phonograph Distr., 1194 Edison Bk., CHICAGO

PAINT \$1 A GAL.

STANDARD GOODS, Varnishes, Stains, Enamels, etc., at greatly reduced prices. Color cards sent on request.

FALVEY PAINT WAREHOUSE, 54-56 Pearl St., Boston, Mass.

There are 375,037 buildings of various kinds in New York City, divided as follows: Manhattan, 84,849; Bronx, 35,163; Brooklyn, 172,380; Queens, 62,525; and Richmond, 20,120.

CANOE BOOK FREE

Canoeing makes you "hungry as a bear"—puts color in your cheeks, sparkle in your eyes, strength in your body. Book tells about paddling, sailing and motoring in a Kennebec. Describes perfect style, great speed, strength, lightness. Write now.

KENNEBEC

Kennebec Canoe Co.
30 R. R. Sq.
Waterville, Me.

Bike-Lite

ELECTRIC

Uses Ordinary No. 6 Dry Cells

Powerful, Convenient,

Clean

Equipped with Focusing Device, regulated at will, securing a wide range of effects—from a piercing beam to a widely diffused ray. Adjusted from the seat.

The New and Efficient Bicycle Searchlight Lamp

does away with the necessity for dirt, grease, oil, smoke and liquids. By means of a scientifically correct parabolic reflector all the light from an incandescent electric bulb is projected down the road in a powerful beam. Always ready, always the same cool, steady, flickerless beam of white light. Made like an automobile headlight.

Battery case is attached to bicycle frame. Cannot rattle or bump the knees. Universal lamp bracket allows attachment to fork, frame or handle bar.



PRICE

\$2.25

Without Batteries

Batteries procurable everywhere

BIKE REAR LITE

Can be used on the same set of batteries. Mounted on the rear mud guard and shows red light directly behind. Easily attached. Price 90c.

From your dealer or postpaid on receipt of money order.

VESTA ACCUMULATOR CO.
2100 Indiana Avenue
Chicago, Illinois

LOW PRICES ON Edwards Metal Shingles

Business is on the mend. Steel mills have renewed operations. Orders are pouring in. That means demand—higher prices. But, before prices start up—NOW is the time to decide on your new roof, and get the rock-bottom price on Edwards **Rust-proof Metal Shingles**—the everlasting roof—the **fireproof** roof—the time-saving, money-saving, trouble-saving roof.

A canvass of experienced farmers has just been made. Man after man says, "Metal Shingles for mine." And they give their reasons. Wood shingles are costly and troublesome. Many "prepared" roofings blow off or dry up. Corrugated roofings sweat.

Weather-Proof But Edwards Metal Shingles last five times as long as wood shingles. Five times easier to lay. The Edwards famous patented "Tightcoat" process makes the roof weather-proof and trouble-proof. Interlocking Device keeps roof tight and intact. Each shingle is dipped in molten zinc **after** it is cut.

For Any Building



One Man Can Do It All

One man with a hammer and nails can do it all. That's easy, isn't it? No after trouble or expense. No "wood" shingle cost, bother or uncertainty. No roof blown off in windstorms. No storm-damaged interiors.

Free Lightning Insurance

That's another advantage. You are covered against lightning loss under our \$10,000 bond.

All in all, you pay less at the outset—you get a longer-lived roof—you pay less after the roof is on. You save every way. And you make a special big saving by acting NOW before prices go up to normal. Write for special Low Price Offer today. Give dimensions of roof if possible. Ask for catalog 400. We give full instructions. Write today—N-O-W!

The Edwards Manufacturing Company
400-450 Lock Street Cincinnati, Ohio

Fireproof

Taxidermy
Book
FREE

Mount Birds



We teach you by mail to stuff and mount all kinds of **Birds, Animals, Game Heads**. Also to tan skins and make rigs. Be your own taxidermist. Decorate your home with your beautiful trophies or increase your income selling specimens and mounting for others. Easily, quickly learned in spare time by men and women. Highest endorsements by thousands of students. Write today for our great free book "How to Mount Birds and Animals" Free—write today.

1194 Elwood Bldg., OMAHA, NEB.
N. W. School of Taxidermy,

\$30 a Week
EASY

**MEN AND WOMEN
WANTED TO SELL
PERFECTO
Kerosene Irons**



No experience necessary. Big profits selling this wonderful self-heating self-irradiation guaranteed iron. Easy to operate and demonstrate. Sells itself. Use Kerosene (Great \$20 or Gasoline with more satisfactory results. Absolutely safe, no smoky odor. Get facts in detail and let us tell you how to obtain free samples and start you in a big selling business. Sample case FREE to Agents.

PERFECTO IRON FACTORY
Dept. G, 176 So. Clinton St., CHICAGO, ILL.

WONDERFUL New Camera



The newest invention in cameras. Scientifically constructed and so easy to operate that errors are practically impossible. Fitted with a genuine Acoustic Lens, automatic focusing device, wide rigid bed to assure accurate optical alignment and new flexible wire release.

Write for the Camera Book. Backed by an unlimited guarantee.

Never before have you been able to get high-grade cameras at anywhere near the low prices at which you can get the great new Ingentos.
Write for "The Camera Book" Send your name and address. No obligations. Write today.
Burke & James Inc. 240-258 E. Ontario St. Dept. 1194, Chicago, Ill.



NEW 1915 EDITION AUTOMOBILE ENGINEERING

No matter what type of motor vehicle you are interested in. No matter what standard make of auto, motor car, motorcycle or motor boat you want to know about.

Here is your opportunity to get a brand new library covering every motor subject. Here is your chance to secure the latest, most practical, most authoritative set of books ever written on automobile and motor engineering at an extremely low, inside price.

If you want help in solving the knotty points you bump up against every day, this set of books is just what you are looking for. If you want to become a Gas Engine expert, this great 5 volume cyclopaedia, written by the biggest men in the business, is the standard text book for you.

\$25.00 Set Now \$14.80—\$2.00 a Month

This auto library contains 2,000 pages, with 1,800 illustrations that make technical points as simple as A-B-C; full page plates that literally pick the mechanism to pieces before your very eyes; drawings and diagrams that show the working of all the principles employed in the various types of motors. Bound in half red morocco, gold stamped. These five volumes are a most remarkable value at the regular price. Yet we offer a limited number of sets at a special introductory price of \$14.80—payable \$2 a month.

SHIPPED FREE Test these books before you buy. You don't buy a motor until you have tried it out. Buy books the same way. We send the full 5 volumes to you, express prepaid, for 7 days' free examination. Use them a whole week free. See if they don't help you work out the problems that come up in your garage or repair shop. If the books are what you want, send us \$2. Otherwise we'll take them back, paying the express both ways ourselves.

Subjects Covered

Explosion Motors—Gasoline Car Features—Ignition Systems—Lighting Systems—Electric Starters—Types of Automobiles—Electric Pleasure Cars—Storage Cells—Electric Motors—Care and Operation of Electrics—Automobile Driving—Road Troubles—Private Garages—Repairs—Electric Delivery Wagons—Electric Trucks—Gasoline Delivery Wagons—Trucks—Taxicabs—Tractors—Trailers—Road Trains—Traction Engines—Maintenance and Costs—Steam Cars—Motor Cycles—Cyclocars—Light Cars—Motor Boats—Glossary.

FREE!! \$12.00 Consulting Membership

We give you absolutely free our \$12 consulting membership. This privilege puts our whole staff of experts at your service for a whole year without cost to you. Ask them any motor question you want. They will give you practical help. The solution of a single problem might easily be worth more than what you pay for the books—you get this service free.

The moment you see the books you will realize that you need them. There is no limit to the good they can do you every day. It costs you nothing to look them over, to use them for a whole week. You run no risk, you incur no obligation. The books come back at our expense if you say so.

Send in the coupon now—today.

**AMERICAN
TECHNICAL
SOCIETY**
Chicago, U. S. A.

FREE COUPON

Worth \$10.20 to You
American Technical Society
Chicago, U. S. A.

Please send me Cyclopaedia of Automobile Engineering for 7 days' free examination. If I decide to buy, will send \$2 in 7 days and balance \$2 a month until \$14.80 has been paid, when \$25 books and \$12 consulting membership will be mine free. Otherwise will notify you and hold books subject to your order. Title not to pass until fully paid.

Pop. Mech. 4-15

NAME.....

ADDRESS.....

As I have had no previous dealings with you, I refer you to.....

Please Mention Popular Mechanics



Kalamazoo Cabinets and Tables \$6 up

Direct From Factory

BEAUTIFUL, all metal, double white enameled inside and out. Finer cabinet cannot be made. Good for lifetime service. Big, roomy pantry cupboard and kitchen table all in one. Sliding Nickeloid Table Top. *Without extra charge* we include 8-piece crystal set, and white glass rolling pin. **Pay as you use**—a little down, a little each month—money returned if not satisfied.

30 Days' Trial We pay freight and guarantee safe delivery. Write today for our big *Free* Cabinet Art Book showing full line of Kalamazoo Cabinets and Tables. Ask for book No. 15

Kalamazoo Stove Company
Manufacturers
Kalamazoo, Michigan

A Kalamazoo Direct to You

Pay As You Use

Rats, Mice, Roaches

—exterminated in one night. No mixing, no muss, no trouble with Rat Bis-Kit Poison. Place a little of either kind wherever these pests annoy you. They quickly seek it, eat it, die outdoors, hunting water. Results guaranteed or money refunded.

Rat Bis-Kit Poison

Biscuit or Paste

Biscuits (for rats and mice) 15c and 25c packages. Paste (for roaches, waterbugs, rats and mice) 15c, 25c and \$1.00 tubes. Keeps indefinitely. At any drugist or direct from us.

The Rat Biscuit Company
545 No. Limestone St.,
Springfield, Ohio





RAT BIS-KIT PASTE
THE NEW POISON IN THE TUBE

GRAY MOTORS \$55 AND UPWARDS



50 leading Boat Builders have joined the Gray Motor Company in issuing a catalog showing the specialty of each. It tells where you can buy any kind of a boat from a \$125 complete fishing launch to a \$200 mahogany finished express launch equipped with self-starting 6-cyl., 4-cycle Gray motor. Write for this big catalog today, free. Also **Gray Marine Engine Catalog** showing full line of 2 and 4 cycle marine motors, \$35 upwards, one to six cylinders.

GRAY MOTOR CO., 498 Gray Motor Bldg., Detroit, Mich.



Diamonds on Credit

20% Down; 10% a Month

Every customer is protected by our written guarantee to refund his money if his dealer can duplicate our diamond at our price. Write for Illustrated Catalog No. 3.

J.M. LYON & CO., 71-73 Nassau St., New York City

High Grade Violins 30 Days' Free Trial

Your choice from a large and carefully graded stock of representative instruments from the leading foreign violin makers. Strictly hand made and of superior tone, these violins are far superior to the average old violins sold at four times the price.

Write Today. Don't fail to send your name and address today for the superb Lewis catalog sent free and postpaid. Of value to everyone interested in high grade instruments. Learn how you can have your choice of these superb instruments on a free trial in your home. Write today.

Wm. Lewis & Son, Inc., Dept. 1194, 225 S. Wabash Ave., Chicago

OUR SPECIALTIES: In ported wood-carvings and tools for violin makers.

WILL YOU TAKE ORDERS?

Many earn \$30 to \$60 every week demonstrating our 1915 Model Steel Automatic Hand-Tool, Lifting and Pulling Jack, Wire Stretcher, Splicer and Mender, Post and Stump Puller, Tire Tightener, Cable Maker, Press, Vice, Hoist, Wrench, etc. Operates automatically. Has power of 40 men. Guaranteed for life. Spare time or permanent work. Demonstrator loaned. Credit given. Write for factory agency offer.

Chas. E. Benefiel Co., 293D Industrial Bldg., Indianapolis, Ind.

ONLY \$5.80



Don't Fail to Send for Our Big Free Catalog Today A Postal Will Do

Save Your "Hard-earned"—Buy Direct From Maker at **Lowest Prices Ever Known**

You cannot duplicate Sterling prices anywhere. Remember when you buy Sterling Furniture, you pay approximately the same price that Mail Order Companies pay for their stock. No danger of added cost. We are not a Mail Order House. We have been building Sterling Furniture right in our own factory with best equipment for 30 years under most scientific and efficient organization and system. Finest quality. Best workmanship. Highest grade materials.

Save \$6.70 on this \$12.50 Rocker
You Pay the Sterling Price of **ONLY \$5.80**

Shipped the day your order is received. Strong, large, handsome, quarter sawed, solid white-oak easy Rocker. Choice of Golden, Fumed, Weathered or Early English finish. Has deep-cushioned spring seat, upholstered in best quality artificial leather. Lasts for years. On this Rocker alone you save \$6.70 by simply setting a few screws. Shipped "K. D." in four sections. Order now or send for free catalog.

BIG CATALOG FREE

Surely you want and need some pieces illustrated in our big free Catalog at such rock-bottom figures as these. Surely such quality as Sterling at such prices should cause you to investigate at once. Sterling Satisfaction, Quality and Representation Guaranteed. Write today for the big free Catalog. Postal will do.

The Sterling Furniture Company
3004 Sterling Bldg. TOLEDO, OHIO

Who Can Use This Machine



Here is a special typewriter offer that will appeal to shrewd buyers. You may choose this Underwood machine, or any other make you

prefer, bar none—with complete equipment and latest improvements—and own it without red tape, on the easiest plan you ever heard of, at $\frac{1}{2}$ or $\frac{3}{4}$ manufacturers' prices. Write for particulars and see.

Each machine is relentlessly tested when completed, and guaranteed by our iron-bound guarantee that's all in your favor. You must be satisfied or no deal. Thousands of satisfied customers from coast to coast.

You can't go Wrong You take no Risk
You can't Lose

A FEW CENTS PER DAY; YOU'LL NEVER MISS IT

Write for Prices—Special inducements, and the big illustrated book "The Truth About Typewriters." Well worth reading. Send no money—just your name and address, TO-DAY.

YOUNG TYPEWRITER CO., Dept. 171, CHICAGO, ILL.

Take Your Pick



Waltham
Illinois
Burlington
Hamilton
Howard
Elgin

The products of the leading watch factories of the world—master time pieces of world renown. All yours to choose from on a great special offer.

\$3.50 a Month
Yes, take your choice of any of these master timepieces. Shipped to you at rock-bottom prices *direct* from us.

Select just the case and just the movement that you want. *We will send it to you without a penny down.* If, after seeing and examining the watch, you decide to buy it, you may pay the rock-bottom price at the rate of only \$3.50 a month. Don't choose a watch that is just "ordinarily good." Demand a master timepiece.

Shipped FREE!

Don't send us a penny. If after seeing the handsome illustrations, you wish to see one of these exquisite timepieces for yourself, we will send it to you without a penny down.

We even will engrave your own monogram or your own lodge emblem or any other design that you wish on the case.

The Newest Cases

Write for handsome illustrations of all the exquisite new watch cases—the latest designs—all yours to choose from.

Send the Coupon!

Put your name and address in the coupon or on a letter or a postcard now and get free particulars of this startling offer. No obligations of any kind. See handsome illustrations of the superb designs that you have to choose from—read our startling money-saving, rock-bottom price offer. Do not delay. Send the coupon now while this great offer lasts.

P. H. FRIMAND
3845 E. Ravenswood
Park - Dept. 1154
CHICAGO, ILL.

Name.....

Address.....

Please Mention Popular Mechanics

P. H. FRIMAND
Dept. 1154
3845 E. Ravenswood Pk.
Chicago, Ill.

Gentlemen: Please send me absolutely free and prepaid full particulars of your special offer on which I can get my choice of the master timepieces of the world, sent day at the rate of \$3.50 a month. Also send me handsome illustrations of the watches I have to choose from.

THROW YOUR VOICE

IMITATE
BIRDS BEASTS MICE BABIES

With our famous Ventriloquist or Swiss Warbler. Greatest fun-maker ever produced. Mystify and fool your friends. Create wonder and merriment with this little INVISIBLE mouth instrument. Send 10¢ for one or 25¢ for four Warblers, and our great Optoon Catalog.

SATISFACTION OR YOUR MONEY REFUNDED
H. A. LATZ CO., ATLANTIC CITY, N.J.

SWEET Detachable Rowboat Long Stroke 4 Horse Power MOTOR

So this is the summer you've actually decided to enjoy the fun of motor boating! And you've made up your mind to be on the safe side and buy a rowboat motor—the kind you'll use right once any small boat—over or a twin—and away you go! Great sport!

But you want a care-free summer, so choose a Sweet, the motor that's built up to a standard, not down to a price.

Factory to You, Freight Prepaid

Finest and fastest. Detachable. Fits any boat. Long stroke 4 h. p. ball bearing motor. 1 1/2 inch woodruff propeller. 2 ring piston, screw on backard car. Highly polished copper water jacket. Float feed carburetor. Battery or magneto. Reversible. Silent under-water exhaust. Steers from any part of the boat. Perfect control from trolling to racing. Drives 14 foot up to 18 miles per hour 25 miles and up per gallon. Uses gasoline and oil mixed. No vibration. No noise. Needs no "linking." Guaranteed for 32¢. Money back, F. D. U., if not satisfied. Write for free catalog, owners letters and special 30 day price.



"Runs Like Its Name"

4 H.P.

This Is The Life

SWEET MFG. CO.
462 Griswold St.
Detroit, Mich.

One Day's Pay One Man's Work \$28.50 With This

made by Jos. Hancock, Lamoni, Iowa. Scheerer, Montana, made \$22.35 in 5 hours. Miller, Iowa, Made \$13.65 in one afternoon. We have proof of this and hundreds of similar reports. No matter who you are or where you live, here's your chance to double your present salary or income, working during spare time or permanently as a one minute photographer. No experience needed. A new, live business of big cash profits. You can work at home or travel, enjoy the healthful, outdoor work and become independent in your own business. Invest one cent for a postal—ask us for proof of what others are doing—of what you can earn with a

Mandel Post Card Machine

A portable post card gallery. Takes, finishes and delivers photo post cards and buttons in a minute's time—makes five different styles of pictures in 3 sizes. No plates, films or dark-rooms. One minute pictures cell like slides. Everybody buys. Pictures, faces, carnivals, busy corners, small towns and large cities—Big Money Everywhere.

This Picture-Taking Outfit

gives you a complete, ready-made business that produces profits for you at once. You can make 100 to 200 sales a day, easy. Each sale brings \$2 to 15c clear profit. Small capital. Sale of first pictures brings back practically your entire investment. Write at once for full particulars FREE.

The Chicago Ferrottype Co.

640 Ferrottype Bldg., Chicago or
Dept. 640 Public Bk. Bldg., New York



The Auto Heel Rest

Used on all cars for the Brake, Clutch and Foot Accelerator Pedals. It brings the foot to just the right height. Takes that strain off the ankle. Saves the floor mat. Locates the heel.

Four Sizes 1/2 in.---1 in.---1 1/2 in.---2 in.
Polished Aluminum

PRICE EACH 75c

Agents Wanted Patented April 9, 1912

Made Only by

Lucas & Son, 60 Fox St., Bridgeport, Conn.



A Daze Ball Jersey



Without a Cent of Cost to You

I give you a very fine pure wool sweater; double collar and cuffs, your choice of color. Just handle for me your club's spring order for baseball goods—at special discount, and this jersey is yours. Send for complete catalogue of my best grade sporting goods at wholesale prices—basketball, baseball, tennis, golf, etc. WRITE ME NOW.

JACK SHANNON CO.
Dept. 33, 54 E. Monroe St., CHICAGO

My New Copyrighted Book is FREE

It explains THE SWOBODA SYSTEM OF CONSCIOUS EVOLUTION and the human body as it has never been explained before. It explains my new theory of the mind and body. It will startle, educate, and enlighten you.

My book is not a dry treatise on anatomy and physiology. It tells in a highly interesting and simple manner just what you have always wanted to know about yourself. You will cherish this book for having given you the first real understanding of your body and mind. It shows how you may be able to obtain a superior life; it explains how you may make use of natural laws for your own advantage.

My book will give you a better understanding of yourself than you could obtain from a college course. The information which it imparts cannot be obtained elsewhere at any price. It shows the unlimited possibilities for you through conscious evolution of your cells; it explains my discoveries and what they are doing for men and women. Thousands have advanced themselves in every way through a better realization and conscious use of the principles which I have discovered and which I disclose in my book. It tells what Conscious Evolution means and what it may do for you. It also explains the DANGERS OF EXERCISE and of EXCESSIVE DEEP BREATHING. I offer my system on a basis which makes it impossible for you to lose a single penny. My guarantee is startling, specific, positive and fraud-proof. Write for my FREE BOOK and full particulars today before it slips your mind. Make up your mind to at least learn the facts concerning the SWOBODA SYSTEM OF CONSCIOUS EVOLUTION for men and women.

ALOIS P. SWOBODA 1307
Aeolian Hall New York City, N. Y.



Grow Mushrooms Add \$5 to \$20 a Week to Your INCOME

Grown at home, in basements, barns, sheds, etc. Does not interfere with regular employment. Others are making money in this business. Why not you? It costs nothing to find out how to start, how to sell, etc. Send for illustrated booklet. Address
A. V. JACKSON, Falmouth Mushroom Cellars, Inc.
342 Gifford Street, FALMOUTH, MASS.
The Largest Modern Mushroom Farm in the World

Drink Pure Water

Perfect health demands it. Disease lurks in impure water. Insure purity by installing a

Bohner Self-Cleansing Filter

Gives you constant supply of crystal water, pure as cream. Inexpensive. Anyone can install without tools. Lasts a lifetime. Full particulars on request.

Bohner Mfg. Co. 10095 So. Wabash Av.
CHICAGO, ILL.



Guaranteed to give satisfaction or money back if returned in 15 days.

During the fiscal year 1914, 45 tenders and 66 light vessels were in commission in the U. S. Lighthouse Service.

During the fiscal year 1914, there was a net increase of 677 in the number of aids to navigation maintained by the U. S. Lighthouse Service, the total at the end of the year being 14,198. Of these 5,004 were lights of all classes, and 567, fog signals.

STUDY LAW BY MAIL

University Methods Theory and practice combined. Three courses—University, Business and Banking Law.

McKinley University, 1554 East 53rd Street, Chicago, Ill.



Erlickson Artificial Limb Co., 38 Wash. Av. No., Minneapolis, Minn.
Light Double Does Not Chafe Overheat or Draw End of Stump
Patented
Information or Catalog Given

We are Under Govt. Bond

MAKE MONEY HERE

AGENTS! DROP DEAD ONES, AWAKE! GRAB THIS NEW INVENTION! AGENTS! THE 20th CENTURY WONDER

LEARN THE NEW WAY

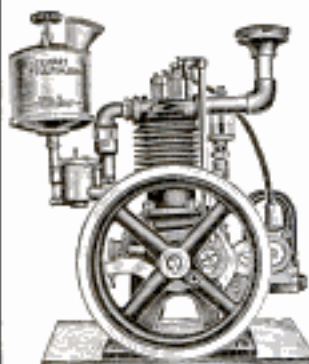
Get started in an honest, clean, reliable, money-making business. Sold on a money-back guarantee

World's magical gift realized by this new invention. The BLACKSTONE WATER POWER VACUUM MASSAGE MACHINE for the home. No cost to operate. Lasts life-time. Price within reach of all. No competition. New field. New business. That's why it's easy. Removes blackheads, wrinkles, rounds out any part of the face or body and brings back Nature's beauty. Endorsed by leading doctors and masseurs. Listen Parker, Okla., says, "8 orders first day." Margwarth, Pa., writes, "I am making \$19.00 per day." Ebea, "First order 12, second 6, third 72." Schermerhorn, Ia., orders eight dozen machines first month. Shaffer, Va., "selling 4 out of 5 demonstrations." Vaughn, Wash., orders one dozen. Four days later wires "Ship 6 dozen by first express." Epaul, Tenn., started with sample. Orders one dozen, then 2 dozen, next 3 dozen. Lewis, Ind., sells 3 machines first hour. Says "Best article he ever saw for merit and money-making." No experience necessary. Territory with protection given free to active workers. Nothing in the world like it. Best agent's article ever invented.

We own all U. S. and foreign patents. Big book entitled, "The Power and the Love of Beauty and Health" Free. Investigate now, today. A Postal will do. A big surprise awaits you. Address
BLACKSTONE MFG. CO.
52 Meredith Bldg. TOLEDO, O.



The Most Marvelous 1/2 H. P. Engine



Stewart Little Major
1/2 horse power with battery
\$27.50; with high
tension magnets - **\$37.50**

ever offered. This Stewart Little Major 1/2 h. p. engine is the simplest, sturdiest, most practical and easiest to operate of any. It will do anything that 1/2 horse power can do. Just the thing to run a hand or foot press, washing machine, ice cream freezer, emery wheel, grindstone, small dynamo, churn, cream separator, pump, saw, feed mill, lathe, horse clipping machine, sheep shearing machine, polishing and buffing wheels, etc.

Half a gallon of gasoline runs it for full 10 hour day. Beautifully made and beautifully finished. Get one to run your hand operated machine. It will pay you big.

Stewart Engines are made in 3 sizes only, 1/2, 2, and 3 1/2 h. p. Every one of high quality. Write for catalogue.

Chicago Flexible Shaft Co.
105 N. LaSalle St., Chicago

The Farm YOU Want

is compact, easy to pay for, and enormously productive—and it must be suburban to a big live city



Here it is — and it's yours for

IN OUR NEW LITHIA TRACT suburban to Tampa, the metropolis of South Florida. It is one of the few choice suburban farm tracts left in Hillsboro County, the recognized center of Florida's grape fruit and orange belt.

This is the third great Hillsboro County tract that has been opened to homeseekers and investors by our old established, responsible, thoroughly experienced organization. Over 2,500 families are now rejoicing because they bought at opening prices in our two former tracts. Every family can tell you they got a square and generous deal.

Our new Lithia Tract now offers you the same wonderful opportunity — and more, because of the rapid growth and development on all sides within the past four years.

The visible supply of select Hillsboro County grape fruit land is melting away very fast. Prosperous homes are scattered around the Lithia Tract—grape fruit and orange groves are flourishing on all sides. Already buyers are building homes on our new Lithia Tract, and values are due to rise here just as they have in our two former suburban farm tracts in this same county.

Free — Absolutely Free — 100 grape fruit and orange trees to each and every purchaser who reserves one of these farms before May 1st, 1915. These trees will be held in our Nurseries until you are ready to plant them. This will give you a splendid start in developing a grove which will bring you an ever increasing income and greatly increase the value of your entire farm. Mail the coupon today.

One judicious investment, remember, means more to your bank account than years and years of labor. Honestly, now, what have you to show for that little 3 1/2 cents per acre per day that might just as well be buying you a beautiful 10 acre farm? Where else could you put aside a few odd dollars so safely, so securely, and with such surety of seeing your modest savings fund develop into a great big investment?

No one trying to make yourself believe that savings bank interest will ever make you independent, nor 6 per cent loans make you rich. Your money isn't working when you tie it up in such ways—it's LOAFING. Make your money work for YOU; right here in these rich fruit lands is your opportunity—here where a few dollars put to work NOW will reap all the benefit of development work constantly being done by the fast increasing population.

You can pay for your land by work. We will sell you ten or more acres and make a contract with you giving you employment clearing land. We will give you enough work to entirely pay for any number of acres you want. All you need is a willingness to work and enough money to pay your fare to Tampa. As clearing land is hard work, we can only make such contracts with those who are physically able to do this kind of work. If interested in this special employment agreement you must write for information when sending us coupon.

Get the facts now. The coupon brings them to you without cost or obligation. Get this new opportunity clearly before you while prices on this newly opened tract are still low and terms easy. Today \$1.00 per acre per month buys you independence and a future. Tomorrow—who can say?

Think of it—a ten-acre farm suburban to a city like this—a farm big enough to keep you in comfort all your lives, yet one you can pay for at the rate of just 3 1/2 cents per acre per day!

Tear off the coupon and mail it NOW and we will lay before you, by return mail, full and complete information showing how you can easily become the owner of one of these beautiful grape fruit and orange groves, and why it is sure to prove the shrewdest, most profitable investment you can possibly make.

**North Tampa
Land Co.**

C. E. THOMAS, President

837 Marquette Bldg.

CHICAGO

ART Resident and Correspondence Courses in Cartooning, Designing, Illustrating, Chalk-Talking and Lettering. Established 1882. BEST, and we can prove it. Send today for Catalog. **THE LOCKWOOD ART SCHOOL, Kalamazoo, Mich., Dept. 19**

Learn by Mail to be a Great WRESTLER
Farmer Burns, Mer. Frank Gotch, world's champion, will now teach you Physical Culture, Wrestling and Self Defense. Be strong, athletic, healthy. Handle big men with ease. **FREE BOOK** Write today for elegant free book and particulars. Give your age. **Farmer Burns School of Wrestling, 1154 Range Bldg., Omaha.**

BE A SIGNAL ENGINEER \$125-\$300 A MONTH

Write at once. Meet wonderful opportunity for the ambitious man. Railroads need hundreds of Signal Engineers—will pay Big Money. We will teach you right at home to be expert. Special offer if you write at once. Two big outfits free. Do practical work while learning. Catalog and full particulars. **DEPARTMENT OF SIGNALING, Room 1194, 1810 Wilson Ave., Ravenswood Station, Chicago, Ill.**

Men Are Needed

Yesterday a new profession was born. The transportation of merchandise at minimum cost is one of the great problems of modern business. Skilled men are needed everywhere. You can get just the training that you need. **Traffic Experts Draw Big Salaries** From \$1,500 to \$10,000 a year are the kind of salaries traffic men make. You can be one of them. Our profession needs ambitious men. Write today. **Write Today for Big Traffic Book** Find out about the golden opportunities in our profession. The big traffic book explains all. It's free. Your name and address is enough. Write now. **INTERSTATE TRAFFIC SCHOOL, Dept. 1194, FORT WAYNE, INDIANA.**

SHORTHAND Now Taught By Mail

In 18 Easy Lessons! Positively guaranteed. System taught by us adopted by public schools in Boston, Denver, Buffalo, Omaha, Seattle and more than 2000 other cities. America's most popular shorthand because easy to learn, read and write. Complete stenographic courses by mail. Typewriters furnished. Low cost, easy terms. Write now for free book on big salaries and opportunities. Positions everywhere. **CHICAGO UNIVERSITY OF COMMERCE, Dept. 1034, Chicago, Ill.**

2c a Week Pays Wash Bill!

Write for
FREE Book

Electricity or Water-Power Does the Work

Just a "Twist of the Wrist" Starts or Stops the Machine!

The 1900 Motor Washers are now at work in thousands of homes. They are doing the work formerly done by women, at a cost of 2c a week for power! Saving thousands upon thousands of dollars in wash bills. Saving worlds of wash-day troubles. Leaving the women free to do other work while the machines are doing the washing.

The 1900 Motor Washer

1900 Water Motor Washer
Can be connected with
any water tap instantly

Washes a Tubful in Six Minutes!

Handles Heavy Blankets or Dainty Laces

The outfit consists of the famous 1900 Washer with either Electric Motor or Water Motor. You turn on the power as easily as you turn on the light, and back and forth goes the tub, washing the clothes for dear life. Then, turn a lever, and the washer does the wringing. All so simple and easy that it is mere child's play.

A Self-Working Wringer Sent With Every Washer!

The motor runs Washer and Wringer. We guarantee the perfect working of both. No extra charge for Wringer, which is one of the finest made. **Write for FREE BOOK and 30 Days' FREE TRIAL OFFER!** Don't doubt! Don't say it can't be done. The free book proves that it can. But we do not ask you to take our word for it. We offer to send a 1900 Motor Washer on absolute Free Trial for an entire month to any responsible person. Not a cent of security—nor a promise to buy. Just your word that you will give it a test. We even agree to pay the freight, and will take it back if it fails to do all we claim for it. A postal card with your name and address sent to us today will bring you the book free by return mail. All correspondence should be addressed to



Doing the wringing with
1900 Electric Motor Washer



1900 WASHER CO., 6176 Court St., BINGHAMTON, N. Y.

OR, IF YOU LIVE IN CANADA, WRITE TO THE CANADIAN WASHER CO., 355 YONGE ST., TORONTO, CANADA.

(23)

Gas Men-Plumbers-Mechanics

Over a million direct lighting Gas Heaters are in use in the United States on which—at small cost—you can apply

The Modern Automatic Control, Distant Lighter and Timer

Lights the Heater from the Kitchen or Bath Room—Automatically Controls the Duration of the Light to the Length of Time Desired. Gas—Time—and Labor Saver.

Conceded to be the greatest of the newer gas appliance inventions. We want the names of men who wish to increase their earnings. For particulars, address

Gas Appliance Corporation

1209 Arch Street Philadelphia, Pa.



Reload your rifle, pistol and shotgun shells and save half the cost of cartridges. Modern shells can be reloaded many times. **Ideal Hand Book** tells all about reloading; 160 pages; Free to shooters—for 3 stamps postage.
MARLIN FIREARMS COMPANY, 65 W ST., NEW HAVEN, CONN

A summary of the trade movements during the calendar year 1914, issued by the Department of Commerce recently, showed that the exports were \$2,114,257,539, as compared with \$2,484,018,292 in 1913, and imports, \$1,780,022,426, against \$1,792,506,480 in 1913.



GEARS SPROCKETS CHAINS

In Stock for immediate shipment

All Kinds sizes and materials made to order.

Send for 48-page New 1915 Catalog
WOBURN GEAR WORKS
Woburn, Mass.

only
25



10 Minutes' Work Saves \$10

Just think of being able to get this rich Colonial Rocker for only \$14.25! No dealer could afford to sell it for less than \$25.00. And it would be worth that in his store, too. But, because you can get it direct from us, the manufacturers, you save his profits, and by our original method we eliminate $\frac{1}{2}$ packing costs, $\frac{1}{2}$ freight costs and $\frac{1}{2}$ factory floor space usually needed. All Brooks "Master-Built" Furniture is

Shipped in Sections — Direct from Factory

You can put any piece together in a jiffy. And that gives you the finest, most beautiful furniture made for almost half usual cost. All selected solid quarter sawed oak—your choice of best Colonial, Mission or Flanders designs—any finish. We guarantee to satisfy you or return your money.

Write today for Brooks Furniture Book and cut your furniture cost.

Brooks Manufacturing Co., 2704 Brooks Ave., Saginaw, Mich.

LARGEST PLANT OF ITS KIND IN THE WORLD



Pat.
Mar. 20, '05
Oct. 6, '14

Model A

\$4⁰⁰ SEISS \$4⁰⁰
Double Acting

Mechanical Automobile Horn

The SEISS Horn can be operated either right or left giving a continuous sound same as a motor driven horn or a sharp blast with a slight touch of the hand.

SEISS Horns have no Springs and only three Bearings, made of the best material and backed with our ten year guarantee.

Finished in Black enamel with Nickel Bell or Brass Bell or all Black and universal Bracket.

\$3⁷⁵ SEISS \$3⁷⁵
Double Acting

Mechanical Motorcycle Horn

The SEISS Motorcycle Horn is identically the same as the Automobile Horn except having shorter projector and is furnished with special Bracket which is universal for attaching to the frame or handle bar tube.

SEISS MFG. CO., 439 Dorr St., TOLEDO, O.



FREE SHOE BOOK SAVES \$20

"The Sole of Steel" describes my light, springy, comfortable, economical, waterproof, all-season, general purpose shoe that saves your feet, health and money. 1 pair of "Steels" outwears 3 to 6 pairs leather workshoes. Investigate before buying shoes again. Address, "The Steel Shoe Man,"

N. M. RUTHSTEIN, Dept. 132, RACINE, WIS.

VENUS PENCILS

FOR PERFECT SATISFACTION

Venus, made in 17 degrees to meet every technical requirement (6B softest to 9H hardest). Also 2 copying degrees for billing and manifolding. Write on letterhead for booklet and free trial sample.

AMERICAN LEAD PENCIL CO.

210 Fifth Ave. NEW YORK



Learn to Write

I can make a good penman of you at home during spare time. Write for my free book "How to Become a Good Penman." It contains specimens and tells how others mastered penmanship by my method. Your name will be elegantly written on a card if you enclose stamp.

F. W. TAMBLIN, 419 Meyer Bldg., KANSAS CITY, MO.

There is Big Money in Automatic Card Printing

The Automatic prints while you wait Business and Calling Cards, Tickets, Invitations Announcements & many others. Prints 100 per minute, 6000 per hour. Write today for our free catalog 36.

S. B. FEUERSTEIN & CO.
542 W. Jackson Blvd., CHICAGO



Make \$60 A Week Repairing Tires

Don't be content to plod along on a small salary. Be independent. Go in the tire repairing business and make \$60 or more a week. One man made \$45 the first day he received his outfit. Others are making \$25 a day and hundreds of wide-awake men are making \$200 to \$500 a month clear profit above all expenses.

Be Your Own Boss

You can make big money in the Automobile Tire Repair business. No experience needed. We teach you how. Very little capital required. But slight risk as every car owner in your town is a possible customer. Jobs are plentiful because tires blow out and puncture every day.

SHALER

Tire Repair Outfit Only Costs \$60

and will do as much and as perfect work as the big \$250 to \$500 vulcanizing outfits. A boy can vulcanize perfectly with this simple machine. It's the only vulcanizer that has Automatic Heat Control. It must vulcanize just right. It can't undercure or overcure a tire. Requires no watching or regulating. You can learn to do expert tire vulcanizing in half an hour with the Shaler. Instructions are easily understood.

Let Us Tell You How

to open an Automobile Tire Repair Shop and make more money. Send the coupon or a postal or letter and get our Big Catalog and Special Offer. Write quick before some hustler gets ahead of you. Our Free Book "Care and Repair of Tires," is full of tire facts. Ask for it.

C. A. SHALER CO., 1501 Fourth St., Waupun, Wis.
Largest Manufacturers of Vulcanizers in the World

Send This Coupon

C. A. SHALER CO., 1501 Fourth St., Waupun, Wis.
Without obligation to me send me Free Catalog and Special Offer.

Name

Street

City.....State.....

Please Mention Popular Mechanics

STANWELD TUBING



700 Miles of Steel Tubing in the Making

Durable Construction

MANUFACTURERS who are striving to improve their product, and at the same time keep costs at a minimum, will find it worth while to investigate the possibilities of Stanweld Steel Tubing.



Stanweld Steel Tubing is light, strong, and has an exceptionally fine finishing-surface. It is used by the world's largest manufacturers of automobiles, motorcycles, and bicycles—and by hundreds of other concerns making mechanical specialties.

If you are the manufacturer of a product that can possibly be made of steel tubing, write us a letter today. Our service-department may be able to show you ways of improving your product, and reducing its cost of manufacture.

Articles Made of Stanweld Tubing

Automobiles
Air - Rifles
Scabbards
Go-Carts
Handles
Novelties
Telescopes
Instruments



Motorcycles
Furniture
Registers
Handles
Bushings
Fixtures
Telephones
Phonographs

THE STANDARD WELDING CO.
West 75th Street CLEVELAND, O.

Special Reinforced Stanweld Tube



Please Mention Popular Mechanics



This Boat
Paid Him
\$516.00 In
63 Days

Then
He Sold It
At a Profit
of \$153.75

Mr. D. H. Durgin, of Blue Creek, Wash., whose boat is illustrated here, writes: "I made this boat pay me \$516.00 in 63 days and then sold it for \$290.00. I built it after a Brooks Pattern and it cost me only \$96.25 complete."

Build Your Boat By The Brooks System

Saves two-thirds cost. We furnish full-size patterns, or furnish patterns and knocked-down frame, or we furnish the complete knocked-down boat. Illustrated instructions always included. The Brooks System brings a beautiful cruiser, a speedy motor boat, a family launch, "V" bottom, run boat, row boat or canoe-any style boat within the reach of anyone.

Write today for Free Boat Book

and see the fine models that you can build easily in spare time. \$3 and up buys complete set of patterns. Only \$17.00 buys complete knocked-down frame for 22-foot power boat with complete patterns to finish. Book tells all. Write for it today.

BROOKS MFG. CO., 8204 Brooks Ave., Saginaw, Mich.
The Largest Plant of Its Kind in the World
Originators of the Pattern System of Boat-Building

FREE TRIAL

Use the **FAMOUS KARNAK RAZOR** for 30 days **FREE**; then pay us \$1.65, or return the razor. Send your name and this ad, (no money) and get razor by return mail.
MORE COMPANY, Temple Bldg., St. Louis, Dept. 182



Make \$15.00 to \$35.00 Per Day

With Our Latest Invention, the Wonderful Ever-Ready Camera. Makes 9 styles single or group pictures direct on postcard or tintypes without film or negative, finished for delivery in less than one minute. **No Experience Necessary.** Get into a good, clean, respectable business of your own and become independent. **Big Money** at fairs, carnivals, parks, picnics, anywhere. Photos cost you from 1 to 25¢; sell at 10, 15 and 25¢ each. **Write Today for Free Proposition and Catalogue.**
THE NEW YORK FERROTYPE CO.
Dept. 70A, No. 168 Delancy Street, NEW YORK, N. Y.
Dept. 70A, No. 1126 S. Halsted Street, CHICAGO, ILL.

Health? Take Turkish Bath at Home—Only 2 Cents



Physicians are abandoning drugs for this new treatment. If your mind or body is tired, open your pores and feel the rapid change in your condition, at cost of 2¢ a bath. The Robinson Bath Cabinet is the only scientifically constructed bath cabinet ever made for the home. **Great \$2 Book Sent Free—"The Philosophy of Health and Beauty."** Write today, Agents Wanted.
ROBINSON MFG. CO.
1027 N. 12th St. TOLEDO, O.

INVENTORS! — "Let Us Be Your Factory"



We manufacture Special Machinery, Patented Metal Specialties of all kinds, Electric Articles, Hardware, Contract Manufacturing, Development, Sample Work. You get the advantage of our splendid equipment, up-to-date methods, and wide experience. **We Do It All.** Tools, Dies, Stampings, Lathe, Screw Machine Work, Milling Machine Work, Metal Spinnings, Metal Drawings, Castings, Plating of all kinds, Enameling, Japanning, Tinning, Galvanizing, Wood and Metal Patterns, Drafting, Designing, Blue-print Work. Send sample for expert advice. Our 25¢ book free, containing tables and valuable information. Write for it today. Address

The EAGLE MFG. CO., 1601 Blue Rock St., CINCINNATI, O.



No. K611 1/2
Price \$0.75
Hammer

No. K5
Price
\$1.25
Plane

No. KB10
Price
\$2.25
Brace

No. KBK 1/2 in.
Price \$0.40
Chisel

Buy Tools You Know

For nearly half a century the famous Keen Kutter trade mark has been the buying guide to people who wanted to be absolutely sure of quality in hardware. Here are some of the reasons why you should buy

KEEN KUTTER Quality Tools

They are made of the highest grade steel, the edges have a razor-like cut, points sharp and the handles are fashioned from straight-grained lumber.

The dealer is authorized to give back your money for any piece that doesn't prove satisfactory.

Send for our Home Furniture Design Booklet No. D 976.

"The Recollection of Quality Remains Long After the Price is Forgotten." Trade Mark Registered. — E.C. SIMMONS.

If not at your dealer's, write us.

Simmons Hardware Company

St. Louis, New York, Philadelphia, Toledo, Minneapolis, Sioux City, Wichita



No. K88 24-26 in.
Price \$2.00
Hand Saw

No. K3
Price \$1.25
Draw Knife

No. K14
Price \$1.25
Steel Square

\$200 for a Name

\$200 cash for the most catchy title for this 1916 Pompeian Art Panel. These titles may suggest better ones; Phyllis; A Symphony in Pink; His Letter; Yes or No; The Pompeian Glow of Youth; A Bit of Sunshine; or any title about this maid with beautiful eyes and glorious Pompeian complexion, reading a letter in this sunny, flowery corner.

Cut out and save this whole rare offer. Talk this over with your family. Two heads are better than one.

Only top-half of 1916 Panel shown here, 28 x 7 1/4 (in colors). Ready Oct. 1, this year.

RULES. 1—Write your title of 5 words or less at the top of a sheet of paper; then your name and address; absolutely nothing more on the sheet. Only one title per family. 2—Contest closes April 17, 1915. 3—Winner announced in May 29 Saturday Evening Post. Contest is free, but you may enclose with your title the coupon below, or you may send coupon without title. Study points below for ideas, and don't miss rare coupon offer.



POMPEIAN Massage Cream



Ask some woman of 40 with a complexion like 20. Ask some man with a clean, wholesome look. They will say Pompeian Massage Cream is the secret. It rubs in and rolls out, and thus cleanses, exercises and youthifies the skin. At all dealers, 50c, 75c and \$1 per jar. Use coupon for trial jar.

25c Tube for Promise

Promise to recommend our new product, Pompeian Night Cream, to 3 friends, and a 25c tube is yours for the cost of postage and packing, if you accept in full the coupon offer below.

In a few months our Night Cream has won thousands of enthusiastic users everywhere. Left on the face over night it soothes, softens and improves any skin made uncomfortable or unsightly by wind, hard water or age. Acts like a cold cream, but leaves no shiny effects, and still it is not a dry "disappearing" cream. The experienced makers of the well-known Pompeian Massage Cream took years to perfect Pompeian Night Cream. An exceptional powder base for her and a soothing after-shaving cream for him. At stores, jars 35c and 75c; tubes 25c. Coupon below *must* be used to get this regular 25c tube practically free, which is a bargain that no one can afford to miss.

COUPON and 16c good for 25c tube of Night Cream, trial jar of Massage Cream and reserving 1916 Art Panel.

Coupon may be sent with or without a picture title. Art Panel is a study in sunshine, pink and lovable feminine beauty. Reserve your copy now. Late comers often disappointed.

Cut Along This Line
NOTE—Coupon good if sent with or without a contest title, but *must* be completely filled out. Coupon *not* good if sent with less than 16c. Please send 10c piece, balance in stamps.

THE POMPEIAN MFG. CO., 147 Prospect St., Cleveland, O.

I enclose 16c (10c being for the Art Panel and Pompeian Massage Cream, and 6c for postage and packing of 25c tube of Pompeian Night Cream). Send Panel October 1, and other goods now. I promise to recommend Pompeian Night Cream to 3 friends. (NOTE—This coupon offer expires April 17. Positively only 1 coupon per family on this unusual introductory offer.)

My Name

Street Address.....
(if any)

City..... State.....

My Dealer's Name and Address

Please Mention Popular Mechanics

30 DAYS FREE TRIAL!



The World Famous
EUREKA
Electric

Vacuum Cleaner

Yes Madam, that is exactly what we mean. We will ship you one of our superb, brand new, easy gliding and deep cleaning Eureka Electric Vacuum Cleaners on **30 Days FREE Cleaning Trial**.

We are going to loan you this splendid cleaner for a full month. Remember, this free loan won't cost you a penny. We even pay the express charges.

We bear every expense. We want to let you find out for yourself the wonderful house-cleaning powers of the Eureka Cleaner.

Without Cost to You!

Simply send us your name and address, and we will mail you the full details of this exceptional free loan offer. We will also send you, **free and prepaid**, our beautiful illustrated booklet. No strings are attached to the proposition. We want you to use the Eureka Cleaner for 30 days just as though it were your own. Clean your carpets and your rugs with it. Try it on all the nooks and corners; subject it to every test you can think of. Prove to yourself that the Eureka is the **smoothest running, most durable and deepest cleaning** Electric Vacuum Cleaner in the world. And then if you are not more than delighted with it, send it back to us at our expense. But, if you decide you simply cannot get along without the cleaner, then keep it and pay for it on

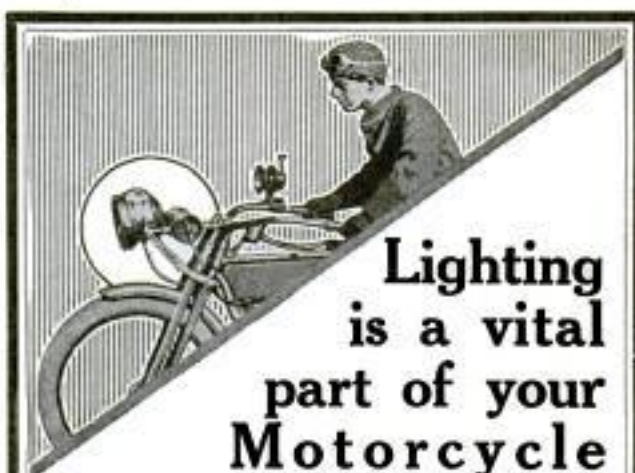
Special Easy Payments

That's a fact. You can buy this splendid machine on easy payments—just a few cents a day at the rock bottom special factory price. You get the machine direct from the manufacturers and best of all, on terms that will suit you.

Beautiful Booklet FREE

Send us your name and address at once. A postcard or letter will do and the minute we hear from you, we will mail you our beautiful Free Illustrated Booklet and the full details of our wonderful Free Trial Offer and special Easy Payment Plan. Remember, no cost to you. Write today. Address:

Eureka Vacuum Cleaner Company
Dept. PM 4 Detroit, Mich.



Lighting is a vital part of your Motorcycle

No motorcycle is stronger than its lighting system.

Your safety and convenience in night riding depend upon it. It must not be affected by vibrations. It must be absolutely reliable under every road condition. It must give you brilliant light—and above all must not fail you in emergencies.

Prest-O-Lite is the only system for motorcycle lighting that satisfies these exacting requirements. It has demonstrated its superior efficiency and absolute reliability in the hands of experienced riders everywhere.

PREST-O-LITE for Motorcycles

Does not depend upon complicated and delicate electrical mechanisms, has no fragile wiring, never needs expensive expert repairing or calls for costly replacements. It is as sturdy as your motorcycle itself. Needs no attention that you cannot give it, easily and quickly.

With all of its strong features—reliability, strength and efficiency—Prest-O-Lite costs less to buy and less to use than any other system of brilliant light. Just one replacement of a "toy storage battery" costs more than years of Prest-O-Lite Service.

Special Equipment Combination

Live dealers are making an offer like this. For about half the cost of an electric outfit you can get "Prest-O-Lite, an automatic reducing valve, a lamp and mechanical horn."

When buying a new machine, or livening up the old one, investigate this offer.

Before putting your money in lighting equipment of any kind, get ALL the facts about all lighting systems. Your name and address on the margin of this page will bring this valuable information to you.

The Prest-O-Lite Co., Inc.

The World's Largest Makers of Dissolved Acetylene
265 Speedway Indianapolis, Ind.

Prest-O-Lite Exchange Agencies Everywhere

Go In Business With Me

Big Money at Once

I want to set you up in business that means personal independence; guarantees better than an average living and a sure return for every honest effort. I have put the best 14 years of my life into this business, and now I am ready to give the benefit of my experience, and coach you straight to success.

Ann Arbor Lamps

solve the problem of small town and farm house lighting; give the most light for the least money—100 candle power lamp costs one cent for three hours' light.

They sell on sight—W. H. Phillips, Painesville, O., says, "I sold and collected for 26 lamps out of 27 trials in 4 days. They sell themselves."

The farmer has the money and needs better lights than the old-fashioned kerosene oil lamps. This is your opportunity. —Write me the very next thing you do—it will be the most important step you ever took. No matter what you think of your ability to sell goods—my plan is a sure-prot.

H. H. SEELEY

President SUPERIOR MFG. COMPANY
294 Second St. ANN ARBOR, MICH.



Agents \$60 WEEKLY

Robinson Folding Bath Tub. Big seller. Costs little, no plumbing, little water. Weight 15 pounds, folds into small roll. Full length baths, far better than tin tubs. Guaranteed 15 years. \$10 a day easily made. Write for free tub or. Robinson Cabinet Mfg. Co., 3511 Sycamore Bldg., Toledo, O.

You Can Make Big Money

C. F. Larsen has made over \$1000, selling Matchless Gas Lighters. E. C. Haines made \$17.10 in one day. You too can make big money.



The Matchless Gas Lighter lights gas or gasoline. Safer, cleaner, handier and cheaper than matches. Send 25 cents for agents' sample and big money making offer.

STEEL STAMPING CO., Dept. 20, 143 W. Austin Ave., Chicago

Make \$20 to \$40 a Day

with the VICTOR Plateless Photo Post Card Machine, which takes 11 styles of pictures directly on post cards, tin types and buttons. The VICTOR is the world's biggest money maker, recognized by thousands of successful VICTOR operators. Positively no experience necessary. Start in business for yourself with a small investment and be your own boss. 10 year guarantee with every VICTOR machine.

Write today to main office and factory of the Ferrotypes and post card machines and supplies.
AMERICAN FERROTYPE CO.
152 Delancy St. Dept. A55 NEW YORK CITY

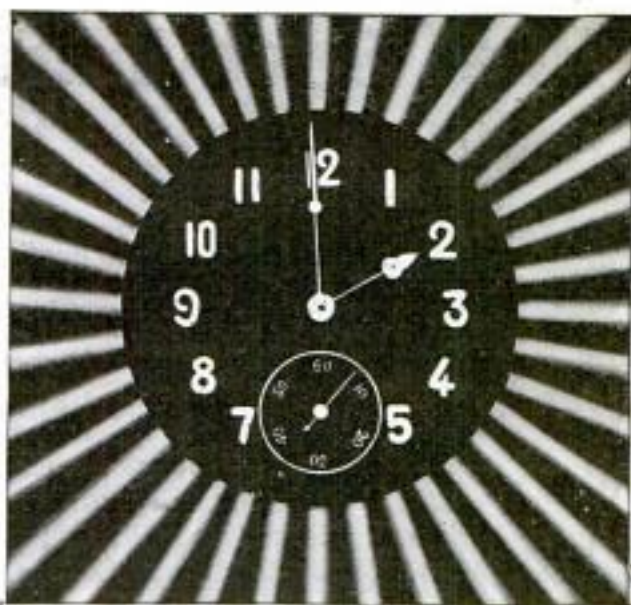


POWERLIGHT HOME LAMP

Highest Award Inter. Exp. of Safety, N. Y., Dec. 1914. Only Lamp passed by Fire Dept. 335 C. P., 20 hrs. one filling—1 qt. Burns Kerosene or Gasoline equal safety without wick. Can't spill or explode.

Simple—Footproof—Classy—Guaranteed Revolutionizing Lighting. Thousands sold N. Y. and other cities. Greatest competitor to Electricity. Sure sale when seen. AGENTS—100% profit—Contract exclusive territory. Samples loaned.

Powerlight Sales Co. 95 Chamber St. NEW YORK



Startling New Ideas in Watches

Tell Time At Night!

Send for watch catalog describing, among others, the new radium dials that shine at night—the remarkable discovery that enables you to read time plainly in pitch darkness!—Also other new ideas:

- Ribbon designs
- Enamel monograms
- Rich gold and color effects—

your initials in colors on a rich gold background. The new catalog shows many other novel ideas in Burlington Watches.

On Approval:

The new radium dial Burlington or any other Burlington, with your own monogram engraved on the superb gold strata case, will be sent to you on approval, prepaid, without a cent in advance. You risk absolutely nothing—you pay nothing—not one cent, unless you want this exceptional offer after seeing and thoroughly inspecting the watch.

If — after examination — you decide to keep it, pay only the direct rock-bottom price—the same price that even the wholesale jeweler must pay. And in order to encourage everybody to secure this watch now we allow this rock-bottom price, either for cash or \$2.50 a month. Remember—we send this watch on approval.



Send the Coupon for New Watch Book

Learn the inside facts about watch prices and the many superior points of the Burlington over double-priced products. Just send the coupon or a letter or a postal. Don't delay—write, get this offer while it lasts.

Burlington Watch Co.
19th Street and Marshall Blvd.
Dept. 1194 Chicago, Ill.

Please send me (without obligations and prepaid) your free book on watches, with full explanation of your cash or \$2.50 a month offer on the Burlington Watches.

Burlington Watch Co.
19th St. and Marshall Blvd., Dept. 1194 Chicago, Illinois

Name.....
Address.....

Please Mention Popular Mechanics

Best Speedometer and Signal ever made for Motorcycles

Stewart Motorcycle Speedometer

MAGNETIC PRINCIPLE

Tells you how fast and how far you have ridden. No motorcyclist gets real enjoyment out of riding unless he has a Stewart Speedometer. Absolutely accurate; dependable and beautiful. No jarring can affect the rigid tube, front-drive Stewart.

Send for catalogue of Stewart Motorcycle Accessories



\$12

Complete

Stewart Motorcycle Warning Signal

Buy a Stewart Warning Signal—the best high-grade, hand-operated motorcycle Warning Signal on the market, and at the lowest price. Outlasts your machine. *Easiest operated. Handsomest signal made.*

Sounds clear, loud, long warning for country roads, and a sharp blast for city riding.

Makes them pay attention!



\$4.75

No need to pay more

30 Days Trial All Stewart Products are sold with the understanding that if not satisfactory after 30 days trial, purchase money will be refunded.

Stewart-Warner Speedometer Corporation, 1906 Diversey Boulevard, Chicago, Illinois

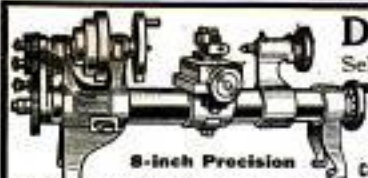
PERFECTION Sleeping Bag With Pneumatic Mattress

Perfection Pneumatic mattresses may be used on damp ground with perfect safety—they are non-absorbent. And they are absolutely sanitary, with no place for dust or vermin to collect.

Easily deflated and inflated—may be rolled into a small light bundle and easily carried in and out of the house. Last indefinitely.

Invaluable for motor, yatching and camping trips. Endorsed by the Federal Government. Write for illustrated catalog and endorsements—today.

PNEUMATIC MFG. COMPANY
536 17th St., BROOKLYN, N.Y.



DRUMMOND

Self-acting, sliding, boring, screw cutting and milling **LATHE**

complete as shown **FIFTY DOLLARS**

Capable of very varied and accurate work

Our book, "Lathe Work by Some Amateurs," will be sent to you free on request
W. R. PRICE, 70 FIFTH AVE., New York City

STOP HERE JUST OUT—New automobile necessity. Deflector for Headlights—puts light on the road,

better driving light. Not a dimmer. No adjustments—no knobs to turn—once put on is permanent. Lasts as long as the car. Price complete, \$2 per Set. Recommended by police in all large cities. Fine for driving on country roads. Fits any car with electric lights. Dealers and salesmen wanted.

HICKMYER DEFLECTOR CO., 4450 S. & B. Bldg., TOLEDO, OHIO

Visit Your Future Home In This Free Book



Among the 130 Lewis-Built bungalows, cottages and homes of every description pictured, described and priced in this remarkable building book, you will find the ideal home for you and yours. Send for the book today and revel in a trip of inspection through all these new homes. When you turn to your future home you will find that the Lewis price has put it within your reach.

THE LEWIS-BUILT READY CUT METHOD, by preparing the house at the mills and shipping direct to you, all ready to erect, means only one small profit to pay. Saves time, expense, labor, waste and worry; insures best grade of lumber; includes plaster, hardware, paint, nails—**everything**; and you can furnish your home on the money saved. Accurate, understandable plans and instructions make it a simple job for any carpenter to assemble the cut-to-fit materials.

LEWIS-BUILT HOMES



Postal today brings the big, free book of homes from \$248 up. Build now, while building is cheap! **WRITE TODAY!**
LEWIS MFG. CO., Dept. 478, BAY CITY, MICH.

Get This Book Free

A LIBRARY ON AUTOMOBILES

"AUTOCRAFT"

By R. A. ENGELMAN

Volume of all sorts of information concerning Automobiles are condensed into this remarkable treatise,

written by a man of thorough experience gained by practical work, both in the shop and on the road. A

book profusely illustrated with photographs and realistic drawings; a book that YOU should own.

"AUTOCRAFT" is a volume of vital interest to car owners, professional and amateur chauffeurs, mechanics and machinists. It contains 240 pages of concise, plain, meaty talks on every phase of Automobiles. Every detail is masterfully treated from top to bottom; inside and out so that anyone can understand it. Important improvements are described; well known makes are discussed. To the beginner, the chauffeur or the owner of the car it is a handy, unlimited source of information and knowledge not to be had elsewhere at any price.

TABLE OF CONTENTS OF "AUTOCRAFT"

Driving the Car. Driving Pointers. Cleaning the Car—Don'ts. Symptoms of Common Trouble. Helpful Hints. Minor Tire Repairs—Different Types. Care of Tires. Self-Starting Devices. Motor Cooling System. Care of Axles. Helpful Hints. Hints for the Tourist. Oils. Magnets. The Chassis. Miscellaneous. Proper Location of the Spark Plug. The Burning Question. Patent Protection.

WHAT READERS SAY

Mr. P. H. Maekerman, Rock Creek, O. writes: "I think the 'AMERICAN CHAUFFEUR' and 'AUTOCRAFT' are simply great."

Mr. W. J. Maloney, Philadelphia, Pa., writes: "I will gladly recommend 'AUTOCRAFT' and the 'AMERICAN CHAUFFEUR.'" Their value cannot be estimated.

Mr. C. C. Burdette, Haleyville, Ala., writes: "I think every owner and chauffeur should receive the 'AMERICAN CHAUFFEUR' and 'AUTOCRAFT.'" I am highly pleased with both.

Mr. Louis Crum, Cadwell, O., writes: "'AUTOCRAFT' and the 'AMERICAN CHAUFFEUR' should be read by every automobile owner."

Mr. Vital Goulette, Montreal, Canada, writes: "'AUTOCRAFT' is a most instructive and interesting book."

Mr. Leland G. Koshler, Donora, Pa., writes: "'AUTOCRAFT' and a year's subscription to the 'AMERICAN CHAUFFEUR' is the best value I have ever realized for the money."

Mr. H. W. Kaurfield, Cambridge, Pa., writes: "I am more than pleased with both the 'AMERICAN CHAUFFEUR' and the 'AUTOCRAFT.'" Mr. Chas. H. Schultz, Pittsburgh, Pa., writes: "The 'AMERICAN CHAUFFEUR' is an excellent magazine, and I find 'AUTOCRAFT' very interesting and instructive."

These are only a few. We have received thousands that praise the value of Autocraft and American Chauffeur.

The American Chauffeur

"AN AUTOMOBILE DIGEST" is a monthly magazine devoted to the study of automobiles. It is of interest not only to chauffeurs, but to the man who owns and drives his car. Technical features are written each month by men who have made life studies in their special departments. Every article is thoroughly practical—check full of sound, solid, meaty, common sense, and in each issue there appear discussions of proper lubrication, fuels, tires, engines, axles, lighting and cooling systems, adjustments and repairs, good roads and all the valuable information you should have at your command. Its Query Department will answer any question that you may ask, free, while hours throughout the country by expert tourists make this a magazine of vital interest to you. It comes down to facts, and tells you just what's what. It helps and urges you in every way to know more about automobiles. A year's subscription constitutes over 600 pages illustrated, of the best helpful, educational information direct from the biggest automobile factories.

READ THIS OFFER how to get

Autocraft Free

YOUR OPPORTUNITY IS NOW

The regular subscription price of the AMERICAN CHAUFFEUR is \$1.00 per year. The price of AUTOCRAFT is also \$1.00. If you will send us \$1.00 in money—money order or check, we will send you the AMERICAN CHAUFFEUR one year and send you De Luxe Edition of AUTOCRAFT absolutely free.

THE AMERICAN CHAUFFEUR
56 Butler Building CINCINNATI, OHIO



MAIL THIS COUPON

TODAY

The American Chauffeur Publishing Co.

56 Butler Bldg., Cincinnati, Ohio

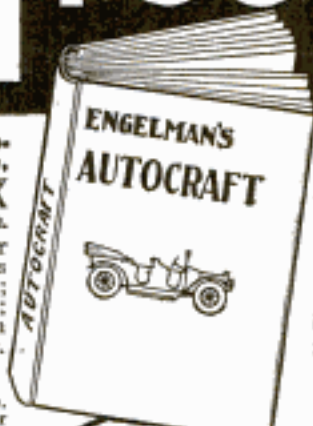
Gentlemen, — Enclosed please find \$1.00 for which send me the "AMERICAN CHAUFFEUR" monthly for one year, and you are to send me Engelman's 240 page illustrated book, Deluxe Edition of "AUTOCRAFT" absolutely free, as per your special offer in "Popular Mechanics." If I am not satisfied with this book "AUTOCRAFT" I will return same and you are to refund my money.

Name.....

Street.....

City..... State.....

Reference: Western German Bank, Cincinnati, O.



LEARN MORE ABOUT
AUTOMOBILES

DIAMONDS ON CREDIT

20% DOWN 10% MONTHLY

Let us send you any Diamond you may select from our catalogue so you may compare our values with those offered by other dealers; be convinced that our IMPORTER'S PRICES offer you a great saving.

We furnish a guarantee certificate with every Diamond and allow the full purchase price on all exchanges. We will send express prepaid any Diamond or other article, for examination and approval, you to be the sole judge as to whether you keep it or return it at our expense.

Write today for our free catalogue de luxe No. 4, and see how easy it is for you to own and wear a beautiful Diamond. L. W. SWEET & CO., Inc., 2 and 4 MAIDEN LANE, NEW YORK CITY.

Be a Diamond Expert—MONEY

Learn to grade and value diamonds—rich rewards are in your reach. Experts practically command their own price—most independent men on earth—all profits for the expert, no losses, quick returns—only profession in the world that is not overcrowded—truly wonderful chances for you if you will learn it. Business opportunities and princely positions. We teach you easily and speedily.

\$ in DIAMONDS as a SIDE LINE
MANY POSITIONS
FINE

what your work or profession, here's your chance. Start with a diamond costing you no more than a dollar. Splendid positions waiting for experts, \$5,000 to \$10,000 a year, but even bigger field for you dealing independently in diamonds. Just write—let us show you amazing facts. Get worth of your money buying diamonds. Loan money on diamonds. Pick up diamond bargains. Make money.

Pick up hundreds of dollars a year conducting a Diamond Business on the Side. Nothing like it for big, quick, easy money if you know how. Our lessons make it plain and we help you in many ways besides. No matter

FREE Fine booklet "PAYING DIAMOND KNOWLEDGE" Learn all about this Educational Course in Diamonds. Write today to

Universal School of Correspondence, Diamond Dept., 73 East 7th St., Chicago, Ill.



If Opportunity Ever Knocked,
It's Knocking Right Here Now

100 USES

The Jiffy Overall Apron is a patented garment which completely protects the front of the clothes. As the name implies it goes on in a "jiffy" and comes off as quickly. It is universally used by autoists, repairmen, carpenters, printers, engineers, mechanics, bench workers, butchers, butlers, chefs, chauffeurs, laboratory men, manual training students, store clerks, postal clerks, freight and express handlers, cartage and baggagemen, as well as men who take care of their own motor car, furnace or garden.

SPECIAL FEATURES

Combination tool or watch and pencil swinging pocket. Two large pockets used for tools or other articles. *Two elbow length over-sleeves with each garment.* Patented Clip at bottom of each leg—holds garment in place. *Union made in Detroit* by the highest skilled labor obtainable. Each garment is guaranteed.



JIFFY

OVERALL APRON

FOUR STYLES

(Patents Applied For)

The Jiffy Overall Apron is made in four different styles. **\$1**

- (1) Highest quality blue denim.
- (2) Extra heavy, blue and white striped Steifel.
- (3) Highest grade water-proofed white duck.
- (4) Extra quality, brown khaki.

All garments are of the best workmanship and sold for.....
If your dealer cannot supply you, we will ship direct by parcel post paid upon receipt of one dollar.

The Jiffy Overall Apron is made in 10 different sizes, — to fit the small man of 5 ft. 3 in., up to the tall man of 6 ft. In ordering give your height to the dealer or direct to us, and you will get the correct size.

Demonstrator Agents Wanted
There are many towns in which we desire successful men to represent us. Liberal commission allowed for such representation. If interested, write quick.



in the shop



in the garage

at the beach

in the store

at the beach

in the garage

at the beach

in the store

at the beach

in the garage

at the beach

in the store

at the beach

in the garage

at the beach

in the store

at the beach

in the garage

at the beach

in the store

at the beach

in the garage

at the beach

in the store

at the beach

in the garage

at the beach

in the store

at the beach

JIFFY APRON CO.
310 Smith Bldg.
Detroit, Mich.

Please send me by parcel post paid one Jiffy Overall Apron complete with over-sleeves, style..... for which I enclose \$1.00. My height is.....ft.....in.

Name

Address



REDEMOTOR SMALLEST GAS ENGINE

in general use. Runs washing machine, churn, pump, cream separator, dynamo, bench lathe, railway speeder, or any machine requiring light power. Starts easy and gives as reliable service as an electric motor, with same floor space and weight. Run it anywhere, anytime.

Invest in a Redemotor and see how much easier your chores will be. Three sizes, No. 15 and 114. P. Send for catalog J. Low Prices.

ELGIN WHEEL & ENGINE COMPANY, ELGIN, ILL.

ARE YOU IN NEED OF ? SEND FOR
Mechanical ? Popular
Information • Mechanics
FREE CATALOG

500 LATEST AND BEST

Mechanical Books

ON 100 DIFFERENT SUBJECTS

MAILED UPON REQUEST BY

POPULAR MECHANICS BOOK DEPT.

6 N. Michigan Avenue, CHICAGO

AMATEUR MECHANICS

Nos. 1, 2, 3, 4 and 5, and

Mechanics for Young America

Are books for boys who like to make things. The price of each is 25 cents postpaid and if you send for one you will want the others.

Popular Mechanics Book Dept., 6 N. Michigan Ave., Chicago

OXY-ACETYLENE

OXY-ACETYLENE
WELDING
AND CUTTING
SWINGLE

WELDING AND CUTTING

Including the Operation and Care of Acetylene Generating Plants and the Oxygen Process for Removal of Carbon

By C. F. SWINGLE, M. E.

200 Pages—76 Illustrations—Pocket Size Bound in Cloth, \$1.00

Full Leather — Round Corners — Red Edges
Stamped in Gold, \$1.50

Here is a brand new practical instruction book on the methods of welding and cutting by the oxy-acetylene process. The thirteen chapters cover the following general subjects:

Welding—Welding Flames—Oxygen Acetylene—Acetylene Gas Purification and Handling—Oxy-Acetylene Torches—Characteristics of Welding Torches—Welding Installations—Preheating and Annealing—Operating a Welding Installation—Metal Welding Practice—Oxy-Acetylene Cutting—Oxygen Carbon Removal—Index.

Sent postpaid upon receipt of price by

POPULAR MECHANICS BOOK DEPT.

6 N. Michigan Ave., CHICAGO

BE A MANUFACTURER

OF HAYWOOD RETREADS MAKE \$3,000.00 A YEAR TO START

and more as you get accustomed to the business. The certainty of success is about as sure as anything in this world can be. You let down the DRAW BRIDGE for SUCCESS to enter into your career by getting into business for yourself.

MAKE
\$3000.00
A YEAR

Put Yourself
Where
This
Man
Is

He Is
Making
Money



HERE IS YOUR OPPORTUNITY!

You might just as well be the first to enter this paying business in your town—open your shop and let the money roll in. Every automobile sold means more tires to mend. You start with one machine. The business grows fast. You need another and then another. Soon it gets to be a regular business of adding machine—after—machine until the first thing you know you are running a big shop—you are operating in a big way—you are a real business man and a factor in your community. You know that punctures and blow-outs are common—tires need retreading and vulcanizing every day—something going wrong all the time—owner after owner forced to buy new tires because they cannot get the old ones fixed.

REPAIR TIRES AT HOME

Young men make money to attend college or start a garage and repair business. Automobile owners—repair your own tires. Save money. Pay for your outfit in a short time. We have special outfits for home use. Mr. Any-Man, it's worth while to invest. There is money in it. It's a field of wonderful possibilities. Make up your mind and send for our catalogue today. Learn of the wonderful money making possibilities in this fascinating new business. Make something—supply a want—become a manufacturer. This is your chance.

The Haywood Tire & Equipment Co.
885 Capitol Ave. Indianapolis, Ind.

HAYWOOD
TIRE &
EQUIPMENT CO.
885 Capitol Ave.
INDIANAPOLIS, IND.

Without any obligation upon my part please send me your complete FREE catalog of tire repair outfits.

Name.....

Address.....

Big Money for You!

BUILDING, SELLING AND REPAIRING AUTOMOBILES

We train you by mail in few easy lessons, and give you exclusive agency for "Coe Junior," World's Champion Light Car. Write immediately and learn how you can get one of these speedy little roadsters.

OFFER STRICTLY LIMITED. HURRY! A POSTAL WILL DO.

C. A. Coey's School of Motoring, 412 Coey Bldg., Chicago



Coe Junior

Bargains in Band Instruments

Used Cornets \$7; Used Trombones \$6.

We have hundreds of bargains in band instruments; Cornets \$7.00, and other instruments at equally low prices. Send for complete list of rebuilt and fumigated band instruments. Tell us what instrument you are interested in.

LYON & HEALY, 33-39 Adams St., Chicago



Waterman PORTO



1915 model, 3 h.p., weight 59 lbs. Sold direct from factory to you, freight paid. The original out-board motor. Tenth year—\$0,000 in use. Guaranteed for life. Fits any shaped stern; has carburetor—no "mixing valve"; Removable bearings; solid bronze gear; projecting 10 1/2 x 16 in. propeller. Blows by rudder from any part of boat. Water cooled exhaust manifold; noiseless under-water exhaust; bronze gear water pump; spun copper water jacket; any ignition equipment desired. Demand these essentials if you want your motor's worth. Write today for free engine book. Our prices will surprise you.

WATERMAN MARINE MOTOR CO.
239 Mt. Elliott Ave., Detroit, Mich.

Makes
Any Boat

A
Motor Boat



BLUE WHITE
GENUINE
DIAMONDS
MODERATE PRICES
EASY
TERMS

Get That Diamond for Your Wife, Sweetheart

or yourself now—Don't wait until you get the money—buy from us now at these startlingly low prices—and pay for it in easy little amounts from time to time. Buy direct from importers and Save Dealers' Profits. We give Certified Guarantee with every Diamond—guaranteeing its weight and quality. A safe way to buy and save money—no inconvenience—and have the Diamond now when you want it. Perfectly cut white Diamonds, gleaming, sparkling, scintillating—genuine high quality. Not a cent to pay until you have carefully examined the Diamond—then if you are perfectly satisfied pay 1/5 down and take the stone on our easy terms plan. We send you free magnifying glass. Any diamond in our

FREE BEAUTIFULLY ILLUSTRATED DIAMOND AND WATCH CATALOG

will be sent for examination without obligation. This offer is open to every honest person—open to YOU. Note the wonderful values shown here. Compare these prices with others. We import the rough Diamonds, cut them here, save 33 per cent duty. Give the saving to you. Write today for our BIG CATALOG and see our Special World-Beating Offers. All diamonds, also watches, on easy terms. Send for Catalog today.

THE WALKER EDMUND CO.,
DIAMOND IMPORTERS

Dept. C

State and Madison,
CHICAGO,
ILL.



Please Mention Popular Mechanics



LAW— the Big Opportunity for the Young Man in Business Today

In answer to your name on the coupon we will send you, free of charge and without any obligation whatever, a book setting forth the wonderful opportunities for advancement in the business world that await the legally trained man. Never before in history has there been such a remarkable demand for men with the right kind of training in law. Almost every move a business makes has its legal aspect, and the men who are trained to handle these legal problems effectively are paid big retaining fees. Moreover, every lawyer is constantly coming in touch with opportunities outside his law that enable him to make money and become prominent in social and political life. Exactly how you can take advantage of these opportunities is described fully and completely in our 80-page book on law which will be sent you

FREE Send your name and address on the coupon below at once. No charge or obligation of any kind. Simply get this booklet and read it carefully. No young man, ambitious to get ahead in the world, can afford to overlook this splendid opportunity. Put the coupon in the mails immediately. Don't run the risk of forgetting. Make this your first step towards a bigger success than you have ever even dreamed of.

**AMERICAN SCHOOL
OF
CORRESPONDENCE
CHICAGO, U. S. A.**



Get this Free Book in Your Hands at Once

American School of Correspondence, Chicago, U. S. A.

Please send me your free 80-page book, "How to Acquire a Legal Training," showing the remarkable opportunities that await the legally trained young man in business today. I am interested in finding out exactly how I can take up this work and make a success of it.

Pop. Mech. 4-25

NAME.....

ADDRESS.....

Please Mention Popular Mechanics

Be a Traffic Expert

Increase your earnings \$50 to \$100 a month

Big paying positions are open for men who know Freight Classifications and Freight Rates. Proper classification of shipments to obtain the lowest rates is one of the most vital problems before business men today. Specialists who know how to classify freight and obtain the lowest rates save hundreds of dollars yearly for their employers—that is why these experts are in big demand. Thousands of large shippers are seeking traffic experts, and the demand far exceeds the supply. You can qualify for one of these well-paid positions by securing

Carr's Traffic Manuscript

Compiled by the traffic manager of a large industrial concern. Based on practical experience. The Manuscript gives you the sources of freight transportation knowledge. Study in your own home—in your own spare time. Don't give up your present position until you are ready to take advantage of a big opportunity. Price of complete Manuscript is now but \$2. We can hold this unusual offer open for a short time only. Do not let this small sum stand between you and a position of splendid opportunities and big pay. Get this Manuscript in your hands at once.

H. A. CARR, Traffic Manager
Box 218, Mt. Vernon, Ohio

ROW BOAT MOTOR FERRO

Don't Go Rowing
Go FERROWING

The Safest Investment of All

The motor you buy must be powerful, speedy, economical, simple and reliable—it must be so constructed as to give best results in hardest service. The price must be reasonable, too. Write at once for our literature and see for yourself why the Ferro is the motor. State whether interested as dealer or user.

The Ferro Machine & Foundry Co.
443 Hubbard Ave. Cleveland, Ohio

\$85

With
Reversible
Waterproof
Magnets

\$65

With
Waterproof
Ignition



Yours On 4 Weeks' Trial

Yes, we will ship you on free trial a highest grade Wing Piano or Player-Piano DIRECT from our own factory all freight prepaid. Your choice of 33 new art styles on four full weeks' Free Trial in your own home. At the end of 4 weeks, if you wish, you may return it at our expense. No money down—no security—no obligations whatever. You'll be amazed at our direct-from-factory prices on the famous Wing Piano guaranteed for 40 years.

One of 33 Styles

Easy monthly payments or cash if you prefer, but first 4 weeks absolute free trial.

Write Now

Send today for valuable free book—the "Book of Complete Information About Pianos" sent free and postpaid. Its 120 pages show you how to judge piano quality and prices. We will also send our catalog of newest art styles in Wing Pianos. Don't delay. Write NOW.

WING & SON, (Incorporated) Wing Bldg. 9th Ave. & 13th St. Dept. 1194 New York

IMPROVED INTERLOCKING
JUST PROOF - FOOL PROOF

Do You Use a SLIDE RULE?

THEN you will be glad to hear of the "INTERLOX" MASTER SLIDE RULE, the only one whereby *inside* measurements of doors, windows, etc., can be taken rapidly and accurately. Best for outside measurements of walls, ceilings, etc., as it can be extended and closed instantly. The exact measurement is always given, as indicated by arrow in cut, without adding or subtracting. Saves time, temper and trouble.

This is the **only interlocking Slide Rule.**
Liberal proposition to dealers and agents.
USE THIS COUPON TO-DAY:

If your hardware dealer hasn't the "INTERLOX" MASTER SLIDE RULE, send us the coupon below, together with 15c per foot for the rule (in any length from 2 to 8 ft.) and it will be sent prepaid.

GET QUANTITY PRICES

Many concerns use large quantities for their employees, to ensure accuracy. Others use the "INTERLOX" as a unique advertising premium with their name and trade-mark printed in colors on the rule and stamped in gold on the handsome pocket case we supply.

Interlox

MASTER SLIDE RULE

TWO RULES IN ONE

INTERLOCKING DIRECT-READING RUST-PROOF

Ideal for Inaccessible Measurements

Progressive hardware dealers display this "INTERLOX" sign

DAHL MFG. CO., 51A East 42d St., New York
Gentlemen: Enclosed find..... for which send me, prepaid, one.....ft. "INTERLOX" MASTER SLIDE RULE, at 15c per foot. (Please write plainly.)

My Name.....

My Address.....

My Hardware Dealer's Name.....



FASTENINGS

of all kinds of fixtures, apparatus and machinery in any hard material made **EASY** by using the Van Expansion Bolt. **Over 100,000 used in the Tower of Jewels at the Panama-Pacific Exposition.**

TRIAL OFFER: Four Van Expansion Bolts with Nickel-Plated Brass Screws sent **POSTPAID** for 10c. Just the thing for use around the house. Complete information free. Send today, stating your business.

VAN EXPANSION BOLT MFG. CO.
1209 Fort Dearborn Bldg. CHICAGO, ILL.

Wins Big Trade!

Scores of drug, candy, fruit, cigar, news and department stores, picture theatres, etc., making \$25 to \$60 profits weekly with the famous

BUTTER-KIST Corn Popper
Runs itself. Pops 1 bag in 48 seconds—\$1.75 per hour. Motion draws crowds. Folks can't resist the coaxing fragrance. **FREE**—handsome book "The Little Gold Mine"—gives photographs, proof of profits, easy terms, etc. Write today.

HOLCOMB & HOKE MFG. CO., 1645 VanBuren St., Indianapolis, Ind.



Oh, You Skinny!

Why stay **thin** as a rail? You *don't* have to! And you *don't* have to go through life with a chest that the tailor gives you; with arms of childish strength; with legs you can hardly stand on. And what about that stomach that finishes every time you try a square meal? Are you a *pill-feeder*?

Do you expect Health and Strength in tabloid form—through pills, potions and other exploited piffle?

You can't do it; it can't be done.

The only way to be well is to build up your body—all of it—through nature's methods—not by pampering the stomach. It is not *fate* that is making you a failure; it's that poor, emaciated body of yours; your half-sickness shows plain in your face and the world loves healthy people. So be *healthy—strong—vital*. That's *living*. Don't think too long; send 4 cents in stamps to cover mailing of my book, "INTELLIGENCE IN PHYSICAL CULTURE," written by the *strongest physical culture instructor in the world*.

LIONEL STRONGFORT
Health and Strength Institute
Dept. S. San Mateo, Cal.

Set six Screws

AND SAVE \$13.25

It takes six minutes to drive these six screws and the saving is \$13.25. If your time is worth more than \$2.21 a minute don't read any further. This advertisement is meant for those who want rock bottom prices and approve a selling plan that actually saves money, 30 to 50 per cent.

No. 500
Library
Table in the
white
\$11.75



No. K-49
\$7.75

No. K-49 style,
Freside chair,
\$7.75 (in white)

This beautiful modern design chair is easily assembled and gives no hint of its sectional construction. Unusually rich, wonderful value, 36 in. high, width 25 1/2 in., seat 18 1/4 x 19, shipping weight 85 lbs. Price, unfinished, \$7.75; price, completely finished, \$9.50 (Imperial Leather Auto Spring Cushion). Cow-hide cover \$2.40, roan skin \$1.45 extra. Finishing materials 50c.

OVER 30,000 HAPPY HOME OWNERS have bought Come-pact Furniture for these substantial reasons. Remember, sold on strong year guarantee.

This handsome quarter sawed white oak table, rich, natural markings, two drawers, choice of old brass or wood knobs, compactly packed. Knock-down rate price, in white, only \$11.75. Finished to your order, \$14.50.

Free Catalog showing 400 pieces, including living room, dining room and bed room furniture—color plates showing actual finish. Take advantage of these low factory prices. We make our own furniture and sell it to you, no middle profits, you get the benefit.

THE COME-PACT FURNITURE CO.
401 Durr Street
Toledo, Ohio

SECTIONAL COME-PACT FURNITURE

Please Mention Popular Mechanics



Can you afford to lose the savings made by Oxy-Acetylene Welding?

Keen manufacturers, machine shop and garage owners, are finding that intelligent use of the Oxy-Acetylene welding torch greatly simplifies and cheapens the manufacture and repair of metal parts.

One "on the spot" repair of damaged equipment often saves more in time alone than the cost of the entire welding outfit. Count the cost of new part not needed as profit. Parts and repairs so intricate that the cost of manufacture by any other method would prohibit their use, are made easily and at small cost as regular routine work by this process. Welding is an inexpensive and superior substitute for most riveting operations.

Cost of equipment is low. We furnish a thoroughly high grade welding apparatus for \$60.00. The average user will also need gas cylinders, at an additional cost, and about \$10.00 worth of welding supplies. Truck and special equipment for cutting operations at extra cost.

Any good make apparatus is made more efficient and widely useful by

PREST-O-LITE Dissolved Acetylene (Ready-made carbide gas)

Prest-O-Lite Acetylene Service furnishes the highest grade of Dissolved Acetylene in portable cylinders, used as conveniently as you use cylinders of oxygen. Saves the large initial outlay and heavy depreciation, trouble and inconvenience of making crude Acetylene in carbide generators. Besides, Prest-O-Lite Dissolved Acetylene is perfectly dried, cleaned and purified — makes better welds and is cheaper to use.

A Profitable Business Opportunity

Doing oxy-acetylene welding for others, presents a good opening for enterprising mechanics to make large legitimate profits quickly. Send for details.

Your name and address on the margin of this page will bring interesting information on equipment and applications, that will probably suggest new and better ways of handling your work. Sign and send today.



The Prest-O-Lite Co., Inc.
The World's Largest Makers of Dissolved Acetylene
816 Speedway Indianapolis, Ind.
53 direct factory branches and charging plants in principal industrial centers.

Please Mention Popular Mechanics



BOYS!

Automatic-Repeating Pistol

FIFTEEN-HUNDRED load reports from one charge. Made of blued gun-metal, 8" long, easy action. Absolutely harmless; no powder or projectile; permitted in any community. Five extra rolls of paper (7500 shots) only 10c.

THE AIRMATIC PISTOL
350 Citizens Building CLEVELAND, OHIO

50c

Postage prepaid anywhere U. S. or Can.

Go to it!

Hello Boys! BUILD NEW MODELS

MAKE LOTS OF TOYS

Help me get new models. I give 307 Prizes—first an Auto. My

ERECTOR BIG PRIZE CONTEST

is described in big folder. Send for it now. Free.

MYSTO MFG. CO.
253 Foote St.
New Haven, Conn.

New Design Engines and Dynamos

1/16 and 1/8 H.P. GAS and GASOLINE ENGINES.
Dynamos, 18, 24, 40, 60 and 80 Watts.
SIMPLE, PRACTICAL, DURABLE. Electrical and Mechanical Supplies. Send stamp for Bulletin 104.

DYNAMIC MFG. CO., First Nat'l Bank Bldg., CHICAGO



Being taken at approximately 100,000,000 at the present time, the population of the United States has more than quadrupled since 1870.

GENUINE PEARLS ONE DOLLAR

Average size as illustrated

Beautiful white pearls absolutely and positively guaranteed real freshwater pearls. Sounding marvelous, but a positive fact. Just think of it. Average size ordinary pea. Solid gold finished scarf or lace pins. No real swell and wear a genuine jewel, not cheap imitations that soon break and crack. Mailed to you on receipt only one dollar. Money returned if dissatisfied. Act quickly—supply limited.

AMERICAN PEARL COMPANY, Great Neck, N. Y.

YOU OWE THE BATTERY ON YOUR CAR SOME ATTENTION

DOUBELAY CHARGOMETER \$1.00
(SPECIFIC GRAVITY SCALE) POSTPAID

Indicates condition of storage battery. The only sure way. All battery manufacturers recommend its frequent use. Saves you money by letting you know in time. Sent with complete battery instructions.

Doublet Glass Works, Van Buren St. & Kostner Ave., Chicago

INCREASE YOUR SALARY \$30

You want more money. Here's an easy way to get it. Spare time—save it—Saturday afternoons.

Make instant sideline. Take orders for world's best Electric Suction Cleaner—The **HARNEY**—lowest priced high quality **CLEANER** made. One order day nets over **\$30.00** a week.

Live Representatives Wanted

For the right man or woman our proposition spells money in capital letters. Maybe this is the big chance you've been waiting for. It costs but a postal to find out. Get our full proposition, guarantee and booklet. Write today.

The Advance Mfg. Co., 403 W. Willard, Kalamazoo, Mich.

\$1,500⁰⁰ Made in One Month



BY THIS MAN

Young men! Middle-age men, with uncertain positions, this is your opportunity. Invest just a small portion of the money you have saved and establish yourself in a pleasant, permanent growing business. Mr. H. W. Eakins, (shown above) paid his last \$10.00 for rent of a store window; started with one of my Crispette Machines. At the end of 30 days he had \$1,500 in the bank. You can do the same—if you go about it right.

I'll help other men to start in the same business

You don't need experience to start but initiative. The place is anywhere.

There's a demand in your locality. No matter if you live in a town of 500 population or more. Why not reap the harvest ready for you. You have been looking for a good chance and here it is. To the right man in each community I've got a great proposition to make. Are you one of them.

Success is yours if you go after it. A splendid opportunity faces you. It may never come your way again. Can you afford to pass it by? Decide now to gain success. Cut loose from irksome tasks—long hours—poor pay. Reap the benefits of your efforts. Work all or part time—just evenings if you wish. Get full particulars—reports from users. See what others have done. Judge what you can do. Act now.



Every Nickel You Take In Nets You Almost Four Cents Profit

COME TO SEE ME—AT MY EXPENSE. Unannounced, just drop in any time. See our store—our Crispette business—you can trust your own eyes. You will know then. See the machines work—see the Crispettes made—make a batch yourself. Within a radius of 500 miles, I'll pay your traveling expenses if you buy a machine. We show you everything—keep back no secrets—give you our confidential formula and every help possible.

FREE BOOKLET "DOLLARS AND SENSE in the Crispette Business".

—an inspiration alone, if you never buy.
Get it—Read it—Don't put it off—
Write today—life is too short.
Send the coupon. Start YOUR
business today.

W. Z. LONG
1050 High St., Springfield, O.

W. Z. LONG
1050 High St., Springfield, O.

Without any obligation at all, please send me free, your book, "Dollars and Sense in the Crispette Business."

Name

Address



\$7.50
11P

MAKE \$20 a DAY

Snapping the crowds with a famous
Diamond Post Card Gun. There's nothing like it for big, quick, easy money. It's a wonder—a world-beater. Takes photo post cards and buttons, finished on the spot, in less than a minute. Circulars Free.
INTERNATIONAL METAL & FERRO CO., 124, CHICAGO

AGENTS—Make \$100 to \$300



per month easy selling our new Triplicate Sauce Pan. Cooking utensil for 3 different foods on one burner. 400 Specialties — all Whirlwind sellers. Write quick for exclusive territory and large catalogue.
AMERICAN ALUMINUM MFG. CO.
Div. 5 61 LEMONT, ILL.

L-A Rowboat Motor

Play Safe: Try It 30 Days

In your own boat. Test it thoroughly. Be your own salesman; keep the salesman's profit—and it is for you to say when the sale is completed.

Thousands of L-A Rowboat Motors sold and running everywhere. Light weight, detachable, reversible engine; speeds up to 8 miles an hour or slow enough to troll; silent muffler, steers with rudder, bronze underwater parts, can be had with either battery equipment or fly wheel magneto.

Take us up on our 30 day free trial offer today; no sale unless you are satisfied. Catalog free—postal today brings it.

LOCKWOOD-ASH MOTOR CO., 436 Horton St., Jackson, Mich.

SENT ON THIRTY DAYS FREE TRIAL

Buy at the Factory Price

Direct from Factory to User

Please Mention Popular Mechanics



REGAL

Through all these many years Regal Cars have been distinguished for sturdy, enduring construction.

Today, these qualities are more than ever embodied in each model—in every car that leaves our factory.

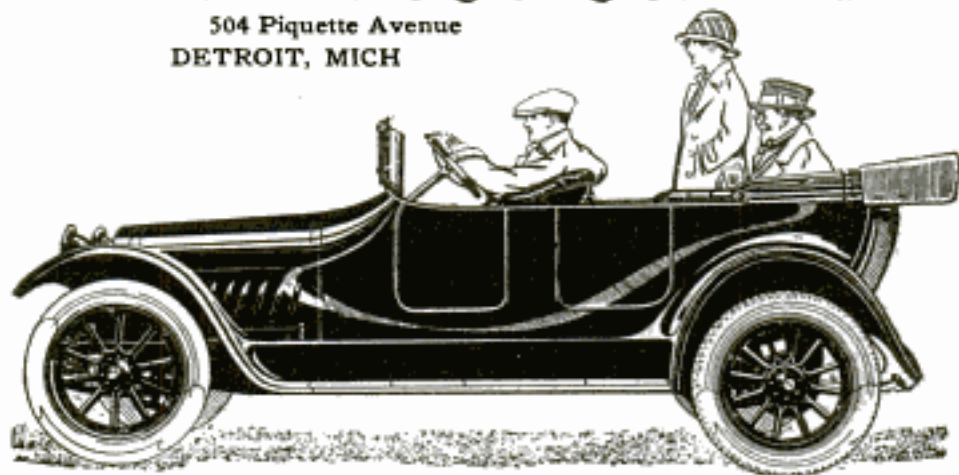
Surely, among these Three Regals is *one* suited to your needs.

A Light "Four" at \$ 650
 A Standard "Four" at 1085
 A "V" Type "Eight" at 1250

All are amply powered—moderately priced—completely equipped—electric starting and lighting included. All models comfortably roomy—with full stream line bodies, and crown fender.

REGAL MOTOR CAR COMPANY

504 Piquette Avenue
 DETROIT, MICH



Out-Door Lamp 300 Candle Power **FREE**

To Try at Your Own Home

Gives better light than gas, electricity or 18 ordinary lamps at one-tenth the cost. For Lawns, Streets, Barns, Barn Yards, Shops, Dairies, Porches, Alley Ways, etc. Storm Proof, Bug Proof. No wick, no chimney, no smoke. Makes its light from common gasoline. **ABSOLUTELY SAFE.**

COSTS 1 CENT A NIGHT

We want one person in each locality to whom we can refer new customers. Take advantage of our **SPECIAL FREE TRIAL OFFER.** Write today. Agents Wanted. **SUNSHINE SAFETY LAMP CO., 295 Factory Bldg., Kansas City, Mo.**



WHEN YOU WANT ANYTHING AND DON'T KNOW WHERE TO FIND IT
 WRITE BUREAU OF INFORMATION,
 POPULAR MECHANICS CHICAGO

LEARN TO PITCH



Lessons by "MATTY," ED. WALSH, "DOC" WHITE, WALTER JOHNSON, "NAP" HUCKER, "SMOKY JOE" WOOD. **PITCH THE FADE-A-WAY, SPITTER, KNUCKLER, SMOKE BALL, etc.** Clearly described and illustrated by 56 Pictures. Entire COURSE OF LESSONS SENT POSTPAID for 50 cents.

J. C. DORN, 721 S. Dearborn St., Dept. 108, Chicago, Ill.



Suppose YOU Were to Lose Your Job?

Yes, just *suppose* you were laid off next Saturday night—what do you think would be your chance for getting another job?

BUT—you don't *need* to worry about losing your job. The *trained* man doesn't have to worry about his job—and if you are willing to spend as little as a half-hour or an hour a day getting ready, you too can get into the trained man's class.

The *trained* man holds his job because he has *special* training—nobody else can fill his job without this training. *Trained* men are *always* in demand.

If you want to get into the trained man's class the *International Correspondence Schools* can help you. Right in your *own home* during your *spare time* they can train you for a good job where advancement and bigger pay will be absolutely sure.

Last year more than 5,000 men reported increases in salary or advancement in position as a *direct* result of the training they got through the *I. C. S.* Next year more than 5,000 others will report—*will YOU be one of them?*

Mark the Coupon NOW

Before you turn this page—cut out the coupon, mark the line of work you would like to follow, and mail it to the *I. C. S.* for full particulars. This is simply an act of investigation—it won't obligate you in the least.

INTERNATIONAL CORRESPONDENCE SCHOOLS

Box 872H

SCRANTON, PA.

Please explain, without obligating me, how I can qualify for the position before which I mark X.

- | | |
|--|---|
| <input type="checkbox"/> AUTOMOBILE RUNNING | <input type="checkbox"/> CIVIL SERVICE |
| <input type="checkbox"/> ELECTRICAL ENGINEERING | <input type="checkbox"/> Railway Mail Clerk |
| <input type="checkbox"/> Electric Lighting | <input type="checkbox"/> BOOKKEEPING |
| <input type="checkbox"/> Electric Railways | <input type="checkbox"/> Stenography & Typewriting |
| <input type="checkbox"/> Interior Wiring | <input type="checkbox"/> R. R. Accounting |
| <input type="checkbox"/> Dynamo Running | <input type="checkbox"/> Good English for Every One |
| <input type="checkbox"/> Electric Car Running | <input type="checkbox"/> SALESMANSHIP |
| <input type="checkbox"/> Telep. and Teleg. Engineering | <input type="checkbox"/> ADVERTISING |
| <input type="checkbox"/> MECHANICAL ENGINEERING | <input type="checkbox"/> Window Trimming |
| <input type="checkbox"/> Mechanical Draftsman | <input type="checkbox"/> Show Card Writing |
| <input type="checkbox"/> Shop Practice | <input type="checkbox"/> ARCHITECTURE |
| <input type="checkbox"/> Gas Engines | <input type="checkbox"/> Architectural Drafting |
| <input type="checkbox"/> STEAM ENGINEERING | <input type="checkbox"/> Contracting and Building |
| <input type="checkbox"/> Locomotive Fireman & Eng'n | <input type="checkbox"/> Concrete Engineering |
| <input type="checkbox"/> CIVIL ENGINEERING | <input type="checkbox"/> Structural Engineering |
| <input type="checkbox"/> Surveying | <input type="checkbox"/> Plumbing and Heating |
| <input type="checkbox"/> Mine Foreman & Supt. | <input type="checkbox"/> AGRICULTURE |
| <input type="checkbox"/> Chemistry | <input type="checkbox"/> Poultry |

Name _____

Street and No. _____

City _____ State _____

Present Occupation _____

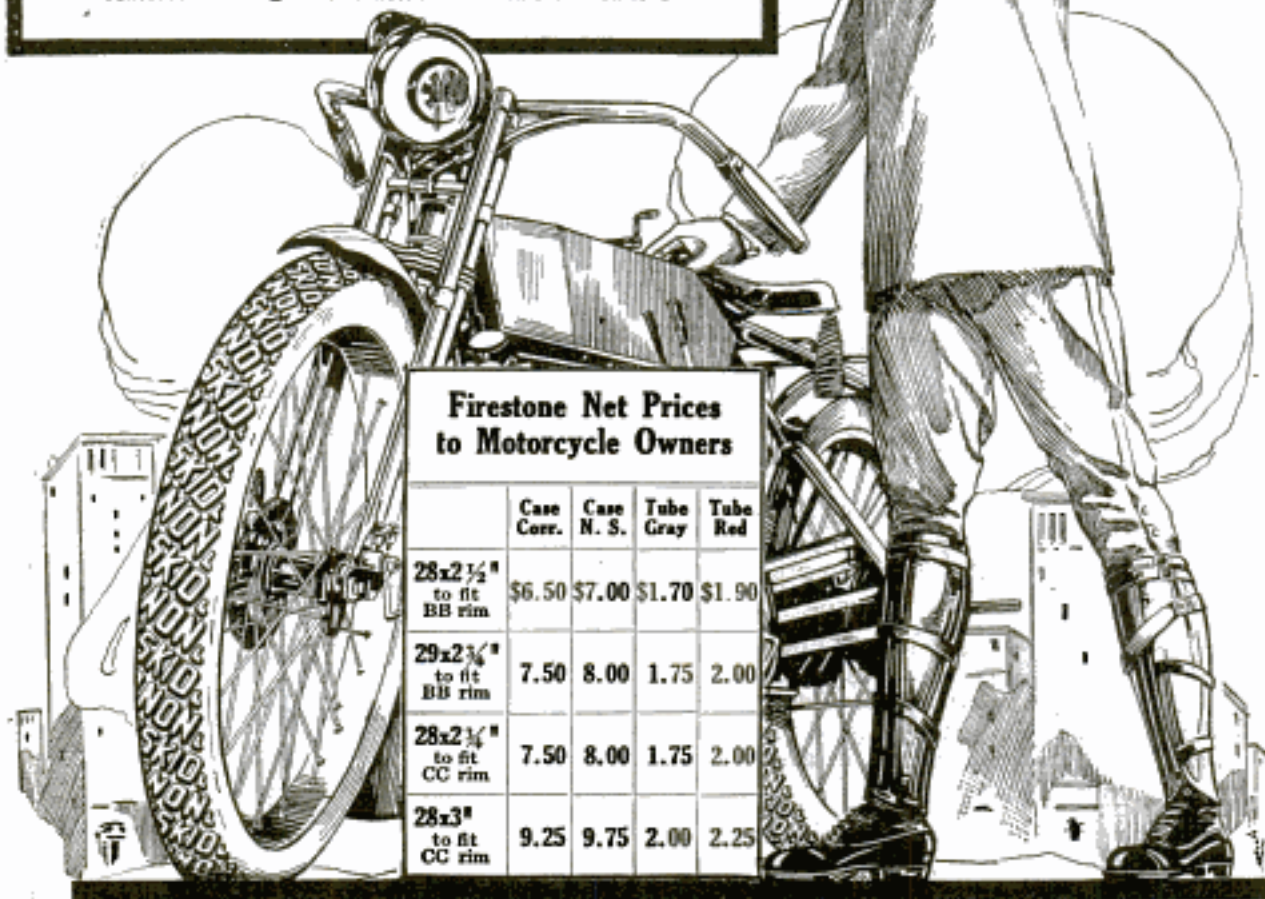
Commanders of the Highways

MOTORCYCLES equipped with Firestone Tires are in the lead on every road that a motorcycle can travel. Firestone Tires guard the rider against tire delays and skidding accidents. Their known strength inspires confidence. Regular automobile tire construction (cushion layer, breaker-strip and all). Extra thick tread, extra layers of strongest fabric with extra rubber between.

Result—Most Miles per Dollar

Your dealer has Firestones in Non-Skid and Corrugated Tread. All standard sizes.

Firestone Tire & Rubber Co., Akron, Ohio
Branches and Dealers Everywhere
"America's Largest Exclusive Tire and Rim Makers"



Firestone Net Prices to Motorcycle Owners

	Case Corr.	Case N. S.	Tube Gray	Tube Red
28x2 1/4" to fit BB rim	\$6.50	\$7.00	\$1.70	\$1.90
29x2 3/4" to fit BB rim	7.50	8.00	1.75	2.00
28x2 1/4" to fit CC rim	7.50	8.00	1.75	2.00
28x3" to fit CC rim	9.25	9.75	2.00	2.25

Firestone

MOTORCYCLE TIRES

Please Mention Popular Mechanics

—and this is the Mark
on the Lamps that light
the Exposition

MAZDA

"Not the name of a thing but the mark of a Service"

You have long recognized in that word MAZDA etched upon a lamp the Mark of that far-reaching scientific Service organized to investigate the problems of better lighting and to supply new ideas, new methods and new materials to the manufacturers of MAZDA Lamps.

But here at the Panama-Pacific Exposition you will find a MAZDA exhibit that will give you a tangible idea of what MAZDA Service does and is—how, by its service to the lamp makers, it steadily brings more light into your home at less cost—and why the Exposition chose the MAZDA Lamp for its Illumination.

GENERAL ELECTRIC COMPANY



46 24

Please Mention Popular Mechanics

MAKE \$250.00 A MONTH

Repairing AUTO-Tires

MOBILE

Sounds like a lot of money
 —IT IS—A WHOLE LOT OF MONEY
 to be earning CLEAR every month—yet it's
 what hundreds of men we have established in the
 Automobile Tire Repair Business are making.

You let down the DRAW BRIDGE for SUCCESS to enter into
 your career by getting into business for yourself. The business for
 you is the one where investment is small—the returns quick and for cash
 —where the margin of profit is large—the demand for your PRODUCT or
 SERVICE constant and ever on the increase.

A Haywood Tire Repair Equipment

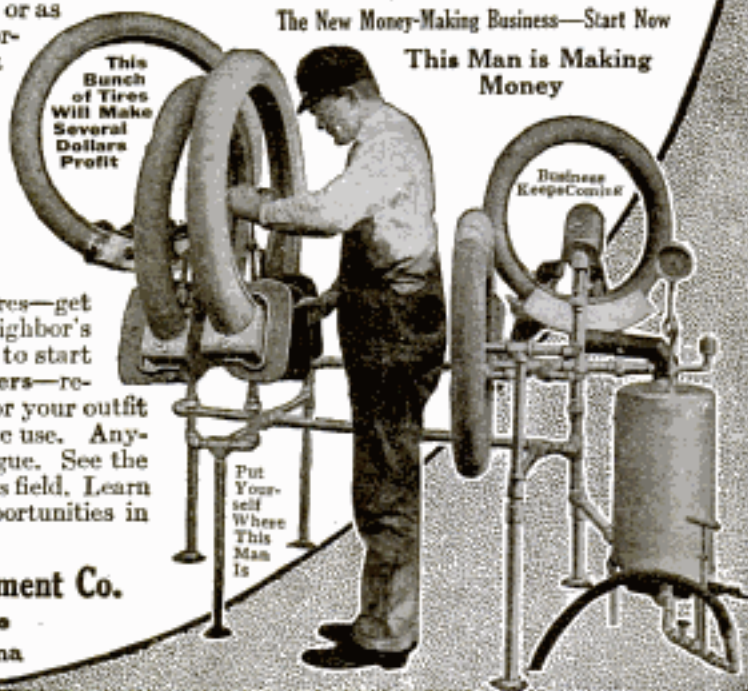
answers to all of these requirements of Old Dame Fortune—the certainty of success in this
 business is as sure as anything in this world can be—Each year adds thousands of new
 Automobile Owners—they need YOU to keep their tires in service.

Here Is Your Opportunity!

Be first to enter this new big paying business in your town. Open your pockets. Let the dol-
 lars pour in. Act quick. Every auto sold means more tires to mend. Automobile business is
 growing fast—enormous field for tire repairing. Punctures and blowouts are common. Tires need
 retreading and vulcanizing. Something going wrong all the time. Thousands forced to buy new
 tires because they can't get old ones fixed. Think of the old bicycle days—repair shops on every
 corner—all making money—busy day and night. Autos make same proposition over again—only
 ten times bigger and better. Users of Haywood Tire Repair Plants are making big money. Johnson,
 Tex., writes: "I have made as high as \$18 in a day." Another man who bought a plant Septem-
 ber, 1911, writes he has cleared over \$3000.00. That's going some! Operate a plant as side line
 in connection with auto business—garage or as
 an independent business. Find neighbor-
 hood where there's a bunch of autos—get
 all the steady business besides transient
 work. Experience unnecessary. You learn
 quick. Simply follow directions—practice
 a few days on a couple of old tires and
 you'll be ready to coin money Business
 comes fast and easy.

The New Money-Making Business—Start Now

This Man is Making
 Money



This
 Bunch
 of Tires
 Will Make
 Several
 Dollars
 Profit

Business
 Keeps Coming

Put
 Your-
 self
 Where
 This
 Man
 Is

Repair Tires At Home.

Young men! and boys repair father's tires—get
 money he pays garage man. Get the neighbor's
 work. Make money to attend college or to start
 a garage and repair business. Auto owners—re-
 pair your own tires—save money—pay for your outfit
 in short time. We have outfits for home use. Any-
 how investigate. Send today for catalogue. See the
 wonderful possibilities in this marvelous field. Learn
 of the enormous money-making opportunities in
 this fascinating new business.

Haywood Tire & Equipment Co.

884 N. Capital Avenue
 Indianapolis, Indiana

"I Can Run It— It Isn't Heavy"

It's not heavy—that's one of the many advantages of this Western Electric Vacuum Cleaner. The easy-running qualities are the first thing to be remarked by every woman who tries it.

Then the design is such a pleasant change from all previous styles of vacuum cleaner construction. Others never got away from the old broom-handle idea. The truss frame of the

Western Electric Vacuum Cleaner

and the comfortable handle grip places the cleaner in a natural position with relation to the body. You can push it without effort and the sturdy motor does the cleaning.

Here is a machine with a reputation back of it—more than thirty years of manufacturing experience. The price is \$32.50, which includes an extension for cleaning under low furniture. We believe this represents the greatest value in the vacuum cleaner market.

Write for booklet No. 5-AW, and name of our representative in your locality.

WESTERN ELECTRIC COMPANY

Manufacturers of the 8,500,000 "Bell" Telephones
463 West St., New York City

Houses in all Principal Cities.

**EQUIPMENT FOR
EVERY ELECTRICAL NEED**



The Cleaner
NOT Built Like a Broom

Please Mention Popular Mechanics

Something
New



"100 MILES
for 10 cents"

Price
Only **\$125**

Weight Only 110 lbs.



YOU can soon save more than the cost of a Miami Motor Bicycle in the amount of time and travel expense it will save you. The pleasure and satisfaction you get from owning and riding your own motor vehicle costs you practically nothing.

Imagine a self-propelling machine much stronger than a pedal-driven bicycle and almost as easy to operate; much lighter than a motorcycle and without its mechanical complications; as safe to run as a bicycle, but without the exertion required to run either kind of machine—then you have a good idea of

THE MIAMI MOTOR BICYCLE
SAFE · SILENT · CLEAN
WEIGHS 110 Lbs. COSTS \$125⁰⁰

Except for high speed, it will do everything that a motorcycle can do—and it costs only a fraction as much. It will take you across country, up and down the hills, and to and from school or work at from four to twenty-five miles an hour—fast enough for business or pleasure with safety.

If you can afford to pay car fare, or know how to manage a bicycle, you cannot afford to be without a Miami Motor Bicycle.

Write us for Free Booklet telling all about the Miami Motor Bicycle.
You can buy one from your Dealer, or direct from our factory.

THE MIAMI CYCLE & MANFG. CO.

"America's Greatest Cycle Makers"

600 Mobile Ave.

MIDDLETOWN, OHIO

Please Mention Popular Mechanics

EVINRUDE + ROWBOAT = MOTORBOAT

EVINRUDE

Make up your mind now that *this* summer you will own an Evinrude. It clamps in a moment to any kind of craft—rowboat, sailboat or canoe—and can be carried anywhere as easily as a valise.

Made in 2 H. P. and 3½ H. P. sizes. Drives a rowboat 7 to 8 miles an hour—a canoe 10 to 12 miles. Runs four hours on less than a gallon of gasoline. The 1915 model has waterproof magneto built into flywheel, Maxim Silencer and automatic reverse.

Send today for free catalog and name of Evinrude dealer in your town.

EVINRUDE MOTOR COMPANY

No. 31 Evinrude Block MILWAUKEE, WIS., U. S. A.

Distributing Branches:

69 Cortlandt St., New York, N. Y. 218 State St., Boston, Mass.
436 Market St., San Francisco, Cal. 182 Morrison St., Portland, Ore.

**DETACHABLE
ROWBOAT AND
CANOE MOTOR**





*A Few
Harley-Davidson
1915 Features*

Three-Speed Sliding Gear
Transmission.

11 Horsepower Motor.

Enclosed Valves.

Automatic Mechanical
Oil Pump.

Step-Starter.

Improved All-Steel Muffler.

Harley-Davidson Hubs.

Harley-Davidson Band
Brake.

Harley-Davidson Clutch.

Double Clutch Control.

Ful-Floteing Seat.

Electric Lighting Equipment
if Desired.



Why The 1915 Harley-Davidson Won The National Championship

THE winning of the one hour National F. A. M. Championship by a strictly stock Harley-Davidson at Birmingham, Alabama, proved conclusively that the Harley-Davidson was fast—very fast.

But speed alone was not all that was needed. The design, the workmanship, and the materials used, had to be such that the machine could stand the awful grind of mile after mile at terrific speed. And remember this was not a specially made machine but a regular stock model, such as you can buy of any Harley-Davidson dealer.

Here then is proof that the 11 H.P. Harley-Davidson motor (horse power guaranteed) really delivers the power and that the Harley-Davidson automatic oiler pumps oil as perfectly at 70 miles an hour as at 3. The winning of the National Championship corroborated the experience of thousands of Harley-Davidson rid-

ers and was added proof that the 1915 Harley-Davidson had even more 'staying qualities' than the models of previous years. Add to this such comfort features as Double Clutch Control, a simple efficient Three-Speed and extra long Foot Boards and you have a few of the reasons why this is—**Harley-Davidson Year.**

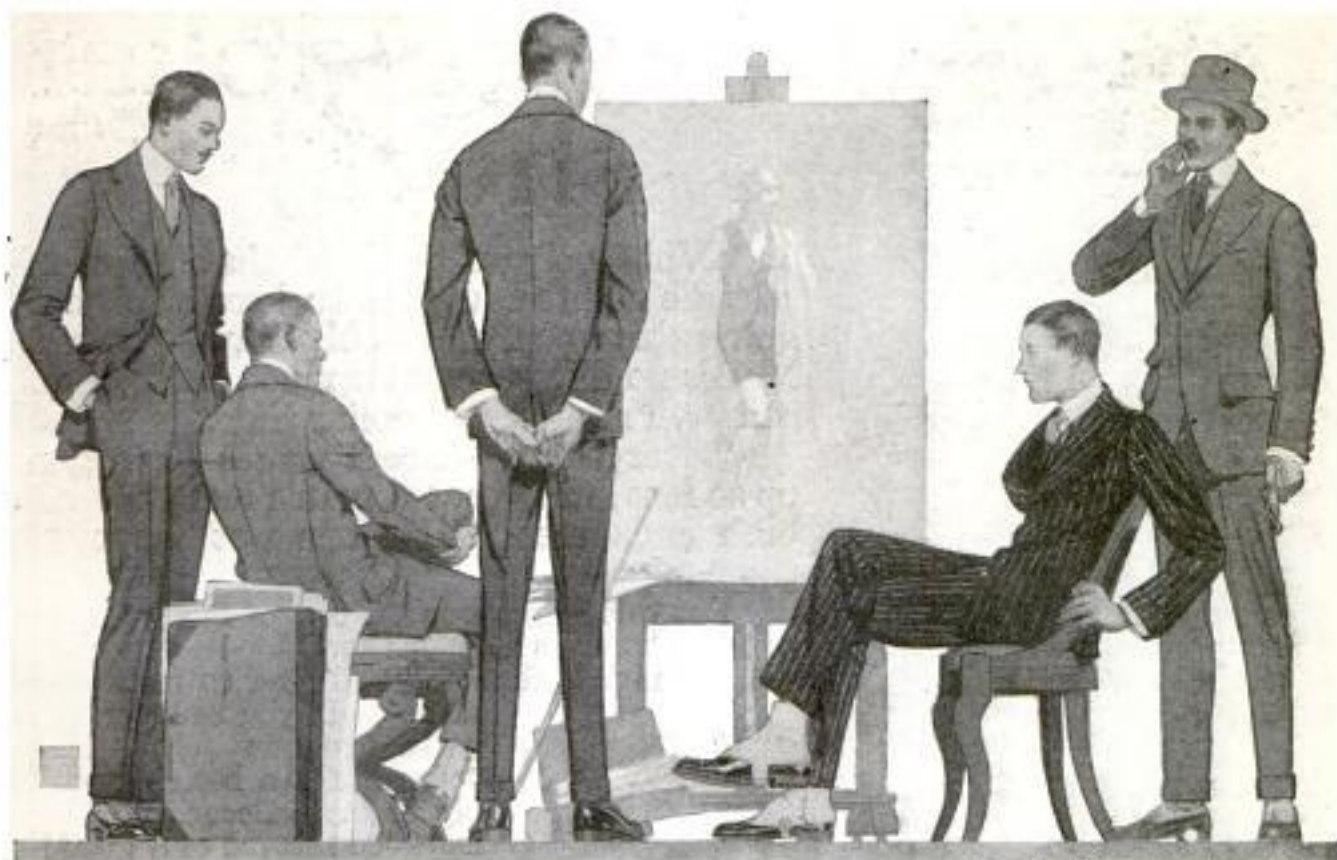
Any Harley-Davidson dealer will be glad to explain to you in detail the many superiorities of 1915 Harley-Davidson or if you desire we will gladly send you a catalog on request.

Harley-Davidson Motor Company

Producers of High Grade Motorcycles for Nearly Fourteen Years

411 B Street

Milwaukee, Wis.



Copyright 1915 Hart Schaffner & Marx

Varsity Fifty-Five for young men

Young men are going to "get the idea" of our Varsity Fifty-Five sack suit the minute they see it; it's a snappy, stylish model that any young man with the right taste for style will want to wear.



Good clothes like these are not expensive either; for \$25, you'll get splendid quality. You can pay more or less and get value for what you pay. Be sure you see our label; a small thing to look for, a big thing to find.

Hart Schaffner & Marx

Chicago

Good Clothes Makers

New York

Please Mention Popular Mechanics

Copyrighted material

Always a dollar short



"What do you think of that? Here it cost me eighteen dollars to keep the house going this week, and I only draw seventeen. Makes no difference how much I pinch and scrape, I'm always a dollar short.

"Everything—**except wages**—has gone up so fast lately that a man's lucky to make both ends meet, let alone put money in the bank."

Has this increase in the cost of living hit you? Are you "always a dollar short?"

Then it's high time you began to make more money. If you can't do it at your present job, prepare yourself for a better one and bigger pay. Become a **trained man**—be assured of a good income and steady work the year 'round, no matter what conditions may be.

How you can make more money

Training—that's what you need to get the fat pay envelope. And you can get this training easily, without giving up your work or leaving home.

For over eighteen years the **American School** has been training men throughout the world for responsible, well-paid positions. It has prepared thousands for entrance into the big resident colleges. It has trained even more in all branches of **Engineering, Business and Law**. The **American School** will give you the training you need to make more money, no matter where you live or what you do. Remember, you don't have to give up your work—we train you at home, in your spare time. Not only this, but you can pay for your course as you progress.

Fill in and mail the coupon—it's the first step toward becoming a **trained man**.

American School

of Correspondence, Chicago, U.S.A.

Your Opportunity Coupon

Mark the position you want and mail the coupon now

- | | |
|-------------------------------|--------------------------|
|Electrical Engineer |Lawyer |
|Elec. Light & Power Supt. |Business Law |
|Hydroelectric Engineer |Business Manager |
|Telephone Engineer |Auditor |
|Architect |Accountant |
|Architectural Draftsman |Cert'd Public Acct't |
|Building Contractor |Private Secretary |
|Building Superintendent |Stenographer |
|Structural Engineer |Bookkeeper |
|Structural Draftsman |Fire Ins. Inspector |
|Mechanical Engineer |Fire Ins. Adjuster |
|Mechanical Draftsman |Fire Ins. Expert |
|Civil Engineer |Sanitary Engineer |
|Steam Engineer |Plumber |
|Shop Foreman |Reclamation Eng. |
|Shop Superintendent |Textile Boss |
|Sheet Metal Draftsman |College Preparatory |

We also prepare for civil service examinations in all engineering subjects

NAME

ADDRESS

Pop. Mech. 4-15

This school has no connection with any other school using the name "American"

Please Mention Popular Mechanics

1/3 SAVED BUY DIRECT FROM MANUFACTURER

J. HARDIN COMPANY
CHICAGO

GUARANTEED GRADE A FIXTURES

Our Highest Grade Guarantee Label appears on all fixtures

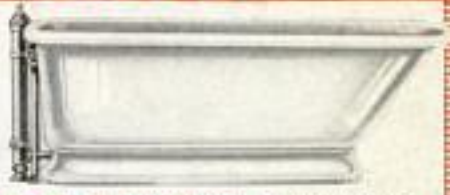
We refund your money if goods are not found as shown and described



No. 67-Zenda Bathtub. Highest grade porcelain enameled. Has our latest designed body and 3 1/2" rolled rim; legs put on with our patented non-come-off attachments; fitted with heavy pattern N. P. Fuller Bathcock, heavy pattern adjustable N. P. Brass Waste and overflow and our N. P. Iron Pipe Supply pipe connections. Width over all 30", height from floor to top of rim 22 1/2", depth inside 17 1/4". Complete as shown and described, 4-ft. \$14.35, 4 1/2-ft. \$14.35, 5-ft. \$15.25, 5 1/2-ft. \$17.45, 6-ft. \$20.75.



No. 69-Modern Siphon Wash-down Closet Outfit. Tank has re-inforced copper lining with heavy trimmings, 2" N. P. connection. Seat re-inforced; heavy brass N. P. Bar Hinges. Highest grade vitreous china bowl; complete with N. P. supply pipe to floor threaded for iron pipe. Oak or Mahogany, \$9.50.



No. 68-Chicago Bathtub. Highest grade porcelain enameled. Has our latest designed body and 3 1/2" roll rim; on extension base with our patented non-come-off attachments; fitted with heavy pattern china indexed Royal Ideal Waste, heavy N. P. Fuller Bathcock, heavy N. P. brass tubing supply pipes with iron pipe connections. Width over all 30", height from floor to top of rim 22 1/2", depth inside 17 1/4". Complete as shown and described, 5-ft. \$21.90, 5 1/2-ft. \$24.75.



No. 70-Latest Pattern Vitreous China Closet Outfit with highest grade Roman pattern vitreous china tank fitted with heavy brass trimmings, and 2" N. P. flushing connection. Re-inforced Mahogany seat with heavy brass N. P. bar hinges, highest grade vitreous china siphon wash-down bowl; complete with N. P. brass supply pipe to floor threaded for iron pipe, \$12.00.



No. 68-New Tiled-in Roman Bathtub. Highest grade porcelain enameled on inside and outside. Latest pattern 3 1/2" flat turned over rim, new Roman body, fitted with heavy china indexed Royal Waste and compression indexed supply faucets. Supplies fitted with iron pipe connections. Water enters through our new bell delivery. Width over all 31", height from floor to top of rim 22 1/2". Complete as shown and described, 5-ft. \$75.00, 5 1/2-ft. \$80.00.

No. 71-New Design Serpentine Vitreous China Closet Outfit. Highest grade vitreous china serpentine tank, with latest heavy pattern trimmings and 2" N. P. flushing connection. Highly polished re-inforced mahogany seat with heavy brass N. P. bar hinges, highest grade vitreous china siphon wash-down bowl. Complete with N. P. brass supply pipe to floor, threaded for iron pipe, \$12.95. With Siphon Jet Bowl, \$15.95.



No. 73-New Design Serpentine Drop Apron Lavatory. Size 18 x 24. Back 10", D shaped basin 11 x 15. Highest grade porcelain enameled one piece lavatory on concealed wall hanger; concealed integral overflow; heavy pattern, low down china indexed compression basin faucets, marked hot and cold; 1 1/4" heavy pattern adjustable N. P. brass trap to floor or wall; adjustable N. P. concealed brass supplies with iron pipe connections. Complete as shown and described, \$9.45.



No. 72-16x19 Lavatory. 6" back and D shaped basin, 11x14. Highest grade porcelain enameled one-piece lavatory on concealed wall hanger. Concealed integral overflow, heavy pattern low-down china indexed compression basin faucets, marked hot and cold. 1 1/4" heavy pattern adjustable N. P. brass trap to floor or wall. Adjustable N. P. concealed brass supplies with iron pipe connections. Complete, as shown and described, \$5.95.



No. 77-Long Drop Apron 1-Pc. Sink. Highest grade porcelain enameled sink combination with drop apron sink, back and drainboard, all cast in one piece, supported on concealed wall hanger; two porcelain enameled adjustable legs so that sink can be set at any height; two 1/2" N. P. flanged faucets; 1 1/2" heavy pattern N. P. brass adjustable trap to floor or wall. Size of sink 20x30", height of back 12". Size of drainboard 20x24", entire length over all 54". Furnished with right or left hand drainboard. Complete as shown and described, \$28.25.

No. 74-Colonial Pedestal Lavatory. Highest grade porcelain enameled lavatory and pedestal with concealed integral overflow, heavy N. P. Fuller Basin Faucets, 1 1/4" heavy pattern adjustable N. P. brass trap to floor or wall, adjustable N. P. concealed brass supplies with iron pipe connections; size 20x24", D shaped basin 11 x 15". Complete as shown and described, \$13.90.



No. 75-1-Pc. Roll Rim Sink and Back with Reversible Drainboard.



Highest grade porcelain enameled one-piece rolled rim sink, supported on concealed wall hanger; two 1/2" N. P. flanged faucets; 20x24" porcelain enameled rolled rim reversible drainboard on concealed bracket; 1 1/2" heavy pattern N. P. adjustable brass trap to floor or wall. Size of sink 20x30", height of back 12", length over all 50". Complete as shown and described, \$11.95.



No. 76-Long Roll Rim 1-Pc. Sink. Highest grade porcelain enameled rolled rim sink combination with rolled rim sink, long sink back and drainboard, all cast in one piece, supported on concealed wall hanger with two adjustable legs so that sink can be set at any height. Two 1/2" N. P. flanged faucets, 1 1/2" heavy pattern N. P. brass adjustable trap to floor or wall. Size of sink, 20x30; height of back, 12". Length over all 53". Furnished with right or left hand drainboard. Complete as shown and described, \$17.95.

Our prices on this sheet are for fixtures complete as shown and described. All supplies are threaded for Iron Pipe Connection.

We carry absolutely everything in Highest Grade Guaranteed Plumbing and Heating Supplies Exclusively

35 YEARS AT 4533-43 COTTAGE GROVE AVENUE, CHICAGO

Send for Our Complete Catalog No. 62

Name _____

Address _____

These prices are for cash with order only

Williams'

Shaving
Luxuries—
Stick,
Powder,
Cream.



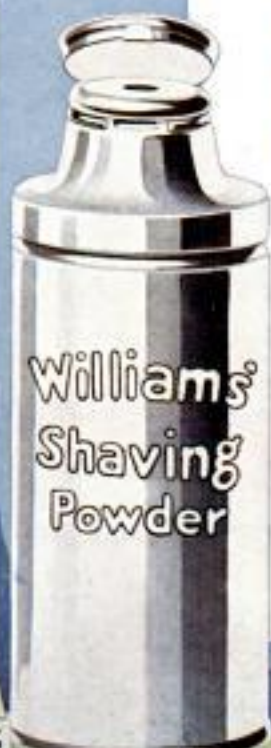
You get in Williams' Shaving Soap a soap that instantly provides a rich, creamy, abundant lather—

a lather that stays moist on the face, softens the beard and leaves the skin refreshed—

and you get in addition a choice of four convenient forms, so that you may have the shaving comfort that Williams' Shaving Soap guarantees in the form you like best.

Send 4c in stamps for trial size of any one of the articles shown.

Address Dept. A
The J. B. Williams Co.
Glastonbury, Conn.



WILLIAMS