

15 CENTS

# POPULAR MECHANICS MAGAZINE

WRITTEN SO YOU CAN UNDERSTAND IT

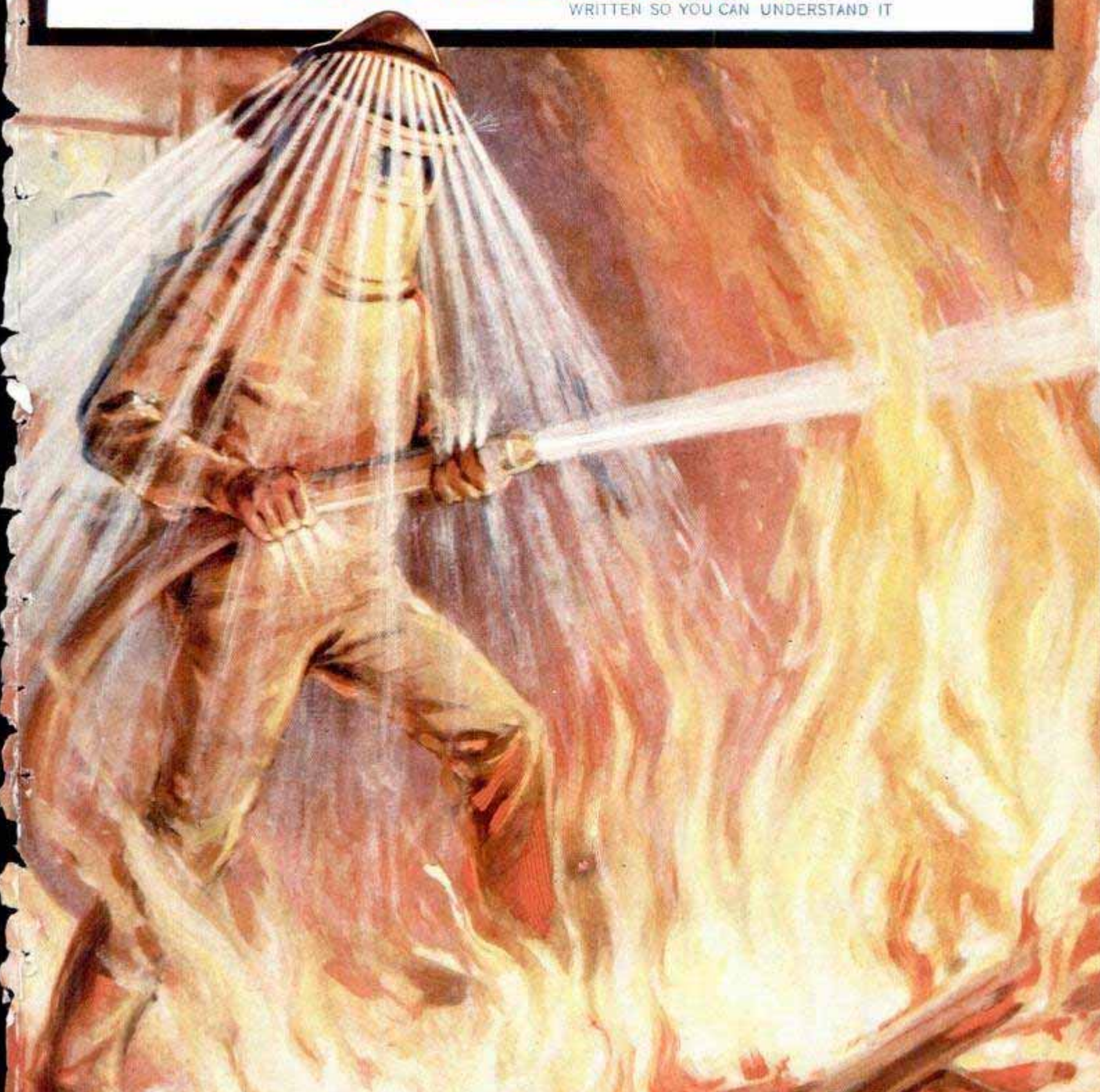

# Material to Build This Home Only <sup>\$</sup>673

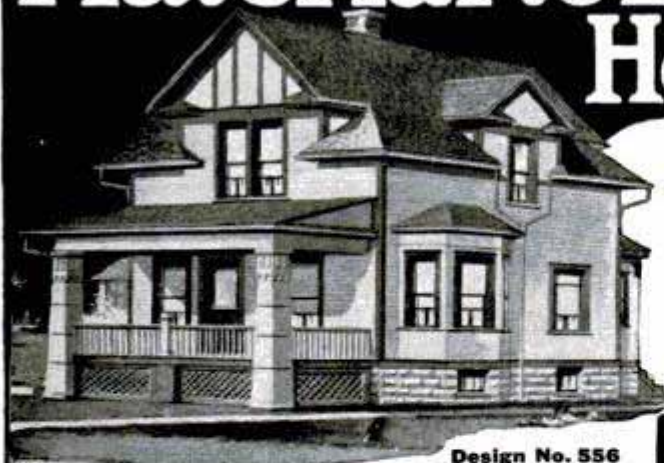

Design No. 556

**\$673** One of our beautiful, modern homes. Six rooms, bath, pantry. Symmetrical exterior—up-to-date interior. Standard construction throughout. Size 21 ft. 6 in. by 28 ft.

## 35% to 50% Saved

### All Building Material Prices Smashed!

Never before has there been an epoch-making offer like this to enable every man to own his own home. No matter how limited your means, you can now buy the material to build any one of these beautiful homes at smashed prices that have never before been heard of for absolutely brand new stock backed by our iron-clad guarantee. We actually save you from 1/3 to 1/2 on complete building—save you middleman's profit.

## Not One Cent Down

### Remarkable Offer

Think of it—we ship you a carload of building material valued anywhere from \$500 to \$1000 **without one cent down**, without a penny in advance—that makes you absolutely safe. We take all the risk and back up every claim and offer with our tremendous \$10,000,000 capitalization and unquestioned reputation for integrity and square dealing. Our stupendous purchasing power for spot cash brings us bargains no one else in the world can duplicate—you get the benefit in wonderful savings. In addition the expert knowledge of our complete Architectural Department enables you to get most practical, up-to-date homes, built without waste to please every taste and every purse. We help you free of charge—give you authentic Blue Print Plans, Specifications,—all this service without a cent of extra charge.

## Our \$50 Free Plan Offer

We will send a complete set of Blue Print Plans of any design in the above Book or on this page, including Specifications and full Descriptive Material List, giving the size, grades, and catalog numbers of material used in construction upon receipt of a temporary deposit of \$2.00, the entire amount of which is credited you when you order, or if plans do not suit and you return them we will refund you all but 50 cents of your remittance.

## \$10,000 Book of Plans Free

Mail coupon below at once and get this most wonderful book sent absolutely free anywhere in the United States. Over 100 pages full of modern, beautiful, practical designs that will simply amaze and delight you. A book that every person needs and should have—full of suggestions and valuable information. Sent outside of U. S. upon receipt of 25c.



Design No. 10

**\$389** Five Rooms with or without Bath. Big Bargain. Size 20 ft. by 20 ft.



Design No. 55

**\$743** Six Rooms and Bath, all rooms convenient and roomy. Size 22 ft. by 31 ft.

### High Grade Bathroom Outfits!



Here is an illustration of a bathroom outfit we are selling at \$37.50. Your plumber would ask you about \$60 for this same outfit. It is only one of many other complete outfits that we are offering at prices from \$35 to \$50.

**Free Catalogs** Send now for Special Building Material Catalog No. 103, Plumbing Catalog No. 137, Heating Catalog No. 140, Furniture and Rugs Catalog No. 134. Latest and best features—absolutely lowest prices.



## Our Guarantee Protects You

Our guaranteed proposition to you is to furnish material *all brand new stock*, in quantities sufficient to complete design strictly according to plans. Prompt shipment of order. This guarantee is backed by our well known reputation for honest dealing and tremendous capital. You can order from us with positive safety.

**Capital Stock \$10,000,000**



Design No. 50

**\$998** Eight Rooms and Bath, very attractive Exterior; Five Closets, Airy Balcony. Size 28 ft. by 28 ft.

## Send this Coupon

**HARRIS BROTHERS COMPANY,**  
Dept. CWX7, Chicago, Ill.

Send me free your \$10,000 Plan Book; full information on

Name .....

Town .....

County ..... State .....

**Harris Bros. Co.**  
Dept. CWX 35<sup>th</sup> & Iron Sts. Chicago



## Dancing is delightful to the music of the Victrola

Every one enjoys dancing to music of such splendid volume, such clearness and perfect rhythm—and the Victrola plays as long as any one wants to dance.

The Victrola brings to you all kinds of music and entertainment, superbly rendered by the world's greatest artists who make records exclusively for the Victor.

Any Victor dealer will gladly play the latest dance music or any other music you wish to hear. There are Victors and Victrolas in great variety of styles from \$10 to \$500.

**Victor Talking Machine Co., Camden, N. J., U. S. A.**

Berliner Gramophone Co., Montreal, Canadian Distributors



This One



New Victor Records demonstrated at all dealers on the

**Burlington Watch Company**  
19th St. and Marshall Blvd., Dept. 8195 Chicago, Ill.

Please send me (without obligation and prepaid) your free book on watches, with full explanation of your cash or \$2.50 a month offer on the Burlington Watch.

Name .....

Address .....

## Send the Coupon For Book of Designs

**WRITE** today for our book of new designs in watches. The new Burlington Watch cases are the latest triumphs of the master goldsmiths—the very acme of the gold designers' art. You must see them yourself to realize their exquisite beauty. The New Inlay Enamel Designs are carved in gold and inlaid with carmine, ultramarine, royal purple and other colors of genuine French enamel you may select. Many of the cases shown in our new watch book are exclusive Burlington designs. You should see especially the **Inlay Enamel Monograms, Block and Ribbon Monograms, Diamond Set, Lodge, French Art and Dragon Designs**, in art colors which we will send you free.

### The Movement

For the purpose of this sweeping *direct* offer, the Burlington Watch Company selected its finest watch. The 19 imported ruby and sapphire jewels represent maximum time keeping efficiency.

Adjusted to temperature *and* adjusted to isochronism *and* adjusted to positions—the Burlington watch is subjected to the most rigid tests—tests that require months after the watch is completed. Then after being fitted at the factory into its proper case, every Burlington watch is retimed so as to meet the highest standard of quality.

**New Book on Watches  
Mail Coupon Above**

## Special! Burlington Offer

The Superb Burlington Watch now offered at the *direct* rock-bottom price—the same price that **even the wholesale jeweler** must pay—and in order to encourage everybody to secure this watch at once, you may pay this rock-bottom price, either for cash or \$2.50 a month on this great special offer! We send the watch on approval, **prepaid**. You risk absolutely nothing—you pay nothing, not one cent, unless you want this *exceptional* offer after seeing and thoroughly inspecting the Burlington watch.

### Learn the Inside Facts

about watch prices, and the many superior points of the Burlington over double-priced products. Just send the coupon above or letter or postal. Get this offer while it lasts.

**New Book on Watches  
Mail Coupon Above**

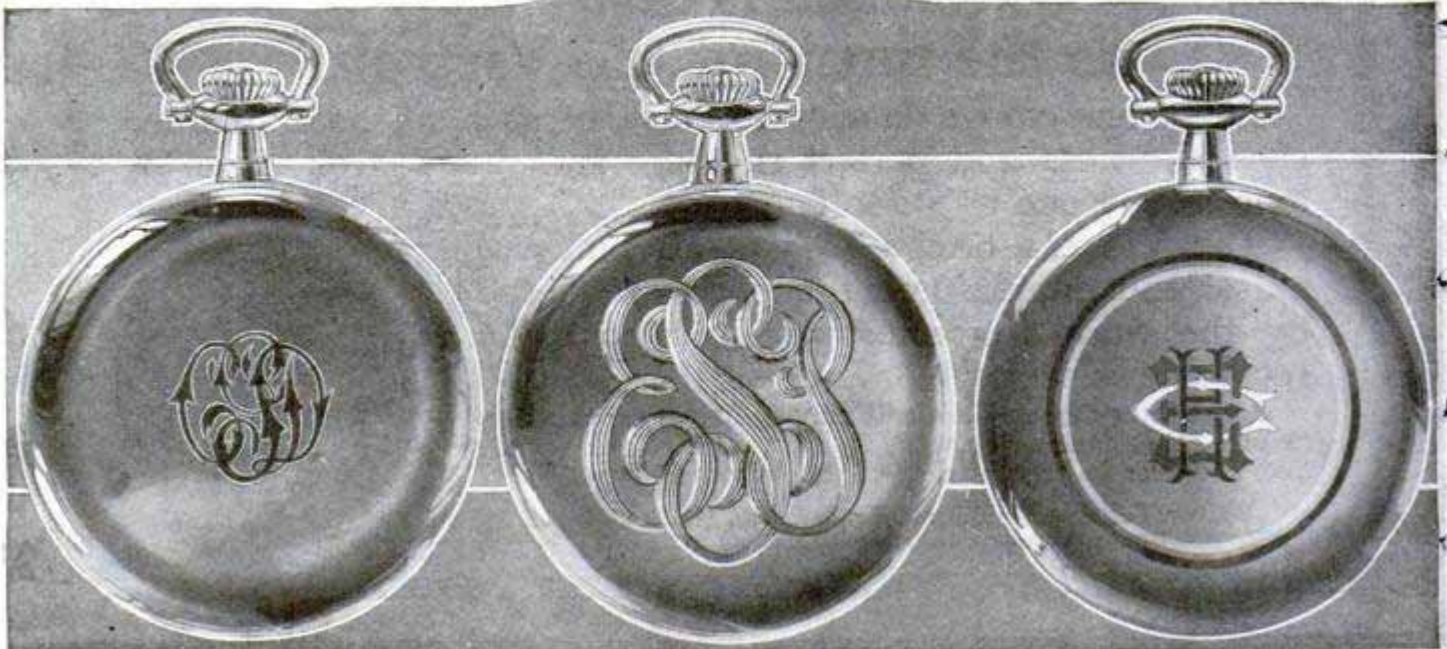

# Popular Mechanics Magazine

6 N. Michigan Avenue, Chicago, U. S. A.

EDITED BY H. H. WINDSOR

ISSUED MONTHLY

SUBSCRIPTION:

SINGLE COPY, 15 CENTS

In United States, and its possessions, Cuba and Mexico, per year, postpaid - - - \$1.50  
To Canada - - - - - 1.75  
To all other countries in the Postal Union - - - - - 2.50

All subscriptions are discontinued at expiration. Please examine the date printed on your wrapper.

Entered as Second Class Matter Sept. 15, 1903, at the Post Office at Chicago, Illinois, under Act of March 3rd, 1879.

Entered as Second Class Matter at the Post Office Department, Canada.

Published monthly by POPULAR MECHANICS CO.

Copyrighted 1914, by H. H. WINDSOR.

The schedule of rates for advertising space in this magazine is based on a guaranteed circulation of 350,000 copies each month. Any issue where the actual number of copies printed and circulated is less than the guaranteed circulation, a pro rata discount will be allowed.

## Contents for May, 1914

Aerial Machines, Transferring Articles to.....	667	Dam, Big Creek, Now Finished.....	725
Aeronautic Station, Naval, at Pensacola.....	644	Dam of Soda, Natural, in New Mexico.....	720
Aeroplane Control, New, Less Tiresome.....	626	Dinner, Upside-Down, Given to Airmen.....	662
Aeroplane Corps, Militia, California to Form....	623	Dishes, Pan and Rack for Drying.....	699
Aeroplane Flight, Long, German Airman Sets New Record in.....	652	Dog, Combination, for Lathes.....	702
Aeroplane Flights, Record-Making, by Russian..	648	Dolls, Mexican Indians Make.....	704
Aeroplane Hauled through City Streets.....	650	Drydocks, Great Floating, in German Shipyards..	630
Aeroplane Scouts in Warfare.....	720	Egg Tester to Replace Candle.....	720
Aeroplane, Transatlantic, to Have Silk Wings..	646	Electric Line, Curious Ceremony Opens.....	721
Air Gun and Target New French Toy.....	704	Electric Locomotives in Transit to Panama.....	621
Airmen, Government Puts to Rigid Tests.....	688	Electricity—High Power Lines, Protection against	625
Airship, German, to Fly at San Francisco Fair	656	Electromagnet, Strongest, is Built in France...	658
Alps, Iron Spikes Give Aid in Scaling.....	685	Eskimo Medicine Man Driving Out Evil Spirits..	708
Arc Lamp with a Chimney.....	700	Explosions, Mill Dust, Government Experts Study	691
Arch, Largest Masonry, under Construction.....	689	Exposition, San Francisco, Color Scheme for....	706
Atlantic, Trip across.....	677	Express Wagon, New System Calls.....	701
Automobile, Armored, for Mexican Rebels.....	643	Fan to Produce Changing Breezes.....	692
Automobile, Bungalow on.....	708	Feed Water Softener, German.....	702
Automobile, Cape-Cairo, Carries Large Gasoline Supply.....	620	Fences, Drift, on National Forest Ranges.....	662
Automobile Jacks, Foot Attachment for.....	703	Fire Engine Makes Long Pumping Record....	650
Automobile Military Field Kitchen, New.....	724	Fires in Mountain Forests, Watching for.....	671
Automobile Testing in a Modern Plant.....	638	Firemen, Salamander Suit Screens from Flame...	675
Automobile Tires, Jack for Relieving.....	706	Fireplaces of All the World—V, VI.....	732
Automobiles, American, Lead in Self-Starting Feature.....	668	Fire, Spectacular Night, Lives Lost in.....	648
Beads, Machine Strings Quickly.....	695	Fish, Bicycle, Seen in Hawaii.....	638
Bed Inclosed by Folding Screen Panels.....	693	Flax Straw, To Make into Yarn and Twine.....	718
Bicycle, New Standard to Support.....	663	Float is a Good Imitation of a General Smash-Up.	617
Bootblack, English, Has a Strange Customer....	632	Flood in Los Angeles, Results of.....	618
Boring a Hole, Eskimo's Method of.....	736	Flood, Protecting Bottom Lands from.....	672
Bridge, Suspension, Laying the Floor of.....	624	Flowers Lend Charm to Busy City Streets.....	726
Building, Tallest West of the Mississippi.....	657	Flying Boat has Novel Control.....	655
Bunsen Burners, Telescoping Attachment for....	705	Flying Boat, New, Has Inclosed Cabin.....	670
Bus, New Electric, Proposed.....	646	Flying Boat Weighs Five Tons.....	708
Camp, Portable, Carried on Automobile Running Board.....	628	Fog, Using an Oil Film to Prevent.....	675
Canals, How Martians Made.....	702	Forests, Replanting.....	632
Canoe Made of an Empty Barrel.....	734	Fossils, Quarrying in Wyoming.....	723
Car, Dump, Operated by Electricity.....	728	Furnace, Electric, for Making Glass.....	700
Cave, Artificial, for Cold Storage.....	734	Fuse Plug That can be Rewired.....	692
Chair, High, Folding Device Makes.....	717	Game Trap, Natural, Found in Northern Mexico	715
Cherries, Handy Bag for Picking.....	667	Garden of Eden, Irrigation to Restore.....	626
Circus Performers Hang by Their Hair.....	620	Gasoline Can Safety Device, Outdoor.....	695
Clock, Hotel Alarm, of Novel Construction.....	709	Goggles, Automobile, to Relieve Eyestrain.....	701
Coaling Device for Locomotive.....	717	Grain, Feterita is New.....	701
Coaling Station, Floating Naval.....	722	Grenade That is Fired from a Rifle.....	684
Colliers for Serving the Panama Canal.....	734	Gun Barrels, European, Proof Marks on.....	706
Comment and Review, by H. H. Windsor.....	639	Gun, Machine, on Armored Aeroplane.....	630
Concrete Form, Novel Bracing for.....	636	Guns, Great, How Hoisted.....	635
Cooking Utensils, Odorless.....	731	Hay, Curing Artificially with Steam Heat.....	670
Cork, Rubber Sleeve Holds in Bottle.....	704	Hedge Trimmer Operated by Electricity.....	659
Corn Popping Machine, Automatic.....	654	Horseshoeing in Paris Streets.....	635
		Hose, Ladies', Paris Sets New Style in.....	736
		House Plans—Brick Cottage of Moderate Cost...	770
		Ice Cream Freezer, Crankless.....	692
		Ice Saw, Power Driven, Recent Invention.....	663

[Continued on Page 6]

Popular Mechanics offers no premiums; does not join in "clubbing offers," and employs no solicitors to secure subscriptions. It is for sale by nearly every newsdealer in the United States and Canada.

## Contents—Continued

Iceberg Dangers, Use Motorboats to Scout.....	717	Water Thieves, Mexican Lookout Tower Foils.....	633
Indian Squaw Carrying Fowls to Market.....	690	Water Tower, Movable.....	703
Kipling's Prophetic Vision of Man's Conquest of Time and Space.....	645	Waterways, Artificial, in Many Lands.....	710
Laces, Pillow, Indian Women Make.....	726	Weapons, Confiscated, are Thrown Overboard.....	654
Lamp, Portable Electric, with Many Features.....	716	Wheel, Steel, for Motor Trucks.....	699
Language, World, Europe Feels the Need of.....	693	Wheelbarrow, Old Chinese, Hauls Big Load.....	651
Life Preserver That Fits the Neck.....	672	Wheelbarrow, Shock Absorber for.....	698
Lifeboat, Unsinkable, Has Novel Features.....	623	Window Boxes, Outside, of Metal.....	646
Lifeboat with Deck and Water-Tight Hold.....	715	Windsor, H. H., Comment and Review.....	639
Lifeboats are Equipped with Wireless.....	685	Wireless Aerials, Cathedral Spires Carry.....	674
Loading Device, Motor Truck.....	691	Wireless Heroes, Memorial to.....	659
Locomobile Designed to Burn Heavy Oil.....	731	Wreck—Collision Poises Car on Smokestack.....	622
Mahogany, Single Log Sells for \$8,000.....	707		
Manila Harbor to be Deepened.....	618	<b>SHOP NOTES</b>	
Medal of Honor Given to Colonel Goethals.....	622	Air Hose Uncoupling Lever.....	749
Medals That Army Men may Wear.....	634	Automobile, Heating.....	738
Mercury Vapor, Power Now Obtained from.....	716	Belt Holder for a Shaft.....	752
Military Salute Fired at Scene of Death.....	643	Belts, Lace Hole Marker for.....	749
Mine Rescue, Emergency Hoisting Cage for.....	724	Bolts, Homemade Expansion.....	751
Monument, Alpine, Erected to Captain Scott.....	668	Chalking a Line.....	749
Motorcyclist Saves African Explorers.....	648	Chuck Plate, Universal.....	739
Mountain, Sliding Down, New Alpine Sport.....	634	Clamp, Staging.....	747
Moving Pictures, Agricultural, for the Farmers.....	668	Cottage, Portable, How to Make.....	741
Moving Pictures, Automobile Smash-Up for.....	735	Cubic Contents of Irregular Object, To Find.....	737
Moving Pictures, "Faking" a Thriller for.....	628	Desk, Bed, for an Invalid.....	751
Mowing Machine Made into a Motor Tractor.....	717	Drawing Board Support, Universal Joint for.....	738
Mummy, Manufacturing in Ancient Egypt.....	669	Drawings, Tracing on Heavy Paper, Lighted Box for.....	748
Novel and Practical Things for Daily Use.....	696	Drill Jig.....	750
Odors, Orchestra, for New Concert.....	690	Drill, Twist, To Lengthen.....	749
Oil Mixer Attached to Egg Beater.....	705	Drinking Fountain, Sanitary, for a Shop.....	752
Oven, Baking, of Novel Construction.....	700	Fire Extinguisher.....	738
Panama Canal, Preparing for Sight-Seers at.....	658	Fireplaces, Proper Construction of.....	753
Panama Canal, Slide That Filled the Maw of.....	687	Flywheel Pattern.....	746
Panama Canal Views.....	660	Gas Stoves, Fireproof Stand for.....	745
Panama Canal, Working Model of, for San Fran- cisco.....	666	Gasoline Engine, Marine, Governor Attached to.....	737
Patents, Interesting New.....	768	Gauge, Emergency Pressure.....	745
Patrol Box, Light Calls Policeman to.....	652	Gears for Model Work.....	739
Photographers, Magnesium Lamp for.....	691	Glass Disks, Cutting.....	755
Post, Clothesline, Cheap Way of Building.....	688	Hay, Bales of, Binding on a Wagon.....	751
Posts, Wooden, Fastening to Concrete.....	668	Hook, Sheet Metal Lifting.....	747
Potatoes, New Device for Baking.....	623	Hopper, Clogged, Cleaning.....	755
Prize, \$10,000, for New Tire Material.....	676	Hydrogen Generator, How to Make.....	750
Raincoat, Mexican, Made of Palmetto Leaves.....	676	Key on a Ring, Singling Out.....	740
Rat Infested House, Model of.....	722	Lathe or Planer Tool, Combination.....	752
Refrigerators, Cold Radiator System in.....	698	Memorandum Book Holder.....	740
Resuscitating Apparatus for Forcing Respiration.....	724	Milcan Spout, Drip Catcher on.....	749
Rifle with Binocular Telescopic Sights.....	618	Paintbrush, Extension Handle for.....	747
Roads, Dynamometer Records Pull on.....	728	Phonograph Records, Wax, Used for Insulation.....	754
Rope Makers, Technical Terms Used by.....	686	Pill Dispensing Box.....	745
Sawmill, Primitive, Used by Filipinos.....	719	Pipe Line, Temporary, Attached to a Tank.....	748
Scale, Zigzag, Graduated Glass with.....	718	Pipe Threads, Holding in a Lathe Dog.....	756
Scissors, Automatic Hone Sharpens.....	705	Sand Bucket for Loosening Dirt.....	747
Seesaw, Novel, for the Children.....	694	Scraping Knife, Refuse Holder on.....	755
Shingles, Fireproof, Government Experts Seek.....	638	Silver, Removing Tarnish from, by Electricity.....	752
Ship Cut to Pieces with Oxyacetylene Flame.....	652	Soldering Iron, Shank for.....	756
Shoe, Fastener Holds Tongue in Place.....	692	Steam Engine Piston Rings, Placing.....	755
Sign, Motor Car, Carries "Red Hand of Ulster".....	656	Stock, Round, To Prevent Slipping on Planer Bed.....	747
Silos, Remarkable, Built of Concrete.....	714	Switch, Simple Electric Pull Socket.....	737
Skates, Rubber, Now Part of Soldiers' Kit.....	621	Tack Puller on a Putty Knife Handle.....	739
Sleeping in the Open, Practical Devices for.....	664	Threading Tools, Clearance Groove for.....	740
Soap, Liquid, Container for.....	694	Trestle, Adjustable Balancing.....	756
Soldering Iron, Compact Self-Heating.....	687	Violin Strings, Wire, To Prevent from Cutting Bridge.....	740
Soldering Iron, Electrically Heated.....	693	Wood, Tapering on a Joiner.....	756
Spring, Cantilever, Gives Flexibility.....	695		
Steam Engine, New Type of.....	699	<b>AMATEUR MECHANICS</b>	
Sundial, Large, Marks Time of Day in Park.....	647	Boats, Small, Landing for.....	761
Swimming Tank, Concrete, Easily Constructed.....	730	Bottle, Wash, for Laboratory Use.....	762
Tailors, Cairo, Iron with Their Feet.....	688	Developing Machine.....	760
Tangoing by Machinery Newest Feature.....	666	Drawer Guide, Nonsticking.....	767
Teeth, Austrian Inventors Find New Way to Make.....	629	Dry Batteries, Renewing.....	766
Telephone Line Strung on Kites.....	703	Fishhook, Automatic.....	765
Telephone, Traffic, in Germany.....	651	Heating Apparatus, Electrical, for the Home.....	763
Thumb Print to Identify Works of Art.....	670	Hoe, Pointed End on.....	762
Timekeeper, Automatic, Electrically Operated.....	707	Jelly Straining Stand.....	766
Tires, Automobile, Making Punctureless.....	700	Nails, Driving to Prevent Splitting.....	765
Tool, Convertible, Has Many Uses.....	636	Oilstone, Cleaning.....	761
Torpedo Boat in Storm Almost Submerged.....	720	Pails, Carrying Two in One Hand.....	766
Torpedo Practice, German Warship in.....	729	Paint, Preserving in Open Cans.....	766
Tractor, Egyptian Farm, 1914 B. C. Model.....	730	Pencil Sharpener.....	761
Trains, English Railway, Speed of.....	736	Purse, Puzzle.....	760
Tree, Eucalyptus, Water Hydrant Imbedded in.....	716	Sandpapering Machine, Emergency.....	760
Tree, Palm, Growing Through a Roof.....	662	Siphon, Starting.....	762
Trees, Big, Transplanting without Injury.....	714	Stove Wood Carrier.....	761
Tug, Powerful Seagoing, for Portland.....	689	Telegraph Code on Typewriter Keys.....	759
Tugs, Air Driven, to Tow Canal Boats.....	694	Typewriting on Card Stock.....	762
Tungsten Largely Used in Electricity.....	620	Windmill, Power.....	757
Turbines, Powerful, of the "Waterland".....	686	Workbench Equipment for a Table Top.....	767
Typewriter, Each, Has Its Own Characteristics.....	691		

# The Long Journey of Science in Search of Perfect Light



"Call me the link boy to  
light my way."—Old Play

Talks about MAZDA  
No. 3

"Not the name of a thing  
but the mark of a Service"



The MAZDA Lamp of  
today which gives three  
times as much light as  
carbon lamps. It em-  
bodies the results of  
MAZDA Service to the  
manufacturers.

**T**URN the button—flash!  
Many lifetimes' study of electricity is summed  
up for you in that quick and splendid radiance.  
Your forefathers had more trouble in getting the light  
of a single, dim candle. Yet we take this modern  
miracle for granted—this cheerful light summoned by the  
fingers, that is so many times more helpful, so many times  
cheaper per candle power than the cheapest candles.

Think of the ancient men conjuring the flame from  
the sapling, the pine knot,  
the grease from animal bod-  
ies, the oil of the earth.  
Think of the world's long  
struggle for more light and  
cheaper light, unguided in  
earlier days by an adequate  
knowledge or by any sys-  
tematic method of reaching  
the goal that was sought.

Think of the joy of the  
Dutch burgomaster von  
Guericke, more than two  
centuries ago, when he  
proved to scientists of his  
time that electricity had the  
power to give forth light.  
Think of these isolated  
experimenters turning cranks to produce light-flashes  
by friction, and of their endless groping to capture  
that light.

Think of Franklin (one hundred and sixty years ago  
this past summer) flushed with excitement on discover-  
ing that the electricity of the sky could be conducted  
by a kite string.

Think of the tremendous obstacles overcome in the  
production of Edison's first carbon incandescent light.

Electrical science was now to settle itself to the sys-  
tematic study of this vast problem which in earlier  
days had been left to slow, blind accidental, advance.  
And manufacture had begun to feel the impetus of  
help communicated by organized research, experiment  
and selection.

Think of that next big step—this time the use of  
filaments of *metal*, such as tantalum and tungsten.

But obstacles were still to be overcome. For example,  
the tungsten paste filament was fragile. The first  
MAZDA lamp gave more light and cheaper light, yet  
left something still to be added—greater sturdiness  
fully to meet the strain of everyday usage.

Then the triumph of the *drawn wire* filament in the  
MAZDA lamp of today—*three times as much light as*  
the old style carbon lamps, with the same amount of

electric current, and rugged enough  
in elements and construction to  
round out the full wonder of its  
practical efficiency.

The plodding scientists had climbed a step higher  
in the great world-journey between the humble candle  
and the ideal light.

Will they stop here?

Will that group of scientists in the Research Labor-  
atories of the General Electric Company at Schenec-  
tady be satisfied with these selected methods of con-  
struction revealed by the lamp marked MAZDA?

The mark MAZDA itself answers that question.  
MAZDA is the mark of a Service and it designates the  
great plan by which the MAZDA lamp shall continue  
to mean the highest achievement in incandescent lighting.

MAZDA Service means that the Research Laboratories  
are not only assembling the results of their own incessant  
and exhaustive investigations, and those of their associ-  
ates in the active developing and manufacturing centers  
at Cleveland and Harrison, but are keeping in close  
touch with great  
experimental lamp  
laboratories in Eur-  
ope.

MAZDA Serv-  
ice means also the  
furnishing to the  
General Electric  
Company factories,  
and to the factories  
of other Companies  
entitled to receive  
this Service, every  
new fragment of  
knowledge, from  
whatever source de-  
rived, which shall  
be selected in the

course of this service to the manufacturers for embodiment  
in the MAZDA lamp. In other words, the mark MAZDA  
on a lamp means that this world-wide MAZDA  
Service has been received by the makers of that lamp.

This is your assurance when you buy a MAZDA  
lamp—whether you buy it today, tomorrow, next  
month or at any future time—that you have the incan-  
descent electric lamp that sums up the latest efforts of  
the broadest lamp service in the world.



Even the shape of glass bulbs is a  
subject for constant experimentation



In one of the testing rooms  
of the Research Laborator-  
ies MAZDA Service in-  
volves unceasing tests and  
experiments with the aim  
that MAZDA shall always  
mean the furthest advance  
in metal filament lighting.



GENERAL ELECTRIC COMPANY

We Assist Students Getting Actual Driving Experience



## WOULD YOU GIVE 2 DAYS' PAY FOR A GOOD JOB IN THE AUTO TRADE?

THEN READ CAREFULLY

\$50 would not buy my course. After I got through Book 4 of instructions 13 and 14, 15 and 16, I had a job grinding valves. I did the job in four hours. Next day I put on four piston rings, which took six hours. These two jobs paid for my Course. I am now overhauling an engine for a party. I am not afraid to tackle any job now. If I get stuck I am sure I can find the remedy in the instructions. I knew nothing at all about an auto before, and I want to thank you for helping me.—Henry G. Ehredt, 523 E. 8th Ave., Homestead, Pa.

**DELO AND OTHER STARTING AND LIGHTING SYSTEMS. EXPLANATIONS SO CLEAR A CHILD CAN UNDERSTAND**

If we *prove* to you that we have started hundreds of others into the repair business and as chauffeurs—who had no previous experience and who knew no more about an auto than you do right now—you must admit we can do the same for you. Write me *today—now—and let me prove it.*

E. Dwyer, 31 N. Willow St., Montclair, N. J., 19 years old, receives \$25 a week and board.  
Harry J. Herbin, Jamestown, Kans., was a farmer, but has doubled his income repairing and selling autos.  
W. R. McClelland, Astoria, Ill., was an auto driver. Became professional chauffeur and more than doubled his salary.  
Donald Stewart, Oakland City, Ind., became a chauffeur at \$25 a week.  
H. M. Fawins and S. T. Slayback, both graduates, are now running a Garage and Repair Shop at Woodbine, Iowa.

And we could continue until we had filled this and several more pages.



Our book of testimonials, showing photos of students and their shops—free.

### All the Result of the Dyke System

We can thoroughly train you. Open a repair shop or drive a car and make many times more than you are making now. Don't forget, we help you get your start with our *Employment Plan*, if you want it.

### DYKE'S NEW IDEA OF TEACHING BY MAIL WITH WORKING MODELS

is something new. We use *real* working models—not just one, but *five*. On these models you get actual practice, see the actual operation and learn more than you could from the auto itself—it's easy and quick. You don't have to study hard with this system—we teach through the eye—a new idea. We are the *originators* of the system of teaching by mail with models. We also use charts—268 of them and a 16 page manikin. Our 40 instructions and Repairman's Instructions are simplicity itself—simple as A B C.

### Our Employment Plan for Students

This represents years of work to provide something that no other school had, namely, a way for the graduate to get acquainted with auto and garage owners, to prove his ability and to immediately secure profitable employment.

Mr. Dyke has been identified as a pioneer inventor, supply man, etc., with the auto industry since its beginning. He originated the first auto supply co. and published the first book on autos in America. No other man with such experience is to-day teaching others. And all the experience and inside information of the auto business he has thus gained, is embodied in this *Employment Plan*.

### WRITE TO-DAY for Details of Employment Plan and THIS FREE BOOK

It is instructive and interesting—does not cost you a cent and places you under no obligations whatever—you need it for your own sake, not mine. Don't wait—there's no profit in waiting—WRITE NOW and learn how you can obtain all this training for only \$15, if you act immediately.

**DYKE'S CORRESPONDENCE SCHOOL OF MOTORING**  
Box 189, Roe Bldg. ST. LOUIS, MO.

NOTE—Beware of Imitators—Deal with the Originator

**HOW  
GET INTO  
THE  
AUTO  
BUSINESS  
AND ITS  
OPPORTUNITIES**

Please Mention Popular Mechanics

## 40 ALPHABETS



Send for New Catalog of Automobile and Motorcycle books FREE.

13,000  
Copies  
Sold  
—  
55c  
Postpaid

Well printed on fine paper and handsomely bound in cloth.

**Spon & Chamberlain** 123 P.M. Liberty St. NEW YORK, U. S. A.



## Build Bodily Strength

And Mental Vigor

Guaranteed Results in 30 Days

Write for my FREE BOOK "PHYSIOLOGICAL EXERCISES." Tells how exercising with my system ten minutes a day will improve your health and vitality, internally and externally. It tells you how to build a constitution that will defy colds and illness, that will give you muscular power, pure blood, perfect digestion, a strong heart and lungs. Send 4c. in stamps to cover postage.

**The Henry Victor System**  
14-16 Fourth Ave., Dept. 65 New York



Our free sample will prove comfort and economy. Send postal stating size and whether you want high or low collar.  
**REVERSIBLE COLLAR CO., Dept. U, Boston, Mass.**

## BUTTERFLIES

and INSECTS WANTED. Summer work. Big prices paid. Beginners get instructions. Send stamp. JAMES SINCLAIR, Entomologist, D.6, Los Angeles, Cal.



### Boy Craftsman

10c Tells how to make all kinds of Toys. New Book just printed. How to make Aeroplane, Canoe, Railroad Model, Talking Machine, Telephones, Balloon, Electric Motor, Bicycle Boat, Pocket Flashlight, and hundreds of other things. Fully Illustrated. Sent postpaid for 10c. 4 for 25c.

**NATIONAL CO., 305 E. 51st St., Dept. 81, CHICAGO**



**BUSINESS LAW**  
Bays Miniature Law Library. Only complete work on Commercial Law. Contains Legal Forms of all kinds. Should be in every Library. Fits the pocket; 9 volumes \$12.00. Safe counsellor. Worth its weight in gold. 2000 pages. Order Now. Sent on approval.  
**CALLAGHAN & CO., Law Publishers, CHICAGO**



### Every Boy His Own Toymaker

Greatest boys' book ever written. Tells how to make a Steam Engine, Telephone, Magic Lantern, Boats, kites, balloons, electrical and mechanical toys, traps, fishing tackle. 200 illustrations; also catalog of 150 puzzles, Keller's Magic Ace Trick Card and "DOUBLE THROAT" warbler and bird call all for only 10c. **WESTERN PUZZLE CO., ST. PAUL, MINN.**



**PRIZE PACKAGE FREE**  
We will send you FREE a big package of Magic Tricks, Puzzles, Cards, Jokes, Riddles, Money Making Secrets, Splendid Games, Toasts, Card Tricks, Feats in Parlor Magic, all FREE. Just send us 10c to pay for postage and adv. and we will send this trick package Free.  
**NATIONAL TRICK CO., Dept. D, CHICAGO**



### DOUBLE THROAT 10c

New invention. Fits roof of mouth. Greatest thing out. Astonish and mystify your friends. Make dogs or cats talk. Neigh like a horse, sing like a canary. Imitate any Bird or Beast of field or forest. Price 10c; 4 for 25c postpaid.  
**NEW VOICE CO., 304 E. 51st St., CHICAGO**



**\$1**

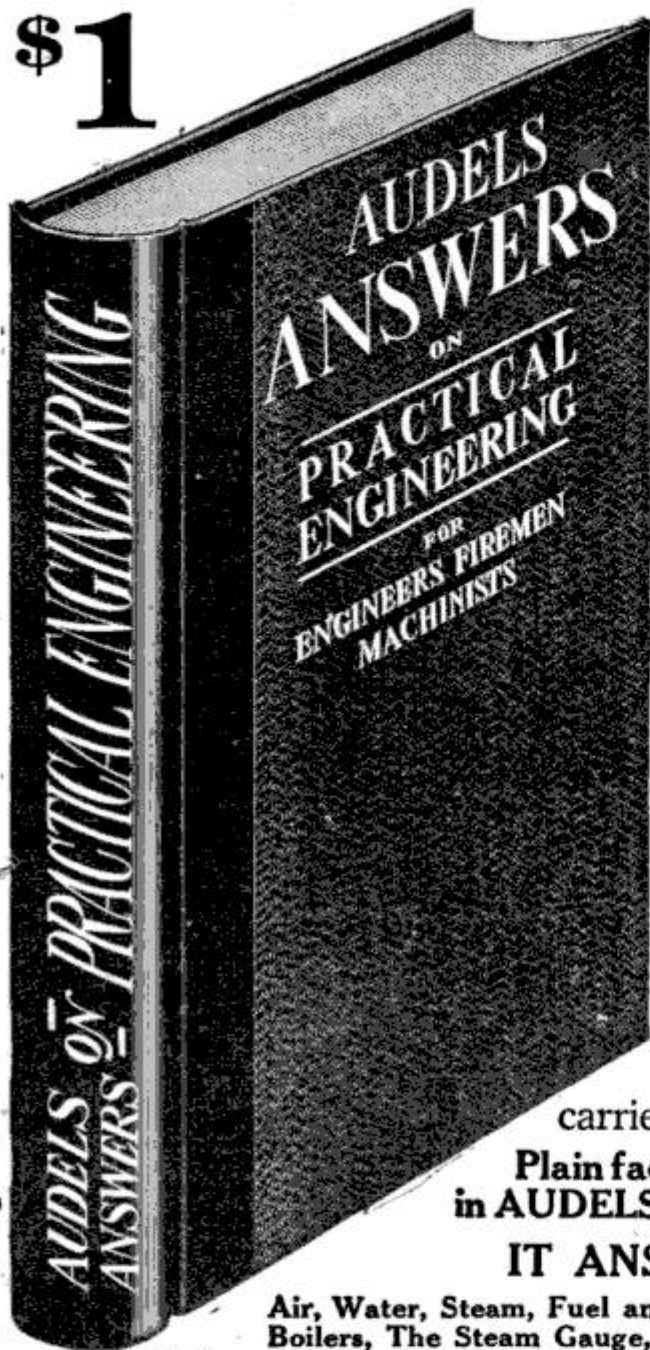

# ENGINEERS

This Book Will Help You

## Audels Answers on Practical Engineering

*When you spend your good hard earned money for books, always make sure that you are going to receive something that will assist you in bettering your position*

**T**HIS book deals largely with the foundation principles which govern the practice of steam engineering. Nothing so soon condemns the applicant as want of knowledge of the every day practice and simple laws relating to the care and management of a steam plant.

No one is expected to know everything, but all are required to be familiar with certain facts which may be called "the beginning of things."

The lack of knowledge of the small things carries conviction of the same lack in the larger.

**Plain facts, that you should know, are plainly explained in AUDELS ANSWERS ON PRACTICAL ENGINEERING.**

### IT ANSWERS YOUR QUESTIONS ON

Air, Water, Steam, Fuel and Heat, Steam Boilers, Boiler Construction, Water Tube Boilers, The Steam Gauge, The Safety Valve, Properties of Steam, Installation of Boilers, Management of Boilers, Engineers' Law, Firemen's Law, Steam Engines, The Valve and Valve Gear, The Corliss Engine, Engine Arithmetic, Lubricators, Installation and Operation of Engines, Steam Pumps, Injectors, Feed Water Heaters, Steam Heating, Steam Traps, Belts, Gears and Pulleys, Steam Turbines, Refrigeration, Practical Electricity, Elevators.

Understand the framework of which your work is but a cross bar. Know something of the cause of which your work is but an effect. Know something of the effect of which your work is the cause. And, above all, know why it is done one way and not another.

**LEARN THE THEORY UNDERLYING THE WORK.** Practical Engineering contains 288 pages fully illustrated, handsomely bound and printed and is in every way a first class book.

## Examination Offer

**If You Are Interested** sign and mail the coupon, and it will bring to your plant a book of sterling merit, for free examination. You can have one week in which to dig out the mine of valuable information contained in its 200 or more pages.

### Carry It in Your Pocket for One Week

and at the end of the time, if you do not think the book is worth one dollar, mail it back to us. If it is, you can mail us \$1.00 in payment for your copy. If you fail to consider this liberal offer you are not dealing fairly with yourself. We take all risk that "Audels Answers on Practical Engineering" is a book you should own. Act now before you forget it.

Please send me for examination one copy

**Audels Answers on Practical Engineering** \$1

If I keep the book, I promise to send you within 7 days after receiving it **ONE DOLLAR**, in full payment; if I do not keep it, I will mail it back to you within 7 days.

Signature.....

Occupation.....

Address..... P.M. May, '14

**THEO. AUDEL & CO., 72 5th Ave., NEW YORK**

# Become An EXPERT ACCOUNTANT!



**\$3,000 to \$10,000 Yearly!**

If you remain a clerk or bookkeeper, salary increases are improbable — an independent future impossible. You can't demand a raise—there are thousands awaiting your job. There is one sure way to overcome your handicap: become an **EXPERT ACCOUNTANT**, by our modern home-training method—**be sought**—don't seek. There are 500,000 big firms today requiring annual or semi-annual audits—and there are only **1,500 certified public accountants in the U. S.** This proves the tremendous, unlimited opportunities for you—the independence—the assured future—the big salary. These firms are willing to pay **Expert Accountants \$3,000 to \$10,000 yearly.** But they pay clerical workers and bookkeepers only \$12 to \$20 weekly. Become an **Expert Accountant** and your rise in the business world will be practically unlimited—many of our graduates are now managers of big firms. Remain a clerk or bookkeeper and you will always be bossed.

## WE TRAIN YOU BY MAIL

in your own home, during your spare time, no matter where you live. You don't give up your present position and income—you don't deny yourself pleasures or sacrifice duties. Devote a little spare time evenings preparing for independence and a big income and you will soon master this lucrative profession.

You can readily master our modern method in your own home—you can complete it in less time than any other. In many particulars it offers more advantages than a college course in Higher Accountancy—you are not held back by plodders.

The La Salle Extension University course in Higher Accountancy was prepared by some of the world's most noted accounting experts. It is under the direct supervision of William Arthur Chase, a nationally recognized leader, who is Ex-President of the American Association of C. P. A. Examiners, and Ex-Secretary of Illinois State Board of Examiners in Accountancy.

Our course is thorough—advanced—covering the Theory of Accounts, Practical Accounting, Cost Accounting, Auditing, Business Law, etc., and prepares you for C. P. A. Examinations in any State.

**Valuable Book FREE** Write at once for "What Every Bookkeeper Should Know"—a free copy of this book which gives exactly the information you require to become an Expert Accountant, studies, kind of examinations, State regulations, salaries paid, positions to be had.

**SPECIAL REDUCED RATE SCHOLARSHIP—Limited Special Offer.** Write quick and learn how, for a limited time, we are able to offer a special reduced rate scholarship.

**We Show RESULTS!** This institution is a strong, conservative organization—with thousands of students and as many letters from successful graduates. There is no other home-study course so thorough—endorsed by America's greatest Accounting Experts. We want you to know facts about the successes of our students and the unlimited opportunities that confront you today by our method of home training, so—

La Salle Extension University, Dept. 772, Chicago

Send at once, without cost or obligation to me, your valuable book of **Accounting Facts**, and full details of your Course in **Higher Accountancy**; also advise me about Special Time-Limited Reduced Rate Scholarship.

### Mail Coupon NOW!

Secure valuable book Free, and learn how you can advance from a small job with a small salary to distinction, independence, a future. Earn \$3,000 to \$10,000 yearly. Act Now!

La Salle Extension University, Chicago

Name.....  
Street No.....  
City..... State.....



## LEARN ABOUT THE BEST COURSE IN SHOW CARD AND SIGN WRITING

**IT IS FREE** to those purchasing our assortment of "LITHOLIA" Ready-to-Use Colors. A great opportunity for ambitious persons, either sex, to earn \$21 to \$50 weekly, salary or in business for yourself. Our show card course is not a book of alphabets. It's a

complete course in lettering compiled by an expert New York show card artist for us. "Litholia" is the only liquid pigment water paint ever made; used the same as cake, distemper or tube colors, but far superior to either. Lasts longer, more brilliant, always ready. Best for show card writers, artists, or interior decorators. **Booklet, Circulars and Full Information FREE.** LITHOLIA COLOR CO., 73 W. 23rd St., New York City



## YOU CAN LEARN To Be a Traveling Salesman

by mail in eight weeks and our Free Employment Bureau will assist you to secure a position where you will have an opportunity to earn **big pay** while you are learning. No former experience required. **Salesmen earn \$1000 to \$5000 a year and expenses.** Write today for large list of good openings and testimonials from hundreds of our students who are now earning \$100 to \$500 a month. Address nearest office.

Dept. A-21 National Salesmen's Training Ass'n. Chicago New York Kansas City San Francisco



I won the World's First Prize in Penmanship. By my new system I can make an expert penman of you by mail. I also teach Book-keeping and Shorthand. Am placing my students as instructors in commercial colleges. If you wish to become a better penman, write me. I will send you **FREE** one of my Favorite Pens and a copy of the Ransomian Journal.

C. W. RANSOM, 311 Essex Bldg., Kansas City, Missouri

## LEARN WATCH REPAIRING

Be a watchmaker—you can learn this profitable trade by correspondence in a few weeks in your own home by the DeSelms Chart System. After you complete the course you will know a watch from A to Z. You will know just what the matter is and how to repair one. When you graduate you will be a practical watchmaker and repairer and competent to fill any position. Positions for our graduates.

Ask for our Free Book. It explains our system and terms. **THE DeSELMS WATCH SCHOOL** 23 Perry Street ATTICA, INDIANA

CYLINDER LANGUAGE RECORD

CORTINA PHONE

## LANGUAGES

German—French—English  
Italian—Spanish

or any other language learned quickly and easily by either the Cylinder or Disc Cortinaphone Method at home. Write for Free booklet today: Easy Payment Plan.

**Cortina Academy of Languages.**  
1058 Mecca Building, 1600 B'way, Cor. 48th St., N. Y.

THE ORIGINAL PHONOGRAPHIC METHOD

**DISK LANGUAGE RECORD**

**"HEAVEN and HELL"** Swedenborg's 400 page work. 15 cents, postpaid. **PASTOR LANDENBERGER, Windsor Place, ST. LOUIS, MO.**

**CACHOO!** Make the whole family and all your friends "just sneeze their heads off" without knowing why, with Cachoo, the new long distance harmless snuff. Sent anywhere for 10c. 3 for 25c. 1 doz. and special premium for 90c. **AMERICAN SUPPLY CO., St. Paul, Minn.**



# LAW

**THIS  
COUPON WILL  
ENROLL YOU AS  
A FULL-FLEDGED  
LAW STUDENT  
ABSOLUTELY  
FREE**

## Most Astounding Free Offer Ever Made!

Here's the opportunity you've been looking for. An opportunity to determine, **without cost**, whether you really want to study law or not. An opportunity to test both yourself and this great new law course without risking a single penny. Yes, we mean it! **You won't even have to make a "deposit!"** Simply fill in and mail the coupon. That is positively **ALL** you have to do.

You will then be enrolled, **ABSOLUTELY FREE**, in our Complete Three-year Law Course. You will receive the first Text-book, "Law of Persons," the first Case Book, and Regular Examination Questions without obligating yourself in any way. You can send us your answers to these questions, and they will be criticised, corrected, graded and returned to you, together with the personal explanations and suggestions of our instructors **without it costing you one cent either now or later!**

This is the most amazing law offer ever made. But there are positively no strings to it! Simply give the information requested in the coupon and we will do exactly as we say. We know this is an **unusual offer**. In fact it is a **very unusual offer!** But it is simply our method of giving you an opportunity to **thoroughly test** our wonderful new system of correspondence law instruction, and at the same time find out whether you really want to study law or not before you decide to become **permanently enrolled**. We believe you will appreciate the **real significance** of this great offer and mail the coupon at once!

## AMERICA'S NEWEST AND BEST CORRESPONDENCE LAW COURSE

Twenty-eight more subjects and thirty more authors than any other correspondence law course. Sixty pocket size text-books, **positively the only law text-books ever written especially for correspondence instruction**. Prepared especially for the American School of Correspondence by fifty-six of America's greatest legal authorities. **HARVARD, YALE, NEW YORK, PENNSYLVANIA, CHICAGO, WISCONSIN, ILLINOIS, MICHIGAN**, and other great resident universities have contributed to this wonderful aggregation of legal talent which no other correspondence school or extension university can equal!

In addition to the sixty pocket size text-books each student receives thirty-six case books and the handsome thirteen volume "Library of American Law and Practice," making a total of **109 books!** Every branch of the law thoroughly covered. Written in plain, easily understood language. All legal terms thoroughly explained and made perfectly clear. **Simple method** enables you to get **ALL** the knowledge contained in the complete course. **Pocket size text-books** enable you to study under any and all conditions. You can have your lesson always in your pocket—with you at all times. Take advantage of every spare moment. Saves time. Means quicker admission to the bar. The easiest, best, most complete, and most practical correspondence law course ever devised.

**THIS OFFER IS FOR**

## IMMEDIATE ACCEPTANCE ONLY!

**You Must Mail The Free Enrollment  
Coupon At Once**

Never before has such an opportunity been extended to you. It may never be extended to you again. Grasp it! Now! Satisfy yourself, by trying this great new law course, **ABSOLUTELY FREE OF CHARGE**, whether you really want to study law or not. Then decide whether you will become **permanently enrolled**. Remember you do not risk a single penny! **You do not bind yourself in any way!** This is by far **YOUR GREATEST OPPORTUNITY**. Don't let it slip by. Mail the coupon **NOW!** Next time you think of it may be too late!

**American School of Correspondence  
Chicago, U. S. A.**



## Free Enrollment Coupon

**American School of Correspondence  
Chicago, U. S. A.**

Gentlemen:—Without cost or obligation on my part, you may enroll me for your **FREE TRIAL LAW OFFER** and send me, **by mail only**, the first Text-book, "Law of Persons," the first Case Book, and first Examination Questions of your regular Complete Three-year Law Course, also your **FREE** book "How To Acquire a Legal Training," and terms under which I may become permanently enrolled should I, after receiving your instruction in the "Law of Persons," decide to continue with the course. It is distinctly understood that, if I decide **not to become permanently enrolled**, I have not obligated myself to you in any way.

POP. MECH. 5-14

NAME.....AGE.....

FIRM.....POSITION.....

BUSINESS ADDRESS.....

SEND MAIL TO.....

CITY.....STATE.....

# Navy Training Counts

**I**N order to win success, you must be trained in mind and body. The **U. S. NAVY** offers young men an opportunity to acquire this useful training, and draw good pay meanwhile. You will be developed physically by the naval drills, the regular and systematic exercises, the wholesome food, the comfortable sleeping quarters, and the healthy, out-of-door life which man-o'-warships necessarily lead.

☛ The mental training which every recruit receives will be of value to him in after life. The course of instruction at the naval training stations teaches the sailor to be alert, obedient, resourceful and self-reliant, besides training him in the duties of seamanship. The various navy trade schools are open to recruits who have some knowledge of a trade, such as electricity, radio, carpentry, copper-smithing, clerical work, etc. While aboard ship every man is thoroughly trained in the duties of his trade or rating.

☛ The pay begins the day you enlist, and is clear of food, lodging, medical attention, traveling expenses and first outfit of uniform. Steady advancement as you become proficient.

☛ You must be over 17 years of age, of good health and character, able to read and write, and an American citizen. If you have no trade, you must be under 25.

☛ Navy Recruiting Stations located in all the principal cities. Send for a list of addresses, and a pamphlet explaining fully the life in the Navy and the advantages offered, and **then consult with your parents.**

ADDRESS

## BUREAU OF NAVIGATION

Box 69, Navy Department

WASHINGTON, D. C.

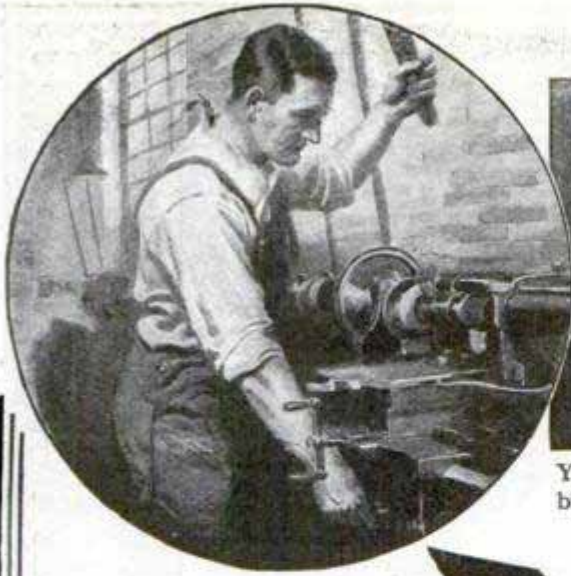

You too can qualify for a bigger position and better pay.



# Not Luck - But Pluck

It is easy for you to assume that *luck* is the *only difference* between you and the men who get the big positions and big pay. But you are *wrong*, it is *pluck*—not luck.

You are both made of the same stuff. It is a case of determination, backbone and training.

Instead of waiting for a "chance"—an opportunity, qualify yourself for a big job. Your opportunity will come.

You too, like the man in the picture above, can lift yourself to a position of big pay, if you have the *pluck*.

You, like everyone else, are especially fitted for *some* line of work.

The International Correspondence Schools will help you decide what that line is, and will bring right into your home the practical training you need to qualify you for the big opportunities and big pay.

As in the picture above, the connecting link between the position you *have* and the position you would *like* to have is the special training you can get with the help of the I. C. S.

Every month more than 400 I. C. S. Students voluntarily report promotions to better positions with increases in salary.

You can do it if others can, so begin—

**Mark on the coupon the occupation you want; cut it out, and mail it today.**

## INTERNATIONAL CORRESPONDENCE SCHOOLS

Box 872-R, Scranton, Pa.

Please explain, without further obligation on my part, how I can qualify for a larger salary and advancement to the position, trade, or profession before which I have marked X.

Electrical Engineering  
Electric Lighting  
Electric Railways  
Electrician  
Electric Car Running  
Dynamo Foreman  
Wireman  
Mining Engineer  
Tel. and Tel. Engineer  
Surveyor  
Civil Engineer  
Automobile Running  
Agriculture

Mechanical Engineer  
Mechanical Draftsman  
R. R. Construction  
Concrete Construction  
Architect  
Contracting and Build'g  
Architectural Draftsman  
General Illustrating  
Chemist  
Bookkeeper  
Advertising Man  
Civil Service Exams.  
Salesmanship

Name \_\_\_\_\_

St. and No. \_\_\_\_\_

City \_\_\_\_\_ State \_\_\_\_\_

Present Occupation \_\_\_\_\_

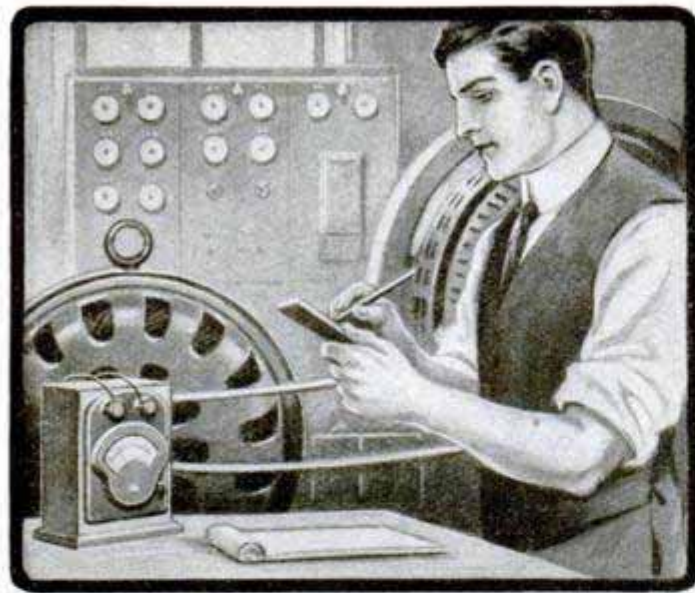

# Here's a Job For You \$175.00 a Month!

That's the salary YOU can earn as expert Electrician. Any one of the Profitable Trades taught by this School pays that much and more—Electricity, Plumbing, Brick-laying, Drafting and Moving Picture Operating. There is a greater demand now than ever before for skilled men. \$5.00 to \$8.00 per day paid at the start. Exceptional opportunities for starting a business of your own.

# Learn In Three Months' Time

—by attending our day classes. Or if you wish to earn your way through School, attend our night classes. No previous training required. No needless theory. ACTUAL and PRACTICAL work done in the Schools. Expert Instructors. Tools FREE. Position SECURED for Graduates.

## FREE!

Mail coupon today for Free Catalog "Trades that Pay" and full particulars. Let us show you how to DOUBLE YOUR SALARY—how to become an expert in a few months time. Get the facts at once. Everything sent FREE.

Mail Today

L. L. COOKE, Director  
COYNE NATIONAL  
TRADE SCHOOLS  
Dept. 1195, 51 East Ill. St., Chicago

Dear Sir:—Please send me your booklet "Trades that Pay" and full particulars of how I can become an expert and earn \$175.00 per month. Send everything FREE AND PREPAID. I assume no obligations.

L. L. COOKE, Director  
COYNE NATIONAL  
TRADE SCHOOLS  
Dept. 1195  
51 East Ill. St.  
Chicago

Name .....

Address .....

Please Mention Popular Mechanics

## This 2 Passenger Roadster Free



### To New Coey Students We Give This \$425 Coey Junior

We want young men in every community to earn a Coey Junior free and then ride around and take orders for us. Write for information. This is the only automobile school in the world that really builds automobiles and gives its students an opportunity to help build them and make big money.

### Make \$100 to \$400 Every Month

We will prepare you to earn from \$100 to \$400 per month. One of the Oldest Automobile Schools in the World, under personal supervision of C. A. Coey, America's Premier Autoist, holder of the 24-hour automobile world-record.

### Interesting Information Free

Write today for particulars. You can earn big money the minute you enroll.

C. A. COEY'S SCHOOL OF MOTORING  
532 Coey Bldg., 1424-1426 Michigan Ave., Chicago, Ill.

## GET A GOVERNMENT JOB

The Parcels Post is creating thousands of openings in Post Office, Railway Mail and Rural Carrier services. These are life jobs with big pay, short hours, annual vacations and no "lay-offs" or strikes. Civil Service Examinations are being held all the time. Our 64 page booklet tells how you can prepare for these and other "Exams" under personal supervision of former U. S. Civil Service Secretary-Examiner. Write for booklet today. It's free without obligation.

PATTERSON CIVIL SERVICE SCHOOL, 305 IRVING PLACE, ROCHESTER, N. Y.



**DO NOT STAMMER**

My book, "How to Stop Stammering"—a treatise on "Scientific Talking and Psychic Training." Price \$1. School and circular literature FREE. M. L. HATFIELD, Prin. of The Pacific School for Stammerers, 1918 Grove St., OAKLAND, CAL.

## HOW TO MAKE ELECTRICAL TOYS



Best book for boys ever printed. Tells how to make all kinds of electrical toys, Telephones, motors, telegraph apparatus, electric machine, wireless outfit and hundreds of other things. 200 Illustrations. Will send this book and our big catalog for only 10c postpaid. National Co., Dept. 82, 305 E. 51st St., Chicago

FOR SPRING BUILDING (OR REPAIRING) USE

# CYPRESS

LUMBER BECAUSE IT'S "THE WOOD ETERNAL"  
& LASTS & LASTS & LASTS & LASTS



## NEW MAGIC Catalogue

160 PAGES OF ILLUSTRATED WONDERS  
PRICE 10 CENTS

SPECIAL THIS MONTH

Siberian Transport Chain, 50 cents  
Prompt Shipments. Satisfaction Guaranteed.

Chicago Magic Co., 72 W. Adams St., Chicago, Ill.

# FREE TO YOU!

**How To Study Music**

**How To Become a Stenographer**

**How To Write Photoplays**

**FREE Book Coupon**

To National Education Bureau  
Box 77 PE, Chicago

You may send me free, and all charges prepaid, the book or books marked below—

How To Become Stenographer  
 How To Write Photoplays  
 How To Study Music

Name.....  
Address.....

**Number of Books is limited, so Write at Once!**

**National Education Bureau  
Box 77 PE, CHICAGO**

SIGN, TEAR OFF AND MAIL NOW!

## FREE \$100 LAW Scholarship Credit

Given absolutely FREE to advertise our School. Legal training NOW within reach of every person. **Free Scholarship Credit** reduces cost of complete Course to less than you ordinarily pay for Text Books. Hurry! Write now—before it's too late—costs nothing to investigate. A postal or letter brings everything FREE.

**LEARN AT HOME — SPARE TIME**

LEARN while you EARN. Your spare time only. Easy payment plan. Learn Law easily and quickly AT HOME by our simple method. No preliminary education necessary. Course covers same ground as Harvard, Michigan, and big resident Law Schools. Large and distinguished Faculty—personal instruction. We Guarantee to coach Free any graduate failing to pass Bar Examination. Demand for Legally Trained Men increases every day. Now is the time to start—to prepare for the future. Don't let old age find you in the untrained class, looking back on lost opportunities. Grasp this opportunity at Once. Write today—Now—no obligation—save \$100.00.

FULL PARTICULARS SENT FREE

**AMERICAN CORRESPONDENCE SCHOOL OF LAW**  
Manhattan Building, Dept. 1195 CHICAGO, ILLINOIS

## Ridpath's History of the World At a Bargain

**FREE**

We will mail free a beautiful 46-page booklet of sample pages from Ridpath's history to all who mail the coupon.

Weights 50 lbs. 2000 Pages 1000 Pictures

We will name our price only in direct letters to those sending us the Coupon below. Tear off the Coupon, write name and address plainly, and mail to us now before you forget it. Dr. Ridpath is dead, his work is done, but his family derives an income from his history, and to print our price broadcast for the sake of quickly selling these few sets would cause great injury to future sales.

### FREE BOOKLET COUPON

**WESTERN NEWSPAPER ASSOCIATION**  
140 So. Dearborn St., Chicago, Ill.

GENTLEMEN:—Please mail your 46-page free sample booklet of Ridpath's History of the World, containing photogravures of Napoleon, Queen Elizabeth, Socrates, Caesar and Shakespeare, diagram of Panama Canal, etc., and write me full particulars of your special offer to Popular Mechanics readers. 5-14

NAME.....  
ADDRESS.....

## TELEGRAPHY

The Only Trade that is not Crowded. It insures steady employment and good wages. Promotion is assured for the ambitious. We are official instructors for the Western Union Telegraph Co., and the only school instructing Western Union employes. Largest attendance of any Telegraph school; also authorized school for Illinois Central Railroad Company. Agency course free. Practical instructors; main line wires. Employment furnished to earn expenses if desired. State your age.

**Jones School of Telegraphy, Dept. M, Traders Bldg., Chicago, Ill.**

EARN \$20. TO \$50. A WEEK

LEARN SHOW-CARD WRITING.

Splendid Opportunities, Big Salaries, Constant Demand for Show Card Writers. I will make you an expert in **14 EASY LESSONS**. Learn at home during spare minutes. Valuable illustrated book, "Daily's Self Instructor," describing course, sent free on request.

Room 69 Rauh Bldg.  
**BERT L. DAILY, Dayton, Ohio**

This Book FREE

Send Today

## Make this car your office—

there is \$900.00 to \$1800.00 a year in it for you

Examinations will likely be held everywhere soon

Rapid advancement to higher Government Positions. "No layoffs" because of STRIKES, FINANCIAL FLURRIES or the WHIMS OF SOME PETTY BOSS. THE POSITION IS YOURS FOR LIFE.

Country residents and city residents stand the same chance for immediate appointment. Common-sense education sufficient. Political influence NOT REQUIRED.

**We will prepare 25 candidates FREE!**

Write immediately for schedule showing the places and dates of all SPRING examinations. Don't delay. Every day you lose means the loss of just so much coaching before the rapidly approaching examinations.

**FRANKLIN INSTITUTE, Dept. G 106, Rochester, N.Y.**

Hundreds of Parcels Post Railway Mail Clerks Needed NOW!

COUPON

Franklin Institute (The pathway to plenty), Dept. G 106, Rochester, N. Y.

The coupon, filled out as directed, entitles the sender to free specimen questions; a free copy of our copyrighted book, "Government Positions and How to Obtain Them," a list of positions now available, and to consideration for Free Coaching for the examination here checked.

..... Railway Mail Clerk (\$900 to \$1800) ..... Customs Positions (\$800 to \$1500)  
..... Bookkeeper ..... (\$900 to \$1800) ..... Stenographer ..... (\$800 to \$1500)  
..... Postoffice Clerk ..... (\$800 to \$1200) ..... Internal Revenue ..... (\$700 to \$1800)  
..... Postoffice Carrier ..... (\$800 to \$1200) ..... Clerk in the Departments at Washington (\$800 to \$1500)  
..... Rural Mail Carrier ..... (\$500 to \$1100) ..... Canadian Government Positions

Name..... Address..... G 106

Use this before you lose it. Write plainly.

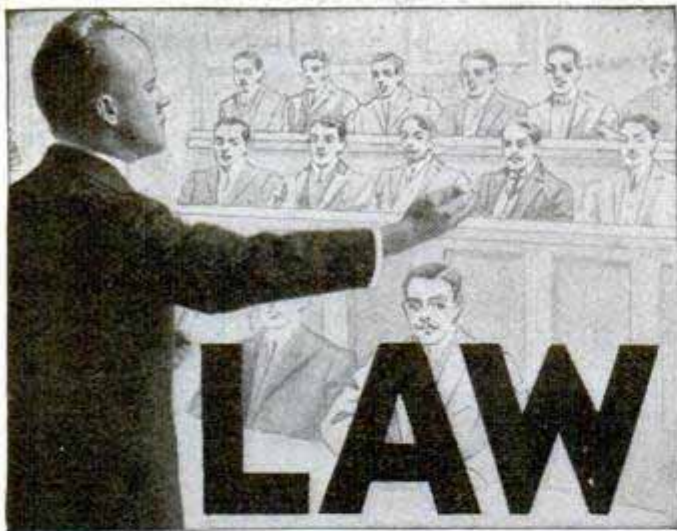

## Become A Lawyer

There are thousands of capable men in small positions with small salaries and no future who need only our training to become successful **Lawyers**. The demand for Lawyers is increasing daily—Law is becoming a vital factor in every business—large firms are seeking competent Lawyers for their regular staff, and are willing to pay big salaries.

### YOU Can Be a Lawyer Now

It is no longer complex—no education required beyond the ability to read and write intelligently. Our instruction is written in plain language—it is the combined knowledge of the world's famous legal experts—Professors of Law in such big resident colleges as Univ. of Wis., Univ. of Chicago, Harvard, Univ. of Mich., N. Western Univ., and Univ. of Nebraska. It is recognized as the foremost home-study Law method by America's greatest legal and educational authorities—it is the **only** method used in colleges. Advanced—simplified—different absolutely from all others—completely covering every branch of American Law. It is like having great Professors in your home.

Learning Law by our method is fascinating—interesting—you will never give it up until you have completed it.

### We Train You At Home By Mail

in spare time. You don't give up your present position, income or pleasures. Makes no difference where you live, what you work at, how small your income or how little time you have. The cost is small—we make payments easy. Some of America's greatest Lawyers learned at home in spare time.

We enroll more students every month than any other university home-study Law school in the world. This is a strong, conservative, reliable institution—the largest, oldest and most complete of its kind on earth. Our graduates hold highest records and pass bar examinations in any State. We guarantee to coach you **FREE** until successful. This is the school that shows actual results—makes no statements it can't prove. Our Diploma gives you a recognized standing.

## Law Library **BIG SPECIAL OFFER!**

If you enroll now we send our complete, standard, authoritative Law Library—14 volumes of American Law and Procedure, completely covering every branch of Law—a massive handsome set; over 6,000 pages, 15,000 illustrative cases; a \$50,000 work.

**Two Great Books FREE** Write quick for **FREE** copy of "Valuable Law Guide"—a book that shows you how to start right—how some of America's most successful Lawyers succeeded—a book everybody should have.

We will also send a copy of our famous book, "EVIDENCE"—evidence of the success of our students and the superiority of our method of home-training. Both of these books are **FREE**.

**\$100 Tuition Credit—FREE**

Write at once and learn how, for a very limited time, you can actually secure a \$100 Tuition Credit Certificate Free.

**Become An LL. B.** The State of Illinois authorizes us to confer on our graduates the Degree of Bachelor of Laws (LL. B.). Every successful man had to make his start **somehow**—**somehow!** This is your opportunity to enter a dignified, lucrative profession. Mail the coupon at once for convincing facts—don't put it off any longer.

La Salle Extension University, Dept. 770 Chicago, Ill.

La Salle Extension University, Dept. 770 Chicago, Ill.

Please send me **FREE**—copy of your two books, "EVIDENCE" and **VALUABLE LAW GUIDE** at once. Also explain how I can secure a \$100 Tuition Credit **FREE**.

NAME.....

ADDRESS.....

CITY..... STATE.....

Please Mention Popular Mechanics

## EARN \$25 to \$75 A WEEK BE YOUR OWN BOSS

### OFFER OPEN TO ONE MAN IN A TOWN

I will start you tomorrow in a permanent, big money making business in your home town or any town without interfering with your present work. You begin making money the first day. A hustler can double his income the first 60 days. I teach you the business, show you how to get trade, give you a

### Free Course in Salesmanship

and push you towards success. You don't need capital nor a stock of goods to get a start. Some men I started earn as high as \$5000 a year after a few years. One man writes us

### "I Made \$27 in TWO DAYS"

I started thousands the past 22 years. I want to start you in the jewelry business, the first step being to teach you, free of cost, how to repair watches, clocks and jewelry, so simple any man soon learns, a few tools is all you need. This is a remarkable offer. You have everything to gain, so investigate it. Write for Free Offers today before I close up your town.

C. F. ELMORE, Prin., Watchmaking College, 69 Madison St., Chicago

## TANGO Hesitation, Argentine, & All New Dances

You can now quickly, easily learn, in your own home, to dance the Tango, Argentine, Castle Walk, Hesitation Waltz, Dream Waltz, and other popular new dances. The new book, "The Modern Dances," by Caroline Walker, gives authentic, plain instructions, correct diagrams and beautiful illustrations, especially posed by experts. **Anyone can learn.**

**The Only Successful Method of Home-Instruction** recognized by Society and Professionals superior to ordinary class or private instruction. Chicago Tribune says: "In 'The Modern Dances,' the movements are clearly set forth and are aided with photographs so that **anyone** can easily master the steps."

First two editions exhausted in one month. Third edition now ready. Better than ten dollars worth of private lessons, and costs

**Only One Dollar** On Sale at best book and music stores everywhere; or send dollar direct to publishers for beautifully bound copy, postpaid. Money-back guarantee. Order today.

SAUL BROS., Pubrs., Dept. 44  
626 Federal St. Chicago, Ill.

## LEARN RAG TIME



Let me teach YOU Ragtime Piano Playing by mail. You learn quickly—easily in 20 lessons. *Even if you can't play a note I'll teach you to play any piece in real Ragtime.* "Money-back" Guarantee.

Write me now for special low terms and testimonials from hundreds of happy students.

Axel Christensen (Czar of Ragtime) Director  
Christensen School of Popular Music  
891 Christensen Bldg., CHICAGO, ILL.



## BE A DETECTIVE

Earn from \$150.00 to \$300.00 per month; travel over the world. Write C. T. LUDWIG, 133 Westover Bldg., Kansas City, Mo.

## LEARN JEWELRY ENGRAVING

in your own home. Earn \$20.00 to \$50.00 Weekly. Personal instructions. Write for free booklet. Chicago Engraving School, 612 Athenaeum Bldg., Chicago

## LEARN TO WRITE EARN \$25 to \$100 ADVERTISEMENTS A WEEK

We can positively show you by mail How to increase your salary. **BOOK MAILED FREE.** PAGE-DAVIS CO., 112 Page Building, Chicago, Ill., or 150 Nassau St., New York

## ARITHMETIC SELF-TAUGHT

A plain, easily-understood volume for all who have not had the opportunity of learning this subject thoroughly, or who have forgotten what they once learned. 257 Pages. Requires no teacher. This great little book sent postpaid for 60 CENTS. Stamps accepted, leather binding \$1.

GEO. A. ZELLER BOOK CO.  
Est. 1876, 4473 W. Belle Place ST. LOUIS, MO.

SPANGENBERG'S  
PRACTICAL  
ARITHMETIC  
Self-Taught



# "The Roll of Honor"

THE reputation of the H. W. Johns-Manville Company has been earned by an unwavering purpose to make only the best materials. Its record of over half a century of roofing achievements is unparalleled, and the full force of this record is behind each roll of

Write Nearest  
Branch for  
Book No.  
3571.

## J-M ASBESTOS ROOFING

"The Roll of Honor"

To ask for "J-M" is synonymous with asking for "The best money can buy." There is not a single doubtful inch in any roll of J-M Asbestos Roofing. Made from Pure Asbestos Rock and Trinidad Lake Asphalt, it is a sheet of pliable stone. Being rock, it endures on its own inherent qualities and requires no protection, such as paint, gravel or sand. Resists fire, climate, acids, gases, chemical fumes for all time.

Every roll made by a \$5,000,000 company whose only known standard has always been "Honest Quality."

Users of rubber type roofings can get J-M quality in J-M REGAL ROOFING.

These roofings are furnished ready to lay with J-M CLEATS, the most efficient roof fastener.

### H. W. JOHNS-MANVILLE CO.

Manufacturers of Asbestos Shingles; Roofing; Stucco; Pipe Coverings; Cold Storage Insulation; Waterproofing; Sanitary Specialties; Acoustical Correction; Cork Tiling; Fireproof Doors, etc.



Albany  
Baltimore  
Boston  
Buffalo  
Chicago

Cincinnati  
Cleveland  
Dallas  
Detroit  
Indianapolis

### ASBESTOS

Kansas City  
Los Angeles

Louisville  
Milwaukee

Minneapolis  
New Orleans  
New York  
Omaha  
Philadelphia

Pittsburgh  
San Francisco  
Seattle  
St. Louis  
Syracuse

**Sweeney Says: "I Can Teach You the Automobile Business in Six Weeks by Actually Working on and Driving Cars."**



## \$80 PER MONTH UP

**IS EARNED BY TRAINED MEN.** If you drive, repair, sell cars, manage garages, or make yourself a competent mechanic, no business in the world offers greater opportunities. Millionaires like Ford rose from the ranks.

### THE SWEENEY SYSTEM OF PRACTICAL INSTRUCTION

has made this school one of the largest, finest, most completely equipped in the world. WE TEACH EVERY BRANCH OF THE BUSINESS—electric starters, traction engineering, trucks—every new development. We have turned out over **1900 Successful Graduates**

**It Makes Young Men Successful.** Learn the opportunities before you.

**Write Today** For full information about this school, many photographs and full details about the opportunities in this business **FREE**

**SWEENEY AUTO SCHOOL** 1168 Fifteenth St., KANSAS CITY, MO.

# Special Reduced Price For Drafting Course

I am now making an extra special reduced price offer in order to have a few more ambitious men start getting my personal training. A great big reduction in price if you enroll right away. You get my regular \$15.00 draftsman's working outfit absolutely free—the same course of instruction and the same personal training until you are holding a position that pays you at least \$125.00 a month. You can't afford to go another day without accepting this offer. Send me the coupon now and get my free book. You will not be obligated in any way.

## \$125<sup>00</sup> a Month to Start

That's what the men get who receive my personal training. Read my guarantee. You do not risk a cent. And remember, on this great special offer you get the same course of instruction at a greatly reduced price. Do not wait—Do not put it off, but find out all about this offer now. Send me the coupon.



## \$15<sup>00</sup> Draftsman's Working Outfit FREE

By starting with me at once you get one of these draftsman's working outfits absolutely free. It's just the kind of an outfit that I use myself. You could not duplicate it for less than \$15.00. On this special offer you don't pay a cent for it either now or later. Send me the coupon now.

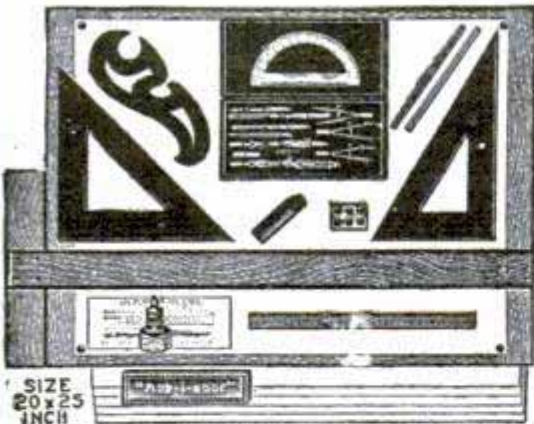

## Realize Your Ambition

Don't "just dream" of the days when you will be the man who gets the fat pay envelope. **Act!** All those little luxuries that you have wanted for so long—all those little extravagances you have wanted to afford are now within your reach. The Drafting profession is open to **you**. The first step toward realizing **your** ambition—and getting the fat pay envelope is to send the free coupon. Do it now.

**I Guarantee**  
To instruct you until competent and in a position at a regular salary, paying from \$125.00 to \$175.00 per month and furnish you free \$15 Working Outfit at once.

## Chief Draftsman will instruct you personally

I am Chief Draftsman of a large and well known company. For nearly a quarter of a century I have been doing the highest paid drafting work. I know just the kind of training the big firms require from the men to whom they pay the biggest salaries. This is just the kind of training that I give to you—practical training that will make you one of the men who gets a fat pay envelope. Send the coupon.

## SEND THE COUPON For NEW FREE BOOK

Just your name and address in the coupon or on a letter or a post card is enough. I will send you my big new book "Successful Draftsmanship" absolutely free. No obligations of any kind. Besides, I'll tell you all about this great special reduced price offer. Don't delay another instant. Send the coupon now.

**CHIEF DRAFTSMAN, DOBE**  
Engineer's Equipment Co., Div. 1195, Chicago, Ill.

**\$3000 SALARY EARNING OFFER COUPON**  
**CHIEF DRAFTSMAN,**  
Engineer's Equipment Co. (Inc.)  
Div. 1195, CHICAGO, ILL.

Without any obligation to me whatsoever, please mail your book, "Successful Draftsmanship" and full particulars of your liberal "Personal Instruction" offer to a few students. It is understood that I am obligated in no way whatever.



Name .....

Address .....

# CLASSIFIED ADVERTISEMENTS

Advertisements in this section, 15 cents per word, each insertion, minimum 10 words, payable in advance. To insure ads being inserted under proper classified head in the June issue, copy must reach this office not later than May 1st.

Popular Mechanics Magazine, Chicago, Ill.

Chicago, Ill.

Gentlemen:—I enclose herewith check for \$7.35 covering my two ads, as usual, and to which please give attention. I am glad to say received an order a few weeks since, from one of my ads in your publication, which netted me over \$160.00 and naturally am pleased to tell you of it. Certainly consider the medium a splendid one and it is a pleasure for me to send you my little check each month.

With best wishes, I am sincerely,

RALPH J. GOLSEN.

We have records to prove that a classified ad in these columns will find a buyer for almost anything which can be sold. Doubtless you have some article of value to some one else which you no longer need. Why not turn it into money?

## AUTOMOBILES

**CYLINDER** Regrinding — First-class equipment, fifteen years' experience, and specializing in this work enable us to do high-grade work at lowest prices. We manufacture the "Neveriak" individual cast piston rings. Prices will interest you. Bridgeport Piston Ring Co., 346 Connecticut Ave., Bridgeport, Conn.

A WRITTEN guarantee for 5,000 miles without puncture. French and German motorists are getting 10,000 miles out of their tires by increasing them about one-half inch in size. In eight months 20,000 American motorists have followed their example. It's so easy you can do it in your own garage in thirty minutes, no matter what condition your tires are in. Send for free catalogue, sample and copy of guarantee. Colorado Tire and Leather Co., 1112 Karpen Bldg., Chicago, Ill., 451 Golden Gate Ave., San Francisco, Cal., 1326 Acoma St., Denver, Colo.

**AUTOMOBILE** Repairs—Automobile owners and repairmen should subscribe for the "Automobile Dealer and Repairer," the big 100-page illustrated monthly, devoted exclusively to the care and repair of the car. The only magazine of the kind in the world. The "Trouble Department," with five pages of numbered questions each month from car owners and repairmen which are answered by experts on gasoline engine repairs, is worth many times the subscription price. \$1 per year or 15 cents per copy. Postals not answered. Charles D. Sherman, 50 Windsor Road, Hartford, Conn.

**AUTOMOBILES**—Live Agents Wanted to sell all makes of overhauled and repainted pleasure and commercial cars. Remarkably low prices and big discounts. Eureka Auto Co., Beavertown, Pa.

**LAMBERT** Light Truck \$225. C. L. Edwards, Sweet Valley, Penna.

1913 METZ—Pleasure and Business bodies, complete, \$375. R. Cowles, Canton, Conn.

**LEARN** to drive an auto. We publish an up to date book on automobile driving. Pocket size, 10c. C. L. Botto, 3234 S. Grand Ave., St. Louis, Mo.

**GET** in the Oxy-Acetylene welding business. Complete new outfit with instructions \$75. J. M. Shevlin, 340 Ellicott Square, Buffalo, N. Y.

20-HORSE double engine radiator transmission. Complete except tank, \$75. R. L. Stanley, Casselton, N. D.

**THOMAS** Chassis with 18-horsepower, double-ported, water-cooled engine. Would make a dandy truck, \$100. Four-passenger Ford in fine condition, \$200. Box 1, Warsaw, Ohio.

**BANKRUPT** sale 50 new automobiles, \$75 up. Fairbanks-Morse stationary 32-hp. gasoline engine almost new, cheap. Wills Automobile Co., Canal Dover, Ohio.

**SIX** Passenger Duryea Buss, 22-hp., 3 cyl., needs brakes, \$50 check. David Jame, Leibhardt, N. Y.

**FORD** Instruction Book, every part explained. Repair your own car, postpaid \$1. Particulars free. Clark, 3308 Elizabeth, Peoria, Ill.

\$185 BUYS Chalmers four cylinder, thirty horse automobile, without body; tires good; make fine roadster or delivery truck. Rubel, Mobile, Alabama.

**REGROUNDING** the cylinders, and fitting new pistons and rings, will make your motor as quiet and powerful as it was when new. The cost is moderate. Advise bore diameter if desire quotation. We also expertly weld broken parts. Send for booklet. Waterbury Welding Corporation, Waterbury, Conn.

**PAINT** Your Car Yourself—Save \$25 to \$75 by doing the work at home with the Arsenal system. Our big free booklet "The Car Beautiful" tells how. Send for it today. Arsenal Varnish Co., Dept. P, Rock Island, Ill.

**AUTOMOBILE** Instruction—\$55.25. Four weeks' course. Best equipped school in the country. Men enrolled from all parts of the U. S. Booklet P. M. on request. West Side Y. M. C. A., 318 West 57th Street, New York.

A NEW technical automobile magazine illustrated, contains valuable information. Send for free copy. American Chauffeur, 851 Butler Bldg., Cincinnati.

METZ, 2 cyl. runabout, \$100. Franklin, 4 cyl. touring, \$175. Warren, 4 cyl. touring, \$350. J. H. White, Lonaconing, Md.

## AUTOMOBILE SUPPLIES

**USE** Hustler Valve Grinding Compound, 3 oz. 25c. W. I. Gregory, 136 St. Marks Ave., Brooklyn, N. Y.

**TIRES**—Cut rates, factory seconds; new. 30x3, \$7.45; 30x3½, \$10.85; 32x3½, \$11.60; 34x4, \$17; 36x4½, \$22.50; 37x5, \$29.50. Send for list. Keystone Tire Co., Bridgeport, Conn.

**ENTIRELY** new field for keen representatives putting our handsome monograms on automobiles, motorcycles, by special "transfer" method. Clean, easy, congenial work, quick profits. Monograms are artistic, durable and practical. Write for plan. Motorists' Accessories Co., Ashland, O.

**RECTIFIERS** for garages. All sizes. Charge one to eight batteries. \$12 upwards. American Battery Company, 1129 Fulton St., Chicago.

**TIRES**—Guaranteed and second tires. Write for prices. We pay express. Sinsheimer, 1505 Michigan Ave., Chicago.

**LOOK!** Gasoline Vulcanizer for tires and tubes, complete \$1. Mosler \$2. Spit fire spark plugs 50c. Raymond Kelly, 5950 Madison St., Chicago, Ill.

**MAKE** your own welding plant. Order from us full set of bronze castings and working drawings. Any mechanic can finish the castings and you will have a practical welder. Entire outfit, including gauges and valves, only \$20. Will ship prepaid on receipt of \$5 with C. O. D. for \$15 subject to inspection at your express office. Address Mgr. Auto Welding & Mfg. Co., Omaha, Neb.

**WIRE** Wheels for Ford automobiles, complete set \$35. Immediate delivery. Raymond Kelly, 5950 Madison St., Chicago, Ill.

**I'LL** Save You Money on Tires by my new co-operative plan. Dollars saved on every size. Printed guarantee of 3,500 miles actual service with every tire. Don't buy another tire until you get price list and new co-operative plan. It will pay you. State size. Write me today—Now! Manager Tuxedo Auto Tire Exchange, 896 S Eighth Avenue, New York City.

**TIRES**—3,500 miles guaranteed, and guaranteed tubes. 28x3, \$8.50, tube, \$1.80; 30x3, \$9.40—\$1.90; 30x3½, \$12.50—\$2.75; 32x3½, \$13.25—\$2.80; 34x4, \$17.50—\$3.90; 36x4, \$18.95—\$4.15; 35x4½, \$23.50—\$4.95. Non-skid 10% more; other sizes, prices accordingly. Write for bargain sheet. 10% with order, balance C. O. D. Examination allowed. Para Auto Tire Co., 1417 Michigan Ave., Chicago, Ill.

**ONE** Ford Owner in every town as agent for heavy Stoddard Tires for Ford cars. Save on your tires and make good profit in spare time. Stoddard Tire Sales Co., Worcester, Mass.; Chicago, 608 S. Dearborn St.

**FOR** Sale—Vulcanizing Plant, full equipment for casings and tubes. John Saddler, 2422 Manderson St., Omaha, Neb.

**PAINT** your own car. We supply material; write for particulars. Economy Service Co., Indianapolis, Ind.

**FOR** Sale—Two-cylinder engine, opposed, 20 hp., with carburetor and coils. A bargain. Claude Downs, Nashville, Mich.

**WELDING** Plants That Are Safe—\$50 to \$175. Carbon Remover with each Welder. Your credit is good with us. The Welder pays for itself and you save the middleman's profit. Write for terms. Address Manager, Dept. D., Bermo Welding Apparatus Co., Omaha, Nebr.

**FIVE** dollars buys Auto Folding Sub Car. Slight pressure of either foot sends you to any desired point under your car. Folds and goes in tool box. Agents wanted. Auto Folding Sub Car Co., Zanesville, Ohio.

**WELDING** Torches, \$10 to \$35; Carbon Burning Torch, \$5; Oxygen Regulators, \$10 to \$45; Acetylene Regulators, \$10 to \$30. Welding material at wholesale prices. Bermo Welding Apparatus Co., Omaha, Neb.

**FIX** up your Automobile with Boyer's Air-Drying Glossy Re-Finisher and Color Finishes. All colors. Write us condition of your car. Boyer Laboratory Company, State and Michigan Streets, Chicago.

**FREE**—Enclose 25c in stamps and we will send you prepaid one dollar can of tire paint. Simplex Vulcanizer Co., Omaha, Nebraska.

**POWERFUL** new signal for Automobiles and Motorcycles. Write for circular. Buell Mfg. Co., 1141 E. 46th St., Chicago.

**REPAIRS** on all makes of magnetos and coils. Estimates furnished. Prices cut 20% on all 1913 magnetos. Send for price list. Pellets Magneto Exchange, 1606 Michigan Ave., Chicago, Ill.

**HEADQUARTERS** for Ford Specialties. For Bargain Sheet No. 6, address The Edwards Co., Wapello, Iowa.

**USE** an Air-Friction 1914 Model "C." Increases power and economy of motor one-half. Absolutely impossible to choke or load. Uses distillate, gasoline or half kerosene with finest results. Starts easy in coldest weather. We fit all motors, guaranteeing definite results or refund money. Exclusive county rights. Liberal exchange on other carburetors. The Air-Friction Carburetor Co., Dayton, Ohio.

**WE** Weld smashed-engine crank cases, cracked cylinders, transmission housings, parts of cast iron, aluminum or brass. Hobbie's Welding Plant, Hampton, Iowa.

**FOR** Sale—R. 7 horse power steam auto engine cheap. Ernest Pile, 165 W. Center St., Akron, Ohio.



"HOW to Run an Automobile." A 25c book for 15c postpaid. Richard Devine, 1145 Wells St., Chicago.

BOOKS About Elevators—Circulars free. Morse, Union Place, Yonkers, N. Y.

WHITE Slavery: A plain exposé of the traffic in white women, by noted State investigator. Startling disclosures. Sent postpaid 25c. H. M. Book Shop, 406 Duke Bldg., Rochester, N. Y.

"WHITE SLAVERS" (illustrated); 192 pages. 40c. G. Olive, Willmar, Minn.

30-DAY Offer—\$1 book for 25c. Valuable mail-order information; buying goods; money-making plans. Money back if unsatisfactory. Order now. King Co., Box 13-P, Little Silver, N. J.

REAL fascinating books and pictures, 25 samples and profusely illustrated catalogue, 10c. Normal Specialty Co., L3, Englewood, Chicago.

MOTION Picture Making and Exhibiting. 240 Pages, fully illustrated. Cloth \$1. Other practical and reliable mechanical books. Send for complete descriptive list. Charles C. Thompson Co., 1126 Wabash Ave., Chicago.

ENGINEERS' questions and answers for license, by Hobson, for twenty-five cents, postpaid. Send stamps. Reilly's Book Store, Philadelphia, Pa.

HOW to Run a Lathe. A 50-cent book for 10 cents postpaid. S. B. Lathe Works, South Bend, Ind.

READ "Electroforce"—a monthly magazine of electrical and allied topics. Printed in understandable language, for practical people. Liberally illustrated and intensely interesting. Keeps you right up-to-date on this fascinating science. \$1.00 per year. Three months, 25c. Electroforce Publishing Co., 21 Stroh Bldg., Milwaukee, Wis.

"CRIMES of White Slavers," thrilling, exciting, true life stories of girls who have "gone wrong." All about "The Underground World" of "Darkest-Chicago." 182 pages, illustrated, only 50c postpaid. B. Williams Publishing Co., 721 North Dearborn, Chicago.

**EDUCATIONAL AND INSTRUCTION**

500% PROFIT in ornamental casting of concrete, artificial marble, plaster, papier-mache, marble dust, imitation wood, soft metals, for manufacturing interior, exterior decorations, garden furniture, statuary, artistic homes, fountains, sanitary marble flooring, tiling, tombstones, cement caskets, stucco buildings, life casting, ornament copying, modeling, coloring, gilding, making elastic and rigid moulds, instructions complete \$1. Free: 200 illustrations beautiful art cast (mail address today), Mahler, 117 Russell St., Brooklyn, N. Y.

LEARN Engraving—Names, initials, monograms in different colors on celluloid. Instructions and sample free. Big income. The National Engravers, 38 West 33d St., New York City.

DOCTOR, Bachelor, other degree courses; resident, non-resident. Address Vetus Academia, West Hoboken, N. J.

ROYAL Road—Extemporaneous speaking, debating; 261-page, gold-cloth book, \$1. University Book Co., 725 Columbus Ave., N. Y.

WORLD'S most expert penman teaches penmanship by mail. Small cost. Journal free. Shall I show evidence? Francis B. Courtney, Box A, 492, Detroit, Mich.

EARN \$25.00 and more weekly. My Scientifically Prepared Shorthand Instruction Course in Gregg Shorthand paves the way to a higher salary. Special Summer Rate. Money refunded if not thoroughly pleased. A postal brings full particulars. Write today. M. H. Wright, 1361 E. 62nd Street, Chicago.

BE a Merchant Tailor. Learn to cut Men's and Women's "Tailor-made" Garments; big profits; small investment. We can teach you by mail. Success School of Cutting, Dept. 11, Jackson, Mich.

MANUFACTURE gold window letters. Big demand, profits, easy work, no capital. Instruction \$1. Germaine, Box 245, Mansfield, O.

BRIEFHAND, a combination of longhand and shorthand, enables you to write as fast as the average stenographer. Send 50c (stamps) for self-teaching manual containing 2,900 illustrations and complete instructions. Saves time and money spent at school. Premier Briefhand School, Washington, D. C.

SHORTHAND home course without money. Marvelously simple. Dougherty, Author, Topeka, Kan.

OSGOODBY'S Pitmanic Shorthand self-instructor by world's greatest court stenographer, \$1.50. Correspondence instruction if desired. Osgoodby School Stenography, Rochester, N. Y.

WE teach by mail, Sanitary Engineering, Sanitary Inspection, Plumbing, Hygiene, Booklet free. Anglo-American Sanitary Correspondence College, Ontario Street, Chicago.

YOU can write 100 words a minute without knowing Shorthand. My new method, Abbreviated Longhand, Simpler than the simplest shorthand; tried and approved by thousands. Your money back if not delighted. Sample lesson 20c. Full particulars free. Write today. A. B. Weaver, Court Reporter, Dept. C., Buffalo, N. Y.

**TELEGRAPHY**

TELEGRAPHY—Morse and Wireless—Railway Accounting (Station Agency) taught quickly. Railroad and Western Union Wires and complete Wireless Stations in school. Big demand. Positions secured. Living expenses low—may be earned. Largest and oldest school—established thirty-nine years. Investment, \$25,000. Correspondence courses, also. Catalogue free. Write today. Dodge's Telegraph Railway and Wireless Institute, 15th Street, Valparaiso, Ind.

TELEGRAPHY taught in the shortest possible time. The Omnigraph Automatic Transmitter combined with standard key and sounder. Sends you telegraph messages at any speed just as an expert operator would. Five styles, \$2 up, circular free. Omnigraph Mfg. Co., 41 G. Cortland St., New York.

**TRADE SCHOOLS**

MAKE \$5 to \$8 a day as skilled Electrician, Plumber, Draftsman, Bricklayer, Moving Picture Operator. We teach you in short time at small expense, profitable trades. Free employment bureau places graduates in good jobs. Special limited offer now. Write at once for catalogue and full particulars—no obligations. Dept. 8195 Coyne National Trade School, 51 E. Illinois St., Chicago, Ill.

PAINTING, Decorating, Paper Hanging taught by actual practice. Free catalogue. Chicago School of Painting, 414 Dearborn Ave., Chicago.

\$1,000 TO \$2,500 a Year. Learn automobile repairing, driving, garage management, salesmanship, self starters, machine shop work, steam vulcanizing, oxy-acetylene welding and cutting in the finest and most completely equipped school in America. Unlimited courses at our school, \$20 to \$50. Home study course \$10, sent on trial. Academy of Automobile Engineering, 1454 Michigan Ave., Chicago, Ill.

**PERSONAL**

ST-STU-T-T-ERING or Stammering. Let me tell you, by mail, how I cured myself, after 30 years of misery and failure. Discovered a natural method which anyone can use at home. Since then have won social and business success. Send me your address, in confidence. Walter McDonnell, Drawer F, 511, Station F, Washington, D. C.

LETTERS of any nature written. Vividly original and compelling. Mutual Service Bureau, Box 848, Atlanta, Ga.

WESLEY Mitchell: Ten years, no word. Need you. Come—Home—Love—Mother—Waiting. Stratford, Conn.

BROTHER—Accidentally discovered root cures tobacco habit. Gladly send particulars. F. Stokes, Mohawk, Florida.

**PICTURES AND POST CARDS**

YOUR name in gold on 12 Floral Postcards, 10c. The Excelsior Co., 1254 Franklin Ave., Bronx, New York City.

BETTER than "September Morn!" Two new pictures by same painter. These and "September Morn," silver quarter. Box 592, Minneapolis, Minn.

FASCINATING Girls—Postals: 10 poses 12c; 25, 25c. Maple Co., 110, Napanoch, N. Y.

20 BEAUTIFUL Post Cards, all kinds, and list of bargains, 10c. A. C. Kennell, Dept. B, Wellersburg, Pa.

MEXICAN Revolution post cards and 3 A prints, real photographs, 60 cents per dozen, six for 40 cents. Texas Photo Co., Box 557, El Paso, Texas.

RECEIVE pretty postcards from many countries! Membership 10c, Elite Exchange, R25, 3827 North Kenneth, Chicago.

CHARMO-SCOPE—Imported, showing charming beauty poses. Sent sealed 15c. Five catchy beauty postals 12c. Both 25c. T. Sullivan, Abbott Ave., S. Fitchburg, Mass.

YOU'LL get cards from everywhere. Membership 10c. Idaho Card Exchange, Dept. K, Box 906, Boise, Idaho.

FREE, five great historical Indian postcards. Famous Chief Sitting Bull and family. Send 10 cents to join big western postcard exchange. Box 285, Norfolk, Nebr.

QUIT your kiddin' and join the Star Postcard Exchange. Membership 1 mo. 10c; 6 mo. 50c. Star Postcard Exchange, Reidsville, N. C.

JOIN our club; get cards from everywhere. Membership 10c. Premium Postal Club (X194), Hampton, Ia.

POSTPAID, twelve cents, a Gem packet of stamps from Gem Stamp Shop, 19 Milk St., Boston, Mass.

RECEIVE pretty postcards from far and near, best club. Membership 10c. Jolly Card Exchange, Box 126, Decatur, Ind.

STOP! Real Indian photograph post cards. Something different. Variety of subjects: War Dances, Chiefs, views of Indian life. 5c each, set of 12 for 50c; all different. The Osage Post Card Co., Fairfax, Okla.

25 BEAUTIFUL high grade Souvenir Post Cards. Also our new illustrated catalog for only 10c. The Rehm Co., Weehawken, N. J.

EXCHANGE Cards. Membership in press immediately, 10c. Pacific Exchange, Bryn Mawr, Wash.

5 FASCINATING Postcards, 10c. Miss A. A. Banner, Station "R," New York City.

IF you really want to exchange post cards, try our splendid club. Lists circulate in many countries. Membership, 10c. Halcyon Club, Box 133, Erie, Pa.

POST CARDS of Irish Scenery, Irish Antiquities, Killarney, Giants Causeway, Dublin, Round Towers, Etc. 50 all different \$1. Lighthouses, foreign and domestic, 50 all different \$1. Famous Liners, Cunard, White Star, etc; 25 cards and 25 Lighthouse cards \$1. Send U. S. dollar bill or post-office money order. S. H. Strain, Lighthouse Mission, Belfast, Ireland.

POSTCARDS from everywhere. Membership Aurora Postcard Exchange and copy Aurora Postcard Monthly, 10c. 6 months 30c. Ed. Gamble, East Liverpool, O.

PHOTOS, "Beautiful Women," gems of art. 24 photo miniatures, 10c. Normal Specialty Co., J-7, Englewood, Chicago.

POSTCARD Exchangers—Join our Exchange. We guarantee our members. Membership 10 cents. Solare Club, Box 1342-M, Jacksonville, Fla.

**CAMERAS AND PHOTO SUPPLIES**

SAVE 40% on Photo Paper from factory, prepaid. "Instanto" has a sparkling quality no other gaslight paper possesses, quick printing, develops easy. Money back guarantee. Send 25c for 3 dozen postals or 4x6 size, price list and full directions. Photo Products Co., Dept. J, 6100 La Salle St., Chicago.

WE develop and print films; only highest grade paper used. Superior work. For trial order we will develop and print one roll any size for 25c. See our work and judge for yourself. Enlargements from films or prints. Moser & Son, 20 Arcade, Cincinnati, Ohio.

FOR Sale—\$20 3A Eastman Kodak for \$16. Never been used. Write quickly. Box 116-B, Loveland, Ohio.

PHOTOGRAPHER'S studio outfit for sale cheap. G. W. Heth, Independence, Mo.

CYKO postcards from your negatives, 3c; any size prints up to 4x6, 3c. Guaranteed work. 12 hour service. Fotokrafts, 324 Broadway, Loveland, Ohio.

ROLL film developed 5c when ordering 6 pictures. On postcards 4c; 100, \$1.50. On prints 3x5, 4c; smaller sizes, 3c. "Kodak Hints" free. 8x10 enlargements, 25c. Sample card free. Caulkins Photo Works, Oneonta, N. Y.

KODAK films developed 10c a roll. Prints 4x5 to 3 1/4 x 5 1/2, 4c. Smaller, 3c. Belfy Co., Middletown, Pa.

RUBY Flashlight, indispensable for the dark-room. Large standard size, \$1.50. J. F. Miller, Darlington, Ind.

LEARN Photo-Tinting for pleasure or profit. Anyone with artistic taste can quickly learn to do marketable work. Send for free booklet. Sample hand-colored print 10c. Keil-Burr Company, 56P, Pine Street, New York.

MONTHLY Exposure Guide—Sample 2c. C. Dum. 74 Guilford Ave., Columbus, O.

PHOTOGRAPHS printed cheap. Send your films. 924 S. Third, Rockford, Ill.

FILMS developed, any size roll, 10c. Prints  $2\frac{1}{4} \times 3\frac{1}{4}$  to  $3\frac{1}{2} \times 4\frac{1}{4}$ , 3c;  $3\frac{1}{2} \times 5\frac{1}{2}$  to  $4 \times 5$ , 4c. Post cards, 4c. Photo supplies. Send two negatives for free sample prints and special offer. Thos. Grove, 1540 E. 64th Street, Chicago.

FREE! Cameras, supplies, etc.! Act quickly! Ames Studios, Sunapee, N. H.

ROLL films developed, 8c, (eight), all prints, 3c. H. B. Mickle, Crete, Neb.

ROLL Film developed 10c a roll. Packs 20c each; Prints, Brownies, 2c; 1a, 3x4, 3x5, and Post Cards 3c each. Work returned next day. Postage paid. Kodak Film Finishing Co., 112 Merchants Station, St. Louis.

QUALITY enlargements, 8x10, mounted for framing, 35c postpaid. Films developed, 10c roll, any size. Post Cards, 50c dozen, \$2 the 100, from one negative. Bargains new and second-hand cameras, lenses, all makes. Charles H. Loeber, 1147 Broadway, New York.

PRINTS 25c doz., any size. Films developed, 10c. Photo Novelty, W. O. W. Bldg., Omaha, Neb.

ENLARGEMENTS for Amateurs and Tourists. The better kind, 8x10 size, 25c. Other sizes from 18c up. Send for attractive price list. Wilkes-Barre Photo Enlarging Co., P. O. Box 288, Wilkes-Barre, Pa.

50c OFFER for 10c. Send 10c and film, any size. Will furnish 6 prints. Beautiful work, prompt service, 8x10 enlargements mounted, 25c. Roanoke Cycle Company, Roanoke, Va.

"BETTER Photos." The liveliest photographic magazine in America for beginners and advanced amateurs. Send 50 cents now for a year's subscription, or ask for a Free sample copy, mentioning Popular Mechanics. Sears, Roebuck & Co., Chicago.

IDEAL Folding Darkroom—Small, light, convenient, economical. Operation visible. \$3.50 postpaid. Pamphlet free. Masko Mfg. Co., Box 750, Indianapolis, Ind.

FORMULAS for ten of the latest fads in photography, 25c. Includes instructions for magic disappearing photos. Photo sofa pillows and neckties, beautiful, transparent, colored pictures on watch cases, chinaware, etc. Phosphorescent photos and other novelties. P. Benson, Stewartville, Minn.

OUR "Studio Method" will give you the best Kodak finishing you ever had. As a sample we will develop and print one roll, any size, for 25c. Lansing Studio, Box 1485, Springfield, Mass.

BEST Symmetrical Anastigmat on earth fitted free to shutter of your postal card 4/5-5/7 Kodak or Camera for \$21. Lafbury Co., 305 North Fifth Ave., Chicago.

EXPERT developing, printing and enlarging. Price list and fine sample print 10c. Johnson Photo Supply, Baltimore, Ohio.

WORLD'S Best Photography Books. Self-Educational. See Higene's Ad, Classification: "Books."

AMATEUR Finishing of the better sort. Samples and list free. H. E. Smith, Clinton, Ill.

HAVE You a Camera? Write for Samples of my magazines, American Photography and Popular Photography, which tell you how to make better pictures and earn money. E. R. Fraprie, 615 Pope Building, Boston.

MONEY in Photography. Start at home with your camera. We teach you retouching; portraiture, by mail. Details free. Photographs, demonstrating retouching, 4c. Wells' Studio, East Liverpool, Ohio.

FILMS developed, 6c, all sizes. Prints  $2\frac{1}{4} \times 3\frac{1}{4}$ , 2c;  $2\frac{1}{2} \times 4\frac{1}{4}$ ,  $3\frac{1}{2} \times 3\frac{1}{2}$ ,  $3\frac{1}{2} \times 4\frac{1}{4}$ , 4c; 40c doz. Post cards, 5c, 50c doz. Work guaranteed and returned 24 hours after receiving. Postpaid. Send negatives for samples. Girard's Commercial Photo Shop, 194 High St., Holyoke, Mass.

ROLL Films developed 10 cents. Printing Post Cards 3 cents each. 15 years' experience. Send for complete price list. F. C. Hoyt, Sac City, Iowa.

KODAK Films Developed, 10c per roll, any size. Prompt attention given mail orders. Prints,  $2\frac{1}{4} \times 3\frac{1}{4}$  to  $3\frac{1}{2} \times 4\frac{1}{4}$ , 3c;  $4 \times 5$  to  $3\frac{1}{2} \times 5\frac{1}{2}$ , 4c. J. M. Manning, Box B, 1062 Third Ave., New York City.

WE buy, sell and exchange. Bargains in Microscopes, Telescopes, Binoculars, Cameras, etc. Bargain list sent. Kahn & Son, Opticians, No. 54 John St., New York. Established 62 years.

GREATEST Photographic Bargain List ever published. Willoughby, 810 Broadway, N. Y.

BIG Money Saved on Photographic Lenses and Apparatus—goods exchanged; repairing done. Ralph J. Golsen, 65 East 46th St., Chicago, Department P.

EVERYTHING Photographic—We bought bankrupt stock largest dealer. Thousand packages Cyko, Argo, Cameras, lenses, sundries. Ridiculously reduced prices. 5x7 Multiplying Cameras, making one to twenty-four on one plate, always \$12, special \$7. Newark Photo Supply Co., Newark, New Jersey.

DEVELOPERS. Ledo M. Q. None better. Six tubes twenty cents. With full size Acid Fixer 30c, postpaid. Lynn Photo Chemical Co., Lynn, Mass.

WRITE for free camera bargain list. New or slightly shopworn Cameras at money saving prices. Full line Kodaks, Premos, Grafex and others. Complete stock Photo Supplies, Gloeckner & Newby Co., 171 Broadway, New York.

## MOTION PICTURES

MOTION picture plays wanted. You can write them. We teach you. No experience needed. Big demand and good pay. Details free. Ass'd M. P. Schools, 601 Sheridan Rd., Chicago.

GO into the Moving Picture Business. We will start you with complete outfit. Best Machine, Films, and supplies, on the Payment Plan. Want to make Big money? Write for free Catalogue. Dearborn Novelty Co., Dept. P, 537 S. Dearborn St., Chicago.

I GUARANTEE \$10 for first photoplay you write by my method. Send for free booklet, "How to Write Photoplays." Elbert Moore, Box 712FE, Chicago.

SCENARIO Writing. Moving-Picture Operation. See Higene's ad. Classification, "Books."

BIG money writing photoplays, spare-time. Complete course \$1. Particulars free. Eureka Supply, B25, 3827 N. Kenneth, Chicago.

WRITE moving picture plots. Good pay. We will show you how. Ripless-Cloag Co., Box 410, Brockton, Mass.

LEARN to write photoplays. Writing motion-picture plays offers a new, easy and fascinating way to earn money in your spare time. Plot all that is required. Literary training or style not necessary. Easily learned. Great demand. Producers pay \$25 to \$100 each. Our short, fascinating course will teach you how to turn your ideas into dollars. Send for free descriptive catalog. Authors' Motion Picture School, Box 130K, Chicago.

MOTION Picture Work—A large 618-page book covering every phase of the moving picture, its production and its theatre. Indispensable for reference and instruction to the thousands of workers in the motion picture field. Price \$3, postpaid. Popular Mechanics Book Dept., 6 N. Michigan Ave., Chicago.

\$50 TO \$100 weekly writing moving-picture plays. Send for free booklet, valuable information and special prize offer. Chicago Photoplaywright College, Box 278 N. O. Chicago.

WHY not you write a photoplay—and sell it? Our experts criticize all your manuscripts free. \$1 yearly membership only charge. Particulars free. Write now. Photoplaywrights' Association of America, Dept. 41, 8 So. Dearborn St., Chicago.

WRITE Moving Picture Plays. \$50 each. All or spare time. Correspondence course unnecessary. Details free. Atlas Publishing Co., 304, Cincinnati, Ohio.

MAKE a complete Motion Picture Camera and Projector from instructions given in our book Amateur Mechanics No. 4. Full details given. Not hard to construct. Worlds of enjoyment taking and exhibiting subjects dear to the heart. Price of book only 25c postpaid. Popular Mechanics Book Dept., 6 N. Michigan Ave., Chicago.

\$35 PROFIT Nightly—Moving Picture Business—small capital starts you, no experience needed. Teach you—furnish everything. Ralph J. Golsen, 65 E. 46th St., Chicago, Dept. M.

## COLLECTIONS

5 FOLLOW-UP collection letters \$1. A systematic approach from all angles, making the debtor pay without losing his business. Sam'l H. Richey, Anderson, Ind.

## BUSINESS OPPORTUNITIES

START a Mail Order Business—First, however, read our magazine. One writes: "So glad I sent for it." Another: "Wish I had seen it sooner." Gives the experience of others with Promoters; puts you on guard. 25c for three months with supplements. The "Lever" Mail Trader, 44, Elizabeth, N. J.

BREED Mink. Big returns. Particulars, stamp. George Norton, Pleasantville, N. Y.

FREE Information on "How to Succeed in Mail Order Business." No fake schemes or outfits. Investigate. B. Newham, Waukegan, Ill.

YOUR advertisement printed on 144 pencils, \$1.90. Pencil Co., Thibodaux, La.

GET into the Penny Slot Machine Business. Make \$20 to \$50 weekly in spare time. I made thousands. Free illustrated booklet tells how. Let me start you. Address "Money-Maker" Chandler, 326 E. Cranston St., Providence, R. I.

BE the Oliver typewriter dealer in your town. Big profits. Write for my wholesale proposition. A. E. Atchison, 112 No. La Salle St., Chicago.

6,000 LIVE bona fide agents' names, \$1.00. Morgan, 312 Madison, Chicago.

\$300,000 IN ten-cent sales. Dealers get next. Profit 400%. Samples, prices 10c. Rudolph, Northwestern Building, Chicago.

CREASO, Noxspotz (powdered cleaner), copyrighted book for men, 60c value, with complete plan, full line advertising matter, postpaid 10c. Humdinger proposition. Dime back if dissatisfied. Eisenberg-Lankes, Marquette Building, Chicago.

MAIL Dealers and Agents: Read the magazine and make more money. 2 issues 10c. Agent's Magazine, Chicago.

SPECIALTIES that sell. 25c sample 10c. Particulars free. Rea Agency, Northwestern Bldg., Chicago.

IF unsuccessful so far, catch up and beat them all. Make success sure. Write today for book. Santen, 4731 Mission, San Francisco.

START Room-Renting Agency, your city. Something different. Complete forms used by Milwaukee concern, cards, advertising, etc. Mailed prepaid fifty cents. Your opportunity. New Business Builder, 959 34th Street, Milwaukee, Wis.

WHERE, what, and how to buy and sell; money-making ideas and \$\$\$\$ getting tips, information and suggestions on mail-order business, canvassing, advertising, mailing, in our magazine, 16 to 32 pages, edited by successful men. Three big copies, silver dime. Mail Order System, 1039 Barry Ave., Room 12, Chicago.

CALIFORNIA Tartaric Mirror Silvering Process. Largest factories users. First time offered public. Free booklet. Barstow Company, 514 23rd St., Oakland, Calif.

START Mail Order Business. Manufacture your own goods. Free booklet tells how. Walnut Co., Box H338, Philadelphia.

MR. Mail-Order Man: Get quick returns. Established corporation supplies fast mail-order sellers; factory prices. Classy proposition. Beginners or established firms. Copyrighted Prospectus free. Mississippi Valley Co., Inc., Box M629, Pittsburg, Kans.

START a mail order business of your own. Small capital. Spare time. 27 plans. Send for particulars. Mutual Opportunities Exchange, Buffalo, N. Y.

SEND 10c for "Key to Success in The Mail Order Business." Contains valuable information where to buy supplies, etc. Thos. A. Hill, 309 Lincoln, Denver.

BIG money made replating silverware. My complete course, simple and easy to understand, for 25c. No stamps. Mills, Box 744, Dallas, Texas.

MANUFACTURE office supplies. Big profits. Particulars free. Charles Krepps, Eccles St., Pittsburg, Penna.

WE will start you in the cleaning and dyeing business, little capital needed, big profits. Write for booklet. Ben-Vonde System, Dept. C, Charlotte, N. C.

INSTALL the new "Universal" (penny box) match machine. 250% profit on safety matches. Vernon Galster, 517 Prospect Ave., Syracuse, N. Y.

\$5 DAILY easily earned at home, spare-time, silvering mirrors. No capital. Free instructive booklet tells you how. Patterson & Co., Dept. 3, Brooksville, Ky.

MAIL Dealers, everybody's a prospect for our big value leader; yields good profit, costs one cent to mail. Imprint circulars furnished. Ajax Company, Bulletin Building, Philadelphia.

"THE Greatest Mail Order Proposition Ever Placed in the Hands of People Desirous of Making Money by Mail"; "The Medical Field"; "Building a Business With Beauty Preparations"; "Mail Order Book Business"—and many other excellent plans fully explained in current *Booster Magazine*—the one bona fide publication devoted exclusively to Agents' interests and all Mail Order People. More read "Booster" than any other trade paper; this alone should convince you that today is the day to learn about *Booster's* money-making suggestions and principles. Join our ranks now. Let *Booster* put you next to money-making propositions—ones that actually make money! 10c brings two copies worth dollars. If dissatisfied we'll return your dime. *Booster Magazine*, Northwestern Building, Chicago.

WANTED—10,000 business, professional and laboring men in rich country now developing. "Opportunities in the Golden West" tells you. 25c the copy. W. H. McMaster, Crescent City, Cal.

MAKE money renewing old dry batteries. Send 25c for complete formula and instructions; regular price \$1.00. If dissatisfied, we'll return your quarter and you may keep the instructions besides! Northern Supply Co., 154 Randolph, Chicago.

CASH for an idea; Patent News, Dept. 28C, Washington, D. C.

INCREASE your sales. Place your proposition before the readers of "Cartoons Magazine," 23,000 copies every month. Classified rate 2c per word. Mail in a trial ad today. Cartoons Classified Dept., 6 N. Michigan Ave., Chicago.

I MADE \$50,000 in five years with a small mail-order business; began with \$5. Send for free booklet. Tells how. Heacock, Lockport, N. Y.

MANUFACTURE chewing gum. No machinery necessary. Particulars for stamp. A. J. St. Germain, 72 Canal St., Lewiston, Me.

RESILVER Mirrors and make plenty of money. Guaranteed process and instructions 25c. Service Bureau, 3311-85, Belleplaine Ave., Chicago.

3,000 RURAL Names, Address, \$1. East of Mississippi. List 1952, Germantown, Philadelphia.

I WILL start you in Mail Order business, furnish you \$50 outfit, allowing you to pay for same out of profits. I will allow you one month's trial. If successful pay me for outfit, if unsuccessful you owe me nothing. Enclose ten cents (to exclude curiosity seekers) for particulars and sample. B. Wagner, Marshall & Thompson, Philadelphia.

"BARGAIN Mail Order Business"—new idea originated by house of ten years' standing. Bargain 26—60c value 25c—costs you 12c. Literature, prices free. Merford Company, Incorporated, Dept. 5M, Chicago.

POLISHING Cloth formula, 10c. Leroy Jipson, Rockland, Me.

INCORPORATE; let us tell you why 9/10 big business concerns America organized Delaware and New Jersey instead of Arizona, Dakota or elsewhere. America Guaranty and Trust Co., 1530 Chestnut St., Philadelphia, Pa.

STOP—If you could learn how to start a prosperous business without capital, would you spend one cent for postage? This is no mail order, canvassing or selling scheme. Write now, Business Opportunities, 406 Dake Bldg., Rochester, N. Y.

MAIL Dealers: Our advertising rate folder gives rates and information. Hundreds of papers. Free. Jukes, 910 Walnut, Philadelphia.

LET the parcels post help you. Add (\$15 to \$25 weekly) to your present salary or income. Start during spare time and build up a permanent mail-order business of your own. We show you how and help you make good. No canvassing. Experience unnecessary. The Parcels Post makes success doubly sure. Our new ideas and up-to-date plans bring the money. No so-called "Course of instruction" to sell. We give that free. Write today. Address Pease Mfg. Co., Inc., Dept. A, 70 Broadway, Buffalo, N. Y.

LEARN metalizing. Transform roses, carnations, butterflies, etc., into exquisite jewelry novelties. Big profits. Stamp brings particulars. P. Benson, Stewartville, Minn.

WE start you in business, furnishing everything; men and women. \$30.00 to \$200.00 weekly operating our "New System Specialty Candy Factories" home or small room anywhere; no canvassing. Opportunity lifetime; booklet free. W. Ragsdale Co., East Orange, N. J.

BE a Magician. Big demand everywhere. Travel over the world and make money. Book and personal advice by well-known retired Magician free. Many of my friends are making \$10,000 yearly. Oaks Magic Institute, Dept. 61, Oshkosh, Wis.

BIG Profits—Manufacture Crisp. Fine confection. Five-cent package costs one cent. Good spare-time business. Can be started at small cost. Sample crisp ten cents. Particulars free. Simplex Mfg. Co., Kewanee, Ill.

KLENENE Kleans. A new idea. Safer, cheaper, better than gasoline. Send dime for sample and our profit-sharing plan. Gordon Walker Company, 5818 Wentworth Ave., Chicago, Ill.

RAILWAY, Steamship, Gas, Electric, Timber, Irrigation, Coal, Oil, Realty, Construction, Industrial, Manufacturing, Trust, Banking and General Corporations Organized, and Directed. Stock and Bond Issues \$100,000, upwards prepared, shaped up and negotiated. L. N. Rosenbaum & Co., 259 Haight Building, Seattle, Wash.

I WILL promote, or purchase outright, small patented article suitable for Mail Order business. Give full particulars. Brooks, 350 W. 18th St., New York.

SPARE Time—No canvassing. Report information, news, names, etc., to us. Markets waiting. Enclose stamp. "Nisco," HDB, Cincinnati.

CAPITAL for meritorious inventions and business propositions, established or contemplated, McCormick, 527 N. Charles St., Baltimore, Md.

MOTION picture plays wanted. You can write them. We teach you. No experience needed. Big demand and good pay. Details free. Ass'd M. P. Schools, 691 Sheridan Rd., Chicago.

IF you want facts instead of fancies about Patents, address Benjamin & Bassett, 140 S. Dearborn St., Chicago, Ill.

WANT install or sell something new, entrance big theatre, also paying traveling proposition. Tiptop O'Reilly, 87, Havana, Cuba.

ESTABLISHED, profitable, clean, honest medical business for sale. Address Gallstone Remedy Co., 219 S. Dearborn St., Chicago.

MAKE big money with mail order or local business. Free trial. Strang, West Unity, Ohio.

PATENTABLE Ideas Wanted—Send for 3 free books. R. B. Owen, 30 Owen Bldg., Wash., D. C.

SILVERING Mirrors and Auto-trimmings. Plating tableware home. Plans free. Clarence Sprinkle, East Grant, Marion, Ind.

ONE hundred dollars reward for information leading to location manufacturing plant in Chattanooga. Cheapest hydro-electric power and coal in country. Good white labor. Chattanooga Trust Co., Tenn.

DO you want to operate a successful candy shop? Send for our Candy Book 50c. Auburn Supply Co., 7745 Peoria St., Chicago.

WE analyze everything. Reliable formulas furnished. Expert chemists. D. Laboratories 721 East 161 Street, New York.

GREAT profits. Making twisted wire brushes by hand. No capital. Write for particulars. T. H. Petty, Dept. 420, Toledo, Ohio.

MAKE money working for us, coloring; new process, no experience; write for particulars. The Art Specialty Co., 12 E. Ontario St., Chicago, Ill., Dept. P.

MAKE big money opening safes and setting combinations. Wayne Strong, 811 Temple, Los Angeles, Cal.

ANYONE earn \$35 weekly making and selling Storm Indicators. Shows weather forecast 24 hours advance. No capital. \$1 tells how. H. W. Willis Co., Hagerstown, Md. Dept. 1.

I MAKE \$5 a day, mail-order business in spare time; I'll send the complete plan and sample free with King's Magazine 3 months, all for 25c. W. E. King, Pub., Box 13-P, Little Silver, N. J.

INCORPORATE. Our lawyers do the work, saving you time, annoyance and money in incorporating under the most liberal laws of Arizona. Laws and forms free. Southwestern Securities & Investment Co., Box D488, Phoenix, Ariz.

LEARN to collect money—by a sure, easy system. Big income. Quick results. No capital required. Send today for free booklet, "Skillful Collecting." Collectors Assn., 1624P, Williamson Bldg., Cleveland, Ohio.

WE start you in a permanent business with us and furnish everything. We have new, easy-selling plans and reasonable leaders in the mail-order line, to keep our factory busy. Small capital. Large profits. Spare time only required. Personal assistance. Write today for plans, positive proof and sworn statements. Kimo Mfg. Co., 220 Kimo Bldg., Buffalo, N. Y.

WRITE Moving Picture Plays. \$50 each. All or spare time. Correspondence course unnecessary. Details free. Atlas Publishing Co., 3046, Cincinnati, Ohio.

MONEY-MAKERS. Over 100 ways explained. Complete collection 10c. Service Bureau, 3311-D4 Belleplaine Ave., Chicago.

BIG money made. Baseball and football machines. Sullivan Amusement Co., St. Albans, Vt.

\$3,000 YEARLY in your back yard. No Ginseng, Mushroom dope. New ideas never before published; particulars free. Metz, 306 East 88th St., New York.

ASK Bode! Anything! Especially about Business and Advertising! Get Particulars "Now"! Bode, 2880p Main, Hartford, Conn.

EVERY Advertiser Needs our New Advertising Rate Book. Lists 2,000 best advertising mediums in America. Gives circulation and rates. Contains special lists and advertising snaps, including "Ads That Pay," sent prepaid for 10c. Dearborn Advertising Agency, 521 Dearborn St., Chicago.

WOULD you like to own a good-paying mail order business? We have a line that gets repeat orders all the time. You can start in spare time; invest a dollar or two a week and soon own a nice business of your own; write for particulars. Nadico, 1664 Belmont Ave., Chicago.

I WILL start you earning \$4 daily at home in spare time, silvering mirrors; no capital; send for free instructive booklet, giving plans of operations. G. F. Redmond, Dept. 306, Boston, Mass.

INDEPENDENCE and fortune quickly attained in the Manufacturing Mail Order business. I furnish Formulas, Manufacturing Processes and Trade Secrets in all lines. Sold under positive guarantee; 18 years' practical experience. Revision and improvement of Formulas and Processes—reduction of manufacturing cost—utilization of waste materials, etc., a specialty. Booklet, Formula List, and Valuable Information Free. W. L. Cummings, Ph. D., 127 Standard St., Syracuse, N. Y.

WE Sell Patents. Established 1900. If you wish to add a new product to your line, write us. Charles A. Scott Co., 596 Central Bldg., Rochester, N. Y.

STOP Here! Let me start you in a home business that will bring you money every day. Experience unnecessary. Spare time. No canvassing. I furnish everything. Send for proofs. Voorhies, Desk C. R., Omaha, Neb.

#### MAIL ORDER SUPPLIES

LATEST imported tricks, jokes, puzzles, magic novelties and mechanical toys. Illustrated catalogs, circulars and goods furnished to mail dealers in small quantities at lowest wholesale prices. A new European novelty, wholesale price list and all particulars 10c. None free. Ernest Graf, Importer, 705 M Eighth Avenue, New York.

INCREASE your sales. Place your proposition before the readers of "Cartoons Magazine," 23,000 copies every month. Classified rate 2c per word. Mail in a trial ad today. Cartoons Classified Dept., 6 N. Michigan Ave., Chicago.

MAIL Dealers—My joke-novelties are paying big profits. Imprint catalogue supplied at actual printer's cost. Joseph Methieu, 203 Court St., Brockton, Mass.

#### FOR ADVERTISERS

EXTRAORDINARY Advertising Proposition. Your 30-Word Advertisement on 1,000 Circulars, 15c. Schwam Press, 68 Jewell St., Brooklyn, N. Y.

YOUR 50-word advertisement in 16-page 7x10 magazine reaching 7,500 boys, 25c. Youths' Magazine, Chicago.

START an original mail-order business. Honest, independent, Small Capital, New Methods. Sole rights. Big money. R. Clement Moore, Business Specialist, New Egypt, N. J.

ADVERTISERS—Special—5c per word places your ads in 133 different magazines. Send copy now for next issue. King's Magazine, Box 13-P, Little Silver, N. J.

30 WORDS in our big Postcard Monthly 25c. Display 50c inch. Elite Exchange, 3827 North Kenneth, Chicago.

**BARGAINS**—15-word ad, one year's subscription 25c; extra words one-half cent. Guaranteed 25,000 circulation. Digest, Grand Rapids, Mich.

THE Classified ad pages of the Denver Weekly Post will sell or swap anything that the human family uses. Reaches over 115,000 subscribers every week by Uncle Sam. No street or news-stand sales. A circulation not duplicated by any other medium. The largest and newest weekly newspaper between the Missouri River and the Pacific Coast. Classified ads—3c per word. Display—30c per line, \$4.20 per inch. One ad convinces. Write for sample copy. Subscription price 35c the year.

#### TO MANUFACTURERS

**ELECTONE**—To manufacturers: If you make electrical devices, write me. I have something new. Relates to vibratory treatment. Will make all existing devices of this character look like thirty cents. Can be secured for small sum. Plans and Drawings. Max Meloy, Excelsior Springs, Mo.

**WANT** Mail Order and General Agency Specialties from Manufacturers. Box 831, El Reno, Okla.

#### AGENTS WANTED

**AGENTS Wanted**—If you know a chance when you see it you'll see this one now. Big money—stylish, nifty clothes—little work—no experience or capital needed—can you beat that? We want agents everywhere to take care of our business in their localities and to advertise our nobby, nifty suits by wearing them. We furnish everything complete and charge nothing for agents' outfit. The swellest dressers everywhere are our agents and all we ask is that you tell people who inquire about your fine clothes where and how they can get them. You make big money—\$10 a day—without trouble. Just a postal brings you full outfit free. Big new sample book of up-to-the-minute suitings sent so you can pick out your first suit; also measuring blanks and everything you need. We pay express on everything—not a penny for you to pay. Send quick before some one else gets the agency there—mail postal today to American Woolen Mills Co., Dept. 514, Chicago, Ill.

**GENERAL Agents**—Capable of calling on the big trade themselves and handling canvassers for the house to house and office to office business, to sell the newest electric specialty on the market; sold everywhere there is electricity, in the home, office, factory, store, hotel; liberal profits; sales-driving sample, weighs a pound, no experience or knowledge of electricity required; shows how to use one light instead of two and get the same results; sells for \$2.50, \$3.50, \$5 and saves the purchaser an investment of \$25. Write for particulars. The Handy Light Co., 154 Handy Light Block, Cincinnati, Ohio.

**\$45 TO \$95 weekly** selling wonderful Air Cell Washers. New invention just out. Makes old-fashioned washboard useless. Every home buys. No power necessary. Costs nothing to operate. Lasts lifetime. Retail only \$1.50. Does work of outfits costing \$10, \$15 and \$25. Enormous demand, 200% profit. Sold on absolute money-back guarantee. Agents, salesmen, general agents wanted. Territory free. Get particulars. Air Cell Washer Co., 491 Valentine Bldg., Toledo, O.

**YOUNG Man**, would you accept and wear a fine tailor made suit just for showing it to your friends? Or a Slip-on Raincoat free? Could you use \$5 a day for a little spare time? Perhaps we can offer you a steady job. Write at once and get beautiful samples, styles and this wonderful offer. Banner Tailoring Co., Dept. 723, Chicago.

**AGENTS—Both Sexes**—We manufacture and control fastest selling household article ever invented. Connolly, 123 Liberty St., New York.

If we had your address we'd send free sample and show you how to make \$25, not one week but weekly. G. Mfg. Co., 20H Warren St., N. Y.

**OUR Steel Wardrobes** sell at sight; 200% profit. No nails or screws necessary. Ten hooks. Holds 150 lbs. Best spring and summer seller on the market. Peck Engineering Co., 2230 Mill St., Rochester, N. Y.

**OUR New Safety Razor** sells itself. Sample 25c. Particulars free. Andrews Specialty Co., Rochester, N. Y.

**AGENTS Wanted**—Right here is the one big chance of your life. If you want to make good money—\$10 a day or more, as easy as rolling off a log, and get your swell clothes free besides, you can do it by acting as our agent. We are the biggest people in the business and want our agents to make big money and be nifty, stylish dressers. Send a postal today for free \$10 outfit, including a big book of nobby suiting samples to select your swell agent's suit from. Then take orders from people who admire your nifty clothes. They come to you—not you to them. This is the way to get rich—the sure, easy way. Remember, you need no money—everything is furnished by us free. We pay express on everything. Just send a postal, but do it today. You can't get started too quick, making this big money and wearing these stylish clothes. Address card to Paragon Tailoring Co., Dept. 514 Chicago, Ill.

**VALUABLE Premiums and Big Profits** to Agents selling our order getting line of Guaranteed Pure Aluminum Goods. Our \$200,000 capital backs you. Write today for territory. Wm. J. Dick, Mgr., Dept. J 21, 20 W. Lake St., Chicago.

**EARN \$50 weekly** selling Genuine Gold Window Letters. 10c brings sample and particulars. Gold Letter Manufacturing Co., Wheeling, W. Va.

**AGENTS wanted.** Honest, hustling agents can make \$5.00 daily. Full particulars. Wilber H. Young, Austin, Texas.

**AGENTS wanted** for our patented Shoe Polishing Outfit. A sale can be made in nearly every home. Live workers make \$5 daily besides building up a large repeat-order business. Agent's sample outfit sent postpaid for 35c. Particulars free. Allan W. McKee, Plainville, Conn.

**AGENTS—Live wire proposition** offered hustlers; exclusive territory on profitable articles; write quick. Schiller Co., 414 Broadway Bldg., Chicago.

**AGENTS—Dealers.** We have the best proposition ever placed in your hands. Good chance for agents and jobbers to take a hand. Send 25c for sample and instructions. Cole, 1309 Madison, Chicago.

**MAKE and sell your own goods.** Formulas by expert chemists. We obtain your government serial number. Catalogue for stamp. B. Mystic Company, Washington, D. C.

**EXCLUSIVE territory.** New article. Big profits. Write for sample. Sweet, 1013 1/2 N. Main St., Los Angeles, Cal.

**AGENTS—Salary or commission.** Greatest seller yet. Every user pen and ink buys on sight. 200 to 500 per cent profit. One agent's sales \$620 in six days; another \$32 in two hours. Monroe Mfg. Co., X 6, La Crosse, Wis.

**AGENTS, economic home-dry-cleaning process;** chemical and instruction 35c; large profits, season on. U. S. Factories Company, Cincinnati, Ohio, sole distributors.

**BEST selling household necessity** of the season. Guaranteed. No talking needed—two minutes demonstration cinches sale. It's a poor one who can't make \$5 to \$10 daily. George Bohner, 1009P So. Wabash, Chicago, Ill.

**AGENTS make \$30.00 weekly** selling our 500 Handy Household articles; catalogue free. Scheff Company, Desplaines, Ill.

**WE start you in a Soap and Toilet Goods business** without a dollar. Experience unnecessary. Carnation Toilet Co., 3024 Easton Ave., St. Louis, Mo.

**AGENTS—A full size 25c stick of razor strop paste** sent for 10c. M. O. Dolson, 207 East 25th St., Los Angeles, Cal.

**SELL safety razors.** 150% profit. Sample 15 cents. C. Beven, Roselle, N. J.

**LARGE income selling Specialty Rugs.** Colored illustrations and important information free. Sample rug forwarded prepaid, \$1.00. Reference, Boylston Nat'l Bank, Boston. Dundee Mfg. Co., 46 Chauncy St., Boston, Mass.

**GET rich quick—Vacuum washer plan** beaten. Opportunity seekers, 10 cents deposit brings convincing details. New—best proposition. Lettle, Plainfield, Ind.

**AGENTS Wanted—Agents make 500 per cent profit** selling "Novelty Sign Cards." Merchants buy 10 to 100 on sight. 800 varieties. Catalogue free. Sullivan Co., 1234 Van Buren St., Chicago, Ill.

**AGENTS, we furnish you samples and catalogue** absolutely free. Sell hosiery, underwear, shirts, and handkerchiefs, direct to homes. Write Madison Mills, 588 Broadway, New York City.

**AGENTS—Get particulars** of one of the best paying propositions ever put on the market. Something no one else sells. Make \$4,000 yearly. Address E. M. Feltman, Sales Mgr., 6718 Sycamore St., Cincinnati, O.

**AGENTS—Make 300% profit.** Sell high-grade line Art Show Cards. Every merchant buys. Send 10c for samples worth 50c and Catalogue. Merchants Specialty House, Chicago.

**AGENTS—New premium proposition;** make \$5 daily; experience unnecessary; 70c profit on \$1.20 sale; sample and particulars free. Le Beau Co., 3311 Belmont Ave., Chicago, Ill.

**PHOTO Pillow Tops, Portraits, Frames, Sheet Pictures, Photo China Plates.** Rejects credited. Prompt shipments; samples and Cat. free to agents. 30 days' credit. Jas. C. Bailey Co., Desk B, Chicago, Ill.

**\$50.00 A WEEK** guaranteed selling Pure Spun Aluminum Cooking Utensils. We are manufacturers of the largest line in the world. First Aluminum Cooking Utensils made bears our trade-mark. Wanted live men at once for protected territory. Answer quick. Divn. PM. American Aluminum Mfg. Co., Lemont, Ill.

**AGENTS—24x28 Framed Pictures, 12c.** Hot sellers at 50c. Everybody buys. Also portraits, frames. Convex work. Pillow tops, 28c. Big profits. Cat. free. Peoples Portrait, Dept. B, 710 W. Madison, Chicago.

**AGENTS—A free course in General Salesmanship** is given to every man of our Sales Organization. This organization is a body of successful men selling the Handy Light; that unique electrical device which cuts the cost of electric lighting in half. Sells for \$3.50, is used in home, office store, factory; weighs only one pound. Sold by demonstration. All agents furnished with well-planned methods for gaining interviews. A high-grade business for a man of ability, and standing in his community. General Agents preferred. Inquire for our full proposition by addressing The Handy Light Co., 1102 Handy Light Block, Cincinnati, Ohio.

**THIS beats all the jobs going.** A new camera, just out, completely finishes 3 photo post cards of any subject in 5 minutes. No experience necessary to do it. Strong money maker, big profits, simplicity itself; complete outfit, \$3.75. Get a circular quick. Autovac Co., 301 Temple Bldg., St. Louis.

**RAY'S total commissions for 1913** over \$12,000. New Feeny Vacuum Cleaning Machine has got all others skinned forty ways. Good men wanted for general agents. Exclusive territory. You risk nothing. If wise, you will write before tomorrow. Feeny Manufacturing Co., Dept. C65, Muncie, Ind.

**AGENTS, earn \$10 per day,** sell three 50c ties \$1. Free Monogram gold cuff links and stick pin. Bowden cleared \$71—5 days. Cooper \$40—4 days. Free samples. Comer Neckwear Co., 3 Eighth St., Dayton, Ohio.

**ATTENTION Agents!** Clear \$30 weekly, year round, mailing music evenings. Why look further? Send 10c for proof, startling facts and elegant sheet music. Weber Music Publishing Company, Boston, Mass.

**AGENTS Wanted—Write for attractive proposition** on button hook puzzle. Latest thing out. Sells at sight. K. & Z. Specialty Co., Dept. F., 638 3rd Ave., Milwaukee, Wis.

**KANTBURN Kooker \$1.** Fastest seller ever invented. Over 100% profit. Exclusive territory. Savage Manufacturing Co., 303 N. Fifth Ave., Chicago.

**AGENTS—To sell the newest electric appliance** on the market; sold everywhere there is electricity, in the home and office; liberal profits; sales-driving sample, weighs a pound, no experience or knowledge of electricity required; it shows how to use one light instead of two and get the same results; sells for \$3.50 and saves the purchaser an investment of \$25. Write for particulars. The Handy Light Co., 16 Handy Light Block, Cincinnati, Ohio.

**AGENTS—Big profit.** Easy sellers. Name plates, House Numbers. Write today for free sample. "Real Flash," Silver Creek, New York.

**AGENTS—Write and learn how to build up a permanent paying business** selling "Quickerlightning" cleaner for the hands easy seller, repeat orders, exclusive territory, free samples. Joliet Novelty Co., Joliet, Ill.

**AGENTS—\$7,035 Culver's sales—\$3,517.50 profit** selling our small bottling outfit to saloons. Two sales a day, \$15 profit. Sample and Salesmanship Course free with first ten outfits. Write Simplex Mfg. Co., Keokuk, Ill.



(CELLULOSIA) Door Plates, new lettering pure gold. Send for sample case. Nothing invested. 100% profit, sell to every home. Public demands them. La Fontaine, Mfr., Sherburne, N. Y.

AGENTS, Biggest Line, Biggest profit. Extracts, Jelly Powders, Spices, Baking Powder, Medicines, Perfumes, Toilet Specialties. Credit Given. Catalogue free. Western Laboratories, 2000 Van Buren, Chicago.

OPPORTUNITY to make \$5-\$10 daily, selling dressy, serviceable raincoats at less than inferior ready-made kind. Empire Tailored Raincoat Co., 2831 Third Ave., New York City.

200% PROFIT. You can't beat it. Free pocket sample. Sells everywhere. Everyone buys. Our reputation and big capital back you. Wm. J. Dick, Mgr., Dept. K4, 20 W. Lake St., Chicago.

If you live in a small town and have a little spare time, get our offer. Easy to make \$100 profit each season; still easier to get your own clothes out of the profit on a few orders. No extra charge for fancy styles, golf bottoms, pearl buttons, etc., makes sales easy. Write for free samples and our new offer. Knickerbocker Tailoring Co., Dept. 70, Chicago.

EARN \$25 to \$50 a week. We are manufacturers. Our co-workers sell the goods for us, mail order or local. Take advantage of our new co-operative "tested out" selling method. New spring and summer leaders, greatest repeat order specialties ever manufactured by us. Start spare time, experience unnecessary, big profits, dealers doing a big business. You need not take our "say-so." If you can personally call upon us do so, "Seeing is believing." If you cannot, write today for our Catalogue and Co-operative Manufacturers' Method, free limited coupon offer, positive proof and sworn statement. Kimo Mfg. Co., 238 Kimo Bldg., Buffalo, N. Y.

AGENTS—Sell Fibresilk Ties. Made by new process on patented machines in many rich, beautiful colors. Brilliant, silky lustre—washable. Sell quickly at 35 and 50 cents each—can sell for 25 cents and still net you 100% profit. Exceptional proposition for spare time and agents. Send 15 cents for sample tie (guaranteed). Fisher Knitting Co., 28 Whitesboro Street, Utica, N. Y.

WANTED—District Representatives to handle "The Bench Machinist," a combination \$750 Miller, \$100 Drill Press and \$150 Lathe. (Absolutely accurate.) Sells at \$125. No other machine like it in the world. Write for agent's inducement. Modern Appliance Co., Los Angeles, Cal.

THE Fuller Dustless Mop and Furniture Duster are advertised in leading magazines. We need live representatives for unoccupied territory. These articles contain exclusive features. Fuller Brush Co., 55 Hoadley Place, Hartford Conn.

SELL the newest and greatest household inventions. Absolute necessities. One a sure repeater. Big money-makers. Logan Mfg. Co., 2312 Lyndale, Chicago.

\$7.50 VACUUM Cleaners, \$2.75; Vacuum Sweepers, the \$10 kind, \$3.75. "Best yet" guaranteed, ball-bearing machines. \$10 daily easily made. Immediate shipments. United Vacuum Products Company, Chicago.

MEN and women wanted for Government jobs, \$65 to \$150 month. Vacations. Examinations everywhere soon. Common education sufficient. Sample questions and schedule of places—free. Franklin Institute, Dept. F22, Rochester, N. Y.

150 PER cent profit, representing exclusive manufacturer, ideal sanitary twisted wire brushes. Highest quality, lowest prices. 28 winners, \$5. Tappan Brush Company, 550 Temple Court, Minneapolis, Minn.

MAIL Order Dealers. Agents Supply Houses. Get our catalog. Best plated specialty in years. Tremendous demand; 25c article; enclose 10c for sample; refunded first order. Douglass Mfg. Co., 1230 Fulton St., Brooklyn, N. Y.

NEW—There is money in it. Swift Belt Splicer for endless belts; every shop, laundry needs one. Write Swift Machinery Manufacturing Company, Hornell, N. Y.

SIDELINE, 300% profit. Used in every home. Samples 10c. L. Flinker, 2631 N. Mozart Street, Chicago.

COST 1c, sell for 10c. Ready-made sign letters anyone can apply. Unlimited demand. Five samples, instructions, 10c. Particulars free. Everbrite Co., 982 Third Ave., New York.

AGENTS make big money and become sales managers for our goods. Fast office sellers. Fine profits. Particulars and samples free. One Dip Pen Company, Dept. 2, Baltimore, Md.

AGENTS, get the latest. Combination egg separator, egg beater and cream whip. Agent's sample 25 cents coin. T. A. Burke, 203 S. Pearl, Galesburg, Ill.

SAFETY Self-Filling pen proposition. Laughlin, Detroit.

AGENTS Wanted—Live men who can make 150% profit on \$1.50 Sanitary Oil Mop or on our 75c American Fibre Broom. Address Columbia, 1434 W. 15th St., Chicago.

WANTED—Agent to act as manager in each county. \$150 month easily made. No canvassing. Success guaranteed. Big, expensive samples. Instructions, plans and starter, all 10c postage. Manager (Dept 48), Myers & Co., Cambridge, Ohio.

AGENTS—\$5.00 daily easily made, brand new household novelty that every woman wants and buys. Write for sample and particulars. R. F. Maddox, Brownsville, Tenn.

START a mail order business of your own. Small capital. Spare time. 27 plans. Send for particulars. Mutual Opportunities Exchange, Buffalo, N. Y.

10,000 AGENTS wanted. New article. Sells on sight. Record-breaking sales everywhere. Sample free. Allen Manufacturing Co., 202 East 99 St., New York City.

AGENTS—Best and fastest selling Aluminum articles on the market—big profits—exclusive territory. Write today. M. & K. Aluminum Co., Brockport, N. Y.

AGENTS make \$5 profit daily. Name Plates, House Numbers, Signs, Particulars free. Roscoe Lynch, Bausman, Pa., Dept. B.

PORTRAIT Agents—Write for prices on Solars, Bromides, Convexed Prints and Pillow Tops. We ship orders back in 24 hours. Try us. Horne Copying Co., 113 S. Jefferson St., Chicago.

RUN a Key Tag business right in your own home. Be your own boss. We sell you all the supplies and show you how to stamp the names on the Tags and Fobs. The work is very easy. Free instructions with each outfit. Pease Dye Works, Dept. M, Winchester, N. H.

MR. Mail-Order Man: Get quick returns. Established corporation supplies fast Mail-Order sellers; factory prices. Classy proposition. Beginners or established firms. Copyrighted Prospectus free. Mississippi Valley Co., Inc., Box N623, Pittsburg, Kan.

AGENTS—Genuine Panoramic Photographs of Panama Canal, 6 1/2 x 3 1/2 inches, on heavy paper; 20 different views. Samples 50 cents. Gordon Photo Co., 143 Baronne, New Orleans.

MONEY! Money! Money! If bang up agent and want easy money, send 10c for 25c package of "Quickbright" the wonderful polishing device. Exclusive territory (none free), great selling plan. Non-Nac B Mfg. Co., Rutherford, N. J.

AGENTS to take orders for Visiting and Business Cards; large profits; outfit free. Forman Printery, Waterbury, Conn.

AGENTS—Make \$5 to \$10 a day; used in every household; easy to handle; sales guaranteed. Write today for particulars. W. H. King, 810 Pennsylvania Ave., Detroit, Mich.

LEARN to Make Gold Sign Letters; \$30 to \$50 per week profit. Complete course \$1. Particulars free. Cushing, 2715 South Main, Los Angeles, Cal.

MAKE \$4 per day easy. Household article sells itself at 25c; cost 5c. Send for free sample and proposition. Douthat, 1802 E. 43rd St., Kansas City, Mo.

25-WORD advertisement in 100 magazines \$1; rates on newspapers; 2c brings lists. Gem Advertising Agency, 362 Appel Bldg., Denver, Col.

AGENTS—A new one: Concentrated soft drinks. Every home, church-fair, picnic, lawn fete, ball park, stand, etc., buys them. Whirlwind sellers. Great profits. Small package makes 32 glasses—orangeade, grape, raspberry, etc. Hurry—don't wait—be ready for the hot season. Write quick. American Products Co., 3011 Sycamore St., Cincinnati, Ohio.

WE need live wire representatives for unoccupied territory to handle The Fuller Sanitary Brushes. Our product is nationally advertised and covers every need. Your territory is valuable. Write for particulars. Fuller Brush Co., 33 Hoadley Place, Hartford, Conn.

LET us start you in a permanent business of your own selling Guaranteed Planto-Silk Hosiery and Underwear direct from factory to the homes. Capital and experience not necessary—we help you. Our representatives are making \$3,000 to \$5,000 a year. Write for spare time and full time plans. Malloch Knitting Mills, 506 Grandville Ave., Grand Rapids, Mich.

"BOOSTER" shows you how to make money! Operate an "Income Mail Business!" Booster's propositions can easily be worked evenings. Don't invest any money until you read "Booster"—the magazine that has actually and accurately placed men in business for themselves by publishing money-making propositions that bring the dollars. Send 10c for two copies worth cash to you. Booster Magazine, Northwestern Bldg., Chicago.

GENERAL Agents everywhere for our new "Sav-Ice" Cloth; especially prepared for preserving ice in refrigerators. Reduces ice bills one-half; exclusive territory to good, responsible parties. Harsch Mfg. Co., Box 654, Indianapolis, Ind.

50 ARTICLES constantly used in every home, all our own specialties; wonderful sellers; sure repeaters; big profits; exclusive agencies; credit given; chance of lifetime for capable, honest, energetic men and women to acquire a business of their own yielding fine, steady constantly increasing income. Write today. Saverio Products Co., 106-108 Reade St., New York.

AGENTS—Male or Female—We have one of the greatest sellers ever offered. A fine proposition, assuring you a big business and a steady income. Our proposition has been tried and proven a success. Write today for full particulars. James Specialty Mfg. Co., 13th Avenue, E. Auburn, N. Y.

SELL Ironing Tables, Step Ladders, etc.; nine wooden household articles. Davis Mfg. Co., Clinton, Maine.

READ the Agents Magazine and make more money. 2 issues 10c. Agent's Magazine, Chicago.

PERFECTION Ford Starters for Ford cars. Guaranteed to start any Ford car that is in running condition. Splendid proposition and inducement for state and county agents. The Perfection Auto Starter Co., 1461 Broadway, Denver, Colo.

ROYAL Incense—Most wonderful, satisfying fragrance known. Rediscovered product of Ancient Egypt. Drives away flies, mosquitoes, moths. Sample 10c; Large, 25c, with premium offer. Traffic Company, 11370 Sheffield Street, Pittsburgh, Pa.

EASY money made selling our Self-Filling Fountain Pen at 25c, regular price \$1.50. Cannot leak; no sweating or soiled fingers; simple self-filling device; flow of ink controlled by writer; 14k gold-plated pen point. Each pen put up in attractive box, and absolute satisfaction guaranteed. Send 25c for sample postpaid. Our Special May Offer tells how pen will cost you 9c each, in small trial quantities. Rollins & Co., Dept. 33, Boston.

\$10.00 A DAY selling \$25 Barnes Electric Suction Cleaners. One sale a day will make this. Write today for further information. Advance Mfg. Co., Kalamazoo, Mich.

NEW patent, \$10 daily. Experience unnecessary. Big income for years. Every housekeeper wants it. 35c starts you. Particulars free. Address Washtenaw Supply House, 1704 North Washtenaw, Chicago.

GOLD Sign Letters. Instructions for making. Johnston Co., Quincy, Ill.

GET cash for names, information, ideas, formulas. Instructive booklet for stamp. Information System, 212, Marietta, Ohio.

WE want representatives in every town. Excellent opportunity to earn big income. Write at once for full particulars. Beardsley Specialty Co., Rock Island, Ill.

LIVE wires make big money. Sell our vacuum cleaners and other articles. Experience unnecessary with our selling plans. General Sales & Mfg. Co., 121W, No. Wabash Ave., Chicago.

WE manufacture household remedies. Articles of merit that insure repeat orders. Live agents wanted to control exclusive territory and sub-agents. Write today. Peram Manufacturing Co., Perth Amboy, N. J.

AGENTS! Sell Maple Flower. 25c package makes 2 gallons delicious syrup. Sale in every home. Profits over 100 per cent. Sample 10 cents. Our agents coin money. Write at once. Wilmington Co., Y10, Cincinnati, O.

WOULD \$40 a week interest you? We seek a representative for old established brand of guaranteed hosiery; sold direct to consumers; protected territory; credit given. N. Parker Mills, 726 Chestnut St., Phila., Pa.

AGENTS and side line men are getting the money with our patented clip. Does away with back collar button. Permits tie to slide easily. Sample 10c. Comfort Collar Clip Co., 304 W. Van Buren, Chicago.

**FOUR-IN-HAND Tie Form.** Simplest made. Tied in 3 moves, 10c; with silk tie 25c. 3 forms 25c. Stanly, Cornhill, Boston.

**AGENTS**—Big money selling our combination aluminum beer pipe cleaners and water filters. Write for illustrated circular and terms. Critteron Company, Naugatuck, Conn.

**AGENTS**—Average \$5 to \$12 daily selling astonishing Aztec massage machine. New. Just patented. Different. No electricity or water power required. Nothing complicated. Affords exhilarating massage without cent expense. Lowest priced but best outfit. Retail \$2.50, allowing you big end of profit. Particulars and "beauty" folder free. Aztec Remedy Co., Dept. 132, Toledo, Ohio.

**\$40 WEEKLY** selling Keyless Lock. Guaranteed. Sells at sight. Sample 65 cents. Money back if wanted. Exclusive territory. Big Money Maker. Thief Proof Lock Co., Box P 1013, Dallas, Texas.

"**EVERYTHING** comes to him who goes after it." Hustlers make big money selling our improved carpet sweeper and vacuum cleaner combined. Most liberal proposition ever offered agents. Western Specialty Mfg. Co., 180 No. Dearborn St., Chicago.

**AGENTS Wanted.** Fancy cigar lighter; wear and looks like solid gold; guaranteed durable. Samples 25c. New Jersey Specialty Co., 16 Bergen Station, Jersey City.

**HUSTLING** agents everywhere to sell the latest, lowest priced, most satisfactory washing machine on earth. Be first in your territory. Diaphragm Washer Company, Detroit, Mich.

**STAMP** Names and Addresses on Key, Checks, Umbrella Plates, Watch Fobs, etc. We supply blank stock and stamping outfits, sample with name and address, 10c. Hart Mfg. Co., Desk 2, 303 Degraw St., Brooklyn, N. Y.

**YOUR** address on postal brings you the biggest money-making proposition you ever received. Try it. X. L. Products Co., 117 Worth St., New York.

**AGENTS Wanted**—Ladies or gentlemen. Two big propositions: one needed by every business firm; the other by every family. If you can sell anything you can sell these. Inland Mfg. Co., Topeka, Kans.

**AGENTS**—Three new games for Cigar Stores, etc. Retail \$1. Also line of new office specialties. Easy sellers. Particulars free. Poola Co., Dept. PM, Harrisburg, Pa.

**LIVE** Agents Wanted: Universal Polishing Cloth. Sells wherever shown. Full size sample and particulars 25c. Universal Specialty Co., Plainfield, N. J.

**ANSWER** this and get our free sample case offer. \$10 a day easy with our complete line of household necessities. Men or women. E. Roberts, 110 Roberts Bldg., St. Louis, Mo.

**LISTEN!** You can make \$15 weekly easy selling high-grade Jewelry 50c weekly. Washburn, 417 West 128 St., New York.

**AGENTS**—500% profit, free sample Gold and Silver Sign Letters for store fronts and office windows. Anyone can put on. Big demand everywhere. Write today for liberal offer to agents. Metallic Letter Co., 406 N. Clark, Chicago, U. S. A.

**WE** are absolutely making agents the best proposition of any manufacturer on our new Vacuum Sweepers; largest profit; sell easiest. Act quick. Manufacturers Home Supply Company, Detroit, Mich.

**AGENTS**—\$50 weekly. We manufacture the best needle case made; a wonderful seller; 200% to 500% profit; talking unnecessary; our "Trust Scheme" Envelopes do the work; general agents can make \$100 weekly; particulars free; 25c sample outfit for 10c; buy direct from the factory. Paty Needle Co., 102 Davis Sq., W. Somerville, Mass.

**THEODORE** Roosevelt is again writing for Scribner's. Magazine subscription solicitors can earn big commissions. Inquire Desk 15, Scribner's Magazine, 597 Fifth Ave., New York.

**HONEST** man wanted in each town to distribute free advertising premiums; \$15 a week to start; experience unnecessary; references required. Address McLean, Black & Co., 11 S. Beverly St., Boston, Mass.

**TO** the agent our perfected acetylene generating and storage system offers great possibilities. Field includes automobiles, motorcycles, horse-drawn vehicles and motor-boats. The Tank-O-Gas Co., 23 St. Ann St., Forest Hills, Mass.

**AGENTS**—Repeater; costs 5c; sells for \$1; sample 2c. Dr. Thornber, Ferris, Ill.

**AGENTS** wanted to handle remarkable money makers; easy to handle; easy to sell; many repeat orders; write quickly. H. Warwick, Dept. S, Box 306, Bridgeport, Conn.

**BIG** money selling Automatic Telephone Disinfectors. Write us. Eucalyptus Parfeno Co., New Bedford, Mass.

**AGENTS**—Streetmen—Eleven New money-makers. Profits exceed 50%. Latest "Live Wire Bulletin" free. Act quick. United Sales Factory, Newburgh, N. Y.

**MEN** Wanted, Handle Branch Agencies paying \$5 day upward. Give references, experience. Modern Specialties, Racine, Wis.

**AGENTS** in every city to handle our Triplex Folding Handbag; big profits; exclusive territory. Write for terms and free catalog. Other big sellers. S. V. Diamond & Bro., 35 West 21st St., New York City.

**RURAL** Agents write for our "10-day free trial offer to prospective agents" on our New Improved 1914 Model Vacuum Cleaner. We pay all express charges. Best and strongest suction cleaner made. Gets both germs and dirt. Guaranteed 5 years. Postal will bring offer. Warner Vacuum Cleaner Company, Dept. "Z," Muncie, Ind.

**AGENTS** would you take a steady job where you can clear \$20 to \$30 weekly to start and work up to yearly profits of \$3,000 or more? No experience required. Great crew managers' proposition. We manufacture. Middlemen profits saved. Get posted on our 1914 exclusive territory—business-building selling plans. Act quick. E. M. Davis, Pres., R64, Davis Bldg., Chicago.

**AGENTS**—\$5 daily selling our Handy Tool, 12 articles in one. Lightning seller. Sample free. Thomas Mfg. Company, 462 Third St., Dayton, Ohio.

**WIDE-AWAKE**, active agents or crew managers can secure special concession and reap the benefit from the best money-making agency proposition on the market by writing immediately for full particulars. Hugro Manufacturing Co., Chicago, Ill.

**500% PROFIT** selling our wonderful sign letters for office windows, store fronts and glass signs; resembles finest gold leaf; easily applied; samples free. Metallic Letter Co., 406 N. Clark St., Chicago.

**SOAP** and Perfume Agents, write us. Big Profits. Goods Guaranteed. Hopfinger and Roth, 212 N. Second St., St. Louis, Mo.

**AGENTS**—250% profit. Wonderful little article. Sells like wildfire. Can be carried in pocket. Write at once for free sample. H. Mathews, 1962 Third St., Dayton, Ohio.

**HOUSEHOLD** necessity recently invented sells at 75c. Costs distributors 25c. Nothing like it on the market. Tested and approved by Good Housekeeping Institute. Get your territory now. Hugro Mfg. Co., Chicago, Ill.

**\$1,000.00 OR \$400.00** a month—which? Agents make \$20.00 a day. Start in small way, grow to big money class. Kochler make \$12.00 first day, \$16.00 second day. "Positive Proof Sales Plan," combined with "Shakit," makes big money certain. Make your friends wonder at your success. Act Quick; particulars for postal. Nat. Dist. Co., 1674 Belmont Ave., Chicago, Ill.

**AGENTS:** We want, at once, a man or woman, one capable of earning good salary, in every community where we are not represented. Write us. Sun Mfg. Co., 309 Dean Bldg., South Bend, Ind.

**WE** have agents making \$200 weekly, selling our new specialty to merchants. Retail \$7.50, your profit \$5.00. No competition; exclusive territory. Samples and descriptive matter free. Sayers Co., 408 Olive St., St. Louis, Mo.

**MAIL-ORDER** Opportunities: 25 new Propositions. No competition! Make 95c profit on dollar order; complete outfit 10c. Mail Dealers Wholesale House, 521 Franklin Bldg., Chicago.

**STOP** Here! Let me start you in a home business that will bring you money every day. Experience unnecessary. Spare time. No canvassing. I furnish everything. Send for proofs. Voorhies, Desk C. R., Omaha, Neb.

**\$35 TO \$100** weekly made easily. Needed in every home and store; enables purchaser to save money and enjoy life. Rapid seller, profit from \$10 to \$50 each sale. Experience unnecessary; exclusive territory to hustlers. Write for full particulars. C. Hemple, Sales Mgr., 174-C, No. Sangamon, Chicago.

**\$5.00 RAINCOATS**—Agents wanted everywhere. You and many others in your section need Raincoats and would gladly pay Agent \$5.00 for one. Why not be that Agent? Boston Raincoat Company, Sales Dept., Boston, Mass.

**AGENTS** sell rich-looking imported 36x68 rugs \$1 each. Carter, Tenn., sold 115 in four days, his profit \$57. You can do as well. Write for sample offer and selling plan. Sample rug by Parcel Post, pre-paid, 98c. A. Condon, Importer, Stonington, Maine.

**AGENTS** make \$5.00 to \$10.00 a day on the start. Atkinson writes: "The best proposition I have found in my forty year canvassing." Permanent work. Household necessity. Saving 80%. Write today for General or Local Agents terms. Free sample. C. H. Stuart & Co., 16 Union St., Newark, New York.

**I WILL** start you earning \$4 daily at home in spare time, silvering mirrors; no capital; send for free instructive booklet, giving plans of operation. G. F. Redmond, Dept. 306, Boston, Mass.

**300 TO 400%** Profit to Agents selling our guaranteed U. S. Fire Extinguishers. Tremendous demand. Orders repeat. Exclusive territory to county and district managers. United Mfg. Co., 1025 Jefferson, Toledo, Ohio.

**BIG Profits** for You! Manufacture Barley Crisp. New confection. 5c package costs you 1c. Machine, instructions complete \$7.50 prepaid. Send 10c for samples. Barley Crisp Co., 1605 Hyde St., San Francisco.

**YOU** can make \$\$\$\$ as our general or local agent. Household necessity; saves 80 per cent; permanent business; exclusive territory; salary or commission; free sample; credit. J. Pitkin, 113 Reidd St., Newark, N. Y.

**AGENTS** Wanted—Mechanics and shopmen make over \$100 a month in spare time selling transparent handled novelty knives and razors. Big profits. Sales easily made. Write for terms today. Novelty Cutlery Co., 67 Bar St., Canton, O.

**MEDALLIONS**—300% profit. Make up your own goods and be independent. Catalogue free. Resag Co., 1205 Randolph St., Chicago.

**AGENTS**—Sell the Primus, genuine Swedish wickless, coal-oil stoves. Smokeless, odorless. Twice the heat of gasoline at one-eighth the cost. No danger of explosion. Big profits. James Anderson & Sons, Sidney, Ohio, American distributors.

**OUR** Agents make good money and get repeat orders easily. Dept. A. Consumers' Direct Supply Co., Boston, Mass.

#### HELP WANTED

**YOUNG** Man, would you accept and wear a fine tailor made suit just for showing it to your friends? Or a Slip-on Raincoat free? Could you use \$5 a day for a little spare time? Perhaps we can offer you a steady job? Write us at once and get beautiful samples, styles and this wonderful offer. Banner Tailoring Co., Dept. 724, Chicago.

**WANTED**—Thoroughly trained mechanic to take charge of the hydraulic inspection and maintenance of a large Hydro-Electric Plant in the East. Should preferably have had similar experience in some other plant or in the installation of water wheels. State full particulars as to training and experience. P. W., 9th floor, 6 N. Michigan Ave., Chicago.

**FREE** illustrated book tells of about 300,000 protected positions in U. S. service. Thousands of vacancies every year. There is a big chance here for you, sure and generous pay, lifetime employment. Just ask for booklet S 29. No obligation. Ear Hopkins, Washington, D. C.

**MOTION** picture plays wanted. You can write them. We teach you. No experience needed. Big demand and good pay. Details free. Ass'd M. P. Schools, 67 Sheridan Rd., Chicago.

**WANTED**—Trustworthy people, either sex, to travel and exhibit our feature attraction, "Horrors of White Slavery" in picture theatres. Great chance to travel see the country and make from \$50 to \$100 weekly. Write us at once. Address Queen City Feature Co., Dept. 549, Carthage, Mo.

**A MONEY** Proposition—Co-operate with me in a profit-sharing mail-order business. Will place trial advertisement, furnish printed matter, goods to fill orders and divide the profits. Particulars. Desk 153. Hazen A. Horton, Tekonsha, Mich.

**BECOME Detectives—**Earn big money; easy work; wonderful opportunities. Write Wagner, 1243 Lexington Ave., New York. Dept. 301.

**GOVERNMENT Examinations.** Most thorough preparation; \$5; returned if not appointed; particulars free. American Civil Service School, Washington, D. C.

**300 TO 400% Profit to Agents** selling our guaranteed U. S. Fire Extinguishers. Tremendous demand. Orders repeat. Exclusive territory to county and district managers. United Mfg. Co., 1026 Jefferson, Toledo, Ohio.

**SPARE Time—**No canvassing. Report information, news, names, etc., to us. Markets waiting. Enclose stamp. "Nisco," HDB, Cincinnati.

**START a mail order business** of your own. Small capital. Spare time. 27 plans. Send for particulars. Mutual Opportunities Exchange, Buffalo, N. Y.

**AUTOMOBILE chauffeurs** get \$25.00 week and over. Demonstrators and Automobile Salesmen get big pay. Pleasant work. Many spring openings. Sample instructions free. Franklin Institute, Dept. F 803, Rochester, N. Y.

**GET Cash for Names, information, ideas, formulas.** Instructive booklet for stamp. Information System, 213, Marietta, Ohio.

**BE your own Master.** Stop wage slavery. Formulas and instructions for manufacturing 24 Big Sellers and many Business Opportunities sent for 10c. E. M. Reynolds, 937 E. 42nd Place, Chicago, Ill.

**BRAKEMEN, Firemen,** all railroads, \$100.00. Necessary signal instruction free. Send age, postage. Railway Association, Dept. 298, Brooklyn, N. Y.

**WANTED—**Circular distributors; enclose stamp. American Distributor Co., Blairsville, Pa.

**PARCEL Post means many Railway Mail Clerks** needed. Commence \$75.00 month. Examinations everywhere. Sample questions and schedule of places—free. Franklin Institute, Dept. F 21, Rochester, N. Y.

**GET a Government Job!** See ad on page 14. Write now—today. Patterson Civil Service School, Rochester, N. Y.

**"UNCLE SAM" wants employees.** Parcel post makes many vacancies. List of positions now available—free. Franklin Institute, Dept. F 21, Rochester, N. Y.

**\$5 DAILY** easily earned at home, spare-time, silvering mirrors. No capital. Free instructive booklet tells you how. Patterson & Co., Dept. 3, Brookville, Ky.

**\$5 To \$150 month** paid men and women in U. S. Government positions. Life jobs. Thousands of appointments coming during 1914. Common education sufficient. "Pull" unnecessary. Write today for free list of positions now available. Franklin Institute, Dept. F 21, Rochester, N. Y.

**RAILWAY Mail Clerk Examinations** coming everywhere. \$75 to \$150 month. Sample questions free. Franklin Institute, Dept. F 21, Rochester, N. Y.

**GOVERNMENT Jobs, \$100 month.** Vacations. List free. Franklin Institute, Dept. F 21, Rochester, N. Y.

**WANTED—**Railway Mail Clerks, \$75.00 month. Sample examination questions free. Franklin Institute, Dept. F 21, Rochester, N. Y.

**"MY Lady of Dreams,"** the coming big song success. A great song with an attractive title page. Ten cents in stamps or coin. Marks-Goldsmith Company, Department D, Washington, D. C.

**BE a detective.** Earn big money. Write John J. Gilles, Licensed and Bonded N. Y. State Detective. Retired Member N. Y. Police Dept. 22 years Experience. 254 Huguenot St., New Rochelle, N. Y. Investigation solicited.

**WRITE Moving-Picture Plays.** \$50 each. All or spare time. Correspondence course unnecessary. Details free. Atlas Publishing Co., 3045, Cincinnati, Ohio.

**PLEASANT Home Work—**Ambitious persons wanted for copying, addressing. No mail-order course or trash to sell. Send today addressed, stamped envelope for particulars. Box 17, Station H. G., New York.

**WANTED—**An Idea! Who can think of some simple thing to patent? Protect your ideas; they may bring you wealth. Write for "Needed Inventions" and "How to Get Your Patent and Your Money." Randolph & Co., Patent Attorneys, Dept. 144, Washington, D. C.

**BE a Detective—**Earn \$25 to \$75 weekly; chance to see the world with all expenses paid. Loraine System, Dept. 304, Boston, Mass.

**\$3,000 YEARLY** in your back yard! No ginseng, mushroom dope. New industry you never heard of. P. and S. F. Magazine explains; editor helps you. Trial copy with Editor's Special "tip," 10c. Mark Walter, Editor, 42 Hanselman Bldg., Kalamazoo, Mich.

**GO on the Stage.** Vaudeville career offered you. Experience unnecessary. Managers endorse my method. Instructive vaudeville book free. Write today. FredERIC LaDelle, Sta. 10, Jackson, Mich.

**WANTED—**Distributors, Men and Women—to give away free pkgs. Perfumed Lorax Soap Powders; no money or experience needed; good pay. S. Ward & Company, 218 Institute, Chicago.

**STOP Here!** Let me start you in a home business that will bring you money every day. Experience unnecessary. Spare time. No canvassing. I furnish everything. Send for proofs. Voorhies, Desk C. R., Omaha, Neb.

**BETTER Light** for 1/5 Cost of Electricity. Suitable for home or store. Easily installed; no experience necessary, big demand. Write for Free catalogue. Doud Lighting Co., 174-D, N. Sangamon, Chicago.

**I WILL start you earning \$4 daily** at home in spare time, silvering mirrors; no capital; send for free instructive booklet, giving plans of operations. G. F. Redmond, Dept. 306, Boston, Mass.

**LEARN automobile repairing, driving** on up-to-date cars; electrical, civil engineering, surveying; methods most practical; room and board while learning; positions secured; satisfaction guaranteed; catalog free. National School of Engineering, 2110 West Seventh, Los Angeles.

**BE a Detective.** Earn \$200 monthly, positions open. A practical course in Detective Work taught by mail. American School of Criminology, Detroit, Michigan. Dept. F.

#### FOR SALE

**FOR Sale—**Nineteen Bi-Una wall type telephones with sixteen stations and a quantity of conductor cable in short and long pieces, used with these telephones, at one-fourth its cost before installation. This outfit is in good condition and just right for communicating around a small mill. Atlas Tack Co., Fairhaven, Mass.

**DUPLEX** drum shell, birdseye maple, perforated, 16"x3". New Jos. Beitz heads, nickel trimmings, a beauty, excellent tone and carrying power. Price with case and sticks, \$35. J. R. Sanford, P. O. Box 1157, Billings, Mont.

**TRAVELING Crane—**Wooden—For sale cheap. 15 ton capacity, 65'x0" span, suited for either motor or wire rope drive. Write G. T., 9th Floor, 6 N. Michigan Ave., Chicago.

**FOR Sale—**Holder for heating soldering irons over a gasoline torch. Will hold and heat ten six-lb. irons in ten minutes, \$2.50. C. E. Goulding, 610 Tampa St., Tampa, Fla.

**SHAPER—**Stroke 16". Cross Feed 1 1/2". Vise opens 8". Complete with countershaft \$225. Grammes Sons, Allentown, Penna.

**GENUINE Fantail Cigars,** box of 50, \$1.75 prepaid. Holst Cigar Co., New Albany, Ind.

**FOR Sale—**Fine Eight-Plate McIntosh X-Ray Machine Cheap. Joseph Fairhall, Jr., Danville, Ill.

**VACUUM** cleaning wagon cost \$2,500, will sell very cheap. 212 Broadway, Camden, New Jersey.

**THIRTY hp. tractor** with plow, 5 gangs, and huge truck wagon. Used but little. Unadapted to our hilly and low lands. A grand bargain. If interested write Flintstone Farm, Dalton, Mass.

**\$1,200 VACUUM** Cleaning Wagon, perfect condition, \$300. Reason. Willis May, Bethlehem, Pa.

**2-CYLINDER, 12-hp.,** air-cooled motor complete. 2-speed planetary transmission. First draft for \$40 takes it. W. F. Schmeltzer, Milbank, S. D.

**I. C. S. ELECTRICAL** Engineering Course. Half price. 834 1/2 33rd St., Milwaukee.

**VACUUM Cleaners.** All makes at half regular prices. Send for list, New York Vacuum Cleaner Exchange, 215 Grand St., New York.

**ONE small farm gas engine.** One Marine engine. Several good rebuilt motorcycles. G. W. Fagan, Cedar Falls, Ia.

#### GUNS, SPORTING GOODS, ETC.

**BARGAINS** in firearms, binoculars and watches; list for stamp. Heard, 126 West 23d, New York.

**OLD Pistols and Guns Wanted.** Will buy or give in exchange almost any sort of modern revolver, rifle or shotgun. Stephen Van Rensselaer, West Orange, N. J.

**FISH lines, 2 years' supply 20c,** including novelty catalogue. John H. Smith, Cohoes, N. Y.

#### WANTED

**MILITARY Band Organ** wanted; description, best cash price. T. S. Culp, Canton, Ohio.

**WANTED—**Patented articles to manufacture. Williams Mfg. Co., P. O. Box 808, Waterbury, Conn.

**WANTED—**Second-hand stone crusher to crush rock to size walnuts and smaller. Material wanted for building driveway on private estate. Machine must be in first-class condition and preferably in New England, as crusher will be used in Maine. Address with full particulars, "W," care Popular Mechanics Magazine, Chicago.

**WANTED** to purchase complete file of magazine (Wayside Tales) year 1904. Address W. T. c/o Cartoons, 6 N. Michigan Ave., Chicago.

**WANTED** United Cigar Store coupons. Send 2c stamp for prices and exchange list. Box 254, New Rochelle, N. Y.

#### SALE OR EXCHANGE

**SHORT lengths lumber,** any thickness, black walnut, oak, etc. Walnuts, young trees. Interest in seed harvester patent, want encyclopedia, reference books, lathe, light engine. Team and driver; harvest seed your locality. R. H. Oneill, R. 6, Cameron, Mo.

**EXCHANGE** Piano Player for high-power motorcycle. Berle Erwin, Britt, Iowa.

#### FLOUR & FEED MILLING MACHINERY

**SPECIAL** bargains in second-hand Attrition mills, burr mills, crushers, corn shellers, bran dusters, dust collectors, purifiers, reels, double, single, 2 and 3-pair high roller mills, sieve bolters, receiving separators, scourers, etc. Write for description and prices. Sprout, Waldron & Co., P. O. Box 429, Muncy, Pa.

#### MACHINERY, TOOLS AND SUPPLIES

**GASOLINE Engine Trouble Chart—**a sectional view showing clearly all parts of a typical four-cylinder gasoline engine of the four-cycle type and outlining distinctly all parts liable to give trouble. Also details the derangements apt to interfere with smooth engine operation. Invaluable to motorists. Size, 25x38 inches. Mailed on receipt of 25 cents by Popular Mechanics Book Dept., 6 No. Michigan Blvd., Chicago.

**ABSOLUTELY** new. Swift Belt Splicer and gluing clamp makes perfect splice—saves time, belting. Endless belts are preferred in every shop; send for circular; trial free. Swift Machinery Manufacturing Company, Hornell, N. Y.

**PULLEYS, Gears, Sprockets, Shafting, Hangers;** see page 132. W. A. Jones Foundry & Machine Co., Chicago.

**125-HP. BOILER** engine, two brick machines, pulleys, shafting. J. P. Vogan, Franklin, Pa.

**MOST** successful miller attachment for lathes, price \$40. Wm. Mielke, Hartford, So. Dak.

**VACUUM** cleaner pumps, tanks, hose and tools for stationary plant for house, flat or wagon. Prices wholesale. Assemble your own machine. Saves half. Vacuum Supply Co., Ann Arbor, Mich.

**SEND** for catalog of our new "Tango" concrete mixer for farmers and contractors. W. C. Kiernan & Co., Whitewater, Wis.

**WRITE** your name on anything, steel, iron, copper, glass, tin or zinc. Send 50c coin. Tells everything. Willis, Box 294, Desk K, Hagerstown, Md.

**LATHES:** 15" x 5 ft. Wagner, comp. rest, chuck, complete, \$135.00; 16" x 6 ft. Gray, comp. rest, \$165.00; 17" x 10 ft. Gray, comp. rest, turret, \$245.00; (4) 16" Shapers; one 6" Shaper. Particulars on application. Western Machinery Co., Cincinnati, Ohio.

**FOR Sale**—30 hp. 4-cylinder gasoline motor, new—completely equipped with carburetor, magneto. A high-grade motor at a bargain. Address D. W. Miller, 3305 Clinton Ave. S., Minneapolis, Minn.

**GET circular**, real Kerosene Mixers; more power, no smoke; for shop and portable engines. Earl W. Johnson, Westfield, N. Y.

**YOUR name** on steel stamp to mark your tools for \$1. Three initials for 50c. Gideon Pike, Attleboro, Mass.

**GODDELL** Pratt bench lathe, complete, \$20.00. Forge blower, \$5.00. Small saw table, \$15.00. Wanted: 12 or 14 inch short lathe. 90 Evans Ave., Ingram, Pa.

**COMPLETE** miniature experimental paper mill, used for experimenting with, and testing fibers and pulps in a practical manner, consisting of rotary digester, 50 pound beater, stuff chest and pump; screen, 18 in. cylinder paper machine, web end. Several dryers, small rotary cutter, calendering rolls, press, etc. E. W. B. 9th floor, 6 N. Michigan Ave., Chicago

**FOR Sale**—Complete rope-drive transmission with clutch, sheaves, hangers, etc., for use in straight or angle driving. Angsten-Koch Company, Chicago.

**10,000 FT.** of belt at 5 cts. per ft. Send for list No. 27. Lucas & Son, Bridgeport, Conn.

**HAVE** for sale several sizes of lathes, milling machines, drill presses, punch presses, shapers, planers, boilers, steam engines, oil, gas and gasoline engines and wood-working machinery. Pinner, 122 Water St., New York, N. Y.

**ENGINE** Lathe, swings 9 1/2", takes 25" between centers. Complete set gears cutting all size threads 3" to 40". \$43.50. Grammes & Sons, Allentown, Pa.

**HOW** to Run a Lathe. A 50-cent book for 10 cents postpaid. S. B. Lathe Works, South Bend, Ind.

#### ENGINES AND MOTORS

**BARGAIN**—One 4-cylinder, 2-cycle, 50-hp. gasoline engine complete from propeller to fly wheel, in excellent condition. Fitted with Bosch magneto, Lavigne oiler, Heinz coil, reverse gear, etc. Ready for inspection. Price \$390 F. O. B. Detroit. Also, one 30-hp., 4-cylinder, 4-cycle Cadillac engine with reverse gear. Price \$100 F. O. B. Detroit. C. W. Kotcher, 639 Gratiot Avenue, Detroit, Mich.

**FOR Sale**—A fully guaranteed 1 hp. B. & V. Hopper-Cooled engine never taken out of crate. The best engine B. & V. ever made. Will sell for \$31. Regular price \$50. Write R. M. Allen, 419 Sixth St., Elyria, Ohio.

**DYNAMOS**, Motors, Small Motors, dynamos, parts, storage batteries, for all purposes. Send for catalogue. Fred R. Hellman, 442 Niagara St., Buffalo, N. Y.

**WILL** sacrifice complete Gas Producer Power plant, including 60 hp. gas producer, 65 hp. triple cylinder, Vertical Westinghouse Gas engine, direct connected, 37 1/2" K. W. D. C. Generator, 125 volts, 300 R. P. M. In excellent condition, operated only a short period. Write for further information. E. W. B., 9th Floor, 6 N. Michigan Ave., Chicago.

**FOR Sale**—One small Universal variable speed motor for 110 volt circuit. Suitable for driving window displays or toy machinery. Price \$3. C. F. Smisor, 4808 Lake Park Ave., Chicago.

**WATER**-Cooled, 4-cylinder 3x3 1/2 engine, new, \$60. A. W. Banister, 629 E. 10th St., Erie, Pa.

**FOR Sale**—Guaranteed 2 1/2 hp. New-Way Engine. Has never been used. Will sell to first comer for \$78. Regular price \$125. Write me today. R. F. Peters, Box 189, Elyria, O.

**GUARANTEED** alternating current motors single phase, 1/4 hp. Holtzer-Cabot, \$25; 1 hp. Wagner, \$53; 2 hp. Wagner, \$67; three phase Westinghouse 1 hp. \$27; 3 hp. 1120 speed, \$50. Motors bought and sold. Fans. Guaranteed repairs. Hyre Electric Co., 613 So. Dearborn St., Chicago.

**1/6 HORSEPOWER** Direct Current Electric Motor, \$11, 110 volts. Dr. Utley, Canton, Pa.

**NEW** and second-hand engines for sale and exchange. Apply with stamps. B. W. Richardson, Peoria, Ill. R. 36.

**FOR Sale** at a Bargain. New 5x6 four-cylinder, governor-controlled engine, fully equipped with carburetor magneto. Will sell for much less than cost. Fred Hanson, 570 Prior Ave., St. Paul, Minn.

**12 STEAM** engines each \$12. Send for list 27. Lucas & Son, Bridgeport, Conn.

**COMPRESSION** restored without rebor-ing. Motor boats, automobiles, pumping and agricultural engines. Wille Adjustable Piston Company, 1534 Fulton St., Brooklyn, N. Y.

**REBUILT** Engines—We have on hand a number of rebuilt "Buffalo" engines, guaranteed, at greatly reduced prices. Write for bargain list. Buffalo Gasoline Motor Co., 1293-1305 Niagara Street, Buffalo, N. Y.

#### ENGINE CASTINGS AND BLUE PRINTS

**GASOLINE** Engine Castings, with drawings. Cheap. Catalog for stamp. Novelty Manufacturing Co., 853 West 6th St., Cincinnati, Ohio.

#### MANUFACTURING

**CLEVELAND** Specialty and Manufacturing Company, Cleveland, Ohio, design or make special articles to order. Inventions developed.

**WRITE** for our proposition on Blanking and Forming dies and metal press work. Complete equipment for all work in any quantity. S. D. Childs & Company, Chicago.

**WIRE** Goods, all kinds, made to order. Cooley Mfg. Co., 553 W. Monroe St., Chicago.

**WE** are equipped to build anything out of Iron and Brass. Builders' supplies, Structural Steel, Stirrups, Anchors, Iron, Brass, and Aluminum Castings. Practical Gas Engine & Machine Works, North Chicago, Ill.

#### BOATS AND LAUNCHES

**PREMIER** enclosed motorboat switches. List \$1.50. Limited number, 60c. coin or stamps. Big value. Beebe Co., 336 York, New Haven, Conn.

**ROWBOAT**, 14 ft. \$12, 5 passenger. Particulars free. B. B. Co., 607 Barrister Bldg., Washington, D. C.

#### BLACKSMITHS

**BLACKSMITHS** who own automobiles or repair automobiles in their shops should subscribe for the "Automobile Dealer & Repairer." See "ad" under "Automobiles." Charles D. Sherman, 50 Windsor Road, Hartford, Conn.

**GOOD** blacksmiths are scarce and few learning the trade and the blacksmiths must make the tools for all—from surgeon to the safe blower. Buy Toy's Modern Methods Forging and Welding different kinds of steel solid, and doing all hard jobs easy, also hardening and tempering to a standard by colored charts. Any smith can be an expert that means good jobs and big money. All for one dollar. Send for valuable samples free. W. M. Toy, Sidney, Ohio.

#### CEMENT

**CONCRETE** Building Block Machines, \$25, slightly shop-worn; quantity limited. 5 Market St., St. Louis, Mo.

**IF** you want the best information on cement and concrete construction, subscribe for Concrete-Cement Age, leading cement and concrete monthly. Sample copy, 10 cents. Yearly subscription, \$1.50. Concrete-Cement Age, 135 Newberry Bldg., Detroit, Mich.

#### MECHANICAL ENGINEERS

**CONSULTING** Engineer—A. M. American Institute Electrical Engineers. Practical advice. Maximilian Weil, 2 Rector St., New York.

#### ELECTRICAL

**RENEW** old dry batteries; 3 best methods with complete instructions, 20c. Guaranteed. Formula Bureau, 3311-E, Belle-plaine Ave., Chicago.

**TRANSFORMERS**—New Star Type "A" rings eight 2 1/2-inch bells, \$1.75. Type "B" rings fourteen 2 1/2-inch bells, \$2.50. Dealers get discount. Star Device, 1253 Pittsfield, Mass.

**FLASHLIGHTS**, the \$1.25 kind, nickel case, 85c postpaid. H. Peters, 114 N. 13th, Philadelphia.

**DETECTIVE** Phone—Make one yourself. You can hear a whisper. Plans and information, 25c. Lobe Mfg. Co., 167 W. 102 St., New York City.

#### RARE COINS

**10 VARIETIES** foreign coins 12c, 20—25c; 50, \$1; 100, \$2.50. Burgess Co., 522 Beacon, Toledo, Ohio.

**OLD** Coins bought and sold. New spring catalog just out free to collectors only. Buying coin catalog quoting prices I pay 10c. Wm. Hesslein, Paddock Bldg., 101-B, Tremont St., Boston, Mass.

**WATCH** your change! Big money paid for old coins. Right now we offer \$100 for dime 1894, S. Mint; \$50 for 1853 half dollar, no arrows; \$750 for certain \$5 gold, no motto, and lesser amounts for thousands of others. Thousands valuable coins circulating. Get posted. Send only 4c. Get our Large Illustrated Coin Circular. It may mean much profit to you. Send now. Numismatic Bank, Dept. 8, Fort Worth, Texas.

**\$4.25 EACH** Paid for U. S. Flying Eagle Cents dated 1856. We pay cash premiums on hundreds of Old Coins. Send ten cents at once for New Illustrated Coin Value Book 4x7. It may mean your fortune. Clarke & Co., Coin Dealers, Box 15, Le Roy, N. Y.

#### STAMP COLLECTING

**FOREIGN** Stamps Free; 52 different foreign, including China and Venezuela, to all who apply for our high grade approval selections. Send two cent stamp for return postage. Edgewood Stamp Co., Dept. H, Milford, Conn.

**STAMPS**—U. S. Postage, Revenue and Department, on approval. Reference necessary. Mrs. Louise Kellogg, West Hartford, Conn.

**205 DIFFERENT** foreign stamps and McKele's Stamp Weekly, Boston, Mass. Six months only 25c. 101 United States, 60 Japanese, 50 Asiatic, 20 Persia, 25 Canada. Choose one.

**200 DIFFERENT** stamps, album and mounts 15c. Burgess Co., 522 Beacon, Toledo, Ohio.

**156 DIFFERENT** stamps from 50 countries, 12c. Edwd. Lufbery, Wallingford, Conn.

**100 DIFFERENT** stamps, cataloging 2c and up; our \$2.00 catalogue, 10c. California Stamp Exchange, Ontario, Cal.

**FREE**—25 stamps to approval applicants. "Hawkins," Raton, N. Mex.

**A POSTAL** brings Ohlman's Philatelic Advertiser. Fine stamps. Low prices. Ohlman, 75 Nassau, N. Y.

**CONFEDERATE** 10c stamp on original cover 25c. R. S. Deitrick, Lorraine, Va.

**TRY** 50% approvals; references. U. S. Local free! Biscayne Stamp Co., Buena Vista, Fla.

**STAMPS** on approval at 50% discount. Kankakee Stamp Co., Kankakee, Ill.

**FREE**—108 foreign stamps, album and catalogs for 2c postage. Payn Stamp Co., Los Angeles, Cal.

**PACKET** of 23 stamps; no two countries alike, 500 hinges. Set of \$1 and \$2 U. S. Rev., all for 5c. Mention paper. Mian. Stamp Co., Toledo, Ohio.

**STAMPS** Free—100 different for the names of two collectors and two cents postage. 10 different foreign coins 15c; 20 Russian stamps, 10c. Lists free. Toledo Stamp Co., Toledo, Ohio.

**STAMP** Album with 538 Genuine Stamps, including Rhodesia, Congo (tiger), China (dragon) Tasmania (landscape), Jamaica (waterfalls), etc., 10c. 100 diff. Jap., N. Zid., etc., 5c. Big list; coupons, etc. Free! We buy stamps. Hussman Stamp Co., St. Louis, Mo.

**25 DIFFERENT** British Colonials to applicants for stamps on approval who send 2c postage. Nickles, Box 2466, Washington, D. C.

**STAMPS**—105 China, etc., stamp dictionary and list, 2c. Bullard, Sta. A, Boston.

**STAMPS**, 10c, all different, free. Postage 2c. Mention paper. Quaker Stamp Co., Toledo, Ohio.

**24 VARIETIES** Cuban stamps, 10 cents. List of 6,000 low-priced stamps free. Chambers Stamp Co., 111 P. Nassau St., New York City.

#### WIRELESS

**WIRELESS** Set. How to Make—96-page book telling how to construct at small cost an outfit suitable for transmitting four or five miles. Price, 50 cents, postpaid. Popular Mechanics Book Dept., 6 N. Michigan Ave., Chicago.

**FORMULAS AND TRADE SECRETS**

**MECHANICS**—Clean hands in two minutes. Removes grease, paint, stains. Cheap and easily made at home. Send 15c for formula. Geo. M. Studebaker, Jr., South Bend, Ind.

**1,000 TRADE SECRETS** and formulas, 25c. 500 special formulas, 20c. Resilver mirrors, guaranteed process, 20c. Make Sneezing Powder and Itch Powder, 10c each. Entire lot 50c. Formula Bureau, 3311-E, Belleplaine Ave., Chicago.

**EXCELLENT Rubber Cement Formula.** Dime, coin. Box 2138, East Bridgeport, Conn.

**MONEY-Making Formulas**—Dry cleaning, silvering mirrors, renewing dry batteries, 25c each; 3 for 50c. Advance Agency, Box 2792, Boston, Mass.

**MAKE** your own Metal, Stove, Furniture and Shoe Polishes. All four Tested Formulas, 25c. "Madrian," 66 Sumner Ave., Brooklyn, N. Y.

**4 FORMULAS** any kind 25c. L. Hutchins, 2831 Burling St., Chicago.

**STOP**—Positively the best formula for resilvering mirrors on the market, 25c. Manchester Mirror Co., 1424 Beaver Ave., Pittsburg, Pa. N. S.

**10,000 SELECTED** scientific, chemical technological, and practical recipes and processes, including hundreds of so-called trade secrets for every business, alphabetically arranged in one large volume of 800 pages. Price \$3 prepaid. Popular Mechanics Book Dept., 6 N. Michigan Ave., Chicago.

**START a Candy Kitchen!** Profit \$40.00 weekly. Details free. Enterprise Publishing Co., (Z) 3348 Lowe Ave., Chicago.

**SILVERING Mirrors** formula; complete working instructions, 20c. Scientific Bureau, W. Lynn, Mass.

**500 VALUABLE** formulas and complete encyclopedia of everyday wants. This splendid book, 10c. H. Essex, Box 476, Baltimore, Md.

**"NATURE'S Way"** preserving eggs—no waterglass, brine, cold storage, nothing to buy. Complete instructions, 25c, was \$1.00. King Co., Box 13-P, Little Silver, N. J.

**SAFETY BLADES SHARPENED**

**DISGUSTED** with "re-sharpening"? Want something better? Then let us re-edge your blades same way we edge new razors. Skilled blademakers work, undergraduate engineer—gives smooth "new-blade" shaves—that's guaranteed. Send for Redge Process prices. Handy mailing case free. Parker-Warren Laboratories, 1433F Broadway, New York.

**SAFETY Razors Resharpened** like new, 2c each. Pay after you try blades. American Tool Co., Columbus, Ohio.

**SAFETY Razor Blades** resharpened "better than new," 2½c each, any make. "Satisfaction guaranteed." Send yours today. Wright Edge Co., Dept. B, Sandusky, Ohio.

**SAFETY Blades Sharpened**, 2c each. W. L. Grant, Snyder, Tex.

**SAFETY razor blades** sharpened 2c each. Barber, Box 234, Poughkeepsie, N. Y.

**SAFETY razors** sharpened; two cents each. Guaranteed. Blade box free. Electric Stropping Co., 134 Shelby St., Detroit, Mich.

**SAFETY Blades** sharpened, 2c each. Excel Razor House, Box 212, Poughkeepsie, N. Y.

**FOR MEN**

**GRAHAM'S Self Gartered Socks**—patented. Guaranteed never creep down. Don't pinch leg. Stylish, medium weight, excellent wearing quality. Send 25c. (Six pair \$1.25.) Size? Graham, 536 Forest Ave., Oak Park, Ill.

**MEN**—\$1 brings you one of the best razor stoppers made. Satisfaction guaranteed. Keen Edge Co., 3014 Walbrook, Balto., Md.

**THREE Burham Blades** 25c (coin). \$1.00 Burham Safety Razor Free. Baker Co., 1728, 61st Street, Brooklyn, N. Y.

**FOR Sale**—40,000 pounds best leaf tobacco; mail stamps for samples. Anton Wavrin, Franklin, Ky.

**SAVE** money on shoes! Factory to feet. You save retailer's profit and get better shoes. Fit and entire satisfaction guaranteed or money back. Style book free. Pathfinder Shoe Co., Dept. P, Dudley, Mass.

**FOR THE HOME**

**PORTFOLIO** of 100 designs drawn to scale easily understood. Attractive, usable, simple, modern furniture. \$2 postpaid. Saves the price on first piece of furniture you make. Crater & Hoyt, Grand Rapids, Mich.

**LOVE** your family more than lawyers; preserve earnings by will; form and instructions 25c. Books of all kinds furnished at one-tenth off; mention publishers. Little recitations for little tots, 100p., 20c. Circular letters multigraphed; cheapest yet; ask prices. Oxford Cooperative Bureau, Jersey Shore, Pa.

**LARGE** Coal Bills, Defective Drafts, Slow Fires cured by the Fenner Draft Drum. Can be installed in 15 minutes. Saves its cost in short time. Price \$33. Agents wanted. Address, H. R. Fenner, Pater-son, N. J.

**ARTISTIC** Lamps and Shades in metal and art glass easily made by the amateur craftsman from instructions given in our book of 18 designs ranging from ordinary reading lamps to pretentious chandeliers. Expense only slight. Price of book 50c postpaid. Popular Mechanics Book Dept., 6 N. Michigan Ave., Chicago.

**MAKE** your own mission furniture at the minimum of expense. Our 3 books "Mission Furniture. How to Make It." Parts 1, 2 and 3, tell in plain, simple language just how to make 98 different pieces. Full dimensions, working drawings and half tones of finished articles. Price, 50 cents each or \$1.50 for the three volumes, postpaid. Popular Mechanics Book Dept., 6 N. Michigan Ave., Chicago.

**SELF-Threading Needles** save your eyes and time. Assorted Package 12c. World's Supply, 1343 Roscoe, Chicago.

**FOR** That Boy—He will appreciate a copy of the great boy's book "The Boy Mechanic" that tells about 700 different things for boys to do and has 800 pictures, 480 (7x10) pages, cloth, big, handsome book for the price, \$1.50 postpaid. Popular Mechanics' Book Dept., 6 N. Michigan Ave., Chicago.

**METAL** Work and Etching—A 96-page handbook for art metal workers telling how to make a great variety of useful and ornamental objects, such as desk sets, arts-crafts, jewelry, etc. Price, 50c postpaid. Popular Mechanics Book Dept., 6 N. Michigan Ave., Chicago.

**TEN** cents each: Three-inch aluminum house numbers; Bray's "Special" gas burners, one to eight foot per hour. George Riley, 132 Ocean Avenue, Jersey City.

**BEAUTIFUL** arts-crafts lamps—Anyone can make them out of paper, cardboard and wood. 16 designs. Inexpensive yet artistic. Complete book of instructions. Price, 50c, postpaid. Popular Mechanics Book Dept., 6 N. Michigan Ave., Chicago.

**LAMP** Shade Frames, all descriptions, made to order. Cooley Mfg. Co., 553 W. Monroe St., Chicago.

**GAMES AND ENTERTAINMENTS**

**MAGICIANS**—We are headquarters for handcuffs, mail bags, strait jackets, milk cans, and everything in the escape line. Large new catalogue, which also contains a complete line of novelties, tricks, puzzles. Free. Oaks Magical Co., Dept. 60 Oshkosh, Wis.

**MINIATURE** Mexicans—Amusement, fun, mystery galore. They fight, run, dance. A ton of laughter for only 25c. National Sales Co., Sheboygan, Wis.

**GREENBACKS**—Stage money. 10c bunch, 4. 25c. Eureka Supply, P25, 3827 North Kenneth, Chicago.

**"MOVIE** Mystery"—The latest novelty! Works at movie; different at home. Amusing; instructive. Only 10c. Movie Mystery Co., Dept. B, San Diego, Cal.

**10** CARD Tricks and Cards, 10c. McGuinness, 109 Weirfield St., Brooklyn, N. Y.

**350** TOASTS, 84 card tricks, 10c each. Smith Co., 734 W. 31st, Chicago.

**13** FUNNY Love Letters (read two ways) 10c; 250 Magic Tricks, with coins, cards, etc., 10c. Magic Bureau, 3311E, Belleplaine Ave., Chicago.

**LEARN** to entertain: Wonderful Magic Trick Cards 10c; stamps or silver. Walwen Co., Dept. 66, 150 Nassau St., New York.

**84** CLEVER Magic Tricks by famous magicians 10c. Catalog Jokes, Puzzles, free. C. L. Winegar, West Fort Anne, N. Y.

**MAGIC** catalogue and five complete tricks, five cents. Gilmore, 11128 Crescent, Morgan Park, Chicago.

**MAGIC** Tricks, Books and Supplies. Biggest line in the world. Large, 160 page, illustrated, professional catalogue, ten cents. See our advertisement on page 14. Chicago Magic Company, 72 West Adams St., Chicago, Ill.

**250** MAGIC Tricks, and Big catalogue, 12c. This and two other books of Entertainment, 30c. Maple Co., 131, Napanoch, N. Y.

**MAGIC** pocket trick free. Worth 25c. With illustrated catalog of 250 tricks, puzzles, illusions for 6c. Stamps. Magic Co., Sta. 10, 249 West 38th St., New York.

**CHICKEN** Inspector Badges (latest joke), 10c pp. Percy Ewing, Decatur, Ill.

**PLAYS,** Vaudeville Sketches, Monologues, Dialogues, Speakers, Minstrel Material, Jokes, Recitations, Tableaux, Drills, Musical Pieces, Entertainments for all occasions. Make-Up Goods. Large Catalog free. T. S. Denison & Co., Dept. 11, Chicago.

**MUSIC**

**HAVE** a Big Laugh! Send us 12c in stamps for song just out, "Don't Tell Me in the Morning What I Did the Night Before." Catalogue of new music free. The Sharp Music Co., 865 Fifteenth St., Denver, Colo.

**ALL** the new and standard music at cut prices. Sheet music 5c and up. Catalog free. Semple's Music House, Norwalk, Conn.

**SEND** for new Intermezzo, composed for piano only. Copy 10c; your last chance. Cameron Flagg, Power, N. D.

**VIOLIN** learned in one hour; no notes. Free booklet. Simplex Music Co., 117 Gates Ave., Jersey City, N. J.

**BEGINNERS** can play piano or organ selections without teacher, immediately—same hour—not next month; by note, not figures, or \$1,000 forfeit. Write Musician Self-Maker, 2817 Lake, Chicago.

**CONCERT** harmonica and complete instructor, 35c; instruction booklet separate, 10c; no stamps. Montfort Maritime Building, New York.

**MY** Lady of Dreams, the coming big song success. A great song with an attractive title page. Ten cents in stamps or coin. Marks-Goldsmith Company, Department A, Washington, D. C.

**ALL** the favorite old songs. Words and music complete in book form with attractive cover. Size 7½x9½ inches; good value. Price 50 cents, postpaid. Popular Mechanics Book Dept., 6 N. Michigan Ave., Chicago.

**PIANOS AND MUSICAL INSTRUMENTS**

**BLUEPRINT** drawing, exact size of every part of violin. From genuine Stradivari, King of Cremona makers. Including Arching, Graduation, etc., \$1. J. A. Sturgis, Cremona Violin School, Sharon, Pa.

**FOR** Sale—Edison Phonograph. A. M. Baugh, Omaha, Neb.

**DUPLICATORS AND DEVICES**

**THE** Modern Duplicator, made without glue or gelatine, is the World's Standard. Fifty to seventy-five exact duplicate copies can be made from each one you write or draw with pen, pencil or typewriter. \$2.40 to \$6.00 according to size. Booklet Free. Durkin, Reeves & Co., Mfrs., 339 Fifth Ave., Pittsburgh, Pa.

**HOW** to get a Hektograph that will make 150 copies in 10 minutes; letter size, \$2. Write for circular. Heyer Duplicator Co., 118 No. La Salle St., Chicago.

**MAILING LISTS**

**6,000** LIVE bona fide agents' names, \$1.00. Morgan, 312 Madison, Chicago.

**ANY** Classification—anywhere. Mention kind wanted, "Nisco," SDB, Cincinnati, O.

**FREE** to business men, copy of our comprehensive "Silent Salesman." Contains over 2,000 different classifications of mailing lists with number and price of each list, and information every business man needs. Accept this free offer. Trade Circular Addressing Co., G 164½ W. Adams, Chicago.

**TYPEWRITERS AND SUPPLIES**

**ALL** standard makes of typewriters. Big saving. Liberal guarantee. Catalogue, bargain list and valuable typewriter information free. The leading mail order typewriter house. A. E. Atchison, 110-112 No. LaSalle St., Chicago.

**ELIMINATE** guesswork. Select a typewriter from specimens of actual writing done on machines costing \$100 each, now \$5 to \$45. Write National Typewriter Distributors, 23 West 125th St., New York.

**WRITE** for our special circular "C" for the best offer ever made on typewriters. Young Typewriter Company, 62 West Madison St., Chicago.

**REMINGTON** Visible, \$40; Monarch, \$39; Royal, \$27.50; Oliver, \$25; others, \$10. A. C. Welland Sales Company, Utica, N. Y.

**DON'T** fail to get our bargain sheet before you buy that typewriter. The M. & M. Typewriter Co., 118-A, No. LaSalle Street, Chicago.

**TYPEWRITERS**, all guaranteed, from \$5 to \$50, free trial allowed. Get our prices before purchasing. Coast Typewriter Exchange, Atlantic City, N. J.

**TYPEWRITER** Bargains, All Makes, slightly used and rebuilt, lowest prices, bar none; satisfaction guaranteed. New appearance, perfect order. Typewriter Sales Co., Ferguson Bldg., Pittsburgh, Pa.

**PICK** out your typewriter and pocket your saving. Typewriters rebuilt in our own factories and guaranteed for one year. Remingtons \$25 to \$65, Smith-Premiers \$23 to \$60, Underwoods \$35 to \$60. L. C. Smiths \$30 to \$50. Royals \$30 to \$40, Oliverts \$30 to \$40. We have all makes. Send for catalog, address of nearest branch office. American Writing Machine Co., Inc., 345 Broadway, New York.

### PRINTING AND ENGRAVING

500 6½ ENVELOPES, \$1. Something nifty in advertising cards. Samples, 2c. Mail Printer, 908 Walnut, Philadelphia.

100 16-lb. BOND Letterheads and Envelopes, postpaid, 75c; 500, \$2.50. Latest style type. Hoyt Bros., New Salem, Mass.

100 NOTE Heads and 100 Envelopes 75c. Business Stationery, Cards, \$2 per 1,000. Samples for stamp. The Letterhead Shop, 4107 Colorado Ave., Chicago.

125 BOND Letterheads and 125 Envelopes, white, pink, blue or green, printed, \$1 prepaid. Samples, W. Kinnier, Box 206 Brooklyn, N. Y.

**CUT-RATE** Multigraphed Letters, Letterheads, Schwartz Bros., Congress St., Detroit, Mich.

**DO** your own printing—Combine pleasure and profit. Book "How to Print," 15c. Cut Book, 10c. Catalogue free. Model Press, York, Pa.

**GUMMED** Labels, 3,000, \$1. 38 pp. catalog, 2c. MacTaggart, 1235 Arch, Philadelphia, Pa.

500 BUSINESS cards printed to your order, 75c. Geo. Birt, Russell Ave., Indianapolis, Ind.

1,000 BOND 3¼x5½ circulars, prepaid, \$1. Smith Supply, Waukegan, Ill. 6x9 press for sale.

**PRINTING**—500 either noteheads, envelopes, statements, cards, \$1; 1,000, \$1.50; 1,000 linen finish letterheads or envelopes, \$2.50; 1,000 typewriter letters, \$2. Samples. Model Company, Manchester, Iowa.

125 WHITE Bond Letterheads and 125 Envelopes, printed, \$1, prepaid. B. Lutz Printing Co., York, Pa.

**GUMMED** Labels—3,000, \$1. 1x2 inches. Catalogue Free. Helmers Company, Hoboken, N. J.

**YOUR** Name on 200 gummed labels, 10c. Starr Co., Clintonville, Conn.

**DIGNIFY** your correspondence. 100 letterheads and envelopes printed on excellent bond, \$1, prepaid. 500 letterheads or envelopes, \$1.50. 1,000 for \$2.50. Samples free. Proper printing. Robison Printery, Carwensville, Pa.

**PRINTING** Presses, type, supplies. Catalog free. L. M. Carroll & Co., 326 Madison St., Chicago.

**PRINTING** Presses, supplies, second-hand, at bargains. List for stamp. Popular Bargains, Richland Pa.

1,000 PURPLE Multigraphed Letters, black heads printed and stock complete, \$2.75; 500, \$1.85. Specimens free. Perfection Letter Company, Muncie, Ind.

**GOOD** Printing at low prices. 1,000 good letterheads, envelopes, cards, billheads, labels, circulars, \$2.50. Samples free. Catalogues, booklets, and circulars our specialty. Ernest L. Fantus Co., 523 S. Dearborn St., Chicago.

### PATENT ATTORNEYS

**FIND** Out for Yourself what to invent and how to procure and sell a patent for the same. My book, "Inventor's Universal Educator," covers the matter from A to Z. 140 pages, elegantly bound. Also contains 600 mechanical movements and 50 perpetual motions. Price \$1.00, postage free. Money returned if not more than satisfactory. F. G. Dieterich, 651 Ouray Bldg., Washington, D. C.

**IT** pays inventors to consult us on patents. Twenty years' practice. Best references. Patent office rules, advice and searches free. Clements & Clements, 704 Colorado Bldg., Washington, D. C.

**INVENTORS**—Write for our special offer for securing patents. Wm. N. Moore & Co., 732 L. & T. Bldg., Washington, D. C.

**THE** Patentome is interesting and instructive. A liberal education in patents and how to get them. Free on request. Established 1865. Anderson and Son, Patent Solicitors, 707 G St., Washington, D. C.

"**PATENTS** and Patent Possibilities," a 72-page treatise sent free upon request; tells what to invent and where to sell it. Write today. H. S. Hill, 905 McLachlen Building, Washington, D. C.

**PATENT** what you invent. It may be valuable. Write me. No attorney's fee until patent is allowed. Estab. 1882. "Inventor's Guide" Free. Franklin H. Hough, 522 Loan & Trust Bldg., Washington, D. C.

**PATENT** your invention. \$10,000 offered for inventions wanted. Booklet and opinion free. Milo B. Stevens & Co. Established 1864. 685 F St., Washington; 353 Monadnock Block, Chicago.

**FOR** dependable advice about Patents, address Benjamin & Bassett, 140 S. Dearborn St., Chicago, Ill.

**PATENTS** procured; prompt, reliable service; terms low; large prizes offered for certain inventions; get my list of inventions wanted; send 4c for new book. "The Last Word on Patents;" send sketch of your invention today. Sanders, 7 Webster Building, Chicago, Ill.

**PATENTS** and how to obtain them. Handsome book free. Babcock Book for inventors. Wm. H. Babcock & Son, Patent Lawyers, Ledroit Building, Washington, D. C. Established 1877.

**WORLD'S** Best Inventor's Books. Self-Educational. See Higene's Ad, Classification "Books."

**OFFICIAL** Drawings Free. Patents procured or fee refunded. Expert services. Send sketch for Free search. The Patent Exchange, Washington, D. C.

**CASH** for an idea. Patent News Dept. 29C, Washington, D. C.

**NO** Attorney fees until patent allowed. Send sketch for free report. Books free. Frank Fuller, Washington, D. C.

**FOR** Honest advice and real patents at Low Cost, consult John O. Seifert, Patent Attorney, 50 Church St., New York.

**PATENT** secured or fee returned; Bank Guarantee; 30 years experience assisting inventors in adapting patents to commercial requirements. Wm. F. Davis, 711 Kansas City Life Bldg., Kan as City, Missouri.

**PATENT** Books Mailed Free—Showing 100 mechanical movements invaluable to inventors and mechanics—and telling what is patentable, how to obtain patent or partner, how to sell, etc. Free on request. Chas. E. Brock, 701 Eighth Street, Washington, District of Columbia.

**PATENT** your invention—Send sketch for free expert search and report as to patentability. Books on inventions and patents, and book of references from congressmen, manufacturers, bankers and inventors sent free. John S. Duffie & Co., 610 F St., N. W., Washington, D. C.

**PATENTABLE** ideas wanted—Send for 3 free books. R. B. Owen, 30 Owen Bldg., Washington, D. C.

**PATENTS** and Trade Marks, electrical and mechanical a specialty. Book Free. Joshua R. H. Potts, Patent Lawyer, 8 Dearborn St., Chicago; 805 G St., Washington; 329 Chestnut St., Philadelphia.

**PATENTS** build fortunes for you. Our free booklets tell how; what to invent, how to choose an attorney. Write today. D. Swift, 317 Seventh St., Washington, D. C. Established 1882.

**PATENTS** that protect and pay. Advice and books free. Rates reasonable—highest references; best results. Watson E. Coleman. Patent Lawyer, 622 F St., N. W., Washington, D. C.

**JOHN R. WOODWORTH**, Registered Attorney. Wardur Building, Washington, D. C.

**INVENTIONS** Worth Thousands—Their value is governed by the strength of the patent. Get the advantages of our 39 years' experience in procuring your patent. Clients in your state. Write and send sketch. Louis Bagger & Co., 609 Barrister Bldg., Washington, D. C.

**C. L. PARKER**, Ex-member Examining Corps Patent Office, Patent Attorney, 910 G St., Washington, D. C. Inventor's handbook "Protecting, Exploiting and Selling Inventions," sent free upon request.

**PATENTS**—Herbert Jenner, patent attorney and mechanical expert, 606 F St., Washington, D. C. I report free of charge if a patent can be had and its exact cost. Send for circular.

**PATENTS** explained in my free books, telling what you should know—what to invent—what not to invent—how to sell your patent, etc. Write today, H. L. Woodward, 902 G St., Washington, D. C.

**PATENTS** Secured—Take advantage of my personal experience; send sketch or model. Get my free book containing 200 mechanical movements. W. N. Roach, Jr., 950 McGill Bldg., Washington, D. C.

### FOR INVENTORS

**INVENTORS**—Our staff of skilled mechanics assist and co-operate with customers to develop and perfect inventions of every description. We build first-class demonstrative models, miniature or regular full-sized machines for inventors, promoters, patentees, salesmen, patent office and manufacturers. Electrical and mechanical experts. Scientific and experimental work a specialty. Write today for further particulars. Regal Model & Tool Works. "Chicago's foremost model and machine works," 122-128 S. Clark St., Chicago.

**WANTED**—An Idea! Who can think of some simple thing to patent? Protect your ideas; they may bring you wealth. Write for "Needed Inventions" and "How to Get Your Patent and Your Money." Randolph & Co., Patent Attorneys, 620 F St., Washington, D. C.

**NEW YORK** Inventors: Be honestly advised. Don't risk your invention. Don't risk your money. Consult F. V. Winters, Patent Lawyer, 125 East 23rd St. N. Y. City.

**WE'LL** tell you without charge why your invention is, or is not, worth patenting. Benjamin & Bassett, 143 S. Dearborn St., Chicago, Ill.

**PLANS** — Drawings — Specifications for anything. The excellence and completeness of our work, as well as our terms, will surprise you. Tell us your needs. The Plan Bureau, 2114 Forest Avenue, Saint Louis, Missouri.

**PATENTS** without advance attorney's fees. Send sketch for free report. Books free. Frank Fuller, Washington, D. C.

**PATENTEES**. Turn your patent into cash. You can do it. Sell it or go into business with it. Our book, "The Value of Patents," tells how. Satisfaction guaranteed. 50c prepaid. Service Bureau, 3311-P5, Belleplaine Ave., Chicago.

**FORTUNES** in good patents. Write today for advice before applying for patent. We save you needless expense. Dawes & Ackers, Washington, D. C.

**PATENTABLE** ideas wanted—Send for 3 free books. R. B. Owen, 30 Owen Bldg., Wash., D. C.

**INVENTORS**: My patent made a fortune. Particulars free. Let me sell yours. Eugene Pearl, 23 Union Square, New York.

**PATENTS**, Trade-Marks and Copyrights. Our handbook on patents will be sent free on request. All patents secured through us are described without cost to the patentee in the Scientific American. Munn & Co., Patent Attorneys, 359 Broadway, New York. Washington, D. C. office, 383 F Street.

### PATENTS FOR SALE

**TO** Street Railway Company or Manufacturers: I have to offer for sale a new invention, a Switch Mechanism, that is operated by the motorman without stopping. It saves time and labor. For further information, write Alderic Lefebvre, 26 Victoria Square, Montreal, Canada.

**PATENT**, an automatic coin-controlled locker for checking baggage, coats and hats; requires no attendant; is needed in all public places. Chr. Lehmann, 936 Belvidere Av., Detroit, Mich.

**HAT Pin Guard and Fastener.** New novelty. Box 810, Bellows Falls, Vt.

**BARGAIN—Patent No. 821,293** for sale at a sacrifice; penholder which carries ink eradicator. Address Gustie Juntunen, Dollar Bay, Mich.

**CANADIAN Patent**, sells on sight to horse owners; costs 25c, sells for \$150. Worth \$25,000 to \$50,000 first year. \$5,000. M. O. Ott, Box 26, Montavilla, Oregon.

**BEST offer gets Patent No. 1,089,696** ('14) Vehicle Tractors. No slipping, no skidding, don't throw mud, always ready, use on one or both wheels. Write at once. S. F. Douglass, owner, Prairie du Rocher, Ill.

**FOR Sale, or on Royalty**, my invention: A Rail-Fastening Device. Write for official drawings. J. J. Winn, Kimball, S. D.

**PATENT on cherry seeder.** Best offer, cash or trade, takes it. Address, C. S. Hendrick, 222 S. Madison, Clinton, Ill.

**FOR Sale, U. S. Patent No. 958,594.** Tongs—working model. Particulars, U. D. Carroll, 1111 Graham Ave., Windber, Pa.

**U. S. PATENT No. 1,083,184** is for sale. The best punch ever invented. J. L. Cuba, B. 5, Taylor, Tex.

**WILL sell patent 1,082,384 on Tobacco Pipe**; price, \$400. Zetterstrom, 156 Babcock St., Hartford, Conn.

**NEW Invention for Sale.** Practical, simple Combination Pad Lock, and Combination Suit-Case and Trunk Lock, more durable than the ordinary key locks. Better than a gold mine. Bernhard Lerback, Mandan, N. D.

**FOR Sale—No. 1,089,698** Single-wheel tractor, power steering, short turns, runs any direction, quickly attached to vehicle or implement; light, simple and cheap. Andrew Frederick, Harmony, Penn.

**WILL sell patent on improved air ship**, that may be provided with hydroplane surface for use on water. Best offer takes it. E. Stoner, 305 18th Ave., Newark, N. J.

**FOR Sale, royalty.** Interest in automatic honing, stropping machine for all razors. Just patented. Emanuel Jacobs, 200 Garfield Ave., Detroit, Mich.

**PATENT on grease gun for sale.** Andreen, 942 Gates Ave., Brooklyn, N. Y.

**HAVE you a Patent to sell?** You'll be interested in my proposition. Write now for free particulars. F. W. Johnson, 6 No. Michigan Blvd., Chicago.

**\$1,500 BUYS Pat. No. 1077707** combination Drinking Fountain and Faucet. Box 483, Richmond, Cal.

**FOR Sale, outright, patent No. 1,082,618,** automatic headlight mechanism for automobiles. Please make offer. George K. Babcock, Millport, N. Y.

**FOR Sale—Patent just allowed on machine;** good; used in every foundry. Address, John Mickitsch, 303 Military Ave., Detroit, Mich.

**FOR Sale or Royalty—Nut lock** applicable to any bolt and nut. Charles C. Cross, 5436 Baltimore Ave., Philadelphia, Pa.

**HOUSEHOLD necessity** cheap to manufacture. Reney, Box 2102, Winnipeg, Can.

**IF you want to know why you cannot sell your patent,** write Benjamin & Bassett, 140 S. Dearborn St., Chicago, Ill.

**MODELS AND MODEL SUPPLIES**

**MACHINE Patterns and Models** made by Experts, from selected materials, accurately, promptly and moderately. Send your drawings or sketches requesting quotation to Teetsow-Marx Mfg. Co., 312 E. 75th St., New York.

**INVENTIONS Perfected;** Working Models Made; Dies, Tools, Special Machinery. Free Booklet, Black Diamond Mfg. Co., Cincinnati, O.

**SERIES of 8 lithographic models—Steamship, automobile, locomotive, gas engines, steam engine, steam turbine, wireless telegraph and dynamo.** Size 8x14 inches. All parts of these machines are shown and numbered to correspond to printed keys of names. Price, each, 50 cents, postpaid, or set of 8, \$3.50, postpaid. Popular Mechanics Book Dept., 6 N. Michigan Ave., Chicago.

**CHICAGO Model Works.** Established 1867. Chicago, Ill. Gear wheels, model supplies, working models. Write for catalogue of model supplies.

**INVENTIONS perfected and manufactured.** Reference, your own banker. Russell Machine Co., Dallas.

**INVENTORS:** We manufacture metal articles of all kinds, to order. Also, special machinery, tools and dies, punchings, lathe and screw machine work, metal spinnings, castings, plating, wood and metal patterns, etc. Send sample for estimate and expert advice, free. The Eagle Mfg. Co., Dept. B, Cincinnati, O.

**FREE catalogue of model supplies.** Castings, metal specialties on contract. North Chicago Tool Works, 15 Grove Ave., North Chicago, Ill.

**WE make working models for inventors;** also dies and stamping of specialties; and carry a complete stock of brass gears and model supplies. Send for catalogue. The Pierce Model Works, 3405 Pierce Ave., Chicago, Ill.

**MODELS made for inventors;** general machine work; designing and perfecting; developing automatic devices and machinery. In a position to do all kinds of light tool and machine work. Prices reasonable; estimates cheerfully given. Ideal Machine Works, 62 Ann Street, New York City.

**REAL ESTATE AND FARM LANDS**

**SUBURBAN home sites—\$2 cash and \$2** monthly at Dalworth Park, Texas, suburb on interurban, midway between Dallas and Fort Worth, the fastest growing cities in the great southwest; millions going into new skyscrapers, hotels, factories, in the two cities, and population has trebled in ten years; fortunes will be made here in suburban property; early buyers will make enormous profits, values already increased over 25 per cent. Dalworth Park offers best opportunity, being on interurban, which is being double tracked, and on railroad, and automobile pike; \$100,000 being spent on waterworks, natural gas, street improvements, etc.; 43 trains daily; beautiful large home sites only \$50 and up in this special sale; \$1 with inquiry as part payment reserves choice lot. Write today for free booklet showing views, map and all particulars. The Dalworth Company, Box 70, Dalworth Park, Texas.

**NEW YORK is expanding more rapidly** than any city in the world. Improved lots in beautiful residential park at Hempstead, Long Island, 6 miles from New York, \$240 up; small amount down; easy monthly payments; all city conveniences; every lot guaranteed high and dry; many fine residences now on property; 5-cent trolley to ocean; title guaranteed; gilt-edged investment; send for photographic map and illustrated booklet. W. Kaye, 277 Broadway, New York.

**SUBURBAN lots, \$25; \$1.50 monthly.** Canyon City, Texas; population increased over 100% between last two U. S. censuses; site of one of the State Normal Schools. We own and have just opened Lake View Addition; lots, 50x140 feet. First 100 go at \$25 each, \$1 down and \$1.50 per month. Bank references given if desired. For full particulars, before the lots are sold, write now. Young & Evans, Canyon City, Texas, or Box 334, Austin, Texas.

**FERTILE Virginia Farms,** small and large, on railroad, \$15 an acre up. Easy payments. Write for list. Send names of two friends interested in Virginia and receive our beautiful magazine one year free. F. H. LaBaume, Agrl. Agt., Norfolk & Western Ry., Room 250 N. & W. Bldg., Roanoke, Va.

**BIG opportunities** await you in the Southern Railway territory. Land \$15 an acre up. No long winters, drouths or blizzards. Apples, truck, poultry and livestock are making farmers rich. "Southern Field" magazine and all facts free. M. V. Richards, Land and Ind. Agt., Southern Ry., Room 64, Washington, D. C.

**MONEY-Making Farms, 21 states, \$10 to \$50 an acre;** live stock, tools and crops often included, to settle quickly. Big special bargain list, free. E. A. Strout Farm Agency, Station 3043, 47 West 34th St., New York.

**CASH for your business or property.** Write me if you want to buy, sell or exchange any kind of business or property. Established 1881. Frank P. Cleveland, 1308 Adams Express Building, Chicago, Ill.

**80-ACRE irrigated alfalfa farm,** near station, within five miles of milk condensary, fair improvements. Will sell on easy terms. Chas. F. Cook, Lamar, Colo.

**BUY \$25 lots Suburban District Houston,** fastest growing city in America. \$1 cash, \$1 monthly. Write for literature. Cypress Park Land Company, 434 Commercial Bank Bldg., Houston, Texas.

**FOR Sale—In the Clover Belt—Beautiful** Lakes—Good soil, good water, wild and partly improved lands from \$12 to \$30 per acre. Where storms and floods are unknown, under the Stars and Stripes. Information free. Ole Larson, Walker, Minn.

**BUY a Perkins County Farm now.** Good soil, good water, coal easily accessible. \$10 per acre. Reasonable and easy terms. Brown Bros., Bison, S. Dak.

**TEXAS school land** for sale by the state. You can buy good land at \$2 per acre; pay 5c per acre cash and no more for 40 years, but 3 per cent interest. Send 6c postage for further information. Investor Pub. Co., Dept. 3, San Antonio, Texas.

**CATTLE, hogs and a silo** make big and sure profits on the cheap lands of Northwest Texas. You can buy land for from \$15 to \$25 an acre, long time, 6% interest. Illustrated folder and leaflet with letters from farmers already making good, free. C. L. Seagraves, Gen. Colonization Agt., AT&SF Ry., 1965 Ry. Exchange, Chicago.

**WRITE Us** before you buy or sell. Bargains everywhere. Inquiries daily. "Nisco" XDB, Cincinnati.

**SELL your property** quickly for cash, no matter where located. Don't pay big commissions. Particulars free. Real Estate Salesman Co., Desk B, Lincoln, Nebr.

**BARGAIN, Irrigated Rio Grande Valley farm.** Write Wiess Hooks, Donna, Texas.

**FRUIT and Chicken Farms.** Send me \$10 and I will send you a deed to five acres in Sunny Alabama. References, any Chicago bank. Address Frank P. Cleveland, Adams Express Building, Chicago.

**VIRGINIA Farms for Sale.** We have the finest list of farms ever offered in Virginia, several on the James, York, Nansemond, Chuckatuck, and other salt-water rivers, and Linkhorn Bay, and many others. We can suit you in the number of acres and price. Write for our list and see. H. C. Hoggard & Co., Norfolk, Va.

**No. 331—VIRGINIA Farm—140 Acres—\$4,000.** 3 miles over good road to railroad village. 92 acres in cultivation or grass, balance woods or timber; well fenced and watered. 6-room house and numerous good outbuildings. 5 acres bearing orchard. For particulars regarding this and other Virginia farms, address Edward S. Wilder & Company, Charlottesville, Va.

**GOVERNMENT Farms Free.** Our official 112 page book "Vacant Government Lands" describes every acre in every county in U. S. How secured free. 1914 diagrams and tables. All about Irrigated Farms. Price, 25 cents postpaid. Webb Publishing Co., Dept. 71, St. Paul, Minn.

**FARM Homes in the Sunny South** at fraction usual cost, through Co-operative Homestead Plan. Club now locating. Desirable members invited. Edward Miller, Crystal Springs, Fla.

**FOR Sale—Easy Terms—160 acre farm,** Morton County, North Dakota, already under cultivation. Five miles from town with schools, stores, grain elevators, bank and all facilities. Chance for right person to make extremely profitable deal. For further particulars write Mrs. Elizabeth Burt, Apartment E, 839 West End Avenue, New York City.

**"DAIRY Farms, fully equipped;** Free list, Ellis Bros., Springville, New York.

**FERTILE farms, near Philadelphia,** mild climate, excellent markets. Catalog. W. M. Stevens, Perkasia, Pa.

**WANTED Information.** Good farm for sale. Send full description. Western Sales Agency, Minneapolis, Minn.

**FREE booklet** about farms, homes. State Board of Agriculture, Dover, Del.

**FARMS for sale or exchange** anywhere in the United States or Canada direct from the owners. Information free. American Investment Association, 37 Palace Bldg., Minneapolis, Minn.

**DOGS, BIRDS, POULTRY, PETS.**

**BOSTON Terriers—**all ages and prices. M. L. Healy, Boston, Mass.

**FEW young (females only)** quality pointers, ready to train, \$20 head. Joseph Kuebbing, Covington, Ky.

**FOR \$1 I will send you dog and cat formulas** for mange, canker, distemper, rheumatism, worms, flea powder, sore eyes and epilepsy. Willis, Box 294, Dept. L, Hagerstown, Md.

**WHITE Collies—Pedigreed, choice.** Information free. Woman's College, Meridian, Miss.

**AIREDALES**—Smartest of dogs, thoroughbred, registered. Woman's College, Meridian, Miss.

**PIT Games, Eggs, \$1.50 per 15.** N. F. Baly, Whitesboro, Texas.

**NEWCASTLE Kennels, Brookline, Mass.** Scottish terriers. Write us for pamphlet.

**POULTRY** paper, 44-124 page periodical, up to date, tells all you want to know about care and management of poultry, for pleasure or profit; four months for 10 cents. Poultry Advocate, Dept. 3, Syracuse, N. Y.

**AIREDALE Terriers and Scotch Collies.** State wants? Sales list free. Phil Savage, St. Charles, Ill.

#### MISCELLANEOUS

**I NEED** one energetic, dependable, representative in every county to take orders for our new Popular Mechanics book for boys called "The Boy Mechanic." This is not a story book, but a wonderful and interesting collection of 700 things boys love to make and experiment with. A very large attractive book for the price, \$1.50. Every boy's father or mother will want to buy it for their son. It sells itself. Good liberal commission and exclusive territory. You don't have to be a professional agent to be successful with this highly meritorious proposition. Work in and around your home town during spare time only if you cannot devote all your time to it. Write today for full particulars to Manager Book Dept., Popular Mechanics Co., 6 N. Michigan Ave., Chicago.

**MAILING** Tubes, all sizes, better than paper boxes. Kirkbride, 102 East Park Ave., Haddonfield, N. J.

**"BOY Electrician,"** Shows how to make Batteries, Dynamos, Motors, Telegraph Apparatus, Telephone, Electric Engine, etc. 75 illustrations 20c. How to renew dry batteries. 3 guaranteed processes, 20c. Electric Shop, 3315 Belleplaine Ave., Chicago.

**LINE** cuts 3 inches square, 60c. Half-tones, Zinc, \$1.00. Copper, \$1.25. Mitchell Bros., 650 Broadway, Newburgh, N. Y.

**\$1.50 SELF-FILLING** fountain pen, 39c. Money back if unsatisfactory. S. E. Muller, Maplewood, Maiden, Mass.

**3 NEW Ones—Vest-Pocket Cigar Lighter, 25c; Pencil or Fountain-Pen Holder Clip, with miniature interchangeable calendar, 25c. Chinese ring Puzzle 25c.** W. V. Watts, Winona, Miss.

**RENEW** old dry batteries. Send 25c for complete formula and instructions; regular price \$1.00. If dissatisfied, we'll return your quarter and you may keep the instructions besides! Northern Supply Co., 154 Randolph, Chicago.

**EARN \$25** weekly, silvering mirrors, no capital. Instructive booklet free. W. Abell, Lima, Ohio.

**CASH** for an Idea; Patent News, Dept. 4B, Washington, D. C.

**INCREASE** your sales. Place your proposition before the readers of "Cartoons Magazine," 23,000 copies every month. Classified rate 2c per word. Mail in a trial ad today. Cartoons Classified Dept., 6 N. Michigan Ave., Chicago.

**PRESTO** Magic Bill-Folder, ten cents. Marshall, Walter & Co., Dept. 6, Milwaukee, Wis.

**STAMPS** free! 50 different, including new issue Egyptian. Send 4c postage; mention Gift E. 104. Bright & Son, 164, Strand, London, Eng.

**YOUR** name and address printed on 100 visiting cards for 25 cents. Samples free. Tyler Sales Co., 44 Stratford Road, Brooklyn, N. Y.

**I WANT** to send you proof of the wonderful pulling power of Popular Mechanics classified pages. What's your proposition? Write me today. F. W. Johnson, Classified Dept., Popular Mechanics Magazine, 6 N. Michigan Ave., Chicago.

**BOOK** of splendid moneymaking formulas and trade secrets 10c. Service Bureau, 3311-E, Belleplaine Ave., Chicago.

**DECORATE** your suitcase; 6 gummed hotel labels from different sections of the country, 25 cents. Elbert Hall, Dept. M, Fitchburg, Mass.

**ADVERTISERS**—Here's your opportunity. 25 word classified ad inserted in "Cartoons Magazine" for 50c, one inch display ad. \$1. 23,000 copies. Send in your ad for the next issue. Cartoons Classified Dept., 6 N. Michigan Ave., Chicago.

**WANTED** to handle all kinds of novelties and cheap household articles. B. J. Haley, P. O. Box 559, Denver, Colo.

**FREE** information on anything about California. We deal in every product of California. Send for twenty-four colored pictures, 15 cents. Our catalogue free. Benson's, 923 West 6, Los Angeles, Cal.

**SEE** the world. Central and South America offer unusual opportunities to American mechanics and clerical men. High salaried positions. Thousands of Americans working in these countries. Send \$2 for list of companies constantly employing Americans, and information relative transportation. State qualifications and experience. The Universal Company, Panama, Republic Panama.

**DO** you want to go on the stage? Be a Handcuff King. I will teach you how; for particulars address Box 902, Springfield, Mass.

**HARDENING, Carbonizing, Galvanizing.** C. U. Scott, Head of Wall St., Davenport, Iowa.

**"SEPT. Morn"** watch fobs, 25c each. Parrish, Box 345, Coldwater, Mich.

**BUY** the Salmimi Adjustable Candle Bracket. Places light where wanted. All mechanics want them. Send for circular. Salmimi Mfg. Co., Hoboken, N. J.

**MAKE** practical printing cuts at 2 cents. Complete instructions 10 cents. Joan Eller, 125 N. Harvey Ave., Oak Park, Ill.

**SENSITIVE** Plant Seed, 10c packet. H. Parr, 90 Escolta, Philippine Islands.

**3,000 SELECTED** Pictures for \$3. A Panorama of World Events, Political, Industrial—Social—Humorous—Tragic—all of intense human interest. A wonderful collection of 3,000 cartoons reproduced from the newspapers of the United States, Canada, Mexico, Cuba and the cities of the Old World, has been made by Cartoons Magazine from more than one hundred and fifty thousand published cartoons, and bound in an artistic and durable cover, are now ready for your library table. Vol. I, Jan.-June, 1912—\$1. Vol. II, July-Dec., 1912—\$1. Vol. III, Jan.-May, 1913—\$1. Cartoons, 6 N. Michigan Ave., Chicago.

**ESTIMATING** and Contracting by Radford—A 900-page manual of up-to-date methods for rapid, systematic, and accurate calculation of costs of all types and details of building construction, with quotations of ordinary prices for labor and materials, standard schedules and forms, labor-saving tables and other data useful to the building trades. Flexible leather, illustrated—\$2 per copy postpaid. Popular Mechanics Book Dept., 6 N. Michigan Ave., Chicago.

**GRANDFATHER'S** Clock Works, \$5. Slightly shop-worn, quantity limited, others with chimes, all prices; also several nice Grandfather's Clock cases, exceptional bargains. Clock Company, 1673 Ruffner St., Philadelphia, Pa.

**"EVERYDAY Law"**—Here it is at last. The essentials of the law "boiled down" and written in A B C language by a wise, experienced lawyer, F. H. Bacon, A. B.—The meat of the law in tabloid form. The very knowledge you want and need compressed into a little pocket size book of only 190 pages. Price \$1.00, postpaid. No need of being handicapped or embarrassed longer by lack of legal knowledge. Popular Mechanics Book Dept., 6 N. Michigan Ave., Chicago.

**BRASS** Nameplates, 25—\$1; 100—\$2. Bonnell, 3847 Calumet Ave., Chicago.

**HOW** to Solder Aluminum. How to make the solder, 25c. J. Eaton, 4512 Colorado Ave., Chicago.

**START** a profitable candy business. Secret of success lies in excellence of goods. We sell a complete illustrated book of best candy and ice cream formulas and recipes obtainable. Guaranteed Correct. Prepared by practical expert, 280 candy and 50 ice cream recipes. Price \$4 postpaid. Popular Mechanics Book Dept., 6 N. Michigan Ave., Chicago.

**SINGLE** column copper halftones seventy-five cents. Rishell, Engraver, Havana, Ill.

**SPEARMINT** sprigs sell themselves. Used for garnishing meats, salads, mint juleps. 25 plants \$1. J. E. Timm, Centreville, Mich.

**HUNDREDS** agents, canvassers, mail-order business opportunities offered in Digest, 25c for one year. Digest, Grand Rapids, Mich.

**INDIAN** Baskets and Relics. Price free. Gilham, Highland Springs, Cal.

**PATENTS** build fortunes for you. Our free booklets tell how; what to invent, how to choose an attorney. Write today. D. Swift, 317 Seventh St., Washington, D. C. Established 1889.

**I WILL** start you earning \$4 daily at home in spare time, silvering mirrors; no capital; send for free instructive booklet, giving plans of operation. G. F. Redmond, Dept. 306, Boston, Mass.

**CURIOS**, Photos, Moonstones, Agates, Orchids. Souvenir from Culebra Cut and Panama guide 25 cents silver. Canal Curio Co., Box 65, Ancon, Panama.

**FLEXIBLE** rubber stamps, rubber type steel dies, metal badges, seals, stencils Catalogue 10c. Buckeye Stamp Works, Market, Dayton, Ohio.

**ALASKA** Curios. Illustrated catalogue free. Address Standley's Olde Curiosity Shop, Seattle.

**DRAWING** Materials. Big catalogue free. Stevenot Company, 7 Cooper Union, New York.

**13 CURIOUS** love letters, read two ways, 10c. Auburn Supply Co., Dept. 13, 7745 Peoria St., Chicago.

**SKELETON** Keys—Just what you need. Opens common door locks, set 25 cents. Special set 50 cents. B. & F. Novelty Co., Box 237, Rock Island, Ill.

**4 MASTER** Keys Open Most All Locks, 25 cents. Jesse Hardman, 609 West 1st, Los Angeles, Cal.

**LUCKY** Fairy Stones Found only in Blue Ridge Mountains of Virginia. Mentioned in "Trail of the Lonesome Pine." Story of age-old native legend of the stones sent with each order. Gold mounted, \$1.00; unmounted, 50c; in rough, 25c each. M. R. Flynn, Box 424 A, Danville, Va.

#### TOO LATE TO CLASSIFY

**KEYLESS** Door Locks placed on any door without tools. Pocket size nickel-plated sample 25 cents, postpaid; fifty-cent value. Hoosier Novelty Co., Indianapolis, Ind.

## This Suit Yours

To learn how you can have a swell tailored suit **without cost** (we pay express) make \$10.00 every day; to learn what beautiful tailoring really is; to offer styles that everybody goes wild about; to get all your own clothes easy, do this now—write us and say "Send me your **New Wonderful Tailoring Offer**," and you will receive a beautiful set of samples and styles to pick from, and an offer so good you can hardly believe it. No money or experience needed. Your spare time will do. Write now—sure. Don't answer unless you live in a small town under 10,000. Address

**BANNER TAILORING CO.**  
Dept. 722 CHICAGO



**LEARN  
PIANO  
TUNING  
At HOME**

Our patented TUNE-A-PHONE simplifies learning, removes guesswork, assures accuracy. Musical ear NOT required. We furnish Action Model & tools. Diploma granted. Guaranteed as represented. Write for FREE illustrated book. NILES BRYANT SCHOOL, 216 Art Inst., Battle Creek, Michigan.

**EARN  
\$5  
to  
15  
ADAY**

**WHEN YOU WANT ANYTHING AND DON'T KNOW  
WHERE TO FIND IT—WRITE BUREAU OF  
INFORMATION, POPULAR MECHANICS, CHICAGO**

**START A  
MAIL ORDER  
BUSINESS**

**30 new propositions. No competition. Make 95c profit on dollar orders. Complete plans, 10 cts. MAIL DEALERS WHOLESALE HOUSE 541 Franklin Bldg. CHICAGO**



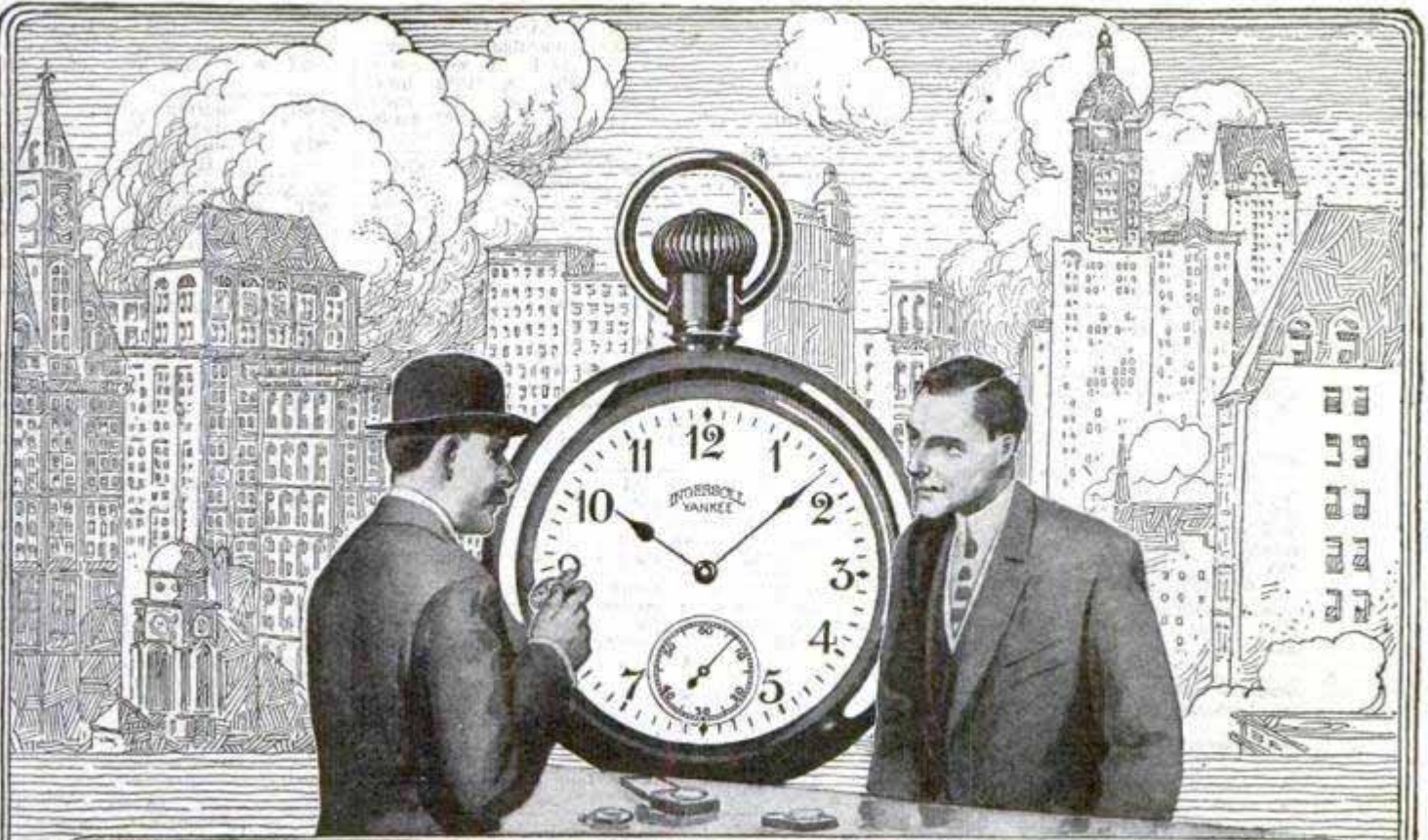

**On Broadway or in Kalamazoo  
The Price is the Same**

# *Ingersoll* Dollar Watch

60,000

Dealers  
Sell  
the  
Ingersoll  
at the  
Same  
Price

No matter where you go you will find one of the 60,000 Ingersoll dealers near you—and a complete line of Ingersoll watches at standard prices.

Your dollar will buy the same Ingersoll on Broadway that it buys in Kalamazoo—and the same guaranteed service that has made the Ingersoll the watch of 35 millions.

Whether you know everything or nothing of watch construction, you are absolutely protected when you buy an Ingersoll. Remember that behind the promise of service and quality stands the Ingersoll guarantee that has backed 35 million watches. The five models are:

"The Watch that made the dollar famous" . . . \$1.00

The Eclipse—a thin model for men . . . \$1.50    The Midget—a model for women and girls \$2.00  
The Junior—a small thin model watch . . . \$2.00    The Wrist Watch—for men and women \$2.50

A remarkable little book—"Pointers"—will be sent free on request.

**Robt. H. Ingersoll & Bro.**

**68 Ashland Building, New York**

This Complete Library of  
**LAW**  
 IN 6 HANDY VOLUMES  
 Only \$1 a Month

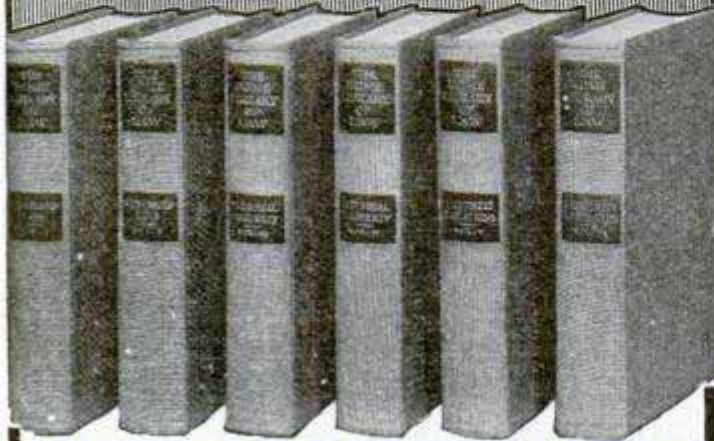

**"Ignorance of the law excuses no man"**  
**THAT'S LAW.** You can't always "guess" the law. You may not have time to "study" law. Lawyers come high—especially some of them. **BUT YOU MUST KNOW LAW.**

**T**HIS splendid little handy LIBRARY OF LAW is prepared for the average man—the business man—the doctor—the teacher—the minister—the man who works for others—the man who works for himself—the man who writes—the man who has money and the man who has not—EVERY MAN. This Library is a work to read at odd times and a reference work combined. The language is simple, direct, plain, and it covers every subject you need to know about. Here are just a few of them: "Wills"—"Mortgages"—"Deeds"—"Farm Laws"—"Landlord and Tenant"—"Leases"—"Copyrights"—"Trade Marks"—"Partnerships"—"Letters of Credit"—"Trustees"—"Corporations"—"Stockholders"—"Dividends"—"Marriage"—"Parental Relation"—"Employer and Employee"—"Assault"—"Defamation"—"Libel"—"Criticism"—"Self Defense"—"Automobile Laws"—"Patents"—"Contracts"—"Fraud"—"Damages"—"Negotiable Paper"—"Indorsements"—"Promissory Notes"—"Checks"—"Bills of Exchange"—"Bonds"—"Agents"—"Banks"—"Bankruptcy," etc.

**HERE IS OUR SPECIAL OFFER**

**W**E can't begin to tell you all about this splendid set of books, so we are not going to try. We want to send you the books themselves—the complete set of 6 handy volumes, measuring 6¾ by 4½ by 7/8 inches, so that you can examine all the volumes and decide for yourself if they are just the books you want—and need. If you decide to keep them, just send us \$1 as first payment and \$1 a month thereafter for 8 months. But if you do not wish to keep the books after seeing them, then you may send them back at our expense. That's fair. Isn't it?

Mail coupon below at once.

NAME.....

ADDRESS.....

The Thompson Publishing Co.,  
 1127 Pine Street,  
 ST. LOUIS, MO.

Send me for examination, one set of your handy LIBRARY OF LAW in six volumes bound in Buckram. If I am satisfied with the books I will send you \$1 as first payment, and \$1 a month thereafter until the special price of \$9 is paid. If I do not wish to keep the books, I will notify you in seven days, and the books are then to be returned at your expense as offered Popular Mechanics Magazine readers.

LEARN TO  
**PAINT SIGNS**  
 and SHOW CARDS  
 THERE'S MONEY IN IT



I'll teach you personally by mail. Three courses: (1) Complete Lettering, Sign and Card Writing—(2) Show Card and Ticket Writing—(3) Lettering. 14 years successful teaching. You will succeed. Wonderful field. Thousands of merchants use window cards, price cards, sale cards, banners, and signs in large quantities. Buy new ones weekly. Gold lettering on glass and wood valuable feature of the course. Course teaches everything. This knowledge helps you wherever you are. Pay good, work easy and fascinating, hours short.

**Earn \$18.00 to \$45.00 a Week**

Many of our students make big money in business for themselves. Natural talent unnecessary. Read what students say. Crawford, B. C., Canada, says: "Earned nearly \$200.00 since taking course." Parrott, Okla., says: "Earned several times cost of course since enrolling." Fritzer, Minn., writes: "Did job recently and got \$10.00, profit \$7.05." Write for large complete catalog, testimonials, pictures, sample of work, terms.

**DETROIT SCHOOL OF LETTERING**  
 Chas. J. Strong, Founder, Dept. 2050, Detroit, Mich.

**Guarantee—**

I guarantee to place my graduates in positions paying \$35.00 to \$175.00 when they have graduated and are competent. We have constantly more requests for men at good salaries than we can supply.



*Learn to Write*

I can make a good penman of you at home during spare time. Write for my free book "How to Become a Good Penman." It contains specimens and tells how others mastered penmanship by my method. Your name will be elegantly written on a card if you enclose stamp.

**F. W. TAMBLYN, 418 Meyer Bldg., KANSAS CITY, MO.**



**DON'T TRY TO BE A CHAUFFEUR**

or go to ANY SCHOOL to learn, or part with your hard earned dollars until you have read our valuable guide FIRST. It tells what you should PAY and what you should GET. Do not be deceived by schools which claim everything and give you nothing. **YOU CAN'T AFFORD TO SPEND ONE CENT TILL YOU GET OUR GUIDE.** It costs nothing and may save you many dollars. Write now for this FREE BOOK.

**PRACTICAL AUTO SCHOOL, 68 Beaver St., New York**

**Stammering Cured**

Write me and I will send you without charge a little booklet, which will tell you how you can be quickly and permanently cured of your speech troubles. I stammered nearly twenty years and cured myself.

SEND STAMP FOR POSTAGE.

**BENJ. N. BOGUE, Speech Specialist, 1114 N. Illinois St., Indianapolis, Ind.**



**IF YOU STAMMER**

attend no stammering school till you get my large FREE book and special rate. Largest and best school in the world curing by natural method. Write today.

**Lee Wells Millard, Pres., North-Western School, Inc. 917 First Street Milwaukee, Wis.**

**LEARN JEWELERS' ENGRAVING**

A high salaried and easily learned trade, taught thoroughly by mail. We will teach the beginner better engraving than he can gain in years of rigid apprenticeship. We will also improve the skill of any engraver. Send for our catalog.

**The Engraving School, 112 Page Bldg., Michigan Ave., Chicago, Ill.**

**Learn Watchmaking At Home**



You can learn by our modern and original system of instruction every part of the Watchmaker's Trade at home as good or better than at a shop. You can earn money while learning and secure a well paying position or start in business after completing our course of instruction. Good watchmakers are always in demand and earn from \$20 to \$35 per week. For particulars apply to the



**Earn \$25 to \$100 a Week**

BECOME A

**PRIVATE**

**SECRETARY**

We train you by mail. No other experience needed. In a short time you can demand \$75 to \$100 a month. Rapid advancement. Positions free everywhere. We cannot supply enough high-grade private secretaries. Wouldn't you like to sit in the private office side by side with the manager, executive or president, learn his business secrets, and become his confidential right-hand employe? Our home-training course will quickly and thoroughly prepare you. Easily learned during spare time. Any bright young person can enroll. Put yourself in touch with the business world's best opportunities. Hundreds of Private Secretaries have advanced quickly to positions of trust paying \$5,000 and upwards. President Wilson's priv. secy. is only 20 years old and draws \$2,500 a year; 5 years ago he was working in the mills at Trenton, N. J.

**FREE TUITION** In order to secure immediate enrollments we will give instruction free to a limited number of capable young men and women. Costs nothing to make application for free tuition scholarship. Students winning these special scholarships will pay only for text books and supplies. No charge for tuition no matter how long you take to complete course. This opportunity may never come again. Send for Free illustrated book telling all about private secretaries, salaries paid, and opportunities open to those having our home study secretarial training. Write now before Free Tuition Offer is withdrawn.

Secretarial School, Chicago Univ. of Commerce, Dept. 1035 Chicago, U. S. A.

**MODERN ELOQUENCE**

10 beautiful, richly bound volumes, 300 after-dinner speeches, 150 great addresses, 60 popular lectures, 2000 short stories. Great Bargain, small monthly payments. Address, GEO. L. SHUMAN & CO., Ohio Bldg., CHICAGO

**LEARN WATCHMAKING**

and become independent. Good-paying positions secured. Easy to learn. Send for FREE CATALOG. F. LOUIS WATCHMAKING SCHOOL, Dept. 5, ST. LOUIS, MO.

**DO YOU LIKE TO DRAW?**

That's all we want to know Now we will not give you any grand prize—a lot of free stuff if you answer this ad. Nor do we claim to make you rich in a week. But if you are anxious to develop your talent with a successful cartoonist, so you can make money, send copy of this picture with 6c. in stamps for portfolio of cartoons and sample lesson plate, and let us explain. The W. L. Evans School of Cartooning 821 Leader Bldg., Cleveland, O.



**CIVIL SERVICE**

Positions are in all parts of the country. Good pay, steady work, life positions, congenial surroundings, promotions on merit, short hours, annual vacation and sick leave with pay. Many thousands appointed yearly. Both sexes. No political affiliation. Nearly 300,000 classified positions. Common school education sufficient. Full information and questions used by the Civil Service Commission free. COLUMBIAN CORRESP. COLLEGE, Washington, D. C.

**Sit at This Table and Earn \$200 a Month**

LEARN TO BE A DRAFTSMAN We will show you how you can do it. Write us and we will send you full particulars. No enrollment. No first payment. Your own ability is what counts. No \$10 down, \$10 a month game. Just write and find out. Circular P free. THE T-SQ. & TRIANGLE CO. 30-32 CLINTON ST., NEWARK, N. J.



**MECHANICAL ENGINEERING**



**Famous \$35.00 Set—Now \$19.80 \$2.00 a Month**

Mechanical Engineering, Gas Engine Operation, Modern Shop Practice—the whole subject covered by experts from A to Z in this great big seven volume Cyclopedic. Everything you want to know on the subjects mentioned below is treated in simple, non-technical language by men who are not only expert engineers themselves, but great teachers and writers. The full, complete \$35.00 edition, for a short time at \$19.80—\$2.00 a month.

**SHIPPED FREE** Here's our offer: We'll ship the entire seven volumes free, express paid, merely at your request on coupon below for seven days' free examination. If you like the books, pay only \$19.80—at \$2.00 a month. Otherwise we'll take them back without charging you one cent.

- Subjects Thoroughly Covered**
- Machine Shop Work—Vertical Milling Machine—Motor-Driven Shops—Shop Lighting—Forging—Electric Welding—Tool Making
  - Metalurgy—Manufacture of Iron and Steel—High-Speed Steel
  - Flaws in Castings—Electric Lifting Magnets—Magnetic Clutches
  - Making a Machinist—The Ideal Foreman—Pattern Making—Foundry Work—Automatic Coal and Ore Handling Appliances—Machine Parts—Construction of Boilers—Types of Boilers—Boiler Accessories—Steam Pumps—Air Compressors—The Steam Engine—The Steam Turbine—Indicators—Valve Gears—Refrigeration—Gas Producers—Gas Engines—Automobiles—Elevators—Sheet Metal Work—Practical Problems in Mensuration—Mechanical Drawing—Drafting Room Organization—Machine Design, etc.

3,092 pages, 7x10 inches; 2,327 illustrations, full page plates, diagrams, etc.; hundreds of valuable tables and formulas; carefully cross-indexed for quick, easy reference. Bound in half red morocco, gold stamped.

**FREE!! \$12.00 Consulting Membership**

Every man who takes advantage of this offer now gets absolutely free our complete consulting membership, under which our entire staff of engineers answers all questions and solves all your engineering problems a whole year absolutely free. One question answered may be worth more than the whole price of the books. Usual price \$12.00—now free with the books. Fill out and mail us this coupon. Books go to you at once, express paid. Our liberal offer protects you. You take no chances. You are not bothered. If the books cannot sell themselves to you strictly on merit, don't keep them. But first inspect them. Mail the coupon today.

**FREE COUPON**  
Worth \$15.20 to You  
American Technical Society:  
Please send me the seven volume set Cyclopedic of Mechanical Engineering for seven days' free examination. If I decide to buy, will send \$2.00 in seven days and balance \$2.00 a month until \$19.80 has been paid, when \$35.00 books and \$12.00 consulting membership will be mine free. Otherwise will notify you and hold books subject to your order. Title not to pass until fully paid.  
Pop. Mech. 5-14

NAME.....  
ADDRESS.....  
As I have had no previous dealings with you, I refer you to

Please Mention Popular Mechanics



**THE OLD RELIABLE SCHOOL**  
We have successful graduates in nearly every State in the Union.

# Come to Detroit THE AUTOMOBILE CENTER to learn the automobile business

Sixty-seven out of every one hundred autos in the country are made in Detroit's forty-four automobile factories. There are greater and better opportunities in Detroit than in any other city in the United States. Detroit's prestige is universal. Detroit's products are known the world over. Automobile men from Detroit are in great demand everywhere. To anyone looking for a position or to anyone starting a garage and repair shop, the very fact that he has learned the business in Detroit, the "Automobile Center," is worth money to him. A Diploma from an auto school in Detroit gives you prestige in the automobile field. This School is equipped to give you unlimited, practical instruction in construction, repairing and driving of standard makes of cars. Our course also includes thorough instruction on

## ALL LEADING TYPES OF ELECTRIC SELF-STARTERS

such as the Gray & Davis, Delco, Westinghouse, Ward Leonard, Deaco, Jesco, U. S. L., Adams-Westlake, Entz, Aplco, etc. We actually have a DELCO ignition, lighting and starting system and a Gray & Davis system IN OPERATION ON A MOTOR for the students to work on. We also have the Ward Leonard in ACTUAL OPERATION and expect others any day. We give our students ACTUAL PRACTICAL experience in installing, repairing and maintaining these systems. In addition to getting actual garage and repairshop experience in overhauling and repairing all kinds of cars, our students ACTUALLY BUILD NEW CARS, right from start to finish, getting regular factory experience in assembling, block-testing, road-testing, etc. We have just purchased Seven New Motors or rather the parts for seven motors. Our students get actual, practical experience in assembling these motors from start to finish after which they are put on the block test.

**Our Block Test Dept.** added two new Six Cylinder Lozier motors, one equipped with Gray & Davis Lighting and Starting System. We now have twelve motors in this department. Here we give our students actual, practical experience in timing motors, adjusting carburetors and magnetos, in adjusting tapets, grinding valves, scraping bearings, etc. Our course covers the automobile thoroughly. While writing to us, we would ask that you kindly write to several other schools and compare them with ours. Write for our monthly paper, the "Auto School News." It is free. It contains interesting information in regard to the automobile industry and tells you why you should come to Detroit, the automobile center, to learn the automobile business.

**Address Michigan State Automobile School**  
Dept. P THE OLD RELIABLE SCHOOL  
11-13-15-17 Selden Ave., Cor. Woodward, DETROIT, MICH.

## Our Guarantee

We guarantee to qualify you for a position as chauffeur, repairman, tester, salesman or demonstrator in a short time, or we will refund your money. **And don't forget, we furnish positions, too** On account of being in the auto center, we can furnish positions that cannot be obtained elsewhere

## The Library of Original Sources

gives inside, rock-bottom facts on every subject. 10 magnificent vols. Great bargain. Small monthly payments. Send for information. UNIVERSITY RESEARCH Dept. G, MILWAUKEE, WIS.

## WHY NOT BE AN ARTIST?

**STUDY** drawing at home under Expert Faculty. We have successful students in every part of the world. **Turn your Talent into money.** Our Students are filling high salaried positions. 14 years successful teaching. Endorsed by high authorities. 18 Courses in Commercial and Illustrative Drawing. Teachers' Normal and Applied Art, Profit or Culture. **Thoroughly Equipped Residence School** Artist's Outfit FREE to Enrolled Students **SCHOOL OF APPLIED ART, 755 Applied Art Bldg., Battle Creek, Mich**

# ACCOUNTANCY

## \$\$\$\$\$ PAYS

Get out of the common rut. Don't drudge as a bookkeeper all your life. Plan for the future. Prepare yourself for a larger salary. It is simply a matter of training. Accountants are in demand. We prepare you to become an auditor, comptroller or certified public accountant. Correspondence and resident courses. It won't interfere with your present work. Why not "Learn While You Earn?" Send for our new booklet **"The Walton Way to Higher Pay"** It explains clearly your opportunity, your short-road to SUCCESS. It explains our Instruction - Instructors - Service. Get this book into your hands NOW - write for it - let it help you decide your future.

**WALTON SCHOOL** 801-811  
**ACCOUNTANCY** Peoples Gas Bldg.  
CHICAGO, ILL.



**ARE YOU AMBITIOUS?** **TO OWN A GOOD BUSINESS OR GET INTO A WELL PAID POSITION.** Practical, thorough complete course with personal guidance of George E. Rosing. Graduates are in demand. Write for booklet N930 and full information today. **LONG BEFORE YOU FINISH YOUR COURSE YOU CAN BE EARNING \$25 A WEEK UP. MAKING SHOW CARDS, SIGNS, DESIGNING COMMERCIAL ART, POSTERS ETC.** **NO INBORN TALENT NEEDED** **The ROSING SCHOOL of LETTERING & DESIGN** 1900 EUCLID BLDG. CLEVELAND

## A GOOD POSITION

with **UNCLE SAM** is most desirable. Life positions, pleasant surroundings, good pay, steady work, short hours, promotions on merit. Both sexes. No political pull. Thousands of appointments yearly. Most thorough preparation \$5. Returned if not appointed. For information and questions used by the Civil Service Commission from **AMERICAN CIVIL SERVICE SCHOOL WASHINGTON, D. C.**

## 1 Year to Get a Practical Electrical Education

In one year spent at this school you get a complete practical electrical education. You learn house-wiring, electric light and motor wiring, complete switchboard installation and wiring, armature winding, power plant operation and power transmission, complete telephone work from instrument setting to switchboard installing. This is one of the most completely equipped and largely attended electrical schools in the country.

Write today for FREE catalog  
**School of Engineering of Milwaukee** Division 136 Milwaukee, Wis.



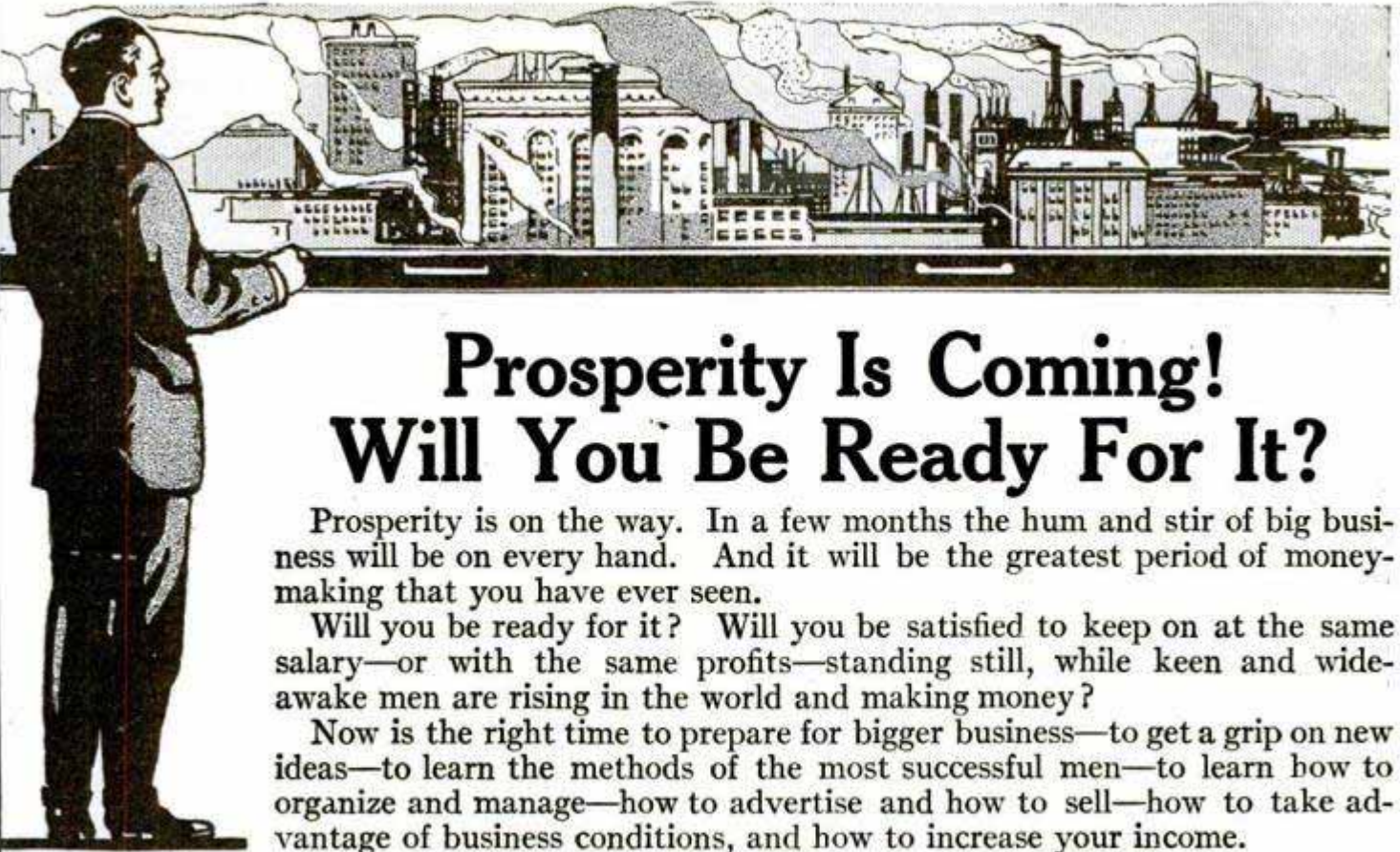

# Prosperity Is Coming! Will You Be Ready For It?

Prosperity is on the way. In a few months the hum and stir of big business will be on every hand. And it will be the greatest period of money-making that you have ever seen.

Will you be ready for it? Will you be satisfied to keep on at the same salary—or with the same profits—standing still, while keen and wide-awake men are rising in the world and making money?

Now is the right time to prepare for bigger business—to get a grip on new ideas—to learn the methods of the most successful men—to learn how to organize and manage—how to advertise and how to sell—how to take advantage of business conditions, and how to increase your income.

## The “Library of Business Practice”

One hundred and seventy-three of the keenest and most successful business men of this generation have written ten books—The “Library of Business Practice”—which point the sure road to success in business.

This Library has been written for you—for every ambitious man—and you can build your business career on it with the certainty that you are headed in the right direction.

No matter whether you own a business or work for salary, the “Library of Business Practice” contains something of VITAL IMPORTANCE to you—some new fact, some clever idea, some business short-cut, that you can turn into money RIGHT NOW.

There are 2016 pages in these ten books, and every page contains a new idea, or some fresh point of view, or some practical, proved and tried plan, or some money-making, profit-increasing, salary-raising suggestion.

How to develop a retail trade—how to write business letters—how to plan an advertising campaign—how to run a cost-keeping system—how to collect money—how to employ the best men—how to manage a business—how to rise in position—how to sell goods—these are a few of the hundreds of business subjects treated in these ten books.

—worth their weight in gold to any man in business, these books are sold at a price so low, and on such easy terms that a few cents a day for six months is all the outlay required. This is real Opportunity looking straight in your face. Do not miss it!

You must see this Library—  
We send it for inspection at  
our expense

There are still left only a few hundred sets of the Introductory Edition, to be sold at the low price of \$17 a set. The coupon cut from this page will bring you a set, sent at our expense. Look it over, and if satisfactory, send us \$2 on receipt of bill, and \$3 a month thereafter for five months. If not satisfactory send it back at our expense. Act now—and be sure of a set at the introductory price.

**A. W. Shaw Company**  
Wabash Ave. and Madison St., Chicago

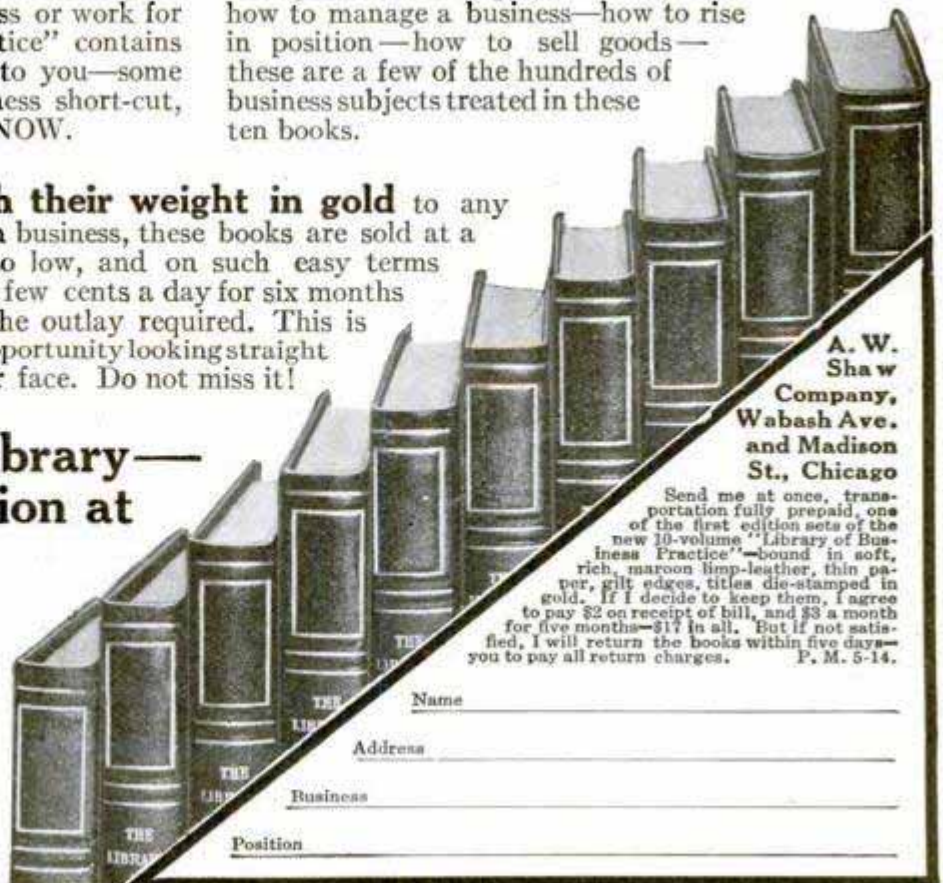

A. W. Shaw Company,  
Wabash Ave. and Madison St., Chicago

Send me at once, transportation fully prepaid, one of the first edition sets of the new 10-volume “Library of Business Practice”—bound in soft, rich, maroon limp-leather, thin paper, gilt edges, titles die-stamped in gold. If I decide to keep them, I agree to pay \$2 on receipt of bill, and \$3 a month for five months—\$17 in all. But if not satisfied, I will return the books within five days—you to pay all return charges. P. M. 5-14.

Name \_\_\_\_\_

Address \_\_\_\_\_

Business \_\_\_\_\_

Position \_\_\_\_\_

# HAWKINS LIBRARY OF ELECTRICITY

In 6 Leather \$1 Pocket Books  
Price per Volume

Here is a set of books that no man in the ELECTRICAL FIELD should do without. This is the ELECTRICAL AGE in which we live; ELECTRICITY now controls more trades, directs more men, offers more opportunities than any other power that man has yet discovered. Do you wish to know the underlying principles of MODERN ELECTRICAL PRACTICE?

If so, HAWKINS ELECTRICAL GUIDES will give you the information. In reality they are a school within themselves, containing a complete study course with QUESTIONS, ANSWERS AND ILLUSTRATIONS, written in plain everyday language so that a practical man can understand the "HOW, WHEN AND WHY" OF ELECTRICITY.

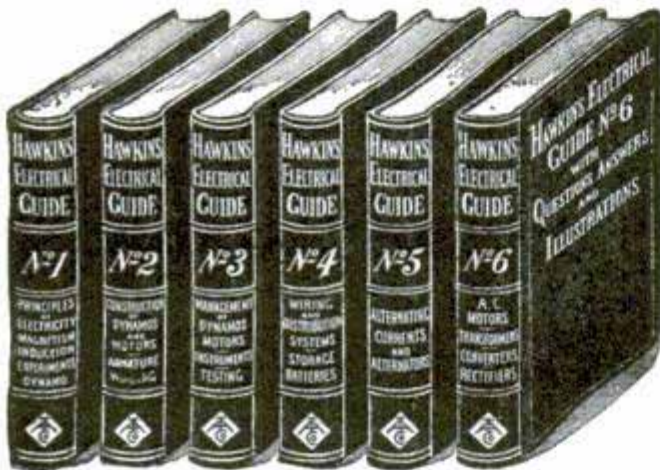

## "THAT'S JUST WHAT I NEED"

Read over the titles shown on the back of each volume, and note the scope of each book. They are handsomely bound in flexible black leather with gold edges and will readily go in the pocket. THEY ARE NOT ONLY THE BEST, BUT THE CHEAPEST WORKS PUBLISHED ON ELECTRICITY.

Each book is complete in itself and will be supplied \$1.00 per copy, but we believe that the complete set is the best bargain.

The books can speak for themselves and a careful examination, page by page, and illustration by illustration, will convince you of their big value.

If you will fill out the following coupon giving all the information requested, WE WILL SUBMIT THE SIX VOLUMES FOR EXAMINATION ON CONDITIONS NAMED.

## FREE EXAMINATION OFFER

**THEO. AUDEL & CO., 72 5th Ave., NEW YORK**

Please submit me for examination HAWKINS ELECTRICAL GUIDES (Price \$1 each.)

Ship at once, prepaid the 6 numbers; if satisfactory I agree to send you \$1 within seven days and to further mail you \$1 each month until paid. May, '14, Pop. Mech.

Signature .....

Occupation .....

Business Address .....

Residence .....

Reference .....

Please Mention Popular Mechanics

## The Pictorial Review of Current Events

# Cartoons

MAGAZINE

By H. H. WINDSOR,  
Editor Popular Mechanics Magazine

15 Cents a Copy \$1.50 per Year

## Get the MAY NUMBER

And keep up with the events of this busy world without wasting hours of your time.

In Its New Garb the Cartoons Magazine Becomes the Magazine for Everybody

Its pages are crowded with the best work of the cartoonists of the world and these clever drawings are accompanied by comment gleaned from the columns of editorials penned by newspaper writers trained to follow the questions of the day.

## Bound Volumes One, Two and Three Now Ready

These bound volumes contain more than 3,000 reproductions of the very best cartoons that have been printed during 1912 and 1913. A collection of more than 120,000 cartoons was made in order to secure them. Bound in the three volumes they make an "instant history" of the past months, for they are a pictorial record of the events of the world.

These three books, artistically and durably bound, are now ready for distribution and will be sent all express charges prepaid to any address in the United States or its possessions upon receipt of **One Dollar Each.**

Cartoons Magazine has become the ready reference book of the up to date man. It is not a mere collection of clever pictures but is a magazine that improves and educates.

Ask your newsdealer to show you the May number, or

Send your order to **CARTOONS**  
6 N. Michigan Ave. Chicago, Ill.

# How to Pitch the "Fade-away"

By **Christy Mathewson**  
of N. Y. Giants  
**FREE**



Boys, it's free! Complete, personal instructions from the great Mathewson, himself, showing you how to pitch his famous "fadeaway" so the best batter in your town can't hit it safe. Send no money—simply write and ask for Mathewson's complete instructions. He will show you plain as day how to throw this baffling, puzzling, un-hittable "fadeaway"—the curve that the best batsmen in the National League can't hit, that has won the

pennant for the New York Giants three consecutive years. Boys, with this curve you can make all the other boys in your town look like monkeys—you can simply play horse with them—you can be as much feared by batters, and cheered by the fans as Mathewson is in the National League. For "Matty" shows it all to you.

## ALL ABSOLUTELY FREE

He explains every secret of his pitching to you—how to stand, how to grip the ball, how to "wind-up," how to let it go. Photographs of every move make it all plain as A-B-C, so anybody can master this great curve at once and become the pitching hero of his town, the boy whose team is bound to win. It doesn't cost you a penny—the complete instruction is free, just for delivering a few papers. Don't wait a day to learn how to throw the "fadeaway," get it first and put one over on the other boys. Send no money—simply write and say "send on the papers to deliver and give me free, Mathewson's complete instructions."

Address, **W. D. BOYCE CO., Dept. 325, Chicago**

## MUSIC TAUGHT FREE AT YOUR HOME

Write Today  
for our booklet. It tells how to learn to play Piano, Organ, Violin, Mandolin, etc. Beginners or advanced pupils.

**AMERICAN SCHOOL OF MUSIC, 50 Lakeside Bldg., Chicago, Ill.**



## Learn by Expert Wrestler

Be strong, athletic, healthy. Handle large men with ease. **Farmer Burns**, the world's most scientific wrestler, trainer of **Frank Gotch**, world's champion, will now teach you by mail. Also complete courses in **jiu-jitsu self defense** and **physical culture**. Only opportunity ever offered to learn **right from champions**. For men and boys, all ages. A wonderful course. Low cost. Investigate now. Send only 10c for 32-p. booklet and full particulars. Send today.

**Farmer Burns School of Wrestling, 1195 Ramage Bldg., Omaha.**



**FREDERICK W. FOOTE**  
Psychologist

## YOUR SUCCESS!

Depends upon a controlled mind. This is only possible through training. A trained mind will show greater results than a trained body. Think! Money and Power obtained on the basis of Self-Improvement. Correspondence course of Twelve Lessons in Mental-Success-Training will give you a **Master Mind**. Send for free book, "Masters of Destiny."

Frederick W. Foote, The Chicago Institute of Menti-Culture, Dept. F, No. American Bldg., Chicago

**\$6 WILL BRING YOU \$600 AND MORE YEARLY**

To introduce our new Institute and new method we will, for a limited time, give our \$30 course for \$6, including free, complete outfit containing colors and brushes, etc. We will teach you to make attractive

## SHOW CARDS



You can clean up a lot of extra money every week in your own town by making classy signs for merchants and if you desire we will give you position (after learning a little) as salesman, worth \$30 to \$60 weekly. Remit \$6 now, or send self-addressed, stamped envelope for particulars (no postal cards). Easy terms if wanted.

**EMPIRE INSTITUTE OF LETTERING**  
37 LIBERTY ST. NEW YORK, N. Y.



# A BIGGER JOB for YOU

Young man—there's a bigger job, a better job, more money, more responsibility waiting for you in a **NEW AND UNCROWDED PROFESSION**. New conditions have arisen, new problems; for modern transportation is a jungle of routes and rates calling for specialists, calling for men who have been trained, men who possess expert knowledge of the trails of traffic. And you can now get this training. Simply clip the coupon below and mail it. You can get the necessary knowledge; at small expense and in a short time; you can command a high salary as

## TRAFFIC MANAGER

For our *Interstate Commerce Course* enables you to study AT HOME, without leaving your occupation or sacrificing your present income. It is a simple, practical, logical course—easy to understand—which makes you thoroughly versed and proficient in the strategy of shipping, including routes and classifications, interstate commerce rules and regulations, etc., etc. The instruction is given by some of the biggest traffic managers in the country. So simple that anyone with ordinary intelligence, with reasonable application, can master this new profession and

## Earn \$35 to \$200 a Week

There are half a million **LARGE SHIPPERS** in the United States. Practically every one of them needs an expert traffic man, and this need is recognized as never before because of the recently enacted railroad rate laws and interstate commerce regulations. The demand for trained and efficient traffic men is many times greater than the supply. **THERE'S ROOM FOR YOU.**

## All you need is training

And you can now get this training easily. Simply clip the coupon below, sign and mail at once, and we will send you **FREE**, postpaid, a handsome portfolio containing complete information concerning the opportunities and requirements of this splendid profession. Get your start now—**RIGHT NOW**. Clip the coupon at once.

## LA SALLE EXTENSION UNIVERSITY

Dept. 771, Chicago

**La Salle Extension University**  
Dept. 771, Chicago, Ill.

I am interested in the new profession—Traffic Management. Please send me full information and Traffic Book, free of all cost.

# Free

Name \_\_\_\_\_

Occupation \_\_\_\_\_

Please Mention Popular Mechanics



LISLE  
**25¢**

SILK  
**50¢**

# Boston Garter

*Velvet Grip*

**Holds Your Sock Smooth as Your Skin**

If you desire an unusually fine garter buy the 50 cent grade

GEORGE FROST CO., MAKERS, BOSTON

# 5000 EASY WAYS

TO DO

## HARD THINGS

in every trade and calling are given in

Popular Mechanics Series of  
**Shop Notes Year Books**

10 VOLUMES—\$5.00 PREPAID

2212 Pages—4965 Illustrations.  
Single volumes 50c postpaid.

POPULAR MECHANICS BOOK DEPT.  
6 N. Michigan Ave. CHICAGO

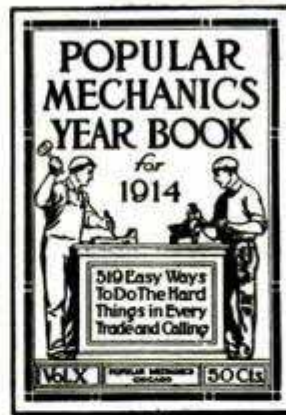

# WARNING

From widely separated parts of the country come reports of the operation of subscription swindlers. These are young men who represent themselves as students working their way through college, and who are offering Popular Mechanics Magazine as a "trial offer" at 49 cents for a full year. Usually one, and sometimes two other magazines are included, all for the 49 cents.

Popular Mechanics Magazine has no subscription solicitors and prints a notice to that effect on its front cover every month, and never offers its subscription at less than the regular price of \$1.50.

**POPULAR MECHANICS COMPANY**  
H. H. WINDSOR, Pres.

# MAKE FURNITURE LIKE THIS

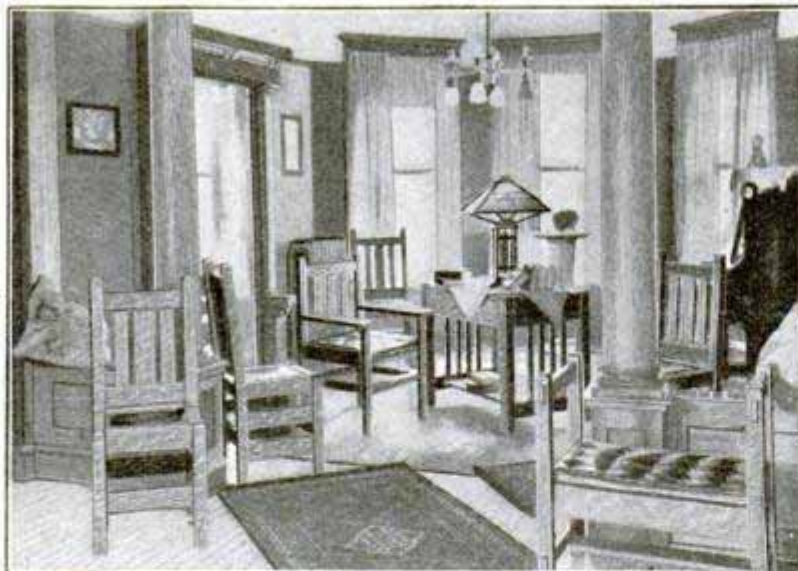

## Shown in the Photograph

ONE of our readers, who is strictly an amateur with tools, experienced no difficulty in making and finishing every piece of furniture, with the exception of the piano, shown in the accompanying picture. It is impossible in a small space to display all the different designs in Mission Furniture which we have published, but this picture shows something of the variety of pieces and how well they go together. The

## MISSION FURNITURE SERIES of 3 Volumes

Comprises 98 Attractive Designs, all different

**MISSION FURNITURE, Part 1**  
New Enlarged Edition 128 Pages, 30 Designs

**MISSION FURNITURE, Part 2**  
Recently Issued 128 Pages, 32 Designs

**MISSION FURNITURE, Part 3**  
New Book—Just Out 128 Pages, 36 Designs

Cloth, Size 5x7 inches Price 50 Cents Per Vol., Postpaid

THESE books describe how to make furniture for every room in the house as well as swings for porch and lawn. Whether you need a complete set or only some special article to fill in with here and there, you will find full directions, dimensions and working drawings for making it in these books. The instructions are easy to follow and even the amateur can obtain most satisfactory results as related above. A complete list of the designs in each book will be furnished free upon request.

ASK YOUR BOOK DEALER or address the publishers  
**POPULAR MECHANICS BOOK DEPARTMENT, 6 N. Michigan Ave., CHICAGO**



# Learn Physcultopathy

The LATEST, MOST FASCINATING and REMUNERATIVE

## PROFESSION

Young man! Young woman! What's your future going to be? Aren't you about tired of drudgery—of aprons and overalls, "straw bosses," and "starvation wages?" And don't you want to take up an agreeable, easily-learned PROFESSION—with money in it? Then learn **PHYSCULTOPATHY**—most down-to-date and scientific of all professions—the only one not over-crowded—the sure road to your LIFE SUCCESS.

### Be a Doctor of Physcultopathy

—but DON'T WAIT—DON'T DELAY—GET STARTED NOW. Be first in the field—while success is quick and easy—while the rich money rewards are regulated only by the practitioners themselves. Envious **SOCIAL AND FINANCIAL SUCCESS**

surely await you in the profitable practice of **PHYSCULTOPATHY**. This great new modern science of **DRUGLESS HEALING**, today flings wide to you the door to robust health, quickly-gained distinction, prosperity. Every city of 10,000 or more affords an inviting opening—a rich field for your efforts.

**THE BERNARR MACFADDEN PHYSCULTOPATHY COLLEGE OF** —world's authority on Physical Culture—today offers you, through its **HOME STUDY COURSE**, complete instruction leading to the Degree of Doctor of Physcultopathy. Take up, NOW, this

### EASY COURSE—BY MAIL—AT HOME

—and only a few short months are between you and an active, paying practice. NO SPECIAL PREVIOUS SCHOOLING needed; no time or wages lost while learning. Thorough personal instruction, by competent faculty members. (Resident School also conducted [day and night], in Chicago, to which correspondence students may transfer, any time.)

### READ THIS SPECIAL OFFER

—to students who enroll AT ONCE: The Famous **MACFADDEN ENCYCLOPEDIA OF PHYSICAL CULTURE** (5 massive and handsome volumes) is now furnished students FREE; in addition, we are just now including, also FREE, FIVE OTHER equally valuable books—"HOW TO MEMORIZE," "NOMENCLATURE," "PHYSICAL EDUCATION," "HYGIENE," "INSTITUTE COURSE IN PLAY."

### THESE TEN SPLENDID VOLUMES—FREE

—if you "get busy" and enroll NOW. YOURS—ABSOLUTELY—the very moment you pay for your series of Lessons. This superb library, alone, worth to you many times what you pay for the complete Course. But DON'T DELAY; this extraordinary offer may be withdrawn, any day, WITHOUT NOTICE.

### Mail This Coupon Today

—just your name and address—that's all. Costs you nothing to investigate this glorious opportunity—and honors and golden independence await the Doctor of Physcultopathy—are actually being GRASPED, today, by others. YOU can now mould your future—but you must ACT—QUICK. Terms easy—arranged to meet your requirements.

**MACFADDEN COLLEGE OF PHYSCULTOPATHY**  
4200 Grand Blvd., Box 23, Chicago, Illinois

(Only Institution of Its Kind in the World)

**FREE INFORMATION COUPON**  
MACFADDEN COLLEGE OF PHYSCULTOPATHY, 4200 Grand Blvd., Box 23 Chicago, Ill.  
Without cost to you please give further detailed information concerning your Home Instruction Course, by mail, in Physcultopathy, and Special Limited Offer.

Name.....  
Town.....  
State.....  
P. L.



## REMOVAL NOTICE

THE OFFICES OF

### Popular Mechanics Magazine

HAVE BEEN MOVED TO

6 NORTH MICHIGAN AVE.

Occupying the entire Ninth Floor  
of the Tower Building  
Chicago

## LEARN DRAFTING

Be a mechanical, architectural or sheet metal pattern draftsman.

### EARN \$75 TO \$200 PER MONTH

There is a constant demand for our graduates. Our employment bureau will secure you a good position. Expert instructors. Complete drawing outfit free. Write for free book today. Colorado Correspondence College, Dept. B-1, Denver, Colo.

## COPY THIS SKETCH

and let me see what you can do with it. You can earn \$20.00 to \$125.00 or more per week, as illustrator or cartoonist. My practical system of personal individual lessons by mail will develop your talent. Fifteen years successful work for newspapers and magazines qualifies me to teach you. Send me your sketch of President Wilson with 6c in stamps and I will send you a test lesson plate, also collection of drawings showing possibilities for you.

**The Landon School** of Illustrating and Cartooning  
1438 Schofield Building, CLEVELAND, O.



## NATIONAL AUTO SCHOOL

June & Reading Rd.  
Cincinnati, O.



Cut Out Mail Today

GENTLEMEN: Please send FREE Booklet telling how I can become expert Chauffeur or repairman. P. M. 5

NAME.....

ADDRESS.....

## GET \$25<sup>00</sup> AND OVER A WEEK

### Be a CHAUFFEUR, EXPERT MECHANIC, AUTO SALESMAN

Over 300,000 automobiles will be built this year. This means a tremendous Spring and Summer DEMAND FOR EXPERT AUTO HELP. Send following coupon immediately.

**COUPON**

F 802  
Franklin Institute,  
Dept. F 802  
Rochester, N. Y.

Send me, without charge, your copyrighted book, "How to become an expert at Automobile Operation and Construction," and free sample lessons from your Automobile Course.

NAME.....

ADDRESS.....

Use this before you lose it. Write plainly.

# Do You Know a Boy Who is Waiting for this Book?

HE may have the few tools and materials to be found in every household, or he may possess his own complete chest of tools and well-equipped workshop, but something is lacking—He needs ideas—suggestions of things to make or do. He is tired of all the things that he and his companions have been able to think of. Now there are hundreds of other boys scattered all over this big country who have many new and interesting ideas he has never thought of, but how can this one boy ever get in touch with all these others? In just one way—through the pages of

## The Boy Mechanic

The Great Book of 700 Things For Boys To Do

These original, practical suggestions have been furnished by hundreds of boys who have actually built and experimented with the devices they are now telling other boys how to build. In no other way could a book containing such a wide and interesting variety of contents have been prepared, for no one author or staff of writers, for that matter, could have possibly gleaned such a wealth of ideas from their own observation and experience.

### THE BOY MECHANIC

Represents the Best Accomplishments of the Mechanical Genius of Young America

for the material used in the book is a careful selection of only those articles which are new, practical and of more than ordinary interest; the selection having been made by mechanical experts who still have active recollections of their boyhood interests. It gives complete directions for making all the things boys love to build and experiment with in the fields of electricity, mechanics, sports, arts and crafts work, magic, etc., such as

Electrical Appliances—Steam and Gas Engines—Turbines—Motors—Wireless and Morse Telegraph—Self-Propelled Vehicles—Toboggans—Ice Boats—Canoes—Paddle Boats—Punts—Camping Outfits—Tents—Fishing Tackle—Magic Lanterns—Searchlights—Cameras—Telescopes—Gliders, Kites and Ballons—Electric Furnaces—Lathes—Pottery Kilns.

A boy would be an old man before he could make half the things described in this wonderful book. It is entirely different from any other published and has

**700 Articles—480 Pages—800 Illustrations**  
(7 x 10)

**Price \$1.50 Postpaid**

It is clearly printed on high-grade book paper and durably bound in cloth. The cover is of an attractive design in four colors showing a boy building a small boat. There are ten solid pages of index alone. Neither care nor expense have been spared to make this the greatest boys' book published, and to enable as many boys as possible to have one, the price has been made absolutely as low as possible. It would be difficult to think of a way of investing \$1.50 that would benefit a boy as much as through the purchase of one of these books.

Sent postpaid to any address upon receipt of price by the publishers

**POPULAR MECHANICS  
BOOK DEPARTMENT**

6 North Michigan Ave.  
**CHICAGO**



#### A Few Practical Features:

☞ A large number of the things described may be made from old cast-off articles which the average boy has at his disposal.

☞ Many articles involving the purchase of only a few cents worth of material will be found fully as serviceable as similar ones costing several dollars.

☞ Scores of handy things the family can use in the home are described.

☞ Finally, this book will develop and interest the boy along mechanical lines and educate him at his play.

*"Wish I  
knew what  
to make"*

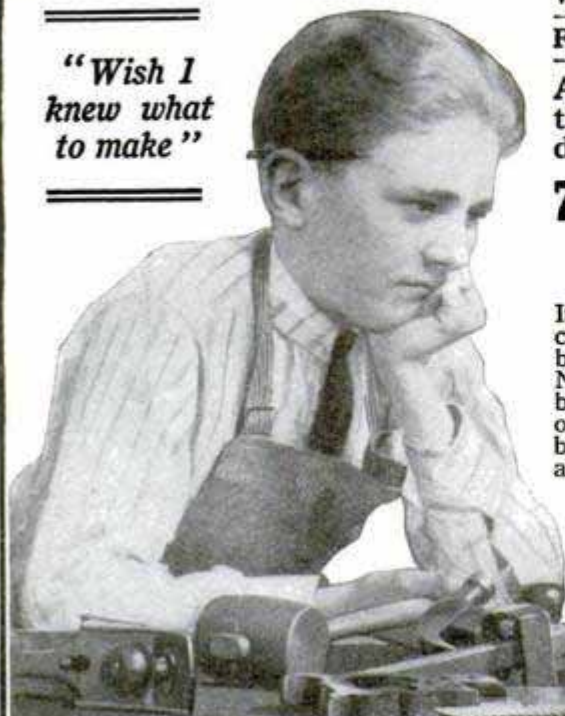

# Expert Electricians Make Big Money

You can learn all branches of **ELECTRICITY** at this school—and you will learn them **by doing** the actual work, step by step, personally guided and coached.

The opportunities open to men who understand **ELECTRICITY** and have had technical training cannot be exaggerated. Write to-day for our free catalog, or come in and inspect the school at your earliest convenience.

**THE NEW YORK ELECTRICAL SCHOOL**  
44 West 17th Street NEW YORK



## HOW TO TRIM SHOW WINDOWS

Shown in this new book, 150 complete windows for every season of the year illustrated by means of over 200 detail drawings and explained in 256 pages of text matter. Shipped prepaid for \$1.50. This is the 10th year for our

## SCHOOL OF WINDOW TRIMMING

**CARD WRITING AND ADVERTISING**  
Best paid and most fascinating professions in the world. A 120-page catalog FREE tells you all about it.

**KOESTER SCHOOL, 306 Jackson Boulevard, CHICAGO**

# LAW STUDY AT HOME BECOME AN LL.B.

Only recognized resident law school in U. S., Conferring Degree of Bachelor of Laws—LL. B.—by correspondence. Only law school in U. S. conducting standard resident school and giving same instruction, by mail. Over 450 class-room lectures. Faculty of over 30 prominent lawyers. Guarantees to prepare graduates to pass bar examination. Only law school giving Complete Course in Oratory and Public Speaking. School highly endorsed and recommended by Gov. Officials, Business Men, Noted Lawyers and Students. Send today for Large Handsomely Illustrated Prospectus. Special courses for Business Men and Bankers.  
**HAMILTON COLLEGE OF LAW, 405 Advertising Bldg., CHICAGO, ILL.**

# DRAWING

Cartoon, Comic, Commercial, Fashion, Newspaper and Magazine Illustrating taught by mail. Illustrated book 6c in stamps.  
**THE BOSTON SCHOOL OF DRAWING, 755M Boylston St. BOSTON, MASS.**

# BE A BANKER

Splendid opportunities. Pleasant work, short hours, all holidays off, yearly vacation with pay, good salary. Learn at home. Diploma in six months. Catalog free. **EDGAR G. ALCORN, Pres.**  
**AMERICAN SCHOOL OF BANKING, 119 McLane Bldg., COLUMBUS, OHIO**

**BE AN ILLUSTRATOR.** Learn to draw. We will teach you School of Illustration 112 Page Bldg. Chicago, Ill.

# LEARN WATCHMAKING AND ENGRAVING

Earn while learning. Most practical watch school. Individual instructions. Graduates in great demand. Book free.  
**Chicago School of Watchmaking, 63 E. Van Buren St., Chicago**

# ADVERTISEMENT WRITERS WANTED

Department stores, merchants, manufacturers. Big demand, small supply. Our graduates earn \$1,500 to \$10,000 yearly. Write TODAY for Free prospectus of our Correspondence System of instruction. **POWELL SCHOOL OF ADVERTISING, Inc. (Est. 1901) 1682 Meyrowitz Building, Fifth Avenue, NEW YORK**

# LEARNED BY ALMOST ANYONE AT HOME SMALL COST

Send today 2c stamp for particulars and proof.  
**A. SMITH, Room D 101, 823 Bigelow St., PEORIA, ILL.**

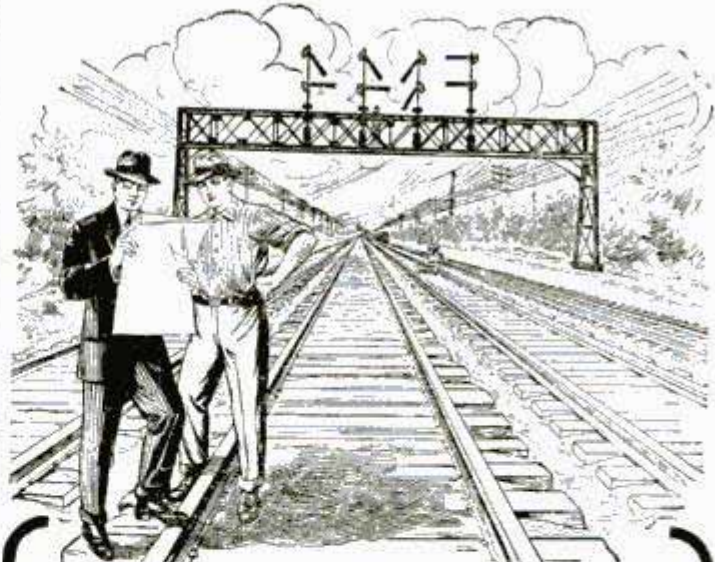

# Be a Signal Engineer

The profession of Signal Engineering is only in its infancy. Thousands of men are needed. At the present time, scarcely more than 25% of the railroads are equipped with automatic electric block signals. We must find more Signal Engineers to superintend the installation of the new systems and the maintenance of the ones that are already installed. **Big money is being paid.** You can get just the kind of instruction you need to hold one of the big jobs in your own home—during your spare time. Send the coupon now for the big new book on Signal Engineering. Find out how you can be the boss and the man who gets the fat pay envelope. Write today.

# Earn \$2,500 a Year

Yes, that is what your salary will be when you are a full fledged Signal Engineer, \$2,500 a year to start. Many men making much more than that. Even while you are learning you can hold one of the positions under a Signal Engineer paying you a handsome salary. Here is your opportunity. Be the man who tells the other fellows what to do. Send in the free coupon for full particulars.

# More Men Needed

Railroads are constantly looking for competent Signal Engineers. There are not enough men to fill the positions. Thousands and thousands of miles of track are now being equipped with automatic signals. More Signal Engineers are needed to superintend the work. Hundreds of new positions will be open. **And there are no men to take them.** Electric Signal Engineering is one of the most fascinating of professions. As a railroad man you travel from coast to coast without it costing you a penny. **You can be the man who knows.** You can be the man who tells the other fellow what to do. You can be the man who gets the fat pay envelope and free transportation. Here is your chance.

**FREE OUTFIT**  
If you will write at once we will tell how you can get the big new Signal Engineer's outfit absolutely free. Our students get practical instruction. The kind the railroads demand. If you act at once the outfit is free to you. Send the free coupon for full particulars.

# Send the FREE Coupon for Big New Book

Just put your name and address on the free coupon and send it in to us at once. Absolutely no obligations of any kind. We will send you the big new Signal book absolutely free. Tells you all about this most fascinating profession. How you can get into the \$2,500 class. The book is free. Get your name and address in at once.

**FREE BOOK COUPON**  
Department of Signaling  
Desk 1195  
491 Cass St.  
Chicago, Ill.

Department of Signaling  
Desk 1195  
491 Cass St.  
Chicago Ill.

Name.....  
Address.....  
Age..... Occupation.....

Please Mention Popular Mechanics

# Wanted Meter Engineers



We have got to find more Meter Engineers somewhere. During the coming year over 500,000 new meters are going to be installed. If you are ambi-

tious we will train you—in your own home—during your spare time to become a competent Meter Engineer. Send the free coupon.

## Salary \$125 to \$225 Per Month

Meter Engineering is one of the best paying professions in the electrical industry. We can show you hundreds of men who are making better than \$3,000 a year. Here is your chance to get the practical instruction right in your own home. You get a diploma and can become a full-fledged Meter Engineer without giving up the job you now hold. Then you get the big job—the fat pay envelope. Write today.

## The New Profession

The profession of Electrical Meter Engineering is now in its infancy. It is calling for men. The Electric Lighting Stations *must* have Meter Engineers. *Thousands of positions are now open.* Meter Engineers are now so scarce that the Electric Lighting Stations are willing to pay huge sums for competent men. *YOU* can get into the profession. *It is calling you.* Write at once for full particulars of this special offer.

### Special Offer

For a limited time we are making a special reduced price offer in order to induce men to start the study of Meter Engineering right away. Send the Coupon.

### FREE Book Coupon

Ft. Wayne

Correspondence School  
Dept. 1195, Ft. Wayne, Ind.

Gentlemen:—Please send me absolutely free and prepaid your new book on Meter Engineering. Also tell me about your great special offer. It is distinctly understood that I assume no obligations of any kind.

### Send the Free Coupon

Put your name and address on the coupon and send it in at once. We will send you absolutely free and prepaid our big new book on Meter Engineering. Tells you about the wonderful opportunities you will have in the New Profession. Explains exactly how you can study at home during your spare time and get your diploma. Absolutely no obligations of any kind in getting this book. Send your name and address on free coupon or letter or postal card. But send today.

Ft. Wayne Correspondence School  
Dept. 1195  
Ft. Wayne, Ind.

Name .....

Address .....

Please Mention Popular Mechanics

# SHORTHAND IN 30 DAYS

We absolutely guarantee to teach shorthand complete in only thirty days. You can learn in spare time in your own home, no matter where you live. No need to spend months as with old systems. Boyd's Syllabic System is easy to learn—easy to write—easy to read. Simple. Practical. Speedy. Sure. No ruled lines—no positions—no shading as in other systems. No long lists of word signs to confuse. Only nine characters to learn and you have the entire English language at your absolute command. The best system for stenographers, private secretaries, newspaper reporters and railroad men. Lawyers, ministers, teachers, physicians, literary folk and business men and women may now learn shorthand for their own use. Does not take continual daily practice as with other systems. Our graduates hold high grade positions everywhere. Send today for booklets, testimonials, etc.

Chicago Correspondence Schools  
969 Chicago Opera House Block, CHICAGO, ILL.



## Learn a Paying Profession

that assures you a good income and position for life. For twenty years we have successfully taught

## PHOTOGRAPHY

Photo-Engraving and Three-Color Work

Our graduates earn \$20 to \$50 a week. We assist them to secure these positions. Learn how you can become successful. Terms easy—living inexpensive. Write for catalogue—NOW!  
ILLINOIS COLLEGE OF PHOTOGRAPHY, 999 Wabash Avenue, Effingham, Ill.

## ELECTRICAL ENGINEERING

men with training are always in demand. Having trained over 2000 young men in the past 21 years in the fundamentals of Applied Electricity, The Bliss Electrical School, with its well-equipped shops and laboratories, is peculiarly well qualified to give a condensed course in Electrical



Including Mathematics, Steam and Gas Engines, Mechanical Drawing, Shop Work, and Theoretical and Practical Electricity, in all branches. Students construct dynamos, install wiring and test efficiency of electrical machinery. Course, with diploma, complete

### IN ONE YEAR

For practical young men with limited time. 22nd year opens Sept 23rd. Catalogue on request. 105 Takoma Ave., Washington, D. C.

## EARN TELEGRAPH

Morse or Wireless. Also superior station agency course. Splendid opportunities. Demand greater than supply. Graduates assisted. We own and exclusively occupy two large modern buildings equipped with R. R. and Western Union Wires and Complete \$3000 Marconi Wireless Station. Oldest and largest school—est. 39 years. Investment \$25,000. Endorsed by Railroad, Wireless and Western Union Officials. Expert practical teachers. Living expenses may be earned. Tuition low. Easy payments. Catalogs Free.

Dodge's Telegraph, Railway and Wireless Institute  
8th Street VALPARAISO, IND.

## JEWELRY ENGRAVING

We teach you, by our new and original method of instruction, this clear fascinating and profitable business right at your home, and furnish you all tools needed absolutely free. Write for free book to the WISCONSIN SCHOOL OF ENGRAVING, Stroh Bldg., MILWAUKEE, WIS.

## LEARN TO PAINT SIGNS and SHOW CARDS

I'll teach you personally by mail. Fourteen years' successful teaching. Big field for men and women. You can EARN \$18.00 TO \$45.00 A WEEK Crawford, B. C. writes: "Earned \$200.00 while taking course." Write today for catalog, samples, etc.  
DETROIT SCHOOL OF LETTERING  
CHAS. J. STRONG, Founder Dent. 205 Detroit Mich.



# I Put Them There

**Give Me Ten Minutes a Day and I Will Do the Same for You**

Thousands of men and women have acquired an accurate, unfailing memory through my system of Memory Training. I have letters from men in nearly all professions and trades thanking me for being of great assistance to them. *Hundreds of them attribute their success and prosperity directly to my training.* These whom I quote below are but a few of them. I want to send you others.

You, young man in college, or you, ambitious worker taking a correspondence course—what good is your study doing you? *Be square with yourself. Are you able to remember what you learn?* If not, you owe it to yourself to train your mind so you can profit by what you learn. No education in the world can help you unless you have a memory—a well ordered mind instead of one that plays you tricks.

Take inventory of yourself. You feel that others do not give you credit for your real worth. There must be a reason. Can you think and talk connectedly or are you always saying things that leap out before you give them serious reflection? *Do You Know How To Think? If not, Learn Now!*



**Prof. Henry Dickson**

America's foremost authority on Memory Training, Public Speaking, Self Expression, and Principal of the Dickson Memory School, Auditorium Building, Chicago.

## A Perfect Memory Means More Money

*Yes, it means money to you every day of your life.* My training will mean promotions, ability to see new opportunities, a real capacity to think out big problems.

There never was a big executive or great man in any line who did not have an excellent memory. If he did not have a *perfect memory* he would be taking orders—not giving them. Size up these big men. Why are they superior to you? Only in this—that they can think—they have perfect memories.

## STOP Forgetting



*A business man wrote: "Since commencing I can endure the grind of a ten-hour business day and come home feeling tiptop—not brain dusty and all in, as heretofore."*

*The curator of entomology in a Public Museum wrote: "The exercises are most excellent and have brought instantaneous results. Within the past week I have been able to memorize a goodly number of scientific names."*

## I Can Train You To Remember Don't Overlook This Opportunity

By modern scientific methods the memory, like any other function, can be trained and developed. All successful men have well developed minds and memories. *I have made thousands of them successful.*

If you want to win in the fearful competition of today *you must train.* The sooner you realize this the sooner you start to advance.

When you start with my wonderful system you will be astonished at your progress—at your ability to think and remember. *You can have a perfect memory.* It will be a revelation to you, and your friends will also notice it. It will increase your value to yourself and to your employer. The man with a *perfect memory* becomes a dominant personality—a man to reckon with.



*J. T. M., Stafford Springs, Conn., wrote: "It has always been hard for me to get up before an audience and speak, but since practicing your exercises I feel quite at home."*

*P. H. B., Alaska, wrote: "I have been using the principles taught, during my selling and am surprised at the results, and I often smile when I have pulled off a sale I had not been sure of."*

## FREE—This Valuable Book "How To Remember"

Simply clip the coupon—and mail it—or drop me a letter or postal *now.* You will receive my booklet by return mail.

## How To Get Free Copy of this Valuable Book—"How to Speak In Public"

De luxe edition, handsomely illustrated, richly bound. Is exactly suited to meet the needs of the man or woman who de-

sires to be a successful public speaker. The price of this 1913 de luxe edition is \$2. I will, however, present a copy absolutely free to every student, who enrolls for my course of memory training within ten days after reading this offer.

**Prof. Henry Dickson**  
Principal  
Dickson School  
of Memory,  
705 Auditorium  
Bldg., Chicago, Ill.

Send me free Booklet, "How to Remember;" also full particulars how to obtain a free copy of Dickson's "How to Speak in Public."

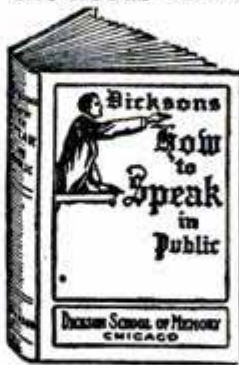

Mail Coupon Today

NAME.....

Street .....

City.....State.....

The Burlington Special

The Burlington Special



Here Is an Exquisite Design

New Inlay Monogram

The latest idea in watch cases. Superbly beautiful. Your own monogram in handsome enamel design, (many colors to choose from) inlaid in superb gold strata case. The newest thing—just conceived and offered direct to you.

# Just Out!

"Inlay Enamel" Monogram

## New Ideas in Watch Cases!

Open face or hunting case, ladies' or gentlemen's sizes. These can be had in the newest ideas: *Block and Ribbon Monograms, Diamond Set, Lodge, French Art and Dragon Designs, Etc.* Imagine a beautiful hunting case with your own monogram on one side and the emblem of your lodge or any emblem on the other side. Our catalog shows complete illustrations. See coupon below.

## Special Offer!

The superb Burlington Special now at the DIRECT rock-bottom price—the same price that even the wholesale jeweler must pay. You may secure one of these superb timepieces—a watch of the very latest model, the popular new thin design, adjusted to the second—19 jewels—adjusted to positions AND temperature AND isochronism—the most perfect product of the world's most expert watch manufacturers—at the price that even wholesale jewelers must pay—and in order to encourage everybody to secure this watch at once pay this rock-bottom price, either for cash or \$2.50 a month! We send the watch on approval, prepaid. You risk absolutely nothing—you pay nothing—not one cent, unless you want this exceptional offer after seeing and thoroughly inspecting the watch. Read the coupon below.

## Write for Free Watch Book

Learn the inside facts about watch prices, and the many superior points of the Burlington over double-priced products. Just send the coupon or a letter or a postal. Get this offer while it lasts.

**Burlington Watch Co.**  
19th Street and  
Marshall Blvd.  
Chicago  
Dept.  
1195

**Burlington Watch Co.**  
19th St. and Marshall Blvd.  
Dept. 1195 Chicago, Ill.

Please send me (without obligation and prepaid) your free book on watches and a copy of your \$1,000 challenge, with full explanation of your cash or \$2.50 a month offer on the Burlington Watch.

FREE  
Book Coupon

Name.....

Address.....

Please Mention Popular Mechanics

## THIS \$2.00 BOOK OF Practical Electricity REDUCED TO \$1.00

38,000 engineers, electricians and students of electricity paid \$2.00 for this wonderful volume. You now have the opportunity of buying it at just half that price—\$1.00.

### Good As A School

This book is a school within itself. It contains twenty chapters of valuable information—and teaches the fundamental principles of electricity including designing, operation and care of dynamos and motors.

Practical Electricity was written out of the day's work—the result of our eighteen years' experience, in repairing every possible kind of electrical machinery and apparatus.

This book has helped boost hundreds of men to bigger and more responsible positions. In return for the electrical knowledge they secured from this book they boosted our repair business. We want to line up half a million more boosters—that's why we're cutting the price of the book in two.

### MONEY BACK IF NOT SATISFIED

We couldn't begin to tell all of the points and merits of Practical Electricity. We would rather send you the book and let you see for yourself. Mail us \$1.00 to-day—and if you aren't perfectly satisfied, return it and get your money back. Order it now.

**CLEVELAND ARMATURE WORKS**  
4734 St. Clair Avenue, CLEVELAND, OHIO

America's Greatest Electrical Repair Works



## 9,059-Word Business Book Free

Simply send us a postal and ask for our free illustrated 9,059-word Business Booklet which tells how priceless Business Experience, squeezed from the lives of 112 big, broad, brainy business men, may be made yours—yours to boost your salary, to increase your profits. This free book deals with

- How to manage a business
- How to sell goods
- How to get money by mail
- How to buy at rock-bottom
- How to collect money
- How to stop cost leaks
- How to train and handle men
- How to get and hold a position
- How to advertise a business
- How to devise office methods

Sending for this free book binds you to nothing, involves you in no obligation; yet it may be the means of starting you on a broader career. Surely you will not deny yourself this privilege, when it involves only the risk of a postal—a penny! Simply say "Send on your 9,059-word Booklet". Send to SYSTEM, Dept. 81-5 Wabash and Madison Sts., Chicago

SEND  
for my  
FREE  
Books



## DO YOU WANT TO KNOW HOW TO DEVELOP VITALITY, ENERGY, ENDURANCE, NERVE STRENGTH, MUSCULAR STRENGTH PERFECT PHYSIQUE?

My FREE BOOKS, "The 'Whys' of Exercise" and "The First and Last Law of Physical Culture," tell you, if you are weak or underdeveloped, how to grow strong; if strong, how to grow stronger. They explain how to develop lungs and muscle, the strong heart and vigorous digestion—in short, how to improve health and strength internally as well as externally. Send TO-DAY—NOW—for these FREE BOOKS. Enclose 4c in stamps to cover postage.

PROF. H. W. TITUS, Department 123, 56 & 58 Cooper Square, New York City



**200 Kinds Iron, Wood,  
Wire & Steel Puzzles**  
Catalog and sample 10c—3 leaders for 25c  
**WESTERN PUZZLE WORKS**  
St. Paul, Minn.



**HERE YOU ARE, BOYS** A medallion pin of Foxy Grandpa. Everyone will notice it on the lapel of your coat and try to get a closer look at it. All you have to do is press the bulb.—Foxy Grandpa will finish the job by squirting a fine stream of water over the inquisitive one. Will squirt 20 feet. Greatest joke out. Order one today and fool your friends. Price 15c. Foxy Grandpa and Hooligan both for 25c. 5 for 50c or 1 doz. for \$1.00. A beautiful fountain pen free with every \$1.00 order.

AMERICAN SUPPLY CO., 918 Union St., St. Paul, Minn.

# The Prudential

A National Institution of Public Usefulness

Assets, over . . . . .	323 Million Dollars
Liabilities, (Including Policy Reserve \$260,000,000)	297 Million Dollars
Capital and Surplus, over . . . . .	25 Million Dollars
Amount Set Aside for Holders of Deferred Dividend Policies, over . . . . .	31 Million Dollars
Dividends Payable to Policyholders in 1914, over . . . . .	6½ Million Dollars
Paid Policyholders during 1913, nearly . . . . .	34 Million Dollars
Total Payments to Policyholders, since organization, over . . . . .	300 Million Dollars
Number of Policies in Force, . . . . .	12 Million
Real Estate Mortgages and Farm Loans, over . . . . .	92 Million Dollars
Voluntary Concessions Paid Policyholders to date, nearly . . . . .	18½ Million Dollars

**New Business Paid for During 1913,  
over 481 Million Dollars**

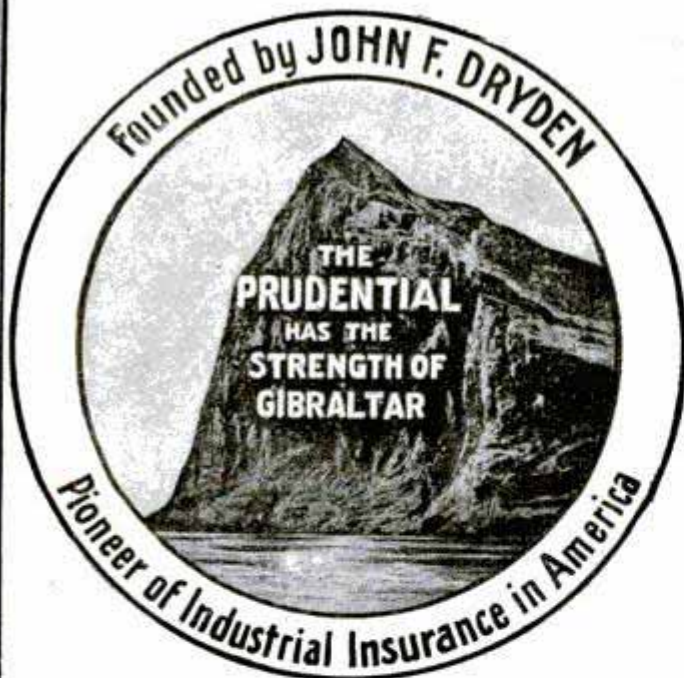

LOWEST EXPENSE RATE IN THE HISTORY OF THE COMPANY

**Over Two Billion  
406 Million  
Dollars  
Life Insurance  
in Force**

**THE PRUDENTIAL INSURANCE CO., OF AMERICA**

Incorporated as a Stock Company by the State of New Jersey

**FORREST F. DRYDEN, President**

**Home Office, Newark, N. J.**

The Prudential Issues Life Insurance for the Whole Family. Write for Information, Dept. 137.

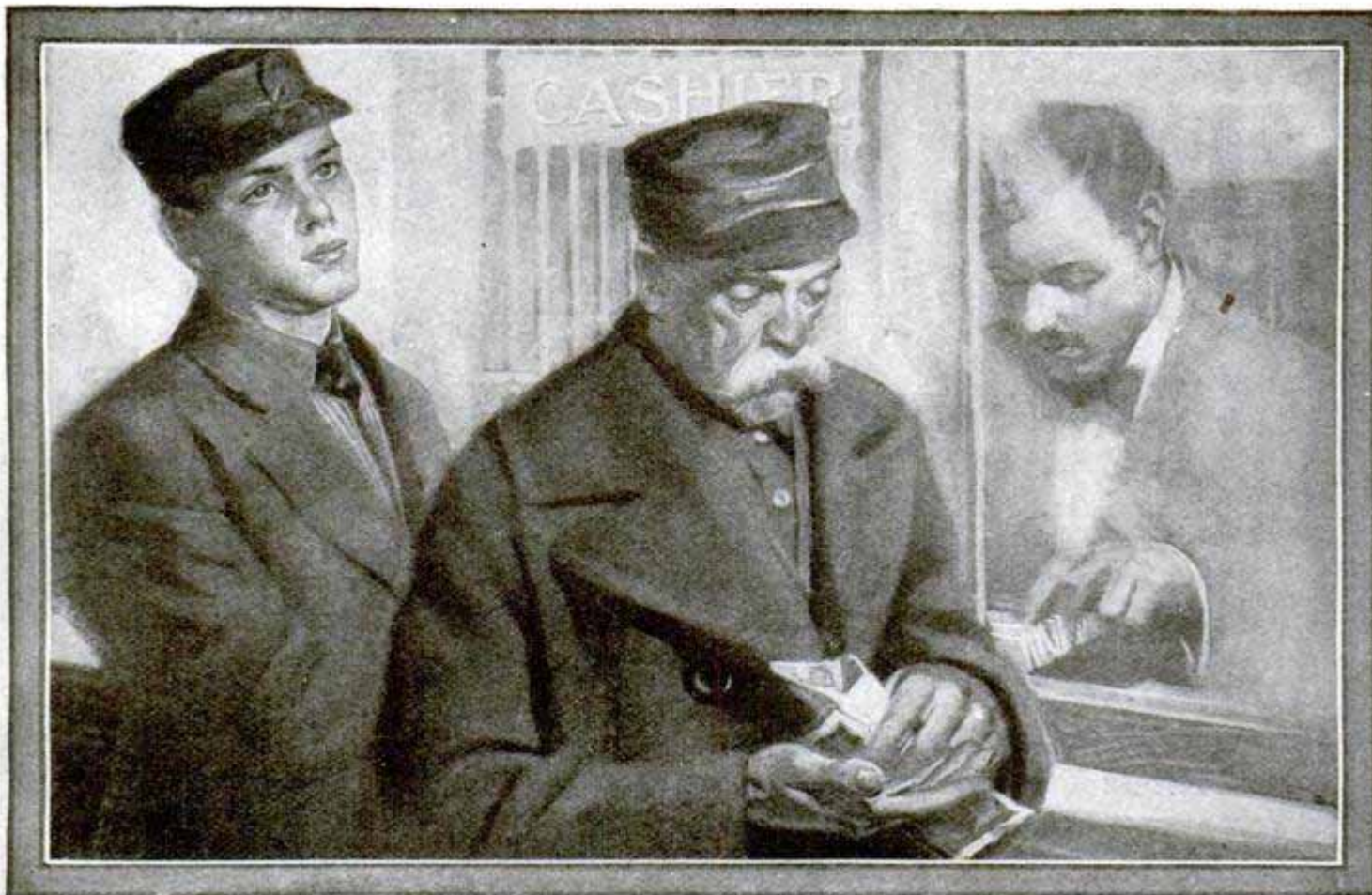

## Story of the Pay Envelope

Whether young or old, if you're untrained, your pay envelope will tell the same old story—skimping along on a small salary—living expenses advancing year by year—no hopes of a raise. Why? Because you lack the **training** that makes promotion sure. Training makes the difference in men and in salaries. The untrained man of sixty, in spite of his years of service, can earn no more at a common job than the untrained youth beside him.

**Become a trained man—get more money**

### Your Opportunity Coupon

Mark the position you want and mail the coupon now

- |                                |                            |
|--------------------------------|----------------------------|
| .... Electrical Engineer       | .... Lawyer                |
| .... Elec. Light & Power Supt. | .... Bookkeeper            |
| .... Electrical Wireman        | .... Stenographer          |
| .... Telephone Expert          | .... Private Secretary     |
| .... Architect                 | .... Accountant            |
| .... Building Contractor       | .... Cost Accountant       |
| .... Architectural Draftsman   | .... Cert'f'd Public Acc't |
| .... Structural Draftsman      | .... Auditor               |
| .... Structural Engineer       | .... Business Manager      |
| .... Concrete Engineer         | .... Fire Ins. Inspector   |
| .... Civil Engineer            | .... Fire Ins. Adjuster    |
| .... Surveyor                  | .... Fire Ins. Expert      |
| .... Mechanical Engineer       | .... Moving Picture Op'r   |
| .... Mechanical Draftsman      | .... Sanitary Engineer     |
| .... Steam Engineer            | .... Irrigation Engineer   |
| .... Municipal Engineer        | .... Textile Boss          |
| .... Gas Engine Engineer       | .... College Preparatory   |
| .... Gas Tractor Engineer      | .... Auto. Mechanician     |

NAME .....

ADDRESS .....

Pop. Mech. 5-14

The *American School of Correspondence*, one of the largest educational institutions in the world, was established over sixteen years ago for just such men as you. It is chartered under the same laws as your state university. It will train you, in your spare time and in your own home, in any branch of **Engineering, Business or Law**, or will prepare you for entrance into any resident college. No matter where you live, the *American School* will fit you for a better job and put you in line for bigger pay.

Follow this advice and start now to prepare yourself for any one of the countless big, well-paying positions always open. Send in the coupon and let us tell you how easy it is. We will not send an agent to bother you in your home or at your work. All business will be carried on privately, by correspondence.

**Sign and mail the coupon now**

# American School

of Correspondence. Chicago, U.S.A.

**This school has no connection with any other school using the name "American"**

Please Mention Popular Mechanics



# Popular Mechanics Magazine

WRITTEN SO YOU CAN UNDERSTAND IT

Vol. 21

MAY, 1914

No. 5

## A Good Imitation of a General Smash-Up

**T**HE carnival season at Nice, the famous pleasure resort of southern France, is one continuous round of hilarity. The city is decked in gala attire and tourists from every land throng the streets. The parades, which are a feature of the occasion, display floats, some sumptuous, some

gendarme or policeman lifts the end of the car, as if to release the horse. The horse is stuffed, the figures of the passengers mostly "dummies" from some clothing store, but the conductor and some of the passengers are real persons, who lend "action" to the piece by their movements.

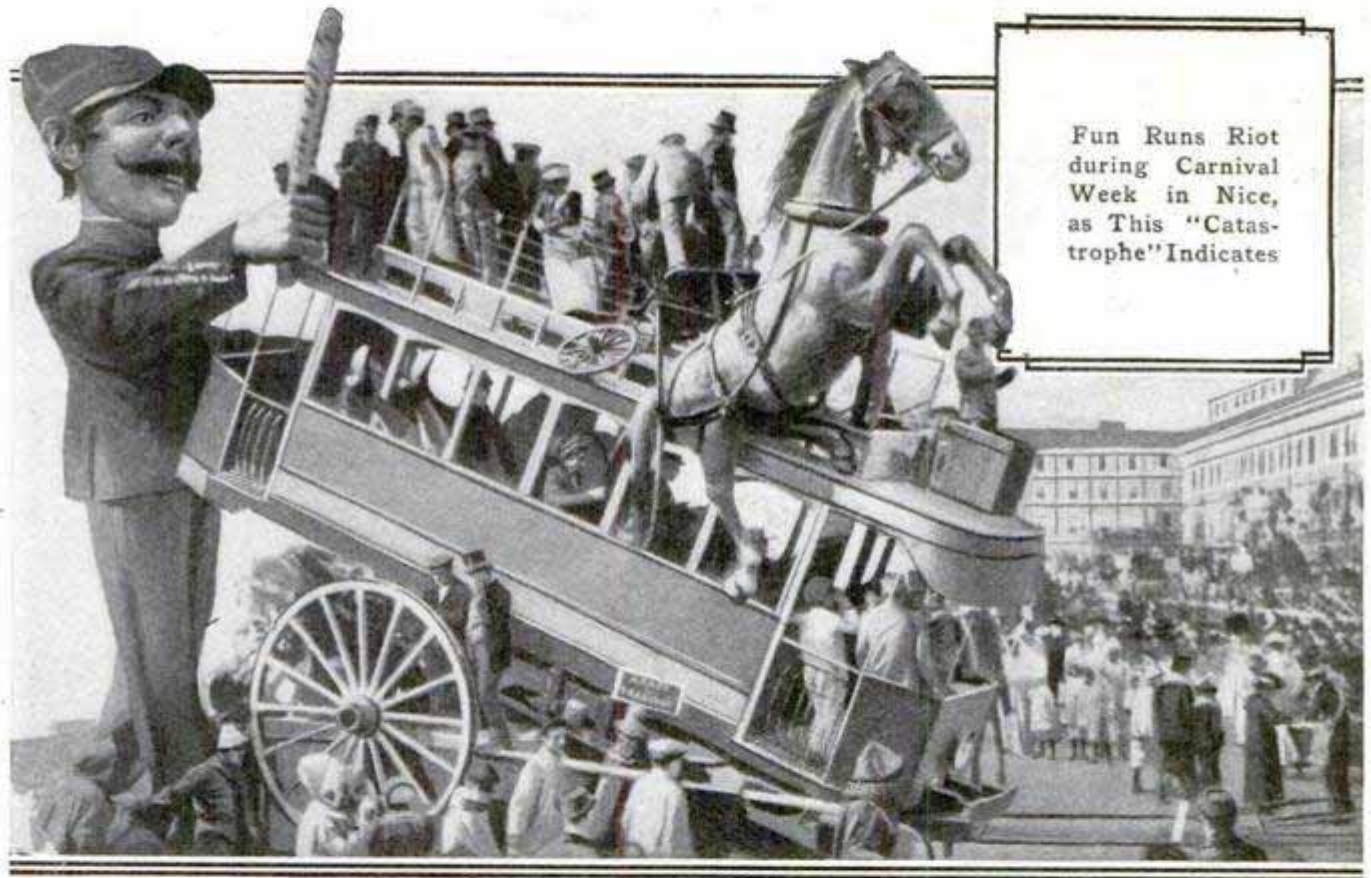

huge bouquets of blossoms, and some so mirth provoking that their progress through the streets is marked by waves of laughter. One of the most curious of these funny floats at the last carnival depicted an unusual collision between a street car and a horse cart, with the horse and cart poised upon the roof of the car, the frightened passengers in every posture of surprise and terror, and the horse plunging to disengage himself from the wreckage. At the rear, a gigantic

Below is a signpost much seen on traffic streets in France, bearing the legend "Arrêt du Tramway," which is the equivalent of our signs "Street Cars Stop Here." Inasmuch as motormen in France, as in other countries, frequently neglect to stop where the sign is displayed, occasioning annoyance equal to that in similar cases on this side of the Atlantic, the addition of the signpost on the float provoked much merriment when it was hauled through the crowded streets.

## RIFLE WITH BINOCULAR TELESCOPIC SIGHTS

A new rifle has been invented which the sportsman rests against his forehead instead of against his shoulder.

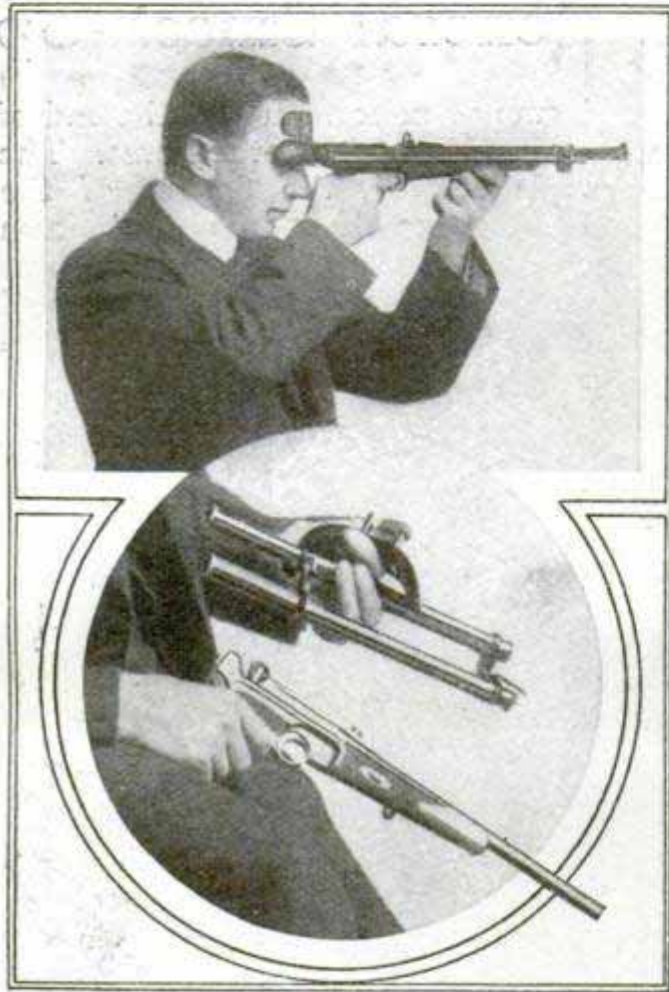

Telescopic Rifle for Shooting Game at Long Range

der. Two telescopes form the sighting device, by means of which accurate shooting is possible at distances impossible with the usual type of gun. The inventor, an Ohio sportsman, in experimenting, used a gun having a range of about 1,500 yd. and a penetration of  $\frac{3}{8}$  in. of boiler steel. A binocular telescope of peculiar design is combined with the gun and makes it unnecessary to squint the eye in sighting. A padded plate shaped to the forehead is so arranged that the recoil of the shot is entirely taken up by flat springs. Rifle and telescope may be taken apart in a few minutes. The eyepieces of the binocular are easily adjusted to different widths between the eyes of

individual users. The focusing of the telescope actuates the mechanism for raising or lowering the gun for different ranges in accordance with the focus.

## MANILA HARBOR TO BE DEEPEINED

The inner harbor at Manila is to be deepened to 32 ft. at low tide, the government having bought a huge suction dredge with a capacity of 1,000 cu. yd. per hour for that purpose. A difference of 5 ft. between high and low tide in the harbor makes it possible for the mammoth freighter, "Minnesota," the largest ship navigating the Pacific, heavily loaded, to dock at the government piers, as after the deepening of the harbor 37 ft. will be provided. At present work is being done nearest the piers, where the churning of the screw propellers has accumulated much mud, making navigation difficult and rendering the docking of large vessels almost impossible. After the Manila job is completed the dredge will be sent to Iloilo to deepen the harbor there.

## RESULTS OF THE FLOOD IN LOS ANGELES

When a most unusual rainfall occurred on the slopes of the Sierra Madre range in southern California recently, the flood swept down the Los Angeles River, and transformed the Arroyo Seco, a dry ravine, into a torrential watercourse, spreading wreck and ruin to the very edge of San Pedro Bay. The rush of waters ate its way into the banks of sand and loam, toppling houses to destruction, fortunately with little or no loss of life. In an effort to prevent the Los Angeles River from cutting away its tracks, one railroad company dumped 10 freight cars, heavily loaded with rock, down the bank at Macy Street. After a brief period of flood, the waters subsided almost as rapidly as they rose, leaving a trail of wreckage totaling many thousands of dollars.

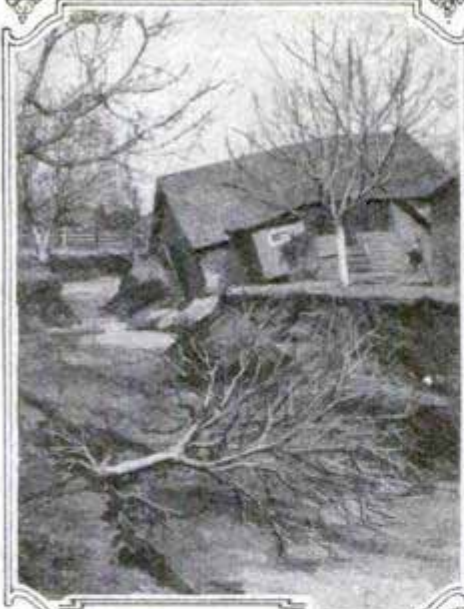

An Orchard  
Washed Out by the  
Torrent



Many Dwellings  
were Destroyed by the  
Rushing Waters in  
the Los Angeles Flood

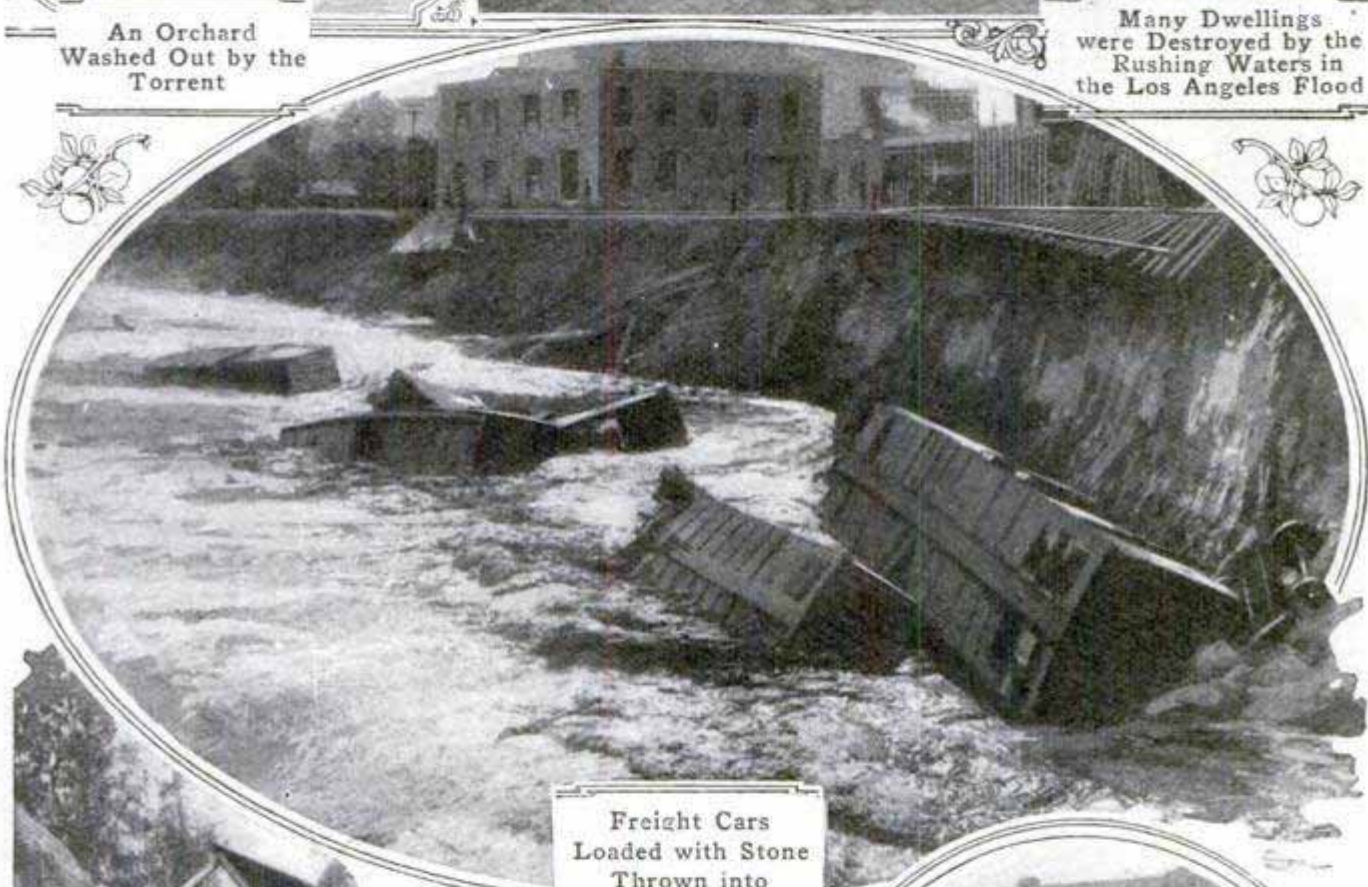

Freight Cars  
Loaded with Stone  
Thrown into  
Los Angeles River  
to Protect Tracks

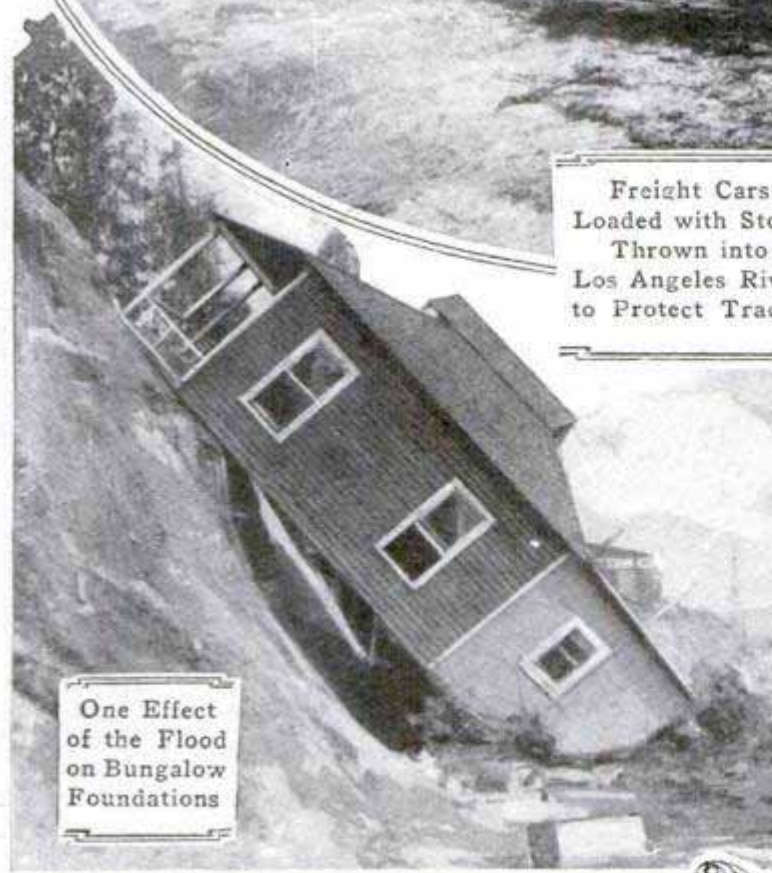

One Effect  
of the Flood  
on Bungalow  
Foundations

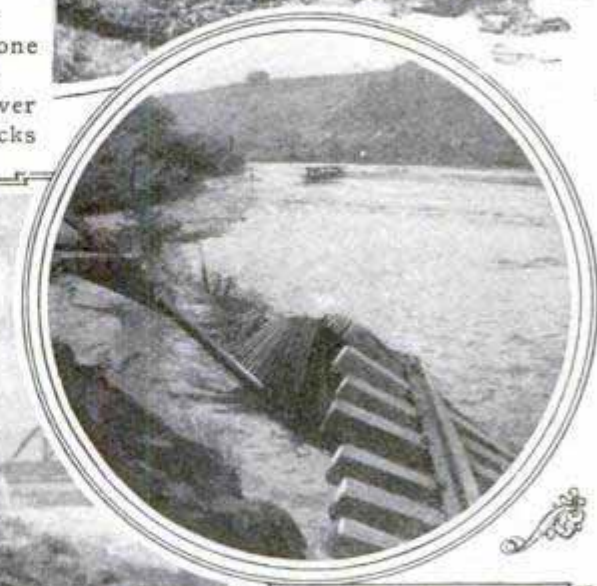

A Curious Effect  
of the Flood

## CIRCUS PERFORMERS HANG BY THEIR HAIR

A remarkable feat was accomplished by two members of a troupe of Chinese performers in a circus, ex-

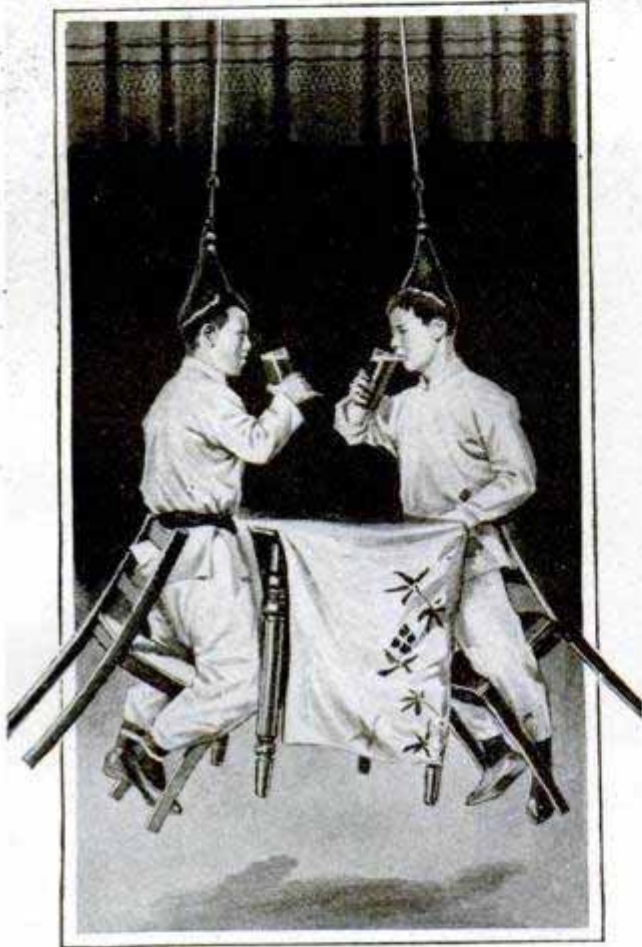

Novel Stunt by Chinese Circus Performers

hibiting in Berlin recently, when hooks connected with ropes swung from the flies were caught in their queues, lifting the performers, the table at which they sat and their chairs high in the air. Here they swung, all the while calmly drinking, for several minutes.

## TUNGSTEN LARGELY USED IN ELECTRICITY

Although the commercial use of tungsten is so recent that it is barely mentioned in most textbooks, it already has an important place in the electrical industry. It has been found advantageous to use tungsten in the targets of X-ray tubes, on account of its high melting point, 3100° Centigrade, which enables it to withstand

the terrific bombardment of the cathode rays, and the consequent high temperatures attained in modern high-speed skiagraphy. In electric furnaces tungsten is used both in strips for winding coils and in tubes. Automobile manufacturers are using more and more of it for sparking points, and some are even adopting tungsten for all electrical contacts. In the form of gauze, tungsten is highly efficient for separating solids from acid baths, as the metal is insoluble in most common acids. Tungsten is slightly heavier than gold, and its use as an alloy for steel is well known, as also is its household usage as a filament for incandescent lamps.

## CAPE-CAIRO CAR CARRIES LARGE GASOLINE SUPPLY

The automobile in which representatives of the Belgian government are to ride from the Cape of Good Hope to Cairo, in the transafrican trip, is equipped with two tanks, one on either side, at the front end of the running board. In these tanks 80 gal. of gasoline may be carried, auxiliary to the usual supply tank at the rear. With this supply, it is believed the 16-hp. car will have no difficulty in making the long runs between stations.



How an Extra Supply of Gasoline is Carried for Long Journey

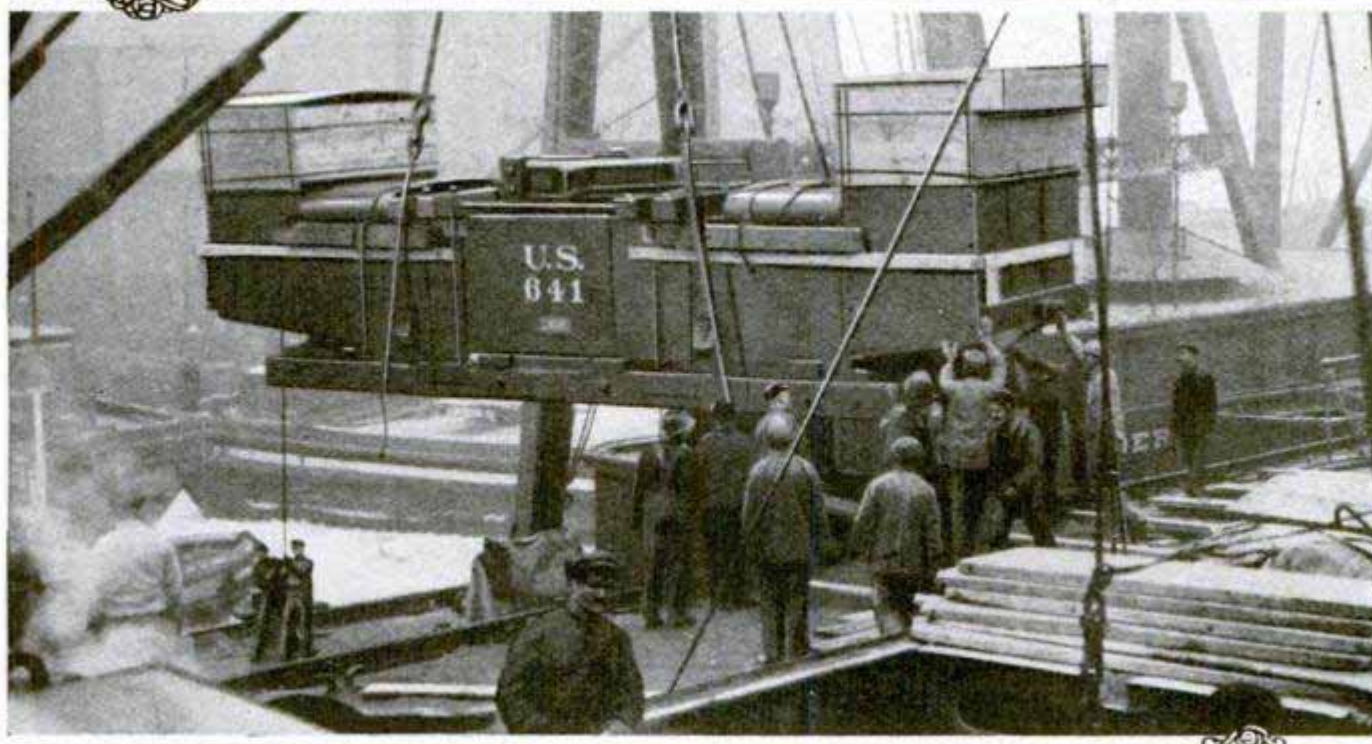

The First of Forty Electric Locomotives being Shipped to Colon

## ELECTRIC LOCOMOTIVES IN TRANSIT TO PANAMA

Marking the last stages in the completion of the Panama Canal, 40 electric locomotives which are to tow the vessels through the locks, are now being shipped to the Canal Zone. These "electric mules," as they are called, weigh 50 tons each, and demonstrate amazing power when installed upon proper tracks. The towing lines are wire ropes, each 400 ft. long, and four locomotives will be used for each vessel at each lock, two hauling on ropes attached to the bow and two at the stern, to steady it. These wire ropes are an inch in diameter and are composed of six strands of high-tension wire around a hemp core. The specifications call for a breaking strength of 37 tons each, and tests show a strength of more than 10 per cent in excess of that called for in the specifications.

A trolley line is to be built from Jerusalem to Bethlehem, a concession having been granted by the Turkish government to a French banking firm. At the same time electric current will be used to light the city of Jerusalem.

## RUBBER SKATES NOW PART OF SOLDIERS' KIT

Experiments have been carried on by German military authorities with a pair of cigar-shaped foot pontoons, or skates, made of rubber, by which it is believed a soldier may be equipped to walk across rivers, carry heavy loads on the water, and fire his rifle with as much steadiness as on land. The device is about 6 ft. long, and is fastened on the foot like a snowshoe. The motion resembles skating rather



Courtesy India Rubber World  
German Soldier Equipped with Rubber Skates

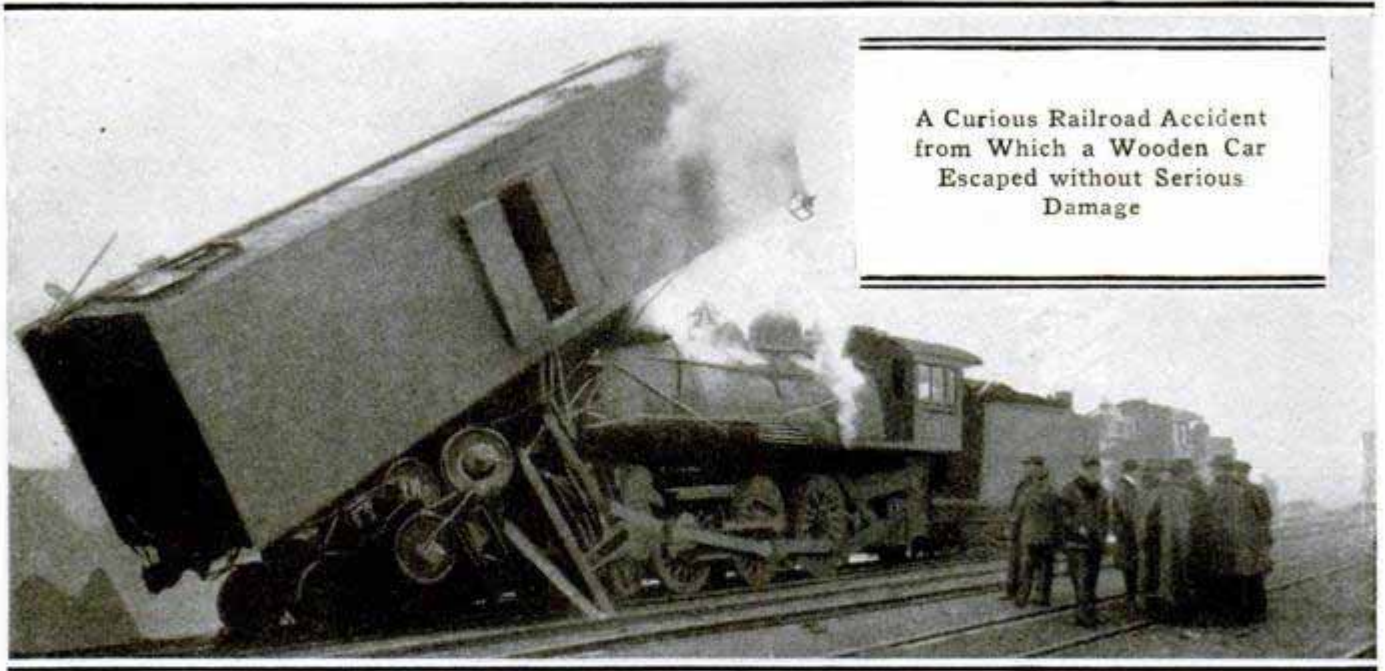

A Curious Railroad Accident  
from Which a Wooden Car  
Escaped without Serious  
Damage

than walking, and because of this the name of rubber skates or water skates has been given the device. A number of these skates fastened together make a very serviceable raft, or they may be used as a basis for a pontoon bridge.

### MEDAL OF HONOR GIVEN TO COLONEL GOETHALS

In appreciation of the distinguished services rendered to the nation by Col. George W. Goethals as Chief Engineer of the Panama Canal, a gold medal was presented to him by the Civic Forum of New York, on March 4th, last. The presentation was made by the head of the New York state department of education, in the presence of army and navy officials of the highest rank, national, state and city dignitaries, and an immense audience.



### COLLISION POISES CAR ON SMOKESTACK

A curious railroad wreck occurred in Chicago recently, when a special train on one road struck a freight train on another at a crossing. Both trains were moving, and the freight was struck near the middle. One car was lifted on the locomotive of the speeding special, and carried quite a distance down the track, nicely balanced on the smokestack. An interesting phase of the accident is the fact that the car was a wooden one and was not materially damaged by its adventure.

### NEW VARIETY OF COTTON IN EGYPT

A new cotton has been developed in Egypt which is said to be stronger than any variety heretofore produced in that country. Careful selection of seed, and particular attention to securing the best plants of each successive growth, after the best modern agricultural practice, is responsible for the long fiber and the silky texture. The plants are short and are covered with bolls, as many as a hundred having been found on a single plant. The cotton is brown in color, and its superior strength, together with its abundant bearing, makes it a most valuable addition to this important family.

## CALIFORNIA TO FORM A MILITIA AERO CORPS

The second state to enlist men in a militia aero corps is California, New York having previously recognized this arm of the service by a duly organized body of fliers. A recruiting office has been opened in Los Angeles where enlistments for the latest branch of the state-militia organization are being received. The corps will be recruited to a full strength of 39 men and five officers. Its first equipment will be two machines with automobile tenders, which will be augmented later to four machines, each with an auto tender. The aeroplanes will be regular two-passenger scout machines, and will be equipped with wireless, if experiments now being conducted prove the feasibility of the idea.

## UNSINKABLE LIFEBOAT HAS NOVEL FEATURES

Recently an English inventor exhibited upon the Thames a lifeboat which is claimed to be unsinkable. It is a cylinder, pointed at both ends, with sliding doors which may be tightly battened, and affords a refuge in emergency for 80 people. This strange-looking craft may be launched in a few seconds, according to the inventor, and is buoyant in the extreme, carrying its large load easily and safely in a heavy sea. Air is supplied to the interior by means of a small pump.

## NEW DEVICE FOR BAKING POTATOES

A potato baker recently placed on the market consists of a bottomless pan having a grate-like top on which

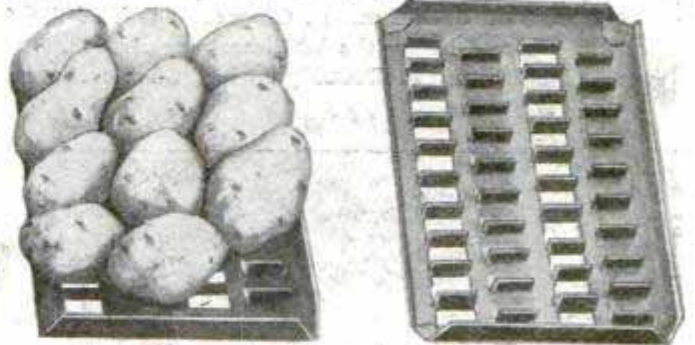

New Baker with Metal Strips That Hold the Potatoes in Place

the potatoes are laid. At the edges of the openings are upright metal strips which serve to hold the potatoes in place and prevent them from rolling together, while the openings permit a free circulation of hot air for baking. This device is designed to be used in an oven.

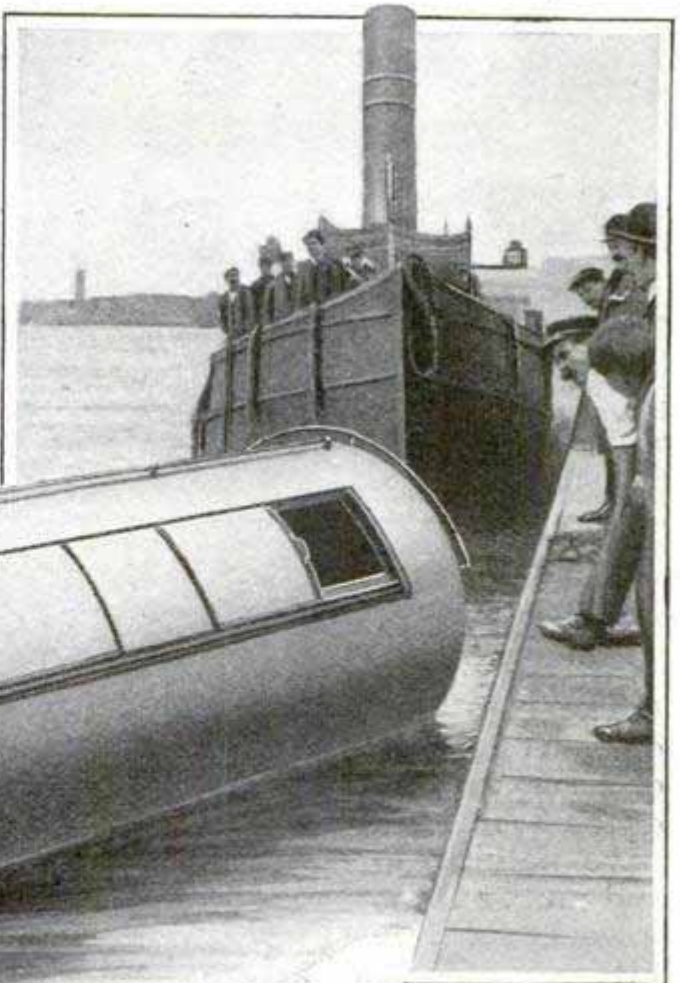

Cylindrical Ark of Refuge Offered by English Inventor as Nonsinkable Lifeboat

Erecting Floor of the Manhattan Bridge over East River, between New York City and Brooklyn. The Floor is Built Out from the Towers and Secured, Piece by Piece, to the Heavy Steel Bars Suspended from the Main Cables. This is the Newest of the Bridges Connecting Manhattan Island with the Borough of Brooklyn. It Crosses North of the Old Brooklyn Bridge and below the Williamsburg Bridge. The Photograph, Taken from the Brooklyn Side, Shows Manhattan in the Distance



Copyrighted by Irving Underhill

## LAYING THE FLOOR OF A SUSPENSION BRIDGE

The most interesting and dangerous-looking stage in the construction of a suspension bridge is the building of the floor. In this work the builders have nothing to rest their work on and must build out each way from the towers, securing the floor, piece by piece, to the heavy steel bars suspended from the main cables far above. The work is done with derricks that

are equipped with booms long enough to reach out ahead of the finished structure and hold the girders suspended while they are being riveted in place. As each section of the floor is completed, the derricks are moved ahead and the construction of the next section is begun. The sagging of the completed portion of the floor, which may be detected in the accompanying





illustration of the new Manhattan bridge at New York City, is caused by the unbalanced weight of the structure, which pulls the main cables down slightly in the vicinity of the towers. With the entire floor in place, the weight is evenly distributed and the cables take the catenary curve intended by the engineers.

☞The Japanese are making waterproof boots, shoes, bags, and trunks from the tanned hides of sea lions.

### PROTECTION AGAINST HIGH-POWER LINES

Where high-power transmission lines cross roadways there is always present the possibility that stress of wind or sleet will break the cable and endanger travelers. To safeguard the lives of those using the roadway, the aluminum cables which transmit 170,000 kw. from the power station to the nitrogen factories at Saaheim, Norway, have arched supports built over the road wherever

the transmission lines cross. These wire networks could scarcely be supposed to prevent the highly charged cables, entirely uninsulated, from burning through the slight screen, but it is believed that such resistance would be

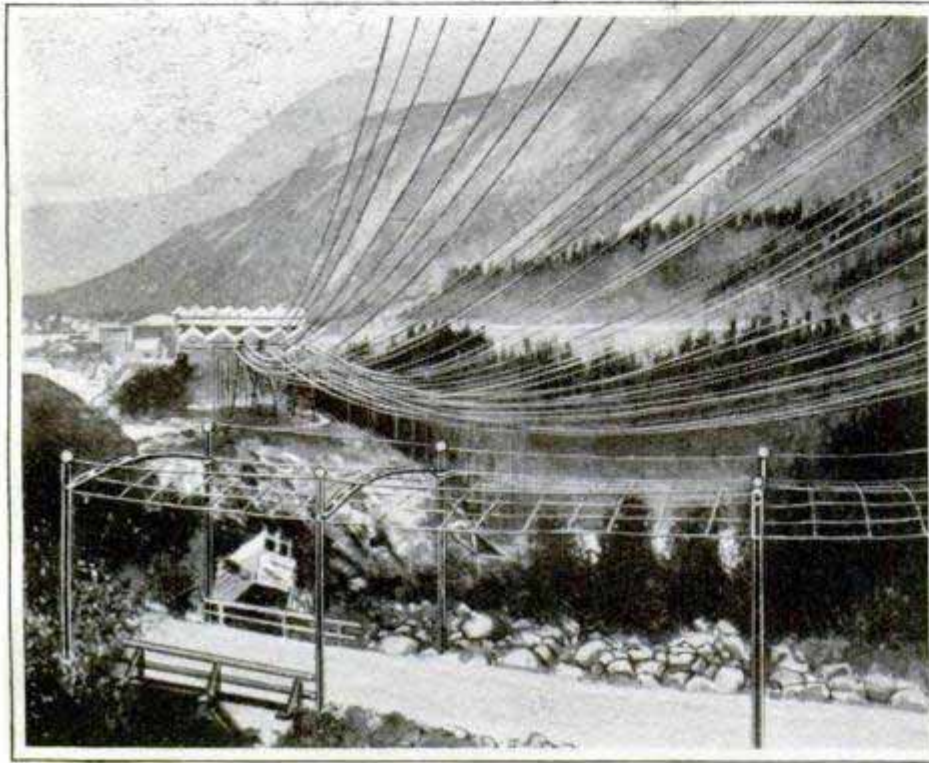

Safeguarding the Traveler on Norwegian Roads

offered as would permit the escape of whoever might be underneath when the cable broke.

Florida buttonwood is highly prized for cooking on ships, as it burns slowly with an even heat and makes little smoke or ash.

## NEW AEROPLANE CONTROL LESS TIRESOME

After five years of lever control, by which both hands of the pilot were continuously engaged in manipulating the forward and backward movements of the warping and turning mechanisms, the makers of the Wright aeroplanes have now adopted the automobile type of steering wheel. The lever system, proved in practice, after it had been once mastered, a very precise method, but in long-distance flights operators found it exceedingly tiresome. The new control, which has been quite generally adopted in Europe, is termed "instinctive," as the movement forward and back of the steering wheel falls in with

the natural movements of the body in accommodating one's self to upward and downward motions of the aeroplane. The wheel also is utilized for turning, banking and wheeling, the rudder being actuated by partially revolving the wheel, as in steering an automobile.

## IRRIGATION TO RESTORE GARDEN OF EDEN

Lying between the Euphrates and the Tigris Rivers is today a desert where once was fertility so abundant that it passed into a proverb; Mesopotamia, the land was called, and here, "Between the Rivers," as the name may be translated, was the traditional location of the Garden of Eden, the original home of the human race. Huge irrigation works, of which the great Nahrwan Canal, and its counterpart, the Dijail, are still traceable, brought the waters of the Tigris to the fields of grain, two thousand years ago.

But these and other great works perished and were swallowed up in the shifting sands long centuries since. Recently, under the direction of an eminent English engineer, the Turkish government has built a dam, or barrage, across the Euphrates, 14 miles above Babylon, as the first step in a vast scheme of irrigation to redeem half a million acres, transforming the desert into a garden spot. The barrage will divert the course of the Euphrates into canals, from which the water will be distributed over a vast territory of

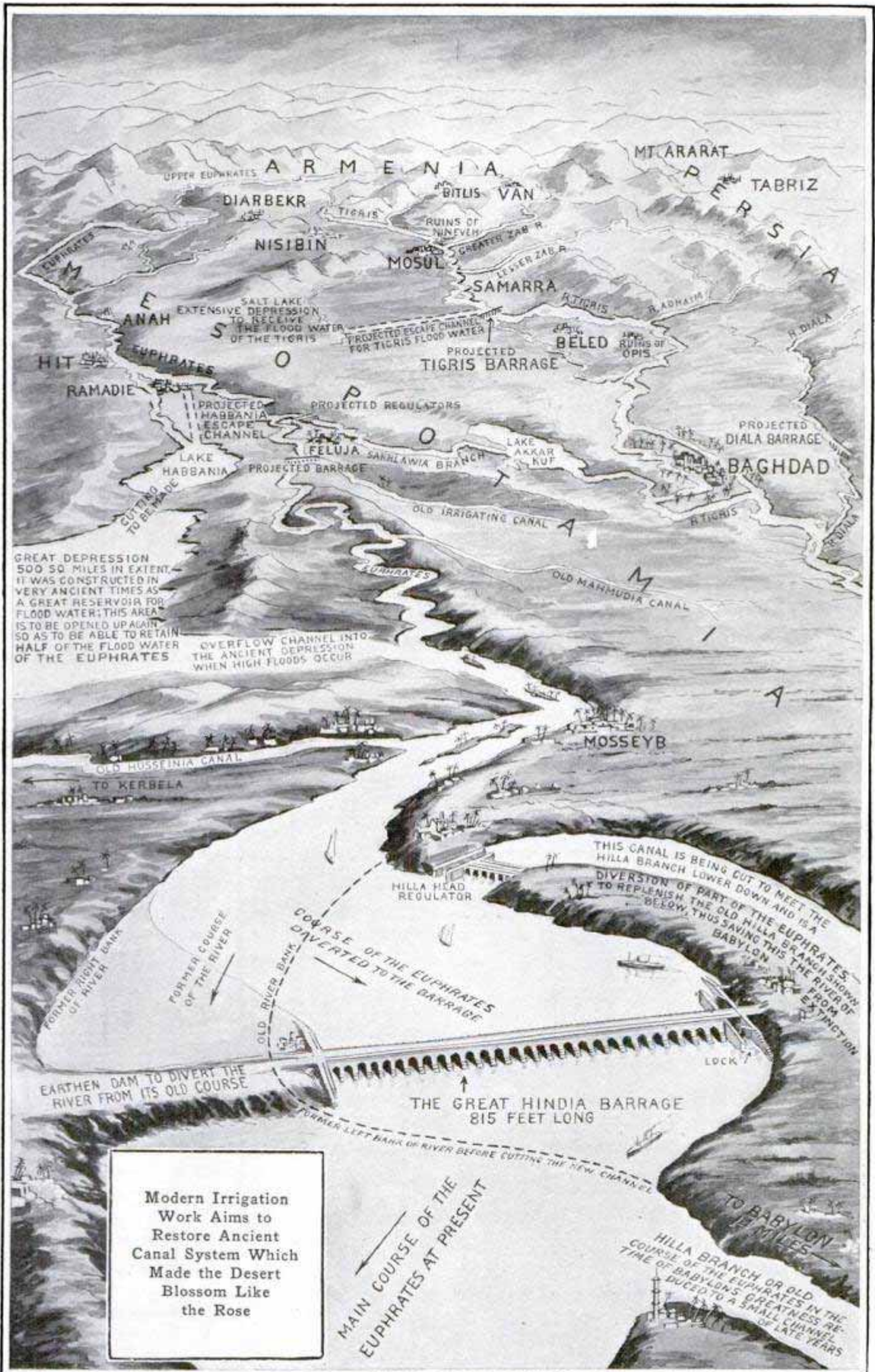

GREAT DEPRESSION  
500 SQ MILES IN EXTENT.  
IT WAS CONSTRUCTED IN  
VERY ANCIENT TIMES AS  
A GREAT RESERVOIR FOR  
FLOOD WATER; THIS AREA  
IS TO BE OPENED UP AGAIN  
SO AS TO BE ABLE TO RETAIN  
HALF OF THE FLOOD WATER  
OF THE EUPHRATES

OVERFLOW CHANNEL INTO  
THE ANCIENT DEPRESSION  
WHEN HIGH FLOODS OCCUR

THIS CANAL IS BEING CUT TO MEET THE  
HILLA BRANCH LOWER DOWN AND IS A  
DIVERSION OF PART OF THE EUPHRATES  
TO REPLENISH THE OLD HILLA BRANCH  
BELOW, THUS SAVING THIS THE RIVER OF  
BABYLON FROM EXTINCTION

Modern Irrigation  
Work Aims to  
Restore Ancient  
Canal System Which  
Made the Desert  
Blossom Like  
the Rose

MAIN COURSE OF THE  
EUPHRATES AT PRESENT

HILLA BRANCH OR OLD  
COURSE OF THE EUPHRATES IN THE  
TIME OF BABYLON'S GREATNESS RE-  
DUCED TO A SMALL CHANNEL  
OF LATE YEARS

highly fertile farming country. Other river-conservation schemes are provided for in the full plans, which are designed to enable the government to conquer the Euphrates as it was mastered by the ancients. The Tigris is also included in the full project, which is estimated to cost in its entirety something like \$75,000,000, though years must elapse before the whole scheme is worked out.

### OUTING HOME CARRIED ON RUNNING BOARD

A portable camp outfit, carried in a neat box upon the running board of an automobile, or fastened behind the seat of a buggy or wagon, forms a complete outing home when set up. A folding spring bed of standard size is provided, which, when set up, affords substantial support for the framework of a tent, whose center pole is clamped to either end of the bed. One side of the canvas covering may be raised and supported to form a porch, while the box in which the outfit is packed forms a table. The case and outfit complete weigh 130 lb. and occupy a space of 10 by 16 by 48 in., packed.

### "FAKING" A THRILLER FOR THE "MOVIES"

The thrilling scenes depicted upon the screen at the "movies," although the result of actual photographs, may not be always what they seem. A recently produced "movie" film shows a dare-devil detective using a dirigible to overtake an express train in which is riding, in fancied security, the criminal who seeks to escape him. The picture shows the detective climbing down a knotted rope from the dirigible to the roof of the speeding train. Few scenarios have called for a more hazardous feat. When shown upon the screen it is so realistic that the spectators involuntarily clutch at their chairs, scarcely breathing until the act is completed in safety.

The making of this film, however, while it involved some risk, was not as hazardous as it appears. The owner of a little airship kept it at an aerodrome in England, alongside of which run the tracks of the Midland Railway. A moving-picture concern hired the airship and the owner took an acrobat with him, cruising about until he saw a train coming. Then he brought his dirigible around to the proper spot and



Tent Set Up,  
and Table Formed  
from the Box

Dinner Time in  
the Outing Home.  
Tent Open,  
Showing Bed



Camp Outfit  
Carried on the  
Running Board

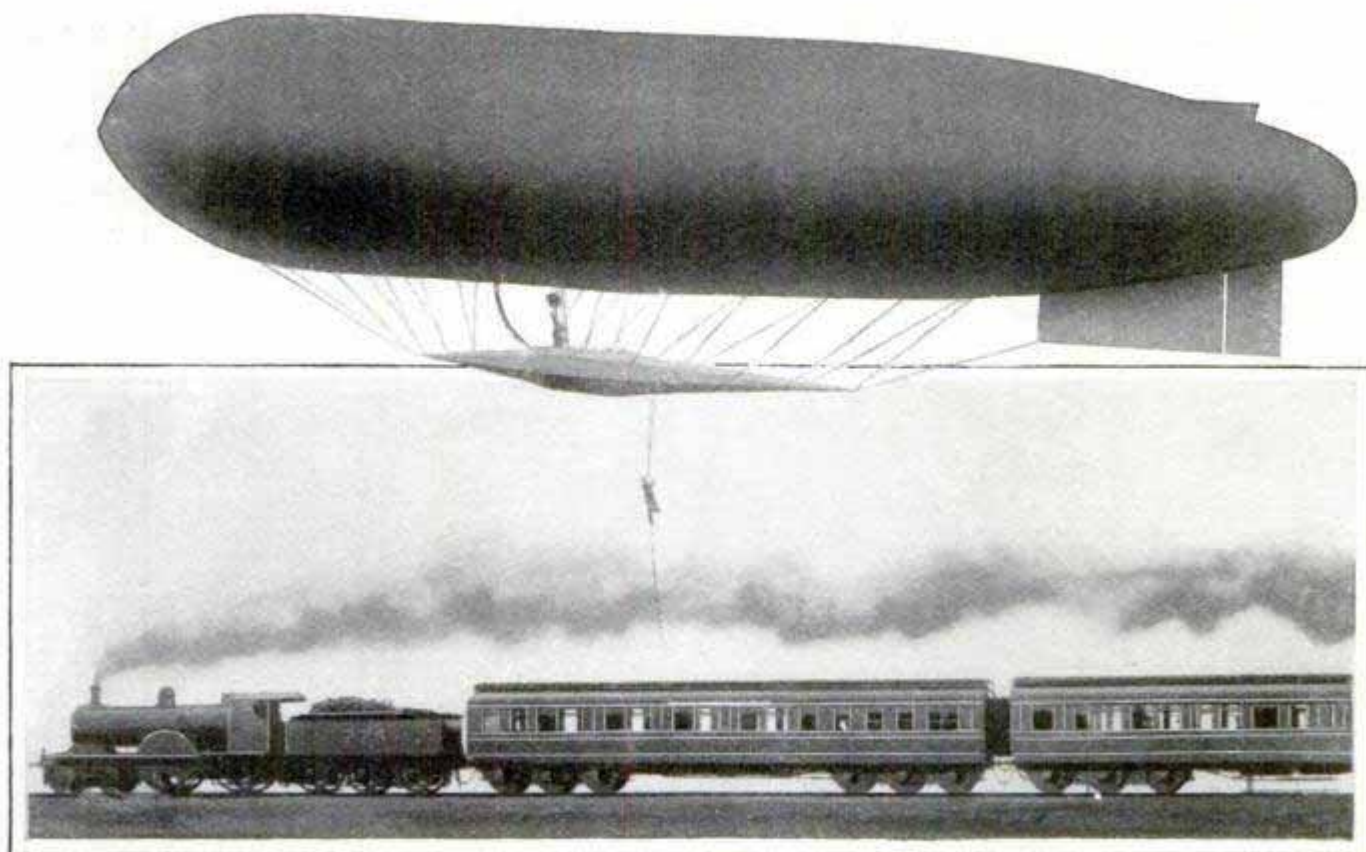

A Real Incident in the Making of a Moving-Picture Film, Which is Only "Make-Believe" Made Possible by Cleverly Cutting Out a Gap in the Film between the Dirigible and the Train

waited for the train. The acrobat climbed down the knotted rope. Just as the train sped beneath, the moving-picture machine was started, and in a few seconds the scene was "filmed." As the dirigible owner considered it far too risky to bring the airship close down over the train, the film showed a large gap of sky between the tail of the rope and the roof of the train. So the gap was "cut out" and the film shows the man within a reasonable distance of the roof, in fact right in the steam and smoke.

The film people, not being satisfied with showing the man climbing down the rope, determined to show him actually alighting on the roof of a railway car. Unable to obtain permission from the English railway authorities to complete what they considered a good scene, they finished the film in France, where a more complaisant set of officials were found. The finished picture shows an English Hawkshaw climbing down from an English airship toward an obviously English train, and alighting on the top of an undeniably French railway carriage from a French dirigible!

Incidentally, airmen say that if a man did climb out of a dirigible and let go, the airship would shoot up to a height of several thousand feet before it could be brought under control. By turning the moving-picture shutters slowly when the picture is being taken and then turning the handle at normal speed when the film is being shown, a very slow train and an almost stationary dirigible can be made to give the effect of great speed on the screen.

### AUSTRIAN INVENTORS FIND NEW WAY TO MAKE TEETH

Machines for casting artificial teeth of various metals have been open to objection in that uniform density could not be obtained, and defects developed owing to lack of proper control of pressure. Two Austrian engineers have lately constructed a device at Prague, which, it is claimed, eliminates such defects. The pressure is automatic, always uniform, and is exerted vertically, something heretofore regarded as impossible in casting the molten metals in such small molds.

## MACHINE GUN ON ARMORED AEROPLANE

French military authorities are experimenting with the first armored army aeroplane, equipped with a



Latest Addition to the French Aerial Navy

machine gun mounted over the engine. Bullet-proof plates of hardened steel protect the working parts of the aeroplane, and a V-shaped shield screens both the gunner and the ammunition. The pilot is seated behind the gunner, and the gun is mounted high enough to eliminate any possibility of hitting the propeller when it is fired. The aeroplane itself is of unusually substantial construction, designed to withstand hard usage and to fly fast and far. The present experiments are directed toward ascertaining the influence of the gun fire upon the stability of the aeroplane, and so far the results have been satisfactory.

This Five-Masted Sailing Ship, an Uncommon Type of Vessel, is Longer Than the L-Shaped Floating Drydock on Which It has been Lifted Out of Water

It is believed that the armored aeroplane equipped with machine guns will be the most formidable antagonist the military dirigible will have to face in the next great war.

## GREAT FLOATING DRYDOCKS IN GERMAN SHIPYARDS

The latest floating drydocks in Hamburg Harbor show improvements in convenience and capacity over older installations. Not only is the size increasing, made necessary by the greater tonnage of the newer vessels, but the mechanical arrangements shorten the time required for docking the great vessels, and lighten the labors of the men employed in that arduous occupation.

These docks are of two designs, the "L" and the "U" types, as they are called, both of which have the decided advantage of permitting the docking of ships whose length greatly exceeds that of the dock. For instance, in a 280-ft. dock, the Hamburg steamer "Modestis" was docked, the vessel projecting 30 ft. fore and aft over the last keel blocks, while in exceptional cases



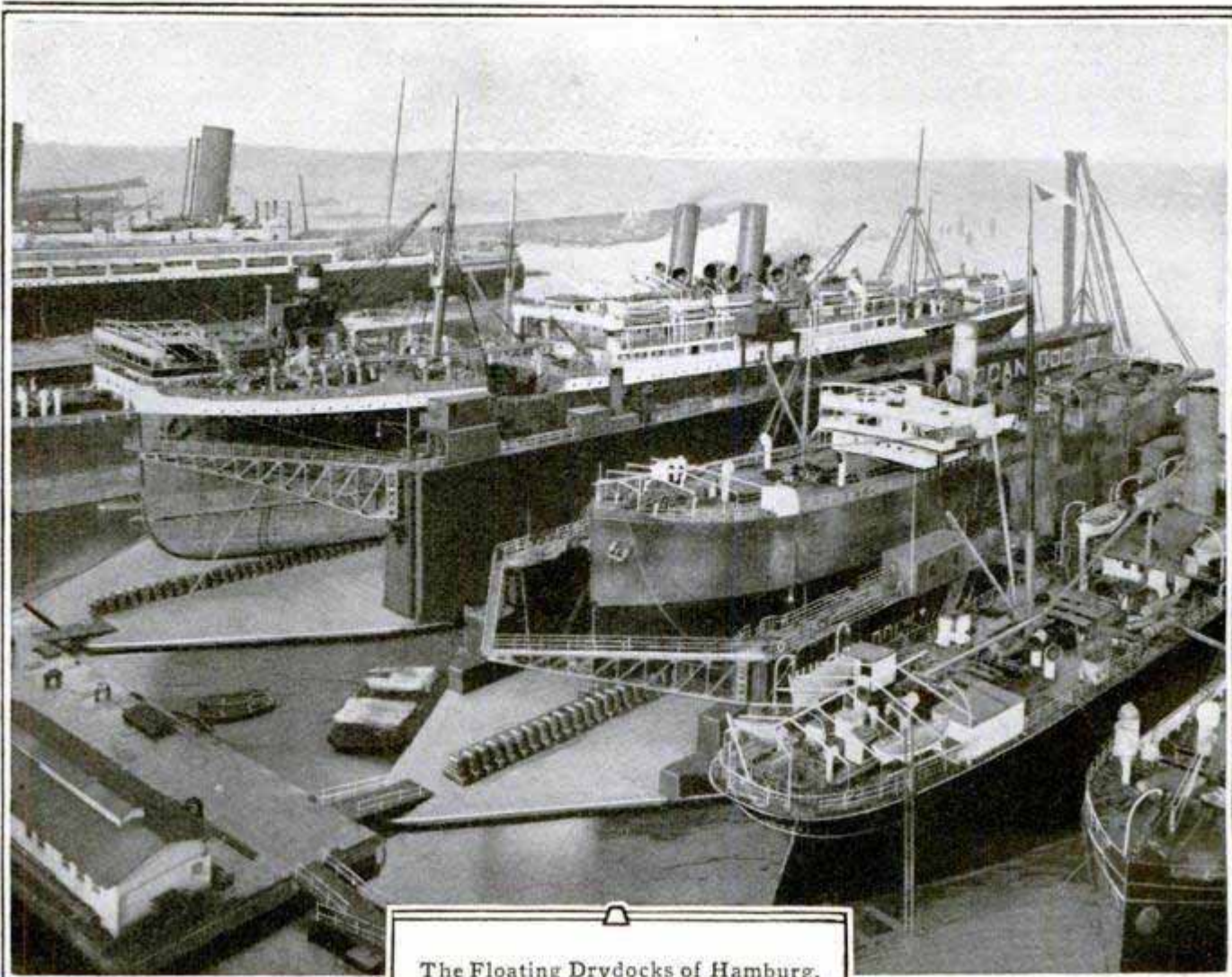

The Floating Drydocks of Hamburg, Germany, Make This Port One of the Most Important Centers for the Repair of Ships, Which can be Lifted Bodily from the Water in a Few Minutes

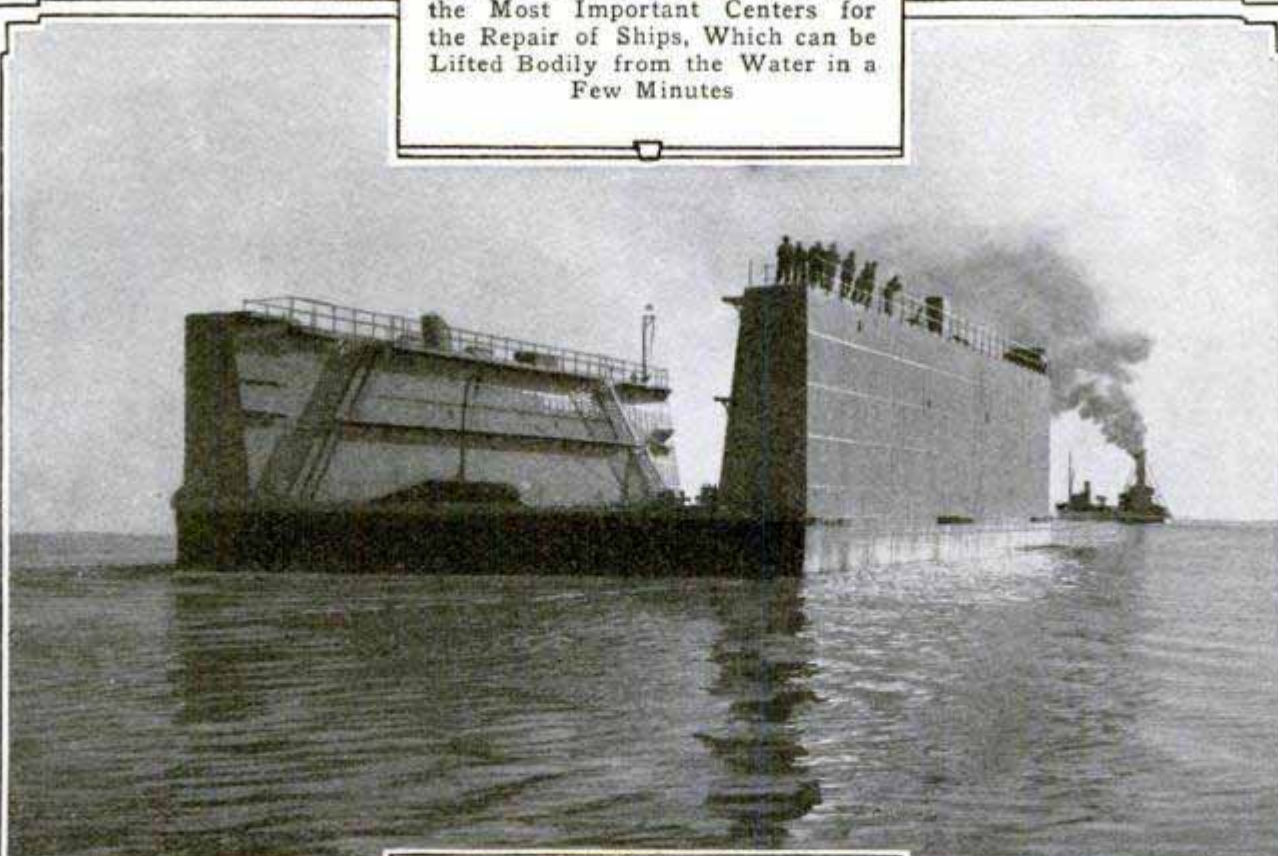

Towing a Section of a U-Type Floating Drydock through the Kaiser Wilhelm Canal: These Docks are Built in Separate Units in Order to Facilitate Their Transportation from Port to Port

vessels 240 ft. longer than the dock have been handled. The floating drydocks are built in two or more sections, to facilitate towing through canals when it is desired to bring them to other ports. So powerful are the pumps with which these floating docks are equipped that it is but a matter of 40 or 50 minutes after the vessel is secured in its place that the dock has lifted it out of water, in shape for overhauling. Huge traveling cranes, capable of lifting 150 tons, are mounted on the sides of the drydocks. Jib and shear cranes of enormous lifting power may be erected at either end on the sides of the docks, so that the mas-

sive machinery with which the largest vessels are now equipped may be readily handled; great propeller shafts, monster boilers and gigantic engines may be removed, overhauled and again installed.

Large as are these newest floating drydocks of the great German port, already plans are being drawn for still larger ones, and so rapidly can they be built that, keeping pace with the construction of naval and commercial dreadnoughts, adequate drydock facilities, beyond anything now known, can be provided promptly.



Carrying the Trees to the Planters

### REPLANTING THE FORESTS

The Forest Service of the United States, among its many activities, is engaged in replanting much timber in the national forests of the West. Near Colorado Springs, great areas were fire-swept some years ago. The soil is much eroded and a replanting scheme of considerable magnitude was projected. At Monument, a point on the mesa not far from Manitou, there is conducted a nursery. As soon as the



The Wavelike Rows in This Picture Show Where Tree Planting has been Done

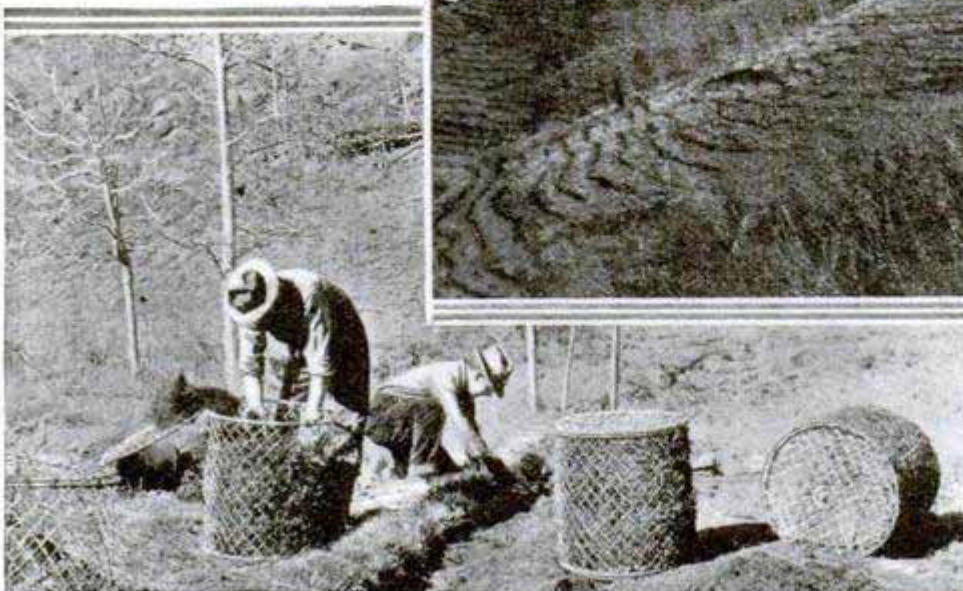

Putting the Young Trees in Baskets for Transplanting



trees are ready for planting they are shipped to the forest station, where they are carefully separated, each young tree having its roots swathed in sacking. A number are then placed in wire baskets and carried on the backs of assistants up the mountain, where the individual trees are distributed to those in actual charge of the planting. The work is carefully done by expert tree planters, who cover a large area in a single day. This reforestation of Pike's Peak is the largest and most important project of the kind yet attempted by the Forest Service.

### ENGLISH BOOTBLACK HAS A STRANGE CUSTOMER

A London tailor believes that the "dummy" upon which he exhibits his latest creations should have his boots blacked regularly, and has engaged a bootblack to shine the shoes every week. The spectacle is one which attracts the attention of every American who passes while the shoes



Copyrighted by International News Service  
Bootblack's Odd Customer Takes Weekly Shine

are being polished. A clerk holds the dummy upright while the bootblack performs the necessary operations.

### MEXICAN LOOKOUT TOWER FOILS WATER THIEVES

A short distance southeast of Mexicali, Mexico, an irrigation ditch brings the water to reclaim half a million



Irrigation Ditch Guarded by Mexican Soldier

acres of the Imperial Valley. The water is taken from the Colorado River, on the Mexican side, and brought into California for use. Unscrupulous persons have been tempted to cut the dikes at night, or throw open gates, by which means great quantities of water might be diverted to other lands. The protection of this ditch falls upon the Mexican company which was formed in conjunction with the American corporation at the beginning of the project, and in order that water thieving may be reduced as far as possible, a watch tower has been built at the point where the water is measured out to the American company. This lookout tower is built of poles, thatched with arrow weed, and interwoven cane stalks form the sides. A notched log forms the stairway, and a uniformed Mexican guard stands in the doorway.

A toll road 20 miles long and costing \$5,000 to the mile has just been completed in Texas.

## SLIDING DOWN A MOUNTAIN NEW ALPINE SPORT

The latest Alpine sport is "volplaning" down a mountain railway in a little car resembling a steamer chair. The machine, which is called an Alpine aeroplane, is built of steel tubing, the

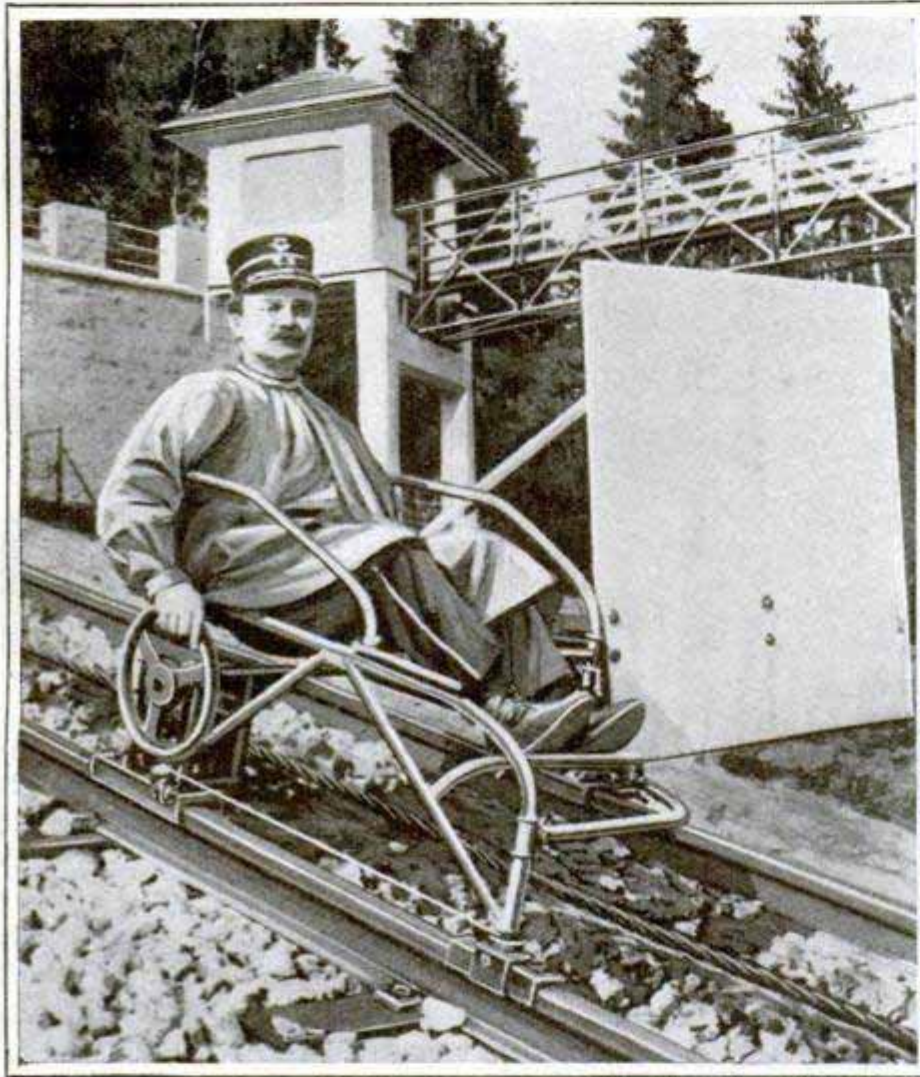

Photo by Edwin Levick

A Railroad Employee Volplaning Down an Inclined Railway

steel supports gripping the rails, and controlled by a powerful brake operated by a side wheel. In front a windbrake, consisting of a square yard of steel plate, may be used as an additional speed control. Over 80 miles an hour has been made on this contrivance, which is fast becoming popular.

¶ In replacing a railroad trestle recently burned along the north shore of Great Salt Lake, engineers found the piles perfectly sound after 43 years of service, due to the timbers being impregnated with salt from the lake.

## MEDALS THAT ARMY MEN MAY WEAR

The military decorations which may be worn by officers and enlisted men of the United States army and navy are strictly limited by orders of the War Department. Even honorary decorations presented to

military attachés or visiting officers by foreign governments, may not be accepted nor worn except by an act of Congress. The Medal of Honor, granted for distinguished services by the authority of Congress, is the highest military decoration conferred in this country. Upon occasions of ceremony it is worn pendant from the neck, the ribbon passing between the upper and lower hooks of the coat collar, so that the medal hangs about an inch below the opening of the collar. The Certificate of Merit Badge, the medals commemorating the battle of Manila Bay, of various engagements in the West Indies, special meritorious medals for service during the war with

Spain, other than in battle, and the Philippines Congressional medal are worn on the left breast of the coat, in a certain order of precedence. Life-saving medals of gold and silver issued by the Treasury Department, as well as good-conduct medals, and such insignia as airmen's and marksmen's badges, may also be worn in uniform. The badges of military societies, such as the Grand Army of the Republic, or societies commemorative of the wars of the United States, including the Philippine Insurrection and the China Relief Expedition and of the Regular Army

and Navy Union, corps and division badges of the Civil War and of the war with Spain, as well as that of the Enlisted Men's Abstinence League, are among the permissible decorations.

### HOW THE GREAT GUNS ARE HOISTED

The huge rifle cannon which are designed to guard our coasts, to protect our harbors and to insure the workings of the Panama Canal in time of war, are of enormous weight, and placing them in position is no easy task. To handle these mammoth pieces, the derrick shown in the accompanying illustration has been built. Weighing over 80 tons, the derrick was first erected at the government proving grounds at Sandy Hook, where the guns are tested before they are dispatched to the coast fortifications for which they are designed. It lifts with ease two rifled cannon, swinging them through a large arc, although the load is 191,000 lb. Later this derrick will be sent to Manila, where it will be used for a like purpose.

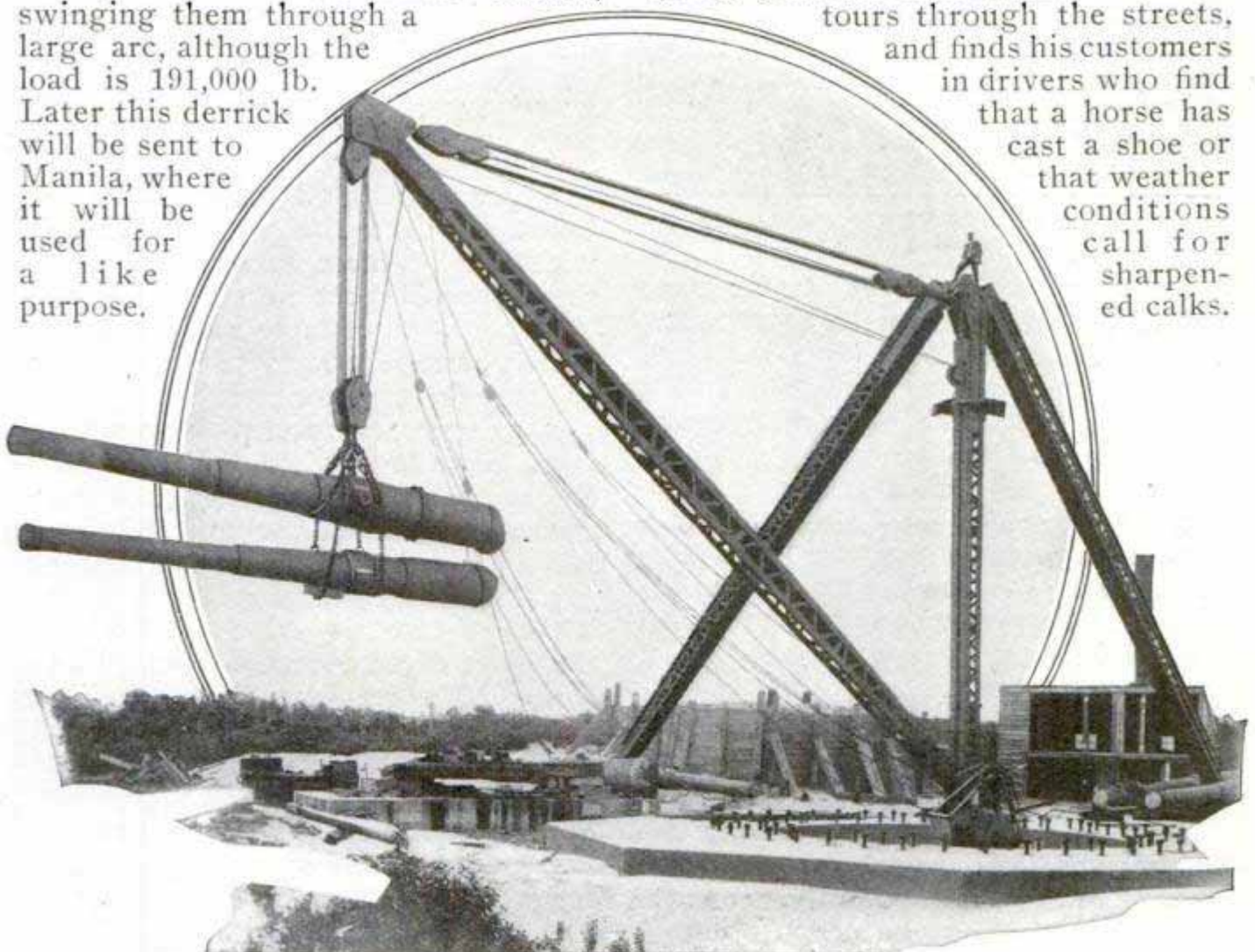

Handling the Big Guns at the Government Proving Grounds

### FARRIER PLIES HIS TRADE IN PARIS STREETS

On the streets of Paris is seen a portable smithy which does a profitable



Copyrighted by Underwood & Underwood

A Street Horseshoer at Work in Paris

business during the winter. The farrier takes his tools with him on his tours through the streets, and finds his customers in drivers who find that a horse has cast a shoe or that weather conditions call for sharpened calks.

## NOVEL BRACING FOR CONCRETE FORM

When a concrete retaining wall, 34 ft. high, was to be built in San Diego, the problem of bracing it strongly without



Ingenious Idea for Temporarily Bracing Retaining Wall

interfering with street traffic was solved by an ingenious scheme. The braces are made of 2 by 6-in. clear Oregon pine, which are sunk in the ground at the street level and fastened at the top to planks, one end of which is secured to stakes driven in the ground above the cut. Ordinary bracing could not be considered in this case, owing to the narrow space allotted. The wall when completed will be 700 ft. long.

## BUREAU OF STANDARDS TO TEST WATCHES

Regular testing of watches for the public was inaugurated by the U. S. Bureau of Standards recently, thus taking up the testing and certification of watches in a similar manner to that

carried on in the Kew observatory in England, the Besancon observatory in France and the Geneva and Neuchâtel observatories in Switzerland. Preliminary tests upon the various types and makes of American watches have already been made, the results of which have been the modification of European testing methods, and the establishment of certain standards of tolerances for practical service. The possession of a government certificate will enable the owner of a "certified watch" to know that he has a time-piece which conforms to the average and reasonable performances of high-grade adjusted watches. The fees for tests will merely cover the actual cost of the trials.

## CONVERTIBLE TOOL HAS MANY USES

Twenty-two different implements may be constructed from the units of a combination tool recently invented by an Englishman. It is so constructed that it can be changed and interchanged quickly for service in mining, hunting, farming, camping, scouting, and practically all outdoor occupations. In fact, the pioneer equipped with one of these instruments has a regular tool chest in small compass. The parts are simple and easily renewed or repaired, and the absence of any weak or intricate parts, nuts, springs or screws to break or get lost is of advantage when far from cities or towns. Weighing less than 5 lb., constructed of tool steel and aluminum, and equipped with an insulating cover of soft rubber for use in handling live wires, the tool is found of service in the most diverse occupations. In the hands of a soldier, it may be used either for offense or defense; it may be used to chop down trees, dig trenches, cut, tighten or twist wire, even when the latter carries an electric current of high voltage, or as a screwdriver, pliers or can opener, as nail puller, nut key or wrench, spanner, pickax, or foot rule.



Shoeing a Horse



Used as a Cutter for Fence Wire



Practical Can Opener



As a Weapon of Offense and Defense



The Reversible Blade Makes an Adz

Tool of a Score of Uses and How It is Carried



As a File



New English Combination Tool in Use as a Trench Digger and Shield

## BICYCLE FISH SEEN IN HAWAII

One of the curious floats seen in the parade during the floral festival in Hawaii recently was a canvas affair,

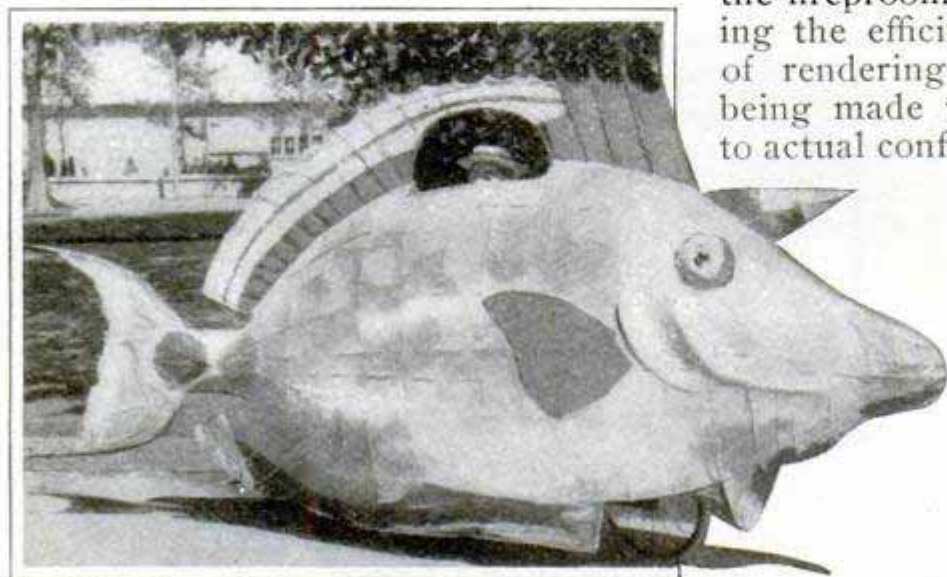

Novel Painted Float for Parade

brilliantly painted to represent one of the varieties of brightly colored fishes which abound in the waters about that island. The means of locomotion was an ordinary bicycle, as may be observed upon closely examining the picture. The head of the rider protrudes from a hole in the top.

## GOVERNMENT EXPERTS SEEK FIREPROOF SHINGLES

At the Forest Products laboratory in Madison, Wis., experts of the Department of Agriculture are studying the fireproofing of wood. Tests showing the efficiency of various methods of rendering wood fire-resistant are being made under conditions as near to actual conflagrations as possible. An electric furnace is used, with a pilot flame of gas to simulate conditions usually existing in a fire. Woods of different kinds are dried, weighed, impregnated with metallic salts, and subjected to rigid tests in these investigations. Just now the work is being directed toward

rendering shingles fireproof. While it is comparatively easy to force ammonia sulphate and ammonia phosphate into a shingle, rendering it very resistant to fire, the problem is complicated by the fact that shingles so treated must be exposed to sun and rain, and the salts are leached out.

## AUTOMOBILE TESTING IN A MODERN PLANT

In one large automobile factory a curious method of testing the machinery previous to putting on the bodies is used. The motor and chassis are assembled complete with the exception of the wheels. In place of the rear wheels, two large pulleys are hung on the axle, and belts are run over them up to overhead fans. Pipes from these fans are led to the front of the chassis and curved downward so that air is blown down upon

the motor, radiator and chassis. In this way the motor drives an actual load, accurately determined, similar to a road test, while at the same time it cools itself just as if it were speeding along the highway at 30 or 40 miles an hour.

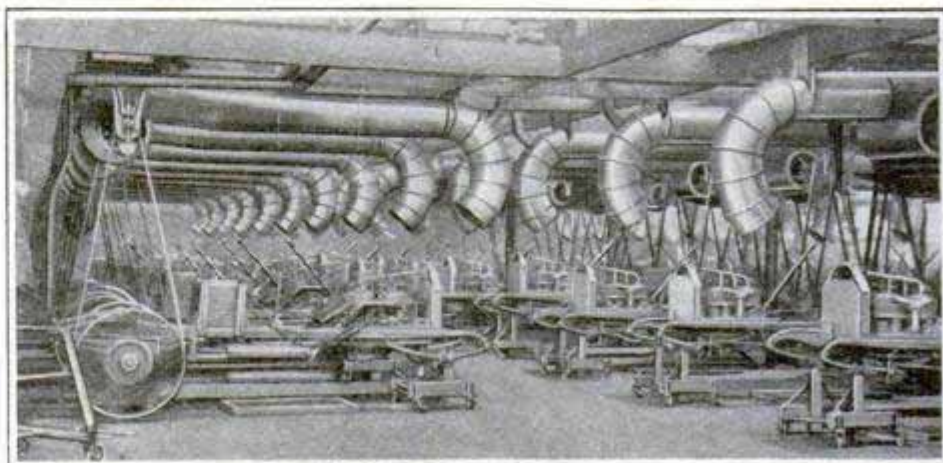

Automobiles That Cool Themselves

# COMMENT AND REVIEW

**H**UMAN life is valuable—some more than others, of course—but after all the great problem is how to get the most of real worth out of life. Some do not even try; they are, in business parlance,

## *Prisons as Schools*

called "dubs." As the other extreme I know a man, a real worker, who actually begrudges every hour he is obliged to spend in sleep, because for want of time he cannot do nearly all the things he would like to accomplish. However, the men who do things in the world are those who conserve their time, and do not spend an hour at some task they can perform in twenty minutes. About the most worthless thing in human life, for years past, has been the time of a convict in our states' prisons. In spots they have been farmed out to contractors, and recently they have built some excellent roads—by far the most logical use of their time. Not all convicts, however, are qualified for that work, and little can be done on roads in winter, so at best there is a lot of time going to waste.

Prisons and jails have been considered schools of crime, but the warden of the state penitentiary of Nebraska is trying to make his place a school in which to learn useful knowledge. A correspondence course has been established there, the studies including all the regular University of Nebraska educational extension work and all the common-school branches. The university remits all fees and gives regular credits for examinations. The experiment is promising thus far, and, in view of the splendid record of correspondence schools generally, Warden Fenton has every reason to believe results will fully justify his expectations.



**F**OR several years past airmen have hopefully looked to "next year" as the one in which the Atlantic Ocean would be crossed in a vehicle of the air. Each year has brought its disappointment;

## *Via Air to Europe*

and while the feat will undoubtedly be accomplished some day, it seems unlikely that 1914 will be able to credit that milestone to its records. In some respects the event seems even farther off than three years ago. While experienced explorers are at this moment battling with untried routes in the Antarctic, none of them has either a dirigible or aeroplane in his outfit. They have air-propelled sledges, but no air craft.

To the layman the dirigible, though slower in its movement than a plane vehicle, seemed the more likely to succeed; but the destruction of the *Vaniman* and several Zeppelins in mid-air has made him skeptical. At present the only suitable gas for the purpose is hydrogen, the explosive dangers of which are well known. It has even been questioned whether a dirigible may not, under conditions of very cold, dry air, by its own passage generate something in the nature of the pale blue flame sometimes seen in cold weather on fast-

moving belts. In which case a very small spark and a very minute gas leak would be as efficiently deadly as a thunderbolt. In aeroplanes, construction is stronger than three years ago, the power is greater and much more dependable, and long-flight records have been made. The Mediterranean has been spanned in flight; mountains with their great variety of atmospheric conditions have been crossed. However, as yet no airman has made a flight of 1,700 consecutive miles over water. To the innocent bystander, who is not supposed to know anything about flying, it would seem sensible, though commonplace, for some one to fly his machine 1,700 consecutive miles over some inland water, like Lake Erie, for example, before casting off the dock lines on a trip across the big pond.

In the opinion of Sir Hiram Maxim, the dirigible, in war at least, is a failure. He says: "We have come to the end of our tether in dirigible balloons; they are useless and practically impossible. It is nothing less than madness to sacrifice any more lives and treasure in attempting what is manifestly an impossibility."

Some day a vehicle will fly the gap; it may even be perfected in time to qualify for the \$150,000 prize offered by the San Francisco Exposition for an around-the-world flight. However, the day, predicted by Kipling, when air craft landing inland will take New York as a port off the map may be considered as sufficiently remote to cause no immediate anxiety.



**T**HE Safety-First movement has now spread over the entire country, and is gaining strength steadily. People are beginning to realize that certain specially hazardous occupations are not wholly

*Safety*

*First*

fateful, and that hundreds of lives can, and already are being saved, through precautions easily taken. In a very large number of cases the result is accomplished by the workman himself; in others, by greater care on the part of those whose carelessness endangered not themselves, but some one else. We are beginning to recover from the speed mania which so long obsessed us, and to realize that the few minutes gained do not compensate for the risk involved; and that a dollar saved in faulty construction eventually costs a hundred when the crash comes. We are dull to learn; and schoolhouses, theaters and factories crushed or burned to death their hundreds, to save a few posts or the cost of a few more stairs or doors, before we learned the dreadful lesson.

With more coal mines and miners than ever before, the safety precautions of the Bureau of Mines alone are saving as many lives as are rescued by all the life-saving crews on our entire seacoast. In many cities Safety-First Day is observed in the public schools, with addresses by experts from police and fire departments.

One of the interesting developments of the movement is the committee of one hundred, which is at work in one of our large cities. These men are carefully selected from among the leading business



and professional men of unquestioned standing, who themselves own motor cars. Their identity is known only to the appointing board. Their province is to report any flagrant violation of safe operation of automobiles and motor trucks which they personally observe. For example, a reckless driver speeds around a busy corner, missing a pedestrian by a few inches. A report is made out and sent in to the Safety Board, with details of time and place. A letter is sent the offender, politely calling attention to the offense, requesting greater care in future, and telling of the committee of one hundred. Usually this is sufficient; but if in a few days a second offense is reported, then a letter couched in stronger terms is sent, with the promise that a third offense will cause the three reports to be sent to the police department. This establishes a previous bad record if the offender is ever arrested, which seriously counts against him. Except in cases of certain absolutely reckless drivers — who sooner or later are bound to come to grief anyway — the cautionary letters, and the feeling that every car he passes may contain one of the unknown one hundred, serve to make the otherwise regardless driver much more careful. In London, when a chauffeur's license is issued, there is a space for entering a report of any previous arrest or accident which occurred to the applicant. I once saw such a license which contained a report of a collision the driver had five years previously. If he should have another accident, the police instantly get a line on his record by demanding his license, which must be carried when driving.

The above are only suggestions of perfectly simple, practical plans, which do not impose onerous restrictions or limitations on the law-abiding, but which apply the brake to the reckless.

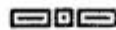

**E**ACH year finds the farmer more of a mechanic, as machine after machine appears to take the place of the decreasing supply of manual labor. The up-to-date farm now has its machine shop and farmer machinist. The farmer complains that for five years past he has been obliged constantly to purchase new labor-saving machinery. On the other hand, had it not been for these new inventions, many would have been obliged to go out of business.

*Steam-  
Dried  
Hay*

The latest thing is steam-cured hay, which makes the farmer independent of cloudy or rainy weather in haying time. The green grass is hauled to the hay factory, unloaded at one end of the plant and, 30 minutes later, emerges at the other end perfectly cured, ready for the barn or bale press. In case of rain, a canvas cover insures arrival at the barn without wetting. The farmer has about given up his time-honored trip to the "grist mill," and here comes the hay mill. Frequent showers make good grass, but much of this is ruined in the process of sun-drying. The steam drier is independent of weather, and moreover turns out a better product, and can work nights. Maud Muller might get a job checking the loads, but there isn't very much romance about watching the steam gauge and a lot of conveyor belts.

**F**IVE years of movies among the tough districts of New York's East Side has produced a very marked improvement. This is vouched for by Frederic C. Howe, director of the People's Institute, doubtless the most cosmopolitan platform in this country, and who also is chairman of the National Board of Censors who pass on the new films. All the best film producers voluntarily submit their new films to this board for approval before allowing them to go out to the public.

*Movies  
a  
Civilizer*

The movies have brought the world to the East Side—the great world of snow-capped mountains, sparkling brooks, great trees and beautiful flowers. It may be hot and stifling in the small, crowded room next the flat roof, but even the poorest may occasionally spare five cents for an hour in which mountain and lake are brought to those who have never been to either. So, too, the works of art from every land, noble buildings, mighty steamships and other great feats of engineering; statues of the world's great men; even the notable events of their lives, in which self-sacrifice and lofty ideals are reproduced, are seen and unconsciously absorbed. The dullest cannot fail to be aroused to some small stimulation of ambition or renewed effort at the swift, graphic story of what high-minded men and women have accomplished. And through it all runs the golden thread of the better things and better life, which inevitably elevates and broadens; for in every life, however narrow, there is some chord which must respond, be it ever so slightly, when the right key is touched.

Of all the inventions, of all the ages, not oratory—the ignorant cannot comprehend it; nor music—the deaf cannot hear it, the moving picture today doubtless possesses and can exert the largest, strongest, quickest influence. With many acknowledged defects, that influence is unquestionably one for good.

H. H. WINDSOR



## ARMORED AUTOMOBILE FOR MEXICAN REBELS

An automobile of a curious type is that recently completed for the use of the "constitutionalist" army operating in northern Mexico. This car is completely protected by heavy steel plates, is provided with port-holes, and is apparently proof against everything but artillery fire. Its principal use is to be the transportation of field guns and other equipment in time of battle. It has space sufficient for seven machine guns.

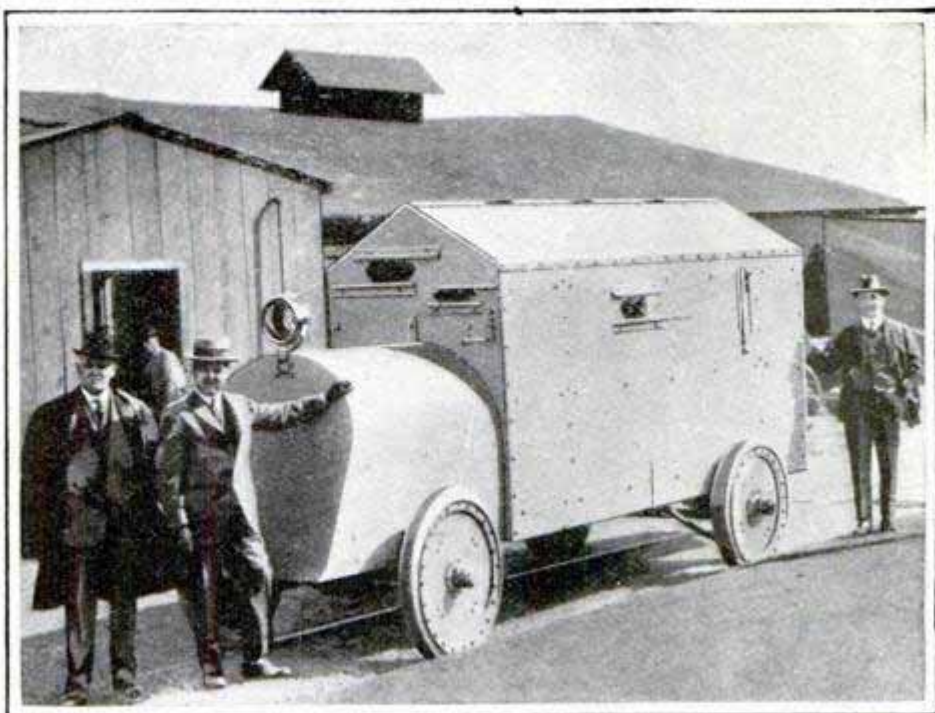

Armored Automobile for Mexican Rebels: Proof against Everything but Artillery Fire

## MILITARY SALUTE FIRED AT SCENE OF DEATH

A remarkable and impressive scene occurred in England recently in connection with the funeral services of a petty officer and a signalman of the British navy, who lost their lives at their posts of duty in the great dockyard fire. The military salute, usually fired over the graves of the dead, was

in this case fired amid the charred ruins where these men met their death.



State of Dockyard after Fire

Such a procedure is unusual, although it is not an uncommon thing to fire a salute over the water in honor of officers who have lost their lives at sea.

Photos by Paul Thompson

Firing Squad from British Warship "Neptune," Firing Salute in Honor of Comrades Who Lost Their Lives in Dockyard Fire

## THE NAVAL AERONAUTIC STATION AT PENSACOLA

**T**HIS picture graphically depicts the air fleet of the United States Navy in quarters at Pensacola, where hangars are ranged on the beach. A navy aviation school has been established here, and the battleship "Mississippi" has been assigned to Pensacola for the use of the navy flying men. Flights will be made from the deck of the warship, and other experiments conducted in developing the use of the aeroplane in connection with battleships.

The school will aim to produce a trained personnel and evolve a complete system of training for airmen. It will also be the aim of the department to bring outside experts into close touch with the work. The manufacture of air craft in this country is to be encouraged and designers will be given financial assistance in providing for our navy the best type of air craft obtainable. The navy now has no dirigibles, but the question of the addition of airships of this type to the naval force is being considered.

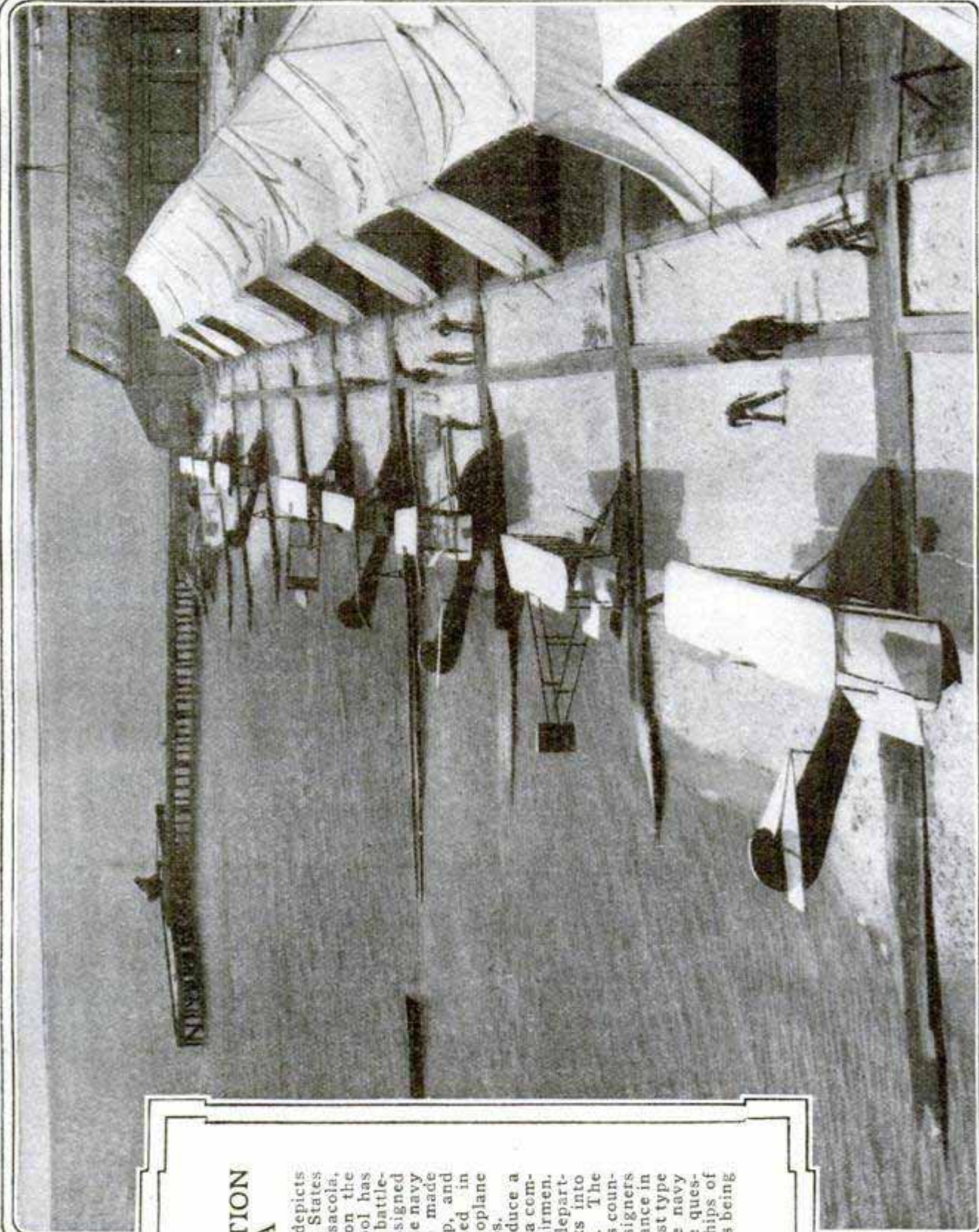

# The "LOST PORT" of NEW YORK

RUDYARD KIPLING'S *Prophetic Vision*  
of Man's Conquest of Time and Space.

[No one has visualized so graphically as Rudyard Kipling the changes that the development of aerial navigation is bound to bring about in human relations and human conceptions. Man's mastery of time and space, with which he dealt so imaginatively and convincingly in "With the Night Mail," furnished the theme of an address recently delivered by this most famous of living English writers before the Royal Geographical Society, from which the following extracts are taken.—Editor]

THE time is near when men will receive their normal impressions of a new country suddenly and in plan, not gradually and in perspective; when the most extreme distances will be brought within the compass of one week's travel; when the word "inaccessible," as applied to any given spot on the surface of the globe, will cease to have any meaning.

Naturally, so long as we travel by sea, we must embark from a port and look out for the landfalls. But the time is not far off when the traveler will know and care just as little whether he is over sea or land as we today know and care whether our steamer is over forty fathoms or the Tuscarora Deep. Then we shall hear the lost ports of New York and Bombay howling like Tarshish and Tyre. Incidentally, too, we shall change all our mental pictures of travel.

The men of the present are already scouting and reporting along the fantastic skyline of the future. Nearly all that can be accomplished by the old means of exploration has been won. The old mechanism has been scrapped; the moods and emotions that went with it must follow.

Up to the present we have been forced to move in two dimensions by the help of the three beasts of burden and a few live coals in a pot. Now we perceive that we can move in three dimensions and the possibilities of our new freedom distract and disturb us in all our relations. This is because our minds are still hobbled and knee-haltered by inherited memories of what were held to be immutable facts—distance, height and depth, separation, homesickness, the fear of accident and foul weather.

Month by month the earth shrinks actually and, what is more important, in imagination. For the moment, but only for the moment, the new machines are outstripping mankind. We have cut down enormously, we shall cut down inconceivably, the world's conception of time and space, which is the big flywheel of the world's progress. What wonder that the great world-engine which we call civilization should race and heat a little!

Only the spirit of man carries on unaltered and unappeasable. There will arise—they are shaping themselves even now—risks to be met, as cruel as any that Hudson or Scott faced; dreams, as worldwide as those Columbus or Cecil Rhodes dreamed, to be made good or to die for; and decisions to be taken, as splendidly terrible as that which Drake clinched by Magellan or Oates a little farther south. There is no break in the line, no loads are missing. The men of the present have begun the discovery of the new world with the same devoutly careless passion as their predecessors completed the discovery of the old.

## NEW ELECTRIC BUS PROPOSED

Designs have been accepted and a full-sized model made of an electric motor bus, to run on the streets of

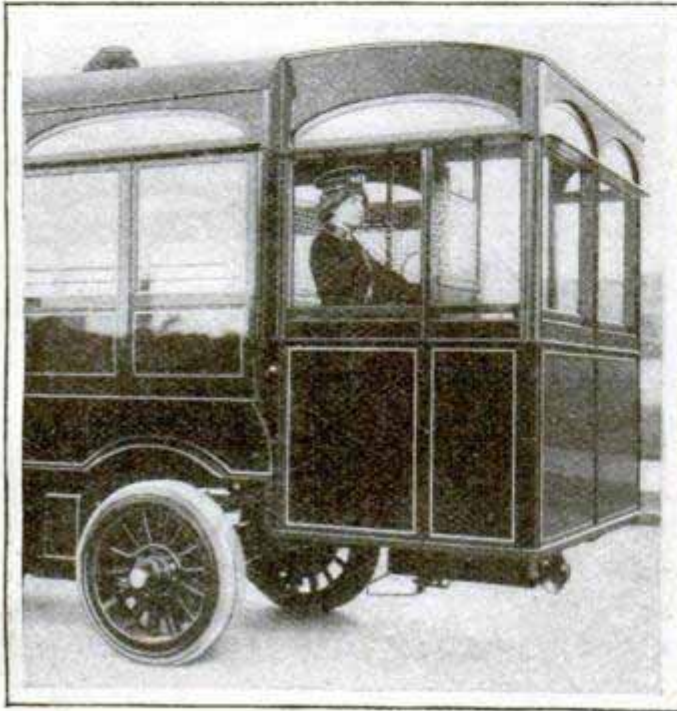

New Motor Bus for Residence Districts of New York

New York not covered by street-car lines. The body is of the semiconvertible type, with comfortable seats. Storage batteries give light, heat and power. The car is a "pay-as-you-enter" style, and it is proposed to have young women in uniform to take up the nickels, for the motor-bus line is to be operated on a five-cent basis. Routes are proposed throughout residence districts, where the noise and dirt of street-car traffic would be objectionable.

## TRANSATLANTIC FLIER TO HAVE SILK WINGS

Silk instead of canvas will be used in the covering of the planes of the flying boat which Glenn Curtiss is building to try for the Lord Northcliffe prize for a flight from Newfoundland to Ireland this summer. The silk will be coated with a preparation similar to collodion. The saving in weight will be 20 lb. As gasoline weighs 6.15 lb. a gallon, this will enable the machine to fly nearly 25 miles

farther, for it is calculated that each gallon will carry the craft eight miles. The flying boat will be painted a bright red, to make it conspicuous, so that captains of ocean liners, who will constantly be on lookout, may be able to make it out at the greatest possible distance, either in the air or on the water. Trial flights will be made at Hammondsport, N. Y., for a month, and the machine will then be sent to Newfoundland, where after a careful "tuning up" it will be prepared to make the attempt as soon as weather conditions are favorable.

## OUTSIDE WINDOW BOXES OF METAL

Metal window-sill boxes for kitchens that have no pantries and for homes that have no gardens have been put on the market. They are made of flat galvanized wire and can be screwed to the window frame in a moment. During the winter such a box can be



A Metal Substitute for Wooden Window Boxes

used as an outdoor refrigerator and during the summer a few flower pots placed in it make a garden outside the window.

## LARGE SUNDIAL MARKS TIME OF DAY IN PARK

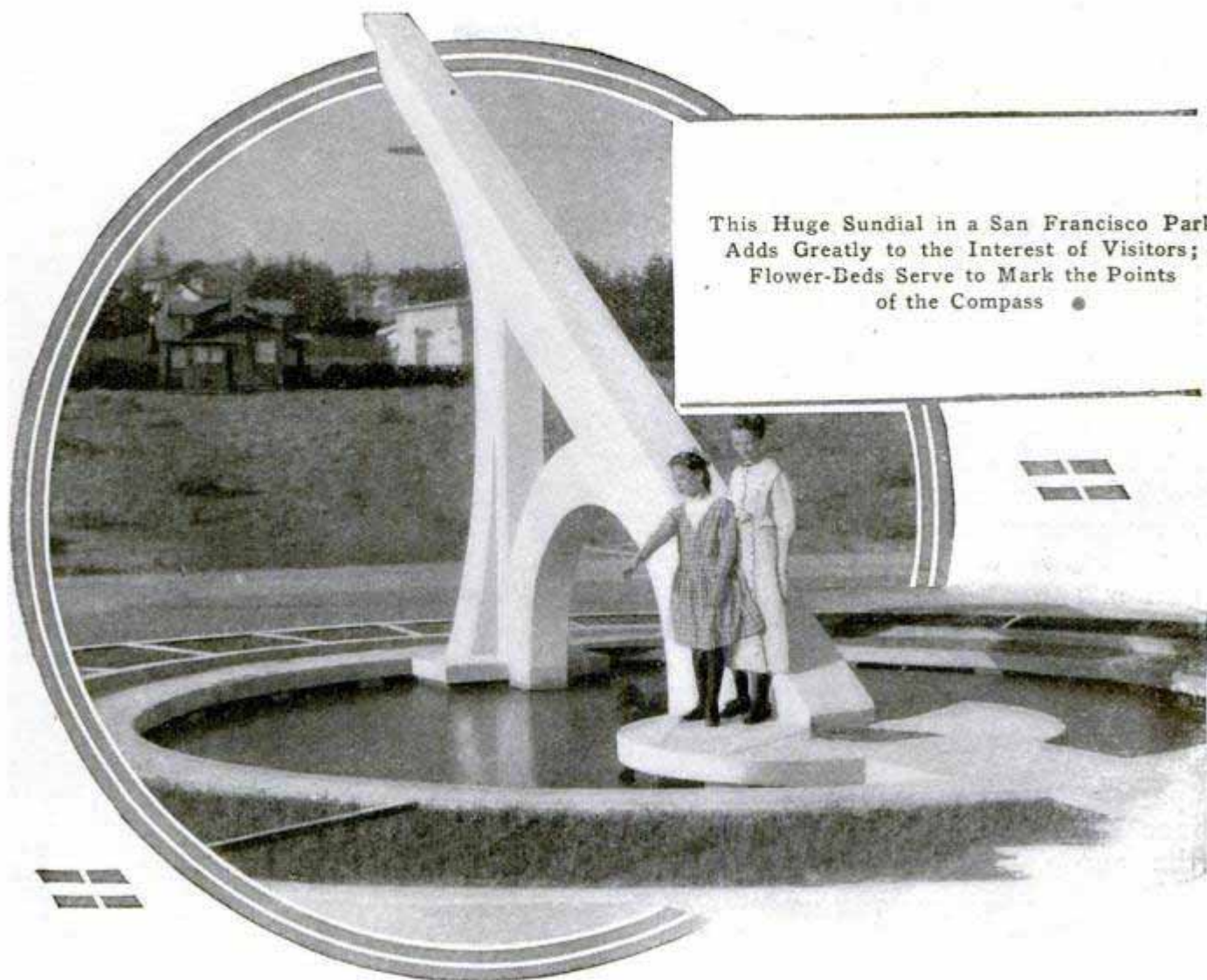

This Huge Sundial in a San Francisco Park Adds Greatly to the Interest of Visitors; Flower-Beds Serve to Mark the Points of the Compass ●

In one of the San Francisco parks a sundial of unusual size attracts attention. The park itself is 150 ft. in diameter, and within, the sundial is 34 ft. across. The gnomon, or index, of the dial, which by its shadow shows the time, is 28 ft. long; the Roman numerals are 4 ft. long. The points of the compass are indicated by initials

in flowers on a closely cropped lawn. Intermediate with these are symbolical columns representing Childhood, Spring and Morning; Youth, Summer and Noon; Manhood, Afternoon and Autumn, and Old Age, Winter and Night. Bronze vases adorn the tops of these columns, and convenient seats of concrete provide resting places.

### GIGANTIC RUBBER TREE IN BOLIVIA

What is probably the largest rubber tree in the world exists in Bolivia, near the frontier of Acre. It is 27 ft. in circumference at the base and towers upward to a vast height. Its recorded yield for 120 days averaged 22 lb. a day, which, at the current price for gum, represents more than \$2,160 per

annum. When it is remembered that, usually, rubber trees do not exceed from 10 to 15 ft. in circumference, while many varieties grow no larger than 8 ft. around, this veritable giant of the forest is a rare exception. The superintendent of the plantation upon which this tree is growing is making a study of the soil, in the hope that he may be able to stimulate the growth of other rubber trees under his supervision.

## RECORD-MAKING FLIGHTS BY RUSSIAN BIPLANE

An enormous biplane made by the Russian builder, Sikorsky, has succeeded in making a flight of 18 minutes' duration with 16 passengers on board, the weight of the passengers and crew carried in this remarkable flight being 2,640 lb. Even more sensational was a cross-country flight made by the same machine when it had the pilot and eight passengers on board and maintained an average height of 3,000 ft. for a period of 2 hr. 6 min. This establishes a record both for duration and altitude for an aeroplane carrying nine persons. This machine is of peculiar construction and is similar to the first one of its type, described in the November, 1913, number of this magazine. The span of the upper plane is 114 ft., while the fore-and-aft length of the aeroplane is 62 ft. The wings are spaced 9 ft. apart and have a total supporting surface of 1,820 sq. ft. The weight of the aeroplane when empty is 8,250 lb. It is fitted with four motors of 100 hp. each, and provision is made for installing a fifth motor if desired.

## MOTORCYCLE SAVES AFRICAN EXPLORERS

When the rear axle of their automobile was damaged, a party of Englishmen who are exploring the dark continent from the Cape to Cairo were saved from disaster through the possession of a motorcycle. One of the party, mounting the "single-tracker," started backward over the jungle paths for an outpost of civilization, where repairs could be obtained, eventually returning in triumph with the necessary parts. The party is equipped, in addition to usual supplies, with a motion-picture machine, with which to record events of special interest.

CA motor cargo boat with a capacity of 70 tons is in service on the Leeds Canal, England.

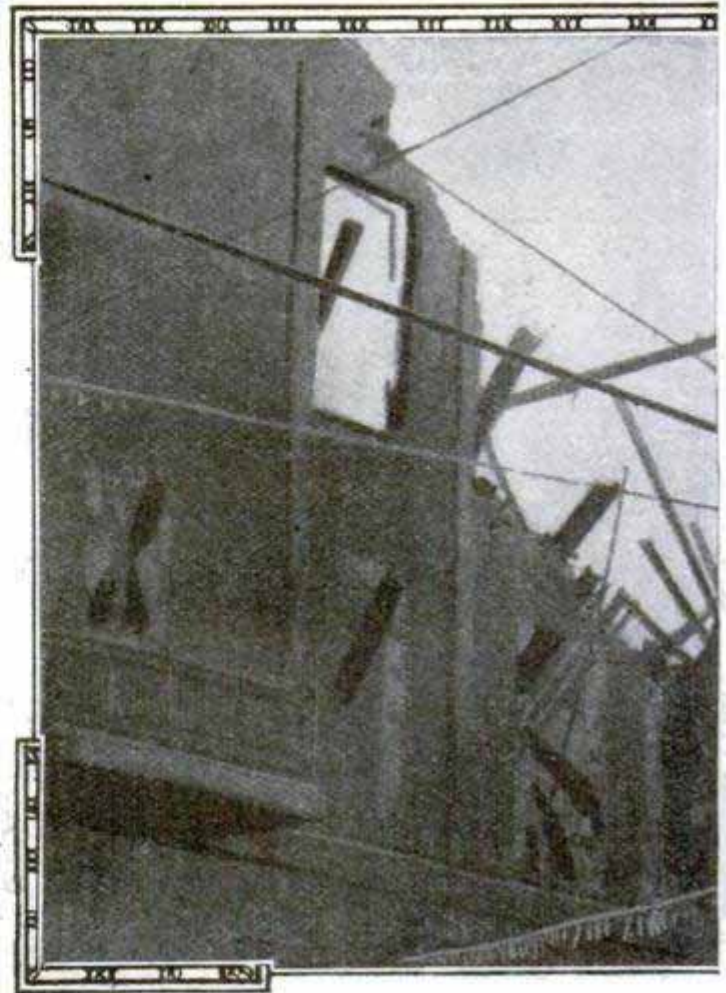

## LIVES LOST IN SPECTACULAR NIGHT FIRE

Early on the morning of March 9, fire was discovered on the third floor of the Missouri Athletic Club, St. Louis. Despite the efforts of the firemen, the entire building was destroyed, and many lives were lost. The first floor was occupied by the Boatmen's Bank, while the upper floors, originally intended for commercial purposes, had been reconstructed for club use. Here nearly a hundred members were asleep when the fire broke out. So rapid was the spread of the flames that many perished in their rooms. Others, jumping from the upper floors, were dashed to death upon the pavement beneath. Thirty-seven are believed to have died in the disaster. A week later, one of the walls collapsed while a crowd watched the workmen exploring the ruins for the dead, and one man was killed beneath the crashing masonry, and 20 more injured. The accompanying view is from a photograph made the morning after the fire.



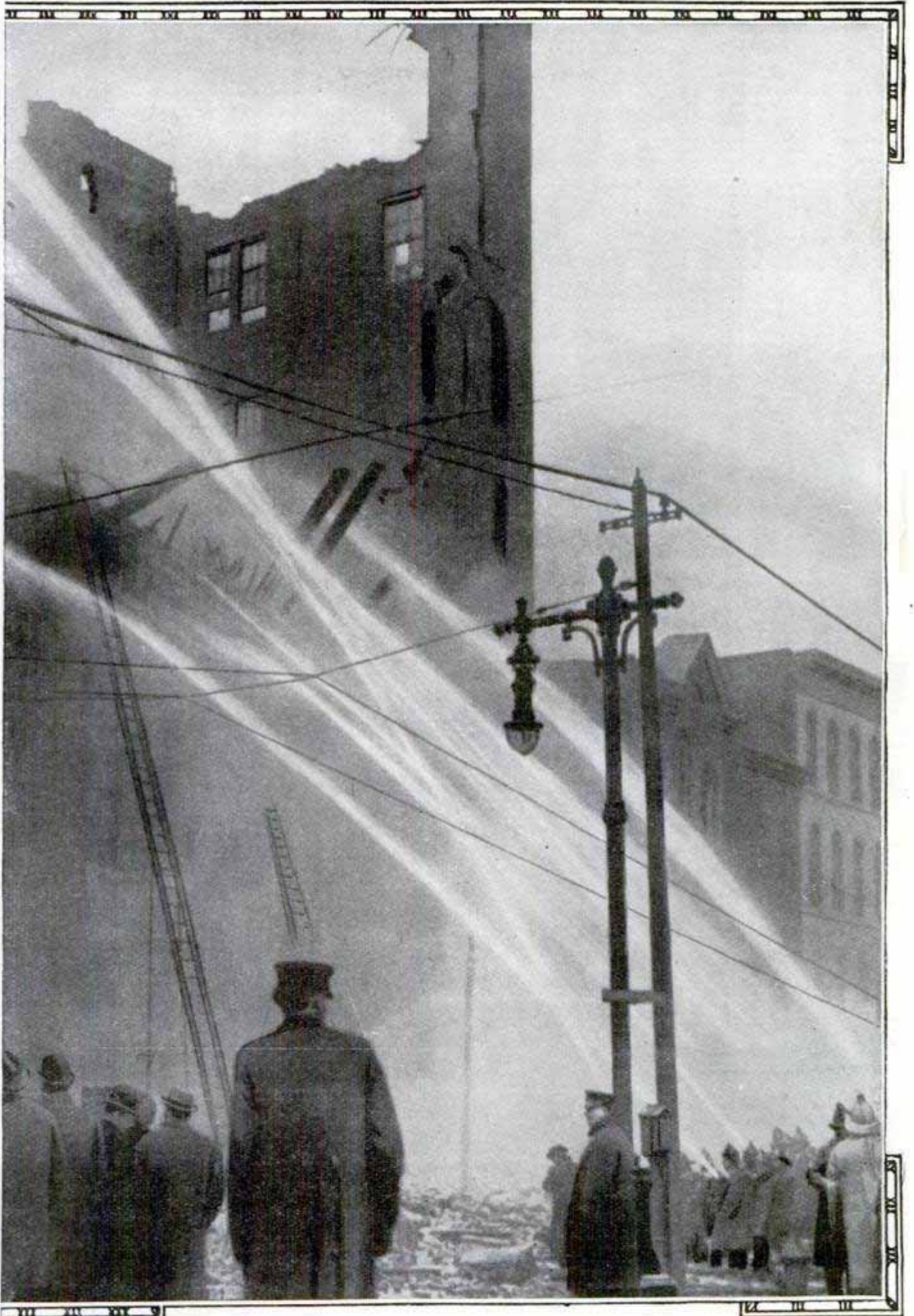

The Burning of the Missouri Athletic Club, St. Louis, in Which Thirty-Seven Lives were Lost

## FIRE ENGINE MAKES LONG PUMPING RECORD

A fire in one of the great coal docks at Superior, Wis., proved to be a stubborn one. A fire engine made a

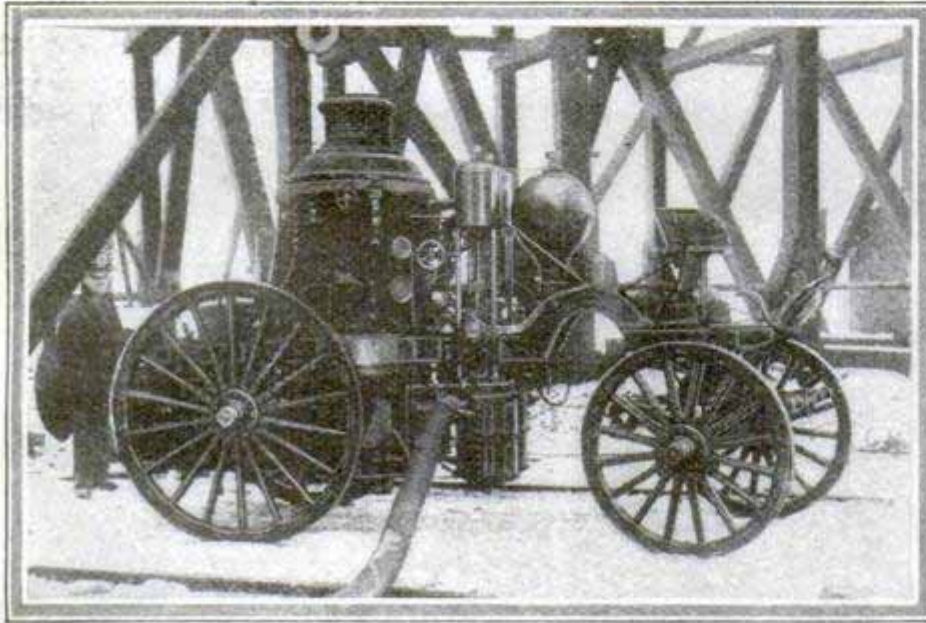

Engine Which Pumped Water on One Fire for Three Months

remarkable record for continuous performance in playing upon this fire, when it pumped from Nov. 18, 1913, until Feb. 18, 1914, just three months, shutting down but five times for repairs. The grates burned out, which caused one of the stops; broken valve springs required three stops, and a broken piston follower was the cause of the other shutdown. Repairs, however, were quickly made, and, as compared with the total length of run, did not amount to anything. The same engine made another long run in 1912 at a similar fire.

## ABANDON THE SUNKEN SUBMARINE "A 7"

The British Admiralty having decided to abandon further efforts to raise the submarine "A 7," which failed to rise when maneuvering on January 16, last, funeral services were held over the spot in Whitsand Bay in the English Channel, where the unfortunate vessel lies submerged in 23 fathoms of water. A procession of ships left Devonport Harbor with flags at half-mast. When the buoy which marked the scene of the disappearance of the "A 7" was reached, the funeral service was read for the 11 men who perished in the

disaster, volleys were fired over the water by the marine guard, and a wreath of flowers was cast over the side of the ship by the little son of one of the engineer officers who died in the ill-fated vessel.

## HAUL AEROPLANE THROUGH CITY STREETS

An unusual spectacle was presented when a truck was seen hauling an aeroplane through the streets of Chicago. The plane was dismembered, the broad wings having been removed

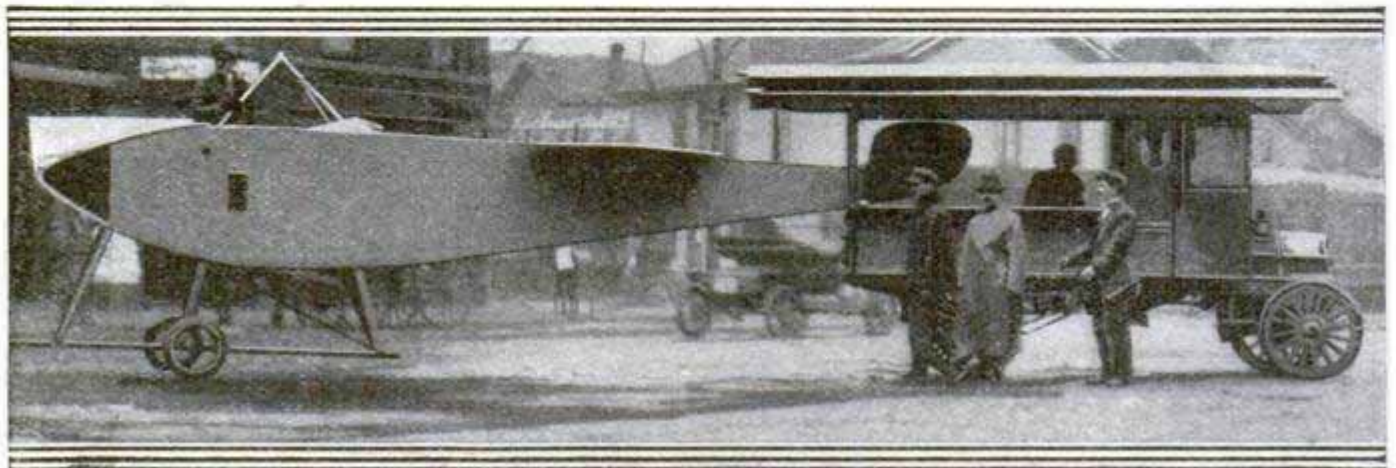

An Aeroplane being Towed by an Automobile is an Unusual Sight in a Busy City Street

and the propeller taken off and carried in the truck. The rear end of the plane was placed in the truck and carefully fastened. The weight of the flying machine was borne upon its two small rubber-tired wheels, and a passenger rode in the pilot's seat during the trip across town.

### HOW FAR A MAN CAN SEE DISTINCTLY

Some interesting experiments have been made in the German army with the object of discovering at what distance the recognition of one soldier by another is reliable. For soldiers with good eyes it was found that a person seen once before could be recognized at a distance of 80 ft., while an acquaintance could be recognized at a distance of 300 ft., and an intimate friend or relative, at a distance of 500 ft. The various parts of a man's body can be distinguished and any decided movement can be detected by an expert rifleman at a distance of 300 ft. At 1,800 ft. a man appears as a spot on the landscape and cannot usually be seen if he keeps still or if his dress does not contrast with the background. Sailors, hunters and farmers can usually see twice these distances, probably on account of their constant training in making out the nature of distant objects.

### TRAFFIC TELEPHONE USED IN GERMANY

An electric street railway in Frankfurt-on-the-Main has recently supplied its lines with a portable telephone to enable the conductors or motormen to report troubles directly to the main office. The telephone is of ordinary construction, but the connection has novel features. A long pole, equipped with uninsulated hooks, is carried on the car, and when connection is desired the pole is taken out and hung on the telephone wires at the side of the track. The battery case and phone is so constructed that it may be easily carried during conversation, straps be-

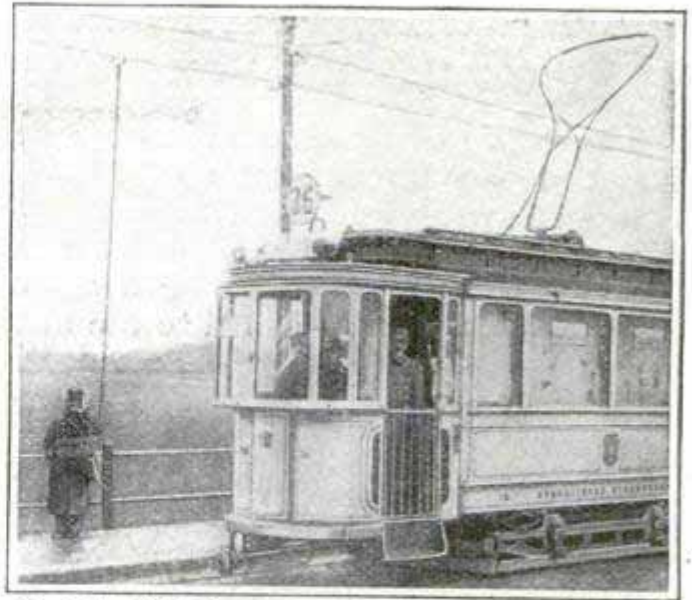

Portable Telephone-Connection Apparatus Used on German Street-Railway System

ing provided for suspending the apparatus over the shoulder.

### ODD CHINESE WHEELBARROW HAULS BIG LOAD

A barrow with a wheel as big as that used on a wagon is used in some parts of China, and loads of considerable weight are hauled upon it. The box or bed of the barrow is divided, so that the wheel occupies the central space, the load being piled or fastened on either side. Such well-balanced loads as that shown in the illustration are not uncommon.

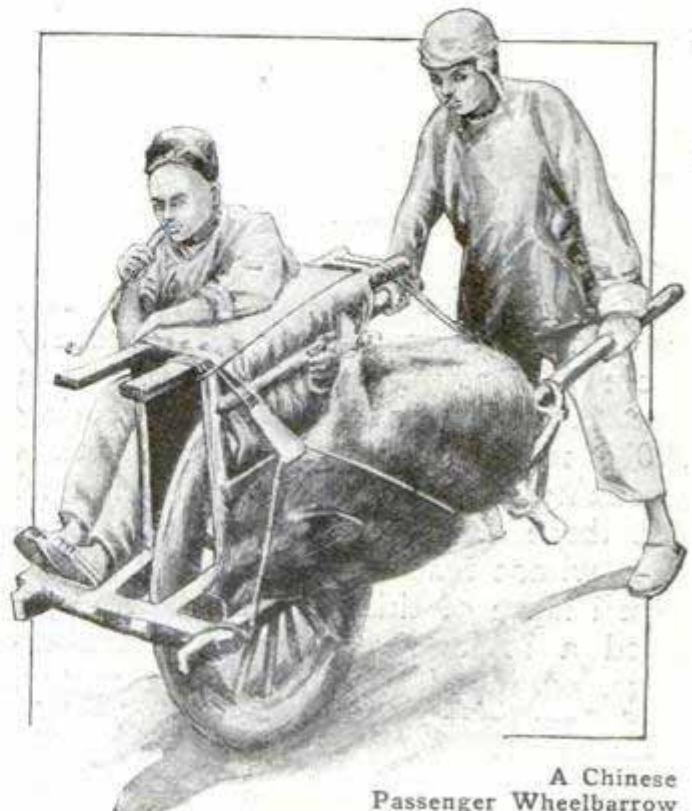

A Chinese Passenger Wheelbarrow

## LIGHT CALLS POLICEMAN TO PATROL BOX

The police of Brockton, Mass., have installed an ingenious signal box equipped with an electric light by which a patrolman may be called to the box by the central office and information given quickly regarding suspects who may be in his vicinity. Beneath the main box is a small compartment, opened by a push button, containing a pair of handcuffs securely chained to the post. These are used when a prisoner becomes unmanageable, or when

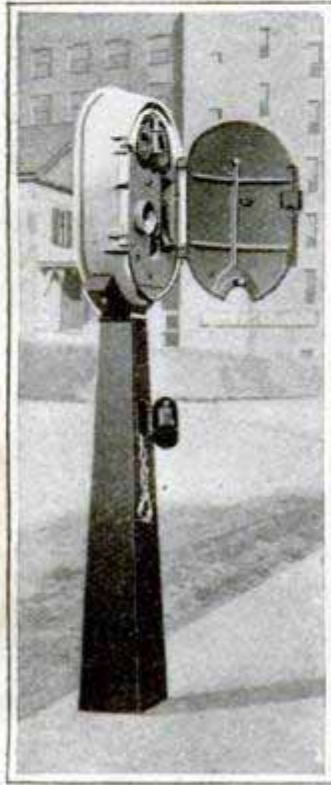

two persons are arrested and one escapes. By hitching one to the post the patrolman is able to pursue the other, and often to capture him. The box was invented and is patented by the electrician of the Brockton Police Department.

## GERMAN AIRMAN SETS NEW LONG-FLIGHT RECORD

Maintaining an average speed of nearly 65 miles an hour, Karl Ingold, a German airman, flew continuously from 7:35 a. m. until 11:55 p. m. on the 7th of February, 1914, covering 1,056 miles in 16 hr. 20 min., thus breaking the previous nonstop record set three days before by Bruno Langer, whose feat was mentioned in the April issue of this magazine. Langer used a biplane of German manufacture, equipped with a 100-hp. motor, and flew from Mühlhausen to Munich, several hours of his flight being made in the dark.

## SHIP CUT TO PIECES WITH OXYACETYLENE FLAME

The hull of the "Alum Chine," the British freight steamship which was destroyed by a dynamite explosion in Baltimore Harbor, as described in the May, 1913, issue of this magazine, has been raised from the bottom of the harbor, cut to pieces by means of the oxyacetylene flame, and sold for scrap.

The 1,800 tons of warped and tangled steel which sank to the bottom in 33 ft. of water when 300 tons of dynamite exploded, constituted a serious menace to navigation. Divers laid strings of dynamite which blew the ship into pieces that could be handled by a floating derrick. The plates and beams were so twisted and bent that ordinary methods of cutting up the scrap would have been hopelessly expensive. By employing the oxyacetylene process, however, the entire hulk was utilized. To this flame, scarcely 3 in. long, plates, beams and rivets formed no serious obstacle, the flame eating its way along at the rate of about a foot a minute until all the scrap had been reduced to pieces small enough to be loaded on wagons. The high temperature of the oxyacetylene flame, about 6,300° F., fuses the metal rapidly, while a jet of pure oxygen injected through the center of the flame against the hot surface oxidizes the steel so that it runs away in a thin stream, leaving a clean, narrow cut in the metal.

The violence of the explosion that wrecked this vessel was almost beyond belief. The entire forward part of the ship was blown away and the deck and upper works were reduced to fragments, pieces of steel from 3 to 5 ft. long being found at distances of from two to three miles from the wreck. The naval collier "Jason" was so seriously damaged by the explosion that it took three months to repair it. The collier had just been completed and was still in the hands of the contractors. It was to depart on the following morning on the preliminary acceptance trials. After the explosion the

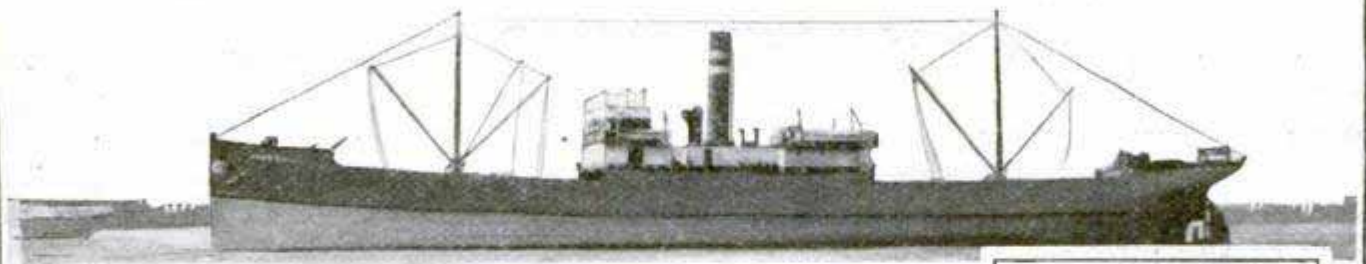

The "Alum Chine" as It Appeared before the Explosion of 300 Tons of Dynamite Which Sank the Ship

Stern of the "Alum Chine," Showing the Propeller Shaft Blown Out and the Sternpost Broken by the Force of the Explosion

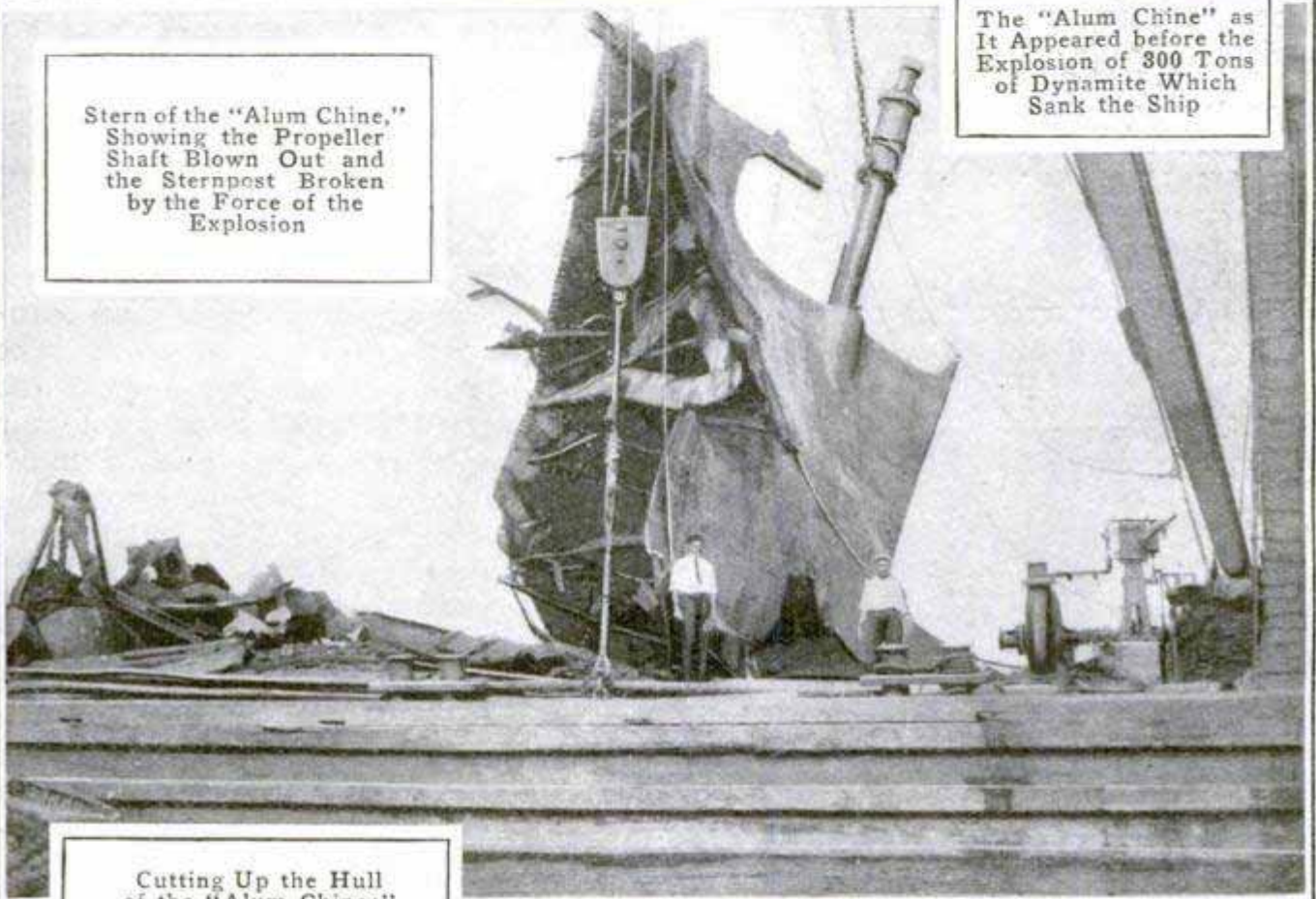

Cutting Up the Hull of the "Alum Chine:" The Small Flame of the Oxyacetylene Torch Eats Its Way Readily through the Tangled Wreckage of Steel

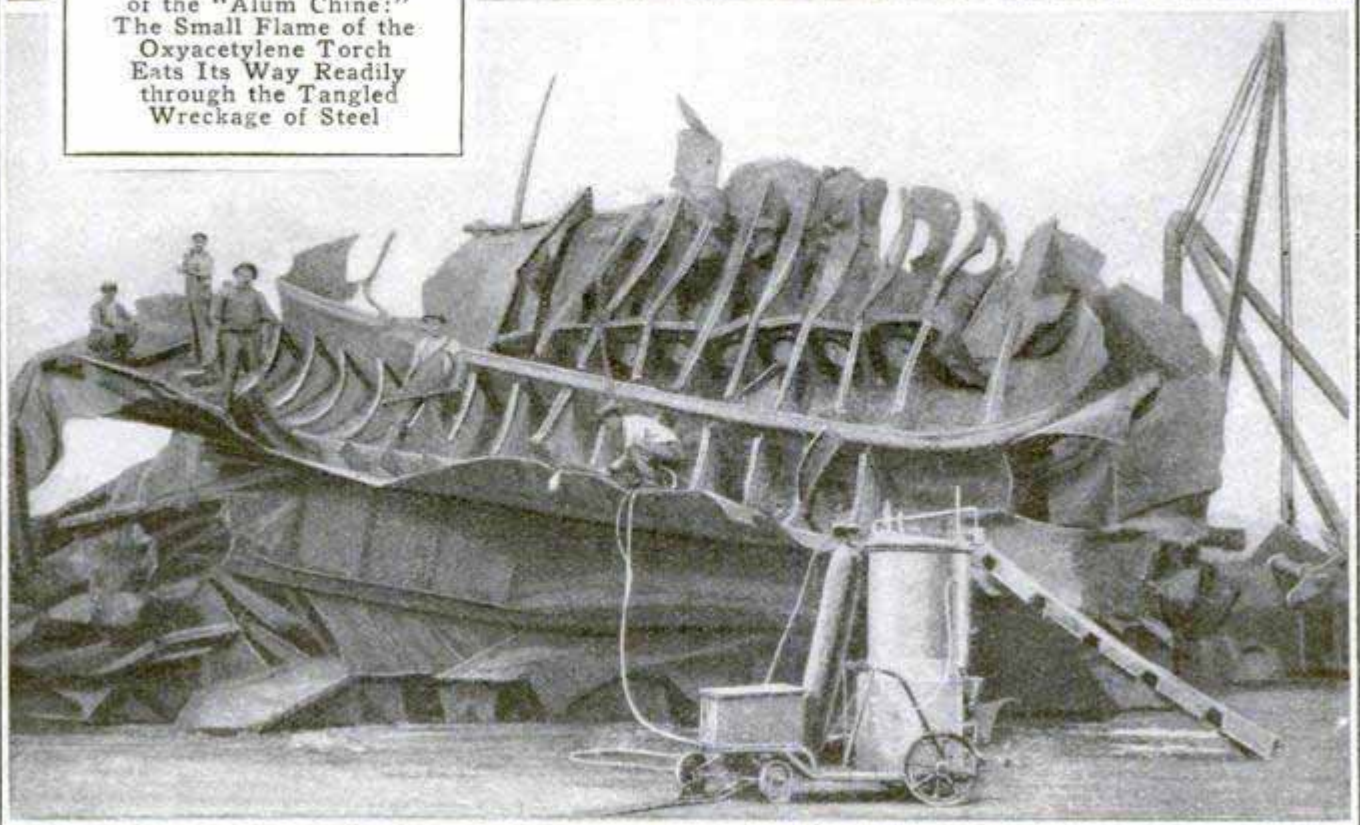

"Jason" had the appearance of a ship that had passed through a severe bombardment. The hull was pierced in many places and much of the steel plating was badly dented. The superstructure was wrenched and twisted, the side bulkheads bulged, and the rigging cut to shreds, while the woodwork of the interior was reduced to a mass of splinters.

### CONFISCATED WEAPONS ARE THROWN OVERBOARD

Every year the harbor patrol of the New York police department takes a

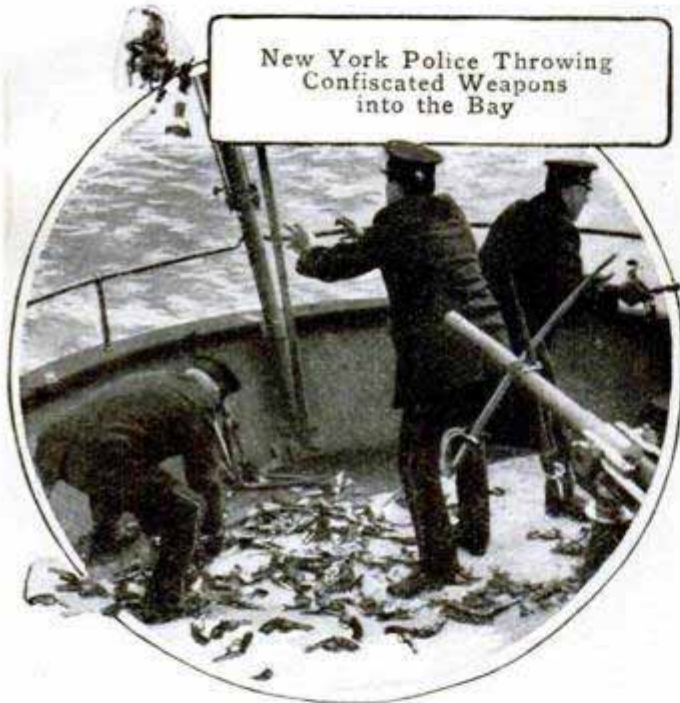

consignment of confiscated firearms, knives, razors, brass knuckles and burglar tools down the bay, and officers cast them overboard by the armful. While the laws of New York prohibit the purchase or possession of firearms by any citizen without a permit, other states are not so particular, and thugs have little trouble in refurbishing their armories. When arrested in New York, their weapons are confiscated and thrown into the bay. Weapons worth \$5,000, or more, were so disposed of recently.

☞The San Francisco-Hawaii cable cost \$20,000,000, while wireless stations for the same service cost only \$500,000.

### BATHROOM LIGHTS SHOULD BE IN CEILING

An extended inquiry has been made by some French scientists, for the Society of Legal Medicine, into accidents from electric shock occurring in bathrooms. Here, it is found, there is peculiar danger, owing to the fact that when the surface of the body is moist, it offers far less resistance to the current than when dry. Currents of as low tension as 46 volts were found to be dangerous, and might even be fatal in such cases. As it is customary to install lighting fixtures in side walls, at such a height that they may be touched by a person standing in a bathtub, or on the floor, a warning was given that this common danger might be eliminated. The logical place for electric-lighting fixtures for the bathroom, so it is stated, is in the ceiling, with a perfectly insulated flush switch just inside the door.

### AUTOMATIC CORN-POPPING MACHINE

Popcorn must be freshly popped to be palatable. This necessity has long kept this popular commodity from being vended in nickel-in-the-slot machines, but at last an inventor has found a way to surmount the difficulty. An automatic corn popper is now on the market which delivers freshly popped corn upon placing a coin in the slot. The machine consists of an upright case, within which a complicated mechanism is started by the revolution of a handle outside the machine, and completes the process automatically. An elec-



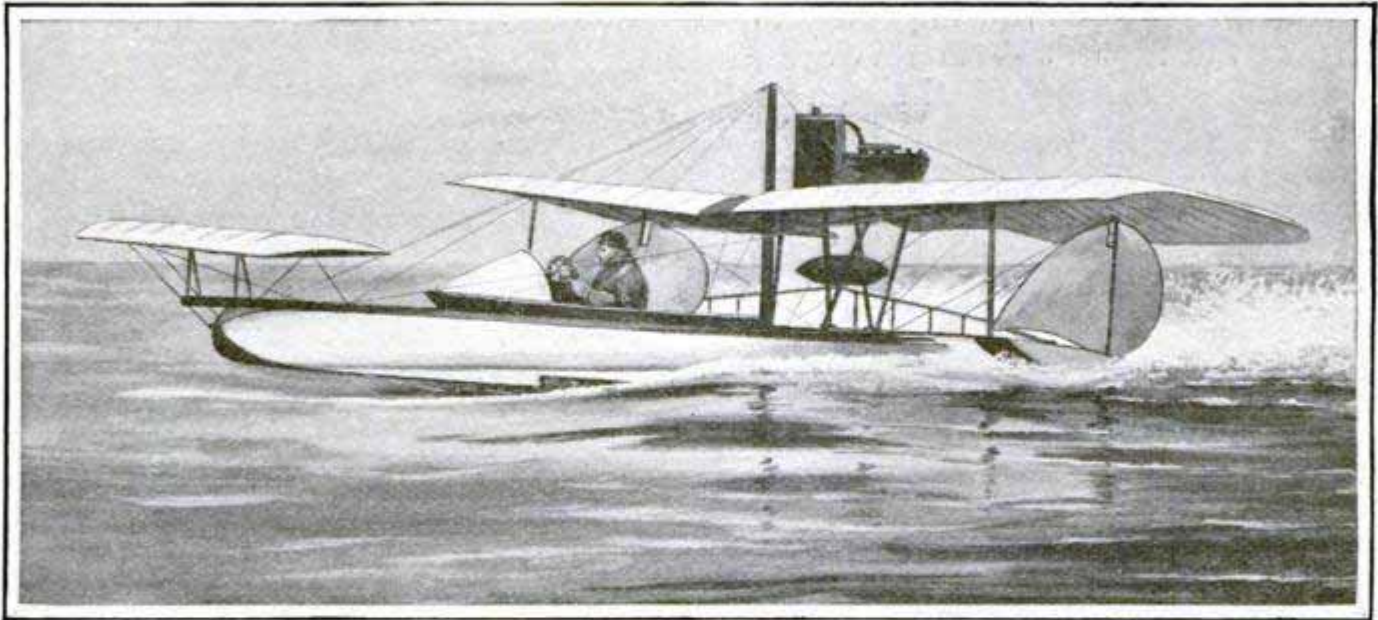

Rudderless Flying Boat Steered by Movable Jibs

tric contact is made, the motor starts revolving the popping cylinder and measures into it just the amount of corn required for one bag. An electric resistance mesh, which lines the cylinder, provides the heat necessary to pop the corn. A paper bag is pushed out for the customer, who holds it beneath the spout, from which the freshly popped kernels are delivered. Unpopped kernels are shunted into a receptacle within the machine. After the corn has been put in the bag, the customer may, if he desires, season it by holding the bag beneath another chute, from which, upon pressing two buttons, butter and salt flow in measured quantities. A plate-glass window in the front of the machine enables the customer to see the corn popping. The case is about 5 ft. high and about 2 ft. square. It must, of course, be connected to a source of electric supply by wire.

### FLYING BOAT HAS NOVEL CONTROL

A tailless flying boat with a jib control which has novel features was exhibited at the motorboat show. Instead of a vertical rudder, used in conjunction with devices for warping the wings, two jibs arranged at the extreme ends of the planes may be partially revolved about an oblique axis

from the lower end of the forward strut to the upper end of the rear strut. By pulling or pushing the steering wheel forward or backward, the pilot turns the jib on the side he desires, toward the engine. This produces a drag in the air on that side and the down pressure results in "banking" the machine, which thereupon makes a turn with the operated jib on the inside, toward the center of the circle. No rudder is necessary, the jibs permitting complete control to be exercised. A small "elevator" is set at the fore end of the hull, by which means the pilot is enabled to rise clear of the water, or direct the machine in climbing.

### MORE DAYLIGHT WORKING HOURS FOR CLEVELAND

A practical way to obtain more daylight during the working day has been worked out in Cleveland, Ohio, by the simple expedient of changing from standard central to standard eastern time. With central time the Cleveland clocks are 33 minutes slower than sun time, while on eastern time they run 27 minutes ahead of the sun. It is estimated that, as a result of the change, 201 more hours of daylight a year will be available between the hours of 6 a. m. and 10 p. m., and that 201 more hours of darkness will be

provided for sleep during the early part of the night. With this system the earliest setting of the sun will occur at 4:55 p. m., so that nearly all factories will close before sunset even during the shortest day, while during the spring, summer and fall, a total of 234 additional daylight hours will be available after 5:30 p. m. for outdoor recreation. The dividing line between central and eastern time is now at Buffalo and Pittsburgh.

### MOTOR-CAR SIGN CARRIES "RED HAND OF ULSTER"

How deep into the past the feelings of the Irish people reach in the present home-rule contest is indicated by



Courtesy The Sketch

the sign carried by the motor-car corps of the Ulster Volunteer Force. On the sign are the shamrock, a crown and the "Red Hand of Ulster." The emblem of the red hand had its origin in the ancient days when Ireland was ruled by rival chieftains who were often at war with each other, and dates from a battle in which the Ulster forces were led by one of the O'Neills. The battle was going against the Ulster forces, and to add to their misfortunes the chieftain's right hand was cut off by a well-aimed blow from the sword of one of the opposing force. Picking up the severed hand, O'Neill threw it as far as he could into the ranks of the enemy and ordered his men to recover it. The fury of the attack of the Ulster army in carrying out this command turned the tide of battle in their favor, and gave them also a symbol of their determination to remain a district distinct from the remainder of Ireland.

### GERMAN DIRIGIBLE TO FLY AT SAN FRANCISCO FAIR

What is expected to be the largest dirigible balloon ever built will be sent to the Panama-Pacific Exposition by a German firm and will be operated as a passenger carrier, on a daily schedule. The dirigible, of the Parseval, or semi-rigid, type, will have a length of 480 ft., a diameter of 80 ft., and will cost more than \$250,000. A portable hangar is to be brought from Germany, along with two licensed crews of eight men each, who are to operate the big airship. A complete gas plant will also be built for the sole use of the German craft. Trips of about 50 miles will be made, the rate being fixed at \$25 each. When not making trips, the dirigible will be on exhibition in its hangar, where exposition visitors will be allowed to inspect it, going through the interior, seeing the observation rooms, sleeping quarters, diner, kitchen, bath and smoking rooms, which make it a modern transportation palace. Passenger dirigibles are familiar sights in northern Europe, but a novelty in America.

### SHALLOW-DRAFT WARSHIPS BUILT BY BRITISH

In striking contrast to the super-dreadnoughts launched by the British Admiralty in the last two years is a new type of battleship with shallow draft and guns especially mounted for attack on aeroplanes and dirigibles. The "Royal Oak" is the first of this type. It will be armed with 5 and 6-in. guns built to be trained almost perpendicularly. These are mostly rapid-fire guns and are expected to give a good account of themselves in action. The shallow draft is designed to present as small a target as possible against submarines. The new vessels are to be of but 25,000 tons and maintain a speed of 28 $\frac{3}{4}$  miles an hour. Both coal and fuel oil will be carried, and a platform will be built from which to launch flying boats.



# TALLEST BUILDING WEST OF THE MISSISSIPPI

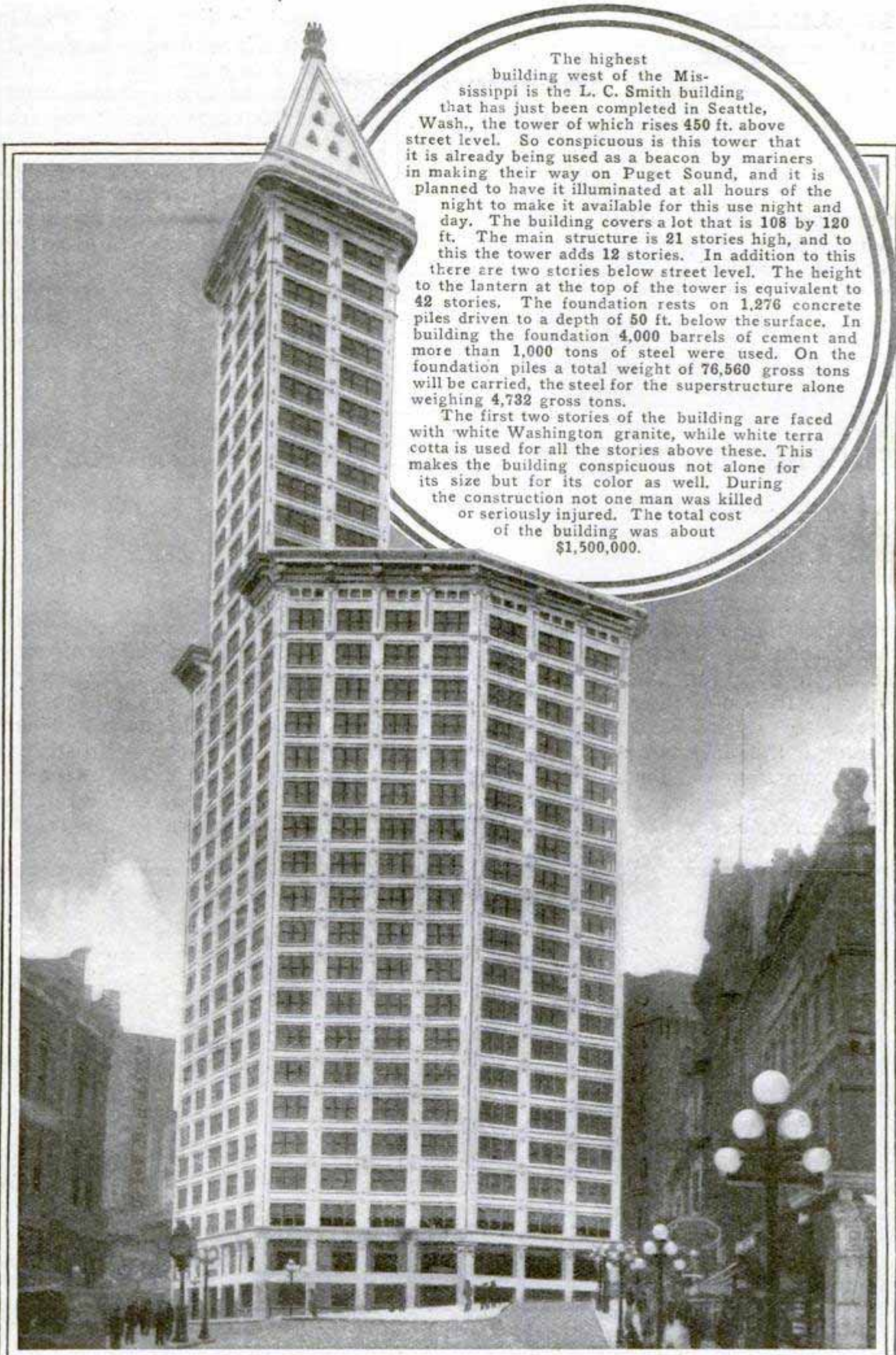

The highest building west of the Mississippi is the L. C. Smith building that has just been completed in Seattle, Wash., the tower of which rises 450 ft. above street level. So conspicuous is this tower that it is already being used as a beacon by mariners in making their way on Puget Sound, and it is planned to have it illuminated at all hours of the night to make it available for this use night and day. The building covers a lot that is 108 by 120 ft. The main structure is 21 stories high, and to this the tower adds 12 stories. In addition to this there are two stories below street level. The height to the lantern at the top of the tower is equivalent to 42 stories. The foundation rests on 1,276 concrete piles driven to a depth of 50 ft. below the surface. In building the foundation 4,000 barrels of cement and more than 1,000 tons of steel were used. On the foundation piles a total weight of 76,560 gross tons will be carried, the steel for the superstructure alone weighing 4,732 gross tons.

The first two stories of the building are faced with white Washington granite, while white terra cotta is used for all the stories above these. This makes the building conspicuous not alone for its size but for its color as well. During the construction not one man was killed or seriously injured. The total cost of the building was about \$1,500,000.

## STRONGEST ELECTROMAGNET IS BUILT IN FRANCE

Recently two French scientists exhibited before the Academy of Sciences in Paris an electromagnet of remarkable power, but the usefulness of which is limited to scientific work. It differs from previous magnets in that the windings are made of metallic ribbons of almost infinitesimal thinness, which are cooled by a circulating bath of gasoline at very low temperature. To give a concrete idea of its power it may be stated that ordinary electro-

magnets used in lifting pig iron in foundries operate with a magnetic-field intensity of from 8,000 to 14,000 units, while the new magnet produces 52,000 units, and a still larger one is projected which will employ 75,000 units. Yet the additional power shown is gained at such a cost that it cannot be commercially utilized. In experiments with polarization of light through the magnetic field, or in deflecting the cathode rays from the X-ray machine, such an electromagnet might have a laboratory value, but otherwise it has only a scientific interest.

## PREPARING FOR SIGHT-SEERS AT THE PANAMA CANAL

For the thousands who will visit the Isthmus to view the completed Panama Canal, ample provision is being made. Special sight-seeing trains are scheduled to leave Colon and Panama on alternate mornings through the week, reaching the opposite end of the canal in time for lunch. Passengers may return on the ordinary trains if they so desire. Excursion trips through the lake, from Gamboa to Gatun, are made on a sight-seeing barge which has been converted for

passenger service by the addition of a main deck, sloping from rear to front, and provided with comfortable seats, while above, an upper deck may be reached by stairways. Nearly 300 sight-seers can be accommodated on the barge, which has a full equipment of life preservers and safety appliances. The fare for the trip on the lake is fixed at \$1.50, and a like sum is charged for the railroad trip along the shore, from one end of the canal to the other.

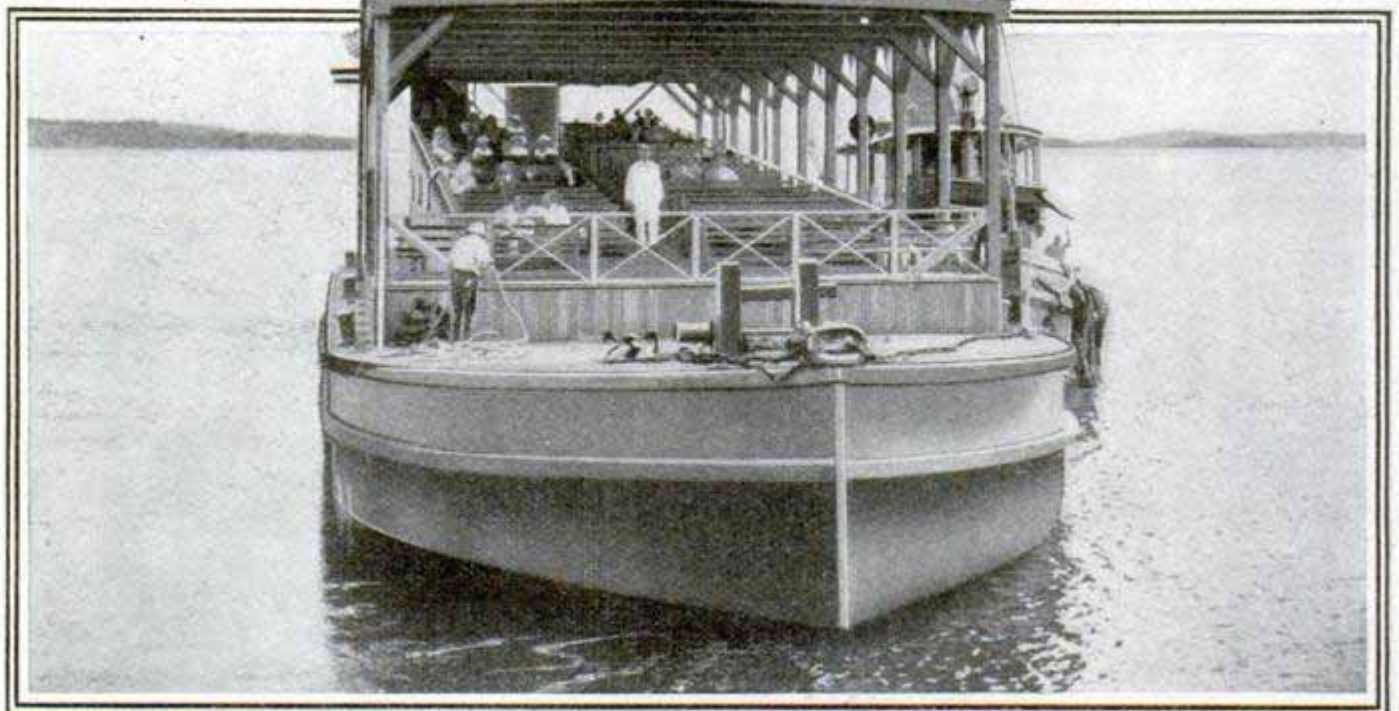

The Excursion Barge from Which the Wonders of the Canal may be Seen: The Rear Seats are Raised So That the View is Unobstructed

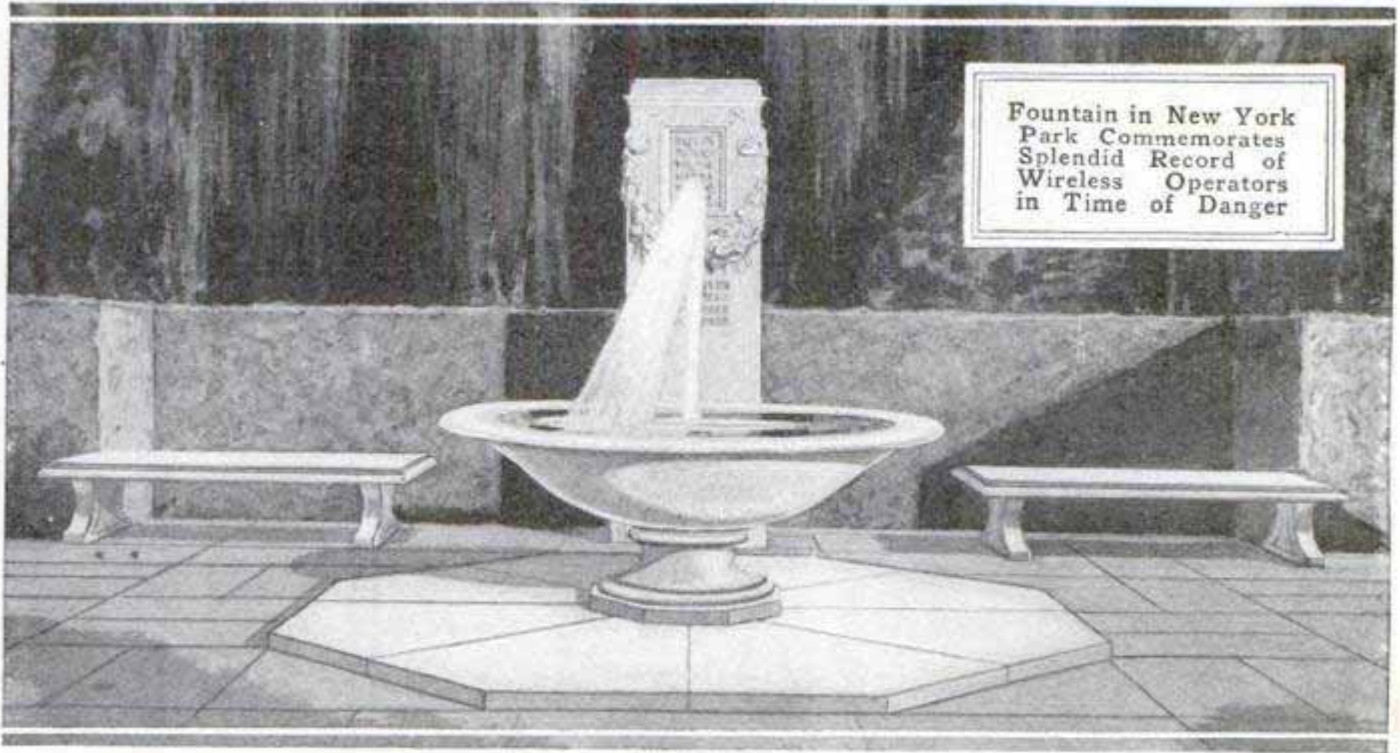

### MEMORIAL TO WIRELESS HEROES

In Battery Park, New York, will soon be erected a memorial fountain dedicated to the wireless operators who have lost their lives at sea. In most of the recent accidents on the ocean, where the wireless has called to rescue work vessels from a distance, the operators in their wireless stations have stuck to their posts to the last, often going down with the ship, and showing a heroism in aiding women and children to escape a watery grave, which betokens a high order of valor. The fountain, which has been designed by famous architects of New York, will keep alive the memory of these courageous men.

### THE CHINESE METHOD OF PRESERVING EGGS

Covering eggs with a thin layer of sea salt and vegetable ashes, made into a paste with water, the Chinese succeed in so preserving them that they do not spoil quickly, and may be shipped long distances. The paste is put on about a quarter of an inch thick, and the eggs are then piled up and allowed to dry. When required for use, they

are placed in water, and the paste dissolves readily. It is found that the salt penetrates the shell and inner membrane, giving a decidedly saline taste to the egg, hence they are used for purposes where the salty taste is not objectionable.

### HEDGE TRIMMER OPERATED BY ELECTRICITY

A machine for trimming hedges has been invented which carries an electric motor. The operator passes the trimmer over the surface to be shorn after the manner of a horse clipper. The machine is built of aluminum with a casing containing the motor. The gear case is completely inclosed so that no dirt can enter the mechanism, and the trimmer is arranged to be used on either side of the hedge, cutting top and sides equally well. The power is controlled by a switch on the handle, operated by the thumb.



**T**HIS view of the Gatun Locks at Panama gives the most comprehensive possible idea of the appearance of this gigantic feat of engineering. The camera was pointed toward the north when the picture was made, showing in the distance the channel leading in from the Atlantic terminus in Limon Bay. The pair of locks in the foreground are the lowest of the three steps up which ships will climb from sea-level to Gatun Lake. In the middle are the tracks on which the electric towing locomotives, hauling the vessels through the locks, will run, with the toothed rack to enable them to exert traction while climbing to the higher levels. The view shows the intermediate gates, which divide the 1,000-ft. lock chamber into smaller compartments, closed.

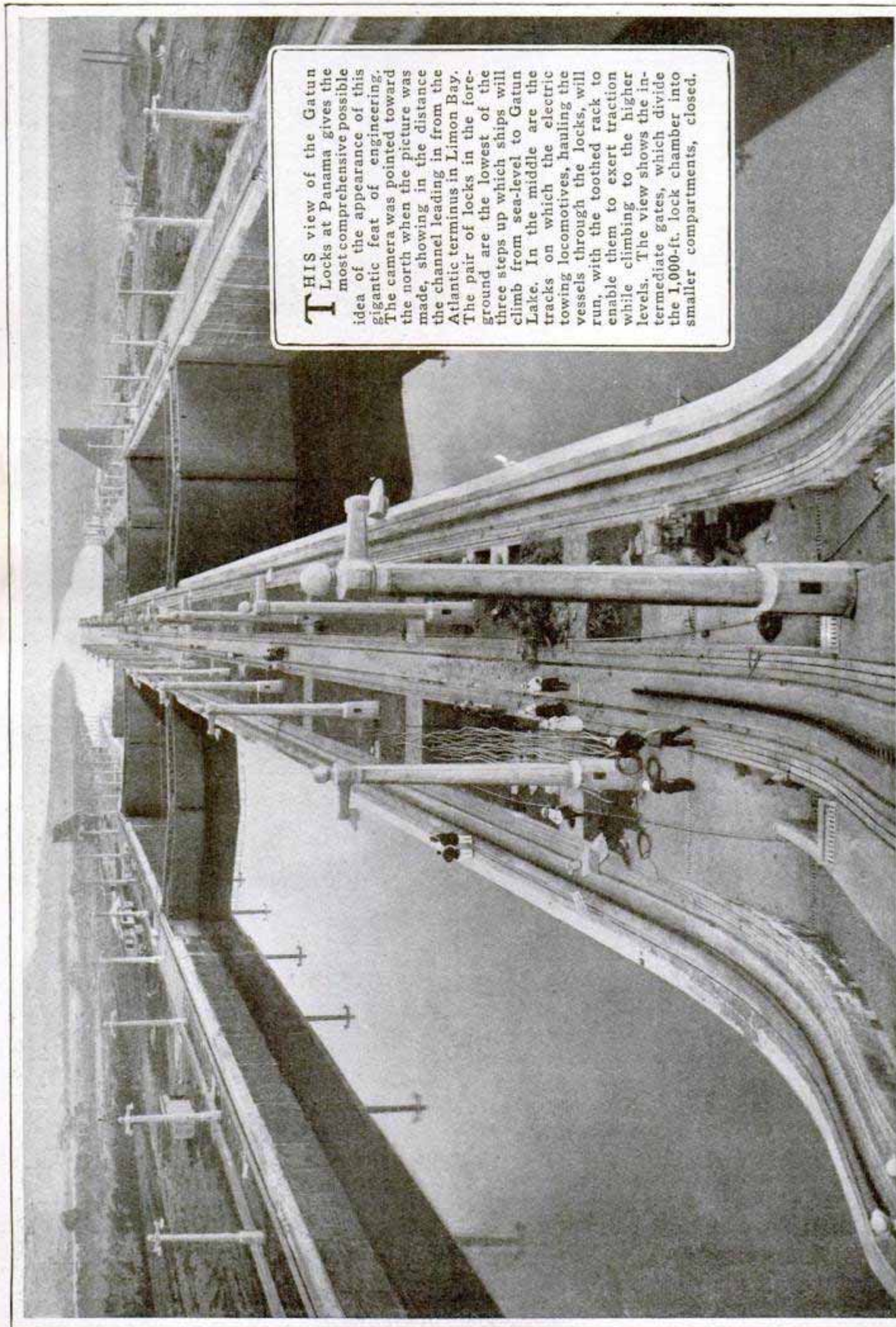

# THE SUBMERGED FORESTS OF GATUN LAKE

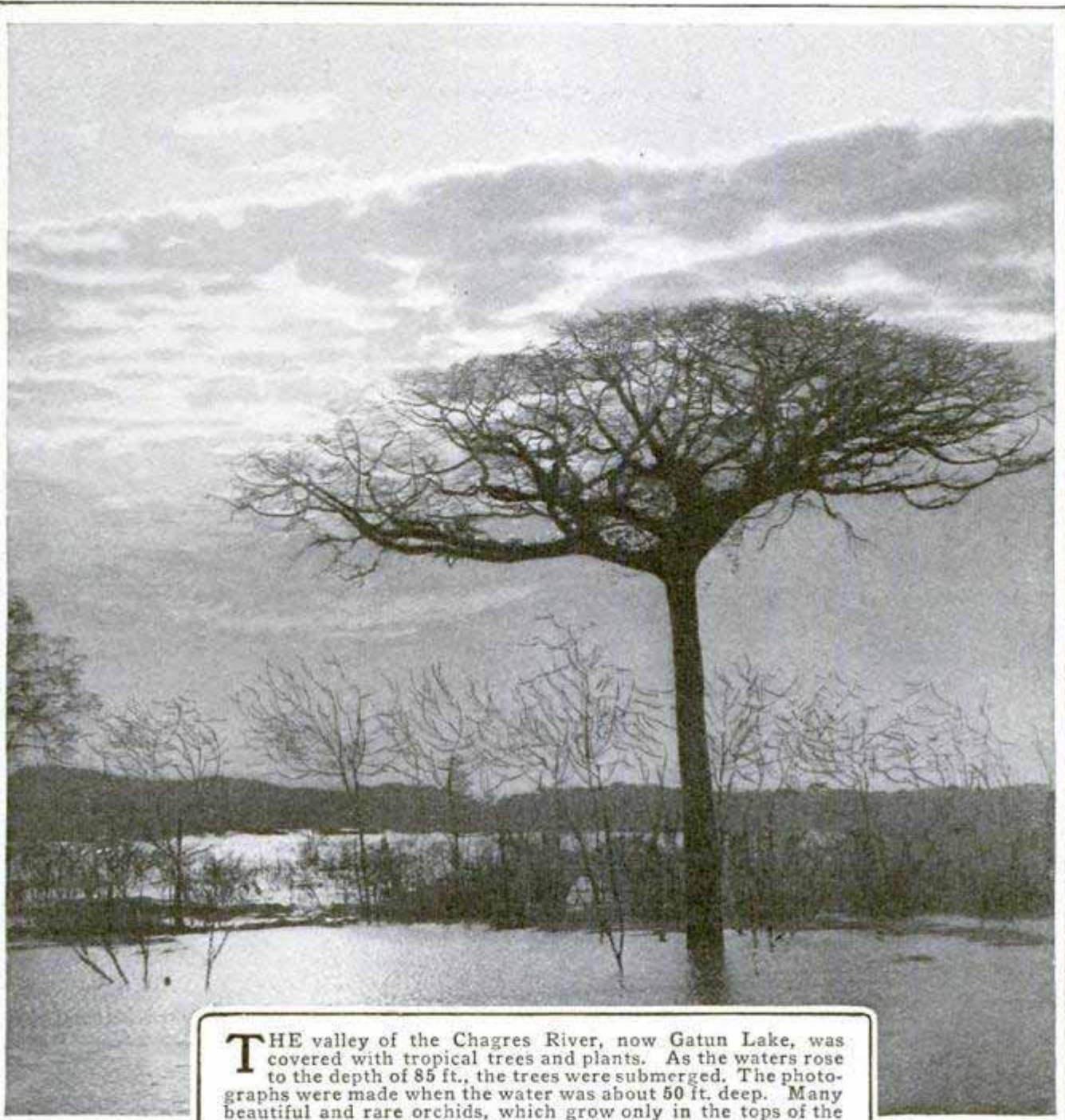

**T**HE valley of the Chagres River, now Gatun Lake, was covered with tropical trees and plants. As the waters rose to the depth of 85 ft., the trees were submerged. The photographs were made when the water was about 50 ft. deep. Many beautiful and rare orchids, which grow only in the tops of the tallest trees, were gathered with small boats as the water rose. Even partial submersion causes these trees to die quickly.

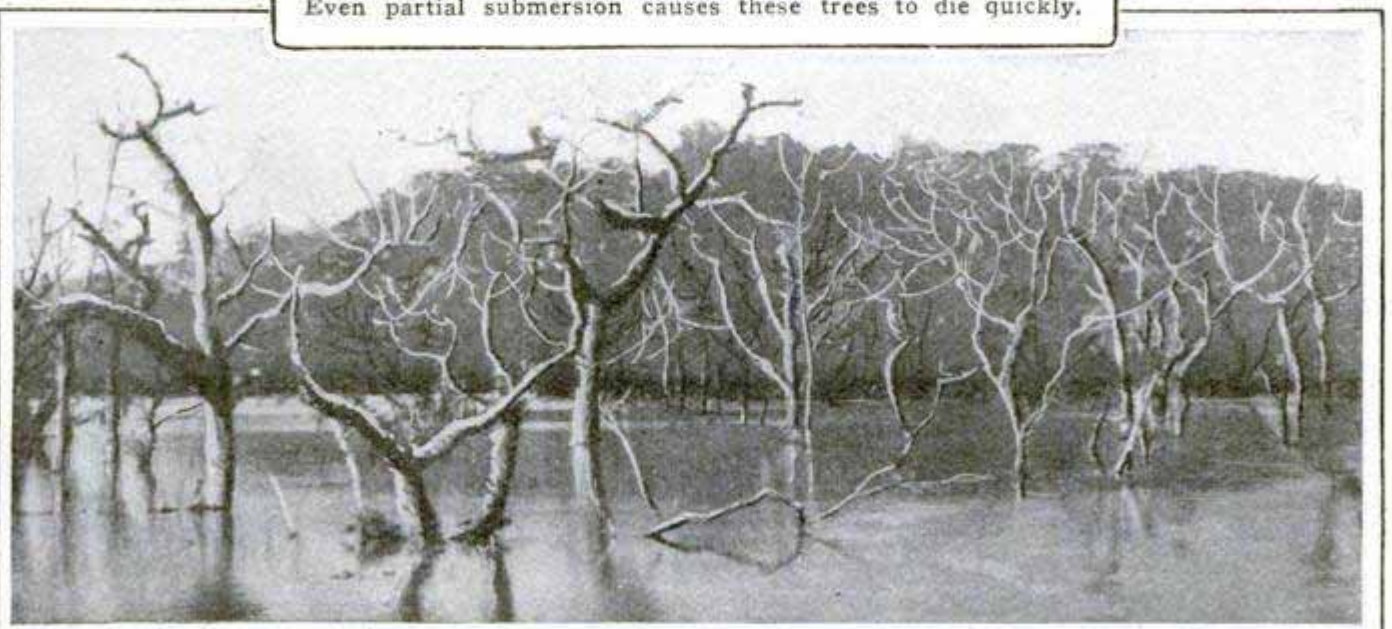

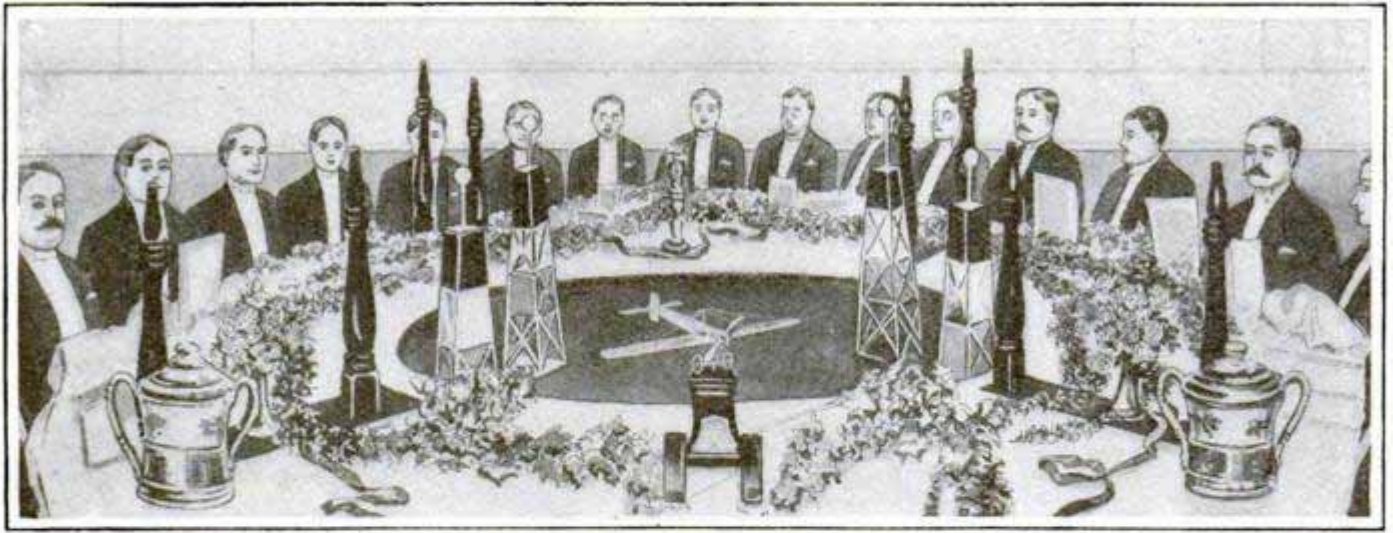

A Topsy-Turvy Banquet in London

### “UPSIDE-DOWN” DINNER GIVEN TO AIRMEN

English airmen were summoned to attend a dinner in honor of several of their profession who had achieved distinction in the art of flying, and appropriately enough, in view of the fact that one of the honored guests had just “looped the loop” with a passenger, the entire dinner was served “upside down.” The photograph shows the table legs in the air, the banquet being spread upon the bottom of the mahogany. The menu was reversed, and instead of eating “from soup to nuts,” toothpicks and black coffee opened the repast, while the fish was the last course. To be sure, the speeches were reserved for the last, but the dinner was otherwise entirely a topsy-turvy affair.

### PALM TREE GROWING THROUGH A ROOF

A building in Los Angeles has a “roof tree” which is one of the sights of that city. Years ago the tree, one of the varieties of palm so plentiful in California, stood before a sightly mansion, built when that part of the city was far from the center of business. When the growth of the city turned

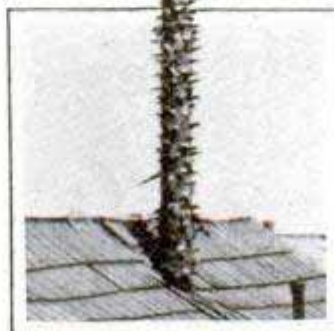

that residence section into a “downtown” district, it became necessary to build upon the property. The tree, then 60 ft. high, was left, and the structure built around it, a hole in the roof giving it access to light and air. Since then the tree has continued to grow, unaffected, seemingly, by the encroachments of commerce, and is a beautiful and stately landmark.

### DRIFT FENCES ON NATIONAL FOREST RANGES

Many miles of “drift” fences have been built by the government in recent years for controlling the movements of stock, grazed under permits on the national forest lands. These fences do not serve to inclose areas, but are simply intended to prevent the animals from going in certain directions, or “drifting,” to use a cattlemen’s expression. In many cases they are used to restrict the animals to certain areas for the summer and to other areas during the winter, as well as to prevent grazing on lands where poisonous plants are found. In one case, five miles of drift fence was built to protect a city water supply from contamination by forest-range cattle. In one forest, a  $4\frac{1}{2}$ -mile fence was built to keep cattle on one range and

horses on another. On the latter range was an abundance of larkspur, a poisonous plant which cattle will eat but which horses will not touch, while on the cattle range there was practically no larkspur. The fences are built of wire in a substantial manner and are so placed that passage from one range to another can only take place at certain well-established gateways.

### NEW STANDARD TO SUPPORT BICYCLE

A quick-acting support for bicycles has been placed on the market in France, by means of which a rider may stop his wheel and without placing his feet on the ground, sit quietly, or perform such actions as shooting, sketching, taking photos, or the like, without falling. The device consists simply of two steel rods, bent in such a manner that on being rotated they describe a conical surface, resting close to the rim of the wheel when not in use, and forming a wide base line when spread out. The device is brought into play by a lever, which is self-acting and easily released, on the handlebar, connecting with wire cables to the supports. Springs bring the rods back to normal position when the lever is released. It is proposed to equip military bicycles

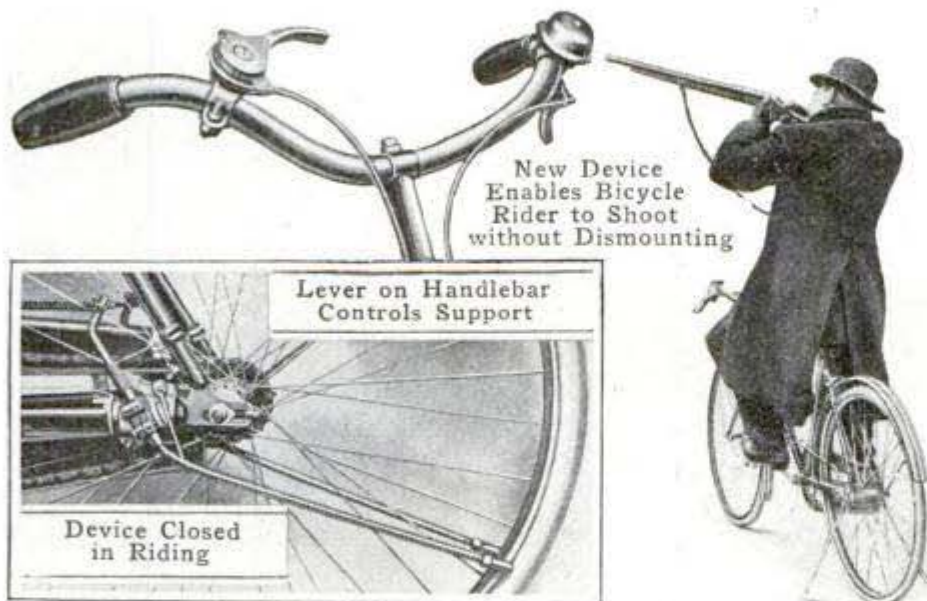

and motorcycles with this appliance, in order to permit soldiers to stop and shoot without getting down out of their seats.

### POWER-DRIVEN ICE SAW RECENT INVENTION

Mounted on a large sled, a 4-hp. gasoline engine furnishes the power to run a circular saw, capable of cut-

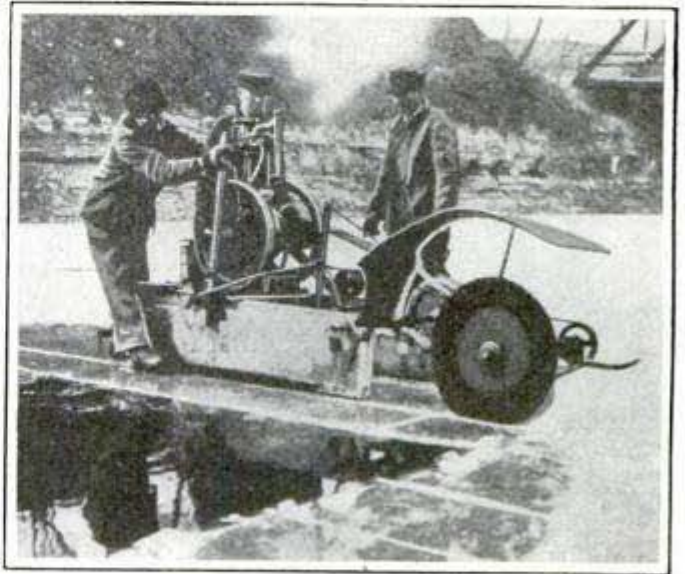

Circular Saw Rapidly Eats Its Way through the Ice

ting 10-in. ice rapidly. The saw is held in a flexible extension of heavy gas pipe, and a chain-and-sprocket device connects with the jackshaft, which in turn is belted to the engine. The machine is kept in line by means of a thin steel shoe fastened to the runner, which travels in the groove made by an ordinary ice marker. The machine propels itself as the

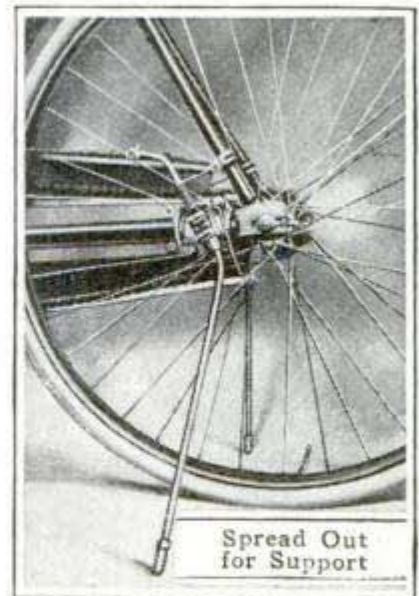

saw takes hold of the ice in cutting. With this machine, the builders state, three men can cut as much ice in one day as 30 men with hand saws.

## PRACTICAL DEVICES FOR SLEEPING IN THE OPEN

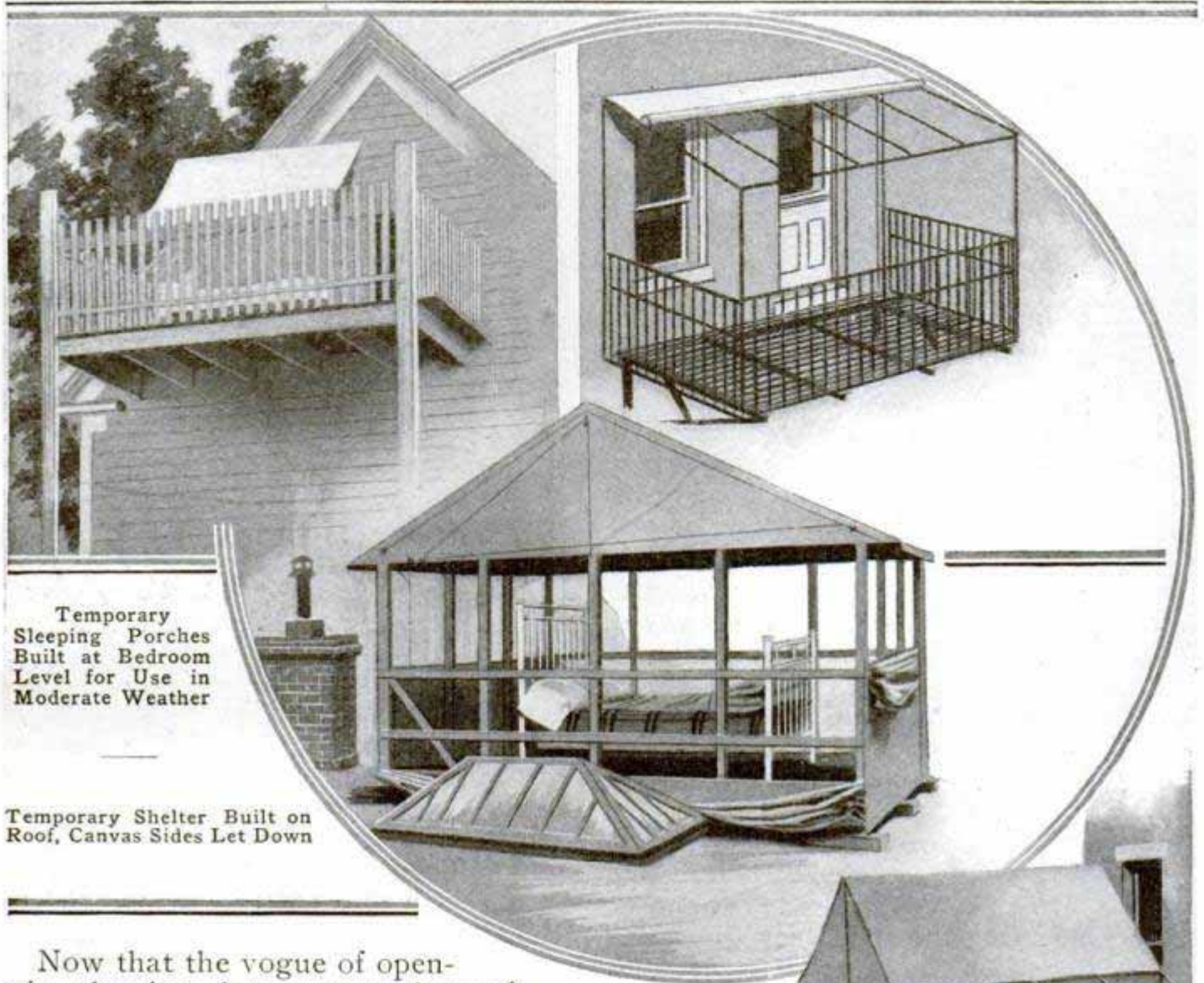

Temporary  
Sleeping Porches  
Built at Bedroom  
Level for Use in  
Moderate Weather

Temporary Shelter Built on  
Roof, Canvas Sides Let Down

Now that the vogue of open-air sleeping has grown beyond the stage of a "treatment" and interests those who want to keep well as much as it does those who want to get well, it is interesting to see how simple, inexpensive and adequate shelter may be provided in or on the ordinary dwelling. A substantial support of scantling, floored and fenced, may be built against the side of the house at the level with a sleeping-room window. Over this a light awning may be drawn for protection against the weather. Here, upon bed or cot, or swinging in a hammock, real open-air sleeping may be indulged in the year around. In brick apartment buildings within fire limits, it may be necessary to make the support of iron, building it like the ordinary fire escape, and supporting it, not from the ground as

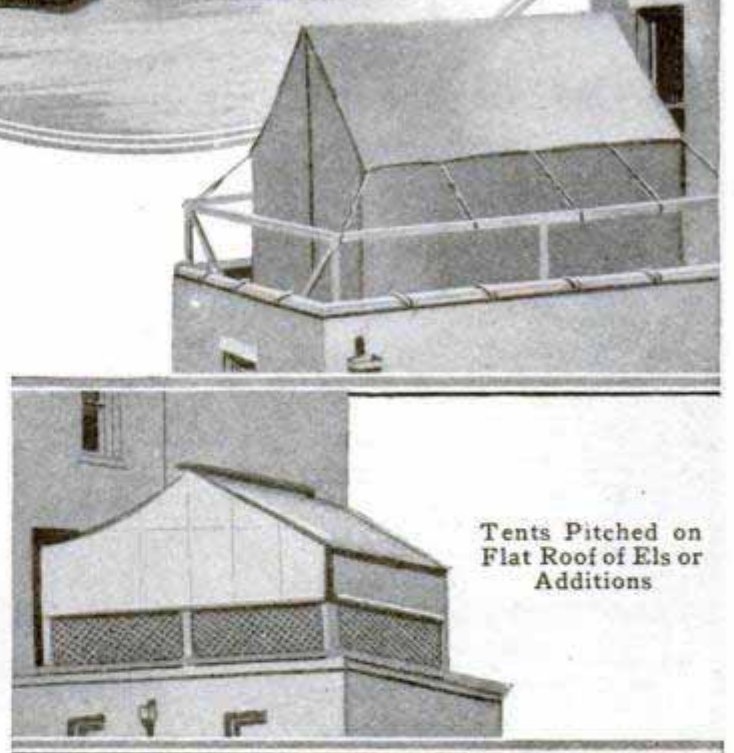

Tents Pitched on  
Flat Roof of Ets or  
Additions

in the case of the wooden shelter, but by iron rods firmly fixed into the brick walls. Where the roof is flat, or only slightly tilted, the building of a shelter is a very easy matter. A

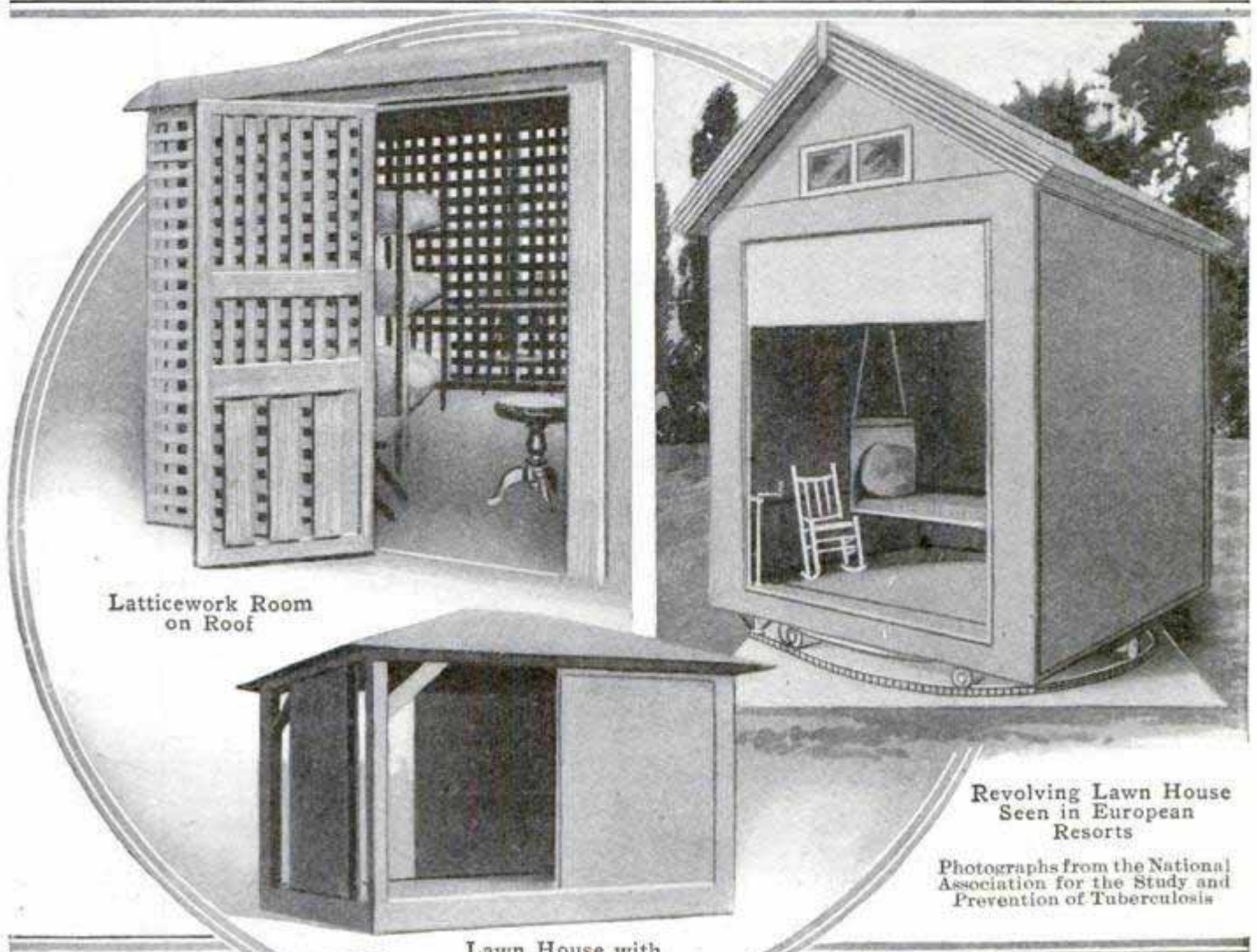

## WHICH ARE SIMPLE AND FEASIBLE IN EVERY HOME

Latticework Room  
on RoofRevolving Lawn House  
Seen in European  
ResortsLawn House with  
Sliding Side  
Panels

Photographs from the National  
Association for the Study and  
Prevention of Tuberculosis

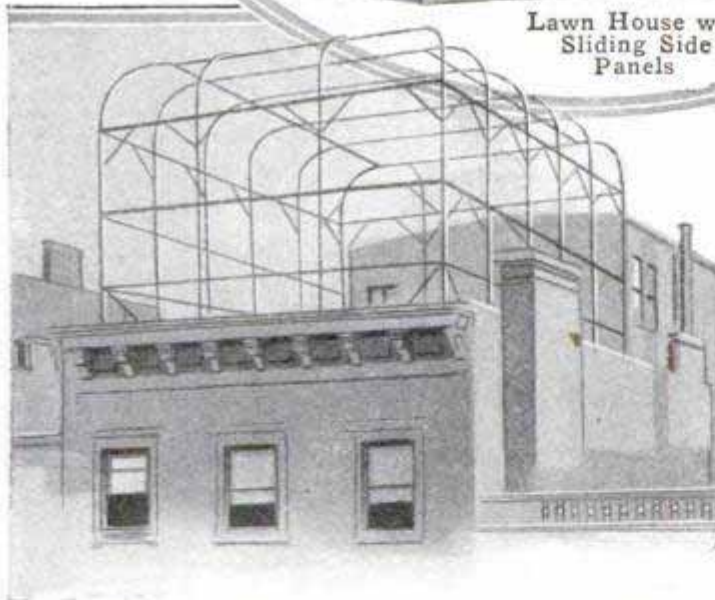

Framework on Roof Supports Canvas Cover by Night,  
and Wire Screens by Day, Affording Playground  
for Children as Well as Sleeping Quarters

light wooden framework, supporting a canvas roof or tent, makes an ideal place for sleep. Usually there is such additional shelter given by chimneys, eaves or side walls, that driving mists

and rains or drifting snows can be avoided.

Often a low addition, or the flat roof of a kitchen or shed, will be found available to erect a tent, the ropes being lashed firmly to a wooden railing or to eyelets set into the roof. A more permanent form of this roof tent has lattice-work sides, the canvas being brought only partially down below the roof. In this type of shelter a maximum of ventilation is always attained. To those who do not care to trust themselves to canvas shelters, a roof room made entirely of latticework appeals, the roof only being substantial and covered with thin boards and roofing paper. This gives a permanent sleeping room, to which many conveniences may easily be added. A more flexible form of roof shelter may be obtained by arched supports of iron pipe, over

which canvas may be drawn, and wire screening on the sides may give a playground by day as well as sleeping quarters at night.

Where a roof is not available, the lawn sometimes offers a solution, and a type of lawn house, very popular in Europe, is built upon a platform, having a circular track upon which the house may be turned in any direction, avoiding annoying winds, or giving access to sunlight when desired. A

much simpler lawn house has sliding panels of wood, or composition, by which it may be entirely closed, or only one side left open. Such a shelter has all the advantages of the revolving lawn house, with much less expense in construction. With the exception of the iron fire-escape type, these shelters can be constructed very economically, especially when second-hand lumber is used, and the work is done by home talent.

### TANGOING BY MACHINERY NEWEST FEATURE

The present popularity of dancing is the excuse for the invention of a mechanical device for use in amusement parks, by means of which a couple, while riding on a small car, are made to revolve, dip, glide and

whirl much as dancers do on a ball-room floor in the newer dances. A door admits to a wire-screened basket, firmly supported upon a platform, which itself rests upon springs connected with the truck. The car is equipped with an electric motor attached and geared to the rear axle. The front wheels are mounted upon a separate and pivoted truck, so that the car takes short curves readily on the special track provided for it. An arrangement of cams and springs gives the car the "tango" motion.

### WORKING MODEL OF CANAL FOR SAN FRANCISCO

The government will exhibit a working model of the Panama Canal at the exposition at San Francisco. The Isthmian Canal Commission has been

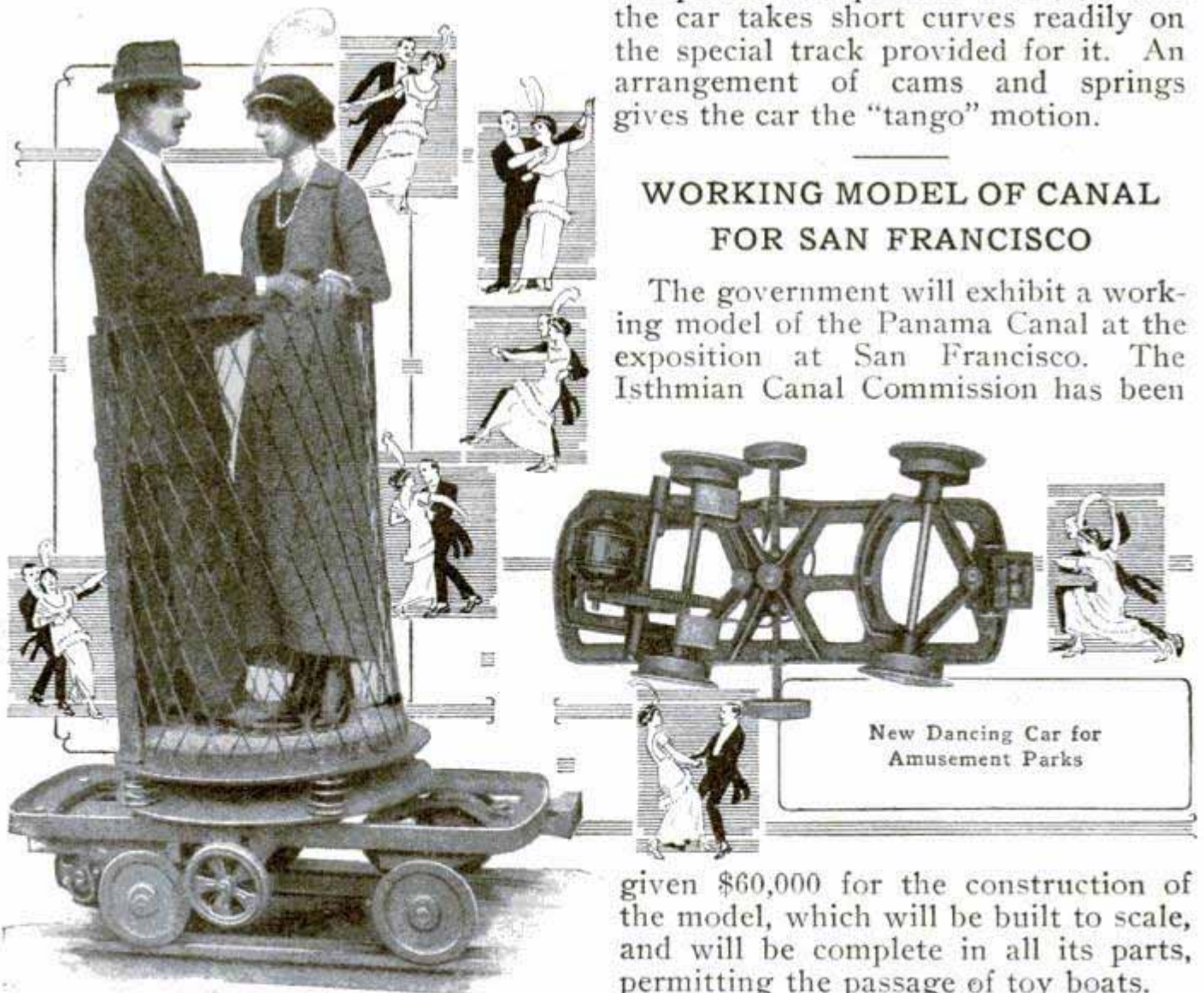

given \$60,000 for the construction of the model, which will be built to scale, and will be complete in all its parts, permitting the passage of toy boats.

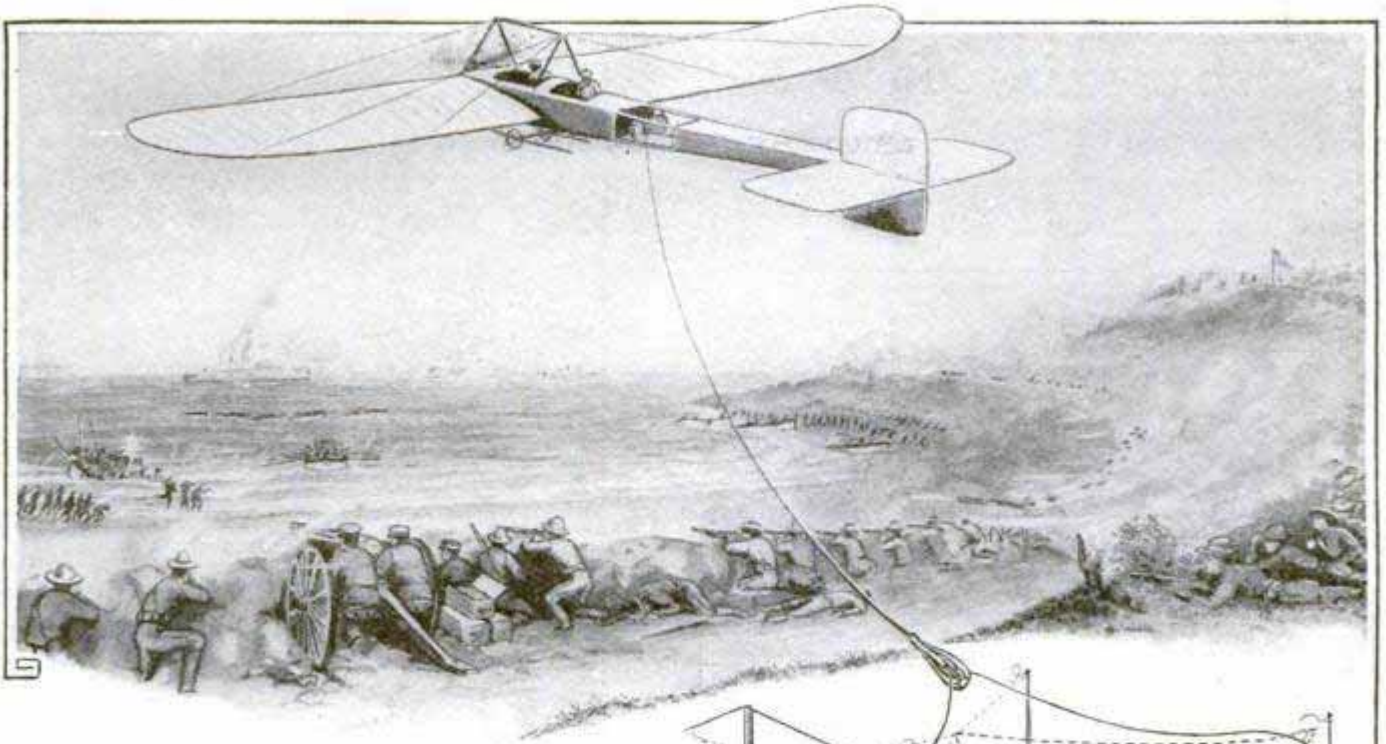

Military Aeroplane Picking Up Dispatches on Field of Battle

## TRANSFERRING ARTICLES TO AERIAL MACHINES

A device designed to solve a troublesome problem in connection with aviation, that of transferring dispatches or other articles to aerial machines in flight, has been patented in England. This device consists of a grapnel, suspended from the aerial machine by a cable, which engages a loop attached to a pannier in which the article is placed. The pannier is carried on a float, or trolley, so that it may be trailed for a short distance before it is hauled up. The cable is operated by a winding drum on the aerial machine, which is put in action automatically by the initial pull of the cable when it engages the load. Danger to the machine is prevented by the slipping of the friction clutch in the winding drum when the winding stress reaches a certain maximum, while if this stress continues, the cable unwinds freely from the drum and falls to the ground. The loop to which the pannier is attached is held extended by being lightly attached to posts, as shown in the illustration. This loop is so connected to the pannier as to operate a brake on the trolley, if it tends to underrun the machine. For use at sea, the stores or dispatches

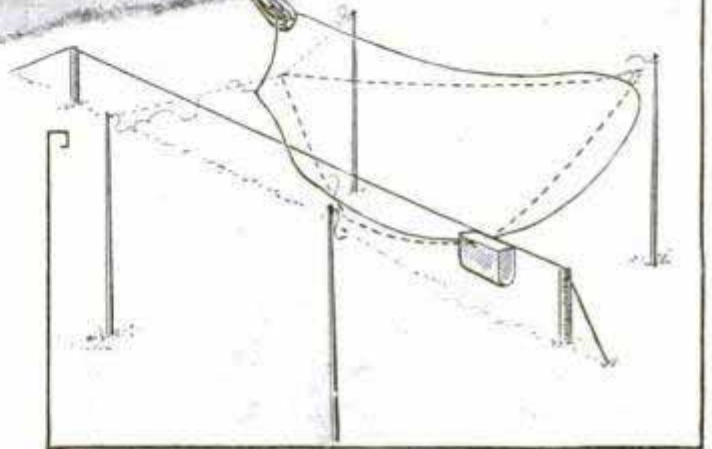

are placed on a float carrier, and the loop is suspended on spars extending from the ship.

## HANDY BAG FOR PICKING CHERRIES

A Michigan mail carrier has invented the contrivance illustrated to aid him in picking cherries. It is a canvas bag, held open by a wooden or metal ring at the top. A small leather strap passes around three fingers of the left hand, and from this the bag is suspended by a hook. Most growers who still adopt the plan of cutting the stems of the cherries with small scissors find the new bag a great convenience. It is patented.



## ALPINE MONUMENT ERECTED TO CAPTAIN SCOTT

At Lautaret, in the French Alps, Captain Scott, the English explorer who lost his life on his return from



French Scientist Raises Monument to Former Pupil

the South Pole, took his first lessons in ice scaling. Here a simple monument has just been erected by his old instructor. It consists of stones heaped in the form of a rude pyramid, and surmounted by a pole. A wooden framework holds the loose rock in place amid the drifting snows.

## AGRICULTURAL FILMS FOR THE FARMERS

The Department of Agriculture is presenting series of films depicting in detail the right way to handle many problems of farm management. Through the Rural Organization Service these films are being sent throughout the country for the instruction of farmers in such subjects as chicken raising, bee culture, rice and cotton planting, and many phases of the dairy

industry. From the southern states, where the present films are being shown, the officials are receiving optimistic reports of large and enthusiastic audiences of farmers who drive in, night after night, with their families and help, to learn better farming methods.

## AMERICAN CARS LEAD IN SELF-STARTING FEATURE

Only five automobiles in every hundred shown at the recent American automobile shows were without some form of engine-starting equipment. The Paris and London shows, on the contrary, reversed these figures, and but five per cent of the automobiles shown there had some form of engine starter. At the American show, 87 per cent of cars produced in this country had electric starting devices as standard equipment, with provision made in the construction of the chassis for adequately housing the mechanism. Air starters were seen on about four per cent of the American-built cars, while the acetylene type of starter was shown on but one per cent of the cars.

## FASTENING WOODEN POST TO CONCRETE

The problem of fastening wooden posts to a concrete wall has been solved in one instance by the use of U-bars firmly imbedded in the concrete, while their loop encircles the post at an angle. The U-bar may be, and often is, homemade. It holds as well when turned out by the village blacksmith as when bought from a city supply house, the main thing being that it holds the post rigidly in place.

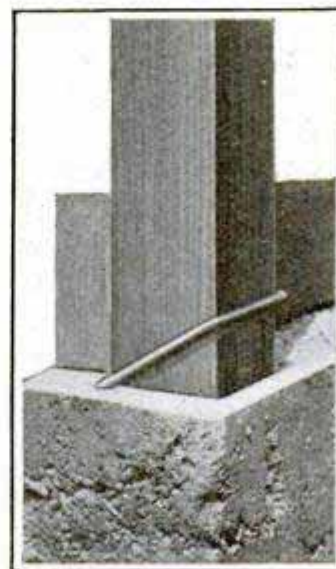

# MANUFACTURING A MUMMY IN ANCIENT EGYPT

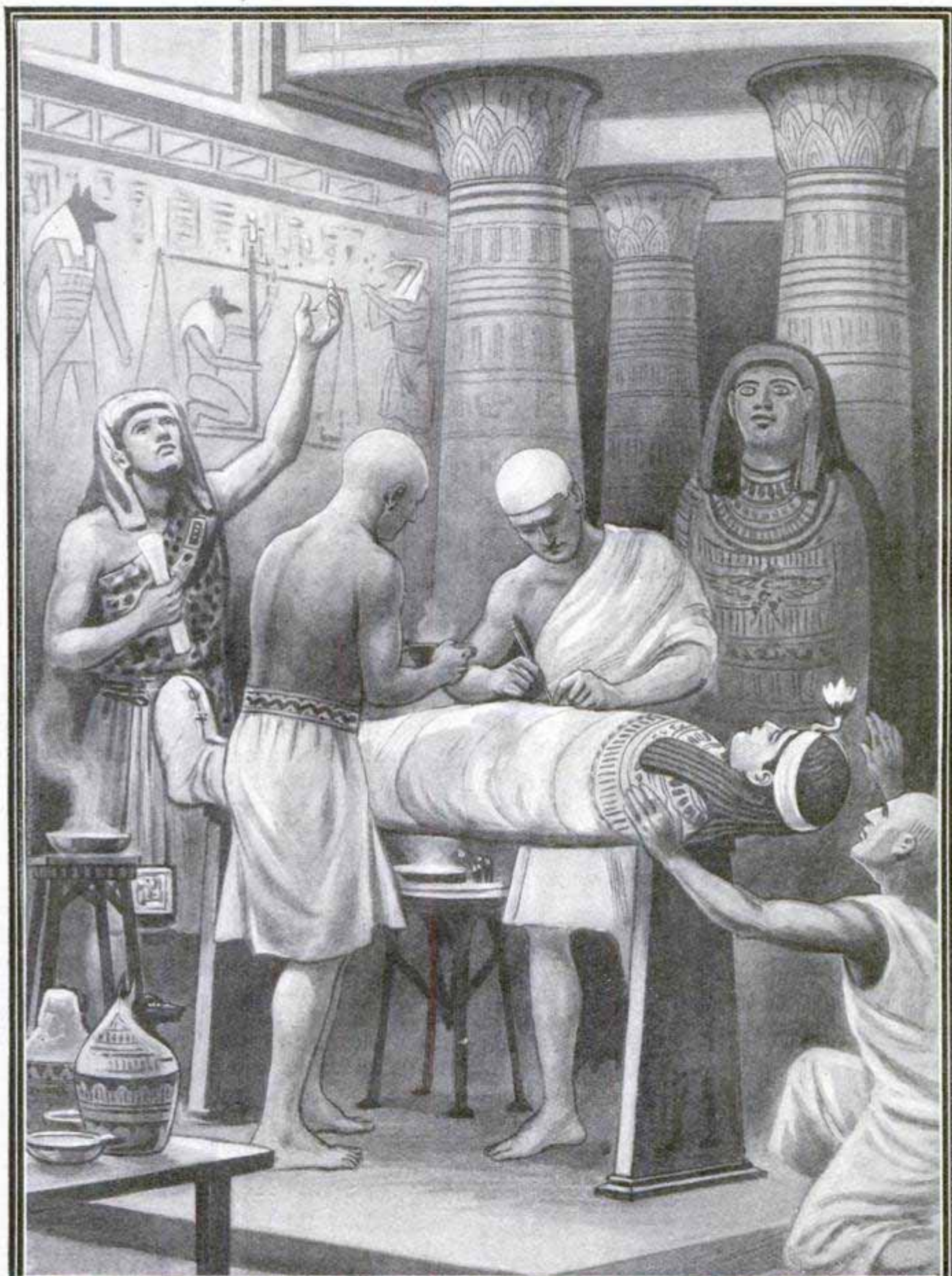

**T**HE ancient Egyptians preserved the bodies of their dead in order to give the soul a home on its return to earth. The preservative climate of Egypt and the use of nitron, asphaltum and gums enabled mummifiers to achieve marvelous results, hundreds of thousands of mummies having been found which were embalmed thousands of years ago. Originally intended as a ceremony only for royalty, the custom spread to include the courtiers, and then the servants and slaves of the latter, as well as the royal guard. Bodies were wrapped in strips of linen, smeared with asphaltum. Within the cavities were placed pungent spices, and designs were painted upon the outer wrappings. The mummy was then placed in a case carved to represent a human figure.

## NEW FLYING BOAT HAS INCLOSED CABIN

Satisfactory tests have just been made on Lake Keuka, N. Y., of a flying boat, differing from the usual type

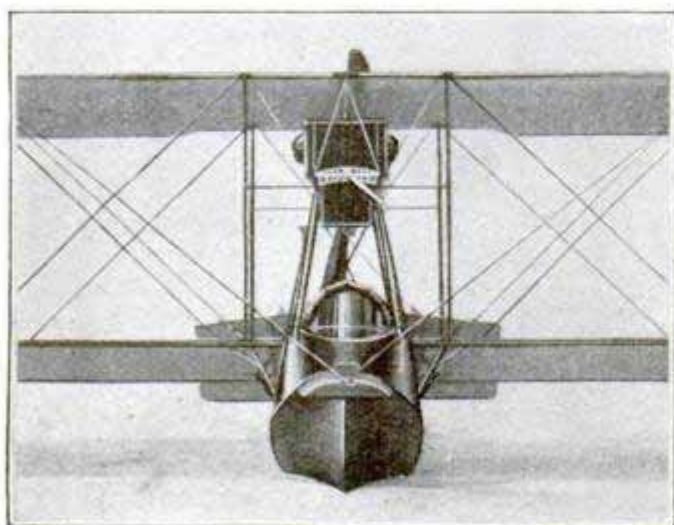

Flying Boat for Cruising

in that it has an entirely closed cabin. An oddly shaped hull, planked with crotch mahogany, is longer and higher in the bow, the seats are arranged in tandem, and celluloid windows protect the passengers and pilot from the elements. Indeed, the body of the boat is designed to afford adequate shelter, even if waves dash entirely over the craft. During the tests, a speed of from 60 to 65 miles an hour was attained.

## CURING HAY ARTIFICIALLY WITH STEAM HEAT

Experiments extending over five years have demonstrated that hay cured by steam heat is preferred by stock to the sun-dried article, and



Farmers may Make Hay Whether Sun Shines or Not

chemical analysis confirms this practical test by showing that the percentage of protein is higher in artificially cured hay. The method calls for a complete steam plant, where steam heat is secured from the exhaust of the engine. The freshly mown hay is drawn under a shed and pitched onto conveyor belts which carry it to the top of the building used in steam drying. The hay is carried back and forth over steam coils underneath the conveyors seven times. An even heat of 240° F. is maintained, and the hay remains on the conveyor from 20 to 40 minutes. When it is discharged it is well cured, of better color, and the leaves are preserved in better shape than hay cured in the fields in the ordinary way. The method lends itself to cooperative action among farmers.

## THUMB PRINT TO IDENTIFY WORKS OF ART

Fraudulent copying of works of art and passing them as genuine simply because of a forged signature upon the canvas, has led several French artists to agree that henceforth they will sign their works in thumb print, in order to prevent such frauds. The idea originated with one of the professors of the Sorbonne, the chief French center of learning. It is proposed that the artist shall press his thumb upon the moist paint in some inconspicuous part of the canvas. Sculptors will make their mark on statues by first impressing their thumb in gold powder for bronze statues, or in dye for marble, while engravers could put the print on the back of engravings. The artists will deposit impressions of their thumb prints with the minister of fine arts, and catalogs containing photographs thereof would be in the possession of all dealers. Identification would thus be easy, for even the cleverest swindlers would be unable exactly to duplicate the print of a master's thumb.

¶The total money in circulation in the United States at the beginning of 1914 was \$3,447,368,355.

## WATCHING FOR FIRES IN MOUNTAIN FORESTS

Every man in the National Forest Service knows what it means to let a fire get a good start. A few hours spent in fighting a small fire may save days of the hard and dangerous work

indication of a fire is discovered. Each lookout station is equipped with a plane table covered with a map on which a large circle, divided into 360 degrees, is drawn. Over this is placed

At Right: Lookout Station on Harney Peak, South Dakota. The Iron Legs of the Table are Fixed in Solid Rock

Below: Lookout in Cabinet Mountains, Montana, Sighting to a Column of Smoke That Reveals the Location of a Small Fire

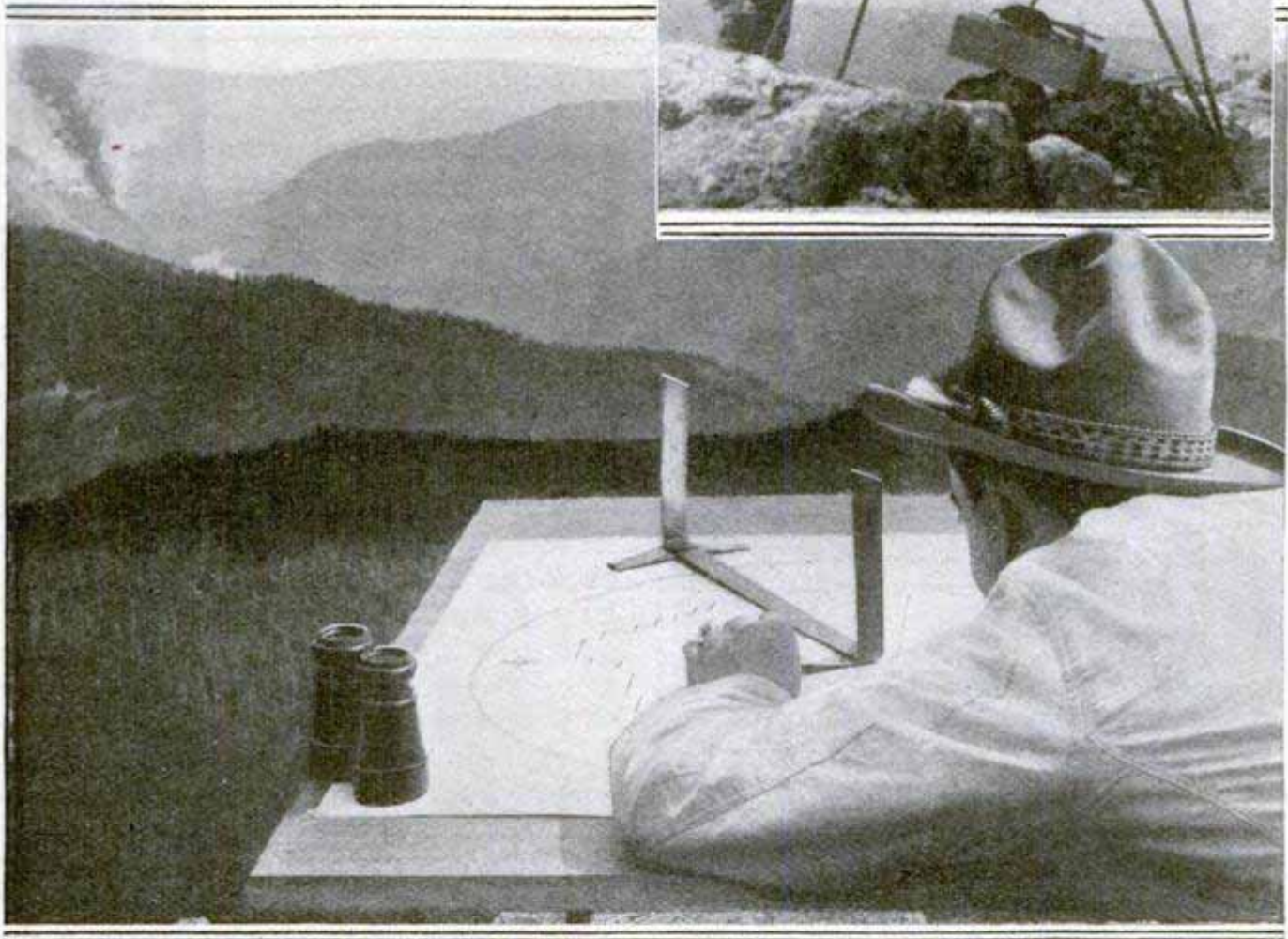

that follows when a fire is allowed to gain headway. The fire-fighting force in the national forests is therefore organized to detect and locate a fire accurately, the moment the first wisp of smoke appears, as well as to get to it and start fighting it without delay. In the mountain forests lookouts are placed on peaks that command extensive views of the forest, a constant watch is kept during the danger season by men equipped with binoculars, and in this way the first

a straightedge which carries two standards for sighting, the straight-edge being pivoted at the center of the circle. When a fire is discovered this instrument is sighted to it and the angle is read at the point where the straight edge intersects the circle. This angular measurement is telephoned to the supervisor's office, and, in combination with a similar measurement from another lookout, serves to locate the fire definitely on the map in the supervisor's office; the

location being found by drawing out the sight lines from the two lookouts to an intersection with each other.

### LIFE PRESERVER THAT FITS THE NECK

A cork life preserver which fits around the neck rather than under the arms and is designed to support even

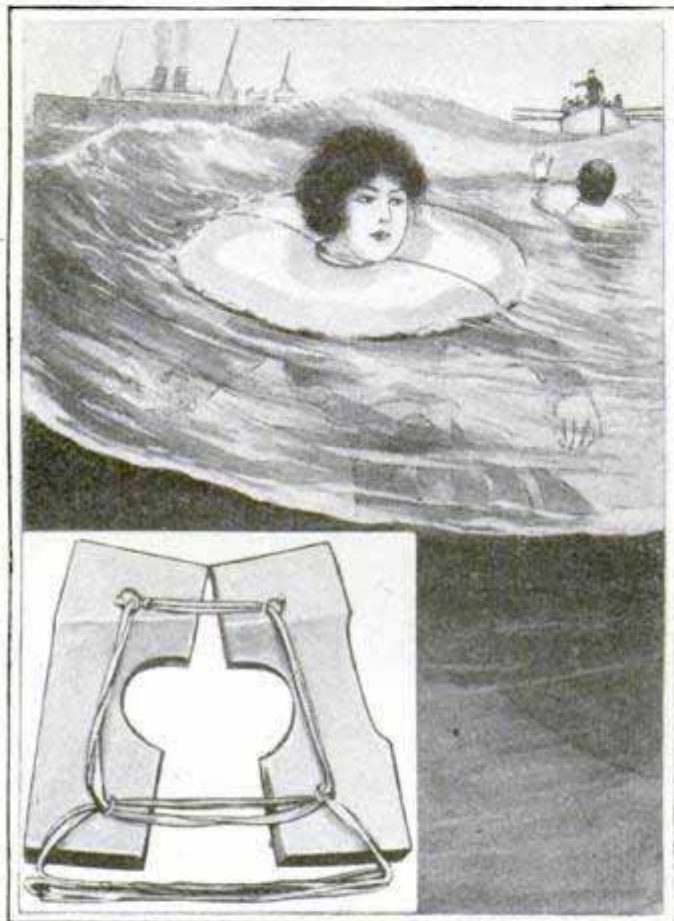

A Cork Life Preserver Which Fits around the Neck and will Support an Unconscious Person

an unconscious person has recently been placed on the market. The advantage claimed for the new life-saving device is that it does not permit the body to overturn and keeps the head above water under any circumstances. The life preserver is made of block cork covered with cotton drill and has under-arm straps arranged so that the body's weight is carried from rust-proof burrs on top.

As the result of several bad explosions due to sparks, most mine owners now forbid the use of a trolley motor for hauling a car containing powder.

### PROTECTING BOTTOM LANDS FROM FLOOD

Almost every kind of problem that can be met with in flood-protection work was encountered in the work of leveeing and draining the 150 square miles of Mississippi River bottom lands that spread out in a fan-shaped area to the north, east and south of East St. Louis, Ill. This district lies along the east side of the Mississippi River. Through the middle of it flows a small stream known as Cahokia Creek, which drains a 200-square-mile section of upland lying to the east and northeast. In time of flood this ordinarily insignificant stream brings down enormous quantities of water from the hills and becomes almost as great a problem as the Mississippi itself. When the two are in flood at the same time the result is likely to be a disastrous overflow, such as that of 1903 when many lives and millions of dollars worth of property were destroyed. Protection work has just been completed at a cost of \$6,500,000.

Although about 31 miles of levee were required, the problem of holding back the flood waters of the Mississippi was comparatively simple. The real difficulty lay in protecting the district from floods in Cahokia Creek. This was accomplished by means of a diversion channel, 100 ft. wide and 20 ft. deep, which taps the creek at the point where it comes out of the hills and carries its waters west along the northern edge of the district to the Mississippi. This channel is much shorter than the old, and if built on a straight grade, would cause the water to flow at a dangerously high velocity. To overcome this, two dams, both heavily protected with concrete and riprap, were placed near the lower end of the channel, and with the direct fall thus provided it was possible to build the remainder of the channel on a safe grade of 2 ft. per mile.

Cahokia Creek is still required to carry to the river most of the local drainage within the district. Where this creek passes through the levee are



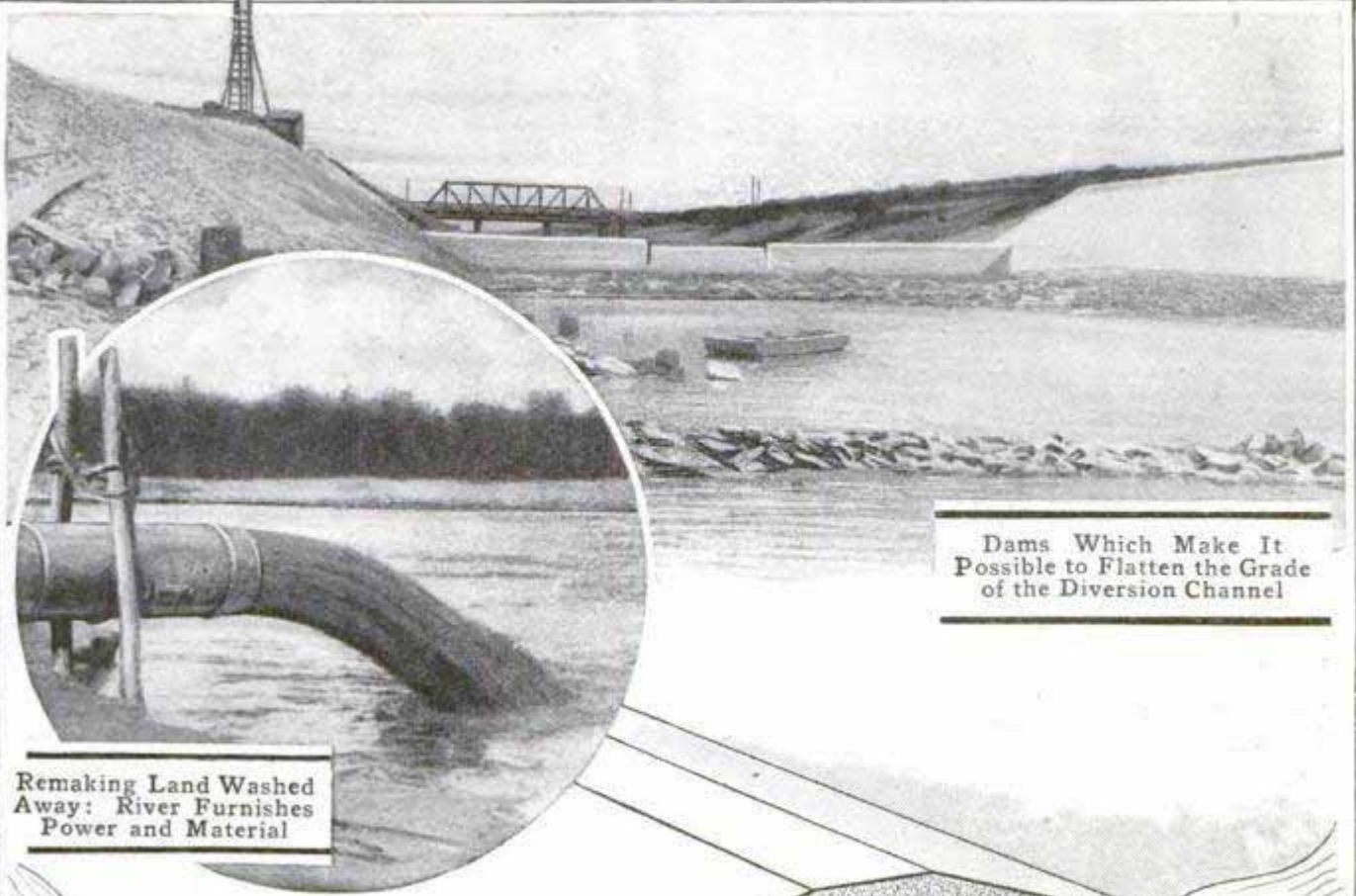

Dams Which Make It Possible to Flatten the Grade of the Diversion Channel

Remaking Land Washed Away: River Furnishes Power and Material

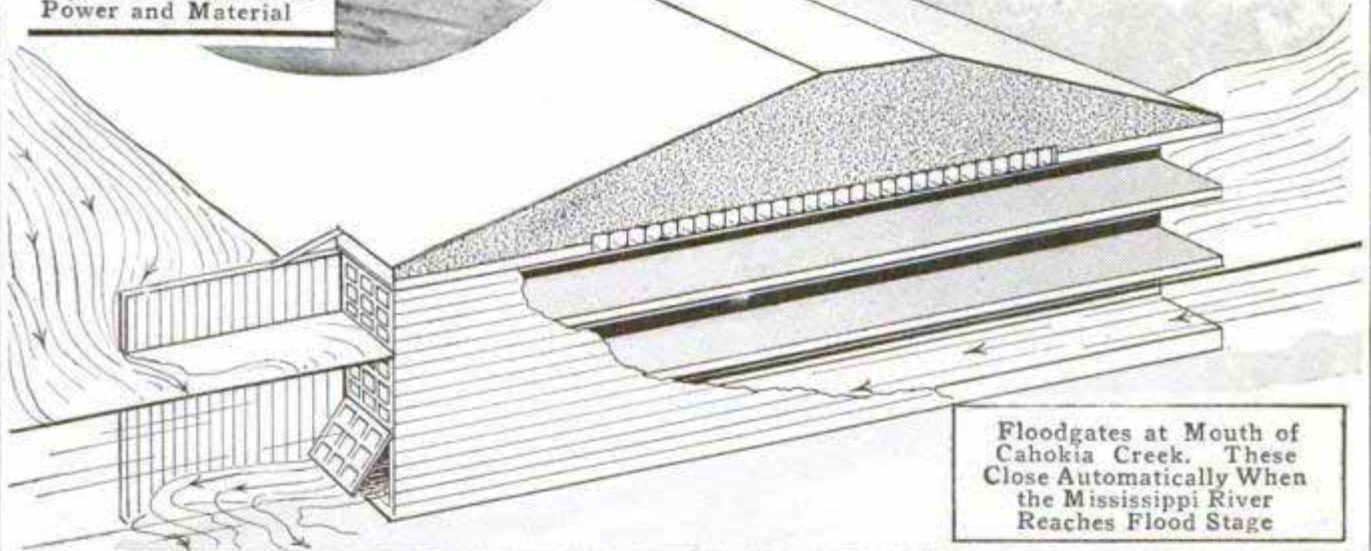

Floodgates at Mouth of Cahokia Creek. These Close Automatically When the Mississippi River Reaches Flood Stage

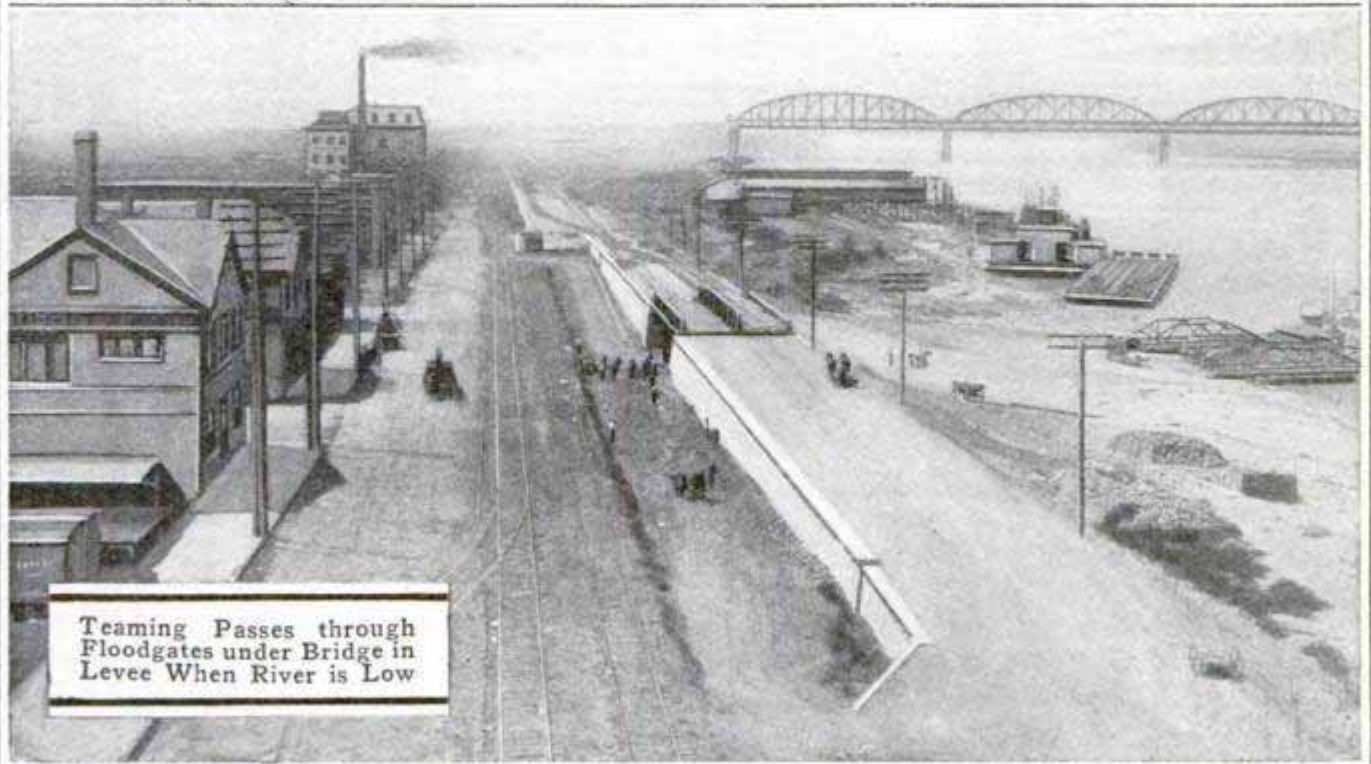

Teaming Passes through Floodgates under Bridge in Levee When River is Low

three steel floodgates, each 20 ft. high and 25 ft. wide, which permit the creek to discharge its waters through the levee at ordinary stages of the river, but close automatically to shut out the floods of the Mississippi. These gates

are hung vertically and operate like transoms. At one point a large area of land lying behind the levee was raised an average of 25 ft. by a hydraulic dredge pumping sand and silt from the bed of the river.

### CATHEDRAL SPIRES CARRY WIRELESS AERIALS

Recent destruction of the land lines and cables of the Mexican telegraph system by the rebels has brought wireless telegraphy to the forefront as



Wireless Aerials Strung between the Spires of a Mexican Cathedral

the only remaining means of telegraphic communication in that troubled country. At the time the wireless stations were erected, the appropriations were not sufficient to establish the elaborate type of installations common in the United States and Europe, but they are much better than nothing at all, and supplemented by the powerful wireless apparatus of the American and British war vessels scattered up and down the east

and west coasts of Mexico, fairly satisfactory results are obtained.

The intense heat of the tropical days precludes the operation of the wireless on account of the peculiar effect of the sun upon the atmosphere, but at night, messages are sent through the air to all parts of Mexico. Mazatlan, on the Pacific coast, is one of the busiest communication centers, as a great deal of relay work from all directions focuses there. Mazatlan is located in a valley, and a serious obstacle arose in the question of the aerial. To operate a wireless station with any degree of efficiency, the aerial wires must be at least 75 ft. above the instruments. This obstacle was overcome by stringing the aerial wires between the spires of the Mazatlan cathedral. The wireless apparatus is located in a small building in the plaza at the base of this structure.

### PILLARS WILL SUPPORT SINKING TOWN

Vast underground workings of big coal mines, beneath the town of West Scranton, so weakened the supporting strata that alarming sinkages were noticed within the city limits. Two coal companies have agreed to place supporting pillars underground, which, it is believed, will stop the dangerous condition, and prevent further sinking. The barrier pillars will be 100 ft. wide in each of 10 veins which have been mined, and will inclose three sides of a rectangle. The engineers estimate that five years will be required to complete the project.

It is estimated that the mails of the whole world carry nearly 6,000,000,000 picture postcards each year.

## USING AN OIL FILM TO PREVENT FOG

The city of Lyons, in the south of France, has long been subject to local fogs, which investigation has traced to the evaporation from the two important rivers which join at that point. French scientists who have studied the conditions, propose to float a thin film of oil over the surface of these rivers, preventing evaporation, and eliminating the humidity to which the fog is due. Sufficient funds have been provided by the municipality to experiment with various oils, in the endeavor to obtain such a combination of tenacity and resistance to wave action, as will prove of service. In practice, tow is soaked in oil and submerged in each river a distance above the city, and the oil, rising to the surface, spreads to a thinness of not more than one one-hundred-thousandth of a millimeter, a mere film, which is yet sufficient to stop evaporation of the water beneath, thus preventing fog

## SALAMANDER SUIT SCREENS FIREMEN FROM FLAME

A fireproof suit, consisting of two layers of specially prepared canvas, with space between for flowing water, has recently been invented, by which firemen are enabled to penetrate to the very heart of quite an intense fire without danger. Water connection with the suit is furnished by a half-inch connection with the fire hose, and a perforated ring of brass encircles the

neck through which the water flows down through the walls of the double suiting, and out at the finger tips and soles of the feet. Another perforated ring, surmounting the metal helmet, showers water continually over the

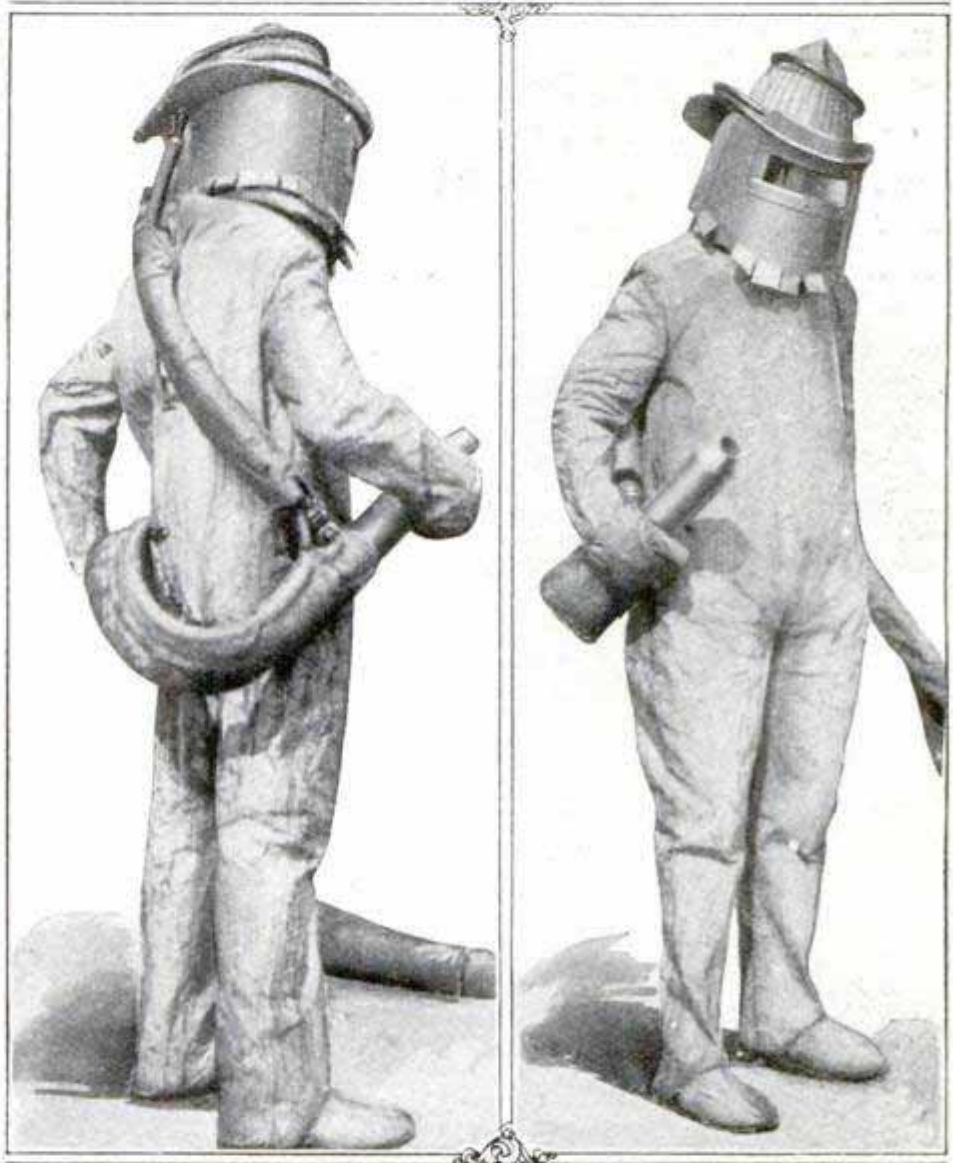

Fireproof Uniform Enables Fire Fighters to Defy the Flames

head and shoulders. Plenty of fresh air is forced into the helmet from an outside supply, pumped by a water motor through a  $\frac{1}{2}$ -in. line of hose spliced onto the fire hose, the motor and air hose being attached to a special section of regulation fire hose which is coupled to the main line. The novel suit can be donned in two minutes, and as it weighs but 25 lb., the wearer is not hampered by the weight. The helmet has mica eyepieces, and its lower part fits under the suit about the neck, making it impossible for steam, smoke or hot gases to penetrate.

The advantage of being able to direct the water directly upon the fire, instead of being obliged to stand at a great distance, is so obvious that the new appliance is interesting fire chiefs the country over.

### MEXICAN RAINCOAT MADE OF PALMETTO LEAVES

The mountaineers of Mexico who have to endure the torrential rains of their climate, wear a serviceable cover-



Mexican Rurale in Palmetto Raincoat

ing made of palmetto leaves, which proves thoroughly waterproof, and is cheaply constructed. A closely woven cloak hung from the shoulders, with a fringe of leaves extending downward from the collar, protects the body of the wearer, while the great hat, its brim turned down, makes a cupola for the

head, and the whole outfit sheds water like a duck. Another advantage is that the palmetto leaves blend so perfectly with the grass and soil, that the wearer is inconspicuous and makes a poor target in a land where targets are perforated on the slightest provocation. The photograph is that of a member of the "rurales," or constabulary, of Mexico.

### MEMBERS OF CONGRESS MAY VOTE BY ELECTRICITY

A subcommittee of the House of Representatives is considering a proposed system of recording and registering the votes of members by means of an electrical device, operated by a series of buttons placed on the desk of each member. A member of Congress from New Jersey, himself an electrician, has evolved the system, which seeks to eliminate the waste of time necessitated by the long roll calls, in which not less than 40 minutes is consumed, while by the installation of the new system not more than five minutes will be necessary to record and tabulate the vote and announce the result. One of Thomas A. Edison's earliest inventions was a device for recording votes electrically, but at the time it was made, more than 40 years ago, he could get no encouragement for its development.

### \$10,000 PRIZE FOR NEW TIRE MATERIAL

A nonrubber automobile tire which will be cheaper than the present kind, yet possess certain standard resiliency and durability, is being sought by the war department of Austria, and a prize of \$10,000 will be awarded to the person who fulfills the conditions, submitting a small or working-size model suitable for motor freight wagons, on or before June 30, of this year. Besides the specific attributes of pure rubber, such as adhesiveness and elasticity, the new material must not be heavier than pure rubber, and it must be more economical in use.

# A TRIP ACROSS THE ATLANTIC

II



Sand Boxes on the Deck  
Provide Amusement for the  
Younger Children.

**I**N THIS second series of photographs illustrating a voyage across the Atlantic in a great modern passenger steamship, some of the more interesting and elaborate provisions for the safety, comfort and entertainment of the passengers are shown. Today ocean travel is more luxurious than ever before, but its cost has not increased proportionally to the accommodations provided.

Few people realize how much less expensive it is to travel by sea than on land. The first-class railroad rate from Chicago to San Francisco, for instance, is \$59.75, to which must be added the cost of a Pullman berth and of meals en route. This figures out at nearly  $4\frac{3}{4}$  cents a mile for transportation alone, while the first-class rate for the 3,300 miles between New York and Southampton, which includes both meals and comfortable sleeping quarters, amounts to less than four cents a mile, and the second-class rate on the largest ships takes the traveler across the ocean, feeds him and provides his bed, all for less than  $2\frac{1}{2}$  cents a mile.

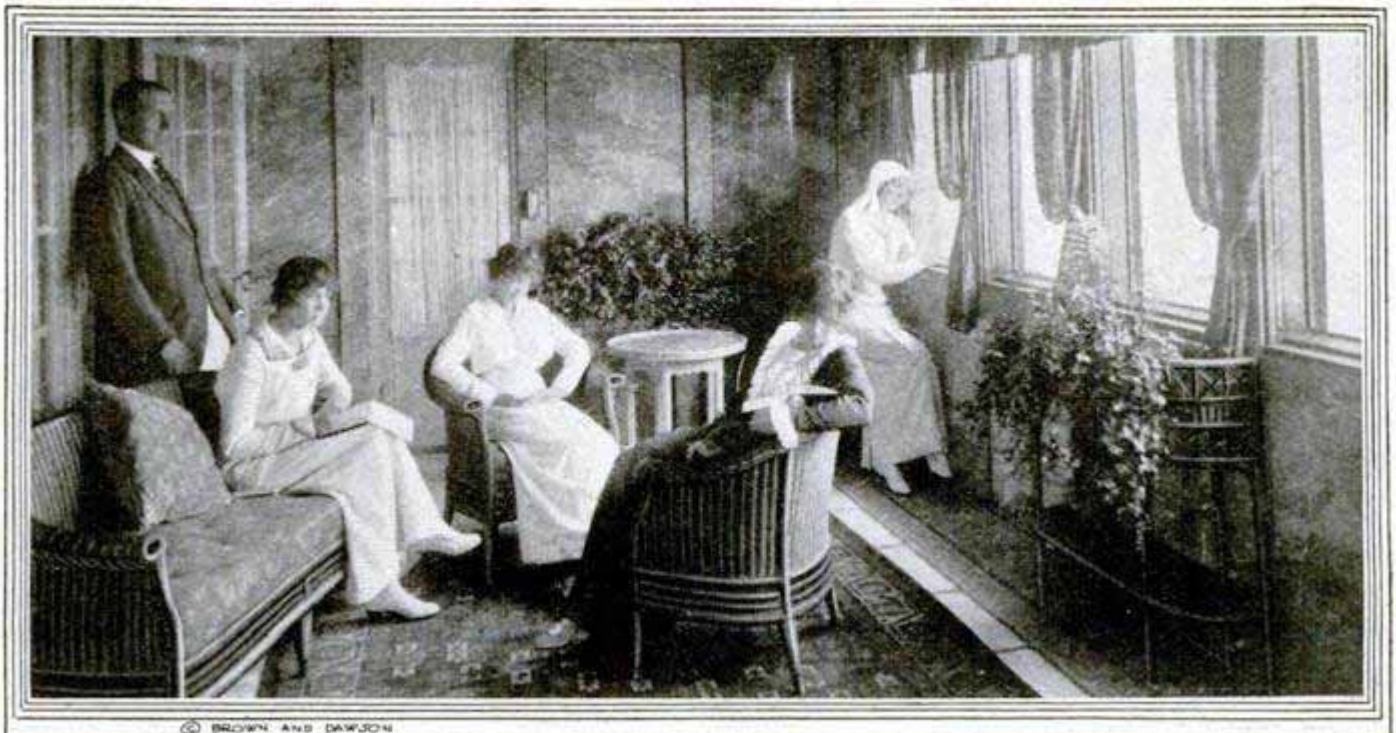

© BROWN AND CAWTON

This View of One of the First-Class Suites Gives an Idea of the Luxury Attainable in Modern Travel

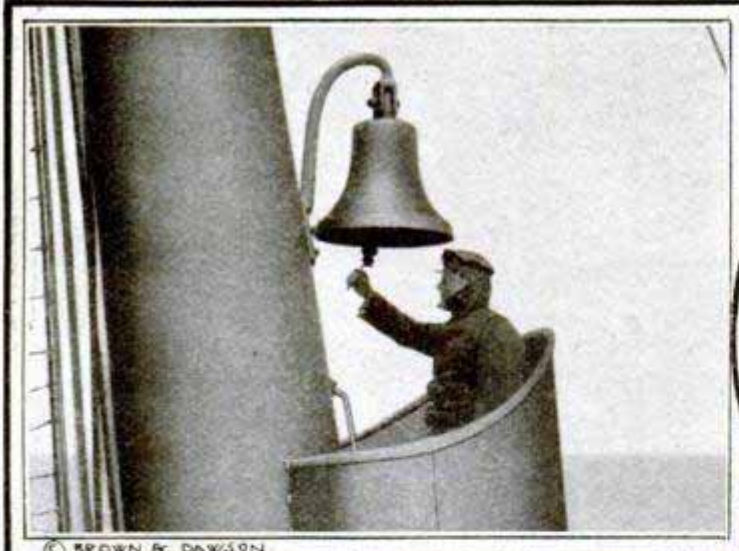

© BROWN & DAWSON

"All's Well." The Lookout in the "Crow's Nest" on the Foremast Watches for Icebergs and Other Ships

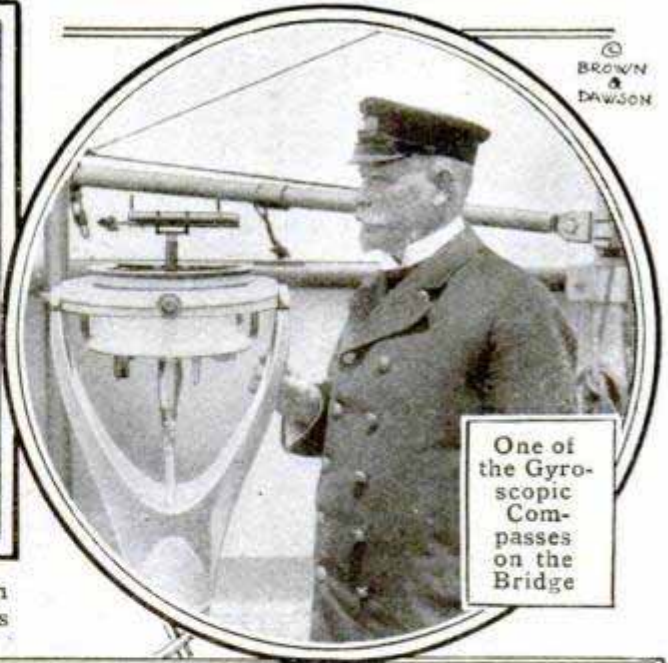

One of the Gyroscopic Compasses on the Bridge

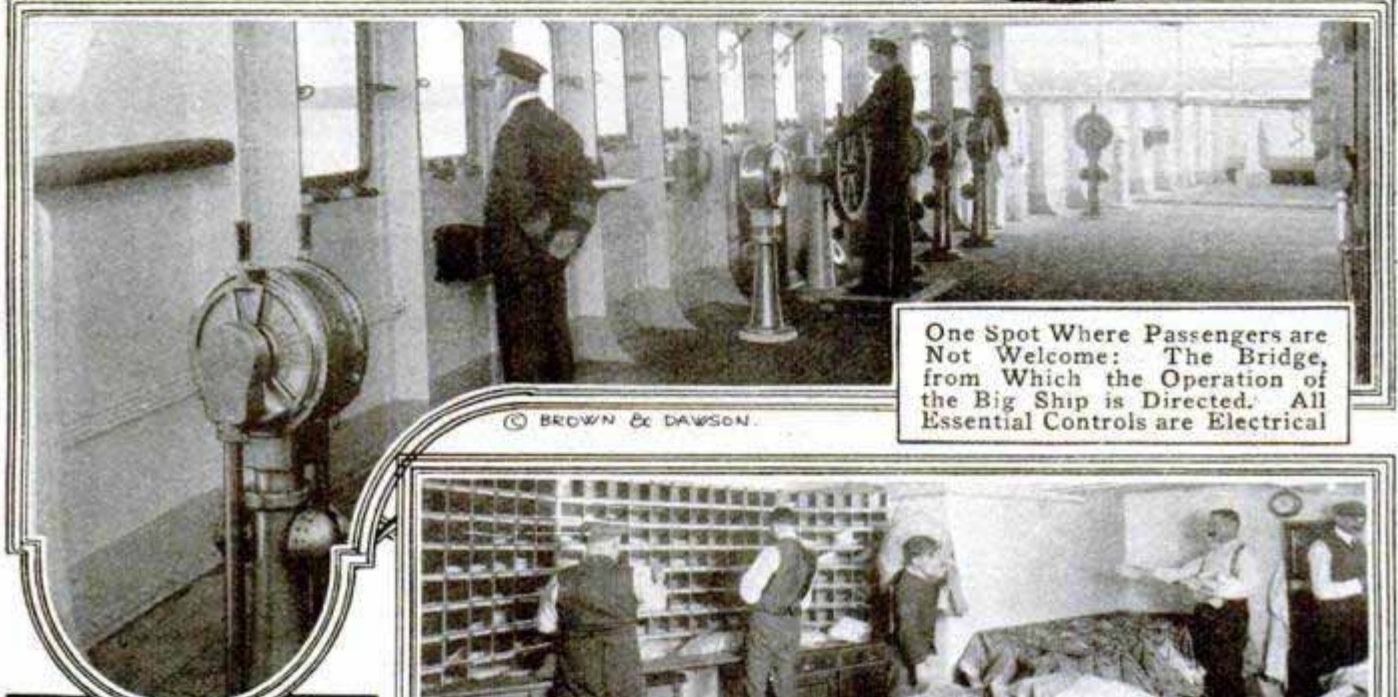

© BROWN & DAWSON

One Spot Where Passengers are Not Welcome: The Bridge, from Which the Operation of the Big Ship is Directed. All Essential Controls are Electrical



The Sea Post Office, Where American and European Postal Clerks Route All Mail

© BROWN & DAWSON



© BROWN & DAWSON

A Telephone Booth: One may Talk to Any Part of the Ship

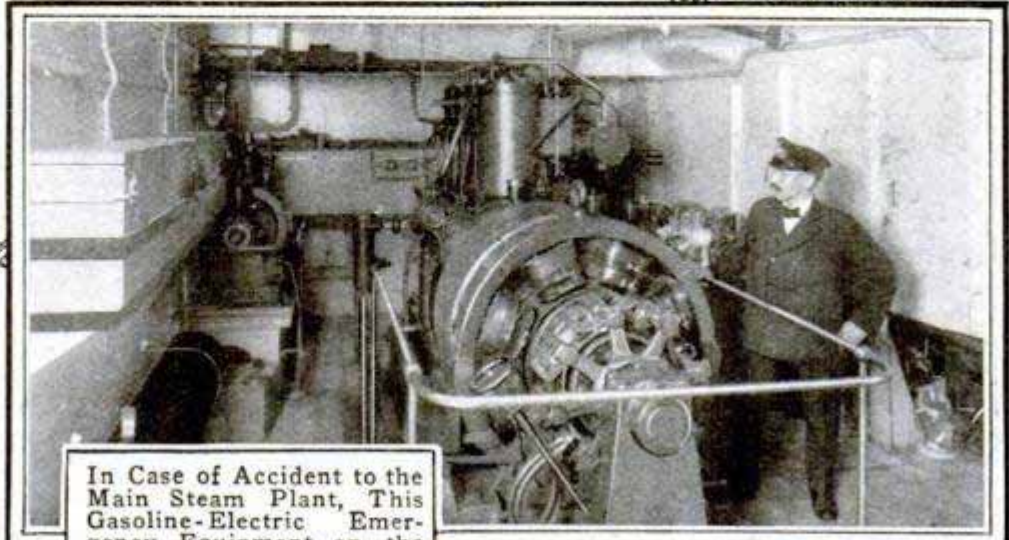

In Case of Accident to the Main Steam Plant, This Gasoline-Electric Emergency Equipment on the Upper Deck would Keep Lights and Wireless Going

© BROWN & DAWSON



BROWN AND DAWSON PHOTO

Third-Class Passengers are Not Barred from the Comforts of Deck Chairs



BROWN AND DAWSON PHOTO

A Scene in the Third-Class Smoking Room—Plain but Comfortable

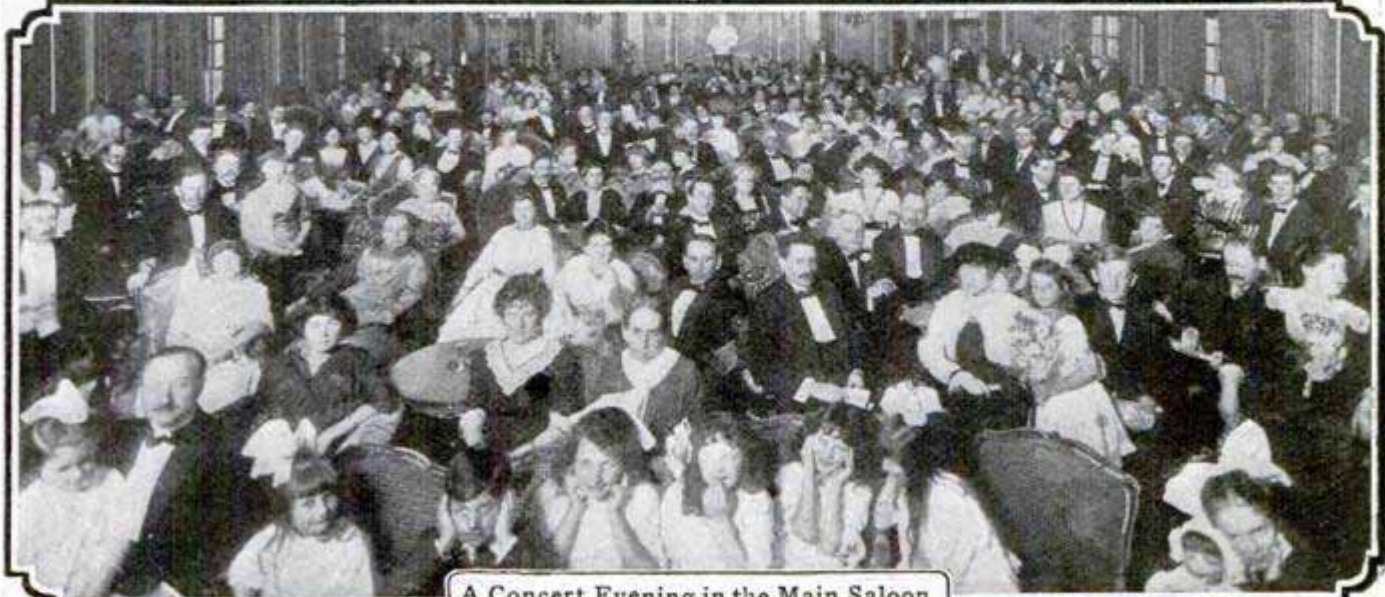

A Concert Evening in the Main Saloon

© BROWN AND DAWSON



© BROWN AND DAWSON

Sports and Games Break the Monotony of the Days at Sea: A Three-Legged Race on Deck



Taking It Easy on the Second-Cabin Promenade Deck

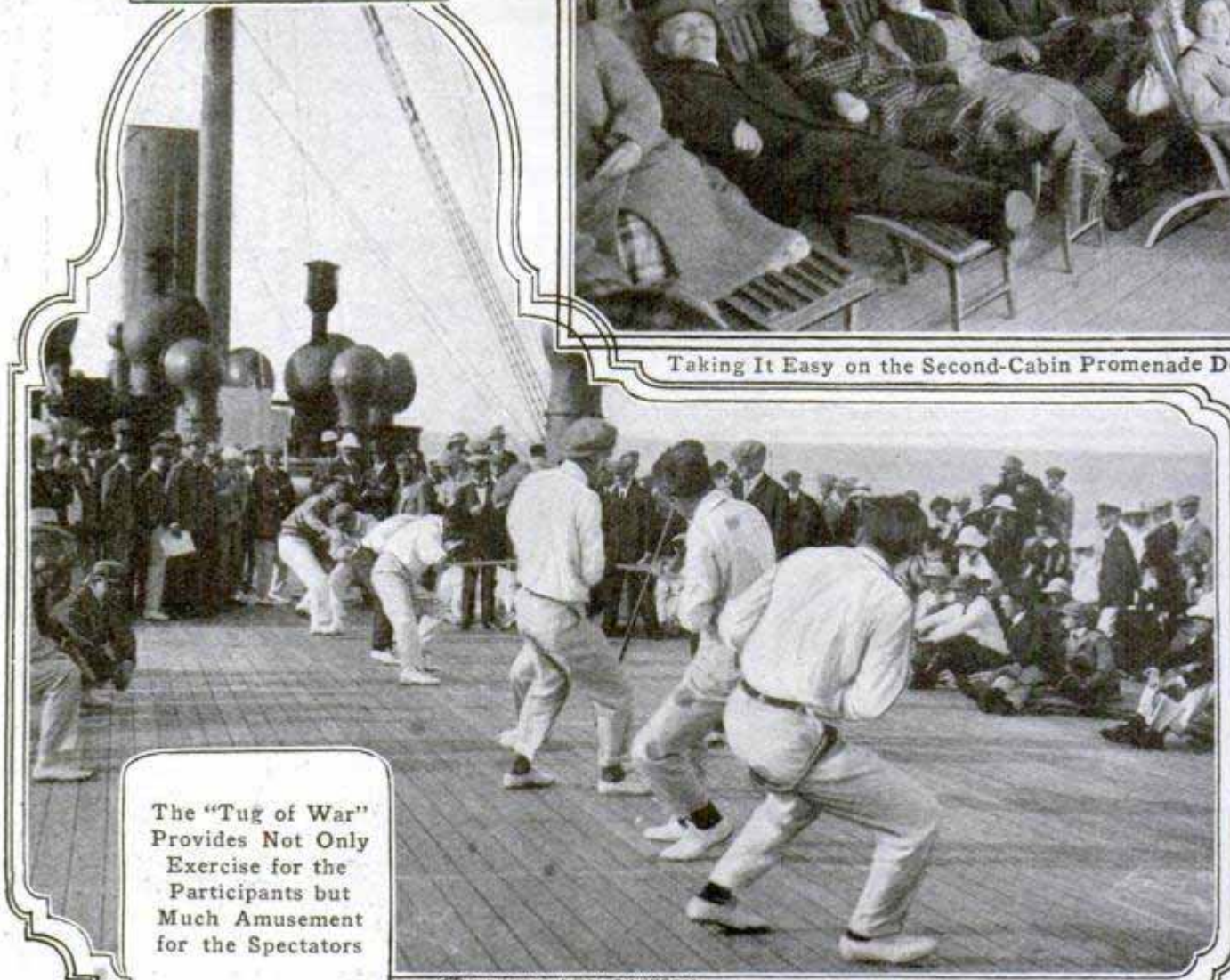

The "Tug of War" Provides Not Only Exercise for the Participants but Much Amusement for the Spectators

© BROWN AND DAWSON





PHOTO BY BROWN AND DAWSON

First-Cabin Passengers Watching a Girls' Potato Race on a Sunny Day at Sea

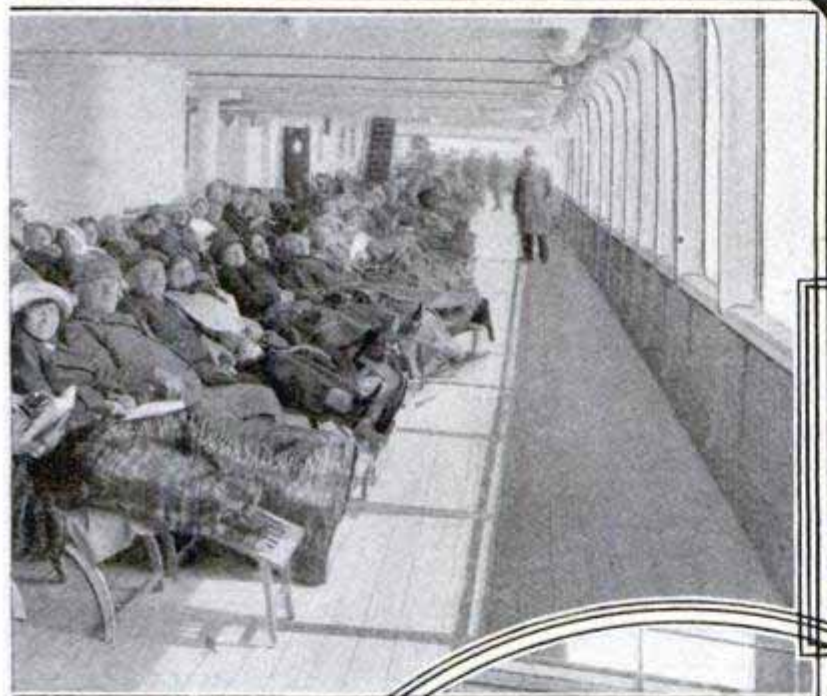

COPYRIGHT BY BROWN AND DAWSON



PHOTO BY BROWN AND DAWSON

The Children Enjoy Listening to the Stories the Social Director Tells Them



Fresh Flowers can be Had Every Day from the Greenhouse on Deck

© BROWN AND DAWSON

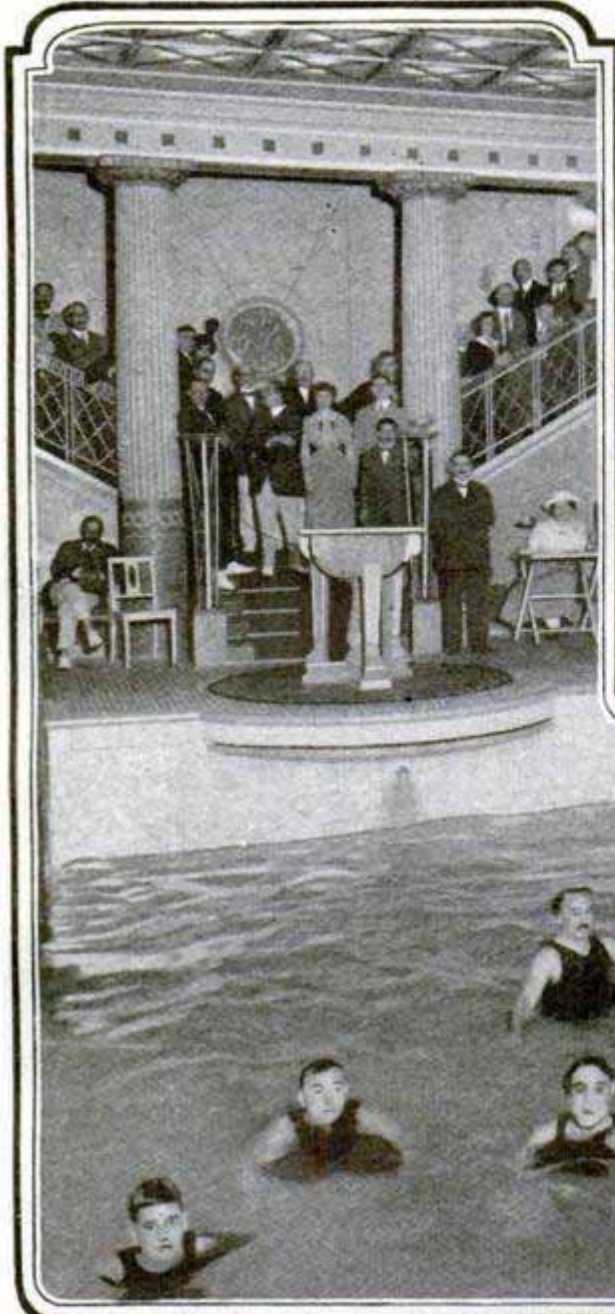

In the Marble Swimming Pool of the Roman Baths

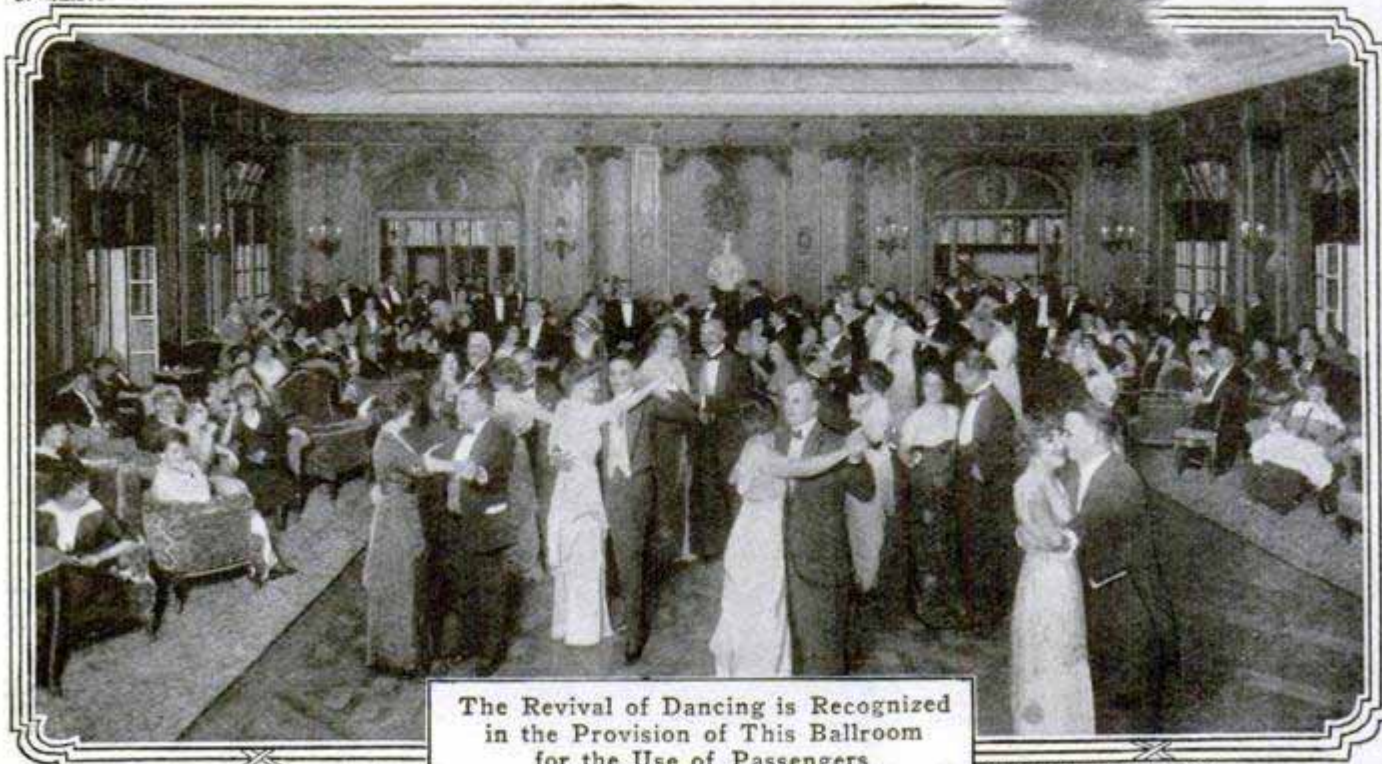

The Revival of Dancing is Recognized in the Provision of This Ballroom for the Use of Passengers

Luncheons  
between Meals  
and Afternoon  
Tea are Served  
by Stewards  
on the Decks



The After  
Deck Gives  
Fresh Air  
and Quiet

BROWN AND DAWSON



BROWN  
AND  
DAWSON

One of the  
Electric Cranes  
for Handling  
Baggage and  
Cargo

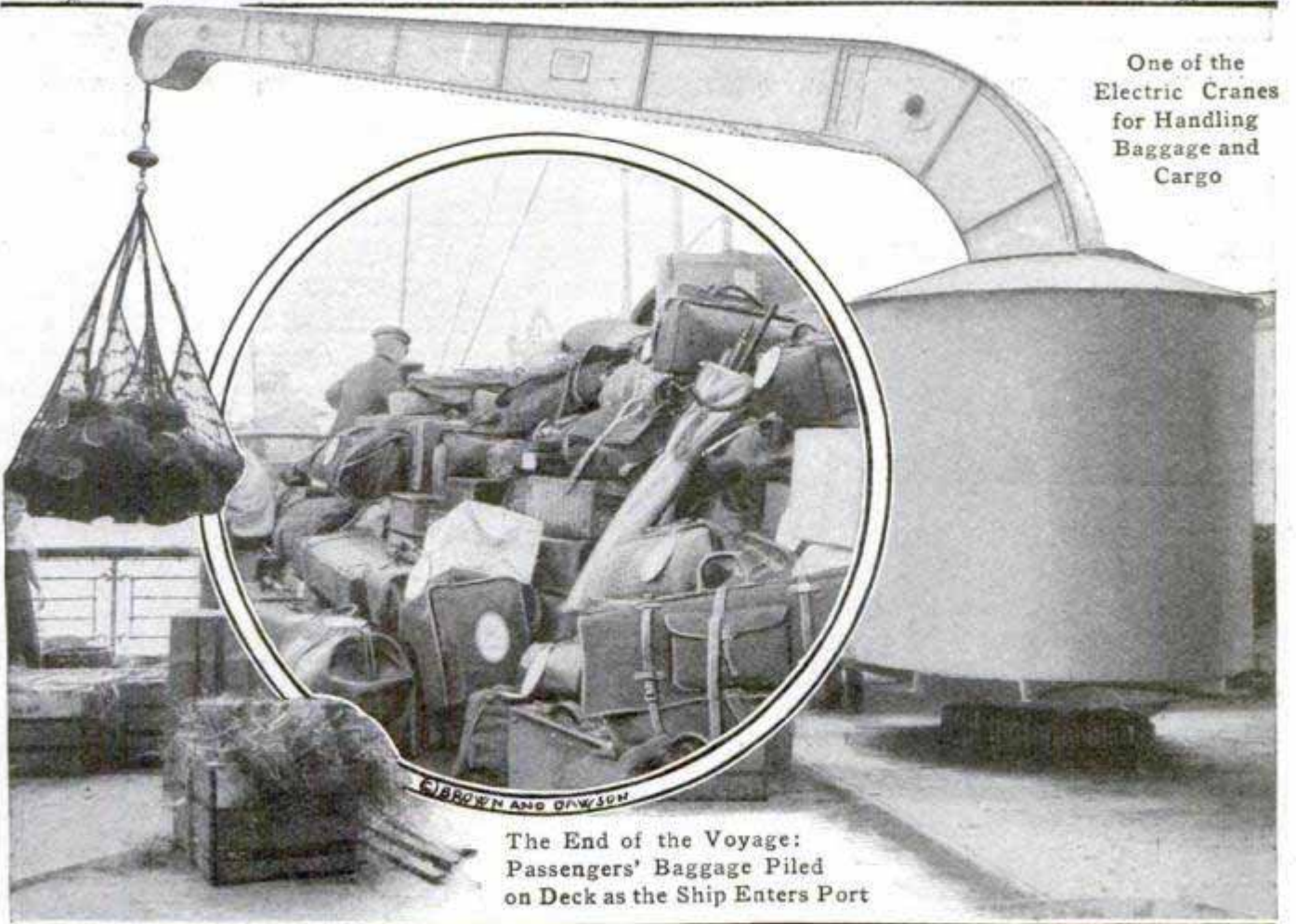

The End of the Voyage:  
Passengers' Baggage Piled  
on Deck as the Ship Enters Port

PHOTO BY BROWN AND DAWSON

## GRENADE THAT IS FIRED FROM A RIFLE

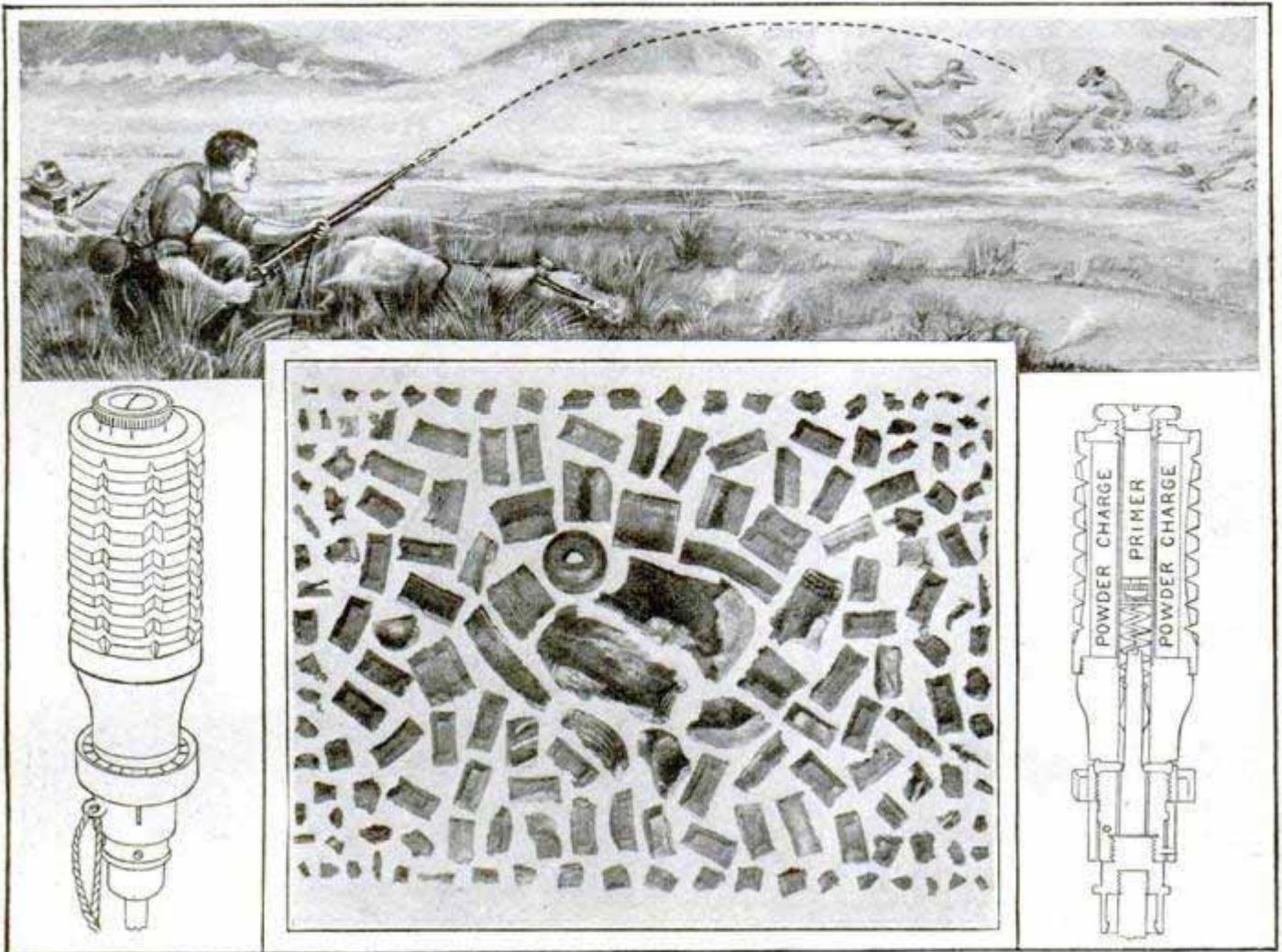

A New Type of Explosive Grenade That is Fired from a Rifle and can be Carried by Infantry Troops

With the development of the rifle grenade to the point where it may be fired without danger of premature explosion and with practical certainty that it will explode when it hits the ground, even at a sharp slant, so effective an instrument of offense and defense has been provided that it is likely to bring about important changes in military tactics. Before the advent of long-range guns, when opposing troops would often get close enough to each other to make it possible to use such missiles effectively, the hand grenade was one of the indispensable implements of warfare. Now, it appears, the same implement, fired from a rifle, is to become more important than ever.

The rifle grenade has already been adopted in some countries as an integral part of the soldier's equipment, and is likely to come into general use

among the armies of the world. It is expected that it will to a great extent supplant the use of the bayonet and do away with the necessity for close-quarter fighting, as it will provide a means for attacking trenches and covered positions and rendering them untenable without recourse to hand-to-hand combat. The grenades can be fired singly or in volleys and the effect of volley firing with such weapons would probably be astounding. In hilly country especially, where the bringing into action of field pieces is extremely difficult, the use of the grenade will prove of incalculable benefit to the troops equipped with it.

This new man-killing device consists of a cylindrical metal case with a rod projecting from one end for insertion in the barrel of the rifle. Inside the metal case, which is deeply serrated so that it will break into

numerous fragments when exploded, is a cylindrical mass of some explosive. Through the center of the explosive is a hole for the detonator and the firing pin, which are arranged so that the pin will be thrown against the detonator and will explode it when the grenade strikes the ground or other object. The firing pin is provided with a shoulder near the lower end, and is held rigidly in place by transverse pins that bear against this shoulder. When the grenade is fired from the rifle the impact against the air sets a small vane wheel in motion, which draws the pins out of contact with the shoulder and releases the firing pin, but not until the grenade has reached a point 15 yd. from the muzzle of the gun. The firing pin is then free to plunge against the detonator and explode it the instant the grenade strikes any object. In this way all danger of premature or accidental explosion is prevented, while the grenade is made a reliable and effective weapon for use against the enemy. For effective work, especially at close range, the rifle is fired at a high angle with a resulting dropping fire, after the manner of a mortar, the desired angle of elevation being obtained by means of a combined sight and angle-measuring instrument fitted to the rifle stock just below the back sight.

### LIFEBOATS ARE EQUIPPED WITH WIRELESS

The latest application of wireless as an aid to navigation is the equipment of the lifeboats of the new transatlantic liner "Aquitania" with Marconi apparatus. With a skillful operator on board and with the storage batteries well charged, there need now be no danger of a lifeboat loaded with refugees drifting away, out of the steamship lanes, to dreadful death. The rapid increase of wireless operators may make this plan of high service, although its complete utilization calls for the extreme limit of efficiency and preparedness in the ship's company.

### IRON SPIKES GIVE AID IN SCALING THE ALPS

The difficulties encountered by Alpine climbers make the ascent of the famous peaks an arduous undertak-



Alpine Climbers on a Stairway of Spikes

ing, even under the most favorable circumstances. In some dangerous spots helps in the shape of iron steps, or ladders formed by driving spikes into the steep sides of the mountain, are resorted to. Even with these aids, the men and women who attempt the feat must be prepared for strenuous exertions. The way to the top is difficult and often dangerous. Many lives are lost every year. The view given here shows how the iron spikes are driven into a mountain side.

## POWERFUL TURBINES OF THE "VATERLAND"

The most powerful steam turbines ever installed aboard ship are those for propelling the "Vaterland," the largest ship in the world, which is now being completed at Hamburg, Germany. The turbines and the last of the other heavy machinery are being placed in position and it is expected that this vessel will make its first trip across the Atlantic early this summer. The turbines are of the Parsons type. Some idea of their size may be obtained from the illustration showing one of the rotors being lowered into position in the ship. This rotor is  $17\frac{1}{2}$  ft. long and 17 ft. in diameter, weighs

from the fraction of an inch at the small end to nearly two feet at the large end of the turbine. The turbine of which this rotor is a part is capable of developing over 22,000 hp. The "Vaterland" is a sister ship of the "Imperator," which entered the transatlantic service in the summer of 1913, but surpasses that ship in every dimension, being 950 ft. in length, 100 ft. in beam, and having a carrying capacity of 58,000 tons.

### TECHNICAL TERMS USED BY ROPE MAKERS

With the average man a rope is simply a rope. But among makers, as well as among sailors and other expert

users, a number of exact technical terms are in use for distinguishing the different parts and types of this common commodity. One curious feature is that fiber and steel ropes are measured in different ways. When the size of a fiber rope is given, the dimension refers to the circumference, while with a steel cable it refers to the diameter. Thus a 5-in. fiber rope is one having a diameter of about  $1\frac{9}{16}$  in. In the manufacture of fiber rope, three or more strands twisted together form what is called a common-laid rope. Each of these strands, in turn, has been made by twisting together two or more yarns or threads, the latter consisting simply of a number of fibers twisted firmly together. The strand has a twist opposite to that of the

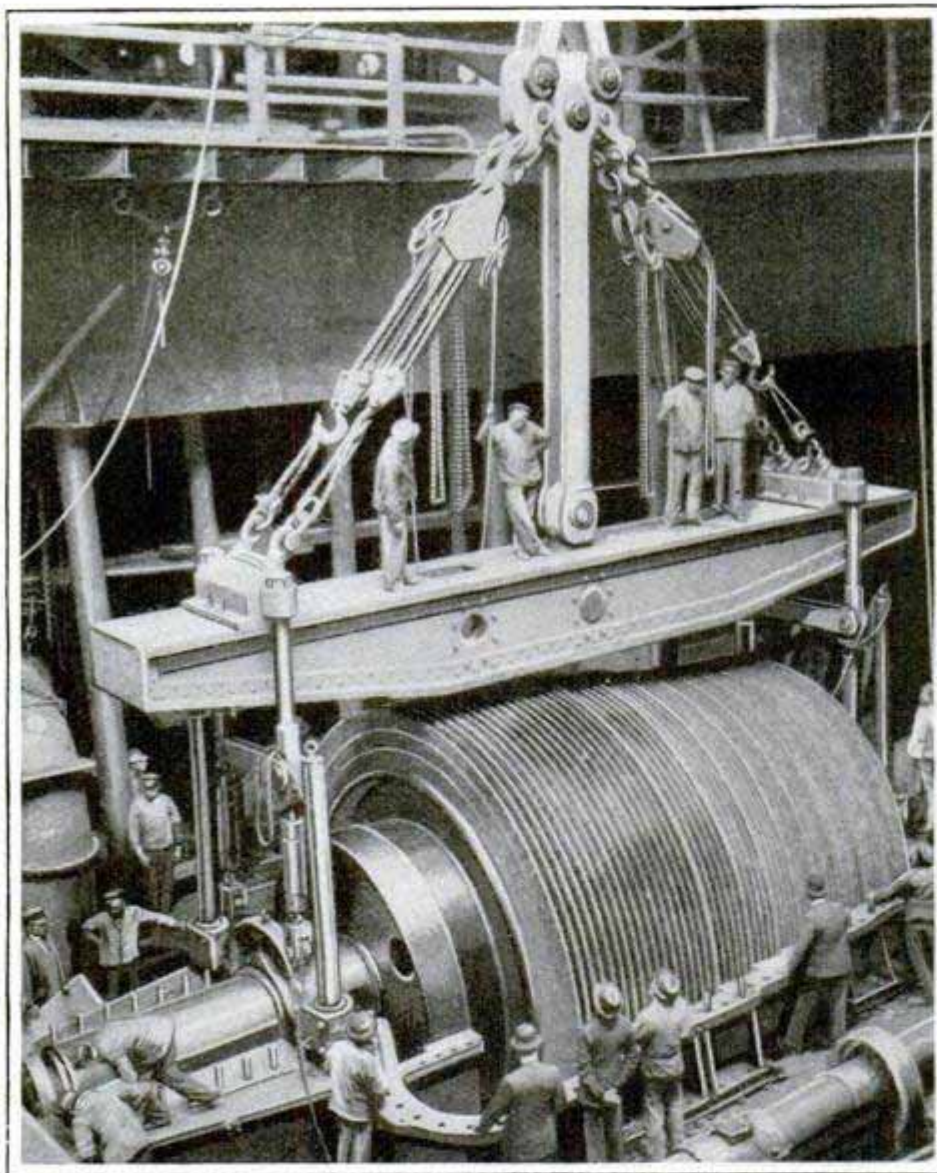

Lowering a 135-Ton Rotor into the Hold of the "Vaterland." The Turbine of Which This is a Part is Capable of Developing over 22,000 Horsepower

135 tons, and is studded with thousands of blades varying in length

yarns or threads, while the rope has a twist opposite to that of the strands

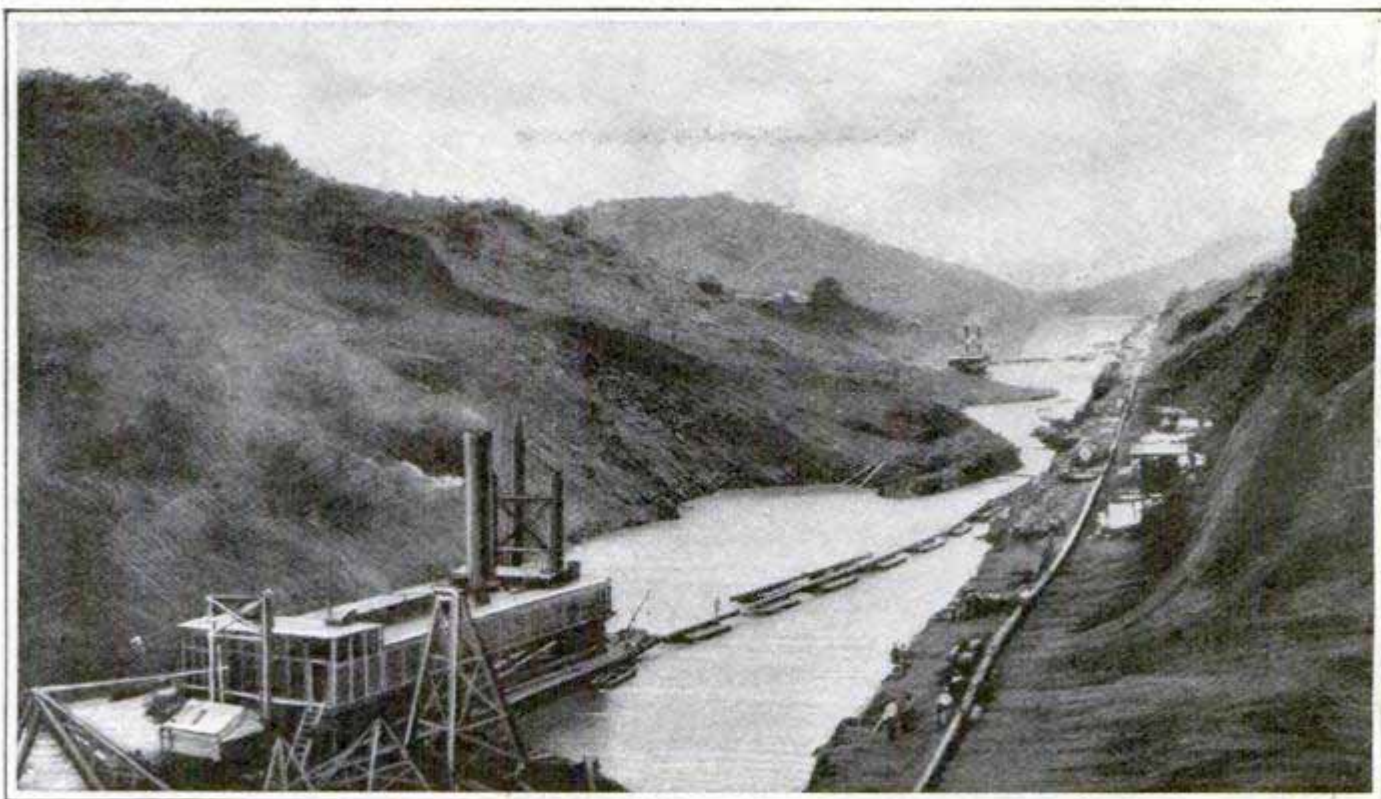

Dredging a Channel through the Cucaracha Slide in the Panama Canal

that compose it. The degree of twist is designated as the lay, which is a term used for giving the number of twists per foot of rope. The more twists to the foot, the harder will be the rope, and the lay is therefore often given as varying degrees of hard and soft. Where the strands are twisted together in a clockwise direction the resulting rope is right-laid. If the twist is in the opposite direction the rope is left-laid. A hawser and a hawser-laid rope are not the same thing. The first is simply a large common-laid rope suitable for towing, while the hawser-laid or cable-laid rope is made of three or four common-laid ropes twisted together. A piece of rope 1,200 ft. long is called a coil, while one half that length is called a half-coil.

### SLIDE THAT FILLED THE MAW OF PANAMA

Cucaracha slide has been the bane of Panama. Lying toward the southern end of Culebra Cut, the earth here has slipped and slid, as the canal was deepened and widened, until the so-called "angle of repose" was reached, where it was supposed no more movement would take place. But the pressure of

the masses of earth, at Gold Hill and on the opposite side of the canal, was so great that apparently the softer under strata of earth flowed out toward the canal, and an earthen glacier moved hundreds of thousands of cubic yards into the cut. The photograph gives an accurate view of the slide, and shows the dredges attacking it from either end. In less than two months the slide had been cleared sufficiently to permit the passing of vessels.

### COMPACT SELF-HEATING SOLDERING IRON

A particularly compact self-heating soldering iron is here shown.



The fuel is carried in the handle. Any degree of heat may be had in a few moments, and the operating cost is about two cents a day. The iron can be converted into a torch by attaching a brazing burner to the generator, and may also be used as a branding iron.



Curious Sight in Cairo Tailor Shop

### CHEAP WAY OF BUILDING CLOTHESLINE POST

A good example of economical construction is shown in a concrete clothesline post

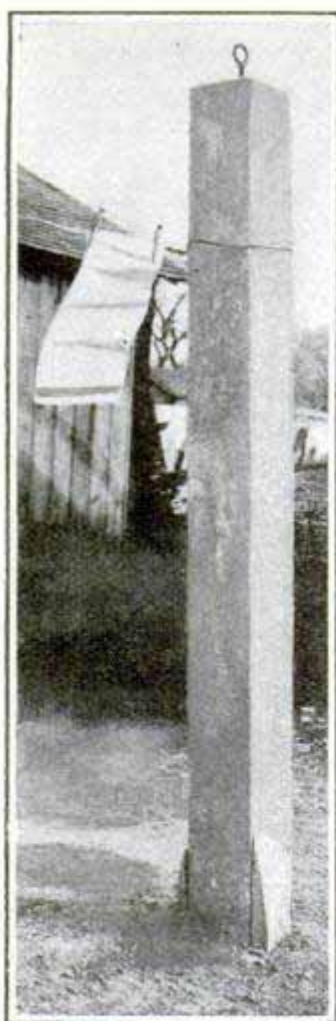

as shown, and serves as a hold for the clothesline.

made by an enterprising suburbanite. The cement and crushed stone were obtained from the surplus left after building a sidewalk, while the reinforcing consists of old wagon end-gate rods dug out of a scrap heap. The form for molding the post was made from old boards that were lying about the place, and the work was done by the owner. One of the end-gate rods was allowed to stick out at the top,

### CAIRO TAILORS IRON WITH THEIR FEET

Of all the curious sights marked by travelers in the East, none occasions more comment than the strange custom observed in the bazars of Cairo, where tailors still use their feet in ironing and pressing clothing. A broad flatiron with a long handle is used, and a block of wood is fitted over the hot iron, upon which the tailor places his foot. He manipulates the iron by means of the iron handle. The posture assumed by these workmen appears to be awkward in the extreme, but it seems to cause them no inconvenience.

### GOVERNMENT PUTS AIRMEN TO RIGID TESTS

Before granting a certificate to airmen, the U. S. Army Signal Corps requires the applicant to pass certain tests of proficiency. He must make a cross-country flight of 20 miles, or more, at a height of at least 1,000 ft. With the wind blowing not less than 15 miles an hour, he must fly for five minutes. Again he must show his proficiency by carrying a passenger to a height of 500 ft. and, on landing, bring his machine to rest not more than 150 ft. from a designated spot, with his



engine entirely shut off before reaching the ground. He must volplane to the ground from a height of 500 ft. with the engine shut off, in another test, stopping the machine within 300 ft. of some point marked by the umpires. The last test required is a military reconnaissance flight of not less than 20 miles, bringing back information concerning the lay of the land, or other specific matters upon which he is ordered to report. In this flight he must maintain an average height of 1,500 ft. above the ground.

Apple wood is used for making saw handles and also for making many of the so-called brier pipes.

## POWERFUL SEAGOING TUG FOR PORTLAND

To enable the largest type of vessels and steamers to negotiate the Columbia Bar, the Port of Portland Commission has authorized the construction of a powerful tug, which will rank with the largest on the Pacific coast. The new vessel will be 165 ft. long, with 30-ft. beam and a draft of from 17 to 20 ft., and will be equipped with a triple-expansion engine of 2,000 hp., two boilers, a powerful towing machine, together with a wrecking pump and a steel boom forward, capable of lifting 15 tons. The new vessel will also have a complete wireless outfit.

## LARGEST MASONRY ARCH UNDER CONSTRUCTION

A fine example of scaffolding is shown in a bridge recently constructed in Switzerland. The bridge itself is about 950 ft. long, and the central arch, shown in the photograph, is over 205 ft. high, with a span of 330 ft., making it, for the moment,

at least, the largest masonry arch in the world. The graceful fan-shaped supports of the scaffolding, while by no means unusual in bridge building, are infrequently seen by others than bridge engineers and construction men. A railway will run over this bridge when completed.



Archway for Viaduct at Langwies, Switzerland

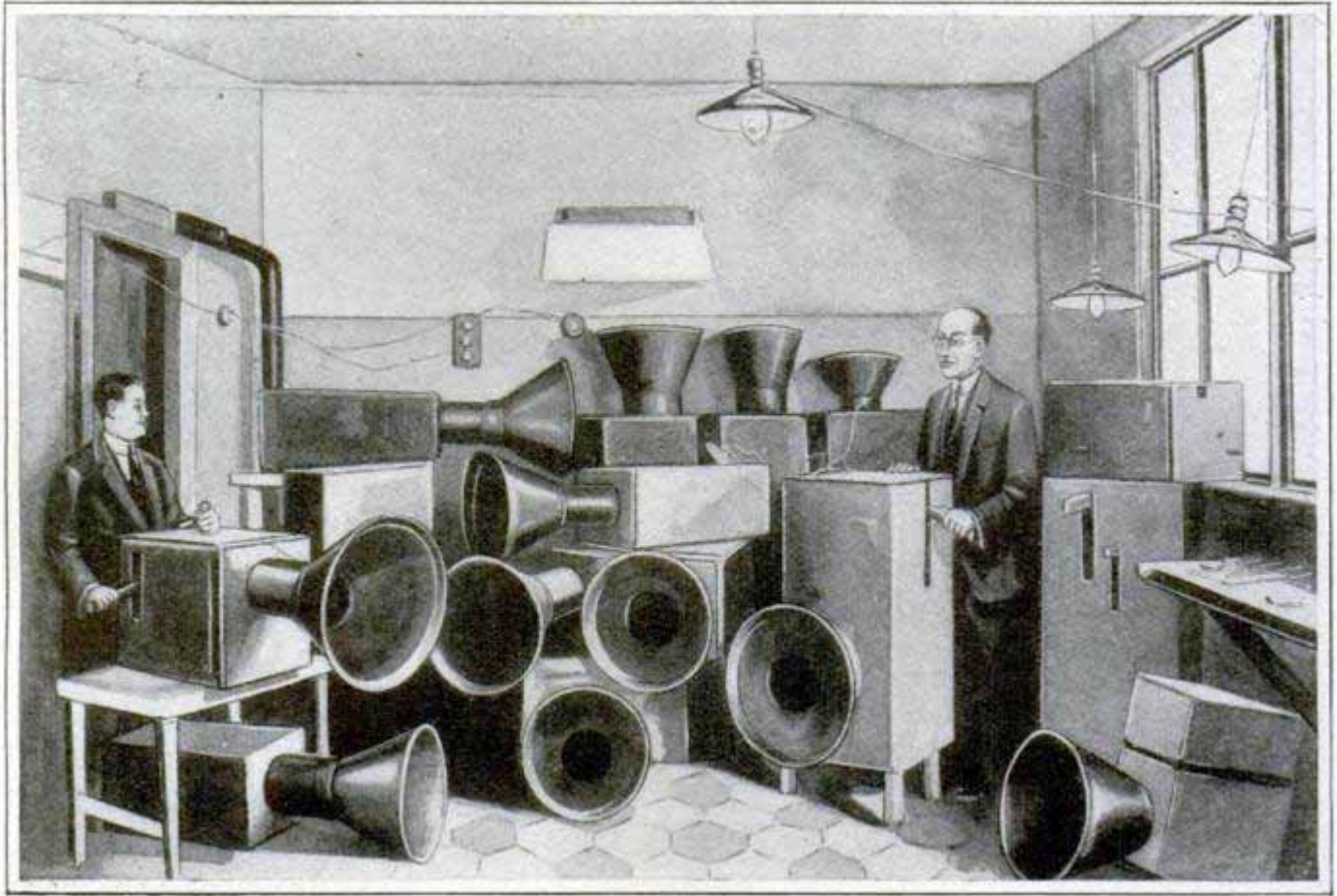

This "Orchestra of Odors" Produces a "Symphony of Scent"

### INDIAN SQUAW CARRYING FOWLS TO MARKET

The Mojave Indians, living on the outskirts of Needles, Cal., engage in poultry farming, and dispose of their product in the city markets, trudging long distances with the chickens tied to boards which the squaws carry on their heads. The fowls are bound with broad linen bands, so as not to interfere with circulation. The Indians, it is said, do not eat



chickens, owing to a superstition, although they do not hesitate to sell them to people who do eat them.

☐ In the foundry of one big automobile factory an average of 18,000 lb. of aluminum is used each working day.

### ORCHESTRA OF ODORS FOR NEW CONCERT

An Italian has invented an electrically operated machine for propelling distinctive odors by which he purposes to produce in a Milan theater a "Symphony of Odors." The inventor insists that a degree of harmony may be sensed through the olfactory nerve not unlike that sensation we term music when sensed through the auditory nerves. Instead of a "Polonaise in E Flat," he would give a "Fantasie in Violets," or a "Nocturne in Apple Blossoms." By combining a number of these instruments, he declares he is able to produce arpeggios of perfume, harmonics of fragrance and haunting nuances of scent which will rival, if not surpass, the crashing chords and melodious phrases of master musicians.

☐ Machinery and equipment used in building the Panama Canal are to be sent to Alaska for railway and coal-mining work.

## EACH TYPEWRITER HAS ITS OWN CHARACTERISTICS

Handwriting experts have been able to solve many mysteries, but the advent of the typewriter was supposed to present insurmountable difficulties to investigators because of the supposed lack of individuality in the writing machine. In a recent trial in New York, however, the question of authorship of a certain telegram became important, and the original copy from the files of the telegraph company was submitted to typewriter experts, together with the machine upon which it was supposed the copy was written. Without difficulty they found certain distinguishing features about the letters and marks on this machine, which were not present on others, and identified the original copy as having been written as alleged. Upon the presentation of this evidence in court, the man suspected admitted that the findings of the experts were true.

## GOVERNMENT EXPERTS STUDY MILL-DUST EXPLOSIONS

Engineers from the Bureau of Mines are investigating all dust explosions where two or more fatalities have resulted. These take in both mine and mill accidents. The explosion in a grain mill in Buffalo not long since, in which 33 lives were lost, was traced to the fine dust engendered in grinding grain for feed. The government experts are working in conjunction with the National Milling Association to

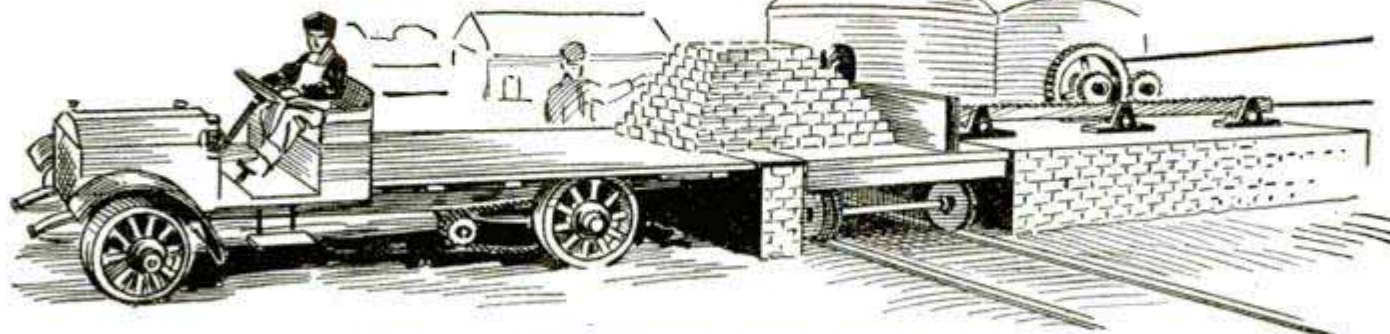

German Method of Loading Brick without Breakage

further investigate conditions, and devise preventive measures relating to inflammable dust.

## MAGNESIUM LAMP FOR PHOTOGRAPHERS

A contrivance is in use in Europe by photographers by which illumination for timed exposures is given by burning magnesium. A certain length of ribbon burns a predetermined time as shown on the dial of the apparatus. The magnesium ribbon is wound within the receptacle, upon the rim of which definite lengths are indicated to burn a certain time. The ribbon is pulled out as far as desired and then lighted, burning till the aperture is reached, when it goes out.

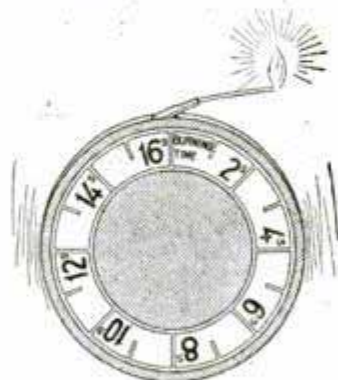

## MOTOR-TRUCK LOADING DEVICE

From Germany comes an ingenious method of loading brick from kiln to motor truck without handling individual brick, thus saving breakage. A low wall separates the truck from the track upon which the car from the kiln is run. A mechanically operated rammer at the same level as the top of the wall, which is also the level of the car platform and the floor of the truck,

pushes the load of brick from the car across the wall, directly upon the truck.

## FAN TO PRODUCE CHANGING BREEZES

Pleasant, changing breezes and gentle puffs of fresh air, instead of a hard, steady blow, are produced by an intermittent electric fan, just brought out in England. The fan not only varies the intensity of the air current continually, but reverses its blades at intervals to drive the air in the oppo-

site direction. The intermittent breeze is produced by reversible blades, automatically rotated on their stems so that they are continually changing their angle.



## FASTENER HOLDS TONGUE OF SHOE IN PLACE

An invention by a Canadian is designed to prevent the tongue of a shoe from slipping down out of place. The contrivance consists of a ball-and-socket fastener, the ball portion being on the tongue and fitting into the socket, which in a man's shoe is part of the hook itself, while in a woman's shoe, where the eyelet is employed, a separate socket is inserted.



## CURIOUS "SHEEP HUNT" SPORT IN RUSSIAN TURKESTAN

A horseman carrying a sheep and pursued by thousands of mounted men constitutes a popular sport in Russian Turkestan, where the "sheep hunt," as it is called, takes the place of football as a national sport. The owner of the swiftest mount has a sheep tied to his saddle, and then gallops away. He is

chased by the other riders until one or another has captured the sheep. This game is carried on before thousands of the half-wild tribesmen, whose knowledge of the game, whose love of the horse and whose sporting proclivities are aroused to the highest pitch of excitement by the chase. It is usually a feature of the Mohammedan New Year festivities.

## A FUSE PLUG THAT CAN BE REWIRED

Ventless electric fuse plugs that can be refilled and used repeatedly after the fuse has blown out may now be bought. In construction they are exactly like the usual fuse plugs except that the short piece of fusible wire, instead of being soldered to the connections, is held in place by binding screws just inside the mica cover. When the old-style fuse plug burns out it must be thrown away, but the patented refillable plug is ready for use again as soon as a new fuse wire has been inserted.

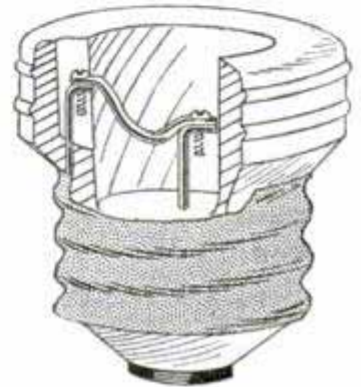

## A CRANKLESS ICE-CREAM FREEZER

No weary cranking is necessary in making ice cream at home, if one has one of the new crankless freezers. It is simply packed with cracked ice and the rest of the operation is automatic. The can which holds the cream, or sherbet, to be frozen has an inside section to hold cracked ice, and all the cream in the narrow space between the two walls is thus brought in close



contact with the melting ice and quickly frozen. The frozen cream comes out of the can in cylindrical form with a hole down the center, so that it can be sliced up into "frozen doughnuts."

### EUROPE FEELS THE NEED OF A WORLD LANGUAGE

In America we hear little of a world language and feel less the need of such than Europe where 20 nations back up into each others' yards, and not less than 27 languages are spoken, beside innumerable dialects and patois, the idioms of limited areas. The United States Consul at Berne, Switzerland, in a recent report, discusses the objects of the Association for the Creation of a Universal Language Bureau which has been founded for the avowed purpose of stimulating interest in an auxiliary language. It is not sought to drive out any existing language, but rather to introduce a tongue which may bring about an easier understanding among all nations, especially for use in commerce. No propaganda is urged for any of the various international systems already established, among which are systems bearing the names Bolak, Esperanto, Europal, Ido (reformed Esperanto), Latino sine flexione, Neutral (reformed neutral), Pankel, Perfect, Romanal, Tutonish, Viva and Volapük. The immediate aim of the association is to induce the government of Switzerland to summon an international diplomatic conference to discuss the advisability of officially recognizing some international language. Should such negotiations be successful it is planned to have a commission examine existing systems of artificial languages, select the most suitable and lay down the lines for future development.

☞ Pajamas of cheap quality are a staple article of commerce in Afghanistan, and lamp ware, fountain pens, barbed-wire fencing and corrugated iron are also in demand.

### BED INCLOSED BY FOLDING SCREEN PANELS

Folding screen panels to protect beds and cribs from flies and mosquitoes are the interesting part of a patent

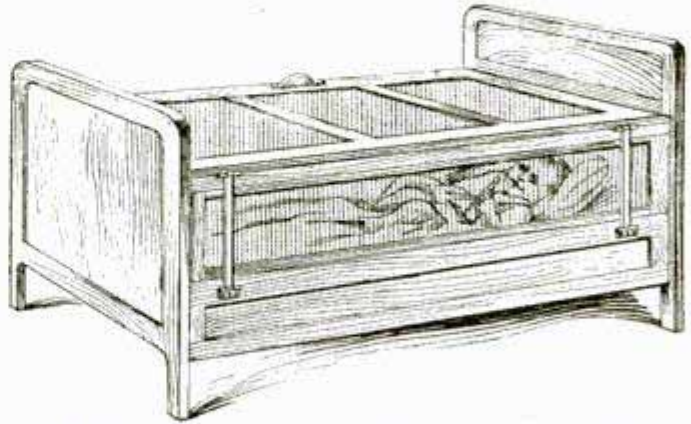

Folding-Screen Cover to Keep Flies off a Bed

recently taken out. The screen arrangement is designed especially for babies' cribs, but it can be built on a larger scale for any bed. It consists of two screened panels fastened permanently above the sideboards of the bed and another screen panel which serves as a cover. An ingenious hinged-lever arrangement is fastened to one side of the cover so that it can be folded down on one side, out of the way.

### ELECTRICALLY HEATED SOLDERING IRON

A portable electric furnace for heating a soldering iron is one of the late applications of utilizing the electric current for mechanical heating, where gas, oil or gasoline have heretofore been employed. The fact that the appliance

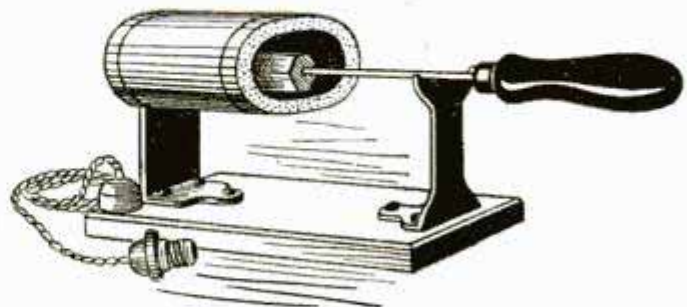

Portable Electric Furnace for Soldering Irons

may be plugged in on any 110-volt lighting circuit makes it convenient in repairing plumbing, soldering wires, and other household adjustments.

## NOVEL SEESAW FOR THE CHILDREN

A novel accessory for the amusement of children while playing on the lawn is a seesaw in the form of an ancient boat that rocks and also revolves about a center

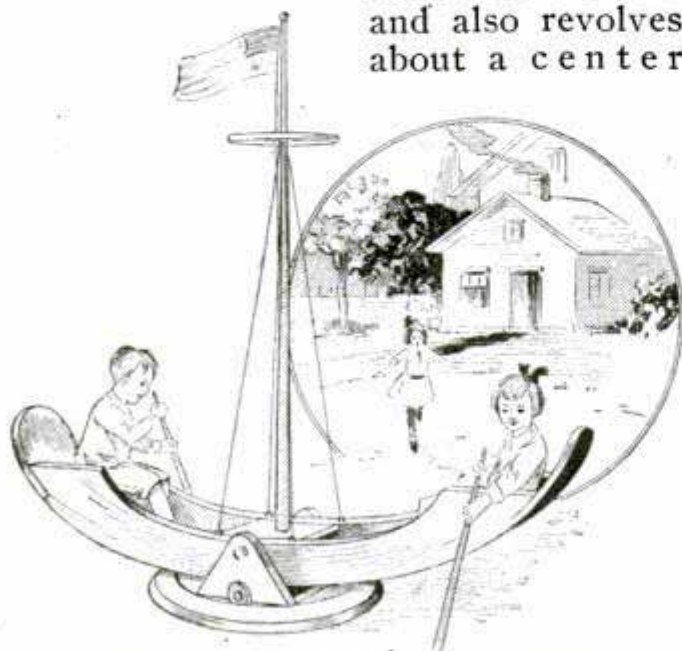

Revolving Boat That is Also a Seesaw

post, which is securely fastened on a circular base. It is a merry-go-round as well as a seesaw and furnishes entertainment for little folk of all ages. At night it may be lighted with Chinese lanterns suspended from the crosstree of the mast, and bells may be hung about it to jingle, if so desired.

## AIR-DRIVEN TUGS TO TOW CANAL BOATS

The air drive, after exhaustive tests on barges propelled by aerial screws on the Surrey Canal by an English syndicate, is to be used on steel tugs towing cane scows on the canals in British Guiana. Some 30 of these steel tugs, having a draft of but 10 to 12 in., will be built, each capable of towing about a dozen punts or scows, each weighing some six or seven tons loaded. From the data obtained in the trials it is believed that in actual practice a load of 50 or 60 tons could easily be towed at four miles an hour by means of the specially designed air screws, which consume 16 hp., without in any way straining the motor used.

Four miles an hour, it is pointed out, could readily be maintained on a busy canal, for the air-drive tugs and their loads could not only easily overtake other barges moving in the same direction, which must hug the towpath, but could at any moment use the whole width of the canal for turning, if necessary. No difficulty is feared from the possible interference of these air-driven tugs with each other in passing, nor in damaging other craft. The propellers used in the trials were less than half as long as the barge was wide, and the danger and impediment arising from the propeller was only trivial.

## NEW LIQUID-SOAP CONTAINER

A new liquid-soap container, coming into use in the wash rooms of passenger coaches, is a great improvement over the type of container which consists of a glass bottle that exudes the soap when rocked. In the new arrangement, the soap container, a jar holding a quart of the liquid, screws up under the wash stand. A nickel fixture, not unlike an ordinary water faucet in appearance, rises from the top of the stand and protrudes over the washbowl. The user places the palm of one hand under the soap faucet and presses together, between the

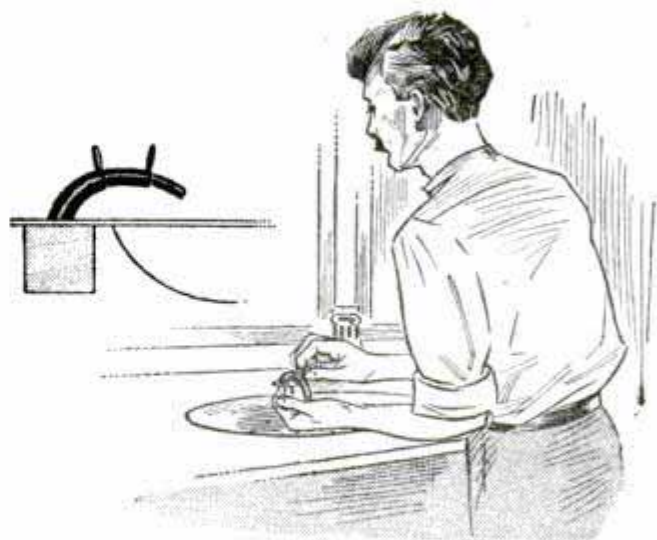

Device That Pumps Liquid Soap

thumb and forefinger of his other hand, the two little tabs or projections shown in the illustration. This action

pumps a certain quantity of soap into the palm of the hand. All but the faucet is out of sight under the wash-stand.

### MACHINE STRINGS BEADS QUICKLY

An ingenious little machine is used in Germany for stringing beads, such as are a part of many embroideries. A hand-revolved axle bears two metallic wings, set something like the blades of a propeller, but with a narrow space between. Inserted in this space a long needle lies on the axle, the point projecting a trifle above the surface. As the machine is turned the beads placed within the receptacle are constantly agitated, and at each revolution one or more beads, striking against the point

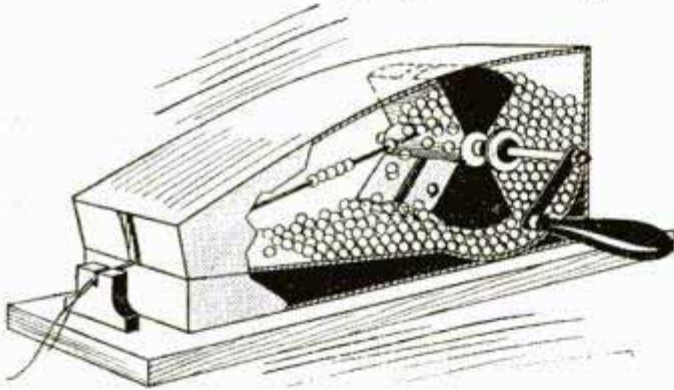

Machine Makes Stringing Beads Easy

of the needle at the proper angle, are impaled, and so continue on down along a thread placed to receive them.

### ANCIENT PRINTING BLOCKS IN KOREA

Thousands of printing blocks have recently been discovered in an old barn back of the Buddhist monastery Hainszu, in Hyopdshong, Korea. These blocks are believed to be more than 800 years old, and refer to old Buddhist religious precepts. The barn was built, according to the Buddhist monks of the monastery, 1,100 years ago, and is surrounded by great maple trees which have attracted tourists by their beauty. So far as known, these printing blocks are the oldest in existence and are of enormous artistic and historical value.

### OUTDOOR GASOLINE-CAN SAFETY DEVICE

The peril of fire, always present when gasoline is kept in quantities within factories or shops, may be in

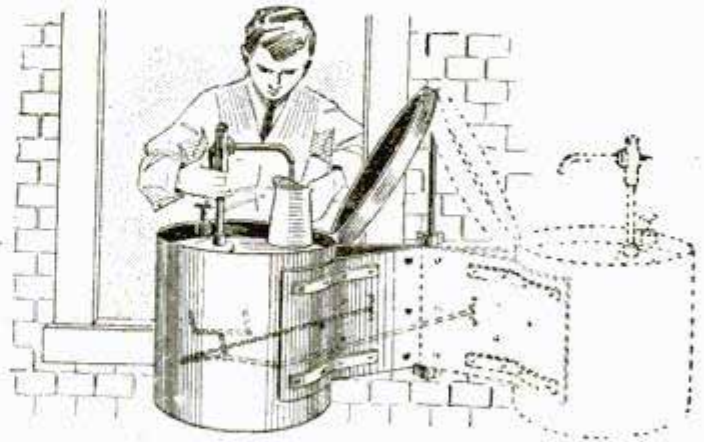

Gasoline Can within Easy Reach of Shop Window

large measure avoided by the use of an outdoor attachment recently patented. The can, which is of the ordinary pump type, swings on a hinged support fastened outside the window. A lever arrangement worked from the inside brings the can around in easy reach when wanted, or swings it back again out of the way. The can is fitted with a hinged cover, excluding rain, snow or dust.

### CANTILEVER SPRING GIVES FLEXIBILITY

An automobile spring pivoted to the frame at the center and shackled at the front end is clipped to the axle at the rear end. This gives true cantilever support and affords a high de-

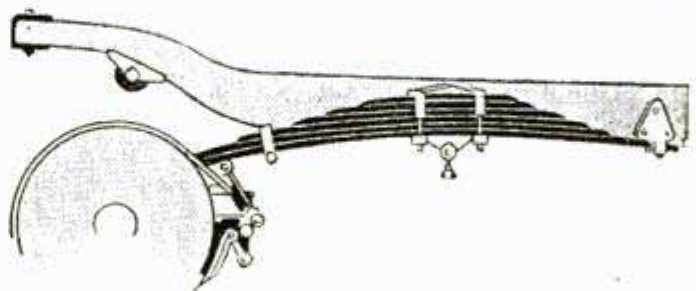

Cantilever Spring for Automobiles

gree of flexibility, when the spring itself is an inverted semielliptic one. This form of support lends itself to the use of a shock absorber also if desired.

## NOVEL AND PRACTICAL THINGS FOR DAILY USE

An aluminum tea bob for use with an earthen teapot has an air chamber at the bottom. Tea leaves are placed on this and boiling water poured in, which drips through small holes upon the tea, and then runs out into the bottom of the teapot. When



Tea Bob Makes a Perfect Beverage

the water has all run out, the bob, relieved of the weight, rises, carrying the tea leaves with it.

Radiators may be converted into convenient stands for various purposes by means of a wooden shelf of suitable size, supported upon metal brackets which are fixed to the radiator firmly. Dishes, silver, or table china may be placed on the shelf; or telephone, filing cabinets and books; flowers and growing plants; or the shelf may be used as a substitute for a mantelpiece.



Radiator Table Easily Made and Convenient

Washing the baby is something of a task in the ordinary household, requiring considerable preparation and resulting usually in a mussy floor. A small enameled bathtub has been devised which is arranged to be placed on the big tub in the bathroom. A broad support also rests on the tub, so the baby may be easily dried and dressed.



Bath Kit for the Baby Relieves Mother

The kitchen table is often too high or too low for comfortable use. An adjustable table, which may be easily raised or lowered, makes it equally convenient for rolling out pastry or for ironing. Steel rods concealed in the wood give it rigidity.



Adjustable Kitchen Table Saves Backache

A practical self-heating flatiron, convenient for travelers, has been brought out, the top of which is in two parts. By turning the iron over, the upper section, which is hollow, may be revolved and filled with alcohol, by which the iron can be heated quickly.

A patented household cream separator consists of a 2-qt. glass container fastened by a ring within the refrigerator. A rod extends through a detachable cover to the bottom, where it plugs a small hole in the glass. Milk poured into the container is separated through gravity. Upon slightly lifting the rod,

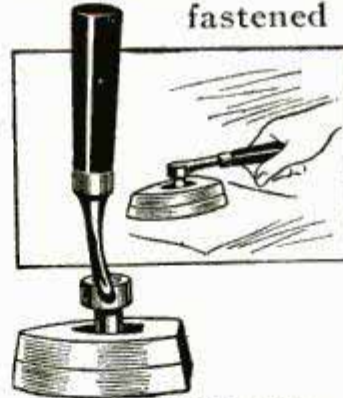

Handy Self-Heating Flatiron for Travelers

skim milk flows out of the bottom into a pitcher or pan, while cream may be obtained from the top of the container, or drawn out after the skim milk.

A framework of springy steel rods affords yielding support for the baby basket and is light and easily put out of the way. The frame

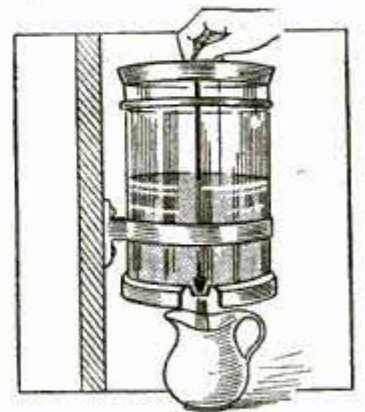

Gravity Cream Separator for Family Use



is broad enough to give stability, and no swinging of the basket can overturn it. Casters at the corners make it readily movable, while a slight rocking of the basket will, by reason of the springiness of the support, continue the rocking motion for a long time.

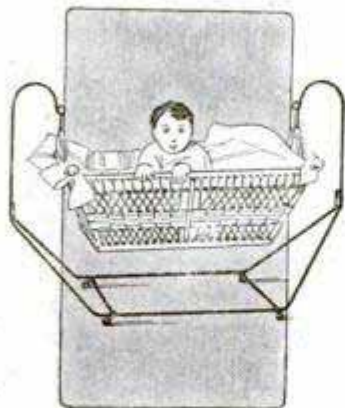

Springy Frame Rocks Bassinet Safely

Measuring a teaspoonful is easy enough, but to get exactly half a teaspoonful was almost impossible before the invention of the half-spoon illustrated here. Upon an ordinary handle, the half of a teaspoon bowl is fixed, a wall of silver cutting the usual bowl in two lengthwise. Its use in the kitchen, in the sick room, or where accurate measuring is desired, safeguards against error.

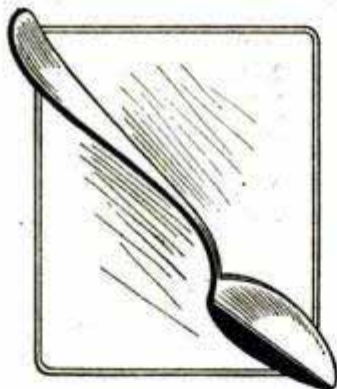

Kitchen Device for Measuring Half Teaspoonfuls

Much coal can be recovered from the ashes drawn from furnace or heater if a sifter is used. Too often the device used leaks dust and makes the task a most unpleasant one.

Recently a dustless revolving sifter

has been put on the market with a seamless cover fitting over the outside, keeping all the fine dust in, yet affording easy access to the sifter for putting in the unsifted ashes and taking out the coal.



Rotary Ash Sifter Rendered Dustless by Cover

When pins are used in any quantity the desire to "have them handy" results most often in a

dust-catching receptacle from which by dint of pricked fingers one may sometimes obtain a pin. A novel pin fountain is manufactured with a glass dome for a top, which holds a quantity of pins, but by an ingenious device the dome, upon being revolved, drops a few pins into a convenient tray, from which they may be picked up readily.

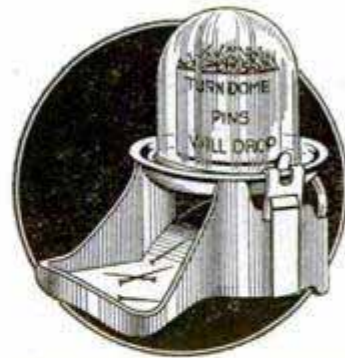

Durable Pin Tray Keeps Out Dust

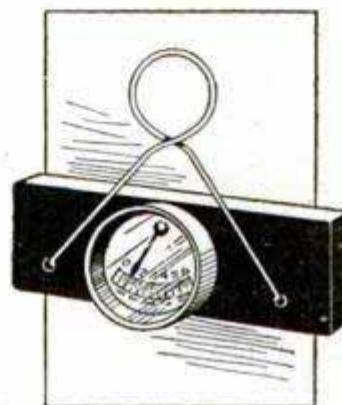

Handy Heat Gauge for Soapstone Disks

how hot the soapstone slab is to be used. A brass plate with steel racks operating a pinion carrying the indicator is the basis of the device. It registers the heat quickly, and when not in use may be hung conveniently near the cooker.

There are few more exasperating things than to lock something securely and then be unable to find the key when required. This unpleasant condition may be avoided by using a keyless padlock. Eight projecting knobs actuate tumblers within the padlock. By pressing certain knobs, forming the combination, the lock opens instantly.



This Lock Requires No Key

the combination, the lock opens instantly.

## COLD-RADIATOR SYSTEM IN REFRIGERATORS

A device made of rectangular tubes in the form of shelves adapted to the interior of a refrigerator has been in-

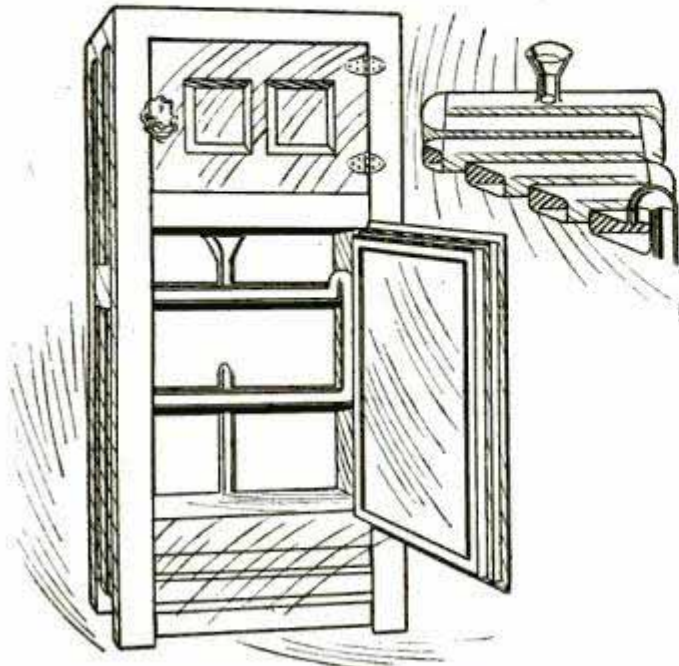

Automatic Ice Saver for the Household

vented. These tube shelves catch and circulate the water dropping from the melting ice, always remaining full of water, and, by gravity, circulating the water to the overflow. The increased cold surface and heat absorption afforded by two gallons or more of ice-cold water is stated to add materially to the value of the refrigerator, cooling the food much more quickly, and maintaining a reduced temperature in the food compartment. The device may be installed in any refrigerator, old or new.

## RATS IN COPPER MINES ARE SCAVENGERS

In the copper-mining district of Michigan rats are highly regarded for the valuable aid to underground sanitation they give. Rats are the scavengers of the mines. They keep the levels clear of refuse. They are protected and made pets of by the men who often share their dinner pails with the rodents. So accustomed to the presence of human beings are these rats that they frisk about the miners

without a shadow of fear. Underground they indulge in no depredations, existing as they do within the rock-bound walls, inclosing nothing possible for them to destroy. That they are largely dependent upon the food furnished by the scraps and leavings from the miners' meals is evident from the fact that the prolonged strikes which occurred in the copper district resulted in thinning out the number of rodents very largely. Not only was their food supply cut off, but many were drowned when the pumps draining some of the levels were put out of commission, and the workings filled with water.

## SHOCK ABSORBER FOR THE WHEELBARROW

A gold medal was recently given in France for a shock-absorbing attachment for the common or garden variety of wheelbarrow. The shock absorber consists of two uprights, one on each side of the wheel, at the bottom of which the axle is inserted so as to bear against vertically supported springs. The device is intended not only to save any fragile load carried on the wheelbarrow, should an obstruction be struck

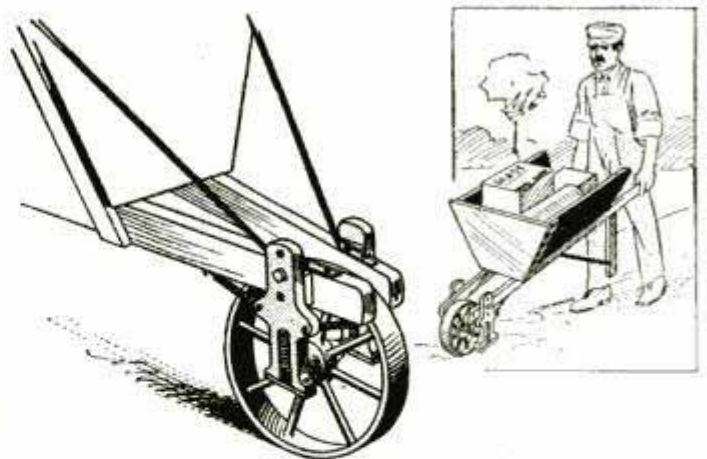

Humble Wheelbarrow Now Has Shock Absorber

on the road, but also to lessen the jar on the hands of the laborer when handling heavy loads on uneven ground.

Alaskan reindeer meat is becoming a popular food in Pacific coast cities.

## A NEW TYPE OF STEAM ENGINE

In the attempt to produce a steam engine that would be more economical of steam, a German professor has developed a new type, called the "uni-flow" engine. The difficulty which he has overcome is the initial cylinder condensation of steam because of the location of the exhaust valves in the ends near the intake valves. In the ordinary engine, the piston in driving out the exhaust steam reduces the temperature of the cylinder head to that of the exhaust steam, and the incoming live steam meets cold walls and is partly condensed. In the new engine, the exhaust ports are placed in the middle of the cylinder, where they

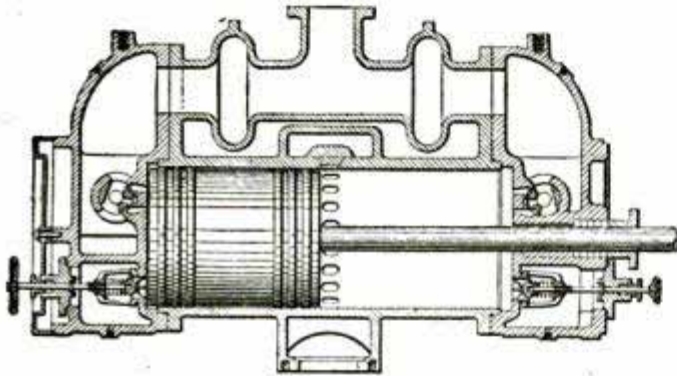

Cross Section of the New Uniflow Steam-Engine Cylinder

are uncovered by the piston at the end of the stroke, and the intake valves are at the ends. Thus there is always a flow of steam from the ends of the cylinder toward the center and the cylinder heads are kept at a more uniform temperature. A single-cylinder uniflow engine which is in use in Germany produces 6,600 horsepower.

## NEW STEEL WHEEL FOR MOTOR TRUCKS

The making of a cast-steel truck wheel that will have both the strength and resiliency required for the severe service to which such vehicles are subjected is a difficult matter owing to the unavoidable weakness of castings of all kinds at the junction of the rim and spokes. This weakness is apparently overcome in a new type of wheel

recently placed on the market. The rim of this wheel is of a channel section, while the spokes are hollow and

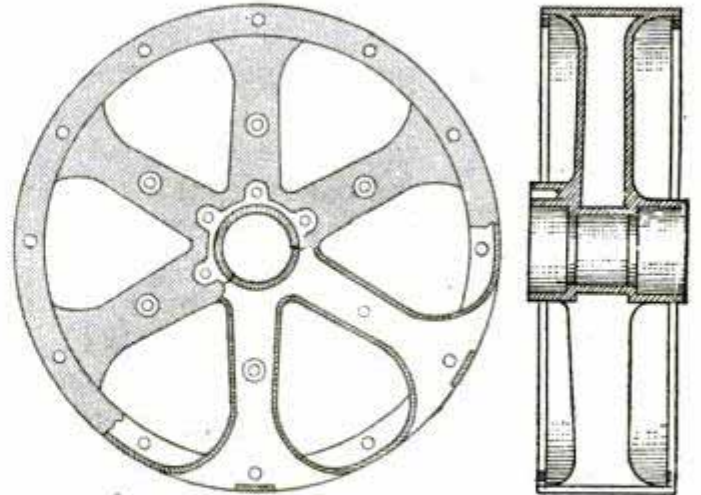

Curved Junction of Spoke and Rim Makes Steel Truck Wheel Strongest at What is Usually the Weakest Point

have sides curved in such a way as to join the rim without a sudden change in direction. This wheel is somewhat lighter than a wood wheel of the same carrying capacity.

## PAN AND RACK FOR DRYING DISHES

A new device for drying dishes consists simply of a pan, 20 in. square, fitted with a removable wire rack to hold the dishes on edge while draining, and to keep them out of the dripping rinse water. After the dishes are washed they are set on edge in the rack, scalding water is poured over them and they are allowed to dry, the



Dish Drier That Consists of Pan with Wire Rack for Holding Dishes on Edge

idea being to eliminate the use of the towel for drying. By this method the dishes are both cleaned and sterilized.

## AN ARC LAMP WITH A CHIMNEY

High efficiency is claimed for this arc lamp because of the method of preventing a deposit of material from the arc upon the inside of the inclosing glass. The electrodes are surrounded by a glass cylinder or chimney, and this, in turn, is held in an outer part consisting of a metal ring piece with concave glasses on each side, one of which is hinged. The ring piece is so made as to form a hollow or annular chamber. The air circulates between the chimney and annular chamber, depositing all suspended matter upon the cold metal walls of the chamber. The latter is protected on the inside by a nonoxidizing coating.

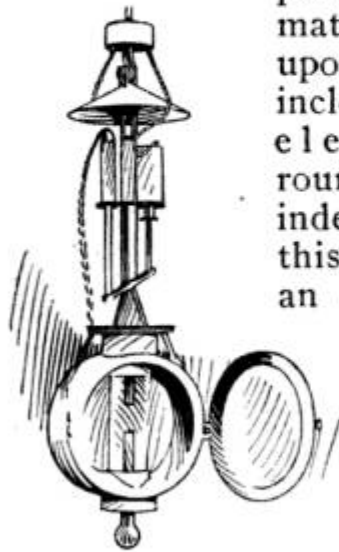

## NEW ELECTRIC FURNACE FOR MAKING GLASS

An electric furnace for the manufacture of glass, patented recently by a French inventor, makes possible a continuous process of manufacture, combining all the operations of melting and refining within a single furnace supplied by one source of heat. The furnace consists of two chambers separated by a dam which floats on the molten glass. The electrodes for melting the glass are in one chamber and close enough together so that only a low-tension current is needed. As the raw materials are fed into this chamber, they float on top of the molten glass until they are melted down and refined. At the same time, refined glass at the bottom passes under the

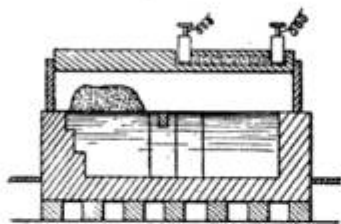

floating dam into the other chamber. As the temperature of the whole furnace is not extremely high, blowpipes can be inserted directly into the second chamber to take out the molten glass ready for working into commercial shapes.

## BAKING OVEN OF NOVEL CONSTRUCTION

A baking oven that embodies a number of novel features is shown in the accompanying illustration. From the

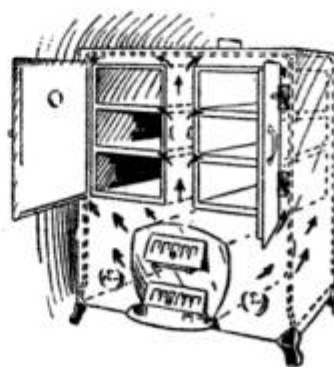

fire box, which is placed at the base of the oven, the heat passes up through a central flue placed between two tiers of compartments, then over the tops of the compartments and down the sides of the oven to the fire box. The passages between the compartments are so proportioned that each receives the same amount of heat, and receives it uniformly from the sides, top and bottom. The smoke and gases from the fire box do not circulate through the flues, but are carried into the chimney through a pipe located in the center flue. For ease of access in cleaning, all compartments and partitions are removable.

## MAKING AUTOMOBILE TIRES PUNCTURELESS

A new way of attacking the pneumatic-tire problem is to make inner tubes punctureless by increasing their elasticity. Rubber tires, after they have been molded, are covered with sulphur or pumice stone to harden them for handling. This treatment also makes them less elastic and more easily punctured.

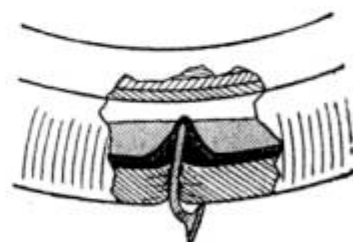

To restore their elasticity, an Iowa man has patented a mixture to be poured into the tire for dissolving the sulphur and softening the rubber. It makes the inner surface of the tube so elastic that when a nail is driven into the tire the rubber stretches and expands about the end of the nail without breaking.

### FETERITA IS A NEW GRAIN OF THE SORGHUM GROUP

A new grain and silo crop is assured by the introduction of "feterita" by the U. S. Department of Agriculture, whose experts are constantly searching the byways of the world for crops which can be adapted to conditions within the United States. Feterita is an early ripening sorghum, valuable for grain and forage, rising on slender stems 5 to 7 ft. high which are fairly juicy and slightly sweet before ripening, much relished by stock. The grain ranks with the kaffir corns and milo as a fatterer, but the addition of a small amount of cottonseed meal is recommended to increase its efficiency as a flesh grower. For use in silos, feterita is claimed to be equal to any of the sorghums. It was first introduced from Alexandria, Egypt, into the United States, but later obtained in quantity from the Sudan, and is adapted to arid regions.

### NEW AUTOMOBILE GOGGLES RELIEVE EYESTRAIN

A recent invention is goggles for use by motorists in which the glasses have portions of different thickness and color, whereby one portion is clear and the other more or less clouded. The field of vision is limited to the clear-glass portion while the glare and flicker is measurably removed by the colored glass in the remaining portions.

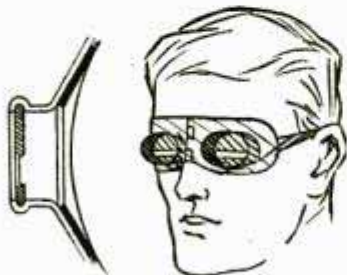

### NEW SYSTEM CALLS EXPRESS WAGON PROMPTLY

Each tenant in a new office building in New York is provided with a number of small metal disks or checks,

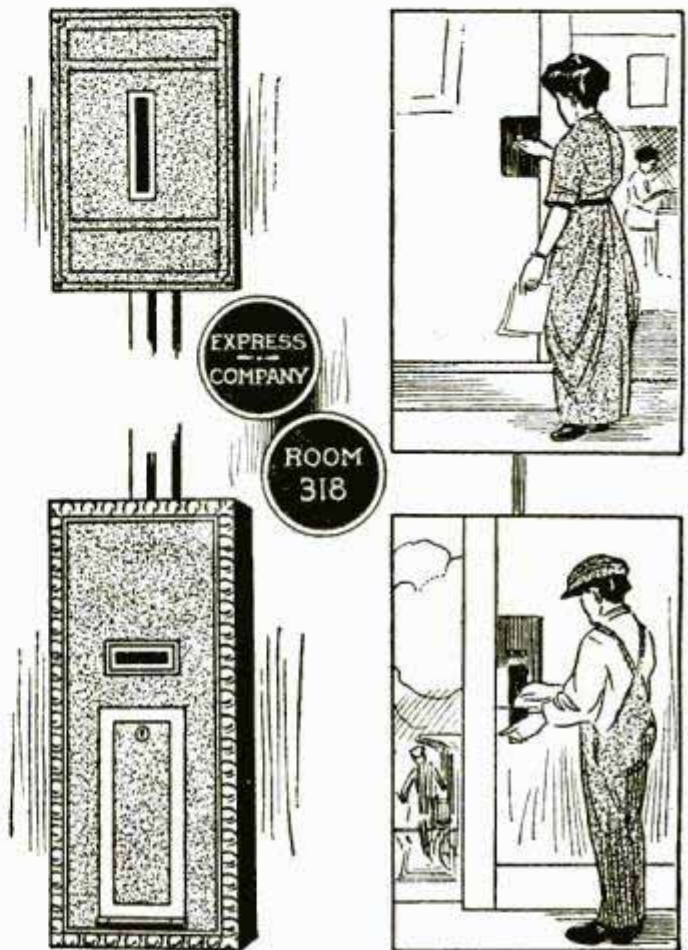

Units Used in Novel Call System for Expressmen

bearing on the one side his room number, and on the reverse, the name of an express company. When he desires to have an expressman call at his office for a package, he deposits a check in a special chute in the elevator wall, and the check drops down to the first floor, where an authorized employe of the building opens the box, records the room number and notifies the proper expressman he is to call at that room. The expressman takes with him the check as evidence of his authority to receive the package.

ⓄThe sledges for Sir Ernest Shackleton's trip to the South Pole, built of a light but strong composition metal, weigh 60 lb. less than wooden sledges and are therefore able to carry that additional weight of food.

## GERMAN FEED-WATER SOFTENER

A new feed-water softener for steam boilers, recently brought out in Germany, is said to be particularly effi-

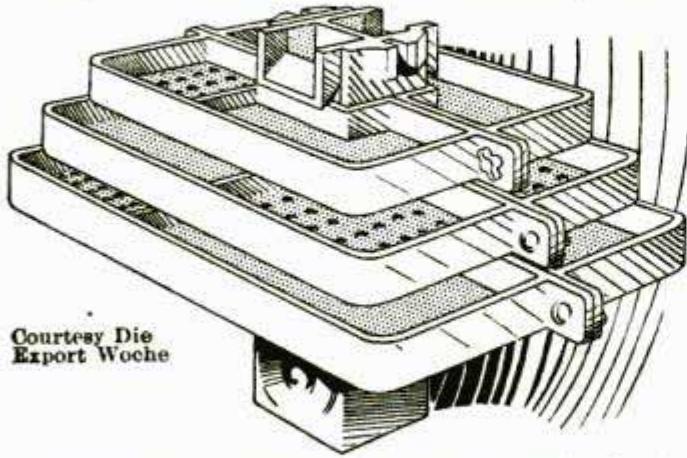

Courtesy Die Export Woche

An Efficient Feed-Water Softener Brought Out in Germany

cient. The apparatus consists of several superimposed shelves, divided into compartments, some of which have perforated bottoms. The water, pre-heated to a temperature of about 300 deg. F., zigzags through these perforated bottoms. All the gases in the water are driven off by the high temperature and the scale is quickly and completely separated, forming as a loose deposit which can be blown out easily.

## A COMBINATION DOG FOR LATHES

This combination dog for turning shaftings holds securely all kinds of crankshafts, eccentrics, and straight work of every description, and can be used



wherever the common lathe dog has formerly been employed. The tool may be adjusted from a 2-in. up to a 6-in. swing.

Rock said to be suitable for lithograph work has been found on the Angat River, in the Philippines.

The only quarry where lithograph rock is obtained in any quantity is in Bavaria.

## HOW THE MARTIANS MADE THEIR CANALS

That the canals on the planet Mars were constructed, not by excavation but by building walls or dikes, is the latest theory put forth by astronomers to account for the enormous size of these waterways. These canals, first discovered by the Italian astronomer Schiaparelli, have given rise to much speculation on the question whether the planet is inhabited. Astronomers now quite generally accept the theory that the canals are the product of intelligent action, artificial aids to agriculture, irrigation projects on a scale impossible on the earth's surface. Instead of being dug, as was once believed, it is now considered by some observers that they are built, or made between two walls on the surface, as they have to be higher than the vast fields they are intended to irrigate. It is obvious that it would cost no more to build up the walls of a canal 20 or 40 miles wide than it would for one only one mile wide, while the volume of water carried and consequently the area of land watered would be far larger. According to this theory, the mountains of Mars have been taken down, the rivers dammed or canalized, and the sea, into which no more fresh water is permitted to run, is evaporating itself, adding to the volume of fresh water. Thus Mars has been transformed into a gigantic garden where the most economic and intensive cultivation is the order.

## DEVELOPMENT IN ALUMINUM REMARKABLE

The rapid increase in the production of aluminum has not kept pace with its extension into different fields of art and manufactures. The fact that copper is cheaper than aluminum and that it is a far better conductor has not served to keep aluminum out of the electrical field, for by combining it with steel strands, huge cables carry high-voltage currents over long distances as satisfactorily as copper would.

Cooking utensils of aluminum, although not superseding enamel ware, are rapidly growing in favor, while the automobile industry is demanding more and more of this metal which, being light and easily workable, is ideal for use in bodies. The powdered metal is used in painting, lithographing and printing, and as a constituent of explosives. The manufacture of aluminum tubing is gaining rapidly. An increase in consumption of aluminum from 46,000,000 lb. in one year to 65,000,000 lb., almost 33 per cent, all the while increasing in price, is evidence that the new plants in course of construction both here and abroad have their work cut out for them.

### FOOT ATTACHMENT FOR AUTOMOBILE JACKS

"Jacking up" an automobile is an easy matter, so far as mere muscular exertion is concerned, when a modern jack is used. But the operation is often marred by the dust and grease which are almost inseparable adjuncts. A device which enables the motorist to avoid these consequences, by operating any auto jack with his foot, is the product of a Chicago manufac-



Keeps Grease and Dirt  
Off the Automobilst's  
Clothes

turer, whose foot-stirrup attachment may be quickly adjusted and is easily operated in a standing position.

### NOVEL MOVABLE WATER TOWER

Differing from the usual form of water tower, which throws only one stream of water upon the roof or inte-

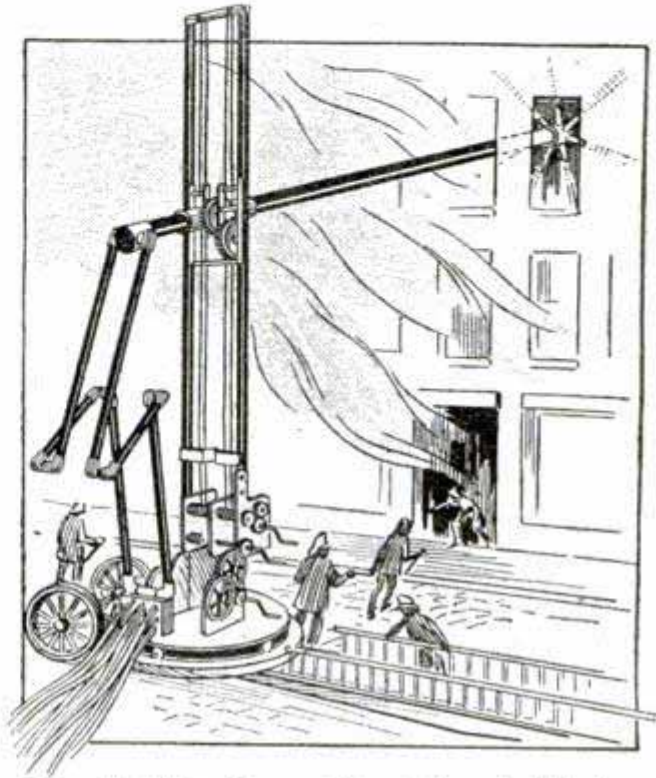

Movable Water Tower Thrust through Window

rior of a burning building, a new type has been invented designed to throw a number of streams of water in various directions against the flames. The discharge pipe of the new tower is constructed so that it may be projected into a window or other opening, the end being equipped with a number of nozzles presented in different directions. The pipe may be raised or lowered, or tilted at any angle.

### TELEPHONE LINE STRUNG ON KITES

During a recent storm in California, a large amount of telephone line was destroyed, and communication between many points cut off. The repair crew was halted at the Salinas River, where the entire line of supports was washed away. Immediate establishment of communication being necessary, and the high water and lack of materials prohibiting the construction of a temporary line in the usual fashion, several large kites were built and flown. On

these a wire was strung and carried across the river. The entire telephone business of the section was carried on over this one wire until a permanent cable could be installed. So successful was the experiment that the repair department of the telephone company now includes kites as a part of its regular equipment.

### RUBBER SLEEVE HOLDS CORK IN BOTTLE

The disheartening experience in traveling, of finding the cork out of a bottle in grip or trunk, is not an uncommon one. A little device of pure rubber which slips over the top of a bottle, holding the cork securely in place, has been invented to obviate the trouble. It consists of a sleeve which slips tightly over the neck of the bottle, and has a band portion engaging the cork, preventing its removal until the band is pushed off.



### MEXICAN INDIANS MAKE TINY DOLLS

Dolls not more than a quarter of an inch in length are made by the Mexican Indians. First a framework of wire is wound with silk thread until the figure is of proper shape. The costumes, cut to represent some character, are then fitted and sewed on. With the smallest-size needles and almost invisible thread, various designs are embroidered on the dolls' clothing in silk, and so clever are these dusky workers that even when viewed under a powerful glass the details appear perfect.

The hair is put on after the doll is properly dressed, the braids are tied with ribbons of appropriate hue, and then the eyes, nose, mouth, and the hands and feet are formed. Some dolls are equipped with tiny baskets of flowers, fancy sombreros, or water jars. The baskets are woven of hair, the pottery is of clay in exact imitation of the practical articles, and the flowers are of silk worked with genuine artistry.

### AIR GUN AND TARGET NEW FRENCH TOY

A revolving target upon which toy pigeons are perched, is a sporting device recently brought out by a French

inventor. A tripod with extension legs is provided with a sliding vertical screw, at the top of which three arms

extend, each bearing the figure of a pigeon in flight. These arms revolve as the screw slides downward through a threaded nut until the bottom is reached, when the screw is raised again. An air gun with rubber darts is used, and when a hit is made the pigeon falls off and hangs by a chain from the arm.

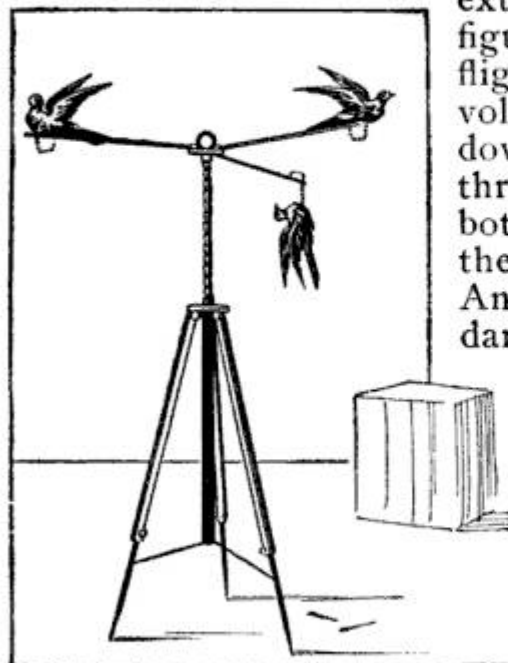

Pigeon-Shooting Toy for Boys



## MOTOR-VEHICLE CENSUS RECENTLY TAKEN

An English automobile magazine recently compiled a census of motor-driven vehicles in the United Kingdom which may be considered authoritative. From data in the hands of license officials in the various cities and towns of Great Britain, it was learned that the total number of motor vehicles of all types in the United Kingdom is 425,838, of which motor cars comprise 227,907; motorcycles, 179,926, and heavy vehicles, 18,005. The same authority gives the number of motor vehicles in France as 90,959; Italy, 20,470; Germany, 77,116; Austria, 14,300; Belgium, 13,250; Switzerland, 10,370; Canada 34,793, and the United States, estimated, 1,435,000.

## OIL MIXER ATTACHED TO EGG BEATER

Oil can be stirred into mayonnaise dressing very quickly by the use of an improved egg beater now on the market. The new mixer is simply a whirling egg beater with a detachable oil funnel hung on one side of the handle. A screw valve in the funnel makes it possible to add the oil a drop at a time, early in the beating, and increase its flow to a steady stream as the mixing progresses.



## AUTOMATIC HONE SHARPENS SCISSORS

A hone with an automatic guide that holds the blade of a pair of shears in the right position by means of a clamping and pressure spring, has been placed on the market and appears to be

simple in operation and sure in results. The base, upon which the carriage slides, is of steel, and so ar-

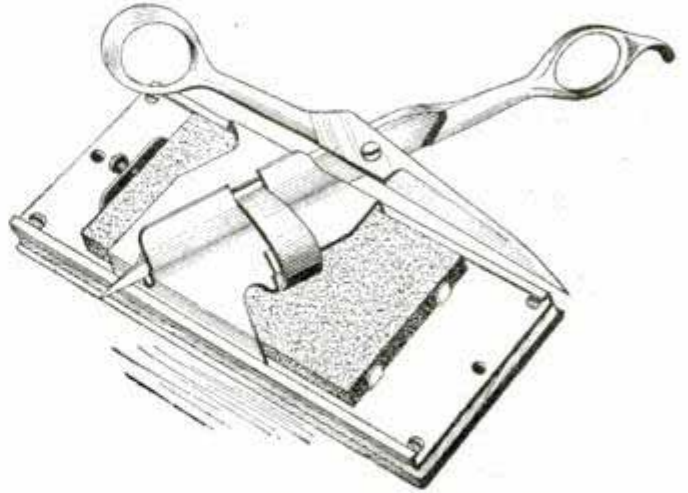

A Shear Hone for Household Use

ranged that the carriage can move only so far. A clamped guide holds the blade of the shear at the right angle upon the surface of the hone. Once fixed in position, the shear is moved back and forth until properly sharpened, as the springs give the requisite pressure and hold the blade rigidly while honing.

## TELESCOPING ATTACHMENT FOR BUNSEN BURNER

A device for regulating the heat from a Bunsen burner without increasing or decreasing the flow of gas has been perfected by a German inventor. This device consists of a telescoping upright by which the work may be done at the proper distance from the flame for securing the degree of heat desired. The principal advantage claimed is the elimination of the back-firing that often occurs when the flow of gas is reduced.

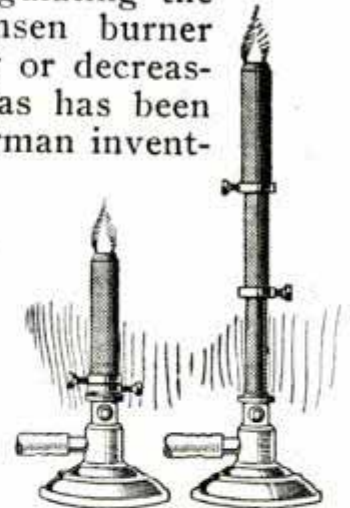

Water that flows from an artesian well at a temperature of 100° F. is used for heating purposes in a South Dakota town.

## PROOF MARKS ON EUROPEAN GUN BARRELS

Following an ancient custom dating back almost to the invention of fire-arms, all European gun makers stamp



Proof Marks Used by European Gun Makers to Indicate the Quality of Their Guns

their gun barrels with graded proof marks indicating the quality of material and workmanship. Before and after each gun is finished, its barrel is subjected to firing tests and to several examinations for defects. All guns that pass the proving tests are graded according to quality, and their barrels are stamped with the maker's proof marks. As every gun maker has five or more proof grades, it is possible to tell from the proof mark on a foreign gun how good a gun it is.

## JACK FOR RELIEVING AUTOMOBILE TIRES

The automobile relief jack provides means for relieving the tires of motor fire trucks, and other apparatus, from

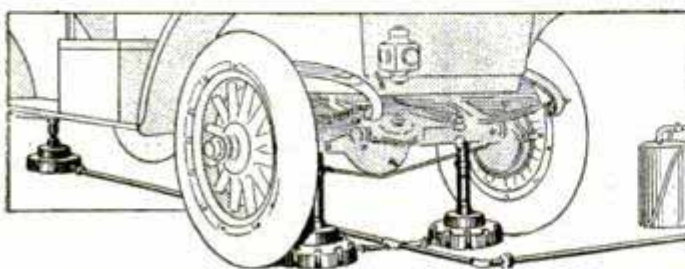

Taking Dead Weight of Motor Car Off Tires by Means of Relief Jack

the constant dead weight resting on a small surface of the tire while the apparatus is in the fire station. The device consists of a heavy diaphragm made of ducking treated with rubber, placed between two concave plates, one fixed in position and the other acting as a piston. The jack is operated by forcing water or other liquid through piping into the diaphragm, which is then locked in position.

## COLOR SCHEME FOR FAIR AT SAN FRANCISCO

In no exposition has the color scheme been more carefully studied than the great Panama-Pacific Exposition to be held in San Francisco in 1915. After prolonged study of local conditions, in which every shadow upon the Marin Hills across the bay were taken into consideration, the yellowish-white tint known as "old ivory" was chosen as the basic color for the buildings. Buff, deepening into rich brown, will be used to accentuate architectural features and secure the antique effect considered desirable. Then eight colors have been added for other decorations. These are French green, used in lattices, flower tubs and small doors; deep cerulean blue, for recessed panels and vaulted ceilings; pinkish red, for flag poles; reddish brown, for colonnades and for interior courts; golden burnt orange, for capitals of columns, smaller domes and architectural moldings; terra cotta, for other domes and roofing material, combined often with copper-green; gold, for groups of statuary surmounting the great courts and the dominant towers which are to be covered with gold and verd antique; a mottled green with pale yellow and black streaks, for the fountains, urns and vases.

Ⓒ Moving-picture exhibitions on trains is an innovation proposed by a French concern to the officials of the Trans-Siberian Railway. It is believed that such installation would be appreciated by everyone who is obliged to undergo the tedium of that long journey.

## AN AUTOMATIC TIMEKEEPER ELECTRICALLY OPERATED

Directly above the center of the ring in the Sydney stadium, where Australian sports are housed, an automatic timekeeper for boxing matches is bolted to the girders, in plain view from every seat in the edifice. It is a four-dial clock, operated by electricity. The dials are 30 in. in diameter and are divided into four minutes, the minutes being again divided into seconds. The hands revolve once in four minutes. At the end of the third minute the clock rings a bell, announcing the end of the round. On the fourth minute another bell rings, announcing "time" for the next round. Underneath the dials are indicators automatically showing the number of the round in progress. When a boxer falls, the timekeeper throws a switch and the clock automatically counts the seconds, ringing a bell to announce a "knockout" at the end of the tenth second unless switched off.

## SINGLE LOG OF MAHOGANY SELLS FOR \$8,000

A mahogany log, 4 ft. square and 24 ft. long, was recently sold in London to a New York firm for \$8,000. This particular log came from Africa, where the mahogany forests have not been exhausted, as have those in Santo Domingo, from which some of the finest mahogany of the past was procured. While the price paid for this log is exceptional, all the rare woods sought by makers of fine furniture bring higher prices than ever before. Vermilion wood, a species of mahogany, comes from the Andaman Islands, in the Bay of Bengal. Its name is descriptive, for the colors are brilliant and the texture close and fine. Tulip wood is pink and white, and when sliced up into veneer strips is more suggestive of the milliner's than of the lumber yard. Satinwood is another West Indian wood, soft and creamy in color, much used for cabinet work, while amaranth, old rose in color, is

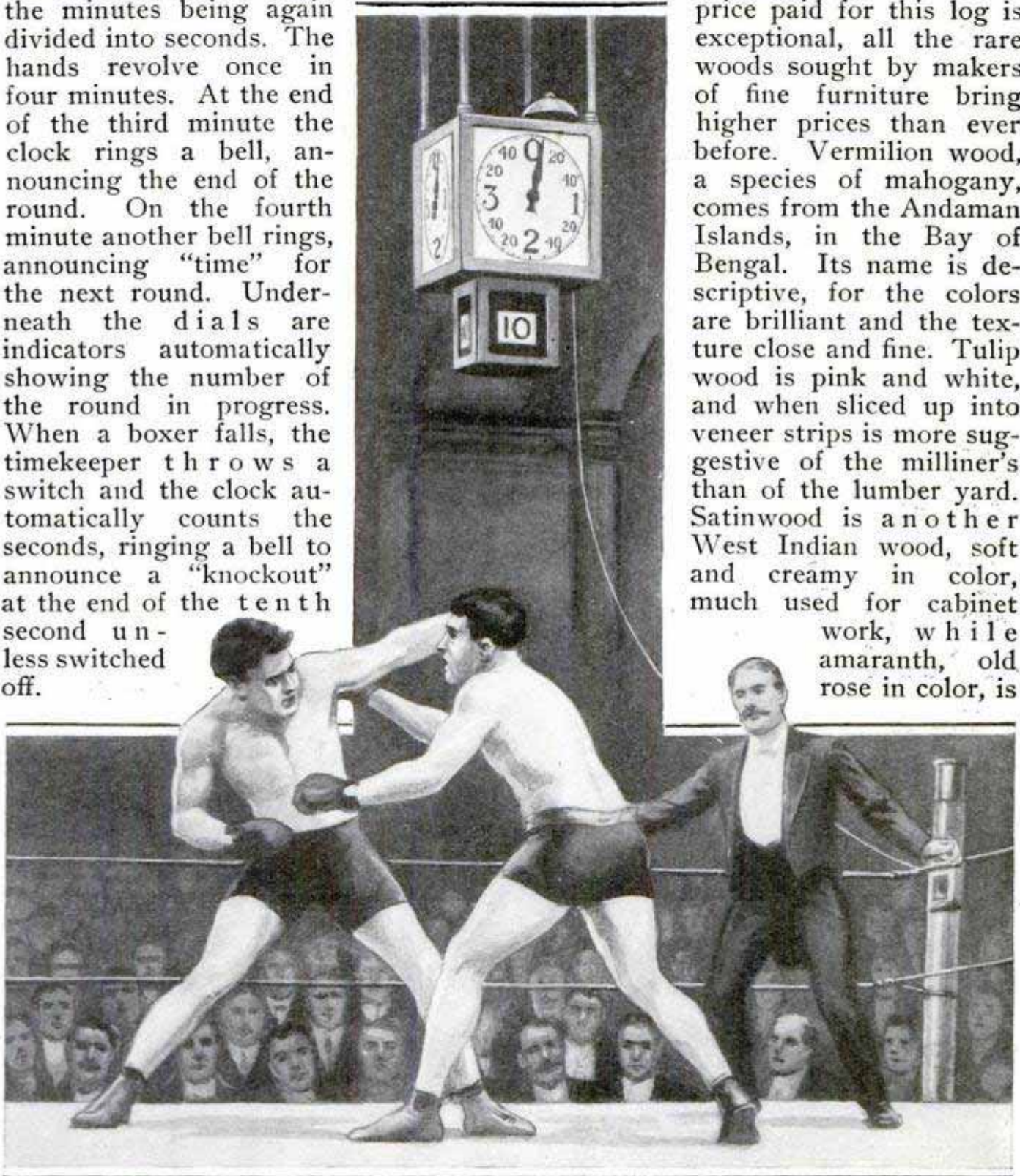

A Clock Which Keeps Track of the Seconds in Boxing Contests

considered one of the most beautiful woods in the whole list. Teakwood, which is a yellowish-greenish white in its natural state, turns dark after years of exposure, and is usually stained dark brown before being made up. Teak is largely used in battleship construction, the floors and doors being almost wholly made of this wood, which does not splinter on impact.

### DRIVING OUT THE EVIL SPIRITS

Treatment of the sick among the Eskimos is a matter of driving out evil spirits, and the job is not always an



Eskimo Medicine Man Driving the Evil Spirits from a Sick Boy

easy one for the medicine man, according to observers who have witnessed the process. In exorcising the evil spirits the grotesque costume shown is

considered an absolute necessity, while to make the cure effective the medicine man must stand in one position for days at a time or until the patient has recovered.

### BIG FLYING BOAT WEIGHS FIVE TONS

Recently the first trial trip was made upon the Seine, near Paris, of a flying boat, 29 ft. long and 9 ft. wide. Two planes, each 89 ft. in length, give a lifting power sufficient to raise the boat with two pilots, two mechanics and enough gasoline, oil and machinery to make its total weight five tons. Two motors, of 200 hp. each, operate a screw 16½ ft. long, and while no effort was made to establish a record for speed, enough was seen to warrant the belief that the craft would be able to negotiate long distances and at fair speed. The engineer is reported to have expressed his intention to build a larger machine next year, and attempt a transatlantic flight.

### KILLING GROUND SQUIRRELS WITH A MOTORCYCLE

A farmer in a western state whose fields had been overrun with ground squirrels, discovered a cheap and effective way of ridding himself of the pests by taking his motorcycle out to the infested fields, and connecting the exhaust of his machine with the burrows by a piece of rubber hose. He then starts his engine and fills the holes with deadly gas. By using a cheap distillate, he finds the method a great saving over older processes, and it is very efficient.

### TRAVELING BUNGALOW ON MOTOR TRUCK

A motor bungalow, mounted on the chassis of a 2-ton truck, was the uncommon conveyance built recently to carry a party of several persons on a three weeks' trip from San Diego, Cal., to Big Bear Valley. Although it con-

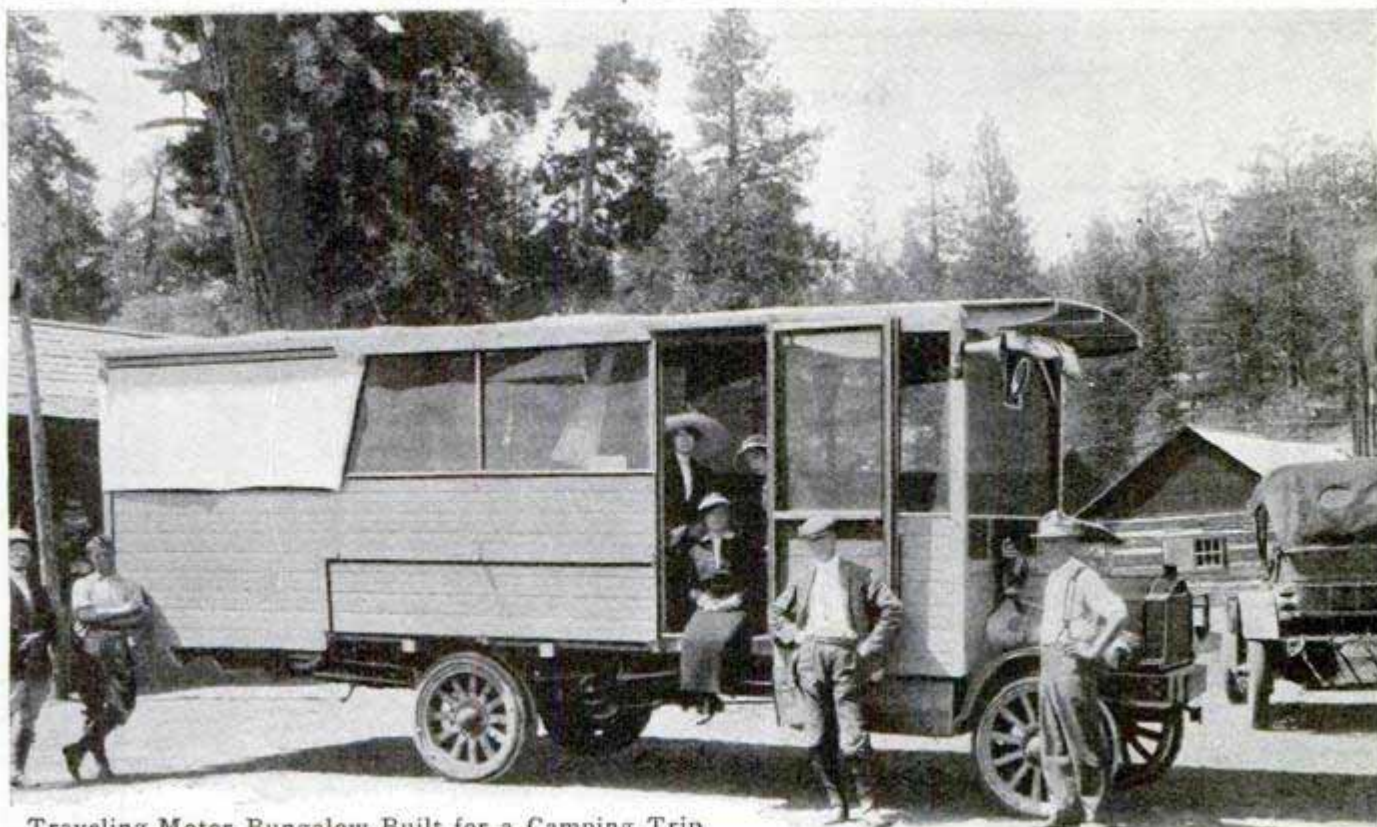

Traveling Motor Bungalow Built for a Camping Trip

tained three roomy compartments, the traveling bungalow was only 26 ft. long, 6½ ft. wide, and 6 ft. high, inside. The four walls were boarded up for about 3 ft. from the floor and screened above, with canvas roll curtains to cover the screens. The roof was made of oiled canvas and had an extension that could be spread over an area, 10 by 22 ft., behind the car to shelter a dining table and several folding cots. The forward compartment, back of the driver's seat, contained four sleeping-car berths. Back of this was a small dressing room and a large observation platform with lockers for cooking utensils and provisions. Folding steps at the back furnished an entrance to the bungalow on wheels.

### HOTEL ALARM CLOCK OF NOVEL CONSTRUCTION

Around the dial of a new "reminder" clock, intended for use in hotel offices, 48 levers are arranged, which permit of setting the alarm to ring at any desired time by an electrical connection. Each lever may be set in three different positions, either up-

right or at 45° either way. If the lever is set upright, the alarm will ring either on the hour, the half or the quarter, as the case may be. If the lever is set at an angle, the alarm will ring five minutes earlier or later, as may be desired. Any number of "calls" may be set up with the certainty that the clock will ring the bell for each in turn. Dry cells furnish the energy to operate the alarm.

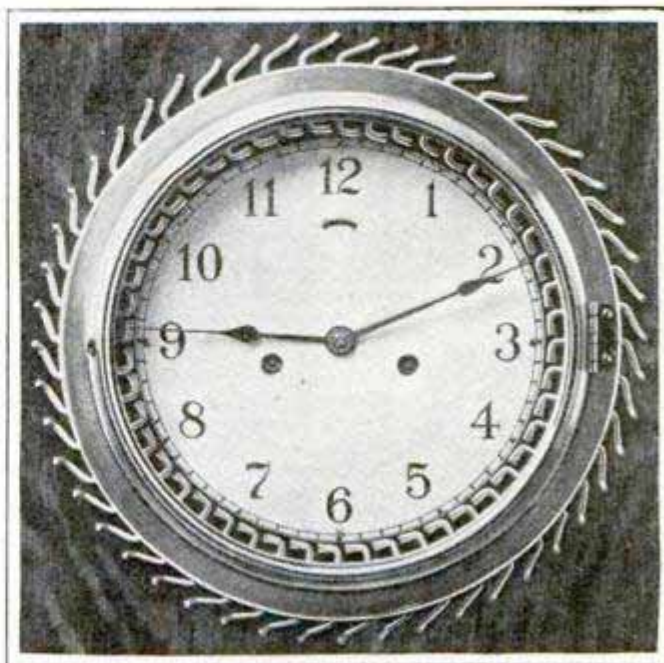

Novel Arrangement of Levers in Alarm Clock

# ARTIFICIAL WATERWAYS IN MANY LANDS

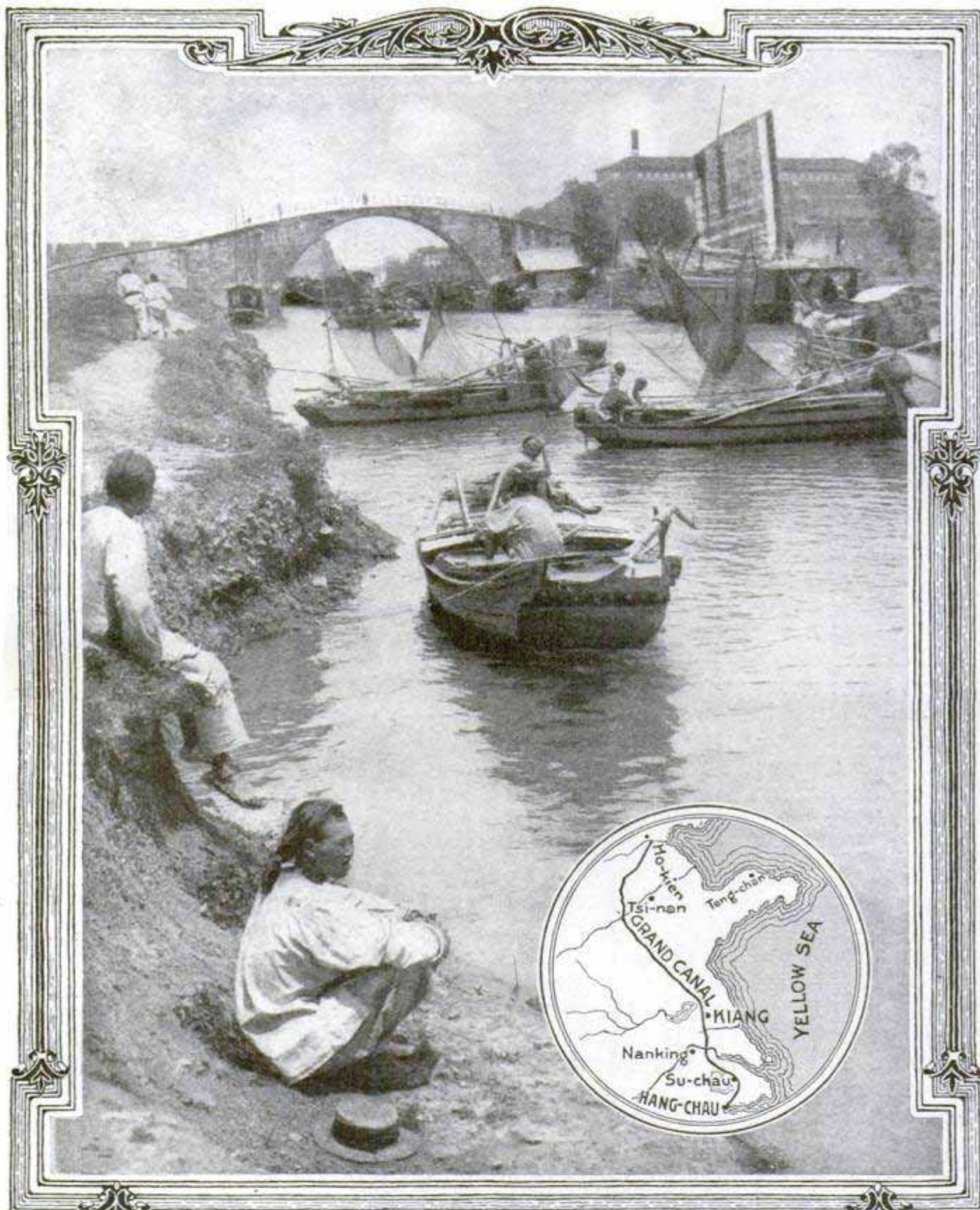

"YUN-HO" is the Chinese name for the Grand Canal, an artificial waterway nearly 1,200 miles long, connecting Hang-Chau with Ho-Kien, Tientsin, and thus providing inland water communication between eastern China and Peking. The depth ranges from 7 to 13 ft., and for long distances it is more than 100 ft. wide. There are no locks, since canal locks are a modern invention, having been devised by Leonardo Da Vinci, who was a contemporary of Columbus, while the Grand Canal was begun about 486 B.C., when the middle section was constructed. The southern part was built about 600 A.D. and the northern part in 1280 A.D. Instead of locks, there are many "barrages," or inclines, up which the flat-bottomed boats are hauled by windlasses, sometimes negotiating a difference of 20 ft. or more in levels. The traffic on the Grand Canal is very heavy, but nowadays mainly local.

## ARTIFICIAL WATERWAYS IN MANY LANDS

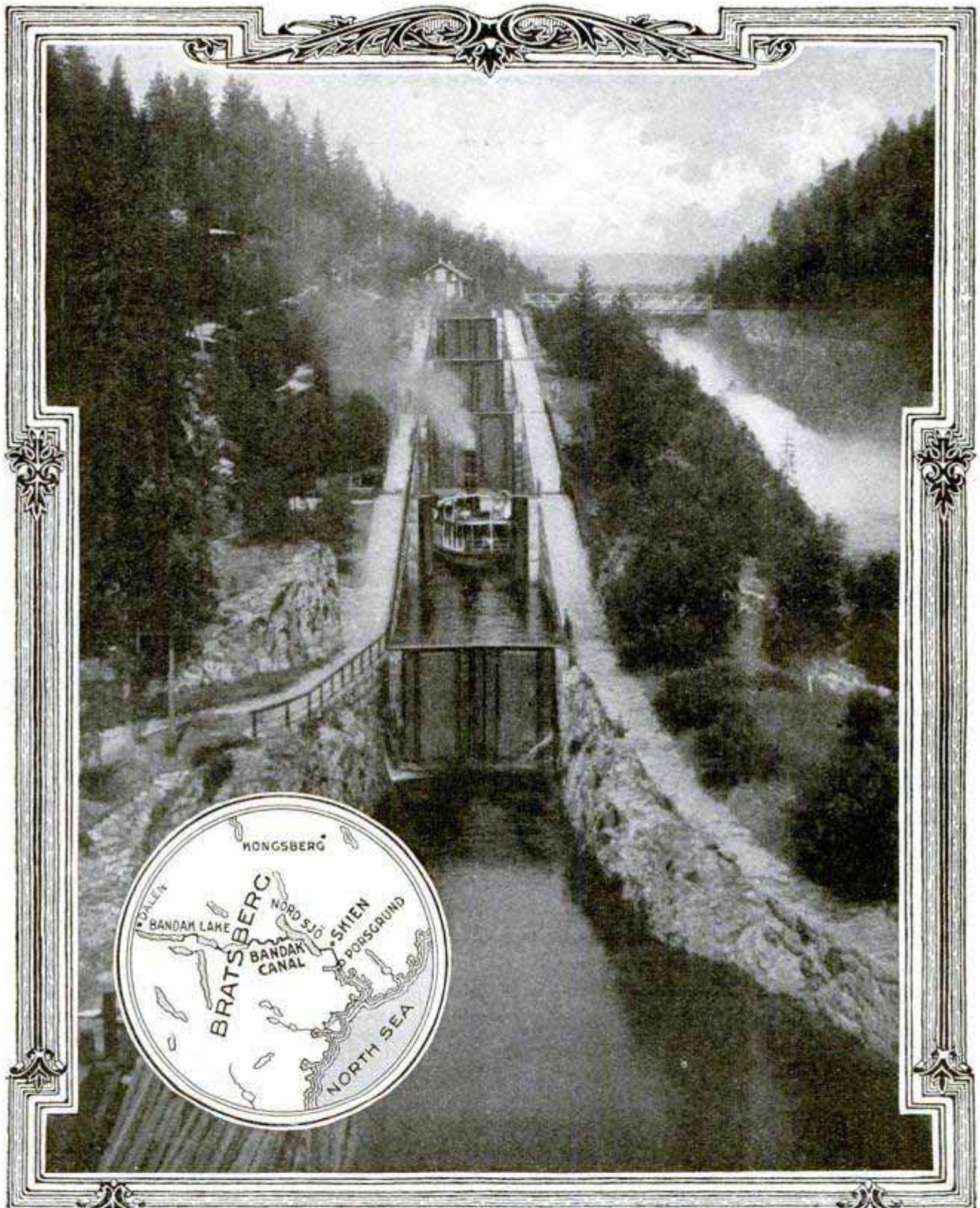

**F**EW of the swift rivers of picturesque and mountainous Norway are navigable for any considerable distance, owing to the innumerable falls and rapids, so inland water traffic has to depend upon the numerous large lakes and a few canals connecting some of them. The Bandak Canal, which gives the city of Dalen water communication with Skien, is narrow and shallow. It climbs several flights of locks on the route from Langesund Fjord to Bandak Lake. Small steamers can thus travel from the Skagerrack, an arm of the North Sea, more than 75 miles into the interior of Norway, both freight and passenger traffic being thus provided for. The photograph shows a vessel climbing the locks at the Vrangfos Falls.

# ARTIFICIAL WATERWAYS IN MANY LANDS

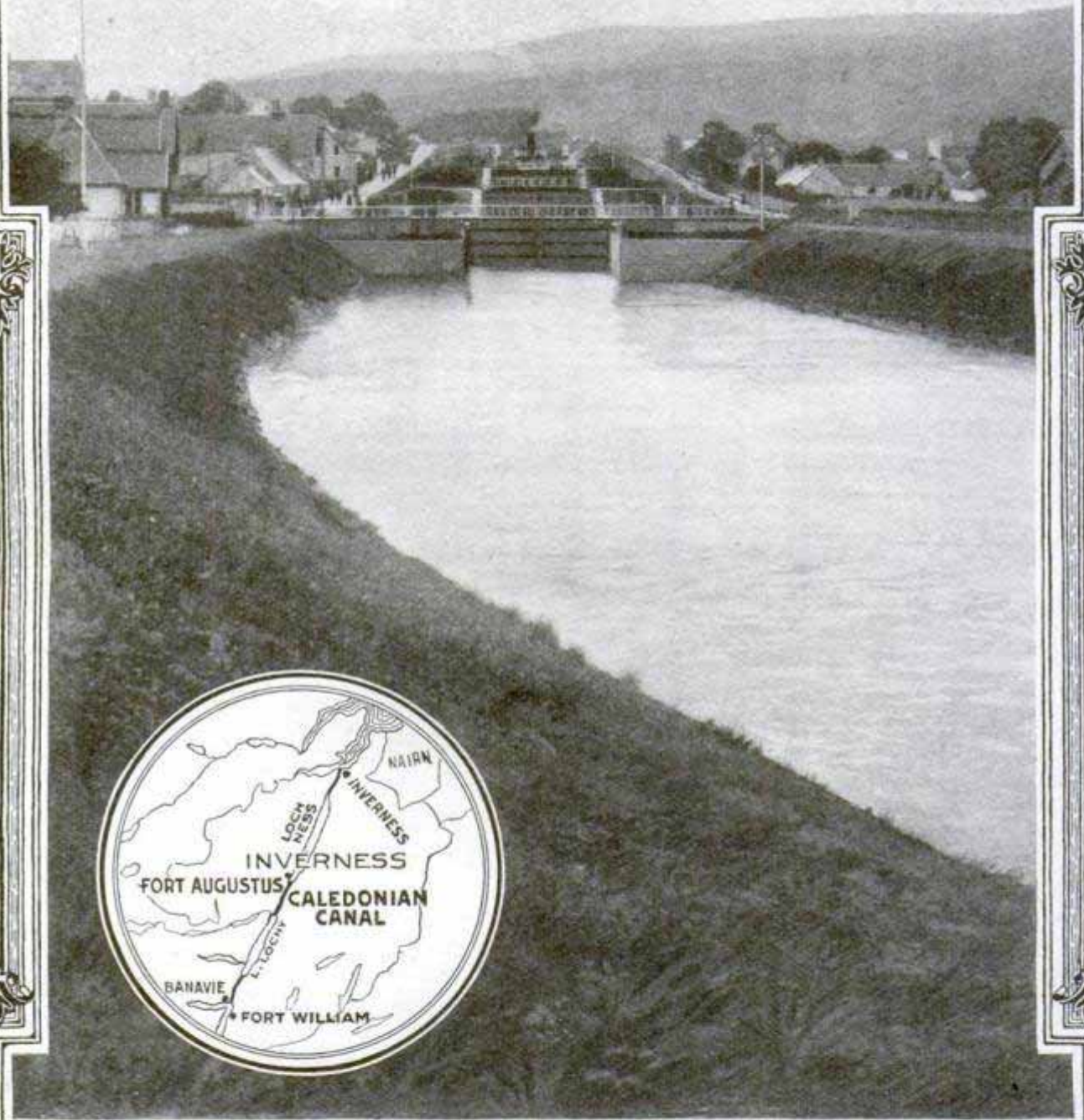

**R**UNNING in almost a straight line across Scotland from the Firth of Beauly, on the northeast coast, to Loch Linnhe, 60 miles to the southwest, the Caledonian Canal cuts off the northern third of Scotland. It was constructed to enable vessels sailing between the North Sea and the Irish Sea to avoid the 400-mile voyage around the north of Great Britain. James Watt, inventor of the modern steam engine, made the first surveys for this canal in 1773, and the work was begun in 1803 under the engineering direction of Thomas Telford, inventor of the system of road building which bears his name. Only 22 miles of artificial channel was found necessary, large lakes being utilized for 38 miles of the distance. There are 28 locks, each 160 ft. long, 38 ft. wide and with 15 ft. depth of water, the average lift being 8 ft. The photograph shows the locks at Fort Augustus.



# ARTIFICIAL WATERWAYS IN MANY LANDS

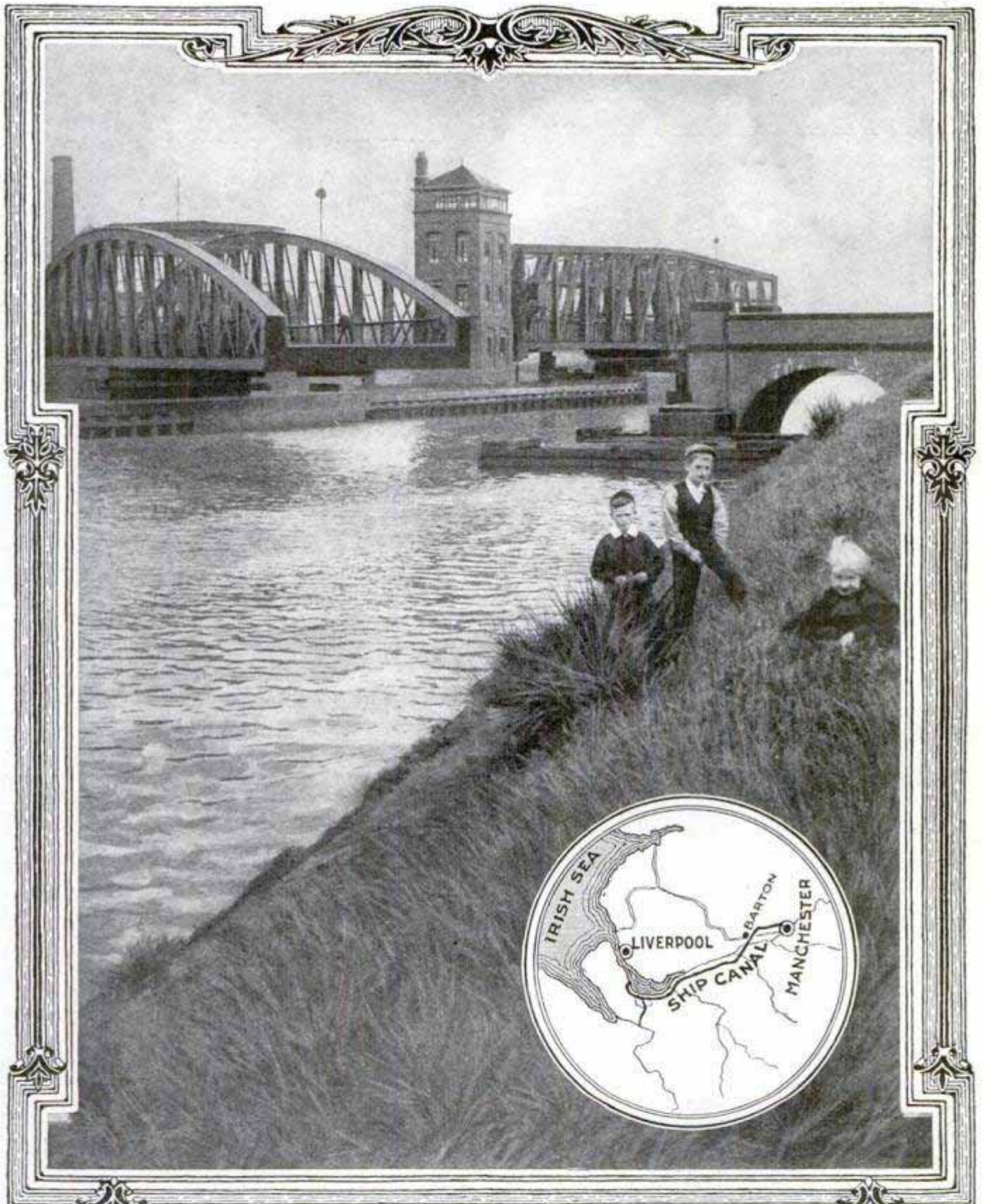

**T**HE famous Manchester Ship Canal, constructed for the purpose of enabling sea-going vessels to reach Manchester, England, was begun in 1887 and opened for traffic on Jan. 1, 1894. It is 35½ miles long and cost \$75,000,000. It connects with salt water at Eastham, on the Mersey River, about 6 miles from Liverpool. Originally 26 ft. deep, it has been dredged to a minimum depth of 28 ft. Ships 550 ft. long, with a 61-ft. beam, a height above water of 70 ft. and a draft of 27 ft. can use this canal. There are five sets of locks with a total lift of 58½ ft., the highest lift being 16 ft. Thirteen barge canals connect with the ship canal, which handles about 6,000,000 tons of freight a year.

## TRANSPLANTING BIG TREES WITHOUT INJURY

In securing full-grown trees for his new residence, a citizen of Americus,

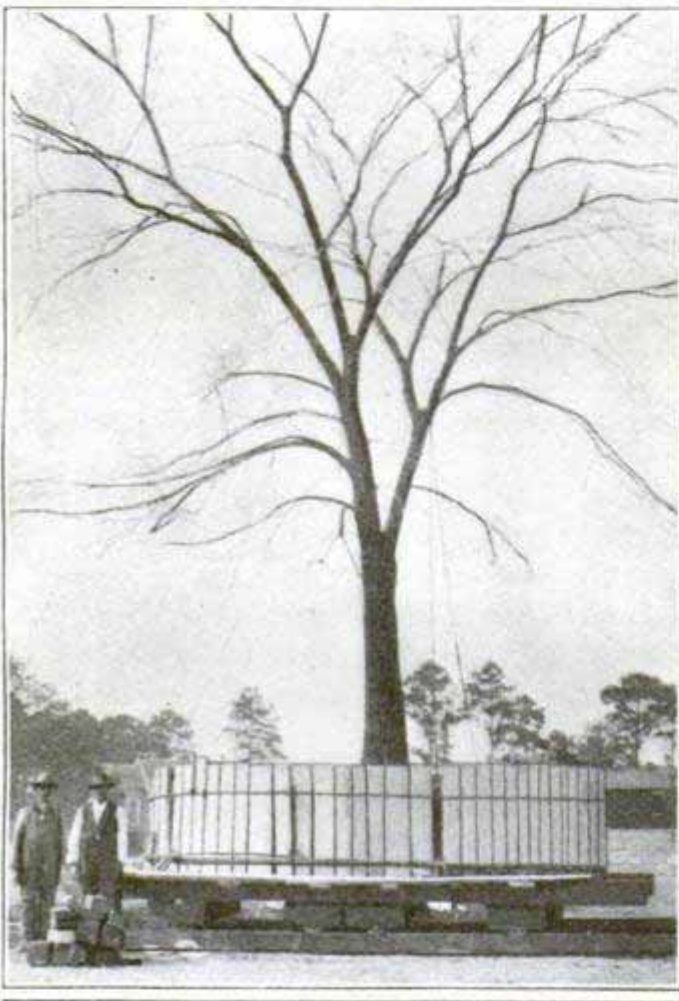

Method of Moving Big Trees

Ga., adopted a method of transplanting elms and other large and heavy trees without injuring them in the slightest degree. A circular trench was dug around the tree, about a yard deep and with a radius of 3 yd. Boards were placed in the trench and secured by steel cables. The tree was then

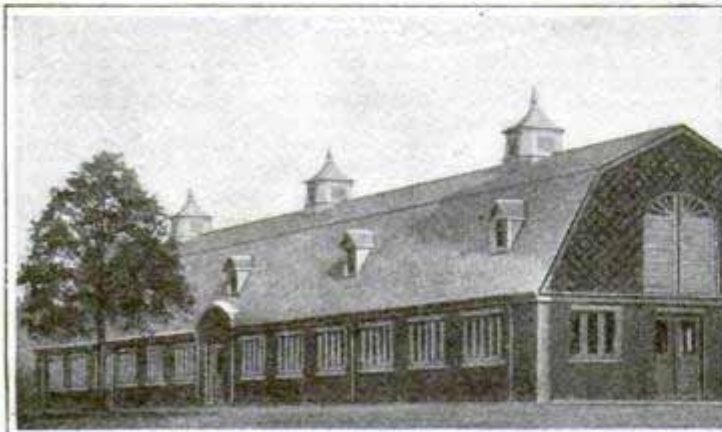

undermined, floored with heavy plank and jacked up. Small roller trucks were placed under the cylindrical box thus formed and timbers laid for a temporary track. Along this improvised roadway the big trees rolled to their new locations, and were planted in pits prepared for them.

## REMARKABLE SILOS BUILT OF CONCRETE

Twin silos, 72 ft. high, are the feature of the dairy barns at the Ohio State Hospital at Dayton. The one on the left has a capacity of 450 tons, while its mate is a combined water tower and silo, the top 11 ft. being used for a water tank, from which water under high pressure is supplied to all parts of the barn. The barns are of monolithic concrete with asbestos shingles, and are practically fire-proof. A similar structure near Aurora, Ill., is a combined water tank and silo. Its height is given as 79 ft. These structures are carried to a great height, while their diameter is kept small in order that as little space as possible shall be wasted at the top, by reason of the settling of the silage. Experience has demonstrated that concrete silos, even if high in pro-



portion to the diameter, stand uninjured even when adjoining buildings are damaged or demolished by violent storms.



These Twin Silos are Built of Concrete and Stand 72 Ft. High

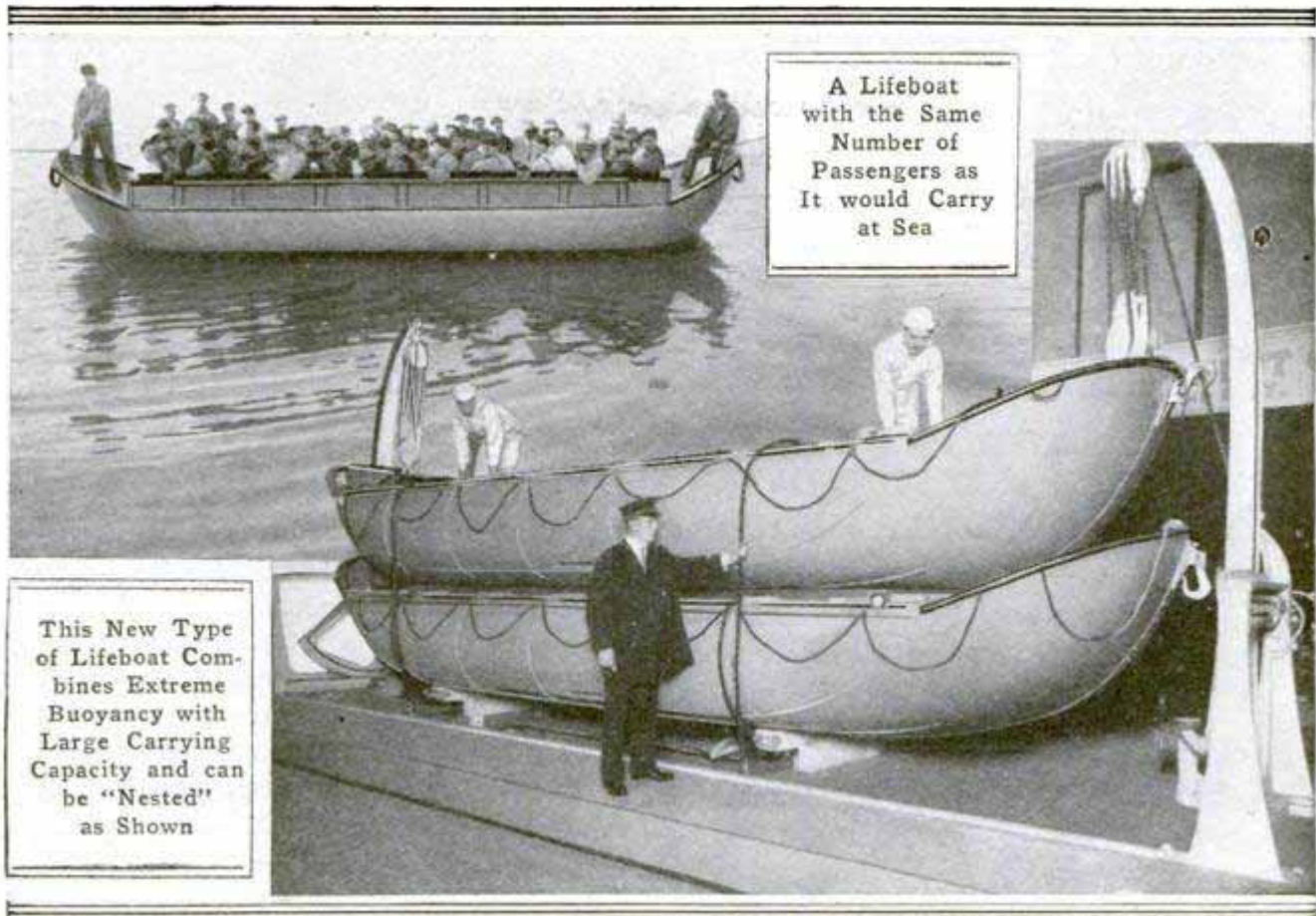

### LIFEBOAT WITH DECK AND WATER-TIGHT HOLD

One result of the succession of startling sea disasters of recent years is the activity shown by shipbuilders in an attempt to devise a lifeboat that will be both unsinkable and unsmashable. A lifeboat for which the claim is made that it meets these conditions as nearly as any boat can has recently been put into service. This boat is completely decked, the space below the deck being water and airtight, and is provided with gunwales that project a sufficient height above the deck to prevent danger of passengers falling overboard. The cross section is wide and low, the bottom of the boat being nearly flat. This construction is designed to enable the boat to ride the roughest sea without capsizing. To prevent, as nearly as possible, the danger of smashing the boat against the side of the ship as it is swung from the davits, the boat is built of the strongest materials throughout, and is provided with a

system of heavy cross bracing in the space between the deck and bottom. Each of these boats is capable of carrying from 60 to 65 persons.

### NATURAL GAME TRAP FOUND IN NORTHERN MEXICO

A hole in the rocky plateau of Pajarito, near the recently excavated community house of Puye, in northern Mexico, becomes filled with noxious



Poisonous Gases Make Cave a Natural Animal Trap

gases which are of sufficient power to overcome a man if he should venture within. This strange natural phenomenon has been used by native Indians as a game trap for many years. A freshly killed rabbit or other small animal placed in the hole serves as bait, luring coyotes, badgers, porcupines, and other wild animals, to descend, where they are overcome before they can scramble out.

### PORTABLE ELECTRIC LAMP WITH NOVEL FEATURES

A number of new features designed for greater convenience in using are embodied in a new portable electric lamp that has recently made its appearance on the market. This lamp has a hook by which it may be hung up, a spring clamp for attaching it to an upright of a bed or chair, and, most important of all, a rubber suction cup by which it may be fastened in a horizontal position to any smooth surface, such as a mirror or wall. It is supplied with a cord, 10 ft. long. This cannot become tangled, as the portion not in use coils up automatically in a receptacle in the base of the lamp.



It is supplied with a cord, 10 ft. long. This cannot become tangled, as the portion not in use coils up automatically in a receptacle in the base of the lamp.

### POWER NOW OBTAINED FROM MERCURY VAPOR

The latest source of power for commercial use is mercury vapor. Experiments by a large electric company have demonstrated that by heating mercury and using its vapor to drive engines just as steam is used, the capacity of a

steam plant may be increased by 66 per cent, with a gain of 44 per cent in output for each pound of coal burned. Mercury is vaporized at 677° F. in a specially designed boiler, from which the vapor is conducted to the nozzles of a turbine. The power having been exhausted in revolving the wheels, the vapor is condensed in coils within a steam boiler, where the heat released through its condensation is utilized to convert water into steam, and other turbines are turned with the steam thus made. The condensed mercury, now in its ordinary liquid form, is drawn off and runs back by gravity to the mercury boiler, where the process is repeated. This combination, it is figured, gives a fuel economy very close to that obtained by Diesel engines, while its mechanical simplicity gives it, it is contended, an advantage over the internal-combustion engine.

### WATER HYDRANT IMBEDDED IN EUCALYPTUS TREE

The rapidity with which the eucalyptus tree grows is illustrated in the yard of the old Hoyt's School at Menlo Park, Cal. The pipe seen in the center is a 2-in. water hydrant and is still in use, although the tree has grown entirely around it. The trunk of the tree measures 19 ft. in circumference at the level of the valve.



In power-transmission ropes, failure generally begins at the core, where the most severe rubbing of fiber against fiber occurs, and not, as is generally believed, at the surface.

## USE MOTORBOATS TO SCOUT ICEBERG DANGERS

Steamships of a line cruising between Liverpool and Montreal are now equipped with motorboat ice scouts, as a precaution against an encounter with icebergs. Each vessel carries two motorboats, the size of a lifeboat, fitted with 30-hp. motors, with wireless and with submarine signaling devices. In foggy weather, these motorboats are sent ahead to act as scouts, to report to the liners by wireless the approach of icebergs or other dangers. In the event of a collision, the motorboats will be available for towing the lifeboats, should it be necessary to abandon ship. Other transatlantic steamers are likewise to be equipped with these small patrols.

## FOLDING DEVICE MAKES ANY CHAIR A "HIGH CHAIR"

A device which converts any chair into an infant's high chair has been invented. When not in use by the child it may be quickly detached and put out of the way. The device is a seat with straps, and hooked attachments for grasping the back of the chair. The grips are covered with rubber so as not to mar the finish of the chair, while holding the seat securely in place. A strap in front permits the youngster to be fastened so that there is no danger of a fall.



## MOWING MACHINE MADE INTO A MOTOR TRACTOR

A homemade farm tractor that is a combination of an old mowing machine and a gasoline engine is being



Homemade Farm Tractor Built of an Old Mowing Machine  
Plus a Marine Engine

used to draw a plow on a farm near Newell, S. D. It is crude in appearance, but will draw a 12-in. breaking plow, 5 in. in the ground, at a rate of about two miles an hour. The old mowing machine, stripped of its knives and machinery, is propelled by a 2-cycle 4-hp. marine engine bolted to the frame just back of the seat. Power is transmitted by a chain running over the old gears of the mower. A solid wooden wheel, mounted in an iron fork and provided with a gas-pipe "tiller," is pivoted on the end of the sawed-off pole to serve as a steering gear. Circulation to cool the motor is provided by a bucket of water on the platform behind, a coil of pipe hung under the pole, and three pieces of hose connected with the engine pump.

## COALING DEVICE FOR LOCOMOTIVE

In a large switchyard where many locomotives coal, one railway has installed a coaling device which operates quickly and with a minimum of labor. Between the tracks is the coal pit, into which is dumped from time to time coal for the tenders. As each engine draws up, buckets filled with half-ton

loads of coal are hoisted by a pneumatic lift and swung over to the tender, dumped, and returned quickly. The entire operation takes but a fraction of the time hand coaling requires, and the actual labor involved is limited to fill-

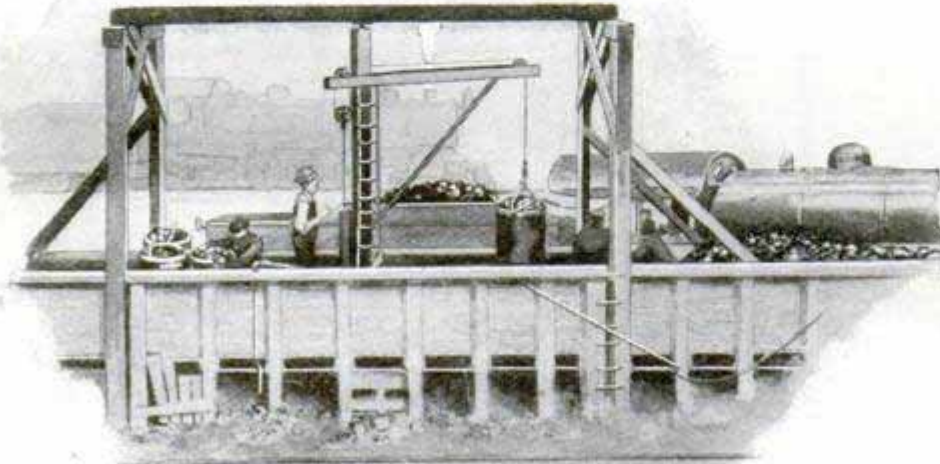

A Simple Contrivance for Coaling Engines Quickly

ing the buckets, a number of which may be loaded at dull times and held in readiness for the rush hour.

### GRADUATED GLASS WITH ZIGZAG SCALE

A graduated measuring glass having the divisions marked on a zigzag line instead of on a vertical line, as has been

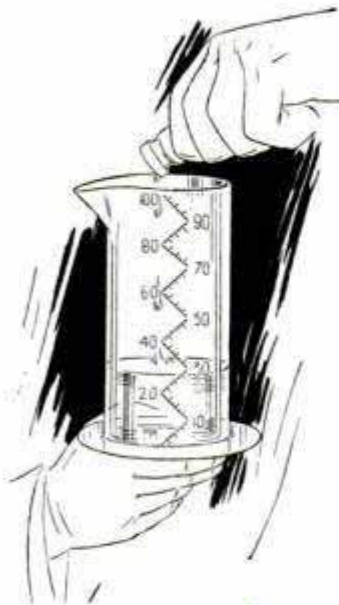

the common practice, has been brought out recently in Germany. It is thought that increased accuracy and ease in reading the measurements can be secured with a scale arranged in this way.

A 35-mile telephone cable is being laid between Vancouver and Vancouver Island, Canada. It weighs 560,000 lb., cost \$100,000, and \$20,000 will be spent in laying it.

### TO MAKE FLAX STRAW INTO YARN AND TWINE

Tests made at English mills on flax straw grown in Montana indicate that this material, heretofore regarded as practically a waste product, can be made successfully into all varieties of yarn and twine, including binder, packing and shop twines. The process of manufacture is simple and inexpensive, the flax straw being taken direct from the field and treated rapidly, then dried in the sun and passed through special machinery that forms it into yarn or twine. It is believed that this treatment can

be applied with commercial success to flax straw grown in any part of the United States. If this proves to be true, a profitable addition will be made to the resources of American farmers. In 1912, about 3,000,000 acres were in cultivation under flax in the United States.

### BIG GLASS TANK USED BY DIVERS BURSTS

A glass tank holding 8,000 gal. of water, which was part of the equipment of the Bermuda aquarium, burst when being used by two moving-picture performers in staging a diving scene. The rush of water drew the performers across the jagged edges of the broken glass, injuring them severely. It is believed that the sudden strain caused by the plunge of the divers caused such pressure within the tank that the glass could not resist it, and one side gave way with disastrous results.

A tube containing \$5,000 worth of radium, lost in a Liverpool infirmary, was found in the garbage of the institution. It had been swept up unnoticed.

# PRIMITIVE SAWMILL STILL USED BY FILIPINOS

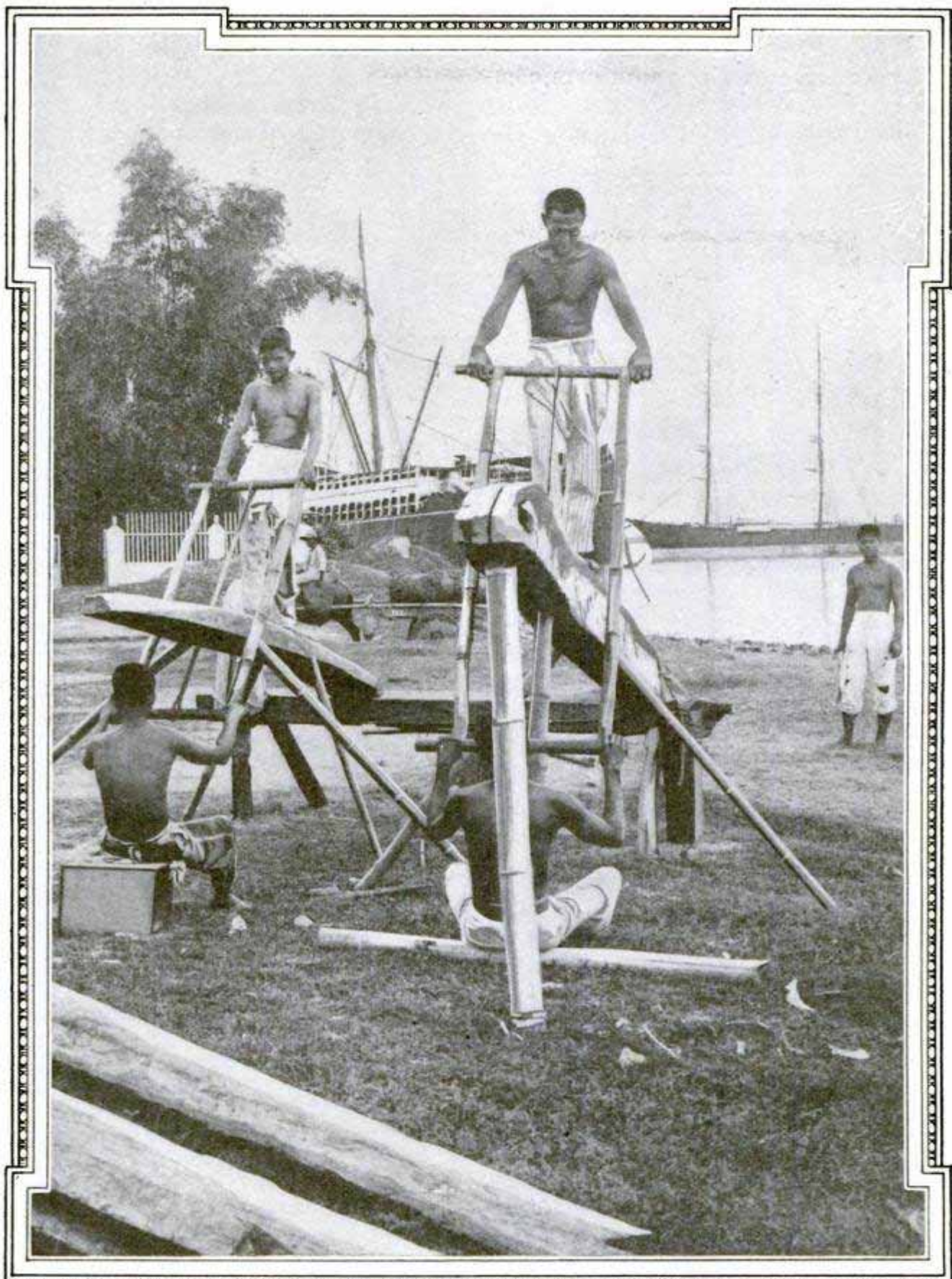

**S**AWMILL installations in the Philippine Islands do not require a large investment. The timber is braced at an angle by bamboo pieces, the lower end resting on a crosspiece of timber. One sawyer mounts the piece to be cut, while his mate seats himself beneath the stick. A saw blade mounted in a bamboo frame is worked back and forth by the two men.



## NATURAL DAM OF SODA IN NEW MEXICO

There is a curious natural dam composed of crystallized soda in the heart of the Jemez Mountains of New Mex-



Natural Dam of Soda Deposited by Mineral Springs in  
New Mexico Mountains

ico. The deposits of some mineral springs have gradually accumulated until they have piled themselves into a snowy-white wall 30 ft. high. The entire surface of the dam is overlaid with beautiful leaf designs, and its edges are fluted with stalactites hanging in little groups. Under the edge of the dam a little mountain stream flows out from the rocks behind.

## EGG TESTER TO REPLACE CANDLE

A compact egg tester has been patented to take the place of the rude contrivances used by many chicken raisers and grocers. An electric light in a neat box,  $6\frac{1}{2}$  by 6 by 3 in., shines through two beveled-edged slots in the top. The outside of the box

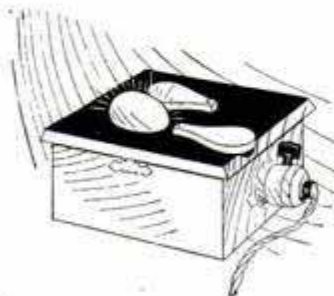

is covered with black felt cloth and the inside is lined with white asbestos. The strong light shining through eggs placed in the slots makes it possible to judge their quality even in daylight.

## AEROPLANE SCOUTS IN WARFARE

The various kinds of aeroplanes best fitted for different duties in war and the number of machines of each kind that should accompany an army in the field have been discussed at length by an officer in the British Royal Flying Corps. At the beginning of a campaign fast single-seated machines that have a large radius of action are needed to ascertain the strength of the enemy. Larger two-seater aeroplanes that can readily be transported on the road when the weather is bad he considers much the best for reconnaissance of the enemy's position during the campaign.

As an army in the field would require machines of both types, he has given the total number of aeroplanes needed by a field army as 15 squadrons of 12 machines each. They are parceled out, according to his plan, among the various divisions as follows: Two squadrons of fast single-seater monoplanes to accompany the army troops; one squadron of two-seater monoplanes to go with the cavalry divisional troops; six squadrons of two-seater biplanes and six squadrons of fighting machines to work with the divisional troops, one squadron of each with each division.

## TORPEDO BOAT IN STORM ALMOST SUBMERGED

The low freeboard of torpedo boats renders them particularly subject to the action of the huge waves met with in storms. A photograph taken from the fighting top of a battleship shows clearly the plight of the torpedo boat in heavy weather. Tons of green water break upon the low deck, washing overboard everything not firmly





The Torpedo Boat is No Place for a Fair-Weather Sailor, as This Photograph Clearly Shows

Courtesy London Illus. News

lashed. First the bow and then the stern are lifted clear, taxing the rigidity of the frame to the utmost.

However tightly the hatches are battened down, considerable leakage results.

## CURIOUS CEREMONY OPENS ELECTRIC LINE

The opening of the first electric street-car line in Constantinople recently was marked by a curious ceremony, in which

two lambs were sacrificed upon the tracks, the rails being smeared with the sacrificial blood while prayers were offered by Mohammedan priests for the success of the undertaking. The officials of the new line took part in the



Sacrificing Lambs upon the Rails of the New Street-Railway Line in Constantinople

ceremony and are shown in the photograph with their hands extended, the attitude of invocation. This ancient rite with its modern adaptation presents strange contrasts. The car line runs from the Karakeny bridge to Sirkedji, within the Ottoman capital.

### MODEL OF RAT-INFESTED HOUSE

A model of a rat-infested kitchen and cellar in San Francisco has been installed in the American Museum of Natural History as an example of what happens when proper precautions are not taken for the exclusion of these disease-bearing animals. Side by side with this model is one showing a house and barn protected by rat-proof construction. The importance of such protection is evident in view of the fact that rats are known to be the carriers of the germs of some of the most dreaded diseases, including the bubonic plague.

### FLOATING NAVAL COALING STATION

For nations that need naval coaling stations in distant parts of the world where they have no colonial possessions, a Russian inventor has designed a floating storehouse for fuel and other supplies. Manned by a small crew of men, the floating naval base can be towed to any advantageous position and anchored, ready to receive supplies from colliers and distribute them to warships. On the approach of a hostile fleet, the entire naval base, crew and all, can be sunk out of sight, to reappear again as soon as danger is past. As patented, the floating storehouse is very much like a huge diving bell, cylindrical in shape, with double walls and roof containing compressed-air tanks for regulating its height in the water. It has no bottom except a wire netting and is usually partly filled with water. All coal, petroleum, and other naval supplies are received

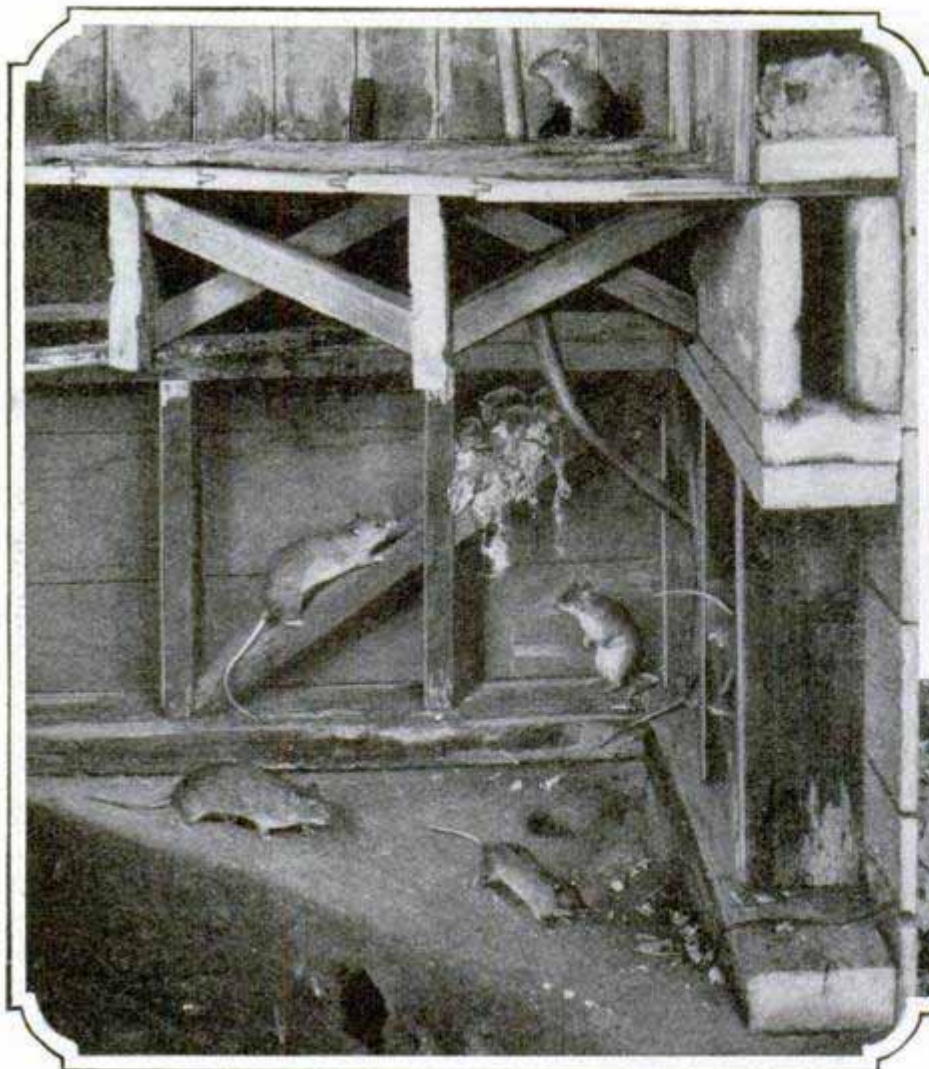

Model in American Museum of Natural History Showing Cellar and Kitchen Where Rats have Taken Almost Complete Possession



Photo by Am. Museum of Natural History

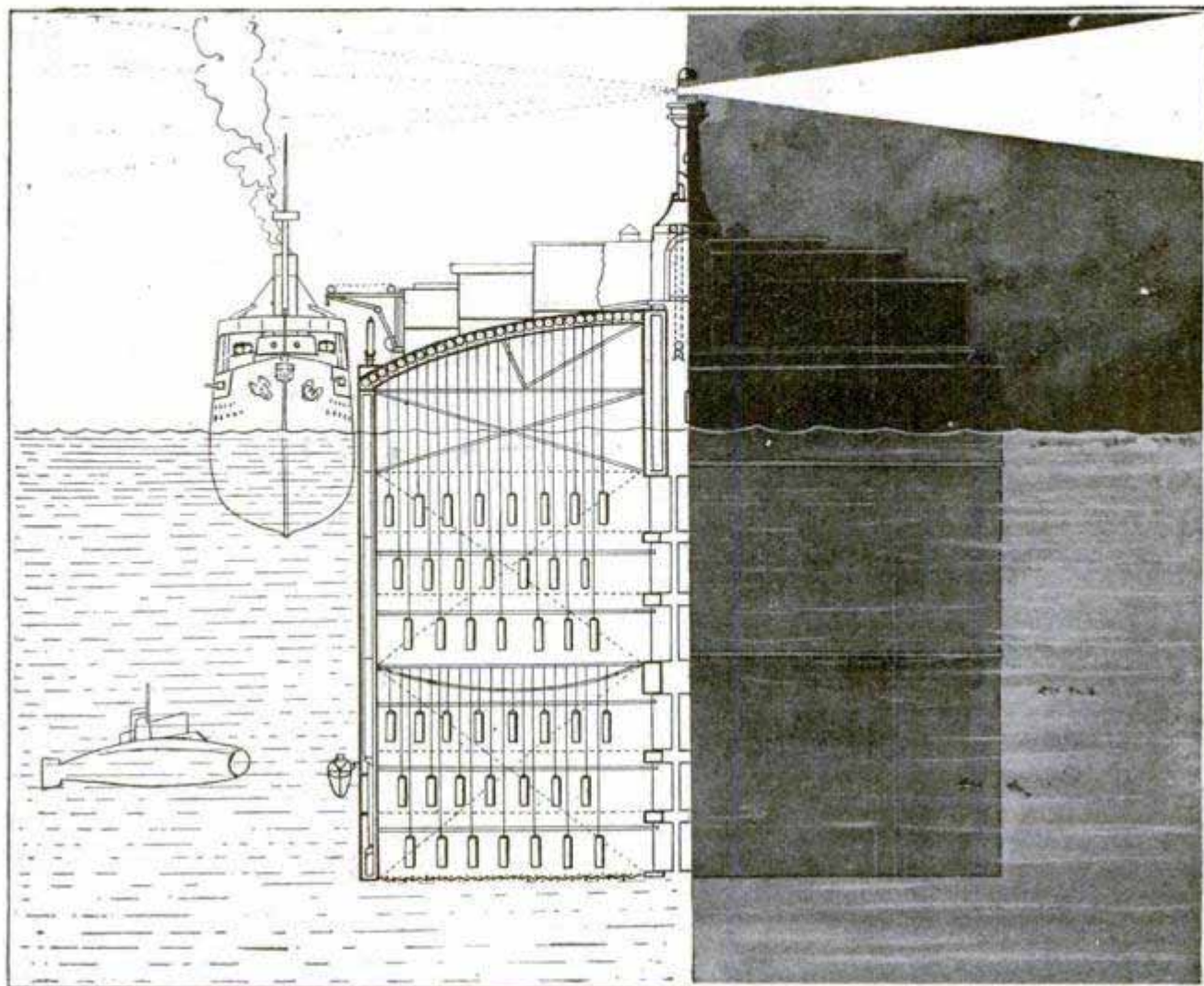

A Floating Naval Coaling Station Which can be Anchored Anywhere and Sinks Out of Sight Whenever Danger Approaches

and stored in small water-tight drums. From the receiving cranes on the roof, the drums are moved to a well in the center, lowered to the proper depth, and shunted off through windows in the well upon concentric tracks, where they remain suspended in the water until needed. All the handling is done by automatic machinery.

## QUARRYING FOSSILS IN WYOMING

The bones of many antediluvian monsters have been found in the rocks of Wyoming, and regular fossil quarries exist, where bones and often a complete skeleton of extinct creatures may be exhumed. Uncovering these fossil remains, however, is the least of the task confronting the scientist. Each bone must be inclosed in a

protective cast of plaster, carefully wrapped and numbered with exactness. Bones shipped without such precautions would surely be broken before they reached their destinations in the laboratories or museums of scientific institutions.



Taking Out the Bones of Prehistoric Monsters from a Wyoming Quarry

## NEW AUTOMOBILE MILITARY FIELD KITCHEN

A military field kitchen mounted on a large automobile truck, as shown in the accompanying picture, has been

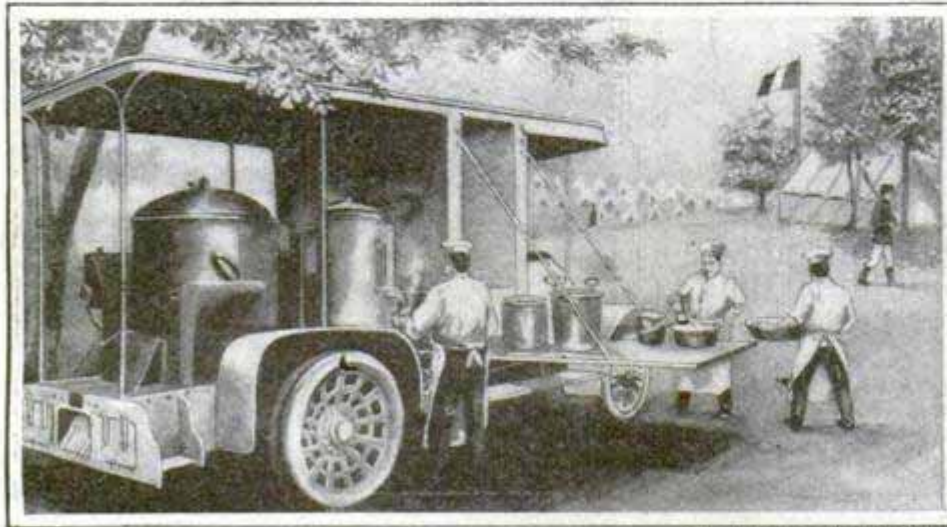

Courtesy of the Sketch  
A French Automobile Military Kitchen Ready to Follow the Army in the Field

designed for the French army. The cooking boilers are mounted on a platform back of the driver and protected by a canopy, and the fully equipped kitchen, in such compact form, is able to follow the rapid movements of the army in the field.

## EMERGENCY HOISTING CAGE FOR MINE RESCUE

To aid in mine-rescue work when the regular hoisting apparatus has been damaged or disarranged, an emergency portable and collapsible hoisting cage has been patented and dedicated to public use by the chief mining engineer of the U. S. Bureau of Mines. The emergency cage consists of a collapsible frame of two flat bars, approximately elliptical in shape and welded together at the ends so that they serve as uprights and as top and bottom frame parts.

Bolted inside of this frame are a number of horizontally arranged hoops which brace the frame and form skeleton sides. The collapsible cage can be easily transported and can be put together ready for use in a few minutes.

## APPARATUS FOR FORCING RESPIRATION

The one-man resuscitating apparatus which was described in Popular Mechanics Magazine some time ago is illustrated by the picture shown here. Its purpose is to enable one man to revive a person who has been nearly

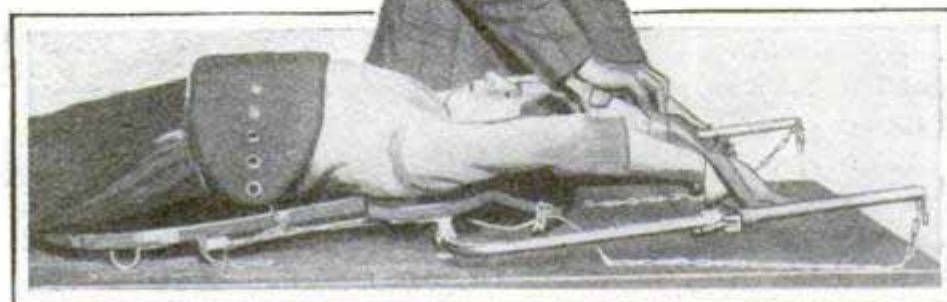

Photo by Paul Thompson  
Life-Saving Apparatus for Reviving Unconscious Persons

drowned, by moving his arms and compressing his abdomen with a rhythmic motion to force respiration. The apparatus consists of a flat, inclined rest for the trunk of the body and two metal arms pivoted under the shoulders. The person to be resuscitated is stretched out on the apparatus with his hands over his head strapped to the pivoted arms. A broad strap placed across the lower chest and abdomen is fastened to ropes which draw it tight when the arms are swung to a vertical position. As the arms are moved up and down the victim's chest is alternately expanded and compressed. One man can

operate the apparatus with one hand while, with the other, he holds the victim's tongue to prevent it from falling back into the throat and obstructing the air passages.

force. Carrying the electric current, at a pressure of 150,000 volts, to Los Angeles, two lines of aluminum on steel towers form one among the longest commercial-transmission lines in

### BIG CREEK DAM NOW FINISHED

East of Fresno in the Sierra Nevadas lies the Big Creek basin, where, at a

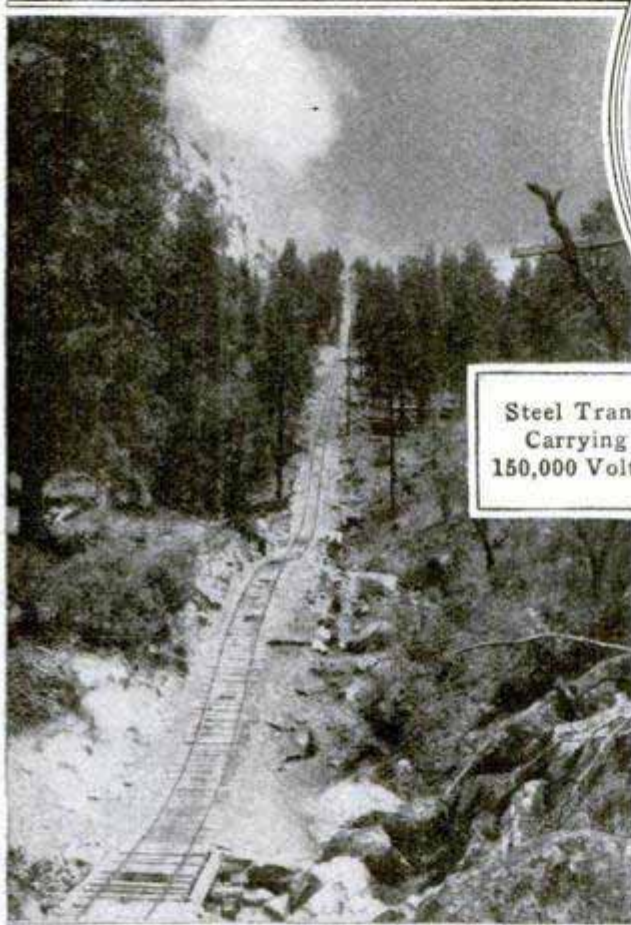

Mountain Railroad Showing Heavy Grades

cost of over \$12,000,000, a great dam has been built, which transforms Big Creek, a branch of the San Joaquin River, into a great reservoir, supplying the power to light the city of Los Angeles, 241 miles away. To build this dam it was necessary to construct a mountain railroad with heavy grades, to make a wagon road a hundred miles in length, and to drill a 12-ft. tunnel six miles through solid rock. Two concrete power houses stand sentinel on either side of the great dam, and water, dropping 2,000 ft. in steel pipes, strikes the wheels with enormous

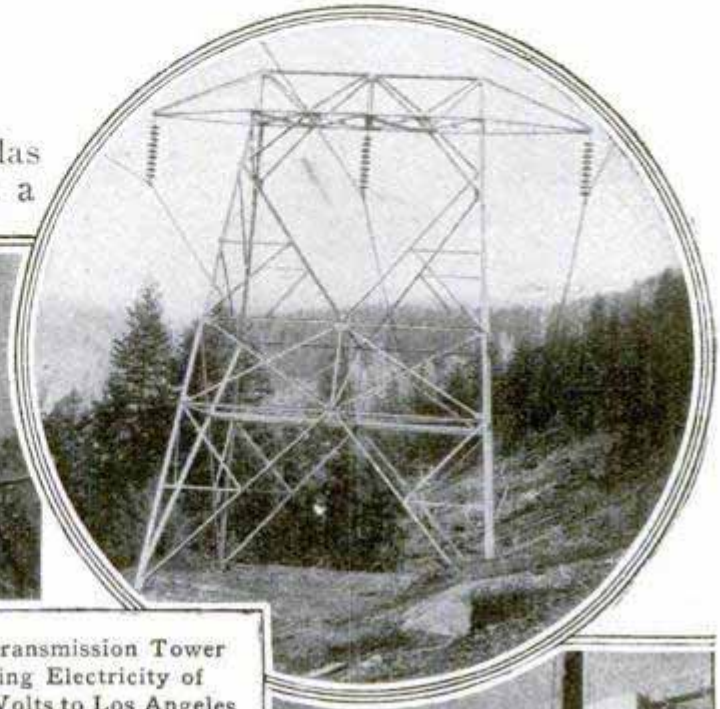

Steel Transmission Tower Carrying Electricity of 150,000 Volts to Los Angeles

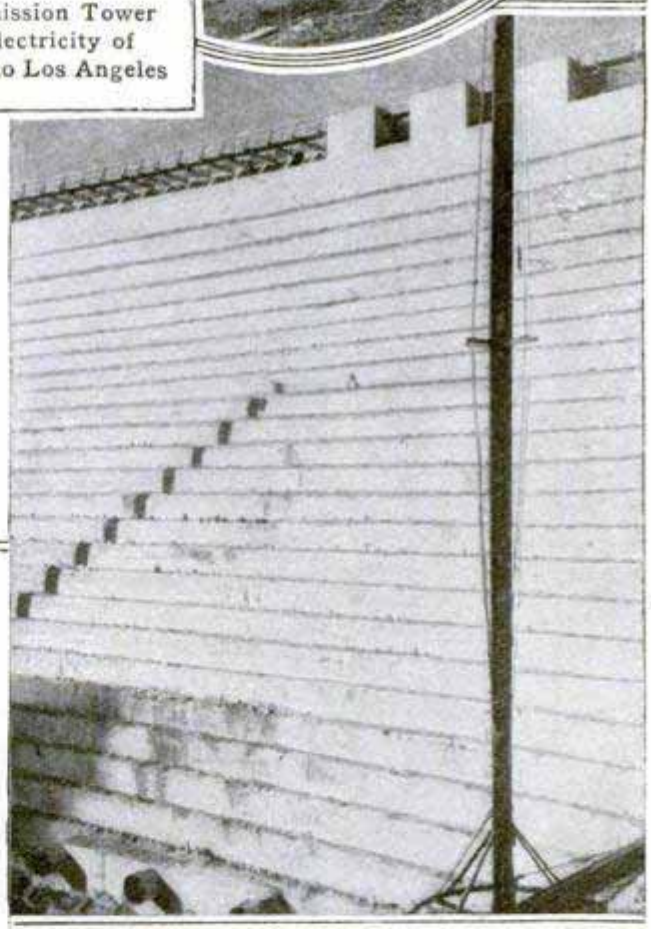

Completed Dam with 6-Ft. Steps

America. The first current was sent over the new line on November 7, 1913, and 80,000 hp. are now available for use.

## INDIAN WOMEN MAKE FINE PILLOW LACES

Teachers provided by the Indian Bureau have been successful in teaching Indian women on the reservation

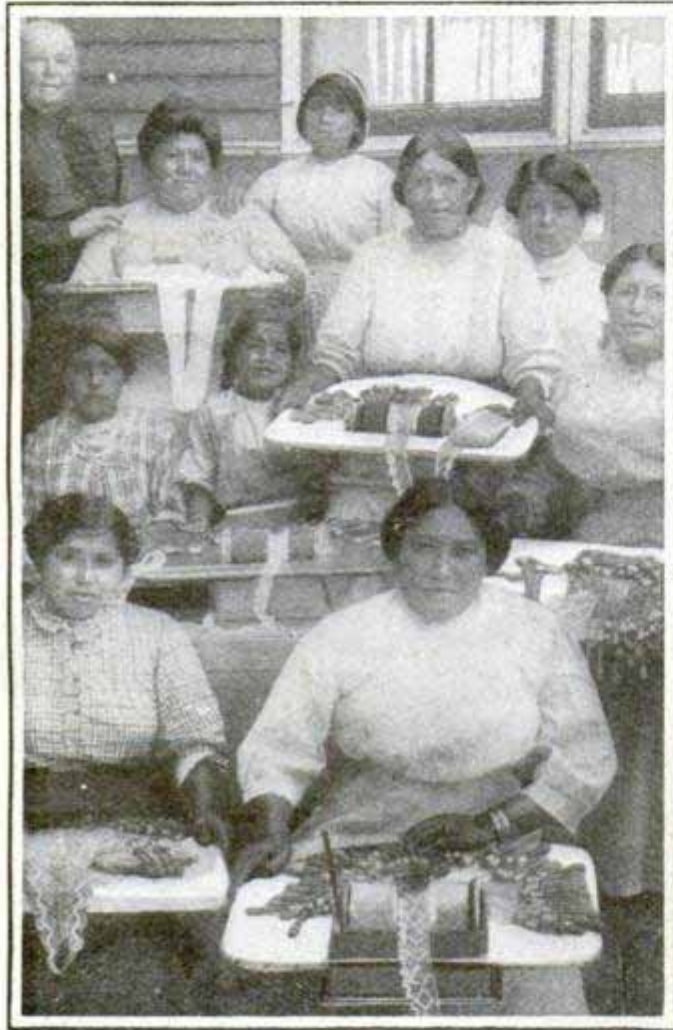

Indian Lace Industry at Pala, California

near Redlands, Cal., to make fine pillow laces. It was noted that these women were remarkably proficient in making baskets, and as there seemed to be no reason why their dexterity and eye for color and design might not be directed along lace-making lines, the experiment was undertaken in the expectation that they might be able to supply a portion of the American demand for fine laces now seeking the products of France, Italy and Belgium. The new industry is well under way, and the women are turning out some beautiful designs.

## FLOWERS LEND CHARM TO BUSY CITY STREETS

The floral window box, which has become an established feature in the business districts of many of the larger cities, is a form of ornamentation that has taken, and is likely to retain, a strong hold on the sympathies of city dwellers. The practice of using miniature flower gardens in this way for relieving the monotony of the brick and terra cotta and asphalt of business sections has developed in this country within the last few years, although it has been common in Europe for a considerable period. Apparently, this movement is only in its beginning, since each year sees more boxes installed, and more foliage and flowers ornamenting the entrances and drooping from the window ledges of business buildings. Last summer there was scarcely a block in the loop district of Chicago, famous as one of the most congested districts in the world, that was not provided with one or more of these refreshing floral displays. The foliage of the window box, however, is not exclusively a summer feature, since in many of the boxes the flowering plants are replaced with evergreens on the approach of winter. There is also a tendency to install plants for the benefit of the workers in a building, and many flower boxes placed in positions too high to be seen from the street are being maintained for the influence they have on the employes and clients of business firms.

Experience has shown that growing plants can be maintained with little trouble in the windows of the downtown buildings, but that a better type of box is required than is commonly used in the home. The boxes are nearly always of metal, to avoid the annoyance and damage from leakage. Sometimes the metal box is incased in a stone or terra-cotta box that is ornamented in an artistic way and made an architectural feature of the building, and in some of the latest buildings this feature formed an important point in the design. The best results in the culti-

☐ Waste used in street-car journals in Denver is cleaned and used over again.

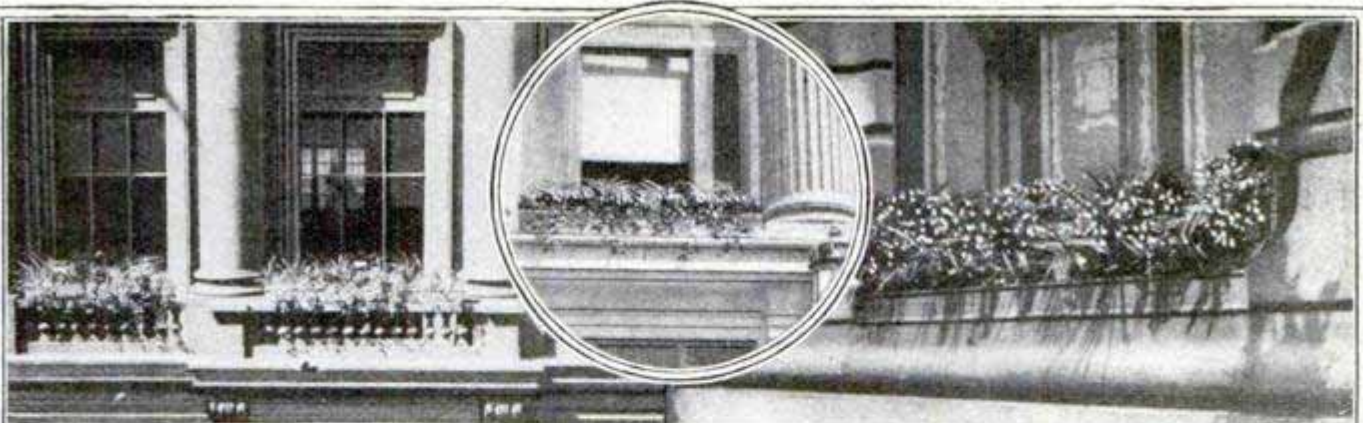

Window Boxes Brighten Windows of Bank Building

Flowers in Bloom over Entrance to Hotel

Below: Elaborate Floral Display of Chicago Hotel

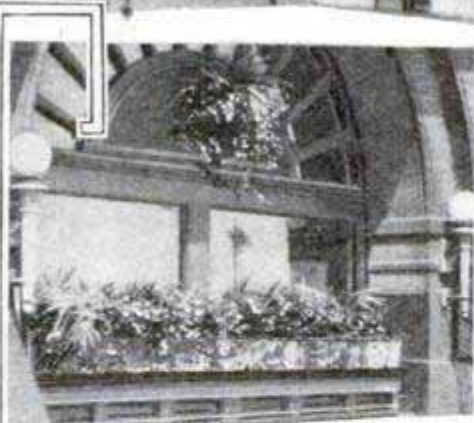
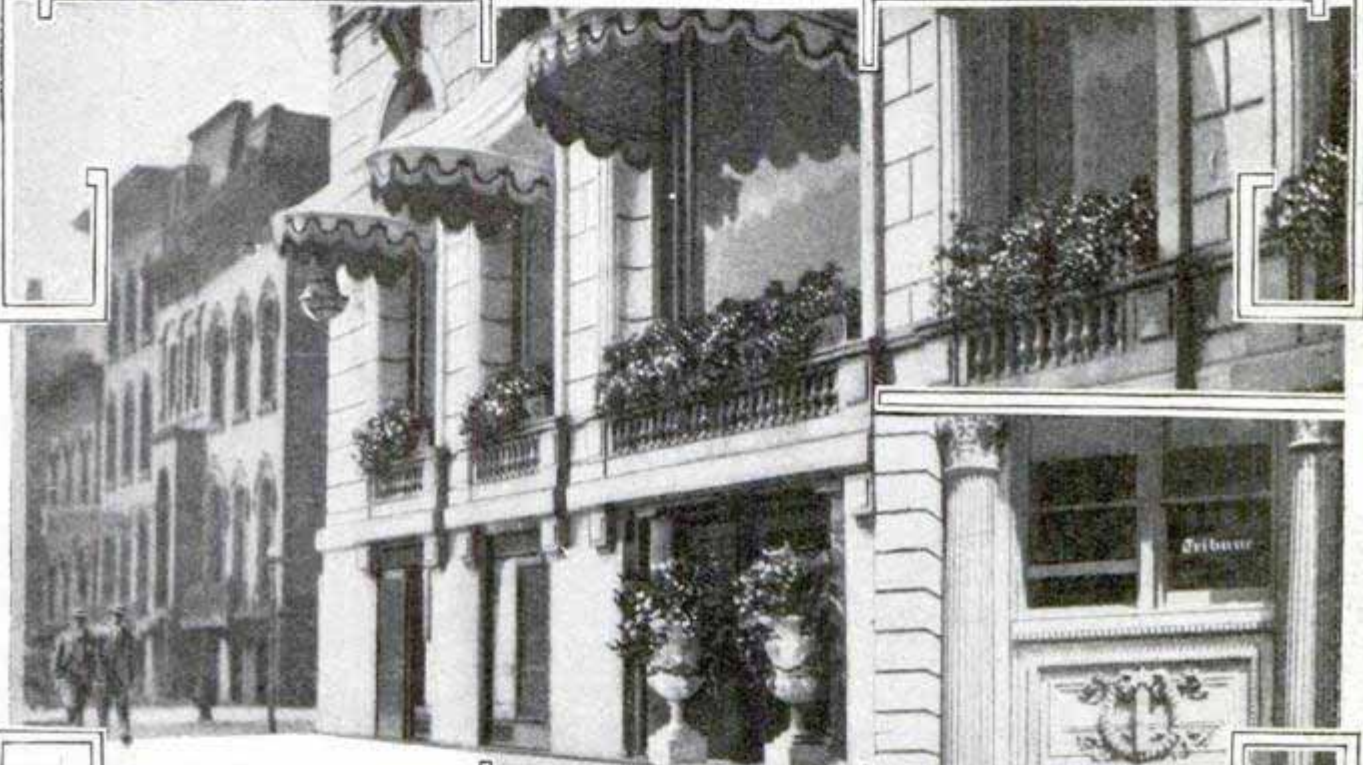

Arch of Hotel Lobby



Artistic Window Box

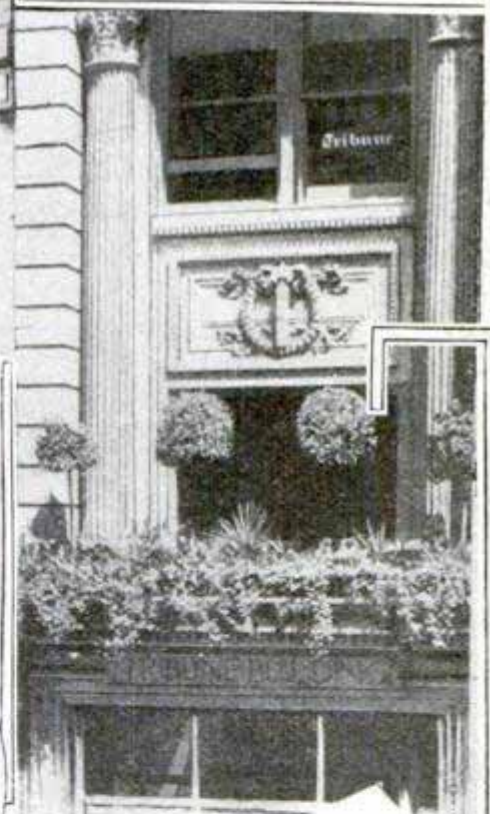

The Front of a Newspaper Building



Terra-Cotta Window Boxes That Form Architectural Feature of Mercantile Building

vation of plants seem to have been secured with subirrigated boxes, largely because these require a minimum of attention. With this class of box the water is poured through a tube into a false bottom from which it is drawn up through sponges into the earth around the roots of the plants. In planning window boxes the tendency was formerly to use a miscellaneous selection of plants without much attention to grouping or effect, with a result that was seldom satisfactory. The expert florist is now more often called in, and an attempt is made to secure strong effects, consideration being given even to the direction in which the window faces. For winter foliage various kinds of evergreen are used, such as arbor vitae, Norway spruce, box and pine.

### NOVEL DUMP CAR OPERATED BY ELECTRICITY

A Connecticut interurban system, operating a network of electric lines throughout the state, has adopted a multiple-body electric dump car having several novel features. Four separately operable compartments, each of 6-cu.-yd. capacity, are so hinged that they may be dumped over either side of the track. In the cab is a 10-hp. motor designed for tilting the com-

partments in unloading, and any one or all of them may be dumped at a time. It takes less than one minute, it is stated, to unload the car when the compartments are dumped separately. The car is self-propelling, four 40-hp. motors giving sufficient power to drive the loaded car at approximately 12 miles an hour. Only two men are required to operate this car, resulting in a direct labor saving.

### DYNAMOMETER RECORDS PULL ON ROADS

The newest machine acquired by the United States Department of Agriculture for gathering data is a dynamometer for recording the "pull" that is required of horses or other motive power to draw vehicles over a given road. The dynamometer is nothing more than a standard city dray, from the bed of which are suspended two coil springs connected with a shaft, rack and pinion; a band wheel, carrying a pencil motion; a platen and a series of feed rolls, over which a metallic-surfaced paper is drawn. A chain and gearing from the hub of a rear wheel operates the mechanism. The pull on the tongue of the dray is transmitted through the coil springs, the compression of which measures the power necessary. This is shown on the paper, over which the pencil point moves an inch for every 500 lb. of

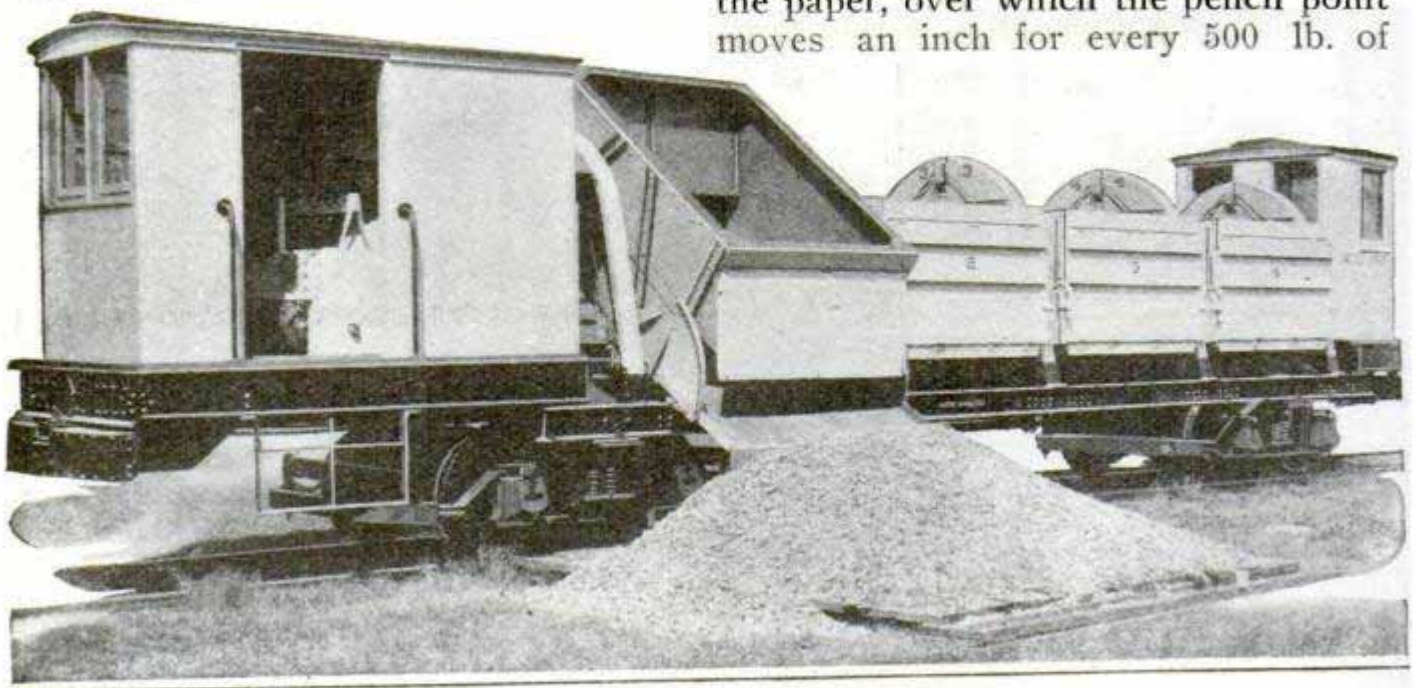

Multiple-Body Dump Car Used by Connecticut Electric Line





draft exerted. A record of 20 ft. of paper represents one mile of travel. All sorts of street-cleaning machinery, water sprinklers, garbage, dump and ash carts, and the like, may be tested by hitching them on behind the dynamometer, the pencil marking accurately the power needed to move them at varying speeds and over all sorts of road surfaces.

### SOME VALUABLE SECRETS AWAITING DISCOVERY

A fortune awaits the man who can produce artificial gutta-percha in large quantities at a price sufficiently low to warrant its use instead of the genuine article, the supply of which is fast diminishing. Cork is another substance of everyday use for which no satisfactory imitation has been provided, the only substitute thus far produced being paper treated with paraffin wax, but this material cannot be used for corking wine bottles. One of the most valuable processes unknown to us is the production of iron that will not rust or decay. That this secret was known to the ancients is proved by an iron monument at Delhi, India, which has stood exposed to the weather for centuries without rusting or decaying.

### GERMAN WARSHIP IN TORPEDO PRACTICE

Owing to the fact that the destruction of a torpedo means an expenditure of about \$2,000, the torpedoes used in practice carry no explosive, and when the force is spent they are recovered and towed back to the ship. The accompanying illustration shows a torpedo being discharged from a German warship. The two sailors in the boat are about to set out in pursuit of it.

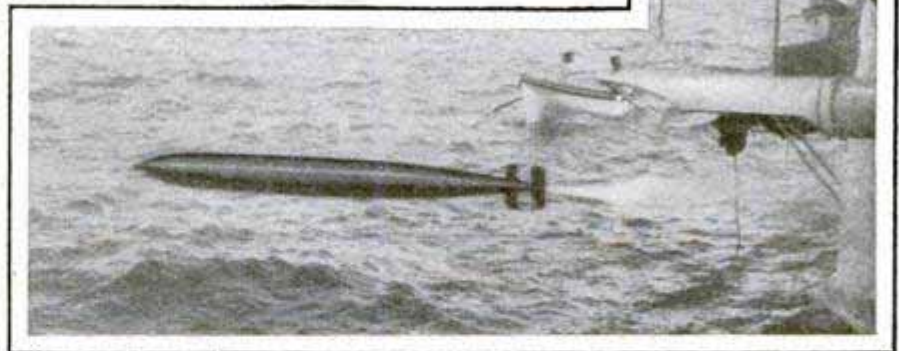

Torpedo Photographed at the Moment of Discharge  
from a German Warship

The escape of the compressed air, which launches the torpedo, and the whirl of the propellers in the air before the plunge into the water produce an uncanny noise having a decidedly plaintive note, which creates a weird and "creepy" feeling in the novice who chances to hear it for the first time.

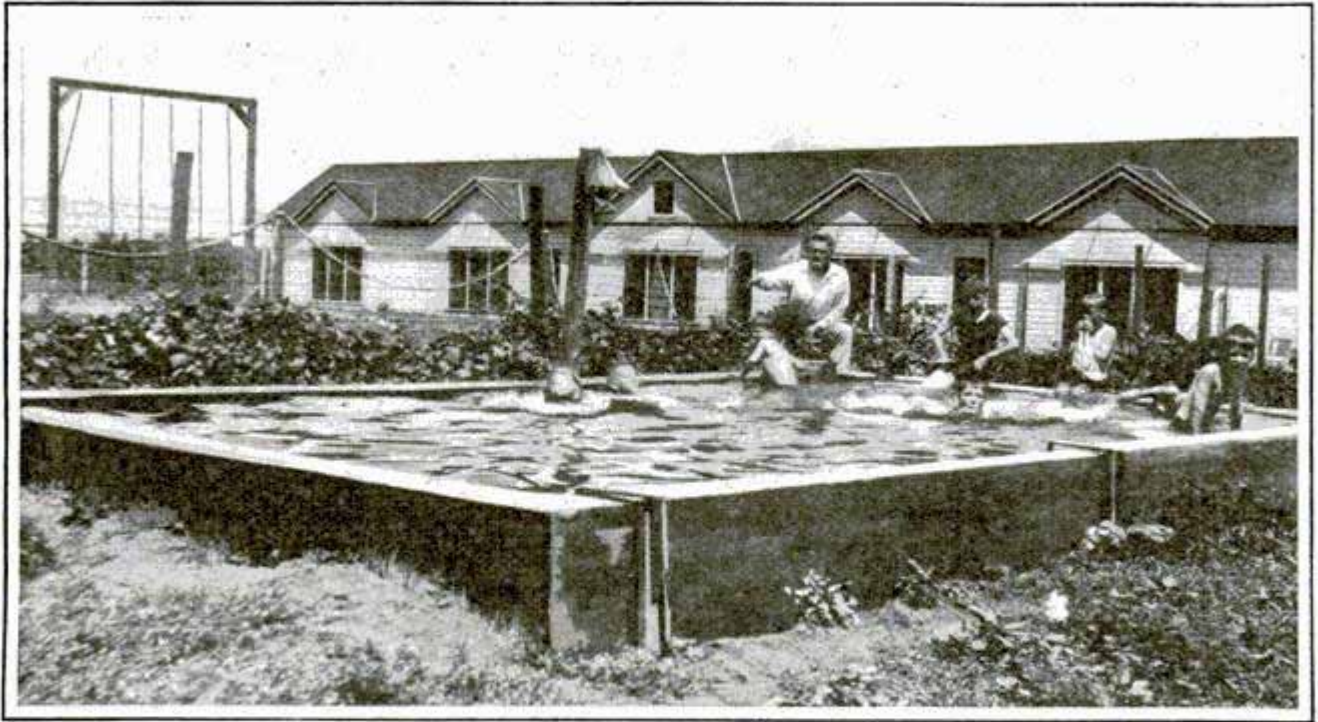

Fun in the New Swimming Hole, Made of Concrete, in the Back Yard

### EGYPTIAN FARM TRACTOR 1914 B. C. MODEL

Agriculture in Egypt is still conducted along old lines, and the sight of a "fellah," as the lower-class rural natives are called, plowing with a camel and a water buffalo yoked together, is not uncommon. The plow is of wood and of the simplest possible construction. It scarcely more than scratches the surface of the soil, but because of the unrivaled fertility of the alluvial deposits along the course of the Nile the crops raised are fairly large.

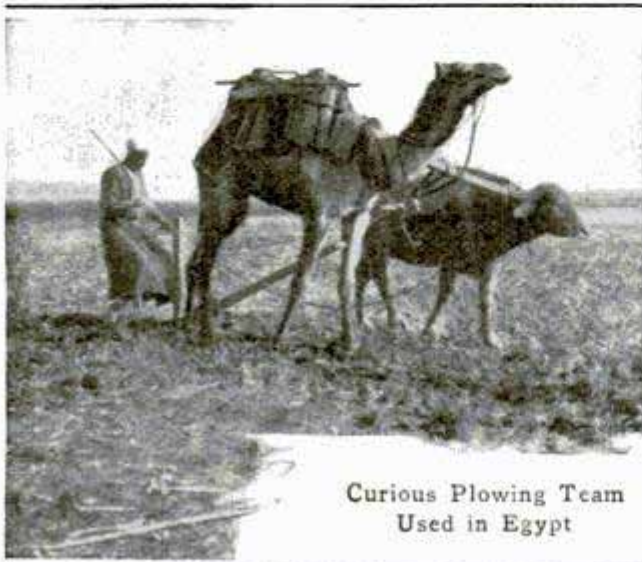

Curious Plowing Team  
Used in Egypt

### CONCRETE SWIMMING TANK EASILY CONSTRUCTED

Cement walls 8 in. thick, not reinforced, form this swimming tank, which is 12 by 20 ft. in size. It is 4 ft. deep at one end and slants to 5 ft. at the other. The water is pumped in by a gasoline engine used in farm work, and there is a valve at the bottom of the tank connected with a tile so that the water may be changed, and the tank scrubbed as often as need be. The whole thing cost but \$90, and is far better for the children than swimming in open ponds or small creeks.

### SEEK OLD GUNS BENEATH THE SEA

A thousand brass cannon, sunk in May, 1692, when the combined English and Dutch fleets worsted the French fleet in the battle of La Hogue in the English Channel, will be raised if the French ministry of the marine receives satisfactory bids. For 222 years these old guns have lain at the bottom of the channel, and only recently a salvage contractor asked permission to raise them. Upon investigation the naval authorities of France concluded that the project was feasible.

## ONE CAUSE OF THE HIGH COST OF LIVING

According to a report from the United States Department of Agriculture the present high cost of living is partly due to the decreasing number of beef and farm cattle raised and their increased cost during the past two years, as follows: Compared with January 1, 1912, milch cows decreased 202,000; other cattle, 1,230,000; sheep, 880,000, and swine, 4,232,000. The price of these various animals increased, however, in average value per head, as follows: Milch cows increased \$5.63; other cattle, \$5.16; sheep, \$0.48, and swine, \$1.86. In total value milch cows increased \$107,369,000; other cattle, \$159,581,000; sheep, \$21,609,000, and swine, \$79,781,000.

## NEW ODORLESS COOKING UTENSILS

In the new down-draft cooking utensils which have just been patented no odors are allowed to escape and cooking is made entirely odorless. Each utensil has a tightly fitting cover and a tube running down through the center to a hole in the bottom, to carry all odors and vapors back into the stove.



The tube has an added advantage in furnishing a larger heating surface. The down-draft idea is to be applied to odorless saucepans, double boilers, frying pans, and other common cooking utensils.

## LOCOMOBILE DESIGNED TO BURN HEAVY OIL

Among the recent developments in engine construction in France is a locomobile, or portable power plant, so de-

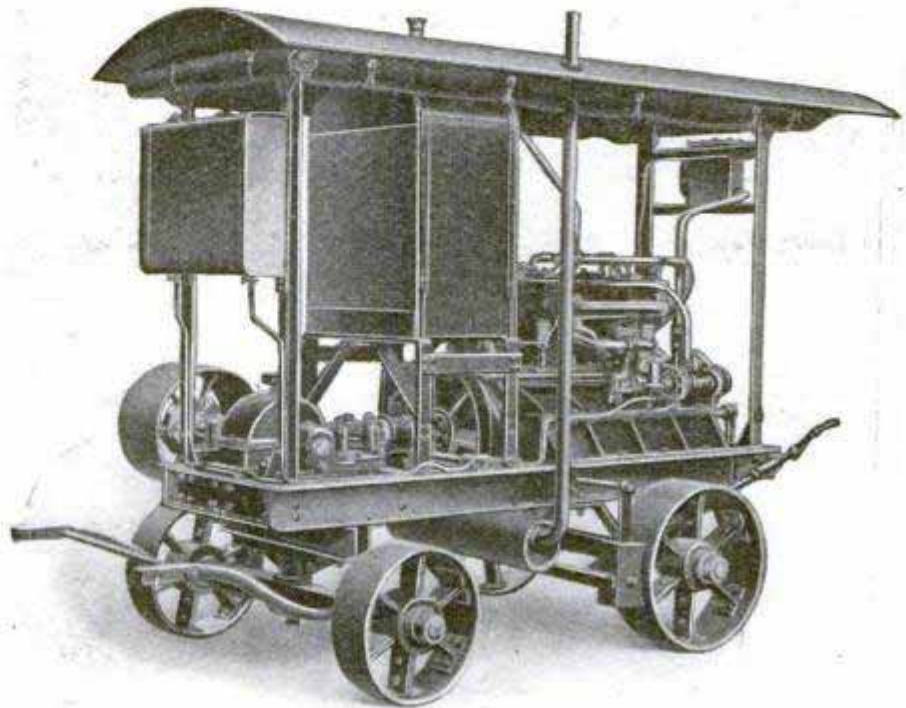

French Locomobile That Burns Heavy Oil

signed that it will readily burn the heavier grades of oil. This improved form of motor is of practically all-metal construction, and is mounted on wheels with wide steel-tired rims. This type of locomobile is built with capacities ranging from 3 to 50 horsepower.

## PIPE LINE TO SUPPLY OIL FOR NAVAL VESSELS

A bill has been presented in Congress providing for the construction of a pipe line from the oil fields of Oklahoma to a port on the Gulf of Mexico, which is designed to bring directly to naval vessels of the United States the fuel oil which they are using in rapidly increasing quantities. Over 400,000 bbl. of oil were required for naval use in 1913, and it is estimated that 700,000 bbl. will be needed for 1914. A national pipe line under the control of the Navy Department will tend, it is believed, to reduce the cost of this fuel to the government.

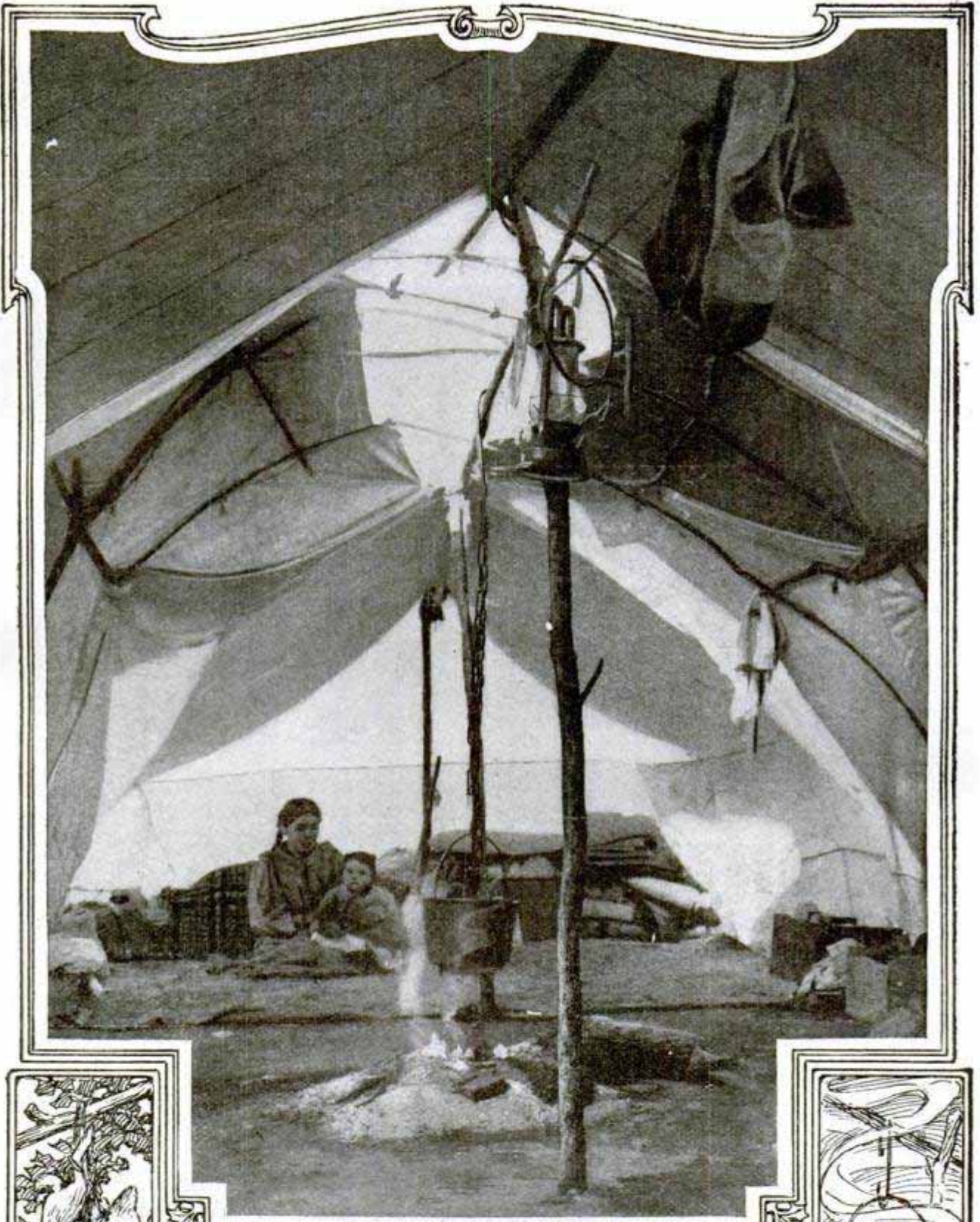

ON the western reservations, many of the American Indians still live in tents which differ in few important respects from the tepees of their ancestors. Woven fabrics manufactured by white people have replaced the deerskins of which the aboriginal tents were made, and larger shelters are thus possible, but they still retain the primitive methods of housekeeping. Food is cooked in kettles over a wood fire, and the hole in the center of the roof to let the smoke out is as much a feature of a modern canvas tent as of the "wigwam" of a hundred years ago.



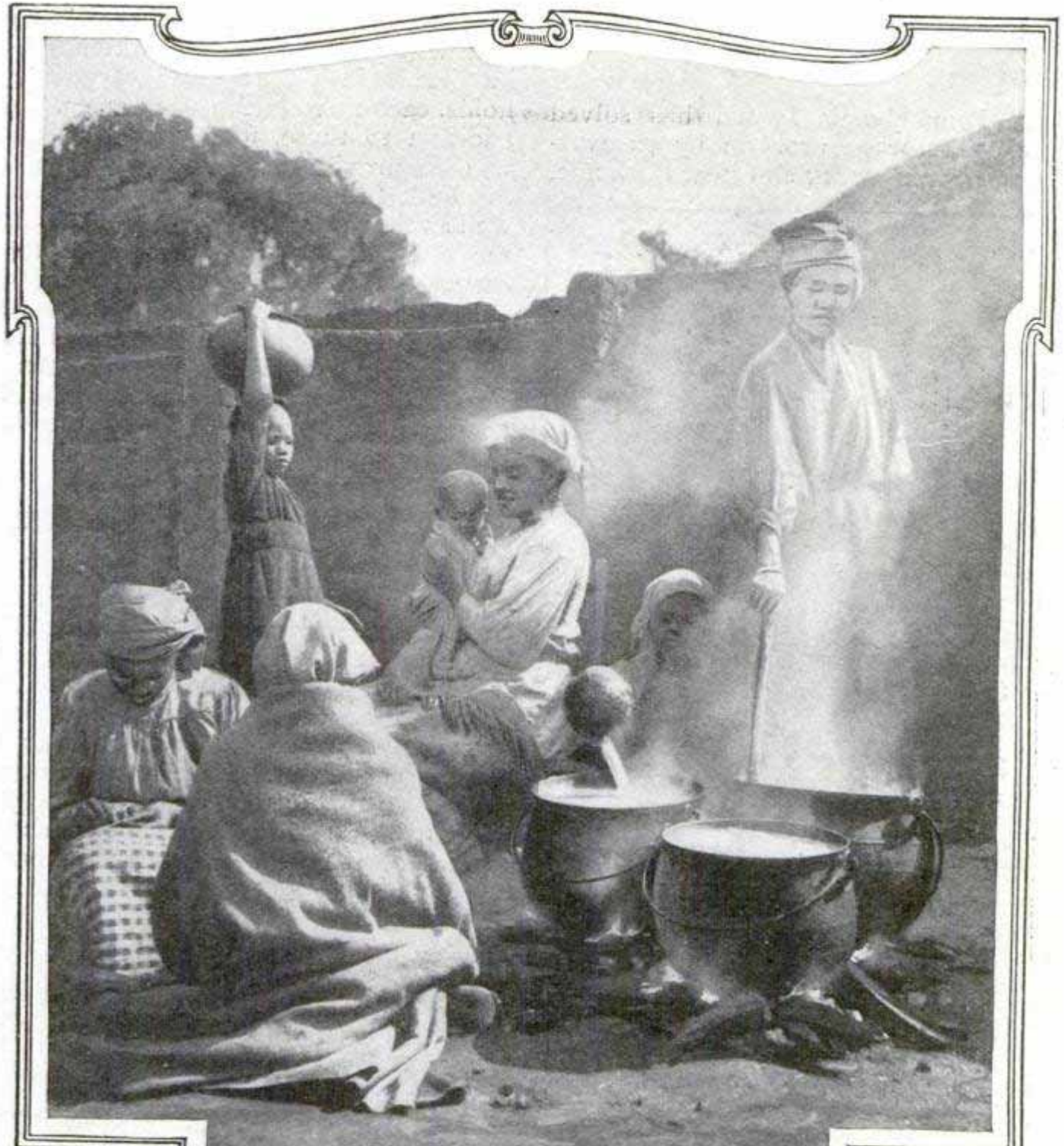

**A**MONG the most curious and interesting of the natives of Africa are the members of the Baralong tribe of the Bechuana race. For many years they were almost constantly in arms against the white settlers in South Africa, but now profess allegiance to the British crown and are governed by a British protectorate with headquarters at Mafeking, Cape Colony. The Baralongs are the most accomplished blacksmiths of all the South African natives, the metal iron being their tribal fetish. The photograph shows a typical group of Baralong women cooking over a wood fire outside of one of their characteristic dwellings, a mud hut with thatched roof.



## ARTIFICIAL CAVE FOR COLD STORAGE

A Pennsylvania farmer has solved the cold-storage problem by excavating a cave in a rock cliff near his home.



Rock Cliff and Entrance to Artificial Cave Made by Pennsylvania Farmer

This artificial cave is in the form of a room 10 ft. square and 12 ft. high, and is provided with a strong door and a lock.

## COLLIERS FOR SERVING THE PANAMA CANAL

Two colliers of a special type are to be built for transporting coal to the Panama Canal for government uses. Each of these vessels is to have an over-all length of 522 ft., beam of 62 ft., and a draft of 28 ft. when fully loaded. They will have twin screw propellers and will be capable of making a sea speed of about 16 miles an hour under full load. The designs provide for the carrying and handling of both cargo coal and fuel oil. The vessels are to be built with double bottoms throughout and will be fitted for

carrying water-ballast tanks. They will also be divided by water-tight bulkheads into four large cargo-coal holds, each fitted with two hatches. In addition to these, four compartments will be provided at the forward end for bulk freight or oil, and these, as well as the machinery compartments at the stern, will be separated from the cargo holds by cofferdams. These ships will carry wireless equipment and will have comfortable quarters for officers and a crew of about 146 men. Each vessel, equipped with overhead coaling gear, is expected to cost a trifle more than a million dollars.

## CANOE MADE OF AN EMPTY BARREL

With an empty barrel, a chunk of iron, and a saw, a small boy at an inland resort in Michigan made himself a seaworthy craft to paddle about the lake. A square hole cut in one side turned the inside of the barrel into a roomy cockpit and a heavy weight attached to the bottom kept it from capsizing. A cork life preserver furnished a comfortable seat back. As the pas-



Empty Barrel Converted into a Seaworthy Canoe

senger's position raised the front end of the barrel almost out of water, the craft was easily propelled and maneuvered with a canoe paddle, as shown in the illustration.

## AUTOMOBILE SMASH-UP FOR THE "MOVIES"

A moving-picture film depicting in a humorous way the dream of a tramp who built an automobile out of odds and ends, and at last dashed in his

clock; a trombone provided the warning signal; a window sash formed the windshield, and a lamp, the headlight. The film showed a real station, but this

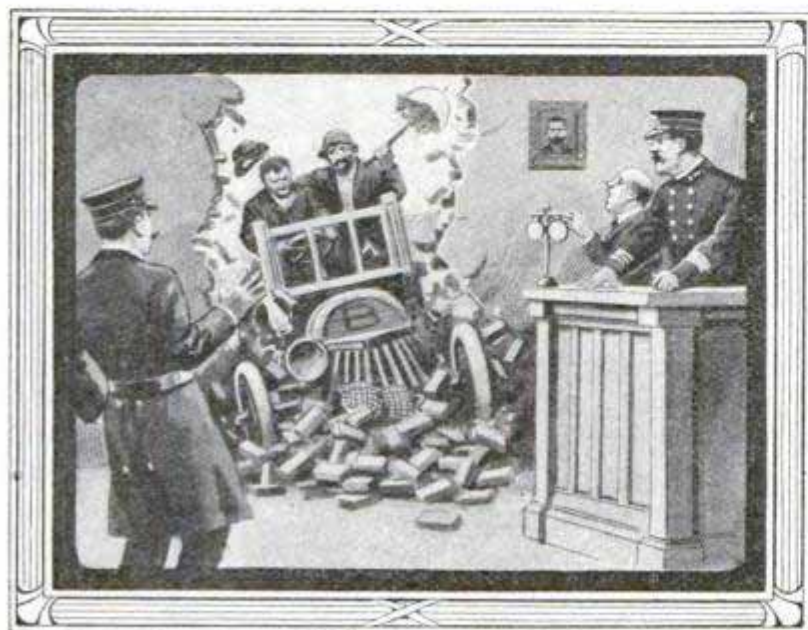

A Simulated Catastrophe for a Funny Film



Photograph Showing How a "Police Station" for a Comedy Film was Set Up in the Open

car through the wall of a police station, was staged at the racetrack at Santa Monica, Cal., recently. The car's hood was made of barrel staves, the speedometer was an old alarm

photograph shows that it was only a false brick wall on the field. The bricks were pieces sawed from a pine scantling, and the plaster was sand and flour.

### HOW AN ESKIMO BORES A HOLE

Naturally of a mechanical turn of mind, the Eskimos are excellent workmen with the crude tools they man-



Eskimo Drilling a Piece of a Walrus Tusk

age to make from odds and ends. They pierce the hard walrus tusks with an ingenious brace and bit which is quite primitive in construction but very effective in practice. A strip of wood is curved like the top of a crutch, and in the convex side a hole is driven to hold a piece of hard wood which constitutes the bit stock. A drill is inserted in one end of this stock, and the curved piece placed against the operator's teeth. A bow-and-string device causes the bit stock to revolve rapidly when the string is drawn back and forth, and a clean hole is drilled in the refractory ivory in short order.

ⒸA flying boat which fell into the water at Stockholm, Sweden, was brought to land by a submarine which dived under the wreck and raised it out of the water.

### SPEED OF ENGLISH RAILWAY TRAINS

Perfect roadbeds have given English railways a solid advantage over their American rivals until a few years ago, and the records made by some of the great trains on the London and North Western, the Midland and the Great Western lines for a long time were standards. The 44 $\frac{1}{4}$  miles between Darlington and York are covered by a North Eastern train in 43 minutes, from start to stop, a speed of 61.7 miles an hour. Another quick run is that between Leicester to Nottingham, 22 $\frac{1}{2}$  miles, which is negotiated in 22 minutes, at a speed from start to stop averaging 61.3 miles an hour. Of long nonstop runs, that from Paddington to Plymouth, 225 $\frac{3}{4}$  miles is accomplished in 4 hours 7 minutes, a speed of 54.8 miles an hour being averaged. The London and North Western fast train between Euston and Rhyl, 209 $\frac{1}{2}$  miles, makes the trip from start to stop in 3 hours 58 minutes, an average of 52.7 miles an hour.

### PARIS SETS NEW STYLE IN LADIES' HOSE

Embroidering on their dainty silken



hosiery the names of their favored suitors is a new Parisian fashion for young women. The use of light or contrasting colors makes the embellishment conspicuous. The novelty is not one of wide appeal, but the fact that it has been adopted at all may be regarded as a sign of the times.





### To Find the Cubic Contents of an Irregular Object

Desiring to measure the cubic inches in some rocks, I knew of no way to calculate it, but after some thought I decided to use the following method: A vessel large enough to admit the rocks was procured and filled with water to such a height that the rocks would be covered when they were placed in it. The water level was marked and after putting the rocks in, the level was again marked. I used a square vessel, and the cubic contents was easily obtained by measuring the height to which the water rose and multiplying this dimension with the inside area of the vessel, both expressed in inches.—Contributed by Ernest Range, Johnson City, Tenn.

### A Simple Electric Pull-Socket Switch

A simple pull-socket switch may be made by tying a strong cord around the base of the electric globe, then screwing the globe into the socket just tight enough to secure a connection. The knot should be at the upper side with one end of the string hanging down on either side. By pulling one end of the string, the globe will be turned outward, thus breaking the connection, while a pull on the other end closes the connection.—Contributed by Paul W. Trier, Maywood, Ill.

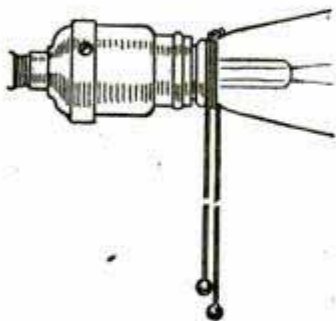

### Governor Attached to a Marine Gasoline Engine

Desiring to use a marine gasoline engine for stationary work, I found, after installing it, that I had a very

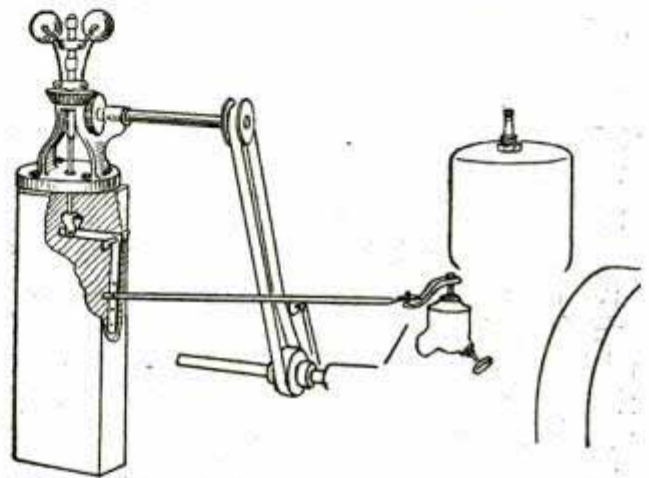

The Speed of the Gasoline Engine is Regulated by the Use of a Steam-Engine Governor

uneven power owing to the lack of a governor. To remedy this trouble, I attached an ordinary steam-engine governor, as shown in the illustration. I purchased the governor from a dealer in junk. As the governor did not have a sufficient stroke, I made a bell-crank lever with the vertical arm of sufficient length to secure the desired throw of the rod. The extending rod is connected to the throttle lever on the carburetor. The illustration clearly shows its application.—Contributed by James Hughs, Mexico, N. Y.

### Universal Joint for a Drawing-Board Support

The device illustrated is fastened securely with screws to the center of the back on a drawing board. The construction of the universal joint permits the board to be revolved and

tilted to any desired angle. The materials are easily obtained, and the making not difficult.

The joint and holder consists of four

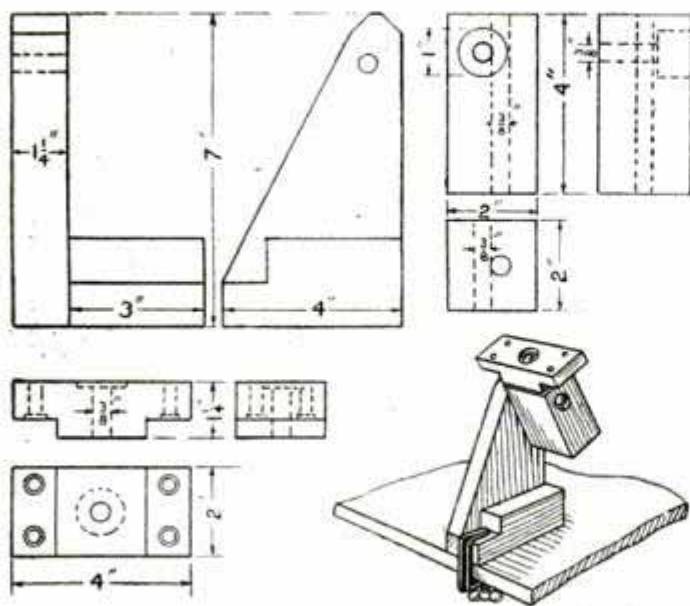

The Universal Joint Permits the Board to be Set at Any Angle Desired

blocks of wood, having the dimensions given in the drawings. When these are fastened to the board and joined with bolts, the device is ready to be clamped to the edge of a table or any other convenient place.—Contributed by Arthur C. Hetrick, Bucyrus, O.

### Heating an Automobile

Working as a chauffeur for a private family and driving a car of the limousine type without front doors, but equipped with complete curtains, I suffered very much from the cold until I constructed a heating device that is very simple to make. The engine pan extended back under the body of the car to the front seat, and all that was necessary to do was to obstruct the heated air passing over the motor and force it up through holes in the foot-board. A piece of wire-insert asbestos was procured and fastened to an old shade roller, which was cut the width of the body under the front seat, the curtain part being made long enough to touch the engine pan. A new floor board was made to prevent mutilating the one in the automobile, and 1-in. holes were bored in it, about 3 in. apart, and the heater was complete.

All the fresh air drawn through the radiator thus was forced to pass over the motor and through the holes entered the front of the automobile in a heated condition. With the side curtains up and the window open into the rear part, a temperature of about 45 deg. could be maintained in zero weather; and by closing the window a temperature of about 60 deg. was obtained in the front of the car.

A very fine mesh screen is attached under the floor board, to catch any dust that may be in the air. In moderate weather, the curtain can be rolled up and the automobile will not become too warm. As the exhaust opens up in the rear, there is no trouble with gas fumes.—Contributed by Walter Broeker, Chicago.

### A Fire Extinguisher

A simple and effective fire extinguisher may be constructed as follows: A piece of brass tubing, 14 in. long by  $2\frac{1}{2}$  in. in diameter, is fitted with a screw cap at each end. One end is drilled and tapped for a petcock and the other for an automobile-tire valve. A cross section of the assembled parts is shown.

The pressure disk, or piston, consists of a cupped leather held in place by a flanged brass plate, A, on one side, and a brass disk, B, on the other, like that used in a bicycle pump but

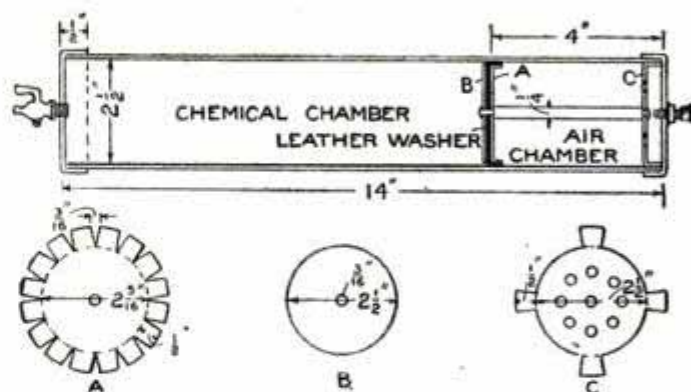

A Chemical-Filled Tube with Driving Disk and Air-Pressure Compartment for Extinguishing a Fire

larger, with a guide disk, C, fastened to it with a  $\frac{1}{4}$ -in. rod, about  $3\frac{1}{2}$  in. long.

Fill the chemical chamber with 1 qt.

of carbon tetrachloride and pump up a pressure of about 80 lb. with a tire pump. The extinguisher is now ready for "fire only" and, if well made, will retain pressure indefinitely to throw a 25-ft. stream.—Contributed by H. W. Loweree, New York City.

### Gears for Model Work

If a pair of gears of any size with teeth of small pitch are at hand, it is an easy matter to make gears of various sizes for experimental or model work. Procure a strip of light tin of a width suitable for the face of the desired gear, and run it through the gears. This will give the shape of the teeth to the tin.

Bore a shallow hole in a block of wood with a carpenter's expansive bit to the size of the gear wanted, and carefully fit the tin in the circle so that all the teeth will touch the wood.

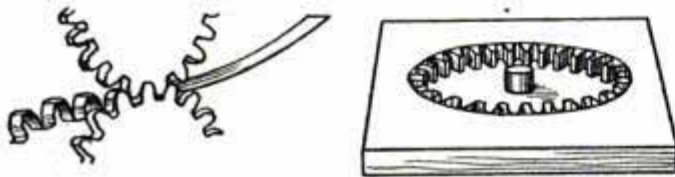

The Tin is Formed by Running It through Gears, and is Then Used in a Mold to Form the Gears

It will be necessary to make a perfect tooth where the ends of the tin meet. Coat the inside of the tin with soldering flux and pour it full of melted babbitt or babbitt and solder, half and half. If the size of the bore is known, a core of wood can be pointed and driven in the center made by the feeder of the expansive bit. The tin should be weighted to hold it in the mold when the melted metal is poured.—Contributed by Edwin M. Davis, Philadelphia, Pennsylvania.

### A Universal-Chuck Plate

The plate shown in the sketch is for use in a universal chuck, to face work against or to prevent the work from pushing back into the chuck. When holding a shaft in the chuck while a cut is being taken, the shaft is apt to work back into the chuck and the cen-

ter drop from the tailstock. Its principal use is for chucking washers or small pieces having one true surface.

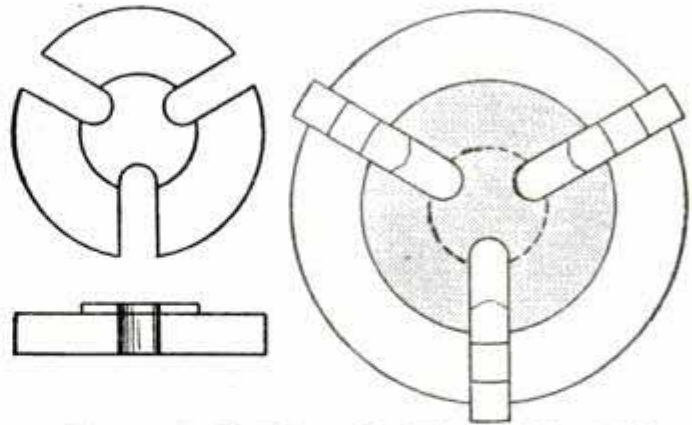
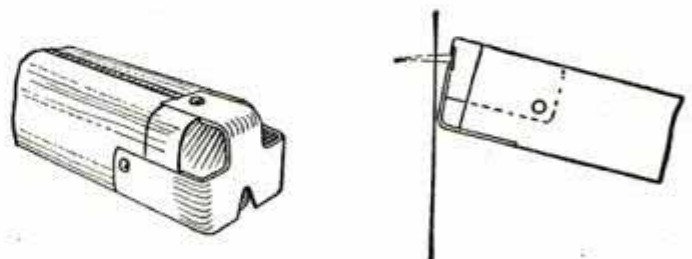

Plate to be Used in a Chuck for Holding Thin Stock to be Faced

The plate is made of a disk, perfectly true on both surfaces and slotted to fit the jaws of the chuck. The slots should be only long enough to allow the jaws to grip the smallest piece to be worked, so that the plate may not be made too weak. The thickness and outside diameter will depend on the kind of work for which it is to be used.—Contributed by L. F. Calhoun, Los Angeles, Cal.

### Tack Puller on a Putty-Knife Handle

The putty knife is the only tool carried by painters outside of brushes and is often used for pulling tacks, nails, etc. The blade of a putty knife is too thin for this purpose and is usually damaged beyond repair. It is better to make a tack puller and attach it to the upper end of the knife handle. Such a puller can be easily made from a piece of sheet steel,  $\frac{1}{16}$  in. thick, bent to



The Puller is Made of Sheet Metal and Attached to the End of the Putty-Knife Handle

shape and fastened on the handle end. The illustration clearly shows the manner of attaching it to the handle and of pulling a tack.—Contributed by J. V. Loeffler, Evansville, Ind.

### Singling Out a Key on a Ring

The latchkey on a ring is usually the one most difficult to find, but if it is attached to the ring as shown in the sketch, it will come out, right side up, ready for use.

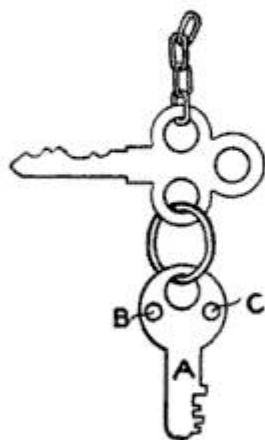

A chain saves one the annoying experience of reaching home to discover that the keys were left at the office, but for those who do not like a chain, an extra ring may be attached to the important key in place

of the chain. It is then easy enough to find the ring among the keys, even in the dark, and on getting hold of it, a slight shake brings the desired key in position for use.

If the head of the key should be of the type shown at A, it will be necessary to drill two holes, C and B, to make the combination work.—Contributed by F. R. Cunningham, Denver, Col.

### A Memorandum-Book Holder

The handiest place to carry a memorandum book is in the upper vest or outer coat pocket, but it is easily dropped out when stooping, and thus valuable data may be lost. The method shown in the sketch of insuring against this loss is simple and effective.

Most vests have a button sewed at the top of the pocket with a buttonhole in the outer part forming the pocket. Remove the button and sew it on a short length of  $\frac{3}{4}$ -in. elastic band, then sew the ends together, thus forming a loop of such

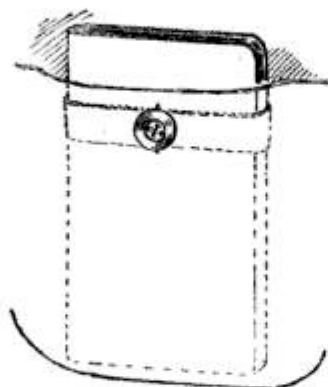

diameter as to fit snugly around the book to be carried. After the elastic has been placed around the book, the whole is put in the pocket and buttoned. To release, simply unbutton and withdraw the book and elastic. A buttonhole can be easily made in the outside part of the pocket.—Contributed by Victor Labadie, Dallas, Texas.

### To Prevent Wire Violin Strings from Cutting Bridge

In using a wire E-string on a violin, it soon cuts into the bridge and lowers its position so that the bow hairs will wear on the side of the violin. The gut string causes a great deal of trouble and will not wear long, and the silk string does not produce the right sound.

Where it is necessary to use a violin from 5 to 8 hours a day, a wire E-string is almost a necessity. To prevent this string from cutting into the bridge, I insert a piece of ivory into a slit cut with a jewelers' saw in the upper edge of the bridge, as shown by the dotted lines. Such a piece may be put in the entire edge for all four strings, but it is only necessary for the E and A-strings.—Contributed by Roy Douglas, Terre Haute, Ind.

### Clearance Groove for Threading Tools

A groove turned in the rod, or shaft, at the termination of the thread will give the tool clearance at the end of the cut. Threads can then be cut without



close attention and the breaking of tool points. The groove should be cut no deeper than the depth of the finished thread.—Contributed by J. Harger, Honolulu.

## How to Make a Portable Cottage

By FRANK L. RUSSELL

The summer camp that provides a shelter for the toiler during vacation days has become one of a more substantial nature, and the cottage has taken the place of the tent. But the short season a cottage can be used increases the expense of a vacation trip, even though the vacationist owns it, as taxes and interest on the investment amount to no small sum, in fact, equal to quite a large rental. Then, too, a cottage naturally is a permanent affair, and if one desires new scenes and surroundings, it cannot be readily moved. This calls forth a desire to have some-

thing better than a tent, more along the cottage line, yet something that can be taken up, stored and easily made ready in a new location, where it can be set on a bit of

ground obtained for a few weeks at a nominal sum.

Many attempts have been made to construct what is called a portable house, originating from the making of portable garages, but when these were set up they were found to be more of a permanent nature than portable. When the time came for a removal many nails and screws had to be withdrawn, which left the parts in bad condition and sometimes so broken that new ones had to be procured. To avoid all these troubles and to make a really portable house in which the parts are almost entirely interchangeable, the building shown in the illustration was designed. A close examination of the drawings will reveal the fact that the sections, when taken apart, can be laid together flat and crated for shipment. Also, that the

door and window sections have the same width and the same joint, so that they can be set in at any place desired, and the building changed from year to year. The manner of construction makes it possible to build a house of two or more rooms, as desired, for as the sections are the same, it only requires a few more of them to add another room. The floor plan, Fig. 1, shows a good size for a three-room cottage.

The description of this portable house being more in detail of the construction of the sections, the stock

list in general will be left to the builder. However, in making it of flooring boards, he should remember that these come in thicknesses and widths of 1 by 4 in.,

and 1 by 6 in., in white pine; and that when finished, they will measure only  $\frac{13}{16}$  by  $3\frac{1}{4}$  in., and  $\frac{13}{16}$  by  $5\frac{1}{4}$  in., respectively. Yellow pine can be had in various widths, but taking only the two mentioned sizes into consideration, the builder can estimate how much material he will require and get the price at which the different kinds of lumber are quoted from a local lumber dealer.

Take the first mentioned size, for instance, 1 in. thick and 4 in. wide. This is the basis on which the lumber dealer figures his selling price, so that while one pays for a certain gross amount of board feet, the space this amount will cover must be reduced in accordance with the finished dimensions of the lumber; in this instance to  $\frac{13}{16}$  in. in thickness and  $3\frac{1}{4}$  in. wide. It is best to figure how many boards will



The Cottage as It Appears with the Front Entrance on the Side, Which can be Changed at Will to Any Other Part of the House to Best Suit the Location

be required at the finished width, namely  $3\frac{1}{4}$  in., then multiply by the gross width to find the amount of board feet for the cost.

4 and 5, are made in the same general manner as the wall section, Fig. 2. The window consists of an eight-light, 8 by 10-in. glass sash, commonly



Floor Plan of the Cottage as Illustrated, with the Large Living Room in the Center

The sections are designed to take lumber of standard lengths and the cost will not be excessive on this account. The side-wall section, shown in Fig. 2, illustrates the general construction of all the sections for the outside, including the gables, also any partitions. The boards are of matched lumber, preferably of good flooring, fastened to battens, one at the top and bottom, and one in the center, the edges being reinforced with upright battens, which project on one side and recede on the other, 1 in. in width. This forms a lapping joint where the parts are set together. The upper cross batten is fastened with its upper edge 4 in. from the top of the wall boards. This provides a place for a 2 by 4-in. piece—finished size,  $1\frac{5}{8}$  by  $3\frac{5}{8}$  in.—to be set on, and makes a depression for the batten on the roof section to be set against when it is hooked. This detail is shown in Fig. 3. The lower batten, Fig. 2, is fastened so that its lower edge will be  $1\frac{3}{4}$  in. above the lower edge of the wall boards. The batten is set on the top of the floor and the ends of the wall boards extend down over the floor boards on the outside.

The window and door sections, Figs.

known as storm sash. A frame for the sash is made of  $\frac{7}{8}$ -in. material, with a width equal to the thickness of the wall boards and the battens combined. The sash is hinged at one side and has a catch at the other. This construction permits these sections to be placed between two wall sections, and the glass is in a safe place where it will not be broken in shipment.

The door is set in a frame in the same manner as the sash, except that the bottom cannot be joined. This makes it necessary to crate the door sections with care, to prevent racking of the whole section. The part with the door will lie flat just as the other sections, but the lock will have to be removed.

The gable sections are made like the wall sections except that the battens are put on to fit the slope of the roof. The outline of the positions the battens take is shown in Fig. 6. The dotted lines in the sketch show the positions the wall boards will occupy. The upper batten, on the center section, is set in such a position that it will form a support for the end of a 2 by 4-in. ridge piece. Dimensions for these sections are given in Fig. 7. The notches at the top should be accurately

cut, after the sections are made, so that they will receive the battens that are fastened to the roof boards. Cross lines are shown on the upright battens, at the edges of the wall and gable sections and at the bottoms, with dimensions giving the location of holes for bolts that are used to fasten the sections together. The detail of this construction, with the bolt A, is shown in Fig. 8. These locations should be accurately laid out and  $\frac{3}{8}$ -in. holes bored so that the sections can be used at any place around the building. The end sections are the same as the sides, and the gable boards overlap the walls, as shown by the lower dotted line in Fig. 6.

The roof sections are constructed in the same manner as the walls, the battens being located as shown in Fig. 9. This is the only place where it becomes necessary to depart from the same general width of the sections. All sections in the roof, save two, are 4 ft. wide. Two sections must be 2 ft. wide, so that an extra 1 ft. will be provided for the eave at the gable ends. The narrow widths should be placed in the roof at the center of the building, so that a wider section will

same general construction except that all battens run crosswise, and that they are flush with the edges. The number of battens on these sections

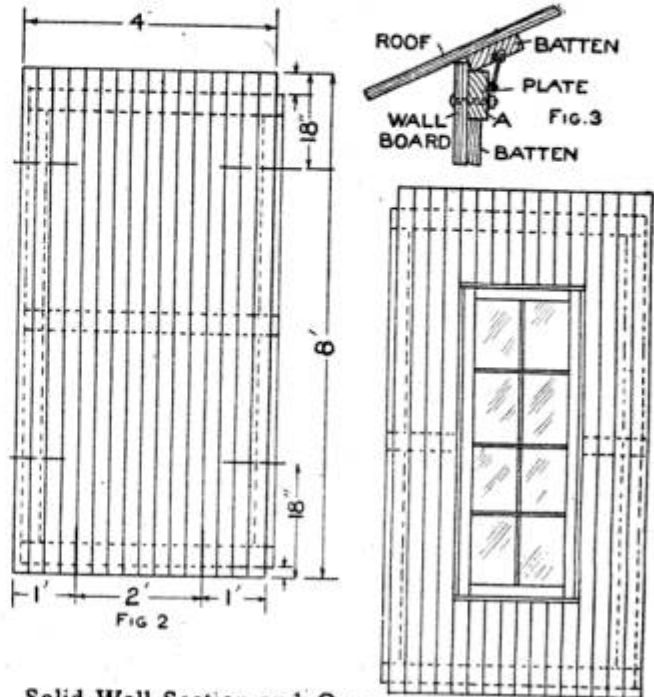

Solid Wall Section and One with a Window, Both Having Same Outside Dimensions; and the Plate Detail

can be determined by the builder and depends on what is intended to be used as a foundation.

In building up the floor, which is the first thing to set up, it will be found

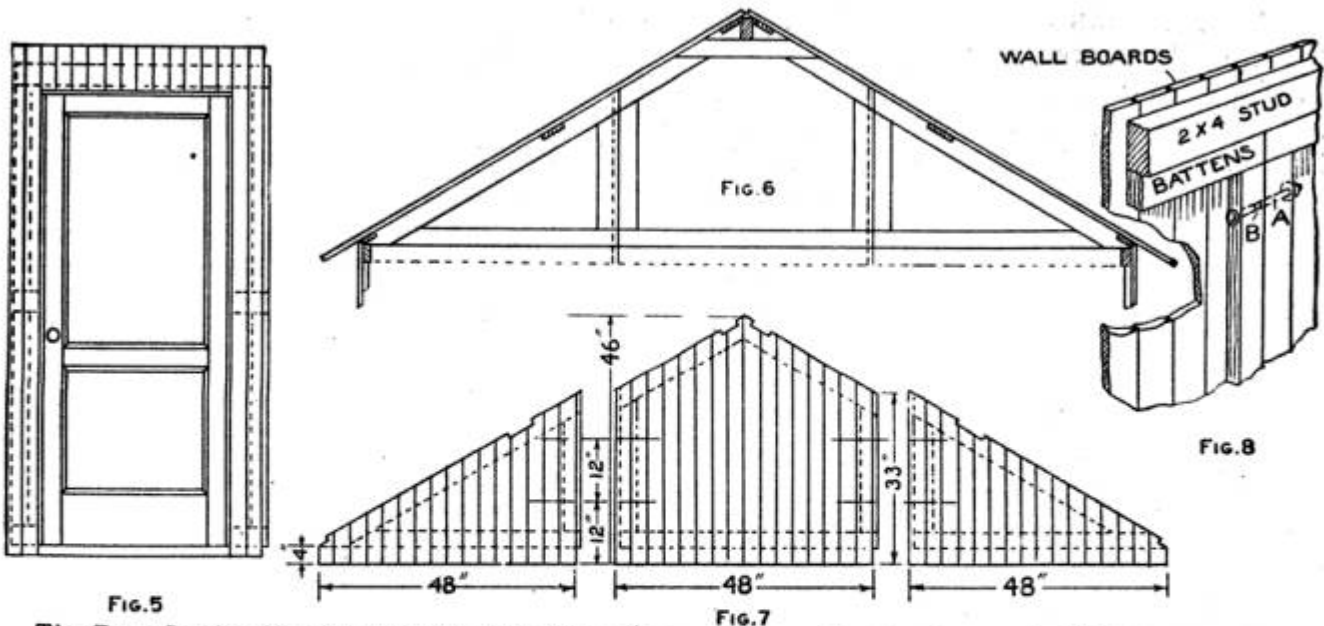

The Door Section Has the Same Outside Dimensions and Same Construction as the Wall Section, But Those of the Gable are Somewhat Different, the Battens being Cut to Fit the Slope of the Roof and the Boards Fitted to Them in the Same Section Widths

come at the end and three-quarters of it will lie on the plate and the ridge, to hold the projecting edge.

The floor sections, Fig. 10, take the

that in placing the corners of the wall boards, as shown in Fig. 11, there will be a space of about  $\frac{7}{8}$  in. at two side and two end corners. This can be taken

care of by tacking a lath on the sides of the sections, also on the ends of both end floor sections.

A  $\frac{3}{8}$ -in. hole is bored through the

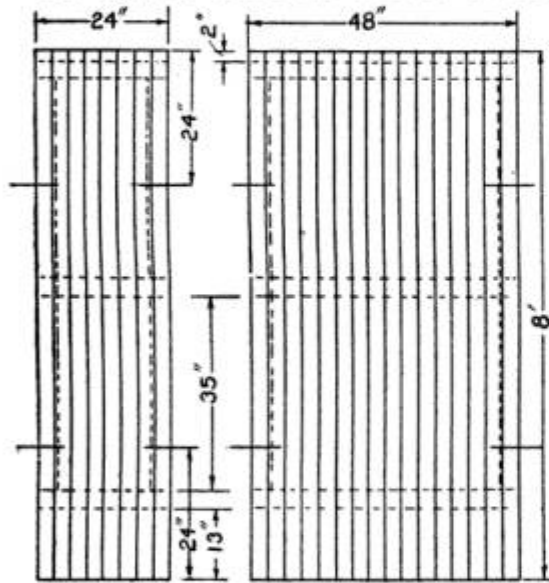

FIG. 9

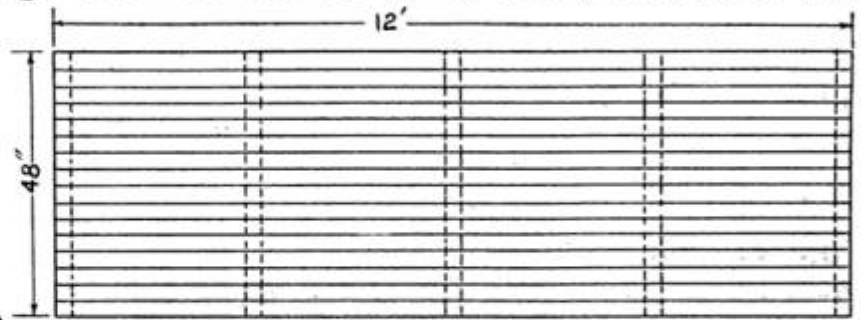

FIG. 10

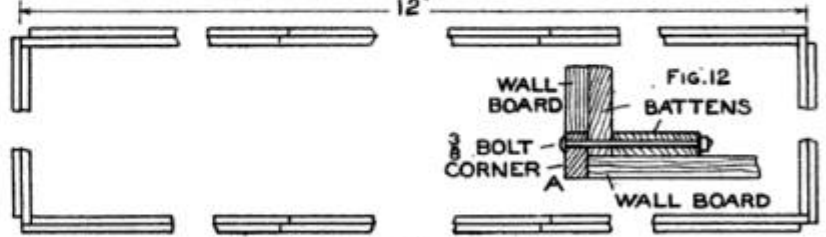

FIG. 11

Two of the Roof Sections are Half-Width, to Provide Eaves at the Ends. On the Floor Sections, Which do Not Lap, the Battens are Flush with the Edges. How the Empty Spaces at the Corners are Filled, and Manner of Joining a Corner

upright battens, as shown at B, Fig. 8, so that if a section is placed with its projecting edge at the corner, a bolt can be used to hold the joint and the corner board A, Fig. 12.

At equal distances apart, on the upper ends of the wall boards,  $\frac{3}{8}$ -in. holes are bored, and holes of the same size are also bored in the plate, or the 2 by 4-in. piece, A, Fig. 3, for bolts to draw them together. These plate pieces should be as long as possible; for instance, for a two-room house that is 20 ft. long, they should be 10 ft. long, two on a side. Those used across the ends should be the length of the width of the house. These plates must fit closely at the corners, one end butting against the side of the other piece running at right angles to it. Where they butt end to end in the center another piece should lap the joint, and longer bolts should be used through the wall boards and plate in the  $\frac{3}{8}$ -in. holes.

Ordinary hooks and eyes are used, in the manner shown in Fig. 3, throughout the construction, and especially for the roof sections in holding them to the ridge and plate. To keep the eyes out of the way for shipment, they should be set in a groove, as shown, or, if possible, in the edge of

the batten. The battens across the lower ends of the wall boards are evenly spaced for bolt holes and bored to receive  $\frac{3}{8}$ -in. bolts; and holes are

also bored in the ends of the flooring boards to match them. Bolts placed in these holes will hold the wall sections to the floor.

If the cottage is to be set up in the woods, small, straight trees can be cut, dressed and laid on a level place, on which to lay the floor sections. As many poles, or joists, are used as there are battens on the sections, and they are located so that the battens will lie on their upper surfaces. If care is taken in placing the underpinning, the floor will be quite solid. Dressed timbers, 2 by 6 in., or 4-in. square, can be used for joists.

All side-wall boards, roofing and floor boards are fastened to the battens with well-clinched nails, but at a trifle higher cost and by expending a little more time, they can be fastened with screws, which will make a much better and more solid section. The roof sections are covered with prepared roofing of good quality, and after placing them in position, a strip of roofing is fastened over the joints, and a strip lapping over the ridge is also attached.

The partitions are made in the same manner as the wall and gable sections, the only difference being that the extending upright battens and the ends of the battens projecting on one sec-



tion will have to be removed, as well as the  $1\frac{3}{4}$ -in. projection of the boards below the lower batten. They will then fit inside of the building at any place. A small notch is cut out of the central gable section to admit the ridge.

A porch can be attached by using sections for a roof held up by porch columns at the outer edge, and by a 2 by 4-in. piece bolted to the house at the end, or under the eave at the side, as the case may be. This can be determined when the location and manner of setting the window and door sections are laid out. Three roof sections and two floor sections will make a good porch. All sections should be well painted and the floor oiled.

### Fireproof Stand for Portable Gas Stoves

To deflect the heat thrown down by a gas stove, I built a low stand, having a sheet of asbestos millboard sandwiched between the wood base and the sheet-metal top. This was secured in place with tacks, fastening the top and passing through the asbestos into the wood base. This device prevents excessive heat on the floor near the stove, and is a safeguard against a possible fire as well.—Contributed by James M. Kane, Doylestown, Pa.

### Pill-Dispensing Box

After having considerable difficulty in dropping a certain number of pills from the box into my hand I hit upon the idea of fixing the box as shown, to drop the pills one by one. A notch, the size of a pill, was cut in the edge of the box, then by

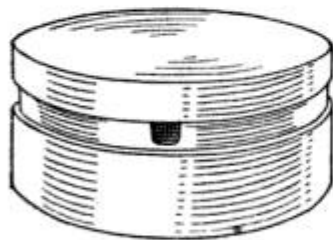

raising the cover partly one pill at a time could be dropped out.—Contributed by Wm. H. Patten, Belleville, New Jersey.

### An Emergency Pressure Gauge

In a case of emergency I used a pressure gauge made as follows: A tee-joint was inserted in the line, and

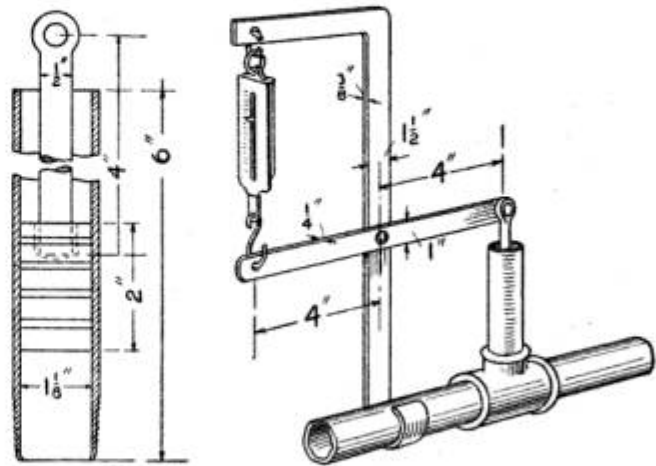

A Pressure Gauge Applied to a Pipe Line Where a Scale Registers the Pressure

in the side outlet of the tee, a piece of pipe,  $1\frac{1}{8}$  in. in diameter and 6 in. long, was fitted. This pipe was bored out smooth, and a piston, made of cold-rolled shafting, was fitted in the bore. The piston was about 2 in. long, and several grooves were cut in its surface for packing. The upper end was drilled to receive a  $\frac{1}{2}$ -in. rod end loosely. The upper end of the rod was shaped into an eye which was attached to a lever, crossing a vertical standard fastened to the pipe. The opposite end of the lever was attached to a spring scale suspended from the right-angle projecting end of the vertical standard.

The inside area of the  $1\frac{1}{8}$ -in. pipe will be so close to 1 sq. in., that the reading on the scale will be direct. To prevent the piston from dropping into the tee, the lower end of the pipe should be turned in a trifle. The dimensions given will make a correct-working gauge.—Contributed by Lee B. Green, Cleveland, O.

☐ In making window screens, put white netting on the outside of the frame and black on the inside; thus the vision of a person inside will not be obstructed while no one on the outside can see through the screens.

### A Flywheel Pattern

There are several methods used in the construction of wheel patterns. They differ mainly in the way the

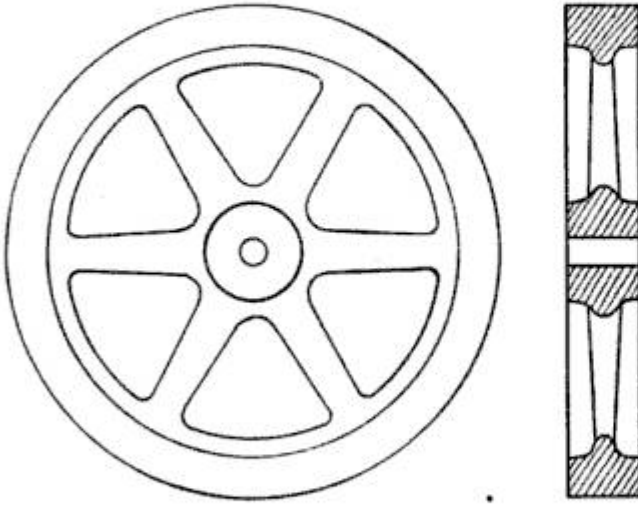

Fig. 1

Design of a 48-In. Flywheel to be Made in a Pattern for the Foundry

arms are fastened together at the hub and in the manner in which they are secured to the rim. The pattern shown in Fig. 1 has stood the test of time and the hard usage of the foundry. A wheel about 48 in. in diameter is shown with arms of the usual elliptic section. The pattern is easily and quickly made in the following manner:

The first thing to be considered is the arms. The stock for these should be planed up to a parallel width and thickness and long enough to extend from the center to a point halfway through the rim. They are then fitted together at the center with the joints running at an angle of 30 deg. to the center line of each piece. These pieces should be fitted on a perfectly smooth surface, or faceplate, to which they are securely fastened with screws. The arms are then laid out and numbered 1, 2, 3, 4, 5, and 6. The arm No. 1 is first removed and cut out on a band saw to the layout lines, and then the taper is laid out and dressed off the flat way of the arm. A flat place, about 1 in. wide, is left on the bottom side of each arm, at the rim end. This is to keep the end from dropping down when the arm is put back into place on the board or faceplate, and the flat surface is trimmed off after the arms are

glued together. This part of the work is shown in Fig. 2. Each arm should be completely finished before it is returned to its place. It is much easier to work the oval, or elliptic, section on each arm separately, than it is to try to shape them up after the arms are fastened together permanently. Arms 3 and 5 are then finished and put back where they belong. Those numbered 2, 4, and 6 are next in order, and are glued in place as soon as they are finished.

While the glue is drying on the arms, a suitable faceplate is turned up in the lathe, and the rim built up. If the arms are not too thick, one course of segments will do for the bead that is to be turned on the inside of the rim, but if the arm is thick, like the one illustrated, two courses will be necessary. The rim is built up and turned, as shown in Fig. 3, the joint between courses 1 and 2 being the center of the rim. One-half of the bead is finished in this operation, a template being used to get it the proper shape.

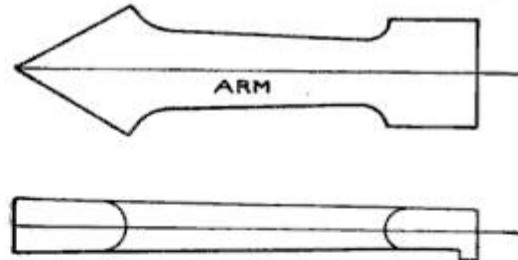

Fig. 2

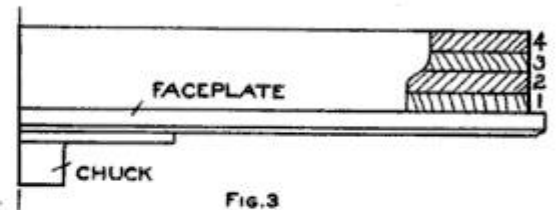

Fig. 3

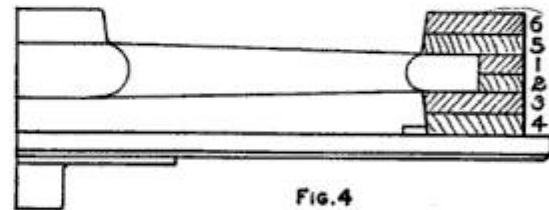

Fig. 4

Layout for the Arms, and the Manner of Building Up the Rim Segments

When the rim has reached this stage, it is taken from the faceplate and re-chucked on thin segments, which are fastened with brads to the faceplate

and turned to fit the finished side of the arm. The other half of the bead is then finished to the template.

The next operation is to fit the arms to the rim. This is done by cutting recesses through the segment courses 1 and 2, to receive the arm ends. If the job has been carefully laid out and turned, the joint between the segment courses 2 and 3 will be the bottom of these recesses.

The cope hub is a loose one and is turned separately and pinned to the arms, but the novel hub should be fastened to the arms before the latter are fastened in place in the recesses cut for them in the rim. A screw with glued surfaces, through each arm, secures the hub and gives added strength where it is most needed. The work proceeds as shown in Fig. 4, by applying the courses 5 and 6, and then finishing the inside and outside, and turning the hub to size.—Contributed by J. A. Shelly, Brooklyn, N. Y.

#### To Prevent Round Stock from Slipping on a Planer Bed

It is frequently necessary to cut a key seat in a long shaft and the work must be done on a planer. There is always a possibility of the shaft sliding along with the tool, even though it is well clamped in one of the slots in the planer bed. A holding device may be had by fastening a lathe dog on the shaft where the dog will rest against the rear end of the table. Of course, if the shaft is short enough, or the key seats so located that a stop can be placed on the front end, it will hold much better.

#### Sand Bucket for Loosening Dirt

Where a sand bucket is used in digging wells the pounding sometimes packs the dirt or sand instead of loosening it. The dirt may be easily loosened and small stones dislodged more readily if the lower edge of the sand bucket is cut in sawtooth fashion.—Contributed by J. V. Day, Stratton, Nebraska.

#### Sheet-Metal Lifting Hook

The illustration shows a hook for lifting and carrying sheet metal in a vertical position. The construction of

this hook makes the grip draw tighter as the load increases. The hook can be made in any size to suit the kind of work. The face of the clamping lever can be corrugated or smooth, as desired.—Contributed by Joseph K. Long, Renovo, Pa.

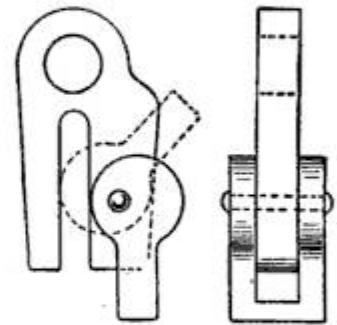

#### Extension Handle for a Paintbrush

Desiring to use an extension on my paintbrush handle, I quickly made one with the use of an old bicycle-lamp bracket clamp. A discarded broom handle was slotted to receive the shank of the clamp, and a small bolt held it in place. The thumb nut on the bolt of the clamp made it easy to clamp the brush handle in the opening.—Contributed by Elvin L. Hartlett, Wausau, Wis.

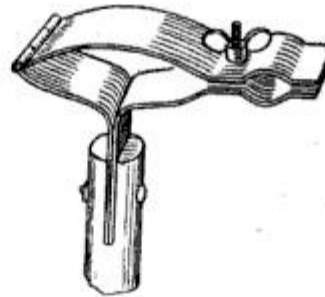

#### Staging Clamp

The illustration shows a clamp which will save much time and many nails when erecting staging. This clamp is made of  $\frac{5}{8}$ -in.

round iron rod. It is applied to the studding, and the board it holds is clamped firmly by driving a wedge between the board and the rod.—

Contributed by Abner B. Shaw, N. Dartmouth, Mass.

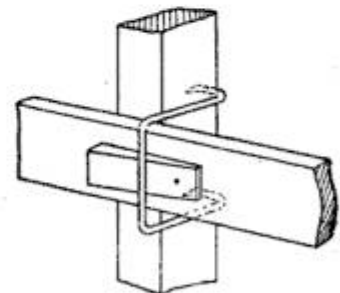

### Temporary Pipe Line Attached to a Tank

A certain piece of work made it necessary to use water temporarily from a tank. The outlet pipe was insulated to keep it from freezing, and it was not considered advisable to connect to this pipe. Also, the new line had to be constructed so that it could be drained so that it could be drained to keep it from freezing.

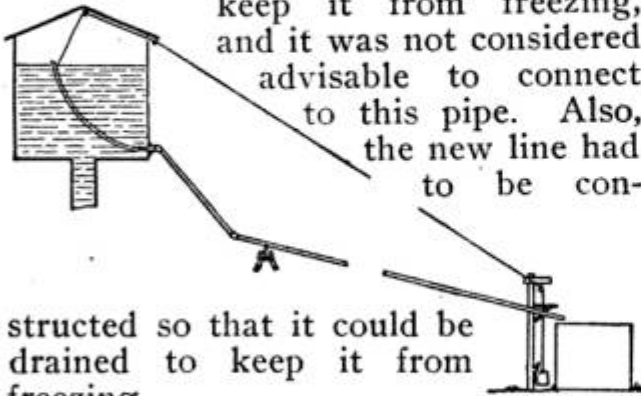

constructed so that it could be drained so that it could be drained to keep it from freezing.

The water was run out of the tank until a man could wade in it with rubber boots, and a hole was cut in the tank near the lower edge and pipe connections made from this point. A long hose was attached to the pipe on the inside of the tank so that its open end could be raised above the water level. A rope was attached to the end of the hose and run over pulleys to a weight near the place where the water was to be used. A shelf was provided for the weight, and when water was wanted, the weight was placed on the shelf. This lowered the hose into the water and started it to run. When the hose was raised out of the water the line drained itself quickly.—Contributed by James E. McCormack, Haliburton, Ontario.

### Lighted Box for Tracing Drawings on Heavy Paper

In the drafting room of a railroad office it was necessary to make copies of a large number of tracings on sheets of thick and hard paper. The paper was too thick to trace through in the usual way, and as it would have taken a great deal of time to copy each drawing, the arrangement shown in the sketch was made, to light the drawing from the under side.

An ordinary drawing board was used for the top, and a hole, 22 in. square,

was cut in the center. A piece of plate glass, 24 in. square, was procured and the wood of the board cut away to let it in flush with the top. A drawer was then made and fitted to hold four 40-watt tungsten globes, placed horizontally under the glass. The tracing to be copied was placed on the glass and the paper over it. When the current was turned on, the lines to be traced could be easily seen through the heavy paper.

The globes were held in sockets of the ordinary wall type, which were mounted on blocks of wood, the latter being fastened with  $\frac{1}{4}$ -in. bolts on two boards, 4 in. wide, which were placed lengthwise through the center of the drawer, as shown. These boards were made with a  $\frac{1}{4}$ -in. longitudinal slot extending to within 1 in. of the ends. The bolts of the socket mountings were passed through this slot. With this arrangement the lights can be slipped to any desired position in the drawer and held tightly with the bolts.

The sockets were connected up, and the terminal ends run out through a hole in the bottom of the drawer and attached to a standard plug. The drawer was 8 in. deep, 22 in. wide and 30 in. long, inside measurements. The entire interior was painted with a gloss white.

The device is useful not only for tracing through heavy paper, but also

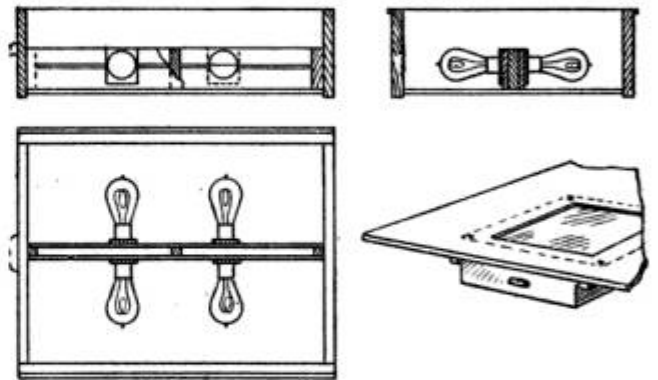

The Lamps in the Drawer beneath the Glass will Light a Drawing on Heavy Paper Sufficiently

for making tracings of indistinct blue-prints, where the white lines would not show through the tracing cloth.—Contributed by J. C. Jacobs, Freeport, Illinois.

### Chalking a Line

A line must be coated with dust from a piece of charcoal or chalk before it can be snapped, which alone requires some time when there are many lines to be made. The sketch shows a simple method of making a chalker for a line, which is of great assistance to a scenic artist, but equally applicable to other work.

Procure an empty tin box, remove the cover, and punch a hole in its center with a nail; also make a hole in the center of the bottom in the same man-

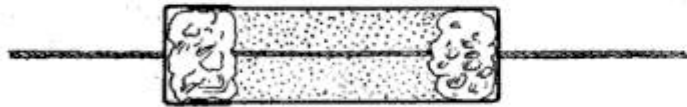

The Coloring Powder is Evenly Distributed on the Line by Drawing It through the Box

ner. Run the line through these holes. Place a small moistened sponge in the bottom of the box and fill the box on top of the sponge with lampblack, or any dry, powdered paint, then place another piece of sponge on top and put on the cover. In chalking the line, it is only necessary to run the box the entire length of the line. The sponges will prevent too much color from adhering to the line. As the color has no binder, it is easily brushed off when dry.—Contributed by Mrs. Harry Marcelle, Honolulu, Hawaiian Islands.

### Drip Catcher on an Oilcan Spout

The drip of an oilcan spout running down on the outside keeps the can covered with grease and in an unclean condition. To catch this drip, I

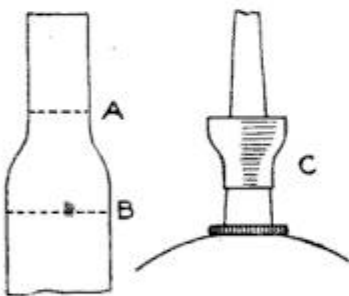

made a cup from a large cartridge shell, cut off on the lines A and B and attached to the spout with solder, as shown at C. A little

clean waste or cotton packed in the cup will catch any oil that runs down on the outside of the spout.—Contributed by Chas. G. England, Washington, Pa.

### Air-Hose Uncoupling Lever

When uncoupling passenger coaches it is very difficult to disconnect the air hose without a leverage. With the

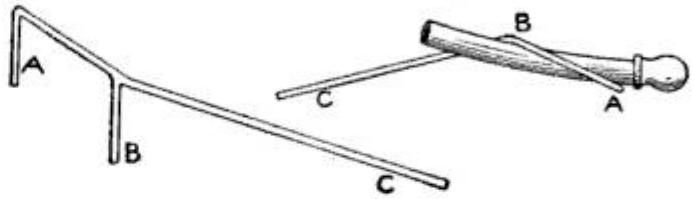

Lever to Use in Disconnecting the Air Hose When Uncoupling Railroad Passenger Coaches

device shown, the proper leverage may be had by placing the prong A under the hose and the prong B above, and bearing down on the handle C. This raises the coupling and loosens the connection. The device is made of  $\frac{5}{8}$ -in. round iron.—Contributed by Benjamin H. Baird, New York City.

### Lace-Hole Marker for Belts

A very practical tool for laying off holes to be punched for wire lacing in belts is shown in the illustration. The

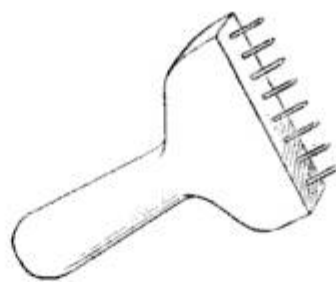

tool is made of hard wood,  $1\frac{1}{2}$  in. thick, 4 in. wide and 6 in. long. A row of wire nails or brads, spaced  $\frac{3}{8}$  in. apart, are driven part way

into the end and lined up evenly, whereupon the heads are filed off and the ends pointed. Finish the block to make a handle, as shown. I find this simple tool very rapid and accurate in scribing holes for punching.—Contributed by John M. Pipp, Muncie, Ind.

### To Lengthen a Twist Drill

Sometimes when drilling a hole in a difficult piece of work, it is found that the drill is just a little too short. The drill can be easily extended to cut through the metal by wrapping the shank with a layer of fine emery cloth or several layers of paper before inserting it into the taper hole.—Contributed by John A. Cook, Birmingham, Alabama.

### A Drill Jig

A simple drill jig that will locate holes centrally in a shaft, or other round stock, accurately and quickly is shown in the sketch. It may be pro-

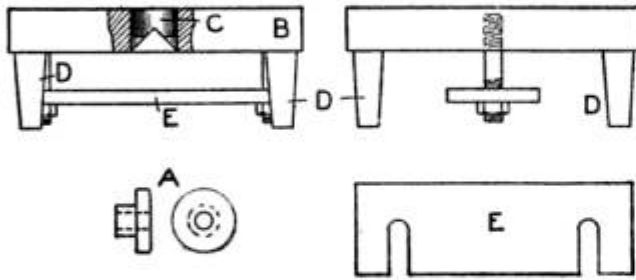

A Jig to Use on a Drill Press for Drilling Holes in Round Stock Centrally

vided with any number of hardened and ground slip bushings, A, to take various sizes of drills and reamers.

The body B is a gray-iron casting with a 90-deg. angle groove machined the full length of it. A permanent bushing, C, is hardened, ground and located exactly in the center of the groove. The result of the work depends on the accuracy of the location of this bushing. The legs D are made of cold-rolled steel and pressed into holes drilled in the corners of the plate.

The clamp E should be slotted, as shown, for rapid work. A small pin may be located close to the lower edge of the bushing C, to prevent the slip bushings A from turning while in use. A slot is made in the bushing A to accommodate the pin.—Contributed by A. Dane, Pottstown, Pa.

### How to Make a Hydrogen Generator

The hydrogen-gas generators used in establishments where a great deal of lead burning is being done, such as storage-battery plants, usually consist of two wooden boxes, one being mounted about 3 ft. above the other. The lower box is made air-tight, but it is connected to an opening in the bottom of the upper box by means of a piece of rubber tubing which is provided with a stopcock or pinch valve, and the upper box is usually partly open. These boxes are both lined with some material, such as lead or

rubber paint, that is not acted upon by the sulphuric acid used in the production of the hydrogen gas. The operation of the device is as follows:

A small quantity of commercial zinc is placed in the lower box through an air-tight opening provided for this purpose, and the upper box is partly filled with sulphuric acid diluted with about 10 volumes of water. When the valve in the tube connecting the two boxes is opened, the acid runs down into the lower box and a reaction takes place, the result of which is zinc sulphate and hydrogen gas. If the outlet from the lower box is closed, a pressure will be established, due to the hydrogen gas, which will force the excess acid back into the upper box—the tube into the lower box should extend inside and the end almost touch the bottom—and reduce or stop the chemical action of the acid on the zinc. As the gas is drawn from the lower box the acid is allowed to run down and again start the chemical reaction.

The arrangement shown in the sketch operates in the same manner, and its construction is a great deal less troublesome. Instead of two boxes, use two 5-gal. water bottles. One bottle should be supported in an inverted position at least 3 ft. above the other. Each bottle should be provided with a large rubber stopper with two openings in them, through which small glass tubes may be inserted. The proper length and arrangement of these tubes is shown in the sketch. The inside end of the air inlet in the upper bottle should extend up to within a very short distance of the bottom of the bottle; while the acid inlet into the lower bot-

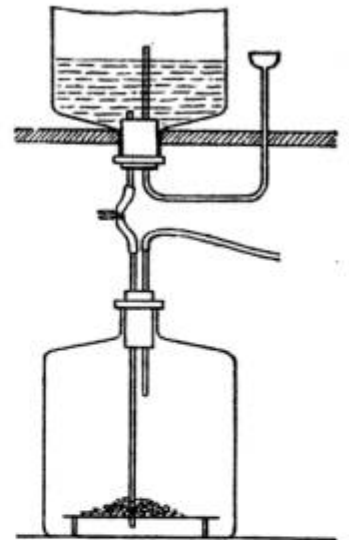

tle should almost touch the bottom. The remaining two tubes should extend just inside the corks. A pinch cock should be provided in the tube conducting the acid from the upper bottle to the lower. Some kind of a small, light support should be made from thin lead and placed on the bottom of the lower bottle, to hold the zinc above any acid that cannot be forced back up into the upper bottle.

Be very careful to get all the air out of the lower bottle before any attempt is made to light the gas, as an explosion is sure to follow if any air remains.

The gas thus generated may be used in many ways, but especially in producing a pure, hot flame. For this purpose a burner is required, which may be purchased at most chemical houses, and a foot bellows to supply air pressure. The air pressure can be produced by using a large can and connecting it to the water faucet; when the water is turned on, the air is forced out.

### Trapping Killies

While out catching crabs one day, we ran short of meat and could get no other bait than killies, but had no net. Having an empty milk bottle in our lunch box, it was tied to a line so that it would hang in a horizontal position. A piece of meat was weighted and placed near the bottom end. The bottle was then hung over the side of the boat. The killies would enter the neck and nibble the meat and thus attract others, and as a result we caught plenty to bait the crabs.—Contributed by Robert Meier, Lynbrook, L. I.

### Binding Bales of Hay on a Wagon

In hauling baled hay on rough roads, the bales can be bound together to keep them from slipping off with wood pins, about 4 in. long, sharpened on both ends and stuck into a bale about halfway before placing another bale on top of it.—Contributed by Ray C. Evans, Meyers Cave, Virginia.

### Bed Desk for an Invalid

An adjustable desk or table for an invalid or convalescent can be made as shown in the sketch. The arrangement

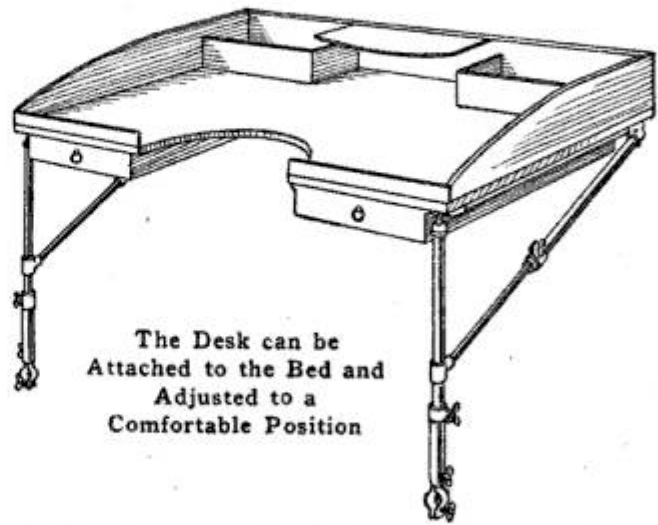

The Desk can be Attached to the Bed and Adjusted to a Comfortable Position

of the top may be in this or any other manner to suit the maker. The length of the desk should be the same as the width of the bed. Two vertical standards made of two pieces of tubing, one telescoping in the other, are used as the supports. Clamps are attached to the upper ends of the larger, or outside, tubes for use in holding the desk at the height set. A brace, also made of two telescoping tubes, is used at each end to adjust the rear part of the desk to a comfortable height for the user. Thumb nuts are used to clamp the desk to the bed.—Contributed by Louis Stankewitz, New York City.

### Homemade Expansion Bolts

When expansion bolts are not available, substitutes can be made of pieces of gas pipe of the required size, each cut slanting with a hacksaw to divide it into two pieces, as shown. A bolt is passed through the center and a large washer holds the bolt head.

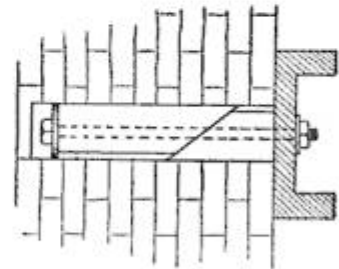

When drawn up, the sloping parts clamp on the sides of the hole.—Contributed by James E. Noble, Toronto, Canada.

### Belt Holder for a Shaft

The unused belt, when there is no loose pulley to shift it on, is usually hung on the running shaft or attached

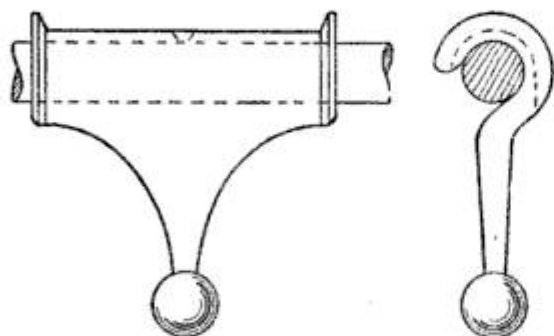

The Holder Swings on the Shaft and is Ready to Carry the Belt When Not in Use

to a wire fastened to the ceiling or joist. A much better way is to make a belt hanger, as shown in the sketch, to hold the belt. It consists of a piece of wrought iron, forged out as shown, to fit over the shaft and an extending end to prevent its turning with the shaft. An oil hole is provided to keep the bearing well lubricated. When a belt is hung on this holder there is no danger of its catching on the shaft and being wound up and broken.—Contributed by S. Gulbransen, Chicago.

### Sanitary Drinking Fountain for a Shop

Wishing to install some sanitary drinking fountains as cheaply as possible, I struck on a very good idea which proved both satisfactory in every respect and strictly sanitary. There were three large wash sinks in the shop, and each was fitted with three plain bibbs and one hose bibb. I merely turned the

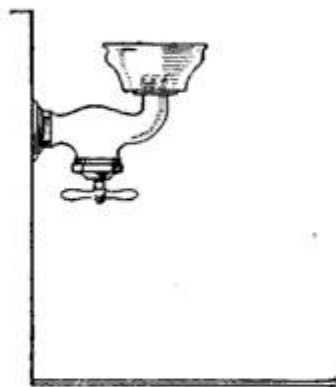

hose bibb around, allowing the hose end to face upward. I then secured three vitreous-china drinking cups which fitted snugly over the hose end and then, by screwing a locknut on the top, the cups were held secure. Each fountain head had four small

holes to allow the water to drain and was so constructed as to make it impossible for the lips to come in contact with the bibb, thus making the device just as sanitary as any drinking fountain on the market.—Contributed by D. Marcus, Madisonville, Ohio.

### Combination Lathe or Planer Tool

The lathe or planer tool illustrated is one that holds cutters made of self-hardening steel,  $\frac{1}{4}$  by  $\frac{3}{8}$  in. These cutters will stand more rough usage and take heavier cuts than a like sectional volume,  $\frac{1}{2}$  by  $1\frac{1}{2}$  in. in size, used on combination tool holders. A wedge instead of a setscrew is used for holding the cutters. The wedge has more bearing on a cutter than a screw and it will not break. If there is any wear, the wedge will take it up.



A Combination Tool Holder Using a Wedge Instead of a Screw for Clamping the Cutter

For cutting-off tools, place two pieces,  $\frac{1}{8}$  by  $\frac{3}{4}$  in., side by side in the holder, allowing the one ground for the cutter to project farthest from the holder.—Contributed by Fred B. Stoner, Mason-town, Pa.

### Removing Tarnish from Silver by Electricity

There is no solvent for silver sulphide, or tarnish on silverware, that is not a better solvent for the silver itself. Therefore the tarnish cannot be removed in a solution. However, this coating can be removed electrically. Make a dilute acid solution, 1 part chemically pure sulphuric acid to 10 parts of water, and use a carbon electrode. The tarnish will disappear in a few minutes without injury to the silver.

In the absence of a battery, suspend the silverware in the solution and bring a piece of aluminum in contact with it. This will restore the luster.



## Proper Construction of Fireplaces

By E. C. KNOPP

After a generation of wood and coal stoves, the open fireplace with its glowing wood fire is again coming into its own, this time taking a permanent place in the home life of those who realize the comfort and enjoyment it lends to a living room or den.

There is a distinct charm about a crackling fire in an open grate, possessed by no other feature of our grandfathers' home life. Colonial furniture, china or architecture are out of place in modern city and suburban life, but the glowing fire of the hearth awakens a spirit that mere age or style of material cannot conjure up. This is nowhere more forcefully seen than in the thousands of homes whose elaborate heating systems, to combat the severe cold of northern winters, are supplemented by the open-grate fire to add cheer to the home. Nor is it out of place among the most modern house furnishings. But the greatest demand for these gloom chasers is in those mild-winter regions where it is desired to heat only one or two rooms.

It has been found, however, that along with some other things which the pioneers did, such as building log houses, the construction of fireplaces which will give satisfactory heating service has become a lost art. Modern masons, with their training based on the demands of modern methods of heating, are not to be censured for their lack of knowledge along this line, any more than the carpenters who do not know how to build a log house.

Out of the large number of fireplaces I have examined, only one—and that one in a mountain camp—was found which possessed the correct principles of construction. In a suburb of a western city, having a district covering a half square mile, 14 fireplaces were found and not one of them was giving satisfaction. Either the smoke came into the room with the heat or both went up the flue together, or it took too much fuel to get the required heat. As a consequence some of these were

closed and stoves installed. If it were not for these disadvantages, there would be three fireplaces to every one now in use.

Having for many years made a study of the principles of fireplace construction, I submit the following plans which have been found to give entire

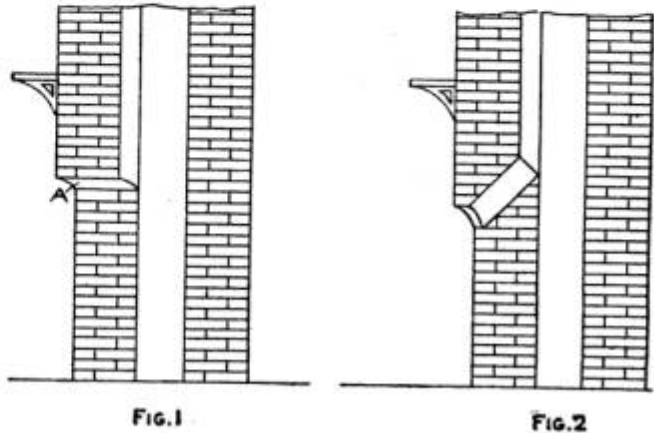

FIG. 1  
FIG. 2  
The Most Common Faults of Fireplace Construction  
Wherein the Heat and Smoke cannot  
be Controlled

satisfaction. Built on these lines, a fireplace will heat as well as a stove, with the same amount of fuel, and no smoke will enter the room. There are many ways which might be illustrated as the wrong method, but the two most frequently found are shown in Figs. 1 and 2. A cross section of one in which the draft carries all the heat up the flue is shown in Fig. 1. The smoke from the front wood strikes the broad, flat arch A, and some of it goes out into the room. In the one shown in Fig. 2 the heat as well as the smoke will pass up the flue.

A properly constructed fireplace is shown in cross section in Fig. 3. The throat is long and narrow, being gradually shortened as it widens into the flue, as shown by the dotted lines in Fig. 4. For the average-sized fire box, the width of the throat A, Fig. 3, should be about 3 in. at the narrowest part, where the point of the shoulder B comes nearest the apron C. The apron should extend at least 6 in. below the point of the shoulder, so as to catch the smoke. In a large fire box, in which

the apron is 5 ft. or more above the hearth, this drop of apron should be at least 1 ft. It may be of arch form, but should not be over 2 or 3 in. thick up to the turn in the throat. Beyond this point it gradually thickens, and the

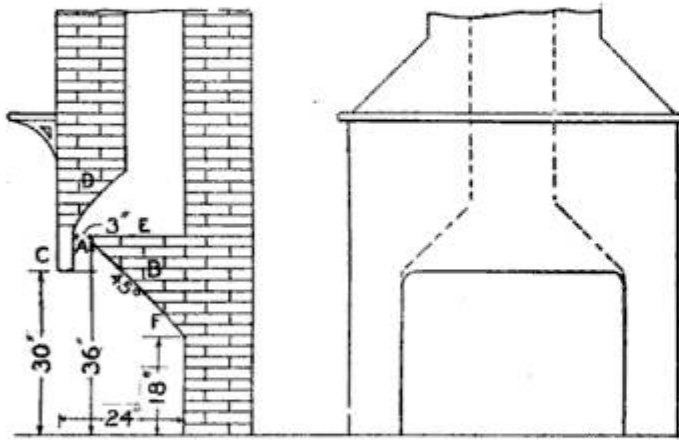

FIG. 3

FIG. 4

Fireplace Construction Where the Heat Enters the Room and the Smoke Goes Up the Chimney

thick wall D, just above the apron, should be built strong enough to support the section of chimney above it. The shelf E is left flat, to stop any down drafts of air from gusty winds. The principle of construction is based on the fact that heat, acting quicker than smoke, strikes the inclined surface F and is deflected into the room while the smoke traveling slower goes up the flue.

The inclined surface, F, of the shoulder, which carries the smoke and heat toward the apron, whether built on a curve or a straight line, should be at an angle of 40 to 45 deg. from the perpendicular. For a fire box 3 ft. wide, the height from the hearth to the apron should be at least 2½ ft. with a 6-in. apron, and the depth should be 2 ft., from the front of the apron to the back of the fire box.

The walls of the throat and flue should be as smooth as possible. If rough stone or broken brick are used, they should be plastered to make a smooth surface. The chimney should extend at least 2 ft. above the ridge of the roof, to insure against down draft in the flue.

☞As the weather gets warmer and the automobile bearings run hot, use thick oil, greases and graphite.

## Wax Phonograph Records Used for Insulation

When sealing up some windings, such as magnets, resistance coils, etc., and not having a sufficient quantity of wax or paraffin for the purpose, I made use of a few broken wax phonograph records. I was much surprised at the properties of this wax. In the first place it was very hard compared with paraffin and had a rather high melting point, so that it would not soften and bend as paraffin, that is, it could not be made as flexible. I used this wax in constructing and repairing electrical instruments by coating the outer windings of the magnets, coils, etc., and then shaving down the wax. This looked exactly like hard rubber and had the advantage of being firmly fastened to the wire. I also used it in repairing broken magnet covers, filling the spots chipped out with the wax, with the result that it would take a close examination to detect the repair. Similarly it was used as insulation in constructing a 1-in. coil, and, although I could not test its dielectric properties, I have had no trouble from leakage.

This wax may be used for innumerable other purposes, as it can be melted and the article soaked in it, but it also can be handled in a more convenient manner, similar to soldering, by melting it with a piece of hot iron and applying it where needed, whereupon it is finished with a file and sandpaper, or turned in a lathe.

The wax can be obtained from any dealer in phonographs, especially those keeping record exchanges. Be sure to get the wax records, not the indestructible ones made of vulcanized composition, as these will not melt. Various colors may be had, but black resembles hard rubber and gives a better appearance. The final finish may be done by polishing with a little benzine on a rag.—Contributed by Arthur Worischek, New York City.

☞A pneumatic or rubber tire placed on a buoy will prevent it from marring the hull of a boat.

### Cutting Glass Disks

The small shop, not equipped with a circular glass cutter, can cut disks for steam and pressure gauges in the following manner: Fasten a wood disk to the faceplate of the lathe, the disk having a diameter larger than the glass to be cut. Apply a thin coat of glue to both the surface of the wood and of the glass. Place a piece of paper on the glued surface of the glass and then apply both to the glued surface of the wood disk. Rotate the lathe spindle by hand and at the same time hold a common glass cutter on the glass at such distance from the center as to make a disk of the proper size. The glass disk can be removed easily before the glue has time to harden.—Contributed by Arthur Hoem, Butte, Mont.

### Placing Steam-Engine Piston Rings

It is sometimes necessary to put packing rings on a solid head without disconnecting the piston from the crosshead to get the rear rings in place. The rear ring must be sprung over the head and slipped over the first ring groove. It is almost impos-

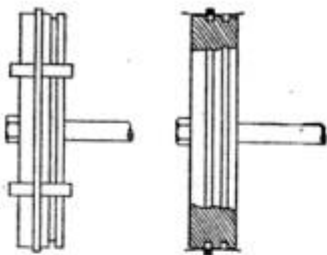

sible to keep the ring from getting into the first groove and sometimes a number of rings are broken before this is accomplished. The sketch shows how some small pieces of sheet iron can be put under the ring to keep it from dropping into the first groove. The ring can then be easily pushed over the strips of iron to its place in the rear groove.—Contributed by F. W. Bently, Milwaukee, Wis.

☐ When a small pipe connection or a petcock becomes so worn or loose that it leaks, never try to remedy it by soldering the joint, but tin the entire length of the threads, and the wear will be taken up.

### Refuse Holder on a Scraping Knife

When scraping calcimine from a ceiling, the dust, scraps, etc., may be prevented from falling to the floor by using a receptacle shaped like the one

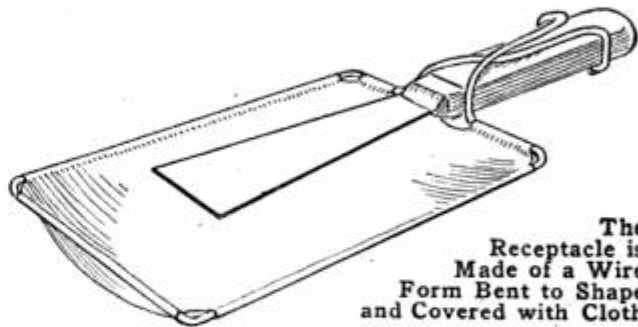

The Receptacle is Made of a Wire Form Bent to Shape and Covered with Cloth

shown in the sketch. The receptacle is made of a wire, about  $\frac{1}{8}$  in. in diameter, bent in the shape shown. A piece of cloth or canvas is then fastened to the wire frame. When necessary the knife can be released and the contents of the receptacle removed.—Contributed by Chas. J. La Prella, Flushing, L. I.

### Cleaning a Clogged Hopper

Any substance like coal or concrete, in passing through a hopper, is liable to clog the narrow portion and prevent any of the material from passing until it is cleaned out. A very good plan to prevent the clogging is to attach a chain at the upper rim of the hopper and allow it to hang on the inside. If the hopper becomes clogged,

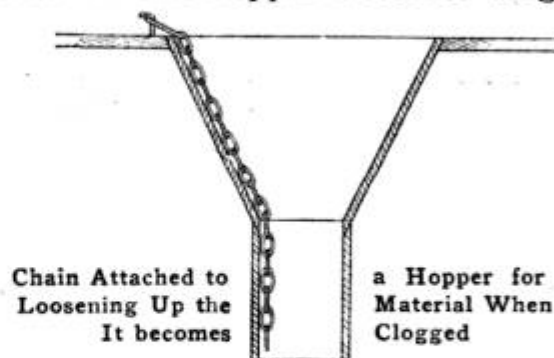

Chain Attached to Loosening Up the It becomes

a Hopper for Material When Clogged

pull on the chain slightly and it will start the material.—Contributed by G. Goodwin, Jr., Ottawa, Can.

☐ A scale filed on a bit, beginning at the cutter end, will save the trouble of pulling out the bit every few turns to see if the hole is deep enough.

### An Adjustable Balancing Trestle

The trestle has three legs so that it can be set on any surface, no matter how uneven it may be. The top hori-

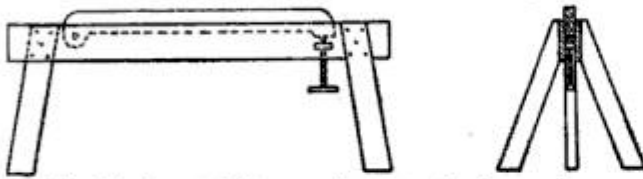

The Horizontal Bar on the Trestle Crosspiece can be Easily and Quickly Set Level

zontal piece is provided with a metal bar, hinged at one end and having an adjusting screw at the other. A spirit level is attached to the bar. A pair of these trestles will enable one to do rapid work, as the leveling surfaces can be quickly set level.—Contributed by John E. Elwing, McCleary, Wis.

### Tapering Wood on a Jointer

Many attempts have been made to cut tapers on a jointer, but as the knives cut too deep at the point where the taper starts, a poor job results, says a correspondent of the Wood-Worker.

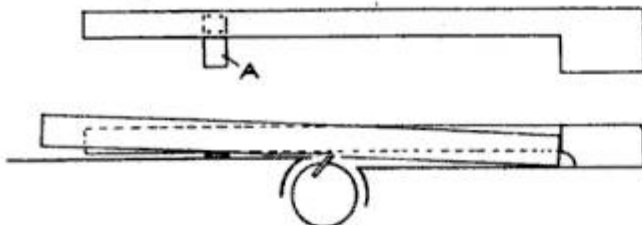

The Form Holds the Work and Starts the Feed, Preventing the Knives from Cutting Too Deep

A form made as shown in the sketch, with a piece of zinc, A, attached will start the feed right and produce nice work.

### To Make a Lusterless Finish on Paint

If it is desired to paint a surface with oil paint and yet have it a lusterless finish, apply a coat of skimmed milk or strained buttermilk over the dry oil paint, or a very thin coat of laundry starch, cooked, which should also be stippled. The advantage is twofold, as it allows the use of oil paint, is easier to apply than flat or turpentine paint, and the protective flat coating can be washed off when it becomes soiled with dust or smoke, leaving the clean oil

paint intact, over which another coating of milk or starch can be applied. This is done very often where soft coal is burned. In this way the oil paint may be preserved indefinitely, barring accidents.

### Holding Pipe Threads in a Lathe Dog

In cutting pipe threads in a lathe I could not grip the pipe with a dog without damage to the threads, so I made a little holder to overcome the difficulty. A pipe coupling was pro-

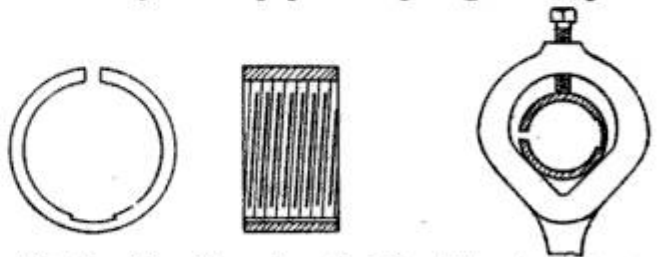

The Coupling Turned on the Pipe Threads Protects Them from the Setscrew of the Lathe Dog

cured and cut to fit in the dog, then a  $\frac{1}{4}$ -in. slot was cut in one side, as shown, and the opposite side filed down thin to allow it to spring slightly. The holder is turned on the threads of the pipe and then the lathe dog is clamped over it.—Contributed by John P. Kolar, Ithaca, N. Y.

### Shank for a Soldering Iron

The sketch shows how I made a very serviceable soldering iron from a discarded extension-bit shank. A large piece of copper was drawn to a point on one end, and the other end was

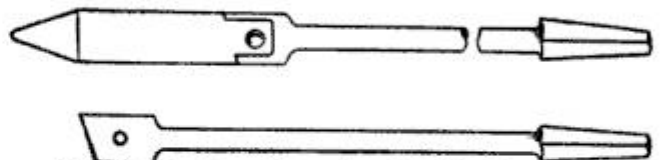

The Shank of an Extension Bit Used as Shank for a Soldering Iron

shaped to fit the shank of the extension bit. A large rivet served to hold the parts together. The square end of the shank was flattened to receive a wood handle.—Contributed by George M. Crawley, Jr., Newark, N. J.

¶ In scouring steel cutlery, use a large cork instead of a cloth; it will wear longer and give better results.

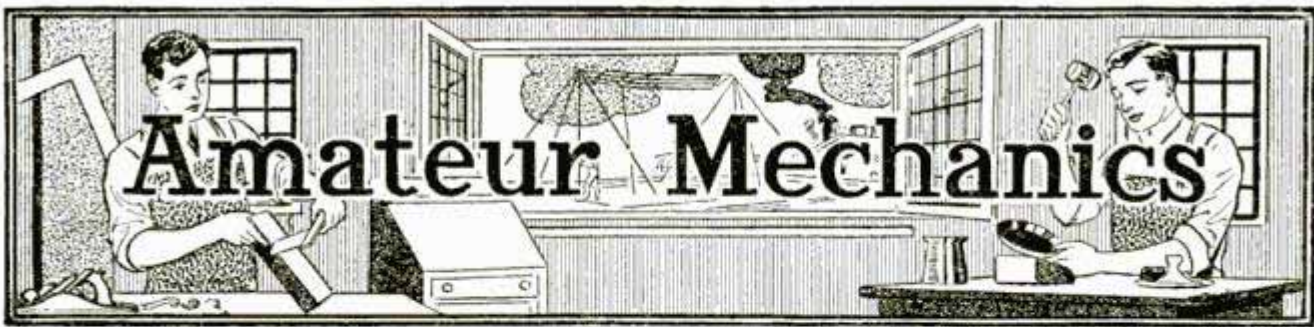

## A Power Windmill

The windmill shown is somewhat different from the ordinary kind. It is not a toy, nor does it approach in size the ordinary farm windmill, but is a compromise between the two, and in a good strong wind, will supply power enough to run a washing machine, a small dynamo, an emery wheel, or any other device used in the home workshop. The wheel is about 5 ft. in diameter, with eight blades. The over-all length is about 6 feet.

The windmill is easily made and the cost is within the means of the average boy. There is not a part used in its construction that cannot be found about an ordinary manual-training shop. The most difficult parts of the construction will be described in

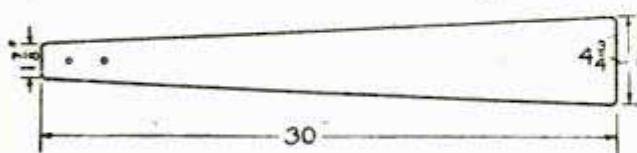
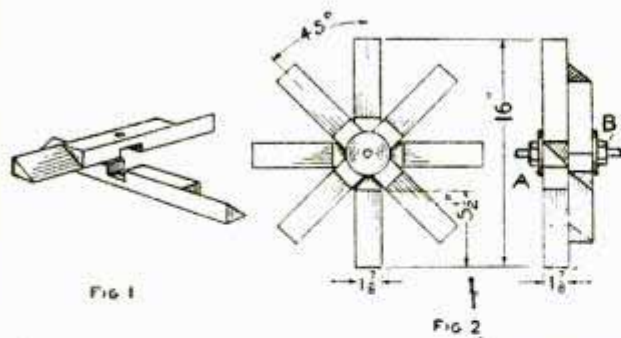

FIG. 3

The Hub Consists of Two Parts, Each Having Four Arms for Holding the Blades

detail. Symmetry and smoothness of design should be preserved and the parts made as light as possible consistent with strength and durability.

### The Wheel

As shown in the drawings, the wheel has eight blades. Ordinarily the use of eight blades makes it difficult to

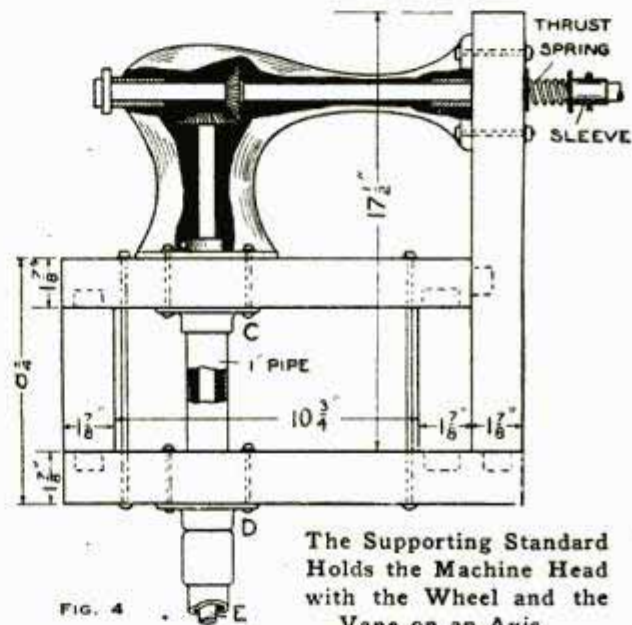

The Supporting Standard Holds the Machine Head with the Wheel and the Vane on an Axis

construct a hub of sufficient strength to carry them. Where so many blades radiate from a common center it is almost impossible to provide an anchorage for each blade. To provide a maximum of strength coupled with simplicity of design, the plan of using two hubs of four arms each was adopted in the construction of this mill. The ordinary hub of four arms is simple to make and quite strong. Four pieces of straight-grained oak, each 16 in. long and  $1\frac{7}{8}$  in. square, are used in constructing the hubs. The manner of notching each pair of pieces together is shown in Fig. 1. The slope for the blades is made to run in opposite directions on the ends of each crosspiece. The slope is formed

by cutting out a triangular piece, as shown.

The two hubs, thus formed, are mounted on the shaft, one behind the other, in such positions that the arms will be evenly divided for space in the wheel circle. These details are shown in Fig. 2. The blades, Fig. 3, are made of thin basswood or hard maple, and each is fastened in its place by means of two  $\frac{3}{8}$ -in. bolts, in addition to which a few brads are driven in to prevent the thin blades from warping.

#### The Gears

This windmill was designed to transmit power by means of shafts and gear wheels, rather than with cranks and reciprocating pump rods, such as are used on ordinary farm mills. To obtain this result, an old sewing machine head was used. Such a part can be obtained from a junk dealer or a sewing-machine agent. The head is stripped of its base plate with the shuttle gearing; likewise the needle rod, presser foot, etc., are taken from the front end of the head along with the faceplate. The horizontal shaft and gear wheel are taken out and the bearings reamed out for a  $\frac{1}{2}$ -in. shaft, which is substituted. The shaft should be 2 ft. in length, and 8 or 10 in. of its outer end threaded for the clamping nuts which hold the two hubs in place, as shown at A and B, Fig. 2. The gear wheel is also bored out and remounted on the new shaft.

The supporting standard is constructed of oak, with mortise-and-tenon joints, as shown in Fig. 4. The width of the pieces will depend on the kind of sewing-machine head used. It may be necessary also to slightly change the dimensions. The machine head is fastened on the support with bolts. A sleeve and thrust spring are mounted on the shaft, as shown. The sleeve is made of brass tubing, of a size to fit snugly on the shaft. A cotter will keep it in place. The sleeve serves as a collar for the thrust spring, which is placed between the sleeve and the standard. This arrangement acts as a buffer to take up the end thrust on the shaft caused by the

varying pressure of the wind on the wheel.

#### The Vane

To keep the wheel facing the wind at all times, a vane must be provided. It is made of basswood or hard maple, as shown in Fig. 5. It is not built up solid, air spaces being left between the slats to reduce the wind resistance. Unless built in this manner, the vane is liable to twist off in a gale. The horizontal slats are  $\frac{1}{4}$  in. thick, and the upright and cross braces  $\frac{3}{8}$  in. thick, while the long arm connecting the vane to the supporting standard is  $\frac{1}{2}$  in. thick.

The supporting standard, carrying the wheel and the vane, must revolve about a vertical axis with the changes in the wind, and this vertical axis is supplied in the form of a piece of gas pipe which runs through the supporting standard at the points marked C and D, Fig. 4. Ordinary pipe fittings, called flanges, are bolted to the frame at these points. The coupling in the gas pipe beneath the supporting standard serves as a stationary collar to support the weight of the whole mill. The vane should be placed correctly to balance the weight of the wheel.

The shaft passes through the framework of the mill on the inside of the pipe, as shown at E. A  $\frac{3}{8}$ -in. soft-steel or wrought-iron rod is satisfactory for the shaft, as no weight is supported by it and only a twisting force is transmitted. The use of a larger rod makes the mill cumbersome and unwieldy. The upper end of the shaft is fastened to the shaft that projects from the under side of the machine head by means of a sleeve made of a piece of  $\frac{3}{8}$ -in. pipe. Two cotters hold the shafts and sleeve together.

At the lower end of the shaft, inside the workshop, the device shown in Fig. 6 is installed. The purpose of this appliance is to provide a horizontal shaft upon which pulleys or driving gears may be mounted. The device is constructed of another sewing-machine head similar to the one already described. The head is cut in two and the separate parts mounted

on suitable supports. The gap between the sawed portions permits a pulley to be fastened on the shaft to serve as the main drive. The wheel propelled by the treadle of the sewing

sewing-machine belts will serve to transmit the power.

#### The Tower

The tower can be built up in any manner to suit the conditions. Ordi-

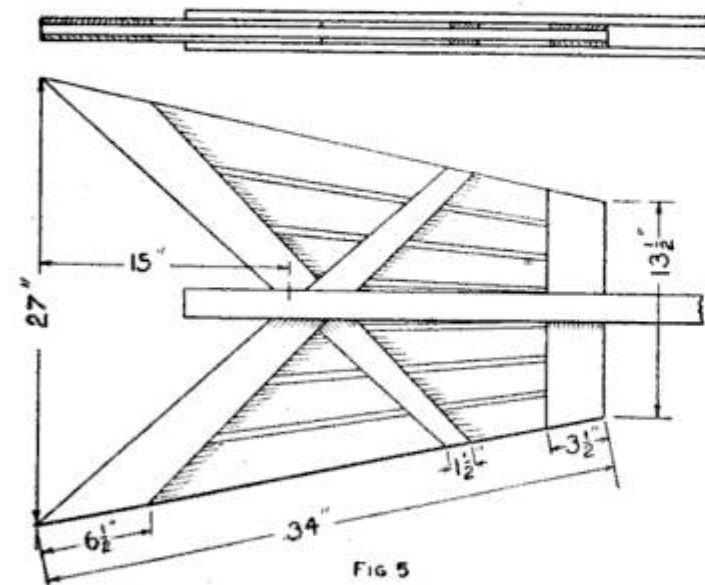

FIG 5

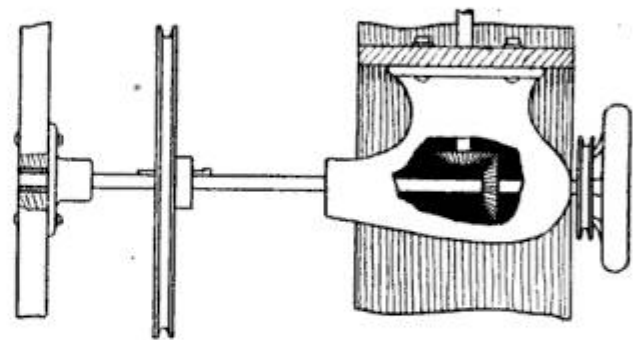

FIG 6

The Lower End of the Shaft has a Horizontal Shaft Geared to It for the Drive Pulleys. The Vane Construction and the Manner of Building the Tower on Which the Supporting Standard Revolves

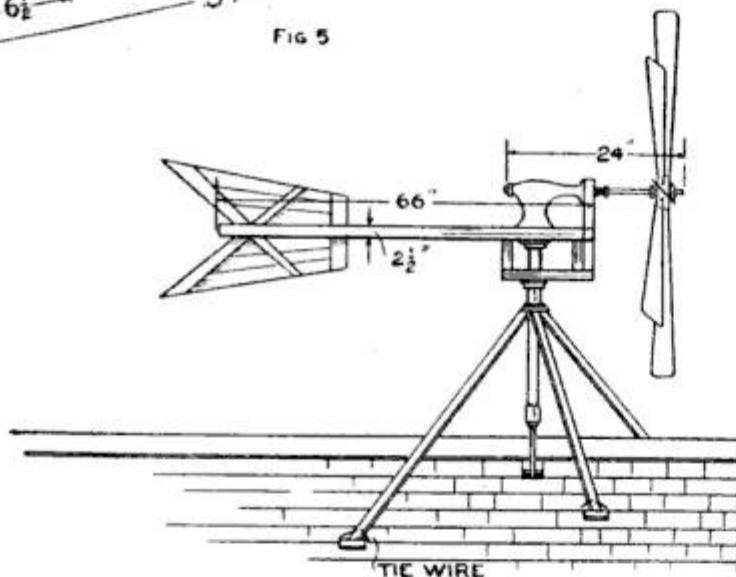
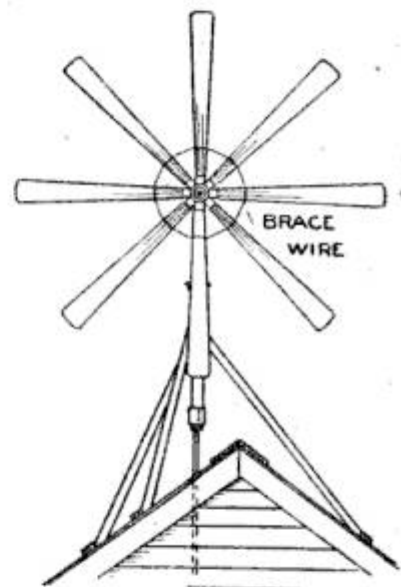

FIG 7



machine will make a good drive wheel. The small handwheel, originally mounted on the machine-head shaft, is left intact. This arrangement gives two sizes of drive wheels. Heavy

narily sticks, 2 in. square, are suitable. These are well braced with wire and fastened securely to the roof of the shop. The arrangement of the tower with the mill is shown in Fig. 7.

#### Telegraph Code on Typewriter Keys

A very simple and practical method of transcribing wireless time and other messages on the typewriter without having such perfect knowledge of the Morse system as to be able to immediately translate it into the common alphabet is the following: The characters of the Morse system are inscribed on small slips of paper—thus, three dots (...), for the letter S; two

dashes (- -), for the letter M, etc.—and these slips are pasted on the corresponding keys of the typewriter. The operator puts on his receiver, and the proper key is struck as he hears the corresponding Morse letter. As there are no capitals, spacing between words, or even punctuation, the manipulation of the typewriter is much simplified, and it is easily learned to record the signals as fast as they are heard.

### A Puzzle Purse

The puzzle purse is made of four pieces of chamois, two of the pieces being merely flaps, one on each side at the upper edge. One of the pieces

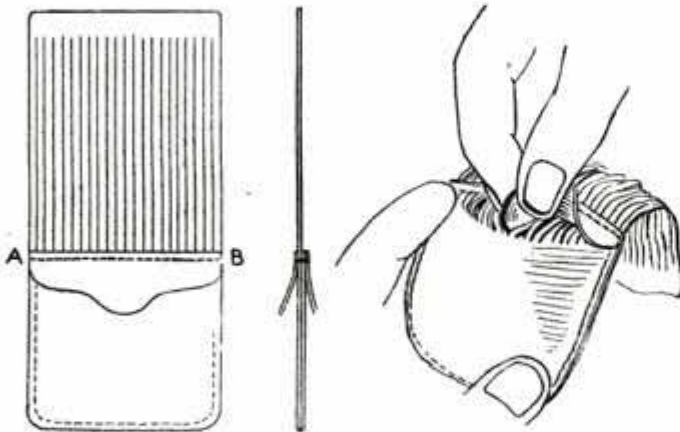

The Strips of Leather Sliding through the Stitches Make the Puzzle Part of the Purse

forming one side of the purse extends upward for about twice the height of the purse part. The part above the purse has a number of slits cut in it to make the width of each strip  $\frac{1}{8}$  in. These slits should be accurately cut in order that the purse may be opened easily. The other half is only the size of the purse proper. The upper edge of the latter piece and the flap on that side are stitched together to the flap on the opposite side, the threads of the stitches running between the strips of the long piece. These stitches are made on the line AB and around the edge.

To open the purse, take hold of each side on the purse part and draw the pieces apart. In doing so, the strips are drawn through the stitches so that they may be separated and a coin taken from the purse. A pull on each end will close the purse.—Contributed by Chas. Motton, Toronto, Ont.

### An Emergency Sandpapering Machine

While doing some work I had several small pieces to be finished with sandpaper. They were so small and of such a shape that it was impossible to do the work by hand. Not having a sanding machine, I used a disk talking machine for the purpose. I placed a sheet of sandpaper over the disk and

fastened it to the felt at the corners with pins. The machine was then set going at its highest rate of speed, and the articles were smoothed by holding them on the disk.—Contributed by Fred S. Barnard, Los Angeles, Cal.

### A Developing Machine

The base of the developing machine consists of a wood tray with sloping ends and high sides, which is placed at the center and provides bearings for the wheel axle. The dimensions given in the sketch are for making a machine to develop a film about 29 in. long. The disk, or wheel, is cut from a board,  $\frac{7}{8}$  in. thick, and the attached cross-pieces are cut from  $\frac{1}{4}$ -in. dowels to make them  $2\frac{1}{2}$  in. long. These are placed about 1 in. apart on the circumference of the disk.

An axle, fastened solidly in the wheel and adjusted in the bearings, is kept from slipping sideways by bushings made of a spool. A crank is attached to one end of the axle. Hot paraffin is applied to the inside of the tank part, to make it liquid-tight. Two pins or hooks are attached to one of the crosspieces to catch into the film end. If the wheel is the correct size, the same pins can be used for fastening the other end of the film.

The film is first attached to the

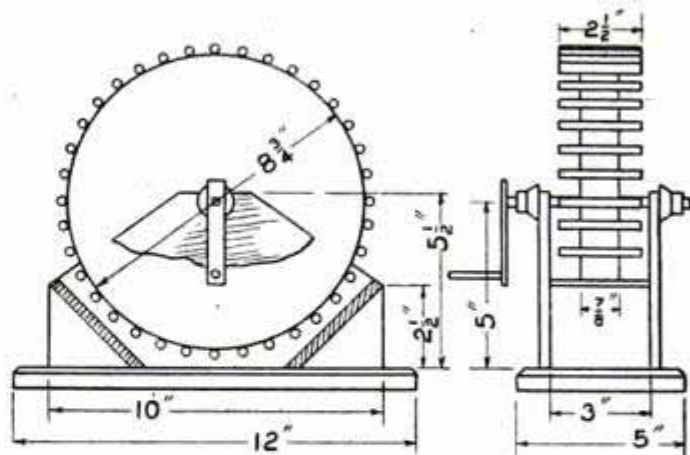

The Entire Length of Film is Placed on the Wheel Where It is Run through the Developer

wheel; then, while turning slowly, the developer is poured into the tray. Keep on turning the wheel until full development is obtained, then pour out the liquid and turn in fresh, clear



water, and turn the wheel to wash out the developer. Remove the film and place it in the hypo bath.—Contributed by Raymond M. Bealer, Baltimore, Md.

### A Stove-Wood Carrier

A handy wood carrier, for bringing wood and kindling from the basement or yard to the wood box in the house, may be made from a grain sack, as shown in the sketch. Use a complete sack and make rope handles at each end. When used, place only sufficient wood or kindling in it to permit the handles to come together over the top of the load. This will make a comfortable grip and it is no harder to carry than a medium-weight suitcase. When the wood is removed the carrier can be taken to the back yard and

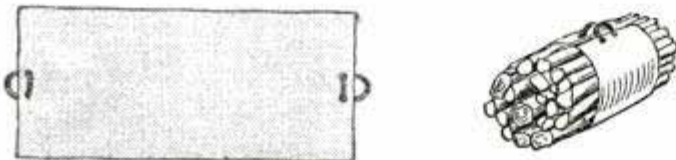

The Ropes at the Ends of the Sack Make a Handle to Carry It Like a Grip

shaken out, thus doing away with the dirt that usually results from other methods of filling wood boxes.—Contributed by Walter Nelson Kidston, Seattle, Wash.

### A Pencil Sharpener

A pencil sharpened with the device shown will have a better point and one that will not break easily while being sharpened. The lower arm A is made from a strip of sheet steel,  $\frac{1}{16}$  in. thick. An extension,  $\frac{1}{4}$  in. wide, is cut and bent in a circle to form the lower finger hold. The upper arm B forms the cutter, which is made from a piece of hacksaw blade. The teeth are ground off and the temper is drawn from the extension that forms the upper circle. A portion of the arm A is bent over, as shown at C, to form a support for the pencil point to rest upon. A hole, large enough for a pencil to turn in, is bored through a stick of hardwood, D, and tapered so that the center of the

hole meets the inner edge of C. It is fastened to the lower arm with screws. A sharp cutting edge is ground

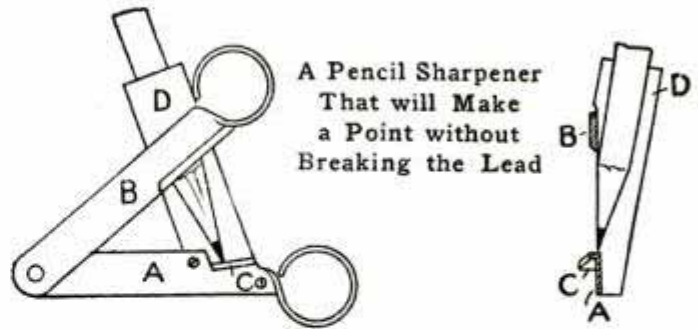

on the blade which is then attached to the arm A with a rivet loosely enough to swing freely.—Contributed by J. V. Loeffler, Evansville, Ind.

### Cleaning an Oilstone

Use kerosene oil and a sprinkling of emery flour and proceed to sharpen tools. It is not necessary to clean a stone thus treated before placing the tool on it, as the emery and kerosene will make a good surface on the stone as well as assisting in producing a sharp edge on the tool.—Contributed by James M. Kane, Doylestown, Pa.

### Landing for Small Boats

Not having a landing for my small boat, I made a series of sectional platforms, rising 2 ft. above the bottom, which served the purpose well and were inexpensive. Each section is about 15 ft. long, 3 ft. wide, and 2 ft. high. The frame is made of material 2 in. thick and 4 in. wide, and on top is a floor made of boards, while the bottom consists of 2 by 4-in. cross-pieces, nailed on 6 in. apart. Stones are laid on these crosspieces to moor it down in place. The whole landing is simple to make and it lasts a long



The Series of Platforms Make a Good Small-Boat Landing on a Slanting Beach

time, as the sections can be drawn out and stored during the winter.—Contributed by Henry Briggs, Lexington, Massachusetts.

### Wash Bottle for Laboratory Use

A large-mouth bottle neck is provided with a stopper, having three brass or glass tubes as shown, the

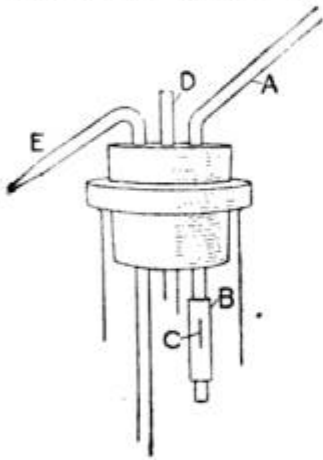

tube A being fitted with a thick piece of rubber tubing, B, stoppered at its lower end. A slit is cut at C, and allows the air blown in through the tube A to pass into the bottle, but will close

automatically and hold the pressure within the bottle.

If the relief tube D is closed with the thumb the water is forced out in a steady stream through the nozzle E. The water will continue to run for some time after the lips are removed from the air tube, but the removal of the thumb from the tube D will stop the flow of water instantly.—Contributed by W. Schilling, San Francisco, Cal.

### Typewriting on Card Stock

Anyone having tried to typewrite on cards or heavy stock has doubtless experienced much trouble in getting the card to feed properly. If at all heavy, it will resist the curving so strongly that it will not be carried around the platen, and the edge of the card is very apt to catch on the pressure rolls and cause the platen to slip.

The remedy is very simple and consists in running a sheet of paper through ahead of the card until an edge of about  $\frac{1}{2}$  in. remains, then inserting the edge of the card inside of the projecting edge of the paper and turning the platen. The paper overlapping the card prevents the edge of the latter from catching on the pressure rolls and keeps it in close contact with the platen so that it will pass through without trouble.—Contributed by Thos. L. Parker, St. Paul, Minn.

### A Furniture Polish

A homemade furniture polish that will compare with any known polish, is composed of the following chemicals and oils. Mix 3 oz. of turpentine very gradually with 6 oz. of linseed oil, then add 3 oz. of grain alcohol, 3 oz. of 5-per-cent acetic acid, and  $\frac{1}{2}$  oz. of butter of antimony. Apply with a cloth and use a good friction. As the substance might prove harmful to children if taken internally, see that it is kept out of their reach.—Contributed by Loren Ward, Des Moines, Iowa.

### Pointed End on a Hoe

The rounding end on the ordinary

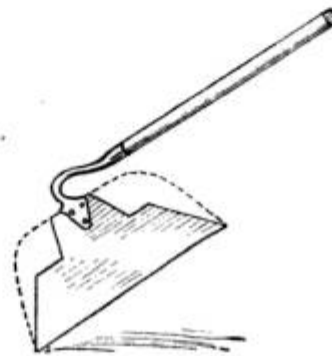

hoe is useless in many instances for getting under growing plants, to cut out the weeds and to loosen up the earth. I find that shaping the hoe ends as shown in the

sketch is very effective in getting up close to a plant and under spreading vines.—Contributed by R. F. Pohle, E Lynn, Mass.

### Starting a Siphon

Roll up a soft rubber hose tightly so that it will be flattened to force out all the air and drop one end into the liquid, then let the coil unwind as it falls down on the outside. The uncoiling causes a slight vacuum in the hose and the liquid follows it up and starts the flow instantly.—Contributed by L. J. Monahan, Oshkosh, Wis.



☞ Paint spots on window glass can be readily removed with a penny.

# Electrical Heating Apparatus for the Home

By ARTHUR MOORE

## PART III—An Electric Foot Warmer

The construction of the foot warmer here described is very simple; the materials required are easily obtained, and if proper care is exercised in carrying out the instructions, excellent results will be obtained in the operation of the completed device. The foot warmer consists of two main parts: the containing case and the heating element, and the construction of each will be treated separately.

The containing case should be made of a fairly heavy piece of Russian iron, similar to that used in stovepipe but about three times as thick, if a piece of such thickness can be procured. For a case to correspond with Fig. 1, the outside dimensions of this piece should be at least 18 by 17 inches.

Draw two lines, A and B, on the piece of iron parallel with the 18-in. dimension,  $3\frac{3}{4}$  in. and  $4\frac{3}{4}$  in. from the two edges, respectively, and two other lines, C and D, parallel with the 17-in. dimension, both 3 in. from the edges. The rectangle formed by these four lines will be the top of the case. On each side of this rectangle lay out two figures identical in shape and dimensions with those shown, also lay out the two parts above and below the rectangle. All the projections marked E should be bent down along the dotted lines at right angles to the surfaces from which they project. These projections are to be used in fastening the case together. Bend the main projecting pieces, at the right and left of the rectangle, down along the dotted lines C and D, until they are at right angles to the surface of the rectangle. These pieces will form the ends of the case, and the upper and lower projections from the rectangle are bent around the curved ends to form the sides. They are fastened in place by means of small rivets or stove bolts that pass through holes in the lugs on the end pieces and holes in the side

pieces. The side pieces should be just a little larger than the horizontal dimension of the rectangle so that they project perhaps  $\frac{1}{16}$  in. beyond the surface of the end pieces, thus giving

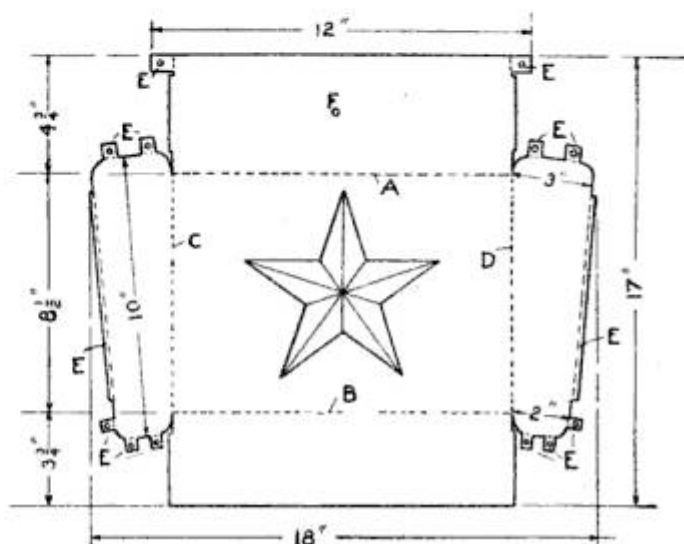

FIG. 1

The Containing Case is Cut from One Piece of Russian Iron and Bent into Shape

a much better construction and presenting a better appearance.

Considerable care should be exercised in handling the sheet of metal to see that it is not bent out of shape or dented. In bending down the lugs and other projections, it would, no doubt, be best to securely clamp the metal between two surfaces with straight edges, such as two boards of hard wood, so that the angle formed will be as near perfectly square as possible.

This case is to contain the heating element, and in order that the heat generated in it may readily pass out of the case, it will be necessary to drill numerous holes in the top portion. These holes may be made in any promiscuous manner, but the appearance will be greatly improved if they are laid out according to some definite design. It is not advisable to drill too many holes, as this would weaken the case and perhaps cause trouble later. A suitable design for the center

in the form of a star is shown, and other designs may be added as desired.

A hole, F, is drilled in the case, as shown, for the conductor leading from the source of energy to the heating

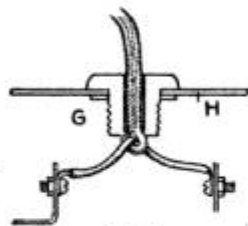

FIG. 2

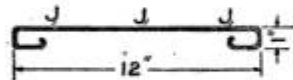

FIG. 3

The Support and Parts for the Heating Element and the Electrical Connections

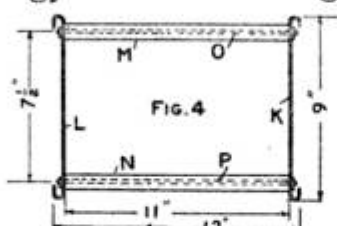

FIG. 4

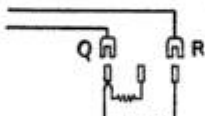

FIG. 5

element. The diameter of this hole should be large enough to take a porcelain bushing with an opening in it of sufficient size for the duplex conductor. The porcelain bushing, which is shown in Fig. 2, is held in place by a copper nut, G, screwed onto the bushing inside of the metal case H.

On account of the temperature of the heater, it will be necessary to support it on suitable legs so that it will not damage the surface upon which it may be resting. These legs can be made from a piece of strap iron,  $\frac{1}{8}$  in. thick and  $\frac{3}{4}$  in. wide, and should have a form and dimensions similar to those shown in Fig. 3. Three holes, J, large enough to take a small stove bolt, are drilled in each piece.

The under side of the containing case is closed by means of a piece of sheet metal, 12 in. long, and wide enough to extend about 1 in. over the edge of each side piece. This piece may be fastened in place by the same bolts that hold the legs, and holes should be drilled through it and through the side pieces to correspond to the holes in the pieces forming the legs. The holes in the case should be smaller and threaded, so the stove bolts can be screwed into them from the inside and will not fall back into the case when the legs and piece of metal are being fastened in place.

The heating element is constructed as follows: The frame upon which the

resistance wire is to be wound is shown in Fig. 4. It consists of two pieces of strap iron, K and L,  $\frac{1}{8}$  in. thick and  $\frac{5}{8}$  in. wide, of the dimensions and form shown, and two porcelain tubes, M and N, mounted upon two rods, O and P, that connect the pieces K and L. The outside diameter of the porcelain tubes should be at least  $\frac{1}{2}$  in., and the length of the frame should be such that it will just slip into the containing case. Two holes are drilled in each end of the containing case to correspond to those in the ends of the pieces K and L. These holes are drilled in such a position that the upper surface of the heating element is parallel with the top of the containing case and about 1 in. beneath it.

A thin sheet of asbestos is wound around each porcelain tube, about two turns, and fastened in place by means of some temporary wires until the resistance wire is in place. The edges of the sheets of asbestos should be on the outside of each tube.

Procure about 60 ft. of No. 24 gauge "advance" resistance wire and proceed to wind it on the frame as follows: Take a turn around one tube, about  $\frac{1}{4}$  in. from its end, and tie the wire by twisting the end of the wire around the main portion so that about 2 in. of the end is free to make a connection. Wind the wire around the tube, spacing the turns about  $\frac{1}{8}$  in. apart. This spacing may have to be changed in order that the wire be properly distributed, but this can be determined after a few turns are in place. The winding should terminate at the opposite end of the tube upon which it started and about 2 in. of free wire be left to make a connection.

A piece of No. 14 gauge asbestos-insulated copper wire, about 10 in. long, is fastened to each end of the resistance wire by means of two very small bolts and washers.

The cord leading to the heater is put through the porcelain bushing, and a knot tied in it, so as to take care of the strain, as shown in Fig. 2. The ends of this cord are then fastened

by small bolts to the pieces of copper wire leading to the heating element. These joints should all be insulated with asbestos sleeving. A heavy sheet of asbestos is placed inside the containing case, so that it will be between the heating element and the bottom of the case. The legs and bottom are then fastened in place.

With the arrangement of the heating element described, the heat generated cannot be varied. An arrangement of heating elements, similar to that shown in Fig. 5, makes it possible to obtain three degrees of heat. Either resistance may be used alone or the two in series. If it is desired to arrange the heater according to the scheme shown, two heating elements, either separately or on the same frame, must be constructed. The resistance of one of these elements should be one-half that of the other. If it is desired that the input to the heater, when connected for the maximum heat, should be about 330 watts, the resistance of the lower element should be about 33 ohms, when operated on a 110-volt circuit, and it should be capable of carrying 3 amperes. If the resistance of the other element is made 66 ohms, its input, on a 110-volt circuit, when connected alone, will be 165 watts. By connecting these two elements in series, the combined resistance will be 99 ohms and the input will be 123 watts. The current-carrying capacity of the 66-ohm element should be 1.5 amperes.

Three plugs may be mounted at some convenient place on the containing case and the heating elements connected to them as shown in Fig. 5. These plugs must all be insulated from the containing case with an insulation that is not affected by the heat. Two clips, Q and R, are then attached to the supply circuit, and the combinations of resistances described above can be obtained by various connections of the clips and plugs. These clips and plugs are easily constructed, or may be purchased from almost any electrical supply house.

The cord used in connecting the

heater should be of a better grade than the ordinary lamp cord, and should have a much heavier insulation and larger copper conductors.

### An Automatic Fishhook

The hook A is made of tempered brass or steel wire of a gauge sufficient for the size of the fish to be caught.

A wire of No. 18 gauge is about right for ordinary fishing, with a No. 20 or 22 gauge for the trigger. Hooks, C C, can be soldered on the points to angle for larger fish. Barbs are not required for smaller fish.

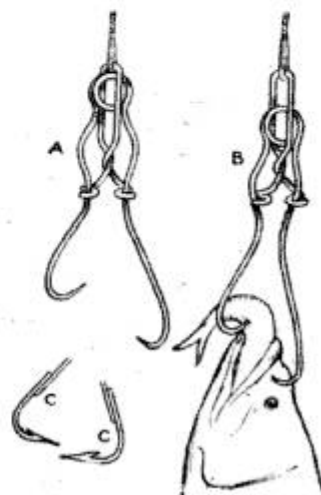

Such a hook will catch the fish, even if they only nibble, and is especially good for fishing through the ice. Use a bob and a pole, and bait the short hook with a minnow or worm. The extreme length of a hook for catching a 1-lb. fish should be 3 in. Fasten the line as shown at B.—Contributed by Robert C. Knox, Waycross, Ga.

### Driving Nails to Prevent Splitting

A nail driven so that it crosses the grain, as shown in the sketch, is not likely to split the board through which it passes. The splitting often results when the nail is driven straight. The nail should be started at different angles according to the grain of the wood.—Contributed by Chas. G. England, Washington, Pa.

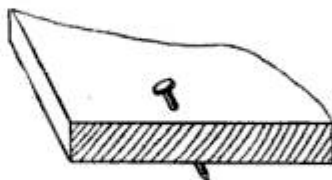

CA razorlike edge can be put on a knife blade by carefully stropping it without lubricant on a piece of smooth aluminum after first whetting on an oilstone.

### Carrying Two Pails in One Hand

When it is necessary to carry two small filled pails in one hand and a package in the other it will be found a

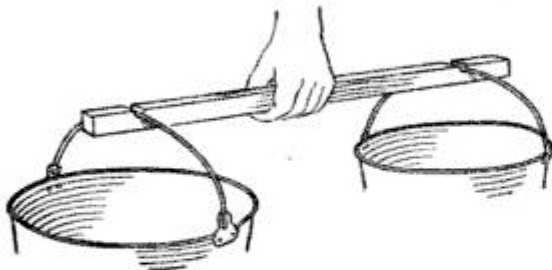

Two Filled Pails can be Readily Carried by Placing the Bails on the Ends of a Stick

very difficult job, if the contents are liquid. Procure a stick of sufficient size to carry the weight of the pails and cut a small notch in each end to admit the bail. Place a pail on each end of the stick and take hold in the center, or, if the pails are not equally filled, a little to one side of the center.

### Preserving Paint in Open Cans

To keep paint from drying out in an open can it is necessary to exclude the air from the oil. This can be done by procuring an air-tight paper sack, which is tested by blowing into it. Set the can into the sack and tie it tightly with a cord. Mixed paint will be kept in a working state in this manner.

### Jelly-Straining Stand

Procure a board,  $\frac{7}{8}$  in. thick and 18 in. square, and cut a hole, about 1 ft. in diameter, in the center. Fasten

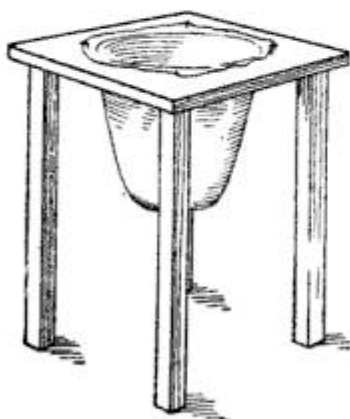

beneath to catch the juice.

posts, 4 ft. long, to each corner. Screw hooks are located around the edge of the hole to catch into the cloth used for holding the fruit. The stand is high enough to be convenient and admit a vessel

### Renewing Dry Batteries

It is a well-known fact that dry cells commence to deteriorate from the time they are manufactured, and it is a matter of considerable uncertainty in purchasing cells to know whether they will continue to be efficient for their supposed natural life under the existing conditions of service, or for only a small part of this period. When the voltage of a dry cell falls below a certain value it is usually discarded and replaced by a new one, which often means quite an expense. The following simple suggestion will enable one to renew the prematurely exhausted cell with very little trouble and slight expense, so that its period of usefulness will be extended for a length of time, at least equal to that for which it could be used if put into service immediately after its manufacture.

The procedure in renewing the cell is as follows: A casing is placed outside of the zinc-containing case, having inside dimensions

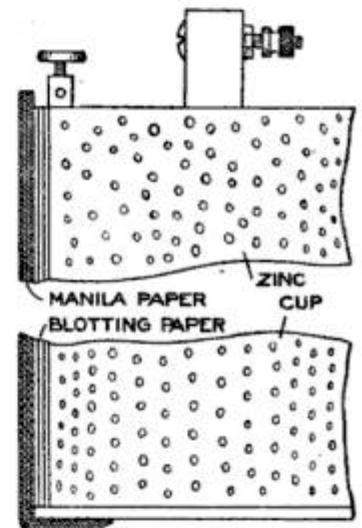

a little greater than the zinc cup. The space between the zinc cup and case is filled with a dry electrolyte, which, upon the addition of moisture, sets up a chemical action with the exterior surface of the zinc, and the latter having been perforated, causes electrical action to be again produced.

The casing, or cup, to be used outside the zinc cup should be made of a waterproof material. The electrolyte instead of being placed between this cup and the zinc in a powdered form, as might be expected, should be held by several layers of blotting paper, formed into a cylinder of the proper diameter to fit snugly on the outside of the zinc cup. This porous cup should be impregnated with a solution containing the following materials in the approxi-

mate amounts given: Muriate of ammonia, 10 parts; bichromate of potash, 4 parts, and chloride of sodium, 4 parts. After the porous cup has thoroughly soaked in the above solution it should be dried by passing a roller over its external surface when it is mounted on a wooden cylinder of proper diameter. The moisture-proof cup may be formed outside the porous cup by covering the latter with several coats of waterproofing paste and winding on several thicknesses of common manila paper, each layer of paper being treated with the paste. A disk of cardboard, properly treated, should be placed in the end of the cylinder to form the bottom, and the edge of the manila paper folded in over it and pasted in place.

The pasteboard covering surrounding the zinc cup of the cell should be removed and the surface of the zinc thoroughly cleaned. The coal tar in the top of the zinc cup should be removed by tapping around the edge with a hammer, and a large number of small holes should be made in the walls of the cup with a sharp instrument. Then put the cell within the porous cup and fill the top with clear water, preferably rain water. A chemical reaction will immediately take place between the outer surface of the zinc and the chemicals contained in the material forming the porous cup, and the terminal voltage of the cell will be practically the same as it was when the cell was new. The water, of course, must be replenished from time to time on account of evaporation, and the useful life of the cell can be prolonged for a considerable time. A part cross section of a cell treated as described above is shown in the accompanying sketch.

### Workbench Equipment for a Table Top

The average home mechanic with a few tools seldom has a place to work and is usually without a workbench. As this was my case, I constructed a bench equipment that I could easily clamp to the kitchen or other table and

thus have the necessary tools at hand for work. A plank, 2 in. thick, 10 in. wide and 18 in. long, was planed and

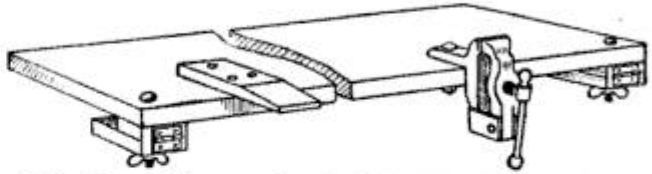

The Bench Top can be Quickly Attached to Any Table Top without Harming It

smoothed up on all sides, and a vise and a bench pin were fastened on one edge.

To the under side of the same edge two blocks were securely fastened, as shown, and to these blocks two other pieces were fastened with hinges. With a bolt, running through from the top, and a thumb nut used underneath, these pieces are used as clamps for holding the bench to the table top. The top can be removed and set away in a closet when not in use.—Contributed by Wm. H. Hathaway, Nutley, N. J.

### A Nonsticking Drawer Guide

The guide shown is nonbinding and has been found thoroughly practical after several years' use on furniture.

The guide A consists of a piece of wood, about  $1\frac{1}{8}$  in. square, with a concave cut in its upper edge, the width being about  $\frac{3}{4}$  in. and the depth such as not to cut through the extending end projecting over the crossbar B.

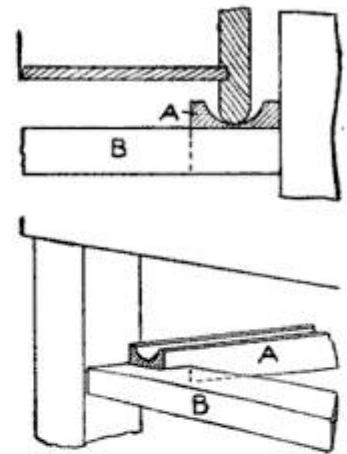

The drawer sides have a half-round edge on the bottom edge to run in the groove in the guide. The difference in width between the groove in the guide and the rounding edge on the drawer side causes the drawer always to ride snugly without binding as the wood expands or contracts with changes in the weather.—Contributed by Herman Hermann, Portland, Ind.

## INTERESTING NEW PATENTS



FIG. 1

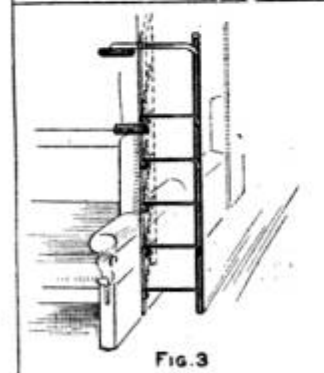

FIG. 3

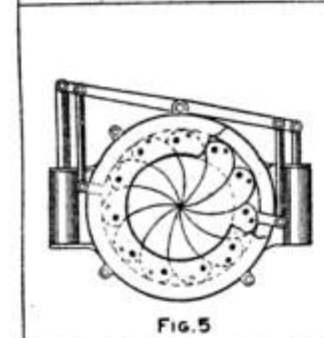

FIG. 5



FIG. 7

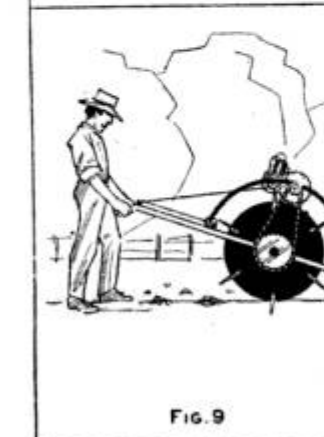

FIG. 9

**SUGAR-DISTRIBUTING BOWL (Fig. 1)**—When the vertical shaft in the center is turned the sugar block is dropped into the hand or into the tea or coffee cup through the aperture in the bottom of the bowl. The lower part of the shaft carries a number of sloping partitions at the bottom, which divide the space into small compartments. Each of these compartments has an opening at its outer edge large enough to admit one block. When the compartment is over the aperture, this opening is closed by a stationary cover supported on the side of the bowl.

**NOVEL PROPELLER FOR ROWBOAT (Fig. 2)**—In this device paddles are carried at the ends of two shafts which work independently of each other, each being supported on the gunwale and a pillow post at the center of the boat. The paddles are cup-shaped and are attached to the ends of rods which slide in openings in the paddle head, the paddles dropping out of the way when in the high position and falling to engage the water when in the low position.

**FOLDING LADDER FOR SLEEPING-CAR BERTHS (Fig. 3)**—With this device a Pullman-car passenger is enabled to get into or out of the upper berth without waiting for the porter to bring the ladder. It consists of a series of steps which are pivoted to the berth partition and to a vertical support that rests on the floor when in use. When not in use, the whole device is folded compactly against the berth partition.

**GRASS SHEARS (Fig. 4; British patent)**—These grass shears are apparently designed for cutting in corners, around trees and shrubbery, and in other places where the use of a lawn mower is difficult. The double-edged cutting blade is pivoted to work closely over the fixed toothed blade and is operated by a swinging bar.

**DIMMER FOR AUTOMOBILE HEADLIGHT (Fig. 5)**—Spiral plates pivoted to the outer flange of the case are arranged to overlap each other in such a way that, when swung inward, they partly or wholly close the front of the case, as desired. When the case is entirely closed, the only light emitted is that which passes through the slots in the plates. The device is operated by a circular wire pivoted to all the plates.

**DEVICE FOR HOLDING DOOR IN OPEN POSITION (Fig. 6; British patent)**—This device consists simply of an arm rigidly attached to the door or other hinged object and provided with notches along its outer surface, used in connection with a spring bolt, supported on the door casing and arranged to engage the notches of the arm.

**TONGS FOR EXTRACTING FRUIT SEEDS (Fig. 7)**—The ends of the tongs are provided with cutters which are easily forced into the fruit. The seed is grasped and held in a depression in one of the arms, being forced into this depression by the pressure of the opposite arm.

**GAS TURBINE (Fig. 8; British patent)**—An explosive mixture of gas and air is introduced into each pocket in succession through the large inlet at the top of the casing, and is fired when the pocket reaches the electric spark plug at the left. The explosion reacts at an angle against the side of the casing and causes the rotor to revolve. The products of explosion escape when the pocket reaches the outlet at the right.

**REVOLVING PLOW (Fig. 9)**—This is a novel attempt to use a motor in the work of plowing. The motor is mounted at the top of the arched frame and drives the cutting wheel by means of a chain and sprocket.

**COMBINED SHOVEL AND HOE (Fig. 10)**—The blade of this tool is pivoted to the handle and is readily secured by a latch in either of two positions, practically at right angle to each other, being used as a shovel in one position and as a hoe in the other.



FIG. 2

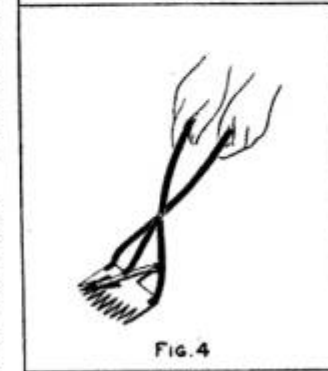

FIG. 4

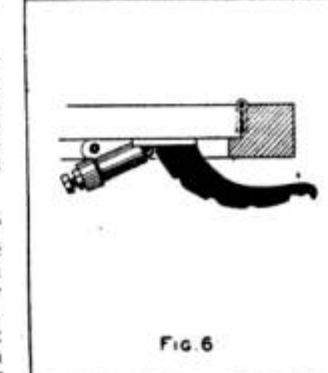

FIG. 6

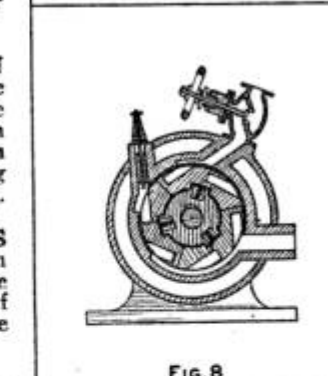

FIG. 8

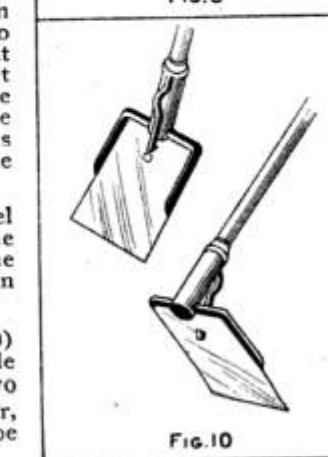

FIG. 10





Fig. 11

**DEVICE FOR LEADING DANGEROUS BULL** (Fig. 11)—The body of this "lead" is a metal tube, 4 ft. in length, provided with a handle on one end and a hook on the other. Inside the tube is a rod, which is pressed against the inner side of the hook by a spring, but is easily released by a pull on the ring at the opposite end of the rod. The user simply stands at a safe distance and clamps the device over the sensitive central wall of the bull's nose. In case of necessity it can be used effectively as a club.

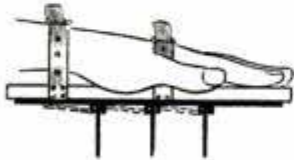

Fig. 13

**SHEARS FOR RIPPING SEAMS** (Fig. 12)—This device works after the fashion of ordinary shears. The blades have vertical cutting edges and project in opposite directions from the arms, the seam being spread and the threads cut at one operation.

**SWIMMING DEVICE** (Fig. 13)—This device, apparently designed as an aid to inexperienced swimmers, consists of a block which is strapped to the hand and on which is carried a number of hinged wings. These wings lie flat against the block during the forward reach, but spread out and engage the water during the propelling stroke.

**APPARATUS FOR SPREADING OIL ON THE SEA** (Fig. 14; British patent to a German)—The purpose of this invention is the calming of the sea in the lee of a vessel so that boats can be launched safely. A number of floating oil-distributing tanks are attached to a cable, and the ends of this cable are connected by other cables to the bow and stern of the ship. A board forming the junction of the cables at each end is placed at such an angle that the apparatus spreads out in a curved line under the action of the wind and waves, scattering oil over a wide area.

**BOOK HOLDER FOR RECLINING READER** (Fig. 15)—This device has a glass panel carried in an adjustable frame, which in turn is supported by a rod attached to the side of the bed. The book is laid face downward on the glass panel, and may then be comfortably read by a reclining reader.

**SAFE-DEPOSIT SHOE HEEL** (Fig. 16)—This curious invention is intended to enable the user to carry valuables in the safest possible way. The receptacle in the heel of the shoe can be reached only from the top. It is closed by a metal disk over which a thin inner sole is laid.

**NOSE-BAG SUPPORT** (Fig. 17)—The interesting features of this device are the brace that runs to the lower part of the hames, and the flexible support attached to the top of the hames. The invention is intended to enable the horse to eat from the bottom of the bag without being compelled to brace it against the sidewalk or other solid object.

**AUTOMATIC GAS CUT-OFF** (Fig. 18)—The valve that supplies the burner is so designed that it shuts off the gas in case the light is accidentally extinguished, being controlled by a spring that keeps it normally closed. When the gas is turned on a pivoted lever engages a ratchet on the valve and holds it open. The other end of this lever is connected with a metal bar having a high coefficient of expansion and placed in position to be heated by the flame. When the flame is extinguished, the bar contracts and draws the lever out of engagement with the ratchet. The spring then closes the valve, shutting off the gas.

**SELF-LEVELING BUNK FOR SHIPS** (Fig. 19; American patent to an English woman)—The bunk is suspended in such a way as to remain practically level regardless of the rolling of the ship. The frame is supported by a toothed rack and sector, while a restraining spring prevents too great a movement.

**GUN CARRIAGE THAT LEVELS FIELD GUN** (Fig. 20; German patent)—The purpose of this apparatus is the placing of the gun in a horizontal position when it is being fired from a hill side. The axle is made in two pieces that are joined together by a pivot at the center. The gun is leveled by tilting the axles with reference to each other by means of a screw jack, as shown.

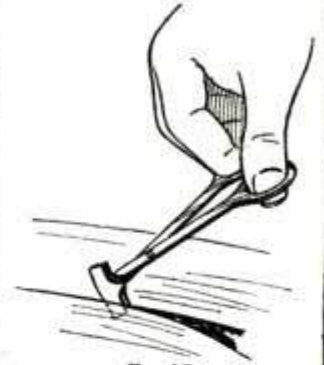

Fig. 12



Fig. 14

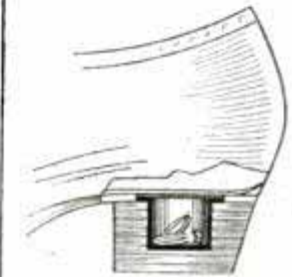

Fig. 16

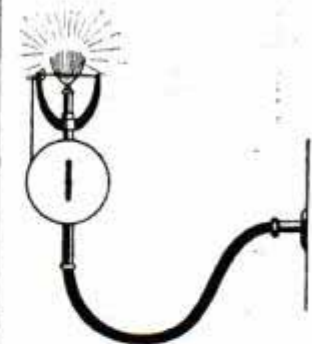

Fig. 18

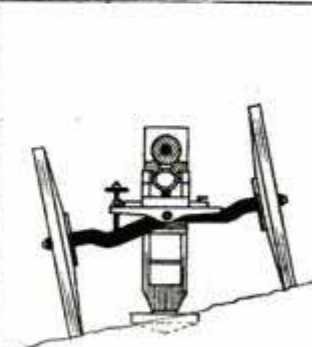

Fig. 20



Fig. 15



Fig. 17

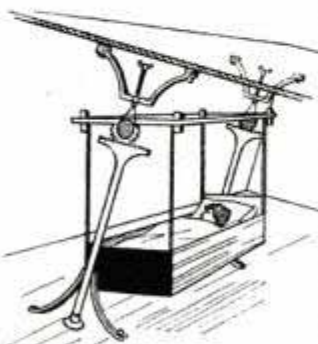

Fig. 19

## A BRICK COTTAGE OF MODERATE COST



Ernest C. Redstone, Architect, Boston, Mass.



First-Floor Plan

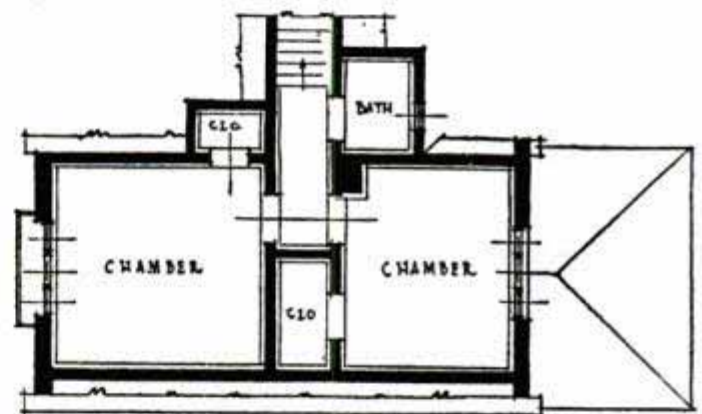

Second-Floor Plan

This attractive dwelling, in which the best of material was used throughout, was built at a cost of only \$3,500. It is 28 ft. wide and 36 ft. long, and seems well adapted to a lot as small as 50 by 100 ft. A cellar with a ceiling height of 7½ ft., which provides ample space for storage, furnace, coal, and cold room with preserve closet, extends under the entire

rear portion of the house, the space under the living and dining room being unexcavated. The outer walls are built of full-range red "texture" brick, laid with a cream-colored ½-in. rough-cut joint. Owing to the rough surface of these brick, they do not reflect the light, and the result is an unusual softness and delicacy of tone.

An interesting feature of the first floor is the combination living and dining room, which extends the full width of the building. The dining room can be screened off if desired, while the arrangement makes an unusually large room available for special occasions. In addition to this room, the first floor contains the kitchen, pantry, entrance hall and an 8½ by 11-ft. chamber, the latter being provided with ample closet room. The stairway to the basement is in the entrance hall under the main stairway. A distinctive feature of the living and dining room is the fireplace, built of "texture" brick similar to those used in the outer walls. The second floor contains the bathroom and two chambers. One of the chambers is 10 by 11½ ft. and the other 12 by 12 ft., and each is provided with a large closet. The ceiling height is 8 feet.

The floors in the living and dining room and in the entrance hall are of hard wood, while the walls are of plaster, rough-floated and tinted. The remainder of the building has pine floors and plastering of a hard white finish. The interior finish is cypress, stained brown.



HY-RIB CONCRETE SAW TOOTH ROOFS

FORD MOTOR CO. - DETROIT -



## Of Myriad Uses

Wherever permanence, fireproofness and economy are desired in building construction, Hy-Rib finds a place. Its field of usefulness includes buildings of all types and sizes from residence to skyscraper, from farm silo to industrial plant.

# HY-RIB

is a steel sheathing combining in a single unit, lath, studs, reinforcement and forms. Hy-Rib is the ideal reinforcement for concrete, stucco, or plaster. To build sidings, partitions, roofs, floors, ceilings, etc. with Hy-Rib is simplicity itself. The easily handled sheets are fastened to the supports and the plaster or concrete is applied. All forms are eliminated. No matter what you intend to build, you should inform yourself about Hy-Rib. Write for Hy-Rib Handbook — free.

**Trussed Concrete Steel Co.**  
 662 Trussed Concrete Building  
 Detroit, Michigan



HY-RIB PARTITIONS



HY-RIB CONCRETE ROOFS



HY-RIB ARCHED FLOORS



HY-RIB CONCRETE CULVERTS



HY-RIB POLO GROUNDS - NEW YORK



HY-RIB CONCRETE RESIDENCE



HY-RIB TANKS



HY-RIB CONCRETE HOLYOKE GAS WORKS



HY-RIB CONCRETE SIDINGS  
 FAVORITE STOVE & RANGE CO. - PIQUA, O.

# FREE



This Handsome 14K

## Gold Plated "Bull" Watch Charm

To Every Man Sending 5c for a Sack of "Bull" Durham Tobacco

This Watch Charm is unusually attractive in appearance and design. It is *14K gold plated*, and will prove a decided ornament to any Watch Fob or Watch Chain. We are making this unusual Free Offer in order to induce more smokers to try "rolling their own" fresh, fragrant, hand-made cigarettes from world-famous

## GENUINE "BULL" DURHAM SMOKING TOBACCO

(Enough for forty hand-made cigarettes in each 5-cent sack)

As many cigarettes are rolled with "Bull" Durham in a year as *all* brands of ready-made cigarettes in this country *combined*. There is a *unique, delightful aroma* to "Bull" Durham that is not found in any other tobacco. It is produced by an exclusive process, known only to the makers of "Bull" Durham. Once you have learned this delicious, distinctive flavor, your taste will *always call for it*, and you will always *recognize* "Bull" Durham anywhere by its savory aroma. There is *nothing else like it* in the world.

Ask for **FREE**  
book of "papers"  
with each 5c sack



**FREE** Send 5 cents and we will mail you pre-paid, anywhere in U. S., a 5-cent sack of "Bull" Durham, a Book of cigarette papers, and this 14K gold plated "Bull" Watch Charm, *Free*. We will also send you an illustrated book-

let showing how to "roll your own" cigarettes with "Bull" Durham tobacco. In writing please mention name and address of your tobacco dealer. Address "Bull" Durham, Durham, N. C. Room 1124.

THE AMERICAN TOBACCO COMPANY

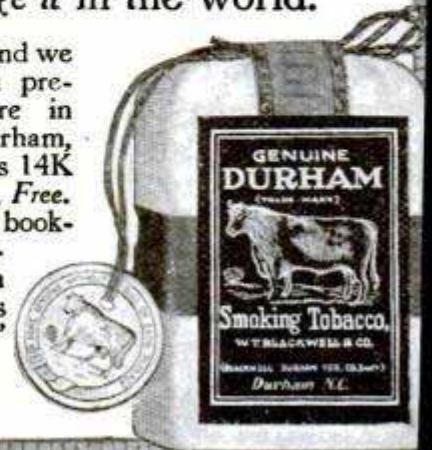

# For Rent This American Adder For 10 Cents a Day

## Ten Days Free

This offer is to workers who must buy their own Adders. To men who add figures in a slow, hard way, and who often make costly errors.

To bring this new Adder within reach of you all we make this rental offer: We will place the machine in your office for a 10-day test, without cost or obligation. Then, if you want it, you may pay the cash price. Or you may pay \$3 down and \$3 monthly until you pay \$37.50.

## All Your Computing Done for 10 Cents a Day

This American Adder does all you could do with a \$150 machine. It adds, subtracts and multiplies. It easily computes a hundred figures a minute. A child can operate it, and it never makes mistakes.

It makes play of addition. The longest columns are totaled quickly and the totals are always correct. For one year it will do this for 10 cents a day, then the Adder becomes your own.

## An Ideal Adder

This machine is ideal—simple, rapid, infallible. In less than nine months it has been adopted by 17,000 offices. Among them are the general offices of some of the largest Railway systems. The U. S. Government employs it.

Good Adding Machines have heretofore cost from \$150 to \$750. This is the first really competent Adder which Railway Agents, and others like them, can afford.

# \$35

Cash Price



## Send This Coupon

We ask you to send this coupon in justice to yourself. Let this machine do your work for ten days. Note the time it saves, the labor and mistakes. Judge for yourself if it earns its way. Then, if you want it and want time on it, you are welcome to a year to pay.

We limit this offer to 1,000 machines.

### AMERICAN CAN CO.

1257 Monroe Bldg.  
Chicago, Ill.

You may send me, express prepaid, one American Adder for ten days' trial. I will then either reject it, pay your cash price of \$35.00, or pay \$3.00 down and \$3.00 monthly until I pay you \$37.50, then the machine becomes mine.

Unless you are rated kindly give references.

The \$2.50 extra charge on the rental plan barely covers interest and the cost of twelve collections.

**American Can Co. (Adding Machine Division) 1257 Monroe Bldg., Chicago**

Eastern Sales Dept., 487 West 14th St., New York

(45)

# The Vest Pocket Kodak

*"As right as a watch."*

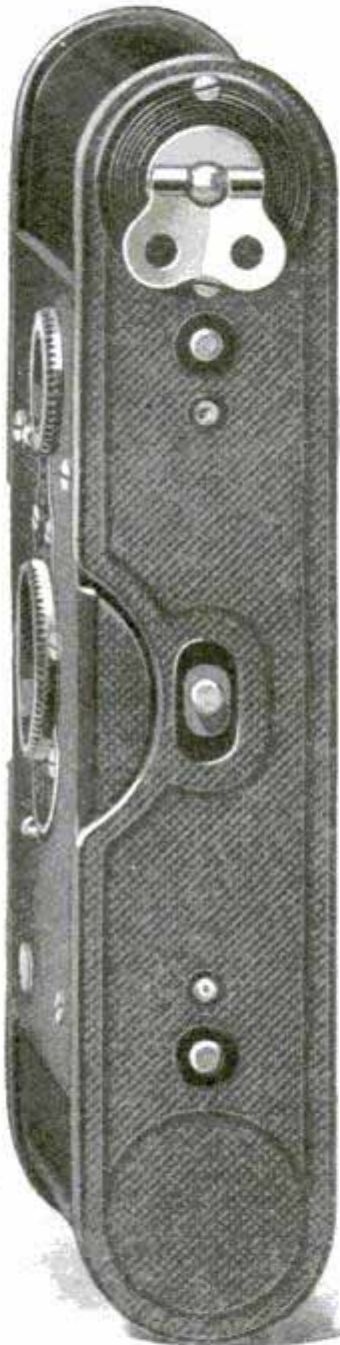

*Actual Size.*

SO small and smooth that it is pocketed without annoyance; is instantly ready for business without focusing. Fitted with Kodak Ball Bearing shutter, Autotime scale, reversible finder. Loads in daylight with Kodak film cartridges of eight exposures. Pictures  $1\frac{5}{8} \times 2\frac{1}{2}$  inches.

So accurate is this little camera that enlargements can be made from the negatives to any reasonable size, and at small cost—to the post card size ( $3\frac{1}{4} \times 5\frac{1}{2}$ ), for instance, at sixteen cents.

*Furnished with three different lens equipments:*

Vest Pocket Kodak, with meniscus achromatic lens,	- - -	\$ 6.00
Do., with Kodak Anastigmat lens, Speed <i>f</i> .8,	- - -	12.00
Do., with Zeiss-Kodak Anastigmat lens, Speed <i>f</i> .6.9,	- - -	22.50

EASTMAN KODAK COMPANY,

*Kodak catalogue free at your dealers, or by mail.*

ROCHESTER, N. Y., *The Kodak City.*

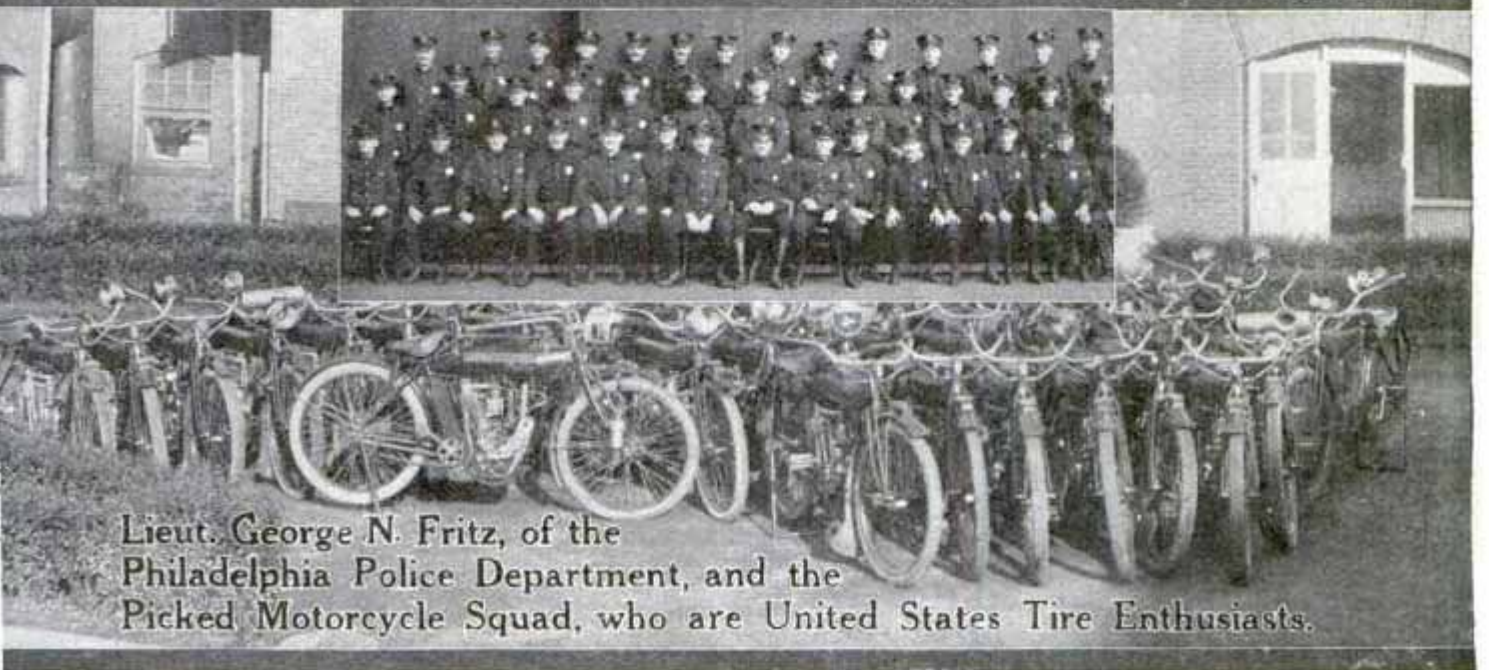

Lieut. George N. Fritz, of the Philadelphia Police Department, and the Picked Motorcycle Squad, who are United States Tire Enthusiasts.

## United States Tires help police departments to rely on the motorcycle as an aid in preserving law and order.

The safety, low cost, reliability, and speed of the motorcycle have made it invaluable to the police.

The Motorcycle Policeman gives his tires the hardest of service. His duty takes him over roads that other riders avoid. Frequently he trusts his very life to his tires. United States Tires withstand hard police service everywhere.

That is why a vast majority of police motorcycles are equipped with United States Tires.

You who ride motorcycles for business or pleasure should profit by the policeman's experience.

You, no less than he, need the safest, lowest cost per mile tires.

Today United States Motorcycle Tires stand alone—in a class absolutely by themselves and are acknowledged to be the standard motorcycle tires of the world.

Their overwhelming popularity is a known fact. In one year—1913—the sales of UNITED STATES MOTORCYCLE TIRES increased 139 per cent.—an increase that is without a parallel in motorcycle history.

**NOTE THIS:—Dealers who sell UNITED STATES MOTORCYCLE TIRES sell the best of everything**

# United States Motorcycle Tires

Made by the  
Largest Rubber Company in the World

Johnson's Wood Dye is equally adapted for use on old as well as new furniture—

# Johnson's Wood Dye

Beautiful results on any wood are easily obtained with Johnson's Wood Dye—

for the artistic coloring of hard and soft wood—floors, woodwork and furniture. With it inexpensive woods may be finished so they are as beautiful and artistic as hard wood. Made in 17 standard shades, including *Mission, Early English, Golden Oak, Weathered, Fumed, etc.*

**Johnson's Wood Dye** is a combination spirit-oil preparation, embodying all the good qualities of both a spirit and an oil stain, with the disadvantages of neither. It is unsurpassed for staining reed baskets and manual training models—also for burlap and other wall coverings.

# Johnson's Prepared Wax

A complete finish and polish for all wood—floors, woodwork, furniture, automobile bodies, etc. Apply with a cloth and polish with a dry cloth. Gives perfect results over any finish—varnish, shellac or oil.

Johnson's Prepared Wax is a lasting artistic finish for floors—new or old—

**Johnson's Prepared Wax** is unsurpassed as a polish for the finest mahogany and mission furniture, including pianos. Restores the lustre to leather cushions, bags, etc. For polishing **automobile bodies** it has no equal. Sheds water and does not gather dust.

Ask your paint, hardware or drug dealer for a free copy of our 25c book "The Proper Treatment for Floors, Woodwork and Furniture." If he hasn't a copy, write us.

**S. C. Johnson & Son**

"Wood Finishing Authorities"  
Dept. PA5  
**Racine, Wis.**

There is nothing equal to Johnson's Prepared Wax for dining room tables



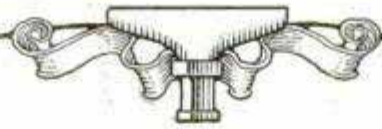

# Washing With Air

There are two great natural cleansers—water and air. The modern housewife is now learning the possibilities of the second of these elements.

We have harnessed air—intensified its cleansing power—and now compel it to draw away every bit of dust, dirt and other accumulations from *under, in and around* carpets, curtains, walls, furniture, bookcases. Every room is cleaned, freshened, sweetened, *washed* by the steady suction of the

## Western Electric Sturtevant Vacuum Cleaner

Simple, powerful, permanent. No complicated mechanism to wear out or break. Light in weight. Cannot injure the article or surface cleaned. Costs only a few cents an hour to run. There are several sizes, both portable and stationary, intended to meet every need of home, apartment and hotel. Prices range from \$47.50 to \$400.

To know the possibilities of this cleaner and its adaptability to your home, write for a copy of our illustrated book, "The Clean Way to Clean." Ask for book 17-AW. It will be sent free.

*There is an opportunity for agents to represent us in some unoccupied territories.*

## WESTERN ELECTRIC COMPANY

Manufacturers of the 7,500,000 "Bell" Telephones

New York	Chicago	Kansas City	San Francisco
Boston	Pittsburgh	St. Paul	Denver
Philadelphia	Cleveland	Minneapolis	Salt Lake City
Buffalo	Cincinnati	Omaha	Los Angeles
Richmond	Indianapolis	Houston	Oakland
Savannah	St. Louis	Dallas	Portland
Atlanta	Milwaukee	Oklahoma City	Seattle
New Orleans			

**EQUIPMENT FOR EVERY ELECTRICAL NEED**



# America's Telephones Lead the World Service Best—Cost Lowest

from *London "Daily Mail"*

from *"Electrical Industries (London)"*

Why is it that Government ownership and management of the telephones is practically always a failure?

Why is it that throughout the length and breadth of Great Britain and the Continent hardly a single efficient long-distance service is to be found? Why is it that in New York one can call

THERE is a certain amount of satisfaction in the fact that Mr. Winston Churchill got so angry over the freaks of the telephone the other day that he flung his receiver on the floor. As a member of the Government which purchased the telephone system, he deserves all the torture that Post Office working can inflict. But his rage, doubtless

From *"Le Petit Phare de Nantes," Paris*

"But today I found I had to talk with Saint-Malo, and, wishing to be put through quickly, I had my name inscribed on the waiting list first thing in the morning; the operator told me—though very amiably, I must confess—that I would have to wait thirteen hours and ten minutes (you are reading it right) in order to be put through."

Herr Wendel, in *The German Diet*.

"I refer here to Freiberg. There the entire telephone service is interrupted at 9 o'clock p. m. Five minutes after 9 o'clock it is impossible to obtain a telephone connection."

Herr Haberland, Deputy, in the Reichstag

"The average time required to get a connection with Berlin is now 1½ hours. Our business life and trade suffer considerably on account of this lack of telephone facilities, which exists not only between Düsseldorf and Berlin and between Berlin and the West but also between other towns, such as Strassburg and Antwerp, etc."

Dr. R. Luther, in the *Dresdner Anzeiger*

"In the year 1913, 36 years after the discovery of the electro-magnetic telephone, in the age of the beginning of wireless telegraphy, one of the large cities of Germany, Dresden, with half a million inhabitants, is without adequate telephone facilities."

- UNITED STATES
- SWITZERLAND
- NETHERLANDS
- NORWAY
- SWEDEN
- RUSSIA
- DENMARK
- GREAT BRITAIN
- GERMAN EMPIRE
- FRANCE
- ITALY
- HUNGARY
- AUSTRIA
- BULGARIA
- BELGIUM
- SPAIN
- PORTUGAL

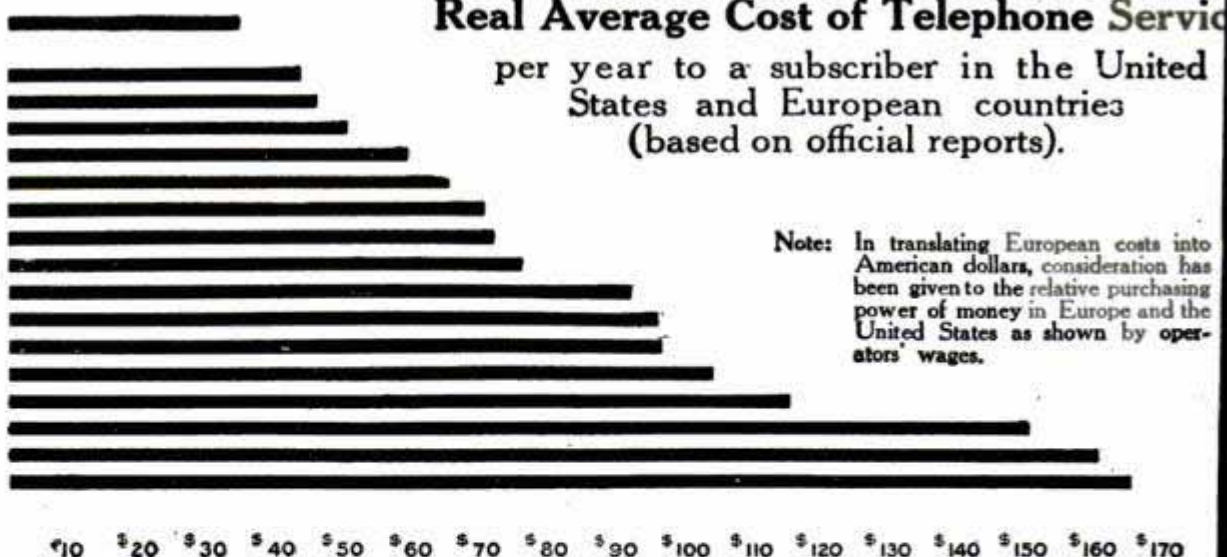

Note: In translating European costs into American dollars, consideration has been given to the relative purchasing power of money in Europe and the United States as shown by operators' wages.

**These are the reasons why there are twelve times as many telephones for each hundred persons in the United States as in Europe.**



**AMERICAN TELEPHONE AND TELEGRAPH COMPANY  
AND ASSOCIATED COMPANIES**

**One Policy**

**One System**

**Universal Service**

Please Mention Popular Mechanics



## The Up-to-date Farmer

knocking about his place finds a mighty big lot of pleasure in a chew of "PIPER." There's something about the open air, the stimulating life of the country that calls for a rich, satisfying chew. And he uses

# PIPER Heidsieck

CHEWING TOBACCO—Champagne Flavor

This is the tobacco that has that famous wine-like flavor. There's no other like it in the world!

PIPER Heidsieck is beyond the shadow of a doubt the *highest grade* of chewing tobacco on the market. It is made by experts who have demonstrated that the leaf used in "PIPER" is the *ripest and mellow-*

*est* that nature can grow and the craft of man improve.

This selection of the best leaves from the cream of the world's crop gives "PIPER" its wonderfully *satisfying and lasting taste*.

Try chewing "PIPER" for a week or two and you will never use any other.

**FREE** Send 10 cents and we will send a full-size 10 cent cut of "PIPER" in a handsome leather pouch FREE to any address in U. S. Also a little folder telling about PIPER Heidsieck tobacco. The tobacco, the pouch and mailing expenses will cost us 20 cents and we are glad to spend the money to get you to try "PIPER." We know that once you have started, you will become a permanent friend of this wonderfully wholesome, healthful and satisfying tobacco. In writing please give name of your tobacco dealer.

Sold by dealers everywhere, in all size cuts from 5c up—also in handy 10c tin boxes

THE AMERICAN TOBACCO COMPANY, Room 1168, 111 Fifth Ave., New York City

# 3-IN-ONE OIL MAKES

The Strop  
Softer—



The Razor  
Keener—



The Shave  
Smoother



It's your face. Why abuse it with a razor that pulls, scrapes and starts the hairs to growing under your skin? What's the sense of that?

Save your face, razor and temper and have perfect joy shaves by always doing this before and after shaving.

Draw your "safety" or "ordinary" blade between your thumb and forefinger, moistened with a little 3-in-One oil. Also put a few drops on your strop or automatic stropping device. Then strop as usual and secure keenest barber edge. Your razor will glide over your face as smoothly as silk. 3-in-One also prevents the soap from burning or itching. There's a scientific reason for all this—the "Razor Saver" bulletin, sent free, explains it to you, and shows you how to really take care of your razor.

**NOW, DON'T SCOFF.** Fill out the coupon and try some 3-in-One Joy Shaves, free! Judge for yourself.

*Library Slips packed with every bottle.* Each slip is worth the equivalent of 5c on every dollar you spend for 3-in-One. Save the slips. 3-in-One is sold everywhere in 3 size bottles: 1 oz., 10c; 3 oz., 25c; 8 oz., ½ pint, 50c. Also in new patented Handy Oil Can, 3½ oz., 25c. This is the real Handy package for shavers—always ready—patented spout—can't leak. If your dealer hasn't Handy Oil Cans, we will send you one full of 3-in-One, by Parcel Post, for 30c in stamps.



**Three-in-One  
Oil Co.,**

42 CNR. Broadway,  
NEW YORK

Send me, without one cent of cost, a generous sample of 3-in-One, "Razor Saver" Bulletin and the 3-in-One Dictionary—all free.

Name.....

Street and No.....

City..... State.....

**THREE-IN-ONE OIL CO.**  
42 CNR. Broadway NEW YORK

**This Coupon Brings You  
a Generous FREE Sample  
Fill it Out Send Today**

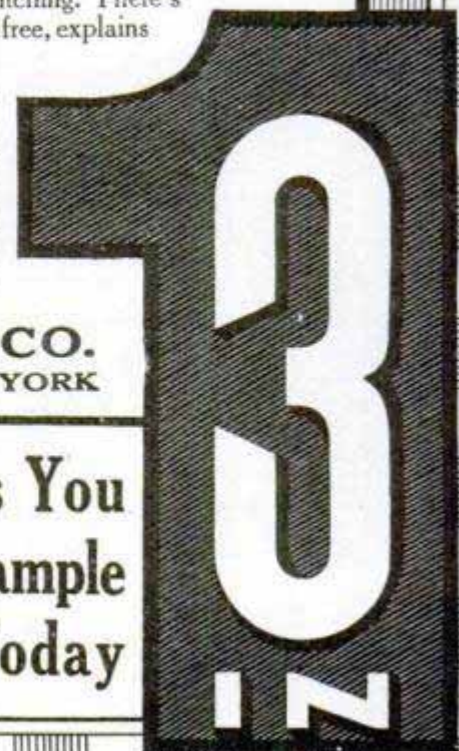

# Williams'

## PATENTED Holder Top Shaving Stick

Nothing ever touches this soap but your face. You hold the shaving stick by the metal holder, which allows you to use the last available bit of soap as conveniently as the first.

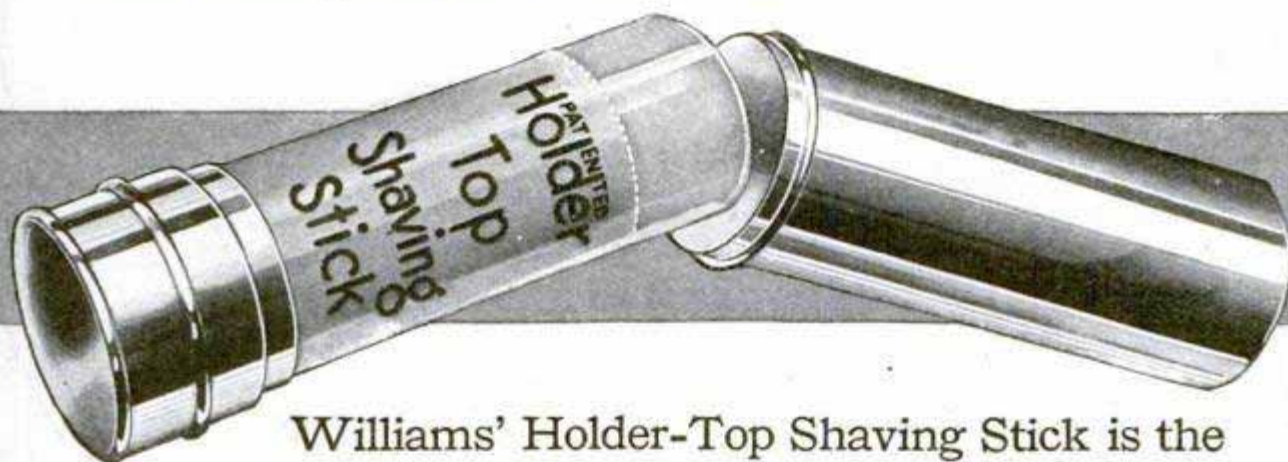

Williams' Holder-Top Shaving Stick is the last word in convenience and economy. Add to these qualities the absolute purity of the soap and its rich, creamy, lasting, abundant lather and you have a shaving luxury that is unsurpassed.

THREE OTHER FORMS OF THE SAME  
GOOD QUALITY:



Stick

Cream

Powder

Williams' Shaving Stick Hinged-Cover  
Nicked Box

Williams' Shaving Powder Hinged-Cover  
Nicked Box

Williams' Shaving Cream (in tubes)

A miniature trial package of any one of these four shaving preparations will be sent postpaid for 4c. in stamps.

THE J. B. WILLIAMS COMPANY  
Dept. A Glastonbury, Conn.

WILLIAMS' JERSEY CREAM SOAP and our extensive line of Toilet soaps have the same softening, creamy, emollient qualities that have made Williams' Shaving Soaps so famous. Ask your dealer for them.

## You Pay for the Name!

The Iver Johnson costs about \$5 more than ordinary bicycles. You pay that \$5 for the name "Iver Johnson."

For if the prestige of our name were not at stake we could use welded instead of seamless tubing; castings instead of drop forgings; hastily tempered bearings instead of the finest bearings that ever went in a bicycle; cheap paint and varnish instead of five coats of hand-rubbed enamel.

You pay \$5 extra because the name "Iver Johnson" guarantees a standardized, well made, fast and durable bicycle. Prices, \$30 to \$55. Juveniles, \$20 to \$25.

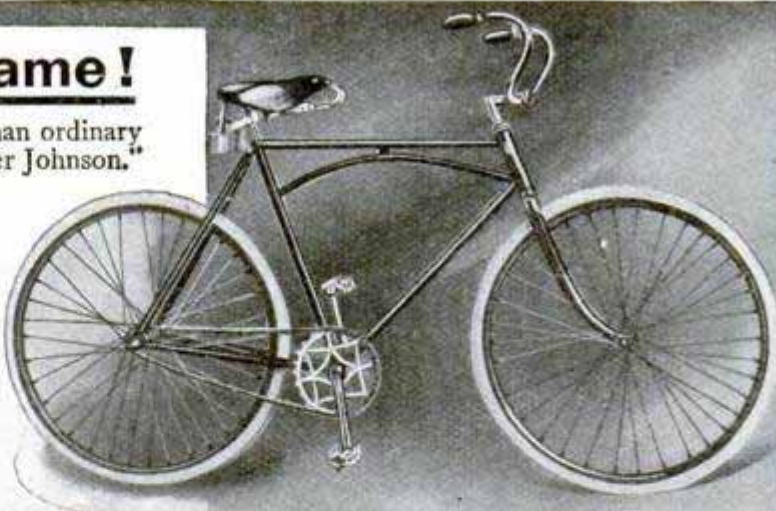

# IVER JOHNSON

The same argument holds good on Iver Johnson Revolvers.

You can buy for much less a revolver that is just as shiny, hard and heavy as the Iver Johnson. You pay the difference because you know that the name "Iver Johnson" stamped on the barrel assures you of absolute safety, positive accuracy, a full equipment of unbreakable, permanent tension wire springs and finest steel and workmanship.

There are 35 points like the following wherein the Iver Johnson Motorcycle differs from other machines. In the Twin motor there are two crank pins. Both pistons occupy relatively the same positions in the cylinders, with the result that the power strokes come at regular intervals. In other motors with one crank pin the power strokes are at irregular intervals. 34 other superiorities are explained in our 82-page book (stiff board covers). This book also tells of Iver Johnson Safety Automatic Revolvers, Iver Johnson Champion Shotguns and Bicycles. It is free.

**IVER JOHNSON'S ARMS & CYCLE WORKS**  
307 River Street, Fitchburg, Mass.

99 Chambers Street, New York  
717 Market St., San Francisco

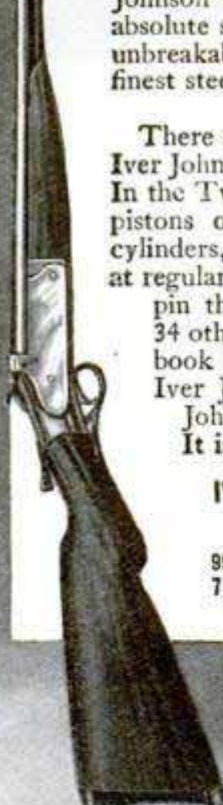
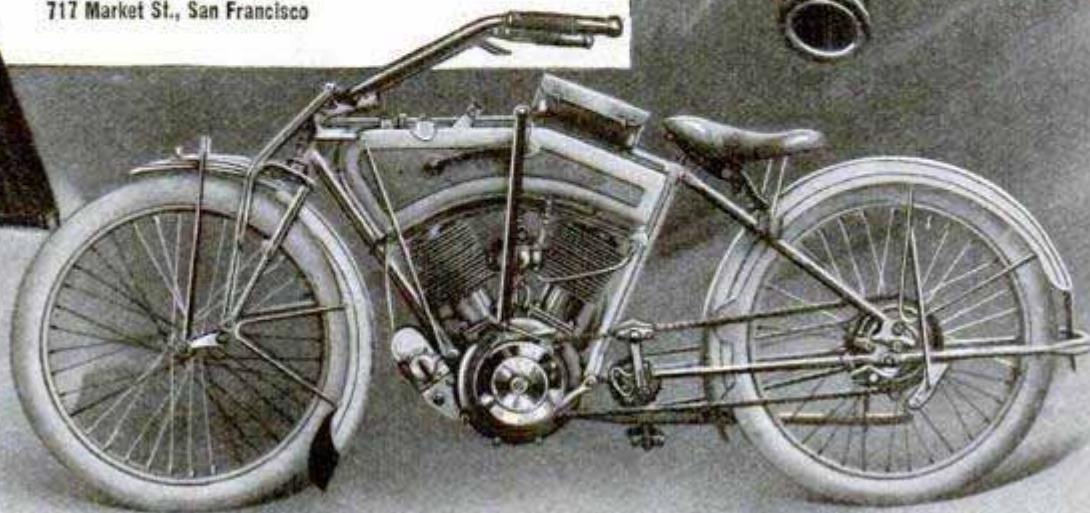

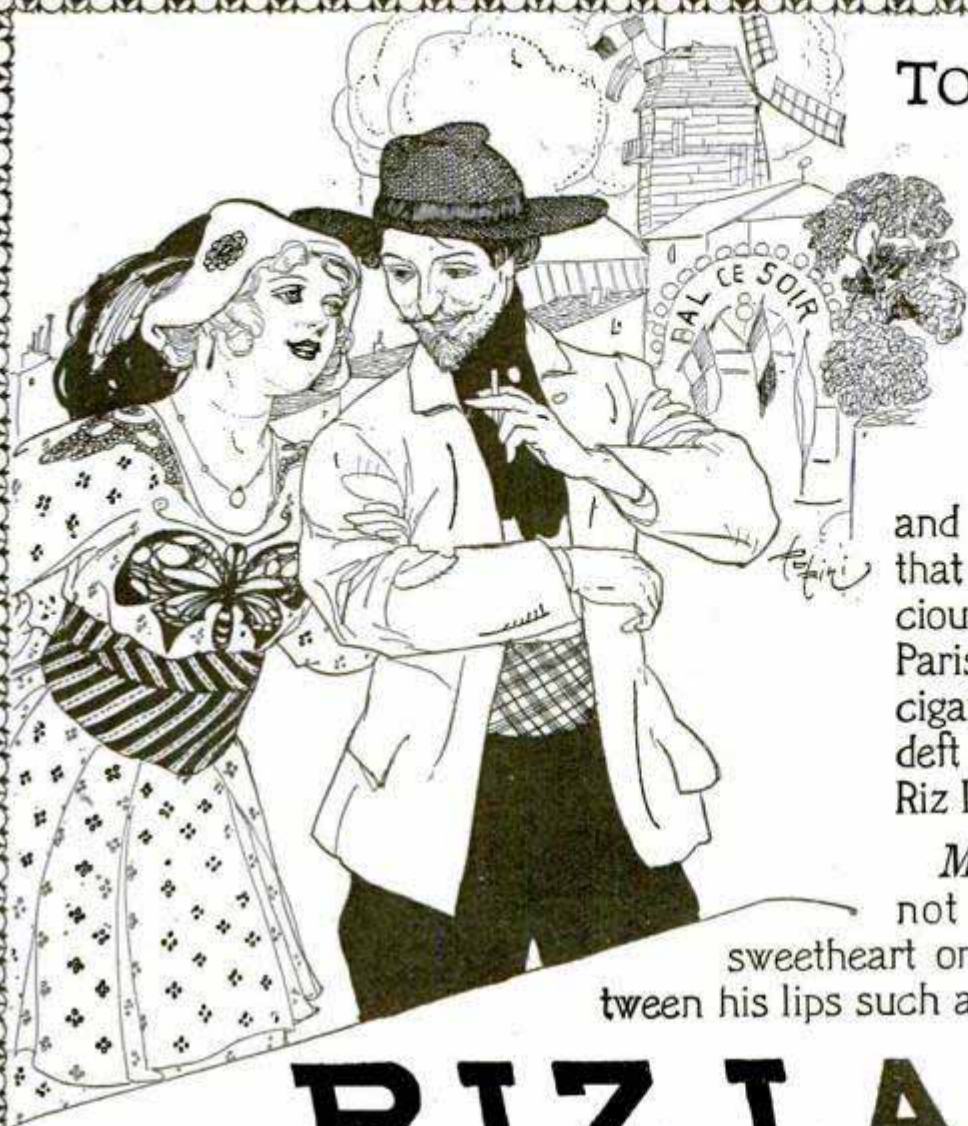

## TOUJOURS GAI!

"Always gay!"

Such is the motto of Paris, from the dance mill on the hill (the Moulin de la Galette on Montmartre) to aristocracy in the Bois; and part and parcel of that gaiety, light, fugacious, aromatic, is the Parisian's cigarette—the cigarette rolled by his deft fingers in the paper Riz La Croix.

*Mais oui!* Who could not be gay with his sweetheart on his arm, and between his lips such a cigarette?

# RIZ LA CROIX

(Pronounced: REE-LAH-KROY)

## FAMOUS CIGARETTE PAPERS

have instigated the new *mode*: the making of your own cigarettes from your own favorite tobacco, rolled in these exquisite papers.

Paris has set the fashion; the rest of the world follows cheerfully.

Riz La Croix are the lightest—thinnest—finest—strongest cigarette papers in the world.

With them you can make the *perfect* cigarettes—of your own tobacco, always fresh, always exactly to your liking.



Two interesting, illustrated Booklets — one about RIZ LA CROIX Cigarette Papers, the other showing how to "Roll Your Own" cigarettes — sent any where in U.S. on request. Address The American Tobacco Co., Room 1184, 111 Fifth Ave., N.Y.

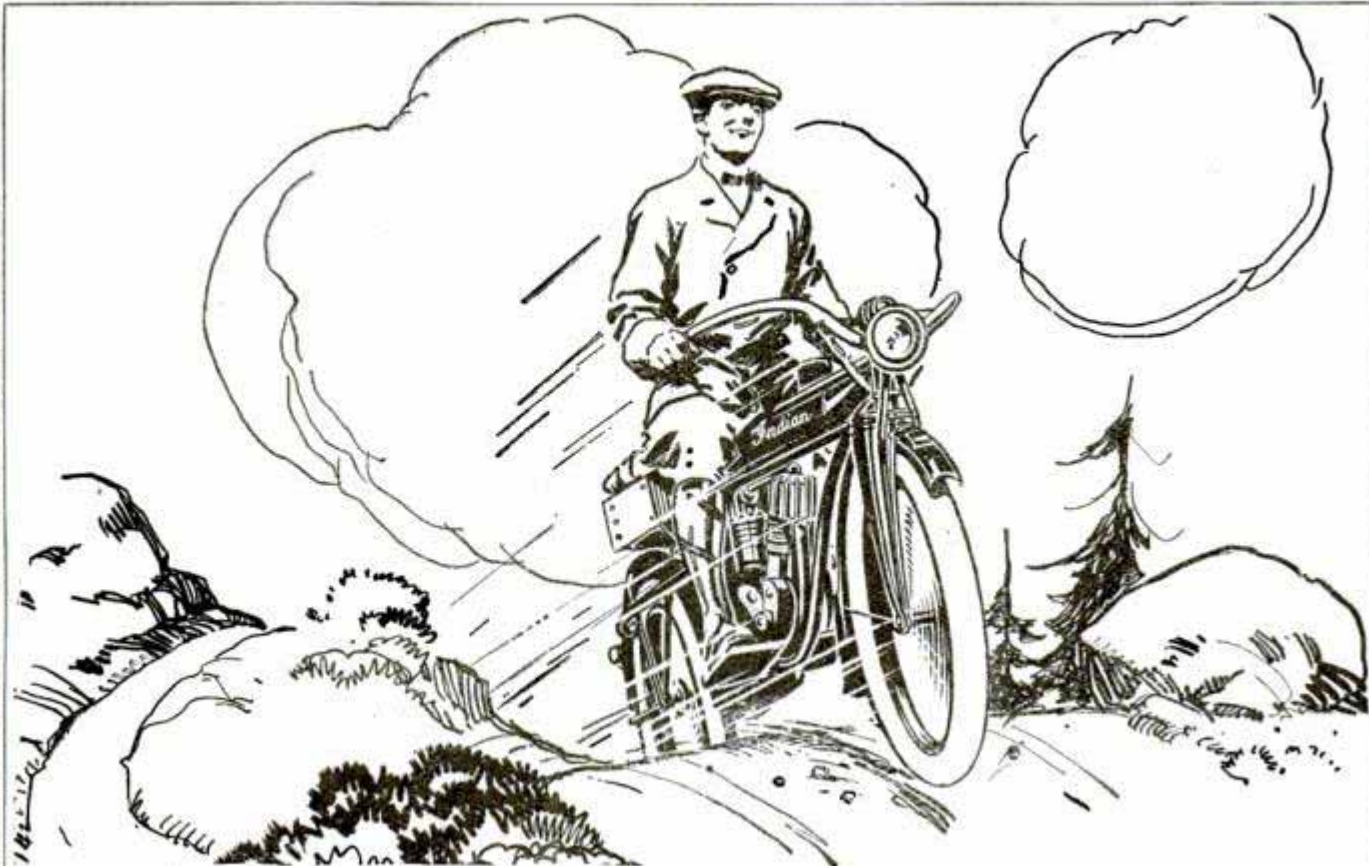

**All Roads are Level Roads  
to the**

# *Indian* Motorcycle

"Rushing" a hill is an unknown experience to the Indian rider. "A twist of the wrist" silently gives the command to the motor for more power. And the power is there. It responds instantly. The rider feels that peculiar "bite"—a thrilling, assuring sensation of the answering motor!—and then the speed deftly picks up—picks up—picks up—without a moment's hesitation. The steepest grade offers no trouble to the Indian-mounted man.

Rough roads, too, mean nothing to the Indian tourist. With his machine fitted with footboards and that incomparable, inimitable comfort feature, the Cradle Spring Frame, shocks and jars are dispelled. Indian riding is smooth riding, whatever the condition of the highway.

*With stupendous power—with perfected comfort devices—all roads are level roads to the Indian*

Write for the 1914 illustrated Catalog showing models priced from \$200 to \$335 F. O. B. Factory

**Hendee Manufacturing Co., 816 State St., Springfield, Mass.**

*(Largest Motorcycle Manufacturers in the World)*

Branches and Service Stations

Chicago Dallas Kansas City Minneapolis Denver San Francisco Atlanta Toronto Melbourne London





## He Mops In Misery Without B.V.D.

**A** TYPICAL summer day—a typical office scene—a round of smiles at the mingled *discomfort* and *discomfiture* of the man who hasn't found out that B.V.D. is "*the first aid*" to coolness. *You*, of course, have B.V.D. on or ready to put on. If not, march to the nearest store and *get it*.

For your own welfare, fix this label firmly in your mind and make the salesman *show* it to you. If he can't or won't, *walk out!* On every B.V.D. Undergarment is sewed

*This Red Woven Label*



*(Trade Mark Reg. U. S. Pat. Off. and Foreign Countries)*

B.V.D. Coat Cut Undershirts and Knee Length Drawers, 50c., 75c., \$1.00 and \$1.50 the Garment.

B.V.D. Union Suits (Pat. U. S. A. 4-30-07) \$1.00, \$1.50, \$2.00, \$3.00 and \$5.00 the Suit.

**The B.V.D. Company,**  
NEW YORK.

London Selling Agency: 66, Aldermanbury, E. C.

*Copyrights U.S.A. 1914 by  
The B.V.D. Company.*



A new  
O-G  
Spring  
model



O-G  
Speedway  
for  
Men

## Order This Smart O-G Oxford Today

O-G Shoes are in demand everywhere, because O-G styles are original, exclusive, up-to-date. No matter where you live you should wear O-G Shoes. O-G "SPEEDWAY" OXFORD comes in patent colt or gunmetal calf, light gray cloth top, stitched tip, flat heel, receding toe. It's a wonderful value at

\$5

Delivered FREE  
anywhere in the  
United States  
on receipt of  
price

**BOOK OF THE O-G BOOTERIES.** We want to place this handsome booklet in every home where fine footwear is appreciated. Order your copy—it's **FREE.**



# O'CONNOR & GOLDBERG

Mail Order Address:

Dept. A, 205 S. State St. (Republic Bldg.), Chicago, Illinois

## Caementum (Pronounced Sementum) The Cement which Repairs Everything



Caementum is a liquid porcelain cement which sets rapidly and becomes absolutely insoluble. It is impervious to steam, water, heat or acids. It repairs everything from the finest china and glass to steam pipes and automobile radiators. With it you can build missing parts of china articles, stop leaks in pots and pans, repair woodenware or metals. Its uses are almost unlimited. It is made in France and is the only preparation of its kind on sale in America.

At dealers or by  
mail postpaid **25c**  
**STANDARD GLUE CO.**  
Dept. A BALTIMORE, MD.  
Sole Agents for U. S. and Canada

AMERICAN CORN IN ENGLAND—There are indications that the old prejudice against green corn as a staple article of food is giving way in England. Sweet corn, on the cob and canned, is appearing on tables, and canned corn is displayed in grocers' windows. Up to

## Shirley President Suspenders

Light as down on  
tender shoulders

50¢

"Satisfaction or money back"  
Be sure "SHIRLEY PRESIDENT" is on buckles  
The C. A. Edgarton Mfg. Co., Shirley, Mass.

## There's Money in Agricultural Blasting

WE TEACH YOU FREE

Our extensive national advertising yields thousands of inquiries from farmers, orchardists, etc., who need blasters to clear land, blast ditches, holes for tree planting, tight subsoils, etc. More than twenty million pounds of agricultural dynamite used in 1913. We refer all inquirers to nearest blaster, supply free advertising matter and help you get the business. We want to start in this independent business, reliable men who have \$200 capital for tools, magazine, and running expenses. Write for free booklet No. 248-B.



Agricultural Division, Du Pont Powder Company, Wilmington, Del.

**\$50—** (manufacturers cost plus 10%) buys a **\$70**

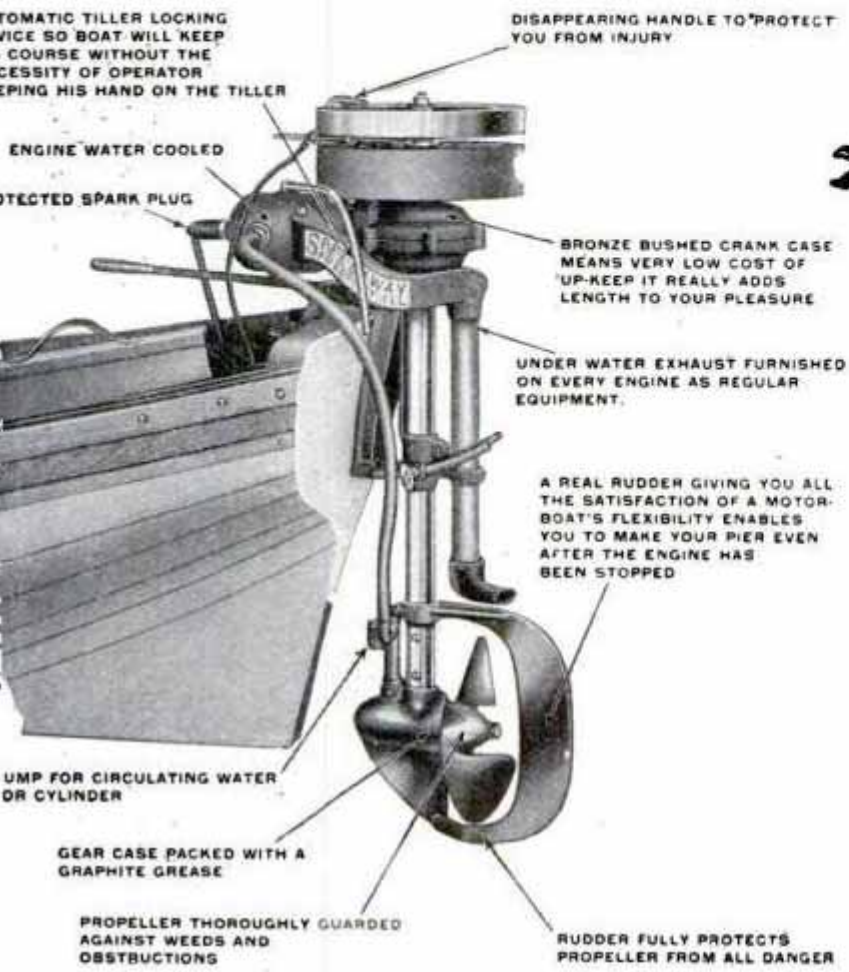

**Speedaway**  
*Detachable*  
**Rowboat Motor**

fully equipped with a noiseless underwater exhaust, automatic self-locking tiller, accident preventing crank-handle, protected spark-plug and circulating water-cooling cylinder pump.

**We Eliminated Dealers**

The Speedway sold at \$70.00 through dealers until now, but our dealers wanted larger profits, allowances for local advertising, special printed matter and other concessions.

The manufacturing cost of this \$70.00 motor would not justify these demands, so we **eliminated the dealer entirely**, and inaugurated the Factory to Consumer Plan whereby

cycle 2 h. p. reversible motor, speed of 8 to 10 miles per hour. Completely equipped with noiseless underwater exhaust, automatic self-locking tiller, disappearing crank-handle and protected propeller.

**You Actually Get the Dealers' \$20 Profit**

Only by eliminating the dealer can we sell this \$70.00 Speedway for \$50.00. The Speedway is a Perfect Motor designed and constructed by a \$500,000.00 organization of mechanical experts who have been building machinery for nearly fifty-five years. Its special features for which you pay nothing additional are **noiseless underwater exhaust, self-locking tiller, disappearing crank-handle, protected spark-plug, water-cooling cylinder pump** and a **real rudder** which enables you to make a landing after the propeller has stopped.

No matter where you live or where you go, there are streams, rivers or lakes. The Speedway makes these waters a constant source of pleasure which starts before breakfast and ends after the moonlight ride. A child can operate it—simply open the gasoline tank, give the crank handle a turn and you're off forward or reverse—up stream or down—in shallow water or deep—it's only up to you.

**Fill in the Coupon—Mail Now!** and we will re-ceive your Motor for either present or future delivery. Do not delay for while we produce a lot many Speedaways each day, you should get your order at once to insure prompt delivery. Enclosed money order or draft for \$12.50—balance C. O. D. Mail the Coupon NOW—the rivers and streams are open and Summer is coming fast.

**COUPON** P. M. May

Speedaway Boat Motor Co.,  
 165 Chicago St., FREEPORT, ILLINOIS

GENTLEMEN: { draft }  
 Enclosed find { money order } **\$12.50** to apply  
 on one complete motor. Ship C. O. D. \$37.50  
 (now) by { express. }  
 { freight. }

Name .....

Address .....

# TYPEWRITER SENSATION!

## 2 DOLLARS A MONTH

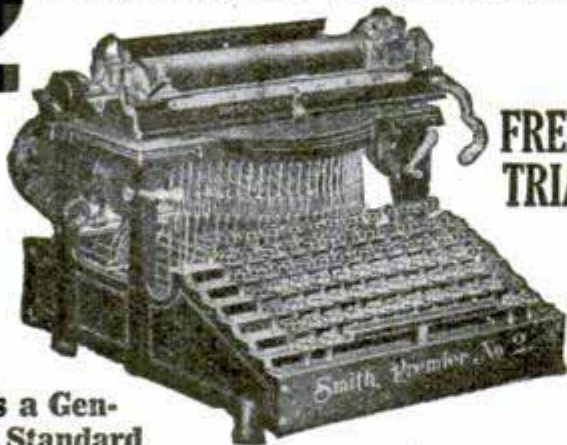

FREE TRIAL

**Buy a Genuine Standard**

**No. 2 SMITH-PREMIER Typewriter and at \$71.20 less than the original price.**

Never before has anything like this been attempted. Dealers get \$3.00 a month rent for this make of machine, not nearly as perfect as the one we will send you, and you pay only **TWO DOLLARS A MONTH AND OWN IT.**

**A Guaranteed Typewriter \$28.80**

Perfect machines only, complete outfit, nothing extra to buy, no strings of any kind to this offer. Just think of buying such a typewriter for \$8.80 down and \$2.00 a month. Cash price \$27.40. Thousands of people have paid \$100.00 cash for Smith-Premiers. It's standard, by many considered the best typewriter ever built. A key for each character, so each character is always the same, a type brush for cleaning the type built into the machine; the tilting carriage throws all previous writing in plain sight of the operator. Comes to you with two color ribbon, complete operating instructions, tools, waterproof cover, practice paper, everything, ready. It runs beautifully. Writes as perfect and clean cut a letter as quickly and easily as any machine bought for \$100.00. It's wonderfully simple, a child can operate it with half an hours practice and rapidly attain speed. It's strongly built and will give you years and years of honest service and complete satisfaction.

**Send the Coupon and We Will Ship You this Smith-Premier Typewriter**

When the typewriter arrives, deposit with the express agent \$8.80 and take the typewriter three days and try it. If you find it to be the best typewriter you ever saw, satisfactory in every respect, keep it and send us \$2.00 each month, until our special price of \$26.80 is paid. If you don't want to keep it, return it to the express agent, and he will give you back your \$8.80, and return the typewriter to us. We will pay the return express charges.

You won't want to send this machine back after you have seen it and tried it. You can't imagine the perfection of these machines till you see one, and the price is \$71.20 less than the catalogue price, and it is guaranteed just as if you paid \$100.

**Only 200 orders will be filled on this offer. Act today to be sure**

This coupon states the terms. Fill it out, send it now, today. You can't lose, and it's the greatest economical typewriter opportunity you will ever have.

### COUPON

**HARRY A. SMITH, Robbins Bldg., CHICAGO**

Ship me a No. 2 Smith-Premier, f.o.b. Chicago, as described in this advertisement. I will pay you the \$20.00 balance of the special \$28.80 purchase price, at the rate of \$2.00 per month. The title to remain in you until fully paid for. It is understood that I have three days in which to examine and try the typewriter. If I choose not to keep it I will carefully repack it and return it to the express agent. It is understood that you give the standard guarantee for one year.

Name .....

Address .....

Pop. Mech. May

# PATENTS

If you have an invention which you wish to patent you can write fully and freely to Munn & Co. for advice in regard to the best way of obtaining protection. Please send sketches or a model of your invention and a description of the device, explaining its operation.

All communications are strictly confidential. Our vast practice, extending over a period of nearly seventy years, enables us in many cases to advise in regard to patentability without any expense to the client. Our Hand-Book on Patents is sent free on request. This explains our methods, terms, etc., in regard to *Patents, Trade Marks, Foreign Patents, etc.*

All patents secured through us are described without cost to the patentee in the *SCIENTIFIC AMERICAN*.

**MUNN & COMPANY**  
SOLICITORS OF PATENTS

359 BROADWAY, NEW YORK  
and 625 F STREET, WASHINGTON, D. C.

## Bausch and Lomb BALOPTICON

THE PERFECT STEREOPTICON

Bausch & Lomb Optical Co., 576 St. Paul St., Rochester, N.

recent period, an attempt to offer green corn in form for sale in England, or even to speak of it a desirable article of food, met with ridicule, except am

**Agents Make \$3 to \$10 a Day**  
**NO-KEY PADLOCK**



Biggest, quickest seller ever offered agents. Sell sight. Nothing else like it. No keys to lose, knobs to turn, no clicks to count. Simply push buttons and lock flies open. 40,000 different combinations, 100,000 in use. Operated as easily dark as daylight. Big demand. Agents make 100% profit. No competition. Write quick for

of free sample. Get this big easy money now. A postal will  
**THE EDWARDS MFG. CO., Factory No. 8, CINCINNATI**

## Guaranteed Used Pianos

A large number of fine instruments at exceptional bargain prices, many like new, exchanged for Kimball Player Pianos thoroughly overhauled and guaranteed to be in splendid condition in every way.

Examples:	Schaefer Upright	\$140	Hallet & Davis	\$1
Briggs Upright	90	Hinz Upright	145	Kimball Upright
Coiby Upright	90	Fisher Upright	165	Steinway Upright
Emerson Upright	110	Whitney Upright	185	Kimball Upright
Decker Bros. Upr't	135	Chickering Upright	175	Knabe Upright

We ship anywhere to reliable people on easy payment terms. Write Today For Complete List, Prices, and Terms and Beautiful Illustrated Musical Herald **FREE**, and catalogue New Kimball Pianos.

**W. W. KIMBALL COMPANY, 1295 Kimball Hall, Chicago,**

## \$19.50 BUYS THIS ENGINE

Your boy wants this H. P. Gas Engine. Practical and reliable—operates with gas or gasoline. Will run small dynamo, lathe, drill, coaster, wagon, cream separator or washing machine—useful and instructive. Price \$19.50. Write for circular and prices on larger engines.



**SIEVERKROPP ENGINE CO.**

# Become An Expert Draftsman

## Learn Mechanical, Structural or Architectural Drafting by Mail

Absolutely the greatest drafting offer ever made. Read it carefully. Then investigate. Sign and mail the coupon at once. Here is your opportunity to get the training you need to hold down a good job and earn big money—\$100.00 to \$250.00 per month paid to expert draftsmen. Our easy, practical method will teach you ARCHITECTURAL DRAFTING, STRUCTURAL DRAFTING or MECHANICAL DRAFTING in a few months. You will receive expert individual instruction in the course you select. All drafting instruments and materials supplied absolutely free of charge. Also big four volume Cyclopaedia of Drawing sent free if you enroll now. Drafting is the foundation of all engineering professions—Learn drafting if you are ambitious to be an engineer. Prepare yourself for a real man's work. And remember—this great special offer is made by the greatest non-resident educational institution in the world—a school whose guarantee is backed by sixteen years of successful teaching by correspondence.

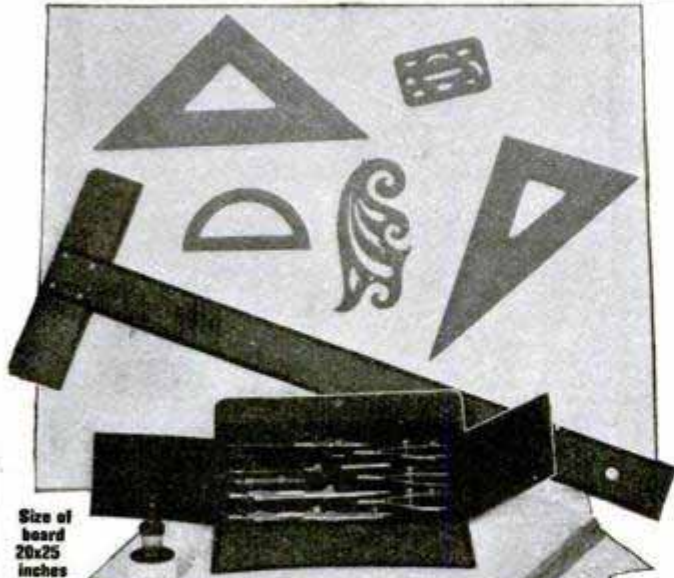

Size of board 20x25 inches

**FREE \$20 Outfit**  
**FREE \$20 Library**

This \$20 Draftsman's Outfit as illustrated. Imported German silver drawing instruments in morocco case; 20 x 25 inch drawing board; ebony lined mahogany T-square; transparent triangles; German silver protractor; French curve; triangular boxwood scale; waterproof ink; pencil; erasers; shield; pencil pointer; handmade drawing paper and thumbtacks. Instruments guaranteed accurate—made by largest and most reliable manufacturer. This handsome, expensive outfit free to you if you enroll now!

# FREE

This \$20.00 Cyclopaedia of Drawing also included absolutely free in this special limited offer. Four big volumes as illustrated below. The only work which thoroughly covers MECHANICAL, STRUCTURAL and ARCHITECTURAL DRAFTING. Worth many times \$20.00 to any drafting student. Not only will you receive the best expert instruction, but you will have these books handy for reference at all times—they will answer all your questions authoritatively and promptly. Just think of it—four big volumes bound in half red morocco, gold stamped, 1,720 pages, 7x10 inches, 1,037 illustrations, page plates, diagrams, designs, etc., and the handsome \$20.00 Draftsman's Outfit. All free if you enroll now under this special limited offer.

### SALARY GUARANTEE

THE AMERICAN SCHOOL OF CORRESPONDENCE GUARANTEES that you will receive an increase of fifty per cent over your present salary within three years from the date of your enrollment; or, failing in this, the School guarantees to refund to you the full amount paid for your course. Back of this guarantee stands the American School—for more than fifteen years the foremost educational institution of its kind in the world. A school that has succeeded because it has been true to its principles of giving its students the instruction for which they enrolled.

### Just Mail the Coupon

Accept this great offer now—today! It never has and never will be equalled. You get the \$20 Drafting Outfit and the \$20 Cyclopaedia of Drawing absolutely free of charge. Don't miss this opportunity. Your future success may depend upon whether you fill in and mail the coupon. It will only cost you a stamp to investigate. It may mean success and a big future for you.

**American School**  
of Correspondence. Chicago. U.S.A.

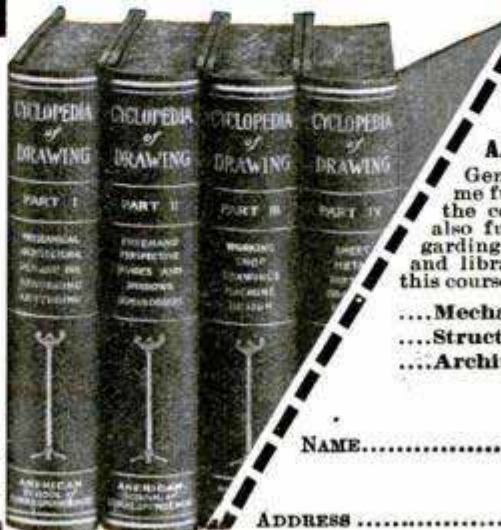

**FREE OFFER COUPON**

A. S. of C.

Gentlemen:—Please send me full information about the course checked below, also further particulars regarding the drafting outfit and library sent FREE with this course.

- ....Mechanical Drafting
- ....Structural Drafting
- ....Architectural Drafting

Pop. Mech. 5-14

NAME.....

ADDRESS.....

Please Mention Popular Mechanics



# No Plates—No Films New Camera Just Out

Here at last is the very Camera the world has waited for—just the camera you have always wanted. No experience needed to make pictures with our sure-shot picture-taker. This new, amazing invention enables any man, woman—yes, even children—to make finished post card photos in one minute. Think of it! Finished pictures made in a minute's time—taken and finished right on the spot.

## The "Mandel-ette"

A new one minute camera. Gives all the joys of picture-taking without the usual labor and expense. Does away with films and plates—trays, tanks and trouble. No inconveniences. No fuss or muss. The "Mandel-ette" cuts down the cost of making finished pictures to one-tenth of what it costs with the ordinary camera. No developer worries. No usual expensive camera accessories. The greatest camera invention of our age. Your vacation is not complete unless you have a "Mandel-ette." Use it for all occasions. You simply can't afford to be without it. Read this

## Special Money Back Offer

We are the inventors and manufacturers of the "Mandel-ette," patterned after the famous "Mandel" Camera. We sell it direct to you at rock bottom price. We want everybody to own a "Mandel-ette" so we make you this special money back offer. Order your outfit right from this ad; make pictures with it by following our simple instructions, and if you find that the "Mandel-ette" will not do everything that we claim for it, send it back and your money will be refunded. Isn't this a fair offer?

## \$5.00 Complete Outfit Free Book

(Add 50c for Parcel Post)

This outfit includes the Mandel-ette" Camera and everything that is needed to make 16 finished post card photos. You begin making finished pictures as soon as outfit arrives. No waiting. If you want a tripod, send \$1 additional. Extra post cards, 25c per package of 16. Send postal or express money order, draft or personal check. Don't wait. Order your outfit right from this ad. Do it now.

Write for this book. Learn all about this new and wonderful process of taking and finishing pictures in one minute. Realize what a big advantage the "Mandel-ette" gives you over the ordinary camera. Consider the time and money you can save. You can make money too by selling these one minute pictures. Each finished picture costs you 1 1/2 c, sells for 10c. Big profits and great fun await you. Order the "Mandel-ette" whether you want it for pleasure or profit, or send for the book today.

### THE CHICAGO FERROTYPE COMPANY

A173 Ferrottype Bldg. Chicago, Ill. or Dept. A173 Public Bk. Bldg. 89-91 Delancey St. New York, N.Y.

This wonderful camera makes pictures DIRECT ON POST CARDS without films, plates, printing or dark room. Camera weighs about 24 ounces and measures about 4 x 4 1/2 x 6 inches; size of pictures, 2 1/2 x 3 1/2 inches. Loads in daylight with 16 or 50 cards at one time—no dark room necessary. Universal focus lens produces sharp pictures at all distances. Perfect working shutter. Combined "3-in-1" Developer eliminates any other solution. Pictures develop automatically in less than a minute—can't over-develop. Plain instructions with each outfit enable you to begin making pictures the very hour outfit arrives. SEND FOR THE OUTFIT TODAY.

## WE TRUST YOU \$2.95 Brings You This Suit BE WELL DRESSED

Thousands of men have charge accounts with us and take six months to pay. You, too, can have a credit account with us and we want you for a new customer—your credit is good—we'll trust you.



### We Give You 6 Months to Pay Guarantee Satisfaction

Remember, we save you big money on made-to-order clothes that are better in quality than can be bought elsewhere. No matter who you are or where you live, we'll sell you order made clothes on credit.

Stanley-Rogers Show You How to Take Your Own Measurements—Don't Hesitate—It's Easy—Order Blank Shows All.

We have the easiest special system of taking measurements ever used. You'll like it when you see the simple instructions.

### \$2.95 Brings You This Suit

This elegant all-wool suit, made in latest style as shown, of fine brown fabric. Sent to you—made to your order—upon receipt of \$2.95 and measurements. Order by No. 799 S.

Price \$12.95. Balance \$2.00 Monthly

No References Asked—No Red Tape

### Free STYLE BOOK and SAMPLES

Write for book showing latest styles and fabrics being worn by swell dressers all over the country. Get your copy now. It's Free. Send a postal for it today. Write to

### STANLEY-ROGERS COMPANY

526 536 South Clark Street

CHICAGO, ILL.

the more intelligent class. The working class look upon corn as good solely for animal consumption. No however, the nutritious qualities of green corn gradually being admitted and its cheapness as an article of food recognized by all classes. As usual in England the practice of using it is dropping down from the high to the lower class.

The total number of establishments in the silk industry in the United States in 1909 was 852.

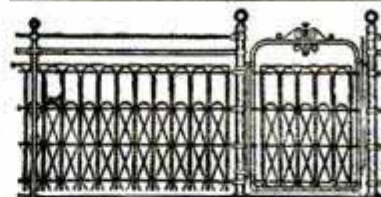

## DWIGGIN LAST LONGER FENCE COST LESS

Greatest values ever offered in fences and gates for lawn and cemetery, farm, field and poultry yards. WRITE TODAY FOR FREE CATALOG AND PRICE LIST. DWIGGINS WIRE FENCE CO., 237 Dwiggins Ave., Anderson,

FINDS THEM!
LEAVES THEM!

## SKAT SOAP

Quickly removes grime, grease, dust, etc., from hands, leaving white and soft. Needed in every household, garage, office and factory. A great cleanser—injures nothing, 10c cans everywhere; out if your dealer hasn't it, send his name for free sample.

**THE SKAT COMPANY**  
Dept. P HARTFORD, CONN.  
AGENTS AND DEALERS  
Write for liberal terms.

## WURLITZER

see years of instrument making

### New Band Catalog Sent Free

Your name and address is enough. We will send you our big new Band Catalog absolutely free. 250 pages. Thousands of instruments described. Write for it today.

Get any instrument you want on Free Trial. Only a few cents a day. Rock-bottom, direct-from-manufacturer price. We supply the U. S. Government. Generous allowance for instruments. Write at once stating instrument in which you are interested.

**The Rudolph Wurlitzer Co., Dept. 1195**  
4th St., Cincinnati, O.  
S. Wabash Ave., Chicago



# Engine Prices Again Reduced

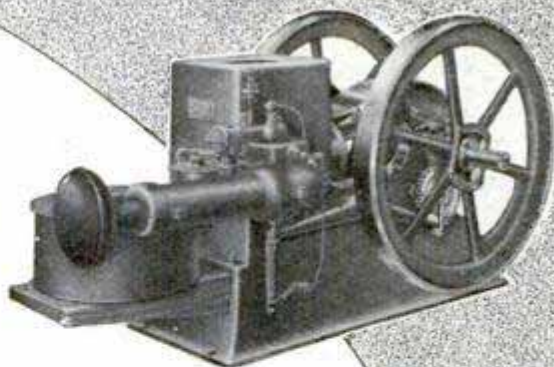

**WITTE Kerosene Engine—Stationary**  
Burns Kerosene, Distillate, Solar Oil, Toppings and all fuels of like grades. Also Gasoline, Naphtha and Gas.

My manufacturing advantages, an important one of which is free gas for power, have always enabled me to manufacture and sell a better engine for less money than anyone else in the business.

Recently I have invested many thousands of dollars in specially designed machinery of the latest types for a more rapid production of my engines and these increased factory facilities have made possible another cut in **WITTE Engine** prices while still maintaining the well known **WITTE** quality.

When I started making engines, 27 years ago, the gasoline engine business was new. Today my factory is the only one which has come through successfully under the continuous management of the man under whom it was started. **WITTE** engine-quality is the **only** thing that did it, because I had nothing else to begin with, and have had nothing except what I have earned. I challenge anyone to show stronger proof of reliable engine-quality.

## WITTE ENGINES

Kerosene, Distillate, Gasoline, Naphtha and Gas  
**Look At These Latest Prices**

*DIRECT FROM FACTORY TO USER*

<b>2 H. P. \$34.90</b>	<b>4 H. P. \$69.75</b>	<b>6 H. P. \$99.35</b>
<b>8 H. P. 139.65</b>	<b>12 H. P. 219.90</b>	<b>16 H. P. 298.80</b>
<b>22 H. P. 399.65</b>	<i>Portable and Sawrig styles priced proportionately low</i>	

### 60 DAYS' FREE TRIAL

You can't buy a better engine at any price and none so good for my price! So why pay two prices for any other good engine or take chances on a poor one, or an unknown engine, when the **WITTE** costs so little and saves you all risk? Every **WITTE** Engine is sold direct from my factory to the user. There is no middleman between me and the buyer of a **WITTE** Engine anywhere on earth. You get, direct from me and backed

up by my 5 year guarantee—a guarantee which is as good in its 5th year as in its 1st year—and by over \$250,000, a full 60 days' free trial on any **WITTE** of your selection. There is a size and style for any kind of work in shop, factory or on the farm—**Stationary, Portable, Skidded or Sawrig.**

Any **WITTE** Engine you select will prove itself dependable. Steady power with small fuel consumption is guaranteed. And it is so simple in

construction that you can easily understand, start and run it whether you are experienced with an engine or not. It's an engine that actually will earn its cost while being paid for.

**Get My Complete New Offer and Copy of My New Book FREE**

You should have a copy of my new Engine Book—the finest in the business. Explains fully my liberal easy terms and sales plans—tells how to judge an engine—how little it costs—how to start it and keep it running. Mail coupon today and I will send you the whole **Witte** story by return mail.

**ED. H. WITTE**  
**WITTE IRON WORKS CO.**  
1743 Oakland Ave., Kansas City, Mo.



#### MAIL THIS COUPON TODAY

**ED. H. WITTE, Witte Iron Works Co.**  
1743 Oakland Ave., Kansas City, Mo.

With no obligation on my part I should like to receive your latest and finest Engine Book, with your new liberal Selling Plan.

Name .....

Address .....

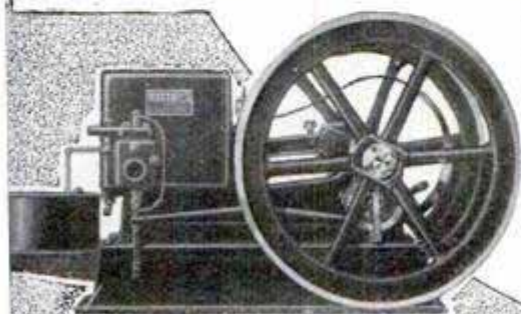

# Your Comfort

is doubled—your home made more cozy and attractive—your electric bills cut down—by  
**The D'LIGHT**

This small portable electric lamp will stick to a mirror. Has an invisible spring clamp that holds it to the back of a chair, head of a bed—anywhere you want the light—an adjustable shade CONCENTRATES THE LIGHT, bringing it directly upon any object. For shaving, dressing, sewing and reading—saves your eyes and light bills—is a COMFORT in homes, offices and stores; a JOY TO TRAVELERS—can be packed in your grip. At dealers. Sent prepaid complete for \$5.00.

**WIZARD ELECTRIC  
LAMP CO.**

143 New Mont'ry  
San Francisco, Cal.

Agents  
Wanted

Positive guar-  
antee of money  
back if not sat-  
isfactory.

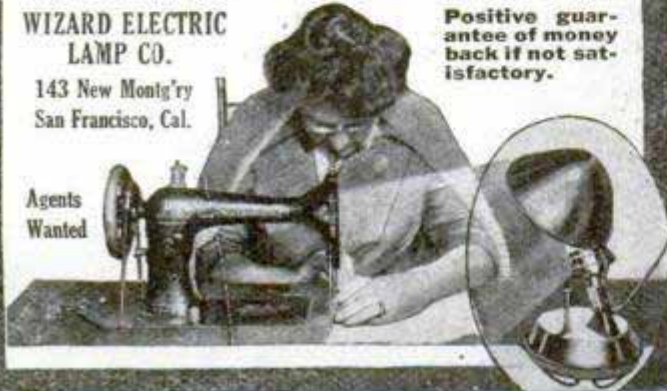

## Two Pieces of Superb Master-Built Furniture for the Price Demanded for One Piece of Ordinary Furniture at Retail

Because we are manufacturers! Own the largest plant of its kind in the world. Not a mail order house or jobbers or wholesalers. We turn the raw materials into finished furniture—and sell Direct. You save every cent of the Dealers' and Jobbers' big profits. What's more, our sectional method—we are the originators—saves 3-4 the packing costs, 2-3 the freight and 1-2 the factory floor and storing space usually required. These are 3 more reasons why you can save 1-2 your furniture expenditure by buying direct. We make everything in home, office or club furniture. Money back guarantee. Write for big book. Learn about the wonderful furniture.

Height, 36 in. Width, 30 in. Depth, 24 in. Price includes cushions and back pillow covered with Marokene leather. Shipping weight, 100 pounds.

Shipped in Easily Assembled Sections.  
It's Play to Put Together This Furniture!



**ROCKER No. 23**  
Retailers' Price, \$18.00  
Our Factory Price **\$9.75**



**Library Table  
No. 308**  
Retail Price \$25.00  
Our Factory Price **\$11.50**

Height 30 ins. Width 28 ins. Length 43 ins. Top 1 in. thick. Legs 2 1/2 in. square. Shipping weight 140 lbs. Write for big book.

**Brooks Mfg. Co.**  
2705 Rust Ave.,  
Saginaw, Michigan  
Largest Plant of Its Kind in the World. Originators of the Pattern System of Boat Building

Send For Big Free Book  
Showing Furniture for  
Every Room in House

Please Mention Popular Mechanics

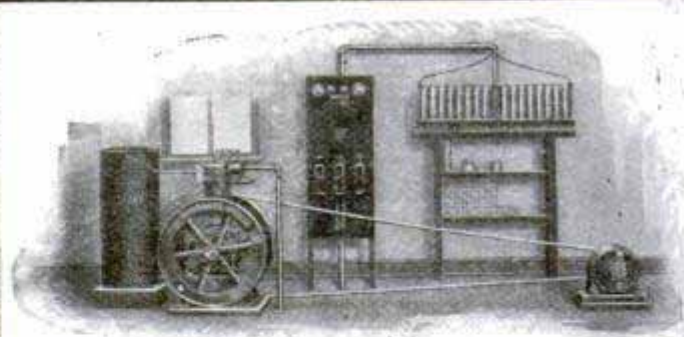

## Light Your Home With Electricity

Electric Light is easiest on the eyes—clean and absolutely safe. A convenience that can now be enjoyed in the country as well as in the city.

## Fairbanks-Morse Electric Light Plants

are complete independent plants, large enough to supply all the lighting needs of a clubhouse or country home. Set includes Kerosene Engine, Dynamo, Switchboard, and Storage Batteries. Easy to install—easy to care for.

Write for Catalog 20A449

## Fairbanks, Morse & Co.

Chicago, New York, San Francisco and many other cities

German foresters are experimenting with Douglas from the United States, trying to find a variety which will combine the fast-growing quality of the Pacific Coast form and the hardiness of the Rocky Mountain form.

## MAGIC FISH LURE!



Best bait for attracting all kinds of fish ever discovered. It sure does get 'em! Seems as though they just can't keep away from it. Will keep you busy hauling in the fish. Makes fishing a REAL pleasure. Use Magic Fish Lure and you'll catch a big string every time while the other fellows go home empty-handed. Fishing at your "luck." Good any season. Won't stop. Not unlawful to use. Send 25c for box containing enough for 500 baits. Money back if not satisfied. Valuable catalog sent FREE. Write for it today.

Lotz Bros. 155 N. Main St., St. Louis, Mo.

## Get Your Canadian Home From The Canadian Pacific

One-twentieth down—the balance in 19 equal annual payments. Good land in Western Canada—every kind of farming—\$11 to \$30 an acre.

## \$2,000 Improvement Loan

20 years to pay—only 6% interest. Best livestock supplied, actual cost. Expert demonstration work at your service. FREE BOOKLETS on Manitoba, Alberta-Saskatchewan, Irrigation Farming. Write today.

G. E. THORNTON, Colonization Agent, 112 W. Adams, CHICAGO

## Rapid Fireless Get M Cooker 1914 Spec

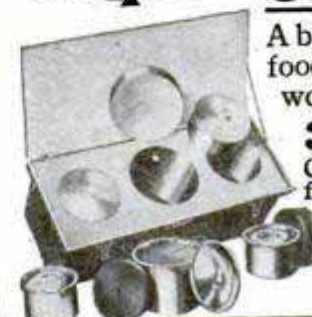

A big saving in Price Off food bills, fuel, work—and food tastes better

## 30 Days FREE Trial

Complete outfit aluminum utensils free. Covers and cooking compartments lined with pure aluminum. Dust-proof, odorless. Write for Free Book and direct-from-factory price.

**WM. CAMPBELL CO**  
Dept. 64 DETROIT, MIC





# Get Your Canadian Home *from the* Canadian Pacific



The Home-maker



**Y**OUR new home is ready for you in the fertile Canadian West, with its magnificent soil, good climate, churches, public schools, good markets, good hotels, unexcelled transportation. Take 20 years to pay. And call on us for a long time loan of \$2,000 for farm improvements, if you want it.

This land is offered only to farmers or to men who will actually occupy or improve it. We make our prices, terms and development assistance so attractive because we want to interest settlers. Come where you can own 10 acres for every acre you now own or farm; where *every* acre will produce *double* what a worn-out acre produces anywhere. Mother Earth provides no better land than this rich virgin Canadian soil. The enormous crop yield

per acre *proves* this every season.

## We Give You 20 Years to Pay

We will sell you rich Canadian land for from \$11 to \$30 per acre—in irrigation districts from \$35 to \$55. You need pay only *one-twentieth* down. Think of it—only *one-twentieth* down, and the balance in 19 equal annual payments with interest at 6%. Long before your final payment comes due your farm will have paid for itself over and over again. Many good farmers in Western Canada have paid for their farms with one crop. Here are some of the startling features of the most remarkable land offer you have ever read:

## We Lend You \$2,000 for Farm Improvements

This offer of a loan up to \$2,000 is for farm development only, with no other security than the land itself, and shows our confidence in the fertility of the soil and in your ability to make it produce prosperity for you and traffic for our lines. This loan will help you in providing buildings, fencing, sinking well and breaking, and you are given twenty years in which to fully repay this loan. While enjoying the use of this money, you pay only interest at six per cent.

### Advance Live Stock on Loan Basis

The Company, in the case of the approved land purchaser who is in a position and has the ability to take care of his stock, will advance cattle, sheep and hogs up to the value of \$1,000 on the basis of the settler's note with interest at eight per cent, to enable him to develop more rapidly, on the right basis of mixed farming.

### Farm Made Ready by Experts if Desired

If you want a place already established, select one which our Department of Agricultural Experts has developed. On our improved farms, house and other buildings are up, well is dug, farm fenced, fields cultivated and in crop. All waiting for those who want an immediate start and quick results—all planned and completed by men who know—our own agricultural experts. Take 20 years to pay if you want to. We give *free* service—expert service—the valuable assistance of great demonstration farms, in charge of agricultural specialists employed by the Canadian Pacific for its own farms. This service is *yours—free*.

### This Great Offer is Based on Good Land

The Canadian Pacific offers you the finest land on earth for grain growing, cattle, hog, sheep and horse raising, dairying, poultry, vegetables and general mixed farming—irrigated lands for intensive farming—non-irrigated lands with ample rainfall for mixed and grain farming. Remember, these lands are located on or near established lines of railway, near established towns. And you can start on an irrigated or non-irrigated farm, improved or unimproved.

Your new home and your fortune are ready for you in the famous, fertile Canadian West, with its magnificent soil, good climate, churches, public schools, good markets, good hotels, unexcelled transportation—and 20 years in which to pay for your farm and repay the improvement loan.

Here is the Last Best West—where your opportunity lies. Don't delay. Mail the coupon here at once. The best land will be taken first—so time is precious to you. Write today.

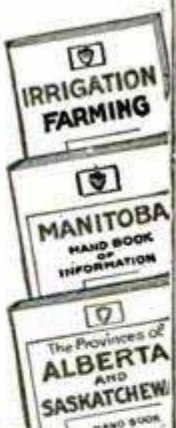

<input type="checkbox"/> Irrigation Farming	<input type="checkbox"/> Book on Alberta-Saskatchewan
<input type="checkbox"/> Book on Manitoba	<input type="checkbox"/> Information on Business and Industrial Opportunities

(Make a cross in the square opposite the book wanted.)  
**G E THORNTON, Colonization Agent,**  
 Canadian Pacific Railway, Colonization Department, 112 West Adams St., Chicago  
 Please send the books indicated above.

Name.....  
 Address.....  
 Town..... State.....

**GE THORNTON, Colonization Agent**  
**Canadian Pacific Railway, Colonization Department**  
 112 West Adams Street, Chicago, Ill.

FOR SALE—Town Lots in all growing towns, on lines of Canadian Pacific Railway. Ask for information concerning Industrial and Business openings in these towns.



# 2c a Week Pays Wash Bill!

Write for  
FREE Book

Electricity or Water-Power Does the Work

Just a "Twist of the Wrist" Starts or Stops the Machine!

The 1900 Motor Washers are now at work in thousands of homes. They are doing the work formerly done by women, at a cost of 2c a week for power! Saving thousands upon thousands of dollars in wash bills. Saving worlds of wash-day troubles. Leaving the women free to do other work while the machines are doing the washing.

## The 1900 Motor Washer

1900 Water Motor Washer  
Can be connected with  
any water tap instantly

Washes a Tubful in Six Minutes!

Handles Heavy Blankets or Dainty Laces

The outfit consists of the famous 1900 Washer with either Electric Motor or Water Motor. You turn on the power as easily as you turn on the light, and back and forth goes the tub, washing the clothes for dear life. Then, turn a lever, and the washer does the wringing. All so simple and easy that it is mere child's play.

**A Self-Working Wringer Sent With Every Washer!**

The motor runs Washer and Wringer. We guarantee the perfect working of both. No extra charge for Wringer, which is one of the finest made. Write for FREE BOOK and 30 Days' FREE TRIAL OFFER! Don't doubt! Don't say it can't be done. The free book proves it can. But we do not ask you to take our word for it. We offer to send a 1900 Motor Washer on absolute Free Trial for an entire month to any responsible person. Not a cent of security—nor a promise to buy. Just your word that you will give it a test. We even agree to pay the freight, and will take it back if it fails to all we claim for it. A postal card with your name and address sent to us today will bring you the book free by return mail. All correspondence should be addressed



Doing the wringing with  
1900 Electric Motor Washer



**1900 WASHER CO., 6145 Court St., BINGHAMTON, N. Y.**  
OR, IF YOU LIVE IN CANADA, WRITE TO THE CANADIAN WASHER CO., 355 YONGE ST., TORONTO, CANADA. (23)

### THIS BUNGALOW \$900 CAN BE BUILT FOR

This and many others in my new book, Building Plans for Modern Homes, will save you hundreds of dollars. One of the most complete and comprehensive books of plans ever published by any architect. Fifth edition just off the press. One hundred and fifty floor plans and photographs of bungalows, etc., costing from \$250 up; gives sizes and cost to build. Sent postpaid for \$1.00



**FREDERICK H. GOWING  
ARCHITECT**  
18 Tremont St., BOSTON, MASS.

Automobile exports from the United States are times as great as a decade ago. Reports of the value of automobiles and parts thereof sent out of the United States in the 11 months ended with November, 1913, justify the statement that the total for the year will approximate \$40,000,000, against less than \$2,000,000 in 1903, a decade earlier. Meantime the imports of automobiles show a marked decline. The total value of automobiles and parts thereof imported in 1909 were nearly \$4,000,000, and in 1913 about \$1,500,000.

### BRASS AND STRINGED INSTRUMENTS

Biggest line of band and orchestra instruments for home use. Cornets, trombones, clarinets, drums, violins, guitars and all wind and stringed instruments. Send for a free catalog of any instrument you may want—we can save you money. We give you a fifty lesson certificate FREE with each instrument. Write today mentioning instrument in which you are interested.

WENKINS MUSIC HOUSE, 40 Jenkins Bldg., Kansas City, Mo.

### DO YOU NEED MONEY?

?

To educate your children, support a family, pay off a mortgage, buy a home or dress better. Then do as thousands of others are doing. Make money selling World's Star Hosiery and Klean Knit Underwear in your home town.

No previous experience is necessary. We show you how to make money in an easy, congenial and profitable way. Two lady agents began in their home town in California and each made over

**\$3000 First Year**

We sell direct from the mill to the home, eliminating the middleman's profit, thereby giving better value for the money. Our lines for men, women and children are famous the world over. We have in 18 years grown to be the largest concern in the world manufacturing and selling knit goods direct to the consumer.

Agents wanted in every town. It is a permanent, pleasant and profitable business. Write today for our free catalog. We protect agents in territory and make prompt delivery.



**WORLD'S STAR KNITTING CO.**  
Dept. 143 BAY CITY, MICH.

**Take Your Home With You**

—wherever you spend your vacation—from year to year. Simplex Ready Made Portable Houses, shipped in sections, can be put up quick with only a wrench and screwdriver. Write today for Ready Made Building Catalog

—illustrates and describes houses, garages, barns, boat houses, etc., from \$68.00 up. Don't build till you get our Ready Made Building Book No. 80P93.

Sears, Roebuck and Co., Chicago

# Make a Cosy Room of your Attic

Just think of all the uses you have for a cheerful, cozy room in the attic. A maid's room—a children's playroom—or a clean store room, absolutely proof against dampness, vermin and mice. You can do this, quickly, easily and inexpensively with

## UTILITY

The ONLY 5-Ply Wall Board

Think of five layers of tough fibre board, cemented into one permanent sheet with hot asphalt under tons of pressure—thoroughly moisture proofed outside. We use 5 layers because it gives us that much more strength than the usual 2 or 3 layers. It is a simple, easy matter to nail Utility to studding and joints, anywhere in the house where plaster could be used. Never chips, checks, cracks or falls off. Takes calomine or flat tone paints beautifully.

Free samples and free book, "Utility Interiors" on request.

The Heppes  
Company

4516  
FILLMORE STREET  
CHICAGO, ILL.

Also Manufacturers  
of Asphalt Paint,  
Asphalt Roofing in  
any Finish and Utility  
Wall Board.



### YOUR CORRESPONDENCE

a pleasure, if you have a smooth, easy-writing

"VULCAN" INK  
PENCIL \$1

Postpaid

Black,  
1/4 or 5 1/2 in.

FREE Supply of ink  
with retail orders.

K. ULLRICH & CO., 27 Thames St., NEW YORK



EVERYTHING in Guaranteed Plumbing  
and Heating Supplies

Wholesale. Our \$200,000 establishment behind our Guarantee.  
Send for complete CATALOG 61.

RDIN CO., 30 years at 4533-35-37-39-41-43 Collage Grove Ave., CHICAGO

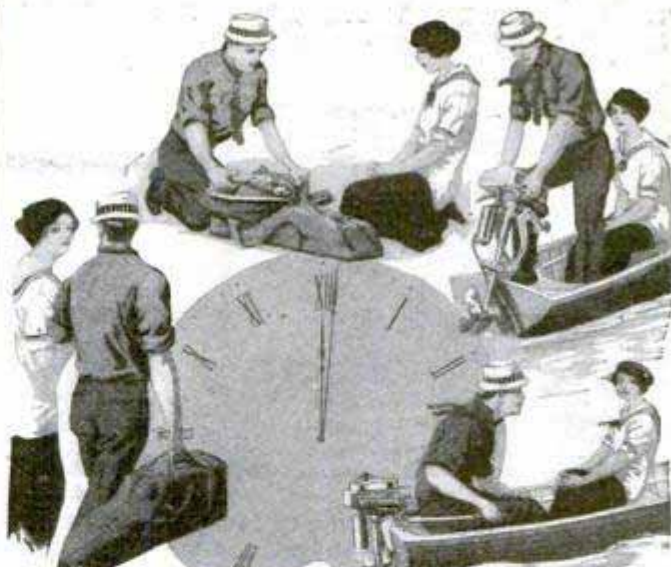

## EVINRUDE

Make a Motor-Boat of Any  
Rowboat in Less Than One Minute

Turn any rowboat into a motor-boat with an



Starts with one-twelfth  
turn of fly-wheel; no  
cranking.

Drives a rowboat 8  
miles an hour—a canoe  
12 miles.

So simple to operate that women and children are "Evinruding" everywhere. Why not get one for *your* vacation? By special arrangement we have procured as an exclusive feature, the

### Famous Maxim Silencer

and can apply it to either 1913 or 1914 models. The "Evinrude" has always been practically silent in operation, but this addition makes it a veritable triumph. No similar motor can use the Maxim Silencer. It has been added to the already long list of exclusive "Evinrude" features. It is the only marine motor in the world having a

### Built-in Reversible Magneto

This magneto is not affected by rain, waves or even complete submersion. The "Evinrude" is built by the largest manufacturers of rowboat motors in the world. Capacity for 1914, 60,000 "Evinrudes".

Has been adopted by twelve governments, including the U. S. A. Weight about 50 pounds, may be carried like a suit case. For sale at Hardware and Sporting Goods Dealers everywhere.



Illustrated Catalog Free Upon Request

EVINRUDE MOTOR COMPANY

236 M Street Milwaukee, Wis.

Branch Offices—San Francisco, 423 Market St.; Jacksonville, Fla., Foot of Main St.; New York, 89 Cortlandt St.; Portland, Ore., 106 Fourth St.; Boston, 218 State St.

Please Mention Popular Mechanics

# Like a clean china dish

Copyright, 1914, by Grand Rapids Refrigerator Co.

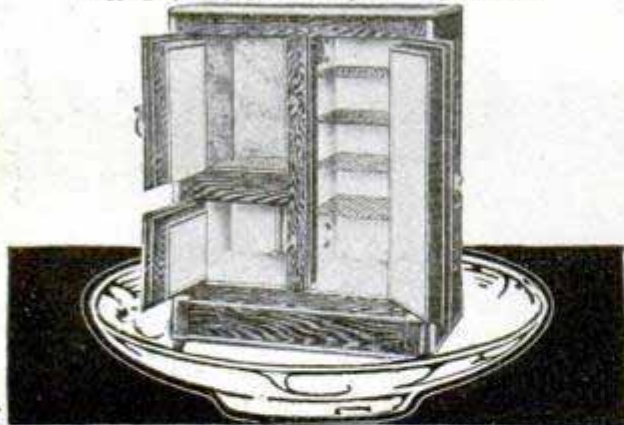

Superb Porcelain Lined—the delight of every woman's heart—the pride of every housekeeper. Here's that famous Refrigerator with the seamless, scratchless, dish-like lining, the genuine

## Leonard Cleanable

Don't confuse this wonderful sanitary lining with paint or enamel. I will mail you—free—a sample of Leonard Porcelain that will quickly show you the difference. You can't scratch it even with a knife. It's everlasting—easily kept beautifully sweet and clean. You'll never be satisfied with anything else.

Style shown is No. 4, in polished oak case. Size 35x21x45 **\$35.00**

**50 Styles, \$15.00 up; Freight Paid**

to Ohio and Mississippi Rivers. I take the risk; send for catalog today. Money returned if you are not perfectly satisfied. Ask for sample of porcelain and I'll mail my booklet, "Care of Refrigerators." Every woman should have a copy of this valuable book.

**C. H. LEONARD, President**

**GRAND RAPIDS REFRIGERATOR COMPANY**  
157 Clyde Park Ave., Grand Rapids, Mich. (1)



It Really  
Costs You  
Nothing  
to  
Own  
a

## SIMPLEX IRONER

"THE BEST IRONER"

In fact, you will be money in pocket, figuring the many hours of time and labor you will save 52 weeks a year for many years. Not to mention the easier work, better finish and longer wear of goods ironed.

If you fully realized the many advantages of using the "Simplex" Ironer you would get one immediately as have many thousands of progressive housewives.

The "Simplex" will do the greater part of your ironing. It will iron a table cloth in 3 minutes that would take you 20 by hand and do it better. It will do an average ironing at two to four cents expense.

Six sizes. To heat by gas, gasoline or electricity. To turn by hand, by engine power or motor.

Write for name of our Local Dealer,  
30 Day FREE TRIAL Offer and Booklet.

**American Ironing Machine Co.**  
562, 168 No. Michigan Ave., CHICAGO, ILL.

# FREE



Yes, we will send you a genuine Lachnite Gem for you to wear for 10 full days absolutely free. This is the most astounding jewelry offer ever made. See a genuine Lachnite for yourself. Wear it for 10 days. Then if you can tell it from a genuine diamond send it back at our expense. They are cut by the world renowned diamond cutters of Europe and their dazzling fire last forever. A superb gem set in solid gold. Write today for our big new catalog.

## Open An Account

Don't save up your money for months and months before you wear beautiful jewelry. Open an account with us. Have all the genuine Lachnites and other handsome jewelry you want. Write today for the big new catalog. We trust you. No red tape. Your credit is good.

## Pay As You Wish

Just a small amount down. Take your time about paying for the rest. Your choice of any of the superb Lachnites and all sorts of other superb, elegant jewelry. All at the rock bottom price. Astounding prices never equalled before. Pay as you are able. The most liberal of terms. Get the free book that tells you all about it. Write today—now.

## Free Book—Write Today

Do not delay an instant. Put your name and address on a postal or a letter and send it in to us at once. We'll send you our big new catalogue of all the finest jewelry absolutely free. Find out about genuine Lachnites. Find out how you can wear one of these superb gems for 10 days absolutely free. Do not delay an instant. Send in your name and get the big new jewelry book absolutely free.

**HAROLD LACHMAN CO.**  
Dept. 1195, 12 N. Michigan Ave., Chicago, Ill.



Formerly the manufacture of cotton was confined largely to England and a few localities in other countries. In recent years, however, not only has the industry increased wonderfully in these established centers, but it has been extended until, at the present time, there are very few countries without some cotton mills. The spinning of cotton by power-driven machinery has been introduced into China, Turkey, Brazil, and, to a large extent, into Indo-China, Australia, Egypt and a number of countries in South and Central America.

## BUY PLUMBING and HEATING SUPPLIES



at WHOLESALE Will Save You 30%

Don't pay retail prices. Full stock on hand for prompt shipment. Send for free catalog.

**B. P. KAROL, 768 to 772 W. Harrison St., CHICAGO**

## DISHWASHING DRUDGERY GONE FOREVER



The Kitchenette Family Dishwasher takes the place of the old dishcloth, dishpan way. Washes and sterilizes in a few minutes. Will not break the most delicate china. Hands do not touch the water. No red, rough, chapped, dishwater hands. Proved by Good Housekeeping Institute of N. Y. and guaranteed by us. Send no money. 30 days free trial and easy payment plan. All freight prepaid. Address: **CARY-DAVIS CO., INC., Dept. P-A3, 42 Pearl St., Buffalo, N. Y.**

## Wide Awake AGENTS

Make  
BIG  
Money



Be Your  
Own  
Boss

You need no experience. Our line sells itself. We have most complete, fully guaranteed, line of knives, razors, stoves and cutlery specialties. Golden Rule Knives are hand made of genuine English razor steel. We will put any photo lodge emblem on one side of the transparent handle and name address on the other. Write for catalog and terms—exclusive territory. **Golden Rule Cutlery Co., 552 W. Lake St., Dept. 114, Chicago**

# Inventors! Send for these Remarkable FREE BOOKS, Today

Complete and full information about patents, everything the inventor or manufacturer should know, has been included in these books. Never before has such an inexhaustible fund of valuable information been at the inventor's disposal. Regardless of the fact that the compilation of this information cost us thousands of dollars, we will send to all interested persons, any or all of these books, entirely without charge or obligation.

## "Millions In Patents"

This volume, 192 pages, tells the story of the romance of invention. The brain of the inventor is the magician that has made the ancient fairy tales come true. Millions have been paid for a hook, fortunes have come from a toy. Read "Millions In Patents," and you will realize that this country and all the nations of the world are ready to enrich you beyond your wildest dreams if you can contribute one useful or amusing thing.

## "What Is a Trademark?"

It is not an exaggeration to say that billions of dollars have been made out of trademarks, labels and copyrights. He who can fashion a trademark or design a label which will make a product stand out above all similar products, is indisputably a genius for whose brains the world offers almost unlimited money.

## "Foreign Patents"

A good invention is bought not by one country but by the world. "Foreign Patents" shows you how the inventor may be paid by other countries and other peoples, as well as by this nation, for his ideas and his inventions. It explains how we, through our representatives in the capitals of the world, maintain for your benefit an endless chain of opportunities which, if you take advantage of them, will girdle the earth and make of your product an agent that may bring back to you rich rewards.

## "Inventions Needed"

This book, 256 pages, lays before you a description of the active and profitable field of invention. It tells you the inventions the world needs today, the devices manufacturers are seeking for their business, the ideas for which the public will pay big money. It gives great men's ideas of the most important things needed in inventions now. Science is the key to wealth, and this key can be turned best by the inventor. This book tells you why.

## "How to Get Your Patent and Your Money"

The man who invents needs the co-operation of the man who invests. This book, 132 pages, is a guide to the inventor. It describes, according to the teachings of our experience and the lessons of men made rich by patents, how the inventor may secure money, the right amount of money, for the device which his brain has constructed. If you have invented something and desire to learn what it will cost you to get your patent and what you must do to find your market, read this book.

## "Special Bulletin of Patent Buyers"

This bulletin, 64 pages, contains copies of hundreds of letters from wealthy men who are seeking to purchase patents. Next to the idea of the invention itself, the most valuable thing to the inventor is a hint of where there is a man ready to buy the invention or to finance the inventor so that his device can be readily marketed. We act as intermediary, without one cent of charge, between the man who invents and the man who invests.

**We Secure Reliable Patents, Trade Marks, Copyrights, On Most Liberal Terms Ever Offered**

**Send Model or Sketch and description of your invention for Free Search of the United States Patents**

**Rejected and Difficult Cases are Our Specialty**

**RANDOLPH & CO.**  
600 F St., N.W., Washington, D.C.

**RANDOLPH & CO.,**  
WASHINGTON, D. C.

Gentlemen: Please send me, without obligation on my part, the books indicated on margin of this coupon. (Write on margin of coupon, names of books desired.)

NAME .....

STREET .....

CITY .....

STATE .....



# WANTED-IDEAS

Manufacturers are constantly writing me for patents procured through me. The demand for good ideas

## Protected by Owen Patents

is greater than ever before. Send for my free books and read the letters from the greatest manufacturers in this country. Read their requests for Owen Patents and see for yourself what ideas they want. You can help supply the unceasing demand for good inventions.

My clients are provided with manufacturing facilities, and I aid them in many ways, without charge, to sell their patents. Applications filed through me advertised free.

You will get a strong patent or I will get no compensation. Your interests are my interests.

# FREE!

A simple request will bring you the following three finest patent books published absolutely free—you will incur no obligation by writing me.

**"SUCCESSFUL PATENTS"**—a new 72 page guide book; tells how to proceed to be successful; describes my advantageous business methods.

**"STEPPING STONES"**—gives lists of over 200 inventions wanted; gives forecasts from interviews of Edison and many other authorities; tells the plain truth about prizes of millions of dollars for inventions.

**"PATENT PROMOTION"**—tells you how to promote your invention; why some inventors fail; the value of your rights, etc.



Write for these books today—NOW! Advice costs nothing

### VERY HIGHEST REFERENCES

Columbia National Bank,  
Washington, D. C.  
National Locktile Co.,  
Washington, D. C.  
The Carnahan Press,  
Washington, D. C.  
Lightning Gun & Cycle Works  
Oklahoma City, Okla.  
Antholene Mfg. Co.,  
Hutchinson, Kans.

National Rack Co.,  
61 Hannover St.,  
Boston, Mass.  
The C. J. Loftus Co.,  
13 Spring Common,  
Youngstown, Ohio  
Whitehead Hosiery Mills,  
Burlington, N. C.  
Dickinson Mfg. Co.,  
Des Moines, Iowa.

And an immense number of others whose letters are printed in my booklets.

### SPECIAL!

Send me a sketch or model of your invention and I will make a search of the U. S. Patent Office Records **FREE OF CHARGE** and report to you concerning patentability, practicability, etc.

Your work will receive my **PERSONAL** supervision—but my fees are no higher than others

**RICHARD B. OWEN** 9-303 OWEN BLDG  
WASHINGTON, D. C.

Inventors submitting their inventions to me are protected in a tangible manner until their applications are filed.

# Patents

Trade Marks and  
Copyrights Secured  
or Fee Returned

## Special Offer—Free Search of Patent Office Records

Send us a model or sketch and description of your invention, and we will make a *Free Search* of the *Patent Office Records* to ascertain if it is patentable. If we report the invention patentable, we will guarantee to obtain a patent or return our fee, and furnish a certificate of patentability backed by a bonded contract to that effect. **This Certificate of Patentability will protect the inventor and serve as proof of the invention until the case can be filed in the U. S. Patent Office.**

### Obtaining Assistance for Inventors

Our certificate is of great assistance to inventors who require financial aid to obtain patents.

### Our Five Books Mailed Free

(SEE COUPON BELOW)

to any address. Send for these books—the finest publications ever issued for free distribution.

#### How to Obtain a Patent

Our illustrated eighty-page Guide Book is a book of reference for inventors, and contains 100 mechanical movements illustrated and described.

#### Money in Patents

Tells how to invent for profit, and gives history of successful inventions.

#### What to Invent

Contains a valuable **LIST OF INVENTIONS WANTED** and suggestions concerning profitable fields of invention; also information regarding prizes offered for inventions, among which is

#### Prize of One Million Dollars

offered for one invention, and \$10,000 for others.

#### Patents That Pay

Contains letters from our clients who have built up profitable enterprises founded upon patents procured by us; also endorsements from prominent inventors, manufacturers, Senators, Congressmen, Governors, etc.

#### We Advertise Our Clients'

#### Inventions Free

In a list of Sunday newspapers with two million circulation, in manufacturers' journals and in the *World's Progress*. Sample Copy Free. We save you time and money in securing patents. After the patent is granted we assist you **TO SELL YOUR PATENT.**

#### Foreign Patents

WE HAVE DIRECT AGENCIES IN ALL THE PRINCIPAL FOREIGN COUNTRIES and secure FOREIGN PATENTS in the shortest possible TIME and at the LOWEST COST. Write for our Illustrated Guide Book on Foreign Patents, sent free to any address.

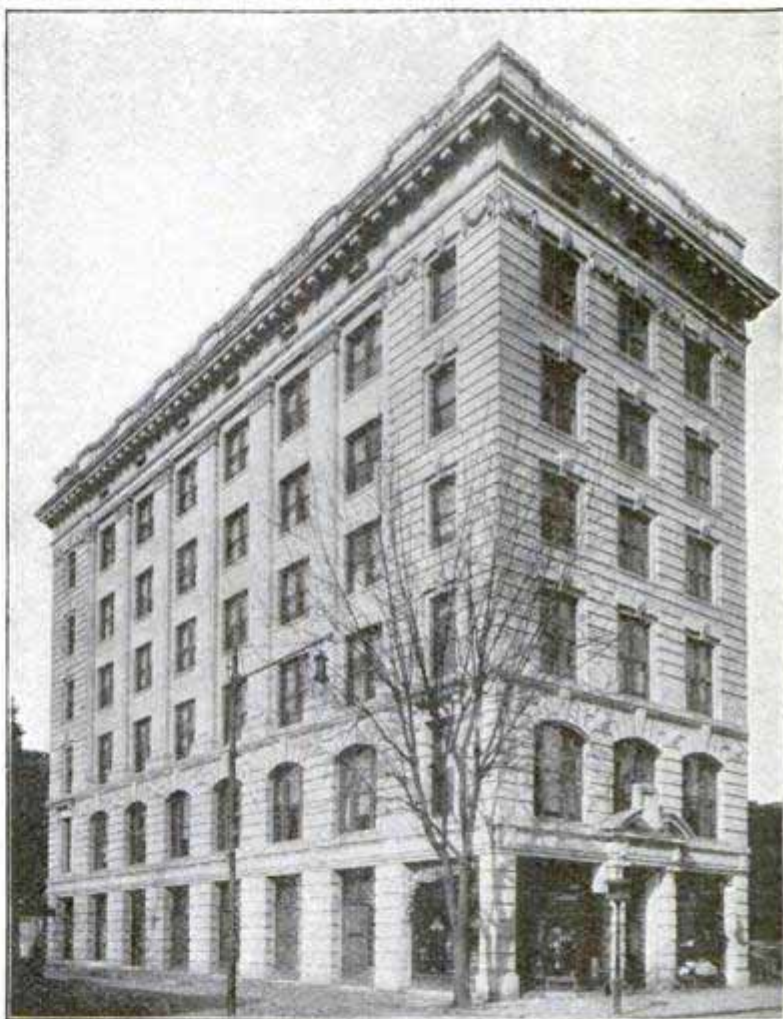

**VICTOR BUILDING**

Our new \$200,000 building opposite U. S. Patent Office  
SPECIALLY ERECTED by us for OUR own use

## WANTED NEW IDEAS

Send for **LIST OF PATENT BUYERS** who consult us when purchasing patents. Contains requests from **MANUFACTURERS, MAIL ORDER HOUSES and PROMOTERS** for patents secured by us, and suggestions as to New Ideas they wish to purchase. We invite manufacturers and promoters to address our Sales Department regarding the purchase or leasing of a number of meritorious patents secured by us.

### REFERENCES

Second National Bank, Washington, D. C.; Union Savings Bank, Washington, D. C.; Chamber of Commerce, Washington, D. C.; Pitner Gasoline Lighting Co., Chicago, Ill.; R. G. Dun & Co., Washington, D. C.; Smethport Glass Co., Smethport, Pa.; The Melvin Gauge and Signal Co., Scranton, Pa.; M. Winter Lumber Co., Sheboygan, Wis.; National Savings and Trust Co., Washington, D. C.

### FREE COUPON!

## VICTOR J. EVANS & CO., Patent Attorneys

NEW YORK OFFICES: 132 Nassau St.

PHILADELPHIA OFFICES: 1429 Chestnut St.

Main Offices: 724-726 9th St., N. W., WASHINGTON, D. C.

GENTLEMEN: Please send me FREE OF CHARGE your FIVE Books as described above.

NAME..... ADDRESS.....

# Wanted—Inventors —or Men with the Inventive Turn

The whole world wants the inventor. To the intelligent inventor it gives its richest prizes. Westinghouse, Marconi, Edison, were all once beginners, like you. The average man of their time thought everything had been invented that could be invented. If you have an inventive mind, their success may be yours. The world wants your work.

To meet the demand for a square, fair deal for small inventors, two young men, G. H. and H. C. Chandlee opened a little office twenty years ago in the Stead Building in Washington. They believed that thousands of men were being shut out from big opportunities because of the huge fees charged by most patent attorneys.

They said: "We will stand by the

small inventor. We will keep faith with him. We will advertise, secure a large volume of business, charge small fees and make our money through the greater number of cases we handle."

The plan succeeded. Now Chandlee & Chandlee give employment to nearly 100 people, including many registered attorneys, and large manufacturing concerns, knowing that they have secured valuable and well-protected patents for their clients, solicit their services, both in the obtaining of patents and in the purchase of patents, to be manufactured on a royalty or bought outright.

Chandlee & Chandlee have built their business in the very shadow of the patent office. They have learned by long practice not only

## How to Obtain Patent Protection at Small Cost

but also how to assist their clients in the sale of their inventions—a double service. Hosts of successful inventors owe their start to the good work done for them by Chandlee & Chandlee. These young men, now grown to middle age, to knowledge and to success, are serving splendidly the men who are beginners, as they were once beginners.

### The Big Thought

And the big thought back of Chandlee & Chandlee is that they want to make inventors. They want inventors to work intelligently along right lines. They believe that the field for great and even startling successes and profits is greater now than ever.

And so out of their knowledge of what succeeds and what makes money, they have prepared two books—

**"What to Invent"**  
and

**"How to Obtain a Patent"**

These two books cover the field. They tell just what inventions are wanted and just what must be done to obtain patent protection. They have started many inventors on the right track and have made inventors of many men who had simply the untrained inventive faculty.

### You May Have These Books Free

Write your name and address in a letter or on a postal card and they will be sent you free. Or, if you have already invented something, send a rough sketch and description of it for a free report as to patentability. Do it now.  
Address

**CHANDLEE & CHANDLEE**  
1009 F. Street, Washington, D. C.

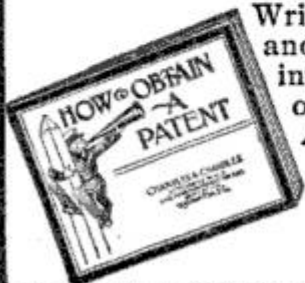





## BRASS GEARS

Cut by an entirely new process. The most accurate made and at prices that cannot be equalled by others. Every gear has a hub, center painted ebony black, edges turned true, highest grade red brass, and much heavier than others. We carry the largest stock in the world and every gear listed is always shipped on date of order.

SEND FOR CIRCULARS  
**CHICAGO STOCK GEAR WORKS**  
16 S. Fifth Av. Chicago

Active Powers of Inventive Genius



## INVENTORS Our Brain Belongs to You. Our Ideas Are Free of Charge.

All we want in return is to build your model, special machinery, dies, tools and jigs to manufacture sheet metal goods, etc. We are expert mechanics, over thirty years experience and have one of the best equipped shops in the country. Ask for Booklet No. 17. Consultation free. Experimental work strictly confidential.

A. NACKE & SON  
236-242 S. 9th St., Philadelphia, Pa.



The rapid development of Wyoming makes it safe for us to pay 6 per cent—because Wyoming legal int. rate is 8 to 12 per cent. Our stringent banking laws give you the same protection you get at home. Why be content with 3 to 4 per cent when we will pay you 6 per cent. Resources over \$100,000. Write today for booklet.

## Double Your Income ON YOUR SAVINGS

**PIONEER SAVINGS BANK**  
TRUST and 12 Pioneer Street, Basin, Wyo.

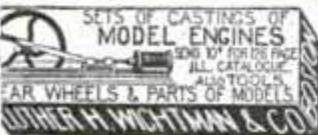

MECHANICAL SUPPLIES AND MATERIAL of all kinds.  
EXPERIMENTAL AND LIGHT MACHINE WORK to order.  
132 MILK STREET. BOSTON



## Models and Supplies

We make working models of any description and material, also dies, tools and sheet metal stampings. Send your drawing or sample for estimate. Write for catalog of gears and model supplies.

The Pierce Model Works, 3405 Pierce Ave., Chicago, Ill.



## MAKE BIG INCOME

Men and Women can do this all the year at home growing mushrooms in cellars, stables, sheds, boxes, etc. Crop sells for \$.50 to \$1.00 a lb. \$20.00 a week easily made. Great demand, markets waiting. Start Now. Write for big 32 page Free Illustrated Booklet and learn how to do it.  
NAT'L SPAWN CO., Dept. 12, BOSTON, MASS.

Send for FREE BOOK { WHAT TO INVENT  
WHAT NOT TO INVENT  
HOW TO SELL YOUR PATENT  
Copies of nearest Patents and report in every case without charge  
I. L. WOODWARD, 900 G St., Washington, D. C.

## PATENTS THAT PAY—\$561,530 Made

by my clients. List Free of PRIZES OFFERED. 127 Page Patent Book—"What and How to Invent—Proof of Fortunes in Patents"—FREE. Opposite Patent Office.  
E. E. VROOMAN, Pat. Atty., 871 F St., WASHINGTON, D. C.

Your Money's Worth Plus 75 to 100%  
**UNREDEEMED PLEDGES**  
PERFECT CUT GENUINE DIAMONDS  
ELGIN WALTHAM ALL RELIABLE MAKE WATCHES  
311 JOS. DE ROY BLDG. PITTSBURGH PA.

EXAMINE FIRST—If Satisfied, Buy—If Not, Return. We Ship, With Privilege of Examination.

The biggest value for your money—that's what interests YOU most when you buy a diamond, watch or jewelry. We have thousands of unredeemed pledges on which we can positively save you as much and more than half of price asked by dealers, or wholesalers. Don't make a purchase of this kind until you get our big illustrated Bargain Bulletin.

As "HEADQUARTERS FOR LOANS" we have been advancing money on fine diamonds, watches, etc. for over 60 years. Our investment is but a fraction of their real value. The necessity for disposing of these unredeemed pledges the reason for our amazingly low prices. Match These Values Anywhere If You Can



No. 215007. This 1/2—1/16, 1/64 Karat, perfect cut, blue-white quality diamond solitaire. Guaranteed cash loan \$50. Try to match \$59.65 it at \$110. **Unredeemed Price, \$59.65**  
No. 254782. Genuine 21-jeweled, adjusted unredeemed Elgin watch in a serviceable dust-proof case. Guaranteed to pass railroad \$15.40/317

inspection. Try to match at \$35 to \$40. **Unredeemed Pr. \$15.40/317**  
Over 60 Years in Same Location is proof of Absolute Square DeRoy Bldg. Dealing—upright and honest. RATED AT OVER THREE With- out ob- ligation of any kind, put my name on your list for Bargain Bulletin

Money Back Guarantee We pay expressage and run all risk of pleasing you in the examination. Your money back if unsatisfactory to you, though always exactly as represented. We guarantee LOAN VALUES. We guarantee to take back any diamond at full price in exchange.

**JOS. DE ROY & SONS, 317 DeRoy Building**  
Smithfield St. Opposite Post Office Pittsburgh, Pa.

REFERENCES: By permission, Farmers Deposit Nat'l Bank, Marine Nation'l Bank, Dun's, Bradstreets, write any bank or newspaper in Pittsburg  
Name.....  
Address .....

## GET YOUR NAME ON OUR LIST

For Interesting and Valuable Information about  
**PATENTSWANTED**  
and bought by Manufacturers, send 6 cents postage for large illustrated paper Visible Results and Terms Book.  
B. S. & A. B. Lacey, Dept. Y, Washington, D. C. Estab. 1869.

**PATENTS** C. L. PARKER  
Formerly Member Examining Corps, U. S. Patent Office  
PATENT LAWYER  
210 MCGILL BLDG.  
WASHINGTON, D. C.  
Patents, Trade Marks, Copyrights, Patent Litigation  
Handbook for Inventors, "Protecting, Exploiting and Selling Inventions" sent free upon request.

# PATENTS THAT PROTECT and PAY

Advice free. Terms reasonable. Highest references. Best results.  
Send sketch or model for FREE examination and opinion.  
Recommended Patent Lawyer in the Bankers' Register and special list of selected lawyers.  
Also in Martindale's Law Directory, Sharp and Alleman's Directory of Lawyers, The Gast-Paul Directory of Lawyers, and Kime's International Law Directory.

## ALL BUSINESS GIVEN PROMPT AND PROPER ATTENTION

A large list of strong recommendations furnished free

LATONE COLEMAN, D. C. 1111 11th St. N. W. Washington, D. C.

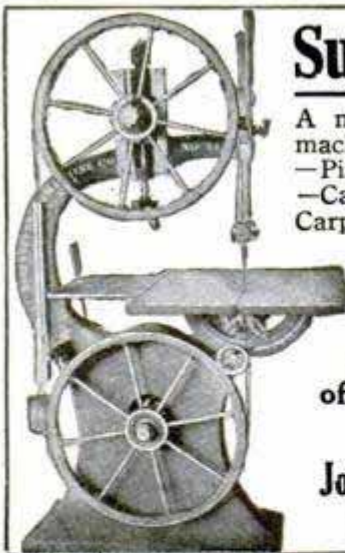

## Superior Woodworking Machinery

A modern line of woodworking machinery for Furniture Factories—Piano Factories—Box Factories—Cabinet Shops—Pattern Shops—Carpenter Shops—Wagon Shops—Repair Shops—Contractors—Manual Training Schools, etc. If interested write for our catalogue and net prices.

Largest manufacturers of woodworking machinery in Chicago.

Jones Superior Machine Co.  
1266 W. North Ave., CHICAGO



Jones Machine Moulded  
**PULLEYS**  
and **GEARS**  
Clutches, Sprockets  
Shafting and Hangers

THE LARGEST LINE OF  
Power Transmitting Appliances

IN THE COUNTRY

SEND FOR GENERAL CATALOGUE A18  
W. A. JONES FOUNDRY & MACHINE CO.  
1400 North Ave. CHICAGO

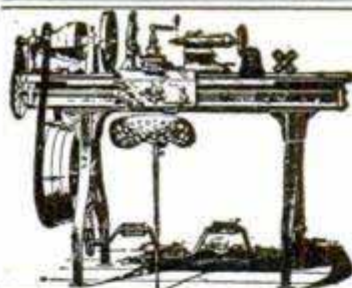

## LATHES

9 to 13-inch Swing

List price \$75 and up according to size. When ready to buy send for Lathe Catalog and prices.

W. F. & John Barnes Co.  
100 Ruby Street, ROCKFORD, ILL.



## South Bend Lathes

9 to 18" Swing  
Foot Power, Steam Power  
Electric Motor Drive  
Straight or Gap Bed

**\$7500**

and up

Write for Catalog and Price  
SOUTH BEND MACHINE TOOL CO.  
423 Madison St., South Bend, Ind.

DO YOU HAVE KNIVES TO GRIND, SILVER TO POLISH, SMALL TOOLS TO OPERATE, WASHING MACHINES OR WRINGERS TO RUN? LET THE RED DEVIL

DO YOUR WORK

Attached to any water faucet will develop up to 3 Horse Power according to size of pipe and water pressure. Only perfect small motor made. Improved bucket wheel construction.

6 in. Motor for Mechanics and Tradesmen. Washing Machine, 1/4 H. P. on 1/2 in. pipe, 80 lbs. water pressure; 1 H. P. on 60 lbs. pressure, 2 in. pipe. Net price \$5, cash with order.

No. 1492—4 in. Motor for grinding, polishing, fans, sewing machines; for Doctors, Dentists, Druggists, etc., with emery buffing wheel, silver polish and pulley, \$3.

No. 1493—4 in. Motor and pulley only \$2.50, cash with order.

Money back for any reason. Order your motor from dealer or from us. Send your water pressure and size of supply pipe. Active Agents wanted. Catalog free.

Only Motor to do this work



6 in. Motor

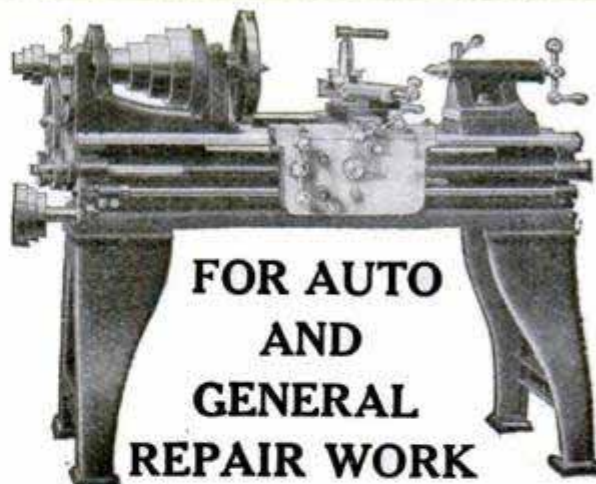

FOR AUTO  
AND  
GENERAL  
REPAIR WORK

THE "SEBASTIAN" Lathe is the Lathe you are looking for. It is high grade in every fine detail, and yet large output enables us to sell the "Sebastian" at a price so low it may surprise you. For general repair work the "Sebastian" Lathe is unexcelled. It is—

EASY TO OPERATE

Send for our latest catalog, full of graphic illustrations

The Sebastian Lathe Co.  
107 Culvert Street CINCINNATI, OHIO

Preliminary estimates by the department of agriculture are to the effect that of the 1,140,000,000 acres tillable land in the United States, 27 per cent is actually under cultivation. The calculations are based upon reports of 35,000 correspondents.



## LEIMAN BROS. ROTARY VACUUM-PUMPS AND BLOWERS

for Vacuum Cleaning, Melting, Forging, Sintering, Sand Blasting. Take up their own work.

LEIMAN BROS., 62P John St., New York

## CRESCENT WOOD WORKING MACHINES

are always satisfactory to men who want high quality at moderate price.

Ask today for complete catalog of band saws, jointers, saw tables, planers, disk grinders, shapers, swing cut off saws, planers and matchers, Universal wood workers, variety wood workers, band saw blades.

THE CRESCENT MACHINE CO.  
93 Columbia St. Leontia, Ohio



## BUILD

## A

## 3FT. CURTISS

## FLYING

## BOAT

## BOAT

We have accurate scale drawings and knock-out parts of all man-carrying aeroplanes for class demonstrations, exhibition purposes.

Students of aeronautics, everyone with inquiring turn of mind, should construct one of these fascinating models.

PRICES OF 3-FL. MODEL SCALE DRAWINGS—Curtiss Flying Boat, 25c; Nieuport Monoplane, 25c; Bleriot Monoplane, 25c; Wright Biplane, 25c; Curtiss Curve Hydroaeroplane, 35c; Cecil Peck Champion Race Complete Set of Six \$1.25 Postpaid

50 pp. Ideal Model Aeroplane Supply Catalog 5 IDEAL AEROPLANE & SUPPLY CO., 82-88 West B'way

PRINCE  
ALBERT

the  
national  
joy

# Coin Money MAKING CEMENT PIPE



Increase Your Income and be Independent

Making cement pipe offers big opportunities. We started over 3000 men and firms in business last year making cement Sewer Pipe and Drain Tile. Every community uses pipe for sewers, land drainage, irrigation, road culverts, well casing or other purposes. 24 inch Bell mouth pipe can be made for 35 cents a foot with sand and cement at ordinary prices. Vitrified clay pipe, the closest competitor, sells up to \$1.25 per foot depending on distance from factory. Attractive profits in every size. This proposition is well suited to the smaller cities and country towns, and every village can support a cement pipe plant. Cement is getting cheaper every year; sand and gravel are found everywhere.

### How to Start at the Business

Our catalog tells all about the manufacture of cement sewer pipe and drain tile and gives data on cost of manufacture. Sent free on request.

Send now and get started early for the big summer trade. We also make a complete line of mixers and concrete machinery for building blocks, brick, burial vaults, sidewalk, tile, fence posts, etc. Write today.



**LANSING CO., 724 Cedar St., LANSING, MICH.**  
Agents everywhere

## BOOK THAT EVERY SHOOTER SHOULD OWN

"A New Chapter in an Old Story"—an intensely dramatic recital of man's development of his means of defense and offense from the stone age to the present day. A temptingly readable volume. Price 50c prepaid. Address **50c**  
Huntington Arms-Union Metallic Cartridge Co., 299 Broadway, NEW YORK

## 3 YEARS TO PAY

**Meister Piano** 30 days free trial in your own home

\$1 A WEEK or \$5 A MONTH Price \$175.00

No cash payment down. No interest—no extras. Piano stool and scarf free.

**ROTHSCHILD & COMPANY**  
Dept. R16 CHICAGO, ILL.

Regular Price \$1.25 **THE RAPID VACUUM WASHER**

Sold on 30 days' trial.

The only Washer with Automatic Suction

Washes everything from blankets to fine laces. Tub of clothes washed in 5 to 10 minutes. A child can operate it.

**AGENTS WANTED. Special price on sample post paid.** Write for terms and trial offer.

**HART-SKINNER CO., 26 Cherry St., Worcester, Mass.**

**LAPIDS** NEXT to **DIAMONDS** OUTSHINE ALL OTHERS.

Every Woman Loves a Real Jewel

An only human desire, which Lapidus fulfill permanently and inexpensively as they represent to the minutest detail—Rubies in Oriental pigeon blood red—Diamonds in brilliant white and canary—Sapphires in rich Oriental blue. All set in Solid Gold and as beautiful as the genuine Oriental stones and guaranteed everlasting. Lady's or man's ring, 1-2 Carat stone, \$5.40 up. Send for jewel book. Patent Ring measure 10c. Albert W. Engel, Expert Since 1879, Desk 10 E, 1456 Leland Ave., Chicago

# CIVIL ENGINEERING THIS \$40.00 SET

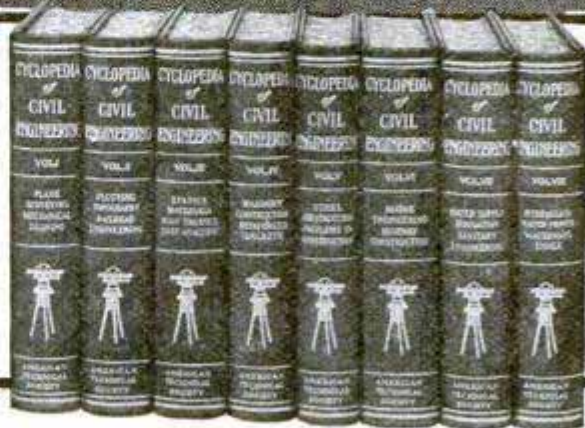

## NOW \$24.80—\$2 A MONTH

No matter what special line of engineering you are interested in—municipal, structural, bridge, railroad or reclamation. No matter whether you are a practicing engineer, a beginner ambitious to make your way to the top, or whether you are in some business where you need special information on a particular branch of civil engineering.

You need this great cyclopedia—the most complete and authoritative work on civil engineering ever compiled. It puts the expert knowledge and practical experience of 20 distinguished engineers at your elbow, ready for consultation or study. It answers all questions, clears up technical problems and difficulties in language that you can readily understand. Cross-indexed, so that you can put your finger on just the information you want in a moment.

These 8 large volumes, bound in half morocco, gold stamped, contain 3,900 pages, 3,000 plates, drawings, diagrams and illustrations, with hundreds of proved facts and tested plans. A great value at the regular price, yet for a limited time you may secure them for the introductory price of \$24.80—\$2 a month.

**SHIPPED FREE** Examine the set before you send a penny. We want the books themselves, not what we say, to help you decide whether you need them. Merely on receipt of the attached coupon we send you the complete library, express prepaid.

Take a whole week to look them over. Test them on some problems that have been bothering you. Then if you decide you want the set, send us \$2. Otherwise tell us and the books come back without a penny of expense to you.

### What These Books Cover

Plane Surveying—Mechanical Drawing—Plotting and Topography—Railroad Engineering—Statics—Strength of Materials—Roof Trusses—Mill Building Construction—Cost Analysis in Relation to Engineering—Masonry and Reinforced Concrete—Steel Construction—Practical Problems in Construction—Bridge Engineering—Highway Construction—Hydraulics—Water Supply—Irrigation Engineering—Water Power Development—Sewers and Drains—House Drainage and Sanitation—River and Harbor Improvements, etc., etc.

## Free \$12.00 Consulting Membership

Besides the practical value of the library itself, you get our \$12.00 consulting membership free as a holder of these books. Our staff of civil engineers takes up and solves your problems and special difficulties, absolutely without cost to you. This privilege, which regularly sells for \$12, is yours for a full year free, if you take the cyclopedia.

To find out how useful these books will be to you, you must see them. It costs nothing to look the set over. It does not obligate you in any way. We stand ready to take the books back without expense to you, if you are not pleased with them. Get the books. Examine them. Then make your decision.

## FREE COUPON

Worth \$15.20 to You

American Technical Society, Chicago, U. S. A.

Please send me Cyclopedia of Civil Engineering for 7 days' free examination. If I decide to buy, will send \$2 in 7 days and balance \$2 a month until \$24.80 has been paid, when \$40 books and \$12 consulting membership will be mine. Otherwise will notify you and hold books subject to your order. Title not to pass until fully paid. Pop. Mech. 6-14

NAME .....

ADDRESS .....

As I have had no previous dealings with you, I refer you to

Please Mention Popular Mechanics

**10  
Days  
Trial  
FREE**



# Monitor Self Heating Sad Iron MAKES IRONING EASY AND A PLEASURE

Pronounced the world's best by over 575,000 satisfied users. No hot stove. Easy to operate. Heat regulated instantly. Satisfaction guaranteed, Highest in quality, Lowest in price, Highly polished and Nickel-plated. Mrs. Larkins, Michigan, writes: "Have ironed six years with perfect satisfaction." Mrs. Cheek of Tennessee says: "Have used my iron regularly each week for three years and like it fine."

**AGENTS WANTED** — Quick, Easy Sales, \$10 to \$20 a day. No experience required. Every home a prospect. McIntosh of Iowa, canvassed twelve homes and sold eleven irons the first day. Trimmer of Illinois writes: "Sold twelve in ten hours." Mrs. Nixon, Vermont, made \$14 in half a day. **Exclusive rights and territory free.**

Write for 10-Day Free Trial Offer and big illustrated circular  
**The MONITOR SAD IRON CO.**  
459 Wayne Street, Big Prairie, Ohio

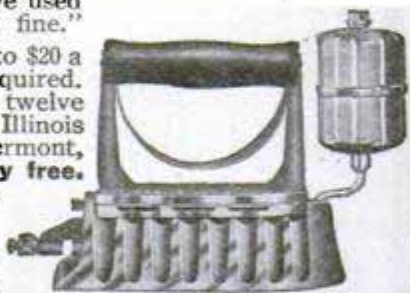

## The "SANITARY" ERASER Handy - Practical - Economical - Always Covered



THE SANITARY ERASER receives, at its open end, a strip of rubber 1/8 inch thick, of a width and length that of the holder.

By slight pressure at the loop end, clean rubber is fed down until used; its narrow edge allows a letter or line to be erased without injuring another. Two rubbers of best quality are made; one for typewriter and ink, one for pencil.

Handsomely finished; Easy to Operate and "They Always Work" EVERYBODY should have this NEW ERASER, Price 10¢. Refills, Typewriter and ink, or Pencil, 5¢ each. Your Stationer.

**O.K.**  
TRADE MARK  
REG. U.S. PAT. OFFICE

When ordering by mail, state whether Typewriter and ink, or Pencil, enclose 2¢ extra for postage. Booklet of our 3 "O.K." Office Necessities Free. The O. K. Mfg. Co., Syracuse, N. Y., U.S.A.

## BIGGER MONEY FROM MUSHROOMS



There never was a time when such big, quick, easy and sure profits could be made in growing mushrooms, today. Learn the great revolutionary improvement in mushroom culture "The Truth About Mushrooms," from the greatest practical authority in America. Grow mushrooms now if you never thought of doing it before. Present occupation will not interfere. At \$10 to \$70 to your weekly income.

Small capital to start. Profits now bigger, quicker, easier. Demand exceeds supply. Grow in cellars, sheds, boxes, etc. Any one can do it. Women and children, too. Now is the time. Send for this book today; it's Free.

BUREAU OF MUSHROOM INDUSTRY, Dept. 163, 1342 N. Clark St., CHICAGO

Potato production in the United States is small, compared with certain other countries having a much smaller area and much less population. The product of Germany in 1911 was 1,263,000,000 bu.; Austria, 426,000,000; France, 424,000,000; and the United States, in the year in question, 293,000,000 bushels.

**Sears,  
Roebuck  
and Co's  
Greatest  
Triumph**

**HARRIS  
VISIBLE  
Typewriter**

**\$39<sup>80</sup>**

**SOLD ON  
30 DAYS  
TRIAL**

THE Harris Visible Typewriter is sold on 30 days' trial. It must give you satisfaction in every particular or we expect you to return it at our expense.

The Harris is standard in size and shape, has every feature that makes for neat, rapid, efficient typewriting. Write today for Special Typewriter Catalog No. 80P97, with liberal cash and time payment offers.

Sears, Roebuck and Co.  
Chicago



Agents  
Wanted

## WRITE 600 WORDS WITH ONE DIP

Why use ordinary pens with the never ending dip — when One Dip Pens make every penholder virtually a fountain pen.

Send 10c for Sample Package

One Dip Pen Co., 34 Daily Record Bldg., Baltimore, Md.

Over 80,000 in Use  
Mostly sold by recommendation.  
For Personal Desk  
or General Office.

It checks mental calculations. Handsome Morocco case free. Buy Thru Your Stationer. Write for 10 day trial offer. E. Ganeher, A. A. M. Co., 119 W. Broadway, New York City.

Agents Wanted

Golden Gem \$10  
PORTABLE  
Adding Machine

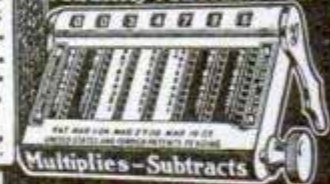

Multiples - Subtracts



## RANGER BICYCLE

Have imported roller chains, sprockets and pedals; Departure Coaster-Brakes and Hubs; Puncture Proof Tires; highest grade equipment and many advanced features possessed by no other wheels. Guaranteed direct to you are less than others ask for. Other reliable models from \$12 up. A good second-hand machines \$3 to \$8.

**10 DAYS' FREE TRIAL** We ship on approval, prepaid, anywhere in U.S., without a cent in advance. DO NOT BUY a bicycle or a pair of tires anyone at any price until you get our big new catalog and special prices and a marvelous new offer. It brings everything. Write it now. TIRES, Coaster-Rear Wheels, lamps, parts, sundries, half usual price. A new machine, the one you need, is yours for nothing.

# STEEL Shingles

**SPECIAL  
30-Day  
Low Price**



We are making a special proposition this month that enables anybody to own a handsome, genuine Edwards Steel Shingle Roof. Before you even think of laying wood shingles, prepared paper, composition roofing or tin, get Edwards' Special 30-Day Low-Price Offer on STEEL Shingles—that never rot, rust, burn nor leak; that outlast best wood shingles four to one; that go on in big sheets of 100 at a time; that you can lay yourself with hammer and nails; that need no paint, no repairs, no extras. \$10,000 Guarantee Bond against lightning.

**Direct from Maker, Freight Paid**

We sell direct from factory to user. No middlemen's profits. You save 25% to 50%. At this Special 30-Day Low Price, Edwards Steel Shingles offer more for the money than any other roof you can lay! Costs nothing to find out. Write today.

**Give Roof Dimensions if Possible**

It will save time if you can give size of roof when you write. If you can't, send anyway for new Bargain Circular No. 550 and we'll quote prices that will astound you. (151)

**THE EDWARDS MFG. CO.**

500-550 Lock Street

Cincinnati, Ohio



## TYPEWRITERS ALL MAKES

All the Standard Machines SOLD or RENTED ANYWHERE at 1/4 to 1/2 MFR'S PRICES, allowing RENTAL TO APPLY ON PRICE. Shipped with privilege of examination. Write for Illustrated Catalog L.

TYPEWRITER EMPORIUM, 34-36 W. Lake St., CHICAGO



## Your Choice, 3000 Typewriters

Underwoods, \$30; Oliviers, \$25; L. C. Smiths, \$15; Remingtons, \$12; Royals, \$24; and other makes as low as \$10. Every one perfect and guaranteed two years. Expert repairing. Free trial. ALL MAKES TYPEWRITER COMPANY, 150 Ashland Block, CHICAGO

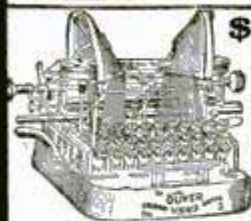

## \$4 Per Month Buys This Visible Oliver Typewriter

Nothing Down—Free Trial. Less than Agents' Prices. Shipped on approval. If you want to keep it, send us \$4 a month. Our booklet is worth sending for because it tells you how to save \$41.50. It's FREE.

Typewriters Dist. Syndicate  
166 R-33 N. Michigan Blvd., Chicago

## Shipped FREE! Superb Wing Piano

Yes, we will ship absolutely free to you a highest grade Wing Piano or Player-Piano DIRECT from our own factory all freight prepaid. Your choice of 38 new art styles on four full weeks' Free Trial in your own home. At the end of 4 weeks, if you wish you may return it at our expense. You alone are the judge. No money down—no security—no obligations whatever.



One of 38 Styles

**Rock-Bottom Offer** You will be amazed at our direct-from-our-factory price on the famous Wing, guaranteed for 40 years. Small monthly payments or cash if you prefer, but first 4 weeks absolute free trial.

**Write Now** For "Book of Complete Information About Pianos" sent free and postpaid. It tells all the secrets of piano making and piano selling. Its 136 pages show you how to judge piano quality and prices. We will also send our catalog of newest art styles in Wing Pianos. Write Now.

WING & SON (Established 1868)

Wing Bldg., 13th St. & 9th Av., Dept. 1195, New York, N. Y.



## Use This Camera 10 Days FREE

Do not send us a penny, merely send your name, address, etc. on coupon below, and the genuine Folding Naco 3-A, the camera with a national reputation, will be sent to you Parcel Post prepaid. Try it for ten days, see how splendidly it works, note the high grade rapid symmetrical lens, Naco automatic shutter, brilliant reversible finder that works either horizontally or vertically, two tripod sockets, and improved spool holder—for either six or ten exposure films. This is an ideal camera, high grade, post card size—3 1/4 x 5 1/2; use it for pleasure or profit; take pictures for making money, or take pictures for fun or study. It is a great pastime and a liberal education.

If at the end of ten days, you find that it's just the camera you want, send us \$2.00, and thereafter \$2.00 a month for nine months—\$20.00 in all. If you do not want it, simply return the camera at our expense. You take no risk.

## This is the Greatest Camera Offer Ever Made in America

This celebrated Naco 3-A Folding Camera sells for \$20.00 cash everywhere in the world, that's the standard price—we offer it to you at the same price on the easy-payment plan, only \$2.00 a month. This is the first time you have ever had the opportunity to buy a standard high grade camera on the easy-payment plan.

**Special Film Offer** You will need one or more rolls of film to try out this camera, and we are making a special offer: Send us 50c and we will send you a roll of films that will take 6 pictures; after you have taken the pictures, send the roll to us and we will develop and print them and send them to you without any additional charge.

**Fill Out This Coupon Today** and try the wonderful Naco 3-A for 10 days, free. We will send it to you prepaid. You take no risk.

Send me for ten days' free trial the Naco 3-A Camera. If I am satisfied with it, I will send you \$2.00 as first payment, and then \$2.00 per month for nine months. If I do not wish to keep the camera, I will return it to you within ten days at your expense. (I enclose 50c for your special film offer.)

**National  
Camera  
Company**  
1415 Chestnut St.  
St. Louis, Mo.

**National Camera  
Company**

1415 Chestnut  
Street  
St. Louis  
Mo.

NAME .....

STREET .....

CITY .....

AGE.....OCCUPATION.....

Please Mention Popular Mechanics

# Our New Invention Will Make You Independent



— yes, it will make you free forever from long hours and small pay. It will "Put you on your feet" in a hurry—where you can easily make \$25 a day and up. Hundreds of fellows just like you have joined the ranks of big Money Makers by becoming the operator of a

## DIAMOND POST CARD GUN

— a wonderful photographic studio complete in itself—an all metal camera that takes post cards direct on the positive paper, in 4 sizes including large official size; also photo buttons, clear, sharp pictures at the rate of 5 to 8 per minute, on the spot, and you make 8 cents net profit on every dime (post cards sell at 10c each or more). Just the thing to take with you to

**BATHING BEACHES, BALL PARKS, CARNIVALS, FAIRS, ETC.**

It's the biggest money maker you ever heard of. Just pose your customers, load the camera, click the bulb and deliver the picture on the spot. It's a "cash" business that pays big.

**NO EXPERIENCE NEEDED—NO PLATES—NO FILMS OR DARK ROOM** The Diamond takes, develops, tones and finishes pictures right on the spot in one minute. Any one can operate the Diamond—only one solution used.

**\$25.00 a Day  
For YOU**

**WRITE us Today** for full particulars, FREE illustrated booklet and our special offer to those who answer this advertisement. At Once tisement quick! Send NOW this minute, and learn how the "Diamond" will make you independent.

**INTERNATIONAL METAL & FERROTYPE CO., 2223 W. 12th St., D. 512, CHICAGO, ILL.**

## DUCK'S BIG 325 PP. ELECTRICAL AND WIRELESS CATALOG

Mailed for 8c, stamps or coin, which you may deduct on first order of \$1.00. Great cost of catalog and low prices prohibit distribution except to those really interested. Most elaborate catalog of its kind published. Catalog contains more valuable information on wireless and electricity than many text books. Contains 125 pages wireless insts. and raw material for making insts., numerous diagrams, hookups, etc. 15 pages telegraph insts., 42 pages motors and dynamos. 150 pages flashlights, lamps, lighting plants, ammeters, guns, radiopticons, miniature railways and mechanical books.

Our lighting plants possess exclusive advantages over all other types. They cannot be surpassed in quality and are absolutely fool proof, requiring less attention and care in operation than any other plant on the market. They are also very reasonable in price.



**Complete Home Electric Lighting Plants.**

If interested in lighting plants ask for special literature.

**THE J. J. DUCK COMPANY, Arcade Bldg., TOLEDO, OHIO**

**Boy Electrician** with 75 illustrations for making Batteries, Dynamos, Motors, Telegraph apparatus, Telephone, Lights, Bells, Alarms, Coils, "Wireless" Current Reverser, Electric Engine, Etc. By Electrical Experts so that anyone can understand it. With Cat. All 10c Ppd.  
**J. C. DORN, 705 So. Dearborn St., Dept. 21, Chicago, Ill.**

**Big Entertainer** 320 Jokes and Riddles, 153 Parlor Games and Magic, 15 Tricks with Cards, 73 Toasts, 7 Comic Recitations, 3 Monologues, 22 Funny Readings. Also Checkers, Chess, Dominoes, Fox and Geese, 9 Men Morris. All 10c. postpaid.  
**J. C. DORN, 709 So. Dearborn Street, Dept. 17, Chicago, Ill.**

**Boys' Own Toy Maker** Tells how to make a Talking Machine, Camera, Electrical Motor, Bicycle Boat, Canoe, Boomerang, Bobsled, Wind Mill, Microscope, Water Wheel and Motor, Stilts, Toboggan, Snow Coaster and Sail Boat, Telephone, Electric Bell, Railroad Wind Mobile, Paddle Raft, Traps, Kites, etc. All 10c, postpaid.  
**J. C. DORN, 707 So. Dearborn St., Dept. 38, Chicago, Ill.**

## A Complete Wireless Station

**\$985**

Receives 1200 Miles  
Sends 12 to 15 Miles

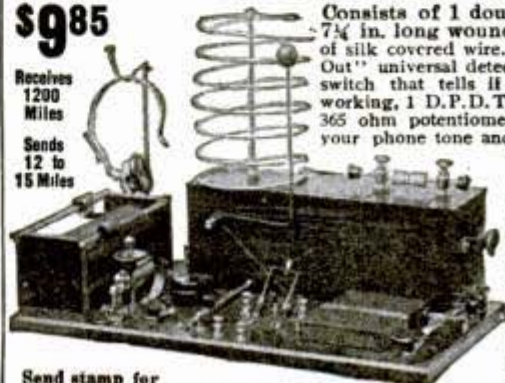

Consists of 1 double slide tuner 7 1/4 in. long wound with 160 feet of silk covered wire. Our "Don't Jar Out" universal detector, 1 buzzer and switch that tells if your detector is working, 1 D.P.D.T. aerial switch, 1-365 ohm potentiometer — it increases your phone tone and distance 30%, 1 fixed condenser, 1 standard wireless key, 1 spark coil guaranteed to give 1 1/2 inch spark, 1 helix & cord, 1 machine turned spark gap, 1 flat 8-plate condenser, 1-1000-ohm double pole receiver and cord, 1 nickel-plated headband, 6 insulators & diagram.

Send stamp for bulletin "P" for other remarkable values.

**Nichols Electric Co., 35 Frankfort St., N. Y.**

## ELECTRIC LIGHT PLANTS

Complete gasoline engine, dynamo switchboard and storage battery \$250

Agents wanted. American Battery Co., 1139 Fulton St. Chicago (Estab. 1894)

**EXPORTS AND IMPORTS OF EGGS**—Twenty one million dozen eggs were exported from the United States in the fiscal year 1913, against 1,500,000 dozen years ago, and 143,000 dozen, 20 years ago. The import of eggs in the natural state, in the same period amounted to only 1,271,765 dozen. The average price at which the eggs were exported was 21 1/2 cents dozen and the average import price was 15 cents dozen.

## New Model Watch-Shaped AUTOMATIC LIGHTER 50

Most attractive and useful article ever presented. Operated with one hand; gives an instantaneous light. No battery, non-explosive, does away with matches. Lights your pipe, cigar, cigarette, lamp, gas jet, etc. Dandy thing for the end of your chain.

**AGENTS WANTED EVERYWHERE**

Write for wholesale terms and prices.  
**P. Brandt Mfg. Co., 148 Duane St., N. Y.**

## Send for Copy of Our New Wireless Manual P1

It contains 96 pages and tells how to erect and maintain wireless telegraph stations. Shows a number of diagrams. Has the Morse and Continental Telegraph Codes. Illustrates the best instruments to use, tells what they are for and how to use them. Do not wait until some other time, but sit down now and send your name and address, and get one. It costs you nothing.



## Send for Our Pocket Catalog P26

It contains 212 pages, with over 1,000 illustrations and describes in plain, clear language all about Bells, Push Buttons, Batteries, Telephone and Telegraph Material, Electric Toys, Burglar and Fire Alarm Contrivances, Electric Call Bells, Electric Alarm Clocks, Medical Batteries, Motor Boat Horns, Electrically Heated Apparatus, Battery Connectors, Switches, Batteries, Gauges, Wireless Telegraph Instruments, Ignition Supplies, etc.

**It Means Money Saved to You** to have our Manual and our Catalog when you want to buy

**MANHATTAN ELECTRICAL SUPPLY CO.**

NEW YORK, 17 Park Place CHICAGO, 114 S. Fifth Ave. ST. LOUIS, 1106 Pine St. SAN FRANCISCO, 604 Mission

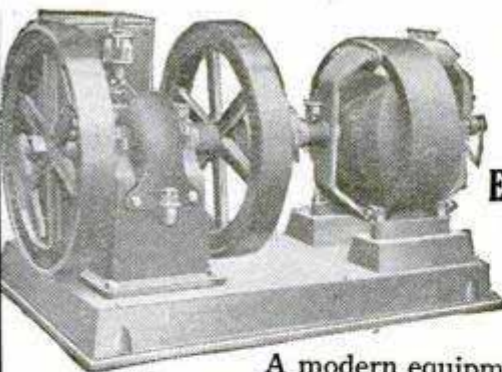

**LIGHT YOUR HOUSE WITH ELECTRICITY**

Put in a Direct Connected Gasoline Engine and Dynamo.

A modern equipment at small cost for farm and house lighting and small isolated plants. Dynamo has an output of 42 volts, charges the battery during the day, and 32 volt lamps are used to light the house. Operation steady and quiet. Write for circular. **E. CARLISLE & FINCH CO., 244 East Clifton Ave., CINCINNATI, OHIO**

**Hello Boys!**

Do You Know thousands of boys like you are having barrels of fun with this toy? Parents give some, many boys "save up" and buy themselves. Can't you get in on this good time? Get now

Make lots of Toys

**The Mysto ERECTOR**

**FREE BOOK** My free, 24 page book, in two colors, describes this wonderful toy, its NEW MOTOR, girders, wheels, etc. **HURRY!** Send postal now. Ask about prize contest. Give dealer's name. Address A. C. Gilbert, Pres., **MYSTO MFG. CO., 53 Foote Street, New Haven, Conn.**



**ELECTRIC HOME, FARM, STORE, THEATRE & TOWN LIGHTING PLANTS.** Water Wheels Engines & Power Motors, Dynamos, Batteries, Ozone & Massage Machines, Bicycle, Hunting, Fishing, Flash & Motorcycle Lights. **PICTURE THEATRE COMPLETE EQUIPMENTS START YOU WITH BIG PROFITS.** Cat. 3 cents. **WILSON ELECTRIC WORKS, CLEVELAND, OHIO**

**SUPPLIES FOR THE WIRELESS EXPERIMENTER** This little ad is just to catch your Eye. Our Catalogue "B" is sure to catch your eye. A 2 cent stamp brings it by return mail. Send for it NOW. **WILSON ELECTRIC & MANFG. CO., 711 So. Dearborn St., CHICAGO, ILL.** Successors to Dawson & Winger Electric Co.

**BUY THIS PRINTING PRESS** The "Ideal" is an absolutely practical printing press, suitable for store, office or home. It's a wonder—always ready for work. Save dealers' profits. Write for a copy of our free catalog of printing presses and supplies. **IDEAL PRESS CO., 2011 N. Lawndale Ave., Chicago, Ill.**

**Do Your Printing!** Cards, circulars, books, newspaper. Presses \$5, Larger, \$18, Rotary \$60. Save money. Big profit printing for others. All easy, rules sent. Write factory for press catalog. TYPE, cards, paper, outfits, samples. **THE PRESS CO., Meriden, Conn.**

**FACTORY TO YOU CLASS PINS** For College, School or Society. Log with attractive prices mailed free upon request. Special offer, either style of pins here rated with any three letters and figures, one color of enamel. **STERLING SILVER, 30c each, \$3.00 SILVER PLATE, 15c each, \$1.50 dozen.** **THE BASTIAN BROS. CO., 278 Bastian Bldg., ROCHESTER, N. Y.**

**Wonders Never Cease BENJAMIN Pump Air Gun** Newly Perfected Air Rifle. Gun that every boy and man is looking for. **MORE REPAIRS. NO MORE RUBBER BANDS. CANNOT GET OUT OF ORDER.** Simple of construction. No springs. Run using compressed air. Force of shot under control. Shoots strong or penetrates one-half inch pine. The ideal practice or small game rifle. Almost silent when discharged. Uses Air Rifle Shot. Gun is finely finished. Circular and literature sent upon request. Order from your dealer. **Benjamin Air Rifle & Mfg. Co., 609 N. Broadway, St. Louis, Mo.**

**Famous Acousticon For the DEAF**

You have heard about the famous Acousticon—you have needed one—you've wanted one. You can secure it from our factory at the factory price wherever you live **NOW DIRECT BY MAIL**

The Acousticon is the instrument everyone knows will positively enable you to hear the slightest sound. It makes no difference what you have tried without satisfaction, you have never used anything like the Acousticon. There is nothing else like it—it must not be confused with any other instrument. The Acousticon is the instrument which you easily regulate instantly to enable you to clearly

**Hear Every Sound**

near or distant—loud or low, indoors or outdoors, under every conceivable condition. One of the advantages that make the Acousticon the great hearing device



of today is the patent that transmits every sound, not only clearly, but absolutely natural. The Acousticon retains and transmits to you the original quality, or tone, of every sound. Not a word blurred—not a single sound is harsh. This remarkable quality of sound is possible only by our patented transmitter, which receives the sound on the indirect principle. The Acousticon is the instrument that covers

**48 Degrees of Deafness**

and defective hearing. It makes absolutely no difference what the cause of deafness, unless you are "stone deaf" or born deaf, the Acousticon will positively enable you to hear every sound—perfectly. We claim this—thousands of people know it—and we prove it.

The Acousticon is not a theory—not a new, untried device—but a world-known success for years. Why is it installed in hundreds of churches, theatres, banks and other public institutions? Why is it used all over the world by thousands?

**NO DEPOSIT Ten Days FREE TRIAL**

Write for our special offer—10 days free trial—no deposit—no promise to buy—let us prove the Acousticon is the instrument you must use.

**EASY TERMS** Learn how to secure an Acousticon on easy monthly payments before special offer expires.

**WRITE** now for free copy of the greatest book of facts for the deaf ever printed, with testimonials from ministers, judges and others.

**General Acoustic Co., 1322 Candler Bldg., 220 W. 42nd Street, New York City**

# "YANKEE" TOOLS

*Make Better Mechanics*



## Two Speeds

Changed by a little lever without taking drill from work.

## Breast Plate

can be turned to right angle of position shown.

**Two jaw chuck** for round or squareshank tools.

**Three jaw chuck** for round shanks only.

## 5 "Yankee" Adjustments

- 1st notch — Plain Drill
  - 2nd notch — Left-hand Ratchet
  - 3rd notch — Right-hand Ratchet
  - 4th notch — Double Ratchet
  - 5th notch — Gears locked (for changing drills)
- Changed at a finger touch

# "Yankee" Ratchet Breast Drill

Made for the tough jobs that you can't get at with ordinary breast drill, without taking apart the work. It operates in places impossible for other drills. The five adjustments of the Ratchet Shifter give you operating control that doubles your working capacity, saves time, saves labor.

With the Double Ratchet the drill cuts continuously with every move of the handle forward and back. No lost motion, every push and pull counts in the cutting. The accurate alignment of the jaws holds the drills absolutely centered.

## "Yankee" Ratchet Breast Drill

Length 17 in.—Weight 6½ lbs.

No. 1555 — 3 jaw chuck **Price \$5.25**  
 No. 555 — 2 jaw chuck

Your dealer can supply you.

Write for "'Yankee' Tool Book," free for mechanics and householders. "'Yankee' Tools in the Garage" for Motorists.

**NORTH BROS. MFG. CO.**  
**PHILADELPHIA**

The Sharpening  
 Stones You  
 Can  
 Depend  
 Upon

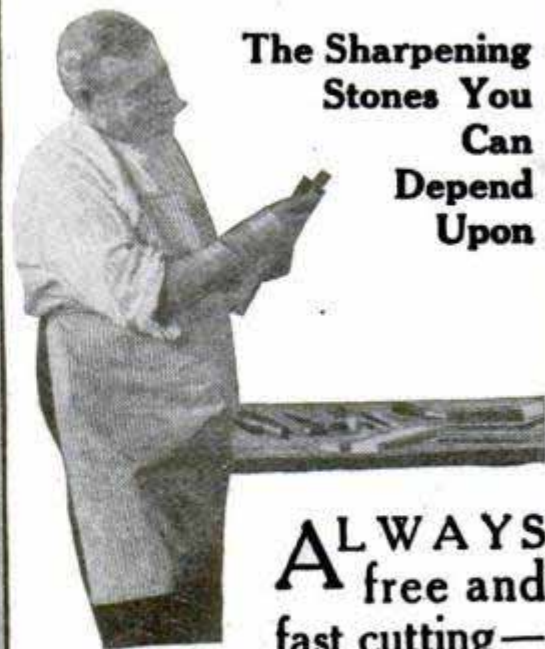

**ALWAYS** free and fast cutting—

uniform in their texture, holding their shape, and showing almost as long a life as your tools.

## Carborundum Sharpening Stones

Have earned a place in the tool kits and on the work benches of users of edge tools everywhere. There is nothing harder, sharper, or faster cutting than Carborundum.

*There is a Carborundum Stone for Every Sharpening Job.*

From Your Hardware Dealer or Direct.

## The Carborundum Company

Niagara Falls,  
 N. Y.





# Are You Making Something?

Have you invented some device or machine that you are anxious to have just right? Are you making a model that you wish to be particularly proud of? Are you experimenting with some delicate apparatus, the success of which depends on your workmanship? Then insure the accuracy of your measurements and speed up your work by using

## Starrett Tools

The measuring tools—rules, gages, caliper-squares, micrometers, vernier calipers, etc., are the last word in accuracy. Work measured with them is right, and the other tools for general purposes, such as the expansion pliers, cut nippers, screwdrivers, etc., are made to give a wide range of service and to last a lifetime. An advertisement can't do Starrett Tools justice.

Let us send you our free catalog 20 AP which describes the full line and gives prices. Do not forget that Starrett Tools are sold at all good hardware stores.

**THE L. S. STARRETT CO.**  
ATHOL, MASS.

42-182

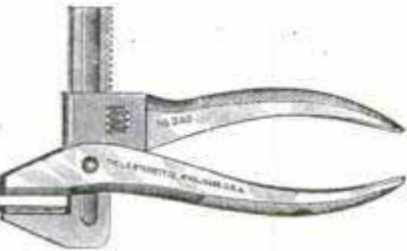
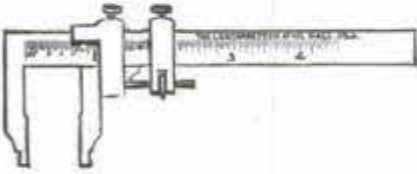
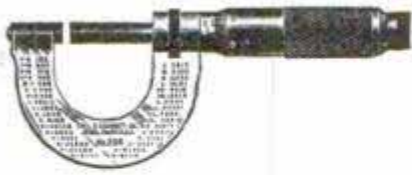

### Portable Cases FOR TOOL MAKERS AND MACHINISTS

Twelve styles, felt lined drawers, solid brass trimmings, best of material, beautiful finish, low prices, satisfaction guaranteed. Ask for booklet of cases built for service.

**The Pilliod Lumber Co.**  
SWANTON, OHIO

### SQUARE HOLE DRILL

A new, simple and practical tool, just perfected



**FOR WOOD  
METAL  
MARBLE**

Fits chuck in any brace, drill press, or lathe and by circular motion drills a square hole at one operation. Made of high grade steel, fully guaranteed. Sizes 1/8 in. to 1/2 inch in sixteenths. When ordering state size and kind (whether for wood, metal or marble.)

**BARNETT TOOL CO.**

1690 Hyde St., SAN FRANCISCO

**PRICE \$1**

per set of Drill and Guide, delivered anywhere

### THE MASTER SLIDE RULE,



The only **RULE IN THE WORLD** whereby inside measurements of doors and windows, etc., can be taken rapidly and accurately. Also superior to any other for outside measurements of walls and ceilings, etc., as it can be extended or closed instantly. **MECHANICS, BUILDERS, AND ARCHITECTS, TRY ONE DAY! DON'T WAIT.** Ask hardware dealer for it. On receipt of 15 cents per lineal foot, a 4, 5, 6 or 8 foot rule will be sent you prepaid. Large profits to agents. Write for circulars and particulars. **AHL MFG. CO. 51-A East 42nd St. NEW YORK CITY**

An Absolutely Accurate

## Core Box Plane

Every pattern-maker realizes the need of a plane that will cut half circle 3/4 to 6 inches. This is the only tool ever devised that will do it. Mechanics who are using this tool tell us it is worth one hundred dollars. Sold on a guarantee—your money back if dissatisfied in any way.

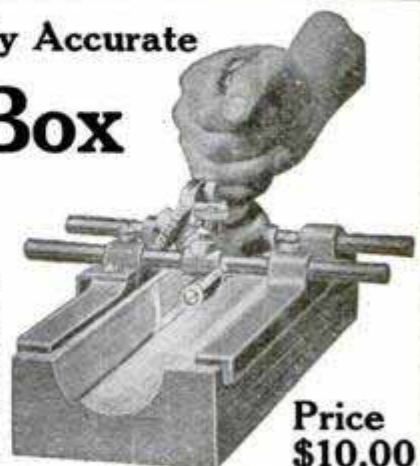

**Price \$10.00**

**Economy Mfg. Co., Columbus, O.**

One sample to one person only, \$1  
Ask about our 3,000 R.D. Tools

### "Red Devil"

SPECIAL

Heavy "Klein" Pattern Electricians' No. 1950 Side Cutting Plier, 8"

**SMITH & HEMENWAY CO.**  
150 Chambers Street, New York City, N.Y., U.S.A.

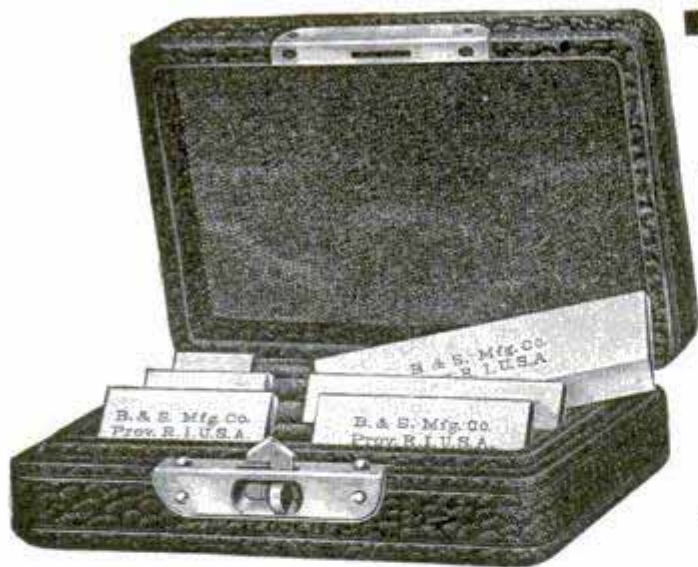

# This Handy Set of Straight Edges

is a valuable addition to the kit of every mechanic

The set comprises six lengths,  $\frac{1}{2}$ " ,  $\frac{3}{4}$ " , 1" ,  $1\frac{1}{4}$ " ,  $1\frac{1}{2}$ " and 2" .

You will find them particularly adapted for testing surfaces where it would be impossible to use a regular straight edge, and for testing flanged and ball bearing washers. They are  $\frac{5}{64}$ ths of an inch thick, and  $\frac{19}{32}$ ds wide.

*Our 365 page catalog free for the asking illustrates this and many other useful tools of quality. Write for one today.*

**BROWN & SHARPE MFG. CO.**  
PROVIDENCE, R. I., U. S. A.

## A HOME BENCH

MADE BY  
Grand Rapids Hand Screw Co.



HERE IS  
THE ONE  
THING I  
REALLY  
NEED

(Cash with the Order) No. 97—\$8.85 Delivered

In U. S. within 300 miles of Grand Rapids, Mich.  
To points beyond add \$1.00 for excess freight.

Made from Michigan white maple. Has two vises, backboard, tool rack. Top is double tongue and groove construction. Size 46 in. long, 18 in. wide, 32 in. high. Just the thing for household repairs. Instructive, entertaining and profitable to boys taking manual training.

OUR BOOK "HOME BENCHES" IS FREE

GRAND RAPIDS HAND SCREW CO.  
1622 Front Av., N. W., GRAND RAPIDS, MICH.

Please Mention Popular Mechanics

WHERE DIAMONDS COME FROM—Most of diamonds imported into the United States, while originating in South Africa, are invoiced from the Netherlands, Belgium, France, and the United Kingdom. Ab

### SOLDERING IRON ALWAYS READY

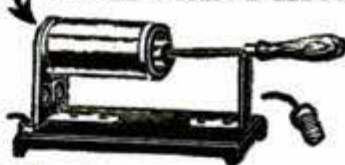

With the use of the Current Electric Furnace, any voltage, comes in three sizes complete. Cost of operation very low, cheaper and by far superior than any other known method. No more expensive delays and danger caused by the use of gas, oil, gas line, etc. Furnace absolutely guaranteed, money refunded if not

satisfactory. Price very low. WRITE FOR PRICES AND CIRCULARS.  
CURRENT ELECTRIC COMPANY, 18 E. Kinzie St., Dept. E19, Chicago, Ill.

\$1.00

Postpaid

Myers' Wonderful Sewing Awl

sews leather, canvas, shoes—anything, heavy or light. Complete repair shop in itself. Saves many trips to town. Mends harness, saddles, wagon covers, blankets, buggy tops, belts, etc. Can't get out of order. Original and only awl with diamond point full grooved needle to protect the thread. BIG MONEY FOR AGENTS.  
C. A. MYERS CO., 6339 Lexington Ave., Chicago, Ill.

## GROBET SWISS FILES



Are the standard of excellence files, and have been for over 100 years. We send post paid as an introducer 48 files especially adapted for tool makers and machinists on receipt of \$5.00. This is a chance to get a set of files you appreciate and we'll get future orders.

**MONTGOMERY & CO.**  
111 Fulton Street NEW YORK CITY



A bolt  
you'll  
swear  
by—

# SEBCO

for fastening electrical or other fixtures to hard walls so they cannot possibly loosen or wobble. Never has—never can fail! Expands when inserted and becomes practically part of wall. SEBCO Screw Anchor serves same purpose for lighter fixtures.

Write for Catalog and Samples

**STAR EXPANSION BOLT CO.**  
147-149 Cedar St. NEW YORK

Two-thirds of the uncut diamonds are imported from the United Kingdom, in whose South African possessions the principal diamond mines of the world are located. Of the cut diamonds imported, more than three-fourths are from Belgium and the Netherlands, about equally divided between those two countries. While the United Kingdom, Belgium, and the Netherlands are large importers of diamonds, a considerable proportion thereof are, in each case, re-exported.

## GASOLINE SOLDERING IRON BLOW TORCH

HERE IT IS   
Address Dept. 1. EMMELMANN BROS. MFG. CO., INDIANAPOLIS, IND., U.S.A.

## THE SPEEDY STITCHER

TWICE LEATHER LIKE A MACHINE

Price \$1.00   
Write for terms to Agents  
Automatic Awl Co., 26 Hermon St., Worcester, Mass.

**Luther Hummer Tool Grinder**  
 Quick and easy. No water needed. Can't draw temper. Steel shafting like automobile. Dust-proof bearings and gears. Perfect lubrication. Patented tool rest.  
Write for free booklet  
**LUTHER GRINDER MFG. CO.**  
904 Point Street MILWAUKEE, WISCONSIN

**Tool Cases for Toolmakers and Machinists.**  
Keep your tools orderly arranged in a Gerstner Portable Tool Case. There's a place for every tool in one of the felt lined drawers. Every up-to-date mechanic needs one and you'll find our Cases the best built, neatest and most practical on the market. We guarantee to please or refund all money.  
  
**Gerstner & Sons.**  
Mrs. of Mechanics' High Grade Tool Cases  
818 Columbia St. DAYTON, OHIO



# "IRWIN"

*stamped on a bit means Quality.*  
Otherwise used it may mean only pattern.

Not every bit made after the Irwin pattern is a genuine Irwin Bit.

Make sure of getting the benefit of both the Irwin pattern and the genuine Irwin Quality.

Look for the registered trade mark "IRWIN" on the shank of every bit.

*Only when so stamped is the bit made by*

**The Irwin Auger Bit Co.**  
of Wilmington, Ohio,  
*Originators*

# The IRWIN Bit

Reg. U.S. Pat. Office

Please Mention Popular Mechanics

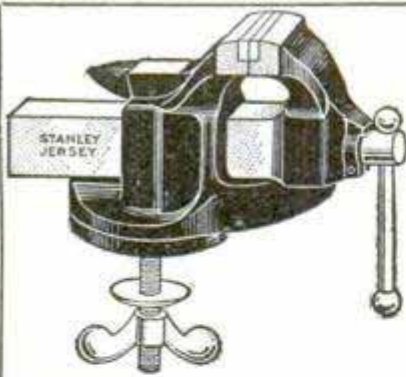

**Stanley  
Tools**

## "Jersey" Vises

**T**HE handiest, most substantial and best Vise ever made. Will prove its worth every day in the week.

Put one in your tool box, on your work-bench or in the kitchen table drawer. You will be surprised how often you will want to use it.

Made in a number of different sizes and in several styles.

**For Sale by All  
Up-To-Date Hardware Dealers**

Special circular describing  
all styles upon application.

Address

**STANLEY RULE & LEVEL CO.  
NEW BRITAIN, CONN. U.S.A.**

## Quick Drilling Where You Want It —by Electricity



Saves time  
and labor.  
It doubles  
efficiency.

Attaches to any  
Electric Light Socket.

### A Portable Machine Shop

Handiest device ever known for drilling, tapping, grinding valves, sharpening tools, etc.—quickly and easily. Does away with tiring hand work.

## TEMCO Electric Portable Drill

Weighs only 11 pounds. Perfect balance between handles makes it seem doubly light and free to place and hold. Has famous Temco motor. Connect with any lamp socket (A. C. or D. C.) Costs only 1 cent per hour to run. Reverses instantly on full speed. Changes tap to drill in one minute. Has multitude of uses. Saves cost quickly in time and hard work. Guaranteed not to burn out.

**Ten Days' FREE Trial**

Mail postal or letter quick—get descriptive CATALOG FREE. Address

**The Temco Electric Motor Co.  
577 Sugar St., Leipsic, Ohio**

Special Designers and Mfrs. of 1-50 to 1-6 H.P. Motors.

## THE UNION

### Combined Punch Shear and Rod Cutting Machine Hand Operated

A very useful machine for any place where metal is worked.

**MADE IN THREE SIZES**

- No. 1. Bench Machine (see cut)
- No. 2. Medium size, for Tool and Machine Room
- No. 3. Large size, for heavy, powerful work.

SEND FOR CATALOGUE

Union Manufacturing Co.  
P. & S. Dept., New Britain, Conn.  
26 Cortlandt St., New York



No. 1 or Bench Machine



## "Ohio" Edge Tools

are made from specially selected tool steel, by careful and skillful workmen. They are tempered by the most improved process and are sold with a money back guarantee.

Insist on "Ohio" Tools when buying Planes, Chisels, Drawing Knives, Auger Bits, Screw Drivers, etc.

CATALOGUE FREE

**OHIO TOOL CO.** (Dept. 3)  
Charleston, W. Va.



"AMERICAN"  
Key Cutter

## A Steady Income—Independence—for You

\$5.00 to \$10.00 a day with little effort and small investment. Others are doing it—so can you.

Why not establish yourself in this immensely profitable business? We show you how and supply everything — everything but a little enterprise; that's up to you! Our two unique machines do the trick. The "American" is the only machine that sharpens, hones, and stropps razors, and all kinds razor blades, scissors, clippers, pocket knives, surgical instruments, etc. No previous experience necessary. The "American" Key Cutter is a little wonder, cuts any shape slot. Booklet of information furnished FREE.

Liberal inducement to State agents with means, who can take a financial interest.

**AMERICAN SHARPENING MACHINE CO., Inc.**  
Dept. 5, 184 W. Washington St. CHICAGO

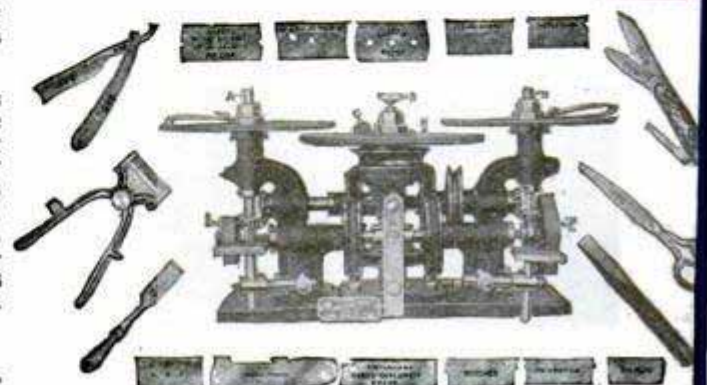

# NEW SLIDE RULE—ADDS—SUBTRACTS—MULTIPLIES—DIVIDES

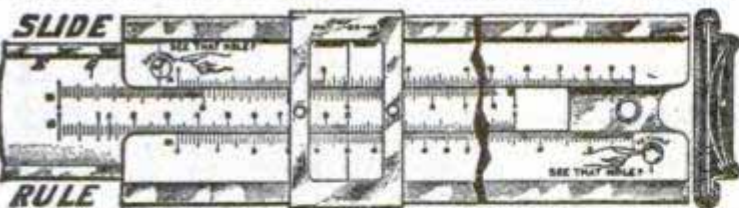

For years the Slide Rule was considered so complicated an instrument that it was used only by Technical men, and there are people today who still have this opinion. The Richardson Direct Reading Slide Rule has put an end to the mystery surrounding this machine, and my 52 p. book, *The Slide Rule Simplified*, shows the actual setting of the rule by 90 full size engravings, for problems which confront men in any vocation. It is written so that you can understand it, and makes the use of the Slide Rule possible for everyone. The examples selected are those which frequently come up for solution by the Banker, Broker, Auditor, Inventory and Insurance

Man, Cost Estimator, Manufacturer, Contractor, Salesman, Manual Training Teacher, Time-Keeper, Book-keeper, Lumber, Land, Marine, and other merchants too numerous to mention.

This Simple Instrument multiplies, divides, adds, subtracts, solves proportion, extracts the square and cube roots, changes fractions to decimals and vice versa, calculates interest, discount, percentage, measurement of superficies, the rule of three, etc., and performs almost any other kind of calculation almost instantly. For Engineers, Draftsmen, Master Mechanics—all technical men—it is indispensable. For Electricians it is a complete wire table. The operation with the use of the key and keyhole is very simple, and the answer is given direct for such problems as, Horse Power of Engines, Pumps, Belts, etc., size of duct for ventilating, radiation and size grate and steam main, change gear and pulley problems, area, circumference and diameter of circles, etc. My new 1914 rule is made in two sizes, coat and vest pocket, 10x1 1/2x3/4" and 5 1/2x1 1/2x3/4". 10" has Sine, Log and Tangent scales on the face of rule always in plain light. No wood in their construction, scales white celluloid, printed from engine divided plates in two colors, washable, and secured by an improved locking device in non-corrodible Monel Metal framing.

Price 10" Rule, Add, Subtract, Multiply and Divide, \$3.00; 10" Rule (non-Add and Subt.) \$2.50; leather case, 50c extra; 5" Rule (non-Add and Subt.), leather case, \$2.50. 10" Dummy Rule bristol board scales, \$1.00. Postage prepaid. If ordered now the book, *The Slide Rule Simplified*, goes Free with each rule. If interested in forming clubs, write for large list of tools GIVEN FREE.

GEO. W. RICHARDSON, 4218 24th Place, CHICAGO, U. S. A.



**Paddington  
Pants-Presser**  
Agents Wanted

Works  
While You Sleep

Three articles in one:  
Pants Presser, Stretcher and Hanger. Absolutely perfect pressing over night. Examine before paying. If our claims fail, return it at our expense. Price \$3.50 and \$5.00. Booklet on request.

2. Paddington Sales & Mfg. Co., 244-46 E. 52nd St., New York

## YOU OUGHT TO HAVE ONE OF OUR Insured "Vandor" Hammers

Drop forged from Vanadium Steel, tempered in oil and warranted for a Lifetime. Will "bite" and draw a

headless nail, that defies the claw of an ordinary hammer. Sent Postpaid anywhere on receipt of \$1 and Dealer's Name. State whether wanted for light, medium or heavy work.

VAN DOREN MFG. CO., Dept. 105, CHICAGO HEIGHTS, ILL.

### Cortright Metal Shingles Will Protect Your Home

Every three minutes an American house catches fire, a large proportion from sparks falling upon the roof.

Cortright Metal Shingles form an absolute protection from flying sparks and brands—they're fireproof, storm-proof, they last indefinitely, are inexpensive, and never need repairs. Our book on roofing tells you why. Send for it now.

CORTRIGHT METAL ROOFING CO.  
Inquiry Dept., 210 S. 7th St., Philadelphia

## Unusual Service Value!



## Williams' Ford Wrench Set

Drop-forged from special steel and designed for extreme and convenient service upon the Bolts and Screws common to the "Ford" construction, the Williams' Superior Drop-forged Wrench Set is without an equal for this service—barring none!

Every tool illustrated in the set is a guarantee of better service and of a longer life of mechanical comfort and usefulness than has ever before been offered for the purpose—an investment in which you must have the utmost of satisfaction.

With Williams' "Ford" Wrench Set and an adjustable wrench you will be prepared for any mechanical emergency which may develop from the use of the popular "Ford" machines. Send for catalog of dependable tools.

J. H. Williams & Co., Superior Drop-forgings  
47 Richards St., Brooklyn, N. Y. City, 32E S. Clinton St., Chicago, Ill.

## Pipe-Threading is so simple with No. 204

It requires only a single operator to handle with perfect ease any size of pipe from 1-in. to 4-in. with the double speed.

### Oster Tool No. 204

One speed for small pipe; another speed for big pipe. Both speeds on the one crank and changeable while in motion without removing crank or any part. No need for wrench or other tool. Ask for free catalog of our 47 famous tools. Use coupon now.

**THE OSTER MFG. CO.**  
2100 E. 61st St. CLEVELAND OHIO

Indy send me by return mail your catalog "List 26A."

NAME.....  
BUSINESS.....  
ADDRESS.....  
CITY.....  
STATE..... (X-100)

THE OSTER MFG. CO., 2100 E. 61st St., Cleveland, Ohio



# Salesmen Wanted

We want 750 five-thousand-dollar a year salesmen. Experience unnecessary. Do not delay. No charge for territory. Exclusive field. Success assured. 150 per cent. profit. Remarkable opportunity. Harvest of real money-making.

We are appointing men every day to manage our business in local territories. We need good, honest, willing workers, and we offer you this opportunity to represent us.

## You Can Make \$5,000 This Year

introducing **THE SWEDISH RHYTHMIC VIBRATOR**, the most amazing seller ever invented. An instrument for home vibratory massage treatment. Needed by every man, woman and family. Endorsed by the highest medical authorities in the world. Produces 30,000 thrilling, invigorating, penetrating, revitalizing vibrations per minute. A masterpiece of mechanical and electrical genius. Sells to the home, to physicians, masseurs, osteopaths, chiropractors, barbers, beauty parlors—unlimited market.

**Investigate** Get free literature and complete information at once. Send just your name and address on a postal card and all will be mailed FREE immediately. Agent's sample furnished at wholesale price. Investigate. Territory being rapidly assigned. But one man allowed in a field. Give the name of your county. Send your name and address today. This is a brilliant opportunity. Do not put it off. Act immediately. Address

**SWEDISH RHYTHMIC VIBRATOR CO.** 131 Vibrator Bldg. Chicago, Ill.  
211-215 Schiller St.

I will send for a short while only my 25c. book

## Improve Your Eyes

For 10c., stamps or coin

A high-grade exercise and massage method that quickly strengthens and beautifies the eyes.

Also a most beneficial system of exercises that will improve the muscles of the temples and side of face, thereby facilitating mastication and vocal pronunciation. Completely illustrated. Entirely without apparatus.

**PROF. ANTHONY BARKER**

4641 Barker Bldg.

110 W. 42d St., NEW YORK, N. Y.

Established 28 years in New York City



## TOBACCO HABIT BANISHED

**In 48 to 72 Hours** Yes, positively permanently banished almost before you know it. Pleasant easy to take. Results quick, sure, lasting. No craving for tobacco in any form after first dose. Not a substitute. Harmless, no poisonous habit forming drugs. Satisfactory results guaranteed in every case or money refunded. Tobacco Redeemer is the only absolutely scientific and thoroughly dependable tobacco remedy ever discovered. Write for free booklet and positive proof.

**NEWELL PHARMACAL CO., Dept. 25, ST. LOUIS, MO**

## Erickson Legs and Arms

Legs that do not chafe, overheat or draw end of stump.

Largest Limb Factory in the World.

**SOLD ON EASY TERMS**

SEND FOR CATALOG

Erickson Artificial Limb Co., 17 Wash. Av. N., Minneapolis, Minn.



## ART STUDIES

### DEN PICTURES IN BEWITCHING POSES

Genuine photos from living models on double-weight stock. 3 swell cabinets, 25c; 6 for 50c, with fine 6 1/2 x 8 1/2 photo FREE with order for 6. Our Dollar Special: 6 cabinets, two 6 1/2 x 8 1/2, and over 50 small photos, all for \$1.00. 10c extra for sealed postage. Money back if not as represented.

**KING CO., 2808 P. M., ANDOVER, OHIO**



## "BOW LEGS and KNOCK-KNEES" UNSIGHTLY

SEND FOR BOOKLET SHOWING PHOTOS OF MEN WITH AND WITHOUT THE PERFECT LEG FORMS  
**PERFECT SALES CO., 140 N. Mayfield Av., Dept. S, Austin Sta., Chicago, Ill.**



# Deafness

Perfect hearing is now being restored in every condition of deafness or defective hearing from causes such as

Relaxed or Sunken Drums, Roaring or Hissing Sounds, Perforated, Partially Destroyed Drums, etc.

## Wilson Common-Sense Ear Drums

"Little Wireless Phones for the Ears"—

require no medicine but effectively replace what is lacking or defective in the natural drums. They are simple devices, which the wearer easily fits into the ears where they are invisible. Soft, safe and comfortable to wear at all times.

Write today for our 168 page FREE book on DEAFNESS, giving you full particulars and plenty of testimonials.

**WILSON EAR DRUM CO., Incorporated**

1002 Inter-Southern Building

LOUISVILLE, KY.



# NO MORE BALD HEADS



When our VACUUM CAP is used a few minutes daily. We accept no pay until you have tried the Cap 60 days and are satisfied. The Vacuum Cap is an appliance that draws the blood to the Hair Roots and starts a new healthy crop of hair. It stops Dandruff stops the hair from falling out. Bought by Doctors and men who

know that it is the only reasonable HAIR GROWER known to science. No Drugs Used. Write for application blank, testimonials, and booklet on "HAIR," sent sealed in plain envelope, FREE.

**THE MODERN VACUUM CAP CO.**

F. 559 BARCLAY, DENVER, COLO.

## Only \$36.00 The Wonderful ILLUSTRATOR LANTERN

With our improved famous ALCO RADIANT LIGHT.

This new 1912 Model has many improvements and double brilliancy. Write for illustrated circular of this and Lanterns of all styles and lights at bottom prices.

IF YOU OWN A LANTERN we should have your name to mail to you our regular announcements of new slides and lecture sets. 75,000 Lantern Slides to rent.

POST CARD MAGIC LANTERN reflects image of postcard or any other picture of object. Prices, \$2.75, \$12.50, \$25.00, \$60.00, express paid.

**WILLIAMS, BROWN & EARLE, Inc., 918 Chestnut St., Philadelphia, Pa., Lantern Dept. 2**  
Engineering, Microscope, Optical, Scientific, Photo Lantern Slide Supplies

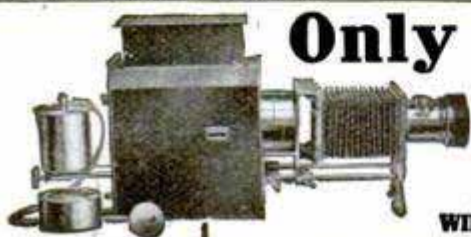

# AGENTS



## A REAL SUMMER SELLER

Everybody, young and old, every home, church, fair, picnic, etc., is a sure customer for our concentrated soft drink extracts for making

## NON-ALCOHOLIC SUMMER DRINKS

Refreshing, healthful. Seven different kinds—Orangeade, Cherry Bounce, Raspberry, etc. Small package—carry it right with you. One bottle makes 32 glasses. Guaranteed pure. Get it while it's new. 100 per cent profit. No competition. No experience needed. Write postal today for special proposition **FREE**.

American Products Company  
2014 Sycamore St. CINCINNATI, O.



## Make \$15.00 to \$35.00

Per Day With Our Latest Invention, The Wonderful Ever-Ready Camera

Makes 9 styles single or group pictures direct on post cards or tintypes without use of films or negative. **NO EXPERIENCE NECESSARY.** Complete picture finished, toned and fixed in 30 seconds **HERE'S AN OPPORTUNITY TO GET** into a **DIGNIFIED, RESPECTABLE BUSINESS OF YOUR OWN** with a **VERY SMALL INVESTMENT** and **BECOME INDEPENDENT. BIG MONEY.** At carnivals, summer resorts, parties, picnics, anywhere. **BIGGEST MONEY-MAKING PROPOSITION** in the **WORLD.** Photos cost you from 1 to 2 1/2 cts. and sell for 10, 15 and 25 cts. each. **WRITE TO-DAY FOR FREE PROPOSITION & CATALOGUE.**

### THE NEW YORK FERROTYPE CO.

Dept. A39 No. 168 Delancey St., New York, N. Y. Dept. A39 No. 1113 Halsted St., Chicago, Ill.  
Largest Manufacturers and Distributors of One Minute Picture Machines and Supplies in the World. Established 1902.



## Your Picture in a Postal Card IN ONE MINUTE

The pictures are developed, toned and finished in a single developing solution. No experience is necessary. Price of machines \$7.50 and \$15.00—circulars describing our machines sent free. We are also headquarters for supplies for all minute picture machines.

AMERICAN MINUTE PHOTO COMPANY  
Desk A 96, 2214 Ogden Ave., Chicago, Illinois  
The largest manufacturers and distributors of minute picture machines and supplies in the world.

## WE START YOU IN MOTION PICTURE BUSINESS

A Postal Card or Letter is all that it costs to learn how we do it. Many of our clients whom we started **WITH SMALL CAPITAL**

are among the most successful exhibitors in the country. The business is just at the height of its prosperity—its profits are now the greatest—you can't fail to get your share if you start at once. **\$35 to \$50 and More Daily Profit.** Write today for our Plan & Full Details.

### ATLAS MOVING PICTURE CO.

Room 230, 608 South Dearborn Street, Chicago, Illinois

## WANT GOOD MEN

Would you take a steady job where you can clear \$10 weekly with opportunity to be district manager at \$3000 yearly? No experience required. Great crew agents proposition. We manufacture—middlemen's saved. Write for our 1914 exclusive territory-business-building plan. I'm an old agent myself—made my six-story factory by hustling you want to also earn big money, write and I'll tell you how I did it. Davis, President, E. M. Davis Company, E14, Davis Bldg., Chicago

## AGENTS WANTED EASILY EARN \$10 A DAY

DIST. MANAGERS WANTED

Selling experience necessary. Just demonstrating what iron will do. Every housewife buys: E-Z Sad Iron only iron combining heat and Spring Cushion Handle. Makes iron heat—runs 4 1/2 hours without attention. No territory, no matter where you live.



\$10 A DAY

# APPLIED ELECTRICITY FAMOUS \$35 SET

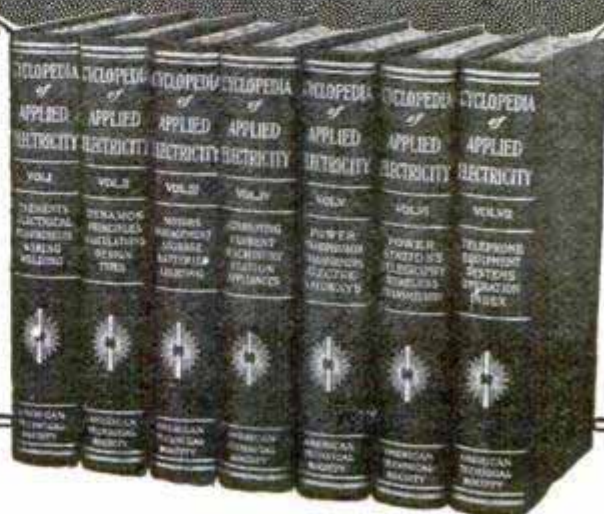

## NOW \$19.80—\$2 A MONTH

Greatest reference work on electrical subjects ever published. Most exhaustive electrical cyclopedia of modern times. 7 big books written by 32 famous experts; 3200 pages, 2600 illustrations, full page plates, diagrams, simple explanations, etc., with hundreds of valuable facts and figures. Bound in half red morocco, gold stamped.

Books that will settle every electrical problem which daily confronts the power engineer who must rely on his own experience. Now at the lowest price ever made.

Big men in the electrical field everywhere recognize these as the standard works on the subject. They have been the making of hundreds of successful electrical engineers.

**SHIPPED FREE** To prove to you what these books will do for you right in your own work every day, we will trust you seven days before you spend one penny. We will pay the express. They must make good with you or we take them back at our expense without question or annoyance. On receipt of coupon below we ship the entire set to you at our risk for absolutely free examination.

### Read These Subjects Carefully

Elements of Electricity—Electrical Measurements—Underwriter's Electrical Requirements—Theory, Calculation, Design and Construction of Direct Current Generators and Motors—Types of Generators and Motors—Management of Electrical Machinery—Electric Lighting—Alternating Current Machinery—Power Transmission—Electric Railways—Self-Propelled Railway Cars—Trackless Trolleys—Power Stations—Switchboards and Switching—Storage Batteries—Applied Electro-chemistry—Electric Elevators—Electric Welding and Heating—Wireless Telegraphy and Telephony—Land and Submarine Telegraphy

## Free \$12.00 Consulting Membership

Our staff of 32 electrical experts answer every question you want to ask on electrical subjects absolutely free for a full year to every holder of a set of these books. This privilege has always cost \$12.00 and men tell us it is worth twice that amount in settling one problem alone. You get this service free if you buy the books after examination.

This means \$15.20 saved if you act now. Read the coupon carefully. Then fill it out and mail today. The books will reach you promptly—express paid by us. After seven days send us \$2.00; otherwise, notify us for their return.

Don't wait. You take no chances whatever. It costs nothing to inspect and you are nothing out if you do not care to buy. Mail the coupon today.

## FREE COUPON

Worth \$15.20 to You

### American Technical Society

Please send me Cyclopedia of Applied Electricity for seven days' free examination. If I keep the books will send \$2.00 within seven days and \$2.00 a month until \$19.80 has been paid, when \$35 books and \$12 consulting membership will be mine. Otherwise will notify you and hold books subject to your order. Title not to pass until fully paid.

Pop. Mech. 5-14

AMERICAN TECHNICAL SOCIETY

Chicago, U. S. A.

NAME.....

ADDRESS.....

As I have had no previous dealings with you, I refer you to



**3 Fine BOOKS FREE**

MR. HARRIS wants to send you his three latest Books FREE—one the story of "The Diamond," its discovery, where and how mined, cut and marketed, the other, "Facts vs Bunc," or all about the Watch Business, both at home and abroad, also our Big Free Watch and Diamond Book.

**Would You Accept This 30-Day Offer?**

*Standard of the World. Endorsed by Government and Railway Officials. Harris-Goar's enlarged Easy Credit Plan now enables you to own one of these superb Elgin Watches without missing the money. Write for Free Catalog.*

**17-Jewel Elgin** Now, during this Special Sale, is the time to buy this elegant 17-JEWEL Elgin. Thoroughly factory tested, fitted in beautiful Gold Strata Case, Factory stamped and

Guaranteed 25 years, hand engraved, plain polished or with your own monogram, and our startling offer is to send you this celebrated 1914 Model free of charge for your approval.

**No Money Down**

Because we want to prove to you that the great volume of our business actually enables us to do better by you than any other Watch or Diamond House in the World, and that on this particular watch, we save you nearly half for it sells regularly at \$20 to \$22, while our

**Special Price is only \$12<sup>75</sup>**

We don't want you to send us one cent—not a penny. Merely give us your full name and address that we may send you this superb 17-Jewel Elgin on approval, and if after you receive it and want to keep it, then pay us the sum of

**Only \$2.00 a Month**

But if after you have worn it 30 days FREE and don't want to keep it, send it back at our expense. You assume no risk whatever. You do not buy or pay a cent until we have placed the watch right in your own hands for your decision. We want no security, no interest, no red tape—just common honesty among men. Write for our BIG FREE WATCH AND DIAMOND BOOK today. Do it now!

**HARRIS-GOAR CO., Dept. 1263, KANSAS CITY, MO.**

*The House That Sells More Elgin Watches Than Any Other Firm in the World.*

**25-Year Gold Case 17 Ruby Jewels**

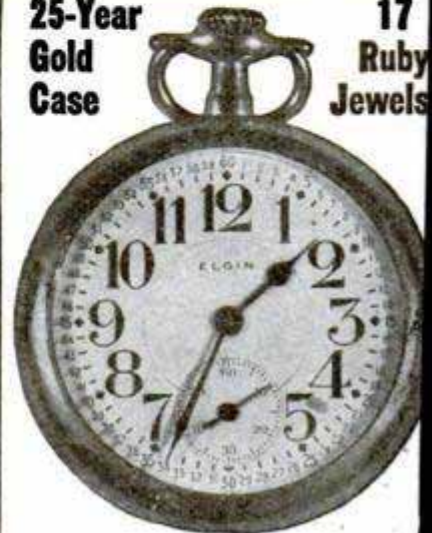

**RAINCOATS**  
GUARANTEED WATERPROOF  
MAKER TO WEARER PRICES

We make waterproof rain coats, beat everybody on prices and guarantee to delight you with style, material, and long wear. Out the middlemen and save \$2 to \$6 on every garment. Water will not go through our coats even at the seams. Our family catalog and samples free on request. Satisfaction guaranteed. Write today. TORPEDO BRAND MFG. CO., BROOKLINE, MASS., DEPT. Y



**8½ Pound Electric Vacuum Cleaner**

At last a vacuum cleaner a woman can handle as easily as a carpet sweeper. Weighs no more. Takes up only two-thirds as much room. Is absolutely guaranteed. Rolls on rubber-tired wheels without effort. As powerful as many big unwieldy machines.

**The Morrow**  
10 Days Free Trial We take all the risk, write today for our Free Book.  
The MORROW CO., Dept. 1195, Waukegan, Ill.  
*Good Territory Still Open—Agents and Dealers Write*

The Russian empire, covering one-seventh of the area of the globe and only sparsely settled in spite of its nearly 170,000,000 inhabitants, today presents a picture of economic development comparable with that of the United States.

**I WILL START YOU**  
earning \$4 daily at home in spare time, silversmithing; no capital; send for free instructive booklet, giving plans of operation. G. F. REDMOND, Dept. 306-A, BOSTON, MASS.

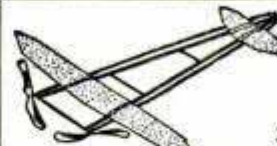

**1914 Champion Racer**  
Designed by Harry Schultz  
Model Editor of Aeronautics  
You build it . . . \$2.50  
We build it . . . \$7.50

**MODEL AEROPLANE**

Send 2c postage for Complete handbook of Models and Supplies.  
**WADING RIVER MFG. CO.**  
WADING RIVER, N. Y.

**80c Profit on Each Dollar**

selling one minute pictures at fairs, carnivals, picnics, busy street corners, and everywhere you can think of. I positively show you how to make this money. You need no experience. You can start at once. I want ambitious men and women to take advantage of my most amazing offer.

**\$12<sup>00</sup> ONE MINUTE CAMERA AND COMPLETE OUTFIT**

Yes, only \$12.00 sets you up in the liveliest, quickest money-getting business of today. This wonderful camera makes pictures on post-cards and buttons without films or plates. Pictures are finished, ready to sell, in one minute. They sell for 10c each—cost you 1½c. Over 8c profit on a sale—80c on each dollar.

I offer you this great chance to earn \$50 a week. Begin now. You can't lose. My \$12 outfit includes the One Minute Camera, tripod and material to make 50 finished 2½ x 3½ inch pictures. First sales bring \$5. Your only expense after that will be the small cost of supplies. Write me today for FREE PARTICULARS.

**M. Cowan, Mgr., ONE MINUTE CAMERA CO., Dept. 480, 536 S. Clark St., CHICAGO**

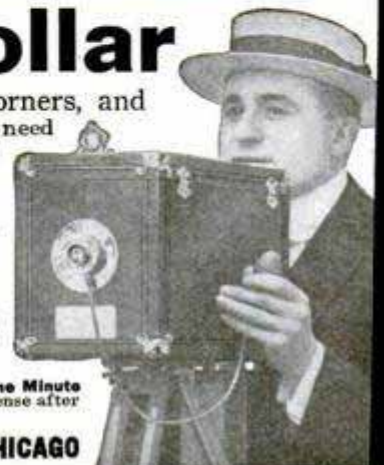



# BLUE WHITE GENUINE DIAMONDS MODERATE PRICES EASY TERMS

Buy direct from  
Importers and Save  
Dealer's Profits. Startling  
low prices—and pay in little amounts  
from time to time.

**Certified Guarantee with every Diamond**—guaranteeing its weight and quality. A safe way to buy and save money—no inconvenience—and have the Diamond now.

Perfectly cut, blue white Diamonds, gleaming, sparkling, scintillating—genuine high quality. **Not a cent to pay** until you have examined the Diamond. We send you free magnifying glass. Any diamond in our

## Beautifully Illustrated Diamond and Watch Free Catalog

will be sent for examination without obligation. This offer is open to every honest person—**OPEN TO YOU.** Note the wonderful values shown here—No. 40—1-2 kt.; No. 42—5-8 kt.; No. 43—1-4, 1-10 kt.; No. 44—3-8 kt.; No. 47—5-8 kt.; No. 48—3-8, 1-10 kt.; No. 49—5-8, 1-10 kt. Compare these prices with others. We import the rough Diamonds, cut them here, save 30 percent duty.

Give the saving to you. Write today for our

**BIG CATALOG and SPECIAL WORLD-BEATING OFFER of One Carat Diamonds for only \$100.**

All Diamonds, also watches, on easy terms—no money first. Send for Catalog today.

The Walker Edmund Co.,  
DIAMOND IMPORTERS  
Dept. C

State and  
Madison Sts.,  
Chicago.



the United States of three or four generations ago. Russia is now chiefly a producer of the raw materials derived from nature, such as grain, timber, hides, and minerals, and is just beginning to develop manufacturing industries of importance. Its exports are almost entirely raw and semimanufactured products, while it imports nearly all of the higher grades of manufactures which its people require.

**ENDLESS NECKTIE** All the rage. Newest style. Ties in different place each week. A wonder. Girl makes \$87 one week; man \$20 one week. **FREE SAMPLE** and amazing offer. Write quick.  
**ENDLESS NECKTIE COMPANY, Dept. 10, Kansas City, Mo.**

## CHAUFFEURS



Send for **Free** sample copy **American Chauffeur.** Contains valuable information about engines, ignition, carburetion, manifolds, motor balance, cooling and lighting systems, etc. All news of motor world. Every amateur or professional chauffeur should read it. Write now.  
The American Chauffeur Publ. Co., 251 Butler Bldg., Cincinnati, O.

## TODAY I MADE \$35.23



With My Camera Taking Pictures — A. I. Hinnbaum. You can do even better. Write for our **New Proposition and Catalogue**, explaining fully how, without any former knowledge or experience, hundreds of young men everywhere are making big money. **Don't Miss this Opportunity of Becoming Independent Financially.** Send today for Full Particulars.  
Westtown Ferrotyp Co., Dept. 440, 1113 S. Halsted St., Chicago, Ill.

## Amazing Profits In Mushrooms



Anybody can add \$8 to \$40 per week to their income, in spare time, entire year growing mushrooms in cellars, sheds, barns, boxes, etc. I tell you where to sell, at highest prices.  
**Free Illustrated Instruction Booklet**  
**HIRAM BARTON**



Convertible Library  
and Billiard Table

# Every Home Can Have Billiards Soon Paid at 20c a Day!

This handsome Brunswick Reading Table goes in any living room or library and is changed on the moment to a Billiard or Pocket-Billiard Table with accurate, quick-acting cushions. Equal in playing qualities to our famous "Baby Grand." Concealed cue rack and accessory drawer hold entire playing outfit—nothing ever in the way.

## Prince of Pastimes

Billiards and Pocket-Billiards abound with fascination—fun for the whole family—royal entertainment for your guests. The daily upkeep for mind and body. The night made as fresh as the morning.

## Brunswick "Baby Grand"

The Brunswick "Baby Grand" Billiard or Pocket-Billiard Table is a masterpiece of cabinet work. Fitted with a genuine Slate Bed, the celebrated Monarch Cushions, and Accessory Drawer to hold entire playing equipment. Sizes 3x6, 3½x7, 4x8. Furnished as a Carom, Pocket-Billiard or Combination Carom and Pocket-Billiard Table. Attractive prices and easy terms.

## Playing Outfit Free

The price of each table includes complete high-grade Playing Outfit—Cues, Balls, Bridge, Rack, Chalk, Markers, Brush, Cover, Rules, Book on "How to Play," etc. Send the coupon or a postal card for richly illustrated Book, Factory Prices and Easy-Purchase Plan.

-----CUT OUT AND MAIL-----

The Brunswick-Balke-Collender Co. (265)  
Dept. Z. J., 623-633 S. Wabash Ave., Chicago  
Please send me the free color-illustrated book—  
**"Billiards—The Home Magnet"**

Name.....  
Address.....

# WATERLOO BOY TRACTORS GASOLINE ENGINES CREAM SEPARATORS



Waterloo Boy Farm Tractors, Engines and Separators are the best for the money the world has ever produced. Any one of these machines will increase the production of your farm at a big saving in labor.

Our light Farm Tractor is a wonder. It turns short and will go anywhere you can work with a team. Our tractors sell at such reasonable prices that you cannot afford to be without one.

All Our Machines are Sold Under Our Strong Five-Year Guarantee. Write today for our catalog and let us tell you about our tractors, engines and separators.

Waterloo Gasoline Engine Company

Waterloo, Iowa

This Marvelous Tractor and Plows only \$1,050.00

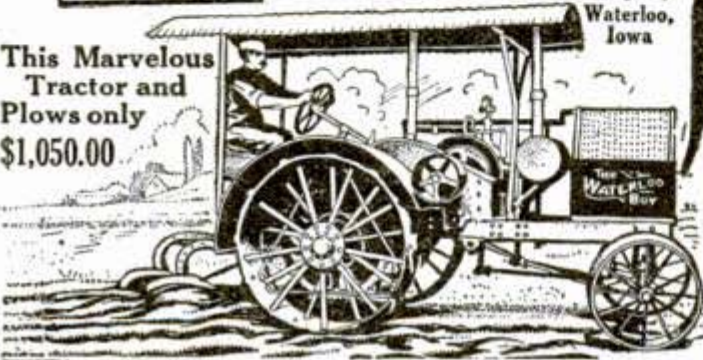

## DUNPHY K. D. FRAMES

Makes it possible for any one to build a classy up-to-date model—all of the particular work done by expert mechanics—every piece fitted together, numbered and marked. Full line of complete boats carried in stock. Beautiful illustrated catalog sent on request.

DUNPHY BOAT MFG. CO. Eau Claire, Wis. BOX 19

## FREE TRIAL 30 DAYS BESSEMER KEROSENE ENGINE

Success with cheap kerosene or coal oil absolutely guaranteed. Try before you buy. Most economical, reliable and durable engine made. So simple and easy the wife or boy can start and run it. People everywhere throwing away their old engines, buying Bessemers and making money by it. Get one for yourself. Be ahead of your neighbors. Runs fast or slow. Will do a dozen things at once. Wonderful beyond belief. Pays for itself in fuel saved. For special discount write at once. The Bessemer Gas Engine Co., 121 Lincoln Ave., Grove City, Pa.



3 to 12 H. P.

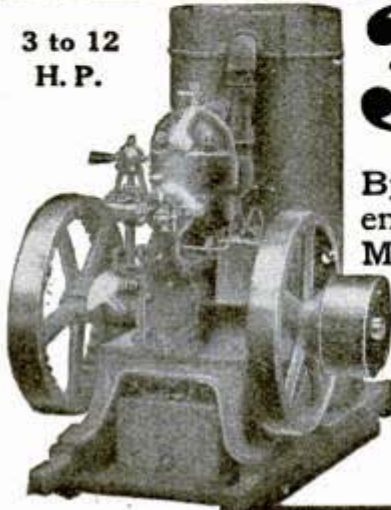

# 34c

Runs this 6 H. P. Engine for a 10 hour day on KEROSENE

By means of the patent throttle you can run it as a 4 H. P. engine for 23 cents a day, or as a 2 H. P. for 12 cents a day. Many other strong points; force-feed lubrication; uniform speed; sight-feed fuel supply; automobile muffler; no cranking; run either way; uses any fuel oil satisfactorily. And it's Guaranteed for 10 Years. Write for catalogue and 30 days' free trial

WE PAY THE FREIGHT

ELLIS ENGINE CO., 65 Mullett St., Detroit, Mich.

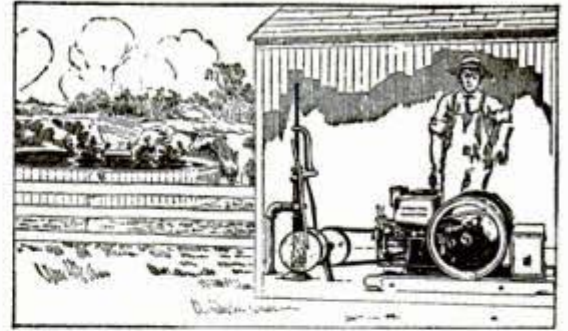

## International Harvester Oil and Gas Engines

A LITTLE careful observation will show you that the most satisfactory, economical engines are International Harvester engines. No doubt is left when features like the following are studied: Detachable valve guides, offset cylinder head, fuel pump, split-hub fly-wheels, extra large intake and exhaust valves, etc.

Ask the men who have used and know International engines. That is the best test. They will explain the excellence of International Harvester construction, simplicity, strength and durability.

International Harvester engines are of all styles, and range in size from 1 to 60-H. P. They operate on both low and high grade fuels.

Write for our catalogues and learn more about these engines.

International Harvester Company of America (Incorporated)

16 Harvester Building CHICAGO U.S.A.

The value of the imports of merchandise from the United States into the provinces which make up the Union of South Africa has risen from \$9,446,626, 1907, to \$15,735,321, in 1912, an increase of more than 55 per cent. We supply more oil, agricultural machinery, timber and lumber, windmills and carriages and more than any other country, including the United Kingdom.

## Don't Buy an Engine

until you investigate the famous TEMPLE Gasoline Kerosene, slow speed, heavy duty, all-purpose engine. Bulk and weight less than horizontal engines; cylinder built low, close to base, eliminating shock and vibration, increasing strength and durability, and giving scientifically correct distribution of strain. Pay for themselves in fuel saving alone. Have won five 1st premiums for lowest operating cost, stability and steady power. Old reliable pioneer concern (manufacturers for 61 years) guarantees the engines. Write today for catalog and particulars of 30-day trial offer.

TEMPLE MANUFACTURING CO., 2100 So. 54th Ave., Cicero, Ill.

**\$50 to \$300 SAVED**  
**Just Write!**

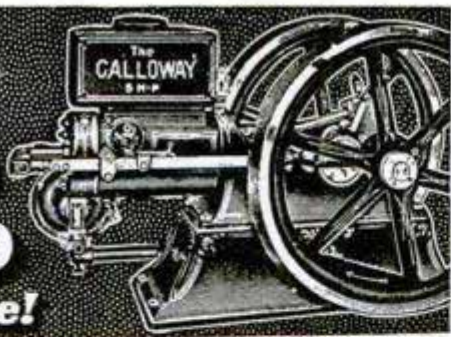

Get my prices—my new offers—get them right way. If you're going to buy an engine I'll put \$50 to \$300 in your pocket sure. All the dealers' profits cut off—you get them. Buy direct from my big factory.

**30 Days' Free Trial** Satisfaction guaranteed or your money back without a word. Any size from 1 3/4 to 15 H.P. Galloway Engines will run on gasoline, kerosene, naphtha, distillate, natural gas or motor oils. Write for my Big Engine Book and Special Offers today.

**William Galloway, Pres., WILLIAM GALLOWAY CO.**  
 965 Galloway Station, Waterloo, Iowa 666

**Light Weight Cushman All-Purpose Engine**



4 cycle, 4 H.P. Weight 190 lbs. A wonder helper, famous for its great power in light weight. Convenient to handle—fits in anywhere—adapted to all duties. **The Original Binder Engine.** Also double cylinder specialty engines for all power work, 6 H.P. to 20 H.P. Throttle governor, Schebler carburetor. Catalog free.

Cushman Motor Works, 900 N. 21st St., Lincoln, Neb.

**Small Gas and Gasoline Engines**  
 Air and Water Cooled. 1/4, 1/2 and 1 H.P.

Electric light plants from 6 to 50 lights. All prices. All kinds of electrical apparatus. Motors, Dynamos and Batteries. Gas, Gasoline and Steam engines from 1/4 h. p. up. Get our No. 2 Toy and Engine or No. 20 Engines and General Catalogs, ten cents each. (Coin preferred.) Refunded on first order.

**AMATEUR MECHANICS SUPPLY CO.**  
 860 G, Monadnock Block, CHICAGO

with the exception of lumber, more than all other countries combined. Today South Africa ranks fifth, following Canada, England, Australia, and Argentina, a purchaser of American motor cars.

In 1909 there were 822 establishments in the United States engaged in the manufacture of pottery, terra-cotta, and fire-clay products.

**Jewel Detachable Electric Rowboat Motor**



Attaches to any rowboat or canoe, runs on 2 six-volt batteries. No odor, noise, or dangerous gasoline.

**JEWEL OPEN WINDOW STORAGE BATTERY**

Look inside your battery through the patented open window. See condition of plates and height of acid. Jewel Special 6-60, \$9. 6-80, \$12. 6-100, \$15. 6-100 Starting Battery, \$18.

Write for Catalog. Business Est. 1880

**J. ELECTRIC CO., Dept. P, 1469 S. Michigan Ave., CHICAGO, ILL.**

**GRAY GEARLESS DETACHABLE BOAT MOTOR**



Attaches to any row boat or canoe. Get the motor for your vacation. Has several superior mechanical features and on no other outboard motor. You will find the Gray Gearless Boat Motor is **Mechanically Better**—you get more power, less weight, fewer parts, greater simplicity, easier starting and longer life at a remarkably low price—\$65 complete. Guaranteed by a responsible concern. Write for full details—ask a Gray agent—your best hardware or sporting goods dealer, get immediate deliveries from factory.

**GRAY MOTOR CO., 5306 Gray Motor Bldg., Detroit, Mich.**

**Go Camping This Year**



Send Today for **Free Camp Guide**

**\$5.90** Special Bargain Price on this Splendid Army Style 7 by 7 ft. Wall Tent—Complete

Right now—if you order quick—you can get this splendid wall tent all complete, with poles, ropes, pins, etc., for only \$5.90. Order one now. There never was such a tremendous bargain offer before on a tent of anything like this size and quality. A regular big camping tent. The style the U. S. Government and National Guards have adopted. Made of 8-oz. white duck—a cracker jack of a tent for camping or outing. Go camping this summer. It is the ideal way to spend your vacation. Thousands of people all over the country are now sleeping outdoors in tents to grow healthy and strong. Don't delay. Remember it is a very special offer. If you want one of these tents order direct. But even if you don't order one now, send the coupon today and get a copy of the *Free Camp Guide*. It's a great book to have. It tells you everything about camps and camping—everything you want to know.

**Special Complete Outfit Offer**

Send the coupon today and learn about the great special offer being made to readers of this Magazine. Learn how you can get a complete camping outfit. Everything you need—at a remarkably low reduced price. Don't fail to learn about this.

**1914 Camp Guide Free**

Send coupon today for the new 1914 Camp Guide. It will give you all the latest information about camps and camping. Tells you how to prepare for trips. What to take along—also expert advice on hunting and fishing. Tells you how you can get rock-bottom prices direct from manufacturer, on everything you need. Send the coupon TODAY—now.

**H. Channon Company**  
 Market and Randolph Sts.  
 Dept. 1195 Chicago

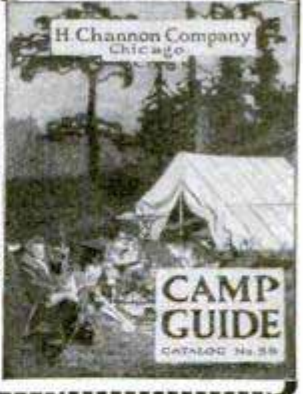

**Send This Coupon Today**

**H. Channon Company**  
 Dept. 1195 Market and Randolph Sts. Chicago

Please send me the new 1914 Camp Guide and full details of your tent and camp outfit offers.

Name .....

Address .....

Please Mention Popular Mechanics



## Off We Go for a Picnic With Our Caille

Far across the lake—too far to row—we know of an ideal spot for an outing. We have often longed to picnic at this place, but the thoughts of the long, tiresome row always discouraged us. But now it's different, Dad has a

### Caille Portable Boat Motor



Rowing is no longer a bug-bear. Distance makes no difference. We can picnic or fish or moon-light ride to our heart's content. All we have to do is steer. Dad even lets us boys run the motor, it's so simple.

#### Turning Two Thumb Screws Attaches It to Any Row Boat

Immediately changing it into a reliable little launch. It develops 2 H.P. and steers with a rudder like a launch—not by the propeller. Rudder is of our folding, stone dodging type (Pat. applied for). Weedless propeller is protected by a substantial fin. Motor is adjustable to any angle or depth of stern. Starts with half a turn of the fly wheel. Weighs but 55 lbs. Drives row boats 7 to 9 miles an hour or slow enough to troll. Can be run in salt or fresh water. Furnished with battery ignition or reversible magneto. Send for beautiful catalog.

**Sporting Goods and Hardware Dealers Wanted.**

### We Also Build

larger motors from 2 to 30 H.P.—one to four cylinders. If interested, ask for our Marine Motor Blue Book.

### THE CAILLE PERFECTION MOTOR CO.

*World's Largest Builders of Two Cycle Motors*

1418 Caille St., Detroit, Mich.

8 H.P. \$150



Please Mention Popular Mechanics

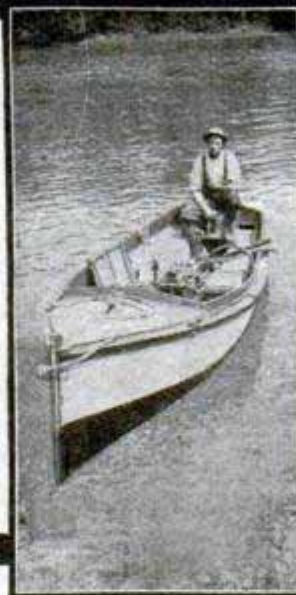

This Boat Paid Him \$516.00 In 63 Days

Then He Sold It At a Profit of \$153.75

Mr. D. H. Durgin, of Blue Creek, Wash., whose boat is illustrated here, writes: "I made this boat pay me \$516.00 in 63 days and then sold it for \$250.00. I built it after a Brooks Pattern and it cost me only \$96.25 complete.

### Build Your Boat By The Brooks System

and save a big part of the price. It's simple and easy work—anyone can do it. We send all parts—you simply put them together, guided by full size patterns and illustrated directions. The Brooks System brings a beautiful cruiser, a speedy motor boat, a family launch, "V" bottom, sail boat, row boat or canoe—any style boat within the reach of anyone.

#### Write today for Free Boat Book

and see the fine models that you can build easily in spare time. \$2 and up buys complete set of patterns. Only \$33.00 buys complete knocked-down frame for 23-foot power boat with complete patterns to finish. Book tells all. Write for it today.

**BROOKS MFG. CO., 8205 Rust Ave., Saginaw, Mich.**  
The Largest Plant of its Kind in the World  
Originators of the Pattern System of Boat Building

The total supply of cotton in the United States the year ended August 31, 1913, was 16,225,734 run bales, counting round as half bales and including lint of which 225,460 bales of 500 lb. each represent the imports. Of this total, 5,826,330 bales, or 35.9 per cent were consumed in this country; 8,800,966 bales, or 54.2 per cent, were exported; while 1,598,438 bales, or 9.9 per cent, remained in the country at the close of year. The mill consumption of cotton in the United States for 1913 was the largest in the history of



### DO YOU KNOW—

That we have brought out a new High Speed "Buffalo" Model—Four cylinder, 16-20 h.p.; bore, 3 3/4"; stroke, 5 1/2"; speed, 800 R.P.M.; weight, 525 lbs.; 3 working parts enclosed; constant level splash lubrication. Write for details.

**BUFFALO GASOLENE MOTOR CO.**  
1293-1305 Niagara St. BUFFALO, N. Y.

### MULLINS STEEL BOATS CAN SIN



The only boats that are a constant source of pleasure not a constant source of expense—Outside of the slight expense of painting they cost nothing to put in commission—They are built of heavy galvanized, tough steel plates like Government Torpedo Boats with air-tight compartments like Life Boats—absolutely Guaranteed against puncture—Never leak—Never warp—Never water log—No seams to open—Designed by Naval Architects—Fitted with Sterling Cycle and Pierce-Budd and Ferro 2 Cycle Motors—Powerful—Simple—Can be operated by the beginner—Never balk—Never stall—Silent under water exhaust.

Send for Free Motor Boat Book and learn how Mullins Boats are built by the World's Largest Boat Builders.

**THE W. H. MULLINS CO.**  
151 Franklin Street Salem, Ohio

Cost Less - Last Longer than Wood Boats

# Throw Away Your Oars!



You won't need them any more. No more back-breaking work, tired muscles or blistered hands. The newest and most powerful attachable row boat motor ever made. **Guaranteed for five years.** Full 2 h. p., three-port, long-stroke motor. Easily attached to any row boat—any speed from 2½ to 8½ miles an hour. (Can be attached and operated by woman or child). Weighs less than 50 pounds.

## New WRIGHT Attachable Rowboat Motor Reversible in Two Seconds

The only row boat motor that can be reversed without stopping the motor. Great new safety device makes it greatest for women and children. Starts under full load at low speed. Brass muffler, 9-in. bronze propeller of special weedless construction. Coils, batteries, etc., complete without extra charge. Suitable for fresh or salt water.

**10 Days Free Trial**

### Write Today

for free book and great special offer. Don't delay. We are making a great special offer to get the Wright into every locality so it may prove its great superiority. This offer is limited. Learn about it. Send your address today.

Extra Special Proposition for Dealers.

C. T. WRIGHT ENGINE CO., Dept. 1195, Greenville, Mich.

Manufacturers of famous Wright Marine Engines and Imperial Launches.

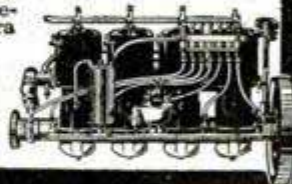

MARINE AERIAL

# ROBERTS

AUTOMOBILE STATIONARY

The Motors That Never Backfire

In Which Motor Are You Interested?

The Roberts Motor Co., 419 Columbus Ave. SANDUSKY, OHIO

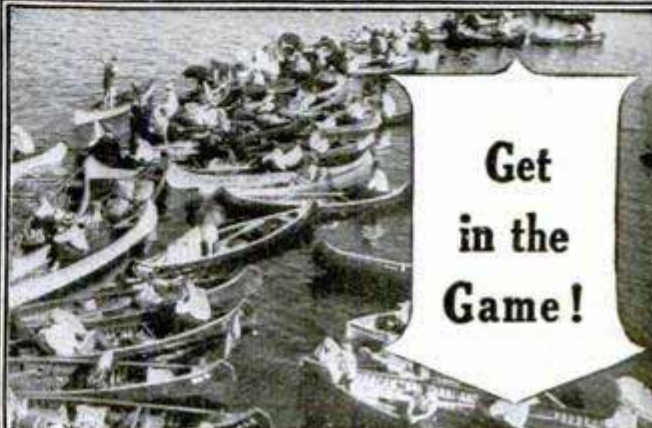

Get in the Game!

YOU, too, can have *heaps* of pleasure in an "Old Town Canoe"—paddling, fishing, exploring during leisure hours—and it provides a dandy vacation. The

## "Old Town Canoe"

is made of seasoned cedar—staunch—light—graceful. Doesn't leak or absorb water. 2000 in stock—agents everywhere. Send for catalog.

OLD TOWN CANOE CO.

1365 Middle St.  
Old Town, Maine, U. S. A.



AMERICA'S STANDARD 12-H.P. MARINE MOTOR

# KERMATH

to depending on point



4 Cycle  
4 Cylinder

Made in one size only by specialists in engine building. The Kermath hasn't an equal in this size and type, absolutely regardless of price. Catalog on request

KERMATH MFG. CO.  
Dept. P  
DETROIT, MICH.

LA Marine Motors Direct from Factory to You



## Save the Dealer's Profit

it won't cost you as much as you thought to enjoy the pleasure of motor boating this summer. The old, reliable, "keep-going" Lockwood-Ash motors are sold direct from factory to you at a big saving. No dealer's profits to pay. **Immediate Delivery**—Six models, all guaranteed for one year, and sold on 30 days' trial. No strings to this offer, no freight to pay. Just send for one of our complete outfits, and if it doesn't delight you send it back at our expense.

The 6 H. P. Motor with Outfit complete, shown in illustration, freight paid, only..... **\$96.00**—a clear saving of at least \$39.00. Post yourself on motor boating and the safest, cheapest way to buy by writing today for our 1914 catalog. It's soon time to start—get busy.

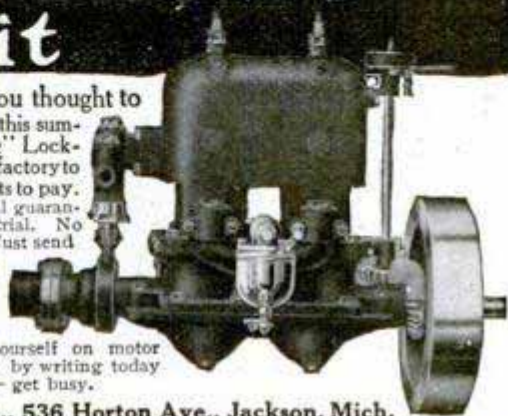

LOCKWOOD-ASH MOTOR CO., 536 Horton Ave., Jackson, Mich.

# WATKINS - 1914 - SPECIALS

LIGHT WEIGHT—HIGH SPEED  
CLASS B—ALL IRON

A MOTOR FOR THE PEOPLE  
AND A PRICE TO SUIT

3 Sizes—3, 6 and 12 HP.

ALSO MANUFACTURE

THE FAMOUS 3 HP. 30 LB. COPPER  
JACKET MOTOR

CATALOGUE FREE

6 HP. 85 Lbs. THE WATKINS MOTOR CO. 839 W. 6th St.  
CINCINNATI, O.

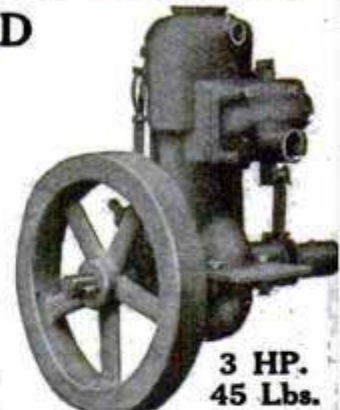
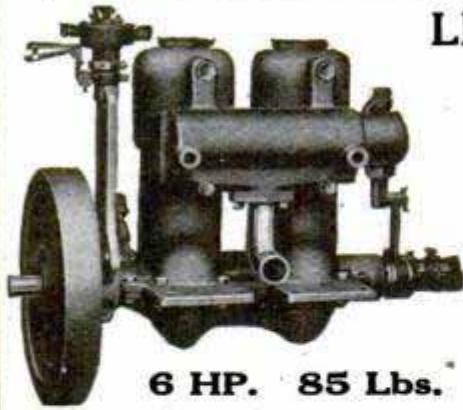

## Only 2 Cylinder Rowboat Motor

MORE POWER  
GREATER SPEED

Here's the latest and finest thing in detachable rowboat motors—the only 2-cylinder detachable rowboat motor made. Beats anything on the market. It's a real engine. Powerful and fast—quiet and smooth running, vibrationless. Has full 3 H. P. and reverses easily.

### KOBAN Rowboat Motor

The Koban Motor overcomes vibration, which has been the biggest objection against rowboat motoring. All revolving and reciprocating parts are perfectly balanced. Fits any rowboat—can be attached or detached in a jiffy—absolutely weedless rudder and propeller—sure and easy starter—can be steered when engine is shut off. Costs less per horse power than anything on the market. If you are going to buy a rowboat motor, this is the one you want. Write at once for full particulars and illustrated pamphlet. Agents wanted.

KOBAN MANUFACTURING CO.  
255 South Water St., Milwaukee, Wis.

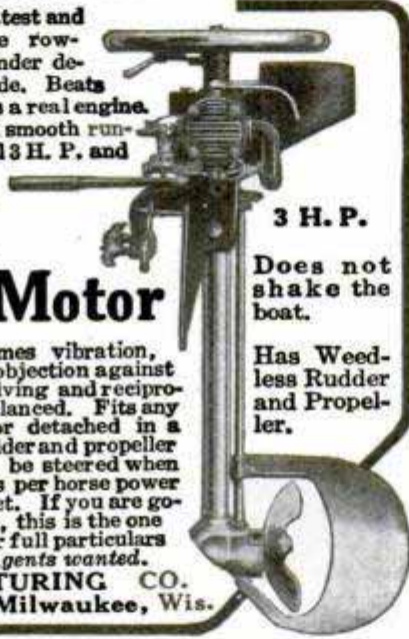

3 H. P.  
Does not shake the boat.

Has Weedless Rudder and Propeller.

## NORTHWESTERN "GIANT"

## MARINE ENGINE

For Fishermen, Guides and Boat Liveries and those who want absolute reliability.

The Most Compact Marine Engines in Existence of medium weight, moderate speed and a very modest price. The standard 2 cycle engine of the world. Planhard carburetor, spark and waterproof commutator. Patented gas-tight bearings, flange couplings, magneto with storage battery, sight feed oilers, etc. 2, 4, 7, 10 and 18 H. P.—Prices \$50 and up. New 1914 catalog in colors. Hundreds of engines on hand for immediate shipment. Get the agency in your town.

NORTHWESTERN MOTOR CO., 774 Spring St., Eau Claire, Wis., U. S.



7 H.P. develops actual 9 H.P.

country, exceeding that for 1912, the next largest, 418,747 bales and exceeding the average for the six years preceding 1913 by 851,253 bales.

## Toledo MARINE MOTORS

"Nothing Cheap but the Price"

3 H. P. 1 cyl. complete	\$ 65.00
6 H. P. 1 " "	84.00
6 H. P. 2 " "	125.00
12 H. P. 2 " "	160.00
18 H. P. 3 " "	250.00

Fully guaranteed by a responsible concern. 2 cycle, 2 port, 3 1/2 x 3 1/2 and 4 1/2 x 4 1/2. Send for free catalog "C."

THE UNIVERSAL MACHINE CO., Pike Ave., Bowling Green, Ohio



## 2 H.P. AMERICAN \$38

Just the thing for the average family launch. It's compact, easy to install, easy to operate. Women and children can run it with perfect safety. No cams, gears or springs to get out of order or need adjusting. Runs in either direction. Has wide range of speed. Can be furnished for gasoline or kerosene. To start, simply turn on fuel and switch, rock the fly wheel and away you go. We also build other sizes up to 30 h. p.—one to four cylinders. Every one is of such perfect design and made of such good materials that we guarantee them for life. You take no chances with an American. Send for beautiful, new catalog today.

American Engine Co.  
414 Boston St.  
Detroit, Mich.



## HUNTERS—TRAPPER

If you want an ideal lamp for night fishing, trapping, hunting or for work about farm machinery, send to-day for a

### BALDWIN LAMP

Projects a 14 candle power light 150 ft. Burns Acetylene Gas. Weight 6 oz. Height 3 3/4 in. Can be carried in hand or worn on cap or belt, leaving both hands free. Oil, soot or glass. Absolutely safe and simple. Fifty hours' bright light costs 1 cent. Useful as well during Automobile repair. Catalogue free and instructive book "Knots and How to Tie Them" mailed on request.



At all dealers or by mail prepaid, \$1.00

JOHN SIMMONS CO., 162 Leonard St., NEW YORK

## MULLINS CANOES CAN'T SINK

Enjoy the delights of canoeing without fear. MULLINS Canoes, when equipped with patented buoyancy pads, and steadied by special keel construction, are the most stable, safest canoes afloat—Graceful in design—Elegant in appearance—Made from carefully selected cedar—Open gunwale construction—Oil finished—One piece duck canvas coverings that cannot crack or wrinkle—Polished brass and copper fastenings—Brass bang plates



Special broad flat bottoms. Two thousand canoes of all sorted lengths, grades and colors in stock for immediate shipment. Write for beautiful canoe catalog illustrated in color.

THE W. H. MULLINS CO.  
362 Franklin St., Salem, O., U. S. A.  
The World's Largest Boat Builders

**"SAFETY AT SEA"**

can be assured only when naval architects, boat builders and manufacturers combine with owners to specify, build and accept only the best.



True co-operation with naval architect, boat builder and owner is the secret of Scripps success. Scripps complete marine



power plants are made in 17 models, including 1, 2, 4 and 6 cylinder sizes, semi-speed, medium duty and extra heavy duty types.

Ask for the 1914 catalog and information on kerosene motors.

**SCRIPPS MOTOR COMPANY**  
637 LINCOLN AVENUE DETROIT, MICHIGAN

SCRIPPS MOTORS ARE CARRIED IN STOCK BY

- New York . . . Bowler, Holmes & Hecker Co., 141 Liberty St.
- Chicago, Ill. . . O. L. Cosgrove & Co., 215-219 Englewood Ave.
- Philadelphia . . . W. E. Gochenaur, 631 Arch St.
- St. Louis, Mo. . . Chan, J. Petzl, 1860 N. Market St.
- Jacksonville, Fla. . . Gibbs Gas Engine Co., Foot of Main St.
- Seattle, Wash. . . S. V. B. Miller, 72 Marion St.
- San Francisco, Cal. . . Ellery Arms Co., 583-5 Market St.
- Los Angeles, Cal. . . Marine Engine & Supply Co., 831 S. Los Angeles St.
- Duluth, Minn. . . Kelley Hardware Co., 118-120 West Superior St.
- Toronto, Ont. . . Schofield-Holden Machine Co., 2 Carlow Ave.
- Winnipeg, Man. . . D. A. Ross.
- New Orleans, La. . . Arthur Duvic, 130 Chartres St.

EXPORT OFFICE—17 Battery Place, New York City

39

**GET THIS CATALOG**

FULL OF VALUABLE INFORMATION TO EVERY BOAT OWNER ON

**RACING PROPELLER WHEELS, REVERSE GEARS AND MARINE ACCESSORIES**

LARGE CATALOG FREE. SEND TODAY  
**MICHIGAN WHEEL CO.**  
1139 MONROE AVE., GRAND RAPIDS, MICH.



**VIM MOTORS**

55 h.p. 3 kinds  
Standard—Regular—  
Heavy Duty

Best, simple-ably dependable. Wins enthusiastic confidence. Accessible. Built a life time. Heavy fittings. Non-back-Double ignition.

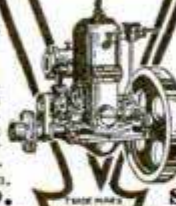

1, 2, 3 and 4 Cylinder  
Use Gasoline or  
Kerosene

Your boat will provide exhilarating and healthful recreation—equipped with a VIM. It's the old boatman's choice. Read 27 reasons why in "Boating Facts"—our new free book.

105 Water Street  
**SANDUSKY, OHIO**

**MOTORGORow Boat Engine**

Let us send you proof that the Motorgo is built right, works right, IS right. The price speaks for itself. Investigate—save \$20.00 or more.

**\$49<sup>95</sup>**

The Motorgo attaches quickly to any row boat by tightening two thumbscrews. All parts in water are rustproof. Has semi-needleless propeller and steers with a rudder.

Write postal card today for all facts. Please request "Motorgo Row Boat Engine Folder No. 802P."

**SEARS, ROEBUCK AND CO., CHICAGO**

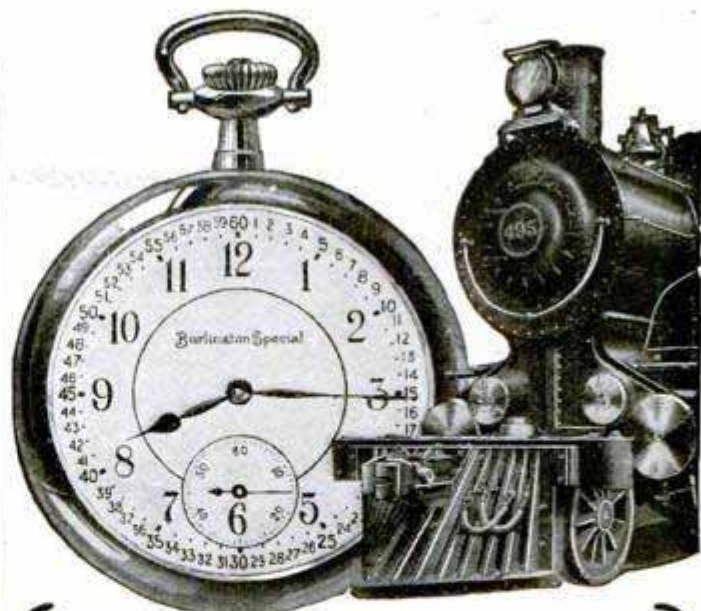

**1914 Timepiece**

The masterpiece of watch manufacture—the Burlington Special—19 jewels, adjusted to the second—adjusted to positions—adjusted to temperature, adjusted to isochronism. This master Timepiece incased at the factory in an exquisite line of new style watch cases. Open face or hunting case, ladies' or gentlemen's sizes.

**Special Offer**

The superb BURLINGTON SPECIAL, now at the DIRECT rock-bottom price—same price that even the wholesale jeweler must pay. Yes—one of these superb timepieces at the price that even wholesale jewelers must pay—And in order to encourage everybody to secure this watch now, we allow this rock-bottom price, either for cash or \$2.50 a month! We send the watch on approval, prepaid. You risk absolutely nothing—you pay nothing—not one cent, unless you want this exceptional offer after seeing and thoroughly inspecting the watch. Read the coupon below.

**Inlay Enamel, Block and Ribbon Monograms, Diamond Set, Lodge, French Art, Dragon Designs.**

**Write For Free Watch Book!**

Learn the inside facts about watch prices, and the many superior points of the Burlington over double-priced products. Just send the coupon or a letter or a postal. Get this offer while it lasts.

**FREE Book Coupon**

**Burlington Watch Co.**  
19th Street and  
Marshall Blvd.  
Chicago  
Dept. 9195

19th St. and Marshall Blvd.  
Dept. 9195  
Chicago, Ill.

Please send me (without obligation and prepaid) your free book on watches and a copy of your \$1,000 challenge, with full explanation of your cash or \$2.50 a month offer on the Burlington Watch.

Name.....

Address.....

Please Mention Popular Mechanics

# The Motor that's Better Built



Look at it from the mechanical viewpoint and you'll see why the Wisconsin is better built and a **better buy**. Back of it is the experience and knowledge - of - what's - needed gained in 12 years of marine engine building. There's nothing freakish about the Wisconsin—it's a **real motor**, one you can always depend on. This is its third season in general use—it has made good under all conditions. Compare the Wisconsin with other detachable motors—realize what we mean by **better built**.

Catalog  
FREE

Write today for our 1914 Catalog—for the facts you ought to have about the Wisconsin and how it's built.

# Wisconsin

## Detachable Row Boat Motor

Size up these specifications:—  
Reversible **High-Tension Magneto**—no missing even at slowest speeds; **Rudder Steering**—complete control even when motor is still; **Improved Carburetor**—20% more power on less fuel; **Nickel Aluminum Crankcase**, **Nickel Babbitt Bearings**, **Phosphor Bronze Connecting Rod and Gearhousing**. Isn't *this* the class of motor you want?  
**WISCONSIN MACHINERY & MFG. CO.**  
989 Canal Street  
Milwaukee, Wis.



## Waterman PORTO Does It

Makes any boat a motor boat. 1914 Model, 3 H. P. Weight 59 lbs. Sold direct from Factory to you, freight paid. Save Agent's profit.

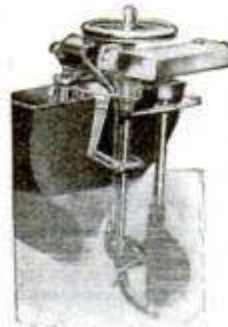

The Waterman PORTO is the original outboard motor. 9th year—25,000 in use. Guaranteed for life. Fits any shaped stern; has Carburetor—not "mixing valve"; 3 Piston Rings instead of 1; **Removable Phosphor Bronze Bearings**; Solid Bronze Skeg, protecting 10½ x 16 in. Propeller and supporting Independent Rudder; Water-cooled Exhaust Manifold; Noiseless under-water Exhaust; Bronze Gear Water Pump; Spun-copper Water Jacket; any ignition equipment desired.

**DEMAND** these essentials in an out-board motor, or you won't get your money's worth.

Write Today for **FREE Engine Book**.

WATERMAN MARINE MOTOR CO., 230 Mt. Elliott Ave., Detroit, Mich.

## MULLINS STEEL BOAT CAN'T SINK

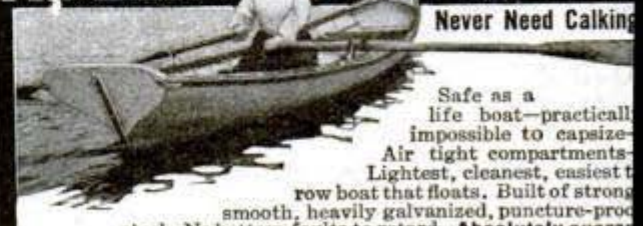

Never Need Calking

Safe as a life boat—practically impossible to capsize—Air tight compartments—Lightest, cleanest, easiest to row boat that floats. Built of strong smooth, heavily galvanized, puncture-proof steel—No bottom faults to retard—**Absolutely guaranteed against punctures or leaks**—No seams to calk—No cracks or leak—No bad odors as from water-logged wooden boats—A dry boat always. **Costs but a coat of paint to keep in commission**. Always ready for use. The ideal all-around row boat for recreation and livery. Over 35,000 in use. Write today for beautifully illustrated catalog of Row Boats, Hunting and Fishing Boats, Motor Boats and Cedar Canoes.

**THE W. H. MULLINS COMPANY, 410 Franklin Street, Salem, Oh**  
The World's Largest Boat Builders

**COST LESS LAST LONGER THAN WOOD BOAT**

## Motor Boat Catalog

FREE  
ON  
REQUEST

### Send for this Valuable Boat Buyer's Guide

Here is a book that will prove a great help in selecting the **right** motor boat. Nothing like it ever before published.

The foremost boat builders from all sections of the country are represented. Stock models and special designs are illustrated and described and prices are quoted on complete outfits with Gray Motors installed. Family pleasure launches, hunting and fishing boats, power canoes, hydroplanes, speed boats, runabouts, work boats and cruisers.

Boats  
from  
**\$142.50**  
Upwards

The book contains a truly wonderful fund of information that will prove of equal value to the man wanting a low priced outfit for inland lakes and rivers or the man wanting a luxurious cruising yacht.

With every request for this book we also send a copy of our Big Engine Book "M," which will give you a lot of general information about marine engines and shows the complete line of **Gray Motors** from 3 to 30-45 H.P. in one, two, three, four and six-cylinder models. Tells you how they are made. The books are absolutely free—no obligations—write for copies today.

**GRAY MOTOR CO., 56 Gray Motor Bldg., Detroit, Mich.**

## GRAY MOTORS

3 H.P. Complete \$55

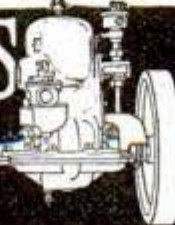

**CANOE \$18 AND UP** **ROWBOATS \$18 AND UP**  
**FISH AND HUNTING BOATS \$18. KAYAK \$22. BOAT FOR DETACHABLE MOTORS. MOTOR BOAT with or without engine, 16, 18, 20, 22 and 24 ft. Catalog Thompson Bros. Boat Mfg. Co., 95 Ellis Ave., Peshtigo, Wis.**

## POMMER BOATS FOR

Designed especially **Detachable Motors** by Naval Architects and built extra strong for use with Detachable Motors. Over all objections of ordinary row boat. Stronger, Safer, Speedier and more economical to run. Non-Capsizable. New 1914 Boat Catalog FREE write us name of Detachable motor you own or intend buying. Write today.  
**POMMER BOAT BUILDING CO. MILWAUKEE**  
Wharf 83

## POWERFUL LITTLE ½ H. P. GASOLINE ENGINE \$22

1 H. P. AIR COOLED \$28.50  
Will run a washing machine, separator, grinder, small lathe or drill or light machinery. Order to-day. **Unique Engine & Mfg. Co., Sycamore, Ill.**

## POWER!

for your lathe, saw, pump, grindstone, washing machine, or any other light machinery. Power delivered quickly at small cost and with absolutely dependability is yours if you own a **RED-E-MOTOR ENGINE**—the most powerful little engine built. Simple, safe, sure and serviceable—the ideal engine for any light power purpose. Fills the requirements of an electric motor. Easy for a child or woman to operate. Runs on gasoline, alcohol, kerosene; city, natural or any kind of gas; very economical in fuel consumption. **Fully Guaranteed** to give perfect satisfaction or money back. Made in 3 sizes, 1-4, 1-2 & 1-1. **Send Today** for catalog No. 145, prices and full particulars. **Send NOW, at once.**  
**ELGIN WHEEL & ENGINE CO. ELGIN, ILL.**





# Why Pay \$17.50?

The material and workmanship of this chair—Genuine, Select, Quarter Sawn White Oak of rare quality—costs less than half of \$17.50 at the factory. Yet that is the price you would pay for it at a store.

Mail  
Postal  
For This  
Catalog

We Ship It Direct From Our  
Factory In Sections—

You Set It Up and Save \$8.55

You pay only for materials, workmanship, and the usual small profit to manufacturer. We save you all other unnecessary expenses—dealer's profit, jobber's profit, traveling men's salaries, high packing expenses—and freight rates, etc.—almost 50%. And back of each piece is our guarantee—if you are not satisfied at any time within a full year you may ship it back and we immediately refund your money, including freight.

SECTIONAL  
**COME-PACKT**  
FURNITURE

only  
\$3.95

Four Sections

Select Quartered WHITE Oak. Built with the skill and skill of the old master cabinet makers—possessing an individuality and artistic charm befitting the home of quality. Eight different shades of finish. Imperial leather cushions. Packed in compact crate—shipped at knock-down rates.

New 1914 Catalog FREE

Shows over 400 other beautiful examples of Come-Packt craftsmanship in living, dining and bedroom furniture—in sections—at 30% price savings. Sent free—postpaid. Mail postal today.

Come-Packt Furniture Co., 501 Dorr St., Toledo, O.



# STAMPINGS

Metal spinnings and stampings a specialty. All sorts of die work

metal patterns. Manufacturers of patent specialties and specialties. Can get out samples at moderate cost. Experts in black enameling. Prices reasonable. Prompt delivery.

STANDARD SPINNING & STAMPING CO., Toledo, O.

# HERE ARE TWO REASONS



Why we send our Daus' Improved Tip Top Duplicator on ten days' trial. FIRST—It proves OUR confidence in the machine. SECOND—By personal use you can positively tell, before buying, whether it meets your requirements. Each machine contains a roll of "Dausco" Oiled Parchment Back duplicating surface which can be used over and over again. 100 copies from pen-written and 50 copies from typewritten original. Complete Duplicator, cap size (prints 8 3/4 x 13 in.). Price **\$5.00**

advantage trial offer. Felix A. L. Daus Duplicator Co., Daus Building, New York, 113 John Street.

# Health? Take Turkish Bath at Home—Only 2 Cents



Physicians are abandoning drugs for this new treatment. If your mind or body is tired, open your pores and feel the rapid change in your condition, at cost of 2c a bath. The Robinson Bath Cabinet is the only scientifically constructed bath cabinet ever made for the home. Great \$2 Book Sent Free—"The Philosophy of Health and Beauty." Write today. Agents Wanted. **ROBINSON MFG. CO.** 1007 N. 12th St. TOLEDO, O.

# Hartman Will Trust You

## Rock Bottom Prices

Furniture, Carpets, Rugs, Etc. Best Terms Hartman's credit terms easiest, most liberal ever offered. No security—no notes—no mortgage. Free from all objections. At the end of a month you may return anything unsatisfactory and we refund your money including freight.

Over 8,000 bargains. Write today for FREE copy. **HARTMAN FURNITURE AND CARPET CO.** 3945-47 Wentworth Av., Chicago



# MODERN AMERICAN HOMES

**FREE THIS 224 PAGE PLAN BOOK**

Here is your chance to secure absolutely Free of Charge the most complete and up-to-date plan book ever published. No carpenter or contractor who wishes to be familiar with the latest in building construction—no man who is contemplating erecting a home—can afford to be without it. This great new plan book, "Modern American Homes," contains plans and specifications for 168 different structures, including excellent exterior and interior views, detailed estimates, etc. Designed by the leading architects of this country. Includes city, country and suburban homes, bungalows, farm houses, summer cottages, tent houses, camps, garages, apartment houses and various public buildings. 224 pages, 9 1/2 x 12 1/4 inches, and 426 illustrations. Printed on heavily enameled paper and substantially bound.

# The Cyclopaedia of Architecture, Carpentry and Building



consists of ten massive volumes; 4,760 pages, 7x10 in.; 4,000 illustrations, full page plates, building plans, diagrams, etc.; hundreds of valuable tables and formulas; carefully cross-indexed for quick, easy reference.

This work covers everything in the building professions, from the first rough sketch of the architect to the acceptance of the finished structure. It includes wood, stone, steel, and reinforced concrete construction; estimating and contracting; a study of the Greek and Roman Orders; interior finishing and decorating; and modern house lighting and sanitation.

### Partial Table of Contents

Mechanical, Freehand, Perspective and Architectural Drawing, Lettering, Pen and Ink Rendering, The Orders, Superintendence, Strength of Materials, Masonry, Reinforced Concrete, Carpentry, Steel Square, Stair-Building, Hardware, Steel Construction, Roof Trusses, Practical Problems, Estimating, Contracts, Specifications, Building Law, Sanitation, Sheet Metal Work, Electric Wiring and Lighting.

## We'll Send the Plan Book FREE

With every order for a Cyclopaedia we will include the Plan Book, absolutely free of charge and send you the Cyclopaedia and the Plan Book, express prepaid, for seven days' free examination. You keep the books a full week—examine them thoroughly at your leisure—and if they don't meet with your expectations they may be returned at our expense. Remember—the complete set—Cyclopaedia and Plan Book, are sent free upon receipt of the coupon below and we pay express charges both ways if they are not satisfactory.

**Another Free Offer** With each set is included a year's Consulting Membership, regular value \$12.00, entitling you to the free advice of a corps of Expert Architects. This will give practical help in handling your difficult building problems. This service alone is worth more than the first cost of the books.

**AMERICAN TECHNICAL SOCIETY, CHICAGO, U. S. A.**

## FREE PLAN BOOK COUPON

AMERICAN TECHNICAL SOCIETY, Chicago, U. S. A.

Please send Free Plan Book, also Cyclopaedia of Architecture, Carpentry and Building for seven days' examination. I will send \$2.00 within seven days and \$2.00 a month until I have paid \$24.80 for Cyclopaedia (Plan Book included free), or notify you and hold books subject to your order. Title not to pass until fully paid. Pop. Mech. 5-14

NAME .....

ADDRESS .....

OCCUPATION .....

EMPLOYER .....

# Prest-O-Lite

for  
Motorcycles

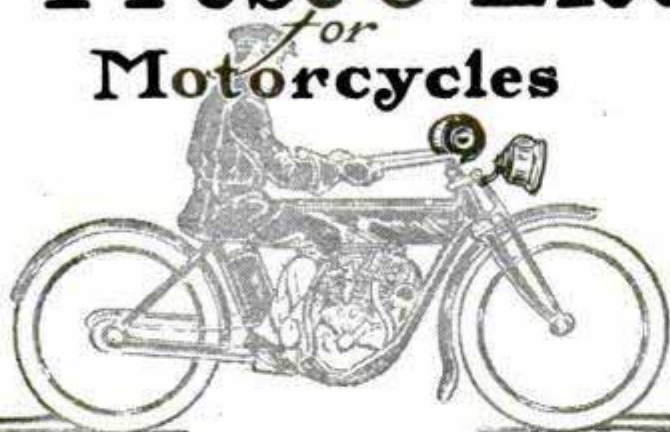

## The only reliable lighting system

Prest-O-Lite spells safety—it is absolutely reliable.

It is simple and sturdy. It stands the rough and tumble work, the jolts and the vibration. Has no delicate connections or frail parts.

Your light may snap out suddenly at a critical time, if it depends on a toy storage battery or any other complicated system.

Prest-O-Lite is *the most convenient* system. Needs practically no attention, has no mysteries, and breeds no troubles.

The first cost is small. The operating expense is no greater than that of a carbide generator, and only one-third to one-fifth that of electric light.

## 30-Day Free Trial

You can prove all our claims for Prest-O-Lite by our 30-day trial plan. Before buying any other system, insist upon the same kind of a test.

## Don't pay for poor light

Any dealer who offers you a combination of equipment, including any other lighting system, will give you Prest-O-Lite instead, if you insist. And if you know the facts, you *will insist*. Tear off on the dotted line, write your name and address below and mail it for complete information about motorcycle lighting.

Prest-O-Lite  
is ideal for  
Stereopticons

**THE PREST-O-LITE CO., Inc.**  
265 Speedway, Indianapolis, Ind.  
Contributor to Lincoln Highway

Please send facts on ALL Lighting Systems to

The New  
ARROW

19  
Mo

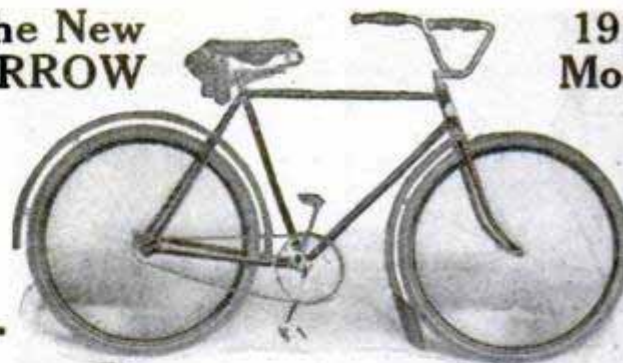

## New Motorcycle Type

Remarkable new improvements make the 1914 "Arrow" a positive wonder for speed, comfort and easy riding. Makes bicycle riding like coasting all the way. The smartest looking bicycle ever built. Latest Eagle easy motorcycle saddle—new Departure coaster brake—special motorcycle pedals—motorcycle handlebars with long rubber grips—ported anti-friction chain—reinforced frame—beautiful finish. All sizes for boys, men, and women. Do not fail to learn about this great new motorcycle model.

## Wonderful Offer

Write today for the low direct offer we are making on the splendid Arrow Bicycle. Get our free catalog. For only a very, very small amount down we will ship direct to you the elegant Arrow, built to last a life time. Pay for it while you ride—a little each month. Enjoy the pleasure of the bicycle while paying.

**Write Today!** Right now, and we will send you the announcement of this remarkable new motorcycle type "Arrow," with full details of machine and astonishing bedrock direct offer. Send a postal now with your name and address **TODAY SURE.**

**ARROW CYCLE CO.**

Dept. 1195, 19th St. and Cal. Ave., CHICAGO, ILL.

The people of the United States are the world's largest importers of diamonds for permanent ownership, they own practically half the diamonds of the world.

## THE MOTOR-BOB 1914 MODEL



Very latest design, classy looking, simple in construction. Boys! here's a real little auto that you can build yourself. Send 25 cts. for a set of our easy to understand plans, instructions and list of parts, telling just how to build the 1914 model Motor-Bob.

**THE IDEA SHOP, Dept. I, BUFFALO, N. Y.**

**Save 25%** By buying your motorcycle sundries and parts from us. Send for our book of motorcycle supplies Absolutely FREE to all riders for the asking.

**MOTORCYCLE CO-OPERATIVE CO., 471 Woodward Ave., DETROIT**



## Morgan Gas Light

Factory Representatives wanted everywhere to handle our Auto and Hardware Needs. Unusual Contract. Large Profits. Increased Demand. Write today, letter—no post office stamps. Exclusive Territory. Samples. FREE SALESMAN.

**Morgan Rolling Wedge Spring Leaf Opener** Only instantaneous spreader on market. For lubricating Wagons, Auto, or any spring. Real Opportunity for Hustlers. Immense field. Popular Prices. Millions will be sold. All our Specialties carry Money-Back Guarantee. Write Now to **MORGAN MFG. CO., Bellevue St., Newport, R. I.**

Please Mention Popular Mechanics

# "Limited" MOTORCYCLES

for  
**The Man Who Cares**

Our IDEA of a Motorcycle is one that is free from VIBRATION (run it on the stand and see if it moves).

Has power to spare and plenty of speed.

That can be depended on to get you there and back with the least trouble 365 days every year.

That is the machine for you to buy.

The LIMITED will do all that and then some. It's worth a minute of your time to write for a catalogue.

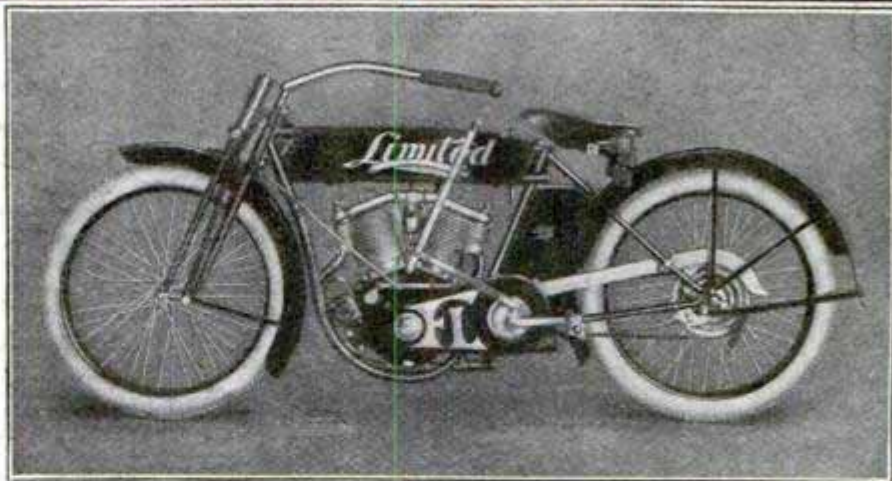

Some territory  
open to dealers  
on  
an Easy Plan

## FEILBACH MOTOR COMPANY

1172 HOLTON ST.

MILWAUKEE, WIS.

**CANNOT SEND COINS IN LETTERS**—Under the British postal laws letters containing coins or other valuables may not be sent through the mails unless registered. This rule, which differs from the American postal practice, results in much confusion in international mails. Every month hundreds of letters sent by Americans in response to advertisements of English concerns, are returned to the writers by the British postal authorities because they obviously contain small coins but are not registered.

Rider, be our representative in your town. **EARN \$40.00 PER WEEK.** Get our **FREE CATALOG** and compare prices with your local dealer. Introduce our electric bicycles and our wonderfully improved everlasting puncture proof tires \$10.00; Sample pair \$5.00. Guaranteed one year. **Park Row Motorcycle Co.,** Dept. A31, No. 36 Vesey St., New York  
*Largest Eastern Supply House*

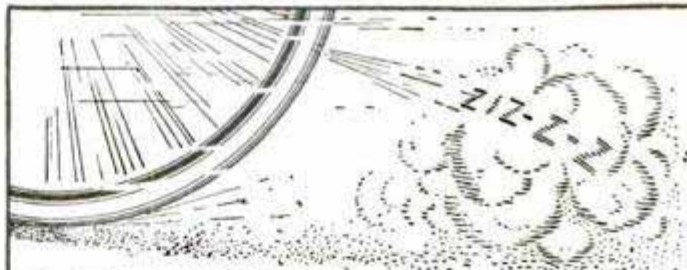

## This Will Never Happen If You Treat Your Tires with **NEVERLEAK**

Don't be bothered with aggravating punctures and porous tires. Just use NEVERLEAK Tire Fluid—it will save you time and money. Instantly heals punctures on the run and doubles the life of your tires for it actually preserves the rubber.

### The Old Stand-by

Be sure you get the genuine NEVERLEAK, used and sold for 18 years by repairmen and dealers everywhere. It is the one reliable preparation guaranteed to give satisfaction. Put up in handy self-injector tubes, 25c each.

**BUFFALO SPECIALTY COMPANY**  
BUFFALO, N. Y.



## Garage \$49.50

Genuine "Edwards." Ready-made, fire-proof garages. Quickly set up any place. Direct-from-factory prices—\$49.50 and up. Postal brings illustrated 64-page catalog.



THE EDWARDS MFG. CO., 320-370 Eggleston Ave., Cincinnati, Ohio

## RIDER AGENTS WANTED

In each town to ride and exhibit sample 1914 model. Write for Special Offer. Finest Guaranteed 1914 Models \$10 to \$27 with Coaster-Brakes and Puncture-Proof Tires. 1912 and 1913 MODELS ALL OF BEST MAKES..... \$7 to \$12  
**100 Second-Hand Wheels**  
All makes and models, good as new  
Great Factory Clearing Sale. \$3 to \$8  
We Ship on Approval without a cent deposit, pay the freight & allow **10 Days' Free Trial**  
**TIRES** coaster-brake wheels, lamps, and sundries, half usual prices. **DO NOT BUY** till you get our catalogue and offer. Write now.



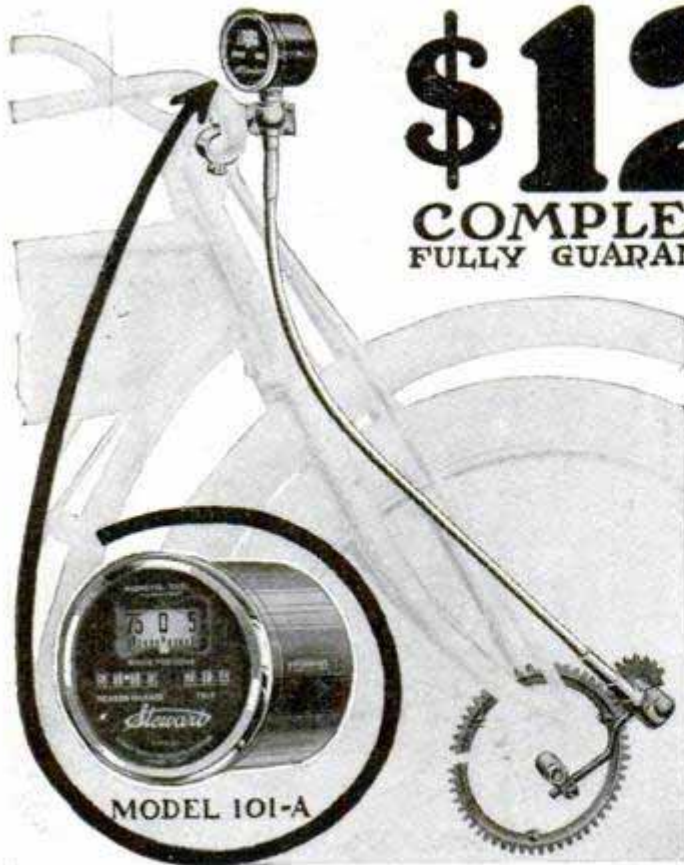

**\$12**  
**COMPLETE**  
**FULLY GUARANTEED**

**Stewart**  
**Motorcycle**  
**Speedometer**  
MAGNETIC PRINCIPLE

**Absorbs Shocks Mechanically**

**T**HE Stewart is the only front wheel drive motorcycle speedometer that has an absolutely unfailing means for taking up front fork shocks. This is the *rigid tube* through which the drive shaft operates. In all other types and makes, the flexible shaft has to stand these strains — and soon goes to pieces.

The "RIGID TUBE" on the Stewart Front Drive Model supports the bracket which holds the angle joint and fibre pinion. The bracket swings free on a swivel on the front wheel axle. With every up-and-down movement of the wheel, the pinion simply rides up and down on the sprocket. Thus all the destructive front fork action is taken up without any injury whatsoever to the rigid tube.

Don't consider a *rear* wheel driven speedometer. They all record false mileage due to slippage and "tuning-up." The Stewart Front Wheel Drive model alone insures satisfaction. It has our famous *magnetic* type speedometer — yet costs but \$12.

Season odometer registers 10,000 miles and repeat; trip odometer registers 100 miles and repeat. All speeds indicated (even fractions of a mile) from 0 to 80 miles an hour.

**Stewart-Warner Speedometer Corporation, Executive Offices: 1906 Diversey Blvd., Chicago**  
**Factories: Chicago and Beloit, Wisc. 17 Branches. Service Stations in all cities and large towns**

**A REAL CAR**  
**FOR A REAL BOY**

**The Lad's Car** is a real automobile designed especially for a boy.

**Send for Booklet!** **BOYS:** Send 20 cents to-day for Booklet, telling how to build this wonderful automobile. Complete instructions and descriptions of parts and sizes, illustrated with diagrams, blue print, cuts made from photographs and price list of parts.

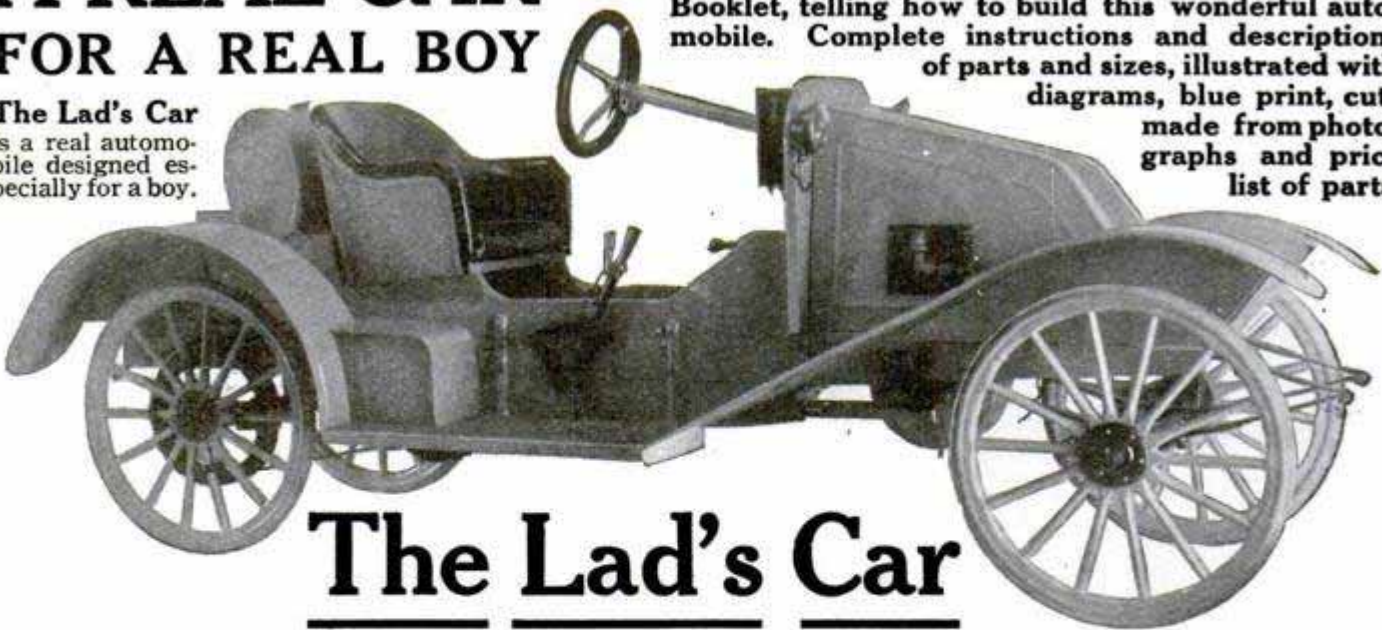

**The Lad's Car**

The illustration will give you a good idea of the sturdy construction and the completeness in detail of the Lad's Car. We supply it as shown, or furnish all necessary parts with instructions from which any boy can assemble the complete car.

Under the racy hood is a five horse power, four cycle engine. It will carry a passenger farther and cheaper on a gallon of gasoline than any other machine known. The car is equipped with a leather cone clutch and a powerful foot brake, which makes its operation perfectly safe.

**SPECIAL INDUCEMENT AWAITING YOUR INQUIRY**

Factory prices direct to you; send 20 cents to-day and learn how to assemble and operate your own car.  
**NIAGARA MOTOR CAR CORPORATION, Dept. A, NIAGARA FALLS, N. Y.**

# ORBIN-BROWN

## SPEEDOMETER

"The Speedometer of Absolute Accuracy"

### For Motorcycles

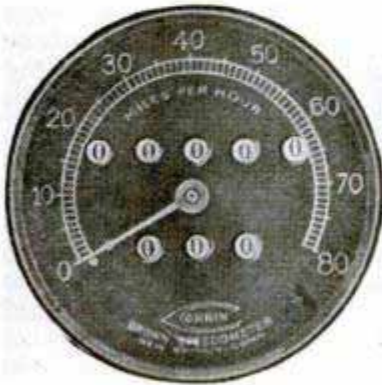

**\$15<sup>00</sup>**

Built with the accuracy and precision of a high grade watch.

Has either front or rear-drive attachment which prevents recording of mileage while machine is being tuned up on stand.

More sold in 1913 than any other make. Guaranteed for twelve months from date of sale. We will replace any defective parts due to mechanical defects or workmanship, if returned prepaid to our factory subject to inspection.

Write for new 1914 Catalog

# ORBIN BRAKES for

## Motorcycles and Bicycles

**Corbin Duplex Band Brake for Motorcycle.** The equipment of more than sixty-five per cent. of all the motorcycles in use during 1913.



**Corbin Duplex Coaster Brake**—You coast at will and save your energy. You stop wheel gradually or instantly as occasion demands.

**Corbin Two-Speed Coaster Brake**—Two gears always at your command. You change from high to low instantly by simply changing your foot pressure.

Sold and equipped by bicycle and hardware dealers everywhere.

Write for new 1914 Catalog

### The Corbin Screw Corporation

The American Hardware Corporation, Successors  
201 High Street - New Britain, Conn.

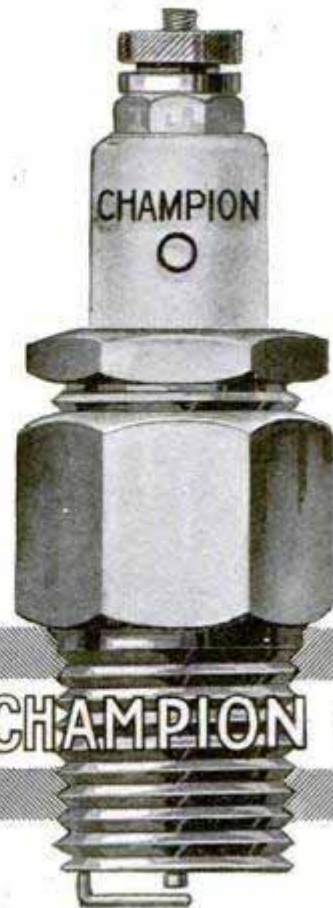

## This Is The Spark Plug With Which All Overland Cars Are Equipped At The Factory

The "Champion O" was designed especially for this season's Overlands. For Overlands of 1910, '11, '12 and '13, ask for the "Champion Long."

In designing these spark plugs, we were required to take into account every feature of the Overland motor.

Then the factory experts tested, tested and tested, until absolutely sure that "Champions" gave the highest possible efficiency to their motors.

75% of American made cars, including the Ford, Overland, Studebaker, Maxwell and Metz, are being equipped at their factories with specially designed Champion Spark Plugs.

The high quality of these plugs comes not only from the use of superior materials, but from our own special manufacturing processes.

"Champions" are oversize. They are built to stand the grief.

Ask for the special 1/2 inch Champion X for your Ford car. It's 75c. The Overland plug sells at \$1.

Consult with your dealer on this important subject. He will advise you as to the "Champion" you should use for your Motor Car, Motor Truck, Motorcycle, Motor Boat, Aeroplane or Stationary Motor.

(Licensed under the Canfield Patent No. 612,701, October 18, 1898)

### Champion Spark Plug Co.

407 Avondale Ave. Toledo, Ohio  
Export Representative, AUTOMOBILE SUNDRIES CO., 18 Broadway, NEW YORK

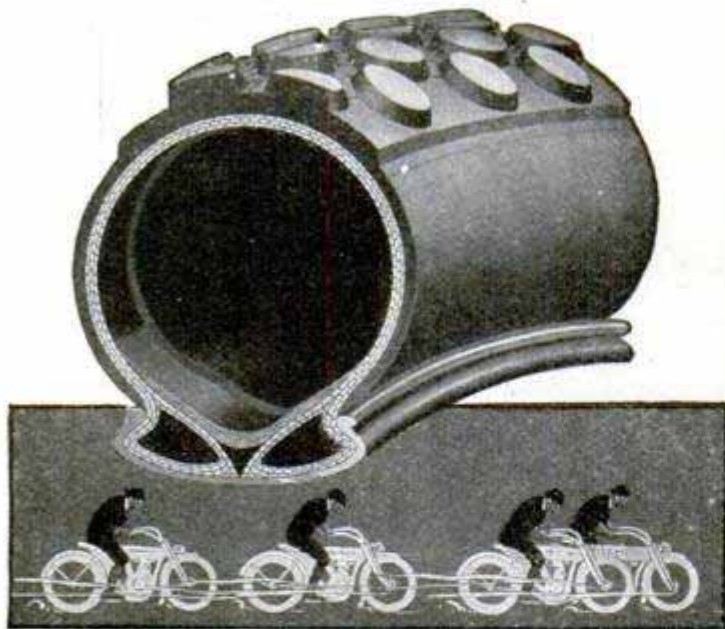

## Three Out of Four Have Come to These Motorcycle Tires

Every road condition is actually anticipated and met in the making of Goodyear Motorcycle Tires. Thus, at the *outset*, you are assured utmost mileage, durability, comfort, economy.

### Choice of Thousands

Three out of every four 1914 motorcyclists have been won to Goodyears. This year Goodyear will tire-equip a total of 115,000 motorcycles. This great output means a minimized producing cost—highest quality tires for the same money.



### Learn More of These

There is a booklet on Goodyear Motorcycle Tires. It is free. Gives the *how* and *why* of Goodyear supremacy. Tells of the exact Goodyear methods and materials that have minimized tread separation, blowouts and other tire troubles. Explains the wonderful machines that distribute all tension exactly throughout the tire carcass. Tells about the machines that test Goodyears against other tires, under actual road conditions, and by which Goodyear leadership is maintained.

### Goodyear Dealers Everywhere

Consult the nearest Goodyear dealer in your town. Also write for the booklet. Getting the right tires *first* means fullest pleasure and service from your motorcycle. And in Goodyears you get the tires that also hold every world's record in speed and durability tests.

The Goodyear Tire & Rubber Company, Akron, O.  
Toronto, Canada London, England Mexico City, Mexico

DEALERS EVERYWHERE

Branches and Agencies in 103 Principal Cities (1503)

## YOU WILL RIDE A HENDERSON

When you Learn of its Advantages

There is the starting device—a neat folding crank at the right side of the motor which responds to a mere "twist" without the aid of a stand.

The special Henderson padded saddle with spring adjustment and so placed as to carry the weight evenly distributed between the wheels.

The exclusive foot position on a comfortable running board in front of the motor away from all heat and moving parts.

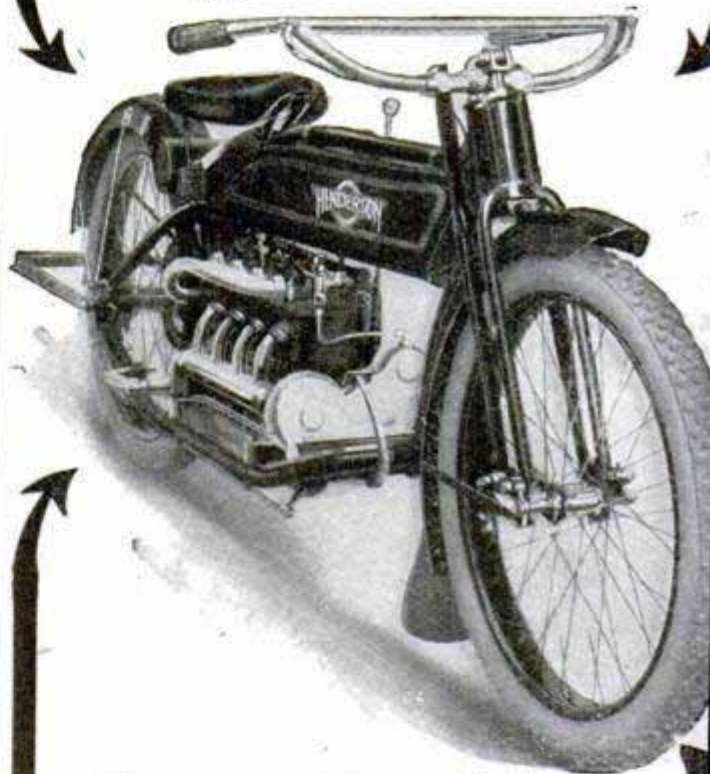

The powerful four cylinder motor that is capable of developing twelve horsepower and entirely dispenses the noise and vibration.

The smooth sensitive control that permits you to climb the dangerous grades slowly, under full power.

These are but a few of the exclusive Henderson features described in our beautiful illustrated catalogue.

"We Mail It on Request"

**Henderson Motorcycle Co.**  
Detroit, Michigan



# The Power of the "X"

Model 7-C, 7-10 H.P.  
Chain Drive  
Price \$225

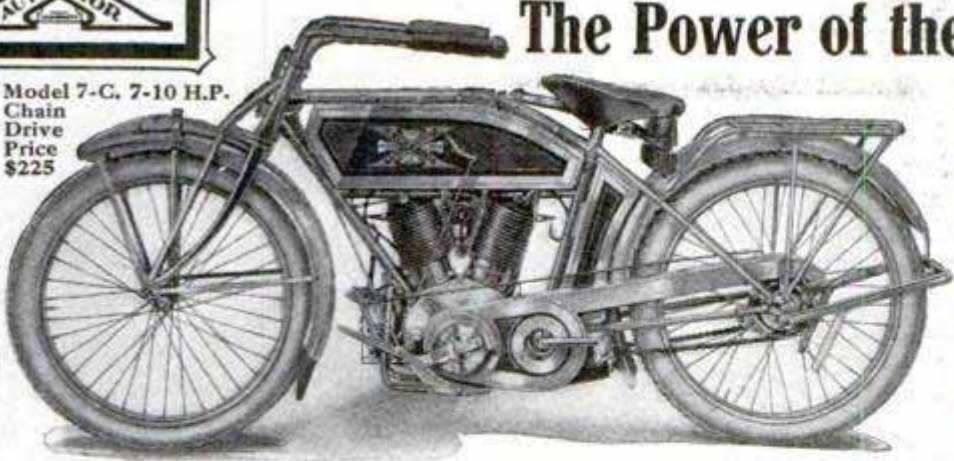

The POWER, SPEED and ENDURANCE of the **EXCELSIOR AUTO-CYCLE** have been proven beyond question. **NOW FOR THE REASONS WHY**

**FIRST**—A motor that is correct in design, perfect in workmanship and that has been brought to the highest degree of efficiency through six years of scientific development.  
**SECOND**—A rigid straight line frame that insures absolute alignment of every component part of the power-transmitting mechanism, a condition that cannot be attained in any frame built up of springs, hinges or other flexible parts.  
**THIRD**—A large and efficient multiple disk clutch located on the motor shaft, where it renders the highest degree of efficiency.  
**FINALLY**—A perfect balanced combination of a big, powerful motor, correctly designed and efficient transmitting mechanism, and a frame that is staunch and absolutely dependable under all circumstances.

Add to the above combination the extremely low center of gravity attained through the Excelsior open bottom frame; the great degree of comfort derived from a low saddle position, large, correctly located folding foot rests, the Excelsior Kumfort Kusion seat post and Complete Grip Control of all operating functions—and you have the nearest approach to perfection obtainable in a motor-cycle.  
Seven models for 1914, ranging in price from Model 4B, a single cylinder belt drive at \$190, to Model 7TS, seven H.P., twin two speed, at \$260.  
Our catalog or the nearest Excelsior dealer will give you full details. If you don't know a dealer, write us for catalog. We will do the rest.

## Excelsior Motor Manufacturing & Supply Co. 2202-2250 South Union St., CHICAGO



**Convert Your Wheel Into a Motor-Cycle** Motor fits any wheel. BEST, MOST RELIABLE. Best Hill Climber. More STEFFEYS in use than any others. Send stamp for circulars. **STEFFEY MFG. CO.**, Girard Ave. and 30th St., Phila., Pa.

**HONEST MAN WANTED**  
In each town for special advertising work; \$15 a week to start; experience unnecessary; references required.  
**LEAN, BLACK & CO., 18 E. Beverly St., BOSTON, MASS.**

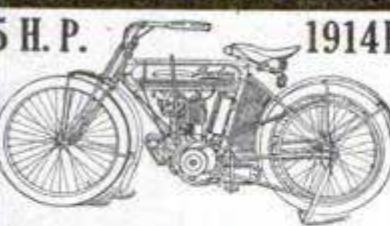

**5 H.P. 1914 Peerless Motorcycle**  
With Free Engine Idler and Bosch Magneto, together with the best there is in motorcycle construction—Power, Silence, Endurance, and those Wearing Qualities so essential for low cost of maintenance.  
**5 MILES FOR ONE CENT**  
Agents Wanted—Liberal Discounts

**PEERLESS MOTORCYCLE CO., 179 Huntington Ave., BOSTON, MASS.**

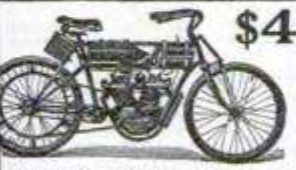

**\$40 Motorcycle**  
We have the largest line of new and used Motorcycles in the country at the lowest prices. We also have a thoroughly equipped repair department and are in position to furnish repairs for any machine. Send us your machine to be overhauled. We pay cash for second hand motorcycles. *Send for Catalog.*  
**HARRY R. GEER CO., 888 McLaran Ave., ST. LOUIS, MO.**



**SAFETY FIRST - MOTORCYCLISTS!**  
**"PERFECTO" TAIL LAMPS**  
AVOID REAR-END COLLISIONS  
The old reliable that you can depend upon. Complies with all state and city ordinances, in illuminating license number, etc. **PERFECTO REGULAR SELF-LIGHTING MODEL**, with Pet Cock Regulator, at the left. Fits all makes of motorcycles. Cuts your carbide and Prest-o-lite bills in two. **PRICE, \$2.00.**  
AT YOUR DEALER OR SENT DIRECT. **FREE CIRCULARS. WRITE US**  
**J. W. ERICKSON MFG. CO.**



**TWO Phonographs For ONE**  
Have you a Victor Victrola or a Columbia Graphophone? If so, these wonderful new quick-attachable **UNION Reproducers** (with diamond points) will enable you to play the beautiful new **EDISON Disc Records**—the sweetest music of their kind—without altering your machine. They give you **Two Phonographs for One**. Order one on trial—there's no risk—your money refunded, if desired, any time within two weeks.  
**UNION Reproducer for Victor or Columbia**  
**PRICES** Gold-plated . . . . \$9.00  
Nickel . . . . . \$8.00  
Sapphire points, \$1.50 less

For descriptive folders write **THE UNION SPECIALTY & PLATING CO.**  
411 Prospect Ave., N.W.  
Cleveland, Ohio  
Or ask your dealer.  
Find enclosed \$..... for **UNION Reproducer** for..... Disc Machine on two weeks' trial.  
NAME.....  
ADDRESS.....  
CITY..... STATE..... (41)  
Use the coupon to get descriptive folders

# Peerless Portable Power For All Purposes—With Flexible Shaft

This Peerless Combination Power Machine is quickly changed from a Floor Finishing Machine to a Portable Power Machine, and gives you an outfit with a wide range of usefulness. As a Floor Surfer and Polisher it is a most effective, time-saving, labor-saving, money-saving machine; for finishing hardwood, marble, tile and terazzo floors, doing the work better in one-third the time it can be done by hand. It is economical to operate and always under perfect control.

As a  
Floor  
Surfacing  
and Polishing  
Machine



As a  
Portable  
Buffer and  
Polisher



**TWO MACHINES  
for  
PRICE of ONE**

Surfacing, Grinding,  
Polishing, Drilling, Sawing, etc.

Converted into a Portable Power Machine, with its various attachments, its field of usefulness is almost unlimited—it becomes a buffing, grinding, sandpapering, polishing, boring and sawing machine for use on wood, marble and metal. Just the machine for office buildings and hotels—for marble, tile and terazzo floor layers, and for hardwood floor finishers. Nothing to get out of order—gears require no oil. Each machine positively guaranteed for a year. Made in two sizes. **SENT ON 10 DAYS FREE TRIAL.** Write today for Free Booklet and prices.

United Manufacturing Company 1051 Commerce Trust Building  
KANSAS CITY, MO

Both  
ways,  
this Grinnell  
**REZISTOL**  
Glove is a wonder

—in resisting current and resisting wear. It has been tested to resist a current of 4,000 volts—and though soft and pliable, is the toughest horsehide and wears like iron. That's why we call it "Rezistol." Washable in soap and water or gasoline—comes out like new. Outwear any gloves you ever had on and free and easy as your bare hand's to work in. Get a pair on approval. If your dealer doesn't carry Grinnell Gloves, send us his name.

Morrison-Richer Mfg. Co., Established 1856, 153 Broad St., Grinnell, Iowa

4315 P. R. F.  
Prepaid \$2.00



We will send your selection on approval. Style book and leather samples free on request.

## MONEY IN MUSHROOMS

Add \$10 to \$50 a Week to Your Income  
Grow Mushrooms

at home in your basements, barns, sheds, etc., without interfering with your regular occupation. Small beds, 5 x 10 ft., costing practically nothing to start often produce 60 to 100 lbs., selling at 50c to \$2.00 a lb. Your whole family can help in raising them. Others are making money growing mushrooms. Why don't you? My illustrated booklet telling how to start, how to see etc., sent free. Write today.

A. V. JACKSON, Falmouth Mushroom Cellars, Inc., 196 Gifford Street, Falmouth, Mass. The largest modern mushroom farm in the world.

## WIN NEXT \$1,200

We tell you how; \$40,000 already won by ten inexperienced people. Stoneman received \$1,200 one month; \$15,000 to date; Korstad \$2,200 in two weeks; Schleicher \$195 first 12 hours. Strange invention, startles the world. Gives every home bathroom with hot and cold running water for \$6.50; abolishes plumbing, water works; self-heating; little wonder Hart 16 in 3 hours, \$5,000 to date; Lodewick 17 first day. Credit given. Investigate today. Beat others to exclusive sale; means fortune. **ALLEN MFG. CO., 3649 Allen Bldg., Toledo, O.**

MAKE MONEY HERE

## AGENTS! DROP DEAD ONES. AWAKE! GRAB THIS NEW INVENTION! AGENTS! THE 20th CENTURY WONDER

LEARN the NEW WAY

Get started in an honest, clean, reliable, money-making business. Sold on a money-back guarantee

World's magical gift realized by this new invention. The **BLACKSTONE WATER POWER VACUUM MASSAGE MACHINE** for the home. No cost to operate. Lasts life-time. Price within reach of all. No competition. New field. New business. That's why it's easy. Removes blackheads, wrinkles, rounds out any part of the face or body and brings back Nature's beauty. Endorsed by leading doctors and masseurs. Listen: Parker, Okla., says, "8 orders first day." Margwarth, Pa., writes, "I am making \$19.00 per day." Shea, "First order 12, second 36, third 72." Schermerhorn, Ia., orders eight dozen machines first month. Shaffer, Va., "selling 4 out of 5 demonstrations." Vaughn, Wash., orders one dozen. Four days later wires "Ship 6 dozen by first express." Spain, Tenn., started with sample. Orders one dozen, then 2 dozen, next 3 dozen. Lewis, Ind., sells 3 machines first hour. Says "Best article he ever saw for merit and money-making." No experience necessary. Territory with protection given free to active workers. Nothing in the world like it. Best agent's article ever invented.

We own all U. S. and foreign patents. Big book entitled, "The Power and the Love of Beauty and Health" Free. Investigate now, today. A Postal will do. A big surprise awaits you. Address **BLACKSTONE MFG. CO., 696 Meredith Bldg. TOLEDO, O.**





# READY Our Big Book of Spring Fashions and Woolens FREE

"We Have No Agents"

Just off the press! Our Big Book of Spring Fashions, a complete guide to correct dress; handsomely illustrated in colors. Contains dozens of samples of newest spring and summer woolens—foreign and domestic fabrics in plain and fancy suitings, explains our new tailoring system, tells how we can make you an

## All Wool Made-to-Measure \$15 Blue Serge Suit for Only \$15

Yes, individually tailored to your measure, that for real style, fit, tailoring and material cannot be duplicated in the ordinary way for less than \$25. Why pay \$25 to \$30 for merely ordinary "ready-made" garments when you can get our classy, made-to-measure, all wool worsted serge suit for only \$15, in light blue, dark blue, gray or black. Up-to-the-minute in style; guaranteed perfect fitting. We satisfy you or you don't pay us one cent.

## \$4 Satin Lining Free

we want your business and in order to get it we are going to line the first suit you order with our regular \$4 Satin Lining, fully guaranteed, without 1 cent extra charge. Be a tailor-made man.

### Spend 1c — Save \$10

Send now, today, for your copy of our Big Book. Contains most wonderful tailoring values ever offered. Mail that postal this minute, right now before you forget it. Your copy of our Big Fashion Book will come by return mail.

**BERNARD, HEWITT & COMPANY**

Desk 25, 564-6-8 W. Monroe St., Chicago



Send for the big book to-day.

Statement of the ownership, management, etc., of Popular Mechanics Magazine, published monthly at Chicago, Ill., required by the Act of August 24, 1912: Editor, H. H. Windsor, 6 N. Michigan Avenue; Managing Editor, F. P. Stockbridge, 6 N. Michigan Avenue; Business Manager, H. H. Windsor, 6 N. Michigan Avenue; Publisher, Popular Mechanics Co., 6 N. Michigan Avenue; Owner, H. H. Windsor, 6 N. Michigan Avenue. Known bondholders, mortgagees, and

## Free to See and Use

Moth-proof



Free Trial

Any Piedmont Southern Red Cedar Chest in our catalog shipped on 15 days free trial. A Piedmont protects furs, woolens and plumes from moths, mice, dust and damp. Useful, beautiful and economical in every home. Pays for itself quickly in what it saves. Finest birthday, wedding or graduation gift. Low factory prices. Freight prepaid. Write today for big, illustrated catalog and book, "Story of Red Cedar." Postpaid, free to you. Piedmont Red Cedar Chest Co., Dept. 97, Statesville, N. C.

Removes INK Instantly leaving No Trace

**RUSH FRASER**

FLEXIBLE DIAMOND BRUSH  
Has over 10000 Diamond points  
That's the Reason

Made of Aluminum and Silver  
Lasts Indefinitely

Indispensable to Typists, Bookkeepers, and all users of pen and ink. The new and better way to erase. Big Money Maker. Sent prepaid for 50c with name of Stationer. Guaranteed Satisfactory or Money Back. Dealers and Side Line Men write today.

68 SACK Bldg. Syracuse, N. Y.

## Ruby for Your Name

To quickly introduce our dazzling blue white Mantec Gems (United States Letters Patent) and to distribute our beautiful art catalog, "The Story of the Mantec Gem." We will, for only 2 two cent stamps to cover cost of mailing, send you free a genuine uncut Navajo Ruby bought from the Navajo Indians together with our low cost-price offer for cutting and mounting. Write today—now. (Sellers of Genuine Gems since 1908.)

FRANCIS E. LESTER CO., Dept. E.T.5R, Mesilla Park, New Mexico

**HELP BOOST!**  
PANAMA PACIFIC EXPOSITION

25c 50c

Wear one of these beautiful San Francisco 1915 Watch Fobs. The 25c fob is a swell article. The 50c fob is made of white metal, high class and artistic. An ideal souvenir. Send 25c or 50c coin or stamps. Mailed anywhere.

E. M. JACOBS, 114A Sansome St., San Francisco, Cal.

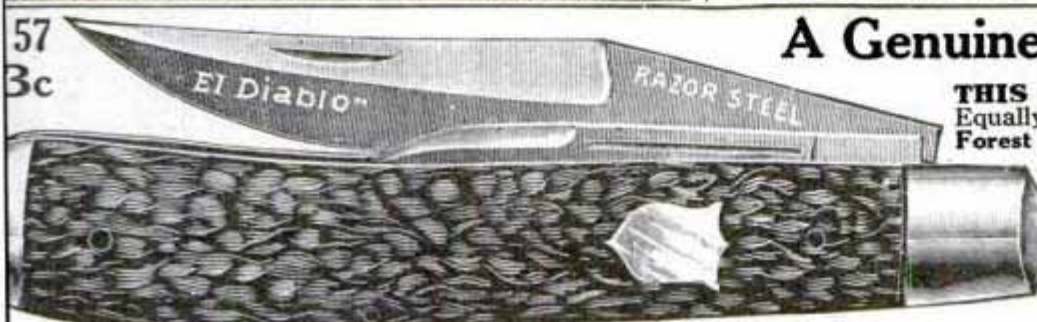

## A Genuine \$2 Knife for 83c

**THIS KNIFE HAS BRAINS IN IT.** Equally good in the Shop, the Farm, or Forest; light but extra strong; resharpened easily. Stag handle, German silver finish; blades file tested, hand forged razor steel and warranted. Sample 83c, 3 for \$2, postpaid. Choicest Pearl, \$2 each.

Send for 80-page Free List and "How to Use a Razor"



Everybody  
Drinks

**Coca-Cola**

—it answers every  
beverage require-  
ment—vim, vigor,  
refreshment,  
wholesomeness.

*It will satisfy you.*

THE COCA-COLA COMPANY  
ATLANTA, GA.



Demand the genuine  
by full name—  
Nicknames encourage  
substitution.

Whenever  
you see an  
Arrow think  
of Coca-Cola

**ASTOUNDING BARGAIN!**

In order to get you acquainted with us, we will for a limited time send prepaid this high-grade compass, warranted to be accurate, for the ridiculous price of 10c. This compass sells everywhere for 25c. It measures 1 1/4" in diameter, glass cover, nickel plated band, dial in two colors. Instructions tell how to use this instrument for orientation purposes, telling polarity of magnets, tell if an electric wire is "alive" or "dead," making a voltmeter with this compass, etc., etc. You cannot afford to be without this wonderful little instrument, AND at no extra charge we will send you absolutely free our famous comprehensive electrical cyclopedia No. 12 containing over 450 illustrations and over 1600 electrical apparatus and supplies. Book contains 16 page "Treatise on Wireless Telegraphy" also 16 page copy of the new magazine "The Electrical Experimenter." Ask for our **FREE** 160 page "Wireless Course" in twenty (20) lessons.

*If you don't wish the compass send 3c. postage for the electrical cyclopedia.*

Electro Importing Co., 233A Fulton St., N.Y.C.  
**"Everything for the Experimenter"**

**Voltamp Motors**  
"Little Dickie" Prepaid \$1.10

**Special Offer, 30 Days**

U. S. or Canada on receipt of \$1.10. Every boy and grown-up should have the new VOLTAMP Catalog.—just the book for the experimenter. Wireless, Telegraphs, Telephones, Motor Dynamos, Transformers, Rectifiers, Miniature Railways and Parts, Raw Materials and hundreds of others. Sent only for 6c in stamps or coin. Largest Electrical Mail Order House in U.S.

**VOLTAMP ELECTRIC MFG. CO.**  
Voltamp Block BALTIMORE, MD

other security holders, holding 1 per cent or more of amount of bonds, mortgages, or other securities: No

H. H. WINDSOR, Editor

Sworn to and subscribed before me this 23rd day March, 1914.

J. GRAHAM,  
Notary Public.

(My commission expires June 17, 1914)

**Ten Days' Free Trial**

allowed on every bicycle we sell. We Ship on Approval and trial to anyone in the U. S. and prepay the freight. If you are not satisfied with the bicycle after using ten days, ship it back and don't pay a cent.

**FACTORY PRICES**

Do not buy a bicycle at any price until you receive our latest Art Catalog of high grade bicycles and sundries and learn our heard-of prices and marvelous new special offers.

**IT ONLY COSTS**

everything will be sent FREE by return mail. You will get much valuable information. Do Not Wait; write it NOW!

**TIRES, Coaster-Brake, rear wheels, lamp parts, repairs and sundries of all kinds at half usual price**

**MEAD CYCLE CO. Dept. T108 CHICAGO**



**SAFETY FIRST**

**Yale Electric Lantern**

and Combination House Lamp  
Search and Flash Light

This is NOT a Toy Turn a switch and you get a flood of light. The safest, handiest, most simple around light for autoists, campers, sportsmen, merchant, farmer, etc. Eliminates: Filling, matches, oils, greasy smoked chimneys, trimming of wick and other troubles. Always ready when wanted.

A sample will be sent prepaid parcel post receipt of remittance.

**Introductory Price \$3.50**

introductory price. Or sample and agents' proposition now—be the first. Sold on money-back guarantee. A big money-maker agents. AGENTS WANTED EVERYWHERE

**YALE MANUFACTURING CO.**  
20-22 So. Clinton St., Chicago

Special  
BARGAIN  
SALE

**"EVERYBODY'S DOING IT"—BUYING  
DIAMONDS, WATCHES, JEWELRY, on CREDIT  
YOU SAVE ONE-THIRD**

**Diamonds  
Watches  
on Credit**

Send for FREE  
Jewelry  
Catalog

(Established 1858)  
STORES ALSO IN:  
PITTSBURGH  
ST. LOUIS  
OMAHA

These are our Big Leaders—always fashionable, always worn by lovers of artistic jewelry. Let us send you any of these handsome pieces, or any article shown in our Catalog, for your examination and approval all delivery charges prepaid by us. If satisfactory, send us one-fifth of purchase price as first payment, balance in eight equal amounts, payable monthly.

No. 529-Diamond Ring, "The Young Man's Favorite," 6-prong "Tooth" mounting, 14k solid gold . . . \$65  
No. 521-Diamond Ring, the famous Loftis "Perfection" mounting, 14k solid gold . . . \$50  
No. 625-LaValliere, solid gold, 1 Diamond, 4 whole Pearls, 2 Sapphires; with 15 in. chain. Our best seller, \$25



Our handsome 116-page Catalog, illustrating over 2,000 bargains, is sent free on request. All the new, popular styles in Jewelry—gorgeously beautiful Diamonds, Artistic solid gold and platinum mountings—exquisite things—that sell in some cash stores at almost double our prices. Our Easy Credit Plan is fully explained in Catalog. Send for it today. IT IS FREE

**LOFTIS BROS. & CO., Diamonds, Watches, etc.**  
Dept. N 894, 100 to 108 N. State Street, CHICAGO, ILL.

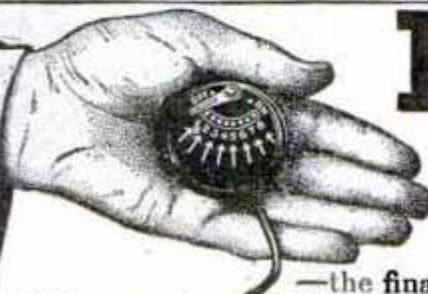

**HEAR**

**Latest 8-Tone  
Mears Ear Phone**

—the final triumph of the inventor of the first successful

multi-tone ear phone. Eight Tones! Eight different adjustments to suit every condition of the ear. Just out. The new Eight-Tone ear phone makes every kind and "shade" of sound as distinct to the deaf as shades of color are distinct to perfect eyes. Send this coupon and get free the Mears Ear Phone Booklet today.

**On Trial:** We will send you an 8-Tone instrument on a 15 day trial. If it fails to help you send it back, we will not cost you a penny.

**Our Offer:**

The New 8-Tone Mears Ear Phone is sold at present only direct from our New York offices at the laboratory price with no jobbers' or dealers' profits added. The highest grade instrument now offered at a price within the reach of all and on easy monthly payments, if desired. Send at once for our rock-bottom offer.

The Mears Ear Phone Book explains all the causes of deafness; tells how to stop the progress of the malady and how to treat it. Write at once—send the coupon—now—for this Free Book with names and addresses of hundreds of satisfied users and our great Special Introductory Offer.

Send Free Coupon Above  
MEARS EAR PHONE CO., Dept. 1195

45 West 34th Street, New York City

Name .....  
Address .....

Mears Ear Phone Co., Dept. 1195  
45 West 34th Street, New York City

Gentlemen:—Please mail me, free and postpaid, your Mears Ear Phone Booklet and particulars of Special Introductory Offer on new 8-tone Mears Ear Phone and free trial.

If you live in New York call at our office, presenting this coupon, for free demonstration.

**Go into THE MOVING PICTURE BUSINESS.**



Write for FREE Catalog  
**Earn \$30-\$50 Per Night  
No Experience Necessary**  
A small investment will start you in this great money making business. We furnish Machine, Film, Lighting Equipment and complete traveling and stationary outfits.  
**ACORN MOVING PICTURE CO.**  
501 Merton Bldg., Dept. C, Chicago

**FOLDING BATH TUB**



Costs but little and will last for years. Weight only 15 pounds. Requires but little water, and no plumbing necessary. Folds into small roll and no more trouble to carry than a valise. Enjoy the delights of a full length bath in your private room. Far superior to a tin tub. Write for description and special offer to agents.  
**ROBINSON MFG. CO., 29 Factories Bldg., TOLEDO, O.**  
Manufacturers Turkish Bath Cabinets

**BUY YOUR FURNACE  
\$10 DOWN \$10 A MONTH**



Our monthly payment plan of selling direct saves you the dealer's profits and excessive charges for installation. The

**Jahant Furnace**

with the patented "Down Draft System" is best for residences, schools, hotels, churches, etc. Saves 1/3 to 1/2 in fuel bills. Install the Jahant yourself. We send complete outfit, freight prepaid with special plans, detailed instructions and all necessary tools for installation. Satisfaction guaranteed or money refunded. Thos. L. Flaherty, Hamilton, N. Y., writes: "Best Furnace made. Had no trouble install it. Had it up and fire started in 12 hours."

Write for Free, Illustrated book  
**THE JAHANT HEATING CO.**  
20 Main Street AKRON, OHIO

**Save 1/3 to 1/2 on Fuel Bills**

**Make this car  
your office—**



There is \$900.00 to \$1800.00 a year in it for you

Examinations will likely be held everywhere soon  
Rapid advancement to higher Government Positions. "No layoffs" because of STRIKES, FINANCIAL FLURRIES or the WHIMS OF SOME CITY BOSS. THE POSITION IS YOURS FOR LIFE.  
Country residents and city residents stand the same chance for immediate appointment. Common-sense education sufficient. Political influence NOT REQUIRED.  
We will prepare 25 candidates FREE!  
Write immediately for schedule showing the places and dates of an SPRING examinations. Don't delay. Every day you lose means the loss of just so much coaching before the rapidly approaching examinations.

Hundreds of Far-Flung Post-Railway Mail Clerks Needed NOW!

**COUPON**  
Franklin Institute (The pathway to plenty), Dept. G174, Rochester, N. Y.  
The coupon, filled out as directed, entitles the sender to free specimen questions; a free copy of our copyrighted book, "Government Positions and How to Obtain Them," a list of positions now available, and to consideration for Free Coaching for the examination here checked.

.... Railway Mail Clerk (\$900 to \$1800)	.... Customs Positions (\$800 to \$1500)
.... Bookkeeper . . . . . (\$900 to \$1800)	.... Stenographer . . . . . (\$800 to \$1500)
.... Postoffice Clerk . . . . . (\$800 to \$1200)	.... Internal Revenue . . . . . (\$700 to \$1800)
.... Postoffice Carrier . . . . . (\$800 to \$1200)	.... Clerk in the Departments at Washington (\$800 to \$1500)
.... Rural Mail Carrier . . . . . (\$500 to \$1100)	.... Canadian Government Positions
.... Automobile Chauffeur	

# Save Money—Build the Lewis Easy Built Way

**LEWIS  
EASY-BUILT  
HOMES**

You can cut a big slice off your building bill. You can put into your own pocket the profits of the middleman, the dealer and the jobber by building the Lewis way. Lewis homes are shipped direct from the mills all ready to erect. The planning and designing, the worry and work of figuring is lifted from your shoulders. The Lewis Easy-Built way means better homes at low cost.

**\$248.00 and up** Lewis Easy-Built Homes come in many sizes, styles and prices. Small, inexpensive cottages, cozy, attractive bungalows and larger homes, each one a masterpiece of design and construction. Lewis Homes are carefully planned and laid out by skilled designers—men with a lifetime knowledge of the business.

Shipped complete direct to you. Easy-Built Homes are made of the best grades of lumber. Lewis specifications include all lumber, millwork, hardware, paints, and plaster—all sawed and worked to fit, ready to put up. Complete working plans come with each home.

**Send for Plan Book** If you are going to build send for the Lewis Easy-Built Book. It shows you every kink of the building game. It tells you how to build better and for less money. Get this valuable book. Every home builder should have it. A postage stamp will save you many dollars. Send for it today.

Lewis Manufacturing Co.,

1019 Lafayette Ave., Bay City, Mich.



Get the price on this attractive semi-Bungalow. 7 rooms and bath

Get it—with a GOERZ!

You get a never-failing series of brilliant pictures with maximum depth of field and sharp definition from center to corners with

## GOERZ LENSES CAMERAS

Speedy? Nothing gets away from them. They are standard with professionals and with amateurs who demand quality first.

You will find your dealer glad to talk Goerz goods to you NOW—and the New Tariff lowers price

Send for article, "The Optics of Lenses," in our Illustrated, Descriptive Price Catalogue

C P GOERZ AMERICAN OPTICAL CO.  
No. 323C East 34th Street New York City



## EXPERIMENTERS

This is the **Experimenter's Reference Book**

It's the latest edition of the famous Amco Catalogue, 128 pages, fully illustrated, complete description and prices of the latest electrical and experimental apparatus—Storage

Batteries, Rectifiers, Transformers, Induction Coils, Wireless Apparatus, Lamps, Flashlights, Meters, X-Rays, Books, Tools, Electric Railways, Steam Engines, Water Motors, Dynamos, Motors, Telegraphs, Telephones, Electrical Supplies, Model Aeroplanes, and Parts for building your own apparatus. 40 in stamps will bring you this wonderful book. The best catalogue of *Wireless Apparatus, etc.*, published.

ADAMS-MORGAN CO. "The Experimenter's Supply House"  
Box 72 M, Upper Montclair, N.J.

## AGENTS—Only One in the World

**KEROSENE (Coal Oil) IRON**

**ABSOLUTELY SAFE**  
Odorless—Cheapest  
Known. Women everywhere want a Kerosene Iron. Low Price Means Quick Sales. Write quick for terms and profits. Your territory is open. **FREE SAMPLE to Workers.**

THOMAS IRON CO., 1248 Lane St. Dayton, Ohio

## Triumph Light

**WE ALL WANT BETTER LIGHT. HERE IT IS**

This new 100 to 700 candle power light turns up and down like gas. One-third cost of electricity, gas or kerosene. For home, church or store. Anyone can operate. Perfection guaranteed or money back. Write for catalog (P.O.P.), Dept. 1. Agents Wanted.

**BRILLIANT GAS LAMP COMPANY**  
1009 C. So. Wabash Ave., Chicago, Illinois



## 300 Candle Power of Light AT A COST OF 1/8c PER HOUR

The Kerosene table lamp has one inverted mantle and **MAKES AND BURNS ITS OWN GAS FROM COMMON KEROSENE OR COAL OIL.** It gives a bright and steady white light **TEN TIMES** as **BRILLIANT** as an ordinary kerosene wick lamp.

**The "Quicklit"** Gasoline table lamp can be **LIT WITH AN ORDINARY MATCH LIKE CITY GAS.**

Both styles equipped with automatic cleaning needle.

**NO smoke, no smell, no wicks to trim. A splendid proposition for dealers**

**LIVE AGENTS WANTED** Write today for further particulars, also complete illustrated catalog

describing the above kerosene and gasoline lamps and hollow wire systems.

**THE NAGEL-CHASE MFG. CO., 146-168 East Erie St., CHICAGO, ILL., U.S.A.**

The largest manufacturers of artificial lighting devices in the world.

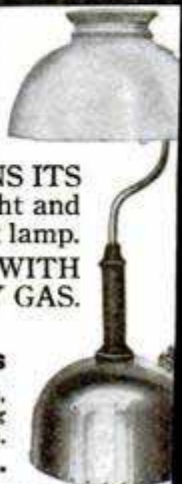

## Water Without Pumping Plenty of It Too



**A**BSOLUTE reliability, low first cost, and no need of attention and repairs are the requisites of a perfect water system. Engines are often a source of annoyance, windmills depend entirely upon the wind, and hand pumping is enough to drive anyone off the farm. Be absolutely free from all water supply troubles—install a

### RIFE RAM

Any stream in your neighborhood having a fall of three feet or more and a supply of three gallons or more per minute, will operate it. The Rife Rams vary in size from a machine for one family's use to a city water system. Thus you can co-operate with your neighbor if there is no stream on your farm.

**REMEMBER:—Low First Cost—No Repairs for Years—No Freezing—No Fuel—No Labor** are the high qualities of the Rife Ram.

No skilled labor required to install it. Over 11,000 in daily use. Satisfaction guaranteed. Write today for catalog and

**Tell Us Your Water Supply Conditions** and we will send free estimate on your requirements.



**RIFE ENGINE COMPANY**  
New York City

3131 Trinity Building

## THE NEW STYLE



### Edison Phonograph

and your choice of over 1500 records now shipped direct to you

## FREE!

Yes, try it out right in your own home. Entertain your family and friends. Send it back at our expense if you don't want to keep it. \$2 a month now pays for a genuine Edison Phonograph at the Rock-Bottom Price and without even interest on monthly payments.

**Write Today for Our Free Edison Book**

about the wonderful entertainers. Shows you all the names and records you have to choose from. No obligations asking for our FREE EDISON BOOK. Write Today—NOW.

**RABSON, Edison Phonograph Distr., 1195 Edison Bldg., CHICAGO**

## Can You Stand Prosperity?

Engesser writes: "I have just returned from a mill town 'Glenn' and in eight hours made \$42.50." With a

### DAYDARK PLATELESS PHOTO POST-CARD MACHINE

Earn big money at home, traveling, at fairs, on streets, kiosk, finishing and delivering 3 photo post-cards a minute—all done with the Daydark.

**NO EXPERIENCE NECESSARY**

Independent—be prosperous. Write today for Free Catalogue, sample post-card showing fine work this machine does and free trial offer.

**DAYDARK SPECIALTY CO.**  
502 Daydark Bldg. St. Louis, Mo.



**FREE TRIAL 10 DAYS PREPAID**

## FREE—Grape Fruit and Orange Trees—FREE

TO ALL WHO USE THE ATTACHED COUPON



In Reserving One of These Choice Citrus Fruit and Truck Farms on Our Special Terms of Only

3 1/3 CENTS per day per acre

**We are giving 100 fine, sturdy Citrus Fruit Trees FREE to each purchaser of one of these Florida farms—a full assortment of 100 Citrus Fruit Trees ABSOLUTELY FREE.**

These trees, when delivered, will be from one and a half to two years old, budded on strong, hardy, rough lemon and sour orange stock—good, sturdy, healthy young trees that compare favorably with those sold by the reliable nurseries at 45 to 85 cents apiece.

There are no strings to this exceedingly liberal offer. Every new purchaser who mails this coupon promptly, receives 100 sturdy Citrus Fruit trees of such an assortment as he may select. During 1914 your trees will be cultivated, budded and cared for by first class nurserymen without charge.

**To Get Your FREE Fruit Trees, Mail Coupon Today**

**OUR NEW LITHIA TRACT** is suburban to Tampa, the metropolis of South Florida, and is one of the few choice citrus fruit tracts left in Hillsboro County, the recognized center of Florida's grape fruit and orange belt.

This is the third great Hillsboro County tract subdivided by our old established, responsible, thoroughly experienced organization. Over 2,500 families are now rejoicing because they bought at opening prices in our two former tracts. Every family can tell you they got a square and generous deal.

Our New Lithia Tract now offers you the same wonderful opportunity—better still, because of the rapid growth and development on all sides within the past four years. Our surveyors have completed their work of subdividing the New Lithia tract into 10, 20 and 40-acre Citrus Fruit and Truck Farms, and it is now being thrown open to home-seekers and investors.

Hillsboro County is building **ONE MILLION DOLLARS' WORTH OF NEW BRICK COUNTRY ROADS**—the first county in the U. S. to vote such an appropriation. Improvements of all kinds are going rapidly forward. Already buyers are building homes on our new Lithia Tract, and values are due to rise here just as they have in our two former suburban farm tracts in this same county.

The visible supply of select Hillsboro County grape fruit land is fast melting away. Prosperous homes are scattered around the new Lithia Tract—grape fruit and orange groves are flourishing on all sides.

One judicious investment beats years of labor. If you do not wish to improve your farm, you can cash in on it from the investment standpoint in a few years without a stroke of work on your part.

Get our big new Florida book and look at the map—four big railroads intersect our suburban farms—all the comforts of modern life right at hand! The completion of the Panama Canal throws the spotlight on Tampa, the nearest deep water port, and now the traffic of the whole maritime world will pause at Tampa's door.

Think of it—a 10-acre farm near a great city like this—a farm big enough to keep you in comfort all your lives, yet yours for just 3 1/3 cents per acre per day!

Get the facts now. The coupon brings them to you without cost or obligation—now, while prices on this newly opened tract are still low and terms easy. Today \$1.00 per acre per month buys you independence and a future. Tomorrow—who knows?

We have prepared a special bulletin and a large illustrated book which we will gladly send you free on receipt of the coupon. Tear it off and mail it NOW and we will lay before you, by return mail, full and complete information showing how you can easily become the owner of one of these beautiful suburban farms, and why it is sure to prove the shrewdest, most profitable investment you can ever make.

## North Tampa Land Co.

**C. E. THOMAS, President**  
1128 Commercial National Bank Bldg., CHICAGO

**NORTH TAMPA LAND CO., 1128 Commercial National Bank Bldg., CHICAGO**  
Please send me FREE assortment blank for 100 Sturdy Citrus Fruit Trees, also your latest and best Illustrated Book on choice Citrus Fruit and Truck Farms suburban to Tampa, Florida. P. M. 5-14

Name \_\_\_\_\_  
Street No. \_\_\_\_\_  
City \_\_\_\_\_  
State \_\_\_\_\_

# BIG PROFITS

## In One Minute Photography No Experience Required

A new, live profession, offering to red blooded, ambitious men and women, a real chance to make money. Now, as you read, you are facing an opportunity that may be a turning point in your life. Strike out for yourself! What's a mere job? What kind of future do the time clock and pay envelope promise? Invest your brains! Better your position! Double your income! **Do Something.** You want opportunity—don't you? Listen!

### \$28.50 PROFIT IN ONE DAY

That's what John Hancock, of Lamoni, Iowa, earned. Rev. J. W. White, Okla., made \$3.50 in 3 hours. Miller, Ia., says: "I made \$13.65 in one afternoon." Shearer, Mont., made \$22.35 in 5 hrs. Hundreds of letters like these show the stupendous possibilities—the enormous money-making power of

## THE "MANDEL" POST CARD MACHINE

A new one minute picture machine, taking and finishing original photographs on post cards and buttons at the rate of 3 per minute. Five different styles of pictures made with the same machine. **No films, plates or dark room required.** The pictures are taken and finished right within the machine in less than a minute's time. No waiting. No delays. You collect your money right away.

## World-Wide Market For One Minute Photographers

Here's a business that gives you an unlimited money-making market. Fairs, carnivals, picnics, circus grounds, aviation fields, busy corners, in small towns and large cities—all that, and more is your field for profit. You can travel and see life and make money besides expenses. Or you can work right in and around your own town—all or spare time. There are a thousand chances, a thousand advantages the "Mandel" Machine gives you to turn hours into cash.

### Small Capital Starts You

Write today! Let us show you what big opportunities this **Portable Post Card Gallery** offers you. Costs nothing to write us—and it may mean the starting of a successful business career for you. Address either office—**TODAY.**



**The Chicago Ferrottype Co.**

490 Ferrottype Bldg., CHICAGO, ILL. OR Dept. 490, Public Bk. Bldg., 89-91 Delancey St., NEW YORK, N.Y.



# 48c

## LIMITED OFFER

For a limited time **ONLY**—just to introduce the wonderful new **Eny-Blade** Safety Razor—we will send you postpaid **ONE ENY-BLADE RAZOR** for 48c.

The **ENY-BLADE** is the only safety razor made that will take any blade. Embraces the desirable features of every safety razor up to the present time. It is simple in design—a boon to every man who shaves himself—mechanically clean, sanitary. No levers, springs or hinges. Adjustable to any angle. No matter what razor you are now using you will discard it once you try the **ENY-BLADE**. You can make big money selling these to your friends. The regular price is \$1.00, but we will send you **one** sample **ENY-BLADE** Safety Razor and a blade by return mail and show you how to make \$35.00 a week and upward for just a little work in your spare time. Positively guaranteed and money back if no more than satisfied. We can appoint only 2,000 agents so act quickly. Send P. O. Money Order **TODAY** or some one will get ahead of you.

**Knarf Manufacturing Company**  
200 Georgia St., Middletown, Ohio, U. S. A.

Nose Glasses  Never-slip when using Low Arntz' Never-slip Prepaid 25c. Agents earn big money.  
**ARNTZ OPTICAL CO., D 10, DES MOINES,**

### \$5.00

POST  
PAID



**GENUINE WALRUS BAG GUARANTEED**

Leather Lined, Three Pockets, French Sewed Edges, Soft Corners, Brass Key Lock and Catch. Just the thing for your trip. Sold by mail only. Regular price, \$7.50 to \$10.00. By parcel post, prepaid, \$5.00. Choice of 16 or 18 in. Send to **AUSTIN'S SHOPS, 6 Court St., Binghamton, N.Y.**

## If You Are Going To Build

or remodel, use **Bishopric Stucco** or **Plaster Board** for interiors and exteriors. Cuts building costs and gives a better and quicker wall. Easy to apply. Nailed dry to studding. Walls instantly ready for cement, plaster or stucco. Makes houses cool in summer, warm in winter and damp-proof. Write for free sample and information booklet.

**THE MASTIC WALL BOARD AND ROOFING CO.**  
548 Este Avenue, Cincinnati, Ohio (1)

**BISHOPRIC  
STUCCO OR PLASTER  
BOARD**



## Sometimes You Want to Cut Metal

Now and then you would find it very handy to be able to cut metal quickly and easily; to shorten a screw or bolt, for instance, or to shape out a piece of sheet steel for a repair job. You can do all this sort of work very handily with our new

### STAR Hack Saw Frame No. 1011

—the frame with the "pistol grip." The shape of the handle gives you the positive grip you need to work easily and maintain perfect control of the Frame. It's a big improvement over Frames made with the usual straight handle. In other respects, too, this Frame excels. Has re-inforced, extensible back for blades from 8" to 12" and blades may be faced in four directions.

Ask your Dealer, who probably carries Millers-Falls Tools and the "pistol grip" Hack Saw Frame shown below. If he doesn't, write us and we'll send you the name of a Dealer who can take care of your needs. New Catalogue showing many tools you need, sent on request.

MILLERS-FALLS CO., Millers Falls, Mass.



**HARD COAL FOUND IN SWITZERLAND**—In giving a water-supply tunnel through a mountain near Natergegen anthracite of good quality and in workable quantity was discovered. This is one of the very few hard-coal deposits known in Switzerland.

## WE SAVE YOU MONEY

Drators, Motors, and Elec. Supplies. Students, Engineers and School Supplies

on everything. Engineering, Surveying and Astronomical Instruments of Precision. Electrical Specialties and School Supplies. Architect's and Draughtsmen's Materials. Drawing Room Furniture, Adding and Calculating Machines, Machinists' Tools and Measuring Tapes, Electrical Vibrators, Oscillators and Electrical Supplies. Richardson's Direct Reading, Adding, Subtracting and Electrical Slide Rules. Winslow's Concrete and Strength Computing Slide Rules. Johnson's Patent Pocket Rules. **We Pay All Delivery Charges.**

Write us for prices and circulars of what you want. No order too large or too small to receive our prompt attention. **MERMAN ENGINEERING & SUPPLY CO., Ft. Wayne, Ind.** Consulting Engineers, Machinery and Boiler Inspections. Patent Work a Specialty

## Furniture On Credit

Write for Mammoth Bargain Book picturing 4,918 articles

**PIEGEL, MAY, STERN CO.**  
1089 West 35th Street, Chicago

### OWN A BUSINESS WHERE THE CROWDS ARE ALWAYS WAITING TO HAND YOU MONEY

**The Motion Picture Business is the Business.** It's the greatest Money making business of the times, and our free book "How to Make Money in the Moving Picture Business" tells you how you can start with a very small capital, and begin making money from the very start.

**ABSOLUTELY NO EXPERIENCE NEEDED**

This book is a guide for the inexperienced; it tells everything pertaining to the business and how to conduct it profitably. Don't wait, send for your copy today. It's free.

& W. SALES COMPANY, 729 Como Bldg., Chicago, Ill.



# Power for YOU!

Power from within! Strength that is *more* than mere muscular strength—the strength of perfect health, a abundant

nerve force—now within your own reach through *Vibration!* Nine people out of every ten are only *half alive!* Are you? Listen—

## The Exhilarating Vigor of Life-Strength-Youth

may be returned to you through *Vibration.* For *Vibration is Life itself.* It will chase away the years like magic. Every nerve, every fibre in your whole body will fairly tingle with the force of your own *awakened power!* Stagnation simply cannot exist. You are made over new from head to foot. Your blood is sent humming along through every vein, artery and tiny



capillary. All the poisonous matters in your system are *washed away.* Every organ is put in *perfect working order.* Your self-confidence—*your self-respect* are increased a hundred fold. Yes, *Vibration* will do all this, and more, *much more.* And it is within your reach. You can enjoy its wonder-working powers right at home, right in the privacy of your own room. You can give yourself the same treatments which you would receive in the offices of the world's most famous specialists—all without extra charge.

### The White Cross Electric Vibrator

### Special Offer for a Limited Time

is the result of years of work and experiment. It is absolutely perfect. If you have your house wired for electricity, you can connect it up as easily as an electric lamp; if not, it will run perfectly on its own batteries.

For a short time only we are making a remarkable Special Introductory Offer on the White Cross Electric Vibrator—amazing discounts—actual rock-bottom prices direct if you act at once.

**FREE BOOK** Sign the coupon and mail it to us today. Get our splendid big FREE book telling you all about the marvels of

*Vibration.* Read what scientists say about it. Post yourself on what it will do for you. Learn all about the White Cross Electric Vibrator and our limited offer. You are under no obligations at all—all you need to do is to send the coupon today—you can send a postal card or a letter, but the coupon will do just as well.



SEND FOR THIS BOOK

Lindstrom-Smith Co.  
1100 S. Wabash Ave.  
Dept. 1195

Chicago, Illinois

Without any obligations on my part, please send me, free and prepaid, your free book on *Vibration*, full particulars of the White Cross Vibrator and your Special 60-Day Offer.

**Lindstrom-Smith Co.**  
1100 S. Wabash Ave.  
Dept. 1195  
CHICAGO, ILL.

NAME .....

ADDRESS .....

We manufacture White Cross electric irons, hair driers, stoves. Dealers write.

My Electrical Dealer's name is



**THE "WATERWAY"**



## "Between Twilight and Dawn"

### A Lake Trip for Rest and Recreation

**E**ARLY every evening from Detroit and Buffalo, the Two Giants of The Great Lakes, Steamers City of Detroit III and City of Cleveland III, the largest and finest side wheel steamers afloat, leave for their run across Lake Erie, arriving at their destination early next morning.

The perfect freedom of the breeze swept decks, the cool, inviting parlors and staterooms with washed air ventilation, excellence of service and cuisine, makes life aboard the D. & C. floating palaces a solace to the weary mind and body. Particular and experienced travelers invariably use "The Water Way" to avoid the monotony of East and West travel by rail.

**RAILROAD TICKETS ACCEPTED**

For transportation on D. & C. steamers, between Detroit and Buffalo or Detroit and Cleveland, either direction. Direct connections at Detroit with steamers for Cleveland, Mackinac Island & Way Ports.

Send two cent stamp for illustrated pamphlet and Great Lakes Map containing information regarding routes and rates. Address

**Detroit & Cleveland Navigation Company**  
 26 Wayne Street Detroit, Mich.  
 PHILIP H. McMILLAN, President      A. A. SCHANTZ, Vice. Pres. & Gen. Mgr.      L. G. LEWIS, Gen'l Pass. Agent  
 All steamers arrive and depart from new Third Street Wharf, Detroit

**\$3.75** Will Buy a Two-Passenger **Cyclecar**  
 Read All About the Cyclecar  
 Send 10 Cents in Stamps for Sample Copy

  
 2200 MICHIGAN AVE. CHICAGO  
 The Journal of Motoring for the Masses

America's First Cyclecar Journal      Monthly \$1.00 Per Year

The losses by fire in the United States and Canada during the 12 months ended December 31, 1913, reach an aggregate of \$224,723,350.

**FREE** to Hunters and Trappers  
 Fine Taxidermy Book Now Free! 48p.  
 with hundreds of photos of mounted birds and animals. Learn this profession. Save your trophies. Decorate your home and den. Great value to sportsmen.

**Learn to Stuff Birds** animals, game heads, tan furs, make rugs and robes. Quickly learned by men and boys. Big Profits from spare time. Intensely interesting. **INVESTIGATE! Write Today for Free Book.** Only a few free—so rush.

  
 Northwestern School of Taxidermy, 1195 Elwood Bldg., Omaha, Neb.



# PHOTOGRAPH YOURSELF

## BIG, NEW, MONEY-MAKING PROPOSITION — JUST OUT

Marvelous invention—perfected after years of experiment by famous mechanical and chemical experts. Wonder of the age. Biggest novelty ever invented—**gold mine money-maker.** Instantly gathers crowd anywhere—everywhere. \$20 to \$40 a day net profit.

### A Photo—A Minute—A Dime

Nothing like it. Customers amazed—delighted—try it over and over. Think of it! You do not need to be there to operate or watch it. Customer just drops dime in slot—machine automatically takes, develops, frames and delivers complete, perfect medallion photo, all in sixty seconds. Takes post card photos also. Write today. Get complete information. Within a week you can have one of these machines dropping dimes for you at the rate of

## \$6.00 An Hour — 75% Profit

One man at Atlantic City averaged 400 to 650 pictures per day. Another at Brighton Beach with two machines took in \$134.00 a day. No experience required. No knowledge of photography needed. Machine is entirely automatic. Absolutely guaranteed. A child can take a picture. Act now. Write at once—today. Make \$5,000 to \$10,000 this year. Send post card or letter for free complete information. Address

**The United Vending Machine Co., Inc.** Dept. 53, 840 E. 93rd St. CLEVELAND, OHIO



**WEIGHS 6 LBS.**

The \$50  
**CORONA**  
Typewriter

**M**ECCHANICAL ingenuity has made possible a standard typewriter—light of weight—economical in price and portable.

It's the last word in typewriter construction and not since the introduction of visible writing has such a notable advance been recorded.

Every Corona is equipped with two color ribbon, back spacer, stencil cutting device, universal keyboard, etc., in fact every worth while feature of its more cumbersome ancestor. It's only in weight, dimensions and price that it's different.

Years of experiment were necessary before the perfected Corona was put on the market. Then the news spread like wildfire—travelers, authors, teachers, scholars, business institutions and even the United States and foreign governments investigated. Yes, and after the investigation they bought—there is hardly a department at Washington but that is already equipped with Coronas.

Think of the convenience a Corona would mean to you. It comes in a small fabric leather case—the typewriter 6 lbs. light, and the case but 2 3/4 lbs. more. Everywhere you go you can take the Corona along.

Send for full particulars—you should be fully informed regarding this invention. Write for catalog No. 21—today.

**STANDARD TYPEWRITER CO., GROTON, N. Y.**  
New York Office, 1493 Broadway  
Agencies in principal cities of the world

**For the Handy Man's Tools**

**I**F you are lucky enough to enjoy using tools at home, you're the sort of man to enjoy sharp edges. Expert mechanics, big machine shops and leading manual training schools now insist on



**PIKE INDIA OILSTONES**

Recent laboratory tests prove that they sharpen faster and hold their shape longer than any others. If properly oiled, they won't glaze and even dropping won't break them.

The handiest style for all around use is the Pike India Combination—one side coarse, the other fine—\$1.00.

Ask your dealer to show you one. Ask also to see Pike Peerless Tool Grinders (the favorite of manual training teachers); the famous Pike Strop-Hone for Razors and Pike India Kantbreak Knife Sharpener for kitchen knives and carvers. "PICK A PIKE."

**FREE** Send us your dealer's name and 4 cents for packing and mailing and we will send you a Pike India Vest Pocket Stone for pocket knives, etc. Also our book "How to Sharpen." You will be pleased. Write today.

**PIKE MFG. CO., 64 Main St., PIKE, N. H.**



**Send Us Only \$200**  
and we will ship you the **Great Ingento Outfit**  
For Personal Examination

Yes, we will send you a genuine Ingento Camera, equipped with the wonderful new Acutic Lens, complete with films, ready to take pictures on receipt of a \$2.00 deposit. Examine it yourself, see the new Acutic Lens that has brought these master instruments within the reach of all. Satisfy yourself that it is the greatest camera value in the country today, pay the balance of the rock bottom price, and the great Ingento Camera Outfit is yours.

However, if you are not absolutely satisfied, send it back at our expense. You don't risk a cent. Your \$2.00 will be refunded instantly and without question. Send the coupon today for the beautiful New Camera Book and full particulars about this great offer.

**Ingento Cameras**

are scientifically constructed by master camera makers—they are the result of 25 years of research and study. Equipped with the genuine Acutic Lens—the latest automatic high speed Ingento shutter that can be timed to 1/100 of a second—a distinct advance in camera making. New compact model—light aluminum case handsomely finished with genuine Seal Grain leather. Takes pictures 2 1/2" x 4 1/4" clear, sharp and brilliant. Ingento Cameras are made in a host of sizes and prices. Write today for New Camera Book.

**Unlimited Guarantee**

With every Ingento Camera goes an iron clad unlimited guarantee—a guarantee on every piece and part. We are manufacturers—we have spent our lives in the study of optics and the manufacture of cameras. We know the kind of material and workmanship that goes into the Ingento Cameras so we do not hesitate to make this great guarantee. Send the coupon now for the new Camera Book and our liberal offer.

**Dealers**

There are a few exclusive Ingento Territories still open. Write today for our attractive offer.

**Films Developed Free**

On this great offer we will develop and print the films included in the outfit absolutely free. Our corps of experts are at your service. If you wish to ask any questions they will gladly give you the benefit of their years of experience. Just think what this offer means to you. Send the coupon for the new Camera Book.

**Mail This FREE Coupon**

Do not delay an instant. Put your name and address in the coupon and send to us now. We'll send you the New Camera Book absolutely free and prepaid. No obligations. Send the coupon or a letter or a post card. But do it now.

**Burke & James, Inc.**  
Mfrs. of Cameras & Supplies  
Dept. 1195  
240-258 East Ontario St.  
CHICAGO, ILL.

**GENTLEMEN:—**  
Please send me free your new Camera Book and full particulars of special offer made here. Also tell me more about Ingento Cameras and the wonderful Acutic Lens. It is distinctly understood that I assume no obligations of any kind.

Name.....  
Address.....  
Ill.....  
Dealer's Name.....

# HAMBURG-AMERICAN

Largest S.S. Co.  
in the  
WORLD

442 Ships  
1,417,710  
TONS



## IMPERATOR

919 ft. long, 52,000 tons

AND

## VATERLAND

950 ft. long, 58,000 tons

## World's Largest Ships

[In Regular Service to  
**LONDON PARIS HAMBURG**

### SUMMER CRUISES

to the Land of the Midnight Sun during  
June, July and August from Hamburg.

### VACATION CRUISES TO JAMAICA AND THE PANAMA CANAL

By the well-known "Prinz" Steamers of  
the Atlas Service. Special Summer rates  
now in effect—25 day Cruise, \$115 and up.  
To Colon and return, \$110 up.

### MEDITERRANEAN SERVICE

by Steamships Hamburg and Moltke.  
Ports of call: Madeira, Gibraltar, Algiers,  
Naples and Genoa.

Grand Cruise Around the World and  
Through the Panama Canal by S. S.  
Cleveland, January 31, 1915, reaching San  
Francisco at the opening of the

### Panama Pacific Exposition

Duration 135 days. Cost, \$900 up

Our Tourist Department arranges tours  
to all parts of the world, furnishes tickets  
and takes care of all travel detail.

Write for full information

### Hamburg-American Line

41-45 Broadway, New York

Philadelphia Boston Baltimore  
Pittsburgh Chicago New Orleans  
Minneapolis St. Louis  
Montreal  
San Francisco

Trade

Mark

# Any Watch You Want ON CREDIT

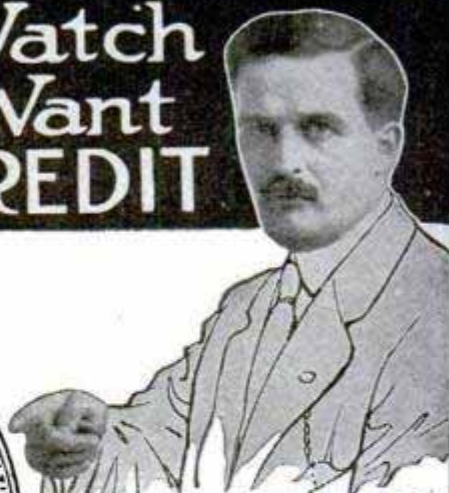

**WALTHAM  
ELGIN  
HOWARD  
HAMILTON  
ILLINOIS**

Sent on 30 Days Free Trial

## No Money Down

Express Prepaid in Advance by Me

You take no chances with me. I am "Square Deal" Miller and I trust the people. That is why I am doing the greatest Credit Watch, Diamond and Jewelry business in the country. Suppose you want any one of the country's best makes of watches? Name any one, I have it for you, No Money Down, Express Prepaid. A full month to carry it in your pocket and the easiest of Long Time Payments. That's the test that tells. All these watches  
**Guaranteed 25 Years**

## I Smash the Terms

No References Demanded

My terms are made to suit you. You get unlimited credit, with no red tape, notes or collectors. All unnecessary detail left out.

An "Open Charge" Account

the same kind of credit you get from your grocer. No matter where you live or what your income is, you can now own the finest watch, a beautiful diamond or any rare jewelry and never miss the money.

## Costly Catalog FREE

Send me your name and address so I can mail you, Free and postpaid, the most beautiful catalog of its kind ever printed. I want you to have this book. It's a gem. It illustrates all makes of valuable Watches, Elegant Genuine Diamonds, and a vast assortment of Beautiful Jewelry, all on the easiest and most liberal terms. Write for this book today and get a letter from me that will make you a friend of mine from the start. **Take My Word For It.**

Square Deal MILLER, Pres.

MILLER-HOEFER CO., 291 Miller Bldg., Detroit, Mich.

# SWEET Detachable Rowboat Long Stroke 4 Horse Power MOTOR

Fits any boat. Ball-bearing Engine. 10 1/2 inch Weedless Propeller. 3-ring Piston, same as in Packard car. Copper Water Jacket, same as in Cadillac car. Kingston Carburetor, same as in highest grade auto and marine engines. Silent Under-water Exhaust, same as in highest priced launches. Steers from any part of the boat. Perfect control from trolling to racing. Sends 18-foot boat 8 to 9 miles per hour. Uses gasoline and oil mixed. No vibrations. No noise. Runs and keeps on running day after day. Guaranteed for life. Money back without argument if not satisfied. Write for free catalog and special 30 day price.



SWEET MFG. CO., 61 Griswold St., Detroit, Mich.

# Signal—the "Speed" Shirt!

Besides their other good points, they are veritably "on and off in a jiffy."

The Signal Flannel Shirt will be a revelation to you if you have never tried one. Style—Comfort—Wear—three things you insist on—you get in one shirt, at less cost, when you buy

## Signal FLANNEL Coat Shirts

UNION MADE

Wear well—keep their style—last a long while. Big arm holes that will never bind, roomy elbows, extra long sleeves, wide cuffs. Snug-fitting yoke that allows plenty of shoulder play. Satin-lined, non-irritating military collar that fits comfortably. Three-inch over-lapping flaps in front. Combination watch and handkerchief pocket, with a flap you can button. Extra button at bottom of breast plait to prevent gapping. Prices \$1.50 up.

Signal Flannel Shirts are also made closed style in a large variety of styles and patterns. You get in Signal Flannel Shirts the same quality, style and service that made Signal Overalls and Workshirts the universal favorite.

**Flannel Shirt Free** Ask your dealer for Signal Flannel Shirts. If he hasn't them, send us his name, and your size. With his first order for Signal Flannel Shirts we will send you one—absolutely without charge. Write for booklet.

**Hilker-Wiechers Mfg. Co., 1254 Mound Ave., RACINE, WIS.**

Manufacturers of the Famous Signal Overalls, Coats and Shirts

Satin-Lined  
Military Collar



Always look for this trade mark—it's the "Safety First" sign in buying shirts and overalls.



Swift and Powerful but Steady and Easy-Riding



Pope Model L-14. Price \$250

The "Greyhound of the Road." Renold imported chain drive; Bosch magneto; Eclipse multiple disc clutch; Pope celebrated rear spring suspension; twin stem handlebars; double operated brake; comfortable foot boards; extremely low saddle position; Pope overhead valves.

Other Models from \$150 to \$285

Write for Catalog

Pope Mfg. Co., 16 Cycle St., Westfield, Mass., U.S.A.

## This Machine Will Earn \$20 to \$50 a Day for You

Owners report daily profit of \$20 and upwards. Some as high as \$50. One reports \$2,430 in 90 days; another a \$90,000 government contract after severe tests on product. Start a concrete factory and do as well. Little capital and no experience required. Only machine necessary is

### The HELM PRESS

80,000 lbs. pressure, no tamping, easy work, automatic, makes highest grade cement blocks and brick known at greatest speed and lowest cost. 1000 blocks or 10,000 brick daily. Salable everywhere. You should know about



### The Helm DRY WALL Building System

It will get you big business. SAVES MONEY for builder as no furring and lathing are required. Endorsed by architects, contractors and builders. Send for this FREE Concrete Book and learn the details of this system, and about Helm presses. Tells what articles pay best, how made, cured and sold. Write today; do it now.

HELM BRICK MACHINE CO., 125 Bank Bldg., TRAVERSE CITY, MICH.



# Own Your Own Home—

"Make Dreams of a Home of Your Own Come True."

Thousands of families are enjoying the pleasures of homes all their own, paid for the Standard Way.

## BE A HOME OWNER—\$6 STARTS YOU

Don't say you can't do it—you can. No matter what your income you can lay aside the few dollars necessary each month to become a home owner the Standard Way. Don't pay rent to the landlord—pay it to yourself.

### THE STANDARD MAKES IT EASY

The Standard plan is so simple, so plain, so easy, you'll be delighted with it.

**WRITE TODAY for valuable book and complete information** of the Standard Home Company plan—it's yours for the asking. Make up your mind now, today, this minute, to become a home owner—take the first step by addressing

W. E. WHITEHEAD & CO., Dept. H, 1410 American Trust Bldg., Chicago, Ill.

Thousands of Families Live in Homes Made Their Own Through The Standard Way. Over 2,400,000 Dollars to Home Owners.



# E.Z. RIDER SAVES

## A MESSAGE TO FORD OWNERS

Big-Car-Luxury is now a reality for owners of Ford Cars. E. Z. Rider Shock Absorbers give that smooth, floating restfulness.

If you would enjoy your FORD to the utmost, learn about these E. Z. Rider Shock Absorbers—and learn what they SAVE you and your Ford

→ **SAVES**—the humps, jumps, vibrations and irritations of rough roads and pavements. The sensitive coiled springs make all roads seem smooth.

→ **SAVES**—wear and tear on your Ford by absorbing the shock and vibrations. E. Z. more than save their cost, by saving car repairs.

→ **SAVES** engine trouble by protecting the delicate mechanism from rousous jar and vibration. Saves you delay, trouble and expense, and E. Z. Rider saves tires by easing the traction strain and preventing bound and rebound.

### Try E. Z. Rider Shock Absorbers 10 Days

We want to send every Ford Car Owner a set of E. Z. Rider on 10 days trial. If not pleased, return E. Z. and receive your money back. Once you know E. Z. you'll never drive without them.

Dust proof, trouble proof, long wearing, fully guaranteed.

Set weights only 20 pounds.

Easily and quickly installed—you can do it, we send all instructions.

\$15 set of four (front and rear) F. O. B. Cleveland

Order a set today for your Ford

The Forest City Electric Co.  
5008 Windsor Avenue CLEVELAND, O.

Reference—Bradstreets



## Tell the Boss to Try "Clipper" Belt Lacer

TRADE MARK

LACES IN THREE MINUTES

and show him that you are alive to his best interests. Every employer is quick to recognize the man who takes enough interest to suggest plans to increase the production of the plant. Tell your employer of the advantages of the "Clipper"

Ask him to write for our 30 days' free trial, with return privilege. After he has given it a trial and sees machine-time and man-time saved you'll be repaid.

The "Clipper" will lace a belt 6 inches wide in three minutes and do it better in the hands of a strong boy than a high priced expert can in 20 minutes by hand the old raw-method. Wider belts in proportion. No skill necessary.

Send for our story, "How Scotchie Made Good." It may mean a lot to you.

Clipper Belt Lacer Co.  
1032 Front Ave. GRAND RAPIDS, MICH.

# I WANT 200 SALES AGENTS AT \$1200 TO \$3600 A YEAR

To introduce my new **Compress and Vacuum Washing Machine** to every home in the country, I want 200 additional representatives to begin work at once in their home counties. I consider this machine the most brilliant inventive achievement of the age in household necessities. It is selling faster than anything I have ever heard of—**going like wildfire.**

## PROFITS START FIRST DAY

No waiting or guessing. The price of only \$1.50 makes a sale at every house—cash business at 200 per cent profit to you. The biggest opportunity ever offered. I want hustlers—men and women who want to make money quick and fast. No large investment needed—**business supplies the capital.**

**NO EXPERIENCE REQUIRED** Just follow instructions. Failure impossible. **Success assured.** Frank Greene sold 45 first three days—profit \$45. Mrs. L. C. Marrick made \$90 first three weeks in spare time only. J. H. Goddard took 18 orders first three hours. **No talking necessary.** Just show it—the order is yours right on the spot.

H. F. WENDELL, Pres., Wendell Vacuum Washer Co., 245 Oak St., Leipsic, O.



The Wendell Compress and Vacuum Washer  
Washes Tub of Clothes in Three Minutes

Every machine sold on money-back guarantee. A child can use it. Saves labor of wash day. Women do \$15 and \$20 machines for it.

### MAIL YOUR APPLICATION TODAY

Don't delay. Get your county under contract, charge for territory. To wait means to lose. Write a letter or a postal card today. If you are honest and want to work I will give you the position. **Do not let someone else get in ahead of you.** I want agents, agents and managers. Write today—then you will do your part. **Do it right now. Address**

6034-\$50.

Only 20% down

and 10% a month

6038-\$75

6258-\$100

## DIAMONDS ON CREDIT

Buying a high grade Diamond is saving money, not spending it. The "Lyon Method" makes it easy for you to save. Lyon Diamonds are Blue-white and perfect. A written Guarantee Certificate with each Diamond. All goods sent prepaid for inspection. No security required. Write now for Catalog No. 3. 10% discount for cash.

**J. M. Lyon & Co.,** 71-73 Nassau Street  
NEW YORK

6226 \$35

6211 \$100

6211 \$100



# The World's Greatest Motorcycle

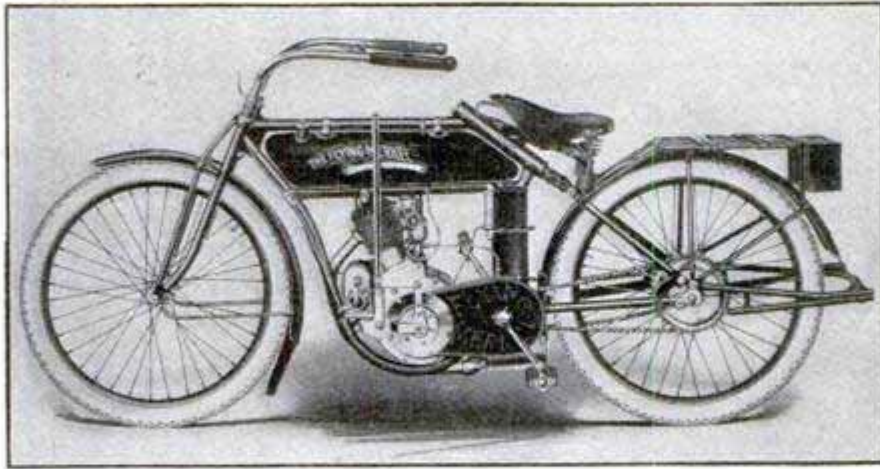

## The Flying Merkel

is the oldest existing motorcycle sold on the American market today. For fourteen years it has set a standard that other manufacturers vainly have attempted to reach. The Flying Merkel still stands supreme in the art of motorcycle construction.

Every feature found on other motorcycles today that is recognized as standard was first inaugurated by the Flying Merkel, and 1914 models contain features that are years ahead of any other motorcycle.

The illustration above shows our single cylinder 4 H. P. model at \$210.00. The regular seven horsepower standard model, in either belt or chain drive, lists at \$225.00, and the same models fitted with foot boards, and dual combination brake system, also with luggage carrier, lists at \$240.00.

The many mechanical features of the Flying Merkel are fully described in our latest catalogue, copy of which may be had by simply addressing a post card.

### DEALERS WANTED

On account of a big increase in our productive facilities we will be able to increase our selling organization by the addition of wide-awake men who desire to represent the best motorcycle in the world in a comprehensive manner. The motorcycle business presents more interesting phases than any other vocation, but we want to be sure of obtaining the proper representation. If you are prepared to sell motorcycles, write today for our proposition. If we are already represented in your locality it will pay you to investigate the Flying Merkel before purchasing any machine, and we will be glad to mail you a FREE DEMONSTRATION COUPON if you will just say the word.

## The Miami Cycle & Manufacturing Co.

Largest Producers of High Grade Bicycles and Motorcycles in the World

570 Hanover Street

Middletown, Ohio, U. S. A.





# Big Money in Pop Corn Crispettes and Candy

## We Will Start You in the Business

Tell you how to make the most money with the least effort—how to get the crowds—how to cash in BIG from the very start! We'll help locate you, too, if you wish, and make it so easy that you can start at once and

### Pay Us Later From Your Profits

Hundreds of men and women everywhere are making BIG money in the ever-popular Pop Corn, Crispette and Candy Business. We will gladly do for you what we have done for hundreds before you. We make the terms so easy that a very small amount is sufficient to start you.

**\$600.00 in 3 days** that's what one man took in at Braidwood, Ill. Another made \$225 in one day. A young woman in St. Louis cleared \$50 in 1 1/2 hours. Think of it! Did you ever hear of such a wonderful business? Yet, you, too, can do as well in this easy business of BIG PROFITS. Now then, don't wait—don't think you haven't enough money, for with our easy payment plan very little is needed.

**Dellenbarger's Kettle-Popped Pop Corn**  
A new process means—large, light, fluffy and tender kernels that melt in your mouth. Makes Crispettes wonderfully rich and delicious—the kind that "wins" the "Come-back-to-get-more" crowds.

#### Start at Once—NOW!

Send for our big, generous co-operation offer. FREE catalogues and full particulars explaining how we start you on easy payments.

**Write Today, SURE!** Now is the time to get started. Our big offer sent by return mail. It's up to you NOW to act—DO SO! Address

**C. T. DELLENBARGER & CO.**  
627 W. Jackson Boul. Chicago, Ill.

We Teach You the Business FREE

NOTE! We also make Complete Wagon Outfits for Transit purposes. Our booklet describes them.



Dellenbarger's Improved Automatic Crispette Pop Corn Ball Machine Made in several sizes

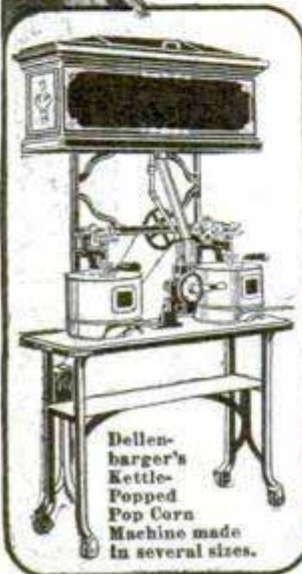

Dellenbarger's Kettle-Popped Pop Corn Machine made in several sizes.

## New Typewriter \$18

in U.S.A.

A remarkable typewriter, carried in grip or overcoat pocket. Standard keyboard. Does all that higher-priced machines do. Over 34,000 in use.

Has less than 250 parts against 1700 to 3700 in others—that is the secret of our \$18 price. All important improvements, visible writing, indestructible type, reversible ribbon, etc.



Bennett

Handiest typewriter built. Easy to operate. Built in famous Elliott-Fisher Billing Machine factory, sold on money-back-unless-satisfied guaranty. Guaranteed one year. Weight 4 1/2 lbs. You can carry for home use, business, trips, or anywhere. Send for catalog and

AGENTS PROPOSITION.

Chas. M. Bennett Typewriter Co., 1305 Cedar St., Harrisburg, Pa.



### The Ideal Lamp for Every Cycle EQUIP YOUR BICYCLE WITH "RAJA" Dynamo-Magneto Lamp

It combines great lighting Power Economy and Durability, needing no expense for Upkeep.

**PRICE \$5.00** Always ready, never fails regardless of wind and weather. The "RAJA" Lamp switched on without the rider leaving the seat.  
FAR EASTERN SALES CO., 90 West St., NEW YORK

## Lighting Fixture Wanted—Salesman

We need a man over 21 in every town, lighted by gas or electricity, to represent us. Give us all or part of your time and make a good income, \$100 to \$300 a month. Sell to people building houses, to churches, stores, etc. You can get the business with our line because you undersell competition 1/4 to 1/3. Start small and grow to a big business of your own. Write today, giving age and references.

UNITED LIGHT & FIXTURE CO., Factory A, Milwaukee

## You Have Enough to Build

Five Room House \$298



North American Construction Company  
185 Aladdin Ave.  
BAY CITY, MICH.

Canadian Branch: C. P. R. Bldg.

## DON'T DELAY BUILDING

Have you decided on a home, the cost, style and size? Are you saving for this home? You can build it today for less. Aladdin Houses are artistic—modern dwellings, cozy bungalows—cost you less. You get better lumber. One dollar for every knot found in our Red Cedar Siding is the 1914 Aladdin guarantee to you.

**ALADDIN Dwellings, Bungalows, Garages \$137 to \$2000**

Aladdin Redit-Cut Lumber comes direct from the forest—no in-between profits. Lumber cut to fit; you save a third on cost of labor. Price includes all lumber cut to fit; all framing, sheathing, siding, flooring, outside and inside finish, windows, frames, stairways, glass, hardware, locks, nails, paints and varnishes—everything to complete the house.

Send today for catalog No. 180.



This House \$1,286



Complete Material

## Start the Season with Tire Service Assured

FOR 100% tire fitness—the splendid all-round service that meets instantly every demand of traffic and traction; that equalizes every changing road condition—equip with

# PENNSYLVANIA Oilproof VACUUM CUP TIRES

Highest actual resistance to the grinding wear and tear of continuous road usage.

Greatest structural strength to withstand the strains and stress of the swift stop or the quick turn.

Perfect traction—through shifting sand or liquid mud, where the V. C. knobs dig down to hard going; on skiddy pavements, when the live, elastic grip of the suction cups maintains the safe straightaway.

Oilproof—through and through the rubber. You can ride V. C.'s right behind the oil wagon without danger of treads softening.

*For Motorcycles*—V. C. Automobile Casings in motorcycle sizes. Guaranteed to give 5,000 miles of actual service.

*For Bicycles*—V. C. Red Treads, in Single Tubes or Clincher Types. Guaranteed for one full season, else replaced or repaired free.

*Go through the season on V. C.'s. Your dealer will demonstrate these superb tires, or write us direct for catalog.*

### Pennsylvania Rubber Co., Jeannette, Pa.

New York Boston St. Paul Seattle  
Chicago Pittsburgh Minneapolis Dallas  
Cleveland Detroit Omaha Atlanta  
Kansas City, Mo. Los Angeles San Francisco

*An Independent Company with  
an independent selling policy*



# Make Your "Bike" a Motorcycle

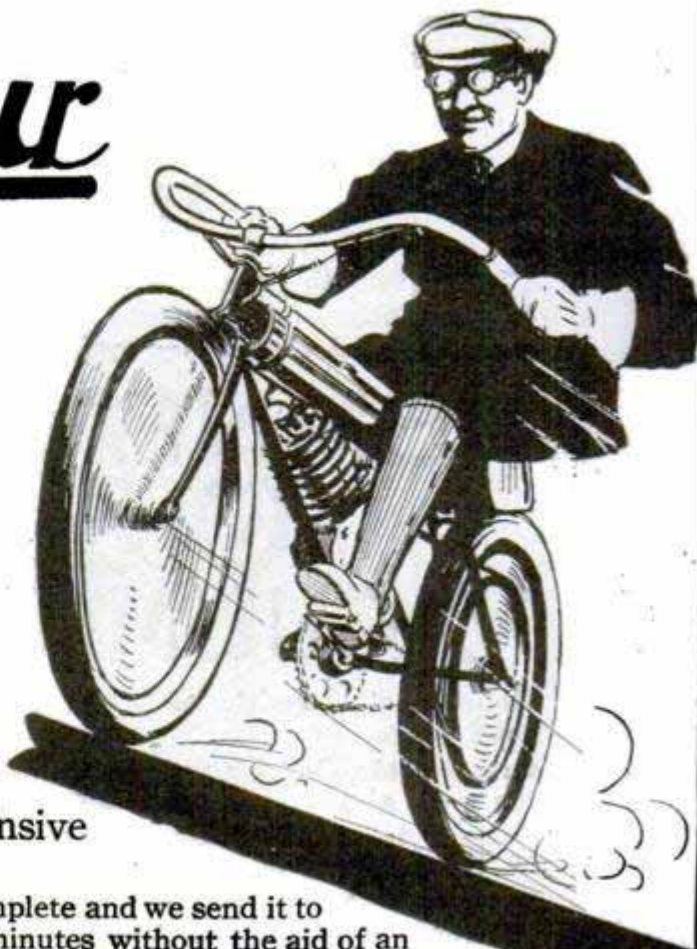

Yes, thousands of others have turned their old-fashioned bicycles into up-to-date, swift, sure, easy riding, high power motorcycles with the easily attached, inexpensive **Shaw motorcycle attachment!**

Fits bicycles of any make or size. Everything is complete and we send it to you all ready to attach to your bicycle in just a few minutes without the aid of an expert mechanic and without any special tools—just an ordinary wrench and screwdriver. Built of highest grade, most serviceable materials; every part guaranteed; plain easily understood directions sent with each equipment. Thousands of enthusiastic owners everywhere. Here is your chance to get a powerful, dependable, durable, fine looking and speedy motorcycle at a price so small you will wonder how you ever got along with the old-fashioned "leg power" machine!

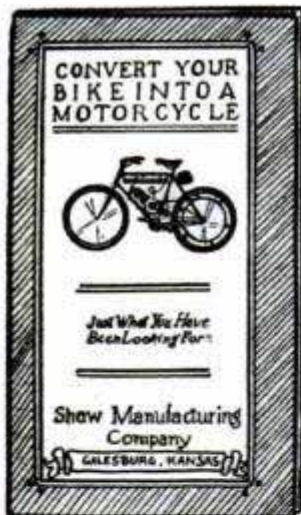

## Read What These Users Say of the Shaw Motorcycle Attachment

### "300 Miles for 40 Cents"

The SHAW Motor which I purchased of you about a month ago, is doing excellent work. I have ridden it about 300 miles with about 40 cents expense. It is certainly the cheapest and best running machine I ever saw. Having ridden several makes of motorcycles, I find it the simplest and easiest controlled of any of them.

W. N. HARMISON, Blockton, Iowa.

### "Climbs Hills in Canada"

I have climbed hills with your motor that large motor cars get stalled on; the sand is several inches deep.

ERNEST PEDEN, Carleton Place, Ont., Canada.

### "Power, Speed and Reliability"

I received my attachment from you in first-class condition. The motor was easily attached and runs fine. It does not take an experienced person to run the SHAW. I recommend it to anyone desiring, at small cost, a motorcycle for power, speed and reliability.

PEARL BLACKETER, Ayshire, Ind.

### "Very Useful"

I have found your motor attachment to be all you claim. Have been using the one I bought for six months, have bought no repairs for engine at all. I find it very speedy and powerful, and very useful in many ways.

L. E. RICKMAN, Ferda, Ark.

### "Perfectly Reliable Outfit"

The motor which I ordered of you in the summer of 1910 has proved to be a perfectly reliable outfit. I have had no trouble whatever with the engine. The cam and gears show no wear, and I have probably ridden it 2000 miles. I can honestly recommend the SHAW Motor to anyone that wants a motorcycle at a small cost and have a satisfactory motor.

OSCAR L. THOMPSON, Cedar Lake, Iowa.

**SHAW**  
Manufacturing Co.  
Dept. 49, GALESBURG, KANSAS

Thousands In Use All  
Over America and  
Europe

Please send me, free and postpaid, copy of your book illustrating and describing the SHAW Motorcycle Attachment as advertised in the April issue of POPULAR MECHANICS. Quote me your lowest net cash, factory price.

NAME .....

ADDRESS .....

## Write For FREE BOOK!

We want to send you, free and postpaid, a copy of our booklet illustrating and fully describing the SHAW Motorcycle Attachment. When you read about the simplicity and the low cost of the SHAW attachment you will no longer be satisfied with your old-fashioned, slow-going, tiresome bicycle, but will want to send and join forces with the thousands of other go-getters who are now hitting the high speed trail with a SHAW!

Send name on the coupon or postal card for the free booklet today.

**Shaw Manufacturing Co.**  
Department 49 Galesburg, Kansas



# A Record Growth

1810

1914



The

'HARTFORD'



From small beginnings in 1810 the Hartford Fire Insurance Company has, in 1914, reached its present preeminent position in the insurance field. Its steady growth in strength has been unreddeled by the enormous losses it paid to its policyholders both the great conflagrations of American History and in those

small but persistent losses which occur somewhere every minute of every day and night.

Willingness to adjust losses fairly, ability to pay fully and readiness to pay promptly are the three great fire insurance virtues and they are the explanation of the "Hartford's" growth and prosperity.

**When you need Fire Insurance  
Insist on the "Hartford"**



Guaranteed  
**VITALIC**  
 TRADE MARK  
**TIRES**  
 Bicycles - Motorcycles



## A Wonderful Bicycle Tire

### This Brutal Test Proves Its Worth

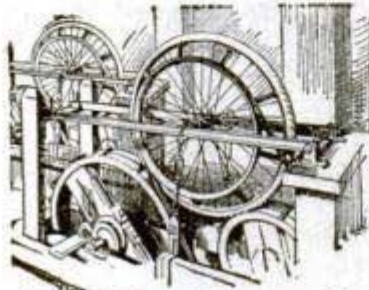

**T**HIS sketch shows our service testing machine. The tire is held by pressure against the rapidly revolving drums. These drums are uneven, with cleats nailed at intervals, patches of sand-paper, etc., thus reproducing hard road conditions. The best tire we ever made, prior to Vitalic Tires, stood this test for 1200 miles before wearing through and yet our tires have always been famous for endurance.

### Vitalic Bicycle Tires have stood this brutal test for 7200 miles!

Backed by such extraordinary evidence of quality and endurance, are you surprised that we dare to make the unlimited, unqualified Vitalic Guarantee?

#### VITALIC BICYCLE TIRE GUARANTEE

If Vitalic Tires do not,—in your judgment and to your entire satisfaction,—prove all we claim for them, you may return them to us and get your money back, or new tires.

There are two basic reasons for Vitalic endurance: An unbreakable tire fabric and the purest rubber obtainable.

We have at last found a way of compound-

ing pure rubber so that it has all the toughness and wear-resisting qualities formerly secured by introducing a lot of foreign materials, at the same time preserving the elasticity and life of pure rubber.

#### Write for FREE Testing Sample of Vitalic Bicycle Tire

Prick the inner tube with a pin—test the pure rubber—examine the rugged tread, then you'll know why Vitalic Tires can be guaranteed. Our booklet, "The Truth from Tube to Tread," tells all the facts about these wonderful tires.

**CONTINENTAL RUBBER WORKS, 19th and Plum Sts., Erie, Pa.**

*Largest Single Maker of Bicycle and Motorcycle Tires in the World*



12  
Tools  
In  
One

#### AGENTS! MAKE \$4,000 A YEAR

Everyone needs one of these new tools. Lifts or pulls 3 tons.

#### Automatic Combination Tool

A lifting jack, wire stretcher, wire mender, post and stump puller, etc. Get big circular. Write quick!

HARRAH MFG. CO., Box 201, Bloomfield, Indiana



1 1/2¢ a Night

A bright, clean, clear, safe Electric Light for your home, store or church. Send for book which tells the story.

#### UNIVERSAL BATTERY CO.

307 N. Peoria St., Chicago

We make all kinds of storage batteries for the trade.

Electric

for  
Light

## Mathematics Made Easy

FOR ALL, BY

### ROPP'S CALCULATOR

Shows the Answer as quickly as a Watch shows Time, to all practical Examples likely to occur in Office, Store, Shop, Bank, Farm or Factory. Over 20 editions—each adapted to some special line of business.

Elucidates and simplifies the science of Arithmetic, Mechanics and Mensuration.

Greatest Time and Labor-saving work on Figures used in the commercial world.

Desk size, \$1.25; Pocket, leather, \$1.00; Pocket, imitation leather, 50c; Vest-pocket, 50c. New 1912 copyright edition.

#### POPULAR MECHANICS BOOK DEPT.

6 N. Michigan Ave., CHICAGO



## Why the Two-Speed Harley-Davidson is the Ideal Machine for Sidecar Use

The two-speed Harley-Davidson is not simply adapted for sidecar use—it is built for it. Five features are extremely desirable on a motorcycle to render efficient service when used in connection with a sidecar—a satisfactory starter, a sturdy two-speed gear, double brake control, double clutch control, and a Ful-Floteing seat. The Harley-Davidson is the only motorcycle offering the advantages of these features.

### Step-Starter

With a sidecar it is decidedly awkward and almost impossible to lift the machine on to the stand for starting. With the Harley-Davidson Step-Starter this is unnecessary. A simple downward push on either pedal starts the motor.

### Two-Speed

The Harley-Davidson two-speed is the simplest, lightest and the most powerful two-speed on the market. Either speed can be engaged by the shifting of a convenient lever, whether the machine is standing still or in motion.

*The many desirable features of the 1914 Harley-Davidson are described in our new catalog, a copy of which will be mailed on request*

### Double Brake Control

With the sidecar the brake must necessarily be extra large in order to handle the double load. The Harley-Davidson auto type band brake may be operated by either foot or, in fact, by both feet if desired. The large Harley-Davidson brake carries a safety factor of more than 200% and is built large enough to stop an automobile.

Perfect control of any vehicle is essential to the safety of its occupants. We believe that the Harley-Davidson has the largest and most powerful

brake of any self-propelled vehicle on the road.

### Double Clutch Control

The Clutch on the Harley-Davidson is operated by hand lever or foot pedal at the option of the rider. It is not necessary to remove either hand from the handlebars in order to engage or release the clutch. This is a decided advantage in heavy sand or mud.

### Ful-Floteing Seat

For the third successive year, every Harley-Davidson incorporates the Ful-Floteing Seat. This patented device absorbs all jolts, jars and vibrations due to rough roads.

# HARLEY-DAVIDSON MOTOR COMPANY

*Producers of High Grade Motorcycles for More Than Twelve Years*

386 B Street

Milwaukee, Wis.

**MAKE \$250.00 A MONTH**

**Repairing AUTO-MOBILE Tires**

Sounds like a lot of money  
**—IT IS—A WHOLE LOT of MONEY**  
 to be earning CLEAR every month—yet it's  
 what hundreds of men we have established in the  
 Automobile Tire Repair Business are making.

You let down the DRAW BRIDGE for SUCCESS to enter into  
 your career by getting into business for yourself. The business for  
 you is the one where investment is small—the returns quick and for cash  
 —where the margin of profit is large—the demand for your PRODUCT or  
 SERVICE constant and ever on the increase.

**A Haywood Tire Repair Equipment**

answers to all of these requirements of Old Dame Fortune—the certainty of success in this  
 business is as sure as anything in this world can be—Each year adds thousands of new  
 Automobile Owners—they need YOU to keep their tires in service.

**Here Is Your Opportunity!**

Be first to enter this new big paying business in your town. Open your pockets. Let the dol-  
 lars pour in. Act quick. Every auto sold means more tires to mend. Automobile business is  
 growing fast—enormous field for tire repairing. Punctures and blowouts are common. Tires need  
 retreading and vulcanizing. Something going wrong all the time. Thousands forced to buy new  
 tires because they can't get old ones fixed. Think of the old bicycle days—repair shops on every  
 corner—all making money—busy day and night. Autos make same proposition over again—only  
 ten times bigger and better. Users of Haywood Tire Repair Plants are making big money. Johnson,  
 Tex., writes: "I have made as high as \$18 in a day." Another man who bought a plant Septem-  
 ber, 1911, writes he has cleared over \$3000.00. That's going some! Operate a plant as side line  
 in connection with auto business—garage or as  
 an independent business. Find neighbor-  
 hood where there's a bunch of autos—get  
 all the steady business besides transient  
 work. Experience unnecessary. You learn  
 quick. Simply follow directions—practice  
 a few days on a couple of old tires and  
 you'll be ready to coin money Business  
 comes fast and easy.

The New Money-Making Business—Start Now

This Man is Making Money

This Bunch of Tires Will Make Several Dollars Profit

Business Keeps Coming

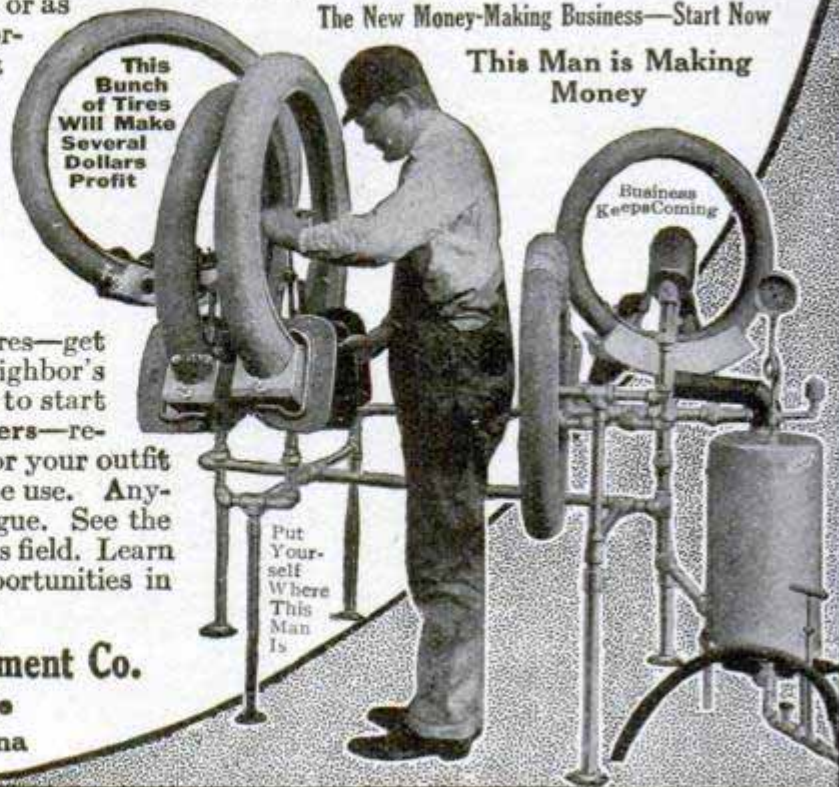

Put Yourself Where This Man Is

**Repair Tires At Home.**

Young men! and boys repair father's tires—get  
 money he pays garage man. Get the neighbor's  
 work. Make money to attend college or to start  
 a garage and repair business. Auto owners—re-  
 pair your own tires—save money—pay for your outfit  
 in short time. We have outfits for home use. Any-  
 how investigate. Send today for catalogue. See the  
 wonderful possibilities in this marvelous field. Learn  
 of the enormous money-making opportunities in  
 this fascinating new business.

**Haywood Tire & Equipment Co.**

729 N. Capital Avenue  
 Indianapolis, Indiana

# SAXON \$395

A Good Low Priced Car



Not a Cycle Car

The price of \$395 includes Top, Windshield, Lamps and Tools

## Everybody *Ought* to Own a Car— Now Everybody *Can* Own a Car

A good car is an economy—not a luxury. It means saving to the business man—ease in getting about—promptness in making appointments. It means health for himself, his wife and children—health and outdoor recreation. It increases efficiency.

Everybody ought to own a car. Now everybody can own a car—a good car; for the Saxon is a high-grade, well-designed, carefully built automobile, with four-cylinder motor, left drive, center control and standard features throughout, produced by an experienced organization, sound financially and in business to stay.

The first cost of a Saxon is less than a good horse and buggy; the upkeep costs far less. Its maintenance is almost negligible. The tires cost little. A gallon of gasoline takes it 25 miles and more. It is so simple that it scarcely ever needs readjustments or repairs. Saving in time considered, it is cheaper than riding on street cars.

### Good—and Good-Looking

The Saxon is the answer to the insistent demand for a low priced car that is not only good, but good-looking. It is a big car for the price—96-inch wheel base, standard head, roomy body, holding two people easily, ample leg room, generous doors. There is nothing skimpy or cramped about

Molded oval fenders, tapered bonnet, and streamline body with graceful, sweeping curves make it a delight to the eye.

The Saxon is amply powered. The high-speed, four-cylinder motor gives great thrilling power and flexibility. It throttles down to five miles an hour or speeds over the road at 40—and without unpleasant vibration or jarring.

### Mail Coupon for Free Demonstration

Prove the Saxon by riding in it. Sign your name on the coupon and mail it now; we will direct you to the Saxon dealer in your locality, and send you, free, a booklet telling the story of this great achievement in the science of motor car development. Also Arthur Brisbane's editorial on automobiling. Accepting our demonstration offer obliges you in no way—costs nothing. If you wish the booklet without demonstration—indicate it on the coupon. But find out more about the Saxon—now.

**SAXON MOTOR COMPANY, DETROIT, MICHIGAN**

## FREE Demonstration and Booklet

SAXON MOTOR COMPANY, DETROIT, MICHIGAN

Please direct me to the nearest Saxon dealer. I understand that a ride in a Saxon will cost me nothing and will obligate me in no way.

Also send me your free booklet telling the story of the Saxon, and Arthur Brisbane's editorial on automobiling.

NAME .....

ADDRESS .....



## The First Born

is a mighty important creature. It is vital that mother's health and strength be maintained so that baby can be properly nourished. The people of America have a true friend in

ANHEUSER-BUSCH'S  
*Malt-Nutrine*

To delicate women it has proven a blessing because of its food and tonic properties.

For sale by all druggists and grocers

Malt Nutrine, when mixed with milk or sparkling water, makes a most palatable and healthful drink.

ANHEUSER-BUSCH · ST. LOUIS, U.S.A.

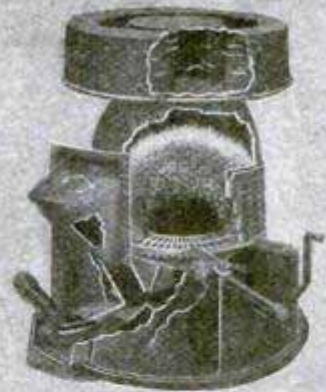

Cut-Out View  
Underfeed Furnace

## Coal Bill Cut From \$90 to \$17<sup>50</sup> With An Underfeed

H. C. Laird, Norfolk, Va., says: "I am using your Underfeed in my residence of thirteen rooms, and two bath rooms, and my total coal bill will be about \$17.50 per winter. I have divided my coal bill by five, and can not recommend your Underfeed system too highly. I spent \$90.00 last winter heating a house one-half the size of above." This is strong money-saving Underfeed evidence, isn't it?

### Government Uses Underfeeds

The United States Government put the Underfeed through the hardest possible tests and *proved* that the following statements *were absolutely true*: "Coal bill \$16.22 for 7 rooms;" "\$5.50 to heat 4 rooms;" "Reduced coal bills from \$109 to \$53;" "Underfeed reduces coal bill 60 per cent;" "Have cut coal bill \$70 each winter for 9 years;" "Saved \$122 a season;" "Even temperature with no smoke or dirt."

Now the Government *specifies* Williamson Underfeeds wherever possible. There are over 25,000 Underfeeds in successful use. May we send you the names and addresses of over 2,000 Underfeed users—some right in your neighborhood—who *know* by experience that *clean, even, economical* heat is obtainable *only* with the Underfeed?

### The Underfeed Is Different

The Underfeed system of heating is *different* from all other systems—it's better. With the Underfeed coal is fed from below. All the fire is on top, causing perfect combustion. Smoke and gases are burned up, making more heat with *no* smoke, smell, clinkers and very little ashes. You can use cheap slack soft coal or pea and buckwheat hard coal and secure same heat as highest priced coal. The Underfeed is adapted to warm air, steam and hot-water systems in homes, stores, churches, schools, halls and other buildings.



Cut Coal Bills 1/2 to 2/3

#### READ THIS GUARANTEE

Every Underfeed Furnace or Boiler, when properly installed and operated, is guaranteed to effect a saving of 50 per cent in coal bills. This is backed by a \$1,000,000 corporation. The strongest guarantee ever put behind any heating system is behind the Underfeed. If you are going to build or want more heat at less cost, send the coupon for full particulars. It will pay you well.

#### THE WILLIAMSON HEATER COMPANY

Successor to The Peck-Williamson Company

201 Fifth Street (20) CINCINNATI, OHIO

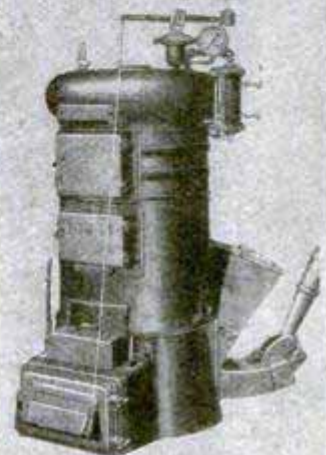

Underfeed Boiler

Get This  
Book



### The Coupon Brings All The Facts

THE WILLIAMSON HEATER COMPANY,  
201 Fifth Street, Cincinnati, Ohio

I would like to know *how* to cut my coal bills from one-half to two-thirds with an Underfeed.

Warm Air.....Steam or Hot Water.....  
(Mark an X after system interested in.)

Name .....

Address .....

My dealer's name is .....

# \$1500<sup>00</sup> MADE with Long's

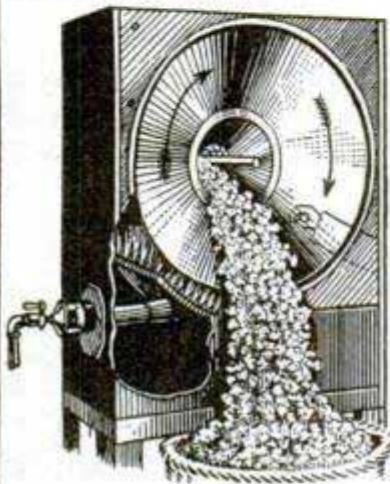

This picture shows the fire in a rotary corn-popper. The fire plays on the corn with an intense heat, like small blow pipes. As it pops, the popped corn is thrown out automatically. By this process the corn comes from the popper dry and not shriveled by the heat. Professional candy makers—the men who know—use this process only, for corn which is to be candied. Any other method is not satisfactory, usually adding grease to the corn which makes it tough. Greasy corn makes soggy Crispettes. Long-popped soggy Crispettes are never soggy.

one will spend a nickel—everyone likes Crispettes—children—parents—old folks. You don't need any experience—you can start anywhere—in a store window, a small store room where rent is cheap, or the kitchen of your home. The Crispette machine and Long's secret formula to the man of limited means is a Gold Mine—a sure way to independence and fortune—to make money from the start.

That's what Mr. Eakins made—paid his last \$10 for rent of a store window—at the end of 30 days had \$1500 in the bank—today he is independent. A Crispette machine and Crispettes did it.

Mr. Perrin, Cal., took in \$380 in one day—every nickel brought him almost 4c profit. What are you going to do in the future? Just barely earn a living—keep wishing for something to turn up? Don't do it.

**Listen**—take that money you have saved up against the day of opportunity

—invest it in a Long Pop-corn Crispette Machine, and make fortune smile on you—build up a big paying business. Think of the fortunes made of 5c pieces

- street cars
- moving pictures
- 5 and 10c stores. Every-

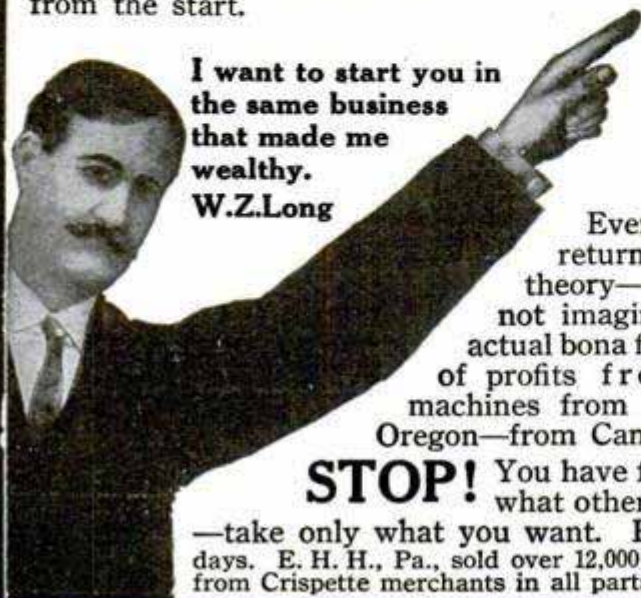
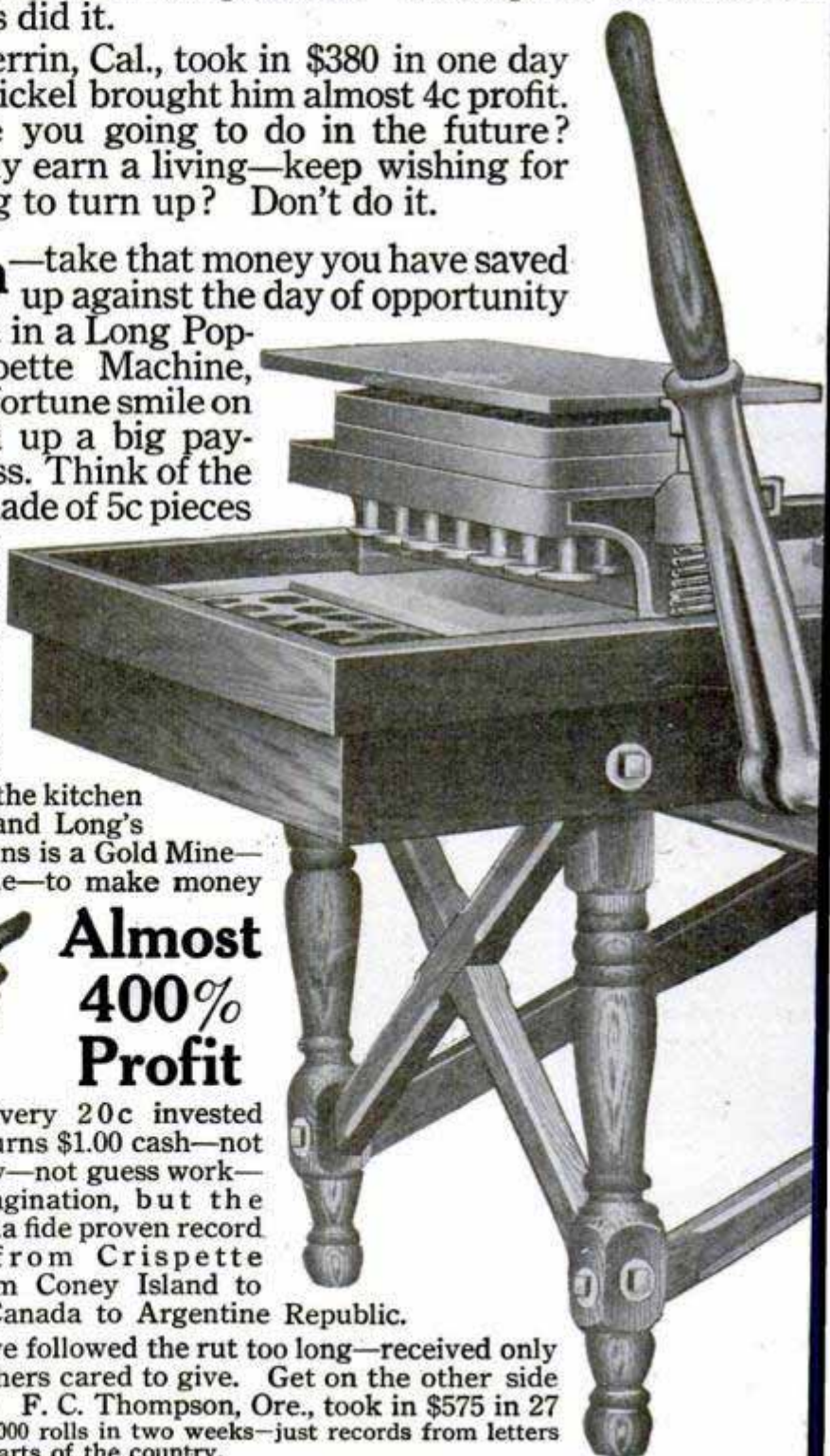

I want to start you in the same business that made me wealthy.  
W.Z.Long

**Almost  
400%  
Profit**

Every 20c invested returns \$1.00 cash—not theory—not guess work—not imagination, but the actual bona fide proven record of profits from Crispette machines from Coney Island to Oregon—from Canada to Argentine Republic.

**STOP!** You have followed the rut too long—received only what others cared to give. Get on the other side—take only what you want. F. C. Thompson, Ore., took in \$575 in 27 days. E. H. H., Pa., sold over 12,000 rolls in two weeks—just records from letters from Crispette merchants in all parts of the country.



# IN ONE MONTH

# *Crispettes*

# *BY THIS MAN*

The money barons began with much less advantage than I offer you today. Write NOW for my handsomely illustrated 48 page free booklet, "How To Make Money in the Crispette Business," or

## **Come to See Me at My Expense**

It's unnecessary to write that you are coming—just drop in any time. I will pay your traveling

*This machine did it*

expenses within a 300 mile radius if you buy a machine. I will give you reference after reference from responsible merchants, bankers, citizens—satisfy yourself and then go over the Crispette business with me.

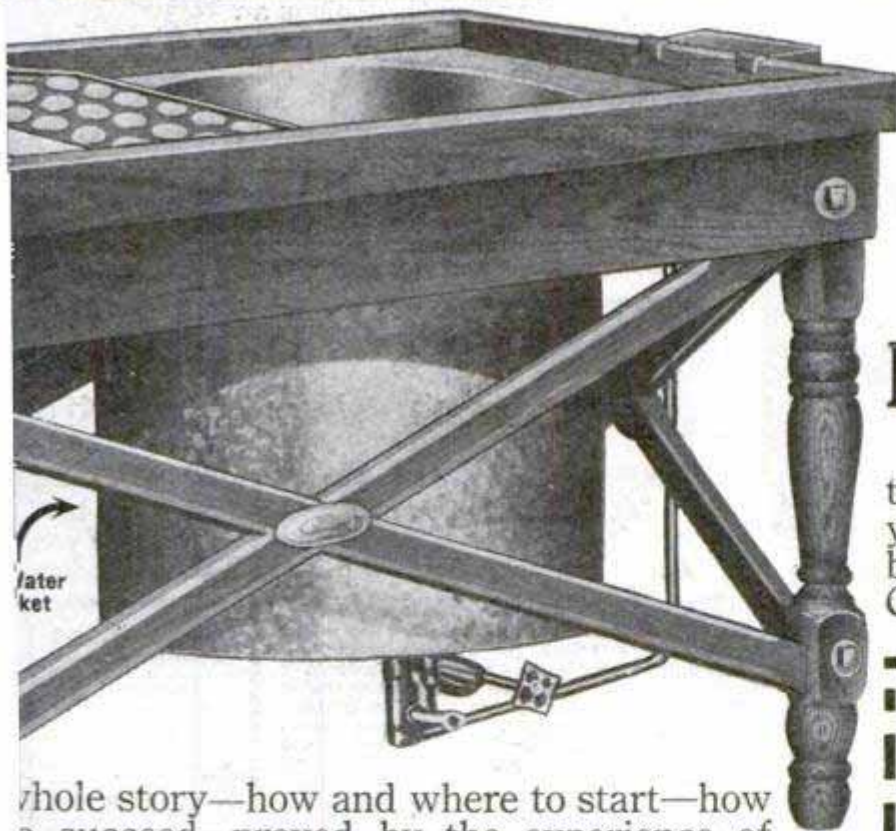

## **Go Into This Business Now—**

The big spring and summer trade is waiting for you right in your own city. Send for my free booklet "Dollars & Sense In The Crispette Business." It tells the

**W. Z. LONG,**  
(885) **Springfield, O.**  
Please send me free, full particulars about Crispette Machine and how to start a big paying business.

Name .....  
Address .....  
.....

whole story—how and where to start—how to succeed, proved by the experience of others. It's worth reading even if you don't start. If you are looking for a good thing and easy money, send for this book—today.

**W. Z. LONG** 885 High Street, SPRINGFIELD, O.

# \$1500 to \$3000 a Year Drafting and Designing

This is the salary that good first class Draftsmen and Designers draw and that is what you can earn if you have any ambition and will let me train you on practical Drafting room work.

## \$125 a Month

Starting salary according to my agreement and guarantee. Draftmen's work is pleasant and profitable.

Positions are open to intelligent men in the best surroundings. They are open everywhere. Thousands of men are needed who have just the kind of training I can give you. You can get this training during spare time in your own home.

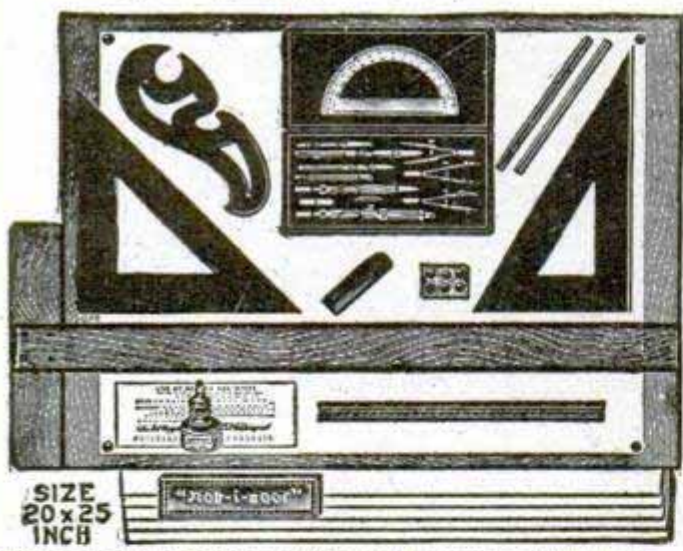

There is a constant and urgent demand for the best trained men in this line of work and I can train you to fill such a position in a reasonable length of time. Send the coupon below for my special offer. Send it today.

## Chief Draftsman Will Train You Personally

on practical Drafting-room work until you are competent and until you are in a permanent position at a salary paying at least \$125 per month. This is an exceptional opportunity for a few selected ambitious men, between the ages of 16 and 40, whom I will train personally.



**Free Book—Write Today** Your name and address on a postal or letter or coupon is enough. I will send you absolutely free and prepaid my big new book "Successful Draftsmanship" and full particulars of my great offer.

## FREE—this \$1500

### Draftsman's Working Outfit

These are regular working instruments, the kind I use myself. I give them free to you if you enroll at once. Send the Free Coupon today.

### Realize Your Ambition

Don't "just dream" of the days when you will be the man who gets the fat pay envelope. Act! All those little luxuries that you have wanted for so long—all those little extravagances you have wanted to afford are now within your reach. The Drafting profession is open to you. The first step toward realizing your ambition—and getting the fat pay envelope is to send the free coupon. Do it now.

### Mail the Free Coupon

at once for my book—"Successful Draftsmanship," also list of open positions, and for the free offer to be earning good money at once while learning at home. This offer is limited and in order to benefit thereby, act at once—NOW.

### I Guarantee

To instruct you until competent and in a permanent paying position at a regular Draftsman's salary of at least \$125 to \$175 per month and guarantee to furnish you free complete Draftsman's working outfit at once.

## Free Offer Coupon Chief Draftsman Dobe

Engineer's Equipment Co. Dept. 9195 Chicago, Ill.

Without any obligation to me whatsoever, please mail your book "Successful Draftsmanship," and full particulars of your liberal "Personal Instruction" offer to a few students. It is understood that I am obligated in no way whatever.



Name .....

Address .....

## CHIEF DRAFTSMAN DOBE

Engineers Equipment Co. (Inc.) Div. 9195 Chicago

# GENUINE PERFECT CUT DIAMONDS

## The Basch Trade-Mark is Your Personal Safe-Guard!

for it tells in briefest sign-language the **ONLY WAY** to buy diamonds **RIGHT!** First, note that price—**\$97.50 per carat**—the world's lowest for Genuine Perfect Cut Diamonds—full \$160 per carat retail value! "Established 1879" means 35 year tested **RELIABILITY!** "Money Back Guarantee"—described more fully below—means **CASH FOR YOUR DIAMOND** if you need it or want it!

## Send No Money—Not Even a Deposit!

You **see** the diamond before you **decide!** We ship any diamond set in your own choice of mountings; allow fullest examination—all at our expense—all without obligating you to buy! We stand **ALONE** in the **conveniences** we offer you, just as we stand **ALONE** in **price!**

## Basch Money Back Guarantee

issued with every diamond—a legal written contract to **REFUND FULL PRICE IN CASH**, less 10% any time within 2 years; to allow **FULL PRICE** on exchanges **ANY TIME!** Carat weight, quality and value legally certified. No equal guarantee in the whole diamond business! "See that your Diamond is Basch Guaranteed."

## A Valuable "Tip" to Diamond Buyers

Always buy diamonds **by the carat!** Jewelers always buy **by the carat.** Why do 999 out of 1000 jewelers refuse to sell by the carat? Simply because they daren't let you know the **tremendous price per carat** they are asking—because they daren't allow you to make a comparison with **BASCH IMPORTERS' PRICES!** Here again **L. Basch & Co.** stand **ALONE!** We have sold diamonds **by the carat** for 35 years!

## These Basch Prices Defy All Competition

C1—14K. Solitaire, 1 carat dia. <b>\$101.25</b>	C8—14K. Ears-crows, Two $\frac{3}{8}$ c. dia. <b>\$138.00</b>
C2—14K. Fancy Ring, $\frac{3}{8}$ c. dia. <b>35.50</b>	C9—14K. Eardrops, Two $\frac{3}{8}$ c. dia. <b>115.50</b>
C3—14K. Twin Ring, Two $\frac{3}{8}$ c. dia. <b>67.50</b>	C10—14K. 6 tooth, $\frac{3}{8}$ carat dia. <b>50.50</b>
C4—14K. Engraved, $\frac{3}{8}$ carat dia. <b>22.50</b>	C11—14K. Belcher, $\frac{3}{8}$ carat dia. <b>73.00</b>
C5—14K. Pierced, $\frac{3}{8}$ carat dia. <b>12.00</b>	C12—14K. Flat Belcher, $\frac{3}{8}$ c. dia. <b>91.25</b>
C6—14K. Fancy Ring, $\frac{3}{8}$ c. dia. <b>35.25</b>	C13—14K. Lion's Paw, $\frac{3}{8}$ c. dia. <b>38.25</b>
C7—14K. Solit. Stud, 1 carat dia. <b>99.75</b>	C14—10K. Cuff Links, 2 diamonds <b>1.75</b>
C15—10K. Tie Clasp, 1 dia., Special <b>\$1.00</b>	

## If you expect to buy a Diamond, do it NOW!

Diamond prices have gone up 25% within the past year! While our tremendous buying power enables us to continue our old price, \$97.50 per carat—conditions may compel an increase any day. **Act quickly** if you want to share in future increases—if you would avoid paying very much higher prices.

## 128 page De Luxe Basch Diamond Book FREE!

The costliest, most complete diamond guide yet produced. Thousands of illustrations. More than a catalogue, for it contains information about diamonds acquired in a life-time of specializing by recognized diamond experts. Enables you to judge diamond qualities, to compare values, to buy intelligently. Shows most artistic new and fashionable ideas in diamond mountings—14K. solid gold, platinum, onyx, inlaid, etc. Full particulars of the Basch Plan, importers' prices and money back guarantee. Shows a complete line of Watches and Jewelry of all standard makes, catalogued at **FACTORY** prices—these prices by comparison are startling.

MAIL COUPON OR WRITE TO

**L. BASCH & CO.**  
Dept. P247, State & Quincy Sts., CHICAGO

**\$97.50** Per Carat  
**DIAMONDS**  
**BASCH**  
**CHICAGO**  
**MONEYBACK GUARANTEE**  
(TRADE MARK)



Please mail me Free, copy of your 128 page De Luxe Basch Diamond Book illustrated in colors. I am not obligated in any way in requesting this book.

Name.....

Address.....

Mail to **L. BASCH & CO.,**  
Dept. P247, State & Quincy Sts., Chicago

**\$97.50** Per Carat  
**DIAMONDS**  
**BASCH**  
**CHICAGO**  
**MONEYBACK GUARANTEE**  
(TRADE MARK)

# COLGATE'S

## SHAVING LATHER

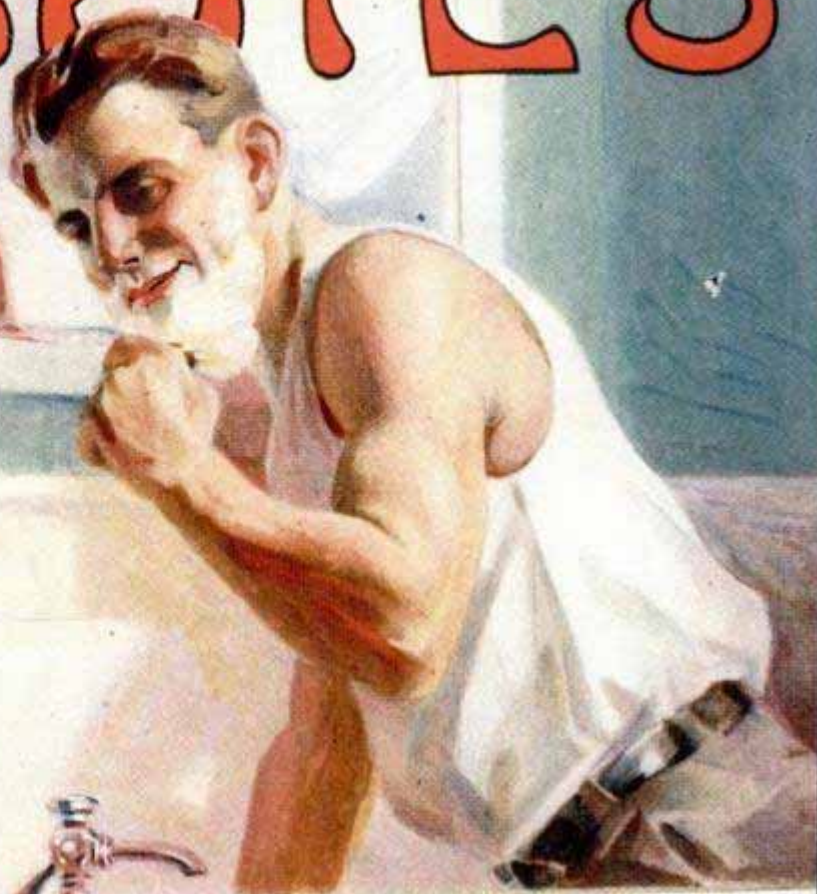

"Papa, why do some people use other kinds of shaving soap?"

"Because they've never used Colgate's."

Learn the comfort of a Colgate Shave. On receipt of 4 cts. in stamps we will send you a trial size of Colgate's Shaving Stick, the Magic Wand of Shaving; Rapid-Shave Powder, the Powder that Shortens the Shave; or Perfected Shaving Cream. Mention your preference.

**Colgate & Co.**

Dept. 81

199 Fulton St.,  
New York

Makers of Cashmere  
Bouquet Soap—luxur-  
ious, lasting, refined.



ANDREW  
LOOMIS