

# Popular Mechanics Magazine

318 W. Washington Street, Chicago, U. S. A.

EDITED BY H. H. WINDSOR

ISSUED MONTHLY

SUBSCRIPTION:

SINGLE COPY, 15 CENTS

In United States, and its possessions, Cuba and Mexico, per year, postpaid . . . . . \$1.50  
To Canada . . . . . 1.75  
To all other countries in the Postal Union . . . . . 2.00

All subscriptions are discontinued at expiration. Please examine the date printed on your wrapper.

Entered as Second Class Matter Sept. 15, 1903, at the Postoffice at Chicago, Illinois, under Act of March 3rd, 1879.

Published monthly by POPULAR MECHANICS CO.

Copyrighted 1913, by H. H. WINDSOR.

The attention of prospective advertisers is called to the policy of this magazine in accordance with which the publisher waives all claim for payment of any advertisement appearing in any issue where the number of copies actually printed and circulated is less than the number printed on the front cover page.

## Contents for October, 1913

Second-Story Bungalow Apartments.....	463	Funeral of Binghamton Fire Victims.....	506
Timing Camera Shutters with Arc Lights.....	464	A Barn Overturned by the Wind.....	508
Salvage Using a Torpedo Boat.....	465	License Card for Japanese Motorists.....	508
Motor Railroad Coaling Station.....	466	Figures Show Popularity of Motorboat.....	508
Given New Proof.....	466	Piano Music Sent by Telephone.....	509
Runs at Uniform Speed.....	466	New Air-Compressor Valve That Is Springless.....	509
Riding on a Plank.....	467	Statues to Commemorate Hero and Warrior.....	510
are Made.....	468	Machine That Washes and Sterilizes Dishes.....	512
at on Musical Instruments.....	468	Parcel Post Now Handles Twenty-Pound Packages.....	512
The Wool Industry of America.....	468	New Centrifugal Gun Has Automatic Feed.....	512
First Telegraph-Office Site is Marked.....	470	Picking Strawberries from a Seat.....	513
Pressure Cooking Adapted to Home Use.....	470	Concrete Horse Blocks in Washington.....	514
Smoke Abatement by Electricity.....	470	The Art of Carving Shell Cameos.....	514
Portable Lawns of Grass Carpet.....	470	Ancient Lanterns Copied in Bronze Lamps.....	516
Making Rich Cream Out of Butter and Milk.....	472	Machine for Administering Anesthetics.....	516
Motor-Car Body Provides Advertising.....	472	Ancient Fishing Boats of South Wales.....	516
The New Idea in Public Playgrounds.....	473	Slot Machine Supplies Gasoline.....	517
By Grant M. Hyde.....		Leipzig Railway Station Largest in Europe.....	517
Novel Method of Building Lighthouse Base.....	477	Large Ingots Handled by Electric Block.....	518
Around the World in Thirty-Five Days.....	478	The Collinwood School Memorial.....	519
New Motorcycle Stage Trick.....	480	Sample Stalk of 93-Inch Red-Top Hay.....	520
Antiskid Rubber Plugs for Dancing Shoes.....	480	Limiting the Speed of Gasoline Section Cars.....	520
Train Elevators Destroyed by Dust Explosion.....	481	Wireless Antennae within a Cathedral.....	520
Monument to First County Court in Illinois.....	482	Professional "Stunts" of Amateur Athletes.....	521
Danger of Electric Wires near Fire Stream.....	482	Flatiron Larger Than an Automobile.....	522
Plane-Testing Tunnel at Cicero.....	482	Brick Building Standing without Side Walls.....	522
Destroying Bacteria in Public Baths.....	483	Luggage Carrier in Place of Auto Top.....	523
Electric Illumination of Public Buildings for Decorative Purposes.....	484	Talking Clock That Calls the Hours.....	523
Ware Stock Case with Glass Top.....	486	Extreme Case of Buckled Rails.....	523
Oil-Glass Automobile Lamps.....	486	Diamond Rattlesnake Necklace.....	524
New Nonstop Aeroplane Record.....	487	Water-Power Development in California.....	524
Apparatus for Filtering Valuable Liquids.....	487	Aluminum-Soled Shoes for Laborers.....	524
New Form of Drive for Motorcycles.....	488	Flying Bicycles Still Unsuccessful.....	525
ovable Dam Which Has 247-Ft. Spans.....	488	Locomotive Derailed on Its First Trip.....	525
Another German Airship Wrecked.....	489	Iron Pipe Used as a Prop for Young Trees.....	526
Artificial Lunch Tables Made of Concrete.....	489	Apparatus for Gauging Breathing Exercises.....	526
Artificial Daylight for World's Fair.....	490	A Machine for Sorting Roller Bearings.....	526
Shipping Package for Choice Apples.....	492	The Great Meadows Prison Nearly Completed.....	526
Racer That Cost \$50 Won Second Place.....	493	Mid-Scotland Ship Canal Proposed.....	528
Railway Furnishes Night Views with Searchlight.....	493	Folding Bed for Small Bedrooms.....	528
Machine for Building Pipe Lines.....	494	Rubber Flowers Solve Bathers' Problem.....	529
Kerosene as Motor Fuel Proves Successful.....	495	Boring Holes in Awkward Places.....	529
Standard Time Announced by Wireless.....	496	Handling the Mail for Foreign Laborers.....	529
Houses That are Built in a Day.....	498	Water-Supply System of Woolworth Building.....	530
Convent Sisters Manage Coal Mine.....	498	Concrete-Arch Bridge of Unusual Size.....	531
The Spanish Armored Automobile.....	500	Saving Birds in English Channel Flight.....	532
War Maps Made During Aeroplane Flights.....	500	Homemade Automobile Plow.....	532
Columbus' Caravels on Long Journey.....	502	Cloth Shields to Shade Young Trees.....	533
An Engine Smaller Than a Fly.....	504	Extinguishing a Burning Gas Well.....	534
Highwayman's Trap for Motorists.....	504	New Tunnel Laid under East River.....	534
Sailing Wheelbarrows in China.....	505	Anatomy of the Malaria Mosquito.....	535
Speeders Restrained by Polite Request.....	505	New Features on English Motorcycles.....	535
Gate Valve Big Enough for Garage Door.....	506	Drawing Wire of Smallest Diameter.....	537
Fall of Rock in New York Subway.....	506	Device for Making Boat Tackles Twistless.....	537
Cleaning and Painting the Capitol Dome.....	506	Baby Cradle for Use in Automobile.....	537

[Continued on Page 6]

Popular Mechanics offers no premiums; does not join in "clubbing offers," and employs no solicitors to secure subscriptions. It is for sale by nearly every newsdealer in the United States and Canada.



## Contents—Continued

Water Sterilizers Using Gas or Electricity.....	538	A Hammock Swing.....	586
Foot-Rest Luncheon Case for Autoists.....	538	Fuel Storage for a Motorcycle.....	586
Steel Barrels Made to be Nested Compactly.....	539	A Stud Driver.....	587
Novel Typewriter Used in Germany.....	539	Clamps to Hold Picture Frames.....	587
Horseshoe Has Removable Calks.....	539	Block to Assist Hammer in Pulling Long Nails.....	587
Nesting a Feature of New Lifeboat.....	540	Electric Lighting of Bubble Glasses in a Level.....	587
The Action of Sea Water upon Concrete.....	540	Locking a Cork in a Bottle.....	588
Combining Pneumatic and Solid Auto Tires.....	540	A Paint-Can Hook.....	588
A Dwelling of the Dutch Colonial Type.....	541	Remedy for Swelling Feet and Enlarged Pores.....	588
Drinking Fountain Used Like a Cup.....	542	Oil Spout Formed in a Bottle Stopper.....	588
Many Tools Combined with Hammer.....	542	Starting a Bolt in a Difficult Place.....	588
Pocket Electric Lamp Has Dynamo.....	543	How to Make an Engineer's Kerosene Torch.....	589
How Indians Make Flint Arrow Heads.....	543	A Pencil and Compass Holder.....	590
Toy Pistols Use Paper as Ammunition.....	543	Cutting Eccentric Slots on a Lathe.....	590
Punctureless Air Cushion for Motor-Car Tires.....	544	Transferring Photographs to Watchcases.....	590
Siphon Action Used in Measuring Water.....	544	Piston-Ring Closer.....	591
How the New Wireless Law Works.....	545	An Inexpensive Post Pipe Vise.....	591
By Geo. F. Worts		A Rivet Clamp.....	591
Color-Changing Hoods for Electric-Sign Lamps.....	547	A Paint-Can Opener.....	592
Collapsible Range for Camping Trips.....	548	Handhold for a T-Square.....	592
Wagen Sprag Found Useful for Motor Trucks.....	548	Starting Holder for a Nut.....	592
Life Preserver Shaped Like Pillow.....	548	An Adjustable File Handle.....	592
French Highway Designed for Safety.....	548	Sawing the Edge of Timbers Straight.....	592
New Tandem Seat for Motorcycles.....	549	How to Test a Storage Battery with Cadmium	
Wrist Purse for Pay-As-You-Enter Fares.....	550	Contacts.....	593
Sanitary Conditions in Mining Towns.....	550	Protecting the Edges of Concrete Curbing.....	594
Piano Chair with Adjustable Seat.....	550	Cup-Valve Extractor.....	594
Enormous Annual Output of Gold.....	551	Pointing Pickets.....	594
Picture Molding Made of Metal.....	552	Removing Tin Roofing.....	594
Device for Studying the Flight of Mosquitoes.....	552	An Elbow Pattern.....	595
Nonexplosive Can for Priming Auto Engines.....	552	An Auxiliary Air Valve for Gasoline Engine.....	596
Useful Attachment for Stove Legs.....	552	Inclosing a Valve Action.....	596
A Motorcycle Health Crusade.....	553	How to Find a Crack in Metal.....	596
Fireman's Helmet Carries Electric Light.....	553	Repairing a Broken Bicycle Crank.....	597
A Floating Flat to Beat the Landlord.....	554	Practical Telephony—Part VII.....	597
By Harry D. Barton		Setting a Band Saw.....	599
Automobile Takes Place of Farm Horses.....	556	Lock for a Bench Drawer.....	599
Costly Bridge to Span Sydney Harbor.....	557	An Automatic Closing Stanchion.....	599
New System of Weights for Gems.....	557	Mending Broken Oilstones.....	599
Individual Care of Trees in Maine Town.....	557	Gauge for Sawing Wedges.....	600
Conveyor for Retarding Fall of Coal.....	557	Repair Joint for Large Pipe Lines.....	600
Moving-Picture Machine for Amateurs.....	558	Remedy for a Kicking Cow.....	600
An Aluminum Fireless Cooker.....	558	How to Attach False Centers.....	601
Underground Garage for Chicago.....	559	How to Make a Pair of Fiber Pliers.....	601
The Sweden Valley Ice Mine.....	560	Spring on a Faceplate Clamp.....	601
The Last Boat Leaving a Sinking Ship.....	562	Motorcycle Cleaner.....	601
Vienna Builds Dwellings for the Poor.....	562	Plug-Cock Lubricant.....	601
A Machine for Picking Cotton.....	562	Block for Setting Castings in a Lathe Chuck.....	602
Gasoline-Electric Power for Railway Car.....	564	An Extension Carpenter's Bit.....	602
A Folding Bed for Automobiles.....	565	Keyway-Cutting Tool for the Drill Press.....	602
Sound Cabinet for Moving-Picture Plays.....	565	A White Paint for Boats.....	602
Cutter for Scaloping Fruit Rinds.....	565	Hose Clamp Used on a Small Hose.....	602
The New Wisconsin State Capitol.....	567	<b>AMATEUR MECHANICS</b>	
By Gertrude G. Walker		How to Make a Hurdle.....	603
Pipe Organ Made of Wall Paper.....	568	Oil Burner for a Cook Stove.....	603
Stone Tree Erected at Hunter's Grave.....	568	A Merry-Go-Round Pole.....	604
Signposts to Welcome Travelers.....	569	A Theatrical Night Scene with the Appearance	
Worm-Eaten Piles Snapped by Locomotive.....	569	of Fireflies.....	604
Making Shingles from Old Stumps.....	570	Hulling Walnuts.....	604
Model House Designed by High-School Pupils.....	570	Stick for Lowering Top Sash of a Window.....	604
Hindoo Juggler Supported on Bayonet Points.....	572	An Adjustable Hacksaw Frame.....	605
Combined Pile Driver and Locomotive Crane.....	572	A Bedroom Cabinet.....	605
Measuring the Growth of Plants.....	573	A Dull Black for Cameras.....	605
International Postage Coupon.....	574	A Door Fastener.....	605
Thormery Rock Still a Menace.....	575	A Hat Hanger.....	606
"Road-Dragging Day" in Iowa.....	576	Repairing a Broken Tenon on a Chair Post.....	606
Long Bridge which Rests on Floating Logs.....	576	Substitute for an Iron-Holder Knob.....	606
The Capacity of the Port of Hamburg.....	576	An Egg-Frying Pan.....	606
Motor Car Somersaults in the Air.....	577	A Sander Mandrel for the Lathe.....	606
Levee Saved by Steel Sheet Piling.....	578	A Pocket Direct-Current Voltmeter.....	607
One-Man Fire Brigade on New Liner.....	579	How to Make Falling Blocks.....	610
Automobile's Acrobatic Feat.....	579	Writing Name Reversed on Paper Placed on	
Horses Groomed with Vacuum Cleaner.....	579	Forehead.....	610
New Hook for Snagging Lobsters.....	580	Use for an Old Table.....	610
Pontoon Bridge Erected in Three Hours.....	580	Waterproof Shoe Dressing.....	611
Pushing a Wheelbarrow 1,500 Miles.....	582	An Adjustable Bench.....	611
An Electric Cooker which Saves Waste.....	582	A Crochet Hook.....	611
<b>SHOP NOTES</b>			
Locating a Broken Line in an Igniting Cable.....	583	Writing Board for Children.....	611
Adapting Gas Fixtures for Inverted Lights.....	583	Geometric Principle in Line Division.....	612
Automobile Lights Directed by the Travel of the		Repairing a Broken Whip.....	612
Wheel.....	583	Repairing a Worn Thimble.....	612
Forced Draft for a Kitchen Stove.....	584	A Small Torch.....	612
Cutting Thin Tubing.....	584	Fountain Attachment for an Ordinary Pen.....	612
Gauge for Cutting Hedges.....	584	To Make Whitewash Stick to Surfaces Coated.....	613
Blank-Tag Holder.....	585	A Mechanical Camera.....	613
A Gauge Siphon.....	585	Gauge Attachment for a Pocket Rule.....	613
An Emergency Split Pulley.....	585	Plate Hangers.....	613
Bending U-Bolts.....	586	Interesting New Patents.....	614
		Jokes.....	616



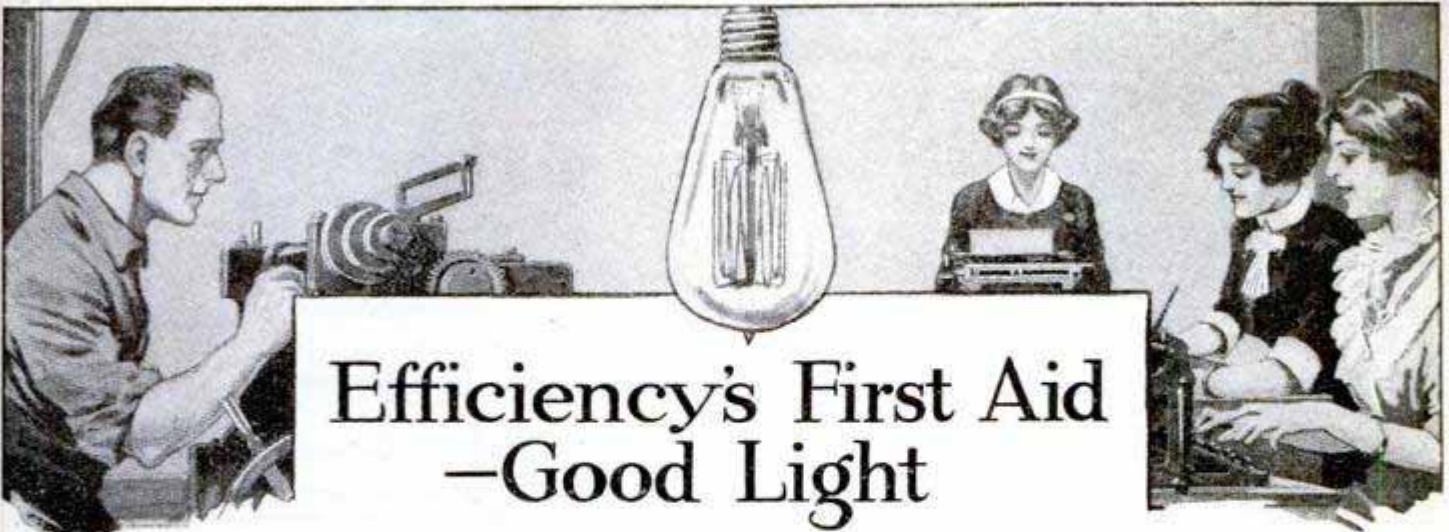

## Efficiency's First Aid —Good Light

"You're working in the dark!" said a Western plant manager to his friend who had asked him to visit the latter's publishing offices in an Eastern Ohio town.

"How do you make that out?" asked the publishing man with a little astonishment. "We've had electricity here for five years."

"That may be," said the Western man. "And I don't mean that you can't see your hand before your face. But you haven't really emerged from the dark age. Honest, have you changed your lighting arrangements in those five years?"

The publishing man admitted that he hadn't.

"I thought so," said his frank visitor. "They were pretty poor to begin with, and they're entirely out of date. They're out of date because we're living in an age of really good light. More than half of your floor space is gloomy, partly because you use old-fashioned lamps—the Edison Mazda gives three times as much light with the same amount of electricity that is used in these ordinary carbon lamps—and partly because they are not placed to advantage. You're handicapping yourself and your entire force. You're putting a check on your office efficiency, which is bad business and you're wasting money on old methods which is bad business again. Good light is a big factor—it's efficiency's first aid. It would be worth all it costs even if it cost a lot of money. And yet it's cheaper than ever it was—been going down in price while the cost of everything else has been going up."

The result of this plain talk was that the publishing man got into communication with the local lighting company next day, and found himself keenly interested in the plans laid out by the electrical engineer who called to see him. Seven months later when he saw his friend again he declared: "You put it bluntly about my lighting, but you saved me money. My system now costs me no more, and you wouldn't know the place as it is now. It has put snap into all our work—I think we turn out fully thirty per cent. more

than we did, and we do it with fully fifty per cent. more comfort. I'm a light enthusiast from now on."

This incident reflects an experience in a certain type of business, but there is no sort of business to which the outspoken philosophy that stirred this particular manager might not apply with equal force. For manufacturer and merchant, banker, broker or business man anywhere, good light is a basic business factor.

Good light is good business. It brings people into a store, for example, and helps sell goods to those people. It helps the display of goods, and it affects not only customers but the selling force.

It affects equally the brain output and the physical output of every sort of business. It raises the percentage of sheer efficiency in every unit of a force, whether it is a small office force of a dozen or a large force of a thousand. That percentage of increase in efficiency would be considered highly important in a group of machines. It is even more so in a group of men or women.

Perhaps you have realized this fact in your business without guessing exactly how the thing might be worked out to meet your special needs and opportunities. It is possible that you have not ascertained the cheapness and facility of modern wiring—that you may not know of the growing cheapness of electric light itself.

These are matters which an electrical engineer knows, and can lay before you.

The electrical expert will tell you about the Edison Mazda lamp. He will show you the comfort—for you personally and for your force—and—he will show you the real economy that lies in modern ways of lighting.

Take up the matter today with your electric power and light company, or any General Electric Company agent in your vicinity. You will find them more than glad to co-operate with you, and no matter how complex your problem may be, they have at their command the service of any part of our organization that may be most helpful to them and to you.

*The Guarantee  
of Excellence on  
Goods Electrical*



# GENERAL ELECTRIC COMPANY

**Largest Electrical Manufacturer in the World**

Atlanta, Ga.	Chicago, Ill.	Hartford, Conn.	Louisville, Ky.	New Orleans, La.	San Francisco, Cal.
Baltimore, Md.	Cincinnati, Ohio	Indianapolis, Ind.	Madison, Wis.	New York, N. Y.	St. Louis, Mo.
Birmingham, Ala.	Cleveland, Ohio	Jacksonville, Fla.	Mattoon, Ill.	Omaha, Neb.	Schenectady, N. Y.
Boise, Idaho	Columbus, Ohio	Joplin, Mo.	Memphis, Tenn.	Philadelphia, Pa.	Seattle, Wash.
Boston, Mass.	Davenport, Iowa	Kansas City, Mo.	Milwaukee, Wis.	Pittsburg, Pa.	Spokane, Wash.
Buffalo, N. Y.	Dayton, Ohio	Keokuk, Iowa	Minneapolis, Minn.	Portland, Ore.	Springfield, Mass.
Butte, Mont.	Denver, Colo.	Knoxville, Tenn.	Nashville, Tenn.	Providence, R. I.	Syracuse, N. Y.
Charleston, W. Va.	Detroit, Mich. (Office of Agt.)	Los Angeles, Cal.	New Haven, Conn.	Richmond, Va.	Toledo, Ohio
Charlotte, N. C.	Elmira, N. Y.			Rochester, N. Y.	Washington, D. C.
Chattanooga, Tenn.	Erie, Pa.			Salt Lake City, Utah	Youngstown, Ohio

For Texas, Oklahoma and Arizona business refer to Southwest General Electric Co. (formerly Hobson Electric Co.)—Dallas, El Paso, Houston and Oklahoma City  
For Canadian business refer to Canadian General Electric Company, Ltd., Toronto, Ont.



**LEARN THE AUTOMOBILE TRADE**

**Be an Auto Mechanician**

Do work at homes of auto owners or if you prefer drive a car, tester or salesman. We will teach you and show you how to start.



NOW RUNNING A GARAGE WAS A CONTRACTOR

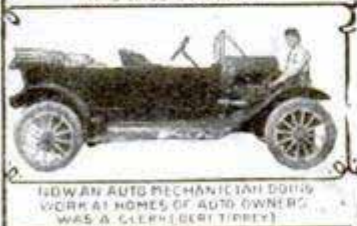

NOW AN AUTO MECHANICIAN DOING WORK AT HOMES OF AUTO OWNERS WAS A CLERK (GERTY TIPPEY)

Everyone in the business is making money and every year it grows four times. **DON'T DELAY — START NOW. YOU DON'T HAVE TO BE A MECHANIC** — It's in knowing the principle and construction and how to diagnose troubles and adjust—**knowing how**—that's the key note.

**NEW ADDITION TO OUR FAMILY OF MODELS**

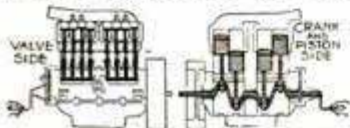

**4 CYLINDER ENGINE MODEL**  
IT WORKS. ALL MOVING PARTS REAL METAL. OTHER MODELS ARE: MAGNETO, CARBURETOR, CLUTCH, GEAR BOX, DIFFERENTIAL.

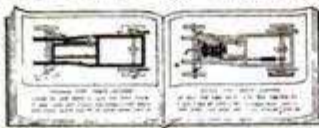

**THE PROGRESSIVE CHART THE MANIKIN**, SHOWING HOW THE CAR IS ASSEMBLED FROM THE GROUND UP

It's easy to learn — easier than working in a shop— **YOU LEARN THROUGH THE EYE** and see the **INSIDE** operation and get actual practice on the **REAL Working Models**. A boy twelve years old can learn — **IF OTHERS CAN — YOU CAN.**

**LET US DESCRIBE OF DYKE'S NEW IDEA WORKING MODEL SYSTEM**

ONE OF THE BEST WORK MODELS

THEY TEACHING BY MAIL

**TESTIMONIALS PROOFS SAMPLE PAGES, CHARTS OPPORTUNITIES OF THE MOTOR BUSINESS**

**SHOW YOU EMPLOYMENT**

A NEW PLAN

HOW WE START YOU

FREE

SEND FOR THEM

**MANY SAY THEY LEARN A LOT FROM THE 32-PAGE, FULLY ILLUSTRATED BOOKLETS ALONE**

**We Will Show You**— how we can teach **YOU**, how we have taught **hundreds** of others — how we can start **YOU** to making money even before you complete Course — how we have started **hundreds** of others who *knew no more than you do right now*—

**We Will Further Show You**— endorsements of the *leading motor authorities of the world*, men who could not afford to endorse this system if it was not absolutely satisfactory in every respect.

**YOU DEAL WITH A RELIABLE FIRM**

Mr. Dyke has been identified as a pioneer inventor, supply man, etc., with the auto industry since the beginning. He originated the first auto supply company and published the first book on autos in America. No other man with such experience is today teaching others. And all the experience and inside information of the auto business he has thus gained, is embodied in this Course and Employment Plan.

**On Trial** — You are allowed a trial examination of the Course—If it isn't perfectly satisfactory you can return it within two days and get your money back. The Course is all sent to you at one time.

**WRITE** **SPECIAL PRICE—Right Now—**  
Complete Course—only . . . **\$15.00**

**NOW**

**DYKE'S CORRESPONDENCE SCHOOL OF MOTORING,**  
Box 188, Roe Bldg., ST. LOUIS, MO.  
NOTE — Beware of Imitators — Deal with the Originator



**Why Don't You Wear Linene Collars?**

Now, honestly, is it for any real good reason except that you have never tried them? For your own future comfort and convenience ask us for a free sample and give it a fair trial. Or, better still, buy a box of ten for 25 cents at the store or send us 30 cents to cover cost of mailing you ten. State size and style, but try them, anyway

**LINENE** collars are made of fine cloth finished in pure starch just like linen. They are totally different from paper, rubber or celluloid collars. They do not require laundering, but are so cheap that they can be thrown away when soiled. Both sides being alike they can be reversed, costing but 1 1/2 cents per wearing, less than the cost of laundering a linen collar.

Send for beautiful free catalogue

**REVERSIBLE COLLAR CO.**  
Dept. U, BOSTON, MASS.



**GACHOO!** Make the whole family and all your friends "just sneeze their heads off" without knowing why, with Gachoo, the new long distance harmless snuff. Sent anywhere for 10c. 3 for 25c. 1 doz. and special premium for 90c. **AMERICAN SUPPLY CO., St. Paul, Minn.**



**WHEN YOU WANT ANYTHING AND DON'T KNOW WHERE TO FIND IT—WRITE BUREAU OF INFORMATION, POPULAR MECHANICS, CHICAGO**

**Cut this Out** **Mail Today**



**NATIONAL AUTO SCHOOL**

**JUNE & READING RD., CINCINNATI, OHIO**

**GENTLEMEN:**—Send free booklet telling how I can become an Expert Chauffeur or Repairman and be placed, at once, in a **GOOD-PAYING** position. **PM10**

Name .....

Address .....

**Pay you to cut this out and MAIL TODAY**





# The Tower of Babel is Still Standing

**D**O you realize that 4000 years after this most wonderful of all towers was built by the ancients (according to the Book of Genesis about 2400 B. C.) its seven stages still rise high above the plains near the site of Babylon? Until a few years ago it had been known as the Mound of Birs Nimrud when Sir Henry Rawlinson discovered in one of the stages the inscribed cylinders which made the identification possible. Other expeditions uncovered many of the thousands of curiously interesting records and documents contained in the great work—

## The Library of Original Sources

now for the first time available to the general public. **By taking over the entire unsold edition from the publishers we secured it at an absolutely unheard of reduction.** So now we can offer the few remaining sets to POPULAR MECHANICS readers at an

### EXTRAORDINARY BARGAIN

**Send us the attached coupon AT ONCE, and we will tell you how to get the Library on EASY MONTHLY PAYMENTS, and mail you FREE a book of rare documents. Remember there are only a limited number of sets, so act quickly. Mail the coupon NOW. You assume no obligation. No salesman will call. The book is FREE.**

**THIS MARVELOUS WORK** is revolutionizing modern thought. It's turning upside down old notions and ideas. It gives the authoritative, rock-bottom sources of our knowledge on ALL SUBJECTS OF HUMAN INTEREST from the earliest civilization down to to-day—the inside facts which the average person has never even heard of.

**OVER 100 RESEARCH SPECIALISTS** spent 10 years gathering the contents of this great work. Ancient and remote and forgotten civilizations in all parts of the globe were uncovered, and age-buried hieroglyphics on monuments, tablets, sun-baked bricks and palimpsests yielded their secrets; untiring workers ransacked the hidden literature of every age, ancient, mediæval and modern, to find the "original documents" that shaped the civilization and influenced the thought and life of the world. Nothing like it has ever been attempted or thought of before. You'll be amazed at the wealth of information this unique library contains.

**DO YOU KNOW** that the old Egyptians, 5000 years B. C., had a Bible which they called the "Book of the Dead"?—Do you know that the Assyrian sacred literature gives the story of the Creation?—Do you know that books and newspapers were printed in Asia thousands of years before printing was invented by Gutenberg?—Did YOU ever read Columbus' personal log of his great voyage—filled with strange happenings and ominous forebodings?—Do you know that there occurred in Mediæval England a great Socialistic protest—the first of its kind ever known?—Do you know by what unique process Harvey demonstrated that the blood does not stand still in the veins, as everyone then thought?—Do you know who Machiavelli was, or what world famous treatise he wrote?

**YOU'LL FIND THEM ALL**—and thousands of others equally as curious and important—in The Library of Original Sources. Every document is in the exact words of the original, translated; every contribution is from the actual eye-witness or person who took part; every idea is in the words of the thinker, investigator, discoverer or inventor.

**JACK LONDON SAYS:**—"It is a whole library in itself. I certainly never could spare these books from my shelves."

10 sumptuous, massive volumes, bound in rich, deep red Morocco; full page illustrations, pure silk headbands, printed in large, clear type on hand-made paper, gold tops—a triumph of the bookmaker's art.

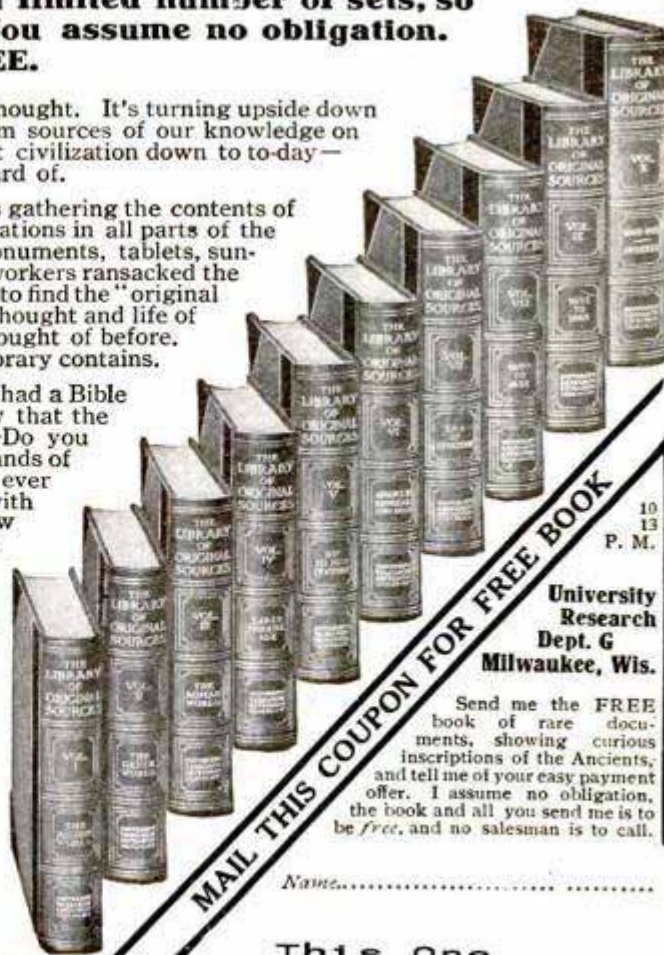

**MAIL THIS COUPON FOR FREE BOOK**

10  
13  
P. M.

University  
Research  
Dept. G  
Milwaukee, Wis.

Send me the FREE book of rare documents, showing curious inscriptions of the Ancients, and tell me of your easy payment offer. I assume no obligation, the book and all you send me is to be free, and no salesman is to call.

Name.....

This One

Please Mention Popular Mechanics





The Burlington Special

19 Jewels Fully Adjusted



The Burlington Special

New Style Thin Model

Here Is an Exquisite Design

New Inlay Monogram

The latest idea in watch cases. Superbly beautiful. Your own monogram in handsome enamel design, (many colors to choose from) inlaid in superb gold strata case. The newest thing—just conceived and offered direct to you.

# Just Out!

“Inlay Enamel” Monogram

## New Ideas in Watch Cases!

Open face or hunting case, ladies' or gentlemen's sizes. These can be had in the newest ideas: *Block and Ribbon Monograms, Diamond Set, Lodge, French Art and Dragon Designs, Etc.* Imagine a beautiful hunting case with your own monogram on one side and the emblem of your lodge or any emblem on the other side. Our catalog shows complete illustrations. See coupon below.

## Special Offer!

The superb Burlington Special now at the DIRECT rock-bottom price—the same price that even the wholesale jeweler must pay. You may secure one of these superb timepieces—a watch of the very latest model, the popular new thin design, adjusted to the second—19 jewels—adjusted to positions AND temperature AND isochronism—the most perfect product of the world's most expert watch manufacturers—at the price that even wholesale jewelers must pay—and in order to encourage everybody to secure this watch at once pay this rock-bottom price, either for cash or \$2.50 a month! We send the watch on approval, prepaid. You risk absolutely nothing—you pay nothing—not one cent, unless you want this exceptional offer after seeing and thoroughly inspecting the watch. Read the coupon below.

## Write for Free Watch Book

Learn the inside facts about watch prices, and the many superior points of the Burlington over double-priced products. Just send the coupon or a letter or a postal. Get this offer while it lasts.

**Burlington Watch Co.**  
19th Street and Marshall Blvd.  
Chicago, Ill.  
Dept. 1197

Please send me (without obligation and prepaid) your free book on watches and a copy of your \$1,000 challenge, with full explanation of your cash or \$2.50 a month offer on the Burlington Watch.

FREE Book Coupon

Name \_\_\_\_\_  
Address \_\_\_\_\_

Please Mention Popular Mechanics

# Honk! Honk!

25c Postpaid

Send to-day for BOOK How to Drive a Motorcycle



and learn how to get the best results from your engine and the greatest pleasure when you ride.

**IT TELLS** How to make an easy start—Styles of Mounting—Driving on the level—Hill climbing—How to take corners—How to stop on the level, on hills—Cooling the engine—Driving with a side car—Lubrication—Roadside adjustments and Repairs—Tires and tire troubles—Care of the Motor Cycle when not in use, etc.

88 pages. Over 30 photographic plates and diagrams

**SPON & CHAMBERLAIN**  
123 P. M. Liberty St., New York, U. S. A.

# 9,059-Word Business Book Free

Simply send us a postal and ask for our free illustrated 9,059-word Business Booklet which tells how priceless Business Experience, squeezed from the lives of 112 big, brainy business men, may be made yours—yours to boost your salary, to increase your profits. This free book deals with

- How to manage a business
- How to sell goods
- How to get money by mail
- How to buy at rock-bottom
- How to collect money
- How to stop cost leaks
- How to train and handle men
- How to get and hold a position
- How to advertise a business
- How to devise office methods

Sending for this free book binds you to nothing, involves you in no obligation; yet it may be the means of starting you on a broader career. Surely you will not deny yourself this privilege, when it involves only the risk of a postal—a penny! Simply say "Send on your 9,059-word Booklet". Send to **SYSTEM, Dept. 81-10 Wabash and Madison Sts., Chicago**

SEND FOR MY FREE BOOKS



## DO YOU WANT TO KNOW HOW TO DEVELOP VITALITY, ENERGY, ENDURANCE, NERVE STRENGTH, MUSCULAR STRENGTH PERFECT PHYSIQUE?

My FREE BOOKS, "The 'Whys' of Exercise" and "The First and Last Law of Physical Culture," tell you, if you are weak or underdeveloped, how to grow strong; if strong, how to grow stronger. They explain how to develop lungs and muscle, the strong heart and vigorous digestion—in short, how to improve health and strength internally as well as externally. Send TO-DAY—NOW—for these FREE BOOKS. Enclose 4c in stamps to cover postage.

**PROF. H. W. TITUS**, 416 Titus Bldg., 156 E. 23d St. New York City



## HERE YOU ARE, BOYS

A medallion pin of Foxy Grandpa. Everyone will notice it on the lapel of your coat and try to get a closer look at it. All you have to do is press the bulb.—Foxy Grandpa will finish the job by squirting a fine stream of water over the inquisitive one. Will squirt 20 feet. Greatest joke out. Order one today and fool your friends. Price 15c. Foxy Grandpa and Hooligan both for 25c. 5 for 50c or 1 doz. for \$1.00. A beautiful fountain pen free with every \$1.00 order.

**AMERICAN SUPPLY CO., 918 Union St., St. Paul, Minn.**

## Over 80,000 in Use

Mostly sold by recommendation. For Personal Desk or General Office.

It checks mental calculations, Handsome Morocco case free. Buy Thru Your Stationer.

Write for to-day trial offer. E. Ganeher, A. A. M. Co., 119 W. Broadway, New York City.

## Golden Gem \$10 Adding Machine



Multiplies - Subtracts

Agents Wanted





CHARGE OF SCOTS GREYS AT WATERLOO

WELLINGTON held this regiment of cavalry in reserve at the battle of Waterloo, awaiting the supreme moment when an overwhelming charge might turn the tide of battle. The instant the French lines wavered the order was given to charge and the Scots Greys Cavalry hurled themselves against the French like a thunderbolt. This charge ended forever the career of Napoleon and his dream of universal empire vanished away with the smoke of his artillery. The celebrated picture shown herewith from Ridpath's History, the original of which was purchased by Queen Victoria, illustrates but one event of all the thousands which makes up the history of every nation, empire, principality or power in the world famed publication

# Ridpath's History OF THE World

WE will name our special low price and easy terms of payment only in direct letters. A coupon for your convenience is printed on the lower corner of this advertisement. Tear off the coupon, write your name and address plainly and mail. We do not publish our special low price for the reason Dr. Ridpath's widow derives her support from the royalty on this History, and to print our low price broadcast would cause injury to the sale of future editions.

## Six Thousand Years of History

RIDPATH takes you back to the dawn of history long before the Pyramids of Egypt were built; down through the romantic troubled times of Chaldea's grandeur and Assyria's magnificence; of Babylonia's wealth and luxury; of Greek and Roman splendor; of Mohammedan culture and refinement; of French elegance and British power, to the dawn of yesterday. He covers every race, every nation, every time and holds you spellbound by its wonderful eloquence.

## 46 Page Booklet FREE

WE will mail our beautiful forty-six page free booklet without any obligation on your part to buy. It will show Ridpath's wonderfully beautiful style. He pictures the great historical events as though they were happening before your eyes; he carries you with him to see the battles of old; to meet kings and queens and warriors; to sit in the Roman Senate; to march against Saladin and his dark-skinned followers; to sail the southern seas with Drake; to circumnavigate the globe with Magellan. He combines absorbing interest with supreme reliability, and makes the heroes of history real living men and women, and about them he weaves the rise and fall of empires in such a fascinating style that history becomes as absorbingly interesting as the greatest of fiction.

WESTERN NEWSPAPER ASSOCIATION  
CHICAGO

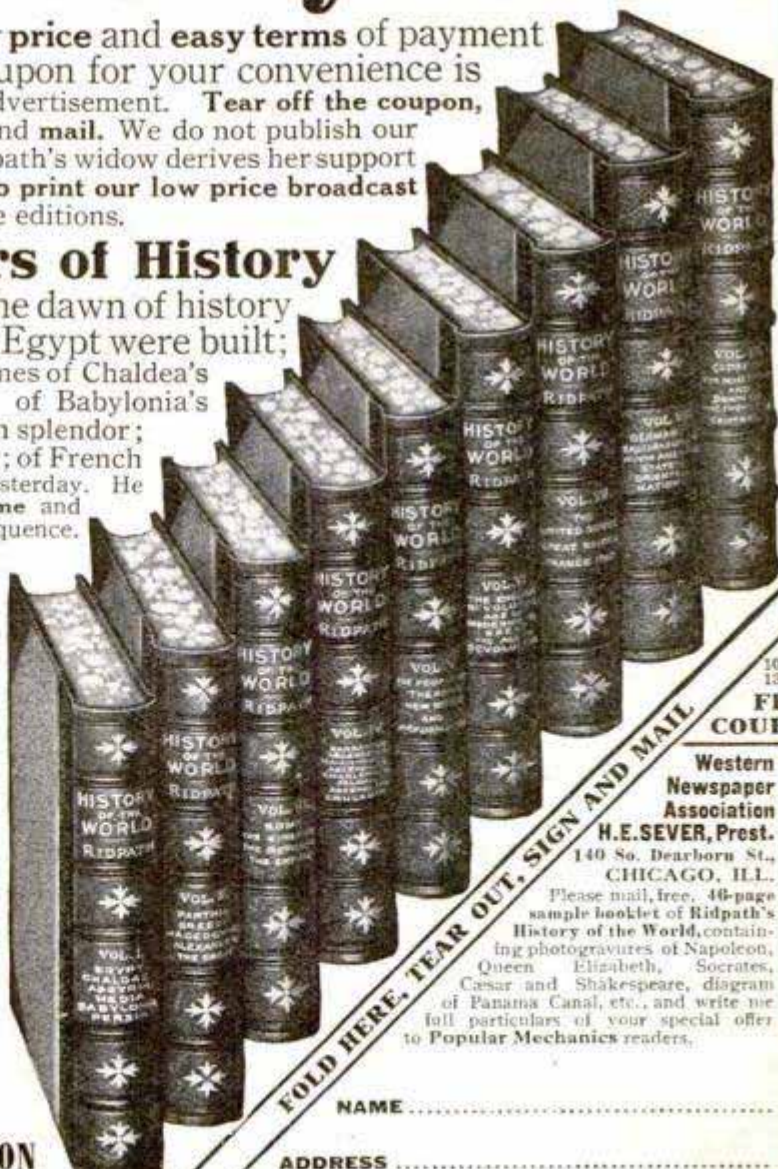

FOLD HERE, TEAR OUT, SIGN AND MAIL

10  
13  
FREE  
COUPON

NAME .....

ADDRESS .....

POPULAR MECHANICS

Western  
Newspaper  
Association  
H.E. SEVER, Prest.  
140 So. Dearborn St.,  
CHICAGO, ILL.

Please mail, free, 46-page sample booklet of Ridpath's History of the World, containing photogravures of Napoleon, Queen Elizabeth, Socrates, Caesar and Shakespeare, diagram of Panama Canal, etc., and write me full particulars of your special offer to Popular Mechanics readers.



*Flag Signalling,  
Naval Trade School*

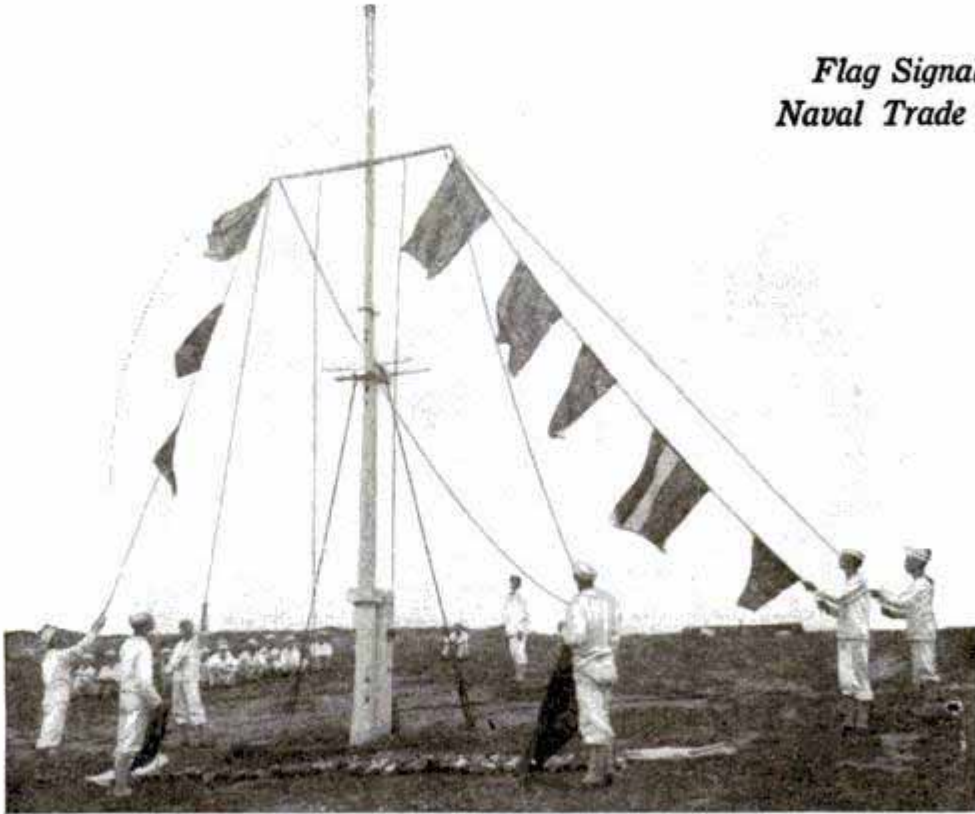

## A Vast Trade School

**T**HE Navy of the United States is more than a military organization. It is a Vast Trade School.

It does not try to reform bad boys. It takes ambitious, respectable young men over 17 and turns them into the best paid mechanics, tradesmen and seamen in the world today.

It gives them a wide knowledge of their own and foreign countries, the instruction of experts—plenty of amusement—the companionship of alert, clean cut fellows.

It pays them good wages and takes the utmost moral, mental and physical care of them.

You could not get such training elsewhere except at great expense. No public trade school would even attempt it on such terms. It is the *next thing* to four years at a high priced technical institution with a trip abroad thrown in.

Isn't this worth investigation? Send postal today for the free book—"The Making of a Man-O-Warsman." Intensely interesting pictures and descriptions of how the Navy trains its men for a healthy, money making future.

Ask us for address of nearest Navy Recruiting Station (or look in the Want ads of your local Sunday newspaper) and get full particulars as to work, pay, hours, etc. Do this for your future—today.

Bureau of Navigation, Box 69, Navy Dept., Washington, D. C.

# UNITED STATES NAVY



\$1

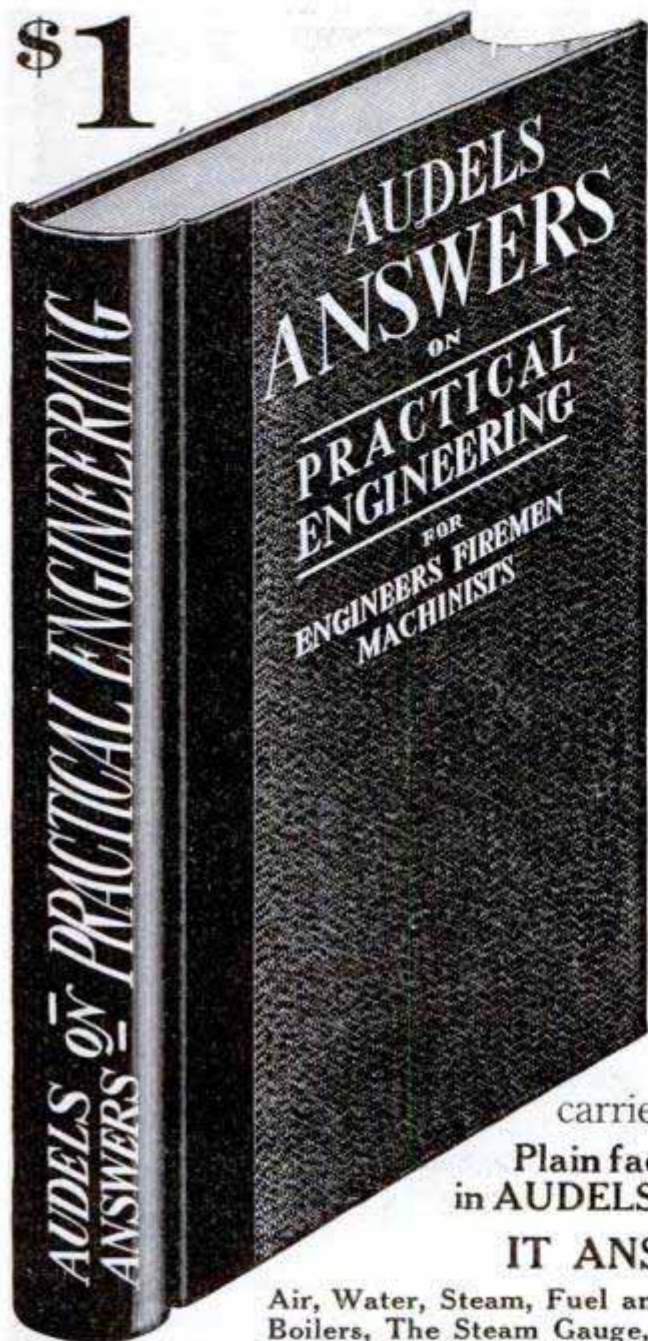

# ENGINEERS

This Book Will Help You

## Audels Answers on Practical Engineering

*When you spend your good hard earned money for books, always make sure that you are going to receive something that will assist you in bettering your position*

**T**HIS book deals largely with the foundation principles which govern the practice of steam engineering. Nothing so soon condemns the applicant as want of knowledge of the every day practice and simple laws relating to the care and management of a steam plant.

No one is expected to know everything, but all are required to be familiar with certain facts which may be called "the beginning of things."

The lack of knowledge of the small things carries conviction of the same lack in the larger.

Plain facts, that you should know, are plainly explained in **AUDELS ANSWERS ON PRACTICAL ENGINEERING.**

### IT ANSWERS YOUR QUESTIONS ON

Air, Water, Steam, Fuel and Heat, Steam Boilers, Boiler Construction, Water Tube Boilers, The Steam Gauge, The Safety Valve, Properties of Steam, Installation of Boilers, Management of Boilers, Engineers' Law, Firemen's Law, Steam Engines, The Valve and Valve Gear, The Corliss Engine, Engine Arithmetic, Lubricators, Installation and Operation of Engines, Steam Pumps, Injectors, Feed Water Heaters, Steam Heating, Steam Traps, Belts, Gears and Pulleys, Steam Turbines, Refrigeration, Practical Electricity, Elevators.

Understand the framework of which your work is but a cross bar. Know something of the cause of which your work is but an effect. Know something of the effect of which your work is the cause. And, above all, know why it is done one way and not another.

**LEARN THE THEORY UNDERLYING THE WORK.** Practical Engineering contains 288 pages fully illustrated, handsomely bound and printed and is in every way a first class book.

## Examination Offer

**If You Are Interested** sign and mail the coupon, and it will bring to your plant a book of sterling merit, for free examination. You can have one week in which to dig out the mine of valuable information contained in its 200 or more pages.

### Carry It in Your Pocket for One Week

and at the end of the time, if you do not think the book is worth one dollar, mail it back to us. If it is, you can mail us \$1.00 in payment for your copy. If you fail to consider this liberal offer you are not dealing fairly with yourself. We take all risk that "Audels Answers on Practical Engineering" is a book you should own. Act now before you forget it.

**THEO. AUDEL & CO., 72 5th Ave., NEW YORK**

Please send me for examination one copy

**Audels Answers on Practical Engineering** \$1

If I keep the book, I promise to send you within 7 days after receiving it ONE DOLLAR, in full payment; if I do not keep it, I will mail it back to you within 7 days.

Signature.....

Occupation.....

Address.....



# Young Men Wanted

To **Become Draftsmen and Designers** At **Once**

The constant demand for trained men always exceeds the supply. Positions paying \$75 to \$100 per week are open now. Some weeks over 250 positions paying the highest salary in all parts of the country stay open. Let me send you one of my regular weekly "Draftsmen Wanted" lists. You can have one of these positions. I'll give you just the training you need.

**\$125 to \$175 Per Month to Start**

You can make it. I have trained the highest priced draftsmen and know exactly the kind of training those men need who draw the biggest salaries. Send the coupon.



**Chief Draftsman Will Train You Personally and Instruct You Properly**

On practical Drafting room work **until** you are absolutely competent in every respect as a first-class Draftsman and **until** you are placed in a permanent paying position at a salary paying at least \$125 per month. This is a most exceptional opportunity for just a limited few selected ambitious men, between the ages of 16 and 40, whom I will train personally and give individual instruction as required in order to fill the constant demand for properly trained men in this line. I give **each** of my students

my own **personal attention**—therefore, I limit the number of my students and if you desire such an opportunity then get busy **now** and **write to me at once**. Don't wait till tomorrow, do it **today**. You can earn more than I charge for my time and personal training.

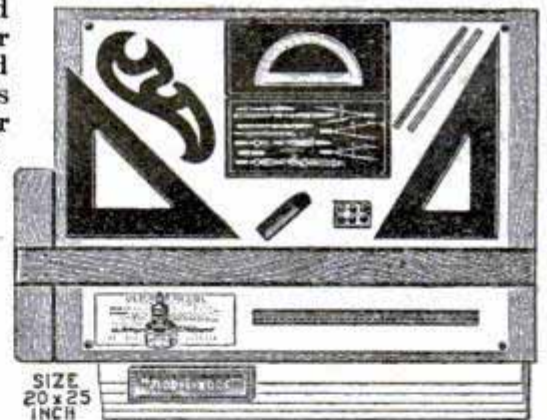

SIZE  
20 x 25  
INCH

## I Guarantee

To instruct you **until** competent and placed in a permanent paying position at a regular Draftsman's salary of at least \$125 to \$175 per month and guarantee to furnish you free the complete Draftsman's working outfit at once from the start.

This \$15.00  
Draftsman's  
Working Outfit **Free**

These are regular working instruments—the kind I use myself. I give them free to you if you enroll at once. Send the Free Coupon today.

**Earn Big Money at Once**  
**While You Are Learning At Home**

Yes, that's exactly what I mean. As soon as you become my student you can begin earning a handsome income while learning at home. I mean just what I say. This is a special offer I am making. Absolutely no obligations of any kind in sending the coupon. But you must write at once, as I will take the names in the order I receive them.

**FREE BOOK and EARNING while LEARNING OFFER COUPON**

Chief Draftsman,  
Engineer's Equipment Co.  
Div. 1197 Chicago, Ill.

Without any obligation on me whatsoever, please mail your book "Successful Draftsmanship" and full particulars of your liberal "Personal Instruction" offer to a few students. It is understood that I am obligated in no way whatever.

**Mail FREE Coupon** at once for my book, "Successful Draftsmanship," also list of open positions and for the free offer to be earning good money at once while learning at home. This offer is positively limited and in order to benefit thereby you must act **at once**.

Name.....

**CHIEF DRAFTSMAN,**  
ENGINEER'S EQUIPMENT CO. (Inc.)

Div. 1197  
Chicago

Address.....



# CLASSIFIED ADVERTISEMENTS

We have records to prove that a classified ad in these columns will find a buyer for almost anything which can be sold. Doubtless you have some article of value to some one else which you no longer need. Why not turn it into money?

Advertisements in this section, 15 cents per word, each insertion, minimum 10 words, payable in advance. To insure ads being inserted under proper classified head in the November issue, copy must reach this office not later than October 1st.

*Popular Mechanics Magazine, Chicago, Illinois.*

Gentlemen:—I take pleasure in informing you that my little 28-word classified ad, appearing in the July and August issues of your magazine, has brought One Hundred and Twenty-Eight replies up to this date. The replies have not ceased at this writing, but I feel sure the average cost per reply will be less than two cents when they stop coming. This same advertisement, in different form, was used in an equally prominent magazine having a higher rate, for the same period, and my files show about two dozen replies. Assuring you that your magazine is the medium that reaches the people, is read by the people, and "gets under the hilt" and produces results, it inspires confidence in a reader to see it in *Popular Mechanics*.

Very respectfully,  
F. D. McNEW.

## AUTOMOBILES

SAVE 40% to 75% on your tires, 28x3, \$6.87; 30x3, \$7.35; 30x3½, \$10.46; 32x3½, \$10.96; 34x4, \$14.90. Every other size. All standard makes. You take no chance. Printed 2,500-mile guarantee with every tire. Send for folder "Facts" Now. State size used. Peerless Tire Company, 1588x Broadway, New York.

FOR Sale—Fifty taxicabs used at Hotel Knickerbocker; are in first-class order; reason for selling, loss of stand under new ordinance, \$250 up; any demonstration given. Universal Taximeter Cab Co., 153 East 53rd Street, New York City.

FIVE-passenger Cadillac, \$100; Indian motorcycle, \$30. Arthur Conley, 154 Union Ave., Bridgeport, Conn.

SPECIAL, White Steam Racing Car. Long wheel base, 2 extra tires. Bargain for quick sale. Photo free. Dr. Seaman, Dows, Ia.

4-CYLINDER Ford roadster; new tires, good shape mechanically. Borden, Campbell, N. Y.

FREE Catalogue, Automobile Books. Nelson Book Co., Barton, Vt.

UNPREJUDICED information on any 1914 automobile. Write us before buying. Small fee, guarantee satisfaction. Folder, Foresight in Buying, free. Dept. P, Professional Information Ass'n, Hartford, Conn.

BARGAINS—Prices will astonish you. Automobiles, Motorcycles and parts. Write for price list. T. S. Culp, Canan, O.

AUTOMOBILE model. Every part shown and named. You can do all, intents and purposes take off the wheels, raise the hood and remove the body, exposing to view the vital parts. The only practical method of studying the automobile. Price, 50 cents postpaid. Popular Mechanics Book Dept., Chicago.

REGROUNDING the cylinders, and fitting new pistons and rings, will make your motor as quiet and powerful as it was when new. The cost is moderate. Advise bore diameter if desire quotation. We also expertly weld broken parts. Send for booklet. Waterbury Welding Corporation, Waterbury, Conn.

THE Last Word in Automobile Literature—New Book, "The Modern Gasoline Automobile," 700 (6x9 in.) pages, 500 illustrations, is superior to any treatise heretofore published. Deals with every modern improvement. Price, \$2.50 postpaid. Popular Mechanics Book Dept., 318 W. Washington St., Chicago.

AUTOMOBILE instruction. A complete home study course that shows you exactly what you want to know about the automobile. 220 page book giving definite, thorough, authentic and practical detailed information about every part of the automobile as well as thorough instruction in regard to driving, repairing and general care of the complete car. 150 illustrations. \$1.50 postpaid. Popular Mechanics Book Dept., 318 W. Washington St., Chicago.

FOR Sale—10 acres Everglade land cheap. Will accept automobile, preferably Ford, and pay cash difference. Hill, 843 N. Sacramento, Chicago.

"The How and Why of the Automobile"—A 200-page book of practical information for seekers after the fundamental facts regarding the gasoline engine and its application to the motor car. Interesting and instructive to both the beginner and the expert. Bound in full cloth—250 illustrations. Price, \$1 postpaid. Popular Mechanics Book Dept., Chicago.

## AUTOMOBILE SUPPLIES

TWO assembled pressed-steel frames 136 in. long, \$6.00 each. Splittorf magneto without coil, \$15.00. Shaft-drive axle complete with propeller, \$18.50. Cone clutches, \$10 and \$15 each. Badger Motor Co., Milwaukee, Wis.

FOR Sale—Fly taximeters in perfect condition, sixty dollars each. Will guarantee to keep in repair and pass inspection bureau. Universal Taximeter Cab Co., 153 East 53rd Street, New York.

SAVE Your Tires—Use Miller Autojacks, \$2 per set 4. Money positively refunded if not satisfactory. Wilbur Lumber Co., Honey Creek, Wis.

FOR Sale—18 horsepower, two-cycle motor with magneto used in taxicabs, suitable for motor boats, \$35 each, in good order. Lects, 153 East 53rd Street, New York City.

IGNITION and Lighting Specialties. Delco Magneto Exchange, 1463 Michigan Avenue, Chicago, Ill.

WHITE steamer power plant, complete, \$60. Box 38, Osgood, Ohio.

WILLIAMS Spark Plugs work where others fail; save dollars and trouble; strongest plug made; satisfaction guaranteed or money refunded; \$1 each, 6 for \$5. E. Q. Williams, 533 So. Clinton, Syracuse, N. Y.

BARGAINS in Spark Plugs, Schebler Carburetors, Metal Polish, etc. Get illustrated bulletin. Automobile Appliance Co., 1714 Michigan Ave., Chicago, Ill.

HIGH Duty Warning Signals—Automobile and Motorcycle. Write for catalog. Buell Auto Company, Chicago.

ELECTRIC lights for Ford cars (self-contained system), including rectifier and battery. Also light controllers for use with head-light sets. American Battery Co., 1129 Fulton St., Chicago.

CYLINDERS reground and fitted with new pistons and rings for \$7 to \$11 per cylinder. The Crown Machine Shop, Crown Point, Ind.

GASOLINE Engine Trouble Chart—a sectional view showing clearly all parts of a typical four-cylinder gasoline engine of the four-cycle type and outlining distinctly all parts liable to give trouble. Also details the derangements apt to interfere with smooth engine operation. Invaluable to motorists. Size, 25x38 inches. Mailed on receipt of 25 cents by Popular Mechanics Book Dept., 318 W. Washington St., Chicago.

KEROSENE For Automobiles—Our new Model B. uses successfully half and half mixture lowest grades kerosene and gasoline. Satisfaction guaranteed or money refunded. Greatly increased power, very slow speed on high. Starts easy at zero. Special Agents' prices. Dept. P. M. The Air-Friction Carburetor Co., Dayton, Ohio.

BIG money vulcanizing at home. Easy learned. Book 25c. Vanderpool's, Springfield, O.

NEW Pressed Steel Frames, 34x163", each \$10. Automobile boilers bought, sold and repaired. New 3 ton chassis and wheels \$100. Lucas & Son, Bridgeport, Conn.

TIRES. New, Standard Makes, 28x3—\$7.20—Tube, \$2.30; 30x3—\$7.65—\$2.40; 30 x 3½—\$11—\$3.50; 32 x 3½—\$12—\$3.60; 34x4—\$17.25—\$4.75. Other sizes, prices accordingly. Write for complete catalog. 16% with order. Balance C.O.D. Examination allowed. Para Auto Tire Co., 1417 Michigan Ave., Chicago, Ill.

STEAM auto boilers bought, sold and repaired. J. L. Lucas, No. 2 Fox St., Bridgeport, Conn.

## MOTORCYCLES, BICYCLES & SUPPLIES

EXCELSIOR Motorcycle for Sale—1913 Model, Eight H. P. Twin, fully equipped. First-O-Lite large lamp, horn, etc. Run about 50 miles. Just like new. Cost \$275; will sacrifice if quick sale at \$165. Will ship subject to inspection, \$25 deposit, balance C. O. D. Address W. E. Wandersee Co., 129 Gratiot Ave., Detroit, Mich.

USED Motorcycles—This Year's Harley \$155; Harley Magneto, \$95; Indian Seven, \$150; New Pierce, \$200. Send for list of bargains. Seiber & Hofheins, Buffalo, N. Y.

200 MOTORCYCLES, Standard makes guaranteed for season, \$50, \$175. Accessories; heavy carrier, \$3; headlight, \$3.50; Speedometer, \$10; tires, \$5. Chicago Motorcycle Works, 738 Sheridan Rd., Chicago.

BRAND new 1913 Model \$35 Bicycles with \$5 Coaster Brake and Puncture Proof Tires for \$21.75. Roanoke Cycle Company, Roanoke, Va.

1912 TWO-SPEED Twin Indian with Sidecar, Prestolite, Cost \$400; will take \$225; \$25 down, balance C. O. D. Robert Bassing, Mendota, Ill.

INDIAN Twin, 7 hp, 1912 model, guaranteed perfect condition; speedometer, luggage carrier, spring seat attachment, free engine, complete \$175. Zell, 1423 Westmoreland Street, Pidda, Pa.

1912 FOUR-CYLINDER, two-speed Pierce, with sidecar (almost new) and equipment, 3-inch tires, \$250. Used ten months. Also single, \$60. Frank Schock, Mt. Joy, Pa.

FREE—Largest Bicycle and Motorcycle Catalog in the South. Geo. W. Beardsley, Houston, Texas.

1912 INDIAN Seven and outfit, run 1,700 miles, \$185. Ray H. Painter, St. Charles, Pa.

ALMOST new 1912 Pierce four-cylinder (two speeds) motorcycle, worth \$400, our price, \$200. Whipple, 1227 West Jackson Blvd., Chicago.

MOTORCYCLE wanted for \$400. Photographic apparatus. Describe motorcycle. H. G. Bailey, Longton, Kans.

GOOD 1912 model, Single Indian, \$125. Wm. Lauterbach, Mendota, Ill.

INDIAN, 2½ hp. Cheap; New tires, first-class condition every way. Borden, Campbell, N. Y.

BICYCLES, new and used models, cheap to clean up. Seiber & Hofheins, Buffalo, N. Y.

FORD Roadster for sale, or will exchange for good Motorcycle, 4-cylinder preferred. Borden, Campbell, N. Y.

FOR Sale—Indian Motorcycle \$45. 924 South Third, Rockford, Ill.

MOTORCYCLES at cut prices. We guarantee to save you \$25 to \$50 on your motorcycle. Second-hand and rebuilt motorcycles \$25 to \$100. Indians, Harleys, Kultures, Thors, Excelsiors, Merckels, Readings, Hendersons. Buy direct. Save dealers' profits. Send for catalogue. Denninger Cycle Co., Rochester, N. Y.

CLEARANCE of used motorcycles at ½ to 1/3 regular prices. Send for free bargain list. Motorcycles sent on approval anywhere. Don't delay writing. Western Supplies Co., 1350 Larimer St., Denver, Colo. Largest Motorcycle Dealers in the West.

BARGAINS: 1913 R-S Twin, run seven hundred miles, \$195. 1913 R-S single, new, never uncrated, \$175. 1911 Wagner, good condition, \$65. General Supply Co., Leipsic, Ohio.



**EXCELSIOR**, 4 H. P. in excellent condition, with tandem, exhaust whistle, etc. Bargain \$85 cash. Thomas Williams, 721 Dearborn Ave., Chicago.

**TRADE** National, four-cylinder, 30-Hp. Roadster, value \$350, for 1913 Indian or Thor, two-speed twin. Zele, 1423 Westmoreland, Philadelphia, Pa.

\$150 **BUYS** Pierce Motorcycle, 4-cylinder, two-speed. Splendid condition. V. Grumm, Zanesville, O.

**FOR Sale**—4-hp. new motor; carburetor and coil, \$27.50. Box 414, Casselton, N. D.

1910 **V BELT** 4-hp. Flying Merkel. Good condition, \$80. Pearl Satterthwait, 1251 Oak St., Chicago.

**FOLDING** Bicycles. Modern telephones; hands free. Kallajian Mfg., Boston, Mass.

**INDIAN** Twin, good running condition, \$75. George E. Egge, Nyack, N. Y.

**NEW** 1913 Eagle, \$175. 1911 Excelsior twin, \$135. 1912 Harley, \$135. Battery Harley, \$95. Arthur Henderlong, Crown Point, Ind.

**MOTORCYCLES** Cheap. Big clearance sale of new and second hand machines, ask for list "M" just out. American Motor Co., 2724 Michigan Ave., Chicago, Ill.

1913 **INDIAN** single, exhaust horn, ridden 300 miles. Guaranteed perfect. Box 55, Cameron, Pa.

**FOR Sale** Cheap—1913 Twin Motorcycle. Box 734, Williston, N. D.

**WANTED**—Twin cylinder motorcycle engine, any make. Engine only. G. Dinger, Summerville, Pa.

1912 **EMBLEM** Twin, good condition; bargain, \$100. Wagner, Warsaw, Ohio.

**BICYCLES**, Tandems, Triplets, cheap. McDougald, 1118 N. Clark St., Chicago.

**MOTORCYCLES**, all makes rebuilt, guaranteed good as new. Indians, Harleys, Excelsiors, Readings, Kultures, Merckels, \$25 to \$100. Tires \$3 to \$6. Buy direct. Save dealers' profits. Deninger Cycle Co., Rochester, N. Y.

**BIG** bargains in good motorcycles we have taken in exchange on new ones. Send for special bargain list. Shaw Mfg. Co., Galesburg, Kansas.

**MOTORCYCLES** and Bicycles  $\frac{1}{2}$  price; over 100 best makes. Motorcycles \$50 to \$150; bicycles \$5 to \$25. Get list today. Brown Music Co., 9119 Commercial Ave., Chicago.

**A-B-C** of the Motorcycle—250 page "Show How" book for owners and operators of motorcycles. Fully illustrated, cloth binding. Price \$1, postpaid. Popular Mechanics Book Dept., 318 W. Washington St., Chicago.

**WE** want you to have our 1913 Motorcycle Supply Catalog. Ask for Catalog 14. Give the name of the motorcycle you ride and ask for the Yellow Sheet. Save money by getting acquainted with us. Saufley Supply Company, Kansas City, Mo.

**BIG** bargains in second-hand motorcycles, \$25 up. Indians, Harleys, Thors, Excelsiors and Merckels. Write for descriptions. Howard A. French & Co., Baltimore, Md.

**DON'T** buy a Bicycle Motor Attachment until you get our catalog and prices. Shaw Mfg. Co., Dept. 27, Galesburg, Kansas.

### CYCLECARS

**CYCLECAR** building easy—If you get our parts—transmissions, frames, axles, wheels. Use only such parts from us as you really need—build the rest yourself. You can have a speedy, dependable, economical, comfortable cyclecar at a price so low that you'll be astonished. Write stating what parts you need and we'll take up individual requirements, give you rock-bottom prices and valuable suggestions on how to build—free, no obligations whatever. Now write fully at once. Ward Butler, 646 Fullerton Ave., Chicago.

### MAILING LISTS

**FREE** to business men, copy of our comprehensive "Silent Salesman." Contains over 2000 different classifications of mailing lists with number and price of each list, and information every business man needs. Accept this free offer. Trade Circular Addressing Co., G 164 $\frac{1}{2}$  W. Adams, Chicago.

### PERSONAL

**BROTHER**—Accidentally discovered root cures tobacco habit and indigestion. Gladly send particulars. F. Stokes, Mohawk, Florida.

### AERONAUTICS

**MONOPLANE** Glider—Exhibition Flyer. Money-maker. Practically new. Has rudder controls and skids. Must sell. Aviation Directory, Lawrence, Kan.

**FOR Sale**—New and used air-cooled aeroplane motors of the highest efficiency. Kemp Machine Works, Muncie, Ind.

**CURTISS** Type Biplane for Sale, \$100. Particulars free. John Knapp, 69 Lafayette St., Winona, Minn.

**BICYCLE** monoplane prints, 30c. Easily made. Thomas Hofmeister, Overlea, Md.

20 **YDS.** cloth, 8 struts, sockets, turn-buckles and wire. Never used. Bargain. Lyle Dye, Box 173, Ionia, Mich.

**COMPLETE** Plan, drawn to scale, with complete instructions for building a Curtiss 3-foot Model Flying Boat, 25c. Other plans: Bleriot, 15c; Wright, 25c; Nieuport, 25c; Curtiss Hydro, 35c; "Peoll" Racer, 25c. Set of six, \$1.25. 48-page Model Supply catalog, 5c. Ideal Aeroplane Co., 82 $\frac{1}{2}$  West Broadway, N. Y.

**The first** boy in every town ordering a "Blue Bird" Racing Aeroplane for \$1.50, and sending us the addresses of five friends, will be appointed official starter, with a handsome badge free. The Blue Bird is the swiftest, longest flighted Aeroplane. Ideal Aeroplane Co., New York.

**TURNBUCKLES**, 5 $\frac{1}{2}$ c; Sockets, 9c; Wheels, \$6.25. Everything else proportionate. There's a reason. Get it. 6 red stamps bring world's largest aeronautical catalogue. Heath Aerial Vehicle Co., Chicago.

**BUILDING** and Flying an Aeroplane—160-page handbook covering the building of small models and full sized gliders and machines. In both biplane and monoplane models the well-known Curtiss and Bleriot types are followed. Fully illustrated with detail drawings. Price, \$1 postpaid. Popular Mechanics Book Dept., 318 W. Washington St., Chicago.

**HOW To Make a Biplane Glider**—Our book "Amateur Mechanics No. 2" contains a complete detailed description of how to make one. Price of book, 25c postpaid. Popular Mechanics Book Dept., 318 W. Washington St., Chicago.

### BOOKS AND PERIODICALS

**GAS** Engine Troubles and Installation. Cloth, \$1; flexible leather, \$1.50; Automobile Troubles and How to Remedy Them. Cloth, \$1; leather, \$1.50. Eight other practical and reliable mechanical books. Send for circular. Chas. C. Thompson Co., Dept. C, 1126 S. Wabash Ave., Chicago.

**FREE**—Descriptive list of world's most popular fiction priced at 50 cents per volume. Write for list to-day. Popular Mechanics Book Dept., 318 W. Washington St., Chicago.

**INEXPENSIVE** books on any subject under the sun; mechanical, industrial, scientific, educational, etc. Ask for anything you want. Send for cut rate list. Brown Co., 99 Nassau St., New York.

**THE Youth's Magazine**, a big illustrated boy's paper containing fascinating stories and departments of unusual interest, sent one year for 10c. Century Pub. Co., Chicago.

**HOW to Run a Lathe**. A 50-cent book for 10 cents postpaid. S. B. Lathe Works, South Bend, Ind.

**HOW to Market Ability**. For the ambitious man, seeking a better position. Postpaid 50c. C. Ericson, 54 Doyle, Buffalo, N. Y.

**FASCINATING** books and pictures, samples and catalogue, 2c. Normal Specialty Co., 14, Englewood, Chicago.

**MECHANICAL** books, 250 titles; prices right; send stamp for catalogues. Crescent Book Store, 329 South Halsted, Chicago.

**BULLY** Books—"Cleopatra" 25c; catalogue 2c. Duff, 2713 Mozart, Chicago.

**TWO** Hundred and Fifty Magic Tricks, 10c. Ketteman Co., Toledo, Ohio.

**WE** sell Civil Service Books. Lamont's Agency, Matteawan, N. Y.

**TO** Builders, Architects, Owners! "Building Arbitrations," second edition, just published. Saves expense. Tells exactly how to adjust disputes quickly, economically, legally; what to do, what to avoid. Invaluable. Price, one dollar, of "Author," 3873 Clay Street, San Francisco. Be an Arbitrator.

**MECHANICAL** Books, low prices. Stamp brings particulars. Lamont's Agency, Matteawan, New York.

**ENGINEERS'** questions and answers for license, by Hobson, for twenty-five cents, postpaid. Send stamps. Reilly's Book Store, Philadelphia, Pa.

**SHOP** Notes—Many valuable kinds for blacksmiths are contained in our series of Shop Notes books, 9 volumes, 50c each postpaid for \$4.50 per set prepaid. Popular Mechanics Book Dept., 318 W. Washington St., Chicago.

3000 **SELECTED** Pictures for \$3. A Panorama of World Events. Political—Industrial—Social—Humorous—Tragic—all of intense human interest. A wonderful collection of 3,000 cartoons reproduced from the newspapers of the United States, Canada, Mexico, Cuba and the cities of the Old World, has been made by Cartoons magazine from more than one hundred and fifty thousand published cartoons, and, bound in an artistic and durable cover, are now ready for your library table. Vol. I, Jan.-June, 1912—\$1. Vol. II, July-Dec., 1912—\$1. Vol. III, Jan.-May, 1913—\$1. Cartoons, 318 W. Washington St., Chicago.

**GAS** for power is taking the place of steam for reasons of economy. Learn all about this great change by reading our new non-technical book on this subject, written by a first-class authority for the practical man. 192 pages, profusely illustrated, cloth binding. Price, \$1 postpaid. Popular Mechanics Book Dept., Chicago.

"**METAL** Spinning" is the name of the only book published on this interesting art. A concise working manual both for those who desire to spin metal as an art recreation and to follow this work as a trade. 80 pages. 33 illustrations. Price, 50 cents postpaid. Popular Mechanics Book Dept., Chicago.

### EDUCATIONAL AND INSTRUCTION

**FOR Sale**—I have one set of Engineering and one set of Applied Electricity, which I will sell cheap, both published by American School of Correspondence, Chicago. Cost me \$18 each. Are as good as new. Will sell for \$6 apiece, as I need the money. Will ship either one or both. C. O. D., subject to examination. Address S. C., 6th floor, 318 W. Washington St., Chicago.

**WANTED**—Young men, learn the linotype business. Biggest field to-day. Big pay. Short hours. Pleasant work. We prepare you at home. Keyboard furnished. Positions easily secured. Particulars. National Linotype Institute, Mansion Bldg., Rochester, N. Y.

**FREE**—Art Scholarship offered to you for a limited time. Don't miss the opportunity. Write at once for full particulars. Our handsome illustrated Art Annual included for 6 cts. in stamps. Fine Arts Institute, Studio 2170, Omaha, Neb.

**STUDY** Sanitary Engineering under the directorship of Prof. Arthur Bateman, M. Inst. S.E., A.R. San. I., M.I.P., R.P.C., Eng. Courses in Plumbing, Sanitary Science, Engineering and Hygiene. Booklet free. Anglo-American Sanitary Correspondence College, 10-12 W. Ontario St., Chicago, Ill.

**HOW** to remember names, faces, facts and figures. Complete, practical memory-training course, two dollars; cheapest and best published. No frills or premiums. Twelve condensed lessons for busy men. Send to-day. Money refunded if you are not satisfied. Post-Graduate Institute, 172 Roncesvalles Bldg., Toronto, Can.

**SHORTHAND** will help you. Why not learn the best system during spare moments? Send 19c for Illustrated Booklet showing six different systems. Unigraph Co., 536 Grant Place, Chicago, Ill.

**FREE** Tuition by Mail. Civil Service, Normal, Academic, Business Engineering, Drawing, Agricultural, English, Law, Real Estate and Physical Culture Courses thoroughly taught by mail. Matr. \$5 tuition free to first applicants. Address Carnegie College, Rogers, Ohio.

**UNCLE** Sam is a Liberal Employer. Qualify for a Government position. We prepare you by mail for any Civil Service Examination. Write today for free Booklet 32. Capital Civil Service School, Washington, D. C.

**RAPID** Calculation. Shortest methods known. Price 50 cents. Satisfaction or money back. Stanley Spurrier, Alva, Okla.

**KNOW** how to write "pulling ads," plan advertising campaigns? You need my unused International Correspondence School scholarship in advertising. Let me explain. H. E. Medlin, Arion, Iowa.



**HOW to do expert show-card writing in twenty minutes' practice for one dollar.** Sample free. Central Stencil Co., Kansas City, Mo.

**FOR Sale**—I. C. S. Text-books, Architectural Drafting and Commercial Law. 3859 Coral St., Phila., Pa.

**MANUFACTURING** and copying simple pottery, bisque, imitation porcelain and china. Plaques, vases, ornaments. Coloring, decorating and glazing. Complete instructions. One dollar. Circular free. F. Reynolds, 211 Marine bldg., Chicago.

**DRAFTING** taught by expert draftsman; \$16 drawing outfit free. Terms easy. Free booklet; write. American Drafting Co., Suite 11, 1358 E. 47th St., Chicago.

**TO Carpenters:** Roof framing and concrete formwork taught by mail. Complete course in either subject, 5 dollars. First set of lessons, 1 dollar. H. G. Walter, 1121 11th Ave. E., Vancouver, B. C.

**SHORTHAND** By Mail. Osgoodby's Speed Method, used and endorsed by experts. No failures. Catalog M-9 free. Osgoodby School Stenography, Rochester, N. Y.

**DANCING** taught by new scientific method. Waltz and two-step positively guaranteed. Send \$2 for floor chart. R. Melbourne Nelson, 3420 Wrightwood Ave., Chicago.

**SHORTHAND**, 12 easy lessons. Rapid, practical, complete. Trial lessons free. Practical School of Shorthand, 5819 DeGiverville Ave., St. Louis, Mo.

**COMPLETE** Business Course (275 pages), 50 cents. J. L. Hardway, Normal, Ill.

**BRIEFHAND**, the wonderful new substitute for shorthand, enables you to write 100 words a minute using longhand characters. Complete self-teaching manual containing 2,900 illustrations, 50c (stamps). Premier Briefhand School, Washington, D. C.

**\$1—COMPLETE** instructions, manufacturing interior, exterior decorations, garden furniture, statuary, mixing, casting artificial marble, concrete, plaster, papier-mache, composition, marble-dust, soft metals. Making elastic, rigid moulds, modeling, gilding, coloring, stuccoing frame houses. Mail name, address, for free booklet, illustrations, beautiful art casts. Mahler, 117 Russell St., Brooklyn, N. Y.

**CHIROPRACTIC** Doctors make big incomes; be independent; work for yourself; complete correspondence course, including diploma, only \$25. National College Chiropractic, Grand Rapids, Mich.

**IF** interested write for my illustrated journal, Pennmanship by Mail. America's greatest teacher. Francis B. Courtney, Box A 492, Detroit, Mich.

**THE Seven Wonders of the Modern World**—What are they? Do you agree with the selection resulting from the international poll of greatest scientists taken by Popular Mechanics Magazine? The complete result of this vote showing the selection of the wonders together with a historical sketch of each one reprinted in pamphlet form mailed to any address for 10 cents in stamps. Popular Mechanics Co., 318 W. Washington St., Chicago.

**YOUNG Man!** Learn Drafting—one of the most practical subjects of study to-day—indispensable in many occupations—engage in individual study successfully with the aid of our new book, "A Practical Course in Mechanical Drawing," 160 pages, 157 drawings, cloth, 50 cents, postpaid. Popular Mechanics Book Dept., 318 W. Washington St., Chicago.

**MATHEMATICS** made easy for all by Ropp's Calculator. Figures out, in the twinkling of an eye, every conceivable problem that occurs in the Office, Store, Shop, Bank, Farm or Factory. Greatest time and labor-saving work on figures in the world. Copyright 1912. Price, \$1. Vest pocket size, 50c. Popular Mechanics Book Dept., 318 W. Washington St., Chicago.

**WOOD-Working** for Amateur Craftsmen—128-page book, profusely illustrated, giving every essential step in wood-working. Valuable for either self-instruction or for use in manual training courses. Cloth, 50 cents, postpaid. Popular Mechanics Book Dept., Chicago.

**YOU** can write 100 words a minute without knowing Shorthand. My new method, Abbreviated Longhand, simpler than the simplest shorthand, tried and approved by thousands. Your money back if not delighted. Sample lesson 20c. Full particulars free. Write today. A. B. Weaver, Court Reporter, Dept. C., Buffalo, N. Y.

## TRADE SCHOOLS

**MAKE \$5 to \$8 a day** as skilled Electrician, Plumber, Draftsman, Bricklayer, Moving Picture Operator. We teach you in short time at small expense, profitable trades. Free employment bureau places graduates in good jobs. Special limited offer now. Write at once for catalogue and full particulars—no obligations. Dept. 8197, Coyne National Trade School, 51 E. Illinois St., Chicago, Ill.

**OUR** experts train you on real automobiles to become a successful Chauffeur, Repairman, Tester, Demonstrator or Salesman. Practical experience guaranteed. The next 5 weeks' course starts Oct. 6, conducted under the personal direction of Mr. H. F. Edwards. Write today for catalog and full information. Peoria School of Motoring, Dept. D, Peoria, Ill.

**WANTED**—Young men to learn Architectural Drafting. Salary \$25 to \$75 weekly. Big demand, short hours, pleasant work. Particulars, Keystone Architectural Institute, Rochester, N. Y.

**PAINTING**, Decorating, Paper Hanging taught by actual practice. Free catalogue. Chicago School of Painting, 414 Dearborn Ave., Chicago.

**\$35 PAYS** for a complete, unlimited, practical course in automobile driving and repairing. We have the best equipped school and most up-to-date shop in Chicago. Guarantee satisfaction or will refund your money. Day and evening classes. Call or write Dept. 1, Academy of Automobile Engineering, Calumet 4707, 1452 Michigan Ave., Chicago.

## PICTURES AND POSTCARDS

**POSTALS**—Just Girls; 10 nifty poses, 12c. 25, 25c. Assorted postals, 100, 35c. Bailey, 110 Maple, Napanoch, N. Y.

**OUR** club has members in China, India, Norway, Switzerland, etc., who would like to exchange postcards with you. Membership, 10c. Elite Exchange, R18, 3827 Keneth Ave., Chicago.

**JOIN** the Oxford Postcard Exchange and receive cards from faraway lands. Membership 10c. Keniston, Publisher, South Paris, Maine.

**RECEIVE** pretty postcards and jolly letters from everywhere. Very best club. Membership 10c. Jolly Card Exchange, Box 132, Decatur, Ind.

**18 PRETTY** Postcards, 10c. New subjects; kind that please. Leslie Carpenter, Corona, N. Y.

**25 BEAUTIFUL** high grade souvenir postcards for only 10 cents. The Reim Co., Weehawken, N. J.

**LADIES** and Gentlemen—Join the Sojour Exchange. Trial membership 10c. Box 1342, Jacksonville, Fla.

**THREE** photographs Adirondack views, postcards, 25c. Hinge, Elizabethtown, N. Y.

**ONE** dozen assorted photograph post cards. Curtiss latest flying boat, thirty cents, postpaid. Benner's Studio, Hammondsport, N. Y.

**24 ARTISTIC** miniature beauty poses, woman beautiful, 10c. Normal Specialty Co., 36, Englewood, Chicago.

**BIRTHDAY** Art Cards, Beauties. Dozen 25 cents. Udell, Printer, Station A, Indianapolis.

**22 VIEWS** Oakland and vicinity in folder, 15c. Hardy's, Oakland, Cal.

**18 PRETTY** postcards, 10c; 40 for 20c. J. R. Dickey, Box A9, Smuggler, Colo.

**DECORATE** your den with art gems. Catalogue ready. Taylor Brothers, 2233 M, Clifton Ave., Chicago.

**5 SPORTING** Postcards, 10c. Miss A. A. Banner, Station "R," N. Y. City.

**HONEST** card exchangers in United States listed free. Systematic Exchange, 79 Sixth Street, Bridgeport, Conn.

**CARDS** exchanged for results. 10c membership. Pacific Card Exchange, Bryn Mawr, Wash.

**HAWAIIAN** Hula Girls; 200 scenes. Dozen, 25c; 100, \$1.25. Hawaii & South Seas Curio Co., Honolulu.

**IF** you really want to exchange post cards, try our splendid club. Lists circulate in many countries. Membership, 10c. Halcyon Club, Box 133, Erie, Pa.

**YOU'LL** get cards from everywhere. Membership 10c. Idaho Card Exchange, Dept. K, Box 906, Boise, Idaho.

## CAMERAS AND PHOTO SUPPLIES

**FORMULAS** for eight of the very latest wrinkles and fads in photography, 25c. Includes instructions for making Magic Disappearing Photos (real money makers). Photo Sofa Pillows and Neckties, beautiful transparent colored pictures on watch cases, chinaware, etc., and other novelties. P. Benson, Stewartville, Minn.

**TRANSPHOGRAPHY**—Make Colored Transparent Photographs on Watch Dials, Chinaware, Metals, etc., with or without Camera. Complete Outfit, Material, and Formulas, 25c. Perfectly Titled Negatives Assured. New Magic Title Process, 10c. Make Red Firelight Photos. Instructions, 15c. Make Scrollograph Art Panels from any Photo. Instructions, 15c. E. Greenhalgh, 816-58th, Brooklyn, N. Y.

**PHOTOGRAPHIC** Postcards made from your films or plates at reasonable prices. Excellent work. Write for price list. Moser & Sons, 2120 St. James Ave., Cincinnati, Ohio.

**FILMS** Developed, ten cents roll, any size; 4x5 prints and postcards, four cents; all smaller prints, three cents. Satisfaction guaranteed. Schall Photo Finishing Works, Decatur, Illinois.

**COLOR** Photography. Print your landscape views in colors. Send 2 stamps for circular. Rud. Isenmann, 385 Bergen St., Newark, N. J.

**TRIAL Offer**—Buy Instanto, the best developing paper, direct from manufacturer; big saving; better, fresher, quality guaranteed. One full gross 4x6 or smaller and one-half gross postal cards for \$1, or three sample dozen postal cards or 4x6, 25c. The Photo Products Co. (Dept. J), 6100 La Salle Street, Chicago.

**HAVE** you a camera? Write for samples of my magazines, American Photography and Popular Photography, which tell how you can make better pictures and earn money. F. R. Fraprie, 229 Pope Bldg., Boston.

**IT'S** all in the developing. Send us your next roll of films to be developed and printed and see how much better your results will be. Send for Price List P. Schaeffer Co., Newark, N. J.

**MAIL**, 12c with any size film—for development and six velvet prints; best material; skilled operators. Roanoke Cycle Company, Roanoke, Va.

**WORLD'S** best German Anastigmat in speed shutter, only \$32, for postcard Kodak. W. J. Lafbury Co., 395 N. Fifth Ave., Chicago.

**TEXAS** climate and water make best kodak pictures on earth. Send six exposure roll with 25c and see. Lum Fleming, Dallas, Texas.

**COLOR** your vacation pictures. Make them live. Photo-tinting a fascinating art, quickly learned, at small cost. Send for free booklet. Sample hand-colored card, 10c. Kell-Burr Company, 58-P, Pine St., New York City.

**KODAKERS**, the Kamera-Meter tells correct exposure—price 10c. Free if you send a six-exposure roll and thirty cents for developing and six fine Velvet prints. Kamera Shop, 179 Auditorium, Chicago.

**BEAUTIFUL** carbon-green postcards printed from any size film, 6c each. Developing 10c a roll, all sizes. Prints, 2 1/4 x 3 1/4, 2c; other sizes proportionate. Maia Photo Company, Box 29, Grove Hall Station, Boston, Mass.

**HYPO** eliminated—immerse prints 5 minutes, wash 10 minutes, saves time and prints. Proven or money back. 1 oz. (dry) chemicals postpaid 50c. Chemical Supply, 144 W. Front St., Missoula, Mont.

**KODAKS**, Cameras, Lenses, Shutters, everything photographic, at New York's largest photographic store; ask for largest bargain list. Koehler's Camera Exchange, 7 East 14th St., New York.

**STEREOSCOPIES** increase the value of your pictures 100 per cent. Write for particulars. T. H. Knight, Racine, Wis.

**KODAK** films developed and printed; send for price list. Henry Baumgartner, 1411 Second Ave., New York City.

**A PEMCO** Camera makes good motion pictures; outfit \$100. Photo-Electric Machine Co., 10 E. 14th St., N. Y. City.

**WILL** pay \$5 for 6 1/2 x 8 1/2 Rochester or No. 4 Ansco. Helland, Galata, Mont.

**PHOTOGRAPHS** wanted by publishers. I'll find a buyer for all prints I deem worthy of publication. Send your name on a postal for leaflet of instruction. A. S. Dudley, Photographic Expert, Box 775 G, Philadelphia, Pa.



**KODAK Films Developed**, 10c per roll, any size. Prompt attention given mail orders. Prints 2 1/4 x 3 1/4 to 3 1/4 x 4 1/4. 3c; 4x5 to 3 1/2 x 5 1/2, 4c. J. M. Manning, Box B, 1062 Third Ave., New York City.

**MONEY in Photography.** You can start home studio. We tell how. Details, portrait, retouching, and convincing sample pictures sent free. Wells' Studio, East Liverpool, Ohio.

**FILMS for your kodak at wholesale prices.** Send name and size of camera. A. Camera, Box 28, Portsmouth, Ohio.

**BIG Money Saved on Photographic Lenses and Apparatus—goods exchanged; repairing done.** Ralph J. Golsen, 65 East 46th St., Chicago, Department P.

**WE buy, sell and exchange. Bargains in Microscopes, Telescopes, Binoculars, Cameras, etc. Bargain list sent.** Kahn & Son, Opticians, No. 54 John St., New York. Established 62 years.

### MOTION PICTURES

**LEARN to write photoplays.** Writing motion-picture plays offers a new, easy and fascinating way to earn money in your spare time. Plot all that is required. Literary training or style not necessary. Easily learned. Great demand. Producers pay \$25 to \$100 each. Our short, fascinating course will teach you how to turn your ideas into dollars. Send for free descriptive catalog. Authors' Motion Picture School, Box 130K, Chicago.

**MOVING picture films four to twenty dollars per reel.** Edison machines sixty to hundred and ten dollars. Send 25c deposit, balance C. O. D. Economy Film Co., 105 4th Ave., Pittsburgh, Pa.

**GO into the Moving Picture Business.** We will start you with complete outfit. Best Machine, Films, and supplies, on the Payment Plan. Want to make Big money? Write for free Catalogue. Dearborn Novelty Co., Dept. P., 537 S. Dearborn St., Chicago.

**WRITE Motion-Picture Plays.** Anyone, anywhere can do this work. Big demand; big money. Send 10c for instructions. Tells find wanted and how to write them. Address, Dempsey, 711 Boyd Avenue, Woodlawn, New York.

**MOTION Picture Work—A large 618-page book covering every phase of the moving picture, its production and its theatre.** Indispensable for reference and instruction to the thousands of workers in the motion picture field. Price \$3, postpaid. Popular Mechanics Book Dept., 318 W. Washington St., Chicago.

**\$50 TO \$100 weekly writing moving picture plays.** Send for free booklet; valuable information and special prize offer. Chicago Photoplaywright College, Box 278 G. R., Chicago.

**WRITE Motion Picture Plays—Big demand.** Anyone anywhere can do this work. Complete instructions 10 cts. Andrew Brems, Corona, N. Y.

**WRITE Photoplays for the Movies!** Our course most complete. Big demand for Western plots; good pay. Write us. Western Photoplay Co., Box 1646, Spokane, Wash.

**MOTION picture plays wanted.** You can write them. We teach you. No experience needed. Big demand and good pay. Details free. Ass'd M. P. Schools, 601 Sheridan Rd., Chicago.

**WRITE Moving Picture Plays.** \$10 to \$100 each. Constant demand. Devote all or spare time. Experience, literary ability or correspondence course unnecessary. Details free. Atlas Publishing Co., 304 Atlas Bank Bldg., Cincinnati, Ohio.

**\$35.00 PROFIT Nightly—Moving Picture Business—small capital starts you, no experience needed.** We teach you and furnish everything. Ralph J. Golsen, 65 E. 46th St., Chicago, Dept. M.

### DUPLICATORS AND DEVICES

**WRITE one copy, print 75 on our Hectograph—note size, postpaid 75c, larger sizes in proportion.** Send for circular. Reproducer, 605 First Ave., N. Y.

**HOW to get a Hektograph that will make 150 copies in 10 minutes; letter size, \$2.** Write for circular. Hoyer Duplicator Co., 118 No. La Salle St., Chicago.

**THE Modern Duplicator, made without glue or gelatine, is the World's Standard.** Fifty to seventy-five exact duplicate copies can be made from each one you write or draw with pen, pencil or typewriter. \$2.40 to \$6.00 according to size. Booklet Free. Durkin, Reeves & Co., Mfrs., 339 Fifth Ave., Pittsburgh, Pa.

### DIAMONDS, WATCHES AND JEWELRY

**RIGHT now is your opportunity—one that occurs but seldom in a lifetime—to secure a diamond at the very lowest price.** Act quick before the new tariff law raises the price! Genuine perfect cut diamonds, \$97.50 per carat. Sent on approval without obligating you. Remarkable Money-Back Guarantee given. Read our big ad, page 149. Free De Luxe Diamond Book contains full information. L. Basch & Co., Dept G240, State and Quincy Sts., Chicago.

**RELIABLE Watches and Jewelry from a reliable house.** 72-page catalogue for stamp. Kelleher Bros. & Sullivan, 76 Front St., Worcester, Mass.

**GOLD Nuggets \$1.** Beautifully cut turquoise 50c. From mines to customer. Lists free. Paris Bush, Hanover, New Mexico.

**BUY direct from wholesaler, C. O. D. on approval.** 2 1/4 carat, blue-white, perfect solitaire diamond ring, \$195, worth \$300. Solid gold watch \$15, worth \$30. Guaranteed 10-day offer. Beck Jewelry Co., 110 Equitable Bldg., Baltimore, Md.

**TIME and Its Measurement—An unusual book, being a readable and instructive history of time measurement from the sun dial of remote ages down to the clock period and the present day.** Of interest to everyone connected with horology and contains much information not available elsewhere. Written by a great authority who has made this study a hobby. Price in cloth binding \$1.50 postpaid. Popular Mechanics Book Dept., Chicago.

### OLD GOLD

**\$1 MAILED you for each full set of false teeth sent us.** Partial sets in proportion. Highest prices for Old Gold, Platinum, Silver, Diamonds and Jewelry. Send by Parcel Post today. Ask for list of wonderful Diamond bargains. Phila. Smelt & Ref. Co., 825W Chestnut St., Phila., Pa. Est. 21 yrs. Keep ad for reference.

### FOR ADVERTISERS

**BARGAIN Advertising Rate—Just to get acquainted.** 15 words, one insertion; guaranteed 18,000 copies printed, and one year's subscription, 25c. Digest, Grand Rapids, Mich.

**ADVERTISERS—Here's your opportunity.** 25 word classified ad inserted in "Cartoons Magazine" for 50c, one inch display ad, \$1. 23,000 copies. Send in your ad for the next issue. Cartoons Classified Dept., 320 W. Washington St., Chicago.

**YOUR 30-word ad in our 32-page postcard magazine, 20c.** Display, 50c each. Elite Exchange, 3827 Kenneth Ave., Chicago.

**YOUR 25-word advertisement in 100 monthly magazines, three months \$1.** Bennett Co., 453 East 186th St., N. Y.

**SALES letters that get business my specialty.** Will H. Myres, Norwood, Ohio.

**I WANT to send you proof of the wonderful pulling power of Popular Mechanics classified pages.** What's your proposition? Write me today. P. W. Johnson, Classified Dept., Popular Mechanics Magazine, 218 W. Washington St., Chicago.

### CEMENT

**If you want the best information on cement and concrete construction,** subscribe for Concrete-Cement Age, leading cement and concrete monthly. Sample copy, 10 cents. Yearly subscription, \$1.50. Concrete-Cement Age, 135 Newberry Bldg., Detroit, Mich.

### COLLECTIONS

**"SKILLFUL Collecting" tells how you can turn bad accounts into cash.** By a sure, easy system. Send today and receive a free copy by return mail. Collectors' Ass'n, 36 Long Street, Newark, Ohio.

**COLLECTIONS — Any kind, anywhere; commission basis.** Great Eastern Mercantile Agency, New Bedford, Mass.

**CLAIMS; all kinds, collected anywhere.** Fidelity Credit Co., Richmond, Va.

### TO MANUFACTURERS

**WANTED—Agency for grocery, ironmongery and other profitable propositions.** Write us. F. W. Rose, Rosemont, Greenacre Rd., Bankstown, Australia.

**WANTED—High-grade article, Missouri and Southeast.** Specialty Sales Agency, Wright Building, St. Louis, Mo.

### BUSINESS OPPORTUNITIES

**OPERATE an "Income Mail Business" the Booster Way!** Booster Magazine—the one one bona fide publication in the world devoted exclusively to the interests of agents and all interested in the Mail Order Business. More people read "Booster" than any other trade paper—this alone should convince you that today is the day to learn all about "Booster"—its money-making suggestions and principles. Join our ranks now—let "Booster" put you next to the best money-making propositions—ones that really get you the money! Ten-cents will bring two copies worth dollars to you. If you don't like it, we'll send your dime back. Booster Magazine, Northwestern Building, Chicago.

**COIN money making Name-Plates and Glass Signs.** We'll teach you the business thoroughly—we know how. 5 years' experience and practice making thousands of signs taught us—we can teach you in less than 30 days. Attracto Sign Co., 2637 North Clark, Chicago.

**MAIL Order Dealers—Add a profitable side line to your mail order business.** \$5 starts you. No stock to carry—repeat orders, printed matter furnished—profits one-half—particulars free. The Merford Co., Dept. P, Chicago.

**YOU can print imitation typewritten letters for about eight cents per thousand!** Complete instructions, source of supply, also how you can make money selling these instructions, 10c. If dissatisfied, we'll send your dime back. P. Rodolph, Northwestern Building, Chicago.

**ANY man or woman who wants to go into a good paying business that can be run at home in spare time,** should write Merford Co., Dept. A-1, Chicago.

**WE start you in business, furnishing everything; men and women, \$30 to \$200 weekly, operating our New System Specialty Candy Factories, home or small-room anywhere; no canvassing. Opportunity lifetime; booklet free.** W. Ragsdale Co., East Orange, N. J.

**JOIN our Mail-Order Club! Membership fee \$1.** Entitles you to regular \$5 course, also to buy goods wholesale prices. Send stamp for particulars. Dept. B, Central Supply Co., Kansas City, Mo.

**CASH for names, information, formulas, ideas, etc.** Steady home business. Instructive booklet for a amp. Information System, 305, Marietta, Ohio.

**YOUNG man to operate penny slot machines; my free booklet tells how you can easily make \$50 to \$100 weekly; something entirely new.** Chandler, 328-L, Cranston St., Providence, R. I.

**START a mail-order business and make good money; our valuable book tells you how.** Worth dollars. Yours for 10c. P. S. Bureau, 3311 Belleplaine Ave., Chicago.

**"HOW to make good in the mail order business."** Read our magazine, 10c copy. Three months 25c. The "Lever" Mail Trader, 44 Elizabeth, N. J.

**USE your spare time to build up a mail order business of your own.** We help you start for a share in profits, 27 opportunities. Particulars free. Mutual Opportunities Exchange, Buffalo, N. Y.

**EARN \$7 to \$12 daily, restoring faded colors in rugs and carpets.** Whole or spare time. Armenian process. Great demand. No capital. Particulars free. Eldred, Dept. 75, Detroit, Mich.

**INCREASE your income.** "Successful Brains" shows ten ways of making big money with little or no investment. Descriptive circular free. Thomas, Box 175, Ann Arbor, Mich.

**NEW Money Maker.** Costs 10 cents, sells for two dollars. Circular free. The Chemist, 2342 Thomas Ave. North, Minneapolis, Minn.

**GET the Mail Order Guide! Only 25c—** but it will start you successfully in business. Free particulars. Mail Order Guide, Dept. 200, Yonkers, N. Y.

**MAIL-Order Books, the kind that sell 200 per cent profit.** Samples 25c. Imprint circulars furnished. B. Newnham, Waukegan, Ill.

**GINSENG \$35,000 acre.** Information on request. Enclose stamp. G. Hartz, Canal Fulton, O.

**500 PRACTICAL ways to make money, 50c.** Hardy's, Oakland, Cal.

**DON'T miss advertisement "Get The Latest,"** miscellaneous column.

**WANTED—State agency, good proposition.** Huntress & Co., Bisbee, Ariz.



\* FOR Sale—Patent and small stock of Comfort Feed Bags, positively the best invention for feeding horses while hitched. Would sell the whole patent for \$2,000 or accept a royalty from good parties able and willing to push the sale. The only reason for selling is that I am otherwise profitably employed. If interested, send for copy of the patent. John Quincy Adams, Westmont, N. J.

YOU can make big money handling our proposition—something unique—an article that can be sold in nearly every house. The business can be worked either along mail order or exclusive lines with unusual profit. Send 10c for sample and wholesale prices, or write for free instructive literature. "How You Can Become Your Own Boss and Establish a Big Income," tells how and gives plans of operation. Northern Supply Co., 154 Randolph, Chicago.

IF you have \$216 I can show you how to get started in a business which will show you a gross profit of 233 1/3%. Only reliable men and women wanted. Must act as our local sales manager. Most wonderful money-making business. W. P. Mitchell, Suite 630, 1011 Chestnut St., Phila.

MR. Mail-Order Man: Get quick returns. Established corporation supplies fast mail-order sellers; factory prices. Classy proposition. Beginners or established firms. Copyrighted Prospectus free. Mississippi Valley Co., Inc., Box M629, Pittsburg, Kans.

WANTED—Men and women to open cleaning, dyeing and pressing shops in every neighborhood; no capital or experience necessary. Pyra Chemical Co., Box 336, La Crosse, Wis.

"THE Art and Process of Dry Cleaning." A fascinating and profitable occupation. 25c postpaid. Auburn Supply Co., Dept. C Y, 7745 Peoria St., Chicago.

ONLY hotel in Ohio town, 2,500 population, clears over \$4,000 year net profit; will check over past years and prove earnings; or will exchange for farm. Write for invoice and particulars. Frank Wilson, Kenton, O.

CANDY—"How to make pure candy and start a profitable business." A splendid and complete course, postpaid, 50c. Auburn Supply Co., Dept. C Y, 7745 Peoria St., Chicago.

LEARN to collect money by a sure, easy system. Big income. Quick results. No capital required. Send today for instructive free book, "Skillful Collecting." Collectors' Ass'n, Long Street, Newark, Ohio.

SEND for booklet, "How You Can Become Your Own Master Without Capital," no competition. Daugherty, 1236 Madison Street, Chicago.

YOUR 25-word advertisement in 100 monthly mail-order magazines, three months \$1. Bennett Co., 455 East 186th St., New York.

PLEASANT spare-time work, mailing circulars. Good pay; no scheme. Details free. Home Pub. Society, 1217 Market St., Philadelphia, Pa.

INVENTORS—I will advance money to secure patents on new and useful inventions. Write to J. B. Miller, 593 Loan and Trust Building, Washington, D. C.

\$300,000—IN Sales—"Something Different" Mail Dealers' Propositions. Samples, 10c. Particulars free. P. Rudolf, Northwestern Building, Chicago.

RESILVER mirrors and make plenty of money. Full instructions, 25c. Auburn Supply Co., Dept. RM, 7745 Peoria St., Chicago.

GOOD RESULTS—Greatest mail order magazine published. Three issues, 10c. Publishers, 2311PM, N. 43rd Ave., Chicago.

AGENTS, mail-order dealers, mechanics, inventors—Send stamp for important information in your line. Howestoll, 102 Summit Street, Brooklyn, N. Y.

ARE you sick of your job? Years of drudgery on small pay. Long weary days. Dreary night work. It saps a man's energy. Grinds him down. Kills ambition. Day in and day out. Same old nerve-racking detail. Your bond-clipping boss gets the benefit of this kind of life. Wake up now. Don't wait until ambition is all gone. Our big money-making propositions will lead you to for me and prosperity. No capital, experience or canvassing required. Five Great Dollar Coining Opportunities worth \$5 free for stamp. Don't put this off a single minute. Send now. It should mean comfort and luxury for you. F. C. Wilson, 11 West 108th St., New York.

INTELLIGENT representative in each town. Profit-sharing proposition. Capital unnecessary. Smith, Box 379, New Bedford, Mass.

STOP making other people rich. Start a mail order business of your own and earn \$50 to \$250 a week. I made \$50,000 the first five years with a small mail order business, \$10,000 the first year. Began with \$5. No matter where you live I will show you how to start small in your own home, in spare time, evenings, at first. Experience unnecessary. No canvassing. Send today for my illustrated free booklet. It tells how I can help you. Heacock, A 5074, Lockport, N. Y.

MANUFACTURE a stove polish that polishes nickel and blackens stove in one operation. Formula \$5. Guaranteed as represented or money refunded. This polish clears me \$50 weekly here. P. Finkbeiner, 416 Seymour St., Syracuse, N. Y.

YOUR 25-word ad inserted in "Cartoons Magazine," 50c. One inch display, \$1. Circulation, 23,000 copies. Send copy now. Cartoons Classified Dept., 322 W. Washington St., Chicago.

FOR Sale—Machine shop with contract drilling, 40,000 pieces yearly at 10c each. Particulars and sample by parcel post for 75c. Henry Frick, Fricks, Pa.

ADVERTISE—20 words in 100 montlies \$1; 100 weeklies \$2; 20 Sunday papers 5; all three lists \$7. Life Co., St. Louis.

LEARN Realty Business. Big income. Free booklet tells how. American Realty League, S'n Francisco.

I CAN show a man with \$2.75 cash the biggest Wall Paper Cleaning Proposition ever offered; good for \$18 weekly, operate in spare time. Full particulars and sample of cleaner 10c. Milliken Co., Davenport, Iowa.

MAKE money in land sales, no large capital needed. Opportunity never was greater, right in your own locality, without experience. Send 50c to-day for complete instructions to start at once. Cevely-Keiser Sales Co., Holton, Kans.

TIME now to get best legitimate game to make money at County Fairs or Parks. Cleared \$120 July 4th. Better than "Nigger-drop" or Weighing Scales. Send \$2 money order for set and instructions. W. Lang, Ironwood, Mich.

SEND 50c for my complete instructions "How to get into the land business without putting up a dollar to buy land." Auburn Supply Co., Box 282, Dept. J, Auburn, Me.

PATENTABLE Ideas Wanted—Send for 3 free books. R. B. Owen, 30 Owen Bldg., Wash., D. C.

ANYONE anywhere, \$5 daily replating silverware. Samples free. E. Fiske, 101 Sheffield Ave., Buffalo, N. Y.

MAIL-ORDER Dealers: Send for our catalogue for brand new articles to sell. Gordon Mfg. Co., Northwestern Bldg., Chicago.

MAKE Big Money Opening Safes and Setting Combinations. Write Wayne Strong, 811 Temple, Los Angeles, Calif.

\$3,000 YEARLY in your back yard. This new industry now making fortunes. I'll help you—as I have helped thousands of others—to an easier living. 20 years of honorable dealing. Your back yard—a city lot—under my instructions, can make you a life income. My unique "schemes in dirt" have aroused workers everywhere. Burdick's "Post Bulletin" starts you and editor boosts. This current number, 10 cents. Benjamin Burdick, Kalamazoo, Mich.

MAKE money making mirrors at home—20c silvers a glass selling \$2 to \$5. Full, explicit directions how to do it for only \$1. Start in this big-paying business. Send \$1 to-day. Patterson & Co., Dept. 5, Brookville, Ky.

BEST imported and domestic novelties, tricks, jokes, puzzles, etc., at lowest wholesale prices. Complete assortment, prompt shipments. Catalogue free. Joseph Methieu, 203 Court St., Brockton, Mass.

BE Independent. \*Star money-making mail order business at home. New plans. Everything furnished. Only small capital required. Free booklet and particulars tell how. W. P. Miller Co., Box 254, Muskegon, Mich.

AN intelligent person may earn \$100 monthly corresponding for newspapers. No canvassing. Send for particulars. Press Syndicate, 700 Lockport, N. Y.

RAISE Ginseng, \$1 per ft. of ground; 1/2 acre, \$25,000. Write Ginseng Gardens, Sheboygan, Wis.

CASH for your business or property. I bring buyers and sellers together. Write me if you want to buy, sell or exchange any kind of business or property. Established 1881. Frank P. Cleveland, 1308 Adams Express Building, Chicago, Ill.

MAKE and Sell Mission Furniture—From our instructions one man who was an amateur made and sold \$400 worth of just one article alone. We give you 98 designs and easily followed directions for making each piece in 3 books at 50 cents each or \$1.50 per set, postpaid. Popular Mechanics Book Dept., 318 W. Washington St., Chicago.

ASK Bode about Buying! Selling! Advertising! Anything! Get acquainted "Now"! Bode, 288p Main, Hartford, Conn.

INDEPENDENCE and fortune quickly attained in the Manufacturing Mail Order business. I furnish Formulas, Manufacturing Processes and Trade Secrets in all lines. Sold under positive guarantee; 18 years' practical experience. Revision and improvement of Formulas and Processes—reduction of manufacturing cost—utilization of waste materials, etc., a specialty. Booklet, Formula List, and Valuable Information Free. W. L. Cummings, Ph. D., 127 Standard St., Syracuse, N. Y.

FOR Sale—An old, well-established Southern school for girls; good opportunity for young man; will sell entire plant at reasonable price, has been good money-maker and has bright prospects for future with right man in control. Party has good reasons for selling. Want to list with some good real estate agency. Address Lock Box 15, Bowling Green, Va.

WE Sell Patents. Established 1900. If you wish to add a new product to your line, write us. Charles A. Scott Co., 596 Central Bldg., Rochester, N. Y.

OPERATE Hahn's Premium Machines, the best seller for cigars and candies. J. Hahn, 1016 Germantown Ave., Philadelphia, Pa.

WE help raise capital at once to start you in retail, manufacturing, patent, real estate, mail-order, or any legitimate business, by means of "our practical method." Particulars free. The Business Aid Co., K 504, Detroit, Michigan.

WOULD you like to own a good-paying mail order business? We have a line that gets repeat orders all the time. You can start in spare time; invest a dollar or two a week and soon own a nice business of your own; write for particulars. Nadico, 1664 Belmont Ave., Chicago.

LET the Parcels Post Help You, Add (\$15 to \$25 weekly) to your present salary or income. Start during spare time and build up a permanent mail-order business of your own. We show you how and help you make good. No canvassing. Experience unnecessary. The Parcels Post makes success doubly sure. Our new ideas and up-to-date plans bring the money. No so-called "Course of Instruction" to sell. We give that free. Write today. Address Pease Mfg. Co., Inc., Dept. A, 70 Broadway, Buffalo, N. Y.

INCORPORATE your business under Arizona laws. Cost small. No franchise tax. Stockholders exempt from corporate debts. Do business anywhere. Laws and forms free. Southwestern Securities & Investment Company, Box D488, Phoenix, Arizona.

BIG Profits for You! Manufacture Barley Crisp. New confection. 5c package costs you 1c. Machine, instructions complete \$7.50 prepaid. Send 10c for samples. Barley Crisp Co., 1605 Hyde St., San Francisco.

TRIAL Offer: \$1 places your 25 word ad in 200 different magazines. Send copy now. King's Magazine, Box 13P, Little Silver, N. J.

I WILL start you earning \$4 daily at home in spare time, silvering mirrors; no capital; send for free instructive booklet, giving plans of operations. G. F. Redmond, Dept. 306, Boston, Mass.

MAIL Order Dealers! Advertisers! You need our 1913 Advertising Rate Book with the latest Dollar-making feature "Ads That Pay." Hot from the press! Gives you cost of Advertising in 2000 recognized magazines and newspapers, location, circulation, closing dates and other useful knowledge. Includes thirty original Mail Order propositions, winners every one of them. A \$10,000 investment at your service. You can make a legitimate profit of 95c on every dollar order. This very valuable manual sent prepaid to you for 10c. Write now! Dearborn Advertising Agency, 521 Dearborn St. Chicago.

STOP Here! Let me start you in a home business that will bring you money every day. Experience unnecessary. Spare time. No canvassing. I furnish everything and guarantee success. Send for proofs. Voorhies. Desk C. R., Omaha, Neb.



## AGENTS WANTED

**AGENTS Wanted**—If you know a chance when you see it you'll see one now. Big money—stylish, nifty clothes—little work—no experience or capital needed—can you beat that? We want agents everywhere to take care of our business in their localities and to advertise our nobby nifty suits by wearing them. We furnish everything complete and charge nothing for agents' outfit. The swellest dressers everywhere are our agents and all we ask is that you tell people who inquire about your fine clothes where and how they can get them. You make big money—\$10 a day—without trouble. Just a postal brings you full outfit free. Big, new sample book of up-to-the-minute suitings sent so you can pick out your first suit; also measuring blanks and everything you need. We pay express on everything—not a penny for you to pay. Send quick before some one else gets the agency there—mail postal today to American Woolen Mills Co., Dept. 1014, Chicago, Ill.

If you want something that's the thing right now—an article with which many agents, local and mail dealers are making \$50 weekly, handle our triple silver-plated safety razor; guaranteed equal in merits, quality and appearance to any \$5 razor! Write for wholesale prices and circulars furnished with imprint. Enclose 25c for sample, which amount may be deducted from first order, or, if razor doesn't shave better than any other, irrespective of price, we'll send your quarter back. Morgan Company, 312 Madison, Chicago.

**YOUNG man**, would you accept and wear a fine tailor-made suit just for showing it to your friends? Or a Slip-on Raincoat Free? Could you use \$5 a day for a little spare time? Perhaps we can offer you a steady job. If you live in a town smaller than 10,000 write at once and get beautiful samples, styles and this wonderful offer. Banner Tailoring Company, Dept. 507, Chicago.

**WANTED**—Live wire specialty salesmen, district managers in West, Middle West and South, to sell the Schemmel Welding and Cutting Machine, which is self-generating and is the best on the market. Right men can make ten thousand dollars annually. Reference required. Must finance yourself. Full particulars first letter. Confidential. Davis Sales Co., Holliday Bldg., Indianapolis.

**WANTED**—Agents in every locality to sell the most positive exterminator of roaches, ants and water bugs ever offered. Every sale means a satisfied customer large commission; exclusive territory to right party; liberal proposition. Vestal Bros. Mfg. Co., Indianapolis, Ind.

**AGENTS Wanted** to sell America's leading non-skid tire protector. Men with automobiles who can devote all their time to the work preferred. Good salesmen can make from \$50 per week up. Write for particulars. Leather Tire Goods Co., Niagara Falls, N. Y.

**DEAD ones** can succeed with our new household article; 1 to 4 in every city and village home; 100% profit. No competition. Sells for ten cents. Samples and proposition ten cents. Get in early. Ivor Glass Co., 293 E. 17th Ave., Columbus, Ohio.

**MAN made \$5.50 one hour, girl \$87 one week, selling Endless Neckties.** Patented. Just show them—sell on sight. Look like any stylish neckties—tie in a different place each time; wear 20 times as long. Sample outfit Free if you mean business. Write: Endless Necktie Co., Kansas City, Mo.

**WHERE did your money go?** Keep track of it. Begin any time with our Daily Expense Record, very interesting and complete. postpaid, 50c. Agents wanted. Auburn Supply Co., Dept. EX, 7745 Peoria St., Chicago.

**AGENTS**—\$50 weekly. We manufacture the best needle case made; a wonderful seller; 200% to 500% profit; talking unnecessary; our "Trust Scheme" Envelopes do the work; general agents can make \$100 weekly; particulars free; 25c sample outfit for 10c; buy direct from the factory. Paty Needle Co., 102 Davis St., W. Somerville, Mass.

**HAND Power Vacuum Cleaner**, carpet sweeper style, straight from carpet sweeper manufacturers of 13 years' standing and worldwide reputation. Sells on 2-minute demonstration to any housewife. Runs easy as a carpet sweeper and like one. Write for agents' terms. National Sweeper Co., 18 Laurel St., Torrington, Conn.

**MAKE and sell your own goods.** Formulas by Expert Chemists. We obtain your Government Serial Number. Catalogue for stamp. B. Mystic Company, Washington, D. C.

**SALESMEN**—Working for us means cash in your pocket every day; Household Device; duplicate orders; profits big, experience unnecessary. Write immediately. Specialties Supply Co., No. 31 Willoughby Street, Brooklyn, N. Y.

**AGENTS**—If you don't make \$4 profit the first day selling Tate's Dust Absorbing Dust Cloths, etc., return samples. Many Agents made \$25. Write quick for particulars. Dept. B-4, Consumer's Direct Supply Co., Boston, Mass.

**WANTED**—Men and women over 18 for U. S. Government positions. \$65 to \$150 monthly. Thousands of appointments this year. Pull unnecessary. Farmers eligible. Common education sufficient. Write for free booklet of positions open to you. Franklin Institute, Dept. T22, Rochester, N. Y.

**MR. Mail-Order Man**: Get quick returns. Established corporation supplies fast mail-order sellers; factory prices. Classy proposition. Beginners or established firms. Copyrighted Prospectus free. Mississippi Valley Co., Inc., Box N629, Pittsburg, Kans.

**IMPROVED Automatic Razor Stropper**. Something very fine for \$2. Agents wanted. Auburn Supply Co., Dept. RZ, 7745 Peoria St., Chicago.

**\$75 MONTHLY** and extra commission for selling our large new line with valuable premiums to customers. 72-page illustrated mail-order catalogs free to agents. Credit given. Best Mfg. Co., Div. 3, Providence, R. I.

**AGENTS, Sign Men**, positively make 500% handling our flexible letters, guaranteed unreturnable; four styles, all sizes, lowest prices; prompt shipments anywhere. Anybody can put them up and make money—we will show you how. Particulars and instructions free; complete samples, 5c postage. New York Sign Letter Co., Arbuttle Building, Brooklyn, N. Y.

**AGENTS**—Automobile necessity, every call a sale, 100% profit. In testing its suitability, agents worked on salary, but later asked to work on commission. Very practical, sells itself. Write at once for free particulars. Woks Mdse. Co., Wesley, Iowa.

If you want 100% to 500% profit quick, sell our assortment of practical and necessary articles for the home. Not found in any stores. Entirely new line at popular prices. Send today for descriptive catalog and terms to agents. Specialty Mfg. Co., 20 Brigham St., Westboro, Mass.

**AGENTS make 500% profit** selling our gold window letters, novelty signs and changeable signs. 800 varieties in enormous demand. Catalogue free. Sullivan Co., 1238 Van Buren St., Chicago, Ill.

**WANTED**—A man or woman all or spare time to secure information for us. Work at home or travel. Experience not necessary. Nothing to sell, good pay. Send stamp for particulars. Address M. S. I. A., 11 L. Bldg., Indianapolis, Ind.

**\$5 TO \$20 daily** to agents who are hustlers selling our new and wonderful line of goods. Large concern. Complete selling outfit free. Exclusive territory. Wm. J. Dick, Manager, Dept. B-4, Chicago.

**AGENTS**—Big profits, quick seller, exclusive territory. New patented article needed in every home. \$10-\$12 daily profit easily made. Tech Sales Co., 1784 Broadway, New York.

**ANYONE** can attach. Gilding Casters, 400% profit. Carried in pocket. No rollers. Save floors, carpets, furniture. Cost 3c, sell 10c. Homes buy dozens. Best agent's article of the century. G. Mfg. Co. (Dept. 104), 20 Warren St., New York.

**PHOTO Pillow Tops, Portraits, Frames, Sheet Pictures, Photo China Plates.** Rejects credited. Prompt shipments; samples and Cat. free to agents. 30 days' credit. Jas. C. Bailey Co., Desk M4, Chicago, Ill.

**WHEN you sell Feeny Vacuum Cleaners** you make pleased customers. New principle—creates wonderful suction. One general agent's total commissions 1912 were \$18,498. Write today for our attractive propositions. Feeny Mfg. Co., G28, Muncie, Ind.

**YOU can't afford to accept ordinary proposition** while agency for Guaranteed Aluminum Cooking Utensils is open. Answer quick. Protected territory. American Aluminum Mfg. Co., Dept. P.M., Lament, Ill.

**\$35 TO \$100 weekly** made easily. Needed in every home and store; enables purchaser to save money and enjoy life. Rapid seller, profit from \$10 to \$50 each sale. Experience unnecessary; exclusive territory to hustlers. Write for full particulars. C. Hemple, Sales Mgr., 174-C, No. Sangamon Chicago.

**AGENTS Wanted**—Right here is the one big chance of your life. If you want to make good money—\$10 a day or more, as easy as rolling off a log, and get your swell clothes free besides, you can do it by acting as our agent. We are the biggest people in the business and want our agents to make big money and be nifty, stylish dressers. Send a postal today for free \$10 outfit, including big book of nobby suiting samples to select your swell agents' suit from. Then take orders from people who admire your nifty clothes. They come to you—not you to them. This is the way to get rich—the sure, easy way. Remember, you need no money—everything is furnished by us free. We pay express on everything. Just send a postal, but do it today. You can't get started too quick, making this big money and wearing these stylish clothes. Address card to Paragon Tailoring Co., Dept. 1014, Chicago, Ill.

**SELL something new and in great demand.** Savir Stove Lids save half of coal. Thousands used. Agents making big money. Write for free trial offer. Pre-Heated Air Co., Suite 634, 1011 Chestnut St., Phila.

**AGENTS, write for particulars;** device for saving fuel on gas, oil and gasoline stoves; exclusive territory given general agents. Gas Saving Grate Co., Columbus, O.

**AGENTS Can Earn \$5 to \$10 per Day** Selling Our Many Patent Specialties. Write today for full list and proposition. Ford Mfg. Co., Inc.; 5-7 Oliver St., Newark, N. J.

**AGENTS Wanted**—To sell lubricating oil and grease in rural districts. Samples supplied. Write for particulars. Caledonian Oil Co., Inc., 135 Front Street, New York City.

**AGENTS, either sex,** for our Polypin; never before sold in this country; 100% profit; also other articles. Write quick. Hubenik Mfg. Co., 5227 Delmar, St. Louis, Mo.

**REMNANT Store, 1331-E, Linn, Cincinnati.** Greatest Dry Goods Bargains on Earth. For agents and store-keepers.

**AGENTS**—Portraits, 35c. Frames, 15c. Sheet Pictures, 1c. Stereoscopes, 25c. Views 1c. 30 days' credit. Samples and catalog free. Consolidated Portrait Co., Dept. 5242, 1027 W. Adams St., Chicago.

**NEWEST Door Plate, never tarnish; low price; equal to any \$3 plate.** Free sample to workers. Gross, 2463 Washington St., Boston, Mass.

**MANUFACTURE "Substitute for Eggs,"** sells like wildfire, no canvassing necessary, enormous profits. Particulars free. W. C. Delzell, 311 South Pickett, Los Angeles, Cal.

**AGENTS, best seller in Christmas season;** very rare and newest Japanese novelties that we have ever seen. Sample 25c. Otsuka Co., 1134 Georgia St., Los Angeles, Calif.

**SAFETY razor—big seller; agent's sample 20c.** Special prices quoted in quantities. Breckenridge, Box 49, Station H, New York.

**SEND for booklet, "How You Can Become Your Own Master Without Capital,"** no competition. Daugherty, 1236 Madison Street, Chicago.

**I NEED one energetic, dependable representative** in every county to take orders for our new Popular Mechanics book for boys called "The Boy Mechanic." This is not a story book, but a wonderful and interesting collection of 700 things boys love to make and experiment with. A very large attractive book for the price, \$1.50. Every boy's father or mother will want to buy it for their son. Right now is the most opportune time to start on account of the approaching holiday season as this is an unusually attractive gift book. It sells itself. Good liberal commission and exclusive territory. You don't have to be a professional agent to be successful with this highly meritorious proposition. Work in and around your home town. Write today for full particulars to Manager Book Dept., Popular Mechanics Co., 318 W. Washington St., Chicago.

**JUST Out—Practically an every-call seller.** Agents wanted. Moore Co., 35 E. Bethune, Detroit, Mich.

**100% PROFIT—San-A-Ta-Ree Dustless Dust Cloths;** ready sellers. Agents, General Agents' proposition ready. Parker, Box 93, Waterbury, Conn.

**USE your selling ability to build a big business** of your own. Free book, "Skillful Collecting," tells how. Collectors' Ass'n, 36 Long Street, Newark, Ohio.

**WIDE-AWAKE agents make big money** handling our easily demonstrated specialty. Particulars free. Write today. Cunlee Sales Company, Dept. S, Big Flats, N. Y.

**AGENTS wanted for good selling preparation.** Barkley's Manufacturing Company, Blairsville, Pa.



AGENTS are making big money selling our new line of household goods. Send for sample and particulars. Rippon Mfg. Co., 338 Hugo Street, San Francisco, Cal.

"BOOSTER" will show you how to make more money! Operate a good, substantial Mail-Order Business—our "Silent Salesman" system can easily be worked during spare time. Don't invest any money until you read "Booster"—the magazine that has, for years, actually and accurately started others like you in business for themselves by publishing money-making propositions that get the dollars. Send 10¢ today—it's worth dollars to you. Booster Magazine, Northwestern Building, Chicago.

SIGN Agents—Painters—Something new and better. Attracto ready-made Gold and Silver letters. 21 kinds, easily applied. Make big money lettering store windows, making signs, and selling our line of flashing, sparkling chipped glass name plates. No experience needed. Write for sample letter and catalogue and start at once. Address Attracto Sign Co., 2655 North Clark Street, Chicago.

CREW Managers! General and Local Agents! Two Million Dollars' worth of Oil Mops are being sold annually. Our new invention will double this first six months. Nothing like it. Every improvement the people have wanted. Agency means a monopoly. Liberal proposition. Big opportunity. Act quick. Frederick Mfg. Co., 11th floor Marbridge Bldg., New York City.

AGENTS—Here is a tailoring proposition for you. We are not offering anything free or making any foolish promises, but we can show you how to make good money and build up a permanent business. We make suits to order at wholesale prices. Our \$16.50 suits as good as others at \$25. No experience necessary. Can hold your present position and make good money with this besides. Highland Tailoring Co., Department 26, Cincinnati, Ohio.

We only want a few honest, hard-working men to sell our full line of Everbrite Gold Glass Sign Products. Salable in every city in the country. Customers in most instances are boosters—help you sell. When writing for catalogue state experience. Sales Dept., Chicago Glass Novelty Co., Marion, Ind.

AGENTS—Every merchant and professional man a prospect. Sell our complete line of high quality, low-priced Window Letters, Glass Signs, Name-Plates and Wood Specialties. Write to us now for New 48 page catalogue and Sample Letter—Free. Attracto Sign Co., 2655 North Clark St., Chicago.

FOUNTAIN Oiler just invented, prevents accidents in oiling machinery. Most convenient oiler for places hard to reach. Oils and factories purchase by the dozen. Specially adapted to automobiles and power boats. Quick profits for prompt agents. Sample 50¢; set of five \$1.50 prepaid. Selective Supply Co., Lynn, Mass.

A MILLION Men Want Prest-O-Lather shaving brushes. Makes its own lather. Bristle stay set in rubber. Smoothest shave ever. Rivaling "Gillette" sales. No competition. General Agents make \$72 weekly. Send \$1 for sample and agency terms. Prest-O-Lather Co., Dept. P, South Bend, Ind.

\$10 AND only one sale a day. You can make one sale, as our goods almost sell themselves. Just think of it, some of our men make three sales a day. Why not you? Get busy—write quick while the place is open. Advance Mfg. Co., Kalamazoo, Mich.

FULLER Dustless Floor and Wall Mop, with adjustable handle, and hand duster are indispensable to housekeepers—sell at sight—100 per cent profit to agents. Write today. Fuller Brush Co., 55 Hoadley Pl., Hartford, Conn.

\$35 WEEKLY easily made as our Sales Representative for automobile supplies and devices. No experience necessary. Exclusive territory to wide-awake salesmen. Economy Auto Supply House, 607 Crilly Bldg., Chicago.

AGENTS—It's the goods, our household specialties clear you \$35-\$65 weekly and repeat orders on first delivery. Sterling Aluminum Co., Canal Station 77, Chicago.

GENERAL Agents Wanted to Sell Ink powder through our original "approval plan" envelopes; no talking required; big profits; sample package 10¢. Delbert McDonald, P. 596 S. Cedar, Sturgeon Bay, Wis.

\$27 DAILY profit sounds good. Let us prove it. Get in the game. Excelsior Mfg. Co., 117 Worth St., New York.

GENERAL Agents—Capable of calling on the big trade themselves and handling canvassers for the house to house and office to office business, to sell the newest electric specialty on the market; sold everywhere there is electricity, in the home, office, factory, store, hotel; liberal profits; sales-driving sample, weighs a pound; no experience or knowledge of electricity required; shows how to use one light instead of two and get the same results; sells for \$2.50, \$3.50, \$5 and saves the purchaser an investment of \$25. Write for particulars. The Handy Light Co., 159 Handy Light Block, Cincinnati, Ohio.

THEODORE Roosevelt is again writing for Scribner's Magazine. Subscription solicitors can earn big commissions. Inquire Desk 15, Scribner's Magazine, 597 Fifth Ave., New York.

AGENTS—Sell Shav-It Shaving Cream. Free premiums. Exclusive territory. Samples prepaid 24¢. Thomas Mears, 1148 La Salle Ave., Chicago.

AGENTS—250% profit. Wonderful little article. Sells like wildfire. Can be carried in pocket. Write at once for free sample. H. Mathews, 1962 Third St., Dayton, Ohio.

UNUSUAL Profits—"The New Asbestos Inner Soles" mean warm feet in coldest weather. Exclusive territory. Two dimes and stamp bring samples and wholesale terms to agents. The Anderson Mfg. Co., Box 1747, Pittsburgh, Pa. Established 1910.

\$20-\$30 WEEKLY selling guaranteed Hosiery, Underwear, Sweaters, Neckties, Handkerchiefs. Credit. Samples free. Sales Manager, Room 811, 366 Broadway, N. Y.

NEW Improved Self-Heating Flatiron; burns gasoline, alcohol, kerosene. Make \$20 a day. Fulton Supply Co., 1608 Fulton St., Chicago, Ill.

AGENTS Wanted—A brand new 25¢ household article that will clear you \$10 per day for the next 6 months. Write outok. J. S. Ziegler Co., Chicago.

CASH for names, information, formulas, ideas, etc. Steady home business. Instructive book for stamp. Information System, 806 Marietta, Ohio.

AGENTS—Mail Order Men: Your 25-word ad in 100 Magazines \$1. Box 22, Station B., Worcester, Mass. The Williams Specialty Co.

AGENTS—Get particulars of one of the best paying propositions ever put on the market. Something no one else sells. Make \$4,000 yearly. Send postal today for particulars. E. M. Feltman, Sales Mgr., 6718 Sycamore St., Cincinnati, O.

AGENTS—\$5 daily selling our Handy Tool, 12 articles in one. Lightning seller. Sample free. Thomas Mfg. Company, 462 Third St., Dayton, Ohio.

HOUSEHOLD Specialty Agents. Send stamp for sample dish cleaner and catalog of helpful household conveniences. F. C. Hanson, Southbridge, Mass.

AGENTS—Ten Dollars a day. New Adding Machine. Guaranteed five years. Price \$5. Phelps Specialty Co., Dept. M, Caro, Mich.

AGENTS—Weeping Doll, patented, very laughable. Lemon Company, Brighton, Mass.

AGENTS—Your profit 76 cents on best selling dollar specialty ever invented. George Spher, 6557 Minerva Ave., Chicago.

AGENTS—You can sell our raincoats. Anyone will buy. We put one on your person. Outfit free. A. Temple Raincoat Co., Templeton, Mass.

AGENTS—Inquire household article that sells; big profits. A. H. Busch, 1306 Gregory, Wilmette, Ill.

AGENTS—A device that saves money, increases efficiency, adds to comfort, convenience; beautifies the home, office and store—and is electrical—is the kind of device to sell. Show these features on an article to the people today and your sale is made. I have that article. If you are alive, wide awake and want to handle a general agency for the most unique, electrical specialty, which will cut lighting bills in half, write for my proposition. Stanley B. Freiberg, 195 Station F., Cincinnati, Ohio.

AGENTS—To sell the newest electric appliance on the market; sold everywhere there is electricity, in the home and office; liberal profits; sales-driving sample, weighs a pound, no experience or knowledge of electricity required; it shows how to use one light instead of two and get the same results; sells for 3.50 and saves the purchaser an investment of \$25. Write for particulars. The Handy Light Co., 111 Handy Light Block, Cincinnati, Ohio.

DEVOTE your whole or part time in dignified remunerative business. Take orders for best tailoring house in America. Complete outfit free containing 400 latest patterns and styles. Every garment guaranteed. Exclusive territory. Davidson, Sales Manager, 503 South Franklin St., Chicago.

VACUUM Cleaner Agents, here it is; absolutely new design in wheel-operated, powerful bellows-type vacuum cleaner; new visible nozzle; exclusive appearance; sells quick at \$7.50; write for particulars about money-back guarantee now. Doty Company, Box 500, Dayton, Ohio.

WE furnish you capital to run a profitable business of your own. Become one of our local representatives and sell high-grade custom-made shirts; also guaranteed sweaters, underwear, hosiery, and neckties, direct to the homes. Write Steadfast Mills, Dept. 10, Cohoes, N. Y.

AGENTS—Earn \$10 per day. Sell three 50¢ Ties, \$1.00. Free Monogram Gold Cuff Links and Stick Pin. Bowden cleared \$71—5 days. Cooper, \$40—4 days. Free samples. Comer Neckwear Co., 2 First St., Dayton, Ohio.

WIDE-Awake, active agents can secure special concessions and reap benefit from best money-making agency proposition on the market by writing immediately for full particulars. Hugro Mfg. Co., 427 S. Dearborn St., Chicago.

SALESMEN making small towns, Whole Time or Side-Line, should carry our fast-selling pocket side-line. Special sales plan allowing return of unsold goods makes quick, easy sales. \$4 commission on each order. Something Entirely New. Write for outfit today. Cranfield Mfg. Co., 208 Sigel St., Chicago, Ill.

AGENTS—Greatest offer ever made. Eleven-piece toilet article set and \$1 carrying set. All cost you 50¢; sells for \$1; twenty sales a day easy. Write today. Pierce Chemical Company, P-3, Pierce Bldg., Chicago.

OVER \$10 profit each sale. Energetic salesmen everywhere to sell Good Health Electric Vibrators; big demand, easily sold, quick action necessary. Good Health Vibrator Co., 806 N. Clark St., Chicago.

ONE person wanted each locality as general agent for complete line Polish Mops, Self-Wringing Mops (5 styles), Fibre Brooms. Hiker Mop Co., 1291 Grand Ave., Chicago.

LIVE Wire Salesmen wanted to introduce a sure winner; 100 per cent profit. Particulars free. Edward Munson Co., Decatur, Ill.

HOSIERY; knit ties; sample free. Sutton sold gross each week besides hosiery. 100% profit; appoint sub-agents, develop permanent, profitable business. Credit. Colby Hosiery Mills, 2332 Kensington Ave., Philadelphia, Pa.

AGENTS, canvassers, crew managers, salesmen wanted in every community for our famous 7 and 8 cake \$1 soap assortments; advertising price 25¢; costs you 12½¢; attractive premiums given; everybody buys; lose no time getting our list money-getters. Moore Bros. Co., Manufacturers, Established 1896, 288 Greenwich Street, New York.

AGENTS—Money maker—we manufacture glass paper. Makes common window glass look like real art glass. Easily applied. Beautifies the home. Two sample sheets. Catalogue in colors 10¢. Parrish Co., Lakeside Bldg., Chicago.

GET in the big-money class, \$35 to \$75 a week. Our new, stylish, snappy, double texture, \$5 raincoats sell rapidly to men and women everywhere. Big commission for you. Write now for agency. Regal Raincoat Co., Albany, N. Y.

LEARN Metalizing Transform Roses, Carnations, Butterflies, etc., into exquisite jewelry novelties. Big profits. Dime brings rosebud pin and particulars. P. Benson, Stewartville, Minn.

BOKARA Diamonds—Agents, everyone, to wear and sell our famous Bokara Diamonds. Write for sample offer and catalogue free. Northwestern Jewelry Co., 2141 Summerdale Ave., Dept. 28, Chicago.

AGENTS—\$50-\$75 weekly selling guaranteed knit-goods for largest manufacturer in America. Write for free outfit and particulars of greatest money-making proposition ever offered. Madison Knitting Mills, 486 Broadway, New York.

AGENTS. Big money made daily selling an article for automobiles and motorcycles. Saves 50% of gasoline. Increases power 20%. Moller Brothers, Main Office and Factory, Lewistown, Pa.



**AGENTS—100% profit—sell to saloons—** machine whirlwind seller. Free sample and salesmanship course. Two sales a day \$15 profit. Write. Simplex Mfg. Co., Kewanee, Ill.

**MAIL-ORDER Opportunities:** 25 new Propositions. No competition! Make 95c profit on dollar order; complete outfit 10c. Mail Dealers Wholesale House, 521 Franklin Bldg., Chicago.

**400% PROFIT—Manufacture Barley Crisp—new confection—whirlwind money-maker.** Women and men can do it. Send for free Crisp. It's fine. Simplex Mfg. Co., Kewanee, Ill.

**AGENTS—Sell good repeater.** 100% profit. Samples. Piscataqua Sales Co., 25 Tanner St., Portsmouth, N. H.

**WATER Filters** costing 2c sells 10c. Detroit Filter, Detroit, Mich.

**READ the Agents' Magazine.** Make more money, 2 months, 10c. Agents' Magazine, Chicago.

**AGENTS—Defy competition** selling our untarnishable gold and silver sign letters. Highest grade goods, rock-bottom prices. Dime brings 5 large samples and instructions. Particulars free. H. Alexander, manufacturer, 980 Third Ave., New York. Established 1905.

**MAKE money in land sales.** No large capital needed. Opportunity right in your own locality. Send 50c for complete instructions. Do it now. New Era Specialty Co., Morton, Pa.

**SELF threading needles.** 10c a paper. Agents' samples and terms free. Ladies' Art Co., Dept. 41, St. Louis, Mo.

**AGENTS—To introduce Oxo-Gas;** a wonderful new invention; a complete individual gas plant for lighting, cooking, heating; cheaper to install and operate than any other known fuel. For cooking it is cheaper than coal or wood. For lighting it is cheaper than a common kerosene oil lamp. The most brilliant light known to science. Gloria Light Company, 1281 Washington Blvd., Chicago, Ill.

**BE Our Agent.** We make the best Vacuum Sweeper manufactured. Women are crazy for them. We will sell you one at lowest agent's prices. Test it at home. Show it to other women tired of sweeping, dusting, etc. Take their orders and make money for yourself. Write at once for agency terms. The Junior Vacuum Cleaner Co., Dept. A, Bradford, Pa.

**AGENTS in every city to handle our** Triplex Folding Handbag; big profits; exclusive territory. Write for terms and free catalog. Other big sellers. S. V. Diamond & Bro., 35 West 21st St., New York City.

**We are the largest manufacturers of** Twisted Wire Brushes in America. Highest grade goods, best service, highest profit. Write for our new catalog. You are sure to win. Fuller Brush Co., 33 Hoadley Place, Hartford, Conn.

**(CELLULOSIA) Door Plates,** new lettering pure gold. Send for sample case. Nothing invested. 100% profit, sell to every house. Public demands them. La Fontaine, Mfr., Sherburne, N. Y.

**AGENTS wanted.** Live wire canvassers. An undoubted winner. Appeals to best in profession. High-class specialty. No competition. Sells \$3, costs half. Unlimited field. Save-Life Window Cleaner Co., 36 East Main St., Amsterdam, N. Y.

**SIGN Painting Agents:** 1000% profit. Best and cheapest window letters made. Mounted sample free. Success positively guaranteed. Embossed Letter Co., 235 West Illinois St., Chicago.

**HOUSEHOLD article.** Saves 80%. Universal demand. Agent's commission 120%. Sample free. Craig Brothers, Detroit, Mich.

**AGENTS, make \$35 weekly** selling the Empress Dustless Dust Cloth. Something entirely new and needed in every home. Send 25c for sample and particulars. Empress Specialty Co., 5702 Easton, St. Louis.

**AGENTS—\$35 weekly** distributing needle cases; sell 115 needles in book for 10c; make 200 per cent profit; send 10c for sample and full particulars; general agents wanted. Empress Specialty Co., 5702 Easton, St. Louis, Mo.

**MANUFACTURER of new exclusive** linen heel and toe guaranteed hosiery wants agent in every county. Sales enormous. Re-orders insured; permanent, increasing income. Protected territory. Credit. N. Parker Mills, 720 Chestnut St., Philadelphia, Pa.

**AGENTS wanted for a new household** labor saver. Quick seller. Big profits. Cary-Dane Co., 102 West 101st St., N. Y.

**YOU can be your own boss with our** Key Check Outfit. Good for \$5 a day stamping names on pocket key checks, fobs, etc. Sample check, with your name and address, 15 cents. Pease Die Works, Dept. M, Winchester, N. H.

**AGENTS—Handkerchiefs, Dress Goods.** Carleton made \$8 one afternoon; Mrs. Bosworth \$25 in two days. Free Samples. Credit. Stamp brings particulars. Freeport Mfg. Company, 59 Main St., Brooklyn, N. Y.

**400% PROFIT** selling our high grade work. Samples free. Gordon Co., Northwestern Bldg., Chicago.

**ATTENTION, Agents—"Mop, Vacuum,** Crew Managers, etc."—Our indestructible cleaning, polishing and dustless mop, just patented, sells at sight, pays 150% profit. Make \$10 to \$15 per day easily. Exclusive territory to business producers. Wonderful opportunity. A record-breaking proposition. Act at once. Duncan Brothers, 2424 W. Division St., Chicago.

**WANTED—Hustlers to take orders for** Made-to-measure high grade men's tailored suits from \$9 to \$22. You can make good money. Elegant large book outfit free. Experience unnecessary. No pocket folder affair. Splendid opportunity to make money. Handy Dandy Line, Dept. K, Sangamon St., Chicago.

**BE Independent—Start a mail order business** in your own home; we tell you how and furnish everything needed, wholesale; an honorable and profitable business for man or woman. Many make \$3,000 a year. Particulars free. Murphy Mfg. Co., South Norwalk, Conn.

**AGENTS—Salary or commission.** Greatest seller yet. Every user pen and ink buys on sight. 200 to 500 per cent profit. One agent's sales \$620 in six days; another \$8.2 in two hours. Monroe Mfg. Co., X 6, La Crosse, Wis.

**AGENTS sell rich-looking imported 36x68** rugs \$1 each. Carter, Tenn., sold 115 in four days, his profit \$57. You can do as well. Write for sample offer and selling plan. Sample rug by Parcel Post, prepaid, 98c. A. Condon, Importer, Stonington, Maine.

**SILVER'S Ten Best Sellers** are big business builders for agents. New, novel; every home a customer. Immense profits for agents who act quickly. Write today. Silver-Chamberlin Co., Dept. M, Clayton, N. J.

**ABSOLUTELY Free for 30 days only.** One dozen guaranteed U. S. Fire Extinguishers with order for 3 dozen. Special offer to one representative in each section. United Mfg. Co., 1025 Jefferson, Toledo, O.

**AGENTS to take orders for visiting and** business cards; large commission; outfit free. Forman Printery, Waterbury, Conn.

**ONE Million Agents Wanted.** Fast sellers costing 2c, selling 25c, in quantities to \$50. Every firm needs. Postal brings samples. Embossed Co., 235 West Illinois St., Chicago.

**AGENTS make big money** selling our new gold letters for office windows, store fronts and glass signs. Any one can put them on. Write today for free sample and full particulars. Metallic Sign Letter Co., 406 N. Clark St., Chicago.

**AGENTS—Our Wonderful Luminous Cru-** cifix; selling better than ever. Some territory still open. Shines all night in darkest room. Write for agency. Pioneer Portrait Company, 1259 W. 63rd St., Chicago.

**AGENTS—\$5 daily** selling our Handy Tool, 12 articles in one. Lightning seller. Sample free. Thomas Mfg. Company, 462 Third St., Dayton, Ohio.

**AGENTS—250% profit.** Wonderful little article. Sells like wildfire. Can be carried in pocket. Write at once for free sample. H. Mathews, 1962 Third St., Dayton, Ohio.

**AGENTS: Cost 2c, sell 25c.** Sign letters put on with roller. Samples free. Embossed Letter Co., 235 West Illinois St., Chicago.

**AGENTS wanted for oriental novelties.** Never before introduced. Quick sellers. Repeaters. Immense profits. Particulars free, or samples 25c. Kanematz, Box H-529, Portland, Oregon.

**I WILL start you earning \$4 daily** at home in spare time, silvering mirrors; no capital; send for free instructive booklet, giving plans of operation. G. F. Redmond, Dept. 306, Boston, Mass.

**PERFECTION Pocket Adding Machine.** Lightning seller. Agents wanted. Cincinnati Specialty Mfg. Co., Dept. R, Cincinnati, Ohio.

**AGENTS make \$5.00 to \$10.00 a day** on the start. Atkinson writes: "The best proposition I have found in my forty years canvassing." Permanent work. Household necessity. Saving 80%. Write to-day for General or Local Agents terms. Free sample. C. H. Stuart & Co., 16 Union St., Newark, New York.

**500% PROFIT** selling our wonderful sign letters for office windows, store fronts and glass signs; resembles finest gold leaf; easily applied; samples free. Metallic Letter Co., 406 N. Clark St., Chicago.

**SOAP agents make more money** selling the celebrated Linro line. Coffee, flavorings, spices, soaps, perfumes, and 135 other items. Big commissions to you. Exclusive territory. Freight allowed. Handsome premiums to your customers. Free sample case. No deposit required. Free catalog. Linro Company, 13 Linro Bldg., St. Louis, Mo.

**MEDALLIONS—300% profit.** Make up your own goods and be independent. Catalogue free. Resag Co., 1205 Randolph St., Chicago.

**AGENTS make \$30.00 weekly** selling our 500 Handy Household Articles; catalogue free. Scheff Company, Desplaines, Ill.

**AGENTS Wanted—Mechanics and shop-** men make over \$100 a month in spare time selling transparent handled novelty knives and razors. Big profits. Sales easily made. Write for terms today. Novelty Cutlery Co., 67 Bar St., Canton, O.

**You can make \$\$\$\$ as our general or** local agent. Household necessity; saves 80 per cent; permanent business; exclusive territory; salary or commission; free sample; credit. J. Pitkin, 113 Redd St., Newark, N. Y.

**STOP Here!** Let me start you in a home business that will bring you money every day. Experience unnecessary. Spare time. No canvassing. I furnish everything and guarantee success. Send for proofs. Voorhies, Desk C. R., Omaha, Neb.

**AGENTS Wanted—Men and women to** sell "Sun" Self Heating Irons. An extraordinary opportunity to make big money by devoting whole or part time to a dignified, congenial business, established for years. Strictly high-grade, simple and indestructible. Thousands in use. Every sale makes many more sales. "Sun" Irons sell themselves. Women buy at sight. A penny's worth of gasoline or alcohol is sufficient for an entire family ironing. We manufacture and guarantee every iron. Write quick. Address: The Modern Specialties Mfg. Co., 109 High St., South Bend, Ind.

## DOGS, BIRDS AND POULTRY

**SEND for our Special offers on German** Canaries, cage, seed, etc., goldfish and aquariums; these make acceptable gifts for mothers, wives, sweethearts, weddings, birthdays. Write today; you'll be pleased. Edwards Bird Store, Detroit, Mich.

**ROSE Comb Buff Leghorns;** the coming breed; domesticated mallard ducks; fancy pigeons. Frank Morris, Galena Road, Aurora, Ill.

**MAKE money at home** raising Rabbits, Pigeons, Poultry. Three books telling how for \$1. Hardy's, Oakland, Cal.

**PETS—Send for our 34-page catalogue** of pets, such as dogs, pups, birds, pet animals of every description. The Original Cogley's, 52 N. 9th St., Philadelphia, Pa.

**FOR Sale—Blue-ticked fox hound;** will guarantee him first-class. Frank Cooper, 19 Mill St., Meriden, Conn.

**2,000 FERRETS.** Prices and book free. N. Knapp, Rochester, Ohio.

**FOR Sale—Thoroughbred Persian kittens** and grown stock. E. D. Shakey, Durand, Ill.

**PURE Bred—Coon, cat, deer, rabbit,** wolf and foxhounds, trained and untrained. Ten days' trial allowed. J. E. Adams, Herrick, Ill.

**SCOTCH Collies, imported strains;** also choice fox terriers. The Edgevale Kennels, Wadena, Minn.

**TRAINED Beagles, Rabbits, Hounds, Fox** Hounds, Coon, Opossum, Skunk, Deer, Bear, Wolf-Hounds, Setters, Pointers, and Ferrets. Brown's Kennels, York, Pa.

**ALREDALE Terriers and Scotch Collies.** State wants? Sales list free. Phil Savage, St. Charles, Ill.

## OFFICE EQUIPMENT

**For Sale—Mimeograph machine** slightly used, cheap. 3859 Coral St., Phila., Pa.



**HELP WANTED**

**BIG money writing songs**—We have paid thousands of dollars to song writers—send us your poems or melodies. Acceptance guaranteed if available by largest, most successful concern of the kind. We publish, advertise, secure copyright in your name and pay 50 per cent if successful. Hundreds of delighted clients. Write today for Big Magazine, Beautiful Illustrated Book and examination of your work—all free. Dugdale Co., 265 Dugdale Bldg., Washington, D. C.

**WANTED**—Men and Women over 18 for U. S. Government positions. \$65 to \$150 month. Thousands of appointments this year. Pull unnecessary. Farmers eligible. Common education sufficient. Write for free booklet of positions open to you. Franklin Institute, Dept. T21, Rochester, N. Y.

**WANTED**—A resident Sales Agent and Manager in your home county for the Benefel Handi-Tool. One tool combining a fence machine, wire stretcher, post puller, lifting jack, press, cable maker, vise wrenches, etc. For Farmers, Teamsters, Contractors, Factories and others. Guaranteed for life. Experience not necessary. We start you with handsome outfit, exclusive territory, and new plans. Art catalogue and complete prospectus free. Chas. E. Benefel Co., 1008 Telephone Bldg., Indianapolis, Ind.

**U. S. GOVERNMENT** wants city mail carriers, postal clerks. \$65 to \$100 month. Ncv. examinations everywhere. Farmers eligible. Full description free. Franklin Institute, Dept. T21, Rochester, N. Y.

**YOUNG man**, would you accept and wear a fine tailor-made suit just for showing it to your friends? Or a Slip-on Raincoat Free? Could you use \$5 a day for a little spare time? Perhaps we can offer you a steady job. If you live in a town smaller than 10,000 write at once and get beautiful samples, styles and this wonderful offer. Banner Tailoring Company, Dept. 508, Chicago.

**LEARN** automobile repairing, driving on up-to-date cars; electrical, civil engineering, surveying; methods most practical; room and board while learning; positions secured; satisfaction guaranteed; catalog free. National School of Engineering, 2110 West Seventh, Los Angeles.

**GOVERNMENT** wants mail carriers, postal clerks. \$90 month. Particulars free. Franklin Institute, Dept. T21, Rochester, N. Y.

**WANTED**—Dictaphone Typists; without shorthand; \$12 to \$18 per week to start and profitable employment, while learning at home in thirty days, guaranteed. Tyro Equipment Company, Consumers Bldg., Chicago.

**MEN** of ideas and inventive ability should write for new "Lists of Needed Inventions," "Patent Buyers" and "How to Get Your Patent and Your Money." Advice free. Randolph & Co., Patent Attorneys, Dept. 35, Washington, D. C.

**GOVERNMENT** jobs open to men and women. \$65 to \$150 month. List of positions free. Franklin Institute, Dept. T21, Rochester, N. Y.

**I WANT** a man as local manager who is accustomed to earning big money. Must be reliable and well connected. Can show such a man how to clear \$100 every week this winter. C. Gilbert, Suite 629, 1011 Chestnut St., Phila.

**BIG money** selling our line! \$10 to \$50 profit on each sale. Great demand. Experience unnecessary. Exclusive territory to hustlers. Write C. Hemple, Sales Mgr., 174-D, N. Sangamon, Chicago.

**BIG Profits**—Open a dyeing and cleaning establishment, little capital needed. We teach by mail. Write for booklet, Ben-Vonde System, Dept. C, Charlotte, N. C.

**AGENTS** make big money and become sales managers for our goods. Fast office sellers. Fine profits. Particulars and samples free. One Dip Pen Company, Dept. 2, Baltimore, Md.

**OCTOBER** examinations everywhere for Government Clerks at Washington. \$75 month. Specimen questions free. Franklin Institute, Dept. T21, Rochester, N. Y.

**WANTED**—Electrical instrument makers for work in connection with our Experimental Department in the development of electrical meters. Address "Employment," P. O. Box 911, Pittsburg, Pa.

**CASH** for names, information, ideas, formulas, etc. Steady home business. Instructive booklet for stamp. Nat'l Information System, 307 Marietta, Ohio.

**GET prepared** for Government "Exams" by former United States Civil Service Secretary Examiner. Like Popular Mechanics, I offer no premiums, have no "Positions Guaranteed" or "Coaching Free" Schemes. Straight propositions. Booklet C without obligation. Write now. Arthur R. Patterson, Rochester, N. Y.

**CITY** mail carriers wanted. \$90 month. Apply Franklin Institute, Dept. T21, Rochester, N. Y.

**\$\$\$ REPORT** local information, names, etc., to us. No canvassing. Spare time. Exceptional proposition. Enclose stamp. National Information Sales Company, BCH, Cincinnati.

**WANTED**—Investigators and Detectives. \$150 to \$300 per month. Some traveling positions. Free particulars. National Detective Agency, Dept. W-3, Chicago.

**WANTED**—Picture Play Writers. Big pay. We will teach you. Address United Picture Play Association, San Francisco.

**\$10 TRIPLE** Bellows Vacuum Cleaning Machine \$4.65. F. L. Sparks, 12 Isabella St., Worcester, Mass.

**HERE'S** a life income! Your back yard or a city lot is good for thousands yearly, under my instructions. The new industry, now making fortunes, is at your disposal. I have put thousands on "easy street" with my unique "Schemes in Dirt." If tired of work and worry—write me. My "Post Bulletin" explains and I'll help you to an easier income. This current number 10 cents. Benjamin Burdick, Kalamazoo, Mich.

**ANY** intelligent person may earn steady income corresponding for newspapers. Experience unnecessary. Address Press Correspondence Bureau, Washington, D. C.

**BE** a detective. Big wages, traveling everywhere. Write Detective Johnson, Department 37, Houseman Bldg., Grand Rapids, Mich.

**TWENTY-FIVE** intelligent, tactful and aggressive salesmen to handle an entirely new and necessary furnace utility. If you can qualify, write us at once. Jackson Utility Co., 224 W. Cortland St., Jackson, Mich.

**WRITE** Moving Picture Plays. \$10 to \$100 each. Constant demand. Devote all or spare time. Experience, literary ability or correspondence course unnecessary. Details free. Atlas Publishing Co., 3045 Atlas Bank Bldg., Cincinnati, Ohio.

**MACHINISTS** Wanted—Floor hands and erecting men for heavy hoisting engines and mining machinery. Address Litchfield Foundry & Machine Co., Litchfield, Ill.

**GO** on the Stage. Vaudeville career offered you. Experience unnecessary. Managers endorse my method. Instructive vaudeville book free. Write today. Fredric LaDelle, Sta. 10, Jackson, Mich.

**NO** expense to learn electricity, automobiles, plumbing. Correspondence lessons furnished; then actual work on contract jobs. Your work pays expense; 300 students last year. Get free catalogue. United Trade School Contracting Co., Los Angeles.

**WANTED**—Distributors, men and women, to give away free packages our famous Perfumed Borax Soap Powder; no money or experience needed; good pay. S. Ward & Co., 218 Institute Place, Chicago.

**PLEASANT** Home Work—Ambitious persons can earn good income in spare time copying letters. Former experience unnecessary. Send today addressed, stamped envelope for particulars. Box 17, Station H. G., New York.

**BE** a Detective. Earn \$200 monthly, positions open. A practical course in Detective Work taught by mail. American School of Criminology, Detroit, Michigan. Dept. F.

**WANTED**. Machinists, Agents, double your salary! Saunders' Hand Book Practical Mechanics; lightning reference. Thousands used. \$1.00, \$1.25, \$1.50. Circular sent. E. H. Saunders, 216 Purchase St., Boston Mass.

**STOP** Here! Let me start you in a home business that will bring you money every day. Experience unnecessary. Spare time. No canvassing. I furnish everything and guarantee success. Send for proofs. Voorhes, Desk C. R., Omaha, Neb.

**GOVERNMENT** Examinations. Most thorough preparation; \$5; returned if not appointed; particulars free. American Civil Service School, Washington, D. C.

**I WILL** start you earning \$4 daily at home in spare time, silvering mirrors; no capital; send for free instructive booklet, giving plans of operations. G. F. Redmond, Dept. 306, Boston, Mass.

**MANUFACTURING MACHINERY**

**WIRE** Goods, all kinds, made to order. Cooley Mfg. Co., 553 W. Monroe St., Chgo.

**PRESS**-stamping work reasonable. Dies and models made. We'll manufacture your novelty, or invention, to order. The Monarch, Boone, Iowa.

**INVENTIONS** Perfected; Working Models Made; Dies, Tools and Special Machinery. Write for Free Booklet. Black Diamond Mfg. Co., Cincinnati, O.

**LAMP** Shade Frames, all descriptions, made to order. Cooley Mfg. Co., 553 W. Monroe St., Chgo.

**CLEVELAND** Specialty and Manufacturing Co., Cleveland, Ohio. Inventions developed. Design or make special articles to order.

**MODEL** making. Write for estimate. A. F. Stearns, Paxton, Ill.

**LIGHT** Machine work for lathe or drill press wanted. Ford Bros., Algonquin, Ill.

**PRACTICAL** Machine Designers and Builders. Electrical Work. Patents and Inventions developed and perfected. Scientific and experimental work a specialty. Our trained staff of skilled mechanics assist customers perfecting inventions. The Regal Model & Tool Works, Chicago's Foremost Model Works, 122-8 S. Clark St., Chicago.

**\$ MADE** by having our factory figure on the manufacturing of your machines. We can furnish castings, Steel or Gray Iron, Brass, and Aluminum. Our shop is the most thoroughly equipped. Our superintendent has had fourteen years of experience. There is nothing that we can not build and save you money on. Practical Gas Engine and Machine Works, North Chicago, Illinois.

**MODELS** made for inventors; general machine work; designing and perfecting; developing automatic devices and machinery. In a position to do all kind of light tool and machine work. Prices reasonable; estimates cheerfully given. Ideal Machine Works, 62 Ann Street, New York City.

**WE** make working models for inventors; also dies and stampings of specialties, and carry a complete stock of brass gears and model supplies. Send for catalogue. The Pierce Model Works, 3405 Pierce Ave., Chicago, Ill.

**IRON** brass and aluminum castings. Metal specialties. Patterns, models, polishing, plating and japanning. Send for catalogue of pattern shop and model supplies. North Chicago Tool Works, 15 Grove Ave., North Chicago, Ill.

**FOR SALE**

**MECHANICAL** Movements—Suitable for moving demonstrations, mechanical electric clock switches. Brass gears accurately balanced. No lost motion. Each, parcels post, ninety cents. Six \$4.80. Frasse, Box 801, Brooklyn, N. Y.

**NIAG-RINE**, a wonderful jet black, free flowing, non-corroding, drawing and writing ink. Water-proof. Large bottle, prepaid 20c. Agents wanted. Chas. Haussner, 1267 Broadway, Albany, N. Y.

**BIG Snap**. 3 "A" folding kodak, Standard typewriter, five by seven folding Premier camera with tripods, Orient bicycle. All in perfect condition. Exchange for motorcycle or sell separate. Five-Eleven Third Street North, Fargo, N. Dak.

**OVEN**—No. 2 McDowell portable bakers' oven, 12 sq. ft. of baking surface. A continuous baker. Practically new. H. E. Hessler Co., 506-512 No. Salina St., Syracuse, N. Y.

**FOR SALE**—H. P. gasoline engine—Indian motorcycle carburetor; good condition. Cheap. Lucian Appelman, Clermont, Iowa.

**HARNESS** and buggies, clean stock; only shop in town; work for two men. Philip Lorbach, Jr., Waverly, Ohio.

**FOR SALE**—Stock of fine jewelry, invoice \$1,100. L. Stacy, Algona, Iowa.

**\$72 TOP Buggy**. \$49. E. W. Harak, Swisher, Iowa.

**FOR SALE**—Machine and auto repair shop. Excellent location. Good business. R. B. Duffey, Urbana, O.

**POLES**: Telephone and trolley. All sizes. Posts, ties and lumber. Albemarle, Orchard Co., Charlottesville, Va.

**\$200 EDISON** Amberola Phonograph, \$125. Greenhalgh, 816 58th, Brooklyn, N. Y.



## SALE OR EXCHANGE

FOR Sale—Fine Autocycle. Want screw-cutting lathe or modern, light runabout. Harry Fesenfeld, R. 2, Black Earth, Wis.

PRINTING in exchange for anything useful. Wilson's World, Chicago, Ill.

## WANTED

WANTED—To purchase established mail-order business. State articles handled and price. John F. Keller, P. O. Box 458, New Orleans, La.

MAIL order ideas and general agency propositions for crew of canvassers. Gerald Toomey, East Orange, N. J.

WANTED. Capital to manufacture an efficient egg packer for parcel post. Send for copy of patent. J. J. Miller, 822 E. St., Aurora, Nebr.

## MACHINERY, TOOLS AND SUPPLIES

FOR Sale—Hale Passenger Elevator. Cage 4½ by 5, guides, cables, weights, water cylinders, and enclosures; also one 700-gallon pressure tank, ¾-inch boiler iron, as good as new. One Imperial Center Crank, automatic engine, cylinder 9 by 10, 50 H. P., 300 revolutions, in good running order, with 2 5-foot pulleys. Must dispose of these at once, at a bargain. H. Herpolsheimer Co., Lincoln, Neb.

4-CYL. Winton auto motor, \$68; 6-H. P. two-cycle marine engine, \$45; 8-H. P. stationary gasoline engine, \$72. Badger Motor Co., Milwaukee, Wis.

SEND me one dollar and I will tell you how to run your engine on kerosene, save ½ fuel bill, and fix it yourself. Address Lock Box 265, Dunlap, Iowa.

BENCH Drill Press—Capacity 0-¼ in. Castings \$5. Send 25c for working drawings. LaRoss Vanding, New Brighton, Pa.

LATHES 12 in., 14 in., 16 in., 18 in. swing; Screw machines, 1 in., 1½ in. capacity; Shaper 16 in.; Punch press; 10 horsepower gas engine; 25 horsepower steam engine. Pinner, 122 Water Street, New York City, N. Y.

GAS engine for sale, 60 Hp., Elyria tandem, with air pump and tank, water pump, magneto, and everything complete in good condition. Taunton Planing Mill Co., Taunton, Mass.

PULLEYS, Gears, Sprockets, Shafting, Hangers; see page 127. W. A. Jones Foundry & Machine Co., Chicago.

FOR electrical machinery, dynamos and motors, alternating or direct current, write Standard Electric Motor Co. See our ad on page 158.

MACHINISTS and Repairmen, send for free treatise, "How to Turn Up and Repair Crankshafts. With Combination Lathe Dogs." Strasburger Mfg. Co., 326 W. Madison St., Chicago.

WE have 100 steam and gas engines for sale, \$12 to \$300 each. Send for list No. 24. Lucas & Son, Bridgeport, Conn.

FOR Sale—32 H. P. Steam Traction Engine, Pt. Huron make, rigged for plowing; practically new. Wm. G. Gage, Saginaw, Mich.

PATTERN makers! A book devoted to the principles of pattern and core making and molding. Written by G. H. Willard, a practical pattern maker of years' experience. This book, just published, treats the subject in a much more simple, direct and effective manner than most books along this line. 224 pages, 312 illustrations. Price \$1 postpaid. Popular Mechanics Book Dept., Chicago.

SERIES of 8 lithographic models—Steamship, automobile, locomotive, gas engines, steam engine, steam turbine, wireless telegraph and dynamo. Size 8x14 inches. All parts of these machines are shown and numbered to correspond to printed keys of names. Price each, 50 cents, postpaid, or set of 8, \$3.50, postpaid. Popular Mechanics Book Dept., 318 W. Washington St., Chicago.

ENGINE Lathe, swings 9½", takes 25" between centers. Complete set gears cutting all size threads 3" to 40", \$43.50. Grammes & Sons, Allentown, Pa.

FOR Sale—Gasoline engines, automobiles, marine and stationary, also castings. Second-hand ones taken in exchange and for sale. Apply with stamps. B. W. Richardson, R. No. 36, Peoria, Ill.

REBUILT Engines—We have on hand a number of rebuilt "Buffalo" engines, guaranteed, at greatly reduced prices. Write for bargain list. Buffalo Gasolene Motor Co., 1293-1305 Niagara Street, Buffalo, N. Y.

## ENGINE CASTINGS AND BLUEPRINTS

MECHANICS and Handy Men. Build your own 2 H. P. water-cooled gasoline engine. Complete sets of rough or machined castings. Send 10c for photo, blueprint, and catalogue. Vigneau Mfg. Co., 500 Biddle Bldg., Detroit, Mich.

½ H. P. GASOLINE engine castings, \$5. Finished engine, \$22.50. Crown Motor Works, Elgin, Ill.

CASTINGS. ½-horsepower gasoline engine \$5. Mustin Mfg. Co., Newport, Kentucky.

GASOLINE Engine Castings, with drawings. Cheap. Catalog for stamp. Novelty Manufacturing Co., 853 West 6th St., Cincinnati, Ohio.

## BOATS AND LAUNCHES

CHART of a modern submarine boat showing and naming over 200 parts. Size, 11x28 inches. Printed on plate paper. Shows clearly and distinctly all the interior. Mailed in a tube for 25c. Popular Mechanics Book Dept., 318 W. Washington St., Chicago.

MOTORCRAFT Encyclopedia—A 150-page book that tells 1001 things every motor boatman should know. How to overcome engine troubles. Price \$1, postpaid. Popular Mechanics Book Dept., Chicago.

## BLACKSMITHS

SHOP Notes—Many valuable kinds for blacksmiths are contained in our series of Shop Notes books, 9 volumes, 50c each postpaid for \$4.50 per set prepaid. Popular Mechanics Book Dept., 318 W. Washington St., Chicago.

BLACKSMITHS—Here is your opportunity to be an expert blacksmith without help as life is short. Try Toy's Modern Methods doing hard jobs easy. Forging and welding all kinds of steel solid, and tempering and hardening all tools to a standard by colored charts. This is real information, not theory. All for one dollar. Send for free samples. W. M. Toy, Sidney, Ohio.

## FLOUR & FEED MILLING MACHINERY

SPECIAL bargains in second-hand: Attrition mills, burr mills, crushers, corn shellers, bran dusters, dust collectors, purifiers, reels, double, single, 2 and 3-pair high roller mills, sieve bolters, receiving separators, scourers, etc. Write for description and prices. Sprout, Waldron & Co., P. O. Box 429, Muncy, Pa.

## PATENTS FOR SALE

IMPROVED Vehicle Tire—Provides pneumatic tire for vehicles having solid rubber tread. So constructed as to entirely protect the pneumatic tire employed with the invention upon all sides. Will sell this patent at a reasonable price. Excellent opportunity for some one to make money. Particulars free. Alex. Kessler, R. F. D. 4, Webster Grove, Mo.

PATENT for Sale—Anti-skid device. Flexible feeding, quick-detachable. Saves 300%, practical, 24 claims, reasonable. Martin, 29 East 120th St., New York City.

PATENT on Combination Eraser Holder and Pencil Clip. Entirely new; millions can be sold. H. Stamm, Maville, Wis.

PATENT pending, coin-controlled lock box, an automatic checking system to check coats, hats or suitcases. Chr. Lehmann, 87 E. Montcalm, Detroit, Mich.

PATENT incubator, runs by itself; overheating or chilling the eggs impossible. Chr. Lehmann, 87 E. Montcalm, Detroit, Mich.

PATENT 738,310, household article. Will sell or exchange for 1913 A Twin motorcycle. George Henne, New Columbia, Ill.

CANADIAN Patent—Combination Tool, wrench and backaw, excellent opportunity for automobile trade. Best offer accepted. J. O'Malley, 143 W. 127th St., New York City.

HAVE Auto Sled patent and two dandy ideas; will sell for \$800 or a good auto. W. C. Niemann, Box 8, Waltz, Mich.

VALUABLE invention on safety lock for buttons and pins of all descriptions. Illustrated circular free. Alfred E. Shupe, 1637 W. 63rd St., Chicago.

PATENT on Sanitary Collapsible Bed bolster. Shipped Parcels-Post to every home. Want someone to finance or royalty. F. Rahn, Dunning, Ill.

DOUBLE action Hay Press. Best offer takes it. Particulars free. George Heiderken, Rapid City, S. D.

WILL sell patent for gas mixer. Saves gasoline, gives more power. Easily applied. August J. Fritz, Farmington, N. Mex.

WILL sell patent of light steel bob sleighs; dandy seller. J. G. Stoen, Cresbard, S. Dak.

LIFEBOAT Necessity; best ever. Must sell. Wm. M. Harris, Jr., L. B. 31, North Scituate, R. I.

FOR Sale—Patent. Just allowed. Fortune sure. Box 77, Xenia, Ill.

JUST patented—(Commercially excellent)—cheap. Hellwig, 49 Clinton St., Albany, N. Y.

PATENTS for Sale—Attention, Manufacturers: Have patents on reed attachment for automatic pianos; also metal player action. Wonderfully compact and simple in construction, employing one vacuum chamber. Possess real merit and worthy of investigation. A. P. Anderson, Box 18, Station L, Brooklyn, N. Y.

PATENTS for Sale—Inventions to order. Kallafian, Inventor, Boston, Mass.

U. S. PATENT No. 904,830 for sale outright or royalty. Sliding Rule. Factory in Germany; not able to attend to American market. A. A. Boeck, 69 Irving Pl., N. Y. market.

PATENT No. 836,556 amusement device for sale cheap; quick action. A. A. Boeck, 69 Irving Pl., New York.

FOR Sale—U. S. and Canadian patent on logging bunk. Is in use and works successfully. Good proposition for investors. Anlauf Bros., Anlauf, Oregon.

## PATENT ATTORNEYS

FIND out for yourself what to invent and how to procure and sell a patent for the same. My book, "Inventor's Universal Educator," covers the matter from A to Z. 140 pages, elegantly bound. Also contains 600 mechanical movements and 50 perpetual motions. Price \$1, postage free. Money returned if not more than satisfactory. F. G. Dieterich, 651 Ouray Bldg., Washington, D. C.

INVENTIONS Worth Thousands—Their value is governed by the strength of the patent. Get the advantage of our 39 years' experience in procuring your patent. Clients in your state. Write and send sketch. Louis Bagger & Co., 409 Barrister Bldg., Washington, D. C.

PATENTS secured; reliable service; highest references; personal preparation and prosecution of all cases; don't write if you want something for nothing; terms very reasonable; inventions of merit meet with success; associate offices in Washington, New York, London and Berlin; send sketch today; 4c postage brings my latest book, "The Last Word on Patents," by Sanders, 7 Crilly Building, Chicago, Ill.

SEND sketch or model for free advice on patentability. Book telling truth about "No patent, no pay." Sent free. John J. Thompson, patent attorney, Box P, 1110 F St., Washington, D. C.

PATENTS of value. Prompt and efficient service. No misleading inducements. Expert in Mechanics. Book of Advice and Patent Office Rules free. Clements & Clements, Patent Attorneys, 704 Colorado Bldg., Washington, D. C.

PATENTS Secured—Take advantage of my personal experience; send sketch or model. Get my free book containing 266 mechanical movements. W. N. Roach, Jr., 350 McGill Bldg., Washington, D. C.

THE Patentome is interesting and instructive. A liberal education in patents and how to get them. Free on request. Established 1865. Anderson & Son, Patent Solicitors, 707 G St., Washington, D. C.

SEND for free booklet, All About Patents and Their Cost. Shepherd & Campbell, Patent Attorneys, 500 A, Victor Bldg., Washington, D. C.

PATENTABLE ideas wanted—Send for 3 free books. R. B. Owen, 30 Owen Bldg., Washington, D. C.

A PATENT experience of 23 years makes my services invaluable in honest inventors. My free book tells the story. Write for it today. A. M. Wilson, 300 Victor Bldg., Washington, D. C.

"PATENTS and Patent Possibilities," is a 72-page treatise which tells all about patents, what to invent and where to sell it. It gives honest advice to inventors, and is full of valuable and interesting information. Write for it today! It is free. H. S. Hill, 905 McLachlen Bldg., Washington, D. C.



**PATENT** your invention. First get our square deal contingent fee plan. Milo B. Stevens & Co., Estab. 1864, 685 F St., Wash.: 353 Monadnock Bldg., Chicago.

**PATENT** Books Mailed Free—Showing 100 mechanical movements invaluable to inventors and mechanics—and telling what is patentable, how to obtain patent or partner, how to sell, etc. Free on request. Chas. E. Brock, 701 Eighth Street, Washington, District of Columbia.

**PATENT** secured or fee returned. Send sketch for Free Expert Search and report as to patentability. Books on inventions and patents, and reference book sent free. John S. Duffe & Co., 665 F St., Washington, D. C.

**REGISTERED** Attorneys make our searches. Send sketch for free report. No Attorney fees until patent allowed. Free books. Fuller & Fuller, Washington, D. C.

**INVENTIONS** patented at moderate cost in the United States and foreign countries. Send for our booklet. Copp & Co., Copp Bldg., Washington, D. C.

**PATENTS** explained in my free books, telling what you should know—what to invent—what not to invent—how to sell your patent, etc. Write today, H. L. Woodward, 902 G. St., Washington, D. C.

**PATENTS**, electrical and mechanical a specialty. Book Free. Joshua R. H. Potts, Patent Lawyer, 8 Dearborn St., Chicago; 805 G. St., Washington; 929 Chestnut St., Philadelphia.

**FOR** honest advice and real patents at low cost, consult John O. Seifert, Patent Attorney, 50 Church St., New York, N. Y.

**PATENTS**—Herbert Jenner, patent attorney and mechanical expert, 606 F St., Washington, D. C. I report free of charge if a patent can be had and its exact cost. Send for circular.

**C. L. PARKER**, Ex-member Examining Corps Patent Office, Patent Attorney, 910 G St., Washington, D. C. Inventor's handbook "Protecting, Exploiting and Selling Inventions," sent free upon request.

**PATENTS** that protect and pay. Advice and books free. Rates reasonable—highest references; best results. Watson E. Coleman, Patent Lawyer, 622 F St., N. W., Washington, D. C.

#### FOR INVENTORS

**BEFORE** spending money on patent or model, get free opinion of successful manufacturers. You are fully protected meanwhile. Van Deventer and Warren, Sumter, S. C., Patent Attorneys, Development Engineers. Write us first. Electrical inventions especially.

**DRAWING**—Patent, mechanical, illustration, map; blueprinting, perspectives. San Jose Drafting Co., San Jose, Cal.

\$20 **GOLD** premium free. Money loaned inventors; particulars free. J. A. Buchanan, Columbus, Ga.

**SUBSCRIBE** to Invention, Washington, D. C. It suggests and develops ideas to hasten success of inventors. Only magazine truthfully reporting patent successes, opportunities and news. Publishes big list of valuable opportunities and suggestions; simplifies patent matters, saves money. Year \$1. Special: Four months 25c cash.

**INVENTIONS** patented free—marketed on commission. Address Inventors' Agency, Chicago.

**WANTED**—Inventions; patents sold; highest references. Higgins, 504 Crilly Bldg., Chicago.

**SEND \$1** for scientific engineering criticism and names of parties interested in your invention. Bureau of Special Information and Research, Buffalo.

**INVENTORS** Wanted—To submit devices or street railway transfer system, also other inventions. For particulars address Inventors' Mutual Development Association, 303 Potomac Bank Building, Washington, D. C.

**PATENTS** without advance attorney's fees. Send sketch for free report. Books free. Fuller & Fuller, Washington, D. C.

**PATENTABLE** Ideas Wanted—Send for free books. R. B. Owen, 30 Owen Bldg., Wash., D. C.

**PATENTS**, Trade-Marks and Copyrights. Our hand book on patents will be sent free on request. All patents secured through us are described without cost to the patentee in the Scientific American. Munn & Co., Patent Attorneys, 359 Broadway, New York, Washington, D. C. office, 383 F Street.

**INVENTORS**: My patent made a fortune. Particulars free. Let me sell yours. Eugene Pearl, 21 Union Square, New York.

#### REAL ESTATE AND FARM LANDS

**GO** South and Prosper. The greatest opportunities in America today are offered by the Southeastern States. Fortunes made from truck, fruit, poultry, cattle, dairying and general farming. Land \$15 an acre up. Climatic and living conditions ideal. Farm lists, "Southern Field" magazine free. M. V. Richards, Land and Industrial Agent, Southern Railway, Room 64, Washington, D. C.

**FARMING**—Safety, large returns. Exceptional opportunity for safe investment of amounts from \$100 and up. Good returns guaranteed and our guarantee is bankable. Favorable letters from bankers and others. It will stand the fullest investigation. Write us. Let us tell you more about this exceptional opportunity. Woodlawn Farm, Sterling, Ill.

**FARMING** on the Texas Gulf Coast pays big profits. There is wonderful fertility, ample rainfall, delightful climate, cheap lands (\$20 to \$50 acre) and low taxes. Good roads and schools. Cotton, corn, potatoes yield high. Dairying and poultry raising making big returns. Gulf Coast folder free. R. P. Kennedy, Colonization Agent, GC&SF Ry., Galveston, Tex.

**STOCK** Ranch—11,000 acres Billings County, North Dakota; good buildings, abundance of coal and located on main line Northern Pacific Railroad, \$5 per acre. Geo. R. Slocum, Pioneer Bldg., St. Paul, Minn.

**480-ACRE** stock farm, \$50 per acre. Eighty miles Kansas City. Write S. S. Irwin, Kincaid, Kan.

**CHEAP** Homes—Wisconsin cut-over lands for laboring people, \$7.50 to \$15 per acre, monthly payments. Write for folder. Geo. R. Slocum, Pioneer Bldg., St. Paul, Minn.

**TRY** locating in Florida—Best situated and most fertile land—rent free for five years, with privilege of buying. G. W. Soule, Camp Walton, Fla.

\$20 **DOWN**, \$10 per month. No interest charged, secures you good home farm investment. Close to big markets. Big crops this year; always good crops. Rich soil, sufficient rainfall. Write today for land owner's success. Government reports, maps, Loveland Company, Minneapolis, Minn.

**CONNECT** land buyers and sellers by mail. Men without experience or capital provide big annual income, constantly increasing. Write for proposition. Dunning Realty Co., Aulander, N. C.

**FLORIDA** Home-Seekers and Investors can secure valuable information on Florida crops, climate, soil, schools, etc. Many business openings and some low-priced land in this vicinity. Address Secretary, Chamber of Commerce, Lake Worth, Palm Beach County, Florida.

**CO-OPERATIVE** Homestead Clubs enable people to own farms. Become independent. Club now locating. Edward Miller, Crystal Springs, Fla.

**1,700 ACRES** of Mississippi Farm and Timber land for sale in one tract. \$10 per acre. Easy payments. R. P. Cook, Utica, Miss.

**HOOD** River Valley, Oregon. Orchard Land. Snap. Would consider nearby income property in part. Fred S. Holsteen, Burlington, Iowa.

**PROFITABLE** New Jersey Farms. Unsurpassed markets and soil. List free. A. W. Dresser, Burlington, N. J.

**FOR** Sale—Colorado quarter. Investigate. Dr. Smyth, Yankton, So. Dakota.

**THE** Truth About Florida. Ours is the only agricultural paper printed in Florida. Questions answered truthfully. Weekly \$1.50; monthly 50 cents a year. Florida Grower, Mechanic St., Tampa, Fla.

**BUY** a farm any place on the continent of North America. We will give you the names of the owners free. American Investment Association, 37 Palace Bldg., Minneapolis, Minn.

**IDEAL** Homes—Fruit, vegetables, poultry, live stock. Illustrated booklet. State Board Agriculture, Dover, Del.

**SELL** your property quickly for cash, no matter where located. Don't pay big commissions. Particulars free. Real Estate Salesman Co., Desk B, Lincoln, Nebr.

#### FORMULAS

**FORMULAS**—3,000 Formulas and Digest. One year, 50c; or silvering mirrors formula and Digest one year, 25c; or 200 formulas, etc., and Digest one year, 25c. Digest, Grand Rapids, Mich.

**20,000** FORMULAS. Price, \$1, prepaid. Complete list 4c (stamps). Edm. Bromley, Watervliet, N. Y.

**SILVERING** Mirrors, Magic Reproducing fluid, Invisible Inks, Formulas. Excellent; send two dimes for instructions. H. W. Cowan, Lewes, Del.

**RENEW** old dry batteries. Four formulas and instructions, 25c. C. Williamson, Floresville, Tex.

**3,000** FORMULAS, recipes, 50c; 100 money-making secrets, 25c; 500 excellent formulas 20c; how to resilver mirrors—renew dry batteries—transfer photos to glass—make printing cuts, rubber stamps—sneezing powder—itch powder, 20c each. All above sent prepaid for \$1. P. S. Bureau, Dept. 10, 3311 Belleplaine Ave., Chicago.

**RUBIES** and other precious stones now chemically made. Send fifty cents for explanation of this wonderful process. No stamps. C. C. Jonas, Engineer and Chemist, Lloyd Hotel Bldg., First and A Sts., San Diego, Cal.

**FORMULA**—Everlasting whitewash. Paint substitute. Paints anything. Complete 35c. Brooks, Mountford St., Hartford, Conn.

**COMPLETE** instructions how to silver mirrors for dime. Navratil, 9 Fleming, Atlantic City, N. J.

**1,000,000** FORMULAS and trade secrets, 1,000-page book, \$1.50. Ell Emm, 667 Ocean Ave., Jersey City, N. J.

**READ** advertisement in miscellaneous column "Get The Latest."

#### GINSENG

**GINSENG** roots, 50,000 one year old, \$10 per 1,000. C. G. McBride, Route 4, Mansfield, Ohio.

**GINSENG** Journal, Arrowsmith, Ill., 44-page monthly, 50c year. Marketing ginseng, golden seal; vital interest.

**GINSENG** and golden seal roots and seeds for sale. Paul Hacker, Leonidas, Mich.

**GINSENG**—Excellent two and three year roots. Our own raising. Healthy. C. N. Cloes, Akron, Ohio.

\$25,000 **MADE** in spare time. Raise Goldenseal. Circulars free. Bowman Gardens, Albany, Wis.

**BIG** money growing Ginseng. One acre yields 5,000 lbs. worth \$7.00 a lb. Easy growing. Write for particulars. Schwartz Bros., Dept. B, Spring Green, Wis.

**GINSENG** Raising is the surest way for you to make Big Money on Little Capital. One acre yields about 5,000 lbs. Sells at \$6 a lb. I will buy all you raise. Write today for my easy natural method. T. H. Sutton, 1000 Sherwood Avenue, Louisville, Ky.

#### FOR MEN

**UNITED** States Army Regulation Shoe. Send for catalog describing shoes adopted by United States government. Designed by Army Surgeons. The most comfortable and durable shoe made. Guaranteed as represented or money refunded. The Haynes Shoe Company, Lewiston, Maine. Reference: First National Bank, Auburn, Maine.

**SAVE** Shoe Money. Buy Men's Fine Union Made Shoes Direct from Factory and save \$1 to \$2 per pair. Satisfaction guaranteed. Prompt shipment. Write tonight for "Booklet P." Pathfinder Shoe Co., Dudley, Mass.

**PURE** Silk Sox, 3 pair \$1. Black, Tan or Gray. State size. Murphy-Lucas, Wallace, Idaho.

**WANTED**—Safety razor blades to sharpen, 2c a blade. Box 212, Poughkeepsie, N. Y.

**RAZOR** Free. Send no money. We will give one \$2 Razor free of charge to the first customer in each locality. Send 5c postage and we will send Razor for a 15 days' trial. If you wish to keep it send us \$1.80 for our High-Grade Strop, Hone and Brush and the Razor is yours. Address Geneva Supply Co., Dept. 174, Chicago.

**FREE!** Barbers' Rival Safety Razor with year's supply of Creaso, 25c. Keeps trousers creased. Money back if dissatisfied. Dealers, agents, write! Rodolph, Manufacturer, Northwestern Building, Chicago.

**QUIT** tobacco entirely, or control amount used, without hardship. Write for free samples of Tobaccocure. The Tobaccocure Co., Carthage, Mo.

**GENUINE** Calabash Gourds. Make your pipe holder, hanging basket, and grow gourds next season from one gourd. Entire gourd, full instructions, prepaid, fifty cents. C. Hopkins, Lamanda Park, Calif.

**SAFETY** razors sharpened; two cents each. Guaranteed. Blade box free. Electro Stropping Co., 134 Shelby St., Detroit, Mich.



## FOR WOMEN

**LADIES:** Earn \$3 to \$5 a day during spare time; sell every member of household: Murphy, Box 295, Wallace, Idaho.

## FOR THE HOME

**MAKE** your own furniture at the cost of raw material. Over 100 designs with instructions, only \$2. Detailed information free. Crater & Holt, Grand Rapids, Mich.

**GOLDFISH,** water plants, aquariums, canaries. Free catalogue. Pioneer Gold Fish Hatchery, Racine, Wis.

**THE Aluminum Percolator Extracts** all Aroma from the Coffee. Millions sold. Fits any coffee pot. It floats. 6 cup size 40c, 12 cup size 60c. Karl Lander & Co., 16-1 1st Ave. S., Minneapolis, Minn.

**MAKE** your own mission furniture at the minimum of expense. Our 3 books "Mission Furniture, How to Make It," Parts 1, 2 and 3, tell in plain, simple language just how to make 98 different pieces. Full dimensions working drawings and half tones of finished articles. Price, 50 cents each or \$1.50 for the three volumes, postpaid. Popular Mechanics Book Dept., Chicago.

**METAL** Work and Etching—A 96-page handbook for art metal workers telling how to make a great variety of useful and ornamental objects, such as desk sets, arts-crafts, jewelry, etc. Price, 50c, postpaid. Popular Mechanics Book Dept., Chicago.

## TELEGRAPHY

**TELEGRAPHY** and train operation taught by retired railway officer. Graduates placed. Expenses earned. Pelmar School of Telegraphy, Madison, Wis.

**TELEGRAPHY**—Morse and Wireless—Railway Accounting (Station Agency) taught quickly. Railroad and Western Union Wires and complete Wireless Station in school. Big demand. Positions secured. Living expenses low—may be earned. Largest and oldest school—established thirty-nine years. Investment, \$25,000. Correspondence courses, also. Catalog free. Write today. Dodge's Telegraph Railway and Wireless Institute, 15th Street, Valparaiso, Ind.

**TELEGRAPHY** taught in the shortest possible time. The Omnigraph Automatic Transmitter combined with standard key and sounder. Sends you telegraph messages at any speed just as an expert operator would. Five styles, \$2 up, circular free. Omnigraph Mfg. Co., 41 G. Cortland St., New York.

## ELECTRICAL

**ARMATURE** punching die 1 1/2 in. diameter, 12 slots. Price \$15. Wagner rectifier, 6 amp., 10 volts, with ammeter. Price \$20. Powerful X-ray outfit, 2 tubes, 2 screens, shield, stand, transformer and coil. New. Cost \$120. Price \$60. Houghton, 141 St. Jerome Ave., Holyoke, Mass.

**\$15 TAKES** 1/4 horse-power motor and vacuum pump, scarcely used. Koren, 1621 Jackson Blvd., Chicago.

## WIRELESS

**WIRELESS** Set. How to Make—96-page book telling how to construct at small cost an outfit suitable for transmitting four or five miles. Price 50 cents, postpaid. Popular Mechanics Book Dept., Chicago.

## PIANOS AND MUSICAL INSTRUMENTS

**ELECTRIC** piano, with keyboards, \$125, good as new. Guaranteed. J. F. Herman, Washington, D. C.

**ELECTRIC** Pianos \$100. Terms. Catalogue. Continental Novelty Co., Omaha, Neb.

**VIOLIN** for sale, cheap. Excellent toned. Sent on trial. Miss Bertha Mardisse, Rose-dale, Kansas.

**TALKING** machines and records at cut prices. 100,000—10 inch records never sold less than 60 cents. Our cut price 20c each. Send for catalogue. Deninger, North St., Rochester, N. Y.

## MUSIC

**SONG** poems wanted—We have paid thousands of dollars to song writers—send us your poems or melodies. Acceptance guaranteed if available by largest, most successful concern of the kind. We publish, advertise, secure copyright in your name and pay 50 per cent if successful. Hundreds of delighted clients. Write today for Big Magazine, Beautiful Illustrated Book and examination of your work—all free. Dugdale Co., 1036 Dugdale Bldg., Washington, D. C.

"JUST a Little Keepsake," the new popular song that appeals to every human heart, arranged for piano, will be mailed to any address upon receipt of 10 cents in coin or stamps. Sunny-Songs Pub. Co., Box 373, Chicago, Ill.

"SWEET Home of Paradise" (new sacred song)—As fine as "The Rosary" or "Face to Face," postpaid 15 cents. Bros. Novelty Co., Dept. 25, Williamsport, Pa.

**BEGINNERS** can play piano or organ selections right off—first trial without teacher, or \$1,000 forfeit. Write Musician Selfmaker Co., Chicago.

**SONGS** of Sunny Southland, "Florida, Florida, You Have Made Me Care," "Way Down South Below the Line," 15c each. O. A. Schmah, Box 188 N. Ashtabula, Ohio.

"KISS-I-MEE" Indian song, "American Girl" waltz song, 25c silver. Box 774, Columbus, Ohio.

**WALTZ** by King, "Come to My Garden," 15c. Dugdale Co., 1431 You St., Washington, D. C.

**GOOD** News—"Lovers' Lane," an exceptionally beautiful melody, will be sent to you free of charge. Write today. H. O. Prell, 900 La Salle Ave., Chicago.

**ALL** the new and standard music at cut prices. Sheet music for 5c up. Catalog free. Semple's Music House, Norwalk, Conn.

## TYPEWRITERS AND SUPPLIES

**SAVE** \$25 to \$50 on manufacturers' prices. Buy our Factory Rebuilt Typewriters. Nearest-to-new on the market. Have trademark and guarantee, like new machines. Are thoroughly rebuilt, highly polished and perfect in appearance. Satisfaction guaranteed. We are the largest rebuilt typewriter concern in the world. Branch stores in leading cities. Write for catalog of standard makes. American Writing Machine Co., Inc., 345 Broadway, N. Y.

**REORGANIZATION** Clearance Sale. Absolutely reliable typewriters (all makes, all models, all prices), shipped anywhere subject to examination. \$5 worth supplies free. Visible, \$10 up. Oldest Typewriter Exchange, Consolidated Typewriter Exchange, Inc., 245 Broadway, New York.

**TYPEWRITERS** and Carbon paper; lowest prices. Ribbons 25 cents. Typewriter Specialty, 15 North 7th St. St. Louis, Mo.

**THIS** Month—100 No. 3 Oliver Visible Typewriters at a sensational price. Terms \$3 a month—5 days Free Trial—completely equipped. Guaranteed same as if regular catalog price were paid. United States Typewriter Exchange, Dept. 34, Federal 1 1/2 Bldg., Chicago.

**SEE** my \$2 a month typewriter sensation on page 112. Harry A. Smith, Chicago.

**BANKRUPT** Sale—Greatest in History: \$100 Typewriters like new. Low as \$10. Get one—save the difference. Send for trial, our expense. Write for catalogue No. 16. Office Supply Co., 235 W. 4th St., Cincinnati.

**ALL** standard makes of typewriters, everything else cut out. Big saving. Liberal guarantee. Catalog, bargain list and valuable typewriter information free. A. E. Atchison, 110-12 N. La Salle St., Chicago.

## GAMES AND ENTERTAINMENTS

**BOOK** "Card Tricks and Sleight of Hand," 182 pages, paper cover, 25c. "Tricks with Coins," 170 pages, 25c. "Practical Ventriloquism," 25c. Elite Exchange, R18, 3827 Kenneth Ave., Chicago.

**TRICKS!** Tricks! Largest assortment of Tricks, Jokes and Novelties in the world. Send 2c stamp for illustrated catalogue No. 4. C. J. Felsman, 164 N. Clark St., Chicago.

**13 FUNNY** Love Letters (reads two ways), dime, silver, J. L. Hardway, Normal, Ill.

**10 CARD** tricks and cards, 10c. McGuinness, 612 East 4th Street, Brooklyn, N. Y.

**THE** wonderful Soap Bubble Cone and a Box of magic soap ointment. The box contains a thousand big rainbow Balloon Bubbles that float and bounce. Fun for everyone. Send 10 cts. in silver to Steinmetz & Groh, 317 Northwestern Bank Bldg., Minneapolis, Minn.

**MAGIC** tricks, books and supplies. Largest line in the world. Old reliable firm. Mammoth illustrated professional catalogue, ten cents. Read & Covert, 821 East 43rd Street, Chicago, Ill.

**PLAYS,** Vaudeville Sketches, Monologues, Dialogues, Speakers, Minstrel Material, Jokes, Recitations, Tableaux, Drills, Musical Pieces, Entertainments for all occasions. Make-Up Goods. Large Catalog free. T. S. Denison & Co., Dept. 11, Chicago.

**LEARN** to entertain! Wonderful magic trick cards 10c. Free catalogue. Walwyn Company, 150 Nassau Street, New York.

**SNEEZING** powder, makes everybody sneeze their heads off without knowing why. Complete formula and instructions 25c. P. S. Bureau, 3311 Belleplaine, Ave., Chicago.

**2,336 DIFFERENT** Tricks, Games, Puzzles, Card Tricks, etc., and fine Boys' Magazine for six months, all for 10c. National Co., Chicago.

**PROFESSIONAL**—Amateurs, send dime for 62 complete (copyrighted) mind-reading tricks and catalogue. Prof. Halloran, 2533 Church Ave., Brooklyn, N. Y.

**250 MAGIC** Stage Tricks, including the "Mystery of the Floating Head," for 10c. Victoria Co., Chicago.

**NEW** and Novel Jokes—great fun producers. So simple a child can operate them. 1. The Spilt Jam (Look what you've done to the table cloth! !). 2. Red Hot Cinder (Drop it on the rug or floor in front of fireplace). 3. Damaged Finger (Deceptive blood-soaked bandage. Great sympathy is expressed by your friends). Price, 10 cents each, postpaid. Address Popular Mechanics Book Dept., 318 W. Washington St., Chicago.

**FREE** Magic Catalog, 208 pages. Send 6c stamp for New Pocket Trick and particulars. Magic Co., Sta. 10, 249 West 38th St., New York.

**BE** a Magician, travel, give shows, make money. I tell how. Send stamp. Prof. Rapp, Box F1115, Madison, Wis.

**BOX** of Ten new stage tricks for One Dollar and latest catalog. Western Sales Company, 950 Cromwell Ave., St. Paul, Minn.

## RARE COINS

**TRADE** dollar 1885 sold for \$1,140; 2) cent 1876cc \$250; \$1 gold 1861d \$230; \$3-1870s \$1,450. Equally high premiums on thousands of coins, stamps, books, paper money. Illustrated circular free. Vonbergen, O. Boston, Mass.

**OLD** coins bought and sold. New Fall Coin Selling Catalog just out, free to collectors only. Buying Coin Catalog quoting prices 1 pay 10c. Wm. Hesselein, Paddock Bldg., 101 Tremont St., Boston, Mass.

**EXCHANGE** old coins, notes for old curious things. C. J. Carey, New Rochelle, N. Y.

**\$1 TO \$1,000** cash paid for all rare money to date. Many valuable coins in circulation. Get posted. Send stamp for large illustrated coin circular. It may mean much profit to you. You certainly have nothing to lose. Send now. Numismatic Bank, Dept. H, Ft. Worth, Texas.

**\$4.25 EACH** Paid for U. S. Flying Eagle Cents dated 1856. We pay cash premiums on hundreds of Old Coins. Send ten cents at once for New Illustrated Coin Value Book 4x7. It may mean your fortune. Clarke & Co., Coin Dealers, Box 15, Le Roy, N. Y.

## STAMP COLLECTING

**STAMPS** Free! 100 different or a grand set of 5 Rhodesia. Mention gift D196; send 4c postage. 500 different stamps 96c. 1,000 different \$3. Bright & Son, 164 Strand, London, Eng.

**FREE!!** 100 different stamps, or a fine set of 6 Tunis; send 4c postage; mention gift 352. Approvals 50 per cent discount. J. Wheeler & Co., 124 Lennard Rd., Beckenham, Kent, Eng.



# If I Send You This Suit

made to your measure, in the latest style, would you be willing to keep and wear it, show it to your friends and let them see our beautiful samples and dashing new styles?

Could you use \$5.00 a day for a little spare time? Perhaps I can offer you a steady job. If you live in a town smaller than 10,000, write me a letter or a postal at once and say: "Send me your special offer," and I will send you samples and styles to pick from and my surprising liberal offer.



Address: L. E. ASHER, President  
BANNER TAILORING CO., Dept. 506, CHICAGO

## LAW TAUGHT BY MAIL

University Methods

Theory and Practice. Faculty, Prominent Attorneys. Courses (UNIVERSITY BANKING, BUSINESS) most Complete, Practical, Easy to learn. University course GUARANTEED. Prepare for bar any state. LAW DEGREES LEGALLY CONFERRED by correspondence. Endorsed by Bench and Bar, Business Men, Graduates, Students. Write for HANDSOME FREE CATALOG, Special Scholarship Offer and evidence of results.

McKINLEY UNIVERSITY, 1523 E. 55th St., Chicago, Ill.

# STUDY AT HOME

50 courses of study in common school and high school branches, in business, shorthand and pharmacy. Our diplomas are honored in 25 universities, colleges and state normals, a recognition earned by honest, efficient service. You cannot afford to study with a school whose standard is lower. Instructors are college graduates and former successful teachers, who devote themselves solely to our work. Ask for information today. State your particular needs.

INTERSTATE SCHOOL OF CORRESPONDENCE, 627-641 Wabash Av. Chicago, Ill.

## FREE BOOK OF MAGIC

Giving information on 573 marvelous sleight of hand tricks, magicians' apparatus and books of mystifying entertainments. For amateurs as well as the Great Professionals. Anyone can learn through our instructions. Easy, interesting and entertaining. Mystify and astonish your friends. Give shows and make money. Our wonderful book sent FREE to any address. To cover packing and mailing enclose 10 cts.

Read & Covert, 821 E. 43d St., Chicago

# You Have the Ability

to make \$20 to \$35 weekly during spare time and soon be permanently established in a profitable business as factory sales representative for economy products—quick selling automobile supplies and devices. Sell to both dealer and consumer. Repeat orders come fast, take no time or effort and bring you immense profits. Experience and capital not necessary—enthusiasm and common sense more essential.

Get full information at once  
ECONOMY AUTO SUPPLY HOUSE, 611 Crilly Bldg., CHICAGO

## 2336 Different Magic Tricks,

Puzzles, Songs, Stories, Games, Cards, Jokes, Riddles, Money Making Secrets, etc. as Itemized:  
33 Splendid Games, 200 Cards, 96 Songs, 89 Fun Cards, Over 300 Magic Tricks, 366 Jolly Jokes and Riddles, 125 Money Making Secrets, and hundreds of other things with a fine Boys' Paper containing fine stories and Departments for 6 months all for 10c postpaid. Send to NATIONAL CO., Dept. E, Chicago, Ill.

## 200 Kinds Iron, Wood Puzzles

Wire & Steel

Catalog and leader, 10c—3 for 25c 7 for 50c; 15 for \$1—no two alike.

WESTERN PUZZLE WORKS  
St. Paul, Minn.

## Every Boy His Own Toymaker

Greatest boys' book ever written. Tells how to make a Steam Engine, Telephone, Magic Lantern, Boats, kites, balloons, electrical and mechanical toys, traps, fishing tackle, 200 illustrations; also catalog of 150 puzzles, Keller's Magic Ace Trick Card and "DOUBLE THROAT" warbler and bird call all for only 10c. WESTERN PUZZLE CO., ST. PAUL, MINN.

## LEARN WATCHMAKING AND ENGRAVING

Earn while learning. Most practical watch school. Individual instructions. Graduates in great demand. Book free.

Chicago School of Watchmaking, 63 E. Van Buren St., Chicago

# Can You Accept a \$2,500 Job

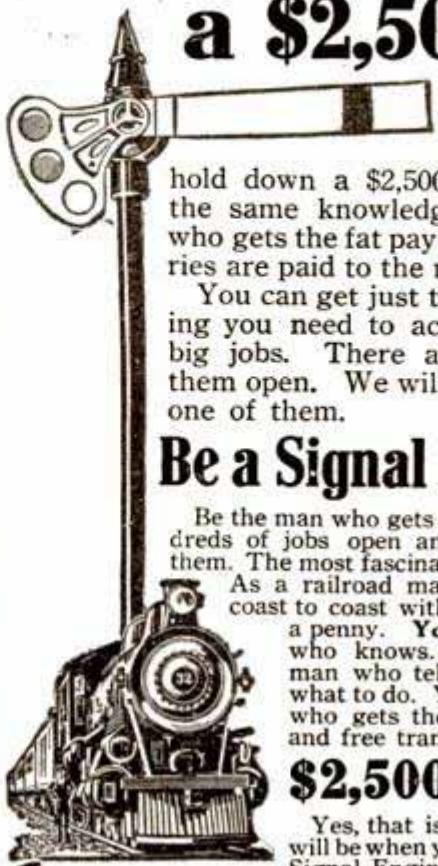

Have you the training that is necessary to hold down a \$2,500 job? Have you the same knowledge as the man who gets the fat pay envelope? Salaries are paid to the men who know. You can get just the kind of training you need to accept one of the big jobs. There are hundreds of them open. We will help you to get one of them.

## Be a Signal Engineer

Be the man who gets \$2,500 a year. Hundreds of jobs open and nobody to take them. The most fascinating of professions. As a railroad man you travel from coast to coast without it costing you a penny. You can be the man who knows. You can be the man who tells the other fellow what to do. You can be the man who gets the fat pay envelope and free transportation.

## \$2,500 a Year

Yes, that is what your salary will be when you are a full fledged Signal Engineer, \$2,500 a year to start. Hundreds and hundreds of men making much more than that. Even while you are learning you can hold one of the positions under a Signal Engineer. Paying you \$75 to \$195 a month. Here is your opportunity. Send in the free coupon for full particulars.

# More Men Needed

Railroads are constantly looking for competent Signal Engineers. There are not enough men to fill the positions now open. Thousands and thousands of miles of track are now being equipped with automatic signals. Hundreds of new positions will be open. And there are no men to take them. Here is your chance.

## Free Outfit

If you will write at once you can get the big new Signal Engineer's outfit absolutely free. Our students get practical instruction. The kind the railroads demand. If you act at once the outfit is free to you. Send the free coupon for full particulars.

# Send the FREE Coupon for Big New Book

Just put your name and address on the free coupon and send it in to us at once. Absolutely no obligations of any kind. We will send you the big new Signal book absolutely free. Tells you all about this most fascinating profession. How you can get into the \$2,500 class. The book is free. Get your name and address in at once.

## FREE BOOK COUPON

Department of Signaling  
Desk 1197  
491 Cass St.  
Chicago, Ill.

GENTLEMEN: Please send me absolutely free and prepaid your big new Signal book. Also full particulars about your great special free outfit offer. It is distinctly understood that I assume no obligations of any kind.

Department of Signaling  
Desk 1197  
491 Cass St.  
Chicago Ill.

Name.....  
Address.....  
Age..... Occupation.....



**SPECIAL**—285 different stamps 25c. Atlas Stamp Co., W. Somerville, Mass.

500 **MIXED** Foreign Stamps, hinges, album, approval sheets and catalogue, 15c. 40 different United States, 8c. Essex Co., 4730 Chickering Ave., Dept F, Cincinnati, Ohio.

**WANTED**—A collection of postage stamps for cash. Paul Riccicci, Schenectady, N. Y.

**STAMPS**—14 Cape, 10c. 15 Transvaal, 10c. 14 Siam, 20c. 12 Brazil, 5c. Pierce & Co., Manchester, Mich.

**STAMPS** for collectors. Good variety, mounted alphabetically, reasonably priced. Reference necessary. Premium, 5 Bolivia. Mrs. Louise Kellogg, West Hartford, Conn.

**FREE**—Fine Zoological packet, 2c stamp postage. Stamps bought; buying list 10c. Lightbown's Stamp Co., Southsea, England.

**TRY** my approvals of U. S. stamps; reference please. If you have any for sale send for my buying list. Guy T. Siltor, Watkins, N. Y.

200 **DANDY** Foreign stamps 20c. 500—40c. P. S. Bureau, 3311 Belleplaine Ave., Chicago.

200 **DIFFERENT** Foreign, 25c; 500 different, \$1. Hardy's Bookstore, Oakland, Cal.

**STAMP** magazine free. A. C. Roessler, 7 Jay St., Newark, N. J.

**FREE!** 110 Foreign Stamps, Album and Catalogs, for 2c postage. Payn Stamp Company, 138 N. Wellington St., Los Angeles, California.

205 **DIFFERENT** foreign stamps, 101 United States, 50 Spain, 30 Sweden, or 25 Canada, free. Remit 25c six months' subscription. McKele's Stamp Weekly, Boston, Mass.

**STAMPS**, 15 varieties, South and Central America, 4c, sent with our net approvals. Palm Stamp Co., Box 174, Arcade Station, Los Angeles, Cal.

24 **VARIETIES** Cuban stamps 10 cents. List of 6,000 low-priced stamps free. Chambers Stamp Co., 111 P. Nassau St. New York City

25 **DIFFERENT** British Colonials to applicants for stamps on approval. Chas. Nickles, 122 Florida Ave., Washington, D. C.

**STAMPS**, 100, all different, free. Postage 2c. Mention paper. Quaker Stamp Co., Toledo, Ohio.

**STAMPS**—105 China, etc., stamp dictionary and list, 2c. Bullard, Sta. A, Boston.

**PACKET** of 23 stamps; no two countries alike, 500 hinges. Set of \$1 and \$2 U. S. Rev., all for 5c. Miami Stamp Co., Toledo, Ohio.

## PRINTING AND ENGRAVING

1,000 **CIRCULARS**, 3 1/2 x 6 bond paper, \$1. 100 envelopes, 100 letterheads, 100 return envelopes, \$1. All neatly printed, postpaid. Udell, Printer, Station A, Indianapolis.

**PRINTING**—500 either note heads, envelopes, statements, cards, \$1; 1,000, \$1.50; 1,000 envelope slips, \$1. 1,000 linen finish letterheads or envelopes, \$2.50. 1,000 typewriter letters, \$2. Samples. Model Company, Manchester, Iowa.

**SAMPLE** 100 letterheads, envelopes or cards printed, 45 cents prepaid. Andrew Brems, Corona, N. Y.

1,000 **CIRCULARS** printed, 65c postpaid (225 words). G. J. Myers, Codorus, Pa.

\$75 **COMPLETE** printing outfit for \$25. United Printing Co., Wilkesburg, Pa.

100 **ENVELOPES** printed to order 30c. Cycle Press, 1081 Jason, Denver, Colo.

**FOR** printing presses, type, rollers recast, etc., send for catalog, "Model Press," York, Pa.

200 **LETTER** Heads and Envelopes and Business cards, \$3. Wilson's World, Chicago, Ill.

500 **LETTER-HEADS**, Bill Heads, or Envelopes, best work, \$1.25. Send for Price List. Riverside Press, Hillman, Maine.

**HALF-TONES**—Send photo and receive half-tone cut any size up to 3-inch square for \$1. Mitchell Brothers, 648-650 Broadway, Newburgh, N. Y.

**PRINTING** That Pleases: 50 white, blue or golden bond letterheads and 50 envelopes matched, 60c; 100 of each \$1, prepaid. Prompt service. Race Bros., Hudson, N. Y.

100 **LINEN** Calling Cards 50c; 250, \$1. Fred Hei mueller, Jamestown, N. Y.

125 **BOND** Letterheads and 125 Envelopes, white, pink, blue or green, printed, \$1 prepaid. Samples. W. Kinnier, Box 206, Brooklyn, N. Y.

**ARTISTICALLY** lithographed letterheads, ten thousand \$25, twenty \$42. Get our samples. International Lithographing Co., Rochester, N. Y.

100 **CARDS**, also imitation leather card case, for 50 cents. M. F. Devancy, Printing, Engraving and Rubber Stamps, Geneva, N. Y.

1,000 **IMITATION** Typewritten letters, heading black, body purple, \$3. 6x9 Circulars, Envelopes, Tags, Statements, Billheads, Letterheads, \$1.50. Elegant samples free. Good's Printery, Harrisonburg, Va.

300 **BOND** letterheads, with envelopes to match, neatly printed, postpaid \$2. Advertiser, Mansfield, Pa.

**YOUR** name on 200 gummed stickers, 10c. Star Co., Clintonville, Conn.

**PRINTING** Presses, supplies, second-hand, at bargains. List for stamp. Popular Bargains, Richland, Pa.

**ALL** for \$1.25: 100 Letterheads, (8 1/2 x 11), 100 Envelopes, 100 Business Cards printed to your order on Bond paper. Prepaid. Samples free. Carter Company, Rochester, N. Y.

**FIFTY** calling cards and card case, 35c. Satisfaction guaranteed. Home Printing Co., Box 162, Washington, D. C.

**MULTIGRAPH** form letters—\$3 for 1,000. Includes stock, letter, letterhead—sent prepaid in U. S. Specimens free. Perfection Letter Company, Muncie, Indiana.

**PRINTING** Presses, type, supplies. Catalog free. L. M. Carroll & Co., 326 Madison St., Chicago.

**GOOD** Printing at low prices. 1,000 good letterheads, envelopes, cards, billheads, labels, circulars, \$2.50. Samples free. Catalogues, booklets, and circulars our specialty. Ernest L. Fantus Co., 523 S. Dearborn St., Chicago.

## MISCELLANEOUS

**STARR'S** Yankee Trader and Mixer will be off the press September 10th, and right at the send off will be read by over 5,000 live wire business men, traders, mixers, schemers and agents. Here is where your "ads" will reach over 5,000 thru a new publication. Alive from cover to cover. Best medium for you to get in touch with live wires for your goods. 25 cents for first three months' subscription, including your 25-word ad one time free. Trial copy 5 cents; first three months, without ad for a dime; \$1 a year. No free copies. Send your 25-word ad and two bits to Starr's Novelty & Printing Co., 810 Cherry St., Toledo, Ohio.

**AN** advance in polishing methods, cleaning of metal simplified. A large size quick shiro polishing cloth for polishing copper, brass, nickel, silver, silver-plated ware, aluminum, etc. and our catalog of novelties, embroidery etc., 25c. R. W. Stahl & Co., Dept. F, Greensburg, Pa.

"**KENO** Knife Sharpener" sharpens any knife in 10 seconds. Will last for years. Nickel-plated, 40c postpaid. Money order preferred. Albert M. Issermoyer, 1319 1/2 Liberty St., Allentown, Pa.

**LET** us tell you about denatured alcohol in solid form. Used for cooking and heating by sportsmen, campers and travelers. Samples 10c. The Lever Company, 44, Elizabeth, N. J.

**HAND-BALL** players, try Black Cover Ball, hand-made, of best material. Price \$1. W. N. Long, Florence, Ky.

**STOP** snoring! Dr. Bond's scientific device makes snoring impossible. Particulars, 2c stamp. Millar Bros., P-422 Dearborn St., Chicago.

**TOBACCO-CURE**—One box cures. Guaranteed or money back. Established 1894. Write for special offer. Allen Distributing Co., 319 Nelson Bldg., Kansas City, Mo.

**HAVE** you a Patent to sell? You'll be interested in my proposition. Write now for free particulars. F. W. Johnson, 318 W. Washington St., Chicago.

**MAGIC** Ink—Correspond secretly. Writing disappears entirely, but can be made visible using Magic Ink Restorer. Common writing paper may be used for it. Complete set, 30c, postpaid. Otto Wilsner, Box 293, Yonkers, N. Y.

**NEW** Departure Silver Plate; Silver Plates Metals. Try it. Sample 50c. Wm. C. Chesbro, St. Joseph, Mo.

**GET** the latest in high class dependable formulas of all kinds. I furnish reliable, up-to-date working processes used by successful manufacturers everywhere. Send today for my latest red seal formula lists and other valuable information to "mixers" free for a stamp. Liscomb Miller, Technological chemist, Marietta, Georgia.

**CUTS** anybody can make. Simple Etching Process, \$1. Particulars, specimens, for stamp. M. Day, Windfall, Ind.

\$10 **RAINCOAT** at half price direct from manufacturer. Our "Chesterfield" double-texture raincoat, made of fine woven Asia cloth, plaid lining, cemented seams, vulcanized. Absolutely rainproof, will stand roughest wear. Very stylish; in tan or olive. Sizes 32 to 44. Postpaid \$5. Money back if unsatisfactory. B. & J. Rubber Co., 161-163 Summer St., Boston, Mass.

**BE** a handcuff king—make \$100 per week in vaudeville. I have the secret. Write me. E. W. Harris, 539 E. 33d St., Chicago, Ill.

**AMBITIOUS** men and women everywhere. My book "Success or Failure" shows how \$5 to \$25 invested brings you \$50 to \$200 monthly. Send 12c for sample copy. Buckland, Box A, 1456, Springfield, Mass.

**SPANISH** course for home study 25c; easily learned. No teacher required. Hardy's, Oakland, Cal.

**TRICKS** and traps of America swindlers, quacks and humbugs exposed. Price 25c. Particulars for red stamp. Address Eagle Supply Co., P. O. Box 671, Oshkosh, Wis.

**ONE** new prest-o-welder, cheap. Box 166, Marietta, Ga.

**WISE** men get my money proposition. Frank Schilling, Navarre, Ohio.

**SKELETON** Keys—Just what you need. Opens all common door locks. 25c a set. B. & F. Novelty Co., Box 237, Rock Island, Ill.

**STUDENTS** Special—20 beautiful college pennants, all different, size 9x18 1/2 for 29c in stamps. Address G. W. Maneval, Williamsport, Pa.

50 **ENGLISH** Money-making Schemes, plans, Propositions, 28c (stamps). Wilkes Publishers, Stockton, Rugby, England.

**MONEY** in minerals! Many common minerals have market value. List free. Minerals identified, 25c. Mineral specimens for sale. Write for complete course in Determinative Mineralogy with free outfit. Mineralogist, Box 155, Cartersville, Mo.

**POCKET** Charm—Why don't you use a pretty, ivory-like shark's tooth as a pocket piece? Extracted from the jaw of a man-eater caught in the shadow of historic Morro Castle, Havana. Many owners claim same to have dispelled their 1913 hard luck. Send 25c in stamps to Jos. Fernandez, Box 1164, Havana, Cuba.

**GRANDFATHER'S** Clock Works, \$5. Slightly shop-worn, quantity limited, others with chimes, all prices; also several nice Grandfather's Clock cases, exceptional bargains. Clock Company, 1673 Ruffner St., Philadelphia, Pa.

**DO** you want to go on the stage. Be a Handcuff King. I will teach you how; for particulars address Box 902, Springfield, Mass.

**I** WILL start you earning \$4 daily at home in spare time, silvering mirrors; no capital; send for free instructive booklet, giving plans of operation. G. F. Redmond, Dept. 306, Boston, Mass.

**BEAUTIFUL** arts-crafts lamps—Anyone can make them out of paper, cardboard and wood. 16 designs. Inexpensive yet artistic. Complete book of instructions, Price, 50c, postpaid. Popular Mechanics Book Dept., Chicago.

## TOO LATE TO CLASSIFY

**ENGINEER'S** transits and levels bought and sold. W. F. Sprengmether, 203 N. 10th St., St. Louis, Mo.



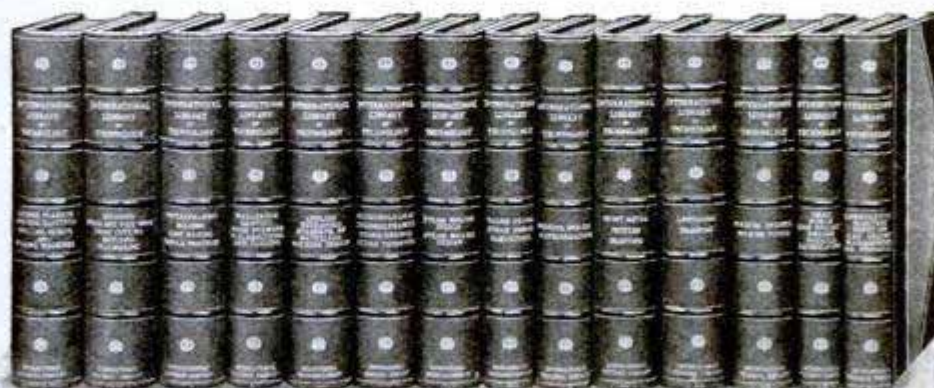
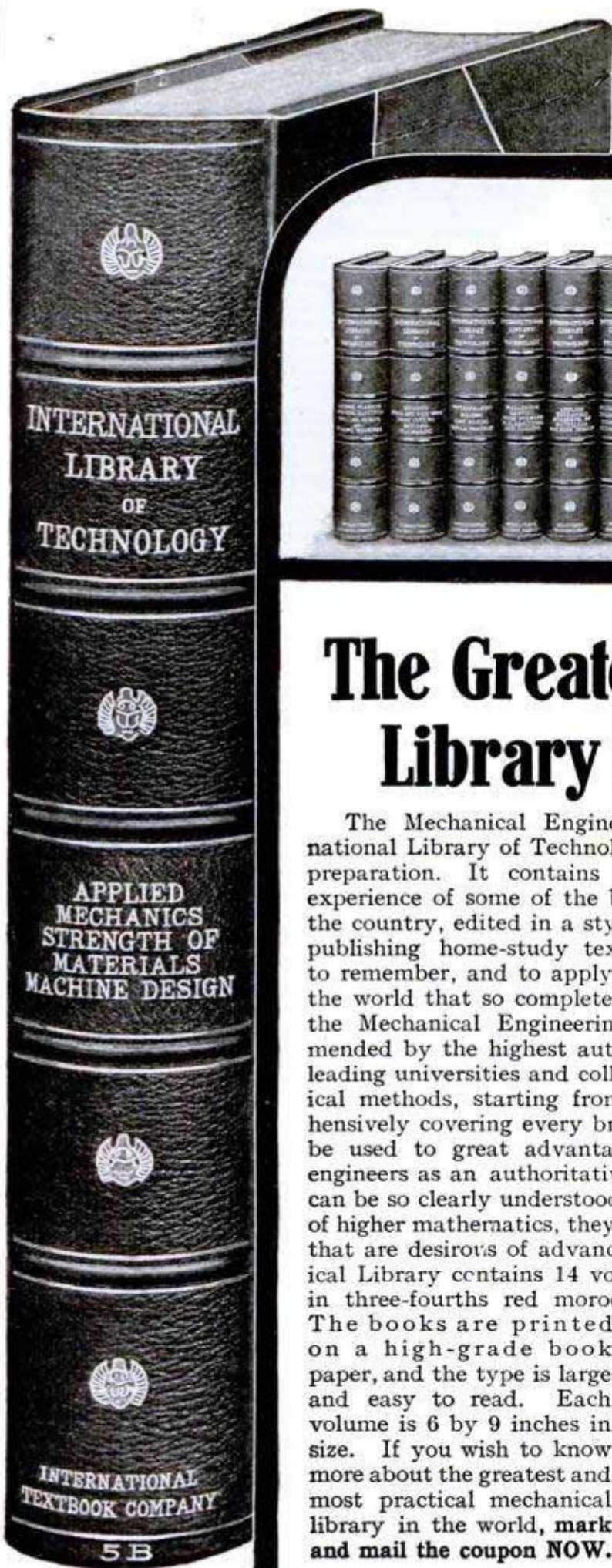

## The Greatest Mechanical Library in the World

The Mechanical Engineering Library is part of the International Library of Technology that cost \$1,500,000 in its original preparation. It contains the knowledge given from the life experience of some of the best mechanical engineering experts in the country, edited in a style that nineteen years of experience in publishing home-study textbooks has proved easiest to learn, to remember, and to apply. There is no other reference work in the world that so completely meets the needs of the mechanic as the Mechanical Engineering Library. The volumes are recommended by the highest authorities and are used in nearly all the leading universities and colleges. They treat of practical mechanical methods, starting from the simplest problems and comprehensively covering every branch of the work. Not only can they be used to great advantage by superintendents, foremen, and engineers as an authoritative guide in their work, but since they can be so clearly understood even by persons having no knowledge of higher mathematics, they can be used by all classes of mechanics that are desirous of advancing to higher positions. The Mechanical Library contains 14 volumes durably and handsomely bound in three-fourths red morocco, stamped and numbered in gold. The books are printed on a high-grade book paper, and the type is large and easy to read. Each volume is 6 by 9 inches in size. If you wish to know more about the greatest and most practical mechanical library in the world, mark and mail the coupon NOW.

**INTERNATIONAL TEXTBOOK COMPANY**

Box 872, Scranton, Pa.

Please send, without further obligation to me, full particulars in regard to the International Library of Technology, with special reference to the Library of Mechanical Engineering.

Name \_\_\_\_\_

St. & No. \_\_\_\_\_

City \_\_\_\_\_ State \_\_\_\_\_





## We Will Help You Get a Big Advertising Position

Sixty-two of the biggest men in the advertising business will train you *at home* for a highly paid advertising position. These are the men who today—NOW—are receiving big incomes as ad writers, plan men, advertising managers, solicitors, outdoor men, street car advertising experts and advertising agency chiefs.

These men, with their close knowledge of advertising needs and opportunities give you *first hand*, in this very latest and most practical advertising course, the inestimable value of their very own experiences.

### These Men Know

These men know the great opportunities in this profession. They know that there are not enough good men to write the advertising on which nearly \$700,000,000 was spent last year alone. So they give you this great opportunity to learn *their* methods—so that *you* can make a real place for *yourself* in this congenial, profitable occupation.

### The Way is Easy

This training *goes to you* no matter where you live. If you have but a *half hour* a day you can qualify. No special literary ability is required. In addition to this Course we teach you advertising English, and how to write business letters with the "punch." The terms are easy.

With this Course you get a veritable university of advertising. Every department of advertising is explained clearly and *practically* by these 62 masters. Heretofore advertising has been taught in but a superficial way. Here for the first time you see the very work, use the very methods, progress along the very success-paths of these 62 advertising leaders.

Learn about the great **new Course now**. It costs you nothing to find out—places you under no obligation. Send the attached coupon today. Don't trust to "blue sky" theories, but learn about the great Course that keeps close to "mother earth," success, and big salaries. Send the coupon today—NOW.

Dept. 1030, Chicago University of Commerce  
CHICAGO, ILLINOIS

Send me free and without obligation on my part full particulars regarding this **new**, practical Advertising Course.

Name .....

Street and No. ....

City and State .....



**THIS JOB PAYS \$25-\$50 Weekly**

### You Can Be an Auto Expert

We teach you the entire subject by mail in 10 weeks' spare time, and assist you to secure good position. Demand for trained men can't be filled. Simple, practical and personal instruction. **Free auto model to each student.**

**Earn While You Learn—FIRST LESSON FREE**

*Sent postal at once to the Original Automobile School*

**Empire Auto Institute, 264 Empire Bldg., Rochester, N. Y.**  
*Owners—We Supply Competent Men.*



### Learn Mechanical Drawing and Machine Design at Home in Your Spare Time

Improve your opportunity. Long and varied practical experience has enabled me to prepare a correspondence course which is simple, and easily understood, even by those who have had only a common school education. With fair intelligence you should become an expert in from six to nine months under my tuition. Elegant set of instruments FREE. Premiums for proficiency. Never had connection with the "Chicago Engineering Works," which has been using my name, coupled with my picture, as "Chief Engineer."

A postal addressed **ROBT. HARDIE, 621 No. Homan Av., Chicago, Ill.,** will bring full particulars

CYLINDER LANGUAGE RECORD

CORTINA PHONE

## LANGUAGES

German—French—English  
Italian—Spanish

or any other language learned quickly and easily by either the Cylinder or Disc Cortinaphone Method at home. Write for Free booklet today: Easy Payment Plan.

**Cortina Academy of Languages,**  
1051 Mecca Building, 1600 B'way, Cor. 48th St., N. Y.

THE ORIGINAL PHONOGRAPHIC METHOD

DISK LANGUAGE RECORD

### COPY THIS SKETCH

and let me see what you can do with it. You can earn \$20.00 to \$125.00 or more per week, as illustrator or cartoonist. My practical system of personal individual lessons by mail will develop your talent. Fifteen years successful work for newspapers and magazines qualifies me to teach you. Send me your sketch of President Wilson with 6c in stamps and I will send you a test lesson plate, also collection of drawings showing possibilities for you.

**The Landon School** of Illustrating and Cartooning  
1438 Schofield Building, CLEVELAND, O.

## LEARN WATCHMAKING AT HOME

You can learn by our modern and original system of instruction every part of the Watchmaker's Trade at home as good or better than at a shop. You can earn money while learning and secure a well paying position or start in business after completing our course of instruction. Good watchmakers are always in demand and earn from \$20 to \$35 per week. For particulars apply to the **WISCONSIN SCHOOL OF WATCHMAKING, Stroth Bldg., MILWAUKEE, WIS.**

**GET THIS BOOK FIRST.**

## DON'T TRY TO BE A CHAUFFEUR

or go to any school to learn, or part with your hard earned dollars until you have read our valuable guide **FIRST**. It tells what you should **PAY** and what you should **GET**. Do not be deceived by schools, which claim everything and give you nothing. **YOU CAN'T AFFORD TO SPEND ONE CENT TILL YOU GET OUR GUIDE.** It costs nothing and may save you many dollars. Write now for this **FREE** book.

**PRACTICAL AUTO SCHOOL, 68 Beaver St., New York**

## LEARN JEWELRY ENGRAVING

in your own home. Earn \$20.00 to \$50.00 Weekly. Personal instructions. Write for free booklet. **Chicago Engraving School, 612 Athenaeum Bldg., Chicago**



**THESE  
BOOKS  
FREE**

# A 50 H.P. AUTO FREE TO STUDENTS

I mean just what I say—I will give a **Six Passenger 50 H. P. Coey Flyer** to every student who takes my course in Motoring and qualifies for the agency.

## There Are More Big Paying Positions in the Auto Business Than There Are Men to Fill Them

That is the condition to-day. Will you step from my school into a job paying from \$100 to \$300 per month or will this fat salary make another fellow rich?

## The Cost is Low—Easy Terms to All

I want to help every boy to make money and have a good trade so that he will never be out of a job, so you can pay for my course in easy payments.

**Don't Let the Other Fellow Beat You to It**

**THIS  
IS THE  
CAR**

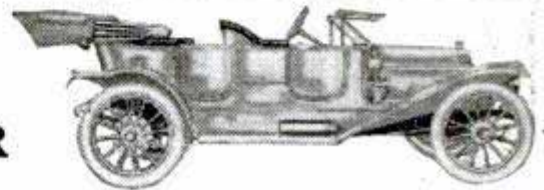

It is the squarest proposition you ever heard of. 4,000 men have found I will do just what I say I will—you can't lose if you study hard and learn these easy-to-understand lessons.

## I Will Send First Lesson Free

Send for it and my catalogue both free.

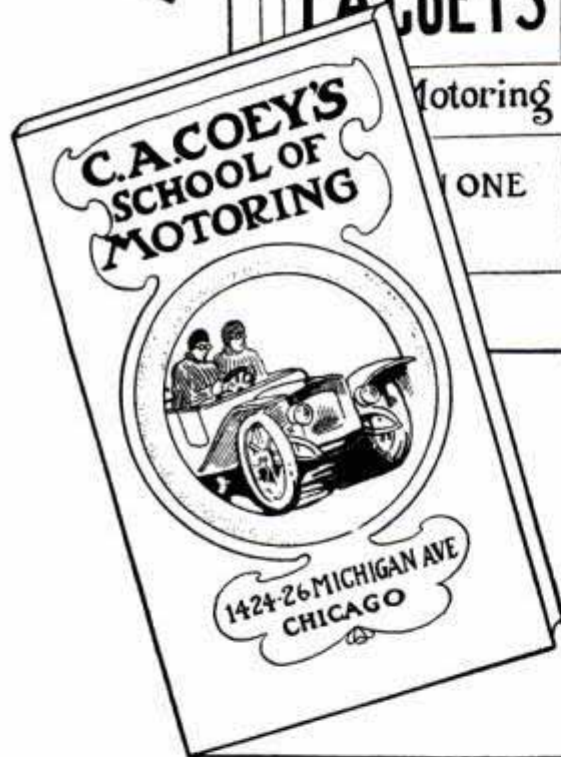
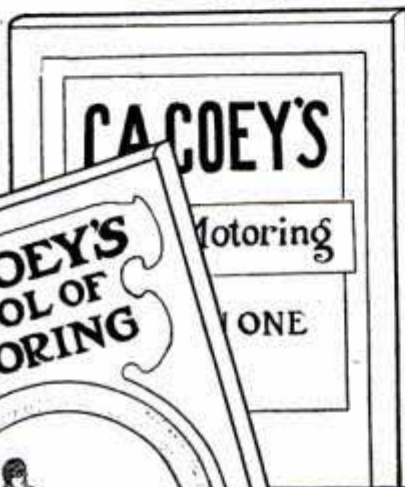

### MAIL THIS COUPON

**C. A. COEY'S SCHOOL OF MOTORING**

Dept. 223, 1424-26 Michigan Ave., Chicago

Send me **free** the first lesson to your great course in Motoring and your catalogue, as per your ad in Popular Mechanics.

Name.....

City..... State.....

R. F. D. or Street Address.....

# GOV'T JOBS OPEN

The latest changes in the **PARCELS POST** will require the appointment of many extra

**Railway Mail Clerks, City Carriers, Rural Carriers, City Postal Clerks**

**\$800 TO \$1800 A YEAR, FOR LIFE**

Rapid advancement to higher Government Positions. No "lay-offs" because of STRIKES, FINANCIAL FLURRIES or the WHIMS OF SOME PETTY BOSS. THE POSITION IS YOURS FOR LIFE.

Country residents and city residents stand the same chance for immediate appointment. Common-sense education sufficient. Political influence NOT REQUIRED.

Write immediately for schedule showing the places and dates of the November examinations. Don't delay. Every day you lose means the loss of just so much coaching before the rapidly approaching examinations.

**FRANKLIN INSTITUTE Dept. W106, Rochester, N. Y.**

**FRANKLIN INSTITUTE**

The Pathway to Plenty

Dept. W106, Rochester, N. Y.

The coupon, filled out as directed, entitles the sender to free specimen questions; a free copy of our copyrighted book, "Government Positions and How to Obtain Them." Full list of positions obtainable and to consideration for Free Coaching for examination here checked.

### COUPON

.. Railway Mail Clerk	[\$900 to \$1800]	.. Customs Positions	[\$800 to \$1500]
.. Postoffice Clerk	[\$800 to \$1200]	.. Internal Revenue	[\$700 to \$1800]
.. Postoffice Carrier	[\$800 to \$1200]	.. Stenographer	[\$800 to \$1500]
.. Rural Mail Carrier	[\$600 to \$1100]	.. Clerk in the Departments	at Washington
.. Bookkeeper	[\$800 to \$1800]	.. Canadian Government Positions.	[\$800 to \$1500]

Name.....  
Address..... **W106**

*Use this before you lose it. It is valuable. Write plainly.*



# Expert Accountants

## Earn \$3,000 to \$10,000 Yearly!



### 500,000 Firms Need Them

#### ONLY 1,500 EXPERTS IN AMERICA

If you are a clerk or a bookkeeper, salary increases are improbable—an independent future impossible. You can't demand a raise—there are thousands awaiting your job. There is just one way to overcome your handicap: become an **EXPERT ACCOUNTANT**, by our modern home-training method—**be sought—don't seek.**

There are 500,000 big firms today requiring annual or semi-annual audits—and there are only **1,500 certified public accountants in the U. S.** This proves the tremendous, unlimited opportunities for you—the independence—the assured future—the big salary. These firms are willing to pay **Expert Accountants** with our training \$3,000 to \$10,000 yearly. But they pay clerical workers and bookkeepers only \$12 to \$20 weekly. Become an **Expert Accountant** and your rise in the business world will be unlimited—many of our graduates are now managers of big firms. Remain a clerk or bookkeeper and you will always be bossed.

### WE TRAIN YOU BY MAIL

in your own home, during your spare time, no matter where you live. You don't give up your present position and income—you don't deny yourself pleasures or sacrifice duties. Devote a little spare time evenings preparing for independence and a big income and you will soon master this lucrative position.

You can readily master our modern method in your own home—you can complete it in less time than any other. In many particulars it offers more advantages than a college course in Higher Accountancy—you are not held back by plodders.

The La Salle Extension University course in Higher Accountancy was prepared by some of the world's most noted accounting experts. It is under the direct supervision of William Arthur Chase, a nationally recognized leader, who is Ex-President of the American Association of C. P. A. Examiners, and Ex-Secretary of Illinois State Board of Examiners in Accountancy.

Our course is thorough—advanced—covering the Theory of Accounts, Practical Accounting, Cost Accounting, Auditing, Business Law, etc., and prepares you for C. P. A. Examinations in any State.

**Valuable Book FREE** Write at once for a free copy of "What Every Bookkeeper Should Know"—a valuable special book which gives exactly the information you require to become an Expert Accountant, studies, kind of examinations, State regulations, salaries paid, positions to be had.

**SPECIAL REDUCED RATE SCHOLARSHIP—Limited Special Offer.** Write quick and learn how, for a limited time, we are able to offer a special reduced rate scholarship.

**We Show RESULTS!** This institution is a strong, conservative organization—with thousands of students and as many letters from successful graduates. There is no other home-study course so thorough—endorsed by America's greatest Accounting Experts. We want you to know facts about the successes of our students and the unlimited opportunities that confront you today by our method of home training, so—

### Mail Coupon NOW!

Secure valuable book Free, and learn how you can advance from a small job with a small salary to distinction, independence, a future, and \$3,000 to \$10,000 yearly. Act Now!

La Salle Extension University, Chicago

La Salle Extension University, Dept. 279 Chicago

Send at once, without cost or obligation to me, your testimonial book of **Accounting Facts**, and full details of your Course in **Higher Accountancy**; also advise me about Special Time-Limited Reduced Rate Scholarship.

Name .....

Street No. ....

City ..... State .....



## FRENCH—GERMAN SPANISH—ITALIAN

Is Easily and Quickly Mastered by the

## LANGUAGE-PHONE

METHOD

Combined with the  
**Rosenthal Method of Practical Linguistry**

This is the natural way to learn a foreign language. You hear the living voice of a native professor pronounce each word and phrase. He speaks as you desire—slowly or quickly, night or day, for minutes or hours at a time. It is a pleasant, fascinating study; no tedious rules or memorizing. It is not expensive—all members of the family can use it. You simply practice during spare moments or at convenient times, and in a surprisingly short time you speak, read and understand a new language.

Disc or Cylinder Records—Send for Booklet and particulars.

**THE LANGUAGE PHONE METHOD**

961 Putnam Building 2 West 45th Street New York



### Are the BEST PAID Class of Men in the World

We will teach you to be a high grade Salesman in eight weeks by mail and assure you definite offers of positions from many reliable firms who will give you an opportunity to earn more money than you ever before dreamed possible, while you are learning. No former experience required. Thousands of leading firms desire to employ our Trained Salesmen and we cannot supply the demand for our students. Write today for particulars, large list of good openings and testimonials from hundreds of men recently placed in good positions where they are earning from two to ten times as much money as they formerly did. Address (nearest office) Dept. 119

**NATIONAL SALESMEN'S TRAINING ASSOCIATION**

Chicago, New York, Kansas City, San Francisco

## A Job with Uncle Sam Is Just Waiting for You

A government position means a job for life with good pay, a liberal vacation, pleasant work, and the assurance that you'll get your pay envelope regularly, in spite of panics or hard times. Wouldn't a job like that look good to you?

Railway Mail, Post Office, Rural Carrier, Custom House, Internal Revenue and Book-keeping "exams" are being held all the time.

Any American citizen, 18 or over, is eligible: a common education sufficient. Decide now that it's what you want, and get your preparation under the personal supervision of a former United States Civil Service Secretary-Examiner. Free Booklet tells all about the details.

WRITE FOR IT TODAY

**PATTERSON CIVIL SERVICE SCHOOL**

The school with the record for "making good." "Send for Proof."

100 Livingston Arcade ROCHESTER, N. Y.

## BE A SUCCESSFUL LAWYER!

Learn Law At Home

Greatest Law School for Home Study in the World. Distinguished faculty and lecturers; superior advantages; same studies as Harvard, Michigan and big resident law schools. Special Business Law Course.

Three Years' Scholarship covering Complete Course Without Charge. Pay only for Text and postage. GUARANTEE to coach FREE graduates failing to pass bar examination. Offer limited—WRITE IMMEDIATELY FOR FULL PARTICULARS.

American Correspondence School of Law, Dept. 1197 Chicago



## DON'T TAKE A COURSE IN Mechanical Drawing

until you have read my proposition. Practical draftsman, regularly employed by the most progressive company in the West, with long experience also as teacher of Mathematics and Drawing, will instruct a few men by mail. **Positively the best way to become a practical well-paid draftsman.** Instruments furnished. Rates reasonable. **Pay a part after in position.** For information write,

**DRAFTSMAN, 252 South Corona Street, Denver, Colo.**

Please Mention Popular Mechanics



# This Book Will Teach You Practical Electricity

Twenty chapters of plain, accurate, compact facts about electricity. Written in an easily understood style, it carries you from the fundamental principles to where you understand the designing, operation and care of a dynamo or motor. It is

## As Good As A School

for it contains questions and answers on each chapter that enables you to examine yourself and fix each subject in your mind as you go along. It tells all about wiring, batteries, lighting systems, and in fact every needful point in practical electricity. It contains one chapter on electric automobiles, their construction, care and operation. Thousands have found it indispensable as

## A Handbook for Practical Men

The tables, rules and formulas it contains are invaluable. It has a dictionary of 1500 electrical terms. No one can stump you if you have this book. 36,000 copies sold.

## Price \$2.00 Per Copy

and it's sold to you on a money-back guarantee. Send \$2.00 for your copy today, with privilege of examination and return if not fully satisfied.

**CLEVELAND ARMATURE WORKS**  
4734 St. Clair Ave. N. E., CLEVELAND, OHIO

Armatures and Fields wound - Commutators filled.



# CIVIL ENGINEERING THIS \$40.00 SET



## NOW \$24.80—\$2 A MONTH

No matter what special line of engineering you are interested in—municipal, structural, bridge, railroad or reclamation. No matter whether you are a practising engineer, a beginner ambitious to make your way to the top, or whether you are in some business where you need special information on a particular branch of civil engineering.

You need this great cyclopedia—the most complete and authoritative work on civil engineering ever compiled. It puts the expert knowledge and practical experience of 20 distinguished engineers at your elbow, ready for consultation or study. It answers all questions, clears up technical problems and difficulties in language that you can readily understand. Cross-indexed, so that you can put your finger on just the information you want in a moment.

These 8 large volumes, bound in half morocco, gold stamped, contain 3,900 pages, 3,000 plates, drawings, diagrams and illustrations, with hundreds of proved facts and tested plans. A great value at the regular price, yet for a limited time you may secure them for the introductory price of \$24.80—\$2 a month.

**SHIPPED FREE** Examine the set before you send a penny. We want the books themselves, not what we say, to help you decide whether you need them. Merely on receipt of the attached coupon we send you the complete library, express prepaid.

Take a whole week to look them over. Test them on some problems that have been bothering you. Then if you decide you want the set, send us \$2. Otherwise tell us and the books come back without a penny of expense to you.

### What These Books Cover

Plane Surveying—Mechanical Drawing—Plotting and Topography—Railroad Engineering—Statics—Strength of Materials—Roof Trusses—Mill Building Construction—Cost Analysis in Relation to Engineering—Masonry and Reinforced Concrete—Steel Construction—Practical Problems in Construction—Bridge Engineering—Highway Construction—Hydraulics—Water Supply—Irrigation Engineering—Water Power Development—Sewers and Drains—House Drainage and Sanitation—River and Harbor Improvements, etc., etc.

### Free \$12.00 Consulting Membership

Besides the practical value of the library itself, you get our \$12.00 consulting membership free as a holder of these books. Our staff of civil engineers takes up and solves your problems and special difficulties, absolutely without cost to you. This privilege, which regularly sells for \$12. is yours for a full year free, if you take the cyclopedia.

To find out how useful these books will be to you, you must see them. It costs nothing to look the set over. It does not obligate you in any way. We stand ready to take the books back without expense to you, if you are not pleased with them. Get the books. Examine them. Then make your decision.

## FREE COUPON

Worth \$15.20 to You  
American Technical Society,  
Chicago, U. S. A.

Please send me Cyclopedia of Civil Engineering for 7 days' free examination. If I decide to buy, will send \$2 in 7 days and balance \$2 a month until \$24.80 has been paid, when \$40 books and \$12 consulting membership will be mine. Otherwise will notify you and hold books subject to your order. Title not to pass until fully paid. P.O. 14 ch. 10-13

NAME .....

ADDRESS .....

OCCUPATION .....

EMPLOYER .....

# SHORTHAND IN 30 DAYS

We absolutely guarantee to teach shorthand complete in only thirty days. You can learn in spare time in your own home, no matter where you live. No need to spend months as with old systems. Boyd's Syllabic System is easy to learn—easy to write—easy to read. Simple. Practical. Speedy. Sure. No ruled lines—no positions—no shading as in other systems. No long lists of word signs to confuse. Only nine characters to learn and you have the entire English language at your absolute command. The best system for stenographers, private secretaries, newspaper reporters and railroad men. Lawyers, ministers, teachers, physicians, literary folk and business men and women may now learn shorthand for their own use. Does not take continual daily practice as with other systems. Our graduates hold high grade positions everywhere. Send today for booklets, testimonials, etc.

## Chicago Correspondence Schools

969 Chicago Opera House Block, CHICAGO, ILL.

# DRAW

**BIG PAY** for drawing cartoons and comics. My system teaches beginners positively, practically. Lowest cost. Easy terms. Full details, testimonials and sample lesson 6c. HAMILTON, Box 361, Chicago

## I TEACH BY MAIL

WRITE FOR MY FREE BOOK "How to Become a Good Penman" and beautiful specimens. Your name elegantly written on a card if you enclose stamp. Write today. Address F. W. TAMELYN, 418 Meyer Bldg., Kansas City, Mo.



## I Can Increase Your Earnings

No matter where you live, if you are honest and want an independent business of your own, send your name and address and I will mail you our Big Free 64-Page Book, showing how you may earn

**\$3,000 to \$10,000 a Year**  
in the Real Estate, Brokerage and Insurance Business.

J. H. JOYCE, Pres. Insurance Business.

Our system is a positive success. We will teach you by mail and appoint you our

## Special Representative

and help you to make money from the start. Write today. INTERNATIONAL REALTY CORP. 2336 Manhattan Bldg., Chicago, Ill.

Please Mention Popular Mechanics



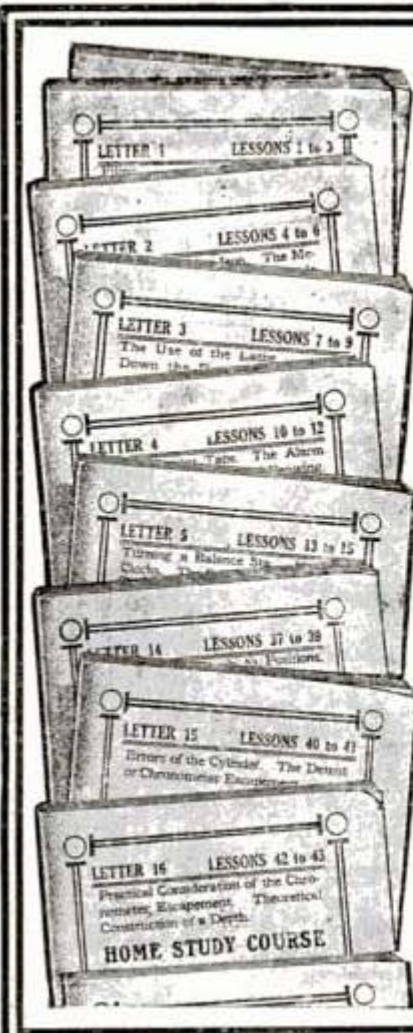

# This great HOME STUDY COURSE in Watchmaking

never before sold for less than \$35.00 is now offered in a limited number at the greatly reduced price of \$10.50. We were fortunate to secure the balance of the 1st edition of this Course of Instruction in Watch Repairing, published and conducted by one of the leading Watchmaking Schools in the country, and it is YOUR opportunity and only chance to get this wonderful set of books at a price barely covering the cost of publishing.

# \$10.50

Regular Price \$35

## You Can Be An Expert Watchmaker

Everything pertaining to the art of Watch Repairing is taught in these lessons; everything that a watchmaker should know will be found therein written in plain English, easy to understand and equally easy to execute. The lessons are eminently practical, they lead you along from step to step from the simplest to the most difficult work, so gradually, that you cannot help succeeding.

### Your Chance to Own a Business

Hundreds who have studied these lessons are now holding lucrative positions or are in business for themselves. You can do the same. Most successful jewelers have started as watch repairers; the smaller the start the surer the success. Here is YOUR opportunity.

#### SEND FOR SAMPLE LESSON

It is impossible to tell in this limited space what these lessons really are, they must be seen to be appreciated. If you do not care to order a set of these books outright then send for our FREE sample lesson and descriptive literature, but remember, the number of these sets of books is limited and you must act quickly.

#### ORDER NOW—There is No Time to Lose

When the sets we now have on hand are sold the price goes back to \$35.00. It's a clear saving of over 70 per cent and it is an opportunity which may never present itself again. Write to-day.

**TRADE BOOKS PUBLISHING COMPANY, Dept. 4**  
161 Michigan Street MILWAUKEE, WIS.

## Reduced 70%

Only a limited number of sets at \$10.50. Regular price \$35. NOW at less than 1/3 actual value the most complete text books on Horology ever published.

## Randolph Military Academy

MORRISTOWN, NEW JERSEY

### Select Home School Limited to 100 Boys

General satisfaction with our ability to get results has made this school a success. We prepare boys 8 to 20 years of age for the Universities, Government Academies and Business. Our location, organization and equipment afford rare advantages. All Field and Track Athletics are encouraged under competent supervision. The Gymnasium, Literary Societies and Horseback Riding are attractive features. Junior and Senior Schools.

FOR DETAILED INFORMATION ADDRESS  
MAJOR J. HAROLD RANDOLPH, Superintendent  
(TELEPHONE 490 MORRISTOWN)

## Learn to be An Auto Expert

Six weeks from the day you commence your studies at this great practical school you will be able to repair any make of automobile and drive any car on the market.

### Earn \$75. to \$200. a Month

Many of our graduates make even more than this. Big demand for competent repairmen, demonstrators, garage managers and chauffeurs. All practical work. No books used. No tools to buy. Write today for big illustrated free book. Address,

AUTOMOBILE TRAINING SCHOOL, 1185 Locust St., Kansas City, Mo.



## The University of Chicago

### HOME STUDY

in addition to resident work, offers also instruction by correspondence. For detailed information address

22nd Year U. of C. (Div. 20) Chicago, Ill.



## ELECTRICITY

offers to you the greatest opportunities and largest paying positions of any profession. It is practically a new field, while the others are filled to their capacity and largely overcrowded. Get a



### Practical Electrical Education

By our thorough and scientific methods under practical and actual working conditions you must master all branches of Electrical Science and Engineering. We combine the theory with the practice. New interesting 64 page school catalog just off the press. It's free. Get it and see what real education is.

**SCHOOL OF ENGINEERING OF MILWAUKEE**  
161-169 Michigan St. MILWAUKEE, WIS.

CLASSES NOW ORGANIZING

Please Mention Popular Mechanics

## AN ART SCHOLARSHIP FREE



WRITE AT ONCE for full particulars of this Special Limited Offer. No charge, no obligations. Your name and address brings you handsome, illustrated Prospectus, and explanation of this unusual offer, by return mail, free. Remember this offer is strictly limited. DON'T TAKE CHANCES. WRITE NOW. FINE ARTS INSTITUTE, Studio 217, OMAHA, NEB.

## Learn to be an Expert Wrestler



Be strong, athletic, healthy. Handle large men with ease. Farmer Burns, the world's most scientific wrestler, trainer of Frank Gotch, world's champion, will now teach you by mail. Also complete courses in jiu-jitsu self defense and physical culture. Only opportunity ever offered to learn right from champions. For men and boys, all ages. A wonderful course. Low cost. Investigate now.

**Wrestling Book FREE**, 32 pp, also full particulars. Write Today, Farmer Burns School of Wrestling, 1197 Range Bldg., Omaha



# FREE—Send for This

## Large Illustrated Catalogue of HOME-STUDY Books

ON

**Electricity, Engineering, Carpentry, Building, Painting, Business**

Check the subjects you are interested in and mail it with your name and address. We will send full particulars by return mail.

- |                                      |                                     |
|--------------------------------------|-------------------------------------|
| ....Electrical Engineering           | ....Gas Engine Engineer             |
| ....Elec. Light and Power Supt.      | ....Automobile Mechanician          |
| ....Electrical Wiring & Construction | ....Bookkeeper                      |
| ....Telephone Expert                 | ....Plumber                         |
| ....Architect                        | ....Mason and Bricklayer            |
| ....Building Contractor              | ....Carpenter                       |
| ....Architectural Draftsman          | ....Painter, Signs and Card Writing |
| ....Concrete Engineer                | ....Letter Writing                  |
| ....Mechanical Draftsman             | ....Railroading                     |
| ....Steam Engineer                   | ....Motorman                        |
| ....Stationary Engineer              | ....Traction Farming                |
| ....Millwright                       | ....Blacksmith                      |

**FREDERICK J. DRAKE & CO.**  
D 8—1325 Michigan Ave. CHICAGO, ILL.

**LEARN JEWELERS' ENGRAVING**  
A high salaried and easily learned trade, taught thoroughly by mail. We will teach the beginner better engraving than he can gain in years of rigid apprenticeship. We will also improve the skill of any engraver. Send for our catalog. The Engraving School, 112 Page Bldg., Michigan Ave., Chicago, Ill.

# ELECTRICITY



**CONDENSED COURSE IN ELECTRICAL ENGINEERING**  
**Complete in One Year**  
**Bliss Electrical School**

Studies restricted to theoretical and practical electricity, mechanical drawing and necessary engineering work. Teaches simplicity, concentration, hard work. For young men of energy and character. 20 years of greatest success. Graduates hold first-class positions. **Opens Sept. 24.** Write for new catalog. 15 Takoma Ave., WASHINGTON, D. C.

# LEARN TO REPAIR AND RUN AUTOMOBILES



Oldest and best equipped School in the West. Modern facilities. Up-to-date methods—Everything practical. **ENROLL NOW AT SPECIAL SUMMER RATE** and save money. You can enter later. Big demand for trained men. Our graduates receive preferred attention. Write at once for full information. **KANSAS CITY AUTOMOBILE SCHOOL** 2187 E. 15th St. KANSAS CITY, MO.

# CIVIL SERVICE

positions are in all parts of the country. Good pay, steady work, life positions, congenial surroundings, promotions on merit, short hours, annual vacation and sick leave with pay. Many thousands appointed yearly. Both sexes. No political pull. Nearly 300,000 classified positions. Common school education sufficient. Full information and questions used by the Civil Service Commission free. **COLUMBIAN CORRESP. COLLEGE, Washington, D. C.**

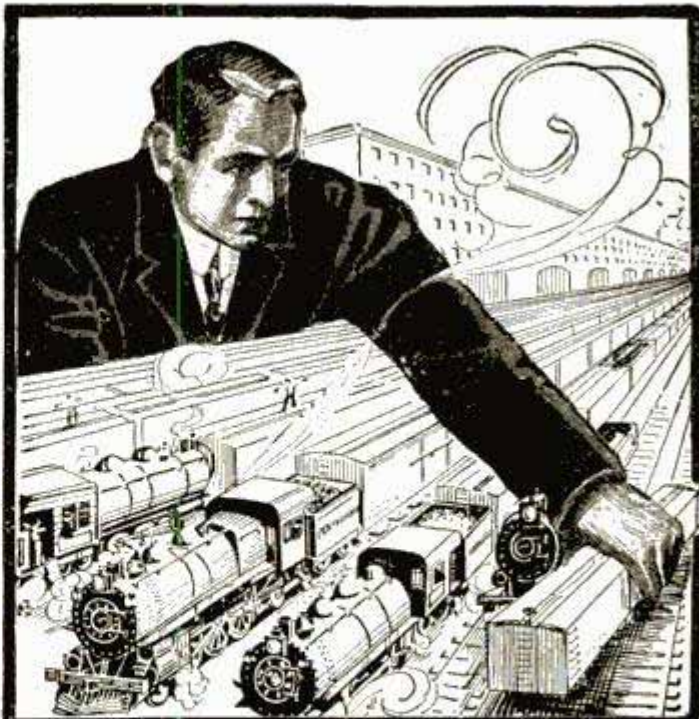

# A BIGGER JOB for YOU

Young man—there's a bigger job, a better job, more money, more responsibility waiting for you in a **NEW AND UNCROWDED PROFESSION.** New conditions have arisen, new problems; for modern transportation is a jungle of routes and rates calling for specialists, calling for men who have been trained, men who possess expert knowledge of the trails of traffic. And you can now get this training. Simply clip the coupon below and mail it. You can get the necessary knowledge; at small expense and in a short time; you can command a high salary as

# TRAFFIC MANAGER

For our *Interstate Commerce Course* enables you to study AT HOME, without leaving your occupation or sacrificing your present income. It is a simple, practical, logical course—easy to understand—which makes you thoroughly versed and proficient in the strategy of shipping, including routes and classifications, interstate commerce rules and regulations, etc., etc. The instruction is given by some of the biggest traffic managers in the country. So simple that anyone with ordinary intelligence, with reasonable application, can master this new profession and

# Earn \$35 to \$200 a Week

There are half a million **LARGE SHIPPERS** in the United States. Practically every one of them needs an expert traffic man, and this need is recognized as never before because of the recently enacted railroad rate laws and interstate commerce regulations. The demand for trained and efficient traffic men is many times greater than the supply. **THERE'S ROOM FOR YOU.**

# All you need is training

And you can now get this training easily. Simply clip the coupon below, sign and mail at once, and we will send you **FREE**, postpaid, a handsome portfolio containing complete information concerning the opportunities and requirements of this splendid profession. **Get your start now—RIGHT NOW.** Clip the coupon at once.

**LA SALLE EXTENSION UNIVERSITY**  
Dept. 278, Chicago

**La Salle Extension University**  
Dept. 278, Chicago, Ill.

I am interested in the new profession—Traffic Management. Please send me full information and Traffic Book, free of all cost.

# Free

Name \_\_\_\_\_

Occupation \_\_\_\_\_

Please Mention Popular Mechanics



# "I Will Teach You How to Run a Traction Engine Free"

- EMORY J. SWEENEY, Pres. Sweeney Auto School

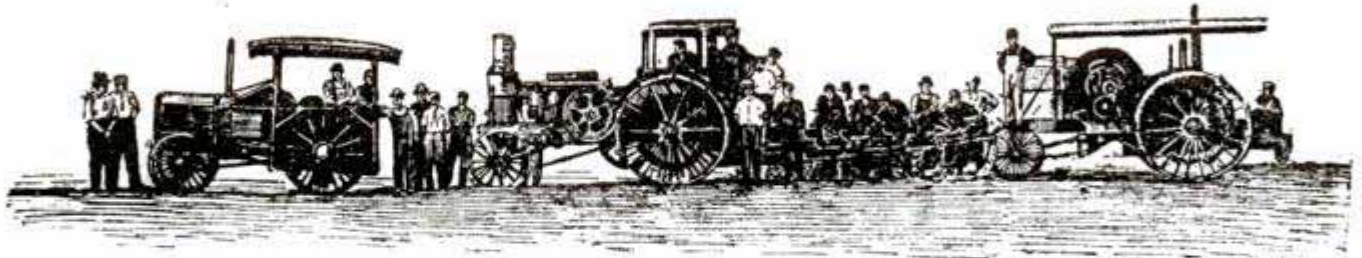

OUR THREE TRACTION ENGINES

**T**HE purpose of this amazing offer is to demonstrate the superior equipment and facilities of this school, and also to celebrate the opening of the fall season in our magnificent new quarters, the finest and largest of the kind in the world. I want every young man mechanically inclined to investigate the **BIG OPPORTUNITY** for making more money that I can give him in a few short weeks, and knowing the demand for traction engineers, I want to give all those who answer this announcement and qualify a **FREE COURSE IN TRACTION ENGINEERING**.

## The Sweeney System of Practical Auto Instruction

is now universally recognized as the most thorough, practical and interesting course of automobile instruction, leading to certain and profitable **EMPLOYMENT**. It embraces every point worth knowing, including vulcanizing, brazing, oxyacetylene welding, lathe work, machine shop practice, testing, driving, truck repairing and operating, etc. **AND YOU LEARN** by doing the work on **REAL CARS** under the watchful eyes of skilled instructors. The only school equipped with all types of **self-starters**.



## \$50 Course Free to Men Who Answer This Advertisement

You know right in your neighborhood of the demand for traction engineers and mechanics. Factories want workmen and demonstrators. We are in close touch with a great traction factory here in Kansas City. We teach you on three different types of tractors in actual work and also give you **FACTORY** experience no other school can offer. Men are wanted right now for good jobs. Here is a wonderful opportunity for young men. You can learn in a few weeks. We want to start out a few graduates right away and so although the regular price of the course is \$50 you **GET THE COURSE FREE** if you enroll in Automobile School now. Sign and return the scholarship coupon today. No previous experience required.

## Learn to Run and Repair Autos and Make Big Money

Think of this. Here's a trade where you are in demand 12 months in the year. Short hours, pleasant work. Outdoor life. Travel. Enjoy the world. Meet nice people. 90 per cent of the cars in use are not in proper adjustment on account of shortage of experienced mechanics. Grasp quickly this chance to make yourself a **SKILLED MAN** who is in demand and gets big pay for his work. No matter who you are we can teach you.

## Everybody in the Automobile Business Today is Making Money

Here is your chance. I want you to come to my school and see for yourself how quickly and easily you can learn the business and become a **HIGHLY PAID MAN**. Six weeks after the day you enroll you will be prepared to properly repair any auto made, drive any car or truck or traction engine, or open a garage or repair shop of your own. You can learn the business thoroughly in my school because I have been years working out this system and the **WONDERFUL PROMPT** success of my hundreds of **PROSPEROUS GRADUATES** proves it.

### Pick Out a Good Job!

- Chauffeur :** \$60 per month
- Mechanic :** \$160 per month
- Salesman :** \$1,500 per year
- Demonstrator :** \$150 per month
- Garage Manager :** \$35 per week
- Stationary Gas Engineer :** \$100 per month
- Traction Engineer :** \$5.00 per day and up
- Repairman :** \$18 per week up

### Eight Trucks in Daily Use Teach Students

We own a truck transportation company operating eight trucks and therefore give our students practical work in handling, repairing and driving trucks as well as giving them an insight into the livery and transportation business. **NO OTHER SCHOOL** in the world offers this valuable service to students and from this alone you can get experience to open up a most profitable business of your own.

## Our Men Learn Quickly and Easily, Because Practical Experience is the Best Teacher

### FREE COUPON

E. J. SWEENEY, President

**SWEENEY AUTO SCHOOL**

1161 E. 15th St., KANSAS CITY, MO.

Send free scholarship offer and catalog. Also magazine.

Name.....

Address.....

Study this picture. This is the only way to learn. Do things with your own hands. Practice beats theory. We do not merely tell you how; we show you how, and you then do the work yourself. We have over 40 cars of all makes on our own floor, eight trucks, three tractors, and our **DRIVING TEACHERS** keep out on the road nearly twelve hours a day. **YOU GET PLENTY** of **WORK** of all sorts.

### No Books Used; Tools Furnished Free

The tuition is low and after you have paid that there are **NO MORE** expenses or extras you have to buy. If you could learn from a book there are lots published you could read at home, but **PRACTICAL WORK** is the only method, and this is what makes my School different from all others.

**Send Today** for my big free catalogue and we will also send you our monthly magazine free, the most interesting magazine for young men who want to get on in the world ever published. The catalogue is full of fascinating **PHOTOGRAPHS** almost as good as a personal visit to the school. Send today, this very minute.



EMORY J. SWEENEY, President

**Sweeney Automobile School, 1161 E. 15th Street KANSAS CITY, MO.**



# This LAW Library Made For YOU!

## SENT FREE

### EXPRESS PREPAID

Every man and woman—especially those in business—should know Law—should know their legal rights—should be able to protect themselves against legal risks on contracts, leases, collections, management, insurance, shipping, mortgages, partnerships, claims for damages, etc. This Complete La Salle Law Library enables you to do it as capably as a lawyer—it makes you your own legal adviser.

## Answers Your Legal Questions

This is the most wonderful, non-technical, complete Law Library ever published. Nothing is left out—nothing half explained—everything thorough, written in plain language so that anybody can read and quickly understand the law when necessary. Covers each point of law authentically—giving quick, easy answers to any legal question that may ever arise in your family or business, that affects the rights of individuals, public officials, corporations, schools, churches, societies, etc. etc. You—everybody—should have this authentic Law Library—many need it every day. Ignorance of law will not excuse you.

### Edited By Greatest Legal Authorities

This remarkable complete Law Library was written especially for your needs by the greatest, legal experts, Law teachers and professors in the big Universities and Law Colleges, such as Harvard, Chicago, Michigan, Illinois, Wisconsin, Iowa, and others.

## Your Quick Reference Legal Adviser

The possession of this massive, authentic Law Library may save you thousands of dollars a year. Thousands of business men and women lose fortunes through ignorance of law that might have been saved with this quick-reference Law Library. Don't hold yourself open to risk—don't lose money—own these books—learn how to act quickly, deliberately, accurately, safely. Sharpen your judgment—don't be imposed upon. These authoritative books make you as capable as a lawyer—save you lawyer's fees. They are a boon to everybody—a necessity to every home and office—a pressing need at last realized—absolute, sound, legal guidance and advice of 26 of the world's foremost legal authorities. You consult these books the same as looking up a word in the Dictionary—simple, quick, easy, just like getting the sound, accurate advice of more than a score of the world's greatest legal advisers.

**Foremost Lawyers Praise It.** America's noted corporation lawyer says: "My examination of the work satisfies me that it possesses great merit as an elementary statement of the body of our law as it exists today. **What a boon such a work would have been to an unassisted student like myself.**" **John F. Dillon, Counsel** for Western Union Teleg. Co., Mo. P. Ry. and other big interests. Hundreds of similar testimonials. This is the greatest Law Library of the century—absolutely unlike all others—only accurate, thorough, standard, authoritative, complete. Recognized by bench, bar and legal educators as most modern and thoroughly reliable nontechnical authority on all American Law.

### Sent Free—Express Prepaid

That's what we mean—what we do—sent FREE, express prepaid—the greatest, biggest most broad and astonishingly liberal offer ever made on anything of such wonderful value. Don't pay us a cent down—these 14 volumes will be sent you express prepaid—right in your hands without trouble or expense to you. All you need do is send the coupon below. Examine the books carefully—satisfy yourself that they should be yours permanently—keep them seven whole days FREE, before you make up your mind. Then if you wish to own them simply send us first payment of \$4.00 and PAY \$3.00 EACH MONTH UNTIL PAID FOR. If you decide not to keep them, we will pay return express charges and you will not be out one cent.

## 1,000 SETS SPECIAL!

This is the most startling offer ever made on Law books. We have set aside 1,000 sets to be sold direct to the public, as a sales test. This cuts out the middlemen's profits which we turn over to the one thousand people who send the coupon now. Thus we knock off exactly \$26 from the regular price, which is \$75.00, making the total cost the insignificant sum of \$49.00 which you can pay in sums of \$3.00 Monthly.

**ACT QUICK**—Send the coupon now—do not send a cent—the books will be sent you express prepaid instantly—without obligation and you keep them for seven days FREE. When you read them you will want to keep them permanently—everybody does—they are the biggest boon to every home and office. Remember this offer is limited—under this offer positively only 1,000 sets will be reduced \$26.00—so be sure of yours—send the coupon now. **LASALLE EXTENSION UNIVERSITY, Dept. 276 Chicago, Ill.**

**FREE, 1,000 Set Coupon—Good For \$26.00—If Used At Once**  
La Salle Extension Library, Dept. 276 Chicago

Gentlemen:—Send your \$75 set of American Law and Proc., 14 vol. bound in ¾ sheep, for 7 days Free Examination. If I am satisfied you are to accept this coupon as credit for \$26 and I will send \$4.00 within seven days and \$3.00 monthly until I pay a total of \$49.00. If I decide not to keep books, I will notify you at once and hold same for your orders. Title not to pass to me until books are fully paid for.

Name.....

Occupation.....

Address.....

AMERICAN  
LAW  
AND  
PROCEDURE

**FREE  
Legal  
Advice**

to everybody taking advantage of this offer now we will give a FREE Consulting Membership certificate which entitles the holder to consult our legal experts and obtain FREE advice and counsel upon any and all questions of law.

LASALLE EXTENSION  
UNIVERSITY



# Wanted Meter Engineers



We have got to find more Meter Engineers somewhere. During the coming year over 500,000 new meters are going to be installed.

If you are ambitious we will train you—in your own home—during your spare time to become a competent Meter Engineer. Send the free coupon.

## Salary \$125 to \$225 Per Month

Meter Engineering is one of the best paying professions in the electrical industry. We can show you hundreds of men who are making better than \$3,000 a year. Here is your chance to get the practical instruction right in your own home. You get a diploma and can become a full-fledged Meter Engineer without giving up the job you now hold. Then you get the big job—the fat pay envelope. Write today.

## The New Profession

The profession of Electrical Meter Engineering is now in its infancy. It is calling for men. The Electric Lighting Stations *must* have Meter Engineers. *Thousands of positions are now open.* Meter Engineers are now so scarce that the Electric Lighting Stations are willing to pay huge sums for competent men. *YOU* can get into the profession. *It is calling you.* Write at once for full particulars of this special offer.

### Special Offer

For a limited time we are making a special reduced price offer in order to induce men to start the study of Meter Engineering right away. Send the Coupon.

**FREE  
Book  
Coupon**

**Send the Free Coupon**

Ft. Wayne  
Correspondence School  
Dept. 1197, Ft. Wayne, Ind.

Gentlemen:—Please send me absolutely free and prepaid your new book on Meter Engineering. Also tell me about your great special offer. It is distinctly understood that I assume no obligations of any kind.

Put your name and address on the coupon and send it in at once. We will send you absolutely free and prepaid our big new book on Meter Engineering. Tells you about the wonderful opportunities you will have in the New Profession. Explains exactly how you can study at home during your spare time and get your diploma. Absolutely no obligations of any kind in getting this book. Send your name and address on free coupon or letter or postal card. But send today.

Ft. Wayne Correspondence School  
Dept. 1197  
Ft. Wayne, Ind.

Name.....  
Address.....

Please Mention Popular Mechanics



## Mechanical, Electrical and Civil Engineering Highland Park College

Thorough instruction by specialists. Get your B.S. degree and be working a year before graduates of other colleges. Three years of 48 weeks each.

### Special One-Year Courses

**Electrical Engineering**—Designed especially to prepare young men for responsible positions, such as superintendency of the smaller electric power and lighting stations, power plants, etc. Diploma.  
**Steam Engineering**—Qualifies young men to take charge of steam power or heating plants and to run stationary engines.

**Machinists' Course**—For those who want to become machinists in the shortest time. Plenty of shop work, not much text-book study.

**Automobile Machinists' Course**—Arranged especially for those who want to secure a position in an automobile factory or to manage a garage.

### Special Courses in Gas, Automobile and Traction Engineering

Three months each. Students work right in machine shops, traction engine house and auto garage; repair and drive engines and automobiles. Gas Engine Course may be taken with the Traction Engine or Auto Course without extra tuition.

Every aid given ambitious students with limited means. Tuition fees small, living expenses low. For catalogue address GEORGE P. MAGILL, President, Highland Park College, Des Moines, Iowa.



## Learn a Paying Profession

that assures you a good income and position for life. For seventeen years we have successfully taught

## PHOTOGRAPHY

Photo-Engraving and Three-Color Work

Our graduates earn \$20 to \$50 a week. We assist them to secure these positions. Learn how you can become successful. Terms easy—living inexpensive. Write for catalogue—NOW!

ILLINOIS COLLEGE OF PHOTOGRAPHY, 999 Wabash Avenue, Effingham, Ill.

## LEARN TO BE A WATCHMAKER

BRADLEY POLYTECHNIC INSTITUTE  
Horological Department, Peoria, Illinois



Largest and Best Watch School in America. We teach Watch Work, Jewelry Engraving, Clock Work, Optics. Tuition reasonable. Board and rooms near school at moderate rates. Send for catalog of information.

BRADLEY, Dept. S., PEORIA, ILL.

## EARN TELEGRAPH

Morse or Wireless. Also superior station agency course. Splendid opportunities. Demand greater than supply. Graduates assisted. We own and exclusively occupy two large modern buildings equipped with R. R. and Western Union Wires and Complete \$3000 Marconi Wireless Station. Oldest and largest school—est. 39 years. Investment \$25,000. Endorsed by Railroad, Wireless and Western Union Officials. Expert practical teachers. Living expenses may be earned. Tuition low. Easy payments. Catalogs Free.

Dodge's Telegraph, Railway and Wireless Institute  
8th Street VALPARAISO, IND.



# 10 Volume Set of De Maupassant GIVEN AWAY

To Popular Mechanics Magazine readers who fill out and return coupon below at once, we will give free, this splendid 10 Volume set of Guy De Maupassant with each order for the 18 Volume "Library Edition" of Balzac's Complete Works.



**G**UY De Maupassant is King of all Short-Story Writers. His stories never dull, deal with Human Passion in both its comic and tragic aspects. Stories of Passions, Stories of Youth and Folly, Stories of Happiness and Good Cheer, Tales of Adventure, Tales of Strange Medical Experiences, Tales of Parisian High Life and of that Mystic "Other Side" of the Seine—the "Latin Quarter";—all this marvelous array from his magic pen is to be found in this splendid Set which is yours free, as a "Premium" with your order for the handsome 18 volume "Library Edition" of

## BALZAC TRANSLATED FROM THE ORIGINAL FRENCH—UNABRIDGED

**N**OWHERE in the literature of any country on the face of the globe are there any books like Balzac's. The most brilliant name of his day in the literature of France. Balzac reached the very pinnacle among the world's greatest writers. His marvelous imagination coupled with his intimate knowledge of life, enabled him to scale every height and sound every depth of human passion. Of himself, he said (and said significantly): "*I am the Secretary of Society.*"



**I**F you would read the great book of life, with its countless thousands of lights and shadows, portrayed by the hand of a master, then you must read Balzac. But if you would read only that which is superficial, then do not read Balzac, for

he deals with things not as they should be, but with things as they are, and his university is the Great University of Human Experience. Balzac's stories literally burn themselves into your brain and memory; they read as though they were his own actual personal experiences, and such is their master-grip and hold upon you that to read them is to live them for yourself. Volumes measure 8¼ by 5¼ by 1½ inches and are bound in deep blue genuine Imported "Library Cloth." Here is your chance to get these wonderful books—at a bargain.

### Balzac and De Maupassant —Both for the Price of One

We were fortunate in being able to procure a limited number of Sets of the 10 Volume Edition of Guy De Maupassant at a very reasonable figure. The regular price of this Set is \$9.00, but we do not want to sell these books. Our plan is to give them away as "Premiums" to those ordering our handsome 18 Volume Library Edition of Balzac, as an inducement to prompt action. When the small number of sets of De Maupassant on hand is exhausted, this offer will be withdrawn, but if you fill out and mail coupon at the right promptly, we will see to it that you get one of the free sets of De Maupassant along with your Set of Balzac. But remember, that in order to get the De Maupassant free, you must fill out and mail coupon at the right at once.

#### MAIL THIS COUPON AT ONCE

To introduce this handsome "Library Edition" of Balzac's Complete Works we will accept orders for our \$54 Library Edition at only \$29.50, on terms of \$2 a month. We do not ask you for any deposit or any guarantee. Just tear off and mail coupon and we will ship you the complete Set of 18 Volumes for 7 days' examination. You can then examine each Volume carefully, and if the books are satisfactory and you wish to keep them, then send us only \$1 as first payment and \$2 a month until the special price of \$29.50 is paid.

To those who answer promptly, we will give as a "Premium," the 10-Volume Edition of De Maupassant, free of charge. So mail coupon immediately.

The Thompson Publishing Company  
1127-29 Pine St.  
St. Louis, Mo.

Send me for examination, one set of Balzac's Complete Works in 18 volumes Library Edition. If I am satisfied with the books, I will send you \$1 as first payment, and \$2 a month thereafter until the special price of \$29.50 is paid. If I do not wish to keep the books I will notify you in 7 days and the books are then to be returned at your expense. In consideration of my prompt reply, I am also to receive free, as a "Premium," the 10-Volume Edition of De Maupassant as offered Popular Mechanics Magazine readers. (10-13)

Name .....

Address .....





**THE OLD RELIABLE SCHOOL**  
*We have successful graduates in nearly every State in the Union.*

## Delco Instruction

and we are now prepared to give you Delco instruction "right." Our school actually has a Delco system in operation on a motor, and is the **only school** that gives students **ACTUAL EXPERIENCE** in wiring the Delco systems. Factories are paying better salaries for lighting, starting and ignition men than for any other factory men. 150,000 cars (1914 models) will have Delco systems. Delco men are very scarce and those who understand Delco systems will be in great demand at high salaries.

## Come to Detroit, the Automobile Center

and learn the automobile business. Sixty-seven out of every 100 autos in the country are made in Detroit's 38 automobile factories. There are greater and better opportunities in Detroit than in any other city in the United States. Why go to some out of way place where they practically don't make autos, when you can go right to Detroit, the automobile center, and learn the business right?

*Our 48 page booklet "How to Drive an Auto" sent free on request*

**Address Michigan State Automobile School**  
**Dept. P 11-13-15-17 Selden Ave., Cor. Woodward, DETROIT, MICH.**

We have just purchased a new 1913 Hudson motor, equipped with a **Delco lighting, starting, and ignition system,**

## Our Guarantee

We guarantee to qualify you for a position as chauffeur, repairman, tester, salesman or demonstrator in a short time, or we will refund your money. Have you ever known any other auto school to give this guarantee? We do it, because we have the equipment, the room and the system and the instructors.

**And don't forget, we furnish positions, too**

On account of being in the auto center, we can furnish positions that schools in other towns cannot.

## WHY NOT BE AN ARTIST?



**STUDY drawing at home under Expert Faculty.** We have successful students in every part of the world. **Turn your Talent into money.** Our Students are filling high salaried positions. 14 years successful teaching. Endorsed by high authorities. 18 Courses in Commercial and Illustrative Drawing. Teachers' Normal and Applied Art, Profit or Culture. **Thoroughly Equipped Residence School** Artist's Outfit **FREE** to Enrolled Students  
**SCHOOL OF APPLIED ART, 755 Applied Art Bldg., Battle Creek, Mich.**

LEARN TO **PAINT SIGNS and SHOW CARDS**

I'll teach you personally by mail. Fourteen years' successful teaching. Big field for men and women. You can **EARN \$18.00 TO \$35.00 A WEEK**

Crawford, B. C., writes: "Earned \$200.00 while taking course." Write today for catalog, samples, etc.  
**DETROIT SCHOOL OF LETTERING**  
CHAS. J. STRONG, Founder Dept. 210 Detroit, Mich.



**\$10 PER DAY EASILY EARNED AS A PIANO TUNER**

**The Tune-a-Phone Does It.**

We will teach you Piano Tuning, Voicing, Regulating and Repairing, quickly by personal correspondence. New Tune-a-Phone Method. Mechanical aids. Diploma recognized by highest authorities. School chartered by the State. Write for our handsomely illustrated free catalogue.

**Niles Bryant School of Piano Tuning**  
13 Music Hall, Battle Creek, Mich.



**LEARN WATCHMAKING**  
and become independent. Good-paying positions secured. Easy to learn. Send for **FREE CATALOG.**  
**ST. LOUIS WATCHMAKING SCHOOL, Dept. 5, ST. LOUIS, MO**

**IF YOU STAMMER**

Attend no stammering school till you get my large **FREE** book and special rate. Largest and best school in the world curing by natural method. Write today. **Lee Wells Millard, Pres., North-Western School for Stammerers, Inc., 917 First St., Milwaukee, Wis.**



**DO IT NOW**

Spring Styles



**SHOWCARDWRITERS EARN FROM \$21 TO \$50 PER WEEK**

**LEARN ABOUT OUR FREE COURSE IN SHOW CARD AND SIGN WRITING**

**A Great Opportunity!** We are offering, for a limited time, a complete course in show card and sign writing to those purchasing our assortment of **"Litholia" Ready-to-Use Colors**

This is a great opportunity for ambitious persons, either sex, to increase their earning capacity. Good show card writers in demand at \$21 to \$50 weekly, salary or in business for yourself. Our show card course is not a book of alphabets. It's a complete course in lettering compiled by an expert New York show card artist for us. "Litholia" is the only liquid pigment water paint ever manufactured, used the same as cake, distemper or tube colors, but far superior to either. "Litholia" lasts longer, always ready. "Litholia" is the best for the show card writer, the artist, or the interior decorator. A letter of request brings booklet, circulars, and full information.

**LITHOLIA P.M. COLOR CO., 71 to 81 W. 23rd Street, NEW YORK CITY**



**WRITE for  
this FREE  
BOOK**

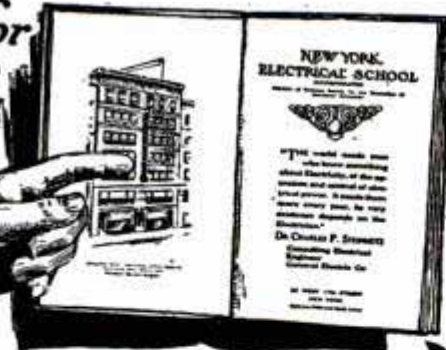

## Expert Electricians Make Big Money

You can learn all branches of electricity at this school—and you will learn them BY DOING the actual work, step by step, personally guided and coached.

The opportunities open to men who understand electricity and have had technical training cannot be exaggerated. There is no limit as to how high you can climb if you have learned electricity at this school.

**WRITE TO-DAY FOR OUR FREE CATALOG,** or come in and inspect the school at your earliest convenience.

**The New York Electrical School**  
44 West 17th Street NEW YORK



### HOW TO TRIM SHOW WINDOWS

Shown in this new book, 150 complete windows for every season of the year illustrated by means of over 200 detail drawings and explained in 256 pages of text matter. Shipped prepaid for \$1.50. This is the 10th year for our

**SCHOOL OF WINDOW TRIMMING**  
**CARD WRITING AND ADVERTISING**  
Best paid and most fascinating professions in the world. A 120 page catalog FREE tells you all about it.

**KOESTER SCHOOL, 306 Jackson Boulevard, CHICAGO**

### DO YOU LIKE TO DRAW?

That's all we want to know. Now we will not give you any grand prize—or a lot of free stuff if you answer this ad. Nor do we claim to make you rich in a week. But if you are anxious to develop your talent with a successful cartoonist, so you can make money, send a copy of this picture with 6c. in stamps for portfolio of cartoons and sample lesson plate, and let us explain.



The W. L. Evans School of Cartooning  
821 Leader Bldg., Cleveland, O.

### BE A BANKER

Splendid opportunities. Pleasant work, short hours, all holidays off, yearly vacation with pay, good salary. Learn at home. Diploma in six months. Catalog free. EDGAR G. ALCORN, Pres.  
AMERICAN SCHOOL OF BANKING, 119 McLene Bldg., COLUMBUS, OHIO



### How To Do It Safely?

Give up struggle for mere existence in city? Plan now safe way out. No cost to investigate. Free Book explains plan for man or woman. (No land to sell. No agents.) We teach Farming by Mail. All subjects. Which interests you?

**American Farmers School** 412 Laird Bldg. Minneapolis, Minn.

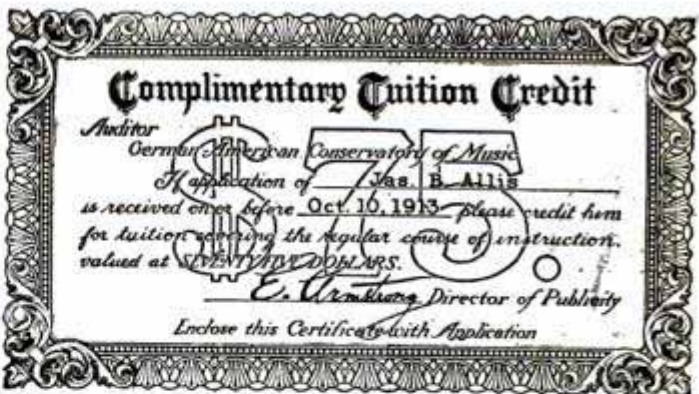

# MUSIC Scholarship FREE

At this particular time we are offering you a credit certificate valued at \$75.00 absolutely without charge. A tremendous, positively astounding offer for the ambitious young people. An opportunity to learn music in the greatest conservatory for home study in the world. This tuition credit entitles you to a complete course in our big conservatory. We make this liberal offer for advertising purposes. This offer is open for a limited time only. Take advantage of this remarkable opportunity now! Hurry, or you may be too late! Clip the coupon and send it to us for full particulars.

## Advantages of a Musical Education

Knowledge of music opens the door to social success. It brings friends, wins respect and admiration, and gives you a money-making profession. And now, no matter where you live, you can learn to play the piano quickly, easily and splendidly by our wonderful system of mail instruction. This wonderful aid—this instructor—simplified guide—the "Music Master" takes you through the hard places to efficiency—the end. It makes you a graduate—secures a diploma—makes you a pianist and a musician. We positively agree to teach you. If we fail, we agree to refund your money; provided, of course, that you have complied with and carried out our instructions, and conformed to our methods. Act this very moment. Write today. Get full particulars of our great, complimentary tuition offer.

### Mail Coupon Now

Don't delay. Grasp the opportunity for yourself or children. Just your name and address will do. But hurry, and we will tell you all about our complimentary tuition credit. Also, our wonderful, easily acquired method of learning how to be an expert pianist. Don't pass this great offer up. Send no money. This offer is limited—so write to us immediately—NOW!

### FREE Coupon

**German-American Conservatory of Music**  
Department A19  
CHICAGO, ILLINOIS

Gentlemen:—Please send full particulars of your free \$75.00 tuition credit offer. Also a copy of the "Music Master" book. I assume no obligations.

**German-American Conservatory of Music**  
DEPT. A19  
Chicago, Ill.

Name.....  
Address.....



# Wonderful BOOK FREE!!

Explains Everything You Should Know About

## How To Study

# LAW

Any one ambitious to study law and become a successful practicing lawyer at the bar, should not hesitate to send for this GREAT FREE BOOK, which explains exactly what you ought to know before taking up this fascinating and valuable study.

### This Book Starts You Right

It shows you how to become a thoroughly competent lawyer—explains the requirements step by step in a plain, simple, direct way that will start you right and save you a lot of time, trouble and expense. There can be no possible failure with this Wonderful Guide to follow. It puts you at once in the path followed by America's Foremost Lawyers—men who have themselves gone through such steps as they now recommend for you. This Free Book shows you

### How To Study Law At Home

Under the World's Greatest Masters of Law—how to utilize your spare moments in preparing yourself for a great profession at very small cost—how to prepare for bar examinations in any State—how to increase your mental powers by training that will make you a leader in your community. If you contemplate studying law, you surely want to master the best course in the shortest time at least expense. This Free Book is invaluable to you, no matter what course or school you have in mind, and you might as well send for it—no risk, expense or obligation—and become thoroughly posted.

### Become An LL. B.

We will not only send you this Wonderful Guide to the Law—absolutely free—but will also point out a way by which you can secure a \$100 tuition credit free. We are in position to do this for a certain time, so it will be just like keeping a lot of money in your own pocket, if you answer this promptly. Remember, we save you half.

**SEND NO MONEY** Just your name and address in letter, postal, or on the Free Coupon below, will promptly bring everything Free by return mail. You will find this Guide to the Law an invaluable aid in putting you on the right track. Don't fail to send for it now!

**\$100.00 Tuition Credit FREE**  
(Tear Off and Mail This Free Coupon Now)

LaSalle Extension University,  
Dept. 277, Chicago, Ill.

Please send me—FREE—Valuable Law Guide and tell me how to secure a \$100.00 Tuition Credit Free.

NAME.....

ADDRESS.....

Please Mention Popular Mechanics

## Earn \$3000 to \$5000 a Year AS a Doctor of CHIROPRACTIC

Easily Learned in Spare Time at Home and in Class  
Our Students Surprisingly Successful



Do you seek financial independence and social prominence? Why depend upon a mere job—work for others—and never rise above the level of a wage or salary earner when you can easily capitalize your spare time now by fitting yourself to become a Doctor of Chiropractic

### The New Drugless Healing Science of Spinal Adjustment

More Scientific, More Simple, Easier to Learn Than Osteopathy

There are 23 million people in this country who believe in drugless healing, and the number is constantly increasing. They are to be found in every community. Splendid openings for Chiropractors everywhere. It's a profession that is far from overcrowded. Immensely lucrative. Dr. Walter, a graduate, made \$500 the third month after starting. R. M. Johnson added over \$3,000 a year to his income. Vern Sharpsteen makes \$40 a day. We taught these men by mail and in class. You can do as well or even better. Treat members of your own family free—earn handsome fees for treating others.

Our simplified home study course, profusely illustrated, and with 14 big free charts and a spinal column, makes it easy to acquire a thorough, practical knowledge of this dignified, profitable profession in a surprisingly short time. A common school education is all you need—our absorbing, easy-to-learn-lessons will do the rest. It means financial independence, social position—a profession that is looked up to, for you.

**FREE** sample lesson sheets, big illustrated book, also names and addresses of successful students mailed free on request. Write today—a lucrative practice awaits you.

**NATIONAL SCHOOL OF CHIROPRACTIC,**  
Dept. 10 1553 W. Madison St. CHICAGO, ILL.

## LEARN WATCH REPAIRING

Be a watchmaker—you can learn this profitable trade by correspondence in a few weeks in your own home by the DeSelsms Chart System. After you complete the course you will know a watch from A to Z. You will know just what the matter is and how to repair one. When you graduate you will be a practical watchmaker and repairer and competent to fill any position. Positions for our graduates.



Ask for our Free Book. It explains our system and terms.

**THE DESELMS WATCH SCHOOL**  
23 Perry Street ATTICA, INDIANA



## MEN WANTED

Prepare as Firemen, Brakemen, Electric Motormen, and colored Train Porters. Hundreds put to work—\$65 to \$150 a month. No experience necessary. **500 more wanted.** Enclose stamp for Application Blank. Name position you want.  
I. RAILWAY C. I., Dept. 35, Indianapolis, Ind.

## DRAWING



Caricature, Cartoon, Comic, Commercial, Fashion, Newspaper and Magazine Illustrating taught by mail. Illustrated book 6c in stamps. **THE BOSTON SCHOOL OF DRAWING,**  
755M Boylston St. BOSTON, MASS.

## MUSIC TAUGHT FREE AT YOUR HOME

Write Today for our booklet. It tells how to learn to play Piano, Organ, Violin, Mandolin, etc. Beginners or advanced pupils.  
**AMERICAN SCHOOL OF MUSIC, 50 Lakeside Bldg., Chicago, Ill.**

## LEARN TO WRITE ADVERTISEMENTS EARN \$25 to \$100 A WEEK

We can positively show you by mail How to increase your salary. **BOOK MAILED FREE.**  
PAGE-DAVIS CO., 112 Page Building, Chicago, Ill., or 150 Nassau St., New York



## LEARNED BY ANY MAN OR BOY AT HOME SMALL COST

**VENTRILOQUISM**  
Send today 2c stamp for particulars and proof.  
O. A. SMITH, Room D 83, 823 Bigelow St., PEORIA, ILL.



# Drafting!

## Learn at Home on This Great Offer!

Yes, learn **Drafting and Designing** right at home—during your spare time. Never before have there been such tremendous opportunities for men who take up this interesting and profitable work. Never before have salaries been so high. You can become an expert Draftsman and Designer in a surprisingly short time by my practical method of instruction. There will be a good paying position waiting for you when you have completed my Course. Send the Free Coupon **at once** for full particulars of the **Limited Free Offer** I am making at this time.

## Limited FREE Offer!

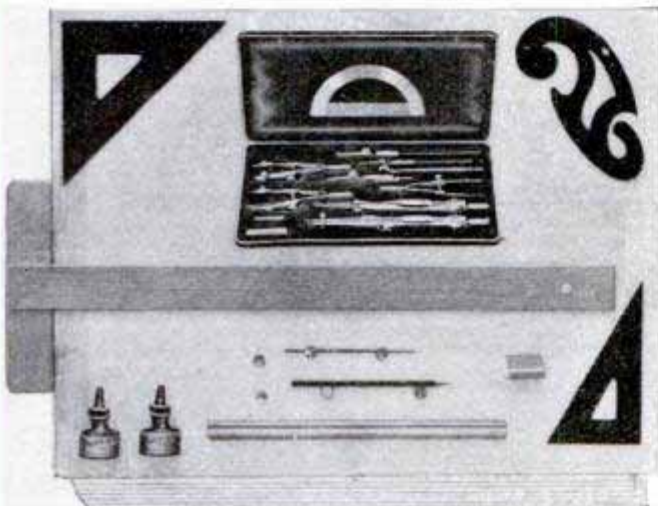

If you enroll now I will give you a Tuition Credit, valued at \$25.00. I want a number of students quickly in order to supply the big demand for expert Draftsmen and Designers. This Free Offer is open for a limited time only and you must act **immediately**. If you enroll now, you save exactly \$25.00—your expense will be nominal. I will instruct you personally—give you the benefit of my years of successful experience. All needless theory is thrown aside. I give you just the kind of training you must have in order to **succeed**—give you the **actual and practical** work to do in your home.

## FREE! \$17.50 Set of Drawing Instruments If You Enroll At Once

As an extra inducement for you to enroll within the next 30 days I will give you **absolutely free** a magnificent set of Drawing Instruments. Handy size, leather bound pocket case.

**Guarantee**  
I guarantee to instruct you until placed in a position paying \$75.00 to \$200.00 per month. Our Employment Bureau is open FREE to students.

This fine set of instruments will last for years and will prove of great service and value when you are working as an expert Draftsman. Don't delay in this matter. Send Free Coupon today for full information.

## \$125.00 to \$200.00 a Month FOR YOU

That's what you can earn as expert Draftsman—and more. My graduates are most successful in filling big paying positions. You can start a business of your own and make \$2,500.00 to \$5,000.00 a year.

## Mail This Free Coupon Today

Mail coupon or send post card today. I will send you my book "The Road to Success" and full particulars of my **Limited Free Offer**. You assume no obligations—everything sent to you **free and prepaid**. This is an opportunity which does not often come your way—an opportunity to learn Drafting and Designing **at home** during your spare moments—to get a \$25.00 Tuition Credit **Free**—to get a magnificent set of Drawing Instruments **Free**. Don't delay. Send Coupon or post card today—**immediately**.

**CHIEF ENGINEER**  
Room 507, Engineering Bldg., Chicago, Ill.

**Free Coupon**  
**CHIEF ENGINEER**  
Room 507  
Engineering Bldg.  
Chicago, Ill.  
Dear Sir:—Without any obligations on my part, please send me your book "The Road to Success" and full particulars of your **Limited Free Offer**. Send everything **Free and Prepaid**.  
Name .....  
Address .....

FOLD HERE, TEAR OFF, SIGN AND MAIL



# STUDY LAW AT HOME

## Become an LL.B.

Only Law School of  
its Kind in America

### Special and Exclusive Features

ONLY recognized resident law school in the United States conferring Degree of Bachelor of Laws—LL.B.—by correspondence. ONLY law school in U. S. conducting standard resident school and giving same instruction, by mail. ONLY law school giving over 450 class-room lectures to its extension students. ONLY law school giving a full 3-year, University Law Course, by mail, having an actual faculty of over 30 prominent lawyers in active practice. ONLY law school in existence giving Complete Course in Oratory and Public Speaking, in conjunction with its law course.

### Written Bar Guarantee

We give an absolute written guarantee to prepare our students to pass bar examinations.

The Hamilton College of Law IS a regular, thoroughly recognized, bona fide College of Law and NOT an "institute," "correspondence school," etc. It occupies the entire third floor of the New Advertising Bldg., where its large and commodious resident class-rooms and executive offices are located.



Our Degree Bachelor of Law, LL.B. NOT A Diploma or Certificate

### Direct From Class-Room to Student



From Lecture Room to Student  
No Other Law School Can Use  
This Illustration

chooses, take part of our course by mail and finish in our resident school where he will receive full credit for all work done by mail. Our resident school is recognized by all standard law schools in the United States.

The Hamilton College of Law is highly endorsed and recommended by Government Officials, Business Men, Noted Lawyers, Graduates, and Students. We have as students a number of practicing lawyers (not graduates of recognized law schools) who are now earning their degree of LL.B. Many other lawyers are using this course as a review. A probate Judge, (one of our active studental says: "I am delighted with the course prescribed and your method of teaching law. It is far in advance of what I expected to receive.")

### Our Law Library

consists of 24 volumes of Student's Standard Text Books, two volumes bound together under one cover, making a total of 12 books. These books were prepared at an enormous cost especially for the students of the Hamilton College of Law, by



These 12 Volumes are Free to Students of one of the largest and best law book publishers in America. This is the only set of law text books ever prepared exclusively for student's use. We would be glad to have you submit these books to any lawyer or judge in the country and get his opinion regarding them.

### Mail Coupon Today

and get our Big, Beautifully Illustrated Prospectus and complete information. Places you under no obligations whatever. This may mean the turning point in your career.

Hamilton College of Law, 327 Advertising Bldg., Chicago, Ill.

Gentlemen: Kindly send me your Illustrated Prospectus and full particulars regarding your method of teaching law by mail

Name.....

Address.....

Write plain and in full

Please Mention Popular Mechanics

# A Course of Lessons In Drugless Healing

(Mechano-Therapy)

# FREE



Not one cent to pay either now or later—no obligation of any kind. Just your simple request will bring you this valuable course of 62 lessons by return mail *without cost*. This offer is *strictly limited*. We reserve the right to withdraw it at any time without notice. *So don't wait a minute.* Send your acceptance *right away*.

### Why We Are Making This Offer

We want the public to know the *real truth* about Drugless Healing. Besides, these free lessons will demonstrate just how thoroughly, and in what a surprisingly short time you can master this wonderful new profession, at home or in class, without interfering with your regular occupation.

### If You Want to Earn \$2500 to \$6000 a Year

if you want an established profession that is remarkably profitable, if you want to become master of your own and others' health and happiness, then send for the free course and see what Drugless healing has to offer you. Hundreds of successful graduates demonstrate the wonderful efficiency of our methods. How about yourself? Are you satisfied—healthy—happy—making all the money you want? If not, get posted on Drugless Healing *right away*.

### Remember--This Offer Is Limited

Write NOW for FREE course of lessons. Don't wait to think it over. Get the facts—the real truth—learn what you can earn as a Mechano-Therapist. The FREE 62-lesson course and our free book explain all. Send a postal or letter **RIGHT AWAY**.

AMERICAN COLLEGE OF MECHANO-THERAPY  
Dept. 859, 81 W. Randolph Street (122) Chicago, Ill.

# BE A TELEGRAPH OPERATOR

Learn at home by mail. Earn \$75 to \$250 per month. Big demand for operators. We send you instrument and instruction on 10 days' FREE trial. Write today for Free Book and Telegraph Code.



MUTUAL TELEGRAPH SCHOOL, 827 DWIGHT BLDG., Kansas City, Mo.

# JEWELRY ENGRAVING

We teach you, by our new and original method of instruction, this clean, fascinating and profitable business **right at your home**, and furnish you all tools needed absolutely **free**. Write for free book to the WISCONSIN SCHOOL OF ENGRAVING, Stroh Bldg., MILWAUKEE, WIS.

# BE A DETECTIVE

Earn from \$150.00 to \$300.00 per month; travel over the world. Write C. T. LUDWIG, 133 Westover Bldg., Kansas City, Mo.

### BE AN ILLUSTRATOR

by mail how to draw for magazines and newspapers. Send for Catalog

Learn to draw. We will teach you School of Illustration 112 Page Bldg. Chicago, Ill.



# Learn Automobile Driving and Repairing

We give you driving lessons and teach you all the technical parts to prepare you for a good paying position. Write for Booklet P. Day and Evening Class.

NORTHWESTERN MOTOR INSTITUTE, 228-230-232 Wisconsin St., MILWAUKEE, WIS.

# ARITHMETIC SELF-TAUGHT

A plain, easily-understood volume for all who have not had the opportunity of learning this subject thoroughly, or who have forgotten what they once learned. 257 Pages. Requires no teacher. This great little book sent postpaid for 60 CENTS. Stamps accepted, leather binding \$1.

GEO. A. ZELLER BOOK CO.  
Est. 1870, 4473 W. Belle Place ST. LOUIS, MO.

SPANGENBERG'S  
PRACTICAL  
ARITHMETIC  
Self-Taught



# Earn Big Money!

## Tremendous Opportunity Now

We are making a most exceptional offer at this time! We offer you an opportunity to learn a profitable trade—to become an expert in **Electricity, Plumbing, Bricklaying, Drafting and Designing, or Moving Picture Operating.** We will teach you in a remarkably short time at small expense.



Never before has the demand for men skilled in these trades been so great. Every day the big companies are sending out calls for men and salaries have never been so high. If you enroll in our big Schools **NOW** you will benefit by the Special Offer we are now making. Clip the coupon and send it to us at once for our **FREE** Book on "Profitable Trades" and full particulars of this Great Special Offer.

### Great Special Offer!

Right now we are making a surprisingly liberal offer to ambitious men. We will teach you a profitable trade at small expense—tuition **VERY LOW** and may be paid on the **EASY MONTHLY PAYMENT PLAN.** We have arranged for day and night sessions so that you may **LEARN** while you **EARN.** We will help you work your way through School if you wish. Our Schools

are the **OLDEST, LARGEST AND BEST EQUIPPED TRADE SCHOOLS IN AMERICA.** Our corps of experts instruct you. We give you the **ACTUAL** and **PRACTICAL** work to do right in the School.

**FREE!** On this special offer we will furnish all the tools and material you use in taking our Course **ABSOLUTELY FREE.** No expense to you whatever. We make this liberal offer in order to put more men out in the field at once.

### \$125 to \$300 a Month

That's what you can make when you have mastered a trade in our Schools. Our graduates all over the country are making that much and more. Our Employment Bureau places students in big paying positions **FREE OF CHARGE.** Right now is the time for you to write for full particulars of this Special Offer.



### Start a Business of Your Own

#### —proof

Coyne National Trade Schools  
Gentlemen:— Have been working every day since leaving School. Am getting \$8.00 a day at Electrical work here with one of the big Electrical firms. Expect to get into business for myself this fall. You have the best Trade Schools in America and I will always give my hearty recommendation,  
**B. W. STEVENS,**  
548 Arlington Place,  
Chicago, Ill.

Hundreds of our graduates are now in business for themselves. With the thorough training we give you, it will be very simple to start a good profitable business in **ELECTRICITY, PLUMBING, BRICKLAYING, DRAFTING AND DESIGNING** and **MOVING PICTURE OPERATING.** You can make

### \$2,000 to \$7,500 a Year

in business for yourself. In every one of these lines of work the demand for expert men far exceeds the supply. Don't delay in this matter—send today for full particulars of our Offer.

### This is Your Opportunity Mail Coupon TODAY

Yes, send the coupon or postal **AT ONCE** for our **FREE** Book and full particulars of this Special Offer. Start on the right road to **SUCCESS** now by learning a trade. Our **FREE** Book will tell you how to increase your earning power—explains the wonderful opportunities waiting for men who learn a trade. The book and information will be sent to you **FREE AND PREPAID**—no obligations on your part. Mail coupon or postal immediately.

**L. L. COOKE, Director**  
**COYNE NATIONAL TRADE SCHOOLS**  
Dept. 1197, 51 East Illinois St.  
**CHICAGO, ILL.**

*Come to Chicago the busiest city in the world. Our students make \$6 a day here.*

**FREE**  
Book and  
Information  
Coupon

**L. L. COOKE, Director**  
**Coyne**  
**National Trade**  
**Schools**  
Dept. 1197, 51 East Illinois St.  
**CHICAGO, ILL.**

Dear Sir: Please send me Free and Prepaid your book on Profitable Trades and full particulars of your Great Special Offer. I assume no obligations.

**FOLD HERE. TEAR OFF. SIGN AND MAIL**

NAME.....

ADDRESS.....

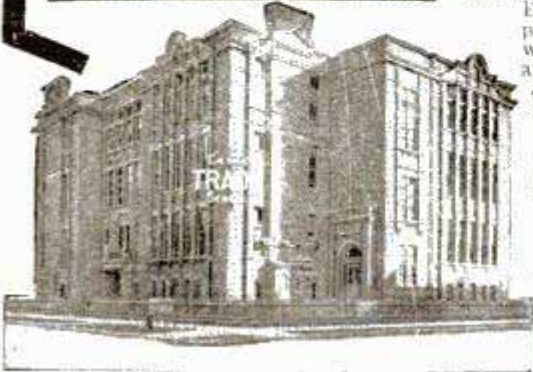



# "I know a College Graduate who is a Dunce"

Elbert Hubbard

"I know a man who is fifty-five years old. He is a student. He is a graduate of three colleges and he carries more letters after his name than I care to mention, but this man is neither bright, witty, clever, interesting, learned nor profound. HE'S A DUNCE! And the reason is that he cannot remember. Without his notes and reference literature he is helpless," writes Elbert Hubbard.

## A Perfect Memory Is The Key To Success

Thousands of intelligent men and women remain obscure because they cannot remember important things. The demands of commercial and professional life are becoming so exacting in their details of facts and figures to be remembered, that to succeed or even hold your own you simply must possess a good memory.

For over 20 years I have been training people to STOP FORGETTING—aiding them to greater business and social success—and I have seen enough and learned enough to know positively that the person with a strong, tenacious memory, though he be far behind at the beginning of the race for success, advances and soon outdistances his forgetful rival.

I prove every day that the great secret of business and social success is the ability to instantly remember experiences and facts and apply them when needed.



# Stop Forgetting!

## I Can Show You How

Easily, quickly, in your spare time, at home by mail. Spend 10 minutes daily and I will make your mind an infallible classified index system from which you can instantly select thoughts, experiences, facts, figures and arguments. I will enable you to concentrate your mind on any one subject to the exclusion of others—I will enable you to absorb, weigh, reject and classify ideas, names and faces for instant reference—I will enable you to think rapidly on your feet, to address an audience without hesitating, with that confident, forceful conviction that wins success.

## My System Is Easy, Infallible

A good memory is not a gift—it must be acquired like muscle, by training. The capacity of the brain is unlimited. The weakest mind instantly becomes interested in and susceptible to my clear, comprehensive method—there are no difficult exercises to memorize.

If your education has been neglected you will find my method an education in itself, embracing exactly the subjects most necessary in modern business and social life. If you are a college graduate my system will enable you to make practical use of your knowledge.

## For 20 Years I Have Trained People To Stop Forgetting

Let me impress upon you emphatically that my system is not a theory—it is scientific and practical—the result of over 20 years of observation while in intimate contact with all kinds of students in schools and colleges where I had been professor. Over 50,000 people all over the world have enrolled for my course.

**These Notables Endorse My System:** Many of the most intellectual men of the day are troubled with mind wandering and have availed themselves of memory training. My method is heartily endorsed by such notables as Elbert Hubbard, Prof. David Swing, Dr. Latson and thousands of others.

**Every Woman as Well as Every Man** should have my course—I will give her command of a well-stocked and well-selected vocabulary—I will enable her to adapt herself quickly to the moods of an audience or meet any emergency.

### How to Get Free Copy of "How To Speak in Public"

If you wish to be able to think on your feet—to meet emergencies—to express yourself clearly, logically and convincingly whether talking to one person or to a thousand, my book "How to Speak in Public" will explain how. This is my 1913 De Luxe edition handsomely illustrated, richly bound. Price is \$2.00, but I will present a copy absolutely FREE to every student.

### Let Me Send You a Free Copy "How to Remember"

Send the coupon at once for your free copy of "HOW TO REMEMBER." Let me show you how to increase your efficiency and income. Don't hesitate—education, vocation, age or residence make no difference.

### The Key to Success—Mail It Today



Prof. Henry Dickson, Principal Dickson School of Memory

Prof. Henry Dickson, Principal, Dickson School Memory, 705 Auditorium Bldg. Chicago

Dear Sir: You may send me FREE—my copy of "HOW TO REMEMBER," also full particulars about free copy of your new book "HOW TO SPEAK IN PUBLIC."

NAME.....

ADDRESS.....

CITY.....STATE.....



# J-M ASBESTOS ROOFING

Used on Largest and Most Expensive Buildings

City Hall, Philadelphia, Pa. Roofed with J-M Asbestos Roofing

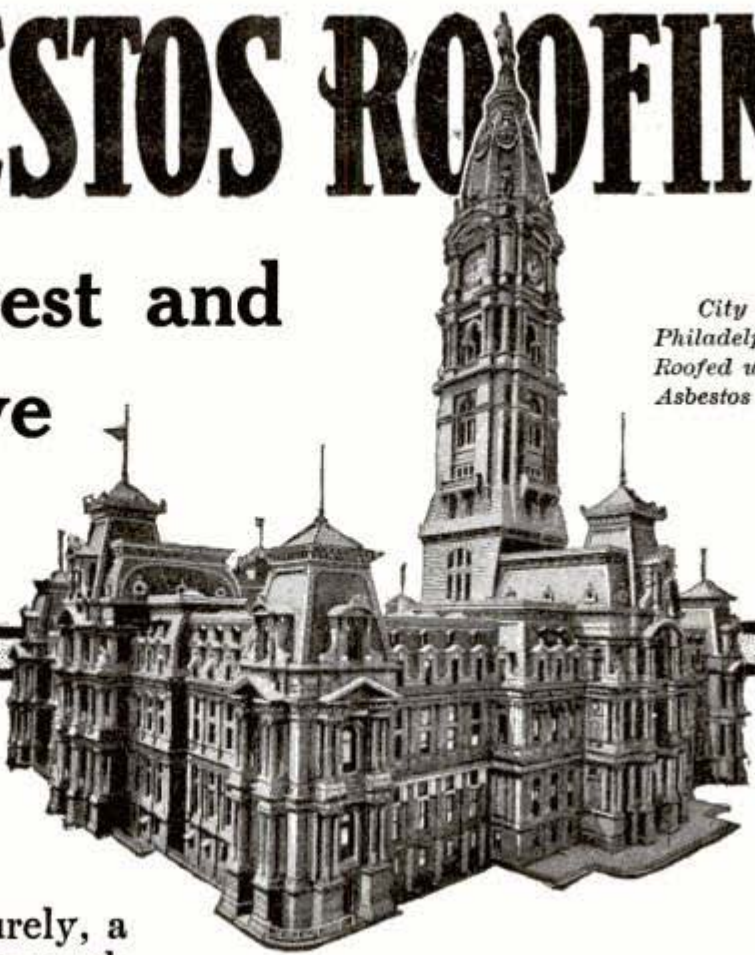

This great building, erected at a cost of \$25,000,000.00, is covered with J-M Asbestos Roofing. Surely, a roofing that is good enough for this monumental structure will answer your requirements.

Hundreds of the largest and finest buildings of all types are covered with J-M Asbestos Roofing—because it is the roofing of *proven permanence*.

J-M Asbestos Roofing is *all-mineral*. It is composed of several layers of Asbestos (rock) felt cemented together with Trinidad Lake Asphalt—the greatest waterproofing substance known.

It contains nothing to rot, rust, melt, crack, or deteriorate. Never requires graveling, coating, or any form of preservative. Its first cost is the last cost. Cheaper than tin, iron, slate or shingles—and the cheapest-per-year roofing on the market. Gives perfect fire protection. Adapted to any climate. Keeps buildings warm in Winter and cool in Summer.

Furnished in built-up form or in rolls. When in rolls it can be applied by any handy man. J-M Roofing Cleats, packed in each roll, make absolutely watertight laps and give the entire roof a handsome white appearance. Suitable for any type of building.

Sold direct if your dealer can't supply you. Write our nearest Branch for sample of the wonderful Asbestos Rock and Book No. 3171.

## H. W. JOHNS-MANVILLE CO.

MANUFACTURERS OF ASBESTOS AND MAGNESIA PRODUCTS

**ASBESTOS**

ASBESTOS ROOFINGS, PACKINGS, ELECTRICAL SUPPLIES, ETC.

- |           |            |              |             |              |               |
|-----------|------------|--------------|-------------|--------------|---------------|
| Albany    | Chicago    | Detroit      | Louisville  | New York     | San Francisco |
| Baltimore | Cincinnati | Indianapolis | Milwaukee   | Omaha        | Seattle       |
| Boston    | Cleveland  | Kansas City  | Minneapolis | Philadelphia | St. Louis     |
| Buffalo   | Dallas     | Los Angeles  | New Orleans | Pittsburgh   | Syracuse      |

THE CANADIAN H. W. JOHNS-MANVILLE CO., LIMITED,

Montreal  
Toronto

**DEALERS WANTED**—Choice territory still open. Quick sales. Liberal profits. Satisfied customers.

Vancouver  
Winnipeg

2122

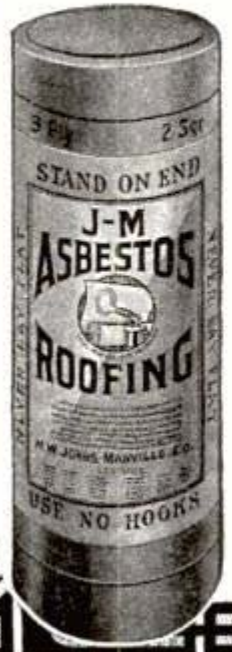





# Story of the **UNTRAINED** man

**At 20** the untrained young man is full of vim, and vigor and push. Nothing daunts him—opportunities are showered upon him—failure seems impossible.

**At 30**—he is not quite so sure of himself. Already he has had unpleasant experiences and realizes that he doesn't know enough—that **trained** men are given the preference, that **trained** men hold the big jobs and get the big salaries. But then, he says, there's plenty of time—I'm only thirty.

**At 40**—he is only a little better off than he was at thirty. Years of service have gained him small raises in salary. He begins to feel a little discouraged—as though the world were really against him. He becomes envious—he looks at the man ahead of him and says—"if I only had his job—if I only had his chance."

**At 50**—he knows that his chances for success are becoming slimmer and slimmer. He is resigned to his small job at small pay. He has reached the age when he thinks every morning and every night "well, what's the use?"

**At 60**—he is just an old man, probably broken in health and spirits. Perhaps he's one of the thousands tramping the streets of the big city in search of odd jobs, caring only for a bite to eat and a "bunk" in the wanderer's "flop."

This is not an extreme case. No young man likes to picture himself going down and out as this man did, but it's the story of the average untrained man.

## *The American School will prepare you for success*

It's just as easy to be a success as a failure—all you need is **training**. For fifteen years the American School has been preparing ambitious men everywhere for better jobs at more pay. The American School will give you the training you need, no matter where you live or what you do. It will train you in any branch of **Engineering, Business and Law**, or will prepare you for entrance into any resident college.

Perhaps you've never realized how easy it is to secure this training. Mark the coupon—let us explain how simple it is to prepare yourself for the position you want. Remember—the American School does not send agents to bother you in your home or at your work. All business will be carried on by correspondence and our easy payment plan will enable you to pay as you progress.

# American School

of Correspondence, Chicago, U.S.A.

### Your Opportunity Coupon

Mark the position you want and mail the coupon now

- |                               |                          |
|-------------------------------|--------------------------|
| ....Electrical Engineer       | ....Lawyer               |
| ....Elec. Light & Power Supt. | ....Bookkeeper           |
| ....Electrical Wireman        | ....Stenographer         |
| ....Telephone Expert          | ....Private Secretary    |
| ....Architect                 | ....Accountant           |
| ....Building Contractor       | ....Cost Accountant      |
| ....Architectural Draftsman   | ....Cert'fd Public Acc't |
| ....Structural Draftsman      | ....Auditor              |
| ....Structural Engineer       | ....Business Manager     |
| ....Concrete Engineer         | ....Fire Ins. Inspector  |
| ....Civil Engineer            | ....Fire Ins. Adjuster   |
| ....Surveyor                  | ....Fire Ins. Expert     |
| ....Mechanical Engineer       | ....Moving Picture Op'r  |
| ....Mechanical Draftsman      | ....Sanitary Engineer    |
| ....Steam Engineer            | ....Irrigation Engineer  |
| ....Municipal Engineer        | ....Textile Boss         |
| ....Gas Engine Engineer       | ....College Preparatory  |
| ....Gas Tractor Engineer      | ....Auto. Mechanician    |

NAME .....

ADDRESS .....

Pop. Mech. 10-13

This school has no connection with any other school using the name "American"



# Popular Mechanics Magazine

WRITTEN SO YOU CAN UNDERSTAND IT

Vol. 20

OCTOBER, 1913

No. 4

## Second-Story Bungalow Apartments

A COLONY of one-story bungalows built about a court on the roof of a block of stores is a new idea in apartment houses which has recently been realized in Long Beach, Cal. From the street the bungalow apartment building looks like an ordinary



One-Story Bungalow Apartments about a Court on the Roof of a Business Block



Sheltered Porch with Entrances to Two Bungalow Apartments; Clothes Drying on Roof

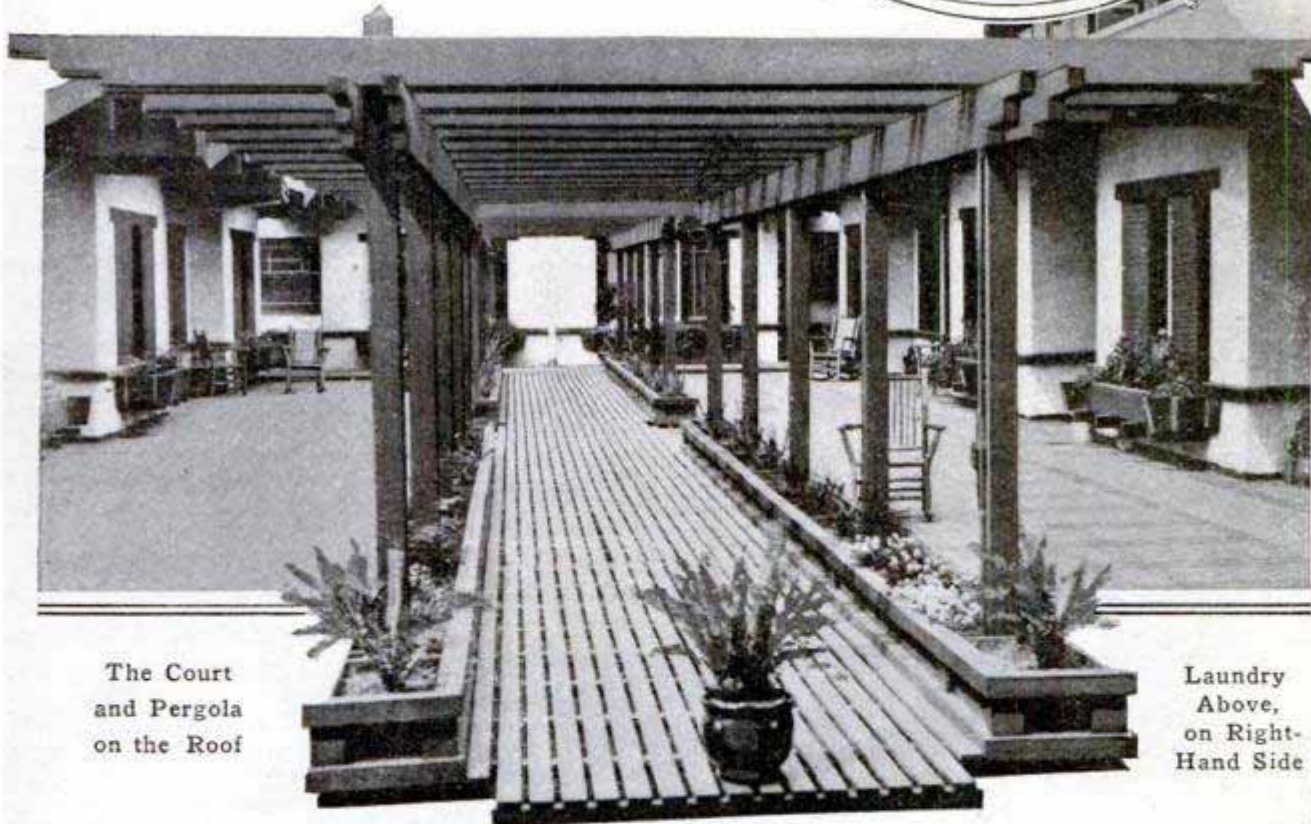

The Court and Pergola on the Roof

Laundry Above, on Right-Hand Side

brick business block with shops below and flats on the second floor. But the stairway from the street, instead of leading to a second story, takes one to a broad, sunny court on the roof of the

shops. Down the center of the court is a pergola with flower boxes beneath it, and around the four sides are the low gables of 17 one-story Swiss-chalet bungalows. Flower boxes under the

*450 H*  
*houses*  
*Long Beach Cal*  
*D. P. Bull*  
*635-6977 st*



windows, and plaster walls trimmed with dark wood make them look like a row of bungalows on the street. In all there are two 2-room, four 3-room, and eleven 4-room bungalow apartments about the court. Each pair of bungalows has a common sheltered porch, recessed so that the entrance doors open into the living rooms. Their kitchens and dining rooms face the court and their living and sleeping rooms overlook the

street. Each has its own bathroom and plenty of closet room. The common laundry is not in the basement, but on the roof of one of the bungalows, and clothes are hung out on the roofs of the kitchens unseen from the street below. The floor of the court is covered with heavy deck roofing, drained by a gutter in the center, and garbage is taken care of in boxes with ventilating pipes leading through the roof.

*Attachments*

### TIMING CAMERA SHUTTERS WITH ARC LIGHTS

A method of testing the speed of camera shutters with the aid of an



Alternating-Current Arc Lights Used to Test the Speed of Camera Shutters: Each Dot on the Negative Indicates an Exposure of  $\frac{1}{120}$  Second

alternating-current electric arc light, without any revolving wheels, swing-

ing pendulums, or other apparatus, has been worked out by a Chicago man. It is based on the fact that an arc light flickers, or rather goes out and relights, once for each alternation in the current, or twice per cycle. That is, in the 60-cycle type of alternating current, usually supplied for street lighting, the current alternates and the arc flickers 120 times a second. If a camera with open shutter pointed toward the light is swung across the light, the resulting negative will show a line of dots. And each dot represents an alternation or  $\frac{1}{120}$  second of exposure. For example, if a camera is moved across the light during the tripping of the shutter and the resulting negative shows 30 dots, then the shutter was open  $\frac{30}{120}$  second and its speed is  $\frac{1}{4}$  second. This method cannot be used with direct-current arcs because they do not flicker, and the only result is a solid streak on the negative. A simple way to test the current is to watch a shining object—a knife blade, for instance—as it is moved through the light. Alternating current will make it look like a picket fence. The number of alternations per second in the current must of course be ascertained.

⌈The Post Office Department is being urged from many quarters to install shower baths in all city post offices, particularly for the benefit of the mail carriers, many of whom walk from 15 to 20 miles a day in the performance of their duty. The newest of the large post-office buildings are now equipped with facilities of this kind.



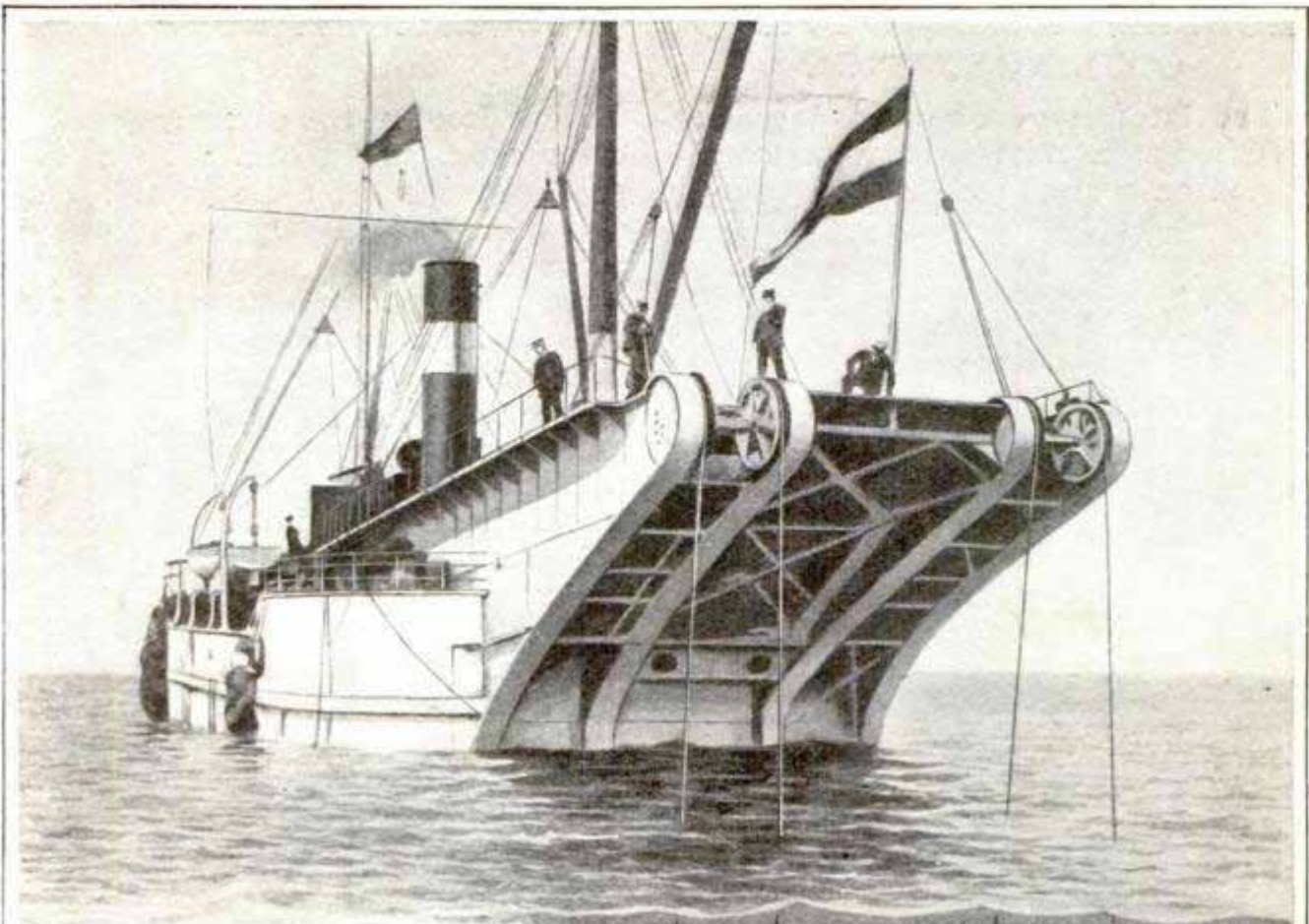

A German Salvage Ship Raising a Sunken Torpedo Boat in the North Sea

### SALVAGE SHIP RAISING A TORPEDO BOAT

A salvage ship recently built for the German navy is shown in the accompanying photograph raising a submarine torpedo boat. The hull of the torpedo boat, "No. 178," which was run down and sunk near Heligoland in the North Sea during the naval maneuvers this summer, was recovered in this manner.

☐ The use of ammonia bombs to extinguish forest fires is being tested in some of the national forests. In the case of brush fires, the fire fighters often have difficulty in getting near enough to beat out the flames, and ammonia bombs have been found very effective. The explosion of a single bomb will extinguish fire in a 15-ft. circle about it.

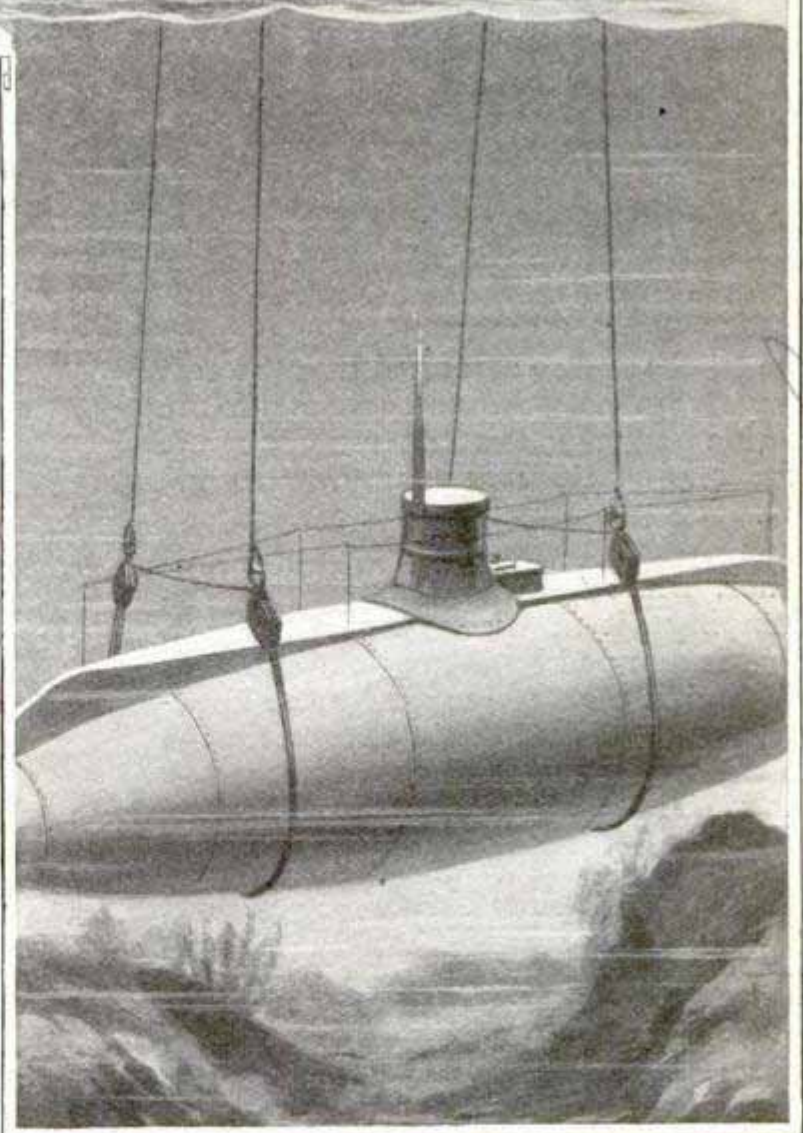

*Barthelme Layzell*

4730  
4

4837



## MODERN TYPE OF RAILROAD COALING STATION

The latest type of railroad coaling station has a steel storage tank supported on a steel trestle directly over



Modern Coaling Plant Hoists and Delivers Coal Automatically

the tracks and so arranged that the coal flows by gravity through chutes into the engine tenders below. At one side of the tracks is an elevator shaft, 75 ft. high, in which two buckets work alternately, thus partly counterbalancing each other, while taking the coal from the dumping pit at the foot of the shaft. Coal is dumped by the carload into this pit, and is then conveyed by the buckets, which fill and dump automatically, to the top of the shaft into the storage tank. The tank is 24 ft. in diameter. Each bucket holds a ton of coal and makes a round trip every two minutes, and in this way the coal is delivered at the rate of one ton a minute. A gasoline engine supplies power for hoisting.

CA lock of wool, 4½ ft. long, was recently exhibited in Australia.

## MOLECULAR THEORY GIVEN NEW PROOF

New proof of the existence of molecules has been discovered by a European physicist as a result of a study of various colored organic substances through the spectroscope. Some of these substances are capable of complete solution in some solvents, while in other solvents they are held in suspension, broken up into particles of greater or less fineness, depending upon the liquid. When the absorption spectra of these solutions are studied, the colors absorbed vary slightly, depending upon the nature of the solution. And the finer the particles into which the organic substance is broken while it is held in suspension, the more nearly its spectrum approaches the spectrum of a complete solution of the same substance. Complete solution thus appears to give the limit of fineness, the molecule, of particles held in suspension.

## SPRING-OPERATED FAN RUNS AT UNIFORM SPEED

One of the greatest objections to spring-operated fans is apparently overcome in a fan recently invented and placed on the market, the mechanism being such that the current is as strong when the spring is nearly run down as when the fan is first started. This fan

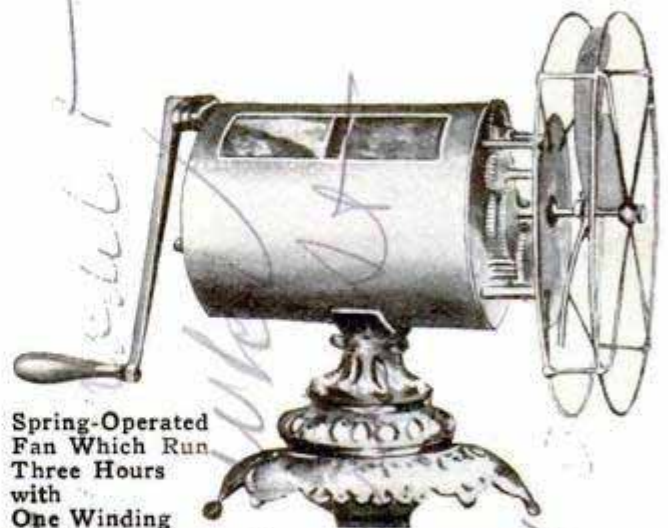

Spring-Operated Fan Which Run Three Hours with One Winding

is made in two diameters, 10 in. and 16 in., and is capable of three hours of sustained service with one winding.



5096

*Aquaplaning*

THE NEW WATER SPORT—RIDING ON A PLANK

Water planing on a plank towed by a speedy motorboat is one of the most exciting water sports that has become very popular this season. It is hardly to be recommended to women and children, but for a good swimmer it is almost as thrilling as flying. All that is necessary for the sport is a fast motorboat and a strong plank, 6 ft. long and 2 ft. wide, with a tow rope attached to the front end and two reins for the rider to use in maintaining his balance. The rider, necessarily in a bathing suit, stands on the rear end of the plank and jockeys the reins to keep his balance

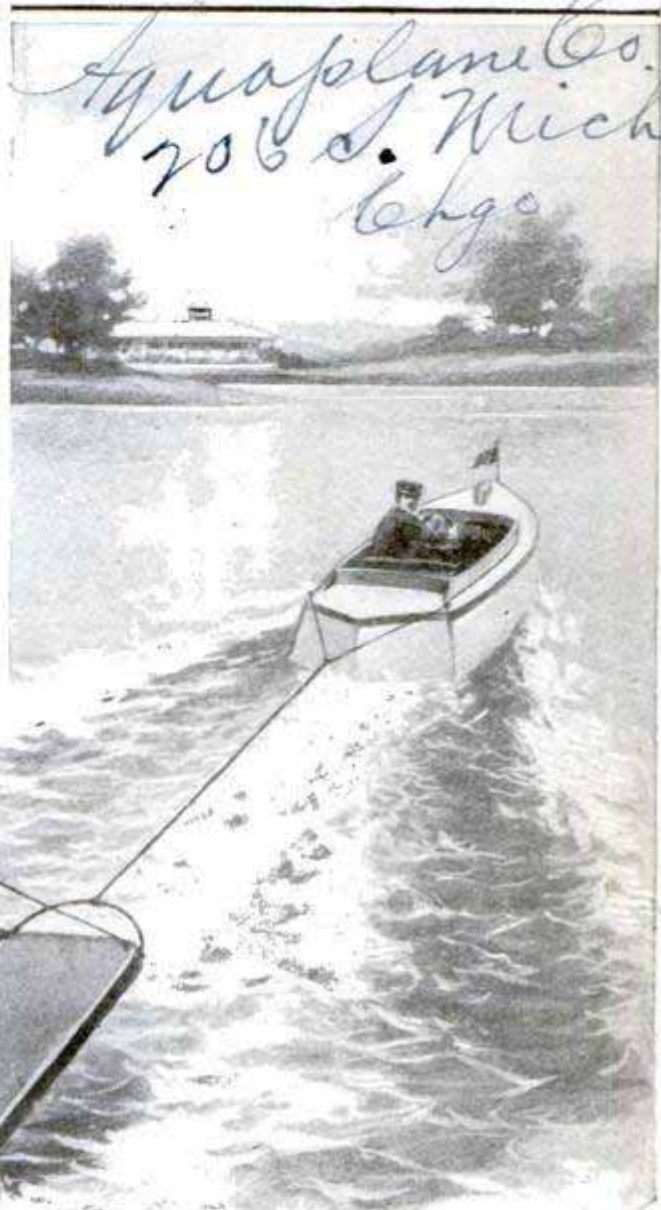

The New Water Sport:  
Riding a Plank behind  
a Motorboat at a Speed  
of 35 Miles an Hour

and guide his craft. Standing still, the plank is hardly sufficient to support a man, but at eight miles an hour it begins to ride lightly on the water just like a hydroplane. As the speed increases to 25 or 35 miles the front end of the plank rises high above the water and the craft skims the surface on its "heel." Skillful balancing will take it around sharp turns without capsizing, and by a slight shifting of the weight, it can be made to climb sideways on the waves of the motorboat's wake. The

sport comes from South America and was described in Popular Mechanics Magazine some time ago. Its American popularity began on the Pacific coast early in the summer. In August plank skimming appeared on Lake Michigan, at Chicago, and a company has now been organized to manufacture the equipment for the sport.

That ancient instrument of martial music, the drum, has been cast out of service in the French army.



## HOW FOUNDATION TESTS ARE MADE

For determining the stability of the underlying clay or other material on which the foundations are to rest, sys-



Getting the Bearing Power of the Clay Underlying a Foundation

tematic tests are now made on the sites of Federal buildings before the work of construction is started. On the site of the post office at Newcastle, Ind., four shafts were sunk to a depth of about 18 ft. A framed column supporting a platform was erected in each shaft, and each of these platforms was then loaded with four tons of pig-iron slugs. These were allowed to stand for a specified time and the slight changes in level were noted by the engineer in charge of the work. In this way the stability of the clay footings was determined before the foundation work was begun.

Practically all the street cars, electric lights and industrial motors in St. Louis, Mo., are now supplied with current generated by the turbines at the big dam at Keokuk, Iowa, the current having been turned into the wires on July 1. This is the largest city in the country supplied with hydroelectric power.

## MILLIONS A YEAR SPENT ON MUSICAL INSTRUMENTS

An army of nearly 42,000 workers is now engaged in making pianos and organs in the United States, according to the last census, and about \$30,000,000 is paid them for their work. In 1909, the value of the products they turned out almost reached \$90,000,000 — over seven times the value of the industry's total output in 1869. But the number of factories is decreasing; small firms are giving way to huge corporations. Of the 374,154 pianos, valued at nearly \$60,000,000, that were built in 1909, about 98 per cent were uprights and some 40,000 had mechanical-player attachments. Half of the \$5,000,000 spent on or-

gans in that year went into pipe organs, although they were outnumbered 50 to 1 by reed organs. The phonograph and graphophone industry is increasing faster than all the others and now amounts to about \$12,000,000 a year, equally divided between machines and records. On the other hand, and probably as a result, every year brings a decline in the number of band and orchestral instruments produced.

## THE WOOL INDUSTRY IN AMERICA

Few people realize the immensity of the wool industry in the United States and at the same time its relative insignificance when compared with other farm products. Although there are nearly 53,000,000 sheep, worth approximately \$235,000,000, in the country, they represent less than five per cent of the total number of domestic animals on American farms, and only about ten



per cent of our farms raise any sheep at all. Yet almost 43,000,000 sheep are sheared every year and the resulting 289,000,000 lb. of wool are worth over \$65,000,000. Over 50 per cent of the sheep are on the large ranches of the West, especially in Wyoming and Montana. In some eastern states, Ohio, for instance, sheep raising is carried on to a large extent on small farms. The illustrations show the contrast between the wool industry of the East and of the West.



Over \$10,000 Worth of Wool being Carted to the Railroad from One Wyoming Ranch.

This Automobile is Used by an Indiana Wool Buyer to Handle the Output of Three Counties; It Carries 650 Lb. at a Load



Below: Power Shearing Machines Used on a Large Sheep Ranch in Wyoming



*J. E. Stinson Chapman Mayo  
1906 W 1874*



## FIRST TELEGRAPH-OFFICE

### SITE IS MARKED

A bronze tablet in memory of Samuel F. B. Morse, inventor of the electric telegraph, has been set up to mark the



Tablet Which Marks the Site of the First Telegraph Office Opened by Prof. S. F. B. Morse on April 1, 1845

site of the first public telegraph office in the United States which Professor Morse opened on April 1, 1845, under the direction of the Post Office Department. The site is on Seventh Street, one of Washington's principal business streets, and is now occupied by a general land-office building. The tablet was unveiled on July 4.

## PRESSURE COOKING ADAPTED TO HOME USE

Steam-pressure cooking, which is used in canning factories because of its economy and efficiency, has been



made possible in the home by the invention of a small pressure kettle for family use. Pressure cooking is economical because water boiled under pressure is hotter than water boiled in an open kettle, and it is efficient because the vapors of the food cannot escape and the confined dry steam breaks up the tissues and fibers of meats and vegetables.

A pressure cooker, used on any fire

like an open kettle, requires less heat than a "fireless cooker," cooks very rapidly, and cannot boil dry or burn the food. The patented pressure kettle is made of heavy aluminum with an air-tight cover held in place by thumb-screws. A pressure gauge, calibrated to 30 lb., a safety valve, and a release cock, on the lid, make the pressure cooker safe for family use.

## SMOKE ABATEMENT BY ELECTRICITY

Electricity appeared as a solution for the smoke problem in a demonstration at Pittsburgh recently. The smoke-abating appliance which was shown removed the soot from 900 cu. ft. of smoke a minute at a total cost of about one cent a day for operation. The action of the apparatus consists in precipitating the solid particles in the smoke by means of a powerful electrical current, and its invention is based on the fact that one-third to one-half of the solid matter in smoke from smelting furnaces consists of particles of iron oxide. Electrical current is applied to the smoke by means of a wire woven through a number of small pipes placed at the top of the chimney so that the smoke must pass through them. As soon as the electricity is turned on the small particles floating in the smoke are changed to large particles which fall back into a bin by their own weight. Its application is not confined, however, to smelting furnaces, for it has been found that the device works as successfully on any kind of smoke, cement or ore dust. Soft coal and ashes were used in the demonstration. As soon as a patent has been obtained the appliance will be placed on the market.

## PORTABLE LAWNS OF GRASS CARPET

Living-grass carpets that can be used as table covers, coats, or for making temporary or permanent lawns are now manufactured in England. They are really living carpets, for the





Laying Down a Strip of Grass Carpet to Make a Permanent Lawn: The Grass Carpet can be Handled as Roughly as a Rug

grass with which they are covered continues to grow in whatever place or use the carpet is put. To make them, millions of grass seeds are sown on a strip of carpet in a greenhouse and allowed



The Grass Carpet Used as a Cloak

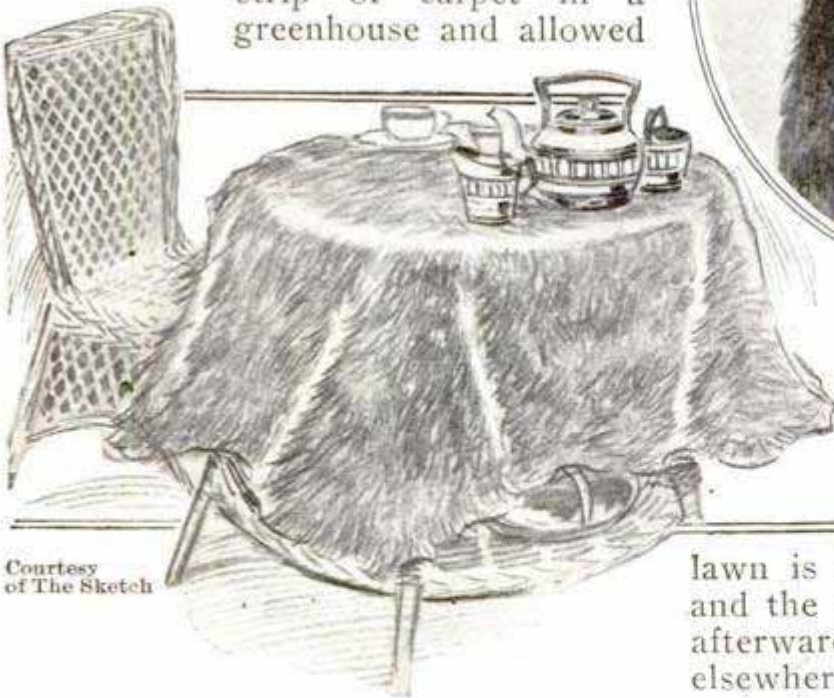

A Tea Table Covered with a Spread of Growing Grass

Courtesy of The Sketch

lawn is desired, the ground is rolled and the carpet is laid down in strips; afterward it can be taken up and used elsewhere. When it is allowed to remain in one place, it takes root and forms a beautiful lawn. An entire lawn can be laid in a day and two lengths of carpet will make a cricket pitch.

*London Daily Mirror  
London*

*Invention of  
D. Mac Donald*

*7/1/13*



**MAKING RICH CREAM OUT OF BUTTER AND MILK**

Just at this time when cream shortage resulting from the increased manufacture of ice cream is becoming one of

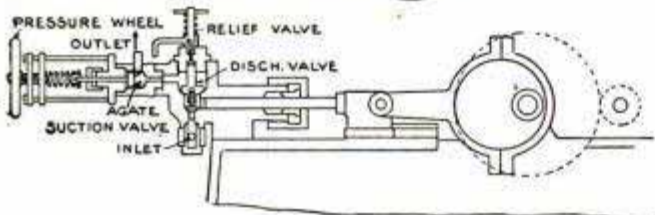
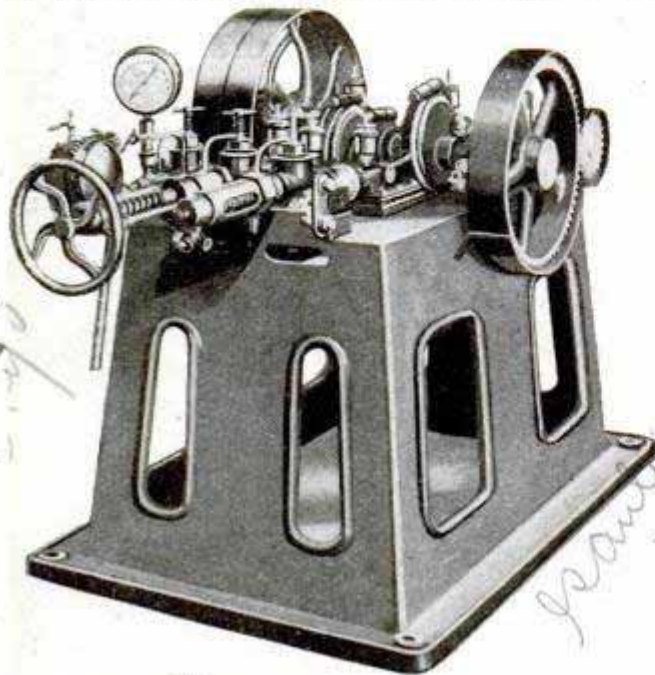

Above: Homogenizer Used in Ice-Cream Factory to Make Rich Cream Out of Butter and Skim Milk

Below: Diagram of the Homogenizing Machine Which Crushes the Fat Globules in Milk

the great dairy problems, a machine has been invented which enables ice-cream manufacturers to make usable cream out of butter and skim milk. The process is called homogenizing. It consists of breaking up butter-fat globules in milk so that they cannot rise to form cream, and was invented originally to make milk more digestible. All milk, as is well known, contains about 87 parts of water and 13 parts of solids; and the greater portion of the solids is made up of minute globules of butter fat. As these globules are lighter than the rest of the milk, they rise to the surface to form cream. Homogenizing breaks up the fat globules with pressure and makes them an integral part of the milk. The machine used, called the homogenizer, consists of a triplex pump, with a suction and

discharge valve on each cylinder. In each discharge pipe is a homogenizer, like a safety valve, which remains closed until the pressure rises to 2,000 or 3,000 lb. per square inch, and when it opens, the space between a ground agate disk and the seat of the valve is so narrow that fat globules cannot pass out without being crushed into particles so small that they will not again separate from the milk. The machine homogenizes from 60 to 400 gal. an hour with a small amount of power. By the process, 4-per-cent milk becomes as rich as 10-per-cent milk, and 25-per-cent cream, homogenized, tastes like 50-per-cent cream. In the ice-cream industry homogenizing is used to put fat globules back into milk. When fresh, unsalted butter is added to skim milk heated to 180 deg. and run through the homogenizer, the resulting combination is richer, smoother, and better suited to ice-cream making than ordinary cream, and a great saving of dairy products results.

**MOTOR-CAR BODY PROVIDES ADVERTISING**

One of the latest advertising novelties is a motor delivery van used by a pencil manufacturer, in which the body of the car is made to represent the sharpened end of a pencil. The pencil portion is removable, and the car can be converted into an ordinary two-seater with a rumble seat in the rear.

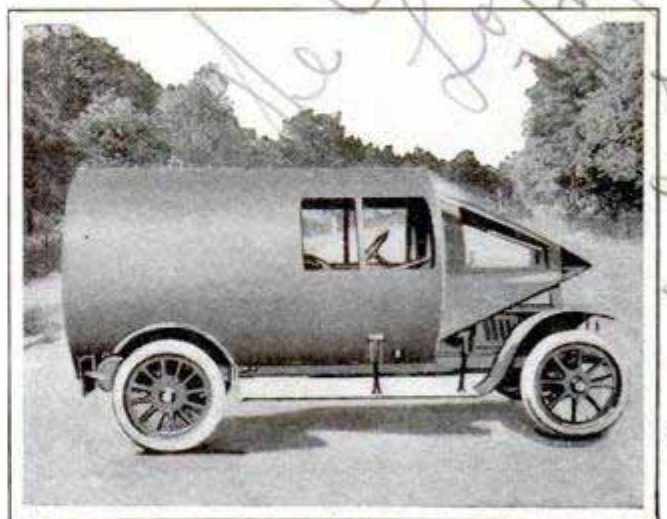

Courtesy of the Car

Motor Delivery Van Used by Pencil Manufacturer

Mess. Johanny Hafer  
England

*61 W King St*

*Power*

*Auto*

*made by J. M. ...*





*The* **NEW IDEA** *In*  
**PUBLIC PLAYGROUNDS**  
 By Grant M. Hyde

5124 H

**T**HE playground movement in America is rapidly becoming a municipal affair, largely because it is developing a new purpose, that of teaching children how to play and directing their play along lines that are useful and instructive.

In trying to direct the play of American youngsters, the playgrounds are making a great number of interesting experiments. Some playgrounds are merely a bit of park or a vacant lot set aside for the children, with or without attendants to direct the play. Others, developed with a more or less instructional purpose, are laid out in public-school yards and have teachers to manage them. Still others have the social center or community idea behind them and provide amusement for grown-up visitors, as well as play for the children. The idea of directing play in some cities takes the movement beyond the limits of a playground, and the young people are sent outside the city on directed excursions and into summer camps.

One playground in New York City occupies a site that is valued at \$1,800,000, but this is unusual. Vacant lots in congested districts, areas useless for commercial purposes, and bits of land in out-of-the-way places are rapidly being made into playgrounds. Philadelphia has laid out tiny playgrounds under railroad viaducts; Reading, Pa., has a playground on the concrete roof of a water reservoir; Springfield, O., is utilizing the grounds around a city

standpipe. Amusement piers have been built in some cities, and Boston has floating bathhouses for the small boys.

Certain standard forms of play and apparatus are pretty generally present in all playgrounds. Swings, seesaws, slides, giant strides, and gymnastic apparatus are always the first things that are provided. Swimming pools are quite as common. For the smaller children, most playgrounds have sand piles and wading pools. The love of competitive play has brought facilities



One of the Many Branches of  
 Playground Instruction:  
 Basket Weaving

for group games—baseball, tennis, basketball, volley ball, and, in some places, football and lacrosse. These are for the older children, but war games, "hikes," hare and hounds, folk dances, and other games, invented sometimes by the attendants





and sometimes by the children themselves, are being developed for the little tots. In some cities the competitive games of the larger boys have grown into organized athletics with playground teams and interplayground games and track meets. All furnish play under direction.

Directed play naturally leads to instruction through play. In many cities, such as St. John, N. B., there is regular kindergarten work for little children. In others, sewing,

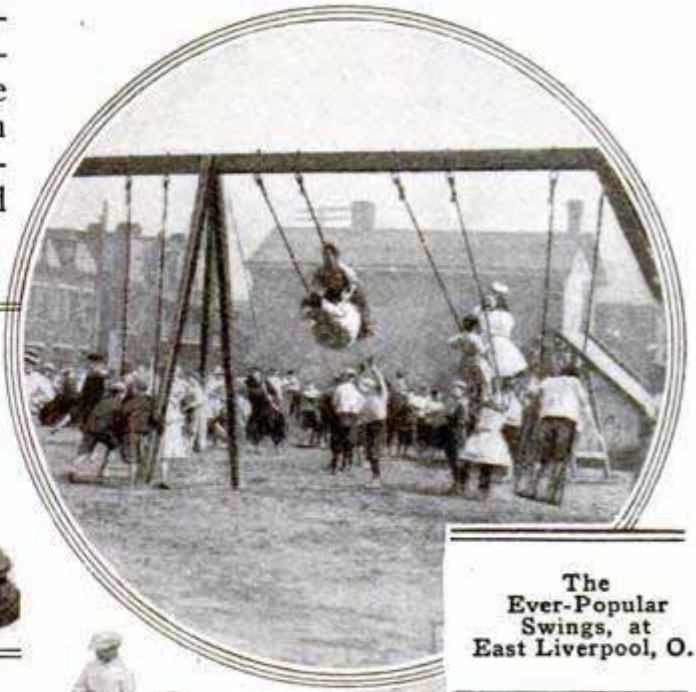

The  
Ever-Popular  
Swings, at  
East Liverpool, O.



One of the School-Yard Sand  
Boxes at Reading, Pa.

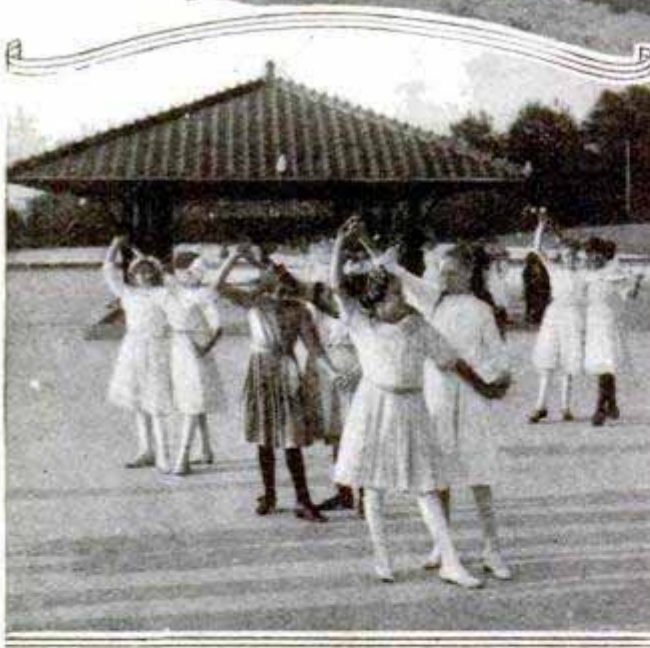

Dancing Class on Roof of a Reservoir at Reading, Pa.

embroidery, basket and raffia work are provided for the older girls, along with manual training and gardening for the older boys. Springfield, O., has this.

New Orleans has regular gardens laid out in the playgrounds and prizes are given for the best crops raised by the children. In Glen Ridge, N. J., and other cities, manual training and cooking are moved from the schoolhouse to the summer playground. Columbus, O., and Holyoke, Mass., do the same thing by teaching the older boys to clean the playground and erect and repair the apparatus. At Youngstown, Pa., the boys dug their own swimming pool on the playground and made water wheels.

Where attendants can be afforded, play is directed into beneficial physical



training; games are made into marching and setting-up exercises. Swimming is taught almost everywhere. Johnstown, Pa., has boys' and girls' brigades to turn recreation into healthful exercise. Music added to the marching and setting-up work turns them into drills and folk dances; many playgrounds make folk

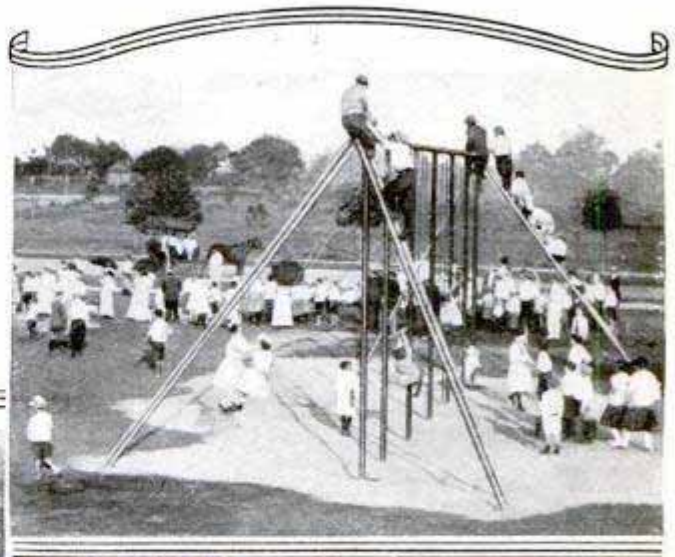

Outdoor Gymnastic Apparatus in Jacksonville, Fla.

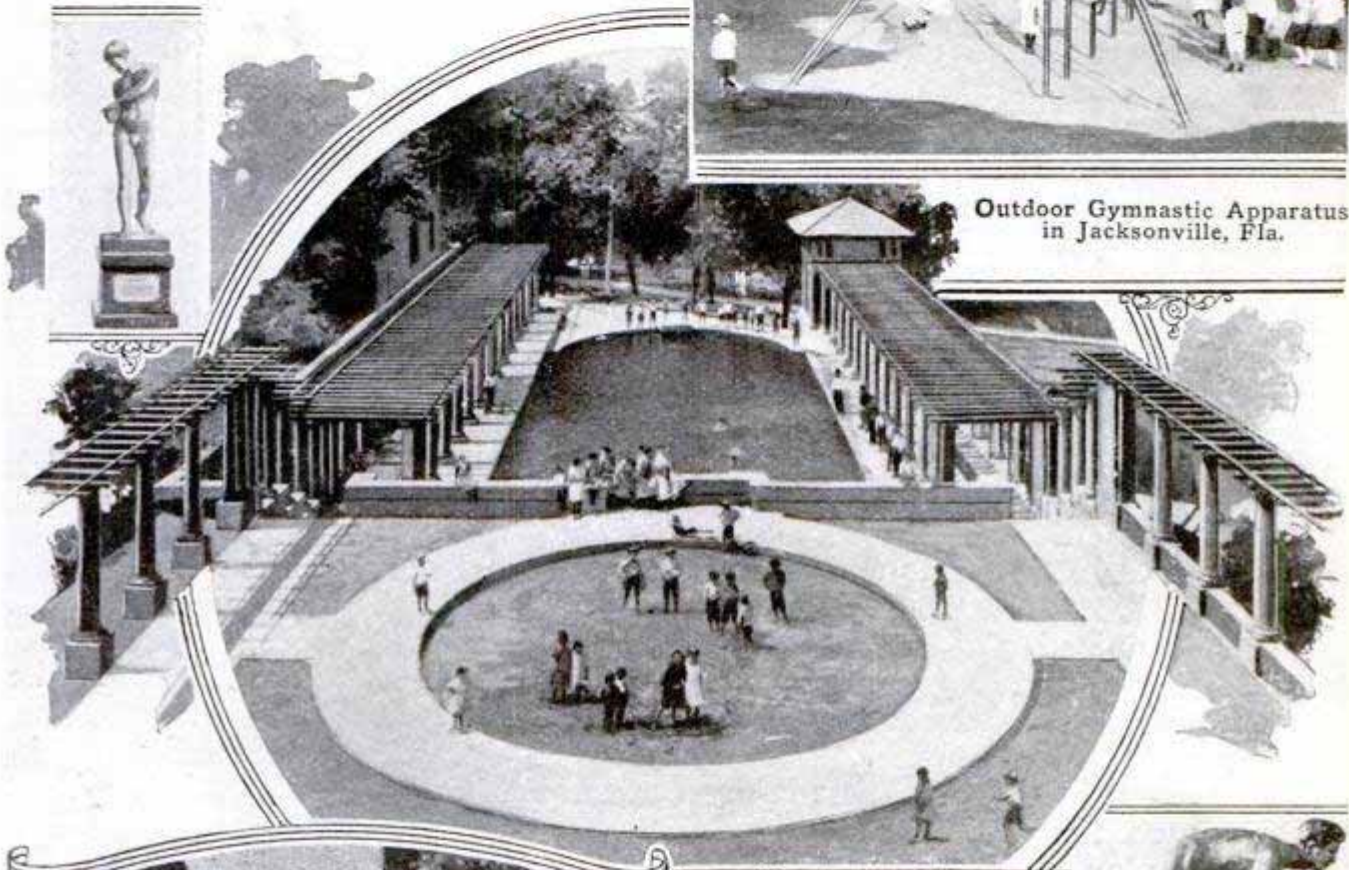

Bamberger Park Playground at Dayton, O.



There Are Always Wading Ponds and Sand Piles for Little Tots: This One is in Philadelphia



dancing a regular part of their instruction, and dramatic pageants are very common. St. John, Canada, has systematic musical drill, and to the idea

of the folk dance, Kalispell, Mont., has added Indian dances in costume. But the development of music in connection with play necessarily brings parents and older visitors to the playgrounds. Where a playground has a boys' band, as in Jacksonville, Fla., the community idea necessarily follows, for the parents come to hear their children play. Many cities provide music on the playgrounds with the direct purpose of bringing the parents. Holyoke, Mass., has regular band concerts on the playgrounds, and Springfield, O., has vocal and orchestral concerts, evening lectures, and com-



munity meetings as an adjunct to children's play. The idea of training the young for citizenship and self-government is beginning to appear; New Orleans is just now making plans for the establishing of self-governing "playground republics."

Many novelties in methods and apparatus have been brought out in various parts of the country. East Liverpool, O., has found that if hammocks are provided, the smaller children can be persuaded to sleep in them during the afternoon, benefiting both themselves and the playground's peace. Croquet and quoits have appeared among the other games at Springfield, O. Kite day is a regular feature at Akron, O. The boys on one of the playgrounds at Buffalo revived the old pastime of stilt walking and the city had a hundred pairs of stilts made for them. Competitive athletics for the boys brings very complete organizations in many cities. At Jacksonville, Fla., regular athletic meets and an annual circus are held; East Liverpool, O., has organized playground teams and interplayground leagues. These in connection with interschool leagues in the larger cities develop an interest in athletics which keeps the small boy out of much mischief. In Oakland, Cal., 14,220 playground baseball games were played last year.

Restful recreation, on the other hand, has its place. Twilight story telling on the playgrounds is becoming very common. An attendant who can tell stories to a group of children at certain hours of the day, especially in the early evening, develops their imaginations and instructs them at the same time. This feature of play-

ground entertainment has been found very successful at Columbus and Springfield, O. To the story telling, Youngstown, O., has added phonograph concerts and moving pictures on the playgrounds. One of the most unusual features that have developed is the fly-swatting contest held on a playground in New Orleans. Prizes were offered for the largest number of flies killed, and 32 children exterminated 4,474,750 flies in about two weeks.

New ideals of usefulness are being developed as the playground becomes more of a municipal affair. When it came into existence, a few years ago, it was entirely in the hands of voluntary organizations of citizens, and most of the necessary money was secured by subscription. This is still true in many cities. But more and more aid is being given to playground associations by city governments, and in many cases the playground is a municipal matter. In one instance, in fact, it has become a state affair. The appointment of a city commission to manage public recreation has meant in most cases the adaptation of the playground to the widest practical use. Philadelphia, in arranging her playgrounds, is considering the parent as well as the child. Orange, N. J., has arranged to keep her playgrounds open every day during the year, including Sundays. Working children are considered in Buffalo, and her playgrounds are kept open at night especially for them; even a twilight playground baseball league has been organized. Many cities have found that, although the playground is of greatest service during the long school vac-



The Swing's Closest Rival, the Slide, at East Liverpool, O.





The School-Yard Playground as It is Laid Out in San Francisco

The Small Figures in This and Other Illustrations are Trophies Given for Playground Games in Various Cities



tion in the summer, winter amusement must not be neglected. An opportunity for skating and safe winter sports is often afforded by flooding and freezing the playgrounds in winter. Little by little municipal recreation is growing beyond the confines of the playground. Directed excursions and picnics for the children are common in many cities. Vancouver, B. C., provides trips to the beach as a regular form of amusement. In Philadelphia,

the summer camp for city children has been taken over by the city.

Nearly 500 cities now have public playgrounds and about half of them receive municipal support. In 257 cities last year over \$2,500,000 was spent on 1,543 playgrounds, and 4,132 attendants were hired. Of these playgrounds, 215 were open in the evening. One purpose actuates the management of most of them—to provide play under intelligent direction.

### NOVEL METHOD OF BUILDING LIGHTHOUSE BASE

The base of a lighthouse to be located near the upper end of Delaware Bay is, in effect, an enormous reinforced-concrete tub, which is being built on dry ground and which will be towed later to the site of the lighthouse and sunk in the required position. This method of preparing a base is not uncommon in bridge building, but has not, so far, been used in lighthouse construction in the United States. Its principal merit is that it eliminates the necessity of building cofferdams. The base is 18 ft. high and has walls 18 in. thick, the height being such that the top will

be clear of the water at high tide. The concrete filling which will be used in

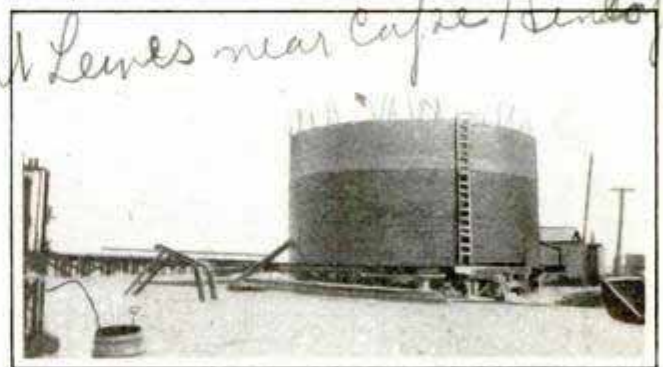

Lighthouse Base That will be Towed Like a Boat to a Final Location

weighting and sinking the base will become a permanent part of the lighthouse structure.

4904

at Lewis near Cape Henlopen

The top is capped



## AROUND THE WORLD IN THIRTY-FIVE DAYS

The world's record for globe-trotting, which has stood for five years, was broken this summer by John Henry Mears, a reporter on a New York newspaper. He traveled around the world from New York City to New York City in 35 days 21 hr. 35 min.  $\frac{4}{5}$  sec., returning to the newspaper office  $\frac{4}{5}$  of a second behind his schedule.

Since the time when Jules Verne's character, Phineas Fogg, made his imaginary trip around the world in 80 days, various travelers have broken his record. In 1889-90, a newspaper woman known as "Nellie Bly" journeyed from New York to New York via the Mediterranean and the Indian Ocean in 72 days 6 hr. 11 min. The completion of the Trans-Siberian Railway offered a chance to beat her record, and in July and August, 1911, André Jager-Schmidt, representing a Paris paper, circled the globe from Paris to Paris in 39 days 19 hr. 43 min. 37  $\frac{4}{5}$  sec. This record stood until this summer, when the establishing of faster liners across the Pacific Ocean offered a new opportunity. Mr. Mears' methods of travel were not as various or romantic as Phineas Fogg's, but what he lacked in Indian elephants he made up for with motorboats, flying boats, and automobiles. And while Phineas Fogg was unheard of during his 80 days, the wireless telegraph enabled Mr. Mears to report his location daily.

At 12:43 a. m., July 2, Mr. Mears left his office in New York and 14 minutes later was aboard the liner "Mauretania," sailing toward England. He landed at Fishguard, Wales, on July 7 and by the evening of the next day had hurried to Paris, by rail and steamer, with a few hours of sight-seeing in London. The Nord Express, leaving Paris at 1:45 p. m. on July 9, landed him in Berlin early the next morning, two hours behind his schedule. The same evening he was aboard the Russian Mail on his way to St. Petersburg. The evening of July 11 found him at Dwinsk, Russia, and the next afternoon he was in the Russian capital, 420 miles farther, on

time. Before evening he was on the Trans-Siberian Express, starting out on his 11-day journey to Vladivostock. All went well until the train reached Ekaterinburg, just beyond the Ural Mountains, in the extreme eastern part of European Russia. There, on July 14, the 13th day of his trip, the express was held up 18 hours by a washout, and the rest of the journey to Vladivostock became a race to make up the lost time, for if he was to catch the fast Pacific liner from Yokohama, Mr. Mears could not be more than four hours late. On the evening of July 15 he was at Chelyabinsk, Russia, only a few miles from Ekaterinburg, and the next evening at Omsk, Central Asia, the train had made up only an hour. Between there and Krasnoyarsk he made up another hour, but when the train reached Irkutsk, Siberia, halfway between St. Petersburg and Vladivostock, on July 18, it was still 10 hours behind its schedule. July 19 brought him to Chita, Siberia, 500 miles farther, 8  $\frac{1}{2}$  hours late and still 1,100 miles from Vladivostock. No time was made up between there and Manchurie, Manchuria, and so on July 21, when he reached Harbin, he changed his plans. He left the slow express and boarded a special train furnished by the South Manchurian Railways to take him to the seaport of Fusan, Korea. Down through Mukden, Manchuria, and Antung, Korea, his special made 60 miles an hour, in time to catch the ferry at Fusan to take him across the Japan Sea. He was three hours late at Fusan, but the ferry waited, and 10 hours later he stepped ashore at Shimonoseki, Japan. The Imperial Government Railway of Japan hurried him in a special train to Kobe, Yamakita, and thence to Yokohama. At 1:05 p. m. on July 24, he was in Yokohama, with five hours to spare for a side trip to Tokio.

The third leg of the race began that evening when he boarded the newest of trans-Pacific liners, the "Empress of Russia," for the 8  $\frac{1}{2}$ -day trip to Victoria,







of a washout, but this was made up, and Mr. Mears arrived in Chicago on the evening of Aug. 5, on time. At 11:30 p. m. he was speeding toward Cleveland. In the morning he changed to a faster train at Cleveland and a few hours later he boarded the Empire State Express at Buffalo. As the train drew into the Grand Central Station,

New York, he was exactly on his schedule, but he lost four-fifths of a second on his way to his newspaper's office, where he arrived at 10:18:00 $\frac{1}{2}$  p. m., on Aug. 6. Two washouts and a fog had almost spoiled his chance of breaking the record, but in each case the courtesy of railroad companies saved him from failure.

### NEW MOTORCYCLE STAGE TRICK

One of the first successful motorcycle tricks introduced upon the vaudeville stage is illustrated by the accom-

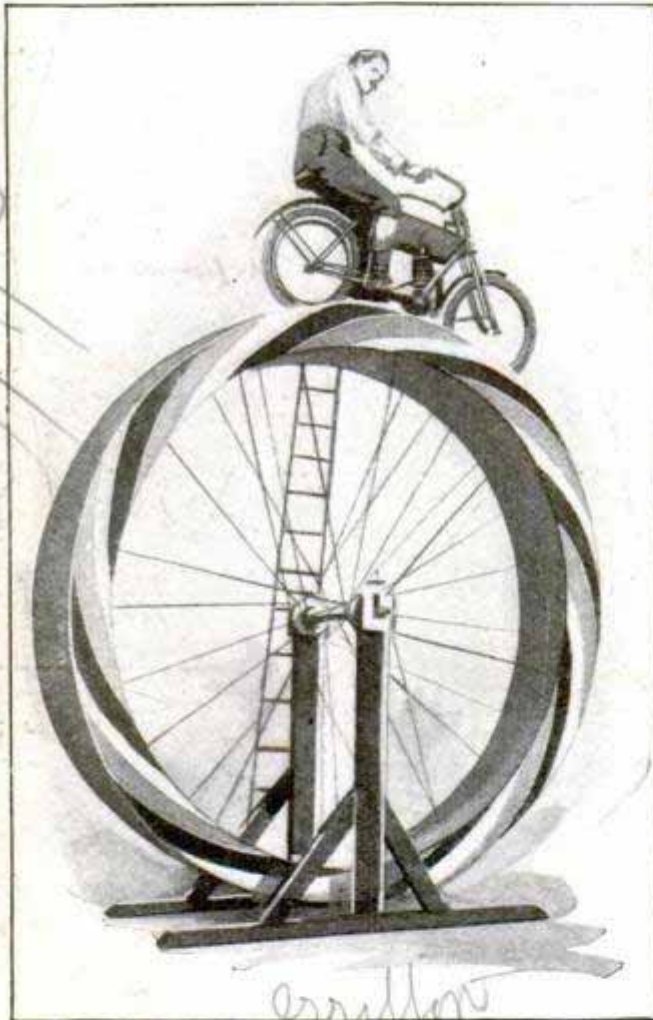

A Stage Trick in Which the Rider Attains a Speed of 60 Miles an Hour without Moving

panying picture. It was invented by an English performer and consists of riding a motorcycle on the top of a large wheel which revolves backward like a treadmill. The large wheel is 12 ft. in diameter and has a tread 2 ft. wide; it runs on ordinary brass bear-

ings and has no attachments except an emergency brake. The rider mounts his motorcycle while it is on top of the large wheel and his machine is held in place by a cable from the flies until he has attained a speed of 20 or 30 miles an hour. Then he detaches the cable and gradually increases his speed until his speedometer registers 60 miles an hour. The emergency brake has to be applied to stop him.

### + ANTISKID RUBBER PLUGS FOR DANCING SHOES

Dancing shoes with nonskid rubber plugs in the soles are one of the strange results of the new eccentric dances. The glassy, slippery dancing soles inherited from former generations are too dangerous for the new steps and many of the dancing pumps seen in the shoe stores today are equipped with safety friction spots. There was a time when slippery soles were needed because dancing floors were rough, but the waxing and polishing of floors nowadays make necessary the use of some kind of a brake on the shoe. Some dancers have tried complete rubber half soles, but they do not slide readily enough. The best combination seems to be a smooth leather sole with a rubber friction spot under the ball of the foot. The friction spot may consist of one square or round piece of rubber or several small plugs, but in either case it is set in a hole cut in the outer sole and cemented to the inner sole.

ⓄThe United States mints made 186,626,871 coins, worth \$37,496,530, last year.

+ *Asst. ...*

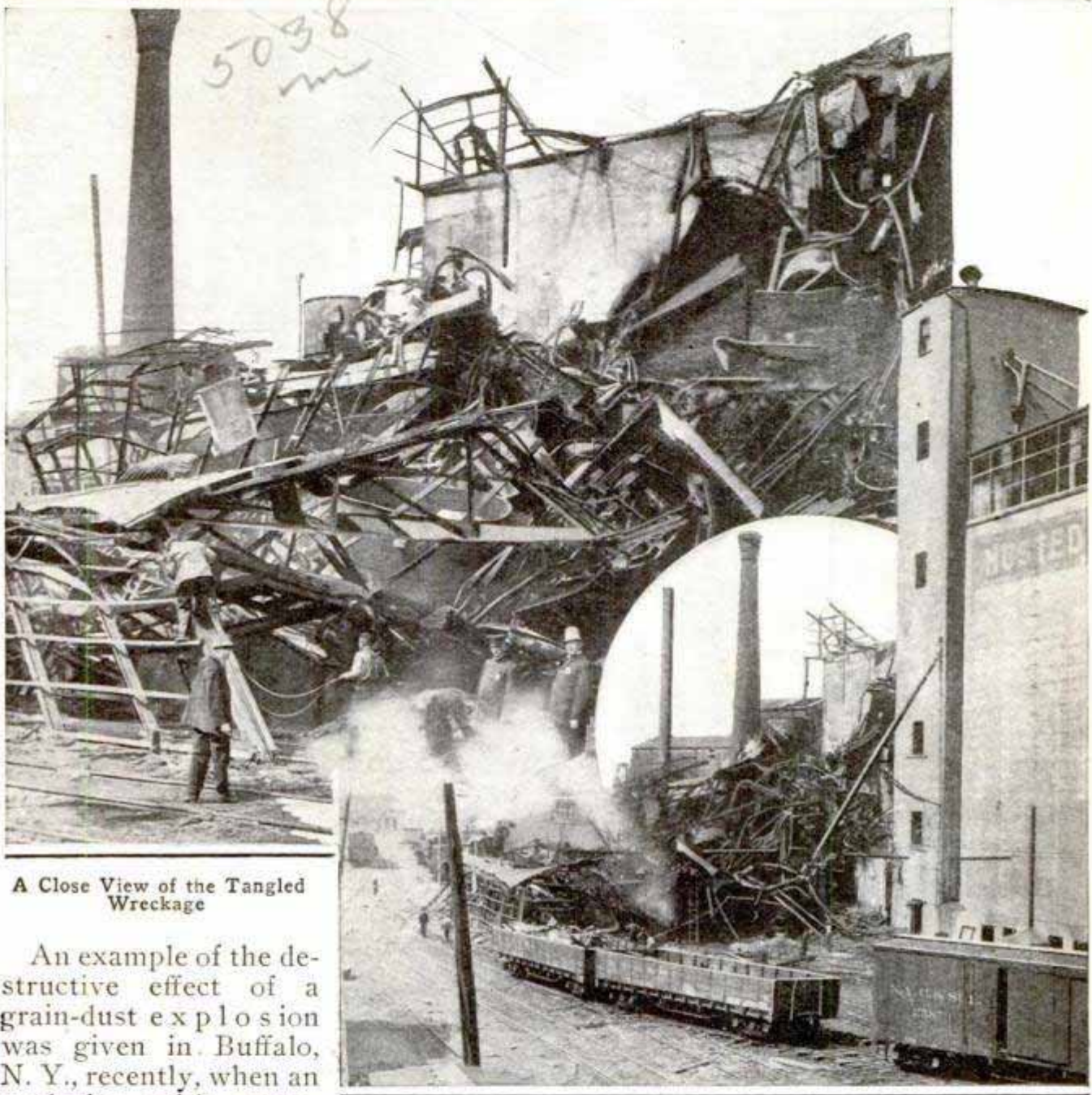

GRAIN ELEVATOR DESTROYED BY DUST EXPLOSION

A Close View of the Tangled Wreckage

Elevator as It Appeared after Explosion and Fire

An example of the destructive effect of a grain-dust explosion was given in Buffalo, N. Y., recently, when an explosion with consequent fire destroyed the greater part of one of the largest grain-elevator plants in the country. About 170 men were working in the plant at the time of the explosion, and of these over 30 were killed and a large number injured. The plant occupied an area 500 ft. long and 170 ft. wide, and comprised an elevator with adjacent steel storage bins and a number of concrete grain bins, as well as the usual engine and boiler rooms and service buildings. It is not known just what structures were wrecked by the explosion and which by the fire, but the

elevator and all the steel tanks were a total loss. It is thought that the original explosion took place in the elevator and that the fire spread to the adjoining structures. Debris from the explosion was scattered all about the vicinity of the plant, the near-by railroad yards being heavily littered with fragments of concrete. Adjoining the tanks was a loading slip built of structural steel, which was destroyed by the falling debris, and much other damage was done to adjacent property.

*Destroyed building is.*



**MONUMENT TO FIRST COUNTY  
COURT IN ILLINOIS**

*5000*  
A memorial has just been completed at Edwardsville, Ill., to commemorate the hundredth anniversary of the estab-



Monument Commemorates First Illinois County Court, Established in 1812

lishment of the first county court in Illinois, which was opened at that point September 14, 1812. This monument, which was designed by Charles J. Muligan, of Chicago, cost \$5,000 and was erected from an appropriation made by the Illinois legislature. It carries four symbolical figures representing, Wisdom, Justice, Virtue, and Plenty.

**EGGS HATCHED BY HOT  
SPRINGS**

*Sturgis*  
Hot water supplied by nature hatches eggs for a rancher near San Bernardino, Cal. His barn stands near the Arrowhead Hot Springs and the hot-air pipes of his incubator have been connected with the springs to make a natural hot-water heating plant which hatches eggs quite as successfully as the incubator

lamp. The possibilities of the scheme were discovered entirely by chance. A brooding hen died about a week before a dozen eggs were ready to hatch, none of the rancher's incubators would work, and the hot springs near the barn seemed to be the only solution. The water in the springs happens to have exactly the proper temperature for hatching eggs, and its temperature never varies.

**DANGER OF ELECTRIC WIRES  
NEAR FIRE STREAMS**

*4917*  
Whether a fireman is in danger of being electrocuted if he directs a stream of water upon a high-tension electric wire has been the subject of recent tests. While the danger is somewhat dependent upon the size of the stream, it has been found that in general if the wire is over 20 ft. away, the stream of water disintegrates sufficiently to become nonconducting. Since high-tension wires are usually more than 20 ft. from the ground, the fireman should be safe unless he is standing on a ladder or using a tower which would bring the nozzle closer to the wire. The grounding of the nozzle through the water in the hose cannot be depended upon, it has been found, to short-circuit around the person handling the hose.

**AEROPLANE TESTING TUNNEL  
AT CICERO**

*4917*  
The first American "wind tunnel" for studying the behavior of small models of proposed flying machines has recently been completed at the Cicero aviation field near Chicago. It works upon the theory that the efficiency of an aeroplane can be tested by a study of a model held in a current of air as effectively as by experimenting with the full-sized machine moving in still air. To secure a current of air moving at a known velocity in parallel lines, air is blown through a cylindrical wind tunnel provided with an experimental chamber in which models can be held in the air current. While the Cicero



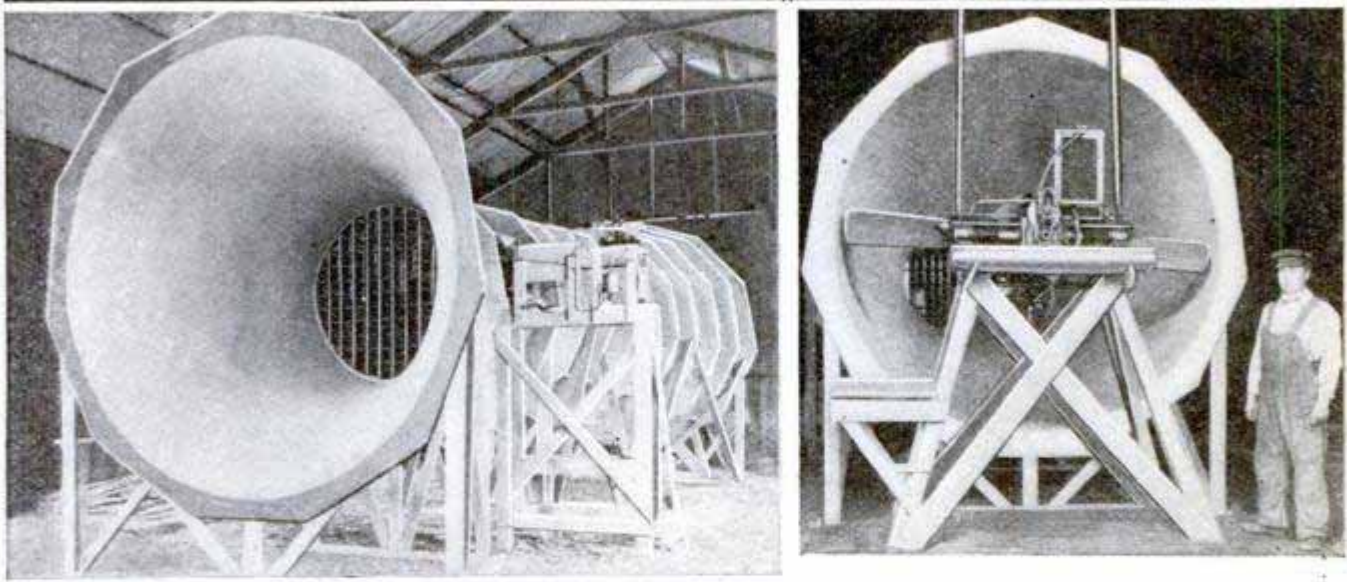

Entrance to Inlet Nozzle Showing  
Equalizing Screen

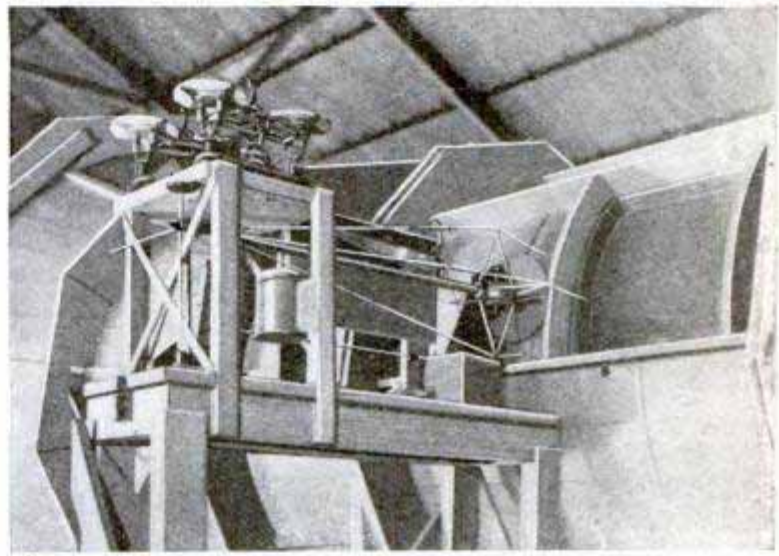

Above: Outlet Nozzle, and Propeller for Producing Air Current  
Below: A Section of the 28-Ft. Tunnel with Some of the  
Measuring Instruments beside the Testing Chamber

aerodynamic tunnel is in general similar to the apparatus used by Eiffel and other European scientists, previously described in this magazine, it differs chiefly in the construction of the experimental chamber. In the Eiffel tunnel, the testing chamber is a room, 13 ft. wide, let into the tunnel so that the air current passes across it; all the measuring instruments are in this room. In the Cicero apparatus no testing room is let in, but the model is hung directly in the tunnel, watched through a glass window in the side and handled from a trapdoor below, with all the instruments outside the tunnel. This arrangement tends to eliminate eddies about the model more completely, and results in smaller apparatus. The inlet nozzle of the Cicero tunnel is 6 ft. long and tapers from 8 ft. to 4 ft. in diameter; the outlet nozzle is 18 ft. long and flares from 4 ft. to 8 ft. The testing chamber is a 4-ft. section of the tunnel, 4 ft. in diameter, between the inlet and outlet nozzles. A 25-hp. gasoline engine driving a 7-ft. 9-in. propeller up to 1,000 revolutions per minute supplies a current of air varying from 30 to 70 miles an hour. The Eiffel apparatus at Auteuil is much larger and requires a 50-hp. motor to supply a current from 4.5 to 72 miles an hour.

## DESTROYING BACTERIA IN PUBLIC BATHS

Electrolyzed sea water, poured into swimming pools in small quantities, has proved to be an effective sterilizer to be used in the fight against noxious bacteria. Its sterilizing action is so great, as experiment has shown, that 30 gal. will keep the water in an 85,000-gal. tank clear and free from bacterial organisms for several days. And the electrolyzed sea water costs only about \$10 per 1,000 gal. The need of such a sterilizer is shown by the fact that in a fresh-water pond of 100,000 gal., used by 380 bathers, the bacteria have been known to increase from 500 to 342,000 per cubic centimeter (about  $\frac{1}{16}$  cu. in.) in one day.

from  
"Lancet"

41-712  
→

11-2-1913  
C. G. ...  
H. C. ...



4512

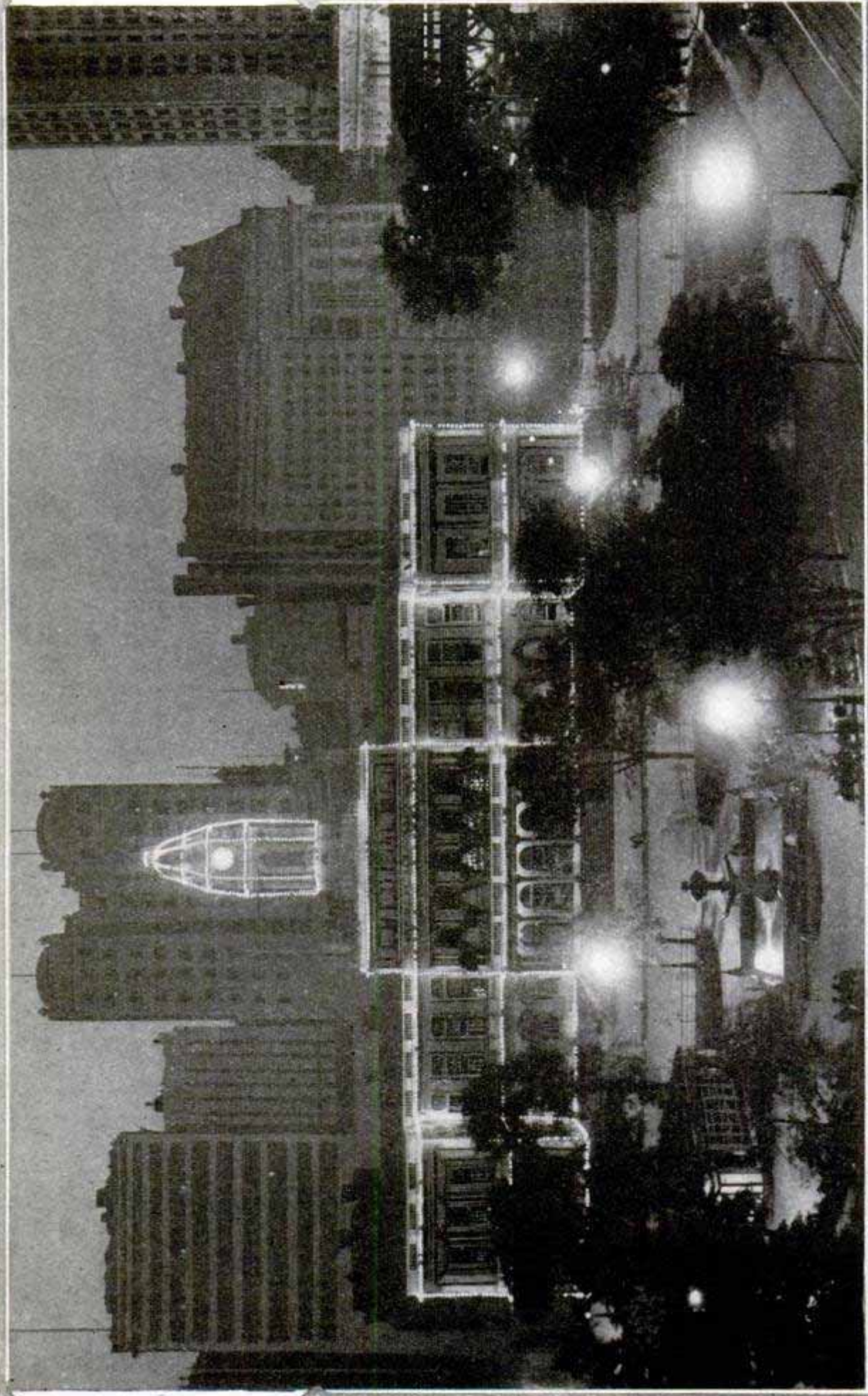

The Old City Hall of New York City, in Gala Attire: Strings of Electric Bulbs, Penciling Every Line of the Building and Framing the Old Clock Tower, Make a Striking Architectural Picture against the Black Sky and the Dark Buildings about It, and Light Up the Little City Hall Park for Public Gatherings





The Beautiful Effect Produced by Clusters and Strings of Electric Lights on Washington Arch, Which Guards the Fifth Avenue Entrance of Washington Square, New York City: Every Line of Light to the Top of the Entablature, Over 65 Ft. in the Air, Stands Out Clear-Cut in the Darkness



**HARDWARE-STOCK CASE WITH GLASS TOP**

A glass-covered showcase for storing and exhibiting small hardware has been patented and is being manu-

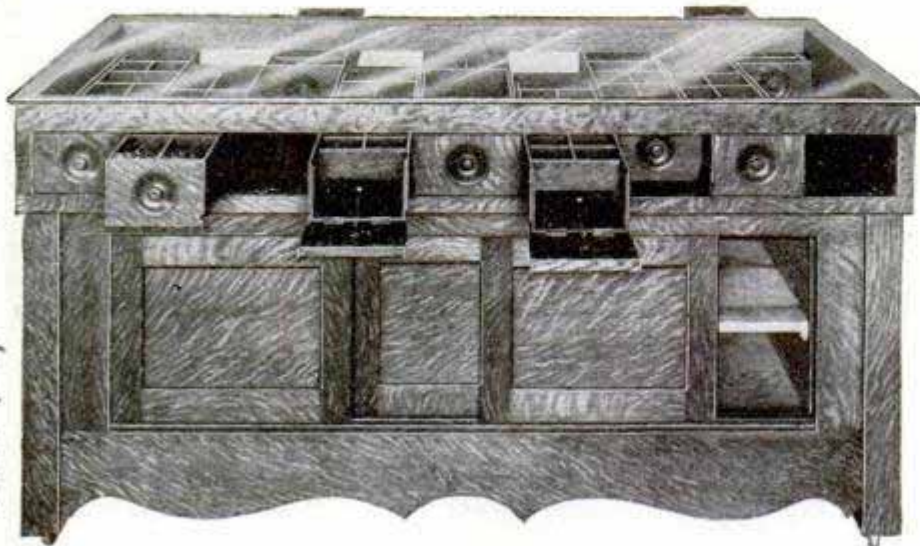

Hardware Case for Storing Small Stock in Plain Sight

factured. It was designed to avoid the showing of tarnished samples and to systematize the storing of slow-selling stock. The principal feature, as the illustration shows, is a series of small stock drawers divided into little compartments, all under a sheet of plate glass, under the customer's hand. A card-index system is also provided with this case.

**DRY BOX FOR PRESERVING TENNIS BALLS**

Tennis balls can be preserved in usable shape for an indefinite length of time if they are kept absolutely dry. They lose their resiliency and become "dead" before they are worn out, because dampness decomposes the rubber. An air-tight box containing a substance that will absorb moisture and prevent decomposition has recently been patented, as well as a similar air-tight case for protecting tennis rackets from moisture.

A moving-picture camera and a microscope will be used at Sheffield, Eng., to show the crystalline changes that take place during the pulling of a piece of metal.

**GERMANY BUILDING AFRICAN RAILROADS**

Germany is extensively pushing railroad construction in its African colonies. The Usambara Railroad, now at New Moschi, 196 miles inland, is to be extended to Mambo, German East Africa, and will finally terminate at Lake Victoria. A railroad is also being built from Duala, on the Kamerun coast, to Bidjoka, 95 miles. Almost as soon as Germany received a portion of the French Congo as a result of the Morocco incident, she considered the advisability of extending the line on the west coast to the Congo at the mouth of the Sanga, and it is reported that either a railroad or automobile route will be built between Bukoba, on Lake Victoria, and Missenge, on Lake Kivu.

**ALL-GLASS AUTOMOBILE LAMPS**

No polishing is required by the all-glass automobile lamps which recently appeared on the market. The body of the lamp, which is of the bullet type, is made entirely of glass and is finished on the inside to match the car. A vacuum between the outside wall and the parabolic reflector preserves the finish and keeps the outside of the lamp from being heated by the electric bulb. As the color or metal finish is on the inside, protected from the air, a rub with a cloth is all that is necessary to clean the lamp. The glass is of course heavy enough so that the lamps are not easily broken.



*E. W. Warner*  
*W. H. K. K.*

*4514*  
*4923*  
*4262*  
*4878 H*  
*26 E 47 road St.*

*Raymond Brown*



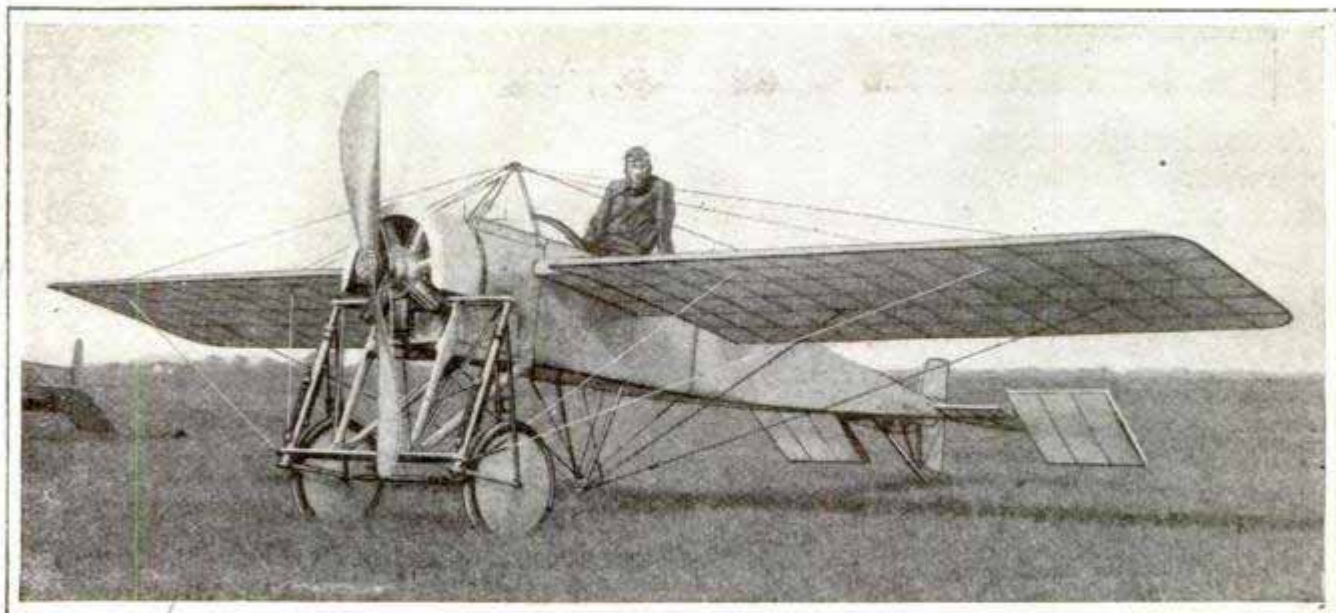

Photo by Underwood & Underwood, N. Y.

Airman C. M. Wood and Moisant Monoplane, "Blue Bird," in Which He Beat a Train from New York to Washington and Broke the American Nonstop Record

## NEW NONSTOP AEROPLANE RECORD *5080 H*

The American nonstop aeroplane record was broken on August 9 by C. Murvin Wood, who flew from Hempstead, Long Island, to Gaithersburg, Md., 287 miles, in 265 minutes. The previous record was held by Lieut. Thomas DeW. Milling of the United States army, who flew 224 miles in 262 minutes without stopping. Wood attempted to race a railway train from New York to Washington, but fog, engine trouble, and city smoke forced him to land a few miles from Washington. He beat the train, however, and laid claim to the duration cross-country record and the speed record up to 287 miles. The train left Jersey City at 4:30 and reached Washington at 9:50. With a handicap of 6 minutes and 30 miles, Wood left Hempstead at 4:36 and landed at Gaithersburg at 9:01, 40 minutes ahead of the train.

## APPARATUS FOR FILTERING VALUABLE LIQUIDS

An automatic siphon filter designed for filtering flavoring extracts, perfumes and pharmaceutical preparations has recently been brought out. With this device the entire operation is carried out in an air-tight vessel, thus avoiding all loss through evaporation.

The siphon is started by exhausting the air from the filtering vessel, and the filter works under a little more than atmospheric pressure by placing it several feet below the container of the unfiltered liquid. The filtering material used is paper of special composition. With the idea of providing a large capacity without interfering

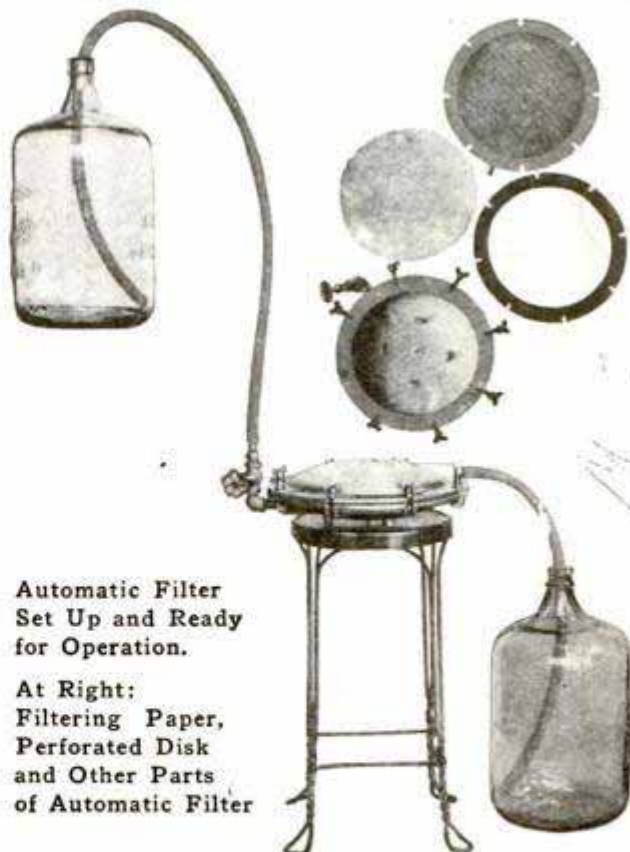

Automatic Filter Set Up and Ready for Operation.

At Right: Filtering Paper, Perforated Disk and Other Parts of Automatic Filter

with the close work obtained through the use of paper, a filtering surface of 131 sq. in. is used.



*Worcester*

### NEW FORM OF DRIVE FOR MOTORCYCLES

A combination chain and belt drive for motorcycles has been brought out which overcomes the objections to the

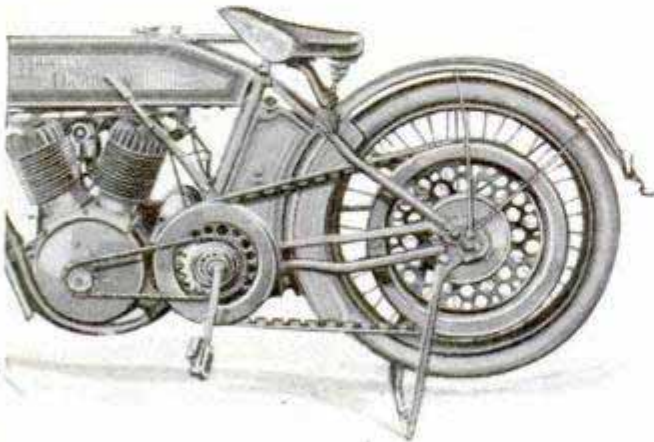

Combination Belt and Chain Drive for Motorcycles

ordinary belt drive and at the same time eliminates most of the road shocks which are transmitted to the motor when a direct chain drive is used. The motor is connected to the crankshaft by means of a chain drive, and from this crankshaft the wheel is

driven by a V-belt. Flexibility and noiselessness are two of the advantages of this type of drive, together with a minimum of wear and tear on the frame and power plant, due to the automatic "give" when an overload is suddenly applied. There is also a large degree of flexibility both longitudinally and laterally.

### AUTOMOBILE TIRE MADE OF HORSEHAIR

Patents for an automobile tire to be made of compressed horsehair have been taken out by a French inventor. The horsehair is made into sheets or bands and wound around a core, which may be of either solid or hollow metal, the whole being covered with canvas. The purpose of this invention is to provide resiliency without the use of a rubber air tube.

### MOVABLE DAM WHICH HAS 247-FT. SPANS

A movable dam with spans of unusual length is one of the features of the New York State barge canal between Buffalo and Albany. Each span is 247 ft. long and has gates operated by steam, while the lock used in connection with this dam is 60 ft. wide and 345 ft. long with gates operated by electric power.

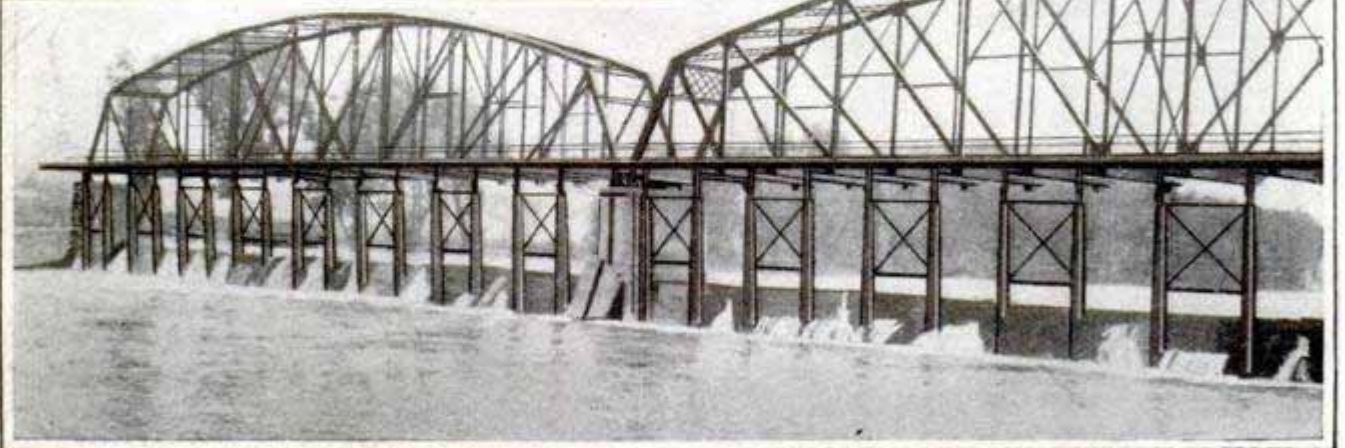
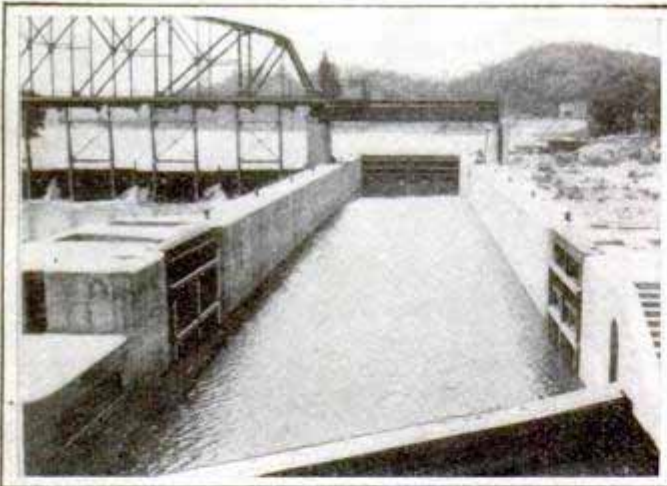

Above: View Showing Lock and Connection with Dam; Below: Movable Dam Viewed from the Downstream Side

*Patented by Worcester*

*Accessories*

*Worcester*

*Patented by Worcester*



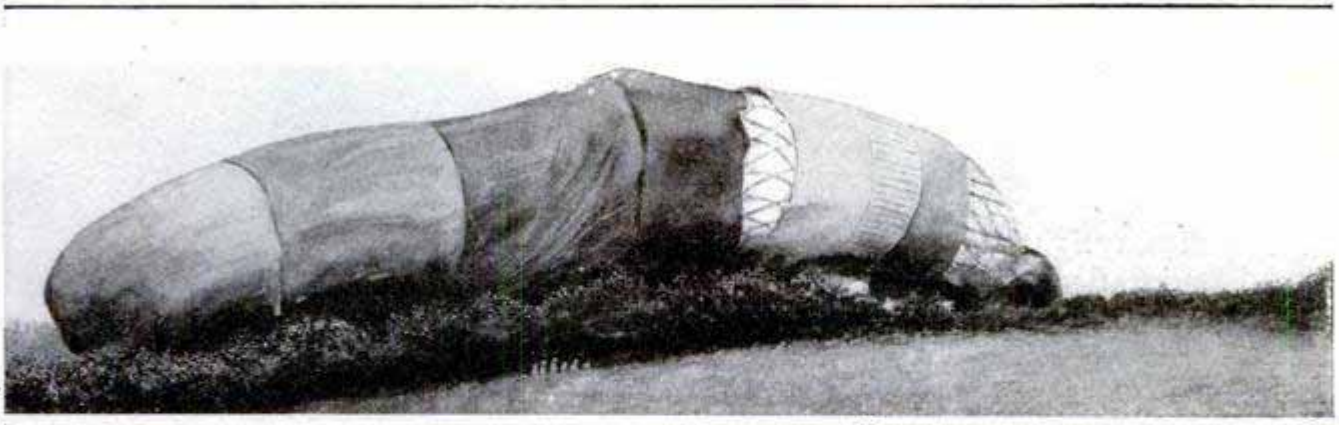

The Wreck of a German Airship Which Uprooted Several Large Birch Trees to Which It was Anchored during a Storm

### ANOTHER GERMAN AIRSHIP WRECKED

Another dirigible wreck was added to Germany's long list of airship accidents late in the summer. The military dirigible, "Schütte-Lanz," was almost totally demolished by a storm during a flight from Königsberg to Berlin. After landing at the village of Schneidemühl, the airship was anchored to several large birch trees and left pilotless to ride out the storm. When the wind became too strong, the dirigible uprooted the trees, tore loose from its moorings, and finally fell in a crumpled mass in a small grove near by. The "Schütte-Lanz" was of the military dirigible type and had a complete framework of aluminum. The wreck crumpled and buckled the frame in several places and tore loose a large part of the outer covering. Some idea of the strength of the wind pressure can be gained from the size of the birch roots that were torn from the ground.

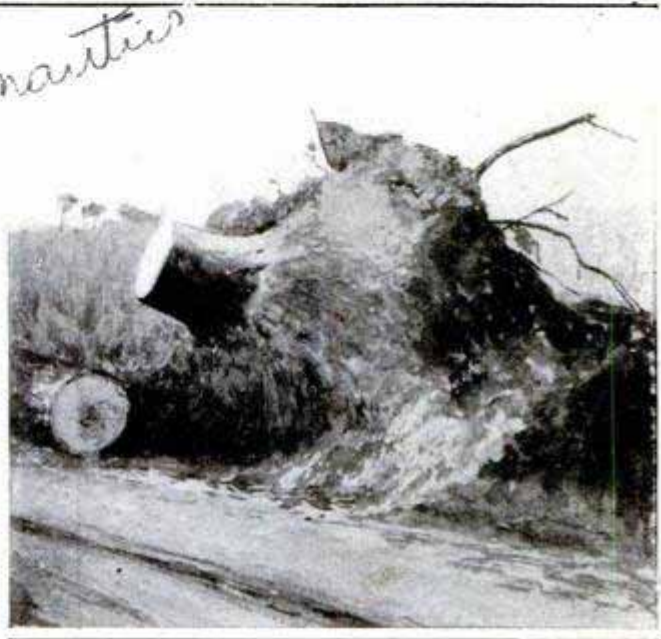

One of the Birch Roots That was Torn from the Ground

Five of them have been set up in the National Zoölogical Grounds and a few of them have replaced the wooden tables in Rock Creek National Park.

### PICNIC LUNCH TABLES MADE OF CONCRETE

Concrete tables and benches are provided for picnickers in some of the parks in Washington, D. C. They are gradually replacing the old wooden tables and benches because they are better able to stand the wear and tear of weather and hard usage. The simplicity and massiveness of the imitation stone makes these necessary conveniences ornamental as well as useful.



Concrete Table and Benches for Picnics in Washington Parks



ARTIFICIAL DAYLIGHT FOR WORLD'S FAIR

The illumination of the Panama-Pacific International Exposition in 1915 will demonstrate the most modern system of lighting by indirect light. Artificial daylight, produced by diffused and reflected electric light, will bathe the entire grounds in a flood of uniform light extending to a height of 125 ft. above the ground. Although almost four billion candlepower will be used, there will be no glare or un-

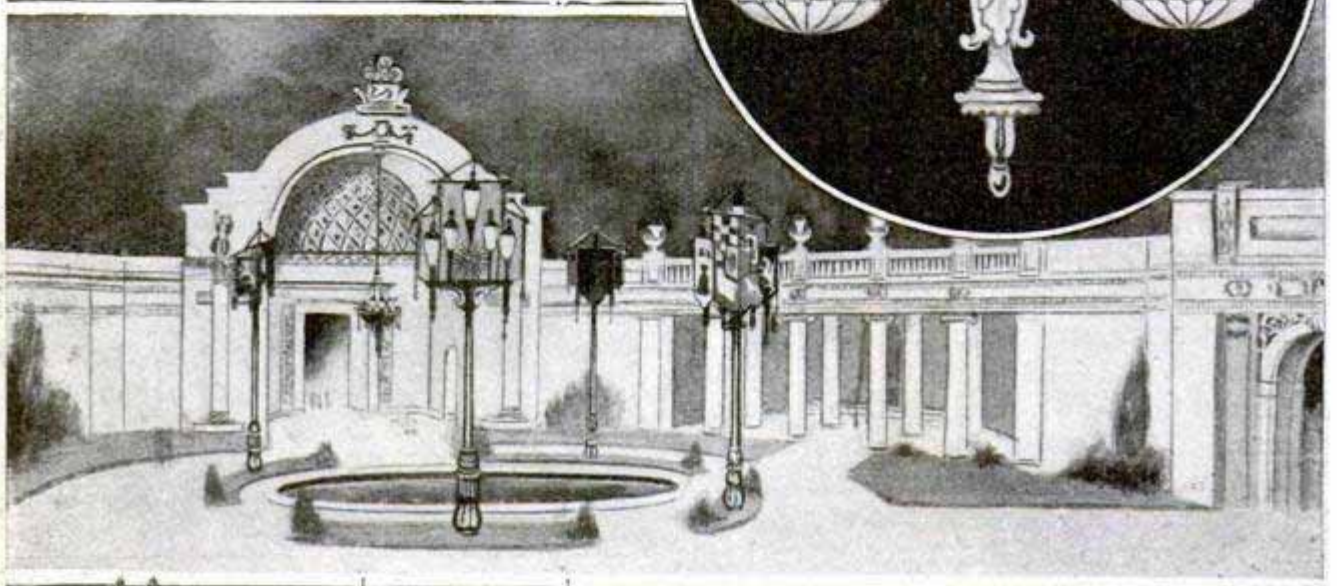
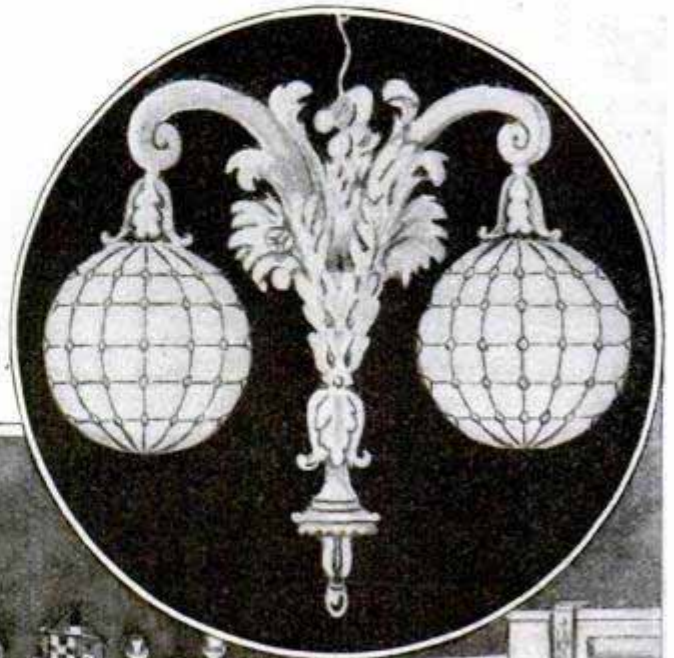

Upper View: Interior Chandelier with Shaded Globes

Lower View: Indirect Lighting in the Court of the Four Seasons



Copyrighted by Panama-Pacific Exposition

Arc Standards, 55 Ft. High, Shaded by Banners Which Reflect Light against the Outside Walls of the Buildings

protected light to tire the eyes. Previous expositions have been illuminated by uncovered arcs, searchlights, and outline strings of electric bulbs on

the exterior of the buildings. The result has been much glare and a great distortion of architectural and sculptural effects at night because of dark spaces and shadows. There will be no outlining at the Panama-Pacific Exposition, and its elaborate scheme of lighting will illuminate the buildings almost as naturally and with as little distortion as daylight. Much of the effect produced would have been impossible five or six years ago. Even now, indirect lighting is receiving further development in the exposition through the use of cut-glass prisms, or "jewels," to reflect and diffuse the glow.

Five principal sources of light will be used. The exteriors of the buildings will be illuminated by thousands of luminous arc standards, like huge lamp-posts, in front of the buildings.



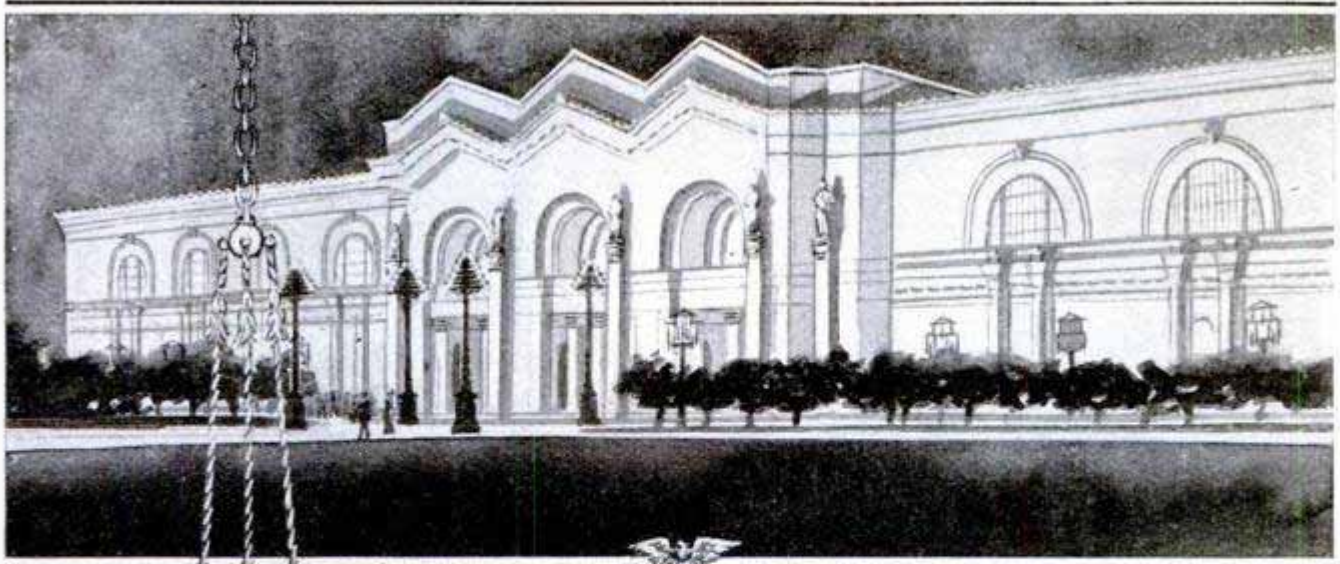

Facade of Machinery

Hall Illuminated by Luminous-Arc Standards

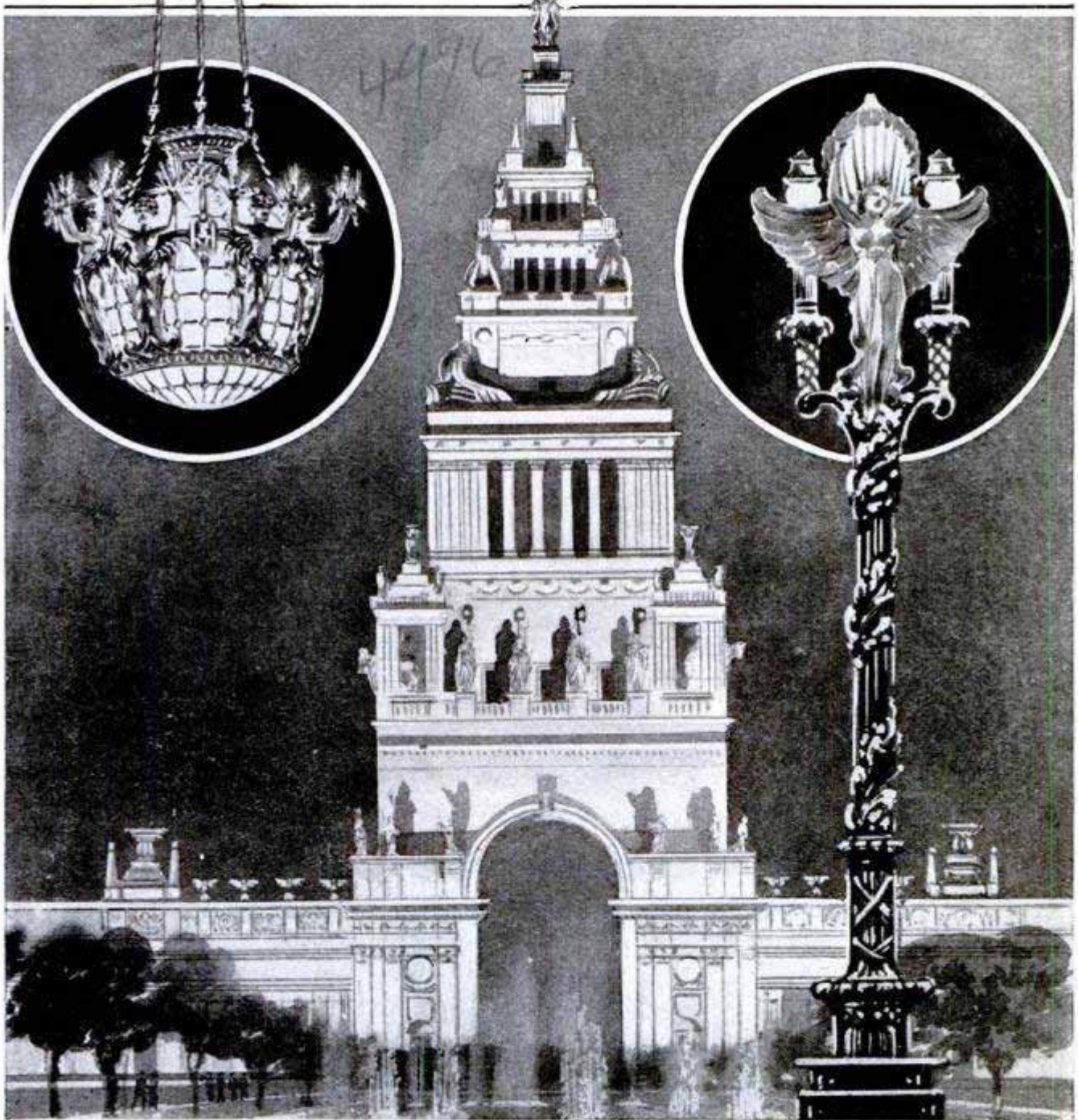

Photos Copyrighted by Panama-Pacific Exposition

The Tower of Jewels Illuminated by Thousands of Glass Prisms Diffusing the Light from Powerful Searchlights



On top of each standard, 55 ft. above the ground, great clusters of electric arcs will send out 8,000 to 10,000 cp. Canvas banners, white on the inside and elaborately painted on the outside, will shield the arcs and reflect their light upon the buildings' facades, bringing out every architectural detail clearly and uniformly. In the center of the courts, large fountains of dense white glass, with waterfalls near their bases, will shed a soft, even, diffused white glow over water and grounds. Two of these fountains, with glass columns 70 ft. high, and arcs developing 50,000,000 cp., will stand in the Court of the Sun and Stars. To light the walls behind colonnades and overcome the shadows cast by other lights outside, shaded arcs will be concealed in niches on the backs of the columns. Their subdued and reflected light will set off the costly paintings on the walls without shadows or distortion; when shadows are desired they will be produced with soft purplish light. Nor will there be any glare inside the exhibit palaces and other buildings. The larger spaces will be flooded with soft white light from arcs concealed in chandeliers, 12 ft. in diameter; smaller spaces will be provided with less pow-

erful "basin" lamps which shed their light on the ceiling. Rows of starlike glass prisms around the huge lantern chandeliers will catch light coming from all directions and spread it uniformly into every corner.

These are the individual lighting units. To weld their rays together and create a solid zone of daylight, masked batteries of powerful searchlights on roofs of exhibit palaces will direct their light upon thousands of quivering glass prisms hung about the buildings. The searchlights will be invisible and their rays will pass unseen through the general zone of light, but the glass "jewels" will reflect their light in all directions and in many sparkling colors. The 430-ft. Tower of Jewels in the Court of the Sun and Stars will be hung with 50,000 glass jewels, quivering and swinging in the wind. About the court a row of hovering female figures, 14 ft. high and bearing 4-ft. stars of glass prisms, will add to the brilliance. On a pontoon out in the harbor a masked battery of thirty-six 24-in. searchlights will play upon the whole scene, throwing various colors to produce auroras in the sky. The resulting zone of daylight will be visible 40 or 50 miles at night.

### SHIPPING PACKAGE FOR CHOICE APPLES

As a result of the difficulty encountered in shipping select apples without



Compartment Pasteboard  
Box for Shipping Select  
Apples without Bruising

bruising, a patent apple-packing box has appeared on the market. It is a heavy-cardboard package, sealed with gummed tape and containing 12 small boxes of the same material for apples. Each small box is just large enough to hold 12 apples, has the name of the grower and the variety of the fruit printed on the cover, and is decorated with paper lace for counter display. In this way, 144 apples can be shipped in a neat package with little risk of damage.

In its war on the housefly, an Alabama town gave a ticket to a moving-picture show to every child who presented 50 or more dead flies. Hundreds of thousands of flies were killed by the children, and the show was crowded to the doors.







## MACHINE FOR BUILDING PIPE LINES

What is probably the only machine ever invented for putting together a pipe line with a minimum of hand labor

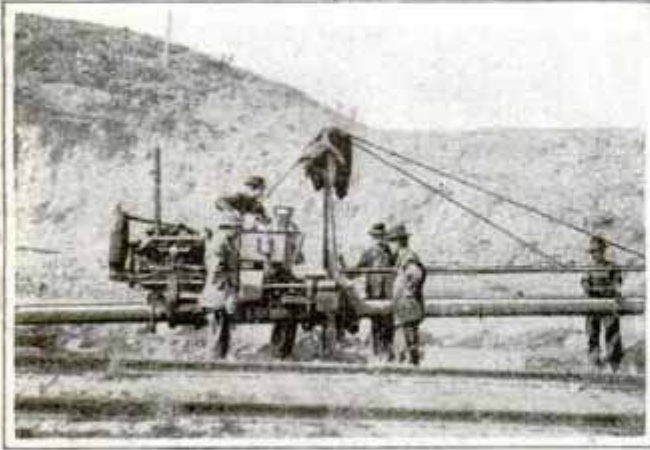

Machine for Laying a Pipe Line without Hand Labor

is shown in the accompanying picture. It was used in laying a pipe line to carry oil from the Midway fields to the harbor at San Pedro, Cal. The machine, driven by gasoline power, travels along the pipe under its own power. At each junction a cranelike arm, projecting forward from the machine, holds up the next section of pipe while

a clutch at the forward end screws the pipe into place. During the joining process the machine is raised in the air on a pair of cogged legs. For making a curve, the machine is raised high on its legs, a wooden horse is placed under the pipe, and the machine is lowered until the pipe has been bent sufficiently.

## TROLLEY WRECK WITHOUT FATALITIES

Two electric interurban cars, a limited and a local, on the Syracuse, Lake Shore and Northern Railroad, collided and telescoped on Aug. 6, near Oswego, N. Y., without killing or fatally injuring a single person. One car passed almost halfway through the other, raising its roof nearly as high as the trolley wires. The remarkable strength of the cars is shown by the fact that although the shock was sufficient to tear loose iron window guards, the car frames held together and not even the windows nearest the shattered portions of the cars were broken. There were 50 passengers on board the cars, and 25 were injured.

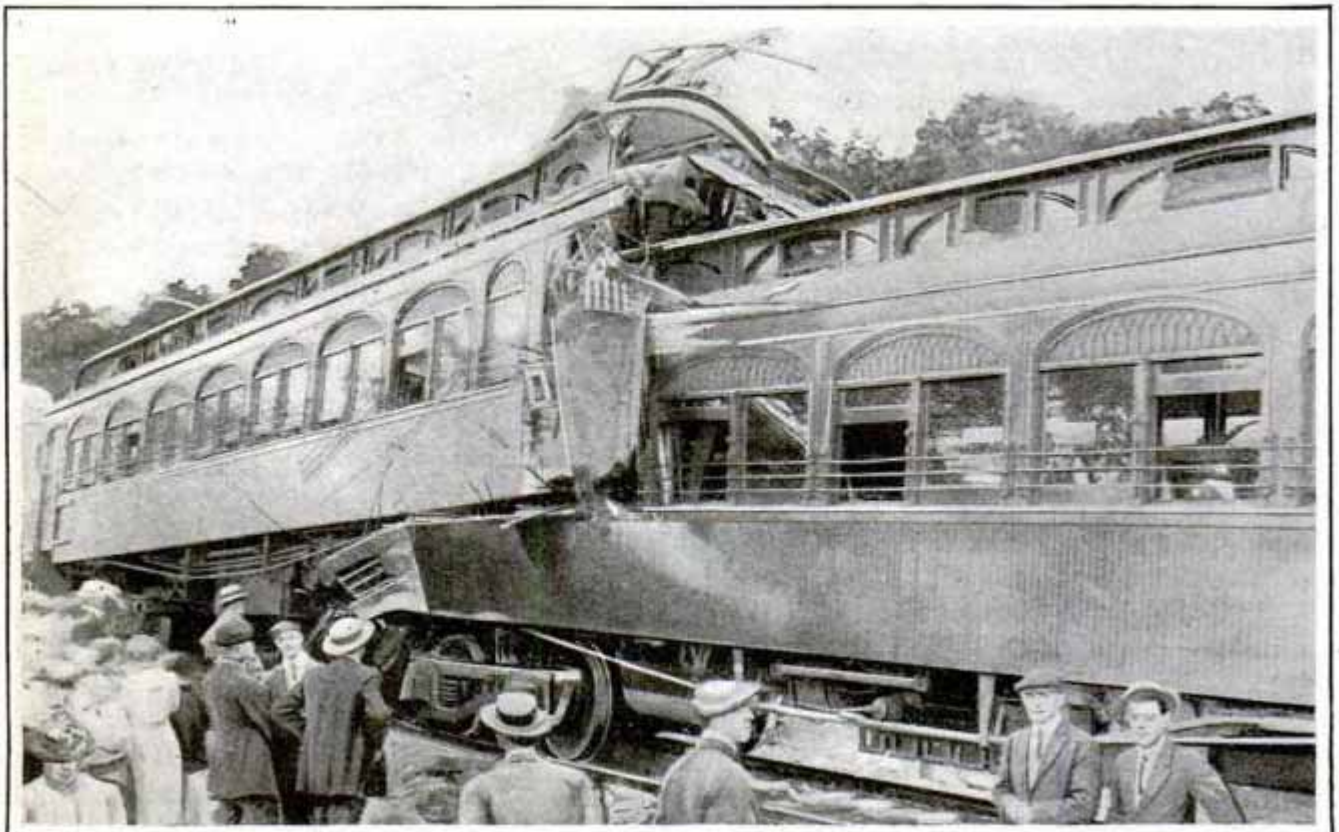

Trolley Wreck in Which the Cars Withstood the Shock So Well That None of the 50 Passengers was Killed



## KEROSENE AS MOTOR FUEL PROVES SUCCESSFUL

Remarkable results have recently been obtained from kerosene carburetors, or vaporizers, according to authentic reports of tests. Some of these reports indicate that properly vaporized kerosene may be more efficient as a fuel than gasoline when the latter fluid is vaporized by the usual methods. The reason for this is that in order to be used at all in an internal-combustion engine, kerosene must be vaporized in a very thorough manner, it being necessary to apply a considerable quantity of heat in the process. Gasoline, on the contrary, vaporizes readily without the application of heat, the ordinary process consisting simply of spraying the oil into a current of air, with which it mixes in the form of a vapor. Since the fuel value of the two oils is about the same it seems probable that the necessary thoroughness of the vaporization of kerosene may make it, as indicated, a more efficient automobile fuel. In addition to this, less lubrication may be required with kerosene on account of the lubricating qualities of the kerosene itself.

A high degree of efficiency was shown by the kerosene carburetor used on one of the cars in the recent Indiana-Pacific tour. This car carried three passengers in addition to the driver, the total weight, including load, being 4,390 lb., and the distance traveled 4,015 miles. From start to finish there was used 250 gal. of kerosene, 8 gal. of gasoline for starting, and 6 gal. of lubricating oil, the total cost for fuel being \$31.76, and for lubricating oil \$2.40. The cost of fuel was .79 cents per mile, or .36 cent per ton-mile. Ignition was by means of magneto and plugs. It is stated that the spark plugs were not cleaned on the entire trip, and that no adjustment was made on the carburetor other than that made from the steering-column control.

Tests have also been made of a carburetor designed to take any liquid containing power-producing elements and form it into a vapor suitable for

firing in the cylinder of an automobile engine. These tests, which were made with a 6-cyl. motor linked to an electrical dynamometer from which horsepower readings were obtained, furnish an interesting comparison of the fuel

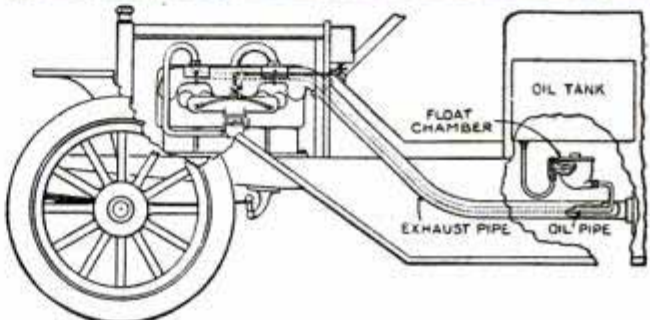
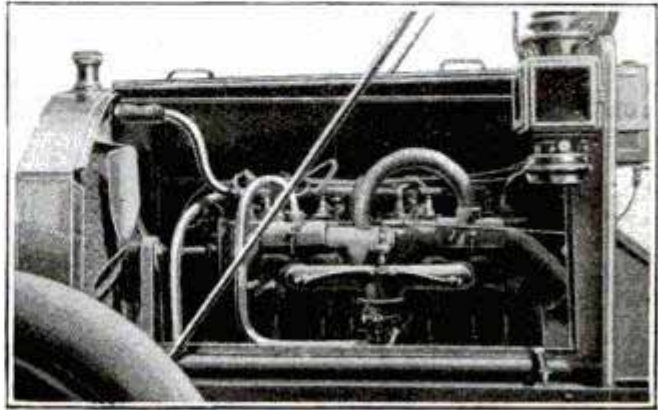

Motor Car Equipped with Heater Pipe in Which Kerosene is Boiled into a Gas by Heat from Engine Exhaust

values of gasoline and kerosene. With the motor running on gasoline at 1,653 revolutions per minute, 56.4 brake horsepower was developed and the amount of gasoline used per horsepower-hour was .98 lb. In a similar test with kerosene the motor was run at 1,692 revolutions per minute, and 70.8 brake horsepower was developed with a consumption of .805 lb. of fuel per horsepower-hour.

All the kerosene carburetors so far subjected to practical test use the heat from the engine exhaust for vaporizing the fluid, and in all but one it is necessary to start on gasoline, which is switched off as soon as the carburetor and cylinders are thoroughly heated. The one that does not use gasoline for starting supplies the necessary preliminary heat by means of an electric current. In one device the oil, with proper regulating devices, flows from the tank into a  $\frac{3}{8}$ -



in. heater pipe placed in the center of the engine exhaust pipe, and is drawn through the heater pipe by the suction

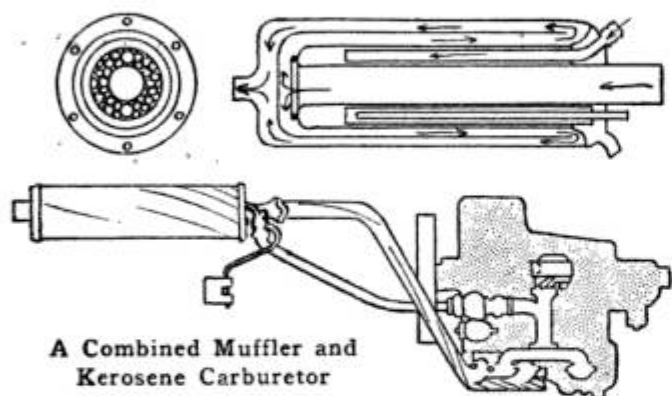

of the engine to the exhaust manifold, where the exhaust heat boils it into a vapor. This vapor passes into the mixing tube where it is mixed with air, and is then fired in the cylinder in the usual way, the proper mixture of kerosene and air being controlled by the throttle. In a recent test, a motor car equipped with this device was driven 110½ miles on 5 gal. of kerosene. Another form of carburetor consists of an ordinary muffler with vaporizing attachments. The space around the central pipe is filled with gray-iron slugs, which become heated by the ex-

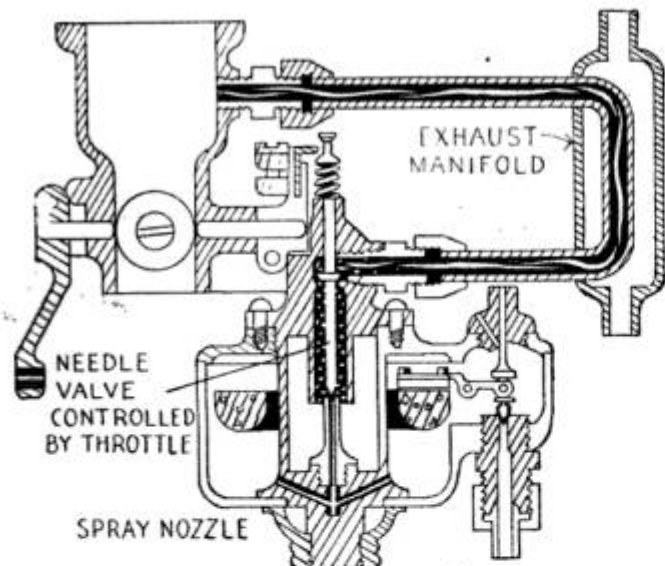

Carburetor in Which the Kerosene is First Sprayed and Then Formed into True Vapor by Heat from the Exhaust Manifold. Black Line Shows Path of the Kerosene

haust as it passes through the muffler. In the upper part of this slug-filled space is the oil pipe, which is perforated with  $\frac{1}{16}$ -in. holes. The oil simply drips through these holes on the hot slugs and is vaporized. The vapor is drawn through a pipe by the suction

of the engine to a mixing valve, after which it is fired in the cylinders. The vapor has a temperature of from 550 to 750 deg. F. as it leaves the carburetor, which is reduced to about 122 deg. F. by the addition of air in the mixing valve. The motor is started with gasoline, but the construction of the carburetor is such that it will maintain a vaporizing temperature for about two hours after the motor is stopped.

One kerosene carburetor that is meeting with success first atomizes the liquid and then converts it into a true vapor. This device is provided with an annular float chamber of the ordinary type and a needle valve which controls the spray nozzle. A small quantity of air is admitted to the air chamber and mixes with the atomized kerosene, the mixture then entering the gas-producing tube. This tube passes through the exhaust manifold where the mixture of air and atomized kerosene is converted into a true vapor, the mixture then passing through the mixing valve. In this device the needle valve which governs the admission of kerosene is controlled by the throttle valve. In order to permit starting on kerosene an electrical current is applied to the gas-producing tube to furnish the requisite heat until the exhaust takes up the work.

## STANDARD TIME ANNOUNCED BY WIRELESS

Greenwich time is flashed to the world now, several times each day, from the powerful wireless station on the Eiffel Tower, Paris, in an international code of signals that can be picked up by operators anywhere within a radius of 2,000 or 3,000 miles. Far out at sea, ships' officers catch the time message and correct their chronometers, and many watchmakers have receiving stations to intercept the time messages. In London, Berlin, St. Petersburg, and Rome amateurs set the family clocks from the dots and dashes caught by their receivers. No correction has to be made for time con-



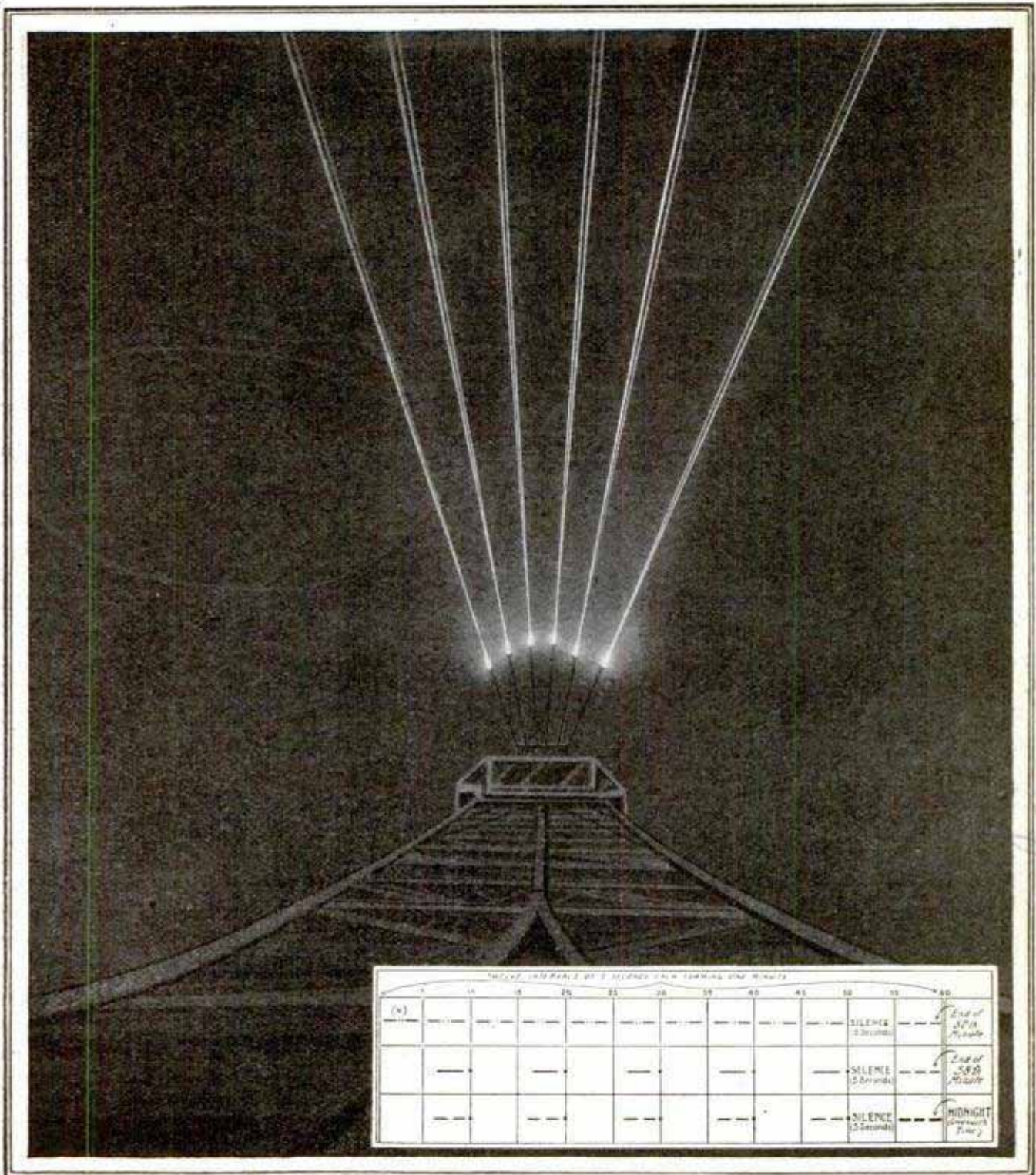

*See page 17*  
*12/15*

Courtesy Illustrated London News  
 Photograph, Taken Vertically Up the Side of the Eiffel Tower, Showing the Glow of the Antenna Wires While Greenwich Time is Being Flashed to the World on a Dark Night. Sketch Shows the Midnight Call of the New International Wireless Code Used to Announce Greenwich Time from Eiffel Tower, Paris

sumed in the passage of the message, for the wireless waves travel at a speed of 186,330 miles a second, and at a distance of 3,000 miles the pressure of the sender's key and the response of the receiver's telephone are simultaneous. The principal time messages are sent at 10 a. m., 11:30 p. m., 11:45 p. m., and midnight. Beginning at 11:30 every night, a "tap" per second is sent for three minutes until the 180th tap

marks 11:33. A more complete message is sent at 11:44—49, followed by a weather report. Beginning at 11:57, the international midnight signal is sent. Three separate calls, each lasting a minute, as indicated in the accompanying diagram, prepare receiving operators for the final 74th dash which marks midnight at Greenwich. The Eiffel Tower apparatus is so powerful that the electrical tension often reaches



millions of volts. On dark nights the wires of its antenna become luminous and look like lines of fire against the black sky while the time messages are

being sent. Even when they cannot be seen by the naked eye, their ultra-violet rays can be caught and recorded on a photographic plate.

### HOUSES THAT ARE BUILT IN A DAY

Building monolithic concrete houses in one day is becoming a common thing, but Hamilton, Ontario, boasts of a large brick house that was built completely in 24 hours. It is 2½ stories high and cost \$6,000. The construction of the house began at 5 p. m. on August 12, and by 5 p. m., August 13, the house was ready for occupancy. The force of men who accomplished the feat consisted of 25 carpenters, 40 bricklayers, 10 steamfitters, 4 glaziers, 8 electricians, 64 laborers, 2 tinsmiths, and a number of plasterers and painters. This record is often beaten in Porto Rico where many families insist upon having a new home once a year and set aside an hour or so at the end of each summer to gather material and construct a new winter residence. Four men can build a Porto Rican bark house in about 50 minutes, spending half the time to gather the material. Its four corner posts are cut from the trunk of a fallen coco palm, a light frame of saplings is built about them, and the whole structure is covered with flat pieces of the dried bark of a royal palm, bound together with strips of banana and coco fiber.

### CONVENT SISTERS MANAGE COAL MINE

A coal mine with a productive capacity of 60 tons a day, sufficient to supply heat, light and power for one of the largest convent schools in the country, has been successfully managed for years by the Sisters of Providence, the Catholic order that conducts the institution known as "St. Mary of the Woods," near Terre Haute, Ind. The convent was founded in 1840, but it was not until 1894 that the discovery of valuable coal deposits, underlying the lands belonging to the institution, was made. A shaft was first sunk to a depth of 97 ft., but this was later abandoned for a shaft 270 ft. deep, where the average thickness of the coal vein is 5 ft. This mine is now operated under the management of one of the sisters, who is well versed in everything pertaining to mining operations and machinery.

The equipment is of modern type throughout. For hauling the coal from the mine to the power house, a distance of three-eighths of a mile, an electric motor-trolley system is used. The power house has five dynamos which furnish electric current for the buildings and grounds, while the exhaust heat is utilized for heating. Water is supplied



This \$6,000 Brick Residence was Built Completely in 24 Hours



It Took 50 Minutes to Build This Porto Rican Bark House

stick by



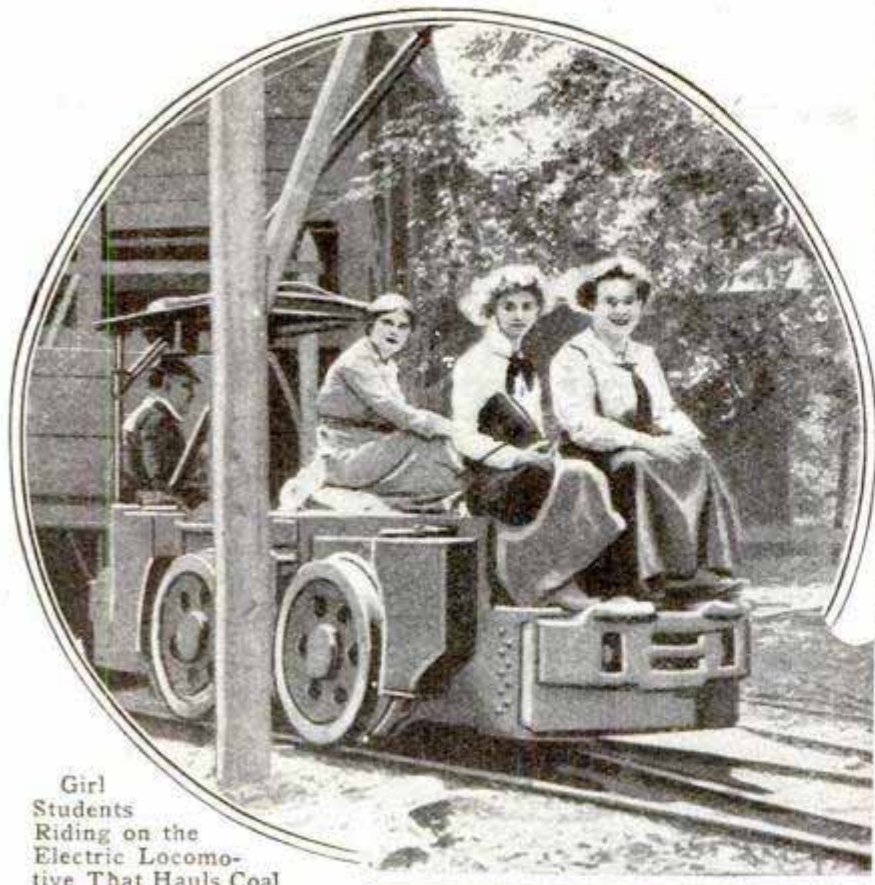

Girl Students Riding on the Electric Locomotive That Hauls Coal from the Convent-Owned Mine. On the Right, a View of the Mine

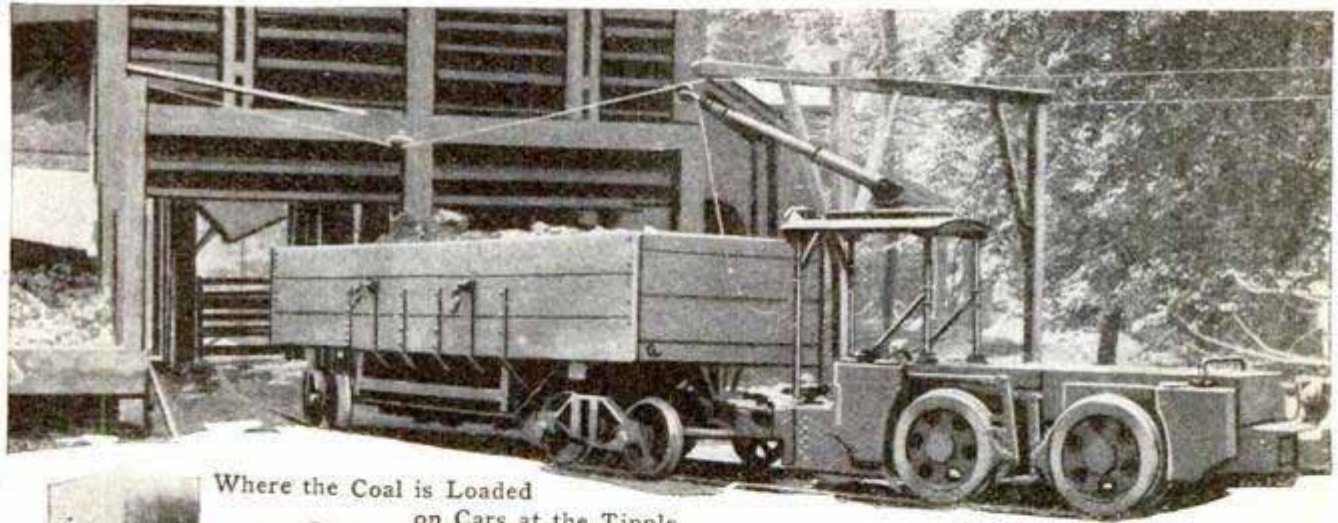
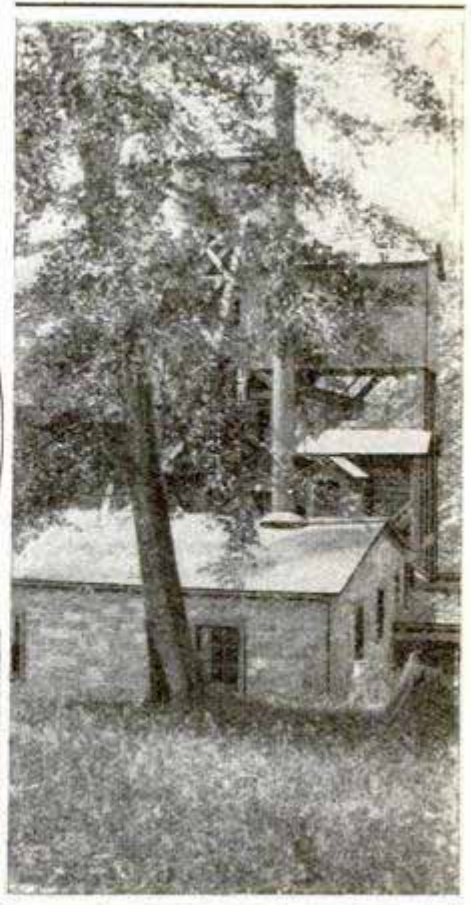

Where the Coal is Loaded on Cars at the Tipple

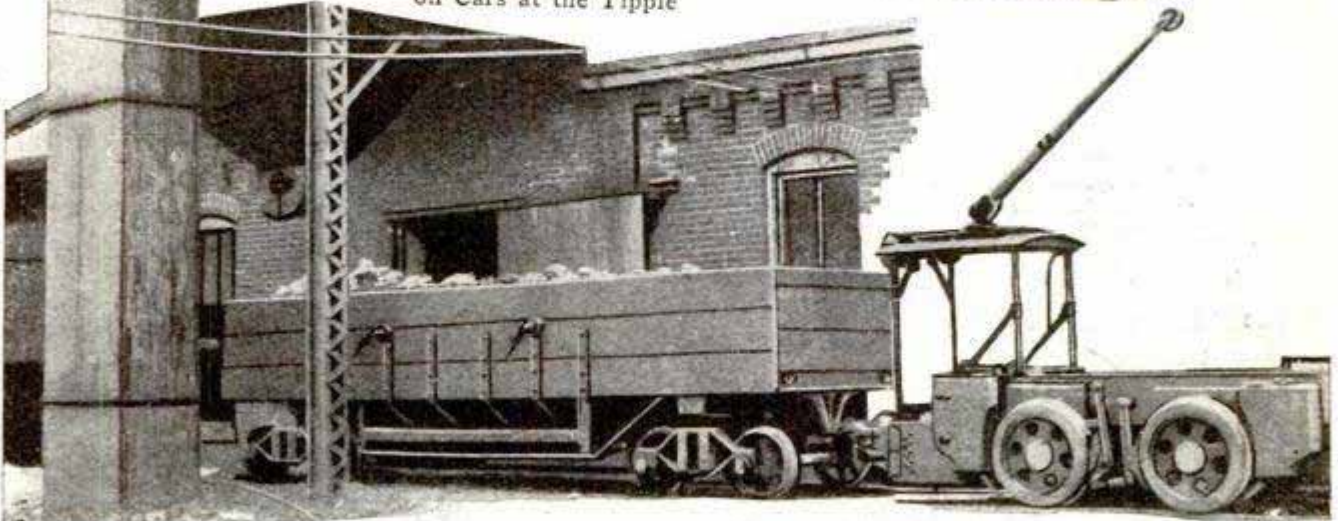

Delivering Coal at the Convent Power House



from a reservoir by a pump driven by two motor generators, and is stored in a 100,000-gal. water tower about a mile distant from the institution, from which it passes through three gravel filters before being used. A duplex fire pump is located at the power house and has a capacity of 1,000 gal. per minute. A total of 44 motors are required about the buildings and grounds for various power purposes, which include an ice machine with a daily capacity of 16,000 lb., an electric laundry, and automatic electric elevators in four of the buildings.

### THE SPANISH ARMORED AUTOMOBILE

*5726*  
The Spanish army has a huge armored automobile which has seen real fighting in the recent African campaign and proved very effective. The entire car, machinery and all, is completely covered with armor plate, heavy enough to turn a rifle bullet. Inside it is divided into three compartments: a cab for the driver, a "blockhouse" for a force of sharpshooters, and a storage compartment for ammunition. Completely equipped, it weighs

9.35 tons and is driven by a 40-hp. gasoline motor with the usual systems of gearing, ignition, lubrication and control. The roof and portholes, when open, are shielded and the interior is practically inaccessible, even if the armored car is overwhelmed by a hostile force.

### WAR MAPS MADE DURING AEROPLANE FLIGHTS

The practicability of making war maps from aeroplanes during aerial scouting expeditions into the enemy's territory has recently been tested by the signal corps of the United States army and found entirely feasible. Several signal officers flying alone or as passengers were able to make usable sketch maps of the country below them, as they flew two or three thousand feet in the air.

Two maps that were made during these tests are reproduced on the opposite page. One of them is the rough sketch map drawn by Lieut. W. C. Sherman while riding as a passenger in an aeroplane with Lieut. Thomas DeWitt Milling on his record flight from Texas City to San Antonio, Tex., on March 28, 1913. It was drawn while they were traveling 56 miles an hour and, by



Powerful Armored Automobile Used by Spain in the Recent African Campaign

Courtesy Motor Age

*Motor Age 8/7/13*  
*Brilliantly designed and built by the Spaniards*



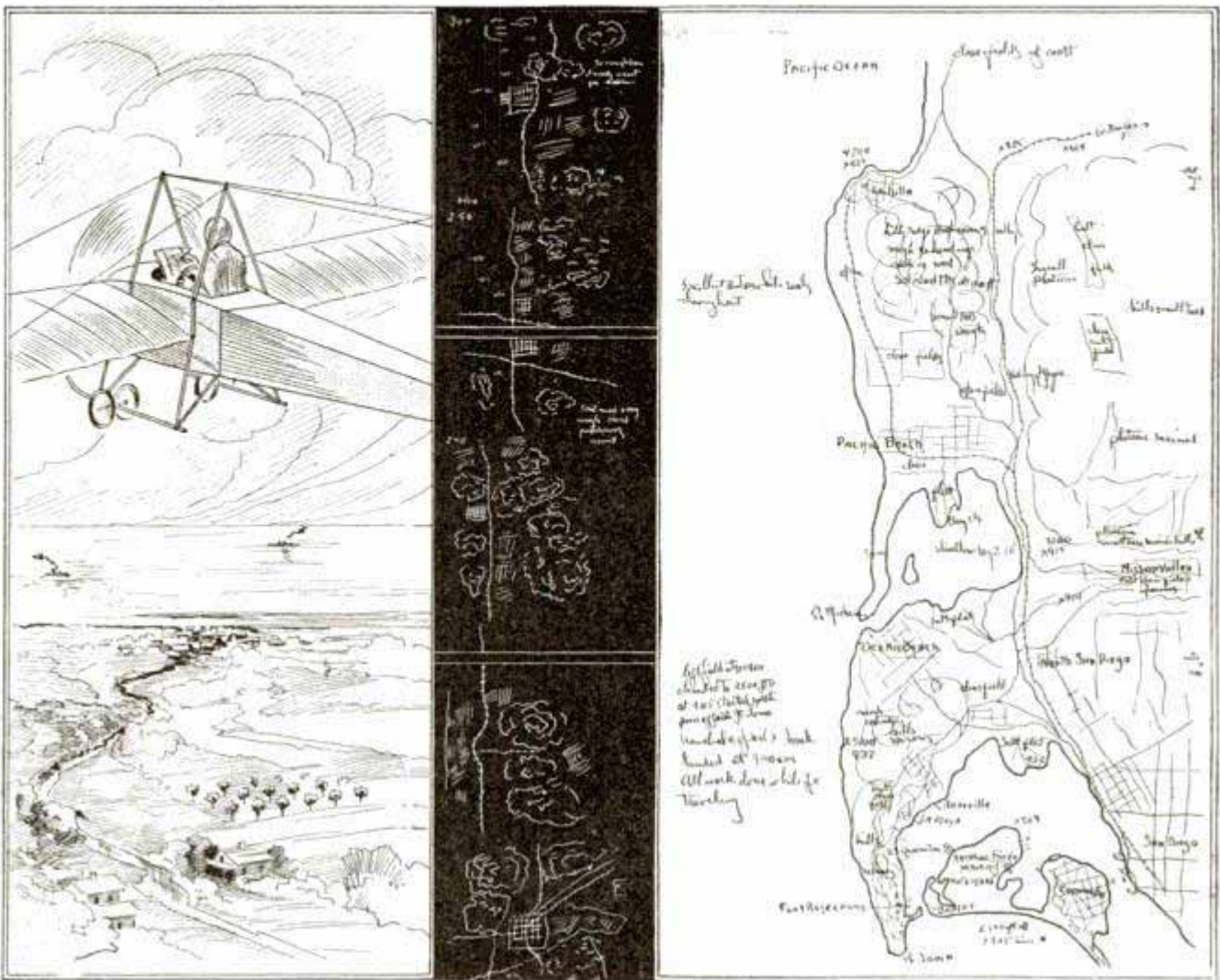

Rough Sketch Drawn by an Officer during a Flight from Texas City to San Antonio

Copy of Sketch Map of San Diego, Cal., and Vicinity Made by Army Pilot Flying Alone

means of the signal-corps symbols, gives a clear picture of the country over which they passed. Railroads, highways, streams, towns, woods, etc., are marked, and the figures on the left-hand margin indicate the aeroplane's time. The original sketch is 12 ft. long and to scale, 6½ in. equaling 10 minutes, and 1 in. equaling 1.44 mile. The other is a completed map drawn from a sketch of San Diego, Cal., and vicinity made by Lieut. J. D. Park while flying alone on May 3, 1913, a few days before his death in an aeroplane accident on May 9. The coast line and the topography of the country are indicated clearly enough to be of value to an attacking force, and at various points clear fields where airmen might make safe landings are marked out. Although the strip of country included in the map is 5 miles wide and 15 miles long, the entire sketch was made during a

35-minute flight from the aviation field at the south along the line of the railroad. At times the airman reached a height of over 3,000 ft. and from there was able to note the character of the country for 10 miles about.

The army signal corps now has 15 aeroplanes and an aviation detachment of 75 officers, of whom 23 are trained pilots. Two flying machines and five pilots are stationed in the Philippine Islands; two machines and one airman in Hawaii; nine machines and 17 officers, six of whom are pilots, at San Diego, Cal.; two machines and two airmen at Texas City. Seven aeroplanes are now being built for delivery on Oct. 31, 1913. Army airmen are trained at a school of aviation at College Park, Maryland, established two years ago. All officers in the signal corps study map drawing as a part of their regular training.

*How to get to San Diego*



## COLUMBUS' CARAVELS ON LONG JOURNEY

The "Santa Maria," the "Pinta," and the "Nina," the three little ships which Spain built to reproduce the caravels of Christopher Columbus and gave to the United States for the World's Columbian Exposition in 1893, are to journey to the Panama-Pacific Exposition at San Francisco, by way of the Panama Canal. They have been repaired and repainted and the "Pinta" has a new keel and stern. The "Santa Maria," carrying what is said to be Columbus' own anchor, sails at the head of the fleet under the command of a Harvard rowing coach, and 60 men, 28 less than Columbus had, man the squadron. False decking, copper sheathing and temporary crew quarters between the decks have been installed for the trip under the direction of a navy master-at-arms who crossed the Atlantic in the caravels in 1892. A bond of \$10,000 has been given to Chicago to secure their safe return at the close of the San Francisco fair.

Their journey will take them many thousands of miles and will last over a year. Their route lies through the Great Lakes and Erie Canal to New York; thence, after a trip to Boston, down the Atlantic coast. Stops will be made at many cities for public exhibitions, and plans have been made to give short trips on the caravels to students interested in ancient ship building and navigation. Part of the way, especially in the Erie Canal and on the Atlantic, they will be towed by tugs. After a visit to San Salvador, Columbus' first landing place in America, they will pass through the new Panama Canal and then proceed under their own sail up the Pacific to San Francisco for exhibition at the Panama-Pacific Exposition in 1915.

The three caravels were built in Spain in 1892, and are very close reproductions. The "Santa Maria" is an exact replica, because Spain has on file the specifications of Columbus' flagship, recorded at the time of her sale shortly after Columbus' trip to America. The "Pinta" and the "Nina" are

not such exact copies, but were built by an American navy officer in imitation of Portuguese merchant ships of the 15th century. In the summer of 1892, 400 years after Columbus' voyage of discovery, the little squadron was towed across the Atlantic by Spanish and American battleships. The crossing was a thrilling one for the men who manned the caravels, but it was made in 20 days, one-third of the time spent by Columbus in sailing across. Since the exposition of 1893 they have lain at anchor in the yacht harbor at Jackson Park, Chicago, within a short distance of the reproduction of the Convento de la Rabida. When they were placed in a motorboat dry dock this summer their only signs of age were a humped keel and a weakened stern on the "Pinta."

The caravels are very small in comparison with modern ocean ships or even with sailing vessels of a century ago. The largest of them, the "Santa Maria," is a vessel of only 127 tons. She is 84 ft. long over all, and 77.9 ft. on the water line. Her beam is 26 ft. and she draws 9 ft. of water. Amidships her hold is 12 ft deep. The overhang of the bow is 11 ft. and of the stern, 5 ft. In all she carries about 5,980 sq. ft. of canvas. The "Pinta," the larger of the other two caravels, is a vessel of only 50 tons. The little "Nina" is the fastest sailer of the three. The complete armament of the "Santa Maria" consists of two bombardars and six falconets throwing 2-lb. balls. On the decks and in the cabin there are racks for swords, armor, crossbows, battle-axes, and other small arms. Cooking is the most difficult part of a voyage on the caravels. The arrangements to be used in the present trip are designed in imitation of Columbus' equipment, consisting of iron-lined boxes of earth for charcoal fires, lashed to the mainmasts.

Ⓒ This year's plantation output of rubber was 50,000 tons, exclusive of Brazil's output of native rubber.



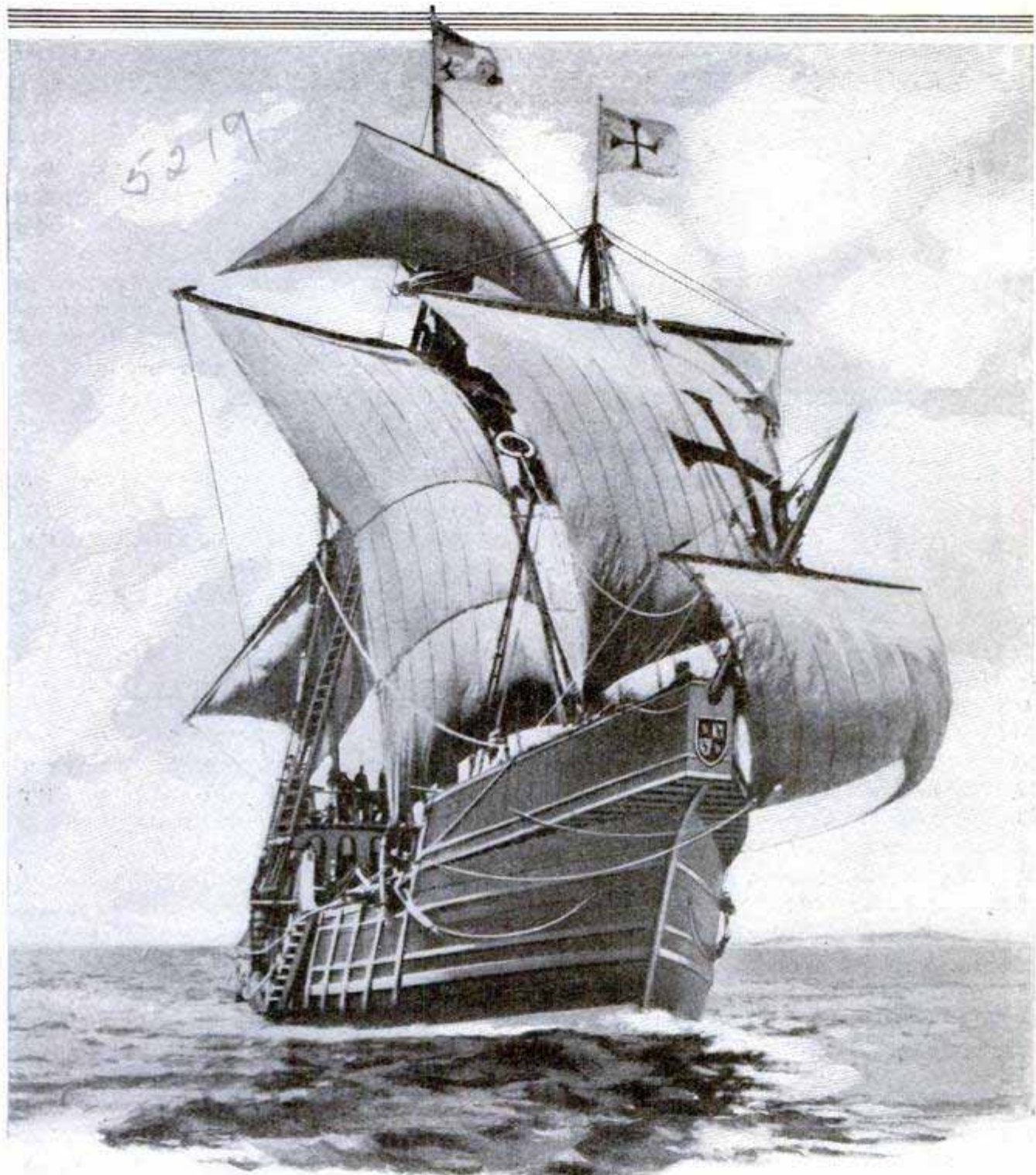

The Flagship "Santa  
Maria" Sailing  
Under a Full Rig of  
Brown Denim Sails

At Left: The  
"Nina," the Smallest  
and Fastest of  
the Three

At Right: The  
"Pinta" being  
Repaired

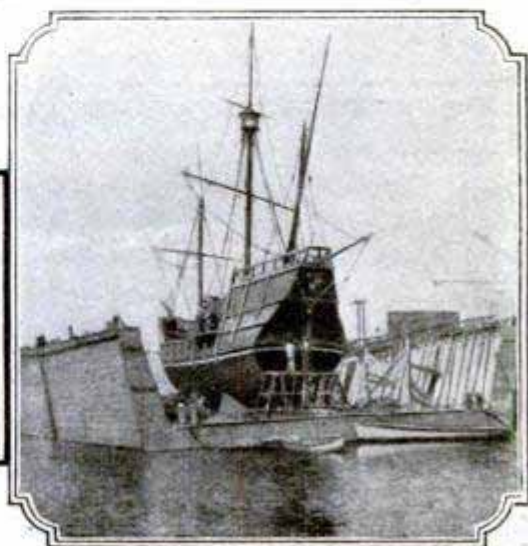



### AN ENGINE SMALLER THAN A FLY

Another "smallest engine in the world" is shown in these two photographs. This one is not only the



smallest engine that has yet been built, but it is too small to be run with steam and must be run with compressed air, because steam is too heavy for its needle-point ports. The engine, built by a North Dakota jeweler, is of the rocking-cylinder type and is so small that it will not cover up the letters on a dime. The engine standing on a pedestal, is shown in the

lower picture. Its length over all is .255 in. and its weight is 2.5 grains. The cylinder has a bore of .028 in. and a stroke of .036 in., and the flywheel is only .142 in. across.

☞The "Idaho" has made the best record in target practice of the 21 battleships in the United States navy and has received the trophy for marksmanship.



Rope Trap Used by European Highwaymen to Stop Motorists on Lonely Roads at Night

### THE ALUMINUM-PLATING OF IRON

Although aluminum-plating of iron has always been a difficult and unsatisfactory operation, a process has just been discovered which makes aluminum adhere to iron so firmly that it cannot be removed by mechanical means, according to the French magazine Cosmos. In the new method, the iron is first tinned, or galvanized, and then plunged into a bath of melted aluminum. While it is immersed it is rubbed vigorously with steel brushes. The tin or zinc leaves the iron and is replaced by a coating of aluminum, and the resulting plate does not tarnish or oxidize by the action of air, water, or heat.

### HIGHWAYMAN'S TRAP FOR MOTORISTS

European highwaymen have devised a clever trap for automobilists passing along lonely roads or through woods at night. The robbers stretch a rope or a wire across the road just high enough to catch the front of the automobile or the motorists' heads. Besides stopping the car very effectively so that its occupants can be robbed, the rope often inflicts serious injuries upon the highwaymen's victims. The frequency of this mode of attack has led to the invention of a metal arm which can be attached to the side of the automobile and bent high in the air so that it catches the rope and throws it completely over the car.



The Metal Arm Which has been Invented to Foil the Robbers

Courtesy of the Sketch



## SAILING WHEELBARROWS IN CHINA

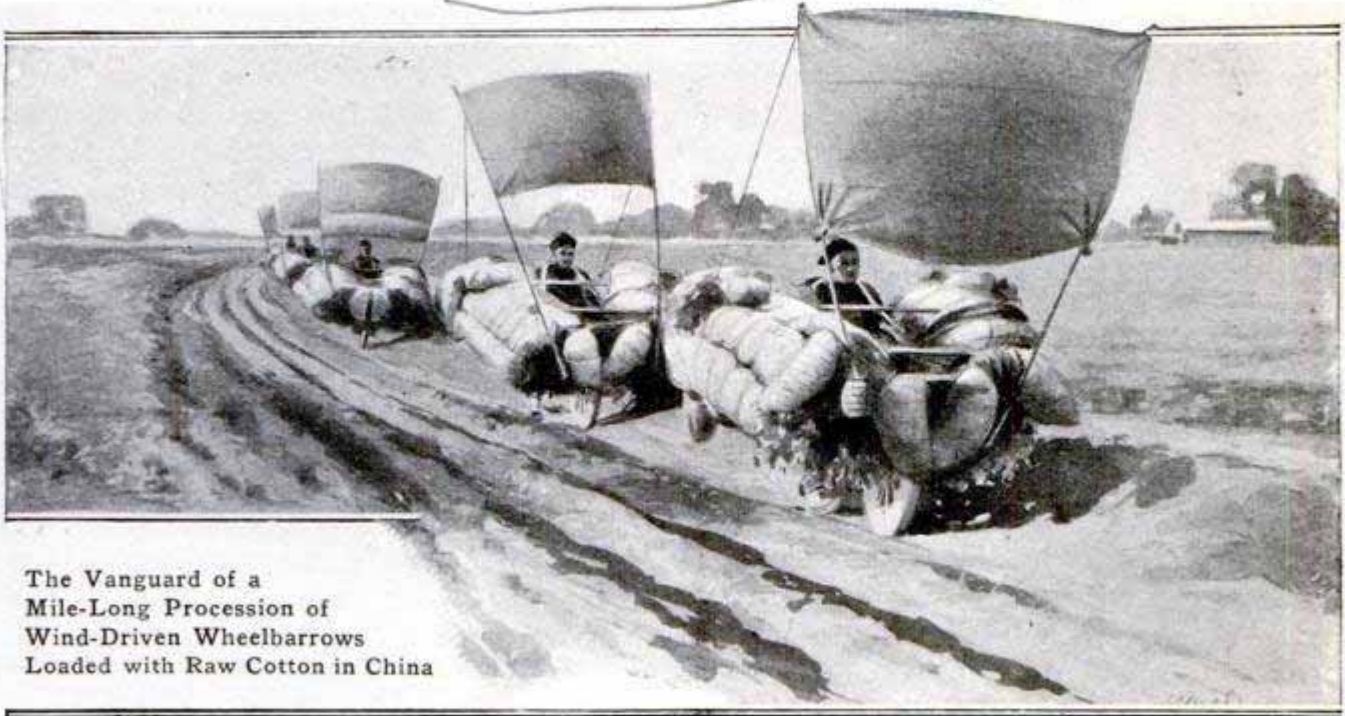

The Vanguard of a  
Mile-Long Procession of  
Wind-Driven Wheelbarrows  
Loaded with Raw Cotton in China

The sailing wheelbarrows of China are a sight to delight the eyes of an old salt stranded inland, particularly in the Shensi district, where mile-long processions of these queer vehicles may be met with. Wheelbarrow transportation would be almost impossible in this district, due to the blown sand, were it not for the ingeniously devised sails. Night and day, for months at a stretch without ceasing, the wind blows steadily from west to east at an average velocity of more than 15 miles an hour. Luckily, this chances to be the direction of the country's produce transportation, so that the heaviest laden of the barrow craft are able to "make port" with a fair wind. A wind "dead astern," however, is by no means absolutely necessary, for, by ingeniously contrived supports on the sides of the barrows, the sails may be set to take advantage of almost every slant of breeze.

With a 20-mile wind astern and a not too "choppy sea" in the road, a Shensi coolie will trot along behind his load of 1,000 or 1,500 lb., at a speed of six or seven miles an hour with scarcely more exertion than a sailor in spinning the steering wheel of a schooner running before a fresh sou'easter. A barrow sailor has to watch his can-

vas just as closely as does a sailor of the seas, and a gusty wind forces one to reef just as quickly as it does the other.

### SPEEDERS RESTRAINED BY POLITE REQUEST

On each of the roads leading into Glendora, Cal., is a sign advising motorists of the speed limits effective within the town, to which is added the statement, "A Reasonable Compliance Will Be Appreciated." This gentle hint is proving more effective in deterring "speed bugs" than the threats of penalties such as are posted on the streets of most cities. For motorists who do not respect this polite request, however, there are the usual laws, with fines and a jail in the background.

ATTENTION MOTORISTS  
GLENDDORA SPEED LIMIT  
20-15 MILES PER HOUR  
A REASONABLE COMPLIANCE  
WILL BE APPRECIATED.  
GLENDDORA BOARD OF TRUSTEES  
AND AUTO CLUB OF SACR.





**GATE VALVE BIG ENOUGH FOR GARAGE DOOR**

A gate valve for a water pipe through which an automobile could be easily driven, was recently completed in Germany. The opening in this valve is 7½ ft. wide, 10½ ft. high, and has an area of about 80 sq. ft. This enormous valve is designed both for hydraulic and hand operation. With the hydraulic devices it opens in 7 minutes, while with the hand mechanism about 100 minutes are required. The material used throughout is annealed cast steel of high tensile strength.



Courtesy Engineering Record

**FALL OF ROCK IN NEW YORK SUBWAY**

A fall of rock, estimated at from 300 to 400 tons, occurred in the Lexington Avenue subway in New York City now under construction, killing nine laborers and a foreman. The fall took place about 20 minutes after a trimming shot had been fired. Examination of the rock surface after the accident revealed two thin water seams from ¼ to ½ in. thick running lengthwise of the tunnel and sloping upward from each side to an intersection about 8 ft. above the neat section of the tunnel, and it was along this cleavage line that the break occurred. The shape of the tunnel roof after the accident was, roughly, that of a gable.

**CLEANING AND PAINTING THE CAPITOL DOME**

Cleaning the deposit of green from the statue of Freedom that surmounts the dome of the capitol at Washington is a difficult job that is done once every three years. A large scaffold is erected for this purpose, and, since there is no elevator, the material is all carried up by hand. In connection with this year's cleaning the entire dome of the capitol is being painted, a job that requires about a hundred men and ten weeks of time. The dome has about 132,000,000 sq. ft. of surface, and it is estimated that 65 tons of paint, or 240,000 gal., will be required for covering the space.

**AN AERONAUTICAL MAP OF THE WORLD**

The preparation of an aeronautical map of the world was proposed at the recent International Geographic Conference in Rome, and famous geographers from many countries are to meet this fall to undertake the work. The chart will include the entire world and will be drawn to a scale of 1 to 200,000. The conventional signs, and rules to be followed, will be determined at the meeting.

**FUNERAL OF BINGHAMTON FIRE VICTIMS**

A great public funeral was held in Binghamton, N. Y., on Sunday, July 27, for the 21 unidentified victims of the overall-factory fire on July 21, in which 65 persons were killed. It was a trolley-car funeral because there were not enough hearses and carriages in the city to carry all the bodies and the mourners to the cemetery. The coffins were carried on flat cars coupled behind trolley cars, covered with crepe and flowers. The fire victims were buried in a circle of graves in Spring Forest Cemetery at the city's expense, and a large monument will be erected to mark their graves.

*474 2/3*  
*492 2/3*  
*480 1/2*  
*my machine + Amature -*  
*fabre vobis + Brewer + Co*  
*Franklin - am - main - Germany*  
*7/13*  
*7/13*  
*7/13*

*7/13*  
*7/13*  
*7/13*





The Funeral of the Unidentified Victims of the Binghamton Factory Fire Held on July 27; Funeral Cars Bearing Coffins and Mourners to Spring Forest Cemetery Where the Burial Took Place at Public Expense

PHOTOS BY  
UNDERWOOD & UNDERWOOD

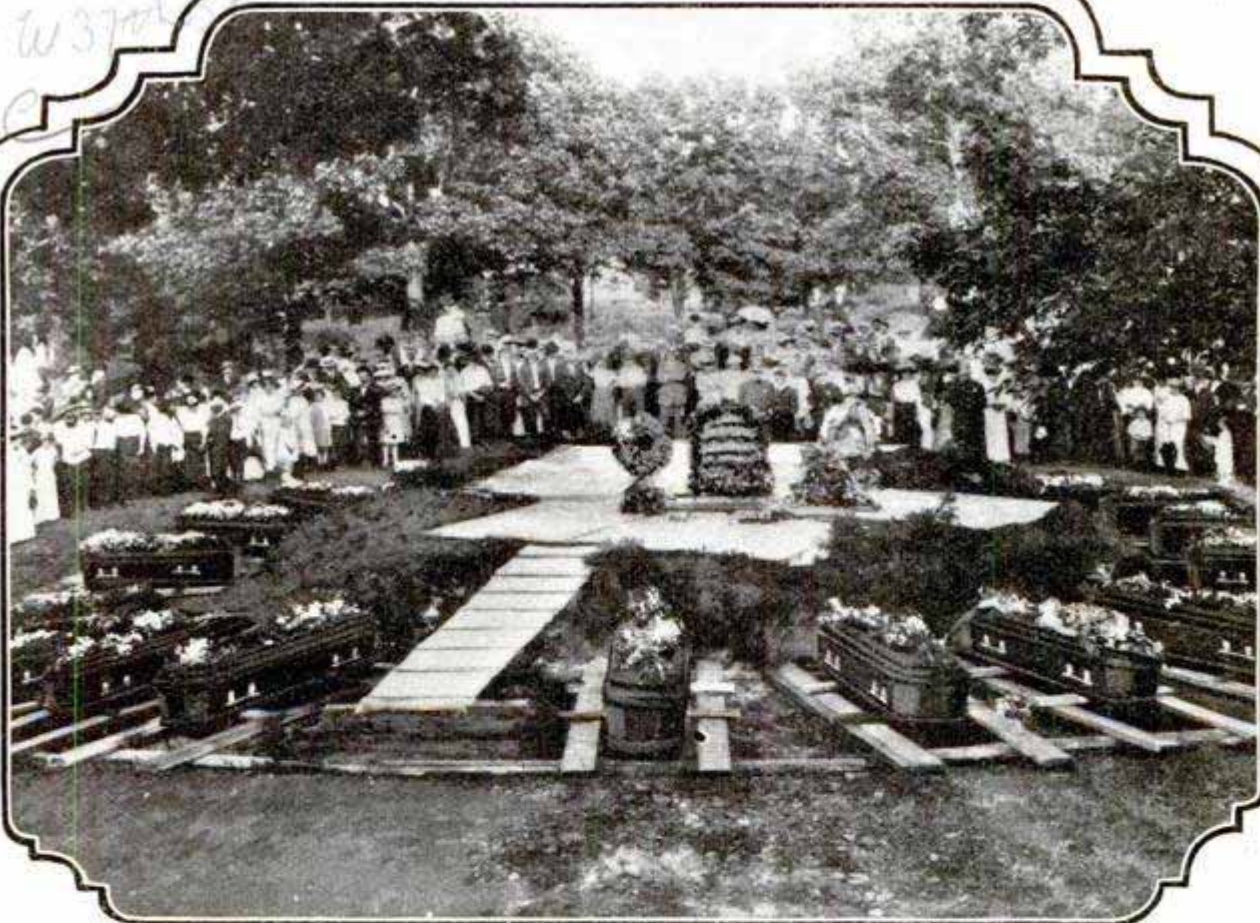

The Coffins of 21 Unidentified Victims: A Monument will be Erected in the Center of the Circle of Graves



## A BARN OVERTURNED BY THE WIND

A barn which was overturned by the wind is shown in the accompanying photograph. It was upset during

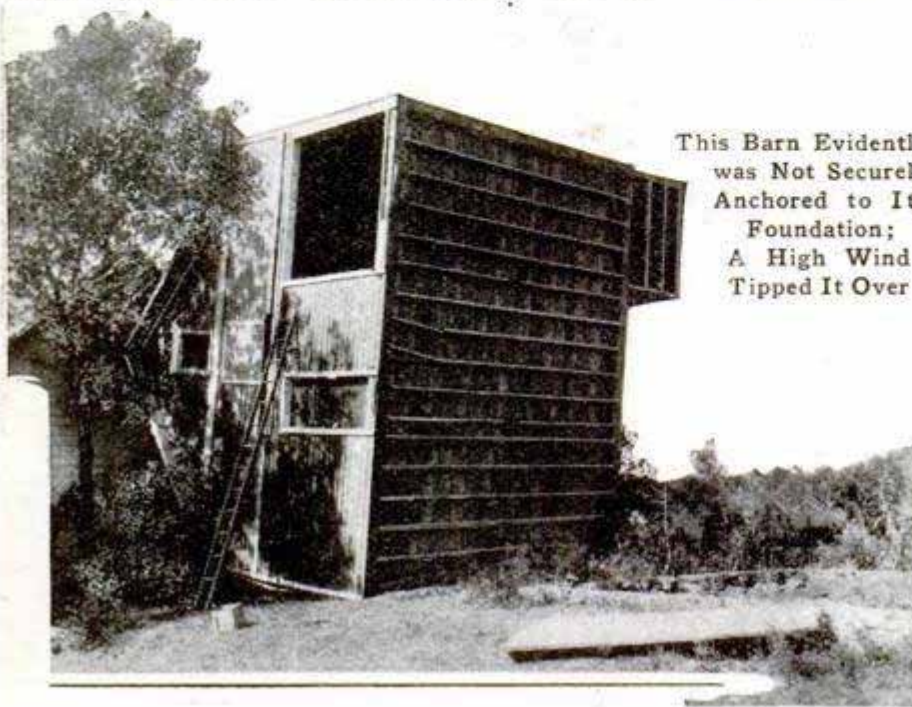

This Barn Evidently was Not Securely Anchored to Its Foundation; A High Wind Tipped It Over

a storm on July 15, at Rockford, Ill., and was left standing on end 20 ft. from its foundation. The building was not greatly damaged, but its interior was rather inaccessible. This is an example of the force exerted by a high wind on the middle western prairies, for this storm was not a tornado.

## LICENSE CARD FOR JAPANESE MOTORISTS

A curious license card is issued to motorists by the Japanese government. It is of diamond shape and carries inscriptions in Japanese symbols, as

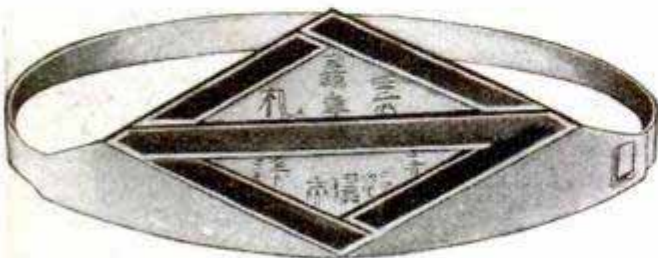

shown in the illustration. It is designed to be fastened around the steering column.

## FIGURES SHOW POPULARITY OF MOTORBOAT

Some idea of the popularity of the motorboat is given by the latest statistics, which show that there are now 256,350 motorboats, representing an investment of over \$250,000,000, in the United States. The distribution of this kind of water craft is interesting as an indication of the maritime tastes of the inhabitants of the different sections of the country. Practically half of all the motorboats, or 155,800, are to be found in the Atlantic states, where there are four to each 1,000 of population. In the Pacific states there are 50,300 motorboats, or

12 to each 1,000 of population. This big difference in the number per capita between the Atlantic and Pacific states is probably due to the more favorable conditions for pleasure boating along the Pacific coast. By far the biggest section of the country, the middle western states, has only 50,600 motorboats, practically the same as the Pacific states, and an average of only 1 to each 1,000 of population. In the western states where there are more mountains and deserts than water courses of any kind, the number of motorboats is only 250, or 1 to each 10,000 of population.

A peculiar use for a motor fire engine was found recently in Kearney, N. J. A policeman arrested a man who had stolen a set of carpenter's tools. The thief broke away and soon outfooted the policeman, who ran into the fire-engine house and requested the use of the motor engine in giving chase. The fire engine raced the thief to a near-by swamp, and then the policeman and crew followed him on foot.







**STATUES OF COLOSSAL SIZE TO COMMEMORATE**

5226



Colossal Bronze Statue of the Great Frithjof, Norway's Legendary Hero, Which Commands the Sogne Fjord. It is 40 Ft. High and was Given by Emperor William of Germany



LEGENDARY HERO AND ABORIGINAL WARRIOR



The Gloomy Figure of America's Indian Chieftain, Black Hawk, Standing Guard Over His Tribe's Lost Hunting Grounds, near Oregon, Ill. It is by Lorado Taft and is 40 Ft. High

© M.L. PHOTO. CO. 84  
1912



## MACHINE THAT WASHES AND STERILIZES DISHES

A simple type of dish-washing machine has been invented and placed on the market. This machine consists of

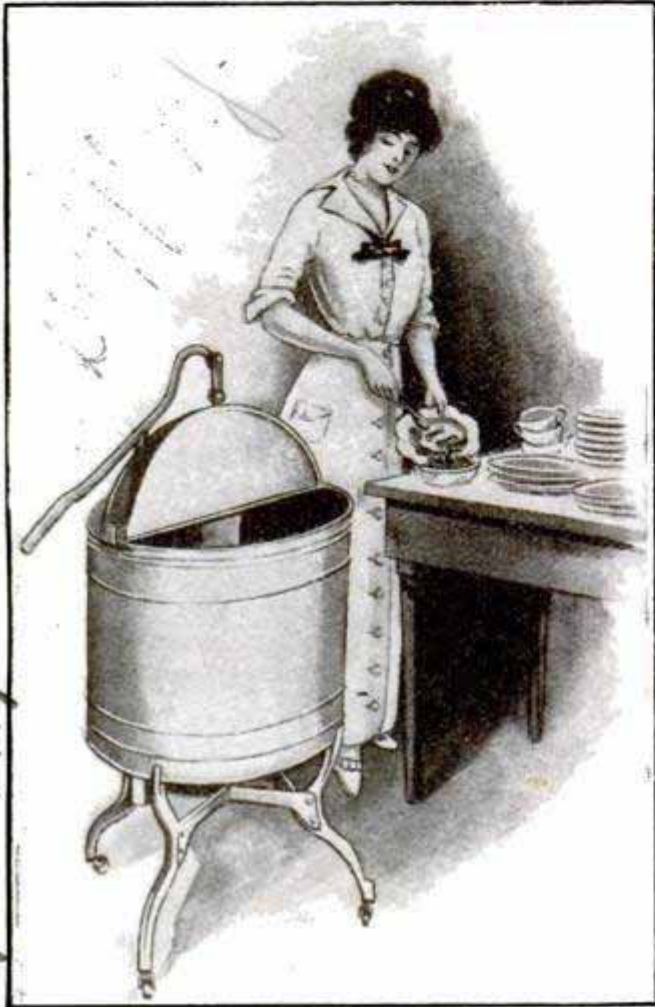

Dish-Washing Machine That Does Away with a Large Part of Kitchen Drudgery

a cylindrical metal tank finished in aluminum and mounted on four stout legs with casters to permit easy rolling about the kitchen or from kitchen to china closet. A pump placed in the center of the tank, and operated by the lever at the top of the machine, works in such a way as to throw the hot water in a strong stream against and among the dishes. China is placed at the bottom of the tank, all pieces being turned toward the center and arranged to drain easily, while glass and silverware are placed in a wire basket near the top of the tank. After all pieces are in place, boiling water is poured into the tank and sprinkled with soap powder, the lid is closed, and the pump handle is worked for one or two minutes. The

suds are then drawn off through a faucet at the bottom, scalding rinse water is poured into the tank and the pumping operation is repeated. The dishes are sterilized by the hot water and are so hot when they come from the machine that they dry quickly.

## PARCEL POST NOW HANDLES TWENTY-POUND PACKAGES

An increase in the maximum-weight limit and a reduction of rates are among the improvements in the parcel-post system which went into effect on August 15. The maximum weight of packages handled has been raised from 11 to 20 lb., and a simple rate chart has been substituted for the elaborate zone maps. The first zone now comprises the territory included within the local delivery, by city carrier or rural routes, of any office at which the parcel is posted, and the second zone includes all points outside the first and within a radius of 150 miles from the office. Rates in these zones have been greatly reduced. Ordinary stamps are now good for parcels and the insurance fee has been reduced from 10 to 5 cents on values of less than \$25. Greater simplicity is the keynote of the recent changes.

## NEW CENTRIFUGAL GUN HAS AUTOMATIC FEED

The greatest difficulty in connection with the operation of a centrifugal gun, that of feeding the missiles into the barrel of the revolving disk, has apparently been overcome by an invention recently patented in England. The barrel is arranged radially in a balanced rotating disk and receives the missiles through the axle of the disk, at intervals controlled by an intermittent feed motion. The missiles are placed in a hopper and feed by gravity through a channel in the axle to a slide plate which has an opening large enough to receive one missile. A spring presses this slide against a stationary plate which carries a cam, so that, as the disk revolves, the slide



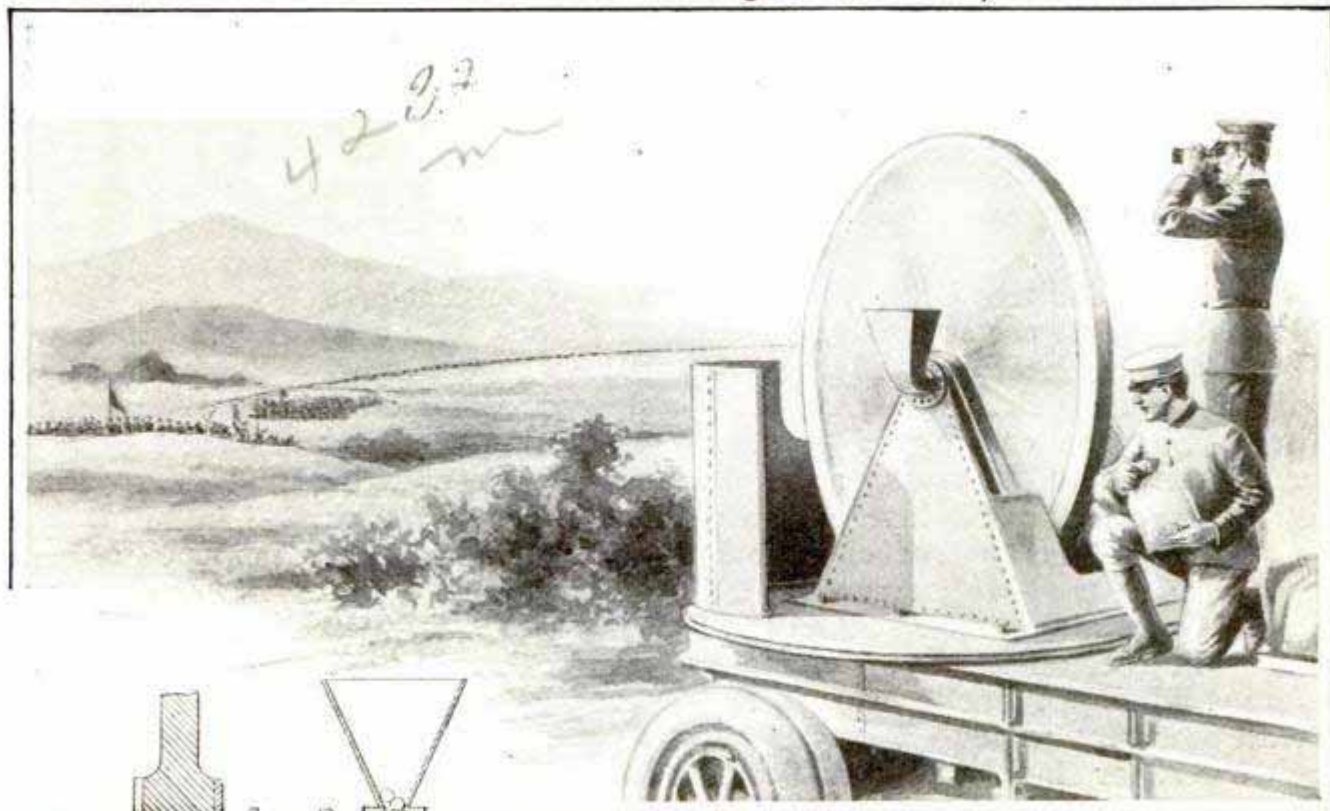

429.2

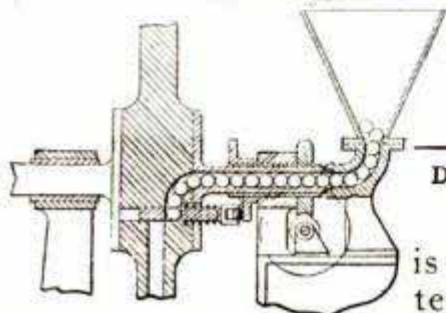

Diagram Showing How Missiles are Fed into Barrel

Missiles Discharged Silently by Centrifugal Gun

is thrust alternately in and out, receiving a missile in one position and discharging it into the barrel of the disk when it reaches the other position. The missile is thrown out through the barrel by the centrifugal action of the disk, and with the disk revolving at a constant speed the missiles will be discharged uniformly in one direction. The entire mechanism can be rotated in a horizontal plane.

way down the row without leaving his seat. Experiments have shown that the cart enables a picker to gather a third more berries in a day. It was

### PICKING STRAWBERRIES FROM A SEAT

Strawberry picking is made easy by a cart that has been designed to furnish a movable seat for the picker. It enables him to sit comfortably astride a row of strawberry plants, instead of standing at one side and bending over. The cart has two large wheels traveling in the furrows beside the row, and is steadied by a pair of short poles which end in round balls to keep them from sticking in the ground. The axle is dropped low enough to carry a seat just above the plants. The picker, sitting in the cart, pushes himself backward with his feet as he picks his



A Movable Seat Which Makes Strawberry Picking Less Laborious

designed by the president of the Second District Agricultural School, at Russellville, Ark., and has not been patented.

H. L. Mobley

McAdams



## THE ART OF CARVING SHELL CAMEOS

The carving of shell cameos is a comparatively modern art, although the fact that it has been gradually dying out during the last century would seem to indicate that it was very old. Not until the sixteenth century was it discovered that the superficial white layer and the delicate underlying colored film of a sea shell made excellent material for the carving of cameos. The Greeks and Romans, although they made cameos out of layered agate, knew nothing about shell carving, probably because the Mediterranean did not supply suitable shells. When shell carving first came into vogue, many different kinds of shells were tried, but all were found faulty, because of size, color, or lack of permanence, except one variety of the helmet shell. Of this variety, only one out of many shells is fit to use because the making of a cameo demands a strong, evenly colored under layer, a solid outer layer, and sufficient usable surface. The process of carving the shell requires great skill and delicacy. If the shell is to be carved as a whole, the artist takes advantage of the fact that the coloring of the inner layer is richest next the mouth of the shell and the

ridges on the last whorl are thick enough to permit deep carving. For commercial purposes, the shell is usually cut into pieces with a tin wheel, running water, and emery powder. The piece that is to be carved has to be shaped with a small grindstone and the surface has to be smoothed and cleared of imperfections. A piece of paper cemented to the back keeps the shell from cracking and is used for fastening a working handle to the cameo. After the design has been drawn on the outer surface with a pencil it is cut in the soft white outer layer with steel gravers much like a wood-engraver's tools. The naturally colored inner layer, which becomes the background, requires polishing and developing with pumice and acid, rubbed in with a boxwood stick. The whole process must be carried out with great care, because the shell is very fragile and can easily be broken or corroded by the acid used in polishing. The photographs of some of the cameos on exhibition in the Morgan gem collection at the American Museum of Natural History, New York, indicate the existence of various schools of shell carving.

### CONCRETE HORSE BLOCKS IN WASHINGTON

Concrete horse blocks to enable women riders to mount or dismount

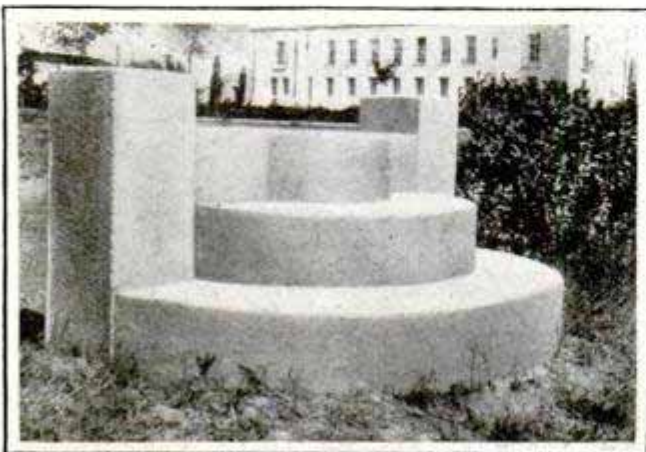

Concrete Horse Blocks Erected beside Washington Saddle Paths for Women Riders

without the assistance of an escort or groom have been erected at the city-side entrances to the saddle paths of Potomac Park, Washington. No assistance is needed by women who ride astride, unless they are very short and their horses are very tall, but some sidesaddles are still used, and the theory is that women riders will have their mounts led from the stable to the soft bridle paths to avoid riding over the hard city pavements. The horse blocks are semicircular in shape and have three steps with square posts at the ends. The one in the picture stands near the Pan-American Building at the end of the drive from Seventeenth Street to the John Paul Jones monument.





Cameo with Brown Background  
Illustrating an Italian Artist's  
Conception of the "Metamorphosis  
of Actaeon"

4884



*Am. Mus. of Nat. Hist.  
M.C.*

A Rare Example of the Art of Carving Cameos  
on the Surfaces of Sea Shells:  
Guido Reni's "Aurora" Carved on a  
Madagascar Helmet Shell



Engraving of an Emblem  
on the Surface of a Pearly  
Nautilus Shell



A Cameo,  
"Phoebus in His Chariot,"  
Remarkable for Its Finish

Photos by American Museum  
of Natural History



### ANCIENT LANTERNS COPIED IN BRONZE LAMPS

Two huge lamps, built in imitation of old-fashioned lanterns with 36 small panes of frosted glass, shed their soft

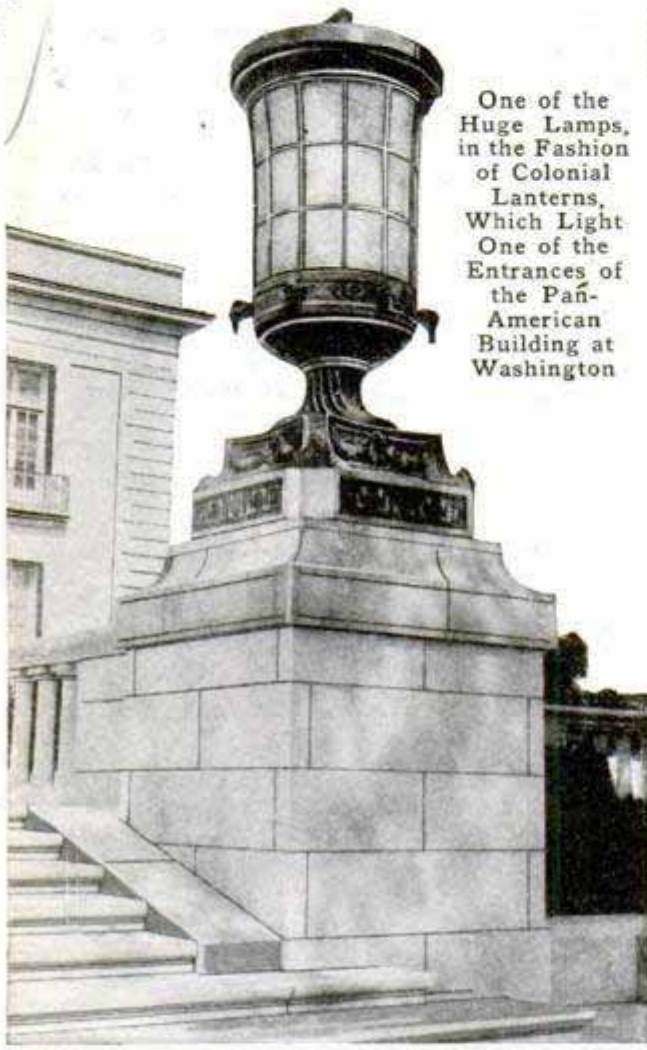

One of the Huge Lamps, in the Fashion of Colonial Lanterns, Which Light One of the Entrances of the Pan-American Building at Washington

glow over the broad, low marble steps at the east entrance of the Pan-American Building, at Washington. Each lantern, done in gray-green bronze, is taller than a man and stands on a square pedestal high over the heads of passers-by. The four corners of each lamp's base end in lion's paws with extended claws, and six tiger heads stand out from the panel below the glass. The circular lantern globes have three rows of small panes in imitation of old colonial windows, and about the same size. The tops are like the covers of huge tureens. The lanterns are beautiful in themselves, but blend with the other artistic features of the white marble building so that they are hardly noticeable except as a part of the whole design.

### MACHINE FOR ADMINISTERING ANESTHETICS

A machine to replace the manual method of administering anesthetics during an operation, has been brought out in France. By means of a pump, an evaporation chamber, and an automatic device used for introducing a measured quantity of chloroform, for instance, the apparatus maintains a continuous flow of a definite, standardized mixture of anesthetic and air. A valveless mask enables the patient to breathe in a current of air containing a known amount of chloroform, and the danger and annoyance attending a too rapid or too slow administration of the anesthetic are eliminated. A tube passed into the nose or mouth can be used instead of the mask after anesthesia has been produced, for operations upon the face. The advantage of the machine lies in the fact that the surgeon knows exactly how much anesthetic he is giving, and the continuous flow eliminates much of the discomfort attending the taking of an anesthetic.

### ANCIENT FISHING BOATS OF SOUTH WALES

A group of the strange fishing boats, called coracles, which have been used for generations and are still used on the coast of south Wales, is shown in the accompanying picture. The villagers,



Villagers of South Wales Carrying Their Ancient Fishing Boats Called Coracles

carrying their craft just as their ancestors must have carried theirs, are on the way to a coracle race in the Swansea regatta.



## SLOT MACHINE SUPPLIES GASOLINE

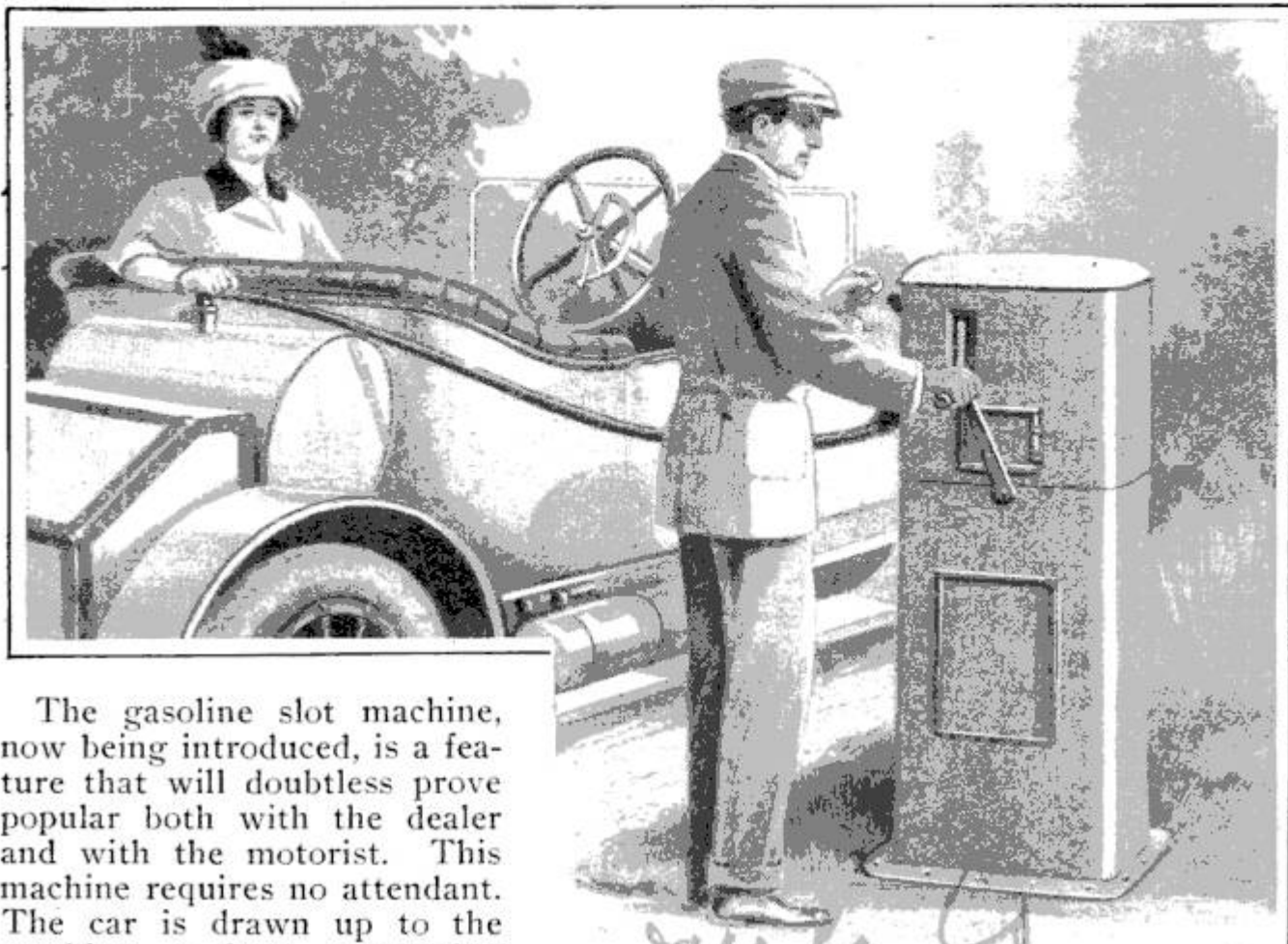

The gasoline slot machine, now being introduced, is a feature that will doubtless prove popular both with the dealer and with the motorist. This machine requires no attendant. The car is drawn up to the machine, a hose connecting with the car tank is inserted, a half-dollar is dropped into the slot, and the crank is turned. This sets a pump in action which delivers the gasoline into the tank of the car. A graduated gauge at the front of the machine shows the buyer just how

Gasoline Slot Machine Designed for Convenience of Motorists

much gasoline he is getting, while, if the supply happens to be exhausted, the money is automatically returned. The mechanism is adjustable to deliver the fluid at current prices.

## LEIPZIG RAILWAY STATION LARGEST IN EUROPE

The largest railway station in Europe, estimated to cost \$35,000,000, is now under construction at Leipzig, in the kingdom of Saxony, Germany. This station is designed to serve as a terminal for all the railways entering Leipzig, which, in addition to being a famous university city, is one of the most important railway and industrial centers in the German empire. The location of this city is near the boundary between Saxony and Prussia, and the cost of the structure is to be borne in varying proportions by the Saxon

State Railways, the Prussian State Railways, and the city of Leipzig. The station is divided into two equal portions, one half being the property of the Saxon administration and the other half the property of the Prussian administration. There are to be 26 platforms, and, under normal conditions, there will be no crossings on the level between the different lines. Half of the station is already completed. The completion of the remainder of the station in two years, as planned, will mark an enormous advance in the construc-





Completed Half of the Railway Station at Leipzig, Germany, Which is to be the Largest Railway Station in Europe

tion of large passenger terminals, and will place Europe on a par with America in the matter of railway-station design.

### LARGE INGOTS HANDLED BY ELECTRIC BLOCK

An electric rotating block is being introduced in the larger forge shops for handling, and particularly for rotating, heavy ingots and forgings at the presses. This block is mounted on a traveling crane and is operated from the cage by the regular operator. It is of steel-plate construction and consists of a  $7\frac{1}{2}$ -hp. motor connected through a reduction gearing to a sprocket wheel and chain. An asbestos-covered steel sheet, with an intervening air space between it and the motor, serves to protect the motor from the intense heat radiated by the ingot below. The entire block is suspended on a 3-in. eyebolt, which is carried on roller bearings, so that it can be turned at any angle easily. The lower section is connected to the upper by four double compression springs which take up the jar and relieve the strain on the crane hook.

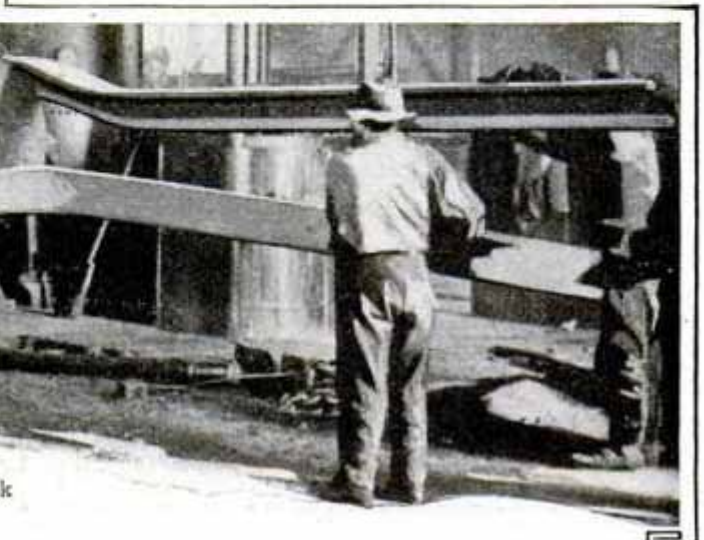
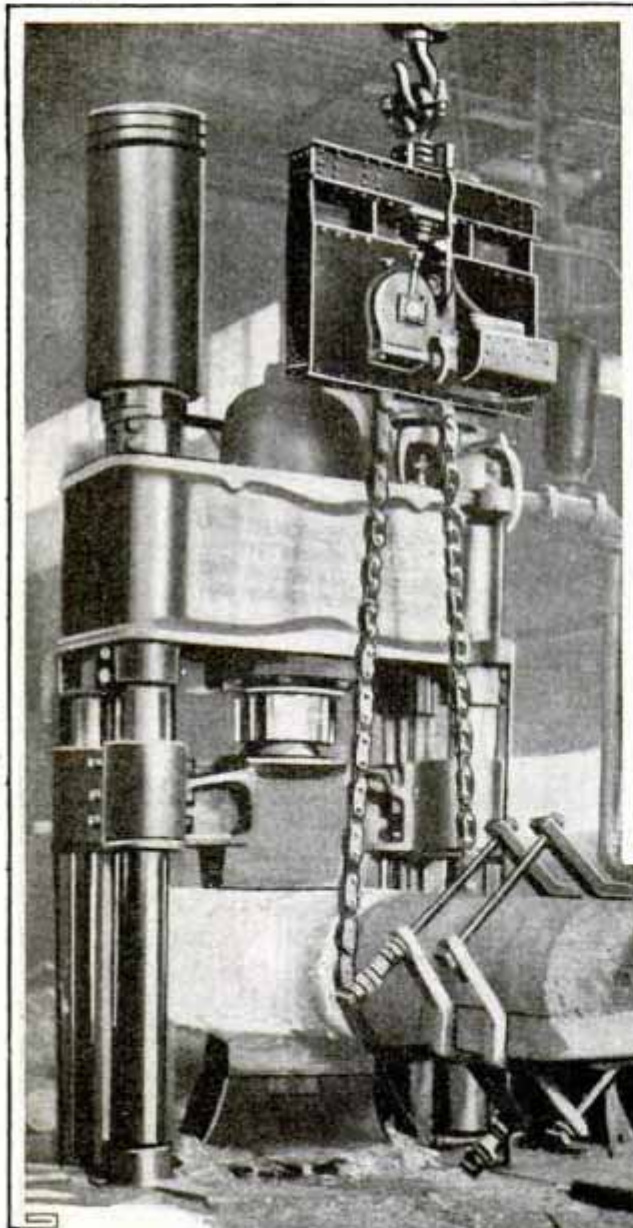

Ingot Weighing 55,000 Lb. Supported and Turned at Hydraulic Press by Electric Block



# THE COLLINWOOD SCHOOL MEMORIAL

A beautiful garden has been laid out on the site of the Collinwood School, in Cleveland, O., in memory of the 173 children who lost their lives in the fire which destroyed it on March 4, 1908. The garden was planned by the school-mates of the dead children, and its care is left to them. Some of the winding paths and blossoming flower beds and the white colonnade which follows the lines of the walls of the old building are shown in a photograph on this page. A quiet pool, fringed with reeds and covered with water lilies, marks the spot where 162 little bodies were found piled against the west doors of the burned school-house. A garden was considered a more fitting memorial than a bronze statue or marble shaft.

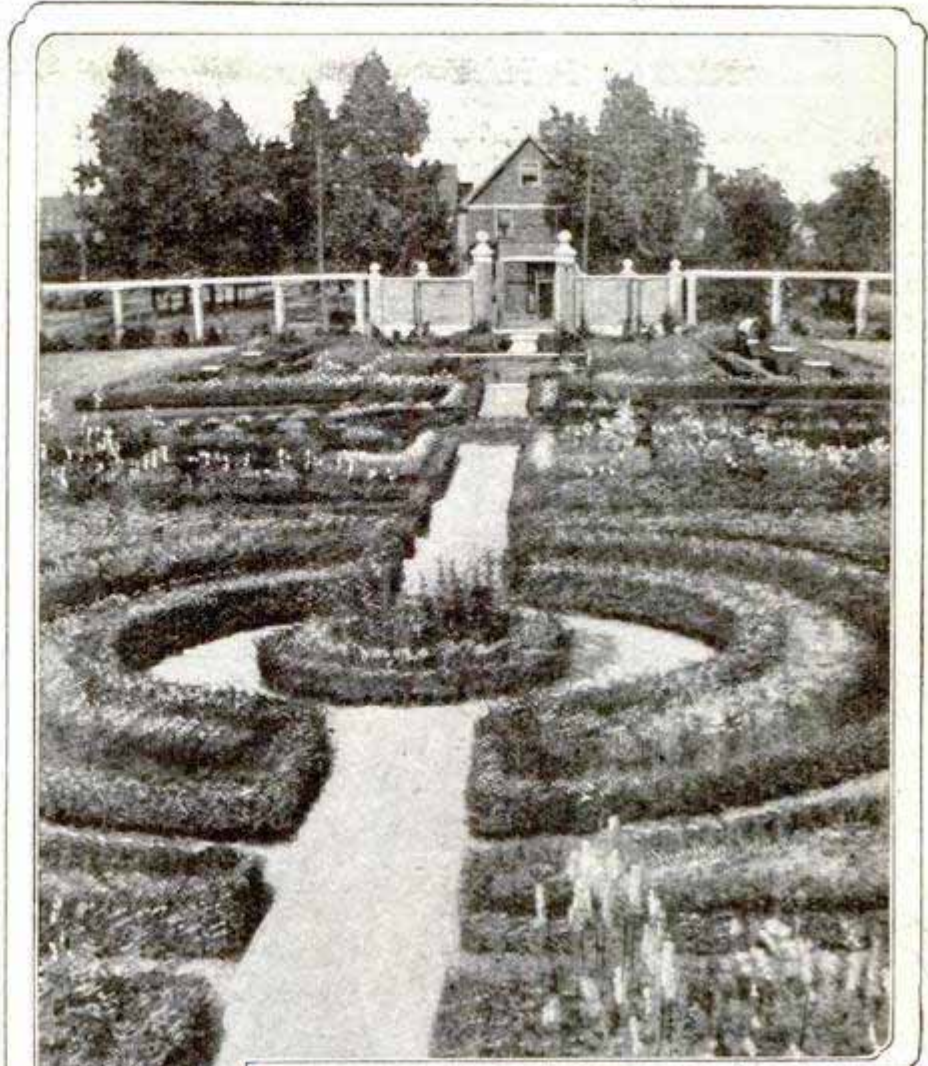

Memorial Garden Which has been Laid Out on the Site of Collinwood School, Where 173 Children Lost Their Lives on March 4, 1908

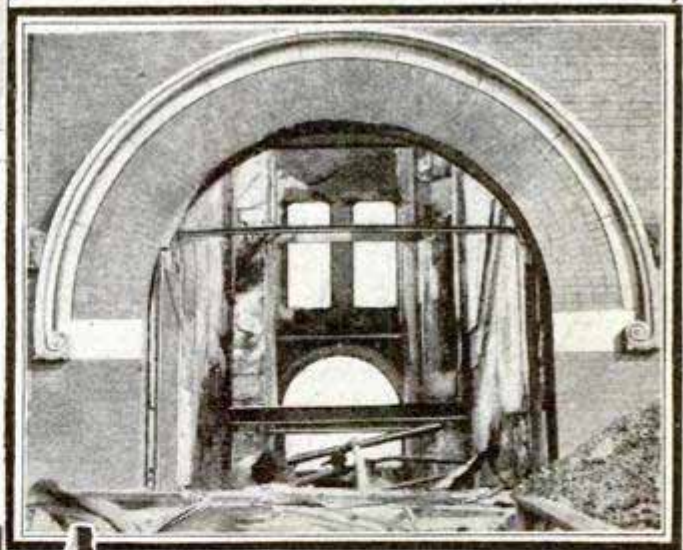

Where 162 Children were Burned to Death, Now the Site of a Lily Pond

Exactly 3,418,020 timber sticks, mainly cedar, were purchased

Ruins of the Collinwood School Which have been Replaced by a Beautiful Garden

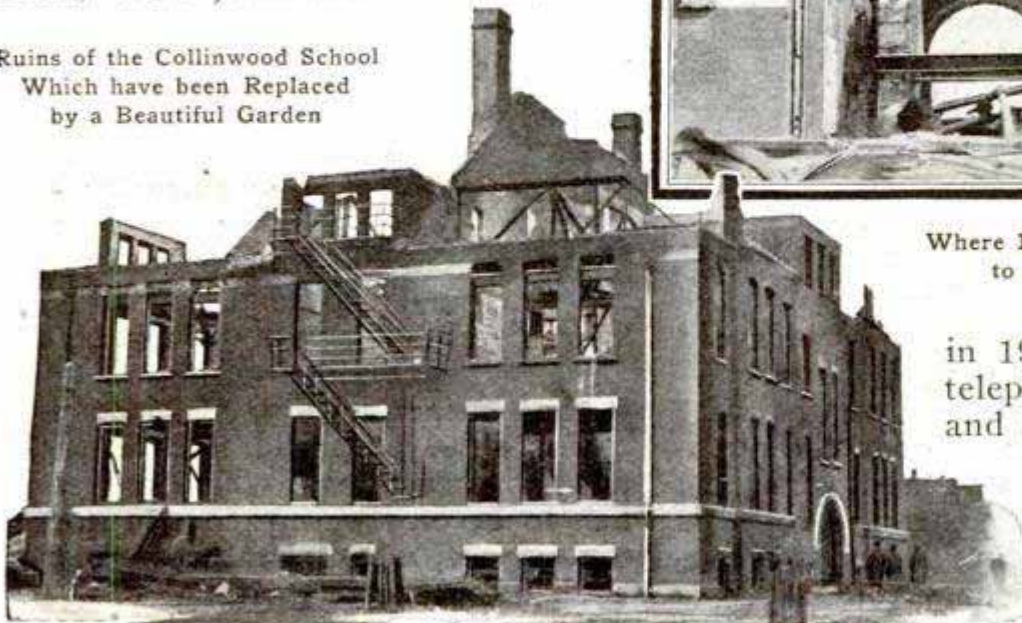

in 1911 to be used as telephone, telegraph, and other electric-purpose poles. This was 452,674 less than the number purchased in 1910.



### SAMPLE STALK OF 93-INCH RED-TOP HAY

4811  
A stalk of red-top hay, 7 ft. 9 in. tall, which was grown on low, swampy ground on a farm near Fennimore, N. Y., is shown in this photograph. From 20 acres of this hay, sowed one, two, and three years ago, 31 tons were cut last year, 20 tons this year, and about one-third of the crop is still standing. The seed came from Wisconsin and grows best in wet soil.

### LIMITING THE SPEED OF GASOLINE SECTION CARS

A gasoline railroad-section car that is automatically limited to a speed of 20 miles per hour has been brought out with the idea of eliminating the danger of speeding, which is one of the greatest objections to power-driven cars for this class of service. The car is controlled by a governor-timer which cuts out the ignition when the speed of the car goes above the limit for which the governor is set. This is accomplished by means of two weight arms revolving on the governor shaft, one of which carries a roller that makes contact, at normal speeds, with stationary rollers, causing sparks successively in the corresponding cylinders. The two weight arms are held together by a tension spring, but are forced apart by centrifugal action when the speed exceeds 20 miles per hour. The traveling roller is carried on an arm that projects from the weight to the opposite side of the shaft, and when the weights are forced apart the roller is drawn in about  $\frac{3}{8}$  in., and misses contact with the stationary rollers. This

causes the engine to miss explosions until the speed is reduced to the limit. The governor-timer mechanism is inclosed in a case which is kept locked by means of a wire seal. In an emergency requiring high speed, the seal is broken, the spring is adjusted to a higher tension, and the car can then be speeded up to 35 or 40 miles per hour.

### WIRELESS ANTENNAE WITHIN A CATHEDRAL

5046  
The penetrating power of electrical waves has been demonstrated in a remarkable way by the successful operation of a wireless station installed in the Cathedral of Florence, with its antennæ entirely within the edifice. The antennæ, consisting of three wires, are stretched from the inside of the cupola to a pillar in the interior of the cathedral and the apparatus is grounded on a lightning rod which ends in a well in one of the walls. To reach the apparatus, wireless waves must pass through several thick walls, and it is probable that much of the electrical energy is intercepted and carried to the earth by the many lightning rods on the cupola. In spite of these obstacles, very distinct messages have been received from the Eiffel Tower, from Nordeich, Germany, and from Toulon, France. No attempt has been made to send messages out from the antennæ within the cathedral.



A Stalk of Red-Top Hay,  
7 Ft. 9 In. Tall

⌈The fishermen of Madagascar sprinkle the lakes and streams with a poisonous substance which causes the fish to become paralyzed and float to the surface, when they are fished out by hand and eaten without danger.

Chicago Press and Publishing Co.



## PROFESSIONAL "STUNTS" OF AMATEUR ATHLETES

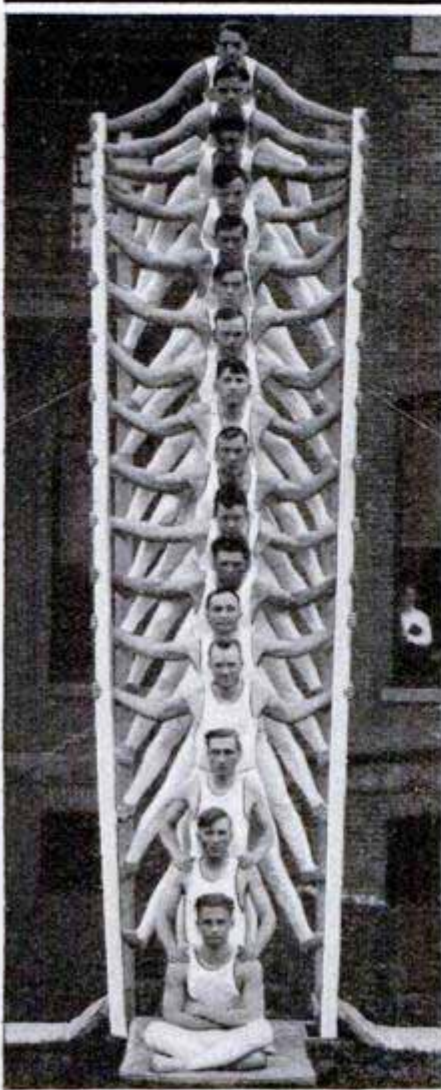

"The Ladder Pyramid"

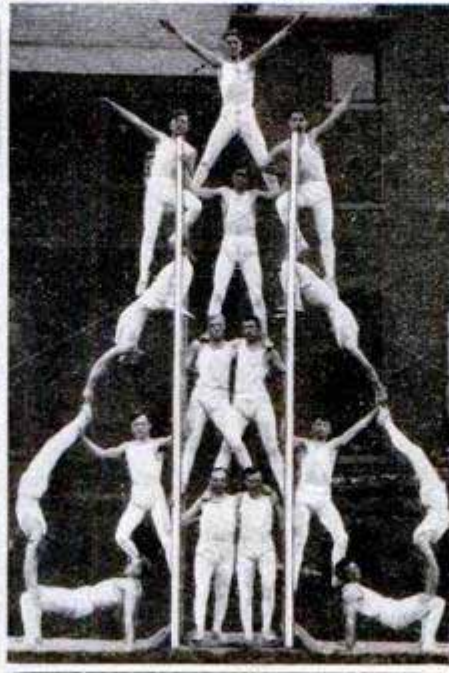

The Novel Pyramid Effects Shown Above and Below are Such as to Require a Grade of Skill and Endurance Seldom Shown by Any but Professional Athletes

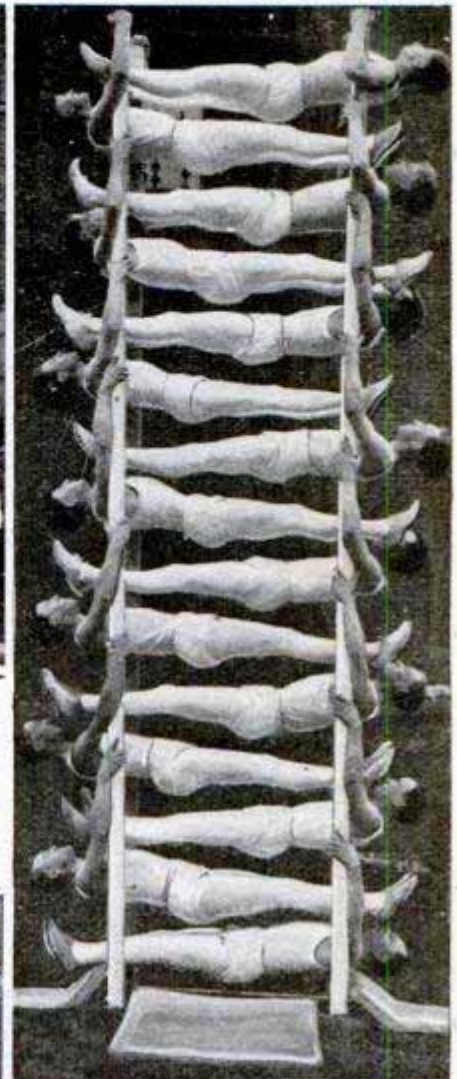

"The City Hall Bunkhouse"

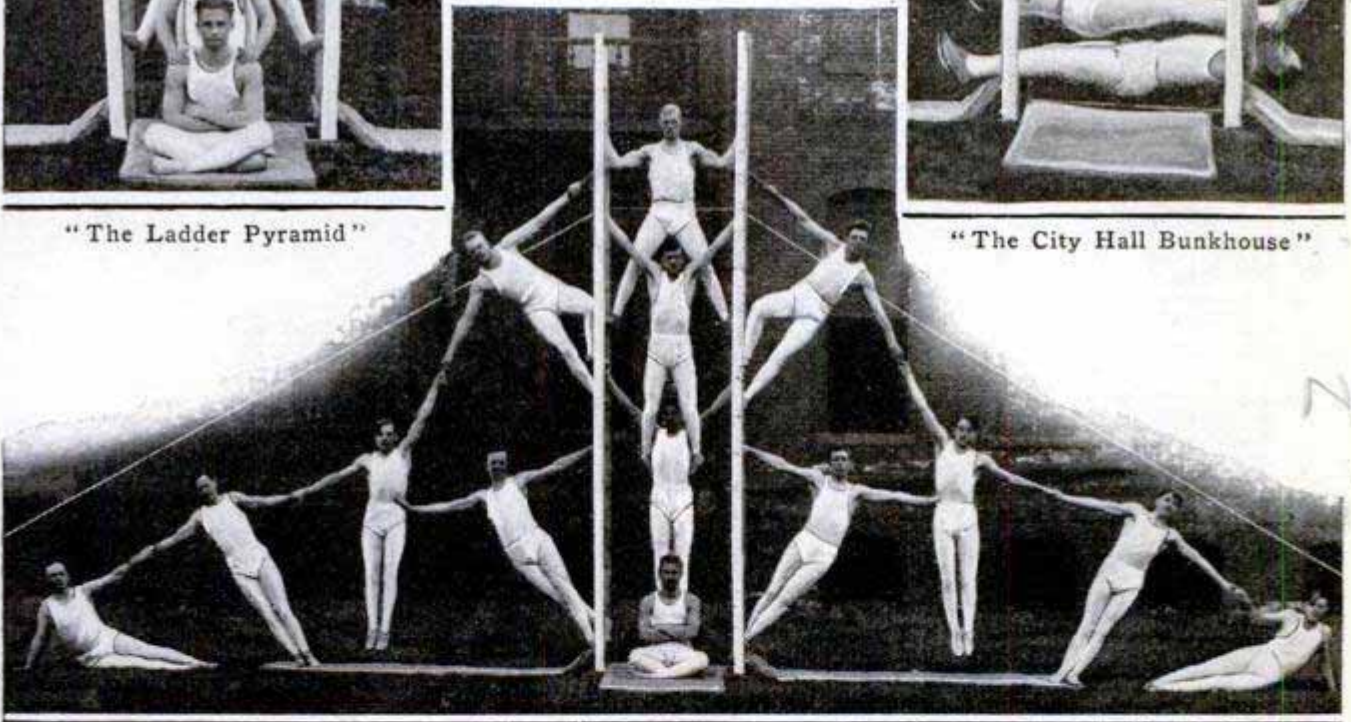

Some of the "stunts" carried out by the athletes of the Bloomington, Ill., Y. M. C. A. compare favorably with the work done by professionals, as will be seen from the accompanying reproductions of photographs taken at the time of the recent annual gymnastic performance. Of the various features,

those known as "The Ladder Pyramid" and "The City Hall Bunkhouse" attracted the greatest attention.

ⒸThe monster bronze eagle figurehead on the liner "Imperator" has four eyes, and a lookout is stationed inside of it to watch for danger ahead.



## FLATIRON LARGER THAN AN AUTOMOBILE

A huge electric flatiron, large enough to conceal completely an automobile inside of it, "ironed" its way down the

There is an Automobile Inside of This Electric Flatiron Which was Built to Take Part in an Industrial Parade

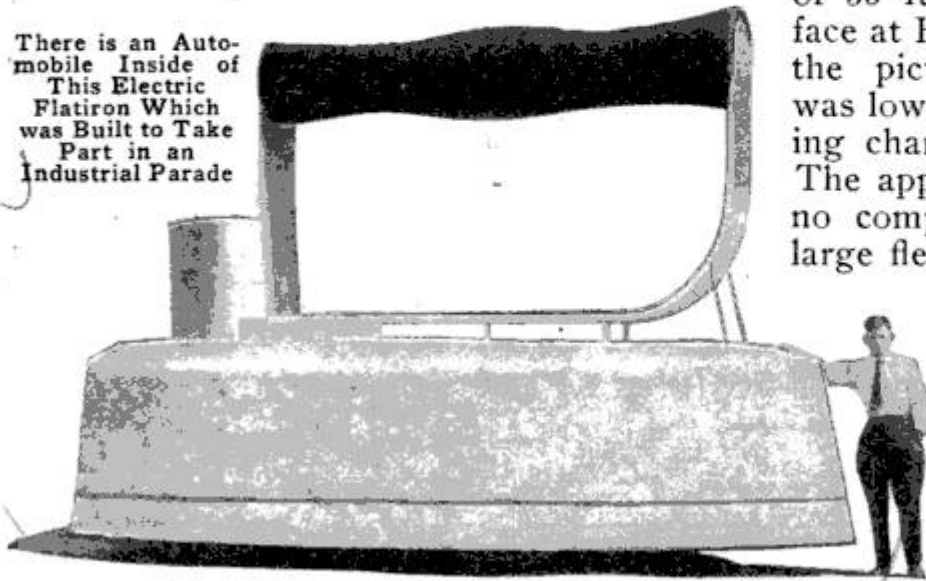

streets of Merrill, Wis., in a recent industrial parade. It was a good reproduction of a standard electric iron, in wood, paper, and cloth, of sufficient size for half a dozen men to stand under its handle. An electric automobile, entirely hidden underneath, furnished the motive power.

## BRICK BUILDING STANDING WITHOUT SIDE WALLS

A building which appears to be resting upon its end walls without any side support, while its side walls are being wrecked and replaced, is shown in a picture on this page. The six-story structure, 125 ft. long and 25 ft. wide, stands on the second lot of the block and the owner wished to build a new six-story building on the corner and connect the two without a dividing wall—all to be done without disturbing the tenants. To make the building strong enough,

## SUBMARINE PICTURE TAKEN

### IN DEEP WATER

Some remarkable submarine photographs of fishes, divers, and other objects, were taken recently at a depth of 35 ft. below the water's surface at Hampton Roads. To take the pictures, the photographer was lowered from a boat in a diving chamber with a glass front. The apparatus was novel in that no compressed air was used; a large flexible tube which extended from the top of the diving chamber to the surface of the water supplied enough fresh air for three men to remain below for hours. Natural light was used for pictures taken in the daytime, but for

night photographs four powerful electric lights with reflectors were lowered into the water from the boat. The lighted chamber attracted all sorts of fish within the range of the camera, and some good snapshots were made of expert swimmers and divers 30 ft. below the surface.

the engineers decided to wreck and replace the two brick side walls. They jacked up each floor on screw posts,  $3\frac{1}{2}$  ft. apart and 6 ft. from the old walls, resting on 6 by 14-in. wooden floor beams and braced with heavy



A Building Resting on Its End Walls and Jack-Screw Supports While Its Side Walls are being Wrecked and Replaced

Edt. J. H. Williams



planks. This left the building without side walls as shown—its elevator and stairways are exposed and a tin-ware factory is operating inside. When the work reached this stage, the city condemned the building as unsafe and a fire trap, and the engineers decided to wreck it completely, floor by floor, and build a modern structure in its place.

**LUGGAGE CARRIER IN PLACE OF AUTO TOP**

An automobile luggage carrier which keeps its load dry and clean and within easy reach of the occupants of the car has appeared in California. It is constructed of steel bows and arms and hangs over the back of the tonneau like a folded top—in fact, it is a false top and top cover, large enough to carry two suitcases, several robes and overcoats, and other articles. This

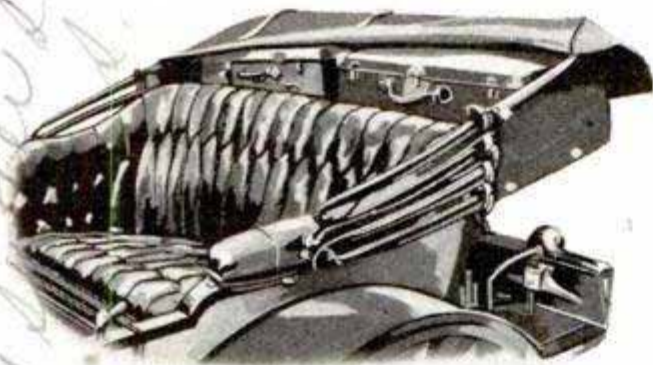

An Automobile Luggage Carrier Which Resembles a Folded Top

luggage carrier is especially useful in the rainless sections of California, where automobile tops are becoming more or less obsolete.

**TALKING CLOCK THAT CALLS THE HOURS**

Speaking clocks are now being made. A German inventor has just patented a talking clock which calls out the hours, half hours and quarter hours in a pleasant, natural tone of voice, instead of announcing them by beating the proper number of strokes on a bell. The power of speech is given to the clock by a phonographic record of spoken words on a film that is wound through the clock's machinery. At each

quarter hour a small phonograph, with horn and sound box within the clock,

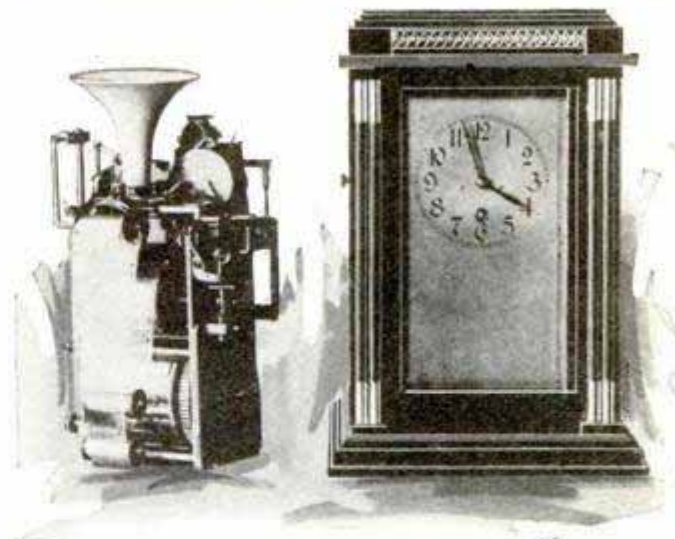

Photo by Paul Thompson

A Talking Clock That Speaks the Time of Day: The Phonograph is Shown Beside the Finished Clock

catches the words recorded on the film and reproduces them aloud.

**EXTREME CASE OF BUCKLED RAILS**

The expansion of rails from the heat, with consequent buckling, is one of the dangers for which railroad trackmen are constantly on the lookout during the hot months of the summer, but it is not often that so extreme a case as that shown in the illustration occurs. In this case the danger was discovered in time to prevent an accident, and the bent rails were quickly replaced by new rails, between the ends of which plenty of space was left for expansion.



Patents have been issued in France on a metal trunk which is constructed by welding thin sheets of steel by means of the oxyacetylene flame.

4752-H

La Marcott

4951-A

→ Markus, a machinist of Berlin.

Paul Thompson  
10 Apr 1910  
La Marcott  
Eg...



## DIAMOND RATTLESNAKE NECKLACE

A diamond rattlesnake, to be worn as a necklace, was recently finished by a Philadelphia jewelry firm after half a

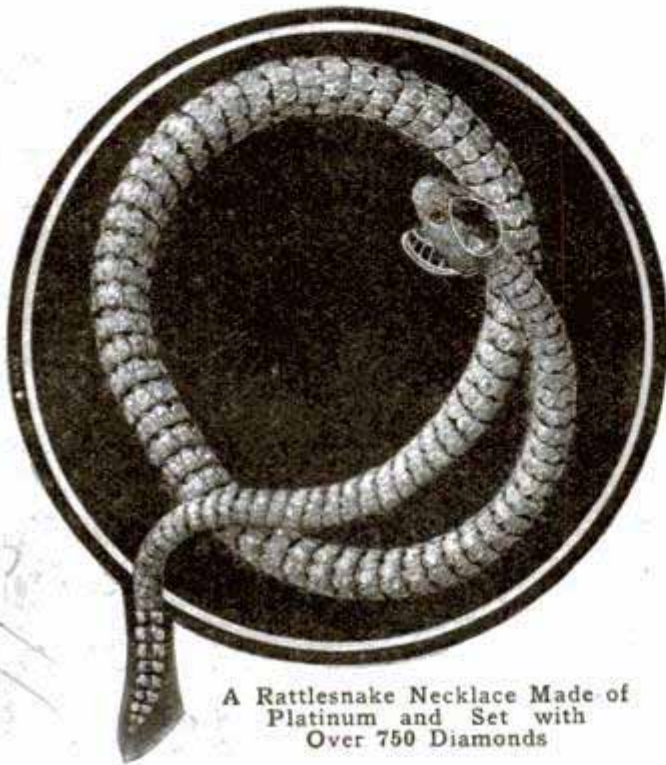

A Rattlesnake Necklace Made of Platinum and Set with Over 750 Diamonds

year's work. It is a perfect model of a North Carolina diamond rattlesnake, 18 in. long, made of a flexible platinum frame, invisibly linked and thickly studded with perfectly cut diamonds. The 629 stones used in the body alone weigh over 30 carats. The head is covered with 112 small diamonds cut in imitation of the scales on a snake's head. Its eyes are deep velvet-green emeralds,  $\frac{1}{4}$  carat each, and the crown of the head is one large canary diamond, weighing  $4\frac{1}{2}$  carats. The gold fangs and tongue control a tiny gold spring which locks the jaws over any part of the snake's body that the mouth touches. Each scale of the body, 629 in all, is carved separately and set with a perfect diamond, the size of the stones varying with the taper of the body. The rattles are also flexible and each one is set with a diamond; the tip ends with a very small stone. The case for the necklace is covered with real rattlesnake skin and has a monogram carved in the form of writhing serpents.

## WATER-POWER DEVELOPMENT IN CALIFORNIA

The greatest water-power development in the history of California is now under way, and most of the plants proposed, or being constructed, will occupy national-forest lands under permit from the Secretary of Agriculture. The first step in this development is the "Big Creek Project," by which about 150,000 hp. will be transmitted for a distance of 240 miles into Los Angeles and vicinity. The power will be transmitted over a double steel-tower line strung with stranded aluminum cables, and at a pressure of 150,000 volts, which is more than the highest voltage so far used in commercial transmission in the United States. Another big project is that on the north fork of the Feather River, where a reservoir of 43 square miles is to be constructed and a power plant of about 350,000-hp. capacity is to be built. Plans are also being made for the development of four plants on the Kern River, while on the South Yuba River one of the highest masonry dams in the world is to be built.

## ALUMINUM-SOLED SHOES FOR LABORERS

Shoes with aluminum soles are now made for farmers and laborers who are required to work in water or on damp floors. The top of the shoe is of leather and the sole is a continuous piece of aluminum which covers the entire bottom and folds up along the sides. Between the foot and the metal is a heavy felt insole, and the heel has a core of wood to decrease its weight. Lack of flexibility in the sole is made up for by a bar under the ball of the foot which gives a buoyant roll to the step and prevents flat-footed walking. Aluminum is used in preference to any other metal because it combines lightness with great durability,





the soles wearing longer than rubber and being more impervious to water. The shoes are made in three heights and are comparatively inexpensive.

### FLYING BICYCLES STILL UNSUCCESSFUL

The possibility of flying without a motor was given another try-out at a recent competition in Paris and every attempt ended practically in failure.



A Wrecking Crew Raising a Locomotive Which Left the Rails and Rolled Down an Embankment on Its First Trip

Fifty bicycles, equipped with wing planes and propelled by muscular effort alone, entered for the \$2,000 prize for a minimum 10-yd. flight, and the competition lasted for three days. All kinds of machines took part, but they were divided mainly into two classes: those depending upon small flat kites to raise them after they had reached a high rate of speed, and those equipped with wings, rudders, and elevators, like monoplanes or biplanes. One cyclist after several attempts succeeded in keeping his rear wheel off the ground for a distance of three yards. Tire marks on a whitewashed cement track indicated clearly the start and finish of the flight.

### LOCOMOTIVE DERAILED ON ITS FIRST TRIP

The raising of a locomotive that left the track and rolled down an embankment on its first trip is shown in the accompanying photograph. The engine, which was a new one on its way from the builders to the Southern Pacific Railway, went into the ditch on the line of the Southern Railway, eight miles from Birmingham, Ala. The wrecking crane has a tackle attached to the locomotive's frame and the derailed tender can be seen hanging over the bank near the water tower. One man had an arm and a leg broken in the wreck.

C. & M. F. L. C. O. N.

47711

Wreck.

47711

H

West G. Correll Co. ...



## IRON PIPE USED AS A PROP FOR YOUNG TREES

Simple, inexpensive tree supports, to keep young saplings from being bent over by the wind, can be made of a



piece of iron pipe and a couple of feet of hose. They are strong and rigid and do not injure the tender bark of the trees. A long piece of galvanized-iron pipe is driven into the ground beside the sapling and a loop of wire, slipped through a piece of hose, is passed around the tree and twisted securely about the upper

end of the pipe. A pipe on each side of the tree would make a stronger support, but a single piece is enough to protect a very young tree. The prop was invented by a woman in New Haven, Connecticut.

## APPARATUS FOR GAUGING BREATHING EXERCISES

A French physician has devised a simple apparatus by which breathing exercises, which are usually taken in



a haphazard manner; may be taken systematically and on a progressive scale and without the risk of overworking weak lungs. A bottle of known capacity and carrying a graduated scale is filled with water, and is inverted and placed in a vessel containing water, so that the liquid in the bot-

tle is retained by the atmospheric pressure. A rubber tube is inserted in the neck of the bottle. The patient inhales through the nose in a natural manner and expels the breath through this tube into the bottle, the air gradually displacing the water in the bottle. The process is continued until all water in the bottle is displaced by air. In this way an accurate measurement of the extent of the breathing exercise is given. The apparatus is intended to be used in the open air or in a well ventilated room.

## A MACHINE FOR SORTING ROLLER BEARINGS

Balls and rollers for bearings are sorted according to size by a new electrical machine which is capable of detecting a difference of  $\frac{1}{4}$  of a ten-thousandth of an inch in the diameter of the units. It is impossible, in the manufacture of millions of balls and rollers, to have the limit of error exactly the same in all of them, but proper sorting obviates any trouble resulting from inaccuracy. The machine which has been invented for the purpose consists of a revolving steel disk with a series of very delicate plungers, or gauges, arranged around its edge at varying distances from the center. Rollers to be sorted are fed on to the disk and moved slowly past the plungers. Somewhere in the circuit every roller strikes a plunger and an electrical contact is made which drops the roller into a canister. Each canister thus receives rollers that are of exactly the same size and, when bearings are assembled, all the rollers in any bearing must come from the same canister.

## THE GREAT MEADOWS PRISON NEARLY COMPLETED

The Great Meadows prison, New York State's new model penitentiary at Comstock, is being rushed to completion to receive the mutinous convicts who have made old Sing Sing prison a place of fire and riot. The

47  
5715/13  
4/3 create machine  
des. 12/1 + order





center of the building and separated from the outside walls by a corridor all the way around. No escape from the cells is possible except across this corridor in plain sight of the guards. Each cell has its own plumbing and is ceiled to afford thorough sanitation. The use of sliding doors prevents obstruction of the passage when cells are opened.

Heligoland, an island in the North Sea, has been converted into a rendezvous for Germany's airship fleet. Its honeycombed cliffs have been bolstered up with concrete, and it is armed to withstand a three-years' siege.

The Cells are Arranged in Four Tiers in the Center of the Building, Separated by a Corridor from the Outside Walls. One of the Fireproof, Sanitary Cells in the New Prison is Shown in the Right-Hand View

new prison is not only fireproof and a model in every way, but a massive, commanding piece of architecture as well. The arrangement of cells in the new building is designed to afford an abundance of light and air, to the corridors as well as the cells, and to minimize the opportunity of escape. Instead of being ranged along the outside walls around central corridors, all of the cells are built in a four-story steel and concrete structure erected in the



12-14 W 37 St  
114

New York State's New and Model Great Meadows Prison at Comstock, Which will House the Mutinous Convicts of Sing Sing: The Great Gateway of the New Prison Nearly Completed

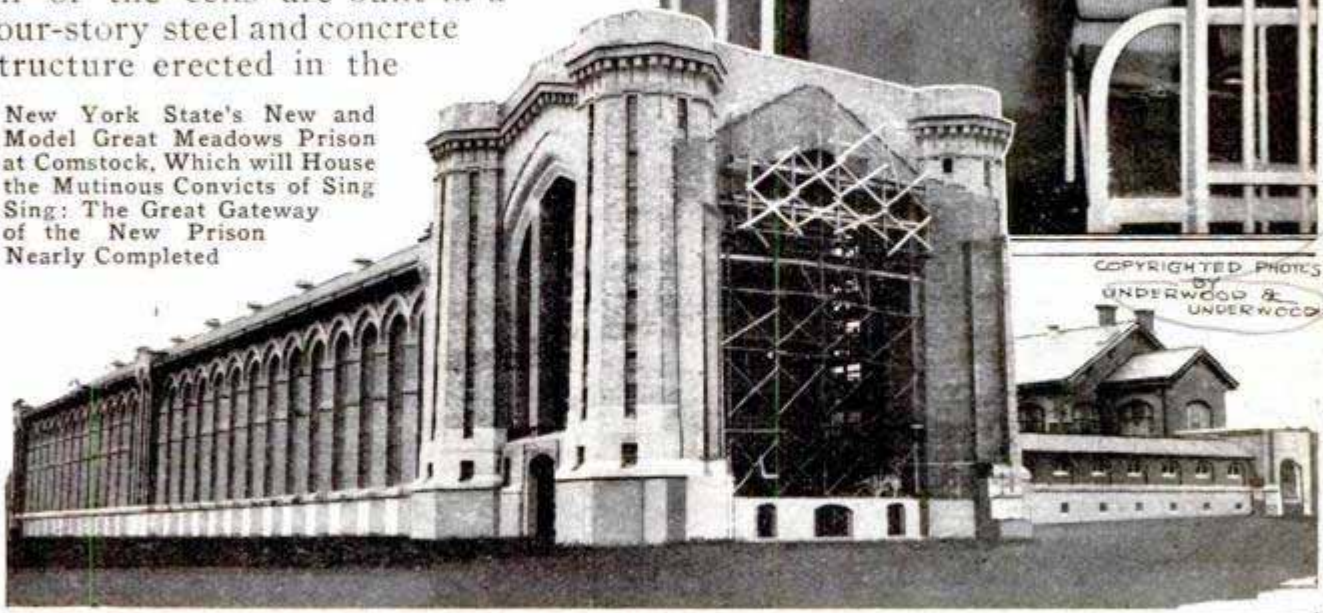

COPYRIGHTED PHOTOS BY UNDERWOOD & UNDERWOOD



## MID-SCOTLAND SHIP CANAL PROPOSED

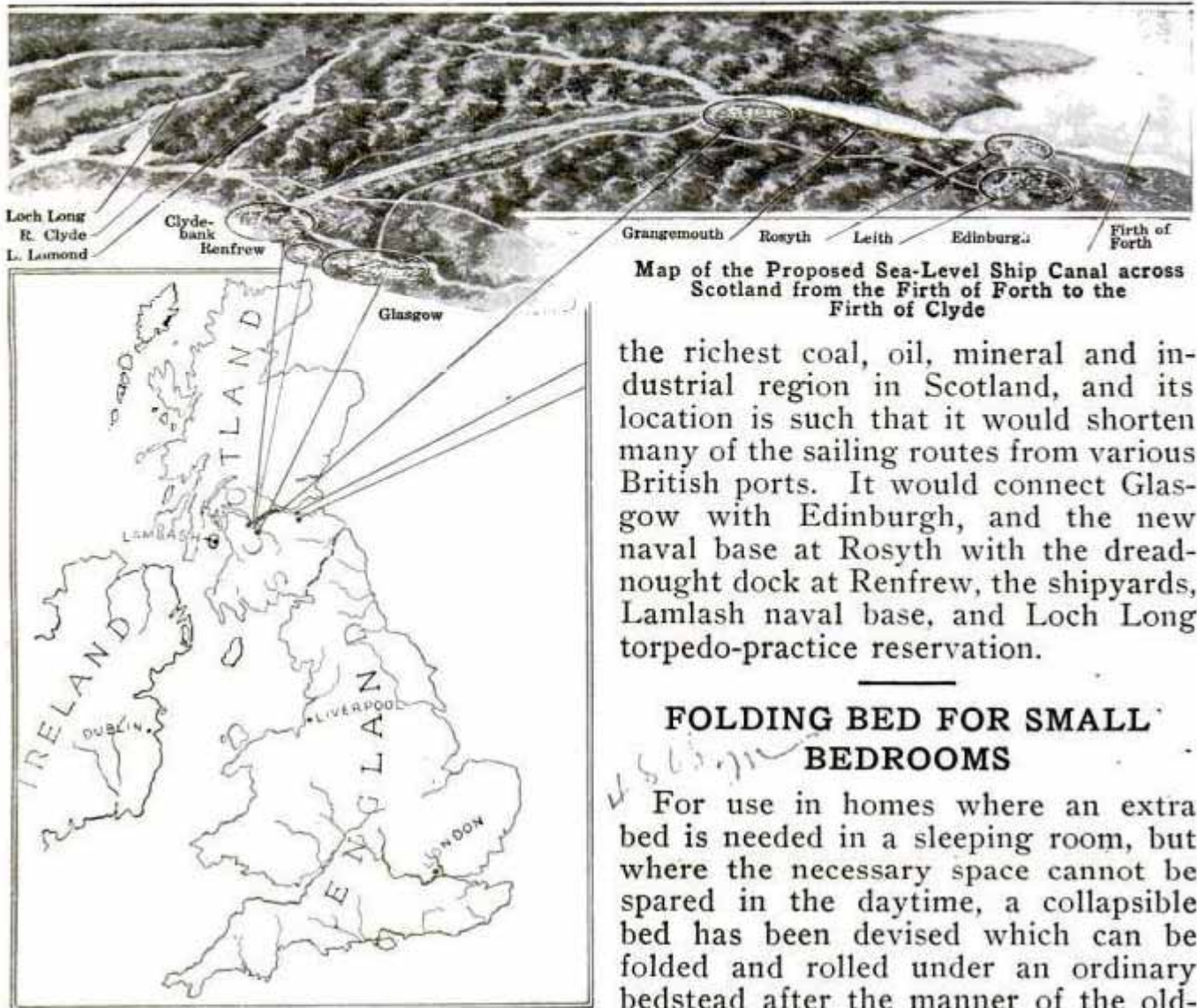

the richest coal, oil, mineral and industrial region in Scotland, and its location is such that it would shorten many of the sailing routes from various British ports. It would connect Glasgow with Edinburgh, and the new naval base at Rosyth with the dreadnought dock at Renfrew, the shipyards, Lamlash naval base, and Loch Long torpedo-practice reservation.

### FOLDING BED FOR SMALL BEDROOMS

4950

For use in homes where an extra bed is needed in a sleeping room, but where the necessary space cannot be spared in the daytime, a collapsible bed has been devised which can be folded and rolled under an ordinary bedstead after the manner of the old-time trundle bed. This bed has permanently attached casters on which it can

A sea-level ship canal across Scotland from the Firth of Forth to the Firth of Clyde has again been proposed and is receiving serious consideration. It is an undertaking that would cost about \$120,000,000 and require five years for completion. The route proposed is not the Loch Lomond route that was suggested 25 years ago, but a "direct route" nearer Glasgow. There is now a small barge canal, built in 1790, along this line, but the present plan proposes the building of a separate sea-level canal with no locks except sea locks at the ends. The distance is 29 miles and the proposed canal would be 148 ft. wide and 36 ft. deep. Little cutting would have to be done except through sand and gravel, as the sea once covered this territory. The valley which the canal would follow is

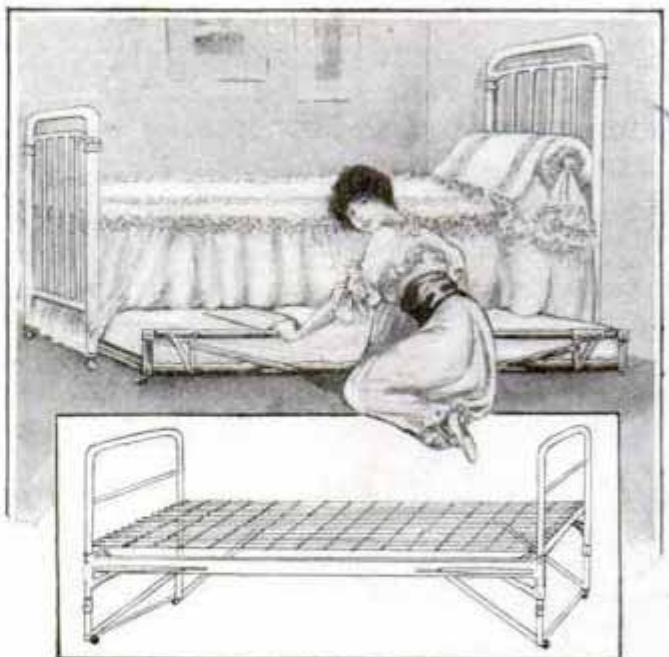

Collapsible Bed Folded and Ready to be Rolled under Any Standard Bedstead



be moved either when set up or folded. By compressing a spring at the head or foot, catches are released and the bed folds automatically, while, for setting it up, it is only necessary to lift the ends to an upright position, when the catches snap into position and hold the parts secure. The parts fold in such a way that it is not necessary to remove the bedding.

### RUBBER FLOWERS SOLVE BATHERS' PROBLEM

Rubber flowers to be worn on bathing suits is one of the latest novelties in the way of personal adornment. Bathing suits were originally intended for bathing, but with the increasing popularity of the seaside resort they have come to be rather extensively used for general display on the beaches, and, consequently, have been made more ornate each year. A bathing suit that will stand the water is still necessary, however, since it has not yet come to be good form to put on a bathing suit and not take at least a momentary dip, and this condition has served as a bar to the use of feathers and flowers for the purpose of adornment. Delicately tinted flowers such as roses and violets are now provided for the convenience of bathers, and these may be worn while taking a dip or an extended swim without danger of injury.

### MOTOR TRUCKS DISPATCHED BY TELEPHONE

A telephone-dispatching system to direct automobile trucks used in inter-factory deliveries has recently been installed by a large automobile manufacturing company. Most of the deliveries between the company's various factories are made by 22 motor trucks and 10 horse-drawn vehicles in the streets. To get the greatest amount of service from them, the company has put them in charge of one dispatcher who directs them from one loading station to another by telephone. The dispatching system has been found to effect a considerable annual saving.

### BORING HOLES IN AWKWARD PLACES

An auger with a long reach for boring holes in inconvenient places is being manufactured for electricians and engineers.

By its use a workman can stand on the floor and bore a hole at any angle in a beam or joist in the ceiling or anywhere within 14 ft. The drilling head which holds the bit is operated by a leather strap running over a spring drum; the bit is turned as the workman pulls the strap and the spring drum winds up the strap ready for another pull. The head is mounted on a telescoping handle which can be extended from 4 ft. 10 in. to 14 ft. 3 in. For vertical or an angle boring an attachment with a pulley for the strap is fitted between the handle and the head. One second is required for the longest pull and the rewinding, and four or five pulls will bore a hole through a 2-in. joist.



### HANDLING THE MAIL FOR FOREIGN LABORERS

Mail for foreign laborers who are unable to speak English is handled in an unusual way in the post office of Coatesville, Pa. Of the 14,000 people in the town, about one-fourth are Italians, Russians, Hungarians, and Rou-



manians, employed in the steel and rolling mills. In order to overcome the language difficulties, the post office has a separate department for these foreigners. It consists of two glass cases, built in the wall between the

## WATER-SUPPLY SYSTEM OF WOOLWORTH BUILDING

A water-supply system that is larger and more complicated than that of most small cities has been installed in

the Woolworth building in New York City. This office building, which is the highest in the world, has 5.5 stories above the street level and three stories below the street level, making a total of 58 stories, and the water-supply system proved to be one of the biggest problems in connection with the equipment. Water is taken from several connections with the city mains at an average pressure of 22 lb., while, for use in emergency only, there is a connection with one of the high-pressure fire mains. All the water is metered and filtered, and, with the exception of that used below the second story, is pumped into storage tanks located at different levels. Each tank furnishes a gravity

supply for the stories between it and the next tank lower down, the tanks being so spaced as to keep the pressure within safe limits. With this arrangement high pressures are only developed in the pump connections to the upper tanks. For supplying water in the main portion of the building there is a 6,000-gal. tank at the fourteenth-floor level and a 20,000-gal. tank at the twenty-seventh-floor level. In the tower there is a tank of 3,100-gal. capacity at the thirty-eighth floor, one of 9,900-gal. capacity at the fiftieth floor, and one of 1,200-gal. capacity at the fifty-third floor, more than 40,000 gal. being thus available at all times.

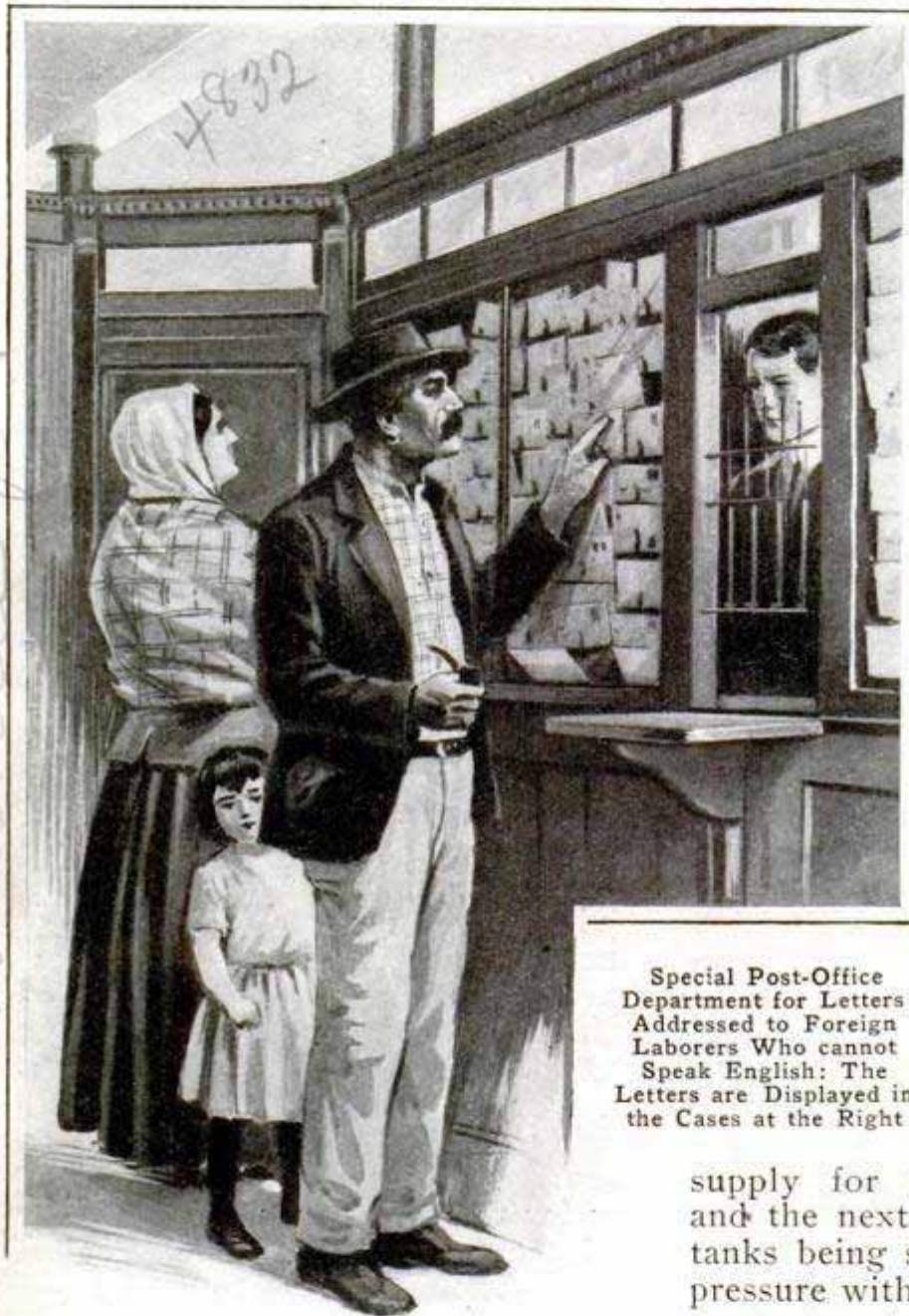

Special Post-Office Department for Letters Addressed to Foreign Laborers Who cannot Speak English: The Letters are Displayed in the Cases at the Right

lobby and the clerical room and provided with clips to hold up the letters so that their addresses can be read from the lobby. The foreigners look over the mail in the cases and when one finds a letter addressed to him he points it out to a clerk and receives it. There are at times 200 letters in the cases, and as many of them come "postage due," because the senders are too poor to pay for them, the collections sometimes amount to \$15 a day.



## CONCRETE-ARCH BRIDGE OF UNUSUAL SIZE

A reinforced-concrete arch bridge that will rank as one of the largest of its kind in the world is now being completed at Pasadena, Cal. This bridge spans the Arroyo Seco, a dry valley between Pasadena and Los Angeles, and is 1,468 ft. long, 38 ft. wide, and has its floor at a level of 167 ft. above the ground. It consists of nine spans, one span being of 223 ft., two of 151 ft. each, and six of 113 ft. each. There is no provision for street cars, the bridge being designed only for highway and pedestrian traffic. Along the center of the bridge is an asphalt road 28 ft. wide, and on each side of this is a 5-ft. sidewalk. Over each pier are bays projecting 8 ft. beyond the sidewalk line and provided with concrete benches.

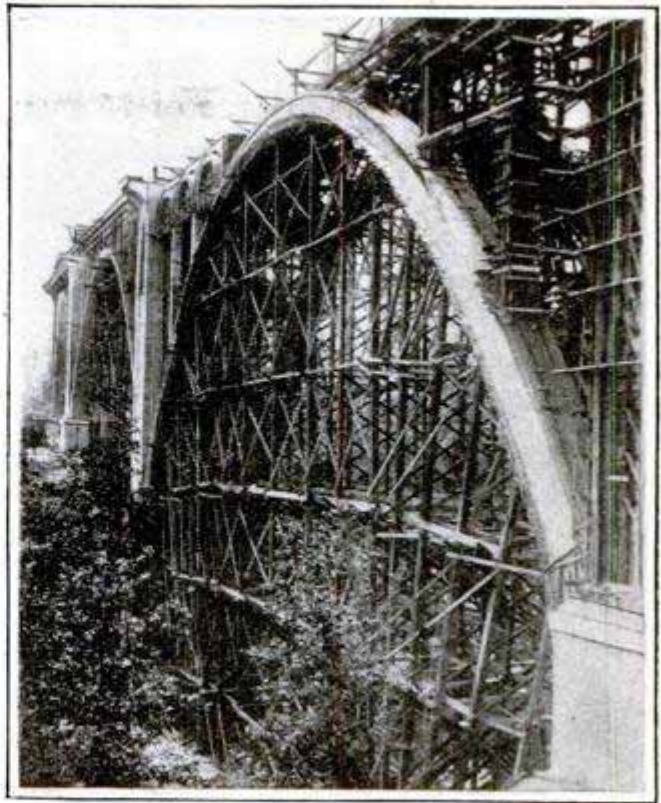

A. General View of the Bridge During Construction

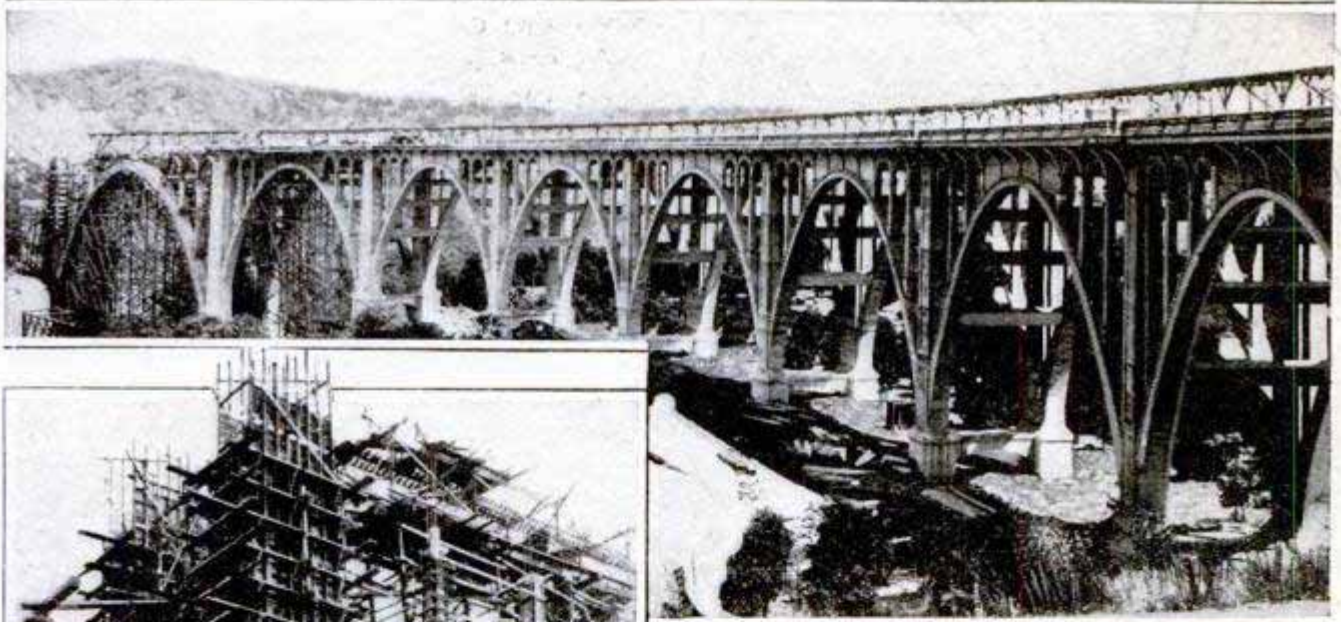

A Close View of the Completed Structure

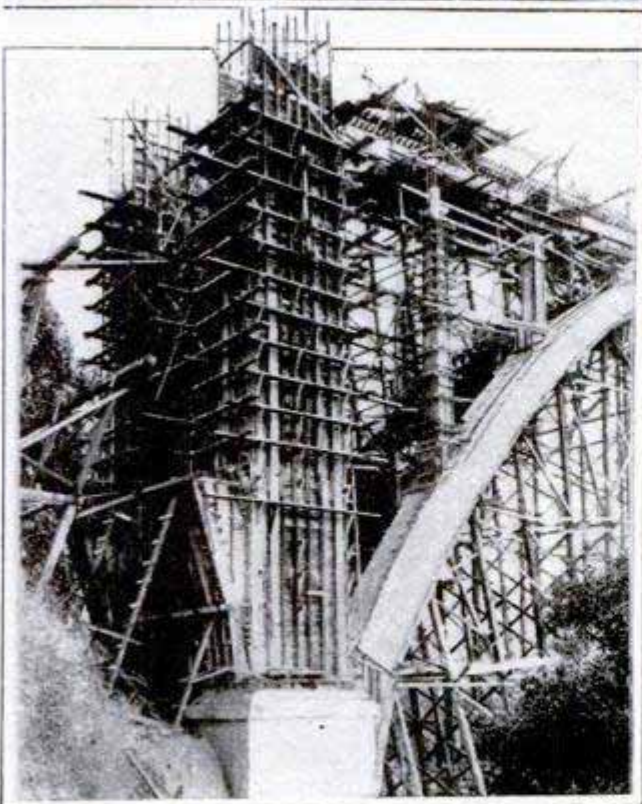

Building a Pier with Its Adjacent Arches

The construction of this bridge called for more than 10,000 bbl. of cement, while the sand and gravel used in making the concrete was secured from the river bed below the bridge. Corrugated steel bars with an ultimate strength of from 60,000 to 70,000 lb. per square inch were used for reinforcing the concrete. The piers, on which the main arches are carried, rest on footings of gravel and boulders which have been tested to 11,000 lb. to the square foot. The roadway is supported on a



series of secondary arches carried on the main arches. The construction of the bridge required a force of 75 men working for over a year.

### SAVING BIRDS IN ENGLISH CHANNEL FLIGHT

In their semiannual migration across the English Channel, thousands of birds are killed through the fascination of the

this unnecessary slaughter. During the autumn the birds cross the channel to the shore of France, returning to England in the spring. It is during the northward trip that the greatest slaughter takes place. It is estimated that the numerous lights, afloat and ashore, between the Start lighthouse, on the west, and the Nore, on the east, are responsible for no fewer than 50,000 deaths among the birds every year. The flight across the channel, which requires from two to four hours, usually takes place during the evening, so that it is always dark when the opposite shore is reached. It has been found that the majority of the birds do not kill themselves, as has been thought, by flying against the thick glass panes that inclose the light, but that they become bewildered by the brilliant light and circle around it until they fall exhausted, afterward dying of cold and exposure on the rocks below.

At one lighthouse experiments have been made with a view to providing racks and perches on which the birds may alight. From these experiments it has been found that the birds will not perch on racks placed above the light, but that they will quickly cease circling and perch on racks that are so placed as to be clearly illuminated by the light. It is expected that all the principal lighthouses and lightships along this coast will be eventually equipped with this kind of bird-saving apparatus.

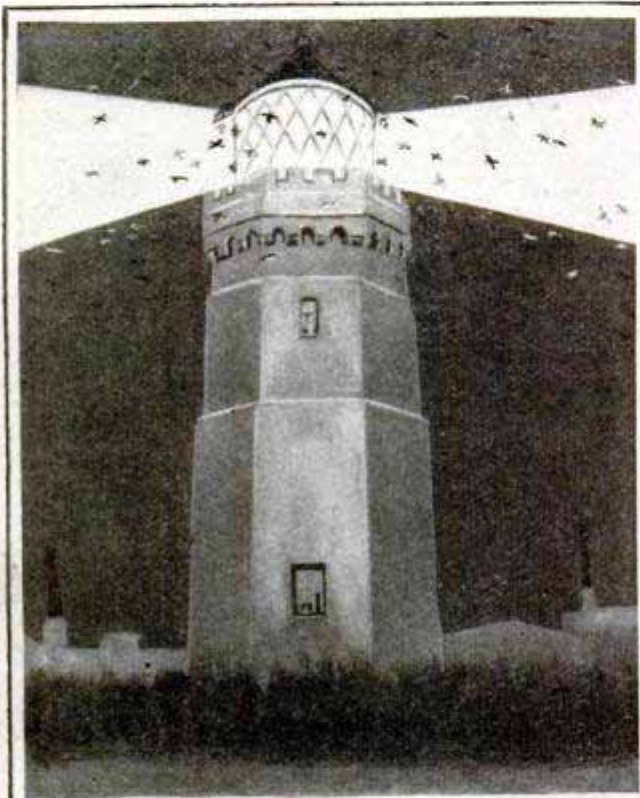

How Lighthouses Attract Birds

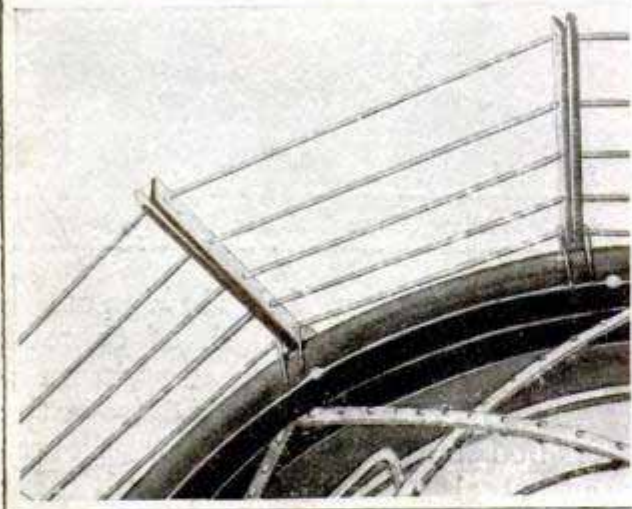

A Series of Perches, in Range of the Light, Saves the Birds by Giving Them a Resting Place

channel lights that line the southern coast of England, and a movement has been started in that country looking to a simple and inexpensive prevention of

### HOMEMADE AUTOMOBILE

#### 4904-4 PLOW

An old automobile has been changed into a very satisfactory and economical farm tractor by two farmers near Bellefontaine, Ohio. Practically every part of the tractor, except the original 20-hp. car, is homemade, and it plows a deep furrow at the rate of four miles an hour. The plow is supported by a wooden framework built out from the rear of the car and weighted down with an old anvil. It is hung in such a way that it can be raised off the ground by a lever beside the driver. Wooden casings with wide rims are built over the

Lee & Sons, Dayton, Ohio





Homemade Power Plow Made of an Old Automobile

front wheels and the rear wheels of the automobile are removed altogether. In their place is a pair of small sprockets connected by chain to the axle and wheels of an old farm implement placed under the plow framework. The improvised tractor will plow 50 per cent faster than a four-horse team and costs about \$1 a day to operate.

### CLOTH SHIELDS TO SHADE

#### YOUNG TREES

Huge linen shields, raised high in the air on slender poles, ward off the sun's rays from the young trees in one of the public squares of Berlin, Germany. They look like the scenery of an open-air stage, but they were set

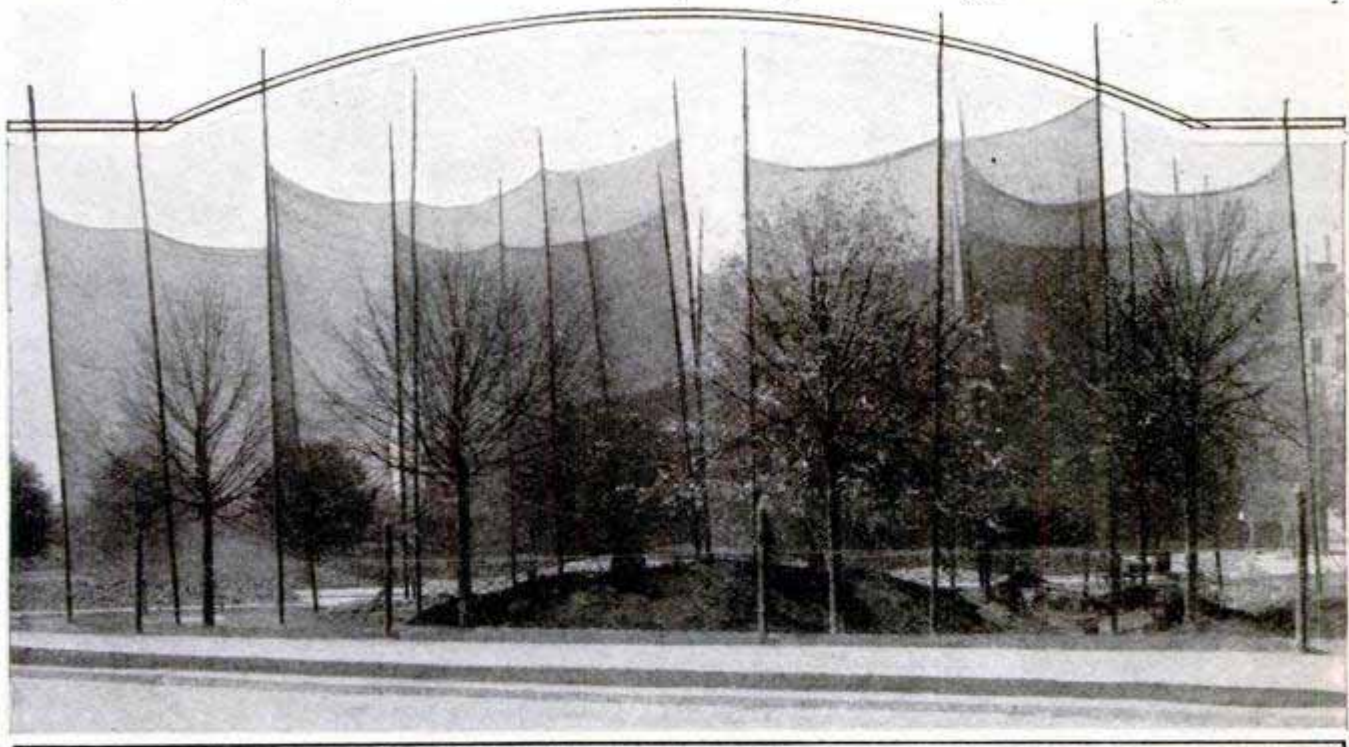

Photo by Paul Thompson

Transplanted Lindens in a Berlin Square Sheltered from the Sun's Rays by Linen Shades



up simply to make a temporary nursery for the young lindens that have been transplanted into Heidelberg Square. The shadeless park has no protection from the hot sun, and until the little trees get a start, they need this artificial shelter to help them grow.

### EXTINGUISHING A BURNING GAS WELL

It took a week of hard work to extinguish a burning gas well at Cushing, Okla., which had been accidentally set on fire after running "wild" for over a month. This gas well is one of the biggest producers in the United States, discharging regularly about 40,000,000 cu. ft. per day. When this well had been drilled to a depth of 600 ft., it began to run "wild" and blew off the casing head repeatedly before a secure fastening could be made. The real trouble began when a cowboy, who is expected to recover, thoughtlessly lit a cigarette within about 15 ft. of the powerful gas stream. The gas was ignited, and the resulting blaze, 100 ft. high, could be seen at night for a distance of 50 miles. The flame was finally smothered by means of a swaged nipple

on the end of an 8-in. casing, arranged as shown in the illustration. This, when in place, conducted the gas to a safe distance from the flame. The string of casing was backed up to the well on a wagon and the nipple worked into position so that when the wagon burned away the nipple would fall over and close the gas pipe. A battery of six 25-hp. boilers had been rigged up, and steam from these was then used to smother the flame from leaks around the casing. Before beginning this operation the casing head was shot off with a 4-lb. ball fired from an old-style cannon.

### NEW TUNNEL LAID UNDER EAST RIVER

Another tunnel under East River, New York City, has been completed. This was built by a gas company to carry gas to the Bronx from its plant. The tunnel is 4,662 ft. long and is nearly 150 ft. below the river bed, at an average depth of 246 ft. below the surface of the water. It is 19.5 ft. wide, 21 ft. high, lined with concrete, and will carry four 6-ft. mains. The tunnel cost about \$5,000,000.

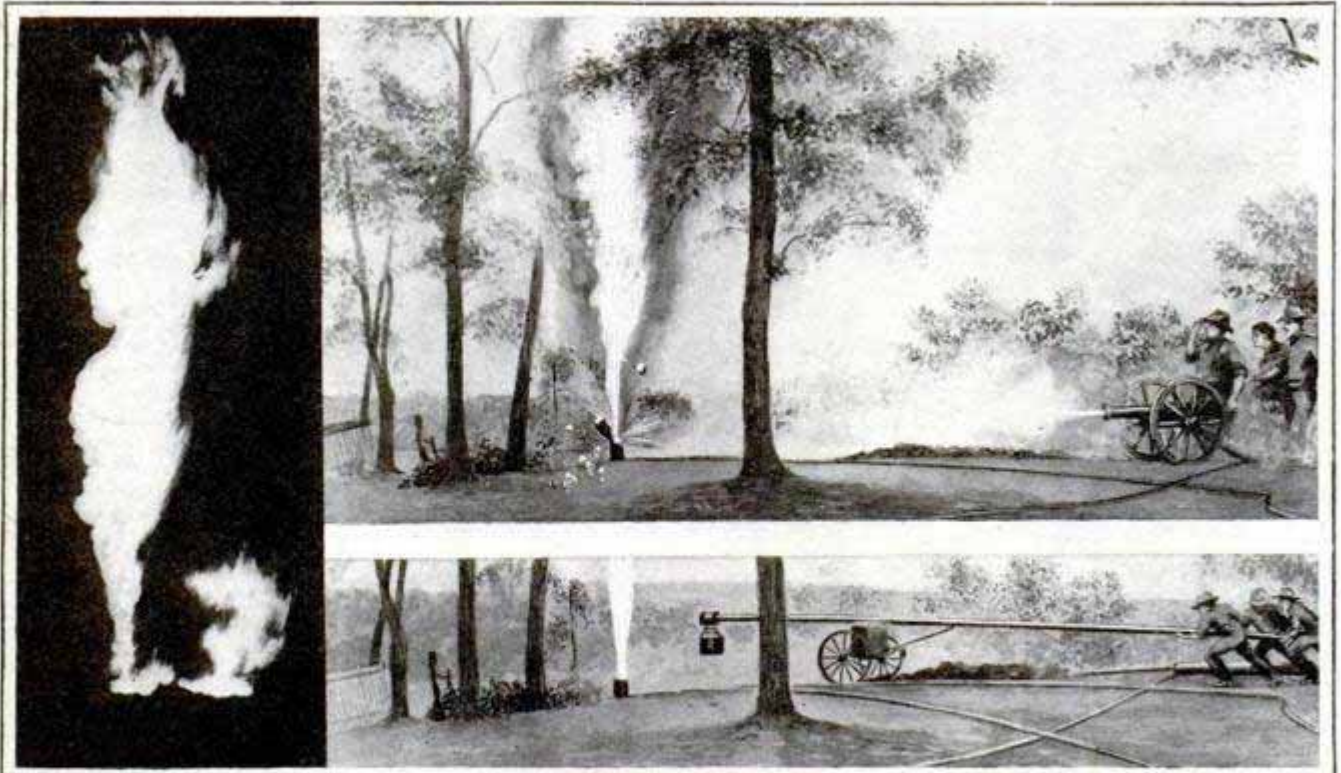

Blaze 100 Ft. High from  
Burning Gas Well

Above: Shooting Off the Heading of a Gas-Well Casing  
Below: Casing Mounted on Wagon and Ready to be Dropped over Gas Pipe



## ANATOMY OF THE MALARIA MOSQUITO

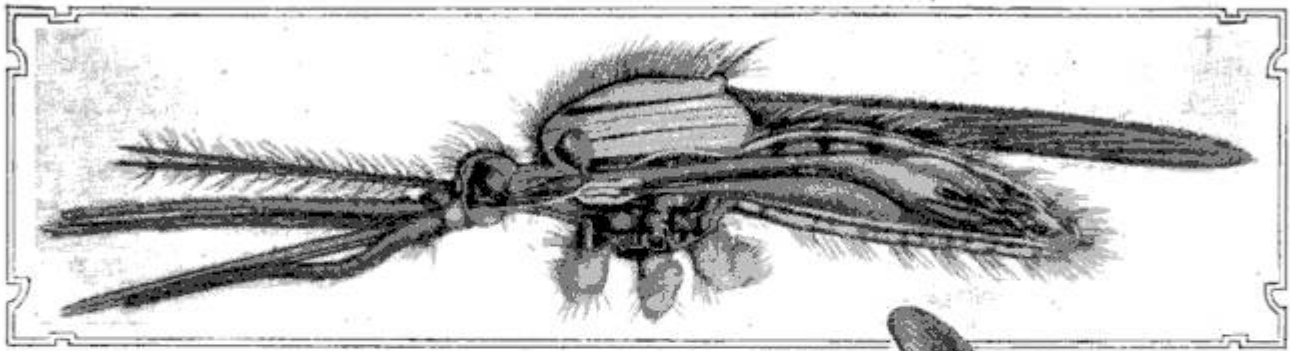

The Anatomy of the Female Malaria Mosquito

The Harmless Male Mosquito  
Which does Not Bite

Since yellow fever and malaria are now blamed on the mosquito, it is interesting to know how the dangerous insect can be distinguished from the merely disagreeable one and how it does its deadly

work. All mosquitoes are not biters and all biting mosquitoes do not carry malaria. Although the male mosquitoes outnumber the female ten to one, only the female feeds on blood. And of all the females, one species alone is to be feared—the malarial mosquito. It can be distinguished by the fact that its hind legs are relatively very long and that it, therefore, holds its body at an angle of 45 deg. while biting or resting. All mosquitoes except the germ-carrying variety rest horizontally. Thus distinguished, certain other characteristics follow. The germ carrier flies only at night and cannot fly more than 100 ft. It is perfectly harmless unless it has had an opportunity to bite a malaria

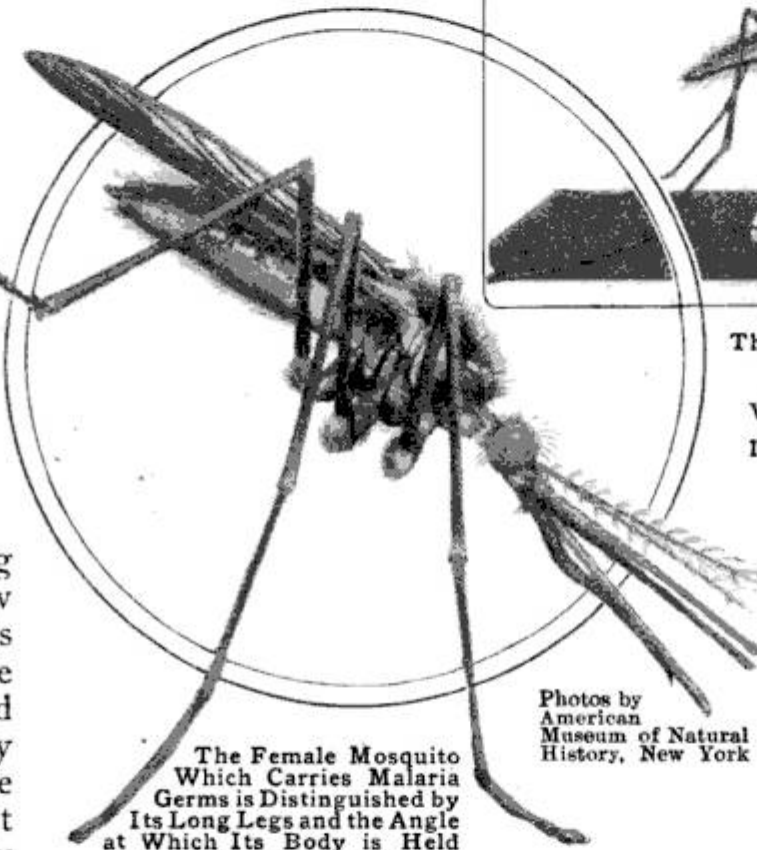
The Female Mosquito  
Which Carries Malaria  
Germs is Distinguished by  
Its Long Legs and the Angle  
at Which Its Body is Held

Photos by  
American  
Museum of Natural  
History, New York

victim, for malaria is not inherent in its nature — it is simply a germ carrier. But if the mosquito obtains any malaria germs while sucking blood, they remain in its stomach, breed myriad other germs, and spread into the

salivary glands, ready to be deposited with the saliva at the mosquito's next meal. The bill of a malaria mosquito is so constructed that it leaves a small drop of saliva, in which there may or may not be germs, while blood is being taken in through another duct.

### NEW FEATURES ON ENGLISH MOTORCYCLES

Many novel motorcycle improvements and attachments appeared on the machines which took part in the recent Grand Prix race in France. Two interesting English models are shown on the next page. The heavier motorcycle with the sidecar has a water-



cooled engine with a radiator on each side of the single cylinder and most of its machinery is carried below the frame. A folding front-wheel stand

ties in Nevada, these gems consisting of dark translucent mineral with a variety of rich colors, and equaling if not exceeding in beauty the opals

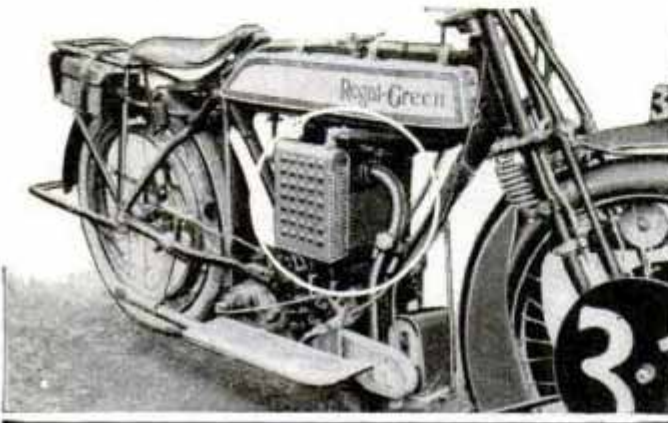
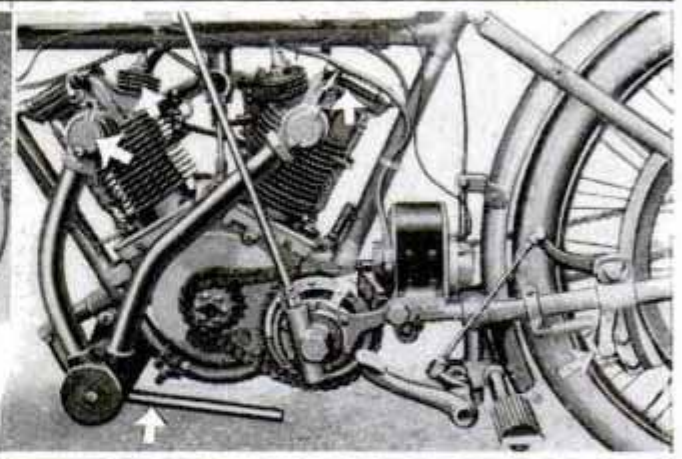
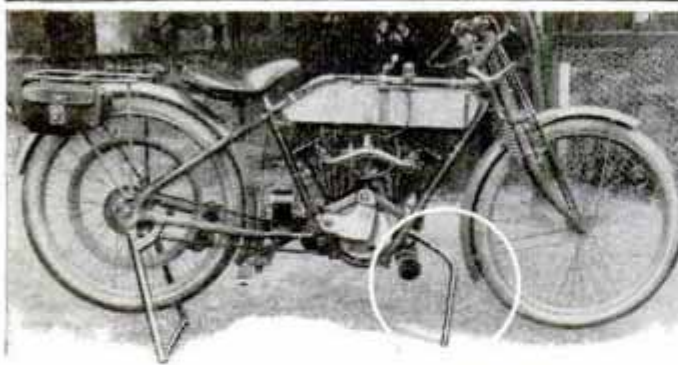

Curious Valve Mechanism, Separate Muffler Cut-Outs, Double-Chain Transmission, Shaft-Driven Magneto, and Shoe Brake on Upper Machine

New Motorcycle Features Appearing on Two English Machines Which Took Part in the French Grand Prix Race. Upper: Two-Cylinder Model with Front-Wheel Stand Shown in Circle. Lower: Water-Cooled Motor with Two Radiators and Machinery Below the Frame

and a shoe brake, working on a large drum on the rear wheel, are the most striking features of the lighter two-cylinder machine. Its motor has overhead valves, operated by push tappets and offset levers, and separate muffler cut-outs over each exhaust valve. Two chains are used to connect the engine shaft with the change-speed gears, and the magneto is shaft-driven.

### PRECIOUS STONES MINED IN THE UNITED STATES

The principal gem mineral mined in the United States during 1912 was Montana sapphire, according to a recent report issued by the U. S. Geological Survey. Of these there was a large output for use both as gems and in mechanical applications, the majority of the stones being of a true sapphire blue. Opals of an unusual type were found in considerable quan-

found in Australia. The tourmaline output of California was small, but some magnificent specimen crystals were found. Beautiful amethyst was found in North Carolina and some fine gems have been cut from sample crystals. The production of agate and associated varieties of chalcedony was large in several of the western states.

### FRENCH ARMY TO HAVE ARMORED AEROPLANES

The French military authorities have decided that all aeroplanes to be used in war are to be protected by armor plate, according to an announcement recently made in Paris. This decision is the result of experiments showing that observations can only be made satisfactorily at heights of less than 2,600 ft., a height at which an aeroplane is well within range of land defenses. The French aerial fleet, on the completion of the armored aeroplanes, will comprise one-seat and two-seat aeroplanes, for reconnoissance, and two-seat aeroplanes, having a minimum speed of 75 miles per hour and armed with quick-firing and automatic rifles, for pursuing hostile aeroplanes and dirigibles.

ⒸCongress has spent \$338,828,273.14 on the Panama Canal up to the present time.



## DRAWING WIRE OF SMALLEST DIAMETER

In the Worcester works of the American Steel and Wire Company copper and aluminum wire is drawn to a diameter of .005 of an inch. This is done, not as an experiment, but as a commercial operation. The dies are of diamond, no other material being hard enough to withstand the wear of the wire's forced passage through this diminutive opening. In drawing the wire to this almost gossamer fineness, it is passed through a series of die holes of successively smaller sizes. Piercing the diamond with these minute holes is an operation requiring the most delicate machines. In one case a diamond has been pierced with a hole only .0001 in. in diameter. This hole is so small that it can be seen only with a powerful microscope. Water will not go through a passage of this size, but alcohol under pressure will penetrate it sufficiently to affect chemically prepared paper placed on the opposite side. To drill this opening required seven months, and it was possible to use a drill for only two seconds before it became dull.

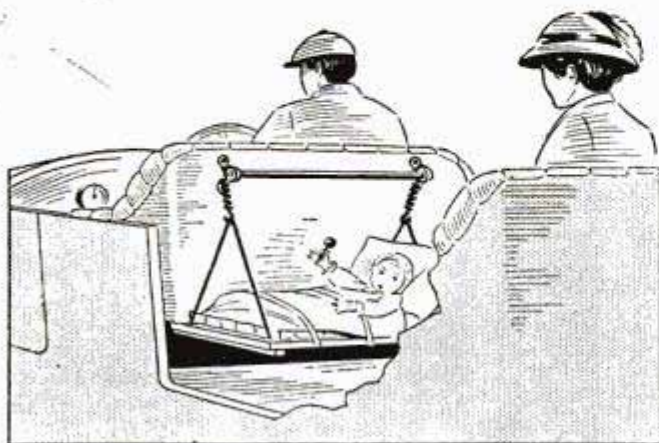

A Detroit Motorist Invented This Cradle for the Accommodation of His Baby

## DEVICE FOR MAKING BOAT TACKLES TWISTLESS

A device that prevents the tackles from twisting while a lifeboat is being lowered down the side of a ship has

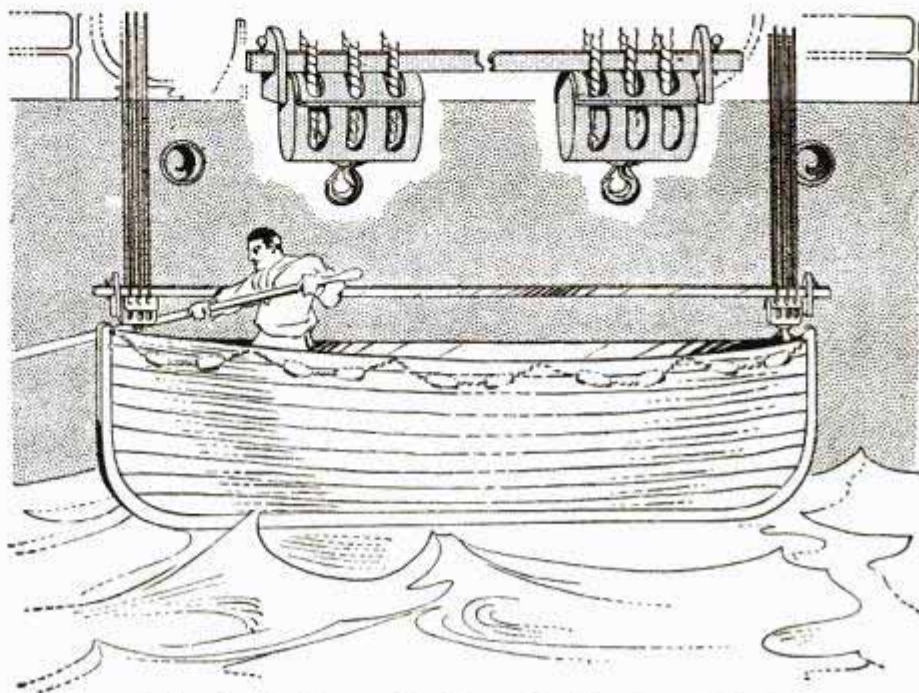

A Device for Preventing Boat Tackles from Twisting

been invented by a sea captain of New York. The antitwisting device consists in fitting to each lower block of the tackle a cap having, on each side, three holes through which is passed the rope, as well as through the sheave holes of each lower block—an arrangement which is intended to keep the blocks from capsizing. A wooden scantling of proper length is also passed from one lower block to the other through each tackle, thus preventing both tackles from twisting.

## BABY CRADLE FOR USE IN AUTOMOBILE

An exceptionally practical and ingenious cradle arrangement is the invention of a Detroit motorist who, having both an automobile and a baby, sought far and wide for some means of conveniently and comfortably carrying one possession in the other. In the making of the cradle he used two wooden slats, about 30 in. long, two crosspieces, 18 in. long, two tension



springs, a pillow, a mattress, and 8 ft. of heavy cord. The cradle is suspended from the blanket rack on the back of the forward seat and from the left-side door of the tonneau.

### WATER STERILIZERS USING GAS OR ELECTRICITY

A water-sterilizing outfit having several interesting features is here shown. It is a combined sterilizer and drinking

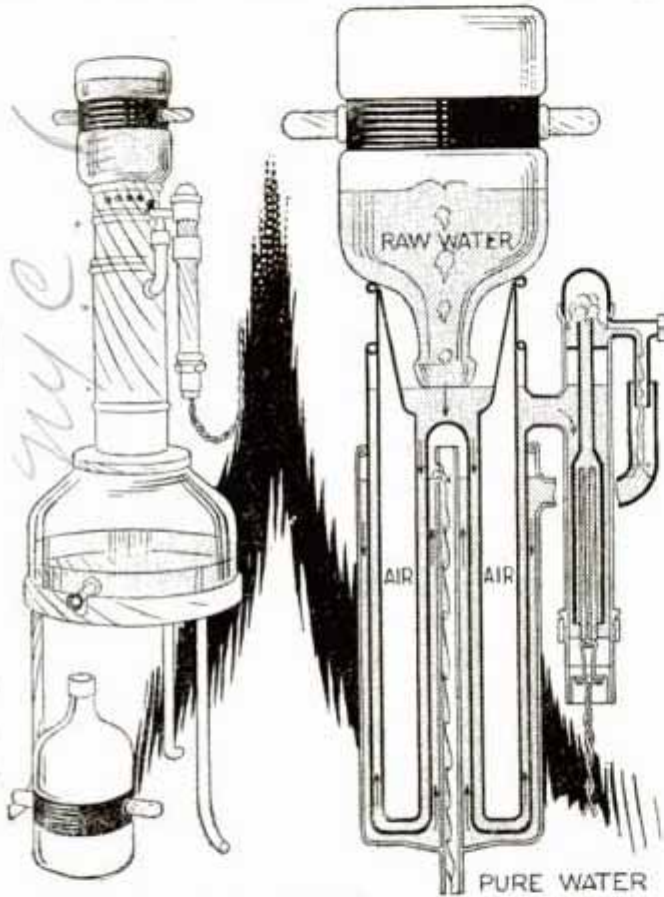

Sterilizer That Brings Ice Water to a Boil and Then Discharges It Nearly as Cool as When It was Received — Sectional View Showing Construction and Action

tank for the office, school room or home. Either electricity or gas may be used for sterilizing the water, the fixture being clearly shown in the illustrations. The most interesting feature of the apparatus is the fact that, even though every drop is raised to the boiling point, the water is discharged at nearly its original temperature. Thus cool, cold or even ice water may be supplied to the sterilizer and be discharged practically as cold as on entering, and without the use of chemicals or refrigerants.

The water to be sterilized flows from the inverted bottle into a feed cup, and

then down between an outside and middle tube, entering the heater at the lower end of a fountain tube, in which it rises until its level, as well as that in the feed cup, reaches and seals the mouth of the bottle. No more water can now run out of the inverted bottle because, its mouth being sealed, no air can enter it. When the electric current, or gas burner, as the case may be, is turned on, the heat causes the water under the flared end of the fountain tube to boil and geyser upward out of the top of the tube. As the cold water passes to the heater it is continually coming in contact with a surface on the opposite side of which is the hot water finding its way to the sterile water tank at the bottom of the apparatus. The cold unsterilized water is thus continually absorbing the heat from the hot sterilized water. By the time the unsterilized water enters the heater it is thus brought nearly to the boiling point, and, conversely, the hot sterile water leaving the heater is discharged nearly as cold as when it left the bottle at the top of the apparatus.

### FOOT-REST LUNCHEON CASE FOR AUTOISTS

A completely equipped luncheon case that can be used as a foot rest in an automobile is one of the many handy outfits recently brought out in England for motor picnickers. The foot-rest luncheon box shown in the picture is designed for two persons and is 18 in. long, 11½ in. wide, and 10 in. high.

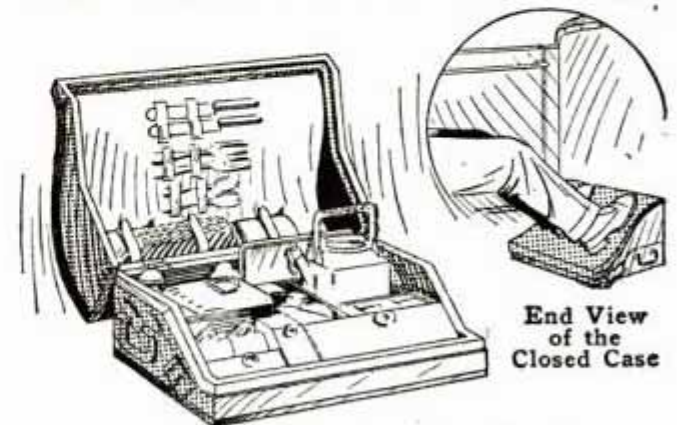

Complete Equipment of Foot-Rest Luncheon Case for Automobilists

Larger sizes are made for four or six persons. The box is dust-proof and has



a corrugated rubber top and brass handles and lock. Every requisite for a complete luncheon is neatly packed inside.

### STEEL BARRELS MADE TO BE NESTED COMPACTLY

A new and ingenious type of steel barrel so designed as to permit compact storage when shipped empty has been placed on the market. The chief feature about this barrel is that it is made in halves that are exactly similar, with flanges provided so that any two halves can be bolted together to form a complete barrel. In the shipping world bulky articles like barrels, when shipped empty, are charged at bulk tonnage rates. Barrels of this

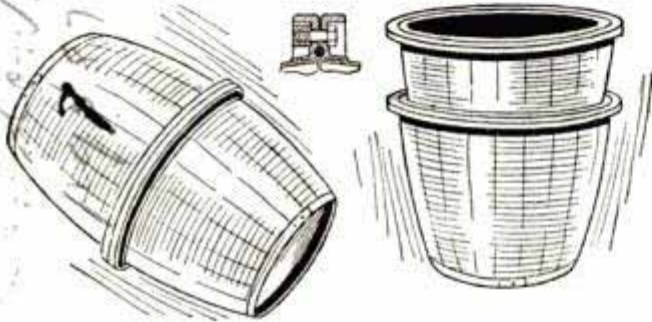

These Barrels are Made in Halves, Which are Bolted Together through the Flanges

type, when nested compactly, will be entitled to weight rates, reducing the shipping charges materially. This invention brings to mind the fact that in the old days of the whaling industry ships were often compelled to put to sea without proper ballast because of the fact that all the available space was occupied by empty barrels.

### NOVEL TYPEWRITER USED IN GERMANY

The typewriter shown in the illustration, which is now being introduced in Germany, will appear strange and probably impractical to the users of standard American machines. A mechanism within the casing, which is controlled by the vertical rod over the keyboard, operates the type cylinder, shifting or rotating it into position for striking the letter. In operation the

vertical rod is shifted with the left hand over each letter, as required, and

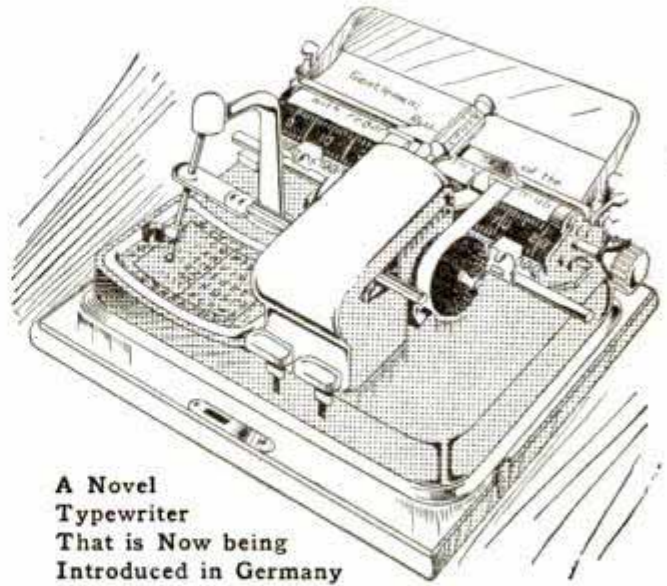

A Novel Typewriter That is Now being Introduced in Germany

the letter is struck with the right hand by means of one of the keys at the front of the machine.

### HORSESHOE HAS REMOVABLE CALKS

A new type of horseshoe recently invented has calks that are easily placed and that fall out of the shoe when nearly worn out. The calks have prongs that are a trifle too large for the opening in the shoe, as shown in the illustration, and have to be driven in. As the tread of the calk wears down, the spring action of the prong is weakened and it finally falls out or

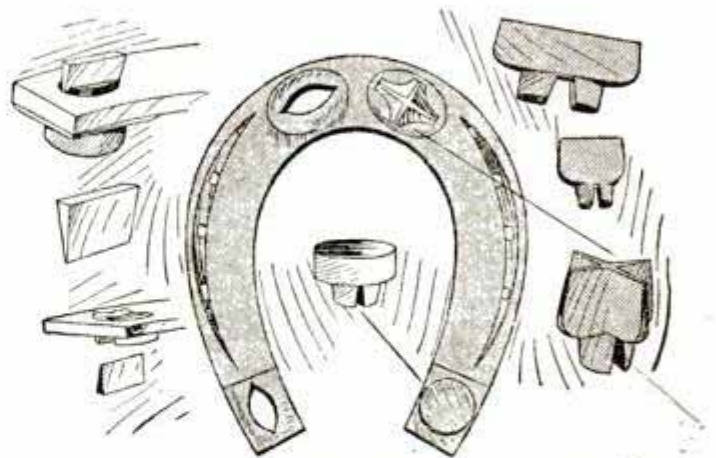

When Nearly Worn Out These Calks Fall Out, Leaving Opening Ready for Insertion of New Calk

becomes so loose that it may be picked out easily, leaving the opening ready for the insertion of a new calk.



## NESTING A FEATURE OF NEW LIFEBOAT

A steel lifeboat made with an inner and an outer hull and so shaped that it will nest compactly with other boats



Steel Lifeboat with Inner and Outer Hulls

is one of the latest improvements in life-saving equipment. The two hulls are spaced apart by steel ribs formed of channel iron, which serve to increase the strength and rigidity of the boat, while the air spaces inclosed by these ribs and the hulls serve to increase its buoyancy. The seats are supported in openings made in the inner hull and are easily removed, making it possible to nest the boats in groups of four or more.

## THE ACTION OF SEA WATER UPON CONCRETE

The ability of concrete to resist the disintegrating action of salt water has been the subject of a series of tests extending over several years at the field laboratory of the U. S. Bureau of Standards at Atlantic City, N. J., and some of the conclusions have recently been published. The problem of marine construction, as the tests

show, is one of method rather than of materials; if concrete can be placed in the forms without undue exposure to sea water, it sets and hardens as well in sea water as in fresh water or in the air. No apparent relation seems to exist between the chemical composition of a cement and the rapidity with which it reacts in sea water. Portland-cement mortar or concrete, if porous, is disintegrated by salt, if crystals are allowed to form during drying. In the case of hydraulic cement, field experiments seem to indicate that the lime on the surface carbonizes and forms a protective coating. When totally immersed, properly made Portland-cement concrete is apparently not subject to decomposition in sea water; whether or not it decomposes when placed between tides has not been determined, but the tests indicate that it does not.

## COMBINING PNEUMATIC AND SOLID AUTO TIRES

A new type of double automobile wheel, arousing considerable interest in France, combines the pneumatic and the solid tire. The outer wheel, on which the car runs under ordinary conditions, is pneumatic-tired. When there is a slight overload, however, or the pneumatic tires are not sufficiently inflated, the inner wheel, which carries

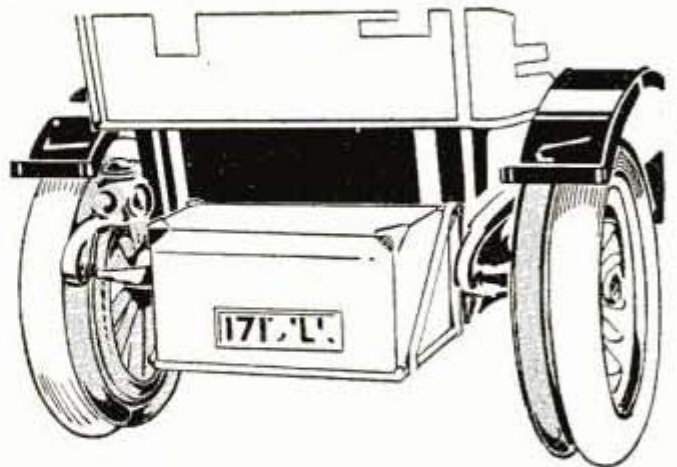

Double Automobile Wheels; The Outer Wheel Carrying a Pneumatic and the Inner a Solid Tire

a solid rubber tire, comes into action. The solid-tired inner wheel is particularly useful when the pneumatic tires are punctured or blow out.



## A DWELLING OF THE DUTCH COLONIAL TYPE

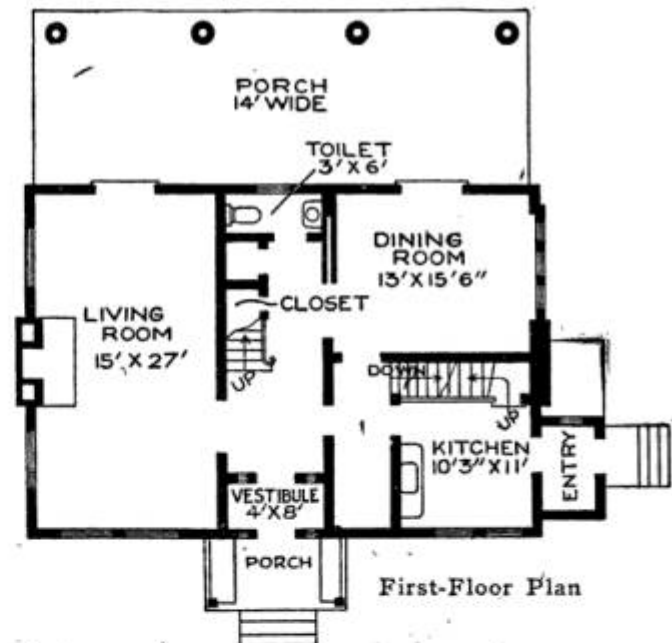
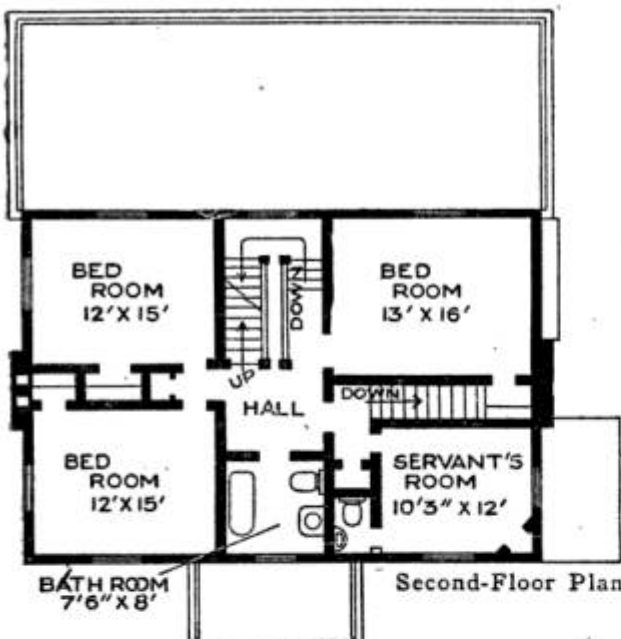

Temple & Burrows, Architects, Davenport, Iowa

In this seven-room dwelling, which is designed to be set at or near the street line, the ideals of the Dutch Colonial type of dwelling are carried out. The kitchen is so placed that it is never necessary for tradesmen to go beyond the side entrance, and the whole arrangement is such as to provide privacy and attractiveness at the rear of the house, where there is a living porch overlooking the private grounds. This building is of frame construction with shingled exterior, has concrete foundations and basement walls, and cost \$6,100.

Iron alloyed with gold is being introduced as a substitute for tin in the making of cans. The resulting

product is proof against corrosion of most kinds, but costs 15 times as much as tin plate.



## DRINKING FOUNTAIN USED LIKE A CUP

A sanitary drinking fountain which does not force the drinker to stoop over and gulp the water upside down has



One can Drink from This  
"Bubble" Fountain  
without Stooping

been patented recently. In this "bubble" fountain the water jet, instead of being fixed permanently in the center of the bowl, is attached to the end of a flexible tube so that it can be raised up to the mouth like a cup while the drinker stands erect. When not in use, the water jet stands in the center of the bowl and the hose is hidden inside the fountain.

## PEAT POWDER AS FUEL FOR LOCOMOTIVES

Powdered peat, which is now being introduced on the market as a substitute for coal, seems to be giving excellent satisfaction as a fuel for locomotives. The powder is fed by an automatic process into the fire box of the locomotive, which is specially arranged to consume it. Tests show that  $1\frac{1}{2}$  tons of this powder, which is burned with an admixture of five per

cent of coal, is equivalent to one ton of coal. There is no difficulty in bringing the powder from the tender, as it passes automatically through a feed pipe into the fire box. Among the advantages claimed for peat powder is the fact that no cold air can get into the fire box and that no sparks or smoke are thrown from the stack. The development of this fuel, which is being promoted by a Swedish engineer, is awakening an interest in the utilization of the extensive peat bogs of Sweden.

## MANY TOOLS COMBINED WITH HAMMER

A whole cabinet of tools, including vise, cutting plier, wrench, and hammer, along with the numerous small tools usually included in combination tool sets—all part of the hammer, or nested in the hammer handle—is a novelty from France. The hammer head may be used as either a vise, a cutting plier or a wrench. The sleeve, which holds the end of the hammer handle and the other leg of the tong together when the tool is being used

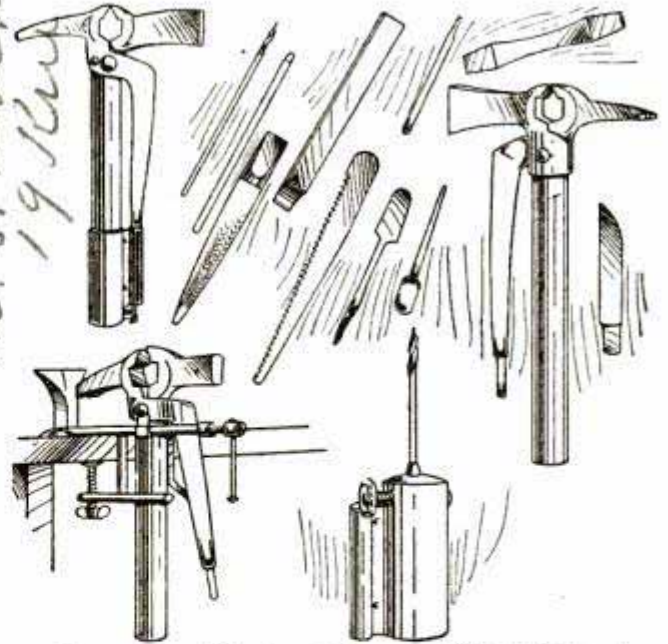

Hammer and Contents Form a Whole Cabinet  
of Tools

as a hammer, serves, when removed, as a handle for the small tools. A small anvil is also provided with the outfit, for use in connection with the vise.



## BAYONETS USED IN FOREST TELEPHONE SERVICE

Army bayonets have been converted into instruments of peace by the United States Forest Service to form a part of the hand-telephone equipment of the forest rangers. It has been found that a bayonet thrust into the ground makes an excellent return connection for the single-wire telephone lines built through the national preserves for the sending of orders and reporting of forest fires. To call headquarters the ranger thrusts his bayonet into a moist spot of ground and throws a bare wire over the nearest telephone wire; this completes the circuit.

## POCKET ELECTRIC LAMP HAS DYNAMO

Instead of the customary dry battery, this ingenious pocket electric-flash lamp is provided with a little dynamo which is driven by a spring motor. The lamp can be made to give a continuous light by simply depressing a lever at regular intervals of about three or four seconds, the action of the lever simultaneously releasing and rewinding the spring. The lamp is  $5\frac{1}{2}$  in. long by  $1\frac{3}{4}$  in. in diameter.



## HOW INDIANS MAKE FLINT ARROW HEADS

The old Indian art of making flint arrow heads was not so difficult as is usually imagined—white men are making “old and genuine” Indian arrow heads now for commercial purposes and by the old Indian methods. Flint is not chipped with stone or with metal, but with water. When an Indian

wished to make an arrow head, he held a piece of flint in a fire until it was very hot and then allowed a drop of water



An Indian Using Fire and Water to Shape a Piece of Flint into an Arrow Head

to drip from the end of a stick upon the spot to be chipped away. The sudden cooling made the flint chip off immediately. Some cunning is of course necessary in the shaping of the arrow head, but the old Indian method is the best that has been found.

## TOY PISTOLS USE PAPER AS AMMUNITION

Nearly every American father has, at one time or another, blown up a paper bag and then exploded it by striking the bottom with his hand, to the great enjoyment of a small son. The illustration shows a safe noise-making toy embodying the same idea. A piece of old newspaper is the ammunition. This is slipped over the opening of the ball or bowl-shaped receptacle, and the pulling of the trigger or

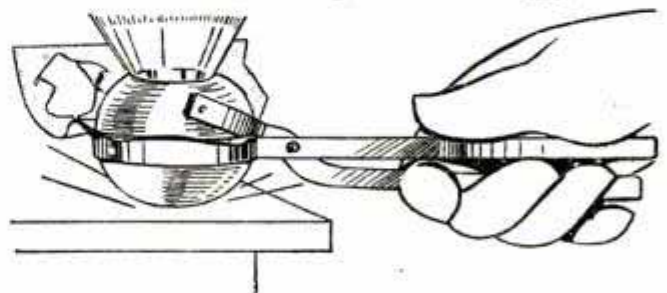

Safe Noise-Making Toy Embodying a Familiar Idea  
exertion of pressure on the handle, results in a pressure of air which bursts the paper with considerable noise.

*Keilon Hdw Co*



## PUNCTURELESS AIR CUSHION FOR MOTOR-CAR TIRES

A punctureless cushion that can readily be applied to any kind of rim or tire, and which is claimed to make

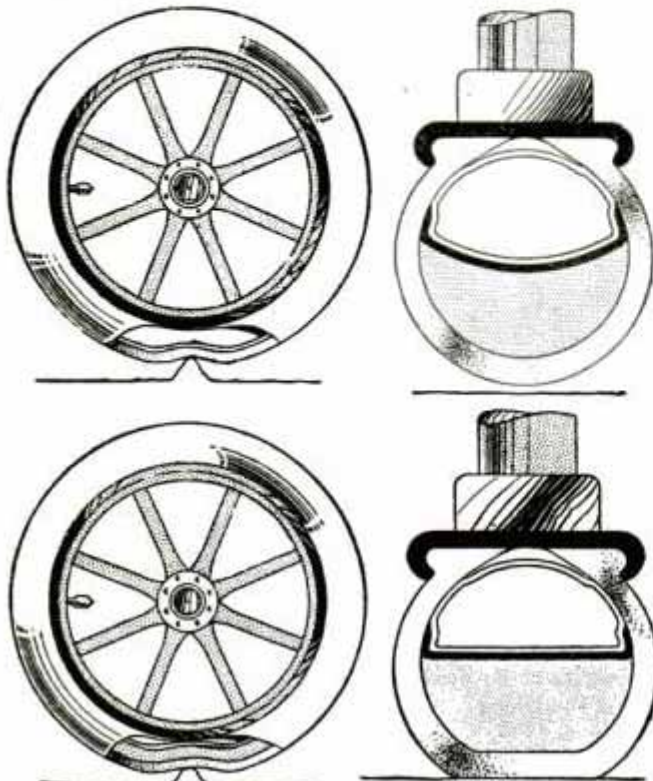

Above: How a Tire  
without Air Cushion  
is Punctured  
Below: How Air Cushion  
Prevents Rupture  
of Tire

Above: Shape of Air  
Cushion When Tire  
is Off Road  
Below: Deflection of  
Air Cushion When  
Tire Rests on Road

automobile tires entirely puncture-proof, is composed of a rubber substitute, made of vulcanized vegetable oil, placed between the wearing surface of the tire and the tube containing the air.

## THE BREEDING OF FOXES FOR THEIR SKINS

The business of rearing foxes for their fur is to receive an impetus by the proposal of the Secretary of Commerce to lease to Americans 12 islands on the coast of Alaska for this purpose. The trade in fox furs has netted the government large sums during recent years, and it is expected that the industry can be greatly improved by the application of up-to-date methods of animal breeding—that is, by the development of pure strains of the valuable blue, silver-gray, and black foxes, and the elimination of white foxes. On

the Pribilof Islands, which are to be leased for this purpose, foxes are reared on waste seal meat, fresh and salted fish. As fox pelts taken from these islands sometimes bring as much as \$131 each in London, the industry is a profitable one and the Secretary of Commerce has undertaken to furnish live blue foxes of the purest breed to develop it.

## SIPHON ACTION USED IN MEASURING WATER

The water weigher shown in the illustration has two compartments, each emptied by a siphon. Water enters through the inlet to the tipping box, where a small portion is intercepted, the remainder passing to the measuring compartment below. When the compartment is nearly filled the float tilts the tipping box, spilling the contents into the compartment. This

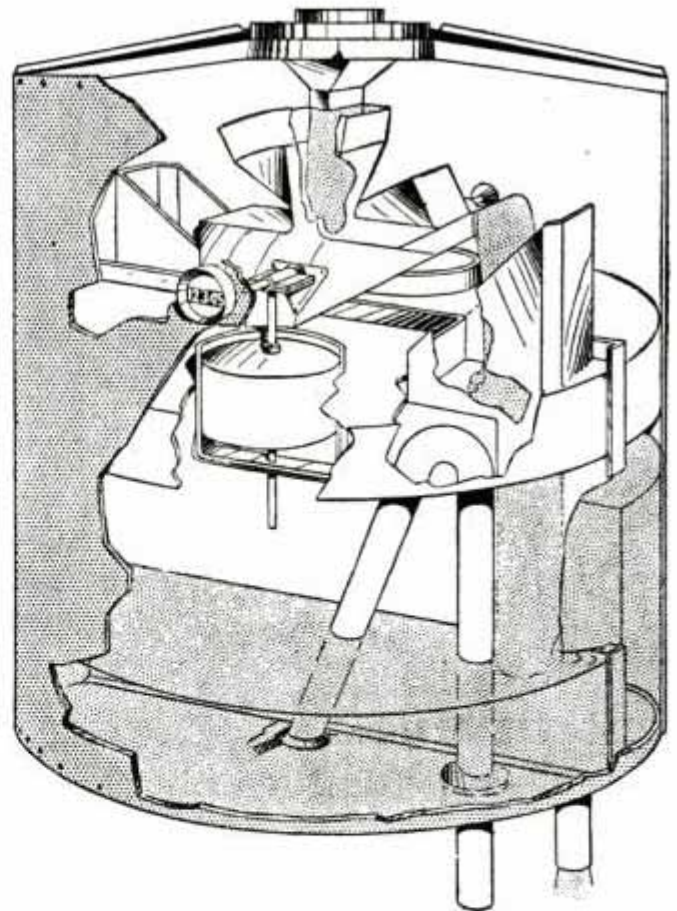

An Automatic Water-Weighing Device That Has  
No Valves or Pistons

completes the charge and starts the siphon. One compartment empties as the other is filled. A counter registers each double charge.



# How the New Wireless Law Works

*By George F. Worts*  
LICENSED OPERATOR - FIRST GRADE

THE confusion in wireless-telegraph circles resulting from the rigid enforcement of the new "wireless law," which requires all wireless stations and all wireless operators to be licensed, has to a considerable extent subsided, so that it is now possible to describe the results of the law with a reasonable degree of accuracy. Federal wireless regulation was an iron long in the fire before it was extracted and molded into its present form. When it came it was a pill without any sugar coating. Congress has an unpleasant way of saying "must" and not "may." But the medicine seems to have done the wireless system of the United States a world of good, even in the short time that it has been tried. Eleven officials in nine districts, armed with the formidable title of "Federal Radio Inspector," are administering generous doses according to the nature of the case by the following plan:

Amateur stations are restricted to a transmitting-wave length of 200 meters (656 ft.), "tuned sharp," and a transformer input of one kilowatt. In the case of stations within five miles of naval or military stations, the current input must be still further reduced to  $\frac{1}{2}$  kilowatt. Amateurs with two years of actual experience can obtain a special amateur-station license from the Secretary of Commerce to use a longer wave and a higher power. This grade of license is difficult to obtain, however, because the applicant must prove conclusively that a "substantial benefit to the art or to commerce" is likely to result; in other words, that his motive is not merely one of individual amusement.

At the Berlin convention—a meeting of the world powers held several years ago to arbitrate wireless questions of an international nature—it was decided that commercial stations the world over should use two wave lengths: 300 and 600 meters (984 and 1,968 ft.), respectively. Each government, however,

may authorize the use of a wave exceeding 1,600 meters (5,248 ft.) for long-distance transmission, as it is exceedingly difficult for high-powered stations to operate efficiently on short wave lengths. But the limits of 600 to 1,600 meters must not be trespassed upon, as wave lengths within that range are reserved for government stations exclusively. Shipboard stations, as far as possible, must operate on a normal wave length of 300 meters, "tuned sharp," to minimize interference. In case a distress signal is to be sent out, the apparatus is adjusted coarsely, so that it can be readily heard whether the desired receiving station is tuned for 300-meter waves or not.

Only two classes of stations are totally exempt from license: First, those whose apparatus is for receiving only; second, those whose influence does not extend beyond the state, or does not interfere with the reception of radiograms from beyond the state.

According to the new law, there are nine different, distinct grades of wireless operators, and they are classified as follows:

Commercial	Amateur	Technical
1, First Grade	6, First Grade	8, Experimental Grade
2, Second Grade	7, Second Grade	9, Instructor Grade
3, Cargo Grade		
4, Extra Grade		
5, Temporary Permit		

The severity of the examination for commercial operators has very effectively weeded out the "bluffers," and, it is reported, a noticeably increased operating standard is already the gratifying result.

In order to secure a first-grade commercial license the operator must be able to receive and send at least 20 words a minute in Continental-Morse—the international code—counting five letters to the word. Some of the inspectors require the applicant to receive in a foreign language, thereby absolutely assuring his accuracy. A single wrong letter in a word spoils an applicant's chance for a license, although, of course, he may take the examination



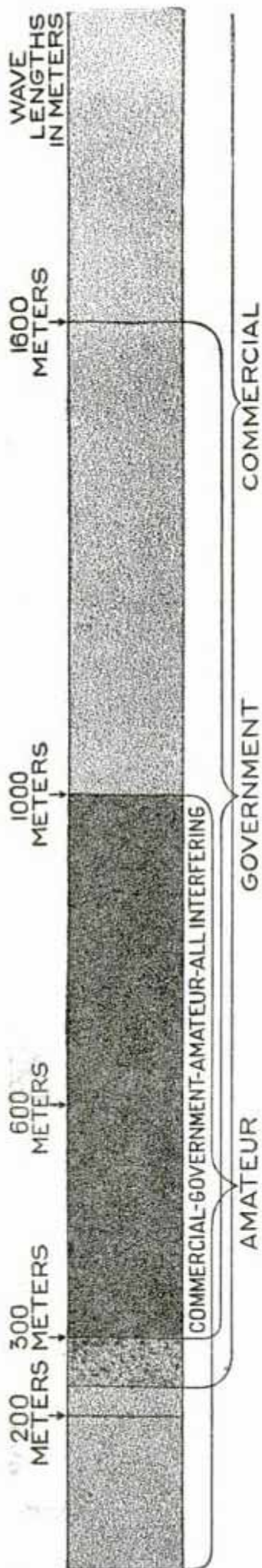

Under Former Conditions

over again at some other time. Next comes a written test covering wireless theory, adjustment and care of apparatus, knowledge of the Berlin Regulations and Radio Acts of Congress. Such practical puzzles are often given as: "What would you do to replace it, if the starting box of the motor-generator burned out?" Or, "How would you erect and insulate an aerial, in case yours blew overboard?"

Finally comes a test in adjustment for different wave lengths and correction of faults. A first-class commercial license qualifies the holder, if a man, for employment at any ship or shore station, or if a woman, for shore-station work. It might be mentioned in passing that very few licenses of any grade have been issued to women.

To gain a second-class license requires a knowledge of theory and apparatus less extensive than is necessary for first-class, and a sending and receiving ability of only 12 words a minute. Second-class operators are usually employed as "assistants" or "juniors" in ship and shore stations.

Cargo-grade licenses are issued in lieu of second-class for assistant operators on cargo vessels. Cargo-grade operators are usually members of the crew.

Temporary licenses, as the name suggests, are issued in cases of emergency, and are valid for one voyage only. The necessity of a provision of this nature can be appreciated when it is explained that a heavy fine is imposed upon the master of a vessel clearing port without an operator.

The highest grade of license obtainable is known as "extra-grade" and is issued only to operators whose first-class licenses, indorsed by the proper authority, record 12 months of satisfactory ocean service, and who can pass a special examination. The United States government plans to use these men in its own service.

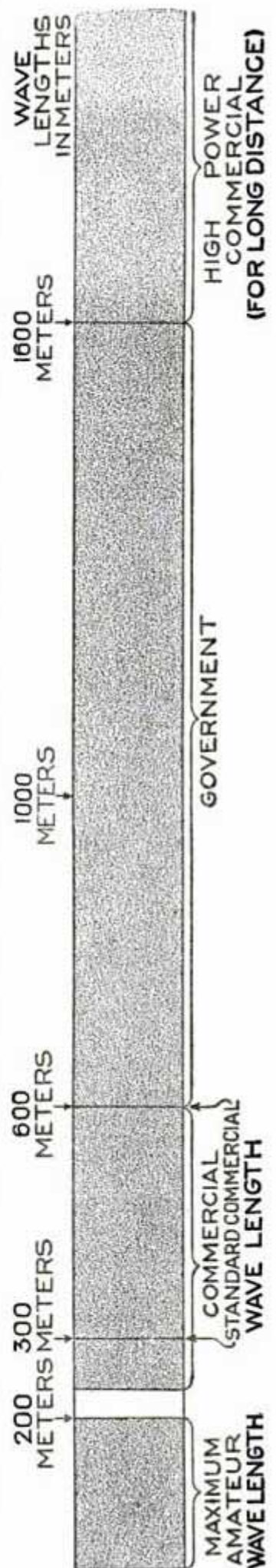

Under the New Law



The requirements for an amateur's license of either first or second grade are just the same, the distinction lying in the ability of the former to appear before the inspector for examination. Either must have a knowledge of the Berlin Regulations, adjustment of apparatus and ability to send and receive Continental-Morse, no speed being stipulated. The second-class license is sometimes granted as a temporary permit until the inspector has the time or opportunity to give the examination. Its real purpose, however, is to provide for the amateurs who, although unable to see the inspector personally, can satisfy him in writing of their sincerity and knowledge of the required subjects.

Experimental and instruction-grade licenses are merely special permits attached to first-grade commercial licenses.

The radio inspectors as a rule have had little trouble in enforcing the law, their most common complaint being

the surprising lack of knowledge of former professional operators applying for commercial licenses. About 5,000 licenses of the different grades have been issued so far, the amateurs, of course, claiming the majority.

One inspector, at least, took advantage of his privilege of enlisting the aid of police power to enforce his authority, when he was assaulted and beaten one night by indignant amateurs while trying to persuade them to comply with the 200-meter rule. Several nights in jail sufficed to impress upon them the majesty of the wireless law; and the publicity given the affair by the local press has made that particular district one of the most orderly of the nine.

Federal radio inspectors are stationed at Boston, New York, Baltimore, Savannah, New Orleans, San Francisco, Seattle, Cleveland and Chicago, and, as a rule, are glad to furnish information to amateurs and others seeking license.

## CAMPAIGN TO EXTERMINATE PRAIRIE DOGS

War against the prairie dogs on the sheep and cattle ranges of the West is being waged by the Biological Survey of the Department of Agriculture. About 277,000 acres of range, sufficient to support 6,950 cattle or 55,600 sheep, made worthless by the little pests, have now been restored to usefulness. Although the survey usually works to prevent the extinction of birds and animals, it justifies this campaign on the same grounds as the war against the bubonic-plague rat and squirrel and the tree-girdling rabbit. Poisoned grain is used to kill the pests.

Consumers are warned by the Department of Agriculture to wash celery stalks thoroughly before they are eaten, to remove the slight deposits of lime and sulphate of copper sometimes caused by the necessary spraying of the plant.

## COLOR-CHANGING HOODS FOR ELECTRIC-SIGN LAMPS

Hoods or cups made of colored glass, such as ruby, amber, green, opal, blue and frosted, designed to be easily slipped over the ordinary electric bulb, provide an ingenious, practical means of changing the color schemes and effects of electric signs and displays. The hoods are held firmly in place over the lamp bulbs by means of spring clips.

In 1911, the Irish depositors had the highest average deposits and the Scotch depositors the lowest in the British Postoffice Savings Bank.

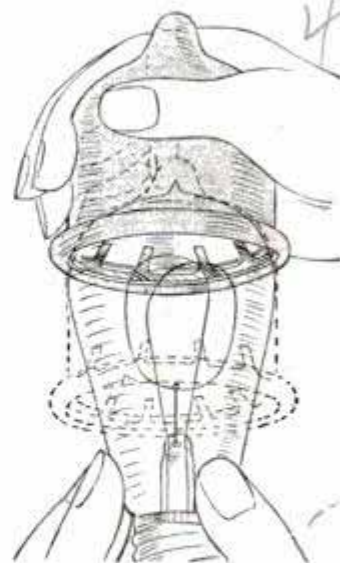



**COLLAPSIBLE RANGE FOR CAMPING TRIPS**

A cook range that can be taken apart and packed compactly for transport, has been placed on the market,

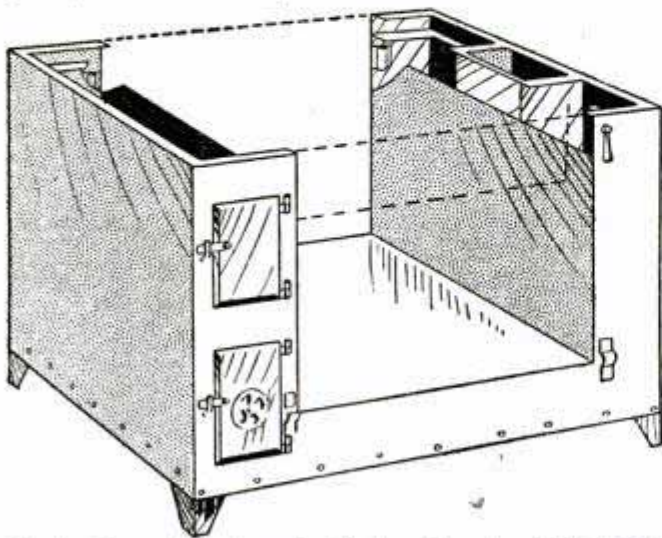

Cook Range That can be Taken Apart and Packed Compactly for Transport

and is designed particularly for use on camping trips in mountainous country, or under other conditions where transportation facilities are limited. The range consists of a U-shaped casing, the sides of which are formed with inner and outer sheet-iron walls and are open at the top. All oven parts are removable, while the top, bottom, and sides are so connected that they can easily be taken apart and set up again.

**WAGON SPRAG FOUND USEFUL FOR MOTOR TRUCKS**

There are several cities in the United States where the hills are sufficiently steep to warrant the fitting to heavy

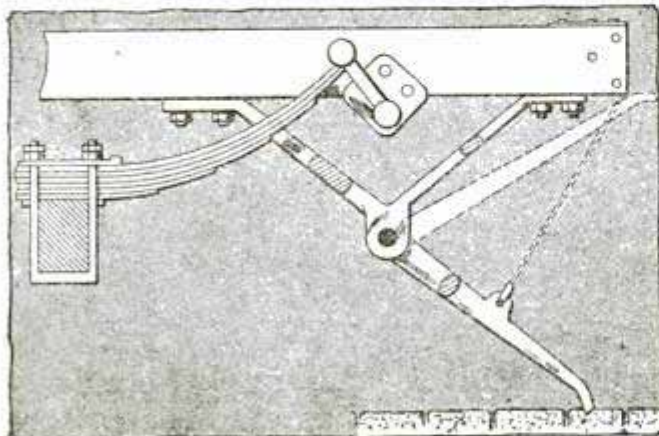

The Sprag of the Farmer's Wagon Finds a Welcome on Motor Trucks in Hilly Cities

motor trucks of the sprag which the farmer, in particular, has always depended upon to keep his wagon from rolling back downhill, when the horses tired and required a minute or two of rest.

The extent to which motor trucks are equipped with sprags is much greater in Europe than in this country.

**LIFE PRESERVER SHAPED LIKE PILLOW**

A life preserver has been invented which is designed to provide buoyancy at the head and shoulders and to make a person secure against drowning when exhausted or unconscious, the time when such protection is most needed. This is accomplished by making the life preserver so that it will spread out like a pillow, supporting the body directly under the armpits, and preventing the head from sinking into the water in case the user becomes un-



This Life Preserver Prevents Head from Sinking into the Water

conscious. Lightness, strength, long floating ability, and ease of putting on are provided in this device.

**FRENCH HIGHWAY DESIGNED FOR SAFETY**

A street with separate roadways for every kind of city traffic is being constructed along the Lille-Roubaix highway in France to decrease the number of traffic accidents. Although this road is unique in the extent to which the idea is carried out, it is merely an amplification of the plan used in the



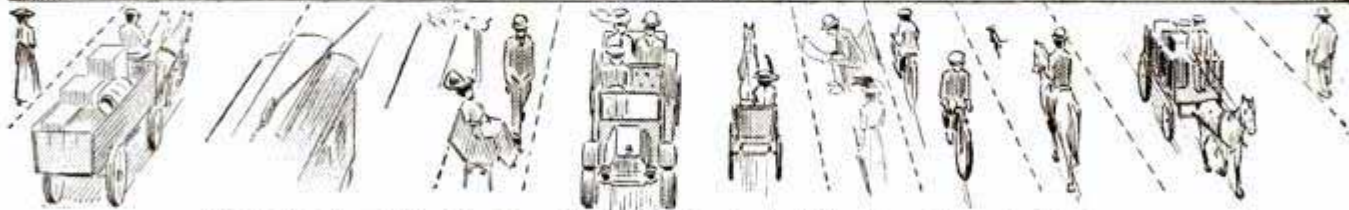
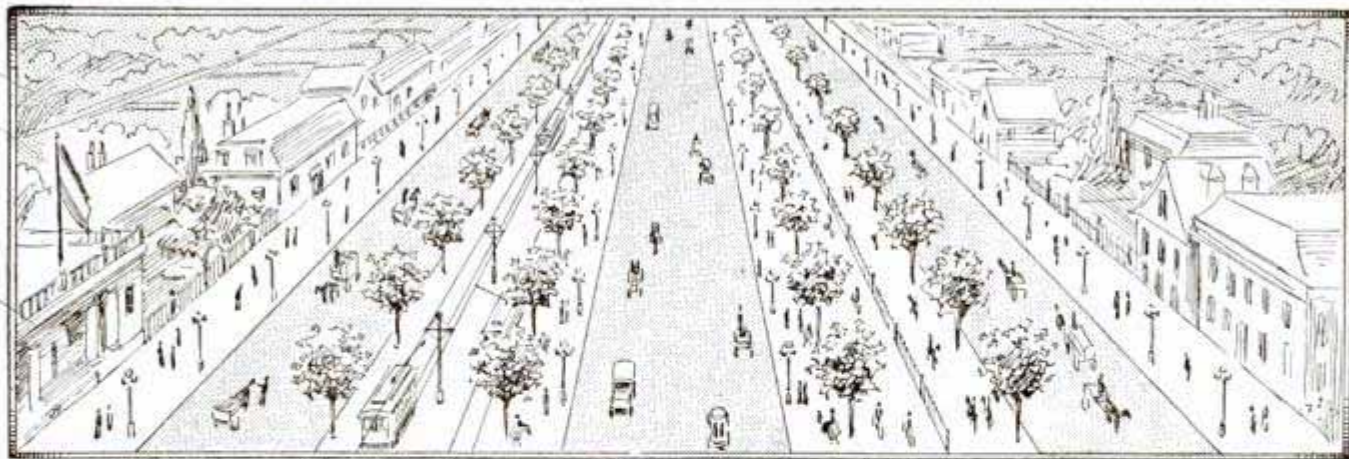

Each Kind of Traffic Has Its Own Road in This New French Highway

Avenue des Champs Elysees, Paris, and in the boulevards of some American cities. The new highway is divided into 10 separate roads or paths and each one has the kind of pavement best fitted for its traffic. The broad drive down the center, lined with lamp-posts, is intended for automobiles and other fast-moving vehicles. On either side of it is a walk for pedestrians with benches under shade trees. On one side of this central section is a double-track trolley line between two rows of trees; on the other side are paths for cyclists and horse-back riders separated by a fence and shaded by two more rows of trees. The outside roads on either side are for carts and other heavy, slow-moving vehicles, and lighted walks for pedestrians separate these from the bordering buildings. Such a division of traffic, it is hoped, will do the work of a large "traffic squad."

shocks, so that the machine may be driven over rough roads without any shocks being felt on the tandem. All springs are inclosed in tubes, the cushions are provided with skirt guards and side pockets, and the foot rests are so constructed that they fold flat when not in use. The seat is also provided with a back rest that can be lowered

New Motorcycle Seat with Springs That Absorb Both Vertical and Horizontal Road Shocks

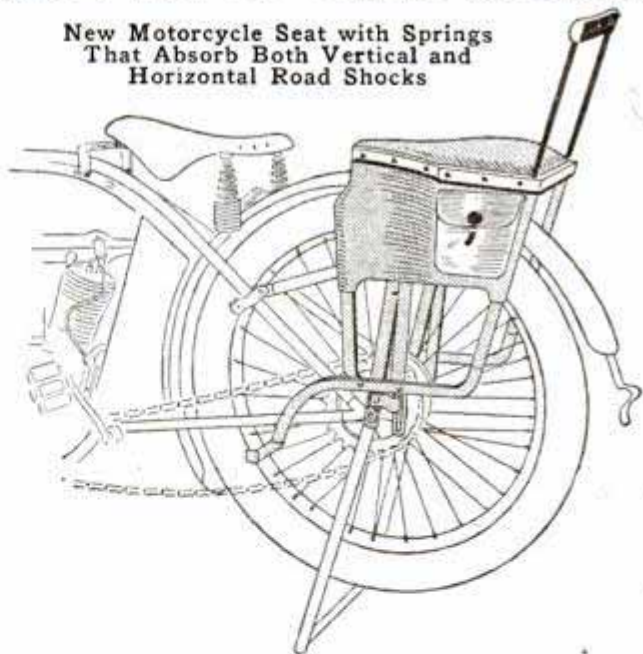

### NEW TANDEM SEAT FOR MOTORCYCLES

Motorcyclists will be able to insure the comfort of their passengers by means of a new tandem seat that has been placed on the market. Besides the usual vertical shock-absorbing springs this seat is provided with springs which absorb the horizontal

instantly while riding, in case it becomes necessary to dismount quickly.

☞The roof garden of a New York hotel has a glass roof over which flows a cascade of water, which, with a special light arrangement, produces the illusion of dining under water.



## WRIST PURSES FOR PAY-AS-YOU-ENTER FARES

About the handiest device designed for the shopping woman who has to pay her fare on entering a street car



Convenient Wrist Purse for Car Fare, Etc.

is the little wrist purse here shown. It is designed like the wrist watch, and straps around the left wrist in such a position that it is a simple matter to unsnap the lip and extract a nickel with the right hand, no matter how many bundles are being carried under the arms.

## SANITARY CONDITIONS IN MINING TOWNS

Just how much insanitary conditions have to do with the death rate of miners, through diseases or accident, is to be studied by the recently organized Mine Sanitation Section of the U. S. Bureau of Mines, with a view to the betterment of living conditions in mining towns. The bureau will reach the mine workers through illustrated lectures, moving pictures, and pictorial circulars, and will assist the managers by studying conditions and

outlining improvements. The chief difficulty in improving mining towns results from the facts that each town is built at a stroke by the mining company and that the individual householders have no pride in their surroundings. But the method of building mining towns easily lends itself, for the same reason, to thorough and sweeping improvement when the necessity is pointed out, since the employer is the landlord of the whole town. Satisfactory water supply is one of the first questions to be treated. Because the private wells drilled in mining towns are ordinarily polluted, it is thought that the distribution of pure drinking water from a common source, the establishment of public laundries and public bath houses at the mine shafts and at the schools will be of great benefit. Sewage systems will also be studied; the installation of a sewage-disposal plant, it is thought, will be the only solution for the sewage problem in these hilly towns. In spite of the utter lack of civic pride and the extreme ignorance of the inhabitants, a great improvement in sanitary conditions and health is expected from the movement.

## PIANO CHAIR WITH ADJUSTABLE SEAT

An article of furniture which looks like an ordinary chair when its seat is down, but which has quite a wide range of adjustability, is being marketed to take the place of the piano stool. The seat is held in position at the



height desired by a pawl-and-ratchet mechanism on the inside of the uprights of the chair's back. The chair is also practical for restaurants, schools and other places where chairs of adjustable height

are desirable or necessary.



ENORMOUS ANNUAL OUTPUT OF GOLD

The annual production of gold is now nearly five times as great as in 1887, when the Witwatersrand, in South Africa, the greatest gold field in the world, was opened. When it is considered that a nugget of gold weighing a pound, which would be about the size of an egg, is worth over \$300, the amount of gold dug out of the earth each year is truly enormous. In 1911, the total production amounted to 785 short tons, valued at over \$472,000,000. If all the gold produced in that year could be collected and made into a slender shaft, 1 ft. thick and 1 ft. 9 in. wide, it would reach from street level to the top of the Woolworth tower, which is a trifle over 750 ft. high, while a train composed of 16 cars, each having a capacity of 50 tons, would be required for transporting the gold to the site. In addition to this a foundation similar to that of the Woolworth building would be required for supporting

comes second on the list with a production of 159 tons, valued at a little more than \$96,000,000, while Australasia comes third, with a production of 101 tons, valued at \$61,000,000. In comparison with these figures the production of other countries is relatively small. In the 25 years from 1887 to 1911 the production in the Rand alone amounted to about 2,500 short tons, valued at over \$1,500,000,000. A train consisting of 50 cars, each having a capacity of 50 tons, would be required for hauling this output. As an indication that the known supply of gold is nowhere near exhausted, it is estimated that the main reef of the Witwatersrand alone still holds something like \$12,500,000,000 worth of this metal.



Gold Production of 1911 would Make a Shaft 1 Ft. Thick and 1 Ft. 9 In. Wide, Reaching to the Top of the Woolworth Tower, New York City

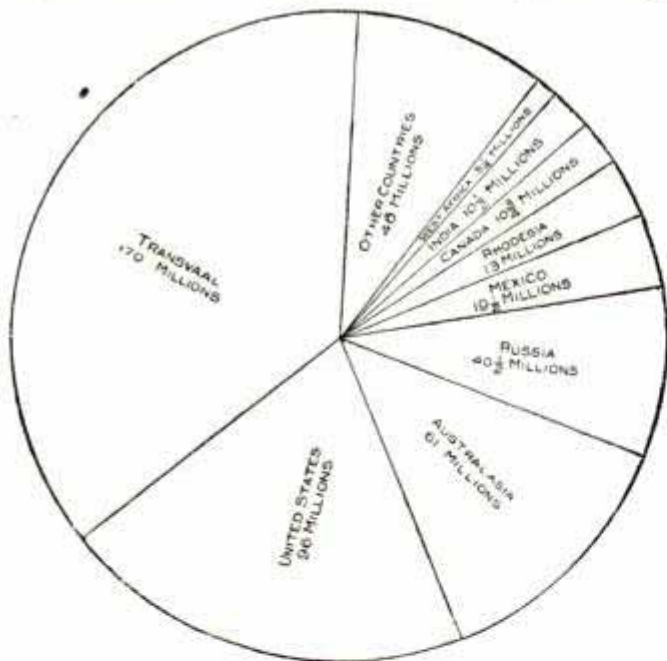

Diagram Showing the Relative Gold Production of Different Countries in 1911

this enormous concentrated weight. Of this, 36 per cent, or 283 tons, valued at about \$170,000,000, was produced in the Transvaal. The United States

A recently invented device for detecting the presence of icebergs consists simply of a flexible strip of material that deflects under a sudden change of temperature and causes an alarm bell to ring.



Train of 16 Cars Required for Hauling the 785-Ton Output of Gold for 1911



## PICTURE MOLDING MADE OF METAL

This style of picture molding is made of galvanized sheet metal instead of wood, and is intended to be nailed in position before the plaster is applied, thus bringing the molding on a level with the surface of the wall, instead of extending beyond it, and providing a stronger support for heavy pictures. If desired, this type of molding can be made invisible by decorating it the same as the wall, or it may be finished in some contrasting color to create an attractive effect.

## DEVICE FOR STUDYING THE FLIGHT OF MOSQUITOES

A device that shows the direction of flight of mosquitoes is now in use on the Isthmus of Panama and is expected to be of great assistance in locating the breeding places of these insects, as well as in determining the relative numbers

of the different species. This device consists of a metal frame holding four plates of glass, each 12 by 12 in., supported on a tripod. The glass plates are held stationary at right angles to each other and the instrument is set up in such a way that the

plates point north, east, south and west. To catch the mosquitoes the plates are coated with a sticky mixture of rosin and castor oil, which is practically transparent. In finding breed-

ing places the instrument is useful in eliminating the areas facing the glass surfaces that do not show a catch. It is designed mainly for use at night when the flight of the mosquitoes cannot be seen.

## NONEXPLOSIVE CAN FOR PRIMING AUTO ENGINES

A special nonexplosive gasoline can, for use in priming the automobile or motorboat engine, has made its appearance on the market.

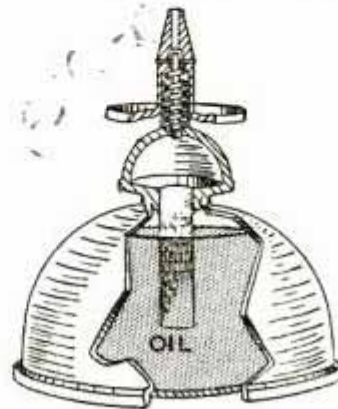

When priming is necessary, the nozzle is placed in the priming cup and the can pressed downward. This forces the nozzle

farther into the cup and at the same time opens a small globe valve, which allows the gasoline to flow. When sufficient gasoline has passed, the nozzle is lifted out of the priming cup, and the valve automatically closes. The can, which holds 1 pt., is thus never left open, and can be kept in a tool box for months without evaporation of its contents.

## USEFUL ATTACHMENT FOR STOVE LEGS

A lifting device by means of which the legs of a stove may be raised and the latter moved over the floor upon casters is being manufactured. A lever projects through the front of each stove leg and, by pressing the foot upon the lever, the stove is raised high enough to rest wholly upon the casters, which are ball-bearing, and can be easily moved in any direction.

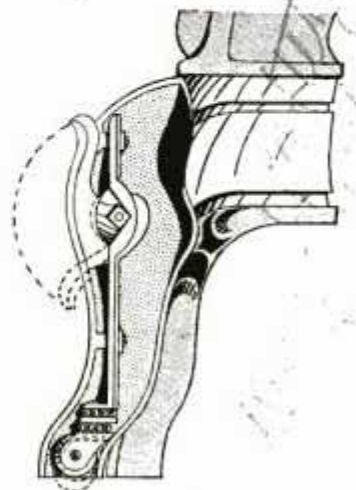



A MOTORCYCLE HEALTH CRUSADE

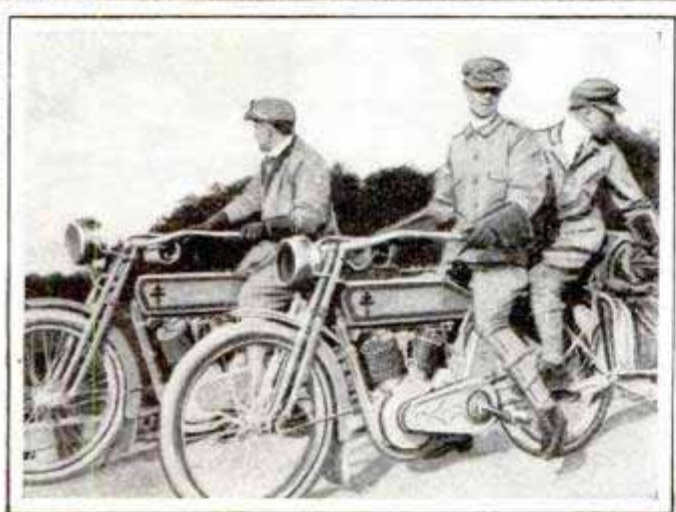
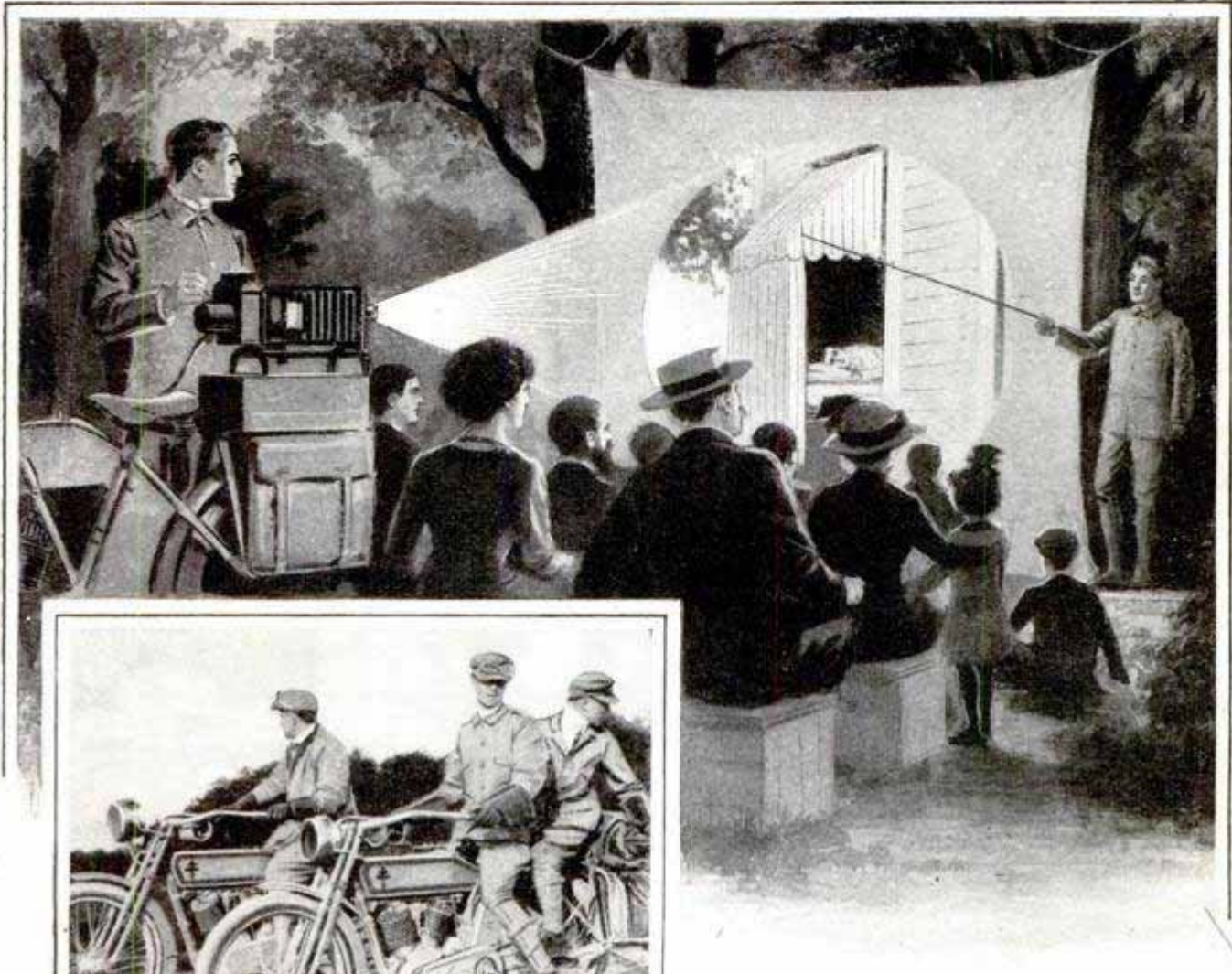

Crusaders against the White Plague Who are Using Motorcycles in a Rural Campaign in Wisconsin

Motorcycles are used in the rural campaign against the white plague which the Wisconsin Anti-Tuberculosis Society carries on in the summer. The work consists in placarding the country with health signs and giving talks at creameries, cross roads, and villages. Evening lectures in the villages are illustrated with stereopticon pictures thrown from a lantern on the luggage carrier of the motorcycle connected with the gas tank which supplies the headlight. Two health crusaders, a lecturer and an assistant, work together, riding on the same motorcycle, sleeping out of doors, and doing their own cooking with an outfit carried on the machine. In eliminating hotel bills and delay caused by train schedules, the motorcycle is reducing the cost of the campaign and increas-

ing its effectiveness. Two photographs of health crusaders are shown here.

**FIREMAN'S HELMET CARRIES ELECTRIC LIGHT**

The fire brigade of Southampton, England, is to be supplied with helmets carrying an electric light, as shown in the illustration. The idea was originated by a young shoemaker, who is an auxiliary member of the brigade. The battery for supplying the current is fixed in the cone of the helmet, and the light can be switched on and off at will.



*4467-111*  
*Worcester County, Massachusetts*  
*5/2/13*  
*1914*



## A FLOATING FLAT TO BEAT THE LANDLORD

By HARRY D. BARTLON

This is the story of my "floating flat" which I built to beat the high cost of living. For over a year, my wife and baby and I have lived in it and traveled in it and saved money as never before, for we have no rent, taxes, gas, water or light bills—nothing but food, clothing, gasoline, and amusements to pay for. We have been happy and healthy.

My floating flat is a 28-ft. cabin motorboat fitted up for a home. We built it a year ago to live in during the summer, but when the season closed we could not bear to leave it. It cost us less than \$1,000, two years' rent, and we have traveled 4,000 miles in it.

When we decided to build our floating flat, I took my plans to various boat yards and secured prices. I wanted a boat with sleeping accommodations for six persons, electric lights, power, bath, toilet, and cooking equipment. I finally found a contractor who would build the hull with gasoline tank, rudder and steering wheel, painted and finished, for \$275. Then I bought a 30-hp. engine with magneto, clutch, propeller, etc., for \$375. For lights I purchased a storage battery for \$75 and we recharge it on the way. The equipment of bell, lights, whistle, fire extinguisher and life preservers, which the government requires, cost \$30.

For beds we copied Pullman berths. The sides of the berths can be raised and fastened to the ceiling, one above the other, and for mattresses we made imitation leather cushions stuffed with moss. They cost us \$65. A plumber installed the toilet for \$16. Our folding bathtub was made out of a frame of brass rods and a piece of canvas 8 ft. square. Hot water is supplied from the intake on the engine and the drain runs into the bilge to be pumped overboard by the engine. The folding tub, waterproofed with paraffin, cost \$19 and a day's work. Our dishes, kitchenware, etc., were taken from home and we cook on a two-burner gasoline stove with alcohol generator.

While we lived on the boat we visited neighboring cities and I commuted to Chicago to my work as foreman in a large job-printing office. When cool weather approached, we decided to go to Louisiana with some friends. We were at Hammond, Ind., then, and made the trip to Chicago, 12 miles, safely through rough water. Our route took us down through the Illinois and Michigan Canal and the Illinois River, then down the Mississippi. At St. Louis, Memphis, Baton Rouge, and New Orleans, I worked at my trade and at Cairo, Vicksburg, Natchez, and other cities, we visited friends or looked around. We reached New Orleans on Dec. 14, just ahead of the cold weather all the way down. I found a harbor for our home, a position for myself, and a school for the baby, and we tied up there for the winter. Now we are going to travel in our floating flat "Thelma," back up the Mississippi and Ohio to Pittsburgh, visiting the flooded cities on the way. Then we shall ship her to North Tonawanda, N. Y., and visit cities in New York State and along Lake Erie on our way back through the Great Lakes to Chicago.

Our floating home is a pleasant one and we are saving money. We buy our groceries wholesale, store them under a seat, and find our little home quite large enough. We have no landlord to bother us and if we find a neighbor undesirable, we can move for a few gallons of gasoline. We have the pleasure and education of constant travel without expense, for I am able to secure positions along the way without difficulty. What I would spend for rent each month goes into the bank.

It is estimated that if the forests of the earth were completely stocked and scientifically worked, they would yield annually the full equivalent to from 30 to 120 times the present consumption of coal.





Some Neighbors on the Mississippi

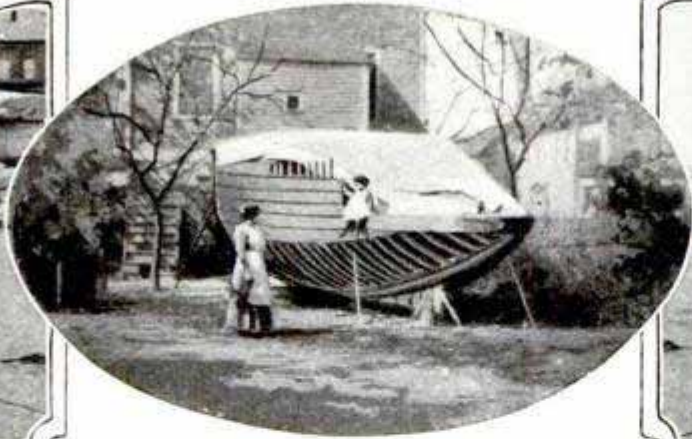

The Floating Home in the Building

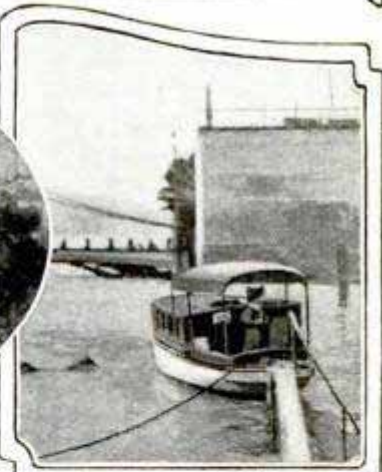

The Winter Anchorage at New Orleans

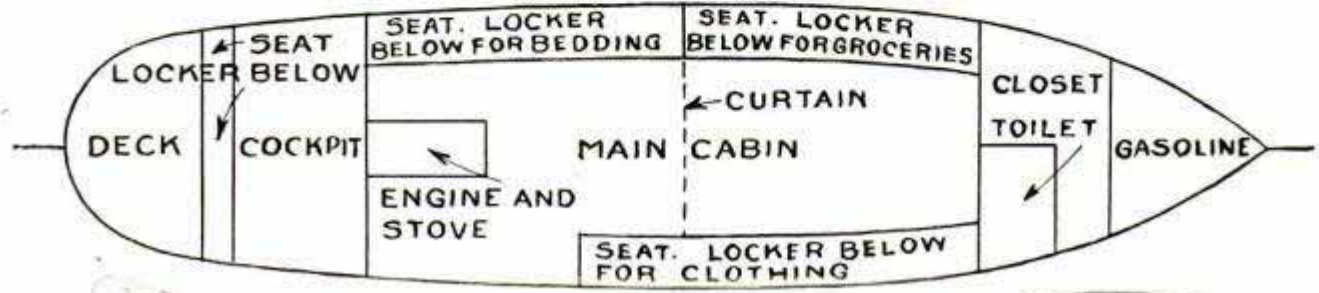

Ground Plan of the Floating Flat



"Thelma" at Lockport, Ill.

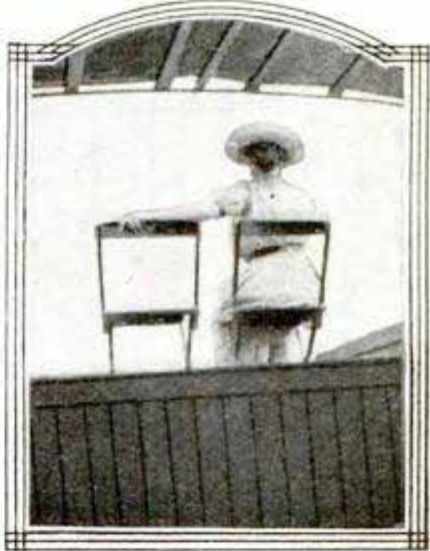

The Mate on the Bridge



Tied Up at New Orleans



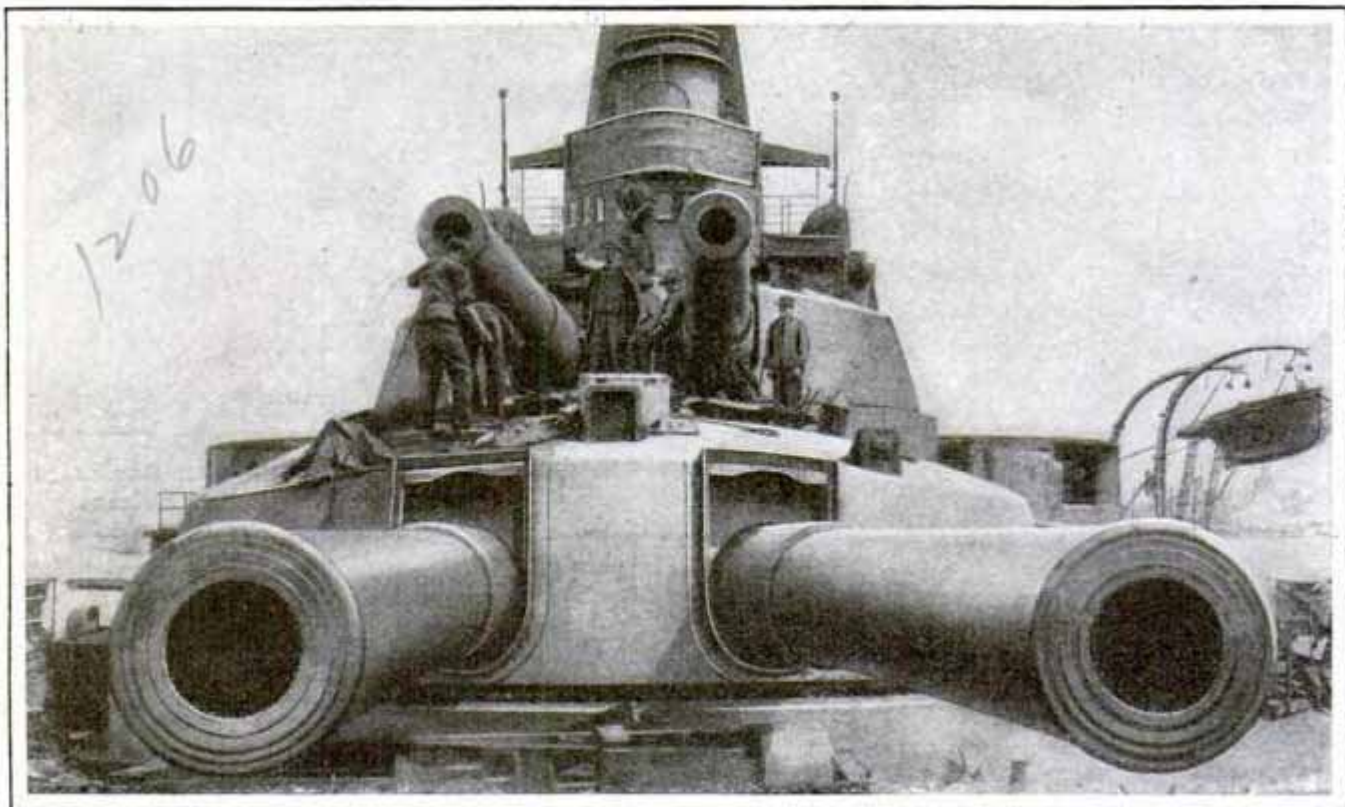

Courtesy London Illus. News

A Remarkable Close-Range View of One of England's Biggest Battleships, the "Conqueror," Which is Equipped with 13½-In. Guns. Two of These Mighty Engines of War with Their Gaping Mouths are Shown in the Immediate Foreground

### AUTOMOBILE TAKES PLACE OF FARM HORSES

Of the many uses to which automobiles are being put one of the most unusual is that shown in the illustration,

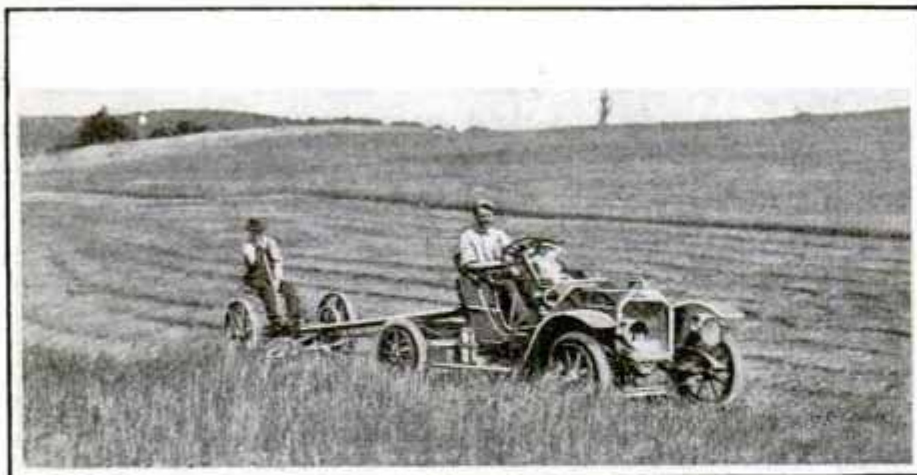

New Hampshire Farmer Uses Automobile for Hauling Mower

in which a runabout car hitched to a mower is doing the work formerly done by horses. This method is used by a New Hampshire farmer, who finds the car a practical and economical kind of motive power for general service about the farm.

### POWER GENERATED BY THE SUN'S RAYS

The heat of the sun's rays has been harnessed successfully in Egypt to furnish power for irrigation work, and the possibilities of the scheme are expected to be of great value in the development of the Sudan and Upper Egypt. As the idea of utilizing the sun's heat is worked out in Africa, huge lenses, arranged to focus the sun's rays upon boilers, generate steam without fuel. A simple clockwork device moves the lenses so that they follow the sun's daily

movement. During the first few days the plant was operated with zinc boilers, but the heat concentrated by the lenses became so great that the boilers were fused. Iron boilers have now been installed and the system is working successfully.

*Franklin D. ...*







## MOVING-PICTURE MACHINE FOR AMATEURS

A moving-picture machine, which is a combined camera, printer, and projector, put up in compact shape for

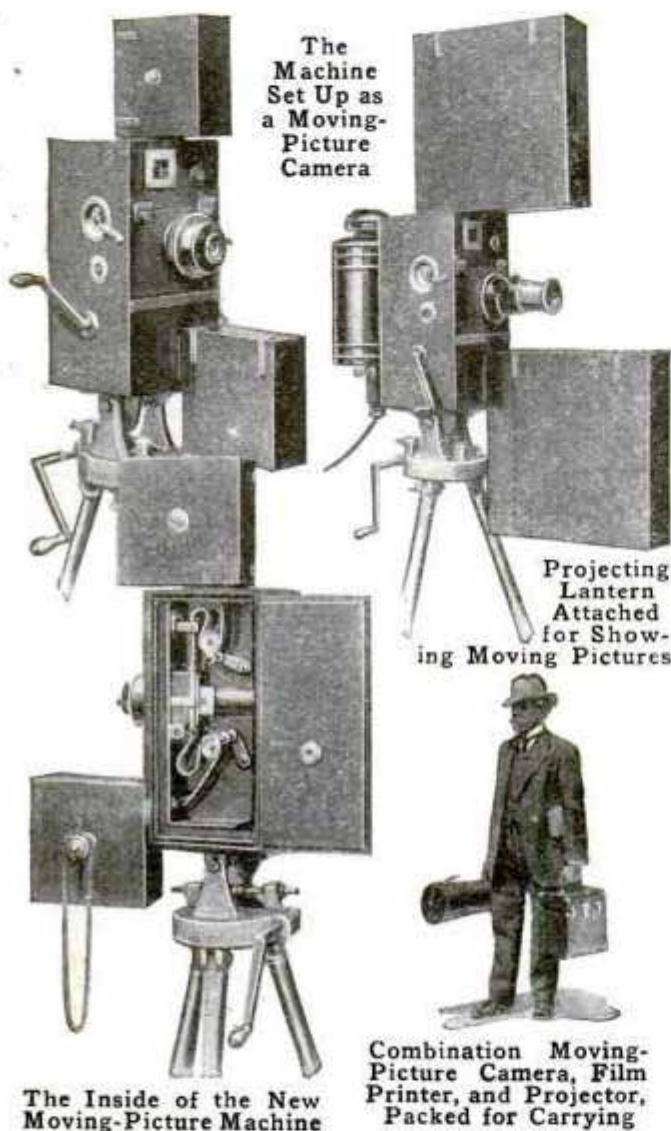

carrying, has recently been invented and patented, especially for the use of amateurs. As a camera, it will take moving, still, flashlight, and time exposures, and by means of its projecting device can be used for enlarging to life size. After the film has been exposed, the same machine can be used to print it. A 300-cp. incandescent lamp, to be attached to any light socket, and an adjustable lens quickly transform the machine into a projector for throwing pictures on a screen. The film can be stopped at any time without danger of burning and the machine can thus be used as a lecture stereopticon—700 ft. to take the place of 4,000 ft. of film. A focusing tube running

through the camera enables the operator to see his picture as it appears on the film and adjust the focus accordingly. A perforator to mark the end of scenes and an indicator to tell how much film has been used are also provided. The tripod furnished with the machine has a panoramic and tilting head.

## TEXAS COUNTIES BUILD A BOULEVARD

A paved highway, 100 miles long, is being built by several counties in Texas to connect some of the principal cities of the state. When it is completed, the county boulevard will extend from Dallas to Fort Worth, thence to Weatherford and Mineral Wells, and it will be as well paved as any street in the cities along its route. The section from Fort Worth through Tarrant County is now under construction, and surveyors are at work laying out the road from the county line to Dallas. The rest of the road is already completed.

## AN ALUMINUM FIRELESS COOKER

Aluminum is used in the construction of the latest type of fireless cooker. It is cylindrical in form and is made in three sizes to hold from 4 to 8 qt. The walls and the tightly fitting cover are made of double sheets of aluminum insulated with ground mica against heat conduction, but the bottom is not insulated. When food is to be cooked, the cooker is placed over a fire until the food is thoroughly heated and then set aside on an asbestos plate, which goes with it, to insulate the bottom. The double walls retain the heat and finish the cooking without burning the food.



*This is not special for Amateurs*

*Handwritten notes and signatures on the right margin.*



4313  
**POPULAR MECHANICS**  
**UNDERGROUND GARAGE FOR CHICAGO**

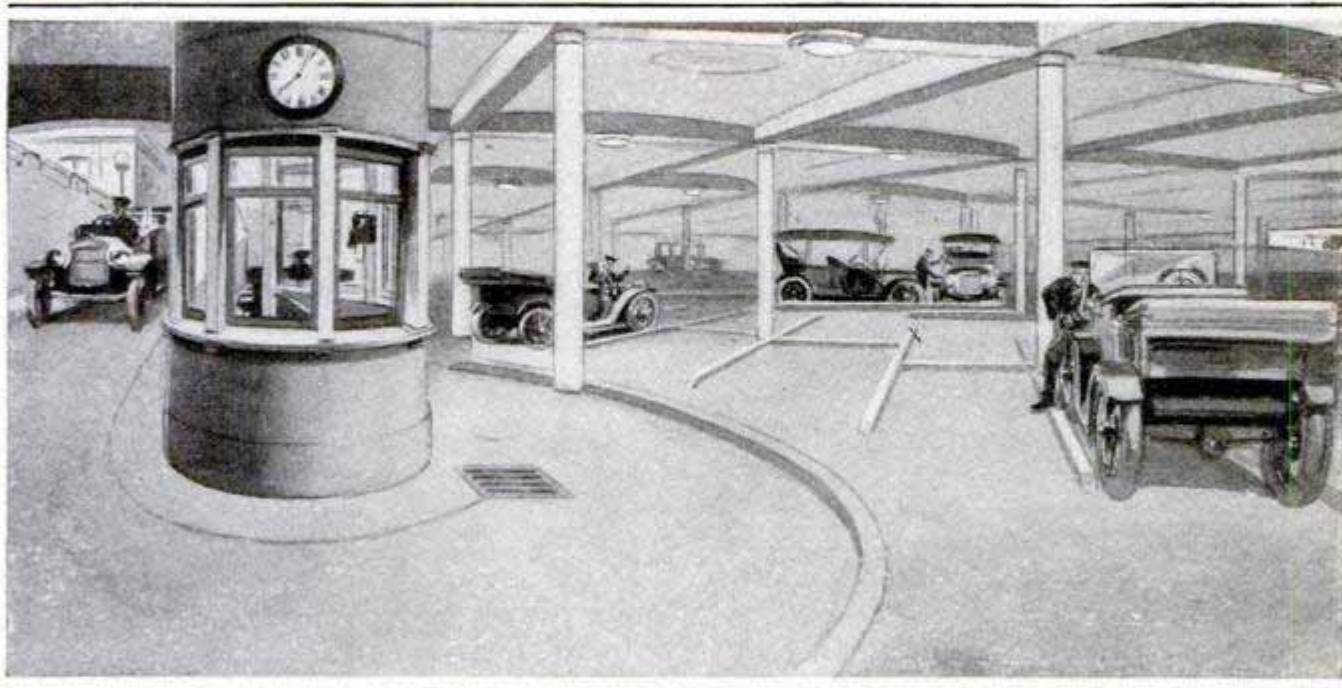

One Section of Proposed Public Garage under Grant Park at Chicago

For relieving the down-town streets of Chicago of the congestion caused by the parking of hundreds of automobiles along the curbing it is proposed to build an underground garage, 13 blocks long, occupying the space under Grant Park between Michigan Avenue and the Illinois Central tracks and extending from Randolph Street to the Park Row station near Twelfth Street. It is estimated that such a garage would take care of more than 2,000 cars daily. If built as planned, this will be the largest and most novel garage in the world, and will cost over \$1,250,000. According to present plans the garage will be constructed in sections, each section to accommodate 225 cars. The material specified in the plans is concrete.

The cars will enter over one inclined roadway and go out over another, so that traffic will be in one direction except when a machine is back-

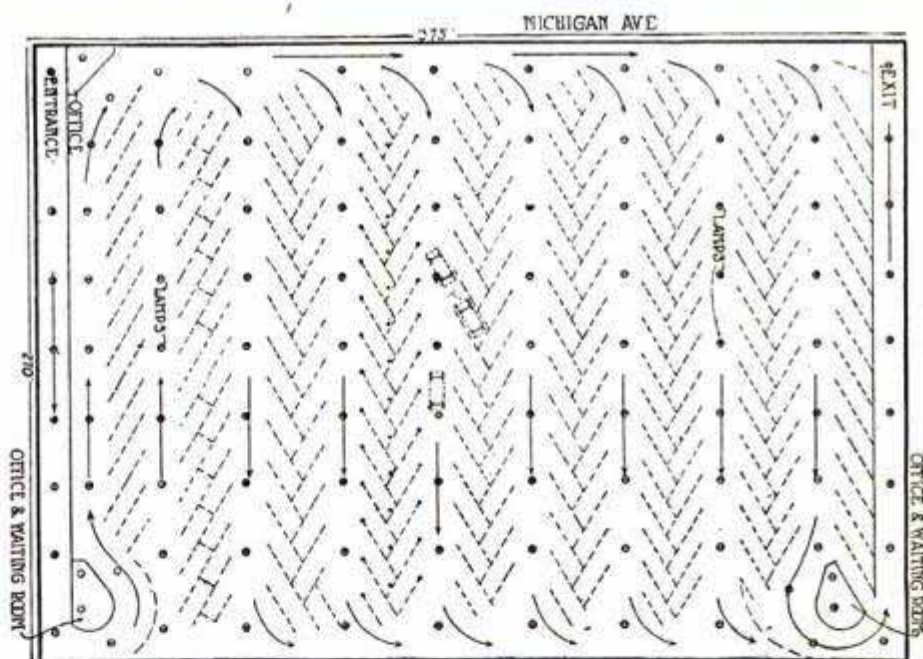

Ground Plan of Underground Garage, Showing Arrangement by Which All Travel is in One Direction

ing out of its stall. Each stall will be 16 ft. long and 8 ft. wide, and curbs of cement will be placed between stalls so that each car will be free from interference by other cars entering or leaving adjacent stalls. The inclined entrances and exits will have a grade of  $4\frac{1}{2}$  ft. to 100 ft., and will extend from the Michigan Avenue front to the rear of the garage. These are so arranged that a car will enter at one end of a section and leave at the opposite end, preventing interference of cars and reducing congestion on the street.

*Handwritten notes:*  
 10  
 11  
 12  
 13  
 14  
 15  
 16  
 17  
 18  
 19  
 20  
 21  
 22  
 23  
 24  
 25  
 26  
 27  
 28  
 29  
 30  
 31  
 32  
 33  
 34  
 35  
 36  
 37  
 38  
 39  
 40  
 41  
 42  
 43  
 44  
 45  
 46  
 47  
 48  
 49  
 50  
 51  
 52  
 53  
 54  
 55  
 56  
 57  
 58  
 59  
 60  
 61  
 62  
 63  
 64  
 65  
 66  
 67  
 68  
 69  
 70  
 71  
 72  
 73  
 74  
 75  
 76  
 77  
 78  
 79  
 80  
 81  
 82  
 83  
 84  
 85  
 86  
 87  
 88  
 89  
 90  
 91  
 92  
 93  
 94  
 95  
 96  
 97  
 98  
 99  
 100



## THE SWEDEN VALLEY ICE MINE

42  
 One of the mysteries of nature, until recently unexplained, is that of natural ice caves in which ice forms during the spring and summer and melts during the fall and early winter. Such caves, of which at least seven are known to exist in the United States, are entirely different from storage caves which, on account of their sheltered location, preserve, through the summer, ice formed during the preceding winter. One of the best known of the true freezing caves is the so-called Sweden Valley Ice Mine, located near Coudersport, Pa., which is said to be a fine example of a natural summer ice factory.

This cave is really a pit or shaft, about 8 ft. in diameter and about 12 ft. deep, and is located at the base of a steep hill. In winter the pit is comparatively dry and free from ice, the temperature inside being the same as that outside. But in the spring the rain water and water from the melting snow is frozen in the form of icicles as it trickles into the cave, the process continuing until, by July, the sides of the pit are completely covered with a coating of ice, a foot or more in thickness. In the early fall the process stops and the ice gradually melts. The sides of the shaft are of loose shale, in which there are numerous crevices extending back and up into the hill, the rock strata being rather sharply inclined. A draft of cold air, which at some places is strong enough to extinguish a small flame, issues from these fissures in the summer time. This draft is variable, being stronger on hot than on cool days. The temperature at the bottom of the shaft varies from 25 to 32 deg. Fahrenheit.

This apparently strange process, like other natural phenomena, is easily explained when all the conditions are known, and is due to the storage of "cold" during the winter by the circulation of air through the crevices of the rock strata above the pit. In the fall of the year, after the ice has entirely disappeared, the temperature of the air over the pit, in the pit, and in the crev-

ices is the same, and there is no circulation. But as cold weather comes on the air over the pit is cooled rapidly and becomes heavier than the warmer air in the crevices, and forces its way down into the pit and up into the crevices, expelling the warmer air through openings at the top of the hill. This cold air, coming in contact with the rocks, absorbs heat from them, becomes lighter, and is in turn forced upward and out through the top by the cold air entering from the bottom. In the course of the winter the rocks become chilled to a great depth and a large amount of "cold" is stored up, the amount depending on the length and severity of the winter.

When the warm weather of spring arrives the flow of air is reversed. The air over the pit becomes warmer and therefore lighter than that in the crevices, and the air in the crevices forces its way downward into the pit, being replaced by air that enters through the openings at the top of the hill. This warm entering air is chilled by coming in contact with the cold rocks in the crevices, and the process is continued until the supply of "cold" in the hill is exhausted. Surface water that trickles over the edge of the pit is immediately frozen by the blast of cold air, and ice continues to form as long as the current of air lasts. When the supply of "cold" in the hills is exhausted the circulation of air ceases, the ice in the pit melts, and the system is again ready for the storing-up process.

### JEFFERSON'S PORTRAIT ON NEW POSTAL CARDS

Thomas Jefferson's portrait will be substituted for the vignette of William McKinley on the new postal cards which will soon be issued. The change is made in accordance with the long-established custom of altering the designs of stamps and postal cards from time to time, especially when it becomes necessary to prepare a new supply of printing plates.





Interior View of Ice Mine, Showing Ice-Covered Steps at Right



The Opening at the Top of the Shaft

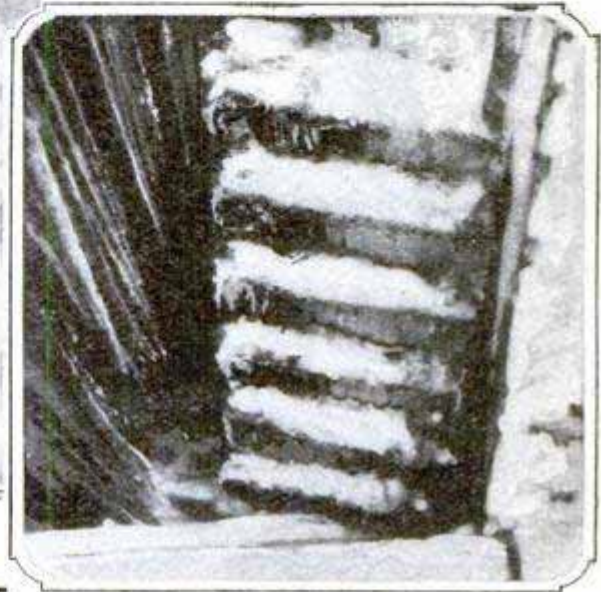

Looking Down the Shaft



Diagram Showing Summer Circulation. Cold Air in Crevices, Being Heavier Than Air Outside, Flows into the Pit

WARM AIR



Diagram Showing How Cold Air, in Winter, Forces Its Way into the Crevices in the Rocks

COLD AIR



General View of the Interior of the Sweden Valley Ice Mine



## THE LAST BOAT LEAVING A SINKING SHIP

Just as the last lifeboat was leaving a sinking steamship off the coast of Alaska, a camera in another lifeboat



The Last Lifeboat Leaving the Sinking "Curacao" Off the Coast of Alaska, a Few Minutes Before the Vessel Foundered

caught the remarkable picture that is reproduced on this page. The vessel was a passenger boat, the "Curacao," sailing between Seattle, Wash., and Skagway, Alaska. As she was leaving the port of Ketchikan, Alaska, on June 21, she struck a rock on the west coast of Prince of Wales Island and went down within an hour. In the picture, the forward end of the main deck is entirely submerged and the last lifeboat is pushing off from the stern. As no lives were lost, the two boats remaining on the hurricane deck indicate that the steamer carried more than the necessary amount of life-saving equipment.

☞The growing popularity of tennis is said to be due to the increased use of inexpensive clay courts instead of costly grass courts.

## VIENNA BUILDS DWELLINGS FOR THE POOR

Municipal dwellings for poor workmen's families are now being built in Vienna, Austria, as a result of the

distress caused by the exorbitant rents charged by private owners. Several buildings containing hundreds of workmen's flats have already been built by the city and more are under construction. Small flats, consisting of a kitchen and a one-windowed room, rent for \$5.50 a month, and larger ones having a kitchen and a two-windowed room, cost from \$6 to \$8 a month. Two serious evils which the poor had to contend with in privately owned flats have been abolished in the city's buildings—tenants can be turned out only for good reasons, after notice has been given, and families

with children are preferred. Each house contains a cooperative store, managed by the tenants, and thrift is encouraged in every way.

## A MACHINE FOR PICKING COTTON

A motor-driven cotton-picking machine has at last been brought to a point which seems to promise commercial efficiency after 21 years of experimenting, and is arousing much interest in the South. To supplant hand cotton picking, a machine must be able to pass along the rows of cotton plants, pluck off and sack the ripe cotton, and leave the unripe bolls, without injuring the plants. The machine in question is based upon the idea of revolving needles to pluck off the ripe bolls—a simple idea but difficult to apply. Out-



side the gasoline engine, mounted on top to furnish power, the four broad-rimmed traction wheels, the conveyors and bags to collect the cotton, and the high frame to support it as it straddles a row of cotton plants, there is little of interest in the machine except the picking drums. One of these is hung on each side of the machine so as to graze the sides of the plants between the wheels. Each drum carries

in the opposite direction, carry the cylinders backward at the same speed, so that the needles turn in the plant without moving horizontally through it.

A Motor-Driven Cotton-Picking Machine Straddling a Row of Plants

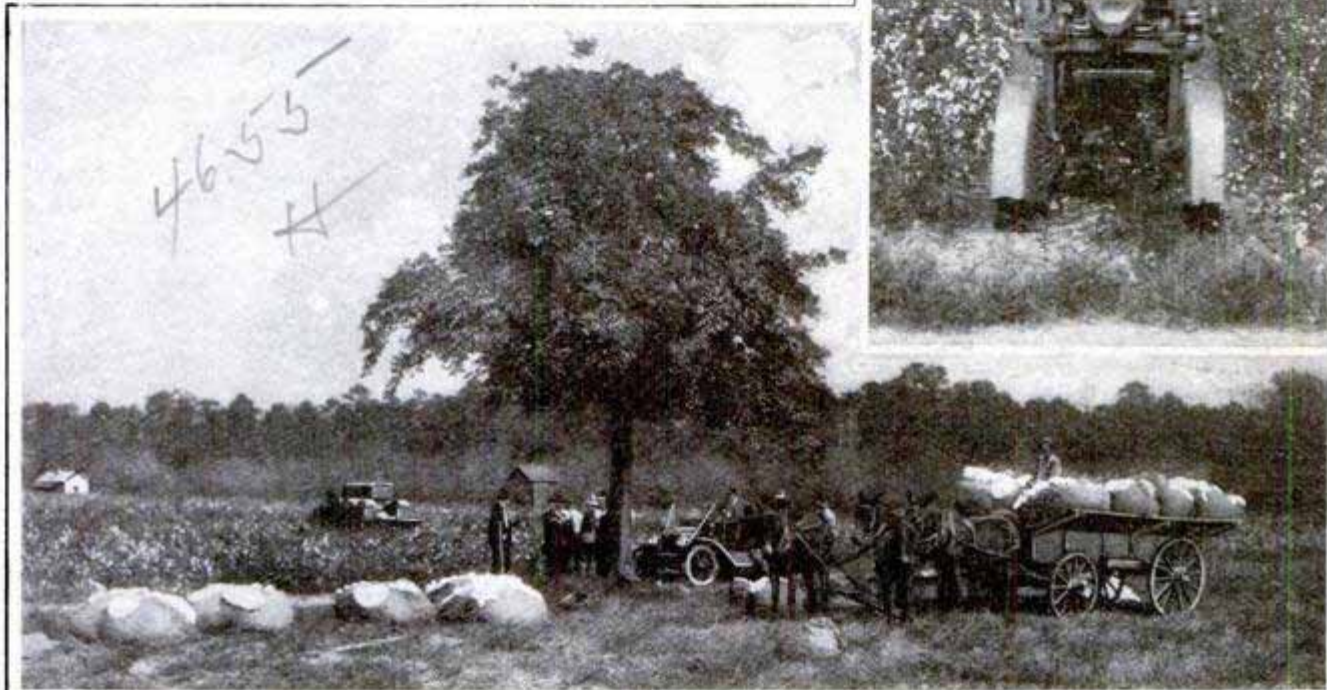
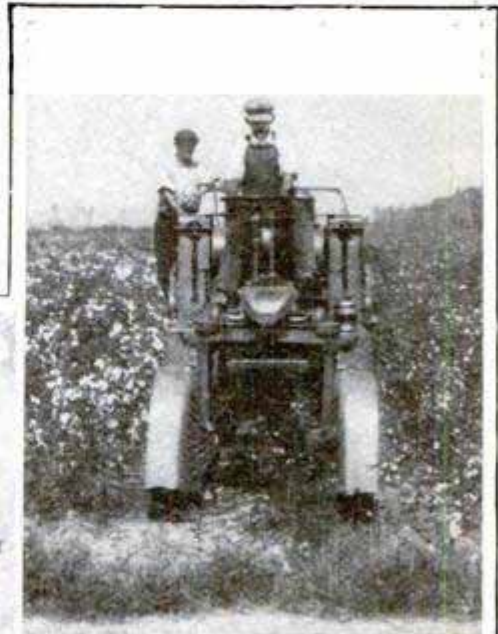

Copyrighted by F. Marchant

Above: A Day's Picking in the Sacks  
Below: These Four Machines will Do the Work of 100 "Hands"

an endless chain of vertical cylinders which revolve and follow each other around the drum. Projecting from the cylinders are horizontal needles which catch the cotton in the opened bolls and pluck them. As the machine moves forward, the drums, revolving

The machine will pick from 5,000 to 10,000 lb. a day, depending upon the field, at a total cost of about \$6. An average "field hand" can pick from 200 to 400 lb. a day. The machine is also designed to be used as a tractor for plowing and other work.

Handwritten notes on the right margin, including a vertical line and some illegible scribbles.



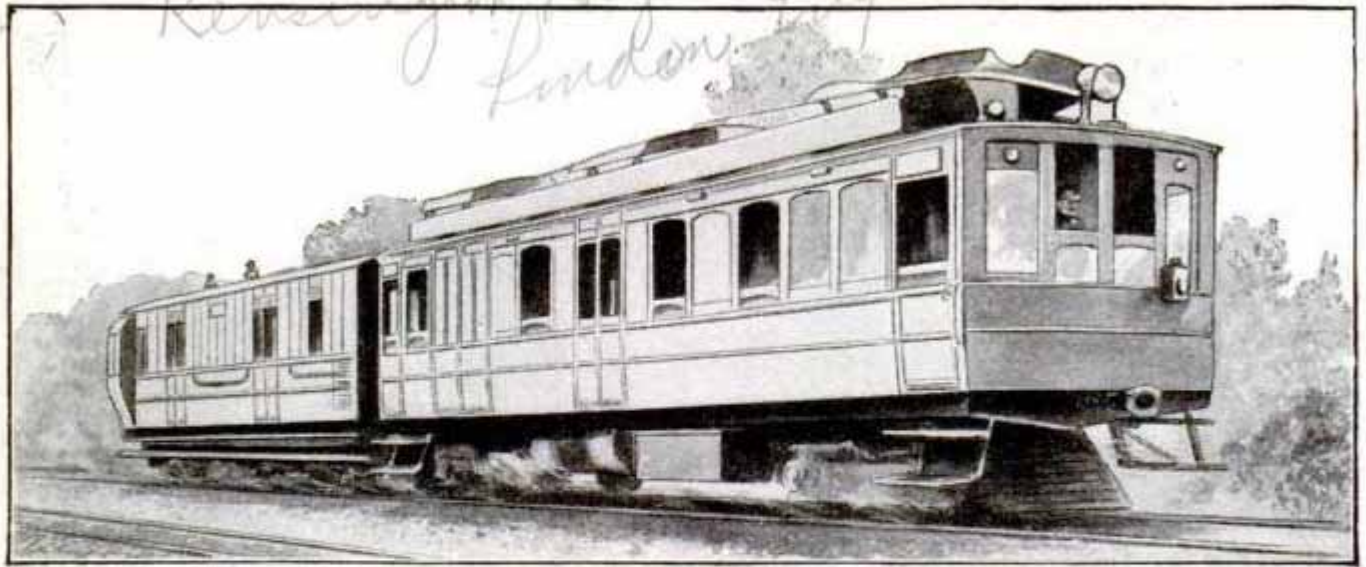

Courtesy of The Railway and Engineering Review

South African Railway Car with Combined Gasoline and Electric Propulsion

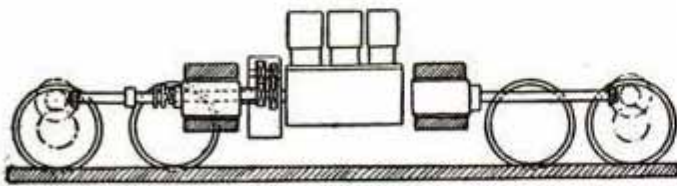

Diagram Showing Arrangement of Transmission System for Railway Motor Car

## GASOLINE-ELECTRIC POWER FOR RAILWAY CAR

A motor car which employs a novel combination of gasoline and electricity for propulsion is in operation on the South African Railways with satisfactory results. This car is 37 ft. 6 in. long over the body and 22 ft. 6 in. between truck centers, and has both baggage and passenger compartments. The total weight of the car is 21 tons, the motor alone weighing about 4 tons, while there is seating capacity for 42 passengers. The car is driven by a combination of direct propulsion from the gasoline engine and secondary propulsion from two electric machines which are operated by the gasoline engine. This is accomplished by planetary gearing carried on a casing rotated by the engine. This gearing turns the two sleeved shafts independently of each other, the outer shaft going to the second electric machine and the inner shaft to the first electric machine and to the propeller of the car. The whole mechanism is handled through one controller. A storage battery which is charged by these machines is capable of propelling

the car in case of emergency for a distance of eight miles at a speed of four miles an hour. This battery is also used for starting and stopping the engine, and for lighting the car. A maximum speed of 50 miles an hour has been obtained in tests of this car, when operated on level track.

## INTERSTELLAR SPACE AND ITS CONTENTS

That interstellar space is not an absolute void, but is partly filled with particles of matter, however small or invisible, is the theory that an American astronomer has evolved through the study of comets. His theory is based upon the fact that all bodies fall at the same rate in a vacuum, but in the open air lighter bodies are retarded by friction and fall at a slower rate. If interstellar space were a vacuum, all stars, comets, and planets would keep the same relative position and speed. But if it were not a vacuum, the lighter celestial bodies, such as comets, would tend to be retarded by friction and fall behind the larger and denser bodies. This retarding would be most noticeable at the part of the comet's orbit which is farthest from the sun, and the comet would tend to change its movement at this point and assume an individual direction. This hypothesis seems to be borne out by his observations.







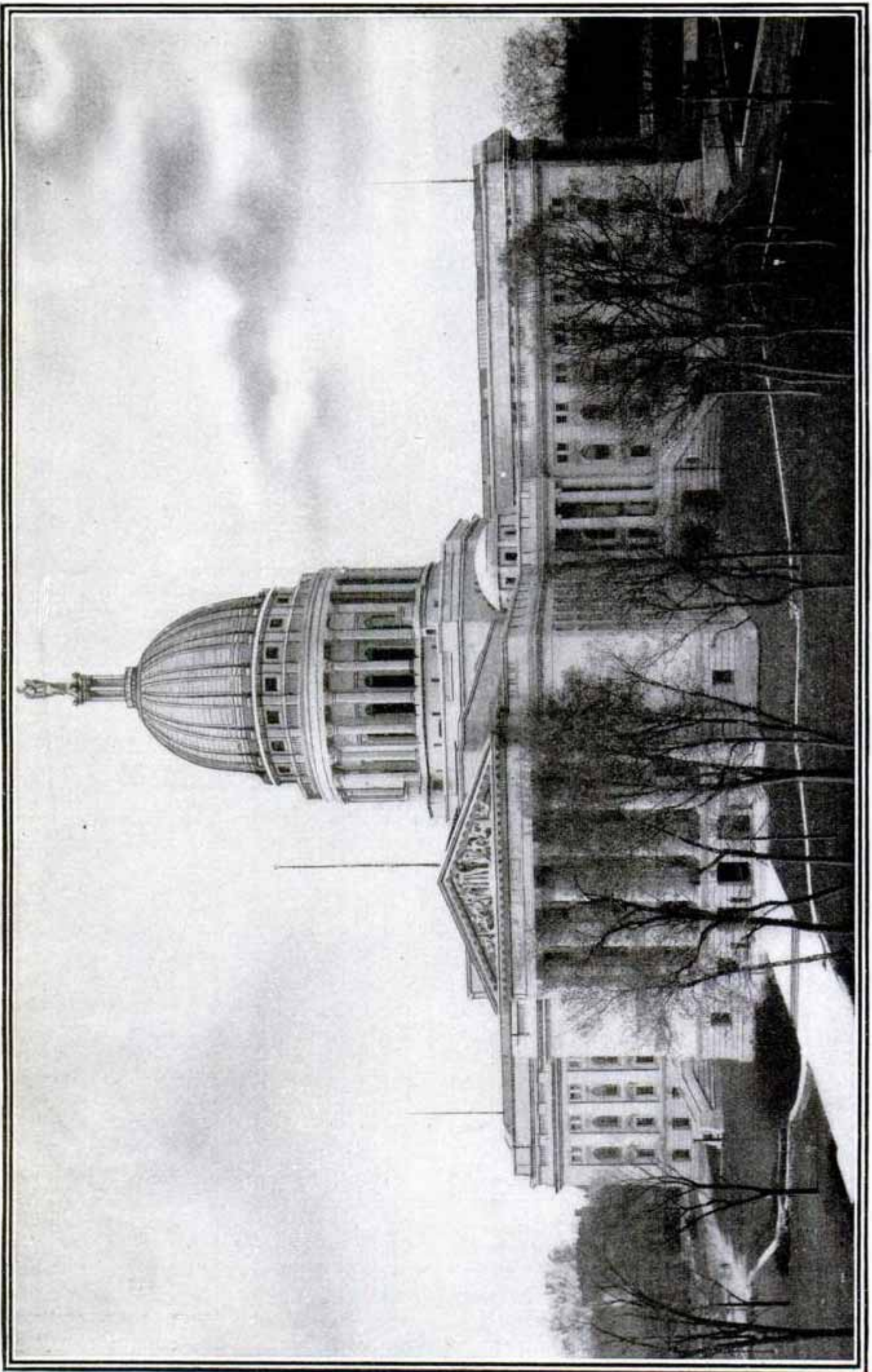

Wisconsin's New State Capitol Building at Madison, Now Nearing Completion



## THE NEW WISCONSIN STATE CAPITOL

By GERTRUDE G. WALKER

The fourth highest dome in the world is that of the new Wisconsin state capitol, with a height from the ground of 269 ft. 8 in. without the bronze statue of a woman which will increase it to 287 ft., more than the width of seven city lots. The three domes which are higher are those of St. Peter's cathedral at Rome, 330 ft.; the Duomo at Florence, Italy, 310 ft.; and the national capitol at Washington, 307½ ft. The dome on the Wisconsin capitol is more than 104 ft. in diameter, nearly as wide as three city lots, at the base. It is constructed of concrete, reinforced with 2,300 tons of steel, with an exterior wall made of 8,000 tons of white granite. In order to place the main steel girders, each of which weighed 23 tons, it was necessary to erect a square steel tower through the center, with derricks which could be moved from corner to corner. The dome alone will cost \$2,500,000, considerably more than one-third the price for the whole building, which is limited to \$6,000,000.

The capitol is built diagonally in the center of a beautiful park of more than 14 acres. It is on the highest point of land in the city of Madison, a hill 80 ft. high between the two lakes, Monona and Mendota. The building corners on the cardinal points of the compass with a wing facing in each of the four directions. The walls of each wing tower four stories to a height of 100 ft. Each wing is 128 ft. wide and 160 ft. long to the central portion below the dome, which is 112 ft. square, making more than two acres of floor space in every story and about eight acres in the building. The walls of each wing are constructed of 4,000 tons of white granite, which cost approximately \$300,000. With furnishings, each wing will cost \$800,000.

The most elaborate room in the new capitol is the governor's reception parlor, which has been fitted up at an expense of \$65,000. The two Turkish

rugs alone are worth \$4,000. The walls and the ceiling are ornamented with historical and allegorical paintings, which cost \$23,000. The parlor is an imitation of the Paolo Veronese room in the Doges' Palace at Venice, Italy. To gain the appearance of age, the artist has given the gilt trimmings a velvet finish and has made the floor of dull-finished teakwood. The furniture was made especially for this room, each piece being of Circassian walnut and bearing the Wisconsin coat-of-arms.

While Wisconsin quarries have furnished the granite for the building, the whole world has been searched for materials for the finer work. Marbles and stones have been secured from Italy, Greece, Africa, Germany, France, Mexico, and from Tennessee, Vermont, and Minnesota. The Circassian walnut for the furniture was imported from the region around the Black Sea.

Heat and power for the new building will be supplied from a private station, half a mile away, connected with the capitol by an underground tunnel, 8 ft. square, with walls of solid concrete, 2 ft. thick, reinforced with steel. Through this tunnel are run heavy cables to transmit the electricity to light the building and to work the elevators and bells. Great pipes through the tunnel will carry steam and water. The pressure on this water will be only 150 lb., not enough to force streams up the 270 ft. to the top of the dome. In order to protect the dome, an electrically driven centrifugal pump is installed within the capitol itself, which will deliver water under pressure of 300 lb. at the pump. In the dome, there will be 19 outlets for hose from this pump.

The construction of the new Wisconsin capitol has been continuous since 1901, when the excavation was begun. The building must be completed before 1917. Parts of it are already in use by state officials.



## PIPE ORGAN MADE OF WALL PAPER

A unique and attractive means of advertising his wares is employed by an Ohio wall-paper dealer, who has



Full-Sized Model of Pipe Organ Serves as Advertisement of Wall Paper

placed in his display window a full-sized model of a pipe organ. The interesting feature of this model is that everything about it—keys, pipes and all parts of the case, as well as the sheet music and music rolls—is made of wall paper, a variety of patterns being used to imitate the different parts.

## EUROPEAN PEARL FISHERS IN AUSTRALIA

That European divers do not have the physical strength to compete with the Asiatics has been indicated very strikingly by the attempt of the Australian government to encourage the employment of white men in the pearl-

fishing industry. All the European divers died or became paralyzed within two years. Financially the attempt was also a failure. The catch of the European diver never amounted to more than a ton a year, while the Asiatic could bring up four or five tons a year. And the white man asked as much as \$70 a month, and traveling expenses from Europe, to compete with Asiatic divers who work for \$10 to \$15 a month.

## DOORWAY IN NEW LINER'S RUDDER

The rudder of the new Cunard liner "Aquitania" is so large that it has a doorway in the bottom to admit workmen to the interior. If at any time it should be necessary to take the rudder off the ship, workmen must get inside the rudder to remove the connecting pin. The pin is 4 ft. long and larger than the heaviest projectile used in modern artillery.

## STONE TREE ERECTED AT HUNTER'S GRAVE

A huge tree stump cut out of stone marks the grave of David Huston, of Bono, Ind., a great hunter and trapper of former days. His gun, powder flask, and horn, in stone, hang from the stub of a branch on one side, and his dogs in miniature are chasing a fox about the base. Ferns and wild sprouts cover the roots and a large grapevine winds its way to the top, 21 ft. above the ground. The monument was designed by a friend of the hunter.





## SIGNPOSTS TO WELCOME TRAVELERS



Motorists are received in a very courteous manner by the city of Aurora, Ill. Signs stationed like outposts on all the roads form a reception committee to welcome the tourist and put him in a pleasant humor before he crosses the city limits. Instead of frightening him away with a warning of a fine for exceeding the speed limit, the signs merely give him a kindly hint that excessive speed is not desirable. To a motorist approaching the city, the signs read, "Aurora. Welcome to Our City; Watch Out for Cops!!" and as he leaves the city, the other side of each sign says, "So Long. Come Often and Stay Longer."



## WORM-EATEN PILES SNAPPED BY LOCOMOTIVE

Teredos, by honeycombing the piles of a wharf, caused the wreck shown in a picture on this page. The wharf, located at Tiburon, Cal., was less than six months old, but the shipworms, or teredos, had weakened the piling so

badly in that time that it crumpled up under a Northwestern Pacific locomotive, June 30. Both enginemen jumped and no one was injured. It will be noticed that the photograph was taken before all the steam had left the boiler.

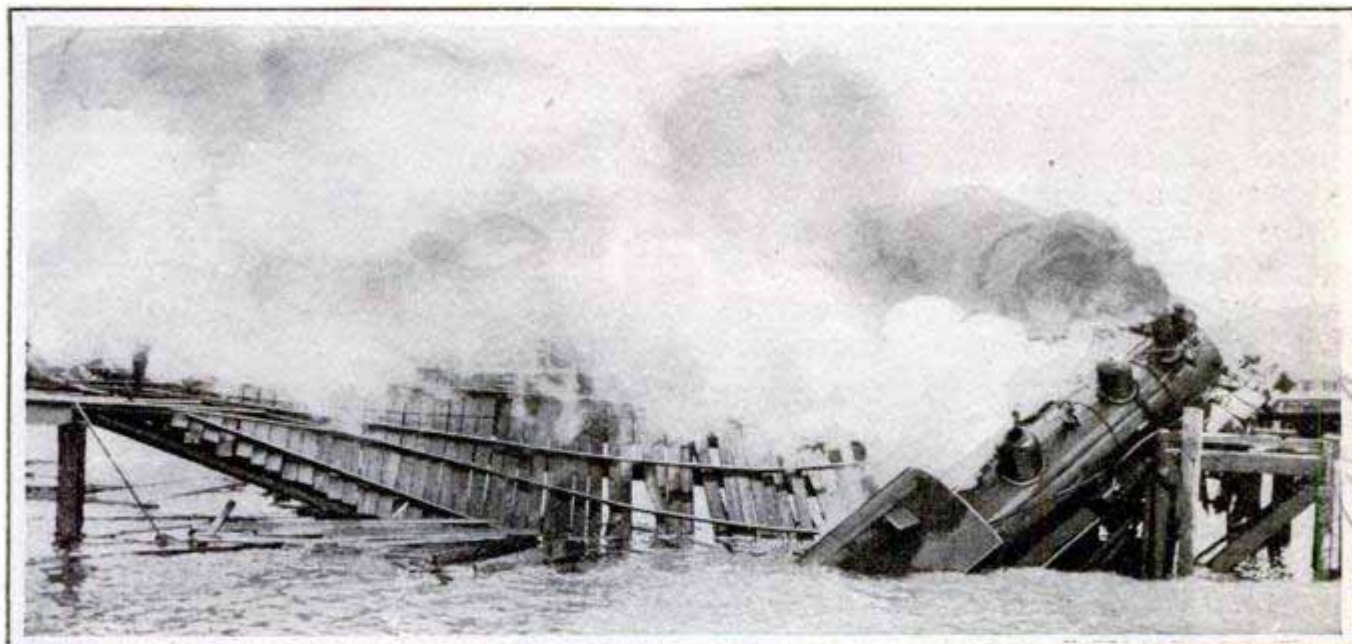

Wreck Caused by the Breaking of Worm-Eaten Piles

*Tiburon Marine Co. Cal.*



## MAKING SHINGLES FROM OLD STUMPS

Making shingles from the old stumps of cedar trees that once covered the western slope of the Cascade range



Stumps of Ancient Cedar Trees of Immense Size: Ten Thousand Shingles have been Made from a Single Stump

of mountains is a profitable though comparatively unknown business. The new forests and swamps are searched for these old stumps, which are sawed into "bolt" lengths and hauled to the nearest shingle mill, of which many are to be found in this region. Many of the old stumps are so large that, in some instances, 10,000 shingles have been obtained from a single one.

## ELECTROSCOPE MEASURES RADIUM DISCHARGES

An electroscope which actually measures current strengths as small as one ten-trillionth of an ampere was recently exhibited before the French Academy of Sciences. The practical value of the instrument has to do with radium. The use of radium emanations for medical treatment is steadily increasing and there has so far been no device sufficiently sensitive to detect the presence of such feeble discharges, excepting the gold-leaf electroscope, which, however, furnishes no measure of the discharge. The

new device, which is a torsion electroscope, acts as a real electrometer, the current causing a pointer to move over a properly calibrated scale.

ⒸAn announcement of considerable importance to motorists is that of the discovery of a substitute for acetone, which, it is stated, can be sold at about half the price of the true acetone.

## MODEL HOUSE DESIGNED BY HIGH-SCHOOL PUPILS

A model house, designed by high-school pupils for the demonstration of household science, was completed a short time ago in Springfield, Mass. With the exception of the paper hanging and a part of the masonry, the house was erected by boys in the technical high school and in the vocational school of that city. The house, which stands in the rear of the technical high school, was begun in 1910. The design and working plans were drawn by a girl in one of the classes, her work receiving the award in a competition. The boys drew the elevations, and the vocational pupils did some of the rough work and the framing. As there is no

class in plumbing for the high-school boys, the students of the evening trades school did this part of the work, and also the electric wiring.

The house is of an attractive bungalow style with an overhanging roof, and is 24 by 35 ft. It is divided into a large living room, hallway, dining room, bedroom, bathroom and storeroom. The rooms are neatly finished in fumed oak, gumwood and Georgia pine. The girl pupils made the tiles for the fireplace, stenciled the designs for the walls and curtains, and made the curtains, bed linen and table linen.

The house is not only attractive and convenient, but decidedly practical for



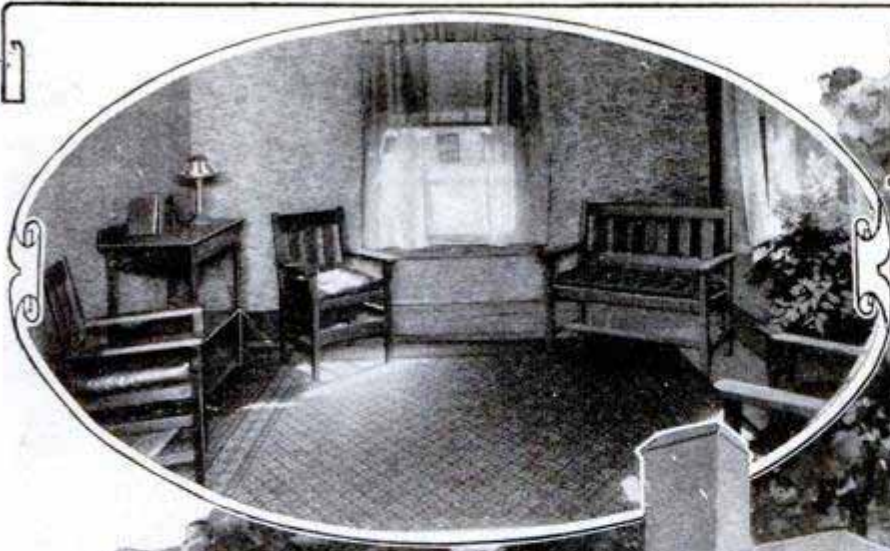

The Large Living Room,  
Tastefully Decorated  
by the Girls



4387

The Model House Designed and  
Built by School Pupils in  
Springfield, Mass.

*W. B. ...  
27 College St. Springfield, Mass.*

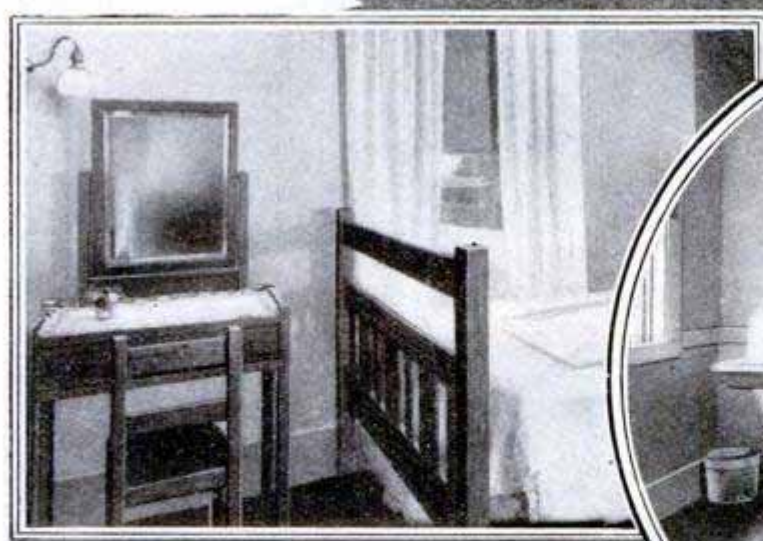

The Bedroom of the Model House  
The Practical, Workaday Kitchen

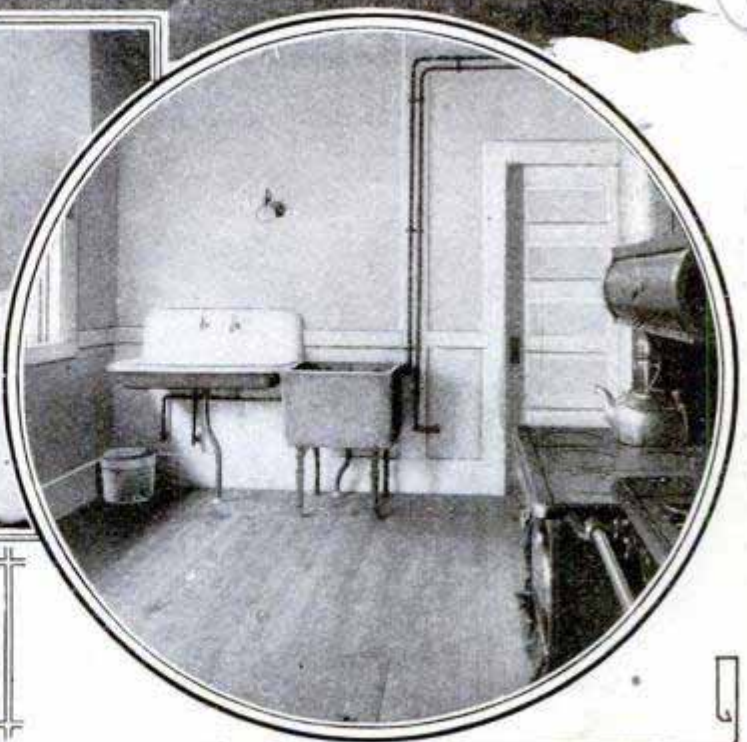







the leaders and the battering attachment. The combination of truss and lead is sufficiently rigid to hold piles upright against any tendency to get out of plumb while they are being driven.

## MEASURING THE GROWTH OF PLANTS

Very delicate and exact instruments are required in the scientific study of plant life. Among them may be mentioned the "auxanometer," which measures the rate of

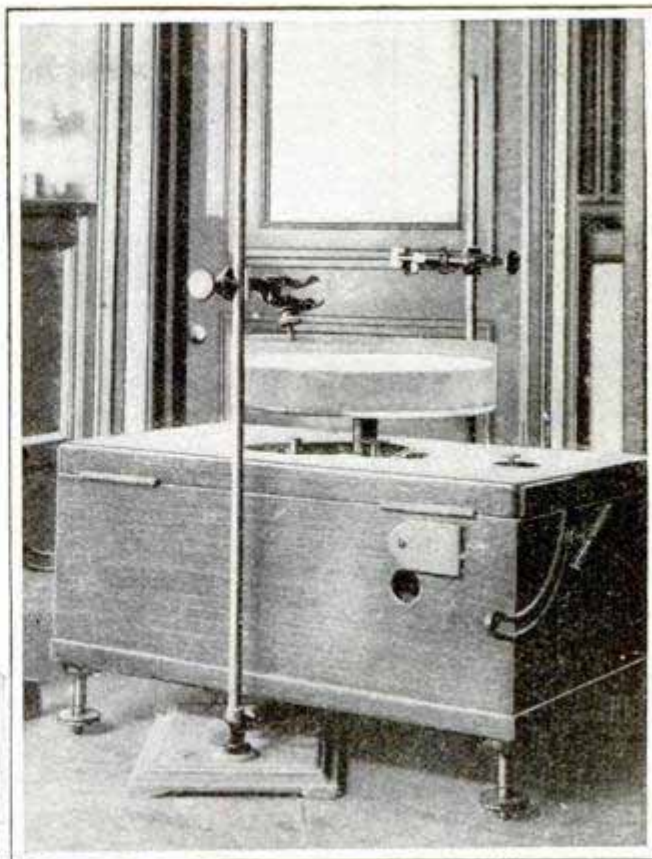

For Showing How a Current of Water Affects the Growth of a Seedling

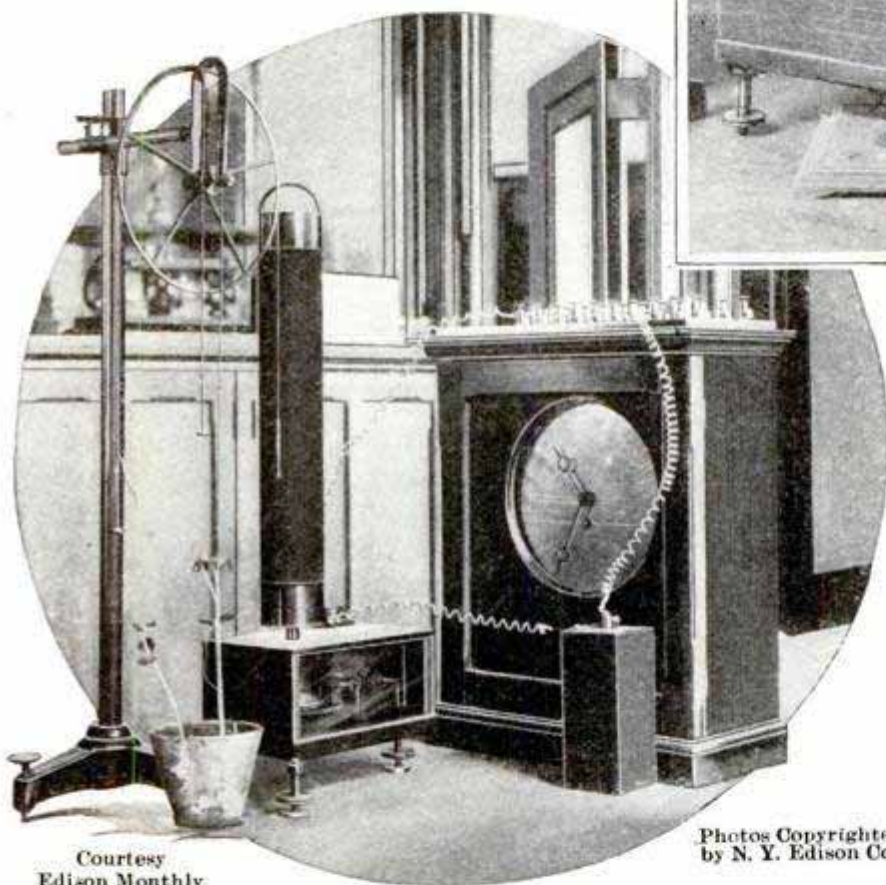

Courtesy  
Edison Monthly

Photos Copyrighted  
by N. Y. Edison Co.

For Measuring the Rate of Growth of a Plant

growth of a plant, and the "klinostat," which illustrates the growth of a seedling. In the growth-measuring machine a thread is attached to the growing apex of the plant and is then passed over a small wheel on a spindle, which also bears a wheel many times the diameter of the first. The large wheel also carries a thread, one end of which is attached to a pen or light straw resting lightly against the surface of a smoked paper covering the recording cylinder, which is made to revolve at

any desired rate. As the plant grows the wheels revolve, the large wheel magnifying the extent of growth measured by the smaller one and registering it upon the smoked paper of the cylinder.

In using the "klinostat," a seedling is suspended in a dish half filled with water, and this dish is made to revolve at a given rate. Ordinarily one would

suppose that the action of the water upon the seedling would incline the latter in the direction of the current, but, on the contrary, the root of the seedling is shown to incline against the stream.

ⒸThe Federal Lighthouse Bureau and the Forest Service are cooperating to use the large reservations attached to the Great Lakes lighthouses for growing timber.

*Handwritten notes:*  
4352-B  
Oct 1911  
pg 163



## INTERNATIONAL POSTAGE COUPON

A system of coupons designed for convenience in forwarding return postage to foreign countries is now in ef-



Coupon Issued by the U. S. Postoffice Department

fect in all the countries included in the Postal Union as well as in some other countries which have made special arrangements for issuing and honoring such coupons. In the United States these coupons can be bought or cashed at any international money-order post-office. A charge of 20 per cent is made for the service, which means that in this country a charge of 6 cents is made for a coupon redeemable in a foreign country for 5 cents worth of stamps, while in France a 25-centime coupon is sold for 30 centimes. In redeeming the coupons an American 1-cent stamp is considered equivalent to



Coupon Issued by the French Government

5 French centimes, and similar equivalents are in effect for carrying out the arrangement in other countries.

## POWDERED COAL LESSENS SMOKE NUISANCE

That the use of powdered coal in puddling and heat furnaces results in a great reduction in smoke as well as in economy, has been demonstrated by an Ohio steel mill. An eight months' test has shown that the average consumption is 1,120 lb. of powdered coal, as against 2,186 lb. of hand-fired coal, per ton of furnace output. In addition, the use of powdered coal, which is practically smokeless, has done away with the loss of time due to cleaning furnaces and has made possible one more heat a day than in the hand-fired furnaces. Waste-heat boilers for generating steam added to the powdered-coal furnaces evaporate from 6 to 7 lb. of water to 1 lb. of coal. The decrease in smoke, added to this economy, has interested smoke inspectors as well as steel manufacturers.

## PLANTING TREES TO BIND DRIFTING SAND

Trees can be used very successfully to hold sand and convert seashore wastes into beautiful pleasure grounds, as has been shown by the reclamation work carried on by the United States forest service in various parts of the country. The building of Golden Gate Park, San Francisco, on an area of shifting sand dunes is a notable example of reclamation in America, which is often compared with the planting of a valuable forest of maritime pine, the source of French turpentine, on the sand wastes of the Landes, France. As a result of its success in this work, the United States forest service has recently been asked by an agricultural colony in Palestine to assist in planting trees to convert the sandy shore of the Mediterranean near Jaffa, the ancient Joppa of the Bible, into a seaside resort.

CA flying boat capable of carrying four passengers is engaged in regular ferry service across Coos Bay in the state of Washington.



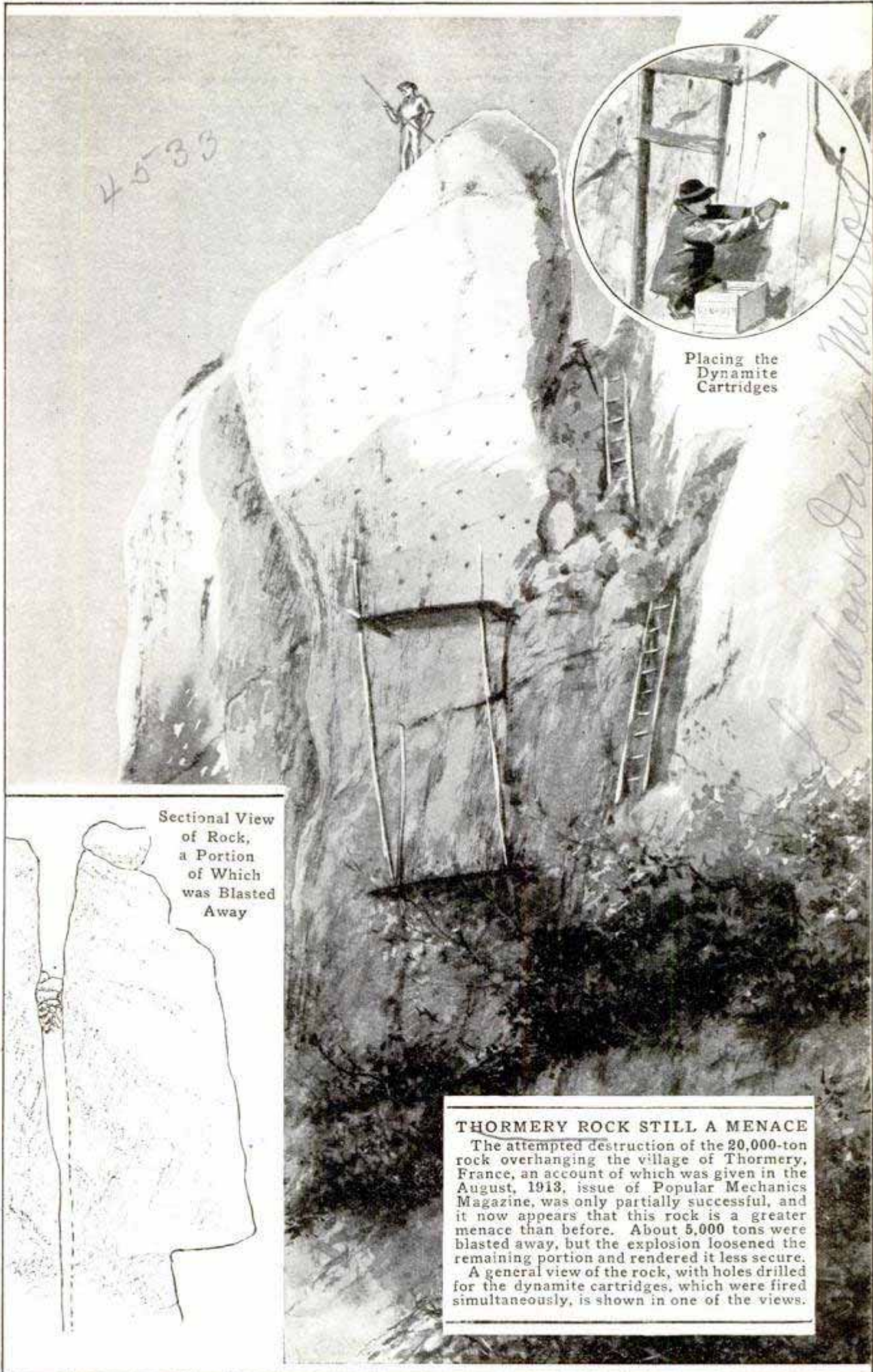

4533



Placing the Dynamite Cartridges

*L. and Mrs. D. M. ... 5/21/13*

Sectional View of Rock, a Portion of Which was Blasted Away

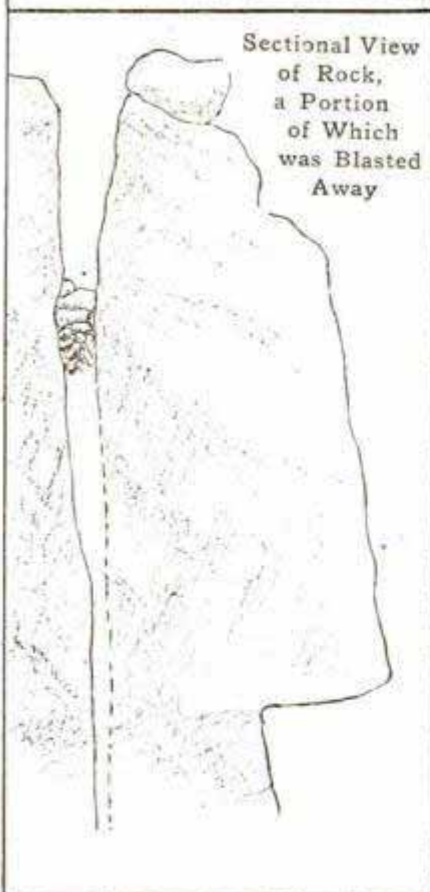

**THORMERY ROCK STILL A MENACE**

The attempted destruction of the 20,000-ton rock overhanging the village of Thormery, France, an account of which was given in the August, 1913, issue of Popular Mechanics Magazine, was only partially successful, and it now appears that this rock is a greater menace than before. About 5,000 tons were blasted away, but the explosion loosened the remaining portion and rendered it less secure. A general view of the rock, with holes drilled for the dynamite cartridges, which were fired simultaneously, is shown in one of the views.



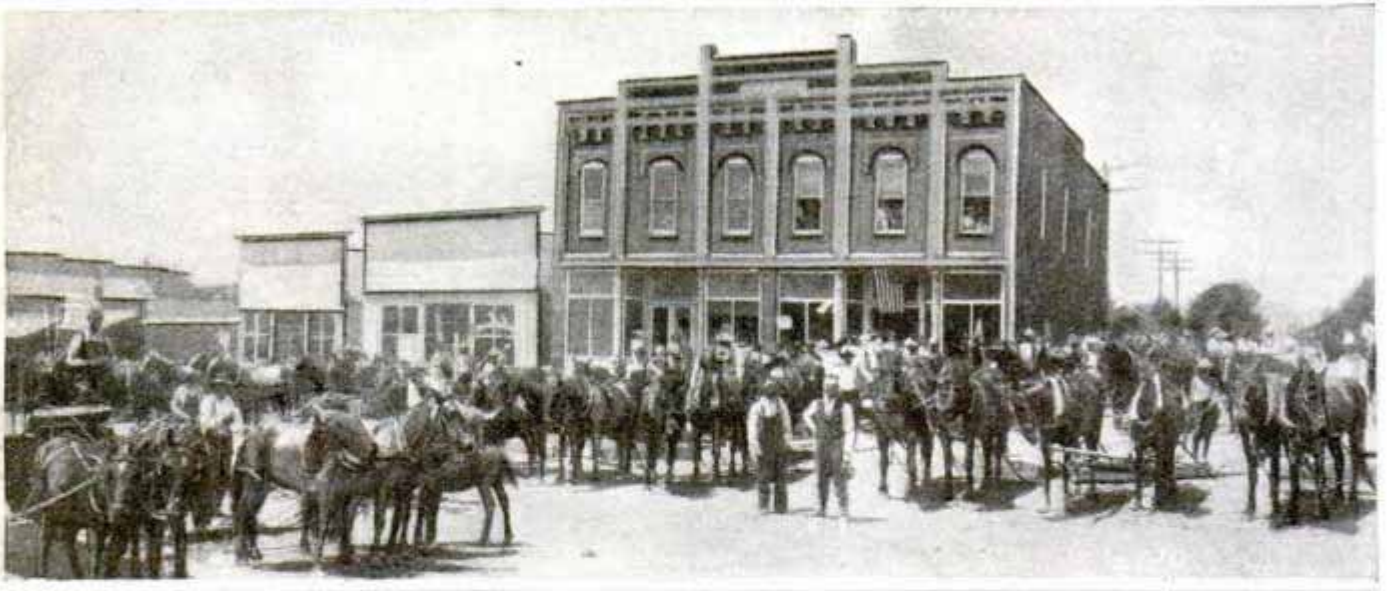

A Typical "Road-Dragging Day" in Iowa. One Drag was

### "ROAD-DRAGGING DAY" IN IOWA

"Road-dragging day" has become an established institution in certain sections of Iowa. On a recent occasion of this kind at Diagonal, several hundred people gathered from the surrounding country bringing with them 166 drags. An idea of the variety of motive power used is given by the fact that one drag was drawn by a goat team while another was drawn by a motorcycle.

### LONG BRIDGE WHICH RESTS ON FLOATING LOGS

Lake Chemong, Ontario, is crossed by a floating wagon bridge a mile long. Its narrow, double-planked roadway



A Floating Wagon Bridge, a Mile Long, on Lake Chemong, Ontario

does not rest on pontoons, but is supported by a floating framework of logs, anchored with stones at short intervals. Although the bridge was built by the municipality nearly 20 years ago, it is still in service. The accompanying photograph was taken from the draw which is provided for small lake boats.

### THE CAPACITY OF THE PORT OF HAMBURG

With a record of 14,000,000 tons of freight unloaded from 18,400 vessels in 1912, Hamburg, Germany, is rightfully called the greatest commercial port in continental Europe. Because of her location on the Elbe River, at the junction of the Alster and the Bille, her river frontage and docks are measured in miles. Over 130,000 linear feet, almost 25 miles, of dockage furnishes an area of 5,000,000 sq. ft. which is reserved for handling package freight alone, and an extension of 40,000 linear feet is now being built. Other quays are provided for bulk cargoes that are unloaded directly into cars, lighters, or warehouses, and an unloading crane has been installed for every 65 ft. of quay. Among others there are 650 three-ton ship cranes, operated by steam or electricity from a municipal power plant, 100 electric traveling cranes, a number of huge double cranes, and several 75-ton Hammer-type cranes which pick up cars and





Drawn by a Goat Team and Another by a Motorcycle

empty them bodily into ships' holds. The quay sheds are 200 ft. wide and their switch tracks connect them with railways running to every part of Europe. From the harbor to the open sea, 50 miles away, the old 15-ft. channel of the Elbe has been deepened to 37 ft., and 12 dredges are now at work lowering the bottom to 40 ft. Traffic across the river is carried by several bridges and a tunnel for pedestrians and teams. The tunnel consists of two 20-ft. wrought-iron tubes with elevators at each end.

### MINE OBSTRUCTION REMOVED BY DIVERS

Two skips which were lodged in a mine shaft near Angels Camp, Cal., and which blocked all attempts to unwater the mine, were successfully removed by deep-sea divers. Following a fire which destroyed the mill, hoist and other equipment, a pumping outfit was installed and it was then found that the water had lodged the skips so firmly in the shaft that it was impossible either to dislodge them or to unwater the shaft below the obstruction. Two deep-sea divers were employed, who not only extricated the skips from their position and sent them to the surface, but retimbered and repaired portions of the shaft that had been damaged. All the work was done under from 50 to 100 ft. of water.

### MOTOR CAR SOMERSAULTS IN THE AIR

A skid in the sand at a speed of 100 miles an hour caused an automobile to fly high in the air and turn a somersault, during a trial race near Johannesburg, British South Africa. The machine, carrying a driver and four passengers, skidded as it made a turn at high speed at the foot of a hill and crashed into a rock beside the road. Eye-witnesses said that the car flew in the air as high as a telegraph pole, somersaulted, and landed 50 ft. beyond the rock, right side up but facing in the opposite direction. Two of the passengers were killed and the other two were seriously injured, but the driver was pinned in by the steering post and unhurt.

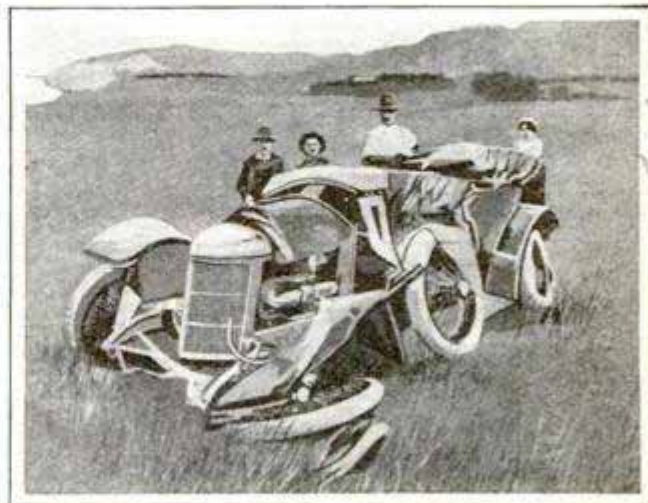

The Wreck of an Automobile Which Turned a Somersault High in the Air

*Auto Race*

*u.s. 12-4*

*The Motor Car  
6/10/13 1298*

*near Angels Camp*

*7/12/10*



## LEVEE SAVED BY STEEL SHEET PILING

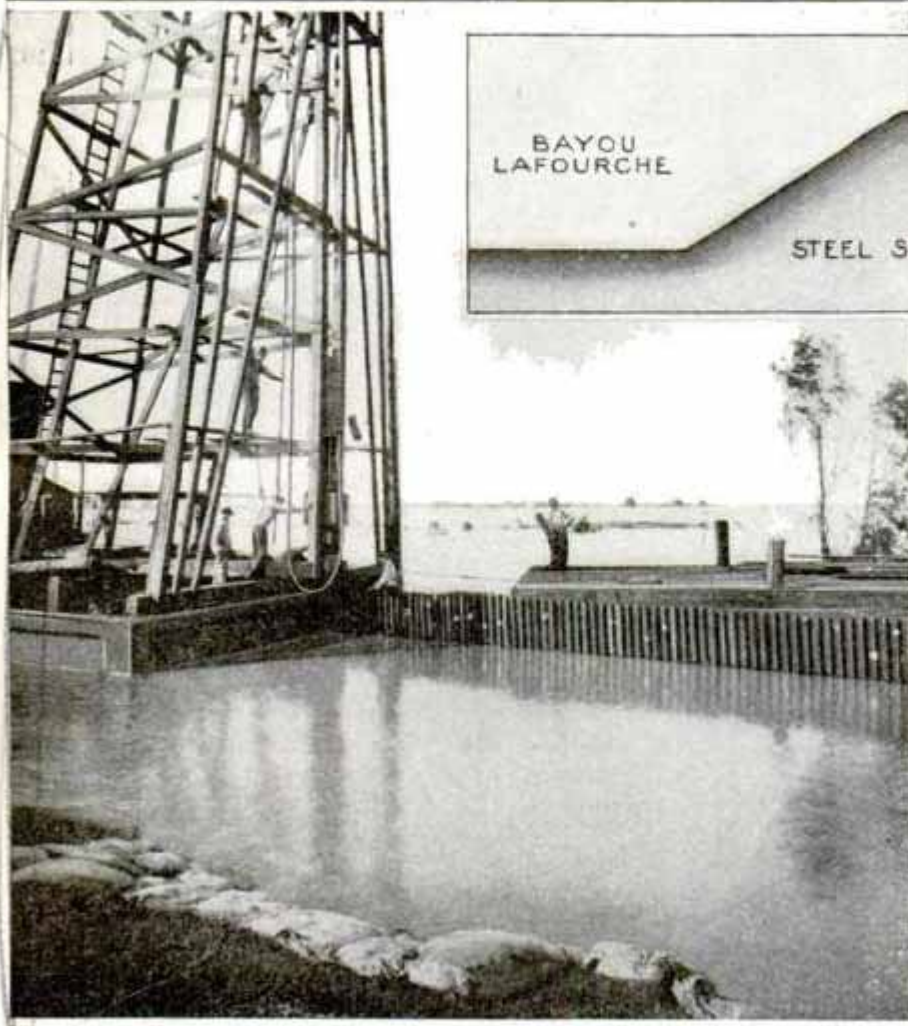

Driving Steel Sheet Piling for Protecting Levee against Mississippi River Flood

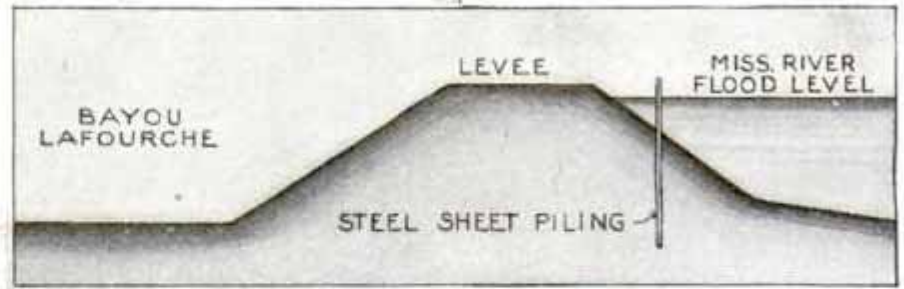

Section of Levee, Showing Location of Steel Sheet Piling

river. This levee is an ordinary earth embankment which under the continual pressure of the high water had become thoroughly saturated, and was developing dangerous leaks and "boils." It was decided to strengthen the embankment with a row of steel sheet piling driven continuously throughout its length. Piling of the length required for this purpose was not to be had in the short time available, but there was an ample

During the recent high water in the Mississippi River an ingenious method was adopted for stopping the leaks in the levee across the Bayou Lafourche in Louisiana. This levee is one of the best known in the South, not only for its size, but because of the successful use of a siphon, 18 in. in diameter, which keeps the bayou at a certain low-water level by drawing water from the

supply of steel sheet piling, in 15-ft. lengths, close at hand. By welding these together in groups of three, 45-ft. piles were produced that served the purpose satisfactorily, the welding being done with an oxyacetylene blow-pipe. Although these piles were of light section, they were driven to a penetration of from 34 to 38 ft. through brick riprap and dense sand.

### MOTORBOAT RULES APPLY TO FLYING BOATS

Flying boats should carry lights and life preservers, like other motorboats, according to the New York Commissioner of the Department of Commerce. Although the usual motorboat equipment may be an impediment when the boats are in the air, it is thought that the safety of other boats demands

that they carry signal lights, if they cruise on the surface after sunset. Whistle, foghorn, and bell are included in the equipment prescribed by the act of June 9, 1910, and if passengers are carried for hire, certain life preservers must also be provided.

CA 575-mile nonstop aeroplane flight from Paris to Berlin was accomplished in 9 hours on July 13.



## ONE-MAN FIRE BRIGADE ON NEW LINER

A new kind of fire-fighting apparatus for ships, which enables one man stationed in an out-of-the-way compartment to detect and extinguish a fire in any part of the vessel, has been installed on one of the new ocean liners. The business end of the apparatus is a tall cabinet, looking much like a small church organ, which stands among the compasses, switchboards, etc., in a little room on the third deck. Standing open in this cabinet are the ends of 28 pipes which lead to the bunkers, boiler rooms, and every other compartment in the ship. If a fire starts in any part of the vessel, a curl of smoke or gas comes up the pipe and is detected by a man on watch. He immediately signals to find whether every one has left the burning compartment, and when it is empty he claps the nozzle of a large steam pipe in the end of the pipe from which the smoke is coming. Instantly the burning compartment is flooded with steam in such quantities that it



Photo by Brown & Dawson

With This Apparatus One Man can Detect and Extinguish a Roaring Fire in Any Part of the Ship

forms a heavy moist blanket sufficient to smother any fire. One man is thus able to do the work of a whole fire brigade.

## AUTOMOBILE'S ACROBATIC FEAT

The automobile standing on its head in the accompanying photograph dived from the top of the culvert beside it



The End of an Automobile's Dive over a Culvert

without injury to any of its seven passengers, six adults and a baby. The accident occurred while the driver was trying to turn around at the end of a street in Massillon, O.; he put his foot on the accelerator button instead of the brake pedal. The front wheels climbed over an 8-in. wall and the car slid over the edge slowly.

## HORSES GROOMED WITH VACUUM CLEANER

A vacuum cleaner for grooming horses is in use at the Central Park stables of the New York City Park Department and has been found to give excellent results. A special curry comb is used to stir up the dirt, which



is then sucked through the cleaner and into the dust bag. The machine is mounted on a truck and is run by electricity, and has the advantage of removing all the dirt without scattering it into the air to resettle upon the horse, or be breathed by the groom. It is par-



Vacuum Cleaner Provides Efficient and Sanitary Means of Grooming Horses

ticularly useful for grooming horses after clipping, as it removes the loose hairs thoroughly.

### NEW HOOK FOR SNAGGING LOBSTERS

A patented lobster hook of the design shown in the accompanying illustration has recently appeared on the market. The circle of sharp points below the bait hooks is intended to snag the lobster and keep it snagged until it can be drawn above the water. This lobster hook is 6 in. in diameter and 7 in. long; it weighs 10 ounces.

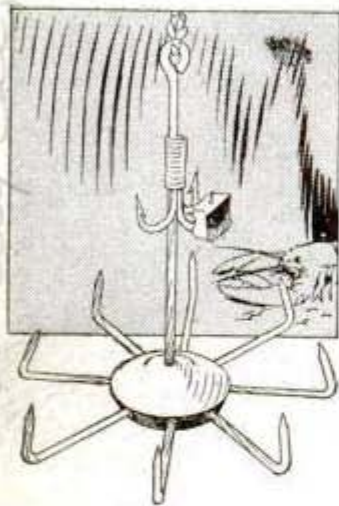

☐The Australian state of New South Wales is planning to build government works for making cast-iron pipe for water, sewerage, and other public uses. It already has its own brick yards and joinery works.

### NEW THEORY REGARDING LOST PICTURE

That the "Mona Lisa" portrait, Leonardo da Vinci's famous masterpiece, was not stolen from the Paris Louvre but was destroyed or hopelessly damaged during an attempt to clean and repair it, is coming to be the generally accepted theory in France. The portrait disappeared from the Louvre on Aug. 21, 1911, and the story of theft given out by the examining magistrate was based on a chain of circumstantial evidence which placed the guilt on a man seen in the corridors after

closing hours. But the portrait as it hung on the wall weighed 212 lb. and, stripped of its frame, the panel that would have to be carried away, 145 lb. in weight, would appear to be a heavy load for one man. The picture, furthermore, was in such disrepair that a jar would have demolished it, and only a few days before it disappeared the official restorer of the Louvre had declared his intention of repairing it. Also no inquiry was made until 24 hours after its disappearance.

### PONTOON BRIDGE ERECTED IN THREE HOURS

Following the flood in March, this year, in which two bridges spanning the Miami River at Miamisburg, Ohio, were swept away, a pontoon foot-bridge, 551 ft. long, was erected and made ready for service in less than three hours. This bridge is carried on 31 floating piers, each of which consists of six water-tight barrels, the barrels being held in position by wooden bucks, or saddles, to which they are firmly wrapped by heavy wire. Each of the barrel piers, or floats, is attached by two stay wires to a double 1/2-in. cable running across the river at a





Swinging the Barrel Pontoons into Position

height of 10 ft. above the water level, while the floor, made in 18-ft. sections, firmly bolted together at the ends, serves to form the bridge into one continuous footwalk. This form of construction provides the greatest flexibility for meeting the rise and fall of the river. The structure was put up at small expense for material only, as all the labor was donated. The bridge is so arranged, that when necessary to permit the passage of boats, or for safety in time of flood, it can be disconnected at the center, and the two ends can be swung in along the shore.

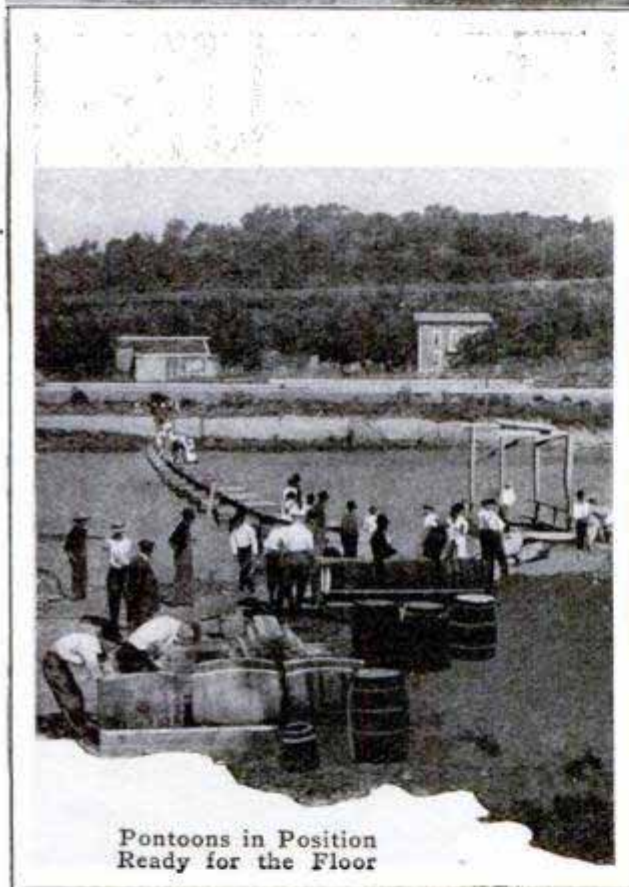

Pontoons in Position  
Ready for the Floor

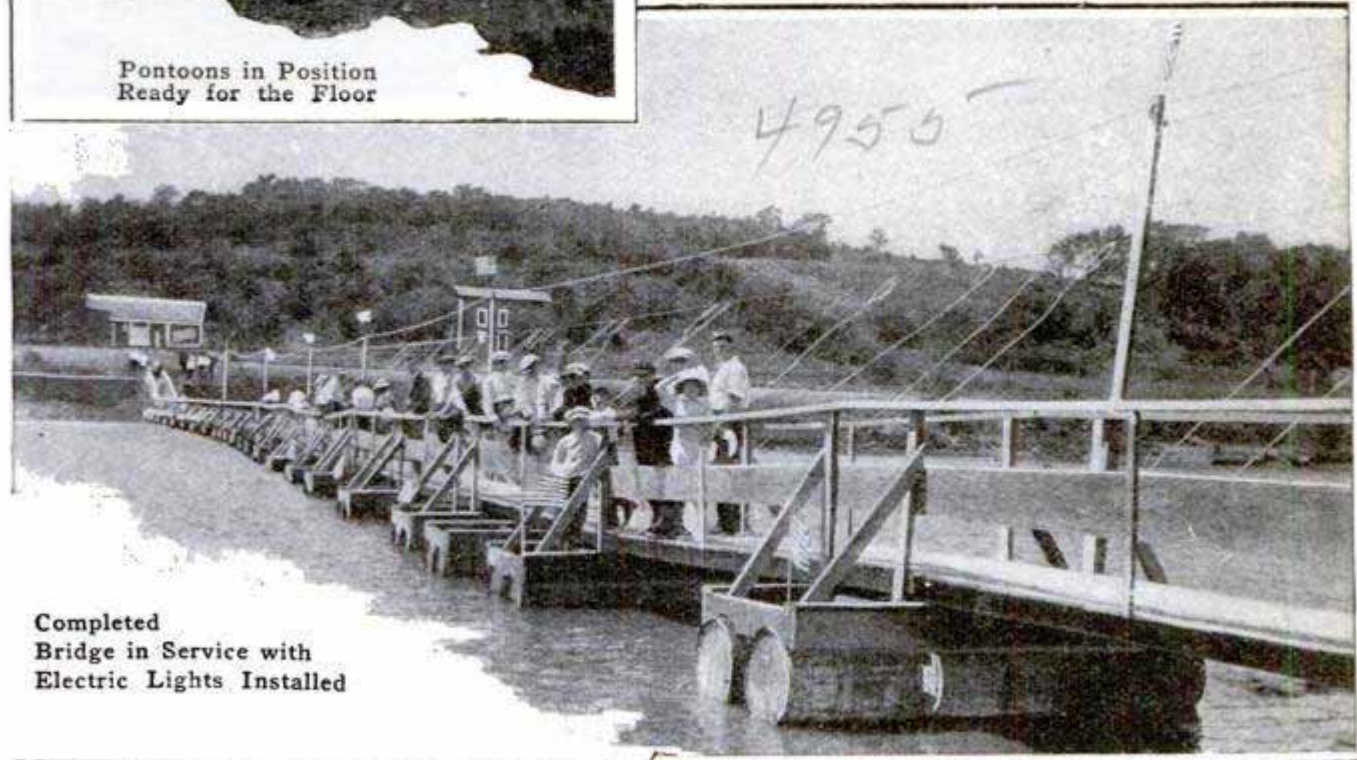

Completed  
Bridge in Service with  
Electric Lights Installed



## PUSHING A WHEELBARROW 1,500 MILES

With their baggage and camp kit packed in a barrel trundled on a bicycle



The Baggage Train Accompanying a Family of Four Persons on a 1,500-Mile Walking Trip

wheel, a family of four persons started out on July 8 to take a 1,500-mile walk from Sandpoint, Idaho, to St. Paul, Minn. Two persons in the party, with the dog, are shown in a picture on this page—their two sons, aged 9 and 11, accompanying them. The barrel carried on the pneumatic-tired wheelbarrow contains a small tent, camp equipment, and extra clothes; two rifles are slung on the handles. The entire outfit weighs only 75 lb. The party is thus prepared to camp wherever night overtakes it, and the trip is expected to take about two months and a half.

## FIRST REPAIRS ON A ROOF 500 YEARS OLD

The old wooden roof of Westminster Hall, London, is about to be overhauled and repaired for the first time since it was erected, in 1399. It is one of the most famous specimens of

the Gothic open timber roofs and after five centuries shows only slight signs of decay. Most of the repairing is needed at the points where the wall posts touch the walls and where the beams and posts cross, in the northern end of the building. The amount of timber affected is so slight that the restoration will not mar the beauty of the old woodwork.

## AN ELECTRIC COOKER WHICH SAVES WASTE

A new type of electric cooker, claimed to prevent shrinkage in meats, has been invented in Denver. Designed particularly for hotels and restaurants, it consists of an air-tight oven heated by electricity and equipped with an electric motor and air-compressing pump. The food is cooked by means of circulating air, which, being under pressure, absorbs a minimum of moisture. While the ordinary methods of cooking meat usually result in a loss of more than 25 per cent in actual substance, this cooker is claimed to reduce the shrinkage to eight per cent. The system also allows no flavor to escape, and so retains the choicest savors. Automatic mechanisms gov-

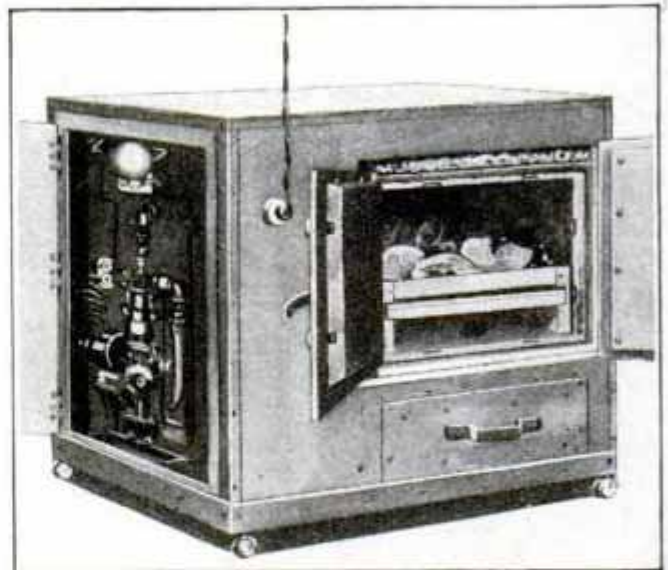

View of Electric Cooker, Showing the Arrangement of Motor, Air Compressor, and Automatic Shut-Off

ern both heat and pressure, and the cooker requires no attention from the time the food is put in until its removal for serving.





### Locating a Broken Line in an Igniting Cable

To find a wire broken inside the insulation in a cable is a very difficult job when one does not know how to go about it. Such breaks can be easily located, however, in the following manner: Procure a cheap pocket compass, draw each wire out at some point, separate it from the others and turn a current through it, at the same time holding the compass about  $\frac{1}{2}$  in. from the wire. If the current flows through, the needle of the compass will be deflected from normal in one direction or the other, but a broken wire will have no effect on the needle.—Contributed by John McDermott, Turtle Creek, Pa.

### Adapting Gas Fixtures for Inverted Lights

When fitting inverted gas lights on certain kinds of fixtures, instead of using goosenecks, use the arms and attach lights as shown in Fig. 1. This will make a better-appearing job than the gooseneck method, as shown in



Fig. 1

Fig. 2

Reversing the Arms of a Gas Fixture to Adapt It for Use of Inverted Lights

Fig. 2. The arms should be adjusted so that there will be no leakage of gas in the joints.

⌈The surface of cement floors may be cleaned of oil for making repairs by a few applications of muriatic acid.

### Automobile Lights Directed by the Travel of the Wheel

Being compelled to use my motor truck a great deal at night over roads that were none too good, I devised a

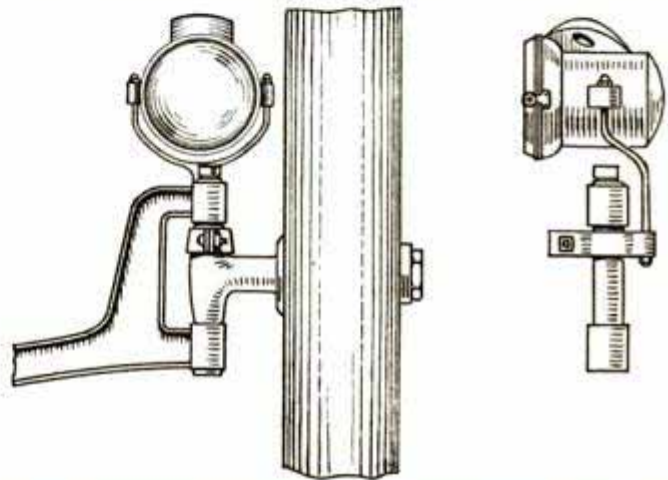

Lamp Brackets Attached to the Wheel-Axle Stub so That the Light will Follow the Wheel's Travel

way to attach the gas lamps so that their light would be directed in the line of the front wheels' travel at all times. The Y-shaped brackets which served to hold the lamps were removed from their original position and were lengthened by means of a piece of strap iron, welded to them at the junction of the forks. A clamp of strap iron was then made to fit around the upper portion of the spindle on which the steering stub turns, and to this clamp the lower end of the enlarged bracket was riveted. The clamp was then put in position and the bolt drawn tight, whereupon the bracket was marked and taken off to be bent so that the turning point of the lamp coincided approximately with the axis of the spindle.

The diameter of the lamp was such that it was necessary to revolve the clamp slightly when it was finally put in place to prevent any part of the de-



vice from coming in contact with the wheel. Naturally, with this arrangement, it is advisable to use lamps of small diameter and weight, not because of limited space alone, but because the location is such that they are subjected to very severe vibration.—Contributed by E. F. Hallock, New York City.

*17 Arden St.*

### Forced Draft for a Kitchen Stove

Having considerable difficulty with the kitchen stove on account of floor draft, I put a few additional lengths of

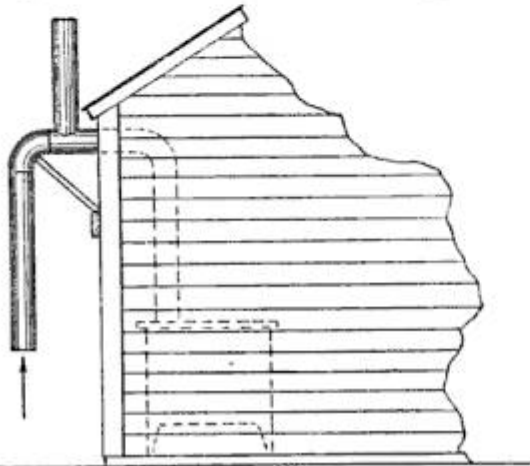

The Open End of the Pipe Extending Downward Admits Air That Causes a Draft in the Main Pipe

pipe on the main chimney without any marked improvement. I then hit upon the plan shown in the sketch, and it worked so well that the damper in the stove must be used frequently. The additional pipe was placed downward with an open end at the bottom, the upper end being connected with a T-joint, as shown, in the main pipe.—Contributed by W. A. Jaquythe, San Diego, Cal.

### Cutting Thin Tubing

Cutting tubing of brass or steel with a hand hacksaw is very hard on the saw blades. Special blades are made for this work, and are commonly called "tubing saws," in which the teeth are so fine that the section of the metal being cut cannot slip up between successive teeth and break them. However, these tubing saws are not always to be had when one wants them. Instead of them, drive a piece of wood inside the tube, completely filling the

hole and the piece can be cut with safety with almost any saw blade. Hard wood is better than soft wood for this work. If a whole length of tubing is to be cut into short pieces, fill the tube with lead, and it can be easily knocked out of the sections after they are cut.

Thin brass tubing or sheet brass may also be cut in another way. Reverse the blade in the frame and begin to saw with the back of the blade. The blade will soon pick up particles of metal and thus roughens up enough to cut quite well. It cuts somewhat on the principle of the friction saw, so commonly used where power is available. It is not a speedy cutter, but where there is only one saw blade to complete a job it is a trick well worth knowing.

### Gauge for Cutting Hedges

A great deal of difficulty is usually encountered when cutting hedges and it is almost an impossibility to get a straight line. The attachment for a wheelbarrow, shown in the illustration, makes the cutting a very simple matter. The attachment consists of two uprights, about 2 in. square and 3 ft. long, graduated in inches on one of their surfaces, and an adjustable crossbar. A  $\frac{1}{4}$ -in. hole is bored in the center of each piece on each mark. The uprights are fastened to the sides of the wheelbarrow with bolts having thumb nuts, as shown at A A. The crossbar is a piece of material, 1 in. thick, 2 in.

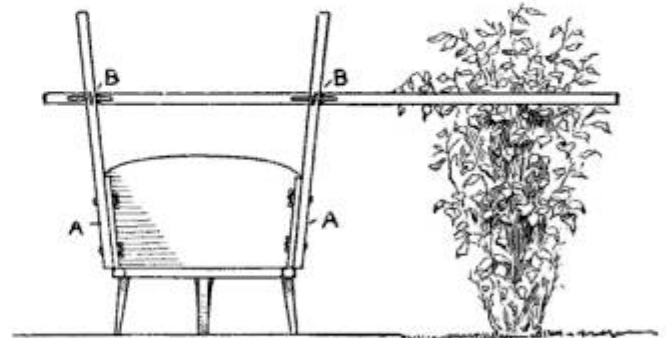

The Crossbar may be of Any Shape to Make a Guide for Cutting the Hedge Tops

wide, and about 4 ft. long. Two slots,  $\frac{1}{4}$  in. wide and about 8 in. long, are cut in this piece, as shown at BB. This



is to provide for the slant of the up-rights. Two bolts with thumb nuts can be used to hold the guide to the up-rights.

When cutting the hedge the guide is set at the desired height and the top of the hedge can be clipped off evenly, the wheelbarrow being moved forward as the clipping proceeds. The advantages are evident. The guide is adjustable, and the clipped tops can be thrown into the wheelbarrow. Any shape of guide may be used, which makes it possible to obtain any variety of fancy shapes on the hedge.

### Blank-Tag Holder

Although a great many tags are used in our store we have never had a good place to keep them, and usually they were placed loose in a box and were not easily found. One day I strung several on a cord and tied a knot in one end and the other end to a nail. The knot was small enough to allow the tag to slip off when pulled and yet large enough to keep them from slipping off by their own weight. —Contributed by Geo. B. Wright, Norwalk, Conn.

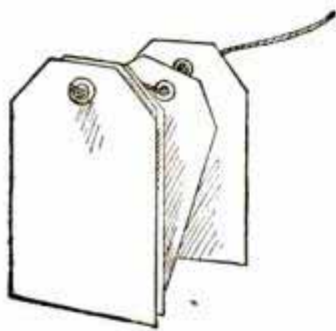

### A Gauge Siphon

The gauge siphon, as its name suggests, is simply a siphon which enables the operator to determine at all times exactly the location of the end of the tube with respect to the bottom of the tank. A simple sketch of the apparatus is shown. The siphon consists of two rubber corks and a glass rod bent to form an ordinary U-tube, to which a rubber hose is attached.

The cork A simply acts as a bearing on the edge of the tank and a support for the U-tube. The cork B is simply put on the tube to take up the side thrust of the tube, due to its own

weight and the weight of the rubber hose. This cork may be used on either

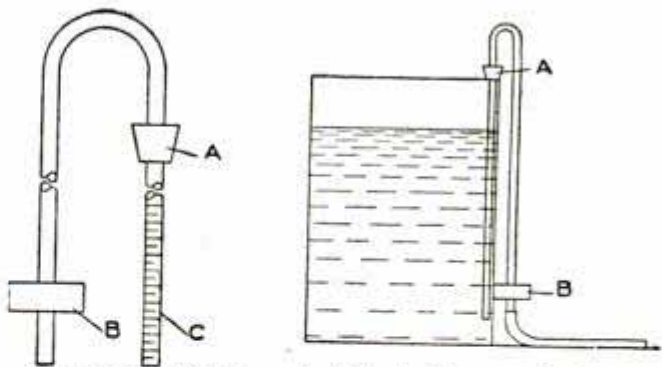

A Siphon That can be Set to Remove Only a Certain Amount of Liquid

tube according to the direction of this side thrust.

A scale, C, might be etched on the tube and a direct reading of the tube's immersion taken. This apparatus will be found practical for use in sieve tests where the residue in the bottom of the tank must not be disturbed, also in oil-storage tanks where it is desired to draw off only the clear oil.

### An Emergency Split Pulley

An emergency split pulley can be easily cut from a plank, and if great width is necessary, several planks can be placed side by side. A circle is drawn on the plank the size of the pulley. If the plank is not wide enough place two of them with their edges together. Draw another circle for the width of the rim and cut out the inside, leaving a crosspiece on one side of the diameter or center line. The saw is run into the part to be cut out on the line A. The shaft hole is cut out to fit snugly on the shaft and two holes bored through the spokes for bolts. A

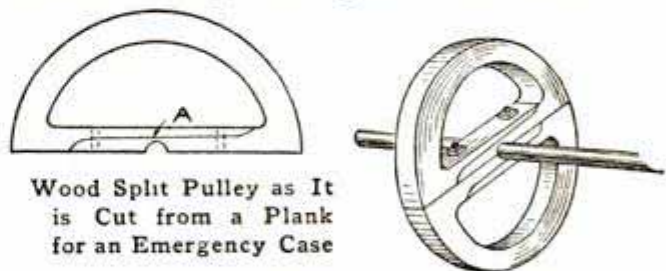

Wood Split Pulley as It is Cut from a Plank for an Emergency Case

pulley can be quickly made in this manner, and it will answer the purpose as well as an expensive pulley.—Contributed by E. Leslie McFarlane, Nashwaaksis, Can.



### Bending U-Bolts

The bending of U-bolts is easily accomplished with the tool shown in the illustration. The shank of the tool A

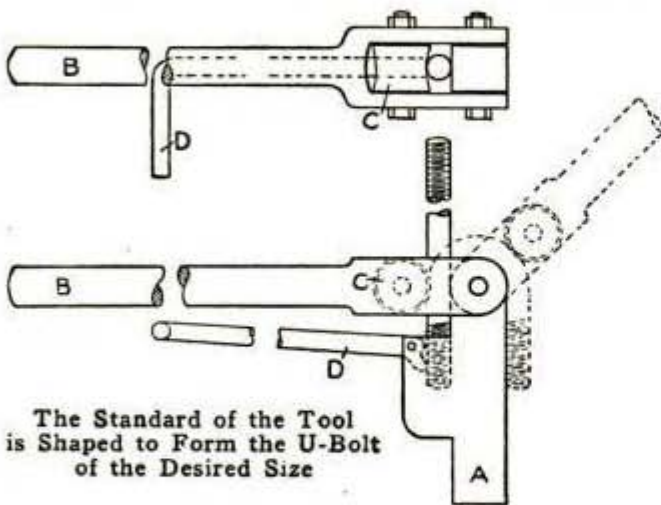

is made to fit the square hole in the anvil, and the lever B carries a roller, C, in a semicircular course over the upper end of the support. The lever D holds the threaded stock and prevents its being drawn out of the tool by the action of the bending lever B.

The tool must be made for a special size of stock and for a certain bend and cannot be used to make any other sizes. Sometimes it is necessary to make a large quantity of the U-bolts of one size and then it will save time and expense to make the bending tool.—Contributed by Roy H. Poston, Flat River, Mo.

### A Hammock Swing

This hammock swing consists of a frame made of gas pipe and fittings and covered with canvas. The size of the

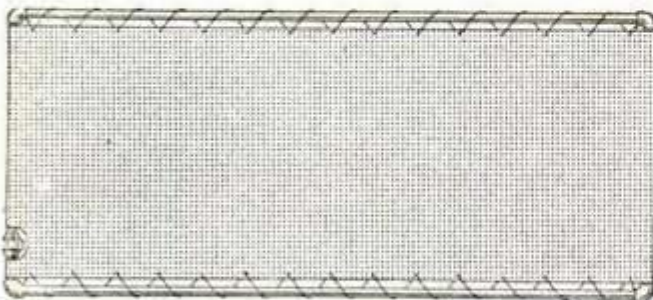

The Frame is Strongly Made of Gas Pipe and the Canvas Stretched Tightly on It

pipe used was  $\frac{3}{4}$  in. in diameter, the two side bars being 74 in. long and the end pieces 30 in. long. The corners

were connected with  $\frac{3}{4}$ -in. els, and one end piece built up of two parts and one union.

The canvas is 1 yd. wide with a 3-in. hem, the ends lapping over the gas pipe and the sides being fastened as shown.

The hammock is hung with ropes or chains of light steel as desired. A pair of hangers for each end will be required. The chains are used by fastening the ends of one chain in the pair to the corners of the hammock, then the other chain in the center and to the beam above, adjusting it to the height desired.—Contributed by Mrs. J. V. Moore, Seattle, Wash.

### Fuel Storage for a Motorcycle

Having a clear glass carboy handy and desiring a receptacle to store several gallons of gasoline for my motorcycle I arranged the carboy as follows: A wood stopper was made for the neck, two holes bored in it, one large enough to pour in the gasoline and the other of a size to admit a piece of copper tubing, about  $3\frac{1}{2}$  ft.

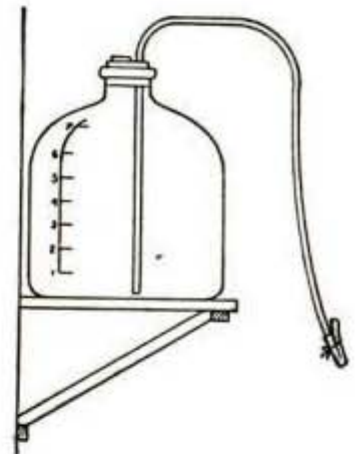

long. The stopper was placed in the neck of the carboy and the copper tubing was inserted into the small hole so that the end almost touched the bottom. The tubing on the outside was then bent over until the end extended below the bottom of the carboy. A small length of rubber tubing was fastened to this end.

The gasoline was poured in through the large hole with the aid of a funnel and the siphon started by drawing out the air until the gasoline began to flow, then the rubber tubing was doubled and tied with a bit of string to keep the liquid from flowing until it was necessary to fill the motorcycle tank. The carboy was kept on a shelf at the right height. When filling the carboy the



level for each gallon of gasoline was marked on the outside, so that I could determine the amount of gasoline on hand at any time.—Contributed by J. A. Hart, Philadelphia, Pa.

**A Stud Driver**

The driver consists of a piece of hexagon bar stock drilled and tapped to fit the threads cut on the stud, and a short pin having a flat surface filed tapering from one end to the other and fitted in a hole drilled through two parallel sides of the threaded piece.

In use, the driver is turned on the stud until the flat side of the pin strikes the top end of the stud. The pin is

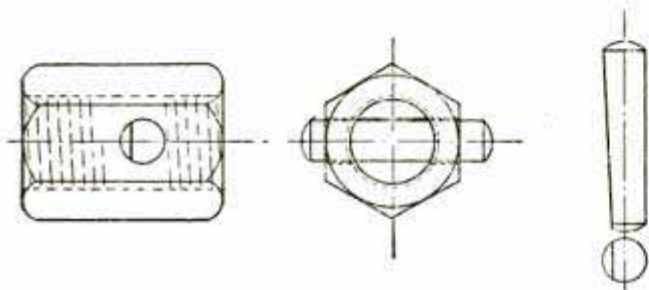

A Driver That is Quickly Attached to a Stud for Turning It into Place

then tapped lightly with a hammer on the large end, causing it to tighten against the end of the stud. A socket wrench of the right size is used for turning it. To remove the driver from the stud, tap the small end of the pin lightly with a hammer and turn the driver in the reverse direction.—Contributed by C. E. Bradley, Fall River, Massachusetts.

*J. N. (5) 2131*

**Clamps to Hold Picture Frames**

An effective way to glue and clamp a picture frame is to use four narrow strips, two of which are shown in the sketch at A, with their ends notched for the clamps. This will bring equal pressure on all corners. — Contributed by J. M. Adamson, Carey, Idaho.

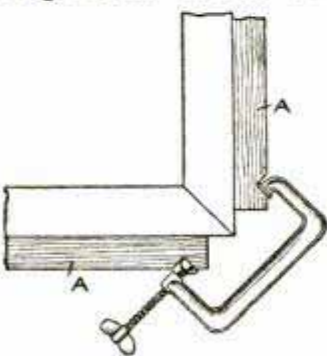

**Block to Assist Hammer in Pulling Long Nails**

The pulling of a long nail with a carpenter's hammer requires a block to

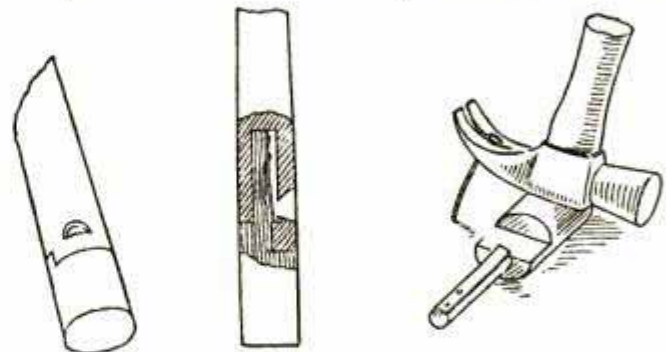

Block Attachment for a Hammer to be Used in Pulling Long Nails from Wood

raise the center of the hammer high enough to draw the nail straight at the end. A block not always being at hand, I put one on the handle of my hammer and found it very convenient. The block constitutes the end of the hammer handle and is fastened with a spring clip, as shown, which can be pressed with the thumb when the block is to be taken from the handle and used for pulling a nail.—Contributed by A. S. Thomas, Gordon, Can.

**Electric Lighting of Bubble Glasses in a Level**

Bore a hole in the end of the level opposite the plumb bubble, large enough to receive a dry cell of battery such as used for flash lamps. Mortise



When the Level is Used in a Dark Place, the Light can be Flashed on the Bubble Glass

a space under each bubble glass large enough to receive a small electric globe, and bore two holes for push buttons. The lines for the wires are shown plainly in the sketch. A hole bored through lengthwise will provide a place for the wires. The bubbles can be lighted when the level is used in dark places.—Contributed by Chas. C. Bradley, W. Toledo, Ohio.

Old paint worn too thin to burn off may be removed by applying a coat of linseed oil before using the burner.



### Locking a Cork in a Bottle

The bottle-locking device shown in the illustration is for use on bottles containing poisons or other fluids that might prove dangerous to anyone not familiar with their nature. A clasp is made of thin metal, as shown by the diagram, which is bent around the bottle neck and over the cork,

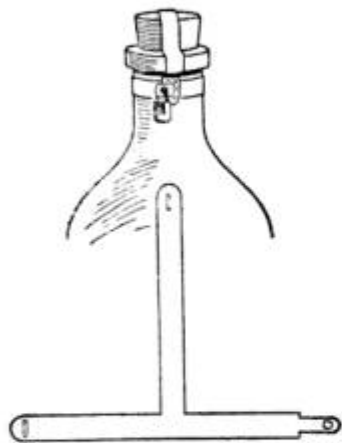

the tongue end with the round hole being inserted through the slots in the other ends and a small padlock attached in the round hole. The size of the clasp will depend on the size of the bottle.—Contributed by Jos. J. Kolar, Maywood, Ill.

### A Paint-Can Hook

The hook is shaped from a piece of round iron,  $\frac{1}{4}$  in. in diameter and about 16 in. long. The bend in the center which forms the hook part is welded together and the upper end flattened to slip under the siding while the lower end is pointed and made sharp to stick into the wood. The flattened part prevents the hook from turning sideways.—Contributed by Charles Gordon, Philadelphia, Pa.



### Remedy for Swelling Feet and Enlarged Pores

Persons who work in boiler rooms or in shops where steam is present are often troubled with swelling feet or enlarged pores. A good solution to be applied which will prevent this as well as the odors of perspiration can be made in the following manner: Mix to-

gether 60 parts alum; 10 parts tannic acid; 5 parts salicylic acid; 20 parts starch and 5 parts talcum; add enough water to dissolve them and make a preparation thin enough to apply easily. The solution is harmless and inexpensive.—Contributed by Loren Ward, Des Moines, Iowa.

### Oil Spout Formed in a Bottle Stopper

Having occasion to use an oilcan when none was at hand, I constructed a substitute by forming a spout in the stopper of a bottle. An ordinary bottle of the smaller size was selected and a wood stick, about 4 in. long, was whittled to fit in the neck of the bottle. The outer end of the wood was cut pointed, and a V-shaped groove cut in the side from the pointed end to the base. The oil will run along the groove and can be dropped into a bearing as well as with an ordinary oilcan.—Contributed by Arthur Koeppner, Cleveland, Ohio.

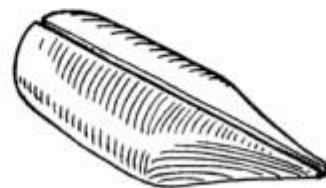

### Starting a Bolt in a Difficult Place

Recently, while working on an automobile, I found it difficult to get a bolt started in its place, and when I had about decided to remove other parts to enter the bolt, I hit upon the following scheme of overcoming the difficulty. A piece of wire was procured and one end lightly soldered to the bolt head. This served as a handle for placing the bolt and was easily removed by giving the wire a few turns. The same means can be used to enter bolts and pins in places not easily accessible, the time of preparation being small as compared with the practical value of the device.—Contributed by Wm. A. Murry, Cold Spring, N. Y.

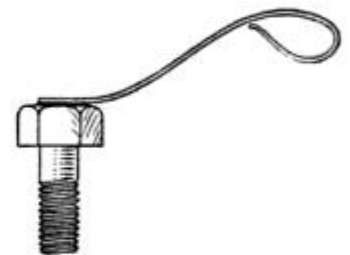



## How to Make an Engineer's Kerosene Torch

By F. W. BENTLEY, JR.

A compact, light and strongly built brass hand torch is the pride of the engineer who owns it. However, in the construction of many torches the maker is forced to combat with a few difficulties coincident with the necessary use of kerosene, that sometimes discourages an extra outlay of time and expense in its construction. In the first place the soiling nature of kerosene will prevent the average torch from being placed in a grip or suitcase with overalls or clothing. In the second place, the construction of many torches of this kind is such that the process of filling the oil chamber necessitates a withdrawal of the large wick, which in itself makes the torch only an objectionable necessity.

In the accompanying sketches the construction of a brass torch is explained which will eliminate almost all of the serious drawbacks generally encountered in the use of a kerosene torch. In addition to other merits of its construction, the most important feature is the small expense of making one. Referring to Fig. 1, the shell or body is of 2-in. brass tubing, which can be purchased for about 10 cents per foot. The top piece can be turned out of a piece of 2½-in. brass rod. The bottom piece is also made with but few operations on the lathe out of a piece of 3½-in. brass rod. The part for the wick, and the base are simply sweated to the tubing.

The throat nipple, containing the tin wick casing, is shown in Fig. 2. The wick casing can be either sweated or riveted into the nipple. A small round-nose chisel should be used to puncture the casing in a number of places, the raised tin portions pointing upward on the inside of the casing. This will enable the wick to be drawn upward, but at the same time will prevent it from dropping down into the torch in case the same is accidentally dropped, or receives a sudden jar. The end of the nipple, holding the wick casing, is screwed firmly into the upper

portion of the torch, and is taken out only for the renewal of the wick.

The cap covering the upper portion of the nipple when the torch is not in

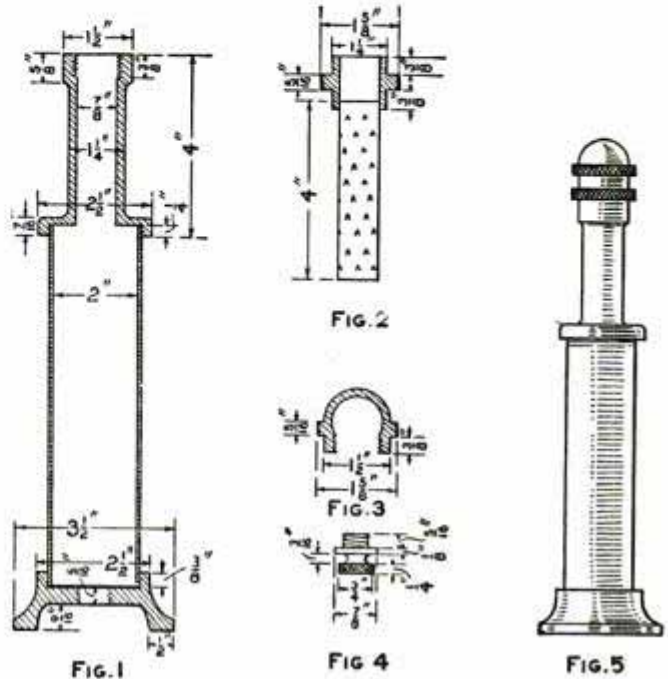

An Engineer's Torch That can be Stored in a Tool Chest or with Clothing without Leakage of Oil

use, is shown in Fig. 3. This covering permits the torch to be placed in contact with anything without danger of soiling it. The filling of the torch is accomplished by the removal of the filling plug in the cupped portion of the lower, or bottom, piece. The details of the plug are shown in Fig. 4. The concave portion of the bottom enables the torch to be filled without spilling and splashing oil. A sketch of the torch assembled, showing its neat exterior appearance, is given in Fig. 5. Of course, the sizes of the several pieces can be varied to suit the requirements of the person for whom it is made, but in the line of a portable torch, using kerosene oil, the points of its construction for durability, cleanliness and inexpensive manufacture will be found hard to excel.

¶If an ignition cable becomes frayed at the ends, one or more strands are likely to come in contact with the metal parts of the magneto, the coil or the car, and cause trouble.



### A Pencil and Compass Holder

Carpenters and other workmen have occasion to use compasses in their work and often need to strike a circular line with a pencil. If no other device is at hand, one can be made in a few minutes from a piece of tin,



A Piece of Metal for Holding a Pencil to the Leg of a Compass

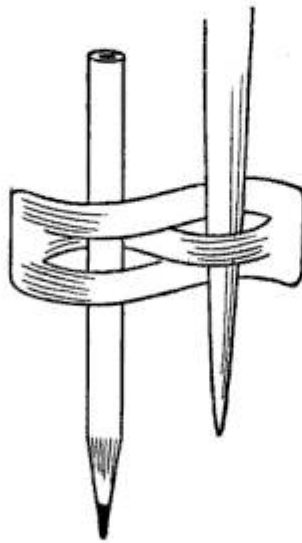

sheet copper or brass. Take a piece of the metal,  $\frac{1}{2}$  by  $1\frac{1}{4}$  in., and make two slits in it, then bend the center piece in an S-shape and the two outside pieces also in an S-shape, but in the opposite direction, and the holder is complete. A compass leg is slipped in one loop and a pencil in the other, and the result is a device that cannot be beaten for utility. The spring of the metal holds the inserted pieces very firmly.

### Cutting Eccentric Slots on a Lathe

The method of cutting two eccentric slots in a cam plate on a lathe is shown in the sketch. Two circles are drawn concentric with their respective slots on the cam plate and the slots laid out

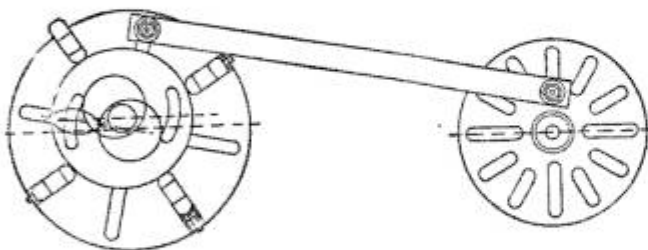

Manner of Oscillating the Chuck of a Lathe so That Eccentric Slots can be Cut

and roughly drilled. The plate is then clamped in a lathe chuck so that the center of one circle runs true. A connecting bar is fastened to a stud on

the faceplate of a smaller lathe, set in line, so that the other end of the bar can be connected to a stud set in the chuck holding the plate.

The smaller lathe is started and the connecting bar gives a rocking motion to the chuck holding the plate. The adjustment of the studs holding the connecting bar limits the length of the rocking motion. It is only necessary to use an ordinary boring tool to cut the sides of the slot accurately.—Contributed by James H. Rodgers, Hamilton, Ont.

### Transferring Photographs to Watchcases

Instructions for making a picture on a watchcase, watch dial, or other similar object, are often sold at a high price and most of them turn out to be a simple carbon transfer, or a process of sensitizing metal which is difficult to carry out. The method herewith given is extremely simple, and with it anyone can do good work from the start, without experience in photography. It makes a perfect, transparent film that appears as if the photograph were taken directly on the watchcase or dial.

First prepare the following mixture: Collodion, 4 oz.; Venice turpentine, 1 dr.; camphor spirits, 10 drops, and 95-per-cent alcohol, 1 oz. Flow this solution over the photograph that is to be transferred and carefully lay it aside to dry for 15 minutes, or longer, then paste the print, face down, on a smooth piece of plain glass, using ordinary library paste. Allow it to dry for at least one hour, then, with the bowl of a spoon, or a finger, rub the picture from the center out, wetting with cold water until all the paper backing is removed, and place the glass with the picture into a bowl of hot water. The composition will free itself from the glass.

Place the film on a piece of ordinary paper and cut it to the desired size. It is usually best to cut it in the shape of a disk to fit the watchcase. Place this disk back into the warm water, and



the film will soon float while the paper sinks to the bottom. With a solution of gum acacia, grease the case that is to receive the picture, then very carefully place the picture in the right position and attach it firmly by pressing with a silk cloth. The best place to put the picture is either on the inside of the cover or on the dial. If placed on the dial, the picture will show up in every detail, yet the figures can be seen through the picture.—Contributed by J. G. Allshouse, Avonsmore, Pennsylvania.

### Piston-Ring Closer

When replacing a piston in the cylinder of a gas engine, it is rather difficult to close the three or four rings so that they will enter the bore. The mouth of most cylinders is countersunk or beveled to facilitate starting the rings, but without assistance, this will be of little help if the rings are new and stiff. Some mechanics tie the rings closed with light copper wire which is removed as each ring starts into the bore.

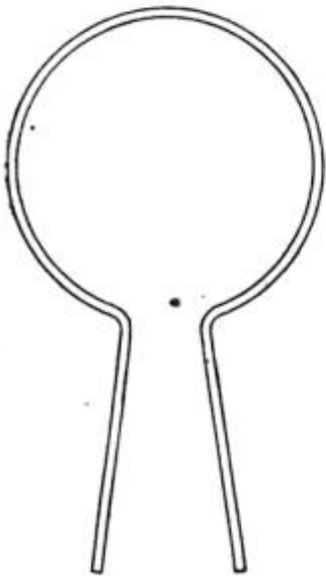

A time and labor-saving tool can be made for this work that will pay for itself in the work on one engine. Secure a piece of metal,  $\frac{3}{16}$  in. thick and 1 in. wide, and bend it to the circle of the piston—for a 4-in. piston, the ring should have a 4-in. inside diameter—leaving a gap of about 1 in. and bending both ends back to form handles as shown. With this clamp one man can easily replace cylinder pistons alone and in a short time.

☞ A filler for ebony is made of lamp-black and plaster of Paris mixed in a paste by using gold size or japan.

### An Inexpensive Post Pipe Vise

A pipe vise of any size suitable for holding pipe up to 3 in. in diameter is an expensive and a heavy tool, and,

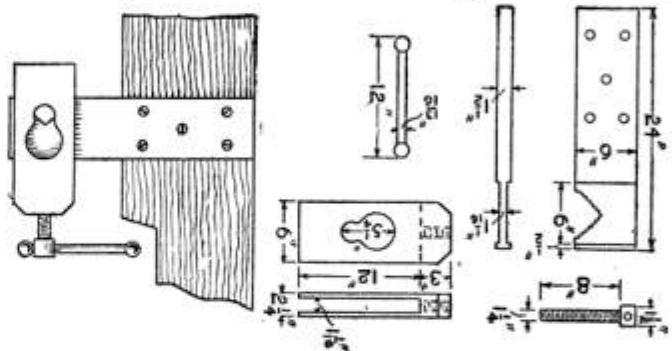

Flat Construction of a Pipe Vise That can be Quickly Attached to a Post

in a great many instances where pipe work of a light nature necessitates only the use of a small pipe vise, a heavy bench or rigging must be carried along to attach the vise to, or a temporary bench must be erected.

A vise that can be very inexpensively constructed and quickly bolted to a post or wall corner of sufficient rigidity to stand the strain of work is shown in the sketch. Its manufacture requires only a few hours' work on the lathe and shaper. Owing to its construction the vise is able to stand a great deal more abuse and heavy usage in rough and hurried work than the finer machine vises intended for use only on the shop bench.

### A Rivet Clamp

Rivets that are placed through holes in square or circular sheet-metal work must be held by the protruding end while the stake or mandrel is placed on the head. A clamping device for holding the rivets can be easily made from a cotter that is of suitable size for the rivet. The legs of the cotter are bent to fit the rivet as shown. Several cotters can be shaped to hold as many rivets.—Contributed by Lorin A. Brown, Washington, D. C.

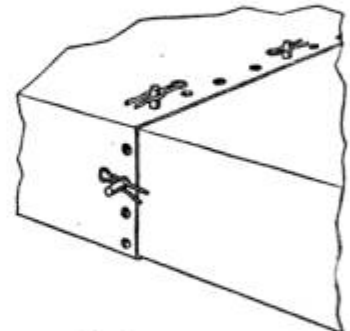



### A Paint-Can Opener

A very handy paint-can opener can be made on the small or upper end of the paint-brush handle. The small end



The End of the Paint-Brush Handle is Shaped to Insert under the Cover Edge

is cut off where it will be large enough not to break easily, and then it is cut wedge-shaped. This is used as a lifting bar to pry off the cover.—Contributed by J. A. Nolan, Woodside, Cal.

### Handhold for a T-Square

A large portion of the dirt and smut that accumulates on a drawing comes from handling of the T-square by the blade. One way to avoid the dirt is to fasten a cleat to the top of the T-square blade for a handhold. This will prevent the fingers from coming in

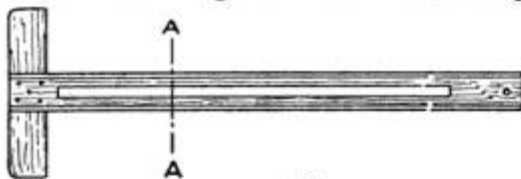

The Handhold as It is Attached to the Top of a T-Square Blade

contact with the drawing, and provides a place for pencils and instruments, as shown in the cross section.—Contributed by W. E. Crane, Cleveland, Ohio.

### Starting Holder for a Nut

The holder is made of sheet metal, rolled into a tube. A nut is then inserted in one end and the metal hammered to the shape of the nut. Any



The Holder Made of Sheet Metal Grips a Nut to Start It on the Threads

length of metal can be used, as desired. In use, the shaped end of the metal is slipped over a nut and a slight pres-

sure on the other end will hold the nut so that it can be turned on the threads of a bolt in otherwise inaccessible places.—Contributed by John E. Holarbush, Huron, S. D.

### An Adjustable File Handle

The handle is constructed of round machine steel,  $\frac{1}{4}$  or  $\frac{3}{8}$  in. in diameter and about 15 in. long, which, when bent over in the shape shown, will leave the handle part about 5 in. long. Before making the bend the ends are threaded with a small die, having the same number of threads as those cut in a  $\frac{3}{4}$ -in. nut. The steel is then bent in the shape

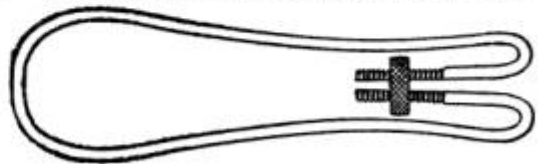

The Tapering Portions of the Threaded Ends are Easily Clamped on the Tool Shank with the Nut

shown, and the inside portion of the threaded ends are filed flat to admit the shank of the tool. A  $\frac{3}{4}$ -in. nut is used on the threads.

The tapering shank on most hand tools can be inserted between the two ends, and the sloping parts are easily clamped on it by turning the nut.—Contributed by G. H. Holter, Jasper, Minnesota.

### Sawing the Edge of Timbers Straight

In cutting a piece of timber both edges of which are crooked or jagged, attach a straightedge, A, on one edge

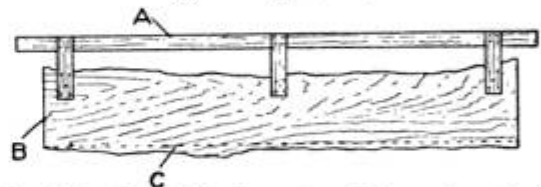

A Straightedge Nailed to One Edge of a Timber to Guide the Other Edge on the Saw

of the timber, B, and the piece can be more easily run through the rip-saw to cut on the line C.—Contributed by Joseph Flood, Philadelphia, Pa.

☞ The priming coat of paint should be put on a building before the plasterer begins his work.



## How to Test a Storage Battery with Cadmium Contacts

The amateur, in building storage batteries, will often be unable to get the desired results, although the color of the positive and negative plates may be correct and a voltmeter connected across the cell may give the proper indication of the condition of the cell, due to the fact that the plates are not properly formed. When the above conditions exist, it is quite necessary to test each plate separately, which may be done by means of a pair of cadmium contact pieces and a low-reading voltmeter.

These contact pieces, according to Lyndon, should be made as follows: Take a piece of  $\frac{1}{4}$ -in. hard copper wire and force it into a hole drilled in the end of a  $\frac{3}{8}$ -in. piece of cadmium. The ends of the pieces of cadmium and copper should now be pointed and a small hole, A, Fig. 1, drilled for the lead to the voltmeter. The center portion of the contact pieces should then be taped to prevent the likelihood of accidental contact with the battery plates. Two such contact pieces are shown in the sketches, but it is not imperative to have two of them, as a piece of copper will serve for one, and a piece of cadmium for the other and they may be interchanged, if the voltmeter readings are reversed.

The total or resultant voltage of the cell may be obtained by placing the copper ends in contact with the positive and negative terminals of the battery. Further readings may be taken as follows: Place the cadmium contact B in the acid and the copper, C, in contact with the positive terminal of the cell, as shown in Fig. 2. If the cell is fully charged the voltmeter should read about 2.30 volts. Now change the copper over to the negative terminal of the cell and the voltmeter needle will go the wrong way, indicating a negative reading; change the connection so that they correspond to those given in Fig. 3, and the voltmeter needle will deflect the right way and give a reading of about .2. The

sum of these two readings is then the voltage of the cell which should be 2.50, when the cell is fully charged. When the reading between the cadmium and the negative plate is less than .10, the



FIG. 1

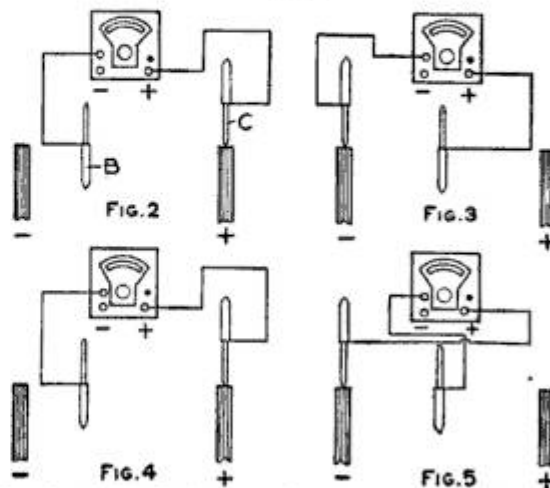

Detail of the Cadmium Contact and the Manner of Making the Test on a Storage Cell

cell is not fully charged and the charging should be continued until the proper value is reached.

Readings on a discharged cell may be taken as follows: The potential of the cadmium with respect to both plates is the same and the resultant is found by subtracting one reading from the other. The connections should be made, as shown in Figs. 4 and 5. When connections are made as shown in Fig. 4, the voltmeter should read about 2.05 and when made as shown in Fig. 5 about .25. The voltage between plates then is about 1.8 volts. The cell should never be discharged beyond this point.

## Drying Blueprints

A factory where a large number of blueprints are used dries the prints quickly with an electric iron. A table is provided for this purpose, which is covered with a piece of oilcloth, cotton batting, and cheesecloth, in the order named. The iron must not be too hot, as this will ruin the print. This drying method, used in connection with an electric printing machine, makes it possible to turn out a print in about three minutes.—Contributed by J. S. Bray, Indianapolis, Ind.



## Protecting the Edges of Concrete Curbing

The edges of concrete curbing may be protected against chipping by means of iron rods or tubing placed in posi-

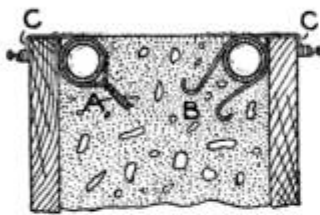

Fig. 1

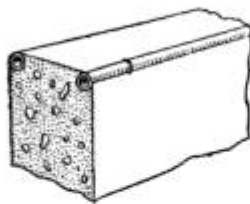

Fig. 2

The Edge of the Curb is Protected with a Piece of Pipe Anchored in the Concrete

tion as shown in the sketch. The anchoring wires are shown in Fig. 1, A being the twisted type and B the hairpin anchor. The rods are held in the forms while the concrete is being poured with wires CC, which are cut close when the forms are removed. The finished curb is shown in Fig. 2.—Contributed by James M. Kane, Doylestown, Pa.

## Cup-Valve Extractor

An extractor for removing carbonized cup valves from an air compressor may be made from a piece of wood, as shown in the sketch. Procure a piece of hard wood, about 12 in. long, 2½ in.

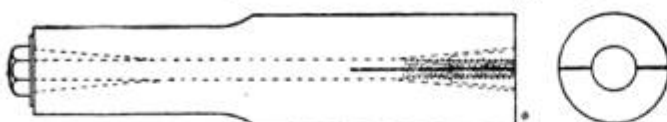

The Ends of the Wood Expand on the Cup in the Manner of the Lathe Chuck

in diameter on the large end and 1¾ in. in diameter on the small end. The size of diameter depends somewhat on the size of the valves. A hole,  $\frac{7}{16}$  in. in diameter, is bored lengthwise through the center to admit a  $\frac{3}{8}$ -in. bolt, 12 in. long, with 3 in. of thread on each end. Both ends are bored out tapering as indicated. These are to receive round, tapering wedges of iron or brass which are threaded to fit the bolt. Two saw cuts are taken through the center of each end, at right angles to each other, to prevent splitting the wood when the wedges are drawn in place.

The end that fits the valve is in-

serted, then the bolt adjusted to expand it. The wood gives ample hand hold to work the valves loose. The bolt and wedges can be reversed as desired to use either end of the stick.—Contributed by A. H. Harrison, Los Angeles, Cal.

## Pointing Pickets

The easiest and quickest way to point small lots of pickets is described by a correspondent of the Wood-Worker. The method is to cut out the shape of a picket from a board and nail on a side and end strip for a stop as shown in the sketch. Drive two brads through from



Pattern Form to Hold Pickets While Pointing Them on the Cutter of a Shaper

the under side and sharpen the points. These will help the stops to hold the piece in the pattern. The pattern and picket is run on a straight-wing cutter on a shaper, allowing the pattern edge to run against the collar.

## Removing Tin Roofing

Having a large amount of tin roofing to remove, I made a tool, as shown in the sketch, to cut the metal at the seams, thus allowing the sheets to be taken off in sections. The tool is shaped like an ordinary can opener, except that it is a little larger and the handle longer. A wire and cross handle are attached so that a boy can draw the tool while a man guides it through the tin. The cutter is made of tool steel, and hardened. The tool can



The Cutter is Made Similar to and Used in the Same Manner as a Can Opener

be used for cutting stovepipes, for furnace jobs and on many other kinds of tin-shop work.—Contributed by E. S. Sites, Muncie, Ind.



## An Elbow Pattern

By J. A. SHELLEY

Elbow patterns are considered by pattern makers generally as rather a mean job; this is particularly so when, for reasons of economy, it is not deemed best to turn them, and they must be finished by hand with a spokeshave. To make an elbow pattern with the least outlay of physical energy requires extreme accuracy in building. The segments should be carefully

fastening the heads securely to this surface and then put on the segments. For the inside, or shorter radii, these may be in one piece, but for the outside it will be more economical to divide the alternate courses into twos and threes.

In getting out the heads and segments, be sure to have enough for both halves, and dowel the end heads together with two pins in each. The

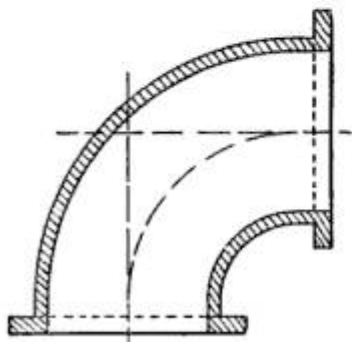

FIG. 1

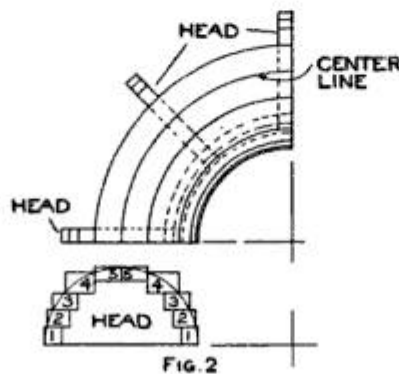

FIG. 2

The Parts as They are Built Up to Make the Groundwork for the Construction of a Special Elbow Pattern, and the Manner of Making a Frame Core Box

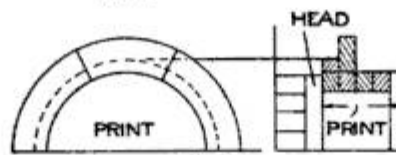

FIG. 3

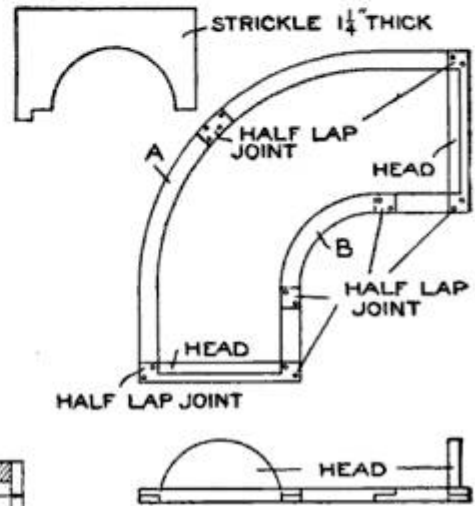

FIG. 4

planed to the proper thickness and sawn to the exact radii so that, when the circles indicating the diameter are laid out on the ends, there will be no excess of stock.

A study of the layout for the 18-in. special elbow, illustrated in Fig. 1, will disclose several interesting constructive features. The end view of the head, Fig. 2, shows all the segments in place, numbered from 1 to 5 and starting at the bottom, or joint, on each side. It will be seen that No. 5 is made in two pieces, sawn exactly on the center line, and fits between the segments marked 4. This prevents the destruction of the center line and eliminates the feather edges that would result if No. 5 were glued on top of No. 4. The plan shows the segments to the left of the center segment removed and the location of the three heads to which the segments are nailed and glued. It is well to have a good straight surface on which to build the first half. Start by

second half is, of course, built on the joint of the first. The prints are built up of segments, as shown in the sectional view of one end of the pattern, Fig. 3, and fastened to the heads with glue and screws. The flanges, with the straight part of the pattern, are built up and turned together and fitted over the prints, to which they are fastened with screws from the inside.

The constructive details of the frame core box are fully shown in Fig. 4. The outer curve A is made in two pieces, fastened together with a half lap joint, and the inner B, in three pieces, which are fastened in the same way. The crosspieces at the ends are halved into these, and the heads fastened to them with screws.

☐ White marks on mahogany caused by dampness may be removed by rubbing the surface with a soft cloth moistened in a little sweet oil. Rub it in well.



## An Auxiliary Air Valve for Gasoline Engine

An auxiliary air valve for increasing the power and decreasing the gas consumption of a gasoline engine can be made of an ordinary grease cup, and it will do the work as well as an expensive valve. Procure a 1 $\frac{1}{4}$ -in. hard-grease cup and cut the slots AA, allowing about one and a half thread intact at the bottom. The slots BB in the upper part can be cut deeper, but in either case each pair of slots should be exactly the same depth. The connecting bar C is riveted to the back of the grease cover D, for turning it.

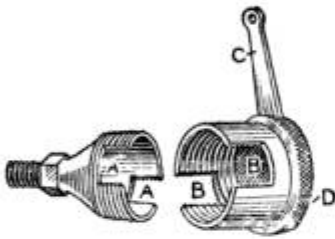

The end of the lower part is screwed into the carburetor intake pipe just below where it branches off to the various cylinders, and its position can be arranged as desired by tightening or loosening it a little. Upon acquiring a traveling speed of, say, 15 miles an hour, with the valve closed, the traveling speed may be increased in varying degree by opening the valve more or less.—Contributed by Frank C. Barks, Denver, Colo.

## Inclosing a Valve Action

Many owners of old automobiles would be glad to know of a way to silence the open-valve action on the motors and prevent the dust and dirt from entering. One of these owners, a correspondent of the Automobile, effectively accomplished this by using a paper tube slipped over the valve stem and spring, as shown in the sketch. The tube may be a piece of one used for mailing drawings, blueprints or calendars, cut to the right

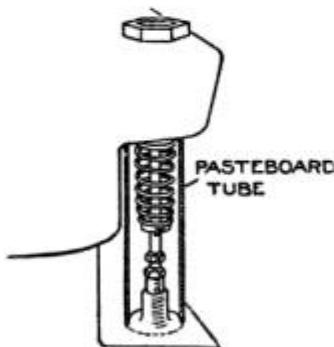

length to make a tight fit lengthwise, and then split for its full length, whereupon it is sprung around the stem and spring. A light hose clamp will hold it in place. The tube may be painted black or covered with aluminum paint, after it is thoroughly coated, inside and out, with shellac varnish to make it waterproof.

length to make a tight fit lengthwise, and then split for its full length, whereupon it is sprung around the stem and spring. A light hose clamp will hold it in place. The tube may be painted black or covered with aluminum paint, after it is thoroughly coated, inside and out, with shellac varnish to make it waterproof.

## How to Find a Crack in Metal

Clean the surface of the metal, turn on a small quantity of kerosene and allow it to stand for a minute or two, then wipe off the oil and strike the piece a sharp blow with a hammer. The oil will show along the outline of the crack. The jar caused by the blow of the hammer will drive the oil out of the crack to the surface of the metal.—Contributed by J. F. R., Bethel, Vermont.

## Repairing a Broken Bicycle Crank

Having broken the locking part on the two-piece crank of my bicycle I decided to fix it rather than buy a new one. Both ends of the shaft part having the locking device were cut off about  $\frac{1}{4}$  in. from the end and slotted as shown. A piece of round steel with a projection on each end to fit into the slots was cut to make the shaft part of the hanger of the right length when the piece was in place. A hole was drilled through the center of the piece to admit the holding bolt. The notches in the ends of the shaft should receive the projecting ends of the center piece snugly so that the three pieces will turn as one.—Contributed by J. E. Nyberg, Jacksonville, Fla.



☐ In painting a smokestack with the use of regular oil paint and not asphaltum varnish it would be well to thin the paint with fish (menhaden) oil, which possesses considerable drying quality and withstands considerable heat.



## Practical Telephony

By HAROLD HINTON

### PART VII—Telephone vs. Telegraph for Train Dispatching

Train dispatching, prior to 1850 when telegraphy was first used on the Erie Railroad for this purpose, was very simple and very slow. The trains were run on a "time-interval system" which allowed the ruling train the right of an hour against any opposing train of the same class. Therefore, if one train was late, all the other trains on the division were late also. The lost time was partly recovered by advancing under the "flag system" whereby a flagman was sent ahead and the train followed after him. When the first man was tired he would wait, on a straight stretch of track, for the train to catch up with him and another man was sent ahead. This method was slow and very unsatisfactory, even in the days when there were no trains that could run at the rate of 70 or 80 miles an hour, so in 1850 Charles Minot, then superintendent of the Erie Road, adopted the telegraph for train dispatching. The troubles which he had with his train crews to get them to take orders from the station agents after they had been sent out by the dispatchers, are a matter of record, but at last a great step in advance had been made in the dispatching of trains even with the comparatively crude instruments of that day.

In 1875, when the telephone was invented and finally used for long-distance communication, the operators on the railroads had used the Morse code so long that they considered it the proper method of dispatching trains. They were inclined to "let well enough alone" and could not bring themselves to adopt the telephone for this kind of work.

In 1883, however, the New Orleans and Northeastern adopted the old magneto telephone for operating trains over a section 100 miles in length. This was a crude system, but it was also a step in the right direction, for, in the latter part of 1906 and the early

part of 1907, a few installations of telephone and selector equipment were given a fair, practical trial, and in October, 1907, the New York Central installed an equipment of this description on a 44-mile section of its main line having 16 stations. This installation was the first of its kind and in December, 1907, the Chicago, Burlington and Quincy equipped 46 miles of double track in the same way. These roads are properly entitled to the honor of being the pioneers in train dispatching by telephone.

Statistics show that there are now 14 railroads in the United States and Canada which have telephone circuits over 1,000 miles of line, the total equipment of these roads including more than 35,000 miles of telephone circuits; the total number of the roads having some telephone circuits being in the neighborhood of 75 with a mileage of almost 50,000 or nearly one-sixth of the entire railroad mileage in the United States and Canada. More systems are being laid out very rapidly and it is only a question of a few years when telegraphy for train dispatching will be a thing of the past, but the equipment will be retained for use in an emergency if the telephone circuits are in trouble, as no system is infallible and naturally the telephone with more complicated mechanism is just as liable to failure as was the telegraph, and it is absolutely essential to any railroad that its means of communicating with its trains must be uninterrupted.

The advantages of the telephone for dispatching are many, a few of them being as follows:

The average telegrapher seldom attains a sending speed of more than 20 to 30 words per minute, while with the telephone a speed of upward of 100 words a minute is attained, and the speed is limited only by the ability of the operator to copy the message.



Experience has shown that seven or eight orders may be sent out in one hour by telegraph, while more than double that amount may be sent by using the telephone, the greatest gain being made in repeating the order for the dispatcher's O. K.

A greater speed also is obtained in reporting the arrival, passing, and departure of trains. In most systems the dispatcher is always on the wire and the operator simply removes his receiver, makes sure that the line is not busy and calls the name of his station. The dispatcher calls "dispatcher" and the report is given.

In reporting accidents, etc., the report is so complete, concise, and speedy that the chance of a misunderstanding is eliminated.

By equipping trains and train crews with portable telephone sets the conductor can get into immediate communication with the dispatcher instead of having to get to the nearest telegraph office or station to send in his call for help.

Some systems are so equipped that the semaphore signals at sidings are operated in connection with the selector, so that the dispatcher may set the semaphore against the desired train and have the conductor call for orders.

When calling, the ringing of a bell at any station may be caused by the dispatcher by turning a button which corresponds to the station wanted. This is accomplished by means of a selector. A few seconds after the station bell is rung, the dispatcher's bell rings and shows the dispatcher that the station wanted has been called.

With the aid of the telephone there is more time for the dispatcher to figure out meeting points, etc., and the saving in time in transmitting orders reduces considerably the mental and physical strain of trying to keep traffic moving and at the same time operating the key continually.

The telephone places the dispatcher in closer touch with his operators and a "call-down" over the telephone is taken in better part than when sent over the Morse route. The latter is a

cold, bare statement while the former gives more of the conversational quality to the order and has a good deal to do with keeping the force in the healthy frame of mind which is necessary to make it efficient.

The chance of misunderstanding is almost entirely removed.

In case of emergency, men may be taken from other departments to assist in the transmitting of orders, as they, of course, do not have to understand the Morse code.

A field is open for old operators who are first-class, except for "telegrapher's paralysis," as they do not have to use the hand.

#### The Installation

The wire which is considered standard by most of the roads is No. 9 gauge hard-drawn copper with which the limit of transmission is about 500 miles. Number 8 gauge copper gives a range of about 900 miles, and No. 8 gauge iron wire has a range of about 145 miles.

Before stringing in new wires, a record should be made of the use of the existing wires on the poles, so that inductive disturbances may be overcome by proper transposition. As in other telephone work, transposition should be made about every 1,300 ft., although every half mile will sometimes do the work. Care must be taken to keep telephone wires as far as possible from quadruplex telegraph wires on the same pole.

The selector is, of course, the most important part of the dispatcher's equipment and the success or failure of the whole system depends upon it. There are many styles in use and most of them are giving very good service. The clock system is probably the most popular and the best all-around selector. This system consists of a number of clocks, exactly alike, at each station, and a master clock in the dispatcher's office. The master clock has a dial upon which is mounted a lug and a push button for each station. An arm is fastened to the main shaft of the master clock so that, by turning



the shaft, the arm makes connection with the various stations and when the desired position is reached the button is pressed and the call is made.

The operator's set, as used on most of the larger eastern roads, consists of a regular telephone operator's common-battery breast transmitter and

(To be continued)

### Setting a Band Saw

In setting a band saw one is liable to have the first few teeth set a little too wide. To overcome this and have the teeth all in line I use the following method: When putting the band saw on the wheels I put it on upside down, so that the teeth will point upward. Then it is tightened until the saw set is drawn to the right width, whereupon the wheels are turned slowly by hand until the saw has made one complete turn. This will put any teeth in line that were out and save the trouble of using the set to draw them back a little.—Contributed by Ernest J. Dickert, Niagara Falls, N. Y.

### Lock for a Bench Drawer

The bench drawer can be easily supplied with a lock that will answer the purpose and protect the workman's tools from the borrowing mechanic. The lock consists of a piece of  $\frac{1}{8}$ -in. flat steel that will fit loosely in a vertical position in the drawer. About one-third of the way from one end drill a hole in the piece and fasten it with a nail or screw on the inside surface of the front part of the drawer. Another screw, A, is turned in where it will catch the longer end of the metal, and when the latch is turned over on this screw it will be out of the way. A

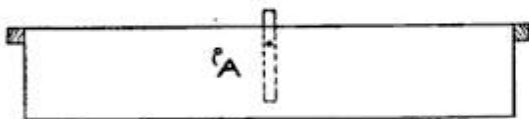

The Lock Consists of a Strip of Metal Attached to the Inside of the Drawer Front

scale or piece of flat steel inserted between the bench top and drawer will turn the latch so that the drawer can be pulled out.

head receiver. This apparatus allows the dispatcher to keep both hands free to move his numbered markers (which represent the trains on his division) about the board which represents the track, sidings, etc., and before which he works, as the reports come to him of their movements along the line.

### An Automatic Closing Stanchion

A practical stanchion that will close automatically by the action of the beast when placing its head through the bars is shown in the sketch. The stanchion is made in the ordinary manner except that it is equipped with the self-closing parts. When turning the stock out, the bar A must be thrown to one side and to set the stanchion after this is done, it is only necessary to place the piece B as shown, so that the coil spring C will hold it in position. When the beast enters, its movement of the head downward trips the piece B, the spring locks the bar A under the loop D, and the stanchion is securely closed.—Contributed by Ralph Crane, Ypsilanti, Mich.

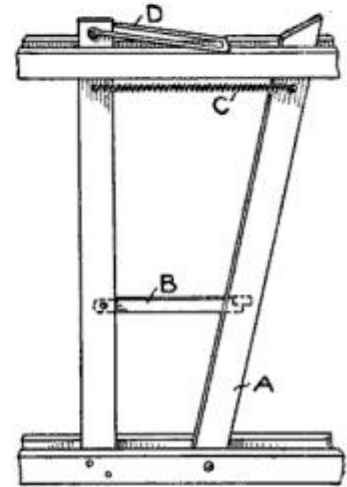

### Mending Broken Oilstones

A broken oilstone can be repaired so that it will last until the stone wears out, in the following manner: The pieces are first heated on an iron plate to remove all oil, then thoroughly cleaned. The surfaces to be joined are well dusted with powdered shellac, which is melted by heating in the same manner. The parts are then placed together and tightly clamped until they become cool. The joints thus made will not interfere with the cutting surface.



### Gauge for Sawing Wedges

The gauge is for use in connection with the gauge on the circular-saw table. The saw gauge is set the width

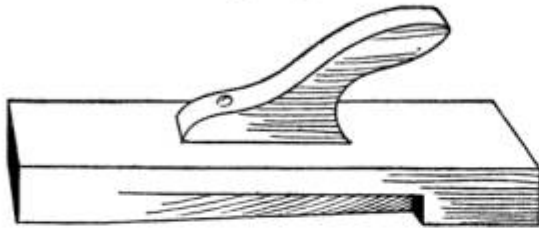

Gauge to Hold Stock on a Saw Table to Cut Wedges for Stair Building

of the wedge gauge plus the thickness of the wedge at the small end. The stock is cut to the length of the wedges and reversed each time a wedge is cut, to keep the grain of the wedge running straight.

The gauge will aid in cutting wedges of all kinds, but it is specially adapted for cutting them for stair construction of the housed-in type.—Contributed by Ernest S. Yawger, Ithaca, N. Y.

### Repair Joint for Large Pipe Lines

The joint illustrated is one that I have used for some time in making repairs on pipe lines of various sizes and under all kinds of conditions. The band surrounding the joint is made of metal, about No. 14 gauge, the diameter being 2 in. larger than the pipe. If the metal band is not over No. 14 gauge, it can be sprung around the pipe and forced back to the size with a chain. Holes are punched along the edges for a double row of rivets which are put in and hammered down, using a 1½-in. bar of steel as a dolly. The

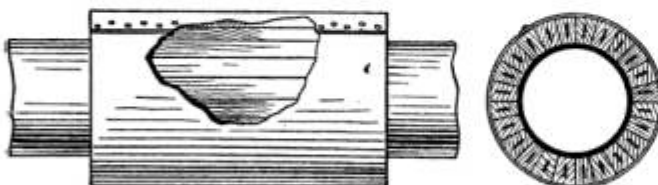

A Joint Made in a Pipe Line by a Band Filled in with Wood Strips and Wedged

bar will easily slip in between the band and the pipe.

When the band is in place and riveted over the joint, make some wood strips, 7/8 in. thick by 1 in. wide and as long as the band, the length of which

will depend on the joint being covered. The strips should be sawed on a bevel as shown, so as to fill the space between the band and the pipe as closely as possible. After the strips are driven in, split the ends of each strip slightly with a chisel and start wedges in the splits all around, but do not drive them in tightly. Then drive each wedge equally until the strips are all tightly wedged together. Wedge the other end in the same manner, then slightly split the ends of the strips in the opposite direction or at right angles to the other split and across the wedge. Drive wedges in these splits in the same manner, to close up any space between the wood and the metal. Do not drive any wedges between the strips, or between them and the metal.

If heavy band metal must be used for a large pipe, make the band in halves and offset the joint so that the inside surface is smooth. I have used these repairs under 1,000-ft. head without a leak. Also on a long line of pipe drawn apart for a considerable distance, a long band was used and a perfect joint made. Care should be taken to secure straight-grained wood for the strips. I find a repair of this kind can be made where the water cannot be taken out long enough to make a lead joint, and where no supplies are available.—Contributed by Geo. A. Nihell, Goodyears Bar, Cal.

### Remedy for a Kicking Cow

Provide two straps similar to a hame strap and buckle each one just above the cow's hoof. Slip a small ring over each strap before they are buckled in place. These will do no harm to the cow if they are left in place all the time. At the milking place have a strap, 12 or 15 in. long, with a snap in each end and fasten it to the rings in the straps on the cow's feet. The cow cannot raise either foot in an effort to make a kick. This only takes a moment's time to attach, and it saves a bruised bucket or the skin of the milker.—Contributed by R. C. Bowden, Magazine, Ark.



### How to Attach False Centers

A piece of hardened steel having no centers cannot be ground perfectly by holding it in a chuck. False centers, that will provide a way to grind the surface for the full length, may be attached as follows:

If a piece of hardened steel, 6 in. long and  $1\frac{1}{64}$  in. in diameter, is to be ground, proceed to polish each end, then solder a piece of cold-rolled steel on this polished surface, as shown in the sketch. Place the steel in a steady rest on the lathe and center each end

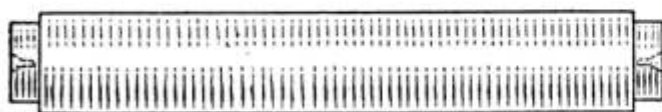

Soft-Steel Ends Soldered to a Hardened Piece of Steel to Provide Centers

in the usual way. These centers serve to hold the steel while grinding the surface, and then they can be removed by striking them with a hammer.—Contributed by Chas. Homewood, Cedar Rapids, Iowa.

### How to Make a Pair of Fiber Pliers

A pair of pliers, that will be found to be very useful to anyone that is called upon to handle "live" wires, replace "blown" cartridge fuses in difficult places, such as behind switchboards, or in "live" circuits where there is no switch to open the circuit while replacing the fuse, may be constructed from some heavy sheet fiber. The general appearance of such a pair of pliers



The Parts Forming the Handles and Jaws of the Pliers are Made of Heavy Sheet Fiber

is shown in the accompanying sketch. Grooves may be cut in the jaws so that the object to be handled may be easily held.

Ordinary calcimine may be made somewhat waterproof by the addition of a little phosphate of soda.

### Spring on a Faceplate Clamp

The ordinary clamp for holding work on a faceplate may be easily fixed to lift its jaw automatically from the work

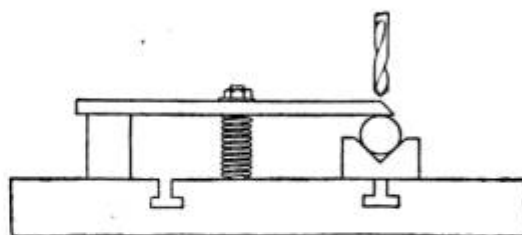

The Clamp Jaw is Raised from Its Holding Position by a Coiled Spring around the Bolt

when the nut of the bolt is loosened. All that is necessary to make this possible is to place a coil spring over the bolt beneath the jaw, as shown in the illustration. The spring also keeps the jaw from turning or changing its position when the nut is released.—Contributed by N. C. Danielson, Moline, Illinois.

### Motorcycle Cleaner

No doubt all riders desire a clean motorcycle, but unless the machine is frequently cleaned of dirt and grease, these are apt to accumulate to an extent that discourages further endeavor in this direction. A correspondent of Motorcycling describes a cleaner made by filling a tin can with a coil of lamp wicking which may be used without soiling the hands. The wicking is soaked in kerosene. When not in use the lid is placed on the can to keep it clean until required.



### Plug-Cock Lubricant

A good lubricating mixture that will prevent leakage, for use on plug cocks, is made of 1 lb. of suet and  $\frac{1}{2}$  lb. of beeswax, melted together. Mix thoroughly while hot, then strain and set away to cool.

A well cleaned talcum-powder can makes a good receptacle for flour of emery.



### Block for Setting Castings in a Lathe Chuck

Having a quantity of flange castings to face on one side, true with the back, it was necessary to provide some quick

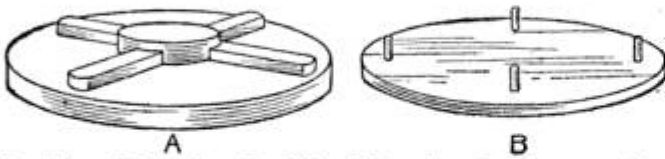

Backing Piece for Rapidly Adjusting Castings to be Turned in the Chuck on a Lathe

way of setting them in the lathe chuck. The back side of the casting, with the four lugs, is shown at A in the sketch. A universal chuck was used on the lathe, in which, of course, a single turn of the wrench would tighten and loosen the grip. To level them up by the back, a disk  $\frac{1}{8}$  in. less in diameter than the flanges was cut out of a  $\frac{3}{8}$ -in. maple board and four  $\frac{1}{4}$ -in. pins were driven in, as shown at B, all being of the same length. These pins projected through the back of the board a trifle and were brought to a common level by fitting on a surface plate. The block fitted loosely in the chuck jaws and between the chuck face and the pieces to be trued up. All that was necessary to set up a flange was to place it in the chuck and tap it back against the pins.—Contributed by Donald A. Hampson, Middletown, New York.

### An Extension Carpenter's Bit

When doing plumbing work or electric installation it is sometimes necessary to use an extension bit and many times the workman does not have one of the proper size at hand, says Electrical Review. A temporary affair can

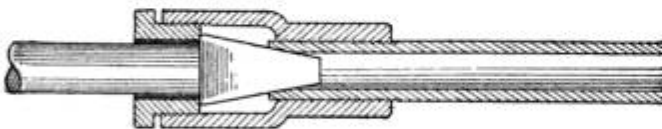

Pipe Connection Used to Make Any Length of Extensions for an Ordinary Carpenter's Bit

be made in emergency cases from a piece of  $\frac{1}{4}$ -in. pipe, a  $\frac{3}{8}$  to  $\frac{1}{4}$ -in. reducing coupling, and a  $\frac{3}{8}$ -in. bushing. The thread on the pipe is cut quite long so that the end will extend slightly

into the coupling. The end is then squared to receive the end of the bit. The bushing is cut in halves and placed over the shank of the bit, which, when tightened, will hold the bit solidly in the coupling. Any length of pipe may be used, also any size of bit, which makes this extension very desirable.

### Keyway-Cutting Tool for the Drill Press

Chipping and filing keyways in holes,  $\frac{5}{8}$  in. in diameter and under, is slow and unsatisfactory work without machinery or special tools. A simple tool for the drill press can be made to do this work far better than by hand. The tool consists of a piece of cold-rolled steel to be held in the drill chuck, one end of which is drilled and tapped for the cutting tool and its setscrew. The lever on the drill press is used to force



Tool to be Placed in a Drill-Press Chuck and Used for Cutting Keyways

it down through the work. After each cut the tool is driven out a little until the desired depth of the keyway is cut.

### A White Paint for Boats

A government formula for a white paint to use on the outside of a boat is as follows: The proportions of the pigment and fluids are varied to suit the requirements. The formula is given for the first coat, which is the thickest. White lead in oil, 7 lb.; zinc white in oil, 7 lb.; raw linseed oil, 2 qt.; turpentine, 2 gills, and japan drier, 1 gill. This will make 1 gal. of paint. If too thin, add more lead and zinc, and if too thick, add more liquids.

### Hose Clamp Used on a Small Hose

An ordinary hose clamp of usual dimensions can be used on pressure hose of much smaller diameter, if a piece of garden hose is forced on the end of the smaller hose. The clamp can then be drawn up on both so that there will be no leak.



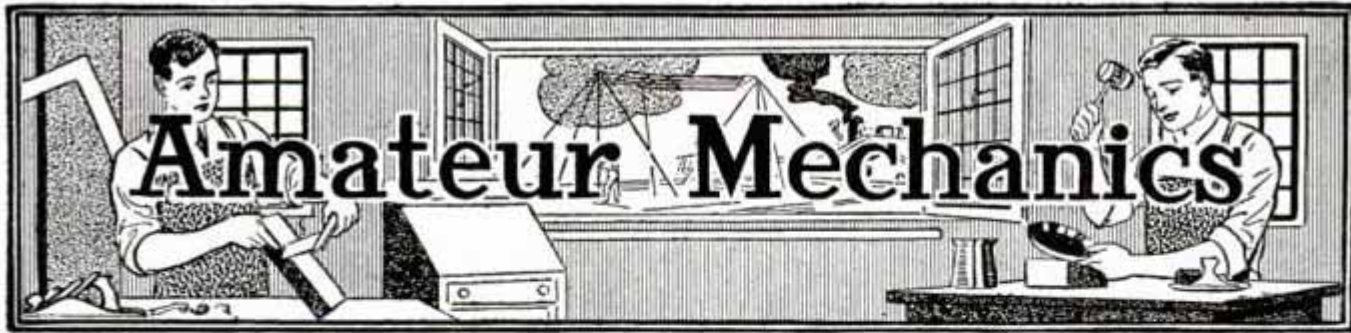

### How to Make a Hurdle

The hurdle consists of two standards, a reach, and a swing. The swing is first made in the shape of a rectangle of four pieces of wood, about  $\frac{7}{8}$  in. thick and  $11\frac{1}{2}$  in. wide, of which two are 36 in. and the others 18 in. long. These pieces are nailed together in the manner shown.

Each standard is made of three pieces of wood,  $\frac{7}{8}$  in. thick, 3 in. wide, and 18 in. long. Nail the pieces firmly together, as shown, and connect their bases with another piece of the same material, 36 in. long. When this is finished, connect the swing to the standards with long nails, A, at the ends slightly off center. Before inserting the nails, make the holes in each standard to receive them large enough to permit the nails to turn freely without allowing the heads to

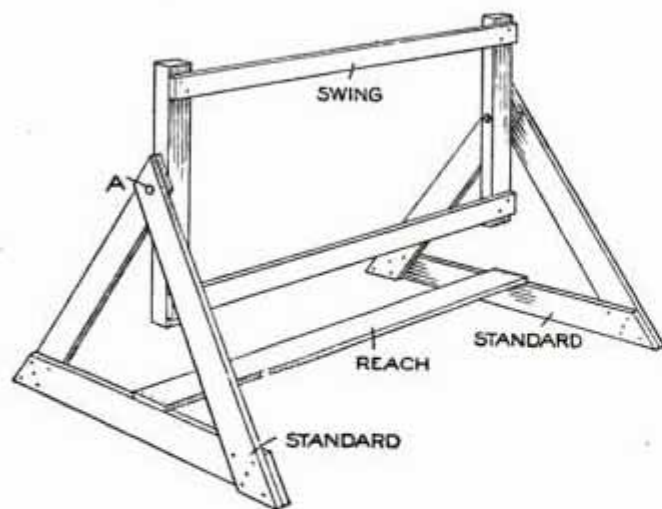

The Swing of the Hurdle will Turn When Slightly Touched and Right Itself Again

pass through. Thus the frame will swing freely at the slightest touch of the jumper's foot, and right itself immediately.—Contributed by C. C. Fraser, Saginaw, Mich.

### Oil Burner for a Cook Stove

The parts of the burner consist of ordinary gas pipe and fittings. The pipe in which the kerosene oil is converted into gas is  $\frac{1}{2}$  in. in diameter and is connected to a supply tank of oil with  $\frac{1}{4}$ -in. pipe.

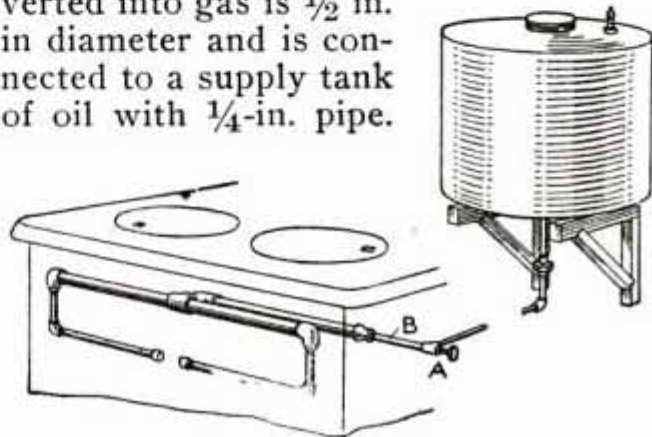

A Very Cheap Grade of Kerosene Oil can be Used in This Burner with Success

The burner part is also constructed of  $\frac{1}{4}$ -in. pipe having three  $\frac{1}{16}$ -in. holes drilled in each end for the gas to escape where it burns. These burners are located just beneath the large pipe so that the flames will heat it and convert the oil into gas. A needle valve, A, is used to control the flow of oil. The burner is placed in the fire box of the stove, and the pipes connected through a hole drilled in the stove door, at B.

The tank may be rectangular or round and should be of sufficient strength to withstand 5 or 10 lb. of pressure. The top of the tank has a pet cock where a connecting hose from an air pump may be attached. The tank is filled about half full and just a little pressure of air is put on the oil. To start the burner, run a little oil in a pan or fire shovel and light it so that the flames will convert the oil into gas in the large pipe, then turn the valve A and regulate the flame.—Contributed by Robert Hays, Siloam Springs, Ark.



### A Merry-Go-Round Pole

An inexpensive merry-go-round can be made of a single pole set in the ground where there is sufficient vacant

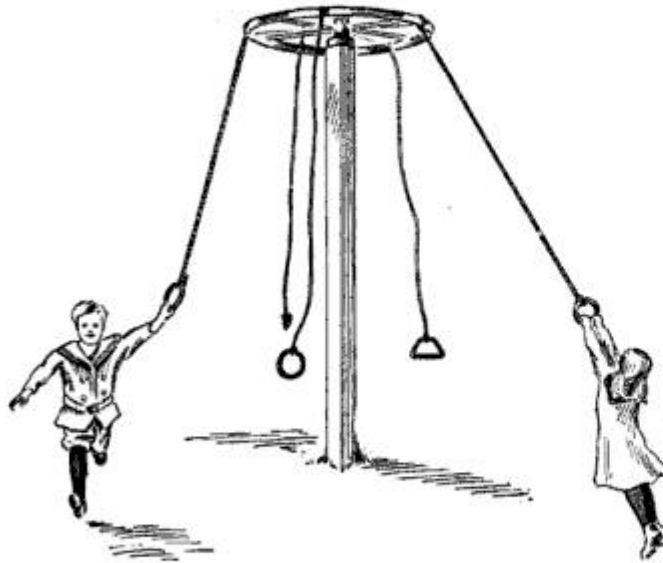

The Ropes being Tied to the Wheel Rim will Easily Turn around the Pole

space for the turning of the ropes. The pole may be of gas pipe or wood, long enough to extend about 12 ft. above the ground. An iron wheel is attached on the upper end so that it will revolve easily on an axle, which may be an iron pin driven into the post. A few iron washers placed on the pin under the wheel will reduce the friction.

Ropes of varying lengths are tied to the rim of the wheel. The rider takes hold of a rope and runs around the pole to start the wheel in motion, then he swings clear of the ground. Streamers of different colors and flowers for special occasions may be attached to make a pretty display.—Contributed by J. Bert Mitchell, Wichita, Kans.

### A Theatrical Night Scene with the Appearance of Fireflies

Use small shining Christmas-tree balls, about the size of a hickory nut, strung on strong black linen threads. The thread is put loosely over a hook at the back of the stage among the evergreens that are used for the background. The ends of the threads are brought, like a pair of reins, to the front of the stage, diagonally, and there manipulated by some one in a wing

near the front, standing high enough to prevent the threads from touching the heads of the actors. These bright little particles darting back and forth among the trees appear very lifelike, and with the addition of a crescent moon just peeping through the trees, the likeness to a summer night is quite striking.

The moon effect is made by using a piece of dark cardboard, about 2 ft. square, covered thickly with small green boughs, and by cutting a crescent-shaped opening in the center, covering it with yellow tissue paper. This cardboard is placed well back in the trees and a lantern hung behind it.—Contributed by Miss S. E. Jocelyn, New Haven, Conn.

### Hulling Walnuts

Procure a barrel that is water-tight and mount it on a shaft so that it runs between standards like a barrel churn. Fill the barrel about half full of walnuts, cover them with water and throw in a small quantity of gravel as grinding material. Close the opening tightly and turn the barrel for about 20 minutes. The walnuts will come out clean and smooth as glass.—Contributed by Arthur Seufert, The Dalles, Oregon.

### Stick for Lowering Top Sash of a Window

To make it easy to raise and lower the upper sash of a bathroom window which is behind the bathtub I devised

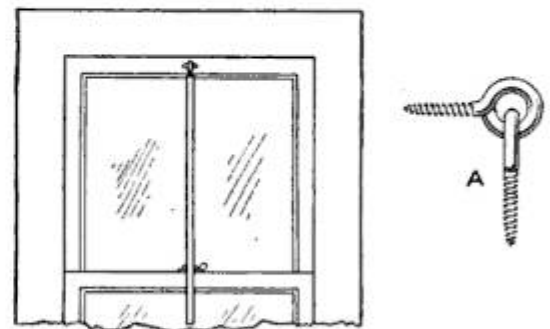

The Stick is Fastened to the Window Sash with Screw-eyes and is Always Ready for Use

the following: Procuring two screw-eyes I opened one sufficiently to slip it into the other as shown at A. Then



one was screwed into the top rail of the sash and the other into the end of a light stick a little longer than the length of upper sash.

The device is left on the window permanently and affords a ready means of handling the sash without stepping into the bathtub, which would otherwise be necessary.—Contributed by W. E. Morey, Chicago.

### An Adjustable Hacksaw Frame

The frame is constructed of cold-rolled steel,  $\frac{1}{4}$  in. in diameter and  $17\frac{1}{2}$  in. long, bent into the shape shown and then cut in two parts at A. Starting at a point about  $\frac{5}{16}$  in. from the ends made by the cut, drill  $\frac{1}{8}$ -in. holes, then space three other holes 1 in. between centers and drill them  $\frac{1}{8}$  in. in diameter.

A piece of steel tubing,  $\frac{1}{4}$  in. in inside diameter and  $6\frac{3}{4}$  in. long, is notched on the ends to receive the pins B and C. Slots are cut in the ends D and E, to admit the blade of a saw,

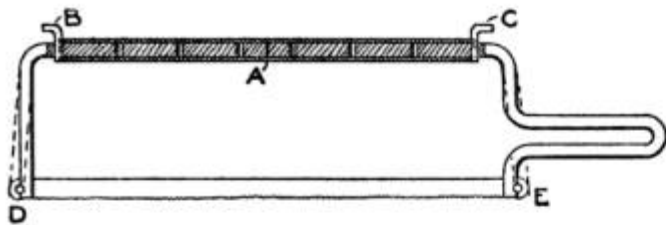

The Frame is Shaped of Cold-Rolled Steel and Made Adjustable with a Piece of Steel Tubing

and half-round notches filed on the outside surface for holding pins used in the hole of the saw blade. The spring of the steel will be sufficient to keep the saw blade in place. The  $\frac{1}{8}$ -in. holes in the frame will permit adjustment for different lengths of blades.—Contributed by Clarence B. Hanson, Fitchburg, Mass.

### A Bedroom Cabinet

The cabinet shown in the illustration can be made an ornament with a little care in workmanship and a choice selection of materials. The cabinet may be either fastened to the head or foot of the bed, facing in either of two directions.

The size of the cabinet will depend

on the choice of the maker, and if the bed is brass, the wood can be finished

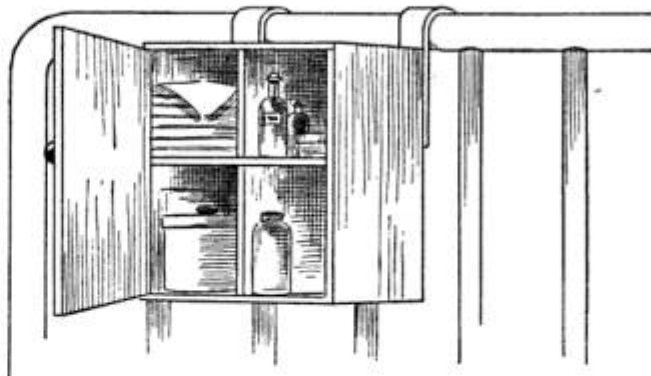

The Cabinet Makes a Handy Place to Keep Necessary Articles for a Sick Person

natural and fitted with brass bands for brackets and holding clips.—Contributed by W. E. Crane, Cleveland, O.

### A Dull Black for Cameras

Such parts of a camera that are apt to reflect light must be covered with a dull black. A mixture for this purpose is made of lampblack, about a teaspoonful, and enough gold size to make a paste as thick as putty. Add about twice the volume of turpentine and apply to the parts with a camel's-hair brush.

As the turpentine fumes are detrimental to the sensitive plate, the camera should be left open until these fumes have entirely disappeared.

### A Door Fastener

Sometimes it is necessary to fasten a door in a manner to prevent children from opening it, yet so that it is easily opened from either side. This can be done by putting a screw or curtain hook on the inside of the door frame and using a piece of cord long enough to loop over both hooks. A person coming in or out can remove the loop from either side.—Contributed by John A. Cohalan, Philadelphia, Pa.

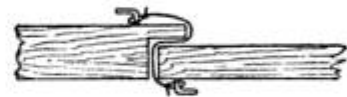

CA floor wax can be made by melting 1 lb. of yellow beeswax in  $\frac{1}{2}$  pt. of hot, raw linseed oil; then adding 1 pt. of turpentine.



### A Hat Hanger

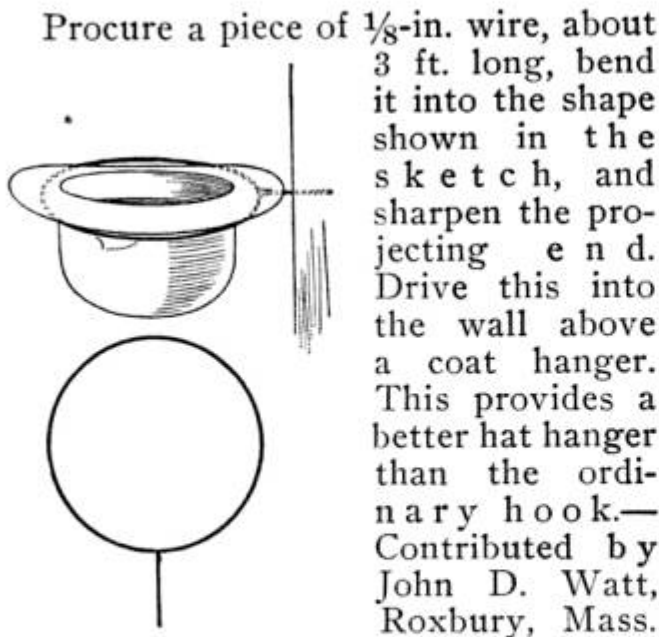

Procure a piece of  $\frac{1}{8}$ -in. wire, about 3 ft. long, bend it into the shape shown in the sketch, and sharpen the projecting end. Drive this into the wall above a coat hanger. This provides a better hat hanger than the ordinary hook.—Contributed by John D. Watt, Roxbury, Mass.

### Repairing a Broken Tenon on a Chair Post

Instead of cutting off the four posts to make new tenons where one tenon was broken I used a metal piece made from a short length of bicycle tubing, as shown. The tube was slotted two ways to make four parts which were turned out and flattened. The remaining end of the tube was slipped over the broken post and the four parts were fastened with screws to the under side of the chair seat.—Contributed by Chas. H. Roberts, Calumet, Mich.

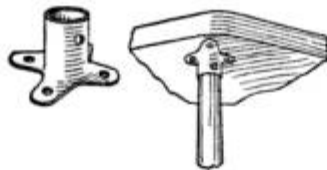

### Substitute for an Iron-Holder Knob



The wood knob on the holder for my irons became charred from the heat and finally broke away from the pin. The pin would get so hot in continued use that it could not be moved without burning my fingers. I remedied the

difficulty by attaching a short string to the handle and the pin. A pull on the string with the forefinger readily released the iron. I have found this better than the knob, as it is handier to use.—Contributed by Mrs. H. C. Dixon, Johnstown, Pa.

### An Egg-Frying Pan

The frying of eggs in an ordinary frying pan is accompanied with some difficulty in removing them when they are cooked without breaking the yolk. Then, sometimes, the pan is too hot and the egg sticks to the pan and the top remains uncooked. A much better way is to shape a piece of sheet metal or tin as shown in the sketch to place



A Metal Plate for Use in an Ordinary Frying Pan to Cook Eggs without Scorching Them

the egg in and use it in the ordinary pan. It will not burn the egg, and the egg can be lifted out of the pan and easily slipped on a plate or toast when it is cooked.—Contributed by W. A. Jaquythe, San Diego, Cal.

### A Sander Mandrel for the Lathe

A cylindrical sander for use in the lathe can be easily made of two pieces of wood, turned to a diameter that will take the stock size of sandpaper, and clamped together with pinch dogs at the ends. One edge of the sandpaper

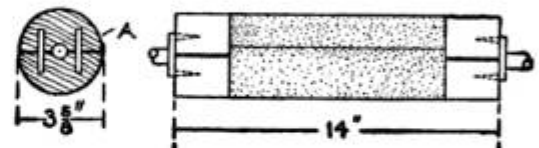

A Wood Mandrel for Attaching Regular Sheets of Sandpaper to Make a Lathe Sander

is clamped between the pieces and then it is wrapped around the wood, the opposite edge being glued to the starting edge, as shown at A. The dimensions given are for a 9 by 12-in. sheet of sandpaper. The sander is easily placed in the lathe centers when needed, and the sandpaper may be replaced at any time.—Contributed by James T. Gaffney, Chicago.



## A Pocket Direct-Current Voltmeter

The assembled drawings of a very simple voltmeter are shown in Fig. 1, and its operation is as follows: The moving portion consists of a pointer, or needle, A; a small permanent magnet, or armature, B, and a counterweight, C, mounted upon a small steel shaft, D. The ends of this steel shaft are pointed and rest in bearings provided in the U-shaped piece of brass E, which is rigidly fastened to the fiber base F, by means of two screws. The permanent magnet B, carried on the shaft D, is at all times under the magnetic influence of the permanent horseshoe magnet, G, which is fastened, by means of thin brass straps, H H, and small screws, to the base F, so that the ends of the armature B are directly above the poles of the horseshoe magnet. The armature B will assume the position shown in the sketch when it is acted upon by the permanent magnet G alone and the moving system is perfectly balanced. A solenoid, J, is mounted in the position shown. When there is a current in its winding its soft-iron core will become magnetized and the magnetic pole produced at the lower end will produce a magnetic force upon the armature B, with the result that the armature will be rotated either in a clockwise or counter-clockwise direction, depending upon its polarity and the polarity of the end of the core adjacent to it. Thus, if the left end of the armature has north polarity, the right end south polarity, and the lower end of the core is magnetized to a south polarity the armature will be rotated clockwise, for the left end, or north pole, will be attracted by the lower end of the iron core, which is a south pole, and the right end will be repelled. This is in accordance with one of the fundamental laws of magnetism which states that magnetic poles of unlike polarity attract each other and those of like polarity repel each other. The amount the armature B is rotated will depend upon the relative effects of the pole of the solenoid and the permanent magnet G. The strength

of the pole of the solenoid will depend upon the current in its winding and the number of times the current passes around the core, or the number of turns in the winding. In other words, the strength of the pole of the solenoid

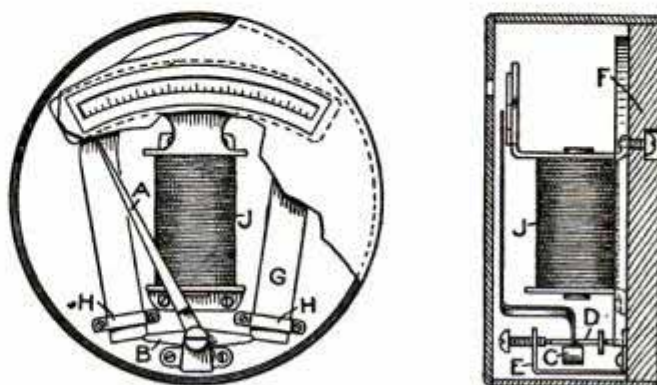

FIG. 1

The Parts as They are Assembled to Make a Pocket Voltmeter for Direct Currents

varies as the product of the current and the number of turns, which is called the ampere-turns. The same magnetic effect can be produced by a large current passing through a few turns or a small current passing through a relatively large number of turns. This simple relation of current and turns gives a means of adjusting the current capacity of the instrument so that a full-scale deflection of the needle will correspond to any desired maximum current. The instrument may be used as either a voltmeter or as an ammeter, and its operation will be identical in each case. The resistance of the voltmeter, however, will be many times the resistance of the ammeter, as it will be connected directly across the line, while the ammeter will always be in series in the circuit in which it is desired to measure the current. The following description and suggestion as to how to proceed in the construction of this instrument may be useful to those who undertake to build one. All the minor details and some of the dimensions will be omitted in the description, but these can be easily supplied.

Procure a piece of hard rubber or fiber, about  $\frac{1}{4}$  in. in thickness and of sufficient size to cut from it a disk,  $2\frac{1}{2}$



in. in diameter. Make a small horse-shoe magnet from a piece of the very best steel obtainable, and magnetize it to as high a strength as possible. This magnet is made of a piece of steel,  $\frac{1}{8}$  in. thick, about  $\frac{3}{8}$  in. in breadth, and of such length that the overall lengthwise dimension of the completed magnet will be about  $1\frac{7}{8}$  in. and the distance between the inside edges of the ends a little greater than  $\frac{1}{2}$  in. Fasten the completed magnet to the base F by means of two or three straps, made from some thin brass, and small machine or wood screws.

Then cut from some  $\frac{1}{16}$ -in. sheet brass a piece having the general appearance and dimensions shown at A, Fig. 2. Bend the ends of this piece over at right angles to the center portion along the dotted lines. Drill the hole at the upper end and thread it for a  $\frac{1}{16}$ -in. machine screw. By means of a pointed drill, make a small recess at the lower end directly opposite the first hole. This small recess is to form the lower bearing for the shaft supporting the moving system, while a small recess cut centrally in the end of a screw, mounted in the upper hole, will form the upper bearing. The screw placed in the upper hole need be only about  $\frac{3}{16}$  in. long. The holes in the two wings are for mounting this piece upon the fiber base, as shown in Fig. 1.

The shaft for supporting the moving system is made of a piece of a hatpin. It is about  $1\frac{3}{8}$  in. long and its ends are pointed so that they will turn freely in the bearings provided for them.

The armature is cut from a piece of  $\frac{1}{16}$ -in. sheet steel. It is made about  $\frac{3}{4}$  in. long,  $\frac{5}{16}$  in. wide at the center, tapering to  $\frac{1}{8}$  in. at the ends. A hole is drilled in its center so that it may be forced onto the shaft. It is mounted so that its lower surface comes about  $\frac{1}{4}$  in. from the lower end of the shaft.

Then cut from some very thin brass a piece, that is to form the needle,  $\frac{1}{4}$  in. wide at one end and tapered to a point at the other, the total length being about 3 in. Drill a hole in the large end of this piece, the same size as the shaft and  $\frac{1}{2}$  in. from the end.

This piece is not fastened to the shaft until some of the other parts are completed.

The spool upon which the winding is to be placed is made as follows: Procure a piece of very soft wrought iron,  $1\frac{1}{4}$  in. long and  $\frac{1}{4}$  in. in diameter, to form the core. The ends of the spool are made of thin brass and are dimensioned as shown in Fig. 2, at B and C. The piece shown at B is to form the lower end of the spool, and is bent at right angles along the dotted line. The two holes at the lower edge are for attaching the end of the spool to the fiber base. The piece shown at C forms the upper end of the spool and at the same time a back upon which the scale of the instrument is mounted. The holes in the lower edge are threaded for small machine screws, as it will be necessary to fasten this piece to the base by means of screws that pass through the base from the under side, as shown in Fig. 1. Bend the upper and lower portion of the piece over at right angles to the center portion along the dotted lines. Make sure that the large hole in the center of each end piece is of such size that it will fit very tight on the end of the wrought-iron core. Force the end pieces onto the ends of the core a short distance, say,  $\frac{1}{16}$  in., and hammer down the edges of the core so that the end pieces cannot be easily removed. In fastening the ends to the core be sure that the parts that are to rest upon the base are parallel with each other and extend in opposite directions; also that the ends are at right angles to the core. Then insulate the inner portions of the completed spool with several thicknesses of onion-skin paper, or any good-quality, thin writing paper, and shellac. The winding will be described later.

Mount the spool and support for the bearings upon the base so that they occupy the positions, relative to each other, indicated in Fig. 1. A paper scale is then mounted upon the brass base provided for it by means of some thin shellac. The upper and lower lines for the scale can now be drawn upon



the paper, using the center of the screw at the lower end of the needle as a center. These lines are best placed about  $\frac{1}{8}$  in. apart and not nearer the edge of the base than  $\frac{1}{4}$  inches.

The needle is bent over at right angles  $\frac{5}{16}$  in. from the center of the shaft. Another right-angle bend in the needle is then made so that the pointed end will be about  $\frac{1}{16}$  in. above the surface of the scale when the large end of the needle is fastened to the shaft  $\frac{3}{8}$  in. from the upper end of the latter. Turn the needle on the shaft so that the pointer is at the left end of the scale when the moving system is at rest. The shaft must be exactly vertical when this adjustment is made. Cut the end of the needle down until its end is midway between the two scale lines. Solder the needle to the shaft, and then place a sufficient quantity of solder on the broad end to balance the system perfectly and allow it to come to rest in any position when the armature B is not influenced by any magnetic field.

A containing case for the instrument may be made as follows: Make a cylinder from some thin sheet brass, having exactly the same inside diameter as the base, and a height a little greater than the vertical distance from the lower surface of the base to the upper surface of the needle. Also a disk from some thin sheet brass, having a diameter  $\frac{1}{8}$  in. greater than the outside diameter of the cylinder. Round off the edges of this disk and cut a curved slot in it directly over the scale, about  $\frac{3}{8}$  in. wide and of the same length and form as the scale. Solder the disk to one end of the cylinder, placing the solder all on the inside. To prevent moisture from entering the case, fasten a piece of thin glass on the under side of the slot in the disk by means of some shellac and several pieces of brass soldered to the disk and bent down onto the glass. The case can now be fastened to the base by means of several screws, passing through its lower end into the edge of the base. Two small binding posts are mounted on the outside of the case, about 90 deg. apart

and well insulated from each other and from the case, to serve as terminals for the instrument.

The instrument is now complete with the exception of the winding. Since this is to be a voltmeter and it

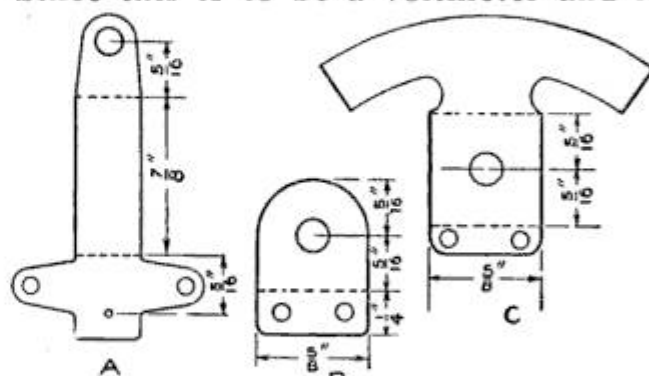

FIG. 2

Details of the Supports for the Coil and for the Needle, or Pointer, Shaft

is always desirable that a voltmeter take as small a current as possible, the winding must consist of a relatively large number of turns of small wire, each turn carrying a small current. The difference in the construction of different instruments necessitates that their winding contain a different number of turns in order that a given voltage may produce a full-scale deflection. A little experimenting with different windings is the easiest means of determining the proper size of wire and number of turns to meet individual requirements. After adjusting the winding so that the maximum voltage it is desired to measure produces a full-scale deflection, the scale is calibrated by marking the positions of the needle in accordance with those of the needle of a standard instrument connected in parallel with it. In marking the scale of an ammeter, connect the instruments in series. Remember that if the instrument is to be used as an ammeter, it must have as low a resistance as possible and that to prevent undue heating, the wire must have ample cross section.

If difficulty is experienced due to the continuous vibration of the needle, although the current be practically constant, this trouble can be greatly reduced by mounting a paper wind vane on the moving system, which will tend to dampen its movement.



### How to Make Falling Blocks

Procure a thin board large enough to cut six blocks, 2 in. wide and 3 in. long; also 2 yd. of cotton tape,  $\frac{1}{4}$  in.

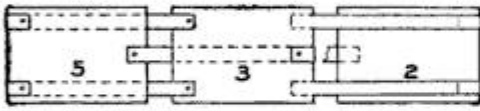
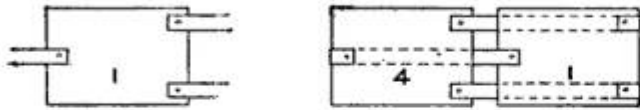

Set of Blocks Joined with Tape So That They Appear to Fall from the Top

wide, and some very small tacks. Cut the board into pieces of the size mentioned, and number two of them on both surfaces, 1, 2, 3, and 4. Cut off three pieces of tape,  $4\frac{3}{4}$  in. long, and on the side of block 1 tack one piece of tape in the center at one end, and the other two pieces at each edge on the opposite end, all being on one side of the block as shown. Take the other block and lay the side numbered 4 up, then draw the two strips of tape on the edges of block 1 under it and back to the end of the surface on block 4, and tack them on this surface at the edges as shown. The center tape is passed under block 4 and turned over the opposite end and tacked. This is clearly shown in the sketch. Thus the second block will hang from either end of block 1 by simply folding them together and separating the ends.

Mark the sides of the third block 5 and 6, and place it with the two others so that the sides numbered 2, 3, and 5 will be up. Cut off three more pieces of tape,  $4\frac{3}{4}$  in. long, and tack them on as shown, being careful not to tack through any of the first three pieces. Put on the fourth block in the same manner as the third block was attached to the second, and so on, until all the blocks are attached.

Take hold of the first block on the edges and tip it as shown by the arrow. The second block will then fall as shown by the second arrow, and the third block falls away in the same man-



ner, and so on, down to the end.—Contributed by Wayne Nutting, Minneapolis, Minn.

### Writing Name Reversed on Paper Placed on Forehead

The following is an entertaining experiment in a party of young people. One of those present is asked if he can write his name, and will, of course, answer "yes." He is then subjected to the following test: He is asked to sit down in a chair, a paper, folded several times, is placed on his forehead, a lead pencil is handed him and he is asked to write his name on the paper. As little time as possible to reflect should be left him; if he hesitates, he should be told to just go ahead, and in most cases it will be found that he starts writing his name at the left temple and, to the amusement of the others present, writes it in the way of many left-handed persons, that is, so that it is legible only when held in front of a mirror, unless one is practiced in reading reversed writing.

### Use for an Old Table

An old table of the extension type, that may have a post broken, can be used against the wall in a kitchen as a work table. If there is a damaged part, that side is removed by sawing the crosspieces of the table in two and attaching it to the wall against the leaf

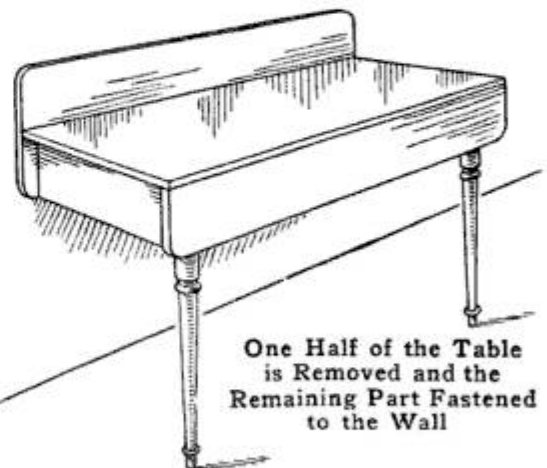

which is turned in a reverse position.—Contributed by A. S. Thomas, Gordon, Can.



### Waterproof Shoe Dressing

Melt some tallow and, while it is hot, put in some scraps of rubber from old rubber shoes or boots. Be careful to select rubber that is free from cloth. Put in as much of the rubber as the tallow will absorb. Stir freely while it is melting, and keep it away from any flames. Allow it to cool and set away for future use. Take enough for immediate use and warm it sufficiently so that it may be applied with a brush.—Contributed by F. S. Cummings, Detroit, Mich.

### An Adjustable Bench Stop

A simple adjustable bench stop for light work may be made from a piece of 1-in. broom handle and a piece of piano wire. Plane a flat surface on the broom stick and drill two  $\frac{1}{16}$ -in. holes, about  $\frac{1}{4}$  in. deep,  $\frac{1}{4}$  in. from each end. Bend the ends of the wire to enter the holes and have the wire of such length as to give it a slight curve between



The Spring Wire will Hold the Stop at Any Desired Position for Height

the ends when it is in place on the stick.

Bore a 1-in. hole through the bench top where it is desired to use the stop and cut several grooves, as shown, in the walls of the hole with a compass saw. The spring wire will slide into a groove and hold the stick wherever it is set. The position of the face can be changed by inserting the stick so that the wire will enter the right groove.—Contributed by Alan H. Andrews, Fall River, Mass.

### A Crochet Hook

In making some kinds of lace work different-sized hooks must be used as the work proceeds. Considerable time will be lost in changing from one hook to another, if they are separate. The

best way is to mount all the hooks necessary on one handle, as shown in the sketch. The handle part is made of a large wire or small rod, bent to the

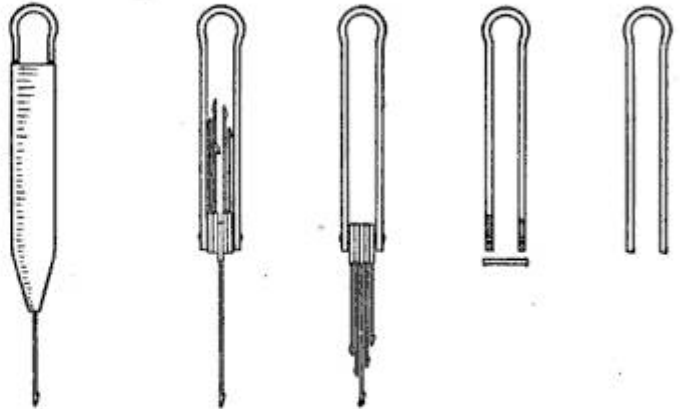

A Crochet-Hook Handle for Holding Several Hooks That are Required for Some Lace Work

shape shown and with holes drilled through the ends for a small rivet. The ends of the hooks are drilled or bent to fit on the rivet. A small tin ferrule is made to slip over the handle and the hooks not in use. All hooks but the one in use are turned back into the handle and the ferrule slipped into place.—Contributed by Miss Nita S. Ingle, W. Toledo, O.

### Writing Board for Children

A writing desk for a child can be easily made as shown in the sketch. The materials necessary are a board of suitable size, two screwhooks, four screweyes and a pair of rods for braces. The hooks are screwed into the back of a chair and the screweyes into the board, as shown. This desk is instantly attached or taken down when desired. If the chair is light and apt

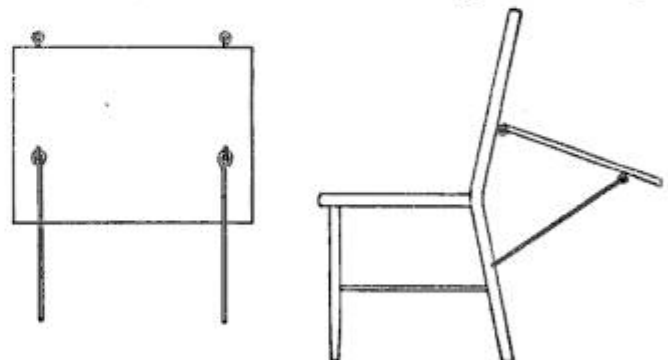

The Writing Board is Easily Attached to, or Detached from, an Ordinary Chair Back

to tip over, make the rods long enough to reach to the floor.—Contributed by John V. Loeffler, Evansville, Ind.



### Geometric Principle in Line Division

When sketching a plan, if any one of the first few lines drawn is found to be the proper length, then this line can be

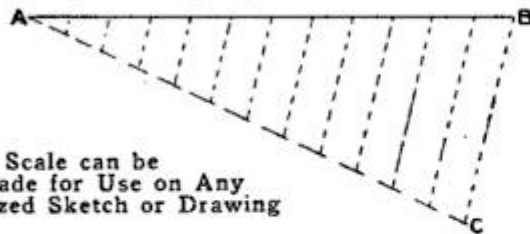

made into a scale by the geometric rule for dividing a given line into equal parts.

Suppose, for example, the line AB, which is to represent 12 ft., is found to be 1 ft. long. Draw a line, AC, at any angle from the point A and step off on it 12 equal parts, beginning at A. The last point, or the one at C, is connected to the end B, then eleven other lines are drawn parallel with CB. Thus AB will make a scale of 1 in. to each 1 ft.—Contributed by James M. Kane, Doylestown, Pa.

### Repairing a Broken Whip

Procure a piece of thin tin—the metal taken from a discarded fruit can will do—and cut it about  $2\frac{1}{2}$  in. long and wide enough to encircle the break. Notch the ends like saw teeth and remove any sharp edges with a file. Place the tin on the break and tie temporarily. Wind the whole from end to end with a waxed linen thread, such as used by harness makers. The threads lying alternately on the whip and on metal at the notched ends eliminate any possibility of the parts working loose. A break near the small and flexible end of a whip is repaired in the same manner, using a quill instead



The Repair on a Whip Made with a Notched Ferrule and a Waxed Thread

of the tin. In either case, do not let the edges of the splicing material meet, and it will clamp tightly on the whip.—Contributed by W. S. Kingsley, W. Gouldsboro, Me.

### Repairing a Worn Thimble

Silver thimbles are easily worn through at the end, and they can be quickly repaired by soldering from the inside. A very neat repair can be made with an alcohol lamp and a blowpipe by using a little silver solder. Borax or resin is used as a flux.

### A Small Torch

A small torch, that will give a very fine and hot smokeless flame, can be made from a piece of glass tube, about 4 in. long, and 4 ft. of rubber tubing. The glass tube is heated in the center

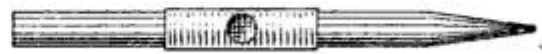

A Torch Made of Glass and Rubber Tubing, to be Used on an Ordinary Gas Jet

until it is red, then the ends drawn apart so that the tube will have a small diameter. After the glass has cooled, make a small scratch with a file on the thin part and break it. One of the pointed ends is connected to a straight piece of glass tube with a short piece of the rubber tube, as shown in the sketch. A small hole is cut in the side of the piece of rubber to admit air to the gas. The torch is connected to an ordinary gas jet.—Contributed by E. K. Marshall, Oak Park, Ill.

### Fountain Attachment for an Ordinary Pen

A quite efficient fountain pen may be quickly made by bending an ordinary



The Space between the Pens Forms the Fountain, Which is Sufficient for Considerable Writing

pen, as shown at A, and inserting it in the holder opposite to the regular pen, as shown at B. For best results, the point of the auxiliary pen should just touch the regular pen.—Contributed by Thos. L. Parker, Wibaux, Mont.

CA little water added to oil paint will make a flat or lusterless finish and will do no harm to the paint, as the water evaporates in time.



## To Make Whitewash Stick to Surfaces Coated

In using whitewash much difficulty is experienced in making it stick to the substance covered. A good way to prevent the coating from cracking and peeling off is to add 2 oz. of pure sodium chloride to every 1 gal. of whitewash mixture. This is not expensive, but should be secured at a drug store because some salts of sodium are not pure and will darken the whitewash. The sodium chloride should be added after the whitewash solution is made up. When this mixture is used in buildings it will destroy all vermin which it touches.

## A Mechanical Camera

The young person who likes to draw will find the device illustrated of great assistance for outlining a portrait or a bit of scenery which can be filled in to make the picture. The camera consists of a box without a cover, about 12 in. long, 6 in. wide and 4 in. deep. An oblong hole is cut in one end, a small hole bored in the other, and a piece cut out of the lower edge so that one eye can be placed close to the hole. The oblong hole, shown by the dotted lines, is covered with a fine perforated cardboard, the kind used for working in mottoes with yarn. Supports are nailed in the corners of the box, their length being calculated to

allow the operator to sit or stand, as desired.

The camera is used in the manner illustrated. If a portrait is to be drawn, then the one sitting for it must be quiet until the outlines are completed. The



operator, looking through the hole, traces the lines on the cardboard between the perforations. When the outlines are drawn in this manner, the

cardboard is removed and placed on the paper or cardboard used for the picture. The outline is then transferred by marking with a sharp-pointed

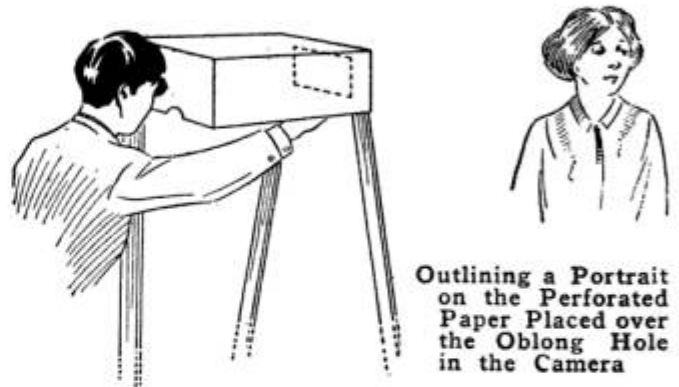

pencil through the perforations on the outlines as drawn. After separating the two pieces, the markings can be connected with a continuous line and an exact outline will be obtained which can be filled in as desired. The outline picture is a sample of work done with the camera.—Contributed by Florence Thomas, Gordon, Ont.

## Gauge Attachment for a Pocket Rule

The base of the gauge A is cut from a block of hard wood, about 2½ in. long, 1 in. wide and ⅜ in. thick. A notch is cut in one side to admit the rule and the wedge B, which has a slot that slides on a pin in the base. A small metal clip keeps the wedge in place. The gauge can be readily set on the rule at any mark.

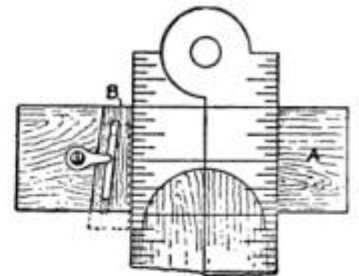

## Plate Hangers

In hanging old china plates for decorative purposes use three large white dress hooks, placed at equal distances apart on the edge of the plate. The hanging wire or cord is run through them from the back side and drawn up tightly. These hooks are much better than the ordinary plate hanger, as they are small and will not show much on the plate.







1.062, 1.3  
Frank J. Fogel  
Westwood

1.065  
1.065.8.14  
1.062, 468  
1.065, 745

John H. Stone  
W. H. Miller  
Arthur S. Lambert  
W. B. Johnson  
Te. 18a  
John  
Urban



Fig. 11

**ADJUSTABLE PONTOONS FOR SMALL BOATS** (Fig. 11; British patent to an Australian)—These pontoons, intended to make a small boat nonsinkable and noncapsizable, can be adjusted according to the load and the height of the gunwale above the water. They are fastened to the boat's side by means of cords passing over pulleys below the water line and cleats on the gunwale, so that the pontoons can be raised or lowered until they rest upon the water.



Fig. 13

**COMPARTMENT HATBOX** (Fig. 12)—By an ingenious arrangement of cardboard partitions, this hatbox is arranged to hold a large number of straw or flat felt hats in a very small space. The hats are arranged so that the brim of one hat laps over the crown of the next without touching it.

**DETACHABLE SHIRT SLEEVES** (Fig. 13)—When a man wears one of these shirts he does not have to roll up his sleeves to keep them clean—he can take them off. The lower half of each sleeve, from the elbow down, is made separately so that it can be taken off and replaced quickly.

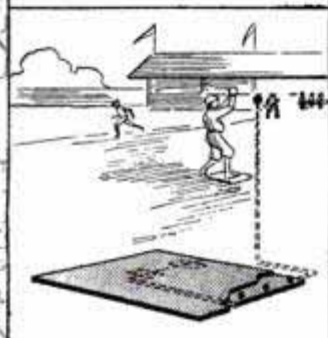

Fig. 15

**COMPARTMENT DINNER PAIL** (Fig. 14)—This dinner bucket is made up of five separate compartments which keep various kinds of food separate and can be used as dishes. Each compartment is flat and circular and has eyelets on each side to slide over the two uprights that make the frame of the pail.



Fig. 17

**AN AUTOMATIC UMPIRE** (Fig. 15)—This signal base for baseball diamonds makes the sharp eye of the umpire unnecessary. When the runner touches the base, a bell rings and the umpire's decision is easily made. The base is made of two boards hinged together and kept slightly apart by a spring. A slight pressure of the foot brings the boards together, makes an electric contact, and rings a gong placed where every one can hear it.

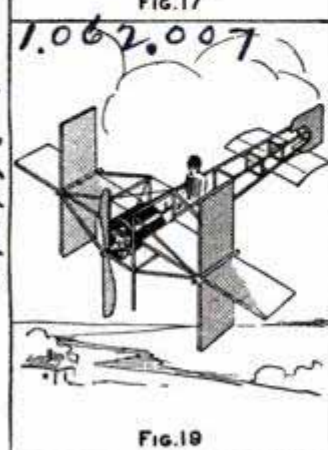

Fig. 19

**COMB FOR APPLYING HAIR TONIC** (Fig. 16)—Working on the principle of a fountain pen, this comb spreads scalp tonic, hair oil, dye, peroxide, or any other preparation, as it is drawn through the hair. The top of the comb is hollowed out to form a reservoir and each tooth is a hollow tube. A small trough which runs along under the main reservoir supplies the hollow teeth with liquid received from the reservoir through valves controlled by a push button. A little pressure on the button on top of the comb allows a small quantity of liquid to run into the trough, ready to flow out through the hollow teeth as the comb is drawn through the hair.

**LIGHTED TAXICAB SIGNS** (Fig. 17; British patent)—Every taxicab displays on its taximeter a little metal flag which announces whether the cab is vacant or occupied, but it is sometimes hard to see the tiny flags at night. This device does away with the difficulty. Two little electric signs, one reading "Vacant" and the other "Occupied," are placed on the edge of the roof of the cab and connected with the taximeter so that one or the other of them is illuminated according to the position of the flag.

**ADJUSTABLE COLLAR BANDS FOR SHIRTS** (Fig. 18)—Men whose necks are too large or too small for standard shirts have difficulty with their collars, which is easily overcome by this adjustable collar band. A number of buttonhole tags are sewed in a row on each end of the collar band and it is not hard to find the proper combination to fit any collar.

**FLYING MACHINE WITH REVOLVING WINGS** (Fig. 19)—The frame of this new flying machine is very much like that of a monoplane and it has horizontal and vertical rudders at the rear end of the frame and a motor-driven propeller in front. But its two wings are each made up of two or more planes or vanes intersecting along the line of a shaft parallel with the direction of flight. These multiple-vane wings are arranged so that they can be freely revolved on their shafts.

**COMBINED HAIRBRUSH AND COMB** (Fig. 20)—This hairbrush has a clip for holding a comb pivoted on its back. A spiral pin on the clip pivot holds the comb tightly against the back of the brush or in a vertical position ready for use. The comb can be used separately.

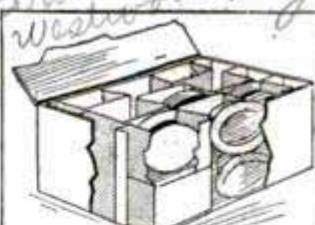

Fig. 12



Fig. 14

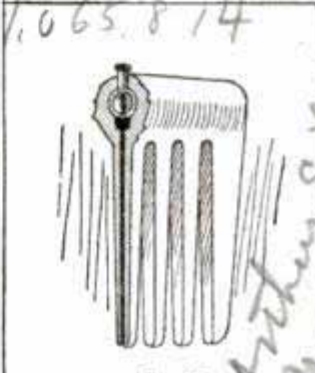

Fig. 16



Fig. 18

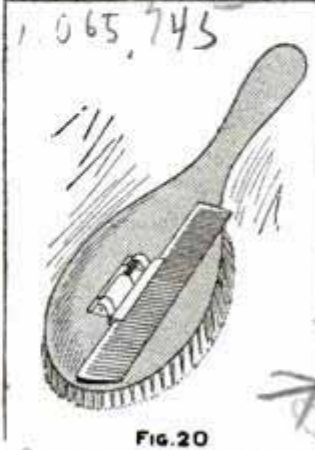

Fig. 20

W. H. Miller  
N. H. H.  
North Conway

Olof



**T**HE teacher of a Sunday-school class tried to impress upon her young charges the necessity of prayer before meals.

"Billy," she asked a little fellow whose father was an elder in the church, "what does your father say before you eat your dinner?"

"I dun know."

"Well, what did he say this morning before breakfast?"

Billy meditated; suddenly he remembered and beamed.

"He said: 'You kids go slow on the butter now! It's 40 cents a pound.'"—School Board Journal.

"My wife and myself are trying to get up a list of club magazines. By taking three you get a discount."

"How are you making out?"

"Well, we can get one that I don't want and one that she doesn't want and one that neither wants for \$2.25."—Washington Herald.

Long—They say that Dame Fortune knocks once at every man's door.

Short—It was her daughter, Misfortune, who called upon me.—Boston Transcript.

"What is an anecdote, Johnny?" asked the teacher.

"A short, funny tale," answered the little fellow.

"Quite right," said the teacher. "And now, Johnny, you may write on the blackboard a sentence containing the word."

Johnny hesitated a moment, and then wrote: "A rabbit has four legs and one anecdote."—Youths' Companion.

"So you don't guide hunting parties any more?"

"Nope," said the guide. "Got tired of being mistook fer a deer."

"How do you earn a living now?"

"Guide fishin' parties. So fer, nobody ain't mistook me fer a fish."—Public Ledger.

"Yes, there are miracles, even in these days," he said, laying his paper aside.

"What has happened?" asked his wife.

"Neither an English nor a German aviator seems to have been killed yesterday, and I can't find anything in the paper about a French torpedo boat being sunk with its entire crew."—Record-Herald.

Paying Teller—I cannot cash this check, madam.

She—Why not?

Paying Teller—There isn't enough money here to meet it.

She—Then can't you meet it halfway?—Marine Journal.

"Pop, what is the difference between an artist and an artisan?"

"An artisan, my son, can usually make at least three dollars a day."—Judge.

"What are you smiling about?" asked Noah.

"I was just thinking," replied Japhet. "how lucky it was we could go ahead and build this ark without waiting for an appropriation from Congress."—Western Druggist.

One day a college youth went West and got work on a farm. He wasn't very well informed about farm life, but, as he was willing to work, the farmer hired him. That night the farmer said, "How are you—a pretty good runner, boy?"

The collegian swelled with pride. "I took the prize at college for being the fastest runner."

"Well, then," said the farmer, "you can bring in the sheep."

Two hours later the young man entered exhausted, his breath coming in short gasps.

"Have any trouble?" asked the farmer, grinning to himself.

"I got the sheep in easy enough," said the youth, "but I had an awful time catching the lambs."

"Why, I haven't any lambs," said the farmer, in surprise.

Together they walked to the pen. There were all the sheep—and also five jack rabbits.—Pathfinder.

"They gave poor Bill three years just for sneezing."

"For sneezing? How d'ye make that out?"

"Well, he was cracking a safe and he sneezed and woke the watchman."—Boston Herald.

Baker—Puffer doesn't believe in hiding his light under a bushel.

Hamilton—I should say he doesn't! He puts it in front of a reflector.—Newark News.

"Did you have a bad toothache?"

"I think so, but if you know of any other kind of a toothache, perhaps it was that kind I had."—Pittsburgh Dispatch.

Smith—Have you taken in the auto show?

Jones—Sure! I never miss 'em.

Smith—You don't own a car. Why are you so interested?

Jones—Well, once a year I like to look at a bunch of 'em I don't have to dodge.—Philadelphia Inquirer.

Uncle Ned—Why, Johnnie, you don't swear, do you?

Johnnie—No, I don't swear, but I know all the words.—Harvester World.

One Kid—I ain't heard none of them giant crackers you was bragging about.

Other Kid—Aw, get up to date, kid! I shot 'em all off, but I put Maxim silencers on 'em.—Chicago Ledger.

"I see that one of our young baseball phenoms is to be sent back to the minors for more seasoning."

"Yes, evidently he lacks pepper."

"But maybe it's another way of saying that he isn't worth his salt."—Detroit Free Press.

He was subject to fainting spells, and before starting out he wrote this note, which he pinned to his shirt:

"To the Doctor. If I fall on the street and am taken to the hospital do not operate. My appendix has been removed twice already."—Ladies' Home Journal.



The man is brave who rides upon the wind,  
But braver still the maid he leaves behind.

—London Motor



# Johnson's Prepared Wax

A complete finish and polish  
for all wood—*floors, wood-  
work and furniture.*

# Johnson's Wood Dye

In 17 shades—for  
the artistic color-  
ing of all wood—  
*soft and hard.*

Use the coupon  
for trial packages  
and FREE In-  
struction Book,  
"THE PROPER  
TREAT-  
MENT OF  
FLOORS,  
WOOD-  
WORK  
AND  
FURNITURE"

S. C. Johnson  
& Son

"The Wood Finishing  
Authorities"

Racine, Wisconsin



PRESENT THIS COUPON TO YOUR DEALER IN PAINTS

**45c—Value FREE—45c**

To Paint, Hardware or Drug Dealer: Furnish the  
bearer, free of all expense, with

- 1—25c Instruction Book
- 1—10c Bottle Johnson's Wood Dye
- 1—10c Can Johnson's Prepared Wax

S. C. Johnson & Son, Racine, Wis.

(Must be presented by an adult.)

P.A.10



**THE  
More  
Mileage  
Strip**

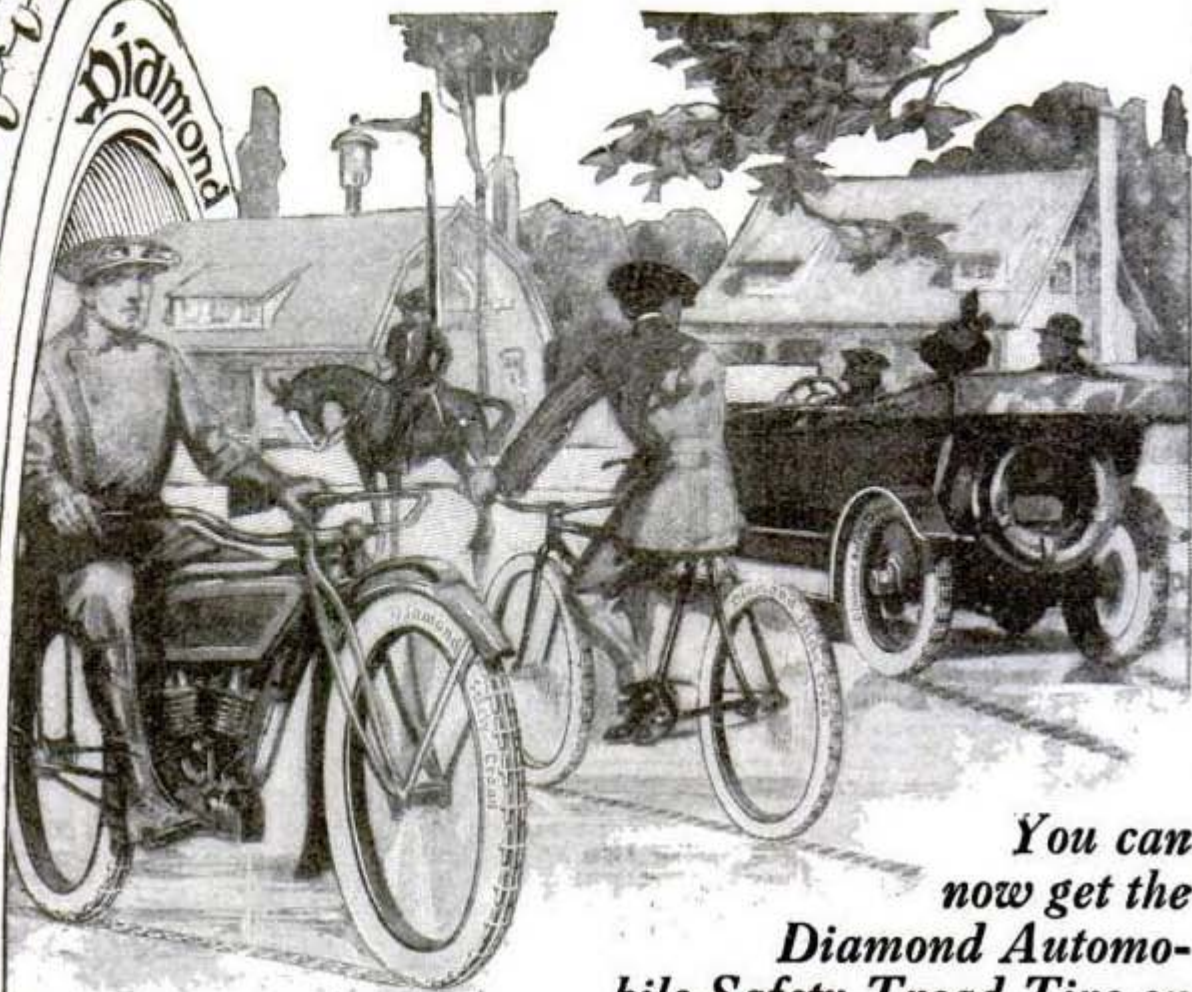

*You can  
now get the  
Diamond Auto-  
mobile Safety Tread Tire on  
your Motorcycle or Bicycle*

You, as a motorcycle rider, have exactly the same tire problems as the automobilist.

Realizing this, we have built for you a tire, made of the same Vitalized Rubber, the same fabric, the same principle of construction, built in exactly the same manner as our automobile tire.

## **Diamond** Motorcycle Tires

**with Safety or Studded Tread and Perfect  
3-Point Rim Contact**

The "More Mileage Strip" of the Safety Tread tire is another exclusive Diamond feature that should appeal to the motorcyclist. All these distinctive Diamond advantages cost you no more—  
"More Mileage" Vitalized Rubber—Perfect 3-Point Rim Contact—the  
Diamond Safety Tread that "won't slip, won't slide, won't skid, it grips!"

**So this time buy Diamond Vitalized Rubber Motorcycle Tires—  
you can get them to fit your rims from**

# **Diamond Dealers Everywhere**

*Ask your nearest dealer for Diamond Motorcycle Tire Catalog*



# A Self-Starting Motorcycle for 1914

## A Triumph of Motorcycle Engineering

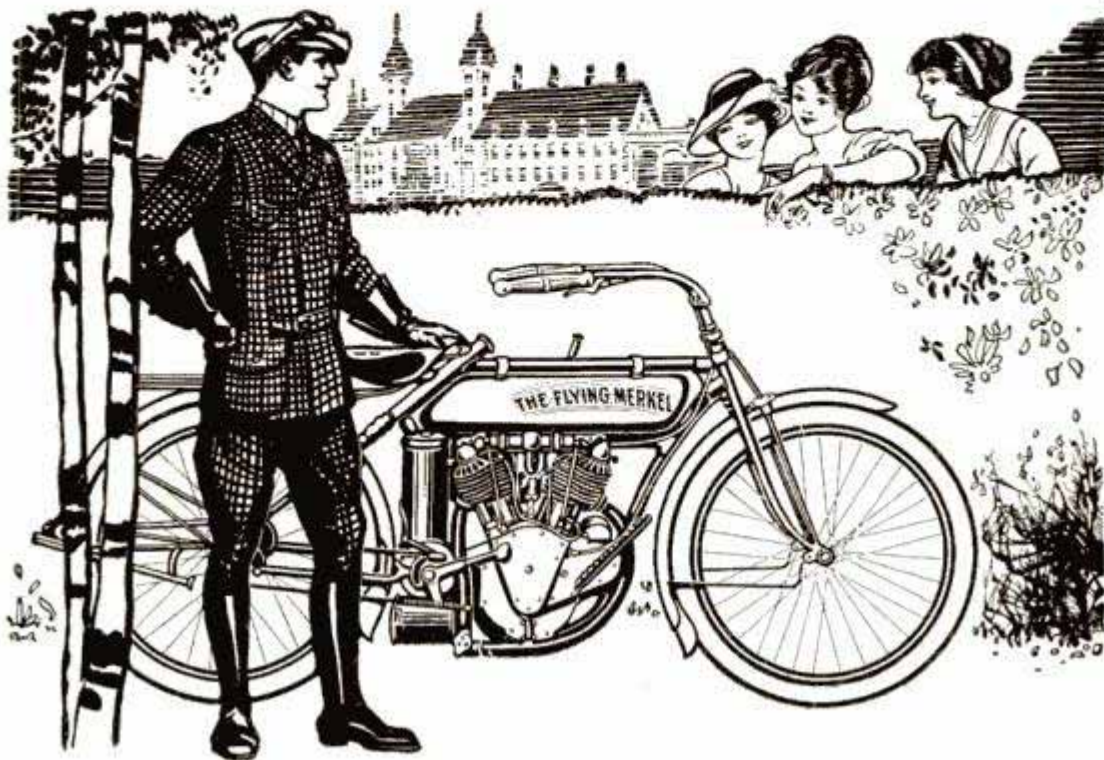

**J**UST think of being able to press a button and starting your motorcycle with both wheels on the ground in positively the same manner as an automobile. No heavy work of hoisting the motorcycle up on the stand, climbing on to the saddle, and pedaling for dear life to make the motor start. Simply twist the grip a fraction of an inch, press a small button-like lever, ease in the clutch and away you go while the other fellow is lifting his motorcycle up on the stand. This can only be accomplished with that wonderful motorcycle that is always five years ahead of any of its competitors—

THE SELF STARTING  
**THE FLYING MERKEL**  
 MOTORCYCLE

With two big plants in full operation, one at Middletown, and one at Indianapolis, Ind., we are able to give you what no other manufacturer can — immediate deliveries on 1914 machines. Why wait until Spring? The finest riding time of the year is right now. You can ride a Flying Merkel motorcycle all through the Winter, and in the Spring you will have had several months' use of the 1914 Flying Merkel, while the other fellow is still waiting for his machine.

Five new models, 4 H. P. single cylinder in belt and chain drive, and 7 H. P. twin cylinders in belt and chain drive, and with the wonderful self-starter. Low saddle position, auto type fenders and tires, exclusive ball bearing engine, the most powerful motorcycle made.

1914 art catalogs now ready for distribution. Write for your copy today. If we have no agent in your town, write for our liberal agency proposition. Remember—

*"IF IT PASSES YOU, IT'S A FLYING MERKEL"*

**The Miami Cycle & Mfg. Co.,** 350-370 HANOVER STREET  
 MIDDLETOWN, OHIO



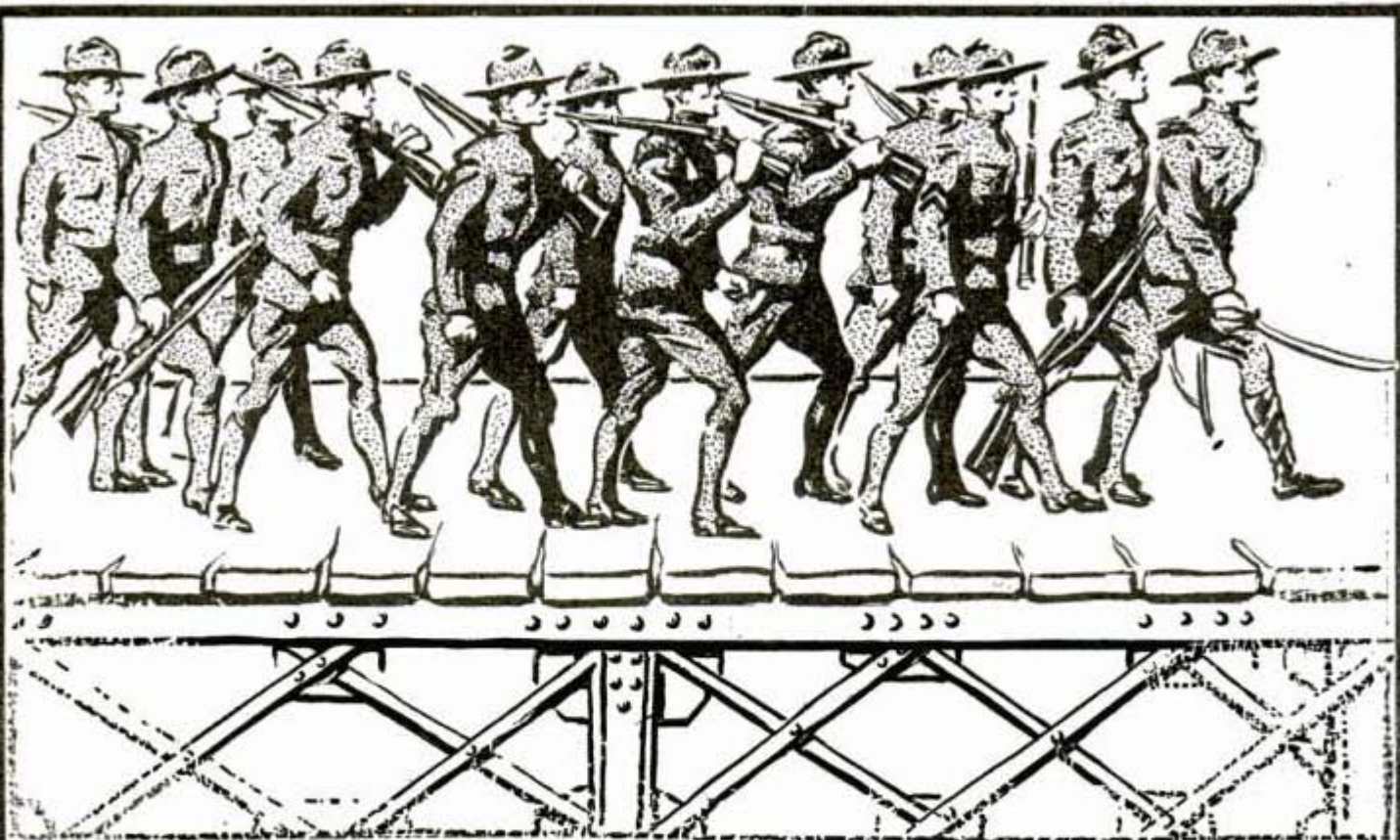

## Why soldiers never march across a bridge

"Rout step" is the command when troops approach a bridge—the men break rank and WALK across, instead of marching in regular cadence. This is done because the vibration due to the rhythmic tramp of many feet endangers the bridge. If the tread of a company of men will shake a bridge, what a shaking-up each MAN must give himself!

This strain, so dangerous to a bridge of iron and stone, falls on your spine and delicate nervous system as you walk on the hard floors and pavements. Protect yourself with O'Sullivan's Heels—they absorb the shock and prevent the weariness and nerve fag that come from pounding along on hard leather. They are invisible,

wear twice as long as leather, and keep the shoes in shape.

O'Sullivan's Heels are made **for men, women and children**, and cost but 50c a pair, attached. All shoe makers and shoe dealers will attach them to your shoes when you buy them, or at any other time. If you prefer, send us 35c in stamps and a tracing of your heel, and we will mail you a pair.

O'SULLIVAN RUBBER CO., 131 Hudson St., New York

**O'Sullivan's**  
**HEELS** Of New  
 Live Rubber







**REMINGTON  
UMC**

**METALLIC  
CARTRIDGES**

*Made by the*  
**Foremost Ammunition Concern in America**

**T**HE biggest name in the ammunition and firearms world today is *Remington-UMC*.

Whether your arm is a Remington or any other standard make, whatever its calibre and the load you need, you want Remington-UMC metallics—not because they are necessarily stamped with the same name as your firearm, but because they give more accurate results.

This Company has been making ammunition for fifty years. We produce metallics for every standard make of arm—and every Remington-UMC cartridge is tested in the arm for which it is made.

There is a dealer in this community who can give you Remington-UMC Metallics for *your rifle, your pistol*. Find him. Ask for them. Look for the Red Ball Mark on every box of metallics and shot shells you buy.

**Remington Arms-Union Metallic Cartridge Co.**

299 Broadway

New York





# Big Output *or* Big Merit?

**W**E could easily quadruple our output by selling a six-cylinder car around \$2500. But it would be a gross violation of confidence.

To sell a Six at \$2500, it would be necessary for us to cut down quality, to skimp on workmanship, or, worse still, to assemble parts from other factories, instead of **building the complete car ourselves**. There are a thousand ways to cheapen a car, and every one of them, in our case, would be dishonest.

## Keeping Faith with Buyers

For a company that has a low-grade reputation, a \$2500 Six might be a step upward. But for the Winton Company, whose Winton Six set the world's standard for six-cylinder quality and drove the best of fours into the second class, even the slightest cheapening of quality would be inexcusable—would be a betrayal of the confidence and good will of those thousands of Winton Six owners who believe in us and in our car, and, in good faith, urge their friends to buy Winton Sixes.

## Millions of Good Will

This Good Will—the result of our producing highest-quality cars and of making good on every promise during our fifteen years in business—has a value, according to commercial reckoning, of millions of dollars.

Many companies list Good Will in their balance sheets as an **asset**. We don't. We regard Good Will as a moral liability and obligation—an obligation never to betray public confidence by marketing under the Winton nameplate anything less than the **utmost best**.

## WINTON SIX

Long stroke motor, left drive, center control, electric lights, self-starter, finest mohair top, easily handled curtains, rain-vision glass front, best Warner speedometer, Waltham eight-day clock, Klaxon electric horn, tire carriers, four-cylinder tire pump, demountable rims, full set of tools, German silver radiator, metal parts nickel finished. Fully equipped, **\$3250**

## Always Quality First

That's exactly why a big output has never tempted us. We make only as many cars as we can make **right**. And we make them **ourselves**. You'll never find a Winton motor in any other make, nor a Winton clutch or transmission, nor a Winton axle or steering gear. Winton Six merit is individual and exclusive.

## Why Price Stays Down

The Winton Six is sold at the lowest possible price that its merit can be sold for. We keep quality up because we will not abuse the trust of our patrons, and we are able to keep the price down because we have no water in our stock, no bonds, no gold notes, no mortgages, no over-expanded plant, no excessive overhead, no wasteful executive methods.

Let us send you a catalog of the Six that leads them all.

**The Winton Motor Car Co.**

24 Berea Road, Cleveland, O.

### Caution

Be careful in selecting a car—this year more than ever before. There are startling reasons why. Read them in our Book No. 18.

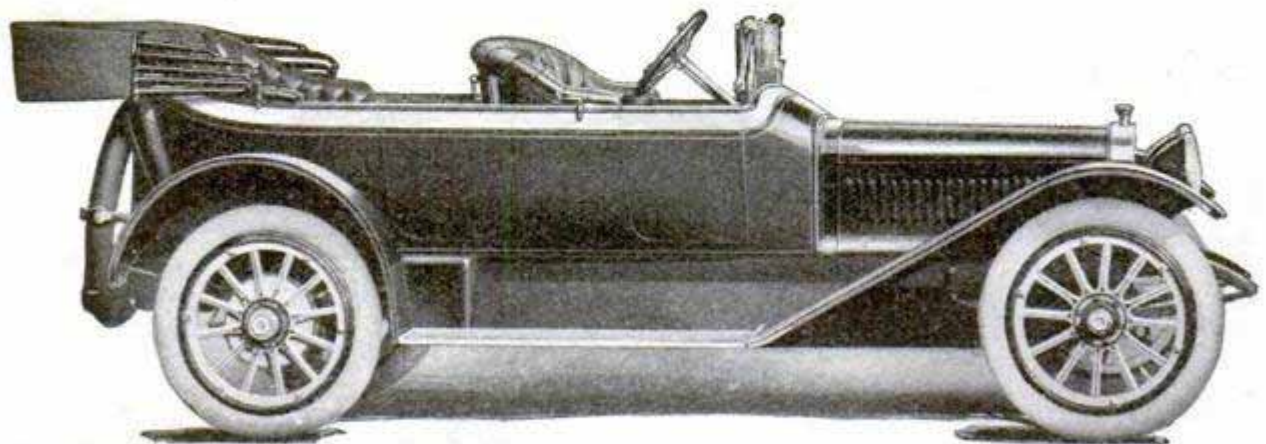



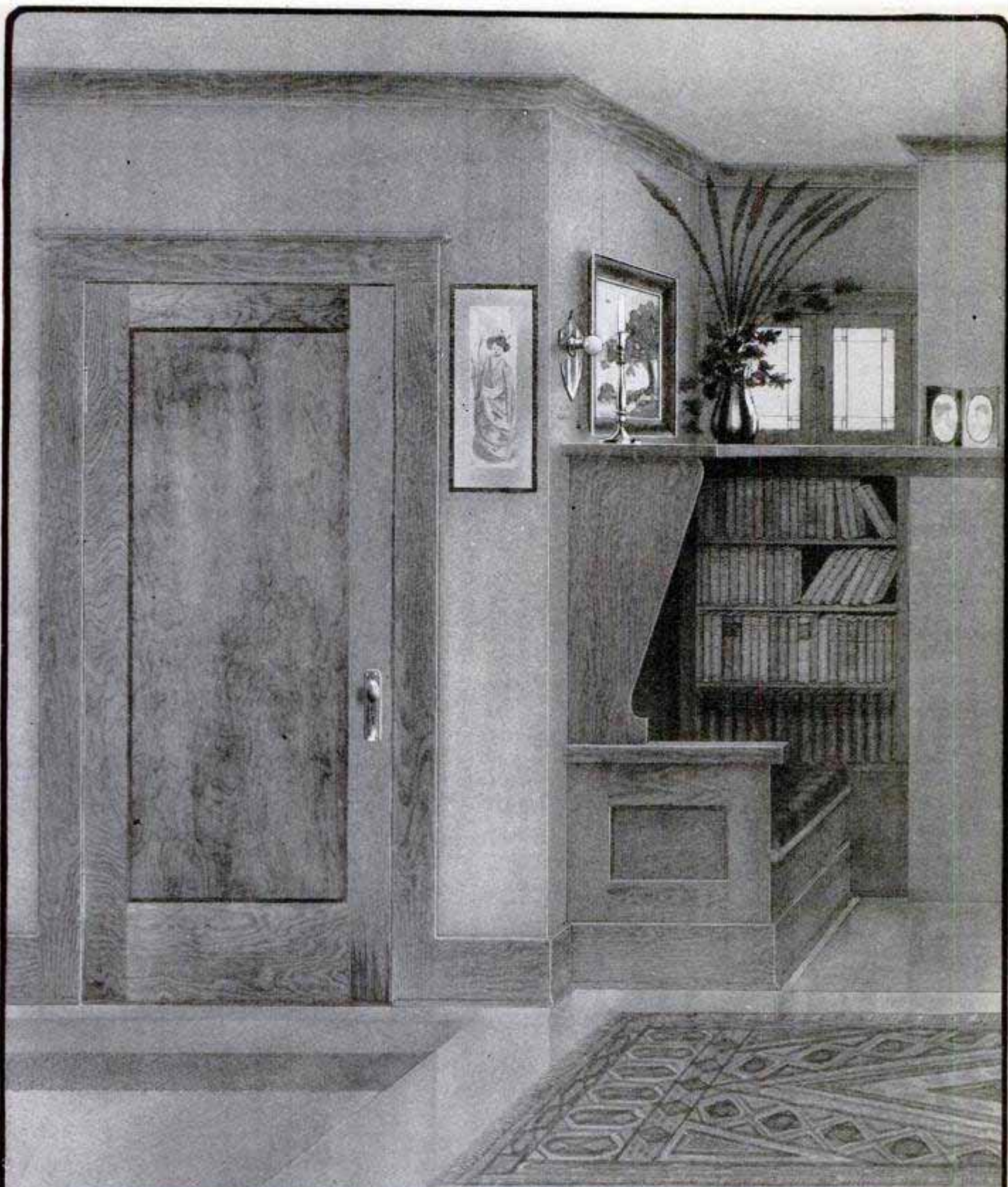

## MORGAN DOORS

The name found on the top rail of every genuine "Morgan Door" is your guarantee of protection in door making. This is perfection both in the wood and the construction which give permanence and lasting satisfaction.

Our book "The Door Beautiful" contains unique suggestions for your home. Send for it. Architects find descriptive details in "Sweet's Index" pages 1004 and 1005.

MORGAN SASH & DOOR COMPANY, Dept. C 24, Chicago, U. S. A.

Factory  
Morgan Company, Oshkosh, Wis.

Distributed by  
Morgan Millwork Co., Baltimore, Md.



# Credit To All **FREE** 408 Page catalog of over 8000 Credit Bargains

One Year To Pay - On Easiest - Long - Time Payments

Save 20% To 50%

**HARTMAN'S 408 Page Catalog - Chicago**

## GET THIS BOOK

**O**UR BIG 1914, color-illustrated book of 408 pages is ready for you—showing over 8000 lowest priced bargains in all Home Furnishings sent direct on easiest payment credit, **FREE**. Don't fail to send your name and address now by postal, or letter to get your copy this season. It will save you from 20 to 50 per cent on everything you order—little things or big things you have wanted to enjoy which you can now have at once. You can furnish your home this way and take your own easy time to pay us.

### Decide After You Get This Big Book Free

You be the judge by what our latest catalog shows you before you order. Then examine, use, and compare what we send with any merchandise at even higher prices—on cash or credit payments. No matter where you live, or who you are, our enormous buying and trusting power can and will save you big money. Open a charge account at once. All you need do is to write us for our new big catalog. We leave all that to you and know our goods will please you and that we can save you at least 20 to 50 per cent.

### All Home Furnishings Sent on 30 Days' Examination

You can send a trial order direct for the bargains shown in this ad—or just ask for our Big Free Book. Everything guaranteed. You can see and use everything in your home 30 days and if not perfectly satisfied it will not cost you a penny. We take it back. Refund anything paid us without argument or question. Order everything you want including newest exclusive designs in Home Furnishings, Carpets, Rugs, Chairs, Tables, Beds, Curtains, Stoves, Ranges, Hoasters, Baby Carriages, Bedding, Bicycles, Clocks, Jewelry, Cameras, Dishes, Glassware, Guns, Silverware, Phonograph records, etc.



**Write for Catalog**  
Write for our confidential proposition and your copy of our **BIG BOOK FREE**. Address



**No. 8E569**  
Our "Magic" Regent Hot Blast Heater. A powerful quick heating stove made of elegantly designed, heavy cast iron and cold rolled steel. Has mica lights in front feed door, perfected hot blast tube and draft features, and is full nickel trimmed. A most wonderful fuel saver and fully guaranteed in every way. Has 14-inch fire pot and is 57 inches high.  
**Price Only \$11.98**  
Terms: \$1.00 Cash—75c Monthly

**No. 8E570**  
Our "Merit" Regent Steel Range. This is without a question one of the finest ranges on the market. Made of finest cold rolled, blue steel and constructed so as to last a lifetime. Has large oven, 16x18x12 inches in size; duplex grates in large fire-box; finest flue system for distributing heat, and steel high closet as shown. Magnificently trimmed with nickel.  
**Price without \$21.75**  
Hot Water Reservoir, only \$1.50 Monthly.  
**Price with Reservoir \$26.75**  
Terms: \$2.50 Cash—\$1.00 Monthly.

**No. 8E571**  
Our "Grand" Regent Oak Heater. At the price we quote this elegant heater, it is a value absolutely beyond duplication, and is a great heat radiator. Very economical as to consumption of fuel. Is built of cold rolled steel and heavy ornamental cast iron. Has heavy grates and 14-inch fire pot of best materials. Stands 50 inches high.  
**Price Only \$8.95**  
Terms: \$1.00 Cash—75c Monthly



**Astonishing Values in Dining Room Table and Chairs.** Here's an offer that saves you big money. The table is made of solid oak and richly finished golden; has a 4-inch top which extends to 6 ft. when opened; is fitted with smooth-running extension slides and has massive pedestal and base, supported by Colonial Scroll legs. Chairs are made of solid oak with rich quartered oak back panel and banister. Finished golden. Have box seats covered with Imperial leather, strong stretchers and shaped front legs. You can order entire set; 6 chairs or table separately.  
**Price of Set**.....(Terms \$2.00 Cash—\$1.50 Monthly)..... **\$21.48**  
**Price of 6 Chairs**.....(Terms \$1.00 Cash—75c Monthly)..... **10.50**  
**Price of Table**.....(Terms \$1.00 Cash—75c Monthly)..... **10.98**

## HARTMAN FURNITURE & CARPET COMPANY

3945 Wentworth Avenue, Chicago, Ill.

—Largest, oldest and best known Home Furnishing Concern in America Selling on Credit  
Established 1855—58 Years of Success 22 Great Stores—1,000,000 Customers

Please Mention Popular Mechanics



# GROW MUSHROOMS

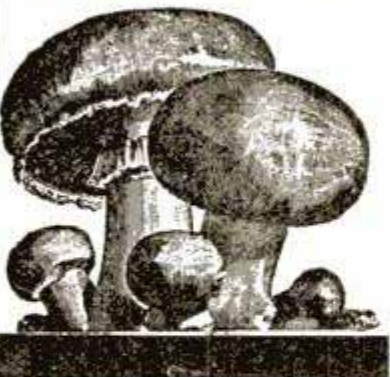

**It's Easy to Add \$5.00 to \$60.00  
a Week to Your Income**

**Here is What You Have Been Looking For  
You Can Start with Practically Nothing  
Your Whole Family will Be Interested  
Little Care Necessary—It will Not Interfere  
with Your Regular Occupation**

1. Mushrooms bring 50c to \$2.00 a pound, and 100 pounds raised on beds 5x10 feet, which cost practically nothing to start. You can readily see the profits in this business.
2. The demand always exceeds the supply, and I tell you how and where to market them.
3. I have started more people in this business and made more successful growers than any man in the world.
4. I have seen people start at home with little beds in basements, barns, sheds, etc., and increase their planting until they got to a point where they devoted their entire time to the mushroom business.
5. Beginners with my instructions often have better crops than old experienced growers. If you can read English, you can by my method, grow mushrooms successfully.

Women succeed in mushroom business as well as men. Mrs. Mary Bonar, Ohio, writes: "I know a woman can raise mushrooms successfully, for I have tried it and succeeded." Mrs. Guillaumne, Wis., says: "Can sell all I have at 80 cents per pound." Boys find a "sure enough" gold mine in mushrooms. Herbert Fickenworth, 12 years old, Chicago, writes: "I am picking and selling mushrooms every day." Webster Jones, aged 14 years, Little Rock, Ark., says: "Any boy who is willing to follow directions can learn to grow mushrooms. Growing mushrooms is just the kind of work a boy likes, and I know I can make more money out of it than anything else."

## MUSHROOMS MAKE MONEY

Just read these extracts from letters such as I am receiving every day:

1. "From my first bed of 50 square feet, I raised 80 pounds of mushrooms which I sold at 70c a pound." It cost \$2.00 to spawn this bed and this customer sold \$56.00 worth of mushrooms, leaving a profit of \$54.00 on an investment of \$2.00.
2. "From the last \$20 worth of spawn I bought of you I sold \$300 worth of mushrooms."
3. A customer who started in 1910 writes me in 1913: "I have never failed yet to grow mushrooms by your method and with your spawn."
4. One of the oldest and largest growers in England writes as follows: "I have read everything that I could find on mushroom growing and I congratulate you most heartily on having produced the best book, in my opinion, on the subject, ever published."
5. Every State Agricultural School in the United States has my book of instructions as a reference book. One of the biggest crops that I ever heard of was grown at one of the Experimental Stations by my method of growing and with my spawn.
6. Two of my customers in Arlington Heights, Ill., last year invested \$75 in the mushroom business and raised \$680 worth of mushrooms in the basements of their homes, leaving a clear profit of \$605 on an investment of \$75.

### I Will Tell You the Facts About This Business

I spent 20 years in the mushroom business. I owned and operated for years the largest plant in America, and I am now associated with the biggest Mushroom Company in the world. We have spent up to date \$100,000.00 building and equipping our plant for growing mushrooms.

I know how to grow them and I can show you how to make larger profits on smaller investments, growing mushrooms, than anything else you can take up. I have put the facts about this business into a beautifully illustrated booklet, entitled "Money in Mushrooms," telling you when, where and how to start, the kind of spawn (or seed) to plant, etc. Information worth many dollars to you, sent absolutely free.

Put your name and address on coupon and mail to:

**A. V. JACKSON**

**FALMOUTH MUSHROOM CELLARS, Inc.**  
26 Gifford St. FALMOUTH, MASS.

**A. V.  
Jackson  
Falmouth  
Mushroom  
Cellars, Inc.  
26 Gifford St.  
Falmouth, Mass.**

Please mail me your book "How to Make Money in Mushrooms," and also give me full information as to the best way to start, cost, etc. All this to be entirely without cost or obligation on my part.

Name.....

Address.....

Town.....

State.....

TEAR OFF THIS COUPON AND MAIL TODAY





## Fairy Magic—Telephone Reality

A tent large enough to shelter his vast army, yet so small that he could fold it in his hand, was the gift demanded by a certain sultan of India of his son, the prince who married the fairy Pari-Banou.

It was not difficult for the fairy to produce the tent. When it was stretched out, the sultan's army conveniently encamped under it and, as the army grew, the tent extended of its own accord.

A reality more wonderful than Prince Ahmed's magic tent is the Bell Telephone. It occupies but a few square inches of space on your desk

or table, and yet extends over the entire country.

When you grasp it in your hand, it is as easily possible to talk a hundred or a thousand miles away as to the nearest town or city.

In the Bell System, 7,500,000 telephones are connected and work together to take care of the telephone needs of the people of this country.

As these needs grow, and as the number of telephone users increases, the system must inevitably expand. For the Bell System must always provide a service adequate to the demands of the people.

**AMERICAN TELEPHONE AND TELEGRAPH COMPANY  
AND ASSOCIATED COMPANIES**

***One Policy***

***One System***

***Universal Service***

*Please Mention Popular Mechanics*



# The Watch That We Don't Want to Sell

## A Genuine Illinois

**With 17 Jewels—a 20-Year Gold-Filled Case  
Priced for This Offer at \$13.75**

We say to you frankly that this watch at this price is something we have no desire to sell.

If you want it and buy it, we will buy it back from you in 30 days if you think that you don't want to keep it.

If you want any other watch—and we carry hundreds—we would rather sell it to you than to sell you this.

And we never again shall sell this watch at this price—or any watch equal to it—when this offer ends.

**But we want an account with you.** We sell thousands of things in Jewelry, etc., and we want you to know this house. So we have bought ten thousand of these watches. We bought them from the Illinois Watch Co., one of the greatest American watch makers.

They are the 17-jeweled movements—exactly the same as are sold all over the country in the highest-class jewelry stores.

We are going to sell these watches at \$13.75—with a 20-year gold-filled case—just to open up ten thousand new accounts. You are welcome to one of them if you order before this stock is gone.

### Send \$1 Only

Send with your order only \$1. We will trust you for the rest. Then send \$1 monthly until the bill is paid. That gives you a year and over.

**Wear the watch 30 days.** Then, if you wish to, send the watch back, and we will return your \$1. There will be hundreds waiting at that time to get this Illinois watch at this price.

### Offer Ends Oct. 15

This offer ends Oct. 15. Or it ends before that if the 10,000 watches are taken. After that, all these special orders will need to be returned. We will send out then our regular jewelry catalog and ask men to order from that.

**But you can get this watch** for \$13.75, and for \$1 down, if you send us the order at once.

Then, as long as you live, you'll remember this offer as the best one ever made to you on a famous, high-grade watch. If you want this watch please send us this coupon. And to save disappointment kindly send it today.

# Spiegel, May, Stern & Co.

3565 Wall Street, Chicago

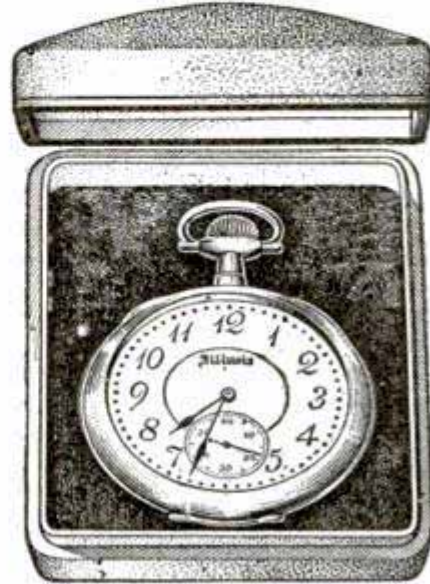

## Our Price \$13.75

### Only \$1 Down A Whole Year to Pay

This watch has a 17-jeweled movement—it is a perfect timekeeper. The price seems impossible. But we guarantee this watch to have 17 fine jewels, and to be a genuine Illinois watch, exactly the same as sold in jewelry stores.

The case is a 20-Year Gold Filled Case. That is, it is warranted for 20 years. It is open-face and a beauty. The back is handsomely engraved. It has a screw back and bezel, so it is positively dust-proof.

The watch is **guaranteed for 25 years.** We send with the watch this guarantee certificate. Think of that—only \$13.75 for almost a lifetime of perfect watch service.

The watch is a **perfect timekeeper.** No better timekeepers were ever made than the 17-jeweled Illinois. Every man who knows watches knows this.

If you want to sell this watch back to us, after 30 days' use, we will return every cent that you pay on it.

**SPIEGEL, MAY, STERN CO.,**  
3565 Wall Street, Chicago

I enclose first payment of \$1.00, for which send, express paid, the 17-jewel Illinois Watch No. X1277, described by your advertisement. If I keep it I will pay \$1.00 each month until \$13.75 has been paid. If I return it within the 30-day trial period you are to send me back my \$1.00.

Name.....

Postoffice.....

St. or Box No.....State.....

**Jewelry Catalog Free**—It contains everything that is new in watches, diamonds and jewelry—all sold on our easy credit plan. Just drop us a postal and it will be mailed you free. But don't fail to use the coupon and send us \$1.00, as this wonderful watch offer will never be made again.



# Typewriter Sensation

**2 DOLLARS A MONTH**  
**2 Buys a genuine Standard No. 2 SMITH-PREMIER Typewriter and at \$71.20 less than the manufacturer's price.**

Never before has anything like this been attempted. Dealers get \$3.00 a month rent for this make of machine not nearly as perfect as the one we will send you, and you pay only **Two Dollars a Month and Own It.**

**Send the Coupon and We Will Ship You This Smith-Premier Typewriter on Approval**

When the typewriter arrives, deposit with the express agent \$8.80 and take the typewriter three days and try it. If you find it the best typewriter you ever saw, satisfactory in every respect, keep it and send us \$2.00 each month, until our special price of \$28.80 is paid. If you don't want to keep it, return it to the express agent, and he will give you back your \$8.80, and return the typewriter to us. We will pay the return express charges. You won't want to send this machine back after you have seen it and tried it. You can't imagine the perfection of these machines till you see one, and the price is \$71.20 less than the catalogue price, and it is guaranteed just as if you paid \$100.00.



**Perfect machines only, complete outfit, nothing extra to buy, no strings of any kind to this offer.** Just think of buying such a typewriter for \$8.80 down and \$2.00 a month. Thousands of people have paid \$100.00 cash for Smith-Premiers. It's standard, by many considered the best typewriter ever built. A key for each character, so each character is always the same; a type brush for cleaning the type built into the machine; the tilting carriage with one slight motion of the hand instantly throws all the previous writing in plain sight of the operator without disturbing the writing position in any way; comes to you with tools, rubber cover, everything ready. It runs beautifully. It's wonderfully simple and strong. It will last a lifetime. I sold a similar supply of these beautiful machines about a year ago to everybody's satisfaction.

**Act today to be sure**

This offer is limited, so tear off the Coupon—mail it today—the typewriter will be shipped to you promptly without any formalities. You can't lose and it's the greatest economical typewriter opportunity you will ever have. The coupon states the terms. Fill it out; send it now, today.

**COUPON**

**HARRY A. SMITH, Dept. P,**  
**No. 180 North Dearborn Street, Chicago, Ill.**

Ship me a No. 2 Smith-Premier f.o.b. Chicago, as described in this advertisement. I will pay you the \$20.00 balance of the special \$28.80 purchase price, at the rate of \$2.00 per month. The title to remain in you until fully paid for. It is understood that I have three days in which to examine and try the typewriter. If I choose not to keep it I will carefully repack it and return it to the express agent. It is understood that you give the standard guarantee for one year.

Name.....  
 Address.....  
 Shipping Point.....

**LET US GIVE YOU THIS TRANSPARENT CELLULOID TRIANGLE**

It is 4 inch size, 30°+60° angles. Lowest retail price, 25 cents. Absolutely essential to everyone who draws. We make this offer to introduce our new catalogue showing

**SPAULDING'S NEW CARRYING CASES AND COMPLETE OUTFITS**

for designers, architects, engineers and students—compact, durable and convenient. Spaulding's Carrying Cases are made light and strong. They provide well arranged compartments, including space for drawing board and T square. Handled like a suit case; unique, practical, inexpensive. Outfits include all necessary equipment. If you draw, send us five 2-cent stamps to-day to pay postage and get the free triangle and the catalogue.

**SPAULDING PRINT PAPER CO.**  
 44 Federal St. BOSTON

**WHY LIGHTNING APPEARS TO GO ZIGZAG**

When lightning flashes came to be photographed, a few years ago, the previously accepted idea of their zigzag form was found to be untrue. According to Dr. Otto Meissner, a German scientist, the zigzag effect is due to an imperfection of our eye. When the eye sees a flash it instinctively jumps a little, causing the image of the flash on the retina to be broken. This movement occupies only a very small fraction of a second and thus we do not realize it, but it is enough to make the flash appear to our mind as being zigzag in form instead of continuous.

**Over 80,000 in Use**

Mostly sold by recommendation. For Personal Desk or General Office.

It checks mental calculations. Handsome Morocco case free. Buy Thru Your Stationer.

Write for 10 day trial offer. E. Ganche, A. A. M. Co., 119 W. Broadway, New York City.

**Golden Gem \$10**  
 PORTABLE Adding Machine

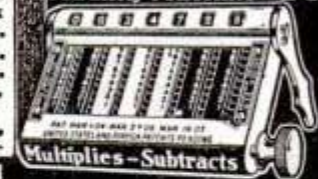

**Agents Wanted**

**For Xmas—Moth-Proof Cedar Chest**



**15 days free trial to prove the economy, utility and beauty of a Piedmont Southern Red Cedar Chest.** Saves furs, woollens and plumes from moths, mice, dust and damp. Ideal Xmas, birthday or wedding gift. Low factory prices. Freight prepaid. **15 Days Free Use In Your Home** Write for beautifully illustrated 64-page catalog showing all charming designs, sizes and amazing prices of Piedmont Chests. Also book, "Story of Red Cedar." Postpaid, free. Write today. **PIEDMONT RED CEDAR CHEST COMPANY, Dept. 355, Statesville, N. C.**

**The Best Business Card**

for your use and for any man's use who desires the distinction of attention to little things is the Peerless Patent Book Form Card. It will get close and careful scrutiny, and that means an audience with most favorable attitude of mind from your prospect.

**Peerless Patent Book Form Cards** not only save fifty per cent of your cards, but they are always together and get-at-able when you want to hand one out. They are always clean, perfectly flat, and every edge is smooth and perfect. Send for a sample and detach the cards one by one and see for yourself.

**OUR SMART CARDS IN CASE**



Send today.

**THE JOHN B. WIGGINS COMPANY**  
 Sole Manufacturers  
 Engravers, Die Embossers, Plate Printers  
 62-64 East Adams Street CHICAGO



# The Rise of A Man Who *Wouldn't* Stay Down

Hard work and low pay are for the man who *thinks* he "hasn't a chance." But the ambitious man trains himself for a better job—and *gets it*.

Only a few years ago the man whose rise we picture here was working 12 hours a day for 7 days a week. But he made up his mind to train himself for something better. He marked and mailed just such a coupon as you see below. He studied at home. His earnings increased. He was made Foreman. And now he is Chief Engineer.

This man had no advantages that *you* don't have. His education was poor. His spare time was limited. And he lived a thousand miles from Scranton. But with the help of the I.C.S. he has "made good." YOU can do the same in the line of work you like best. If you can read and write and really *want* to make something of yourself, the I.C.S. can help you.

Mark and mail the attached coupon. It won't obligate you in the least—and the I.C.S. will show you how you too can rise to a high-salaried position through their simple and easy system of home instruction.



Now Chief Engineer



Made Foreman



Studies at Home



Marks the Coupon

**Mark  
and  
Mail  
the Coupon  
NOW**

**Take the  
First Step  
Toward a  
Good Job  
TODAY**

## INTERNATIONAL CORRESPONDENCE SCHOOLS

Box 872-X, Scranton, Pa.

Please explain, without further obligation on my part, how I can qualify for the position before which I have marked X.

Electrical Engineering  
Electric Lighting  
Electric Railways  
Electrician  
Electric Car Running  
Dynamo Foreman  
Wireman  
Mining Engineer  
Telephone Expert  
Surveyor  
Automobile Running  
Agriculture  
Poultry Raising

Mechanical Engineer  
Mechanical Draftsman  
Shop Foreman  
Concrete Construction  
Architect  
Contracting and Build'g  
Architectural Draftsman  
General Illustrating  
Chemist  
Bookkeeper  
Advertising Man  
Civil Service Exams.  
Salesmanship

Name \_\_\_\_\_

St. and No. \_\_\_\_\_

City \_\_\_\_\_ State \_\_\_\_\_

Present Occupation \_\_\_\_\_



## Get Holstein Cows' Milk For Your Baby

Perhaps you cannot nurse your baby. Then take the precaution to use clean, fresh Holstein milk, the nearest substitute for breast milk. Then you will have every right to expect your baby to make rapid progress and establish a strong constitution.

In Holstein milk, as in human milk, the cream or fat is divided into minute particles or globules less than half the size of those in ordinary milk. So when Holstein milk reaches the stomach it acts just as human milk does. The curds formed are small, soft, flaky and easy to digest. In common milk on the contrary, the curds formed are large and heavy and show a tendency to stick together in a solid mass.

Holstein cows have long been famous for their size, health and strength so it is not surprising that their milk proves to be the most wholesome.

Holstein milk costs no more than common milk. If your milk man cannot supply you, send us his name and we will help you secure some.

Write for our free Booklet "The Story of Holstein Milk."

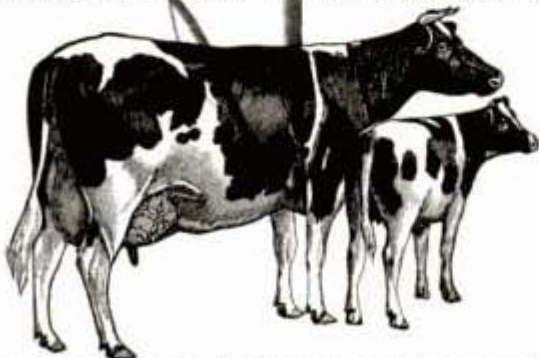

**HOLSTEIN - FRIESIAN ASSOCIATION**  
1-F American Building Brattleboro, Vermont

## "JUNK" THAT SOLD STOVE

IT HAS EARNED A REST

An IMPERIAL, with its stone oven-bottom, ash sifter, odor-hood and oven thermometer, saves Dealers' profits, cuts your fuel bills one-third and your work one-half. Test it 30 days at our risk. Lasts a life-time. Credit if you want it. You ought to know all you can learn about ranges before you buy any range. Our stove and range book tells you. It's free.



Write for it NOW

**THE IMPERIAL STEEL RANGE CO.**  
269 Detroit Ave. Cleveland, O.

## BUY YOUR FURNACE \$10 DOWN \$10 A MONTH

Our monthly payment plan of selling direct saves you the dealer's profits and charges for installation. The

### Jahant Furnace

with the patented "Down Draft System" is best for residences, schools, hotels, churches, etc., because it delivers plenty of heat wherever and whenever desired at a saving of 1-3 to 1-2 in fuel bills. Install the Jahant yourself. We send complete outfit, freight prepaid with special plans, detailed instructions and all necessary tools for installation. Satisfaction guaranteed or money refunded.

Write for free illustrated book.

**THE JAHANT HEATING CO.**

168 Mill Street

Akron, Ohio

Save  $\frac{1}{3}$  to  $\frac{1}{2}$  on Fuel Bills

This No. 1 Jahant Down-Draft Furnace (weight over 1000 lbs.) as it stands \$48.00 cash, delivered east of Omaha and north of Ohio River.

## Suppose We Give You \$25

—That's practically what we do. \$5 or \$25 or \$30 or \$40—different sums depending on which Kalamazoo stove you buy. You keep the dealer's profit. You get your stove direct from the Kalamazoo factory. It's shipped the day your order comes. You try it for 30 days free—and if you keep it you can still send it back any time within a year if you're dissatisfied with its work. We pay freight charges.

### Book of 400 Stoves

For a  
Postal

Read facts about making and selling stoves that you must know before buying. Our easy terms explained. Bank guarantee. Letters from a few of the 250,000 owners.

Ask for Catalog 473

**KALAMAZOO STOVE CO.**

Manufacturers  
Kalamazoo, Mich.

We make a full line of Stoves, Ranges, Gas Stoves and Furnaces. We have three catalogs. Please ask for the one you want.



**"A Kalamazoo Direct to You"** And Gas Stoves Too  
Trade Mark Registered

**SUN SPOTS**—There is some excitement in Europe over the fact that the spots in the sun have disappeared. The economists have yet to be heard from. At first sight there may not seem to be much, if any, connection, between astronomy and finance, except that certain financiers seem to have been born under a lucky star; but, as a matter of fact, sun spots, in the opinion of a number of famous economists, play a great part in the prosperity

## DON'T PAY TWO PRICES

Save \$8.00 to \$22.00 on  
**Hoosier Ranges and Heaters**

Why not buy the Best when you can buy them at such low, unheard-of Factory prices. Our new improvements absolutely surpass anything ever produced. Save enough on a single stove to buy your winter's fuel. Thirty days' free trial in your own home before you buy. Send postal today for large free catalog and prices.

**HOOSIER STOVE CO.**  
249 State St. Marion, Ind.



**Giddap!**

## THE AMERICAN SELF-HEATING FLAT IRON

demand the instant attention of all agents who like to ride in the main band wagon. Life is too short to fiddle around with worthless articles. This iron has no competition when it comes to construction, appearance, general satisfaction and selling qualities. One hundred per cent profit and cash rebates. Exclusive territory and full protection guaranteed. Swell sample cases. Shall we reserve a seat in our band wagon for you? Write quick.

**American Gas Machine Co.,** 301 Clark Street, ALBERT LEA, MINN.





**You Burn a Light,  
DON'T YOU?  
YOU PAY FOR IT TOO  
DON'T YOU?**

If You Positively Know You Could Have a  
**Much Better Light**  
That Was Thoroughly Reliable,  
Safe, and Durable and would  
Save 75% of Your Light-Bills

AND  
**GET TEN TIMES YOUR PRESENT LIGHT**  
You Would Buy It, WOULDN'T YOU?

**The International Lamps Will Do It!**

**We Guarantee It!**

No Ugly Wires or Rubber Tubes to Hold Them.  
Can Be Carried Anywhere

**300 to 800 CANDLEPOWER**  
Send for Catalog and Prices Today.

**The Best Agency Proposition in America.**

Exclusive, Protected Territory to Wide-Awake Men.

**BIG PROFITS QUICK SELLERS**

Needed In Every Home, Store, Shop.

Write at once. Get our "Help Sales" Plan. Make a business man's income.

This Is Your Opportunity  
Get Your Territory

**INTERNATIONAL LIGHT, NOVELTY & SPECIALTY CO., 311 River St., Dept. 55, Chicago**

of countries. For one thing, the magnetic storms, which are said to be occasioned by them, sometimes play hob with the crops, and that's where they get into the books on political economy. For another—well, there are all sorts of theories about sun spots and most of them have yet to be proved correct. But there's something on which all the authorities seem to agree; which is, that the earth is very much better off when there are not any spots on the sun than when there are.

**ANY PERSON CAN MAKE \$25.00 to \$60.00**  
weekly all or spare time with wonderful **WHITE FLAME BURNER**. Sells like wild fire. 6 to 8 in every home. **USERS DELIGHTED**. 35c. each or coin gets complete sample and particulars. Satisfaction or money back. Exclusive Territory.  
**WHITE FLAME LIGHT CO., 206 Clark Bldg., Grand Rapids, Mich.**

**KEYLESS PADLOCK**  
No knobs to turn—no clicks to count. Press the buttons and it flies open—40,000 combinations possible. Operated as easily in dark as in light. Solid brass. **AGENTS making 100% profit**. Sells on sight—no competition. Write today for terms of free sample. A postal card will do. Address **AMERICAN KEYLESS LOCK CO., 653 W. Jackson Blvd., CHICAGO**

**The BEST LIGHT**  
A handsome portable lamp that gives a brilliant, economical light. Makes and burns its own gas. Makes you independent of gas or electric lighting companies. Over 200 styles of lamps, ranging from 100 to 2,000 candlepower. **AGENTS MAKE BIG MONEY**. Write quick for catalog.  
**The Best Light Co.**  
324 E. 5th St., Canton, O.

# Salt Mackerel, Codfish Fresh Lobster

FOR THE CONSUMER

NOT THE DEALER

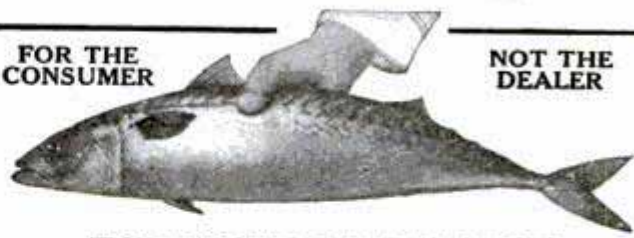

FOR YOUR OWN TABLE

**FAMILIES** who are fond of **FISH** can be supplied **DIRECT** from **GLOUCESTER, MASS.**, by the **FRANK E. DAVIS FISH COMPANY**, with newly caught **KEEPABLE OCEAN FISH**, choicer than any inland dealer could possibly furnish.

We sell **ONLY TO THE CONSUMER DIRECT**, sending by **EXPRESS RIGHT TO YOUR HOME**. We **PREPAY** east of Kansas on orders above \$3.00. Our fish are pure, appetizing and economical and we want **YOU** to try some, payment subject to your approval.

**SALT MACKEREL**, the fat, meaty, juicy fish are delicious for breakfast. They are freshly packed in brine and will not spoil on your hands.

**CODFISH** as we salt it, is white and boneless and ready for instant use. It makes a substantial meal, a fine change from meat at much lower cost.

**FRESH LOBSTER** is the best thing known for salads. Right fresh from the water, they are simply boiled and packed in **PARCHMENT LINED CANS**. They come to you as the purest and safest lobster you can buy and the meat is as crisp and natural as if you took it from the shell yourself.

**FRIED CLAMS** are a relishable, hearty dish that your whole family will enjoy. No other flavor is just like clams, whether fried or in a chowder.

**FRESH MACKEREL**, perfect for a fried fish, **SHRIMP** to cream on toast, **CRABMEAT** for Newburg and devilled, **SALMON** ready to serve, **SARDINES** of all kinds, **TUNNY** for salad. **SANDWICH FILLINGS** and every good thing packed here or abroad, you can get here and keep right on your pantry shelf for regular or emergency use.

With every order we send **BOOK OF RECIPES** for preparing all of our fish products.

Our list tells how each kind of fish is put up, with the delivered price, so you can choose just what you will enjoy most. Send the coupon for it now.



**FRANK E. DAVIS FISH CO.**  
29 Central Wharf, GLOUCESTER, MASS.  
Please send me latest Fish Price List

**BUY PLUMBING and HEATING SUPPLIES**



**at WHOLESALE Will Save You 30%**

Don't pay retail prices. Full stock on hand for prompt shipment. Send for free catalog.

**B. P. KAROL, 768 to 772 W. Harrison St., CHICAGO**

**TRIUMPH STAND LAMP**

A 300 Candle Power Lamp for Home, Store, Shop, work bench, library, desk, or wherever a stand lamp can be used. Can be turned up and down like gas, and carried around with more safety than a kerosene lamp, and gives 10 times the light at less than 1/4 the cost to operate. We have 6 distinct lines of gasoline hollow wire systems and lamps, **SMALL** lamps for **SMALL** rooms and **LARGE** lamps for **LARGE** rooms in most attractive styles at less than 1/4 the cost of gas or electricity. Our **POP** Catalog tells all about them. Get it now and decide which line you want.

**BRILLIANT GAS LAMP CO.**  
Dept. 1, 1009 S. Wabash Ave., CHICAGO, ILL.





# 30 Miles of Sportsmen

Each of them a member of our School and a good Taxidermist.

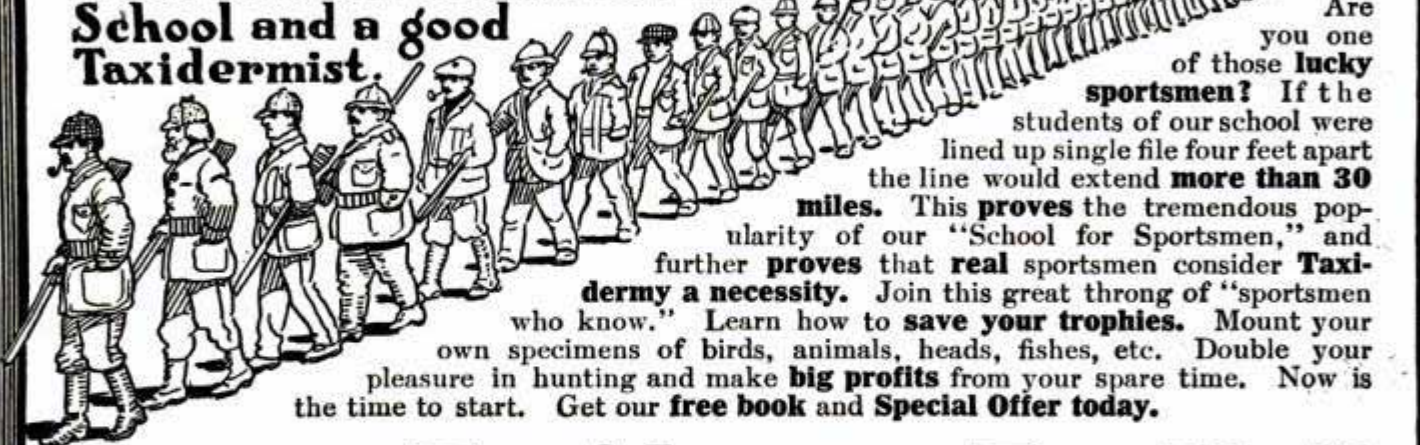

Are you one of those lucky sportsmen? If the students of our school were lined up single file four feet apart the line would extend **more than 30 miles**. This proves the tremendous popularity of our "School for Sportsmen," and further proves that **real sportsmen consider Taxidermy a necessity**. Join this great throng of "sportsmen who know." Learn how to **save your trophies**. Mount your own specimens of birds, animals, heads, fishes, etc. Double your pleasure in hunting and make **big profits** from your spare time. Now is the time to start. Get our **free book and Special Offer today**.

## Learn Taxidermy By Mail

Complete course of 40 lessons. Teaches **all** branches of taxidermy. Learn to stuff and mount your valuable trophies of **birds, animals and fishes**; also to **tan** hides and make rugs and robes. Delightful work, easily learned **at home**, by men, women or boys. Decorate your home, den or office with nature's choicest trophies. You positively **double your interest** in hunting and fishing. **Big profits in Taxidermy**, \$20 to \$50 per week from your spare time of \$2,000 to \$5,000 a year if you go into the business. You are losing half the pleasure of hunting if you throw your specimens away. **Get in line with the best sportsmen and learn taxidermy.**

**Taxidermy Book Free** Beautiful illustrated 48 page book and copy of the "Taxidermy Magazine" sent **absolutely free**. Write for them **today**. Don't miss this opportunity. **Investigate!** If you are a sportsman you can't afford to delay a moment for delay means loss to you. Let us explain what taxidermy is and how we teach it by mail. Send for our **free books now**.

**Northwestern School of Taxidermy, 1197 Elwood Bldg., Omaha, Neb.**

## I WILL START YOU

earning \$4 daily at home in spare time, silvering mirrors; no capital; send for free instructive booklet, giving plans of operation. G. F. REDMOND, Dept. 306-A, BOSTON, MASS.



### Amazing Profits In Mushrooms

Anybody can add \$8 to \$40 per week to their income, in spare time, entire year growing mushrooms in cellars, sheds, barns, boxes, etc. I tell you where to sell, at highest prices.

Free Illustrated Instruction Booklet

**HIRAM BARTON**

Desk 2, 329 W. 48th St., New York

OVER 65 YEARS' EXPERIENCE

# PATENTS

TRADE MARKS  
DESIGNS  
COPYRIGHTS, &c.

Anyone sending a sketch and description may quickly ascertain our opinion free whether an invention is probably patentable. Communications strictly confidential. **HANDBOOK on Patents sent free**. Oldest agency for securing patents. Patents taken through Munn & Co. receive **special notice**, without charge, in the

## Scientific American.

A handsomely illustrated weekly. Largest circulation of any scientific journal. Terms, \$3 a year; four months, \$1. Sold by all newsdealers.

**MUNN & CO. 359 Broadway NEW YORK**

Branch Office, 625 F St., Washington, D. C.

**EXPORTS OF FRUIT**—Fruits are a rapidly growing factor in the foreign trade of the United States. The value of fruits and nuts passing through the custom houses of the United States, in the fiscal year just ended, approximates \$90,000,000, and is twice as great as that of a decade ago. The exports of the fiscal year 1913 amount to \$37,000,000, speaking in round terms, against \$18,000,000 in 1903, a decade earlier; and the imports approximate \$42,000,000 against \$24,000,000 in 1903. These figures do not include the trade with Hawaii and Porto Rico, which sent to continental United States over \$6,500,000 worth of fruits and nuts during the last fiscal year.

**We Have Paid Thousands of Dollars to Amateur Song Writers.** You may be able to write a steady seller and share in future profits. Send us your poems or melodies for only **Original square deal offer. Acceptance guaranteed if available by Largest, Most Successful Music Publishers of the kind.**

**SONG POEMS WANTED**

We arrange music, publish, advertise, secure copyright in your name and pay you 50 per cent of profits if successful. Past experience not necessary. Hundreds of testimonials from delighted song writers. Don't delay—write today for subscription to our Big Song Writer's Magazine—valuable illustrated book on song writing and examination of your work **FREE**.

**DUGDALE CO., 1052 Dugdale Bldg., Washington, D. C.**

## Amateur Cornet Players Should Always Use PROFESSIONAL CORNETS



There's a big tone difference—ask any Band Master. Write for our 40 per cent saving offer. **American Professional Cornets** mean to you a \$50 quality Cornet for \$30—other instruments similar proportion and quality.

Particularly want to hear from Band Masters and Teachers. They will learn something to their advantage. Easy terms if desired.

**LYON & HEALY, 29-43 East Adams St., CHICAGO**  
WORLD'S LARGEST MUSIC HOUSE



# POWER for YOU!



Power from within! Strength that is **more** than mere muscular strength—the strength of perfect health, abundant nerve force—the strength of the **perfect man** now within your reach through **Vibration!** Nine people out of every ten are only **half alive**. They exist—they do not really live. How about yourself. Listen—

## All the Benefits of Life—Strength—Youth

may be returned to you through **Vibration**. For **Vibration is Life itself**. It will chase away the years like magic. Every nerve, every fibre in your whole body will fairly tingle with the force of your own **awakened power!** Stagnation simply cannot exist. You are made over—new—from head to foot. Your blood is sent humming along through every vein, artery and tiny capillary. Poisonous matters in your system are **washed away**. Your self-confidence—your **self-respect**—are increased a hundred fold. Yes, **Vibration** will do all this and more, **much more**. And it is within your reach. You can enjoy its wonder-working powers right at home, right in the privacy of your own room. You can give yourself the same identical treatments that you would receive in the offices of the world's most famous specialists—all without extra charge.

You may give yourself Swedish Movement, Vibrating Chair Treatments, Electric Baths, Faradic or Galvanic Electric Treatments—just such treatments as you would have to pay from \$2.00 to \$3.00 for—yours without charge through the White Cross Electric Vibrator.



**The White Cross Electric Vibrator**

is the result of years of work and experiment. It is absolutely perfect. If you have your house wired for electricity, you can connect it up as easily as an electric lamp; if not, it will run perfectly on its own batteries.

### Special Offer for a Limited Time

For a short time only we are making a remarkable Special Introductory Offer on the White Cross Electric Vibrator, in order to place at least one of these splendid instruments in every city, town and village in the country—an amazing offer to those who write at once—amazing discounts—actual rock bottom prices direct if you act at once.

**FREE BOOK** Sign coupon and mail it today. Get our splendid big FREE book telling you all about the marvels of **Vibration**. Read what great scientists say. Post yourself on what it will do for you. Learn all about the **White Cross Electric Vibrator** and our limited offer. No obligations at all—send coupon, post card or letter today.

**LINDSTROM-SMITH CO.**

1100 S. Wabash Ave. Dept. 1197 Chicago

*We also manufacture electric irons, electric hair driers, electric stoves, etc., etc.*

Send for  
This Book

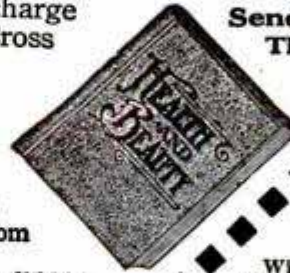

**FREE  
BOOK COUPON**  
**LINDSTROM,  
SMITH CO.**  
Dept 1197  
1100 S. Wabash Ave.  
Chicago, Ill.

Without any obligation at all, please send me, free and prepaid, your free book on **Vibration**, full particulars of the **White Cross Vibrator** and your Special 60 Day Offer.

NAME .....

ADDRESS .....

My Electrical Dealer's Name is .....





### 3 Books FREE!

I want to send you my three latest books—one the story of "The Diamond"—its discovery, where and how mined, cut and marketed—the other, "Facts vs. Hunc" or all about the Watch Business both at home and abroad, also our big Free Watch and Diamond Catalog.

P. Stephen Harris, Pres.

## SPECIAL THIS MONTH!

# 17 JEWEL ELGIN ON CREDIT

## HAND ENGRAVED

## 25 YEAR GOLD CASE

### 30 DAYS

# FREE TRIAL \$12.75

Now—during this Special Sale—is a splendid time to buy a fine Watch. We would like to send you this 17-Jewel Elgin in hand engraved 25-year gold case for your inspection. It sells regularly at \$20.00. We save you nearly one-half. If you answer this advertisement you can buy it for \$12.75.

## NO MONEY DOWN

We don't want you to send us one cent. Not a penny. Merely give us your name and address that we may send you this handsome watch on approval. If after you receive it and want to keep it, then we ask you to pay us only **\$2.00 A MONTH.** If you don't want to keep it, send it back at our expense. You assume no risk whatever in dealing with us. You do not buy or pay one cent until we have placed the watch right in your hands for your decision. We ask **No Security, No Interest.** No red tape—just common honesty among men. If this offer appeals to you write today for **Our Big Free Watch and Diamond Book.**

**HARRIS-GOAR CO.**  
Dept. 1023 KANSAS CITY, MO.  
*The House that Sells More Elgin Watches than Any Other Firm in the World.*

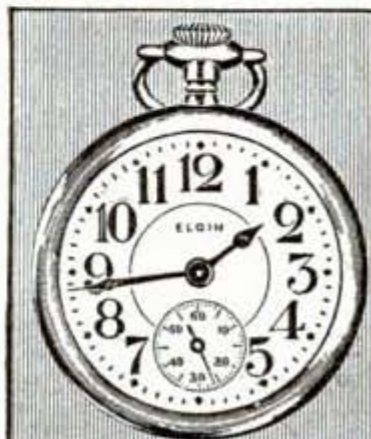

### Have you a copy of our wonderful 212 page ELECTRICAL CYCLOPEDIA?

If not you are doing yourself an injustice. The book contains the following: 450 original illustrations. 31 different wiring diagrams. 76 pages of Electrical apparatus and experiments. 28 pages of raw materials, parts, supplies, etc. 17 pages of Electricians' and Mechanics' Tools. 5 pages of Wireless Course coupons. 10 pages Treatise on Wireless Telegraphy. You will find more instruction and enjoyment reading this book than you can find in a \$10.00 cyclopaedia. With our catalogue, for a limited time, we also furnish, free of charge, a five cent sample copy of the **ELECTRICAL EXPERIMENTER**, containing 25 illustrations and 14 original articles on Wireless and Electricity. With every dollar purchase from us you get a free lesson of our famous Wireless Course, as explained in our Cyclopaedia. Send to-day a 3 cent stamp for our big book and you will not regret it.

**THE ELECTRO IMPORTING CO., 233A Fulton St., New York**  
"Everything for The Experimenter"

## MONMOUTH OUTFITS

COMPLETE—COMPACT—EFFICIENT

Send stamp for our Bulletin MC which contains codes. Expertly built outfits in many cases for less than you can make a set at home. Ready-for-use and of proved merit. Monmouth's "exceed their guarantee" **MONMOUTH ELECTRIC CO., Inc.** 92-94 Murray St. New York City

Please Mention Popular Mechanics

## The AutoStop Safety Razor

Guarantees 500 Shaves  
Ask Your Dealer About It

**POSTAL RATES IN 1825**—The rates of postage established by Congress in 1825 were: On a single letter, composed of one piece of paper, for any distance not exceeding 30 miles, 6 cents; over 30 miles, 10 cents; over 80 miles, 12½ cents; over 150 miles, 18¾ cents; over 400 miles, 25 cents; a letter composed of two pieces of paper was charged double these rates; of three pieces, triple, and four pieces, quadruple these rates. For newspapers the rate was one cent for 100 miles, and 1½ cents for over 100 miles.

**ELECTRIC LIGHT PLANTS** Complete gasoline engine, dynamo, switchboard and storage battery \$240.  
Agents wanted. American Battery Co., 1139 Fulton St., Chicago (Estab. 1889.)

**ELECTRIC HOME, FARM and MOTION PICTURE THEATER LIGHTING PLANTS.** Carriage, Bicycle, Fishing, Flash & Auto Lights, Fan Motors, Dynamos, Engines, Belts, Books. Catalog 3c.  
**OHIO ELECTRIC WORKS, CLEVELAND, OHIO**

## EXPERIMENTERS IN WIRELESS

Blue-print and working specifications for either ¼-½ or 1-K. W.—Open or Closed Core Transformers, 50c. Send Money Order—not stamps. The 50c may be deducted from the first \$2.00 order for Transformer parts within six months. Send 2c stamp for **Wireless Catalogue.**

**WINGER ELECTRIC & MANFG. CO.,** Successors to Dawson & Winger Elec. Co. 711 So. Dearborn St., CHICAGO, ILL.

## Light Your House with Electricity

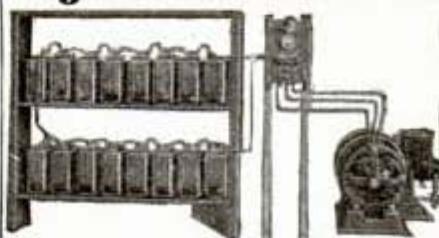

Complete outfit of Storage Battery, Switchboard and Direct Connected Gasoline Engine and Dynamo. Dynamo charges the battery during the day and 32 volt lamps are used to light the house.

Modern equipment at small cost. Write for circular.

**THE CARLISLE & FINCH CO., 244 E. Clifton Ave., Cincinnati, Ohio**



# Remoh Gems

Look and Wear Like Diamonds

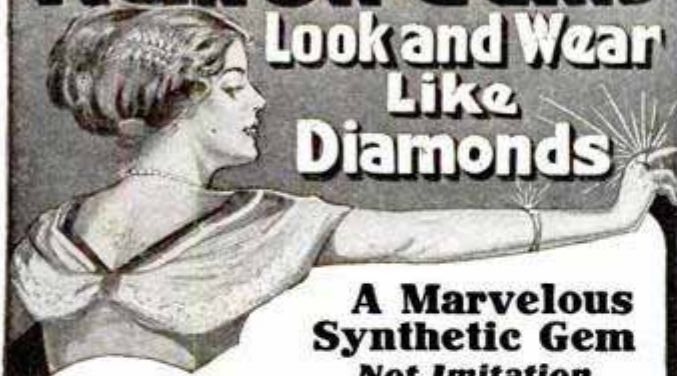

## A Marvelous Synthetic Gem Not Imitation

—the greatest triumph of the electric furnace. **Will cut glass**—stands filing, fire and acid tests like a diamond—guaranteed to contain no glass. Remoh Gems have no paste, foil or backing—their brilliancy is guaranteed forever. One-thirtieth the cost of a diamond. These remarkable gems are set only in 14 Karat Solid Gold Mountings.

**Sent On Approval Anywhere In U. S.**—your money cheerfully refunded if not perfectly satisfactory. Write for our 4-color De Luxe Jewel Book—yours for the asking. Address

**Remoh Jewelry Co.,**  
622 Washington Ave., St. Louis



# APPLIED ELECTRICITY FAMOUS \$35 SET

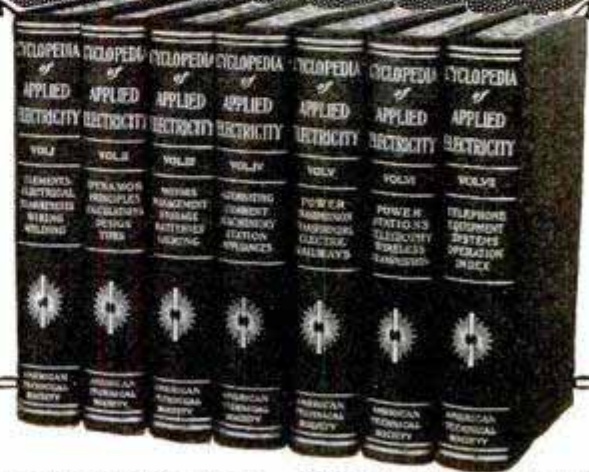

## NOW \$19.80—\$2 A MONTH

Greatest reference work on electrical subjects ever published. Most exhaustive electrical cyclopedia of modern times. 7 big books written by 32 famous experts; 3200 pages, 2600 illustrations, full page plates, diagrams, simple explanations, etc., with hundreds of valuable facts and figures. Bound in half red morocco, gold stamped.

Books that will settle every electrical problem which daily confronts the power engineer who must rely on his own experience. Now at the lowest price ever made.

Big men in the electrical field everywhere recognize these as the standard works on the subject. They have been the making of hundreds of successful electrical engineers.

**SHIPPED FREE** To prove to you what these books will do for you right in your own work every day, we will trust you seven days before you spend one penny. We will pay the express. They must make good with you or we take them back at our expense without question or annoyance. On receipt of coupon below we ship the entire set to you at our risk for absolutely free examination.

### Read These Subjects Carefully

Theory, Calculation, Design and Construction of Generators and Motors—Electrical Measurements—Electric Wiring—Electric Welding—Types of Generators and Motors—Management of Generators and Motors—Storage Batteries—Electric Lighting—Alternating Current Machinery—Station Appliances—Power Stations—Power Transmission—Central Station Engineering—Electric Railways, including Single-Phase—The Electric Telegraph—Telephone Equipment, Systems and Operation—Wireless Telegraph and Telephone—Telautograph, Telephonograph, etc., etc.

### Free \$12.00 Consulting Membership

Our staff of 32 electrical experts answer every question you want to ask on electrical subjects absolutely free for a full year to every holder of a set of these books. This privilege has always cost \$12.00 and men tell us it is worth twice that amount in settling one problem alone. You get this service free if you buy the books after examination.

This means \$15.20 saved if you act now. Read the coupon carefully. Then fill it out and mail today. The books will reach you promptly—express paid by us. After seven days send us \$2.00; otherwise, notify us for their return.

Don't wait. You take no chances whatever. It costs nothing to inspect and you are nothing out if you do not care to buy. Mail the coupon today.

### FREE COUPON

Worth \$15.20 to You

#### American Technical Society

Please send me Cyclopedia of Applied Electricity for seven days' free examination. If I keep the books I will send \$2.00 within seven days and \$2.00 a month until \$19.80 has been paid, when \$35 books and \$12 consulting membership will be mine. Otherwise will notify you and hold books subject to your order. Title not to pass until fully paid.

Pop. Mech. 10-13

**AMERICAN TECHNICAL SOCIETY**  
Chicago, U. S. A.

NAME.....  
ADDRESS.....  
OCCUPATION.....  
EMPLOYER.....

Please mention Popular Mechanics

**RAILROADS USE ENORMOUS QUANTITIES OF WATER**—One American railroad, 6,500 miles in length, uses annually 16,500,000,000 gal. of water. Another of 2,000 miles uses 5,736,838,000 gal. Reduced to an average per mile, 2,703,440 may be taken as a fair mean water consumption per mile of line. Reports for the last fiscal year show that on June 30, 1912, there were 248,000 miles of line in the United States. Figuring the yearly water consumption for the total mileage, the aggregate is 672,853,774,720 gal. of water.

**Poultry Paper** 44-124 page periodical, up to date; tells all you want to know about care and management of poultry for pleasure or profit; four months for 10 cents. **Poultry Advocate, Dept. 98, Syracuse, N. Y.**

**Never Before**  
This Remington Typewriter—factory rebuilt—in perfect condition—yours for only per month—less than renting. Regular \$100 typewriter—our price \$30. We guarantee LONGER than make. Free examination before you pay a cent—send no money—take no risk. Other makes as low as \$12. Post brings complete Bargain List NOW.  
**Commercial Typewriter Sales Co., Dept. 112, Chicago**



**Wash With Compressed Air**  
**THE NEW WAY**

No wear, no tear. Daintiest articles washed without injury. Tub of clothes washed in 5 to 10 minutes. A child can operate it. It is well made and as light as a washboard. **Send for Terms to Agents.**

Instantaneously attachable to any stationary, or ordinary wooden or sheet metal tub.

**RAPID VACUUM WASHER CO.**  
26 Cherry St., WORCESTER, MASS.

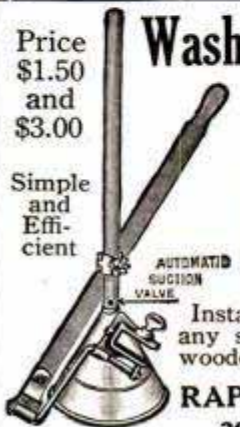





"Am using your Tungsteel razor with splendid satisfaction. Would not take \$5.00 for it."

*Ernest Hubbard*

## The "Curved" Shumate Tungsteel

embodies a new, scientific principle. The delicately curved blade gives the new double sliding stroke both in shaving and stropping. By holding the razor at the usual angle, you automatically obtain the stroke which insures a shave equaling that of the best barber.

The razor is full concaved, hand ground, honed and stropped; made of the very finest six temper Sheffield English razor steel. Price \$2.00.

# Shave the right way

—use the best razor—and the best type of razor—the kind real men use—the only kind you would permit a barber to put on your face—the only kind that will give a clean, "smartless" shave.

Young man, your beard is soft now and any sort of a razor may do, but later on you will realize the necessity for a regular razor. Form the right shaving habit now—begin with and continue to use the

"Curved"  
**Shumate**  
Tungsteel

—the razor that is guaranteed for life. Any time it fails to give satisfaction, we will exchange it without a word.

The most prominent men in America are using this razor, and 40,000 dealers sell it under our guarantee. If your dealer cannot supply you, we'll send you the "Curved" Shumate Tungsteel postpaid for \$2.00

Dealers who are not selling Shumates should write at once regarding the line, and our special FREE DISPLAY CASE OFFER.

**SHUMATE RAZOR CO.** Established 1884  
1021 Locust Street, ST. LOUIS, MO.



The Curve makes you shave right



## Learn to Play the Violin!

You can have your choice of the finest collection of Violins, Cellos, etc., in America on 30 Days' Trial

**WRITE TODAY** for Free Copy of the new Lewis Catalog of Violins, Cellos, etc. Don't think of buying a Violin, Viola, Cello, or other stringed instrument until you have seen this book. It will post you thoroughly on violin values; tells you how to judge a violin by the wood, varnish and construction; and why we send our instruments on free trial. Write now for this book. Don't pay enormous profits to jobbers, brokers and dealers. Every one of these gets part of your money when you buy a violin in the regular way.

We MAKE and IMPORT All Our Own Instruments and SELL DIRECT, giving you the benefit of the regular middleman's discounts.

The Celebrated Lewis Own Make Violins are made in our own workshops by the best of foreign makers, and are far superior to most old violins costing two or three times as much.

**On 30 Days' Trial** Try any instrument in our stock before you decide to buy. Don't buy any kind of a musical instrument any other way. You can't tell anything from a printed description, or a few minutes' trial in a showroom. We insist that you shall be satisfied, and we will pay the express charges both ways on all returned instruments.

**Write Today** for our Free Catalog. Your name and address is all that is necessary. If you have an idea of ever buying a stringed instrument, you need this book. Write now.

**WM. D. LEWIS & SON, Makers and Importers**  
(Est. 1869) 225 So. Wabash Avenue, Chicago, Ill.

**VIOLIN MAKERS!**—We make a specialty of Imported Woods, Varnishes and Tools.

**ANTS THAT MAKE BREAD**—Some remarkable stories are told of a species of ant common in Dalmatia. According to Doctor Neger of the Dresden Forestry School, this ant not only cuts leaves and gathers seeds, but actually makes bread or biscuit. It seems that the seeds are first sprouted, carried into the sun and dried, then taken back to the underground chambers where they are chewed into a dough. This dough is then finally made into tiny cakes which are baked in the sun, then carefully placed in storage for future use.

## MECHANICAL PERFECTION

in writing equipment is guaranteed in the World's Standard **WATERMAN'S IDEAL FOUNTAIN PEN.**  
SOLD BY LEADING DEALERS EVERYWHERE.

WEAR

Trade Mark Registered **B.V.D.** U. S. Patent Office and Foreign Countries  
UNDERWEAR

## SAVE YOUR FACE OIL YOUR RAZOR

Rust causes razor dullness. 3-in-One absolutely prevents rust on the minute "teeth" of every razor blade. Always do this before and after shaving: Draw blade between thumb and forefinger moistened with a little 3-in-One. If an "ordinary" razor, oil strop, too. Then—strop and have the most luxurious shave of all your life. Oil blade again before putting away.

3-in-One is sold everywhere in 3 size bottles: Trial size, 10c; 3-oz., 25c; 8-oz., (half pint) 50c. Also in Handy Oil Cans, 25c.

**FREE**—Generous sample and scientific "Razor Saver" circular.

**3-IN-ONE OIL COMPANY**  
42 CNR Broadway, New York City





# 22 Handbooks of Practical Information

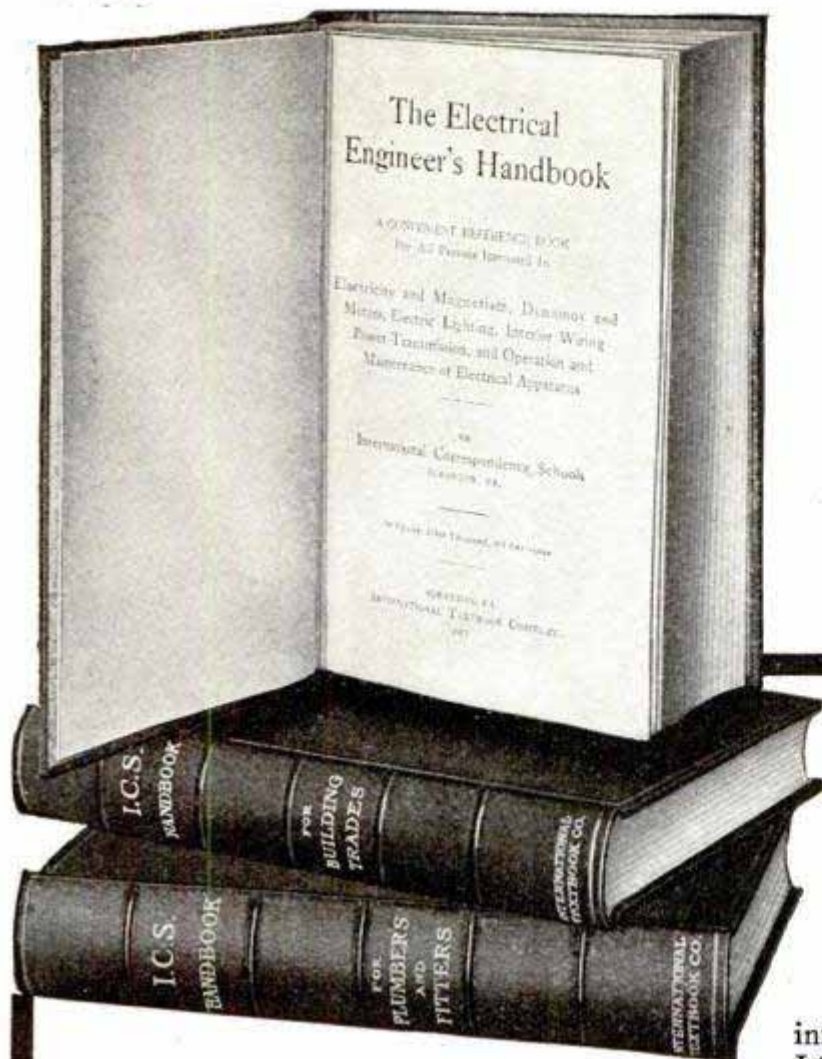

**W**HEN the boss asks a puzzling question—when an unusual piece of work comes along—THEN it pays to be able to put your finger on the exact rule, formula, or bit of information that holds the key to the situation. For it's at these critical moments that the boss finds out who is "onto his job"—who is in line for promotion.

No books in existence contain as much information in so small space as these I.C.S. Handbooks. One book is devoted to each trade or profession. They contain all the rules, formulas, and other data that you've got to have right off the bat. They are thoroughly indexed—any desired information can be located instantly. They have been compiled from the "Easy to Learn, Remember, and Apply Home-Study Courses" of the International Correspondence Schools. Every fact and formula is clearly stated. They are indispensable helps to quicker and better work. Bound in silk cloth they retail regularly for \$1.25 each.

**Mechanics':** Tables; formulas; measurements; belting; mechanical powers; hydromechanics; specific gravity; strength of materials; shafting; boiler design; care of boilers; power of boilers; chimneys; exhaust heating; machine design; machine tools; slide valve; pulleys; horsepower; cylinders and steam chests; pistons; gearing; dynamos and motors; batteries; transit surveying; curves; radii and deflections; earthwork; trackwork; etc. Contains 330 pages and 174 illustrations.

**Electrical Engineers':** Tables; chemistry; mechanics; electricity; electrical units, symbols and quantities; physical and electrical properties of metals and alloys; wire gauges; magnetism; dynamos and motors; armature winding; electrical batteries; alternating current apparatus; alternators; transformers; wattmeters; transmission; electric lamps; wiring; electric heating and welding; electromagnets; controllers; car wiring; etc. Contains 414 pages and 238 illustrations.

**Chemists':** Definitions and fundamental laws; atomic weights; pressure; volume and temperature of gases; weights and measures; specific gravity; hydrochloric-acid, nitric-acid, and sulphuric-acid solutions; solubilities of chemical compounds; heat measurement; qualitative analysis; special tests of acids; general table for analysis; classification of rare metals; the spectroscope; nitrogen; blowpiping; determination of gold and silver ores; methods of assaying; composition of alloys; tables; antidotes of poisons, etc. Contains 332 pages and 11 illustrations.

### Other Handbooks Now Ready

Automobile  
Air Brake  
Civil Engineer's  
Steam Engineer's  
Telegraph and  
Telephone Engineers'  
Mariners'  
Coal Miner's  
Concrete Engineer's  
Building Trades

Plumbers and Fitters'  
Poultryman's  
Farmers  
Textile Worker's  
Business Man's  
Bookkeeper's  
Stenographers and Correas.  
Salesman's  
Advertiser's  
Window Trimmer's

**International Textbook Co.**  
Box 872-F, Scranton, Pa.

### Special Offer

For a limited time we will sell these regular \$1.25 Handbooks, durably bound in silk cloth in a convenient pocket size, at a price for each Handbook of only—

## 50c

International Textbook Co., Box 872-F, Scranton, Pa.

Enclosed find \$ \_\_\_\_\_  
Handbooks \_\_\_\_\_

Name \_\_\_\_\_  
St. & No. \_\_\_\_\_  
Town \_\_\_\_\_  
State \_\_\_\_\_

TEAR OFF HERE  
for the following I.C.S.



# PATENT YOUR IDEAS



*—There is a Constant Demand  
for Good Inventions*

Thousands of the biggest money-making inventions have been the "little" things that have made people wonder why they were never thought of before.

## "WHAT TO INVENT"

*and*

## "HOW TO OBTAIN A PATENT"

*These Books Sent Free*

If you have an invention send us a sketch, photograph or model of it. We will give you a report as to its patentability absolutely free. If you have no invention send for our book, "What to Invent." It contains hundreds of valuable suggestions. We are recognized authorities on patent matters and have helped hundreds to find a ready and profitable market for their ideas. We can prove it. If you wish to sell your patent we will advertise it in manufacturers' journals at our expense.

***Don't Wait—Find Out NOW!***

Your idea will never do you any good if some one else patents it ahead of you. Act quick! Let the other fellow say "he thought of it a long time ago." You reap the profit. Let the others wish they had.

***Advice Free—All Matters Confidential***

We have secured patents for thousands of inventors and have many letters proving the value of our services. Write us. Send rough drawing or model of your invention for our opinion. We will guard it carefully and report quickly. You are under no obligations to proceed further. Our plan is simply a square deal to all. Our books, "What to Invent" and "How to Obtain a Patent" are the best publications written for the man who has an idea to patent, or who is of an inventive turn of mind. They show just how to proceed with your idea and tell of hundreds of things to invent. We gladly send these books free. The sooner you write for them the sooner you will know all about patents and the many different lines in which new inventions or improvements may be made.

*If you have an invention send us a sketch of it for report and ask for the books at the same time.*

**CHANDLEE & CHANDLEE, 970 F Street, Washington, D. C.**

REGISTERED ATTORNEYS

(Combined with H. Ellis Chandlee & Co.)



# Patents

Trade Marks and  
Copyrights Secured  
or Fee Returned

## Special Offer—Free Search of Patent Office Records

Send us a model or sketch and description of your invention, and we will make a *Free Search* of the *Patent Office Records* to ascertain if it is patentable. If we report the invention patentable, we will guarantee to obtain a patent or return our fee, and furnish a certificate of patentability backed by a bonded contract to that effect.

**This Certificate of Patentability will protect the inventor and serve as proof of the invention until the case can be filed in the U. S. Patent Office.**

### Obtaining Assistance for Inventors

Our certificate is of great assistance to inventors who require financial aid to obtain patents.

### Our Four Books Mailed Free

to any address. Send for these books—the finest publications ever issued for free distribution.

#### How to Obtain a Patent

Our illustrated eighty-page Guide Book is a book of reference for inventors, and contains 100 mechanical movements illustrated and described.

#### Fortunes in Patents

Tells how to invent for profit, and gives history of successful inventions.

#### What to Invent

Contains a valuable **LIST OF INVENTIONS WANTED** and suggestions concerning profitable fields of invention; also information regarding prizes offered for inventions, among which is

#### Prize of One Million Dollars

offered for one invention, and \$10,000 for others.

#### Patents That Pay

Contains letters from our clients who have built up profitable enterprises founded upon patents procured by us; also endorsements from prominent inventors, manufacturers, Senators, Congressmen, Governors, etc.

#### We Advertise Our Clients' Inventions Free

In a list of Sunday newspapers with two million circulation, in manufacturers' journals and in the *World's Progress*. Sample Copy Free. We save you time and money in securing patents. After the patent is granted we assist you **TO SELL YOUR PATENT**.

#### Foreign Patents

**WE HAVE DIRECT AGENCIES IN ALL THE PRINCIPAL FOREIGN COUNTRIES** and secure **FOREIGN PATENTS** in the shortest possible **TIME** and at the **LOWEST COST**. Write for our Illustrated Guide Book on Foreign Patents, sent free to any address.

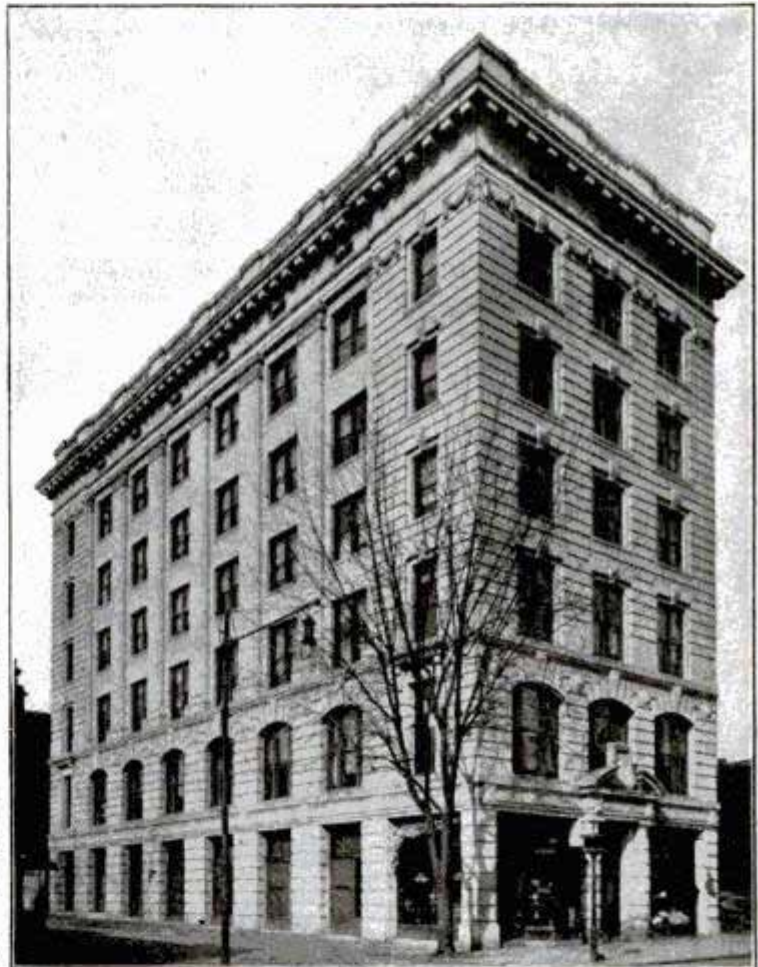

**VICTOR BUILDING**

Our new \$150,000 building opposite U. S. Patent Office  
SPECIALLY ERECTED by us for OUR own use

## WANTED NEW IDEAS

Send for **LIST OF PATENT BUYERS** who consult us when purchasing patents. Contains requests from **MANUFACTURERS, MAIL ORDER HOUSES** and **PROMOTERS** for patents secured by us, and suggestions as to **New Ideas** they wish to purchase. We invite manufacturers and promoters to address our Sales Department regarding the purchase or leasing of a number of meritorious patents secured by us.

### REFERENCES

Second National Bank, Washington, D. C.

Union Savings Bank, Washington, D. C.

Chamber of Commerce, Washington, D. C.

Pitner Gasoline Lighting Co., Chicago, Ill.

National Savings and Trust Co., Washington, D. C.

R. G. Dun & Co., Washington, D. C.

Smethport Glass Co., Smethport, Pa.

The Melvin Gauge and Signal Co., Scranton, Pa.

M. Winter Lumber Co., Sheboygan, Wis.

**VICTOR J. EVANS & CO., Patent Attorneys**

NEW YORK OFFICES: 132 Nassau St.

PHILADELPHIA OFFICES: 1429 Chestnut St.

**Main Offices: 724-726 9th St., N. W., WASHINGTON, D. C.**



# WANTED-IDEAS

Manufacturers are constantly writing me for patents procured through me. The demand for good ideas

## Protected by Owen Patents

is greater than ever before. Send for my free books and read the letters from the greatest manufacturers in this country. Read their requests for Owen Patents and see for yourself what ideas they want. You can help supply the unceasing demand for good inventions.

My clients are provided with free manufacturing facilities, and I aid them in many ways, without charge, to sell their patents. Applications filed through me advertised free.

You will get a strong patent or I will get no compensation. Your interests are my interests.

# FREE!

A simple request will bring you the following three finest patent books published absolutely free—you will incur no obligation by writing me.

**"SUCCESSFUL PATENTS"**—a new 72 page guide book; tells how to proceed to be successful; describes my advantageous business methods.

**"STEPPING STONES"**—gives lists of over 200 inventions wanted; gives forecasts by Edison and many other authorities; tells the plain truth about prizes of millions of dollars for inventions.

**"PATENT PROMOTION"**—tells you how to promote your invention; why some inventors fail; the value of your rights, etc.



Write for these books today—NOW! Advice costs nothing

### VERY HIGHEST REFERENCES

Columbia National Bank,  
Washington, D. C.  
American Loktile Co.,  
Alexandria, Va.  
National Metal Tile Co.,  
Washington, D. C.  
National Supply Co.,  
Berlin, N. H.

Louden Machinery Co.,  
Fairfield, Iowa.  
Antholene Mfg. Co.,  
Hutchinson, Kans.  
Whitehead Hosiery Mills,  
Burlington, N. C.  
Dickinson Mfg. Co.,  
Des Moines, Iowa.

And an immense number of others whose letters are printed in my booklets.

**SPECIAL!**  
Send me a sketch or model of your invention and I will make a search of the U. S. Patent Office Records **FREE OF CHARGE** and report to you concerning patentability, practicability, etc.

Your work will receive my **PERSONAL** attention—but my fees are no higher than others.

**RICHARD B. OWEN** 9-303 OWEN BLDG.  
WASHINGTON, D. C.

Inventors submitting their inventions to me are protected in a tangible manner until their applications are filed.



# PATENTS THAT PROTECT and PAY

Advice free. Terms reasonable. Highest references. Best results.

Send sketch or model for FREE examination and opinion.

Recommended Patent Lawyer in the Bankers' Register and special list of selected lawyers.

Also in Martindale's Law Directory, Sharp and Alleman's Directory of Lawyers, The Gast-Paul Directory of Lawyers, and Kime's International Law Directory.

**ALL BUSINESS GIVEN PROMPT AND PROPER ATTENTION**

**A large list of strong recommendations furnished free**

**WATSON E. COLEMAN, Patent Lawyer, 622 F St., N.W., Washington, D.C.**

## PATENTS OF FULL VALUE OBTAINED OR ALL FEES BACK

Write us at once for particulars, and proof that we will aid you most to get most money for your invention.  
E. S. & A. B. LACEY, Dept. M, Washington, D. C. Estab. 1869.

## PATENTS

**C. L. PARKER**  
Formerly Member Examining Corps, U. S. Patent Office  
**PATENT LAWYER**  
210 MCGILL BLDG.  
WASHINGTON, D. C.

Patents, Trade Marks, Copyrights, Patent Litigation

Handbook for Inventors, "Protecting, Exploiting and Selling Inventions" sent free upon request.

## PATENTS BUILD FORTUNES FOR YOU

Our free booklets tell how, what to invent, How To CHOOSE AN ATTORNEY, and save you money.

Prosperous clients in all states. Best bank and other references. **WRITE TODAY**

**D. SWIFT & CO.,** 317 SEVENTH ST., WASHINGTON D. C.

## INVENTORS Our Brain Belongs to You. Our Ideas Are Free of Charge.

All we want in return is to build your model, special machinery, dies, tools and jigs to manufacture sheet metal goods, etc. We are expert mechanics, over thirty years experience and have one of the best equipped shops in the country. Ask for Booklet No. 17. Consultation free. Experimental work strictly confidential.

**A. NACKE & SON**  
236-242 S. 9th St., Philadelphia, Pa.



Active Powers of Inventive Genius

**A FIFTY-TWO-YEAR-OLD LETTER**—A letter written at Fort Washington, Md., on May 30, 1861, by Henry C. Russel, of Pottsville, Pa., a Civil War soldier, reached his widow in Pottsville a few days ago, through the regular channels of the United States mail. The letter had been intrusted to a comrade, M. E. Richards, of Pottstown, to mail, and was never sent. Recently Mr. Richards died, and the letter sealed and stamped, was found among some old papers. It was posted and forwarded to the widow. Russel died about

## BRASS GEARS

Cut by an entirely new process. The most accurate made and at prices that cannot be equalled by others. Every gear has a hub, center painted ebony black, edges turned true, highest grade red brass, and much heavier than others. We carry the largest stock in the world and every gear listed is always shipped on date of order.

SEND FOR CIRCULARS

**CHICAGO STOCK GEAR WORKS**  
16 S. Fifth Av. Chicago



**TRY**



**ME**

Get "MY FIRST INVENTION" Story

Only Patent Attorney with 25 years' practical experience. Inventing, Making, Selling, his own and other patented devices. I guarantee originality.

H. G. THOMAS 66 Essex Bldg., Boston, Mass.

## LEARN HOW A PATENT MAY BE MADE VALUABLE

Send for This **FREE BOOK** which tells you

What You Should Know  
What To Invent  
What NOT To Invent  
How To Sell Your Patent

Copies of nearest Patents and report in every case without charge  
**H. L. WOODWARD, 9th & G Sts., Washington, D. C.**

## PATENT POINTERS

Things to know before applying for a patent:

1. Is my invention perfected or complete?
2. Is it new and patentable? If so, what will a patent cost?
3. Does it infringe any patent?
4. Is there a demand for such an invention?
5. Can a demand be created at reasonable expense?
6. What will it cost to demonstrate the utility of and demand for my invention?
7. Who are likely to be interested in the manufacture and sale of such inventions?
8. Where can I get reliable information and advice on the above points?

We will be glad to demonstrate to your satisfaction that we can render the service required to fully post you upon the above points.

**BENJAMIN AND BASSETT**  
Patent Attorneys and Mechanical Experts  
Provident Savings Bank Bldg., WASHINGTON, D. C.



Ask for Bulletin 21  
of Fully Guaranteed  
**Rebuilt  
Electrical  
Machinery**

You can—with profit—dis-  
pose of any outgrown electrical

machinery to us, or buy from us at attractive prices, fully guaranteed rebuilt **Motors** or **Dynamos**. It will pay you to read our **Free Monthly Bulletin**. Send for it today.



# MOTOR AND DYNAMO BARGAINS

We'll Buy From You Any  
**Electrical  
Machinery**  
You Have Outgrown

We do not  
handle  
novelties or toys



We are giving prompt repair service to  
patrons in all parts of the United States

The F. Bissell Co., 226 Huron St., Toledo, Ohio

## LET THE RED DEVIL WATER MOTOR DO YOUR WORK

### 6-inch Motor

Improved construction, absolutely perfect, runs your washing machine and a hundred other things. Power for small tools.  $\frac{1}{4}$  horse power on  $\frac{1}{2}$ -inch pipe, 80 pounds pressure; 1 horse power on 2-inch pipe, 60 pounds pressure. New net price, \$5.00 cash with order.

No. 1492 4-inch Motors for grinding, polishing and buffing. Runs sewing machines, fans, bottle washers, etc. Price with emery, buffing wheel, silver polish and pulley, \$3.00. No. 1493 Motor and pulley only, \$2.50.  $\frac{1}{8}$  horse power on 80 pounds pressure. Improved construction. Speeds, 3,000 to 5,000 revolutions per minute. Only scientifically and mechanically perfect small water motor manufactured. Patented construction makes it possible. Tremendous output warrants the price. Money back for any reason.

**CATALOGUE AND  
LARGE SHEET FREE**

**DIVINE WATER MOTOR CO.**

Dept. T UTICA, NEW YORK, U.S.A.

For the name of your local hardware or tool dealer, we will send you free booklet on "Theory and Design of Water Motors."

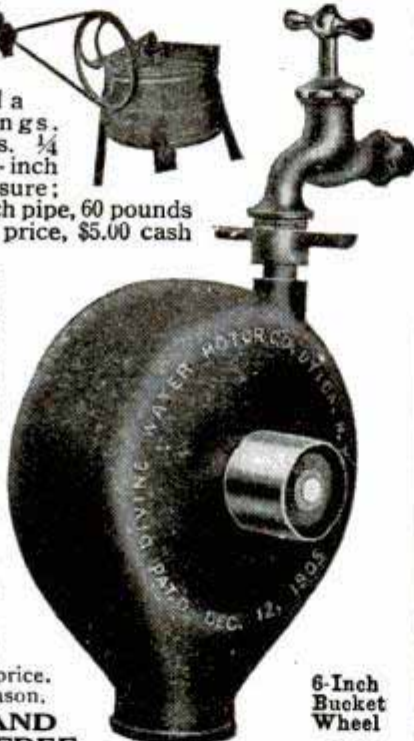

6-Inch  
Bucket  
Wheel



## CRESCENT MACHINES ARE RIGHT IN QUALITY.

moderate in price, always give satisfaction, and will please you. Send today for our catalog of wood working machinery, hand saws, jointers, saw tables, planers, swing saws, disk grinders, shapers, borers, planers and matchers, variety wood workers, Universal Wood Workers.

**THE CRESCENT MACHINE CO.**  
93 Columbia St., LEETONIA, OHIO, U. S. A.

Send for our illustrated  
catalogue



## AMATEUR EXPANDING MANDREL

for lathe work  $\frac{3}{8}$  to one  
inch. We have been manu-  
facturing these goods for fifty years.

**WM. G. LE COUNT, Box 591, SOUTH NORWALK, CONN.**

five years ago. The letter contained what the writer said was a piece of the shirt of Col. E. E. Elsworth, worn when he was shot and killed a short time before at Alexandria, Va., after he hauled down the Confederate flag from the Marshall House. The relic is in an excellent state of preservation.



SETS OF CASTINGS OF  
**MODEL ENGINES**  
SEND FOR FREE PAGE  
ALL CATALOGUE  
ALSO TOOLS  
**GEAR WHEELS & PARTS OF MODELS**  
**WILHELM H. WICHTMANN & CO.**

**MECHANICAL  
SUPPLIES AND MATERIAL**  
of all kinds.  
EXPERIMENTAL AND  
**LIGHT MACHINE WORK**  
to order.  
132 MILK STREET, BOSTON

## PIONEER TRUST and SAVINGS BANK

The enormous, rapid development of Wyoming makes it safe for us to pay 6 per cent—the highest savings bank interest rate—because legal interest rate in Wyoming is 8 to 12 per cent. Our stringent banking laws give you the same protection you get at home. Why be content with 3 to 4 per cent when we will pay you 6 per cent? Write today for booklet, also how to get miniature bank FREE.

**Pioneer Trust & Savings Bank, 12 Pioneer Bldg., Bush, Wyo.**

## JARVIS POWER PUMP

An absolute necessity for country and suburban homes. Furnishes an endless supply of water from any ordinary well and does away with hand-pumping. Can be operated by electric motor or gasoline engine. Once started, needs no further attention except oiling occasionally. The cost of operation is a mere trifle. Easily and quickly installed by anyone. We supply everything necessary—pipe fittings, fixtures, etc. Send today for catalog No. 20, which is a valuable guide on water supply systems.

DEALERS—Write for our interesting proposition.

**Jarvis Engine &  
Machine Works  
Lansing, Mich.**

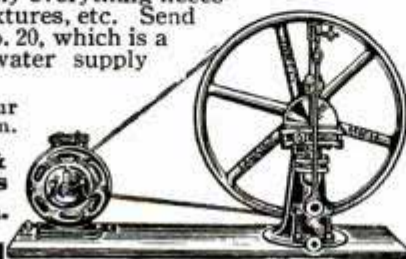

## South Bend Lathes

9 to 18" Swing  
Foot Power, Steam Power  
Electric Motor Drive  
Straight or Gap Bed

\$7500

and up

Write for Catalog and Price  
**SOUTH BEND MACHINE TOOL CO.**  
423 Madison St., South Bend, Ind.

## LATHES

9 to 13-inch Swing

List price \$75 and up according to size. When ready to buy send for Lathe Catalog and prices.

**W. F. & John Barnes Co.**  
100 Ruby Street, ROCKFORD, ILL.



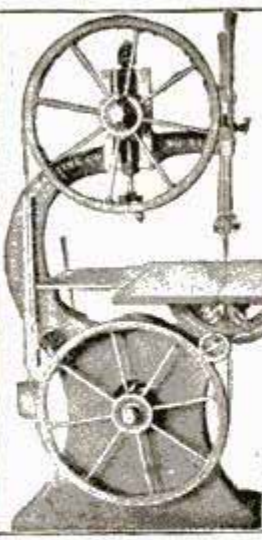

## Superior Woodworking Machinery

A modern line of woodworking machinery for Furniture Factories—Piano Factories—Box Factories—Cabinet Shops—Pattern Shops—Carpenter Shops—Wagon Shops—Repair Shops—Contractors—Manual Training Schools, etc. If interested write for our catalogue and net prices.

Largest manufacturers of woodworking machinery in Chicago.

Jones Superior Machine Co.  
1266 W. North Ave., CHICAGO



## Jones Machine Moulded PULLEYS and GEARS

Clutches, Sprockets  
Shafting and Hangers

THE LARGEST LINE OF Power Transmitting Appliances IN THE COUNTRY

SEND FOR GENERAL CATALOGUE A18  
W. A. JONES FOUNDRY & MACHINE CO.  
1400 North Ave. CHICAGO

**THE PROLIFIC BANANA**—The banana is probably the most prolific tree, and the produce of an acre will support 25 times as many people as the produce of an acre planted with wheat; 30 or 40 banana trees yield 4,000 lb. of nutritive substance. It was estimated by Humboldt to produce per acre 44 times more weight than the potato and 133 times more than wheat. The coconut palm yields about a ton of nuts and the date palm produces from 100 to 400 lb. each year.

## LEIMAN BROS. ROTARY BLOWERS and VACUUM PUMPS

1 oz. to 10 lbs. pressure  
1 to 20 inches Vacuum  
4 to 338 cubic feet Capacity per minute



take up their own wear  
Used with all Gas or Oil Burning Appliances and for **VACUUM CLEANING**

WHERE TO BUY THEM

Anderson, Ind., Webb-Baxter Co.  
Ashtabula, O., Mitchell Hdw. Co.  
Baltimore, Fairbanks Co.; Nat. Vac. Sales Co.  
Boston, T. Crowther & Co.; Holt, Shattuck & Co.; Taylor Machy. Co.  
Buffalo, Beals & Co.; J. L. Osgood; Root, Neal & Co.; Jos. Strauss & Son.  
Chicago, Machinists Supply Co.; Manufacturers Sales Co.; E. Schmidt, 1850 North Ave.; Willis C. Squire & Co.; Swartzchild & Co.  
Cincinnati, Thoma Bros. Co.; E. & J. Swigart Co.; E. A. Kinsey Co.; Wm. T. Johnston Co.  
Cleveland, Strong, Carlisle & Hammond; W. M. Pattison Supply Co.  
Denver, Mine & Smelter Sup. Co.; Denver Fireclay Co.; Kettering Mercantile Co.; Scott Supply & Tool Co.  
Detroit, Chas. A. Strelinger Co.  
El Paso, Tex. Mine & Smelter Sup. Co.  
Hoquiam, Wash., Lamb Machine Co.  
British Isles, Thos. Ashton, Ltd.  
Shelfield, Austria, White, Child & Bency, Vienna.  
Italy, White, Child & Bency, Milan.  
Russia, White, Child & Bency, Moscow.  
Victoria, Australia, Eckersley & Sons, Melbourne.  
Montreal, Canada, Canada Machy. Agency; Williams & Wilson, Ltd.; International Agency; G. J. Lunn & Co.  
Toronto, A. R. Williams Machy. Co.  
Paris, France, Sang & Raffinque.  
Charlottenburg, Germany, Victor Curstadt.  
New Zealand, B. Harkness, Stratford.  
All Machinery Dealers and Export Houses

LEIMAN BROS., 62P John St., New York

# STEAM ENGINEERING

## THIS \$35 EDITION



Now \$19.80—\$2.00 a Month

You men in charge of stationary, locomotive or marine engines and boilers—men who operate gas or gasoline engines—central station engineers—young men ambitious in the electrical field:

Here's your chance to own the famous Steam Engineering Library, written by 27 of the biggest and best known engineering experts in America, at a simply phenomenal price. The regular \$35.00 Edition for a short time at \$19.80 complete—\$2.00 a month.

Seven big, handsome books; bound in half red morocco, gold stamped; 3,300 pages; 2,500 absorbing illustrations, full page plates, diagrams, etc.; hundreds of valuable tables and formulas; cross-indexed so that you can get at any subject instantly, at an astounding introductory price.

### SHIPPED FREE

Look this entire set over for a whole week FREE. See if it really does fit in with your needs. Then decide whether or not you want to keep them. And don't send us any money until you decide. We'll ship the set absolutely free, express paid by us. See coupon below.

### These Subjects Covered

Construction of Boilers—Boiler Accessories—Fuel Economizers—Mechanical Stokers—Steam Pumps—Steam Engines—Indicators—Valve Gears—Steam Turbines—Gas and Oil Engines—Fuels—Automobiles—Carburetors—Locomotive Boilers and Engines—The Air-Brake—Single-Phase Electric Railway—Elevators—Marine Boilers—Marine Engines—Heating and Ventilating—Compressed Air—Transmission—Absorption and Compression Refrigeration—Ammonia Machines—Direct Current Dynamos and Motors—Management of Dynamos and Motors—Electric Wiring—Electric Lighting, etc.

## FREE!! \$12.00 Consulting Membership

Our big board of consulting experts, men actively engaged with engineering departments of prominent Chicago concerns, will answer any question or solve any problem you have for a whole year absolutely free when you own these books. This privilege alone sells for \$12.00, but you get it free if you keep the books.

### SEND THE COUPON

Merely send us this coupon. Books shipped at once free, express paid. Send us no money. Study the books a whole week. Then make up your mind. Then pay only the special price—\$19.80—at the rate of only \$2.00 a month, if you wish. But first see the books. The coupon brings them quickly. Mail it today. You take no risk, for we take the set back if you say so, and you are not out a penny.

## FREE COUPON

Worth \$15.20 to You  
American Technical Society:

Please send me 7 volume set Cyclo-pedia of Steam Engineering for seven days' free examination. If I decide to buy, will send \$2.00 in seven days and balance \$2.00 a month until \$19.80 has been paid, when \$35.00 books and \$12.00 consulting membership will be mine free. Otherwise will notify you and hold books subject to your order. Title not to pass until fully paid. Pop. Mech. 10-13

AMERICAN TECHNICAL SOCIETY  
CHICAGO, U.S.A.

NAME.....  
ADDRESS.....  
OCCUPATION.....  
EMPLOYER.....





## FREE TO MECHANICS

Our latest 365 page catalogue right from the press, listing our entire line of machinist's fine tools and cutters.

It contains much valuable information for both mechanic and apprentice.

Send for one today  
Ask for catalog 25

**Brown & Sharpe Mfg. Co., Providence, R. I., U. S. A.**

### Building Contractor Agents

Wanted to use and help sell the

#### Rapid Floor SCRAPER

One man scrapes more floor than three by hand  
Get our Free Catalog



**FREE TRIAL**  
**MONARCH MFG. CO.**  
510 Shepard Bldg.  
Grand Rapids, Michigan

"MOVE UP" IN JAPANESE—The City Electric Bureau of Tokyo has started a prize competition to obtain the best term to be used by the street-car conductor when urging the passengers to "move up" to the middle of the car. In response to the offer, 2,719 suggestions were received up to May 31, of which a few are being selected to be taught the conductors. Some of the suggestions are more interesting than useful, says the Japan Times. The following are selected as more appropriate: "O-tachi-no-kata, Go-junni, Nakae." (Those who stand,

## Something New in Calculating Machines

**Addition and Subtraction** now made possible on the Richardson Direct Reading Slide Rule without impairing in any manner the performance of *Multiplication and Division* on the same instrument.

There seems to be a misunderstanding about what the Slide Rule will accomplish, many think it an instrument, the use of which is applicable **only** to Engineers and Technical men. So frequently have I heard this remark that I have completely re-written and enlarged my instruction book, **The Slide Rule Simplified**, which shows the actual setting of the rule by **90 full size engravings**, 52 pages 7x10, each illustration and example is explained and "written so you can understand it." In fact any person who has never seen a Slide Rule, and not a technical person, could not help but learn its use. The examples selected and shown by illustrations are those which frequently come up for solution by the **Banker, Broker, Auditor, Inventory Man, Cost Estimator, Printer, Paper Mfr., Contractor, Salesman, Time-Keeper, Bookkeeper, Lumber, Land, Marine,** and other merchants too numerous to mention.

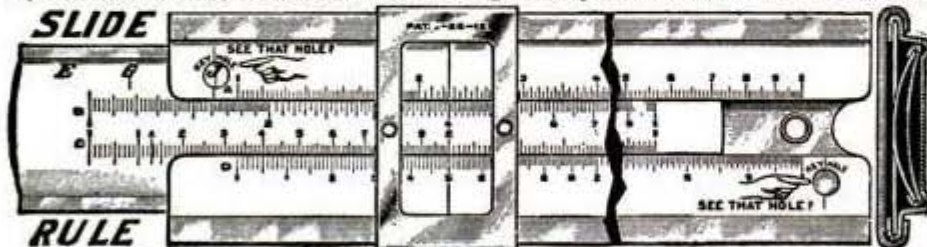

This Slide Rule will multiply, divide, add and subtract, solve proportion, extract the square and cube roots, find the decimal equivalent of vulgar fractions or "vice versa," calculate interest, percentage. Also the mensuration of superficies, and the rule of three. For Engineers, Electricians, Draftsmen, Superintendents, Master Mechanics, etc., the rule is indispensable in their work. It is one of the most valuable instruments ever offered to mankind. For Electricians it is a complete wire table in itself. The Richardson Direct Reading Slide Rule is specially designed for those who wish to learn its use. Its operation being very simple. You simply place the key to the problem wanted in the keyhole (the key is printed in red on slide, see cut) and answer is given direct, such as the Horse Power of Engines, Pumps, Boilers, Belts, Water Falls; size of duct for ventilating; radiation and size grate, and steam main; change gear and pulley problems; areas, circumference and diameter of circles. This Rule is my 1914 type now on the market for the first time. Made in two sizes, **coat and vest pocket** 10" x 1 1/4" x 3/4" and 5 1/2" x 1 1/4" x 3/4". 10" has Sine, Log, and Tangent scales, and the Addition and Subtraction feature possessed by no other slide rule. No **wood** in their construction, scales white celluloid, printed from **engine divided plates** in two colors, and washable, secured by an improved locking device in an absolutely non-corrodible **Monel Metal** framing. Blackened to ease the eyes.

Price of 10" Rule, ordinary case, **\$2.50**. Adding and Subtracting features, 50c extra. **Full leather case, 50c extra.** 5" rule and **full leather case, \$2.50**. 10" dummy rule, paper scales, **\$1.00**. If ordered now the book, **The Slide Rule Simplified** goes **FREE** with each rule. If interested in forming Clubs write for large list of tools **GIVEN FREE**.

**Geo. W. Richardson**

**CONSULTING ENGINEER** 4218 24th Place  
Ex-Chief Electrician, U.S. Navy **CHICAGO, U. S. A.**

THE SLIDE RULE  
SIMPLIFIED

1913

Geo. W. Richardson



Mechanics with Years of Experience  
WHO USED

## The Barber Ratchet Brace

when they were young, are still using the same tool because of its many good qualities.

Our latest pattern, Nos. 30 to 34.

includes every feature that can in

any way add to convenience and durability. It is free acting and non-splitting; has ball thrust, forged steel jaws and will outlast the average brace two to one.

Send for details and complete catalog.

Millers Falls Company, 28 Warren St., New York



"Just apply and heat"

No soldering iron-

No acid-no rosin

Alcohol Torch

and 50c can

**TINOL**

Paste

Postpaid

\$1

**SO EASY**

TO SOLDER WITH

the modern combined solder and non-acid flux

Paste and wire forms

Mends kitchen-ware instantly-A hundred uses in home, shop and laboratory

HESS & SON, Dept. F, Watkins Bldg., Phila., Pa.

in order, to the middle!)

"O-orini-naranu-Okatawa, Nakahodo-ni, Negaimasu."

(Those not getting off, to the middle, please!)

"Nakahodo ga, Orakude Gozaimasu." (The middle is more comfortable!)

"Dōka Okue Negaimasu." (Please go forward.)

"Okino-dokusama, Hitokawazutsu, okue-negaimasu."

(I'm sorry, but all move on by one strap!)

Rather comical are:

"Nakahodo ni wa beppin ga orimasu." (There's a pretty girl about the middle of the car!)

"Nakahodo no kata wa Kippu ga irimasen." (No ticket

## WE SHIP ON APPROVAL

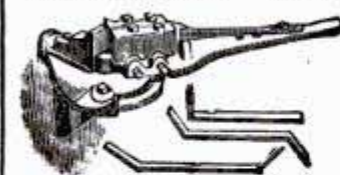

Our Hand Power Angle Benders are so indispensable for bending rods, squares, and flat pieces into all sorts of angles that we do not hesitate to ship tools for 10 days free trial. Made in 3 sizes to cover a wide range of work. We also make hand power tools for bending eyes, hooks, "U" shapes, hinges, rings, etc. Write for complete descriptive catalogue.

WALLACE SUPPLY CO., 124 No. Jefferson St., Chicago; 233 Broadway, New York City



One sample to one person only, \$1.

Ask about our 3,000 R. D. Tools

**"Red Devil"**

SPECIAL

Heavy "Klein" Pattern  
Electricians' No. 1950  
Side Cutting Plier, 8"

SMITH & HEMENWAY CO.

150 Chambers Street, New York City, N.Y., U. S. A.

# Stanley Tools

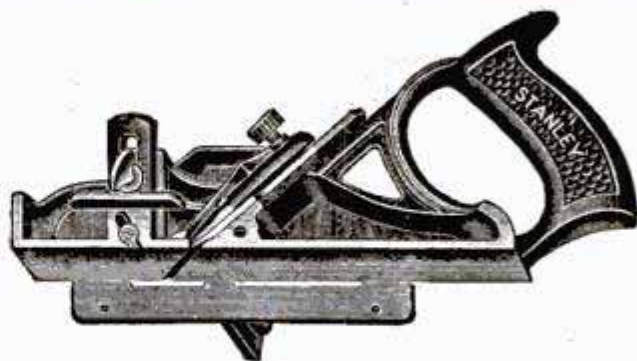

No. 289

## Stanley Skew Cutter Filletster and Rabbet Plane

☞ A Plane that is fast finding its way into the "kit" of every lover of good tools.

☞ It has an extra wide cutter ( $1\frac{3}{4}$  inches) which is set on a *Skew*.

☞ It is provided with a *Fence* and a *Depth Gauge* which can be attached to either side, so that the Plane can be used equally well for right or left hand work.

☞ Furthermore, the *Fence* is so hung that it slides under the bottom, enabling the user to regulate the width of the cut.

☞ It has two adjustable spurs, one on each side, a valuable feature. By removing the *Fence* and *Arm* a very superior Rabbet Plane is obtained.

8½ in. long.

Weights 3¾ lbs.

List Price, \$1.75

Ask your Hardware Dealer to let you see it, or send to us for Catalogue No. 34-C which contains complete description of this and other special planes.

**STANLEY RULE & LEVEL CO.**  
NEW BRITAIN, CONN. U.S.A.



# "YANKEE" CHAIN-DRILL

Automatic  
Friction-and-ratchet feed



**T**HE "YANKEE" Chain Drill is the only chain drill with Automatic Friction and Ratchet Feed.

The "YANKEE" won't break your drills. The automatic ratchet feed keeps an even, steady pressure on the cutting point all through the job. The "YANKEE" is quickly and easily adjusted,—by a few turns of the brace, the automatic friction feed tightens the chain and starts the drill with least effort.

Just one movement of a little lever from upright to horizontal accomplishes this change from the friction to the ratchet feed. No complicated parts to handle, nothing to do but turn the brace and change the lever position.

## "YANKEE"

Chain Drill No. 1500  
Automatic  
friction-and-ratchet feed

Ingeniously constructed and as carefully made as every "YANKEE" Tool. Three-jaw chuck. Jaws of tool steel. Holds round shank drills to 1/2 inch diameter. Square-thread, steel feed screw insures durability. Made also with two-jaw chuck. "YANKEE" Chain Drill 9 3/4 in. long, 3 1/4 lbs. weight.

No. 1500—Price \$3.00  
Your dealer can supply you

Write for "Yankee Tool" Book"—free—showing styles of Yankee Ratchet, Breast, Hand Drills and other "Yankee" Tools.

NORTH BROS. MFG. CO., Philadelphia

# "YANKEE" TOOLS

Make Better Mechanics

Please Mention Popular Mechanics

WHEN YOU BUY

# LUFKIN

Measuring  
Tapes  
and Rules

YOU ARE SURE OF

ACCURACY—DURABILITY  
—EFFICIENT SERVICE

Send for catalogue and sample  
piece of steel tape with  
*Instantaneous* Readings.

**THE LUFKIN RULE CO.**

SAGINAW, MICH.



WITH THE

## PERFECT AUTOMATIC SHEAR HONE

You can sharpen your own shears better than you have ever hired them sharpened.

The Shear Blade is automatically held by a Clamping and Pressure Spring at just the right pressure on the Hone, and at the same time is guided to the proper Oblique Bevel to give the Cutting Edge the Right Grain. It will last a Life Time; is 6"x2 1/4"; weighs 14 oz.



Sent prepaid  
on receipt of  
**\$2.00**

Trial proves satisfaction or your money refunded.

**THE CHEMUNG MFG. CO., Elmira, N.Y.**

collected from the middle of the car.)

"Irikuchi wa busso de gozaimasu." (The entrance is full of danger.)

"Tadaina suriga-nori-mashita." (A pickpocket has just come on board.)

Gold production in the Philippines increased from \$189,953 in 1911 to \$570,212 in 1912, and is expected to be three or four times that amount this year.

## Everyone Interested in Mechanics

Increase your  
efficiency  
by using the

### So-Easy Center Finder

A handy little tool for laying out work. Can be used for centering and drawing radial lines on round, square, or hexagon stock; also for laying out keyways, etc. Sent anywhere by return mail on receipt of 25 cents.

**THE BENNINGTON CO., 265 Purchase St., BOSTON, MASS.**

\$1.00

Postpaid

Myers' Wonderful Sewing Awl

sews leather, canvas, shoes—anything, heavy or light. Complete repair shop in itself. Saves many trips to town. Mends harness, saddles, wagon covers, blankets, buggy tops, belts, etc. Can't get out of order. Original and only awl with diamond point full grooved needle to protect the thread. BIG MONEY FOR AGENTS.

**C. A. MYERS CO., 6339 Lexington Ave., Chicago, Ill.**



## Portable Cases

FOR TOOL MAKERS  
AND MACHINISTS

Twelve styles, felt lined drawers, solid brass trimmings, best of material, beautiful finish, low prices, satisfaction guaranteed. Ask for booklet of cases built for service.

**The Pilliod Lumber Co.**  
SWANTON, OHIO



# Write Now for Your Copy

OF THE

# Starrett Catalog

# No. 20

Sit down and fill in the coupon and let us send you our latest 320-page catalog No. 20. It gives information, prices, and illustrations of all kinds of mechanics' tools. It contains also tables and information of value to the machinist and engineer. The Starrett catalog, as you know, has the most complete list of mechanics' tools there is.

The L. S. Starrett Co.  
Athol, Mass.

Please send me a free copy of your catalog No. 20.

Name .....

Street.....

Town.....

State ..... P. M.

Fill in the coupon now

## The L. S. Starrett Co.

WORLD'S GREATEST TOOLMAKERS

ATHOL, MASS.

42-225

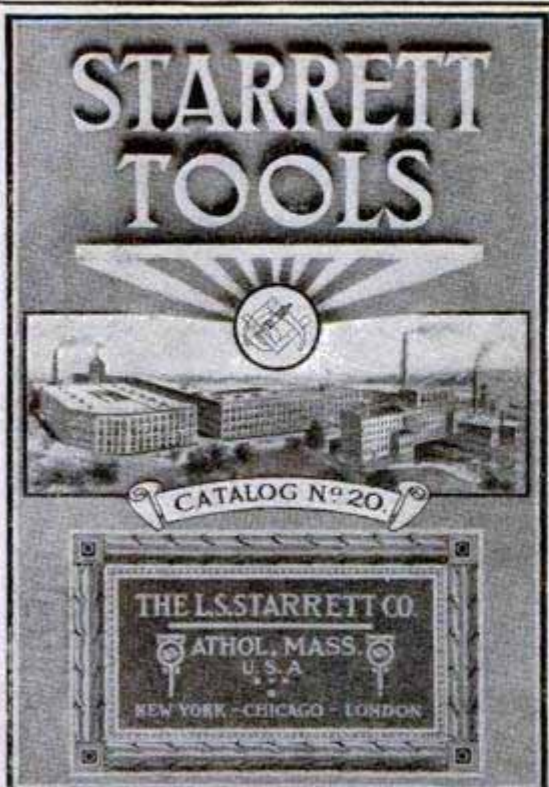

**MOVING PICTURES IN EUROPEAN SCHOOLS**  
—The use of moving pictures in schools is spreading rapidly in Europe. Recently a professor in a Brussels school excited great interest by presenting a series of pictures illustrating the progress of aviation from the earliest days to the present. In Prussia, the minister of public instruction has approved the use of the cinematograph in all the higher schools to illustrate lessons in geography, history and science. The expense of material is met by appropriations from the government and the municipalities, and by private subscriptions.

**SELF HEATING SOLDERING IRON TORCH**  
CUTS TIME AND FUEL BILL 50%  
ADDRESS DEPT. 1  
EMMELMANN BROS. MFG. CO. INDIANAPOLIS, IND. U.S.A.

**STOP THAT LEAK**

**Solderene** TRADE MARK

and a Candle are all you need to make a permanent repair.

Full directions with each stick. It requires no skill. Anybody can use it. Price, Ten Cents.

SOLDERENE MFG. COMPANY, 90 Portland St., BOSTON, MASS.

**A Mile of Cutting Surface Per Minute**

**Marvel Foot-Power Grinder**

Equal to highest priced power machines. Has 8-inch Corundum cutting wheel which does not affect temper of finest edge; ball bearings; self lubricating. Any boy can operate. Cheap, durable; easily carried—only 8 pounds. Fastens rigidly by thumb screws to any bench, table, etc. Sent ready to use, **ONLY \$4.00**. Money back in 10 days if not satisfied.

**BISON GRINDER MFG. CO.**  
410 Morgan Bldg. BUFFALO, N. Y.

Side-line men and agents write for proposition

Descriptive Folder **FREE**

**"AMERICAN" Key Cutter**

**A Steady Income—Independence—for You!**

**\$5.00 to \$10.00 a day with little effort and small investment. Others are doing it—so can you.**

Why not establish yourself in this immensely profitable business? We show you how and supply everything —everything but a little enterprise; that's up to you! Our two unique machines do the trick. The "American" is the only machine that sharpens, hones, and stropps razors, and all kinds razor blades, scissors, clippers, pocket knives, surgical instruments, etc. No previous experience necessary. The "American" Key Cutter is a little wonder, cuts any shape slot. Booklet of information furnished **FREE**.

State Agents wanted

**AMERICAN SHARPENING MACHINE CO., Inc.**  
Dept. 10, 184 W. Washington St. CHICAGO





## Edges That Cut Clean

The high quality of Keen Kutter steel produces blade edges that cut clean—cut easily—cut quickly.

Pocket Knife  
No. K0153  
Price \$1.75

Keen Kutter pocket-knife blades are firmly pinned and the handles do not loosen or crack.

## KEEN KUTTER Pocket Knives—Razors

Keen Kutter safety-razor blades are made of the finest Swedish cutlery steel. The Keen Kutter Regular Safety Razor and Keen Kutter Junior Safety are set at the correct cutting angle, which enables the most inexperienced man to start shaving right away without practice. At \$1.00 the Keen Kutter is a wonderful value.

Every Keen Kutter article is not only guaranteed, but your dealer will refund its cost if it is in any way unsatisfactory.

*"The Recollection of Quality Remains Long After the Price is Forgotten."*

—E. C. SIMMONS.  
Trade Mark Registered.

If not at your dealer's, write us.

**SIMMONS  
HARDWARE COMPANY, Inc.**  
St. Louis  
New York Philadelphia  
Toledo Minneapolis  
Sioux City Wichita

Pocket Knife No. K2551  
Price \$0.85



Keen Kutter  
Junior Safety  
Razor  
No. KJ10  
In neat  
traveling  
case  
Price \$1.00

PETE TEACHES THE YOUNG  
TO USE

## Carborundum Sharpening Stones



PETE'S first advice to the budding carpenter or the student craftsman is:

"Learn to take the proper care of your tools, so, first of all, get a good oil stone. Get a stone that will cut the edge on the tool, not one that rubs it on. A stone that will cut quick, holds its shape, and not glaze."

The experienced workman, too, should heed Pete's advice. He means a Carborundum Sharpening Stone. Ask your hardware man to show you the rectangular or the round combination Carborundum Bench Stone.—They are the greatest stones for all around work you could ever put in your kit. For your gouges, get Carborundum gouge stones.

Ⓜ

From your hardware dealer or  
order direct

Ⓜ

The  
Carborundum  
Company  
Niagara Falls, N. Y.







## "Ohio" Edge Tools

are made from specially selected tool steel, by careful and skillful workmen. They are tempered by the most improved process and are sold with a money back guarantee.

Insist on "Ohio" Tools when buying Planes, Chisels, Drawing Knives, Auger Bits, Screw Drivers, etc.

CATALOGUE FREE

**OHIO TOOL CO.** (Dept. 3)  
Columbus, Ohio

## Grobet Swiss Files

and other high-class Tools are shown in "THE TOOL-MONGER" - it's 465 pages, and will be mailed on receipt of 8 cents in stamps.

**MONTGOMERY & CO.,** 107 Fulton Street  
NEW YORK CITY

## THE MASTER SLIDE RULE,



the only **RULE IN THE WORLD** whereby inside measurements of doors and windows, etc., can be taken rapidly and accurately. Also superior to any other rule for outside measurements of walls and ceilings, etc., as it can be extended and closed instantly. **MECHANICS, BUILDERS, AND ARCHITECTS, TRY ONE TODAY! DON'T WAIT.** Ask hardware dealer for it.

On receipt of 15 cents per lineal foot, a 4, 5, 6 or 8 foot rule will be sent to you prepaid. Large profits to agents. Write for circulars and particulars.

**DAHL MFG. CO.** 51-A East 42nd St. NEW YORK CITY

Exports from the United States to Canada have practically doubled in the last three years according to the official figures of the Bureau of Foreign and Domestic Commerce.

The United States supplied, according to Canadian figures, 63 per cent of the imports of Canada in 1912, against 58.4 per cent in 1902.



### Duplicate Keys for all Pin Tumbler Locks can be made in a minute with The Harrison M. I. P. Key Filing Machine

Invaluable for Machinists, Building Superintendents, Hardware and Repair Shops, Locksmiths, Carpenters, Electricians, Garages, etc. Anyone can make a perfect duplicate key without injuring the original. A customer writes: - "We made 65 keys in one hour and 16 minutes. Can you beat it?" Every machine unconditionally guaranteed, money refunded if not entirely satisfactory. Price \$3.00 net. Send us P. O. order or N. Y. draft and receive the complete machine by return Parcel Post. Special diamond shaped files for angular keys 35c each or 4 for \$1.00. Testimonials sent on application.

**HARRISON & COMPANY, 81 1/2 New Street, NEW YORK**

## GET EVERLASTING RESULTS

by the **ALLEN-FLUX** route

No longer the word **solder** to identify us, it's because the goods have **spoken** for themselves.



For hard-to-get-at places, big joints for electric-light wiring, switch-boards, annunciators, etc., use **Allen Soldering Paste**. Saves a great deal of joint scraping. Acts equally well on very fine work or heavy connections. Never fails to **hold the joints**. We want you to test severely **Allen Soldering Paste**. If your dealer hasn't it - electrical or hardware - send his name and lie for can; 25c for collapsible tube with attachable aluminum nozzle.

**L. B. ALLEN CO., INC., 4530 NO. LINCOLN ST., CHICAGO**



## Tool Cases

for Machinists & Toolmakers

You need one of the many styles shown in our free catalogue. They are the best built and most practical on the market and it's the up-to-date way to keep tools in good condition and orderly arranged. We ship direct to you and guarantee complete satisfaction.



Mfrs. of Mechanics' High Grade Tool Cases  
818 Germantown Street, DAYTON, OHIO

# 100% Safety

## That is what you want!



The new form of "VULCAN" Safety Dog Neck and Screw

# "VULCAN" Safety Lathe Dogs

## will give it to you

☐ The logical application of safety lies in the use of tools which are fool-proof—which lack attachments that you can forget to use.

☐ "Vulcan" Safety Lathe Dogs provide for the simplest and only non-encumbered means, assuring safety automatically.

☐ Until recently your employer was without the means to furnish real safety dogs but the "Vulcan" tools have made another story of it.

☐ Help yourselves and you will help your employer. Suggest 100% "Vulcan" Safety.

Send for dependable tools catalogue

## J. H. WILLIAMS & CO.

Superior Drop-forgings

47 Richards St. BROOKLYN, N. Y. CITY

40 So. Clinton St. CHICAGO, ILL.



The common form of old style dog neck and vicious screw





## Rent This Transit or Level for Nine Months THEN IT'S YOURS Engineers and Surveyors

Here is the most wonderful offer that has ever been made in high grade instruments. High prices and cash payments are eliminated. For the first time it is possible for every surveyor and engineer to own his own Transit or Level, and to secure it on terms so easy that it is much cheaper to buy your own instrument in this way than to rent one even occasionally.

**THE TRANSIT** is fully equipped with 9-inch achromatic telescope, three spirit levels, vertical circle, horizontal limb, leveling screws, canvas, vernier, etc.



**THE LEVEL** has 18-inch telescope, erecting eye piece, rack and pinion movement, 8-inch spirit level.

## 50 Years of Quality

For more than fifty years Aloe's surveying instruments have been recognized as a reliable product.

Engineers and surveyors of national reputation have given these instruments their unqualified endorsement. They are sold to you with an absolute guarantee that is backed by a **ten day free trial offer.**

**FULL PARTICULARS** and descriptions of these high grade instruments, and details of our extraordinary selling plan, will be sent upon request.

A. S. Aloe Co., 515 Olive St., St. Louis, Mo.

**New  
Type-  
writer**

Typewriters cost too much and are too heavy for general use. The wonderful Bennett Typewriter costs *only* \$18, brand new—is light, and easily carried for home use, business or trips. Does all the work of high priced machines.

## Sent on Approval

Money back if not satisfactory. Write for catalog and trial offer. The Bennett is low priced because so simple. Only 250 parts. Others have 1700 to 3700. Built in famous Elliott-Fisher Billing Machine factory. Write today. Live agents wanted.

**Q H Bennett Typewriter Company**  
366 Broadway New York



## FREE Catalog

illustrating True-Tone band and orchestra instruments, violins, drums, drummers' traps, etc., also

## "HOW TO ORGANIZE A BAND"

ADDRESS, DEPT. 15

**BUESCHER BAND INSTRUMENT CO.**  
ELKHART, INDIANA



## Quality

is of course the most essential requisite of a lathe for **Garage work**, as well as for **Automobile and general repair work.** We have it in our lathes, but we have kept the **price very low.**

We would be glad of an opportunity of convincing you that we offer both **high quality and low price** in the **Sebastian Lathe.** Our catalog free.

**The Sebastian Lathe Co.**  
107 Culvert Street CINCINNATI, OHIO

**SINGLE MAHOGANY LOG WORTH \$14,000—** A log, one of the finest specimens of African mahogany, arrived in Liverpool from the port of Axin, was acquired, in competition from nearly every civilized country in the world, by a New York firm, which paid \$14,000 for it. This is one of the highest prices ever paid for a single mahogany log.



**FREE** If interested in Tool Grinders, send for our new booklet "A Sharp Edge in a Hurry." If you enclose 4 cents for packing and mailing, we'll include **FREE** a Pike India Vest Pocket Stone, also our famous book "How to Sharpen."

**PIKE MANUFACTURING CO., 100 Main St., PIKE, N. H.**

## FOR SEWING LEATHER

The **Speedy Stitcher** is the latest and best of anything ever offered for \$1.00.

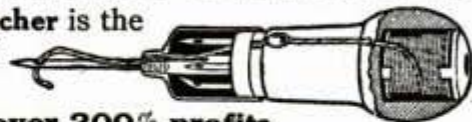

**Agents make over 200% profits.**

Send at once for catalog and terms.

**AUTOMATIC AWL CO., 26 Gardner Terrace, WORCESTER, MASS.**

## A CORRECTION

Our announcement pertaining to our new "Drilhammer"—Drills ten times faster than by hand—will appear in the November issue of this magazine. Send for an advance copy of our descriptive booklet.

**ORR & LOCKETT HARDWARE CO.**  
14-16 W. Randolph St. CHICAGO



SIDE VIEW



TOP VIEW

NEW IMPROVEMENTS WITH COMPASS NOW MAKE

## The American Combined Level and Grade Finder Most Practical, Durable and Convenient Instrument Made

At one glance you can get the true slant on any line or grade either in degrees, inches or percentage, or all at the same time, and will at once give the exact distance needed to plumb up to a true level. The additional spirit level glass now placed in middle of instrument with points on dial will give 3 grades for leveling. The longitudinal recess shown in cut is well worth the low price of the instrument. Write **AT ONCE** for circular and Testimonials. Special Introductory Price given to First Applicants with privilege of taking Agency. Address **EDWARD HELB, Mfr., Box 75, RAILROAD, PENNA.**



# GOING TO BUILD?

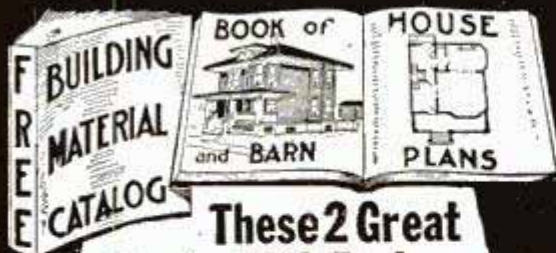

## These 2 Great Books Will Reduce Your Building Expense

A big 224-page Catalog of Millwork and Building Material, containing cuts and net prices of 8,000 money-saving bargains. A handsome Plan Book of Modern Houses, bungalows, summer homes, barns and ready-built garages, showing 60 splendid exterior views with floor plans, priced from \$30 to \$4000. Don't pay dealers' prices—we sell direct, factory to user. You can save money.

### STORM WINDOWS - STORM DOORS

Save their cost in coal bills. Makes home comfortable in winter.

Everything in lumber, flooring, roofing, doors, windows, mouldings, porchwork, building paper, lawn and home furnishings, hardware, paints, plumbing, heating, fancy hardwood floors, metal ceilings, etc., all at wholesale prices.

Don't build, repair or remodel without these valuable books. We guarantee quality, safe delivery, satisfaction or money back. Write today for Catalog No. 103 and if you intend a new home, also get Plan Book No. 113. Both are Free.

**CHICAGO MILLWORK SUPPLY**  
AMERICA'S GREATEST SASH AND DOOR HOUSE  
1444 West 37th St., Chicago, Ill.

**ODD ANIMAL INTERIORS**—Four cows of Watertown, N. Y., and one hen of Bayonne, N. J., revealed themselves as possessed of most remarkable interiors recently. The cows strolling through a meadow came to a fence near which some workmen had temporarily laid a dozen sticks of dynamite. The cows considered the dynamite in the day's eating task and proceeded to swallow and prepare the sticks for future cud chewing. The horrified workmen arrived on the scene just as ten of the sticks had disappeared. They grabbed



## MAKE BIG INCOME

Men and Women can do this all the year at home growing mushrooms in cellars, stables, sheds, boxes, etc. Crop sells for \$.50 to \$1.00 a lb. \$20.00 a week easily made. Great demand, markets waiting. Start Now. Write for big 32 page Free Illustrated Booklet and learn how to do it.

NAT'L SPAWN CO., Dept. 12, BOSTON, MASS.

## Used Piano Bargains

A good standard make used piano is a better investment than a cheap new piano. We carry a large stock of used standard make pianos, taken in exchange as part payment on new Starck Pianos and Player Pianos. Prices \$75.00 to \$195.00. 30 days' free trial; easiest payments; 50 FREE MUSIC LESSONS.

WRITE TODAY FOR BARGAIN LIST.  
P. A. STARCK PIANO CO., 387 Starck Building, Chicago, Ill.



## BE YOUR OWN BOSS



### Agents

Earn Big Money Selling Golden Rule genuine hand forged English razor Steel Knives,

that will cut and hold the edge. We will put any photo or lodge emblem on one side of the transparent handle and name and address on the other. We have a complete, fully guaranteed line of knives, razors, strops and cutlery specialties. Quick sales. Big Profits. Exclusive territory. Experience unnecessary. We teach you how. Write today for Catalog and Terms. Golden Rule Cutlery Co., 552 W. Lake St., Dept. 207, Chicago

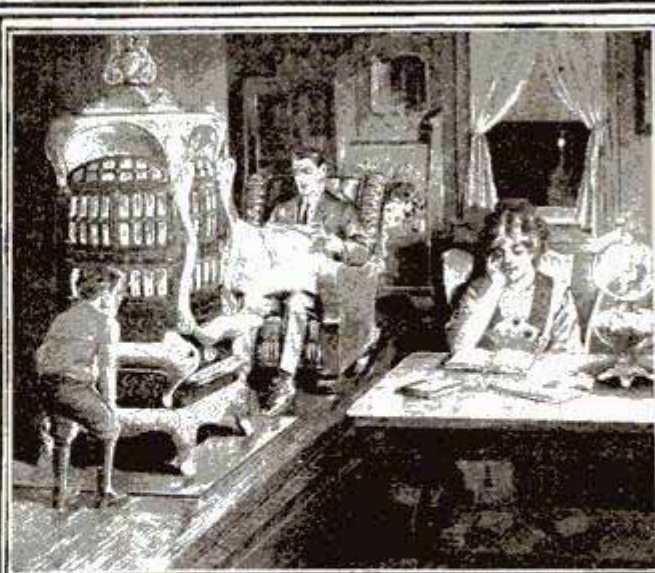

## Pay Next Year Furniture on Credit No Red Tape—No Rigid Rules

We give credit to home lovers—give it gladly—on terms which no one else ever offered.

No references required, no contract, no mortgage. We open your account when we mail you our catalog. Order when you wish.

We make this offer after selling on credit for 48 years, and to 1,200,000 homes.

### Pay 3 Cents a Day

Pay a little each month by saving up just 2 or 3 cents a day. If sickness comes, or loss of work, ask for extra time. We have no collectors. There will be no interest, no extra price, no annoyance of any kind.

Goods will be sent on 30 days' trial, subject to return. If you return them, we pay freight both ways.

And we guarantee to save you from 15 to 50 per cent under the lowest prices others quote. Return the goods if we don't.

### Dollar Book Free

Our Fall Bargain Book is a mammoth book, which costs with the mailing \$1 per copy. It pictures 4,915 things for the home, many in actual colors.

We mail this book free, and we want you to have it. With the book we will send your credit certificate showing your charge account.

In writing us, kindly state what articles in the list below will interest you most. We have special books on some of these lines which we also will send if wanted.

Fill out and mail us the coupon now.

## Spiegel, May, Stern Co.

1239 West 35th Street, Chicago

Please check the lines in which you are interested, as we have special books on some lines.

- .. Furniture
- .. Carpets—Rugs
- .. Stoves—Ranges
- .. Women's Garments
- .. Ladies' Dress Goods
- .. Watches—Jewelry
- .. Silverware
- .. Chinaware
- .. Sewing Machines
- .. Kitchen Cabinets
- .. Baby Cabs, etc.

SPIEGEL, MAY, STERN CO.  
1239 W. 35th Street, Chicago, Ill.

Mail me your Fall Bargain Book. Also books on the lines checked above.

Name .....

Address .....

Give full address. Write clearly.

Please Mention Popular Mechanics





## The Demands of Business

are a constant tax upon mental, physical and nervous forces. The effects of concentration, worry and overwork soon become evident. Unless proper nourishment for brain and nerves be provided, complete breakdown is the inevitable result.

## Pabst Extract

The Best Tonic

quickly dispels the effects of overwork, nerve exhaustion and brain-fag. It feeds the nerve centres, strengthens the muscles and quickly restores both mind and body to a normal, healthy state.

Order a Dozen from Your Druggist

Insist Upon It Being "Pabst"

FREE BOOKLET, "Health Darts," tells all uses and benefits of Pabst Extract. Write for it.

Pabst Extract Co., Milwaukee, Wis.



## RIFLES and SHOT GUNS ON CREDIT

THIS ACCURATE, STRONG-SHOOTING, HAMMERLESS SHOT GUN

\$4<sup>50</sup>  
DOWN

Price \$17.50

This high grade shot gun is fitted with Rummel's No. 14 Armory Steel barrels, full tapered choke, bored for either black or smokeless powder—12 or 16 gauge, 28 or 30 inch lengths, 7½ to 8 pounds. Top lever action—hammers cock and throw safety automatically. Sent for \$4.50 Down and \$2.00 a month—no interest—no extras and you have 7 months in which to complete payment on this gun that will compare favorably with any \$40 or \$60 gun made. Every man wants a good gun, but not every man can afford to pay the full amount cash down—therefore, we have just lately decided to sell high grade fire arms on

### CONFIDENTIAL CREDIT

If you want a guaranteed shot gun or rifle why not open a credit account? We have been selling high grade guns for thirty-five years.

Write us for Complete Information and Catalog

A. J. RUMMEL ARMS COMPANY  
302 St. Clair Street Toledo, Ohio

the remaining two and fled. The cows were watched by the angry and apprehensive owner for quite a time, but nothing exploded.

The hen swallowed something that made it gape and open and shut its eyes a dozen times a second. She was a fine breed of hen and the owner was a veterinarian. He slit open her crop, took therefrom a small roll of emery paper, sewed up the crop again with silk thread and looked to see a very sick hen stagger off

## Regular Salaries Better Than Commission Only

I'll make a regular weekly salary offer to any man or woman who wants to act as my representative and devote four hours every day selling my world beating line of Toilet products, Soaps, Perfumes, etc. I want honest men and women quick. No experience necessary. I'm an old agent myself. I will show you how to make \$25 to \$50 per week. I couldn't afford to pay a regular salary if the goods were hard to sell. It's a cinch—the big bargains almost sell the goods themselves. Seventeen years in business. Pay day every Saturday—no bonds or references. I will furnish most attractive outfit. Simply send name and address on postal and say "send full particulars—weekly salary offer." I want to put you on the payroll immediately.

E. M. DAVIS, Pres.

E. M. DAVIS SOAP COMPANY, Dept. L14, Chicago





# Need a Good Flannel Shirt?

Look these over. The makers of the widely worn Signal line make Signal Flannel Coatshirts of first class, quality-tested flannels, carefully cut and perfectly sewed by expert union workmen, with numerous unusual and ingenious comfort features added to give you extra value.

## Signal FLANNEL Coatshirts

UNION MADE

You know what these mean in a shirt:

Big armholes, roomy elbows, full length sleeves, wide cuffs, and a gathered yoke at the back of each shoulder. You couldn't get greater arm-freedom with your shirt off. Flaps that overlap each other a full 3 inches in front. Combination watch and handkerchief pocket, with a flap you can button. Cut coat style with full length body. Extra button at bottom of breast plait to prevent gaping. Satin-lined military collar.

Signal Flannel Coatshirts give more actual wear than similarly priced shirts, and about twice ordinary comfort. They are sold in a variety of desirable patterns by most all dealers for \$2.00, \$2.50, \$3.00 and \$3.50. Whatever you pay, count on double that amount in value.

We also manufacture a splendid line of Signal Workshirts, sold by our dealers at \$1.00, which have the same remarkable comfort features of Signal Flannels. If you don't find Signals at your particular dealer's, give us his name and let us send you some sample swatches and a descriptive booklet.

If you don't need shirts today tear this out as a reminder, for you can't afford to get less value for your money by buying any shirts but Signals.



**HILKER-WIECHERS MFG. CO.**  
1256 Mound Ave., Racine, Wis.

Manufacturers of  
Signal Service Shirts



to lie down and very likely die. Instead she went to her nest box and promptly hatched out ten chickens.

ANCIENT EGYPTIANS USED ROUGE—The "tear bottles" which women of the Orient carried centuries ago reveal the hypocrisy of the women. Several of these bottles are included in a collection of glassware which has been bought for \$13,000 for the

## BAND INSTRUMENTS WURLITZER



Catalog contains 282 pages, 788 illustrations, 67 color-plates. 2561 articles described—all musical instruments and supplies. Superb quality and lowest direct prices. Free trial and easy payments. We supply the United States Government. Mention what instrument you are most interested in. Write for the big **FREE CATALOG**

at 2 Points of Supply. Address the nearer one.  
**THE RUDOLPH WURLITZER CO.**  
101 E. 4th St., Cincinnati 308 S. Wabash Av., Chicago

## IF IT ISN'T AN EASTMAN IT ISN'T A KODAK

**Shirley** Feel better, look better,  
**President** fit better, wear better  
**Suspenders**

50¢

"Satisfaction or money back"

Be sure "SHIRLEY PRESIDENT" is on buckles  
The C. A. Edgerton Mfg. Co., Shirley, Mass.

## Hello Boys! Make lots of Toys

It's fun to read my new 24 page booklet full of pictures of toys easy to make quickly with the **Mysto Erector**, the Toy that resembles structural steel. Has 20% more parts than any similar toy. You alone can build big towers, bridges, cars to go by little electric motor, etc. My real square steel girders look like the big bridges and steel buildings. It's great fun. Toy dealers sell it; \$1.00 and up.

Write me now for my book giving your toy dealer's name.

A. C. GILBERT, Pres.  
**THE MYSTO MFG. CO.**  
53 Foote Street NEW HAVEN, CONN.



**EARN \$10 TO \$15 AND A WEEK HOLD YOUR PRESENT POSITION**

**SPARE-TIME DOLLARS**

WE start you in a permanent business with us and furnish everything. We have new, easy selling plans and seasonable leaders in the Mail Order line to keep factories busy. No canvassing; Small Capital; Large profits; Spare time only required; Personal assistance. Write today for plans, positive proof and sworn statements.

**J. M. PEASE MFG. CO., 13 Pease Bldg., Main St., Buffalo, N.Y.**



## The Original Electric Vibrator — Costs Less than Imitations

Everybody knows the wonderful results that have been achieved by massage, and everybody knows that the **ARNOLD Electric Vibrator** is the most scientific way of giving this beneficial massage *in the home*.

It is the most widely used electric vibrator in the country — solely because it is the **BEST**. It is the original electric vibrator.

### *Arnold* Massage Vibrator

**ARNOLD features**—Die mold motor casings, high nickel plate finish, keeps lustre and good looks, every part interchangeable, U. S. Government high speed motor bearings for hardest kind of usage; speed control by new, unique, patented device in handle; **ARNOLD** armatures give maximum power *without overheating*; light, compact and easily handled—weighs only 30 ounces and is covered by a broad, liberal guarantee.

Why not get an **ARNOLD** for use at home? It's concentrated exercise that keeps muscles and mind in good trim. Write at once for our free 80-page book called "**ARNOLD Vibratory Massage**," —gives full details of the **ARNOLD**.

**STANDARD ELECTRIC WORKS**  
1200 12th Street RACINE, WISCONSIN



# Deafness



Perfect hearing is now being restored in every condition of deafness or defective hearing from causes such as

**Relaxed or Sunken Drums, Roaring or Hissing Sounds, Perforated, Partially Destroyed Drums, etc.**

### Wilson Common-Sense Ear Drums

"Little Wireless Phones for the Ears"—

require no medicine but effectively replace what is lacking or defective in the natural drums. They are simple devices, which the wearer easily fits into the ears where they are invisible. Soft, safe and comfortable to wear at all times.

Write *today* for our 168 page **FREE** book on **DEAFNESS**, giving you full particulars and plenty of testimonials.

**WILSON EAR DRUM CO., Incorporated**  
185 Inter-Southern Building LOUISVILLE, KY.

## ERICKSON LEG

Arms, Braces, Wheel Chairs, Stockings.  
**SOLD ON EASY TERMS**

**E. H. ERICKSON ARTIFICIAL LIMB CO.,**  
17 Wash. Av. N., MINNEAPOLIS, MINN.



Does not chafe, overheat or draw end of stump.  
SEND FOR CATALOG

Largest Limb  
Factory in World.

AGENTS  
WANTED



POSTPAID  
\$2.00

IMPROVED

### Automatic Razor Stropper

for Old Style or Safety Blades

Sharpens blade with diagonal stroke. Strop is specially treated and has pulling and sharpening qualities. Stropper fully guaranteed.

**AUBURN SUPPLY CO., Dept. RS, 7745 Peoria St., Chicago**

## NO MORE BALD HEADS



When our **VACUUM CAP** is used a few minutes daily. We accept no pay until you have tried the Cap 60 days and are satisfied. The Vacuum Cap is an appliance that draws the blood to the Hair Roots and starts a new healthy crop of hair. It stops Dandruff, stops the hair from falling out.

Bought by Doctors and men who know that it is the only reasonable **HAIR GROWER** known to science. No Drugs Used. Write for application blank, testimonials, and booklet on "**HAIR**," sent sealed in plain envelope, **FREE**.

**THE MODERN VACUUM CAP CO.**

Y. 559 BARCLAY, DENVER, COLO.

University of Pennsylvania museum. In ancient prints and histories the women of fashion of 1000 B. C. are represented as carrying the "tear bottles" in which to give vent to their grief on public occasion. It now develops that when the woman raised one of the bottles

## TOBACCO HABIT BANISHED

**In 48 to 72 Hours** Yes, positively permanently banished almost before you know it. Pleasant, easy to take. Results quick, sure, lasting. No craving for tobacco in any form after first dose. Not a substitute. Harmless, no poisonous habit forming drugs. Satisfactory results guaranteed in every case or money refunded. *Tobacco Redeemer* is the only absolutely scientific and thoroughly dependable tobacco remedy ever discovered. Write for free booklet and positive proof.

**NEWELL PHARMACAL CO., Dept. 25, ST. LOUIS, MO.**

## Make Big Profits—Own Business and Your



Send  
for the  
"Profit Facts"  
Today

Join the army of business men who are piling up big profits from **Ten-Pinnet**—the newest amusement that is sweeping the country. **Ten-Pinnet** is the newest, quietest automatic bowling alley in existence. A marvel of money-making mechanism—the only *real* automatic *ten-pin* alley. All kinds of combination shots—something new in nearly every game. Every alley capable of earning 75 cents to \$1.50 per hour. *And it's nearly all profit!*

Easy to set up and take down. No special foundation needed—no helpers to set pins and return balls. Nothing but room rent stands between you and all the money you take in.

Only \$150 needed to start you. Our special trial proposition guarantees your success or purchase money, less receipts, is refunded. This is a great big opportunity for you. Only one person appointed in your locality. Decide to grasp this hand of fortune *now*—this very minute. *Start your letter to us today.*

**THE PROFIT-AMUSEMENT COMPANY, 106 Draper St., Indianapolis, Ind.**



# Weekly Salary Guaranteed

## How's That Strike You?

Some liberal offer, Hey? It's just exactly what we do for you. We put you on a regular salary basis besides enabling you to make the *biggest cash profits on regular sales* in the tailoring business. All we ask is that you wear and show our high grade, hand-tailored, made-to-measure suits, overcoats, genuine English slip-ons, etc., and be

## The Best Dressed Man in Your Town—And We Pay You a Salary

The Knickerbocker Tailoring Company is the one house that *really* boosts the game for you—we're the Big Tailoring House that does things on a big, generous scale. We give you *more* at the start than others can figure out in 20 years. *We prepay everything*—and if our garments are not satisfactory you don't accept them. Quit fooling around with the old plan—cast your lot with the BIG house that pays you like a prince and treats you like a gentleman.



### We're the ONLY House Paying Salaries

Don't forget that: we want you to know this is true yourself. Not only do you get a big weekly salary, but we furnish you with a complete Sample Outfit—the swiftest ever put out—everything necessary—FREE and Express Prepaid. No money needed with us. In addition to all this, just to show you what kind of people we are, we'll give you a **FREE SUIT and RAINCOAT** for good measure. YOU CAN'T BEAT IT. We've simply knocked the props from under 'em all. Now get this!

### We'll Put You on Our Pay Roll AT ONCE!

So send us your name and address today—be the first in your town to get this wonderful, liberal salary. Do it now.

**Knickerbocker Tailoring Co., Dept. 444, Chicago**



**FREE SUIT**

## The Burlington Special

19 Jewels Fully Adjusted



## The Burlington Special

New Style Thin Model

Here Is an Exquisite Design

New French Art Design

The French Art Designs are something entirely new in fine art watches. The entire background has a deep, rich, velvety appearance which is impossible to reproduce in an illustration. This is but one of the many new styles of cases used for the Burlington watch—the

# 1913 Timepiece

French Art Design Cases

## New Ideas in Watch Cases!

Open face or hunting case, ladies' or gentlemen's sizes. These can be had in the newest ideas: *Block and Ribbon Monograms, Diamond Set, Lodge, French Art and Dragon Designs, Etc.* Imagine a beautiful hunting case with your own monogram on one side and the emblem of your lodge or any emblem on the other side. Our catalog shows complete illustrations. See coupon below.

## Special Offer!

The superb Burlington Special now at the DIRECT rock-bottom price—the same price that **even the wholesale jeweler must pay**. You may secure one of these superb timepieces—a watch of the very latest model, the popular new thin design, adjusted to the second—19 jewels—adjusted to positions AND temperature AND isochronism—the most perfect product of the *world's* most expert watch manufacturers—at the price that **even wholesale jewelers must pay**—and in order to encourage everybody to secure this watch at once pay this rock-bottom price, either for cash or \$2.50 a month! We send the watch on approval, **prepaid**. You risk absolutely nothing—you pay nothing—not one cent, unless you want *this exceptional* offer after seeing and thoroughly inspecting the watch. Read the coupon below.

## Write for Free Watch Book

Learn the inside facts about watch prices, and the many superior points of the Burlington over double-priced products. Just send the coupon or a letter or a postal. Get this offer while it lasts.

### FREE Book Coupon

**Burlington Watch Co.**  
19th St. and Marshall Blvd.  
Dept. 9197 CHICAGO, ILL.

Please send me (without obligation and prepaid) your free book on watches and a copy of your \$1,000 challenge, with full explanation of your cash or \$2.50 a month offer on the Burlington Watch.

Name .....

Address .....

Please Mention Popular Mechanics

to her eyes she was just daubing powder over a red spot on her cheek.

Examination of the "tear bottles" in the museum collection disclosed traces of rouge, powder, paint and cold cream still sticking to the bottom of the glass.

**RABBITS OVERRUN TOWN**—Rabbits are declared to have taken entire possession of the aristocratic little town of Patterson Heights, two miles from Beaver Falls, Pa. The town is inhabited mainly by wealthy families of the Beaver Valley and wealthy folk from Pittsburgh who maintain summer homes there. The town is such a center of wealth and luxury that dogs and cats are

## FACTORY TO YOU CLASS PINS



For College, School or Society

Catalog with attractive prices mailed free upon request. Special offer, either style of pins here illustrated with any three letters and figures, one or two colors of enamel. **STERLING SILVER, 30c each, \$3.00 dozen; SILVER PLATE, 15c each, \$1.50 dozen.**



**BASTIAN BROS. CO., 278 Bastian Bldg., ROCHESTER, N. Y.**

## BARODA DIAMONDS



Flash Like Genuine  
For Years Supreme in Their Class

A true archetype of the genuine diamond. Not manufactured stones, but mined like all true diamonds. Nature gives fire and life to its minerals more penetrating and beautiful than any devised by artificial methods. Baroda Diamonds are mined much cheaper than genuine diamonds and their intrinsic value is much less. However, they are mined and cut in identically the same manner; have fire and lasting qualities and can be bought for 1-50 the cost of genuine diamonds.

When you wear a Baroda Diamond you have the satisfaction of knowing you are wearing a genuine mined stone and set in solid gold. See special offers: 14k Ladies' Ring, Tiffany style, \$5.98; Men's Flat Belcher, \$6.98; Fancy Stud or Pin, \$4.98. Goods made and sent C.O.D. subject to inspection. Catalog showing full line on request. Patent ring measure included for 10 cents.

To Agents—When full amount is sent with order deduct 50 percent from prices and if goods are not satisfactory return in five days for exchange or get your money back

**THE BARODA CO., 05, 4711 Clark St., Chicago, Ill.**







**We Start You**  
*in the*  
**Motion Picture**  
**Business**

**With Our Assistance and Small Capital** you can begin at once and share in the ever-increasing profits of the **GREATEST OF ALL INDUSTRIES**—

## Motion Picture Business

Any man or woman can succeed in their home town, or as a traveling exhibitor. The business is still in its infancy—the possibilities unlimited.

**\$35 to \$50 and More Daily Profit**

We manufacture and furnish everything—Machine, Film, Lighting, etc.—and teach you the business. No experience necessary. Many good locations are just waiting for the right exhibitor to come.

**We've Helped Make Hundreds Rich—Why Not YOU?**

This is unquestionably the greatest money-making opportunity you will ever have. A postal card or letter is all it costs to get full particulars. **WRITE TODAY!**

**ATLAS MOVING PICTURE COMPANY**

Room 201, 508 S. Dearborn St., Chicago

**Get Full Information by Return Mail**

**\$7.50 and up**



**Here's Big Money for You**  
Hundreds of operators are making \$75 weekly. You can do as well with this wonderful **DIAMOND POST CARD GUN**. It makes three sizes post cards including mailing size, also photo buttons without plates or films. Finished pictures delivered on the Spot in a Minute. **No Dark Room Required**—No canvassing, experience unnecessary. **Be Profit on Every Dime.** Write today for samples of work and full description. Grasp this opportunity NOW. **INTERNATIONAL METAL & FERROTYPE CO.** Dept. 601 CHICAGO, ILL.



**Your Picture in a Postal Card IN ONE MINUTE**  
The pictures are developed, toned and finished in a single developing solution. No experience is necessary. Price of machines \$7.50 and \$15.00—circulars describing our machines sent free. We are also headquarters for supplies for all minute picture machines. **AMERICAN MINUTE PHOTO COMPANY** Desk E 695, 2214 Ogden Ave., Chicago, Illinois The largest manufacturers and distributors of minute picture machines and supplies in the world.

**\$100 to \$300 Weekly**

**GO INTO THE Moving Picture Business**  
We supply you with complete traveling and stationary outfits on our Easy Payment Plan. Our New 1914 Model Machine—a winner. Write for Free Catalog. **ACORN MOVING PICTURE CO.** Dept. F 173 N. Green St., Chicago



**GET YOUR CAMERA NOW** PAY FOR IT **50¢ A WEEK**  
**EARN A BIG INCOME WITH THIS FILMLESS POST CARD CAMERA**  
You can simply coin money with it. Fine, sharp post cards (five sizes), also photo buttons finished and delivered on the spot. **NO FILMS—NO PLATES—NO DARK ROOM—NO EXPERIENCE NEEDED**—We start you in this wonderful business—we trust you with the camera—pay for it later out of your profits. Other operators making \$50 to \$100 weekly. You can do the same. **WRITE TODAY—NOW**—for full details of our liberal proposition.  
**FILMLESS POST CARD CAMERA WORKS**  
601 Douglas Sta., CHICAGO, ILL.



**AGENTS WANTED EVERYWHERE**  
A gold mine for crew managers. Make big money the year round. **Every Home Needs Our Specialties**  
Vacuum Sweepers, Gasoline Irons, Lamps and Lighting Systems.  
**Secure Territory Write Today P. M. Yale Mfg. Co., 20 So. Clinton St., Chicago**

**1 4 IN ONE**  
Do your wringing, mopping, scrubbing and scraping easily in half the time—standing up. **WE WANT AGENTS.** Sample, \$1.50 prepaid. Covered by broad guarantee. **Clark & Dupre Manufacturing Co.** 213 Foster St., Worcester, Mass. **\$1.50**  
**SELF-WRINGING MOP**



**Do Your Printing!**  
Cards, circulars, books, newspaper. Press \$5, Larger \$18, Rotary \$60. Save money. Big profit printing for others. All easy, rules sent. Write factory for press catalog. **TYPE, cards, paper, outfits, etc. THE PRESS CO., Meriden, Conn.**

dispensed with as a matter of pride and personal convenience. A most elaborate and expensive country club is maintained and hundreds of automobile tourists from various regions make this a stopping place. Large grassy tracts, shady groves and flower gardens have been ideal breeding places for the cottontails, and nearly all the shrubbery and small trees and plants in the town have been killed within the last few days. The little animals have become so numerous and so tame that they do not hesitate to make playgrounds of front porches.

**We Pay \$10 to \$50 A Week For Your Spare Time**  
Successful men have made their start in life by doing something worthwhile in their spare time. We have a plan to utilize some of your spare moments. You will be generously paid for the time you devote to our proposition. You do not need any capital, but can easily build up in a short time a successful business of your own. Write at once for our plan.  
**The Beck Manufacturing Co.**  
222 East 41st Street New York City



**Be Your Own Boss**  
Do as many others have—Operate a Kingery Peanut Roaster and Corn Popper. Over 30 styles. Liberal terms, excellent profits. Kingery's book of possibilities and No. 41 catalog tell you all about it.  
**KINGERY MFG. CO., Pearl, east of Broadway, Cincinnati, Ohio**

**Only \$36.00 The Wonderful ILLUSTRATOR LANTERN**  
With our improved famous **ALCO RADIANT LIGHT.**  
This new 1913 Model has many improvements and double brilliancy. Write for illustrated circular of this and Lanterns of all styles and lights at bottom prices. **IF YOU OWN A LANTERN** we should have your name to mail to you our regular announcements of new slides and lecture sets. 75,000 Lantern Slides to rent. **POST CARD MAGIC LANTERN** reflects image of postcard or any other picture or object. Prices, \$2.75, \$12.50, \$25.00, \$60.00, express paid.  
**WILLIAMS, BROWN & EARLE, Inc., 918 Chestnut St., Philadelphia, Pa., Lantern Dept. 20**  
Engineering, Microscope, Optical, Scientific, Photo Lantern Slide Supplies







## QUALITY AND SERVICE

These are the two factors of Remington Typewriter Supremacy.

Remington quality is *in* the machine; Remington Service is *back* of the machine. The one goes with the sale; the other follows the sale. And both are essential to the permanent satisfaction of the typewriter user.

The great expansion of the Remington Sales Organization has advanced our service facilities beyond any standard attained or attainable in the past. *We reach everybody and everybody can reach us.* Whatever your need in the typewriter service line, whether ribbons, carbons, inspections, adjustments, rentals or operators, the means to supply that need are bound to be close at hand if your machine is a

## REMINGTON

Remington Typewriter Company  
(Incorporated)  
New York and Everywhere



**RELATIVE STRENGTH OF SOME AMERICAN WOODS**—The toughest American wood is that of the Osage orange, which is not an orange at all, but belongs to the nettle family. This has been proved by a series of tests made by the United States Forest Service, but



## TYPEWRITERS ALL MAKES

All the Standard Machines **SOLD** or **RENTED** ANYWHERE at  $\frac{1}{4}$  to  $\frac{1}{2}$  MFR'S PRICES, allowing **RENTAL TO APPLY ON PRICE.** Shipped with privilege of examination. Write for Illustrated Catalog L. TYPEWRITER EMPORIUM, 24-26 W. Lake St., CHICAGO



## TYPEWRITERS ALL MAKES

\$100.00 Underwoods, Smiths, Oliviers, Remingtons, etc., from \$10.00 up. Every machine in perfect condition, guaranteed two years, with privilege to exchange at any time. Three hundred typewriters at \$15.00 each, Free Trial Offer while they last. Write for cut rate prices, and ALL-MAKES TYPEWRITER EXCHANGE, 157 N. Clark St., CHICAGO, ILLINOIS

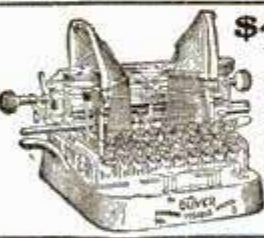

## \$4 Per Month Buys This Visible Oliver Typewriter

Nothing Down — Free Trial. Less than Agents' Prices. Shipped on approval. If you want to keep it, send us \$4 a month. Our booklet is worth sending for because it tells you how to save \$41.50. It's FREE.

Typewriters Dist. Syndicate  
166 J12 N. Michigan Blvd., Chicago



## AGENTS WANTED

The fastest growing vacuum sweeper sales organization in the West needs bright, energetic, ambitious men. To young men who can sell, train others to sell, open up and manage new territories for the sale of the only guaranteed vacuum sweeper on the market—an exceptional proposition will be made. Territorial directors now working are averaging \$25 daily profit—a few make even more. Exclusive territory given to men or women workers. WRITE TODAY. ASSOCIATED MANUFACTURERS CO. 1114 123 W. Madison St., Chicago, Ill.

\$9.95

# MECHANICAL ENGINEERING

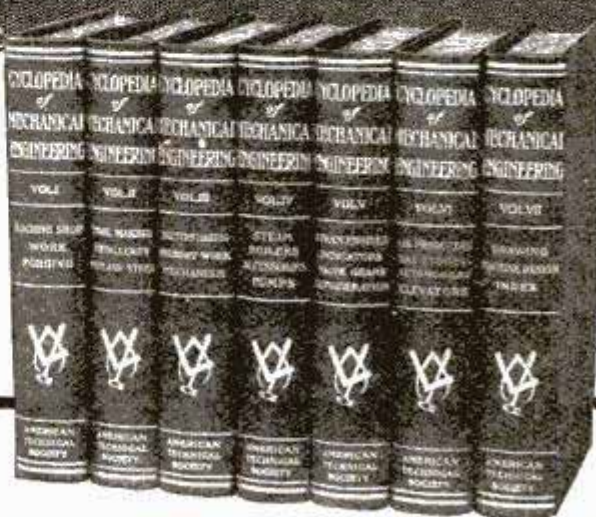

**Famous \$35.00 Set—Now \$19.80 \$2.00 a Month**

Mechanical Engineering, Gas Engine Operation, Modern Shop Practice—the whole subject covered by experts from A to Z in this great big seven volume Cyclopedic. Everything you want to know on the subjects mentioned below is treated in simple, non-technical language by men who are not only expert engineers themselves, but great teachers and writers. The full, complete \$35.00 edition, for a short time at \$19.80—\$2.00 a month.

**SHIPPED FREE** Here's our offer: We'll ship the entire seven volumes free, express paid, merely at your request on coupon below for seven days' free examination. If you like the books, pay only \$19.80—at \$2.00 a month. Otherwise we'll take them back without charging you one cent.

### Subjects Thoroughly Covered

Machine Shop Work — Vertical Milling Machine — Motor-Driven Shops — Shop Lighting — Forging — Electric Welding — Tool Making — Metallurgy — Manufacture of Iron and Steel — High-Speed Steel — Flaws in Castings — Electric Lifting Magnets — Magnetic Clutches — Making a Machinist — The Ideal Foreman — Pattern Making — Foundry Work — Automatic Coal and Ore Handling Appliances — Machine Parts — Construction of Boilers — Types of Boilers — Boiler Accessories — Steam Pumps — Air Compressors — The Steam Engine — The Steam Turbine — Indicators — Valve Gears — Refrigeration — Gas Producers — Gas Engines — Automobiles — Elevators — Sheet Metal Work — Practical Problems in Mensuration — Mechanical Drawing — Drafting Room Organization — Machine Design, etc.

3,092 pages, 7x10 inches; 2,227 illustrations, full page plates, diagrams, etc.; hundreds of valuable tables and formulas; carefully cross-indexed for quick, easy reference. Bound in half red morocco, gold stamped.

## FREE!! \$12.00 Consulting Membership

Every man who takes advantage of this offer now gets absolutely free our complete consulting membership, under which our entire staff of engineers answers all questions and solves all your engineering problems a whole year absolutely free. One question answered may be worth more than the whole price of the books. Usual price \$12.00—now free with the books. Fill out and mail us this coupon. Books go to you at once, express paid. Our liberal offer protects you. You take no chances. You are not bothered. If the books cannot sell themselves to you strictly on merit, don't keep them. But first inspect them. Mail the coupon today.

## FREE COUPON

Worth \$15.20 to You  
American Technical Society:

Please send me seven volume set Cyclopedic of Mechanical Engineering for seven days' free examination. If I decide to buy, will send \$2.00 in seven days and balance \$2.00 a month until \$19.80 has been paid, when \$35.00 books and \$12.00 consulting membership will be mine free. Otherwise will notify you and hold books subject to your order. Title not to pass until fully paid.

Pop. Mech. 10-13

Name.....  
Address.....  
Occupation.....  
Employer.....

Please Mention Popular Mechanics





# JAP-A-LAC

**Renews**  
Everything from Cellar to Garret  
Sold in Paint, Hardware, Drug & Department Stores  
Cleveland      The Glidden Varnish Co.      Toronto



## Irons Better than the Flatiron

**Hand  
or  
Power**

**Y**OU get through with your ironing in one-fourth the time, obtain a perfect and more uniform finish with no liability of scorching and practically no expense for fuel when you use a

## Simplex Ironer

*"The Practical Household Machine"*

Ease takes the place of tiring effort. It soon saves its cost. The Simplex does 80% of the ironing and presses men's trousers to perfection. Run by hand or any power. Heated by gas, gasoline or electricity. Sizes to suit needs of any family, institution or hotel.

*Write today for FREE Catalog, 30 days' FREE Trial Offer and name of local dealer.*

**AMERICAN IRONING MACHINE CO.**  
526, 168 N. Michigan Ave.      CHICAGO, ILL.

## Details of Building Construction

### 18,000 SOLD

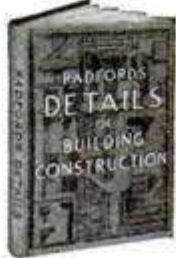

200 (9x12 inch) pages, 1800 illustrations. Contains 38 full-page plates showing complete details of interior trim, 44 full-page plates detailing every point in frame, brick, concrete and stone construction. 100 full-page plates of built-in work, furniture, etc.

**PRICE \$1.50 POSTPAID**

**RADFORD ARCHITECTURAL CO.**  
1827 Prairie Ave.      CHICAGO, ILL.

the Indians knew it before the coming of the white man, and it was known to them as the bow tree, because they used it for making their finest bows. The early French explorers and settlers in Louisiana called the tree, "bois d'arc," or "wood of the bow," and wagons built of it are still known in the southwest as "bois d'arc wagons." Some idea of its strength may be had from a report made by the Forest Service, which shows that a block, 30 in. long and 2 by 2 in. in cross sec-

### THIS BUNGALOW \$900 CAN BE BUILT FOR



This and many others in my new book, Building Plans for Modern Homes, will save you hundreds of dollars. One of the most complete and comprehensive books of plans ever published by any architect. Fifth edition just off the press. One hundred and fifty floor plans and photographs of bungalows, etc., costing from \$250 up; gives sizes and cost to build. **Sent postpaid for \$1.00**

**FREDERICK H. GOWING**  
ARCHITECT  
18 Tremont St., BOSTON, MASS.

## Let Your Engine or Motor Do the Work



and make an end to washday drudgery in YOUR home. Of course, NONE of the unsanitary, old-fashioned wooden rotary washers will do. ONLY THE MOST UP-TO-DATE machine ought to be good enough for YOUR wife. EXPERTS will tell you that NO MORE DURABLE and PRACTICAL washer can be found than the famous

### All Metal Sanitary Paragon Revolving Cylinder Power Laundry Machine

Indestructible. NO WOOD used in any part. The PARAGON is a true reproduction of the expensive and powerful Cylinder Washers exclusively and successfully used in Steam Laundries, Hotels and Hospitals. Over 100,000 Paragon Washers used in the U. S.

### A Golden Opportunity for 30 Days Only

to secure one of these wonderful genuine laundry machines, complete with REVERSIBLE POWER WRINGER at a very considerable REDUCTION in price, if you write AT ONCE for Catalog No. 1 and further details of the most generous proposition made.

**PARAGON MFG. CO., 2401-03 W. 14th St., CHICAGO**

**A Blessing For Women**



# THE BEST WATCH ILLINOIS ON EASY CREDIT

Send for our handsome **Free** Catalog and select your Illinois Watch—the watch that is **sure** to meet your demands for accuracy, wear and beauty. Every model guaranteed absolutely by both the manufacturer and ourselves, and sent you **prepaid** subject to your satisfaction—if you like it, you keep it and pay **only a small amount each month.**

## The Highest Grade Watch

We are an exclusive Illinois Watch House selling the highest grade of Illinois Watches only. Don't confuse the Illinois Watches we sell with offers made by department stores, general mail order houses and dealers, who handle various inferior grades of watches as a side line. When you buy from us you are **absolutely protected** in getting the **best watch, because all models sold by us contain 17 jewels or more, adjusted to 3 positions or more, besides adjusted to temperature and isochronism.**

**Freddro Terms Easy To Pay**

Freddro Watch Co. Dept. 300 St. Louis, Mo.



### Easy Credit Terms

You can't duplicate the Illinois Watches we sell at our prices on credit terms, with the 25 year guarantee and service that we give. Sent on approval anywhere. We do as we say we do—live up to every assertion in our guarantee. Handsome Catalog **FREE**. Write today.

**Freddro Watch Co.**  
Dept. 300 St. Louis, Mo.

## Freddro Watches Will Please You

tion, when bent breaks under a stress of 13,660 lb., its nearest rival being a variety of the hickory called mockernut. When bent by the impact of a 100-lb. hammer it stands a stress of 15,520 lb., certain sugar maples and the honey locust being its nearest rivals. It exceeds the hickories, and its only rival in hardness, tested by the force required to imbed a .444-in. ball to one-half its diameter, is the honey locust.

**Your Advertising on High Grade Pencils** Up to date idea. Minimum cost. Samples free. Send letter head. **Curran Adv. Co., Manufacturers, Ottumwa, Iowa**

## A Penny Pays the Bill



**Heats It-Self**  
Sold on trial and Guaranteed  
Saves its cost in fuel alone over and over again, saves time and labor. Burns better and anywhere, no wires or tubes to connect, always ready.

We have a big money making Proposition for live Agents.  
**Write Us** for Descriptive Circular and Special First Order Offer.  
**MODERN SPECIALTIES CO.**  
108 High Street South Bend, Ind.

## 8½ Pound Electric Suction Cleaner

At last a suction cleaner a woman can handle as easily as a carpet sweeper. Weighs no more. Takes up only two-thirds as much room. Can be packed away in small box. Rolls on rubber-tired wheels—moved without effort. More powerful than big unwieldy machines.

The **"Morrow"**  
**10 Days Free Trial**

We take all the risk. Write today for our Free Book. Just send a postal with your name and address.  
**THE MORROW COMPANY, Dept. 1197, Waukegan, Ill.**  
*Good Territory Still Open—Agents and Dealers Write*

# Billiards for Boys of Sixteen to Sixty



The "Baby Grand"

Cultivate "the play spirit"—it pays in health and efficiency.

Play billiards or pocket-billiards at home —on the matchless "Baby Grand." Billiards is the finest of all indoor games for boys of sixteen to sixty.

Good exercise for body and brain. Relief from business tension. Pure, unadulterated fun, with just enough spice of rivalry to give keen zest to the game. The

## Brunswick "Baby Grand"

The Home Billiard Table de Luxe

These superb Billiard and Pocket-Billiard Tables are found in thousands of refined homes throughout the world.

They are billiard tables for rooms of average size, on which *real billiards* can be played. Made of finest Mahogany, with classic inlay design.

Fitted with genuine Vermont Slate Beds, covered with Imported Billiard Cloth; Baby Monarch Quick-Acting Cushions; Concealed Cue Rack and Accessory Drawer for entire playing equipment. The same accurate angles and scientific construction as Brunswick-Balke-Collender *regulation size* tables, which are used exclusively by the billiard experts of the world. Furnished as Carom Billiard Tables, Pocket-Billiard Tables or Combination Carom and Pocket-Billiard Tables. Sizes 3x6; 3½x7; 4x8 feet.

## Brunswick "Convertible" Billiard Tables

These ingenious tables make *any* room available for billiards—dining room, living room, library or den. Three styles—The Davenport-Billiard Table, the Dining-Billiard Table, and the Library-Billiard Table.

Equal in playing qualities to the "Baby Grand." When not in use for billiard playing, they serve as handsome, practical pieces of household furniture.

### Over A Year To Pay

We sell Brunswick Home Billiard Tables *direct from factory* at very moderate prices and exceptionally easy terms.

### Playing Outfit Free

with each table, including cues, balls, cue rack, markers, Book of Rules, "How to Play," etc., etc.

### Free Color-Illustrated Book

### "Billiards—The Home Magnet"

This beautiful book describes and illustrates in actual colors the complete line of Brunswick Home Billiard and Pocket-Billiard Tables. Quotes lowest factory prices. Gives details of Easy Purchase Plan and much valuable information. Write for your copy today. (116)

**The Brunswick-Balke-Collender Co.**  
Department HS, 623-633 S. Wabash Avenue, Chicago

Gentlemen:—Please send to the address below, your book, "Billiards—the Home Magnet"

Name.....  
Address.....  
Town.....State.....



## Be Well Dressed We Trust You

Send your name and address for our big new 1913-1914 **Fall and Winter Style Book**. It's absolutely FREE FOR THE ASKING and contains all the newest fashions and free samples for this season's wear.

WRITE  
TODAY



We  
Have  
No  
Agents,  
Collectors or  
Canvassers

### Our Prices Lower Than Cash Tailors

We guarantee you'll save big money, for our prices are ABSOLUTELY LOWER than those asked by cash tailors; and we'll give you all the credit you want. We help you dress like the best.

### Made to Order to Your Own Measure

Our garments are all made-to-order—MADE FOR YOU YOURSELF, from the measurements you send us. They're not "ready-mades" altered to meet your requirements. COMPARISON PROVES the superiority of our woollens and tailoring.

### Shipped On Approval

You run no risk whatever. You're sure to be pleased in every way. We guarantee to fit you perfectly and thoroughly satisfy you or you get your money back.

### Six Months to Pay

No matter where you live, we trust you. Your simple promise to pay us in six months is sufficient. Our confidential charge account credit plan is one of the most modern conveniences of the day.

### Get Our Big New Style Book

Now don't delay—write for our big encyclopedia of Fall Fashions TODAY—GET YOUR POSTAL RIGHT OFF IN THE MAIL—We will send the book postpaid as soon as we receive your name and address. WRITE TO

### **STANLEY-ROGERS COMPANY**

526 • 530 So. Clark Street Chicago, Illinois  
*World's Foremost Credit Tailors for Men*

When you want anything and don't know where to find it—write Bureau of Information, Popular Mechanics Chicago



## The Truth About Mushrooms

**Big, Quick Profits. Small Capital.  
Now Is Best Time.**

Biggest, quickest, surest and easiest money-maker is growing mushrooms. Bigger money is being made in mushrooms now than ever before, by those who are today putting in practice the great revolutionary improvement in mushroom culture explained in our new book, "The Truth About Mushrooms." Open your eyes to an opportunity you never realized. No matter what your occupation or location, you can now

### **Add \$10 to \$70 a Week to Your Income**

without interference with present work. Small capital to start. Men and women can easily do it. Now is time to start. This great book explains everything from A to Z, and things which even many mushroom growers never knew before. Get first-hand information from the greatest practical authority. Start in the world's best-paying business now. Grow in cellars, sheds, boxes, etc., or increase your profits many fold if you are already a grower. Send for the free book today sure.

Bureau of Mushroom Industry, Dept. 77, 1342 N. Clark St., Chicago, Ill.

**SEATTLE'S NEW DRY DOCK**—The new 12,000-ton floating dry dock, which was completed early this year, is a valuable addition to the port of Seattle. Some of the larger vessels of the United States, which in the past have had to be docked at the Puget Sound Navy Yard, will now be able to avail themselves of the excellent facilities offered by this dock. It is 468 ft. long, and will be increased later to 600 ft.; 110 ft. wide, and has a 30-ft. draft over the sill.

### **TRY IT YOUR SELF FOR 10 DAYS WITHOUT DEPOSIT**



If not satisfactory, return it and no questions asked. DAUS IMPROVED TIP TOP DUPLICATOR with "Dausco" Oiled Parchment Back negative roll is the result of 25 years' experience and is used and endorsed by thousands of business houses and individuals. 100 copies from pen-written and 50 copies from typewritten original—Clear, Clean, Perfect. Complete Duplicator, Cap size \$5.00 (prints 8 3/4-4 1/2 in.), price

FELIX A. L. DAUS DUPLICATOR CO., Daus Building, 111 John St., New York

36278 \$150.	36034 \$45.	20% = 10% DOWN MONTHLY	36030 \$25.	36184 \$100.
36043 \$100.		<b>DIAMONDS ON CREDIT</b>		
36254 \$50.		<b>SAVE</b> money on your diamonds, watches and jewelry by buying from our new Catalogue de luxe, which explains our easy payment system. We are Importers and guarantee you every advantage in price and quality. 20% DOWN and 10% MONTHLY. Guarantee certificate with each diamond. Full credit allowed on exchange. Transactions strictly confidential. Write today for Catalogue Numbers		
36226 \$25.		<b>L. W. SWEET &amp; CO.</b>		
36071 \$55.		2 and 4 MAIDEN LANE NEW YORK CITY		
				36055 \$300.
				36211 \$90.
				36080 \$100.



# 42c a Day

## Runs this 6 H.P. Engine on Kerosene

This statement as to fuel cost is not a theory that we would like to realize, but is based on actual working conditions in our factory where Ellis Engines are used for our own power. Equally good results can be secured from other sizes, ranging from 3 to 12 H. P.

The big advantage of a **successful** kerosene engine lies in the fact that this fuel is not only much cheaper to buy per gallon, but it also contains one-sixth more power than gasoline; in other words it takes 7 gallons of gasoline to do as much work as 6 gallons of kerosene **when used in Ellis Engines.**

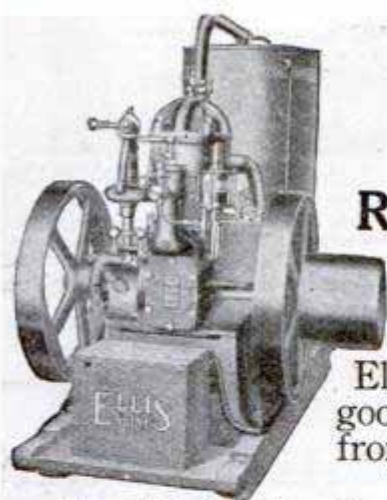

The Ellis "Six"

Don't miss the last five words, **"When used in Ellis Engines."** That's the secret of the low cost. It isn't the kerosene alone; it's kerosene **used in Ellis Engines.**

No engine will use kerosene successfully unless it was designed especially for that fuel. You can burn wood in a coal stove, but you can't burn coal in a wood stove; and it is equally true that while you can use gasoline in a kerosene engine, you can't use kerosene in a gasoline engine.

## Other Strong Features

Every Ellis Engine is equipped with our own exclusive patent throttle giving you **three engines in one**; force-feed lubricator positively oiling all working parts; double duty cooling tank (a great convenience in severe weather); ball-bearing governor adjustable while running, and guaranteeing uniform speed; extended crank shaft suitable for any standard plain or clutch pulley; high-grade muffler; sight feed fuel supply; bearings die-cast of genuine Babbitt metal; bronze piston bushings, copper asbestos gaskets, and other special equipment.

And remember too, that while the Ellis Engine is light in weight, it is strong enough to last a lifetime; starts without cranking; has no cams, push rods or springs to cause trouble or wear out; is of very simple construction; runs with less vibration; will run equally well in either direction and can be reversed while running.

The larger sizes are equipped with Wico Igniter (better than any magneto), and device for injecting water with kerosene.

## Sent on Approval

We are so confident our engines will more than satisfy any reasonable man, that we send them anywhere in America on **30 days' approval with freight prepaid**, and then the engine is backed by a binding and definite **10-year guarantee.**

*Write today for big new catalog and opinions of satisfied users in all parts of the world.*

## Ellis Engine Company

64 Mullett Street

Detroit, Mich.

## Read What These Men Say

"I run my engine on kerosene which costs only half as much as gasoline and gives more power. It is one of the best engines I ever saw; so easy to operate."

W. M. Dixon, Landover, Md.

"Can get more power from 12½c worth of coal oil than from 30c worth of gasoline. The Ellis people are among the best with whom I have done business."

W. J. Wraith, Lucknow, Ontario

"After it is warmed up it runs fine on either Distillate or Coal Oil, and will do more work on a gallon of gasoline than any engine I have ever seen."

E. F. Showers, Ferndale, Wash.

"One turn of the fly wheel in the morning and it is off for the day. It is one of the most economical engines on the market."

R. C. Maurer, Elizabethtown, N. J.

"Have given the Ellis Engine a thorough trial on pure kerosene. It is simple to manage and the power is more than I expected, and am very much pleased with it."

T. Scandrett, Mullett Point, New Zealand

"The engine has big power. Runs on common lamp oil satisfactorily. Everyone who sees it says, 'I never saw the like.'"

J. J. Friesen, Meade, Kans.

"Even with kerosene at 22c a gallon, I am saving fully 50% of the expense I was put to when using my steam outfit."

Juan Long, M. D., Musquiz, Coah., Mexico

Thousands of others could say the same

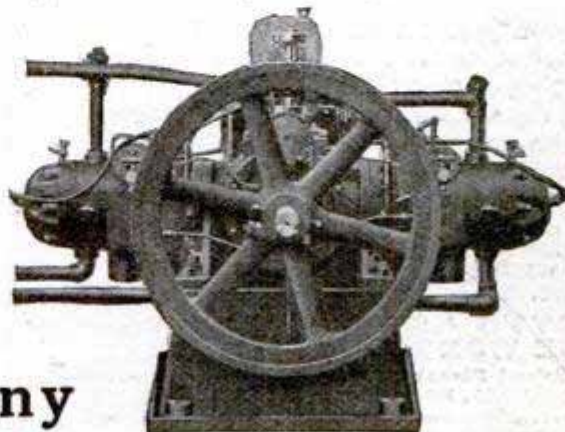

The Ellis 2-cylinder "Twelve"



# 3 Years to Pay

for the Sweet-Toned

# Meister

Piano

# \$175

## 30 Days' Free Trial We Pay the Freight

You are not asked to deposit, or pay or advance a cent in any way until you write us and say that the MEISTER is entirely satisfactory and you wish to keep it. Then these are the terms of sale:

**\$1 a Week or  
\$5 a Month**



No cash payment down. No interest on payments. No extras of any kind. Piano stool and scarf free.

Sold direct from the maker to you at a guaranteed saving of \$100. No dealer's profit for you to pay. Send now for our beautiful Free Catalog, which shows eight styles of Meister Pianos. Our resources exceed \$4,000,000. We sell more pianos direct to the home than any other concern in the world.

**Rothschild & Company**  
Dept. G 16, Chicago, Illinois

## Don't Buy an Engine

until you investigate the famous **TEMPLE Gasoline-Kerosene**, slow speed, heavy duty, all-purpose engines. Bulk and weight less than horizontal engines; cylinders built low, close to base, eliminating shock and vibration, increasing strength and durability, and giving scientifically correct distribution of strain. Pay for themselves in fuel saving alone. Have won five 1st premiums for low operating cost, stability and steady power. Old reliable pioneer concern (manufacturers for 61 years) guarantees these engines. Write today for catalog and particulars of 30-day trial offer.

**THE TEMPLE ENGINE & PUMP CO., 435 Meagher St., Chicago, Ill.**

## OTTO KEROSENE OIL AND DISTILLATE ENGINES

are built in just the size and type to suit your needs. Whether for the shop or farm, for pumping, hoisting or electric light service, an Otto will give you dependable power. Costs the least of any in the long run. All sizes, 4-6-8-10 up to 120 H. P. Gas Engines up to 250 H. P. Catalog and bulletins free. Dealers wanted everywhere.

**THE OTTO GAS ENGINE WORKS**  
3420 Walnut Street  
PHILADELPHIA, PA.



Please Mention Popular Mechanics

# Cheaper Power for Every Purpose

The **WATERLOO BOY GASOLINE ENGINE** will run all day without attention, furnish exactly the power you need, maintain a uniform speed and save you money every hour it works. Uses either **Kerosene or Gasoline for fuel—equipped for both at no extra charge**

The recent award of **Gold Medal at Budapest, Hungary, in open competition with the best engines of all countries** is clinching proof **Waterloo Boy leads the World** that the in Construction, Power, Service and Durability.

Has many important exclusive features—Speed Lever works like throttle on a locomotive; old reliable fly ball governor, automatic feed regulation, open jacket, starts easy in Winter, interchangeable parts, etc. Lowest in price because made in largest quantities, at low manufacturing cost. **Guaranteed 5 Years.** Book free. Write today. **Waterloo Gasoline Engine Co.**

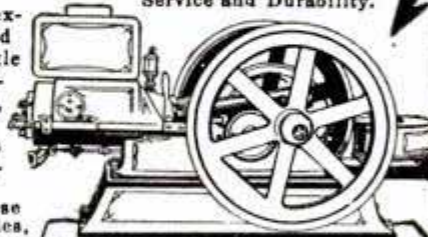

**Awarded Gold Medal, First Prize at the International Gasoline & Oil Engine Show Budapest, Hungary**

1021 W. 3rd Ave.  
Waterloo, Iowa.

## Buy Your BOY One of Our \$19.50 Gasoline Engines

The educational value of this proposition to a boy cannot be over estimated. It will prove a good investment. This little engine will run a washing machine, small cream separator, grinder, corn sheller or any small machine. Shipped on trial. Fully equipped, ready to run.

**SIEVERKROPP ENGINE CO., 1224 18th St., Racine, Wis., U. S. A.**

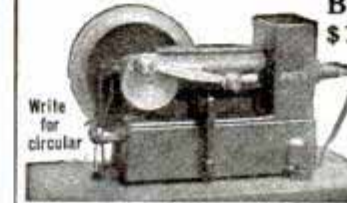

Write for circular

**LARGE YIELD OF CALIFORNIA OIL FIELDS—**Statistics for the first six months of 1913, including the estimated June figures, credits the California oil fields with a total output of 47,250,000 bbl., an increase of about 935,000 bbl. over the final half of 1912. Total consumption for the half year is placed at about 47,800,000 bbl., a gain of more than 4,200,000 bbl. over the record of the preceding six months.

## Small Gas and Gasoline Engines

**Air and Water Cooled. 1/4 - 1/2 and 1 H. P.** Unsurpassed for laboratory, experimental work and for operating washing machines and light machinery. Can be used for small individual electric light plants; complete circulars for stamp, also big catalogue of steam engines, boilers, pumps, electrical goods for 10 cents (coin preferred) refunded first order. If in need of an engine write today.

**AMATEUR MECHANICS SUPPLY CO. CHICAGO**  
860 G Monadnock Block,



## I H C Gasoline Engines Make and Save Most Money

They are most dependable, simplest, most economical, most efficient, most durable and strongest, and they are adaptable to most kinds of work. I H C Gasoline Engines are made in all styles, 1 to 45-horse power. Write today for the I H C catalogue, and read about the I H C engine that meets your needs best.

Address, **INTERNATIONAL HARVESTER COMPANY of AMERICA (Incorporated)**  
16 Harvester Building Chicago U S A

## 2 1/4 HORSE POWER

HERE is the most reliable 2 1/4 H. P. Engine in America. It gives such perfect satisfaction that we ship it anywhere in the world on terms of only one-half the purchase price or **only \$24.75** with your order and six months' time on the balance. If you want an engine any size, 1 1/2 to 12 H. P., write me today for Big 4-color Engine Catalog and Price List, lowest you ever heard of. Save you \$20.00 to \$100.00 sure. Do it now—today!



**OTTAWA MFG. CO., 946 King St., Ottawa, Kans**



Cheaper Power  
from Gasoline  
Kerosene  
Naphtha  
Distillate  
and Gas.

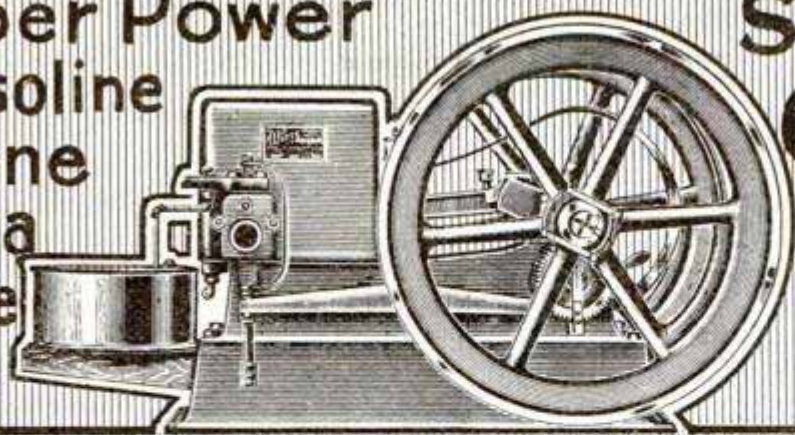

Sold on  
60 Days  
Free  
Trial.

# The Famous WITTE Engines

You can't buy any better engines for any price, and none as good for my price!

That's my offer in a nut shell.

And I sell on any easy, reasonable terms, if you don't choose to pay cash—and I don't raise the price, for this accommodation, either.

You get, right direct from me, backed up by over \$250,000.00, a full 60-days' free trial on any WITTE of your selection. I make 54 styles and sizes, from 1½ H.P. to 40 H.P.—a size and style for all shop, factory or farm work—Stationary, Portable, Skidded and Sawrig styles.

I am the only man in the U. S. making his own engines in his own factory, from his own designs, using his own patterns and special machinery, and selling his entire output Direct from his Factory doors to the Users' hands. There is no middleman between me and any prospective engine-user, anywhere on earth. Fast mails and fast freights give our customers quick service to all points. I ship engines to every state of the Union, every day.



I Sell only Direct from my Factory to Users, at Strictly Factory Prices.

My factory is one of three of the first ones in America, making successful gasoline engines. For 27 years, the WITTE has always proved itself reliable—easy to understand and run—steady power, and small fuel consumption. No gas or oil engine can out-last the WITTE, and very, very few of them can work on so little fuel.

I have written a New Book to tell the inside of the engine selling, as well as the manufacturing, business. Everybody who has seen it, tells me it is worth dollars to everyone who has steady work to do.

No need now to pay double price for a good engine, or to take a poor engine for any kind of a price. Under my plan, you are sure of knowing what any engine ought to do, besides knowing what my engine can do, before you finally decide to buy any kind. My New Plan of Direct Selling makes it easy for you to be your own engine agent, and to make for yourself the full dealer's profits.

## Five-Year Guaranty

I insure every WITTE Engine to make good, by guaranteeing it for five years against defects, and any consequent faulty operation.

ED. H. WITTE

## My Most Understandable Engine Book Will Be Mailed To You Absolutely FREE

Send me your address to-day, so I can send you free, and postpaid, My Great New Book, that tells you, better than any other, How to Judge an Engine—how to pick the winner. Use the Free Coupon at the right.

ED. H. WITTE, Desk A  
WITTE IRON WORKS CO.  
1749 Oakland Ave.  
KANSAS CITY,  
MO.

ED. H. WITTE  
DESK A  
WITTE IRON WORKS CO.  
1749 Oakland Ave.  
Kansas City, Mo.

Without any obligation on me, send me free and postpaid, your New Book, and your Special Offer under your New Plan of Selling.

Name \_\_\_\_\_

Address \_\_\_\_\_

Please Mention Popular Mechanics

WITTE  
ENGINES  
Sold only  
Direct from  
Factory to user  
Send the Coupon  
for the great  
Free Engine  
Book

FILL OUT AND SEND ME THIS COUPON RIGHT AWAY



## How FESLER Agents Build Up an Equity For Themselves

**T**HIS is the FESLER FOUNTAIN SHAVING BRUSH, and its distribution offers the best and most equitable agents' plan ever perfected. The agent who sells this brush not only makes an immediate and generous profit, but he begins at once the creation of an estate—an equity—that in five years runs into five figures!

### Your Action In This Matter Should Be Immediate.

Agents and salesmen seeking a rich side-line, should write at once for full particulars. We have a sales-plan unequalled in its broad possibilities, and unique in the history of agency propositions. No matter what you are now selling, or how much you are making at it, we can increase your income, and create a business that will pay you profits for years to come.

If you want to try a brush, one will be sent prepaid on receipt of \$1.00.



### FESLER SALES COMPANY

258 W. Twenty-third Street, - - - New York

## Makes Any Boat a Motor Boat

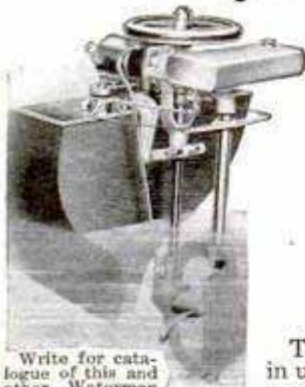

Write for catalogue of this and other Waterman motors.

This simple, light boat engine makes a motor boat of any boat in a jiffy—as quickly detached. Will take you 28 miles per gallon of gasoline in an 18 foot boat. *Seven miles an hour in a rowboat!*  
*The most Power for the Price.*  
*The most Power for the Weight.*

### “PORTO”

2 Full H. P.—55 Lbs.

The original, portable motor—20,000 in use, guaranteed a year and sold on a month's trial.

Waterman Marine Motor Co., 230 Mt. Elliott Ave., Detroit, Mich.



Model 2-0, 6 H.P.

## ROBERTS MOTORS

From 3 to 125 H. P.

Either Marine or  
Aeroplane Type

Speed Boats, Runabouts, Cruisers and Working Boats use the versatile Roberts Motors successfully. Hydroplanes making 36 miles per hour and Flying Boats making 70 miles per hour use Roberts Motors.

CATALOG FREE

**THE ROBERTS MOTOR CO.**  
1419 Columbus Ave., SANDUSKY, OHIO, U.S.A.

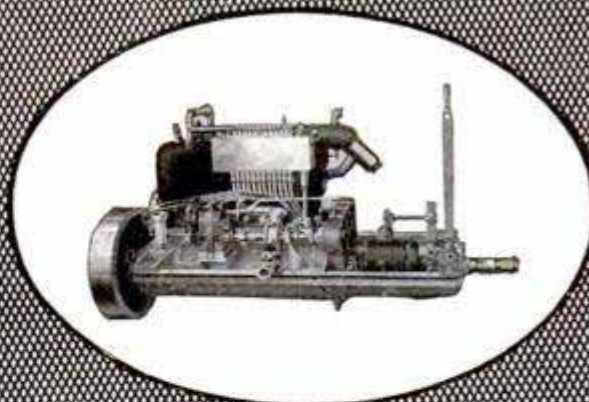

## “Buffalo” Marine Engines

“Buffalo” four-cycle marine engines are built in 20 models—3 to 150 h. p.—in slow, medium and high speed designs, for powering work boats, speed boats, launches and cruisers of all kinds.

They can be operated on gasoline or kerosene.

The strong points of “Buffalo” engines are reliability and economy.

Shall we send you the “Buffalo” Book? It tells the whole story.

**Buffalo Gasolene Motor Co.**

1293-1305 Niagara St., Buffalo, N. Y.

**AFRICAN OSTRICH FARMING**—In the Union of South Africa there are 746,736 ostriches, according to a consular report, and of this number 728,087 are in Cape Province. The weekly sales there average more than 1,000,000 feathers, not including the lowest grades.

**POPULAR  
PLEASURE  
AND  
PRICE**

**—IN THIS—16-Ft. Family Launch**

SEND FOR OUR LIST OF BARGAINS

**THE VALLEY BOAT & ENGINE CO.** 1206 Hess Street  
SAGINAW, MICH.

## GRAY MOTORS FOR BOATS



Largest Builders of  
2-cycle Motors in the  
World. Over 1000  
responsible dealers.

**3 H.P. with Complete Outfit ready to install** \$55  
ALSO A&T O 36 HR

Guaranteed by a big responsible concern. Write for big catalog—tells and shows you all about these high grade motors and how they are made.

**GRAY MOTOR CO.,** 1098 Gray Motor Bldg., Detroit, Mich.

## The Baldwin Camp Lamp



No. 30  
Price, \$1.00  
Other Sizes Made

Projects a 14-candle power light 150 feet. Burns Acetylene gas. Weight, 6 oz.; height, 3½ in. No oil, soot or glass. Absolutely safe and simple. Fifty hours' light costs 25c. Ideal for Night Fishing, Trapping, Hunting or for work about the farm or machinery. Useful as well to replace automobile tires in the dark. If your dealer cannot supply you write us direct and ask for catalogue and free instructive booklet, “Knots and How to Tie Them.”

**JOHN SIMMONS CO.**  
11 Franklin St., New York City



# GENUINE PERFECT CUT DIAMONDS DIRECT FROM IMPORTER \$97.50 PER CARAT



No. D1001. 14K. Solitaire. Mtg. \$3.75. Complete with 3/8 c. Diamond - \$35.00



No. D1002. 14K. Tooth Ring. Mtg. \$5.50. Complete with 1/4 carat Diamond - \$73.00



No. D1011. 14K. "Lion's Paw" Ring. Mounting \$7.00. Complete with 3/8 c. Diamond - \$38.25



No. D1006. 14K. Stud. Mtg. \$2.25. 3/8 carat Diamond \$88.50



No. D1003. 14K. Twin Ring. Mtg. \$5.00. Complete with 2 3/8 carat Diamonds \$95.00



No. D1015. Tie Clasp. 10K. Solid Gold. 1 Dia. \$1.00



No. D1016. La Valiere. All Platinum. 3 Dia. \$45.00



No. D1012. Cuff Buttons. 10K. Solid Gold. Engraving Free. Pair \$1.50



No. D1013. Solid Gold Ring. Genuine Goral Cameo. 2 Diamonds - \$12.50



No. D1005. 14K. Solitaire Scarf Pin. Mtg. \$5.00. Complete with 3/8 carat Diamond \$72.50



No. D2011. Gold Filled Coat Chain. 8 in. long. Engraving Free - \$1.00

### World's Lowest Prices:

1/8 Carat \$ 8.25	1/2 Carat \$45.00
1/4 Carat 17.50	3/4 Carat 67.50
3/8 Carat 31.25	1 Carat 97.50

**Full \$150 per carat value!**

## FREE EXAMINATION!

Any diamond from our million dollar stock sent to you on approval at our expense, without deposit, without obligating you to buy! A careful comparison will convince you that our Importers' prices save you at least 1/3 of the jewelers' price!

### We Legally Guarantee to REFUND FULL PRICE IN CASH

Less 10% any time within 2 years; to exchange our diamonds allowing the full purchase price, at any time! The exact carat weight, quality and value we legally certify in writing. This guarantee gives you absolute security against loss or dissatisfaction!

## NEW 128 PAGE DE LUXE BASCH DIAMOND BOOK FREE!

The costliest, completest Diamond, Watch and Jewelry Guide ever produced. Illustrated with thousands of the latest fashions. Tells you all about Diamonds; how to judge Diamond qualities, how to compare values, how to buy a Diamond safely, intelligently, and at the right price. Our 35 years of experience as diamond specialists has been written into this book for your benefit.

**L. BASCH & CO., Dept. G247, State & Quincy Sts., CHICAGO, U. S. A.**

NAME \_\_\_\_\_

ADDRESS \_\_\_\_\_

Please mail me at once, one of your 128 page DE LUXE BASCH Diamond Books FREE!

Dept. G247, State & Quincy Sts. CHICAGO, U. S. A.

Orange shipments from Florida for the past season, September 1, 1912, to June 14, 1913, totaled 8,829,000 boxes, or over 2,000,000 boxes more than the best previous season.

### Mullins Steel Boats Can't Sink!



Built of puncture-proof galvanized steel plates. One man control, never stall, silent under-water exhaust. Catalogue free.

**THE W. H. MULLINS CO.**  
151 Franklin St., Salem, O.

## \$2850 NEW VIM ENGINE



No valves, cams, gears, or complicated parts. Has sensitive governor, silent muffler, hopper cooled cylinder, automatic lubrication, nothing to get out of order. Runs shop machines, models, washing machines, churns, separators, spray pumps, pump jacks, etc. 15 days' free trial. Money back if not satisfactory.

Write today for catalogue. Agents and jobbers wanted.

**THE VIM MOTOR CO., 110 Water St., SANDUSKY, OHIO**

### WATKINS' SPECIAL MOTORS

3 H. P. Single Cylinder	30 lbs.
6 H. P. Double Cylinder	60 lbs.
12 H. P. Four Cylinder	100 lbs.

A strictly HIGH GRADE Motor that will give CONSTANT and EFFICIENT service. Especially adapted for CANOES and LIGHT BOATS. Aluminum base, copper water jacket, steel shaft, bronze bearings.

**THE WATKINS MOTOR CO.**  
837-839 West Sixth Street CINCINNATI, OHIO

## AS YOU LIKE IT—

### Colgate's Shaving Lather in Stick— Powder or Cream Form

Without rubbing in, each of them produces a creamy, softening lather that adds to the delight of a keen razor. Send 4 cents in stamps for a trial size of the method you prefer.

**COLGATE & CO. Dept. 81 199 Fulton St., N. Y.**

### GET THIS CATALOG

FULL OF VALUABLE INFORMATION TO EVERY BOAT OWNER ON

## RACING PROPELLER WHEELS, REVERSE GEARS AND MARINE ACCESSORIES

LARGE CATALOG FREE. SEND TODAY

**MICHIGAN WHEEL CO.**  
1138 MONROE AVE., GRAND RAPIDS, MICH.

## TOLEDO MARINE MOTORS

"Nothing Cheap but the Price"

3 H. P. 1 cyl. complete	\$ 65.00
6 H. P. 1 " "	84.00
6 H. P. 2 " "	125.00
12 H. P. 2 " "	160.00
18 H. P. 3 " "	250.00

Fully guaranteed by a responsible concern. 2 cycle, 2 port, 3 1/2 x 3 1/2 and 4 1/2 x 4 1/2. Send for free catalog "C."

**THE UNIVERSAL MACHINE CO., Pike Ave., Bowling Green, O.**



## DEN PHOTOS

Here Are Two of Them Nos. 8 and 17

Real photos of the cutest girls. **ALL NEW POSES.** 3 styles — Plain, Sepia, Hand Painted — and mounted. Sizes, 5/7, 8/10, 11/14. Prices for 5/7 plain 20 cents. Sepia or Painted 40 cents.

**SPECIAL POSING for Calendars and Advertising at moderate prices.**

Free Illustrated Circular. We go any place to do any kind of photographic work.

**MELLEN PHOTO CO., 102 N. 5th Avenue, CHICAGO**





## THE RACYCLE

will bring you close to nature with maximum ease and minimum effort.



### THE REASON

**"It's all in the crank hanger"**

The Racycle crank hanger requires 27.9% less pressure on the crank bearings than is exerted on an ordinary bicycle. In connection with the large, exclusive Racycle sprockets—a saving of 33 $\frac{1}{3}$ % strain on the chain is gained.

Racycles last a life time, and that's why we positively guarantee them for five years. You know you need a bicycle. Why not buy a Racycle and save money?

Free illustrated art catalog, and agency terms on request.

**THE MIAMI CYCLE & MFG. CO.**  
53 Grand Ave. MIDDLETOWN, OHIO



**Convert Your Wheel Into a Motor-Cycle** Motor fits any wheel. BEST. MOST RELIABLE. Best Hill Climber. More STEFFEYS' in use than any others. Send stamp for circulars. **STEFFY MFG. CO.**, Girard Ave. and 30th St., Phila., Pa.



### Solar Motorcycle Lamps

are the neatest looking, strongest and most efficient lamps made. The product of light specialists, makers of 90% of the automobile lamps used on the high grade cars of America. Catalog shows many styles—gas, oil and electric. Write for it today.

**BADGER BRASS MFG. CO.**  
Kenosha, Wis. New York City, N. Y.



### \$40 Motorcycle

We have the largest line of new and used Motorcycles in the country at the lowest prices. We also have a thoroughly equipped repair department and are in position to furnish repairs for any machine. Send us your machine to be overhauled. We pay cash for second hand motorcycles. Send for Catalog. **HARRY R. GEER CO.**, 888 McLaran Ave., ST. LOUIS, MO.



### RANGER BICYCLES

Have imported roller chains, sprockets and pedals; New Departure Coaster-Brakes and Hubs; Puncture Proof Tires; highest grade equipment and many advanced features possessed by no other wheels. Guaranteed 5 yrs. **FACTORY PRICES** direct to you are less than others ask for cheap wheels. Other reliable models from \$12 up. A few good second-hand machines \$3 to \$8.

**10 DAYS' FREE TRIAL** We ship on approval, freight prepaid, anywhere in U.S., without a cent in advance. **DO NOT BUY** a bicycle or a pair of tires from anyone at any price until you get our big new catalog and special prices and a marvelous new offer. A postal brings everything. Write it now. **TIRES, Coaster-Brake Rear Wheels, lamps, parts, sundries, half usual prices.** Rider Agents everywhere are coinng money selling our bicycles, tires and sundries. Write today. **MEAD CYCLE CO., Dept. P108, CHICAGO**

## MAKE YOUR BIKE A MOTORCYCLE

at a small cost, by using our attachable outfit. Fits any Bicycle. Easily attached. No special tools required.

**"Gives Perfect Satisfaction"**

Mr. H. A. Griffin, of Georgia, writes: "The motor attachment I bought of you about a year and a half ago has given me perfect satisfaction. It has never given me any trouble and is still running as good as the day I got it. I recommend the SHAW Motor to anybody wanting a good motor cheap. I weigh about one hundred sixty-five pounds and my little motorcycle will carry me anywhere on ordinary roads. It will go anywhere my twin motorcycle will go. It is also fast enough for me."

**FREE BOOK** Write today for bargain list and free booklet, fully describing the SHAW Bicycle Motor Attachment. Motorcycles all makes, new and second-hand, \$35.00 up. **SHAW MANUFACTURING CO.**  
Dept. 6 GALESBURG, KANSAS



Send 25 cts. for complete plans, large working drawing, plain instructions and list of parts, showing how any boy can build this wonderful shaft drive, four speed and reverse, 1913 model Motor-Bob, which will carry you anywhere you want to go. **THE IDEA SHOP, Dept. I, BUFFALO, N. Y.**

**WHY MILK DOES NOT KEEP**—The U. S. Department of Agriculture has found a simple explanation of why milk that comes from apparently good dairies frequently shows an excessive number of bacteria and is bacteriologically bad. Dairies take the morning milk and combine it with the afternoon milk of the same day, and ship this combination the next morning. As a result, the day's milk is kept through the heat of the day, and by the time it is 24 hours old shows a high bacteriological count. Experiments were made in taking night



**Schickel**  
VALVELESS TWO-STROKE  
**Motorcycle**  
SIMPLE—NEAT  
SERVICEABLE

Send postal for catalog  
**THE SCHICKEL MOTOR CO., 69 Garden St., STAMFORD, CONN.**

**Save 25%** by buying your motorcycle sundries and parts from us. Send for our book of motorcycle supplies. Absolutely free to all riders for the asking.

**MOTORCYCLE CO-OPERATIVE CO., 471 Woodward Ave., DETROIT**



**WE SELL YOU AT WHOLESALE**

Agents' Price One  
**AMERICAN Motorcycle or Bicycle**

\$139<sup>85</sup>

Honest hand-made machines at factory cost. Write now for catalog. Say whether interested in Motorcycle or Bicycle.

\$18<sup>85</sup>

**AMERICAN MOTOR CYCLE CO., 1010 American Bldg., CHICAGO**





# FEILBACH LIMITED MOTOR CYCLE ::

The new machine that has leaped into instant popularity because faster, stronger, more comfortable, more dependable than any motor cycle heretofore produced. Here are a few of the reasons why:

**Frame**—a rigid truss of great strength, unbroken by hinged joints or springs. Extra heavy tubing, long reinforcements, securely brazed. Feilbach frames never break.

**4-Wire Grip Control**—safer, more flexible than any other control. Any one of the 4 wires affords safe control.

**Motor**—large bearings, wide faced gears. Valve chamber at front, giving greater radiation. Cam shaft supported by two full bearings.

**Automatic Oiling**—positive in action—no pumps to cause trouble. Oiling controlled automatically by speed of engine. All parts perfectly oiled, yet impossible to overfeed.

Other improved features of the "Limited," horizontal spring seat support, spring fork, etc. will interest every prospective buyer.

**Write for Booklet A** giving full details and showing why the Feilbach Limited will give you greater satisfaction, better service and cost you less in the end than any other motorcycle. Write today for the booklet.

*Established Dealers Wanted in unassigned territory*

**Feilbach Motor Co.**  
1148 HOLTON ST., MILWAUKEE, WIS.  
Price, Single Cylinder \$240  
Price, Twin Cylinder \$290



milk, keeping it through the cooler hours of the night, combining it with the morning milk, and shipping it. There was radical improvement in the condition of this milk. In this case, the farmer ships the milk by train or electric car an hour or two later than he did under the old practice.

Hides and skins imported into the United States show a larger total in the fiscal year just ended than in any earlier year and exceed in value any other class of imports, except coffee.



**Agents Wanted**  
To sell our Side Car.  
**FREE to any \$90**  
part of U.S.A.  
*The Sweetest Thing On Earth*  
**Baxter Side Car Co.**  
119 Broadway, Cambridge, Mass.

## EDWARDS FIREPROOF STEEL GARAGES

For Automobiles and Motorcycles  
**\$30 and Up**  
Easy to put up. Portable.  
All sizes. Postal brings latest illustrated catalog.

THE EDWARDS MFG. CO., 320-370 Eggleston Ave., Cincinnati, O.

**5 H. P. 1913 Peerless Motorcycle**

With Free Engine Idler and Bosch Magneto, together with the best there is in motorcycle construction—Power, Silence, Endurance, and those Wearing Qualities so essential for low cost of maintenance.  
**5 MILES FOR ONE CENT**  
Agents Wanted—Liberal Discounts

PEERLESS MOTORCYCLE CO., 179 Huntington Ave., BOSTON, MASS.

# MODERN AMERICAN HOMES

— P. V. von Holtz —

## NOW SENT FREE

Here is your chance to secure absolutely **Free of Charge** the most complete and up-to-date plan book ever published. No carpenter or contractor who wishes to be familiar with the latest in building construction—no man who is contemplating erecting a home—can afford to be without it. This great new plan book, "**Modern American Homes**," contains plans and specifications for 168 different structures, including excellent exterior and interior views, detailed estimates, etc. Designed by the leading architects of this country. Includes city, country and suburban homes, bungalows, farm houses, summer cottages, tent houses, camps, garages, apartment houses and various public buildings. 224 pages, 9 1/2 x 12 1/2 inches, and 426 illustrations. Printed on heavily enameled paper and substantially bound.

## The Cyclopedia of Architecture, Carpentry and Building



consists of ten massive volumes; 4,760 pages, 7x10 in.; 4,000 illustrations, full page plates, building plans, diagrams, etc.; hundreds of valuable tables and formulas; carefully cross-indexed for quick, easy reference.

This work covers everything in the building professions, from the first rough sketch of the architect to the acceptance of the finished structure. It includes wood, stone, steel, and reinforced concrete construction; estimating and contracting; a study of the Greek and Roman Orders; interior finishing and decorating; and modern house lighting and sanitation.

**Partial Table of Contents**

Mechanical, Free-hand, Perspective and Architectural Drawing, Lettering, Pen and Ink Rendering, The Orders, Superintendence, Strength of Materials, Masonry, Reinforced Concrete, Carpentry, Steel Square, Stair-Building, Hardware, Steel Construction, Roof Trusses, Practical Problems, Estimating, Contracts, Specifications, Building Law, Sanitation, Sheet Metal Work, Electric Wiring and Lighting.

**We'll Send the Plan Book FREE**

With every order for a Cyclopedia we will include the Plan Book, absolutely **free of charge** and send you the Cyclopedia and the Plan Book, **express prepaid, for seven days' free examination**. You keep the books a full week—examine them thoroughly at your leisure—and if they don't meet with your expectations they may be returned at our expense. Remember—the complete set, Cyclopedia and Plan Book, are sent **free** upon receipt of the coupon below and we pay express charges both ways if they are not satisfactory.

**Another Free Offer** With each set is included a year's Consulting Membership, regular value \$12.00, entitling you to the free advice of a corps of Expert Architects. This will give practical help in handling your difficult building problems. This service alone is worth more than the first cost of the books.

**AMERICAN TECHNICAL SOCIETY, CHICAGO, U. S. A.**

### FREE PLAN BOOK COUPON

AMERICAN TECHNICAL SOCIETY, Chicago, U. S. A.

Please send Free Plan Book, also Cyclopedia of Architecture, Carpentry and Building for seven days' examination. I will send \$2.00 within seven days and \$2.00 a month until I have paid \$4.00 for Cyclopedia (Plan Book included free), or notify you and hold books subject to your order. Title not to pass until fully paid. Pop. Mech. 10-13

NAME .....

ADDRESS .....

OCCUPATION .....

EMPLOYER .....





# Your Boy Will Go Wild With Delight

## Over "The American Model Builder"

The most wonderful, amusing, instructive and fascinating game for boys ever invented. Your boy and his chums will spend hours, building miniatures of the great mechanical feats of the age. While they play, they will learn how steel—the greatest industrial force of the day—is used in building all sorts of things. They'll learn how to do it.

### The American Model Builder

is made of steel and brass, nickered, and consists of beams, girders, angle irons, wheels, bolts, etc. in miniature, exactly the same as used by the steel builders. With it your boy can build hundreds of models complete, just like the real ones. We furnish book of complete instructions. If your boy is mechanically inclined this game will develop his ingenuity wonderfully. If not, it will teach him things, invaluable in after years. A noiseless game for boy and parent. Endorsed by leading educators, schools and Y. M. C. A's, on account of its educational value. Games in seven sizes \$1.00 up. Can be added to any time.

### Free Illustrated Catalog No. 20

Send today for our complete illustrated catalog. That boy you're interested in should surely have "The American Model Builder."

**The American Mechanical Toy Company**  
420 East 1st Street DAYTON, OHIO  
NERLICH & CO., Toronto, Canada

**A few of the things it builds**

- Wind Mills
- Printing Press
- Derrick
- Inclined Chin Ry.
- Ferris Wheel
- Aeroplane
- Suspension Bridge
- R. R. Semaphore
- Steam Shovel
- Merry-Go-Round
- Drill Press
- Auto Trucks
- Etc.

Look for this Trade-Mark on every box



## HARLEY-DAVIDSON "5—35"

### THE SILENT GRAY FELLOW

Climbs hills, pulls through sand and over roads impassable to the average automobile. The "5—35" motor will pick up from a standing start to 40 miles an hour in 300 feet. Ful-Floeting Seat and Free Wheel Control are exclusive Harley-Davidson features.

Description of these and other features on request.

Harley-Davidson Motor Co., 294 B St., MILWAUKEE, WIS.



## Morgan Gas Lighter

Agents wanted everywhere to handle this Specialty. **LARGE PROFITS** Increasing Demand. Send for Territory and Sample.

B. MORGAN, Bellevue St., Newport, R. I.

## \$3,000.00 IN ONE YEAR



Make it repairing automobile tires. Punctures and blow-outs are common. Tires need retreading and vulcanizing. **EACH AUTO SOLD MEANS MORE TIRES TO MEND.** Auto tire repair field a hundred times bigger and better than old bicycle days. Johnson, Tex., writes, "I made as high as \$18 profit in one day." Investigate today. Ask for FREE catalog.

Haywood Tire & Equipment Co.

646 Capitol Ave. Indianapolis, Ind.

## PENNSYLVANIA

### Oilproof

## VACUUM CUP TIRES

## INDIAN MOTOCYCLES

CRADLE SPRING FRAME. SEND FOR CATALOG.

HENDEE MFG. CO., 911 State Street, Springfield, Mass.

**REO THE FIFTH** Final and crowning achievement of R. E. Olds, pioneer designer of Autos. A standard size 30 to 35 horsepower four cylinder car of modern refinements priced at only \$1,095.

R. M. OWEN & CO., General Sales Agents  
REO MOTOR CAR CO. LANSING, MICH.

**GOOD YEAR** NO-RIM-CUT TIRES  
10% Oversize—save half on tire bills—Write for latest Tire Book.

THE GOODYEAR TIRE & RUBBER COMPANY, Main Office and Factory, Akron, Ohio  
Branches and Agencies in 103 Principal Cities. More Service Stations than Any Other Tire

## Try This Victor or Victrola FREE

with 12 popular songs, dances, band and rag-time pieces selected by you.

**WE PAY THE FREIGHT**

You don't pay a cent unless satisfied. If the Victor don't suit you, return it at our expense. If you keep it, we will trust you.

**TERMS AS LOW AS 50c A WEEK**

Write at once for our big 300-page Victor book, containing list of over 5,000 records, also showing all the different styles and prices of Victors and Victrolas. **WRITE TODAY.**

Field-Lippman Piano Stores

1114X Olive St.

ST. LOUIS, MO.



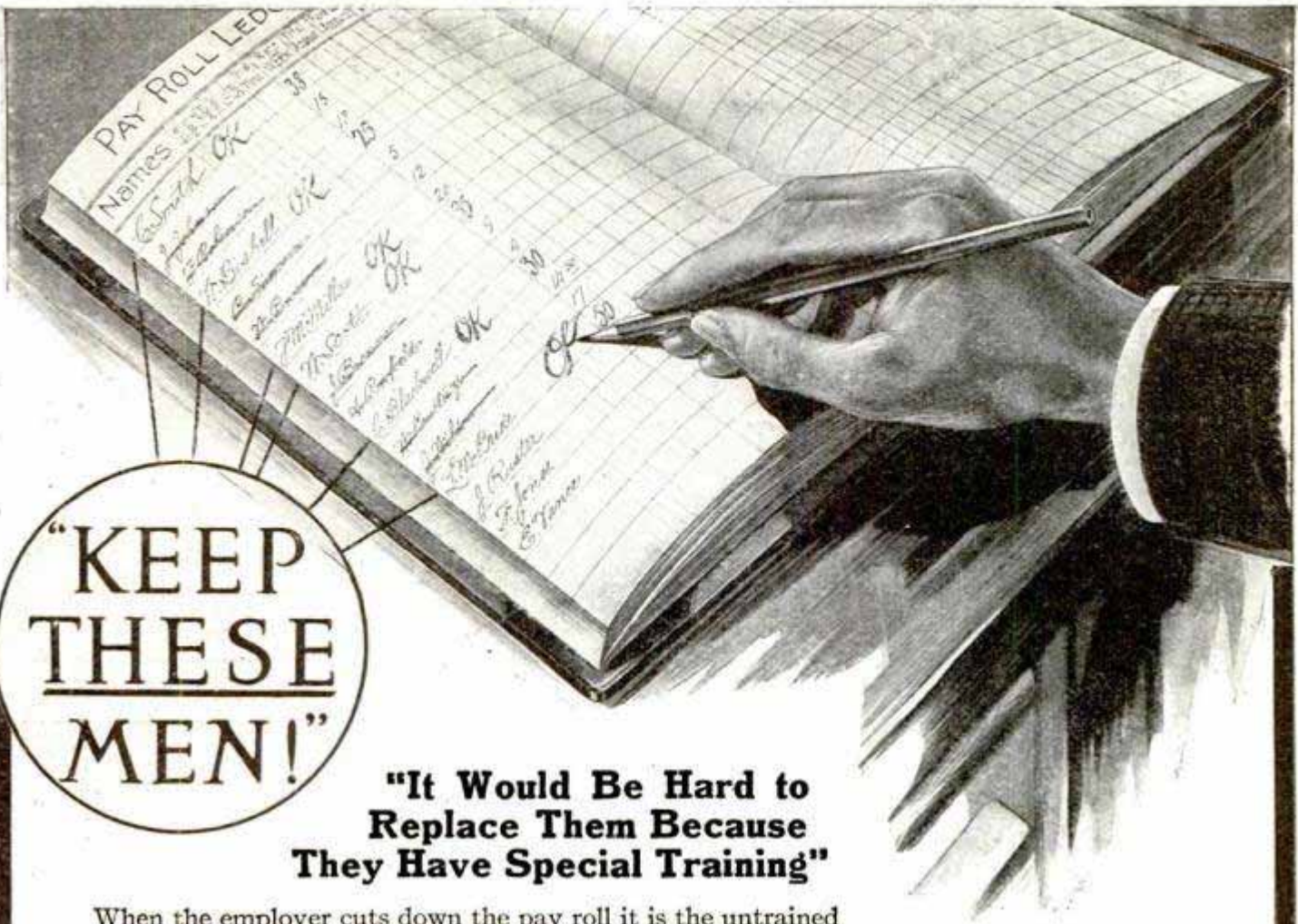

**"It Would Be Hard to Replace Them Because They Have Special Training"**

When the employer cuts down the pay roll it is the untrained men that go. Untrained men are easy to get at any time. But the employer keeps the trained men as long as possible, as he knows it will be difficult to replace them. His finger will sooner or later go down the pay-roll list on which your name appears. Are you one of the men whom he would like to hold? If you are not, I. C. S. training will keep you on the pay roll.

It makes no difference where you live, under what conditions you work, the I. C. S. will bring to you in your spare time, at small cost, the kind of training that the employer values—the training that will qualify you for a more congenial position—the training that means advancement and a larger salary.

You can get this training. Simply mark an X in the coupon opposite the name of the Course in which you are interested, write your name and address, and send it to us. We will tell you how thousands of men who were situated just as you are have risen to positions of trust and responsibility through I. C. S. training. We have trained thousands and can train you. Make the employer say "Keep That Man" when he reaches your name. It will cost you only a two-cent stamp to find out how it can be done.

**Mark and Mail the Coupon TODAY**

**International Correspondence Schools  
Box 872, Scranton, Pa.**

Please explain, without further obligation on my part, how I can qualify for a larger salary and advancement to the position, trade, or profession before which I have marked X.

Electrical Engineering Electric Lighting Electric Railways Electrician Electric Car Running Dynamo Foreman Wireman Mining Engineer Telephone Expert Surveyor Civil Engineer Automobile Running Agriculture	Mechanical Engineer Mechanical Draftsman R. R. Constructing Concrete Construction Architect Contracting & Building Architectural Draftsman Plumbing & Heating Chemist Bookkeeper Advertising Man Civil Service Exams. Salesmanship
--	--

Name \_\_\_\_\_

St. and No. \_\_\_\_\_

City \_\_\_\_\_ State \_\_\_\_\_

Present Occupation \_\_\_\_\_



# 2c a Week Pays Wash Bill!

## Electricity or Water-Power Does the Work

Write for  
**FREE Book**

Just a "Twist of the Wrist" Starts or Stops the Machine!

The 1900 Motor Washers are now at work in thousands of homes. They are doing the work formerly done by women, at a cost of 2c a week for power! Saving thousands upon thousands of dollars in wash bills. Saving worlds of wash-day troubles. Leaving the women free to do other work while the machines are doing the washing.

## The 1900 Motor Washer

Washes a Tubful in Six Minutes!

1900 Water Motor Washer  
Can be connected with  
any water tap instantly



Handles Heavy Blankets or Dainty Laces

The outfit consists of the famous 1900 Washer with either Electric Motor or Water Motor. You turn on the power as easily as you turn on the light, and back and forth goes the tub, washing the clothes for dear life. Then, turn a lever, and the washer does the wringing. All so simple and easy that it is mere child's play.

**A Self-Working Wringer Sent With Every Washer!**

The motor runs Washer and Wringer. We guarantee the perfect working of both. No extra charge for Wringer, which is one of the finest made. Write for **FREE BOOK** and **30 Days' FREE TRIAL OFFER!** Don't doubt! Don't say it can't be done. The free book proves that it can. But we do not ask you to take our word for it. We offer to send a 1900 Motor Washer on absolute **Free Trial** for an entire month to any responsible person. Not a cent of security—nor a promise to buy. Just your word that you will give it a test. We even agree to pay the freight, and will take it back if it fails to do all we claim for it. A postal card with your name and address sent to us today will bring you the book free by return mail. All correspondence should be addressed to

Doing the wringing with  
1900 Electric Motor Washer



**1900 WASHER CO., 6087 Court St., BINGHAMTON, N. Y.**

OR, IF YOU LIVE IN CANADA, WRITE TO THE CANADIAN WASHER CO., 355 YONGE ST., TORONTO, CANADA.

(23)

## Sunshine Lamp 300 Candle Power FREE!

To Try in Your Own Home

Turns night into day. Gives better light than gas, electricity or 18 ordinary lamps at one-tenth the cost. For Homes, Stores, Halls, Churches. A child can carry it. Makes its own light from common gasoline. Absolutely SAFE.

**COSTS 1 CENT A NIGHT**

We want one person in each locality to whom we can refer new customers. Take advantage of our SPECIAL FREE TRIAL OFFER. Agents Wanted.

**SUNSHINE SAFETY LAMP CO.**

511 Factory Bldg. Kansas City, Mo.



**CACHOO!** Make the whole family and all your friends "just sneeze their heads off" without knowing why, with CACHOO, the new long distance harmless snuff. Sent anywhere for 10c. 3 for 25c. 90c a dozen. Catalog included FREE.

PEERLESS TRICK & NOVELTY CO., Dept. B, CHICAGO



**TELEPHONES IN ENGLAND**—The telephone lines in England were taken over by the postoffice department about two years ago. The service, which was then "maddening," has grown so bad under government administration, that it is now declared to be "the worst in the world. A prominent citizen in an open letter to the Postmaster General says:

"It has now become an almost constant practice for

**PATENTS BRING WEALTH;** PROOF, BOOKS, ADVICE FREE  
LOW RATES, EASY TERMS

**"PROFIT"** Will teach you something about patents you never dreamed of. It's free also.

A. J. Wederburn, Pat. Atty., Dept. 140, Washington, D. C.

**PATENTS THAT PAY—**  
**\$561,530 Made**

by clients. Patent Book—"What and How to Invent—Proof of Fortunes in Patents"—FREE. 112 page guide. E. E. VROOMAN, Pat. Atty., 871 F St., Washington, D. C.

**Models and Supplies** We make working models of any description and material, also dies, tools and sheet metal stampings. Send your drawing or sample for estimate. Write for catalogue of gears and model supplies.  
**THE PIERCE MODEL WORKS, 3405 Pierce Ave., CHICAGO, ILL.**

WRITE FOR BOOKLET OF  
**INVENTOR'S SUPPLIES**

UNION MODEL WORKS (Established 1882) 119 S. Clark St., CHICAGO

The oldest, most reliable, most efficient model making and experimental house in the west

## Savo Air Moistener

Fill with water and hang on back of any Radiator

Prevents air dryness. Makes it fit for the lungs. No doctor bills. Saves furniture shrinking, piano warping, wall paper cracking. Money refunded if not satisfactory after 30 days' free trial. Order now, or write for free Booklet.

Savo Mfg. Co., Dept. F, 5856 S. Park Ave., Chicago



IN USE



Price \$2.00

## The "E-Z" Self-Filler Pen — \$1.50

The Pen you need. Made right to write right. Lasts a life-time.

Patent  
Clip



14 Karat  
Gold Pen

(Remove Cap—Insert Pen in Ink-Well—Press ball of clip in hole—Pen fills instantly)

A perfect Self-Filling Pen at moderate price — \$1.50 complete by Parcel Post

Agents Wanted. Small investment. Big profits. Write Now. J. C. ULLRICH & CO., 27 Thames St., N. Y.



## HOW MUCH MONEY Do YOU Need?

If \$100 to \$500 a month will satisfy you, we don't know any better way to make it than by acting as agent in your territory for the famous

## ROWE Sanitary Washstand

Gives all the advantages of running water in any room without a cent's worth of

plumbing. Replaces the old insanitary slop-bowl and jar.

Don't pass this up as the stereotyped "bunk" handed to agents. We've been selling thousands of these Washstands by mail-order every year. If we could, we'd prefer to keep on selling that way. The business has grown too big, the demand too widespread—that's all.

So there's a dandy opportunity for the right man—or woman—in every locality. Homes, stores, offices, factories are quick customers. One hotel bought sixty-three. Exclusive territory—no competition. And we turn over all inquiries to you.

Write quick for free booklet and terms.

**ROWE SANITARY LAVATORY COMPANY**  
Dept. B, DETROIT, MICHIGAN

your operators, immediately after one subscriber is connected with another, to cut off the connection and ask, "What number do you want?" The other day, speaking on the House of Commons cloak-room telephone to the city, this happened to me three times during one short conversation.

"If the present chaotic and maddening telephone service you supply to the public is to continue I would suggest that the Government provide special lunatic asylums for those subscribers who will be driven mad by the use of what I believe to be the most inefficient and exasperating telephone service in the whole world."

## HEALTH AND BEAUTY

are yours when you use

## Tibbals' Electric Massage Machine \$7.50

Complete, including battery, sponge electrode and brush attachment for hair and scalp treatment.

Here's sure relief for all ailments caused by imperfect circulation—a marvelous complexion beautifier, removing wrinkles and facial blemishes of all kinds quickly and pleasantly—invaluable for athletes, causes relaxation of tired muscles at once—the most convenient and inexpensive massage machine on the market today. After you've used it for a short while, you would not part with it for five times its cost.



It's so simple a child can use it—weighs only one pound—carries its own battery, so does not need outside current. Use in the privacy of your home—you'll find it indispensable.

Send us \$7.50 and we'll send you the Tibbals' Electric Massage Machine complete, including battery. If you're not perfectly satisfied when you've tried it, we'll refund your money instantly. Order today.

Agents Wanted To sell this remarkable machine—liberal commission—big possibilities for aggressive workers—sit right down and write for our money making agents' proposition.

**THOBAL ELECTRIC CO.**  
405 Broadway ST. LOUIS, MO.

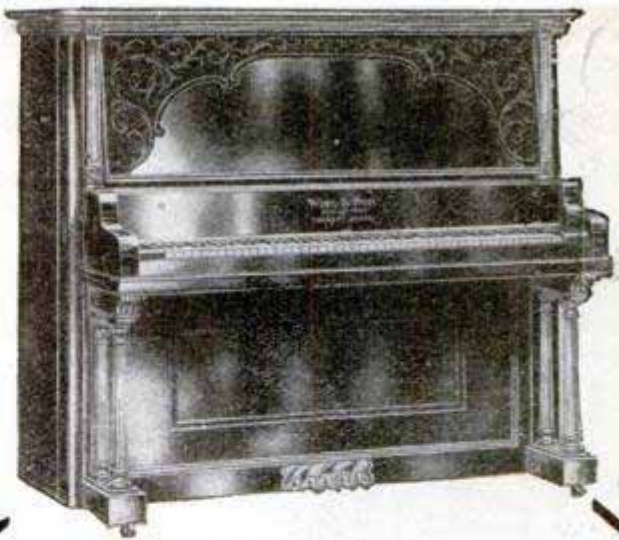

One of the \$8 Styles

## Shipped FREE To You—Superb Wing Piano

Yes, we will ship on absolute free trial to you a Genuine highest-grade Wing Piano or player-piano DIRECT from our own factory freight prepaid. The most amazing piano offer ever made. We will allow you to use any Wing piano—your choice of 38 superb new styles—in your own home for 4 full weeks at our expense.

## No Money Down—Freight Prepaid

We ask no money down—no security—no bank deposit—no C. O. D.—no obligations. Just choose any Wing from our large catalog. We'll ship the instrument no money down, freight prepaid. Use it just as if you owned it. Let your friends play it. At the end of 4 weeks' trial, if you wish, you may return it at our expense. You alone are the judge. We employ no salesmen to visit and annoy you.

## Rock-Bottom DIRECT Offer

You will be amazed at our rock-bottom direct-from-our-factory proposition on the genuine highest-grade Wing, guaranteed 40 years. No other manufacturers dared to meet our baffling offer. Let us quote you prices that local dealers cannot approach. Cash or easiest monthly payments as you prefer—but first four weeks' free trial. Since 1868—for 45 years—we have been building Wing pianos—renowned everywhere for their sweetness of tone and sterling merit. The Wing has all the fine qualities and every improvement of any strictly high-grade piano and a superior tone.

## Valuable Book on Pianos Free

"The Book of Complete Information About Pianos"

The N. Y. World says: "This is a book of educational interest every one should own." Tells you all about pianos, how to judge the fine points of quality and price in buying a piano. You will be astonished at the amount of information about piano quality and piano prices, and how to answer the arguments of piano salesmen. The Coupon brings this 136-page book FREE. This magnificent book, a complete encyclopedia on the piano, posts you on the making of a piano from start to finish. Free and prepaid, provided you write at once. With this piano book we will send free our beautiful catalog showing new art styles and full explanation of our Rock-Bottom Prices on the Wing Piano. Just drop a postal or a letter, or mail the coupon—today.

**WING & SON, Dept. 1197, (Estab. 1868)**

Wing Bldg., 9th Ave. and 13th St.

New York

N. Y.

Piano Book  
**COUPON**

WING & SON (Est. 1868) Wing Bldg.

9th Ave. & 13th St. Dept 1197, New York, N. Y.

Gentlemen:—With the understanding that I am not buying anything, you may send me the 136-page Piano Book containing the ten tests, also your free shipment offer on the Wing Piano.

Name.....

Address.....



Here are shown a few selections from our CATALOGUE which contains illustrations of the highest grade of Perfect Blue-white Diamonds, Watches, Jewelry and Silverware, and tells how they may be bought on easy payments under the well-known Lyon Method.

**DIAMONDS ON CREDIT**

Terms 20% down and 10% a month. 10% discount for cash. Transactions are confidential—no security required. A binding guarantee with each Diamond. May be exchanged at full purchase price. A Diamond makes a most acceptable gift or is an excellent medium for investment. For full particulars, write for Catalog, to Dept. 3

**J.M. LYON & CO., (EST. 1843) 71-73 Nassau St. New York**

7773- \$30.  
7243- \$100.  
7212- \$135.  
7260- \$150.  
7115- \$150.  
7106- \$50.  
7235- \$150.  
7310- \$150.  
7527- \$75.  
7534- \$60.  
7589- \$25.  
7101- \$20.  
7404- \$50.  
7111- \$100.  
7403- \$100.  
7131- \$450.  
7561- \$10.  
7263- \$50.  
7267- \$25.  
7269- \$35.  
7659- \$14.  
7169- \$75.  
7130- \$50.

**Build a Flying Boat**

We have accurate scale drawings and knock-down parts of all man-carrying aeroplanes for class-room demonstrations, exhibition purposes, etc. Students of aeronautics, everyone with an inquiring turn of mind, should construct one of these fascinating models.

PRICES OF 3-FT. MODEL SCALE DRAWINGS—Curtiss Flying Boat, 25c; Nieuport Monoplane, 25c; Bleriot Monoplane, 15c; Wright Biplane, 25c; Curtiss Convertible Hydro-aeroplane, 35c; Cecil Peck Champion Racer, 25c. Complete Set of Six \$1.25 Postpaid

**For Immediate Sport Fly a "Blue Bird" Racing Aeroplane**

Send \$1.50 for our Blue Bird Racing Aeroplane—the swiftest, most graceful flyer on the market. The first boy in every town to order a "BLUE BIRD" and send us the names of five friends will be appointed official starter of all BLUE BIRD Contests and a handsome badge will be given him free. 50 pp. Ideal Model Aeroplane Supply Catalog 5c.

**IDEAL AEROPLANE & SUPPLY CO. 82-88 West Broadway, NEW YORK**

**\$6.50 SUIT**

**MADE TO ORDER**

**Linings and Trimmings Guaranteed for Two Years**

Amazing low price for a suit made to your individual measure from your choice of cloth in latest fashionable style, guaranteed to fit you perfectly. We send big selection of cloth samples **Free** and **save you half**. Don't buy a suit or overcoat anywhere at any price until you see our samples and wonderful offer. Everything guaranteed.

**The Capitol Tailors, Dept. 424, Chicago**

**New KEROSENE LIGHT BEATS ELECTRIC OR GASOLINE**

**10 Days FREE—Send No Money**

We don't ask you to pay us a cent until you have used this wonderful modern light in your own home for ten days, then you may return it at our expense if not perfectly satisfied. We want you to prove for yourself that it gives five to fifteen times as much light as the ordinary oil lamp; beats electric, gasoline or acetylene. Lights and is put out just like the old oil lamp; costs

**ONLY 1 CENT FOR 6 HOURS**

Gives a powerful white light, burns common coal oil (kerosene), no odor, smoke or noise, simple, clean, won't explode. Guaranteed.

**\$1000.00 REWARD**

will be given to the person who shows us an oil lamp equal to this Aladdin in every way (details of offer given in our circular). Would we dare make such a challenge to the world if there was the slightest doubt as to the merits of the Aladdin? We want **one person in each locality** to whom we can refer customers. Write quick for our 10 Day Absolutely Free Trial Proposition. Agents' Wholesale Prices, and learn how to get **ONE FREE**.

**MANTLE LAMP CO., 448 Aladdin Bldg., Chicago, Ill.**

**AGENTS WANTED**

to demonstrate in territory where oil lamps are in use. Experience unnecessary. Many agents average five sales a day and make \$300.00 per month. One farmer cleared over \$900.00 in 6 weeks. You can make money evenings and spare time. Write quick for territory and sample.



Try One in Your Home

**FREE**



VICTOR

Choose any VICTOR Talking Machine or VICTROLA from my big, illustrated catalog—pick out six double-faced records (12 pieces to play) and I'll send the outfit to



VICTROLA

your home for a FREE trial. Don't send a cent. No catches or conditions. This is a straightforward offer that makes it possible for anyone to own a Victor or Victrola. Just say which machine you want and send list of records. Give it a fair trial. Then if you want to keep it pay for it on

## My Easy Payment Plan

As little as \$2.00 a month will buy a Victor or Victrola. The best entertainment in the world at a price easily within your means. On almost every machine, you have as long as

## One Year to Pay

and there's no risk. If you don't want the machine after the free trial send it back at my expense. You pay no more on this easy payment plan than if you paid cash down and I charge you no interest.

## My Complete Free Catalog

will be sent at your request. Handsomely and completely illustrated with detailed descriptions of all machines and lists of records. A card will bring it absolutely free. Write NOW.

Peter Goodwin, Pres., Peter Goodwin Mercantile Co., Victor and Victrola Distributors, 1022 Century Bldg., St. Louis, Mo.



**\$1.00 Adder** Adds accurately, quickly and easily. Durably made. Easily reset to zero. Capacity 5 columns. Over 17,000 sold. Guaranteed as represented. **Price \$1.00 delivered.** Our Self Indicating Adder, price \$3.50 delivered, is the best low priced adding machine made.

Order one today. Agents wanted.

J. H. Bassett & Co., Dept. 11-B, 5921 Indiana Ave., Chicago

## Paper is Stronger Than Wood

Railroad car wheels have been made of paper, they are strong as steel. Wooden car wheels are never used. Wood splits. A genius has now invented indestructible paper file handles. They cannot split or splinter, are smooth and don't raise blisters. Hold the file tang with a grip many times as tight as that of wooden handles. Guarantee two new ones for every split handle returned. Remember that Elastic



Grip Paper Handles will outlast a vast quantity of the ones you are using now. Low price—long life. Special offer: 50 ass't handles for one dollar plus postage. Samples 10c prepaid. Ask your dealer. Agents wanted.

Chuchardt & Schutte, 90 West St., N. Y. 307 Coristine Bldg., Montreal, Can.

## FREE LOAN

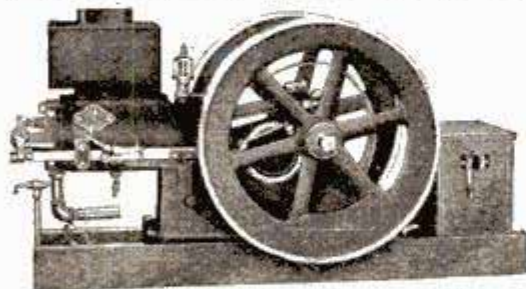

## Save Your Engine Money

Get the facts about the wonderful Union Engine, 2 to 7 horse power. Get our

## AMAZING FREE OFFER

that is throwing engine makers into panic. No notes, mortgage or C. O. D.: just a free loan. Let the Union do your work at our expense. Pumping, shelling, grinding, runs cream separator, saw, hay press, crusher, cutter, dynamo, drills, wells, etc. Lowest priced and most perfect farm engine made. Absolutely guaranteed. Fully rated, skid mounted. 4 cycle, long stroke, slow speed, hopper cooled, water jacket, automatic mixer. This big factory has been making engines for 30 years. Simply send name today for full details of our great free offer.

UNION GAS ENGINE WORKS, Dept. 902, KANSAS CITY, MO.

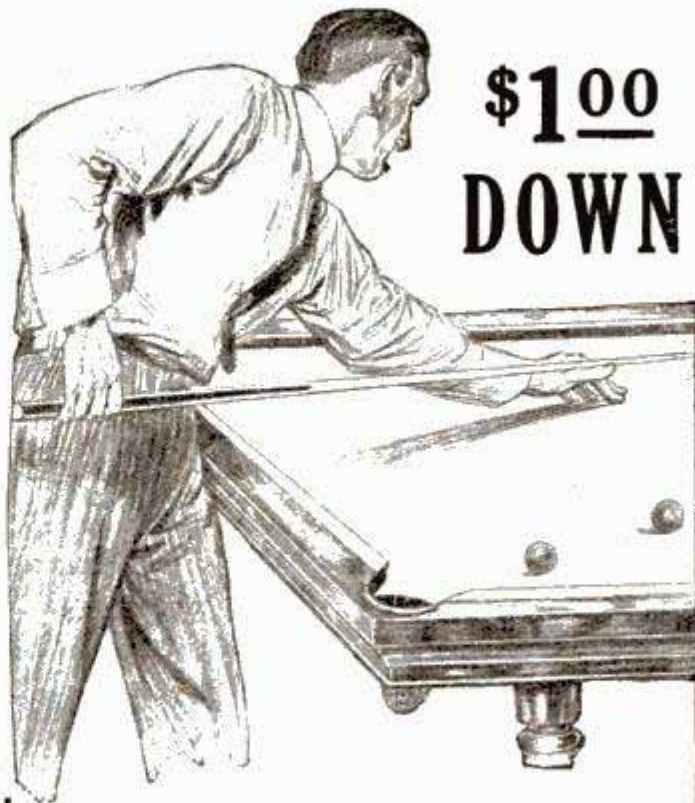

**\$100  
DOWN**

## Play Billiards at Home

Billiards and Pool are fine, clean, interesting games—games that fascinate with their close, exciting, constantly changing situations—games that test the skill of hand, eye and brain, and arouse the keenest sort of friendly rivalry—games that the whole family will enjoy. Billiards and Pool are expensive if played in a public poolroom, but almost anyone can afford to have at home a

# BURROWES

## Billiard and Pool Table

You can play on it while you are paying for it. The prices are from \$15 up, on easy terms of \$1 or more down (depending on size and style selected), and a small amount each month. Sizes range up to 4 1/2 x 9 feet (standard). Complete playing equipment of balls, cues, etc., free.

No special room is needed. The Burrowes Table can be set on your dining-room or library table, or mounted on its own legs or folding stand, and quickly set aside when not in use. Burrowes Tables are

## Used by Experts

for home practice. The most delicate shots, calling for skill of the highest type, can be executed with the utmost accuracy.

### FREE TRIAL—NO RED TAPE

On receipt of first installment we will ship Table. Play on it one week. If unsatisfactory return it, and on its receipt we will refund your deposit. This ensures you a free trial. Write today for illustrated catalog, giving prices, terms, etc.

THE E. T. BURROWES CO.

160 Spring St.

PORTLAND, ME.

Please Mention Popular Mechanics



# I SMASH The Terms

Watches  
on  
**CREDIT**

16 Size  
Thin Model



ELGIN  
HAMILTON  
HOWARD  
ILLINOIS  
Any Watch  
You Want

on

**30 Days' Free Trial**

**No Money Down**

**Express Prepaid in Advance by Me**

That's the way I smash terms. That's the reason why I am doing the greatest credit watch and jewelry business. I am "Square Deal" Miller and I trust the people.

I do business on your terms, send you what you want. Suppose it is a watch. I have it for you, **no money down**, express prepaid by me, and a full month to carry it in your pocket. **That's the test that tells.** All these watches

**Guaranteed 25 Years**

**Now for Business:** Send me your name and address and I will send you my

**Costly Catalog FREE**

I want you to have our catalog. It is a gem, it illustrates all kinds of valuable watches, diamonds and jewelry on the easiest and most liberal terms ever offered.

**You Take no Chance** My terms are made to suit your convenience. I assume all the risk, you are the sole judge of value and quality. I prepay the charges, trust you, give you the easiest, best and squarest terms and live up to my title as "Square Deal" Miller. Write for this catalog today and get a letter from me that will make you a friend of mine from the start.

**"Square Deal" MILLER, Pres.**

MILLER-HOEFER CO., 198 Miller Building., Detroit, Michigan

# New-Skin, For Cuts

New-Skin is an antiseptic liquid for emergency use on cuts, scrapes and little hurts. It dries and forms a flexible coating, not affected by washing.

Carry it with you always. Keep a bottle in the house and in the shop.

Home size 25c; Pocket size 10c; Surgeon's size 50c. See directions and circular. 200 Uses. There is only one New-Skin. Be sure to get the genuine. At druggists, or send 25c in stamps for Home size by Parcel Post. Address Dept. L, New-Skin Company, New York.



**LEAD ONE OF EARLIEST KNOWN METALS—**  
The Egyptians used lead in glazing pottery and in making ornaments. The Chinese are supposed to have used lead as early as 2000 B. C., although they made as little practical use of it as they did of their numerous other discoveries, says Mining and Engineering World. The Greeks and Romans mined lead along the shores of the Mediterranean at an early date. The mines of Larium, Greece, are presumed to have been worked before the Trojan War, and it is well known that they were worked extensively in the fifth and sixth centuries.

**2 H.P.**

**\$45**

Complete  
Ready  
to Run



**AMERICAN**

The marine engine that is absolutely right in design and principle of operation—and **must run.** Starts without cranking, reversible, runs on gasoline, kerosene or other fuels. All sizes, 2 to 30 H. P. Lowest possible prices. Send for catalog. **Agents wanted; liberal terms.** Also small stationary engines. Ask for circular. American Engine Co., 490 Boston St., Detroit, Mich.



## Record-Breaking — Trust-Busting — Prices

**Induction A. C. Motors on 30 Days' Free Trial  
Sold Direct from Our Factory to Your Hands  
Prices that Talk for Themselves**

Our New 1/8 H. P. Alternating Current Motor, Complete	\$16.75
Our New 1/6 H. P. Alternating Current Motor, Complete	19.25
Our New 1/4 H. P. Alternating Current Motor, Complete	21.50
Our New 1/2 H. P. Alternating Current Motor, Complete	39.00

The above Motors are 1750 R. P. M., Single Phase, 110 Volts, 60 Cycles Induction A. C. Motors.

These Motors are specially adapted to run Washing Machines, Sewing Machines, Electric Pianos, Butter Churns, Dentists' Lathes, Jewelers' Lathes, Printing Presses, Drill Presses, Blacksmiths' Forges, Wireless Instruments or anything where small power is required. These Motors can be run off of the Electric Light Socket, and are Self-Starting.

Thousands of Them in Use To-Day. Quality Equal to Any Motor on the Market.

Our Motors are sold with a Bona-Fide Written Guarantee for Two (2) Years to be free from Electrical and Mechanical defects. The above prices are Net Cash, f. o. b. Chicago. Send Check and Order to-day. We carry a Full and Complete stock (all sizes) of Dynamos, Motors and Fans.

**The Best Guarantee on Earth:** — We will ship to you any size Dynamo or Motor desired, on a 30 day free trial basis, and after you have used and tested same for that length of time and find that same is not satisfactory, you can return the Motor or Dynamo to us, Freight Prepaid, and we will promptly Refund your Money without question.

**MONEY REFUNDED IF NOT SATISFIED**

**Standard Electric Motor Company, 118-120-122-124 South Clinton Street Chicago, Ill.**  
Manufacturers of Electrical Machinery.



# Pump Water the Cheap Easy Way



1,000 Gallons an hour against 80 ft. head for a pint of Gasoline costing about 2 or 3 cents.

## Fairbanks-Morse Eclipse Engines

are complete and compact. Fit any windmill pump. Bolt direct to well platform and pump standard. Frostproof cooling jacket. Make and break ignition. Cylinder and piston *ground to fit* as in automobile engine. Made in two sizes; either furnished with or without Pump Jack.

Two belt pulleys for running light machinery as cream separator, washer, churn, ice cream freezer, printing press, etc.

Write for catalog GG449 and price

**Fairbanks, Morse & Co.,** 900 S. Wabash Ave. Chicago, Ill.

Oil and Gasoline Engines, Oil Tractors, Water Systems, Electric Light Plants



**AGENTS** My Sanitary Coffee Maker produces pure, sweet coffee, needs no settler and never wears out. Saves coffee, money and health. Every wife buys at sight; new invention, exclusive territory. Send 15 cents for 50-cent size, postpaid.

**DR. LYONS, 408 Day St., PEKIN, ILL.**



## Folding BATH TUB

Costs little, no plumbing, requires little water. Weight 15 pounds, and folds into small roll. Full length baths, far better than tin tubs. Lasts for years. Write for special agents offer and full description.

**ROBINSON MFG. CO., 130 Vance Street, TOLEDO, OHIO.** Manufacturers Turkish Bath Cabinets.

## Will you take this:

We want 55 or 40 men right away who can use the following tools: auger, screw-driver, hammer and wrench. We want you to install or put in our Hydro-Carbon Lighting System, and fill orders. We furnish full instructions and complete charts so you can do the work with the common tools named above.

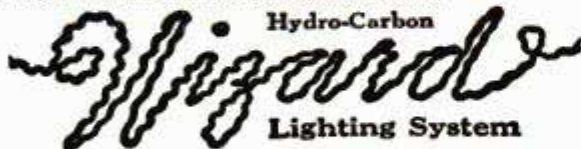

Our lighting system is for farm, village or town homes where for a slight cost we fully equip a house with a perfect, safe, simple, lighting system. The combination of hydro carbon flame and gas mantle produces a bright, steady light, remarkable for its brilliancy compared with regular gas or kerosene lamps. Lights as easily as ordinary gas. No lamps to fill. No grease, grime or dirt. No expensive piping to do, simply a hollow copper conduit wire no larger than a slate pencil. No tearing of floors, breaking plaster, no mess or litter. The wire is easily and quickly passed through partitions attached to mouldings, walls or ceilings.

**If you will** accept our catalogue and the description of our system, if you are interested in starting a profitable, pleasant business, where you can be kept busy and make big money quick. Let us hear from you. Write us today—just on a postal or in a letter addressed to us, write as follows: "Mail full particulars." We will offer you a very attractive opportunity that may mean very much more to you than you think. Address

**NAGEL-CHASE MFG. CO.**  
156 East Erie St. Chicago

# 56 Volumes Free

New Law Text

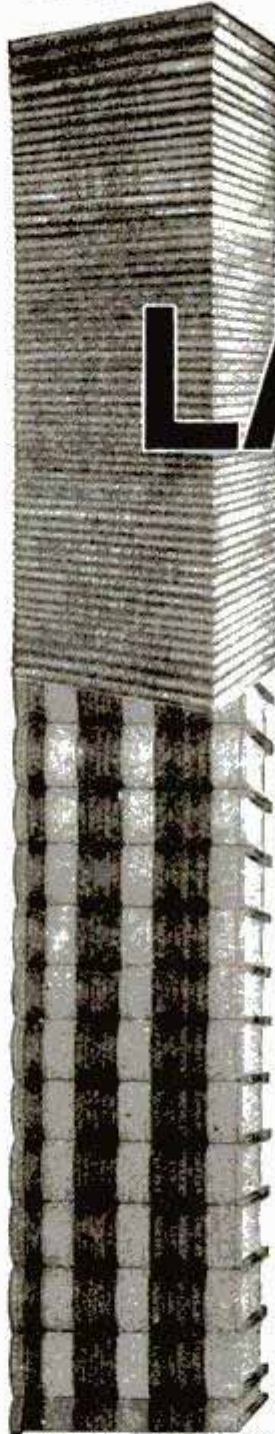

**THE** greatest law offer ever made. Absolutely unparalleled in the history of home study. These 56 volumes of great new law text have been prepared for you by Deans and Professors of the largest universities, judges of federal and state courts, and celebrated attorneys.

## LAW

Harvard, Yale, Pennsylvania, Chicago, Wisconsin and Michigan have contributed to this great aggregation of legal talent which no one university can equal.

These books constitute a remarkable training for the legal profession. Stripped of non-essentials and frills. A wonderful combination of practice and theory. **No other school can even sell you these great books at any price.**

The 13 large, handsome volumes shown below, "Library of American Law and Practice," sent you at once.

## Free Lesson

Absolutely free—to show you how clearly the lessons have been written and how easily you can learn law through this great new system of teaching. **Tells you many things you should know about the law.** It will give you valuable information on great legal principles which govern business affairs. Send for this free lesson at once. It comes to you prepaid.

## Greatest of All Correspondence Schools

The American School of Correspondence stands pre-eminent. **It is the world's leading home study educational institution.** A vast university for higher learning with students and graduates in every part of the English speaking world. The world's leading legal authorities cooperated with the American School in this great work.

## Send Coupon Today FREE

You must act immediately to secure this free law lesson and the benefits of this wonderful offer. Learn the details at once. The offer is **very limited.** Don't delay. Act now. Get an envelope and stamp and send the free lesson coupon today—**now.**

**American School of Correspondence**  
Dept. 1197  
58th Street and Drexel Avenue  
Chicago, Illinois  
U. S. A.

Gentlemen: Without any obligations, please send me Free Lesson in Law. Also tell me about your special free offer on the new 56 volumes "The Key to Law Success."

Name.....  
Address.....

Please Mention Popular Mechanics



LEARN THE NEW WAY

# AMAZING INVENTION

MAKE MONEY HERE

**DROP THE DEAD ONES. AWAKE! AGENTS START WITH THIS NEW INVENTION**

**THE 20th CENTURY WONDER.** Get started in an honest, clean, reliable, permanent, money-making business. Sold on a money-back guarantee. **THE BLACKSTONE WATER POWER VACUUM MASSAGE MACHINE**

**FOR THE HOME. NO COST TO OPERATE. LASTS A LIFE-TIME**

**LISTEN** No Competition, New Field, New Business. Price within reach of all. That's why it's easy to sell. Endorsed by **Doctors and Masseurs**. Removes **Blackheads, Wrinkles**, rounds out any part of the **face or body**, brings back **Nature's beauty**. Almost **instant relief** can be given all kinds of pains. A demonstration **convincing** the most skeptical person. **Sales easily made.**

**Read On! What Others Do, So Can You**

**Margwarth** says, I am making **\$19.00 per day**. **Schermerhorn**, eight dozen machines first month. **Shaffer**, Am selling **four out of five** demonstrations. **Vaughn** wires, "Ship **six dozen** by first Express." **Lewis** sells **four first hour**. **Men, women, everybody makes money**. No experience necessary. **Protected territory**. Big book, "**The Power and Love of Beauty and Health**," Free. Investigate now. A postal will do. **A big surprise awaits you. Address BLACKSTONE MFG. CO., 777 Meredith Bldg., TOLEDO, O.**



**Buy Your Clothes at the Mills**

**and SAVE BIG MONEY**

We take the goods directly off the looms—cut to your measure according to latest New York style patterns, hand-tailor them here in our own shops and guarantee fit, material, workmanship, or your money back.

**Made-to-Measure Suits and Overcoats \$10 to \$22**

the kind for which you'd pay \$18 to \$30 anywhere else. You save two dealers' profits and we deliver free anywhere. Send postcard today for our new free style book with samples attached, rules for measurement, etc.

**GLEN ROCK WOOLEN CO.**  
219 Main Street Somerville, N. J.



**You ought to have one of our Insured - "VANDOR" - Hammers**



**"VANDOR" - Hammers are drop forged from Vanadium Steel, tempered in oil and are Warranted Against All Defects for a Lifetime**

Attached to every **"VANDOR"** hammer is a numbered guarantee certificate, insuring lifetime service.

A **"VANDOR"** will bite and draw a headless nail that defies the claw of an ordinary hammer.

**Sent by Parcel Post Anywhere - "VANDOR"**

Send us \$1 and your dealer's name. We'll ship the postpaid by return mail. Please state whether wanted for light or heavy work.

**VAN DOREN MFG. CO., Dept. 107, CHICAGO HEIGHTS, ILL.**  
Reference 1st Nat. Bank, CHICAGO

**ELECTRICITY**

This is your "elbow book." It's the latest edition of the **VOLTAMP ELECTRIC Catalog**—128 pages full of cuts, complete description and prices of latest experimental apparatus—Dynamos, Motors, Rheostats, Transformers, Wireless Coils—Electrical Repair Material: Raw Materials; Telephone, Telegraph and Wireless Outfits; Handbooks; Miniature Electric Railways and parts, Toys, etc. 6c in stamps or coin will bring you this book (with valuable coupon)—you'll find it worth dollars. (No postals answered.)

**VOLTAMP ELECTRIC MFG. CO.**  
Voltamp Block Baltimore, Md.

**WE DON'T WANT "AGENTS"**

—but **REPRESENTATIVES** to handle Six Patented Specialties of Proven Merit under contract for Exclusive County Rights. "Boss" Clothes Rack, "Never Slip" Clothes Line Bracket, "Security" Door Holder, "Nupantz" Creaser, "New Idea" Hose Supporter, Automatic "Clean" Curry Comb. Large and permanent business quickly established as branch agency. No charge for Rights. Ask for details of our \$1,000.00 contract. Address:

**MODERN SPECIALTY CO.**  
26th Avenue  
Racine, - - - Wisconsin

**Guaranteed Used Pianos**

A large number of fine instruments at exceptional bargain prices, many like new, exchanged for **Kimball Player Pianos**, thoroughly overhauled and guaranteed to be in splendid condition in every way.

Examples:	Schaefer Upright	\$140	Hallet & Davis	\$190	
Briggs Upright	70	Hinze Upright	145	Kimball Upright	220
Colby Upright	90	Fisher Upright	165	Steinway Upright	275
Emerson Upright	110	Whitney Upright	185	Kimball Upright	275
Decker Bros. Upr't	135	Chickering Upright	175	Knabe Upright	175

We ship anywhere to reliable people on easy payment terms. Write Today For Complete List, Prices, and Terms and Beautiful Illustrated Musical Herald **FREE**, and catalogue New Kimball Pianos.

**W. W. KIMBALL COMPANY, 1297 Kimball Hall, Chicago, Ill.**

**Our Big Cash Purchase Enables You to Buy a Beautiful Diamond from GEO. E. MARSHALL at a Great Saving**

**We Have Been the Leading Diamond Merchants for Over 30 Years—Ask Anybody**

A pre-holiday opportunity to buy a perfect cut, blue white, 1-4 carat diamond, set in 14K gold mounting, at a saving of \$11.25. The regular price is \$40.00. We will fill orders from this lot while they last, at **\$29.75**

If not satisfied we return your money. We have a few larger stones at proportionately low prices—send for list. Cash with order insures prompt shipment by return Parcel Post to your door. State Ladies' or Gents' and finger size. Send today and avoid disappointment.

**MARSHALL DIAMOND CO., Dept. P.M. 13, Chicago, Illinois**

**You Get a Marshall Guarantee Bond**





## Always Under Control

No danger of your bicycle ever getting away from you if it is fitted with the famous

## Musselman Automatic Coaster Brake

*"The Little Fellow with the Big Grip"*

The strongest bicycle coaster brake in the world, and so simple in construction that a child can take it apart and put it together again. Every rider of a bicycle who will send us the name of his local bicycle dealer will receive by mail postpaid a beautiful felt pennant, FREE OF CHARGE.

**THE MIAMI CYCLE & MFG. CO.**  
350 Ashby St. MIDDLETOWN, OHIO

## Invisible Suspender Belt

Fits instantly inside trousers waistband entirely out of sight. Does away with unsightly suspenders and tight belts. Keeps trousers up and shirt down—neat—comfortable. For fat men, lean men, office men, mechanics, boys.

THE KO-KO-MO INVISIBLE SUSPENDER BELT is for winter wear as well as summer. Sold by all good clothiers and furnishers. Or send us



50c

for sample belt—in silk. \$1. Money refunded if not entirely satisfactory.

**KO-KO-MO BELT CO., Desk P, KOKOMO, INDIANA**



## As Much and More than 1/2 Saved On Unredeemed Pledges Diamonds and Watches

**Examine—If Satisfied, Pay—If Not, Return. We Ship, Privilege of Examination**

Before buying a diamond or other jewelry let us prove by satisfied buyers the tremendous savings in our prices under dealers, mail order, retail or even wholesalers.

**Our Big Bargain Bulletin** tells the whole story—how as "Headquarters for Loans" for over 60 years, we have advanced money on fine diamonds, watches, etc. Our investment but a fraction of their real value. Thousands of unredeemed pledges—the necessity for disposing of which is a real reason back of the amazingly low prices. Send for free copy of illustrated listings fully described.

### Worthwhile Christmas Gifts

*On Which We Accept A Deposit For Later Delivery.*



No. 24699. 1-3/16, 1/32 kt. guaranteed genuine perfect cut blue-white diamond solitaire in ladies' regulation ring. Try to match it at \$250. With Guaranteed Loan \$110, **Unredeemed Price, based \$128.35** on loan.....



No. 342793. 3/8-1/16, 1/64 kt. guaranteed weight genuine diamond solitaire; perfect cut blue white quality in gentleman's ring. Try to match it at \$65. **Unredeemed Price, hard \$33.85** to believe, but.....

No. 345964. Celebrated 21-jewel, Father Time grade Elgin railroad watch—fully adjusted. In genuine 20-year gold filled case. Prime new condition. Try to match it at \$40 to \$45. Complete, **\$16.90** **Unredeemed Price,.....**

### Money-Back Guarantee

We pay expressage and run all risk of pleasing you in the examination. Your money back if any article should not be perfectly satisfactory to you, even though exactly as represented. This guarantee is backed by our \$750,000 capital. Sixty years in one location is proof of our reliability.

**Jos. DeRoy & Sons**  
Smithfield Street 310 DeRoy Bldg., Pittsburgh, Pa.  
*References, by permission, Farmers' Deposit National Bank, Marine National Bank, Dun's, Bradstreet's*

## When Buying CLOTHES You Need This BOOK

and Our Sample Folders.  
**Free Upon Request.**

Our 48-page **Style Book** shows the Season's Best in **CLOTHING, UNDERWEAR, HABERDASHERY, ETC.**

Say which **FOLDER** you want or all five if desired. **FOLDER A**—Men's ready-made Suits and Extra Trousers. **FOLDER B**—Men's ready-made Overcoats and Cloth Raincoats. **FOLDER C**—Boys' ready-made Suits and Overcoats. **FOLDER D**—Men's, Boys', Women's, Misses' and Children's Slip-on Raincoats. **FOLDER T**—Men's Tailored-to-Measure Clothing.

Prices one-third to one-half less than you pay elsewhere, for Style, Quality and Fit.

**C. V. BOLLER COMPANY**  
*The House for Men and Boys*  
374 Bridge St., New York



## Send for Copy of Our New Wireless Manual P1

It contains 96 pages and tells how to erect and maintain wireless telegraph stations. Shows a number of diagrams. Has the Morse and Continental Telegraph Codes. Illustrates the best instruments to use; tells what they are for and how to use them. Do not wait until some other time, but sit down now and send your name and address, and get one. It costs you nothing.



## Send for Our Pocket Catalog P26

It contains 212 pages, with over 1,000 illustrations and describes in plain, clear language all about Bells, Push Buttons, Batteries, Telephone and Telegraph Material, Electric Toys, Burglar and Fire Alarm Contrivances, Electric Call Bells, Electric Alarm Clocks, Medical Batteries, Motor Boat Horns, Electrically Heated Apparatus, Battery Connectors, Switches, Battery Gauges, Wireless Telegraph Instruments, Ignition Supplies, etc.

**It Means Money Saved to You to have our Manual and our Catalog when you want to buy**

**MANHATTAN ELECTRICAL SUPPLY CO.**  
NEW YORK, 17 Park Place    CHICAGO, 114 S. Fifth Ave.    ST. LOUIS, 1106 Pine St.    SAN FRANCISCO, 604 Mission St.



# SAVE 30% TO 50% ON YOUR FURNITURE

Build it in your own home from finished sections bought direct from our factory—at actual factory prices.

All you need is a screw-driver and your spare time. All you pay is for actual value of materials and workmanship.

We build the complete "Come-Pack" line of high quality living, dining, bedroom and den

**SECTIONAL  
"COME-PACK"  
FURNITURE**

furniture in sections, finished to your order—your choice of eight shades—hand rubbed polish—and ship direct to you with full directions so that you can set up any piece right in your home in just your spare time and save from 30 per cent to 50 per cent of what you

would pay for common, old style furniture elsewhere.

## SOLD ON A FULL YEAR'S TRIAL

When you buy your furniture on this new plan—this new idea that has surprised the furniture world—you get 100 per cent quality, because you see each piece in sections before they are assembled. Nothing can be covered up—you get actual quality.

Every piece of Come-Pack Furniture is of pure quarter-sawn WHITE oak—not red oak, or any other cheap grade of oak or imitation—it has the character that befits and distinguishes the home of quality. It is guaranteed—and sold upon a full year's free trial. Learn all about the

## SOLID WORTH AND BEAUTIFUL CREATIONS OF COME-PACK CRAFTSMANSHIP

If you love beautiful things in the home—furniture of actual quality in choice designs—solid worth and character throughout—then send for our big new catalog today and learn how this great, new idea of furniture built in sections and shipped direct from factory to you will save you one-half in price and will offer you a choice of designs and finishes that will give your home an atmosphere of harmony and taste.

Take this beautiful Mission Library Table, for instance, measure out its dimensions with a tape measure. Compare it with any piece equally good at any dealer's. It saves you more than one-half—and it is sold to you on a full year's money-back guarantee.

Although our business is comparatively new, we are now supplying regularly over 30,000 American homes who appreciate the wisdom of buying quality at less than is usually paid for ordinary grades of furniture.

## SEND FOR THIS NEW CATALOG TODAY

Our advance 1914 catalog is ready for distribution. It is the most beautiful furniture book ever given away—tells all the details—gives you a choice of over 400 pieces in living, dining and bedroom furniture—color plates showing the exquisite finish and upholstery—factory prices. Write for this beautiful big book today—it is free—prepaid.

COME-PACK FURNITURE CO., 1001 Fernwood Ave., TOLEDO, O.

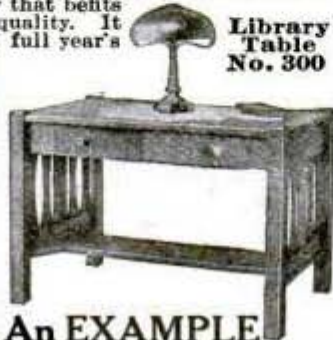

An EXAMPLE of Come-Pack Bargains

This handsome table is Quarter-Sawn White Oak, with rich, deep, natural markings; honestly made; beautifully finished to your order, shipped completely stained—your choice of eight shades—hand rubbed polish. Height, 30 inches; top, 44x28 inches; legs, 2 1/4 inches square. Two drawers; choice of Old Brass or Wood Knobs. It comes to you in four sections, packed in a compact crate, shipped at knock-down rates—shipping weight 150 lbs.

With a screw-driver and just your spare time you have a table that would ordinarily sell for \$25.00!

Our Factory Price, Shipped in Finished Sections, Only \$11.75



## This Powerful \$20 Little Gas Engine

Our new model "Elgin" is a radical departure from old style heavy types. It is built simply, durably and for maximum service. Has remarkable power for its size; will pull a load considerable in excess of its rated horse power.

1/4 H. P. **Elgin Engines**

1/2 H. P. are small, strong, light and easy to handle with no heavy or intricate parts to wear out. Will last for years with reasonable care.

**Absolutely Guaranteed**

Elgin Engines are sold with trial privileges. Will operate row boats, washers, sewing machines, light machinery, etc. Write today for our catalogues.

Elgin Wheel & Engine Co., Dept. 148, Elgin, Ill.



# Prest-O-Lite



## The Only Practical Light for Motorcycles

Prest-O-Lite is the only lighting system that makes night riding possible, pleasant and SAFE.

This ready-to-use gas costs no more—usually costs less—than the carbide a generator consumes.

The first cost is low [\$10]. Prest-O-Lite never gets to be second-hand, and is always a READY CASH ASSET.

You can easily afford it. You cannot afford to be without it if you ride at night. One accident might cost you more than years of Prest-O-Lite service.

Easily attached to any motorcycle. We will arrange for immediate exchange service for anyone, anywhere.

See any motorcycle (or automobile) dealer, or write us.

## DON'T ACCEPT AN IMITATION!

The genuine Prest-O-Lite, when empty, can be immediately exchanged for a full one, ANYWHERE AND ALWAYS. Imitations cannot.

THE PREST-O-LITE CO., 265 Speedway, Indianapolis, Ind.

Branch offices and Service Stations in all principal cities. Charging plants in all parts of the country.

Exchange Agencies Everywhere

## POP-CORN FRITTERS MAKE BIG MONEY



Perrine, Cal., says: "One day's sales \$380.00." Start in safe, easy, profitable, fascinating business. Everybody likes fritters—everybody buys. Think of fortunes made in 5c pieces. Get full particulars—reports from others. Hurry. Write a card now.

786 High St. W. Z. LONG CO. SPRINGFIELD, OHIO.

## Health? Take Turkish Bath at Home—Only 2 Cents



Physicians are abandoning drugs for this new treatment. If your mind or body is tired, open your pores and feel the rapid change in your condition, at cost of 2c a bath. The Robinson Bath Cabinet is the only scientifically constructed bath cabinet ever made for the home. Great \$2 Book Sent Free—"The Philosophy of Health and Beauty." Write today. Agents Wanted. ROBINSON MFG. CO., 319 Robinson Bldg., Toledo, O.

## SAVE THE DEALER'S PROFIT

\$36.25

Freight Paid

on any of our 6 models, with outfits complete. Lockwood-Ash Motors sold only from factory to user, and every one guaranteed for a year.

## 30 DAYS' TRIAL

Will Ship at Once

freight paid. It must please you or send it back at our expense. 1 1/2 H.P. motor and outfit complete, \$36.25—a clear saving of \$13.25. Post yourself on motor boating and the best way to buy motors by sending today for our beautiful 1913 catalog.



1 1/2 H. P. Outfit Complete

LOCKWOOD-ASH MOTOR CO. 208 Horton Street, JACKSON, MICH.



# DRAFTSMEN GET BIG PAY

Learn at home by our  
new, easy method

The American School is making a **Special Offer** to those who never had a chance to get a technical education. This is a wonderful opportunity for you to get the training you need—in your spare time and in your own home. Learn drafting. It will bring you big returns—you can earn from \$75 to \$200 per month. Your success depends only upon your ability and the kind of instruction you have had. There is a constant demand for draftsmen. It is one of the few professions where the demand exceeds the supply. Send for our big **Special Offer** today. Fill in and mail the coupon now. We will send you our general bulletin and complete information about your course. Remember, this is the greatest offer ever made—by the largest correspondence educational institution in the world—with a capital of over half a million to back it up.

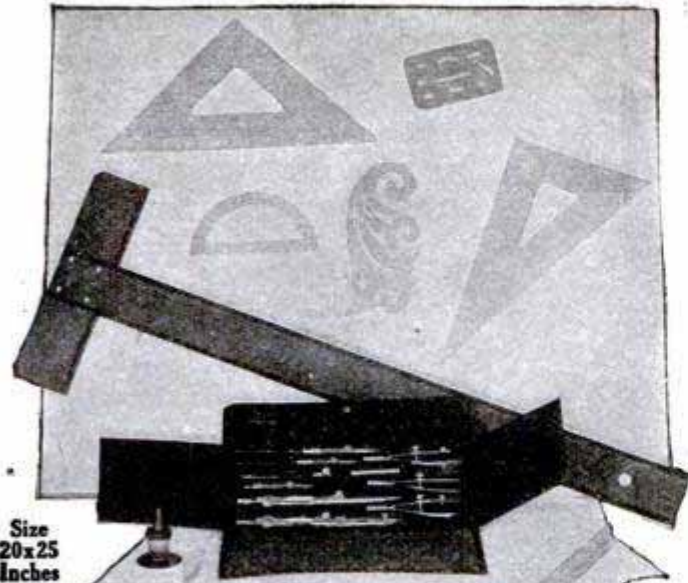

Size  
20x25  
Inches

**FREE** This \$20 Draftsman's Outfit

exactly as illustrated, consisting of imported german silver drawing instruments in morocco case, drawing board, ebony lined mahogany T-square, two transparent triangles, german silver protractor, French curve, triangular boxwood scale, waterproof ink, pencil, ink and pencil erasers, erasing shield, pencil pointer, handmade drawing paper and thumbtacks. The instruments are manufactured by one of the largest makers of mathematical instruments in the world, and are guaranteed absolutely accurate.

# FREE

This complete Cyclopedia of Drawing, value \$20, included absolutely free if you enroll at once. This great work, consisting of four big volumes as illustrated below, covers completely the entire work of the architectural and mechanical draftsman. Its value as an adjunct to the course we now offer cannot be estimated. Not only will you receive personal instruction from our expert draftsmen, but you will have these books at your elbow to settle immediately any question that may arise. The four volumes are bound in half red morocco, gold stamped, and contain 1,720 pages, 7x10 inches; 1,037 illustrations, full page plates, diagrams, designs, etc.

Remember, these books do not cost you one penny—they are included without charge with the course.

## SALARY GUARANTEE

**THE AMERICAN SCHOOL OF CORRESPONDENCE GUARANTEES** that you will receive an increase of fifty per cent over your present salary within three years from the date of your enrollment; or, failing in this, the School guarantees to refund to you the full amount paid for your course. Back of this guarantee stands the School—for more than fifteen years the foremost educational institution of its kind in the world. This school has succeeded because it has been true to its principles of giving its students the instruction for which they enrolled.

## MAIL THE COUPON — NOW

Don't fail to take advantage of this great offer—an offer that has never before been equalled. Keep in mind that the \$20 draftsman's outfit and an up-to-date four volume reference work of the same value are sent absolutely without charge when you enroll in this course. Don't pass up this opportunity. At any rate, mail the coupon and get complete information regarding this great offer. It will cost you nothing to investigate—it may be the turning point of your fortunes. Send the coupon now!

**American School**  
of Correspondence. Chicago, U.S.A.

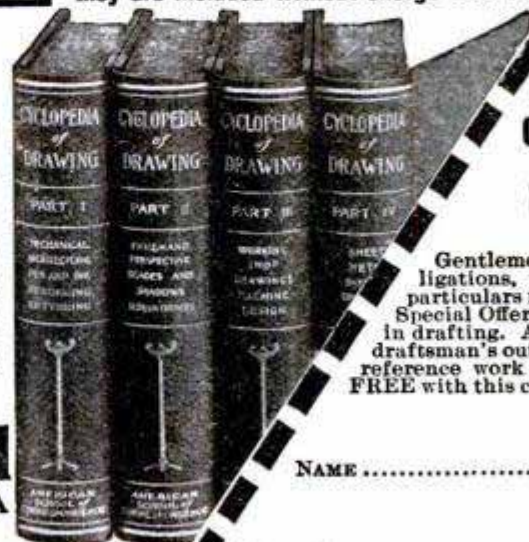

## SPECIAL OFFER COUPON

AMERICAN SCHOOL OF  
CORRESPONDENCE  
Chicago, U. S. A.

Gentlemen:—Without any obligations, please send me full particulars regarding your great Special Offer on a complete course in drafting. Also tell me about the draftsman's outfit and four volume reference work which are included FREE with this course. Pop. Mech. 10-13

NAME .....

ADDRESS .....



# DUCK'S CATALOG

## Big 300 Page Electrical and Wireless

Supplies (Including a big line of Xmas Novelties)

mailed for 10c. stamps or coin, which you may deduct from first order of \$1.00. Great cost of catalog and low prices prohibit distribution except to those interested.

### Most Elaborate Catalog in Its Line

this catalog for everybody, and there is nothing but will be found to bear the stamp of highest quality. Just one example: Our toy and commercial motors embrace practically the complete output of five leading motor manufacturers. But the great impelling value of this complete catalog is the attractive prices at which these high grade goods are sold.

### 20% to 33% is Saved in Purchasing from Us

On the single item of flash-lights we sell them to you at most dealers' cost price, and this is true of many other articles.

### 125 PP. Xmas Gifts

(See brief contents opposite) will be found in this great catalog.

THE J. J. DUCK COMPANY, Arcade Bldg., Toledo, Ohio

### What Our Catalog Contains :

100 pages wireless insts. for commercial and amateur use, with over 30 diagrams; 10 pp. raw material for wireless insts.; 15 pp. telegraph insts.; 35 pp. toy and commercial motors; 15 pp. flash lights and miniature lamps and 125 pages ammeters, transformers, lighting plants, miniature railways, Xmas novelties and general electrical supplies.



### "THE CHESTERFIELD"—a thoroughbred

The aristocrat of "rough surface" hats. Equal for dress with overcoat. Sold only by us. Of wool Chinchilla. Colors—Dark Gray; Dark Brown; Black. Silk-serge lined; silk band. Easily worth \$3. We charge \$2 PREPAID. Money back if you don't like it. Order now—simply state size and color and enclose \$2. Write for "1923 Fall Style Book"—FREE.

FRENCH CO., 271 ARCH STREET, PHILADELPHIA, PA.



## Beacon BURNER FREE!

Fits Your Old Lamp 100 Candle Power Incandescent pure white light from (kerosene) coal oil. Beats either gas or electricity.

COSTS ONLY 1 CENT FOR 6 HOURS We want one person in each locality to whom we can refer new customers. Take advantage of our Special Offer to secure a Beacon Burner FREE. Write today. AGENTS WANTED.

HOME SUPPLY CO., 11 Home Bldg., Kansas City, Mo.

PORTUGUESE MINES WORKED 2,500 YEARS AGO—Evidence of Roman mining operations over 500 years B. C. still exists in Portugal. These mines yielded ores rich in copper, gold and silver. With the crude facilities for breaking rock then available, these workings were not very extensive and much valuable ore was left in place to be mined under modern conditions.

## Tailoring Salesmen WANTED

We want live, energetic hustlers, men who can make good; who are ambitious to start in a business of their own. No canvassing; no experience required; no capital necessary. We furnish everything to start. Hundreds are making from \$100 to \$200 per month and expenses. We guarantee absolute satisfaction and take all the risk. We are one of the largest woolen mills in the country and positively have the only up-to-date, high-quality, low-priced tailoring on the market.

A great many of our men are making from **\$25 to \$50 Every Week**

We furnish a complete agents' outfit, consisting of large sample book (not a folder), order blanks, tape measures, advertising matter—in fact everything essential to the conducting of a high-class tailoring business.

Write today for this big outfit It is sent express prepaid. Drop a postal and say "Send me your agents' outfit." We will start you at once on the road to Success. Be sure and write today

DANIEL WOOLEN MILLS, Dept. W, 300 Green St., Chicago



### Complete Wireless Receiving Set \$2.65

Consists of 1 DOUBLE slide tuner 7 1/4 inches long wound with 150 ft. of No. 24 wire, our "Don't Jar Out" universal detector, a remarkable 75 ohm 75c receiver and cord, 1 fixed condenser, 1 buzzer and switch that tells you if your detector is working. Ginsulators and diagram. Send stamp for bulletin No. for other remarkable values. Nichols Elec. Co., 35 Frankfort St., New York

### \$15.00 TO \$20.00 PER DAY PROFIT FOR YOU!

Here is your chance to go in business and make BIG MONEY this summer. No knowledge or experience in photography required. Photos made direct on POST CARDS or TIN TYPES without the use of plates, negatives or dark room. Developed, toned and fixed in one solution, and delivered on the spot in ONE MINUTE. Don't miss this opportunity to become independent. Write today for our new catalogue and price list.

JAMESTOWN FERROTYPE COMPANY  
Dept. 146, 1113 S. Halsted Street, Chicago, Ill.



## Guaranteed, Full Jeweled, High Grade Watch at a Big Saving

A Wonderful Opportunity to Purchase a "Lifetime" Watch For a limited time only, we offer this superb, latest thin model, 20 year guaranteed, full jeweled \$25 watch at \$12.75. An exceptional opportunity to purchase at a big saving.

Lowest Price Ever Made on a High Grade Watch

We are known nation wide as leading watch dealers and have never made such a remarkable reduction before. You get a MARSHALL Guarantee bond which protects you against defects for TWO YEARS. All orders on this offer must be in within 30 days. State size and style. We ship at once by insured parcels post to your door.

MARSHALL WATCH CO., Dept. P. M. 14, CHICAGO, ILL.



\$25.00 Value for \$12.75



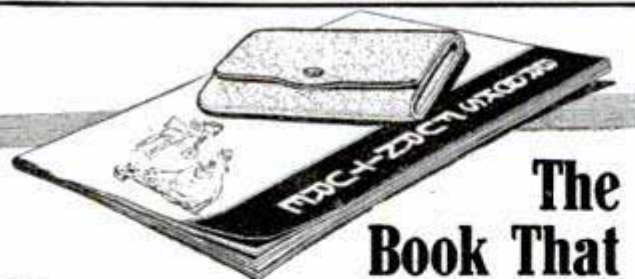

## The Book That Helps Little Pocket Books Grow Big—Mailed FREE

Thousands of the best homes have been furnished in elegant style, yet with surprising economy with Brooks Quarter-Sawed Oak Furniture.

Our plan of shipping Master Built Furniture direct from factory helps both big and little pocket books save money. No matter what you need in furniture you ought to have this book. Learn how easy you can either save half your money or get twice what you expected to buy. It has scores of real bargains on

## Brooks Master Built Furniture At Brooks Factory Prices

All pieces guaranteed. Money back if not satisfied. Finished complete in our factory, then shipped in sections. Any one can re-assemble them in a few minutes.

This system is outlined fully in Brooks Furniture Book. It shows how easy you can save \$25.00 to \$50.00 or more in furnishing your dining room or bedroom and perhaps twice as much more in furnishing your home complete.

Hundreds of dealers are buying and assembling Brooks Furniture, then adding 40 to 50 per cent to our prices and selling it to their best trade. Dealers pay us the same price you would. Our catalog prices are the same to everybody, no matter whether it's one piece or a car load.

## Mail a Postal for the Book

You will be convinced of the saving when you see the hundred or more bargains we offer in it. Let us send you a copy—it's free. Address

**BROOKS MFG. CO.**

2710 Sidney St.

Saginaw, Mich.



Dining Table No. 311

Brooks Price **\$2250**

Dealer's Price \$45

Height 30 inches, 54 in. top—extends 90 inches, 1/4 in. thick.

Dining Chair No. 13

Brooks Price **\$250**

Dealer's Price \$4

Height 39 inches, width 17 1/2 inches—Depth 18 inches.

# Just Out!! A New Camera



Weights  
24 Ounces

## The "Mandel-ette"

The most wonderful sensation of this age. A gigantic success. Every man, woman and child can now be his own photographer. The "Mandel-ette" is

## A One Minute Camera

that takes and finishes pictures in one minute.  
No Experience Needed

### No Plates or Films—No Printing or Dark Room

This is just what you have been waiting for—a camera that can be operated easily and without one bit of experience in photography. The pictures are snapped DIRECT ON THE POST CARDS and are finished right within the camera in less than one minute.

The "Mandel-ette" weighs only 24 ounces and embodies a camera, dark room and developing chamber all in one. Capacity 50 paper post cards (2 1/2 x 3 1/2 inches) at one time. Loads in day light. The "Mandel-ette" has a special lens with universal focus. Perfect working guaranteed shutter. Our "3 in 1" developer finishes the pictures in less than one minute without any other solutions. No over-developing. So simple that a child can make pictures as well as grown-ups. Get a "Mandel-ette" for your vacation and know real "picture-taking" joys. No fuss or muss—no bother or expense. Everybody will soon have his "Mandel-ette". GET YOURS NOW. Take advantage of this

## Special Introductory Offer

To introduce the "Mandel-ette" everywhere, we make this special, attractive offer to you.

**\$5 For a Complete Outfit \$5**

By Parcel Post 50 Cents Extra

This outfit includes the wonderful "Mandel-ette" camera and everything that is needed to make sixteen finished pictures. Additional Post Cards 25c per package. The "Mandel-ette" is sold upon our absolute guarantee—

**Your Money Back If Not Satisfactory**

Send \$5.00 With This Coupon Today

## SPECIAL OFFER COUPON

The Chicago Ferrottype Co.

ABI Ferrottype Bldg., Chicago, or Dept. A81 89-91 Delancey St., New York  
GENTLEMEN:—Enclosed please find \$5.00, (50c extra by parcel post). Send me at once one "MANDEL-ETTE" camera and complete outfit for making sixteen finished photographs.

Name .....

Address .....

Town .....

State .....

Send today for free descriptive booklet to either office.

**THE CHICAGO FERROTTYPE COMPANY**

ABI Ferrottype Bldg., Chicago, or Dept. A81

89-91 Delancey St., New York

Please Mention Popular Mechanics



The Pictorial Review of Current Events

# Cartoons

15 Cents a Copy

Magazine

\$1.50 per Year

[By H. H. WINDSOR, Editor Popular Mechanics Magazine]

Get the October Number

And keep up with the events of this busy world without wasting hours of your time.

In Its New Garb the Cartoons Magazine Becomes the Magazine for Everybody

Its pages are crowded with the best work of the cartoonists of the world and these clever drawings are accompanied by comment gleaned from the columns of editorials penned by newspaper writers trained to follow the questions of the day.

Cartoons Magazine has become the ready reference book of the up to date man. It is not a mere collection of clever pictures but is a magazine that improves and educates.

Ask your newsdealer to show you the October number, or

Send your order to **CARTOONS**, 318 W. Washington St., Chicago, Ill.

Bound Volumes  
One, Two and Three  
NOW READY

These bound volumes contain more than 3,000 reproductions of the very best cartoons that have been printed during 1912 and 1913. A collection of more than 120,000 cartoons was made in order to secure them. Bound in the three volumes they make an "instant history" of the past months, for they are a pictorial record of the events of the world.

These three books, artistically and durably bound, are now ready for distribution and will be sent all express charges prepaid to any address in the United States or its possessions upon receipt of **One Dollar Each**

**YOUNG MAN! LEARN DRAFTING**

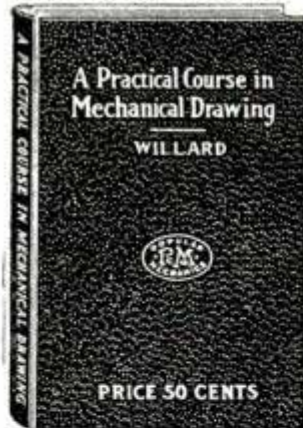

**ONE** of the most practical subjects of study today; an essential in most lines of engineering; indispensable in many occupations and often the secret of successful advancement; of no less importance to the farmer than the mechanic. There is bound to come a time when you will feel the need of the ability to "lay out" something in accordance with the rules and conventions used in the drafting profession.

**Individual Study**

may be successfully engaged in with the aid of our new enlarged edition of the book

**A Practical Course in Mechanical Drawing**

By **WM. F. WILLARD**

(For several years instructor in Mechanical Drawing at Armour Institute of Technology, Chicago)

**160 PAGES — SIZE 5x7 — 157 DRAWINGS — CLOTH COVER**

**Price 50 Cents, Postpaid**

There has been a real need for a book of this kind, as it clinches each problem in the mind of the student by giving the practical application of that problem to every day practice in some phase of the world's work. It meets every modern requirement and is in advance of any other work on the subject. Excellent for use in shop classes, trade or high schools. *A complete detailed description of the contents of this book sent free upon request.*

Order of your Book Dealer or direct from the publishers

**POPULAR MECHANICS BOOK DEPT.**  
318 W. Washington St., CHICAGO

**Farming with Power**

"Written So You Can Understand It"

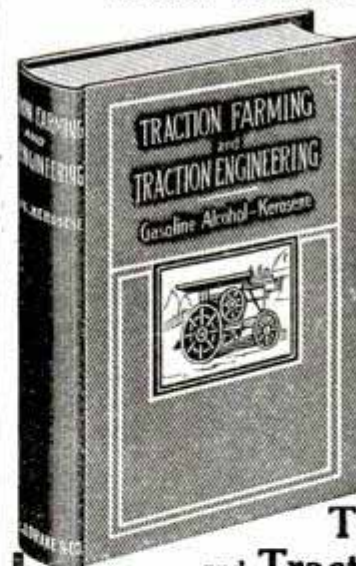

The development and use of machinery as one of the most important factors in modern farming is too well known to require comment. What we want to emphasize is that a proper understanding of how to run, care for and repair this machinery is a requisite for every farmer who would be up with the times. An urgent demand for such information has prompted the publication of

**Traction Farming and Traction Engineering**

**GASOLINE — KEROSENE — ALCOHOL**

**A book that shows the how and tells the why of power farming**

**PART I — Farm Tractors. PART II — Water Supply and Electric Lighting System for Farm Homes. PART III — The Science of Threshing and Types of Threshing Machines.**

This book treats in a thoroughly practical manner all there is to know of Traction Engineering and was written by practical men.

**336 Pages — 151 Illustrations and Working Diagrams**

**Cloth — Price \$1.50, Postpaid**

**POPULAR MECHANICS BOOK DEPT.**  
318 W. Washington St. CHICAGO





LB4901. 18K. Lewy Solitaire. Platinum Setting. 1/2 carat Violet Blue Diamond.



LB4904. Lewy Tooth Ring. 14K. Solid Gold Mounting. 1/2 carat Steel Blue Diamond.

## VIOLET BLUE DIAMONDS

Your choice from our \$1,000,000.00 stock for FREE EXAMINATION



### NOW IS THE TIME TO BUY A DIAMOND

The new tariff law raises the duty to 20%! Act quickly if you want a diamond at our present importers' prices!

### DIAMONDS of QUALITY APPROVED BY OUR EXPERTS

Nothing in our stock less fine in color than the best BLUE WHITE; you are assured the utmost in QUALITY if your diamond comes from us. Our standards of Quality in selling to you are the same as followed by our experts when they buy in Europe. STEEL BLUE means STEEL BLUE; PERFECT means PERFECT with Lewy Bros. Co.

**LEWY BROS. CO. GUARANTEE** is in writing—tells you legally, color, perfection of every diamond. It guarantees to you 12% per year MORE THAN YOU PAID! in exchange, any time. We are the only importers in the world who give you the full benefit of the 12% yearly rise in diamond values. Full price refunded if not satisfied. Protect your investment with our Guarantee.

WE SEND YOU ANY DIAMOND AT OUR EXPENSE, ALLOW EXAMINATION—NO OBLIGATION TO PURCHASE

**FREE!** LEWY DIAMOND BOOK! Illustrated. Considered by experts the most practical, beautiful and costly book for the guidance of diamond buyers ever produced. Write for a free copy right away!—and learn facts about Diamond Qualities and values it has taken our experts 78 years to acquire.

Most Prominent Diamond House in Chicago—Founded 1835—79th Year  
**LEWY BROS. CO., Dept. D27, STATE & CHICAGO**



LB4902. 14K. Twin Ring. Platinum Stg. Two matched 1/2 carat Blue White Diamonds.



Platinum La Valliere. Paved with Steel Blue Diamonds. LB 4903. Platinum Chain.



LB4905. Special Lewy Solitaire. 1 1/2 carat Blue White Diamond.



LB 4906. 14K. Solitaire Stud. 3/8 carat Blue White Diamond.



LB4907. 14K. Solitaire Scarf Pin. 5/8 carat Steel Blue Dia.

**OIL FIELD FOUND IN CUBA**—Oil has been discovered in the province of Matanzas, Cuba. The well was drilled near Legunilla and 100 bbl. per day are being secured by pumping. The discovery of oil in this quantity is an encouragement and will result in the sinking of a number of test wells.



**\$15.00 to \$35.00 Per Day** Easily Made  
 Taking photographs with our **ONE MINUTE TINTYPE and POSTCARD CAMERAS**. Pictures made direct without use of negatives. Toned, fixed and developed in one solution. No experience or dark room necessary. **Cameras from \$10.00 up to \$35.00 each**. Complete photos cost 1c to 2c each, sell for 10c, 15c and 25c each. Send for Free Catalogue and Price List today.  
 NEW YORK FERROTYPE CO., 168 Delancey St., New York City, Dept. III  
 Branch 1113 S. Halsted Street, Chicago, Ill.

**WHITE VALLEY GEMS** LOOK LIKE DIAMONDS  
 Stand acid and fire diamond test. So hard they easily scratch a file and will cut glass. Brilliance guaranteed 25 years. Mounted in 14k solid gold diamond mountings. See them before paying. Will send you any style ring, pin or stud for examination—all charges prepaid. No money in advance. Money refunded if not satisfactory. Write today for free catalog.  
**WHITE VALLEY GEM CO., 701 Wulsin Bldg., Indianapolis**

# Kwicksharp

**AGENTS WANTED**

**KNIFE SHARPENER AND SCISSORS GRINDER**

**Make Big Money**

Sell something everybody needs and will buy. Kwicksharp, in the hands of man, woman or child puts the keenest edge on the dullest cutlery in a moment or two. Small price, big profit. Exclusive territory. No competition. Field for sale—everybody using knives and scissors and wanting to keep them sharp.

**Agents MAKE \$5 to \$10 a DAY**

**SPENGLER BROS. CO.**  
 436 Atlas Blk., Chicago, Ill.

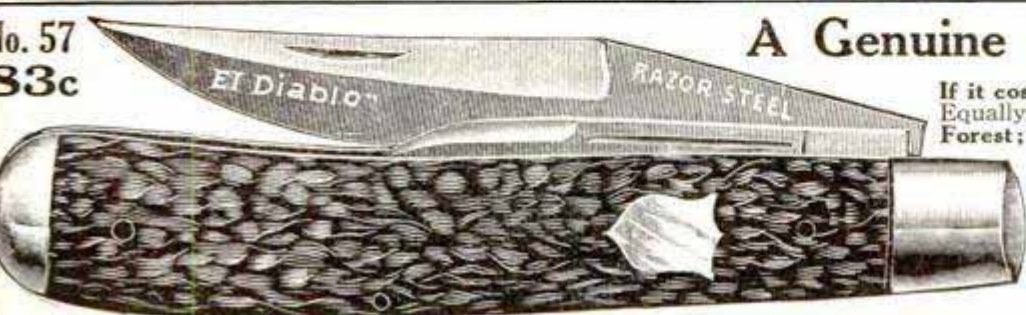

No. 57 83c

A Genuine \$2 Knife for 83c

If it cost \$10 it could not be made better. Equally good in the Shop, the Farm, or Forest; light but extra strong; resharpened easily. Stag handle, German silver finish; blades file tested, hand forged razor steel and warranted. Sample 83c, 3 for \$2, postpaid. Choicest Pearl \$2 each. Send for 80-page Free List and "How to Use a Razor"  
**MAHER & CROSH CO.**  
 106 A Street TOLEDO, OHIO



Independence  
and a  
Competence  
for  
Life



You are on  
LONDON BRIDGE  
Today

## Do You Remember

the experience of the philosopher who offered English sovereigns for pennies on London bridge a century ago without finding a taker—how the passers-by ignored the opportunity and lost the profit because they thought it *too good to be true*?

And do you realize today that *YOU* are face to face with an offer, every whit as profitable to *YOU* as the exchange of copper for gold—if you are quick to grasp it?

## \$2,000 to \$5,000 a Year

net income from ten acres of matured apple and cherry orchard in the *frostless* and *wormless* Bitter Root Valley with a *home and six months vacation* annually in one of the most magnificently endowed natural environments on the Creator's footstool, with *golf links, hunting, fishing and mountain climbing* and with neighbors of culture, education and refinement—is the opportunity we offer you.

We believe you will *investigate* this opportunity because this appeal for investigation is directed to broad-minded and sensible readers, living in an age of scientific progress which has made the impossible of yesterday the reality of today. This is *not* an offer of something for nothing. It is an opportunity for you to make an immensely profitable compact based on mankind's partnership with nature. *We are now growing more than three thousand acres of fruit trees, one to three years old, for satisfied customers who would not consider selling their orchards at a large advance over their cost.*

## \$2,000 to \$5,000 Yearly From Ten Acres

A Bitter Root Valley apple orchard bears commercially in its fifth year. Ten acres, fully developed, should be capable of returning you during early maturity, strictly net, a profit of \$2,000 to \$5,000 yearly. Beginning with the 10th year from planting, judged by experience of others, 10 acres should net you an income of \$5,000 yearly and employ only half your time.

If you have a fair-sized income now and are willing to improve your condition, *you do not need much capital* to possess one of these big-paying orchards.

### Our Proposition and Plan

briefly stated is this: We will sell you a **CHOICE 10-ACRE PLANTED and GROWING ORCHARD**, best standard varieties apples and cherries—with the *Company's definite written contract* to care for and develop your orchard under expert horticultural supervision for five full growing seasons from date of planting, including all land taxes and irrigation charges. You may, if desired, assume personal charge of your orchard at any time and secure a refund.

The land should easily become worth, conservatively stated, in fair comparison with other improved land, \$1,000 an acre. There is a clean profit to you of 100 per cent on a 5-year investment to count on at the outset. Only a \$300 cash payment required now to secure your orchard tract—balance in easy payments divided over a ten year period. Your payments for the first few years are practically **ALL** the cash outlay you will have, as *your orchard tract should meet all payments falling due while in commercial bearing period and yield you a handsome profit besides*. Our reservation plan provides for *inspection of the land by you*, and your money back if dissatisfied.

— **INVESTIGATE by using this coupon TODAY** —

**BITTER ROOT VALLEY IRRIGATION CO.**

849-855 First National Bank Building, Chicago, U. S. A.

Robert S. Lemon, General Sales Manager:

Please send me full information concerning your Riverview Orchard Tracts in Bitter Root Valley.

Write your name and complete address plainly on the margin below

# Clark Heaters for WINTER DRIVING

In Auto, Sleigh or Carriage

In coldest weather a Clark Heater will always keep you warm. It is neat, compact, attractive and unbreakable; supplies the heat without flame, smoke or smell. We make twenty styles of these heaters from 90c to \$10 each. Most of them have attractive carpet covers with asbestos lining. They have been on the market nearly twelve years and have pleased every purchaser. We guarantee that you will be well satisfied or money refunded. They fit in at the feet, occupy little space and are just the thing for real comfort.

Don't shiver and get cold.  
Use a Clark Heater

and keep warm, cozy and comfortable on every business or pleasure trip in cold weather. Ask your dealer for a **Clark Heater**—the only kind that will last indefinitely, never get out of order, and heat as much or as little as you want. Insist on the **Clark**.



Write for complete free catalog—a postal will bring it. Why not **WRITE NOW**?

**CHICAGO FLEXIBLE SHAFT CO.**  
105 La Salle Ave. CHICAGO

## A pocket KNIFE SHARPENER FREE

The tough, sharp crystals of a Pike India Oilstone just *eat* steel. It's fun to see how quickly they put a dandy, keen edge on carvers, kitchen knives, tools, etc. No other

stone cuts so fast without losing its shape.

Adopted now by manual training schools, big machine shops, etc. Nothing like it. This is only one of the famous

## PIKE SHARPENING STONES

"The only line that includes every sharpening substance—natural or artificial—each the best for some sharpening need."

Every home needs one. Hardware and tool stores everywhere sell them.

Let us mail you a Pike India Vest Pocket Stone for pocket knives, office use, etc. Just send your dealer's name and 4c. for packing and mailing.

We'll include "How to Sharpen"—greatest book ever written on sharpening and how to select and care for oilstones. You'll be pleased. Write today.

**PIKE MANUFACTURING CO.**  
169 Main St., Pike, N. H.



# ÆTNA-IZED?



## \$3,250 INSURANCE FOR \$10

**LIFE and ACCIDENT Insurance under the famous  
ÆTNA TEN DOLLAR COMBINATION**

Issued by the **ÆTNA LIFE INSURANCE COMPANY**, of  
Hartford, Connecticut—the largest company in the world  
writing Life, Accident, Health and Liability Insurance.

In extent and variety of protection this policy is without  
a rival.

For \$10 a year (in "Preferred" Occupations) this Policy pays:

**\$2,000** for death from Travel, Elevator or Burning Building Accident.

**\$1,000** for death from Ordinary Accident.

**\$2,000** for loss of limbs or sight as a result of Travel Accident.

**\$1,000** for loss of limbs or sight as a result of Ordinary Accident.

The above amounts accumulate Ten Per Cent. each year for five years,  
without additional cost.

**\$250 FOR DEATH FROM ANY CAUSE—No Medical Examination Required.**

The Accumulations, Double Benefits and Life Insurance provided by this  
Ten Dollar Combination make possible the payment of \$3,250 at a  
cost of less than **THREE CENTS A DAY** in addition to weekly  
indemnity for total or partial disability from accident.

SEND IN THE COUPON TO-DAY

**Ætna Life Insurance Co. (Drawer 1341) Hartford, Conn.**

Pop. Mech.

**I am under 55 years of age and in good health. Tell me about ÆTNA Ten Dollar  
Combination. My name, business address and occupation are written below.**



# MAKE FURNITURE LIKE THIS

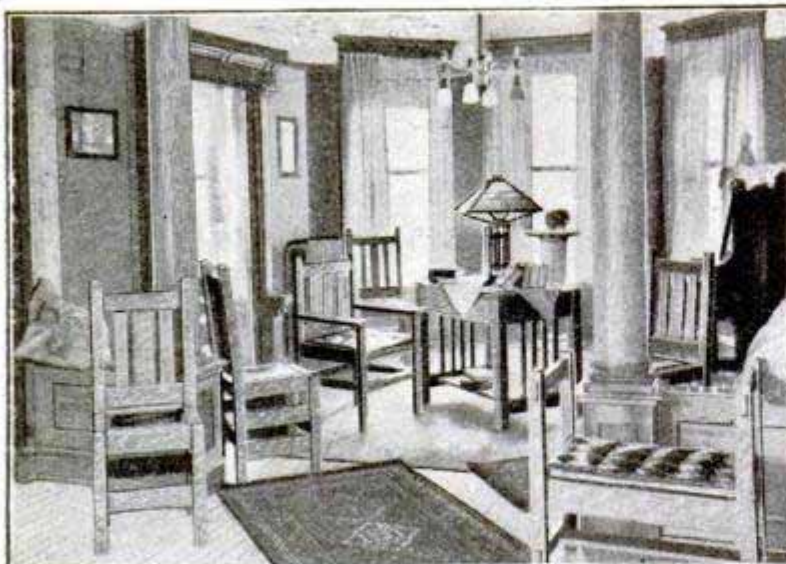

## Shown in the Photograph

ONE of our readers, who is strictly an amateur with tools, experienced no difficulty in making and finishing every piece of furniture, with the exception of the piano, shown in the accompanying picture. It is impossible in a small space to display all the different designs in Mission Furniture which we have published, but this picture shows something of the variety of pieces and how well they go together. The

## MISSION FURNITURE SERIES of 3 Volumes

Comprises 98 Attractive Designs, all different

**MISSION FURNITURE, Part 1**  
New Enlarged Edition 128 Pages, 30 Designs  
**MISSION FURNITURE, Part 2**  
Recently Issued 128 Pages, 32 Designs  
**MISSION FURNITURE, Part 3**  
New Book—Just Out 128 Pages, 36 Designs

Cloth, Size 5x7 inches Price 50 Cents Per Vol., Postpaid

THESE books describe how to make furniture for every room in the house as well as swings for porch and lawn. Whether you need a complete set or only some special article to fill in with here and there, you will find full directions, dimensions and working drawings for making it in these books. The instructions are easy to follow and even the amateur can obtain most satisfactory results as related above. A complete list of the designs in each book will be furnished free upon request.

ASK YOUR BOOK DEALER or address the publishers

**POPULAR MECHANICS BOOK DEPARTMENT, 318 W. Washington St., CHICAGO**

# They Show and Name Every Part

Cut Shows Auto Model Partly Unfolded

Actual Size 9 1/2 x 25 Inches

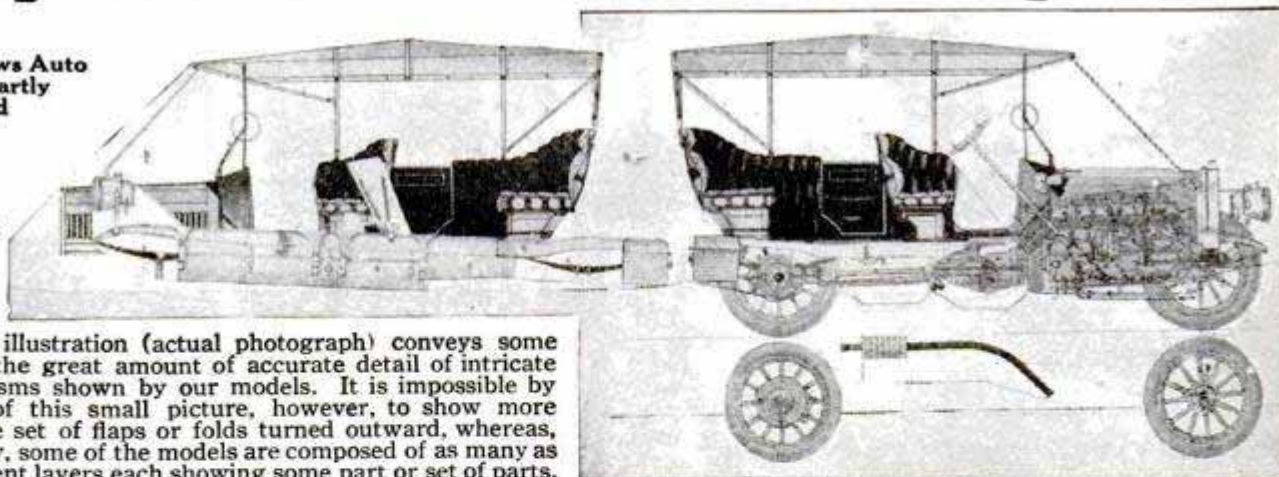

The illustration (actual photograph) conveys some idea of the great amount of accurate detail of intricate mechanisms shown by our models. It is impossible by means of this small picture, however, to show more than one set of flaps or folds turned outward, whereas, in reality, some of the models are composed of as many as 14 different layers each showing some part or set of parts.

## Series of Eight Lithographic Models

Price 50c Each. Complete Set of Eight Models, \$3.50 Postpaid

The ingenious way in which all the interrelated mechanism is thus clearly shown can only be appreciated by seeing and examining the models themselves. The ease with which the detail may be studied will be readily understood as by turning the flaps the models can be practically disassembled and put together again. Each part is numbered to correspond with its name found on a printed key.

You can get more information about the construction and operation of these machines by use of the models than in any other way. No detail is omitted. Everything is accurate and in true proportion and they have the approval of the manufacturers of the machines represented. They are not toys in any sense but are educational in character and worth many times their cost. Invaluable for individual study or supplementary to school courses.

**POPULAR MECHANICS BOOK DEPARTMENT**

SOLE AGENTS

318 W. WASHINGTON STREET

CHICAGO

Automobile  
Locomotive  
Steamship (Ocean Liner)  
Wireless Telegraph  
Steam Turbine  
Steam Engine  
Gas Engine  
Dynamo



## Satisfaction Guaranteed

Your order for an Aladdin house is placed under an absolute and signed guarantee of complete satisfaction. Every Aladdin house shown in our big 100 page catalog (mailed free upon request) is backed by an absolute written guarantee to give 100 per cent satisfaction to the owner, besides cutting 1-3 to 1-2 off the cost of building the house you want.



**ALADDIN**

Aladdin Ready-Cut houses can be put up in much shorter time than the ordinary dwelling. All material necessary (except brick for chimney and masonry) is furnished—even the paint and nails. All lumber is cut to size in the mills and numbered, accompanied by complete detailed instructions and illustrations. Aladdin houses are not portable.

**"Marsden"**  
**\$1341.40**

**Eliminate Architects' Fees, Middlemen and Contractors' Profits.**

Save hundreds of dollars of your money and several days' time in erection. Dwellings from 2 to 12 rooms. **NOT PORTABLE.** Prices from \$125 up. Dwelling houses, bungalows, summer cottages, garages, barns, sleeping porches, and trellises. Your money will be instantly returned if what you purchase from us is not found to be entirely satisfactory in every particular and exactly as represented. Safe arrival of all material in perfect condition is also guaranteed. Send today for catalog 1.

**NORTH AMERICAN CONSTRUCTION CO.**

280 Aladdin Avenue  
BAY CITY, MICH.

Canadian Branch: Sovereign Construction Co., C. P. R. Building, TORONTO, ONTARIO.



**"Portland" \$797.05**

## MODEL AEROPLANES

Complete Handbook **FREE** on Request of models and supplies

Nieuport Monoplane — Langley Tandem — Curtiss Hydro-aeroplane — Bleriot Monoplane — Wright Biplane, etc.

Wading River M. F. G. Co., Wading River, N. Y.  
Successors to White Aeroplane Co.

## D-I-A-M-O-N-D-S!

Their Most Perfect Substitute **FREE!**

On approval. Don't send us a penny for these marvelous Lachnite Gems. Will stand tests just like a REAL diamond and can't be distinguished from it. Exceptionally brilliant MOUNTINGS IN 14 KARAT SOLID GOLD.

**Your Credit Is Good**

Don't bother about the money. Our credit plan enables you to pay an outfit you best—a little each month. **WRITE TODAY** for full particulars and our big catalog—all free. No obligations. Write immediately.

Harold Lachman Co., 12N. Michigan av. Dept. 1197, Chicago

**\$50 to \$300 SAVED**  
**Just Write!**

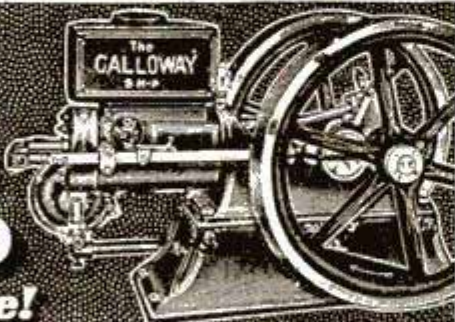

Get my prices—my new offers—get them right away. If you're going to buy an engine I'll put \$50 to \$300 in your pocket sure. All the dealers' profits cut off—you get them. You buy direct from my big factory.

**30 Days' Free Trial** Satisfaction guaranteed or your money back without a word. Any size from 1-3-4 to 15 H.P. Galloway Engines will run on gasoline, kerosene, naphtha, distillate, natural gas or motor spirits. Write for my Big Engine Book and Special Offers today.

**William Galloway, Pres., WILLIAM GALLOWAY CO.**  
965 Galloway Station, Waterloo, Iowa 665

# Elgin

## 17-Jewel

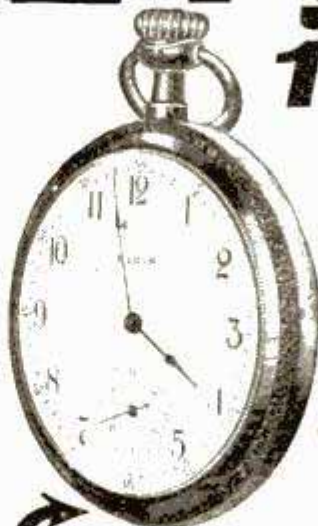

20 Year Gold Filled Case  
A Superb Watch

Only  
**\$11.75**

Think of it! Only \$11.75 for a genuine 17-Jewel Elgin in a 20 year gold filled case. Sold to you on terms on a great sweeping watch offer. Write at once for our new catalog and Special Bulletin, showing not only this splendid opportunity but hundreds of other jewelry chances.

## Monthly Payments

Only \$1.00 per month and you can become the owner of a genuine Elgin 17-jewel watch—\$2.00 down and \$1.00 a month—total price of \$11.75. Remember, this is not an ordinary watch, but a genuine 17-jewel movement—incased in a 20 year gold filled case—one of the greatest time-keepers ever made—at a price far below that asked by your local jeweler.

## Genuine Diamonds

Pure color flashing stones now offered along with our other jewelry opportunities. Here are two resplendent, solitaire, genuine diamond rings; selected, glittering, pure colored diamonds, in 14 karat gold rings.

Sold to you on the easiest terms—only a small amount down, then a very small payment each month. Wear these magnificent jewels—look prosperous—while paying for them. Besides, remember that diamonds are constantly going up in price—a diamond is a good investment.

No. A104—14 karat solid gold Men's ring, set with beautiful, scintillating, perfectly cut diamond, \$5.25 down, \$2.50 per month. Price . . . **\$34.50**

No. A103—Ladies' solitaire 14 karat solid gold ring, set with genuine, extra fine diamond, a splendid offering, \$5.25 down, \$2.50 per mo. Price **\$34.50**

**Free Trial!** We give you a positive 30-Day Free Trial on any article bought from us. 30 entire days to make up your mind whether you wish to keep it. And if for any reason you are not satisfied return to us and we will return every cent you have paid most cheerfully.

**Big Jewelry Book FREE**

Send today for our big jewelry catalog and special 30-Day Bulletin. Those show the most remarkable offers on high grade Elgin watches, genuine pure colored diamonds and other high grade jewelry. And all sold on terms of \$1.00 a month and up.

**STRAUS & SCHRAM**  
INC.  
Dept. 867  
35th St.  
CHICAGO

**FREE COUPON**  
**STRAUS & SCHRAM**  
INC.  
Dept. 867 35th St.  
Chicago

Without any obligation whatever on my part, you may send me free and post-paid your Special Wholesale Jewelry Catalog of watches, diamonds, etc.; also your special offers.

Name.....  
Address.....

(If you wish to order any of these extra special bargains, send only the small first payment.)



# Velvet

THE  
SMOOTHEST  
TOBACCO

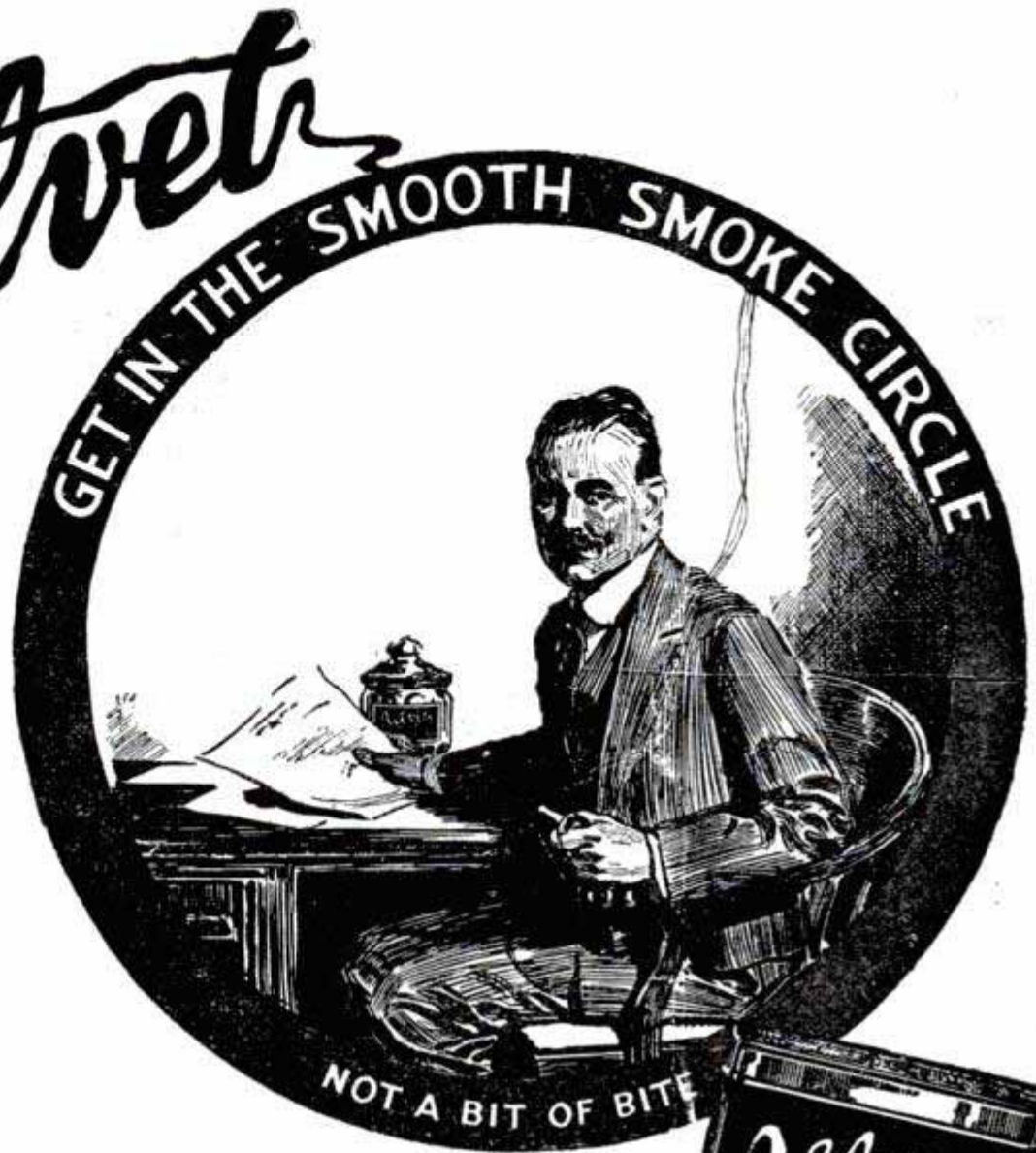

A great smoke for busy people!  
The choicest of old Burley leaf  
matured to a perfect mellowness.

*Liggatt & Myers Tobacco Co.*

**10¢ TINS**  
Handy 5¢ bags  
One pound glass  
humidor jars



## IN YOUR HOME WORK SHOP



A good bench of unestimable value. It provides a proper working surface together with strong vises which enable you to do your work as it should be done—conveniently and satisfactorily.

### Grand Rapids HOME BENCHES

fulfill every requirement. Built from selected Hard Maple with rapid acting or wood screw vises. Make your work about the house enjoyable. The little "odd jobs" will prove a source of much amusement and you will repair many things that now require the expense of a mechanic.

*Our free catalog gives complete information regarding this and other Home Benches. Write for copy.*

**GRAND RAPIDS HAND SCREW CO.**

1620 FRONT AVE., N. W.

GRAND RAPIDS, MICH.



# Practical Bungalows



## Golden West Homes

—the first and latest *genuine* Bungalows—offer intensely interesting ideas in beautiful exteriors, artistic interiors with built-in conveniences and all at a surprising economy of space and cost.

*Real* Bungalows are profitable home-investments. Efficient, fully equipped homes simplify the business of house-keeping. They solve the servant problem.

Your own home—reflecting the family character, happiness, aims, aspirations, financial and social standing—may be attractive though inexpensive.

Our practical books show 128 ideal homes with plans.

“REP. CALIFORNIA HOMES”—50—\$1600 to \$6000—Price 50c

“WEST COAST BUNGALOWS”—50—\$500 to \$2000—Price 50c

“LITTLE BUNGALOWS”—28—\$300 to \$1400—Price 25c

SPECIAL OFFER—At our risk send a Dollar bill now for all 3 books postpaid. If not satisfied we will refund.

**E. W. STILLWELL & CO.** PLAN BETTER HOMES  
4127 Henne Bldg., 122 Third St., Los Angeles

The total value of all United States imports for the fiscal year 1913 was \$1,812,978,234, against \$1,653,264,934 in 1912, and of exports \$2,465,884,149, against \$2,204,322,409 in 1912, which was a record year for both imports and exports.

The distribution of American automobiles extends to practically all parts of the world, the official figures for the fiscal year 1913 showing exports to 75 countries and colonies.



## SANTIAGO GEMS

Are the Only and Everlasting Substitute for GENUINE DIAMONDS

They are not imitations of diamonds, but a genuine stone, cut and faceted by skilled diamond cutters exactly like a diamond. Stands fire, fire and acid tests like a diamond. Contains no glass, paste or foil backing, will not crack, and on account of their great hardness will retain their brilliancy forever. To advertise these Santiago Gems we will for a short time send a Ladies' Solid Gold Tiffany ring set with a 3 4 carat Santiago Gem, C.O.D. \$5.00 by express or insured parcel post. Give it any test you desire, and if you find it not all we claim return it at our expense. Order at once; this ad may not appear again.  
DIAMOND JEWELRY CO., R19, 189 W. Madison St., Chicago, Ill.

## Use This Genuine Folding Naco Camera 10 Days FREE

Don't send us a penny—just your name and address, and we will send the wonderful Naco camera on ten days' free trial. Take pictures of your family—of your friends; of scenes you will treasure in future years. Test it in every way, note the famous Woolensack "Victus" shutter and high grade rapid symmetrical lens; the easy method of inserting roll films in daylight. The Naco camera is post card size and retails for \$20.00 cash the world over. If after a thorough trial you decide it is just the camera you want, send us \$2.00 a month for ten months. If you don't want it, return it at our expense. You take no risk. Send today for this camera and our free film developing offer.  
NATIONAL CAMERA CO., 901 Lucas Ave., ST. LOUIS



# DIAMONDS ON CREDIT

Of the many fashionable Diamond Rings for Gentlemen's wear, the 6-prong Tooth Mounting is the most popular. The large illustration shows the graceful lines and deep groove, enhancing the beauty of the diamond setting. The heavy prongs afford absolute protection and safety.

Extra heavy 14k Solid Gold.

Beautiful white Diamond, perfect in cut and full of fiery brilliancy. Specially Selected by our Diamond Experts.



The Young Man's Favorite Diamond Ring

Write for Catalog Today. It is Free to You.

Our large 100-page Catalog (sent free on request) shows the various diamond sizes and prices of this favorite ring. Marvels of beauty as low as \$25, \$60 and \$75. Others at \$85, \$100, \$125, \$150, \$175, \$200 and up. Make your selection and let us send it to you for your examination and approval, shipping charges prepaid. If you are perfectly satisfied that you have an unusual bargain, send us one-fifth of the purchase price and keep it; balance divided into eight equal amounts, payable monthly. If not just what you wish, return at our expense and ask us to send you another selection. Our Catalog contains over 2,000 handsome photographic illustrations of diamonds, watches, artistic jewelry, silverware, etc. We give better values and easier terms than any house in America. Send for Catalog today.

**LOFTIS** THE RELIABLE ORIGINAL DIAMOND AND WATCH CREDIT HOUSE  
BROS & CO. EST'D 1858 Dept. E894, 108 N. State St. CHICAGO, ILL. Branches: Pittsburgh, Pa., and St. Louis, Mo.

# PIPE-THREADING

## USE OSTER BULLDOG TOOLS



NOTE these Oster features: Self-locking dies. Self-locking guides. No loose parts. One movement of the hand opens or closes the dies. No time wasted resetting the dies for each cut. No running back over the finished threads.

Twenty years' experience in building and improving pipe-threading tools for every trade guarantees to you easy control, easy operation, and long service.

Ask for our catalog to-day.

The Oster Mfg. Co.



2100 East 61st St. CLEVELAND OHIO

Kindly forward catalog to

NAME.....  
ADDRESS.....  
CITY.....  
STATE..... (2100)



# Big Business—Big Profits—Small Investment

The Crispette, popcorn and candy business is making hundreds of men independently wealthy. It's the business of quick cash sales and enormous profits. It's the business you want to get into.

## We are Ready to Help You

its ins and outs; ready to help you in every way, shape and We have lists of hundreds of splendid openings—perhaps your own town is the very place for you to start.

We are ready to start you in this big money making business at once; ready to teach you all of manner to a tremendous success.

## Start on the Road to Wealth

Start on the Road to Wealth Now. Get out of the old rut; get into the crispette, popcorn and candy business. It's the biggest money maker of them all. It's a wonder, a world beater. Every moment you delay your start you can count as so much money out of your pocket.

## Dellenbarger's Complete Outfits

are the most efficient, up-to-date popcorn, crispette and candy machines in the world. They produce absolutely the finest goods. Great, fluffy kernels of corn, deliciously seasoned while popping, that fairly melt in your mouth.

### Start Right Now

We want you to get started right away. We have a wonderful proposition to offer you. We extend you liberal monthly payment terms—pay for the outfit with part of the profits. That's the faith we have in your ability to make good. We teach you absolutely free how to make an immense success.

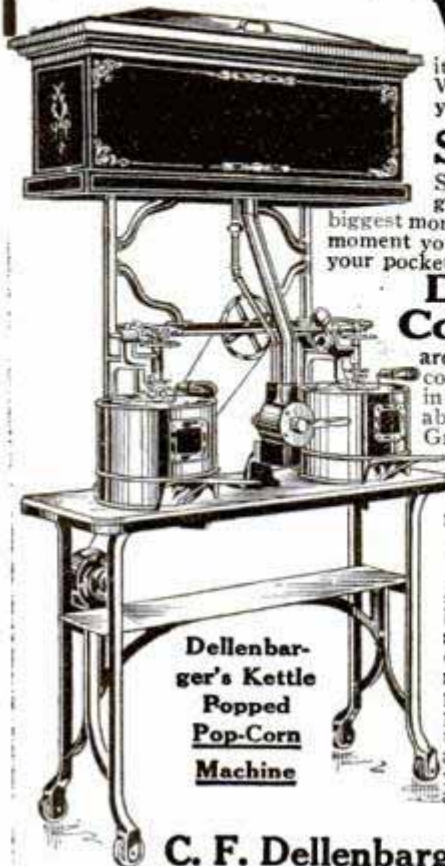

Dellenbarger's Kettle Popped Pop-Corn Machine



Dellenbarger's Improved Automatic Crispette and Pop-Corn Ball Machine

Your Profits Pay for the Outfit EASY PAYMENTS

We teach you the business FREE

Send Now for Our Great Co-operative Help Plan

Get our catalogues, our prices, our assistance; they're all free for the asking. It's up to you to act and act quick, if you want to make great big money right from the jump. **WRITE TODAY.**

C. F. Dellenbarger & Company, 619 W. Jackson Boul., Chicago, Illinois

## Chauffeur's Law Book! Get your copy today

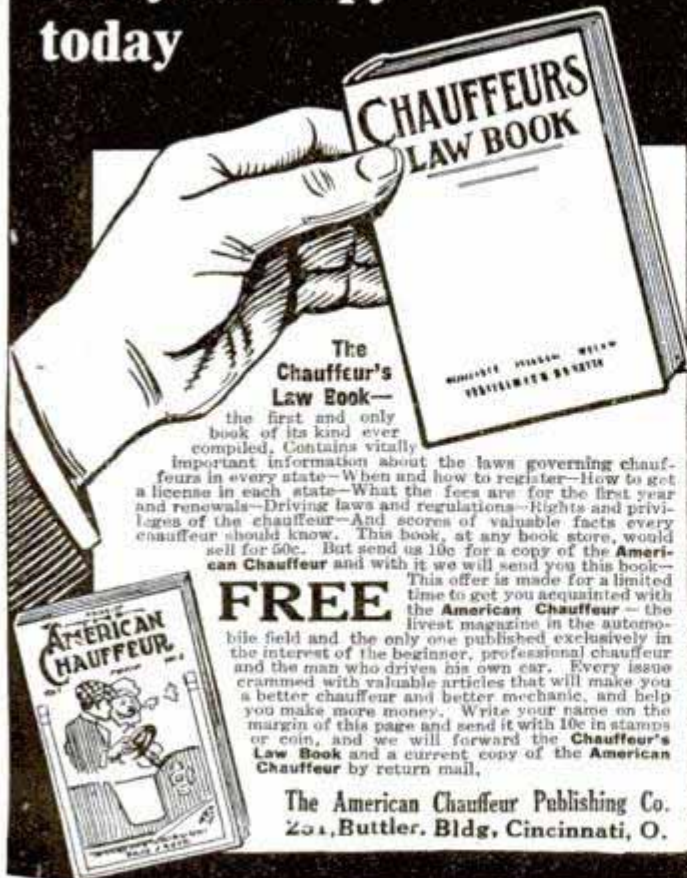

The Chauffeur's Law Book—

the first and only book of its kind ever compiled. Contains vitally important information about the laws governing chauffeurs in every state—When and how to register—How to get a license in each state—What the fees are for the first year and renewals—Driving laws and regulations—Rights and privileges of the chauffeur—And scores of valuable facts every chauffeur should know. This book, at any book store, would sell for 50c. But send us 10c for a copy of the American Chauffeur and with it we will send you this book—

### FREE

This offer is made for a limited time to get you acquainted with the American Chauffeur—the best magazine in the automobile field and the only one published exclusively in the interest of the beginner, professional chauffeur and the man who drives his own car. Every issue crammed with valuable articles that will make you a better chauffeur and better mechanic, and help you make more money. Write your name on the margin of this page and send it with 10c in stamps or coin, and we will forward the Chauffeur's Law Book and a current copy of the American Chauffeur by return mail.

The American Chauffeur Publishing Co. 231, Butler Bldg. Cincinnati, O.



THE SCRIPPS MARINE POWER PLANT



"I never saw a motor stand up and give better service than this motor has."

(From) JOHN W. HUBBARD (letter)

The motor which Mr. John W. Hubbard speaks of in this letter is a 6-cylinder which he has used for 6 years.

Such enthusiastic comment from a Scripps owner should indicate to you, in some measure at least, the exceptional ability of the Scripps Marine Power Plant.

Here's another one from a man who has had a chance to make a comparison:

"The 4-cylinder Scripps has given excellent satisfaction in every way. In fact, I took more pleasure out of the boat this season than during the last two seasons when it was equipped with another make of engine which gave me considerable trouble. My repair expense bills ranged from \$75.00 to \$100.00 a season, but this year they have cost practically nothing, as I have had no trouble whatever, and the gasoline consumption was about half that used by my last engine." GEORGE L. LEONHARD.

Scripps Motors are made in 2, 4 and 6 cylinder sizes. Medium and Extra Heavy Duty Types. Send for catalogue and information about self-starters, kerosene motors, and the \$500 7-horsepower Scripps Midget, a High-Grade Tender Motor.

Insure a satisfactory and successful motoring season by specifying Scripps.

You will not be disappointed. Let us have your specifications early.

## SCRIPPS MOTOR COMPANY

637 Lincoln Ave., DETROIT, MICH.

SCRIPPS MOTORS ARE CARRIED IN STOCK BY

- New York.....Bowler, Holmes & Hecker Co., 141 Liberty Street
- Boston, Mass.....Walter H. Moreton, 218 State Street
- Chicago, Ill.....O. L. Cosgrove & Co., 215-219 Englewood Ave.
- Philadelphia.....W. E. Gochenaur, 631 Arch Street
- Jacksonville, Fla.....Gibbs Gas Engine Co., Foot of Main Street
- Seattle, Wash.....S. B. V. Miller, 72 Marion Street
- San Francisco, Cal.....California Gas Engine & Motor Boat Co., 76 Clementina Street
- Los Angeles, Cal.....Marine Engine & Supply Co., 109 East 7th Street
- Duluth, Minn.....Kelley Hardware Co., 118-120 W. Superior Street
- Toronto, Ont.....Schofield-Holden Machine Co., 2 Carlow Avenue
- New Orleans, La.....Arthur Davic, 130 Chartres Street



## Get Your Canadian Home From the Canadian Pacific



**The Home Maker**

**WE** will make you a long-time loan — you will have 20 years to pay for the land and repay the loan — you can move on the land at once — and your Canadian farm will *make you independent.*

### 20 Years to Pay

Rich Canadian land for from \$11 to \$30 per acre. You pay only one-twentieth down — balance in 19 equal annual payments. Long before your final payment comes due your farm will have paid for itself over and over. This advertisement is directed only to farmers or to men who will occupy and improve the land.

### We Lend You \$2000 for Improvements

The \$2,000 loan is used only for erecting your buildings, fencing, sinking well and breaking. You are given twenty years in which to fully repay this loan. You pay only the banking interest of 6 per cent.

### Advance of Live Stock on Loan Basis

The Company, in case of approved land purchaser who is in a position and has the knowledge to take care of his stock, will advance cattle, sheep and hogs up to the value of \$1,000 on a loan basis, so as to enable the settler to get started from the first on the right basis of mixed farming. If you do not want to wait until you can complete your own buildings and cultivate your farm, select one of our Ready-Made farms — developed by C. P. R. Agricultural Experts — with buildings complete, land cultivated and in crop, and pay for it in 20 years. We give the valuable assistance of great demonstration farms — free.

### This Great Offer Based on Good Land

Finest land on earth for grain growing, cattle, hog, sheep and horse raising, dairying, poultry, vegetables and general mixed farming, irrigated lands for intensive farming — non-irrigated lands with ample rainfall for mixed and grain farming. These lands are on or near established lines of railway, near established towns.

Ask for our handsome illustrated books on Manitoba, Saskatchewan and Alberta — mention the one you wish. Also maps with full information *free.* Write today.

**G. E. THORNTON, Colonization Agent**

## Canadian Pacific Railway

Colonization Department 112 W. Adams St., Chicago

**FOR SALE** — Town lots in all growing towns — Ask for information concerning Industrial and Business openings in all towns.

# WIPE YOUR FEET



Mud, snow, dust and dirt will not be tracked over your floors if you use

## Grab's Foot Scraper

outside your door. The only device made which cleans bottoms and sides of shoe in one operation. Has ten parallel plates for scraping soles and two stiff bristle brushes which clean sides of shoe.

## AUTOMATICALLY ADJUSTS ITSELF

to any size shoe. Handsomely enameled. Looks neat. Can be rotated and swept under. Fastens to door step or any handy place. Get one and save useless work. Price \$1.00. If your dealer will not supply you, don't take substitutes, but order direct to us. Illustrated folder **FREE.** AGENTS WANTED.

**FACTORY M. GRAB & CO., DEPT. F, 118 ASHLAND BLOCK, CHICAGO, ILL.**



# The New Edison!

Mr Edison's wonderful new instrument—the perfection of the Phonograph—now ready for shipment—on a wonderful sweeping offer **DIRECT** from us—shipped on

# Free Trial!

I want you to see and hear this phonograph, to convince you of its enormous superiority over anything you have ever heard in the line of talking machines. I want your friends and neighbors to hear this superb product of Mr. Edison's skill. I will send you your choice of any of the new style instruments you select **without a penny down**—no deposit—no C. O. D., no obligations to buy. Take the instrument to your home—*hear all the latest up-to-date songs, the latest waltzes, two steps, vaudevilles and minstrel shows. Listen to the old fashioned hymns—the peal of the organ, crashing brass bands, orchestral concerts. Entertain your family and your friends with solos, duets, quartettes—the funniest comic sketches and the grandest symphonies. Then when you are through with all this entertainment, you may return the outfit at our expense.*

## Why?

We offer this free trial to convince you and to show you what the new Edison means. If you wish you may keep it at the rock-bottom price; the lowest price anybody is allowed to pay, and either for cash or on easiest terms; terms as low as \$2.00 a month. If you decide you don't want to keep it, we won't blame you in the least. We will be sure that after you have entertained your family and friends with this new instrument, we will have gained at least in letting the people know the superiority of this wonderful new Edison. Hence the free trial.

## Our New Edison Book Sent Free

This is an important book. Besides listing the new Edison styles, and a complete list of the new wonderful Edison Blue Amberol Records, this book tells you how and where you can use the phonograph to the best advantage; how to use it in the home and at the dance — in private and in public. With this catalogue we give you full explanation of our remarkable free trial offer. Send postal or letter, or simply sign this coupon and the coupon alone will do. No obligation in getting the catalogue. Be the first in your town to get this new Edison, so write for the catalogue today.

**F. K. Babson, Dept. 1197**  
Edison Phonograph Distr.  
Edison Block, Chicago, Ill.

Western Office:  
65 Post St. San Francisco, Cal.  
Canadian Office:  
355 Portage Avenue  
Winnipeg, Manitoba.

Please send me, without any obligation, your New Edison Phonograph Catalogue, list of Amberol Records and Free Trial Certificate entitling me to your grand offer, all Free.

## Coupon

**F. K. Babson**  
Edison Phonograph Distributors  
Dept. 1197 Edison Bldk.  
Chicago

Name.....

Address.....



# HAMBURG-AMERICAN

Largest S.S. Co.  
in the  
WORLD

Over 400 Ships  
1,306,819  
TONS



## Hamburg-American Cruises During 1914

### New Cruise-Orient-India

By the **S. S. Cleveland**, 17,000 tons, from New York, January 15th, 1914. Through the *Mediterranean, Suez Canal, Red Sea and Indian Ocean to Bombay and Colombo*, including side trips through INDIA, THE HOLY LAND and EGYPT, stopping at interesting points in Europe, Asia and Africa.

**Duration 93 days. Cost \$700 up** including shore excursions and necessary expenses.

### S. S. Imperator

World's Largest Ship

will make two special trips to the Mediterranean from New York February 4th and March 5th, to Monaco, Genoa and Naples.

**NILE SERVICE** by superb steamers of the Hamburg and Anglo-American Nile Company.

### Cruises to West Indies, Venezuela and the Panama Canal

By the largest ships visiting the Caribbean Sea. **S. S. Amerika** (22,500 tons) and **Victoria Luise** (17,000 tons) during January, February, March and April. **Duration 16 to 29 days. Cost \$145-\$175 up.**

**From NEW ORLEANS**—Two 15-day Cruises during January and February. Shore trips optional.

1915

### Around the World, through the Panama Canal

From New York, January 27th, 1915 by **S. S. Cleveland** (17,000 tons). **Duration 135 days. Rates \$900 up**, including shore trips and necessary expenses.

### Atlas Service

Weekly sailings to Cuba, Jamaica, and the Panama Canal, Hayti, Colombia, Costa Rica, Nicaragua by new fast Twin-Screw Steamers.

Write for information stating cruise.  
Offices in principal cities.

### Hamburg-American Line

41-45 BROADWAY, NEW YORK  
Philadelphia, Boston,  
Pittsburgh, Chicago,  
St. Louis  
San Francisco

Trade

Mark

Please Mention Popular Mechanics

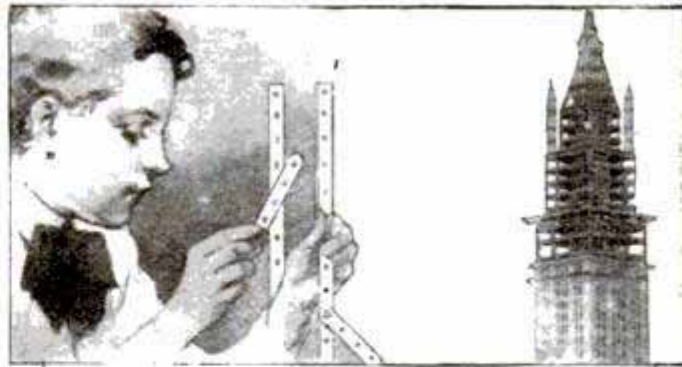

Get that boy you are interested in  
a set of **MECCANO**

The steel frame work that a boy  
bolts together today with pieces of

## MECCANO

not only is a wonderful structure to him,  
but it may become a giant skyscraper  
tomorrow.

See a set of the brass and nicked steel pieces of Meccano at your toy or sporting goods store. Look through the book of designs at the wonderful things a boy can build with Meccano, yet these designs only hint at the possibilities of Meccano in the hands of a boy with originality.

*Be sure name MECCANO is on box*

If your dealer does not keep Meccano, write to us for catalog showing models any boy can build and let us tell you more about this most instructive and most interesting Meccano.

**THE EMBOSING COMPANY**  
15 Church St., Albany, N. Y.

MAKERS OF  
*Toys that Teach*



### TYPEWRITER BARGAINS

Don't buy a typewriter until you have seen for our price lists and see for yourself the big Saving on all Standard Machines. All are in perfect condition and accompanied by our written guarantee for 2 years. Send for prices and terms, a postal will bring them.

Address: **The M & M Typewriter Co., 116 N. LaSalle St., Chicago**



### ARE YOU A FAILURE?

You can bluff the world for a time, but you cannot fool yourself. Don't try to develop Brains at the expense of your Health, by ignoring your bodily development.

### This World is Full of Failures

on account of the fact that they are failures physically. Your success in life depends upon your physical condition. If you are handicapped by an emaciated body, brought on by weak internal organs, then you are nothing but a perambulating corpse, and all your efforts to gain success in this world are futile.

### You want HEALTH, STRENGTH, VITALITY Get it from LIONEL STRONGFORT

The Strongest Physical Culture Instructor in the World

Don't pin your faith to pills, potions and piffle if you want really to grow robust and strong. What is your trouble? Are you too fat? Too thin? Are your organs weak? Do you eat your meals with relish or merely as a matter of routine? Whatever your trouble, you need personal and individual instruction. My charges are very moderate. I give every client my individual attention. Write me today. Give a full description of your trouble, and I will guarantee to make a new man of you within three months. Do not put this advertisement aside until you have written me. My book "Intelligence in Physical Culture" Free for 4c to cover mailing.

**LIONEL STRONGFORT**  
Dept. PS-10, 1628-30 Broadway, NEW YORK



# CRASH!!

## Go Building Prices!

### WRITE FOR BIG MILLWORK CATALOG ALSO BEAUTIFUL PLAN BOOK FREE

Sign and mail the convenient coupon or send postal for the Grand Free Millwork Catalog, Lumber Book, Roofing Book, etc. This book is crowded with the most astonishing cut-price offers on everything in the building material line. Everything shown in the catalog is carried in stock ready for immediate shipment under our guarantee of quality, safe delivery and satisfaction or money refunded. Now is the time to build, while these low prices are in effect. Write for it before you spend a dollar for building material and get the benefit of our record-breaking low prices. In writing for the Plan Book, enclose 10c for postage and mailing.

### Cost of Houses Cut \$500 to \$1,000

Here's big, important news for home builders everywhere. If you are planning to put up a new house, cottage or bungalow—a barn, garage, or even a corn crib—wait till you get our **Big Free Millwork Catalog and Free Estimate**. We've knocked the bottom out of millwork and lumber prices! Comparison will prove it. Our immense millwork plant and warehouses, covering many acres, are piled to the roof with bargains, and we carry in our big lumber yards many million feet of the finest grade of lumber, on which we can in many cases save you \$100 to \$300 per car.

### 50 Cents on the Dollar—That's the Saving

We offer you a saving of 50 per cent on much of the building material you want. On some items the saving is considerably more; for instance, window glass. We are among the largest dealers in American window glass in the United States. We do immense business in builders' hardware. We sell thousands of gallons of paint. It's the tremendous scale on which we do business that makes our low prices possible.

The combined saving on all of the different materials to build a complete house in many cases reaches a total of \$500 or \$1,000. Whether you build from your own plans or from plans which we furnish to you free of charge, you get this big saving.



All Lumber, Millwork, Paint and Hardware for this House, \$468.00



All Lumber, Millwork, Paint and Hardware for this House, \$557.00



All Lumber, Millwork, Paint and Hardware for this House, \$709.00



All Lumber, Millwork, Paint and Hardware for this House, \$813.00



All Lumber, Millwork, Paint and Hardware for this House, \$943.00

### Quality and Satisfaction or Your Money Back

All our material is bright, new stock of the highest guaranteed quality. Our millwork is guaranteed up to the standard of the Sash and Door Manufacturers' Association, and our lumber is graded strictly according to the rules of the Lumber Manufacturers' Association.

We guarantee quality, safe delivery, goods as represented and satisfaction or agree to refund every penny of the purchase price and pay the freight both ways.

**GORDON-VAN TINE CO.**  
5221 Case St., DAVENPORT, IOWA

### Blue Print Plans Free

#### Save \$50 to \$150 in Architect's Fees

Our Architectural Bureau will supply the complete blue print plans, specifications, etc., free with your order for material to build the house. This means a saving to you of the Architect's fees of \$50 to \$150.

#### Write for Our Beautiful Plan Book!

Our famous Book of Plans contains over seventy designs of modern houses, cottages, bungalows, etc.

This is without question the most complete, practical Plan Book on the market. Our plans keep cost of building within original estimate.

In writing for Plan Book, enclose 10c for postage and mailing.



GORDON-VAN TINE CO.,

5221 Case St., Davenport, Ia.

Gentlemen:—Please send the books checked below.

Name.....

Address.....

Occupation.....

Millwork

Plan Book

Roofing

Lumber

In sending for Plan Book, enclose 10c for postage and mailing.





# Dustless, Sanitary Cement Floors

TRUS-CON FLOOR ENAMEL stops dusting of concrete floors. Gives a smooth, tile-like surface. Wear-resisting; stainproof; oilproof. Easily cleaned by mopping. Furnished in a variety of colors. Applied with a brush.

## TRUS-CON FLOOR ENAMEL

is used in Factories, Warehouses, Power Plants, Hospitals, Schools, Offices, Residences, Garages, etc.

FREE—Color Card and valuable suggestions. Write to-day.

**THE TRUS-CON LABORATORIES**

462 Trus-Con Building

Detroit, U. S. A.

Waterproofings—Dampproofings—Technical Paints

# Do You Want Money?



LISTEN! \$5 to \$20 a day easy. Be a one-minute photographer. LOOK! Cable, Wyo., writes: "Made \$27 in 2 hours." Perry, Ky., writes: "Made \$50 in 2 days." Hundreds of similar reports on file. Start business for yourself. Small capital. No experience. Big, quick profits at fairs, picnics, private houses—everywhere. Profits start at once. Write us today. Get out of the "time

## "Mandel" Post Card Machine

New invention—wonderful machine. Takes, finishes and delivers original post card photos at the rate of 3 a minute—right on the spot where you take them. New, startling, sensational photographic success—

### Photos Direct on Post Cards

No Plates, Films, Printing or Dark Room

Machine is everything in one—a complete portable post card gallery. Get the interest, attention and order from every onlooker. Sale of first supplies gives you back practically entire investment. You make money on same day outfit arrives. Immediate sales—immediate profits. Do you want to make \$2,000 this year? Then write at once. INFORMATION FREE. Address either office:

**THE CHICAGO FERROTYPE COMPANY**  
743 Ferrotyping Bldg., CHICAGO, ILL. or Dept. 743 Public Bank Bldg., NEW YORK, N. Y.

# LEARN RAG TIME



Let me teach YOU Rag-Time Piano Playing by MAIL. You learn EASILY—in just a few lessons AT HOME. My system is so simple you'll play Mendelssohn's Wedding March in the fifth lesson. You'll say

*Gee, but I'm Crazy for Rag!*



Even if you can't play a single note, I'll teach you to play ANYTHING in Happy Rag-Time. Think of the pleasure for you—and the SURPRISE for your friends! Get Busy! Everybody's doing it! Write me for special low terms, positive guarantee, and testimonials from hundreds of happy students. Axel Christensen (the Czar of Rag-Time) Director Christensen School of Popular Music 802 Auditorium Building, Chicago, Ill.

Sapphires comprised nearly two-thirds of the value of gem minerals produced in the United States last year.



## Sleep an Hour Longer! DRESS IN A WARM HOUSE

The AUTOMATIC FIREMAN Sent to You on 30 Days' Free Trial. Anybody can install one. The Automatic Fireman is an attachment connecting with the drafts on the furnace. Just set it for any time. It will open the drafts, start a roaring fire and leave the house comfortable when you arise. Express prepaid \$5.00. Send for it now. Be ready for the First Cold Day. Agents wanted. MACK'S MACHINE & ENGINE WORKS, HARTFORD, MICH.

### TERMS TO SUIT

# FREE TRIAL FOR 30 DAYS

## NON-CRANKING

# KEROSENE ENGINE



"The Masterpiece of the Largest Makers of Two-Cycle Engines in the World."

The astounding success of Gaso-Kero two-cycle kerosene engines is based upon the perfect Bessemer Universal Fuel Feeder, controlled exclusively by us.

## The Wonderful Bessemer Gaso-Kero Engine

This perfect fuel feeder has sounded the death knell of carburetors, and is the only thoroughly successful device for feeding kerosene, gasoline, distillate, etc., without change of equipment. It is revolutionizing the engine business. It is the one big, right idea; we discovered it and control it—you cannot get it on any but a "Gaso-Kero." "Gaso-Kero" two-cycle engines are simple—only three moving parts—are constant and steady as clocks. 2 to 350 H. P. Immediate shipment.

Write for Catalogue #13.

**BESSEMER GAS ENGINE CO., Grove City, Pa.**  
Largest Makers of Two-Cycle Engines in the World.



Pays for itself in fuel saved



# A Rife Ram Without Attention or Operation Expense will Supply as Large a Water System as You Care to Install

If you have on your farm or country estate a brook, spring or artesian well with a flow of three or more gallons a minute you can have running water wherever you lay the pipes. The initial cost is the only cost. There will be no operating expense and no need for attention. There will be no fuel to buy, no engine to run, no hand pumping to do, yet neither you nor your help need carry water ten feet. Just install a

## RIFE RAM

start it and forget it. It is absolutely automatic, for the water it pumps operates it. It runs day and night, winter and summer. A Rife Ram will pump from 100 to 200,000 gallons a day according to the amount of supply. It will supply a pneumatic tank in your cellar and maintain the air pressure up to 100 pounds at your option. The only conditions for the successful operation of a Rife Ram are that it be placed three or more feet lower than the water level at the supply and not less than thirty feet distant from the supply. The Ram will raise water twenty-five times the height of the fall. Fully guaranteed.

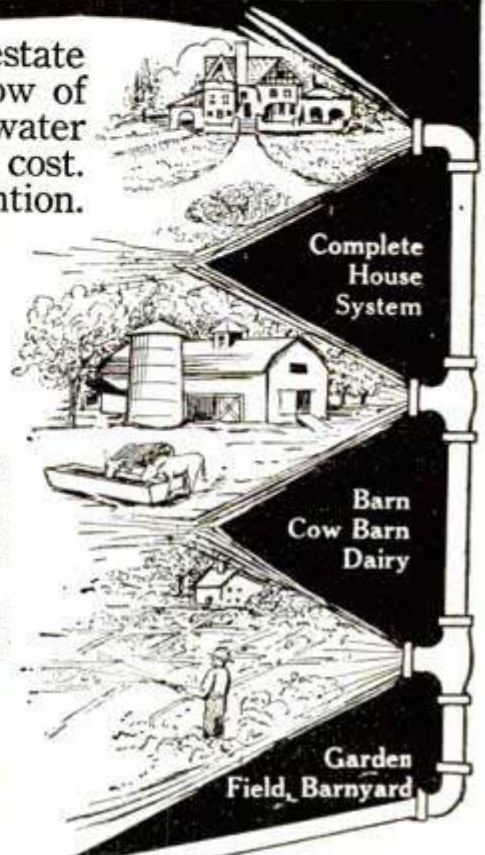

### MAIL THE COUPON

and we will send you catalog and estimate, free, so you can see how little it will cost to have an abundance of running water.

If you haven't the above conditions on your place, we can supply the best gasoline engine pumping outfit.

### COUPON

**RIFE ENGINE CO.**  
2131 Trinity Bldg., New York

Send catalog and estimate for water system under these conditions:

1. Flow of water in gallons per minute.....
2. Fall in feet.....
3. Distance in which fall is obtained.....
4. Height above Ram water is to be pumped.....
5. Gallons required per day.....

NAME .....

ADDRESS.....

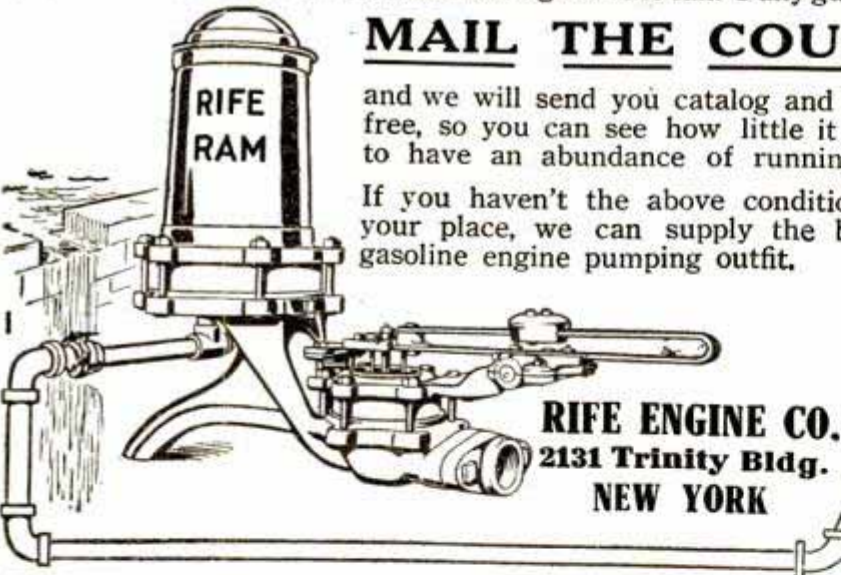

**RIFE ENGINE CO.**  
2131 Trinity Bldg.  
NEW YORK

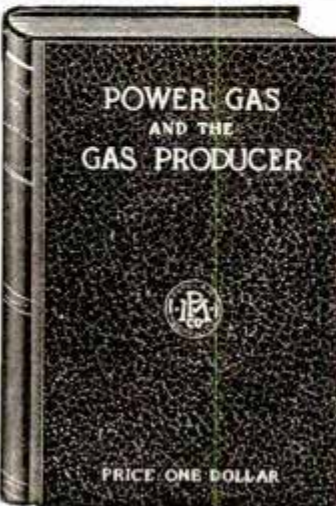

## ARE YOU INTERESTED IN Cheaper Power?

Under certain conditions the gas producer makes a startling saving in the cost of power and it is worth every power user's time to know whether or not his present system is the best.

To meet a demand for information which has not been hitherto available except by the employment of an expert, we have been fortunate in securing the services of an eminent gas power engineer, Mr. J. C. Miller, M. E., who has written a book on this subject which we have recently published. It gives just the information a man wants to have, comparing the first cost of steam engines and boilers with the gas producer and gas engine, and the comparative cost of maintenance and operation. It tells all about the advantages and troubles of gas producers, and gives full details of how to run them. It is written in an absolutely impartial manner, and not with a view to increase the sale of gas plants, leaving the decision as to the advisability to the individual reader. It will also enable the Steam Engineer to understand thoroughly the working of the new system if the change is made, and to handle a plant competently and with confidence.

### POWER GAS AND THE GAS PRODUCER

has 200 pages, is printed on the best book paper, profusely illustrated with half-tones from photographs, diagrams, etc., and durably bound in extra cloth. **SENT POSTPAID TO ANY ADDRESS FOR \$1**

Popular Mechanics Book Dept., 318 W. Washington Street, Chicago



# BOOKS-THAT-TELL-HOW-TO-DO-THINGS

A uniform series printed on the best book paper and durably bound in extra cloth. Size 5 x 7 inches.



## Mission Furniture, How to Make It IN THREE VOLUMES

PART ONE—Plain directions with working drawings and illustrations for making 21 different designs. 96 pages. PART TWO—32 additional designs treated in the same manner. 128 pages. PART THREE—36 excellent new plans entirely different from those in the other two books. 128 pages. Price of each volume, 50 cents.

Artistic. Inexpensive. Easily made in the home

## Arts-Crafts Lamps, How to Make Them By J. D. ADAMS

Explicit instructions for making 16 different beautiful lamps out of paper, cardboard and wood. A working drawing and illustration accompany each design. 96 pages.

18 beautiful designs which the amateur can easily make

## Lamps and Shades in Metal and Art Glass By JOHN D. ADAMS

Four different kinds of construction, built up—soldered—etched and sawn shades are treated. The designs range from ordinary reading lamps to pretentious chandeliers. 128 pages.

Covers every essential step in wood-working

## Wood-Working for Amateur Craftsmen By IRA S. GRIFFITH, A. B.

Special chapters bring out every cut, joint and process, proper use and care of tools, working up of material, etc. 125 illustrations. 128 pages.

A complete handbook for art metal workers

## Metal Work and Etching By J. D. ADAMS

Gives every detail for making a great variety of useful and ornamental objects such as book ends, desk sets, jewelry, hinges, drawer pulls, paper knives, letter openers, match boxes, tie and pipe racks, pad corners, etc. 50 illustrations. 96 pages.

The only book published on this interesting art

## Metal Spinning By PROF. F. D. CRAWSHAW

A practical working manual for those who desire to spin metal as an art recreation or to follow this work as a trade. 33 illustrations. 80 pages.

Authorities proclaim it one of the best books on the subject

## Electroplating By HENRY C. REETZ

A treatise which will not only enable the humblest beginner to make a start, but which gives pointers of value to even the most experienced electroplater. 62 illustrations. 112 pages.

Any boy can construct this at a trifling cost

## How to Make a Wireless Set By ARTHUR MOORE

Explains in an understandable manner the construction of an outfit suitable for transmitting 4 or 5 miles. Fully illustrated. 96 pages.

A wonderful story

## HEAT By PROF. J. G. OGDEN

An immensely interesting and instructive book pertaining to heat and its relation to modern mechanics. 50 illustrations. 128 pages.

One of the most remarkable non-technical books written

## The Kingdom of Dust By PROF. J. G. OGDEN

The author deals with this vast kingdom as: A Boundless Domain, The Friend of the Housewife, The Foe of the Workman, The Skeleton in the Closet, The Right Hand of Death, Earth's Winding Sheet, Beginning and Ending of All Things Earthly. 40 illustrations. 128 pages.

PRICE PER VOLUME, 50 CENTS POSTPAID

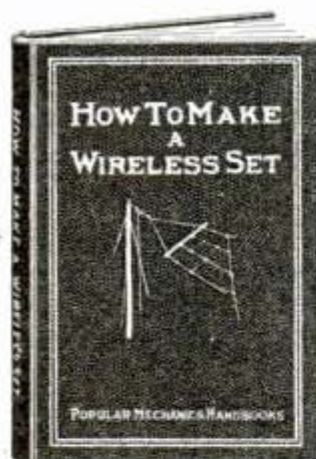
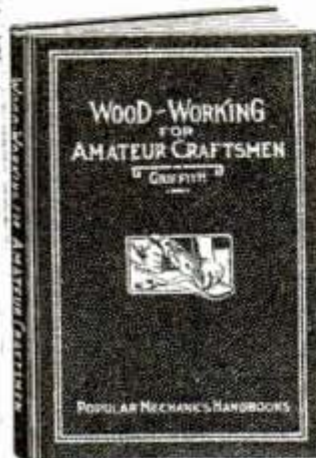
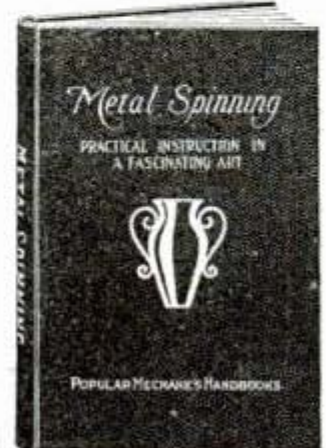
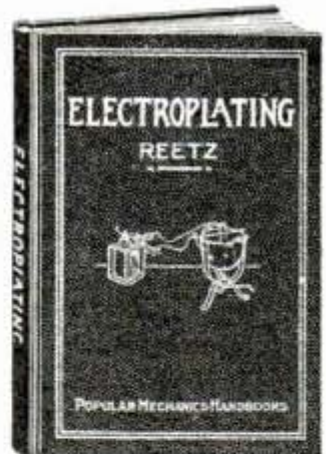
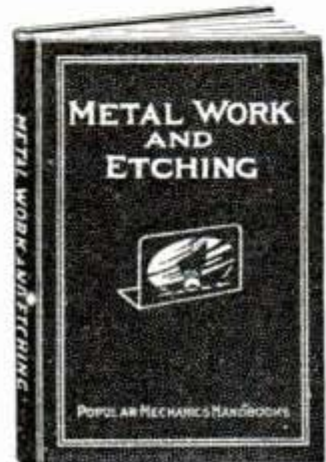
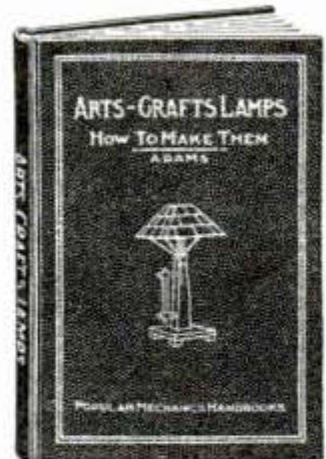

Popular Mechanics Book Department, 318 W. Washington St., Chicago



## Make Money with Poultry

AMERICAN POULTRY is a magazine devoted entirely to helping earnest men and women make a financial success of poultry raising. Its staff of writers is composed entirely of those who have made a practical, instead of theoretical, success of poultry farming, and who are glad to pass on the results of their hard-earned experience to AMERICAN POULTRY readers.

There are many pitfalls in the path of the novice which may be entirely avoided by those who will follow the teachings set forth in this magazine. It fully explains how to make a start, how to construct houses, coops, and other devices, how to get a large egg-yield, how to cure and prevent disease, how to exhibit, how to get the top price for eggs, how to use incubators and hundreds of other points which everyone wishes to know. It explains the famous secret system through which poultrymen have become rich and afterwards sold for hundreds of dollars.

AMERICAN POULTRY is a large, handsomely illustrated, monthly journal, well printed on fine paper, and should be found on file in the home of every poultry lover. No beginner in the poultry business should think of being without it. It will save him many times the small subscription price. The advanced poultryman will also find it of great value; the articles being varied in their scope.

**SPECIAL OFFER.** The regular price of AMERICAN POULTRY is 50c per year, but in order to introduce it to several thousand new readers, we will, for a short time, give a large 200-page poultry book, which is a complete guide in the poultry business, *absolutely free* to everyone sending 50c for a yearly subscription or \$1.00 for a three-year subscription to AMERICAN POULTRY. A trial six months' subscription (without book) will be sent for 25c. Never has so much been offered for so small a sum. Advantage of this offer should be taken at once.

### American Poultry

Savoy Building Wilkes-Barre, Pa.

According to figures issued by the Department of Commerce \$40,000,000 worth of automobiles and parts thereof were sent out of continental United States in the fiscal year 1913, against about \$1,000,000 worth in 1903. The imports of automobiles in the year 1913 were less than \$2,000,000.



## FREE TAILOR BOOK



Shows how to earn this swell tailored-to-order suit in an hour. How to make \$33 to \$65 a week, just by showing your fine FREE SAMPLE SUIT and our beautiful samples to your friends.

**Lowest Wholesale Prices** ever heard of. We pay express charges. Follows everywhere going wild about our styles. Finest quality guaranteed tailoring in America. We send magnificent SAMPLE OUTFIT and everything FREE. You pay nothing, sign nothing, promise nothing—and need no experience. Wait until you see how handsome your FREE SAMPLE SUIT is before you decide to be our Agent. More quick money in this than you ever thought possible. So easy to make it you will be astonished. Only one FREE SAMPLE BOOK to each court. Territory going fast. Send your name today.

Chicago Tailors' Ass'n. Dept. 580 Van Buren St., Chicago

## New Titles Just Added to Our Practical Handbook Series

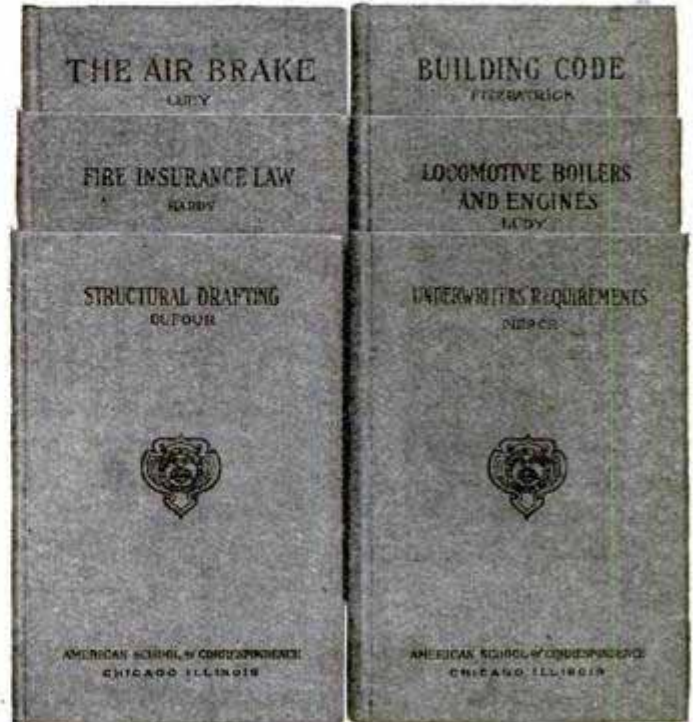

Air Brake . . . . .	\$1.00
Building Code . . . . .	1.00
Fire Insurance Law . . . . .	1.50
Corporation Law . . . . .	3.00
Real Property Law (Future Interests) . . . . .	1.50
Locomotive Boilers and Engines . . . . .	1.00
Structural Drafting . . . . .	1.00
Standard Legal Forms . . . . .	2.00
Motion Picture Work . . . . .	3.00
Modern American Homes . . . . .	2.50
Underwriters' Requirements for Safe Electrical Installation . . . . .	1.00

The following titles have just been revised and rewritten:

Alternating Current Machinery . . . . .	\$3.00
Architectural Drawing and Lettering . . . . .	1.50
Carpentry . . . . .	1.50
Electric Railways . . . . .	1.50
Electric Wiring and Lighting . . . . .	1.00
Estimating . . . . .	1.00
Gas Engines and Producers . . . . .	1.00
Machine Shop Work . . . . .	1.50
Power Stations and Transmission . . . . .	1.00
Refrigeration . . . . .	1.00
Steam Engines . . . . .	1.00
Surveying . . . . .	1.50
Steam Engine Indicators and Valve Gears . . . . .	1.00

Our Practical Handbook Series now numbers 80 live, up-to-date titles. Send for our new catalog listing these single volumes. If your dealer does not have the particular book of this series that you want, ask him to order it for you or order it direct from us yourself. Any book ordered direct will be sent postpaid upon receipt of price, and may be returned after a five-day examination if not suited to your needs in every way. Upon its receipt we will refund your money promptly.

**SOLD AT ALL BOOK STORES**

**American School of Correspondence  
CHICAGO, U.S.A.**



# The Boy Mechanic



**700 THINGS FOR 700  
BOYS TO DO**

*480 Pages—700 Articles—800 Illustrations  
Cloth—Price \$1.50 Prepaid*

**THE IDEAL BOOK for the  
Wide-Awake American Boy**

All the things described in this volume have actually been built or experimented with by boys. The ideas contained in "The Boy Mechanic" would more than keep a boy occupied until he grows up and also be an incentive to original thinking and achievement.

### The Most Interesting Boys' Book

Unlike so many other books of a somewhat similar nature, it is not confined to only one or a few subjects but describes 700 different things boys can make and do in the fields of mechanics, electricity, sports, arts and crafts work, magic, etc.

An unusually generous book; size 7 by 10 in. and 1½ in. thick; printed from large, clear type on high grade book paper and durably bound in cloth. Attractive four-color cover design.

### Wholesome, Practical, Instructive

Besides telling how to make scores of things useful about the house, full and complete directions are given for constructing the following and hundreds of other things which appeal to the heart of every boy:

Many Electrical Appliances—Steam and Gas Engines—Turbines—Motors—Wireless and Morse Telegraph—Self-Propelled Vehicles—Toboggans—Ice-Boats—Canoes—Paddle Boats—Punts—Camping Outfits—Tents—Fishing Tackle—Magic Lanterns—Searchlights—Cameras—Telescopes—Gliders, Kites and Balloons—Electric Furnaces—Lathes—Pottery Kilns, etc.

Many hours of enjoyment are in store for the boy who becomes possessor of this book.

**PRICE \$1.50, PREPAID TO ANY ADDRESS**

Your book dealer will supply it or you can send direct to the publishers

**POPULAR MECHANICS BOOK DEPARTMENT**  
318 W. Washington Street, CHICAGO



# Wood Shingles? No! No!! No!!!

**STOP the Awful Waste** of wood shingles—the cause of disastrous fires, leaky roofs and endless expense and trouble. Use beautiful, indestructible Edwards "STEEL" Shingles. Cost less, last longer than wood—better in every way. Over 100,000 men now use Edwards "STEEL" Shingles—the shingles that never rot, rust or burn. Ten times easier to put on. Each one dipped in molten zinc after it is cut. No raw or exposed edges. Patented Edwards Interlocking Device permits contraction and expansion—makes joints water-tight FOREVER! \$10,000 guarantee against lightning loss FREE.

**START Saving Money by Using**

## Edwards STEEL Shingles

### Fire-Proof! Rust-Proof! Leak-Proof!

We sell direct from factory and pay freight. SHINGLE BOOK FREE. Write for book and Prepaid Factory Prices. See for yourself how much less Steel costs than wood—then get busy! If you give dimensions of your roof, we will quote prices on entire job. Send postal right off—Catalog No. 1050 and special prices will come by return mail.

### THE EDWARDS MANUFACTURING COMPANY

1000-1050 Lock Street CINCINNATI, OHIO

Largest Makers of Sheet Metal Products in the World.

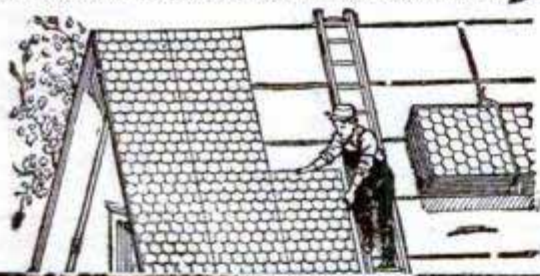

(127)

**BENDING OF CAST-IRON PIPES**—In laying part of a cast-iron water-pipe line near Preston, Cuba, through oversight no bends or sleeves were ordered, says Iron Age. To avoid the delay occasioned by ordering specials it was decided to try to bend the pipe, as had been done with steel and wrought-iron pipe. A cradle of old rails of the desired curvature was built. About 1 ft. of each end of the pipe was left outside to prevent collapse, and a hardwood fire was built under and around the remainder. Six or eight pipes were bent at a time in from 1½ to 2 hours, the pipe settling by their own weight into the cradle. The short radius used was 50 ft.

## Be a Land Title Abstracter



Earn \$1200 to \$5000 and upwards, yearly. Know all the ins and outs of Real Estate transactions. Have your services in demand wherever land is bought and sold. Be a professional man. Easy to learn. I'll tell you how. Write RICHARD ROBERTSON, THE LAND TITLE INSTITUTE OF AMERICA, 610 Gumble Building, Kansas City, Mo.

## AGENTS WANTED

We want good agents in every county to sell our goods. Literature and complete information free. Write today. Make from \$50 to \$100 a week.

THE UNIVERSAL MFG. COMPANY  
115 State St. FREMONT, OHIO

## Be good to your hands



THEY are your fortune; neglect of them is bad business. For trade, profession or sport, Hansen's Gloves give the only perfect protection with full liberty of fingers and fist. Hansen's Gloves are made of horsehide, tanned by a special process, soft, strong, easy, durable.

## Hansen's Gloves

are made in hundreds of styles, all sizes and various colors for automobilist, cyclist, hunter, farmer, electrician, ironworker—you can not name a field of play or work for which there is not a Hansen Glove "Built Like a Hand." They are economical, too—cost no more and outlast the ordinary kind, and washing in gasoline leaves them soft and shapely.

FREE BOOK OF GLOVES

—Send today to

O. C. Hansen  
Mfg. Co.

291 Milwaukee St.

Milwaukee

Wis.



Hansen's  
"Glad Hand"  
one of a  
hundred  
styles



## Soiled Hands Cleaned Quickly with Kwik Hand Cleaner



A wonderful boon to motorists, chauffeurs and mechanics. Kwik Hand Cleaner removes dirt, grease and graphite stains in a jiffy. Applied like cold cream and rubbed off with cheese cloth or tissue paper, the dirt disappears like magic.

### No Soap or Water Needed

Kwik Hand Cleaner will not injure the most delicate hands. It contains no free alkali or other harmful ingredients. Soothes and heals hands, making them soft and smooth.

### MOTORISTS, MECHANICS, ENGINEERS

Don't be embarrassed by soiled, unsightly hands. Kwik Hand Cleaner will keep your hands in perfect condition; every motorist should keep a jar in his car for emergencies.

To the Man Working in the Shop or Garage Why not make big money in your spare time selling Kwik Hand Cleaner to your fellow workmen, chauffeurs and motorists?

SATISFACTION GUARANTEED. Send 50¢ today for a full size jar. Try it. If you don't find it everything claimed we'll refund your money. Order today.

KWIK SALES CO Dept 147 849 Peoples Gas Bldg Chicago '11

Please Mention Popular Mechanics



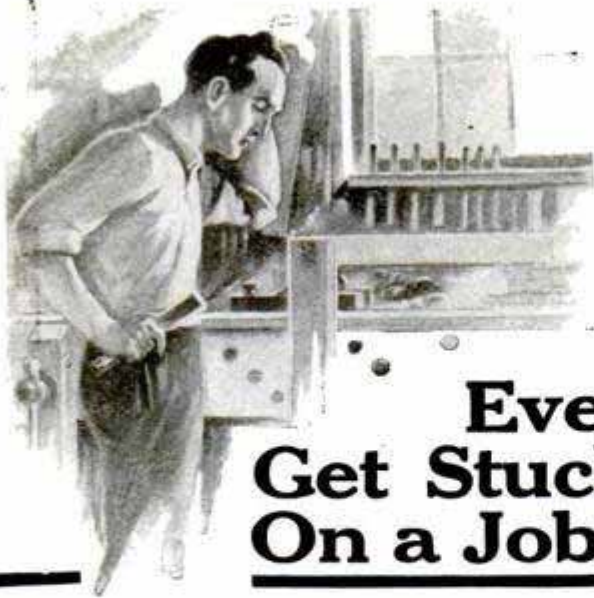

## Ever Get Stuck On a Job?

WERE you ever confronted with an emergency job where something unusual had to be done quickly with the few tools at hand or no tools at all? You could have done that unfamiliar job in a jiffy if only some one could have informed you how he did it.

¶ Has it occurred to you that every day, everywhere, men in every department of mechanics, engineers, firemen, carpenters, machinists, plumbers, painters, iron and wood workers, electricians, masons and in fact men in all the trades are meeting and solving these problems in economical, time and labor saving ways?

¶ If a collection of all this useful experience of years, of hundreds of the most successful mechanics could be made, "boiled down" and written so it could be readily understood by anyone who uses tools, would it not be of priceless value to the owner?

¶ This is just what **Popular Mechanics Magazine** has been doing for years, and now our

### Series of Shop Notes Year Books

constitutes a veritable encyclopedia of Easy Ways to Do Hard Things

¶ Naturally these books must be handy of reference to be of value and this feature has not been overlooked as each volume is indexed fully and with great care, so that any subject may be turned to at once.

¶ Why not save yourself the trouble of puzzling out the "kinks" and "short-cuts" when some one has already done it for you? Some one little suggestion may be worth more to you than the price of the entire set of books.

### Shop Notes Year Books

VOLS. I TO IX INCLUSIVE  
CONTAIN

4595 Articles—1988 Pages—4503 Illustrations  
Size 6 x 9 in. Bristol Covers.

PRICE  
PER VOLUME **50c** PER SET of nine Books in Handsome Case Prepaid **\$4.50**  
Postpaid

Order or complete your set to-day

Popular Mechanics Book Dept.  
318 W. Washington St. CHICAGO

# Pattern-Making

BY G. H. WILLARD

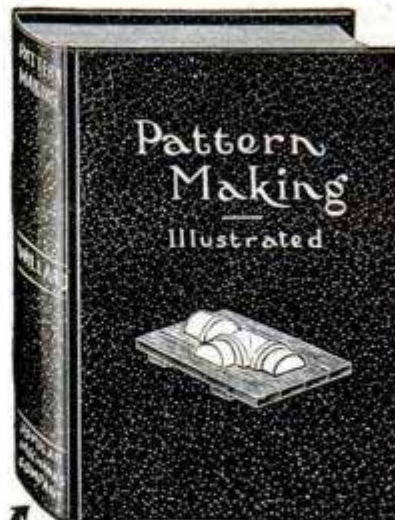

With Additional Chapters on Core-Making and Molding

224 Pages  
312 Illustrations  
Cloth Cover  
Price \$1.00 Postpaid

"Written So You Can Understand It"

A book for the man who has to do the work. Written by a practical pattern-maker of many years' experience.

**CHAPTER HEADINGS.** I. Pattern-Making as a Trade. II. The Tools. III. Woods. IV. Joints. V. Turning. VI. Turning (Continued). VII. Turning (Continued). VIII. Turning (Continued). IX. The Circular Saw. X. The Circular Saw (Continued). XI. Machine Tools. XII. Machine Tools (Continued). XIII. Simple Patterns. XIV. Simple Patterns (Continued). XV. Simple Patterns (Continued). XVI. Crooked Patterns. XVII. Large Pattern Work. XVIII. Large Pattern Work (Continued). XIX. Crosshead Guide Patterns. XX. Sweep Work. XXI. Pipe Work. XXII. Stove Pattern Work. XXIII. Molding—Machine Work. XXIV. Molding Pattern Work.

**PART II—Core-Making and Molding.** Chapter I. Core-Making, Simple and Complex. II. Principles in Molding. III. Loam Patterns and Loam Molds.

Every one following this trade, or intending to learn it, should have a copy of this valuable book.

POPULAR MECHANICS BOOK DEPT.  
318 W. Washington St., CHICAGO

## Hand-Forging and Wrought-Iron Ornamental Work

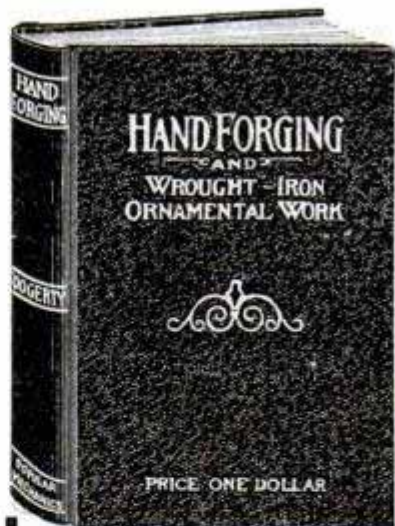

### Brief Outline of Contents

Introductory—The Spirit of Decorating—Correct Principles in Designing—Equipment—How to Draw the Iron—Working at the Forge—Various Processes described—Various Forms of Welding—Brazing—Twisting—Banding—Riveting—Scrollwork—Grilles—Welded Scrollwork—Box Forging—Embossing—Forms in Relief—Raised Forms—Special Designs—Drawer Pulls and Hinges, etc.—Door Plates—Iron Lamps.

A New Book on a Fascinating Handicraft  
By THOS. F. GOOGERTY

208 pages, 122 illustrations, 12mo. Printed on a special grade of book paper and bound durably in extra cloth. Special quotations to schools ordering in quantities. Price \$1 Postpaid

POPULAR MECHANICS BOOK DEPT.  
318 W. Washington St., CHICAGO



# PRICES OF ELECTRIC WASHERS HAD TO *COME DOWN!*

**T**HE RAPID alone has brought the cost of Electric Washing down to Everybody's reach. No need now to pay exorbitant prices to enjoy this wonderful labor-saving convenience. And the Rapid, on points of quality and service, is the leader of them all. Just investigate. Remember, it costs you nothing to try out the Rapid Electric Washer in your home. We send it to you, prepaid. Use it for four washings. Pile in your heaviest blankets—rugs even. Or entrust your daintiest laces. Snap on the power and the Rapid does in a few minutes what it would take you hours of weary rubbing to accomplish. It washes clothes snow-white—injures nothing.

## RAPID Electric Washer

### About Half Price—30 Days' Free Trial

Try the Rapid entirely at our risk. Return it at our expense if you are not more than satisfied. No salesman follows you up. You decide for yourself strictly on the merits of the machine.

The Rapid is the only washer with one operating handle which controls both the washer and wringer. The only washer with all gears enclosed—so there is no danger of catching the fingers or clothes in the machinery.

### Special Added Value

The motor of the Rapid produces more power than required by the heaviest washings and can be used for running sewing machine, ice cream freezer, meat chopper, buffer, etc.

**THE RAPID WASHING MACHINE COMPANY, 520 First National Bank Bldg., Chicago**



### Write for Facts Today!

Learn our astonishing price offer—our 3-Year Guarantee. Learn why it is possible for us to save you from \$25 to \$45 on the best electric washer ever made. Address today,

California's olive crop this year is estimated by the California Olive Producers' Association at 1,125,000 gal. pickled olives and 1,000,000 gal. of oil, a record output.



HONEST VALUES

TRADE MARK REGISTERED

**WOMENS AND MENS  
WEARING APPAREL  
OF ALL KINDS**

LONG LIBERAL CREDIT

**BERNARD  
MAYER ©**

Write for our style books  
They are free to you

Seven hundred styles to select from  
Bernard Mayer Co., 3941 Gage St., Chicago

## Go into the Moving Picture Business

### You can't beat it for MAKING BIG MONEY QUICK

It's the Greatest Money Making Business the World Has Ever Known. Anyone, Anywhere May Become Rich in It.

### A Small Capital Starts You and Starts You Right

For a small cash payment you can get one of our machines or outfits—everything you need—and embark in the business, pay the balance from your profits.

### NO EXPERIENCE NECESSARY WE TEACH YOU EVERYTHING

You need no experience. We sell you the proper equipment for your purpose and teach you how to conduct the business. You begin earning money right at the start and with our help you can compete with the oldest and most experienced exhibitors.

### Our Big Free Offer Will Double Your Profits

It will enable everyone who purchases an outfit from us to put up the most attractive show in his locality and to overcome all competition. Here it is:

### A Guaranteed Professional MOTION PICTURE CAMERA FREE With Every MOVING PICTURE MACHINE

This means greater money making possibilities than the man with a motion picture outfit has ever before dreamed of. To take advantage of it will give you the greatest, quickest and surest money making combination of the times—the moving picture machine and camera enabling you to take and show your own pictures.

### This Offer Good for a Limited Time Only. Act Quickly

Don't let some one else beat you to it, but take advantage of this offer. You will make more money out of your exhibitions and at the same time get started in the film producing business, the branch of the motion picture business in which the greatest fortunes have been made. Send for more particulars about this great offer and our book on "How to Make Money in the Moving Picture Business." Sent free upon request.

**P. & W. Sales Company, 836 Como Bldg., CHICAGO, ILL.**





# CASH PRIZES

FOR

## Our Young Readers

The following cash prizes will be paid for the 20 best original articles suitable for publication in the Amateur Mechanics Department of Popular Mechanics Magazine.

First Cash Prize	\$35
Second Cash Prize	25
Third Cash Prize	20
Fourth Cash Prize	15
Fifth Cash Prize	10
Sixth Cash Prize	10
Seventh Cash Prize	10
Eighth Cash Prize	10
Ninth Cash Prize	10
Tenth Cash Prize	5
Eleventh Cash Prize	5
Twelfth Cash Prize	5
Thirteenth Cash Prize	5
Fourteenth Cash Prize	5
Fifteenth Cash Prize	5
Sixteenth Cash Prize	5
Seventeenth Cash Prize	5
Eighteenth Cash Prize	5
Nineteenth Cash Prize	5
Twentieth Cash Prize	5

### Contest Closes December 10, 1913

To be available, the descriptive articles must be new, original and suitable for publication in the Amateur Mechanics Department. Where necessary to a better understanding by our readers, photographs, plans, or pencil sketches should accompany the manuscript. We do not want mere descriptions of things that have been done, unless they are such as young people generally would be likely to make and that can be built with ordinary tools and materials.

Contributors may submit as many articles as desired, but no one will be awarded more than one prize.

Articles failing to win one of the prizes, but suitable for publication, will be promptly paid for at usual rates; all others will be returned.

On December 15th, 1913, the articles will be judged and the prize money sent at once. Publication of the names of the winners will follow in the February, 1914, issue.

Mark your article "For Prize Contest Amateur Mechanics Dept.," and mail to Editor

**Popular Mechanics Magazine**

318 W. Washington St., Chicago

## JUST OUT AMATEUR MECHANICS No. 4



Another Big Book for Those Who Like to Make Things

SIMILAR IN STYLE to Amateur Mechanics Nos. 1, 2 and 3, but contains entirely different matter

The scores of ideas of practical things to construct, which are all clearly illustrated as well as thoroughly explained, will profitably occupy any boy's

time and afford many hours of enjoyment.

Among the many interesting things it tells how to make are:

Roller Coaster—Camps—Monoplane Glider—Wireless Telephone Set—Electric Incubator—Arts Crafts Leather Work—Wood Lathe—Canoe—Water Wheel—Enlarging Camera—Motion Picture Camera and Projector—Leaded Glass Panels for Furniture.

All told there are over 200 articles and 200 illustrations. The book contains 128 pages (size 6½x9½ in.) nicely printed on good book paper and bound in three color illuminated cover.

**PRICE 25 CENTS, POSTPAID**

Ask your Book Dealer or send direct to the Publishers

**POPULAR MECHANICS BOOK DEPARTMENT**

318 W. Washington St., CHICAGO

WHEN YOU WANT ANYTHING AND DON'T  
KNOW WHERE TO FIND IT  
WRITE BUREAU OF INFORMATION,  
POPULAR MECHANICS CHICAGO

## MONTHLY CASH PRIZES

Until further notice in this magazine the Editor of Popular Mechanics will pay two cash prizes each month for the best original contributions to its

### SHOP NOTES DEPARTMENT

\$10 for the Best Contribution  
\$5 for the Second Best

THIS IS IN ADDITION to our usual rates for such contributed articles.

Quality, not length counts.

Checks will be sent on the last day of each month for the prize articles received during that month. Publication in the magazine will follow in about two months.

### PRIZES AWARDED FOR AUGUST, 1913

First Prize—JAMES E. COOLEY, Hartford, Conn.....\$10  
"A Safety Step Ladder"

Second Prize—LEROY BRADLEY, Lorain, O.....\$5  
"A Fountain Scrub Broom"

### EXTRA AWARD

On account of there being five contributions this month each of which deserved second prize, we have made an EXTRA AWARD of four additional second prizes, as follows:

C. R. DREESE, Kansas City, Kan.....\$5  
"Fasteners for Small Metal Tubes"

FORREST CLARK, Coronado, Cal.....\$5  
"A Floating Mooring"

EDWIN M. DAVIS, Philadelphia, Pa.....\$5  
"Removing Dents from Aluminum Ware"

A. R. CUNNING, West New Brighton, N. Y.....\$5  
"Cleaner for a Soldering Copper"

All accepted contributions to our departments, "SHOP NOTES" and "AMATEUR MECHANICS," are paid for immediately; checks for prize awards are sent at the end of each month.

Address, EDITOR POPULAR MECHANICS  
318 W. Washington St., Chicago



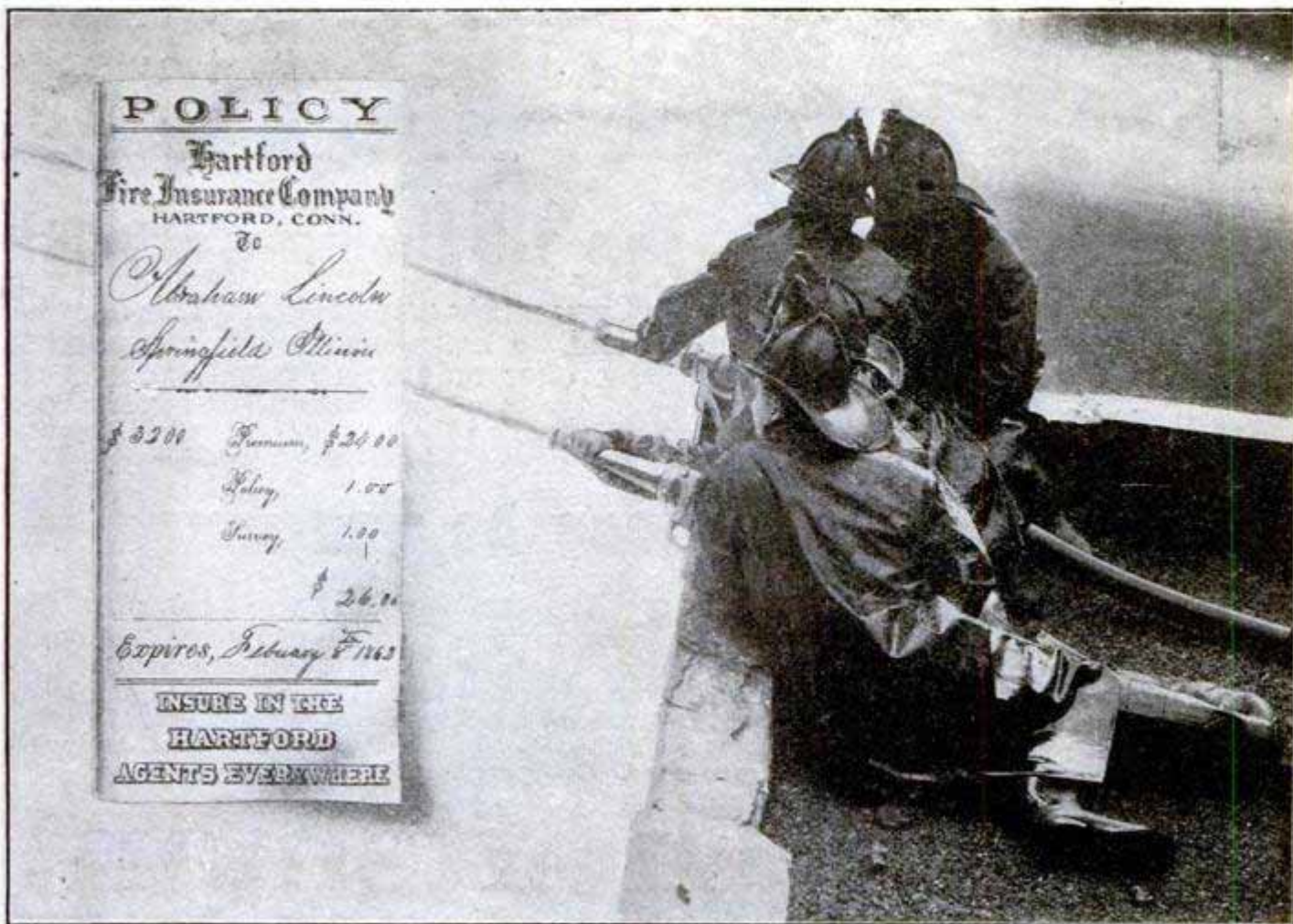

**POLICY**  
**Hartford**  
**Fire Insurance Company**  
 HARTFORD, CONN.  
 To  
*Abraham Lincoln*  
*Springfield Illinois*  
 \$2200 Premium, \$24.00  
 Policy 1.05  
 Survey 1.00  
 \$ 26.05  
 Expires, February 5, 1913  
**INSURE IN THE**  
**HARTFORD**  
**AGENTS EVERYWHERE**

The sales of American locomotives and railway cars in foreign countries have been increasing steadily for the past five years, and according to official figures, \$8,300,000 worth of railway cars were exported during the first 10 months of the fiscal year 1913.

## WIN NEXT \$1,200

We tell you how; \$40,000 already won by ten inexperienced people. Stoneman received \$1,200 one month; \$15,000 to date; Korstad \$2,200 in two weeks; Schleicher \$195 first 12 hours. Strange invention, startles the world. Gives every home a bathroom with hot and cold running water for \$6.50; abolishes plumbing, water works; self-heating; little wonder Hart sold 16 in 3 hours, \$5,000 to date; Lodewick 17 first day. Credit given; investigate today. Beat others to exclusive sale; means fortune. **ALLEN MFG. CO., 3649 Allen Bldg., Toledo, Ohio**



### Concerning Shoes

Do you pay a dollar to have your shoes resoled? Why not send that dollar to the List Manufacturing Co., 416 W. Church St., Newark, Ohio, and get a shoe nailer with which you can do it yourself in a few minutes? The nails are driven outside the uppers, and for finish, durability and comfort excel sewing. The shipping charges are prepaid.

### Danda Leather Key-Purse



With Your Name Stamped In Gold  
**25c** By Mail With Pocket **40c**  
 Postpaid for Pen-Knife  
 It's convenient, prevents keys from rusting, saves the clothing and is a neat case for the pocket. Made of strong leather with key ring and your name handsomely embossed in gold letters on the purse. Write for illustrated Catalog of Danda leather goods and novelties.  
 Live-wire AGENTS Make Big Sales.  
**DANDA P. S. MFG. CO., 82 JOHN ST., NEW YORK**



## It's Mighty Handy

for sharpening knives, tools, shears; for oiling guns, sewing-machines, locks, clocks—there's a hundred uses for a

### HOME OIL OUTFIT

A dandy Home Oil Stone, a curved-spout Oil Can and a 3 oz. bottle of Home Oil—the best oil by every test—all given with a regular 25c bottle of Home Oil.

*If your dealer hasn't it, we will send you a complete outfit, postage prepaid, for 25c.*

**BUFFALO SPECIALTY CO.**  
 The LIQUID VENEER People  
**BUFFALO, N. Y.**



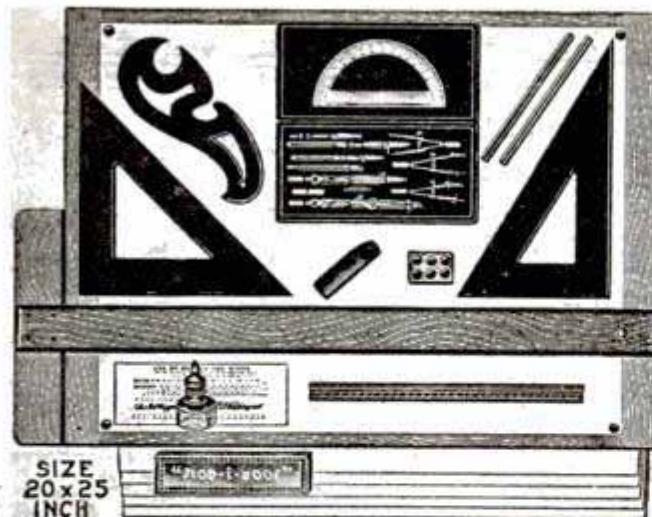

SIZE 20x25 INCH

# FREE

## This \$15 Draftsman's Outfit

But you must write at once. This offer is limited. I make this most exceptional great offer only to a limited number of selected students.—Just think of it! A complete, regular Draftsman's \$15 Working Outfit with high grade Imported German Silver Set of **INSTRUMENTS—ALL FREE**

## Drafting Work As Soon As You Enroll— Earn While Learning

Yes, that's exactly what I mean. As soon as you become my student you can begin earning a handsome income while learning at home. Send the free coupon to me today and I will tell you just exactly how you can begin. I mean just what I say. This is a great extra special offer I am making. You should write at once. Absolutely no obligations of any kind in sending the coupon. But you must write at once. I cannot make this offer broadcast to everyone. So I will take the names in the order that they are received. Get yours in early.

# Be a Draftsman!

Draw \$125 to \$175 per month at once

There is an urgent demand always for skilled draftsmen. Our companies are issuing calls every day for men to fill positions paying from \$125.00 to \$175.00 per month. Many positions paying \$75 to \$100 per week always open. Work is light, pleasant and profitable. Unlimited opportunities for expert draftsmen and designers. Mail coupon for valuable book, "Successful Drafting." It explains how you can become a skilled draftsman in a short time. It's free—Just think:



### Chief Draftsman Will instruct you personally

A most wonderful opportunity for a limited and selected number of ambitious men! For over twenty years I have been doing the highest paying expert drafting work. I am **Chief Draftsman** of a large and well known company. Long ago I saw the urgent demand for practical, trained draftsmen and I organized my practical method for ambitious men whom I trained personally. Each month the demand for

**I Guarantee**  
To instruct you until competent and placed in a position at a regular salary, paying from \$125.00 to \$175.00 per month and furnish you free \$15 Working Outfit at once.

practical, trained draftsmen is growing—higher salaries are being paid right along. Never before have we felt the need as we do today for men who **really know** practical drafting—the way I am training my students. At this time I can accommodate a few more men (from the ages of 16 to 40) in my spare time. If you write me **at once** I will send you my book, "Successful Drafting," with full particulars—all free. But you must write to me—

### FREE Outfit Coupon

Chief Draftsman:  
**ENGINEER'S EQUIPMENT CO.**  
Div. 9197 CHICAGO, ILL.

Without any obligation on me, please mail your book "Successful Draftsmanship" and full particulars of your liberal "Personal Instruction" offer to a few students. It is understood that I am obligated in no way whatever.

## Mail Free Coupon Now

Mail this Free Coupon at once and I will send you my book "Successful Draftsmanship" and full particulars—all FREE.

I will send my book if you write at once, absolutely free—also particulars about my offer to a few ambitious men who want to make from \$2,500 to \$5,000 a year. No obligations whatever on you in sending the coupon.

NAME .....

ADDRESS .....

Address **CHIEF DRAFTSMAN**  
Div. 9197, Engineer's Equipment Co. (Inc.) CHICAGO, ILL.



# Makes Tool Sharpening Speedy, Easy and Accurate

No other hand tool grinder can compare with Luther's "BEST MAIDE" in efficiency. It is the speediest, smoothest, quietest, most accurate and easiest running tool sharpener possible to produce. The secret of its success lies in its wonderful DIMO-GRIT wheel, its ball-bearings, its worm gear and shaft and the tilting frame.

## Worm Gear

The worm gear and shaft on the Luther "BEST MAIDE" Grinder are perfect in every detail. We cut them from solid steel with special machines of our own designing. Not even the very highest priced cream separators are supplied with better or smoother gears. "BEST MAIDE" gears and shafts are of extra large diameter, which means greater wearing surface. The grinding wheel held by this extra heavy shaft must run true and without vibration. Ball bearings are used to take up all side thrust and give as perfect and easy running a piece of mechanism as it is possible to build.

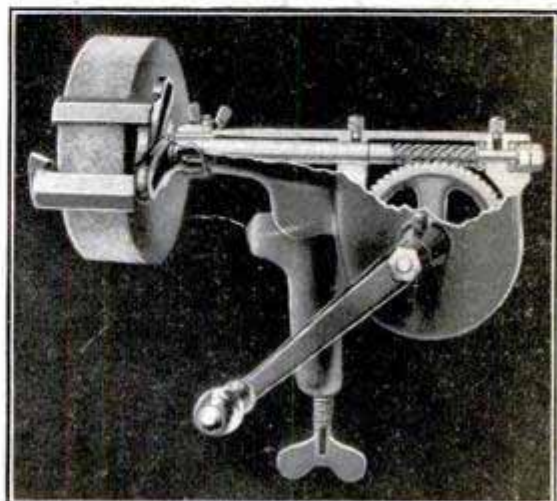

Horizontal Position—Sectional View  
Showing Worm Gear and Shaft

## Tilting Frame

The Luther "BEST MAIDE" Grinder can be tilted so that any side of the grinding wheel can be utilized. No matter how awkward a tool may be to "get at," it is easy to sharpen it with this adjusting feature. Our new patented arrangement for swivelling the frame allows quick and accurate adjustment to ANY ANGLE—horizontal or vertical—and holds the machine rigidly in any position.



Upright

## Double Faced Sharpening Wheel

The "BEST MAIDE" has a double-faced sharpening wheel. The body is of medium grit for quickly bringing a tool to an edge. The smooth and keen edge finishing is done on the side face of the wheel, which is of very fine grit, like a finishing hone. This "two in one" feature is exclusive with the "BEST MAIDE" Grinder.



With Chisel and  
Plane Bit Guide

## Dimo-Grit Wheels

DIMO-GRIT, the wonderful new artificial diamond sharpening substance, used in the "BEST MAIDE" Grinder Wheels, cuts steel as emery cuts soft copper. It makes tool sharpening so easy that your tools are always in perfect edge, your work speeds up and production is increased. Will outwear any number of emery wheels. No water needed—no danger of spoiling a tool as DIMO-GRIT will not draw temper. Guaranteed for 5 years.

## Carried by Every Leading Hardware Store

Luther's "BEST MAIDE" Grinders are on sale by leading Dealers everywhere. If yours doesn't handle it, send us his name with the line of grinders he carries, and we will send you Free a Special Descriptive Folder, and will also give you—FREE—a handy little pocket hone in handsome leather case. MAIL THE FREE COUPON TODAY.

## Luther Grinder Mfg. Co.

707 Point Street Milwaukee, Wis.

### Mail this FREE Coupon

Luther Grinder Mfg. Co.,  
707 Point St., Milwaukee Wis.

Please send me Free your Special Folder illustrating and describing Luther's "BEST MAIDE" Tool Grinders and a DIMO-GRIT hone in leather case.

MY NAME .....

ADDRESS .....

DEALER .....

GRINDER HANDLED .....



# Williams

## PATENTED Holder-Top Shaving Stick



The economy and ease of using Williams' Holder-Top Shaving Stick is exceeded only by the luxury and comfort it affords

### SPECIAL OFFER—Suit Case Sets

In order that those who are not familiar with our new toilet requisites may have an opportunity to try some of them, we have prepared very attractive sets of samples which we call "Men's Suit Case Sets" and "Women's Suit Case Sets." These are handsomely decorated boxes containing trial size reproductions of our regular packages. Either set named below will be sent for 24 cents in stamps.

#### Men's Suit Case Set

Contains

Holder-Top  
Shaving Stick  
Shaving Cream  
Dental Cream  
Talc Powder  
Jersey Cream  
Toilet Soap

Address: The  
J. B. Williams  
Company

#### Women's Suit Case Set

Contains

Talc Powder  
Dental Cream  
Cold Cream  
Jersey Cream  
Toilet Soap  
Violet Toilet  
Water

Department A,  
Glastonbury,  
Conn.



After Shaving use

Williams' Talc Powder