

MARCH

THIS ISSUE 137,500

10 CENTS

POPULAR MECHANICS

WRITTEN SO YOU CAN UNDERSTAND IT

PUBLISHED IN CHICAGO

LARGEST CIRCULATION OF ANY MECHANICAL PUBLICATION IN THE WORLD

Aeroplane Makes First Long Flight

With Heavier-Than-Air Machine—Wins \$10,000 Prize

The Causes of Mine Disasters

In Which 22,000 Have Been Killed in 17 Years—Underground Hospitals

Whence Came America's First Cement

Poor Land Owners Made Suddenly Rich

Electric Ice Box Without Ice

Automatic System Requiring No Attention; Not Expensive

Seeking the Speed Limit of Safety

Experiments with Steam and Electric Locomotives

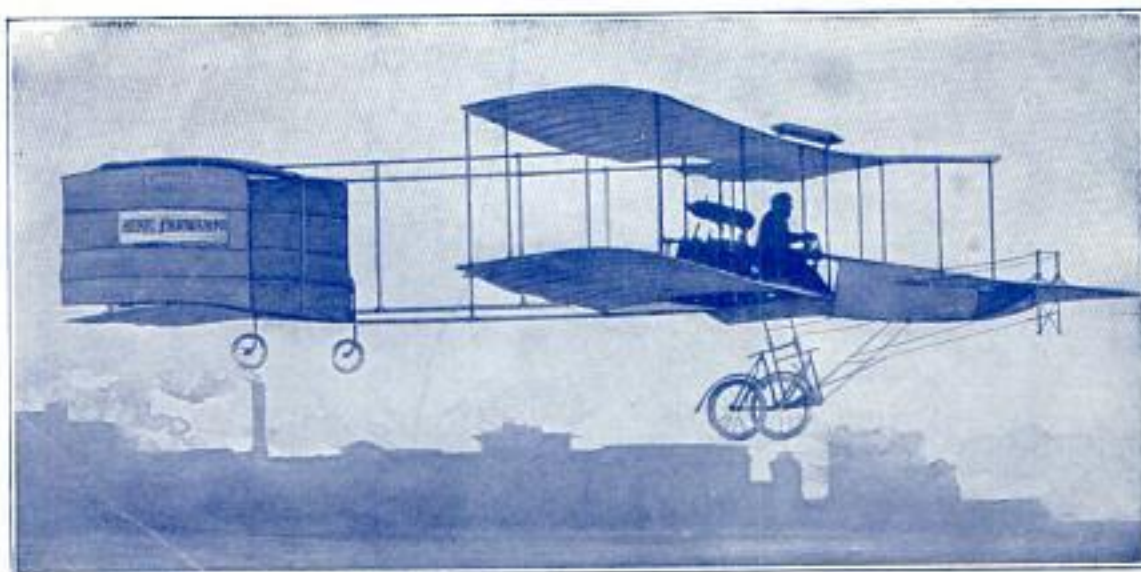

Won \$10,000 Prize; Flight Nearly One Mile

"SHOP NOTES FOR 1908" NOW READY—PRICE, 50 CENTS—ASK YOUR NEWSDEALER

Copyrighted material

HOW OFTEN DO YOU

Have Something to Fasten to

Brick, Stone, Marble, Tile, Concrete or Masonry?

Such fastenings used to take a lot of time and cause a lot of trouble—but that was in the "old days" when people used wood plugs and fussed around with molten lead. In those times there really wasn't any other better way, but nowadays the man who knows—uses

STAR EXPANSION BOLTS or STAR SCREW ANCHORS



For use with all lag screws ($\frac{3}{4}$ to $1\frac{1}{2}$ in. diameter)
Either malleable iron or lead composition metal



For use with all wood screws (No. 5-18 inclusive)
Furnished only in lead composition metal

Star Expansion Shields and Anchors possess following distinct advantages:

- Maximum strength Great ease in using
- Extremely small hole required for insertion
- Being able to use with all styles and sizes of stock bolts and screws and a
- Clean cut, finished appearance which ornaments rather than defaces

We claim that you can save 50% in Time, Labor and Expense. Don't take our word for it. Write today for Free Catalog and Samples and you can see for yourself. Write us today and we will tell you the nearest dealer carrying Star Shields in stock.

Remember Samples are free for the asking

STAR EXPANSION BOLT CO.

Humphrey, Trask and Second Streets
BAYONNE, N. J.

Founded by Mathew Carey, 1783.
A House in touch with Three Centuries.
THE PIONEER INDUSTRIAL PUBLISHERS
OF AMERICA.

HENRY CAREY BAIRD & Co.

Industrial Publishers, Booksellers and Importers
810 Walnut Street, Philadelphia, Pa., U. S. A.

Our new and Revised Catalogue of Practical and Scientific Books, 96 pages, 8vo. (March 1, 1907); Catalogue of Chemical Technology and General Chemistry, July 1, 1905 (New and Up-to-Date); a Catalogue of Books on Metallurgy, Mining, Prospecting, Mineralogy, Geology, Assaying, Analysis, etc.; a Catalogue of Books on Steam and the Steam Engine, Machinery, etc.; a Catalogue of Books on Sanitary Science, Gas Fitting, Plumbing, etc.; and our other Catalogues and Circulars, the whole covering every branch of Science applied to the Arts, sent free and free of postage to any one in any part of the world who will furnish his address.

VALUABLE BOOKS ON MINING, PROSPECTING, MINERALOGY, ASSAYING, ETC.

ERNI AND BROWN.—Mineralogy Simplified: Easy Methods of Identifying Minerals, including Ores, by means of the Blow-pipe, by Flame Reactions, by Humid Chemical Analysis, and by Physical Tests. By Henri Erni. Third Edition, revised, with entirely new matter, including Tables for the determination of Minerals by Chemical and Pyrognostic Characters and Physical Characters. By Amos P. Brown, Ph. D., Prof. Univ. of Pa. 96 engravings, Morocco. \$2.50

LIEBER.—The Assayer's Guide, or Practical Directions for Assayers, Miners and Smelters, for the Tests and Assays, by Heat and by Wet Processes, of the Ores of all the Principal Metals of Gold and Silver Coins, Alloys, and Coal, etc. 12mo., Ills. \$1.50

ORTON.—Underground Treasures: How and Where to Find Them. A Key for the Ready Determination of all the Useful Minerals within the United States. New Edition, with Ore Deposits and Testing Minerals with the Blow-pipe. Ills. \$1.50

OSBORN.—The Prospector's Field Book and Guide in the Search for and Easy Determination of Ores and other Useful Minerals. By Prof. H. S. Osborn, LL.D. Illustrated by 66 engravings. Seventh edition, revised. 12mo. (1907) \$1.50

Elaborate Illustrated Circulars of the above Books mailed to any one in any part of the World who will furnish his address.

The above books sent by mail free of postage at the publication prices to any address in the world.

HENRY CAREY BAIRD & CO.

Industrial Publishers, Booksellers and Importers
810 Walnut Street Philadelphia, Pa., U. S. A.

HERE THEY ARE!!

INDUSTRIAL ALCOHOL

Second Edition

The authority on the manufacture of denatured alcohol. By F. B. WRIGHT. \$1.00.

WIRELESS TELEGRAPHY

A handbook on the principles of Radiotelegraphy and the Construction and Making of Apparatus for Short Distance Transmission.

By R. P. HOWGRAVE-GRAHAM, 160 pages, 51 illustrations, 12 mo., cloth. Price \$1.00

FLYING MACHINES

A popular account of Flying Machines, Dirigible Balloons and Aeroplanes.

By A. W. MARSHALL and HENRY GREENLY, 128 pages, 24 illustrations and 28 page plates, 12 mo., cloth. Price 50c

EDUCATIONAL WOOD WORK

By A. C. Horth. A complete manual of teachers and organizers of woodworking classes. Contents of Chapters: 1, First Year Course. 2, Second Year Course. 3, Third Year Course. 4, Fittings and Furniture. 5, Discipline. 6, Organization and Method. 7, The Instruction of the Physically and Mentally Deficient and Blind. 8, Object Lessons. Fully illustrated with reproductions from photographs, drawings and facsimile blackboard lessons.

158 pages, 12mo., cloth. Price \$1.00 net

SPON & CHAMBERLAIN

123 P.M. LIBERTY ST., NEW YORK

Navy Trade Schools

The Navy trains young men for every branch of the service. Even men who have mastered a trade may take advantage of the opportunity offered for a higher technical course.

The **ELECTRICAL SCHOOL** receives electricians by trade, and students of electricity with a good education, if over 18. The course is most complete, and includes a Theory Section, Ship's Watch, Mechanical, Practical Electricity, and Wireless Telegraphy.

The **ARTIFICER SCHOOL** consists of the Carpenter or Shipwright class, Blacksmith class, Plumber and Fitter, Painter and Shipfitter classes.

The **YEOMAN SCHOOL** trains men for clerical duties of the Navy, and consists of classes for Captain's yeoman, Equipment, Pay and Ship's Writer, embodying instruction in stenography, bookkeeping, penmanship, etc.

The **SCHOOL FOR SHIPS' COOKS, BAKERS, etc.**, instructs men in the duties of the various trades in the Commissary Branch. The instruction is of a practical nature.

The **SEAMAN GUNNERS' CLASS** is open to men of the Seaman Branch on re-enlistment; while the **MACHINISTS' SCHOOL** is open to honorably discharged men of the Engine Room.

The **HOSPITAL CORPS TRAINING SCHOOL** instructs recruits in the duties of caring for the sick and injured.

Write for full particulars, stating your trade and age

ADDRESS:

BUREAU OF NAVIGATION

....DESK 69....

NAVY DEPARTMENT, - - - WASHINGTON, D. C.

Please Mention Popular Mechanics

This One



L4WX-7S1-X5LX

2 Years for \$1

and a handsome Pocket Tape with Nickle Plated Brass Case, Spring Winding with Centre Push Pin and Stop is **FREE**

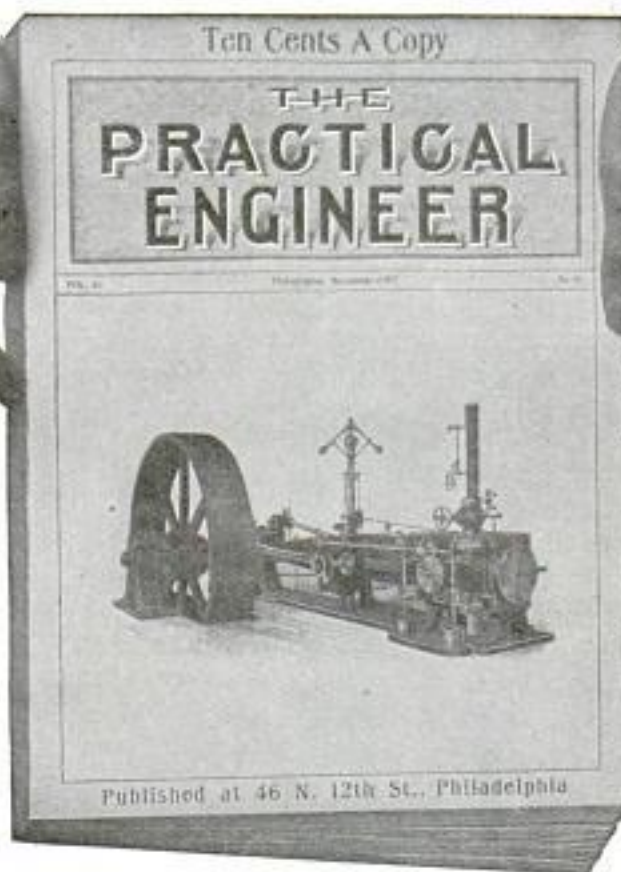

A popular monthly journal of 100 pages, for

**Engineers,
Managers,
Superintendents**

and all others interested in stationary power plant work.

A Practical Paper for Practical Men. Devoted to

**Steam, Electrical
and Hydraulic
Engineering.**

Edited in popular English, free from all unnecessary technicalities.

For this month we are making this remarkable Double Special Offer to Engineers, Managers, Superintendents and all others interested in Steam, Electrical and Hydraulic engineering.

We want to enroll ten thousand more new subscribers for "The Practical Engineer", the popular, practical, high grade engineering paper, the paper that tells you how to do things in the power plant in a practical way.

To accomplish this quickly, we will give every new subscriber, absolutely free, a handsome, Nickle Plated, Spring Winding Tape, with Centre Push Pin and Stop.

2 Years' Subscription for \$1



FREE One of these handsome Pocket Tapes, Spring Winding, with Centre Push Pin and Stop, will be sent free to every new subscriber. The Tape and a copy of the current issue of The Practical Engineer will be sent immediately upon receipt of order.

One Dollar sent now pays for two years' subscription in advance and the tape. If, after reading "The Practical Engineer" for two months, you are not satisfied that it is worth five times the price you have paid, send back the tape and we will immediately return the dollar and make no charge for the copies sent you. **SAMPLE COPY 10 CENTS.**

Engineering Advice Free

If you want to install a new power plant, new engines, boilers, pumps, dynamos or other equipment, write us full particulars, the advice of our staff of expert engineers is free to subscribers. Do it now.

THE PRACTICAL ENGINEER
44 N. 12th Street Philadelphia, Pa.

POPULAR MECHANICS

H. H. WINDSOR, Editor

160 Washington St., CHICAGO, U. S. A.

Copyrighted, 1908, by H. H. Windsor.

Exchange Editors are at liberty to quote from these pages by giving the usual credit.

CONTENTS FOR MARCH, 1908

SEEKING THE SPEED LIMIT OF SAFETY.....	140
FLOWER-BOX NOVELTY IS ARTISTIC.....	141
Remarkable Shallow Draft Craft.....	142
German Fighting Automobile.....	142
THE CAUSES OF MINE DISASTERS.....	143
Gas Power to Run Great Steel Plant.....	149
OPERATING TABLE FOR HORSES.....	149
New Automobile Seat.....	149
ICE BOX WITHOUT ICE.....	150
Queer Pranks of Wireless Telegraphy.....	150
TERRIFIC LOCOMOTIVE EXPLOSION.....	151
Violins Aged by Electricity.....	151
THE STEADY GROWTH OF THE U. S. NAVY.....	152
Decay of Paper Due to Bacteria.....	153
Proposed Wonders with Radio-Telegraphy.....	153
Rotary Pump on Auto.....	154
The First American Grain Mills.....	154
East River Tunnel Stops Congestion.....	154
CONCRETE DOME IN MOLD.....	154
HUGE MINE PUMPS.....	155
What Does it Cost to Run an Automobile?.....	155
Queer Foreign Locomotive.....	156
CHARTS FOR AIRSHIPS AND BALLOONS.....	156
Locomotives Turn Themselves.....	156
LARGEST METAL PLANER EVER MADE.....	156
Clock Made of Straw.....	158
Wreck in Which Many Were Killed.....	158
Onyx in the Rough.....	158
WHENCE CAME AMERICA'S FIRST CEMENT?.....	159
Ship Built to Carry Submarines.....	160
FIRST SECTION OF OCEAN RAILWAY COMPLETED.....	161
RAPID-FIRE GUN OF NEW DESIGN.....	162
Exploding a Mine in Granite.....	162
Rail Brakes for Stopping Cars.....	162
Sun's Rays Damage Ships.....	163
LOCOMOTIVE RUNS TOY FACTORY.....	163
Giant Safety Pins.....	163
Boat Built of Bronze.....	163
A REVOLVING CYLINDER MOTOR.....	164
DRIVE WHEELS EXTENDED UNDER TENDER.....	164
Stove Made of Revolvers.....	165
Modern Cliff Dwellers.....	165
ELEVATOR MOVED ACROSS A RIVER.....	165
Million Dollar Concrete Power Plant.....	166
SHEET METAL TUBES DRIVEN INTO GROUND FOR WELLS.....	166
"Motorite" to Double Speed Possibilities.....	166
Gas Engine Exhaust Utilized for Heating.....	167
What Makes Rain in Moving Pictures.....	167
SQUARE SECTION CONCRETE PILES.....	167
DRILLING CLOSELY SPACED HOLES.....	168
Shipbuilding Activity on the Great Lakes.....	168
SAND SUCKER TURNS TURTLE.....	168
A YEAR OF SCIENTIFIC MECHANICAL TRIUMPHS.....	169
Elephant Balloon.....	169
Concrete Railway Station.....	169
Wheels Too Large for Material Used.....	170
Chimney of Cobblestone and Brick.....	170
AUTOMATIC REEL FOR OCEAN CABLE-WAY.....	170
Traveling Sling for Inspecting Wires.....	171
DIRIGIBLE BALLOON IN TWO PARTS.....	171
Compartment Street Cars Necessary in Turkey.....	171
SPRINKLING TANK WRECKS BUILDING.....	172
RESCUED AFTER BEING ENTOMBED 1,000 FT. UNDERGROUND FOR 45 DAYS.....	172
The New York to Paris Automobile Race.....	172
Steel Shaft Cut by Quartz Sand.....	173
AN ELECTRICAL HORSE.....	173
Car Falls Half Over Elevated Structure.....	174
LARGEST AND STRONGEST VAULT IN THE WORLD.....	174
FUNERAL PROCESSION ON SKATES.....	175
How the Airship "La Patrie" Escaped.....	175
Old Posts and New.....	176
FRENCH AERONAUT WINS \$10,000 PRIZE.....	176
TWO ELEVATORS TO RUN IN SAME SHAFT.....	177
Largest Growing Plant Ever Moved.....	178
Direct-Coupled Rotary Steam Engine.....	178
MICE ON SUBMARINE ENSIGN.....	178
Mining with Electric Air-Drill.....	179
Pacific Fleet in High Seas.....	179
Duel Beneath the Sea.....	179
Sampling Dust for Analysis.....	179
Pyramid Monument to a President.....	180
ASPHALT IN PAVEMENTS.....	180
Tunnel for Joint Use of Water Mains and Railway.....	181
Electric Light Bath Cabinet.....	181
UNDERLINE ASH EXPELLER.....	181
Mississippi River Jetties.....	182
ENGLISH CARAVAN CAR.....	182
Life-Saving Tender Sten.....	182
Starting a Dutch Windmill.....	183
LINE WORK 800 FT. ABOVE CANON.....	183
Fish Inspect Torpedoes.....	183
GYROSCOPIC ENGINES FOR AEROPLANES.....	184
French Barrel Motor Truck.....	184
Boiler Hurlled Long Distance by Explosion.....	185

(Continued on Page 6.)

Issued Monthly

SUBSCRIPTION:

Single Copy 10 Cents

In United States, and its possessions, and Mexico, per year, postpaid - \$1.00
To Canada and all countries in the Postal Union, per year, postpaid - 1.50

All subscriptions are discontinued at expiration. Please examine the date printed on your wrapper.

Eastern Advertising Office :: 116 Nassau St., New York

Entered as Second Class Matter Sept. 15, 1903, at the Postoffice at Chicago, Illinois, under Act of March 3rd, 1879
Published monthly by POPULAR MECHANICS CO.

The attention of prospective advertisers is called to the policy of this magazine in accordance with which the publisher waives all claim for payment of any advertisement appearing in any issue where the number of copies actually printed and circulated is less than the number printed on the front cover page.

CONTENTS—Continued

EMERGENCY OVERSHOES FOR HORSES. 185
 Carving Fowl with Clippers..... 185
 To Stop Wireless Messages in War Time.... 185
**SUGGESTED TYPE OF DIRIGIBLE BAL-
 LOON**..... 185
 Raising Galveston 15 ft..... 186
 Stone Boulder Breaks Dredge Pump..... 186
 Quick Unloading Car Chute..... 186
 German Automobile Coal Wagon..... 186
AMATEUR MECHANICS—
 How to Enlarge from Life in the Camera 204
 How to Make a Small Motor..... 205
 Home-Made Shoe Rack..... 205
 Eleven-Year-Old Engineer..... 206
 How to Make a Flving-Machine..... 206
 How to Make an Ironing Board Stand... 206
 A Home-Made Electric Plug..... 207
 How to Make an Electric Fire Alarm..... 207
 Home-Made Boy's Car..... 207
 Swing Arm-Rest on Trains..... 208
 Natural Gas and Electric Light in Popcorn
 Wagon..... 208
ALARM FOR PUNCTURED TIRES...... 208
 Ship Stopped While Appendix Was Removed 208

SHOP NOTES.

Holding Up a Gear on a Vertical Shaft..... 187
 How to Make a Tool Stand..... 187
 A Home-Made Washing Machine..... 187
 A Sandpaper Kink..... 187
 Cutting and Storing Ice..... 188
 Turning Nuts on Mandrels..... 188
 How to Remove Stumps..... 189
 Flexible Drive for Small Boring Bar..... 189
 An Ever-Ready Wrench..... 189
 Repairing a Bursted Lubricator..... 189
 How to Drill Curved Holes..... 190
 A Simple, Effective Negative Washer..... 190

Placing a Pipe in an Old Trench..... 191
 A Sack Holder..... 191
 Another Pattern-Maker's Clamp..... 191
 Straightening a Large Armature Shaft..... 192
 A Lock for the Window..... 192
 Increasing the Life of Coal Hods..... 192
 How to Make a Poultry Feed Trough..... 193
 Holder for Flow Discs While Sharpening.... 193
 Removing a Broken Tuning Valve..... 193
 How to Make a Water Strainer..... 194
 How to Repair Lathe Bronze Bearings..... 194
 How to Tighten a Worn Blower Fan..... 194
 An Emergency Bake Oven..... 195
 A Tandem Crucible Furnace..... 195
 A Home-Made Brooder..... 196
 How to Machine an Arc on a Planer..... 196
 A Paint Brush and Pail Holder..... 196
 Home-Made Instrument to Draw Parallel
 Lines..... 196
 How to Make Pine Coverings..... 197
 Home-Made Pipe Cap..... 197
 Increasing the Ink Capacity in a Drawing
 Pen..... 198
 A Home-Made Boiler Grate..... 198
 How to Fit Handles to Carving Knives.... 198
 Gasket Made of Wound Asbestos Cord..... 199
 How to Tighten a Worn Screw..... 199
 How to Cut Stovepipe..... 199
 Emptying Oil Barrels with Compressed Air..... 199
 A Holder for Tool Grinding..... 200
 Wheelbarrow Bucket for Handling Concrete. 200
 Quickly Made Pipe Reducer..... 201
 Steam Brake for Threshing Machine..... 201
 A Tool for Cutting Hardened Steel Wire... 201
 Keeping an Ink Bottle from Turning Over.. 201
 How to Attach Drop Wires..... 201
 How to Harden Fine Circular Saws..... 202
 How to Remove Old Putty..... 202
 Making a Well House..... 202
 A Substitute Boiler Compound..... 203
 Ready Lumber Table..... 203



Valuable Book for Letterers

Modern Show Card Lettering, Designs, Etc.

NEW AND REVISED EDITION

A practical treatise on Up-to-Date Pen and Brush Lettering, giving instructions respecting many styles of lettering, position, movement, shading, spacing, designing and arrangement; with illustrations of large and small letter for each alphabet, together with a full analysis and diagrams of making neat and prominent figures off-hand for Price Tickets, etc.

Over 150 illustrations of finished show cards and price tickets are given with practical instruction, outside of a large variety of standard show card alphabets.

This book is far beyond anything ever published in this line. It contains solid, practical common sense instruction—a book that is free from absurd theories and mystifying kinks and contains 2,000 advertising Phrases for Card Signs, Posters, etc.

The price of the book is but \$1.00 delivered to your address. If you find book not as represented, you have the privilege to return the same in good condition within three days, and I will return the money.

Address **W. A. THOMPSON, Pontiac, Mich.**

A NEW MONTHLY MAGAZINE

The accompanying illustration shows a small outline of the cover page design of a new publication—"The Show Card Writer," a handsome new illustrated monthly. The first number was published September first, 1907.

No Card Writer can afford to be without it a single month. It will be a credit to the craft, an inspiration to the worker and a delight to the eye. Every page, every article, every illustration will be clear and distinct. It will show you how to improve your skill, how to enlarge your field and how to make money.

One Dollar per Year Ten Cents a Copy No Free Samples

Writes for prospectus. Address

W. A. Thompson, Publisher, Pontiac, Mich.



SELF-EDUCATION

TEACH YOURSELF AND INCREASE YOUR WAGES

ONLY DRAKE'S PLAINLY WRITTEN PRACTICAL BOOKS

CAN TEACH YOU WITHOUT THE AID OF INSTRUCTORS

Every volume positively UP-TO-DATE and written in a language so plain that even a child can understand. DRAKE is the largest publisher of Modern Mechanical Books for home and shop study in the world. We publish good books on every mechanical subject. Our large illustrated Catalog now ready. Sent free.

FREDERICK J. DRAKE & COMPANY
350 Wabash Avenue CHICAGO, U. S. A.

In ordering our catalog please mention this paper.

HOW TO MAKE

ELECTRICAL BOOKS

10 Cents Each—Order by Number

- | | |
|------------------------------|----------------------------|
| 1 Dynamo | 15 Toy Motor |
| 2 Telephone | 16 Electric Bell |
| 3 Motor | 17 Telegraph Instrument |
| 4 Storage Battery | 18 Wind Armatures |
| 5 Wimshurst Machine | 19 Wind Field Magnets |
| 6 Magneto | 20 Ammeter |
| 7 Medical Coil | 21 Thermostat |
| 8 Pocket Accumulator | 22 Motor Rotation |
| 9 Plunge Battery | 23 Electric Soldering Iron |
| 10 Voltmeter | 24 Electric Heater |
| 11 Galvanometer | 25 Electric Furnace |
| 12 Hand Dynamo | 26 Hand Feed Arc Lamp |
| 13 Talking Machine | 27 Jump Spark Coil |
| 14 1/2 H. P. Dynamo or Motor | 28 Rheostat |

Recent 25c Books

- 101 Transformer
103 Condenser
New Bulletin on Rough Castings for Dynamos and Motors will be sent with any of above. Also Catalog of Books on Electricity and Mechanics
BUBIER PUBLISHING COMPANY, Department 3, LYNN, MASS.

A School Within Itself

point where the careful student comprehends the complete designing, care and operation of a dynamo or motor, and 1 chapter on electric automobiles, outlining their construction, care and operation, and all about storage batteries and how to handle them.

There are XX chapters in all, XIX carrying you from the fundamental principles of electricity on through the various branches to a complete designing, care and operation, and 1 chapter on electric automobiles, outlining their construction, care and operation, and all about storage batteries and how to handle them. Each subject is carefully written and to the point. After a student studies a subject, he is questioned on that subject in such a manner as to bring clearly to his mind the points he needs to know regarding same. A DICTIONARY in back of book will enable him to learn the meaning of any electrical word, term or phrase used in this book, as well as hundreds of others in common use. All required tables necessary in the study are in it.

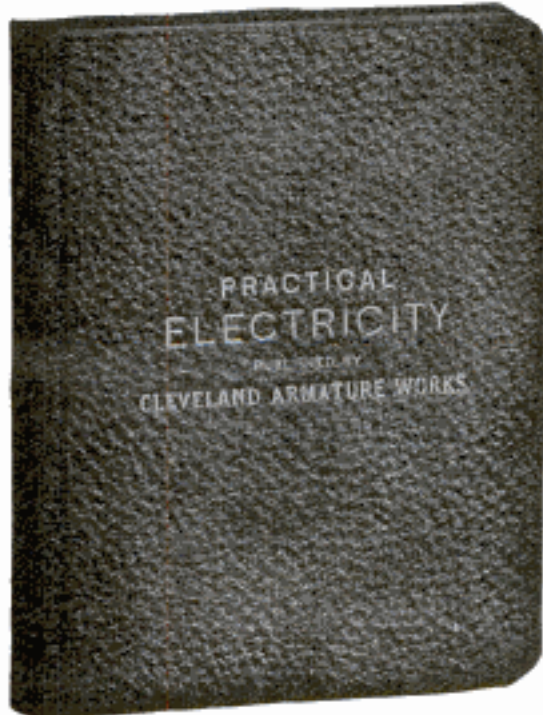

TABLE OF SUBJECTS:

CHAPTER	CHAPTER
I—Wiring	X—Counter E. M. F.
II—Electric Batteries. Electric Plating.	XI—Hysteresis and Eddy Currents
III—Magnetism	XII—Armature Reaction
IV—The Magnetic Circuit	XIII—Sparking
V—Magnetic Traction	XIV—Winding of Dynamos and Motors
VI—Magnetic Leakage	XV—Proper Method of Connecting Dynamos and Motors—Self-Excitation and others
VII—Energy in Electric Circuit	
VIII—Calculation of Size of Wire for Magnetizing Coils	
IX—Calculation of E. M. F.'s in Electric Machines	

\$2.00 PER COPY—FOURTH EDITION—16,000 COPIES SOLD.

The offer we make of refunding money if book is not satisfactory upon examination is AN UNUSUAL ONE in connection with the sale of a book. But we have no fear of its return. Your decision will be what thousands of others has been. Money would not buy it if it could not be duplicated. We could print testimonials by the hundreds. It is best to order and be your own judge of its merits.

CLEVELAND ARMATURE WORKS, Cleveland, Ohio.

AMERICA'S GREATEST REPAIR WORKS. Armatures and Fields Wound—Commutators filed.

EARN \$80 TO \$150 A MONTH

WANTED—Young Men for Firemen and Brakemen.

We prepare you by mail in from four to six weeks for either of the above positions. More calls recently for our competent men than we were able to supply. Positions secured as soon as competent. Rapid promotion.

Remember, this Association is directed by Railroad Officials of four of the largest roads in the United States. If you want to be a railroad man, cut out coupon and send to us at once for full particulars. Write name and address plainly. Hundreds of positions now open. Address

NATIONAL RAILWAY TRAINING ASSOCIATION
OMAHA, NEB. or KANSAS CITY, MO.



Name _____
P. O. _____
State _____ Age _____
Litt. No. _____

Please Mention Popular Mechanics

Shop Notes for 1908

"Written so you can understand it"
Vol. 4, Ready November 15, 1907

Best Volume of the Series. 200 pages and 500 illustrations. Contains matter entirely different from Vols. 1, 2 and 3. A copy of the 1908 "Shop Notes" added to your set will double its value.

Notice to Newsdealers

A stock of the Popular Mechanics Shop Notes Series is carried in stock by all branches of the American News Co., and your orders will be filled promptly. Usual discount to dealers.

The books are returnable; no time limit.

The Shop Notes sell throughout the entire year.

**For sale on all News Stands
or sent postpaid by the publishers.**

: : Price 50 cents : :

Popular Mechanics Co.
160 Washington St. : : : Chicago, Ill.

You are ALL CONFUSED about Pianos!

—You want the sweetest toned
—You want that sweet tone to last
—You dislike to spend any more money than necessary:—But every adviser, and so-called expert, recommends a different make. You are like a man lost in the woods. You don't know which way to turn. This surely describes your position.

R THE REMEDY:—Educate yourself on the subject! Study—read—Read more—Study more. Then listen in the quietness of your own parlor to the tone of the highest grade piano you can get, but without agreeing to purchase it. Call in all those musical friends who you *know* are not under past obligations to any piano dealers or friends of dealers. Resolve you will study attentively piano tone and will be deaf, while studying, to the magnetic talk and persuasiveness of salesmen. This is the *intelligent* way. It's the way you planned your new home. You made a long study of it calmly, thoroughly, and you became quite an expert. You can be just as expert about pianos.

We are willing to send you free two books:

One officially entitled "The Book of Complete Information about Pianos."

YOU NEED THIS BOOK of 156 Pages handsomely bound, if you ever intend to buy a piano, no matter what make.

It tells how to test a piano and how to tell good from bad; what causes pianos to get out of order. It makes the selection of a piano easy. If read carefully it will make you an expert judge of piano tone, of action, workmanship and of durability.

It tells everything that any one can possibly want to know about pianos; gives a description of every part of the piano, how put together and all the processes of manufacture. Gives description of the new invention for aiding learners to play called **THE NOTEACCORD** (endorsed by Paderewski and other great pianists). It explains Agents' and Dealers' Methods and Devices.

It tells about the very first piano,

the qualities of labor, the felt, ivories and woods used in every high-grade piano, and compares high qualities with the cheaper kind (used in inferior pianos). Describes what constitutes a musical-piano-tone, and in fact is a complete *encyclopedia*.

You need and should have **THIS EDUCATIONAL BOOK** to thoroughly inform you whenever **CONFUSED ABOUT PIANOS**.

Its scores of illustrations (all devoted to piano construction) are not only interesting but are *instructive*—to children as well as to adults.

You will certainly learn a great deal about pianos that you could not hear of or read **ANYWHERE ELSE** for it is absolutely the *only* book of its kind *ever published*. Nevertheless we send it free.

The other book is also copyrighted but is a short *story* named **"JOHN HONEYWELL'S REASONS."** The story of an

average American family which was **ALL CONFUSED** about Pianos—it is interesting, readable and prettily illustrated—gives a little hint of a love affair which the piano helped along, as many pianos have done.

These two books cost quite a sum to produce, print, bind, illustrate and mail. Upwards of 400,000 have been issued and without a single exception have been highly commended.

SO FAR not one word about ourselves. We are and have been the manufacturers of **THE FAMOUS WING PIANO** for the past 39 years!



Also 23 Plain Styles

We Have Supplied Over 40,000 American Homes With WING PIANOS

We refer to Banks, Governors of many States, and Judges; to Merchants, Conservatories of Music, Singers and Professors of Music. We have been students of vibration and of musical tone and strength of materials during all these 39 years. The first patent issued to our Mr. Wing, Senior, for improvement on pianos was in 1876, and other improvements have been invented since at the average rate of more than one yearly. These facts prove our skill and long experience, but would not be mentioned if we did not wish to show you that we know the piano subject as few others have had the opportunity; for 39 years is a long—long time for a business house to "live and learn" and constantly prosper.

Write for the books at once or fill in the coupon. Take it out and mail to us now while you think of it (and while you have the coupon). You will be under no obligations whatever.

WING BUILDING
360-369 West 13th Street, New York

WING & SON

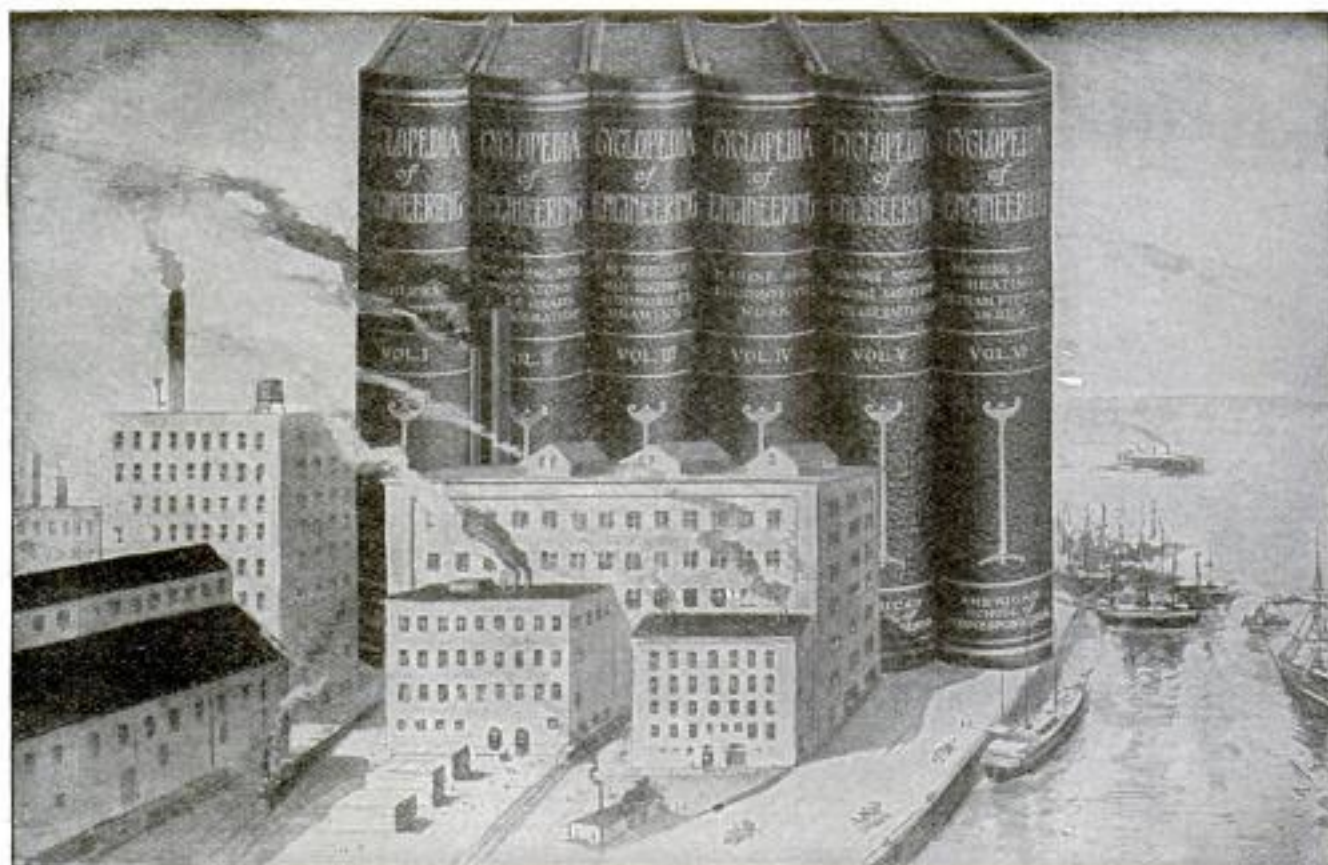

INDUSTRY'S REAL BACKING

Steam, Gas, Gasoline, and Oil Engines furnish the power which keeps the whole country in motion. Eliminate the engine and business is at a standstill; each country, city, and village is practically cut off from all commercial intercourse.

Yet the engines which move these great wheels of progress depend entirely upon the engineering knowledge of man for their operation and the man who has this knowledge commands unlimited opportunities. The wonderful industrial progress made the past few years is the best proof of the expert engineer's opportunities.

These great opportunities are within your reach. The knowledge, the discoveries, the inventions of hundreds of experts are accumulated in compact, easily accessible form in the

CYCLOPEDIA OF ENGINEERING

Six Volumes, page size 7x10 inches; 3,000 pages, 2,000 illustrations, diagrams, full page plates, sections, tables, formulae, etc. Bound in half red morocco.

Based on the methods so successfully used by the American School of Correspondence in fitting thousands of engineers for license examinations. Covers in addition to the operation of boilers and engines, the management of dynamos and motors, electric lights, wiring for power and light, heating, ventilation, refrigeration, turbines, elevators, machine shop work, mechanical drawing, blue-printing, etc.

Every section contains many practical problems with full solution, and each section is carefully followed by a series of practical test questions carefully chosen by men who know what a man ought to know in these subjects. The Cyclopedia contains the kind of practical information that is ordinarily found only in the note books of progressive superintendents or managers.

To advertise the superior methods of instruction of the American School of Correspondence, we are making a

LESS THAN HALF PRICE OFFER

Special Price, \$14.80

Regular Price, \$36.00

Sent express prepaid for five days' FREE examination. If it meets your needs send \$2.00 and \$2.00 a month until the special price of \$14.80 is paid; otherwise notify us to send for the books at our expense. This work is invaluable in the library of any progressive man whether he is an engineer, fireman, mechanic, superintendent, shop owner, student, inventor, or user of power in any form.

We employ no agents to sell our books, thus giving us the opportunity of selling direct to you at the very lowest price.

CHAPTER HEADS

Boilers, Calorimeters, Pumps, Elevators, Indicators, Valve Gears, Turbines, Compression and Absorption Refrigeration, Steam, Gas and Oil Engines, Marine Engines and Boilers, Condensers, Navigation, Locomotive Engines and Boilers, Air Brakes, Machine Shop Work, Ventilation, Heating, Mechanical Drawing, Air Compressors, Principles and Management of Direct Current Dynamos and Motors, Electric Wiring and Lighting, Storage Batteries, Automobiles, Etc.

AMERICAN SCHOOL OF CORRESPONDENCE

CHICAGO

Pop. Mech. 3-08

AMERICAN SCHOOL OF CORRESPONDENCE

Please send set Cyclopedia of Engineering for 5 days' free examination. I will send \$2 within 5 days and \$2 a month until \$14.80 is paid; otherwise I will notify you to send for the books.

NAME.....

ADDRESS.....

EMPLOYER.....

COUPON

The Test of a Tool is Practical Use

"YANKEE TOOLS"

have been in practical use for ten years. There's hardly a mechanic in America who hasn't one or more in constant use.

They are satisfactory, substantial—save your time and temper. There are over 18 styles. The line is constantly growing. Keep in touch. Ask your dealer to see them.

Send for Our
New Tool Book

NORTH BROS. MFG. CO.
Philadelphia, Pa.



Let there be Light

RELIANCE ACETYLENE GAS GENERATOR



**MAKES LIGHT
FOR THE
Home, Factory,
Church, School,
Etc.**

Automatic Water-Shift — Water-Feed Valve

Reliance Generators are equipped with a rotary water-valve which, not being directly connected to the water feed-pipe conveying the water to the carbide, absolutely prevents the water from reaching the carbide until this valve is brought into operation, automatically, by the downward movement of the bell, which occurs when the gas becomes sufficiently low to require an additional supply. This positively prevents any waste of gas after lights are turned off.

WRITE FOR FREE ILLUSTRATED CATALOG

Giving full information regarding all styles of RELIANCE Generators.

**The Gem City
Acetylene Generator Company**
DAYTON, OHIO

Have you seen the New Improved BUCKEYE TRACTION DITCHER?



Sold to contractors on 6 days' test before asking for settlement.

Works in hard pan and shale rock, where it can be taken out with the ordinary pick. Passes over the work but once, cutting to a perfect grade if desired.

Write for catalog H, also reprint article giving cubic yards Ditcher will handle per day and the cost of operating.

Read the following testimonial:

24"x7½' Machine.

CANADA

Fincher Creek, Alta., Can., 7th March, 1908.

The Buckeye Traction Ditcher Co., Findlay, O.

Gentlemen:—After using for four months the 24 in. x 7½ ft. Ditcher I purchased from you, I am able to give you the following results:

In good loam the machine can average 1,500 feet of 6 foot ditch per 10 hours, including delays and stops. In hard, dry clay that leaves a polish on the sides the machine can be counted on to cut 900 feet per day. In gravel the size of a man's fist it will dig 750 feet per day; numerous stops are required to pick the stones that may roll into some part of the machinery.

I have dug in ground composed of gravel and boulders larger than a man's head, but it is not economical. I am satisfied that the machine will do the work of 100 men at one-tenth the cost of hand labor.

Yours truly,

J. E. Woods, C. E.

The Buckeye Traction Ditcher Co., Findlay, O.

The Miner-Lawrie Laboratories



**Chemical Analysis and
Consultation**

**Expert Aid to Manufac-
turers**

Factory Problems

**Patent Processes and
Litigation**

*Consulting Chemists to
Popular Mechanics*

**355 Dearborn Street
Chicago Illinois**

CARL S. MINER
JAMES LAWRIE, Ph. D.

Telephone Harrison 3332

Please Mention Popular Mechanics



CARBORUNDUM RAZOR HONES

The only Hone that the
AVERAGE man can use

Puts a keen, smooth, lasting edge on a razor and does it in an incredibly short time.

Barbers who have tried Carborundum hones say they are unquestionably the finest razor hone ever produced.

If your dealer doesn't sell Carborundum Sharpening Stones, send us his name and \$1 and we will mail you, prepaid, one razor hone in a neat box.

There's a special Carborundum stone for every sharpening requirement—

- For Machinists
- For Carpenters
- For Physicians and Surgeons
- For Farmers
- For Sportsmen

For everyone who has a knife, or a tool to sharpen.

WRITE FOR THE BOOK

THE CARBORUNDUM COMPANY
Niagara Falls, N. Y.

SHARPEN YOUR TOOLS

You can save trouble and save time, you can do better work with less effort if you have in your shop or home a

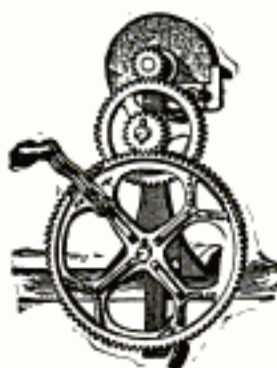

PRACTICAL GRINDER

It will sharpen any edged tool in one tenth the time that an ordinary grindstone will sharpen it. The aluminum wheel will not heat the metal and take the temper out either. We guarantee that. Clamp it on table or bench, hold knife or tool *lightly* on grinding wheel and turn. That's all. Any one can do it.

Uniform wheels for general purpose work—special beveled wheels for certain styles of implements.

A NECESSITY IN THE SHOP

A time and bother saver in the home. Nothing to get out of order, no water necessary, no chain to buckle or belt to break. Small and portable, will save its cost in a week when drills and tools are carried out of the shop on outside work.

SEND FOR FREE BOOK

Practical Talks About Practical Grinders. It will settle the dull tool and dull knife business for you. Ask your dealer or send to us direct.

ROYAL MANUFACTURING COMPANY
133 E. Walnut Street, - Lancaster, Pa.

The POPULAR EMERY GRINDER

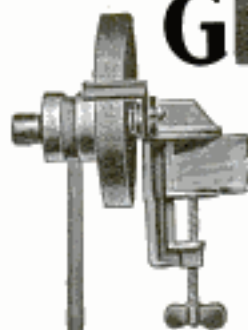

A Practical Tool

for blacksmiths, plumbers, carpenters, farmers and mechanics of all trades. It is strong, durable and simple in construction.

Wheel is 6 inch diameter, 1 inch face, and made of best abrasive material for sharpening tools. Makes 3,000 revolutions per minute.

Tool-rest may be adjusted to give any desired bevel.

Can be carried in small box and set up anywhere in field or shop. No belts, cogs or lost motion. Buy it, try it, and if you don't like it, send it back.

PRICE \$3.50

Mechanics Tool Works

185 Dearborn Street, - CHICAGO, ILL.



Running Water in Your Home

You can add as much to the comfort and convenience of the other rooms in your home as you can in the kitchen, by having a supply of running water always available, day and night.

Whether your home is in the country, in a village, a town or a city—anywhere—where there is no waterworks, you can have running water in any room—kitchen, bathroom, bedroom, laundry—at little cost.

You can have running water under high pressure for your lawns, flower beds, gardens or barns—without unsightly storage tanks or complicated machinery.

The Kewanee System of Water Supply

will save innumerable steps in housework, and enable you to have your home hygienic and sanitary as well as convenient and comfortable.

It will give you the same service that a city water supply gives at less expense—for you have no water tax to pay.

Every Kewanee System is sold under a guarantee of absolute satisfaction. You take no risk. We guarantee satisfactory service.

Write today for complete illustrated catalogue showing how easy it is for you to have this perfect water supply service—no matter where you live.

Complete Kewanee Systems cost from \$75 up, according to the requirements.

Simply fill out and mail us the attached coupon.

Kewanee Water Supply Company,
14-19 Franklin St., Kewanee, Illinois.

No. 32 Broadway, New York.

820 Marquette Bldg., Chicago.

404 Equitable Bldg., Baltimore, Md.

**Kewanee
Water Supply
Co., Kewanee, Ill.**

Gentlemen:—

I would like to have
running water in my
...house, or.....

.....and also special information regarding the Kewanee System.

Mention kind of building to be supplied.

Name.....

Street and No.....

Town..... State..... 14-10

Fill Out and Mail Coupon Today.

CATALOG NO. 8

Shows a great variety of tools and light machines. It will be of interest to every lover of good tools and we shall take great pleasure in forwarding a copy, entirely free, to anyone interested enough to ask for it.

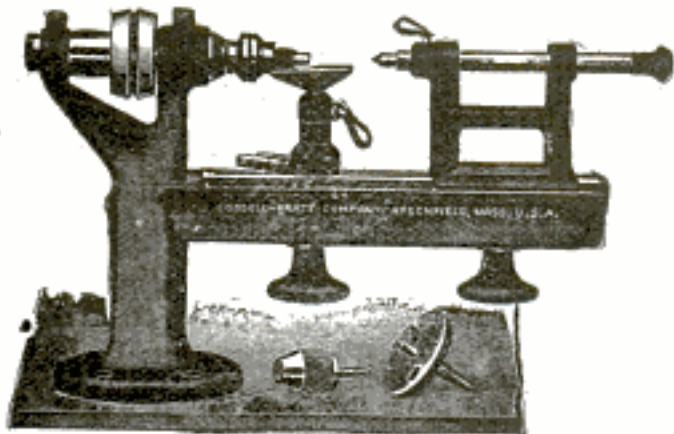

Polishing Lathe No. 29

This little Lathe is only one of the many handy and useful articles that you will find described. Perhaps others will interest you.

GODELL-PRATT COMPANY

GREENFIELD, MASS., U. S. A.

FOR HOME SHOPS



SEVENTEEN SIZES

The only Hand Screw with the Saw-Cut Threaded Spindle and Michigan Hard Maple Jaws.

That is why they last longer and still cost no more than the "just as good" kind.

Be sure and ask, when buying, for the Grand Rapids make.

GRAND RAPIDS HAND SCREW CO.

920 Jefferson Ave.

GRAND RAPIDS

MICHIGAN

MR. REPAIR MAN!

You are blind to your own interests if you fail this Spring to install one of the famous

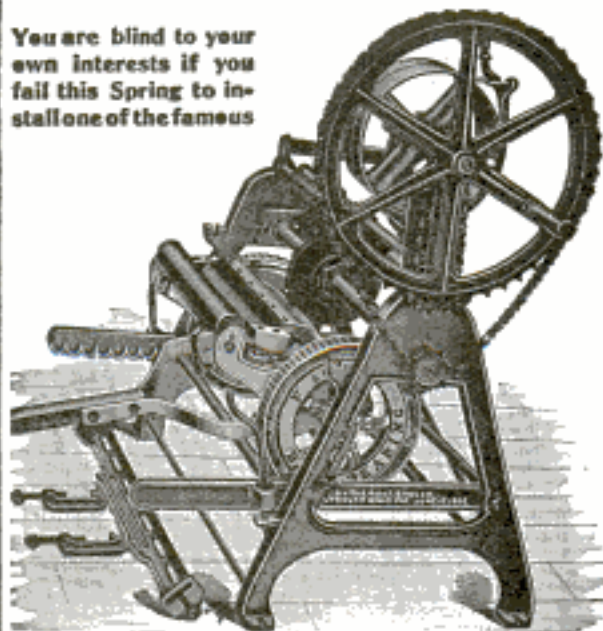

IDEAL LAWN MOWER GRINDERS

and sharpen your Lawn Mowers in the only up-to-date, rapid, accurate and scientific way. The 1908 model is now ready and contains features that make it useful the year round. We can't begin to mention them here, but a postal will bring full description, price, etc.

The Root Bros. Co., Sole Manufacturers
PLYMOUTH, OHIO

Please Mention Popular Mechanics

Do You Wear Glasses?

Does Your Wife, Mother, Sister?

Perhaps you know, then, how irritating it is to find that the little screws have become loose, also how very often this happens. Here are several little tools for quickly and effectively attending to such cases, made especially for that purpose:



No. 556 Screw Driver for Eye Glasses is made in two pieces and screwed together, telescoping the blade when not in use. Nickel plated. Price, 15 cents.

No. 558 is threaded on the end opposite the blade. This may be reversed and screwed into the part with the ring, thereby making a longer handle. Nickel plated. Price 20 cents.



No. 554 is made with a chuck to hold the blade firmly in a split socket when in use. The blade is removed by slightly loosening the chuck, then reversed and inserted into the socket nearly full length and held safely by tightening the chuck. Nickel plated. Price 25 cents.



Carry one in your pocket, on your key-ring or watch chain. Either style mailed on receipt of price.

Ask for Complete Catalog No. 17AP of Fine Tools

The L. S. Starrett Co.

Athol, Massachusetts, U. S. A.

YOUR INTERESTS AND OURS ARE IDENTICAL.

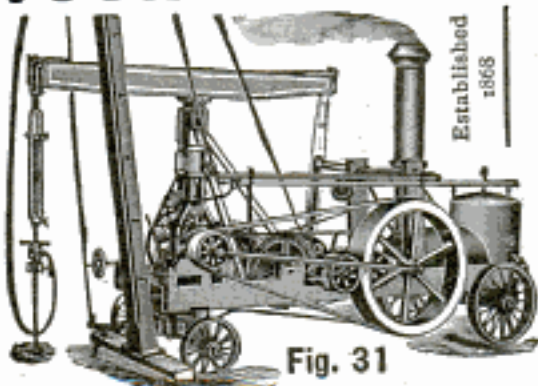

You Want Practical
WELL DRILLING MACHINERY
to develop that
Mineral, Oil or Water

proposition; we have it. Guarantee it to work satisfactorily.

Tell us about the formations, depth, diameter holes; will send printed matter and can save you money.

THE AMERICAN WELL WORKS,
 Aurora, Ill., U. S. A.
 Chicago, Ill. Dallas, Texas

Ann Arbor Lighting
 Systems
GASOLINE WIRE FEED

A Complete Lighting System for Homes, Stores and Churches

Ann Arbor Lighting Systems are brighter than gas, steadier and clearer than electric light, and cost about one-tenth as much to operate. Each lamp gives 300 to 600 candle power for less than 3/4 cent per hour. Fuel is gasoline; perfectly safe.

Prices \$10 up, according to number of lamps desired. These systems especially adapted for use in stores, halls, factories, etc.

WE WANT AGENTS who will push our line. Special terms to those who write early. Catalog and prices on request.

SUPERIOR MFG. CO.,
 294 Second St., Ann Arbor, Mich.

ANN ARBOR LAMPS—What complete system are you desired. Ann Arbor Lamp is made the most satisfactory substitute. Each lamp completely built, glass 2 1/2 in. p., can be had in many pleasing styles. To illustrate is now to it only, we will send model 110, shows burner—brass or enameled finish. For \$1.50, express prepaid in U. S. If not enclosed if not satisfactory.

SUPERIOR MFG. CO.,
 294 2d St., Dept. F, Ann Arbor, Mich.

THE ASCO GAS LAMP

BIGGEST VALUE - LOWEST PRICE
TRADE MARK



We want to show you how you can have this brilliant light in your own home. The ASCO GAS LAMP is simply a generator made in the form of a table lamp. It is so constructed that it will last a lifetime as it is made entirely of metal, not even glass chimneys being used. With each lamp is supplied a quantity

of calcium carbide which can be bought afterwards at very low cost.

In operating lamp you simply place a portion of carbide in lamp and fill jacket with water and acetylene gas is instantly generated, giving the most brilliant white light ever discovered.

The ASCO GAS LAMP is absolutely safe and can be upset and rolled on the floor without any danger whatever.

To be brief, the ASCO GAS LAMP is cheaper than Kerosene, safer than Kerosene, gives many times more light and much less trouble to use.

Can you afford to be without "Why Country Homes Need Better Light." We want agents. Write for special terms.

New York & Lima Trading Co.
 Dept. M. 203 West Broadway, N. Y.



Learn

Photo-Engraving or Photography

Engravers Earn from \$20 to \$50 Per Week

The only college in the world where these paying professions are taught successfully. Endorsed by the International Association of Photo-Engravers, and the Photographers' Association of Illinois. Terms easy and living inexpensive. Graduates placed in good positions. Write for catalogue, and specify the course in which you are interested. Address **Illinois College of Photography or 999 Wabash Ave., Bissell College of Photo-Engraving, Effingham, Ill.** L. H. BISSELL, President.



SCROLL SAWS

I will send this beautiful design with 300 miniatures and my illustrated catalog of Scroll Saws, Lathes, Fancy Words, Metal Trimmings and Tools, postpaid on receipt of 15c, or send 6c for catalog only. Address

The POMEROY Scroll Saw Co.

440 Asylum St., Hartford, Conn.

Div. 2

SCROLL SAWS
 FROM 50c TO \$22.50

From Cottage to Skyscraper



The CYCLOPEDIA of ARCHITECTURE, CARPENTRY and BUILDING

Covers everything from the modest two-story cottage to the towering skyscraper; from "two-by-fours" and clap-boards to steel frames and reinforced concrete; from lath and plaster and Georgia Pine to stucco, marble and mosaic; from the hall stairs and back-yard well to express elevators, and hot and cold water in every room.

TEN VOLUMES, PAGE SIZE 7 x 10 INCHES, bound in half red morocco; over 4,000 pages; 3,000 illustrations; full page plates, plans, sections, etc. De Luxe books in every particular.

To advertise the superior methods of instruction of the American School of Correspondence, we are making the following offer:

Final Closing Sale of Remaining Sets At Less Than $\frac{1}{3}$ Regular Price

Free for examination. Sent by prepaid express. Pay \$2 within five days and \$2 a month thereafter. If not adapted to your needs, notify us to send for them at our expense.

There are over 200 plans of artistic moderate priced houses, chosen by a staff of architects as typical of the best work of the best architects of the entire country—invaluable to any one contemplating building or altering.

Hundreds of hints and suggestions to house builders and house owners in this work will save them many times its cost. The chapters on plumbing, heating, including furnace, steam, hot water and exhaust steam, and ventilation are especially complete.

The man who is working in any of the building trades cannot afford to ignore this great work, if for nothing more than the information it contains on Reinforced Concrete. This knowledge is hard to get and in view of the tremendous progress being made in this industry and the immense popular interest shown in it, the practical man must take every means possible to secure the latest and best information concerning the actual work being done—and how it is done.

A Few of the Many Subjects Included in this Work

Reinforced Concrete—Estimating—Contracts and Specifications—The Law of Contracts—Building—Superintendence—Building Materials—Masonry—Carpentry—Stair Building—Hardware—Plastering—Painting—Heating—Ventilation—Electric Wiring—Steel Construction—Elevators—Sheet Metal Work—Mechanical, Architectural, Free-hand and Perspective Drawing—Lettering—Blue Printing—Shades and Shadows—The Greek and Roman Orders of Architecture—Rendering in Pen and Ink and Wash—Water Color Hints for Draftsmen.

**AMERICAN SCHOOL OF CORRESPONDENCE
CHICAGO**

**American
School of
Correspondence**

Please send set Cyclopaedia Architecture, Carpentry and Building for 5 days' free examination. I will send \$2 within 5 days and \$2 a month until \$19.80 is paid; otherwise I will notify you to send for the books.

NAME.....

ADDRESS.....

EMPLOYER.....

CUT OFF COUPON HERE

Pop.
Mech.
3-08

Please Mention Popular Mechanics

Popular Mechanics **Shop Notes Series** of Year Books

☞ One of these books is issued the first of each year, and is a reprint of all the articles which have been published during the year past, in our "Shop Notes Department."

200 Pages Vol. I, "Shop Notes for 1905" 385 Illustrations

228 Pages Vol. II, "Shop Notes for 1906" 555 Illustrations

228 Pages Vol. III, "Shop Notes for 1907" 580 Illustrations

212 Pages Vol. IV, "Shop Notes for 1908" 536 Illustrations

☞ These books are a perfect gold mine of information for every one interested in mechanics, or who uses tools for pleasure or as an occupation. Of equal value and help to the professional mechanic and the amateur.

☞ These articles are the cream of the experience of years, of hundreds of the most successful mechanics in the country. There is nothing on the market equal to these books at five times their price.

☞ The Popular Mechanics Shop Notes Series TELLS EASY WAYS TO DO HARD THINGS, and like Popular Mechanics, is "Written so you can understand it."

☞ These books are indexed very fully and with great care.

☞ The subjects treated cover every department of mechanics, with useful time saving "kinks" for engineers, firemen, carpenters, machinists, plumbers, painters, iron and wood workers, electricians of all kinds, masons, and in fact all the trades.

☞ "WORTH ITS WEIGHT IN GOLD" is a frequent expression from our readers, and one young mechanic in the far west who started a repair shop for himself, says he owes his success to "Popular Mechanics Shop Notes." Many a time when a customer brought in a job new to him, he consulted his "Shop Notes," which told him how to do it.

☞ Each volume contains entirely different matter from that published in the other. A set of these books covering several years will make an encyclopedia of priceless value to the owner.

Price 50 Cents per Volume, Postpaid

For Sale by all Newsdealers or can be ordered direct from the Publishers

POPULAR MECHANICS :: :: :: CHICAGO

**DESIGNS—FULL
SIZE PATTERNS**

BOAT FRAMES

For Amateur and Professional Boat Builders, designed by our Naval Architect



Semi-Speed Frame, shipped
in Two Sections

Our **EASY TO BUILD SYSTEM OF CONSTRUCTION** puts within reach of the amateur the handsomest and latest designs in **SPEED HULLS MOTOR BOATS CABIN CRUISERS**. Shipped knock down or erected in sections, ready to plank—Any man or boy who can use tools can build his own boat—Faults of other systems done away with. Hard parts simplified. Ask for Frame catalog D—Motor catalog E.
AMERICAN GASOLINE MOTOR COMPANY, 52 Canton Street, Baldwinsville, N. Y.



THE TURNER BRASS WORKS SYCAMORE, ILL.

Manufacturers of Marine Hardware and Motor Boat Specialties. Sole Manufacturers and Licensees of Harroun Auto Bumpers, Martin Alarm and Reserve Valves, Martin Gasoline Separator and Strainer.

Write for Catalogue No. 28, Dept. I.



ARE YOU BUILDING A BOAT?

You want the best of marine hardware for it—house hardware will not do. Send for our new catalog. It shows the latest patterns of fittings for all sorts of boats as well as tools for the amateur builder.

A. S. MORSS CO., 4 Lewis St., Boston, Mass.



NEW MARINE PORTABLE GASOLINE ENGINE 2 H. P. Weight 40 lbs.

Can be instantly attached by two thumb screws to the transom of any row boat. Engine is air cooled. Just the engine for anglers and owners of dinghys and sail boats. Speed 5 to 7 miles per hour. For particulars address **WALNUT MACHINE & BRASS FOUNDRY CO., 316 Walnut Street, Toledo, Ohio**

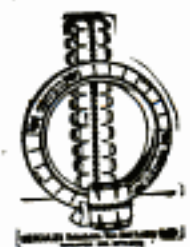

"Hercules Detachable Cover"

The most wonderful invention in the Automobile Tire Industry. Agents wanted everywhere. This is a big seller. Territory being rapidly taken. Write today for booklet and prices. Special inducements to dealers and supply houses.

THE REPUBLIC RUBBER TIRE & SHOE CO., 449-451 West 53d Street, N. Y. City

NEW RADIUM FLASH LIGHT

Gives 6 times more light than old styles; pure white, dazzling; casts no shadow on account of new metallic radia filament used in the bulb. Battery lasts 4 times longer than old styles; costs less; just fits the pocket. Greatest invention of year. Send for our large catalogue. It's free.



\$1.09 Each Complete
Sent by express, prepaid, 15c extra Recharges, 20c each; postage, 5c

THE VIM CO., Dept. B 39, 68 E. Lake St., Chicago

BUSINESS OPPORTUNITY

Men of Business interested in a new field for making money will find in our proposition what they are seeking. We have a **New Plan in the Mail Order Line** that will please those seeking a good investment with large profits. A Fortune for the right person. **The F. H. Alden Co., 139 E. 4th St., Cincinnati, O.**

FLITCRAFT'S Savings Bank Clock

**SEE THE 1908
MODEL**

**Requires a Daily
Deposit in order
to wind it**

Patent No. 775058



This is a novel combination of an alarm clock and savings bank, provided with a coin chute, also automatic locking and unlocking mechanism. The clock in its normal condition is locked, and cannot be wound until a coin is deposited into the slot. Within a brief period after it is wound, the clock is automatically locked again and cannot be wound until another coin is deposited. It takes nickels, dimes and pennies, and holds over eighty dollars in dimes.

**Save Your Dimes and Prepare for
Your Next Summer's Vacation**

I will make a special agency proposition to the first person in your town who orders one of these Savings Bank Clocks.

It's a Winner—Price \$2.00

**E. B. Flitcraft, Room 504 Majestic Bldg., Chicago
N. B.—Exclusive rights for Connections have been sold.**

A REAL Bargain in Marine Motors

Without any ifs and ands about it, the Scripps 4-cycle Engine is absolutely the **greatest value in marine motors on the market today, regardless of price**—and we will back that statement up to the limit.

Don't confuse low first cost with economy; where in the name of reason is the economy in buying a (so-called) "cheap" motor that almost eats up its own cost in repairs and unconsumed gasoline in a year, and then after one or two seasons' work is fit only for the scrap heap?

SCRIPPS MOTORS

are constructed of the very finest material money can buy; Parson's manganese bronze connecting rods; positive automatic system of lubrication; roomy hand holes in crank chamber; no cranking—a half turn of the fly wheel starts her off (generally starts on the spark); exceptionally handsome appearance with highly finished castings and all trimmings polished brass. 1, 2 and 4 cyl. $4\frac{1}{2}$ in. x $4\frac{1}{2}$ in.; 2 and 4 cyl. $5\frac{1}{2}$ in. x 6 in. Heavy Duty Motors; 4 and 6 cyl. $5\frac{1}{2}$ in. x 6 in. racing motors.

Do not purchase a motor until you at least look over our catalog. We are a financially responsible concern, with our own factory, and we make good every word of our guarantee. Send for catalog today.

SCRIPPS MOTOR CO., 602 Trumbull Ave., Detroit, Mich.

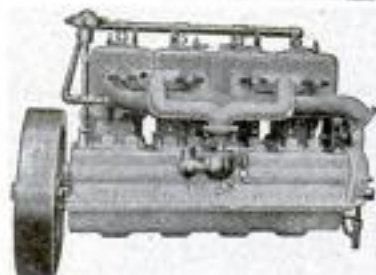

The Bond to Give \$10,000 in Cash and \$50,000 in Stock

of The Miami Cycle & Mfg. Co., earning 10% annually, is the offer made by the largest manufacturers of high grade wheels in the world, that

The
World's



Best
Bicycle

has less pressure on its crank hanger bearings, therefore pushes easier and with less energy than any ordinary bicycle. The acme of easy foot power is obtained in the Racycle.

1908 Models are built with drop forged steel heads, crowns, and seat post clusters, and frames made of the highest grade seamless English cold drawn steel tubing, making Racycles as nearly non-breakable as money, material and workmanship will permit. We ship Racycles all over the world, because of their reputation for durability and easy running.

Write for our 1908 Catalog and Pamphlet—"The Three Reasons", which contains the conditions of above offer. We build no cheap RACYCLES, but you can get yours cheap by securing us an agent.

THE MIAMI CYCLE & MFG. CO., MIDDLETOWN, OHIO, U. S. A.

Please Mention Popular Mechanics

"Want" and "For Sale" Ads. 3 cents per word, payable in advance. Replies may be sent to a number, care Popular Mechanics, and will be forwarded without extra charge. In answering such, let the number appear on your envelope. These classified pages close on the 3rd of each month for the next month's issue.

AUTOMOBILES

AUTOMOBILE SCHOOL—Chicago School of Motoring; the original automobile school in Chicago. Four hundred and fifty graduates the past year, to whom we refer upon request. Automobile owners, prospective buyers and young men wanting to become expert chauffeurs will save a great deal of money and a lot of worry by studying the mechanism, care and repair of gasoline automobiles in our shop, where all parts are open so you can see how they are made, and how they operate. We give thorough and practical instruction. Competent chauffeurs supplied. Address Chicago School of Motoring, Dept. B., 1436 Wabash Ave., Chicago, Ill.

WAVERLY ELECTRIC AUTOMOBILE. Fine condition, with top and storm curtains, new Balley non-slip tires, \$280.00. Address 220, care Popular Mechanics.

1907 FORD RUNABOUT, with top and complete equipment, \$500. C. R. Baker, Salem, Ohio.

FOR SALE—Locomotive Steamer. Running gear complete; has four springs, differential gear and sprocket wire wheels, 28x3. Wheel base, 82-inch. Standard tired. Price, \$20. A. E. Roth, 1423 North Ave., Bridgeport, Conn.

LEARN TO BE A CHAUFFEUR at home. Course, 15 lessons, \$10. Sample lesson, 50c. Special course for prospective owners. Philadelphia Motor School, 226 W. Johnson St.

FOR SALE—Locomotive Steamer Runabout, in good running order. Full particulars on application. R. J. Edwards, Shullsburg, Wis.

FOR SALE—Locomotive Steamer, Dos & Dos. Seating two or four persons. Has all late improvements; 5 H. P. This machine is in A1 condition. Price, \$125.00. North Ave. Auto Exchange, 1423 North Ave., Bridgeport, Conn.

FOR SALE—Marion four-cylinder runabout; no trades. Geo. W. Pierce, Anderson, Ind.

AUTO SUPPLIES

GLASS FRONT for all cars. Get prices before ordering. Catalogue on request. H. S. Ross, 5607 S. Halsted St., Chicago.

FORD RUNABOUT OWNERS—Modernize your car with Rumble Seat and Trunk, \$15.00. Glass front, \$12.00. Three-hinged Folding Hood, \$8.00. Roadster Fenders with brass bound running board, \$12.00. Discount to dealers. State your wants for catalogue. Auto Rebuilding Co., Chicago, Ill.

REBUILD YOUR CAR into "Gentleman's Roadster." We make latest style Hoods, Radiators, Tanks, Fenders, "hood dashes," Glass Fronts, Auto Trunks, Rumble Seats, etc. Twenty per cent saved. Your old car re-designed free. Hood and Dash outfits for 03 and 04 Ford, Cadillac and Winton in stock. Smashed lamps and radiators repaired like new. State your needs for catalogue. Auto Rebuilding Co., Chicago, Ill.

MOTORCYCLES

WILL PAY \$50 for 1907 Indian Motorcycle; condition no object. Address 234, care Popular Mechanics.

FOR SALE—Marsh Motorcycle, 3-horsepower, \$60; running order; inclose stamp for reply. Clifford Hiatt, Neoga, Ill.

FOR SALE—Motorcycle, less engine. Jesse Depoy, 701 Powers St., Muncie, Ind.

WANTED—Motorcycle frame, loop design, old or new, in good condition; cheap. Address, with full particulars, Box 271, Fremont, Ohio.

WANTED—Pair motorcycle wheels for 2 or 2½ inch clincher tires, with or without tires. State condition and lowest price. Box 264, Fremont, Ohio.

INDIAN MOTORCYCLE, good as new; price, \$165. Box 56, Walnut, Iowa.

BUSINESS OPPORTUNITIES

CASH for your business or real estate—no matter where located. If you want to buy, sell or exchange any kind of business or property anywhere, at any price, address Frank P. Cleveland, 1308 Adams Express Building, Chicago, Ill.

SAFE EXPERT—Frank E. Neilson. Opening or repairing, in the South. 1427 Franklin St., Tampa, Fla.

DON'T SLAVE FOR OTHERS. Reap the benefits for yourself. Fortunes made operating automatic penny weighing machines. Our scale speaks your weight. Write for Talking Scale circular. The United Vending Machine Co., 629 Caxton Bldg., Cleveland, O.

OPEN A MIRROR FACTORY IN YOUR TOWN, or travel and do the work, and make from \$5 to \$25 daily. **WE TEACH** and trust you. 10c brings 32-page booklet and full particulars; none without; no time for idlers. Hullinger's Mirror School, Francesville, Ind.

FOR SALE—Patent recently granted on an envelope for mailing merchandise, books, seeds, etc. The invention of a postoffice employee who has studied the requirements for many years, and has produced an envelope which is pronounced far superior to anything on the market. No complicated machinery required—or can be made by hand. Will hold contents under all conditions of handling in the mail. Big demand for the goods. Can be manufactured anywhere and in a small shop. Am a postal employee—not manufacturer—therefore desire to sell either patent or rights on reasonable terms. Address 230, care Popular Mechanics.

WANTED—A promoter to exploit and finance my inventions. Have sold two patents myself direct the last few months. Commercial successes. Now wish to place U. S. Patent, 1907, on non-bursting steel flywheel in competition with old-style cast-iron wheels which fly apart. Ten men killed, one million dollars loss from this cause first half of 1907, only! Also own patent for changing existing municipal reservoirs into automatic gravity filtration plants using slow sand process, covering construction of intake dams. Another patent on filter for mill race water supply by revolving screen. Of interest to hydraulic engineers. Also patent on household water filter and ice cooler combined, to be made of sheet metal at big profit. Geo. W. Schultz, Wayne, Pa.

WE START you in a permanent business with us and furnish everything. Full course of instructions free. We are manufacturers and have a new plan in the mail-order line. Large profits. Small capital. You pay us in three months and make big profit. References given. Pease Mfg. Co., 380 Pease Bldg., Buffalo, N. Y.

PATENTS FOR SALE

PATENTS—H. W. T. Jenner, patent attorney and mechanical expert, 608 F Street, Washington, D. C.; established 1883. I make free examination and report if patent can be had and exactly how much it will cost. Send for circular.

PATENTS—The Popular Mechanics Patent Bureau renders efficient service. Following letter is dated May 25, 1907:

Dear Sirs: Please allow me to acknowledge the receipt of yours of the 13th, the official notice of the allowance of my application for patent on Paper Clips. I wish to say I am highly gratified with the efficient manner in which you have attended to my interest in this matter, and that the drawings and specifications were far ahead of my expectations, and that if I ever have any other work, I wish you to do it. I beg to remain, respectfully yours, John H. Atter, 439 Main St., Conneaut, O.

Write for free booklet, "What to Invent." Address Popular Mechanics Patent Bureau, 160 Washington St., Chicago.

PATENT—Invisible hairpin, when put on the market will become a necessity. Enormous profit. Cheaply produced. D. W. McNeil, 1910 Colerain Ave., Cincinnati, Ohio.

LATEST PATENTED gentleman's (metal) cuff holder; no adjusting, no trouble; the only perfect holder. Nothing like them on market. 15c a pair. G. M. Meyneke, Brookville, Ind.

INVENTORS needing assistance in marketing patents or ideas, address, inclosing stamp, D. Tappan, Watervliet, N. Y.

FOR SALE—U. S. patent for improved lawn mower. For further particulars address 223, care Popular Mechanics.

FOR SALE—Patent No. 780526, for non-loosening and keen-cutting of scissors. Geo. Reitz, Lynnport, Pa.

PATENT ATTORNEYS

MASON, FENWICK & LAWRENCE, Washington, D. C., established 47 years. Illustrated Booklet free. Highest references. Terms moderate. Intelligent service. Be careful in selecting an attorney. Don't be misled by free offers.

BUSINESS CARDS

EVERY ENGINE works better when packed with "Eureka Packing." Your dealer will furnish it.

Please Mention Popular Mechanics

MACHINERY FOR SALE

MARINE ENGINES—Equip your boat this spring with one of our up-to-date engines. Gas-tight bearings; positive starting device. 2, 3, 4 and 8 h. p. Prices very reasonable. Write Northwestern Steel & Iron Works, Box 523, Eau Claire, Wis.

ELECTRIC LIGHTING PLANT—Complete, with engine, dynamo, lamps, etc. Excellent condition. Ten 16-candle-power lamps' capacity. Must be sold. \$115. Address 227, care Popular Mechanics.

FOR SALE—1½-h. p. Motorcycle Engine. \$20. Castings, \$6.50. C. E. Shook Mfg. Co., Waterloo, Iowa.

MOULDS MADE for white metal castings. Prices right. L. J. Thorp, 426 Newport Ave., Chicago, Ill.

FOR SALE—¼-in. flexible shaft; good as new; cheap. L. J. Thorp, 426 Newport Ave., Chicago, Ill.

MOTORCYCLE ENGINE, 2¼-h. p., for sale, cheap. Wanted—Odell Typewriter. Please inclose stamp. Address Mr. G. W. McGory, R. No. 1, Huron, Ohio.

FOR SALE—Gasoline Engines for automobile, marine and stationary work; also castings and a few second-hand engines, cheap. Apply, with stamps, B. W. Richardson, R. 36, Peoria, Ill.

FOR SALE—Two 10-h. p. auto engines (gasoline); 1 Oldsmobile, 1 Cadillac, with transmission, water pump, radiator and spark coil complete. Address Box 385, E. Palestine, Ohio.

ONE H. P. HORIZONTAL side crank steam engine, new; cylinder 2x4 in., flywheel 14x2¼ in., length 29 in., width 19 in., weight 175 pounds. This engine complete, with throttle valve and lubricator, \$28. Salineville Model & Machine Works, Salineville, Ohio.

FOR SALE—2½-h. p. horizontal steam engine and boiler, both in first-class condition; an exceptional bargain. Price, \$50. Geo. R. Jackson & Son, Clinton, Mo.

FOR SALE—One set castings, drop forged crank shaft, connecting rod, etc., partly machined for four-cylinder, air-cooled engine. W. L. Braley, Springfield, Ohio.

\$7.00—20-WATT dynamo motor, lamps, rheostat, wire, 250 ohms coil and vibrator, 10-volt duplex motor and reverser; all new. H. L. Gordon, Jr., 57 Montrose St., Somerville, Mass.

FOR SALE—Buffalo-Pitts 25-horsepower, straight-line engine, two steel tanks, 41x66, Niagara Second separator, Linsey feeder, high weigher, Maple Bay blower; rig in first-class condition; has run 100 days. Price, \$1,900, \$1,000 cash. Box 28, Route 2, Chokio, Minn.

2-H. P. WATER MOTOR for sale or exchange. Box 660, Fredericton, N. B.

ONE 10-H. P. Horton Par. Oil-Cooled Gasoline Engine; first-class operating condition. C. F. Freehauf, Cresco, Iowa.

AUTO GASOLINE ENGINE, 4-h. p., air-cooled, second-hand, carburetor, coil, etc.; \$50. Write Roy Hay, Goshen, Ind.

FOR SALE—Two-horsepower stationary gasoline engine; new, ready to run; \$45. Also four-seated steam auto; perfect condition; \$155. John W. Gardner, 5015 Delmar Ave., St. Louis, Mo.

FOR SALE—A new 25-h. p. Russell general utility traction engine and two hauling wagons. Levi Lewis, Radnor, Penn.

MACHINERY FOR SALE—Lathes, screw cutting, second-hand, good as new, 12-inch swing, 5-foot bed, \$55; 14-inch swing, 5-foot bed, \$75; 16-inch swing, 6-foot bed, \$125; and 100 different sizes and makes, cheap. You can save money by buying from us. R. W. Herfurth Co., 39-41 Cortlandt St., New York.

MACHINERY FOR SALE—Pumps! Second-hand, good as new; for home or factory use. Write us what you want; we can save you money. R. W. Herfurth Co., 39-41 Cortlandt St., New York.

SPECIAL SALE—ODD SIZES—34 engines at less than cost, while they last. When preparing our new catalogue, we cut out several sizes of engines which we formerly made, and have on hand a few engines, all complete, which we propose to sell at prices that will turn them into cash at once. These engines are first-class in every respect, and are sold under exactly the same guarantee as our regular stock. This is an unusual opportunity to get a bargain with the manufacturers' guarantee behind it. Further details on request. Two 2½-h. p. engines, \$65; ten 3-h. p. engines, \$75; ten 4-h. p. engines, \$100; seven 6-h. p. engines, \$200; two 20-h. p. engines, \$450; three 30-h. p. engines, \$685. Dept. P. M., Dean Gas Engine & Fdy. Co., Newport, Ky.

MACHINERY FOR SALE—A 60-h. p. Mletz & Weiss 4-cylinder Kerosene Marine Engine, used one season; propeller and everything complete; will sell at a sacrifice. R. W. Herfurth Co., 39-41 Cortlandt St., New York.

PUMPS! Of Every Description—Suitable for Home and Factory use. Illustrated Catalogue Free. H. E. Trotman, 107 N. Third St., Philadelphia, Pa.

FOR SALE—Engine lathe, swings 9¼ in., takes 25 in. between centers. Complete with full set change gears to cut all size threads, 3 to 40 in.; price only \$43.50. Address L. F. Grammes & Sons, Allentown, Pa.

FOR SALE—Complete sets of casting for opposed motors or 4-cylinder vertical, water or air-cooled. Comet Motor Works, 47-49 Canal St., Chicago, Ill.

FOR SALE—24 H. P., four-cycle, marine engine, second-hand, cheap; also second-hand spark coils, timers, etc. Termaat & Monahan Co., Oshkosh, Wis.

FOUR CEMENT BLOCK MACHINES (new). Price, \$25. Will sell one or two at \$15 each (quick). Address 204, care Popular Mechanics.

MANUFACTURING MACHINERY

SPECIAL MACHINERY DESIGNED—Your ideas developed, drawings made. Box 1264, Paterson, N. J.

WE BUILD all kinds special machinery, models, dies, experimental work. Thoroughly equipped to turn out work on short notice at reasonable charge. Send drawings for estimates on contracts. Prompt attention to inquiries. Portchester Machine Works, Portchester, N. Y.

MODEL AND EXPERIMENTAL WORK—Tools and dies for sheet metal blanking, forming and bending; manufacturing. Let us estimate. The Krug Mfg. Co., 7 Bleeker St., Jersey City, N. J.

WE WANT for manufacturing, dies, stamping, spinning, casting, plating; have special facilities for manufacturing patent articles, special machinery, tools. Do metal work in all its branches. Let us develop your idea; get our estimate; if made in metal we make it. National Stamping & Elec. Works, 157-161 Jefferson St., Chicago.

FOR SALE

FOR SALE or exchange, one 10-hp. gas engine, cost \$450; one 80-light 110-volt dynamo, cost \$200; one automobile running gear, cost \$300. American Publishing Co., Columbus, Ohio.

FOR SALE—Complete set of tracings and blueprints for 1 H. P. latest improved design valveless marine motor, \$20. Address 220, care Popular Mechanics.

FOR SALE—19-foot gasoline launch, 2½ horsepower, complete. Address 221, care Popular Mechanics.

ORIENT BUCKBOARD—One 3, one 6-horsepower Lackawanna marine engine, 24-foot, fast speed boat, 16, 18 and 20-inch propellers. Drills. Reamers. Address, "Broke," care Popular Mechanics.

EIGHT EDISON BATTERIES, in use one year. Excellent condition. Railroad type; \$10 takes them. Address 222, care Popular Mechanics.

ONE-HORSE stationary gasoline engine, fine condition, \$40.00. Kodak panorama camera, \$4.50. Address 225, care Popular Mechanics.

ONE 12-INCH CARRIAGE Oliver Typewriter, almost new, excellent condition, complete with metal office case and copyholder. Costs new \$110.00. Will sell for \$60.00, if taken soon. Address 229, care Popular Mechanics.

FOR SALE—4 H. P. gasoline engine, 6 H. P. automobile boiler, 3 H. P. vertical shop boiler, sliding gear transmission, 16 H. P. electric storage battery. Graham Auto. Co., 601 Madison St., Chicago, Ill.

\$\$ SAVED \$\$ MADE IN BRAZING—Old or new castings. Cast-Iron, Steel, Bronze, Copper or Brass. New Process Brazing Compound, \$1.25 per lb. Cherry Heat Welding Compound, 80c per lb. By mail, 18c extra per lb. All compounds guaranteed. Cummings Compound Co., 364 Avery Ave., Detroit, Mich.

FOR SALE—\$15 magazine focusing plate camera, \$3. Address 235, care Popular Mechanics.

STEEL RAILS—All sections, new and relaying. In stock for immediate shipment. Rails cut to length. M. K. Frank, Pittsburg, Pa.

FURNITURE POLISH—Costs 40c to make one gallon, cleans and leaves a lustrous "body" instantly. Excellent for all classes of furniture, pianos, etc. Injurious to nothing, and no offensive odor. Why pay 50c for a little bottle every week or so? I guarantee mine as good as any other polish and better than most of them. Receipt promptly mailed to you for \$1. Your dealer has all ingredients. You can mix same in two minutes. Address A. P. Shaffer, 171 Fifty-first St., Chicago.

Please Mention Popular Mechanics

FOR SALE—One 1-8 K. P. 110 volt alternating current motor. It has self-oiling oil cup and self-adjustable brushes. It has only been used once or twice and is practically new. Will trade with something else for 1/2 H. P. electric motor or 1 H. P. gasoline engine. For lowest cost prices write F. Mayle, Box 507, Blair, Neb.

FOR SALE—A brand new I. C. S. drawing outfit. Cost \$13.50. Will sell for \$9. John Sanders, Burlington, Vt.

SAMPLE STEREO-PHOTO, postpaid, 15c, twelve for \$1.00. Your money back if not satisfied. Hopson Photo Co., Bedford, Iowa.

FOR SALE—Must sell before June my stock and tools for general blacksmith and wood shop; shop and house can be rented. Address for particulars, Ed. Grotenhuis, Hospers, Iowa.

FOR SALE CHEAP—Two long-distance telephone instruments in good condition. Suitable for private use, \$4.00 each. Richard F. Mokros, 1429 Fond du Lac Ave., Milwaukee, Wis.

MANUFACTURE IT YOURSELF—Brilliant, self-shining shoe polish. Agents sell it for you; big money in it. Receipt 25 cents (silver) "nuff sed." A. C. Tytler, Basin, Wyo. (Agents please write.)

NEW GERMAN SILVERING PROCESS, by dipping in hot liquid, no electricity used. This process is new in this country. Big money-maker for plating small articles. No machinery required. Explicit directions in German and English. Price, 25c silver. Address, Paul M. Janke, Mt. Carmel, Ill.

FOR SALE—Three money-making formulas, 10c silver. A. Wagner, Celina, Ohio.

PHONOGRAPH OUTFIT FOR SALE—Consisting of Edison concert size machine using 5-inch diameter wax records, 56-inch brass horn, stand, 150 concert records, about 50 of them are original master records and cost \$3.00 each. Recorder, reproducer and complete outfit cost over four hundred dollars. Will sell all or part for one third of original cost. Outfit is like new. Guaranteed. A. W. Boothroyd, Newburgh, N. Y.

PRIZE WINNING White Langshans, Buff Rocks, R. C. Reds. Utility stock, \$1.00 each. Mrs. L. Mumpower, Chillicothe, Mo.

FOR SALE—A \$35 typewriter in good order at \$15. Also a photographic outfit. Address, L. E. Mattson, Dassel, Minn.

FOR SALE—First mortgages on improved Iowa farms. Write us if you have \$100.00 or \$1,000.00 or more to invest. Thirty years successful experience. Shaw & Kuehne, Proprietors, Bank of Denison, Denison, Iowa.

FERRETS—Fine working stock. Prices reasonable. Daniel Phelps, Nova, Ohio.

FOR SALE—Barnes Scroll Saw, Six-inch Wood Lathe set. Scroll saw attachment for screw cutting lathe. Water motor. Lot tools for iron and woodwork. John Holtz, 213 Fourth, Evansville, Ind.

\$250.00 ANGELUS PIANO PLAYER and music rolls, \$60.00. C. Hodge, East Bethany, N. Y.

FOR SALE—6x9-inch lightning jobber, footpower, printing press, good condition, \$35.00. Anderson, 225 First St., Batavia, Ill.

FOR SALE—Magnesium wire, 1 cent per foot. Stamps accepted. Chas. Eichinger, R. 2, Brussels, Wis.

FOR SALE—A formula telling how to make ashes burn as easily as wood or coal; a new discovery. Purchase this formula, then start in business selling it to others. Price, \$1. Address S. W. Halbert, Jr., Augusta, Wis.

FOR SALE—\$10—5x7 camera, with rapid rectilinear lens, Wellensak shutter, tripod, two plateholders; almost new. C. H. Granstrom, Catawba, Wis.

FOR SALE—Monarch Runabout, 28x3 in. tires, good order, \$175; also 5 2nd screw cutting engine lathes. P. O. Box 593, Burlington, Wis.

BANTAMS—Earn extra pin money with poultry. Send 2c stamp for circular. Sebrights, Japanese, Cochins, Games. A. A. Fenn Co., Box 67, Delavan, Wis.

SILVER PLATING! Without battery, acids or mercury. Solution for making Etchings on Steel. Beautiful Pictures made in one minute of any object. All three formulas for 25c. Address George L. Cook, Silver Hill, Milford, Mass.

FOR SALE—6 C. P. lamps, key socket, wire, batteries, complete, only \$2. J. Clarence Maguire, Macomb, Ill.

FIVE perfect Smith Premier Typewriters, \$23 each. Trial allowed. Executor, Box 105, Waterford, N. Y.

SALE OR EXCHANGE

WILL EXCHANGE small 1/2-inch Rhumkorf coil for "Omnigraph" set or \$2.50. Address 224, care Popular Mechanics.

FOR SALE OR EXCHANGE—Columbia Type N Cylinder Graphophone, 36-in. horn, forty-four records, \$10.00. R. S. Thomas, Blue Mound, Kan.

EDISON MOVING PICTURE outfit to exchange for steam automobile engine and boiler, 8 to 15 H. P., or marine or automobile gasoline engine, 8 to 20 H. P., vertical cylinders, water-cooled. Address 231, care Popular Mechanics.

STEAM AUTO OUTFIT and boiler sheets, 14x16-inch. Also one Westinghouse 4 H. P. steam engine and boiler, 2-cylinder, automatic. Will exchange on an automobile. Box 217, Meyersdale, Pa.

COLUMBIA MOTORCYCLE and Gold Watches and other watches. Want dynamo, gas engines, or what? R. Hendley, Wolcottville, Ind.

FOR SALE—3 H. P. engine and 4 H. P. boiler, all fittings. Boiler new, fired throughout, \$65 cash, or trade for gasoline engine. V. Perry, Stafford, N. Y.

FOR SALE OR TRADE—Automobile Year, American Pub. Co., 44 W. Broad St., Columbus, Ohio.

TO EXCHANGE—For Touring Car with or without engine, 26-foot Launch and 16-inch Lathe. Address D. A. Crawford, Emlenton, Pa.

WANTED TO EXCHANGE—Five lots in the city of Medina, Ohio, for touring car; lots are 50 by 150; eight minutes walk from Public Square and one block from street car line; value of lots, \$200 each. Will pay difference, if any. A. D. Alexander, Akron, Ohio.

FOR SALE OR EXCHANGE—22-foot steam launch, propelled by 7 H. P. double engine. Will exchange for gasoline automobile. Ralph Tice, Dowagiac, Mich.

PLUMBERS' SUPPLIES

SAVE YOU 25 to 50 per cent. Complete line up-to-date plumbing and steam goods at wholesale to the public. Get catalogue. John Hardin, 1/4 century at 4542 Cottage Grove Avenue, Chicago.

BLACKSMITHS

GOOD BLACKSMITHS are scarce and but few learning the trade. And the smith comes first of all professions or trades. The smith must make the tools first for all from the surgeon to the safe blower, by using Toy's Treatise on new steels explaining how to work them with 75 new methods for working all difficult jobs. Ten receipts for making your own compounds for welding different kinds of steel solid. Thermite welding fully explained; also two colored tool tempering charts; Chart A explains all annealing and hardening; Chart B explains both scientific and plain tempering to a standard. All the above for \$1.00. Valuable samples free. W. M. Toy, Sidney, Ohio.

WANTED

WANTED—Manufactured Patented Specialties to handle as selling agents. General Specialty Co., Syracuse, N. Y.

WANTED—Patented specialties to handle as selling agents. General Specialty Co., Syracuse, N. Y.

WANTED—Lathe or Civil Engineering course. Will give good exchange. George Thorpe, Jr., Millville, N. J.

WANTED—Responsible party to handle the "Pharo" Gasoline Stationary and Marine Motor, a good proposition for live party; 10c stamp for catalogue. "Pharo," Greenwich, Conn.

WANTED—2,000 Locomotive Firemen to buy a 25 cent book that teaches all you need to know. Send 25 cents to G. Morgan Miller, 810 Wyoming St., El Paso, Texas.

WANTED TO PURCHASE—A second-hand diamond drill; also some black carbons. Address 217, care Popular Mechanics.

WANTED—We buy all classes of Machinery, Boilers and Engines, etc. Write describing what you have for sale, with price. R. W. Herfurth Co., 39-41 Cortlandt St., New York.

WANTED—Binoculars of standard make, in first-class condition. Address 233, care Popular Mechanics.

BOYS, if you are interested in mechanics, electricity, etc., send 25c for a year's subscription to "The International Youth." Alpha Pub. Co., Dept. K, Chicago, Ill.

WANTED—Small dynamo, about 1 h. p., suitable for incandescent lighting; also small motors. P. O. Box 5, Route 5, Mt. Carmel, Ill.

WANTED—Spark coil or dynamos for 2-cylinder engine. O. W. Allen, Trenton, Mo.

WANTED TO BUY—Good second-hand auto gasoline engine, 6 to 10 h. p. Give price and description in first letter. Address E. E. Vadner, Ulen, Minn.

WANTED—A 3-h. p. boiler, in good condition; have a bicycle will exchange for same. W. H. Fife, R. F. D. 3, Canonsburg, Pa.

WANTED—Position as expert general repairman. E. F. Goodman, Union, S. C.

Please Mention Popular Mechanics

AGENTS WANTED

\$100 PER MONTH SALARY—Paid weekly. Energetic man in each county to represent Hardware Dept. Established business. Expense money in advance. The Columbia House, H-7, Chicago.

WANTED—Agents, machinists, toolmakers, draftsmen, attention! New and revised edition Saunders' "Hand Book of Practical Mechanics" now ready. Machinist says, "Can't get along without it." Best in the land. Shop kinks, secrets from notebooks, rules, formulas, most complete reference tables, tough problems figured by simple arithmetic. Valuable information condensed in pocket size. Price, postpaid, \$1.00, cloth; \$1.25, leather with flap. Agents make big profits. Send for list of books. E. H. Saunders, 216 Purchase St., Boston, Mass.

AGENTS CAN MAKE \$10 PER DAY selling our burnished gold and silver letters for office windows, store fronts and glass signs. Anyone can apply these letters by following directions sent with each order. Write for our 8-page illustrated circular. S. H. Parrish & Co., Clark and Adams Sts., Chicago.

WANTED—Mechanics to sell our fine line of Callipers and Levels. Good pay. Address E. G. Smith Co., Columbia, Pa.

SALESMEN WANTED—Must be experienced selling power transmitting, mill and factory supplies. Salary and commission. Give age, experience and reference. L. F. Grammes & Sons, Allentown, Pa.

\$100.00 WEEKLY positively made selling and appointing agents to sell Hydro Carbon Lighting Systems. Our demonstrating system makes failure impossible. Wanted—A good man in every village and city in the world. Security Light & Tank Co., 160 S. Jefferson St., Chicago.

AGENTS—\$25 a week easily made selling our 14 new patented articles. Each one a necessity to every woman, and a rapid seller. No scheme. Sample free to hustlers. A. M. Young & Co., 209 Howland Bldg., Chicago.

AGENTS WANTED in every shop and factory. You can, if ambitious, earn from 5 to 8 dollars per week in addition to regular income, selling "Clenem," the perfect hand soap. Guaranteed not to chafe the hands. We are offering agents greater inducements for 1908. Write for terms, etc. Clenem Mfg. Company, 42 Stanhope Street, Boston, Mass.

AGENTS—Good seller, our Labor-Saving Washboard Holders, 500 per cent profit, sell in almost every home. Circulars free. Samples, 10c for postage to agents only. De Waldo-Taylor Co., Warren, Ohio.

SALESMEN, ENGINEERS sell simple appliance for boilers. Thousands used; 25 per cent commission, same on reorders. A square deal. Joseph J. Dillon, 2202 Cass St., La Crosse, Wis.

MALE HELP WANTED

WANTED—Engineers, Firemen, Electricians, Mechanics, etc. New 25-page pamphlet containing questions asked by examining boards sent free upon request. Address Geo. A. Zeller Book Co., 4466 W. Belle Place, St. Louis, Mo., Established 1870.

OPPORTUNITIES—Hundreds of office, clerical and sales positions. Information free, if you will write, stating age, experience, and location desired. Service confidential. Hapgoods, 305 Broadway, N. Y., or 1010 Hartford Bldg., Chicago.

EDUCATIONAL AND INSTRUCTION

STUDY ELECTRICITY AT HOME—A complete electrical course at home, containing 30-page detail book, 220-page text-book, 200 experiments and over 100 pieces of apparatus. Price, complete, only \$5.00. Catalogue "PS" explains this and other remarkable offers. Thomas M. St. John, 848 Ninth Ave., New York.

ARE YOU MAKING less than \$25 or \$30 per week? Mechanical and Structural Drawing taught by experts. Send for circular. Low tuition, including Free Books, Drawing Instruments, etc. Columbia Correspondence School, Drexel Bldg., Philadelphia, Pa.

MONEY IN NOVELTIES—Our advertisers and readers are looking for good new novelties to put on the market. They have money for the right inventions in utility, amusement and advertising novelties. What have you got that's good? Reach this field through "The Novelty News," 171-5 Washington St., Chicago. Trial 3 months, 25 cents.

\$350.00 MONTHLY easily made fitting eyeglasses. Short, thorough course by mail. Easily learned. Diploma. Big demand for opticians. We start you. Free "Booklet 4" tells how. National Optical College, St. Louis.

LEARN THE HOT WATER HEATING BUSINESS AND WORK FOR YOURSELF—I teach you absolutely free of charge and enable you to make a good income while learning. Men handy with tools make big money. No expense. For full information write 10008, care Popular Mechanics.

FOR SALE—I. C. S. complete drawing outfit, good as new, \$6.00 cash. Address 232, care Popular Mechanics.

I CAN TEACH you by mail in two lessons to do perfect lettering without a brush. C. W. Gray, Greenfield, Mass.

FOUR NEW TEXTBOOKS of the International Correspondence School on Electric Railways and Lighting, \$8.00. Richard F. Mokros, 1429 Fond du Lac Ave., Milwaukee, Wis.

FOR SALE—Complete stenographic course with International Correspondence School. Will take \$50.00 for it. Send P. O. order or certified check and same will be forwarded at once. Address H. E. Bays, Box 36, Bedford City, Va.

FOR SALE—I. C. S. course in Architectural Drawing, \$50 cash gets it. Address J. E. Hazelton, 1225 Torch St., Lansing, Mich.

WANTED—Course in Civil Engineering, or Surveying. State particulars. George Thorpe, Jr., Millville, N. J.

BOOKS AND PERIODICALS

LET THE ENGINE do the work. Our new book tells how to convert your buggy or road wagon into a motor car, or your bike into a motorcycle, at moderate cost. Many mechanics build their own motor. Price per copy, postpaid, 25 cents in coin. Stanley Shaw, Galesburg, Kan.

GET A GOVERNMENT POSITION—Our book fully instructs how. Failure if studied impossible. Address Frank B. Pergande, Publisher, Whitefish Bay, Milwaukee, Wis.

IF IT'S PRINTED—MacDonald can supply it—Domestic and Foreign publications of every description—Plays—reading and recitation books—Dramatic Journals supplied by mail. "Catalogue P. M. sent free." Chas. MacDonald, 53 Washington St., Chicago, Ill.

ELECTRICIAN AND MECHANIC—The best practical monthly magazine for all interested in electricity and mechanical work. Illustrated working directions for building dynamos, motors, gasoline engines, wireless telegraphy, electroplating, electrical wiring, mechanical drawing, using tools, furniture construction, photography, all kinds of mechanical work. One dollar yearly; single copy ten cents. F. R. Fraprie, 1135 Beacon Building, Boston, Mass.

A GOLD MINE of ideas, money-making recipes and trade secrets contained in one great book. Ten cents silver. L. A. Bennett, 105 Baxter St., Buffalo, N. Y.

FOR SALE—Cyclopedia of Engineering. Steam, electrical, mechanical. Bound in three-quarters red morocco leather. Five volumes. Cost new \$19.00. Used but slightly. Are in fine condition. Will sell for \$9.00. Address J. T. B., Box 425, Chicago, Ill.

FOR SALE—A ten-volume set Cyclopedia of Architecture, Carpentry and Building. Nearly new. Bound in half red morocco. Cost \$19.00. Will sell for \$12.00. Address A. H. D., Box 425, Chicago, Ill.

FOR SALE—Engineering Library of twelve volumes. Steam, electrical, mechanical. Bound in three-quarters red morocco leather. Cost new \$60.00. Are in excellent condition. Used but short time. Will sell for \$18.00. Address P. M. R., P. O. Box 425, Chicago, Ill.

ACTRESSES' photos, sidesplitting song and joke book. Five samples, 35 cents. Stag Art Co., Elkhart, Ind.

FOR SALE—A thorough treatise on Electricity. Covers entirely electricity in all branches. Five volumes. Cost new \$19.00. Used but short time. Are in fine condition. Will sell for \$9.00. Address T. F. B., Box 425, Chicago, Ill.

START A BUSINESS with small capital. My new book tells how. Particulars free. Address P. W. Ostwald, Box 116, Bayfield, Colo.

FOR SALE—Cyclopedia of Modern Shop Practice. A complete reference work for machinists, foundrymen, etc. Leather binding. Four volumes. Cost \$18.00. Will sell for \$6.00. Address P. M., Box 425, Chicago, Ill.

LAUNCH AND STEAMBOAT MACHINERY

SAFE AND SURE, therefore NOT gasoline. Economical and long-lived, therefore STEAM. Nothing complicated or uncertain. Built to order to meet conditions. Catalogue free. Marine Iron Works, N. Halsted Station, Chicago.

Please Mention Popular Mechanics

CEMENT

IF YOU WANT the best information on cement and concrete construction subscribe for Concrete, leading cement and concrete monthly. Sample copy, 10 cents. Concrete, 135 Newberry Bldg., Detroit, Mich.

LAND FOR SALE

OIL LANDS FOR SALE—Worth the money. Offer undeveloped leases and production, in the Glenn Pool and over the Mid-Continent Field. Chas. E. King, Tulsa, Okla., Box 576.

10 ACRES of irrigated land in Yakima Valley will make you rich. For reliable information address Box 525, Seattle, Wash.

WHAT HAVE YOU to trade for some good Florida land? Give good description of your property. Box 411, Washington, Ill.

320 ACRES of fine laying land, 11 miles northwest of Stratford, Texas. Price, \$12.00 per acre, if taken soon. S. L. Thomas, Washington, Ill.

FOR SALE—80 acres rich land, 15 acres timber, large new buildings, 7-room house, 1,100 fruit trees. Bearing—2 acres berries, 10 acres wheat. All stock, chickens, crops, implements. Nicely located. Price, \$3,450. Terms, \$1,000 cash; balance mortgage. Close to good markets. Possession. Free catalogue. Chas. H. Butler, Dover, Del.

WHEAT LAND in northern Colorado. Only \$10 per acre. Easy terms. The Nicholson Co., Dept. B, Lamoni, Iowa.

MISCELLANEOUS

WIRELESS TELEGRAPHY—Something new. Make your own instruments. Instructions, with blue prints, for making, sending and receiving apparatus sent on receipt of 25 cents (no stamps). Address 7503, care Popular Mechanics.

WANTED—Manufactured Patented Specialties to handle as Selling Agents. General Specialty Co., Syracuse, N. Y.

WATCH FOB FOR MECHANICS. Leather strap with a fine solid nickeloid emblem of your trade attached. Emblem is a miniature tool, and may be used as a chain charm. Price, 25 cents, postpaid. Agents wanted in every factory. Ask for catalog. National Selling Co., Allentown, Pa.

ELEVATOR SAFETY GATE IRONS furnished to agents, contractors and elevator builders. Good agents wanted in all territory not taken. A safe money-making business for the right men. Write for full particulars. Elder Manufacturing Co., Indianapolis, Ind.

BARGAIN LIST of dynamos, magnetos, carburetors, spark coils, etc. Don't miss it. Prices will surprise you. Address, 228, care Popular Mechanics.

ANYBODY CAN MAKE GOOD CUTS with my simple zinc etching process; price, \$1; specimens and particulars for stamp. T. M. Day, Box M, Windfall, Ind.

MONEY-MAKING BOOK—Tells how anyone (regardless of age, sex, location, experience or present occupation) can at once start a spare-time business without capital; how I started with \$2 and made thousands; unusual and fascinating home or office work; 1,000 suggestions; circular free. Hollis Corbin, 1374 Chestnut St., Philadelphia.

DRY BATTERIES—How to recharge them at very little cost; sent on receipt of 25c. The secret of making Aluminum Solder and how to recut old files, 15 cents each, or the three sent postpaid for 40 cents. Address Mr. H. McCoy, Sandusky, Ohio.

LOOK! Send me one dollar. I guarantee nothing, but if you should receive twenty-five or fifty dollars, tell your friends about it. This is your last chance. I. Moncrief, Howell, Mich.

PUZZLES, Electrical Novelties, Hand-Books, Mechanical Toys, Masquerade Supplies, Magical Tricks, Post Cards, Guns, etc. Catalogue for stamp. Ewing's, 190 Thatcher Place, Decatur, Ill.

POLARITY TESTING PAPER—The greatest novelty in the electrical line. Send ten cents for sample to H. M. Nichols, 26 Congress St., Lynn, Mass.

INVENTORS looking for parties to manufacture or finance their inventions, send copy of your patent to the Industrial News Bureau, Ithaca, N. Y.

I MAKE drawings and blueprints. D. Tappan, Water-vliet, N. Y.

INKLESS PENS. Send 10 cents silver for three, and sample of writing. Address P. W. Ostwald, Box 116, Bayfield, Colo.

URSINUS ACADEMY, Collegeville, Pa. Young men and women here receive mental, moral and physical strength amid beautiful surroundings at lowest cost. Write Principal for "Ursinus Beautiful."

ENGINEERS, ELECTRICIANS, Managers or Superintendents—Did you ever try to do something in your line of work and get stuck; then sit up late at night, reading books, data, etc., trying to find the information that would put you right, and go to bed no wiser? Next day say, "I wonder who could enlighten me on this subject?" If you send me two dollars I will give you the desired information correctly, and written in plain language, or sketched so that you can understand it. Am confident I can supply your wants. Give me a trial. If you think you did not get your money's worth, I will refund it promptly. Address Geo. W. Richardson, M. E., 2181 W. 24th Place, Chicago, Ill.

USE A RUPRECHT CORRECTOR to change your Alternating to a Direct current. It will charge storage cells, give a noiseless arc for stereopticons and operate direct current apparatus. Three types and prices. Ruprecht Electrical Co., 7117 Cedar Ave., Cleveland, Ohio.

WIRELESS TELEGRAPH APPARATUS. Complete sets, \$12.00 to \$100.00. Separate parts, etc. Send two-cent stamp for booklet of Corrector or Wireless. Ruprecht Electrical Co., 7117 Cedar Ave., Cleveland, Ohio.

\$24.15 PROFIT with an investment of 85 cents. This and twenty other dollar-getting chapters in our big \$1.00 book. Special 60-day reduction. Twenty-five cents silver. Postal Trading Co., St. Roch de Quebec, Canada.

THE BIG ROUND DOLLAR. How to acquire it easily, honorably and quickly. A 50 cent book for one dime. Postal Trading Co., St. Roch de Quebec, Canada.

FOR YOUR DEN—Polished, mounted steer and buffalo horns. Antique guns, pistols, prehistoric stone relics, Indian trappings. Old crockery. Filipino weapons. Alaskan curios. Elk tusks. Illustrated list, 6c. N. Carter, Elk-horn, Wis.

CUTS, BRUISES, BURNS and Contusions yield readily to the miraculous healing, cleansing, soothing power of "Burgandy Ointment." Prevents Blood Poison. Send 25 cents for a large box. The Johnson Co., Advertising Dept., South Amboy, N. J.

BUCKEYES—Most beautiful, most useful fowl. Eugene Cowles, Shelbyville, Ky.

FREE FACTORY SITES and natural gas at 2c per 1,000 cubic feet at Bartlesville, Oklahoma. Write the Commercial Club at Bartlesville for further information.

FOR SALE—Five Gold Mining Claims, one patented. One claim showing a fine view of Tungsten. Investigate S. Davidson, Sunshine, Colo.

MODEL FLYING MACHINE—Build a flying machine for one cent that will fly. Directions, ten cents (no stamps). J. Crawford, P. O. Box 641, Schenectady, N. Y.

ARCHITECTURAL TRACER—Homer H. Knodle, Decatur, Ind. Write us today.

GOOD ELECTRIC GOODS of all kinds at special prices. Send stamp for catalogue. Ketteman Electric Co., Toledo, Ohio.

THE EFFICIENCY of your wireless station may be increased 600 per cent by using Tuned Circuit Apparatus. Twenty standard wiring diagrams of tuned transmitting and receiving instruments, 50c; twelve detail construction drawings of same, \$1.00; four wireless telephone diagrams, 25c. W. C. Getz, 645 N. Fulton Ave., Baltimore, Md.

MECHANICAL DRAWINGS prepared. Will personally assist developing ideas. Strictly confidential. C. L. Cook, care Popular Mechanics.

STEEL GASOLINE BURNERS (New), 14-in. and 16-in., \$5 each. Send for list No. 8. J. L. Lucas, No. 2 Fox St., Bridgeport, Conn.

FOR ADDITIONAL CLASSIFIED SEE BACK OF BOOK

Increase Your Earnings

We have an attractive money-making proposition to make to those who would like to make **MORE MONEY**.

Our proposition offers an exceptional opportunity to men employed in manufacturing plants, machine shops, etc. Such men can easily make **MORE MONEY** without interfering with their regular work.

The work is pleasant. The compensation is liberal. What others have done you can do.

Write to us today and receive full particulars by return mail.

POPULAR MECHANICS

Desk A...160 Washington Street, Chicago

NEW YORK SCHOOL OF AUTOMOBILE ENGINEERS

You Can Earn \$25 to \$100 a Week

Our course of study will fit you in two months to be a Chauffeur, Auto Salesman or Garage Manager, and there is no better paid occupation nor pleasanter work in the world. Our Home Study Course by mail gives full instruction by charts and text, and does not interfere with your present occupation. Our graduates are recognized as experts and good positions seek them. **WRITE TODAY** for free prospectus. Personal teaching with road practice at our big New York School if preferred.

NEW YORK SCHOOL OF AUTOMOBILE ENGINEERS, 130 West 56th St., N. Y.

MAKE YOUR BIKE A MOTORCYCLE



at small cost by attaching the efficient, powerful, light weight **ERIE 2 H. P. ATTACHMENT**. This includes all parts to make a powerful, strong motorcycle, 1000 in use. Bolts to any size frame. Speed, 2 to 30 miles per hour. Fits any bicycle. Send stamps for catalog.

MOTORCYCLISTS Send 15 one cent stamps for new book, "The Motorcycle." It tells about the mechanism, care, operation, how to get more power, etc. Name make of motorcycle for low prices on accessories.

MOTORCYCLE EQUIPMENT CO.

50 Lake Street, Hammondsport, N. Y.

A MOTOR-CYCLE OR LAUNCH



at SMALL COST by using one of our Attachable Outfits. A complete line of Finished Motors and Rough Castings for Bicycle, Auto-Marine or Stationary. Send stamp for catalogue.

STEFFEY MFG. CO.
Girard Ave. & 30th St., Philadelphia



MAKE A MOTORCYCLE OF YOUR BIKE

at small cost, by using our Attachable Outfit. It fits any bicycle. Send stamp for catalog. Send 15 cents for "The Motorcycle Manual." It treats of motorcycles; how to get more power, etc.
SHAW MFG. CO., Dept. B, Galesburg, Kan.

JUDSON Freight Forwarding Co. Reduced rates on household goods to and from all points on the Pacific Coast. 349 Marquette Building, Chicago; 1501 Wright Building, St. Louis; 851 Tremont Bldg., Boston; 101 Columbia Bldg., San Francisco; 100 Stimson Block, Los Angeles.

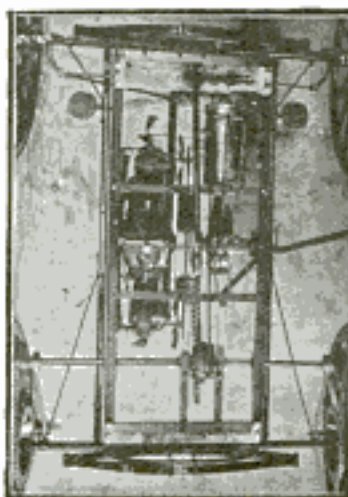

BUILD YOUR OWN AUTOMOBILE

You can do so by purchasing your chassis or parts complete from us. We give you the benefit of our years of experience in this line.

We are building hundreds of these machines and they are a decided success. Reliable, durable and powerful. Engine is silent and simple in construction—9-10 H.P. Buy a chassis from us and build you an Auto Buggy. Send today for complete information and prices.

A few special built automobile bodies for sale at a great sacrifice. Will sell in the white or painted and trimmed.

Auburn Motor Buggy Chassis Co., Auburn, Ind. Box No. 10

AUTOMOBILES \$100 UP



FREE, our large Illustrated Bargain Sheet of slightly used Automobiles showing accurate photographs of nearly 60 different makes of Automobiles offered as low as \$100. Send name and address only. Write plainly to

H. GRAHAM AUTOMOBILE CO.

Established 16 years. 601-603-606 Madison St., Chicago, Ill.

\$40 MOTOR CYCLE



We have the largest line of New and Used Motor Cycles, Parts and Supplies in the country, at the lowest prices. Every machine guaranteed. We are the largest and only exclusive Motor Cycle house in the world. Send for our 1907 Catalog. Repairs a Specialty.
Harry R. Geer Co., St. Louis, Mo.
Motors and Castings for Air Ships

THE LARGEST ENGINES IN THE WORLD



Keep **CHICAGO & ALTON** Trains
On Time Between
CHICAGO · ST. LOUIS · KANSAS CITY.
"The Only Way"

GEO. J. CHARLTON, GENERAL PASSENGER AGENT. CHICAGO.



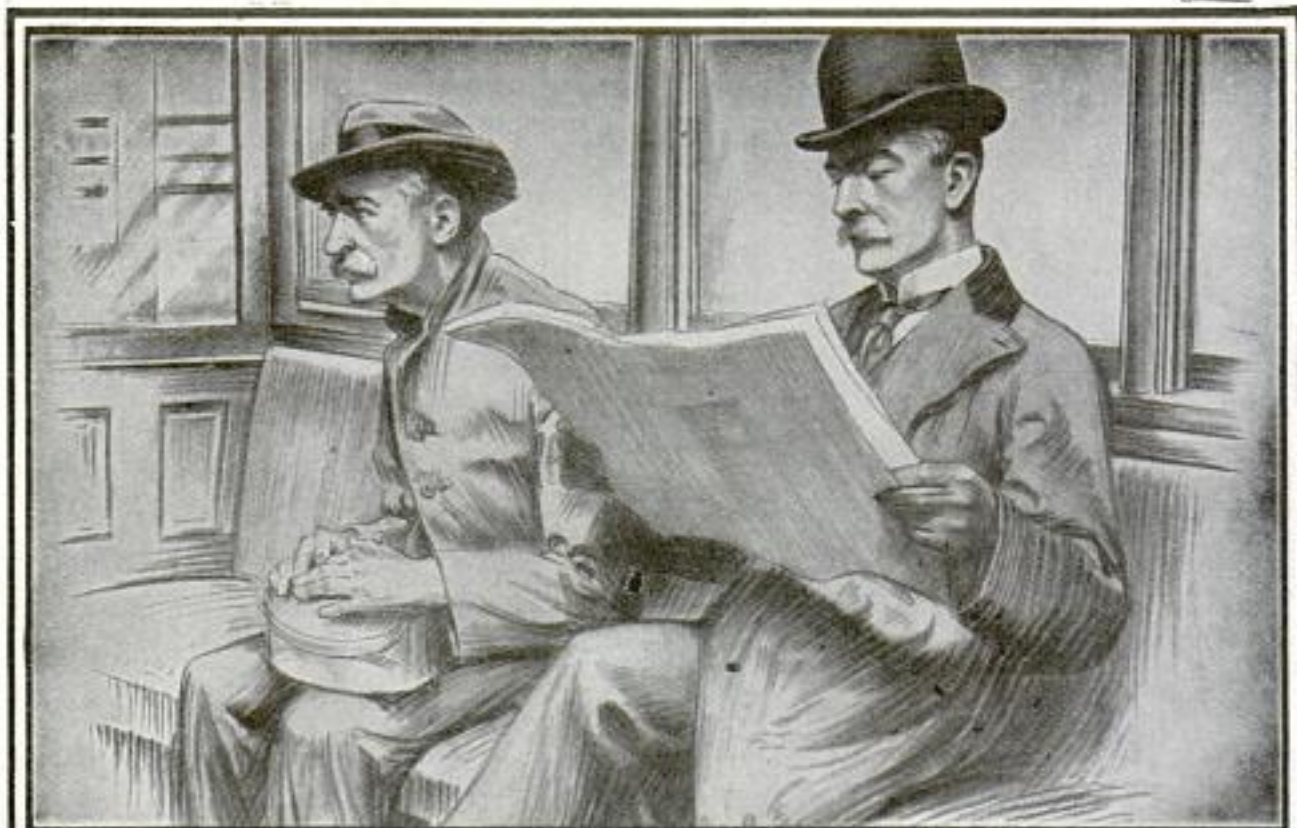

The Story The Street-Car Tells— The Trained and the Untrained Man

Side by side they sit,—one filling an important position in the world—the other poorly paid and discontented. The difference between them is due to the fact that one man is *trained*—an expert in his line of work, while the other is *not*.

If you're the *untrained* man and want to advance, write to-day to the International Correspondence Schools and learn how you can better *your* position—how you can have *your salary raised*.

You'll be surprised when you learn how easy it all is. Do it *now*, while it's fresh in your mind. Tear out the coupon, mark it opposite the occupation you like best and mail it to-day. There's no string to this—no obligation on your part—no charge for the information and advice that the coupon will bring. Isn't your *whole future* worth the finding out? Then, *do it now*.

Doesn't matter how old you are, where you live or what you do—so long as you can *read and write* the I. C. S. can help you without your having to lose a day's work or leave home. Mark the coupon.

Doesn't the fact that during November 265 students *voluntarily* reported better positions and higher salaries obtained as a direct result of I. C. S. training prove the willingness and ability of the I. C. S. to raise *your* salary? This is the average number of similar successes reported every month. **Mark the coupon NOW.**

International Correspondence Schools, Box 872, SCRANTON, PA.

Please explain, without further obligation on my part, how I can qualify for a larger salary in the position before which I have marked X

Bookkeeper	Mechanical Draftsman
Stenographer	Telephone Engineer
Advertisement Writer	Elec. Lighting Supt.
Show Card Writer	Mechan. Engineer
Window Trimmer	Surveyor
Commercial Law	Stationary Engineer
Illustrator	Civil Engineer
Civil Service	Building Contractor
Chemist	Architect
Textile Mill Supt.	Architect's Draftsman
Electrician	Architect
Elec. Engineer	Structural Engineer
	Banking
	Mining Engineer

Name _____

Street and No. _____

City _____ State _____

POPULAR MECHANICS

Vol. 10.

MARCH, 1908.

No. 3.

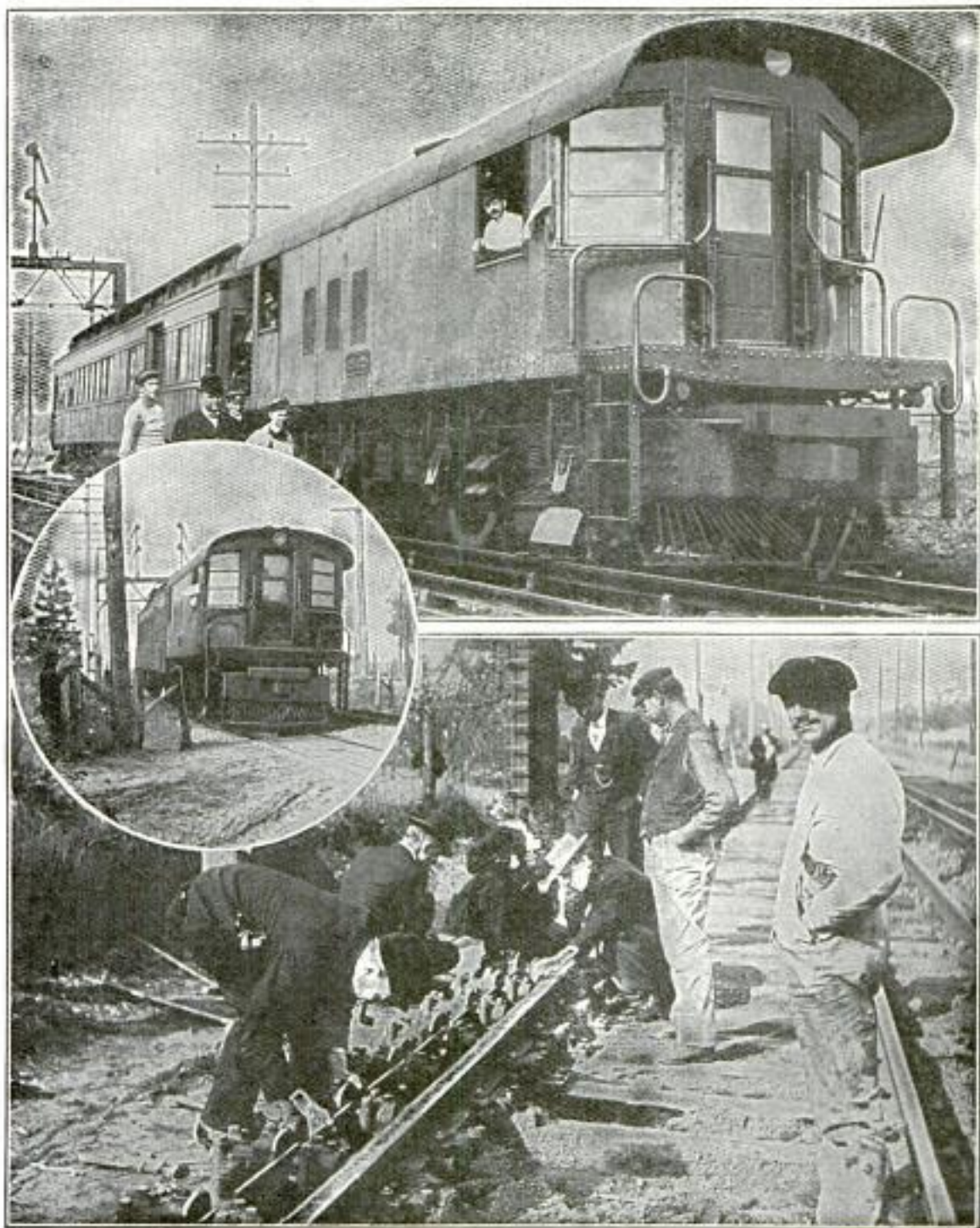

Seeking the Speed Limit of Safety (See Page 140)

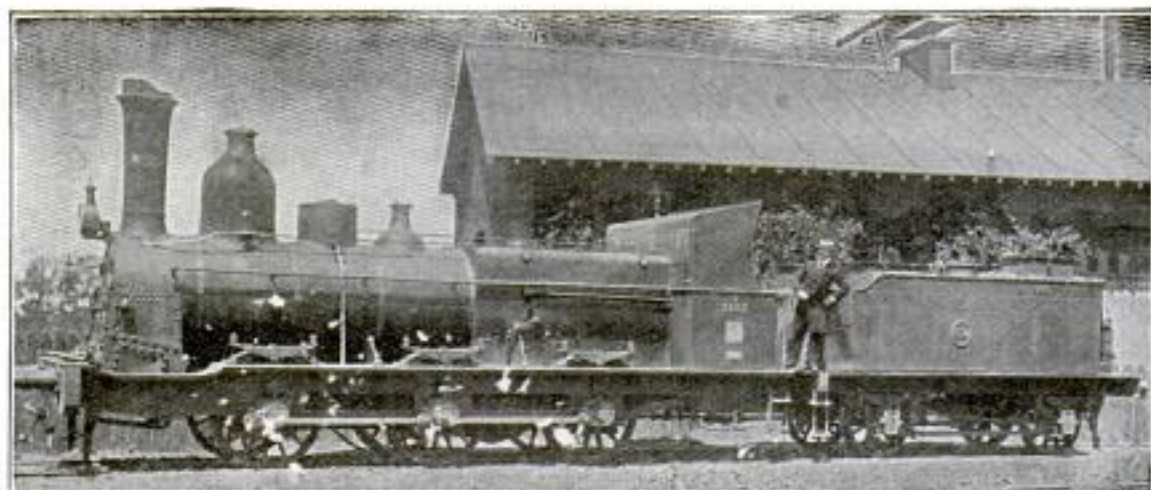

Curious Freight Locomotive on the Belgian State Railways

SEEKING THE SPEED LIMIT OF SAFETY

Electric Locomotives in Tests Develop Speed of Over 90 Miles an Hour

Special Devices Register the Strain on Rails

There was a time when, a new stretch of railway line having been completed, the engineers of the road ordered a train crew to run a train over it at full speed, with the idea that if no accidents occurred the track had been sufficiently tested and found safe. Such a time has passed. New devices have come into use which make it possible to determine to the very letter the amount of strain to which a piece of track can be subjected.

For several months the Pennsylvania railroad has been conducting a series of tests along its lines to determine the relative safety of highest speed with steam and electric locomotives.

To carry out these tests a half mile of track was built through a rural section. The half mile of track has a sharp curve in the center and lies on a stretch of almost perfectly level ground. Over this, hundreds of runs have been made with three powerful electric locomotives and some of the largest steam engines the road owns. Speeds of from 90 to 96 miles an hour, timed by accurate electrical apparatus, have been made.

To enable the locomotives to attain a high speed the runs commence on the main line several miles distant from the special track. For the half-mile stretch, steel beams support the rails, and at the outer ends, which are a trifle higher at the curve, are delicate gauges which measure the impact of the heavy locomotives as they pass over it. The gauge consists of a vise through which a plunger runs. One end of the plunger rests against the upper edge of the rail and the other end is bored out until a cup 5 in. in diameter is made. In this cup is placed a polished steel ball of the hardest tempered steel. Within the vise is placed a strip of boiler plate 3 in. wide and 14 in. long. One side is highly polished and marked off by rectangular lines about $1\frac{1}{2}$ in. apart. This plate is so adjusted that the ball in the cup-shaped chamber in the end of the plunger rests against the polished surface of the plate at the point where the lines cross. As the locomotives pass over the track the arrangement of the gauges brings all the outward and downward pressure to bear upon the plungers. This pressure is transferred by the

steel balls to the polished surface of the plates, upon which it makes indentations. It is upon the comparative diameter and depth of these indentations that the experts figure the pressure on the rails. Seismographs mounted in the locomotives measure the degree of sway in rounding the curve.

The electric engines used in the tests weigh 95 tons and are each equipped with four 500-hp. motors. In reality the engines are each just one-half of the complete locomotives which will be used to draw trains through the Pennsylvania tunnels now under construction beneath New York city. It was considered too hazardous to use the complete engines in the tests because of their great weight. Only on one occasion was the experiment tried of coupling two of the locomotives together, and then the weight and speed drew the spikes from the tracks as the wheels passed with a racket like the clatter of a gatling gun.

FLOWER-BOX NOVELTY IS ARTISTIC

One of the most unique as well as artistic arrangements ever conceived as a novelty creation for the presentation of flowers is the surprise gift box shown in these illustrations. At first sight the box might contain only bonbons, with a few flowers passed through the ribbon tied around it. The moment the ribbon is untied, however, and the cover of the box is lifted, the sides fall perfectly into the shape of a centerpiece, and a beautiful bouquet of roses, surrounded by bunches of violets, greets the eyes of the recipient of

the gift, says Florists' Review. The ground work on which the flowers are arranged is a point-lace doily.

In Colombia, South America, half the miners are women. In hydraulic mining they work up to their waists in water side by side with the men. In fact, if the women did not do this work the gold fields of Colombia would to a great extent be undeveloped. The wage paid ranges from 15 to 25 cents per day.

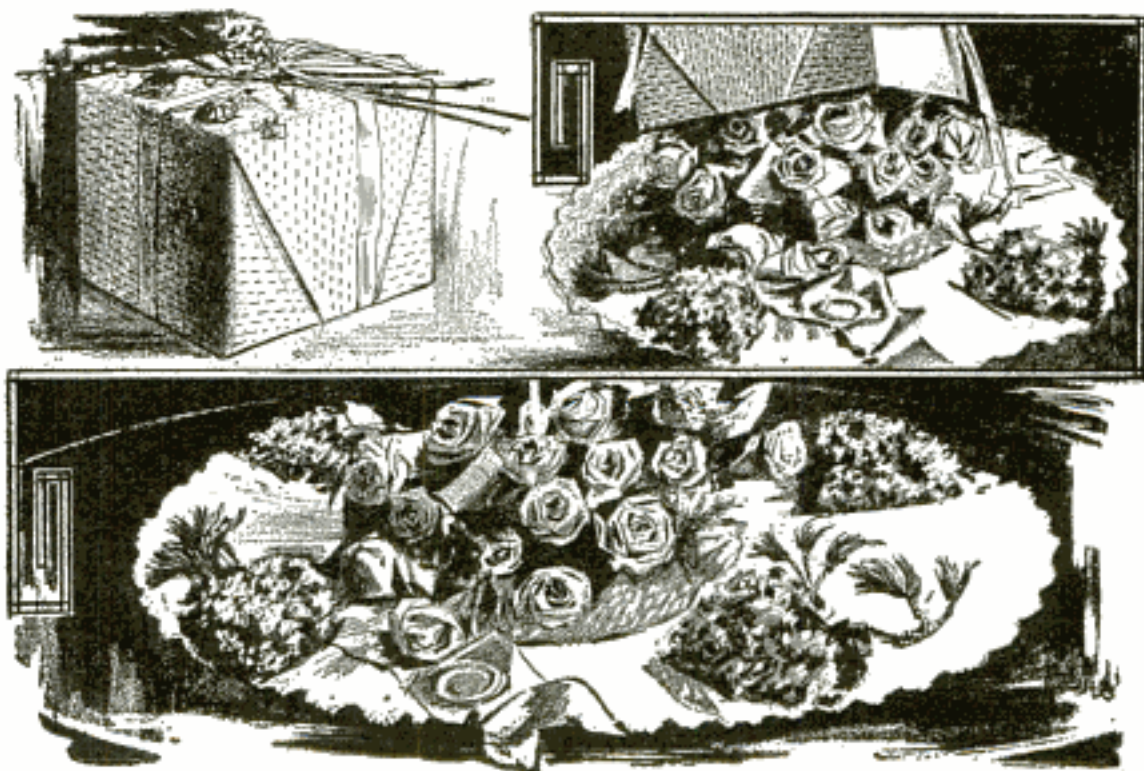

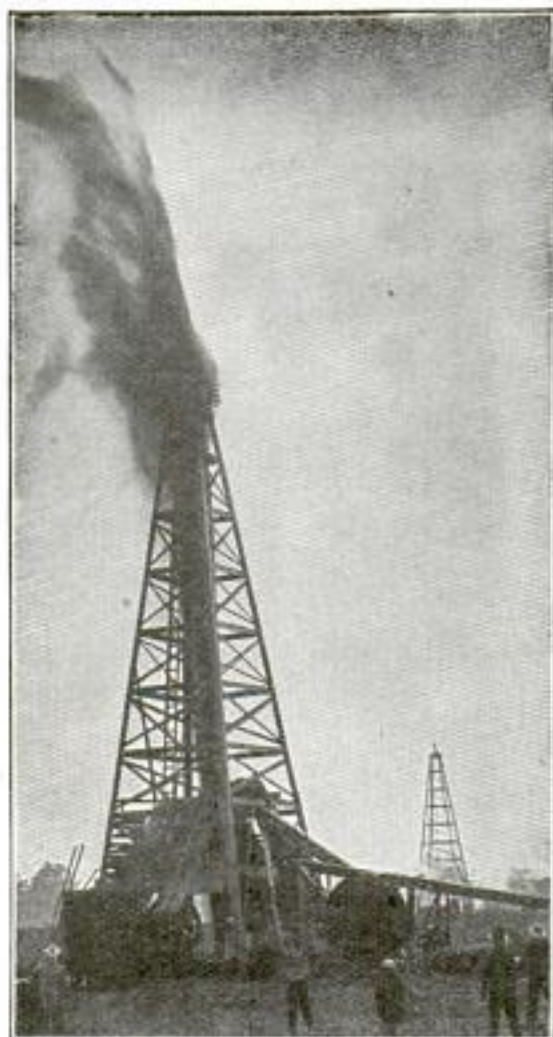

Shooting an Oil Well at Chanute, Kan.

REMARKABLE SHALLOW-DRAFT CRAFT

For the navigation of lakes and streams where the depth is only one or two feet, launches, although of comparatively large size, must be constructed on the most shallow lines.

This steam launch, which is one of an English type of shallow-draft launches, is 75 ft. long and has a beam of 9 ft.



English Shallow-Draft Boat

3 in. Running at a speed of 10 miles an hour, with only a light load, the boat only draws 11 in. of water. With a load of 10 tons, at the same speed, she draws 20 in.

GERMAN FIGHTING AUTOMOBILE

This armored fighting machine is the latest type of rapid-firing automobile in the German military service. It is armored with nickel steel plates heavy enough to withstand infantry shots or shrapnel at 1,000 ft. The machine carries 5 men, 100 lb. of ammunition and one gun, which is capable of shooting a distance of 22,000 ft. The

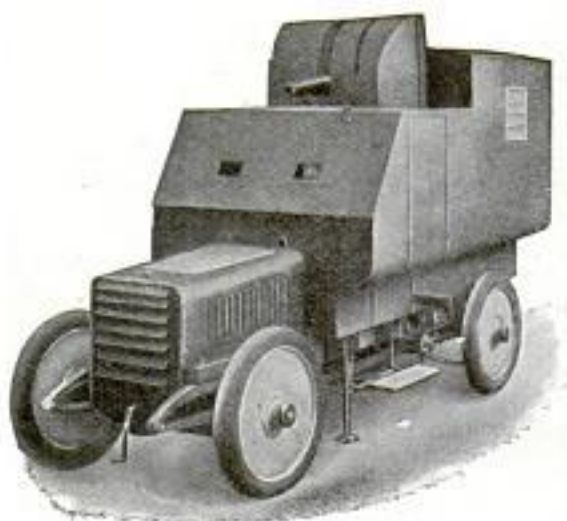

Rapid-Fire Gun Auto

weight of the automobile is 7,000 lb. and its speed from 30 to 45 miles an hour.

The 130 miles of street railways in St. Petersburg are all to be equipped with electricity within the next six years.

THE CAUSES OF MINE DISASTERS

Deadly Gases Lie in Wait for Miners—Perfect Ventilation and Continual Watchfulness Necessary—Carelessness and Greed of the Ignorant a Menace—22,000 Killed in 17 Years

By Francis M. Buzzell

Many stories have been written about a lump of coal, in which the reader has followed its travels from the moment the miner struck his pick into the

task of wresting it from the earth to make warmth or steam for mankind. If it were really animate, how many stories it might tell of disaster, in



Courtesy The Black Diamond

Entrance to No. 8 Shortly After the Explosion

seam it was part of, many hundreds of feet underground, and in the author's fancy it became animate, until after many experiences it at last found itself in a scuttle before a fireplace or stove in some quiet, peaceful home, far distant from the depths where its first knowledge of life was strife, misery and death.

Few people stop to think when they toss a lump of coal into the fire how many lives may have been lost in the

which it saw strong men, hopelessly struggling and praying for a breath of fresh air, die in agony in the deep, dark holes under ground.

From the year 1890 to the close of 1906, 22,840 men met such a death in the coal mines of the United States. Not since 1897 has the annual list numbered less than 1,000, and each year the number has grown larger. In 1906 the fatalities were 2,061, and 1907, when the figures are all in and

compiled, will number more than that. Notwithstanding the added precautions taken and the new safety devices installed, the climax came when, in the



One of the Chambers

course of but 19 days, 759 men were killed in four awful disasters which have appalled the entire country.

The first of these was in the Naomi mine, Monongahela, Pa., 30 killed; the second, Monongah, W. Va., 398 killed; the third, Yolande, Ala., 81 killed; the fourth, Jacobs Creek, Pa., 250 killed.

All four disasters were caused by the explosion of fire-damp and coal dust, but the causes of the explosions themselves are not known, nor what atmospheric conditions, in or out of the mines, caused them to occur when they did. All that the best mining experts in the country have been able to do is to state their beliefs. When all is said and done the fact remains that some of the best-equipped and best-managed mines in the country have been the

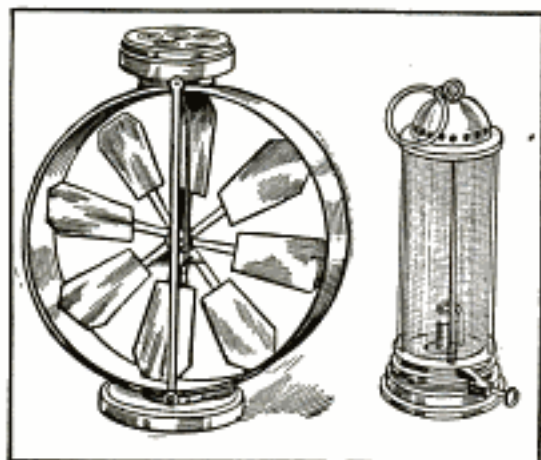

Air Meter

Safety Lamp

ones to suffer disaster, and experience seems unable to cope with the conditions noted.

Some of the experts who made investigations believe the explosions were partly due to climatic conditions. They remark that the catastrophes occurred at about the same hour in the day, in a zone of certain altitude, in about the same longitude and under other similar conditions. They suggest, therefore, that if the air forced into the mines by fans were gathered from a higher point and treated to remove impurities, the accidents would be less numerous.

In all the mining districts of the British Isles this important factor in the protection of the men, who seldom see the sunshine, is given more serious consideration than in most countries. Reports are issued every day, as weath-

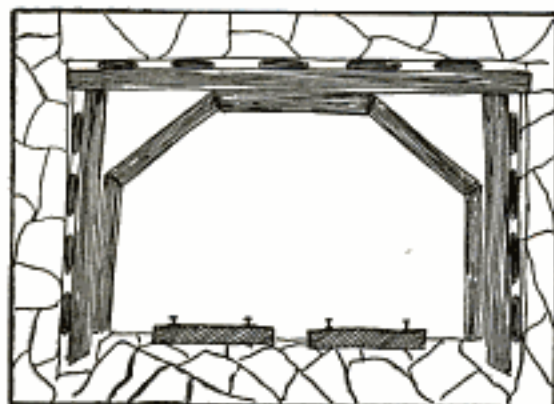

A Main Entry

er reports are issued by the U. S. Weather Bureau, warning mine superintendents of sudden atmospheric changes and advising what cautions should be taken to meet such conditions successfully. These reports are published daily in every English newspaper having a circulation in the mining districts.

This brings us to the subject of ventilation and the different death-dealing mine gases. To obtain proper circulation through the mine one shaft must be constructed by which the warmer and lighter air can ascend while the cold air rushes down another shaft to take its place. The ventilation must also be so arranged that as many independent ventilation districts as pos-

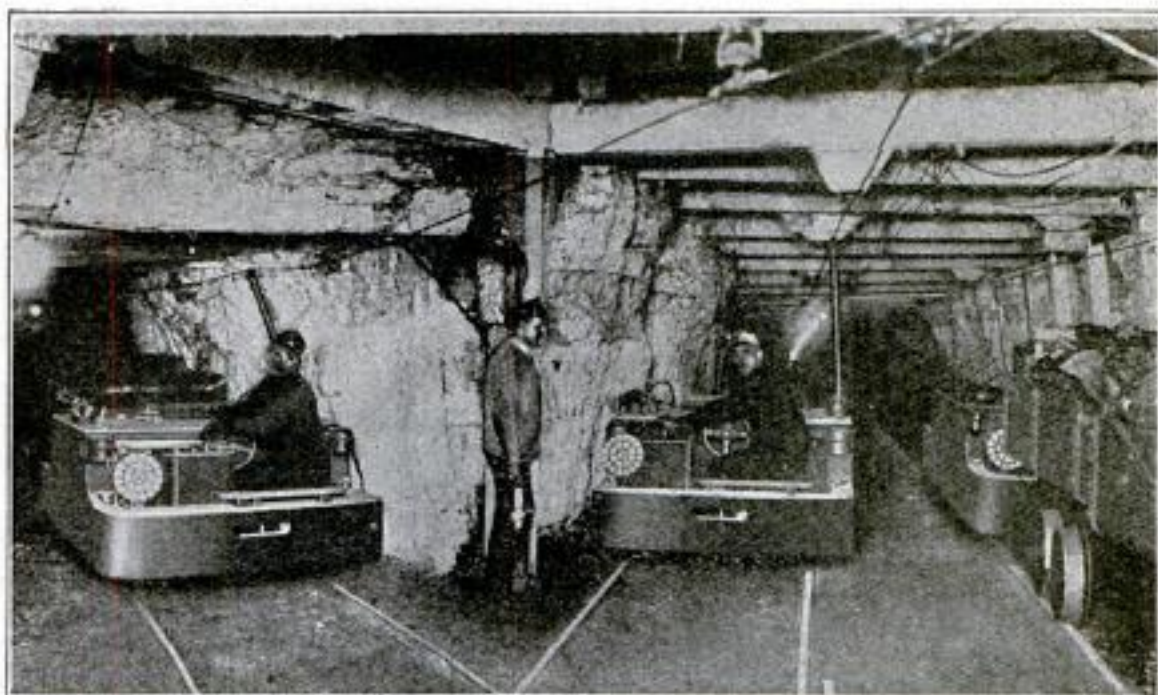

Electric Mine Locomotives

Courtesy Jeffrey Co.

sible be provided with separated air-currents. Especially must each "lift" of workings, which is the term for all mine workings connected with, opened from and mined out at one level, be supplied by the shortest way with the necessary quantity of fresh air. This is in part accomplished by building doors or hanging heavy canvas curtains across the levels at intersections to turn the currents of air toward the direction desired. Within the separate "lifts" of workings the air-current must always be ascending, except in cases in which the descending currents are not used for further ventilation purposes.

The four dangerous mine gases are light carburetted hydrogen gas, called fire-damp; carbonic acid gas, called choke or black-damp; carbonic oxide gas, called white-damp; and after-damp, the result of a mixture of air with the oxygen burned out by an explosion of fire-damp, and a little black-damp.

Fire-damp is the most dangerous. It issues from the pores of the coal and from seams in the surrounding strata. Sometimes it will burst forth from cavities in the rocks like steam under pressure, filling the excavations so quickly that the miners are suffocated

before they can get away from it. When pure, or nearly so, it is not explosive, but the moment it mixes with the air it renders the whole surrounding atmosphere so combustible that when it comes in contact with an open light an explosion is inevitable. This gas is only one-half the weight of air and seeks the higher levels. The principal object of modern ventilation is to remove this damp by air currents, or to so dilute it as to render it non-explosive. Experiments have proven that fire-damp and air just below the explosive point becomes explosive when suddenly compressed, as by the discharge of a heavy shot, a sudden and extensive fall, or a heavy explosion in adjacent workings. To this end in all European mining countries regulations have been made forbidding the use of such explosives as are known to be the most liable to ignite fire-damp, and limiting the amount used in any single charge.

The only safe and sure detector of fire-damp is the safety-lamp. The flame is surrounded with a sheet of iron-wire gauze having a mesh of 784 holes to the square inch. This is such a good absorbent of heat that the flame in contact with it could not readily pass



Emergency Hospital—300 Ft. Underground

through and ignite the damp. The blue flame which burns in a safety-lamp the moment the atmosphere becomes filled with fire-damp warns the miner of its presence and the danger which threatens him.

Black-damp is detected by watching the flame of the lamp. When the air is filled with black-damp the light burns dimly, and will sometimes be nearly extinguished. This gas is produced by decaying organic matter, by the breathing of animals and men, and from the combustion of all substances containing carbon. It is dangerous to breathe air containing 8 per cent, and lights are extinguished at 10 per cent. Being $1\frac{1}{2}$ times the weight of air, it finds the lower levels and requires powerful currents to remove it. The reason of its injurious effects is the close affinity between the oxygen and the carbon, the lungs being unable to separate them. This is why the miners speak of it as choke-damp.

Now comes its one redeeming feature. The presence of one-seventh of this gas in an atmosphere of fire-damp

will render it non-explosive. This in mining language is called "damping the gas," and arguments have been advanced that if it were not for the black-damp present in the extensive waste of collieries, where falls of rock have made ventilation almost impossible, the whole of the abandoned workings would become a dangerous magazine of explosive mixture. Thus it is seen that black-damp is the lesser of the two evils where ventilation is impossible.

White-damp, caused by the combustion of wood or coal, is not often accountable for serious accidents, but when it does exist in large quantities it is the most dangerous of all mine gases as the cause of the kind of accidents which kill a few miners here and there, but do not extend to the entire workings. Very little experience is necessary to detect fire-damp with the safety-lamp, and black-damp quickly makes its presence known by quenching the light. But a miner might enter an atmosphere vitiated by white-damp and fall insensible before his lamp gave any indication of danger.



Mine Ambulance Car for Injured Miners

It is detected, by those who have had experience with it, by its peculiar sweet odor. Three per cent of it in the atmosphere of a mine will cause death. Whenever the smell is detected it is time to retreat to fresh air. One volume of it to seven of air will become a mass of flame when ignited, but the explosive force is small.

After-damp is the resultant mixture left after an explosion of fire-damp, and contains about 7 parts of free nitrogen to 1 part of carbonic acid and 2 parts of steam. Practically, as before stated, after-damp is the air with the oxygen burned out by the explosion, mixed with a little black-damp.

The instruments used to determine whether or not the ventilation of a mine is sufficient are safety-lamps of different types, used for detecting the presence of gas; the anemometer, the barometer, the thermometer, the hydrometer and the water-gauge. The first of the "meters" is an instrument for measuring the velocity of the air current; the second detects changes in the pressure of the atmosphere, caused

by the movement of the ocean air which surrounds the earth; the third measures the variations of temperature, and the fourth is a combined instrument for determining the amount or proportion of moisture in the air of a mine, so as to ascertain its density and capacity for heat. The latter instrument, however, is only used for fine scientific experiments. The water-gauge measures the pressure or force expended on every unit of surface of the area of section, to create the velocity and overcome the resistance to currents of air.

Ventilation is produced by fans, furnaces, displacement machines, steam jets, the exhausts from underground steam engines, and sometimes, in case of accident, compressed air. Falls of water have also been used in shafts to start a current of air after accidents. All these appliances practically explain themselves. The fans force the air into the mines; the furnaces placed at the bottom of the mine, in the passage between the two shafts, heat the air, thus forcing it upward; and displace-

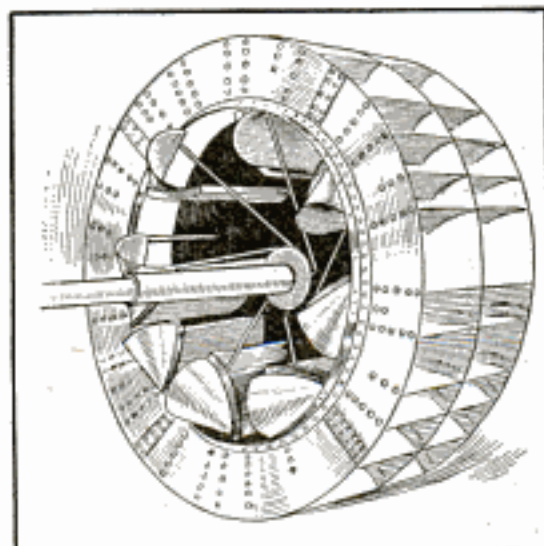

The Ventilating Fan

ment machines achieve the same results by drawing the air away so more must take its place. All motion creates air currents, therefore the action of steam jets and falls of water is explained. The difference in the volume of air needed must necessarily be judged by the time of year and climatic conditions, so it becomes necessary to watch closely every atmospheric change. The anthracite mine law calls for 200 cu. ft. of air per minute for each employe. Allowance must also be made for animals and lights. In a mine where 30 mules are at work and 300 lamps are burning an additional 65,000 cu. ft. per minute is necessary.

Poor ventilation is not always responsible for mine disasters. Side by side with this menace to human life walks the ignorant, obstinate miner, who refuses to adhere to the rules gov-

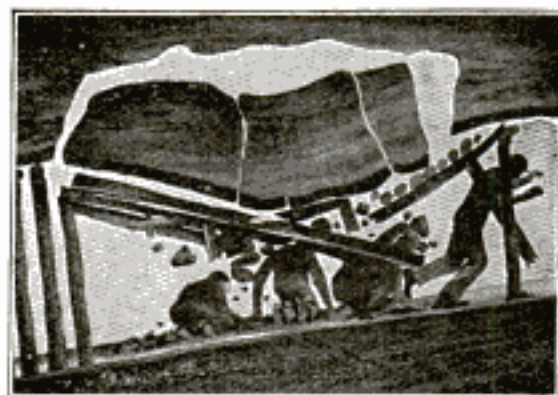

When the Roof Falls

erning his part of the work. By carelessness he holds the lives of his companion workers within the hollow of his hands. If he is working in a mine where fire-damp is prevalent, and his safety-lamp is extinguished by some accident, he has orders to return to the surface to relight it. But that takes time, and time to him means just so much more money. "What's the difference?" he says to himself. "It won't cause an explosion to light it here." The next moment the naked flame may have caused an explosion, and he with hundreds of others be fighting a losing fight for life. A day or so later the experts arrive to try and determine the cause of the disaster. This is only one example of the fatal results of carelessness. It may be a naked flame, or it may be an overcharge of powder, deliberately used by a miner who thinks to gain by the extra amount of coal dislodged. Sooner or later the result is disaster, and recognizing this, laws have been enacted in some coal-producing countries making such carelessness criminal, whether disaster results or not.

One of the longest wireless messages ever sent under similar conditions was received at the Eiffel tower station, Paris, from the warship "Kleber" at Casablanca, Morocco, 1,174 miles away.

Asbestos sheets are being instituted under the mattresses of sleeping cars on some of the railways of the United States to shut out the heat from the radiators underneath.

A novel method of pumping liquids from bore holes is by means of an endless rope, somewhat after the fashion of the chain pump, only in this case the liquid to be raised is absorbed by the rope and squeezed out between rollers at the surface, says Mining Science. As the rope is in balance the only power required is to overcome friction and raise the liquid,

GAS POWER TO RUN GREAT STEEL PLANT

The machinery of the greatest steel plant in the world, now under construction near Chicago, is to be driven by a gas power plant which will be the largest in the United States, and one of the largest in the world. To drive this machinery it is estimated that fully 100,000 hp. will be required. Sixteen blast furnaces and 1,200 coke ovens of the by-product type will constitute the gas plant, the company believing that by-product coke will be the best for the purpose. It is impossible to determine at the present time the amount of gas that will be thus obtained, but it will be many millions of feet daily.

The gas engines will be gigantic in size. Many of them will be of 3,000 hp., each of which will require a building 100 ft. wide. The estimated cost of the steel plant is \$75,000,000. Such a gas plant will also cost millions.

OPERATING TABLE FOR HORSES

On the roof of the largest hospital for horses in the world, which is located in New York, is a sun parlor. Within its pleasant confines the convalescent horses bask in the warm sunshine with

the selfsame enjoyment felt by human patients in the sun parlors of hospitals for ailing mankind.

In the room below is the operating table shown in this illustration. It is a great steel frame which revolves like a wheel on an axle. The horse to be operated upon is led to the frame and securely fastened by straps and padded bars. When all is ready, and the anesthetic administered, the frame is swung into the position most convenient for the operation.

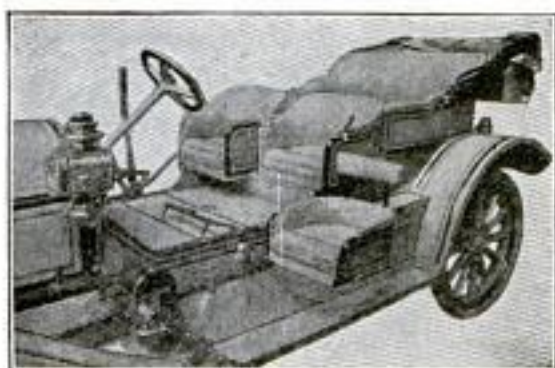

NEW AUTOMOBILE SEAT

A feature of one of the new 1908 automobile designs is an extra seat for a mechanic. This seat is fastened on the footboard of the automobile and can be folded up when not in use. The

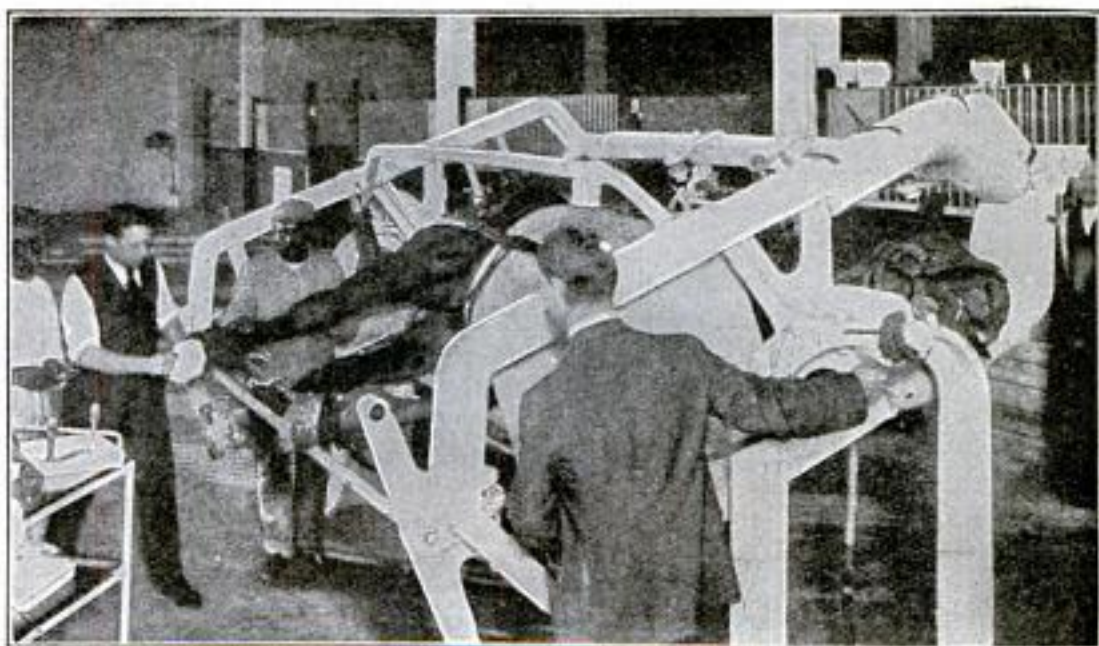

Operating Table in New York Veterinary Hospital

seat was added as a place for the chauffeur when the owner wishes to drive and the car is crowded.

ICE BOX WITHOUT ICE

The modern kitchen refrigerator has been reduced to a science. There is no longer any need to hang out cards or watch for the ice man; no spoiling of food because the ice melted away too fast; no cleaning of slime or stopping of the waste pipe, because there is no dirty ice to melt and no water to get rid of. There being no ice, all danger of typhoid germs coming into the house through that medium is removed. When one begins to count the inconveniences in connection with the use of ice in the household the number is surprising.

In our January number some of the labor-saving features of electrical household utilities were described, but none of them were self-acting; each required starting and more or less attention afterward. The illustration shows to what perfection and simplicity a small cold storage system has now been brought. The outfit consists of an electric motor belted to a pump, which keeps a cooling solution moving through a set of pipes which are placed in the refrigerator. These pipes are similar to the steam or hot water radiators in the living rooms, only they cool instead of heat the apartment. The machine is entirely automatic, and constantly maintains whatever degree of cold is selected. The moment the thermometer rises above that point the machine starts up of itself and works until the apartment is sufficiently cooled; then it stops of itself. The whole affair is so simple as to require practically no attention, except an occasional oiling which is no more difficult than to oil a sewing machine. At trifling expense one can also

fix up a basement room as a cold storage for large supplies such as barrels of apples, jars of butter, sacks of potatoes, etc., which are now impossible to keep in the average residence. In many families the saving effected by purchasing supplies in quantities instead of from day to day would be enough to pay the entire cost of operating the cold storage system; if not, the amount formerly spent for ice certainly would.

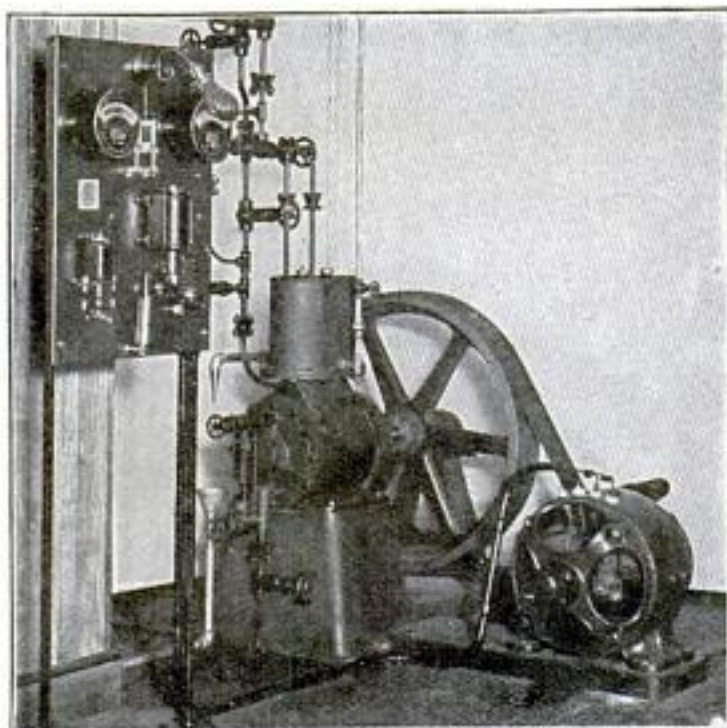

Residence Cold Storage Outfit

Such a plant takes little room, can be placed out of the way in the basement, does not cost a great deal to install and lasts for many years.

QUEER PRANKS OF WIRELESS TELEGRAPHY

The queer pranks of wireless telegraphy when conditions are not just right have been exemplified at a Swiss Marconi station, where a variety of messages not intended for that station were received from all parts of Europe.

A snowstorm put the St. Gothard station out of commission, and a temporary station was erected in a valley at the foot of the Dent des Morcles, the receiving apparatus being fixed on the

summits of two pinnacles of rock instead of the usual poles. When the operators attempted to communicate with the Righi station they were unsuccessful, but were swamped with messages from nearly every Marconi station in Europe, in English, French, Italian, German and Russian.

TERRIFIC LOCOMOTIVE EXPLOSION

By the recent explosion of an engine on the Northern Pacific railway near



Scene Immediately After the Explosion

Mace, Idaho, three men were killed. The body of one of them was thrown into the yard in front of his mother's house, which the train was slowly passing when the accident occurred. The force of the explosion was terrific, as can be seen by the illustration. Part



Blown 300 Ft. Up Mountain

of the boiler was blown 300 ft. up the side of the mountain.

VIOLINS AGED BY ELECTRICITY

A noted violinist and violin maker believes he has discovered a method for giving, by the aid of an electrical machine, the same quality of tone to a violin that age has been credited with providing. The theory of the violinist is that it is not the age of the violin which really gives it its superior tone, but the amount of "bowing" or vibration it has received. By the use of the electrical machine the violin is expected to get as much "bowing" in 30 days as the same instrument would receive in 50 years of ordinary use. The details of the machine, which works the bow across the strings with almost human touch, are as yet a secret.

The Argentine Republic is planning to hold an exposition in Buenos Ayres in 1910.

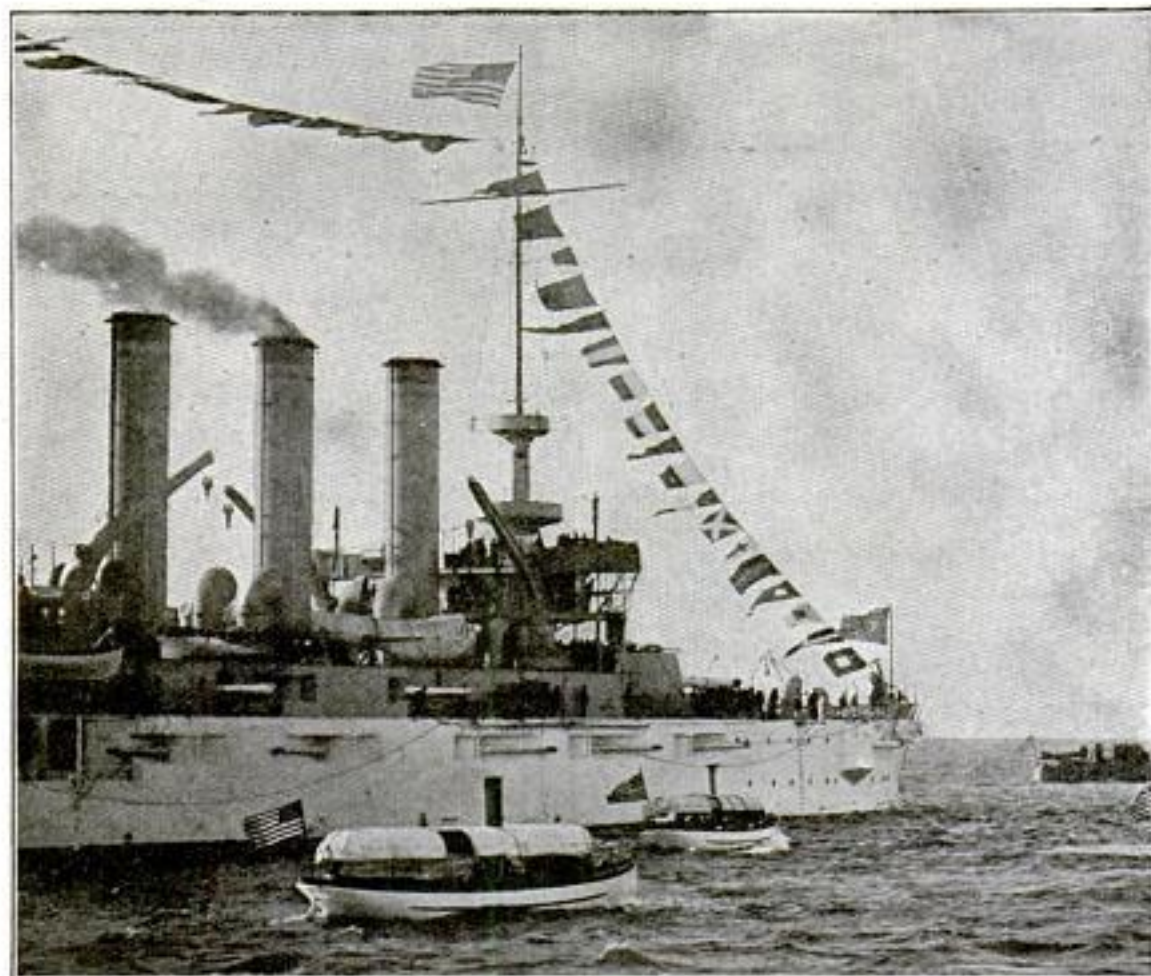

Copyrighted 1907 by

The above view and that on the opposite page are from one photograph taken at Hampton Roads just before the sailing of the American Armada. The mosquito fleet of

THE STEADY GROWTH OF THE U. S. NAVY

Although the average American would fight the moment his patriotism were questioned, very few realize how much or how little the Navy is growing or how many or how few fighting machines are being constructed. He reads in his morning paper that the keel of a great ship is about to be laid, or the hull of another launched. For the moment a glow of satisfaction is felt and then the incident is forgotten in the stress of business or other cares.

Only when such events as the sailing of the Battle Fleet for the Pacific are taking place does the American seem to be alive to what is occurring. Foreigners coming to this country, especially the English, are struck with this seeming indifference and cannot understand it. Later, however, they see be-

hind it the patriotism which remains dormant when "it is to talk," and comes forward when "it is to fight."

There are at present 29 ships building for the U. S. navy, against 22 a year ago. They comprise the battleships "Mississippi," "Idaho," "New Hampshire," "South Carolina," "Michigan," "Delaware" and "North Dakota"; armored cruisers "North Carolina" and "Montana"; scout cruisers "Chester," "Birmingham" and "Salem"; 5 torpedo boat destroyers, and 7 submarines. The battleships "North Dakota" and "Delaware" are of the "Dreadnaught" class, with a displacement of 20,000 tons. The other battleships have a displacement of 16,000 and 13,000 tons.

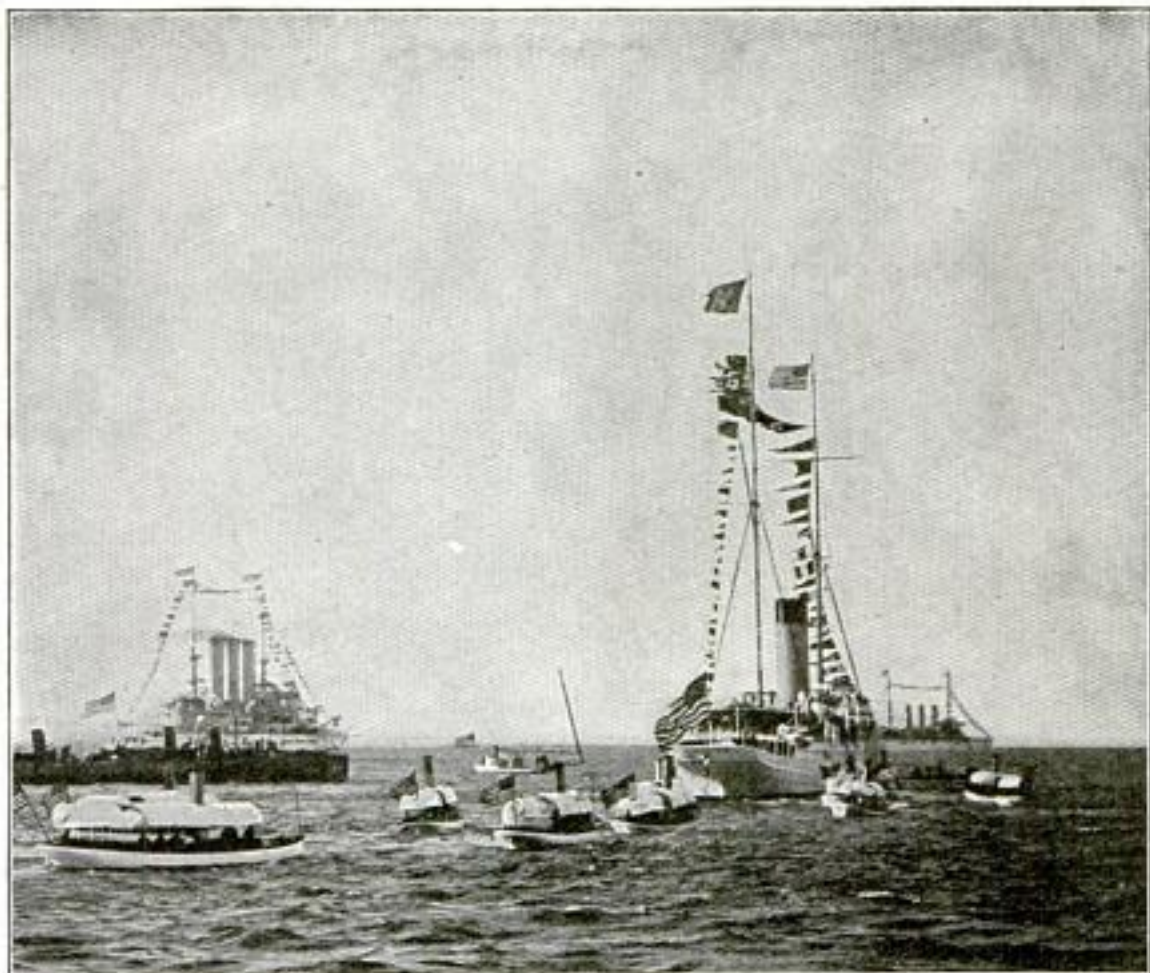

Edwin Levick, New York.

steam launches are bearing the Admirals and other naval officers to the President's yacht, the "Mayflower," seen at the right.

DECAY OF PAPER DUE TO BACTERIA

German scientists, after devoting deep study to the question of the decay of paper, have found that bacteria is the chief enemy to be met with in the preservation of valuable books and manuscripts.

The brownish spots which appear in old books are really due to the ravages of bacteria. The tiny destroyer is especially fond of starchy material, and its propagation is promoted by damp. It has been well understood that damp produced discoloration and decay, but the share of the microbe in the operation has not hitherto been suspected. Working shoulder to shoulder with the bacteria (presuming bacteriites have shoulders) is the tiny fungus or mold, which is responsible for gray and black

marks upon old papers. In spotting the surface the fungus helps to break down the fabric and hasten the process of its destruction.

PROPOSED WONDERS WITH RADIO-TELEGRAPHY

The report comes from Paris of a device which will enable an operator in a distant station to control with radio-telegraphy the explosion of mines, firing of rockets, steering of torpedoes and other military operations. The principal feature of the reported contrivance is what is called an automatic telegraph. Over it comes a radio-telegram from the object being operated upon, which notifies the operator whether or not he has succeeded in setting the mechanism running. The radio-telegram is received on a band of paper through a Morse receiver.



A rotary pump mounted on the rear of an automobile and belted to the flywheel. Used instead of hand pumps for pumping out the manholes of electric light conduits in New York City.

THE FIRST AMERICAN GRAIN MILLS

People the solitude this illustration shows with the Indian squaws of a hundred years ago and you have a typical Indian grain mill in full action. Close to nearly all the springs of the western states, whether they be located in fertile valleys or among mountain peaks, can be found these peculiarly hollowed stones. On them the Indian squaws ground the corn and other



Early Flour Mills

grains with which they fed their bucks when on the warpath or following less savage pursuits.

EAST RIVER TUNNEL STOPS CONGESTION

The Brooklyn bridge crush which has for years been the wonder of all who looked upon it from the outside and the despair of all who had to become part of it, is over, according to those who had tried nightly to regulate it. On the first day the subway tunnel under the East river was opened 140,000 passengers went through the tube. That means that 140,000 less people crossed the bridge.



CONCRETE DOME IN MOLD

This concrete dome, with the forms or molds still in place, is part of the roof of a beautiful chapel in Los Angeles, Cal. The dome is 32 ft. in diameter and about one-half that height. The ribs of the form were first set, and then workmen placed the short boards in place as the concrete was poured in. At certain points the outer and inner forms were fastened together with $\frac{1}{2}$ -in. bolts. The concrete is 5 in. thick.

An electric forge designed for sharpening drills is being tested in one of the South African mines. If it proves successful drills will no longer have to be carried to the surface for sharpening.

HUGE MINE PUMPS

The difficult problem of designing a mine pumping plant of the small dimension required, because of limited space, and yet capable of making an impression upon the immense inrush of water, has been solved in an English mine by the use of electricity and high velocity pumps. The two shafts in which the pumps are being used are only 8 ft. by 6 ft. in dimension.

This illustration shows one of the pumps, driven by direct-connected motors, capable of delivering 4,000 gal. of water per minute to a height of 395 ft. On reaching a depth of 278 ft. two of these pumping sets are joined in a series. Together they can deliver the full quantity of 4,000 gal. per minute as high as 780 ft. The pumps rest upon carriages of structural iron which run on rails having a gauge of 6 ft. 6 in.

The weight of the pump, complete with motor, suction and delivery pipe, suspension cable, electric cable and its own column of water is about 75 tons.

**WHAT DOES IT COST TO RUN
AN AUTOMOBILE?**

It would appear as if this simple query were susceptible of about as many shades of answer as the famous one regarding matrimonial ventures, says Automobile. It costs one autoist several hundred dollars for tires alone in the course of a year, while another finds that he spent but a fraction of that amount to cover almost the same distance under very similar circumstances.

One man's repair bills are excessive, while another gets an equal mileage

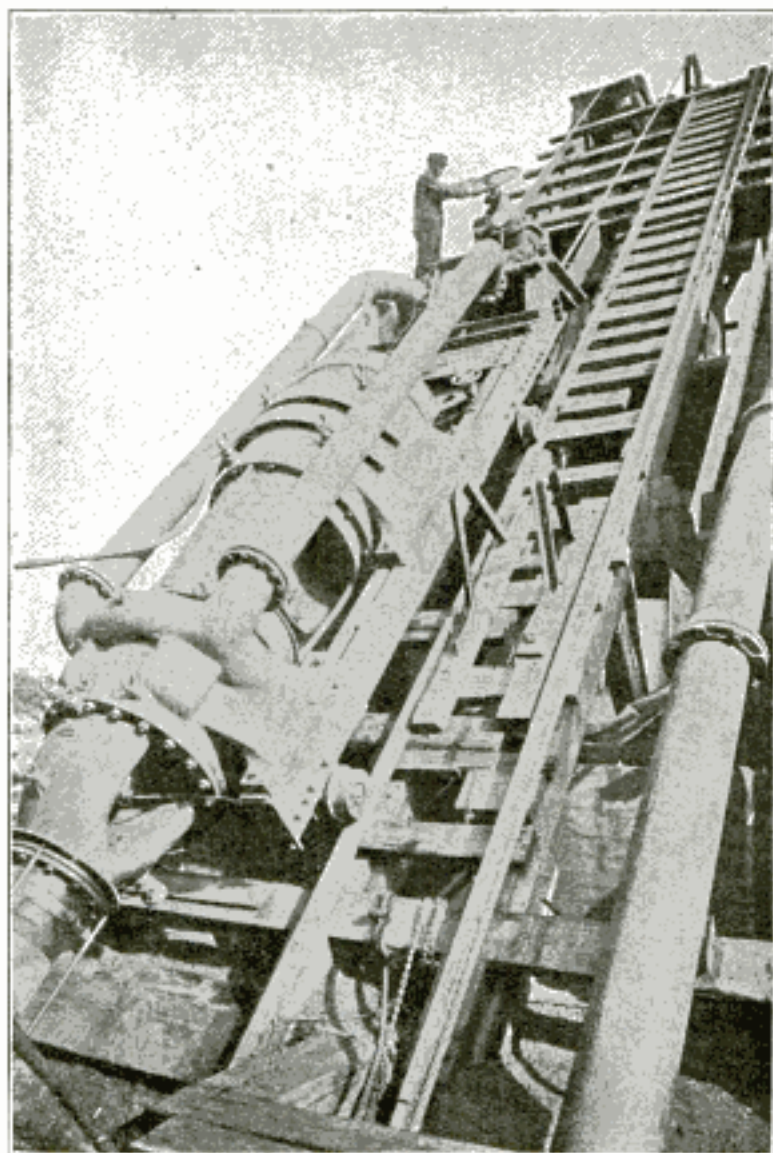

and more enjoyment out of his at a cost but slightly in excess of what he would have had to pay to keep a horse in oats and shoes during the same time, and the queer thing about it all is that frequently the various cars have been maintained under rather similar conditions. The carefully itemized account of the Californian who spent almost half the first cost of the car in maintaining it the first year finds its antithesis in that of the autoist who ran his car for two years for little more than \$100.

England has just laid the keel for its sixth "Dreadnaught."

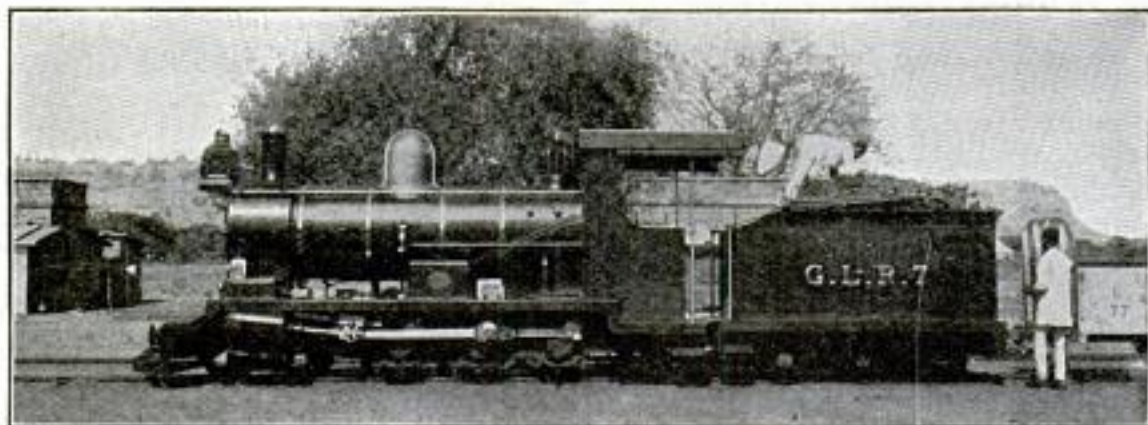

A locomotive on a railway belonging to the Maharajat of Gualior. It is used for passenger and goods traffic.

CHARTS FOR AIRSHIPS

From the action just taken by the French Aero Club it seems that airships as well as the ships that ride on the sea have to have charts and maps to point out obstacles and show a clear path ahead. A series of maps are now being drafted, and for this purpose a vast number of documents have been collected. The first charts will show the position of telegraph wires, overhead cables and all dangerous obstacles which might be struck by a balloon's guide rope at night. Many overhead cables convey currents of 20,000 volts or more, and contact with such might mean disaster to balloon and occupants when landing.

LOCOMOTIVES TURN THEMSELVES

The operation of changing the direction of a locomotive on a turntable is one which always attracts the attention of the passerby. To the hostlers or helpers around a roundhouse it is only a tedious routine which happens every time an engine comes in and goes out. Gasoline engines and electric motors have taken the place of manual labor in pushing the table with its tons of weight, in the larger places. These mechanical powers have reduced the cost of operating a turntable by hand from about \$15 per 24 hours to \$5 for turning 400 locomotives.

Now a bright genius has thought of

a method the expense of which is so small it can hardly be estimated. It consists of a compressed air motor placed beneath the turntable and operated from air furnished by the air-brake pump on the locomotive being turned. Connection is made between the engine and the motor with a piping and hose. An air pressure of 50 lb. will turn the locomotive, and as the turning is all done in two minutes, the amount of steam used to work the pump is too small to reckon.

The London Times says that the work of pioneers in color photography has reached a promising stage and that a plate is now on sale upon which a fairly satisfactory heliochrome transparency may be made with one exposure, and with little more trouble than an ordinary negative.

LARGEST METAL PLANER EVER MADE

The largest machine for planing metal, and one of the largest machines in the world, has been built for a Pittsburg iron works. This gigantic tool planes great slabs or beams of steel with less fuss than an average carpenter makes in planing a 6-in. board. The total weight is 845,000 lb.; the table is 60 ft. long with a stroke of 30 ft.; height, 35 ft.; between uprights, 14 ft.; driven by five electric motors aggregating 207 hp.—sufficient power to run a large factory.

LARGEST METAL PLANER IN EXISTENCE

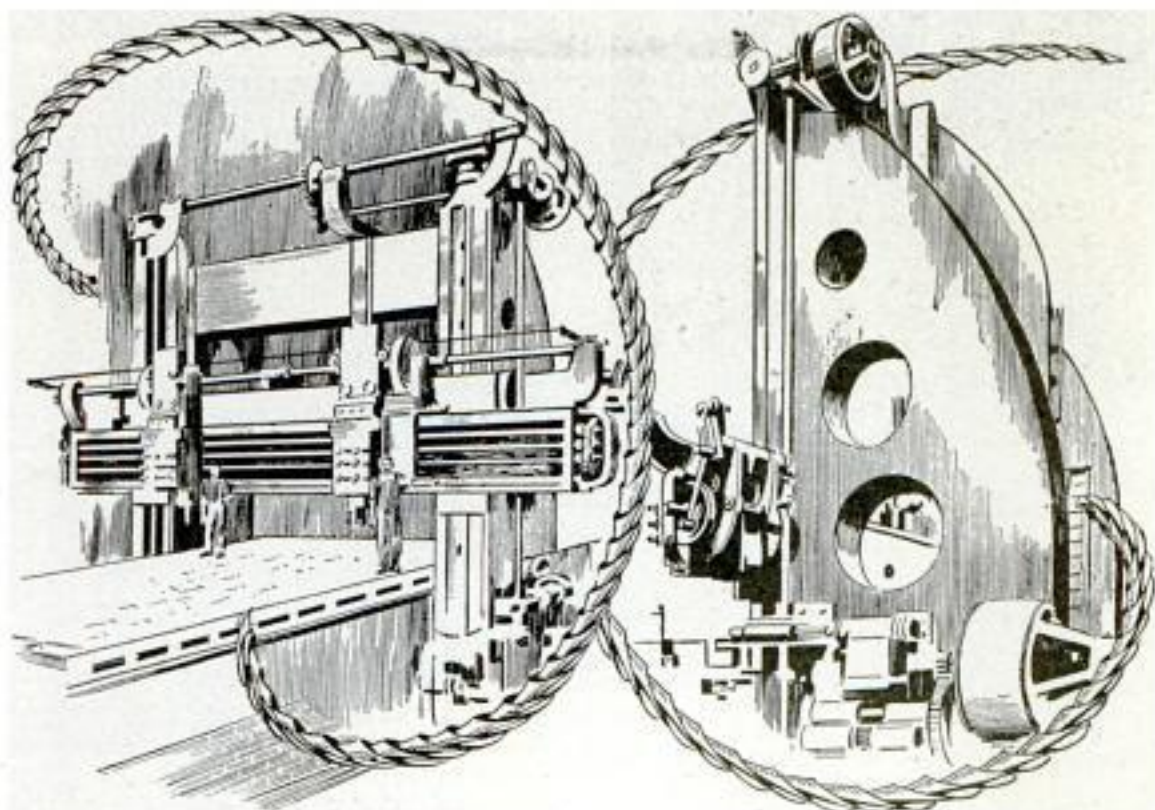

The Mammoth Bed Plate

End View; 35 Ft. High

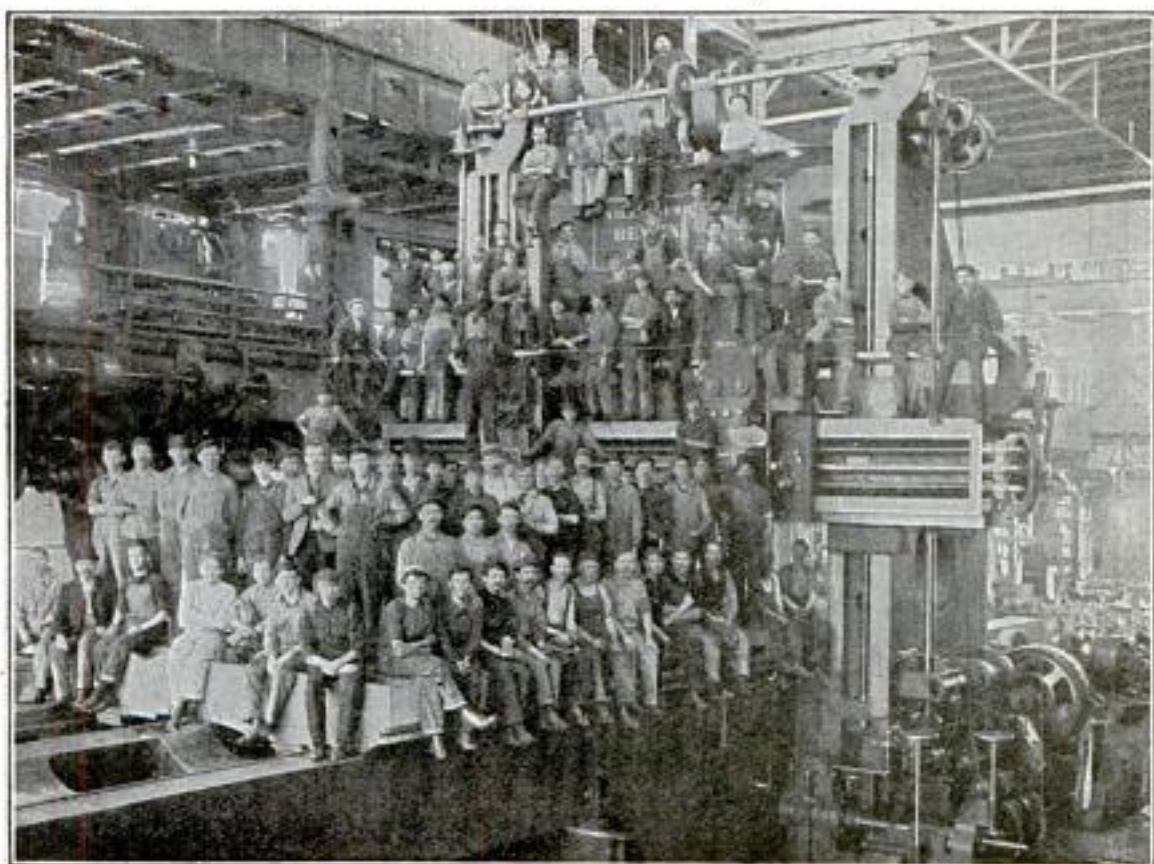

Eighty-five Men Grouped on the Big Machine

Courtesy Niles-Bement Co.

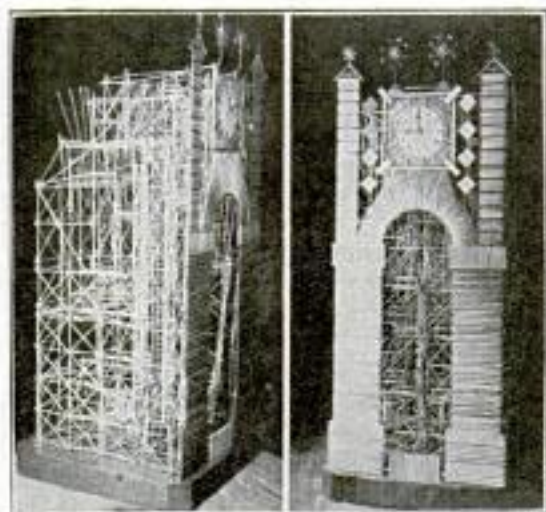

CLOCK MADE OF STRAW

This clock, made entirely of straw, is 25 in. square and stands 66 in. high. The figures, dial, pointers, pendulum, even the clockwork itself, are constructed of this material. The clock is wound up and the pointers on the dial set by pressing a button. There are no springs used. The complete clock, composed of many thousands of straws, weighs only 7 oz. It was made by a German shoemaker who worked on it 15 years during his leisure hours.

**WRECK IN WHICH MANY WERE
KILLED**

In this tangled mass of passenger coach and engine occurred the majority of the fatalities which attended the appalling wreck on the Great Western railway at Shrewsbury, England. The English corridor coach shown in the center of the illustration lies on top of the locomotive. To the right is the debris of the engine tender, the running board of which is completely buckled up. Just beyond the coach is the remains of the mail car, in which six postoffice officials

met death. The disaster was one of the worst in England's railway history.

ONYX IN THE ROUGH

These two illustrations show onyx as it is taken from one of the Mexican quarries and the same material turned out in the rough on a common iron turning lathe, as half-round spheres to

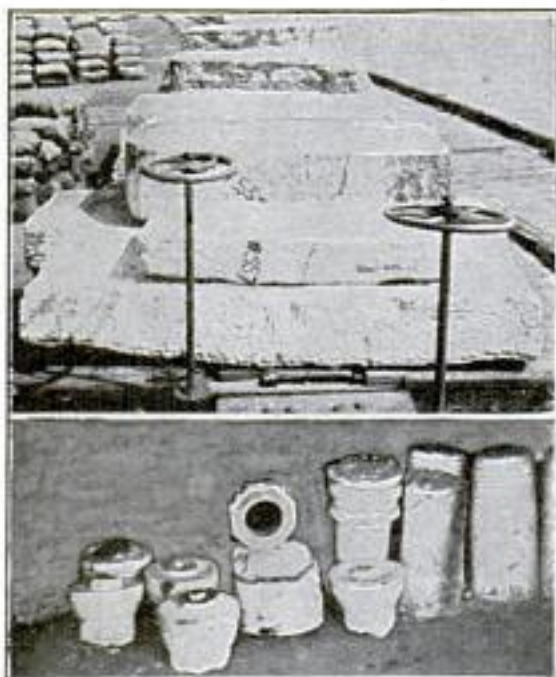

Mexican Onyx

cover electric light bulbs. This product when not more than $\frac{1}{2}$ in. thick is somewhat transparent. It is only recently that onyx has been mined in such large pieces.



Smash-up on English Railway



Coplay, Pa., Plant Where First Cement in U. S. Was Made

WHENCE CAME AMERICA'S FIRST CEMENT

By Wm. J. Richardson

When the history of the cement industry is written much space must be devoted to the Lehigh region of north-eastern Pennsylvania, where, way back in 1850, a "Pennsylvania German," who had heard that the mighty pyramids of Egypt were made of rock ground up and baked into huge blocks, began experimenting with the rocks which cropped out of the ground near his home, and finally founded a business which now, from a narrow strip of land along either side of the Lehigh river, furnishes over 60 per cent of the world's supply of the material which in these days is becoming so extensively used in every form of building operation.

Here, within a belt less than a mile wide and about eleven miles long, nearly 20,000 men are employed every day in the year, turning the cement rock into the ordinary forms of cement and combining it with limestone to form Portland cement, which takes its name, not from the Maine city as generally is believed, but from the little town of Portland, Pa.

As in the steel industry, so with the cement business, the chemist plays the most important part. Portland cement is simply a combination of argillaceous limestone with the natural cement rock, but there are some secrets in the combining process to be guarded, and the cement magnates surround their mills

with an almost impenetrable veil of mystery. No stranger is allowed to enter, and even a near approach is met with a forcible protest, to be followed with a strenuous ejection should the wanderer venture too near.

In the early days of the industry the processes were crude in the extreme. The rock first was baked in huge "dome" ovens, much like pottery kilns in appearance and construction, and then ground in mills run by horse or water-power. Nowadays, once the rock is hoisted from the quarries, everything is done automatically. Machinery conveys it to up-to-date roasters, from the roasters it is carried to the crushers, and from them it goes to the stock houses and into barrels without being touched by a workman.

There is much of the romantic in

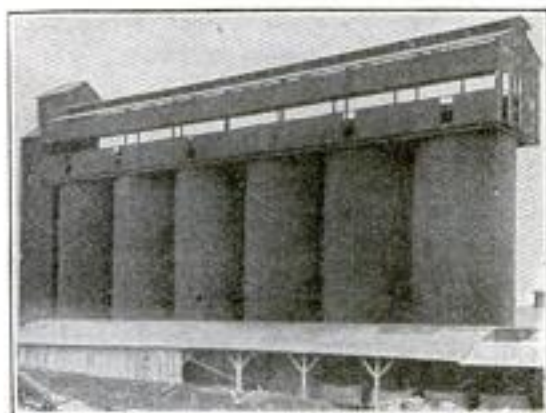

Vertical Cement Kiln

the development of the "Cement Belt" from a farm land, none too rich at that, to a teeming valley filled with laborers, skilled and unskilled. Farmers who for years barely succeeded in making enough from their farms to meet the mortgage interest suddenly found themselves rich beyond the most extraordinary flights of their imagination. Barren, rocky soil, upon which the wild carrot, the goldenrod and the Canada thistle were the most prolific crops, and where the tiller of the soil more frequently than not dammed the rocks which were to prove his fortune, suddenly became worth hundreds of dollars an acre.



A Poor Farmer Received \$100,000 for This Quarry

One of the accompanying illustrations shows a limestone and cement rock quarry—the two kinds of rock often lie but a few feet apart—located on a farm of 157 acres, for which the owner received \$100,000 in cash. For the honest, simple-minded old man put no faith in promises or checks and demanded spot cash, and he had to feel the gold in his hands before he would sign the deed. And when it came to signing the deed his good wife would not attach her name until she was assured a new dress, and the dress she was given before the deal was consummated.

But the era for high prices for cement land is past. No longer will a few acres of the rock elevate a man from shanks' mare to an automobile. The average price paid for a property

containing the deposit so much in demand is now about \$300 an acre, although there are many tracts which the big cement companies have not secured because the owners are holding out for more money. Probably the present owners and their sons and grandsons will own the land before it is sold, for it is said that the manufacturers now own enough land to supply the expected demand for a half-century to come.

The cement belt has been so thoroughly defined that a map shows its sinuous windings as clearly as the courses of a river. Beyond its confines no cement exists that has a commercial value. The deposits of cement rock seem almost inexhaustible, but there is an appreciable lack of the right kind of limestone, and a man who owns land upon which there is a goodly quantity of argillaceous rock need have no fear of the wolf ever howling about his door. Today much limestone is being brought to the Lehigh region from distant points, and it is said that a fortune awaits the man who can devise some method by which ordinary limestone can be made to produce equal results when fused with cement rock as the sort that now is used.

What titanic convulsion of nature threw up the two ridges of rock, sometimes close together, sometimes with one superimposed upon the other, no one knows, but it aptly illustrates what fortunes dwell upon the hazard of a die and what Fate had in store for the one man who dared to put it to the touch to win or lose it all.

SHIP BUILT TO CARRY SUBMARINES

A report from Paris states that Japan is having constructed by the Maxims in France a new type of ship the express purpose of which will be to transport submarine boats to the scene of battle. The submarines will be stowed away in a tunnel traversing the hold of the vessel, and by means of locks they can emerge from this safe

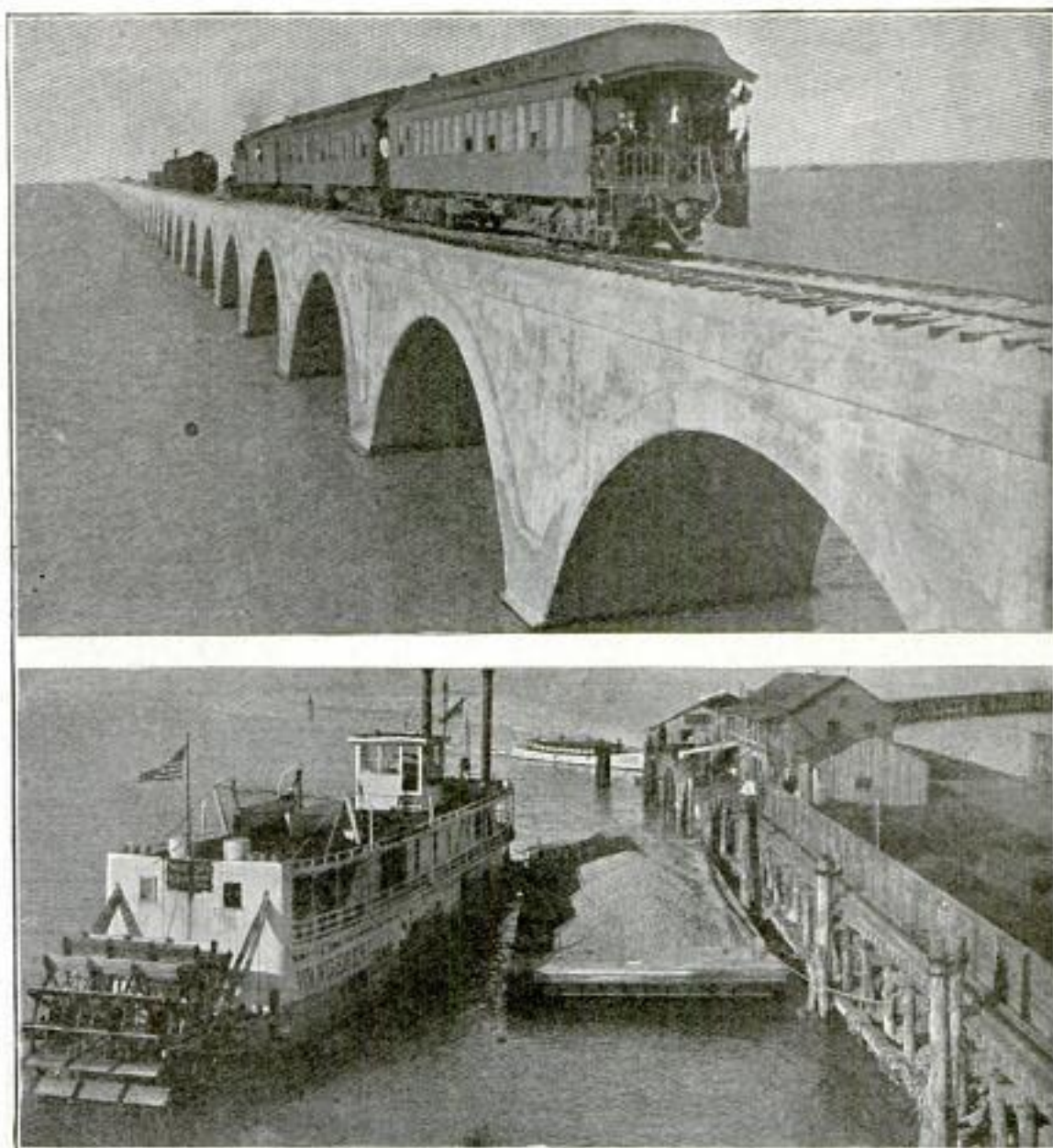

First Train Over Completed Section of Ocean Railway

haven unperceived by the enemy. By this arrangement a long sea voyage, which is one of the greatest difficulties to be faced in submarine warfare, will have no terrors.

FIRST SECTION OF OCEAN RAILWAY COMPLETED

The first section of the ocean railway to Key West has now been opened and trains are daily running over it to Knight's Key, the temporary terminal. From the 2,000-ft. trestle extending out from this key to the new steamship

dock, passengers can board a ship and after a trip of only 115 miles, accomplished in a little over 7 hours, be landed in the Cuban capital. Already the time between New York and Havana has been reduced half a day, and when the road is eventually completed the time will be still shorter. In the meantime work is being pressed on the remaining 47 miles which intervene between Knight's Key and Key West.

There are nearly 5,000,000 subscribers' telephones in operation in the United States, or one for every 18 persons in the country.

• RAPID-FIRE GUN OF NEW DESIGN

Major W. H. Fitzgerald, of the English army, said to be the inventor of the first machine gun, is also the inventor of the latest. The new production of his inventive genius will, if as successful as many European gun experts believe, displace all other machine guns for many kinds of warfare.

The gun contains 8 barrels, arranged in two tiers of four, and will discharge 460 shots a minute. Its greatest feature is the patent cooling chamber, which allows it to be fired for an unlimited time without becoming overheated. The "Maxim," the gun it most closely resembles, can only fire for a period of 10 or 15 minutes before an interval is allowed for it to cool.

The second great feature is its construction, which makes it possible to fire it down the precipitous side of a mountain, straight into the air, and to any point of the compass. The inventor claims it is as cheap to make as the "Maxim" and that the mixture required for the cooling chamber costs only 12 cents a month per gun.

••••• EXPLODING A MINE IN GRANITE

One of the methods of quarrying granite is to dislodge a huge sheet from the surface of the formation through the medium of a powder mine. A large perpendicular shaft is first blasted to a depth of about 30 ft. At the bottom of this, and radiating in all directions, horizontally, like the spokes of a huge wheel, long holes are drilled. The extremities of these holes are then shot with light charges of dynamite in order to create chambers large enough to re-

ceive large quantities of black powder. This takes weeks of ever increasing charges. Then the final charge is loaded. The now huge chambers at the extremities of the spokes are packed with hundreds of pounds of powder,

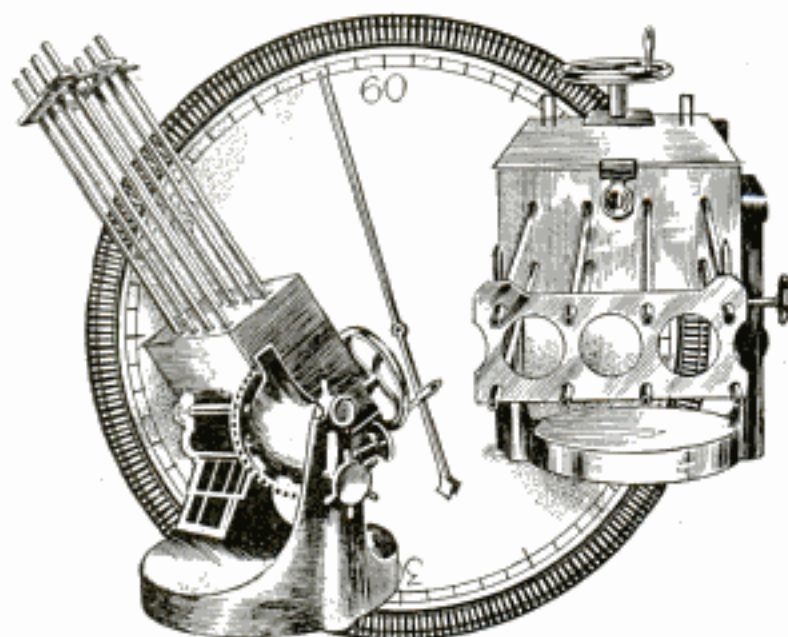

numerous electric wires attached, and the whole mine tamped with fine material. A mighty roar and rumble in the bowels of the earth and the huge sheet is detached from the ledge.

••••• RAIL BRAKES FOR STOPPING CARS

Instead of having a force of brakemen in many of the German railroad yards, the track brake, or shoe, shown in the illustration, accomplishes the task at the desired time and place.



The yards in which they are used have a hump at one end from which the cars run down into the yard by gravity. An operator with a number of these shoes, or "gleisbremse," as they are called, in his hands, judges the speed with which the cars are running and places a shoe on the track at just

the right point to stop them where wanted. When the car strikes the shoe the wheel comes nearly to a rest. The shoe then slides along the track until it strikes a cut-off in the rail and shoots into the pan, while the wheels are kept in position by the guard rails on the other side.

SUN'S RAYS DAMAGE SHIPS

In docking vessels on the Great Lakes during the winter months the bows are pointed in one direction one winter and in the opposite direction the next. This is done because while lying at the docks one side is much more exposed to the weather than the other; not the bad weather of snow and rain, but the finer weather of bright sunshine. Sunlight reflected from the water has a strong tendency to rot timber, and vessels always wintered in one position will require new decking and bulwarks on the water side in nearly half the time required to rot the timbers on the dock side.

LOCOMOTIVE RUNS TOY FACTORY

During the installation of new boilers at a large toy manufacturing plant in Massachusetts recently it would have been necessary to shut down the machinery for a few days and allow a rush of "hurry up" orders to go unfilled had it not been for the Yankee wit of one of the superintendents. He



A Yankee Trick

solved the problem by chartering a locomotive from a railroad and blocking it on a side track in the factory yard. The pipe leading from the boiler of the locomotive to the cylinders was disconnected and attached to another pipe leading into the factory engine room and thus furnished the required power to run the factory engine.

GIANT SAFETY PINS

It is quite a stretch of imagination between the safety pins in common everyday use to those large safety pins



used in a meat packing plant for hanging up strips of bacon and hams in a smokehouse. The pins are 12 in. long by 6 in. wide, and are made of $\frac{1}{4}$ -in. steel wire.

BRAZILIAN BOAT BUILT OF BRONZE

Owing to the great amount of decomposed vegetable matter contained in Brazilian waters, which causes rapid deterioration of thin steel, the hull of the new dispatch boat "Guanabara," built for the Brazilian government, is constructed entirely of bronze. Against this metal the corrosive action of the Brazilian waters has no effect, and although more costly, both in material and construction, the vessel is much lighter than if built of steel or wood. The propeller shafting and propeller are also of bronze.

The British government is building a number of immense oil tanks at various ports around the British Isles for the use of her warships now using oil for fuel. The tanks will be surrounded by mounds to protect them against gun fire from the sea.

A REVOLVING CYLINDER MOTOR

In building the various types of motors containing more than one cylinder for automobile use, light weight with as much power as possible are the two principal things to be considered. There seems to be little change from the main order of construction in these motors. A new motor is now made in which the cylinders form the fly-wheel and revolve around the shaft. This dispenses with the heavy weight of the flywheel and the material used in making the long crank shaft, crank box and bearings. It has a gyroscopic effect and spins something like a top, causing lubrication by centrifugal force as well as closing the valves without springs and forcing the heaviest part of the mixture to the ends of the cylinders. No fan or other method is used for cooling, as the rapidity with which the cylinders revolve throws off the hot air.

DRIVE WHEELS EXTENDED UNDER TENDER

The two heavy trucks under the engine tender form part of the driving

force of this large locomotive in use on the Southern Railroad. The idea of gearing the trucks of the tender in the same manner as the locomotive itself is to add the power more driving surface and weight gives. The wheels are turned by a shaft and beveled gear

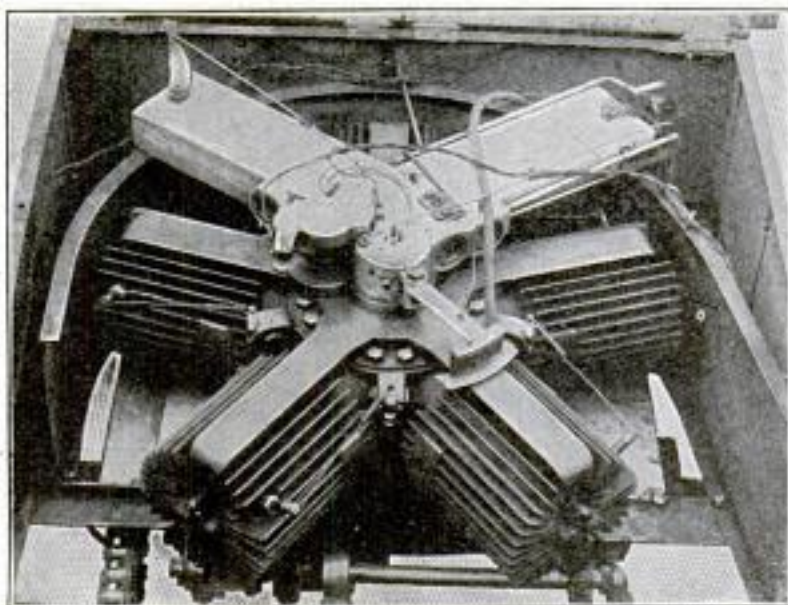

The Cylinders Form the Fly-Wheel

driven by three cylinders. The driving wheel base is 58 ft. and the weight on drivers in working order is 297,500 lb. The gearing of the locomotive more than doubles its hauling capacity.

One of the remarkable features about the locomotive is its high tractive power as compared with its weight and the sharpness of the curves around which it will run. The maximum tractive power is 53,000 lb., and the sharpest curve that may be taken is of 150 ft. radius.

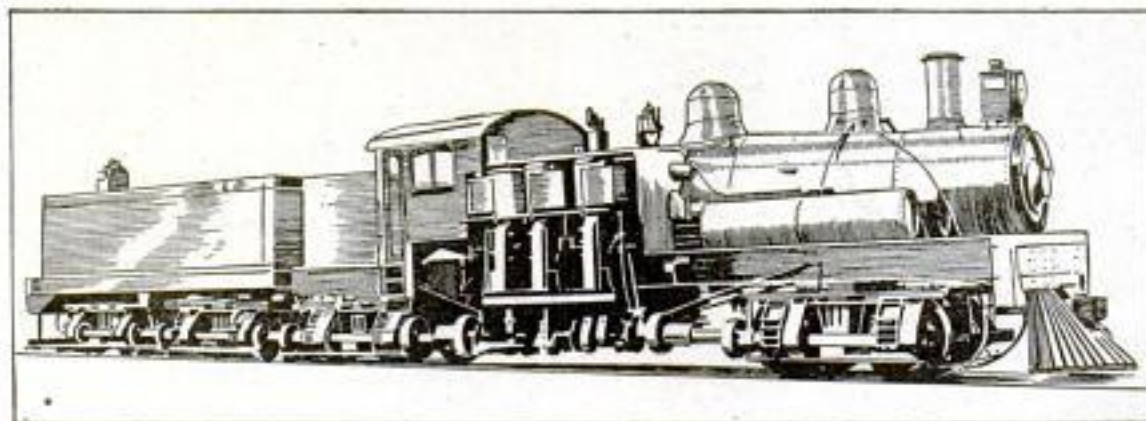

Every Wheel is Made a Driving Wheel

STOVE MADE OF REVOLVERS

It is understood that the police court at Portland, Ore., is to have one of the most unique stoves in existence, made of revolvers taken from prisoners during the past few years. The idea of having them made into a stove came from Municipal Judge Cameron, who believed it would be a questionable procedure to sell them at auction, and could think of no other way to dispose of them. Consequently the firearms were turned over to a foundryman, who promised to make them into a stove.

MODERN CLIFF DWELLERS

The steady expansion of the high building idea seems destined to produce a race of modern cliff dwellers, who will be able to spend their entire lives, if so disposed, without the absolute necessity of going once outside their lofty dwelling. The trend of city life as measured by the past few years makes the prediction of Theodore Starrett, who recently completed a 40-story building in New York, seem well within a possibility. He says:

"Attacks on tall buildings as monstrosities may be all right from an esthetic point of view, but one learns to doubt the motives of these attacks.

"The top stories of these tall buildings are great places in which to live and of all places to sleep in—so quiet, so well ventilated. Some chap will come along with hotels and apartments in one end of his buildings and with a market place and a theater at the middle, and with an office building at the other end and a railway terminus under it all. If there is a roof garden on the top, there you have it all.

"Back to the simple life for the inhabitants of this building. No weary journey home at night. No half hour or so wasted every morning trying to read a newspaper in a suburban train.

"The tenant in one of these 'ultimate' buildings can go from his office to his apartments or to the roof garden in two minutes; or, if he lives in the

suburbs, he can take his train, just as he now takes the elevator, in his building. It will prove a conservatism of energy, impossible even to the most luxurious plutocrat.

"It looks to me as though we are just starting to get our ideas in shape; we have really done no more than make the first beginnings in building improvements."

ELEVATOR MOVED ACROSS A RIVER

It was found necessary to move this elevator to a new site because a rail-



A Roving Elevator

way company had taken up the tracks leading to it. A river lay across the path to be taken, but this seemingly un-

surmountable obstacle was overcome by building a crib trestle up from the bottom of the river between two wagon bridges. The top of the trestle rose several feet above the surface of the water.

MILLION-DOLLAR CONCRETE POWER PLANT

Many features are found in this California million-dollar power plant,

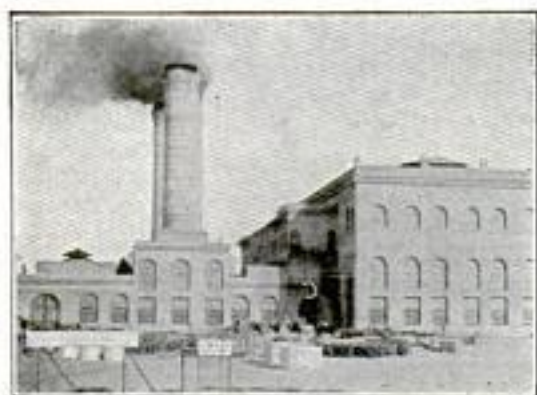

Built on Sand

among the most interesting of which is the fact that it is built of concrete, its two reinforced stacks rising 160 ft. into the air. The entire plant, including three upright compound engines of 7,000 hp. each, rest on foundations built on dense sand. Although some difficulties with sea weed and kelp have been met with, the condensers are cooled with sea water. The plant is situated at Redondo, about 20 miles from Los Angeles.

SHEET METAL TUBES DRIVEN INTO GROUND FOR WELLS

The sheet metal tubing or pipe shown in this illustration is being successfully

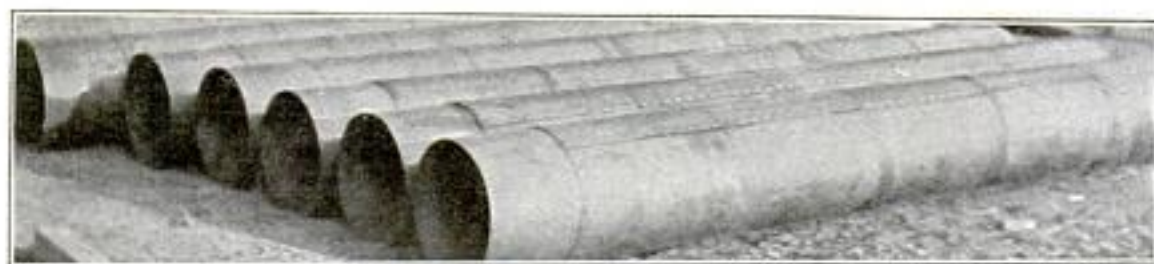

Sheet Steel Tubing for Driving Wells

used in the west for driving deep wells in place of the more expensive screwed pipe usually used for the purpose. The process is simple. Two pieces of No. 16 steel tubing, one piece slightly smaller than the other, are alternately slipped together, effectually doing away with all joints. On the end of the first section, which must be four or five times as long as the others, is placed a steel shoe. As the pipe is driven into the ground the short inside and outside sections of tubing are added until the pipe has been driven the required distance. In this way the tubing can be driven several hundred feet into the earth.

"MOTORITE" TO DOUBLE SPEED POSSIBILITIES

A new motive power known as "motorite" has been invented by Hudson Maxim, who believes it will revolutionize torpedoes and torpedo boats, and possibly in the future replace steam as a motive power for ships of all kinds. As the inventor of the machine gun which bears his name, Maxim has a world-wide reputation, and whenever he is prepared to launch something new he is watched with expectation.

The new power is said to be a combination of certain powerful explosives. Maxim is reported as saying that by the means of it the ordinary-sized torpedoes can be sent through the water at a speed of 60 miles an hour, while the best of the gasoline-propelled torpedoes cannot be driven faster than 35 miles. In connection with "motorite" Maxim is at work on a torpedo boat which he believes can be propelled by it at a speed of from 50 to 60 miles an hour. Not only does he believe that

the new power will revolutionize in this line, but, according to reports from England, he thinks it possible that the future will see "motorite" used to drive merchant ships at twice their present speed.

GAS ENGINE EXHAUST UTILIZED FOR HEATING

In this illustration the heat in the exhaust gases from a two-cylinder 50-hp. gasoline engine is being utilized by means of two heaters or pipes into

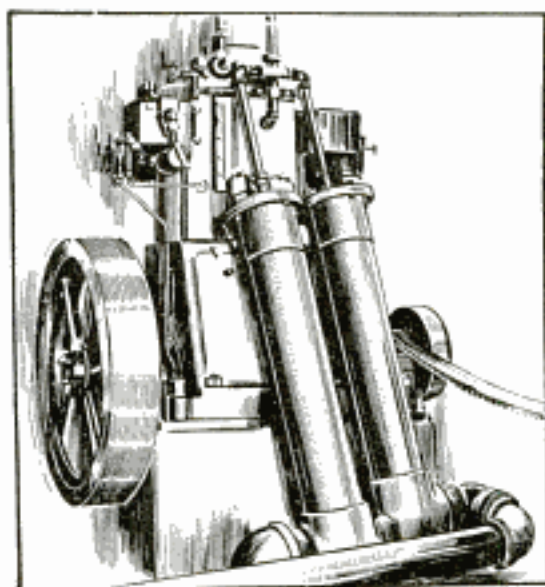

Exhaust Heating

which the exhaust pipes discharge. The heat thus received was sufficient to displace a large hot water heater.

WHAT MAKES "RAIN" IN MOVING PICTURES

Moving-picture films are practically spoiled long before their life of usefulness should end because of the "rain" which blots out the clearness. This injury comes from the continuous winding and rewinding of the film through the machine at the rate of a foot a second, forming static electricity. The electricity attracts all the particles of dust and dirt floating in the atmosphere to the films, and in pulling the film up tight these particles scratch, hence the "rain."

SQUARE SECTION CONCRETE PILES

For the first time in that part of the country, concrete piling is being employed by the Detroit park commission in the reconstruction of a large steamboat dock at Belle Isle. The piles are pointed at one end, to permit their being driven, and have a flange on one side which fits into a groove in the next pile where it is desired to drive two of them close together. Something over 100 of these piles will be used in the work. Their cost has not been definitely determined, but the park commission estimates that it will not exceed that for creosoted piles of the regular type. Concrete piles have been employed by

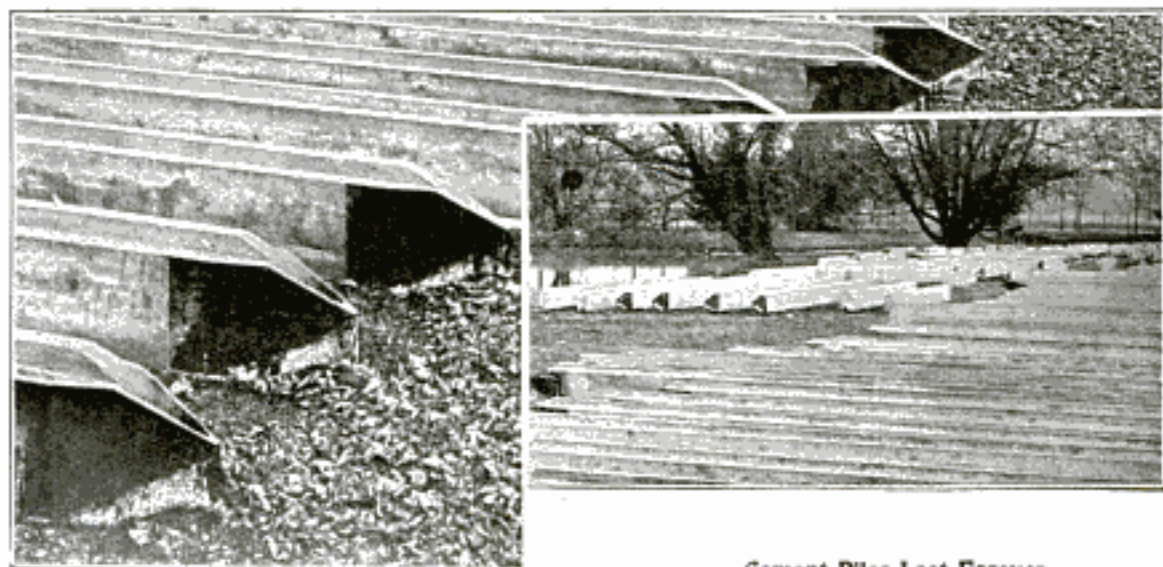

Cement Piles Last Forever

the government for dock purposes with very satisfactory results. The driving point is cast sharp and the upper end flat. The piles are 20 ft. in length.

DRILLING CLOSELY SPACED HOLES

The drilling of closely spaced holes is always a problem for the designer. The smallest distance holes can be

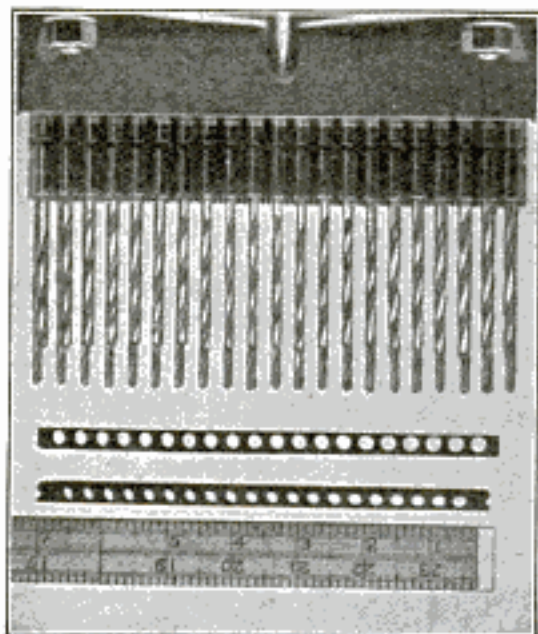

Arrangement of Drills

spaced by the usual method is determined by the diameter of the drill spindle and of the gear or pulley driving them. The engraving shows the finished work where two rows of $\frac{1}{4}$ -in. holes were drilled by using a drill head where only the size of the drill spindle and the chuck, together with the spindle bearing, had to be taken in consideration, says American Machinist. The drilling head is a complete unit in itself, and it can be removed at will and another entirely different drilling head substituted for other work. The drill spindles are of tool steel, hardened and ground. Each spindle has a crank on the upper end, the crank-pin or driving portion going into a revolving driver which has a main driving pin. This pin enters a hole which is drilled eccentric to the outside in the main

driving spindle. The small cranks nest closer together than is possible with gears, or pulleys with belts.

SHIPBUILDING ACTIVITY ON THE GREAT LAKES

During the year 1907 the ship yards on the Great Lakes, exclusive of the Canadian yards, launched 56 vessels, of which 40 were bulk freighters. The combined carrying capacity of the 40 bulk freighters is 368,000 gross tons for a single trip, or 7,360,000 tons in an average season of 20 trips. The Canadian yards during the year launched two bulk freighters and two car ferries. The vessels now under construction in the Great Lakes ship yards for 1908 number 42, of which 26 are bulk freighters.

SAND SUCKER TURNS TURTLE

The steam sand sucker "Root" suddenly turned turtle recently in the harbor at Kenosha, Wis., drowning three of its crew who were asleep in its cabin. The accident was caused by its load of wet sand shifting over to one side. The vessel was righted by driving piles on

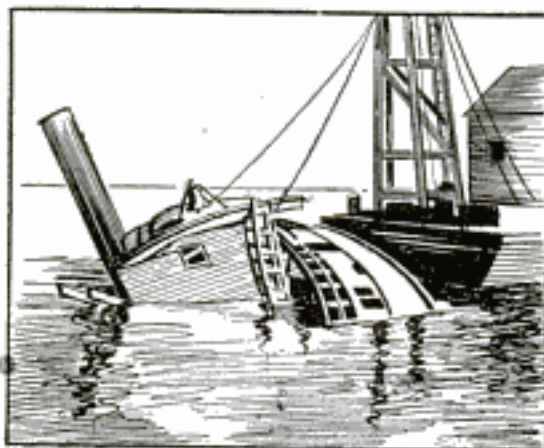

Raising the Boat

each side and connecting them with beams. Heavy chains were so placed that when the work of pumping out the water and sand was commenced the boat gradually turned over again, properly righting itself.

A YEAR OF SCIENTIFIC-MECHANICAL TRIUMPHS

The year 1907, now numbered among the countless years gone by, held its own with any of them as far as the world's advancement in science is concerned. In every part of the civilized world scientists and inventors, some known to fame and others still undiscovered, enlisted their brains and hands to clutch the forces of nature and harness them to the work of man.

Among the most prominent advances in applied science was the practical completion of trans-Atlantic wireless communication. There are still many details to be solved, but the two continents of Europe and America are now within the wireless zone.

Following closely upon wireless telegraphy comes wireless telephony and the transmission of photographs from one place to another over telegraph wires. The former is receiving practical demonstration every day through Admiral Evans, who sits in his quarters on the flagship "Connecticut" and talks with his officers on the other ships of the Battle Fleet. The latter is not so far advanced, but it has been proven practical by actual results, and the close of 1908 will probably see it in general operation.

Flights in Germany, France and England have proved the dirigible airship practical for warfare, with the result that military experts are being kept busy devising new lines of defense.

Old cavalry equipments fell into disuse by the advance in artillery projectiles; the two largest passenger steamships in the world were launched and broke all trans-Atlantic records. Great advancement was made in the electrification of railroads, and Edison has invented a concrete house which will cost no more than \$1,000. More inventions have been made and more scientific problems solved than are realized, and countless more will startle the world before the year 1908 joins 1907 as part of the past.

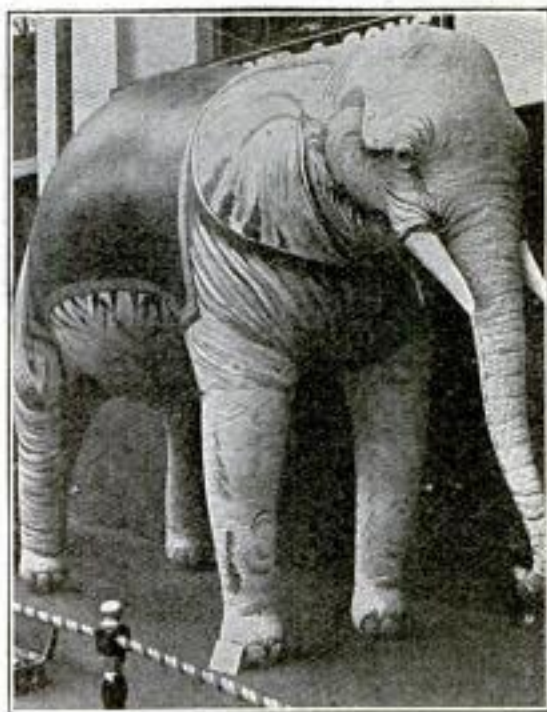

This elephant, which looks like the real article at first glance, is a novel air-filled balloon, shown at one of the recent airship exhibitions in London, Eng.

A Chicago street railway manager proposes to place uniformed newsboys on the pay-as-you-enter cars to put an end to the present brand of newsboys who jump wildly into cars during rush hours.



CONCRETE RAILWAY STATION

This concrete interurban station was practically cast in one piece, following out the idea of Edison and his \$1,000 concrete dwelling. The building is 40 ft. square and has but very little reinforcement.

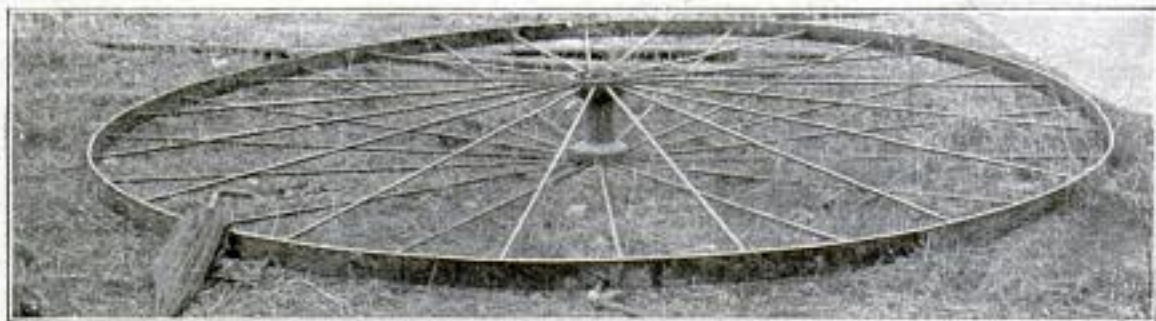

This Wheel Failed Because Improperly Planned

AUTOMATIC REEL FOR OCEAN CABLEWAY

Makes Life-Saving at Sea Possible with Breeches Buoy

By the use of an automatic reel, which will maintain a uniform tension on an elevated line or hawser and yet permit its length to vary as the motion of the ships demands, a life-saving cableway and breeches buoy has been made practicable for use on ships.

In fact, it has solved the problem so well that the first ship to be so equipped is a U. S. government revenue cutter now under construction in response to the demand for better life-saving facilities on some parts of the Pacific coast. The cutter will be stationed at Neah bay, 5 miles from Cape Flattery. She will be 150 ft. in length, and is to cost \$190,000.

The function of the automatic reel is to pay out the cable without jerks under tension as the ships separate, and wind it in as rapidly as they approach. It must permit the breeches buoy to be operated as close as 300 ft. or as far distant as 1,000 ft., should it be necessary. The reel will have a maximum in-pulling power of 2,000 lb., which may be reduced at will, and will wind in the hawser at the rate of 1,000 ft. per minute, which is believed to be far in excess of requirements.

The rescued persons will be landed on the deck of the cutter by the same hauling-down device that has been so successfully employed in coaling at sea. In many trials, whether the sea has been rough or smooth, the practicability of the device has been proven.

WHEELS TOO LARGE FOR MATERIAL USED

These large wheels, 10 ft. in diameter, were intended to be used to straddle a ditch and lower 12-in. cast-iron gas pipes into place, but after completion it was found impossible to get the rims true. The spokes are made of $\frac{1}{2}$ -in. drawn steel. The fact that the rims were only $\frac{1}{2}$ in. by 3 in. and the hub only 12-in. long probably accounted for the impossibility of truing the rims.

CHIMNEY OF COBBLESTONE AND BRICK

The chimney of this artistic looking cottage was designed to harmonize with the other parts of the house. The foundation is of cobble or field stone. A chimney of this size built entirely of the same material would look too heavy for the shingled upper part, so the chimney was built of red brick with cobble stones interspersed.



A Freak Chimney

TRAVELING SLING FOR INSPECTING WIRES

By the use of a simply devised trolley seat this man works himself for miles along covered bunches of telephone wires, high above the heads of the crowds who watch him from the

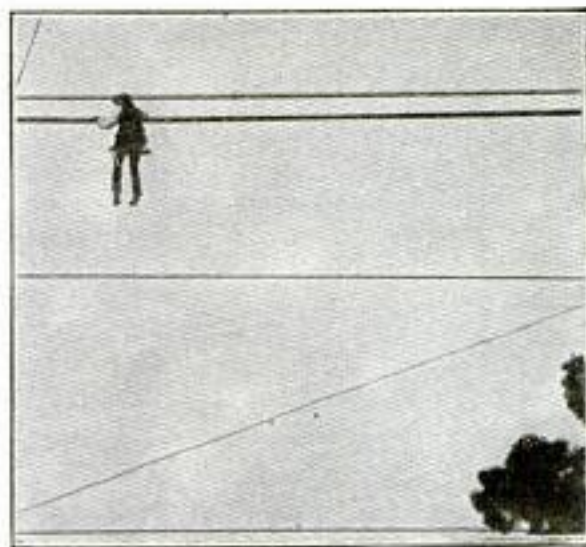

Getting up in the World

streets. His task is to travel along the entire length of such lines, searching for breaks in the tube and making repairs.

DIRIGIBLE BALLOON IN TWO PARTS

With the idea of overcoming the lack of stability generally found in dirigible balloons of the "Patrie" type, a French aeronaut has constructed a novel dirigible balloon, divided into two equal parts, rendered rigid by a metal carcass and communicating by means of four tubes. The propeller, its two arms describing a circle of larger diameter than that of the balloon, rotates on a central shaft which is fastened to a frame between the two parts. With the usual type of dirigible balloon the propellers are carried beneath

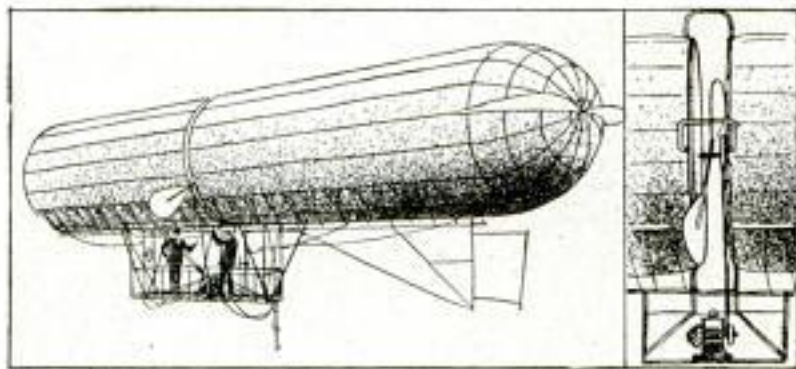

and in front of the envelope, where high winds interfere with their efficiency.

COMPARTMENT STREET CARS NECESSARY IN TURKEY

In Turkey, where the customs, especially those concerning the privileges accorded to women, differ so radically from the customs of more advanced nations, it becomes necessary to alter in one way or another every modern innovation installed. In the electrification of the street railway in Salonica, a

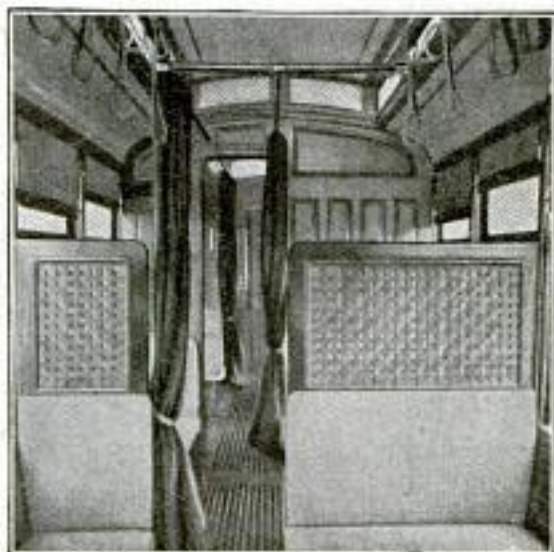

Courtesy Brill's Magazine
Turkish Street Car

Turkish city of 60,000 inhabitants, specially designed street cars had to be built by an American firm before women were allowed to ride. These

cars are divided into first and second-class compartments, and each seat has a curtain, so that the moment a woman enters she can hide herself from sight.



SPRINKLING TANK WRECKS BUILDING

In cutting a large connecting doorway through a dividing wall at the first floor of a 7-story building, no account was taken of the great weight of a sprinkler system reservoir supported by two steel beams resting on the top of the wall directly over the opening being made. As a result the wall collapsed, precipitating the tank and its contents from the roof to the basement, completely wrecking a portion of the building. Fortunately, the work was being done after business hours and no loss of life occurred.

Visual proof that the earth moves is being made at Columbia university by suspending a 91-ft. pendulum from the dome of St. Paul's chapel. As the earth turns one way the pendulum will

swing out the other, its plane of oscillation shifting in the same direction as the sun.

RESCUED AFTER BEING ENTOMBED 1,000 FT. UNDERGROUND FOR 45 DAYS

The three miners who were entombed on Dec. 4 in the narrow pump station at the 1,000-ft. level of the Alpha shaft of the Kimberly mine, Ely, Nev., were at last rescued on the night of Jan. 18, after being buried 45 days; 28 days longer than any person has ever been so entombed and lived to describe the sensation. The horror lived through the passing of the 1,080 hours that intervened between the accident and the rescue can never be fitly described. Each hour seemed a day to the men entombed and but a minute to the rescuers.

Thousands of tons of earth and fallen timbers had to be cleared away, and rescue gangs worked day and night, advancing less than 10 ft. some days, until victory was won and they gathered into their arms the three men so miraculously saved.

A 6-in. pipe through which water had been pumped from the mine was the means of preserving their lives. Through it food and water were lowered in iron bottles made of short lengths of 2½-in. pipes. Air was forced down the same pipe. The telephone was not injured and by it they were able to make their wants known.

THE NEW YORK TO PARIS AUTOMOBILE RACE

Preparations have been completed by well-known French autoists for the polar automobile race which is to start from Times square, New York, and end some time during the coming summer in Paris, after a run across the ice fields of Alaska and Siberia.

The feasibility of the run, with its many possibilities of accidents and disaster, is in no way doubted by the French. Authorities upon conditions

in Alaska and Siberia have declared their belief that a successful run is possible, and that some of the contestants ought surely to get through.

Among the French machines ready for the race is the automobile which will be driven by Hansen, the Norwegian engineer who was sent in search of the ill-fated André. This machine is provided with a powerful windlass for use in case it gets into a bad position. Rope tackle will also be carried for the purpose of hoisting or lowering the machine over steep places. A number of the contestants expect to economize in fuel by hoisting a sail where conditions make this means of propulsion possible.

STEEL SHAFT CUT BY QUARTZ SAND

The deep grooves in this large 7½-in. steel shaft were caused by the action of quartz sand in the water of the Carbon river, a glacial stream of Mt. Tacoma. The shaft was connected to the wheel of a low-pressure turbine engine that supplied electrical power to a coal



Sand Cuts Steel

mine. The worn part passed through a gland and the sand lodging in the packing material gradually ground the steel away.

AN ELECTRICAL HORSE

In this illustration is shown one of the queerest steeds that ever supported a saddle. It is nothing more or less

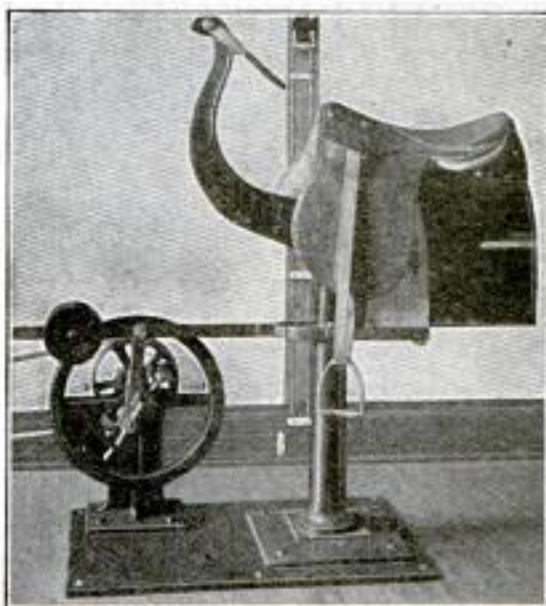

Stands Without Hitching

than an exerciser operated by an electric motor, on which its owner is able to enjoy a canter of long or short duration at any time of the day, without leaving the comfort and warmth of his office.

Mounting the "steed," the electric current is turned on and the ride begins, the teetering motion being precisely the same as that of a horse in action. Any desired gait can be obtained by merely adjusting a screw. A counter weight permits adjustment of the mechanism to accommodate any weight.

Although the device is being used to a great extent in Germany for training cavalymen, this is one of the first to be imported to this country. For the training of new beginners in the art of horseback riding it is considered excellent.

CAR FALLS HALF OVER ELEVATED STRUCTURE

A motorman on an elevated railway lost control of his car and it ran half



Crib Work to Raise Car

over the end of the structure, balancing itself partly in the air. The fact that the trucks carrying the heavy motors fell to the ground, thus relieving the front end of the car from this weight, was all that prevented it from falling to the ground. The car was lifted back to the tracks by building a cribwork of ties under the overhanging end and using screw jacks.

LARGEST AND STRONGEST VAULT IN THE WORLD

This enormous armor-plate vault, the largest in the world, is to be filled with strong boxes and rented to the patrons of the Carnegie Safe Deposit Co. in New York. Comparatively a new development in vault building, the use of warship armor plate has become a factor which in many respects is revolutionizing such construction. Many advantages are claimed for armor plate, the most important of which are that it is absolutely fire, burglar and earthquake proof.

This vault is built in two stories, with a connecting passage between them carrying an elevator and stairway. The lower story is 9½ ft. high,

106 ft. long and 30 ft. wide. The whole structure weighs 1,200 tons. The steel plates are 4-in. armor plate, of the same kind furnished the government for war vessels. Except for the doors, the walls are free from openings of any kind. The plates are dovetailed together in such a way as to make separation impossible except from the inside, and the entire vault is incased in a 16-in. coating of concrete.

There are no holes through the doors for the locking mechanism, and the automatic time locks are the sole means of opening the vaults after they have once been locked. For each of the three doors there are four clocks. All of these would have to fail simultaneously to make an accidental permanent locking possible. The clocks are set for the hour of opening and the vault doors closed. When the hour arrives they automatically throw the bolt-operating mechanism into action and the doors are released so that they can be opened from the outside.

The large circular vault door, shown in the illustration, is large enough to admit a horse and carriage, or an automobile, being 9 ft. in diameter. Its massiveness, however, would prevent the admittance of anything smaller and less forceful than the projectile of a

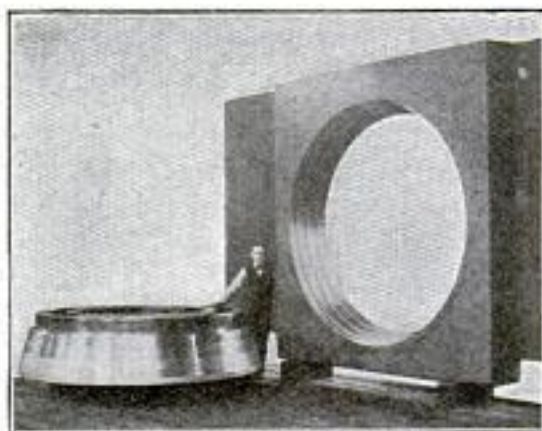

Courtesy Bethlehem Steel Co.

The Big Steel Door

14-in. gun, when closed. The exact cost of the vault has not been made public, but it is understood that the figure is close to \$500,000.



FUNERAL PROCESSION ON SKATES

Among the Wends, a remnant of the ancient Slavonic race inhabiting the Spreewald, a region enclosed by an arm of the Spree river, about 50 miles south of Berlin, are seen the most curious funeral processions of the civilized world. As in Holland the thoroughfares are waterways. In the winter time, when these are frozen over, funeral processions pass along the ice on skates. The coffin is carried on a sledge, drawn by six mourners on skates. The immediate relatives of the dead, men and women, alike, skate along behind the coffin, surrounded by their friends. The women carry a Bible in one hand and wear the ancient national costume.

HOW THE AIRSHIP "LA PATRIE" ESCAPED

France has not yet recovered from the stunning blow delivered by the element of the air when "La Patrie," the pride of all loyal Frenchmen, broke loose from the hundreds of restraining hands that tried to hold it, and in the course of a few short hours scattered parts of itself over the peat bogs of Ireland and the waters of the Atlantic.

France's misery is not all in the fact that the airship was valued at \$60,000, nor altogether because "La Patrie" was depended upon to gain the "blue ribbon" of the atmosphere for France, but because the wrecking of the great airship was the result of such a matter-of-fact procedure as the entanglement of the chief mechanic's long, flowing coat with the distribution gears. Little things have caused great disasters in the world's history. A little rain on the field of Waterloo resulted in Napoleon's fall, and a long coat was the primary cause of "La Patrie's" loss.

The ship was over Toul and had only two miles to travel to complete its 150-mile journey from Paris to Verdun when the accident occurred. The engine was fitted with double ignition, but as distribution was from the same shaft, the accident put both out of commission. It would have been easy to drag the airship the remaining two miles to its shed at Verdun, but the pilot decided to repair the damage then and there. All night the airship was held to the ground by 800 troopers. A squall came up and blew itself into a hurricane. By some oversight the valve cord, which if pulled by any weight would have allowed the gas to escape from the bag, had not been at-

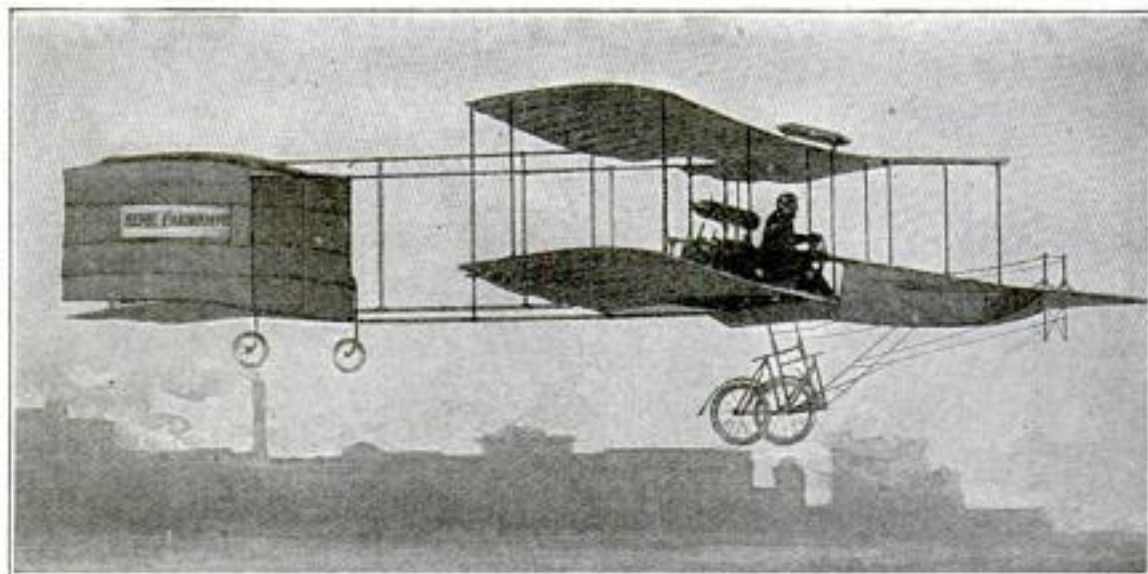

Farman's French Aeroplane--First to Make Long Flight

tached to ballast, and when the airship was at last torn away from the troops it could not be located.

OLD POSTS AND NEW

Side by side in this illustration are shown the new and the old in poles

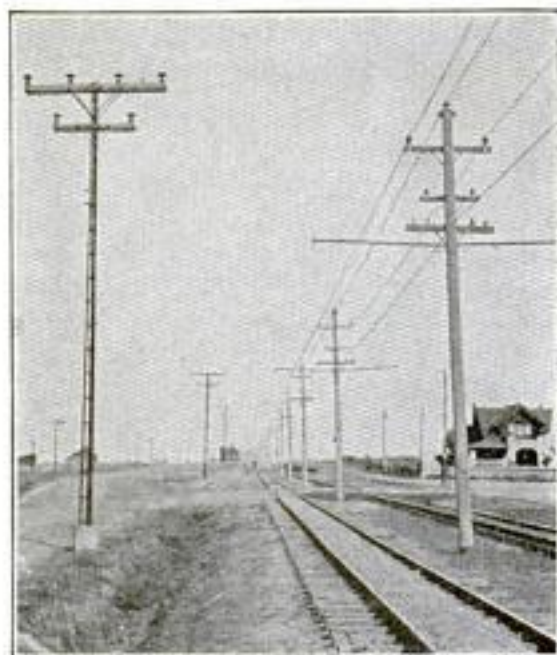

Steel Displaces Wood

for carrying heavily charged wires. The steel post is made of three pieces of U-shaped steel, held apart by castings and triangular hoops, no holes being drilled. A solid concrete base is cast around the steel after the pole is set in position.

FRENCH AERONAUT WINS \$10,000 PRIZE

Henry Farman, the French aeronaut, who for the past few months has been startling France with his wonderful flights in an aeroplane, won the Deutsche-Archdeacon prize of \$10,000 in January by making a circular kilometer, which is a little more than a circular half-mile, without his machine touching the ground.

With a preliminary run of 100 yd. over the ground the aeroplane rose to a height of 15 ft., then with outstretched wings it sailed away across the fields at a height of from 25 to 35 ft. at a speed of 24 miles an hour. It reached the outer mark, described a graceful circle, and went sailing home on an even keel. It is estimated that with the curve described by Farman the aeroplane covered a distance of nearly a mile. The motor used has 8 cylinders and developed 50 hp. It weighed 176 lb.

Count Henri de la Vaulx, Farman's most feared competitor for the prize, met with serious accidents in his first trials, which placed him out of the contest. One of the wings of his aeroplane bent at the shoulder and the great bird-like machine shot to earth at a tremendous speed, seriously injuring its owner and completely wrecking itself.

TWO ELEVATORS TO RUN IN SAME SHAFT

Safety Devices Make Collisions Impossible—Floor Space Worth Thousands Saved

An invention which, it is asserted, will revolutionize elevator service in skyscraper buildings, causing a saving of space worth from \$25,000 to \$100,000 a year in rents, according to the size of the building and the number of elevators necessary, will be installed soon in two large skyscraper buildings, one in Chicago and the other in New York, by a well-known architect.

The key to the invention is the operation of two elevators in one shaft, a feat which sounds impossible at first thought, but which is simple and practical. Take, for instance, a building of 20 stories. One-half the elevators are run as expresses and the other half as locals; each car having a separate shaft. The new system cuts this elevator space exactly in half by running two cars in each shaft.

The arrangement is as follows: The express elevator is at the first floor, loading; the local elevator directly underneath it in the basement. As soon as the express elevator is loaded it leaves and makes its first stop at the tenth floor. Meanwhile the local elevator rises to the first floor and loads. The local leaves the first floor at the same time the express leaves the tenth. They both travel up ten stories serving locally, then both travel down ten stories serving locally. While the express elevator is descending from the tenth floor to the first the local elevator unloads at the first floor and drops into the basement. The express elevator then unloads at the first floor and the same process is repeated.

The upper elevator is never delayed. The lower elevator is only delayed while the upper elevator is loading or unloading at the first floor, which on a two-minute schedule would be about 20 seconds. The upper elevator is lifted by central cables and the lower by side cables. Not only will the elevators be protect-

ed by the ordinary means, but they have mechanism, simple and effective, which when the cars get within a predetermined distance of each other slows them down and at a closer point absolutely stops them.

The saving of floor area is great. Take, for instance, a modern skyscraper 20 stories high, having 20 elevators. Each shaft, with hall serving it, occupies 160 sq. ft. per floor. One-half of

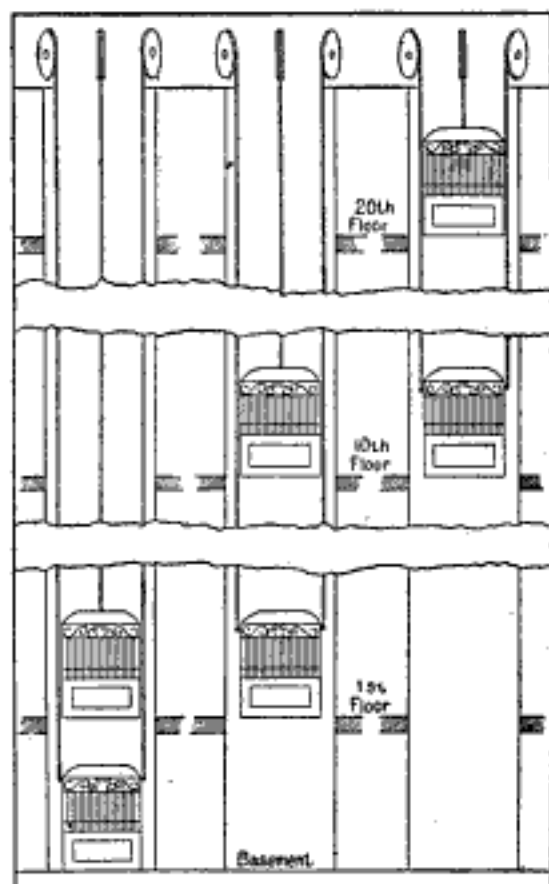

Courtesy Jarris Hunt, Arch.

Plan of Double Elevator

the elevator shafts and hall space is done away with, which gives an additional renting area on each floor of 1,600 sq. ft. Multiply this by 20, the number of floors, and the amount of renting area saved is 32,000 sq. ft. Such space is worth \$2 per square foot yearly rental, which means an additional rental income of \$64,000.

It is estimated that the value of the electrical and auxiliary manufactures in the United States for the year 1907 was \$315,900,000.

LARGEST GROWING PLANT EVER MOVED

At the cost of a small fortune a giant palm, 50 ft. high when in the ground, 20 ft. in circumference at the base, and

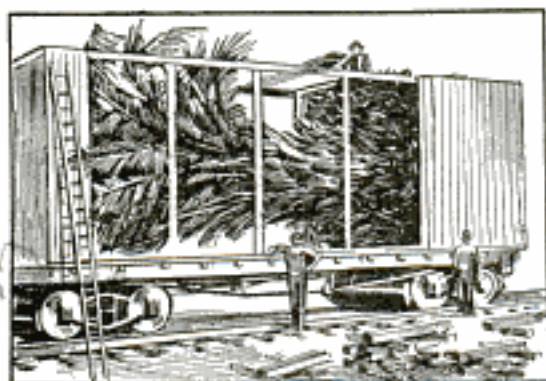

Crating the Big Palm

weighing 40 tons in its case, has been moved from the W. J. Dingee estate at Redwood City, Cal., to Santa Cruz. The palm was first cut out of the earth without disturbing the dirt around the roots more than absolutely necessary, as a large frame, or box, resembling the uncompleted first story of a large frame house, was built around dirt, roots and trunk. The palm was slowly moved to the railroad tracks as a house is moved, on rollers, and lifted to the flat-cars with powerful derricks.

DIRECT-COUPLED ROTARY STEAM ENGINE

This rotary steam engine, direct-coupled to a 15-hp. dynamo, is the

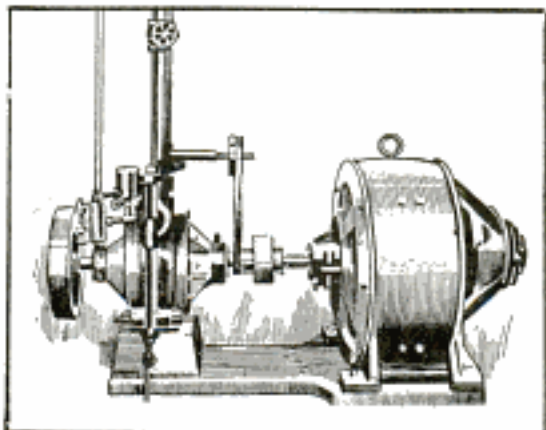

New Steam Rotary

next thing to a turbine, with the added advantage that it is reversible and has not one ounce of back pressure. The assembling of its parts is such that it has no dead center and will start at any point in either direction. It will operate with steam from one pound up to as high a pressure as a modern boiler can stand.

On vessels it can be used for many purposes, such as operating steam steering gear, steam capstans, windlasses, hoisting machines, dynamos for electric lighting, ventilating fans, circulating pumps, bilge pumps, etc.

MICE ON SUBMARINE ENSIGN

On the new flag designed for the submarine branch of the British navy mice have for the first time in the history of



New Submarine Flag

the civilized world been placed on an emblem which typifies honor, strength and craftiness. The last of these is certainly appropriate, as the submarine boat, like the mouse, craftily burrows to destroy.

The flag measures 18 ft. by 12 ft., and has a background in three vertical sections colored red, blue and yellow. In the center is the black shield or design shown in the illustration. The shield is divided into four parts, two of which are occupied by a submarine and three torpedoes. In each of the two remaining quarters is a white mouse.

The uninitiated would say at once that mice have been so distinguished because they, like the submarine, craftily burrow underneath an enemy to destroy. But this is the least important of two reasons. The real consideration is the fact that white mice are among the most important members of a submarine boat crew, their intense dislike of the odor of gasoline making them quick and unerring alarms. The moment a gasoline tank commences leaking the loud squeals of these diminutive members of the British navy notify the human members of the impending danger, thus preventing disastrous explosions.

MINING WITH ELECTRIC AIR-DRILL

The electric air-drill shown in this illustration has proven itself the most successful solution of the problem of drilling rock in mines by electric power.

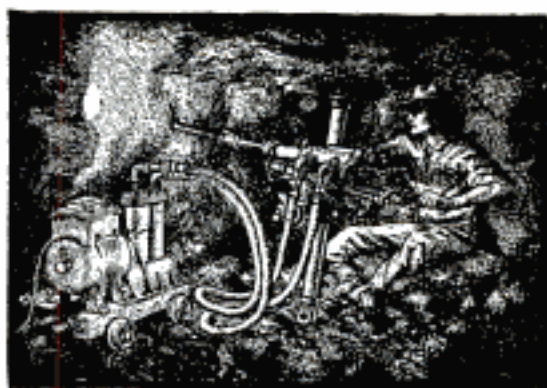

Electric Air-Drill

The drill is propelled by compressed air produced by a portable electrically-driven compressor. The entire apparatus is brought down to such a small compass that every part of it is really portable, a great advance over the ordinary air-drill, with its necessary air compressor plant and pipe lines.

PACIFIC FLEET IN HIGH SEAS

When the battleship fleet put out of Hampton Roads there was a strong wind blowing, which increased to a gale

lasting several days. One of the sailors took a photograph the third day out, from the main deck of the "New York," from which this illustration was drawn. The distance from the small boat hanging from the davits to

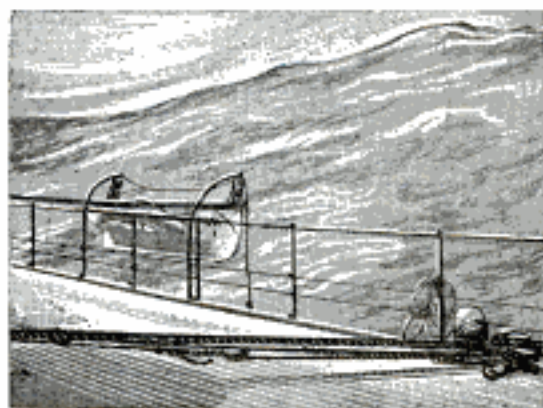

The Waves Ran High

the water line is 25 ft., showing the waves which looked "mountain high" to the new men.

DUEL BENEATH THE SEA

Six miles off the Florida coast, 57 ft. under the surface, Nicholas Andreas and John Bastoni, Greek sponge divers, fought desperately with sponge hooks for possession of a big sponge. Both received painful wounds, but when Andreas later attempted to institute prosecution he found that no court had jurisdiction over the bottom of the ocean.

SAMPLING DUST FOR ANALYSIS

The city authorities of Berlin have set up a number of instruments in different parts of the city to collect samples of dust for chemical analysis. The result of this analysis determines the localities where dust is most dangerous to health. Steps are then taken to eliminate it as far as possible, which in Germany means much.

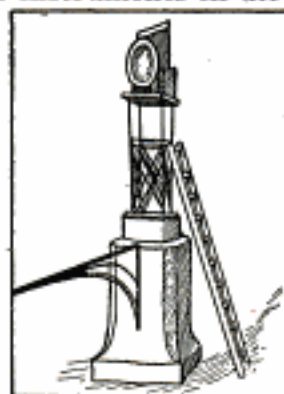

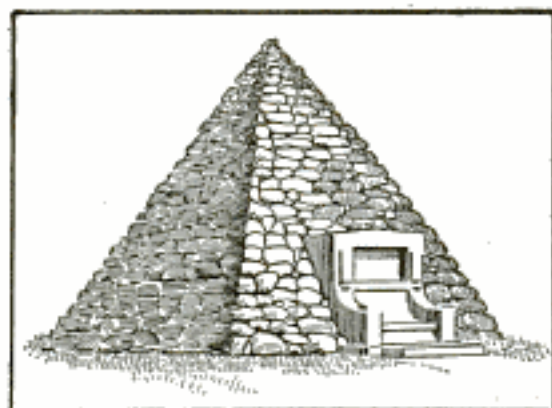

PYRAMID MONUMENT TO A PRESIDENT

Of all the monuments erected to the memory of the presidents of the United States, one of the most interesting is the pyramid of native stones which has just been placed on a lonely mountain side at Stony Batter, Pennsylvania, to mark the log-cabin birthplace of James Buchanan, the only president ever given to the country by that state.

The monument consists of a pyramid of native stone, set in cement, 31 ft. high and 38 ft. square at the base. Upon one side is a granite tablet with an appropriate inscription. The monument was erected with money left for that purpose by the will of President Buchanan's niece.

ASPHALT OIL PAVEMENTS

After watching a flock of sheep walk over a newly plowed field a western pavement contractor invented a rolling tamper which is mechanically the same flock of sheep as far as the effect is concerned. After the sheep had passed over the plowed field the soil was so hard that a pick could hardly make an

impression upon it. The rolling tamper accomplishes the same result, and it is due to this fact that the asphalt oil pavements of California are so satisfactory.

The tamper is a huge roller, from the circumference of which project innumerable steel feet. Instead of packing the earth from the surface down, as is the case with other rollers, it packs it from the bottom up. When the roller starts over the plowed roadbed the tampers sink to their hilts. Gradually, as the rollers pass back and forth, the earth grows so hard that the tampers ride entirely upon the surface and fail to make an impression.

The construction of the asphalt oil pavement is simple, but at the present time the process is practically confined to the far western states, as the crude oil of the eastern states does not contain the desired qualities. California crude oil is usually more than half asphaltum, while the base of the crude oils of eastern states is generally paraffin. In constructing the pavement the roadbed is first plowed up to a depth of about 6 in., sprinkled with water, and tamped for a thickness of 2 in. Oil tank sprinklers are then driven over until one gallon of oil per square yard is distributed. A cultivator next mixes the oil and earth, the roller tamper is run back and forth until no impression can be made, and the operation is completed with a few turns of a common road roller.

The first Chinese School of Forestry has just been opened at Mukden. The Chinese Empire paid no attention in the past to the destruction of its forests.

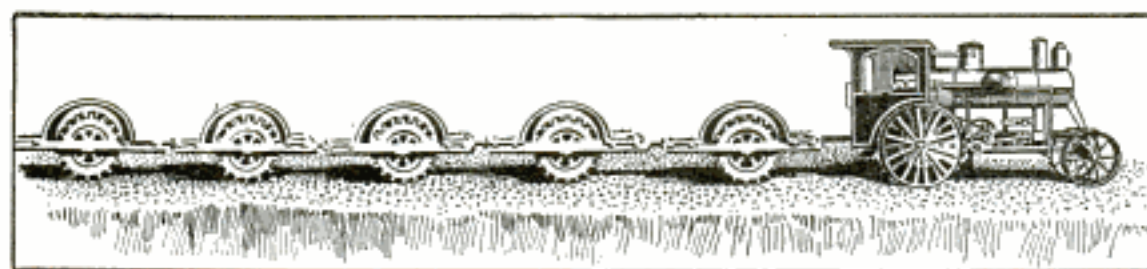

Road Machine Suggested by Flock of Sheep

TUNNEL FOR JOINT USE OF WATER MAINS AND RAILWAY

In the construction of a number of tunnels through the part of the Rocky mountains in Colorado known as the "Continental Divide" the same bore is utilized for both mining transportation and to divert water from the west side of the divide to the east side. The water mains are a little smaller than generally used, but are four in number, placed in a bed of concrete underneath the railway track.

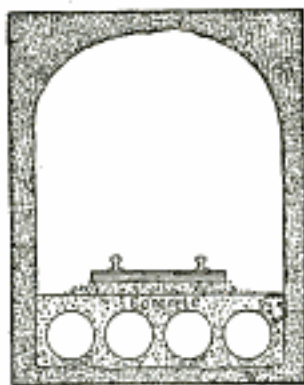

ELECTRIC LIGHT BATH CABINET

Every kind of a bath from a mud to an alcohol bath is being given by physicians in different parts of the world as the best cure for a multitude of troubles. Among these baths electricity in the form of electric rays is receiving recognition in the medical world. The accompanying illustration shows an

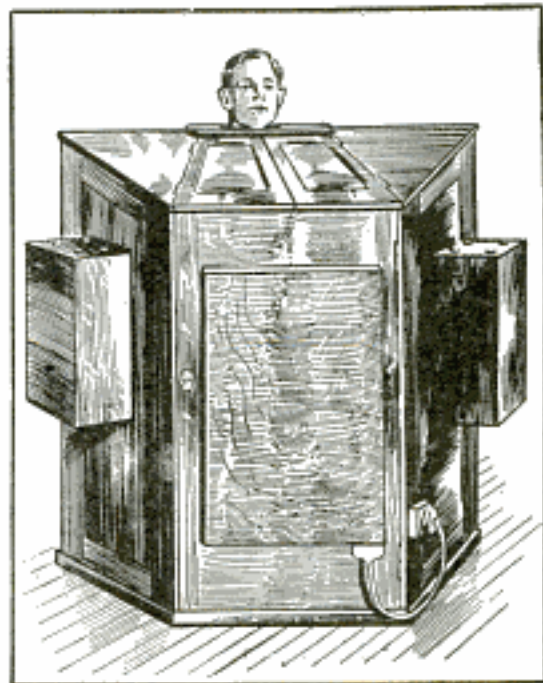

The Light Cure

electric light bath cabinet equipped with incandescent lamps.

UNDERLINE ASH EXPELLER

A new way of disposing of the large amount of ashes and clinkers which materialize every day in the stoke-hole of a ship has been found in this machine, which expels the ashes and clinkers straight down through the bottom of the ship instead of from the side. The latter method has many disadvantages, such as the necessity of study-

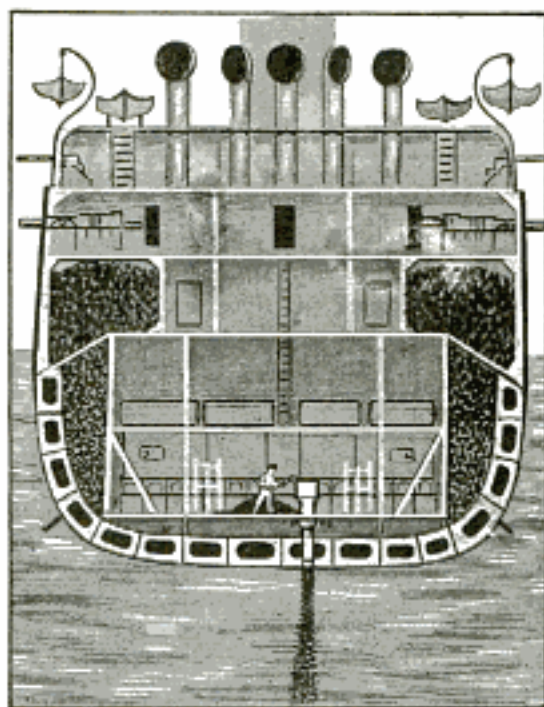

Shoots the Ashes Out

ing the weather conditions on deck, working ashes up on the leeward side of the vessel, or holding the ashes below until the weather changes.

The underline expeller, which is driven by air motor, eliminates all these disadvantages. The machine is absolutely silent in its workings, all its parts are at all times accessible for examination, and the ashes are projected with sufficient velocity to carry them deep enough to clear all suction. It is also claimed that there is absolutely no scouring action of ashes on the hull, or possibility of their coming in contact with the stern tube.

MISSISSIPPI RIVER JETTIES

The two immense jetties at the mouth of the Southwest Pass of the Mississippi river, just completed, have succeeded in giving the southern states

ENGLISH CARAVAN CAR

Our European manufacturers continue to maintain the lead with new ideas in automobile construction. House cars, or caravans, as they call

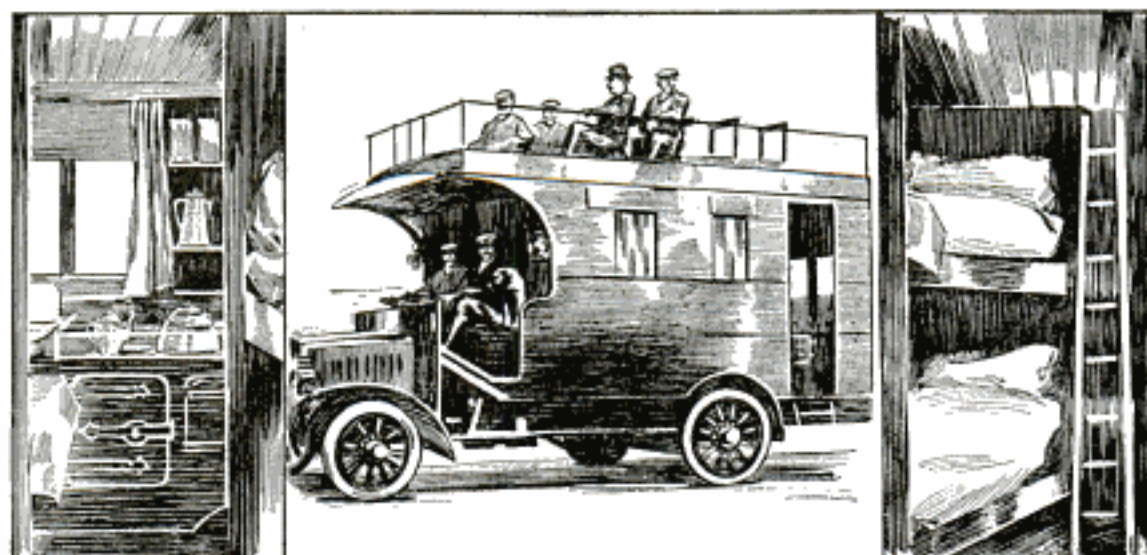

Kitchen



Caravan Car



Bunks

a deep and always accessible harbor by opening the 100 and 200 ft. depths of the Mississippi river to the largest ships afloat.

The jetties were begun four years ago and have cost \$2,700,000. They are nearly parallel walls, one three and the other four miles long, lying over half a mile apart and built in shoal water at the juncture of the pass with the Gulf of Mexico. The swift currents which they produce, aided by dredging, caused a tremendous washing out of river bottom even before completion, making 50 to 85 ft. of water in some places, where at the beginning of the work the depth was but little over a man's head.

The construction of the jetties was carried out under many difficulties, among which was the necessity of bringing the material from distances ranging from 100 to 500 miles. The completed walls have no foundation, but rely for stability upon their extremely broad bases, 100 to 150 ft. wide at the bottom. The capping is a concrete sea-wall 4½ ft. high, and is the only portion not submerged.

them over there, are rapidly passing from experiment to practical use. The car illustrated contains a completely equipped kitchen and sleeping berths for six persons, and Motor of London says the owner, Mr. Fletcher, with friends, made a 4,000-mile tour in it during the past few months.

The only delay from failure of engine was one of five minutes when a small valve spring broke.

The kitchen is placed at the rear, where odors of cooking do not reach the passengers. The outside seats follow the lines of the time-honored London bus.



French Coaching Auto

Another type of outside-seat car was displayed at the recent motor car show in Paris.

LIFE-SAVING TENDER STEP

Many serious accidents have occurred to engineers and firemen when climbing off and on to locomotives and tenders because the steps were covered with ice and slush. This step was adopted by the Canadian Pacific railway to make the danger of such accidents as small as possible. The 2-in. holes in the step allow the snow and ice to fall through, while the projections or lugs afford a secure foothold. The high flanges prevent the feet from slipping over the ends.



STARTING A DUTCH WINDMILL

The simple Dutch millers, ignoring the advancement of the years in mechanical appliances, still cling to the simple devices used by their fathers and grandfathers. In this illustration is shown a miller starting one of the windmills that thickly dot the rim of the Zuyder Zee. The immense wings, with an expanse like the sail of a ship, must be swung out to catch the wind. To accomplish this a wheel, resembling the steering wheel of a ship, is used. The miller places his feet upon the spokes and diligently treads until the rope, attached to a brake-beam, releases the wings and starts them swinging lazily in the wind.

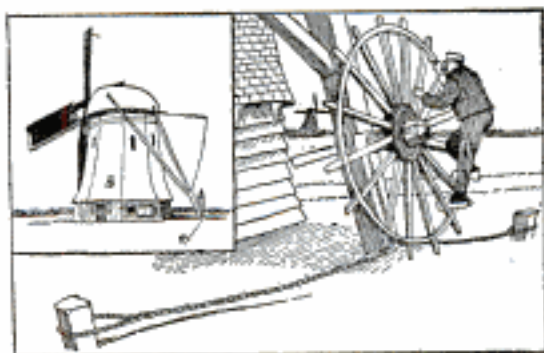

Seen in Holland

LINE WORK 800 FT. ABOVE CANON

Along this mountainous trail near Ouray, Colo., the telephone poles were set out on a trestle to avoid interfer-

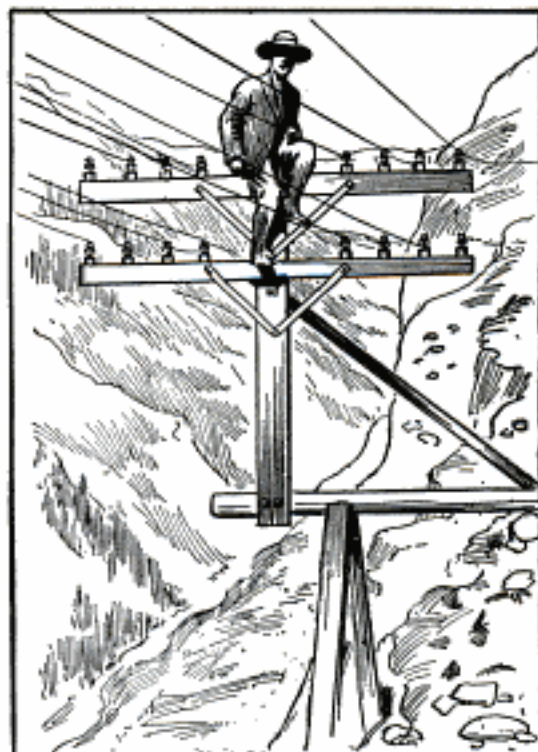

800 Ft. to Rock Bottom

ence with passing teams. One of the linemen who did the work is seen perched on the crosspiece 800 ft. above the bottom of the cañon. The illustration is redrawn from a photograph furnished by the courtesy of the Colorado Telephone Company.

FISH INSPECT TORPEDOES

The curiosity of fish is in no way better demonstrated than by watching their antics when torpedo practice is in progress. Recently a school of big fish swam up the bay near Sag Harbor, L. I., while a torpedo boat was firing at a target, and began to investigate. The result was a great number of mangled fish and a noticeable zig-zagging of the torpedoes before they struck the target. A shark at another practice tried conclusions with a torpedo, with similar effect on the shark.

GYROSCOPIC ENGINES FOR AEROPLANES

By Prof. George H. Morse
Department of Electrical Engineering, University
of Nebraska

At first thought the use of gyroscopes to steady an aeroplane while in flight appears chimerical. Yet when one reflects that the boomerang depends for its stability entirely upon its rapid rotation the principle seems worthy of some consideration. Even the ordinary playing card, in the hands of an expert, may be sent whirling and flying accurately to a mark at a distance of a hundred feet or more. While it is out of the question to load an aeroplane with a gyroscope of sufficient mass to be of utility, it occurs to the writer

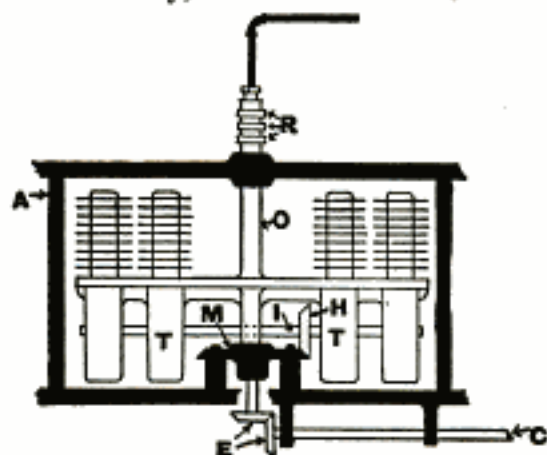

Details of Proposed Mechanism

that invention and mechanical evolution may ultimately make available for gyroscopic action the mass of the propelling motors themselves, even including necessary fuel and rations.

The arrangement shown in the accompanying drawing is intended merely as a suggestion leaning toward a possible solution of the problem. In this drawing the members shown in solid black, as A, are stationary parts, integral with the framework of the aeroplane. The parts shown in outline all revolve. TT is a four-cylinder gasoline engine, I being the main engine shaft. The shaft I carries a bevel pinion, H, which meshes with a stationary bevel gear, M. The weight of the engine is supported by the vertical shaft, O, which gets its bearing upon the face of

gear M. The shaft O extends through the gear M, and carries a bevel pinion which is one of a pair serving to supply motion to the propeller shaft, C. A hole is provided in the lower part of shaft O, through which the engine shaft I passes. The upper end of O may be made hollow where it passes through the upper bearing. Electric wires may thus be led from the insulated slip rings, R, through shaft O, to various electro-magnetic controlling apparatus on the engine cylinders. Fuel may also be sent from a stationary retainer to the engine by means of the opening in the end of O. Of course, the engine unit here shown would need to be operated in connection with a similar unit revolving in the opposite direction in order that the reactions on the frame of the aeroplane be balanced. The engine arranged as described is virtually its own flywheel. In order to reduce the retarding effects of the air the revolving engine should be incased in a large vertical cylinder, only such air currents being permitted to exist about the engine cylinders as are necessary to keep them cool.

It should be possible also to apply the principle I have described to light water craft with the effect of keeping them on even keels in rough water.

FRENCH BARREL MOTOR TRUCK

A specially constructed motor truck for hauling casks of wine and other liquids is coming into general use in Paris. It has been found the load is



Cannot Roll Off

carried better in the manner shown in the illustration than when the casks are set up on end.

BOILER HURLED LONG DISTANCE BY EXPLOSION

In a recent boiler explosion in the Kern River oil fields of California a horizontal tubular boiler was thrown a distance of 1,220 ft., an accident unusual for a boiler of this description, although happening often to vertical boilers.

The explosion completely wrecked the boiler house and hurled the boiler across two gulches and over the top of a 74-ft. derrick which stood in the direct line of its flight. The boiler was one of three 70-hp. cylindrical return-flue boilers, weighing 5 tons each.

EMERGENCY OVERSHOES FOR HORSES

In large cities, like Chicago and New York, icy asphalt pavements cause the death of hundreds of horses every winter. Many styles and shapes of shoes are now being introduced in an endeavor

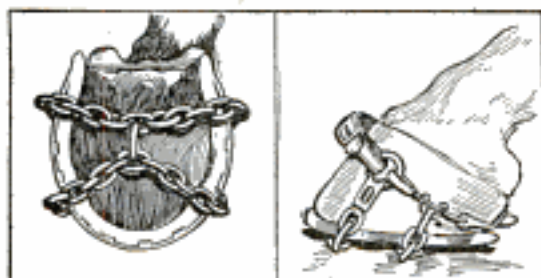

Ice Creepers for Horses

or to stop such accidents, one of the most promising of which is the emergency shoe, here shown. It consists of a chain "tread," which can be quickly buckled on and as quickly taken off the foot of a horse without the use of tools. It is practically self-adjusting, is strong, cheap and durable.

CARVING FOWL WITH CLIPPERS

The most expert sometimes find carving fowl an awkward task, and many times the first cloud to arise on an otherwise sunshiny matrimonial horizon has been caused by an unsuccessful tussle with a turkey. This pair of

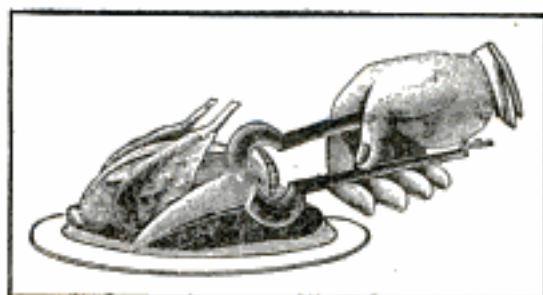

No Skill Required

carving shears was devised especially for those who find the talent of carving hard to acquire. The upper blade is a carving knife and the dented lower blade forms a clip. The shears are easy to handle and permit one to successfully attack any part of the fowl.

TO STOP WIRELESS MESSAGES IN WAR TIME

An Austrian electrician has invented a device for destroying wireless messages during times of war. It consists of a revolving tower from which flashes of varying strength are thrown out. By this means all receiving instruments within a wide radius could be so deluged with flashes that the operators would not be able to distinguish messages.

SUGGESTED TYPE OF DIRIGIBLE BALLOON

The dirigible airship is a type suggested by persons enthused with the flying fever, who believe that airships would sail better against the wind if pierced through the center of the envelope by an aluminum tube open at both ends. Their idea is that the air resistance would not be as great as it is with the usual type of dirigible balloon.



RAISING GALVESTON 15 FT.

This illustration shows one of the scenes attending the raising of the grade in Galveston, Texas. The house shown in the foreground was raised 15



Method of Filling

ft., half of which height has been already filled in. The two large piles of soil are at the ends of two discharge pipes from the big dredge working in the canal.

**STONE BOULDER BREAKS
DREDGE PUMP**

The object shown in this picture is the broken casing of a large centrifugal pump used on a powerful suction dredge. The damage was inflicted by a heavy stone boulder which was sucked in by the dredge with such force



An Unusual Break

that it burst the upper casing of the pump. The casing was cast-iron 3 in. thick.

QUICK UNLOADING CAR CHUTE

It takes time for a crew of men to unload crushed stone, sand, or other

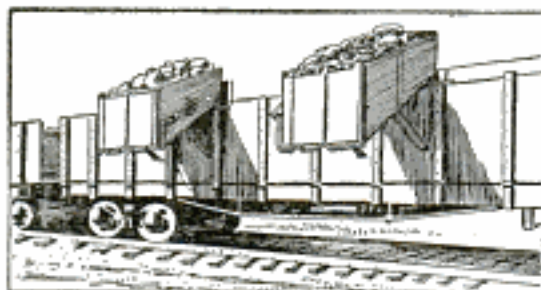

Loads in an Instant

material from a car into waiting wagons. Time means money, therefore the reason for the quick unloading chute in this illustration. The chute is attached to the side of the car and filled by the unloading crew. When a hauling wagon arrives it is driven under the chute, the catch is kicked out, and the wagon box filled in a moment. These chutes are made in different sizes, the medium size holding one cubic yard.

**GERMAN AUTOMOBILE COAL
WAGON**

Automobile coal wagons, the boxes of which are tipped to discharge the coal

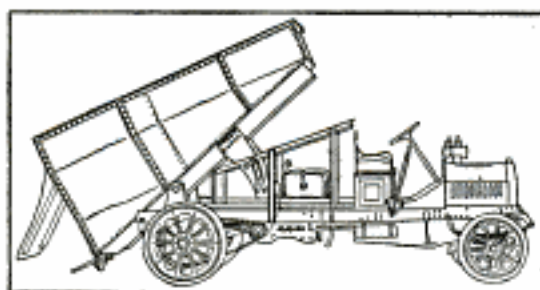

Carries Three Tons

by means of the 18-hp. gasoline engine which runs the truck, have been introduced in Berlin, Germany. The box, or coal bunker of the wagon, has an inclined bottom, which aids in the discharge of the coal. The truck has a carrying capacity of three tons, and is operated at a normal speed of from 8 to 10 miles an hour.

SHOP NOTES

Holding Up a Gear on a Vertical Shaft

The large wheel of a gear drive on a vertical shaft was put on with a key without a set screw, and consequently it would keep slipping down on the shaft and had to be raised every three or four weeks. As it was impossible to take it off and fix it, we had a blacksmith make a collar as shown in Fig. 1.

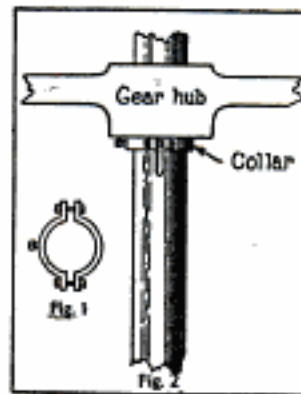

Two pieces of iron about 3 in. long and $\frac{5}{8}$ in. thick, bent to fit the shaft, leaving a space between the ends, were used. A set screw was placed in this collar and two $\frac{1}{2}$ -in. bolts passed through the ends to clamp it on the shaft. The wheel was raised to the proper place and the collar adjusted so the key on the shaft came between the ends of the collar, and the place was marked for the set screw. A small cup was cut in the shaft to receive the set screw. When placed in position and tightened up, no more trouble came from that source.—Contributed by L. F. Groger, Concord, Mich.

How to Make a Tool Stand

Two boards about 16 in. square are fastened one on each end of a square post or center-piece. An equal number of holes are drilled in each board to receive the tools as shown. The top board may be a little larger than

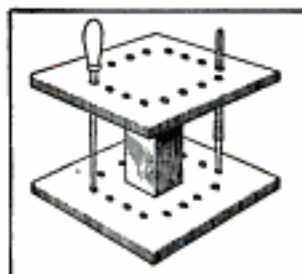

the bottom and the holes made to slope toward the center at the bottom. If a handle be placed in the middle of the top board, this device can be used on a bench or floor, as desired.—Contributed by Harold Beecher, Toronto, Canada.

A Home-Made Washing Machine

Secure a good water-tight cask, thoroughly cleanse it and cut a hole for a lid. The cask should then be mounted on two good rockers whose arc is small enough to give the machine a good tip downward, says the Pathfinder. A

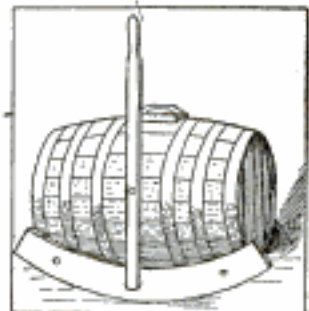

handle is nailed on to one rocker and the machine is ready. Put into the cask the warm washing solution and then follow with the laundry; clap the lid on tight, and begin to rock the machine. The cleansing is accomplished simply by the shock of the laundry and water against the ends of the cask as it tilts back and forth.

A Sandpaper Kink

Turn an ordinary straight spindle and saw a slot in the middle on a bench saw. Place one end or side of the sandpaper in this slot and turn the sheet

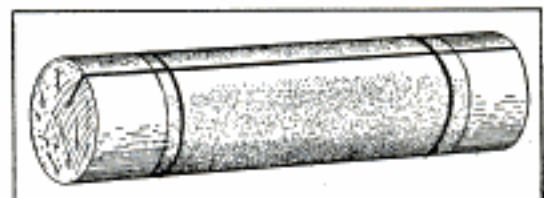

Sandpaper Kink

around the spindle. A rubber band is placed on each end to hold the sandpaper in place, says a correspondent in *Woodworkers' Review*. This spindle is placed in an ordinary lathe, with the sandpaper turning in the proper direction, for use in sanding irregular surfaces.

Cutting and Storing Ice

Many farmers go without ice all summer because they think it too hard work to secure it safely packed in some sort of an ice house or shelter. Some who have the houses or sheds fail to harvest a crop on account of the cost for hired help. But the work can be done to advantage with two men if a derrick is used.

We used a regular crosscut champion tooth saw, detaching one handle therefrom, says a correspondent in *Hoard's Dairyman*. A square was made of two pieces of narrow fence board as shown at A in sketch, with a brace to make it rigid. This, with a 16-ft. 2-in. plank, was used to lay out and mark the squares of ice. The derrick was made by using two strong white oak poles to make the vertical post and the sweep. The vertical post, B, may be cut from any strong piece of lumber, or made up by spiking together two pieces of 2 by 4-in. studding. It should be about 15 ft. long and braced at the base as shown in the sketch. The bottom should be smooth in order to slide freely over the ice. The sweep, C, should be about 16 ft. long, or over, with a rope attached to each end as shown. The sweep is pivoted on top of the vertical post, B, from one-quarter to one-third projecting over to the side, where the ice tongs are attached to the lower end of the rope. The rope, D, at the opposite end allows plenty of leverage to handle and swing

the heavy cakes up and around into the box.

After a lot of cakes have been cut loose from the ice, one man seizes the tongs and gets a cinch on the first one that comes along. The other man pulls down on the rope and elevates the cake very easily. The sketch shows how the work is done, and a load is quickly made ready for hauling to the ice house.

Turning Nuts on Mandrels

A great many persons use a hammer to turn a nut on a mandrel where it is

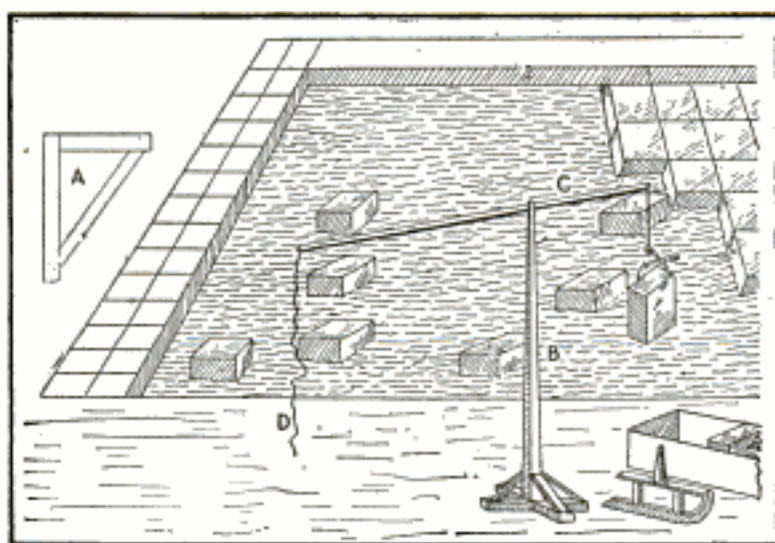

necessary to have a close fit. In the case of setting a nut on a saw mandrel, if a hammer is used as shown in Fig. 1, the blow would be a good many hundred pounds. The striking force of any falling body is equal to the weight multiplied by the square of its velocity, says *Wood Craft*. A hammer should

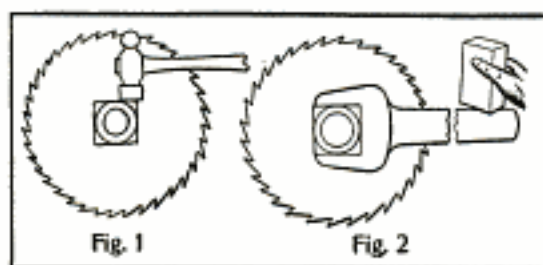

Use a Solid End Wrench

never be used to turn a saw mandrel nut. Procure a solid end wrench that will fit the nut closely, put the wrench

in position as shown in Fig. 2, and strike on the end of the wrench with the hand, or with a bit of wood—almost any block will answer—and the nut will be started quickly.

How to Remove Stumps

A soft wood stump may be removed by boring a large hole, say 1 in., in a downward direction to a depth of 16 or 20 in. Fill this hole with kerosene, and as the oil penetrates the wood fill the hole again. After each filling cork the hole with a wood plug. After a month or two apply fire to the oil in the hole, which will entirely consume the stump.

Flexible Drive for Small Boring Bar

It is sometimes desirable, when using a drill or boring bar, in cases where the bar is used in connection with guide bushings in a fixture to provide a flexible drive in order to avoid any tendency to cramp the bar. The accompanying sketch shows a simple and inexpensive form of universal joint which has been used successfully for driving small boring bars and drills

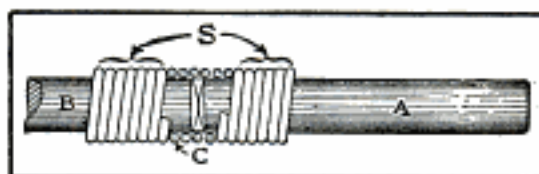

Inexpensive Universal Joint

in cases where the fixture bushings have been more or less out of line with the driving spindle. It consists of a drill or boring bar, B, and the short shank, A, the ends of each being slightly convex as shown. The spring, C, is wound close, slipped over the joint and soldered at each end as shown at S. The spring should be wound so as to fit the cores, and in such direction as to cause it to have a tendency to close tighter on the cores from the resistance of the cut, says American Machinist. The ends of the bar and shank being convex, the flexibility of

the spring will readily permit of considerable deflection in the alignment of the bar and driving spindle.

An Ever Ready Wrench

Forge an old file into the shape shown in Fig. 1, forming a screw-driver on the handle end. Cut a piece of sheet metal in the shape shown in

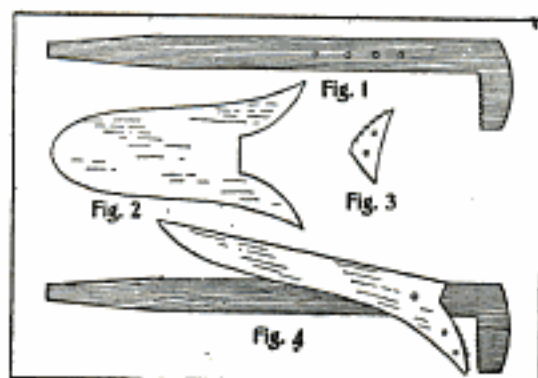

Handy Pipe Wrench

Fig. 2 and make a small piece of steel the same thickness as the handle and with small notches as in Fig. 3. Bend the sheet metal to fit around the handle and rivet the small piece of steel in between the curved ends. This piece is then placed on the handle, as in Fig. 4, and a pin inserted in a hole to suit the work at hand. This will make a handy tool for any light work.—Contributed by R. Doyle, New York.

Repairing a Bursted Lubricator

Recently I had my 1-pt. lubricator freeze and burst, which bulged it out so at the point marked B in sketch that it was useless. After removing the body from the fittings, I placed it on an anvil and hammered it back to the original shape by light careful blows. A clasp was found which

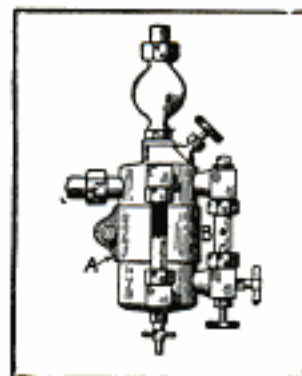

Bandaged Lubricator

I used as a bandage, A, with a piece of leather for a gasket. The lubricator worked as well as ever after placed in position, and saved the cost of a new one.—Contributed by P. W. Ostwald, Bayfield, Colo.

How to Drill Curved Holes

The accompanying cut illustrates a method of drilling holes that follow the arc of a circle. Fig. 1 shows the piece after it is finished. The tongue-piece, A, is milled so it fits into the groove of the holder, B, Fig. 2. This holder fits closely into a hole in the angle

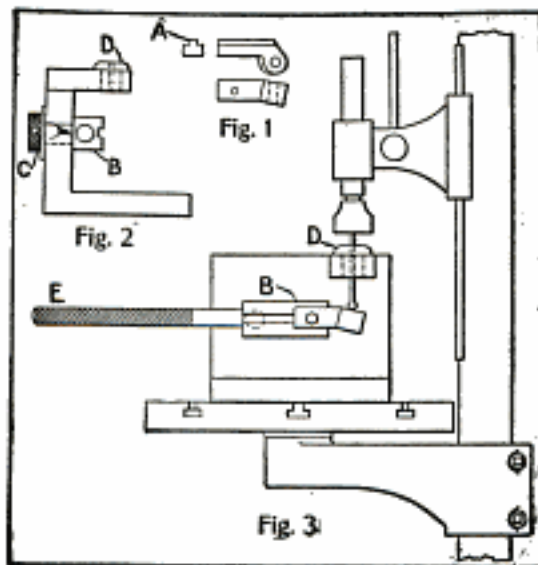

For Drilling Curved Holes

plate, and it is held against the plate by the nut C, which is just loose enough to permit the holder being turned on its axis. The drill bushing, D, is located above the work as shown. The hole through the bushing which guides the drill is made to fit the shank of the drill instead of the point, says Machinery. The drill is flat-pointed, and its shank is much smaller than the point, so that it will allow the work, when being drilled, to turn without rubbing against the shank. The reamer is of the ball type, and it is essential that the ball be round if the hole is to be accurate. The shanks of both drill and reamer are ground and lapped to fit the hole in the bushing D.

Fig. 3 illustrates the way in which the jig and the work are placed on the drill-press. The work is fastened to the holder by a bolt, as shown, and its position located with a height gauge. By pressing down on the handle, E, the work is fed against the drill, and the hole is drilled on an arc, the radius of which will depend upon the distance from the axis of the holder to the drill.

A Simple, Effective Negative Washer

The device consists of a V-shaped trough with the end pieces square to furnish a support. It should be made of sufficient dimensions to accommodate the sizes of plates being used. A few coats of some good waterproof paint will make it practically indestructible. If for 5 by 7-in. plates the sides should measure 30 by 7½ in. and be joined together at right angles at the bottom, says Camera Craft. The water enters the washer through a piece of hose attached to the tap and fitting over a short piece of pipe at the end. After passing through the washer it leaves through a siphon formed of piping at the other end. This pipe should be a trifle larger than the inlet pipe and then there will be no danger of overflow. The plates should be placed in the washer as shown with their film sides down. Sediment or dirt cannot come in contact with the film, and instead of the water pushing the dense

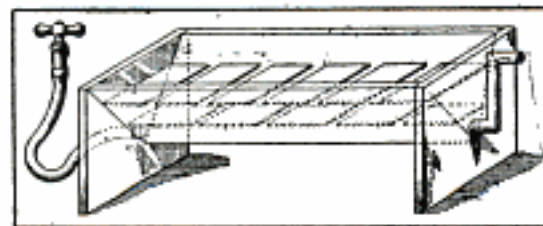

Negative Washer

hypo solution against the plates and then out over the top, as in many forms of washers, this simple device gives the plates a constant soaking in fresh water in such a position that the hypo falls to the bottom, where it is carried off through the outlet pipe.

Placing a Pipe in an Old Trench

A corporation owning several hundred flats in Hoboken, New Jersey, proposed to heat and light them with exhaust steam from a power plant recently constructed. An old trench was

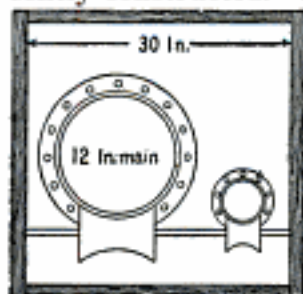

in the street 3 ft. below the pavement and 220 ft. in length from one man-hole to the other. As the city would not give a permit to dig up the old trench, the construction company decided to use it temporarily for a vacuum return pipe during the winter. The trench was 30 in. square and already contained a 12-in. main with projecting flanges at the joints, and a 4-in. pipe as shown in the illustration. The heat had not been turned off from the pipes for ten years previous. After the heat was turned off and the trench allowed to cool for two days, an attempt was made to send a sewer dog through, which failed. The next thing to do was to send the smallest man employed through. The man that volunteered started on his trip with a wire attached to one foot and a string to the other. The important feature was that the string could be broken, pulled out and used as a measure above ground to locate the man for the digging gang in case he got stuck. The wire was to draw a cable through if he succeeded in getting through himself. The extremely narrow quarters, the projecting flanges at each joint, and the intense heat made the trip a perilous and extremely difficult one, but it was successfully accomplished in one hour and a half.

As a small portion of zinc greatly aids the reduction of silver in the bath, small steel articles should be brass plated instead of copper plated previous to dip-silvering. The zinc contained in the brass makes the silver appear whiter and a heavier deposit is formed.

A Sack Holder

The accompanying illustration shows a very handy device that may be applied to a truck or attached to a stand of its own. It is composed of a circular piece of sheet metal that is made funnel-shaped at the top and the proper size to fit the mouth of the sack at the



Sack Holder

bottom, says American Miller. Around the bottom part is a strap attached with a clamping device as shown to hold the sack in place while in operation. The device is attached by two braces to a truck or may be fitted to a special truck frame.

Another Pattern-Maker's Clamp

In a recent issue of Popular Mechanics an illustrated article on a pattern-maker's clamp was given. The

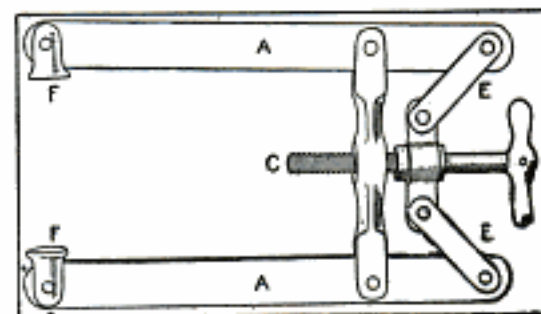

Toggle Links, E E, Work in Reverse

device as shown in the accompanying sketch is an improvement on this clamp. The toggle links, E E, work in reverse and allow the screw to back away from the work as it tightens on the material that may be clamped in the jaws, F F.—Contributed by L. N. Tanner, Lowell, Mass.

Straightening a Large Armature Shaft

A large 7-in. direct connected armature shaft was sprung $\frac{1}{8}$ -in. in one bearing close to the spiral gear. It was a case of straighten or make a new shaft. As there were two steel discs

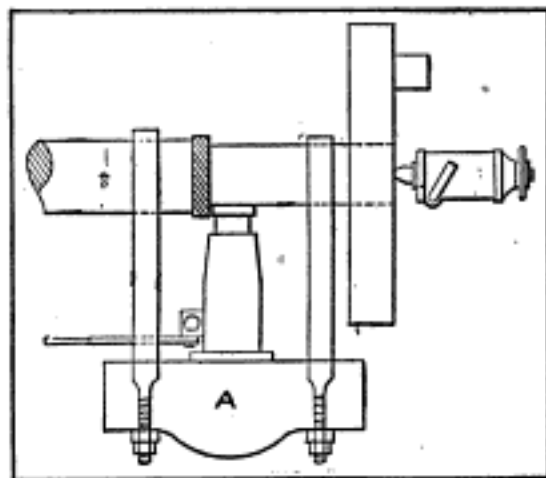

Straightening a Bent Shaft

and two spiral gears that were shrunk on and an armature to remove it was decided to straighten it. The shaft was hung in the lathe centers, and a piece of sheet iron placed on the lathe bed, on which fire brick was built up around the shaft, thus forming an arch to hold the coke. A blowpipe of air and gas was placed through the side of the arch and directly under the shaft, which was turned occasionally to get an even heat, says a correspondent in American Machinist. When red hot a 100-ton hydraulic press, A, was attached by blocking up even with the centers and using two U-bolts around the shaft with a clamp on each across the back end of the press as shown. After 80 tons pressure was placed upon it and released it still was

found to be $\frac{1}{8}$ in. out of true. After repeating the operation twice with less pressure the shaft ran true. The shaft was allowed to revolve in the lathe until cold, and after filing and polishing it was replaced in the engine.

A Lock for the Window

Secure a small plain hinge about $1\frac{1}{2}$ in. long and 1 in. wide when closed. Place the hinge on the lower right-hand corner of the upper window sash, as shown, and fasten one side to the sash with screws.

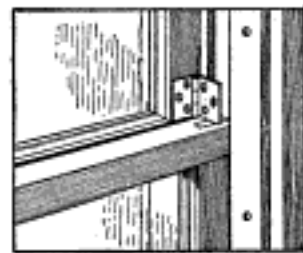

This will leave the other side of the hinge to turn. To lock the window, turn the free side of the hinge as far back as possible, which brings it over the lower sash. The hinge will not be noticed from the outside, but will prevent the lower sash from being raised or the upper one lowered. When the hinge is closed it will not be in the way of raising the window.

Increasing the Life of Coal Hods

The bottom of coal hods wear through quicker than the sides on account of receiving more force from the coal and rust caused by dampness. If a wood bottom is placed on top of the metal one it will take up the wear.

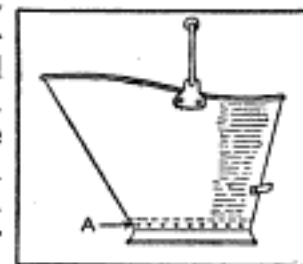

A piece of paper is cut to fit the bottom of the hod and used as a pattern in marking out a piece of wood. A $\frac{3}{8}$ -in. thick board will do, which should be free from cracks. After marking the wood from the pattern it is cut and shaped to fit the slope in the front and back of the hod. After placing the wood on top of the metal

bottom, holes are punched through the metal sides at the bottom, as shown at A in the sketch. Drive nails through these holes into the wood bottom to hold it in. This will increase the service of a coal hod several times.

How to Make a Poultry Feed Trough

A large feed trough to feed poultry may be made from two pieces of lumber, 6 or 8 in. wide and nailed together, forming a V-shaped trough, says the Poultry Keeper. Nail a piece of board 10 by 14 in. at each end, which will stop up the ends and also serve as legs.

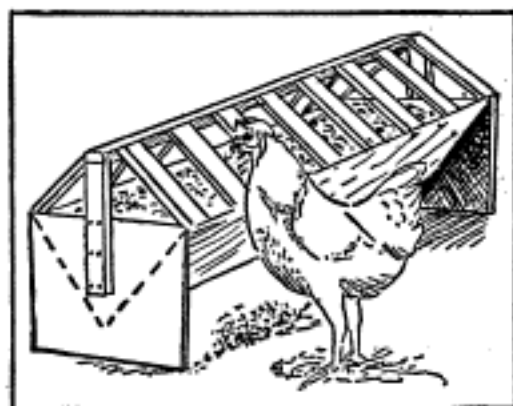

Poultry Feed Trough

On these ends nail two uprights and a strip across the top, which will serve as a handle. From this handle strip to the edge of the trough nail other strips about 3 in. apart to prevent the fowls from getting into the feed with their feet.

Holder for Plow Discs While Sharpening

A piece of 2 by 4-in. block, A, is beveled on the upper end and fastened to the anvil block as shown. Another piece of 2 by 4-in. material, B, is fitted on top of the small block, which should be long enough to stand about 3½ in. above the anvil. A ½ by 8-in. bolt, C, with a ¼-in. hole in one end and a thread made on the other serves to hold the upright piece, B, in position. A hardwood pin, D, about 4 in. long is

fitted in the upper end of the upright piece, B, to receive the disc. When the disc is heated it is removed from

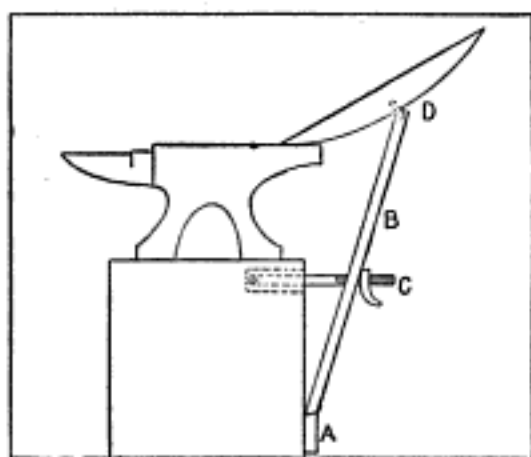

Disc Can Be Turned on Pin

the fire and placed on the pin, D, and adjustment made by the bolt C. The disc can be turned around on the pin and the hammering will be made even all around.—Contributed by Farmer Williamson, Durango, Colo.

Removing a Broken Tuning Valve

After several trials to remove a stuck tuning valve in a horn the part on the outside was broken off flush. The problem was to remove the broken part remaining. After some thought the workman secured a round piece of brass near the size of the hole in the broken valve. One end of the brass rod was cut out in a wedge-shaped notch as shown at D, Fig. 1, and a wedge was made to fit this notch with its outside roughened. The part of the brass rod back of the wedge was filed flat, as shown in the end view, A, Fig. 1, while the other end, B, including the wedge, remained round. This tool was inserted into the broken valve and a thin piece of metal placed in the space, C, left by the flat part filed on the rod, and used to drive the wedge tight against the broken valve part. A little heat

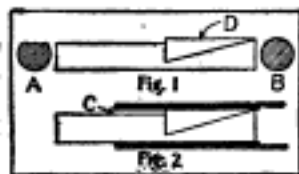

was applied and the part removed and repaired without trouble.

How to Make a Water Strainer

Bend a piece of heavy wire in a circle as shown in Fig. 1, forming a handle, B, on one end of the wire and

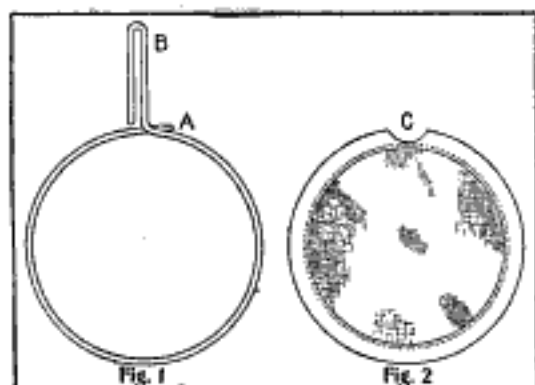

Water Screen

the other is lapped over a little, as shown at A. This circle should be about 12½ in. in diameter. Cut a circular piece of cheese cloth about 15 in. in diameter and make a broad, loose hem around the edge, Fig. 2, cutting out a small notch, C, in the edge. After the hem is made the diameter of the cloth should be about 13 in. The end of the wire, A, Fig. 1, is inserted in the hem of the cheese cloth circle, C, Fig. 2, and the cloth is pushed around until the wire circle is enclosed in the hem of the cloth. Before pumping a pail of water lay the strainer thus made over the pail. When through pumping remove the strainer and give

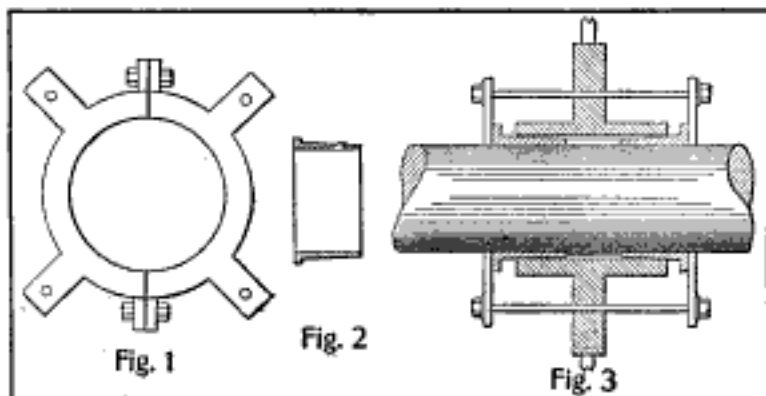

Fastening a Blower Fan to the Shaft

it a vigorous shake and hang up to dry. Two or three cloth circles should be provided, so that the one in use may be removed and dried.—Contributed by R. B. Reynolds.

How to Repair Lathe Bronze Bearings

File or plane the joints of the bronze bearings and after placing together cover the outside with solder. Turn the spindle to remove all wear. Center the bearings in the chuck and bore out to fit the turned spindle. Then place them on a mandrel and turn off the solder to fit the housing. Saw them apart at the old joints and place in position. This will give a new wearing surface on both the spindle and bronze bearings, making them as good as new.—Contributed by E. R. Thompson, Harvard, Ill.

It is easy to determine in what part of the country brass foundry ashes and skimmings originate when found in the hands of the metal dealer, as in New England anthracite coal is used in melting. In the West, South and Middle West coke is used.

How to Tighten a Worn Blower Fan

A large fan in the heating system of a manufacturing plant had become quite racked. All the rivets were loose and the spiders were so worn that they did not fit the shaft by about ¼ in. The shaft was 5 in. in diameter. The fan could not be spared long enough to have a new shaft made and the spiders re-bored, says a correspondent in Power. A plan was adopted as illustrated by the accompanying sketch. Two taper brass sleeves, Fig. 2, were made for wedges, the inside diameter being just a trifle over that

of the shaft, each with a flange on the thick end. Then two cast-iron spiders were constructed in four sections, and the halves bolted together, as in Fig. 1. These were bored to fit loosely on the shaft. After slipping the cone sleeves under the hub of the fan, as in Fig. 3, the cast-iron spiders were put on, one on each side, and four $\frac{5}{8}$ -in. tie-rods, with threads and nuts on each end, were passed through the holes in the spiders' arms, going between the arms of the fan. Turning up the nuts on the rods drew up the spiders and wedged the sleeves solidly in place under the fan bearing without throwing the fan off center.

A Tandem Crucible Furnace

For many purposes the tandem crucible furnace will be found quite useful and well worth the cost of installation. Most furnaces in use at the present time are based upon the principle of the tandem furnace. The old tandem furnace was the form in which the waste heat was utilized. The furnace shown in the sketch consists of two similar ones placed in tandem, so that the waste heat from one is utilized for heating the other. If a good natural draught is had, the problem is not difficult. In constructing a tandem furnace all that is needed is to place two similar furnaces together with the flue from the

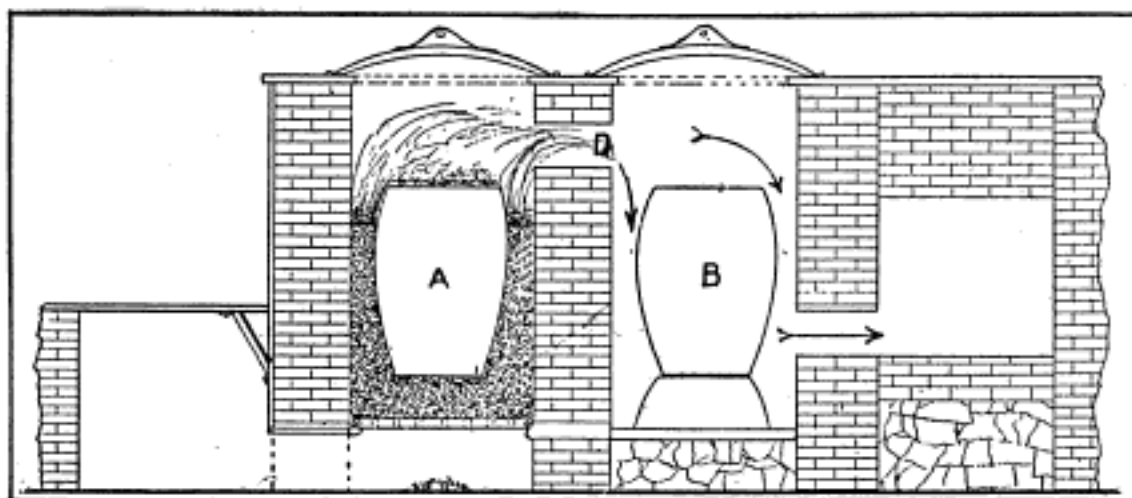

Crucible Furnace Which Utilizes Waste Heat

An Emergency Bake Oven

Quite recently my wife had just gotten a dish of beans ready for cooking, when to her dismay she discovered that the gas had been turned off. She also had a pan of biscuit dough ready for the oven. What to do she did not know. More for a joke than anything else I replied, "I will show you how to cook them."

I went to the hard coal stove, shook down the ashes and dumped them and put the beans and biscuit dough in the ash pan, covering them with a tin cover, and then replaced the pan in the stove and awaited developments. I never tasted better beans and biscuit in my life.—Contributed by Charles Clement Bradley, West Toledo, Ohio.

second passing out from the bottom and into the chimney.

The first furnace is of the usual type, and the crucible, A, sets upon the coke or coal in the regular manner. The covers should close the furnace as tightly as possible, says *The Brass World*. The flame passes through the flue, D, into the second furnace in which the crucible, B, rests. The bottom of an old crucible is used in the furnace and the crucible sets upon it. From this furnace the flame passes through the bottom flue into the main chimney. The heat that passes into the second furnace is usually insufficient to melt copper, or even brass, but for aluminum, soft metals or warming up a crucible so that it can be introduced into the first furnace it serves a good purpose.

A Home-Made Brooder

The accompanying sketch shows how to construct a brooder that will not require much time to make, says a correspondent in the Poultry Keeper. See

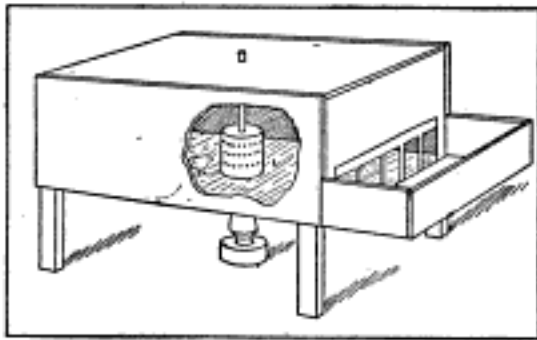

Inexpensive Brooder

cure a box and in the center of the bottom cut a circular hole just large enough to receive a common tomato can. Holes are punched in the side of the can and also a hole cut in its bottom large enough for a 1½-in. pipe. A hole is then cut in the top of the box for this pipe to extend through from the top of the tomato can, which rests on the bottom of the box, as shown. A common lamp furnishes the heat to the radiator formed by the tomato can.

How to Machine an Arc on a Planer

The following is a description of an attachment used on a planer to machine arcs: Referring to the illustration, T is the table of the planer, S the slide moving in the gibs C and G which

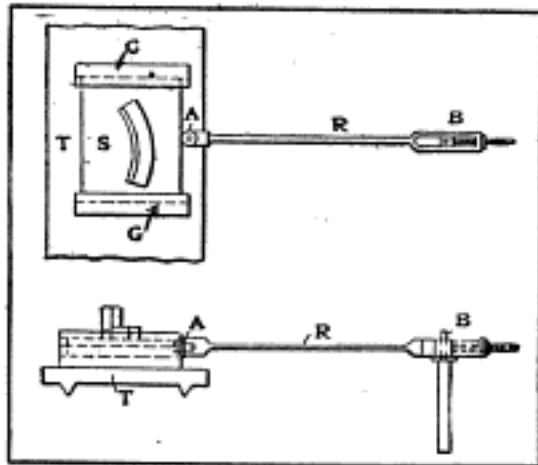

Cutting Arcs on a Planer

are fastened on the planer table. The point A of the slide and a vertical shaft, B, are connected by the rod R. This rod R is made adjustable for different radii, says the American Machinist. The part to be machined is placed on the slide and the tool is clamped on the planer head. The machined line obtained is an exact arc.

A Paint Brush and Pail Holder

Various hooks are used by painters on ladders to hold the paint pail. In the sketch is shown how to make a paint brush and pail holder combined by using a heavy wire. A hook formed as shown may be attached to any rung of the ladder and not interfere with the climbing of the workman.

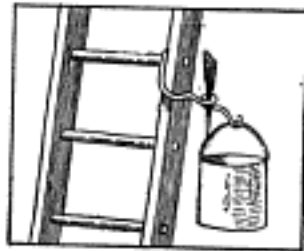

Home-Made Instrument to Draw Parallel Lines

A device that consists of a thin sheet of tin or aluminum, bent as shown, with two common lead pencils held in pockets at each edge of the sheet, makes it possible to draw two parallel lines to be used as guide lines for lettering on a drawing. A cross section of the pockets, A B, is shown in Fig. 2. The pencils may be moved up or down to vary the spacing of the lines, and can easily be removed for sharpening, says American Machinist. This instrument is a time saver, but its chief merit lies in the fact that by its use the lettering on a drawing is more uniform in height than when the guide lines are spaced by guess.

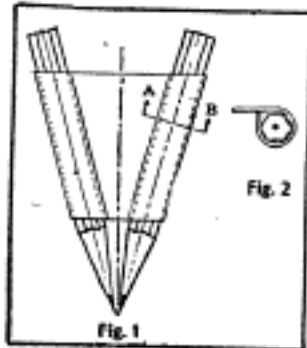

How to Make Pipe Coverings

Coverings may be made in small shops by means of rolls supported by pipe and fittings as shown in the sketch. Coverings are composed of a layer of asbestos paper, then wool felt building paper and finally a canvas jacket. The size depends on the size of pipe used and wooden rolls must be provided for each size of pipe. These rolls are divided longitudinally into halves so that the end of the paper can be clutched between them when the rolling of the paper is started. The roll of wool felt is mounted on an iron pipe which, extending beyond the roll, is supported by a tee cut longitudinally to serve as a bearing for each end of the pipe roller, as shown at A in the sketch. The paper in unrolling is then passed between two rolls, the lower one of which is partly submerged in paste in a box for holding the paste, so that the wool felt in passing over the roll receives an application of the paste carried up by the roll in its turning. The upper roll serves as a weight to bring the paper in close contact with the paste roller and also to squeeze the wool felt against the roller so that only the proper amount of paste is used, says *The Metal Worker*. The paper is then passed over an idle roller, and is finally drawn to the work bench, on which is mounted the wooden form needed for each size of pipe. It will thus be seen that it is only necessary to keep rolling the wool felt on the form, after the single thickness of asbestos paper has first been applied, until the desired thickness is obtained, when the covering is ready to be dried before wrapping in the light canvas protection.

The finished roll will dry quickly in an ordinary atmosphere, but if made at times when it should not dry quickly, mold might set in and the paste not set properly. A small drying room may be constructed and heated with a set of horizontal pipes connected at the ends by return bends to be used for the circulation of hot water. The

coverings are stacked vertically in this drying room and when the hot water is circulated the heat serves to drive off

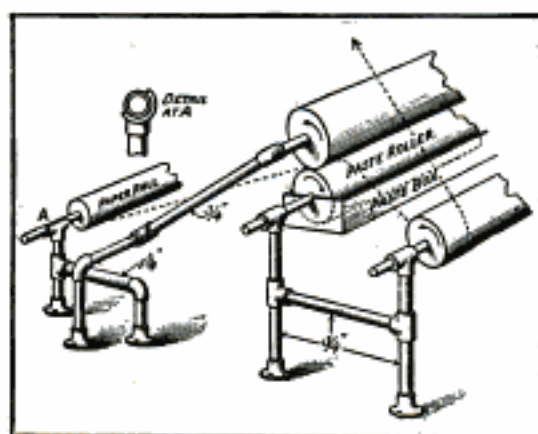

Making Pipe Coverings

the moisture from the paste quickly. The water may be heated by a gas water heater using illuminating gas and placed just outside the drying room. A small circular saw is used for trimming the ends of the coverings when finished, although where a large quantity is not made a common hand saw will answer the purpose.

Home-Made Pipe Cap

Bore a hole in a block of wood about 1 in. deep and $\frac{3}{4}$ to 1 in. larger than the pipe on which the cap is to be used. Plug the threaded end of a short piece of pipe with putty or clay. If clay is used, it must be dried after placing in the pipe. Hold this plugged end of the pipe in the hole made in the wood block, allowing equal distances on the sides as well as the end, as shown in the sketch. Pour into the space, A, around the pipe threads melted lead, and when cool the pipe is unscrewed. By adding some zinc to the lead a cap can be made that will hold the pressure of most city water mains.—Contributed by James E. Noble, Toronto, Canada.

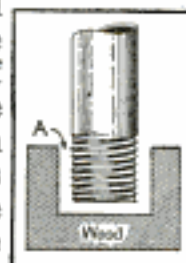

Increasing the Ink Capacity in a Drawing Pen

The ordinary drawing pen will not hold sufficient ink to enable one to draw a broad line of reasonable length. A simple attachment as shown in the sketch will supply the pen to be used with plenty of ink for broad lines, says the American Machinist. A thin piece of steel is filed and bent to shape. A hole is drilled a little smaller than the diameter of the adjusting screw of the pen. When screwed in, the strip is kept tight on the screw and central between the nibs. The strip can be swiveled around so that the pen may be easily cleaned, and can be taken off when not in use.

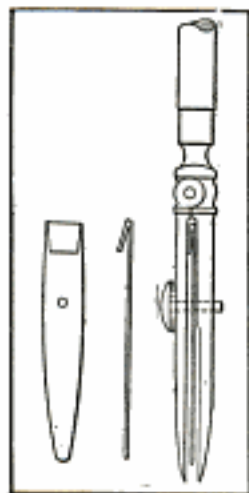

A Home-Made Boiler Grate

A construction company had to ship their outfit a considerable distance and when putting their power plant in order found that the grates for the boilers were lost in transit. As it was several hundred miles from a manufacturing plant, the engineer had to construct a makeshift grate for immediate use. Some old $\frac{3}{4}$ -in. pipe, including some fittings, was found about the



Home-Made Boiler Grate

place. Two pieces of 2-in. pipe were cut as long as the width of the firebox. A malleable 2-in. tee was placed on each end of the pipe. One side of each 2-in. pipe was drilled and tapped, one with right hand and the other with left hand threads, to receive the $\frac{3}{4}$ -in. pipe. Threads were cut on each end of the $\frac{3}{4}$ -in. pipe, one end with right hand and the other with left hand threads, leaving a long thread and making them the length of the firebox. Collars were made by cutting small pieces from 1-in. pipe and tapping one set with right hand and the other with left hand threads. When putting the whole device together, as shown in the sketch, the collars were used as lock-nuts on each end of the $\frac{3}{4}$ -in. pipe. The 2-in. pipes were capped on the ends, leaving the opening in the tee to form a circulation of air through the pipes. Water was kept in the ash pit and this device was used for several months without a sign of burning out.

How to Fit Handles to Carving Knives

The shank of the blade should be forged the same shape as a flat file shank, tapering and square, as shown in Fig. 1. A piece of wood is secured and a hole bored in the end to receive the shank. The wood should be dressed to the shape desired for a handle while on the shank to keep it straight with the blade. After removing the blade, bore a $\frac{3}{8}$ -in. hole through the handle, A, Fig. 2, and wrap the handle with paper, covering the hole, A, and extending it over the end of the handle about $\frac{1}{2}$ in. The shank of the blade is again placed in the handle, and while held in an upright position melted solder poured into the space between the paper and the blade. This will fill the space around the square shank and the hole A, and will make a

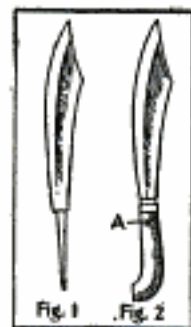

ferrule at the end of the wood handle. This will always hold the blade solid in the handle. Solder must be used and not babbitt.

Gasket Made of Wound Asbestos Cord

This is a simple method of making a gasket or washer of $\frac{3}{8}$ -in. wound asbestos packing, or cord. The cords are alter-

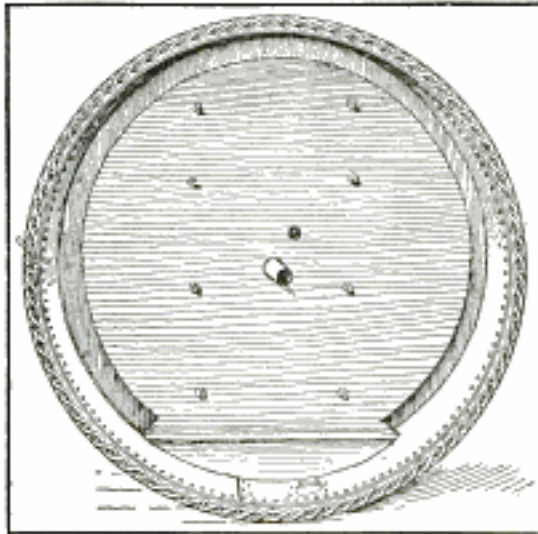

Asbestos Packing Gasket

nately passed around short bolts, as shown by this tank, which is used to separate crude oil from the sand brought up by the pumps. It is subjected to a slight steam pressure when the lid is on.

How to Tighten a Worn Screw

A screw was worn so that it was too small for the hole in a certain place on a printing press, and not being able to obtain one of suitable shape and size, a correspondent in Machinery used the old one by placing it between two pieces of wood in a vise and cutting a slot as shown in the sketch. The slot was opened a little and a flat iron wedge driven in. The screw was then turned into its place, where it held as good as a new one. This method could be used also with bolts where the nut will not stay.



How to Cut Stovepipe

Where short joints of stovepipe are needed the cutting of them with tinners' shears or a chisel does not make a very good piece of work. Use a common can opener as shown at A in sketch

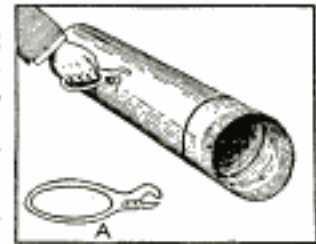

and the work will be easily done and the ends will have a smooth edge.—J. E. M.

Emptying Oil Barrels with Compressed Air

A great many barrels of oil had to be emptied and, as compressed air was close at hand, a correspondent in Power made a device as illustrated to do the work. On one end of a 7-in. length of 1-in. pipe, threaded at both ends, was screwed a 1-in. tee, A, and a 1 by $\frac{1}{2}$ -in. bushing, B, was turned to one side of the tee.

A long thread was cut on one end of a 35-in. section of $\frac{1}{2}$ -in. pipe, and in the other end were filed four notches $\frac{1}{8}$ in. deep. This end of the long pipe was inserted in the 1-in. pipe and the threaded end of the $\frac{1}{2}$ -in. pipe was turned into the bushing, $\frac{1}{2}$ in. of the thread extending from the top to receive a $\frac{1}{2}$ -in. coupling, D. One end of a 16-in. section of $\frac{1}{2}$ -in. pipe, which was threaded on both ends, was inserted into the coupling, and an elbow turned on the other end. The side outlet, E, of the tee was used for the air connection.

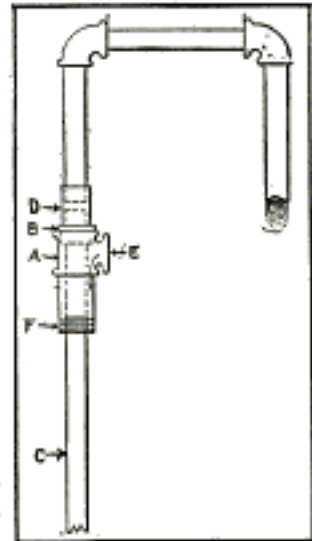

A $1\frac{1}{8}$ -in. hole is bored into the bung of the barrel and the free end of the 1-in. pipe, F, turned into it. The compressed air connection may be made by means of a rubber hose, or any suitable means will do. By being careful not to use too much air pressure, the device will empty a barrel in five minutes as thoroughly as if drained.

A Holder for Tool Grinding

Edge tools, such as chisels and plane irons, are now put on the market

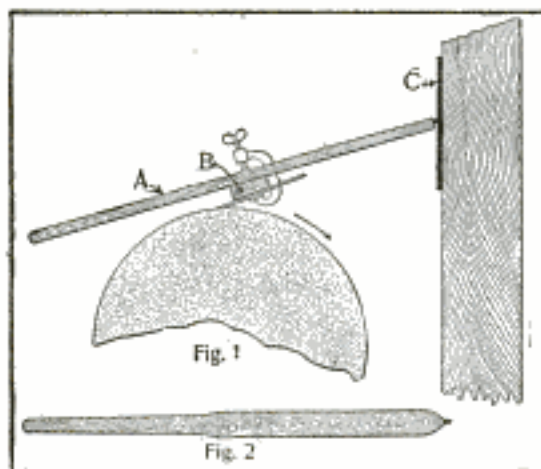

Holding Tools for Grinding

ground and honed, but the ordinary shop appliances for grinding them are often far from satisfactory. Every worker knows that the bevel on the cutting edge of a plane iron or chisel should be uniform and flat, but there are many workmen that will hold these tools in their hands and attempt grinding without the aid of any support. More often the result is a convex instead of a flat or concave bevel. The accompanying sketch shows a device for holding these tools while grinding. A wood bar, A, Fig. 1, is made from 1 or $1\frac{1}{8}$ -in. material, about $2\frac{1}{2}$ in. wide and $3\frac{1}{2}$ ft. long. Fig. 2 shows the top view of this bar. One end is shaped into a handle, into the other has been turned a screw the depth of the threads, the head is clipped off and the end of the shank filed rounding for a pivot. The block B, 4 or 5 in. long, and the width of A, is screwed to it and carries the tool to be ground. In this case the

tool is a plane iron clamped to the block with a thumb screw.

On the post just back of the grindstone is fastened a strip of $\frac{3}{8}$ by 1-in. iron with holes drilled in a row about $\frac{3}{4}$ in. apart and numbered. These holes should only be drilled a part of the way in the metal. When the plane iron has been clamped to the block so that the cutting edge is not more than 1 in. ahead of it, the pivot is set in any hole and the iron dropped on the stone. A few seconds of grinding will show the new bevel and if this should not be what is wanted, set the pivot in another hole and try again. Not more than one or two changes will usually be required. When the proper hole has been found note its number.

With this device the stone may be turned by one hand and the tool managed with the other. Even on a power-turned stone one hand is better than two, says Wood Craft. The tool may be turned over as many times as desired in the process of grinding to note its progress and it drops back on the same bevel when replaced. Should the pivot slip out of the hole, be sure and replace it in the same hole. It is rapid and accurate, and even in the hands of a boy it is quickly mastered and gives the best of results.

Wheelbarrow Bucket for Handling Concrete

This wheelbarrow was designed for the handling of concrete. The central stem by which the bucket is hoisted carries a wheel, so that, with handles attached, the bucket becomes a wheelbarrow. The handles are detachable. The proportions of concrete are measured by rows of rivets around the bucket. It is also adaptable for handling coal, earth and other materials, and can be hoisted.



Quickly Made Pipe Reducer

If in doing some pipe fitting you do not have a reducer at hand you can



make one out of a pipe coupling. Place the coupling on the end of a pipe and clamp the whole in a vise.

Cut threads about one-half the way over the outside of the coupling and you will have a first-class reducer.—Contributed by Wm. Erickson, Chicago.

Steam Brake for Threshing Machines

The modern method of threshing is not only one involving power for operation, but the same power is used to draw the outfit from one place to another.

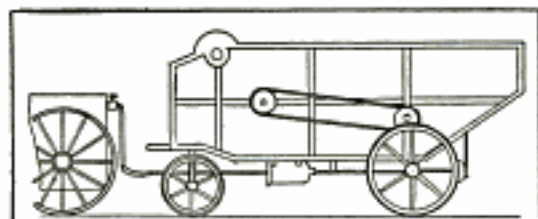

Wheel Brake Operated by Steam

These wagon trains often have steep hills to descend which call for considerable skill to prevent the train from running away. A recent invention has provided a wheel brake operated by steam from the boiler of the traction engine. The steam pipe is carried beneath the bodies of the several vehicles the entire length of the train and is controlled by the engineer.

A Tool for Cutting Hardened Steel Wire

Pliers and chisels are often spoiled by trying to cut hardened steel wire. Grind the chisel with a face about $\frac{1}{32}$ in., as shown in the sketch at



A. This will cut the wire without injury to the tool.—Contributed by G. M. Coleman, Sandusky, O.

Keeping an Ink Bottle from Turning Over

Cut a circle about 5 in. in diameter from a heavy piece of cardboard. Make a hole in the center that will fit tightly over the neck of the bottle as shown in Fig. 1. After it is placed on the neck of the bottle, Fig. 2, the bottle cannot turn over far enough to spill the ink.

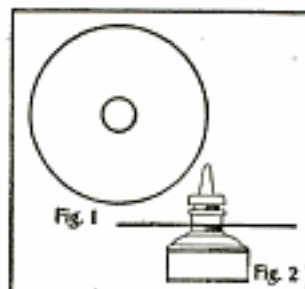

How to Attach Drop Wires

The following rules have been found to cover the installation of drop wires to an extent sufficient to insure good work: Drop wires are to be securely fastened to the outside of the building by means of heavy knobs and screws, and left long enough to project through the window casing and up to the protector. About 6 ft. of wire will be sufficient. The drop wire must be run through the window casing in tubes of approved insulating material. In boring the holes through the window casing for the tubes they must be bored so that they will have a slant downward of about $\frac{1}{2}$ in. in 6 in. toward the outside of the building, says the American Telephone Journal. This will prevent water from dripping through the tubes into the building. The tubes must be cut long enough to allow a projection of about $\frac{1}{2}$ in. on the outside of the window casing, and must be cut of the requisite length for the casing on the outside. Just before the drop wires reach the outside ends of tubes they are to be bent into a drip loop, to prevent water from following the wires into the building. The holes

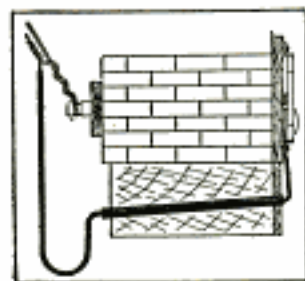

for the tubing must be bored not less than $2\frac{1}{2}$ in. apart, nor more than 5 in. The drop wires always must run directly to the posts marked line on the protector.

How to Harden Fine Circular Saws

Secure a bucket, a can or small pail and two pieces of flat-surfaced material larger than the saw to be hardened. Place one of the blocks in the bucket and fill with water barely to cover, as

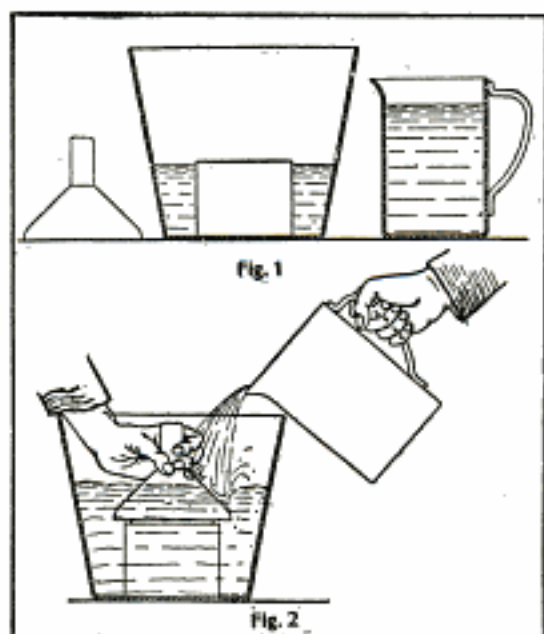

Hardening Circular Saws

shown in Fig. 1. Have the can or small pail filled with water and within reach. The saw is now given the proper heat and quickly placed on the block in the pail and the other flat piece placed on top immediately, the whole being quickly covered with the water from the can or small pail. The result will be a hardened saw free from warps.

According to L'Electricien, a Vienna firm has recently placed on the market brushes made of glass, which are to replace emery cloth for cleaning and polishing the commutators of dynamos and motors. These brushes are said to clean the commutators without scoring the metal, and their use avoids the inconveniences and dangers of emery cloth.

How to Remove Old Putty

Remove the window sash and lay it flat on a table with the putty side up. Take a common spring-bottom oiler filled with gasoline and squirt a small quantity of gasoline on the putty all around the sash. Apply a match and the heat of the burning gasoline will soften the old hard putty so that it can be removed with a putty knife without cutting or defacing the sash. If the putty is very hard a second application of the gasoline may be necessary.

Making a Well House

A well house helps to keep the water in the well cool in summer, and also prevents the pump from freezing in the winter. If it is constructed along the lines as shown in the illustration, a well house may be made to add beauty to the surroundings, says the Country Gentleman. The one here shown is built directly upon the usual square well plat-



form of plank, this being allowed to project some 6 in. all about the house. The roof is made to curve gracefully out to the eaves that overhang the walls. If the doorway is on the north side, no door need be used during the summer; but this should be in place in the winter, and the latticed windows should then have a sash fitted to them, or one opening can be fitted with sash and the other two covered with board shutters. A few vines or a shrub or two may be planted at the base of the walls to add to the attractiveness. So simple a little building can be easily made by the household mechanic.

A Substitute Boiler Compound

A contractor's plant was situated at a place where transportation facilities were not very good, and it was many miles from a manufacturing city which was their source of supply. The water used in the boilers contained so much alkali that it was impossible to run very long without cleaning the boilers from scale. No chemical or compound was at hand to be used. The engineer happened to notice some small shrubs known as sumac. He secured a quantity of the berries that are found on these shrubs and cooked them with steam in a tank, making a fluid which was used in the boilers and kept them satisfactorily clean.—Contributed by C. W. Greenleaf, Somerville, Mass.

READY LUMBER TABLE

1	2	3	4	5	6	7	8	9	10	11	12	13	14	15	16	17	18	19	20	21	22	23	24	25	26	27	28	29	30	31	32	33	34	35	36	37	38	39	40	41	42	43	44	45	46	47	48	49	50	51	52	53	54	55	56	57	58	59	60	61	62	63	64	65	66	67	68	69	70	71	72	73	74	75	76	77	78	79	80	81	82	83	84	85	86	87	88	89	90	91	92	93	94	95	96	97	98	99	100		
1	1.00	1.01	1.02	1.03	1.04	1.05	1.06	1.07	1.08	1.09	1.10	1.11	1.12	1.13	1.14	1.15	1.16	1.17	1.18	1.19	1.20	1.21	1.22	1.23	1.24	1.25	1.26	1.27	1.28	1.29	1.30	1.31	1.32	1.33	1.34	1.35	1.36	1.37	1.38	1.39	1.40	1.41	1.42	1.43	1.44	1.45	1.46	1.47	1.48	1.49	1.50	1.51	1.52	1.53	1.54	1.55	1.56	1.57	1.58	1.59	1.60	1.61	1.62	1.63	1.64	1.65	1.66	1.67	1.68	1.69	1.70	1.71	1.72	1.73	1.74	1.75	1.76	1.77	1.78	1.79	1.80	1.81	1.82	1.83	1.84	1.85	1.86	1.87	1.88	1.89	1.90	1.91	1.92	1.93	1.94	1.95	1.96	1.97	1.98	1.99	2.00

Showing the Board Foot for Each One Linear Foot for Each Dimension Given. One inch. to 15 inches, by half inches.

Contributed by E. W. Bowen.

1	2	3	4	5	6	7	8	9	10	11	12	13	14	15
1	1.00	1.00	1.00	1.00	1.00	1.00	1.00	1.00	1.00	1.00	1.00	1.00	1.00	1.00
1 1/2	1.50	1.50	1.50	1.50	1.50	1.50	1.50	1.50	1.50	1.50	1.50	1.50	1.50	1.50
2	2.00	2.00	2.00	2.00	2.00	2.00	2.00	2.00	2.00	2.00	2.00	2.00	2.00	2.00
2 1/2	2.50	2.50	2.50	2.50	2.50	2.50	2.50	2.50	2.50	2.50	2.50	2.50	2.50	2.50
3	3.00	3.00	3.00	3.00	3.00	3.00	3.00	3.00	3.00	3.00	3.00	3.00	3.00	3.00
3 1/2	3.50	3.50	3.50	3.50	3.50	3.50	3.50	3.50	3.50	3.50	3.50	3.50	3.50	3.50
4	4.00	4.00	4.00	4.00	4.00	4.00	4.00	4.00	4.00	4.00	4.00	4.00	4.00	4.00
4 1/2	4.50	4.50	4.50	4.50	4.50	4.50	4.50	4.50	4.50	4.50	4.50	4.50	4.50	4.50
5	5.00	5.00	5.00	5.00	5.00	5.00	5.00	5.00	5.00	5.00	5.00	5.00	5.00	5.00
5 1/2	5.50	5.50	5.50	5.50	5.50	5.50	5.50	5.50	5.50	5.50	5.50	5.50	5.50	5.50
6	6.00	6.00	6.00	6.00	6.00	6.00	6.00	6.00	6.00	6.00	6.00	6.00	6.00	6.00
6 1/2	6.50	6.50	6.50	6.50	6.50	6.50	6.50	6.50	6.50	6.50	6.50	6.50	6.50	6.50
7	7.00	7.00	7.00	7.00	7.00	7.00	7.00	7.00	7.00	7.00	7.00	7.00	7.00	7.00
7 1/2	7.50	7.50	7.50	7.50	7.50	7.50	7.50	7.50	7.50	7.50	7.50	7.50	7.50	7.50
8	8.00	8.00	8.00	8.00	8.00	8.00	8.00	8.00	8.00	8.00	8.00	8.00	8.00	8.00
8 1/2	8.50	8.50	8.50	8.50	8.50	8.50	8.50	8.50	8.50	8.50	8.50	8.50	8.50	8.50
9	9.00	9.00	9.00	9.00	9.00	9.00	9.00	9.00	9.00	9.00	9.00	9.00	9.00	9.00
9 1/2	9.50	9.50	9.50	9.50	9.50	9.50	9.50	9.50	9.50	9.50	9.50	9.50	9.50	9.50
10	10.00	10.00	10.00	10.00	10.00	10.00	10.00	10.00	10.00	10.00	10.00	10.00	10.00	10.00
10 1/2	10.50	10.50	10.50	10.50	10.50	10.50	10.50	10.50	10.50	10.50	10.50	10.50	10.50	10.50
11	11.00	11.00	11.00	11.00	11.00	11.00	11.00	11.00	11.00	11.00	11.00	11.00	11.00	11.00
11 1/2	11.50	11.50	11.50	11.50	11.50	11.50	11.50	11.50	11.50	11.50	11.50	11.50	11.50	11.50
12	12.00	12.00	12.00	12.00	12.00	12.00	12.00	12.00	12.00	12.00	12.00	12.00	12.00	12.00
12 1/2	12.50	12.50	12.50	12.50	12.50	12.50	12.50	12.50	12.50	12.50	12.50	12.50	12.50	12.50
13	13.00	13.00	13.00	13.00	13.00	13.00	13.00	13.00	13.00	13.00	13.00	13.00	13.00	13.00
13 1/2	13.50	13.50	13.50	13.50	13.50	13.50	13.50	13.50	13.50	13.50	13.50	13.50	13.50	13.50
14	14.00	14.00	14.00	14.00	14.00	14.00	14.00	14.00	14.00	14.00	14.00	14.00	14.00	14.00
14 1/2	14.50	14.50	14.50	14.50	14.50	14.50	14.50	14.50	14.50	14.50	14.50	14.50	14.50	14.50
15	15.00	15.00	15.00	15.00	15.00	15.00	15.00	15.00	15.00	15.00	15.00	15.00	15.00	15.00



Amateur Mechanics



How to Enlarge from Life in the Camera

Usually the amateur photographer gets to a point in his work where the miscellaneous taking of everything in sight is somewhat unsatisfying. There

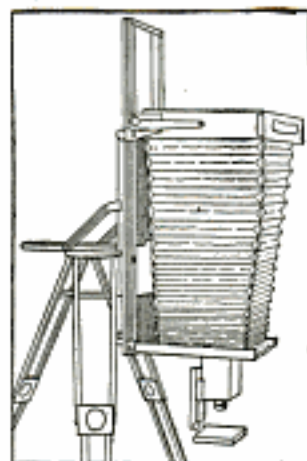

are many special fields he may enter, and one of them is photomicrography. It is usually understood that this branch of photography means an expensive apparatus. If the worker is not after too high a magnification, however, there is a very simple and effective means of making photomicrographs which requires no additional apparatus which cannot be easily and quickly constructed at home.

Reproduced with this article is a photograph of dandelion seeds,—a magnification of nine diameters or eighty-one times. The apparatus which produced this photograph consisted of a camera of fairly long draw, a means for holding it vertical, a short focus lens, and, if possible, but not essential, a means for focusing that lens in a minute manner. On top of the tripod is the folding arrangement, which is easily constructed at home with two hinged boards, an old tripod screw, an old bed-plate from a camera for the screw to fit in, and two sliding brass pieces with set screws that may be purchased from any hardware store under the name of desk sliding braces. To the front board is attached a box carrying the lens and the bed of the sliding object carrier, which is actuated in a forward and back movement by the rack and pinion, which also can be obtained from hardware stores. If the bed for the object car-

rier be attached to the bed of the camera instead of the front board, the object carrier need have no independent movement of its own, focusing being done by the front and back focus of the camera; but this is less satis-



Magnified Nine Diameters

factory, particularly when accurate dimensions are to be determined, says the *Photographic Times*. This outfit need not be confined to seeds alone, but small flowers, earth, chemicals, insects and the thousand and one little things of daily life—all make beautiful and unique subjects for enlarged photographs. These cannot be made by making a usual photograph and enlarging through a lantern. When a gelatine dry plate is magnified nine diameters, the grains of silver in the negative will be magnified also and produce a result that will not stand close examination. Photographs made by photomicrography can be examined like any other photographs and show no more texture than will any print.

How to Make a Small Motor

The accompanying sketch shows how to make a small motor to run on three or four cells of dry batteries and to have power sufficient to run mechanical toys. The armature is constructed as shown in Figs. 1 and 2 by using a common spool with eight flat headed screws placed at equal distances

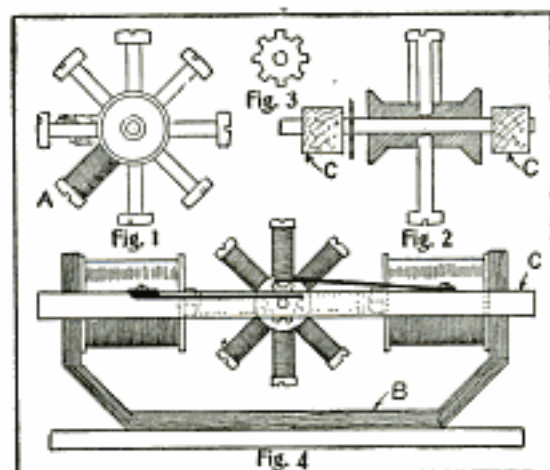

Details of Small Electric Motor

apart and in the middle of the spool. Each screw is wound with No. 24 iron wire as shown at A, Fig. 1. The commutator is made from a thin piece of copper 1 in. in diameter and cut as shown in Fig. 3, leaving eight points $\frac{1}{2}$ in. wide and $\frac{1}{8}$ in. deep. The field is built up by using eight strips of tin 12 in. long and 2 in. wide, riveted together and formed in the shape as shown at B in Fig. 4. Field magnets are constructed by using two $\frac{3}{8}$ -in. bolts $1\frac{1}{2}$ in. long. A circular piece of cardboard is placed on each end of the bolt, leaving space enough for the bolt to pass through the field, B, and to receive a nut. Wind the remaining space between the cardboards with 30 ft. of No. 22 double wound cotton covered copper wire. A light frame of wood is built around the magnets as shown at C, Fig. 4. Holes are made in this frame to receive the shaft of the armature. Two strips of copper $\frac{1}{4}$ in. wide and 3 in. long are used for the brushes. The armature is placed in position in its bearings and the brushes adjusted as shown in Fig. 4, one brush touching

the shaft of the armature outside of the frame, and the other just touching the points of the commutator, which is placed on the shaft inside of the frame. Connect the outside wire of one magnet to the inside wire of the other and the remaining ends, one to the batteries and back to the brush that touches the shaft, while the other is attached to the brush touching the commutator. In making the frame for the armature bearings, care should be taken to get the holes for the shaft centered and to see that the screws in the armature pass each bolt in the magnets at equal distances, which should be about $\frac{1}{8}$ in.

Home-Made Shoe Rack

The accompanying sketch explains itself as to how a boy can make his own shoe rack that can be placed on the wall in the clothes closet. Figure 1 shows the construction of the bottom to permit the dirt to fall through. Two boards, 9 in. wide and about 3 ft. long, with six partitions between as shown, will make pockets about 6 in. long.

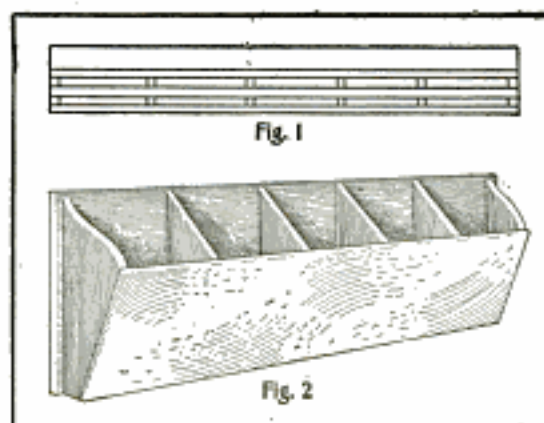

The width of the pockets at the bottom is 2 in. and at the top 5 in.—Contributed by Guy H. Harvey, Mill Valley, Cal.

Active construction work has been begun on the telephone lines which are to link the leading towns of China together. The construction and operation is entirely under control of the Chinese government.

Eleven-Year-Old Engineer

Probably the youngest engineer in the world is Marvin Wilkinson, 11 years old, who operates a big traction threshing engine for his father. During the past season he fired, oiled, kept water in the boiler and steam up, and ran the engine without a single stop or

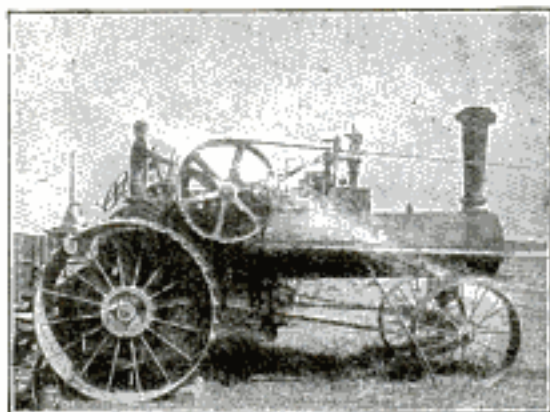

Courtesy Am. Thresherman
Youngest Engineer at Work

accident of any kind. Marvin is a Kansas boy.

How to Make a Flying-Machine

By Will Patsul

While a great many people are looking forward to the time when we shall successfully travel through the air, we all may study the problem of aerial navigation by constructing for ourselves a small flying-machine as illustrated in this article.

A wing is made in the shape as shown in Fig. 1 by cutting it from the large piece of an old tin can, after melting the solder and removing the ends. This wing is then given a twist so that one end will be just opposite the other and appear as shown in Fig. 2. Secure a common spool and drive two nails in one end, leaving at least $\frac{1}{2}$ in. of each nail projecting after the head has been removed. Two holes are made in the wing, exactly central, to fit on these two nails. Another nail is driven part way into the end of a stick, Fig. 4, and the remaining part

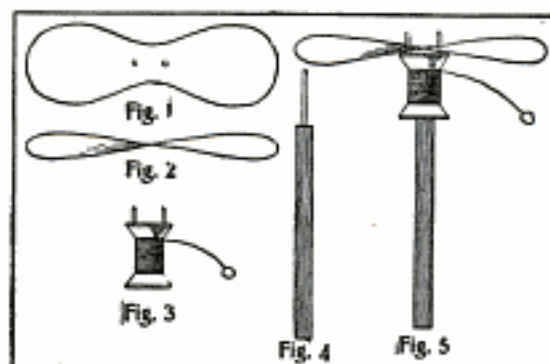

Home-Made Flying-Machine

is cut off so the length will be as long as the spool. A string is used around the spool in the same manner as on a top. The wing is placed on the two nails in the spool, and the spool placed on the nail in the stick, Fig. 5, and the flyer is ready for action. A quick pull on the string will cause the wing to leave the nails and soar upwards for a hundred feet or more. After a little experience in twisting the wing the operator will learn the proper shape to get the best results.

How to Make an Ironing-Board Stand

Secure some 1 by 3 in. boards about 3 ft. long and plane them smooth. Cut the two pieces A and B 30 in. long and make a notch in each of them, about one-third of the way from one end, 1 in. deep and 3 in. long. These notches are to receive the piece D, which has a small block fastened to its side to receive the end of the brace C. The brace C is 36 in. long. The

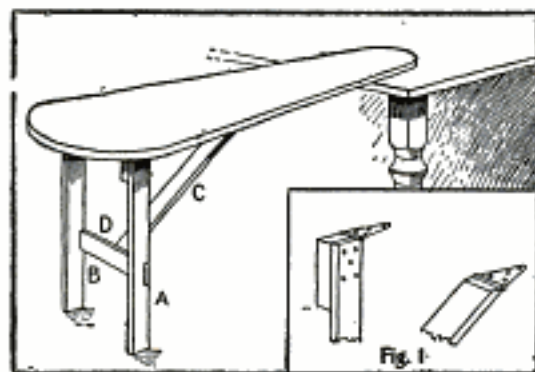

Ironing-Board Stand

upper ends of the pieces A, B and C are fastened to a common ironing board by using iron hinges as shown in Fig. 1. As the piece D is fitted loosely, it may be removed and the brace, C, with the legs, A and B, folded up against the board.—Contributed by Bert Kottinger, San Jose, Cal.

A Home-Made Electric Plug

A plug suitable for electric light extension or to be used in experimenting may be made from an old electric globe. The glass is removed with all the old composition in the brass receptacle, leaving only the wires. On the ends of the wires, attach two small binding-posts. Fill the brass with plaster of paris, and in doing this keep the wires separate and the binding-posts opposite each other. Allow the plaster to project about $\frac{3}{4}$ in. above the brass, to hold the binding-posts as shown.—Contributed by Albert E. Welch, New York.

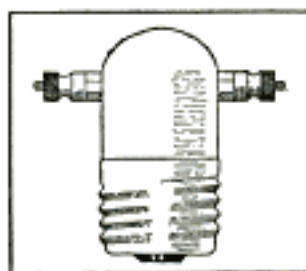

How to Make an Electric Fire Alarm

On each end of a block of wood, 1 in. square and $1\frac{1}{2}$ in. long, fasten a strip of brass $\frac{1}{4}$ by 3 in., bent in the shape as shown in the sketch at A, Fig. 1. These strips should have sufficient bend to allow the points to press tightly together. A piece of beeswax, W, is inserted between the points

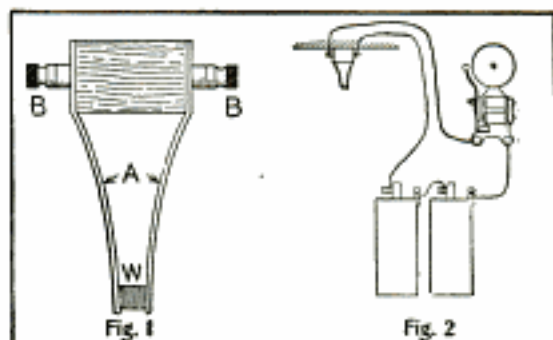

Fire Alarm Device

of the brass strips to keep them apart and to form the insulation. A binding-post, B, is attached to each brass strip on the ends of the block of wood. The device is fastened to the wall or ceiling, and wire connections made to the batteries and bells as shown in the diagram, Fig. 2. When the room becomes a little overheated the wax will melt and cause the brass strips to spring together, which will form the circuit and make the bell ring. Each room in the house may be connected with one of these devices, and all on one circuit with one bell.

Home-Made Boy's Car

The accompanying cut shows how a boy may construct his own auto car. The car consists of parts used from a boy's wagon and some old bicycle parts. The propelling device is made by using the hanger, with all its parts, from a bicycle. A part of the bicycle frame is

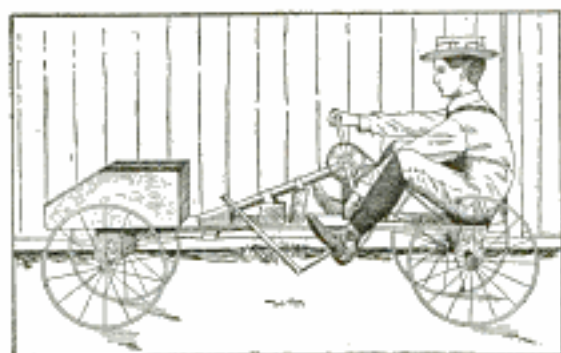

Boys' Home-Made Auto

left attached to the hanger and is fastened to the main board of the car by blocks of wood as shown. The chain of a bicycle is used to connect the crank hanger sprocket to a small sprocket fastened in the middle of the rear axle of the car. The front axle is fastened to a square block of wood, which is pivoted to the main board. Ropes are attached to the front axle and to the back part of the main board to be used with the feet in steering the car. To propel the auto, turn the cranks by taking hold of the bicycle pedals.—Contributed by Anders Neilsen, Oakland, Cal.

SWING ARM-REST ON TRAINS

A swing device on which the passengers can rest their arms while reading, or on which letters can be written if so



Comfortable Arm-Rest

desired, is being experimented with on a German railway. The swing is made of a board about $2\frac{1}{2}$ ft. long and quite narrow. To the ends of this are attached cords by which it is suspended from the top of the car. The rests can be raised or lowered to suit the convenience of the passengers.

NATURAL GAS AND ELECTRIC LIGHT IN POPCORN WAGON

This popcorn wagon, which stands every night on a street corner in Kansas City, is equipped with all the most advanced heating, cooking and light-

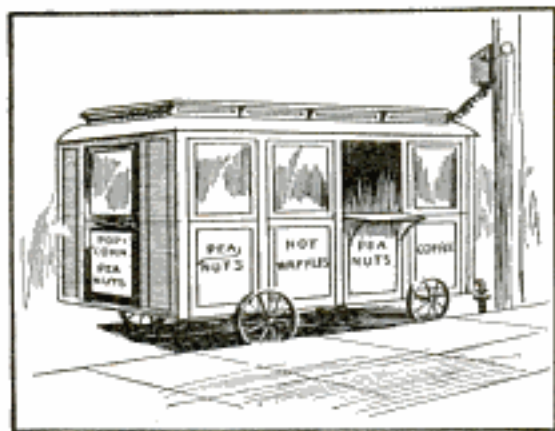

Modernly Equipped Popcorn Wagon

ing devices of the modern American home. The moment the wagon is drawn up to its stand a pipe attached to a natural gas main is run into the wagon and utilized for heating the interior, popping corn, roasting peanuts and cooking waffles. On the top of the wagon a plug connects with an electric light wire which furnishes current for lighting. Both the gas and electric meters are in the wagon.

ALARM FOR PUNCTURED TIRES

The device illustrated has been introduced to give warning when an automobile tire is punctured, and the car running on wholly or partly deflated tires. The arrangement is a bell and plunger attachment fastened to a spoke of the wheel. The moment the tire begins to get soft the plunger strikes the ground at every revolution of the wheel and so rings the bell. It is a simple matter for a driver to run a long distance on a deflated tire without knowing it, especially if he is on a well-sprung car.

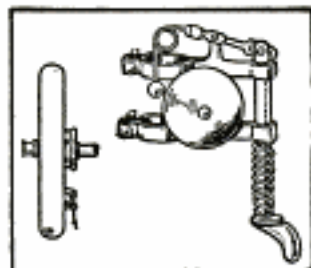

SHIP STOPPED WHILE APPENDIX WAS REMOVED

Because one of the intricate parts of the human machine became deranged and threatened the destruction of the entire mechanism, the machinery which gives life to the steamer "Panonia," en route from the Mediterranean to New York, was stopped for an hour in mid-ocean while the ship physician performed an operation on one of the male passengers for appendicitis. The ship lay as nearly motionless as possible for an hour while the delicate cutting and stitching was done.

WONDERFUL Edison Phonograph Offer

At any time you wish you can have a free concert in your own home—not a concert of one instrument or voice alone, but a concert of band and orchestra music, vocal solos, grand opera as well as comic opera—*anything you like.*

This is the regular Standard Phonograph with the regular horn—a fine outfit—but we furnish besides at only a slight extra expense our **Parlor Grand Equipment.** This we describe fully in our free catalog and circular.

TRADE MARK
Thomas A. Edison



Mr. Edison says:

"I want to see a Phonograph in every American Home."

FREE TRIAL!

WHILE this offer lasts we will send to any reader of this paper a Genuine Latest Style Edison Phonograph for **free trial in your own home**—a trial lasting two days to a week. Try the Latest Style Edison in your own home. *Then if you do not want to keep this wonderful instrument, you may send it back to us at our expense and we charge you absolutely nothing for the free trial.* If you like the instrument with its marvelous variations of entertainment, including the latest popular songs, side-splitting minstrel dialogs, beautiful operatic airs sung by the greatest artists, its dreamy waltzes and stirring two-steps, its orations and elocutionary recitals, you may keep the instrument and send either cash in full or the smallest monthly payments at the **Surprising Rock-Bottom Prices** on the finest Edison outfits.

\$2 a Month now buys a genuine Edison outfit including one dozen genuine Edison gold moulded records. The finest improved latest style Edison outfit with our **Parlor Grand Equipment** only \$3.50 a month. And at **rock-bottom price**, no matter whether you send cash in full or pay on our easiest terms.

For Cash in full: So many cash purchasers are getting the finest Edison outfits on free trial that we are obliged to announce again that we can allow no discount for cash. We have already given those who buy on easy payments the **lowest possible price** and we must treat all Edison customers alike.

LOOK FOR THIS
TRADE MARK
ON EVERY INSTRUMENT
Thomas A. Edison

**SIGN the
Coupon
Now!**

Edison Catalogs FREE

SIGN the Coupon and get our great Edison catalog, quoting the **rock-bottom prices** on the finest Edison outfits. Remember you get an **absolutely free trial** and can send either cash in full or **easy monthly payments.**

F. K. BABSON,
Edison Phonograph Distrs.,
Edison Bldg.,
Suite 1193
CHICAGO

Name.....

Address.....

FREE
COUPON

F. K. BABSON
EDISON PHONO-
GRAPH DISTRIBTRS.
EDISON BUILDING
Suite 1193 Chicago, Ill.

Without any obligations on me please send me your Edison catalog free, prepaid.

— CUT OR TEAR ALONG THIS LINE —

Don't bother with a letter; the coupon will do.

Please Mention Popular Mechanics

Practical Telegraphy

Taught by experts at my school. My institution only one graduating qualified operators. Thorough, practical, copy-right methods. Good positions guaranteed. Living expenses earned while learning. Easy payments. Correspondence course if desired. Catalog FREE.

Geo. M. Dodge, Pres.
Dodge's Institute of Telegraphy.
Eighth Street, Valparaiso, Ind. Established 1874

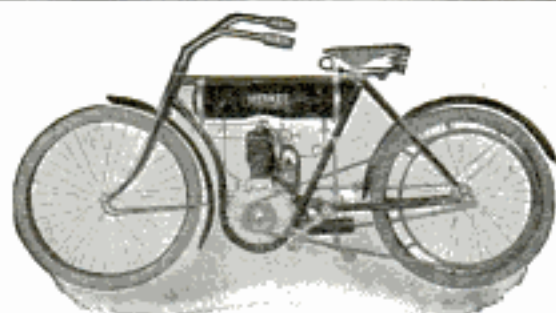

THE MERKEL

is the most comfortable riding motorcycle in existence. With its spring frame and extra long wheel base, it compares with others about as a Pullman car compares with a freight train.

Double Grip Control and Full 3 H. P. Ball Bearing Motor with Magneto Ignition. Highest efficiency guaranteed.

Illustrated catalogue with full particulars free on request.

Agents wanted in all unoccupied territory.

MERKEL MOTOR CO., 1126 26th Avenue, MILWAUKEE, WIS.

REPRESENTATIVES:

Pacific Coast:

Ollier & Worthington, 1030 So. Main St., Los Angeles, Cal.
Brooklyn:

John Pfeiffer, 1604 Bushwick Ave., Brooklyn, N. Y.
New York, Jersey City and Long Island:

E. J. Willis Co., 8 Park Place, New York City.
Cook County, Ill.:

I. H. Whipple, 260 W. Jackson Boulevard, Chicago.

Curtiss World's Record Motorcycles



Single and Double Cylinder Models for 1908
Now Ready.

Diamond Medal. Highest Award National Endurance Run 1907, won on a Curtiss
Send Stamps for Booklet "Achievements" and Catalog C

G. H. CURTISS MANUFACTURING CO.
Hammondsport, N. Y.

★ THE SAW THAT NEVER BALKS ★

It's a Star Saw and Star among Stars. Prominent dealers in all countries sell them



They are not as low in price as some other blades offered, but more than 100% the cheapest. We stand by this statement. Ask for catalogue showing our full line.

Millers Falls Company
28 Warren Street, NEW YORK

UP AMONG THE CLOCKS AND BELLS.—When the tower of the Metropolitan Life Building, in Madison square, is completed New York will have the largest clock in the world. That distinction has belonged for many years to "Big Ben," in Westminster Abbey, London, the dial of which is 22½ ft. in diameter, while that of the Metropolitan building will be 25 ft. The clock will occupy part of the 25th, 26th and 27th floors, and will be 346 ft. above the street. Notwithstanding the fact that the clock will only be a little more than half way to the top of the tower, which will be 658 ft. above the street, it will be far above all surrounding buildings. The letters on the dial will be 4 ft. high and the hands 12 ft. long.

Among those who tend the clocks and the bells are two men who have just celebrated anniversaries in their profession. The master ringer of the chimes in Lincoln Cathedral, England, has just completed half a century of his task. During that time he climbed the stairs so often that the total of steps is 975,000.

N. T. Shore, who winds and regulates the big clock in the steeple of the Moravian church in Hope, Ind., has finished his 25th year of such duty. He has wound the clock on an average of once every 24 hours since Oct. 23, 1873, missing only one day. In winding the clock 200 revolutions of the arm are required on the striking side, and 50 on the winding side, making a total of 1,320,250 revolutions since his task commenced.

NEWSPAPER PRINTED ON BATTLESHIP.—The U. S. Battleship "Nebraska" has an up-to-date printing establishment and a monthly newspaper, edited by members of the crew. The first issue of the newspaper was run off the press Dec. 1, 1907. It is known as the "Antelope" and contains news of the navy and gossip about ships and crews. The ship's menu cards and all the orders of the day are also printed in the shop. The subscription price of the "Antelope" is \$1 per year.

HOW TO STOP A NOSE-BLEED.—When the bellboy responded to the signal he found the elderly traveling man standing in the center of the room holding a handkerchief to his nose, from which the blood was oozing.

"Give me a slap alongside the head, good and hard," said the elderly man, turning his face toward the boy and speaking with difficulty.

"But, sir, I—don't know what you mean, sir," stammered the boy, backing toward the door.

"Don't stop to talk," sputtered the traveling man. "Slap me, I tell you," again holding his head forward. The boy hesitated for a moment, then timidly slapped the man's face. "Harder!" commanded the smitten one. The boy hesitated no longer, but with his open palm dealt the man a vigorous blow.

"That's better," grunted the gory one as he removed the handkerchief and after a test found the bleeding had stopped. "I'm subject to these attacks of nose-bleed," he explained to the astonished youth, handing him a tip. "I have tried all sorts of remedies, but nothing acts more promptly than a blow alongside the head. The shock seems to paralyze the ruptured blood vessels and they quit work at once. Try it some time if you have the occasion. I got the idea from an old physician in Mexico."—N. Y. Press.



Motorcycle Frame Parts and Engine Castings

Complete Motorcycles, Engines and Frames.

W. HOFFMAN MOTOR WORKS
1254 N. Halsted Street, Chicago, Ill.



WANTED--A RIDER AGENT

Model "Ranger" bicycle furnished by us. Our agents everywhere are making money and exhibit a 1908 fast. Write for full particulars and special offer at once.

NO MONEY REQUIRED until you receive and approve of your bicycle. We ship to anyone, anywhere in the U. S. without a cent deposit in advance, *prepay freight*, and allow **TEN DAYS' FREE TRIAL** during which time you may ride the bicycle and put it to any test you wish. If you are then not perfectly satisfied or do not wish to keep the bicycle you may ship it back to us at our expense and *you will not be out one cent.*

FACTORY PRICES We furnish the highest grade bicycles. It is possible to make at a small profit above actual factory cost. You save \$10 to \$25 middlemen's profits by buying direct of us and have the manufacturer's guarantee behind your bicycle. **DO NOT BUY** a bicycle or a pair of tires from anyone at any price until you receive our catalogues and learn our unheard of factory prices and remarkable special offers to rider agents.

YOU WILL BE ASTONISHED when you receive our beautiful catalogue and study our superb models at the *wonderfully low prices* we can make for you. We sell the highest grade bicycles for less money than any other factory. We are satisfied with \$2.00 profit above factory cost. **BIKE DEALERS**, you can sell our bicycles under your own name plate at double our prices. Orders filled the day received.

SECOND HAND BICYCLES. We do not regularly handle second hand bicycles, but usually have a number on hand taken in trade by our Chicago retail stores. These we clear out promptly at prices ranging from \$3 to \$5 or \$10. Descriptive bargain lists mailed free.

TIRES, COASTER-BRAKES, single wheels, imported roller chains and pedals, parts, repairs and equipment of all kinds at half the usual retail prices. **DO NOT WAIT,** but write today and we will send you free by return mail our large catalogue, beautifully illustrated and containing a great fund of interesting matter and useful information; also a *wonderful proposition* on the first sample bicycle going to your town. It only costs a postal to get everything. Write it now.

MEAD CYCLE COMPANY

Dept. M 108 CHICAGO, ILL.

**ALL GENUINE ARMSTRONG
ARMSTRONG
GOODS HAVE**

**Stocks, Dies,
Pipe-Threading
and
Cutting Tools**



Accomplish **REAL** Work.

ARMSTRONG MFG. CO.

315 Knowlton St.
BRIDGEPORT, CONN.

ON THEM

Send for Catalogue

STEEL BRASS BALLS

**BALL BEARING
All-Steel and Rubber-Tired
Skate Rolls**

"Knipe" Pat.

BALL BEARINGS

1-4 in. Shaft and up.
No fitting, just push them on.
10 cts. in stamps for sample.

Pressed Steel Mfg. Co., 454 The Bourse, Philadelphia, Pa.



The Largest Parts and Supply House in America

Everything for the Automobile and Automobilists

Manufacturers, Distributors and Jobbers

AUTOMOBILE PARTS AND ACCESSORIES

NEUSTADT AUTOMOBILE & SUPPLY CO.

"The Growing House"

3944 Olive St., St. Louis, Mo.



Our 1908 Catalogue, 200 pages, over 1000 illustrations and 8000 descriptive quotations, yours for the asking



ANGLE BENDERS

We make hand-power Benders for forming angles in stock, 1 inch thick and under. Light stock can be bent cold.

Wallace Supply Co., 24 W. Washington St., Chicago, Ill.



The Pilley Combination Flue Brush and Scraper

It's easy to handle and leaves the tubes in splendid condition. Tackles dirt and scale in the most thorough and economical manner.

Get our Catalog No. 9

Pilley Packing and Flue Brush Mfg. Co.
610 South Third Street, St. Louis, Mo.



The "KICKDRIVE" is for driving all kinds of light machinery by foot power. The following articles are built complete with the "KICKDRIVE":

Circular Saws, Polishing and Buffing Machines and Forges.

Get a Booklet

MAYER SLOTKIN, 210-212 A Canal St., NEW YORK, N. Y.

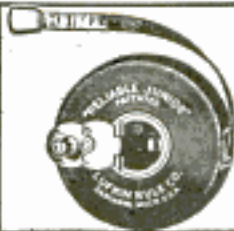

**LUFKIN
TAPES AND RULES**

ARE THE BEST
FOR SALE EVERYWHERE SEND FOR CATALOG No. 20

THE LUFKIN RULE CO.

SAGINAW, MICH., U.S.A.

DETROIT, SIOUX FALLS, AND WYOMING, COLORADO

VIM \$4.95 ALLIGATOR PUNCTURE PROOF SELF-HEALING BICYCLE TIRES

Have you trouble and money. The best tire made. Nails, tacks, glass and snags will not let the air out. Made from best quality extra tough rubber, close-woven tension fabric chemically treated, automatic solidifier, extra heavy tread, strong, durable, resilient. Accept no imitations, guarantee tag on each tire. Order at sale price. Give size tire wanted. Out price catalog of Bicycles and Sporting Goods free. Dealers wanted.

4.95 A PAIR

THE VIM 68 LAKE ST. DEPT. T-41 CHICAGO

\$39.85 Buys This **\$60** BUGGY

Our 1908 Special. Wheels, compressed band or sarven 38-42 or 40-44. $\frac{3}{4}$ or $\frac{1}{2}$ inch tread screwed rims. Axles, long distance arch or drop. Shafts, split hickory, high bend, 36-inch leathers and stitched shaft straps. Quick shift couplers. Springs, 3 and 4 leaf, oil tempered, 36 inches and adjusted to easy riding; Bailey loop hangers. Upholstered with heavy wool cloth, either blue or green full length velvet, and leather covered dash and whip socket. Spring back and cushions. Top, leather quarter 3 or 4 bow. Gear, track 4 feet 8 in. or 5 ft. 1 in. Improved Brewster fifth wheel. Body, piano 20-22-24 or 26 x 56 inches. We give a

TWO-YEAR GUARANTEE with every vehicle. Send us your name and address at once and we will send you our beautiful catalogue describing and illustrating a full line of Buggies, Surreys, Phaetons, Carriages, Spring Wagons, Carts and all kinds of Harness; also thousands of other articles on which we can save you money. Just a minute's time and the cost of a postal card will bring you this valuable information. Don't delay. Write now—today and address

ALBAUGH-DOVER CO.

914-565 MARSHALL BOULEVARD **CHICAGO, ILL.**



USE THIS LAMP FOR 60 DAYS FREE

Let us place this 100-candle power No 106 Brilliant Gas Lamp in your home. Use it and test the light in every way and prove that every claim we make is true.

We defy comparison with gas, kerosene, or electricity, and claim the saving will pay for this Lamp in a few months. If you are dissatisfied and find that it is not the very best reading and working light made, we will gladly refund your money.

1c A DAY

operates this lamp and gives you a home as bright and cheerful as in any city. Shipped anywhere. Safe delivery guaranteed on receipt of **\$5.00**

BRILLIANT GAS LAMP CO.,
Room 203—42 State St., Chicago, Ill.



16 Ft. Steel Launch with 2HP Engine

18-21-25 foot launches at proportionate prices. All launches fitted with two cycle reversing engines with speed controlling lever; simplest engine made; starts without cranking, has only 3 moving parts. Steel rowboats, \$30.00. All boats fitted with water-tight compartments; cannot sink, need no boat house.

We are the largest manufacturers of pleasure boats in the world. Orders filled day they are received. We sell direct to user, cutting out all middlemen's profits. Free catalogue.

MICHIGAN STEEL BOAT CO.,
1271 Jefferson Ave.
Detroit, Michigan



CHIPS FROM THE WOODWORKER.—There is no waste so wasteful as economy overdone.

Next to haste, persistency is one of the best elements to have in one's make-up; but a good combination of both makes the surest winner.

Keep a camera around and when you turn out a good job make a picture of it.

To hire a cheap man is no sign you are going to get your work done at small expense. Cheap men, like cheap machines, frequently produce more trouble than profit.

One of the best ways to make a glue brush is to wet the end of a strip of basswood bark, then pound it until the fibers separate. Such a brush is as soft as camel's hair, wears longer than the best bristle, and if a fiber does come off in a joint, it is so fine and soft that it does no harm.

In Montana there is practically no merchantable native hard wood, unless cottonwood and poplar be so classed. Such as is used comes from the south or east, and is sold by the pound, a practice which would seem to discourage thorough drying.

A Norwegian firm has patented a process of manufacturing colored woods. Whole stems of green trees are colored, the sap being pressed out of the stem by force, and the dye injected in its place. It is claimed that wood treated by this process is much more durable than ordinary wood, and will not warp.

WHITE OAK LEADS HARD WOODS.—White oak is the most widely distributed and commercially important tree of the hardwood variety in the United States. Its annual product of over 2,000,000,000 ft. of lumber is more than double that of any other hard wood. The wood is compact and close grained, hard, tough, strong, heavy, and durable in contact with the soil. It is the favorite timber for railway ties, and of the 90,000,000 ties purchased each year nearly one half are oak. Its other uses are for car stock, boards, planking, beams, dimension stuff of all sizes, ship building, tool handles, wagon spokes, and furniture.

Get Our Book and We'll Make Right Prices To Interest You To Trade



Get our interesting "Black Motor Buggy" Book Free and find out about the only motor buggies and surreys that are good country road "mudders" and "hill climbers" and built for practical use. No jarring—No blowups on tires—Speed 2 to 15 miles an hour—Run 20 miles on 1 gallon of gasoline—Safe—Reliable. Women can easily run



BLACK MOTOR BUGGIES AND SURREYS

Buggy is 10 horse power—Surrey, 15 horse power. Both "get there" and "back again" every trip, and save time, worry and expense. Investigate and we will make you right prices. Write for Book No. A-204

BLACK MFG. CO., 124 E. Ohio Street, Chicago, Illinois

Please Mention Popular Mechanics

PLUMBING MATERIAL

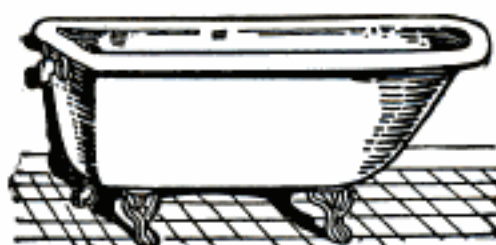

Bath Tubs only \$6.00

Laundry
Tubs
\$5.00 and up

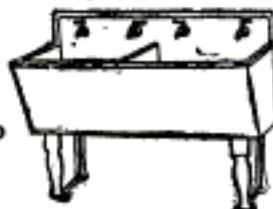

GALVANIZED
RANGE
BOILERS

All tested to
200 lbs.
pressure;
30 gallons

Only \$5.00



This
Complete
Closet
Outfit

Only
\$11.50

**DIRECT
to the
CONSUMER**

At less than wholesale prices; you also save the plumber's profit. Send us a list of your needs. All we ask is an opportunity to figure on your wants. We carry everything necessary for installing this class of work. Soil pipe, lead and water pipe and fittings of all kinds, etc. All Goods are Brand New, High Grade and Perfect.



**Kitchen
Sinks**

All kinds of Porcelain Enameled Kitchen Sinks, with backs, drain boards, etc. Our stock is complete with sinks of every description, both for corner or straight wall.

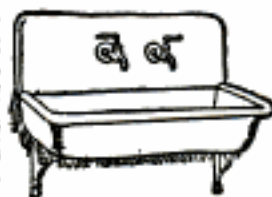

Complete Bathroom Outfits only \$36.50

White
Enameled
Sinks,
size 18x20,
Only \$2.00

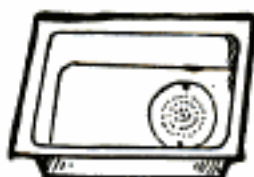

White
Enameled
Backs,
size 30 in. long
Only \$2.50



SEND US YOUR BILL FOR OUR ESTIMATE

WRITE FOR OUR FREE ILLUSTRATED **CATALOG No. 35**

CENTRAL MACHINERY & SUPPLY CO., 547-559 State St., Chicago, U. S. A.

The Characteristics of a Good Engine

First of all, it should be simple, both in design and construction; so simple that anybody can understand it, and so simple that it is almost impossible for it to get out of order.

Again, it must be safe, economical in fuel consumption, absolutely dependable under all conditions, and certain of supplying abundant power.

I. H. C. Gasoline Engines

have all these characteristics, besides another very important one, which most engines do not possess, that is, they are

THOROUGHLY ADAPTABLE TO THE WORK IN HAND

No matter how excellent a power may be, if it is not adapted to your particular requirements you do not want it. The designers of I. H. C. Engines kept uppermost the purposes to which such an engine could be adapted, and constructed the engine with a view of meeting every requirement.

The line is extensive, and an I. H. C. agent will always recommend the engine which is best adapted to your requirements. Made in the following styles and sizes:

Vertical in 2 and 3 horse power.

Horizontal (Stationary and Portable) in 4, 6, 8, 10, 12, 15 and 20-horse power. 1-horse air-cooled. Also, sawing, spraying and pumping outfits.

Apply to the International local agent for catalog and particulars, or write

INTERNATIONAL HARVESTER COMPANY of AMERICA
16 HARVESTER BLDG. (Incorporated) CHICAGO, ILL.

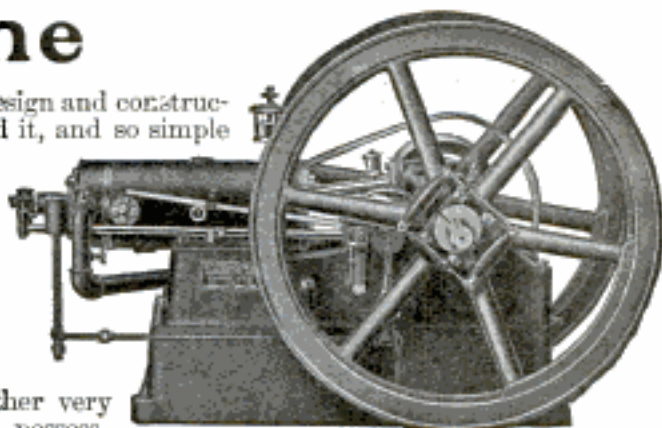

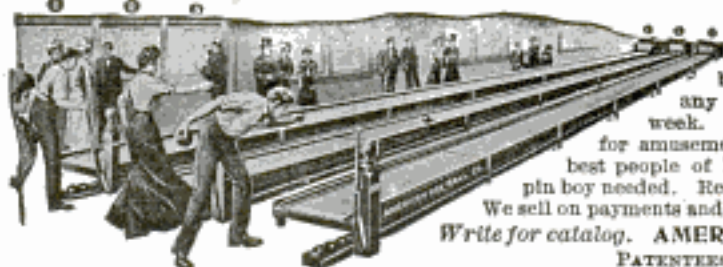
\$513 CLEAR PROFIT IN 51 DAYS FROM AN INVESTMENT OF \$150

Is the result from the operation of one American Box Ball Alley in Sullivan, Ind. Why not go into this business yourself? It is the most practical and popular bowling game in existence. It will make big money in any town. These alleys pay from \$25.00 to \$65.00 each, per week. This is no gambling device, but a splendid bowling game for amusement and physical exercise. Liberally patronized by the best people of both sexes. Quickly installed, conveniently portable. No pin boy needed. Receipts are nearly all profit. More than 3,000 already sold. We sell on payments and our catalog is free.

Write for catalog. **AMERICAN BOX BALL COMPANY,**
PATENTERS, 1375 Van Buren St., Indianapolis, Ind.

How to Judge Investments

Before you invest a dollar in anything, send for my book "How to Judge Investments."

This book tells you about everything you should know before making any kind of an investment, either for a large or small amount.

It tells how you may safely start on the road to wealth.

It explains the growth of capital and how small investments have brought wealth and fortune to others.

It tells how others have grown rich.

It tells how to select a 5 or 6% security.

It explains how an investment in a development enterprise may pay profits equal to 100%, 200% or even 500% on the money originally invested.

Stocks and bonds, both listed and unlisted, real estate, investments of different kinds and financial matters are fully described in simple language.

This book gives good, sound advice, and will help you to invest your surplus earnings (if only a few dollars a month) in securities that promise the best possible returns.

A financial critic says of this book: "It is the best guide to successful investing I ever read."

The regular price is \$1.00, but to introduce my magazine, the "Investor's Review," I will send the book postpaid on receipt of a two-cent stamp and in addition will send you the Review for three months free.

The Investor's Review is of interest to all persons who desire to invest their money safely and profitably. Address Editor,

INVESTOR'S REVIEW, 461 Gaff Building, Chicago, Ill.

MOVING PICTURE MACHINES

STEREOPTICONS

You Can Make BIG MONEY Entertaining the Public.

Nothing affords better opportunities for men with small capital. We start you, furnishing complete outfits and explicit instructions at a surprisingly low cost.

THE FIELD IS LARGE comprising the regular theatre and lecture circuit, also local fields in Churches, Public Schools, Lodges and General Public Gatherings. **Our Entertainment Supply Catalogue** and special offer fully explains everything. **Sent Free.**
CHICAGO PROJECTING CO., 225 Dearborn Street, Dept. 4 Chicago.

THIS IS ON THE FIREMAN.—A man applied for a position as motorman on the trolley cars the other day, and after being shown how to operate a car was sent out alone with the instructions to stop his car whenever he saw any fire apparatus coming down the street. In the afternoon he was sending his car as rapidly as possible down Washington street, Boston, when the warning screech of an engine whistle caused him to stop his car. He waited until the engine, hose wagon and chemical had passed and then started up his car again. Just as he got under headway a ladder truck swerved around the corner and ran into the trolley car. At the investigation the motorman was called up before the officials and asked why he had not obeyed instructions and stopped his car. "Sure, but I did not know that that gang of crazy painters with their ladders were a part of the fire department," he replied.

He still has his position.—Lowell Mail.

THE JANITRESS AND THE CASHIER.—She walked into a branch bank on upper Broadway and pushed a check through the paying teller's window.

"You will have to be identified," said the cashier. "I don't know you, madam."

"You don't, eh?" said the woman, with fire in her eye. "Aren't you the father of the Smith family that has a flat in the Pilemmin apartments?"

"Y-e-s."

"Well, I'm the red-headed janitress that your wife's always complaining about. When you left home this morning I heard you say: 'Emily, if our children get fighting with that old fury in the basement, don't quarrel with her. Wait till I get home and let me talk to her.' Now, if you think you can get the best of an argument with—"

"Here's your money, madam," said the cashier.

Some New York boys, according to the Sun, have a yell which goes like this:

Pooh, Pooh, Harvard! Pooh, Pooh, Yale!
We learn our lessons through the mail!
We're no dummies, We're no fools!
Rah! Rah! Rah! Correspondence Schools!

ORIGIN OF PLUG TOBACCO.—In the jury room at the court house a few days ago a farmer said, as he took a chew of tobacco:

"All the difference in the world in tobacco, I've tried twenty different kinds and none is as good as that we used to make ourselves down on the farm. We would take a maple log while it was green and bore a dozen holes in it with a 2-in. auger. They were our molds. We selected our choicest tobacco and soaked it for a week or more in wild honey. Then we'd take the leaf to the log, get a good hickory 'tamping' stick and go to work.

"A little ball of the honey-soaked tobacco would be put in the auger-hole and tamped in with the stick and a hammer. We'd pound it in solid. Ball after ball would be rammed in and pounded until the whole became a solid plug. When the hole was nearly full we would pound in the plug and then the log would be put away to season. As the wood dried the moisture would be drawn from the tobacco. And when it was split the sweetest tobacco ever made was taken from it. We called it 'plug' tobacco, and that's where the name originated."—Kansas City Star.

WIRELESS TO SPAN THE PACIFIC.—The British Colonial office has recently made the announcement that the installation of a system of wireless telegraphy between Vancouver, Somos, Fiji and Australia is entirely practical. It is understood that before long steps will be taken to effect the same.



Mullins Steel Boats Can't Sink

—the fastest and safest boats built. Made of pressed steel plates, with air chambers in each end like a life boat, they are absolutely safe. Faster, lighter and more buoyant than wooden boats—practically indestructible—they don't leak, crack, dry out or wear out, and every boat is absolutely guaranteed. The ideal boats for pleasure, summer resorts, boat liveries, etc.

Send for catalog of Motor Boats, Marine Engines, Row Boats, Hunting and Fishing Boats
THE W. H. MULLINS COMPANY, 151 Franklin Street, Salem, Ohio.

Please Mention Popular Mechanics

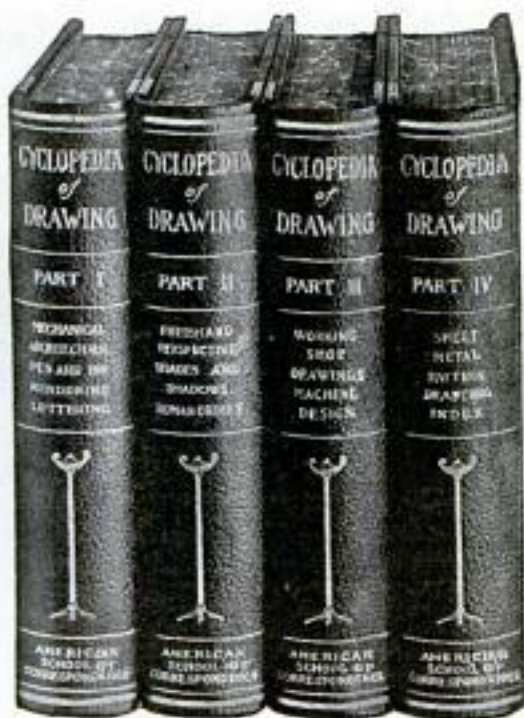

Don't Turn Your Back To

Opportunity

Train your eye to note its coming, and your hand to grasp it. So many and varied are the chances that are offered the ambitious man that you can almost pick out your own occupation. You have means of preparing for a career that in your father's time was not even dreamed of. This advertisement offers you the means of getting a working knowledge of **Drawing** in all its branches without taking a moment from your regular work.

Drawing is the language of the Engineer, Architect, Draftsman, Contractor or Builder. It speaks to every man in his own tongue and through his own knowledge. It records the ideas of the man who plans, and guides the hand of the man who executes. It conveys orders more quickly, more clearly, more exactly than speech or writing.

Take up today's newspaper. Compare the number of bookkeepers, stenographers, clerks, etc., looking for work, with the large number of advertisements for competent draughtsmen, etc.

CYCLOPEDIA OF DRAWING

Four Volumes, Page Size, 7 x 10 inches. 2,000 Pages. 1,500 Illustrations. Tables and Formulæ, Etc. Half Red Morocco

This work offers you an unusual opportunity for self betterment. Compiled from representative instruction papers of the American School of Correspondence. It is thoroughly practical for home study work—every chapter is complete in itself, every subject is thoroughly analyzed, dissected and discussed by well known authorities. It is entirely free from purely technical descriptive matter so easily misunderstood by the layman. It is also a complete reference library for the technical man who wishes to use it for consulting purposes or to brush up on his weak points. We are so confident of the superior home study instructive value of this Cyclopedia, that as an advertisement for the regular courses of the school, we will sell a limited number of sets at nearly

ONE-THIRD REGULAR PRICE

FREE FOR EXAMINATION

Sent by prepaid express for five days, FREE examination to enable you to carefully examine the work at your leisure in your own home. If satisfied that the books can help you, send \$2.00 within five days and \$2.00 a month thereafter until the

SPECIAL PRICE \$9.80

is paid. If not adapted to your needs, we will remove the books at our expense. Regular price is \$24.00.

Some of the Chapters: Mechanical, Architectural, Perspective, Isometric and Freshand Drawing—Blue Printing—Lettering—Pen, Ink and Watercolor Rendering—Shades and Shadows—Roman Orders of Architecture—Machine Drawing—Shop Drawings—Machine Design—Tinmithing—Sheet Metal Pattern Drafting—Skylights—Roofing—Cornice Work—Practical Problems—Etc.

AMERICAN SCHOOL OF CORRESPONDENCE
CHICAGO

CUT OFF COUPON HERE!

Pop. Mech. 3-08

A. S. of C.
Please send set of Cyclopedia of Drawing for 5 days' free examination. I will send \$2 within 5 days and \$2 a month until \$9.80 is paid, otherwise I will notify you to send for the books.

Name.....
Address.....
Employer.....

Please Mention Popular Mechanics

Copyrighted material

DON'T BUY GASOLINE ENGINES

Until you investigate "The Master Workman" a two-cylinder gasoline, kerosene or alcohol engine, superior to any one cylinder engine; revolutionizing power. Its weight and bulk are half that of single cylinder engines, with greater durability. Costs Less to Buy—Less to Run. Quickly, easily started. Vibration practically overcome. Cheaply mounted on any wagon. It is a combination portable, stationary or traction engine. SEND FOR CATALOGUE.

THE TEMPLE PUMP CO., Mrs., Meagher and 15th Sts., Chicago. THIS IS OUR FIFTY-THIRD YEAR

WATERLOO VAPOR COOLED GASOLINE ENGINES

The only horizontal vapor cooled gasoline engine in the world.

Absolutely frost proof and cannot freeze.

Patented May 13, 1906

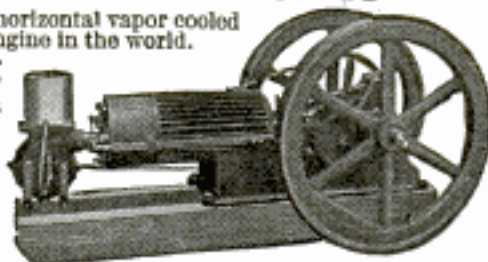

The king of all gasoline engines. Our catalog will tell you all about them, also our power and sweep feed grinders. Send today.

WATERLOO GASOLINE ENGINE CO.
1021 Cedar Street Waterloo, Iowa



The ECONOMIZER carries any load up to 2 h. p.

That name means something. Five years' sales and not a single dissatisfied customer, means something. It's all in the engine—no shoddy goods. Want to know more?

Address,

H. L. CHAPMAN, Lock Box 595, Marcellus, Michigan

High-grade MARINE and AUTOMOBILE ENGINES

2 to 30 H. P. 2 and 4-cycle, latest improvements; best material; lowest prices. Also sell castings, with drawings.

State your want.

HOULE MOTOR WORKS,
580 East St., Holyoke, Mass.

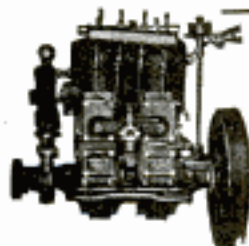
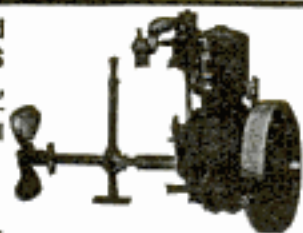

MARINE ENGINES

That Start and Reverse on the Spark
ALWAYS WIN RACES

All Sizes in Stock. Send for
Prices and Catalog

TERMAAT & MONAHAN CO.
Oshkosh, Wis.

Gas and Gasoline Engines

For all power purposes. Electric light plants from 10 to 2000 lights. Engines from 1 to 250 H. P. New or 2d hand. Write us for prices.

Empire Machine Works, 210 3d Avenue,
PITTSBURG, PA.

No Better Gas or Gasoline Engines made than the

FOSS ENGINES,

Simple, Substantial, Efficient.
Catalog on request.

Foss Gasoline Engine Co.,
Kalamazoo, Mich.

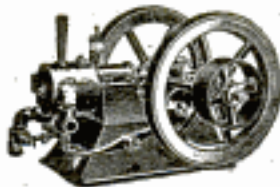

GOES LIKE SIXTY
SELLS LIKE SIXTY
SELLS FOR SIXTY

\$60

GILSON

GASOLINE ENGINE

For Pumping, Cream Separators, Churns, Wash Machines, etc. FREE TRIAL Ask for catalog—all sizes

GILSON MFG. CO., 26 Park St. Port Washington, Wis.

WICKED DEMONS OF THE DEEP.—Although the shark and the octopus share about equally the reputation for being the greatest enemies to mankind in the sea, a much worse creature than either shark or octopus is the devil-fish—a large ray that is common in the warm waters of the Atlantic. The fish grows to a weight of a ton and a half, and besides formidable teeth, is armed with a horrible barbed and poisoned spike in the tail. It has often been known to attack boats. Another nasty customer is the green moray of Bermuda, which resembles a conger eel in form but is of a very savage nature. The swordfish, sought for its oil and flesh, especially along the Atlantic coast of the United States, is another dangerous creature. Swordfish are harpooned in the same manner in which whales used to be killed. Quiet enough until attacked, the swordfish then seems to go raving mad and fights with unmatched ferocity.

LETTING OFF STEAM.—Some officer had disobeyed or failed to comprehend an order.

"I believe I'll sit down," said Secretary Stanton, "and give that man a piece of my mind."

"Do so," said Lincoln; "write him now while you have it on your mind. Make it sharp. Cut him all up."

Stanton did not need a second invitation. It was a bone-crusher that he read to the president.

"That's right," said Lincoln, "that's a good one."

"Who can I send it by?" mused the secretary.

"Send it!" replied Lincoln; "send it! Why, don't send it at all. Tear it up. You have freed your mind on the subject and that is all that is necessary. Tear it up. You never want to send such letters. I never do."

FLYING STONE IGNITES OIL WELL RIGGING.—Flying stone recently caused the destruction by fire of the rigging of an oil well in one of the western states. The well was being shot with nitroglycerin in the customary manner, when rocks were hurled out of the mouth, striking a drill stem, and causing a spark which set fire to the gas.

NEW BOOKS.

HIGHWAY CONSTRUCTION. By Austin T. Byrne and Alfred E. Phillips. 140 pp., 80 illus. Price, \$1.00. A complete course for road builders, landscape gardeners, civil engineers, public servants. Methods of locating, constructing and maintaining roads under all conditions. American School of Correspondence, Chicago.

BANKERS MATURITY GUIDE AND HOLIDAY CALENDAR, 1908-1909 edition. Compiled and published by Sperry & Morgan, Hartford, Conn. 32 pp., with thumb index, 50 cents.

MEN WHO SELL THINGS. By Walter D. Moody. 294 pp. Paper covers. Price, \$1.00. A work of interest to all who have anything to do with selling goods in every line and trade. Written by a sales-manager and embracing the experiences and observations of a lifetime in this line. A. C. McClurg & Co., Chicago.

THROUGH THE CHICAGO STOCK-YARDS. By John O'Brien. Paper cover, 100 pp.; illus. Price, 25 cents. A handy guide to the great packing industry. Rand, McNally & Co., Chicago.

GASOLINE ENGINE PRICE PROPOSITION

Stationary, Portable, Pumping, Marine and CREAM SEPARATOR ENGINES
Sizes 1½ to 9 H. P.

WRITE TODAY for our price proposition

Kneeland Mfg. Co., 20 Division St., Battle Creek, Mich.



Pumps 2,000 Gallons Up Per Hour

This "Jack-of-All-Trades" Engine and Horizontal Pump pumps 1,680 to 2,000 gallons per hour night and day. The engine also churns, runs your separator, saws your wood, grinds your feed, does more chores than three or four hired men. It's the ideal farm engine—easiest to understand—uses least fuel—needs fewest repairs.

Strongly built of best materials throughout to stand hard knocks. Our name on every engine is your best guarantee. Comes to you complete so you can set it to work at once.

We make several styles and sizes of engines. Tell us what you want an engine to do—we will advise what is best for you to get.

DOES THIS

Runs Buzz Saw, Pump, Grinder, Churn, Separator, and many other machines.

Engines 2 H. P. to 200 H. P.



WRITE TODAY FOR FREE ENGINE BOOK No. T 449

FAIRBANKS, MORSE & CO.
CHICAGO, ILL.



"GET THE BEST"

which means

The Clipper Water Motor



We do not claim it THE CHEAPEST, but we do claim it THE BEST.

Send \$7.50 and get one of these 6-inch motors—regular price \$10. Send P. O. order, Registered letter or N. Y. draft.

L. E. RHODES
HARTFORD, CONN.

Faucet WATER MOTORS



Complete with emery wheel, buff wheel, pulley to run sewing and washing machine, polish. In some cities where we have no agents, and where the water pressure is good, a sample motor will be given free; apply at once if you want to make some extra money, or if you can devote your whole time, liberal salary and commission will be paid.

\$2.50 up

ENGINEERS WANTED

to send for catalog of Indicators, Reducing Wheels, Planimeters. Address,

LIPPINCOTT M. S. CO.,
Newark, :: :: New Jersey



ROBERTS MARINE MOTORS

Received the enthusiastic endorsement of every visitor at the New York Boat Show.

THE ROBERTS HAS NO PEER.

Sizes 1½ to 60 h. p.

Write for catalog.

The Roberts Motor Co.

Box 317, CLYDE, OHIO

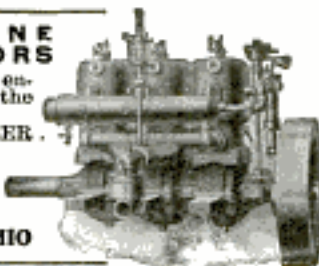

PALMER MOTORS

1½ to 25 Horsepower; One, Two and Four Cylinder; Jump or Snap Spark Ignition; Two or Four Cycle. Send for Catalog.

PALMER BROTHERS, COS COR, CONN.

New York, 262 Fourth Ave. Philadelphia, The Bourse
Boston, 80 Union St. Portland, Me., 48 Portland Pier



LOOK HERE

Amateur Electricians and Wireless Enthusiasts! ! !

Our 1908 line of Coils and Apparatus is fully described in our free literature, which we will send postage prepaid, on receipt of your name and address.

NEW ENGLAND COIL WINDING COMPANY, - Atlantic, Mass.

AIR COOLED MOTORS

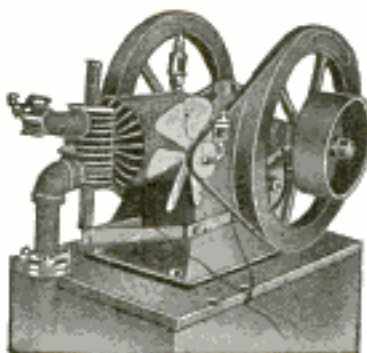

1½ H. P. to 10 H. P.

1¼ and 2¼ H. P. equipped with short connections for spray pump and walking beam attachment for pumping water from wells. Will work against 200 pound pressure all day without heating. Gasoline in base of engine.

Write for agency

AIR COOLED MOTOR CO., Lansing, Mich.

Perfection

MARINE MOTORS

The Perfection is a wonder—speedy, powerful, strong, reliable, economical. Comparison proves that it beats anything else on the market. Reversible. Easy starting. No vibration. Quiet operation.

5 H. P. \$95
(complete with full boat equip.)

Sold on the "square deal" basis. Each one guaranteed to give satisfaction or replaced free of expense to you. We put better workmanship and better finish into Perfections than you can get in any other engine. Our guaranty is backed by one of the largest and best equipped factories in the business. Write for Catalog of complete line, THE CALLE PERFECTION MOTOR CO., 1311 24 Avenue, Detroit, Mich.

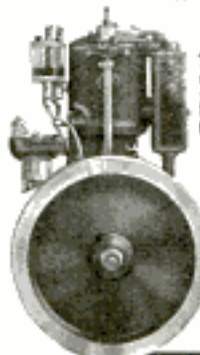

Please Mention Popular Mechanics

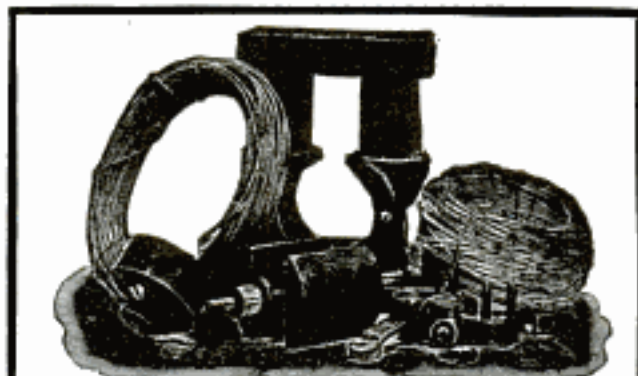

BUILD YOUR OWN DYNAMO. We furnish complete sets of castings. Also Electric Railways, Trolley Cars, Track and Switches. Send for Catalogue "B."

THE CARLISLE & FINCH CO., 262 E. Clifton Avenue, CINCINNATI, OHIO

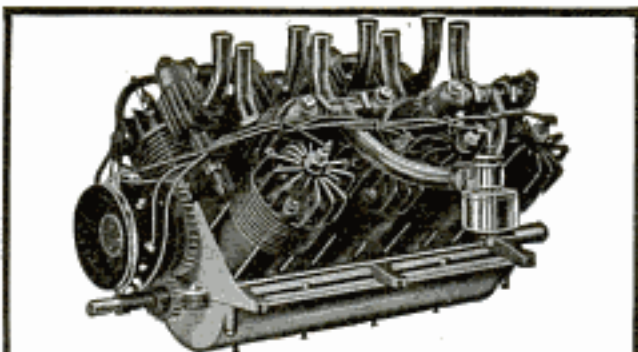

CURTISS LIGHT WEIGHT MOTORS

For aerial navigation and other purposes where great power and light weight are required. Adopted by the War Department and used by all prominent Aeronauts. One to eight cylinders. Two to one hundred H. P. Send stamps for catalogue X. G. H. CURTISS MFG. CO., Hammondsport, N. Y.

Write to-day.

Catalog free with full information.



Molsinger Auto-Sparker

Starts and runs GAS ENGINES WITHOUT BATTERIES

No other machine can do it successfully for lack of original patents owned by us. No twist motion in our drive. No belt or switch necessary. No batteries whatever. For make and break or jump-spark. Water and dust-proof. Fully guaranteed.

MOLSINGER DEVICE MFG. CO.
128 Main St., Pendleton, Ind., U. S. A.

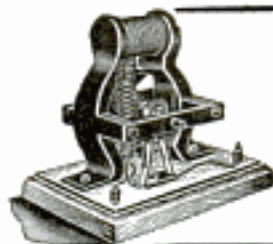

THE White Eagle Electric Motor

Postpaid, 75c

We make working models of inventions. Send for illustrated catalogue of Model Supplies.

The Pierce Model Works
134 Pierce Avenue Chicago, Ill.

1½ H. P. \$58.00

Look at the Neat Design!

The finest little 1½ H. P. Engine on the market.

Handsomely finished.

Bore 3¼ inches; stroke 3 inches.

These engines will develop over 2 H. P.

Write for Catalog "P" of 1½ to 16 H. P. Motors.

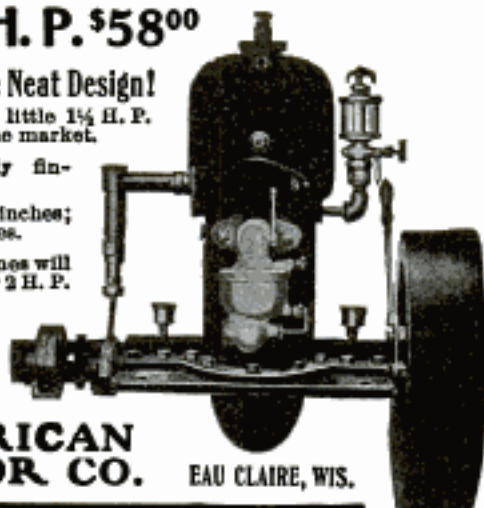

AMERICAN MOTOR CO.

EAU CLAIRE, WIS.

THE LATEST DOG STORY.—A saying runs to the effect that the flesh of the bear is so delicious that Providence will wreak vengeance on those who over-indulge in this meat. The proverb has recently been verified by an incident brought to light a few days ago in Osaka. The bear season sets in with the winter, and its flesh is most relishable between now and next spring. Many salesmen go about nightly crying out "Boar flesh, all alive O!" are eagerly patronized. Yoshiya Okinaga, of Nishiku, Osaka, is a great lover of the meat, and whenever the bear season comes he is the first to eat it and seldom omits eating it at supper almost every evening in winter. He has patronized the same hawk for nearly five winters. The other day he called the salesman, named Hatsutaro, and bought a pound and a half of boar flesh. At supper he was doing justice in his usual way of eating as he boiled the meat. He had devoured half when he was called on by a detective who beholding him eating advised him in a diplomatic way that he was eating dog's flesh and that Hatsutaro and several of his colleagues had been arrested on a charge of fraud. These men had been selling nothing but the flesh of dogs, which they bought from a butcher in Hyogo, whose business it is to steal and kill dogs. Yoshiya felt an instant sickness in his stomach, but we drop the curtain. According to the confession of the arrested rogue, nearly all the itinerant vendors of the so-called boar flesh are his colleagues. The dog flesh is bought at about 40 sen per kan and they go about with the flesh covered in a boar's bristling fur. By selling two kan they generally realized a net profit of 4 or 5 yen.—Japan Times, Tokyo.

BURNED SNAKES FOR FUEL.—The spring crop of snake stories opens up early and unusually promising. The Philadelphia Record leads out with this one:

Men getting out bluestone above Narrowsburg blew off a top dressing of earth and stone to get at the marketable product beneath. The blast exposed a cavern which contained a mass of snakes. They were of the blacksnake, rattlesnake and milksnake variety, and had evidently crawled into the rocky retreat for the winter. They were frozen stiff, and thrown out of the way by the workmen.

Patrick Hoolan, a charcoal burner, saw the snakes in a pile, and, mistaking them for wood, threw them on a fire. When they began to thaw out and writhe over the ground, he thought the woodpile was bewitched. Not so with his son and wife. They attacked the reptiles with such vigor that in the course of a few minutes they had slain thirty-six snakes.

The surest and easiest way to get perfect ignition for your engine is to use a

SPLITDORF COIL

Gives more power with less trouble and expense

Ask Department M for catalog

C. F. SPLITDORF, 261 Walton Avenue, NEW YORK

SETS OF CASTINGS OF MODEL ENGINES
SEND 10¢ FOR 126 PAGE ILL. CATALOGUE.
ALSO TOOLS.
GEAR WHEELS & PARTS OF MODELS.
LUTHER H. WIGHTMAN & CO.



BUILD YOUR OWN MOTOR!

Complete sets of Castings, with blue print working drawings, for your Auto, Lanch or Motor-Cycle Engine.

Our Remarkable Offer!

6-Actual Brake Horse Power—2 Cycles—3 Port Engine. \$100 complete with accessories. IT'S GUARANTEED! We sell Blue Print Working Drawings—2 or 4 Cycle. Send stamp for Catalog.

THE GERHARDT MOTOR CO.
27th Street, above Dauphin, Philadelphia, Pa.



GAS POWER

A monthly magazine devoted exclusively to the gas and gasoline engine subject. It will tell you how to keep your engine running and save you money in expensive repairs. Its contents are of a semi-technical character that cannot fail to interest people operating or contemplating the purchase of a combustion engine.

PLAIN GAS ENGINE SENSE

presenting the primary principles of the Gas Engine in simple language—but supplying enough practical knowledge to successfully operate a gas engine. Regular subscription price of Gas Power, \$1.00 a year. Plain Gas Engine Sense sells for 50 cents a copy.

A special limited offer is now open of Gas Power, One Year, and One Copy of Plain Gas Engine Sense for \$1.00. Mail orders at once. Address

GAS POWER PUBLISHING COMPANY

120 Court Street,

St. Joseph, Michigan

Free sample copy of Gas Power, if desired



The Campbell Tool

Every one who uses a rule should have this tool
SQUARE, DEPTH GAGE,
MITER, LINE GAGE, Etc.

Price, 25 cents, U. S. or Canada

CAMPBELL, 117 Marshall St.
ELIZABETH, N. J., U. S. A.

DYNAMO-MOTOR, \$3.50

(A Dynamo and Motor in One)
As a dynamo, it will light four 6-c. p. lamps easily; operate induction coils; charge storage batteries; decompose water, electroplate, etc. As a motor, will operate sewing machine, jewelers' lathe, emery wheel, circular saw, advertising devices, and other useful appliances.

NEW ADVANCE MOTOR, new design, has two field coils and improved brush holders. Price 75c, postage 20c.
Send stamp for catalog, No. 8 of new things electrical.



ARROW ELECTRIC CO., 103 South Canal Street, Chicago, Ill.

RESULTS will be satisfactory to you if you buy one of our Engines.

PEERLESS MOTOR CO.
1218 Clinton St., Lansing, Mich.



Electric

OHIO ELECTRIC WORKS, CLEVELAND, OHIO.
The World's Headquarters for Dynamos, Motors, Fans, Toys, Batteries, Belts, Bells, Lamps, Books. WE UNDERSSELL ALL. WANT AGENTS.

SUPPLIES, TELEPHONES NOVELTIES. Catalog of 200 Free. If it's Electric, we have it. Big Catalogue 4 cts.

ELECTRICIAN AND MECHANIC

A finely illustrated monthly magazine publishing practical educational articles on all branches of electricity and mechanics. Complete directions and working drawings for making steam and gasoline engines, dynamos and motors, furniture, wiring instruction, wireless telegraphy, mechanical drawing, etc. Three months' trial, twenty cents. One dollar a year. Catalogue of electrical and mechanical books free. Sampson Publishing Co., 1133 Beacon Building, Boston, Mass.

2 H.P. STATIONARY ENGINE \$29.50 (ENGINE ONLY)

FOR FARM AND SHOP WORK. Run Separators, Corn Shredders, Grist Mills, Pumps, Dynamos, etc. Start without cranking; no cams or gears. Burns Alcohol, Kerosene, and Gasoline. All sizes in stock; 2 to 20 horsepower. Steel connecting rods, anti-friction bearings; no vibration. Write for free catalogue

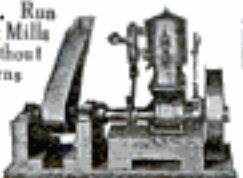

DETROIT ENGINE WORKS
213 BELLEVUE AVE. DETROIT, MICH., U.S.A.

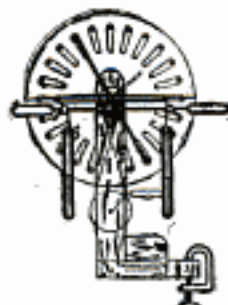

WE LEAD AS USUAL

"Everything for the Experimenter"
The "Electro"-Static Machine

GENERATES IN ANY KIND OF WEATHER. Humidity does not bother this wonderful machine, due to a new discovery incorporated for the first time in a static generator. The machine gives a FAT, powerful THREE inch spark.

We absolutely guarantee these two points and will at once refund your money if the facts are not exactly as stated. No batteries needed. Just turn the handle slow and the machine generates.

We supply our machine with: Two 8-in. glass plates revolving in opposite directions, 2 Leyden jars, 2 spark ball dischargers, 1 clamp to attach body to table, all exactly as cut. Size over all 10x12 inches. Thousands of wonderful experiments in static electricity can be performed with it. It works wireless sets, Geissler tubes, charges big Leyden jars, etc., etc.

You cannot afford to be without it. Guaranteed in every respect..... Price \$3.50 boxed.

The "Electro"-Lytic Detector. Just out. It is guaranteed to catch messages 300 miles away, with a 12-in. spark coil at the sending end. Just the thing for the experimenter to "rubber" in. You can hear far off stations and learn telegraphy FREE OF COST. A child can operate it; a marvel of simplicity. CAN BE CARRIED AROUND and messages received at ease AS YOU WALK. Guaranteed not to "break down" as other detectors. Sent postpaid complete for \$2.00

If you haven't got our 92-page electrical cyclopaedia-catalogue No. 4, send 2 cents postage.

It's free. 100 experiments in it. If you have it please state this in your letter and enclose 2 cents postage for printed matter on the "Electro"-Static machine and the "Electro"-Lytic detector.

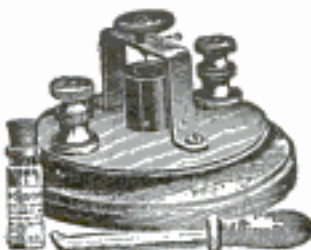

ELECTRO IMPORTING CO., 87 Warren St. New York

Largest makers of experimental wireless material in the world

ELECTRICITY BOYS WHO ARE INTERESTED

In the fascinating and elevating study of Electricity should send a 2-cent stamp today for our 80-Page Catalog. A big book of electrical education containing pictures and descriptions of hundreds of Electrical Toys, Bells, Lamps, Telephones, Railways, Motors, etc. Something electrical for everybody. Lowest Prices.

Get the Catalog - You'll Profit by It.

VOLTAMP ELECTRIC MFG. CO., Voltamp Block, Baltimore, Md.

Little Giant

GASOLINE MOTORS

Reliable-Reversible Two Cycle \$87.00 (Bare)

Light, simple and easy to operate. Only three moving parts. Main bearings lapped. Material and workmanship of the highest grade and guaranteed. Jump spark ignition.

BUILT IN MULTI-CYLINDER TYPES

Write Today for Free Catalog D-4, and Circular

Send 10c for our book "Ignition, Vaporization and Operation of a Motor."

No. 5 Motor 5 to 8 H. P.

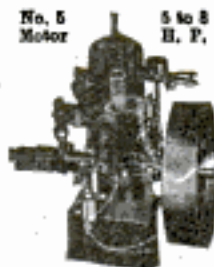

UNITED MANUFACTURING CO.

Detroit, Mich.

Gasoline Soldering Iron and Blow Torch



YOU can save time, money, patience and make your work a pleasure. Our booklet on request.

EMMELMANN BROS. MFG. CO.
INDIANAPOLIS, IND., U. S. A.



GEARS

INTERNAL and EXTERNAL of all kinds

Ask for Catalog
Grant's "Treatise
on GEARS" a dollar

Philadelphia GEAR Works, Inc.

1120-1122 Vine St.

GEORGE B. GRANT, Pres. & M. E.

Philadelphia

THE OLD RELIABLE

JESSOP STEEL

IS YET ON TOP AND THE VERY BEST FOR ALL FINE TOOLS

WILLIAM JESSOP & SONS, LIMITED

91 JOHN STREET, NEW YORK



WORKING MODEL ELECTRIC CAR

30 inches long

Blueprints No. 8 and full description, 10c

EMPIRE ELECTRIC WORKS, Bridgeport, Ct.

If you are interested in any kind of a Firearm, write for our beautiful "Gun Guide and Catalog" for 1907. It's **FREE**

Gives more points on guns than any catalog published. Gives best prices and most complete line.

THE HOPKINS & ALLEN ARMS CO.
32 Chestnut St., Norwich, Conn., U. S. A.

RULES FOR CHAUFFEUR.—An English motorist has compiled the following rules for his own driver for town driving, says Automobile Topics:

If there is a doubt whether you can "get through," don't try. Remember, if any accident occurs it is a discredit, and a bad job for someone.

Don't go too quickly near the pavement, in case a deaf person, or one engaged in other thoughts, steps off into your track. When passing a tram, face on, toot loudly to provide for a person walking across from behind the tram, who might be bewildered by the confusion. Go too slowly rather than too quickly. If you make an error, make it on the safe side.

Always remember that any useless revolutions of the engine—that is, when the engine is running light, are so many moments less life to its existence. It is an unnecessary cost of petrol, lubricating oil, and wear and tear—a noise, a discomfort, and an irritation to people and mechanism.

A revolution saved is a revolution gained. There is an economic, a durable, and a pleasant speed to an engine, just the same as there is to a living person; a speed at which a person can walk and run without destroying the tissues or over-exerting the muscles of the system, so with the piston of an engine.

And an engine working the car, and running light, is under two distinct differences. Working, the car has the flywheel power of the car; it is "backed" by a ton in motion with itself, and it is thus held "steady." Running light, it has no staying power; it has no 1-ton flywheel. Therefore, before declutching, throttle down your engine. Before starting your engine, throttle down. Before starting your car, throttle down to the extent that the engine will easily "take hold."

Never draw up with your brake if you can do so without; it is a penny wasted on tires every time you do so. Withdraw your clutch in anticipation of the place to stop at, and just bring the "stand still" with the brake. It is an act of bad driving to rush up to a stopping place and then apply the brakes—

Because it scares the people about, and the people inside may think that perhaps the brakes won't act; because it savors of a wish to draw attention and give an impression of ability, which is not becoming; because it costs as much in tires to stop by brake power as it does to start with the same quickness. In the case of starting or quick acceleration, the engine is the motive power. In the case of slowing down suddenly by fierce brake power, the momentum (of, say, 1½ tons) is the motive power, and the brakes are the retarding power. In both cases the tires in contact with the road surface have to communicate the power, and they depreciate accordingly—

Because the power of retarding is transmitted through the gears and reduces the life of the mechanical parts.

Therefore, don't use brakes indiscriminately for drawing up. They are for down-hill and emergency work.

TEST FOR COLOR BLINDNESS.—The superintendent of a railway in Indiana received the following letter from one of his men, says Electric Traction Weekly:

Montmorency, Ind.
My Inspector—Dere sur—The day before yesterday at nine I got word to cum down and have me be looked after fur colr blinness. I had 45 tise and 10 rales to put in beyant the sand cut and me hands were to short to spare me. The ly that was first in me, was put out by a blow from a pik and me glass ly is a perfect figger of the ly that was not put out, and is sent to you and me watch for examination. I cud spare the glass one better than the one in me head. If she is colr bline I'll get one that ain't.
Anthony P. Scoll, Foreman Sec. 10.

A HIGH GRADE FAMILY LAUNCH AT SMALL COST

CAN BE MADE FROM AN ORDINARY ROYBOAT BY INSTALLING A

Catalog Free

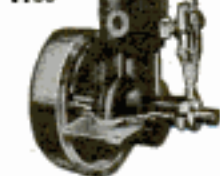

SKIDOO! 2 to 2 1-2 H. P., BARE ENGINE \$23
Complete Engine With Accessories and Fresh Water Boat Fittings - \$43.75
Salt Water Boat Fittings - \$5 Extra

A strictly high-grade 2-cycle engine, designed especially for use in small boats. Anyone can install and run it. Absolutely safe under all conditions. New 1908 model, improved and perfected in every detail. Swiftest, most powerful, efficient, and reliable engine of its size on earth. Excels all others in simplicity, compactness, strength, and durability. Reversible. Drives 14 to 20 ft. boat 5 to 8 miles an hour. Runs smoothly, steadily, and quietly, perfect speed control, unflinching endurance power. Sold from factory to user on 30 days' approval and 5 year guarantee. Thousands of satisfied users. Prompt shipment. Order early. Write today.

BELLE ISLE MOTOR COMPANY, DEPT. 10, DETROIT, MICH.

' Banished From American Market The New Americanized ENCYCLOPEDIA BRITANNICA

Bids farewell to American readers in most sensational price slaughter book sale ever known.

American Publishers were compelled to stop printing the Encyclopedia Britannica by decision of International Copyright Law taking effect November 1st, 1907.

The American Publishers have sold 270,000 sets—the greatest sale of encyclopedias ever made on the American Continent. We bought from the American Publishers the entire stock of the American Edition on hand November 1st, 1907, at practically our own price and are closing it out at a small advance on cost to us.

When our stock is gone you are in the clutches of the British Publishers, whose high priced sets will cost you \$125 to \$275. Remember the American Publishers can never print another copy of the Encyclopedia Britannica. The British lion has shown its teeth and the American Edition is banished. The few sets we have will last but a short time when this truth dawns upon the American people.

We Offer These Sets at About 1/4 Price

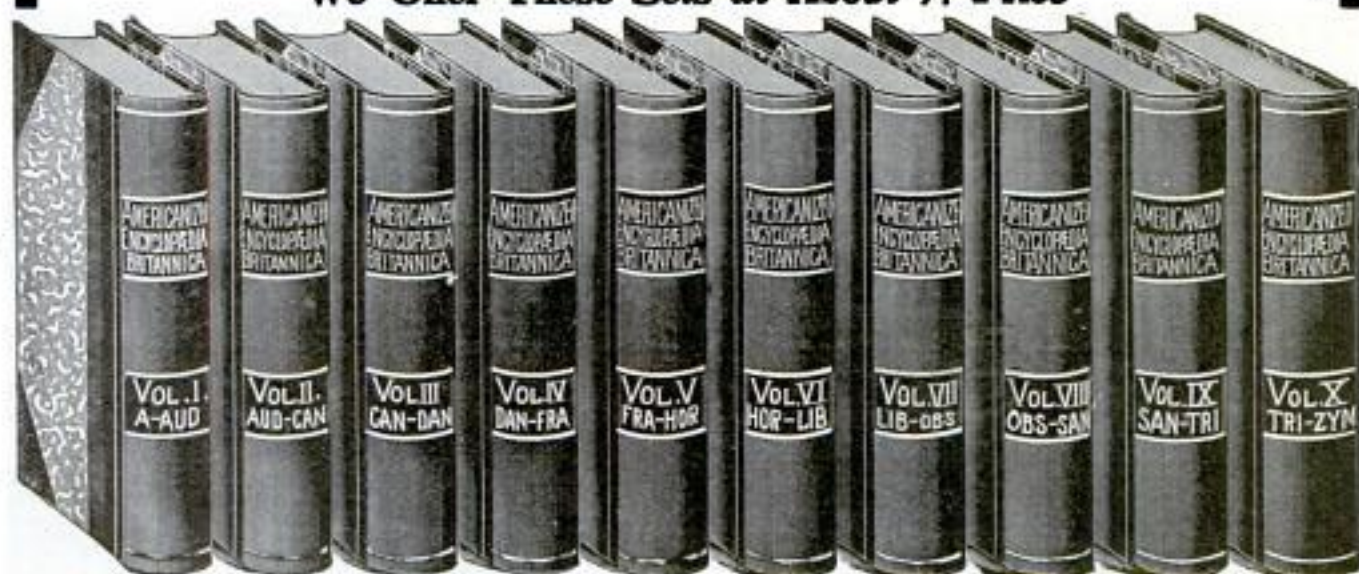

Regular Price \$39.00. Our Price \$10⁷⁵

NEW EDITION. REVISED AND COPYRIGHTED 1907.

10 massive volumes. Weight nearly 25 pounds. 6,902 large double-column pages, 7x9 1/4 inches. 192 pages colored maps. Many page plates and innumerable illustrations. Clearly printed from brierly type on specially made book paper, restful to the eyes. Bound in dark red Russia leather with marbled sides. Will last your lifetime and that of your children and their children.

For 125 years the Britannica has been the world's great reference work. Contains the world's wisdom and knowledge gathered by 1,500 of the world's greatest scholars at an authorship expense of \$2,000,000.

Three hundred of America's ripest scholars, each a specialist in his line, have revised every word and line in this Americanized edition, added, enlarged here, condensed there, and improved and brought all information down to date.

Covers the field of Art, Literature, Mechanics, Invention, Geography, Astronomy, Agriculture, Law, Political Economy, Medicine, Science, Religion, History, Manufacture, Biography, Music, Legends, Natural History, Anatomy, Electricity, etc., etc., as no other American encyclopedia ever did.

Covers American topics more fully than does the British edition. Bolls down articles of essentially foreign interest. The encyclopedia for the American student, reader, teacher, professional man, merchant, mechanic, the school and the home. Treats 250,000 subjects. Takes the places of thousands of books. Big library in itself. The most economical work you can possess.

Sent on Approval, Freight Prepaid By Us

We will ship the set, freight prepaid by us, and you can examine it five days in your own home. If you want it, you may send us \$10.75 at the end of the five days, otherwise, ship it back to us at our expense. Fill out the attached coupon and send to us and we will ship you without delay the entire set of 10 volumes.

**The Standard Book Co.,
342 Wabash Avenue
Chicago**

**The
Standard
Book Co., 342
Wabash Avenue,
Chicago.**

Gentlemen:—Please send me, right prepaid, the New Americanized Encyclopedia Britannica, 10 vols. in half Russia leather binding. If I decide to keep it, I will send you \$10.75 within five days after receiving it. Otherwise I will ship it back to you in that time at your expense.

— Cut Out Coupon—Sign and Mail Today —

Name.....

Street No.....Street.....

City.....State.....

Please Mention Popular Mechanics

Copyrighted material

Broken Cast Iron Brazed

Successfully by the
NATIONAL BRAZING CO.
 83 W. Jackson Blvd., Chicago

TELEPHONE MAIN 2982

Don't throw your broken machine parts or any other casting away, as we can braze them successfully and guarantee the same to be as strong as when new. Consider the **time** and **money** we can save you occasioned in waiting for new parts to be sent from distant points or for the re-casting of same. **Rush orders given special attention.**

WE BRAZE IN OTHER METALS ALSO—BUT CAST IRON IS OUR STRONGHOLD

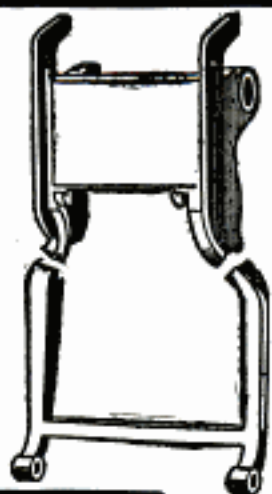

Greatest of all Scissors
 EIGHTEEN TOOLS COMBINED
 AND EVERY TOOL
 PRACTICAL
 KEEL EDGE

1. Scissor
 7. Measure
 8. Nail File
 9. Screw Driver
 2. Buttonhole Scissor
 3. Gaspipe Tong
 4. Cigar Cutter
 5. Wire Cutter

12. Hammer
 13. Penknife
 14. Glass Cutter
 15. Glass Breaker
 16. Marking Wheel
 11. Cartridge Extractor
 10. Cigar Box Opener
 17. Ink Eraser
 18. Stereoscope

MUCH HANDIER THAN A KNIFE

Just the Article for Office men, Clerks, Bankers, Travelling salesmen, or the House wife. Made of 1st quality of steel—fine workmanship—nicely finished. Nickel plated. Put up in elegant leather sheath.

AN EXCELLENT GIFT

10. Postpaid upon receipt of \$1.00

WM. C. HOCKING & CO., 152 Lake St., Chicago

The Optimist and Pessimist, the difference is droll:
 The Optimist sees the doughnut, the Pessimist the hole.

You can't be a Pessimist and own a

STRELINGER

4 Cycle, 1 to 4 Cylinder. IT ALWAYS GOES
 Best Marine Engine Made

We also carry in stock several of the best makes of 2-Cycle Marine Engines, and a full line of Stationary Engines, Pumping and Electric Lighting Outfits, Boat Accessories, Etc., Etc.

WRITE FOR OUR 1908 CATALOG
 Let us know your wants and we will quote prices.

Engines 1 1-2 to 50 H. P.,
 \$33 to \$2,500



THE STRELINGER

THE STRELINGER MARINE ENGINE CO.

Dept. L, 46 Congress St., Detroit, Michigan, U. S. A.

AMERICAN MANUFACTURERS PLAN GREAT TRADE CAMPAIGN.—Preparations are being made by well known industrial leaders of the country for the launching of a great national trade exposition or campaign in South America, where the American manufacturer will be brought face to face with the South American consumer. The contemplated exposition will start in Buenos Ayres next winter and will then make the circuit of South America, leaving there in time to go to the big Japanese world's fair in 1912. In the exposition opportunities will be afforded the American manufacturer to learn what the South American consumer wants, as well as to teach him that the things the United States has to offer are the best. It is not proposed to ask Congress for any aid. The campaign is to be exclusively a trade promoter, and the states and general government will simply be participants like other exhibitors, except that it is intended that there shall be an advisory directorate made up of high government officials, the governor of states, and the presidents of the chambers of commerce of the principal cities.

MECHANICAL DRAWING. By Ervin Kenison. 160 pp., 140 illus. Price, \$1.00. This work is designed, not so much as a manual for the teacher of drawing, as a means of self-help and self-instruction for the student. Gives complete practical instruction. American School of Correspondence, Chicago.

A COURSE IN MATHEMATICS. Volume I. By Frederick S. Woods and Frederick H. Bailey. 8vo, cloth, 385 pp. With diagrams. Price, \$2.25; postage, 15 cents extra. For students of engineering and applied science. Contains algebraic equations, functions of one variable, analytic geometry, differential calculus. Ginn & Co., New York.

PROBLEMS IN STRENGTH OF MATERIALS. By William Kent Shepard. 8vo, cloth, 70 pp. Price, \$1.25; postage, 5 cents extra. A collection of over 500 practical problems in the strength of materials for students in all branches of engineering. Ginn & Co., New York.

THE SCIENCE YEAR BOOK FOR 1908. Edited by Maj. B. F. S. Baden-Powell. Price, \$3.00, postpaid. The fourth year that this valuable work has appeared. Contains astronomical, physical and chemical tables; summary of progress in science; directory, biographies and diary. Tables and data revised and brought up to date, and new matter added. King, Sell & Olding, Ltd., 27 Chancery Lane, London, W. C.

SMALL STEAM TURBINES WANTED.—There seems to be quite a demand for steam turbines of small powers. Several times each month this magazine receives requests for information as to where the writers can obtain steam turbines ranging from 1 to 10 hp. The larger number want a 3 to 5-hp. The requests moreover are from concerns in good standing and not from unknown individuals.



PROTECT YOUR BLUE PRINTS

From Fire and Dust

Manufacturers of all kinds of
 Draughting Room Furniture.

Write us for Catalogue

FRITZ & GOEDEL MFG CO.
 99 Alabama Street Grand Rapids, Mich.

BUILD A BOAT

Send for Catalog L, 1908, 64 models. Full size patterns and K. D. Frames. Frames set up and filled—no moulds required. Launches 9 ft. to 40 ft. Yachts and tenders, sail boats, row boats, launches.

BAY CITY BOAT MFG. CO. Bay City, Mich., U. S. A.

TEN CENTS

PAYS FOR A COPY OF

The Law of Financial Success

BY EDWARD E. BEALS

An absolutely new departure along this line of thought

All progress—whether physical, mental, moral, spiritual or **financial**—is based on **LAW**. And he who wins success in any line does so because he has followed the **LAW** or **LAWs** pertaining to his business, whether he does it consciously or unconsciously.

Some of the great "Captains of Industry" who have won marvelous success in financial affairs, and for whom we have no great admiration, are miserable failures as moral and spiritual beings. But they have won great **Financial Success** because they concentrated on that alone to the exclusion of all other kinds.

What the most of us want is all round success, but we must remember that no one can be an all round success without **Financial Independence**. No matter how much good a person may want to do, he is handicapped by a lack of money. All the air-castles he has built; all the beautiful plans he has created; all the cherished desires to do good go unfulfilled because there is no money to complete them.

But these air-castles can become real buildings; these plans can become realities; these great desires can be fulfilled. The question is, "How to do it?"

The writer has seen the need for several years, among all classes of people, of a book to answer this question. In his own life he has found that **Financial Success** is not a matter of grind and rush and fight and struggle. It is a matter of getting in harmony with the **LAW** and then following the **LAW** to its logical conclusion. He has placed this information in the book, "**THE LAW OF FINANCIAL SUCCESS**." In it he states the **LAW**, shows how to get in harmony with it, and then gives specific instructions for keeping in the closest possible touch with the powers that be in the **World of Finance**.

This book is no magic scheme to make you rich over night, neither is it a story of what other men have done. Just a plain, simple statement of truths that all can understand and put into practice by a little thought and study. Here are the chapter heads.

- | | | |
|--------------------|--------------------|-----------------------|
| 1. Money | 6. Ambition | 12. Concentration |
| 2. Mental Attitude | 7. Desire | 13. Persistence |
| 3. Fear and Worry | 8. Will Power | 14. Habit |
| 4. Faith | 9. Auto-Suggestion | 15. Claiming Your Own |
| 5. Latent Powers | 10. Harmony | 16. Making Money |
| | 11. Creation | |

Whether rich or poor, successful or unsuccessful—it matters not—this book will be of great value to you. If you are a natural money-maker, perhaps you have been using the **LAW** unconsciously. This book will tell you how to handle it consciously. If you are unsuccessful and money seems to come hard, it will guide your thought and actions into the proper channels where you will get the highest possible results.

"**THE LAW OF FINANCIAL SUCCESS**" combines theory with practical knowledge. It not only states the **LAW** but tells how to apply it. It not only informs one how to make money, but also tells him how and in what way to invest it to get the largest possible returns.

Now in its fifth edition consisting of 100,000. Send your order today—NOW—before the thought passes from your mind.

Light board cover, 25c; cloth, 50c.

Fill out, tear off and mail this coupon and we will send you a **SPECIAL INTRODUCTORY COPY** for TEN CENTS.

THE FIDUCIARY PRESS,
1074 Tacoma Building Chicago, Ill.

THE FIDUCIARY PRESS,

1074 Tacoma Bldg.
Chicago, Ill.

FOLD HERE
Find enclosed 10 cents for a special introductory copy of "**THE LAW OF FINANCIAL SUCCESS**."

Name.....

City.....

State.....

Postage stamps are welcome—send dime if you prefer.

Please Mention Popular Mechanics



Wood Working Machinery

Foot, Hand and Light Power

For ripping, cross-cutting, mitering, rabbeting, grooving, dadoing, boring, scroll and band sawing, edge moulding, beading, mortising, etc. Built for hard work, accurate work and long service. Send for catalogue "A."

SENECA FALLS MFG. CO. 102 WATER ST. SENECA FALLS, N. Y.



Dixon's Flake Graphite

Gives you "positive principle" lubrication. Good for steam or gas cylinders, bearings, gears, and all friction surfaces. Free booklet 194-C, gives full information.

JOSEPH DIXON CRUCIBLE COMPANY
JERSEY CITY, N. J.

FOOT and POWER

AND TURRET LATHES, PLANERS
SHAPERS AND DRILL PRESSES ::::

SHEPARD LATHE CO.

A181 W. 2d St., Cincinnati, Ohio

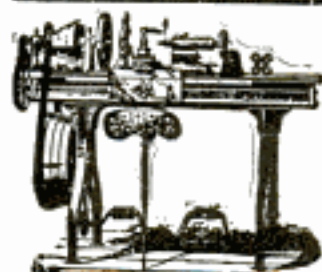

LATHES

9 to 13 Inch Swing

List price, \$75.00 and up according to size. When ready to buy send for Lathes Catalog and prices

W. F. & John Barnes Co.
100 Ruby St., Rockford, Ill.

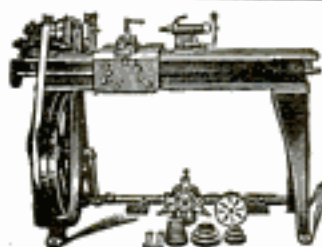

B. F. BARNES' ELEVEN-INCH SCREW CUTTING LATHE

For foot or power as wanted. Has power cross feed and compound rest. A strictly high-grade modern tool. We also build a 9-inch lathe. Descriptive circulars of each lathe upon request.

B. F. BARNES CO., Rockford, Ill.

PHOTOGRAPHS WANTED

Photographs of new and interesting subjects, suitable for publication in this magazine, may be submitted to its editor and those accepted will be paid for promptly.

Editor Popular Mechanics
160 Washington St. Chicago



9 to 15 In. Swing.
New Features.

If It's a Sebastian, It's a Good Lathe

BUILT UPON HONOR—ACCURACY, EFFICIENCY, MODERATE PRICES.

Foot and Power Lathes, all sizes. Send for Catalogue.

Sebastian Lathe Company, 107 Calvert St., Cincinnati, O.

IMPRESSIONS OF A LOCOMOTIVE ENGINEMAN.—

When I started railroading an engine cab was to me as fairyland, a sort of sacred and mysterious place to be entered with awe. The smell of cylinder oil—that smell which is ever present on an engine—was as incense to my nostrils, and the odor of a torch had its charm. I was a night hostler helper and the engines then burned coal—I know this for I shoveled it the first half of every night. The other half was devoted to wiping and cleaning fires and front ends.

But if I was pleased with my job then I was infinitely more so when sent out as an engine watchman, to watch a work train engine near Albuquerque. There were five of us watchmen at this point, and we worked hard, for the coal we had was very low quality and the fires to clean were frightful. But we toiled cheerfully, and around those nights memory clings with tenderness. Two of us are now engineers, one has quit railroading, one has passed to the great beyond and I do not know where the other is now.

At that time I was not up to the standard in weight and had considerable difficulty in getting onto the list of firemen. But I was finally given a switch engine to fire, thanks to the efforts of a roundhouse foreman in my behalf, and from that to road fireman was a short jump. I have fired for many engineers since that time; and I must say that they were all fine men, though some had their faults and some were better than others. I venture the assertion that in no body of men are opinions on small matters incident to their profession so diversified as among locomotive engineers, and an extra fireman finds this out. A certain way of carrying water, of sanding the flues, of managing the fire, which pleases one man will not meet with the approval of another.

But how different many things seem to me since reaching the right-hand side. The element of professional pride enters somewhat, and I become possessed of the determination to be a man who knows his business, for I have ever admired such men in any profession anywhere. To be a successful runner, with the minimum amount of delays and failures; to use my allotted supplies without wasting any—for I have always held that a thing wasted does no one any good; to see that the fireman does his work properly, yet instruct him in such a manner that I hold his respect; to work harmoniously with the train crews, between whom and the engine service there is frequently a certain amount of needless friction; these are the things I would like to attain. And the sense of responsibility weighs heavily, filling me with a certain seriousness hard to describe. All enginemen feel the weight of it, though they may not say so.

Still there is a charm about it, of working in all kinds of weather, of moving along under the stars and beholding the beauties of the night, of gliding past farmhouses and fields bathed in the moonlight or seeing meteors flash across the sky, of working in stormy weather when the wind and rain cut your face like knives if you put your head out of the cab, once in a while catching the roar of the exhaust above the sound of the storm, while the lightning flashes and the thunder rolls. And we have fog, too, when you cannot see more than two car lengths ahead, and the word "if" is ever present in your mind. Again, the conditions to be met are never alike on any two trips, and this calls for a constant display of watchfulness and judgment. Our hours are irregular, and many times long. Day and night is a continuous stretch of time to an engineman, with enough interval between trips to obtain needed rest.

There is no other trade or calling similar to railroading. It stands alone. I would advise those who envy the men in the cab to pause and consider. All is not roses in the life of an engineman, entailing as it does working under any and all conditions. And, to those who are possessed of a prejudice against railroadmen, I would say that the majority of them are men of fine character, very much human, possessed of large hearts, most of us with homes of which we are proud and in which culture and refinement are found.—E. B. H. in *Sante Fe Employees' Magazine*.

Knowledge Moulds Ambition

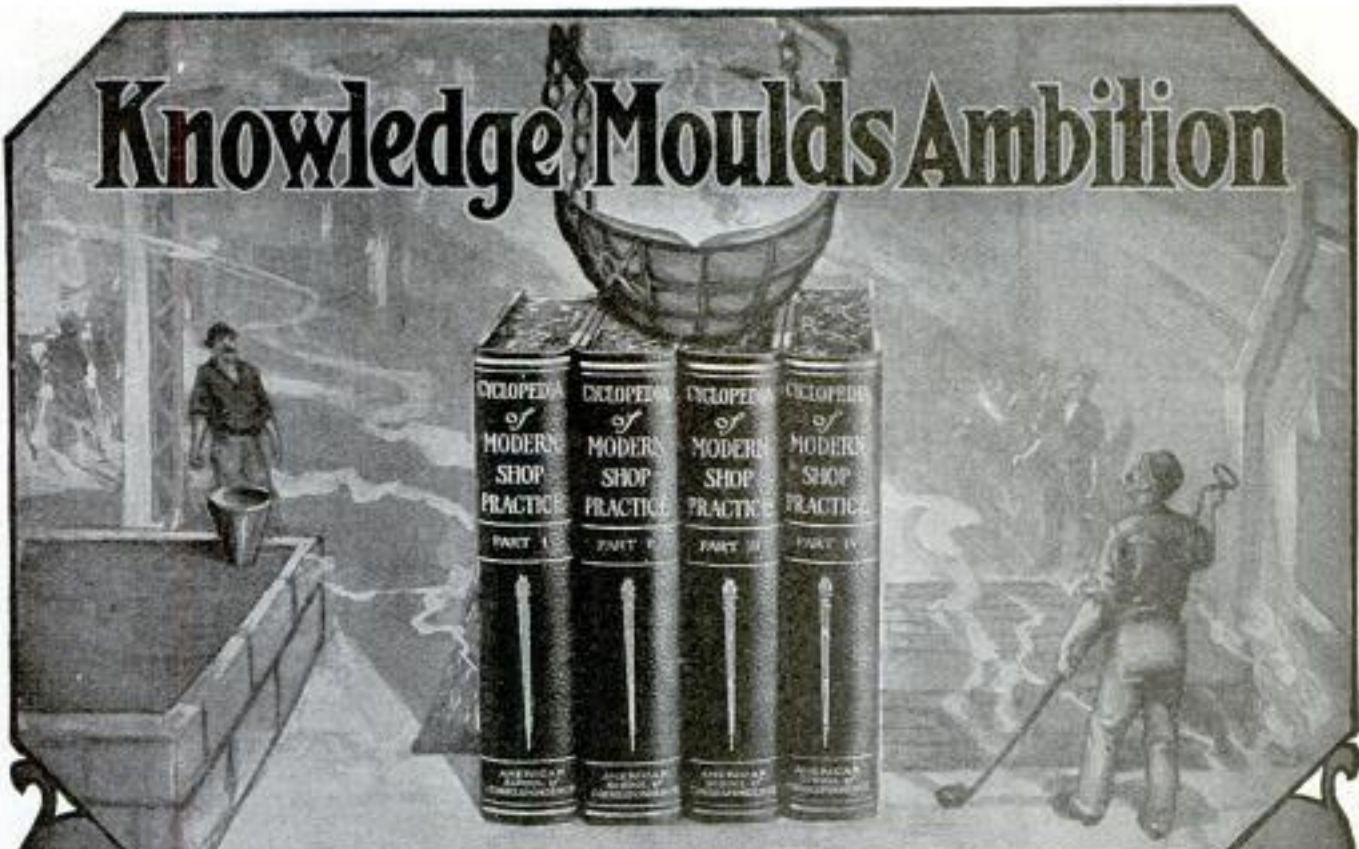

Ambition is the white hot metal which is to form a man's career; knowledge is the mould which gives it shape and purpose. Ambition without knowledge is as useless as the molten steel that flows from a broken crucible. It is not enough that you have the desire to get ahead, you must have the ability to work and the knowledge that will make your work count.

CYCLOPEDIA OF MODERN SHOP PRACTICE

Four Volumes, Page Size 7x10 inches; 2,500 pages, 2,043 illustrations, full page plates, diagrams, etc. Bound in one-half red morocco.

Editor-in-Chief, HOWARD MONROE RAYMOND, B. S., Dean, Armour Institute of Technology.

Compiled from representative instruction papers of the American School of Correspondence, this work embodies the teachings of the foremost experts in shop work throughout the country. Everything is explained in a plain and easy manner, especially designed for HOME STUDY.

It does not simply give general instruction, but it gives every detail from the start to the finish of the work. For example: it tells the DRAFTSMAN how to letter his drawings, as well as how to make a working drawing of every part of an engine; THE MACHINIST, how to choose his tools and to use the latest device in the vertical milling machine; THE DESIGNER, where to place each bolt and screw and how to plan his whole work; THE BLACKSMITH, how to calculate stock for every sort of work, and temper and anneal a difficult piece of work; THE SHEET METAL WORKER, how to make his patterns and how to make a boiler breeching; THE ENGINEER, how to start a gas engine or how to handle the latest type of steam turbine; THE TOOL MAKER, how to choose his steel or how to make a die or a gauge; THE PATTERN MAKER, the names of his tools or how to pattern a gear wheel or figure shrinkage; THE FOUNDRYMAN, how to select his sands or how to build an intricate mould; THE FOREMAN, how to lay out work, or how to light his shop; and innumerable other things, big and little, as you can see from a glance at the partial table of contents given herewith.

ORDER NOW AT 1/2 PRICE
Reduced from \$24.00 to \$12.00

Sent express prepaid on receipt of coupon. Send \$2.00 within five days and \$2.00 a month thereafter until the special price of \$12.00 is paid. We will send for the books at our expense if you decide not to keep them. We are making this liberal offer merely to advertise the American School of Correspondence.

WE EMPLOY NO AGENTS, believing our books will best demonstrate the superiority of our home study instruction methods.

SOME CHAPTER HEADS

Machine Shop Work—Tool Making—Pattern Making—Machine Design—Metallurgy—Gas and Oil Engines—Producer Plants—Automobiles—Elevators—Steam Engines—Steam Turbine—Management of Dynamos and Motors—Forging—Sheet Metal Pattern Drafting—Tin-smithing—Mechanical Drawing—Mechanism.

AMERICAN SCHOOL OF CORRESPONDENCE, Chicago

CUT OUT THIS COUPON

NAME

ADDRESS

EMPLOYER

Pop.
Mech.
3-08

A. S. of C.

Please send set
Cyclopedia Modern
Shop Practice for 5
days' free examina-
tion. I will send \$2
within 5 days and \$2 a
month until \$12 is paid;
otherwise I will notify you to
send for the books.

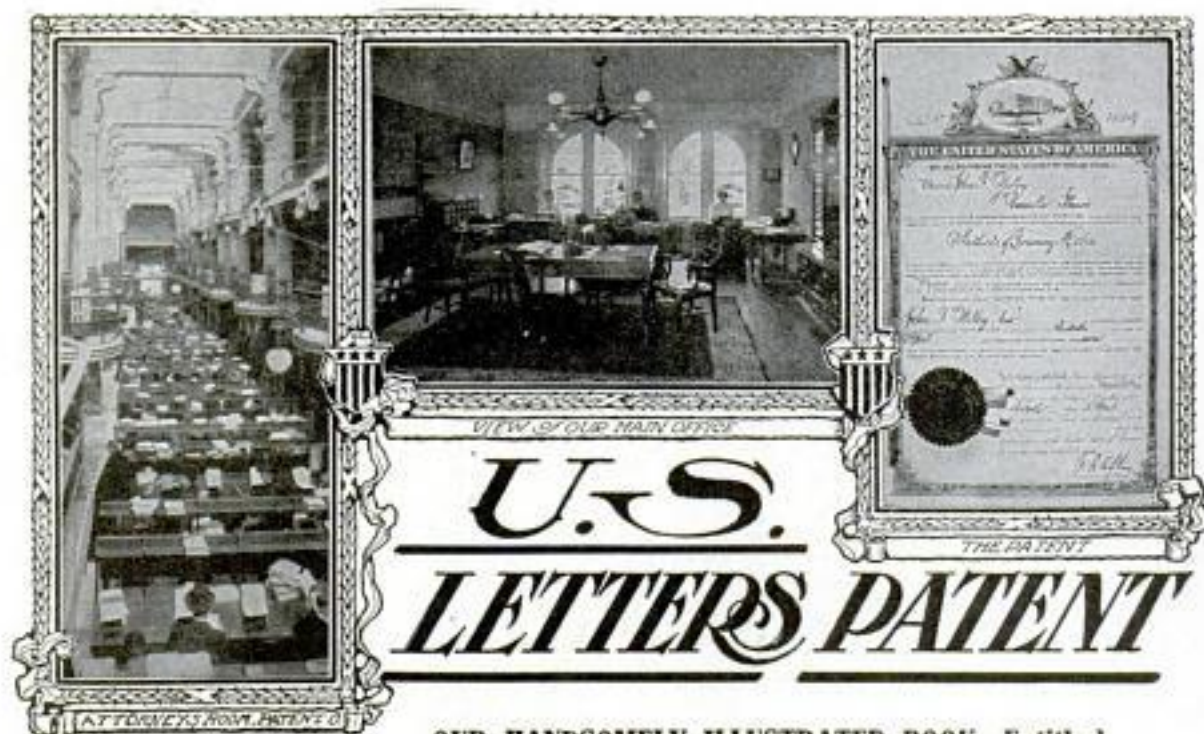

OUR HANDSOMELY ILLUSTRATED BOOK, Entitled

"U. S. Letters Patent," giving full information in Patent Matters, mailed free. Also

"Thoughts That Pay," giving a list of what to invent, and :

"Thoughts That Have Paid," giving a history of successful inventions. These three books should be in the hands of everyone interested in inventions and patents. **Write for them!**

Patent What You Invent

IF YOU HAVE AN INVENTION, send us a rough sketch or model of it for our opinion as to its patentability *which will be rendered without charge.* If our report is favorable, we will issue as a guarantee of its correctness a Certificate of Patentability, by which we bind ourselves *to refund the fees,* if an application is filed and we fail to obtain the patent. Our prices are standard, and our work is conscientious and thorough.

We advertise the *patents obtained through us* for sale free of charge in prominent dailies, and otherwise assist you toward a sale.

OUR FREE BOOKS WILL GIVE YOU VALUABLE INFORMATION. WRITE FOR THEM.

WOODWARD & CHANDLEE

PATENT ATTORNEYS,

1255 F STREET, WASHINGTON, D. C.

References: American National Bank; Darrell Advertising Agency, Washington, D. C.; A. J. Zimmerman, 416 Corondelet Street, New Orleans; Robert B. M. Taylor, 81 Claremont Ave., Montclair, N. J.; J. F. Willey, Versailles, Ill.; and many others.

Please Mention Popular Mechanics

Copyrighted material

PATENTS PROTECT YOUR IDEAS

Money in inventions.
Correspondence Confidential. Patent ad-
vertised free.

MILO B. STEVENS & CO., Estab. 1864
885 14th Street, Washington, D. C.
Branches at Chicago, Cleveland, Detroit.

PATENTS Properly
Procured

Write for our handsome new book.
Full information.

Bevans & Bevans Rm. 630 Colorado Bldg.
WASHINGTON, D. C.

PAID CAR FARE WITH BREAD.—A passenger on a Marion-Gas City car, at Marion, Ind., gave an exhibition of what may be done in the time of financial stringency. The passenger in question was carrying six loaves of bread when he boarded the car. Subsequently the conductor asked him for his fare, which is five cents between Marion and Gas City, and he found he did not have a cent. A bright thought of applying the asset currency idea struck him and he handed the conductor a loaf of bread. The conductor cheerfully accepted the bread and the passenger was carried to his home in Gas City.—Electric Traction Weekly.

STAIR-BUILDING AND THE STEEL SQUARE. By Fred T. Hodgson and Morris Williams. 130 pp., 180 illus. Price, \$1. Complete instruction. The entire process of stairway construction is here explained by easy stages. The section on The Steel Square is a complete guide to the many uses of this versatile tool. American School of Correspondence, Chicago.

GIVES HIS LIFE TO SAVE TOWN.—The business section of the town of Nacozari, Mexico, owes its existence to-day to the bravery of the Mexican engineer of a burning train in which there were two cars of dynamite. While the train was standing at the depot in the center of the town a blaze was discovered in a box car adjoining one of the cars of dynamite. The engineer, Jesus Garcia, rushed to his engine and pulled the train out of the town. Less than a mile out the dynamite exploded, blowing the engineer to atoms.

ORE SHIPPING SEASON BREAKS ALL RECORDS.—From the opening of navigation, April 22 to December 1, 1907, the total shipments of iron ore from the Mesaba and Vermillion ranges in Minnesota, was 29,545,000 tons, an increase over 1906 of 3,458,781. This is the largest shipment ever sent to the ore docks at the head of the Great Lakes in the history of the two ranges. From the Mesaba range was shipped by far the greater amount, its portion being about 27,000,000 tons. This breaks the world's record for one season's shipments.

WATCHES SET IN FINGER RINGS.—The latest fad of society women is the wearing of the watch over one of the gloved fingers of the right hand. These tiny time-pieces are attached to ordinary gold finger rings and seem likely to prove popular, for not only do they keep time but they are always in view of the owner and the possibility of losing them is diminished. In addition to the safety which the new fad insures, the watches look exceedingly cute on a well-gloved hand. The fad originated in England.—The Keystone.

PATENTS PROCURED

OR NO FEE CHARGED

PAMPHLET FREE
PROMPTNESS ASSURED

WRITE US IF YOU WANT RESULTS

COCHRAN & CO., 907 G Street,
WASHINGTON, D. C.

Room 40. Endorsed by 50 Members of Congress

MODELS and GEARS

INVENTIONS PERFECTED

CATALOGS FREE

UNION MODEL WORKS, 191 South Clark St., Chicago, Ill.

EVERY INVENTOR

Who Wants to know

1. What are the most profitable inventions,
2. How to perfect inventions,
3. The first step to take in getting a patent,
4. How to protect himself from parties who might steal his invention before he can get a patent
5. How to find out what patents have been granted on inventions like his, or intended for the same purpose.
6. How much it costs to get a patent,
7. How long it takes to get a patent,
8. What protection a patent is,
9. How he can sell his patent after he obtains it
10. How to handle his patent to get the most money out of it,
11. Where and at what expense he can have working drawings made of his invention,
12. Where and at what expense he can have models or experimental machines made,

should send his questions to

POPULAR MECHANICS PATENT
BUREAU,

Journal Bldg. - - Chicago, Ill.

PATENTS SECURED PROMPTLY and with special regard to the Legal Protection of the Invention.

HAND BOOK FOR INVENTORS AND MANUFACTURERS SENT FREE UPON REQUEST.

Consultation Free. No charge for opinion as to the patentability and Commercial Value of Inventors' Ideas.

HIGHEST REFERENCES FROM PROMINENT MANUFACTURERS

C. L. PARKER, PATENT LAWYER

Patents, Caveats, Trade Marks, Copyrights, Validity Reports, Interference Contests
Patent Suits Conducted in All States

REFERENCES:—Globe Machine and Stamping Co., Murray Engineering Co., Morgan Machine and Engineering Co., Berkshire Specialty Co., Stewart Window Shade Co., Macon Shear Co., Acme Canopy Co., Lippencott Pencil Co., Salisbury Tire Association of America, Oakes Manufacturing Co., By-Products Co., Alabama Brewing Co., National Offset Co., Antiseptic Supply Co., Richmond Electric Co., Railway Surface Contact Supplies Co., National Electric Works.

Mr. Parker on November 1, 1903, after having been a member of the Examining Corps of the U. S. Patent Office for over five years, resigned his position as Examiner to take up the practice of Patent Law.

Address 210 Dietz Building

WASHINGTON, D. C.

PATENTS

Careful attention given to the prosecution of business before the patent office. Patents procured and no attorney fee called for until patent is allowed. (23 years experience.) Write for "Inventor's Guide." Address

Franklin H. Hough

Washington Loan & Trust Bldg., Washington, D. C.

PATENTS that PROTECT

Our 3 books for inventors mailed on receipt of 6 cts. stamps
R. S. & A. B. LACEY, Washington, D. C. Estab. 1869.

We give you PROOF of the money value of the patents we procure.—L. & L.

LET ME SELL YOUR PATENT

Booklet explaining how mailed pages, 17 years' experience.

Patent Sales exclusively. If you have a PATENT for sale, call on, or write

WILLIAM E. HOYT

PATENT SALES SPECIALIST

290 (J) Broadway, New York City



"MR. INVENTOR"

Our Business is to Perfect, Develop and Manufacture your invention. All modern facilities are ours, and we are at your service. We employ Expert Mechanics on

Specialties, Dies, Punch Work and Models

Send us your drawing or model and we will submit our lowest price.

MONARCH TOOL COMPANY, 124 Opera Place, Cincinnati, Ohio

PATENTS THAT PROTECT AND PAY

WATSON E. COLEMAN

Registered Patent Attorney

626 F Street, N. W.

WASHINGTON, D. C.

Advice and Book Free; Highest References; Best Services.

NEW INVENTIONS

DESIGNED, PERFECTED, SIMPLIFIED and IMPROVED

We develop New Ideas to their Practical and Patentable Form. Send pencil sketch and we will quote you price for making a drawing showing every piece and part of your invention, correctly designed and MADE MECHANICALLY RIGHT, with full typewritten description. Strict secrecy guaranteed. Thirty years' experience.

Expert Examinations, Reports on Value, Lists of Manufacturers, Drawings, Etc. Address Engineering Dept.

INDUSTRIAL NEWS BUREAU, Ithaca, N. Y.

WHAT AN OBSERVER SAW.—I saw a bakery proprietor behind his counter with his hat on and a squirt of tobacco juice on his beard. He should have been currying the horse.

I saw the head of an establishment sweeping out the store the other day, a job that a boy at three dollars a week could have done better and left the boss a chance for a few "thinks" about his day's business. This boss has been doing this for twenty-five years, and is still making boy's wages.

I saw a baker's ad in one of the daily papers recently in which he was represented as sitting in his office like a banker and looking as pleased with himself as the manager of the street railway. People have since been wondering whether it is better to bake bread or own a gold mine.

I saw a bread wagon on one of the streets the other day with the name of a prominent baker that looked as though it had been superannuated and the city dog catchers had taken it over.

I saw a man talk to one of his employees like a dog, and I said that fellow is a sort of a mean dog himself or he would not snarl like that.

I saw a small-sized shop without any pretensions to elaborateness that was the best equipped for its size I have ever been in. What struck me was the conciseness, cleanliness and thoroughness of the whole place. There were no frills and evidently everything in the place is made to do its part well. The good things are not all in the large shops.—Canadian Baker and Confectioner.

PERVERTED PROVERBS.—The engineer is worthy of a higher hire.

A rolling stone gathers no cement.

A touch from a live wire is breakfast for a coroner.

A survey goeth before construction, and a power plant before a fall.

Too much anchor-ice breeds lament.

The flat wheel makes the greatest sound.—Power and Transmission.

BLEEDING THE COMPANY.—"Did yer get anything from the claim agent, Bill?"

"Yes; \$25 for me and \$25 for the missus."

"I didn't know the missus was hurt."

"She weren't; but I had the presence of mind to fetcher her a good one on the head with me boot. Her face looked bad, and the company paid."—Express-Gazette.

FISHERMEN'S GOOD LUCK.—A great haul of cuttlefish, numbering more than 800,000, was made in one night a few weeks ago off Uwajima, Iyo province, Japan. The catch was valued at \$1,500.

SPECIAL MACHINERY

We design and build special machinery to order in any quantity desired. Cut gearing.

CARY MACHINE WORKS

35-41 Indiana Street, Chicago

THE INVENTOR'S UNIVERSAL EDUCATOR

TELLS ALL ABOUT PATENTS,
HOW TO SECURE THEM. HAS

**600 MECHANICAL MOVEMENTS
also 50 PERPETUAL MOTIONS**

Every inventor should have a copy. Price \$1.00 by mail.

— Address —

F. G. DIETERICH,

Ouray Bldg., Washington, D. C.

FREE
TWO BOOKS:
68-Page
"Inventor's Guide"
AND
"Fortunes in Patents"
"What and How to Invent"

PATENTS GUARANTEED

Protect Your Idea!

SPECIAL OFFER: Send sketches or model and description of invention for FREE SEARCH of Patent Office Records and Report as to patentability. You will save TIME and MONEY.

E. E. VROOMAN, Registered Patent Attorney
Box 71, Washington, D. C.

REFERENCES:
American National Bank,
Washington, D. C.
Popular Mechanics,
Chicago, Ill.
Little Giant Hay Press Co.,
Dallas, Texas.
Gray Lithograph Co.,
New York City, N. Y.



PATENT YOUR IDEAS

\$100,000 for one invention; another \$8,500. Book "How to Obtain a Patent" & "What to Invent" sent free. Send rough sketch for free report as to patentability. We advertise your patent for sale at our expense. Patent Obtained or Fee Returned.
CHANDLEE & CHANDLEE, Patent Att'ys,
945 F. Street, Washington, D. C.

INVENTORS

Our Brain Belongs To You

We have helped a great many over mechanical difficulties. Our Ideas are Free of Charge. All we want in return is to build your Model, Special Machinery or Tools to manufacture sheet-metal goods or novelties of any kind. We are expert mechanics and our experience covers over thirty years. Consultation free, also our Booklet No. 16.

A. NACKE & SON, 240 S. 9th Street, Philadelphia, Pa.

METAL SPECIALTIES

MANUFACTURING CO., Inc.

Dies, Tools, Metal Stampings, Screw Machine Work
18-24 West Randolph Street, Chicago, Ill.

PATENTS and TRADE MARKS obtained, defended and prosecuted by Alexander & Dowell, Patent Lawyers. (Established 1857.) "F." 607 7th St., N. W., WASHINGTON, D. C. Book of information sent FREE.

PATENTS GUARANTEED. PATENTS SECURED OR FEE RETURNED. Send model or sketch for free report as to Patentability. Send for finest publications ever issued for free distribution "HOW TO OBTAIN A PATENT," with 100 MECHANICAL MOVEMENTS illustrated and described, and "WHAT TO INVENT," containing valuable LIST OF INVENTIONS WANTED.

ONE MILLION DOLLARS offered for one invention, \$16,000 for other. Patents advertised free in "WORLD'S PROGRESS." Copy free.

EVANS, WILKENS & CO., 615 F Street, WASHINGTON, D. C.



Send for FREE BOOK on patents. We charge no fee unless we secure a patent. Opinion as to the patentability of your invention free.

Shepherd & Campbell
214 A McGill Bldg.
Washington, D. C.

PATENTS

Valuable Book on Patents FREE. Tells how to secure them at low cost. How to sell a Patent and What to Invent for Profit. Gives Mechanical Movements invaluable to Inventors. Full of Money-Making Patent Information. NEW BOOK FREE to all who write.

O'MEARA & BROCK, Patent Att'ys.,
918 F. STREET, WASHINGTON, D. C.

WHEN YOU WANT ANYTHING

AND DON'T KNOW WHERE TO FIND IT

WRITE POPULAR MECHANICS

PATTERNS and MODELS

Inventors and Manufacturers can avoid loss and failure by writing us. Many good articles end in the scrap pile through defective patterns. We are practical pattern makers with wide experience in all departments of Light Manufacturing. Our advice is free; our work and charges honest.

Metal and Wood Patterns and Models; Ornamental Designed Patterns; Engraved Name Plates.

Keystone Pattern Works, 173 S. Clinton St., Chicago



TYPEWRITER

We save you more than 50% on all typewriters. Typewriters from \$10.00 up.

Write for Catalogue M

AMERICAN DESK & TYPEWRITER CO.
174 to 188 Dearborn St., CHICAGO



TYPEWRITER BARGAINS

\$15.00 and up. Many of these machines have been in use less than sixty days, are as good as new and we guarantee them to give exactly the same service. Write us before you buy, stating make of machine you prefer. We will give you the best typewriter bargains ever offered, shipped subject to your examination.

McLaughlin Typewriter Ex.
121 Ozark Bldg., St. Louis, Mo.



TYPEWRITERS AT SAVING OF 50%

500 SMITH PREMIERS, Extra Special. All makes—good as new, big bargains. Shipped on approval for trial. Rent all makes at \$1.00 per month and allow rent on price. Send for CATALOG and BARGAIN LIST.

ROCKWELL-BARNES CO., 1435 Baldwin Bldg., Chicago, Ill.



TYPEWRITERS ALL MAKES

All the Standard Machines SOLD or RENTED ANYWHERE at 1/2 to 3/4 OFFER'S PRICES, allowing RENTAL TO APPLY ON PRICE. Shipped with privilege of examination. Write for Illustrated Catalogue **TYPEWRITER EMPORIUM 92-94 LAKE ST., CHICAGO**

Any one can Play any Guitar WITH IT IN 10 MINUTES

Write - **ALBERT PIETSCH,**
613 Cedar St., Milwaukee, Wis.



STATE _____
TOWN _____
NAME _____



EARN \$2,000 to \$10,000 A YEAR

We will teach you to be one in eight weeks BY MAIL, and secure you a position with a reliable firm. Fill out coupon and send to our nearest office for free book, "A Knight of the Grip," today. Address letter to **NATIONAL SALESMAN'S TRAINING ASSN., Dept. 119** **Flonadnock Bldg., Chicago, Ill., Lumber Exchange, Minneapolis, Minn., or Scarritt Bldg., Kansas City, Mo.** Write nearest office and mention this paper.

**YOU
CAN GET
\$5
A DAY**

January to December

SUN	MON	TUE	WED	THU	FRI	SAT
	\$5	\$5	\$5	\$5	\$5	\$5
6	\$5	\$5	\$5	\$5	\$5	\$5
13	\$5	\$5	\$5	\$5	\$5	\$5
20	\$5	\$5	\$5	\$5	\$5	\$5
27	\$5	\$5	\$5	\$5	\$5	\$5

After a 2 to 3 months' course in the
**PLUMBING, BRICKLAYING
PLASTERING
OR ELECTRICAL TRADES**

We teach by Practical and Individual instruction given under actual working conditions, Trades That Pay and enable you to earn \$5 a day and over upon graduation.

Tools take the place of Books.

If you cannot attend school, we teach by mail giving Practical Instruction at your own home.

Our free catalogue tells all about it. Write for it today.

COYNE TRADE SCHOOLS

508 W. 24th St.
NEW YORK
857 N. Ashland Ave.
CHICAGO
237 Eighth St.
SAN FRANCISCO



C.T.S.

**I TEACH
Penmanship
BY MAIL**

I am the man who won the World's First Prize in Penmanship. By my new system I can make an expert penman of you by mail. I also teach Bookkeeping and Gregg Shorthand by mail. Am placing my students as instructors in commercial colleges. If you wish to become a better penman write me for full particulars. I will send you FREE one of my Favorite Pens and a copy of the Ransomer Journal. Inclose stamp.

C. W. RANSOM,

3859 Euclid Ave. KANSAS CITY, Mo.



Please Mention Popular Mechanics

THE MAN BEHIND.

By the Bard of the "Australasian Hardware and Machinery."

In almost any newspaper
You're pretty sure to find
A lot of gush, in printer's ink,
About the man behind.

There's the man behind the counter,
And the man behind the gun,
The man behind the kodak,
And the man behind the sun.

The sleepy man behind the times,
The man behind his fist,
The man, alas! behind his rent,
And so throughout the list.

But they've skipped another fellow,
Of whom nothing has been said—
The fellow who is even,
Or a little way ahead.

Who pays at once for what he gets,
Whose bills are always signed;
He's a blamed sight more important
Than the man who is behind.

All the editors and merchants,
And the whole commercial clan,
Are indebted for existence
To this honest fellow-man.

He keeps us all in business,
And the town is never dead;
And so we take our hats off
To the man who is ahead.

FROM THE ATCHISON (KANSAS) DAILY GLOBE.—If you have any confidence in the judgment of the editor of The Globe, buy the magazine printed in Chicago known as Popular Mechanics. It contains an enormous amount of practical information written and illustrated in a simple way the ordinary reader can understand. It is equal to a new school book appearing once a month. And all of its information is of positive value.

**LET ME SHOW YOU
HOW TO MAKE
\$250.00 TO \$500.00 PER MONTH**



I will teach you the REAL ESTATE BUSINESS by mail and appoint you my SPECIAL REPRESENTATIVE. I handle Real Estate on the co-operative plan and need YOU, no matter where you are located or what business you are in. A splendid opportunity for men without capital to become independent. Let me send you my free book. Address

C. H. GRAY, Pres.,

454 Century Bldg., Kansas City, Mo.



Learn Bricklaying

and earn from \$5 to \$8 per day. Ours is the only thoroughly practical school in America. We teach bricklaying exclusively. Large, well lighted work-rooms. Instructors are men of wide experience in bricklaying and contracting. Only 2 or 3 months required to master the trade. Positions always open to our graduates. Demand greater than the supply. Day and evening classes. Write today for FREE ILLUSTRATED BOOKLET. CHICAGO SCHOOL OF PRACTICAL BRICKLAYING, 215 W. Adams St., Dept. 1, Chicago.

SUCCESSFUL DRAFTSMEN

Drawing \$125 to \$250 monthly require more than Schoolroom Knowledge.

As Chief Draftsman of Eng'g firm I know exactly the Quality and Quantity of experience and practical training you must have, and will prepare you in few months home instructions for above paying positions, which I furnish free anywhere.

Complete Highest Grade Drawing Outfit, everything included, with German Silver Set of Tools, value \$13.85, FREE next ten days.

Address, CHIEF DRAFTSMAN, Div. 19, ENG'S EQUIP'T CO., Inc., Chicago.

GOOD PIANO TUNERS

Earn \$5 to \$15 per Day

We will teach you Piano Tuning, Voicing, Regulating and Repairing, quickly by personal correspondence. New Tune-a-Phone Method. Mechanical aids. Diploma recognized by highest authorities. School chartered by the State. Write for free illustrated catalogue.

Miles Bryant School of Piano Tuning
50 Music Hall, Battle Creek, Mich.



ENGINEERING:

A thoroughly equipped College of Engineering. Standard four-year courses, also one year courses in Steam and Electrical Engineering. Three months' courses in Traction and Gas Engineering. One-year Machinist's Course. Shop work from the beginning. Send for catalogue giving full information.

Highland Park College of Engineering, Des Moines, Iowa.

WHY GO TO COLLEGE TO LEARN BOOK-KEEPING

WHEN I WILL MAKE A FIRST-CLASS BOOK-KEEPER OF YOU AT YOUR OWN HOME

in SIX WEEKS for \$1 OR REFUND MONEY. Fair enough? Distance and experience immaterial. I find POSITIONS, too, EVERYWHERE. FREE. Placed pupil Dec. 20 at \$60 WEEKLY. PLEASURES I CAN PLACE YOU, too! Have 9,114 TESTIMONIALS. SAVE THIS AND WRITE.

ROOM 563, 1215 BROADWAY, NEW YORK.
J. H. GOODWIN, Expert Accountant.

The publishers of Popular Mechanics have on hand a limited number of complete

VOLUMES OF POPULAR MECHANICS FOR 1907

These include one copy of each of the twelve issues from January to December, inclusive. These volumes are unbound and will be sent to any address, postage prepaid, on receipt of \$1.25.

BECOME A CARTOONIST



You can easily earn \$20 to \$200 a week or run your own studio and get first price for your work, when you are competent. I guarantee to qualify you at your home by mail during spare time or refund your tuition money. Let me send my Test Lesson Free to determine your ability and needs. If you can succeed, I will be glad to teach you; if I can't help you, I will tell you so honestly and you pay me nothing. I don't want you to enroll with me if you can't succeed. Acme students become educated artists—not mere copyists. They are taught practical methods and gain knowledge as well as skill. "The Acme Way is the only way," say successful Acme students. Write today and learn your natural tendencies. **DORR ELDRED WOOD, President**
THE ACME School of Drawing, 895 Acme Bldg., Kalamazoo, Mich.
If interested ask about our Resident School.

WE CAN TEACH YOU TO DRAW

You can earn \$20 to \$50 and upwards per week.

We have Successfully taught all branches of drawing by correspondence since 1898. Practical, personal instruction. Experienced teachers. Art Director educated in Europe. Positions guaranteed. Successful students everywhere. Illustrated Year Book free.

SCHOOL OF APPLIED ART,
59-73 Fine Arts Bldg., Battle Creek, Mich., U.S.A.

Learn Watch Repairing

Be a watchmaker—you can learn this profitable trade by correspondence in a few weeks in your own home by the DeSelm's Chart System. After you complete the course you will know a watch from A to Z. You will know just what the matter is and how to repair it. When you graduate you will be a practical watchmaker and repairer and competent to fill any position. Positions for our graduates.

Ask for our Free Book. It explains our system and terms.

THE DeSELMS WATCH SCHOOL
23 Perry St. ATTICA, INDIANA



The Greatest GOLD Dredging Enterprise in the World

THE YUKON BASIN GOLD DREDGING COMPANY is an international company organized under the territorial laws of the United States, registered and sanctioned by the strict laws of the Dominion of Canada. Its properties are 165 miles river frontage, or more than 10,000 acres on the famous Stewart River, the richest gold bearing placer field in the world. Title absolute from the Canadian Government through William Ogilvie, former governor of Yukon Territory and now president and actual field manager of the Yukon Basin Gold Dredging Company.

THE GOLD DREDGE A WONDERFUL MODERN INVENTION Each dredge put in the field will do the work of 1,000 men, and we propose to install twelve as rapidly as it is possible to make the arrangements. Our first mammoth dredge is now being built by Hilsdon Iron Works Co., San Francisco. The ground is fully tested and immensely valuable. This is the biggest gold dredging proposition in America. Careful tests covering 30 miles of our leaseholds went as high as \$11.00 and averaged more than \$1.06 per yard. Fabulous fortunes are being made dredging in California on ground averaging only 15c per yard.

PRICE OF STOCK NOW 15 CENTS We consider this stock intrinsically worth par, and in a reasonable length of time it will be paying large dividends on that amount. A limited amount of full paid, non-assessable stock will be sold for development purposes at 15 CENTS per share. Soon to be advanced to 25 Cents. Par Value \$1. Stock may be had on ten monthly instalment payments. Write for prospectus containing minutest details. Write and ask questions. Address **Yukon Basin Gold Dredging Company** 784 Scarritt Building KANSAS CITY, MO.

Rapid Calculators Make Money!

You can do the work of minutes in seconds and immediately command the favorable attention of the man who raises the salary! We teach you thoroughly by mail—(Four cents a lesson.) Ask us for our new book, "Rapid Calculation." It's FREE! Commercial Correspondence Schools, 197 Com'l Building, Rochester, N. Y.

OUR
GREAT BOOK
FREE

LEARN TELEGRAPHY BOOKKEEPING OR SHORTHAND BY MAIL--AT YOUR OWN HOME

Anyone can learn it easily in a few weeks. We are unable to supply the demand for telegraph operators, bookkeepers and stenographers. No charge for tuition until position is secured. Write today for particulars. MICHIGAN BUSINESS INSTITUTE, 580 Institute Building, Kalamazoo, Mich.

HOROLOGICAL DEPARTMENT BRADLEY POLYTECHNIC INSTITUTE

Formerly Parsons Horological Institute

PEORIA, ILLINOIS.

LARGEST AND BEST WATCH SCHOOL
IN AMERICA

We teach Watch Work, Jewelry, Engraving, Clock Work, Optics. Tuition reasonable. Board and rooms near school at moderate rates. Send for Catalog of Information.



I TEACH SIGN PAINTING

SHOW CARD WRITING or LETTERING by mail and guarantee success. Only field not overcrowded. My instruction is unequalled because practical, personal and thorough. Easy terms. Write for large catalogue.

CHAS. J. STRONG, President.

DETROIT SCHOOL OF LETTERING
DEPT. PM. DETROIT, MICH.

"Oldest and Largest School of Its Kind."



DO YOU LIKE TO DRAW? That's All We Want To Know.

Now we will not give you any GRAND PRIZE—or a lot of FREE STUFF if you answer this ad. Nor do we claim to make you rich in a week. But if you are anxious to develop your talent with a successful cartoonist, so you can MAKE MONEY, send a copy of this picture, with 6 CENTS in stamps for RECEIPTS OF CARTOONS and SAMPLE LETTERS plate and let us explain. THE W. L. EVANS SCHOOL OF CARTOONING, 421 Garfield Bldg., Cleveland, Ohio

ARITHMETIC

SELF TAUGHT

Plain, easily understood volume for ALL who have not had the opportunity of learning this subject thoroughly, or who have forgotten what they once learned. 257 pages. Requires no teacher. Send 60c. (stamps accepted) for this great book in cloth.

Edition de Luxe, \$1.00

GEO. A. ZELLER BOOK CO.

4478 Belle Place, St. Louis, Mo. Est. 1870

We teach Furniture Designing, Rod Making, Stock Billing, Ornamental Drawing, Water Coloring and Interior Decoration by mail.

GRAND RAPIDS
SCHOOL OF DESIGNING,
A. KIRKPATRICK, Instructor.

544-545 Houseman Bldg. : : Grand Rapids, Mich.



\$5 EARN \$5.00 A DAY \$5
Learn to be a plumber in from 4 to 6 months, on easy payments. For particulars address

MASTER PLUMBERS' TRADE SCHOOL, 3415 LINDELL AVENUE, ST. LOUIS, MO.

Please Mention Popular Mechanics

MY BOOK
FREE



"HOW TO REMEMBER"

Sent Free to Readers of this Publication

Stop Forgetting

THE
KEY TO
SUCCESS

Your are no greater intellectually than your memory. Easy, inexpensive. Increases income; gives ready memory for faces, names, business details, studies, conversation; develops will public speaking, personality. Send for Free Booklet.

Dickson Memory School, 705 Auditorium Bldg., Chicago

15 CENTS for trial 13 weeks. In this illustrated national weekly all the important news of the world is stated clearly, fairly and briefly, for busy readers. Many special features of great interest. It is sincere, reliable, entertaining—THE paper for the home. \$1 year; takes place of \$2 to \$4 papers. Try it, 13 weeks for 15c.

The Pathfinder
EVERY WEEK
THE NATIONAL NEWS REVIEW

PATHFINDER, Washington, D. C.

A "HOLY TERROR" STEAMER IN THE HANDS OF JIM SKEEVERS.

By John A. Hill in Railway and Locomotive Engineering.

Skinny Skeevers, him of the object lessons, ran Mike Monnihan's engine for a long time, while Mike went to visit the "ould sod," and Skinny's engine got a new fire-box and a coat of varnish.

The first time Skinny oiled around, he yoked up to Patsy Killigen, the fireman, to put on the injector, and cool her off, so he could see the oil holes; she was howling so it gave him the blind staggers.

"How does she steam, Patsy?" asked Skeevers, as they started out.

"She's a 'holy terror' for wind," said Pat, proudly. "She's always crazy wid it."

Skeevers was somewhat annoyed at the constant howl of the pop, but it did little good to speak to Pat—Pat fired by the pop, and a "holy terror" was his ideal.

Skeevers thought he'd try an object lesson. "What size nozzle has she got?" asked Skeevers.

"Oh, Lord! you ain't agoin' to go monkeying with her nozzles, are ye, Skeevers? They are 2½ or 3-inch now."

"She burns too much coal, and howls too much."

"There ain't another steamer like her on the road," moaned Patsy. "Why, you can't shut off her throttle, but up goes her white tail—steam! Why, she's the darlin' of 'em all, Skeevers."

Skeevers got a smaller scoop, but Patsy piled it industriously, and the "96" still held the first prize as a "holy terror" for steam.

Skeevers bribed the coal shovelers to put on a tank load of lumps, none to weigh less than 200, but Pat paralyzed the lumps and reported the coal shovelers beside.

Skeevers thought of putting a flat car between the engine and tender, but gave the idea up as impracticable.

Patsy would put in a fire within two minutes of a regular stop, and be happy when the black smoke rolled, and the white feather stood proudly up 48 ft. above the howling pops of the "Holy Terror." Skeevers was in despair.

"Pat, did you ever stop to think that you are shoveling a lot of coal through that pop for nothing?" he asked.

"I don't mind the work, Skeevers," said he. "Don't mind it a bit; it makes the other lads green wid envy to see how she do steam."

"But it wastes coal."

"Bless ye, me boy, the company own their own mines, and it's proud they ort to be to have such steamers."

Skeevers couldn't get Patsy mad, and could awaken no other feeling in his heart but worshipful admiration of the prolific steam production of the "Holy Terror."

(Continued on page 126.)

BE A RAILROAD MAN

Firemen and Brakemen
Earn from \$100 to \$185
a month. Graduates of

this school in great demand. Actual railway officials teach you by mail during your spare time, at small cost. Free catalog, etc.

The Wenthe Railway Corres. School,
Box 504,
Freeport, Ill.



LEARN WATCHMAKING

Refined, profitable labor—Competent men always in demand. We teach it thoroughly in as many months as it formerly took years. Does away with tedious apprenticeship. Money earned while studying. Positions secured. Send for catalog.

ST. LOUIS WATCHMAKING SCHOOL, ST. LOUIS, MO.

How to Grow Tall and Broaden Your Shoulders

A Startling Discovery That Will Revolutionize the
Physical Condition of Mankind

Why Remain Short and Stunted When
You May Learn Free the Secret
of How to Grow Tall?

No Matter How Short You Are or What Your
Age, You Can Increase Your Height



No new discovery has attracted more attention in the scientific world than that made by K. Leo Minges, of Rochester, N. Y. Mr. Minges is to short men and women what the great wizard, Edison, is to electricity. He has gathered more information relative to bone, muscle and sinew than anyone else in existence. Making people grow tall has been a hobby with Mr. Minges for years, and the results he has accomplished are startling to a high degree. By his method every man or woman not over 50 years of age can be made to grow from two to five inches in height, and anyone older than that may increase his height perceptibly. His method has the indorsement of leading physicians, and several prominent educational institutions have adopted it for the better physical development of their pupils. If you would like to increase your height you should read the book which tells how this remarkable discovery was made and reveals to you the secrets of how to grow tall. It is free. You are not asked to spend a single cent and if you desire it we will send you the statements of hundreds who have grown from two to five inches in height by following this method. The results are quickly accomplished. Many have grown as much as three inches in two months. There is no inconvenience, no drugs or medicines or operation. Merely the application of a scientific principle in a perfectly hygienic and harmless way. Your most intimate friends need not know what you are doing. All communications will be sent in plain envelopes. The book C, "How to Grow Tall," contains illustrations that will interest and instruct anyone. One thousand of these books will be given away absolutely free, postage prepaid, while the present edition lasts. If you want to grow tall, write today, in strictest confidence, for a free copy. Address The Cartilage Co., 19 K, Unity Building, Rochester, N. Y., U. S. A.

For STYLE **LITHOLIN** For COMFORT
WATERPROOFED LINEN

Be Like the Stylish "Wise Men of Gotham" and Wear
**Litholin Waterproofed
Linen Collars and Cuffs**
which are linen, and look it. No wear, no tear,
no laundrying. They wipe pure white, like
new, with a damp cloth. The only water-
proofed linen made. Don't crack, wilt nor
fray. Every new shape made as soon as intro-
duced. A style for every face and every fancy.
Collars 25c Cuffs 50c
If not at your dealers, send, giving style, size, num-
ber wanted, with remittance, and we will mail, post-
paid. Booklet of styles free on request.
The Fiberoid Co., Department 25, 7 Waverly Place, New York

Earn \$25 to \$75 a Week
I Teach You FREE By
Watch Repairing Mail

give you a diploma after graduating by the Elmore System, and help you, as I have hundreds of others, to start a successful business of your own, paying from \$25.00 to \$75.00 according to your capabilities. Act now—today. Write me at once and be the one in your neighborhood to get my

**FREE SCHOLARSHIP IN
WATCH REPAIRING**

This is one of the cleanest, easiest, most interesting and most profitable professions in the world. Don't work for small wages when you can master this art without a penny of expense for my instructions. By steady application you can graduate from my Watch Repairing College and be ready to start a shop of your own inside of three months. All text books, diagrams, photo illustrated charts, etc., absolutely free. Don't put off writing to me for particulars and Lesson 1F. For a 2-cent stamp you can find out how to get a start in a good paying business.

CHAS. F. ELMORE, Principal,
Correspondence College of Watch Making
Rogers, Thurman & Co., Props. 39 Michigan Ave., Chicago

Please Mention Popular Mechanics



GLASSES ARE NEEDLESS

in most cases. For weak eyes they are crutches—not a cure. For diseased eyes they are useless. Only a gentle *medicated massage* can strengthen weak eyes and cure optical diseases. The

NATURAL SIGHT RESTORER

applies a *soothing, strengthening* treatment that is *healing* but *harmless*; gently exercises the proper muscles and makes weak eyes strong by proper massage. *Brings eye-health* by aiding nature. *Young or old* treated at home and normal eye-sight secured for the cost of a pair of glasses. Don't wear "specks," but write today for our free illustrated book. *If we can't help you, we will say so.*

The Natural Sight Restorer Co.
104 Broadway :: Detroit, Michigan



Continued from page 124

The run was a light passenger one, and after some scheming Skeevers got Pat on the "Holy Terror" on heavy freight run for a week. Skeevers managed to use all the steam that was made on the road, but Pat insisted on a pop solo at every stop.

Skeevers hated to disturb the front end adjustment of another man's engine; he finally determined to enlarge the nozzles, but concluded that this might give them trouble on the road, and besides that, Skeevers didn't believe in patching an engine to repair a man, any more than he believed in feeding a fireman soda ash to keep scale out of a boiler.

But right here the road got a new master mechanic, and the very first month he put up a bulletin of the amount of coal burned on each engine, and the "Holy Terror" was away down in the middle of the passenger engine list.

Pat was pretty mad about it, and said, if they would figure on who made the most miles or the most hours with the steam pressure at or above 140, he and the "Holy Terror" would take first money.

The next month he stole a few lumps of coal, gave the shovelers cigars for big measure, etc., but the bulletin appeared again with the "Holy Terror" advanced but one point.

Then came a bulletin notice that firemen would be promoted on merit, especial preference given for a coal record.

Pat had a nightmare that night when he thought of the "Holy Terror" and himself at eighth place, and Jim Bean, who was hired four months after he was, leading the list for coal—and promotion.

That evening after they got to going up the hill, and the pop sat down to rest a minute, Skeevers called Pat over, and, in a friendly way, told him that the Old Man had said he should have to promote three or four men in the fall, and that he was afraid that Pat would lose his chance and see a lot of younger fellows pass him, if he didn't mind. Skeevers suggested that the man trouble was with the "Holy Terror," and not Pat, and proposed that they prove it to the Old Man by having Pat transferred for one month to the "94," that was then leading the coal burners.

Pat agreed to this if Skeevers would arrange it—he didn't know that Skeevers had arranged it.

When the next bulletin came out, the "Holy Terror" was at the head, and the "94" was fifth. Pat was improving some.

Pat was glad to get back with Skeevers and the "Holy Terror"—said Old Man Martin on the "94" kept "picking at him" about opening the door and monkeying with the dampers.

Jimmy Bean was sent to running switch engine in a week or two, and Patsy's heart was broken.

"Skeevers," said he, "I'm disgraced. What the devil is the matter with the '96,' or—or—me?"

"The '96' is, without a doubt, the best engine on the road, Patsy," said Skeevers, "and honestly I think you are the best fireman, or rather would be the best, except that you haven't figured out plainly just what you are trying to do—you don't realize what you burn the coal for."

Concluded on page 128

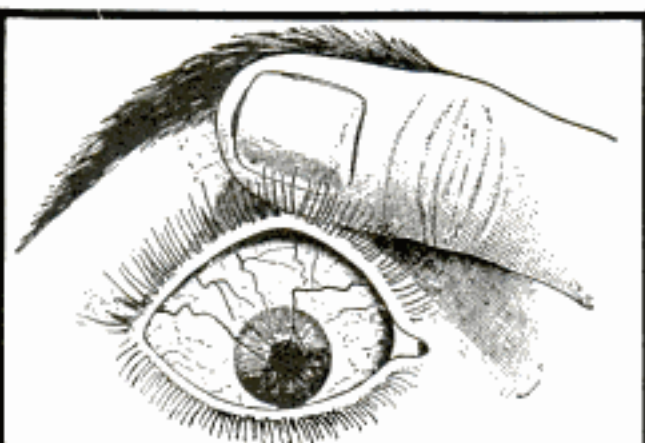

JUST LOOK IN OUR FREE EYE-BOOK THEN CURE YOUR OWN EYES.

It doesn't matter what your eye trouble is, or how serious or chronic it may be, this great Eye-Book will show you how to treat your own eyes at home. No knife. No pain. No trouble.

Our book about eyes, sent free, tells all about it; things you ought to know, but which your doctor has never told you, and contains pictures of and letters from hundreds who have been cured.

A postal card will get the book and we will give you our free advice if you will write us a short description of your case.

Write now while you think about it. Address,

NORTH AMERICAN EYE AND EAR SPECIALISTS,
1804 North American Bldg. :: Chicago, Ill.

POSTAL SCALE \$1.00

Tells at a glance postage in cents on all mail matter. Capacity, 1 pound by half ounces, 3 inches high. Cuts down the stamp bill. We make several styles for the office, store and large business houses, as well as the individual desk. All leading dealers sell them.

Catalogue P free, showing 12 styles.
PELOUZE SCALE & MFG. CO.
122 W. Jackson Boulevard CHICAGO

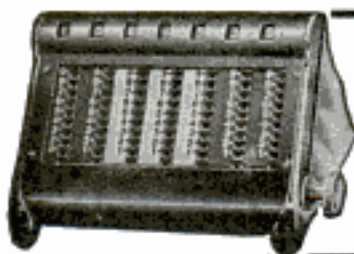

\$15 "GEM" ADDING MACHINE

Over 15,000 in Use

Carries automatically. Automatic resetting device. Collapsible holder. Visible total. Two years' written guarantee. To prove our faith in what it will do for you it will be sent on

10 DAYS' TRIAL AT OUR EXPENSE

Does the work as accurately as any Machine at any price. Special offer to Agents.

Address me Personally, **E. GANCHER, AUTOMATIC ADDING MACHINE CO.**
332 Broadway, - - - New York

Build Your Own Boat Brooks Build Your Own Furniture BY THE System



I CAN sell you a boat for one-fourth of what a factory would charge. I can sell you furniture for one-third of what a dealer would charge.

I will sell you 100 cents' worth of actual value and results for 25 or 35 cents. Is it worth considering?

I cannot tell you my whole story here, but if you will send for my catalogues, they will prove what I claim. Give me a chance—right now, today. Read my guarantee—it means you take no risk.

MY GUARANTEE.

Whether you buy boats or furniture of me, I absolutely guarantee that you will be satisfied. I will instantly refund your money if you are not. I stand back of every statement made in this advertisement. I have made them as strong and convincing as I know how. The goods warrant it. G. C. BROOKS

You Can Save Two-Thirds to Three-Fourths

I have revolutionized the boat-building business. I have spent the last twenty-two years in building or sailing boats, and am a practical boat man.

Seven years ago I originated the Pattern System of boat building. Today my customers are found in every civilized country on earth.

Over 50,000 boats (more than the combined out-put of all boat factories) have been built from my system, mostly by inexperienced men and boys.

Over half of these have built several boats—a large number have established themselves in the boat-building business.



for suitable raw material.

Every piece of knock-down frame is accurately shaped and machined ready to put together.

I also send free the patterns and complete illustrated instructions needed to finish the boat. I can save you (1) boat-builder's profit, (2) labor expense, (3) big selling expense, (4) seven-eighths freight. You can figure this out yourself.

Boat Patterns \$1.50 and up



The Set-up Frame



A Semi-Speed Model

cannot fail to build as good a boat as the professional boat builder.

My boat catalogue shows all kinds of boats, tells why the patterns cannot fail to be right and why any one can build a boat from them.

Anyone can build a boat by using my exact size printed paper patterns and illustrated instruction sheets, telling how to do every little detail. You

LAUNCH



ROW BOAT

Knock-Down Boat Frames.

Many people prefer to buy my knock-down frames (all ready to put together) for their boats, instead of working up the rough lumber.

Owing to my immense factory facilities, I can in many cases supply knock-down frames at a lower price than you would pay

Knock-Down Furniture

I have adapted to furniture practically the same idea that made my boat business such a success, and it is revolutionizing the furniture business. My high-grade, heavy art furniture is fast taking the place of the expensive factory product.

I have been selling this furniture for three years. Every customer is enthusiastic over it.

All pieces are solid oak and are machined, smoothed, fitted all ready so any one can put them together. You can make a beautiful Mission or Art and Craft chair, davenport, table or bookshelf in a few minutes. Apply the stain (only one coat—no rubbing) and you have a solid and handsome piece of furniture. Every piece and every result is guaranteed to be satisfactory in every way or money refunded.



Height 27 in.
Depth 27 in.
Width 31 in.

You save (1) in the factory cost, (2) in the factory profit, (3) all dealers' profits, (4) two-thirds of freight, (5) finishing expense, (6) the expense of crating and packing—making a saving of two-thirds or three-fourths, according to the piece.

\$4 buys this chair (shown in cut) without cushion. Settee same style \$7.00.

By the Brooks System you can own \$14.00 chairs for \$4.00; \$25.00 davenports for \$7.00; \$12.00 porch swings for \$4.00; \$30.00 tables for \$8.00, etc.



As she received it

\$6.00 Buys this Morris Chair



Width 27 in.
Height 35 in.

My catalogue explains everything. Mailed free. It shows how no skill is required, how you take no risk. Beautify your home for very little money.

SPECIAL ENGINE OFFER



Type E
\$65.00

Here is an engine I know is all right. The "Brooks Special" has copper water jacket, complete marine and electrical equipment, ready to install. Weight about 50 lbs. 3 h. p. Will supply this engine together with special 15 1/2 foot K. D. launch frame built especially for it for \$70.00.

Don't buy before you investigate this.

Send for my engine catalogue—it's free. Save money by getting our special combination prices on all sizes of engines and frames when bought together.

Write me personally for my boat, engine or furniture catalogue, whichever you want. Sent free. C. C. BROOKS, President.

BROOKS BOAT MFG. CO.
(Originators of Pattern System of Boat Building)

**3703 SHIP STREET
SAGINAW, MICH., U.S.A.**

BROOKS MFG. CO.
(Originators of Knock-Down System of Home Furnishing)

HELP TO TRUSS WEARERS

Is your truss uncomfortable? Ever SLIP? The AKRON TRUSS has patented SPONGE RUBBER PADS. Comfort and relief, soft but CANNOT SLIP. You know a truss is necessary and cures are very rare. All wearers, and especially MECHANICS and MACHINISTS will find great relief by wearing one of our TRUSSES. We guarantee you help. For sale by best druggists and truss fitters, or direct from us.

Write For Booklet H. It Will Pay You.

THE AKRON TRUSS COMPANY, Akron, Ohio

Airship Stock Pays Well

Master Cromwell Dixon, 14 years of age, the youngest aeronaut in the world, has already booked a large number of engagements for the coming summer. He made a flight last October over St. Louis at an elevation of 1,200 ft. and traveled across the Mississippi, landing 8 miles distant in Illinois. This was during the International Balloon Race. He ascended in his "Sky-cycle," made by himself and propelled by foot power. He now desires to build a much larger airship, equipped with mechanical power, and for this purpose a stock company has been organized and a limited amount of stock is offered for sale at \$50 per share. The profits on his few exhibitions last summer and the engagements already booked, make certain the payment of large dividends on this stock.

For full details, address his mother—

MRS. CROMWELL DIXON

221 West 11th Avenue, -:- Columbus, Ohio

NOTICE OF FRAUD

The public are warned against a man who operated recently in Wisconsin under the name of J. B. Raymond and in St. Louis as J. B. Collins. He pretends to be an agent for "The United Publishers Ass'n, J. W. Cameron, Manager, New York," which the postmaster in New York is unable to locate.

This fraud Collins or Raymond offers a clock, and a year's subscription to any two \$1. magazines for \$2—a case of something for nothing.

Popular Mechanics is not clubbed with any other magazine and never offers any premium of any nature whatever as an inducement to prospective subscribers.

When You Want Anything and Don't Know Where to Find It, Write Popular Mechanics.

(Concluded from page 126.)

"To make steam, of course," said Patsy.

"What do you want of the steam?"

"To pull the cars av course."

"Where do you put it for that?"

"Into the cylinders, surely."

"Suppose you have more than you want?"

"Out of the pop she goes—can't hurt nothin'."

"But the coal pile?"

"Coal pile?"

"Yes, don't it take as much coal to make steam to

blow through the pops as it does to make the same amount

of steam to be used in the cylinders?"

"But there don't much go out of the pops."

"That's where your mistake has been, Patsy. Pop Mar-

tin told me this morning that if he had all the steam

that the '94' made and wasted at the pops while you were

on her, he could make four round trips without coal or

water."

Pat put in a fire and gave a big lump a few vigorous

whacks with his coal pick, and then came back.

"I've a notion to quit, Skeevers," said he.

"You fire this engine the best you know how for another

month, take my advice, and if she don't head the list,

I'll quit," said Skeevers.

"You want to remember that in making steam to throw

away, you not only waste fuel to make it, but you waste

water. Water is cheap, but it takes coal to haul it around,

and the '96' takes more water than the other engines do,

and hauls many tons of it a month for nothing; then

we have to stop for water oftener, and that takes coal—

takes coal to stop and coal to start."

"Coal to stop! How d'ye make that out?"

"There you are again, Pat; you see you haven't figured

on your business or followed cause and effect up very much.

Don't you know that it takes just as much power to stop

a train, leaving out friction, as it does to start it?

When you set the brake it commences to use up and

lose 'stored energy' that has been put into the train by

the coal, through the medium of the cylinders.

"Then your brake will use more steam to get its pressure

back again, and the '96' will get rid of more coal to get

the train back into motion, and use more to haul the

extra water. It all counts, Pat, because we do this all

day, every day in the month; if it was only once it

wouldn't amount to much. Think about your work, and

figure on how little you can do in the way of coal shoveling

to get this train over the road, and I will bet on the

result."

Last Thursday the new bulletin was put up. The "Holy

Terror" stood at the head, and Patsy Killigen hummed

"Comrades" as he was polishing the hand-rail in the round-

house, when the Old Man came along, touched Pat's leg

with his umbrella, and said:

"Come into the office after dinner—I want to talk

with you."

TALES OF LOFTY TUMBLES.—The "irony of life" was

strikingly illustrated in the newspapers the other day when

one read, in the same column, of a rustic who slipped from

a 6-barred gate and broke his neck, and of an Italian

aeronaut who fell 1,000 ft. with his collapsed balloon with

no worse result than a sprained ankle.

It is not long since a French lady, Mme. Morel, and her

daughter, while climbing in the Alps, near Zermatt, fell

a distance of 1,200 ft. (not much less than a quarter of

a mile), and, although the mother was killed on the spot,

her daughter escaped with a few bruises. Mr. Whymper,

the famous mountaineer, had a similarly miraculous de-

(Concluded on page 130.)

FREE



DON'T WEAR A TRUSS

RUPTURE CURED by STUART'S PLASTER-PADS means a permanent cure, absolutely guaranteed and you do away with the painful irritating unsatisfactory truss altogether. No buckles—no straps—no springs. Adheres closely to body, holds rupture in place and cures the most obstinate cases. Easily applied—soft as velvet—will not blister or irritate most delicate skin. Only short time required for permanent cure. Treatment is private, costs very little and does not interfere with your work. Has cured thousands, on our guarantee. If you wish to be cured, write at once for FREE "Trial of Treatment" and illustrated booklet.

Address STUART PLASTER-PAD CO., 37 Chestnut St., St. Louis, Mo.

Please Mention Popular Mechanics



BALL BEARING FAUCET WATER MOTOR

\$6.00 agent sample outfit \$3.50. This is the biggest bargain ever offered to the public. Our new 1908 creation. If it isn't the biggest bargain for the money and if it isn't satisfactory money refunded. This agent's price we have decided to make to the readers of *POPULAR MECHANICS* just to advertise our motors. We know you will show the motor to your friends. For sharpening and polishing and for light power purposes. Not a toy. Water motors are used by dentists, butchers, doctors, mechanics, etc. Indispensable in every home. We sell larger motors for heavier power purposes. Correspondence with dealers and agents wanted. Our water motor books sent FREE. THE EDGAR MFG. CO., 462 East Bldg., Boston, Mass.

IT PAYS BIG To Amuse The Public With Motion Pictures



NO EXPERIENCE NECESSARY as our instruction book and "Business Guide" tells all. We furnish Complete Outfit with Big Advertising Posters, etc. Humor as dramas beautiful of fun, travel, history, religion, temperance work and songs illustrated. One man can do it. Astonishing Opportunity in any locality for a man with a little money to show in churches, school houses, lodge halls, theaters, etc. and to **Five Cent Theatres** in stores operate Motion Picture Films and Song Slides rented. Profits \$10 to over \$100 per night. Others do it. why not you? It's easy; write to us, we'll tell you how. Catalog free. AMUSEMENT SUPPLY CO., 471 Chemical Bldg., CHICAGO.

Our patterns or materials cost you only half the price asked by others.

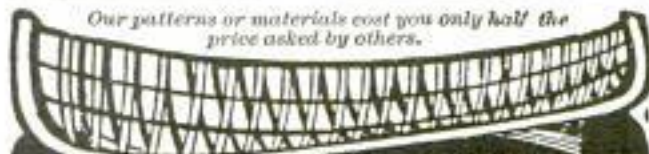

BUILD YOUR OWN BOAT

We are the largest builders of pleasure boats in the world. We sell you full size working patterns, knock-down frames and materials from bone-dry stock, at half the price asked by others. We use these patterns and stock every day in building our regular boats. You are not buying theories. Catalog free.

DETROIT BOAT CO., No. 73 Bellevue Ave., Detroit, Mich.

USE KEROSENE —WITH— DuBrie Marine Motors IF YOU WISH.

Our Generator is different from the ordinary. Our Valve forces mixture directly into cylinder without drawing it into base, so kerosene and distillate are used as well as gasoline with equally excellent results. Ordinary Generator Valves do not vaporize kerosene perfectly.

Each **DUBRIE** Motor is proved perfect by water tests, and shipped to you ready. There's no nursing or humoring—install one yourself—runs all day—first trip—without a hitch. Quarter turn back of fly-wheel starts immediately—no cranking.

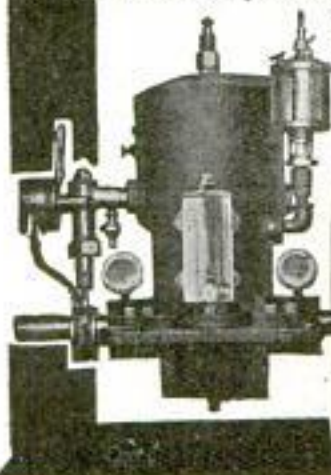

Send for fully descriptive catalog. Write for it today. Agents write for uncovered territory.

16 and 18 foot launches and 22 foot speed boats.

DuBrie Motor Co., 425 Grand Street, Detroit, Mich.

SHOP NOTES, SET OF FOUR VOLUMES \$2.00

Containing 868 pages, and 2,056 illustrations, \$2.00

Positively the greatest value ever offered in a work of this character

SETS Containing the Four Volumes in Strong, Attractive Box, only \$2.00 Express Prepaid

VOL. I

"Shop Notes for 1905"
200 pages; 385 illustrations

VOL. II

"Shop Notes for 1906"
228 pages; 558 illustrations

VOL. III

"Shop Notes for 1907"
228 pages; 580 illustrations

VOL. IV

"Shop Notes for 1908"
212 pages; 536 illustrations



For Sale by all newsdealers or by the publishers, Popular Mechanics, Chicago

Please Mention Popular Mechanics



\$3,000 to \$10,000.
A YEAR IN THE REAL ESTATE BUSINESS.

We will teach you by mail the Real Estate, General Brokerage, and Insurance Business, and appoint you

SPECIAL REPRESENTATIVE

of the oldest and largest co-operative real estate and brokerage company in America. Representatives are making \$3,000 to \$10,000 a year without any investment of capital. Excellent opportunities open to YOU. By our system you can make money in a few weeks without interfering with your present occupation. Our co-operative department will give you more choice, salable property to handle than any other institution in the world. A THOROUGH COMMERCIAL LAW COURSE FREE TO EACH REPRESENTATIVE. Write for 62-page book, free. THE CROSS COMPANY 1106 Seaper Bldg., Chicago, Ill. The original real estate co-operative company—no connection with any other concern of similar name.

DO YOU HEAR WELL?

How Prominent Business Men Hear with the "Electrophone"

Eardrums, trumpets, speaking tubes and such old fashioned and harmful things are no longer necessary; the "Electrophone" (protected by U. S. Patents Nos. 858,984 and 855,458) is a small pocket telephone which enables men and women who are deaf or partially deaf to hear distinctly and at the same time electrically exercise the vital parts of the ear, so that the natural hearing is gradually restored.

STOLZ ELECTROPHONE CO., Chicago. I am pleased to say that the Electrophone is very satisfactory. Being small in size and great in hearing qualities makes it preferable to any. I can recommend it to all persons who have defective hearing. M. W. HOYT, Wholesale Grocer, Michigan Ave. and River St., Chicago.

THE STOLZ ELECTROPHONE CO.

Gentlemen:—Before I used the "Electrophone" people had to shout directly into my ear to make me hear anything. With it I could at once hear any person speaking in an ordinary tone 15 or 20 feet away. Now, after using the Electrophone eight months, its use so improved my natural hearing that I can hear an ordinary toned voice six to ten feet away without it. It is a wonderful instrument, and as there are so many worthless instruments on the market, I will show my appreciation to you by answering all inquiries from doubtful investigators.

Very truly yours, M. W. BENJAMIN,
5253 Prairie Ave., Chicago.
E. H. STOLZ, Mgr. Dear Sir: I got so deaf I could not hear with my speaking tube and was advised to try the Electrophone. After fifteen years of deafness, discomfort and worry I now hear perfectly and can direct my salesmen, carry on a conversation with anyone and hear perfectly at church and at concerts.

W. B. UTLEY,
Sales Mgr., S. A. Maxwell & Co.,
430-434 Wabash Ave., Chicago.

"Electrophone" in Use.
Free trial of Electrophone to all who call. Free descriptive booklet and names of satisfied users to all who write.

STOLZ ELECTROPHONE CO.
767 Stewart Building, 92 State Street, CHICAGO
Eastern Office: Oliver Bldg., 409 Walnut St., PHILADELPHIA, PA.



WORK BENCH

—the best made. Improved iron vises, steel legs. Built up maple top, 20 in. wide, length 3 ft. 8 in. over all, one vise \$6.25; two vises \$7.50. 20 in. wide, length 4 ft. 6 in. over all, one vise \$6.75; two vises \$8.00. Side vise only, \$1.80. Tall vise only, \$1.95.

Give the boy a chance Heavy braces
COLUMBIA SCHOOL SUPPLY CO., Indianapolis, Ind.



The "NULITE" VAPOR GAS LAMPS

For Home, Store and Street

We also manufacture Table Lamps, Wall Lamps, Chandeliers, Street Lamps, Etc. 100 Candle Power seven hours ONE CENT. No Wicks. No Smoke. No Odor. Absolutely safe. THEY SELL AT SIGHT.

CHICAGO SOLAR LIGHT CO., 6 River St., CHICAGO

Exclusive territory to good agents.
Write for catalogue and prices.

THE LIGHT THAT NEVER FAILS



Will produce better light and more of it for less money than any other artificial lighting device made. Complete satisfaction guaranteed. Special inducements and territory consigned to the right party. We want a good man in every city, town and village in the world. Write to-day for complete catalogue No. 29.

NATIONAL STAMPING & ELECTRIC WORKS
153-159 South Jefferson Street, CHICAGO, ILL.



(Concluded from page 128.)

liverance from what seemed to be certain death when scaling the Matterhorn a few years ago. Losing his footing, he fell from rock to rock to the bottom of a precipitous gully, 100 yd. in depth, only to recover his feet with no worse damage than a badly cut head.

While climbing a waterworks tower 240 ft. high in Chicago not long ago a steeplejack called Sutherland dislodged a loose stone and was precipitated to the ground from a height of 175 ft., fortunately striking the telegraph wires 40 ft. above the street and thus breaking his fall. The spectators gasped with horror as they saw the man drop swiftly to destruction; a rush was made to pick up his shattered remains, only to discover that he was practically unharmed. Not a bone was broken, and a week later he was walking about as if nothing had happened.

More remarkable, and, indeed, almost incredible, was the experience of Charles Woolcot when he was making a parachute descent in Venezuela. At a height of 3,000 ft. Woolcot flung himself off his balloon into space, when, to the horror of the thousands of onlookers, the parachute failed to open. The man dropped like a stone with terrible speed, until, when about 200 ft. from the earth, the parachute flew open, and at once collapsed. He was dashed to the ground, his right thigh and hip were broken, both ankles and knees were badly crushed, and his spinal column was dislocated. And yet, after a year spent in a hospital, Woolcot was restored to soundness of limb after surely the most terrible adventure of which any man has lived to tell the story.

But it is in the history of ballooning that one encounters the most remarkable cases of sensational drops from the clouds. When Mr. Wise, a famous aeronaut of seventy years ago, was once making an ascent, his balloon exploded at an altitude of 13,000 ft., and began to drop swiftly to the earth, more than a couple of miles below. "The descent at first was rapid," Mr. Wise writes, "and accompanied by a fearful moaning noise, caused by the air rushing through the network and the gas escaping from above. In another moment I felt a slight shock, and, looking up to see what caused it, I discovered that the balloon was canting over, being nicely doubled in, the lower half into the upper."

The balloon had, in fact, formed itself into a parachute; and, oscillating wildly, continued its descent until it struck the earth violently, throwing the aeronaut 10 yd. out of his car. "The car had turned bottom upwards, and there I stood," says Mr. Wise, "congratulating myself, the perspiration rolling down my forehead in profusion."—London Tid Bits.

IT PAYS THE FARMER TO HAVE A TELEPHONE.

The telephone has become as great a factor of farm life as the harvester and reaper and other labor-saving devices that contribute to the farmer's prosperity. The farming implements help prepare the crop for market, but without the telephone the farmer cannot sell the crop to the best advantage. His handicap used to be that he was too far away from all agencies of business, now the agencies of business are no farther away than the telephone box on the dining-room wall.

An apple grower in an eastern state had an experience last fall that illustrated how large may be the return on the money invested for a telephone. One day when his crop was just in the right condition to market, a traveling agent offered \$1 a barrel for the 1,000 bbl. he had to dispose of. The buyer insisted that the price was as high as anybody was paying, and the deal was almost closed, when it occurred to the apple grower that it would do no harm to see how much somebody else would offer. So he called up the city commission house that had bought his fruit in previous years and they not only offered him \$1.50 a barrel but agreed to send a man to the farm to do the packing. The additional \$500 made on that transaction will pay telephone bills for a good many years to come and leave a snug little sum over.

100% HATCHES 100% Every Fertile Egg

The Globe Incubator does this all the time—has done it for 16 years—and hatches strong, healthy chicks—chicks that live and grow. Our Globe Incubator Book with beautiful color plates tells you how to make more money out of poultry. Sent for 4c in stamps. Write today.



C. C. SHOEMAKER. Box 362. Freeport, Illinois

TALK IT OVER WITH YOURSELF

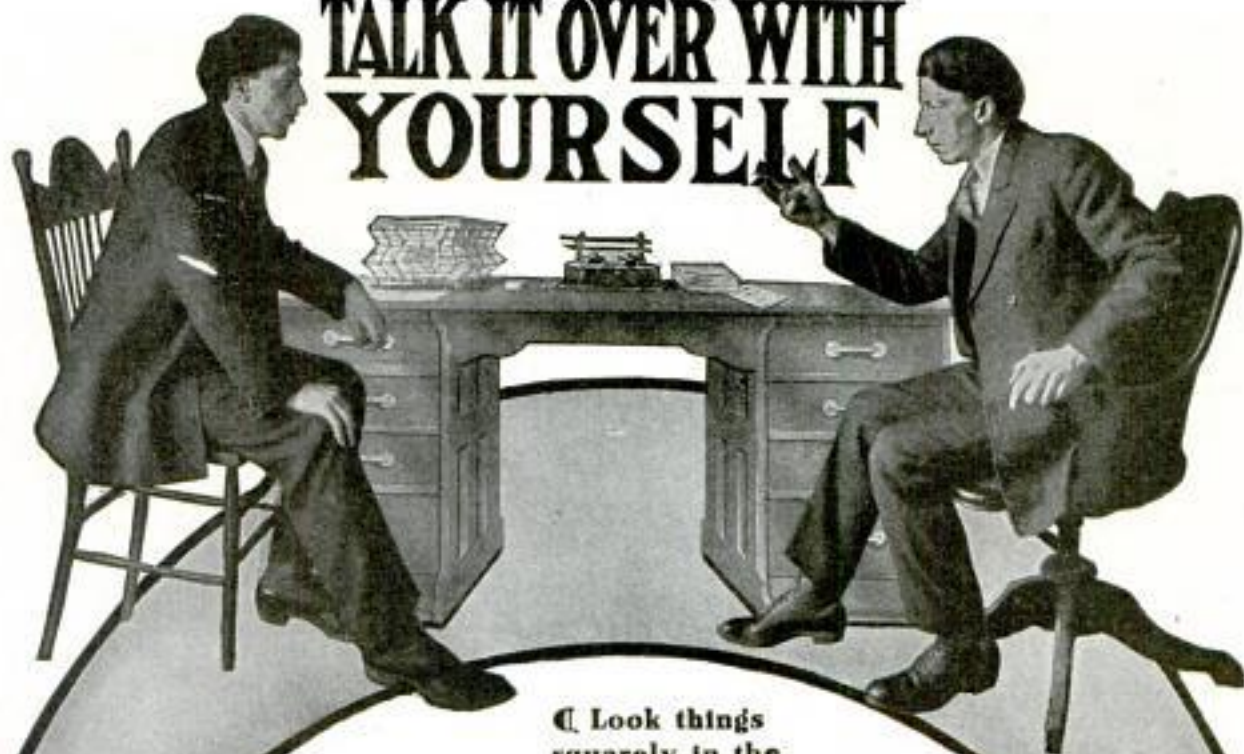

☐ Look things squarely in the face.

No matter how you may wish to impress others, you cannot deceive yourself. **You know** what your failings are—**You know** what you lack in the way of training.

You know why you do not occupy a better position. Do you consider yourself of too poor material for improvement? Don't you believe that you can advance from the ranks as well as the thousands of ambitious men who are doing so every year through the medium of specialized training? Have you no desire to better yourself? Is it your ambition to remain where you are, **in your present position** for the rest of your life?

☐ **Talk it over with yourself.** Confront yourself with your future prospects—**your present position**, and the positions that hundreds of your former fellows now occupy. Isn't it worth a few hours a day to get into step once more with your old associates **who have got out of the line**? Isn't it worth a little effort to break away from the binding influence of poorly paid work that offers nothing in the future and little enough in the present?

☐ The American School of Correspondence, Chicago, is constantly fitting thousands of ambitious men to begin life in positions which offer an assured future. It is taking older men from poorly paid uncongenial work and placing them where they secure better pay, better hours, better work and better futures. Half an hour a day spent in study instead of amusement is all that is necessary to put behind you all that is disagreeable, distasteful and unremunerative in your present work. Before you turn this page, consider carefully what you are putting behind you if you ignore this opportunity for advancement. **Talk the thing over with yourself** and if you decide to take the first step now, we will help you by making the following liberal offer:

WITHOUT COST TO YOU

☐ We will send you, without extra charge, a set of the Reference Library of "Modern Engineering Practice," in 12 volumes, Half Morocco, 6,000 pages, page size 7 x 10 inches, provided you enroll in a full course before April 1st, 1908. This is the most comprehensive and authoritative reference work on Engineering Practice ever published.

☐ Mark the subject on the coupon that interests you most, sign your name and address plainly, and mail at once. **Take the first step today.**

AMERICAN SCHOOL of CORRESPONDENCE, Chicago

COUPON

A. S. of C. Pop. Mech. 3-08
Please send me handsomely illustrated 200-page hand book of engineering information. I am interested in the course marked "X."

..Mechanical Drawing ..Heating, Ventilation, Plumbing
..Electrical Eng. ..Architecture
..Mechanical Eng. ..Hydraulics
..Stationary Eng. ..Surveying
..Civil Eng. ..Telegraphy
..Locomotive Eng. ..Textiles
..Structural Drafting ..College Preparatory Course
..Telephone Practice ..Sheet Metal
..Pattern Drafting

Name

Address

Occupation



"A Kalamazoo Direct to You"

We have more than 100,000 satisfied customers in more than 17,000 cities, villages and towns in the United States who have each saved from \$5 to \$10 by buying a Kalamazoo stove or range on

360 DAYS APPROVAL

direct from our factory at actual factory prices. No stove or range has a higher reputation or gives better satisfaction. You run no risk. You save all dealers' profits. We pay the freight.

Send Postal For Catalog No. 473

and see list of towns where we have satisfied customers.
Kalamazoo Stove Company, Mfrs., Kalamazoo, Mich.

Our patent oven thermometer makes baking and roasting easy.



NEW ORLEANS

THE GRUNEWALD

LARGEST, NEWEST, BEST HOTEL IN THE SOUTH

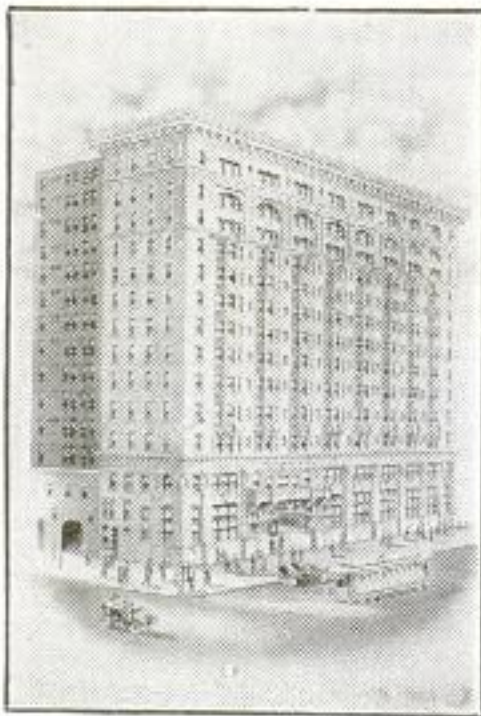

Cost Over \$2,000,000.00

	RATES
400 Rooms	\$1.00 AND UPWARDS
European Plan	With Bath
	\$2.50 AND UPWARDS

INDUSTRIAL EDUCATION NECESSARY IN SCHOOLS.

—The National Society for the Promotion of Industrial Education, at its recent conference held in Chicago, adopted a resolution providing for the creation of a commission of ten members to consider and report on the relations of industrial training and the public school system. During the week's conference educational men from all parts of the United States spoke on the shortcomings of the present school system, in that the student is not prepared in any way for skilled work in manual labor, and on the best means of bringing about the required changes.

The keynote of the conference was the need of teaching youth how to make a living. Many of the speakers maintained that the high schools are maintained by the people for the people and not as preparatory schools for colleges, and that 90 per cent of those who pass through the elementary schools go into a life of manual labor with no preparation for the performance of skilled labor. Not only does the society believe that the elementary and high schools should teach skilled handwork, but that each state should support trade schools.

FAVORS A BIG NAVY.

—That there will eventually be a conflict between the yellow race and the white race that will shake the earth is the opinion of Justice John Marshall Harlan, of the United States Supreme Court. In an address before the Navy League of the United States last week, this eminent jurist, according to The Washington Post, said:

"If I had the opportunity I would vote for an appropriation of \$50,000,000 a year for a period of ten years for a larger navy. The great importance of a navy is shown in the constitution, which restricts the appropriations for the army, but sets no limit for those for the navy. There is no such thing as friendship between nations as between men. Nations make no sacrifice to preserve friendships and do not forbear to do certain things because they do not meet with the approval of another nation. Do you think England cares a cent for what we think of her navy? Or Germany cares a cent for what we think of hers?"

"How large a navy ought we to have? That is a question I cannot answer any more than whether a hospital ship ought to be commanded by a naval officer or a surgeon. I don't care how large a navy we have, but I want to see a navy large enough to take care of the Pacific and Atlantic oceans and our ports on those oceans.

"The trend of the immigration of the white people in the past has been from the east to the west. There has been none from the west. Just across the water there is a country with an immense population whose commerce we are seeking. We refer to the people of Asia as the yellow race. There are 400,000,000 Chinese, as strong physically and mentally as we are.

"There is over there another nation whose people are progressive and ambitious. We may some day see a skilled army in Japan of from 5,000,000 to 10,000,000. They will say: 'You claim Europe as your country. This is ours. Get out!' I don't think they have any such idea now, and we have no hostility toward them. But there will be a conflict between the yellow race and the white race that will shake the earth. When it comes I want to see this country have a navy on both oceans that will be strong enough."



The Man Who Owns a Mechanical Cleaning Wagon Makes Money

\$3,000.00 CAN BE MADE

This year, next year and the years thereafter, cleaning houses by our patented machinery, by energetic, competent men, with a capital of \$2,500 and upwards. Over 300 operators in as many towns in the United States.

We make the most efficient stationary systems for residences, hotels, office buildings, etc.

The Machine that
Makes the Money

We own the patents and are prosecuting all infringers. Write for catalog.

GENERAL COMPRESSED AIR & VACUUM MACHINERY COMPANY
4452 Dept. "C," Olive Street ST. LOUIS, MO.

RHEUMATISM

Don't Take Medicine, but Try Magic Foot Drafts, the Great Michigan External Remedy which is Curing Thousands—
Let us send you a

\$1 Pair on Free Trial

Magic Foot Drafts are curing every kind of Rheumatism without medicine, no matter where located or how severe. Muscular, Sciatic, Lumbago, Gout—chronic or acute—all yield quickly to these wonderful Drafts, which have brought comfort to hundreds of thousands, including cases of thirty and forty years' standing.

Magic Foot Drafts are today in use all over the civilized world. They are curing where doctors and baths and medicines fail.

Magic Foot Drafts are the only American external remedy ever protected by the courts of England, the worst rheumatic country on earth, where Magic Foot Drafts have become a universal household remedy.

Magic Foot Drafts are always sold on free trial, their world-wide success having been accomplished on the "pay after satisfied" plan. Only a true cure could succeed on our plan.



If you have Rheumatism, let Magic Foot Drafts cure you. Simply send your address. You will get a \$1 pair of Drafts by return mail. If you are satisfied with the benefit received, you can send us one dollar. If not, keep your money. We take your word and trust you for a square deal. Our new illustrated book on Rheumatism comes free with the trial Drafts. Magic Foot Draft Co., 351 Oliver Bldg., Jackson, Mich. Don't delay, but write today.

Plumbing Supplies



AT WHOLESALE

If you need anything in my line, and wish to

Save Money

on every article, write for my free illustrated Catalog. Shipments promptly made from a very complete stock of new latest pattern goods. Small orders are as carefully handled as large ones.

B. P. KAROL, 235 W. Harrison St., Chicago, Ill.



Mount Birds

We teach you by mail to stuff and mount all kinds of Birds, Animals, Game Heads. Also to tax skins and make rugs. Be your own taxidermist. Decorate your home with your beautiful trophies, or increase your income selling specimens and mounting for others. Easily, quickly learned in spare time, by men and women. Highest endorsements by thousands of students. Write today for our great free book "How to Mount Birds and Animals." Free—write today. N. W. SCHOOL OF TAXIDERMISTRY, Box 58T, Omaha, Neb.

It's Best to Buy in New York Everything for Your Home WRITE NOW For 700-Page Catalog



Just write us—postal or letter—for this our Free 700-page illustrated 1917-8 Buyers' Guide of lowest wholesale prices on over 75,000 reliable articles needed for the home—office—or shop. As the oldest mail-order house in America, we refer by permission to the Publishers of this Magazine. We show you

75,000 Reliable Articles

Watches	Fancy Goods
Jewelry, Clocks	Lamps
Silverware	Groceries
Knives, Razors	Whips
Seeds, Paists	Carriages
Baby Carriages	Wagons
Freezers	Hardware
Men's Machines	Revolvers
Elect. Supplies	Rifles
Tool Cabinets	Shot Guns
Stoves, Ranges	Traps
Boots, Shoes	Shells
Sweaters	Cartridges
Fishing Tackle	Farm Tools
Skates, Blades	Incubators
Ice Tools	Brooders
House Furnishing Goods, Etc.	

This 700-Page **FREE** CATALOG

You Positively Save 1/4 to 1/3

on local dealers' prices anywhere. Safe, prompt delivery and absolute satisfaction or money back Guaranteed. For nearly a century, since 1818, we have dealt with the people everywhere direct to their homes through our big catalogs. We also send you list of 100 Valuable Premiums Free. Also our grocery list of guaranteed Food Products of highest quality saves you one-third. Just write us. Then you'll prove by a first trial order that it pays to have our Grand Free Catalog No. 94 all the year round. It costs us \$1 to print it, but it's free to you.

White, Van Glahn & Co., 30 Barclay St., New York City
Oldest Mail-Order House in America, Estab. 1818

WATERMAN CANOE MOTOR

Small, neat, complete. Standard type, 2 H. P. Weight 35 pounds Height, 14 inches. Gray iron cylinder. Span copper jacket. Aluminum crank case. Float-feed Carburetor. Pump and all fittings of brass. Shipped complete (including foundation pieces) all ready for immediate installation.

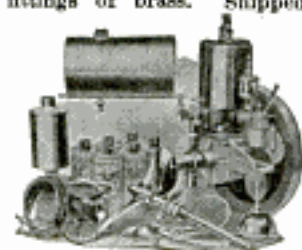

Will drive a canoe ten to twelve miles per hour. If you own a canoe, you want this motor. Immediate shipments can be made. Send for catalog.

Waterman Marine Motor Co.

1507 Fort St. West
Detroit, Mich.

Best grade cedar canoe for \$20

Best grade of Cedar Canoe for \$20.00. We sell direct, saving you \$20.00 on a canoe. All canoes cedar and copper fastened. We make all sizes and styles, also power canoes. Write for free catalogue giving prices with retailers' profit cut out. We are the largest manufacturers of canoes in the world. DETROIT BOAT CO., 156 Bellevue Ave., Detroit, Mich.

PRINTING 100 Letter heads, 100 Envelopes, 100 Cards, all three for \$1.50 postpaid. Visiting Cards, 100 for 85c; Shipping Tags, 100 for 40c. Samples, 2c. 100 Billheads or Statements, 50c.

RICHARD ELLIOTT, Box 1376, St. Louis, Mo.

Please Mention Popular Mechanics

Are Your Boiler Flues Clean?



Clean boiler flues mean higher efficiency. The soot and scale which forms in the flues prevent the heat from penetrating the metal and making steam.

THE PERFECTION FLUE CLEANER cuts away all the soot and scale, leaving the flue like new. Its blades cut under the scale and dirt like a knife and owing to its construction the blades are self-sharpening in use.

Made in sizes from 1½ to 6 inches. Let us send you one on trial. If satisfactory, pay us; if not, return it.

Scully Steel & Iron Co., Dept. 16, Halsted and Fulton Streets, Chicago, Ill.



Our 6 Inch RED DEVIL Water Motor

will run your Washing Machine on 50 pounds pressure and up, and will furnish power for a hundred other purposes.

NET PRICE \$8.00

Our 4 inch Red Devil Motor will grind your cutlery, polish your silver, run your sewing machine, run fans, wash bottles, etc., etc., on 35 pounds pressure and up. Price of outfit

\$4.00 NET

Motor and pulley only

\$3.50 NET

We refund your money if not satisfactory, so

You Run No Risk

Order from your dealer or from us.

Catalog free.

DIVINE WATER MOTOR CO.

Box 192, Utica, N. Y.

References: Dun and Bradstreet

CROSSING THE EQUATOR.—When the "Battle" fleet crossed the equator on its way to the Pacific ocean three-fourths of the crew of 14,000 men experienced their first shave at the hands of Neptune, and although they did not overly relish the treatment received from the monarch of the seas, they took the fun with the best of grace and were thankful to receive the certificate of initiation which in the future will place them among the tormenters, not the tormented. It is a time-honored tradition in the navy that a sailor crossing the line for the first time must be shaved by "Neptune Rex." The origin of the custom is wrapped in mystery and it is difficult to find any seafaring man who knows it by a more comprehensive name than "initiation." Ships generally try to reach the equator at noon, and Neptune pays each ship a preparatory visit the night before reaching the line, and this is the way it is done:

A hail is heard, apparently a hundred yards from the bow: "Ship ahoy!" The officer of the deck on the forward bridge replies "Ahoy! and who may you be?" The reply comes "Neptune Rex, monarch of all the seas." "Come aboard, sir," says the officer courteously, at which invitation Neptune climbs on board and is met on the quarterdeck by the captain or the admiral, to whom he presents a bag of fish and a warrant of summons to be served on the unfortunate members of the crew whose names he has not yet placed on his rolls. Then with many bows and interchange of florid compliments Neptune goes over the bow again, after informing the captain of his intention to return the following day with all his court, and having received the officer's assurance that everything would be ready for his reception.

The following day the ship crosses the line and shortly after the engines slow down and Neptune comes over the bow, accompanied by his wife, clerk, barber, doctor, bears, and policemen with stuffed clubs with which to belabor the victim who may show fight. Neptune is attired as grotesquely as possible and to an elaborate degree according to the ingenuity of the crew, and of late years the ceremony has been attended by a showing of splendid costumes and innovations never dreamed of by the older man-of-war-men. Neptune and Amphitrite wear crowns. The barber carries a bucket and a whitewash brush and a razor usually made of wood or a barrel hoop. Preparations on deck had already been made, there being a large canvas basin filled with water, spilling line, etc. The clerk opens his books, using a coil of rope as a desk, and Neptune calls out the names of the victims, and one by one

(Continued on Page 136.)



INVINCIBLE Marine Motors

Not toys, but high grade, 2 cycle engines for practical use—simple, sensible, strong and serviceable. Two sizes, both new models of latest and most approved type. Sold under factory guarantee at net factory prices as follows:

- | | | |
|--------|--|-------|
| No. 1. | 3½ H. P. single cylinder for 18 to 23 feet boats, complete outfit, | \$80 |
| No. 2. | 7 H. P. double cylinder for 23 to 28 feet boats, complete outfit, | \$175 |

Outfit consists of complete engine with all accessories and parts, electrical equipment and fresh water boat fittings—everything ready to install and run. Prompt delivery and absolute satisfaction guaranteed. Descriptive catalog free. Send today

INVINCIBLE MOTOR CO. Chicago, Ill.

Baldridge

Reverse Gear

DIRECT CONNECTION



from engine to propeller shaft, running smoothly and noiselessly. Simple, compact, ease of adjustment, powerful clutch and perfect lubrication. Write for descriptive catalog.

GIES BROS., 511 Wayne Co. Bank Bldg., DETROIT, MICH.

WOULD YOU HAVE THE WISDOM OF THE AGES?

GET THE NEW

RIDPATH LIBRARY OF UNIVERSAL LITERATURE

JOHN CLARKE RIDPATH, A. M., LL. D., Editor-in-Chief

With Revisions and Additions to-date by
WILLIAM MONTGOMERY CLEMENS

Since the dawn of civilization there has never been a great thought that has not been handed down to posterity. We are heir to the wisdom of the ages. "The dwarf on the giant's shoulders can see farther than the giant." The man who has at his command the wisdom and learning of all the great men knows more than did Aristotle, Plato or Bacon, because he has added to their knowledge that of all the others. It isn't necessary to spend thousands of dollars to obtain this nor to have a building like the Congressional Library to hold it. Every man has produced his best thoughts in a few pieces. If we have these best things of all the great writers from the beginning of time to the present, we have the sum and substance of human wisdom. These best things have been collected and printed in

TWENTY-FIVE MAGNIFICENT VOLUMES

Think of it! The learning that has transformed the world from the barbarism and darkness of the past to the civilization and enlightenment of the present all at your command. It is now universally conceded that we must read. Let us read the best; nothing but the best and all of the best. Thousands have testified to its worth. Buy now and be convinced.

This marvelous work is now ready for distribution, from entirely new type and new plates, at the following special prices:

Half Leather, \$150.00. Full Leather, \$200.00. Terms 10 per cent discount for cash, or net price on moderate monthly payments.

SOLD BY THE PUBLISHERS EXCLUSIVELY AND ONLY ON SUBSCRIPTION

A Few Chicago Opinions

Permit me in acknowledging the receipt of my Half Leather set of the Ridpath Library of Universal Literature (twenty-five volumes) to say, that although from my knowledge of Mr. Ridpath I was prepared for something better than the ordinary, I am much surprised at the representative breadth of the work, as well as the fine discrimination employed in its selections. I cannot at this time assume to say that I have given the entire work a critical examination, but only to have carefully studied its plan and scope, and in this I find abundant assurance of its extreme usefulness. Particularly will it be valuable to the busy man, who, having only a limited time to devote to general reading, can here find the best ready at hand. It is this feature of the work which especially commends it as providing in much greater degree than anything I have seen, a literature which will enable the ordinary man to enjoy that which heretofore has been accessible only to the scholar. For this reason I doubt not that as the work shall become known it will—as it should—be generally found in the libraries of every booklover.

JAMES PRABODY, Statistician, The Atchafalpa, Topeka & Santa Fe Ry. System, Chicago, Ill.

I beg to acknowledge receipt of my set of the Ridpath Library of Universal Literature. To me it is a work of rare merit, most valuable, interesting, and highly instructive, embracing as it does in a convenient form, the cream of literature for ages. I am indeed happy at being the possessor of such writings.

E. A. WHIFFLE, Mgr. Grand Pacific Hotel.

I have received my set of the Ridpath Library of Universal Literature in the Half Leather Binding, and upon thorough examination find I have an indispensable and most valuable addition to my library. The work surpasses anything of its kind and unlike them is not a digest. The index is the simplest, most complete and convenient I have yet seen. I give the work my fullest endorsement and believe the future will see it in every complete library.

DR. WILLIAM A. HILLEMAYER.

It gives me pleasure to say that my Ridpath Library of Universal Literature, consisting of full leather binding, is far beyond my expectations. I have examined it thoroughly and cannot recommend it too highly. It should be found in every well appointed library.

PARKER A. JESSE, Men's Furnishings.

I have examined my Half Leather set of the Ridpath Library of Universal Literature which I received a week ago, and find it the most complete work of its kind that I have ever seen. As a work of reference it is beyond comparison. It is a most liberal education in itself and no lover of books should be without it. I regard it as an invaluable acquisition to my library.

C. J. MURPHY, D. D. S.

Fifth Avenue Library Society, 114 Fifth Avenue, New York.
Gentlemen—Please ship to me one set of RIDPATH LIBRARY OF
UNIVERSAL LITERATURE in Full Leather at \$200.00 Half
Leather at \$150.00 for which I agree to pay you \$15.00 on
receipt of the books and \$10.00 each month thereafter until
the full price is paid.
It is understood that the title remains in you until
books are paid in full.

Name.....
Street.....
City.....
State.....

Please Mention Popular Mechanics

Pipe Perfection

The Spiral Cleanable Pipe is the coolest, cleanest and most sanitary pipe made.

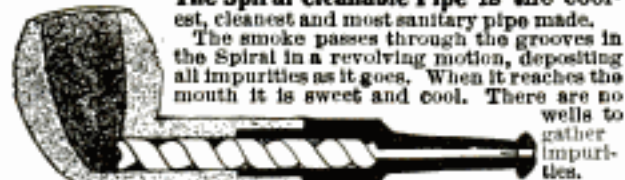

The smoke passes through the grooves in the Spiral in a revolving motion, depositing all impurities as it goes. When it reaches the mouth it is sweet and cool. There are no wells to gather impurities.

CLEANED IN A SECOND

by removing the Spiral and wiping with a piece of waste rag or paper. No poking with straws or pipe cleaners.

Made of Imported French Briar

PRICE 50 CENTS POSTPAID. A BETTER ONE FOR \$1.00

Spiral Novelty Works, 3948 Prairie Ave., Chicago

HOW TO MAKE MONEY



Send today for our FREE book and descriptive matter telling all about the profits that can be made in the manufacture of concrete building blocks. With a FRANCIS BLOCK MACHINE any man of ordinary ability can make from \$5 to \$15 a day. No capital or experience necessary. Building blocks made with the Francis Machine under the Berlin System are guaranteed damp proof, frost proof, fire proof and will not crack or crumble. Contractors and builders in your town need your entire output. Write today.

FRANCIS MACHINERY COMPANY
Room 40, 710 N. 8th Street - St. Louis, U. S. A.



\$75 HAND POWER CONCRETE MIXER

14 year old boy can operate it

Send for free booklet "True Concrete" Sidewalk or Block makers

SARNSON MACHINERY CO.
Room 3, 806 Chestnut St., St. Louis, Mo.

BUILD WITH CEMENT



Do it yourself with our \$16.50 HOLLOW BLOCK MACHINE. SAVE MONEY. We give complete instructions. Catalog Free. BOOK OF DESIGNS and Floor Plans, 10 etc. in silver or stamps. REED MFG. CO., Box 118, Springfield, Ohio

LEARN CEMENT CONSTRUCTION In All its Branches for \$1.00

Building Blocks, Water Proofing white or any color, Bridge, Roof, Sidewalk and Floor Construction. Write for descriptive circular. CEMENT INSTITUTE, 3822 Page Boulevard, St. LOUIS, MO.

MECHANICAL DRAFTING

Working Drawings, Patent Drawings, Machine Designing and Detailing.

Estimates on all work free. Correspondence Solicited.

W. C. HART, P. O. Box, 708 Westfield, N. J.

WHEN YOU WANT ANYTHING AND DON'T KNOW WHERE TO FIND IT WRITE POPULAR MECHANICS

SAY?

If a cook stove heats, why won't a heat stove cook? It sure will and save dollars, if you use our PATENT BASE BURNER OVEN

Bakes meats, breads, pastry. Completely hidden; entirely odorless. Price \$2.00. In ordering state length and width of ash tray and dimensions of door opening.

Agents Wanted Everywhere Liberal Commission
ADVANCE BAKER CO., 374 So. Senate Ave., Indianapolis, Ind.

(Continued from page 134.)

they go through the ceremony to the delight of the audience which crowds the rails, turrets, bridges and tops. If a man foolishly hides himself away the policemen go after him and whack him so that he wished he had remained to take his medicine. A victim is seated on the edge of a platform, and when he opens his mouth to answer a question a large unsavory pill made of soap, pepper, etc., is inserted in his mouth. Then the barber gets to work and lathers him, using the whitewash brush, and covers his face and clothes with a composition of sand, molasses, flour, salt, and anything that will make a disagreeable mess. With a final shove the almost initiated goes backwards into the tank where the seabears are waiting to welcome him, with brooms and swabs and a hose of running sea water. No matter how roughly some of the men may be used, none ever thinks that the trouble is not worth while the pleasure experienced when the certificate of initiation is handed him by Neptune after the ceremonies. The officers are not exempt from the initiation, and sometimes one will be found who prefers the real experience to paying a forfeit of wine, beer and cigars. Every dog has his day, and so has the enlisted man, for from the time Neptune's flag is hoisted to the truck until pipe down after the ceremonies there is no restriction upon any reasonable amount of fun, and rank is not excused from the good-natured though respectful pranks of the petty officers and men.—The Blue Jacket.

EXPORTS OF MACHINERY.—Of the estimated total of 200 million dollars worth of merchandise exported from the United States during 1907, machinery of various forms approximates 95 million dollars. The exact figures for the eleven months for which statistics are available show 87 1/2 million dollars worth of machinery which is made up as follows: Metal working machinery, nearly 10 millions; electrical machinery, nearly 9 millions; sewing machines, about 8 millions; locomotives, 8 1/2 millions; typewriters, over 6 millions; mining machinery, nearly 6 millions; stationary engines and boilers, over 5 millions; wood-working machinery, 1 1/4 millions; pumps and pumping machinery, 3 1/2 millions; cash registers, 2 1/3 millions; printing presses, 1 2/3 millions; shoe machinery, over 1 million; and laundry machinery, over a half million dollars.—Am. Machinist.

JOIN OUR HISTORY CLUB.—This magazine is able to offer to its readers today one of the most remarkable bargains in books ever known. The Union Book Company, of Chicago, a publishing house which failed a short time ago, published the Library of Universal History and we have agreed with the receiver to form a club and take 150 sets of the publisher's greatest publication, the world famous Library of Universal History, a magnificent publication consisting of fifteen volumes, beautifully bound, each volume being 10 in. high, 7 in. wide and 2 in. thick. It is one of the most handsome and sumptuous sets ever put out by any publisher.

The Union Book Company sold these sets for \$56, but through our arrangements with the receivers, we are able to offer them for only \$24.50, or less than half the original price, and can give you a whole year to pay for the set. Besides, we do not ask you to buy the books until you have examined them free in your own home. We will send the books to you free, prepaid, without asking you to pay one cent down. All you need to do is to ask if you may see them in your own home and they will be sent to you at once. You are absolutely under no obligations to purchase just because you ask to see the books in your home any more than you would be expected to purchase if you went into a store and asked a bookseller to show a book from his shelves. Because we know

(Continued on page 138.)



HAND POWER METAL PLANER

Only \$40.00

Ideal Machine Works
Brooklyn, N. Y.

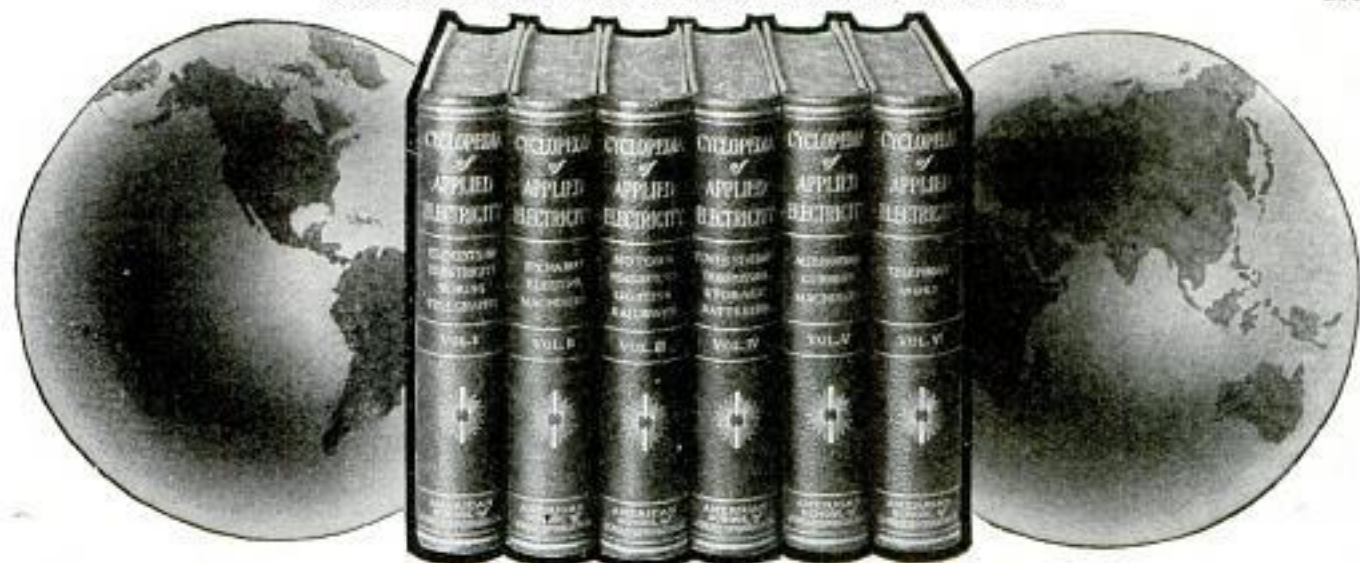

Electricity Is The Connecting Link

Electricity unites the hemispheres. Yesterday men talked across the ocean by wireless. What will tomorrow bring forth?

Are you keeping abreast of the times? Every new discovery or invention means greater opportunities, greater power, greater chances of advancement for the man who is up-to-date. You must understand the application and make it your own if you would get any real benefit from it. Franklin has the honor of discovering electricity, but the man who applied it made the money.

CYCLOPEDIA OF APPLIED ELECTRICITY

Just Off the Press—Enlarged to Six Volumes

Special diagrams, tables, formulas, sections, etc. Complete set of test questions follow each section. 3,000 Pages, 7 x 10 Inches, Bound in Half Red Morocco

This six volume edition is just out. The editors have revised it page for page, to make sure that it is right up-to-date in every particular, and have added 500 pages of new matter.

This work is the connecting link between the man who knows and the man who wants to know. It will post the *Electrical worker* on all the latest developments of his trade, it will teach the *student* the principles of electricity and its newest application. It will tell *any man* anything he wants to know about electricity, and tell it so simply, so clearly, so concisely that he cannot help understanding.

Special Introductory Price, \$18.00—Regular List Price, \$36.00

— READ EASY PAYMENT OFFER —

We will send you the entire set absolutely free, express prepaid, upon receipt of this coupon. If you keep them send \$2.00 within 5 days and \$2.00 a month until you have paid the special price of \$18.00—list price, \$36.00. Otherwise return the books at our expense. We employ no agents to annoy you. We know that the books will sell themselves.

Some of the Subjects Treated

Elements of Electricity; Electric Current; Electric Wiring; Electric Bell Wiring; Electric Telegraph; Wireless Telegraphy; Telautograph; Insulators for Transmission Lines; Theory, Calculation, Design, and Construction of Generators and Motors; Types of Dynamo and Motors; Elevators; Direct Current Motors; Direct-Driven Machine Shop Tools; Electrical Measurements; Electric Lighting, including Arc and Incandescent Lighting, Nernst Lamp, Cooper-Hewitt Lamp, Osmium Lamp, etc.; Electric Railways, including Third-Rail System, Multiple-Unit Control, Electro-Pneumatic Control; Alternating Current Motors, etc.; Single Phase Electric Railway; Electric Welding; Mercury Vapor Converter; Management of Dynamos and Motors, including the Location and Remedy of Troubles, such as Sparking at the Commutator, Heating, etc.; Power Stations; Central Station Engineering; Central Station Design; Storage Batteries, including Charging and Discharging, Troubles and their Remedies, Tests for Impurities, etc.; Power Transmission; Alternating Current Machinery, including Alternating Current Generator; Synchronous Motor, Induction Motor, Transformer, Rotary Converter, Frequency Changer, etc.; Telephony, including Instruments, Lines, Exchanges, Common Battery Systems, Operation, Maintenance; Automatic Telephone; Wireless Telephony; Telephone Line Protection; Telegraphy, etc.

**AMERICAN SCHOOL
of CORRESPONDENCE**

CHICAGO

COUPON

Pop. Mech. 3-08
American School of Correspondence Chicago
Please send me Cyclopedia of Applied Electricity for five days' free examination. I will send \$2 within five days and \$2 a month until I have paid \$18; otherwise, I will notify you to send for the books.
Name.....
Address.....
Employer.....

S & B 6 H. P. TWO CYCLE \$98 Marine Engine

The simplest, strongest and most durable Marine Engine ever put on the market at this price. Noiseless—no cranking—easy to start—easy to operate—nothing to get out of order.

Three port designs	Smooth running
Jump spark ignition	Economizes fuel
Float feed carburetor	Fewest moving parts
	Automatic water circulation
	No "back firing"
	Will not "skip"
	No packing to blow out
	Highest grade accessories
	Reverse clutch or
	Solid propeller



Every engine tested over and above rated H. P.

Materials and workmanship guaranteed

Write for printed matter going into the details of its superior advantages over other engines of its class

Smith & Baldrige Machine Co.
62 Amsterdam St. Detroit, Mich., U. S. A.

Territory open to responsible agents
alive to a quality proposition



A Rare Tobacco

awaits the smoker who has not discovered the exquisite aroma of

French's Mixture

The Aristocrat of Smoking Tobacco

It pleases instantly and satisfies continuously. Only the choicest grades of ripe and mellow North Carolina Red and Golden Leaf are used. Blended by hand with a care that shames ordinary factory methods. Pure, clean, wholesome and always in perfect condition, because it is sold only

Direct from Factory to Smoker

Send 10 cents (silver or stamps) for large sample pouch and booklet.

FRENCH TOBACCO COMPANY
Dept. P. Statesville, N. C.



THE FREEMAN PIPE, A Clean Smoke for Clean People

French Briar, Hard Rubber Bit, straight or
SMOKE PASSAGE bent. \$1.00, postpaid.

ALWAYS CLEAN DRY & SANITARY

WRITE FOR BOOKLET. RETENTION CHAMBER
GRADED WITH ADOPTED COTTON
FREEMAN PIPE CO., Dept. 6, Kalamazoo, Mich.



Smoke our Anti Nicotine TWO WAY Briar Pipe and enjoy for once a cool, delightful smoke. Nothing but smoke enters the mouth. Smokes absolutely dry. Note the cold air Inlet and TWO WAY Outlet, that's why our ANTI NICOTINE PIPE has no equal. Guaranteed as represented or money refunded, postpaid 50 cents.
ANTI NICOTINE PIPE CO., Dept. A, Ottawa, Ill.

Continued from page 136.



Pioneer Perfect Frames

The Standard of Knockdown Boat Construction

The only frames in which every part is completely finished, set up, tested and tried before being knocked down for shipment. With Pioneer Perfect Frames you can build your boat complete for one-third the boat-builder's price. With Pioneer Perfect Frames come, absolutely free, plank patterns and detailed instructions for finishing your boat, so accurate and simple you cannot fail. Each piece is marked where it should go. Re-assemble them, nail on planks and the lines of your boat are perfect. Order today—have your boat in the water early. Set up the frame—see the simplicity of the Pioneer System. If it seems too much labor to finish it yourself, we have planking, decking, coaming, etc., necessary to save you this work—also hardware, fittings and engines—perfect as our frames and at the same low price.

By securing Pioneer Perfect Frames on the easy-payment plan you "pay for your boat as you build it."

Write TODAY—for FREE Booklet—how to build your boat from Pioneer Perfect Frames, Plankings, etc., or from Pioneer Full-Size Patterns of every part. Or send 25c for BIG 104-page, 9x12 Boat-Builders' Book—over 300 illustrations and all about boats, engines, etc. Money back if not satisfied.

Pioneer Boat and Pattern Co. Originators of the Boat Pattern System
Wharf 204, Bay City, Mich.

that you cannot realize how magnificent these volumes are, and how thrillingly interesting is every page, how entrancing are the 700 illustrations, many of them in color, and how every one of the 5,000 pages teems with beautiful descriptive and wonderful portrayal of events which have moulded the world for sixty centuries.

Every one of our readers should be interested in this offer—should at least ask to examine this work in their own home without paying anybody anything. After you have examined the books for a week, after your children have read parts of them and after you have secured the views of your friends, send the books back at our expense or enclose only 50 cents as the first payment and then send \$2 a month for twelve months. That is all.

We would like to have you read further details of this offer on back inside cover of this magazine where we give you a further description of the books and tell you more about this offer. Just read our offer, anyway.

WIRELESS TREATY RATIFIED.—The treaty proposed by the international conference held in Berlin recently has been ratified by Belgium, Denmark, Mexico, Norway, Holland and Roumania. Great Britain, Argentina and Brazil are ready to ratify it, and France is only awaiting the action of Great Britain. Bills are now before the United States Senate and the German Reichstag.

The treaty provides for an interchange of messages between the various systems of wireless telegraphy, of which there are now at least twenty in use. The formulating of the treaty was largely brought about by the refusal of ships equipped with one system to receive and transmit messages from ships and shore stations equipped with other systems. The Marconi Company contends that its patents would be infringed if the ships of all nations should exchange or forward messages regardless of the systems operating them, and is therefore opposed to such a treaty.

LET US BE YOUR FACTORY

We make anything to order—Stampings, Sheet Metal work—anything a good machine-shop should do—we do—because we're good ones. We publish "The Silent Partner." Ask for a sample copy. Write us.

THE GLOBE MACHINE & STAMPING CO.
3610 Hamilton Avenue, N. E. Cleveland, Ohio

The Electric Washer and Wringer

YOU can now have your washings done by electricity. The 1900 Electric Washer Outfit (Washer, Wringer and Motor complete) does all the heavy work of washing and wrings out the clothes. Any electric light current furnishes the power needed. You connect up the washer the same way you put an electric light globe into its socket. Then all there is to do to start the washer is—turn on the electricity. The motion of the tub (driven by the electricity) and the water and soap in the tub wash the clothes clean. Washing is done quicker and easier, and more thoroughly and economically this way than ever before.



30 Days' FREE Trial—Freight Prepaid



Servants will stay contented—laundry bills will be saved—clothes will last twice as long—where there is a 1900 Electric Washer to do the washing.

These washers save so much work and worry and trouble, that they sell themselves. This is the way of it—

We ship you an Electric Washer and prepay the freight.

Use the washer a month. Wash your linens and laces—wash your blankets and quilts—wash your rugs.

Then—when the month is up, if you are not convinced the washer is all we say—don't keep it. Tell us you don't want the washer and that will settle the matter. We won't charge anything for the use you have had of it.

This is the only washer outfit that does all the drudgery of the washing—washes and wrings clothes—saves them from wear and tear—and keeps your servants contented.

Our Washer Book tells how our washers are made and how they work. Send for this book today.

Don't mortgage your pleasure in life to dread of wash-day and wash-day troubles with servants. Let the 1900 Electric Washer and Wringer shoulder your wash-day burden—save your clothes and money, and keep your servants contented.

Write for our Washer Book at once. Address—

The 1900 Washer Co., 3131 Henry Street, Binghamton, N. Y. (If you live in Canada, write to the Canadian 1900 Washer Co., 355 Yonge Street, Toronto, Ont.)

DIAMONDS ON CREDIT

20% Down; 10% A Month

Every customer is protected by our written guarantee to refund his money if his dealer can duplicate our diamond at our price. Write for Illustrated Catalogue No. P. M. J. M. LYON & CO., 71-73 Nassau St., New York City



BARODA DIAMONDS

Flash like the genuine—at 1/30 the cost
SOLID GOLD MOUNTINGS

Stand acid test and expert examination. See them first, then pay. Catalog FREE. Patent Ring Gauge included for 5 two-cent stamps. The Baroda Co., Dept. M, 230 North State St., Chicago

BEWARE OF IMITATIONS

For the protection of our customers we advise that Klein's Pliers are being imitated, to look like Klein's. This, however, does not make them Klein's.

CAUTION Look for this stamp, M KLEIN & SONS, on the inside of handles—some are genuine without this stamp. Use only genuine Klein's. They are the product of years of experience and have stood the test of time.



MATHIAS KLEIN & SONS 96 W. VAN BUREN ST. CHICAGO, ILL.

WHEN YOU WANT ANYTHING
AND DON'T KNOW WHERE TO FIND IT
WRITE POPULAR MECHANICS

GROW MUSHROOMS

For Big and Quick Profits.

I can give practical instructions worth many dollars to you. No matter what your occupation is or where located, get a thorough knowledge of this paying business. Particulars free. JACKSON MUSHROOM FARM, 3243 N. Western Ave., B-146, Chicago.



MELLO-TONE

Attachment, a great improvement for the Talking Machine or Phonograph. Produces tones natural. Eliminates all metallic sounds and blasts. Regulates and mellows the tone. Can be adjusted while machine is playing. Goes in the horn, opens and shuts.

Retail Price, \$1.00 Each
MELLO-TONE CO. :: Springfield, Mass.

PUZZLES

FAMOUS TRIPLE HORSE-SHOES

Made of polished steel, fine pocket-piece and entertainer, postpaid, with secret solution, 10c. Western Puzzle Co., Adv. Dept., St. Paul, Minn.

Please Mention Popular Mechanics

A Valuable Book

JUST OFF
THE PRESS

PRICE 25¢

AMATEUR MECHANICS

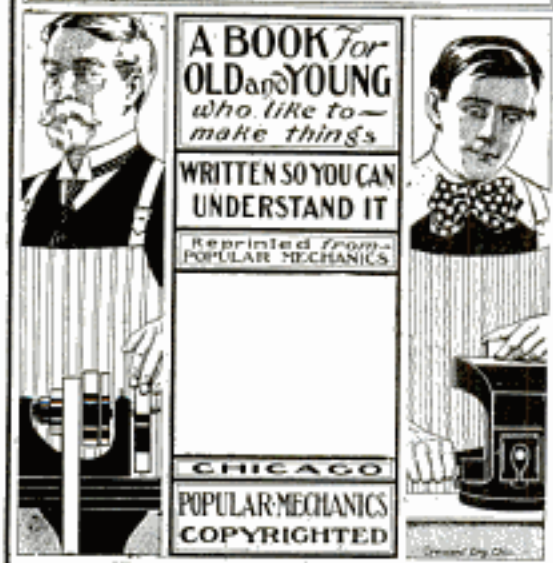

174 Articles
165 Illustrations

Tell how to make hundreds of different articles of daily use. Very interesting for boys and men. This book should be in every American home.

WRITTEN SO YOU
CAN UNDERSTAND IT

Price 25¢

For sale by all newsdealers or can be ordered direct from the Publishers—

Popular Mechanics Chicago

2 H.P. Detroit Engine

starts without cranking; no cams, valves, springs or sprockets. Only 3 moving parts. All bearings bab-bitted. For your Row Boat, Sail Boat, Launch 10,000 in use.

Send for testimonials

DETROIT ENGINE WORKS
1271 Jefferson Ave., Detroit, Mich

For \$29.50

2-5-7-10 L. P. Proportional prices. Cylinders and pistons ground. Crank shaft drop forged steel. All sizes ready to ship

SEND FOR FREE CATALOG.

NEXT FEW YEARS WILL ECLIPSE ALL AGES IN INVENTION.

By Edward B. Moore, Commissioner of Patents.

The age of invention has just begun to dawn. The accomplishments of the last half-century, while marvelous almost beyond conception, will not begin to compare with what will be done in the next half-century.

I base this conclusion upon a definite knowledge of what is being done at present and an appreciation of the great world scope that invention is assuming. There is no evidence of a waning of inventive genius, while greater stores of knowledge, better trained hands, and both these in vastly greater numbers, are being brought to bear in the field of invention.

The number of patents applied for and the number granted at the patent office last year were greater than at any time in its history. With the increased number there is no decrease in the individual importance, but merely an evidence of increased industrial activity that demands the articles patented.

There are periods of activity and depression along certain lines of industrial art. Some years ago we had ten men at work on bicycles alone, while now one man devotes but half his time to them. Eight men formerly worked on reapers, while they are so nearly perfected that but three are so engaged.

This does not mean, however, that any line of machinery is ever made so perfect that no further inventions will follow, for there are as many patents issued today for the improvement of plows as at any time in the history of the world, and the plow in the form of a forked stick was among the first tools invented. There are, however, certain lines of great activity at present and in the near future.

Electricity offers an unlimited field, and the number of patents bearing upon it is without end, while the dying machine is but beginning to show its possibilities. Wireless telegraph and telephone are just being heard from, while at any time a great basic principle like that of the Bell telephone may be discovered that will open up new vistas.

The inventor of today is a different man from the long-haired, erratic genius of a generation ago. He is in nearly all cases an inventor by profession, trained in the best technical schools and devoting his life to the creation of new things. He is, above all, a practical man of affairs.

The people of the United States have gained more than any other nation from their inventions. These have enabled them to enter the markets of the world and force out competition in many grades of machinery. The patent laws of this country have been a greater protection to the inventor than have those of any of the other nations and are being widely adopted.

Treaties for the protection of patents are being universally adopted. Such treaties are now being arranged by the state department with China and all the nations of South America. Japan is but just finding that her people have the same inventive mind that is shown in America.

The awakening of new minds and new nations is going to bring on renewed activity and competition, and matters will go forward at a still greater rate. World's fairs have done much to make this activity world wide, and the promise is that our children will live in a world that we would not recognize.—Chicago Journal.



Geisha Diamonds

THE LATEST SCIENTIFIC DISCOVERY

Bright, sparkling, beautiful. For brilliancy they equal the genuine, standing all test and puzzle experts. One twentieth the expense. Sent free with privilege of examination. For particulars, prices, etc., address

THE R. GREGG MFG. & IMPT. CO.
Dept. H, 52-58 W. Jackson Boul., Chicago, Ill

Refinish Your Furniture Woodwork and Floors



FREE Sample of
JOHNSON'S WOOD DYE

for the artistic coloring
of all wood, Johnson's

Prepared Wax for polishing the wood and Johnson's Electric Solvo for removing old finish, also 48-page color book giving instructions. See offer below.

Johnson's Wood Dye is made for
the express
purpose of properly and permanently coloring wood.

It penetrates deeply, bringing out the grain of all woods, greatly increasing its beauty. Our Wood Dye is entirely different from colored varnishes, oil stains and other finishes offered for this purpose. If the color is in combination with a varnish, oil or finish, or the color is applied over old finish, the wood cannot absorb the color and is simply coated over, not dyed. Wood that is properly and permanently colored always absorbs the color. **JOHNSON'S WOOD DYE** can be easily applied, dries quickly and does not rub off. It should always be applied upon the bare wood, followed by Johnson's Prepared Wax for the most satisfactory, artistic and beautiful effect, but any other finish may be used.

For refinishing furniture, woodwork and floors, Johnson's Electric Solvo will immediately remove old finish, leaving the wood bare and clean ready for the dye. Full instructions given in our booklet, "The Proper Treatment for Floors, Woodwork and Furniture."

Johnson's Wood Dye

"For the Artistic Coloring of All Woods"

IS MADE IN THE FOLLOWING SHADES:

No. 126	Light Oak	No. 128	Light Mahogany
No. 123	Dark Oak	No. 129	Dark Mahogany
No. 125	Mission Oak	No. 110	Bog Oak
No. 130	Weathered Oak	No. 121	Moss Green
No. 131	Brown Weathered Oak	No. 122	Forest Green
No. 132	Green Weathered Oak	No. 172	Flemish Oak
No. 140	Manilla Oak	No. 178	Brown Flemish Oak

By mixing two or more shades any colors may be obtained. To lighten use wood alcohol; to darken add Flemish Oak No. 172.

Half pints, 30c; pints, 50c; quarts, 85c., at your dealer who sells paint.

FREE Offer: Send today your paint dealer's name and 10c (coin or stamps) to pay postage and wrapping and we will forward samples of Johnson's Wood Dye, Johnson's Prepared Wax and Johnson's Electric Solvo. 48-page color book "The Proper Treatment for Floors, Woodwork and Furniture" sent FREE.

S. C. JOHNSON & SON,
RACINE, WIS.

"The Wood Finishing Authorities."

PA 3

FREE
COUPON

S. C.
JOHNSON &
SON,

Racine, Wis.

Please send me
FREE as per your
offer, cans of Johnson's
Wood Dye, Johnson's
Prepared Wax, Johnson's
Electric Solvo and 48-page
instruction book for which I
enclose 10c to pay postage and
wrapping. My paint dealer's name

is.....

His address is.....

My name.....

Town and State.....

Please Mention Popular Mechanics

Start a Moving Picture Business In your own town or for traveling exhibitions. Most profitable business for small capital required. Rent outfit if you can't afford to buy. We sell or rent Moving Pictures and Machines. By our special plan it is easy to start and run such a lucrative enterprise. Has enabled many to make small fortunes in a few months. Write for Particulars and Terms. **GLOBE FILM SERVICE, UNITY BLDG., CHICAGO**

"CURE YOURSELF BY ELECTRICITY"

New Book—Illustrated from Life—Sent FREE to all who write.

Write to-day for our new Free Book—"Cure Yourself by Electricity"—Illustrated with photos from life. Shows how the New Home Batteries cure Rheumatism, Neuralgia, Lumbago, Headache, Insomnia, Constipation and all nerve affections and diseases arising from sluggish circulation; also how they afford electric baths and beauty massage without cost at home.

THIS BATTERY

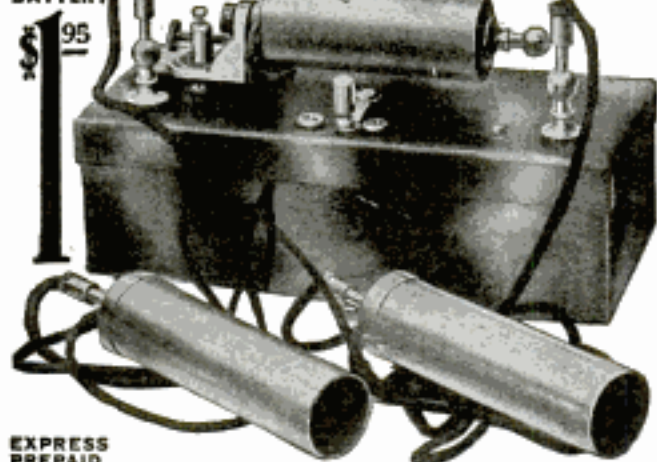

EXPRESS PREPAID

Every Home Should Have a Home Battery.

We send our batteries Prepaid without a cent in advance (prices \$1.50 and up) and allow 10 DAYS' FREE TRIAL. Write for our Book.

DETROIT MEDICAL BATTERY CO.,
390 Majestic Bldg., Detroit, Mich.



VENTRILOQUISM

LEARNED BY ANY MAN OR BOY AT HOME.

Small cost. Send to-day 2c. stamp for particulars and proof.

O. A. Smith, Room 623, 2040 Knoxville Ave., Peoria, Ill.



Pencil Pistol: Exclusively a weapon for defense; size of pocket knife; a protection against hold-ups. 32 caliber. \$1.50, prepaid.

C. S. Webber,
Box 570 CHICAGO



Every Boy His Own Toymaker

Greatest boys' book ever written. Tells how to make a Steam Engine, a Camera, Windmill, Microscope, an Electric Telegraph, Telephone, Magic Lantern. Boats of every kind, kites, balloons, electrical and mechanical toys, traps, fishing tackle, rustic cottages, 200 illustrations. Every boy should have this great book. Price only 10 cents, postpaid, 3 for 25 cents.

WESTERN PUZZLE CO.

St. Paul, Minn.

WAITING-ROOM FOR LADIES IN A HORSE-SHOEING SHOP.—An enterprising blacksmith in a small Pennsylvania town has added to his horse-shoeing establishment a comfortable and well furnished waiting-rooms in which women can rest and read the latest magazines and newspapers while the horses are being shod. The room is furnished, not with the traditional furniture of most waiting-rooms, but so far as possible with productions of his own art. In the place of ordinary seats and sofas this ingenious smith mounted a number of his best upholstered carriage seats on riding springs. An open fireplace, discharging into the same chimney as his forge, warms the room. Before it are artistically fashioned andirons, and on the walls are many appropriate pictures, among which is "The Village Blacksmith," framed in fancifully twisted iron bars.—Blacksmith and Wheelwright.

THE DIFFERENCE BETWEEN DIAMONDS AND RUBBER.—According to an English scientist now in this country, Europe is making a great fuss about manufactured diamonds. "They seem to forget that the moment a real diamond is manufactured the goose that layed the golden egg is killed," says the scientist. "When diamond dog collars become so numerous that anyone can wear them diamonds will no longer be valued. If it is possible to manufacture diamonds it would pay the mine owners to buy up the formula no matter what it cost, and it would pay the men engaged in such experiments much more if they would turn their energies to discovering a means by which rubber could be manufactured instead. If we could make a rubber as good as the product of Africa we would benefit the whole world. Regardless of every effort the supply has failed to keep up with the demand."

GREATEST LUMBER CUT.—These figures give some idea of how vast is the lumber industry and how great the demand for its products. More lumber was cut in the United States last year than in any other year in its history. The enormous amount of 37,550,736,000 board feet was produced, the mill value of which was \$621,151,388. Besides the board feet production, 11,858,260,000 shingles were produced at a value of \$24,155,555, and 3,812,807,000 lath, valued at \$11,490,570. It is safe to say that the present annual lumber cut of the United States approximates 40,000,000,000 feet, and that its total value will not fall under \$700,000,000.

The record for the year shows clearly the passing of white pine and oak, one the greatest softwood and the other the greatest hardwood which the forest has ever grown. Since 1899 the cut of white pine has fallen off more than 40 per cent, while that of oak has fallen off more than 35 per cent. Today yellow pine leads all other woods in amount cut, while Douglas fir comes second. Since 1899 the cut of Douglas fir has increased 186 per cent.

A comparison of the lumber-producing states shows that since 1899 there have been many changes in their relative rank. Washington, which then stood sixth, now leads, while Wisconsin, which 8 years ago led all others, is now third. In the same period Oregon, Louisiana, Mississippi, Idaho and California made great strides as lumber producing states, while Michigan, Minnesota, Georgia, Kentucky, Tennessee and Missouri fell off 40 per cent.

PROGRESS IN WYOMING MINES.—Henry C. Beeler, State Geologist of Wyoming, has compiled a pamphlet entitled "Wyoming Mines," which gives a clear and concise summary of the conditions and progress in the copper, gold, placer, iron, asbestos, sulphur, stone, plastic minerals, gravel, oil, natural gas, and coal industries of his state.



AGENTS

\$100 A MONTH EASILY MADE selling our "LIGHT-HANDLED POCKET KNIVES. Name and address on one side; photo and lodge emblem on the other. Just the right thing for a nice present. Write TODAY for agents' terms. GOLDEN RULE CUTLERY CO., 40-p Wendell Street, CHICAGO.



Every user of Dry Cell Batteries should have a

Pocket Battery Ammeter

quality, thus insuring continued accuracy. It is the size and weight of a watch.

THE ELDRIDGE BATTERY VOLTMETER 0 to 3 volts in 1-10 divisions. Is convenient and practical. Eldredge Electric Manufacturing Company, 11

that indicates correctly. The readings of our instrument, 0 to 30 amperes, are controlled by a fine phosphor-bronze spring of highest quality.

No. 6 Post Office Square, Springfield, Mass.



$$\frac{5}{8} + \frac{9}{16} + \frac{3}{64} + \frac{17}{32} + \frac{11}{16} = ?$$

You can figure it in 10 seconds if you use the

Fractional Adding and Subtracting Rule

A valuable invention for technical men, engineers, draftsmen, office men and all mathematical workers.

JUST THE THING! That's what everybody says about it. This rule is entirely practical and absolutely infallible. Very simple in construction and easy to manipulate, it readily commends itself to the user. A few moments practice will enable you to add or subtract any combination of fractions with perfect facility and ease. We absolutely guarantee the rule to be correct and practical in every way. The amount of time saved alone will pay for it very quickly.

Send for circular and descriptive matter

Burgess & Sauerberg
406-407 Kortlander Bldg.,
Grand Rapids,
Mich.

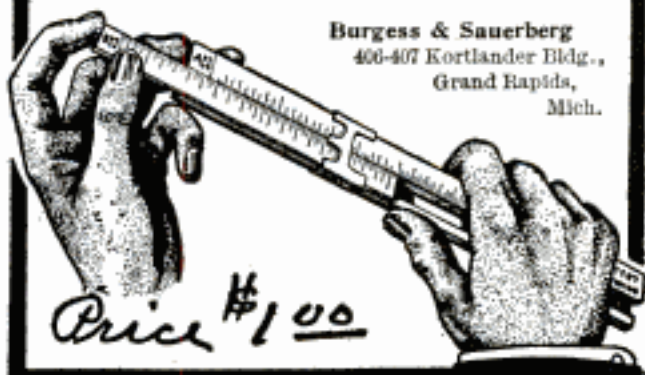

Price \$1.00

THE LEADER

IN NAME IN QUALITY

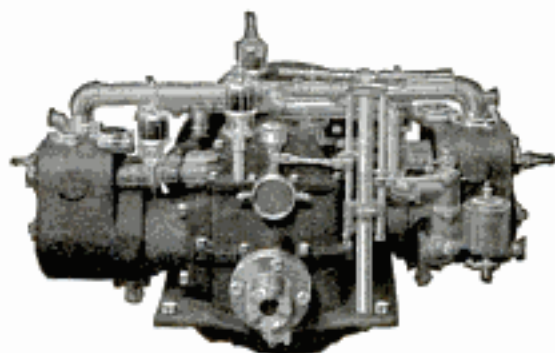

8-10 H. P. ENGINE

The Non-Vibrating "Leader"

The first successful horizontal opposed marine engine on the market

Three years ahead of its nearest competitors

Write today for Catalog
It will be worth your while

THE SINTZ-WALLIN CO.,

284 S. Front St., Grand Rapids, Mich.

150 Nassau St., New York 340 Carondelet St., New Orleans



KOETH'S KOMBINATION KIT

Made of tempered tool steel by expert workmen, highly polished, strong and handsome, contains sixteen distinct tools and only one set of handles for them all, adapted to the needs of the masses. If your dealer cannot supply you we will for \$3.50, charges paid; money back if not satisfied.

Catalogue for the asking.

CURRIER-KOETH MFG. CO.,

Coudersport, Pa.

DON'T WEAR A TRUSS



Brooks' Appliance is a new scientific discovery with automatic air cushions that draws the broken parts together and binds them as you would a broken limb. It absolutely holds firmly and comfortably and never slips, always light and cool and conforms to every movement of the body without chafing or hurting. I make it to your measure and send it to you on a strict guarantee of satisfaction or money refunded and I have put my price so low that anybody, rich or poor, can buy it. Remember, I make it to your order—send it to you—you wear it—and if it doesn't satisfy you,

you send it back to me and I will refund your money. The banks or any responsible citizen in Marshall will tell you that is the way I do business—always absolutely on the square and I have sold to thousands of people this way for the past five years. Remember, I use no salves, no harness, no lies, no fakes. I just give you a straight business deal at a reasonable price.

C. E. BROOKS, 7161 Brooks Building, Marshall, Mich.

A Rare Opportunity

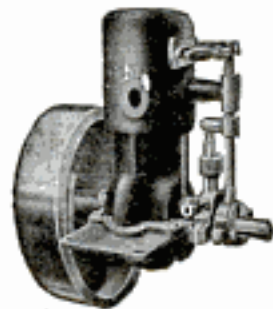

To Secure a
Powerful, Speedy, Dependable
2, 4 or 6 H. P.
Two Cycle Marine Engine

We have recently purchased the entire plant of the St. Clair Motor Co., and offer a limited number of

The Famous Little
Skipper Marine Engines

at very interesting prices. They are selling rapidly. The price will be increased when the present lot is

sold. Ask for Catalog P. M.

Gray-Hawley Mfg. Co., Detroit, Mich.

Manufacturers of
Gray Mufflers, Autochimes, Valves, Foot-Pedals,
Steam and Air Chime Whistles, etc., etc.

NEVER-LOSE RULE CLAMP

Where's
my rule?
Another
rule to buy



The Never-Lose Clamp is easily adjusted to fit any rule and is always ready to take or give up your rule instantaneously. Every mechanic should have one of these very useful articles, which we send to any address on receipt of 15 cents. MONEY BACK if dissatisfied with it.

State and County Rights for sale by our new plan. Write.

Mr. J. T. MOYER, :

111 Milford Square, Penna.

YOU NEED MONEY WE WANT AGENTS \$1200 PER YEAR

PHOTO KNIVES
OF QUALITY

Sell at sight to
everybody, net

you \$25 per week steady. Razor steel blades guaranteed. We place any photo, name or emblem under the transparent handle. Exclusive territory to agents. Write for terms and photo of handsome pocket sample case.

THE CANTON CUTLERY CO., 1294 W. 10th St., CANTON, OHIO

GLOBE INCUBATORS

do this all the time—have done it for 16 years. They hatch strong and healthy chicks—chicks that live and grow. Every latest improvement—patented hot waterpipe system and automatic heat regulator. The best machine, either for beginners or for professional poultry raisers.

100% Hatches Every Fertile Egg

Our FREE BOOK ON GLOBE INCUBATORS tells you how to make more money out of poultry. Marvelously complete, with beautiful color plates, and worth dollars to those using Incubators. Sent Free on application. A postal will bring it.

C. C. SHOEMAKER
Box 436 Freeport, Ill.



HOW TO KNOW AUTOMOBILES



An Illustrated Booklet containing 1000 distinguishing features of Automobiles, enabling you to know and name any motor car at sight. Brief, concise and to the point; the whole subject thoroughly covered in every detail. Highest testimonials and endorsements ever offered a publication of similar character. 50 cents by mail. Postage prepaid.

THE AUTOMOBILE PRESS
1329 Masonic Temple, CHICAGO, ILL.

\$1.00 THE "READY" Draughting Instrument combines Compass, Protractor, Rule, Square, etc., ALL IN ONE, and you can carry it in your vest pocket. Made of special grade of Aluminum. Send for it now. You need it. Money returned if you aren't pleased.

READY MANUFACTURING COMPANY
Dept. B. Rochester, N. Y.

Graduated in
10ths and 20ths.

REDUCED RATES ON HOUSE-
TO OR FROM COLORADO, CALIFORNIA, WASHINGTON AND OREGON. Write



BELINS HOUSEHOLD GOODS CO., 551 First Nat'l Bk Bldg., Chicago

Gas—Gasoline—Steam Engines

$\frac{1}{4}$ to 3 H. P.

BROOKLYN MACHINE COMPANY
824 Gates Avenue, Brooklyn, N. Y.

SKIDOO! Marine Engine

2 to 3 H.P. Bare Engines

Swiftest, most powerful, efficient and reliable 2-Cycle engine of its size on earth—entirely new design, improved and perfected in every detail—makes speedy little launch from an ordinary row-boat. Catalog describing all sizes FREE.

Belle Isle Motor Co., Dept. 10 Detroit, Mich.

23

Please Mention Popular Mechanics

EUGENE DIETZGEN CO.

Manufacturers and Importers of
DRAWING MATERIALS AND SURVEYING INSTRUMENTS

181 Monroe St., Chicago 214-220 E. 23d St., New York
14 First St., San Francisco 615 Common St., New Orleans
10 Shuter St., Toronto

New Catalog P. on application

ISOMETRIC PAPER

For simplified sketching.

Easy—Quick
Accurate



In Sheets, 3 sizes
Size 9x12 inches costs 60 cts. per pad of 40 sheets.

R-U INTERESTED IN THE STUDY OF ELECTRICITY

Limited offer. One Set (No. 1) Comprising 10 Leading Instruments \$8.50. Junior Set (No. 2) 7 Instruments \$4.50. For circulars, address **PALMER ELECTRICAL INSTRUMENT CO., N.W. cor. Filbert and 38th Sts., Philadelphia, Pa.**

HOW TO READ PLANS.—Charles G. Piker is the author of a book entitled "How to Read Plans," which gives a simple and practical explanation of the meaning of the various lines, marks, symbols and devices used on architectural working drawings, so that they can be correctly followed by the workmen.

A FLOATING CHURCH.—The Rev. Louis Ives, of England, who has taken charge of the Missions to Seamen at the port of Newcastle, New South Wales, has been provided with a steam vessel for his work in the harbor. With this vessel he will steam from ship to ship to preach sermons to the crews or minister in case of illness or trouble.

AUCTIONEERING BY PIN AND CANDLE.—The old custom of leasing land to the highest bidder by the aid of a candle and pin is still being observed at Vadmouth, a village between Reading and Newburg, England. The candle is lighted and a pin stuck into it. Bids are then called for until the pin, owing to the softening of the candle, drops out.

BURNED BANK NOTE A CURIOSITY.—Among the curios preserved in the Bank of England is a bank note that passed through the Chicago fire. The paper was consumed but the ash held together, and the printing is quite legible. It is kept carefully under a glass. The bank paid the note.

Start a Concrete Factory

A small investment pays \$1,000 and up annually. We furnish the machinery and teach you the entire business.

CONCRETE MACHINERY

FOR BRICK AND BLOCK PLANTS

Make Sidewalk Tile During Spare Time

A \$15.00 outfit makes 50¢ profit on each hour's labor. Big demand for the product. Particulars free or 24 sample plans of concrete houses included for 25¢.

Queen City Brick Mch. Co. 417 Bank Building, Traverse City, Mich.

HAIR GROWS!

when our Vacuum Cap is used a few minutes daily. Sent on 60 days FREE trial at our expense. No drugs or electricity. Stops falling hair, cures dandruff. A postal brings illustrated booklet.

MODERN VACUUM CAP CO.
562 Barclay Block, DENVER, COLO.

Be Your Own Boss!

START A MAIL ORDER BUSINESS AT HOME. Devote whole or spare time. We tell you how. Very good profit. Everything furnished. No catalog outfit proposition. Write at once for our "Starter" and free particulars. **P. M. KRUEGER CO., 155 Washington St., Chicago, Ill.**

SECOND SECTION CLASSIFIED.

This is a continuation of the classified ads. For first section classified see pp. 21 to 25, inclusive.

AUTOMOBILES

FORD RUNABOUT OWNERS—Don't swear any more; order one of our commutator outfits; any one can put them on with our careful instructions. Your troubles are ended. Prices upon application. Good proposition for repairmen and garages. Write today. Auto Rebuilding Parts Co., 37 Franklin St., Newark, N. J.

FOR SALE, AUTO SUPPLIES—Magneto for Ford runabouts, with full instructions. No batteries. No trouble. Auto Rebuilding Parts Co., 37 Franklin St., Newark, N. J.

16 AUTOMOBILES—Second-hand, closed out at once; motor gears and parts. Send for bargain sheet prices; will surprise you. Write today. T. S. Culp, Canton, Ohio.

FOUR-CYLINDER light delivery truck, \$850; Stephens-Duryea 4-cylinder touring car, \$1,100; White Steamer, full equipment, \$850. Running gear complete with 30" wood wheels and 30x3" tires, \$55; Goodson magneto, \$12; Apple dynamo with governor, \$1,200; transmission gear suitable for 3 to 5 ton truck, \$25; about 50 other bargains in second-hand autos. Write for any make you want and save money. A. Trabold, Johnstown, Pa.

AUTOMOBILE BODY AND RUNNING GEAR for runabout, with top, lamps and horn; good as new, \$75. E. G. Olmstead, New Philadelphia, Ohio.

MOTORCYCLES

BRAN NEW Oliver or Williams typewriter and some cash for good motorcycle, Indian preferred. Give model, condition and difference wanted. Box 635, Lincolnton, N. C.

FOR SALE—New Curtiss 2-cylinder 5 hp. motor cycle engine, half price. Bates, 281 Oak St., Chicago.

FOR SALE—Two Indian motor cycles, with new G. & J. tires; late models and in fine condition. Write for particulars. Renner Repair Company, New Midway, Md.

"HIPKINS AUTOMATIC change speed pulley" for motor cycles. Automatically reduces gear for hills and sand. Fits all motors. Drawings and prices, address Advance Sales Co., St. Paul, Minn.

MOTOR CYCLE, NEW—Has been run less than 200 miles; machinery in perfect condition; tires new. First check \$60 takes it. Earl Severson, Box 78, Constantine, Mich.

"CONSTRUCTION, Management and Care of Motor Cycles," a new booklet, valuable to any rider, indispensable to the beginner, gives pointers to the prospective buyer that will save him dollars when selecting a Motor Cycle. Sent prepaid for 25c silver or stamps. Advance Sales Co., St. Paul, Minn.

BUSINESS OPPORTUNITIES

\$3,000 TO \$10,000 YEARLY easily made in real estate business; no capital required; we will teach you the business by mail, appoint you special representative of leading real estate company, list with you readily salable properties, co-operate with and assist you to permanent success; valuable book free. Address The Cross Company, 1165 Reaper Block, Chicago. See display ad of this firm on page 130.

ELEVEN HONEST BUSINESS PLANS and trade secrets, including plating process. A chance to be "your own boss" and make from \$15 to \$75 weekly. Circulars free. Ohio Enterprise Co., No. 280 W. Jefferson St., Springfield, Ohio.

I MADE \$50,000 in five years in the mail order business; began with \$5. Anyone can do the work in spare time. Send for free booklet; tells how to get started; Manager, Box 570, Lockport, N. Y.

FOR SALE

SPARK COILS. Data on 24 coils up to 12-in., 25c. Silverplating without battery, 25c. How to restore faded photographs, 25c. All three, 60c. No stamps. E. C. Peterson, 615 North Park Ave., Chicago.

FOR SALE—Separate bound volumes of Popular Mechanics for years 1906 and 1907. Price, \$2.50 per volume. Address Popular Mechanics, 100 Washington St., Chicago.

RIFE AUTOMATIC HYDRAULIC RAM, pumps water by water-power—no attention—no expense—2 feet fall elevates water 50 feet, etc. Guaranteed. Catalogue FREE. RIFE RAM CO., 2131 Trinity Building, New York City.

FOR SALE—Will sacrifice my 35 hp. five-passenger touring car; also runabout. Everything complete. Just been thoroughly overhauled. 29 E. Spruce St., Chippewa Falls, Wis.

FOR SALE—Patent "Color Photography" Process. R. Iseemann, 385 Bergen St., Newark, N. J.

CASTINGS AND DRAWINGS for the twentieth century $\frac{1}{2}$ -1-hp. horizontal high speed side crank steam engine, \$7.50. Circular A. B. R. Wicks, Bridgeport, Conn.

NEW SEVENTEEN Jewel Elgin watch, gold hunting case, fine gold fob, \$15; cost \$25. New Edison Phonograph outfit, twelve records, \$20; cost \$35. Ernest Denmore, Danville, Ill.

FOR SALE—Mitchell Motorcycle, 1 $\frac{1}{2}$ -hp.; tires in good shape and the running condition guaranteed. Price, only \$50. Thos. H. Boll, 25 North Clay St., Coldwater, Mich.

WE HAVE portable storage batteries, 2 to 8 volts. Write for particulars. Victor Storage Battery Co., 1536 W. Sixteenth St., Chicago.

FOR SALE—Lathe, foot power, rigged for iron, brass, wood, etc., Barnes, No. 4 complete. Chuck and full set tools go with it. A great bargain for some one. Address with stamp. H. G. Blaine, Chicago, Ohio.

FOR SALE—Castings for 2-cylinder vertical motor, 5 $\frac{1}{4}$ x6 crankshaft, fly wheel, cylinders and valves are finished, price \$40. Photo for six cents. H. A. Pixler, Marcus, Iowa.

FOR SALE—Launch patterns (Brooks), No. 7. Address 240, care Popular Mechanics.

SOLDERING ALUMINUM—I will sell you my own guaranteed formula for making solder for aluminum, or soldering brass, copper or iron to aluminum. Price, \$1. W. C. Loy, Rochester, Ind.

FOR SALE—Spanish language phonographic course complete, graphophone, records, and text books. Cost \$60. Price, \$25. R. T. Webster, 43 Triangle Building, Rochester, N. Y.

FOR SALE—Two hp. vertical steam engine, or will exchange for one hp. stationary gasoline engine. H. C. Thurston, 2205 Fifth Ave., Terre Haute, Ind.

FOR SALE—Launch 24x4" 6", 3-cylinder engine, 15 hp., guaranteed speed 16 miles. One launch 24x4" 4", 2-cylinder engine, speed 13 miles. Both nearly new; a bargain. For particulars, address A. J. Tooley, Baldwinville, N. Y.

HIGHEST GRADE alarm clock. Bell on back. Shut-off lever. \$1.50, prepaid. Babcock & Frost, Box 231, Chicago.

FOR SALE—Two hp. upright engine and boiler, new lines in boiler, engine in good repair. Price, \$60. W. P. Lloyd, Sterling, Kan.

FOR SALE—Launch patterns (Brooks), No. 7. Address 239, care Popular Mechanics.

FOR SALE—One Fairbanks-Morse gas engine, 6 hp., \$175; one horizontal gasoline engine, 4 $\frac{1}{2}$ x6, \$85; one Curtis, 1 $\frac{1}{2}$ x4", power pipe machine, \$85; one 3" steam engine governor, \$20; one $\frac{1}{4}$ to 2" hand pipe machine, \$25. Address Box 412, McConnellsville, Ohio.

FOR SALE—Nose bag, great feed saver. Will sell invention outright at once. Particulars. Address Harry Curry, Hudson Heights, N. J., Box 136.

FOR SALE—110 volt motors, $\frac{1}{8}$ to $\frac{1}{2}$ hp. Dynamos, two to ten light, finished or parts only. F. E. Averill, 28 Verplanck St., Buffalo, N. Y.

FOR SALE—Warehouse, wheat elevator and coal business. Warehouse can be used for blacksmith shop. Will rent to right party. No shop here. Wm. H. Seifert, Caborn, Ind.

PARADOX GAS ENGINE, 75c. 40-watt dynamo; some other bargains. Address Earl G. Asker, Campbellton, Canada.

FOR SALE— $\frac{1}{2}$ hp. vertical steam engine, in good condition. Price, \$15. Also one 75-watt dynamo, in good condition. Price, \$10. Write for photo. Otto Johnson, Box 33, Springdale, Ark.

FOR SALE—One new 100-watt dynamo, shaft connected to powerful water motor. \$10 if sold at once. P. C. Gunton, 941 O St., Washington, D. C.

NEED THE MONEY—Seven \$1 electric whistles, 50c each; 2 or more, 45c each. Entire lot, \$3. Gas cannon, worth \$3, 75c. Car motor, wheels, track, for toy railway, 50c, worth \$1.50. Address 241, care Popular Mechanics.

WORKING DRAWINGS for ten different articles in wood-burning or wood-carving, for 15c silver. Carl Rett, 895 Main, Akron, Ohio.

FOR SALE—Anything you want. If you want to buy or sell anything we can help you quickly, as we are in a position to know who has what you want or who wants what you have. New plan. Full particulars free. Postals ignored. U. S. Exchange Bureau, 11 N. Main St., Northville, N. Y.

FOR SALE—One 40 hp. gasoline engine, in good condition. Address W. H. Vander Hayden, Ionia, Mich.

\$12—1½ hp. vertical tubular boiler with grate, hood and all fittings. A 1 condition. A. E. MacCarter, 218 Spruce St., Reading, Pa.

AUTOMOBILE and marine motors, new, for either gasoline or kerosene. Two-cylinder copper water jacket, 20 hp., \$68. Box 224, St. Anne, Ill.

FOR SALE—4½ hp. engine, complete with coil, carburetor, pump and radiator. Fine running order. \$60. A. W. Banister, 629 East Tenth St., Erie, Pa.

FOR SALE—Engine lathe, swings 9½ in., takes 25 in. between centers. Complete with full set change gears to cut all size threads, 3 to 40 in.; price only \$43.50. Address L. F. Grammes & Sons, Allentown, Pa.

SALE OR EXCHANGE

20"—8' lathe for auto or launch, also graphophone and records for field glass or small motor. Box 143, Clear Lake, Iowa.

FOR SALE OR TRADE—One "Maestro Piano Player" and seven rolls music; mahogany; slightly shop-worn; cost \$125; sell for \$30. Claude Dix, New Philadelphia, Ohio.

FOR SALE OR EXCHANGE—1-15 hp. electric motor. Address 238, care Popular Mechanics.

FOR SALE OR EXCHANGE—1906 model 60 National electric runabout in first-class condition. Consolidated Electric Co., Nashville, Tenn.

FOR SALE OR EXCHANGE—For 10 to 20 light dynamo 1-12 hp. D. C. Crocker-Wheeler motor, 115 volts; one \$20 Eastman folding kodak, 3A, 3¼x5½, new. J. L. Portz, Fosteria, Ohio.

FOR SALE OR EXCHANGE—For 2 to 8 hp. gasoline marine engine one 303 Savage ride with extra fine engraving and checking; also \$30 worth of extras, such as loading tools, belts, cases, cartridges, etc. This is a bargain as it is in A-1 condition. I also have an Eastman No. 1 kodak; has been used only a few times. Raymond B. Thompson, Potsdam, N. Y.

FOR SALE OR TRADE—22 hp. undermounted Double Star engine. Write for particulars. R. H. Funk, Macon, Ill.

WANTED

WANTED—Second-hand marine steam engine and boiler, 2 or 3 hp. Jas. M. Ballantyne, Hobart, Ind.

WANTED—Why pay big prices to have your machine work done? We will do it for 35c per hour. New Philadelphia Machine Co., New Philadelphia, Ohio.

WANTED—Steam locomobile, runabout body. Clement Wegeng, Norborne, Mo.

WANTED—An opportunity to submit estimate on articles you want manufactured. Small sheet metal articles a specialty. The Strock Manufacturing Co., Garrettsville, Ohio.

WANTED—9 or 11-inch Star lathe; also Press Vise, etc. Hedderich, Mulberry, Ind.

MALE HELP WANTED

GOING WEST? Want a position? State what you want. Big list of employers' names, \$1. A. J. Matter, Commonwealth Bldg., Portland, Ore.

MEN WANTED—For locomotive firemen or brakemen; no strike; experience unnecessary; railroads in this vicinity; \$75 to \$100 monthly; rapid promotion to conductor or engineer, \$150 to \$200 monthly. Call Railroad Recruiting Station, Rooms 416-17, fourth floor, take elevator, 23 Quincy St., Brooklyn, N. Y.

WANTED—Draftsmen and others to sell "slide rule reference tables" among draftsmen and others; 6 samples 60 cents. A. J. Matter, Commonwealth Bldg., Portland, Ore.

PATENTS FOR SALE

PATENT OF GREAT UTILITY—Strictly novel, issued July 7, 1907; money maker; requires some money, brains and energy. Will sell. Anything to get started. Full particulars by addressing W. A. Giboney (Patentee), Mineo, Okla.

AGENTS WANTED

AGENTS, TEACHERS, STUDENTS—Here's your opportunity. Shoes for flatirons; new device to iron with; sells like hot cakes, \$5 daily easily made; spare time valuable; investigate; begin at once, you can not lose; it's a winner. Information free. Dexter Supply Co., 334 Dearborn St., Chicago.

AGENTS—\$300 every month selling wonderful 7-piece kitchen set. Send for sworn statement of \$12 daily profit; exclusive territory. Outfit free. P. Thomas Mfg. Co., 162 H St., Dayton, Ohio.

AGENTS make \$103.50 per month selling wonderful self-sharpening patented scissors and cutlery. V. E. Glebner sold 22 pairs in 3 hours, made \$13; you can do it. We show you. Free outfit. P. Thomas Mfg. Co., 162 H St., Dayton, Ohio.

WANTED—Capable agents to handle new, high grade, up-to-date articles; lightning sellers in all homes, offices, stores, shops; \$3 to \$10 daily guaranteed. Promotion assured. P. Thomas Mfg. Co., 162 H St., Dayton, Ohio.

AGENTS WANTED—Men, women, boys, girls everywhere; particulars free. C. M. Turnquist, 757 N. Lawndale Ave., Chicago, Ill.

LIVE AGENTS wanted to sell razor paste. Sample 10 cents. J. H. Murray, Racine, Wis.

AGENTS—\$150 per month easily made selling my new patent floor mop. Sells like wildfire. If you want a crackerjack article write to E. Hilker, 371 Grand Ave., Chicago.

AGENTS—Everybody delighted and will buy from one to 25 sets; send 15c for samples; words and scenes of the Lord's Prayer on eight gilt embossed postal cards. Frontenac Co., 2015 Fairmont Ave., Philadelphia, Pa.

AGENTS' MONEY MAKER—Sell the "Eureka Door Knob Bell," patented. New bronze metal, anyone can put on. Write for agency and sample. F. B. Black Co., Kansas City, Mo.

WE WANT a representative in every store, shop and factory. Good pay, without loss of time. Manager, Drawer Z, Chicago.

WANTED—Agents to sell our tools to mechanics. Send \$1.25 for sample of pinch bars, cold chisels and punches. Flynn Pinch Bar Mfg. Co., Morris, Ill.

BURGLAR PROOF—Greatest thing of the age; windows locked with 6-inch opening; put on in one minute; send for sample, 15c each. Agents wanted. Cannon Mfg. Co., 1322 Kenmore Ave., Chicago, Ill.

MACHINIST AND DRAUGHTSMAN'S table of standard, steam, gas and water pipes and tapping sizes, 10 cents per copy. Shop agents wanted everywhere. E. E. Meyer, Allegheny, Pa.

PICTURES AND POSTCARDS

ONE DOZEN PHOTO POST CARDS made from any photograph for 50 cents. Your photograph returned with order, postpaid. All work guaranteed. Enough said. Give us a trial. Photo Card Co., 395 W. 17th St., Chicago, Ill.

TWENTY-FIVE DIFFERENT POST CARDS given with a six months' subscription for 25c to largest and oldest 100-page monthly on Coins, Stamps, Post Cards, Curios, Minerals, Photographs, Relics, Old Books. Collectors' World, Superior, Neb.

EDUCATIONAL AND INSTRUCTION

LEARN MORE AND EARN MORE. We teach Law, Engineering, Oratory, Advertising, Business Correspondence, Short-Story Writing and 150 others. Best school on earth. Small cost. Easy payments. Ask for catalog 10 and name course wanted. Intercontinental University, Washington, D. C.

LUBRICANTS

LUBRICANTS, asbestos, graphite and mica candles for loose pulleys and shaftings; no drip; no dirt; economical. Swain Lubricator Co., 250 E. Lake St., Chicago.

MISCELLANEOUS

NEW IDEAS PROPERLY DEVELOPED bring greater wealth than any science, industry or profession. Read the advertisement headed "New Inventions" on page 120 of this magazine.

"**TAT'S GRIT SOAP**" is the only soap that will remove any kind of dirt from the hands without injury. Shop agents make big money selling to fellow workmen. Send \$4 for a 6-dozen case and make \$3.20 clear. We guarantee the sale or money refunded. This offer good only thirty days. Sample and circular for 10 cents. Tatlock Bros., Rochester, N. Y.

"**LET US HAVE FACTS**, real, certain, unmistakable facts; there can be no Science without them."—Robert Dick, Trade Secrets for sale. The ten formulas listed below can be obtained for 25 cents (silver) each, or the entire set for \$2: 1—Celebrated French Polish. Cannot be excelled as a finisher for Pianos and Furniture. 2—Formula for rendering wood indestructible. 3—Formula for deodorizing (removal of odor) from benzine. 4—Formula to prevent steel from rusting (never known to fail). 5—Formula for coppering the surfaces of steel, iron or iron wire. 6—Chemical process for the prevention of corrosion in lead pipes. 7—Process for preventing explosion of lead when pouring same around damp or wet joints. 8—Formula for the making of artificial meerschau (difficult to detect from original). 9—Chemical compound for writing inscription on metal or glass. 10—The U. S. Government tempering process for imparting extraordinary hardness and durability to the poorest kind of steel. The second issue (5,000) of these formulas is now going to print, the first edition of 5,000 being nearly exhausted. Over 650 copies of each number were requested last month by students in Chemistry, Physics, Mechanical and Electrical Engineering of two well-known Technical Institutes in New York City. Send order at once to Crawford Experimental Laboratories, No. 2108 West 20th St., Chicago, Ill.

FOR \$2.50 I will send you, express prepaid, six only, new 10-in. Disc Talking Machine Records. If they are not as good as what you pay 60c for will refund your money. L. M. Peterson, Stanchfield, Minn.

WILL PAY CASH for phonograph outfit. Address Geo. Slegel, Huron, Ohio.

MAGIC TRICKS.—Our latest illustrated book tells you how to do all kinds of tricks. GET ONE and shine as a star entertainer among your friends. Price only 25c. Send for catalog. Peerless Trick & Novelty Co., 3148 State St., Chicago, Ill.

HOUDENE PUZZLE, the wonder of the age, 12c. "Rabbit," "Sweetheart," "Keys," "Flanagan," "Links," "Tantalus," "Spider Web," and "Rat Trap" Puzzles, 10c each. Wizard's Trick Cards, 25c. Rubber Snakes, 25c. "Cachoo" (it makes people sneeze), 12c. Set Chessmen, 37c. Games "Pit" or "Finch," 50c each. Japanese Spiders, 15c. Skate Sharpeners, 17c. All postpaid. O. K. Pub. Co., 719 North Water, Decatur, Ill.

SWEDENBORG'S "Heaven and Hell," four hundred pages, postpaid for only fifteen cents in stamps. Pastor Landenberger, Windsor Place, St. Louis, Mo.

EVERYONE INTERESTED in Constructive Engineering should send 50 cents for our Introduction to that Science. Just out. The Mechanics' Correspondence School, Box 455, Lockport, N. Y.

CONTRACTING MANUFACTURERS names wanted. Glassware, Tools, etc. Address 236, Popular Mechanics.

CEMENTING METALS UPON GLASS, wood or marble, iron upon iron, leather or stone. Directions, 25c each. Address 237, Popular Mechanics.

AN AIRSHIP FLIGHT is the most popular and drawing attraction for any fair or outdoor event. Cromwell Dixon, 15 years of age, who flew 8 miles at St. Louis in October, 1907, is building a much larger ship for the season of 1908. For particulars and open dates address Mrs. Dixon, 221 West Eleventh Ave., Columbus, Ohio.

WE WILL double \$30.00 for you in 90 days and pay 20 per cent royalty for five years. Particulars for stamp. The Marzian and Gutterman Co., Co-Operative Music Publishers, Louisville, Ky.

LIGHT METAL SPECIALTIES of sheet steel and brass. Stamping, drawing and die work. Prompt service. Send sample for estimate. George C. H. Kredel, manufacturer of metal goods, 80 Tracey Ave., Newark, N. J.

THEY WORK WHILE YOU SLEEP. Talking Scales. "They Speak Your Weight." The invention of the century. Fortunes have been made operating automatic weighing machines. Write to-day. United Vending Machine Co., 629 Caxton Bldg., Cleveland, Ohio.

SEND 25 CENTS in coin for complete blueprints of 2½ hp. motorcycle or marine engine. Woodward Engineering Co., 6607 So. Halsted St., Chicago.

MACHINISTS! DRAFTSMEN! 10 cents (silver) gets the following tables: Standard screws, nuts, bolts, sizes of twist drills, ¼-in. to No. 80; power to drive rivets and two other good ones. Mech. Drawing Co., Box 386, Davenport, Iowa.

AUTOMOBILE BARGAINS: We can save you from one hundred to five hundred dollars on a slightly used or secondhand Automobile. Our assortment is the largest and our prices the lowest. Complete list mailed free. The Starin Company, 1094-1100 Main St., at St. Paul St., Buffalo, N. Y.

PRINTING—100 envelopes, 50c, postpaid. 100 letter-heads, 50c. 100 calling or business cards, 35c. Other prices proportionately low. Send for samples. Joe C. Patterson, Princeton, Ind.

RECEIPTS—Household, Medical and Trade. Write your wants to J. E. Barnum, Room 7, 318½ N. Main St., Hutchinson, Kan.

LEARN HOW to open any padlock instantly without a key. I will send secret and guarantee it to work perfectly for 50 cents. Jos. McDonough, 2610 Eighth Ave., Altoona, Pa.

BARGAINS—Set of either instrument or switchboard telephone circuits for 50c. Both for \$1. Reardon, 20 Covert St., Brooklyn, N. Y.

DON'T FEAR PANIC. Send 10 cents for "Money Making Secrets." Follow instructions and become independent for life. Box 480 Cayahoga Falls, Ohio.

FOR WOOD and Metal Patternmaking and Model-work figure with W. F. Peeler, Goshen, Ind.

MAKE YOUR OWN FURNITURE from our full size patterns. New plan. Simple and easy. Send ten cents for sample pattern of Bookrack or Candlestick and illustrated catalogue showing other pieces. The Home Furniture Pattern Co., 2016 First National Bank Building, Birmingham, Ala.

NOTICE—3,000 Priceless Recipes for everybody. Mechanics, farmers and people in all walks of life. Up to date. Price, \$1.00. Elegantly bound. Retlaw Book Co., 905 Fulton St., Chicago.

TOO LATE TO CLASSIFY

GET YOUR GAS AND ELECTRIC FIXTURES at wholesale prices, and save big money. Put them up yourself and save more money—it's easy. Or get your local gas fitter or electrician to put them up for you, and still save good money. Write for our catalogue sheets and see. State whether you want gas only, or combination gas and electric fixtures. Western Chandelier Co., Mail Order Department, 19 West Lake St., Chicago.

AUTOMATIC DOUBLE COMB, 25c; cuts hair more even than barbers. Write for illustrative circular. Hodge Mfg. Co., E. Bethany, N. Y.

STEEL STAMPS, Seals, Door Plates, Embossing Dies, Sawed Monograms, Photographers' Presses, Plain Name Cuts. (Correspondence invited.) J. Kiola, Engraver, 155 West Madison St., Chicago, Ill.

WE MAKE miniature automatic steam power plants for driving model boats, small dynamos, etc. They are the very best power for the purpose, and sell for \$10.50 complete, ready to run. Engine only \$5.00. Boiler and all accessories, \$5.00. Miniature marine fittings made to order: 3½-inch screw propeller, 25c. O. N. Hansen, No. 183 Du Boise Ave., Elgin, Ill.

MAKE that little steam engine now. Castings and all material for either marine or horizontal engine of 1-inch stroke and ¾-inch bore, \$1.00. Working blueprints, 25c. O. N. Hansen, No. 183 Du Boise Ave., Elgin, Ill.

1,000 POST-CARDS, 20c. Join our BIG Club and you will receive cards from all over the world. Eclipse Novelty Co., Dept. 1 C. Rochester, N. Y.

MODEL AIRSHIPS, 50 cents. Complete set of blueprints and directions for making inexpensive and easily-made model airship. This little machine offers a splendid opportunity for studying the fascinating problem of aerial navigation. Of profound interest to the master mechanic as well as the amateur experimenter. P. Ganz, Box 951, Billings, Mont.

**FREE**

This \$13.85
**DRAWING
OUTFIT**

See offer, page 123 of
Successful Draftsmen

This
Book
is
FREE



Make Your Future Sure

Earn \$3000 to \$5000 a Year

Booklet That Tells All is Free

Ambitious Men and Women, Make Your Future Sure. You Can.

In a few months' time, by home study without interference with your present occupation, you can have at your fingers' ends a profession of class and elevated degree that will make you forever superior to position-hunting and position-holding.

In a few months' time you can prepare yourself to face the future with a mind calm and content in the knowledge that you possess a new skill of brain and hand that will unfailingly produce enough income to enable you to live elegantly for the rest of your life.

In a few months' time you can raise yourself socially to a level with the best people in the community by becoming a recognized professional man or woman, a Doctor of Mechano-Therapy; lay the foundation of a future fortune and start to build up a practice in one of the most delightful and fascinating callings imaginable.

Learn Mechano-Therapy — Earn \$3000 to \$5000 a Year.

Any man or woman of ordinary common school education may come to this college and learn in class or be taught with the greatest success at his or her convenience at home by mail the principles and practice of this absorbing and elevating profession that is simpler and more effective than Osteopathy and which has the unqualified endorsement and active support of the medical profession.

Write us at once and we will send you a large illustrated book that tells all about Mechano-Therapy; tells why it offers an ideal opportunity for those without capital to rise financially and socially; tells why men and women succeed in it so quickly and gives the names and photos of a number; explains how we guarantee success in the study of this splendid calling, describes the authorized diplomas granted our graduates, and explains the reasonable cost of tuition and the convenient terms of payment.

Write for this book now—while special rates for tuition are in force—it is sent free and prepaid to the address of any man or woman in the world.

Do this at once and learn how you may become in a few months really and actually independent in future of any chance of financial misfortune or distress—address

THE AMERICAN COLLEGE OF MECHANO-THERAPY
DEPARTMENT 475 . — 120-122 RANDOLPH STREET. — CHICAGO, ILLINOIS

**PANIC
IN
WATCHES**

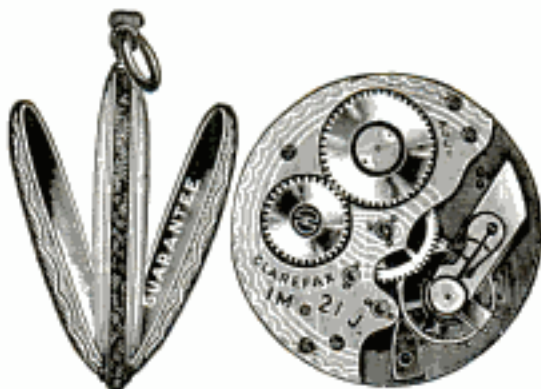

**Genuine
Clarefax
Watch
\$5.45**

WHEN the tight-money panic struck the country last November, one of the world's biggest and best manufacturers of watches was put in a bad way for money. He needed money just as bad as you need air to breathe. He simply had to have it. The banks tightened up and called in their loans and wouldn't make any more. They wouldn't let him have money. He had just one way of getting it. That was to sell off at once, at any price, the great stock he had made up for the winter trade. These 10,000 watches were his only hope, and he sold them to us at a price that was almost like giving them away. But we gave him the money he had to have and we got the watches at our own figure, and that's why we can sell you a **\$20 WATCH FOR ONLY \$5.45**. This is a genuine Clarefax watch, made to sell regularly in stores for \$20. We are not trying to exaggerate. We don't want to tell you the watch is a \$40 watch or a \$50 watch because it isn't, but it is a real \$20 Clarefax, and when we sell you such a watch for only \$5.45 that's the greatest real bargain ever offered in watches in America. But we are satisfied with a small and quick profit.

This Clarefax Watch which we will sell you for **\$5.45** is an im. 21 jeweled, finely balanced and perfectly adjusted movement. It has specially selected jewels, dust band, patent regulator, enameled dial, jeweled compensation balance, and handsomely engraved. Each watch is thoroughly **double hunting case, genuine gold-laid** and regulated before leaving the factory, and both the case and movement are **GUARANTEED FOR 20 YEARS**.

These watches will certainly sell fast, so you'd better send in for yours at once. Clip out this advertisement and mail it to us today with your name, postoffice address and nearest express office. Tell us whether you want a lady's or a gent's watch (we have large and small sizes in both) and we will send the watch to your express office at once. If it **SATISFIES** you after a careful examination, pay the express agent **\$5.45 AND EXPRESS CHARGES** and the watch is yours, but if it doesn't please you, return it to us at our expense.

A 25-YEAR GUARANTEE

will be placed in the front case of the watch we send you and to the first 10,000 customers we will send free a beautiful gold-laid watch chain charm.

NATIONAL CONSOLIDATED WATCH CO. Dept. 733 CHICAGO

Please Mention Popular Mechanics

This Magazine Invites You

TO JOIN OUR HISTORY CLUB

Just send your name and address on the coupon below, that is all you need to do to become a member. It does not cost one penny and as soon as your name and address is received a set of the World famous Library of Universal History will be sent to you prepaid.

HERE is the greatest opportunity ever offered — an opportunity for our readers to secure at less than half price these fifteen beautiful volumes all printed from large new type, embellished with over 100 double page maps and plans, 700 full page illustrations, many of which are in colors, and over 5,000 pages of reading matter.

This offer is made possible by the failure of the publishers, The Union Book Co., of Chicago, and knowing this magnificent work has been selling at \$56.00 a set, we gladly agreed with the receiver of this Company to form a Club among our readers and take 150 sets at the rock-bottom bankrupt price of only \$24.50 and extend terms to our readers of 50 cents down and \$2.00 per month for twelve months, believing that not only 150 but perhaps 500 of our readers would be glad to take advantage of such an exceptional opportunity; however we are promised only 150 sets, therefore suggest your writing us at once.

Before you decide to buy we invite you to examine this work in your own home for an entire week absolutely free of charge, and should you not want the books after examination we will have them returned at our expense. We earnestly request you to examine this Library; let your wife and children and friends see it. No better set of books could be placed in the hands of children than this; it reads like a thrilling novel, and is in fact a complete connected History of every country, nation and people from the beginning of time to the present year; the greatest World History ever written and endorsed by scholars everywhere.

Prof. George Fellows, of Indiana, says: "Most histories of the World are dreary compilations. This work, however, is clear, interesting and accurate."

Ex Vice-Pres. Stevenson says: "It is a complete record of the human race and should find a place in every Library."

E. Benjamin Andrews, Chancellor of the University of Nehr., says: "Its educational value in the home is sure to be very great."

Rev. Frank W. Gunsaulus, of Chicago, says: "These volumes will be of immense service in stimulating history study in our country. It is a work of real genius."

Prof. Dabney, of Virginia, says: "Southern readers will be gratified at the impartial spirit in which the war for Southern independence is treated."

The St. Louis Globe Democrat says: "This work invests the study of History with a new charm that will be felt by both young and old."

15 Massive Volumes

Each volume 7 inches wide and 10 inches high; weight, boxed, nearly 75 lbs.

NEVER BEFORE in the annals of the publishing business have we seen such a bargain. We do not hesitate to recommend this offer to every reader of this magazine; indeed we believe every family should own a standard World History, for by knowing how other countries than ours are governed, it gives us a better knowledge and higher appreciation of our own system of government and makes us better citizens.

We will be glad to give you an opportunity to see for yourself and make your own decision after you have seen the beautiful binding, the magnificent illustrations and have read parts of this great History of man on earth. Then you can decide. Should you not wish to keep the work you will notify us and we will have it returned at our expense.

The illustration of the books given here does not do them justice; you must see them to realize what they are. You assume no obligation to us or any one else by making this request, you simply ask for a free examination in your own home without paying any one anything, and remember, too, this bankrupt rock-bottom price of \$24.50 for this \$56.00 Library has been made possible only on account of the failure of the Union Book Company, thus necessitating a receivers' sale at a price which barely covers the cost of the paper and binding.

MAIL THE COUPON

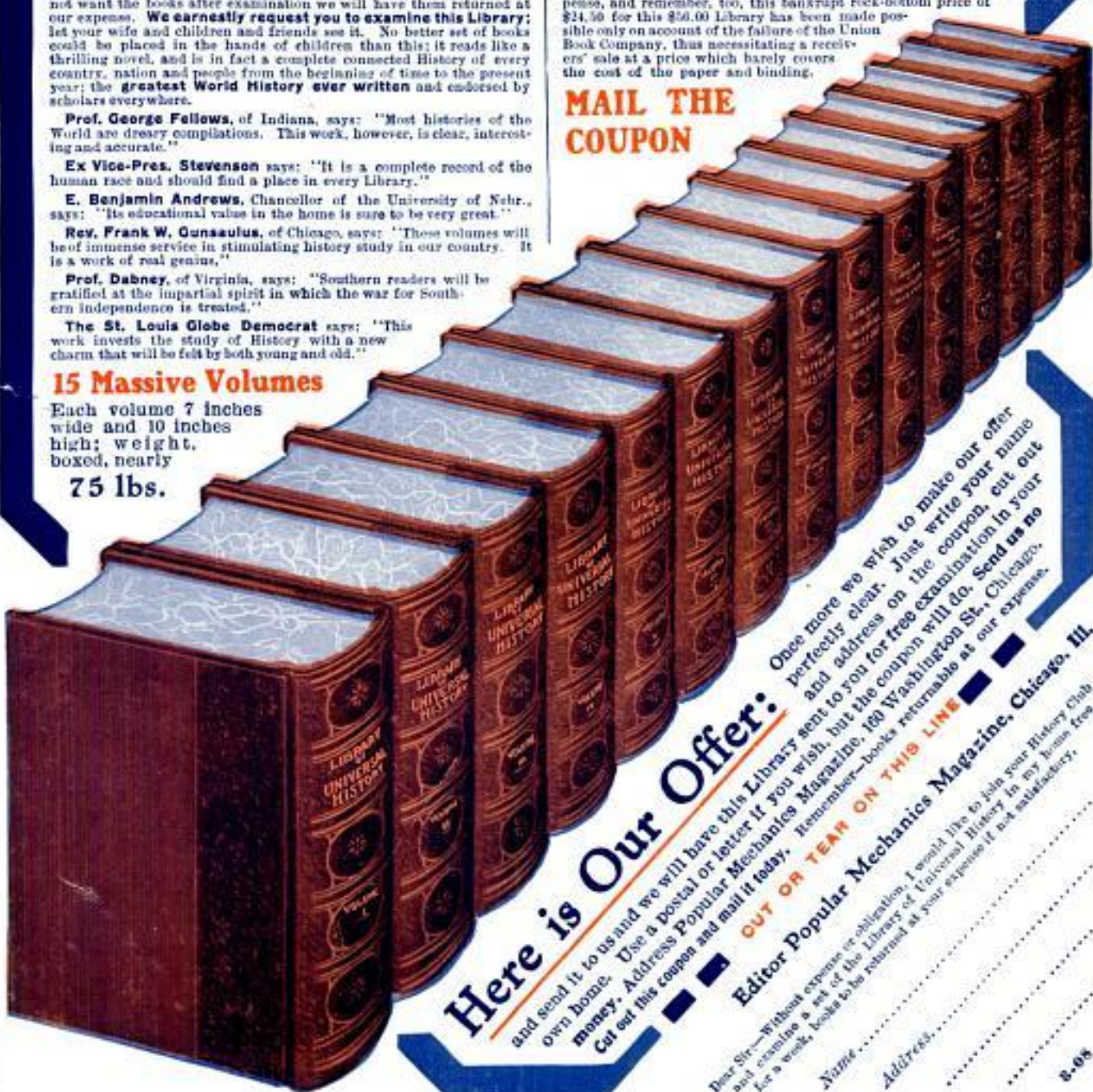

Here is Our Offer: Once more we wish to make our offer perfectly clear. Just write your name and address on the coupon, cut out and send it to us and we will have this Library sent to you for free examination in your own home. Use a postal or letter if you wish, but the coupon will do. Send us no money. Address Popular Mechanics Magazine, 160 Washington St., Chicago. Cut out this coupon and mail it today. Remember—books returnable at our expense.

OUT OR TEAR ON THIS LINE

Editor Popular Mechanics Magazine, Chicago, Ill.

Dear Sir—Without expense or obligation I would like to join your History Club and examine a set of the Library of Universal History in my home free for a week, books to be returned at your expense if not satisfactory.

Name

Address

Everybody using
Electric Current
needs this



CURRENT TAP

Fits into lamp socket. Carries the current from any electric light fixture to portable lamp, drop light, motor, solder-iron—in fact any electrically operated device—without disturbing light from lamp already in socket.

Plug can be detached by pulling cord at any angle, leaving body of socket undisturbed.

Price, with 10 feet Lamp Cord 75 cents
Price, without Cord 30 cents
Postage extra.

Electrical Supplies

Highest Standards Maintained—Prices Right

"MESCO" ELECTRIC ENGINE for the boys Postpaid \$1.10
"MESCO" DRY BATTERY for door bells, etc. Each 15 cents
"RED SEAL" DRY BATTERY for ignition, etc. Each 25 cents

If you can't buy "Mastro-Made" goods locally, buy from the manufacturers' immense stocks. You want the best for your money. Get what you want when you want it.

Ask for Catalog No. "22 P. M." today
You will need it tomorrow. Contains 750 illus.—144 pp.

"Something Electrical for Everybody"
at prices everybody is willing to pay

MANHATTAN ELECTRICAL SUPPLY CO.

17 Park Pl., New York 188 5th Ave., Chicago

Largest Exclusive Mfrs. of Electrical Supplies in America



A SAFETY RAZOR SENSATION "SHRP SHAVER"

Price
25c
In Cash

Or
13-2c
Stamps



5
Extra Blades
25c.

Shrp Shavr
Stropper
10c.

EASY TO SHAVE

Because the Blade is the best money can buy. The Frame is made at the proper shaving angle which gives the best result and insures safety.

EASY TO ADJUST

The Blade slides into the right side of Frame. Is held rigid. Cannot work loose or fall out.

EASY TO CLEAN

The Frame is made of highly finished nickel steel, in one piece; can be readily washed and dried.

EASY TO BUY

A Sensational Price; Razor, 5
Extra Blades and Stropper **60c**
The COMPLETE OUTFIT **60c**

"The Razor at the Top"

We guarantee satisfaction or money refunded
You can make money as our agent

CLEMENS SCHROEDER CO., 320 Broadway, NEW YORK

Utica Giant Button's Plier

The strongest, the handiest, the most powerful and the easiest cutting tool of its kind.

Can be used as a pipe grip, a flat-nose plier, and a wire cutter. It has four wire cutters, two of which are so designed that the wire is held between the jaws after cutting.

A Handy
Plier
That
Everyone
Should
Have



TOOLS
OF QUALITY
ARE STAMPED



Only the genuine
bear this mark. It's
a guarantee of quality

Write for Plier Palmistry
and Catalog

UTICA DROP FORGE & TOOL CO.

73 Genesee Street, :: UTICA, N. Y.

HOW TO RUN AN AUTO



Are you interested in
Automobiles?

If you are, an early purchase of "HOMANS' SELF PROPELLED VEHICLES" will prove a good investment.

This work is now the accepted standard on the practical care and management of motor cars—explaining the principals of construction and operation in a clear and helpful way, and fully illustrated with many diagrams and drawings.

The presentation of subjects has been determined by consideration of the needs of the man behind the wheel. It is clear and concise in its treatment, and comprehensible to the most inexperienced automobilist, at the same time it is so thorough that the expert will learn much from its pages.

Contains 608 pages, over 400 diagrams and illustrations, printed on fine paper, size 5 1/2 x 8 1/2 inches, with generously good binding. Highly endorsed.

This good book will be sent to any address in the world, postpaid, upon receipt of two dollars, or if desired, will be sent on approval to be paid for after examination.

No money in advance required, sign and return
This book will be sent to any address in the world, postpaid, upon receipt of two dollars, or if desired, will be sent on approval to be paid for after examination.
Factory I will immediately remit \$2.00 to you
AUDEL & CO., 63 Fifth Ave., New York
NAME.....
ADDRESS.....
CITY.....
STATE.....
DATE.....