

JANUARY

THIS ISSUE 133,000

10 CENTS

POPULAR MECHANICS

WRITTEN SO YOU CAN UNDERSTAND IT

PUBLISHED IN CHICAGO

LARGEST CIRCULATION OF ANY MECHANICAL PUBLICATION IN THE WORLD

Proposed Waterway Lakes to Gulf

1,625 Miles Long—To Cost \$125,000,000

Touch a Button: Electricity Does Housework

Cooking, Cleaning, Washing and Sweeping Made Easy

The French Distill Perfumes at Home

With Small Portable Stills Suitable for Making Denatured Alcohol

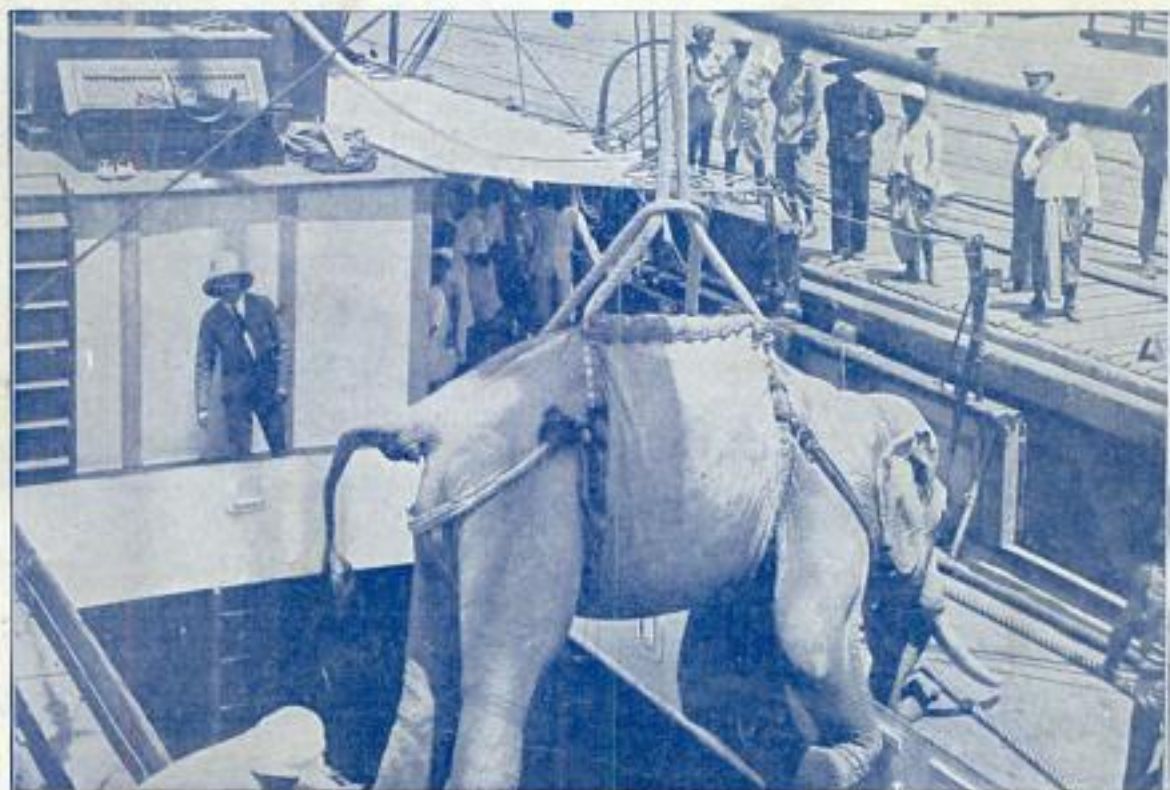

"SHOP NOTES FOR 1908" NOW READY—PRICE, 50 CENTS—ASK YOUR NEWSDEALER

Copyrighted material



Earn \$25 to \$75 a Week
I Teach You Watch Repairing FREE By Mail

give you a diploma after graduating by the Elmore System, and help you, as I have hundreds of others, to start a successful business of your own, paying from \$25.00 to \$75.00 according to your capabilities. Act now—today. Write me at once and be the one in your neighborhood to get my

FREE SCHOLARSHIP IN WATCH REPAIRING

This is one of the cleanest, easiest, most interesting and most profitable professions in the world. Don't work for small wages when you can master this art without a penny of expense for my instructions. By steady application you can graduate from my Watch Repairing College and be ready to start a shop of your own inside of three months. All text books, diagrams, photo illustrated charts, etc., absolutely free. Don't put off writing to me for particulars and Lesson 1F. For a 2-cent stamp you can find out how to get a start in a good paying business.

CHAS. F. ELMORE, Principal,
 Correspondence College of Watch Making
 Rogers, Thurman & Co., Props. 39 Michigan Ave., Chicago

DRAW

A HIGHER SALARY

Why exist on low wages when a little spare time mail instruction will positively qualify you for A Higher Salary?

MECHANICAL DRAWING LEADS TO ENGINEERING SUCCESS

The demand for draftsmen in mechanical and electrical engineering always exceeds the supply because the frequent promotions make vacancies. We guarantee that any ambitious young man, without previous experience can complete our course and successfully fill a well-paid drafting room position.

OUTFIT FREE

to all enrolling through this ad. Prices low. Terms easy. No books or instruments to buy. 100 courses prepared by experts in Mechanical, Electrical and Civil Engineering. Languages, Law, Oratory, Correspondence, Real Estate, Advertising, Agriculture, etc. Write now for free Catalog 110, stating what profession interests you.

INTERCONTINENTAL UNIVERSITY
 1412 L Street,
 Washington, D. C.

Founded by Mathew Carey, 1785.
 A House in touch with Three Centuries.
THE PIONEER INDUSTRIAL PUBLISHERS OF AMERICA.

HENRY CAREY BAIRD & Co.
 Industrial Publishers, Booksellers and Importers
 810 Walnut Street, Philadelphia, Pa., U. S. A.

Our new and Revised Catalogue of Practical and Scientific Books, 36 pages, 8vo. (March 1, 1907); Catalogue of Chemical Technology and General Chemistry, July 1, 1905 (New and Up-to-Date); a Catalogue of Books on Metallurgy, Mining, Prospecting, Mineralogy, Geology, Assaying, Analysis, etc.; a Catalogue of Books on Steam and the Steam Engine, Machinery, etc.; a Catalogue of Books on Sanitary Science, Gas Fitting, Plumbing, etc.; and our other Catalogues and Circulars, the whole covering every branch of Science applied to the Arts, sent free and free of postage to any one in any part of the world who will furnish his address.

VALUABLE BOOKS ON MINING, PROSPECTING, MINERALOGY, ASSAYING, ETC.

ERNI AND BROWN.—Mineralogy Simplified: Easy Methods of Identifying Minerals, including Ores, by means of the Blow-pipe, by Flame Reactions, by Humid Chemical Analysis, and by Physical Tests. By Henri Erni. Third Edition, revised, with entirely new matter, including Tables for the determination of Minerals by Chemical and Pyrognostic Characters and Physical Characters. By Amos P. Brown, Ph. D., Prof. Univ. of Pa. 96 engravings, morocco \$2.50

LIEBER.—The Assayer's Guide, or Practical Directions for Assayers, Miners and Smelters, for the Tests and Assays, by Heat and by Wet Processes, of the Ores of all the Principal Metals of Gold and Silver Coins, Alloys, and Coal, etc. 12mo. 11ls. \$1.50

ORTON.—Underground Treasures; How and Where to Find Them. A Key for the Ready Determination of all the Useful Minerals within the United States. New Edition, with Ore Deposits and Testing Minerals with the Blow-pipe. 11ls. \$1.50

OSBORN.—The Prospector's Field Book and Guide in the Search for and Easy Determination of Ores and other Useful Minerals. By Prof. H. S. Osborn, LL.D. Illustrated by 66 engravings. Seventh edition, revised. 12mo. (1907) - \$1.50

Elaborate Illustrated Circulars of the above Books mailed to anyone in any part of the World who will furnish his address. The above books sent by mail free of postage at the publication prices to any address in the world.

HENRY CAREY BAIRD & CO.
 Industrial Publishers, Booksellers and Importers
 810 Walnut Street Philadelphia, Pa., U. S. A.

HERE THEY ARE!!

Wireless Telegraphy FOR AMATEURS

A handbook on the principles of Radiotelegraphy and the Construction and Making of Apparatus for Short Distance Transmission.

By R. P. HOWGRAVE-GRAHAM, 160 pages, 8 illustrations, 12 mo., cloth Price \$1.00

Flying Machines

A popular account of Flying Machines, Dirigible Balloons and Aeroplanes.

By A. W. MARSHALL and HENRY GREENLY 128 pages, 24 illustrations and 23 page plates 12 mo. cloth Price 50c

Inventions HOW TO PROTECT SELL and BUY THEM

Practical, Concise. Everyone interested will find this book of value.

By FREDERIC WRIGHT, Patent Attorney. Price 25c

SPON & CHAMBERLAIN
 123 P.M. LIBERTY ST., NEW YORK

THE

Naval Training Stations

receive young men between 17 and 25 years of age, and give them a course of instruction fitting them for the duties of seamen, preparing them for advancement in the Naval Service. Young men with an aptitude for a mechanical trade may be given special instruction before being assigned to a sea-going vessel.

Pay while at the Training Station, \$16 a month, with wholesome food, lodging, medical attention and \$60 outfit of uniform free. This pay is increased when the men finish the instruction.

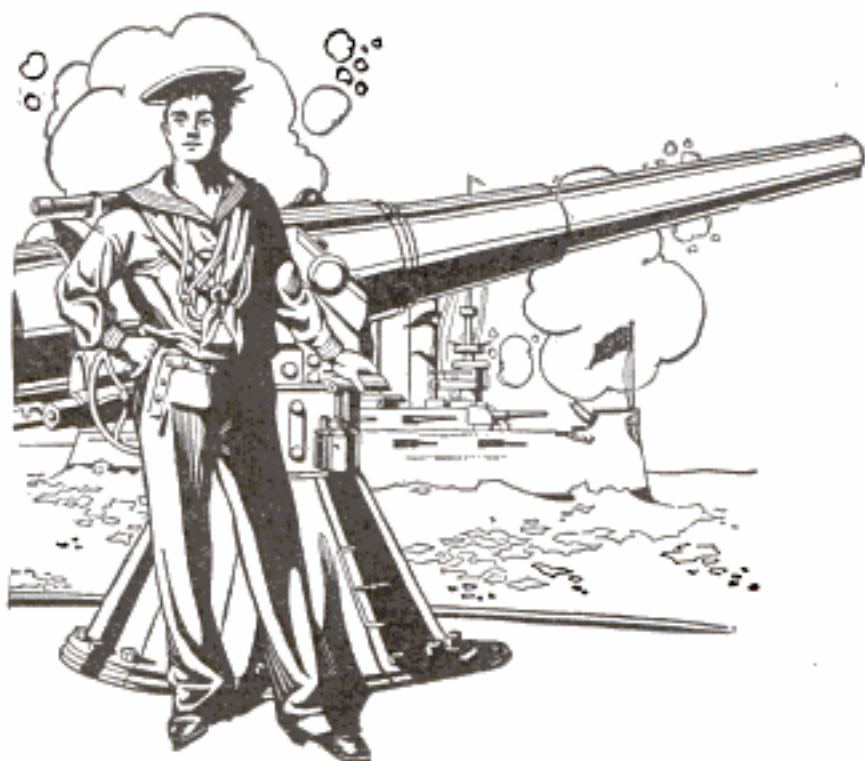

Every facility for athletics and out-door recreation; well equipped gymnasium for developing soft muscles.

Leave of absence granted at frequent intervals to men with a good record.

For full information regarding enlistment, and the opportunities offered, call at any NAVY RECRUITING STATION, or address

Bureau of Navigation

DESK 69

Navy Department

Washington, D. C.

Please Mention Popular Mechanics

This One



KGCY-L98-8LL1

Do You Wear Glasses?

Does Your Wife, Mother, Sister?

Perhaps you know, then, how irritating it is to find that the little screws have become loose, also how very often this happens. Here are several little tools for quickly and effectively attending to such cases, made especially for that purpose:



No. 556 Screw Driver for Eye Glasses is made in two pieces and screwed together, telescoping the blade when not in use. Nickel plated. Price, 15 cents.

No. 558 is threaded on the end opposite the blade. This may be reversed and screwed into the part with the ring, thereby making a longer handle. Nickel plated. Price 20 cents.



No. 554 is made with a chuck to hold the blade firmly in a split socket when in use. The blade is removed by slightly loosening the chuck, then reversed and inserted into the socket nearly full length and held safely by tightening the chuck. Nickel plated. Price 25 cents.



Carry one in your pocket, on your key-ring or watch chain. Either style mailed on receipt of price.

Ask for Complete Catalog No. 17AP of Fine Tools

The L. S. Starrett Co.

Athol, Massachusetts, U. S. A.,

POPULAR MECHANICS

160 WASHINGTON ST., CHICAGO, U. S. A.
H. H. WINDSOR EDITOR

SUBSCRIPTION:

In United States, and its possessions, and Mexico, per year, postpaid = \$1.00
To Canada and all countries in the Postal Union, postpaid, per year = \$1.50

All subscriptions are discontinued at expiration
Please examine the date printed on your wrapper

Published Monthly by POPULAR MECHANICS COMPANY
Entered as mail matter of the second class at the postoffice at Chicago, Ill.

Eastern Advertising Office :: 116 Nassau St., New York

The attention of prospective advertisers is called to the policy of this magazine in accordance with which the publisher waives all claim for payment of any advertisement appearing in any issue where the number of copies actually printed and circulated is less than the number printed on the front cover page.

CONTENTS FOR JANUARY, 1908

THE GREAT AMERICAN WATERWAY.....	1
Huge Traction Engine.....	4
HYDRAULIC UNLOADING MACHINES.....	5
The Rolling Stock of Railroads.....	5
Steeple-Jack Works 672 Ft. Above Ground.....	5
Treadmill to Be Abolished.....	5
CARRIAGE TOP FOR BOAT.....	6
Blowing Off a Gas Well.....	6
ELECTRIC HOUSEHOLD UTENSILS.....	7
Ocean Travel in 1907 Breaks Record.....	9
Blackwell's Island Bridge.....	10
Army Water Sterilizer.....	10
New Lamb-Tailing Instrument.....	10
Steel Freight Cars in India.....	10
GERMANY AND FRANCE BATTLE FOR AIR-SHIP SUPREMACY.....	11
Testing the Big Nile Bridge.....	13
HUNTING IN AN AUTOMOBILE.....	14
CABLE REPAIRING BUOYS.....	14
Steered by Her Propellers.....	14
How to Rescue Man Sinking in Marsh.....	15
PHOTOGRAPH OF WIRELESS TELEGRAM.....	15
Freak Photograph.....	15
LOADING RAILROAD CARS WITH SAND.....	15
Economy in Fuel on Ocean Liners.....	16
FOOD FROM THE AIR.....	17
Marconi Wireless Transmitter.....	19
Diablo: A Century Old.....	20
Kerosene Traction Engine.....	20
Don'ts in Electric Lighting.....	20
Road Grader on Hinged Axles.....	20
DIRECT CURRENT ELECTRIC LOCOMOTIVES.....	21
Whitest Cracker in the World.....	21
SAFE WAYS OF HUNTING BIG GAME.....	21
THE AMPHIBIOUS AUTO.....	22
Odd Engines to Supplant Mules.....	22
AN AMERICAN AEROPLANE.....	23
Boat Driven Like a Fish.....	23
Floating Hospital for Needy Sick.....	23
Hydraulic Press of Huge Size.....	24
DETROIT RIVER MAIL BOAT.....	25
Europe's Largest Ice-Skating Rink.....	25
Mahogany Log of Great Value.....	25
STILLS FOR MAKING FRENCH BRANDIES AND PERFUMES.....	26
WHERE ELEPHANTS DO REAL WORK.....	28
TREE DENTISTRY.....	29
"Compressol" System of Foundations.....	29
Concrete Mixer Bucket.....	30
Timber for Mines Expensive.....	30
Stone Lighter of Steel.....	30
BIG BALLOON'S LONG FLIGHT.....	31
To Cross Ocean in Balloon.....	31
TYPEWRITER TELEGRAPH INSTRUMENT.....	32
Ore Train Wreck.....	32
"Mauretania" Wins One-Day Record.....	33
Inexpensive Fire Alarm System.....	33
LOCATE ORE VEINS BY WIRELESS ELECTRIC WAVES.....	33
Tramps' Sign Code.....	34

German Bridge Construction.....	34
AUTOS SPREAD DISEASE.....	34
Nitro-Glycerine Lets Go.....	35
Hot Water Tank Hitching Post.....	35
Six-Wheel Runabout.....	35
WALKING ON THE WATER.....	35
FINEST COLLIER AFLOAT.....	36
Marine Death Rate Low.....	36
Ground Leveler.....	36
Stern or Side-Wheel Propeller.....	37
DEVICE GETS PENNY CONTRIBUTIONS.....	37
Automobile as Wrecker.....	37
SINGLE-WHEEL ROLLER SKATES.....	38
Improved Lard Barrels.....	38
Rhine Steamers.....	38
HOW CHARCOAL IS MADE AND ITS USES.....	39
Powerful Logging Locomotive.....	40
Splicing a Rail.....	40
MUST TRAVEL 62 MILES AN HOUR IN WATER OR FORFEIT \$10,000.....	41
Dirt Pusher Solves Problem.....	41
CABLE BADLY TWISTED.....	42
Ice Boat and Steamboat Run Side by Side.....	42
Divert River to Save Mine.....	42
Huge Battleship Target.....	42
AMATEUR MECHANICS—	
A Microscope without a Lens.....	59
Prince Rupert's Drops.....	59
How to Balance a Cup on a Knife.....	60
Photographs Lightning Flash.....	60
How to Make Small Gear Wheels without a Lathe.....	60
How to Make a Paper Phonograph Horn.....	61
How to Bind Magazines.....	62
FARMERS' ADVERTISING BULLETIN.....	67
Deck of a Lake Freighter.....	67
Padded Costumes for Aeronauts.....	67
River Telephone Service.....	67
PALM-STEM PORCH CHAIRS.....	68
Bees Build Model House of Honey.....	68
GIANT STERN FRAME FOR COLLIER.....	68

SHOP NOTES.

Unscrewing Pipe with a Chisel.....	43
How to Make an Ice Block Recording Device.....	43
Home-Made Riveting Machine.....	43
How to Insert a Cog in a Gear.....	44
Removing a Stuck Fountain Pen.....	44
Making Vents in Cores.....	44
Automobile Used as a Hoist.....	44
A Simple Mission Stain.....	45
How to Make an Adjustable Socket Wrench.....	45
Quick Repairs on a Gas Generator Furnace.....	45
Tongs for Holding Chain Links.....	45
Fitting Balusters to the Lower Porch Rail.....	45
Cost of Reinforced Concrete Posts.....	45
How to Prevent Wooden Faucets from Cracking.....	46
Gasoline Storage Tank.....	46
Etching on Steel.....	47
A Home-Made Greenhouse.....	47
How to Make a Bolt-Holder.....	47
Using a Well to Cool Milk and Butter.....	48
How to Make a Ground Glass.....	48
To Prevent Leader Tubes from Bursting.....	48
How to Keep a Tap from Breaking.....	49
How to Figure Radiation.....	49
A Substitute for a Lock Nut.....	49
Home-Made Negative Washer.....	49
A Light Punch for Removing Rivets.....	50
A Home-Made Well Auger.....	50
Utilizing Heat from a Gas Engine Exhaust.....	50
How to Make a Handy Nail Picker.....	50
Cobble Stones for Ditch Lining.....	50
How to Place Glass for Small Greenhouse.....	51
Cutting Channels in a Bearing for Graphite.....	51
Connecting a Horizontal Kitchen Boiler.....	51
How to Make a Worn Reamer to Size.....	51
Extending a Brick Stack.....	52
Catalog Case for Everyone.....	52
How to Make a Handy Shop Stand.....	52
Removing Dents in a Gas Holder.....	52
How to Measure a Wagon Skein.....	53
How to Make Concrete Steps.....	53
How to Handle Heavy Bar Stock.....	53
How to Prevent an Oil Can from Dripping.....	54
Quickly Made Door Jack.....	54
Building an Ice House.....	54
Bench Vise Anvil.....	55
Lifting Out a Motor.....	55
How to Tighten Pulley on Shaft.....	55
How to Make an Acid Receptacle.....	56
A Coal Bin for a Narrow Porch.....	56
Lubricating Loose Pulleys.....	56
A Door Bell Substitute for the Dead.....	57
A Kink for the Sign Writer.....	57
Trouble in Starting a Gasoline Engine.....	57
Blueprint Washing Tank.....	58
Setting Electric Light Poles in Frozen Ground.....	58



**Do you live in the country?
Or in the suburbs?
Or anywhere away from a city water supply?
How is your house supplied with water?**

Every one must have water.

Water is necessary for animal and man; and nature demands it too for irrigation.

The success of your home as a comfortable and sanitary abiding place, depends largely on your water supply.

Artificial heat is required only in winter—artificial light only at night.

Water is required during all seasons—day and night.

Impossible as it may seem, the subject of water supply had been almost entirely neglected until recent years, while great improvements had been made continually in lighting and heating methods.

This water supply problem is now completely solved by

The Kewanee System of Water Supply

The Kewanee System insures every convenience, comfort and protection offered by the most up-to-date city water works system.

This means an abundant supply of water with ample pressure behind it, available at any hour of the day or night.

The Kewanee System will enable you to have that water delivered to the bathroom, kitchen, laundry, barn, garden, lawn—anywhere, under strong pressure.

The Kewanee System does away with the drudgery of carrying this water in buckets, a task which men shirk and women detest.

The Kewanee System obviates the old style elevated tank, which is expensive, unsightly and unsafe—which may leak, freeze or collapse.

And no leaky and inefficient attic tank need be used.

Use the water from your own well, cistern or other natural source of supply.

The plant may be placed in the cellar, located in a special pump house—or under ground if necessary—out of sight and thoroughly protected.

Kewanee Systems are easy to install, easy to operate and cost nothing for repairs.

The Kewanee System is not an experiment by any means.

Over 8000 Kewanee Systems in successful operation. Complete plants furnished to supply any requirements, from those of a cottage to a small town.

Kewanee Systems are now supplying country and city homes, clubs, hotels, schools, apartment buildings, public institutions and towns.

Our engineers can solve your water supply problem; and no charge will be made for preliminary prices and plans.

Every Kewanee System is fully guaranteed—we take all the risk and responsibility.

Let us show you what we can do for you.

Write for our complete 64-page illustrated catalog which explains everything.

Ask for catalog No. 14.

Kewanee Water Supply Company, Kewanee, Illinois.

No. 32 Broadway, New York City.

820 Marquette Building, Chicago.

404 Equitable Building, Baltimore, Md.





Valuable Book for Letterers

Modern Show Card Lettering, Designs, Etc.

NEW AND REVISED EDITION

A practical treatise on Up-to-Date Pen and Brush Lettering, giving instructions respecting many styles of lettering, position, movement, shading, spacing, designing and arrangement; with illustrations of large and small letter for each alphabet, together with a full analysis and diagrams of making neat and prominent figures off-hand for Price Tickets, etc.

Over 150 Illustrations of finished show cards and price tickets are given with practical instruction, outside of a large variety of standard show card alphabets.

This book is far beyond anything ever published in this line. It contains solid, practical common sense instruction—a book that is free from absurd theories and mystifying kinks and contains 2,000 advertising Phrases for Card Signs, Posters, etc.

The price of the book is but \$1.00 delivered to your address. If you find book not as represented, you have the privilege to return the same in good condition within three days, and I will return the money.

Address W. A. THOMPSON, Pontiac, Mich.

A NEW MONTHLY MAGAZINE

The accompanying illustration shows a small outline of the cover page design of a new publication—"The Show Card Writer," a handsome new illustrated monthly. The first number was published September first, 1907.

No Card Writer can afford to be without it a single month. It will be a credit to the craft, an inspiration to the worker and a delight to the eye. Every page, every article, every illustration will be clear and distinct. It will show you how to improve your skill, how to enlarge your field and how to make money.

One Dollar per Year Ten Cents a Copy No Free Samples

Write for prospectus. Address

W. A. Thompson, Publisher, Pontiac, Mich.

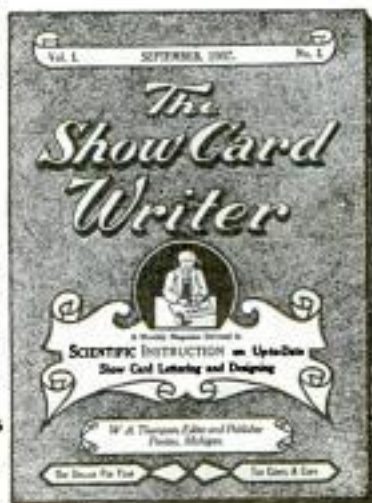

GAS POWER

A monthly magazine devoted exclusively to the gas and gasoline engine subject. It will tell you how to keep your engine running and save you money in expensive repairs. Its contents are of a semi-technical character that cannot fail to interest people operating or contemplating the purchase of a combustion engine.

PLAIN GAS ENGINE SENSE

presenting the primary principles of the Gas Engine in simple language—but supplying enough practical knowledge to successfully operate a gas engine. Regular subscription price of Gas Power, \$1.00 a year. Plain Gas Engine Sense sells for 50 cents a copy.

A special limited offer is now open of Gas Power, One Year, and One Copy of Plain Gas Engine Sense for \$1.00. Mail orders at once. Address

GAS POWER PUBLISHING COMPANY

120 Court Street,

St. Joseph, Michigan

Free sample copy of Gas Power, if desired



ELECTRICAL HANDBOOKS 10 CENTS EACH

1. How to Make a Dynamo
2. How to Make a Telephone
3. How to Make an Electric Motor
4. How to Make a Storage Battery
5. How to Make a Wimshurst Electric Machine
6. How to Make a Magneto Machine
7. How to Make a Medical Induction Coil
8. How to Make a Pocket Accumulator
9. How to Make a Plunge Battery
10. How to Make a Voltmeter
11. How to Make a Galvanometer
12. How to Make a Hand Dynamo
13. How to Make a Talking Machine
14. How to Make a 1-3 H. P. Dynamo or Motor
15. How to Make a Toy Motor
16. How to Make an Electric Bell
17. How to Make a Telegraph Instrument
18. How to Wind Armatures
19. How to Wind Field-Magnets
20. How to Make an Ammeter
21. How to Make a Thermostat
22. Motor Rotation
23. How to Make an Electric Soldering Iron
24. How to Make an Electric Heater
25. How to Make an Elec. Furnace
26. How to Make a Hand Feed Arc
27. How to Make a Jump Spark Coil
28. How to Make a Rheostat

BUBIER PUBLISHING COMPANY, Department 3, LYNN, MASS.

SELF-EDUCATION

TEACH YOURSELF AND INCREASE YOUR WAGES

ONLY DRAKE'S PLAINLY WRITTEN
PRACTICAL BOOKS

CAN TEACH YOU WITHOUT THE AID OF INSTRUCTORS

Every volume positively UP-TO-DATE and written in a language so plain that even a child can understand. DRAKE is the largest publisher of Modern Mechanical Books for home and shop study in the world. We publish good books on every mechanical subject. Our large illustrated Catalog now ready. Sent free.

FREDERICK J. DRAKE & COMPANY

350 Wabash Avenue CHICAGO, U. S. A.

In ordering our catalog please mention this paper.

Train Load of Books

Books to be closed out at less than cost of paper and printing. Binding free.

Failed National Book Concern, Cash Buyers' Union, Merrill & Baker, Colonial Pub. Co.

I bought entire stock of three of these Bar Bankrupt Book Houses and a big lot of the other. I am closing it out now at 10c to 50c on the dollar.

Sample Prices

Late copyright books, were \$1.50. My price 35c. List includes The Prospector, The Masqueraders, Conquest of Canaan, Richard Carrel. Hundreds of others at from 35c to 45c.

Encyclopedia Britannica, half morocco binding, installment price \$38.00. My price \$7.75. Dickens Complete Works, 15 vols., regularly \$15.00. My price \$3.75.

I am closing out at less than half price the following complete works in half morocco bindings:—Dickens, Thackeray, Balzac, Scott, Irving, Dumas, Hugo, Bulwer, Carlyle, Eliot, Cooper, DeFoe, Fielding, Hawthorne, Poe, Beads, Ruskin, Smollett, Gibbon, Galton, Green, Shakespeare, etc.

Millions of books, thousands of titles. Chance of a lifetime to get almost any book at a discount of from 50 to 90 per cent from regular price while stock lasts.

Books Shipped on Approval

subject to examination in your own home before paying. Every book guaranteed new and satisfactory, or subject to return at my expense. Write for my big Free Bargain List of this stock before ordering. It costs nothing. Will save you money. Postal card will bring it.

DAVID B. CLARKSON, The Book Broker,
123 Bosh Bldg., Chicago.

POSTAL SCALE \$1.00

Tells at a glance postage in cents on all mail matter. Capacity, 1 pound by half ounces, 3 inches high. Cuts down the stamp bill. We make several styles for the office, store and large business houses, as well as the individual desk. All leading dealers sell them.

Catalogue P free, showing 12 styles.
PELOUZE SCALE & MFG. CO.,
132 W. Jackson Boulevard CHICAGO



Manufacturers of Various Styles and Sizes of Draughting Tables, Drawing Boards, Blue Print Filing Cabinets, Blue Print Frames, Etc.
Send for Illustrated Catalogue or ask your jobber.



FRITZ & GOEDEL MFG. CO.,
99 Alabama Street, Grand Rapids, Mich.

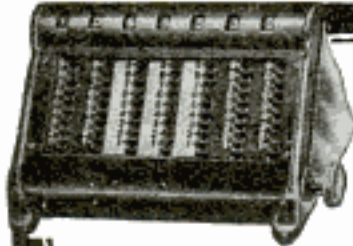

OVER
15,000
IN USE

There is a reason
for it

GEM ADDING MACHINE

Carries automatically. Automatic resetting device. Visible total. Collapsible holder.
Sent on Ten Days' Trial at our Expense

E. GANCHER
Automatic Adding Machine Co.
332 Broadway
New York

\$ 15

A School Within Itself

point where the careful student comprehends the complete designing, care and operation of a dynamo or motor, and 1 chapter on electric automobiles, outlining their construction, care and operation, and all about storage batteries and how to handle them.

There are XX chapters in all, XIX carrying you from the fundamental principles of electricity on through the various branches to a complete designing, care and operation of a dynamo or motor, and 1 chapter on electric automobiles, outlining their construction, care and operation, and all about storage batteries and how to handle them. Each subject is carefully written and to the point. After a student studies a subject, he is questioned on that subject in such a manner as to bring clearly to his mind the points he needs to know regarding same. A DICTIONARY in back of book will enable him to learn the meaning of any electrical word, term or phrase used in this book, as well as hundreds of others in common use. All required tables necessary in the study are in it.

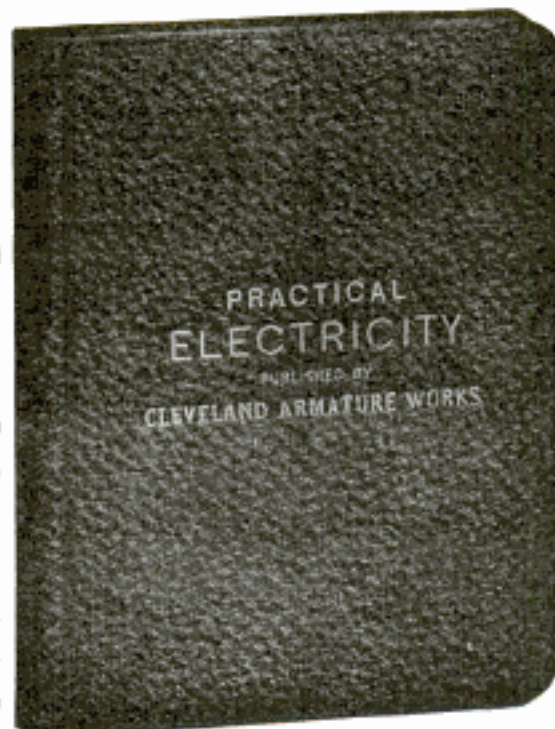

TABLE OF SUBJECTS:	
CHAPTER	CHAPTER
I—Wiring	X—Counter E. M. F.
II—Electric Batteries. Electric Plating.	XI—Hysteresis and Eddy Currents
III—Magnetism	XII—Armature Reaction
IV—The Magnetic Circuit	XIII—Sparking
V—Magnetic Traction	XIV—Winding of Dynamos and Motors
VI—Magnetic Leakage	XV—Proper Method of Connecting Dynamos and Motors—Self-Excitation and others
VII—Energy in Electric Circuit	
VIII—Calculation of Size of Wire for Magnetizing Coils	
IX—Calculation of E. M. F.'s in Electric Machines	

\$2.00 PER COPY—FOURTH EDITION—16,000 COPIES SOLD.

The offer we make of refunding money if book is not satisfactory upon examination is AN UNUSUAL ONE in connection with the sale of a book. But we have no fear of its return. Your decision will be what thousands of others has been. Money would not buy it if it could not be duplicated. We could print testimonials by the hundreds. It is best to order and be your own judge of its merits.

CLEVELAND ARMATURE WORKS, Cleveland, Ohio.
AMERICA'S GREATEST REPAIR WORKS. Armatures and Fields Wound—Commutators Filed.

Please Mention Popular Mechanics

Shop Notes for 1908

"Written so you can understand it"
Vol. 4, Ready November 15, 1907

Best Volume of the Series. 200 pages and 500 illustrations. Contains matter entirely different from Vols. 1, 2 and 3. A copy of the 1908 "Shop Notes" added to your set will double its value.

Notice to Newsdealers

A stock of the Popular Mechanics Shop Notes Series is carried in stock by all branches of the American News Co., and your orders will be filled promptly. Usual discount to dealers.

The books are returnable; no time limit.

The Shop Notes sell throughout the entire year.

**For sale on all News Stands
 or sent postpaid by the publishers.**

: : Price 50 cents : :

Popular Mechanics Co.

160 Washington St. : : : Chicago, Ill.

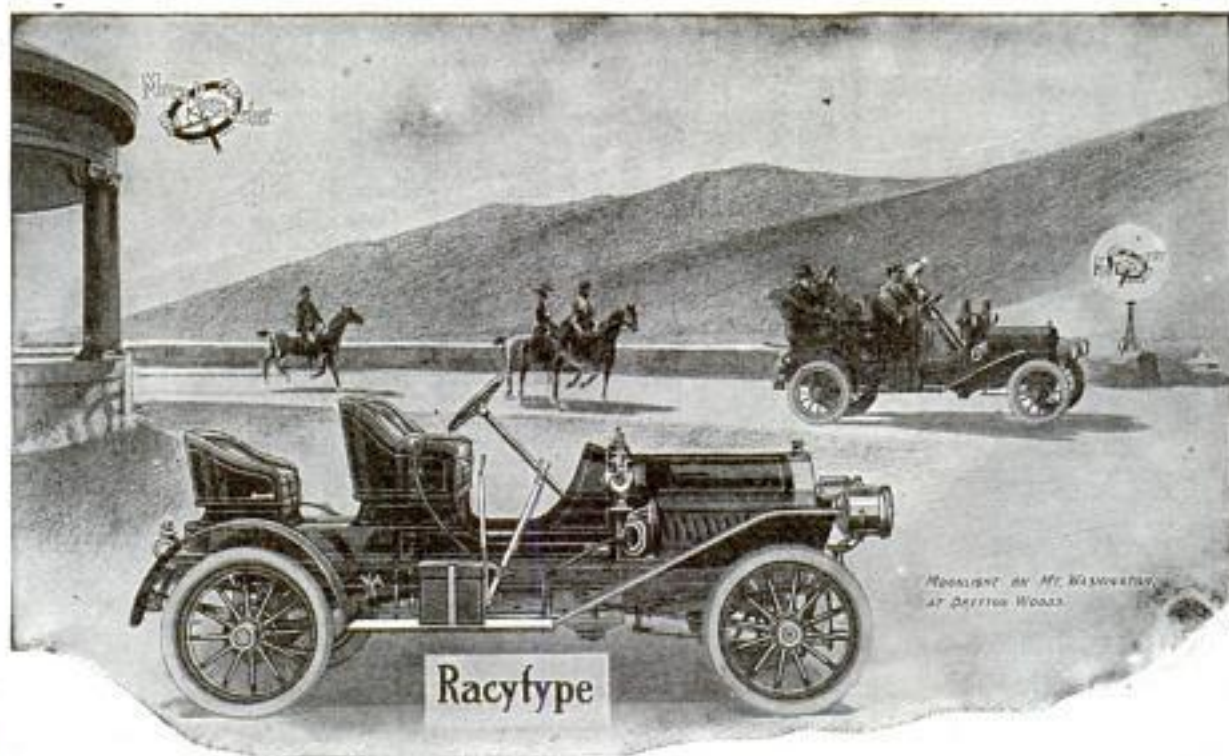

Racytype

MORNING BY MR. WASHINGTON
AT DERRICK WOODS.

DO YOU KNOW THE

Over eight thousand miles without a single adjustment to power plant; that's the record which motor car authorities challenge all Europe to equal. Moreover the engine is yet in running condition with original New York, Chicago and Cleveland Motor Clubs seals intact.

A "Mechanically Right" MORA power plant and MORA Mud Proof Construction is what made this feat possible.

When you own a

MORA

MECHANICALLY RIGHT.

you're assured of a right racy car equally suitable for town or cross country running.

Its low speed motor runs smoothly on high gear as slow as four miles an hour, also as fast as most drivers care to go.

Wheel base, 98 inches; weight, 1750 pounds; 24 horse power; La Coste magneto. Price, \$2,300.

Write for the last edition of "The Sealed Bonnet," free. Being a complete story of the most wonderful world's endurance record ever created in motor car history.

The "All Admired" of the "All America" Show

Mora Motor Car Co.
23 Mora Pl., Newark, New York, U. S. A.



The
Sealed
Bonnet

Please Mention Popular Mechanics

Copyrighted material

"YANKEE" TOOLS

ARE
WITHOUT EQUAL
IN QUALITY
OR EFFICIENCY
IN PRACTICAL USE

RATCHET AND
SPIRAL-RATCHET
SCREW DRIVERS
also DRILLS

ASK YOUR DEALER
TO SHOW THEM

SEND FOR OUR
"YANKEE" TOOL BOOK
SENT FREE

NORTH BROS.
MFG. CO.
PHILADELPHIA, PA.



Home Benches



THE NO. 42 BENCH; ALSO MADE WITHOUT CABINET

Write for Catalog and Prices

GRAND RAPIDS HAND SCREW CO.

920 Jefferson Avenue

Grand Rapids - - Michigan

Largest Manufacturers of Manual Training and Home
Benches in the World.

Let there be Light

RELIANCE
ACETYLENE GAS
GENERATOR

MAKES LIGHT
FOR THE
Home, Factory,
Church, School,
Etc.



Automatic Water-Shift — Water-Feed Valve

Reliance Generators are equipped with a rotary water-valve which, not being directly connected to the water feed-pipe conveying the water to the carbide, absolutely prevents the water from reaching the carbide until this valve is brought into operation, automatically, by the downward movement of the bed, which occurs when the gas becomes sufficiently low to require an additional supply. This positively prevents any waste of gas after lights are turned off.

WRITE FOR FREE ILLUSTRATED CATALOG
Giving full information regarding all
styles of RELIANCE Generators.

The Gem City
Acetylene Generator Company
DAYTON, OHIO

Have you seen the New Improved BUCKEYE TRACTION DITCHER?



Sold to contractors on 6 days' test before asking for settlement.

Works in hard pan and shale rock, where it can be taken out with the ordinary pick. Passes over the work but once, cutting to a perfect grade if desired.

Write for catalog H, also reprint article giving cubic yards Ditcher will handle per day and the cost of operating.

Read the following testimonial:

24" x 7½' Machine. CANADA

Fincher Creek, Alta., Can., 7th March, 1908.

The Buckeye Traction Ditcher Co., Findlay, O.

Gentlemen:—After using for four months the 24 in. x 7½ ft. Ditcher I purchased from you, I am able to give you the following results:

In good loam the machine can average 1,500 feet of 6 foot ditch per 10 hours, including delays and stops. In hard, dry clay that leaves a polish on the sides the machine can be counted on to cut 900 feet per day. In gravel the size of a man's fist it will dig 700 feet per day; numerous stops are required to pick the stones that may roll into some part of the machinery.

I have dug in ground composed of gravel and boulders larger than a man's head, but it is not economical. I am satisfied that the machine will do the work of 100 men at one-tenth the cost of hand labor.

Yours truly,

J. E. Woods, C. E.

The Buckeye Traction Ditcher Co., Findlay, O.

Popular Mechanics **Shop Notes Series** of Year Books

☞ One of these books is issued the first of each year, and is a reprint of all the articles which have been published during the year past, in our "Shop Notes Department."

200 Pages **Vol. I, "Shop Notes for 1905"** 385 Illustrations

228 Pages **Vol. II, "Shop Notes for 1906"** 555 Illustrations

228 Pages **Vol. III, "Shop Notes for 1907"** 580 Illustrations

212 Pages **Vol. IV, "Shop Notes for 1908"** 536 Illustrations

☞ These books are a perfect gold mine of information for every one interested in mechanics, or who uses tools for pleasure or as an occupation. Of equal value and help to the professional mechanic and the amateur.

☞ These articles are the cream of the experience of years, of hundreds of the most successful mechanics in the country. There is nothing on the market equal to these books at five times their price.

☞ The Popular Mechanics Shop Notes Series TELLS EASY WAYS TO DO HARD THINGS, and like Popular Mechanics, is "Written so you can understand it."

☞ These books are indexed very fully and with great care.

☞ The subjects treated cover every department of mechanics, with useful time saving "kinks" for engineers, firemen, carpenters, machinists, plumbers, painters, iron and wood workers, electricians of all kinds, masons, and in fact all the trades.

☞ "WORTH ITS WEIGHT IN GOLD" is a frequent expression from our readers, and one young mechanic in the far west who started a repair shop for himself, says he owes his success to "Popular Mechanics Shop Notes." Many a time when a customer brought in a job new to him, he consulted his "Shop Notes," which told him how to do it.

☞ Each volume contains entirely different matter from that published in the other. A set of these books covering several years will make an encyclopedia of priceless value to the owner.

Price 50 Cents per Volume, Postpaid

For Sale by all Newsdealers or can be ordered direct from the Publishers

POPULAR MECHANICS :: :: :: CHICAGO

SPECIAL 30 DAY OFFER

\$5.00 BUYS IT



To introduce our line of Home Companion Tool Sets among the readers of Popular Mechanics we are offering for a limited time only our

No. 710 Set for \$5.00 and Expressage.

These Tool Sets of ours comprise tools of our own manufacture, whose quality is well known, put up in handsome hardwood cases.

A complete list of the tools in each of these assortments will be found in our No. 8 Catalog which we will send free to any address.

No. 700 \$3.50. No. 711 \$8.00. No. 712 \$10.00. No. 713 \$12.00.

**GODELL-PRATT COMPANY,
GREENFIELD, MASS., U. S. A.**

The POPULAR EMERY GRINDER



A Practical Tool

for blacksmiths, plumbers, carpenters, farmers and mechanics of all trades. It is strong, durable and simple in construction.

Wheel is 6 inch diameter, 1 inch face, and made of best abrasive material for sharpening tools. Makes 3,000 revolutions per minute.

Tool-rest may be adjusted to give any desired bevel.

Can be carried in small box and set up anywhere in field or shop. No belts, cogs or lost motion. Buy it, try it, and if you don't like it, send it back.

PRICE \$3.50

Mechanics Tool Works
185 Dearborn Street, - CHICAGO, ILL.

SHARPEN YOUR TOOLS

You can save trouble and save time, you can do better work with less effort if you have in your shop or home a

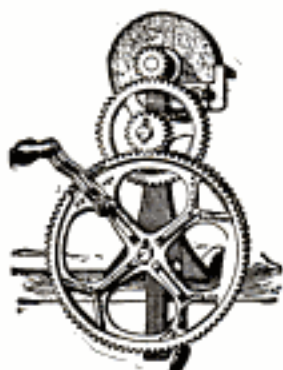

PRACTICAL GRINDER

It will sharpen any edged tool in one tenth the time that an ordinary grindstone will sharpen it. The aluminum wheel will not heat the metal and take the temper out either. We guarantee that. Clamp it on table or bench, hold knife or tool *lightly* on grinding wheel and turn. That's all. Any one can do it.

Uniform wheels for general purpose work—special beveled wheels for certain styles of implements.

A NECESSITY IN THE SHOP

A time and bother saver in the home. Nothing to get out of order, no water necessary, no chain to buckle or belt to break. Small and portable, will save its cost in a week when drills and tools are carried out of the shop on outside work.

SEND FOR FREE BOOK

Practical Talks About Practical Grinders. It will settle the dull tool and dull knife business for you. Ask your dealer or send to us direct.

ROYAL MANUFACTURING COMPANY
133 E. Walnut Street, - Lancaster, Pa.

Please Mention Popular Mechanics

NEW YORK SCHOOL OF AUTOMOBILE ENGINEERS

**You Can
Earn \$25 to \$100 a Week**

Our course of study will fit you in two months to be a Chauffeur, Auto Salesman or Garage Manager, and there is no better paid occupation nor pleasanter work in the world. Our Home Study Course by mail gives full instruction by charts and text, and does not interfere with your present occupation. Our graduates are recognized as experts and good positions seek them. **WRITE TODAY** for free prospectus. Personal teaching with road practice at our big New York School if preferred.

NEW YORK SCHOOL OF AUTOMOBILE ENGINEERS, 130 West 56th St., N. Y.



SCROLL SAWS

I will send this beautiful design with 300 miniatures and my illustrated catalog of Scroll Saws, Lathes, Fancy Words, Metal Trimmings and Tools, postpaid on receipt of 15c, or send 6c for catalog only. Address

**The POMEROY
Scroll Saw Co.**

410 Asylum St., Hartford, Conn.
Div. Z

SCROLL SAWS
FROM 50c TO \$22.50

SIMPLE? Simplicity Itself!

To start or stop, simply turn on steam and throw lever.

NO WAITING
NO ADJUSTMENTS

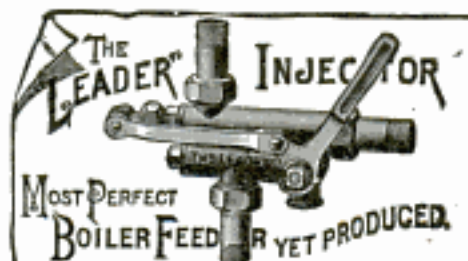

NO COMPLICATIONS
ALWAYS RELIABLE

Manufactured only by
THE RANDLE MACHINERY COMPANY
1761 Powers Street, Cincinnati, Ohio

BUILD YOUR OWN AUTOMOBILE

You can do so by purchasing your chassis or parts complete from us. We give you the benefit of our years of experience in this line.

We are building hundreds of these machines and they are a decided success. Reliable, durable and powerful. Engine is silent and simple in construction—9-10 H. P. Buy a chassis from us and build you an auto Buggy. Send today for complete information and prices.

AUBURN MOTOR BUGGY CHASSIS CO.

Auburn, Indiana

Box No. 10

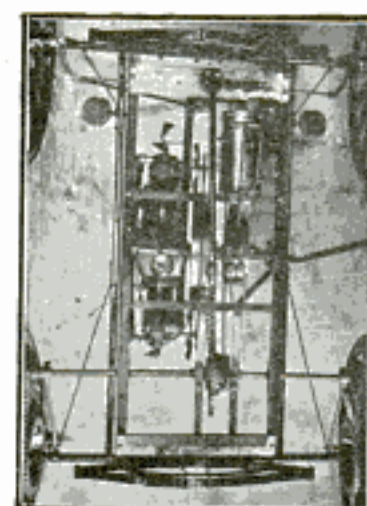

The "KICKDRIVE" is for driving all kinds of light machinery by foot power. The following articles are built complete with the "KICKDRIVE":

Circular Saws, Polishing and Buffing Machines and Forges.

Get a Booklet

MAYER SLOTKIN, 210-212 A Canal St., NEW YORK, N. Y.

BEWARE OF IMITATIONS

For the protection of our customers we advise that Klein's Pliers are being imitated, to look like Klein's. This, however, does not make them Klein's.

CAUTION Look for this stamp. M. KLEIN & SONS, as the inside of handle—none are possible without this stamp. Use only genuine Klein's. They are the product of years of experience and have stood the test of time.



MATHIAS KLEIN & SONS 99 W. VAN BUREN ST. CHICAGO, ILL.

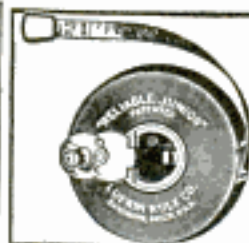

LUFKIN
TAPES AND RULES

ARE THE BEST

FOR SALE EVERYWHERE SEND FOR CATALOG No. 28

THE LUFKIN RULE CO.

SAGINAW, MICH., U.S.A.

NEW YORK, LONDON, SINGAPORE, AND WINDSOR, CANADA



EYE BENDERS

We make hand power benders for forming eyes from stock 1 1/2 inch thick and under. Any size eye, 7 inches outside diameter and under.

WALLACE SUPPLY CO.
24 W. Washington St.
Chicago Illinois

The Miner-Lawrie Laboratories



Chemical Analysis and Consultation
Expert Aid to Manufacturers
Factory Problems
Patent Processes and Litigation

Consulting Chemists to
Popular Mechanics

355 Dearborn Street
Chicago Illinois

CARL S. MINER
JAMES LAWRIE, Pa. D.

Telephone Harrison 3332

BUILD YOUR OWN BOAT

BY THE
BROOKS SYSTEM

Of Full Size Patterns and Illustrated Instructions

You need no tool experience—no previous knowledge of boats. Our big free catalog gives hundreds of testimonials—tells how a profitable boat building business may be established. Send for it. We sell knock-down frames with patterns to finish for less than it costs others to manufacture. 21,311 inexperienced people built boats by the Brooks System last year. Why not you?

SATISFACTION GUARANTEED OR MONEY REFUNDED.

BROOKS BOAT MFG. CO.

ORIGINATORS OF THE PATTERNS SYSTEM OF BOAT BUILDING.
3711 SHIP ST. SAGINAW MICH. U.S.A.



KNOCK DOWN FURNITURE

You Save $\frac{3}{4}$ the Cost

By putting together and finishing it at home. We furnish it—art and mission designs—heavy solid oak—every piece fitted and smoothed—includes stain and fastenings. You save $\frac{1}{2}$ manufacturing cost— $\frac{1}{4}$ the freight and all dealers' profits.

Send trial order for this \$4 chair. Bottom cushion cover of leatherette, \$1.50. Particulars of other pieces sent on request.



BROOKS MFG. CO.

ORIGINATORS OF THE K.D. SYSTEM OF HOME FURNISHING.
3711 SHIP ST. SAGINAW MICH. U.S.A.



25c. BOOKS 25c.

ELECTRICITY. The study of, and its laws for beginners, comprising the laws of electric current generation and flow, Ohm's law, galvanism, magnetism, induction, principles of dynamos and motors, wiring, with explanations of simple mathematics as applied to electrical calculations. By N. H. Schneider. With 55 original illustrations and 6 tables. 25 cents, postpaid.

DRY BATTERIES. A practical handbook on the designing, filling and finishing of dry batteries, with tables, for automobiles, gas engine, medical and cell work, electric bells, alarms, telephones, experiments, and all purposes requiring a first-rate battery. Fully illustrated with 30 original drawings. 25 cents, postpaid.

ELECTRICAL CIRCUITS AND DIAGRAMS. Being a selection of original up-to-date and practical diagrams for installing annunciators, alarms, bells, electric gas lighting, telephones, electric power light and wiring circuits, induction coils, gas engine igniters, dynamos and motors, armature windings. By N. H. Schneider. 25 cents, postpaid.

ELECTRIC BELLS AND ALARMS. How to install them. By N. H. Schneider. Including batteries, wire and wiring, circuits, pushes, bells, burglar alarms, high and low water alarms, fire alarms, thermostats, annunciators, and the locating and remedying of faults. With 56 original diagrams. 25 cents, postpaid.

MODERN PRIMARY BATTERIES. Their construction, use and maintenance, including batteries for telephones, telegraphs, motors, electric lights, induction coils, and for all experimental work. By N. H. Schneider. 94 pages, 55 illustrations. The best and latest American book on the subject. 25 cents, postpaid.

EXPERIMENTING WITH INDUCTION COILS. H. S. Norris, author of "Induction Coils and Coil Making." A most instructive little book, full of practical and interesting experiments, fully explained in plain language with numerous hints and suggestions for evening entertainments. Arranged under the following headings: Introduction; The Handling of Ruhmkorff Coil; Experiments with Sparks; Effects in the Vacuum; Induction and Wireless Telegraphy. With

36 original illustrations. [In the press.] 25 cents, postpaid.

ELECTRIC GAS LIGHTING. How to install electric gas lighting apparatus, including the jump spark and multiple systems for all purposes. Also the care and selection of suitable batteries, wiring and repairs. By H. S. Norris. 101 pages, 57 illustrations, paper. 25 cents, postpaid.

THE LOCOMOTIVE, simply explained. A first introduction to the study of the locomotive engine, their designs, construction and erection, with a short catechism, and 26 illustrations. 25 cents, postpaid.

WOODWORK JOINTS. How to make and where to use them; including mortise and tenon joints, lap joints, dovetail joints, glue joints and scarfing joints. With a chapter on circular woodwork, revised and enlarged edition, 101 pages, 178 illustrations. 25 cents, postpaid.

SMALL ELECTRICAL MEASURING INSTRUMENTS, describing the making and using of the different instruments, fully illustrated. 25 cents, postpaid.

METAL WORKING TOOLS AND THEIR USES. A Handbook for Young Engineers and Apprentices. Shows how to use simple tools required in metal working and model making. Illustrated. 25 cents, postpaid.

THE SLIDE VALVE. Simply explained for working engineers. Fully illustrated. 25 cents, postpaid.

DIAGRAM OF CORLISS ENGINE. A large engraving giving a longitudinal section of the Corliss engine cylinder, showing relative positions of the piston, steam valves, exhaust valves, and wrist plates when cut-off takes place at $\frac{1}{4}$ stroke for each 15 degrees of the circle. With full particulars. Reach-rods and rock shafts. The circle explained. Wrist plates and eccentrics. Explanation of figures, etc. Printed on heavy paper, size 13 in. x 19 in. 25 cents, postpaid.

INDUCTION COILS. A practical handbook on the construction and use of shock and spark coils. With 35 illustrations. 25 cents, postpaid.

JOINT WIPING. Practical hints for beginners in plumbing. Fully illustrated. 25 cents, postpaid.

POPULAR MECHANICS

160 Washington St.,

::

CHICAGO

MECHANICAL TOOLS

A FULL LINE OF SUPPLIES FOR.

PLUMBERS,
BLACKSMITHS,
PATTERN MAKERS,

MACHINISTS,
CARPENTERS,
MILLWRIGHTS.

WE SELL EVERYTHING

Mechanical Tools, Devices, Appliances and every home need and necessity direct to you at wholesale prices. Do you have home needs or business needs of any kind? If so, you are losing money if you do not order from our Catalog No. 68, The Economy Guide Book. A postal will bring it. Write today. We sell everything direct to the user. Do you want to Save \$50.00 or More Each Year?

Tool Grinder \$3.65

XXX. Thoroughly practical, powerful and efficient Bench Tool Grinder, speeded to 2,080 revolutions per minute. Has steel shafts, bearings are fitted carefully. It is equipped with a new tool holder, which insures a perfect edge; a skate grinding attachment and a shear grinding attachment. Emery wheel is 6x3/4 inch. Each machine is packed complete and can be very easily carried in a tool chest.



Davenport Couch \$5.10

This fine Davenport bed couch has a fine drop front with patented lazy tong. Workmanship and material is the best; very easy to sit or sleep on; 6 ft. 2 in. long, 4 ft. 2 in. wide. Seat is 18 ins.



Oval Slide Bench Vise 95c

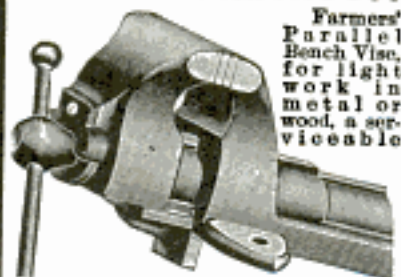

Farmers' Parallel Bench Vise, for light work in metal or wood, a serviceable vise for the farm workshop; 3 sizes. Jaws 2 1/2 in., wgt. 6 lbs., 95c. Jaws 3 in., wgt. 12 lbs., \$1.15

Easy Rocker \$2.95

Here is one of the handsomest chairs that can be found for the price, material and workmanship considered. It is strongly made, finished in golden oak and birch mahogany. The panels are deeply carved and connected by a highly polished banister. It has a cobbler seat of ample proportions.



Our latest Economy Guide Book explains how. It is a necessity for the mechanic, farmer, laborer, painter; in fact, everybody who desires to make every dollar go as far as possible. We pay the postage on this book; we will give one copy FREE to every grown person who asks for it. We invite you to be one of them.

This catalog contains nearly one thousand pages, full of pictures, photographed from the original articles, which are fully and accurately described and shows everything quoted at wholesale prices. Our catalog has become a reference book in every home and our name a household word throughout the country. The articles shown here are good values for the money. Send a trial order today. Order one or more articles from this page and send the money with the order. We guarantee safe delivery.

Order One or More Articles from this ad.

Our Guarantee We positively guarantee that all purchases of every kind from us will be absolutely satisfactory and that the goods ordered will be exactly as represented. We protect you by refunding your money if you are not satisfied. Send us an order today.

Our References We are incorporated for One Million Dollars and refer you to Dun's or Bradstreet's Commercial Agency, or any railroad or express company. Write to the editor of this paper.

Advertising Coupons In our New Economy Guide Book No. 68 we explain all about the large list of valuable articles given absolutely free to our customers for helping us advertise. In this list are found Gasoline Engines, Paint and Roofing, Planos, Buggies, Sewing Machines, Watches, Clocks, Jewelry, Harness, Shoes, Carpets, Rugs, Curtains, Clothing, Tools, Stoves, etc., etc., all Free.

Freight Allowance In the Index Section of this Mammoth Catalog we show hundreds of articles which we put in each shipment extra to help pay the freight and express. Our Advertising Coupons and Freight Allowance Articles are offers that no other Mail Order House has ever been able to make. Send for our catalog today. By using it, others have saved \$50.00 annually. IT WILL PAY YOU.

Albaugh-Dover Co.
900-965 Marshall Blvd., CHICAGO, ILL.

House Paint 87c Per Gal.



Aldoco House Paint is intended for either outside or inside use, except white, which is made up under two formulas; one for exterior work and known as "Outside White," and the other for interior and known as "Inside White." Use only absolutely pure linseed oil for priming.

White." Use only absolutely pure linseed oil for priming.

26-Inch Hand Saw \$1.00

Our special high grade New York Saw is made of London spring steel of the highest grade; guaranteed perfect, patent ground and tempered. Every saw is hand filed and ready for use.



Bit Set \$1.75

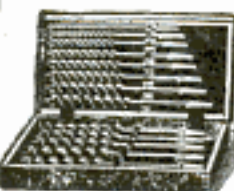

This set of 18 special selected Auger Bits with double spur, sizes 1/4 inch to 1 inch inclusive. These bits are made of the very best material and put up in nice wood box.

made of the very best material and put up in nice wood box.

Asphalt Roofing \$1.40 Per Square (10 x 10 ft.)

This roofing is made from the finest grade wool felt, guaranteed to contain no coal tar; will not dry out, is coated with superior damp-proof material and cannot evaporate. A special grade at a special price.



Please Mention Popular Mechanics

POPULAR MECHANICS

Vol. 10. No. 1.

CHICAGO, JANUARY, 1908.

10 Cents a Copy
\$1.00 a Year

THE GREAT AMERICAN WATERWAY

Mid-Continent Lakes-to-Gulf Project--The Proposed Route--Costs Four Times as Much to Build as a Railroad, but Will Transport Freight at One-Seventh Present Rail Rates

Throughout the entire length and breadth of the Mississippi Valley and its tributaries, far-seeing men, versed in statecraft and in business, are directing their brains and energies toward the successful continuance and ultimate completion of the greatest waterway project ever undertaken within the boundaries of the United States--The Deep Waterway from the Great Lakes to the Gulf of Mexico.

Combine with this the waterway projected to run directly across Canada from Lake Huron to Montreal and the Atlantic coast, via Georgian bay and the Ottawa river, which the Canadian government is now ready to undertake at a cost of \$100,000,000, and it is easily seen that one of the most salutary eras of the commercial and industrial history of the United States and Canada is now in the making.

When these two waterways are completed the benefit to the middle west will be almost incalculable. The output of the industrial activities and the products of the western farmer can then be shipped from the Great Lakes ports or the cities of the Mississippi valley through the "Lakes to the Gulf" waterway to the Gulf of Mexico. From there the ships can continue southward without breaking bulk to Central and South American ports, or, passing through the Panama canal, proceed along the Pacific coast. Eastward bound the distance by water from Chicago to Montreal and tide water, via the

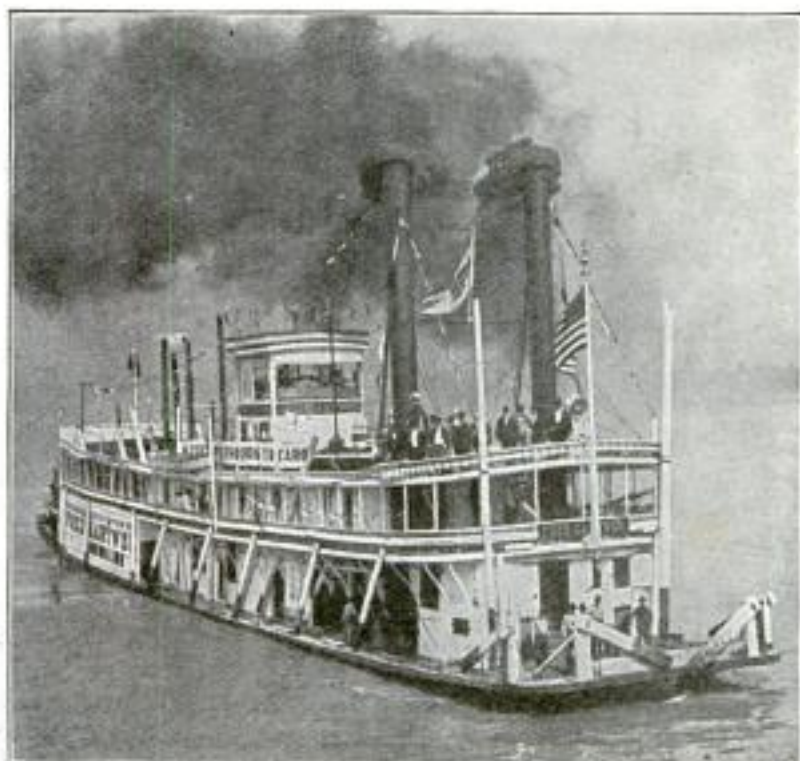

From Sternmagazin, Copyright, 1907, Cassenmuller & Co., London

The "Hertwig"--Type of Present River Freighter

Georgian bay and Ottawa river waterway, will be no further than from Chicago to Buffalo through Lake Erie and Lake Ontario.

Today the first stage of the waterway, the Chicago sanitary and ship canal, has been practically completed at a cost of \$55,000,000 to the Chicago Sanitary District. This canal proper is 22 miles long, besides 6 miles of the Chicago river and 8 miles of the Desplaines river, making a total length of 42 miles. The canal now finished is 22 ft. in depth and 200 ft. wide. The Sanitary District has yet to complete the short stretch of canal from Lockport to Joliet, which work will cost about \$3,000,000.

The proposal of the trustees of the Chicago Sanitary District is to turn over to the government this magnificent ship canal, which has cost nearly one-third of the estimated cost of the entire undertaking, as a voluntary offering, without other consideration than that the federal government complete the canal from Joliet to St. Louis. This offer is now "tabled" at Washington, awaiting further developments at the hands of the deep waterways commission.

The second section, embracing the route from Joliet to St. Louis through the Illinois river, is 230 miles in length. The cost of a 14-ft. waterway through it, with the canal work necessary, is estimated at \$31,000,000.

The third section, between St. Louis and Cairo, Ill., a distance of 186 miles, is now being surveyed. This stretch of the system will be the most expensive, as it will be necessary to build a canal parallel with the Mississippi for the entire distance, instead of as part of it; the river bed being too uncertain to insure an uninterrupted channel. The estimated cost of this section is \$73,000,000.

The fourth section, from St. Louis to the Red river through the Mississippi, a distance of 764 miles, will require no more work than the ordinary dredging. The fifth section to New Orleans presents comparatively few difficulties. The estimated total cost of the undertaking, in addition to the \$55,000,000 spent by the Chicago Drainage District, will be about \$125,000,000. The length of the waterway will be 1,625 miles.

As the figures show, the cost of the undertaking will be enormous, but the resultant good will be so much greater that in years to come the outlay will be considered only a drop in the bucket compared to the benefits accruing therefrom.

It is estimated that 80 per cent of the entire cost of living is expended for



Levee Scene on the Mississippi River, at Memphis

Diagram, Copyright, 1907, Colver & Colver



Illustration, Copyright, 1907, Underwood & Underwood

Present type of boats and system of transferring freight on Mississippi River. Unloading cotton at New Orleans. These boats and methods will largely give place to those shown on Page 5, when the Deep Waterway is completed.

the transportation of goods and persons from place to place. A large proportion of the goods transported costs less than \$2 a ton at the point of production. With this figure in mind anyone can calculate with reasonable accuracy the tax imposed by the transportation companies. The cost of transporting freight by rail is $7\frac{1}{2}$ mills per ton-mile, while the cost of carriage by water is from .92 of a mill on the Great Lakes to .1 mill on the Ohio and Mississippi rivers. Transportation by water is also more rapid than by the average freight car service. For instance: The rate on coal from Pittsburg to Lake Erie by rail, a distance of 135 miles, is 90 cents a ton, while the rate by water from Lake Erie to Duluth, a distance of 1,000 miles, is only 35 cents.

The people of the South American countries are purchasers of the products of the United States to the extent of \$40,000,000 annually, while the purchases of the United States from them are more than double that amount. With direct water communication between the heart of the American continent and South and Central America, so that vessels loaded at the ports of these countries could, without breaking bulk, discharge their cargoes at ports on the shores of the upper Mississippi and the Great Lakes, it is hardly possible to form an estimate of the impetus that would be given to the central west.

The building of the "Lakes to the Gulf" waterway will be followed by wonderful development. The Mississippi itself is navigable for steamboats for 2,161 miles, while small boats go 650 miles further. It has 55 navigable tributaries, the aggregate length of which is 16,000 miles.

While the average construction cost per mile of the canals of this country is about four times that of the railroads, the outlay for equipment and cost of operation is so much in favor of the waterway that there is hardly any comparison between the two methods of transportation.

The possibilities of water transportation with flat-bottom steamers and barges is illustrated in the trip of the river steamer "Sprague," which passed Memphis with a fleet of 56 barges containing 50,000 tons of soft coal. The fleet was 1,132 ft. long by 312 ft. wide, and handled by the one steamer with a crew of 25 men. To transport this cargo by rail would require 1,000 cars of 50 tons capacity each, making 25 trains of 40 cars each. The cost of equipment in these cars and locomotives alone would be \$1,350,000 and require 125 men for train crews on each division of the road.

The proposed waterway is also needed to furnish an outlet to the shipbuilding interests of the Great Lakes. With cheap iron plates and an entrance to tide water, the inland shipbuilders could compete with any shipbuilding concern in the world. Steel plates cost in England 30 per cent less than in this country, but with these plates made in the west by the cheap assembling of coal, and iron ore upon the lake shore, no shipwright anywhere could undersell in the shipbuilding industry.

One of the chief obstacles to the waterway was overcome last November when the Canadian government practically withdrew its contention that such a waterway would lower the level of the Great Lakes.

At the Deep Waterways convention held at Memphis, Tennessee, President Roosevelt in his address on the waterway question said:

"The wonderful variety of resources to be found in different portions of the Mississippi valley makes the demand for transportation altogether exceptional. Such being the case, and this valley being the heart of the United States, the Mississippi and all its tributaries ought to be utilized to their utmost possibility. Facility of cheap transportation is an essential in our modern civilization and we cannot afford to any longer neglect the great highways which nature has provided for us. Natural resources have been and are still being abused, and we have at last reached the forks of the roads. Lands, forests and streams will have to be conserved, and the nation must solve the problem."

HUGE TRACTION ENGINE

This extraordinary traction engine and soil-tilling equipment was built

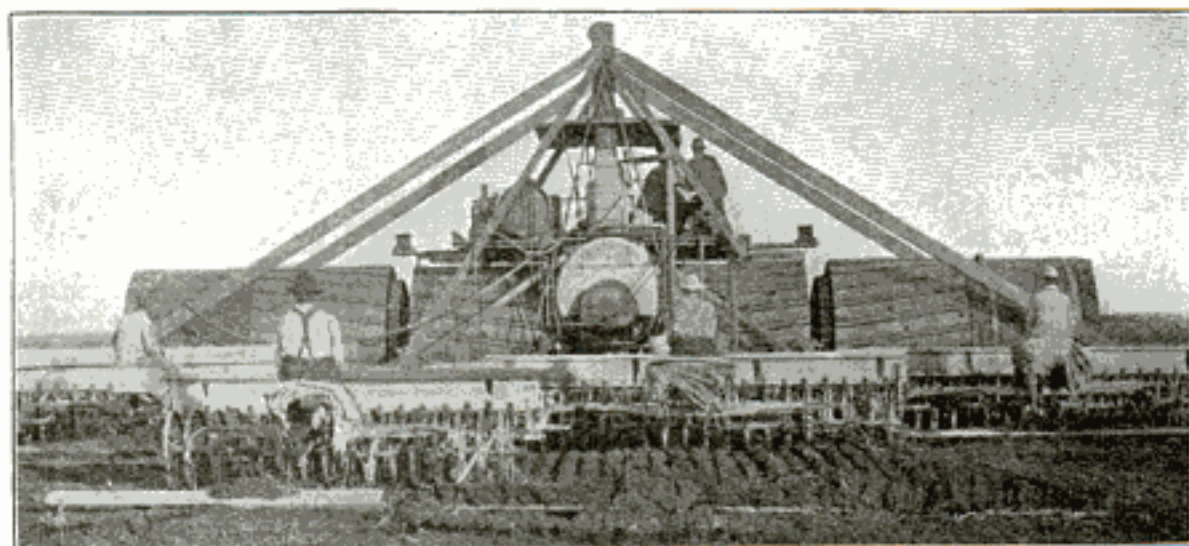

This Mammoth Machine Plows, Harrows and Plants a Strip 44 Ft. Wide at One Time; an Average of 100 Acres per Day

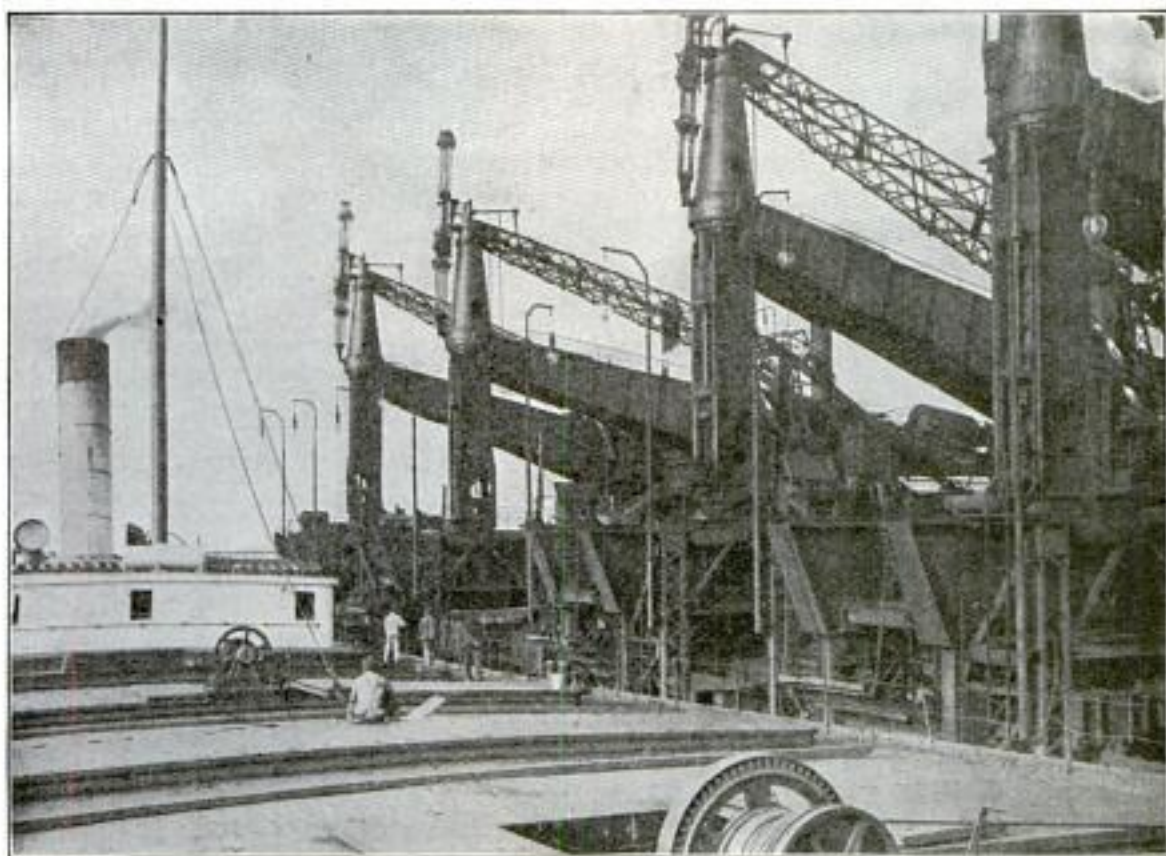

Illustration Copyright, 1907, Underwood & Underwood

Hydraulic unloading machines on docks at Cleveland, O., which will lift 10 tons at a time. Boat sea-going type. These will take the place of the boats and men seen on Page 3.

especially for work on the soft peat land reclaimed from the San Joaquin river west of Stockton, Cal. It has two main wheels, both of which are 7 ft. 6 in. in diameter and 6 ft. wide, and two auxiliary wheels of the same proportions. When used for plowing each auxiliary wheel has a 6-ft. extension, forming a bearing surface 36 ft. wide. The width of tread is 44 ft. 4 in.

In this illustration the machine is plowing, seeding and harrowing a strip of land 44 ft. wide at an average of nearly 100 acres a day.

THE ROLLING STOCK OF RAILROADS

Approximately 300,000 freight cars and 6,000 locomotives were manufactured in the United States in 1906 for use on the railroads of the country. The lumber for these cars involved a consumption of about 1,000,000,000 ft. of timber. To transport the ma-

terial used in the construction of both cars and locomotives at least 200,000 cars were used. Add to this figure the number of cars required to haul the material for bridges, ballast, ties, steel rails, etc., while the railroads have been making improvements and extensions on a grand scale, and one of the reasons for a shortage in cars is accounted for.

STEEPLE-JACK WORKS 672 FT. ABOVE GROUND

E. Capelle, the steeple-jack who painted the steel flag pole which towers 60 ft. above the top of the Singer building, 612 ft. in height, met with many thrilling experiences. The wind velocity at that great height ranged from 10 to 40 miles an hour when no perceptible movement of air was felt below. With a stiff breeze blowing nearer the ground, a velocity of from 40 to 80 miles an hour made itself felt where the steeple-jack was at work. In the

latter instance the pole swayed in a radius of about one foot. Contrary to the general impression, this movement is an indication of strength. A flag pole or steeple which does not bend is dangerous because likely to snap and fall.

TREADMILL TO BE ABOLISHED

It will surprise our readers to learn that there is any such relic of a bar-

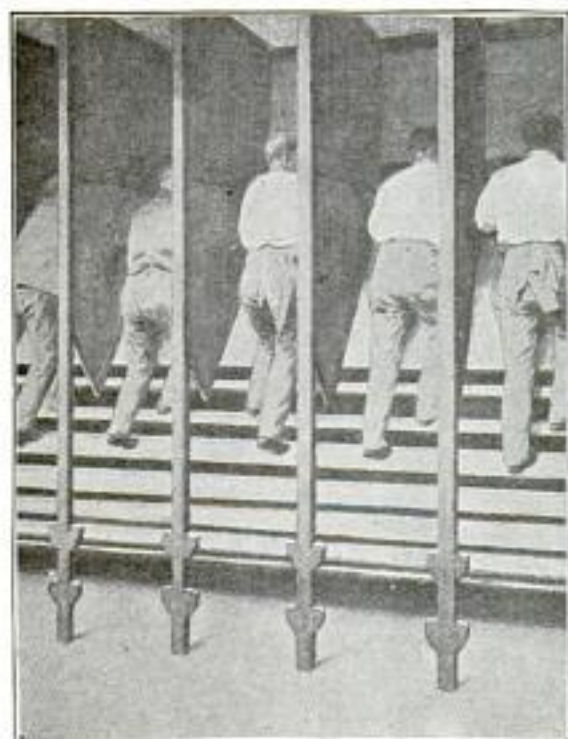

Present Day Treadmill

barous civilization to abolish. Such, however, is the case, and in some of the English prisons the treadmill is this moment turning its monotonous course. Its power serves no other useful purpose than prison discipline.

When a prisoner enters upon his sentence he is given two days at the tread. He does not return to it unless he violates some rule of the institution, and it is said to be an excellent promoter of good behavior, for the recollection of the first experience is not soon forgotten. The guard sits on a lever which acts as a brake to keep the machine from moving too rapidly. The speed is graduated to about 30 steps a minute. If a man misses a step he is

carried down to where a crossbar strikes the calves of his legs, which has an instantly stimulating effect. The performance is like climbing the steps of an endless skyscraper, and ascending at the rate of about 1,000 ft. per hour. The subject is now being agitated, with the probable result that the treadmill will be abolished.

CARRIAGE TOP FOR BOAT

A removable top for motor boats built on the same lines as a carriage top is a recent novelty. The top is made



It Folds up Quickly

of waterproof leather or canvas, as preferred, mounted on a frame which can quickly be taken down and folded up. Side curtains button on.

BLOWING OFF A GAS WELL

Salt water finds its way into the Texas natural gas wells and is forced up to the top in small quantities. About once a week enough accumulates so it has to be blown out, with the result shown in the illustration. The force of the gas sends the water about 15 ft.



Emptying a Gas Well

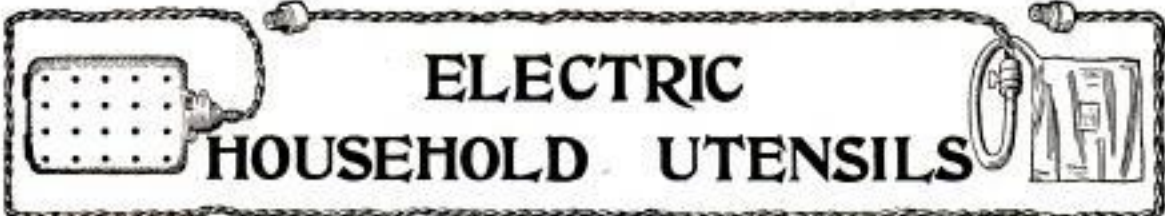

ELECTRIC HOUSEHOLD UTENSILS

While Marconi has been working night and day on a system of wireless telegraphy that is this moment flashing commercial messages across 2,400 miles of ocean, scores of other as earnest inventors have been perfecting electrical devices of practical everyday domestic utility. The names of these inventors are not heard or known outside the electrical trades, but where one woman sends or receives a wireless message, thousands of others will be making use of an electric dishwasher, flatiron or kitchenette.

Machinery which has lightened the hardest labor of the farmer, miner and all other industries which were once laborious and severe, has at last been adapted to the less strenuous but exhausting household work, and electricity has proved to be the medium. To such extent have the labor-saving devices been developed, there is now scarcely anything to be done about the house which cannot be performed by turning a switch or touching a button: Cleaning, sweeping, washing, heating, cooking, chopping,—all these and many more are now done without the expenditure of any strength. The wire that brings in the light brings also a tireless, ever-ready force which instantly responds to every call by day or night.

In order to actually show the workings of electric household utensils, many electric service companies have fitted up a demonstration room at convenient places, where the public may come to see and learn. One of these exhibits is shown in the illustration below, where the practical utilities and labor-saving possibilities of electric utensils for a modern residence are seen in operation. The electric flat iron, the meat chopper, with roasters, bakers, and a great variety of

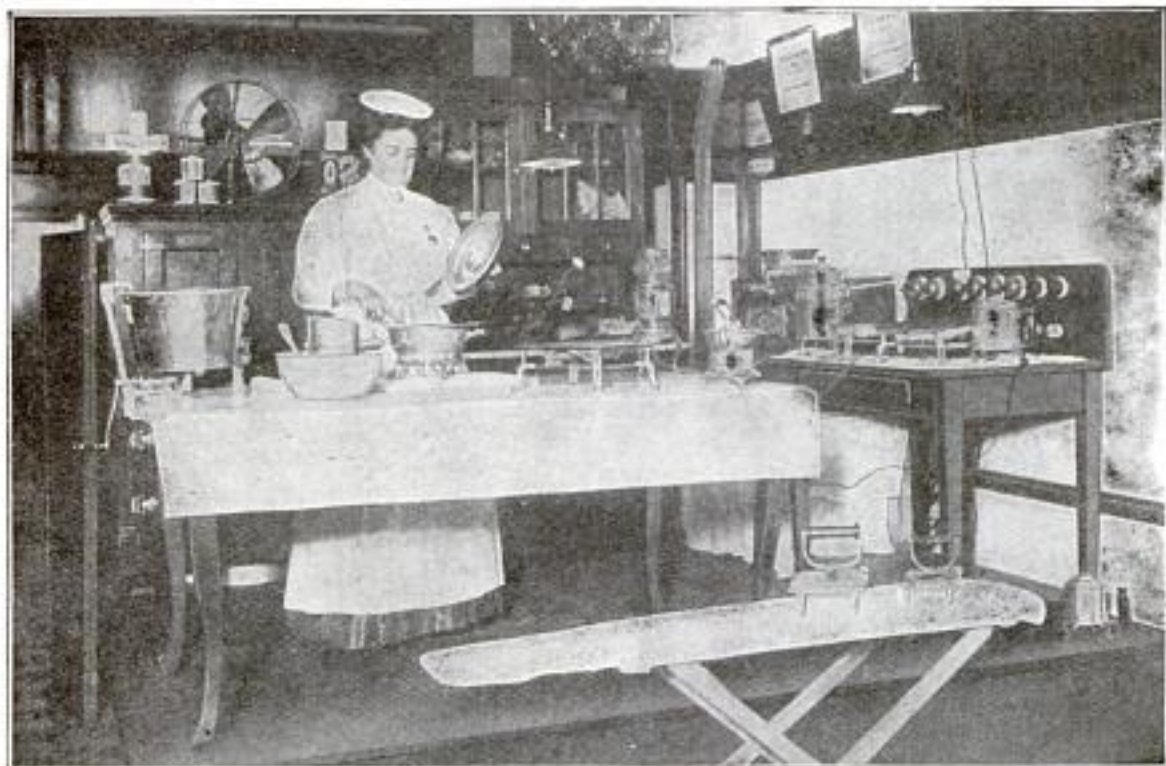

Demonstration Room—Free Lessons in Electric Cooking

other cookers are all there. No fire to wait on a tardy supply of kindling, no chimney which fails to draw, no oven which refuses to heat to the necessary temperature. Instead we find a row of switches by means of which ten fires can be kindled in as many seconds, and each fire instantly attains the desired amount of heat. No coal or wood to bring in, no ashes to remove with the accompanying dust and dirt, and when the fire is no longer needed it is put out as quickly as it came. Meanwhile a bright light making the room cheerful, and an electric fan to keep it cool, has helped to make the electric kitchen a joy and a satisfaction. Not so many years ago it would have ranked as a marvel of passing wonder.

For the heavier work of operating the washtub and wringer, running the



Household Electric Utensils Now Coming Into General Use

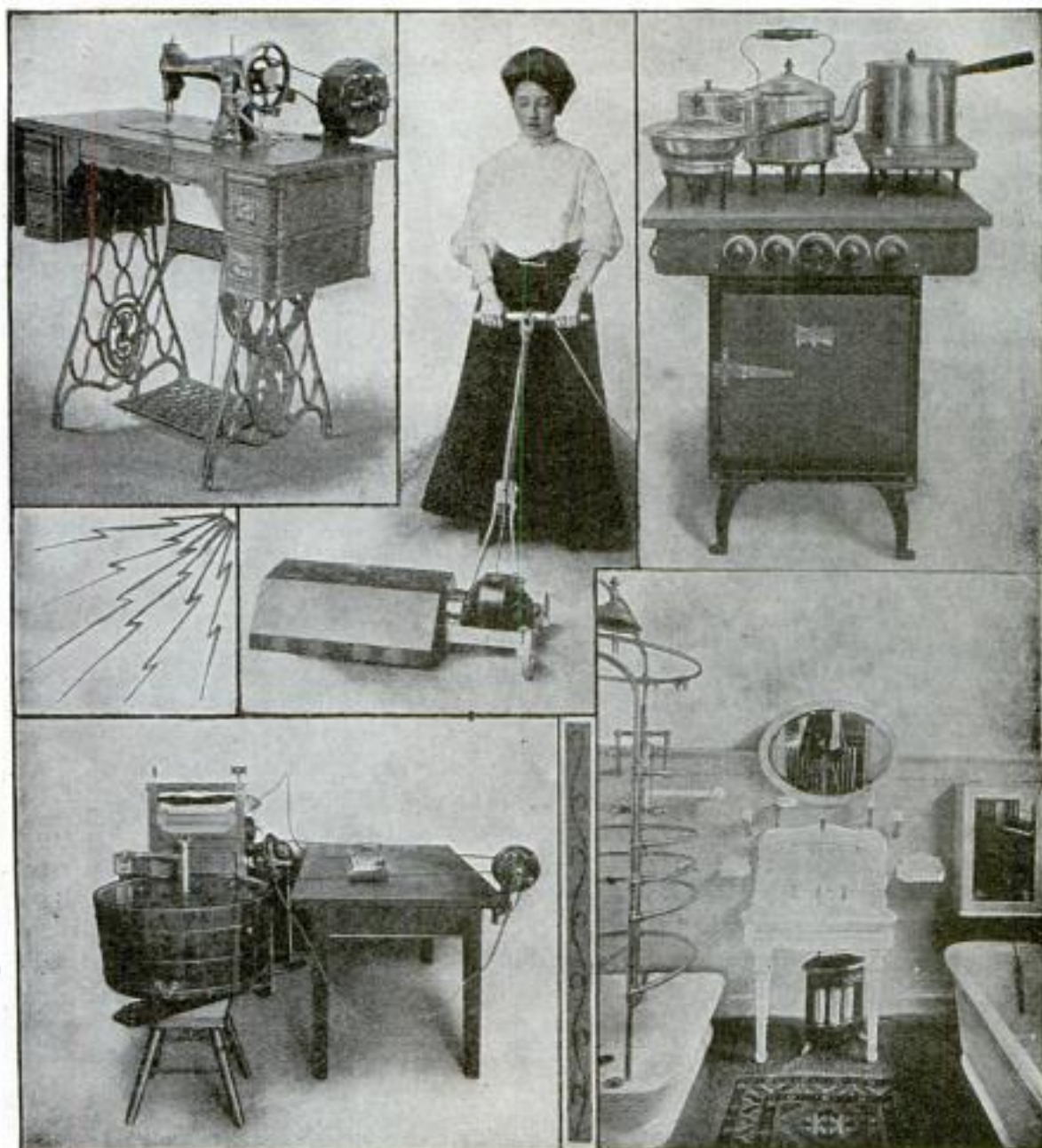

Sewing Machines, Sweepers and Wringers Run by Motors

sewing machine, or driving the floor polisher and sweeper, there are motors which require no effort and are as easy to operate as a front door bell.

Automobiles, airships, and submarines were all predicted half in earnest, half in jest, a century or more before they were achieved, but no prophet thought to foretell or dared to voice the coming of the day when the weary duties of daily housekeeping should be largely robbed of their terrors.

OCEAN TRAVEL IN 1907 BREAKS RECORD

All records in the transportation of passengers across the Atlantic were broken during the first ten months of 1907, during which 2,000,000 traveled

across. If only \$40 were allowed as the average passage money, this volume of human traffic would represent an expenditure of \$80,000,000.

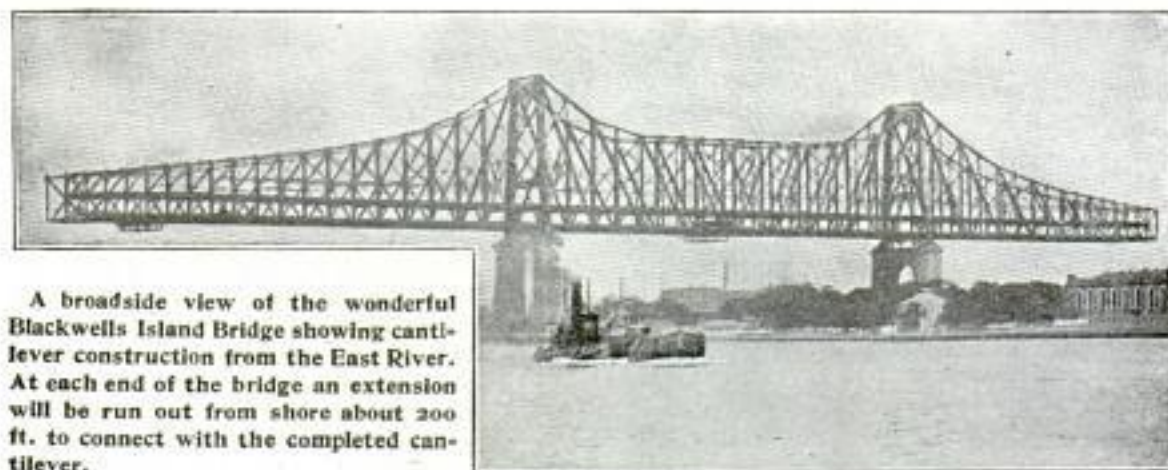

A broadside view of the wonderful Blackwells Island Bridge showing cantilever construction from the East River. At each end of the bridge an extension will be run out from shore about 200 ft. to connect with the completed cantilever.

From Stategraph Copyright 1917 by Underwood & Underwood N. Y.

ARMY WATER STERILIZER

This portable army outfit for water sterilizing was turned over to the United States government in August. It has a capacity under test of 400 gal.



Capacity 400 Gal. per Hour

of water per hour, 270 gal. more than the requirement demanded by the government. Exhaust steam from the pump is used to operate the heater of the sterilizer.

NEW LAMB-TAILING INSTRUMENT

A new device is being manufactured in Australia for use by breeders in the task of separating young lambkins from their tails. This machine sears or burns the tail off in a simple and effective way.



The knife has been the usual instrument used for this operation, but it is

always attended with loss of blood, which hinders the growth of the lamb.

STEEL FREIGHT CARS IN INDIA

The freight cars on the Bengal-Nagpur railway in India are small compared to the freight cars of this country, and resemble somewhat a large covered wagon. The body of the car

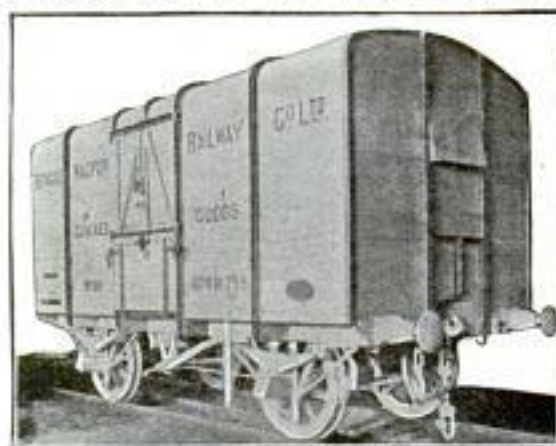

Courtesy of Indian Ry. Gazette

Steel Car Used in India

is constructed of light steel plates and the flooring is made of teak-wood boards. This car is used for heavy goods traffic and carries a load of 32 tons. The ends of the car are fitted with ventilators.

The Hamburg-American liner "Borussia", running between Hamburg and Brazil, foundered recently while coaling. A strong tideway caused the ship to list and the water rushed into her coaling ports.

GERMANY AND FRANCE BATTLE FOR AIR-SHIP SUPREMACY

Military Dirigible Balloons of Both Nations in Wonderful Flights--Talk of Prohibiting Foreign Air-Ships from Germany's Atmospheric Zone

Germany and France have for the past year been indulging in a duel of brains for the supremacy of the atmosphere, which, gradually gaining interest as first one and then the other tossed into the air a military dirigible air-ship of superior power and perfection, has done much to stimulate other nations to achievement in this line.

The changes are so rapid that one, not watching closely the efforts of the two countries, becomes lost in a maze as first one air-ship and then another is heralded as the best. Three months ago a German air-ship had made the longest flight. Then "La Patrie," the pride of the Parisians, in a wonderful flight, eclipsed anything hitherto accomplished by dirigible balloons. September 24 was ushered in by the ascension of a German air-ship which outpointed the "Patrie" in distance and speed. Today, unless watching the duel to the very minute, you will not know which country holds the record.

Germany is straining every effort to gain the advantage and France is losing no time. One million dollars has been voted by France for the construction of a fleet of the "Patrie" type. Both Germany and France are frankly uneasy at each other's success. An air-ship of the "Patrie" type could fly over Germany and photograph all the German fortifications, and vice versa.

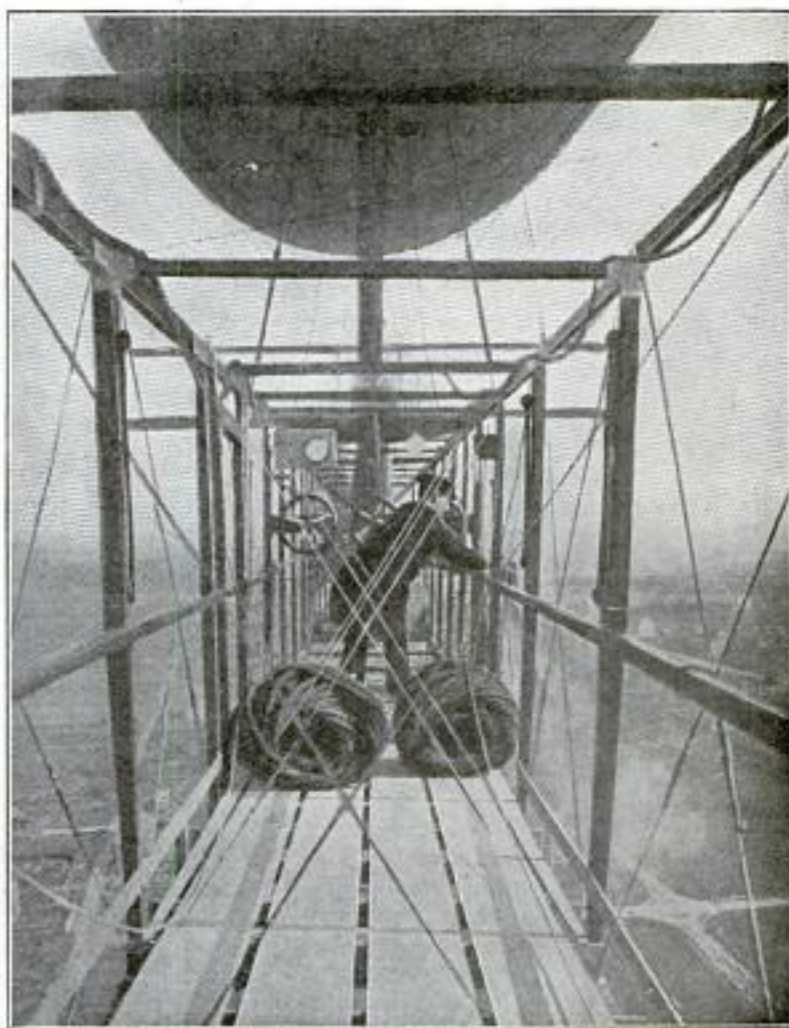

On the Deck of an Aerial Warship--1,500 Ft. Elevation

Germany is now stirred by the idea that considerations of national defense render it essential to regulate aerial navigation by legislation. One German military writer urges that foreign air-ships should be prohibited from sailing Germany's atmospheric zone even in times of peace, and that a law should be passed enabling the military authorities to destroy by artillery or otherwise all foreign air-ships perceived in the firmament above.

"La Patrie," the French air-ship, is a dirigible balloon about 250 ft. long over all. It can carry six men with ease, and two months ago was the near-



Spanish War Balloon in Flight

est approach to aerial navigation by a vessel lighter than the atmosphere. M. Clemenceau, the French premier, and Gen. Picquart, minister of war, made successful ascensions in the "Patrie." One of the most interesting flights of the French air-ship was accomplished under schedule. On August 8 the ship visited President Fallieres at his country seat at Rambouillet, 21 miles distant, arriving at the minute scheduled and at the exact spot designated for



Ascension of the Wellman Ship, 1907

the landing. The ship made the 21 miles in 45 minutes.

On July 23 one of the German dirigible balloons made a remarkable flight over Berlin, remaining in the air $3\frac{1}{2}$ hours, a quarter of an hour longer than the "Patrie's" record at that time. Both of these flights, however, were distanced on September 24 by the German air-ship under the command of Count Zeppelin, one of the inventors of the ship. He is 69 years of age and the oldest aeronaut ever in active control of an air-ship in flight. This dirigible balloon completely circum-

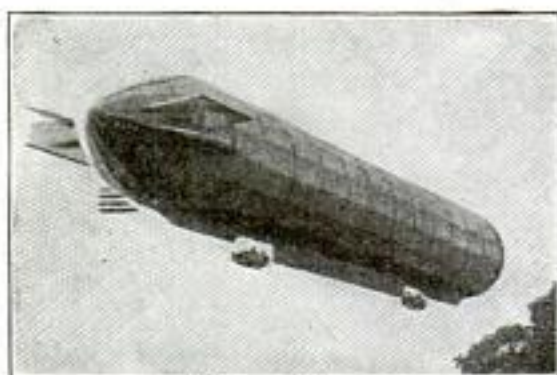

Zeppelin--"Dreadnaught" of the Air

navigated the Lake of Constance and passed over five different states. The speed of the ship was estimated at about 38 miles an hour. The time spent in the air was 4 hours, 17 minutes.

When the battle for supremacy of the air commenced England was hardly considered as a rival and the United States even less so. Great Britain suddenly set to work, and a shadowy form arose, took shape, and England's first dirigible balloon unfurled the British flag, 1,500 ft. above the British isles in answer to France and Germany's challenge. Illustrations of the English air-ship were shown in previous pages of this magazine. In one of its recent flights the English air-ship crossed the Thames at Blackfriar's bridge and then circled around Trafalgar square, over the war office and past Westminster abbey and the houses of parliament.

The United States war department has recently decided to construct its first dirigible balloon, but no date has

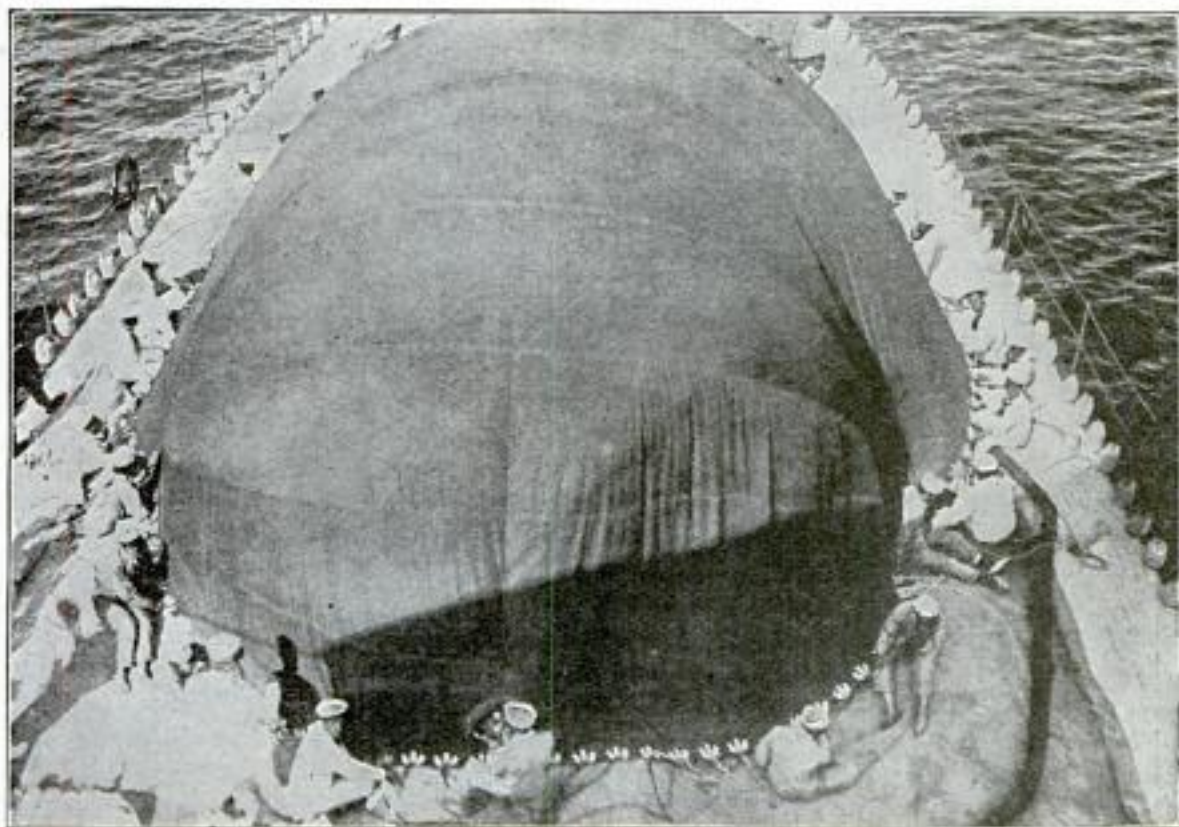

Inflating the great war balloon "Dragon" on board the Italian battleship "Elba." The Italians are the first to adapt the balloon to naval work. The balloon, which was kept captive by the vessel, was sent up 300 ft., carrying two aeronauts who made observations during the naval manœuvres.

been given out as to when the construction will begin. It is expected that the American airship will bring into service all the foreign inventions and several added contrivances which are being kept secret by the government. Many of the details are withheld from

the public, as the policy of the war department is to keep as quiet as possible until the balloon is completed. According to present plans the dirigible balloon will be 190 ft. in length, have a capacity of 50,000 cu. ft. of gas, and run 35 miles an hour.

TESTING THE BIG NILE BRIDGE



After three years of work, the largest bridge across the Nile has just been completed from Cairo to the island of Rodah. The bridge is 1,740 ft. long, and 65 ft. wide. The official test subjected the bridge, span by span, to a weight equal to 400 lb. per square yard. To accomplish the test 20 cars, 24 water carts, and 20 dust carts, all of which were loaded with cement, sand and water, and 8 steam rollers stood on each span for 24 hours. The entire procession crossed the bridge from end to end.

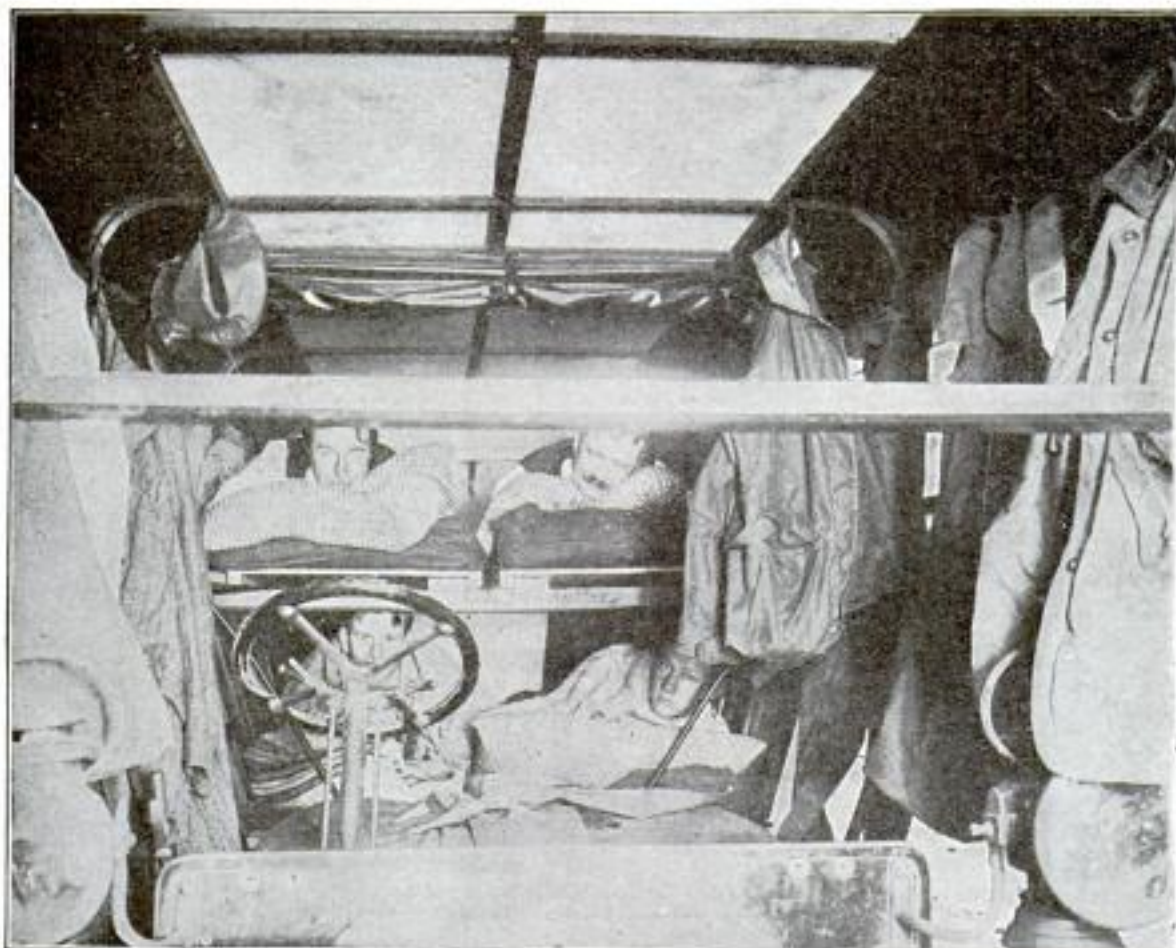

HUNTING IN AN AUTOMOBILE

Automobiles are being used for about everything these days by ingenious owners, from sawing cordwood and driving printing presses to carrying money in a Wall street panic, but the possibilities are not yet exhausted, apparently. Roy Faye, a Boston autoist, has converted his car into a traveling camp for hunting in the Maine woods. He has built an extension top of heavy waterproof canvas and fitted up the rear end of the interior with bunks for sleep-

ing quarters at night. Along the inside of the tonneau and canopy are arranged hooks on which to hang clothing and hunting accoutrements.

The berths in the car have been adjusted by widening their hangers 4 in. This makes it possible to keep the beds made up ready to be dropped into place when needed. The blankets have been converted into semi-sleeping bags that fold up with the pneumatic mattresses in such a manner that they fall easily into place when the berths are lowered. A large canvas tent is taken along, which can be attached to the car and give additional quarters, making the whole as spacious a camp as any built for permanent use. The provisions are packed in chests in the body of the car, each chest having many compartments. Folding tables, cooking utensils arranged in nests for more convenient transportation, and other things add to the comfort of camping expeditions.



Extension Top is Canvas

CABLE REPAIRING BUOYS

The two immense steel buoys recently added to the equipment of the big cable repairing steamer, "Restorer," stationed in Honolulu harbor, were used for the first time in repairing the break in the Pacific cable between Midway island and the island of Guam.

The buoys are 11 ft. high and 7 ft. in diameter at the middle. They weigh 8,600 lb. each. When submerged to a depth of 6 ft. each buoy will carry a weight of 14,391 lb. The buoys are made with three airtight compartments, with man-hole doors in each. One of these doors is through the outer shell at the top and the others inside on the bulkhead. The buoys are visible from the deck of a vessel 10 miles distant.

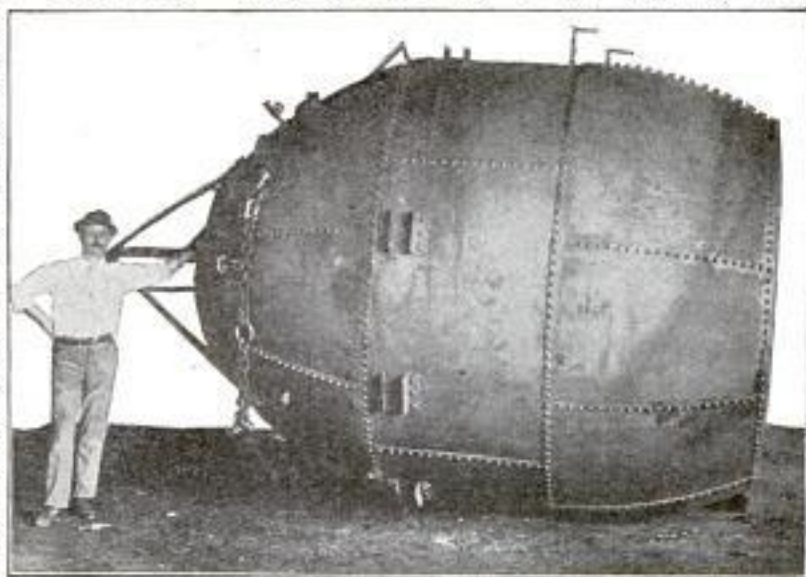

Courtesy of DeLima, Hall & Co., Brooklyn

Buoys for Cable Repair Ship's Kit

the mire oozing back almost as fast as they could throw it aside, 50 men formed a human chain and pulled him out. As they worked the captive gradually sunk deeper and deeper until his nose and mouth were beneath the surface when they reached him.

STEERED BY PROPELLERS

The North German Lloyd steamer "Kaiser Wilhelm der Grosse," en route from New York to Cherbourg, by way of Plymouth, England, lost her rudder in a raging storm when two and a half days out from New York. She steamed the rest of the distance to Plymouth, 1,750 miles, steered by her propellers alone. This was accomplished by alternately driving and stopping the screws on one side and then on the other.

HOW TO RESCUE MAN SINKING IN MARSH

The necessity for quick thinking, followed by as quick action, sometimes brings out a startling ability to cope with difficult situations. Recently, while a number of men were going to their work they saw the head of a man slowly sinking into a marsh near Williamsburg, Pa. The mire was in the bed of a narrow creek and the men

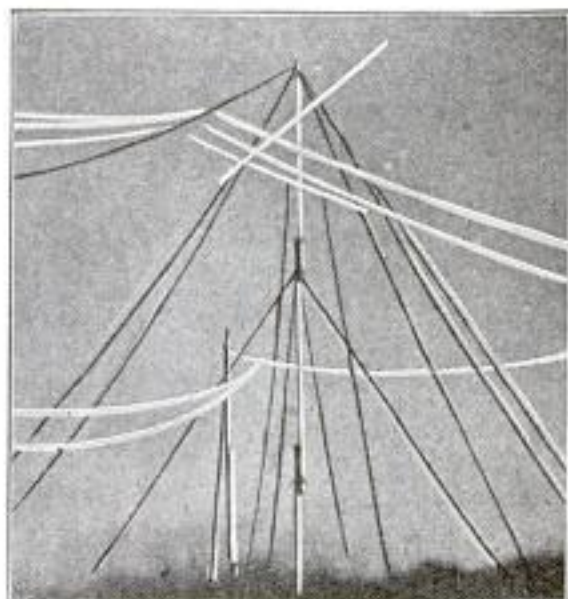

Although the electric waves which transmit wireless messages are invisible to the naked eye this wonderful photograph is believed to be an actual reproduction of a Marconi message leaving the wires on its journey across the Atlantic ocean. The plate was exposed at night while experiments were in progress.



Curious freak photograph taken by a Portland, Me., artist at Sebago Lake, Maine.—Courtesy the Motor Boat.

BRIDGES FIRST; THEN CANAL EXCAVATION

A novelty in engineering construction will be a feature of the digging of the Evanston channel of the Chicago drainage canal system. The bridges which will span the canal will be made of concrete and placed in position on heavy concrete foundations ready to use before the ground is excavated. Engineers have informed the drainage board that the erection of the bridges before the trench is dug will prove not only possible but more economical than otherwise.

LOADING RAILROAD CARS WITH SAND

This structure was built to simplify the loading of railroad cars with sand. To get an easy grade for the teams the approach was made 80 ft. long. Brakes on the wagons made it possible to construct the down incline much shorter. A trap door in the floor allows the sand to fall through.

The break in the Pacific cable has been found and repaired.

ECONOMY IN FUEL ON OCEAN LINERS

Wonderful advances have been made in marine engines during the past few years, not only in construction, but in economy of fuel as well. An 8,000-ton ship built for the Hamburg-American line in 1890 burns nearly twice as much coal as a 17,000-ton ship built for them in 1906. The White Star liner "Baltic," 24,000 tons, burns less fuel than the 7,000-ton "Bretagne," built in 1886. At the beginning of ocean steam navigation it took 550 tons of coal to drive a 2,000-ton vessel across the Atlantic at a speed of 9 miles an hour. Today a 20,000-ton vessel can be driven across at a speed of 23 miles an hour on a



Sand Falls Through Trap Door Into Car

consumption of only 3,000 tons of coal.

Work has commenced on the Cape Cod canal.

FOOD FROM THE AIR

**Chemical-Mechanical Process Which Scientists Have Sought for Years
Apparently a Great Success**

By Carl Shelley Miner, Consulting Chemist for Popular Mechanics

The first great step in the series of experiments that will eventually result in the substitution of the processes of the laboratory for the processes of life in producing food, is an accomplished fact. Quietly, almost without our realizing what has happened, this thing has come to pass. We can actually make food out of air. Not a food for man,

often fifty million of them exist in a single ounce of soil have the power of "fixing" the nitrogen of the air or, putting it more clearly, they are capable of making the nitrogen of the air into a food for plants. The plants then take the nitrogen as it has been prepared for them by the bacteria and make of it a food for animals by their

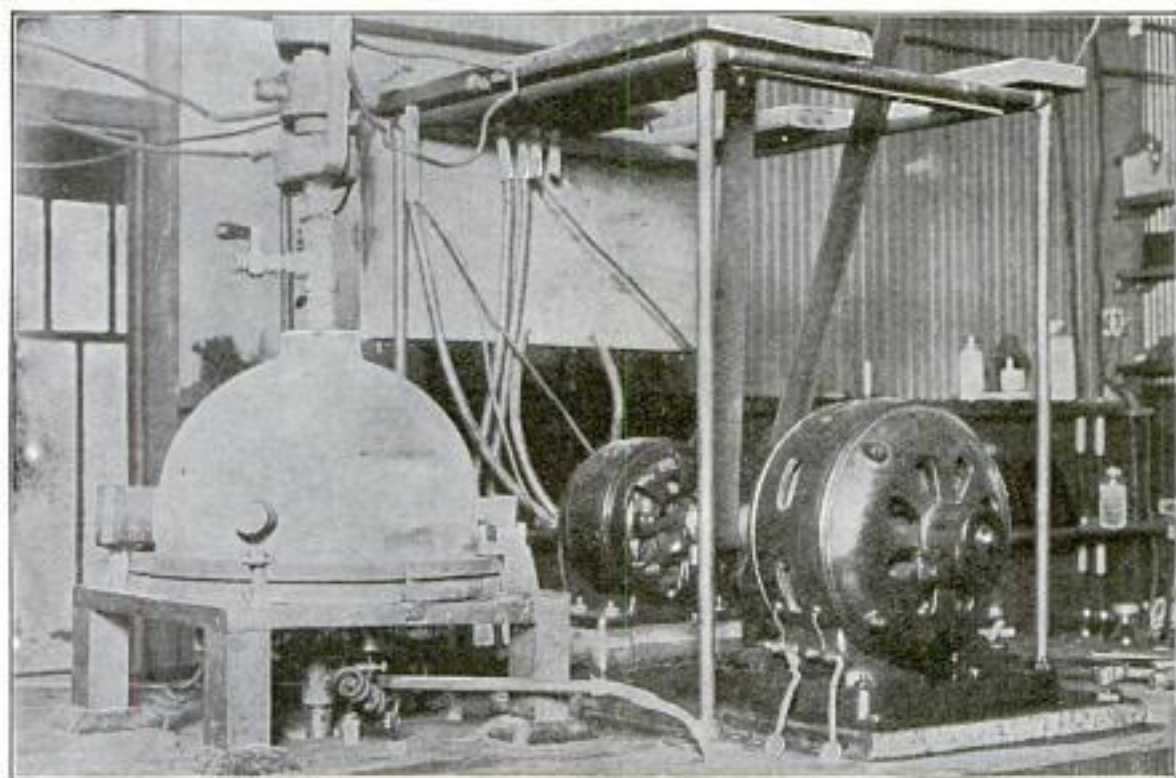

Courtesy of William Thomas, inventor of the process.

Apparatus Which Extracts Nitric Acid from Air

only a food for plants, but made directly from the air around us by a chemical-mechanical process.

Nitrogen is the most important element in our food, and though it comprises four-fifths of the air, it must go through a series of intricate processes before it can be of any value as a food for man. As it exists in the air it can not be used even by plants, but certain species of bacteria so small that

own processes; but plants, with exception of the legumes such as beans and peas, are not concentrated nitrogen foods, and it remains for the animals, by eating the nitrogenous compounds of the plants, to make of them a highly concentrated nitrogenous food, meat, which despite the struggles of the vegetarians still remains the great staple of human diet.

It is this series of processes that the

chemist must imitate in the laboratory before he can hope to produce food-stuffs without the assistance of plants or animals and already he has succeeded in doing the work of the nitrogen fixing bacteria, for he now makes a nitrogenous plant food from the air without their help.

A few years ago Sir William Crookes, one of the most noted of living scientists, called public attention to the fact that if some new method of furnishing nitrogenous food for plants were not discovered in less than 50 years a tremendous famine would sweep the race of men from the earth. It had long been known that the bacteria were not able to furnish nitrogen for the plants as rapidly as it was needed for our enormous crops and for years they had been helped out by the use of fertilizers, materials containing nitrogen



30,000-Volt "Fixation" Flame

in more or less concentrated form, chief of them being Chile saltpetre or sodium nitrate. It was the certainty of the eventual exhaustion of the beds of this material that brought out Sir William Crookes' warning. Since then only a few years have passed, but chemists everywhere have been investigating this problem and several satisfactory solutions have been offered, two of which are already being operated profitably. All the processes combine the nitrogen of the air, where it exists in absolutely unlimited quantities, with some other element in such form as to make it available for fertilizer.

In Italy and Germany, an invention of Professor Adolph Frank is being used to produce an excellent fertilizer called calcium cyanamide. This compound is produced by passing nitrogen

gas considerably purer than that of the air over heated calcium carbide, with which it combines to form a readily available fertilizer material. Several foreign and American processes make use of the well-known fact that when a mixture of nitrogen and oxygen such as air is brought into contact with the flaming electric arc, a chemical combination of the two gases called nitrous oxide is formed, which may readily be combined with minerals such as calcium or sodium to form excellent fertilizers. By one method used at Niagara for a time, a shaft carrying a large number of points electrically charged, revolved inside a cylinder carrying an equal number of points electrically charged, and thus by continually making and breaking a very large number of connections a great number of flaming arcs were formed and by passing air through the cylinder nitrous oxide was produced. This process, however, did not prove to be a commercial success and the company has now abandoned operations.

The Norwegian company has been more successful. They use the Birkland-Eyde process. In this process a flaming electric arc is drawn out by means of a magnet into a fan shape and the air is driven through this intensely hot arc. By this means a considerable quantity of the nitrogen and oxygen are brought into combination as nitrous oxide and by a simple subsequent process it is combined with lime to make calcium nitrate. This process has been operated successfully for some time and will undoubtedly be of great value wherever exceedingly cheap power is available, as it is at Notodden, Norway, where the present plant is in operation. That it can be made universally available is still doubtful.

The aim of the Chicago investigators, who have been working for many years, has been to perfect a process to make possible the utilization of the nitrogen of the air at a price that would make the operation of factories commercially profitable wherever power at ordinary prices is available. At present they are operating an experi-

mental plant in Chicago, where they claim to produce nitric acid at something like one-tenth of its present market price. They make use of the same principle which forms the basis of the Bradley-Lovejoy and Birkland-Eyde processes—namely, the action of the flaming arc on air—but their process is distinctly different from either of its predecessors. The main feature of their plan is the use of a closed chamber in which the gas is treated under pressure. In this way a more concentrated product is produced, and waste of power by heating large quantities of air is avoided. The second important feature is the flame, a peculiar elongated arc which is produced by using a pressure of 33,000 volts, but which is several thousand degrees colder than the Birkland-Eyde flame. In fact, the gases come from the chamber almost as cold as when they enter it, thus showing that the electrical energy has been used, not to heat the gases, but to actually combine them, which goes far to prove the superiority of this "fixation flame," as they call it, over the arcs formerly used. As the process is now operated in their plant it is briefly as follows:

The air is introduced into a small hemispherical chamber under pressure. The valves are closed and the arcs turned on for a period of about five seconds, during which there is a considerable rise in temperature and a consequent increase of pressure. The outlet valve is then opened and practically all the air is driven out by its own pressure. The outlet valve then closes automatically, the inlet valve opens at practically the same time, a new charge rushes into the chamber and the operation is repeated. The gases as they leave the chamber consist of a mixture of air, with a small amount of nitrous oxide which combines with oxygen and water to form nitric acid or with lime to form calcium nitrate. I have seen the plant in operation and there can be no question that the nitric acid is actually produced, and if the process works out as

satisfactorily on a large scale as it has in this experimental plant, the fertilizer problem is solved and incidentally the fortune of the inventor is made.

With two commercially successful methods of utilizing the nitrogen of the air in operation and this latest one which bids fair to lower the cost of production still further, we may fairly consider this problem solved and the danger of a strike of the International Federation of Nitrogen Fixing Bacteria a thing of the past.

MARCONI WIRELESS TRANSMITTER

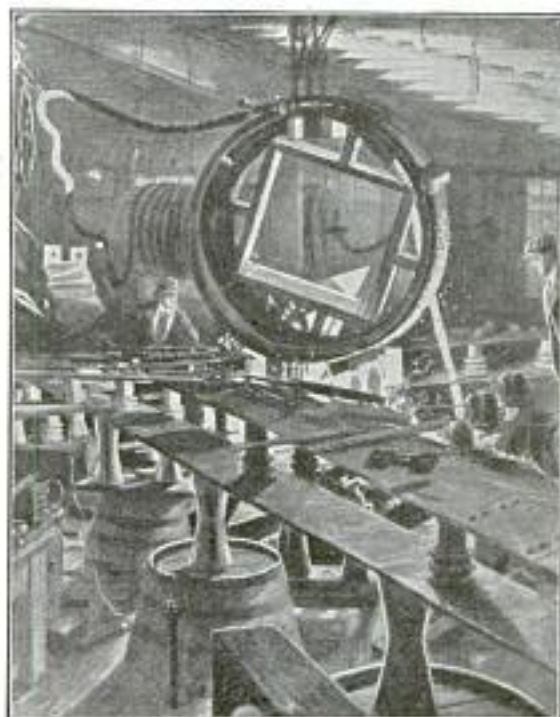

The Transmitter

This illustration shows while at work the Marconi transmitter which catches the spark that speaks across the Atlantic ocean. The plates which radiate from the huge coil in the center of the shed are connected with a great series of galvanized iron plates hung parallel to one another in an adjoining room. For a second or two before the message begins to arrive there is a sound like a deep growl of thunder, then the spark passes with a rending detonation. For the rest of the time taken to receive the message, the noise resembles that of a machine gun in action.

DIABOLO A CENTURY OLD

Diabolo, the fascinating game which, for the past few months, has been the



From an Old Print

rage in England and on the continent, has at last been whirled across the ocean to this country by the enthusiasm of the players. It is not a new game, however, as many suppose, but a return to one of the most popular pastimes of the French court during the earliest days of the Empire. It is said that the game was introduced just before the final fall of the Monarchy to keep the court so busy with "foolishness" that there would be no time for intrigue.

KEROSENE TRACTION ENGINE

The latest improvement in traction engines is the one driven by a gasoline-kerosene engine. It is air-cooled, which does away with the water jacket entirely, making the machine especially adapted to winter use or cold climates.

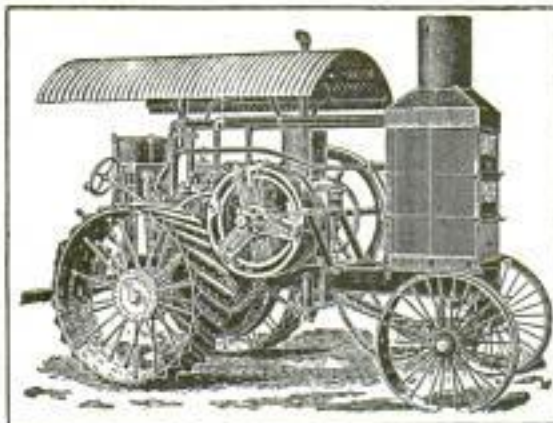

It Is Air-Cooled

As no steam is made, there is an entire absence of sparks and smoke.

DON'TS IN ELECTRIC LIGHTING

Don't let the office boy or any one else who does not understand make changes in electric wiring or lights. They may do the very thing they ought not.

Don't let a socket on a fixture hang loose. Have it repaired. Otherwise it may cause trouble where least expected.

Don't try to save a little by running flexible wires over boxes, partitions, and into closets. Have permanent wires installed. These flexible wires used this way are dangerous.

ROAD GRADER ON HINGED AXLES

This road grader leaves as clean a

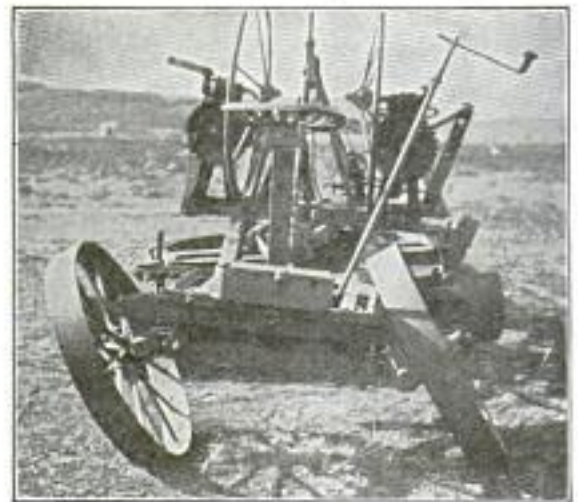

Works on Hillside

path behind it on a road that slants abruptly toward the curbing as on a road absolutely level. The scraper blade is set at an angle. This would put a severe strain on the spokes of the wheel and cause the rims to slip sideways on a slanting street if it were not that the axles are hinged, allowing the wheels to be tipped to suit the work required.

The average man can lift 225 lb.

DIRECT CURRENT ELECTRIC LOCOMOTIVES

The Pennsylvania railroad is experimenting with the different types of

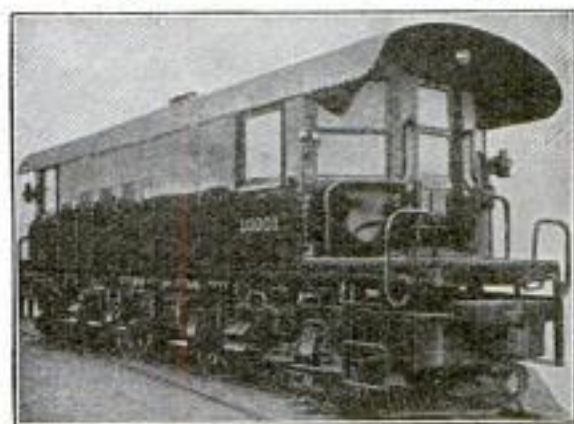

Electric Locomotive

electric locomotives for the purpose of determining which is the best adapted for pulling its heavy passenger trains through the New York tunnels. This illustration shows one of the direct current locomotives undergoing tests. It is equipped with four 350-hp. geared motors. The trucks are of the 4-wheel type. The driving wheels are 56 in. in

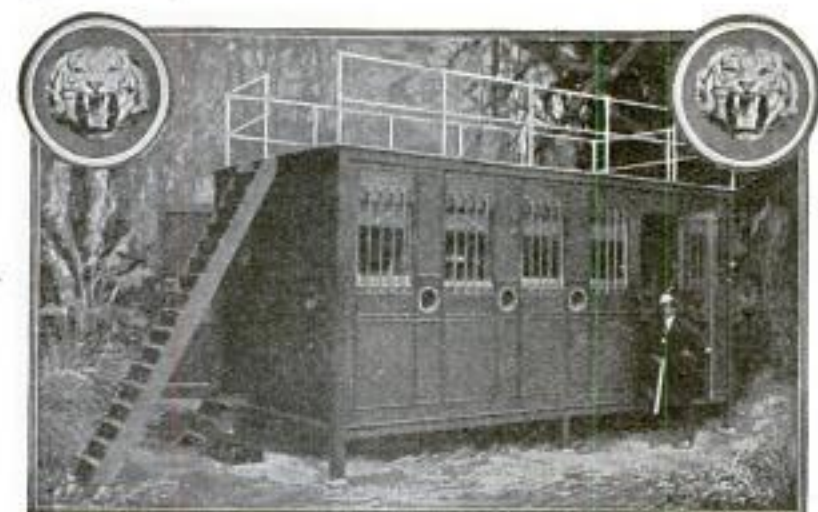

The Jam's Luxurious Shooting Box

diameter, fitted with removable tires.

Another engine, almost identically the same in exterior appearance, is equipped with four gearless motors.

White spots on table tops may be removed by applying a wet cloth pressed down for a few minutes with a hot flatiron.



WHITEST CRACKER IN THE WORLD

The rice flour cracker of China is by far the whitest biscuit product in the world. In comparison with it the whitest American biscuit looks dingy. This cracker, however, is altogether too sweet for most occidental palates and the Chinese much prefer their black cracker, which differs but little in taste from the American sweet biscuits.

SAFE WAYS OF HUNTING BIG GAME

Prince Ranjitsinhji, the Jam of Nawanagar, India, hunts big game and has had constructed for this purpose a wonderful movable shooting-box. The windows are heavily barred and port-holes are pierced every 3 ft. around the sides. The interior is decorated in Queen Anne style, and filled with sofas, writing desks, bridge whist tables and comfortable chairs. The floor is covered with Persian rugs. The exterior is painted green in order that it may blend with the jungle.

The box is taken to pieces, sent by rail to a given point, and drawn by oxen or elephants into the heart of the jungle. It is left there until the tigers have become accustomed to it, and when the royal sportsman arrives later there is no lack of game. The shooting is done through port-holes provided for the purpose.

THE AMPHIBIOUS AUTO

Navigates Land and Water Successfully—Climbs Hills and Banks



The Machine Repeatedly Entered the River and Climbed the Bank

"Waterland," the French auto which climbs river banks and hills, or dives into the river and swims, was given a demonstration in the Hudson river. It was brought over by its inventor, Jules Reveillier, and is the same type of machine exhibited in France a year ago and fully described in these pages at that time. It is a boat having four

solid wheels for travel on land, in addition to a propeller for use in water. The power is shifted from one to the other by means of a lever. The land speed is 20 miles an hour; the water speed 9 miles. The demonstration was a complete success, as seen in the illustrations, but the commercial value of the machine appears to be doubtful.



"Waterland" Attracted Attention When Traveling Along the Street

AN AMERICAN AEROPLANE

America is rapidly contracting the flying fever, and with the "hustle" which characterizes the American in business or pleasure, it will not be long before this country becomes a seriously considered rival to France.

The latest American aeroplane to spread its wings to the breeze in trial flight is the "Aeriator," a machine constructed by George A. Lawrence, Sayre, Pa. In its first trial the machine flew a distance of 200 ft. at a height of 40 ft. above the ground. The second trial was attended with about the same amount of success.

A larger aeroplane, of the same model, is being constructed with which the inventor hopes to compete at the next airship contest. The new machine will be capable of carrying three ordinary persons, and will measure 37 ft. from tip to tip of wings. Motive power will be generated by a 60-hp. engine capable of driving a 7-ft. wheel 900 revolutions a minute. A 9-hp. emergency engine will also be installed to drive a 3-ft. wheel at 1,500 revolutions a minute.

BOAT DRIVEN LIKE A FISH

Predictions are made that before long the "vertebrate" propeller, a new invention shown privately to a party of naval engineers and yachtsmen in New York, will become a subject for serious consideration by engineers.

The piston rods of the four cylinders used to drive the propeller pass through the bottom of the boat and connect directly with a flexible steel plate, which, lying parallel with the hull, forms the propeller. The vertical movements of the piston rods impart to this plate a sinuous motion similar to the movement of a fish's tail. The

rods are supplied with suitable stuffing boxes where they pass through the bottom of the boat.

FLOATING HOSPITAL FOR NEEDY SICK

Ploughing her way through the water, carrying a load of suffering humanity on health-giving trips, Boston's

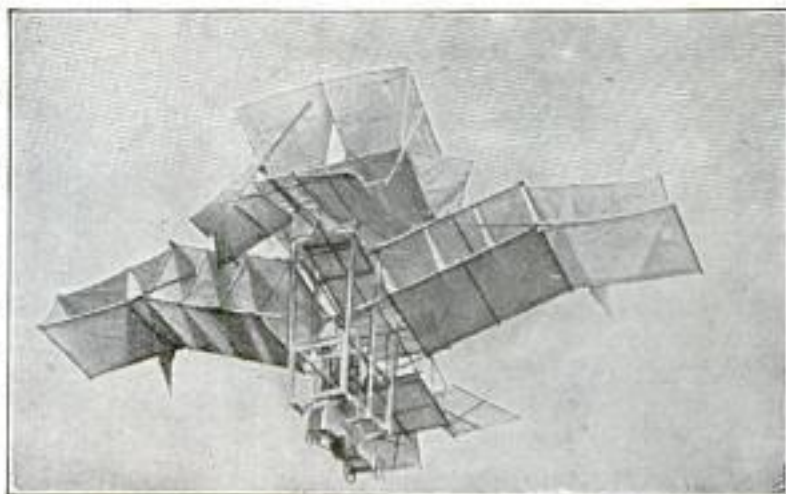

The Lawrence Aeriator

new floating hospital has become one of the sights of Boston harbor. The boat was built especially for this mission and every day carries the needy sick from the poorer sections of Boston into the clear, pure atmosphere.

The boat is twin screw, built of steel and has four decks, designated as the main, hospital, out patients' and hurricane decks. The length of the boat over all is 170 ft., beam 45 ft., depth



On Red Cross Duty

at side 10 ft. 8 in. The gross tonnage is 594. The hull is of steel, subdivided into seven water-tight compartments.

Asbestos shingles, made of asbestos fiber and cement, absorb about 5 per cent of their weight in water.

SPECIAL INDUSTRY EXPOSITIONS FAVORED BY GERMANY

The German Commercial Union some time ago sent circular letters to the German chamber of commerce to learn their views with reference to a world's exposition at Berlin in 1913. In answer the chamber of commerce at Mayence adopted the following resolution, which seems to voice the opinion generally entertained:

"We cannot recognize the holding of a world's exposition at Berlin as in the interests of Germany's industries, and believe it more advisable to organize for all products of human activity international expositions of a special industry, as only such can have the effect of fructifying and stimulating the industries and trades."

Concerning this resolution Kumlow's German Trade Review says:

"The chamber is therefore of the opinion that from its district no substantial participation can be expected in a general world's exposition, but that such could be expected in special industry expositions, providing they do not succeed each other too quickly."

COST OF SPEED AT SEA

Many people do not realize the great price the owners of fast ocean liners pay for every mile of speed added to the average day's run. Statistics show that when an ocean liner exceeds a speed of 15 or 16 miles an hour, the expense of operation must be sought after outside the receipts for cargo—in government subsidies, perhaps.

The average ocean freighter rarely exceeds a speed of 12 miles an hour, and at this economical rate can profitably carry freight to any part of the world, providing she flies a foreign flag. American ships are at a disadvantage, because the operating expense—size and wage of crew, etc.—are so much greater.

The shipbuilding plants on the Clyde are now ready to build 1,000-ft. ships and before long the length will be reached, but it is not likely that a greater speed than at present will be attained until some revolutionary change in propulsion is made which will materially cut down the cost of operation. With this in view great

marine engineers all over the civilized world are experimenting to find the means for more speed at less cost.

ODD ENGINES TO SUPPLANT MULES

Within the next few weeks there will be in operation between the railroad and great borax mines in Death Valley, Southern California, a cable locomotive that will do away entirely with the famous "20-mule team," of which so much has been written and so many pictures published.

The unique feature of the new enterprise is the method of applying the power. In the center of a railless road 40 miles long will be laid a strong steel wire cable, 1½ in. in diameter. Instead of the cable drawing the 4-ton locomotive, it remains stationary and the locomotive, clutching hold of it, draws itself along. Beneath the locomotive are two sprocket wheels upon which runs an endless chain made up of links, each one of which grips the cable in turn. Sixteen links take hold at once. The locomotive thus fairly pulls itself over the ground, and so great is its power that grades of 50 per cent can be traversed. The engine of the locomotive is similar to that of an automobile and can develop 200 hp.

The new method of hauling out borax to a point where the regular railroad connection may be reached is a great improvement over the present mulepower which has been used for so many years, and because of the death-dealing climatic condition of the valley it is the only feasible plan.

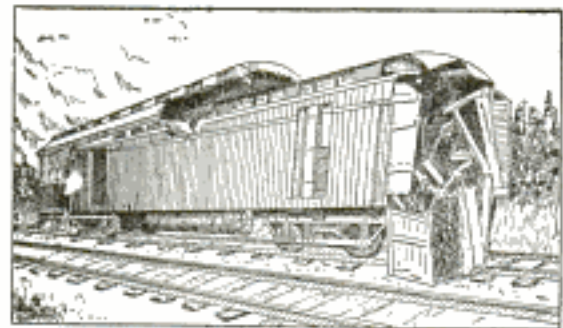

Car Telescoped in Wreck on C. M. & St. P.
at Lenark, Ill.

DETROIT RIVER MAIL BOAT

The mail boat "C. F. Beilman Jr.," which has just been completed for service in connection with the United States Marine post office at Detroit, delivers mail to all the shipping of the great lakes as it passes through the Detroit river.

The boat has a maximum speed of 13 miles an hour and hovers in the center of the river day and night, ready as soon as a vessel approaches to glide swiftly alongside and by means of a basket or bag attached to a pole, receive and deliver mail to crews and passengers. When so many vessels are passing at once it is impossible for the mail boat to get to all of them, hence two auxiliary row-boats are always in readiness to row alongside the ships, make fast by throwing a light tow-line to the towering decks above, and pass up the mail in a bucket.

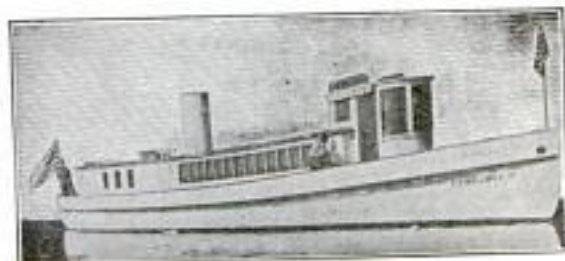

Great Lakes Post Office

The mail boat, constructed of steel throughout, is 75 ft. long, 14 ft. beam and 7 ft. in depth. The water-tube boiler is of 300 hp. at 250 lb. pressure. The engine is a 150-hp. compound making 450 r. p. m.

EUROPE'S LARGEST ICE SKATING RINK

The largest artificial ice-skating rink under cover in Europe has just been completed at Glasgow, Scotland, and thrown open to the lovers of the premier winter sport. The area of ice surface is 137,204 sq. ft. The actual weight of water frozen to produce this expanse of ice is 100 tons. The refrigeration system is driven by two gas engines, fed from a suction producer gas



Ice Surface of 137,204 Sq. Ft.

plant. Each engine is capable of giving 90 hp. The rink will be open each year from the first of October until the end of May. During the four summer months of the year the machinery will be applied to the manufacture of ice for refrigeration purposes.

MAHOGANY LOG OF GREAT VALUE

The forests of Honduras furnish to the United States every year great quantities of wonderfully figured mahogany of great value. This mahogany log, 16 ft. long and a little over 6 ft. through the center, only part of a gigantic tree, is valued at \$10,000. Some day in the future it will be found



Section of \$10,000 Mahogany Tree

in artistically shaped and carved furniture, but will have nothing to identify it as part of this log,—except price.

Egypt's great dam at Assouan, built to harness the Nile, is to be raised 15 ft.

STILLS FOR MAKING FRENCH BRANDIES AND PERFUMES

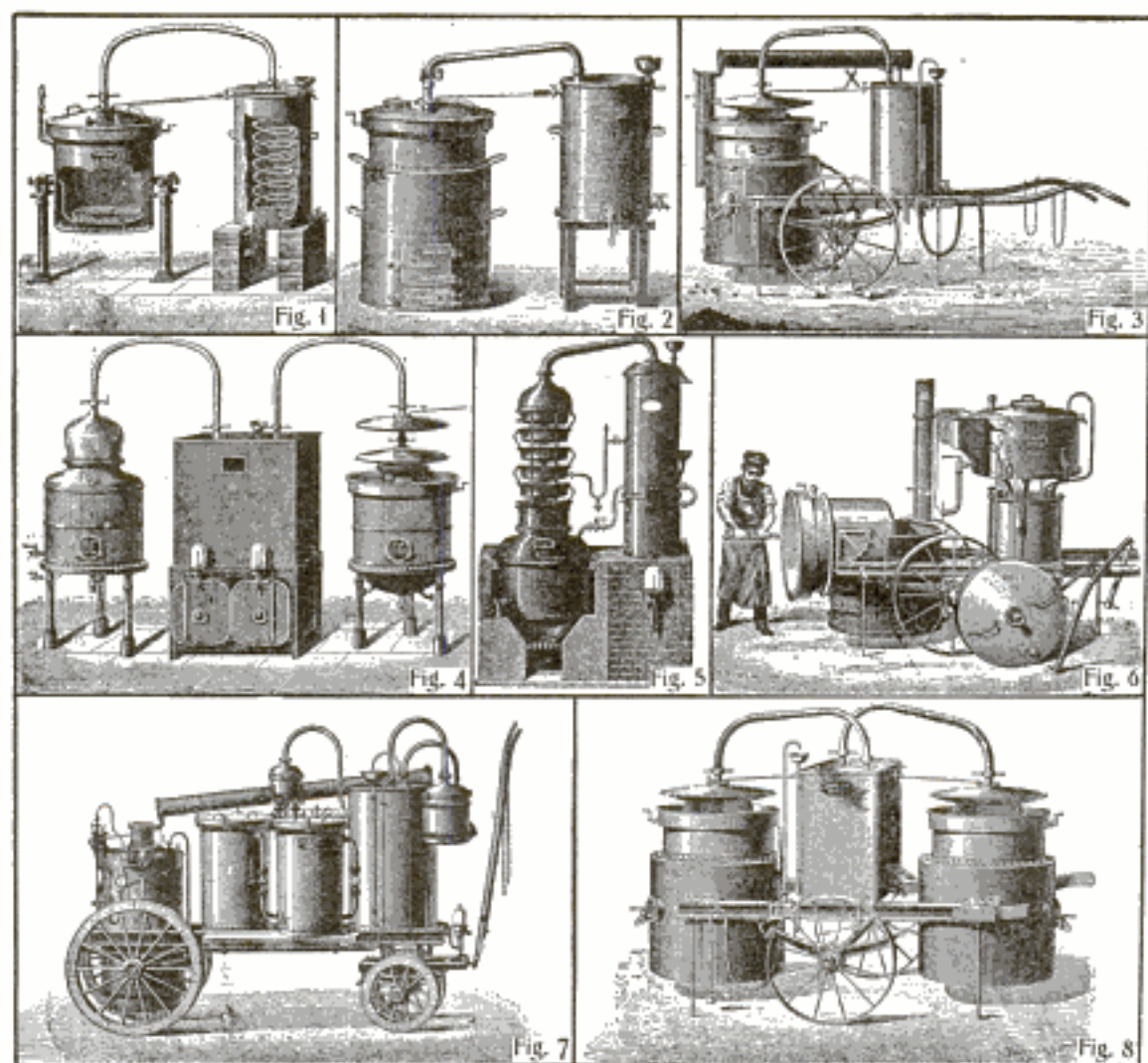

A Few Common Types of French Stills

In the United States we are accustomed to associate the word "distillery" with a massive building from whose towering stacks belch clouds of smoke visible miles distant; the ownership and operation of the business being vested in some trust. France, on the contrary, has many thousand distilleries, ranging all the way from the simple affair of a small vineyard or rose farm, with a capacity of a few gallons or even ounces per day, up to the concerns whose establishments cover acres. Distilling outfits can be bought as low as \$20, with a capacity of only one quart of material to be distilled, and heated with a small alcohol lamp. Some out-

fits are built on two-wheel carts, which can be pushed from town to town by hand; others are drawn by one or more horses. So great an industry is the manufacture of stills that a single firm in Paris catalogs over 100 stills for the making of brandies, rum, cordials, perfumes, essential oils, etc., and has at the present time more than 4,000 of its stills in use in France alone.

Fig. 1 shows a sample type much in use, in this case heated by steam, and arranged to tilt for emptying the "copper" or container when heavy solids or thick liquids are being treated. The outer shell is shown cut away to reveal the interior construction. From the



Indian Elephants Towing Rafts and Rolling Logs

copper the steam rises and passes through a copper pipe to the still at the right, the worm or coil being immersed in water, which is frequently cooled to assist condensation. The steam condenses in the worm and the liquid resulting is drawn off at the bottom.

The still shown in Fig. 2 is the same as Fig. 1 except it is heated by a furnace burning any convenient fuel. In this case a double bottom and layer of water keeps the fire from direct contact with the contents of the copper. These stills are largely used in making brandies, which are produced in one operation, without restilling.

Figure 3 shows a still of the same capacity with furnace and hinged smokestack, mounted on wheels and intended to be drawn by one horse. The copper will contain about 50 gal. at each filling. These portable stills are often taken to the vineyards in grape pressing time, and after the juice has been pressed from the grapes the "grape cake" is put in the still and from it is produced tartar crystals and certain grades of brandies. These stills are much used in making high grade brandies from wine. The small straight pipe marked "X" in Fig. 3

has a control valve, by means of which the operator can regulate condensation of the alcoholic vapors and thus control the strength and quality of his product. Fig. 4 is an absinthe still, with two condensers in same cooler.

Perfumes are made by distilling the juices of flowers—which are first put through a chopper—by a process quite like that of making brandy. Instead of one solid mass, however, the flowers are spread in pans with distilled water running from one pan to the next, the pans being inclosed in an air-tight metal cylinder, which can be attached to the top of ordinary stills. The parts forming the rectifying column for a flower still are shown in Fig. 5. The stills shown in Figs. 6, 7 and 8 are types of portable steam stills. We are indebted to Deroy, Paris, for the illustrations used in this article, which deals with only the simplest and smallest types of stills. The larger machines are complicated affairs, difficult to describe or understand, although working on the same general principle.

—•••—
To remove oil spots on marble apply a paste made of 1 oz. potash and $\frac{1}{2}$ lb. whiting. Leave on for five hours.

POPULAR MECHANICS

WHERE ELEPHANTS DO REAL WORK

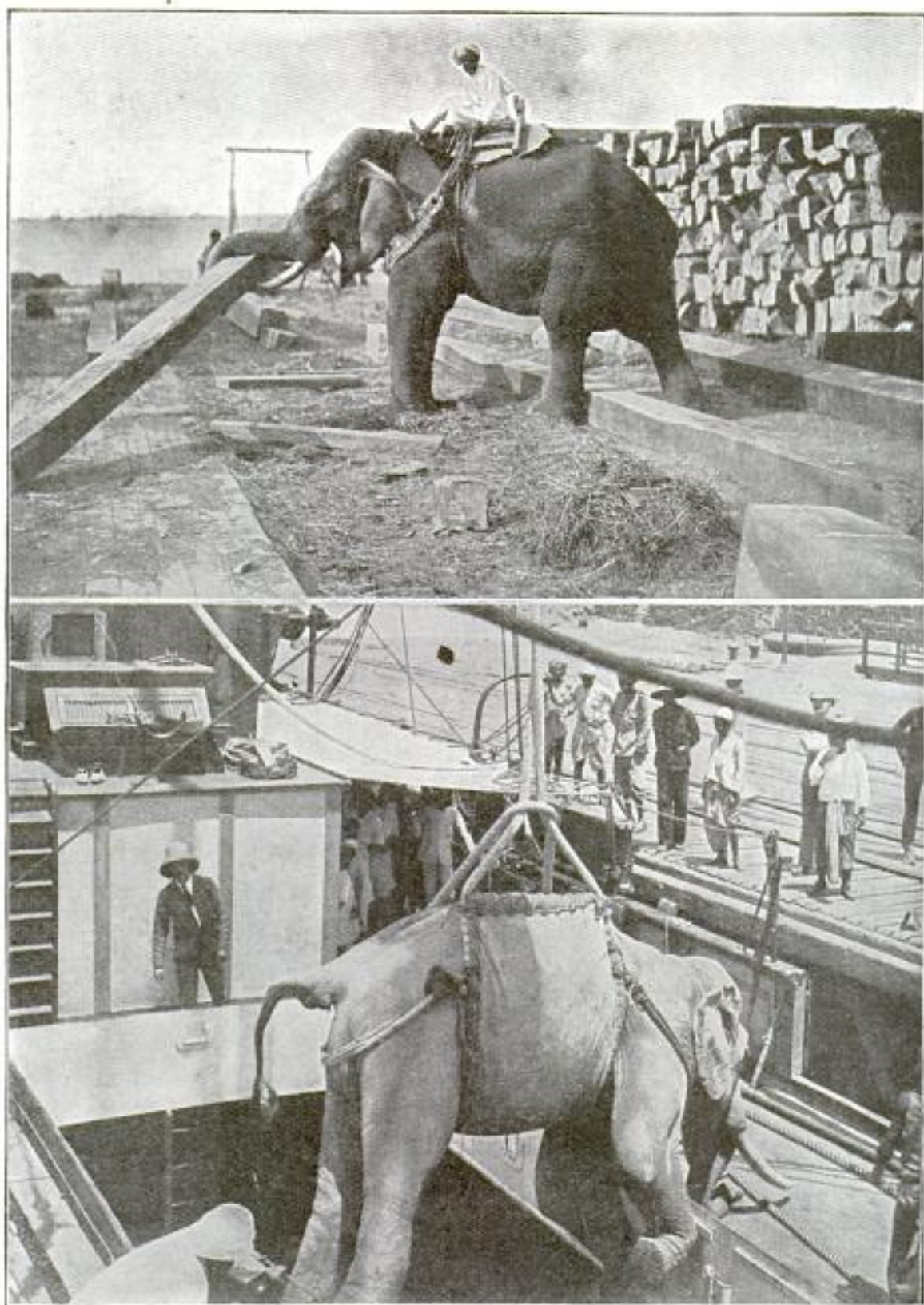

The above pictures are unusually fine illustrations of the Indian elephant who does real work, hard work, and lots of it. A trained working elephant is a valuable piece of property. On the preceding page they are seen towing rafts, and rolling the heavy logs up on high land. In lifting, carrying and piling heavy railroad timbers they take the load on their tusks and hold it there with their trunk. It is frequently necessary to transport a herd of workers, and this is usually done by ship. The process of loading and unloading these big beasts from the ship's hold is one more enjoyed by the spectators than the elephant, who is placed in a strong canvas sling and hoisted with a steam derrick.

TREE DENTISTRY

Many methods are being tried for the preservation of old and historical trees in the east, some of which are intensely interesting. On the estate of



Pear Tree—Cement Filling

John J. Little, at Bala, Pa., is a very old sycamore, the trunk of which had become decayed. The cavity was filled with stone and cement and around its base was then built an outer stone wall, so arranged that the water would drain away from the trunk of the tree.



Filled with Stone and Cement

"COMPRESSOL" SYSTEM OF FOUNDATIONS

The French "compressol" method of foundation construction has opened up a new and interesting field in modern foundation building. The method is simple. A conical ram, having a diameter of 3 ft.

at its base, and weighing 3 tons, is employed to make the excavation. The action of the ram, which is worked the same way as a pile driver, bores a hole down to a solid foundation. After reaching a compact bed of gravel or stone, loads of cement and broken stone are rammed down in separate layers, forming a foundation pile or block of high resistance.

These piles have the shape of an inverted mushroom stalk, the base widening out to a diameter of 4 or 5 ft., according to the soil density.

This system does away with the necessity of excavation with the usual shoring up, ventilation and pumping required. It is claimed that a foundation pile of this character cannot collapse when carrying heavy loads and that one



of such will take the place of six piles of any other construction.

CONCRETE MIXER BUCKET

The cube or circular concrete mixer shown in this illustration is fed by a



new bucket attachment which is raised by power after the ingredients are measured in, thus saving shoveling.

TIMBER FOR MINES EXPENSIVE

Last Only 2 Years—150,000 Acres of Forest Depleted Annually

It is estimated by the government that the cost of anthracite coal is increased 8 cents per ton by the expense

of mine timbers used for cross ties, tramways and supports. To supply this timber requires each year the product of 150,000 acres of forests.

As the average life of timber in a mine is approximately only two years it is of great importance to know what method of treatment will preserve best at the least expense. For this reason the government has conducted experiments which prove that peeled timbers, saturated in a solution of creosote, have almost twice the life of unpeeled timber. This method costs about \$2.85 cents per set of mine timbers.

STONE LIGHTER OF STEEL

The stone lighter shown in this illustration is built of steel and is 200 ft. long, 37 ft. beam and 13 ft. deep, having a capacity of 2,000 tons. The stone is all carried on the deck and to support this, five fore and aft trusses have been constructed, giving both the deck and hull great rigidity and strength.

At each end is a derrick rising 56 ft. above the deck, the legs of which are built of heavy channels of steel latticed together. The boom is 85 ft. long and can pick up a load 65 ft. from the edge of the dock. Each derrick has a safe load of 10 tons. The only wood in the boat is the 2-in. planking laid on the deck to take the surface wear.

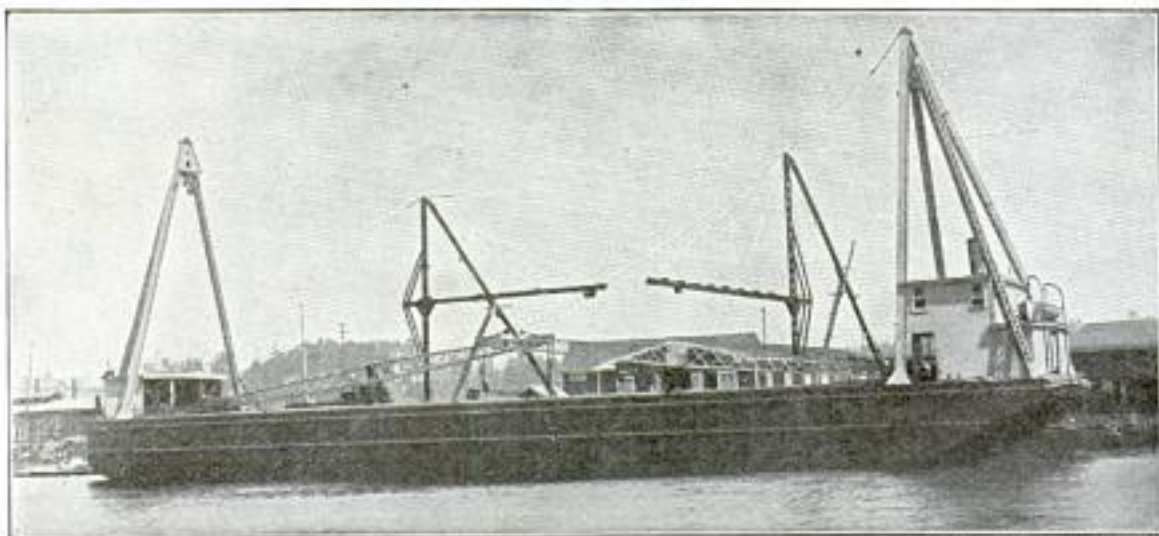

Courtesy of MacLure Dry Dock Co.

New Type of Construction for Stone Barge

BIG BALLOON'S LONG FLIGHT

Sails 500 Miles in Less Than 9 Hours in Charge of Oldest Active Aeronaut in the World



500 Miles in 9 Hours—Prof. King, Veteran Aeronaut, at the Left

Barred from the great international balloon race for the James Gordon-Bennett cup, which started from St. Louis Oct. 21, 1907, the Philadelphia owners of the "Ben Franklin," the largest gas bag airship ever built in America, having a capacity of 100,000 cu. ft. of gas, decided to have a contest of their own, which resulted in several remarkable experiences.

Piloted by the oldest aeronaut in the country, Professor Samuel A. King, 83 years old, who has made 451 ascensions without a mishap, and carrying in addition six persons, probably the greatest number who ever traveled any distance in a single balloon, the "Franklin" started from Philadelphia late one afternoon and alighted 30 miles to the eastward near Aura, New Jersey. There the balloon was tied to a tree and the aeronauts took supper with the farmer whose unexpected guests they were.

Although the statorscope, the instrument which shows at what height the

balloon is sailing, would not work, all but two of the party decided to risk another flight. The first breeze encountered carried them back almost to their first starting point, but striking a northerly current, they started on a new course. All night the aeronauts sailed, crossing five states and finally alighting at Dwight, a small town near Amherst, Mass.

TO CROSS OCEAN IN BALLOON

The Danish aeronaut, Ludwig Johansen, who has made more than 500 balloon ascensions, has come to America in hopes of interesting the editor of some American newspaper in a projected flight across the Atlantic in his new dirigible balloon. He proposes to attempt the trip from France to the United States, with two companions selected by the editor, if he finds it possible to get some newspaper to furnish the funds.

TYPEWRITER TELEGRAPH INSTRUMENT

A Californian has invented a typewriter telegraph instrument, designed to take the place of the ordinary Morse instrument, on which messages can be received and sent by any person who knows the English alphabet. Only a little larger than an ordinary typewriter, provided with a keyboard quite similar, and operated in identically the same way, the machine is expected to print letters, numerals and punctuation marks in plain English. The depression of any key on the board causes a wheel to revolve and at the same instant the corresponding letter or figure

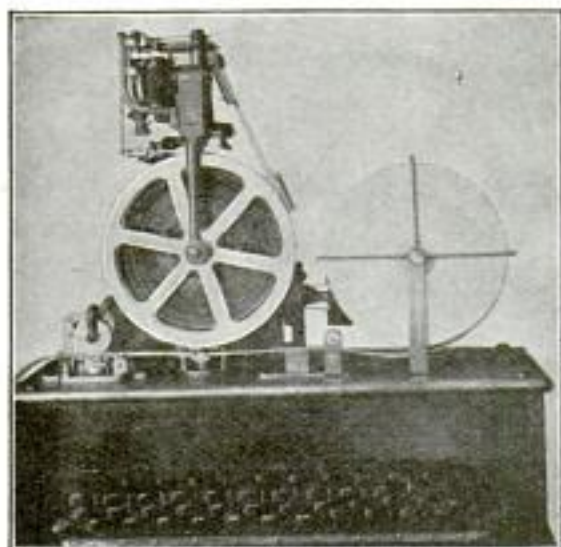

Typewriter-Telegraph

on the key is printed automatically at the receiving station without the necessity of a receiving operator. The same instrument is used for both sending and receiving.

On the outer rim of a revolving wheel of aluminum are placed all the letters of the alphabet, the numerals and the punctuation marks. This wheel is controlled by three sets of magnets. The first regulates the starting and stopping of the wheel, the second brings the characters on the wheel in contact with the paper at the proper time, and the third operates a clutch which causes the letter-carrying rim to revolve. To begin operating, the starting key is released, which causes the re-

ceiving wheel to revolve once, setting itself at zero. At this point the letter-carrying wheel stops, but the internal apparatus, which carries the magnets, continues to revolve. The character on the keyboard is then depressed and instantly a current of electricity passes over the wire. The clutch magnets of the receiving instrument grasp the letter wheel and revolve it to the proper point. The working of the instrument is instantaneous and the speed of a fast typewriter operator can be maintained.

By strengthening the electric waves so that they will actuate a magnet it is claimed that experiments have proved the instrument adaptable for wireless telegraphy. It is likewise claimed that in sending press dispatches the receiving instrument can be attached to a linotype and the words set into type by the same manipulation which flashes them over the wires.

In many respects the machine is not new. In the United States patent office are records which show that over 400 patents have been issued to cover similar machines. Many of these have proved successful under ideal conditions, but none has as yet succeeded in displacing the Morse instrument. Only four of these machines have been thus far completed.

A motor boat of the hydroplane type made a speed of 34 miles an hour recently on the Seine in Paris.

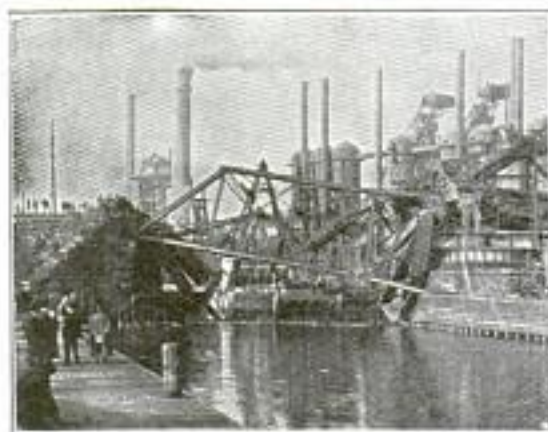

The ore train shown in this illustration was thrown into the Cuyahoga river by the collapse of the Erie railroad bridge No. 5. The train collided with a locomotive on the bridge and the span gave way.

"MAURETANIA" WINS ONE-DAY RECORD

Buffeted—as much as a ship of her immense size can be buffeted—by one

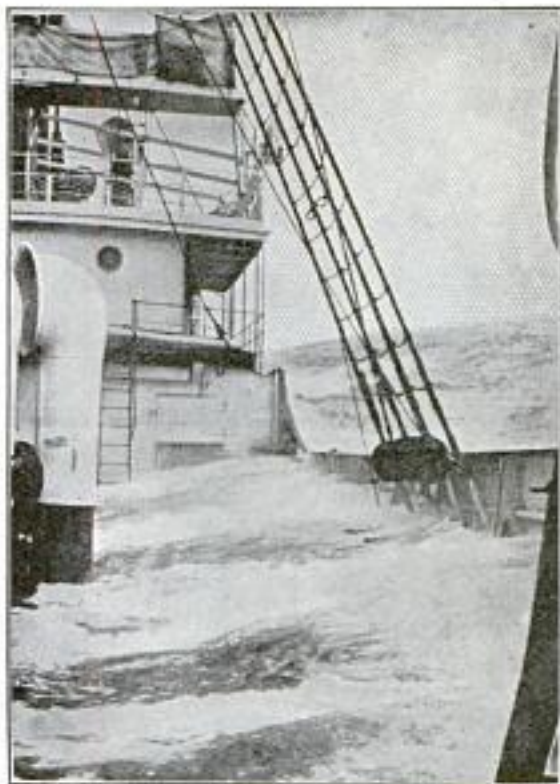

Remarkable Photograph of Huge Wave Sweeping over Forward Deck

of the fiercest storms of the season, and then held motionless for hours in a dense fog, the "Mauretania," sister ship of the "Lusitania," made her maiden voyage, and although far behind the record run of the "Lusitania" from land to land, won the coveted right to fly one blue ribbon at its peak. On Thursday, November 21, the ship was driven 624 knots (671 land miles), or 7 miles faster than the fastest day's run ever made.

INEXPENSIVE FIRE ALARM SYSTEM

An inexpensive fire alarm device has been invented, which, attached to any telephone wire, will instantly and automatically give notice of the presence of fire. The contrivance consists of a box containing two magnets. When the temperature surrounding the box reaches

170° the circuit is closed and fire headquarters and central immediately warned. Should the subscriber detect the fire first, a button on the box can be pressed and the same result achieved.

For small towns and cities having no fire alarm system, the telephone company could furnish such a system by placing the boxes on street corners and in public buildings, at one-tenth the cost of the usual fire alarm system. For public alarm boxes the automatic contrivance is dispensed with.

LOCATE ORE VEINS BY WIRELESS ELECTRIC WAVES

One of the latest ore-prospecting devices placed before the public is an electrical instrument, which, according to its inventor, will locate free metals at almost any depth, map out the course and width of the vein and ascertain its exact position below the surface.

The metal box to the right of the illustration contains apparatus for projecting in a straight line a powerful flux, or, more clearly, a field of inductive electricity, somewhat similar to the wave flux employed in ordinary wireless telegraphy. It is claimed that this flux will penetrate through any but metallic substances. When the flux strikes upon a vein of free metal ore the wave is impeded and a humming



Electric Ore Finder

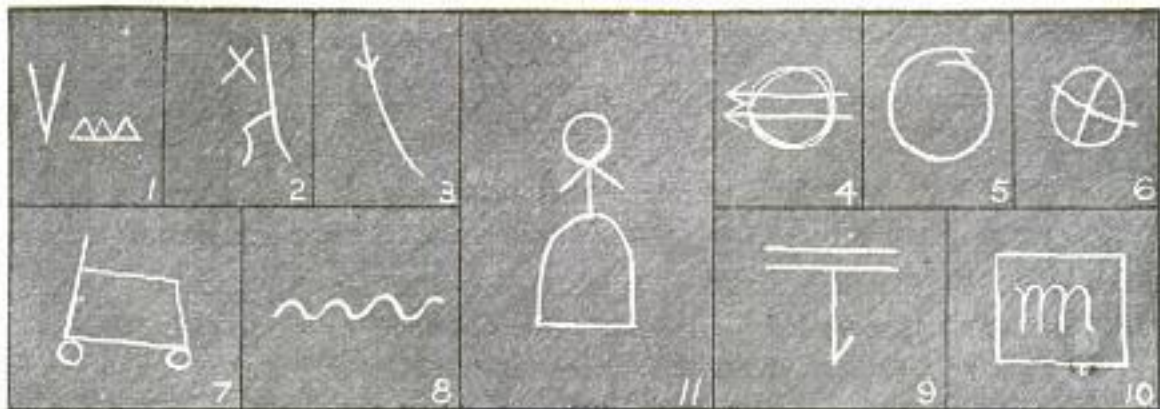

A strange sign language by which tramps help tramps on their weary way: Fig. 1—Three women in the house. Fig. 2—No food without work. Fig. 3—Public official lives in house. Fig. 4—Be off as quick as possible. Fig. 5—Nothing doing. Fig. 6—Food given here. Fig. 7—Traveling money will be given. Fig. 8—Poor people; arrange tactics accordingly. Fig. 9—Allowed to spend night in hayloft. Fig. 10—Dog in garden. Fig. 11—Stop! the wife is at home.

noise in the telephone receiver attachment announces the find. By passing the small case over the surface of the ground the extent of the ore body can be ascertained, the indication of the presence of ore ceasing when the edge of the vein is reached.

GERMAN BRIDGE CONSTRUCTION

The steel staging shown to the right of the accompanying illustration somewhat resembles the steel framework of a modern skyscraper, and is being used in the construction of a bridge of the cantilever type across the Rhine at Ruhrort-Homburg, Germany. The staging moves forward on a track as the work progresses. The three central

cantilever spans measure 390 ft., 660 ft. and 415 ft. respectively from left to right.

AUTOS SPREAD DISEASE

According to a report made by the American public health congress, the introduction of automobiles has tremendously increased the death problem—not the accidental death problem, the result of reckless driving—but the death problem which has for its cause disease germs carried in the dust. The improvement of public highways by laying the dust with tar, oil or other preparations, was recommended as the most necessary step toward the elimination of this danger.

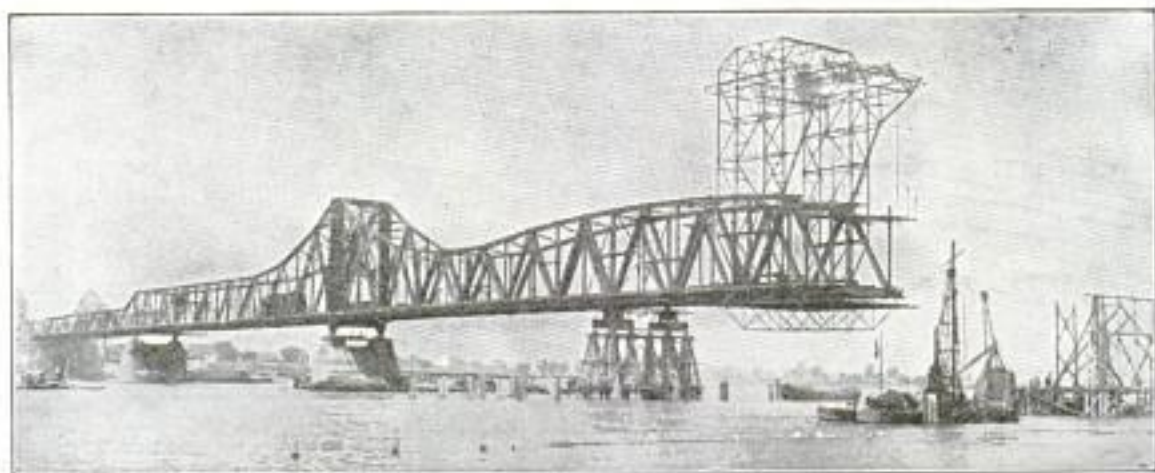

Highway Bridge over Rhine, near Ruhrort-Homburg

NITRO-GLYCERINE LETS GO

Following the recent explosion of a nitro-glycerine magazine near Petrolia, Ont., hundreds of people awakened from sleep went out to search for the scene of the accident, and in the darkness passed the spot where the magazine had stood, unable to locate the place because of the general change that had occurred in the landscape.



The Building Site Was Saved

At last one party of searchers stumbled over a small pile of broken bricks and fell into a formerly unknown hole in the ground. This was the place where the magazine had stood. The torpedo factory buildings 250 ft. away were completely razed, and many plate glass windows broken in the business district of Petrolia, three miles away.

HOT WATER TANK HITCHING POST

Many uses have been found for old kitchen hot water tanks, but it remained for a western blacksmith to use one for a hitching post. It cost no more than its worth as scrap iron and is easily located in the dark. When filled with sand it becomes very heavy and a horse cannot pull it over by jerking on the hitching strap.



Filled With Sand

SIX-WHEEL RUNABOUT

A recent idea in self-propelled vehicles is the 6-wheel runabout. The motor outfit is mounted on two wheels where the weight is evenly balanced,



Six-Wheel Motor

and the forward section attached to an ordinary buggy. Both sets of forward wheels respond to the steering wheel.

WALKING ON THE WATER

The lovers of the "freak" in water craft are manifesting considerable interest in the experiments of a French inventor who has constructed a pair of water shoes on which he walks on a smooth water surface with apparently as much ease as the spectators who follow his movements along the shore.

His water-boots are light shells, about 7 ft. long, and turned up at the ends. They greatly resemble the ski, a type of long, narrow snow shoe used in Norway, and are not more uncomfortable to use.



M. Redmond Walking on Water

FINEST COLLIER AFLOAT

The new steel collier, "Everett", built for carrying coal on the Atlantic coast between Boston and southern

MARINE DEATH RATE LOW

England's marine statistics for the year 1906 show that of the 955 masters and seamen who sailed their last voy-



New Type of Steel Collier

ports, has no equal in her class. The special feature in her construction is the self-trimming system by which she can keep on an even keel. Equipped with exceptionally powerful pumps, all water ballast can be discharged in six hours. The hold of the vessel is divided into five cargo-carrying compartments. The ship is 400 ft. long, 53 ft. in extreme width, and has a depth of 32 ft.

The officers' and engineers' quarters are as expensively fitted out as on many passenger liners, having baths, electric lights, steam heat and telephones.

age in this world during that time, 442 of them met death on land, either by accident or illness. This rate is the lowest in 16 years, being only 1 in every 557.

◆◆◆

GROUND LEVELER

A combination scraper, harrow and roller outfit is proving effective in leveling ground for building and other purposes. If the ground is too hard and bumpy for the scraping blade the harrow teeth are dropped. The roller leaves the surface perfectly level.

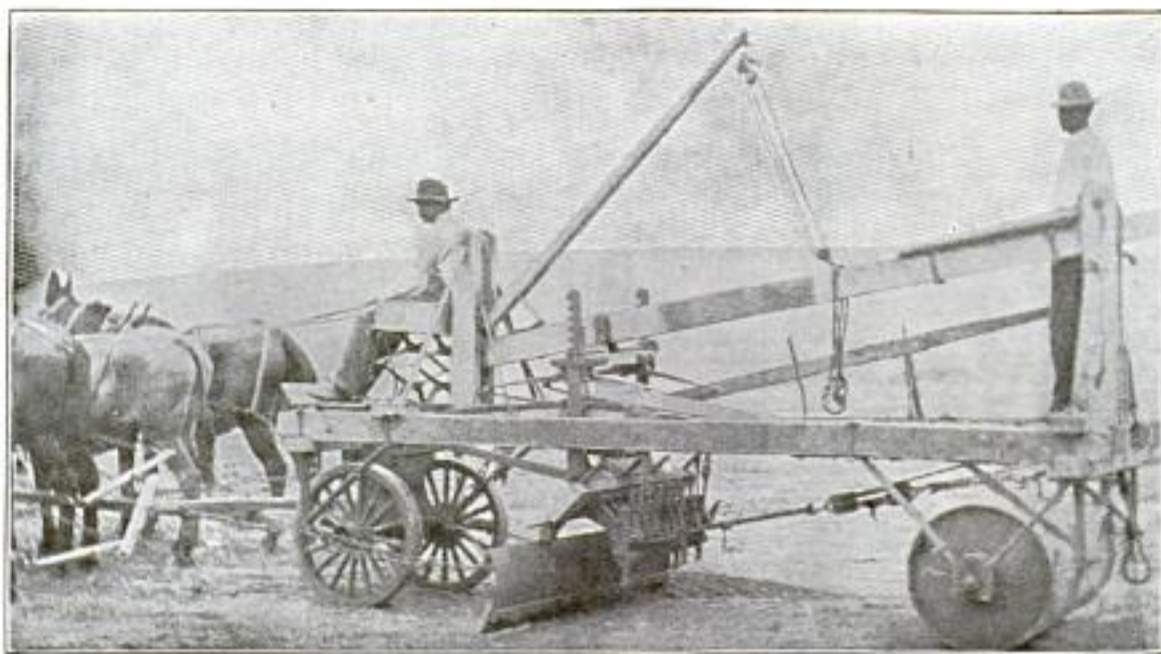

Road Machine—Scrapes, Harrows and Rolls

STERN OR SIDE-WHEEL PROPELLER

In all parts of the world there are countless lakes and streams so shallow or so thickly grown with weeds as to make screw propellers useless. The paddle-wheel in this illustration was especially constructed for motor boats contending with such conditions.

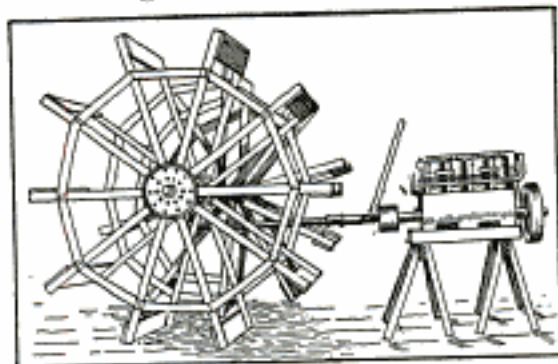

Stern Wheel Arrangement

This wheel is really two wheels, with the buckets or paddles set so they will strike the water alternately, giving a much smoother motion to the boat than if the wheel were in one section and the buckets striking the water in unison. The wheel, 7 ft. in diameter, is driven by a worm gear which gives it a ratio of one turn in 17 revolutions of the engine. By using a longer shaft the wheel can be pushed further apart, and straddling the boat become a side-wheel arrangement.

DEVICE GETS PENNY CONTRIBUTIONS

As is seen by this illustration, which is a novel device for obtaining small contributions, it costs 1 cent per second to run a large London hospital. Unlike the hospitals in this country, the London hospitals are entirely supported by voluntary contributions, and were it not for the donations of private persons and the general public, whose pennies even are solicited, these institutions would have to close up.

The London hospitals are regarded as strictly charitable institutions and it is for this reason that they can boast among their attending physicians even

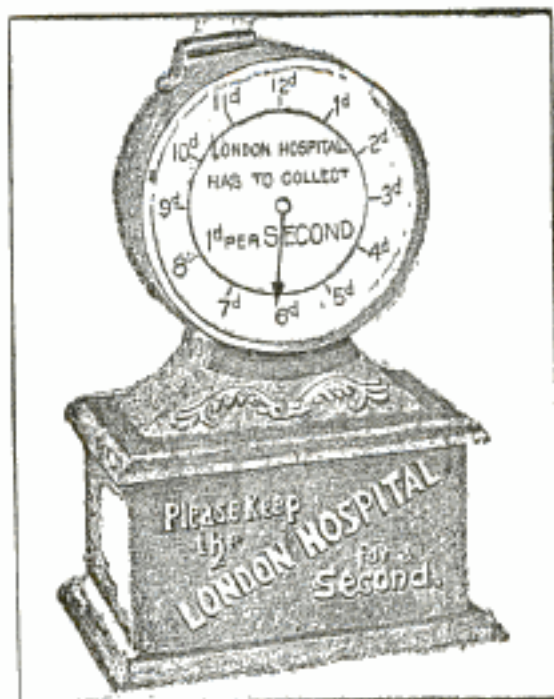

English Charity Clock

the King's own physicians and some of the greatest medical and surgical practitioners in the world.

AUTOMOBILE AS WRECKER

One 30-hp. automobile proved of more assistance than a large squad of workmen in tearing down the columns on the court of honor which had been erected for the Elks' reunion in Philadelphia. A manufacturer of automobiles, while passing in his car, noticed the trouble the workmen were having and immediately volunteered to help. Ropes were attached to the columns and the car, and the former were soon reduced to ruins.



Auto Makes Quick Work

SINGLE WHEEL ROLLER SKATES

A one-wheeled roller skate, with cushion tires, of the extraordinary design shown in the illustration, has been invented by a Swiss engineer, who



Roller Wheels Beat Skates

claims that the one wheel enables the skater to execute turns impossible on other skates. He intends to increase the value of his invention by driving the skates by motor power derived from alcohol.

The department employes at Washington have decided to use roller skates in going to and from their work, the

superior condition of the streets of the capital city making the plan a practical one.

IMPROVED LARD BARRELS

An improved metal lard barrel is now being used by many shippers. Formerly lard was shipped in tapering firkins and the empties nested together, or placed one in another for return shipment. In this way the dirt on the bottom of one firkin was transferred to the otherwise comparatively clean interiors of others. In the metal barrel or cask shown in this illustration the clamps for fastening the cover down are eccentrics,—that is, they swing on an off-center pivot.



RHINE STEAMERS

The paddle steamers on the Rhine are unique and interesting and different in design and construction from most of the other river boats in Europe or America. The accompanying illustration shows the "Hugo Stinnes," which has two stacks and a large observation deck. During the past year seven sister boats were built, their dimensions being: Length, 240 ft.; beam, 26 ft.; draft, 3½ ft.

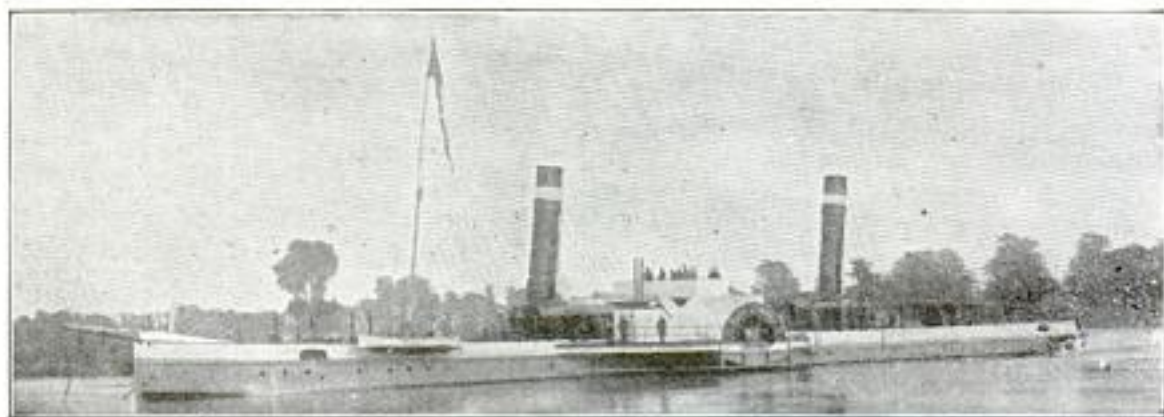

Popular Day Boat on the Rhine

HOW CHARCOAL IS MADE AND ITS USES



A Group of Charcoal Kilns

Despite the rapid decline of forests the charcoal industry in the United States has developed wonderfully during the past few years. Only a short time ago it was chiefly confined to the lumber regions of Michigan and the lumber belt of the Northwest. Today charcoal kilns can be found along railroad lines in some of the most thickly populated central states.

Originally valued only as an intense heat producer, its uses have steadily grown in number, causing a consequent growth in the importance of the industry. It is an ingredient in the manufacture of gun powder; a decolorizer of solutions; a medicine for dyspeptics and a purifier of water. As an antiseptic and cleanser its power is

universally recognized. In a hospital a piece of charcoal will soon absorb and decompose obnoxious gases and sweeten the atmosphere. All these are but a part of its uses.

Charcoal is wood burned in a kiln with only a limited amount of air. The limiting of the supply of air while burning is in progress keeps the wood from being reduced to ashes. In its production the volatile matter,—or the part of the wood subject to evaporation, is decomposed or burned by the fire, and the carbon remains. Before the present kiln came into use the crude method of covering the wood with earth and leaving air-holes at intervals in the mound was resorted to by the charcoal burners.

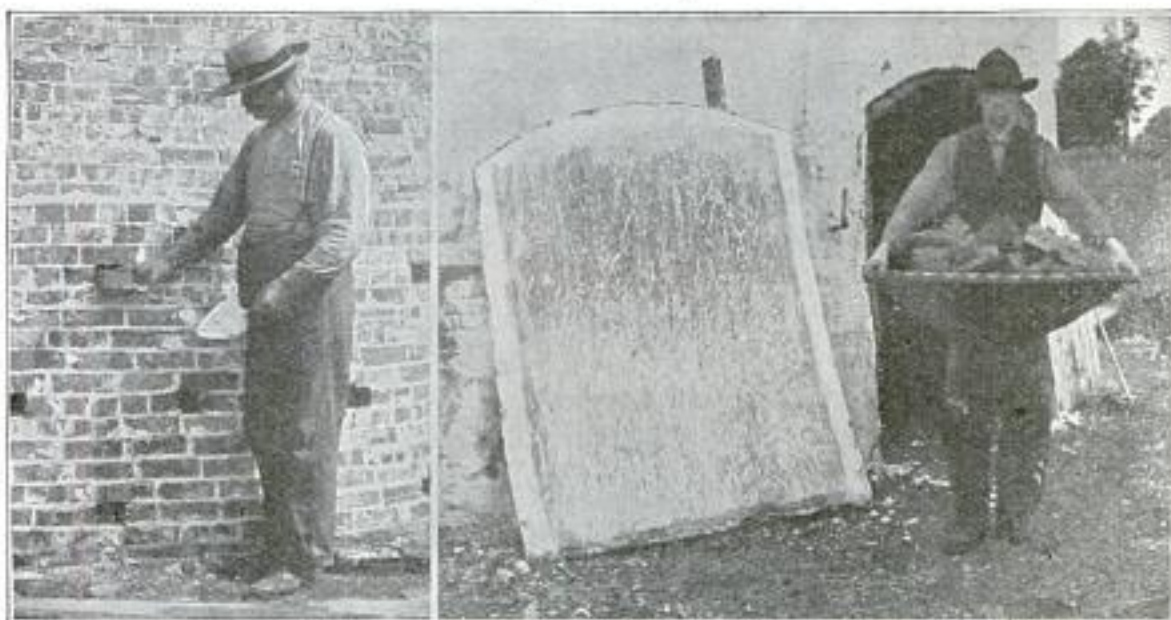

Closing the Holes — Burning Ended — Door Removed

The charcoal kilns shown in these illustrations are operated day and night, requiring 200 cords of wood every 24 hours. The supply of wood is supplied a year in advance of the demand to insure its proper dryness. A plant of 10 kilns requires the almost continual labor of a gang of 40 woodsmen to keep it well fed.

A charcoal kiln is usually 22 ft. in diameter at the bottom, 20 ft. at the

but hemlock can be used for the manufacture of charcoal, although some kinds are better for certain purposes than others.

POWERFUL LOGGING LOCOMOTIVE

An interesting type of locomotive, equipped to burn oil, has just been completed for a lumber and logging

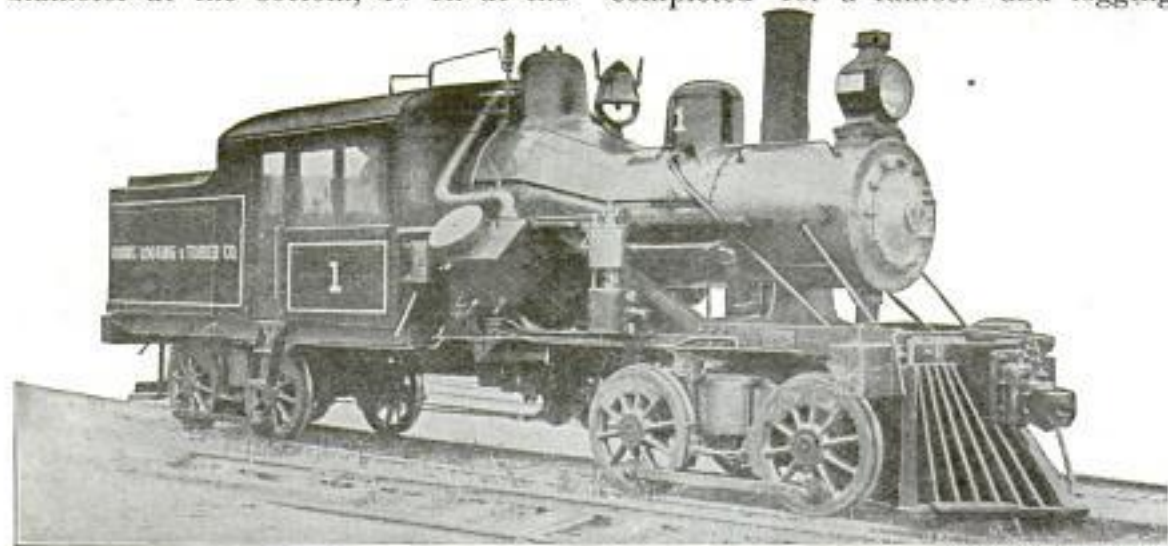

Courtesy Hilde Locomotive Works

Logging Locomotive That Burns Oil

top and 9 ft. in height through the center. The wood is placed in the kiln in chunks about 4 ft. long. The metal door is then closed and the fire lighted at the dome. The air is admitted through small holes in the sides and dome of the kiln.

For four days the wood is allowed to burn slowly. The air holes are then closed with bricks and mortar until the kiln is airtight. With all air supply cut off, the fire dies out for lack of oxygen. The exact time for the closing of the holes and the smothering of the fire is determined by the color of the smoke as it comes from the openings.

The same time is required for the cooling of the kilns as for the burning of the wood. When cooled the metal door is opened and the charcoal carried out in specially designed metal baskets. The weight of a bushel of charcoal is usually from 16 to 20 lb., the exact weight depending upon the kind of wood used. Nearly every kind of wood

company near Seattle, Washington, and will be used for hauling heavy loads. The locomotive was designed to pull a train load of 2,500 tons on a level track at a maximum speed of 12 miles an hour. Its total weight is 104,000 lb., oil tank capacity, 1,700 gal., and working pressure 160 lb.

SPLICING A RAIL

About the only practical way to join an 80-lb. rail to a 60-lb rail, is to bend the heavy rail at an angle and cut away a portion of the head or bulb. The outward bent portion is then dressed down about $1\frac{1}{4}$ in., so that the wheels will not touch the bent portion. The 60-lb. rail is also cut at an angle and rests securely on the lower flange of the heavy rail.



MUST TRAVEL 62 MILES AN HOUR IN WATER OR FORFEIT \$10,000

Santos-Dumont has completed the hydroplane with which he expects to attain the stupendous water speed of 62 miles an hour, and is about to make the trials which will win or lose for him his \$10,000 wager with Fernand Charron, well known in the automobile world. To win this wager does not only mean that his boat must attain a speed of 62 miles an hour, but that it must cover that distance in an hour, a proposition vastly different. His machine may tear through the water at the required speed for 50 minutes and then some accident occur to defeat him.

The hydroplane on which he relies to win the wager consists of three cigar-shaped floats, built of aluminum and wood, and covered with a silk waterproof envelope. The center tube is 32 ft. in length and the other two about one-third this size. The three tubes or floats are held together by a light metal cross frame. Above the center tube is

a raised skeleton platform on which the motor rests. At the rear is a transverse wood float attached to the tail of the middle tube. Above the float the

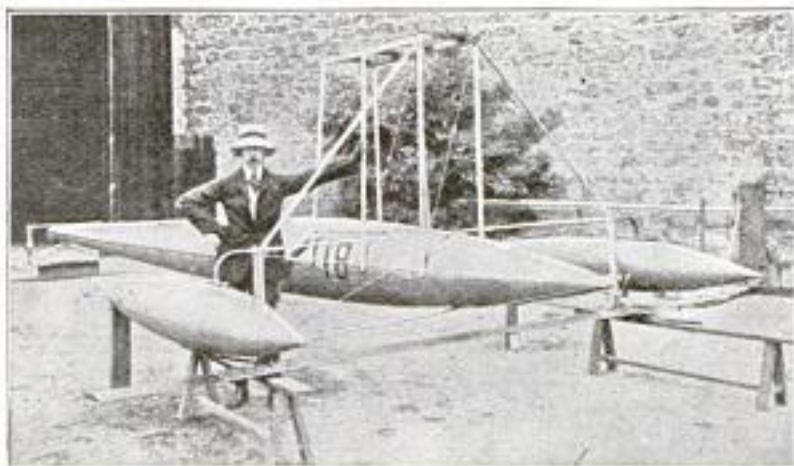

Santos-Dumont's Latest Invention

operator's seat has been placed. The rudder is placed just back of the float. Without motor and propeller the hydroplane weighs less than 200 lb. The motor weighs about 260 lb. and is capable of developing 120 hp. The cigar-shaped floats are filled with compressed air and in flight cut the water like a torpedo.

DIRT PUSHER SOLVES PROBLEM

Again the moment's necessity is the mother of invention. The contrivance in this illustration, which looks like a common dirt scraper, is just the reverse. It was designed as a dirt pusher by the foreman of a gang of men at work on a high fill adjacent to a body of water. The teams could not drive down the steep dump, so the dirt was dumped on top and pushed over. The machine can handle 500 yd. of dirt per day with one team and two men. The second man sits on a plank extending out beyond the axle. The machine is so equally balanced that by his weight

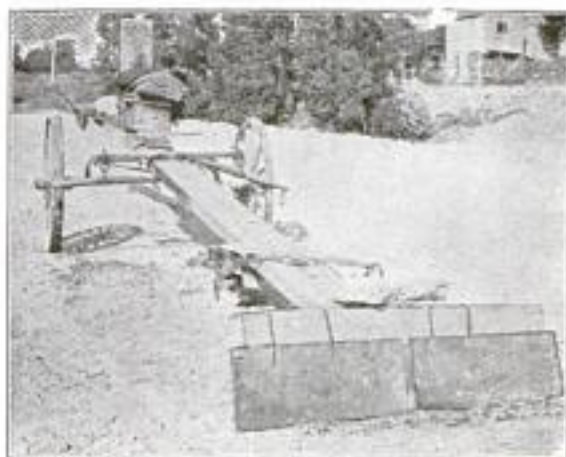

Novel Dirt Pusher

he can lift the "pusher" off the ground when returning for another push.

CABLE BADLY TWISTED

The extraordinary looking objects shown in this illustration, somewhat resembling a deep sea growth, are two of

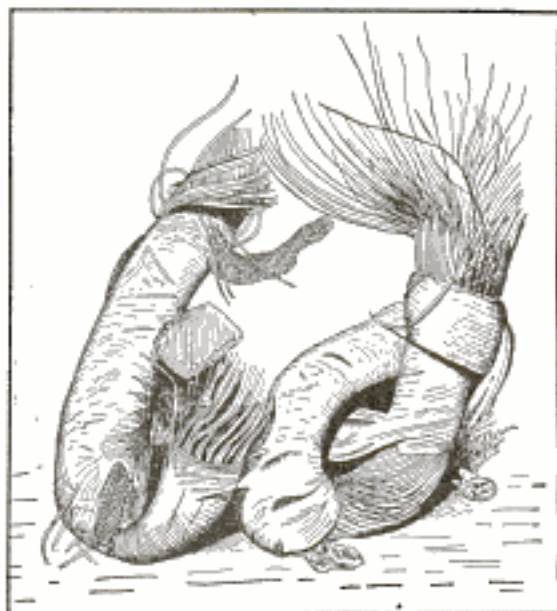

Two Bad Kinks

the kinks found in one of the high tension feeder cables run across the harbor at Sidney, New South Wales, by the Sidney Electric Tramway Co.

Only recently service on the street car line was suddenly interrupted and it was found that a vessel dragging its anchor in the harbor during a storm had picked up the cables and effectually broken and snarled them up. As the cables were particularly stiff and heavy, it can be readily imagined that considerable force was necessary to bend them into such a snarl.

ICE BOAT AND STEAMBOAT RUN SIDE BY SIDE

The unusual sight of an ice boat and a steamboat sailing along the same stretch of water is often seen during the winter months near Sandusky, Ohio. The vessel keeps a narrow channel broken through the ice by its frequent trips. The ice boats flash by on either side at a speed yet unattained by water craft.

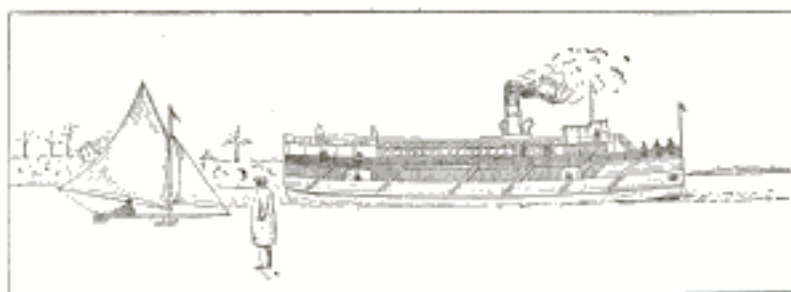

DIVERT RIVER TO SAVE MINE

Fear that the Sturgeon river will break through and flood the underground workings of two iron mines near Iron Mountain, Mich., has caused the mining company to decide to divert the water into a new channel. The work will take six months, but its accomplishment will mean safety to men and property and make ore bodies available.

HUGE BATTLE-SHIP TARGET

This huge battle-ship target, about 60 ft. high and 100 ft. long, is now being used by the British navy for big

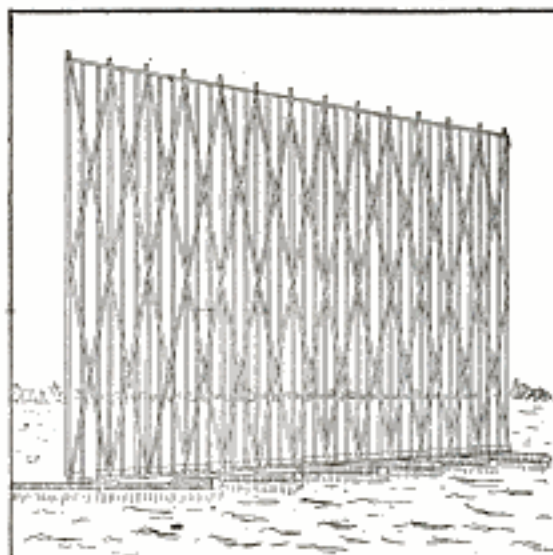

For Big Gun Practice

gun practice. The steel frame rests upon a raft or foundation of steel cylinders filled with compressed air. In practice the heavy missiles tear through the framework, leaving a jagged hole to show where the shot took effect. At the close of practice the target is towed back to its harbor and repaired.



SHOP NOTES



Unscrewing Pipe with a Chisel

The pipe in an oil filter became very tight after considerable use and as the filter was only 8 in. in diameter no wrench could be used to turn the pipe. After removing the nipple A, as shown in the sketch, a cape chisel, C, was inserted through the tee and into the pipe. With a wrench placed on the upper end of the chisel, the pipe was removed with ease.—C. H.

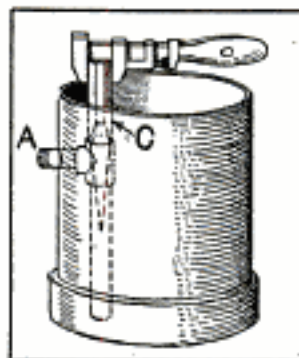

arrangement. The cake of ice when passing beneath A presses this lever against B, which closes the circuit and causes the bell to ring, also operating the recorder by the small rod, D. After the cake of ice is passed, A is returned to its original position by means of the spring C. If it is not necessary to have a bell to ring, the electric bell and batteries may not be included.

Home-Made Riveting Machine

To construct a small riveting machine usually requires special patterns

How to Make an Ice Block Recording Device

Managers of ice storage plants find it not easy to keep a correct record of the number of ice blocks stored. A small device can be made so the blocks of ice will do their own counting while passing a certain point in the course. The device consists of a small job press counter, which can be purchased at small cost, and a large vibrating bell, says a correspondent in Southern Engineer. Some dry batteries and insulated wire are also needed. The accompanying sketch shows the ar-

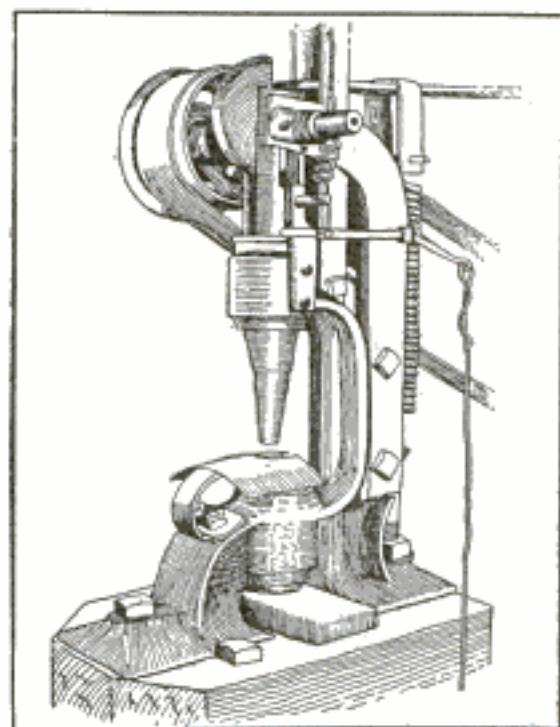

Riveting Machine

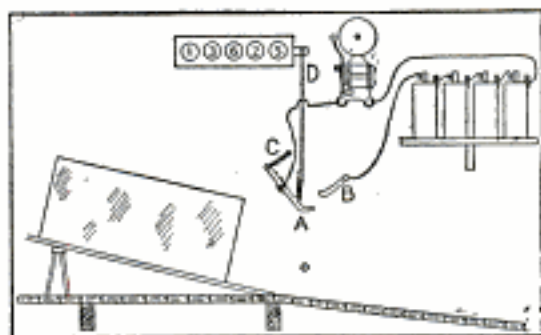

Ice Recording Device

for castings and considerable machine work. The accompanying sketch shows how a small machine is built from a shaft hanger and a few easily made forgings, which does not require much time to construct and is efficient when put in operation. The plunger drop is $2\frac{1}{4}$ in. The cam should be made of tool steel and the working part or face

hardened. It will handle a $\frac{1}{4}$ - and $\frac{5}{16}$ -in. rivet nicely at 360 r. p. m.—Contributed by Jeane Carbon, Warwood, W. Va.

How to Insert a Cog in a Gear

A good method of placing repair cogs in a cast wheel is shown in the sketch. Hammer out a piece of wrought iron and bend it at an angle, leaving enough material to reach down on the web of the wheel twice the length of the cog (Fig. 2). Holes are drilled, and rivets placed in, as shown

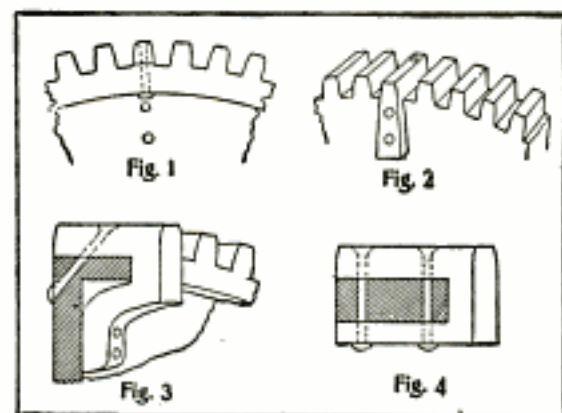

Inserting a Cog in a Gear

in Figs. 1 and 2. No groove is needed for the cog. If the projecting part interferes with the turning of the wheel, place the angle of the cog on the other side of the wheel (Fig. 3) and cut a notch in the side of the rim to make the cog come even with the outer edge of the rim. Bend the angle in to the web and rivet as before. If it is an open wheel, make the cog shaped like a U and let the rivets pass through as in Fig. 4.

Removing a Stuck Fountain Pen

Another way to remove a fountain pen when stuck is to wrap a wide rubber band around the nozzle several times, which will stick tightly to the hard rubber of the pen and furnish a good grip for the fingers. The pen can easily be unscrewed.—Contributed by Albert E. Welch, New York.

Making Vents in Cores

Select a piece of metal tube about 3 in. in diameter and 4 or 5 in. long, to which solder a metal plate over one end. Fit a plunger in the other end the same length as the tube. Drill a

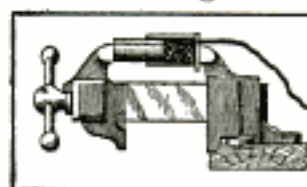

small hole about $\frac{1}{16}$ in. or smaller through the metal plate close to one side of the tube. Fill the tube with molten wax and when partly cool place the plunger in the tube and place the whole in a vise as shown in sketch. Turning the vise screw will push the plunger into the tube, forcing the wax through the small hole which will make a wax string. These wax strings are moulded into the body of the core and when the core is baked the wax is burned, leaving a hole in the place of every piece of wax.—Contributed by Fred McVittie, Lima, N. J.

Automobile Used as a Hoist

The roof of a factory building was damaged by the falling of a tree and they decided to use the owner's automobile as a hoisting engine. This proved so successful that all the repair supplies were rapidly hauled on top. It may be suggested that the motor car might be made pay for itself on the farm by sawing wood, while on Sunday it could replace the old top buggy and take the entire family to church.



Hoisting with an Auto

A Simple Mission Stain

Mix boiled linseed oil and asphaltum together in portions of half and half and apply with a brush. In one or two minutes rub off with a rag and one of the finest mission stains is obtained. This may be varnished. One gallon will cover about 600 sq. ft. of smooth lumber.

How to Make an Adjustable Socket Wrench

Bend a piece of steel in the shape shown at A and make a square hole in it at the bend, B. Fit a square piece of iron, C, in this square hole.

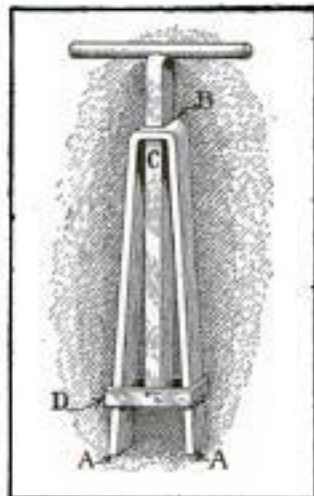

Rivet a band, D, to the lower end, and weld a handle on the upper end of the iron, C. When using this wrench the jaws, AA, are pushed through the band, D, and placed on the nut in the socket. Pressure on the handle in turning will cause the jaws to grip the nut. The wrench can be made in various sizes to suit the requirements.

Quick Repairs on a Gas Generator Furnace

"One of our water-gas 'springer' sets burned the lining out of the firebox on New Year's day," says a member of the Pacific Coast Gas Association. "We had no time for ordinary repairs to the generator, so it was a question of immediate repairs. We pulled out the fire and made a protection from the heat above of sheet asbestos, doubled, so there would be an air space between. We then placed electric fans at the ash doors and with a relay of masons replaced the lining, covering an area of about 10 sq. ft. In spite of the tre-

mendous heat and the confined limit in which the work was done, a fire was started in the machine at 1:30 a. m., January 3rd, and gas was being made on the morning of the 4th.

Tongs for Holding Chain Links

Make a pair of common straight-jawed tongs, says a correspondent in the Blacksmith and Wheelwright. After heating the jaws to a working heat,

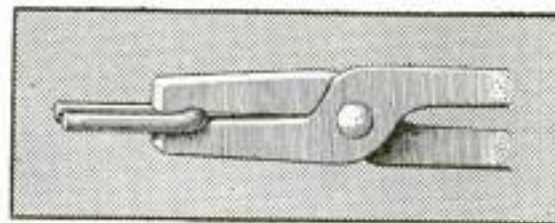

Chain Tongs

place a chain link between them and hammer enough to imbed the link in the jaws and let them cool.

Fitting Balusters to the Lower Porch Rail

A good way to saddle porch balusters to fit the beveled top of the lower rail is to make a device as shown in Fig. 1. EE is the saw table and D is a board with one corner cut off and block C nailed to one side along the lower edge, as shown. Put on a small saw

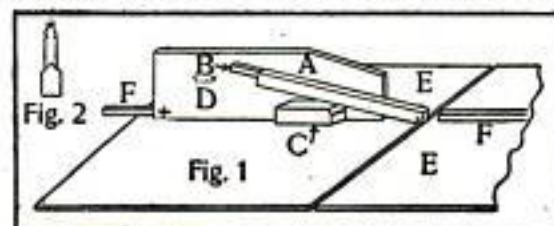

To Saddle Balusters

and place the board D against the guide FF, moving it along the guide until it is in position, so that when baluster, A, is placed in the position shown the saw will cut the desired bevel, says The Wood-Worker. Fasten the board D to the guide with a clamp.

Lower the saw or raise the table so that the saw cuts just half way through the baluster. Clamp the block B to the

board for a stop to put the end of the baluster against, as shown. Turn the baluster over and cut the other side. Balusters can be saddled this way in less time than they can be marked for sawing on a band saw. Fig. 2 shows the end view of the baluster and rail fitted together.

Cost of Reinforced Concrete Posts

A tract of land near Chicago, containing 62 acres, has just been fenced with 1,500 concrete posts, 1,000 of which were 9 ft. long and the remainder 7 ft. The average cost of the 9-ft. posts was 65 cents each, based on the

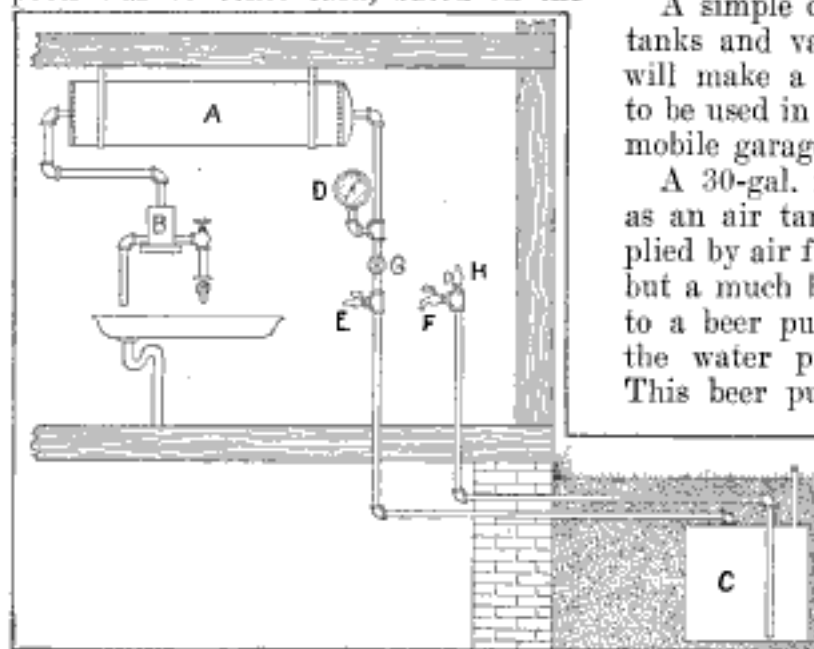

Gasoline Storage Tank Installed

following prices: Cement, \$2 a barrel; screenings, 75 cents a cubic foot; reinforcement steel, 3½ cents a pound, and the two laborers, \$2 a day each.

Each post was reinforced by four ¼-in. corrugated bars, one on each corner. In casting a post, a layer of concrete was placed in a form, then two reinforcement rods were set in position, followed by another layer of concrete, the two other rods and the balance of concrete. The posts were kept wet three weeks after making, the first week of which they were covered. Two laborers were employed on the work, making an average of 40 posts a day, as well as mixing the concrete, and moving and watering the posts.

How to Prevent Wooden Faucets from Cracking

Place the faucets in melted paraffin that is heated to a temperature of 212 deg. F., and let them remain until the bubbles cease to rise from the wood. The whole is then allowed to cool to about 120 deg. F., when the faucets are taken from the bath and the adhering paraffin is removed by rubbing with a dry, coarse piece of cloth.

Gasoline Storage Tank

A simple connection of a few pipes, tanks and valves, as shown in sketch, will make a supply tank for gasoline to be used in plumbing shops and automobile garages.

A 30-gal. range boiler may be used as an air tank, A, which can be supplied by air from a common foot pump, but a much better way is to connect it to a beer pump which is operated by the water pressure from the mains. This beer pump, B, is placed near a sink and connected to the water supply pipe and the discharge piped to run into the sink. The gasoline tank, C, is placed in the ground outside of the building and fitted with a pipe that will reach to the surface for filling. An air gauge, D, a globe valve, G, and a pet cock, E, are placed in the pipe between the two tanks. A faucet, F, and a pet cock, H, are connected on the end of the pipe leading from the gasoline tank.

The pump is started and the air tank filled (2 or 3 lb. pressure will raise gasoline) and everything is ready for use. The pet cock, E, is closed and the globe valve, G, opened, which brings the gasoline to the faucet, F. When not in use the globe valve, G, is closed and the pet cock, E, opened to relieve the gasoline tank of any air pressure.—Contributed by W. L. Brown, Seattle, Wash.

Etching on Steel

Take a piece of blue vitriol the size of a walnut, one tablespoonful of common salt, and mix with 8 oz. rain water. Let this solution stand for 8 or 10 hours and it is ready for use. Cover the part of the tool to be marked with paraffin or soap and scratch the name with a steel pen. Put on a few drops of the solution and let it remain for one minute and then rub off the solution and paraffin, or soap.

A Home-Made Greenhouse

A small house 36 ft. long, of even span, made in the following way, will prove useful and inexpensive. The foundation may be made of brick, concrete or grout, whichever is most convenient to build, and should be 12 in. wide and 3½ ft. high, of which 3 ft. is in the ground.

On this is built a frame the length of the house and high enough to hold a 14 by 24-in. pane of glass, the sash bars being set at right angles to the foundation. The top of the side frame is made of 4 by 4-in. stud, planed and finished like a hot bed sash frame, to hold the sash bars. The ridge, made of 2 by 4-in. material, is supported on iron pipe posts, which are strong and light. There are two rows of sash on each side of the house. Half of the distance between the ridge and the side there is a 2 by 4 running the length of the house and supported in the same manner as the ridge with pipe posts. The sash, 6 by 3 ft., glassed with 10 by 12 panes are just laid on and then held in place by two wood screws, which pass through the sash and take hold of the wood beneath.

Provision is made for ventilation by making every third sash of the upper row on each side of the house movable at its lower end. This admits fresh air just over the walks on both sides of the house. These ventilating sash are hinged to the opposite sash at the upper end, says The Country Gentleman. The joints of the sash are cov-

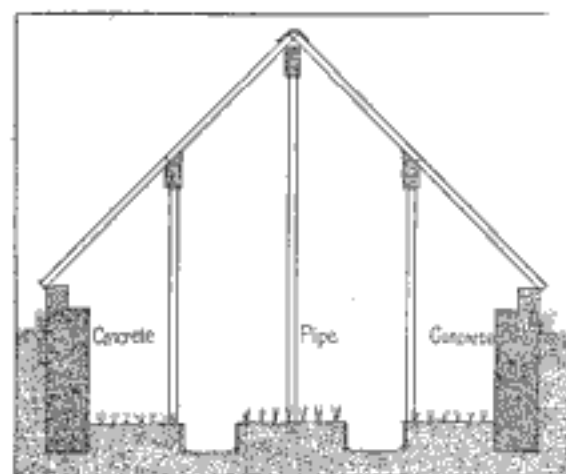

End View of Greenhouse

ered with weather strips to keep out the cold, and along the peak of the roof where the sashes come together there is nailed a strip of roofing paper, which turns the rain and snow. The beds are made directly on the ground, three in number, separated by sunken walks, a little over a foot in width and a foot deep. From the top of the middle bed to the peak is 6 ft.

How to Make a Bolt Holder

The accompanying illustration shows a very serviceable bolt holder for holding plow bolts and many other bolts that you want to hold, says a correspondent in the American Blacksmith. The bar consists of a piece of ½-in. round iron, 12 in. long, welded to a piece of ½-in. square steel about 15 in. long. The point of the welding be-

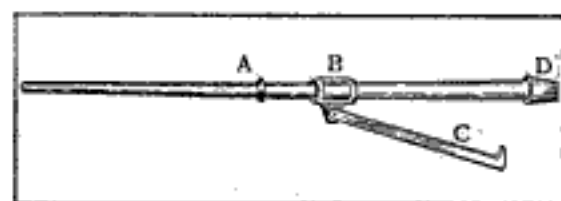

Bolt Holder

tween the iron and steel carries a shoulder, A. A slide as shown at B is made to slide over the piece of ½-in. square steel. The dog, C, is 6 in. long and the turn on the end is 1 in. long. The point of the bar at D is 2 in. wide and drawn to a chisel edge and tempered.

Using a Well to Cool Milk and Butter

On farms where ice cannot be conveniently obtained, or where facilities are not at hand for storing ice, the well

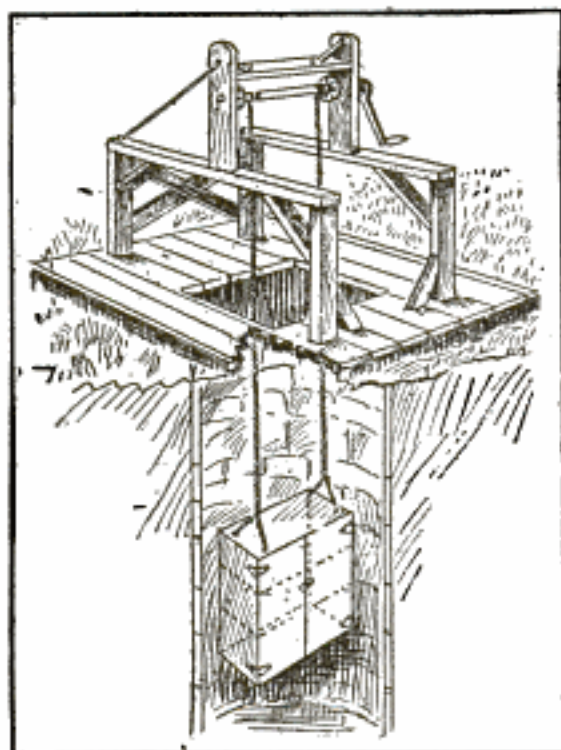

Milk and Butter Cooler

may be made into a very fair substitute. The accompanying cut shows how this may be done. A windlass is placed on a frame made of 2 by 4-in. material securely braced to prevent shaking, says Hoard's Dairyman. The size of the box depends on the size and shape of the well. The box is hung by two ropes to prevent its turning and should be strengthened with galvanized iron at the corners. If milk is to be cooled, it should be so placed that the box can be lowered into the water, otherwise the milk will not cool rapidly enough and may cause trouble from souring.

How to Make a Ground Glass

Take two old plates and remove the film. Cut them to fit the rabbeting in the ground glass frame of the camera by using a common glass cutter. Use flour of emery between the glass and

grind by giving them a rotary motion. If no flour of emery is at hand, use some fine emery cloth or paper soaked well in water and rubbed on one of the plates. A quantity of the emery will stick to the plate and the grinding is done in the same manner.—J. J. V.

To Prevent Leader Tubes from Bursting

The bursting of conductor pipes by the freezing of the water in them is not an uncommon occurrence. Schemes have from time to time been developed for securing a form of pipe that would allow for the expansion of the water in changing to ice, but these have failed in the long run, says The Metal Worker.

The cut shows a leader tube draining the valley back of a cornice. The elasticity of the tube, allowing it to expand when needed and yet to take its original form when possible, is effected by giving the sheet metal a re-entrant angular seam, the construction being indicated in the sketch. The expansion ring is also arranged outside of the pipe, where it is found to be equally ef-

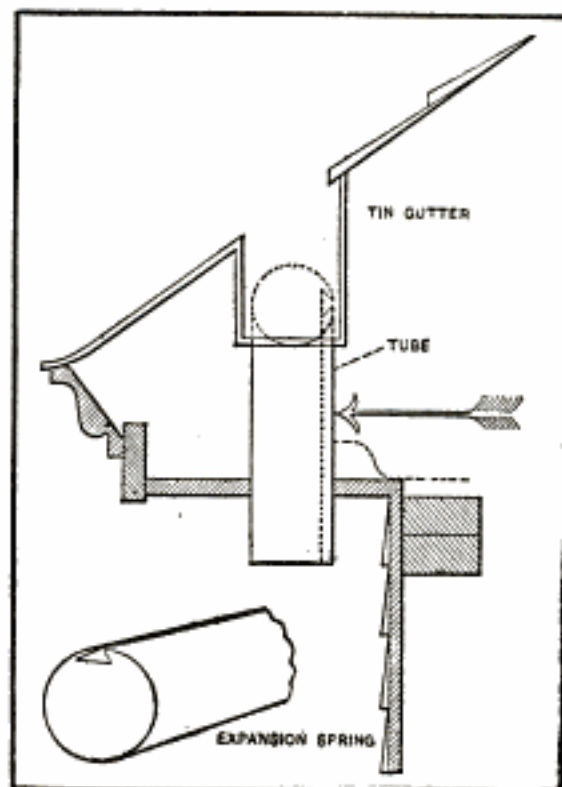

Expansion Leader Tube

ficient, with the additional valuable feature that it affords a means for the fastening to the building. In other words, when the spring is on the outside of the pipe, it is suitable for use as a regular conductor pipe, and when it is within the pipe the pipe can be passed through a circular hole in a cornice, as illustrated in the cut. It is in this part of the roof drainage system that most of the leakage troubles occur, the successive freezing and thawing usually bursting the tube at about the point shown by the arrow.

The leaders are made of copper and of galvanized iron or tin and where for architectural reasons it is desired can also be rectangular in section, the expansion spring being provided in the same way.

How to Keep a Tap from Breaking

A great many small taps break just where the thread and shank meet. This point can be overcome almost entirely,

says American Machinist, by drawing the temper at the point



A as shown in sketch with a torch, a pair of hot tongs, or by dipping the shank into hot lead and letting the blue just begin to run into the thread.

How to Figure Radiation

A good rule for estimating radiation is as follows:

For water: 1 sq. ft. of radiation to every square foot of glass; 1 sq. ft. of radiation to every 10 sq. ft. of wall; 1 sq. ft. of radiation to every 150 cu. ft. of the contents of the room.

The foregoing rule refers to rooms with one exposure, says Building Management. In rooms with two exposures the ratio of cubical contents should be 1 to 100. For steam, take two-thirds of the above results for radiation.

It is best for a water and steam job to figure out the work as if it were to

be for water, using the above water rule, and then for steam, take two-thirds of that result.

A Substitute for a Lock Nut

When a valve stem requires a lock nut but cannot be lengthened sufficient for one; also, when the single nut is

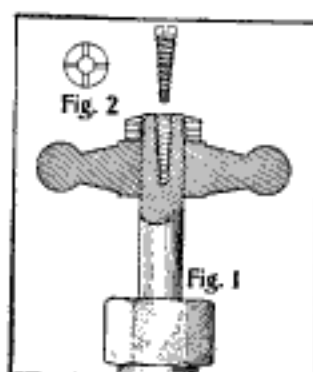

too close to the end to admit another, drill a hole in the end of the stem and tap with a tapering tap as shown in Fig. 1. Slit the end of the valve stem with a hack saw (Fig. 2), and place a conical screw in the threaded hole as shown.

Home-Made Negative Washer

A very simple and efficient negative washer can be made of two or three boards the width of the negatives.

A ledge $\frac{1}{4}$ in. high is fastened along each side of the boards. One end of one board is hung just below the tap and the

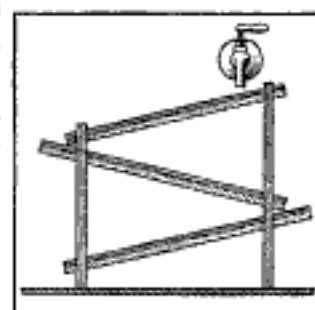

water is allowed to run down it in a gentle stream, says American Photography. The upper end of the second board is placed just below the lower end of the first board, and so on for as many boards as desired and will fit under the tap and in the sink. The water runs from the first board on the succeeding boards and into the sink. The arrangement is shown in the sketch. The plates are laid, film side up, on the boards.

Denver has the largest American flag in the world. It measures 115 ft. in length and 58 ft. in width.

A Light Punch for Removing Rivets

The accompanying sketch shows how a punch may be made that will save the assistance of a helper, says the Blacksmith and Wheelwright. The

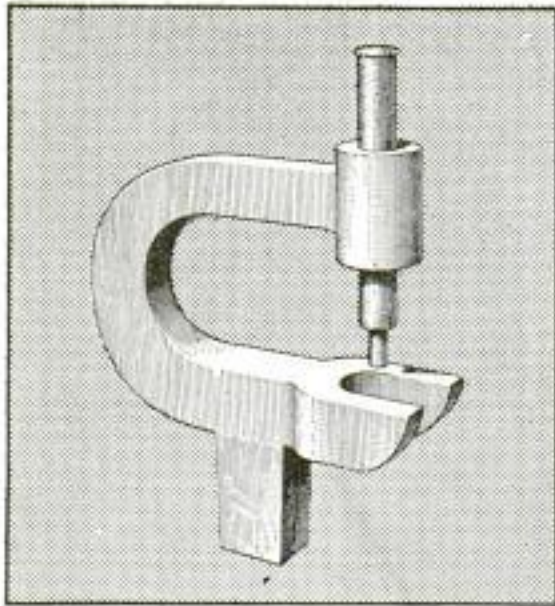

For Punching Rivets

body of the tool is forged out of a piece of iron with a projection on the bottom to fit the square hole in the anvil. The punch is a $\frac{3}{8}$ -in. steel rod drawn down to $\frac{1}{16}$ in. on the end, and is made to fit the hole in the arm a little loose. This makes a handy tool for removing rivets from light work.

A Home-Made Well Auger

Pumps are usually furnished with a 1½-in. pipe below the cylinder and in sinking the well it is found better

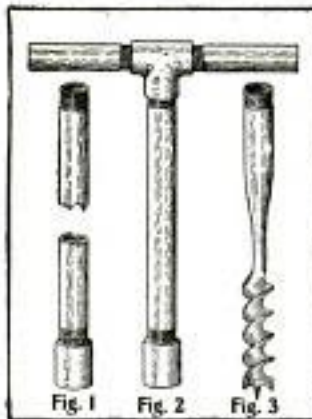

to bore a hole to gravel before driving the joint. An auger to bore this hole may be made out of an old wood auger 2 in. or more in diameter welded into a piece of $\frac{3}{4}$ -in. pipe as shown in Fig. 3. Make a handle by fit-

ting two pieces of pipe in a tee as shown in Fig. 2. Cut several pieces of $\frac{3}{4}$ -in. pipe about 6 ft. long to use in extending the handle as the hole is bored.

Utilizing Heat from a Gas Engine Exhaust

An enterprising laundryman recently had installed a 15-hp. gas engine to take the place of the steam engine he had been using. After installing the engine he connected the exhaust with the pipe which he had used for steam to heat a large mangle. It was a successful experiment, and saves the fuel otherwise necessary for that purpose.

How to Make a Handy Nail Picker

Cut a piece of hard wood $\frac{1}{2}$ in. thick and about 6 in. long in the shape as

shown in the sketch, and attach a handle to it. To keep the wood from splitting, drill small holes in the edge of the wood in



which to drive the nails as shown. Pulling this device through a bunch of nails will arrange them all straight and with the heads one way so they can be picked up by the hand ready for use.—Contributed by E. Kane.

Cobble Stones for Ditch Lining

The protection of earth slopes by means of a wall paved with cobble stones and plaster is proving effective in a number of irrigation canals constructed in this manner in California.

By this method the canal is lined with large cobble stones and small boulders, the stones of the side

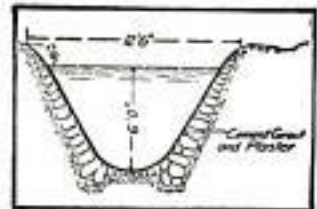

walls imbedded in mortar and faced with cement to prevent loss of water by leakage. The larger cobble stones are placed at the base of the walls, gradually growing smaller as the top is reached. The walls are laid in irregular layers, cement mortar and stones being used for two-thirds their thickness and the rear third filled with slightly wetted earth.

How to Place Glass for Small Greenhouse

The accompanying sketch shows how to place two sets of glass for a greenhouse or hot bed.

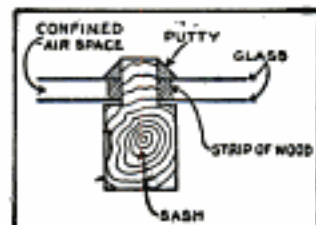

The first set of glass is embedded in the sash with putty, says The Rural New-Yorker. A small square strip of wood is then fastened to the sash and on the first set of glass as shown. The second set of glass is then laid in putty, placed on the strip of wood, and then finished with putty in the usual manner.

Cutting Channels in a Bearing for Graphite

If flake graphite is to be used in a bearing, cut the channels in the babbitt as shown in the sketch. The side grooves should lead into the center groove in the direction the shaft turns. The center channel is the one to be filled with the graphite. Channels cut in this manner will give proper lubrication, also prevent the graphite from working out at the ends.



A German mechanic has built the smallest motor in the world. It is used as a scarf pin and is run by a battery in his pocket. He keeps it in constant operation.

Connecting a Horizontal Kitchen Boiler

A great many ways have been suggested in regard to connecting a kitchen boiler horizontally placed. Some of the ways are good ones, yet improvements

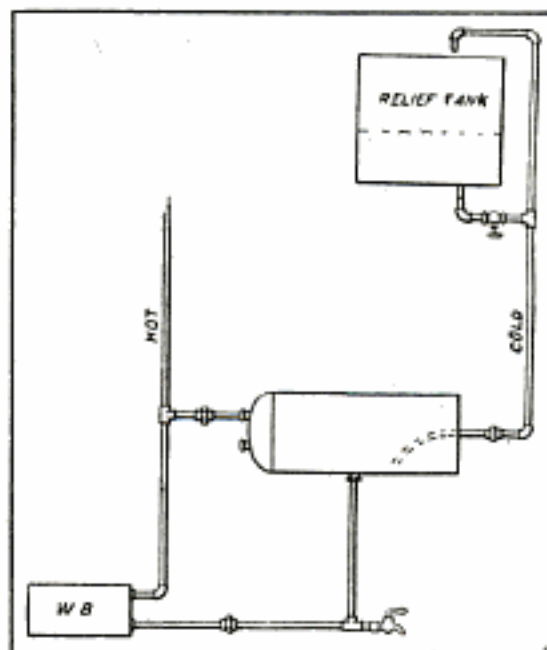

Connecting a Horizontal Boiler

can be made. The accompanying sketch shows a system of connections which is the most satisfactory way of connecting a range boiler in a horizontal position, says The Metal Worker. Making the connections in this manner provides a way to entirely empty the boiler, which is necessary on account of sand or sediment that will accumulate in the bottom.

How to Make a Worn Reamer to Size

Anneal the reamer and with a flat end set drive against the cutting edge as shown by the direction of the arrow in the sketch. This will drive up a ridge that can be turned to size and then tempered.

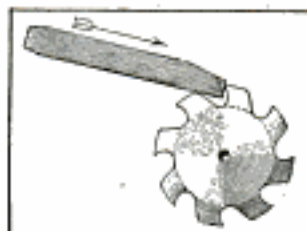

—Contributed by Charles W. Partridge, New Haven, Conn.

Extending a Brick Stack

The accompanying illustration shows how a brick stack may be raised while the power plant is kept in operation. The scaffold is bolted to the top of the stack with braces fastened into the side as shown. A wooden flue is made to fit the interior of the stack for the purpose of carrying away the smoke and gases which makes it possible for the brick layers to work. The wooden flue is raised as the work progresses. This method was recently used to raise a brick stack from 60 ft. to 90 ft. high.—Contributed by C. R. McGahey, Cedartown, Georgia.

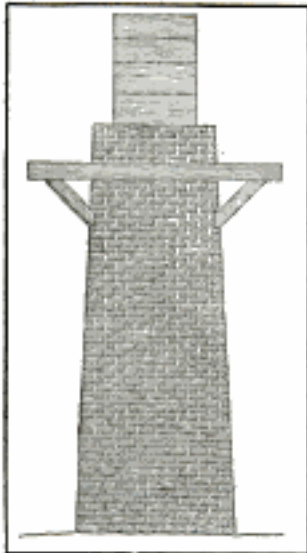

Catalog Case for Everyone

Catalogs are valuable text books, and it pays to make a case to keep them in. Take two pine boards about 1 in. by 10 in. by 12 ft. Make a shelf by fastening one of the boards to the wall with three 8-in. by 10-in. steel shelf brackets. Place the second board

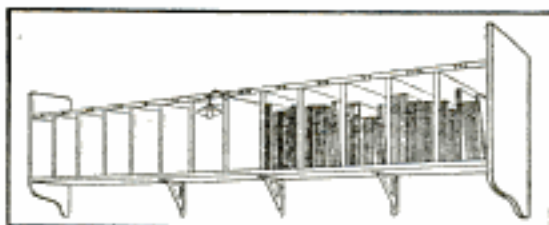

The Catalog Case

14 in. above the first and fasten to the partitions $\frac{3}{4}$ in. thick, dividing each section. Sandpaper until smooth, then oil, shellac and varnish. Neatly letter each division and place catalogs in section bearing the initial of maker's name. It is preferable to have one long shelf, but if crowded for room divide into two.

Some salesmen are more valuable

than others because they are familiar with the catalogs of the lines carried and know where to find the right book at the right time.

How to Make a Handy Shop Stand

A stand to be used in connection with the drill press when drilling long stock can be made as shown in the sketch. The body is made from 1-in. gas pipe flattened to receive the bar of iron, A. Four pieces of $\frac{3}{4}$ -in. round iron are welded in the bottom of the gas pipe and bent outward to form feet. The top, B, is made on a swivel attached to the bar, A, and is fitted with a roller. Holes are drilled through the gas pipe and the bar A in which to place a bolt for adjustment.

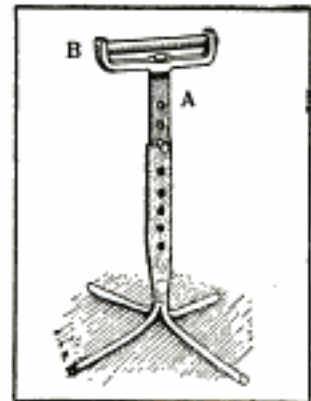

Removing Dents in a Gas Holder

A flood caused some damage to a gas holder, taking away the guide frames and making numerous leaks with some indentations in the holder itself, says a member of the Pacific Coast Gas Association. As the holder was an old one it was a question if the indentations could be removed. Temporary guide frames were erected and the holder raised up by a block and tackle with specially made hooks grasping the lower rim of the holder. While preparations were being made to force out the sides of the holder to their proper shape one of the blocks holding up the holder gave way, causing the other blocks to do the same, and the holder dropped back into the water of the tub. The air inside of the holder was compressed with such force that the indentations were removed by the pressure on the sides—doing gently and efficiently what was planned to do at considerable expense.

How to Measure a Wagon Skein

When ordering wheels to fit old or new skeins all the dimensions needed are those that are shown in the accompanying sketch. The diameters

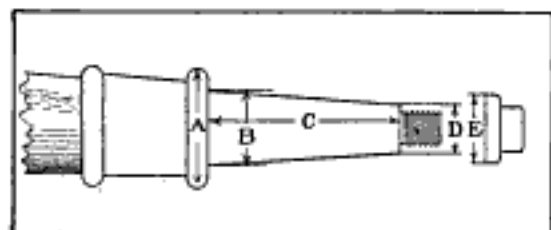

must be given at the largest part of the axle, B, and the smallest part, D, with the length, C. The diameter of the round part of the nut, E, should be given as well as the raised part at A.

How to Make Concrete Steps

Concrete may be used in the construction of steps, particularly in damp places, and in the open or where the ground is terraced, concrete steps and walks can be made exceedingly attractive. Where the ground is firm it may be cut away in the form of steps, with each step cut 2 or 3 in. lower than its finished level.

Where the nature of the ground will not admit of its being cut away in the form of steps, the risers are moulded between two vertical forms. The front one may be a smooth board, but the other should be a thin piece of sheet metal, which is more easily removed after the earth has been tamped in behind it, says the Concrete Review. A simple method of reinforcing concrete

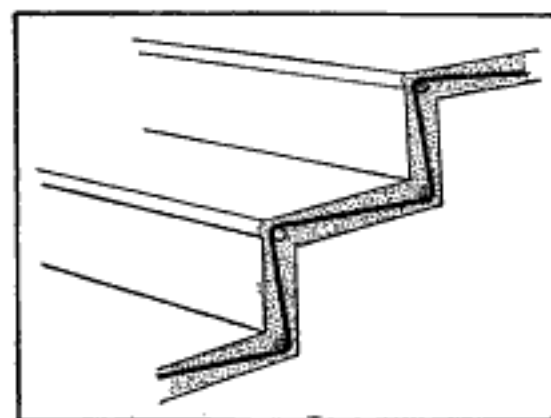

Reinforced Concrete Steps

steps is to place a $\frac{1}{2}$ -in. steel rod in each corner, and thread these with $\frac{1}{4}$ -in. rods bent to the shape of the steps, as shown in the sketch, placing them about 2 ft. apart. For this class of work a rich Portland cement concrete is recommended, with the use of stone or gravel under $\frac{1}{2}$ in. in size. Steps may be given $\frac{1}{2}$ -in. wearing surface of cement mortar mixed in the proportion of 1 part cement to 2 parts sand. This system is well adapted for stairways in houses.

How to Handle Heavy Bar Stock

Short, heavy bars are not easy to handle, and are dangerous to a workman's toes and fingers in a machine

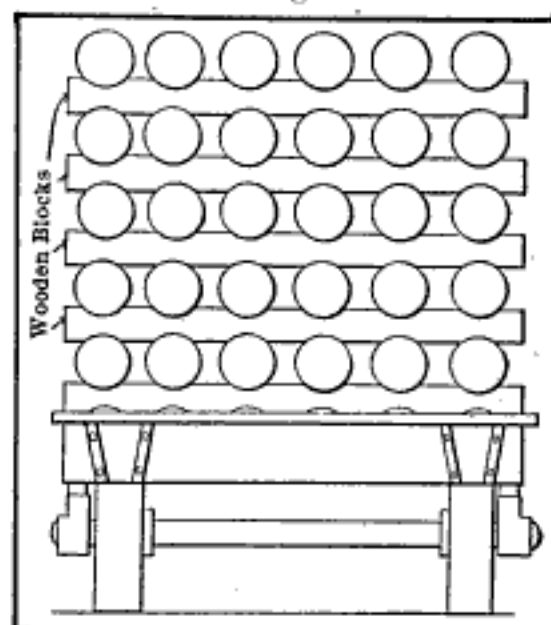

Handling Heavy Bars

shop. Such bars are generally piled up in the form of a pyramid, and in that shape they are difficult to handle, says American Machinist. A certain firm uses a great quantity of short, heavy steel bars. These bars are piled around the different departments of the shop mainly on trucks, as shown in the accompanying cut, which gives the end view of a truck load. Pieces of timber running across the truck are grooved to fit the bars and holding the bars apart, so that the workman can get his hands under them or pass a leather loop around them to lift with a hoist.

How to Prevent an Oil Can from Dripping

The accompanying sketch shows a kink in regard to oil cans. A leather washer is placed on the spout as shown at A, says a correspondent in *American Machinist*, which will prevent any oil from running down the outside of the spout on the bench, or wherever the can happens to be.

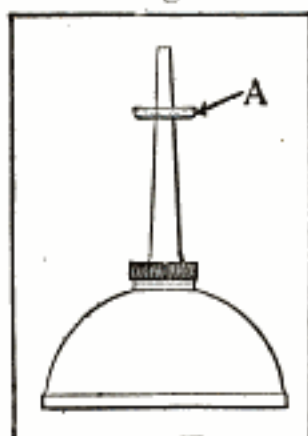

Quickly Made Door Jack

Make two blocks 8 in. long from 2 by 4 in. material and nail a common lath across them as shown in the sketch at A. Fasten two triangular blocks, C, made from a piece of 2 by 8 in. wood, to the lath, leaving a space between them. The door placed in this space with its weight on the lath, will bend

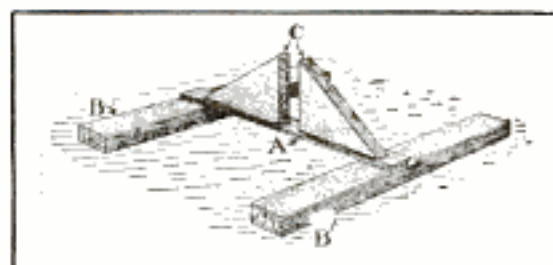

Door Jack

the lath down, bringing the tops of the angle blocks together like a vise. Lifting on the door opens the angle jaws and releases the door.—Contributed by E. E. Harriman, Los Angeles, Cal.

Building an Ice House

It is not necessary to have an expensive building for an ice house, but certain essentials must be observed, and the ice properly packed. In the first place the house should be tight and well drained at the bottom. How to

accomplish this depends somewhat on the conditions in each case.

The house in question was built on a clay bank. An excavation was made about 18 in. deep and some old railroad ties used for sills, with gravel to fill up the inside, and a porous draintile put in around the outside and down the bank, the soil being well packed around the outside. The structure is on a frame of 2 by 4 in. studding, 14 ft. long. The house was sided with 12-in. barn boards, put on like clapboards and lapped 1 in. The roof is of ordinary tar felt. As an ice house must be well ventilated at the top, so that the packing will keep dry, a slatted ventilator 2 by 4 ft. was put in the roof, a floor laid loosely 10 ft. from the bottom and a layer of straw placed on this floor. The house is 18 ft. square.

By all means use sawdust for the packing, says *The Country Gentleman*. The ice is cut in cakes longer one way than the other, so that, in placing one layer on the other, joints may be broken; 22 by 28 in. is a good size. Sawdust is placed on the bottom about 6 in. thick and the cakes of ice are placed on this sawdust, keeping them away from the sides of the house about 1 ft. The cakes should be laid to fit as closely as possible and all the cracks and corners carefully chinked with fine particles of ice tamped in with a bar or some convenient tool. The next layer is placed in the same manner, taking care to break joints. When the house is packed the last melting will cause the whole mass to freeze in one solid block. As each layer is put in the house sawdust should be packed around the sides as firmly as it can be tamped down. About 2 ft. of sawdust is placed on top as the ice will gradually settle and need occasional packing around the sides. Remember to get the ice as clear as possible, and that the crop harvested in zero weather will keep much better than when gathered near the freezing point. Ice from 10 to 12 in. in thickness is the most convenient to handle, and there will be least waste.

Bench Vise Anvil

The accompanying cut shows a very handy bench vise anvil for the tool room, model-maker, or amateur mechanic. The anvil is made from a piece of steel rail about 12 or 15 in. long, and as heavy as can be obtained, and the top, edges and ends are planed smooth,

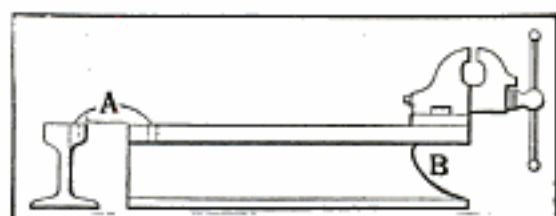

Bench Vise Anvil

true and square. The web is cut out, as shown at B, so a clamp or swivel vise of about $1\frac{1}{2}$ or 2 in. length of jaw, can be fastened to the end of the rail. A taper hole is made at A for the different shaped stakes. The top and edges may be case-hardened if so desired. This makes a handy outfit, says Machinery, as the top of the rail is a good place for straightening work, and the edges for bending work.

Lifting out a Motor

A good example of the ingenuity that is more often born of the lack of facilities than of repair shop necessity is sketched herewith. The problem in

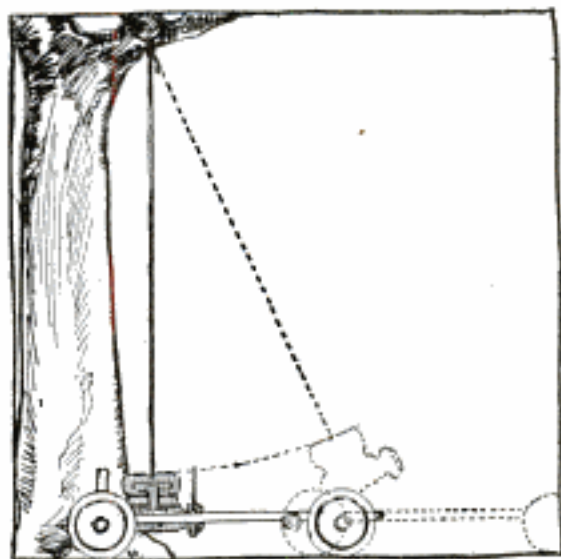

Lifting out a Motor

this case was to lift a 400-lb. motor out of a car which had to be dismantled a good many miles from the nearest block and tackle, says Motor Age. The engine was first freed of all piping and wiring, and unbolted from the frame. One end of a rope was tied about the engine, the other end being given a couple of turns around a horizontal limb of a tree directly overhead. All slack being taken out of the rope, one man maintained a slight tension on its free end, meanwhile keeping one hand on the motor to prevent its bumping around as it came loose, while another pushed the car back down a grade. As the rope swung out of the vertical, the engine had to lift until it was free from the frame, and after a few oscillations in the air it came to rest hanging like a pendulum from the limb. Easing up on the rope, the engine was brought to the ground.

How to Tighten a Pulley on Shaft

A certain electric motor gave trouble on account of the pulley tearing away the side of the keyseat, until at last the side of the groove gave away entirely. The shaft being of small diameter, another keyway would have weakened it still more, and the turning of another shaft would have compelled the dismantling of the machine. This was avoided by adopting the method shown in the sketch, says American Machinist.

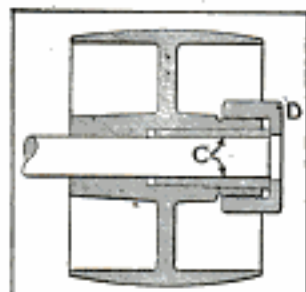

The hub of the pulley was tapered internally and threaded externally for a certain length. Three wedges, C, were obtained by cutting a solid piece with a hole of the diameter of the shaft and turning the outside taper to fit the taper in the pulley hub. These projected about $\frac{1}{4}$ in. and were forced between the pulley and the shaft by the

threaded collar, D. This simple arrangement will make a strong and sure grip on the shaft.

How to Make an Acid Receptacle

As glass is the proper material for a receptacle to hold acid, take an ink or mucilage bottle and encase it in sheet metal, as shown in Fig. 1, filling the space between the glass bottle and the metal casing with plaster of paris,



Will Not Tip Over

which will prevent the bottle from being broken or upset, says The Metal-Worker. The bottom is then soldered to it. If a bottle or mug can be obtained with an opening large enough to make a receptacle as shown in Fig. 2, it can be upset or fall from a roof and the acid will not be lost.

A Coal Bin for a Narrow Porch

A coal bin made as described makes a most excellent one for use on verandas of tenement buildings. In the sketch the bottom, A, is shown pitched from all sides toward the opening. This throws the last pieces of coal where they can easily be reached with a shovel, and without scraping around the corners. An inclined board, B, is placed over the opening which prevents the coal from falling and scattering over the floor. This board should not be less than 12 or 14 in. wide.—Contributed by Albert Pott, Waterbury, Conn.

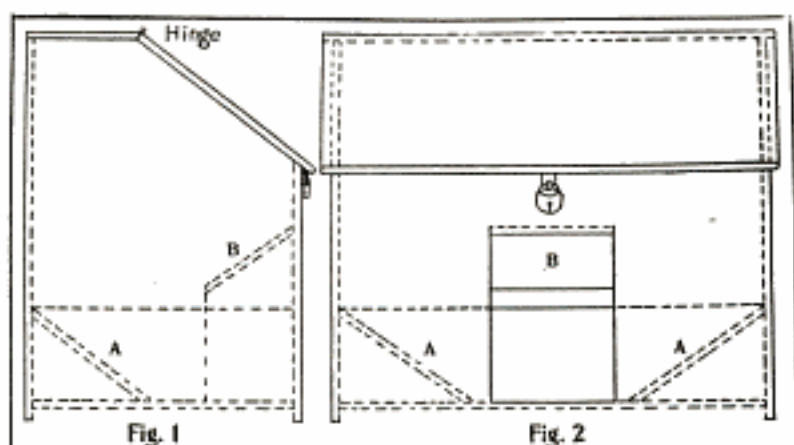

Details of Coal Bin Construction

remove the lining metal and fill the space with short rods of $\frac{1}{4}$ -in. round steel (Fig. 5).

A very good system of lubricating loose pulleys is to drill a hole from the

Lubricating Loose Pulleys

It is not always easy to properly lubricate loose pulleys. A correspondent of the Wood-Worker states that he had a loose pulley on a saw bench.

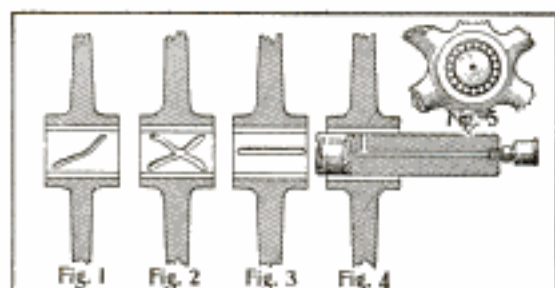

Prevents Hot Pulleys

even though it had an oil channel, that gave trouble. The pulley was fitted with a grease cup, so the grease could be forced in. The wheel would go for a while, but would soon get hot. When taken off, the end next the tight pulley was quite dry, the other end well greased. The oil channel was cut in the wheel, not straight through, but screw-wise, as shown in Fig. 1, and was drawing the grease away from that end. By cutting another channel in the opposite direction (Fig. 2) the trouble was overcome. The lesson taught is that straight through is the best line for an oil channel in loose pulleys (Fig. 3). Another plan, adopted as a makeshift, but seeming to answer well, is to

end of the spindle to the middle of the place where the loose pulley runs, then drill a hole from the side to meet it (Fig. 4). The grease cup is fastened in the end of the spindle so the grease can always be supplied where most wanted; that is, when the machine is idle and the loose pulley at work. There are cases where this arrangement is hardly practical, but it could often be adopted with advantage.

A Door Bell Substitute for the Deaf

As red lights can be noticed any time during the day or night a little device constructed as shown in the sketch, to place in connection with the bell circuit, will make a fine arrangement for those that do not have good hearing.

The front view of the device is shown in Fig. 1, and the end view, Fig. 2. In this instance three drops are needed—for the front door, hall door and the side entrance. As the rooms have electric lights, the lights in each room are wired to the panel box by breaking one wire and connecting as shown in Fig. 1. When the circuit is closed on one of the bells, it also operates the magnet holding the drop in the same circuit. This releases the drop and the knife switch, K, closes the light circuit.

The sketch shows one of the drops complete at A, Fig. 1. The drops are returned to their position by the crank, D, and the little projections, E.—Contributed by H. B. French, New York.

A Kink for the Sign Writer

To draw an object that has two sides alike is one of the hard things encountered by the sign writer. A good way to do this is to take a piece of paper, a little larger than the object to be drawn, and fold it in the center,

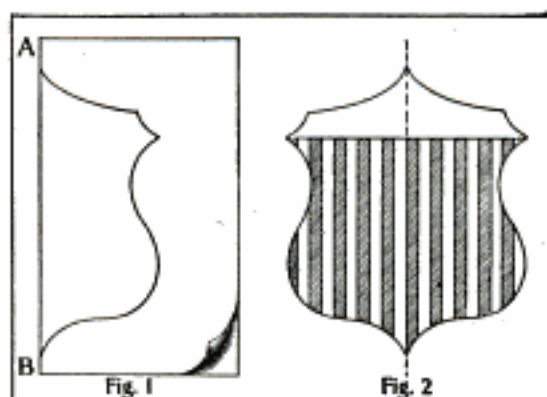

Pattern with Two Like Sides

as shown at AB Fig. 1. Commencing at the fold cut out one side of the object. Unfold the paper and the part cut out will make a pattern with both sides alike.

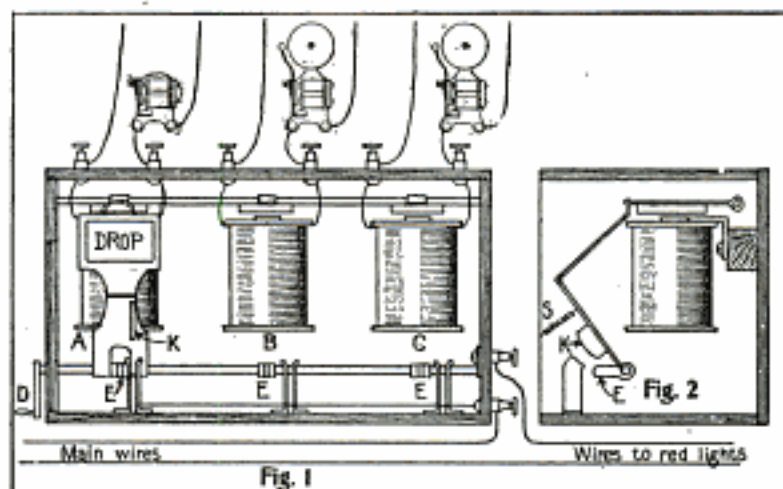

Flash Lights and Door Bells

Trouble in Starting a Gasoline Engine

The bucking and snorting refusal in starting a gasoline engine is often due to moisture in the cylinder, states Power and Transmission, preventing the regular ignition until dried by the heat of several explosions. The difficulty may be overcome by shutting off the cooling water a few minutes before starting of the engine and not turning it on again until after the engine begins to explode regularly when again started. The hint here contained may be of use to the autoist who has trouble of this nature in cold weather where extra cylinders next to fire are left full of gasoline vapor and air, which condenses when the cylinder

walls get thoroughly cold and deposits considerable moisture.

Blueprint Washing Tank

The capacity of cylindrical machines for printing blue and sepia papers is so great that special preparation for

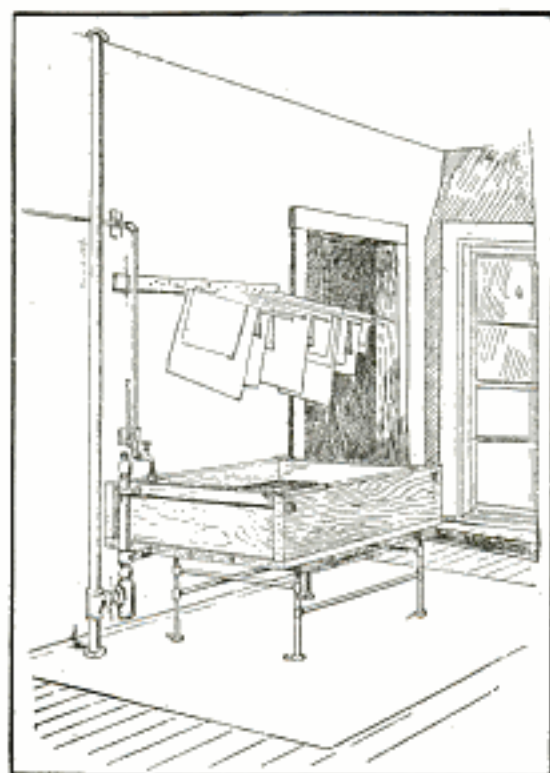

Blueprint Washing Tank

developing the prints is necessary. A wood sink 5 ft. long, 40 in. wide and 12 in. deep, inside measure, lined with zinc, seems to meet every requirement. There should be no standing overflow plug or other obstruction inside to interfere with floating the paper. The boards may be of any clear 1 $\frac{3}{4}$ -in. material with the ends mortised into the sides 2 or 3 in. from the ends. The bottom can be nailed flat to the frame. One $\frac{1}{2}$ -in. tie rod near the top at each end, in addition to good nailing will keep the frame in good shape, says *The Metal Worker*. The bottom pieces should not be over 8 in. wide, grooved and stripped, and not nailed nearer than 2 in. from the joint. Bevel the frame inward at the top so as to make the depth $\frac{1}{2}$ in. less at the inside edge than from a line stretched over

the top. If the zinc lining is held snugly to the bevel and evenly bent at both angles and tacked to the outside, shrinkage of the frame in height will merely square up the top to some extent, while if the lining is bent over a square top, shrinkage soon inclines the top outward so that drippings run on the floor and the acute angle without support is more easily injured. The sketch shows a $\frac{3}{4}$ -in. pipe frame support under the tank. No better means than pipe will be found, but in any event the tank or sink should rest on strong cleats or girders that entirely cross the bottom. Cast soil pipe or galvanized wrought pipe will do for the waste. The trap should hold a good body of water.

To control the waste outlet and maintain the level desired (nearly full), a standing bath waste gives the best service. A standing waste as purchased has the overflow too high, but it is only necessary to drill some holes in the stand pipe at the proper level, after the waste is in place.

Setting Electric Light Poles in Frozen Ground

The following method was used in placing electric light poles in frozen ground: Steam was obtained from the boiler of an ordinary traction engine and conveyed through a pipe to a vertical jet pipe, says *Engineering-Contracting*. The jet pipe was connected by a tee to a horizontal pipe, 24 in. long, capped at one end and connected at the other by nipples and four elbows to the steam pipe. The nipples and elbows were placed to allow the necessary play in handling the appliance. The jet pipe was manipulated by two wooden handles 10 ft. long, connected by stirrups to the two ends of the 24-in. horizontal pipe. The jet pipe was forced down by two men pressing on the handles, and as the earth thawed, the steam would carry the particles out alongside the pipe. As the depth increased, more steam would be condensed in the hole, until finally the overflow was liquid mud.



Amateur Mechanics



A Microscope Without a Lens

By E. W. Davis

Nearly everyone has heard of the pin-hole camera, but the fact that the same principle can be used to make a microscope, having a magnifying power of 8 diameters (64 times) will perhaps be new to some readers.

To make this lensless microscope, procure a wooden spool, A (a short spool, say $\frac{1}{2}$ or $\frac{3}{4}$ in. long, produces a higher magnifying power), and enlarge the bore a little at one end. Then blacken the inside with india ink and allow it to dry. From a piece of thin transparent celluloid or mica, cut out a small disc, B, and fasten to the end having the enlarged bore, by means of brads. On the other end glue a piece of thin black cardboard, C, and at the center, D, make a small hole with the point of a fine needle. It is very important that the hole D should be very small, otherwise the image will be blurred.

To use this microscope, place a small object on the transparent disc, which may be moistened to make the object adhere, and look through the hole D. It is necessary to have a strong light to get good results, and, as in all microscopes of any power, the object should be of a transparent nature.

The principle on which this instrument works is illustrated in Fig. 2. The apparent diameter of an object is inversely proportional to its distance from the eye, i. e., if the distance is reduced to one-half, the diameter will appear twice as large; if the distance is reduced to one-third, the diameter will appear three times as large, and so on. As the nearest distance at which the average person can see an object clearly is about 6 in., it follows that the diameter of an object $\frac{3}{4}$ in. from the eye would appear 8 times the normal size. The object would then be magni-

fied 8 diameters, or 64 times. (The area would appear 64 times as large.) But an object $\frac{3}{4}$ in. from the eye appears so blurred that none of the details are discernible, and it is for this reason that the pin-hole is employed.

Viewed through this microscope, a fly's wing appears as large as a person's hand, held at arm's length, and has the general appearance shown in Fig. 3. The mother of vinegar examined in the same way is seen to be swarming

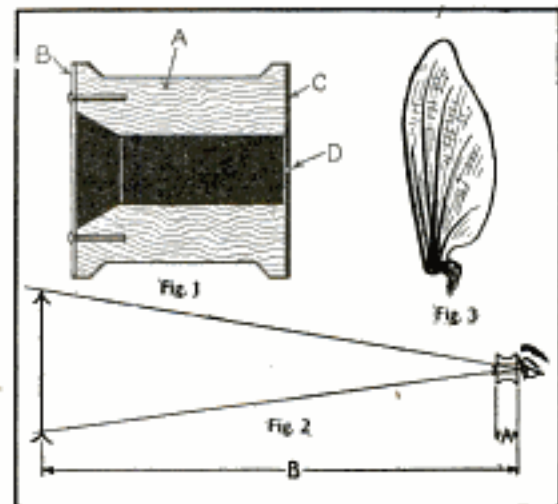

Details of Microscope

with a mass of wriggling little worms, and may possibly cause the observer to abstain from all salads forever after. An innocent looking drop of water, in which hay has been soaking for several days, reveals hundreds of little infusoria, darting across the field in every direction. These and hundreds of other interesting objects may be observed in this little instrument, which costs little or nothing to make.

Prince Rupert's Drops

Prince Rupert's drops are made by letting drops of melted glass fall into cold water. These drops become oval in shape with a tail or neck resembling a retort. Their peculiarity is that when a small portion of the tail or neck is

broken off the whole bursts into powder with an explosion and a considerable shock is felt by the hand that grasps it.

How to Balance a Cup on a Knife

If you were told that you could balance a cup one-quarter full of coffee

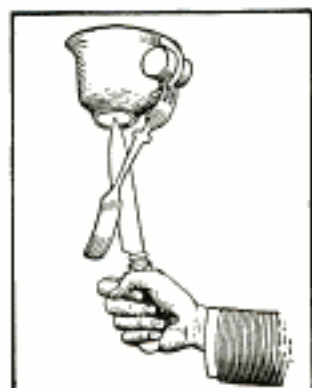

on the point of a carving knife you would hardly believe it. Insert a cork in the handle of a cup tightly, says the Detroit Free Press. Stick two of the prongs of a fork into the cork, in the position shown in the sketch. This arrangement lowers the center of gravity of the whole, and if you have a steady hand, you may now place the cup on the point of the knife.

Photographs Lightning Flash

This interesting letter and lightning flash photograph were received from Fred M. Roberts, Paterson, N. J., and describe how he profited from an article published in Popular Mechanics.

"Receiving a suggestion from an article published in Popular Mechanics on the subject of photographing lightning flashes, I took my camera out and focusing it on the setting sun marked its position on the scale. This



Brilliant Cloud Effect

enabled me to obtain the correct focus quickly the first night an electrical storm occurred, with a result, as you can see, to be proud of. The exposure was taken about 8:30 o'clock in the evening with the camera set due south. I had often thought of the possibilities of photographing flashes but never gave it a trial until after reading the above mentioned article."

How to Make Small Gear Wheels Without a Lathe

To make small models sundry small gears and racks are required, either cut for the place or by using the parts from an old clock. With no other tools than a hack-saw, some files, a compass and with the exercise of a little patience and moderate skill, very good teeth may be cut on blank wheels.

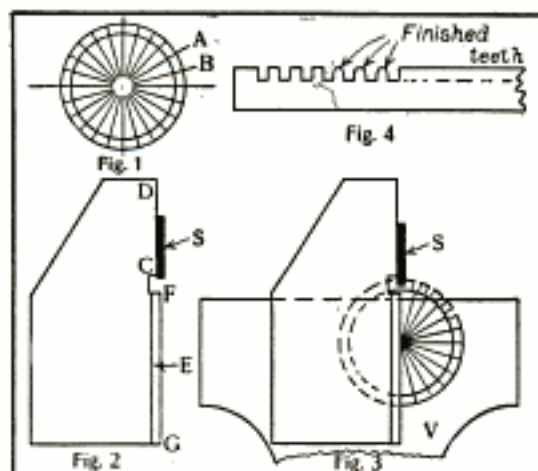

Making Model Wheels

First take the case of a small gear-wheel, say 1 in. outside diameter and $\frac{1}{16}$ in. thick, with twenty-four teeth. Draw a circle on paper, the same diameter as the wheel. Divide the circumference into the number of parts desired, by drawing diameters, Fig. 1. The distance A B will be approximately the pitch. Now describe a smaller circle for the base of the teeth and half-way between these circles may be taken as the pitch circle.

Now describe a circle the same size as the largest circle on a piece of $\frac{1}{16}$ -in. sheet metal, and having cut it out and filed it up to this circle, fasten the

marked-out paper circle accurately over it with glue. Saw-cuts can now be made down the diameters to the smaller circle with the aid of a saw guide, Fig. 2, made from $\frac{1}{8}$ -in. mild steel or iron. This guide should have a beveled edge, E from F to G, to lay along the line on which the saw-cut is to be made. The straight-edge, C D, should be set back one-half the thickness of the saw-blades, so that the center of the blade, when flat against it, will be over the line F G. A small clearance space, F C, must be made to allow the teeth of the saw to pass.

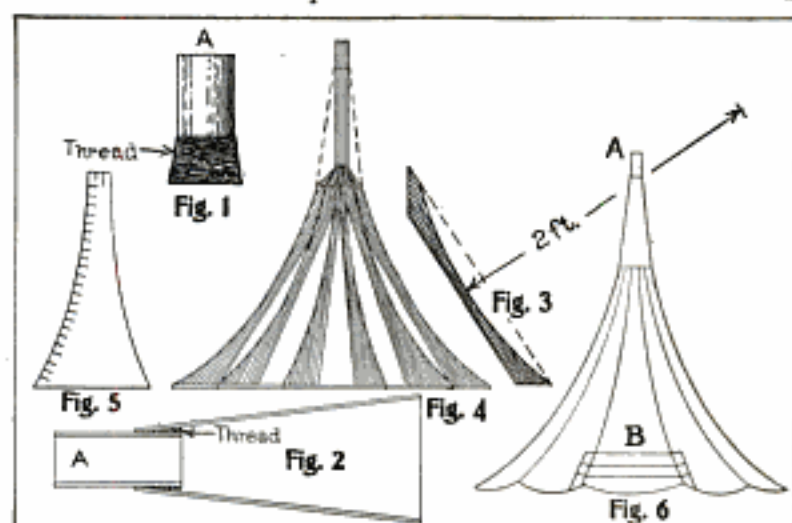

Details of Phonograph Horn

The guide should then be placed along one of the diameters and held in position until gripped in the vise, Fig. 3. The first tooth may now be cut, care being taken to keep the blade of the saw flat up to the guiding edge. The Model Engineer, London, says if this is done and the saw-guide well made, the cut will be central on the line, and if the marking out is correct the teeth will be quite uniform all the way round. A small ward file will be needed to finish off the teeth to their proper shape and thickness.

In making a worm wheel the cuts must be taken in a sloping direction, the slope and pitch depending on the slope and pitch of the worm thread, which, though more difficult, may also be cut with a hacksaw and file.

A bevel wheel should be cut in the same manner as the spur wheel, but the

cut should be deeper on the side which has the larger diameter. To cut a rack the pitch should be marked along the side, and the guide and saw used as before (Fig. 4).

How to Make a Paper Phonograph Horn

Secure a piece of tubing about $1\frac{3}{4}$ in. long that will fit the connection to the reproducer, and wrap a quantity of heavy thread around one end as shown in the enlarged sketch A, Fig. 1. Form a cone of heavy paper, 9 in. long and 3 in. in diameter, at the larger end with the smaller end to fit the diameter of the tube A, making it three ply thick and gluing the layers together. Attach this cone on the tube A where the thread has been wrapped with glue, as shown in Fig. 2. Fig. 2 is also an enlarged sketch. Make ten pieces about 1 ft. 10 in. in length and 3 in. wide from the thin boards of

a biscuit or cracker box. Cut an arc of a circle in them on a radius of 2 ft. (Fig. 3). Make a stick 10-sided, 12 in. long, that will fit loosely in the tube, A, to which nail the 10 pieces as shown in Fig. 4, connecting the bottom by cross pieces, using care to keep them at equal distances apart and in a circle whose diameter is about 2 ft.

The cone is placed over the stick as shown by the dotted lines in Fig. 4 and temporarily fastened in position. Cut out paper sections (Fig. 5) that will cover each space between the 10 pieces, allowing 1 in. on one side and the top in which to cut slits that will form pieces to overlap the next section and to attach with glue. Fasten the sections all around in like manner. The next course is put on in strips overlapping as shown at B, Fig. 6. Finish by putting on sections in the same way

as the first course, making it three-ply thick. Remove the form, trim to suit and glue a piece of paper over the edge. When the glue is thoroughly hardened, put on two coats of white and one of blue paint, shading it to suit and striping it with gold bronze.—Contributed by B. H. Haver, Houston, Tex.

How to Bind Magazines

An easy way to bind Popular Mechanics in volumes of a year each is to arrange the magazines in order and tie them securely both ways with a strong cord. It is well to put two or three sheets of tough white paper, cut to the size of the pages, at the front and back for fly leaves.

Clamp the whole in a vise or clamp with two strips of wood even with the back edges of the magazines. With a sharp saw cut a slit in the magazines and wood strips about $\frac{1}{2}$ in. deep and slanting as shown at A and B, Fig. 1. Take two strips of stout cloth, about 8 or 10 in. long and as wide as the distance between the bottoms of the sawed slits. Lay these over the back edge of the pack and tie securely through the slits with a string thread—wrapping and tying several times (C, Fig. 2).

If you have access to a printer's paper knife, trim both ends and the front edge; this makes a much nicer book, but if the paper knife cannot be used, clamp the whole between two boards and saw off the edges, boards and all, smoothly, with a fine saw.

Cut four pieces of cardboard, $\frac{1}{4}$ in. longer and $\frac{1}{4}$ in. narrower than the magazines after they have been trimmed. Lay one piece of the board on the book and under the cloth strips. Use ordinary flour paste and paste the strips to the cardboard and then rub

paste all over the top of the strips and the board. Rub paste over one side of another piece of board and put it on top of the first board and strips pressing down firmly so that the strips are held securely between the two boards. Turn the book over and do the same with the other two boards.

After the paste has dried a few minutes take a piece of strong cloth, duck or linen, fold and cut it 1 in. larger all around than the book, leaving the folded edge uncut. Rub paste over one of the board backs and lay one end of the cloth on it, smoothing and creasing as shown at A, Fig. 3. Turn the book over and paste the other

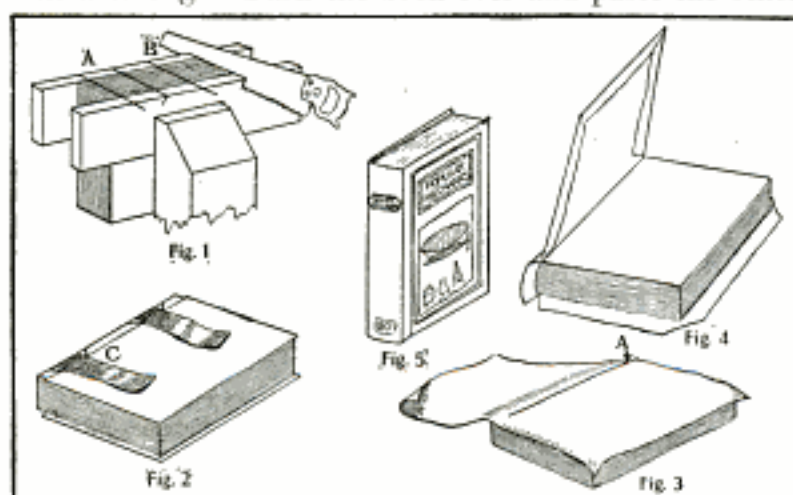

Process of Home-Made Binding

side. The back edges should have a good coat of paste and a strip of paper the width of the thickness of the pack pasted on before pasting the cloth to the second board back.

Cut off the corners and fold over the edges of the cloth, pasting them down (Fig. 4). Rub paste on one side of a fly leaf and press the back down on it. Turn the book over and paste a fly leaf to the other back after the edges of the cloth have been folded down. The backs must not be opened until the fly leaves are thoroughly dry. Trim and tuck in the ends of the strip at the back edge.

When fixed this way your magazines make one of the most valuable volumes you can possibly add to your library of mechanical books.—Contributed by Joseph N. Parker, Bedford City, Va.

FARMERS' ADVERTISING BULLETIN

An advertising bulletin board, similar to the one shown in this illustration, placed at a central point in a rural community, has proved an excellent arrangement to draw farmers together to make good sales and satisfactory trades. The bulletin consists of a blackboard on which the farmers offer farm stock, machines, etc., for sale or trade. Ignoring the bulletin's value to the farmer alone, the manager of an elevator company who has placed one of the boards on the side of his building, says that he would not part with it for \$100.

Farmers' Wants
or Whom it May Concern

*Auction March 10 at Black horse for sale
Sam Smith's farm. by Eli Huckleberry.*

*Work team to trade
for family surry.
Ed Johnson*

*Choice seed wheat for
sale by Farmers Elevator Co.*

DECK OF A LAKE FREIGHTER

To stand on the bridge of one of the big 600-ft. lake freighters and look down the long, bare expanse of steel deck, only broken by low hatchways, to the boiler house and after cabins is a sight calculated to make a person almost lonesome. For a stretch of 450 ft. nothing breaks the barrenness, and it is quite as possible to get



Longer Than a City Block

away from the rush and stress of things as in a "deserted village." A few trips each day from after cabin to pilot house, with the wind almost lifting you off your feet, is as much of a constitutional as most people care to take on land.

PADDED COSTUMES FOR
AERONAUTS

A European aeronaut has devised a padded suit for use on ballooning trips. With this suit he expects to escape the bruises which every aeronaut gets now and then when making descents.



RIVER TELEPHONE SERVICE

To insure the safety of large ocean vessels running through the St. Lawrence river from Montreal to Quebec, a distance of 180 miles, the Canadian Department of Marine Fisheries has established a marine signal system of telephones by which captains can be warned of unusual or unexpected dangers to be avoided.

THE WORLD'S CRY FOR TRAINED MEN

THE MAN WHO GETS A BIG SALARY—
HOW HE GETS IT—WHY HE GETS IT.

By VICTOR FORTUNE.

There was once a time when it was extremely difficult for anyone without years of schooling to succeed in life.

Now it is different. Look where you will today—in whatever walk of life—you will find men who have risen from small positions to places of importance and independence—commanding the respect of themselves and their fellow men.

The "dollar-a-day" man is not a real man. He has long ceased to be considered a factor in any business. He is merely a cog—a small part of a wheel. His little responsibility ceases with the 6 o'clock whistle. His pay doesn't increase. He knows that if he loses his job there are a hundred and one other men as good as he waiting to fill it.

But with proper training this man *can* succeed. Where before he was merely tolerated, *training* puts him in *demand*. He commands a better salary, and goes on *earning more all the time*.

But how is he to get this training? His hours are long—his capital small—often he lives miles from any large center where such a training is to be had. A few years ago such a question would have been hard to answer; but today, with a great man-helping institution such as the International Correspondence Schools at the ready command of every untrained man, the solution of the difficulty is, indeed, simple.

NOW EARNS MORE A DAY THAN HE FORMERLY DID IN A WEEK.

When R. E. Tuttle of 230 Highland Ave., Portland, Me., first enrolled with the I. C. S. he was a clerk earning only \$10.00 a week. Tuttle says: "I am now a general

contractor and civil engineer, and *earn sometimes more per day now than I did per week when I enrolled*. I unhesitatingly recommend the I. C. S. to the serious consideration of every ambitious man."

MADE UP HIS MIND TO BE PROMOTED, TOO.

Another man, formerly a general shop hand, says: "I saw a number of men promoted to positions much higher than I held, and became a little discouraged. Since enrolling with the I. C. S. I have been gradually advanced to the position I now hold as electrical engineer of Yonkers Works of the Otis Elevator Company at *five times my former salary*—due entirely to I. C. S. instruction."

From shop hand to electrical engineer—think of it! Yet this experience of Frederick W. Newell of the Otis Elevator Company, Yonkers, N. Y., is but one of thousands of other parallel cases where the I. C. S. has helped men to success.

Doesn't this prove that training counts?

HIS WAGES INCREASED 250 PER CENT.

It is an error to suppose that to become proficient in any line of work requires a long course of college study, absence from home, and large capital. The I. C. S. will train you in *your spare time* without requiring you to leave home or lose a day's work.

This is especially evident in the case of R. A. Norling, 311 High Street, Aurora, Ill., whose wages since enrolling with the I. C. S. have increased 250 per cent—two and one-half times the amount he received before the I. C. S. put him on the road to

success. Norling writes: "I was working as a factory hand at the Elgin Watch Factory when I took out my course in the I. C. S. I now have charge of the pattern-making, experimental room, and the drafting room of the Aurora Automatic Machinery Company. *My earnings have increased 250 per cent. since I enrolled.* I have secured many patents on special mechanical devices, and feel that my own experience warrants me in recommending the I. C. S. to any ambitious man who wishes to advance in his trade."

There surely must be something in training when it will take a man from the factory bench and raise him to such a position of importance, and almost treble his salary.

Not only this, but it develops a man's inventive powers—powers that would otherwise remain dormant and unproductive. Norling says: "I have secured many patents on special mechanical devices." Norling knew he had this gift, but not until he and the I. C. S. got together did he find himself able to turn that gift into dollars and cents.

OFFICE BOY BECOMES ASSISTANT TO PRESIDENT.

The interesting story of the office boy's rise to success has often been told. The I. C. S. has made it a *fact*. The following experience of L. J. Hellenthal, of 18 Ward Street, Seattle, Wash., is positive proof that I. C. S. training is not only for the grown-up, but also for the youth—the boy just starting out to make his own living.

This young man says: "My I. C. S. course has certainly been a great benefit to me. I enrolled *when I was an office boy.* I am now assistant to the President of the Union Machinery and Supply Company, and have increased my earnings from \$5.00 a week to \$150 a month.

NO AGE LIMIT.

It was young Hellenthal's good fortune to realize, in time, the importance of training, with the result that his promotion has been rapid. But the I. C. S. has no age limit. Some of the most successful men

the I. C. S. has developed were past their prime when they enrolled. These men had been filling menial positions, and not until they joined the I. C. S. did they break the bonds that had held them in the ranks of poorly paid and dissatisfied men.

RULE OF THUMB VS. RULE OF MIND.

Rule of thumb works well enough up to a certain point, but there it stops. By opening a throttle you can set a train in motion, but unless you understand the principle by which the steam drives the huge wheels, you cannot be considered an engineer.

To succeed in any trade, business or profession, it is absolutely necessary to thoroughly understand the *hows, whys and wherefores—the very instruction that the I. C. S. gives.*



WHICH POSITION CAN YOU FILL?

This is exemplified in the case of J. H. Reynolds, of Glen Mills, Pa., who says: "When I enrolled for the I. C. S. Stationary Engineers Course, I *had no knowledge of the theory of my trade.* I now have charge of a large heating plant and have increased my earnings 300 per cent, with bright prospects for the future."

Reynolds' salary would never have taken such a jump had he continued along the "rule of thumb" path. Before taking the I. C. S. Course he was paid for what he did with his hands only—now he is paid for what he knows; and, as he says, "with bright prospects for the future."

There's a big financial difference between rule of thumb and rule of mind.

WHAT I. C. S. TRAINING MEANS.

Have you ever realized what I. C. S. training can do for you? Do you realize that it will make you *successful*?

Men in all lines of business everywhere owe their rise in life to the I. C. S. The I. C. S. takes the apprentice and makes him an expert. It takes the underpaid clerk and makes him manager. It takes a man from an uncongenial position and places him at *the work he likes best.*

It gives knowledge and training to the man with little schooling, so that he can meet life on a more substantial footing. I. C. S. training minimizes the struggle for existence—takes men from the line and puts them in the lead—*makes men satisfied, successful, independent.*

From Machinist to Chief Engineer is a long step—a step that I. C. S. training made short for William P. Harley of 112 Church Street, Charleston, S. C. Mr. Harley says: "While working as a machinist I enrolled with the I. C. S. I would not take any amount for the benefit and knowledge I received from this course. It enabled me to accept a position as Chief Engineer for the Ashpoo Fertilizer Works, and to increase my earnings from \$15.00 to \$30.00 a week."

MACHINIST BECOMES PRESIDENT OF COMPANY.

No more striking example of how the I. C. S. helps men rise from the ranks is to be found than the case of E. A. Bostrom, 51 Houston Street, Atlanta, Ga. It proves beyond any question of doubt that age is no barrier to a man's success. It also proves that I. C. S. training develops a

man's inventive powers so that he can put them to practical use. This is what Bostrom says:

"I was working in a machine shop when I heard of the I. C. S., and although considerably advanced in years I decided to enroll. The training I received enabled me to advance to foreman, then to superintendent. I then invented a simple levelling instrument which I patented, and I am now President of the Bostrom, Brady Mfg. Co. My income, of course, has been greatly increased, and I shall never forget the day I entered your Schools."

Bostrom doesn't say: "I decided to take a big chance, throw up my job and start afresh." He doesn't say: "I attended school every night." He merely says: "I enrolled." The I. C. S. went to him—helped him right in his own home—in his spare time. He didn't have to lose a minute's work. So helpful was the I. C. S. to this man that despite his advanced age it *developed* his inventive powers, so that from machinist to foreman, then to superintendent, he soon found himself President of a manufacturing company—with *an increased income.*

THE I. C. S. CAN ALSO HELP YOU.

The I. C. S. took W. F. Sampson, of 1309 Santa Clara Ave., Alameda, Cal., a clerk in a small hardware store, and enabled him to rise to the position of consulting accountant and systematizer in one of the largest flour mills on the Pacific Coast, with an increase of salary of over 200 per cent.

The I. C. S. took C. E. Handshy, 315 Luckroad, Zanesville, Ohio, and helped him to the position of draftsman and super-

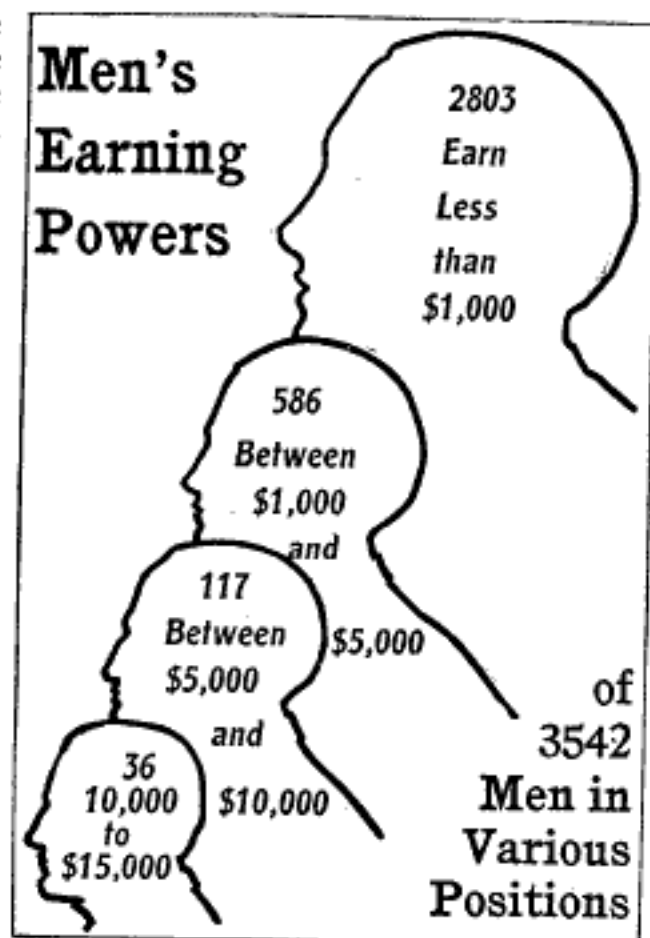

intendent for R. H. Evans & Co., Toledo, Ohio, where his salary was doubled within a month.

It took a grocer's clerk and advanced him to the position of mechanical draftsman at nearly four times the salary. His name? Fred W. Emmert, 143 Mt. Pleasant Ave., Hamilton, Ohio.

It took a bricklayer earning 40 cents an hour and *in a short time* enabled him to enter into partnership with his father in the contracting business, where he now earns \$3,500 a year. This young man, I. J. Isrigg, of Greensburg, Ind., says: "I think your instruction is wonderful. I have been quite successful in planning buildings." Think of it!—from laying bricks to planning buildings.

It takes a stationary engineer and makes him an *editor*. This is exactly what it did for Warren O. Rogers of 16 Garden Ave., Cleveland, Ohio, who says: "I enrolled when I was working as stationary engineer. I am now employed as associate editor of the *Engineer's Review* of Cleveland, and am earning *nearly three times over that which I received when I took up my course*. I consider my present success due to my ambition to get ahead and the means that your course provided for my realizing my ambitions."

It made a Patent Office Draftsman of H. O. Rastetter of 617 Cassilly Street, Canton, Ohio, who took the I. C. S. Course while working as an apprentice in a steel roofing establishment. Rastetter says: "I am now Patent Office Draftsman, employed by F. W. Bond, and my salary has been increased nearly 275 per cent. I recommend the I. C. S. to any ambitious young man."

WHAT ARE YOU GOING TO DO ABOUT IT?

Now, how does all this affect you? You can't dodge the fact that training pays—and *pays well*. You can't deny that there's a big demand for the *trained* man. You cannot but admit that at best the position of the *untrained* man is ever a precarious one. And right here you have been given abundant proof that the I. C. S. *can* and *does* help poorly paid but ambitious men succeed.

It doesn't matter who you are, what you are, what you do, what your color, race, religion or nationality. It makes no difference whether you live in a crowded city or in a quiet country village thousands of miles off. There is nothing whatever to hinder you from becoming an expert in your chosen occupation through the help of the I. C. S. All that is necessary is the ability to read and write. The I. C. S. doesn't look for the man with the big bank account.

OPPORTUNITY AND THE MAN.

Opportunity is said to knock but once. This may be *your* chance to rise from a humdrum "dollar-a-day" existence to a position where your talents, properly trained, will receive recognition and reward.

It is for you to say *NOW* whether you will take full advantage of the opportunity thus offered—whether you will remain in the "down-and-out" class or rise to a position that will bring you happiness in your working days and comfort in your old age.

Be a rolling stone. *Who* wants to gather moss? Take the first step today—this very minute—by selecting your occupation, marking it on the attached coupon and mailing the coupon.

This is Opportunity—are you the Man?

International Correspondence School's

Box 872-W, SCRANTON, PA.

Please explain, without further obligation on my part, how I can qualify for a larger salary in the position before which I have marked X

Bookkeeper
Stenographer
Advertisement Writer
Show Card Writer
Window Trimmer
Commercial Law
Illustrator
Civil Service
Chemist
Textile Mill Supt.
Electrician
Electrical Engineer

Mechanical Draftsman
Telephone Engineer
Electric Lighting Supt.
Mechanical Engineer
Surveyor
Stationary Engineer
Civil Engineer
Building Contractor
Architect's Draftsman
Architect
Structural Engineer
Banking
Mining Engineer

Name.....

Street and No.....

City.....State.....



PALM-STEM PORCH CHAIRS

In California palm-leaf stems are thrown away as waste material because of the sharp prongs along the edges. With a little ingenuity many useful articles can be made from them. The chair shown in this illustration was made by an old man, 70 years of age. He makes two a day, the material costs him nothing, and he sells them for \$2.50 each.

BEEES BUILD MODEL HOUSE OF HONEY

One of the curious and interesting exhibits at the Missouri Inter-state fair was the model of a 2-story building



Built by Bees

constructed of honey, which was placed by the bees themselves. A rough model of the building, 5 ft. long, 2 ft. wide and 3 ft. high, was placed in a large box or hive with a swarm of bees. At the end of 42 days the bees had completed the work by filling in all the parts with honey.

The electrification of the St. Clair river tunnel at Port Huron, commenced a year ago, is now practically completed at a cost of \$1,000,000.

GIANT STERN FRAME FOR COLLIER

The stern frame of the new collier "Malden," built for the transportation of coal between Boston and southern ports, is a giant in construction. The dimensions of the frame are: Length of rudder post, 36 ft. 8 in.; length of propeller aperture, 21 ft. 8 in.; width of propeller aperture, 7 ft. 5 in. The frame weighs 13½ tons.

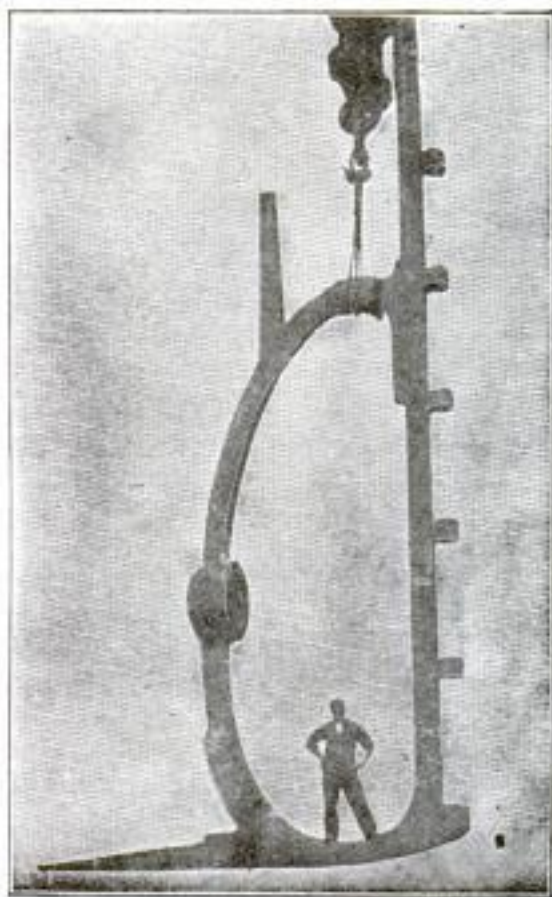

13½-Ton Stern Frame

WONDERFUL Edison Phonograph Offer

At any time you wish you can have a free concert in your own home—not a concert of one instrument or voice alone, but a concert of band and orchestra music, vocal solos, grand opera as well as comic opera—*anything you like.*

This is the regular Standard Phonograph with the regular horn—a fine outfit—but we furnish besides at only a slight extra expense our Parlor Grand Equipment. This we describe fully in our free catalog and circular.

TRADE MARK
Thomas A. Edison



Mr. Edison says:

"I want to see a Phonograph in every American Home."

FREE TRIAL!

WHILE this offer lasts we will send to any reader of this paper a Genuine Latest Style Edison Phonograph for **free trial in your own home**—a trial lasting two days to a week. Try the Latest Style Edison in your own home. *Then if you do not want to keep this wonderful instrument, you may send it back to us at our expense and we charge you absolutely nothing for the free trial.* If you like the instrument with its marvelous variations of entertainment, including the latest popular songs, side-splitting minstrel dialogs, beautiful operatic airs sung by the greatest artists, its dreamy waltzes and stirring two-steps, its orations and elocutionary recitals, you may keep the instrument and send either cash in full or the smallest monthly payments at the **Surprising Rock-Bottom Prices** on the finest Edison outfits.

\$2 a Month now buys a genuine Edison outfit including one dozen genuine Edison gold moulded records. The finest improved latest style Edison outfit with our Parlor Grand Equipment only \$3.50 a month. And at **rock-bottom price**, no matter whether you send cash in full or pay on our easiest terms.

For Cash in full: So many cash purchasers are getting the finest Edison outfits on free trial that we are obliged to announce again that we can allow no discount for cash. We have already given those who buy on easy payments the **lowest possible price** and we must treat all Edison customers alike.

Edison Catalogs FREE

SIGN the Coupon and get

our great Edison catalog, quoting the **rock-bottom prices**—on the finest Edison outfits. Remember you get an **absolutely free trial** and can send either cash in full or **easy monthly payments.**

F. K. BABSON,
Edison Phonograph Distrs.,
Edison Bldg.,
Suite 802
CHICAGO

Name.....

Address.....

FREE
COUPON

F. K. BABSON
EDISON PHONO-
GRAPH DISTRIBUTRS.

EDISON BUILDING

Suite 802, Chicago, Ill.

Without any obligations on me please send me your Edison catalog free, prepaid.

LOOK FOR THIS
TRADE MARK
ON EVERY INSTRUMENT
Thomas A. Edison

**SIGN the
Coupon
Now!**

Don't bother with a letter; the coupon will do.

Please Mention Popular Mechanics

Learn Telegraphy

The demand for telegraph operators is greater than the supply. I am in a position to absolutely guarantee good paying positions to all my graduates, because my school is the only one graduating thoroughly qualified telegraph operators, and railroads invariably prefer my graduates because they are proficient. Unlike many other schools, my instructors are practical telegraph operators and teach practical telegraphy. Mine is the only school owning a building devoted exclusively to the teaching of telegraphy. My methods of instruction are copyrighted. My text book on telegraphy is recognized as superior to all others. **Living expenses in Valparaiso are very low** and can be earned while learning. Easy payments. Correspondence Course if desired. Write me today personally for illustrated descriptive catalog and interesting testimonials.

GEO. M. DODGE, Pres.
DODGE'S INSTITUTE OF TELEGRAPHY
 Eighth Street, Valparaiso, Ind.

Good Positions Guaranteed



G. M. Dodge

EUGENE DIETZGEN CO.

181 Monroe Street, Chicago

New York San Francisco New Orleans Toronto

DRAWING MATERIALS SURVEYING INSTRUMENTS

New Catalogue Sent on Application

Send for one of our No. 3379
Adjustable Erasing Shields.

Price, 30 cents.



You Don't Know Tobacco

In all its excellence unless you have smoked French's Mixture, which comes to you direct from the factory in all its original freshness and richness. Just try it once, and note how superior it is to the average tobacco sold by dealers.

FRENCH'S MIXTURE

is carefully blended from the choicest North Carolina Golden Leaf, and gives a fragrant, rich and smooth smoke that is a revelation to those who have relied upon the store-bought kind. Our direct-to-consumer plan insures a perfect, satisfying smoke at all times. Try it once and note the difference—see offer at the right. It is truly

"The Aristocrat of Smoking Tobacco"

Not sold by dealers, but direct to smokers in perfect condition

French Tobacco Company
Dept. 51, Statesville, N. C.

Send 10 cents in silver or stamps for a large sample pouch and booklet; both will be a delight to you.



LEARN HOW TO JUDGE INVESTMENTS

My book "How To Judge Investments" tells how you may safely start on the road to wealth. It tells you about everything you should know before making any kind of an investment. A financial critic says of this book, "It is the best guide to successful investing I ever read." The regular price is \$1.00, but to introduce my magazine, the "INVESTOR'S REVIEW," I will send the book postpaid on receipt of a two-cent stamp and in addition will send you the Review for three months free. Address Editor

INVESTOR'S REVIEW, 1461 Gull Bldg., Chicago, Ill.

THE WANING HARDWOOD SUPPLY—Although the demand for hardwood lumber is greater than ever before, the annual cut to-day is a billion feet less than it was seven years ago. In this time the wholesale price of the different classes of hardwood lumber advanced from 25 to 65 per cent. The cut of oak, which in 1899 was more than half the total cut of hardwoods, has fallen off 36 per cent. Yellow poplar, which was formerly second in point of output, has fallen off 38 per cent, and elm has fallen off one-half.

The cut of softwoods is over four times that of hardwoods, yet it is doubtful if a shortage in the former would cause dismay in so many industries. The cooperage, furniture, and vehicle industries depend upon hardwood timber, and the railroads, telephone and telegraph companies, agricultural implement manufacturers, and builders use it extensively.

This leads to the question, Where is the future supply of hardwoods to be found? The cut in Ohio and Indiana, which, seven years ago, led all other states, has fallen off one-half. Illinois, Iowa, Kentucky, Michigan, Minnesota, Missouri, New Jersey, Tennessee, Texas, West Virginia, and Wisconsin have also declined in hardwood production. The chief centers of production now lie in the Lake States, the lower Mississippi Valley, and the Appalachian Mountains. Yet in the Lake States the presence of hardwoods is an almost certain indication of rich agricultural land, and when the hardwoods are cut the land is turned permanently to agricultural use. In Arkansas, Louisiana, and Mississippi the production of hardwoods is clearly at its extreme height, and in Missouri and Texas it has already begun to decline.

The answer to the question, therefore, would seem to lie in the Appalachian Mountains. They contain the largest body of hardwood timber left in the United States. On them grow the greatest variety of tree species anywhere to be found. Protected from fire and reckless cutting, they produce the best kinds of timber, since their soil and climate combine to make heavy stands and rapid growth. Yet much of the Appalachian forest has been so damaged in the past that it will be years before it will again reach a high state of productivity. Twenty billion feet of hardwoods would be a conservative estimate of the annual productive capacity of the 75,000,000 acres of forest lands in the Appalachians if they were rightly managed. Until they are we can expect a shortage in hardwood timber.

Circular 116, of the Forest Service, entitled "The Waning Hardwood Supply," discusses this situation. It may be had upon application to the Forester, Forest Service, Washington, D. C.

BRICK FOR HOUSE BUILDING—One of the greatest advantages of brick for house building is that it can be bought nearly everywhere as a home-made material. Almost every town and village has its brickyard, by which it is possible to escape the added price of freight. A brick wall is substantial, dry and non-conducting. It can be made attractive in texture by various widths and colors in the joints. Brickwork is dependent on no other material for its trimmings, but is sufficient in itself.

A brick wall never needs paint. If it ever does become shabby, brush it down with a weak solution of muriatic acid, but don't paint it any more than you would paint stonework.

SCHOOL TEACHES SKYSCRAPER CONSTRUCTION—A school has been started in New York by the Young Men's Christian Association for the express purpose of training young men in the work of skyscraper building. Instruction is given in structural engineering, structural draughting and detailing, estimating, reading, and general building construction.

YOU NEED MONEY WE WANT AGENTS \$1200 PER YEAR

PHOTO KNIVES OF QUALITY

Sell at sight to everybody, net you \$25 per week steady. Razor steel blades guaranteed.

We place any photo, name or emblem under the transparent handle. Exclusive territory to agents. Write for terms and photo of handsome pocket sample case.

THE CANTON CUTLERY CO., 1294 W. 10th St., CANTON, OHIO



PLUMBING MATERIAL



Bath Tubs only \$6.00

Laundry
Tubs
\$5.00 and up

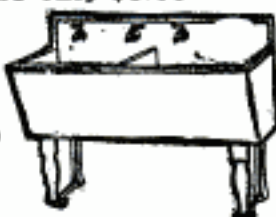

GALVANIZED
RANGE
BOILERS

All tested to
200 lbs.
pressure;
30 gallons

Only \$5.00



This
Complete
Closet
Outfit

Only
\$11.50

**DIRECT
to the
CONSUMER**

At less than wholesale
prices; you also save
the plumber's profit.

Send us a list of your
needs. All we ask is an
opportunity to figure on
your wants. We carry
everything necessary for
installing this class of
work. Soil pipe, lead and
water pipe and fittings of
all kinds, etc. All Goods
are Brand New, High
Grade and Perfect.

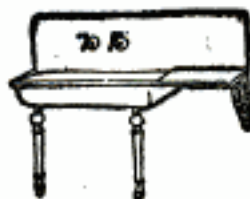

**Kitchen
Sinks**

All kinds of Por-
celain Enameled
Kitchen Sinks,
with backs, drain
boards, etc. Our
stock is complete
with sinks of every
description, both
for corner or
straight wall.

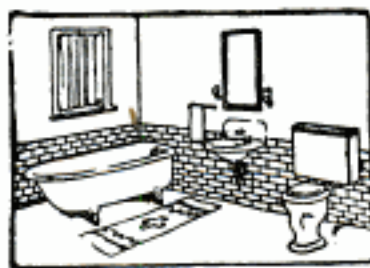

Complete Bathroom Outfits only \$36.50

White
Enameled
Sinks,
size 18x30,
Only \$2.00



White
Enameled
Backs,
size 30 in. long
Only \$2.50

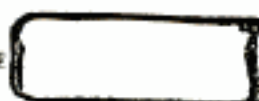

SEND US YOUR BILL FOR OUR ESTIMATE

WRITE FOR OUR FREE ILLUSTRATED CATALOG No. 35

CENTRAL MACHINERY & SUPPLY CO., 547-559 State St., Chicago, U. S. A.

25c.

A BOOK FOR BOYS

25c.

How to Make a Paper Boat—How to Make a Barrel Boat—How to Make a Water Wheel—How to Make Your Own Fishing Tackle—Temporary Camps and How to Build Them—Permanent Camps and How to Build Them—How to Build an Imitation Street Car Line—How to Make a Water Bicycle—How to Make a Miniature Windmill—How to Build an Ice Boat—A Novel Burglar Alarm—A Mechanical Ventriloquist and How to Make It—How to Make a Boot-Blackening Cabinet—Renewing Dry Batteries—How to Make Water Motors—How to Make "Antique" Clocks from Up-to-date Materials—Lettering a Clock Dial—How to Make a Windmill of One or Two Horsepower—How to Make a Trap for Rabbits, Rats and Mice—How to Make a Small Searchlight—Kites of Many Kinds and How to Make Them—Jug Fishing—How to Do Ornamental Iron Work—Ornamental Metal Guards for Open Fireplaces—How to Make a Propelling Vehicle—How to Make a Water Telescope—How to Make Paper Balloons—How to Make a Hectograph—Useful Articles and Ornaments Made of Old Bicycle Parts—Devices for Winter Sports,

Your Newsdealer will
order it for you,
or sent postpaid for
25cents by
THE PUBLISHERS

MECHANICS FOR YOUNG AMERICA

How to Build

BOATS, WATER MOTORS, WIND MILLS, SEARCHLIGHT,
ELECTRIC BURGLAR ALARM, ICE BOAT, WATER
BICYCLE, CABINS, CAMPS, CLOCKS, FISH-
ING TACKLE, KITES, IMITATION
STREET CAR LINE, ETC.

The Directions are Plain and Complete

Revised from Popular Mechanics
COPYRIGHT BY
POPULAR MECHANICS
CHICAGO

PRICE 25 CENTS

How to Make and Use Them—Coasting Sleds, Chair Sleighs, Toboggan Slides and Skis—How to Make Rubber Stamps—How to Make a Baggage Carrier for Bicycles—A Water Candlestick—Boy's Hand-Power Auto, How Made—How to Make a Pair of Dumb-Bells—How to Rid Your Yard of Cats—How to Make an Easel—To Light a Gaslight Without Matches—Things a Boy Can Make Out of Old Bicycle Parts—How to Make a Wind Propeller—Photographing from a Captive Balloon—How to Make a Simple Burglar Alarm—To Make a Binder for Popular Mechanics—How to Make a Ham-mock—Electric Rat Exterminator—How to Make a Miniature Steam Turbine—How to See Through Your Hand—How to Make a Wood-Turning Lathe Out of an Old Sewing Machine—How to Remove Stains from Marble—How to Make a Turbine Engine—How to Make a Lead Cannon—How to Make a Wireless Telegraph System—How to Make a Toy Battery Motor Lift a 10-lb. Weight—To Renew Old Dry Batteries—Weatherproofing for Tents—How to Make an Electric Furnace Regulator—How to Make a Simple Fire Alarm—How to Make a Bell Tent.

Published by
POPULAR MECHANICS
160 Washington St.
CHICAGO

Please Mention Popular Mechanics.

THIS IS YOUR CHANCE

The time is fast approaching when iron castings, both grey and malleable, must give way to soft and hard steel castings—conditions of strength and durability demanding the substitution of the superior product. The U. S. Steel Company has demonstrated the immense profits to be made from steel manufactures. Three years ago its common stock could be bought for 9 cents on the dollar; today it is 22 cents, and at no time has there been any danger of loss or failure in this great industry. Steel is as staple as corn, wheat or cotton, and less liable to fluctuations in price, because the production is easily controlled.

One of the most important branches of the steel industry, and one that is in its infancy, is the making of specially hardened steel castings. They are to ordinary steel castings what malleable iron is to grey iron. The Armor Steel & Foundry Co. is turning out steel castings by a process discovered by a man named Gebhard, in which a hardened surface is produced on a soft steel base. This surface may be from $\frac{1}{8}$ to $\frac{3}{4}$ of an inch in depth and applied at any desired points of the casting. The surface coating is not brittle, but tough, and the result is the life of the casting is increased from six to seven hundred percent, while the additional cost of producing the hardened castings is nominal.

This process has been used by the inventor at the Joliet mill of the Illinois Steel Co., and he received a royalty of \$5.00 per ton on all castings produced under the process. The Armor Company is now the sole owner of all rights to this process, and at its foundry at Matthews, Ind., is turning out castings for the Illinois Steel Mills; the National Tube Co., of Pittsburg; American Sheet & Tin Plate Co., Pittsburg; Detroit Steel Tube Co., Detroit; Cambria Steel Co., Johnstown, Pa.; American Ship Building Co., Cleveland; Jones & Laughlin Co., Pittsburg; Pressed Steel Car Co., McKees Rocks, Pa.; Dayton Steel & Iron Works, Dayton, Ohio, and many others.

The following letters from the men who know, show the merits of castings produced by the Gebhard process:

Illinois Steel Company, Joliet, Ill.

Joliet, Ill., May 18, 1906.

Armor Steel & Foundry Co.

Sir: Replying to your request relative to the merits of the Gebhard process for hardening wearing surfaces of steel castings, I beg to say we have been using it in the mills here successfully for four years on spike machine cams, cams for blow engines, spur-gears, bevel and miter gears, traction wheels for our hydraulic 40-ton traveling cranes, wheels for hydraulic cranes, and for pawls on hydraulic steering guides for rolls, hardened by the Gebhard process, and have demonstrated in a practical way, that this has prolonged the life of the castings five times and in some cases much longer. I can't say too much in its favor for automatic spike machine cams, and we find the use of the process is practically unlimited.

George Burgess,
Master Mechanic.

Joliet Works, Illinois Steel Co., Joliet, Ill.

Joliet, Ill., Oct. 8, 1906.

Armor Steel & Foundry Co.

Mr. Howe: I received yours of Sept. 21st. With regard to the Gebhard process of hardening gears, it is all right; we have been using them in the billet mill for the last year.

We put a set of hardened gears on the bloomtable last December; they are as good as when we put them in. We have changed soft gears in the same place about every month or six weeks.

With regard to how long hardened gears will last, I cannot say, as there don't seem to be any wear out to them.

H. Reid,

Chief Engineer, Billet Mill, Illinois Steel Co.

The Armor Steel Foundry Co., in order to increase its equipment and thereby meet the demands for their castings, has placed with me to sell \$100,000 worth of stock at 25 cents on the dollar, at which price \$25 will pay for \$100 worth of stock, and no subscription will be received for less than \$25. The stock is non-assessable, and there is no preferred stock or bonds. The foundry at Matthews, Ind., is worth \$50,000 and, as Master Mechanic Burgess says, "the use of the process is practically unlimited."

A great deal of the stock of this company is held by steel men who are familiar with the products turned out and know the demand that exists for same. There are no high-salaried officers to eat up profits, no expensive experiments to be carried on, the business being just making steel castings for the trade.

As rapidly as conservative management will justify, additional foundries will be built in sections where there is a sufficient demand for these process hardened castings, and stockholders in the Armor Company will participate in the profits of the subsidiary companies.

Now, this is your chance to make a safe and profitable investment of a small amount of money. If the amount offered is oversubscribed the company reserves the right to scale the subscriptions so that each purchaser will receive his proper pro rata number of shares.

Send all subscriptions or requests for information to

Joliet Works, Illinois Steel Co., Joliet, Ill.

Joliet, Ill., Oct. 8, 1906.

Armor Steel & Foundry Co.

Dear Sir: Your inquiry in regard to Gebhard process for hardening surface of steel castings, at hand. Answering the same, will say, that the wearing life of castings so treated, and used in my department during the last four years, has been increased from six to seven times over that of similar castings heretofore used. Yours truly,

J. W. Murray,

Superintendent of Factory Department.

Joliet Works, Illinois Steel Co., Joliet, Ill.

Joliet, Ill., Sept. 26, 1907.

Armor Steel & Foundry Co.

Dear Sirs: In reply to yours of Sept. 22nd, I take pleasure in lauding the merits of the hardening process for steel gears now in service in our various departments, which you spoke about. We are using an average of 50 per cent less in all gears, and some of these have been rendered practically endless in their lasting qualities. As you may readily understand, such articles comprise many forms of gears, and used under many conditions. I am fully convinced from actual experience that this indeed is a most wonderful discovery and can be applied to any wearing surface of steel castings. If at any time I can be of service to you, or any interested parties, I am yours to command. Yours very respectfully,

J. W. Brockway,

Foreman of Machine Shops.

FREDERICK BENJAMIN, Fiscal Agent,

204 Dearborn St.,

CHICAGO

Do You Know the Marks of a Good Engine?

First of all, it should be simple both in design and construction; so simple that anybody can understand it, and so simple that it is almost impossible for it to get out of order.

Again, it must be safe, economical in fuel consumption, absolutely dependable under all conditions, and certain of supplying abundant power.

I. H. C. Gasoline Engines

have all these characteristics, besides another very important one, which most engines do not possess, that is, they are **Thoroughly Adaptable to the Work in Hand.**

No matter how excellent a power may be, if it is not adapted to your particular requirements you do not want it. The designers of I. H. C. Engines kept uppermost the purposes to which such an engine could be adapted, and constructed the engine with a view of meeting every requirement.

The line is extensive, and an I. H. C. agent will always recommend the engine which is best adapted to your requirements. Made in the following styles and sizes: Vertical in 2 and 3-horse power; Horizontal (Stationary and Portable), in 4, 6, 8, 10, 12, 15 and 20-horse power. 1-horse air cooled. Also sawing, spraying and pumping outfits.

Apply to the International local agent for catalog and particulars, or write

International Harvester Co. of America, 16 Harvester Bldg., Chicago, Ill.
(Incorporated)

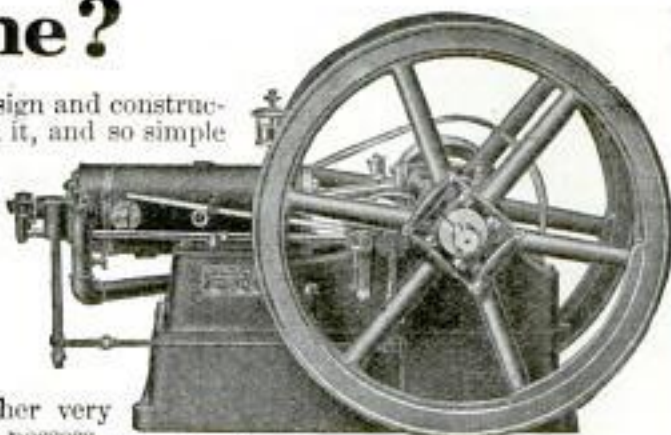

Smoothest of Cylinders, Most Perfect Compression, Most Accurate Timer makes

DuBrie Marine Motors 100% Right

Each DuBrie Motor is proved perfect by water tests, regulated to absolute accuracy of gasoline supply, generator, etc., and shipped to you ready. There's no nursing or humoring—install one yourself—runs all day—first trip—without a hitch. Quarter-turn back of fly-wheel starts immediately—no cranking.

Generator with float-feed and throttle gives even, forceful mixture and perfect control.

Our valve forces mixture directly into cylinder without drawing it into base, so kerosene can be used as well as gasoline.

Ordinary generator valves do not vaporize kerosene perfectly.

Send 6 cts. in stamps for full descriptive catalog. Write for it today. Agents write for uncovered territory.

DuBrie Motor Co.
500 Cass St
Detroit, Mich

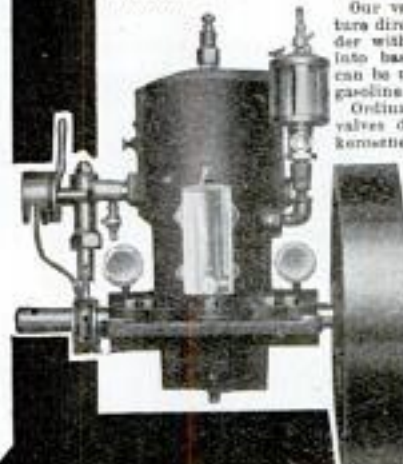

SCRIPPS MOTORS

"The 4-cycle Engine That Is Simple."

From casting to crate, the Scripps Motor is built in our own factory, out of the finest materials money can buy. Every one given 48 hours actual running test. 1 cyl. 4-5 h. p., 2 cyl. 8-10 h. p., 4 cyl. 15-20 h. p.—4½ in. x 4½ in. Heavy Duty (commercial) Engines 2, 4 and 6 cylinder, 5½ in. x 6 in. High Speed (racing) Motors, 4 and 6 cylinder (over 100 H. P. M.) Send for Catalog.



SCRIPPS MOTOR CO.
602 Trumbull Ave., Detroit, Mich.

WATERLOO VAPOR COOLED GASOLINE ENGINES

The only horizontal vapor cooled gasoline engine in the world.

Absolutely frost proof and cannot freeze.

Patented May 15, 1906



The king of all gasoline engines. Our catalog will tell you all about them, also our power and sweep feed grinders. Send today.

WATERLOO GASOLINE ENGINE CO.
1021 Cedar Street Waterloo, Iowa

DON'T BUY GASOLINE ENGINES

Until you investigate "The Master Workman" a two-cylinder gasoline, kerosene or alcohol engine, superior to any one cylinder engine; revolutionizing power. Its weight and bulk are half that of single cylinder engines, with greater durability. Costs Less to Buy—Less to Run. Quickly, easily started. Vibration practically overcome. Cheaply mounted on any wagon. It is a combination portable, stationary or traction engine. SEND FOR CATALOGUE.

THE TEMPLE PUMP CO., Mfrs., Meagher and 15th Sts., Chicago. THIS IS OUR FIFTY-THIRD YEAR

No Better Gas or Gasoline Engines made than the

FOSS ENGINES.

Simple, Substantial, Efficient. Catalog on request.

Foss Gasoline Engine Co., Kalamazoo, Mich.

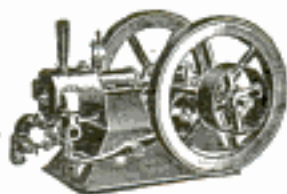

Gas and Gasoline Engines

For all power purposes. Electric light plants from 10 to 2000 lights. Engines from 1 to 250 H. P. New or 2d hand. Write us for prices.

Empire Machine Works, 210 3d Avenue, PITTSBURG, PA.

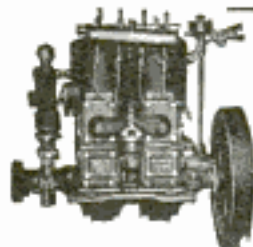

MARINE ENGINES

That Start and Reverse on the Spark ALWAYS WIN RACES

All Sizes in Stock. Send for Prices and Catalog

TERMAAT & MONAHAN CO. Oshkosh, Wis.

High-grade MARINE and AUTOMOBILE ENGINES

2 to 30 H. P. 2 and 4-cycle, latest improvements; best material; lowest prices. Also sell castings, with drawings.

State your want.

HOULE MOTOR WORKS, 580 East St., Holyoke, Mass.

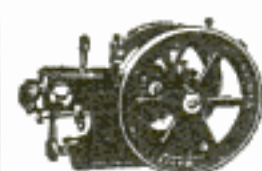
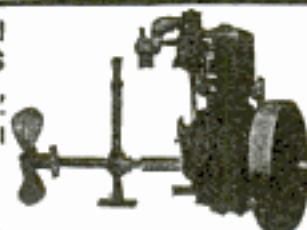

The ECONOMIZER carries any load up to 2 h. p.

That name means something. Five years' sales and not a single dissatisfied customer, means something. It's all in the engine—no shoddy goods. Want to know more?

Address,

H. L. CHAPMAN, Lock Box 595, Marcellus, Michigan

Popular Mechanics File for the Year 1907

We have 100 sets of the unbound, 12 issues of this magazine for 1907. These copies are fresh and clean and suitable for binding. Index for the entire year included. As the supply will not last long, orders should be sent in at once. Price, express prepaid, \$1.25.

POPULAR MECHANICS

160 Washington Street

CHICAGO

GOES LIKE SIXTY
SELLS LIKE SIXTY
SELLS FOR SIXTY

\$60

GILSON GASOLINE ENGINE

For Pumping, Cream Separators, Churns, Wash Machines, etc. FREE TRIAL. Ask for catalog—all sizes.

GILSON MFG. CO. 26 Park St. Port Washington, Wis.

IMPRISONED IN BOILER WITH FIRE UNDERNEATH—Imprisoned in a big boiler, underneath which a fire was gradually heating the flues to a point which would have meant a horrible death if his escape had been delayed but a few minutes longer, is the experience recently undergone by Arthur McDonald, a young boiler-maker of Arkansas. He has just left the hospital, a nervous wreck. His hair, which was coal black, now hangs over his forehead, a soft, glistening white.

The experience occurred at a saw mill at Hope, Ark. A new set of boilers had been put in, and negro firemen were relied upon to attend them. Something went wrong, and McDonald was called upon. After fixing the first boiler, he ordered the firemen to fill it with water and build a fire under it, when they had finished the work they were then doing. McDonald then entered the second boiler, and had been working about an hour, when he noticed his candle growing dim, and started to investigate. He found that the manhole cover had been replaced, and, sick with horror, realized that the negroes had misunderstood his orders and were building a fire underneath him. A moment later he heard the rush of water and frantically called for help and struck his hammer against the sides of the boiler, hoping to attract their attention. Soon the heat began to be felt. He touched a flue and started back with a gasp. It was warm—ever so slightly, but warm, nevertheless.

With hands torn and bleeding, and eyes almost bursting from their sockets, the now thoroughly crazed man crawled back and forth in his prison, punting, praying and moaning. The flues became so hot they burned his feet, and his head swam with the heat.

At last more dead than alive, he threw himself down on the flues to hasten the end, and then at almost the last moment a way of escape dawned upon him. Grasping his chisel, he placed it against one of the flues under water and dealt it terrific blows, driven by frenzy. The first blow missed, and, striking his little finger, smashed it off. The other blows fell true, and the chisel broke through the flue, letting the water follow. The negroes heard the water when it struck the fire, and, believing that the boiler still leaked, opened the water plug and raked out the fire.

McDonald had a faint recollection of a patch of daylight when the manhole was opened, but knew nothing more for five days.

PLAN TO LIMIT THE HEIGHT OF SKYSCRAPERS—The race among builders for the honor of putting up the tallest skyscraper may be brought to a sudden end by drastic regulations which have been adopted by the building code revision commission of New York. These regulations, slated for adoption in January, provide that no new building shall be over 250 ft. in height. The new code will not prevent the construction of reasonably tall buildings. The Waldorf-Astoria hotel, regarded by many as tall enough for any building, would be able to add at least three more stories to its present structure before overtopping the limit. Buildings of 20 stories could easily be kept within the limit.

2 H.P. STATIONARY \$29.50 (ENGINE ONLY)

ENGINE

FOR FARM AND SHOP WORK. Run Separators, Corn Shredders, Grist Mills, Pumps, Dynamos, etc. Start without cranking; no cams or gears. Burns Alcohol, Kerosene, and Gasoline. All sizes in stock; 2 to 20 horsepower. Steel connecting rods, anti-friction bearings; no vibration. Write for free catalogue.

DETROIT ENGINE WORKS
121 BELLEVUE AVE. DETROIT, MICH., U.S.A.

Please Mention Popular Mechanics

Pumps 2,000 Gallons Up Per Hour

This "Jack-of-All-Trades" Engine and Horizontal Pump pumps 1,680 to 2,000 gallons per hour night and day. The engine also churns, runs your separator, saws your wood, grinds your feed, does more chores than three or four hired men. It's the ideal farm engine—easy to understand—uses least fuel—needs fewest repairs.

Strongly built of best materials throughout to stand hard knocks. Our name on every engine is your best guarantee. Comes to you complete so you can set it to work at once.

We make several styles and sizes of engines. Tell us what you want an engine to do—we will advise what is best for you to get.

DOES THIS
Runs Buzz Saw,
Pump, Grinder,
Churn, Separ-
ator, and many
other machines.

Engines 2 H. P.
to 200 H. P.



**WRITE TODAY FOR FREE
ENGINE BOOK No. T 449**

**FAIRBANKS, MORSE & CO.
CHICAGO, ILL.**

Faucet WATER MOTORS



Complete with emery wheel, buff wheel, pulley to run sewing and washing machine, polish. In some cities where we have no agents, and where the water pressure is good, a **sample motor will be given free**; apply at once if you want to make some extra money, or if you can devote your whole time, liberal salary and commission will be paid.

\$2.50
and
up

ENGINEERS WANTED

to send for catalog of Indicators, Reducing Wheels, Planimeters. Address,

LIPPINCOTT M. S. CO.,

Newark, :: :: New Jersey



1 1/2 H. P. \$58.00

Look at the Neat Design!

The finest little 1 1/2 H. P. Engine on the market.

Handsomely finished.

Bore 3 1/2 inches; stroke 3 inches.

These engines will develop over 2 H. P.

Write for Catalog "P" of 1 1/2 to 16 H. P. Motors.

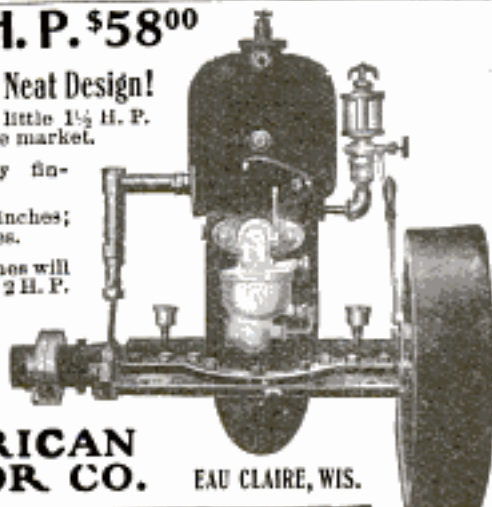

AMERICAN MOTOR CO.

EAU CLAIRE, WIS.

MOTORS

For Marine and Vehicle Use

Williamson Motor Co.

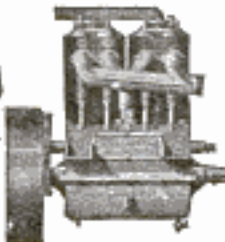

1 1/2 to 60 H. P. (Air and Water Cooled)

Experimental Work Solicited

8-12 S. 39th St., Phila., Pa.

Perfection

MARINE MOTOR

2 H. P. \$45 For real service, for looks, finish and power the Perfection beats any motor ever sold at anywhere near its price and can't be beat at any price. Simple, speedy, reliable and reversible. No cranking. Price is for engine complete with full boat equipment—not bare. Fully guaranteed and guaranty backed by one of the largest plants in the business. Can you afford to buy on any other terms? Handsome catalog of all sizes, free.

Caille Perfection Motor Co.
1311 2d Ave., DETROIT, MICH.

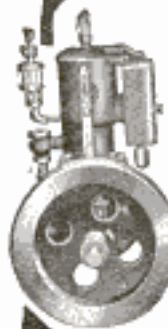

"GET THE BEST"

which means

The Clipper Water Motor

We do not claim it THE CHEAPEST, but we do claim it THE BEST.

Send \$7.50 and get one of these 6-inch motors—regular price \$10. Send P. O. order, Regist'd letter or N. Y. draft.

**L. E. RHODES
HARTFORD, CONN.**

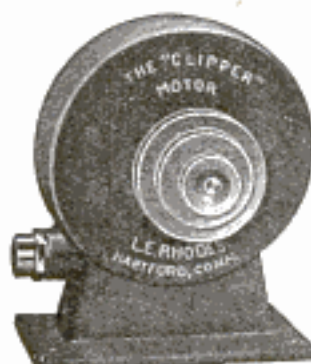

Gies Reverse Gear

Successor to the reversible propeller

Solves the Reversing Problem.

Gives absolute control of the motor-boat at all times.

1 to 80 H. P.—\$15 to \$90.

More made and sold than all other reverse gears combined. Catalogue on request.

GIES GEAR COMPANY, Detroit, Mich.



PALMER MOTORS

1 1/2 to 25 Horsepower; One, Two and Four Cylinder; Jump or Snap Spark Ignition; Two or Four Cycle. Send for Catalog.

PALMER BROTHERS, COS COB, CONN.

New York, 242 Fourth Ave. Philadelphia, The Bourse
Boston, 85 Union St. Portland, Me., 48 Portland Pier

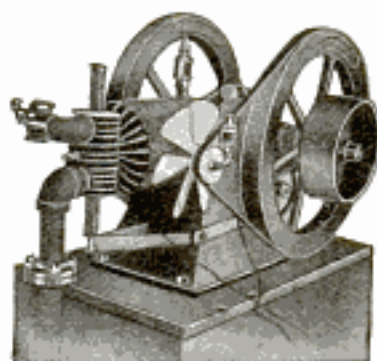

AIR COOLED MOTORS

**1½ H. P. to
10 H. P.**

1¼ and 2¼ H. P. equipped with short connections for spray pump and walking beam attachment for pumping water from wells. Will work against 200 pound pressure all day without heating. Gasoline in base of engine.

Write for agency

AIR COOLED MOTOR CO., Lansing, Mich.



\$49 Little Giant
3 to 5 H. P. (BAR) **GASOLINE MOTORS**

Guaranteed for One Year.

Car Free Catalog C4 is worth your having.

Send 10 cents in stamps for our book "Ignition, Vaporization, Installation and Operation of a Motor."

UNITED MFG. CO., DETROIT, MICH.

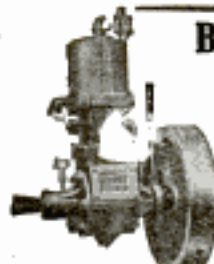
**BUILD YOUR OWN MOTOR!**

Complete sets of Castings, with blue print working drawings, for your Auto, Launch or Motor-Cycle Engine.

Our Remarkable Offer!

6-Actual Brake Horse Power—2 Cycle—3 Port Engine. \$100 complete with accessories. IT'S GUARANTEED! We sell Blue Print Working Drawings—2 or 4 Cycle. Send stamp for Catalog.

THE GERHARDT MOTOR CO.
27th Street, above Dauphin, Philadelphia, Pa.

**THE NEW ADVANCE MOTOR**

This is the finest battery motor ever put up to be sold at a popular price.

A new design; has two field coils; new improved brush holders. Size, 3¼x3 inches. **PRICE \$1.00**

Send for free Catalog on Everything Electrical and Automobile Specialties.

Geen Electrical Mfg. Co., CHICAGO
180 East Lake Street

**DYNAMO -
FUEL-GASOLENE -**



**ENGINE - SETS
OIL - ALCOHOL.**



**THE BUFFALO
MECHANICAL &
ELECTRICAL
LABORATORY.**

201 ERIE COUNTY BANK BLDG., BUFFALO, N. Y., U. S. A.

**2 H. P. Detroit
Engine**

For
\$29.50

Starts without cranking; no cams, valves, springs or sprockets. Only 3 moving parts. All bearings babitted. For your Row Boat, Sail Boat, Launch, 10,000 in use.

Send for testimonials

DETROIT ENGINE WORKS
1271 Jefferson Ave., Detroit, Mich



8-5-1.10 L. P. Proportionate prices. Cylinders and pistons ground. Crank shaft drop forged steel. All sizes ready to ship

**SEND FOR
FREE
CATALOG.**

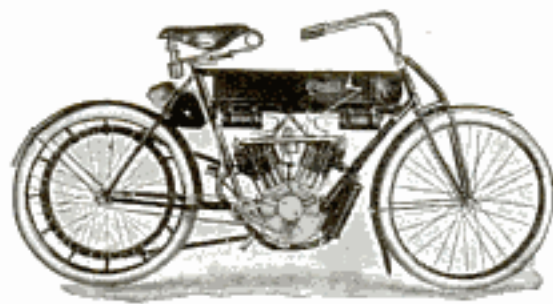
Curtiss World's Record Motorcycles

Single and Double Cylinder Models for 1908
Now Ready.

Diamond Medal. Highest Award National Endurance Run, 1907, won on a Curtiss.
Send for Booklet "Achievements" and Catalog C.

G. H. CURTISS MANUFACTURING CO.
Hammondsport, N. Y.

ADVANCES IN THE ELECTRIC INCANDESCENT LIGHT

The electric incandescent light is undergoing a great change. Carbon is being replaced by metal wires. It has been found possible to make wires of high enough resistance of tungsten, osmium, tantalum, and a few other metals and compounds. The osmium lamp was the first of these but there was difficulty in making it of high enough resistance. The tantalum lamp is now in great demand. It is made for 100 to 130 volts, and is much more efficient than the carbon lamp. It will not last long on alternating currents, however. The wires of a lamp that have been run for some time on a direct current show a curious notched or crinkled appearance under the microscope. But a wire that has been run on an alternating circuit looks as if the metal had been melted into short cylinders with rounded ends, and these cylinders had stuck together end to end without their centers being in a line. Sometimes the little cylinders are nearly separated, merely touching at a corner. This action is very extraordinary, and has never been explained. In addition to this, when a lamp breaks down on an alternating circuit, the wire sometimes goes at one point, and sometimes it breaks in several places, and tangles itself up in an extraordinary way; at other times it breaks up into numerous little pieces, which will be found lying on the inside of the globe. Some of the other lamps show a change under the action of the current, but it is not so marked as in the case of tantalum.

One of the most interesting of the new lamps is the Zircon. It is said to be made of zirconium and tungsten and lamps of this material have been made for 200 volts a matter of the greatest importance from a distribution point of view. It is possible that the conductor is really a zirconide of tungsten, and this opens up a new series of compounds. A Zircon lamp for 100 volts has really six separate loops of wire mounted in series inside a bulb. A recent improvement is to provide an extremely light spring for each loop, so as to keep it taut. The lamp can then be used in any position.

Tungsten seems to be the favorite metal, as it gives a very high efficiency. It is probable the lamp of the future will have an efficiency of nearly a candle per watt, and this is promised by the use of tungsten. At the same time it must be admitted that to make a wire with a resistance of 500 ohms small enough to give 20 candles with 20 watt is a triumph of inventive skill.—J. Swinburne, Chemical News.

**When You Want Anything and
Don't Know Where to Find It,
Write Popular Mechanics.**

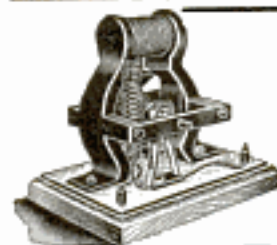

**THE
White Eagle Electric Motor**
Postpaid, 75c

We make working models of inventions. Send for illustrated catalogue of Model Supplies.

The Pierce Model Works
134 Pierce Avenue Chicago, Ill.

Please Mention Popular Mechanics

A RAILROAD OF YOUR OWN is possible if you buy Electrical Outfits from us. Send stamp for 80 page catalogue—a wonderful book of electro-mechanical knowledge, illustrating hundreds of Electrical Toys and utilities. If you want the best Motor made for boys of every size and age, send \$1.75 for our Model BS Jim Dandy Practical Motor, sent post-paid. Send 2-cent stamp for catalogue to

VOLTAMP ELECTRIC MFG. CO.
 Voltamp Building,
 Baltimore, Md.

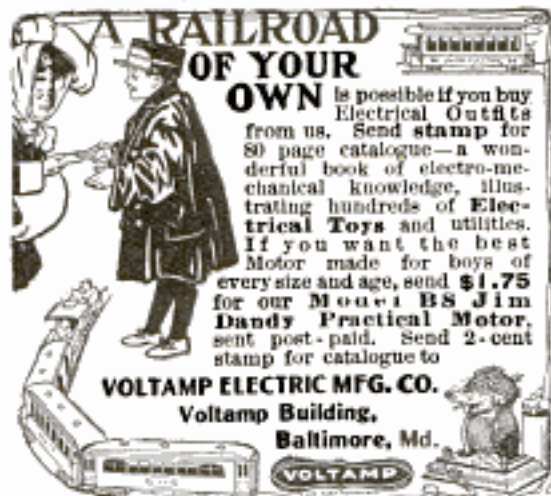



BUILD YOUR OWN DYNAMO. We furnish complete sets of castings. Also Electric Railways, Trolley Cars, Track and Switches. Send for Catalogue "B."

THE GARLISLE & FINCH CO., 262 E. CHURCH AVENUE, CINCINNATI, OHIO

Gas—Gasoline—Steam Engines

1/2 to 3 H. P.

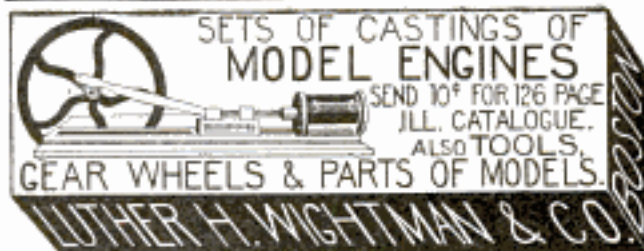
BROOKLYN MACHINE COMPANY
 824 Gates Avenue, Brooklyn, N. Y.



SETS OF CASTINGS OF MODEL ENGINES
 SEND 10¢ FOR 126 PAGE ILL. CATALOGUE. ALSO TOOLS.
GEAR WHEELS & PARTS OF MODELS.
LUTHER H. WIGHTMAN & CO.

98¢ FAN MOTOR COMPLETE
 This electric fan is substantial and practical in all details and nicely finished, fan is removable so motor may be used separately. We furnish extra grooved pulley with each. We are Cut Price headquarters for everything electrical. Send for large free catalog. Dealers wanted everywhere.

THE VIM 68 LAKE ST. DEPT. E 19 CHICAGO



Motsinger Auto-Sparker
 Starts and runs GAS ENGINES WITHOUT BATTERIES
 No other machine can do it successfully for lack of original patents owned by us. No twist motion in our drive. No belt or switch necessary. No batteries whatever. for make and break or jump-spark. Water and dust-proof. Fully guaranteed.

MOTSINGER DEVICE MFG. CO.
 128 Main St., Pendleton, Ind., U. S. A.

Write to-day.
 Catalog free with full information.



The surest and easiest way to get perfect ignition for your engine is to use a

SPLITDORF COIL

Gives more power with less trouble and expense

Ask Department M for catalog

C. F. SPLITDORF, 261 Walton Avenue, NEW YORK

DYNAMO-MOTOR, \$3.50

(A Dynamo and Motor in One)

As a dynamo, it will light four 6-c. p. lamps easily; operate induction coils; charge storage batteries; decompose water, electroplate, etc. As a motor, will operate sewing machine, jewelers' lathe, emery wheel, circular saw, advertising devices, and other useful appliances.

NEW ADVANCE MOTOR, new design, has two fold coils and improved brush holders. Price 70c, postage 2 c.
 Send stamp for catalog, No. 8 of new things electrical.

ARROW ELECTRIC CO., 103 South Canal Street, Chicago, Ill.

ELECTRIC BOOK FREE
 Shows all the Newest High Grade Electrical Supplies and Novelties at Lowest Prices in the world. Full of Holiday Suggestions. A. C. Dewey Electrical Co., Milwaukee



WRITE FOR OUR 170 PAGE BOOK ON ELECTRICITY FREE

We will send you with it our special plan by which you can secure absolutely free any article in our big catalogue.

JULIUS ANDRAE & SONS CO. 1003 West Water Street, Milwaukee, Wis.

Electrical Supplies

For the Amateur

Lowest prices :: Send Stamp for Catalogue

THE BRIDMAR CO., Chicago, Ill.

TRADE "Gibridge" MARK

YOUNG ELECTRICAL ENGINEERS
 The Midget Dynamo and Motor

Is the very best experimental machine obtainable. During the past ten years it has been used by the leading schools and colleges for illustrating the construction of modern Dynamos and Motors and for furnishing current for experiments. It is a perfect model of commercial generators. No details are lacking. Just the thing for young electricians. Will light several small lamps, operate induction coils, do electroplating, operate powder, etc.

Send for printed matter

PRICE AS SHOWN \$7.50 WITHOUT HAND POWER \$4.50
 With each machine we send a very instructive booklet, telling how to perform 25 very important electrical experiments. Post for Booklet 001.

Gibridge Electrical Mfg. Co.
 Chicago, Ill. U.S.A.

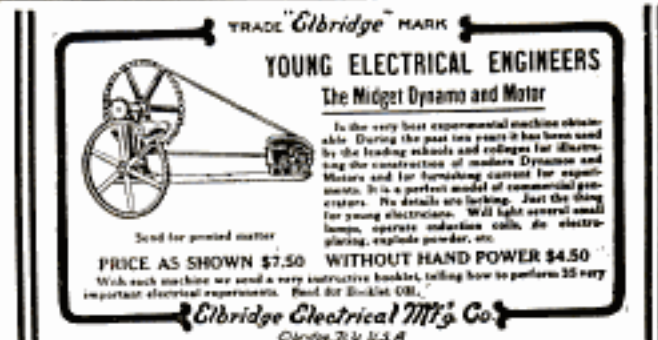

Electric

SUPPLIES, TELEPHONES NOVELTIES. Catalog of 200 Free. If it's Electric, we have it. Big Catalogue 4 cts.

OHIO ELECTRIC WORKS, CLEVELAND, OHIO.
 The World's Headquarters for Dynamos, Motors, Fans, Toys, Batteries, Belts, Bells, Lamps, Books. WE UNDERSSELL ALL. WANT AGENTS.

HAND POWER METAL PLANER
 Only \$40.00

Ideal Machine Works
 Brooklyn, N. Y.

THE "IDEAL" HAND PLANER.



A - Loose Feed
 B - Adjustable Feed
 C - Trip
 D - View of Wheel
 E - Round Spring Bar
 F - View, General

\$40 MOTOR CYCLE

We have the largest line of New and Used Motor Cycles, Parts and Supplies in the country, at the lowest prices. Every machine guaranteed. We are the largest and only exclusive Motor Cycle house in the world. Send for our 1907 Catalog. Repairs a Specialty.

Harry R. Gear Co., St. Louis, Mo.
Motors and Castings for Air Ships

A MOTOR-CYCLE OR LAUNCH

at SMALL COST by using one of our Attachable Outfits. A complete line of Finished Motors and Rough Castings for Bicycle, Auto-Marine or Stationary. Send stamp for catalogue.

STEFFEY MFG. CO.
Girard Ave. & 20th St., Philadelphia

**MAKE A MOTORCYCLE OF YOUR BIKE**

at small cost by using our Attachable Outfit. It fits any bicycle. Send stamp for catalog. Send 15 cents for "The Motor-Cycle Manual." It treats of the motorcycle; how to get more power, etc.

SHAW MFG. CO., Deot B. Galesburg, Kan.

**"Hercules Detachable Cover"**

The most wonderful invention in the Automobile Tire Industry. Agents wanted everywhere. This is a big seller. Territory being rapidly taken. Write today for booklet and prices. Special inducements to dealers and supply houses.

THE REPUBLIC RUBBER TIRE & SHOE CO.
449-451 West 53d Street, N. Y. City

AUTOMOBILES \$100 UP

FREE, our large Illustrated Bargain Sheet of slightly used Automobiles, showing accurate photographs of nearly 60 different makes of Automobiles offered as low as \$100. Send name and address only. Write plainly to

H. GRAHAM AUTOMOBILE CO.
Established 16 years. 601-603-605 Madison St., Chicago, Ill.

ELECTRICIAN AND MECHANIC

A finely illustrated monthly magazine publishing practical educational articles on all branches of electricity and mechanics. Complete directions and working drawings for making steam and gasoline engines, dynamos and motors, furniture, wiring instruction, wireless telegraphy, mechanical drawing, etc. Three months' trial, twenty cents. \$1.00 a year. Catalogue of electrical and mechanical books free. **P. M. Sampson Publishing Co., 6 Beacon St., Boston, Mass.**

THE OLD RELIABLE
JESSOP STEEL
IS YET ON TOP AND THE VERY BEST FOR ALL FINE TOOLS
WILLIAM JESSOP & SONS, LIMITED
91 JOHN STREET, NEW YORK

If you are interested in any kind of a Firearm, write for our beautiful "Gun Guide and Catalog" for 1907. It's **FREE**

Gives more points on guns than any catalog published. Gives best prices and most complete line.

THE HOPKINS & ALLEN ARMS CO.
32 Chestnut St., Norwich, Conn., U. S. A.

**Motorcycle Frame Parts and Engine Castings**

Complete Motorcycles, Engines and Frames.

W. HOFFMAN MOTOR WORKS
1254 N. Halsted Street, Chicago, Ill.

TRANSPLANTING ELECTRIC LIGHT TOWERS—One by one the tower lights so long a feature in the downtown districts of Detroit, Mich., are being taken down and removed to the outskirts. The advent of skyscrapers and the heavy growth of foliage in the sections where the towers used to shed their rays played a prominent part in hastening the departure of these landmarks. The work of taking down the iron towers, 150 ft. high, is done from the bottom upward. As each section is taken off the tower is lowered until the lamp platform is reached. Only two or three of the towers are now left in the downtown districts, and as rapidly as possible they will be transferred to the outlying districts.

THE MAN TO KEEP—If you have a workman in your employ that is a little slow—slower than you like—but he does his work well, is always looking after your interests, doing his work methodically, picking up and caring for little things, careful that his time is occupied in your service, does not object if he works a little overtime, if any emergency arises—in fact, approves of it—never grumbles at his task, but does it with care, whatever is set apart to him—never encourages the insubordination of others, but rather discourages it, keep him. You might get a better man, but ten to one you will get a worse one when all the little things are taken into account.—Building Management.

SAVED BY A SONG—Several years ago, on one of the eastern coast bays, when, as yet, steamers were infrequent visitors, a small boat used to ply, touching at various points. The crew was somewhat limited, consisting of the captain, first mate—whose name was Barnabas—and the cook.

The cook was afflicted with an impediment in his speech, which made him somewhat backward himself, especially if excited. Fortunately, however, he could sing as straight as anyone. One day the captain was below, taking a nap, while Barnabas and the cook were running the boat. A sudden squall brought the boom around with such unexpected violence as to knock the unwary Barnabas overboard. Then upon John rushed into the cabin in the wildest excitement to inform the captain of what had occurred, but was unable to get out a coherent sentence.

"B-b-b-b—" he stuttered, until the captain, in a rage, shouted: "Thunderation! man, sing it, if you can't say it!" and John, catching at the happy suggestion, sang:

"Half a mile astern of us,
Overboard is Barnabas."

The boat was immediately put about, and the luckless Barnabas rescued.

**WORKING MODEL ELECTRIC CAR**

30 inches long

Blueprints No. 8 and full description, 10c

EMPIRE ELECTRIC WORKS, Bridgeport, Ct.

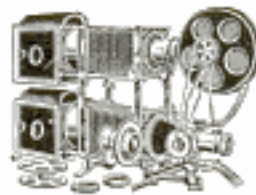
IT PAYS BIG To Amuse The Public With Motion Pictures

NO EXPERIENCE NECESSARY as our instruction Book and "Business Guide" tells all. We furnish Complete Outfit with Big Advertising Posters, etc. Humorous dramas brimful of fun, travel, history, religion, temperance work and songs illustrated. One man can do it. **Astonishing Opportunity** in any locality for a man with a little money to show in churches, school houses, lodge halls, theaters, etc and to **Five Cent Theatres** in store rooms. **Motion Picture Films and Song Slides** rented. Profits \$10 to over \$100 per night. **Orders** do it, why not you? It's easy; write to us, we'll tell you how. **Catalog free.**

AMUSEMENT SUPPLY CO., 471 Chemical Bank Bldg., CHICAGO.

Please Mention Popular Mechanics

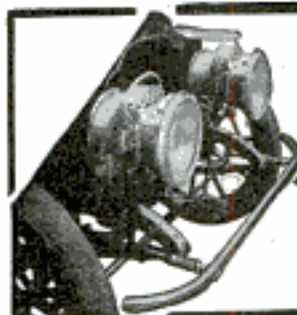

THE TURNER BRASS WORKS

SYCAMORE, ILL.

CHICAGO, ILL.

Manufacturers of Marine Hardware and Motor Boat Specialties. Sole Manufacturers and Licensees of Harroun Auto Bumpers, Martin Alarm and Reserve Valves, Martin Gasoline Separator and Strainer.

Write for Catalogue No. 28, Dept. I.



"Electro" Jump Spark Balls

(Patents Pending)

For Wireless Telegraphy. Adjustable for any size spark. Easily detachable. Postpaid complete, \$1.25. Headquarters for experimental wireless material, Geissler and X-Ray tubes, cheap storage batteries, Multiplex lamps, Tantalum lamps, etc. Send for free 92 page electrical Cyclopaedia, containing over 100 experiments, plans, instructions on wireless, etc.

ELECTRO IMPORTING CO.,

87 Warren Street,

New York

DON'T PUT IT OFF

Write today, get our free booklet, every tool we make is put under an actual fire test and must be just right before it leaves us. Take no other so called just as good, get the genuine; costs no more.

EMMELMANN BROS. MANUFACTURING CO.,
INDIANAPOLIS, INDIANA

The Good Old Reliable Work Bench

That never gets out of style. For many years made exclusively by

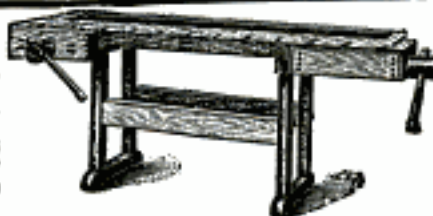

C. CHRISTIANSEN, 792 Grand Avenue, CHICAGO



GEARS

INTERNAL and EXTERNAL of all kinds

Ask for Catalog Grant's "Treatise on GEARS" a dollar

Philadelphia GEAR Works, Inc.
7th and Cherry Sts. Philadelphia

Dixon's Flake Graphite

Gives you "positive principle" lubrication. Good for steam or gas cylinders, bearings, gears, and all friction surfaces. Free booklet 194-C, gives full information.

JOSEPH DIXON CRUCIBLE COMPANY
JERSEY CITY, N. J.

The INDEX

to Vol. IX (1907)

POPULAR MECHANICS

is now ready. Mailed to any address on receipt of 10 cents in stamps.

Tool rack



Give the buy a chance

Heavy braces

WORK BENCH

—the best made. Improved iron vises, steel legs. Built up maple top. 20 in. wide, length 3 ft. 8 in. over all, one vise \$6.25; two vises \$7.50. 20 in. wide, length 4 ft. 6 in. over all, one vise \$6.75; two vises \$8.00. Side vise only, \$1.80. Tail vise only, \$1.95.

COLUMBIA SCHOOL SUPPLY CO., Indianapolis, Ind.

"COMFORT" SELF-HEATING FLAT IRON \$5

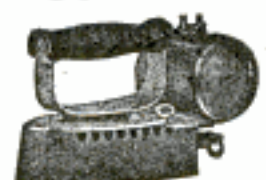

Safe Simple Economical AGENTS Wanted Everywhere Costs ONE CENT per day. Makes its own gas. No hot stove. Most convenient and economical household article ever invented. For further particulars and printed matter, write THE HAWKES FLAT IRON CO. 375 Dearborn St., Chicago

\$1.00 THE "READY"

Draughting Instrument combines Compass, Protractor, Rule, Square, etc., ALL IN ONE, and you can carry it in your vest pocket. Made of special grade of Aluminum. Send for it now. You need it. Money returned if you aren't pleased.

READY MANUFACTURING COMPANY
Dept. B. Rochester, N. Y.

Graduated in 10ths and 20ths

SPECIAL MACHINERY

We design and build special machinery to order in any quantity desired. Cut gearing. CRARY MACHINE WORKS
35-41 Indiana Street, Chicago

When You Want Anything and Don't Know Where to Find It, Write Popular Mechanics.

Greatest of all Scissors
EIGHTEEN TOOLS COMBINED
AND EVERY TOOL
PRACTICAL
KISS EDGE

1. Scissor
2. Buttonhole Scissor
3. Gaspipe Tongs
4. Cigar Cutter
5. Wire Cutter
6. Ruler
7. Measure
8. Nail File
9. Screw Driver
10. Hammer
11. Penknife
12. Glass Cutter
13. Glass Breaker
14. Marking Wheel
15. Cartridge Extractor
16. Cigar Box Opener
17. Ink Eraser
18. Stereoscope

MUCH HANDIER THAN A KNIFE

Just the Article for Office men, Clerks, Bankers, Travelling salesmen, or the House wife.

Made of 1st quality of steel—fine workmanship—nicely finished. Nickel plated. Put up in elegant leather sheath.

Postpaid upon receipt of \$1.00

AN EXCELLENT GIFT

WM. C. HOCKING & CO., 152 Lake St., Chicago

Sterling Novelty Mfg. Co.

SPRINGFIELD, OHIO Established 1890

Manufacturers of Metal Novelties and Specialties to order. We have facilities for making Metal Novelties and Specialties in large quantities on short notice and at reasonable figures. We solicit your order and guarantee satisfaction.

THE AMERICAN LEVEL AND GRADE FINDER

All progressive and up-to-date mechanics are getting one. An instrument with which at one glance you can get the true slant on any line or grade, either in degrees, inches or percentage, or all at the same time and will at once indicate and give the exact distance out of true level. A Civil Engineer that you may have with you at all times. The most practical, durable and convenient instrument of the day. The longitudinal recess shown in cut is well worth its price of the instrument. For agency and terms apply to

EDWARD HELB, Manufacturer, Railroad, Pa.



Induction Coils for Wireless Telegraphy

Put powerful sparks that CRASH from ball to ball with instantaneous ZIP, insure accurate transmission and perfect reception. Our coils are used in Colleges, High Schools and by Scientists generally. If you want to hear words of praise for our coils, visit the progressive Institution of Learning of your section and ask questions. Also, we suggest that you send for our illustrated bulletins describing \$5, \$8, \$10, \$14 and many other coils; also other Wireless Supplies.

NEW ENGLAND COIL WDG. CO., Atlantic, Mass.

Are You Building A Boat?

You will need fastenings, tools, anchors, rope, paint, deck fittings and a hundred other things. Write for our illustrated catalog of marine hardware. Sent free on receipt of 5c. for postage.

A. S. MORSS CO., 4 Lewis St., Boston, Mass.

DIAMONDS ON CREDIT

20% Down; 10% A Month

Every customer is protected by our written guarantee to refund his money if his dealer can duplicate our diamond at our price. Write for Illustrated Catalogue No. P. M.

J. M. LYON & CO., 71-73 Nassau St., New York City

BEGIN RIGHT



Begin the New Year right, with New Collars. New Cuffs of the right kind, LITHOLIN—linen which is waterproofed. You wipe them clean and white as when new with a damp cloth. The saving in laundry expenses will swell your bank account, and you will have style and comfort at all times.

Collars 25c. Cuffs 50c.

Free booklet on request showing latest fashions. If not at your dealers remit to us, giving size, style, number wanted and we will mail, post-paid.

THE FIBERLOID COMPANY

Dept. 25 7 Waverly Place, New York

LITHOLIN

WATERPROOFED LINEN

LET US BE YOUR FACTORY

We make anything to order—Stampings, Sheet Metal work—anything a good machine-shop should do—we do—because we're good ones. We publish "The Silent Partner." Ask for a sample copy. Write us.

THE GLOBE MACHINE & STAMPING CO.
3610 Hamilton Avenue, N. E. Cleveland, Ohio

When You Want Anything and Don't Know Where to Find It, Write Popular Mechanics.

Plumbing Supplies



AT WHOLESALE

If you need anything in my line, and wish to

Save Money

on every article, write for my free Illustrated Catalog. Shipments promptly made from a very complete stock of new latest pattern goods. Small orders are as carefully handled as large ones.

B. P. KAROL, 235 W. Harrison St., Chicago, Ill.

**YOU
CAN GET
\$5
A DAY**

January to December

SUN	MON	TUE	WED.	THU.	FRI.	SAT.
	\$5	\$5	\$5	\$5	\$5	\$5
6	\$5	\$5	\$5	\$5	\$5	\$5
13	\$5	\$5	\$5	\$5	\$5	\$5
20	\$5	\$5	\$5	\$5	\$5	\$5
27	\$5	\$5	\$5	\$5	\$5	\$5

After a 2 to 3 months' course
in the
**PLUMBING, BRICKLAYING
PLASTERING
OR ELECTRICAL TRADES**

We teach by Practical and Individual instruction given under actual working conditions. Trades That Pay and enable you to earn \$5 a day and over upon graduation.

Tools take the place of Books.

If you cannot attend school, we teach by mail giving Practical Instruction at your own home.

Our free catalogue tells all about it. Write for it today.

COYNE TRADE SCHOOLS

508 W. 24th St.
NEW YORK
857 N. Ashland Ave.
CHICAGO
237 Eighth St.
SAN FRANCISCO

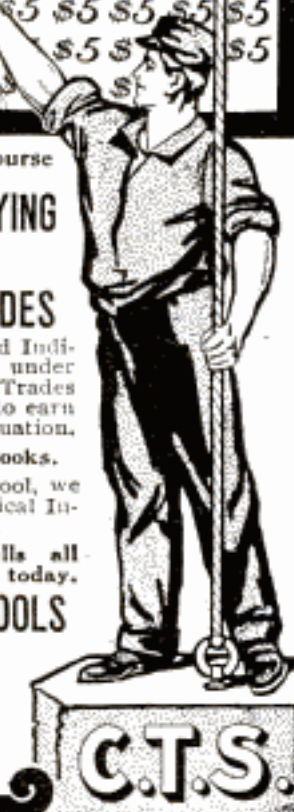

It's Best to Buy in New York
Everything for Your Home
WRITE NOW For 700-Page Catalog



Just write us—postal or letter—for this our Free 700-page illustrated 1907-8 Buyers' Guide of lowest wholesale prices on over 75,000 reliable articles needed for the home—office—or shop. As the oldest mail-order house in America, we refer by permission to the Publishers of this Magazine. We show you

75,000 Reliable Articles

Watches	Fancy Goods
Jewelry, Clocks	Lamps
Silverware	Groceries
Knives, Razors	Whips
Seeds, Paints	Carrriages
Baby Carriages	Waggons
Freezers	Hardware
Sew'g Machines	Revolvers
Elect'l Supplies	Rifles
Tool Cabinets	Shot Guns
Stoves, Ranges	Traps
Boots, Shoes	Shells
Sweaters	Cartridges
Fishing Tackle	Farm Tools
Skates, sleds	Incubators
Ice Tools	Breaders
House Furnishing Goods, Etc.	

This 700-Page **FREE** CATALOG

You Positively Save 1/4 to 1/3

on local dealers' prices anywhere. Safe, prompt delivery and absolute satisfaction or money back Guaranteed. For nearly a century, since 1836, we have dealt with the people everywhere direct to their homes through our big catalog. We also send you list of 100 Valuable Premiums Free. Also our grocery list of guaranteed Food Products of highest quality saves you one-third. Just write us. Then you'll prove by a first trial order that it pays to have our Grand Free Catalog No. 93 all the year round. It costs us \$1 to print it, but it's free to you.

White, Van Glahn & Co., 30 Barclay St., New York City

Oldest Mail-Order House in America, Estab. 1836

Storage Batteries

Their Theory, Construction and Use
By **A. E. WATSON, Ph. D., E. E.**

An up-to-date book that will be appreciated. It contains all the essentials of an adequate treatment of the subject. The general scheme of the storage of electrical energy is explained, the theory of the chemical actions given in descriptive language, as well as the ordinary equations. In the "How to Make" chapter, the most approved constructions are followed, with descriptions of the author's effective method making plates. Rules for the setting up and care of batteries are comprised in a clear and orderly manner. The author writes from practical experience, extending over many years. To record only the essentials and leave out the accidental is a requirement hard to comply with, but we believe this result has been attained in an unusual way in this new book. Price, Cloth, \$1.50

For sale at all bookstores, or will be mailed postpaid, by the publishers, upon receipt of price.

BUBIER PUBLISHING COMPANY, Dept. 3, Lynn, Mass.



Learn

Photo-Engraving or Photography
Engravers Earn from \$20 to \$50 Per Week

The only college in the world where these paying professions are taught successfully. Endorsed by the International Association of Photo-Engravers, and the Photographers' Association of Illinois. Terms easy and living inexpensive. Graduates placed in good positions. Write for catalogue, and specify the course in which you are interested. Address Illinois College of Photography or 999 Wabash Ave., Bissell College of Photo-Engraving, Ellingham, Ill. L. H. BISSELL, President.

When You Want Anything and Don't Know Where to Find It, Write Popular Mechanics.

MOVING PICTURE MACHINES

STEREOPTICONS

You Can Make **BIG MONEY** Entertaining the Public.



THE FIELD IS LARGE

comprising the regular theatre and lecture circuit, also local fields in Churches, Public Schools, Lodges and General Public Gatherings. Our Entertainment Supply Catalogue and special offer fully explains everything. Sent Free.

CHICAGO PROJECTING CO., 4 Dearborn Street, Dept. 4 Chicago.

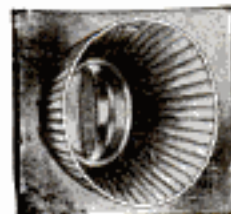

MELLO-TONE

Attachment, a great improvement for the Talking Machine or Phonograph. Produces tones natural. Eliminates all metallic sounds and blasts. Regulates and mellows the tone. Can be adjusted while machine is playing. Goes in the horn, opens and shuts.

Retail Price, \$1.00 Each

MELLO-TONE CO. :: Springfield, Mass.

Be Your Own Boss!

MANY MAKE \$2,000.00 A YEAR. You have the same chance. Start a mail order business at home. We tell you how. Money coming in daily. Very good profits. Everything furnished. Write at once for our "Starter" and FREE particulars.

P. M. KRUEGER CO., 155 Washington Street, Chicago, Ill.

Please Mention Popular Mechanics

EVERY INVENTOR

Who Wants to know

1. What are the most profitable inventions,
2. How to perfect inventions,
3. The first step to take in getting a patent,
4. How to protect himself from parties who might steal his invention before he can get a patent
5. How to find out what patents have been granted on inventions like his, or intended for the same purpose.
6. How much it costs to get a patent,
7. How long it takes to get a patent,
8. What protection a patent is,
9. How he can sell his patent after he obtains it
10. How to handle his patent to get the most money out of it,
11. Where and at what expense he can have working drawings made of his invention,
12. Where and at what expense he can have models or experimental machines made,

should send his questions to

**POPULAR MECHANICS PATENT
BUREAU,**

Journal Bldg. - - Chicago, Ill.

Patent What You Invent



Your ideas may bring you a fortune if properly introduced.

Our three books mailed free.

"U. S. LETTERS PATENT" gives full information in patent matters.

"THOUGHTS THAT PAY" gives list of what to invent.

"THOUGHTS THAT HAVE PAID" gives history of successful inventions.

Write for them.

Cash offers for certain inventions. No charge for reports as to patentability; send sketch or model.

Patent obtained or fee returned.

Patents advertised for sale, free.

WOODWARD & CHANDLEE

PATENT ATTORNEYS

1255 F Street, WASHINGTON, D. C.

ADVICE TO INVENTORS—The maxim that "A little learning is a dangerous thing," is especially applicable to inventors, as may be seen upon investigation of the patent office records in relation to almost any branch of industry. For example, the records of patents granted on "improvements in brakeshoes" show one case where a patent was for a brakeshoe provided with allways on the face and with an olecup mounted on the back of the shoe, the idea being to lubricate the rubbing surfaces in order to prevent rapid wear of the shoe. Another patented brakeshoe was designed to have a set of rollers on the face so that the anti-friction bearing thus provided would greatly reduce the wear of both shoe and wheel. Naturally, the patentees of such devices would believe that failure to adopt them was due entirely to prejudice, and perhaps it will be found that the investigation which it was announced some weeks ago was to be undertaken by the block signal and train control board under the direction of the interstate commerce commission into the charges that an association of manufacturers had combined to suppress meritorious patents which would result in the improvement of operating conditions on railroads, was instigated by promoters of devices analogous to the brakeshoes cited. Those who have even the slightest acquaintance with the vast sums of money which the manufacturing concerns of America are spending on patents which promise well, but which turn out to be worthless, find absurd the suggestion that meritorious inventions are deliberately suppressed.—Editorial in Railway Age.

ANTHRACITE COAL CENTENNIAL—An appropriate celebration of the centennial of anthracite coal is being considered by the citizens of Plymouth, Pa. In 1807 the first shipment of "black stone" was made by boats down the Susquehanna river. This date marked the beginning of the use of hard coal. It was the discovery that hard coal must be freed from every impurity and crushed to a uniform size before it could be successfully barged which started the great industry that this year will probably have an output of 70,000,000 tons.

Unlike soft coal, which can be dumped into cars at the shaft of the mine and directly transported to the consumer, hard coal requires preparation for market almost as complicated as the manufacture of flour from wheat. A long series of processes and washings are necessary to produce the accurately sized pure coal. As it comes from the mines it varies in size from a lump as large as a watermelon to sizes no larger than a walnut. Every lump is examined by men who are experts in detecting layers of slate or other impurities which look just like coal. The lumps are cracked with axes and every vestige of unburnable material removed before the coal is passed on to be crushed and sorted into the different sizes.

PATENTS PROTECT YOUR IDEAS

Money in inventions.
Correspondence Confidential. Patent advertised free.

MILO B. STEVENS & CO., Estab. 1864

885 14th Street, Washington, D. C.

Branches at Chicago, Cleveland, Detroit.

MODELS and GEARS

INVENTIONS PERFECTED

CATALOGS FREE

UNION MODEL WORKS, 191 South Clark St., Chicago, Ill.

<p>FREE TWO BOOKS: 68-Page "Inventor's Guide" AND "Fortunes in Patents" "What and How to Invent"</p>	<p>PATENTS GUARANTEED Protect Your Idea! SPECIAL OFFER: Send sketches or model and description of invention for FREE SEARCH of Patent Office Records and Report as to patentability. You will save TIME and MONEY. E. E. VROOMAN, Registered Patent Attorney Box 71, Washington, D. C.</p>	<p>REFERENCES: American National Bank, Washington, D. C. Popular Mechanics, Chicago, Ill. Little Giant Hay Press Co., Lufkin, Texas. Gray Lithograph Co., New York City, N. Y.</p>
--	---	--

PATENTS that PROTECT
Our 3 books for inventors mailed on receipt of 6 cts. stamps
R. S. & A. B. LACEY, Washington, D. C. Estab. 1869.

We give you PROOF of the money value of the patents we procure.—L. & L.

"MR. INVENTOR"
Our Business is to Perfect, Develop and Manufacture your invention. All modern facilities are ours, and we are at your service. We employ Expert Mechanics on
Specialties, Dies, Punch Work and Models
Send us your drawing or model and we will submit our lowest price.
MONARCH TOOL COMPANY, 124 Opera Place, Cincinnati, Ohio

PATENTS
Careful attention given to the prosecution of business before the patent office. Patents procured and no attorney fee called for until patent is allowed. (23 years experience.) Write for "Inventor's Guide." Address
Franklin H. Hough
Washington Loan & Trust Bldg., Washington, D. C.

LET ME SELL YOUR PATENT Booklet explaining how mailed FREE. Sixteen years' experience.
Patent Sales exclusively. If you have a PATENT for sale, call on, or write
WILLIAM E. HOYT
PATENT SALES SPECIALIST
290(J) Broadway, New York City



PATENTS GUARANTEED. PATENTS SECURED OR FEE RETURNED.
Send model or sketch for free report as to Patentability. Send for finest publications ever issued for free distribution "HOW TO OBTAIN A PATENT," with 100 MECHANICAL MOVEMENTS illustrated and described, and "WHAT TO INVENT," containing valuable LIST OF INVENTIONS WANTED.
ONE MILLION DOLLARS offered for one invention, \$16,000 for other. Patents advertised free in "WORLD'S PROGRESS." Copy free.
EVANS, WILKENS & CO., 615 F Street, WASHINGTON, D. C.

PATENTS THAT PROTECT AND PAY
WATSON E. COLEMAN
Registered Patent Attorney
626 F Street, N. W. WASHINGTON, D. C.
Advice and Book Free; Highest References; Best Services.

Invent
"HOW AND WHAT TO INVENT," and "HOW TO OBTAIN PATENTS," explained FREE. CHESTER W. BROWN, Patent Attorney, 996 F. Street, Washington, D. C.



PATENTS
Valuable Book on Patents FREE. Tells how to secure them at low cost. How to sell a Patent and What to Invent for Profit. Gives Mechanical Movements invention valuable to Inventors. Full of Money-Making Patent Information. NEW BOOK FREE to all who write.
O'MEARA & BROCK, Patent Attys.,
918 F. STREET. WASHINGTON, D. C.

PATENTS Properly Procured
Write for our handsome new book. Full information.
Bevans & Bevans Rm. 630 Colorado Bldg. WASHINGTON, D. C.

PATENT YOUR IDEAS
Cash offers for certain Inventions. Book "How to Obtain a Patent" and "What to Invent" sent free. Send rough sketch for free report as to patentability. We advertise your patent for sale at our expense.
Patent Obtained or Fee Returned.
CHANDLEE & CHANDLEE, Patent Attys.,
(Established 15 years)
945 F. Street, Washington, D. C.



INVENTORS
Our Brain Belongs To You
We have helped a great many over mechanical difficulties. Our Ideas are Free of Charge. All we want in return is to build your Model, Special Machinery or Tools to manufacture sheet-metal goods or novelties of any kind. We are expert mechanics and our experience covers over thirty years. Consultation free. Also our Booklet No. 16.
A. NACKE & SON, 240 S. 9th Street, Philadelphia, Pa.

WE CAN SELL YOUR PATENT
We can form, finance, and promote corporations. Send \$0.25 for terms and three months' subscription to
LAMSON'S INVESTOR, 153 Milk St., BOSTON, MASS.

PATENTS and TRADE MARKS obtained, defended and prosecuted by
Alexander & Dowell, Patent Lawyers. (Established 1857.) "P." 607 7th St., N. W., WASHINGTON, D. C. Book of Information sent FREE.

PATENTS

SECURED PROMPTLY and with special regard to the **Legal Protection of the Invention.**

HAND BOOK FOR INVENTORS AND MANUFACTURERS SENT FREE UPON REQUEST.

Consultation Free. No charge for opinion as to the patentability and Commercial Value of Inventors' Ideas.

HIGHEST REFERENCES FROM PROMINENT MANUFACTURERS

C. L. PARKER, PATENT LAWYER

Patents, Caveats, Trade Marks, Copyrights, Validity Reports, Interference Contests
Patent Suits Conducted in All States

REFERENCES:—Globe Machine and Stamping Co., Murray Engineering Co., Morgan Machine and Engineering Berkshire Specialty Co., Stewart Window Shade Co., Macon Shear Co., Acme Canopy Co., Lippencott Penell Co., Sallis Tire Association of America, Oakes Manufacturing Co., By-Products Co., Alabama Brewing Co., National Offset Co., Aseptic Supply Co., Richmond Electric Co., Railway Surface Contact Supplies Co., National Electric Works.

Mr. Parker on November 1, 1903, after having been a member of the Examining Corps of the U. S. Patent Office over five years, resigned his position as Examiner to take up the practice of Patent Law.

Address 210 Dietz Building

WASHINGTON, D. C.

PATENTS Send for FREE BOOK on patents. We charge no fee unless we secure a patent. Opinion as to the patentability of your invention free.



PAY.

Shepherd & Campbell
214 A McGill Bldg.
Washington, D. C.

BE YOUR OWN BARBER

Complete Set \$2.75 (worth \$4.50)



Finest Steel, Hollow Ground, Standard size Razor, Leather and Canvas Strop (Superior) and 5 1/4 inch 10 year brush and nickeled box shaving stick for only \$2.75. Order of

EDWARDS CO., 1104 Lawrence Ave., Chicago, Illinois

Try an Ad in our Classified Section. Three cents per word. Brings Results.



Ann Arbor Lighting System
GASOLINE WIRE

A Complete Lighting System for Homes, Stores and Churches

Ann Arbor Lighting Systems are brighter than gas, steadier and clearer than electric light, and cost about one-tenth as much to operate. Each lamp gives 300 to 600 candle power for less than 1/4 cent per hour. Fuel is gasoline; perfectly safe.

Prices \$10 up, according to number of lamps desired. These systems especially adapted for use in stores, halls, factories, etc.

WE WANT AGENTS who will push our line. Special terms to those who write early. Catalog and prices on request.

SUPERIOR MFG. CO.,
287 Second St., Ann Arbor, Mich.

ANN ARBOR LAMPS.—When complete systems are not desired, Ann Arbor Lamps make the most satisfactory substitute. Each lamp complete in the U. S. gives 1200 c.p., can be had in many pleasing styles. To get data in new territory, we will send model 110, showing how to burn or install fuel, for \$2.50, express prepaid in U. S. Money returned if not satisfactory.

SUPERIOR MFG. CO.
294 2d St., Dept. F, Ann Arbor, Mich.



I STOP FALLING HAIR CONSULT ME BEFORE IT IS TOO LATE

The **ONLY WAY** to tell the cause of falling hair in men and women is to make a **MICROSCOPIC EXAMINATION** of the hair. When the **DISEASE IS KNOWN** the **CURE CAN BE PRESCRIBED**. Send a few hairs to Prof. J. H. Austin, the thirty (30) years' Bacteriologist and Specialist in Diseases of the Hair, Skin and Scalp, and receive, **ABSOLUTELY FREE**, a diagnosis of your case, a booklet on Care of Hair and Scalp, and a box of the Remedy which will prepare for you.

Enclose 2 cent postage and write today.

PROF. J. H. AUSTIN, 1621 McVicker's Theatre Bldg., CHICAGO, ILL.



SUCCESSFUL DRAFTSMEN

Drawing \$125 to \$250 monthly require more than Schoolroom Knowledge.

As Chief Draftsman of Eng'g firm I know exactly the Quality and Quantity of experience and practical training you must have, and will prepare you in few months home instructions for above paying positions, which I furnish free anywhere.

Complete Highest Grade Drawing Outfit, everything included, with German Silver Set of Tools, value \$13.85, FREE next ten days.

Address, CHIEF DRAFTSMAN, Div. 19, ENG'S EQUIP'T CO., Inc., Chicago.

LEARN JEWELERS ENGRAVING

"The Engraving School that Graduates Experts"

A fascinating, high-salaried and easily learned trade, taught thoroughly and practically by correspondence. We will teach the beginner better engraving by correspondence than he can gain in years of rigid apprenticeship. We will improve the skill of any engraver one hundred per cent and make him master of the trade. The demand for competent engravers far exceeds the supply. Send for handsome illustrated prospectus.

The School of Engraving Dept. 112, 90 Wabash Av., Chicago
Dept. 112, 150 Nassau St., N. Y.

BE AN ILLUSTRATOR—Learn to Draw. We will teach you by mail how to draw for magazines and newspapers. School of Illustration, Office 112, 90 Wabash Av., CHICAGO

Send for catalog.

Learn Watch Repairing

Be a watchmaker—you can learn this profitable trade by correspondence in a few weeks in your own home by the DeSelms Chart System. After you complete the course you will know a watch from A to Z. You will know just what the matter is and how to repair one. When you graduate you will be a practical watchmaker and repairer and competent to fill any position. Positions for our graduates.

Ask for our Free Book. It explains our system and terms.

THE DeSELMS WATCH SCHOOL
23 Perry St. ATTICA, INDIANA



MY BOOK
FREE



THE
KEY TO
SUCCESS

"HOW TO REMEMBER"

Sent Free to Readers of this Publication

Stop Forgetting

You are no greater intellectually than your memory. Easy, inexpensive. Increases income; gives ready memory for faces, names, business details, studies, conversation; develops will, public speaking, personality. Send for Free Booklet.

Dickson Memory School, 705 The Auditorium, Chicago



Learn Bricklaying

and earn from \$5 to \$8 per day. Ours is the only thoroughly practical school in America. We teach bricklaying exclusively. Large, well lighted work-rooms. Instructors are men of wide experience in bricklaying and contracting. Only two or three months required to master the trade. Positions always open to our graduates. Demand greater than the supply. Day and evening classes. Write today for free illustrated booklet

CHICAGO SCHOOL OF PRACTICAL BRICKLAYING, 2115 W. Adams St., Dept. 1, Chicago



\$5 EARN \$5.00 A DAY \$5

Learn to be a plumber in from 4 to 6 months, on easy payments. For particulars address MASTER PLUMBERS' TRADE SCHOOL, 3415 LINDELL AVENUE, ST. LOUIS, MO.

LEARN WATCHMAKING

Refined, profitable labor—Competent men always in demand. We teach it thoroughly in as many months as it formerly took years. Does away with tedious apprenticeship. Money earned while studying. Positions secured. Send for catalog.

ST. LOUIS WATCHMAKING SCHOOL, ST. LOUIS, MO.

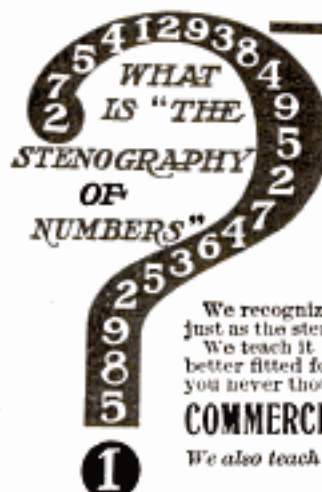

QUICK at FIGURES

Rapid Calculation is the same short cut to figuring that shorthand is to longhand writing.

It does the work of minutes - in seconds. The stenographer writes as fast as she hears the words - the Rapid Calculator writes the answer as fast as he hears the numbers. We all know that the young boy or girl stenographer can write entire lines while the average layman writes words. The Lightning Calculator adds or multiplies five or six columns while the average mathematician does one column.

We recognize stenography as a simple system. Just so with Rapid Calculation—it teaches you to read your sums just as the stenographer reads his or her word-signs.

We teach it by mail during your leisure moments. "THE MAN WHO CAN" do things quicker and better is better fitted for bigger opportunities—bigger pay. Our great book, "Rapid Calculation" will set you thinking as you never thought before; it's free. It's yours for the asking. It's good. Write to the

COMMERCIAL CORRESPONDENCE SCHOOLS, "The School of Prosperous Graduates" 19 G. COURT BUILDING ROCHESTER, N. Y.

We also teach by mail, Book-keeping, Letter Writing, Shorthand, English, Penmanship, Banking, Arithmetic, "Principles of Law."

LEARN SIGN PAINTING

Sign painters make \$5 to \$10 per day. My book of designs and instructions will teach you how to paint both advertising and commercial signs. No long period of instruction. My plan is complete and inexpensive. Price, complete by mail, only ONE DOLLAR. Remit with order, ONE DOLLAR. No correspondence solicited. Money back if you are not pleased. Address



WILLIAMSON SIGN SYSTEM
Delmar Blvd and Clara Ave., St. Louis, Mo.

**SPANGENBERG'S
PRACTICAL
ARITHMETIC
Self-Taught**

ARITHMETIC SELF TAUGHT

Plain, easily understood volume for ALL who have not had the opportunity of learning this subject thoroughly, or who have forgotten what they once learned. 257 pages. Requires no teacher. Send 60c. (stamps accepted) for this great book in cloth.

Edition de Luxe, \$1.00
GEO. A. ZELLER BOOK CO.
4478 Belle Place, St. Louis, Mo. Est. 1870

LEARN TELEGRAPHY BOOKKEEPING OR SHORTHAND BY MAIL--AT YOUR OWN HOME

Anyone can learn it easily in a few weeks. We are unable to supply the demand for telegraph operators, bookkeepers and stenographers. No charge for tuition until position is secured. Write today for particulars.
MICHIGAN BUSINESS INSTITUTE,
580 Institute Building, Kalamazoo, Mich.

HOROLOGICAL DEPARTMENT BRADLEY POLYTECHNIC INSTITUTE

Formerly Parsons Horological Institute

PEORIA, ILLINOIS.

**LARGEST and BEST WATCH SCHOOL
IN AMERICA**

We teach Watch Work, Jewelry, Engraving, Clock Work, Optics. Tuition reasonable. Board and rooms near school at moderate rates.

Send for Catalog of Information.



I TEACH SIGN PAINTING

SHOW CARD WRITING or LETTERING by mail and guarantee success. Only field not overcrowded. My instruction is unequalled because practical, personal and thorough. Easy terms. Write for large catalogue.

CHAS. J. STRONG, President.

DETROIT SCHOOL OF LETTERING
DEPT. PM. DETROIT, MICH.

"Oldest and Largest School of its Kind."



DO YOU LIKE TO DRAW? That's All We Want To Know.

Now we will not give any GRAND PRIZE—or a lot of FREE STUFF if you answer this ad. Nor do we claim to make you RICH in a WEEK. But if you are anxious to develop your talent with a successful cartoonist, so you can MAKE MONEY, send a copy of this picture, with 6 cents in stamps for portfolio of cartoons and SAMPLE LESSON plate and let us explain. **THE W. L. EVANS SCHOOL OF CARTOONING,** 421 Garfield Bldg., Cleveland, Ohio.



VENTRILOQUISM

LEARNED BY ANY MAN OR BOY AT HOME.

Small cost. Send to-day 2c. stamp for particulars and proof.
O. A. Smith, Room 544, 2040 Knoxville Ave., Peoria, Ill.

We teach Furniture Designing, Rod Making, Stock Billing, Ornamental Drawing, Water Coloring and Interior Decoration by mail.

GRAND RAPIDS SCHOOL OF DESIGNING.

A. KIRKPATRICK, Instructor.

544-545 Houseman Bldg. : : Grand Rapids, Mich.

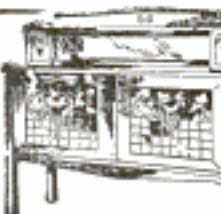

FISHING IN DINING-ROOM—"There is a large hotel in Colorado," says Cassell's Saturday Journal, "which has a notable feature of interest in the fact that a trout stream runs right through its dining-room! A guest is allowed to take rod and line and angle for the fish, which when caught, are cooked and served to him at the table, and it is quite a regular custom for a visitor to catch trout for his own breakfast. Needless to say, the stream is kept well stocked with fish, and is a great attraction to the guests. The water comes from a genuine mountain brook, and everything about the portion of it which flows through the hotel is kept as true to nature as possible."

NO PASSES FOR RAILROAD'S DEAD—The rule made on the anti-pass law by the Texas attorney-general in answer to questions asked by the attorneys of one of the railroads running through that state, has brought to the fact that free transportation cannot be furnished the body of an employee killed on the line away from home. The body cannot be taken from place of death to place of burial free, nor can relatives, other than immediate relatives of the dead employee, be furnished transportation to come to the funeral.

Not only in these two instances does the law prohibit the simplest acts of duty and humanity toward an employee or his family, but it even prohibits the railroad from carrying free to any other part of the line the wife and children, or the household goods. If such services rendered by the railroads the expense entailed must be deducted from the damage settlement, if there is any net by the road itself in real money. This law seems to work both ways, at least as interpreted by the Texas jurist.

Louis Grouch (having trouble with the operator)—Hello! Hello! What's the matter? Is there some fool at the end of this wire?"

Operator—"Not at this end."—Operating Bulletin.

CONCRETE WALLS DAMP!—An Ohio man who is anxious to engage in the making of concrete blocks said: "I have heard brick men talk about the dampness of concrete walls, and when one of them recently advanced this line of knock to me, I answered, 'If you are right, how is it that contractors all place a coating of cement plaster over brick walls in foundations, so as to keep out dampness?'"—Concrete.

WE CAN TEACH YOU TO DRAW

You can earn \$20 to \$50 and upwards per week.

We have Successfully taught all branches of drawing by correspondence since 1896. Practical personal instruction. Experienced teachers. Art Director educated in Europe. Positions guaranteed. Successful students everywhere. Illustrated Year Book free.

SCHOOL OF APPLIED ART,

49-75 Fine Arts Bldg., Battle Creek, Mich., U.S.A.

BE A RAILWAY MAIL CLERK

Earn \$83 to \$130 a Month—Work Only Half the Time. We prepare you by mail to pass a successful Civil Service Examination.



Most complete course. Uncle Sam wants Mail Clerks. Write today for free catalog and special offer. The Wenthe Corres. School, Box 505, Freeport, Illinois.

15 CENTS for trial 13 weeks. In this illustrated national weekly all the important news of the world is stated clearly, fairly and briefly, for busy readers. Many special features of great interest. It is simple, reliable, entertaining—THE paper for the home. \$1 year; 50c a month. Place of \$2 to \$4 papers. Try it, 13 weeks for 15c.

The Pathfinder
EVERY WEEK
THE NATIONAL NEWS REVIEW

PATHFINDER, Washington, D.C.

CARBORUNDUM

A keen, lasting edge on tools is an essential to good workmanship.

Carborundum Sharpening Stones

are made into thousands of different sizes and shapes and grits to meet every possible sharpening need. They do their work faster and better and more economically than any other sharpening stone ever made. Every man ought to have a Carborundum pocket stone—in neat case—by mail 35 cents. If your dealer doesn't sell Carborundum Sharpening Stones, order direct.

The Carborundum Company

Niagara Falls, N. Y.



NAME.....
TOWN.....
STATE.....

TRAVELING-SALESMEN

EARN \$2,000 TO \$10,000 A YEAR.

We will teach you to be one in eight weeks *by mail* and secure you a position with a reliable firm. Fill out coupon and send for our free book, "A Knight of the Grip" today. Address nearest office.

NATIONAL SALESMAN'S TRAINING ASSOCIATION, 219 Scarritt Bldg., Kansas City, Mo.,
or, LUMBER EXCHANGE, Minneapolis, Minn.



\$75 HAND POWER CONCRETE MIXER

14 year old boy can operate it

Send for free booklet "True Concrete"
Sidewalk or Block makers

SARNSON MACHINERY CO.
Room 3, 806 Chestnut St., St. Louis, Mo.

BUILD WITH CEMENT



Do it yourself with our
\$16.50 HOLLOW BLOCK MACHINE. SAVE MONEY
We give complete instructions. Catalog Free.
BOOK OF DESIGNS and Floor Plans, 10 cts. in silver or stamps.
REED MFG. CO., Box 118, Springfield, Ohio

HOW TO MAKE MONEY



Send today for our FREE book and descriptive matter telling all about the profits that can be made in the manufacture of concrete building blocks. With a FRANCIS BLOCK MACHINE any man of ordinary ability can make from \$3 to \$15 a day. No capital or experience necessary. Building blocks made with the Francis Machine under the Berlin System are guaranteed damp proof, frost proof, fire proof and will not crack or crumble. Contractors and builders in your town need your entire output. Write today.

FRANCIS MACHINERY COMPANY
Room 40, 110 N. 8th Street - St. Louis, U. S. A.

ENGINEERING:

**CIVIL,
ELECTRICAL,
MECHANICAL,
TELEPHONE,
MACHINIST,
STEAM
GAS.**

A thoroughly equipped College of Engineering. Standard four-year courses, also one year courses in Steam and Electrical Engineering. Three months' courses in Traction and Gas Engineering. One-year Machinist's Course. **Shop work from the beginning.** Send for catalogue giving full information.

Highland Park College of Engineering, Des Moines, Iowa.

Please Mention Popular Mechanics

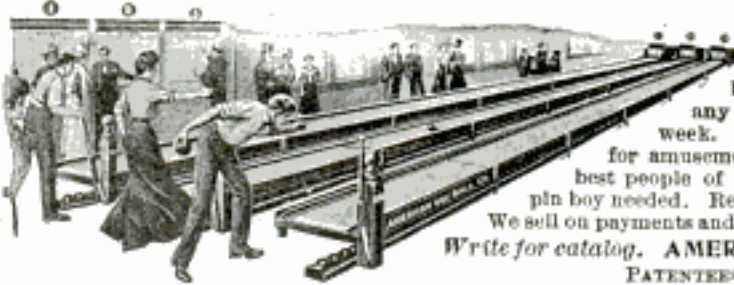
513 CLEAR PROFIT IN 51 DAYS FROM AN INVESTMENT OF \$150

Is the result from the operation of one American Box Ball Alley in Sullivan, Ind. Why not go into this business yourself? It is the most practical and popular bowling game in existence. It will make big money in any town. These alleys pay from \$25.00 to \$65.00 each, per week. This is no gambling device, but a splendid bowling game for amusement and physical exercise. Liberally patronized by the best people of both sexes. Quickly installed, conveniently portable. No pin boy needed. Receipts are nearly all profit. More than 3,000 already sold. We sell on payments and our catalog is free.

Write for catalog. **AMERICAN BOX BALL COMPANY,**
PATENTERS, 1375 Van Buren St., Indianapolis, Ind.

**PAY
NOW &
THEN**

\$5.00
DOWN

\$30.00
A MONTH



This Genuine, Com. White Perfect Diamond Set in 14k Solid Gold Mounting (any style)

\$30.00 on Approval
\$5.00 Down; \$3.00 a Month. Gent's open face 12, 16 or 18 size, or Ladies' 6 size watches, plain or engraved, 20-year gold filled case, with Elgin or Waltham movement

\$12.50 \$2 Down \$1.50 A Month

Let us send you Watch or Ring upon terms indicated. You may remit first payment with order or we will send goods C. O. D. first payment, express paid, subject to examination.

Our Attractive Catalogue FREE. Ask for No. 5-71

Herbert L. Joseph & Co.

DIAMOND IMPORTERS WATCH JOBBERS
217 State Street 5-71 CHICAGO

SEWS UP WOUND BEFORE HE FAINTS—"Get me a needle and thread, quick, or I'll bleed to death," demanded James Cassidy, when his right forearm was terribly mangled by machinery at the Edlystone Print Works.

Needle and thread were brought, and Cassidy calmly sewed up the wound, which was 4 in. in length.

"Now send me to the hospital, and I guess the doctors can fix me up a little better," was Cassidy's injunction as he swooned. Dr. Frank J. Evans, the company's physician, says he has never seen anything to equal the man's pluck during his twenty-five years' experience as a practicing physician.—Philadelphia North American.

OYSTER FARMS IN JAPAN—In the United States the gathering of oysters is spoken of as a "catch." In Japan, however, this could not apply, as the oysters are really a crop, cultivated as carefully and systematically as any production grown on dry land.

The Japanese use vast quantities of bamboo brush in breeding and growing their oysters. At low tide in the Sea of Aki, the network of straits and river mouths bristles with closely set oyster farms. Most of the bamboo stakes used retain their smaller branches, and as various patterns are affected by the oyster growers in setting the stakes to control the tide currents for the benefit of the feeding oysters, the low-tide view of an oyster farm is startling and beautiful. Seen from a distance, it looks as though some ocean workers had been constructing a feathery city, symmetrical and exact.

One of the most interesting features of the industry is the fact that the government surveys the farms and rents them by auction to the highest bidder. The tenant during his lifetime has the right of renewal of lease, but only for so much of a farm as he can work himself. This leaves no gate open for speculation.

RAILROAD ONLY 317 FT. LONG—The shortest railroad in Louisiana—probably the shortest in the United States—runs from Burnside station, on the Yazoo & Mississippi Valley Railway, to Houma's Landing, 317 ft. away. The rolling stock of the road consists of an old street car, formerly used in New Orleans, and the motive power is a pale bay mule. Capt. P. T. Badin is owner, and the engineer is generally picked from the field hands of a big plantation close by. The line is used to convey passengers from the railroad station to the steamboat landing. The distance is merely a trifle over a block, and passengers never fail to quiz the road and its management, from the president down to the driver of the mule. No fares are collected.

IT PAYS TO BE CAREFUL—An enthusiastic motorist, on approaching a turn in the road where a number of children were at play, told his chauffeur to slow down. Fearing that the chauffeur would misunderstand, he tried to square himself in the following manner: "I don't at all mind about running down grown-up people and dogs, but do be careful about the children and babies."

"Yes; them feeding bottles do cut up the tires dreadful," the chauffeur replied.



GROW MUSHROOMS

For Big and Quick Profits.

I can give practical instructions worth many dollars to you. No matter what your occupation is or where located, get a thorough knowledge of this paying business. Particulars free. **JACKSON MUSHROOM FARM, 3243 N. Western Ave., B-146, Chicago.**

GLASSES ARE NEEDLESS

in most cases. For weak eyes they are crutches—not a cure. For diseased eyes they are useless. Only a gentle *medicated massage* can strengthen weak eyes and cure optical diseases. The

NATURAL SIGHT RESTORER

applies a *soothing, strengthening* treatment that is *healing but harmless*; gently exercises the proper muscles and makes weak eyes strong by proper massage. *Brings eye-health by aiding nature. Young or old treated at home and normal eye-sight secured for the cost of a pair of glasses. Don't wear "specks," but write today for our free illustrated book. If we can't help you, we will say so.*

The Natural Sight Restorer Co.
104 Broadway :: Detroit, Michigan



Increase Your Earnings

We have an attractive money-making proposition to make to those who would like to make **MORE MONEY**.

Our proposition offers an exceptional opportunity to men employed in manufacturing plants, machine shops, etc. Such men can easily make **MORE MONEY** without interfering with their regular work.

The work is pleasant. The compensation is liberal. What others have done you can do.

Write to us today and receive full particulars by return mail.

POPULAR MECHANICS

Desk A...160 Washington Street, Chicago



If It's a Sebastian, It's a Good Lathe

BUILT UPON HONOR—ACCURACY, EFFICIENCY, MODERATE PRICES.

Foot and Power Lathes, all sizes. Send for Catalogue.

Sebastian Lathe Company, 197 Culvert St., Cincinnati, O.

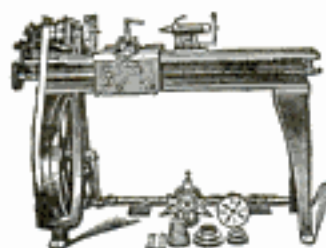

B. F. BARNES' ELEVEN-INCH SCREW CUTTING LATHE

For foot or power as wanted. Has power cross feed and compound rest. A strictly high-grade modern tool. We also build a 9-inch lathe. Descriptive circulars of each lathe upon request.

B. F. BARNES CO., Rockford, Ill.

CAN CARRY AN ARMY—German army officers seem greatly perturbed over the possibilities of the "Lusitania" and her sister ship, the "Mauretania," as army transports. The two ships, they say, could transport an army of 20,000 men from England to the continent in very short order, if the necessity should arise. The officers and crews are members of the British naval reserves, and the vessels could be turned over to the admiralty with but very little preparation.

LIFTING A 360-FT. DRAWBRIDGE WITHOUT TOOLS was accomplished under the pressure of necessity in a very ingenious manner some years ago. A recent report of how a battleship turret was made to lift itself by its own turning power has resurrected the story. About 14 years ago a draw span 360 ft. long crossing the Ouachita River, on the Houston, Central Arkansas & Northern Railroad, near Columbia, La., built on a pile and concrete foundation, settled on one side, throwing it out of line. Mr. E. P. Terry was sent down to correct the trouble. The bridge was in a jungle hundreds of miles from a city, and Mr. Terry had absolutely no tools. Some old stovepipe iron found on the site of the old construction camp was placed under the track, one piece at a time, and the drawbridge was then turned backwards and forwards, being raised by the thickness of one piece of the sheet metal at each operation. After bringing the bridge up to proper grade, he raised the different track segments to the proper level, and then tamped a rust joint under each segment. This was done with four men to assist him, in about a week's time.—Engineering News.

FAST LOCOMOTIVE—A firm in Munich has built for the Bavarian State Railways a locomotive capable of hauling a train weighing 165 tons at a speed of 93 miles an hour. This engine was tested on July 1 and 2, and, it is said, maintained for a prolonged time a speed of 96 miles an hour, which is declared to be the greatest speed ever made in Europe by a steam locomotive. It is a four-cylinder compound with 6-ft. drivers, and fitted with a superheater.

ORIGINAL CHAUFFEUR WAS FIERCE—That the modern chauffeur often develops a reckless disposition is not to be wondered at, when one reads his ancestry as told in Motor Print, London, which says:

"History tells us that along about the year 1795 there sprang up in France, principally in the eastern and central regions, fantastically dressed men with their faces blackened with soot and their eyes carefully concealed, who gained admittance to farmhouses and other isolated dwellings at night and committed all kinds of depredations and outrages. These ancient hold-up artists had an atrocious habit especially, from which they obtained the name that posterity has preserved for them. They first garrotted their victims, and dragged them in front of a great fire, where they burned the soles of their feet. Then they demanded of them where their money and jewels were concealed. Such interrogatories could scarcely be resisted. It is from this that is derived the appellation of chauffeur, which once so terrified old ladies."

FOOT and POWER

AND TURRET LATHES, PLANERS SHAPERS AND DRILL PRESSES ::::

SHEPARD LATHE CO.

A131 W. 2d St., Cincinnati, Ohio

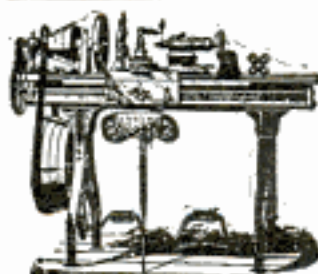

LATHES

9 to 13 inch Swing

List price, \$75.00 and up according to size. When ready to buy send for Lathe Catalog and prices

W. F. & John Barnes Co. 109 Ruby St., Rockford, Ill.

PHOTOGRAPHS WANTED

Photographs of new and interesting subjects, suitable for publication in this magazine, may be submitted to its editor and those accepted will be paid for promptly.

Editor Popular Mechanics

160 Washington St. Chicago

JUDSON Freight Forwarding Co. Reduced rates on household goods to and from all points on the Pacific Coast. 349 Marquette Building, Chicago; 1005 Carleton Building, St. Louis; 851 Tremont Bldg., Boston; 101 Columbia Bldg., San Francisco; 109 Stimson Block, Los Angeles.



The "NULITE" VAPOR GAS LAMPS

For Home, Store and Street

We also manufacture Table Lamps, Wall Lamps, Chandeliers, Street Lamps, Etc. 100 Candle Power seven hours ONE CENT. No Wicks. No Smoke. No Odor. Absolutely safe. THEY SELL AT SIGHT.

CHICAGO SOLAR LIGHT CO., 6 River St., CHICAGO

Exclusive territory to good agents. Write for catalogue and prices.



Wood Working Machinery

Foot, Hand and Light Power

For ripping, cross-cutting, mitering, rabbeting, grooving, dadoing, boring, scroll and band sawing, edge moulding, beading, mortising, etc. Built for hard work, accurate work and long service. Send for catalogue "A."

SENECA FALLS MFG. CO. 102 WATER ST. SENECA FALLS, N. Y.



Please Mention Popular Mechanics

The man who owns a Mechanical Cleaning Wagon, **MAKES MONEY**

We are ready to prove that **\$3,000.00 Can be Made**

This year, next year, and the years after Cleaning houses by our patented machinery by energetic, competent men. Over 300 operators in as many towns in the United States.

We make the most efficient stationary systems for Residences, Hotels, Office Buildings, Etc.

The Largest Manufacturers of Cleaning Machines in the World

Genl. Compressed Air and Vacuum Machinery Co.

4452-B Olive Street, ST. LOUIS, MO.



THE MACHINE THAT MAKES THE MONEY

WRITE FOR CATALOG

WE OWN THE PATENTS AND ARE PROSECUTING ALL INFRINGERS



Smoke an Anti-Nicotine Pipe

Two Way

and enjoy for once a cool, delightful smoke, free from every trace of nicotine. Nothing but smoke enters the mouth. Smokes absolutely dry—no sizzling. Every particle of tobacco burned—a saving of 25%. Never bites the tongue or mouth. No offensive odors. Lasts longer than ordinary pipe. Satisfaction absolutely guaranteed or money refunded. Postpaid 50c. Anti-Nicotine Pipe Co., Dept. A, Ottawa, Ill.



DO YOU SHAVE YOURSELF?

Then get a brush, the hairs of which will never come out. Our new **EVERLASTING SHAVING BRUSH** has the hairs cemented and set in an aluminum ferrule by our patent process; guaranteed perfect for three years.

A new brush free if a single hair comes out.

SPECIAL: To introduce our catalog of razors and supplies for homeshaving, we offer this 7c brush for **25c**

Complete catalog on home shaving **FREE**.
HOME BARBER SUPPLY CO., 283 E. Madison St. Chicago

HOW TO SAVE ON PURCHASES

There are many things which for all practical purposes are just as serviceable second hand as new. You buy a new buggy, use it one day carefully. It is "just as good as new," but it is second hand, and if sold will bring much less than you paid for it. Hundreds of needed machines, tools, vehicles, etc., can be bought at from one-third to one-half the price of new and serve you just as well. If you can't afford a new one or want to save money, don't go without, but read or advertise in our classified pages. (3 cents a word.)

SELL WHAT YOU DO NOT NEED

Few things except land increase in value with age. Don't keep on piling up junk in your factory, home or office. Somebody can use it and wants it if only they knew of what is to them an opportunity, and to you a conversion into cash of an otherwise useless article. You can fill your want, or sell the article, by a few words in our classified pages. (3 cents a word.)

WHY DON'T YOU TRADE?

The exchange of something you no longer need for something else you do want is a ready and sane means of making two people pleased. There are scores who want what you do not and who have what you desire. Why not exchange? You two who don't know where the other is, can quickly get together in our classified pages. (3 cents a word.)

HOW TO FILL ALMOST ANY WANT

No matter what you want, from an album to an airship (both have actually been sold through our classified ads), you can find it in two or three lines in our classified pages. (3 cents a word.)

Our classified ads are about as cheap in price and as prolific of the result for which the ad is intended as any advertising in any tongue or place.

A 3-line ad in the December issue, containing 20 words, was printed in 122,000 copies, which certainly will be read by 244,000 people, and the cost is 60 CENTS. In other words, for each cent the 3-line ad is seen by 4,066 readers in all parts of the United States, Canada and Mexico, and a good many in foreign countries.

For instance: A 2-line ad in our October issue, which cost 26 CENTS, brought 120 replies, and seven of them contained checks, drafts or money orders for the purchase. The other 113 replies wanted more information, as the 26 words really did not go into minute details. The article in question was a second-hand typewriter.

Turn to the classified pages; they are good reading.
Try a classified ad yourself next month.
3 cents a word—for one time—3 cents a word.

POPULAR MECHANICS, - - - CHICAGO

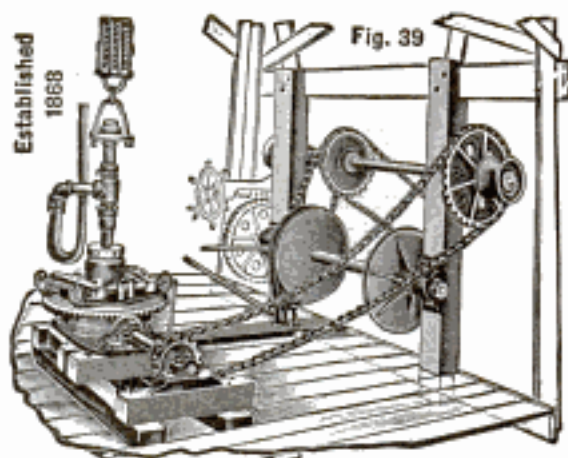

LIGHTNING WELL MACHINERY,

Rotary, Coring or Rock Drilling,

Any Diameter, Any Depth, for
Water, Oil, Coal or Mineral
Prospecting,

Descriptive Catalog on request.

The American Well Works,
Aurora, Illinois, U. S. A.

CHICAGO, ILL. DALLAS, TEX.

MORE HEIGHT? BROAD SHOULDERS?

Prof. K. Leo Minges can increase your height two to six inches—he can broaden your shoulders—he can improve your stature and symmetrical appearance just as certain as fresh air, sound sleep and exercise improve the health.

A success in 30 different countries. Scientists endorse it—physicians approve of it—the press praises it—gymnasiums and colleges use it—users recommend it. Short people everywhere have put this simple, practical appliance to the severest tests. Civil Service, Military and Municipal requirements have no terrors for the tall—it's the short and stunted who are handicapped. It's the skeptics that develop into the strongest endorsements of our method—which is safe, simple, sure, painless, quick and harmless—private, convenient and inexpensive—positively pleasing and effective.

Thousands of undersized men and women have grown tall, erect and healthful through our wonderful method. You'll not be the first—it's neither an experiment or uncertainty.

Our beautiful, free, 32-page book tells, explains, illustrates and proves everything—mailed free, postpaid. Will you write for it?

A
VERY
VALUABLE
BOOK FREE

THE CARTILAGE
COMPANY
Unity Bldg.
Rochester,
N. Y.

DILWORTH ADDER



Just the Size
of Your Pocketbook
\$1

A Practical POCKET ADDER that saves tedious memorandum work and is used to great advantage many times during the day. Sent postpaid for \$1.00. Made of very durable material, is enclosed in neat case with full instructions and hardwood pointer for operating. Has no mechanism and is operated with the point of a pen or pencil. Nothing like it on the market. Used for totaling miscellaneous items from books or bills, cross adding, trial balances, checking, etc. Saves a large amount of tiresome calculation; is practical, simple, compact and cheap. Capacity \$9,999,999.99. Reference, Lincoln National Bank, Pittsburg.

DILWORTH ADDER CO., 1229 Fulton Bldg., PITTSBURG, PA.

FINDS COAL MINE IN CELLAR—Thomas H. Cooper, manager of one of the mines in the Pocahontas coal field, West Virginia, has become rich by the accidental discovery of a vein of coal under his house. The house was built some time ago in such a hurry that the work of excavating the cellar was left until later. A short time ago, the two men at work on the excavation ran their picks into a seam of coal 9½ ft. thick.

SAD TALE OF A MOTORIST.

There was a man of modest means,
But inclinations gay,
Who sold a corner lot and bought
A motor car one day.
He closed his business up to ride
Within the big machine,
And parted with his diamond ring
To buy the gasoline.

Before, along the country roads,
The sumac lit its fires
He put a mortgage on his house
To purchase rubber tires;
And next he auctioned off his beds,
His tables and his chairs
To give the car a coat of paint
And make some slight repairs.

But speeding in the early dusk,
Without his lamps alight,
A man in blue and brass appeared
And stopped his dizzy flight.
He didn't have a single cent
To pay the fine imposed;
They took the auto for the debt,
And so the tale was closed.

—Minna Irving.

PAPER BAG AS A KETTLE—"I had no hot water for shaving at the little country hotel, and accordingly heated some in a paper bag."

"Heated hot water in a paper bag?"

"Sure."

"How can that be done?"

"You take a stout paper bag—or an envelope will do as well—all it with water and hold it over a gas flame or lamp. The water heats readily. The paper doesn't burn, because it is wet, and wet paper is a singularly tough and non-combustible substance."

"Many and many a time have I heated over the gas jet an envelope or a paper bag of hot water for my shaving, and not once have I had an accident."—Kansas City Independent.

PRINTING 100 Letter heads, 100 Envelopes, 100 Cards, all three for \$1.50 postpaid. Visiting Cards, 100 for 85¢; Shipping Tags, 100 for 40¢. Samples, 2¢. 100 Billheads or Statements, 50¢.

RICHARD ELLIOTT, Box 1376, St. Louis, Mo.

THE VACUUM CAP CURES BALDNESS 60 DAYS' TRIAL

Thousands cured. Our MODERN VACUUM CAP when used a FEW MINUTES EACH DAY draws the blood to the scalp and forces the hair into new healthy growth, cures baldness and stops the hair from falling out. Cures Dandruff. Harmless and healthful. We send it to you on trial. We only want pay if you are pleased. Is not this fair? Write for free booklet.

THE MODERN VACUUM CAP CO.

654 BARCLAY BLOCK

DENVER, COLO.



Please Mention Popular Mechanics

DON'T PAY TWO PRICES FOR STOVES & RANGES

Order direct from our Stove Factory and save for yourself all Jobbers' and Dealers' big profits **Hoosier Stoves and Ranges**

HOOSIER STEEL

"The best in the world." Are heavily made of highest grade selected material, beautifully finished, with many new improvements and features

"Hoosiers" are guaranteed for years, and "backed by a million dollars." Hoosiers are "fuel savers and easy bakers." A child can operate them. We sel. them on 30 days' free trial. We pay the freight.

Write for Catalog and Special Free Trial Offer. **Hoosier Stove Co.**
249 State St. Marion, Ind. **BASE BURNER**



\$3,000 to \$10,000 A YEAR IN THE REAL ESTATE BUSINESS.

We will teach you by mail the Real Estate, General Brokerage, and Insurance Business, and appoint you

SPECIAL REPRESENTATIVE

of the oldest and largest co-operative real estate and brokerage company in America. Representatives are making \$3,000 to \$10,000 a year without any investment of capital. Excellent opportunities open to YOU. By our system you can make money in a few weeks without interfering with your present occupation. Our co-operative department will give you more choice, salable property to handle than any other institution in the world. **A THOROUGH COMMERCIAL LAW COURSE FREE TO EACH REPRESENTATIVE.** Write for 62-page book, free. **THE CROSS COMPANY, 1672 Rosper Bld., Chicago, Ill.**



Use This Lamp 60 Days Free

Let us place this 100-candle power Brilliant Gas Lamp in your home. Use it and test the light in every way and prove that every claim we make is true.

We defy comparison with gas, kerosene, or electricity, and claim that the saving will pay for this Lamp in a few months. If you are dissatisfied and find that it is not the very best reading and working light made, we will gladly refund your money.

2c A WEEK operates this lamp and gives you a home as bright and cheerful as in any city. Shipped Anywhere. Safe delivery guaranteed on receipt of \$5.00.

BRILLIANT GAS LAMP CO.
47 State Street Chicago, Ill.



TYPEWRITER BARGAINS

All Standard Makes, \$15 to \$65. Most of these machines have been only slightly used—are good as new. Shipped on approval. Don't buy a Typewriter before writing us. We will give you the best typewriter bargains that can be offered. Address **McLaughlin Typewriter Exchange**
102 Ozark Bldg., St. Louis, Mo.



ACCURACY Not guess work with a patented **LEMON MEASURING-CALIPER**. Meets the requirements of and exceeds the limits of all other calipers. The only instrument for reaching over and measuring inside of reinforced edges or heavy rims. Sold Direct—Ask for Description and Price.

THE WEST MFG. CO., Columbus, O.
(Note—If you have a Patented Article to manufacture, write us.)



THERE IS MONEY IN MONEY!

Some coins you handle are worth two to ten times their face value. Get informed on the value of United States money of different dates. It may be worth dollars to you; 25 cents in coin or stamps brings you book worth 100 times the price if it helps you find a rare coin.

Address XX,
Care R. F. D. NEWS
160 Washington St., :: Chicago

TRY IT TEN DAYS FREE at my Expense Write Today

I WILL Prepay the Express Charge To Prove Its Merit Write at once



CURE YOURSELF BY ELECTRICITY

IF YOU SUFFER from Rheumatism, Neuralgia, Constipation, Nervousness, Headache, Stomach Trouble or any other disease, I will send you a battery on ten days' trial. **MY VALUABLE NEW BOOK FREE** to all who write. Explains how my wonderful inexpensive batteries cure you in your own home. Tells how Electricity treats disease by striking the root. How it removes the cause, then cures the disease to stay cured. How it builds up and nourishes wasted tissue. It tells how I send a battery without a cent in advance and allow ten days free trial. Write today for this valuable book, I will send it free.

DETROIT MEDICAL BATTERY CO., E. C. Harkness, Gen'l Manager
190 Majestic Building Detroit, Michigan



* \$90 A Month for Men to advertise and distribute our sample Mail Order Mags. Catalogue. Unity Supply Co. Chicago *

Rider Agents Wanted

In each town to ride and exhibit sample 1908 model. Write for Special Offer.

Finest Guaranteed 1908 Models \$10 to \$27 with Coaster-Brakes and Puncture-Proof tires.

1906 & 1907 Models \$7 to \$12 all of best makes

500 Second-Hand Wheels All makes and models, good as new, \$3 to \$8

Great Factory Clearing Sale. We **Ship On Approval** without a cent deposit, pay the freight and allow **TEN DAYS' FREE TRIAL.** Tires, coaster-brakes, parts, repairs and sundries, half usual prices. Do not buy till you get our catalogs and offer. Write now.

MEAD CYCLE CO., Dept. P 111 Chicago



Please Mention Popular Mechanics



DON'T WEAR A TRUSS

RUPTURE CURED by STUART'S PLASTER-PADS means a permanent cure, absolutely guaranteed and you do away with the painful irritating unsatisfactory truss altogether. No buckles—no straps—no springs. Adheres closely to body, holds rupture in place and cures the most obstinate cases. Easily applied—soft as velvet—will not blister or irritate most delicate skin. Only short time required for permanent cure. Treatment is private, costs very little and does not interfere with your work. Has cured thousands, on our guarantee. If you wish to be cured, write at once for FREE "Trial of Treatment" and illustrated booklet.

Address STUART PLASTER-PAD CO., 37 Chestnut St., St. Louis, Mo.



RHEUMATISM

Let Us Send You FREE TO TRY, a Dollar's Worth of the Great Michigan External Remedy That is Curing Thousands

Let Us Have Your Address Today

We have found a quick and positive remedy for Rheumatism. We are proving this fact day in and day out by thousands of cures, including old chronic cases of 30 and 40 years' suffering from this cruel torture. We know this, and if anyone doubts, we will introduce him or her to hundreds we have cured. We will let everybody know, as we know, that Magic Foot Drafts are a real, genuine cure for this dread disease.



Magic Foot Drafts are so sure to cure that we gladly send them to anybody Free on approval and wait for our pay until the work is done. Send us your name today. Return mail will bring you a regular dollar pair of Drafts, prepaid, to try free. Then if you are satisfied with the benefit received, you can send us One Dollar; if not, they cost you nothing. You decide. You can see that we couldn't afford to make such an offer if the Drafts didn't cure. Address Magic Foot Draft Co., 151 Oliver Building, Jackson, Mich. Write today.

Rheumatism SUCCUMBS to the TREATMENT of Richmond's Rheumatic Eradicator

Price, \$2.00 Prepaid Does Not Blister

RICHMOND LINIMENT CO., Chemists

Hartford, Conn., U. S. A.

Department 1

The verses published in the November issue of Popular Mechanics, entitled "The Old Folks at Home," were written by Maxwell Reynolds, Worcester, Mass., who describes himself at the time it was written as a lonely man on a stormy night.

PILE SHARPENING MACHINE—An English contracting firm engaged upon the construction of harbor works in Rotterdam, Holland, has built a machine for the purpose of sharpening piles, which resembles a gigantic pencil sharpener. Piles of 28 in. in diameter are sharpened to a 5-in. point in 15 minutes.

HIGH BELL BUTTONS—Of all the foolish notions recently recorded, the most unthinking is that of the New York architects who are putting the street door push buttons higher than usual, so that they will be above the reach of mischievous small boys. These deluded persons must be so old that they have forgotten all about kids. Otherwise they would realize that it is a mighty poor excuse of a boy that could be circumvented in any such trivial way. As it is a fair inference that the Manhattan boys are like boys everywhere else, a high door bell will present merely an added temptation to their enterprise. The architects would better capitulate to the small boys if they can think of nothing more effective than they have now devised.—Building Management.

CONCRETE IN FREEZING WEATHER—In the construction of dams for Huronian Company's power development in Canada, a large part of the concrete work in dams, and also in power-house foundations, was done in winter, with the temperature varying from a few degrees of frost to 15 degrees below zero, and on several occasions much lower. No difficulty was found in securing good concrete work, the only precaution taken being to heat the mixing water by turning a 3/4-in. steam pipe into the water barrel supplying the mixer, and, during the process of mixing, to use a jet of live steam in the mixer, keeping the cylinder closed by wooden coverings during the process of mixing. No attempt was made to heat sand or stone. In all the winter work care was taken to use only cement which would attain its initial set in not more than 65 minutes.—Engineering Contracting.

DON'T WEAR A TRUSS



Brooks' Appliance is a new scientific discovery with automatic air cushions that draws the broken parts together and binds them as you would a broken limb. It absolutely holds firmly and comfortably and never slips, always light and cool and conforms to every movement of the body without chafing or hurting. I make it to your measure and send it to you on a strict guarantee of satisfaction or money refunded and I have put my price so low that anybody, rich or poor, can buy it. Remember, I make it to your order—send it to you—you wear it—and if it doesn't satisfy you, you send it back to me and I will refund your money. The banks or any responsible citizen in Marshall will tell you that is the way I do business—always absolutely on the square and I have sold to thousands of people this way for the past five years. Remember, I use no salves, no harness, no lies, no fakes. I just give you a straight business deal at a reasonable price.

C. E. BROOKS, 6066 Brooks Building, Marshall, Mich.

HELP TO TRUSS WEARERS

Is your truss uncomfortable? Ever SLIP? The AKRON TRUSS has patented SPONGE RUBBER PADS. Comfort and relief, soft but CANNOT SLIP. You know a truss is necessary and cures are very rare. All wearers, and especially MECHANICS and MACHINISTS will find great relief by wearing one of our TRUSSES. We guarantee you help. For sale by best druggists and truss fitters, or direct from us.

Write For Booklet H. It Will Pay You.

THE AKRON TRUSS COMPANY, Akron, Ohio

Please Mention Popular Mechanics

INDEX TO ADVERTISERS

	PAGE		PAGE
Acme Engraving Co.....	135	Cleveland Armature Works.....	8
Air Cooled Motor Co.....	114	Coleman, Watson E.....	121
Akron Truss Co.....	132	Columbia School Supply Co.....	117
Albaugh-Dover Co.....	18	Commercial Correspondence School.....	123
Alexander & Dowell.....	121	Coyne Trade Schools.....	119
Alden Co., F. H.....	136	Crary Machine Works.....	117
American Box Ball Co.....	126	Cross Co.....	131
American Motor Co.....	113	Currier, Koeth Mfg. Co.....	13
American School of Mechano Therapy.....	Curtiss Mfg. Co., G. H.....	114
.....	DeSelms Watch School.....	123
American Well Works.....	130	Detroit Engine Works.....	112-114
Amusement Supply Co.....	116	Detroit Medical Battery Co.....	131
Andrae, J.....	115	Detroit School of Lettering.....	124
Anti-Nicotine Pipe Co.....	129	Dewey, A. C.....	115
Arrow Electric Co.....	115	Dickson School of Memory.....	123
Armstrong Mfg. Co.....	13	Dietzen Co., E.....	108
Auburn Motor Buggy Chassis Co.....	16	Dilworth Adder Co.....	130
Audel & Co., Theo.....	Dixon, Joseph.....	117
Austin, Prof. J. H.....	122	Dodge's Institute of Telegraphy.....	108
Automatic Adding Machine Co.....	8	Drake & Co., F. J.....	7
Babson, F.....	107	DuBrie Motor Co.....	111
Baird & Co., H. C.....	Duplex Phonograph Co.....	14
Barnes Co., B. F.....	128	Edwards Co.....	122
Barnes, W. F. & John.....	128	Elbridge Elec. Mfg. Co.....	115
Baroda Co.....	136	Electro Importing Co.....	117
Barton Collier Co.....	Elliott, R. D.....	130
Benjamin, F.....	110	Emmelmann Bros. Mfg. Co.....	117
Bevans & Bevans.....	121	Empire Electric Works.....	116
Bissell College Photo-Engraving.....	119	Empire Machine Works.....	112
Bradley Polytechnic Institute.....	124	Engineers' Equipment Co.....	123
Bridmar Co.....	115	Engraving, School of.....	123
Brilliant Gas Lamp Co.....	131	Evans' School of Cartooning, W. L.....	124
Brooklyn Mch. Works.....	115	Evans, Wilkins Co.....	121
Brooks Coat Co.....	17	Fairbanks, Morse Co.....	113
Brooks, C. E.....	132	Fiberloid Co.....	118
Brown, C. W.....	121	Foss Gasoline Engine Co.....	112
Bubier Pub. Co.....	7, 119	Francis Mchy. Co.....	125
Buckeye Traction Ditcher Co.....	11	French Tobacco Co.....	108
Buffalo Mech. & Elec. Laboratory.....	114	Fritz & Goedel Mfg. Co.....	8
Bureau of Navigation, U. S.....	3	Gancher, E.....	8
Callie Perfection Motor Co.....	113	Gas Power Pub. Co.....	7
Canton Cutlery Co.....	108	Gebhardt Motor Co.....	114
Carlisle & Finch Co.....	115	Geen Elec. Mfg. Co.....	114
Cartilage Co.....	130	Geer Co., H. R.....	116
Central Mchy. & Supply Co.....	109	Gem City Acet. Generator Co.....	11
Chandlee & Chandlee.....	121	General Com. Air & Vacuum Mchy. Co.....	129
Chapman Co., H. L.....	112	Gies Gear Co.....	113
Chicago Projecting Co.....	119	Gilson Mfg. Co.....	112
Chicago Solar Light Co.....	128	Globe Mch. & Stamping Co.....	118
Chicago School of Bricklaying.....	123	Golden Rule Cutlery Co.....	135
Christiansen, C.....	117	Goodell-Pratt Co.....	15
Clarkson Co., D. B.....	8	Graham Auto Co.....	116

	PAGE		PAGE
Grand Rapids Hand Screw Co.....	11	O'Meara & Brock.....	121
Gregg Mfg. Co., R.....	136	Palmer Bros.	113
Hart, W. C.....	136	Parker, C. L.....	122
Hawkes Flat Iron Co.....	117	Pathfinder Pub. Co.....	124
Helb, Edward	118	Pelouze Scale & Mfg. Co.....	8
Highland Park College.....	125	Philadelphia Gear Works.....	117
Hocking Co., W. C.....	118	Pierce Model Works.....	114
Hoffman, W.	116	Pomeroy Scroll Saw Co.....	16
Home Barber Supply Co.....	129	Pressed Steel Mfg. Co.....	136
Hoosier Stove Co.....	131	Randel Machinery Co.....	16
Hopkins & Allen Arms Co.....	116	Ready Mfg. Co.....	117
Hough, F. H.....	121	Reed Mfg. Co.....	125
Houle Motor Works.....	112	Republic Tire & Shoe Co.....	116
Hoyt, Wm. E.....	121	Rhodes Co., L. E.....	113
Ideal Machine Works.....	115	Richmond Liniment Co.....	132
Illinois College of Photography.....	119	Rogers-Thurman Co.....	Inside front cover
Illustration, School	123	Royal Mfg. Co.....	15
Intercontinental University.....	Inside front cover	Sampson Pub. Co.....	116
International Corres. Schools.....	64, 65, 66, 67	Sarnson Mchy. Co.....	125
International Harvester Co.....	111	School of Applied Art.....	124
Investors' Review	108	Scripps Motor Co.....	111
Jackson Mushroom Farm.....	126	Sebastian Lathe Co.....	128
Jessop Sons, Wm.....	116	Seneca Falls Mfg. Co.....	128
Joseph & Co., H. L.....	126	Shaw Mfg. Co.....	116
Judson Frt. Forwarding Co.....	128	Shepard & Campbell.....	122
Karol Co., B. P.....	118	Shepard Lathe Co.....	128
Kewanee Water Supply Co.....	6	Slotkin, Mayer	16
Kingsland, G. A. & H. S.....	13	Shrp Shavr Co.....	Outside back cover
Kirkpatrick, A.	124	Smith, O. A.....	124
Klein & Sons, M.....	16	Splitdorf Laboratory	115
Krueger & Co.....	119	Spon & Chamberlain.....	Inside front cover
Lacey, R. S. & A. B.....	121	St. Louis Watch School.....	117
Lamson's Investor	121	Star Expansion Bolt Co.....	13
Lippincott Steam & S. Co.....	113	Starrett Co., L. S.....	4
Lufkin Rule Co.....	16	Steffey Mfg. Co.....	116
Lyon Co., J. M.....	118	Sterling Novelty Mfg. Co., J. N.....	118
Magic Foot Pad Co.....	132	Stevens, M. B.....	120
Manhattan Electric Co.....	Outside back cover	Stuart Plaster Pad Co.....	132
Master Plumbers' Trade School.....	123	Superior Mfg. Co.....	122
Mathias Klein & Sons.....	16	Temple Pump Co.....	112
McCartney, James	135	Termaat & Monahan Co.....	112
McLaughlin Typewriter Exchange.....	131	Thompson, W. A.....	7
Mead Cycle Co.....	131	Turner Brass Works.....	117
Mechanics' Tool Works.....	15	Union Model Works	120
Mello Tone Co.....	119	United Mfg. Co.....	114
Michigan Business Institute.....	124	Unity Supply Co.....	131
Miner-Lawrie Laboratories.....	17	Utica Drop Forge Co.....	Outside back cover
Modern Vacuum Cap Co.....	130	Vim Co.	115
Monarch Tool Co.....	121	Voltamp Electric Mfg. Co.....	115
Mora Motor Car Co.....	10	Vrooman, E. E.....	121
Morss, A. S.....	118	Wallace Supply Co.....	16
Motsinger Device Co.....	115	Waterman Marine Motor Co.....	135
Nacke & Son, A.....	121	Waterloo Gasoline Engine Co.....	111
National Salesman's Training Asso.....	125	Webber, G. S.....	136
Natural Sight Restorer Co.....	126	Wenthe Ry. Corres. School.....	124
National Stamping & Elec. Works.....	135	West Mfg. Co.....	131
New England Coll Mfg. Co.....	118	White, Van Glahn & Co.....	119
Nickel, F. F.....	136	Wightman, L.....	115
N. Y. School Auto Engineers.....	16	Williamson Motor Co.....	113
N. Y. School Taxidermy.....	135	Williamson Sign System.....	124
North Bros. Mfg. Co.....	11	Williamson, W. F.....	135
Ogden Co., J. Edward.....	14	Woodward & Chandlee.....	120
Ohio Electric Works.....	115	Zellar, Geo. A.....	124

Taxidermy Book FREE



Write
today

depending on a job.
N. W. School of Taxidermy, Box 58 R.

Mount Birds and Animals

Sportsman! Fisherman! Hunter! Naturalists and others seeking to better themselves by learning a great profession. The wonderful art of Taxidermy, so long kept secret, can now easily be learned right in your own home during your spare hours. No need to give up your business.

We Teach By Mail how to mount birds, animals, game heads, tax skins, make rugs and mount all trophies. A delightful, entrancing and money-making profession for men and women. Easily and quickly learned. **Success guaranteed or no tuition.** Endorsed by thousands of delighted graduates all able to secure big incomes. **Great Book FREE!** Our beautiful, illustrated book, "How to Learn to Mount Birds and Animals," and our handsome Taxidermy Magazine sent absolutely free to all who write. Stop. Be a professional man or woman. Write today. Omaha, Neb.

ARMY ENGINEERS RUSHING PANAMA CANAL—Astounding progress has been made in the work on the Panama Canal since the army engineers took hold of the work, in March, 1906. Col. Goethals, the engineer in charge, has not yet had an opportunity to show what he can do in dry weather, but in the face of a rainfall unusually heavy even for the isthmus, he attained the extraordinary figure of 1,844,000 cu. yd. in the single month of October. He increased the excavation 23 per cent over September, in the face of an increase of 45 per cent rainfall.

On November 1 there remained to be excavated 97,091,000 cu. yd. At the rate of progress made during the month of October, 53 months, or 4 years 5 months, would be required to complete the excavation. Were it not for Col. Goethals' warning that the construction of the massive locks, rather than the excavation of the canal prism, will, from now on, control the date of completion, the opening of the canal might be looked forward to at no later date than the summer of 1912.

AN AERONAUT'S PROSE POEM—Now the clouds shut out from view all that human eyes are used to know, and a new world strange to man is all our own.

We are alone in space, where for eternal years only time has dwelt. Without direction to our way we travel on, for in these regions so remote to all mankind direction is unknown—no east nor west nor north nor south does mark our path. The horizon, man's constant friend below, has disappeared, and eyes, burdened by the never-ending distance, give up the quest of limitless space.

Sound fled from solitude so great, afraid to be alone, and even in our care she seems to be afraid, and echoes back to safety from the cloud below. As far as eye can reach the scene is clothed in white, as though the snow of ages, piled on snow of ages gone before, is bleached forever by a never-sinking sun.

Fantastic shapes of splendor undescribed are reared within the time of thought, but for a glance alone, and soon dissolve to give us a chance to view new shapes of greater splendor far, arisen at our side. The sun in splendor undisturbed since placed on high by nature's God shines down through blue which skies imprison, and will shine on until the end of time shall come and man will be no more.

Facilities brought from below and used to tell us where we are and where we go are all at fault in this strange place, and though we fly as on the winds and with a speed equaled by thought alone, still it is as if we yet stood still and let the sloth pass by, for here no speed is known short of the speed at which the light is launched from worlds unseen and travels yet to meet our sight.—J. C. McCoy.

ARE YOU GOING TO ST. LOUIS?

The HOTEL WINDERMERE is a delightful place in the Best Resident Section and away from the noise and smoke; yet within easy access. Transient Rate: \$1.60 to \$3.00 a day, European Plan. Special Rates by the week. Write for Booklet.

Address, W. F. WILLIAMSON, Manager.



Agents Wanted

\$100 weekly can positively be made selling and appointing agents to sell our Hydro-Carbon Lighting Systems and Lamps. Our Success Demonstrating System makes failure impossible. We offer a grand opportunity to make money. Wanted a good man in every town, village and city in the world.

Light Dept.,
National Stamping & Electric Works
151-159 Jefferson St., Chicago, U. S. A.

HOT WATER IN 2 MINUTES Cost—Two Cents

The Peerless Kitchen Boiler has solved the hot water problem, in city and country homes, hotels, restaurants, clubs, bath-houses, gymnasiums—every place where hot water is required. Burns either gas or gasoline; heats water to 185° and keeps it hot at one-half cent per hour. A hot bath for two cents. The PEERLESS is simple in construction—only three parts—disk, burner, drum. Absolutely noiseless; creates no odor. Occupies but a very small space; easy to install and connect. No pipes to clog or mechanisms to get out of order. The water is kept in constant circulation, the capacity almost unlimited. PRICE, surprisingly moderate. Ask your plumber about the PEERLESS, or write for catalog, prices and discounts.



JAMES McCARTNEY
39 State Street, • CHICAGO

WATERMAN CANOE MOTOR

Small, neat, complete. Standard type. 2 H. P. Weight, 35 pounds. Drive a canoe 10 to 12 miles an hour. Gray iron cylinder. Spun copper jacket. Aluminum crank case. Float-feed Carburetor. Shipped complete, including foundation. Ready to put in canoe. Immediate delivery. Send for catalog.

Waterman Marine Motor Co.
1507 West Fort St., Detroit, Mich., U. S. A.



AGENTS

\$100 A MONTH EASILY MADE selling our "LIGHT-NING SELLING" TRANSPARENT HANDLED POCKET KNIVES. Name and address on one side; photo and lodge emblem on the other. Just the "git thing" for a nice present. Write TODAY for agents' terms. GOLDEN RULE CUTLERY CO., 40-9 Wendell Street, CHICAGO.

The publishers of Popular Mechanics have on hand a limited number of complete

VOLUMES OF POPULAR MECHANICS FOR 1907

These include one copy of each of the twelve issues from January to December, inclusive. These volumes are unbound and will be sent to any address, postage prepaid, on receipt of \$1.25.

CUTS
WE MAKE THEM CLEAN, BRIGHT, & SHOWY, TO ILLUSTRATE CATALOGS & ADVERTISEMENTS. SEND FOR SAMPLES
JACME ENGRAVING CO.
155 WASHINGTON ST. CHICAGO.

STEEL
BRASS
BRONZE

BALLS BALL BEARINGS

"Knipe" Pat.

$\frac{1}{4}$ in. Shaft and up. No fitting, just push them on. 10 cts. in stamps for sample.

PRESSED STEEL MFG. CO.
454 The Bourse, Phila., Pa.



Geisha Diamonds

THE LATEST SCIENTIFIC DISCOVERY

Bright, sparkling, beautiful. For brilliancy they equal the genuine, standing all test and puzzle experts. One twentieth the expense. Sent free with privilege of examination. For particulars, prices, etc., address

THE R. GREGG MFG. & IMPT. CO.

Dept. H, 52-58 W. Jackson Boul., Chicago, Ill.

BUSINESS OPPORTUNITY

Men of Business interested in a new field for making money will find in our proposition what they are seeking. We have a New Plan in the Mail Order Line that will please those seeking a good investment with large profits. A Fortune for the right person. The F. H. Alden Co., 139 E. 4th St., Cincinnati, O.

WHEN YOU WANT ANYTHING
AND DON'T KNOW WHERE TO FIND IT
WRITE POPULAR MECHANICS

MECHANICAL DRAFTING

Working Drawings, Patent Drawings,
Machine Designing and Detailing.

Estimates on all work free.
Correspondence Solicited.

W. C. HART, P. O. Box, 708 Westfield, N. J.

ACCURATE SHOP DRAWINGS

Twenty-five Years' Experience

F. F. Nickel, 25 Winans St., East Orange, N. J.



BARODA DIAMONDS

Flash like the genuine—at 1/30 the cost
SOLID GOLD MOUNTINGS

Stand acid test and expert examination. See them first, then pay. Catalog FREE. Patent Ring Gauge included for 5 two-cent stamps. The Baroda Co., Dept. M, 236 North State St., Chicago



NOTHING SO FASCINATING

as making Silhouettes traced from the living model with the **Profilograph**. Outfit \$1.00.

G. S. WEBBER, Box 570, Chicago

Turn Your Spare Time Into Money

- ☐ We would like to communicate with ambitious men and boys who would like to improve their spare time.
- ☐ Why not make more money?
- ☐ By our plan this is not a difficult thing to do.
- ☐ Write us and we will send full particulars by return mail.

DESK A

Popular Mechanics

CHICAGO, ILL.

"Want" and "For Sale" Ads. 3 cents per word, payable in advance. Replies may be sent to a number, care Popular Mechanics, and will be forwarded without extra charge. In answering such, let the number appear on your envelope. These classified pages close on the 3rd of each month for the next month's issue.

AUTOMOBILES.

DO NOT RISK buying an automobile without consulting an expert; I am buying cars for customers all over the U. S. and guarantee satisfaction; if you are thinking of buying a machine drop me a line; state kind of car wanted and price. Arthur E. Pray, 172 St. Botolph St., Boston, Mass.

FOR SALE—14-hp. double cylinder shaft drive touring car, barely used, cost \$1,050 last spring; a bargain, \$495. 3-hp. Armac motor cycle, tandem attachment, run only 400 miles, \$95; cost \$225. Merkel motor cycle in good condition, \$45. E. H. Peshak, Marshall, Wis.

SHAFT DRIVE RUNABOUT means power, good condition. H. E. Burlingame, 53 Redwing St., Providence, R. I.

FOR SALE—12-passenger 30-hp. sightseeing car, or will exchange for land. Address G 99.

CADILLAC, first-class condition, top glass front; Presto-Lite tank gas lamps; odometer; will sell at about half price. Simplicity Motor Car Co., 1460 Cleveland Place, Denver, Colo.

PACKARD, Knox, Ford, Rambler, Loco and Waverly. Prices from \$150 to \$1,500. Many other bargains. Write now. Balch & Currier, Salem, Mass.

AUTOMOBILE SCHOOL—Chicago School of Motoring; the original automobile school in Chicago. Four hundred and fifty graduates the past year, to whom we refer upon request. Automobile owners, prospective buyers and young men wanting to become expert chauffeurs will save a great deal of money and a lot of worry by studying the mechanism, care and repair of gasoline automobiles in our shop, where all parts are open so you can see how they are made, and how they operate. We give thorough and practical instruction. Competent chauffeurs supplied. Address Chicago School of Motoring, Dept. B., 1436 Wabash Ave., Chicago, Ill.

AUTO SUPPLIES

FOR SALE—One irreversible steering device for automobile, \$5; one vertical flat tube brass radiator, 50 ft. surface, \$6. Photo furnished. Address "C," 791 Superior St., Milwaukee, Wis.

STEERING COLUMN, small frame, with springs, cheap. Address 200, Popular Mechanics.

WILL SELL my entire stock of auto parts and accessories, inventories \$5,000 at manufacturer's price, for \$2,500, or will sell the following in any quantity: Helme and Kingston new spark coils, \$10 each; Mosler's spark plugs, 60c each; new oilers, \$3.50 each; also tops, windshields, transmissions, clutches, steel frames, leather cushions, wheels, rear and front axles, horns, lamps, steering wheels, etc. Address Robt. Wachman, 229 Rowena St., Detroit, Mich.

AUTO TIRES—Closing out, all new G. & J. clincher castings, 28x2½, \$10; 28x3, \$16.50; 30x3, \$17.50; 30x3½, \$21; inner tubes, 28x3, \$4; 30x3, \$4.40; 30x3½, \$6; 32x3½, \$6.45; single tube tires, 5 or 8 lugs, 28x2½, \$11; 28x3, \$12.50. Many other sizes; shipped privilege of examination. Wm. Vanderpool, Springfield, Ohio.

INCREASE POWER, Maxwell 1905 and 1906 runabouts, using our 4½-in. cylinders. Will sell castings. Empire Auto Co., Greenwich, Conn.

GLASS FRONTS, \$19.40; auto heaters, \$21; auto trunks, \$12; rumble seats, \$9; baggage racks, \$5.40; new hood and dash outfits for 1903 and 1904 Ford, Cadillac, Winton and other cars, \$15 up. Write us. We will save you money. Catalogue ready. Auto Rebuilding Co., Chicago, Ill.

FORD RUNABOUT OWNERS. Don't swear any more. Order one of our three-tinge folding hoods to fit your car. Price, \$12; with strap, \$13.50. Auto Rebuilding Co., Chicago, Ill.

GLASS FRONT for all cars. Get prices before ordering. Catalogue on request. H. S. Ross, 5607 S. Halsted St., Chicago.

20" AUTO BOILERS, each \$50; 18" auto boilers, each \$45. J. L. Lucas, Bridgeport, Conn.

MOTORCYCLES

SAVE CHAIN TROUBLE by using Ball Bearing Fiber Idler, ready to apply to Indian or B-S motorcycles. For cut and prices apply to A. C. Mount, 1158 Washington St., Elizabeth, N. J.

MOTORCYCLE AGENTS for the '08 M. M.; paying proposition. L. E. French, Am. Motor Co., Brockton, Mass.

WANTED—Second-hand Ideal hand planer; also bench and slitting shears. B. 2. Thos. R. Brown, 1707 N. 7th St., Terre Haute, Ind.

FOR SALE—1906 Reading motorcycle. Stevens double-barrel hammerless shotgun; 12-shot magazine camera. Percy Ewing, Decatur, Ill.

M. & M. MOTORCYCLE for sale cheap. 1907 model, good as new, \$100. A. Corwin, Riverhead, L. I.

INDIAN MOTORCYCLE, '06 model, for sale, \$95. Engine just overhauled. Jay Whitbeck, Kinderhook, N. Y.

FOR SALE—Thomas Auto-Bi. with tri-car attachment, also 2-hp. motorcycle engine; will trade same for second-hand electric auto. Warren J. Baumann, Lock Haven, Pa.

WE PAY CASH for second-hand motorcycles. Send description and lowest price. Harry H. Geer Co., 888 McLaren Ave., St. Louis, Mo.

BUSINESS OPPORTUNITIES.

DON'T SLAVE FOR OTHERS. Reap the benefits for yourself. Fortunes made operating automatic penny weighing machines. Our scale speaks your weight. Write for Talking Scale circular. The United Vending Machine Co., 629 Caxton Bldg., Cleveland, O.

THEY WORK WHILE YOU SLEEP. Talking Scales. "They Speak Your Weight." The invention of the century. Fortunes have been made operating automatic weighing machines. Write to-day. United Vending Machine Co., 629 Caxton Bldg., Cleveland, Ohio.

LEARN MORE AND EARN MORE. We teach Law, Engineering, Oratory, Advertising, Business Correspondence, Short-Story Writing and 150 others. Best school on earth. Small cost. Easy payments. Ask for catalog 10 and name course wanted. Intercontinental University, Washington, D. C.

WE WILL double \$30.00 for you in 90 days and pay 20 per cent royalty for five years. Particulars for stamp. The Marzian and Gutterman Co., Co-operative Music Publishers, Louisville, Ky.

SEND FOR BOOK containing full instructions how to Silver Mirrors, Paint Portraits on Glass, Grow Mushrooms, and Eight more Arts and Secrets, all for 25c. Address "Manager," 660 W. Jefferson St., Springfield, Ohio.

START a mail order business; we furnish everything necessary; only few dollars required; new plan, success certain; costs nothing to investigate. Milburn-Bicks, 809 Pontiac Bldg., 358 Dearborn St., Chicago.

\$3,000 TO \$10,000 YEARLY easily made in real estate business; no capital required; we will teach you the business by mail, appoint you special representative of leading real estate company, list with you readily salable properties, co-operate with and assist you to permanent success; valuable book free. Address The Cross Company, 1986 Reaper Block, Chicago. See display ad of this firm on page 131.

OPEN A MIRROR FACTORY IN YOUR TOWN, or travel and do the work, and make from \$5 to \$25 daily. WE TEACH and trust you. 10c brings 32-page booklet and full particulars; none without; no time for idlers. Hullinger's Mirror School, Francesville, Ind.

BUSINESS CARDS.

EVERY ENGINE works better when packed with "Eureka Packing." Your dealer will furnish it.

GEO. W. RICHARDSON, CONSULTING ENGINEER, 819 Chamber Commerce Bldg., Chicago—Machinery inspected and purchased for parties in and out of the city. Patents secured, expert information furnished, engine indicated, valves set, complete reports made on steam, electric lighting and power plants.

PATENTS FOR SALE

MODELS made for inventors; low prices. Howard Merryman, Towson, Maryland.

PATENT FOR SALE—Trace holder, just what the buggy trade wants. Can be manufactured for 1c per pair and retailed for 10c. Send for circular and price. L. M. Campau, Callaway, Neb.

FOR SALE—Canadian patent just issued. Address W. C. Vernon, 30 S. Eureka Ave., Columbus, Ohio.

FOR SALE—U. S. and Canadian Patents, applied for, cash receipt holder and pocket cash register for all collectors, canvassers, railway conductors, insurance collectors, restaurant waiters, to be used in all branches of commerce. Address L. J. T. Decary, Architect, 229 Centre St., Montreal, Canada.

DON'T LET patent agents swindle you. Sell invention yourself and save big commissions and fees. Complete course of instruction by mail, \$5. A. J. Matter, 518 Commonwealth Bldg., Portland, Ore.

PATENTS—The Popular Mechanics Patent Bureau renders efficient service. Following letter is dated May 25, 1907:

Dear Sirs: Please allow me to acknowledge the receipt of yours of the 13th, the official notice of the allowance of my application for patent on Paper Clips. I wish to say I am highly gratified with the efficient manner in which you have attended to my interest in this matter, and that the drawings and specifications were far ahead of my expectations, and that if I ever have any other work, I wish you to do it. I beg to remain, respectfully yours, John H. Atter, 439 Main St., Connemat, O.

Write for free booklet, "What to Invent." Address Popular Mechanics Patent Bureau, 160 Washington St., Chicago.

PATENTS—H. W. T. Jenner, patent attorney and mechanical expert, 608 F Street, Washington, D. C.; established 1883. I make free examination and report if patent can be had and exactly how much it will cost. Send for circular.

MACHINERY FOR SALE.

A.—36x36x12-ft. PLANER; 20-in. x 10-ft. lathe, with power cross-feed; 42-in. segment resaw, swing saw punch and shears; Lincoln Miller 25-hp. gas engine, 6-ton foundry crane; portable drill; 31-in. Dresser radial drill. C. H. Norton, 228 Broadway, New York City.

FOR SALE—Patterns of a 1½-hp. bicycle engine; ½-in. generator valve; ½-in. spark plug; Mesinger motor saddle, handle bar, 8th Marsh. R. A. Cribfield, 225 Third St., Lincoln, Ill.

FOR SALE—1½-hp. marine engine. Price, \$30. Apply A. E. Bruddebeck, 124 Carpenter St., Reading, Pa.

CORLISS engines and others, large and small, low prices and warranted. 111 Haverhill St., Boston, Mass.

FOR SALE—Two-horsepower steam engine and boiler, \$25. Maurice Goodwin, 1205 E. Leafand, Decatur, Ill.

MARINE ENGINE, 2-hp., with all boat and electrical fittings, \$27. Address 128, care Popular Mechanics.

PUMPS! Of Every Description—Suitable for Home and Factory use. Illustrated Catalogue Free. H. E. Trotman, 107 N. Third St., Philadelphia, Pa.

FOR SALE—Engine lathe, swings 9½ in., takes 25 in. between centers. Complete with full set change gears to cut all size threads, 3 to 40 in.; price only \$43.50. Address L. F. Grammes & Sons, Allentown, Pa.

RIFE AUTOMATIC HYDRAULIC RAM, pumps water by water-power—no attention—no expense—2 feet fall elevates water 50 feet, etc. Guaranteed. Catalogue FREE. RIFE RAM CO., 2191 Trinity Building, New York City.

FOR SALE—Complete sets of casting for opposed motors or 4-cylinder vertical, water or air-cooled. Comet Motor Works, 47-49 Canal St., Chicago, Ill.

FOR SALE—25 h. p. double cylinder vertical stationary two-cycle gasoline engine; very steady power. Low price. Termaat & Monahan Co., Oshkosh, Wis.

FOR SALE.

FOR SALE—Fully equipped power shop; new machinery, \$1,200. Address owner for particulars. M. H. Davis, Cowles, Neb.

FOR SALE or exchange, one 10-hp. gas engine, cost \$450; one 80-light 110-volt dynamo, cost \$200; one automobile running gear, cost \$300. American Publishing Co., Columbus, Ohio.

FOR SALE—\$35. Premo Film-pack Camera, 4x5, B. & L. automatic shutter, convertible Planatograph lens, almost new, \$27.50. Edward Huntsman, Palma Sola, Fla.

LATEST DIAGRAMS of Wireless Telegraph Circuits. Blueprints of 4 tuned transmitting circuits, 25c; 6 tuned receiving circuits, 35c; 4 wireless telephone circuits, 25c; complete set, 75c. W. C. Getz, 645 N. Fulton Ave., Baltimore, Md.

FOR SALE—One Oliver Typewriter No. 3, in good condition, \$37.50. Address L. T. Graham, Sunset, Ky.

FOR SALE—Several spark coils, 1½-in. x 1½-in. spark, \$7.50. Glen McWilliams, Decatur, Ill.

CASTINGS AND DRAWINGS for the twentieth century ½-1-hp. horizontal high speed side crank steam engine, \$7.50. Circular A. B. R. Wicks, Bridgeport, Conn.

FOR SALE—¾-hp. electric motor (in good running order) or will exchange for motorcycle engine in good shape. Address 131, care Popular Mechanics.

FOR SALE—One Rockford Air Brush complete, with foot pump and tank. Used on one picture. Address 132, care Popular Mechanics.

\$55 BUYS good Gas gasoline 3-hp. shop engine, including spark coil, carburetor, etc. \$20 buys upright steam boiler, 3-hp., with fittings. \$15 buys locomobile steam auto boiler, 14-in. \$60 buys new Cleveland sliding gear transmission with cone clutch. H. Graham Automobile Co., 691-695 Madison St., Chicago.

FOR SALE—An electrical jobbing business in city of 25,000 population, near Chicago; established 17 years. 129 care Popular Mechanics.

FOR SALE—Several locomobile steamers, running gears, complete less tires and body, consisting of front and rear frame, side bars, springs, side steering lever, differential gears and sprocket, 4-wire wheels, heavy spokes for 28x2½ tires, brake complete, ready for power, in A1 condition. Price \$20. R. Roth, 1423 North Ave., Bridgeport, Conn.

MACHINIST AND DRAFTSMAN'S TABLE, U. S. standard, steam, gas and water pipe tapping sizes. Five cents in stamps. E. E. Meyer, Allegheny, Pa.

FOR SALE at \$250, if taken at once, 24-hp. delivery truck, first-class order. Horton Model Works, Detroit, Mich.

FOR SALE—DAMPER REGULATOR. Patent No. 356507, issued 1907. Will sell cheap for cash. E. F. Miller, Box 45, Laverne, Ill.

THE ONLY RELAY on the market producing the most marvelous experiments in connection with any wireless telegraph outfit. Lights and extinguishes electric lights, starts and stops small motors, electric cars, takes photographs and shoots firecrackers by wireless regulation, etc., etc. Indispensable for entertainers and lecturers. Price \$5.00. A. E. Joeren, 446 Wells St., Chicago.

FOR SALE—2½-hp. 2-cycle air cooled motor castings and blueprints to build the only 2-cycle air cooled motor-cycle engine made giving satisfaction; castings and blueprint, \$15.00. Stine & Parks, Fremont, Ohio.

TOQUET double cylinder marine motors, 5 and 8 hp. Send for prices. E. C. Smith, 235 Penn St., Vallejo, Cal.

I AM SELLING blueprints of a simple, efficient electric soldering iron for 50 cents. Address Box 295, Minneapolis, Minn.

Please Mention Popular Mechanics

HOUDENE PUZZLE—"The Wonder of the Age." 12 cents prepaid. Percy K. Ewing, Decatur, Ill.

FOR SALE—Receipt for making waterproof self-shining shoe or leather polish, 25 cents. Gloss equals patent leather. No rubbing necessary. Sells for \$1 per bottle. Costs few cents to prepare. For 25 cents will also send receipt and full directions for making best smokeless powder. P. Casperson, Coeur d'Alene, Idaho.

ARMY AUCTION SALE BARGAINS. Large 200-page illustrated 1907 Catalogue mailed, 15c (stamps). Francis Bannerman, 501 Broadway, New York.

BAKERY—Finest little bakery, confectionery, ice cream parlor and fine soda fountain. Only one in town. Large candy trade in Bitter Root valley. \$1,400. Owner going on fruit ranch. W. Higman, Hamilton, Mont.

HERE IS A BARGAIN—A new Stereopticon, suitable for all kinds of projection work. Complete with condensers, objective, hand feed electric lamp, rheostat, switch, fuse block, projection microscope complete, 12-foot square muslin screen and 100 slides. Also a new analytical balance with set of gold plated weights. This balance cost \$50 and the weights \$12.50. In perfect condition. Will sell for \$42. Address F. M. Cockrell, Robinson, Ill.

FOR SALE—Good plumbing and heating business in a city of 46,000. Only shop in immediate vicinity. Great prospects. Address 124, care Popular Mechanics.

FOR SALE—Moving picture machine. Standard make, just new, at half price. Also Edison phonograph, way below cost. Address 126, care Popular Mechanics.

FOR SALE—Typewriters. Eleven Typewriters in perfect condition; prices reasonable. New Sun Typewriters cheap. Wm. E. Davis, Sioux City, Iowa.

FOR SALE—4x5 Century Camera. Excellent condition. Two double plate holders, \$7.50. L. Thompson, 75 Elkensburg St., South Haven, Mich.

FOR SALE—1-16 horse power steam power plants, the most powerful miniature power plants on earth for their size. These outfits are operated by automatic flash boiler, and will without question give better service and more power than any other power producer. They are absolutely safe, for though the highest pressures can be used, boiler explosions are impossible. No attention is required after starting, as water feed and pressure regulation is entirely automatic. They are well built and durable and the small boy can operate them himself without danger. We make both marine and horizontal engines, and furnish boiler with either gas or alcohol burner; when ordering please state which is wanted. Complete power plant piped upon base ready to run, \$10.50. Complete engine, either type, \$5.00. Boiler feed pump, etc., \$5.00. Castings and all material for either type engine, \$1.00. Working blueprints, 25c. O. N. Hansen, 183 Du Boise Ave., Elgin, Ill.

FOR SALE—Formulas for varnishes, fillers, liquid glue equal to Le Page's, luminous paint. Guaranteed genuine trade secrets; all for \$1. Separate formulas, 25c. G. F. Twidle, 470 Broad St., Bloomfield, N. J.

"FORMULAS" for recharging dry batteries and renewing old files, 15 cents each, or the two for 25 cents. Box 34, Sandusky, Ohio.

DESIGNING, DRAFTING and blue prints made from sketch or model; strength of material carefully considered in all designs. Aden Benner, So. Whitley, Ind.

KEYLESS DOOR LOCKS can be placed on any door instantly without tools; carry in the pocket; nickel-plated sample 25 cents; five for \$1.00, postage paid. Hoosier Novelty Co., Indianapolis, Indiana.

FOR SALE—Castings and blueprints for 1/2 and 3/4-hp. steam engine, single or double cylinders. James Bell, 137 Franklin Ave., Brooklyn, N. Y.

FOR SALE OR EXCHANGE.

FOR SALE OR EXCHANGE, 5-hp. stationary gasoline engine, front auto axle; 3-hp. marine engine, 10-in. rev. propeller, tubular auto frame, 3x32 G. & J. casing, 12-feed multiple oiler; 6-hp. heavy duty marine engine; 8-hp. opposed auto engine; 4-hp. single, both air cooled, 1253 N. Halsted St., Chicago, Ill.

EXCHANGE 5-hp. automobile engine with accessories for good screw-cutting lathe; also watchmakers' lathe for motorcycles; 10-hp. engine for sale cheap. Chas. Lapp, 144 South 20th St., Pittsburg, Pa.

CASH for your business or real estate—no matter where located, if you want to buy, sell or exchange any kind of business or property anywhere, at any price, address Frank P. Cleveland, 1308 Adams Express Building, Chicago, Ill.

FOR SALE OR EXCHANGE—Complete first-class bakery, including improved portable oven, extra good wagon, counter, showcase, etc., etc. Will sell cheap or exchange for good automobile. Address Herbert Barber, Ashland, Ky.

IF YOU have anything for sale or exchange we know who wants it and who has what you want. No commission to pay. Quick returns; new plan. Particulars free. United States Exchange Bureau, 11 N. Main St., Northville, N. Y.

FOR SALE OR EXCHANGE for runabout, new 20-ft. launch, 2 1/2-hp., speed 10 miles, upholstered. 127 care Popular Mechanics.

FOR SALE OR EXCHANGE—One running gear and body, one 2-cylinder motor, one Schebler carbureter, one double dash coil, one ball transmission, one equalizing gear and countershaft. Joseph Jackson, 2114 Main St., Anderson, Ind.

FOR SALE or Exchange—A \$200.00 pop corn stand at \$100.00 and a 1906 friction drive Orient, \$200.00. Want to trade for Ford auto. Merrill M. Mether, 615 Fowler St., Waterloo, Ia.

LAND FOR SALE.

OIL LANDS FOR SALE—Worth the money. Offer undeveloped leases and production, in the Glenn Pool and over the Mid-Continent Field. Chas. E. King, Tulsa, Okla. Box 576.

TEXAS FARM LANDS are booming. 160 acres of our North Texas lands at \$30 per acre will double in value in three years. Buy now. Illustrated booklet free. Address Texas Farm Land Co., 277 Dearborn St., Chicago, Ill. Agents wanted.

PLUMBERS' SUPPLIES.

SAVE YOU 25 to 50 per cent. Complete line up-to-date plumbing and steam goods at wholesale to the public. Get catalogue. John Hardin, 1/4 century at 4542 Cottage Grove Avenue, Chicago.

BLACKSMITHS.

FOR SALE—My entire blacksmith and wagon shop, with or without stock and tools; cheap, and a good stand. Box 62, Lockspring, Mo.

FOR SALE—Blacksmith shop, house, lot, tools and stock, in rich farming country. Cheap if taken at once. Reason, failing health. Address S. Risch, Appleton, Minn., Route No. 1.

BRAZE THAT AND SAVE \$\$. Cast Iron, Steel, Copper, Bandaws, Bronze or Brass with our New Process Compound, 80c per lb. By express, with guarantee. Cummings Compound Co., 364 Avery Ave., Detroit, Mich.

FOR SALE—Blacksmith shop, including gasoline engine, trip hammer, emery stand, power drill; a good business in a good farming country. Address Box 462, Burwell, Neb.

GOOD BLACKSMITHS are scarce and but few learning the trade. And the smith comes first of all professions or trades. The smith must make the tools first for all from the surgeon to the safe blower, by using Toy's Treatise on new steels explaining how to work them with 75 new methods for working all difficult jobs. Ten receipts for making your own compounds for welding different kinds of steel solid. Thermite welding fully explained; also two colored tool tempering charts; Chart A explains all annealing and hardening; Chart B explains both scientific and plain tempering to a standard. All the above for \$1.00. Valuable samples free. W. M. Toy, Sidney, Ohio.

WANTED

WANTED—Manufactured Patented Specialties to handle as selling agents. General Specialty Co., Syracuse, N. Y.

WANTED—Good patented or unpatented invention. A. J. Matter, Commonwealth Bldg., Portland, Ore.

WANTED—Inexpensive method for brass and gilt plating. H. M. Greener, Streator, Ill.

SECOND-HAND stationary gasoline engine, $\frac{1}{2}$ or $\frac{3}{4}$ hp. Le Roy H. Brown, 31 Rutland St., Dover, N. H.

WANTED—At once, 20,000 permanent monthly members for my monthly premium list. Fine, valuable premiums given free to all. Write for list and full particulars to Charles L. Lowe, P. O. Box 42, Howard, R. I.

WANTED—Small 12-light dynamo and engine, and boiler suitable for same. Second hand or new. Address A. B. Clark, Silsbee, Texas.

WE WANT for manufacturing, dies, stamping, spinning, casting, plating; have special facilities for manufacturing patent articles, special machinery, tools. Do metal work in all its branches. Let us develop your idea; get our estimate; if made in metal we make it. National Stamping & Elec. Works, 157-161 Jefferson St., Chicago.

WANTED—Patented specialties to handle as selling agents. General Specialty Co., Syracuse, N. Y.

AGENTS WANTED.

AGENTS make \$103.50 per month selling wonderful self-sharpening patented scissors and cutlery. V. E. Giebler sold 22 pairs in 3 hours, made \$13; you can do it. We show how. Free outfit. P. Thomas Mfg. Co., 162 F St., Dayton, Ohio.

\$100 PER MONTH SALARY—Paid weekly. Energetic man in each county to represent Hardware Dept. Established business. Expense money in advance. The Columbia House, H-7, Chicago.

BIG VALUE Premium Package. A little of everything; bonanza for agents; entertaining, amusing, delightful, instructive. Worth \$5, price 10c. A. B. Burnett, Knoxville, Iowa.

MACHINIST AND DRAUGHTSMAN'S table of standard, steam, gas and water pipes and tapping sizes, 10 cents per copy. Shop agents wanted everywhere. E. E. Meyer, Allegheny, Pa.

AGENTS Money Maker—Sell the "Eureka Door Knob Bell," patented. New, bronze metal, any one can put on. Write for agency and sample. F. B. Black Co., Kansas City, Mo.

AGENTS sell the only Pancake Griddle in world that bakes square cakes. Turns them. Bakes six each time. Canton Griddle Co., Canton, O.

MOTORCYCLE agents for the 1908 Marsh Metz; paying proposition. L. E. French, American Motor Company, Brockton, Mass.

AGENTS STOP PEDDLING—You can easily make \$10 a day dealing direct with merchants, selling our ready made advertising signs, gold and silver window letters, and changeable signs. Harry Ostrand & Co., St. Louis, Mo.

AGENTS—A new preparation, used in every house the year round, big seller, good profits, reorders assured, sample free. Barker Chemical Co., Auburn, Me.

AGENTS—Portraits, 35 cents; frames, 15 cents; sheet pictures, 1 cent; stereoscopes, 25 cents; views, 1 cent. 30 days' credit. Samples and catalog free. Consolidated Portrait Co., 172 W. Adams St., Chicago.

WANTED—Capable agents to handle new, high grade, up-to-date articles; lightning sellers in all homes, offices, stores, shops; \$3 to \$10 daily guaranteed. Promotion assured. P. Thomas Mfg. Co., 162 F St., Dayton, Ohio.

AGENTS, here is the chance of a lifetime. Something entirely new, household article, for ladies, that sells in every home. Agents are making over \$150.00 monthly. For agents' proposition address Dexter Supply Co., 334 Dearborn St., Chicago.

\$300 EVERY MONTH selling our wonderful Seven-piece Kitchen Set. Send for affidavit; \$12 daily profit; exclusive territory. Outfit Free. P. Thomas Mfg. Co., 162 F St., Dayton, Ohio.

GREAT BUSINESS OPPORTUNITY—Everybody wants to wear our pure Aluminum "Comfort" Sanitary Hose Supporters. Just patented. Hold up socks, sleeves, and drawers. Not affected by wear or perspiration. Lock to garment. Never slip on fat or slim. Does away with all harness, buckles, straps, cords and elastic. Regular price 25 cents. Sample pair prepaid 18 cent., or two pairs for 35 cents. Agents wanted everywhere. Thos. H. Devero Manufacturing Co., Monon Block, Chicago.

AGENTS make big money selling our new sign letters for office windows, store fronts and glass signs. Easily put on. Write to-day for a free sample and full particulars. Metallic Sign Letter Co., 77 No. Clark St., Chicago.

WANTED—Agents, machinists, toolmakers, draftsmen, attention! New and revised edition Saunders' "Hand Book of Practical Mechanics" now ready. Machinist says, "Can't get along without it." Best in the land. Shop kinks, secrets from notebooks, rules, formulas, most complete reference tables, tough problems figured by simple arithmetic. Valuable information condensed in pocket size. Price, postpaid, \$1.00, cloth; \$1.25, leather with flap. Agents make big profits. Send for list of books. E. H. Saunders, 216 Purchase St., Boston, Mass.

AGENTS—Portraits, 35 cents; frames, 15 cents; sheet pictures, 1 cent; stereoscopes, 25 cents; views, 1 cent. 30 days' credit. Samples and catalog free. Consolidated Portrait Co., 290, 172 W. Adams St., Chicago.

AGENTS CAN MAKE \$10 PER DAY selling our burnished gold and silver letters for office windows, store fronts and glass signs. Anyone can apply these letters by following directions sent with each order. Write for our 8-page Illustrated Circular. S. H. Parrish & Co., Clark and Adams Sts., Chicago.

BURGLAR PROOF—Greatest thing of the age; windows locked with 6-inch opening, put on in one minute; send for sample, 15c each. Agents wanted. Cannon Mfg. Co., 1522 Kenmore Ave., Chicago, Ill.

REPRESENTATIVE WANTED in every machine shop and factory to sell "Tat's Grit Soap." Big demand. Large profits. Increase your weekly income two to five dollars. Send ten cents for postage on full size can. State occupation. Tatlock Bros., Rochester, N. Y.

AGENTS. If you are an ambitious man and are anxious to increase your income without interfering with your regular work and would like to know of a means by which you can make a snug sum of money write us today and we will tell you how by return mail. Address Popular Mechanics, Desk C, Chicago, Ill.

SALESMEN WANTED—To place our fire extinguishers in residences and business houses in their locality. An easy proposition. No city license required. \$5.00 necessary for sample extinguisher. W. O. Tobias, Clinton, Mo.

MALE HELP WANTED

MEN, make money redilvering damaged mirrors; new process, never spots or clouds. For particulars and samples of work address C. S. Minter, Little Rock, Ark.

WANTED—1000 chauffeurs and repair men. Our demand for professional automobile engineers exceeds the supply; calls for men of intelligence and mechanical bent, commanding \$100 to \$150 monthly, upon graduation. Resident courses \$15 to \$50. Home correspondence courses in construction and repair, completed by practical road and shop work at any of our branches or affiliated schools, highly successful. Look this up. Auto Schools of America, 1677 Michigan Ave., Chicago.

WANTED—Competent saw flier, knife grinder and one who can keep in order hand re-saws. A permanent position to the right party. Address 125, care Popular Mechanics.

WANTED—Mechanics to sell our fine line of Calipers and Levels. Good pay. Address E. G. Smith Co., Columbia, Pa.

SALESMEN WANTED—Must be experienced selling power transmitting, mill and factory supplies. Salary and commission. Give age, experience and reference. L. F. Grammes & Sons, Allentown, Pa.

3,000 POSITIONS OPEN, sales, office and technical. Particulars free. Write, stating age, experience and location desired. Hapgood, 305 Broadway, N. Y., or 1010 Hartford Bldg., Chicago.

Please Mention Popular Mechanics

EDUCATIONAL AND INSTRUCTION.

"TO EVERY ACTION there is an equal Reaction." Our short course in Engineering Mathematics tells how this law affects your salary. The Mechanical Correspondence School, Box 455 Lockport, N. Y.

*DRAFTSMEN—New paper for you Jan. 1st, 25c four months' trial. Our plan will save you money. W. D. B., Box O, Cleveland, O.

FOR SALE—Course in Mechanical Drawing in International Correspondence Schools. Address 1563 Popular Mechanics.

I. C. S. Electric Lighting Course, fully paid, for best offer. 508 E. Bennett, Cripple Creek, Colo.

STUDY ELECTRICITY AT HOME—A complete electrical course at home, containing 30-page detail book, 220-page text-book, 200 experiments and over 100 pieces of apparatus. Price, complete, only \$5.60. Catalogue "PS" explains this and other remarkable offers. Thomas M. St. John, 848 Ninth Ave., New York.

ARE YOU MAKING less than \$25 or \$30 per week? Mechanical and Structural Drawing taught by experts. Send for circular. Low tuition, including Free Books, Drawing Instruments, etc. Columbia Correspondence School, Drexel Bldg., Philadelphia, Pa.

MONEY IN NOVELTIES—Our advertisers and readers are looking for good new novelties to put on the market. They have money for the right inventions in utility, amusement and advertising novelties. What have you got that's good? Reach this field through "The Novelty News," 171-5 Washington St., Chicago. Trial 3 months, 25 cents.

BOYD'S Syllable Shorthand, \$3.00, complete course, same as sells for \$20.00. Book Form, Learn in 30 days. C. A. Weller, Mitchell, S. D.

FOR SALE—I. C. S. Correspondence Course "Complete Steam Engineering." Cost \$100; a bargain at \$50. Will exchange for best offer. Elmer Calkins, Cross Village, Mich.

\$350.00 MONTHLY easily made fitting eyeglasses. Short, thorough course by mail. Easily learned. Diploma. Big demand for opticians. We start you. Free "Booklet 4" tells how. National Optical College, St. Louis.

LEARN THE HOT WATER HEATING BUSINESS AND WORK FOR YOURSELF—I teach you absolutely free of charge and enable you to make a good income while learning. Men handy with tools make big money. No expense. For full information write 10008, care Popular Mechanics.

BOOKS AND PERIODICALS.

ENCYCLOPEDIAS, 16 brand new volumes of "Encyclopedia Americana" at a bargain. W. M. Paige, Traverse City, Mich.

LET THE ENGINE do the work. Our new book tells how to convert your buggy or road wagon into a motor car, or your bike into a motorcycle, at moderate cost. Many mechanics build their own motor. Price per copy, postpaid, 25 cents in coin. Stanley Shaw, Galesburg, Kan.

BOYS, if you are interested in mechanics, electricity, etc., send 10c (silver) for a 6-months' trial subscription to "The International Youth," Dept. S., Chicago, Ill.

FOR SALE—I. C. S. bound volumes and drawing outfit of ornamental design course; 1 set (5 vol.) Cyclopaedia Applied Electricity; 1 set (2 vol.) Compendium of Drawing. Best offer. Address 94 Prospect St., Dover, N. J.

FREE—To every reader of this magazine, our large illustrated catalog. We can save you on your magazines and papers. All combinations. Lowest rates. B. R. Hopkins Subscription Agency, Rockland, R. I.

WANTED—Modern engineering library, twelve volumes; also cyclopaedia of architecture, ten volumes. Particulars, Address A. E. R. 130, care Popular Mechanics.

"CONSTRUCTION, Management and Care of Motor Cycles," a new booklet valuable to any rider, indispensable to the beginner, gives pointers to the prospective buyer that will save him dollars when selecting a Motor Cycle. Sent prepaid for 25c silver or stamps. Advance Sales Co., St. Paul, Minn.

GET A GOVERNMENT POSITION—Our book fully instructs how. Failure if studied impossible. Address Frank B. Pergande, Publisher, Whitefish Bay, Milwaukee, Wis.

IF IT'S PRINTED—MacDonald can supply it—Domestic and Foreign publications of every description—Plays—reading and recitation books—Dramatic Journals supplied by mail. "Catalogue P. M. sent free." Chas. MacDonald, 53 Washington St., Chicago, Ill.

ELECTRICIAN AND MECHANIC—Practical monthly magazine for electrical and mechanical students and workers. Publishes illustrated directions for constructing dynamos, motors, gasoline engines, wireless telegraphy, electroplating, electrical wiring, mechanical drawing, using tools, furniture construction, photography, all kinds of mechanical work. One dollar yearly; single copy with book catalogue, ten cents. P. M. Sampson Publishing Co., 6 Beacon St., Boston, Mass.

PICTURES AND POST CARDS.

25 SOUVENIR POST CARDS GIVEN with a 6 mos. subs. for 25c to largest and oldest 100-page monthly on Coins, Stamps, Post Cards, Curios, Minerals, Autographs, Photographs, Relics, etc. Phil. West Collectors World, Superior, Neb.

ENGINEERS ATTENTION. The greatest railroad post cards ever published. Beautiful views of the "Railroad Over the Sea" from Miami, Fla., to Key West, Fla., over the picturesque Florida Keys: Showing the work and construction on the most gigantic piece of engineering ever attempted. Thirty-two views in set, postpaid for \$1.00. Dept. A., C. B. Pennock, Miami, Fla.

ONE DOZEN PHOTO POST CARDS made from any photograph for 50 cents. Your photograph returned with order, postpaid. All work guaranteed. Enough said. Give us a trial. Photo Card Co., 395 W. 17th St., Chicago, Ill.

JOIN the American Co-operative Post Card Exchange, the only exchange in the world that makes money for members. Send 10 cents and receive ten beautiful post cards and full particulars. Wm. Hemingway, Dept. 10, Belvidere, N. J.

LAUNCH AND STEAMBOAT MACHINERY.

SAFE AND SURE, therefore NOT gasoline. Economical and long-lived, therefore STEAM. Nothing complicated or uncertain. Built to order to meet conditions. Catalogue free. Marine Iron Works, N. Halsted Station, Chicago.

CEMENT.

IF YOU WANT the best information on cement and concrete construction subscribe for Concrete, leading cement and concrete monthly. Sample copy, 10 cents. Concrete, 135 Newberry Bldg., Detroit, Mich.

MISCELLANEOUS.

WIRELESS TELEGRAPHY—Something new. Make your own instruments. Instructions, with blue prints, for making, sending and receiving apparatus sent on receipt of 25 cents (no stamps). Address 7503, care Popular Mechanics.

LOOK! LOOK! LOOK! Every reader should have a look of 499 easy ways to make money. Will be sent to any address, postage prepaid, for \$1. C. M. Abrahamson, 25 Temple St., Chicago, Ill.

ALL KINDS of Electrical Supplies, Apparatus and Novelties. Tell us what you want. We have it. Balch & Carrier, Salem, Mass.

MECHANICS—Make your own Gloves and Mittens. Send 10 cents for patterns. E. C. Moulton, East Bethany, N. Y.

LIGHT METAL SPECIALTIES of sheet steel and brass. Stamping, drawing and die-work. Prompt service. Send sample for estimate. George C. E. Kredel, manufacturer of metal goods, 80 Tracey Ave., Newark, N. J.

DRAWINGS BY MAIL. Send rough sketches for working drawings or patent office drawings. Special machinery designed. A. J. Matter, Commonwealth Bldg., Portland, Ore.

EVERY INTELLIGENT PERSON should investigate my system of Telepathy (thought transference) for experimental or for use in health or diseased conditions. Inclose 2c stamp. T. Adams, P. D., 396 W. Polk St., Chicago, Ill.

PRINTING. One hundred each fine bond letterheads and envelopes, prepaid, for 90c. Samples for a red stamp. The People's Press, Preston, Minn.

Please Mention Popular Mechanics

WANTED—Manufactured Patented Specialties to handle as Selling Agents. General Specialty Co., Syracuse, N. Y.

BY MY SYSTEM you can with two dry batteries light one or any number of gas lights by simply pushing a button. Instructions and blue print showing how it is made for 25 cents. C. Brierly, 162 Greenwood Ave., Detroit, Mich.

FORMULA. Coat your own plates or paper or tintypes. Information, 50c. Altz Photo Co., Box 939, Buffalo, N. Y.

I MAKE accurate mechanical drawings from rough sketches. Address 123, Popular Mechanics.

BUILD an 8-in. footpower screw cutting lathe in your spare time. Complete blueprints, \$1; worth \$5. W. E. Morey, 2563 Frink St., Chicago.

WIRELESS TELEGRAPH RECEIVERS make an ideal Christmas gift. Instruments are very sensitive. Works 6 miles with $\frac{1}{2}$ -in. spark and no aerial. Imperial receiver consists of telephone receiver, cord, battery and Imperial detector. Postpaid, \$2.50. Imperial detector alone, \$1. Prompt shipments. Send stamp for circulars. International Wireless Co., Lima, Ohio.

THE RUPRECHT CORRECTOR will charge your storage battery from an alternating current. Simplex corrector for charging one to four cells at a time at 3 ampere rate. Complete with instructions for setting up and operating. Price, \$7.50 with order. Correctors for electric auto charging and operating motors, etc. Send for booklet. Ruprecht Electrical Co., 7117 Cedar, Cleveland, Ohio.

COMPLETE X-RAY and High Frequency Outfits: Ten-inch spark coil with variable inductance, electrolytic interrupter and rheostat. Compound high frequency coil, giving three different currents. Fine tube, tube stand and fluoroscope, a complete set of vacuum electrodes. All complete in Mission style oak cabinet. Price, \$200. Ruprecht Electrical Co., 7117 Cedar, Cleveland, Ohio.

WIRELESS TELEGRAPH APPARATUS: New detector for use with telephone receiver. No battery needed. Detector alone, \$1. With telephone receiver and connected ready for use, \$2.25. Coils, condensers and complete sending outfits, \$5 to \$20. Ruprecht Electrical Co., 7117 Cedar, Cleveland, Ohio.

AN AIRSHIP FLIGHT is the most popular and drawing attraction for any fair or outdoor event. Cromwell Dixon, 15 years of age, who flew 8 miles at St. Louis in October, 1907, is building a much larger ship for the season of 1908. For particulars and open dates address Mrs. Dixon, 221 West Eleventh Ave., Columbus, Ohio.

ETCHING ENGRAVING on glass or steel, complete instructions, 25c silver, each; both for 40c. Make big money. A. Bieling, 87 W. Main, Battle Creek, Mich.

TOO LATE TO CLASSIFY

GET YOUR GAS and electric fixtures at wholesale prices, and save big money. Put them up yourself and save more money—it's easy. Or get your local gas fitter or electrician to put them up for you, and still save good money. Write for our catalogue sheets and see. State whether you want gas only, or combination gas and electric fixtures. Western Chandelier Co., Mail Order Department, 19 West Lake St., Chicago.

STEEL GASOLINE BURNERS (New), 14-in. and 16-in., \$5 each. Send for list No. 8. J. L. Lucas, No. 2 Fox St., Bridgeport, Conn.

ABOUT 7,000 assorted handles, hammer, hatchet, sledge, etc. What have you to trade. Frank M. Arnold, Grand Rapids, Ohio.

LAUGHING CAMERA makes everybody laugh. Price, 25c. Experience of a pretty typewriter girl in Chicago, 25c (fine). Send for catalogue. Peerless Trick & Novelty Co., 3148 State St., Chicago.

FIFTEEN DOLLARS WEEKLY easily earned during spare time. Pleasant work; no canvassing; particulars free. P. M. Duboc, Oskaloosa, Iowa.

MEN, make your own Malt Liqueurs. Particulars free. G. Hampton, Pittstown, N. J.

A BIG BARGAIN for \$25. Write quick. Will raise to \$30 next issue. Bert H. Leavitt, Cloverdale, Sonoma Co., Cal.

WE BUY, sell or exchange good homes anywhere. Write us if you want to move. We can suit you. C. J. Samuelson, 611 Penn St., Kansas City, Mo.

AT A BARGAIN: One each, Regina Concerta, Regina Orchestral; both automatic; in first-class order. Haynes Bros., Newark, Ohio.

GRIDDLE CAKES baked on your breakfast table. Only way to have them hot and wholesome. Great convenience. No smoke nor odor with Alcoloric Griddle. Alcohol is cheap now. The device complete, neatly nickel-plated, \$3.50, express paid, or send for booklet. Alcoloric Utensil Co., Isabella Bldg., Chicago.

3000 GUMMED LABELS, \$1, two colors; samples mailed free. Archway Book Store, Philadelphia.

\$500 YEARLY PROFIT from 12 hens. Our book mailed for 50c shows how it can be done by man, woman or child. Circulars and testimonials mailed free. Archway Book Store, Philadelphia.

MODEL AIRSHIPS, 50 cents. Complete set of blueprints and directions for making inexpensive and easily-made model airship. This little machine offers a splendid opportunity for studying the fascinating problem of aerial navigation. Of profound interest to the master mechanic as well as the amateur experimenter. P. Ganz, Box 951, Billings, Mont.

I MAKE drawings and blue prints. D. Tappan, Watervliet, N. Y.

CIGAR BANDS—Imported direct from Europe; entirely different from American bands; 3,000 kinds, all new, stamped with real gold, beautifully colored. Samples, 10 cents, or 40 cents per 100 (no duplicates), postpaid, including illustrated catalogue on professional plate making. Order quick. National Selling Co., Allentown, Pa.

MODEL AIRSHIPS—Complete set of blue prints and directions for making inexpensive and easily made model airship. This little machine offers a splendid opportunity for studying the fascinating problem of aerial navigation. Of profound interest to the master mechanic, as well as the amateur experimenter. Price, 50 cents. P. Ganz, Box 951, Billings, Mont.

When You Want Anything and Don't Know Where to Find It, Write Popular Mechanics.



FREE

**This \$13.85
DRAWING
OUTFIT**

See offer, page 123 of
Successful Draftsmen

MAKE STEAM with Kerosene

5 POINTS which make a Perfect Steam Power Unit

POWER—Always there.

ECONOMY—Kerosene, costs less than coal, no smoke, no ashes, no odor, one cent per horse power hour.

SAFETY—Any boy can run it.

DURABILITY—Practically indestructible, with ordinary care.

ADAPTABILITY—Anything a small power plant can be used for, Mines, Irrigation, Small Shops and Electric Light Plants, Factories and especially places where space is an object or fuel an important item. Light and easily transported. No stack required.

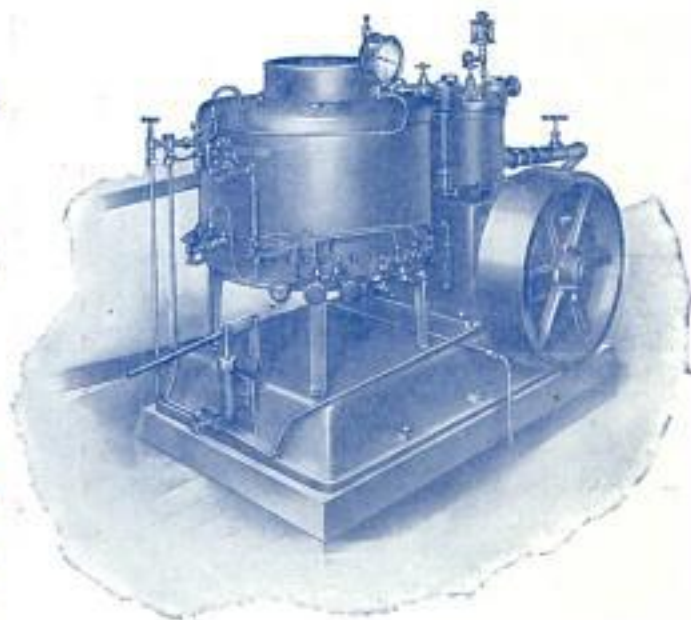

These points place the **BARTON FLASH BOILER SYSTEM** in the front rank
10, 15 and 20 H. P. Outfits

BARTON BOILER CO., 2427 CALUMET AVE.
CHICAGO, ILL.



Earn Big Money By Being a Mechano-Therapy Doctor We Teach You By Mail

In six months you can be making big money. You don't even need to leave home to make your fortune in this elevating and highly paid profession for men and women. We teach you Mechano-Therapy in all its branches by mail. Only an ordinary education is required. We issue authorized diplomas to graduates and help them establish themselves in this dignified and money-making profession. The study is intensely interesting. We take you step by step through the course until you are master of every detail. There is no chance for failure and the practice of Mechano-Therapy gives you a standing in your community that few attain. More comprehensive than Osteopathy.

Big Demand for Doctors of Mechano-Therapy

The most prominent business men and physicians endorse this form of treatment. It consists of Manual Manipulation, Swedish Movements, Vibration, Hydro-Therapy, Dietetics, Schott's Method, Ling's

System, and Suggestive Therapeutics. Treatments by Mechano-Therapy are pleasant and easy to give. You have no idea of the wonderful results produced by a Mechano-Therapist.

Special Rates Now Be the first doctor of Mechano-Therapy in your community and secure all the profits.

Write to-day—now, for our new prospectus telling all about our course and Mechano-Therapy—all there is to know. There is a fortune in it for you. A postal will do.

American College of Mechano-Therapy,
120-122 Randolph Street, (Chartered) Chicago, Illinois

Send this coupon by mail today.

AMERICAN COLLEGE OF
MECHANO-THERAPY
Dept. P. M.
120-122 Randolph St., Chicago.

Gentlemen:—Without obligation on my part, please send me your 56-page book on Mechano-Therapy.

Name

Address

"MESCO" BUY THIS Electric Engine For Your Boy



"As the twig is bent So is the tree inclined." A practical toy, instructive, interesting—absolutely safe. Similar in appearance and action to a steam engine. Runs toys, etc., on one or two Red Seal Dry Batteries. Controlling lever governs speed and direction of drive. Current consumption nominal. Price \$1. (Postage extra, 10c.)

Miniature Decorative Lamp Outfits, operated by Electric Light Current or Dry Batteries. Complete, ready to put up—4 to 52 lamps. Prices \$5.00 and up. Ask for Circular X.

"Mesco" Dry Battery, 2 1/2 x 6, for door bells and telephones.....	80.15
"Red Seal" Dry Battery, 2 1/2 x 6, "Best by Test" for ignition.....	1.25
Electric Call Bell Outfit, complete with instructions to put up.....	.60
Mesco Current Tap with 10 feet Lamp Cord.....	.75
Gen Motor, runs on one battery, postpaid.....	.90
Learner's Telegraph Instrument, postpaid.....	1.45
"A-4-Do" Medical Apparatus.....	1.00
"40-feet" Line Telephone, with instructions to put up.....	2.50
Electrician's Pocket Tool Kit.....	2.50
No. 4 Home Medical Apparatus.....	1.50

To Be a Successful Electrician

you need good material and tools. Place a trial order with us. We can please you.

Visit us at the Chicago Electrical Show, January 13-25, 1908.

If you cannot get "Mesco-Made" goods from your local dealer, buy direct from manufacturers' complete stock. Send for Catalog 22 P. J. Address nearest house.

Manhattan Electrical Supply Co.

188 5th Ave., Chicago
17 Park Place, New York

Largest Exclusive Manufacturers of Electrical Supplies in America



1908 SENSATION - ORDER QUICK

A Real Safety Razor. No Toy

OUR GUARANTEE SATISFACTION OR YOUR MONEY BACK

"SHRP SHAVER"

Price 13 2-c Stamps

Or 25c In Cash



Positively Can't Cut Yourself.

Two Parts Frame and Blade

100,000 Now in Use

QUICK ADJUSTMENTS AND EASY SHAVER

Price is good for 30 Days. Order one and you will sell 100 to your friends. It is beautifully finished and put in neat box.

Remember, Money Back if you Want it

It is worth its Weight in Gold

SHRP SHAVER CO., Inc. 71 Wall Street
New York City, U. S. A.

References: Carnegie Trust Co., New York, and Two Banks

Utica Round Nose Burner Plier

A handy tool in the home, in the office, in the study when on a hunting or fishing trip. Convenient to carry in the pocket. You cannot fully realize its value until you have used it, then you will not part with it.

Have you stopped to think what an acceptable CHRISTMAS gift it would make? You have not a friend but what would be highly pleased with such a present.

If your dealer has not got them we will send it to any address in the U. S. on receipt of price.

Regular Finish Black Handles, Polished Head, 70c Each

Full Nickel Plated \$1.00 Each

Every Tool Guaranteed



UTICA TOOLS

Are Unequaled in QUALITY, DESIGN and FINISH

Take no Substitute

If your dealer has not got them write us.

EVERY TOOL GUARANTEED

Only the Utica bear this Mark



TRADE MARK
Reg. U. S. Pat. Office

WRITE FOR COMPLETE CATALOG

Utica Drop Forge & Tool Co.

73 Genesee St., UTICA, N. Y.

HOW TO RUN AN AUTO

Are you interested in Automobiles?

If you are, an early purchase of "HOMAN'S SELF PROPELLED VEHICLES" will prove a good investment.

This work is how the accepted standard on the practical care and management of motor cars—explaining the principals of construction and operation in a clear and helpful way, and fully illustrated with many diagrams and drawings.

The presentation of subjects has been determined by consideration of the needs of the man behind the wheel. It is clear and concise in its treatment, and comprehensible to the most inexperienced automobilist, at the same time it is so thorough that the expert will learn much from its pages.

Contains 608 pages, over 400 diagrams and illustrations, printed on fine paper, size 5 1/2 x 8 1/2 inches, with generously good binding. Highly endorsed.



This good book will be sent to any address in the world, postpaid, upon receipt of two dollars, or if desired, will be sent on approval to be paid for after examination.

No money in advance required, sign and return to:
Audel & Co., 635 E. 113th Ave., New York
Kindly mail me copy "Homan's Auto" and if found suitable I will immediately remit the return book to you.
Name.....
Address.....
Date.....