

LARGEST CIRCULATION OF ANY MECHANICAL PUBLICATION IN THE WORLD

135 Articles

111 Illustrations

SEPTEMBER, 1905

VOL. VII. NO. 9

Price
10 cts.

POPULAR MECHANICS

WRITTEN SO YOU CAN UNDERSTAND IT

MAKE A CAMERA FOR 50 CENTS

THE FIRST SUBMARINE 100 YEARS AGO

RAISING SUNKEN SUBMARINES

MICROSCOPE DETECTS FORGERIES

QUICK-FIRING FIELD GUNS

TELEGRAPHING PHOTOGRAPHS

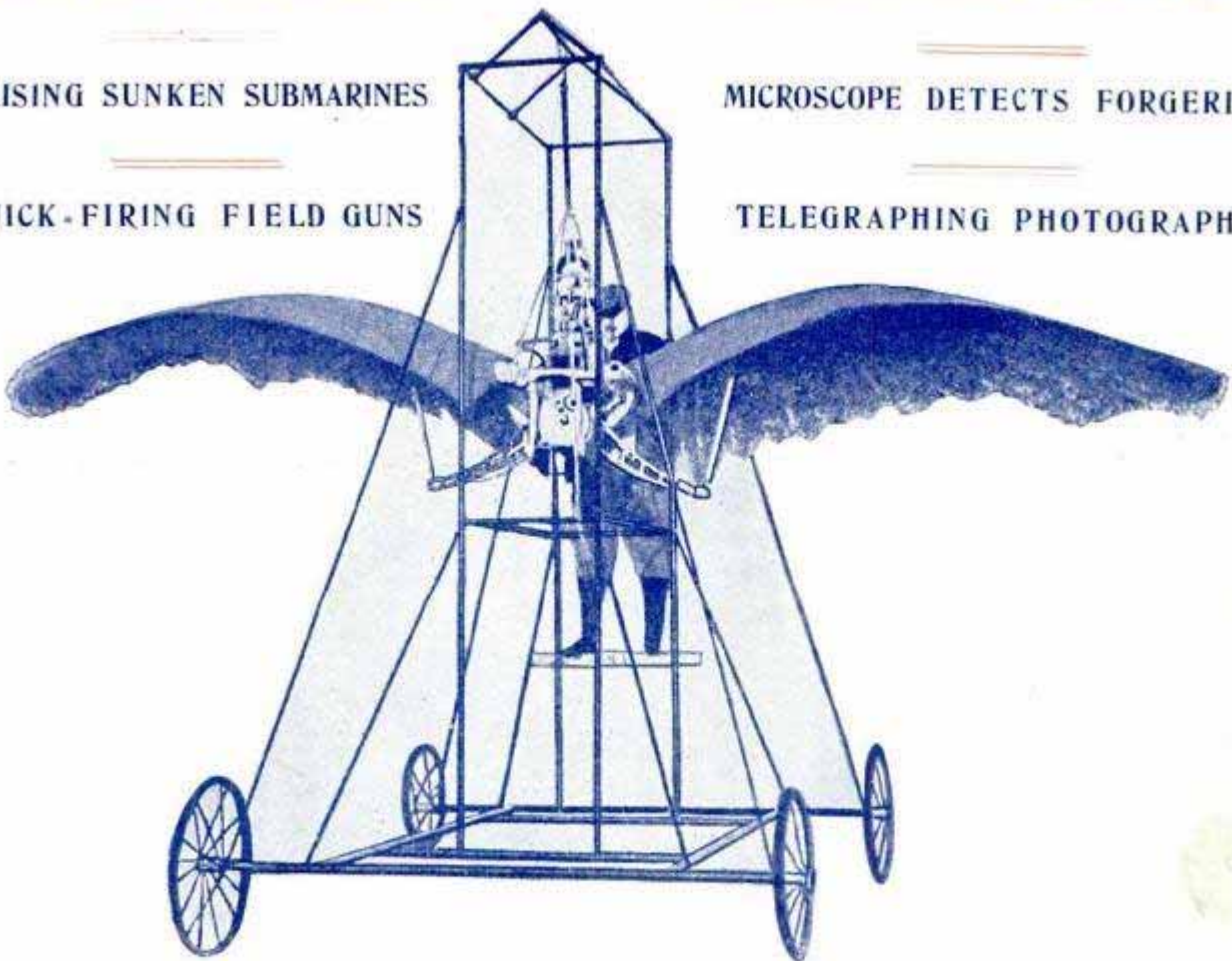

REMARKABLE EXPERIMENTS IN ENGLAND WITH ARTIFICIAL WINGS

Machinery and Supplies from the St. Louis World's Fair

The Chicago House Wrecking Company bought the complete LOUISIANA PURCHASE EXPOSITION, which cost over Fifty Million Dollars to construct. Here is an opportunity for you to purchase supplies of every kind at extremely low prices.

We are the largest Machinery Dealers on earth. Our plant covers 25 acres, and we are in a position at all times to supply anything needed in the Machinery or General Supply line.

<p>ELECTRICAL APPARATUS A Million Dollars' worth of material, good as new. Rubber Covered Wire in sizes from No. 14 to 500,000 C. M. Weatherproof Wire, sizes No. 14 to No. 2-0. Slow Burning Weatherproof Wire, 16 to 600,000 C. M. Lead Covered Cables, all voltages and sizes. 100,000 used Incandescent Lamps, practical for further service, each 5 cts. 200,000 new Incandescent Lamps, 104 Voltage, 8 candle power in natural colors, Amber, Green, Opal and Ruby. 200,000 No. 9171 Receptacles. Weatherproof Sockets, Knobs, Cleats and thousands of other items. Write for our complete list.</p>	<p>MOTORS 50 Motors, ranging from 1/2 to 45 H. P. These Motors were used only during the Exposition and are practically new; Voltages 110 to 500. PIPE 10,000,000 feet of Standard Black and Galvanized Wrought Iron Pipe; also Hydraulic Pipe, extra heavy pipe, steel riveted pipe, spiral riveted pipe, converse joint pipe, cast iron pipe, tile pipe and pipe of every kind. VALVES AND FITTINGS Thousands of them for sale, good as new. Also fittings of every kind. BOLTS, RODS, LAG SCREWS ETC. 1,000 tons Bolts, Rods, Lag Screws, Turnbuckles and Washers. 150 Track and Lever Jacks.</p>	<p>LUMBER AND BUILDING MATERIAL 100,000,000 feet of highly seasoned Lumber from the Exposition. Also Sash, Doors, and Building Material of every kind. Send us your bills for our estimate. We will save you big money. CONTRACTORS' SUPPLIES 4,000 Steel Shovels. 500 Steel Picks. 600 Mattocks, Lanterns, Axes, etc. 500 Wheelbarrows. Thousands of other items: Furniture and Office Equipment, Household Goods, Settees, Fire Extinguishers, Tanks, Safes, Flags and Flag Poles, Roofing Material, and in fact anything manufactured.</p>
---	--	---

WRITE FOR OUR SPECIAL CATALOGUE NO. 539

CHICAGO HOUSE WRECKING CO., West 35th and Iron Sts., Chicago

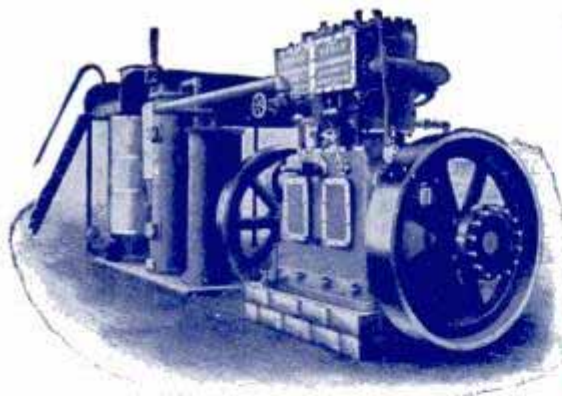

WEBER GAS POWER

Would you be interested if we could prove to you that our **Suction Gas Producer** and **Producer Gas Engine** would pay first cost in the saving in less than one year?

COMPLETE PRODUCER PLANT

1 Pound
H. P.
Hour

Charcoal.
Anthracite
Pea Coal,
Coke,
Lignite

Read the names of Wise Power Users (partial list only) using Gas Producer Power Plants, and saving \$

Write to
all of
them

- Brooks Elevator Co., Minneapolis, Minn., 125 H. P.
- Hermosillo Electric Light Co., Hermosillo, Mex., 225 H. P.
- Pierce Electric Light Co., Pierce, Neb., 60 H. P.
- Regent Shoe Co., Omaha, Neb., 50 H. P.
- Purdy Roller Mills, Purdy, Mo., 50 H. P.
- Gilliam Electric Light Co., Gilliam, Mo., 50 H. P.
- Hunkins-Willis Lime & Cement Co., St. Louis, Mo., 60 H. P.
- Lustre Mining Co., El Oro, Mex., two 100 H. P.
- Pablo Gaudin, Parral, Mex., 125 H. P.
- C. E. Hertline, New York, N. Y., 125 H. P.
- The Gamer Co., Ft. Worth, Texas, 60 H. P.
- Archbishop's Palace, Oaxaca, Mex., 16 H. P.
- Sonora Mining & Development Co., Nacozari, Mex., 30 H. P.
- Caesar Marburg, Hermosillo, Mex., 16 H. P.

7 H. P. up--Suitable for all Power Purposes

WEBER GAS AND GASOLINE ENGINE COMPANY
BOX 358, KANSAS CITY, MO.

Please mention Popular Mechanics when writing Advertisers.

SEPTEMBER, 1905.

Popular Mechanics

100 WASHINGTON STREET

JOURNAL BUILDING, CHICAGO, U. S. A.

H. H. WINDSOR.....EDITOR

SUBSCRIPTION. \$1.00 PER YEAR

MAILED POSTAGE FULLY PREPAID TO ANY ADDRESS IN THE WORLD

All subscriptions are discontinued at expiration Please examine the date printed on your wrapper

Published Monthly by POPULAR MECHANICS COMPANY Entered as mail matter of the second class at the postoffice at Chicago, Ill.

Eastern Advertising Office: 116 Nassau St., New York

CONTENTS.

RUSSIAN BATTLESHIP "OREL"	902
Finest Gunpowder Plant is in Japan.....	904
Steel Street Cars.....	904
TELEGRAPHING PHOTOGRAPHS	904
Ocean Turbines Declared Too Slow.....	906
MOSLEMS SACRIFICE EYES AT PROPHETS' TOMB	906
Germany to Sell Pneumatic Tools Here.....	907
World's Largest Steam Turbine.....	907
Edison Storage Battery Again Perfected.....	907
DETECTING FORGERIES BY THE MICROSCOPE	907
How Auto Scorchers are Caught.....	908
THE MODERN QUICK-FIRING FIELD GUN	909
Hills to Stop Trains.....	911
FRENCH TANDEM COMPOUND SUBURBAN LOCOMOTIVE	911
Side Lights on Vessels.....	911
EXPERIMENTS WITH ARTIFICIAL WINGS	912
DEVICE TO RESCUE SUNKEN SUBMARINES	914
Learning to Run a Trolley Car.....	916
Portable Suction Gas Producer and Engine.....	916
Tunnels to Replace Snow Sheds.....	916
WIRELESS TELEGRAPHY IN THE AMERICAN NAVY	917
CURING OF CEMENT BLOCKS	918
Combined Locomotive and Car.....	918
Effect of Iron and Pneumatic Tires on Roadway.....	919
JAPANESE TEACHING RUSSIAN TO RUSSIANS	919
Sault Sainte Marie Canal.....	919
QUEER STREET CARS FOR AFRICA	920
Refrigeration for Office Buildings.....	920
Why Rails Fall in Service.....	921
BIGGEST AIR-SHIP EVER BUILT	921
HOW TO BUILD A MODEL YACHT	922
How Lions are Carried.....	924
New Sugar Beet Harvester.....	924
Great Lakes Shipyards Busy.....	924
THE FIRST SUBMARINE	925
Cleaning the Government Mint.....	925
JAPANESE BATTLESHIP "KATORI" LAUNCHED	926
Time-Recording Camera for Trapping Motorists.....	926
Food Depots on Desert Islands.....	926
THE HARNESSING OF HEAT. Part IV —The Steam Engine.....	927
Haul Railroad Train by Ropes.....	928
Instantaneous X-Ray Photographs.....	928
THE AMERICAN DIESEL ENGINE	929

Fire Alarm Box that Handcuffs Tricksters	932
Why Motor Buses Will Not Displace Street Cars.....	932
Tin Production in 1904	932
Paris Motor Bus.....	932
FATAL ACCIDENT WITH AEROPLANE	933
THE MANUFACTURE OF CEMENT POSTS	934
MECHANICS FOR YOUNG AMERICA— A Practical Camera for Fifty Cents.....	952
How to Make a Very Simple Steam Turbine.....	954
Power of Small Coils for Sending Wireless Messages.....	954
Ring a Bell by Touching a Gas Jet.....	955
THE BENNINGTON DISASTER	955
CHEMISTRY FOR MECHANICS—Part I	956
Portable Electric Conveyer.....	957

SHOP NOTES.

Cheap Paint for Rough Wall Signs.....	935
How to Fasten a Ring to a Rope.....	935
Piercing Punch of Piano Wire.....	935
How to Make Six-Sided Nuts.....	935
Emptying an Oil-Barrell.....	935
Pipe Clamp that Will Not Crush or Mar Pipe	936
Size for Plaster Wall.....	936
How to Estimate Weights of Wrought Iron and Other Metal Bars.....	936
A Hook Kink.....	936
Handy Burr Reamer.....	937
Dressing Oil or Whetstones.....	937
Advantages of Zinc Roofing.....	937
Convenient Center Gauge.....	937
Firing a Gas Engine with a Telephone Magnet.....	938
Solder for Aluminum.....	938
Use of the Compass in Locating Poles of a Generator.....	938
How to Make a Lead Hammer.....	938
Interchangeable Scriber Points for Prick Punches.....	939
Filling for Cracks in Floor.....	939
How to Make a Whistle for a Steam Plant.....	939
Steel-Blue Enamel for Any Metal.....	939
Tools and Devices for Bending Pipe.....	940
To Stop Humming of Telephone Wires.....	941
United States Standard Boiler Iron Thickness	941
Safe Bushing for a Wood Split Pulley.....	942
Hot Blast Stove for Skin-Drying Mold.....	942
Fence Posts Bottom Upwards.....	943
Linoleum Covers for Work Benches.....	943
Apparatus for Thawing Out Pumps.....	943
Air Whitewasher.....	944
Machine for Straightening Pipe and Shafting	944
Device for Bending Electric Conduit.....	945
Hints on Gue.....	945
Improving a Washer.....	945
A Good Flulg Paste.....	945
To Find Center of Shaft Without Center Punch.....	945
Improving the Clinograph.....	946
A Good Staple Puller.....	946
Strainer for Air Pump.....	946
Driving Stakes by Compressed Air.....	947
Crow Bridges for Drilling Holes in Difficult Places.....	947
How to Make a Spark Plug for a Small Gas Engine.....	947
Hot Water for Office Use.....	948
How to Revive Burnt Steel.....	948
Storing Range Boilers.....	948
To Apply Asbestos Neatly.....	948
Sharpening Digging Bars.....	949
Handy Belt Clamp.....	949
Springing Packing Rings Over Piston.....	949
Mixing Concrete.....	949
How to Make an Electric Illuminated Fountain.....	950
Installing Intercommunicating Telephones.....	951
Another Method of Reversing Countershaft Without Crossing Belt.....	951

FREE! To Those Accepting Our Proposition

**DRAUGHTSMEN! TOOL MAKERS! MACHINISTS!
ELECTRICIANS! PATTERN MAKERS! EVERYBODY!**

A New, Handy and Convenient Device for Taking Measurements is the

Wiet-Goethe Combination Gauge

Now Offered
for the
first time
to
those
Interested

Full Size

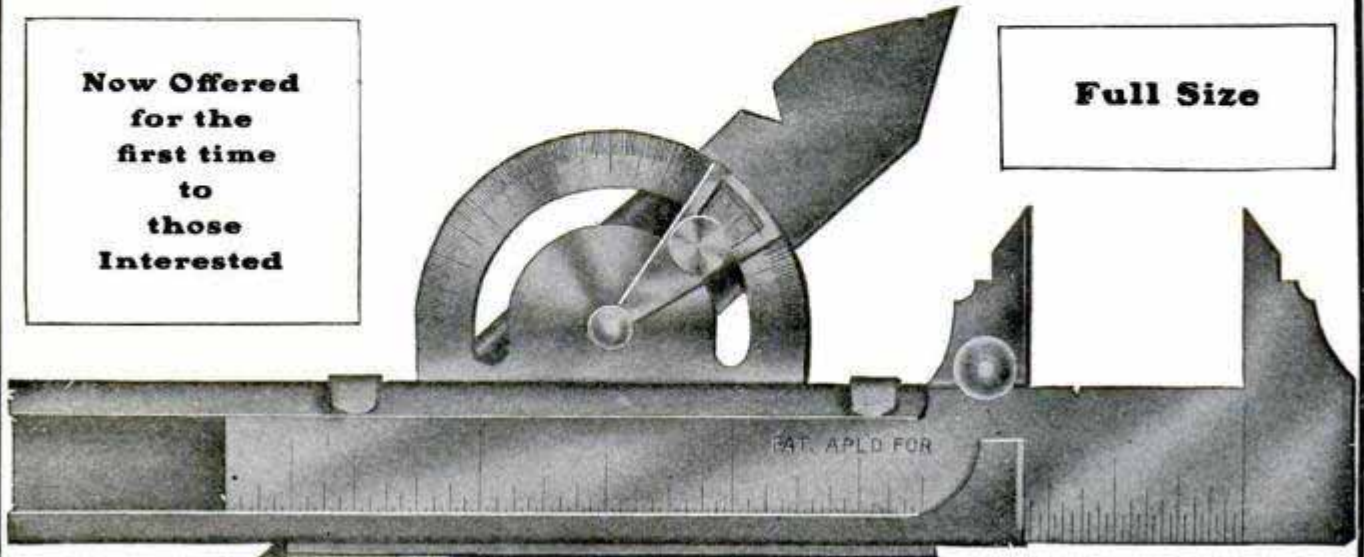

The Scale is graduated to 64ths of an inch.
The Protractor in degrees and numbered.

Did it ever occur to you when called upon to perform some mechanical work to be confronted by almost insurmountable difficulties because you did not have handy the right kind of a tool to take measurements?

Is it practical for any man to carry a cumbersome tool chest to take measurements?

Suppose you could carry in your vest pocket all in one instrument

An Outside Caliper An Inside Caliper A Divider A Straight Edge An Angle Edge
A Depth Gauge A Try Square A Center Square An Angle Protractor A Center Gauge
and many other combinations too numerous to mention, but understood and appreciated at once by all having to deal with any kind of measurements.

We now present a tool which will enable you to fill all these requirements and take all measurements, within its scope, accurately and quickly.

It is made of superior steel, carefully and thoroughly tested as to its accuracy.

It will be found to be a novel and valuable addition to the tool chest of any mechanic.

The practical men will find constant and novel uses for it under any and all circumstances.

It will enable one to solve all the different and difficult problems which arise in the shop or elsewhere.

It is so portable and convenient—being small enough for the pocket—that it can always be at hand.

The gauge is made by first-class mechanics and no expense is spared to insure accuracy. We commend it as a finished and perfect tool for the various uses to which it can be put.

The combination gauge is enclosed in a neat leatherette case with metal trimmings, so as to be conveniently carried in the pocket.

HERE IS A SPECIAL OFFER. READ IT.

We want to increase the Subscription List to our Monthly Journal

MODERN MACHINERY The foundation of civilization rests on inventions of new machinery. To keep abreast of mechanical progress should be the aim of every intelligent man. Our publication keeps you informed, and it is written so all can understand it, and the best illustrated of its class. **MODERN MACHINERY costs \$1.00 a year.** We want to get you started reading this paper regularly, and therefore make you this offer.

Send us your subscription, at once, enclosing \$1.00, and we will mail you **MODERN MACHINERY** every month for one year and a **WIET-GOETHE COMBINATION GAUGE FREE** at once. If not just as represented, send the gauge right back and we will refund your money. Don't delay accepting this proposition; write to-day. Remember, money back to-morrow if dissatisfied.

If you are at present a subscriber to **MODERN MACHINERY** you may take advantage of our offer, and we will extend your subscription one year ahead from present date of expiration.

Modern Machinery Publishing Co., Security Bldg., Chicago, Ill.

COUPON

MODERN MACHINERY PUBLISHING CO., 13 Security Building, Chicago

Date _____

Gentlemen:—Enclosed find \$1.00 for which please send me **MODERN MACHINERY** for one year, and also send me one **WIET-GOETHE COMBINATION GAUGE FREE** as advertised in your Journal. It is understood that if I am dissatisfied that I may return the gauge and my money will be refunded.

\$1.00

No. 108 WM. M. PRATT Automatic Drill

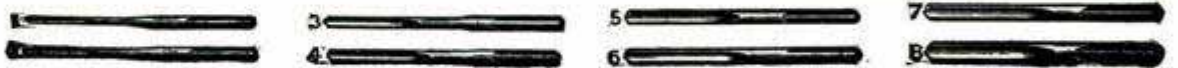

Never heard of it? That's funny. Then hadn't you better send for our new Catalogue No. 7 right away? That tells all about it.

No. 111 WM. M. PRATT Spiral Ratchet Screw Driver



But you've surely heard of that. Yet perhaps you haven't heard all.

That's another reason for sending for our new Catalogue. It tells of more new tools than you can shake a stick at--tools you ought to know about.

GOODSELL-PRATT CO., Greenfield, Mass., U. S. A.

This One



Spon's Mechanic's Own Book

Is the most useful and handy book ever published for anyone interested in mechanics or who likes to use tools, because it contains real practical information on almost every mechanical subject including

Mechanical Drawing
Mechanical Movements
Casting & Founding
Forging
Soldering
Turning & Turning Lathes

Carpentry
Log Huts, Building, Etc.
Cabinet-Making
Carving & Fretwork
Picture Frame Making

Painting
Staining
Polishing
Paper Hanging
Electric Bell & Bell Hanging

OVER 700 PAGES. 1420 ILLUSTRATIONS. PRICE CARRIAGE PAID \$2.50.

An 8-page circular giving full contents sent free on application.

SPON & CHAMBERLAIN, - 123 P. M., Liberty St., New York

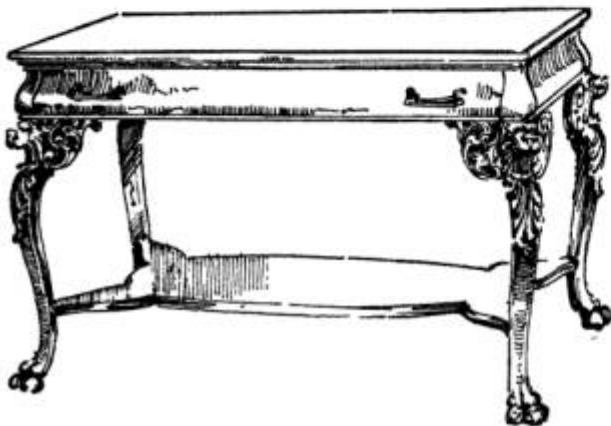

Learn Furniture Designing

DO you know that the Furniture business is one of the most rapidly growing trades in this country? Those who will enter this line now will have a splendid future before themselves. The public demands new ideas at all times, and there is a great field for practical and original people who may wish to become

Furniture Designers

We always have an opportunity to place our graduates in good paying positions. Some of them are now earning between \$1200.00 and \$2500.00 per year with plenty of chances for further advancement. Write for full particulars and testimonials.

COLLEGE OF FURNITURE DESIGNING
Porter Block, Dept. M, Grand Rapids, Mich.

Spangenberg's Steam and Electrical Engineering

Some of the Authors

This book is really a text-book of the St. Louis School of Engineering, the entire mechanical portion, except that pertaining to the locomotive, having been written by Prof. E. Spangenberg, C. E., the Superintendent of that institution, a graduate of the shop and work bench as well as of the University. Mr. Spangenberg has been eminently successful as a teacher, having enabled hundreds of men to pass satisfactory examinations for stationary and marine engineers' licenses.

Mr. E. W. Pratt, author of the portion on Locomotive Engineering, is master mechanic of one of the large railroads, and has made the locomotive his life-study.

Mr. Albert Uhl, A. I. E. E., Instructor in Practical Electrical Engineering at the St. Louis School of Engineering, is a successful electrical contractor who has risen from the ranks, having worked as dynamo tender and wireman's helper in his younger days.

695 Pages—648 Illustrations

Written so You can Understand It. A practical book for practical men. Intended especially for the use of Stationary, Steam and Locomotive Engineers and Firemen, Electrical Workers and others interested in Engineering. The work is written in the form of **1,035 QUESTIONS and ANSWERS** and gives a complete course in Engineering, Stationary and Locomotive, Compressed Air, Refrigeration, Gas and Gasoline Engines, Elevators, Repairs and Electrical Engineering.

When Ordering use Attached Coupon

Price \$3.50

\$3.50 is the price, and it is sold with the understanding that it may be returned if not satisfactory, and your money will be refunded immediately. Out of 10,000 books sold only one has been returned. This fact speaks for itself.

COUPON—CUT OUT AND MAIL TO-DAY

GEO. A. ZELLER BOOK CO., 7 So. 4th Street, St. Louis, Mo.

DEAR SIR: I accept your offer to send me express prepaid, one of Spangenberg's Steam and Electrical Engineering, a complete library in one volume: 695 pages, 648 illustrations, price \$3.50, and enclose \$2.00 as first payment. The balance, \$1.50. I agree to remit in 50 cent monthly installments, money or express order, or stamps.

NAME
Street or Box No. City and State

Please mention Popular Mechanics when writing Advertisers.

THIS WRENCH IS MADE OF 50-POINT OPEN HEARTH DROP FORGED CARBON STEEL, JAWS WILL TAKE 1-4 TO 3-4 INCH PIPE.

PATENTED IN UNITED STATES, CANADA, FRANCE, GERMANY AND GREAT BRITAIN. PATENTS PENDING



Bolts before and after using the Hawkeye . .

5 IN 1
NUT
WRENCH

PIPE WRENCH, THREAD CUTTERS.

Will Remove "Neverslip" and "Rowe" Calks

No. 200 Regular
No. 400 same as No. 200 only full Nickel Plated
The dies in wrench for English and foreign trade, furnished with Withworth style of thread, if wanted.

This wrench should be in the tool box of every mechanic. Will be mailed on receipt of \$1.00. Better order one today.

Best Wrench Made For Automobiles Has More Uses Than Any Wrench Made

Manufactured by **The Hawkeye Wrench Co., Marshalltown, Ia.**

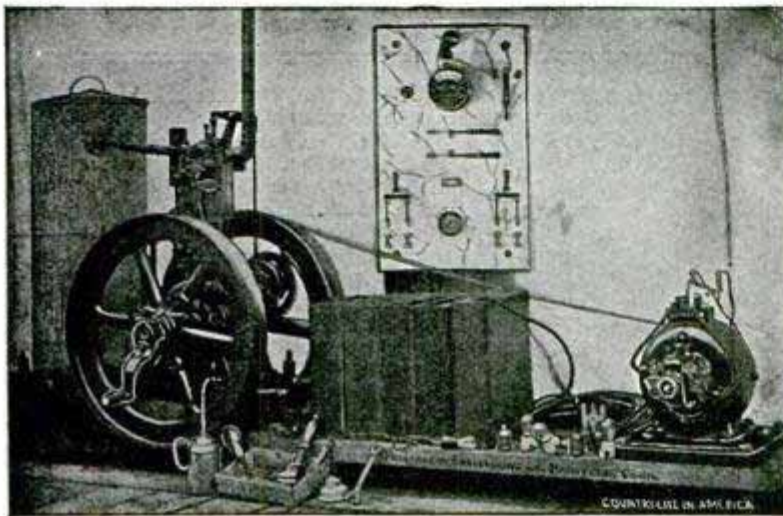

ELECTRIC LIGHT Outfits

STANDARD EQUIPMENTS FOR Residences, Yachts, Launches, Etc. Best Material, Thoroughly Practical, Over 130 in our 60-page catalogue.

Address ELECTRIC LIGHT DEPT., Richardson Engineering Co., HARTFORD, Conn.

If You Like "Pop." Why Not Send it to a Friend FOR ONE YEAR?

Cannot fail to please any man and will please him for twelve months

Fill in address and mail with One Dollar at our risk.

POPULAR MECHANICS, Journal Building, Chicago

Send your Magazine one year, commencing with the month of _____

NAME _____

STREET _____

CITY _____ STATE _____

and notify party named above that the subscription has been paid for, and is sent with the compliments of _____

Mechanical Engineering Technical

BOOKS

You can get any book published on Mechanics, Engineering, Electricity, Steam, Fuels, Metal or Woodworking, and all the Individual Trades and Professions, in fact any book on any subject, published in this country or Europe, that is obtainable, through the **Popular Mechanics Book Dept.**

In every case we prepay in full all mailing or express charges.

Any book desired can be earned by securing one or more subscribers to Popular Mechanics. State book wanted and we will advise you how many subscribers will secure it. This is a very easy way to get the best books.

ENGINEERING

GAS ENGINES, With Instructions for Care and Working of the Same. By G. Lieckfield; translated by Geo. Richmond. 120 pages; illustrated; 12mo.; cloth. Price, \$1. To which has been added full directions for the management of oil engines.

TRACTION ENGINE ITS USE AND ABUSE. By James H. Maggard. Small 12mo.; cloth; illustrated. Price, \$1. Revised and enlarged by an expert engineer. Deals in detail with the principles and parts of a traction engine; directions for starting an engine; use of gauge, try cocks, pumps, governor, slide valve, etc.; water supply; the boiler, its care and management; methods of a good fireman; the engine; handling a traction engine. The book is teeming with practical points and suggestions put in very simple language and very effective manner. It should be in the hands of every man who runs a traction engine. The farmer and creamery operator, especially, should not be without it.

HANDBOOK OF MODERN STEAM FIRE-ENGINES. (Roper's Engineers' Handy Book series.) Price, \$3.50. The only book of the kind ever published in this country. Contains descriptions and illustrations of all the best types of steam fire-engines, and fire pumps, injectors, pulsometers, inspirators, hydraulic rams, etc.; and treats more extensively of Hydraulics than any other book on the market.

SIMPLE PROCESS FOR ESTIMATING THE HORSE POWER OF STEAM ENGINES. By Edwin R. Keller, M. E. New edition. Price, 50c. Contains various methods of estimating and calculating the horse power of boilers and engines and ascertaining the power required to run line shafts, individual machines, etc., etc.

MODERN MACHINE SHOP TOOLS. By W. H. Vandervoort. Large 8vo. 555 pages; 673 illustrations; cloth. Price, \$4. Just out, this "masterpiece of the machine shop," no machinist can afford to be without it. Treats the subject of Modern Machine Shop Tools in a concise and comprehensive manner. Each tool is considered from the following points: First—its construction with hints as to its manufacture; second—its operation, proper manipulation and care; third—numerous examples of the work performed. A book in which the apprentice will find a thorough course of instruction, the mechanic a valuable manual of practice and the superintendent and foreman many valuable suggestions. In fact, it is in all respects the most complete, concise and useful work ever published on the subject. Of incalculable value as a work of reference. In 34 chapters.

PRACTICAL GAS ENGINEER. What It Is and How To Do It. Cloth. Price, \$1.

RECORD BOOK—VALVE SETTING. By A. B. Low. 120 pages; quarto; stiff covers. Price, 60c. For the use of marine engineers.

WATER WHEELS. By A. B. Cullen. 63 pages; 12 plates; quarto; cloth. Price, \$2. Of all the books on Pumps and Hydraulic Motors this is one of the

most practical. Treats of the construction of horizontal and vertical water wheels.

COMPRESSED AIR: ITS PRODUCTION, USES AND APPLICATIONS. By Gardner D. Hiscox, M. E. 4th edition, revised and enlarged; 820 pages; 545 illustrations; cloth. Price, \$5. The most thorough and comprehensive treatise on the subject of compressed air that has ever been published. Well printed and substantial. No phase of the subject is omitted. Is a complete compendium in 36 chapters, valuable for reference and for study. Contents: The physical and operative properties of air from a vacuum to its liquid state; its thermo-dynamics; compression, transmission and uses as a motive power in operation of stationary and portable machinery in engineering, mining and manufacturing work; air tools; air lifts; pumping of water, acids and oils; the air blast for cleaning and painting; the sand blast and its work; and the numerous appliances in which compressed air is a most convenient and economical transmitter of power for mechanical work, railway propulsion, refrigeration and the various uses to which compressed air has been applied. Contains a list of patents on compressed air from 1875 to date, and 40 tables of the physical properties of air, its compression, expansion and the volumes required for various kinds of work.

ELECTRICAL ENGINEERING FOR ELECTRIC LIGHT ARTISANS AND STUDENTS. By Slingo and Brooker. 346 illustrations; 12mo. Price, \$3.50. This new and revised edition contains all data and formulae relating to this branch of electrical application.

ENGINEERS' PRACTICAL TEST. Actual size. 6x4½ inches; stiff silk cloth. Price, \$1. A guide for all men in or about power plants. Indispensable to engineers, mechanics, machinists, firemen, etc. Tells how boilers and engines should be managed. All about gas engines, engineers' license examination questions and answers.

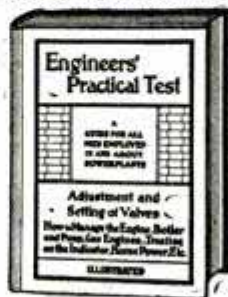

MECHANICAL ARTS SIMPLIFIED. By D. B. Dixon, comp. 497 pages; actual size, 8¾x5½ inches; illustrations. Price, \$1.50. With an appendix containing a thorough electrical department, an exhaustive treatise on ice making and a large collection of miscellaneous practical examples. A thorough and original reference book for architects, iron workers, boiler-makers, contractors, civil and mechanical engineers, firemen and ice machine men.

BOOKS OF TABLES. BOOKS OF RECEIPTS

ROPP'S NEW CALCULATOR. 200 pages. Actual size, 5 $\frac{1}{2}$ x9 $\frac{1}{2}$ inches. Cloth. Price, \$1.50. Pocket size, \$1.00. Sustains the same relation to the commercial world that the new Century Dictionary does to the literary world. Fully abreast with



the age of air ships, submarine boats and wireless telegraphy. Designed for and adapted to the particular wants of bankers, accountants, mechanics, farmers, manufacturers, merchants, miners, etc., etc., and must prove of incalculable value to them—unless the book itself can calculate its own worth—for it calculates almost everything that is calculable.

QUESTIONS AND ANSWERS. Based upon the Standard Code of Train Rules. By G. E. Collingwood, Ed. Revised edition. 80 pages. Diagrams. Cloth. Price, \$1. Intended for use in the examination of trainmen. The general rules, train rules, train orders, and the whole handling of trains is set forth in so simple and at the same time comprehensive manner that a careful reading of the book will fit any one with sufficient knowledge to meet any contingency that may arise in the conduct of a train. Endorsed by high railway officials from all sections of the country. Every transportation man should have a copy.

FERRIC AND HELIOGRAPHIC PROCESS: A Handbook for Photographers, Draughtsmen and Sun Printers. By George E. Brown. 149 pages. Diagrams. Cloth. Price, \$1. For architects, surveyors, draughtsmen, engineers and others who find the reproduction of tracings a matter of everyday necessity. It embraces: The ferro-prussiate process, toning blue prints, uses of blue prints; ferro-prussiate in tri-color work; the kallitype process; the Obernettor process; the wranotype process; prints on fabrics, prints in dyes; heliographic processes compared; preparation of heliographic papers, making tracings for sun-copying; outfit for heliographic printing; ferro-prussiate or white line on blue ground; pellet or blue line on white ground; ferro-gallic, or black line on white ground; brown line on white ground; minor heliographic processes. A comprehensive little bibliography at the end of the volume and an index add greatly to its value and interest.

THE LOCOMOTIVE UP TO DATE. By Charles McShane. 736 pages. 380 illustrations. Cloth. Price, \$2.50. Covers the whole range of locomotive construction and management down to the present day, including its latest development and all modern appliances, together with a classification and comparison of all kinds of locomotives, both simple and compound. It is a book culled from the mechanical books and papers of the world and so contains all the really valuable information to be found in a complete mechanical library. Every subject is fully illustrated and the descriptions given of all new devices were prepared by the inventors themselves. The contents include: Compound locomotives; combustion; air brake; breakdowns; locating blows and pounds; incrustation; injectors; inspirators and boiler checks; slide valves; valve gears; errors by the link motion; locomotive valve setting; steam indicator; modern locomotives; extraordinary fast runs; lubricators; metallic packings; general information; locomotive construction-erecting department; machine work; metric system; steam and air gauges; compressed air; modern counter-balancing and the history of the locomotive.

ONE THOUSAND POINTERS for Machinists and Engineers. By Charles McShane. 342 pages. 187 illustrations. Cloth. Price, \$1.50. Includes articles from the best authorities on each subject.

Embraces the most modern and approved practice in the construction, care and economical management of the locomotive. Written in plain language and condensed form, no mathematical demonstrations being given or required.

JOHNSON'S HANDY MANUAL. Price, \$1. An authority on steam, hot-water heating and ventilating, plumbing and gas fitting. A valuable reference book for architects, those in pipe trades, engineers, janitors and those intending to install or alter heating or plumbing systems. All kinds of measurements arranged in tables. Fully illustrated with cuts and complete working plans.

FIFTY-CENT SERIES

HANDICRAFT SERIES—A Series of Practical Manuals. Edited by Paul N. Hasluck. Price, each, 50c.

BOOT-MAKING AND MENDING Including repairing, lasting and finishing. Illustrated. 179 engravings and diagrams. Price, 50c. Contents: Repairing heels and half-soleing; patching boots and shoes; re-welting and re-soleing; boot-making; lasting the upper; sewing and stitching; making the heel; knitting and finishing; making riveted boots and shoes.

Others of the set are:

HOUSE DECORATION. Price, 50c.

HOW TO WRITE SIGNS, TICKETS AND POSTERS. Price, 50c.

WOOD FINISHING. Price 50c.

DYNAMOS AND ELECTRIC MOTORS. Price, 50c.

CYCLE BUILDING AND REPAIRING. Price, 50c.

DECORATIVE DESIGNS OF ALL AGES FOR ALL PURPOSES. Price, 50c.

MOUNTING AND FRAMING PICTURES. Price, 50c.

SMITH'S WORK. Price, 50c.

GLASS WORKING BY HEAT AND ABRASION. Price, 50c.

BUILDING MODEL BOATS. Price, 50c.

ELECTRIC BELLS: HOW TO MAKE AND FIT THEM. Price, 50c.

BAMBOO WORK. Price, 50c.

TAXIDERMY. Price, 50c.

TAILORING. Price, 50c.

PHOTOGRAPHIC CAMERAS AND ACCESSORIES. Price, 50c.

OPTICAL LANTERNS. Price, 50c.

ENGRAVING METALS. Price, 50c.

BASKET WORK. Price, 50c.

BOOKBINDING. Price, 50c.

BENT IRON WORK. Price, 50c.

PHOTOGRAPHY. Price, 50c.

UPHOLSTERY. Price, 50c.

READY SHORTLY.

LEATHER WORKING. Price, 50c.

HARNES MAKING. Price, 50c.

SADDLERY. Price, 50c.

TECHNICAL INSTRUCTION. Important new series. Edited by Paul N. Hasluck. With numerous illustrations of the text. Each book contains about 160 pages. Crown 8vo. Cloth. Each, \$1.

PRACTICAL DRAUGHTSMAN'S WORK. Price, \$1.

PRACTICAL GASFITTING. Price, \$1.

PRACTICAL STAIRCASE JOINERY. Price, \$1.

PRACTICAL METAL PLATE WORK. Price, \$1.

PRACTICAL GRAINING AND MARBLING. Price, \$1.

OTHER VOLUMES IN PREPARATION.

SPON'S MECHANICS' OWN BOOK. 702 pages. 1420 illustrations. Half leather. Price, \$2.50. General method of treatment of each subject is first, the raw materials worked upon, its characteristics, variations and suitability; secondly, the tools used, the sharpening and use; thirdly, devoted to typical examples of work to be done, materials and how to do similar work. Nearly all of the mechanical trades are here included and some of the professions.

VAN NOSTRAND SCIENCE SERIES. 16mo. Boards. 50c. each. Amply illustrated when the subject demands. Put up in a uniform, neat and attractive manner. Subjects are of an eminently scientific character and embrace a wide range of topics. The following citations may be noted as types of this notable set:

CHIMNEYS FOR FURNACES AND STEAM BOILERS. R. Armstrong, C. E. 3rd American edition. Revised and partly re-written, with an appendix on "Theory of Chimney Draught," by F. Idell, M. E.

STEAM BOILER EXPLOSIONS. By Zerah Colburn. New edition. Revised by Prof. R. H. Thurston. Price, 50c.

FATIGUE OF METALS UNDER REPEATED STRAINS. Price, 50c. With Various Tables of Results and Experiments. From the German of Prof. Ludwig Spangenberg, with a preface by S. T. Shreve, A. M.

TRANSMISSION OF POWER BY WIRE ROPES. Price, 50c. By Albert W. Stahl, U. S. N. Second edition. Revised.

TRANSMISSION OF POWER BY COMPRESSED AIR. Price, 50c. By Albert Zahner, M. E. New edition in press.

GAS-LIGHTING AND GAS-FITTING. Specifications and Rules for Gas-Piping. Price, 50c. Notes on the Advantages of Gas for Cooking and Heating, and Useful Hints to Gas Consumers. 2nd edition. Re-written and enlarged. By Wm. Paul Gerhard, C. E.

TWENTY-FIVE CENT SERIES

STUDY OF ELECTRICITY FOR BEGINNERS. Comprising the Elements of Electricity and Magnetism as applied to Dynamos, Motors, Wiring, and to all Branches of Electrical Work. By Norman Schneider. 54 illustrations and 6 tables. Price, 25c.

DRY BATTERIES. Especially adapted for Automobile, Launch and Gas Engine Work; Medical Coils, Bells, Annunciators, Burglar Alarms, Telephones, Electrical Experiments, and all purposes requiring a good battery. 30 illustrations. 25c.

SMALL ELECTRIC MOTORS. How to make and use them, including design, examples of small motors and their applications, speed controllers, starters, fuses, etc. 48 illustrations. Price, 25c.

SIMPLE SCIENTIFIC EXPERIMENTS. How to perform entertaining and instructive experiments with simple home-made apparatus. 59 illustrations.

MODEL BOILER MAKING. Contains full instructions for designing and making Model Stationary, Marine and Locomotive Boilers. Fully illustrated. Price, 25c.

METAL WORKING TOOLS AND THEIR USES. A Handbook for Young Engineers and Apprentices. Shows how to use simple tools required in Metal Working and Model Making. Illustrated. 25c.

THE LOCOMOTIVE, SIMPLY EXPLAINED. A first introduction to the study of the Locomotive Engine, their Design, Construction and Erection, with a short catechism. 26 illustrations. 25c.

ACETYLENE GAS, HOW TO MAKE AND USE IT. A practical handbook on the uses of Acetylene Gas, suitable apparatus for its generation, hints on fitting up, etc. 34 illustrations. Price, 25c.

JOINT WIPING. Practical hints on, for beginners in plumbing, describing in detail the various operations and fully illustrating them from actual work. Price, 25c.

WOODWORK JOINTS. How to make and where to use them. Mortise and tenon joints, lap joints, dovetail joints, glue joints, scarfing joints, circular work, with 137 illustrations. Price, 25c.

DIAGRAM OF THE CORLISS ENGINE. A large engraving giving full particulars. Explanation of figures. 13x19 in. Price, 25c.

ELECTRICAL CIRCUITS AND DIAGRAMS. Illustrated and explained. New and original drawings comprising Alarms, Annunciators, Automobiles, Bells, Dynamos, Gas Lighting, Motors, Storage Batteries, Street Railways, Telephone, Telegraph, Wireless Telegraphy. By Norman Schneider. 25c.

HOW TO INSTALL ELECTRIC BELLS, ANNUNCIATORS AND ALARMS, including Batteries, Wires and Wiring, Circuits, Bushes, Bells, Burglar Alarms, Fire Alarms, Thermostats, Annunciators, and the Location and Remedying of Troubles. By Norman Schneider. Price, 25c.

MISCELLANEOUS

ELEMENTARY FORGE PRACTICE. By John Lord Bacon, Instructor in Forge Work, Lewis Institute, Chicago. 262 pages. Cloth. Price, \$1.50. Contents: General description of forge and tools; welding, calculation of stock for bent shapes; upsetting, drawing out and bending; simple forged work; calculation of stock and making of general forging; steam hammer work; duplicate work; manufacture of iron and steel; tool-steel work; tool forging and tempering; miscellaneous work; tables.

LOCOMOTIVE OPERATION. By G. A. Henderson. 536 pages; illustrations. Cloth. Price, \$3.50. The object of this work is to give a complete and systematic discussion of the theory and practice of locomotive operation with the results accomplished and the effect of the action upon the various parts, as well as the amount of fuel and water needed to perform such needed work, rather than an exclusive treatise upon the mere manipulation of the machine. The order of contents is: Inertia, steam action, resistance, slipping, braking, steam capacity, hauling capacity, water consumption, fuel consumption.

TEXT BOOK ON ROOFS. By Mansfield Merriam. Part I. Sixth edition rewritten and enlarged. 326 pages; illustrations. Cloth. Price, \$2.50. The contents include treatises on stresses in roof trusses, highway bridge trusses, railroad bridge trusses, miscellaneous trusses, deflection and internal work, historical and critical notes.

WIRELESS TELEGRAPHY. By A. Frederick Collins. 500 pages; illustrations. Cloth. Price, \$3. Describes the history, theory and practice of wireless telegraphy in a way to rouse the enthusiasm of the layman, as well as the professional. A happy regard for details and minor points makes the whole a remarkably clear and interesting account of the Science.

MODERN ELECTRICITY. By Henry and Hora. 355 pages; 150 illustrations. Cloth. Price, \$1. Thoroughly accurate and scientific in its explanation of X-rays, wireless telegraphy, radium, transmission and distribution, power stations, wiring, and written in plain English. An essentially practical handbook for students, apprentices and electrical engineers.

ARITHMETIC SELF TAUGHT. By Spangenberg. 228 pages. Price, 55c. Undoubtedly the best book published for students of arithmetic. Do not despair because through neglect you have forgotten what you once knew about this branch of mathematics. This new method requires no teacher.

YOUNG ENGINEER'S GUIDE. New edition revised and enlarged. 254 pages; illustrations. Price, \$1. Covers the entire subject of care, management, operation, repairing, engineer's license and various points of equal importance, and is endorsed by leading engineers in all parts of the country.

HOW TO RUN ENGINES AND BOILERS. By E. P. Watson; illustrated. Price, \$1. Written in plain language and well adapted for use as a textbook by the engineer and boiler maker.

MODERN COTTAGE ARCHITECTURE. By M. B. Adams. Large quarto; 79 pages; illustrated. Cloth. Price, \$4.50. Contains an introductory essay on cottage building and notes on the subjects, illustrated from works of well known architects.

UNTECNICAL ADDRESS ON TECHNICAL SUBJECTS. By James Douglas. 90 pages. Cloth. Price, \$1. Contents: The characteristics and conditions of the technical progress of the nineteenth century; the development of American mining and metallurgy and the equipments of a training school; wastes in mining and metallurgy.



THIS LITTLE PICTURE TELLS A WONDERFUL STORY

The three eagles in the above illustration, two of them with double heads and each wearing a crown, represent the monarchies of Russia, Austria and Prussia, combining their strength to partition Poland, that nationality being represented by the fallen soldier. As the Poles fought for the independence of their country, the Goddess of Liberty is represented defending the soldier and trying to beat back the crowned powers, but Liberty was overcome and falls with broken sword in hand on the shield bearing the Latin inscription "Finis Polone," which means "The End of Poland." Looking more closely you will observe the burning firebrands, the battered walls, the broken cannon, the burning cities in the distance, and the flag of Poland trailing in the dust, this little illustration having wrapped up in it the history of the downfall of a nation. This is only one of 2000 illustrations in

Ridpath's History of the World

each one driving home to the mind some great historical event.

Poland is once again dreaming of Liberty, and one of the blackest crimes ever perpetrated by a combination of great powers against a weaker nation may yet be righted. To appreciate the tremendous historical importance of present events it is absolutely essential to have a thorough knowledge of the history of the past.

These Are History-Making Days.

This present year, not half over, has seen a new power (Japan) take its place among the great nations of the earth; has seen an open seaport taken from Russia, for which she had planned and intrigued for sixty years, curbing for at least a generation her dream of predominance in the East; has seen the outcropping of what may become the greatest revolution of all time, and through which Poland may again be free; has seen our own great Republic take her place absolutely at the head of the great nations of the world and universally recognized as the power best fitted to take the initial step towards bringing to a close one of the bloodiest wars in history.

Do you understand and can you intelligently discuss these great happenings, and are you familiar with the rise and fall of nations in the past, and the rocks of disaster upon which every Republic save our own has gone down?

In ONE WAY, and in ONE WAY ONLY, can you understand these events—by knowing history. To you, to every one, a history of the world is a necessity. There is one satisfying history of the whole world, JUST ONE, Ridpath's History of the World.

It is endorsed by ex-Presidents Harrison, Cleveland and McKinley, Jefferson Davis, Lew Wallace, John L. Stoddard, Henry W. French, Bishop Vincent, Dr. Cuyler, Rabbi Emil G. Hirsch, Presidents of Ann Arbor, Amherst, Brown, Boston University, Dartmouth, Tufts, Trinity, Bates, Colby, Smith, Vassar, Yale, and other Colleges, and by the Great American People, 200,000 of whom own and love it.

The Failure of Merrill & Baker, Publishers

finds us with a few sets on hand of this, their greatest publication, which we must sell to pay advertising bills, and for these few sets the price fits your purse, and our terms are so easy as to bring this monumental work within the reach of all.

Ridpath is in 9 royal octavo volumes, 11 inches tall, 8 inches wide and 2 1/4 thick. It contains 4000 pages and 2000 illustrations. The complete set boxed weighs 65 pounds. The few sets at our disposal are the very latest edition, down to the Fall of Port Arthur, and are beautifully bound in Half Morocco. This is your chance to buy the work at a nominal price, much less than ever before, and you may pay in small sums monthly if you prefer.

CUT OUT THIS COUPON AND MAIL TO-DAY

WESTERN
NEWSPAPER
ASSOCIATION
204 Dearborn Street
Chicago

Please send me Ridpath
Sample Pages and full par-
ticulars as offered in POPULAR
MECHANICS for August.

NAME.....

ADDRESS.....

A STRONG ARGUMENT BUT NO PICTURES—READ IT

The Phillips Seven Powers in One

—DUPLEX GASOLINE FARM MOTOR—

Can be used on the farm for any work a farmer has to do

He doesn't have to call in his neighbors to grind his feed, cut his ensilage or fodder, neither does he have to run a **GREAT BIG 8 H. P. ENGINE** to pump water and run his cream separator that only takes $1\frac{1}{2}$ H. P.; he can't afford to do this; it takes too much gasoline.

Every farmer needs an 8 horse power engine at oftentimes and only about 2 horse power most of the time. Most farmers can't afford to put so much money in a big engine, and so limp along with a 2 or 3 horse power engine when they would really like an 8 horse power, and if they could get

A First-Class 8 H. P. That Does Not Cost Any More Than the Common 4 H. P Engine to Buy

and one that would **RUN ON AS LITTLE GASOLINE AS ANY SMALL ENGINE** when doing a small engine's work; one that the farmer could use anywhere and any place that any 2, 3, 4, 5, 6, 7 or 8 horse power engine could be used, either as a mounted engine or as a semi-portable, or a stationary, on a foundation, or as a marine engine, if desired—I say, if the farmer could get **ALL THIS IN ONE**, providing the engine was as simple and durable as the old fashioned kind, that he would then have **Just the ideal farm power.** The **WONDERFUL PHILLIPS FARM MOTOR** is all this and more.

Let Us Tell You More About It. Write for Circular No. 23

PHILLIPS MOTOR WORKS, 415 Tacoma Bldg., CHICAGO, ILL.

Correspondence solicited regarding complete marine motor outfits; also automobile motors, transmissions, etc.

WATER MOTORS

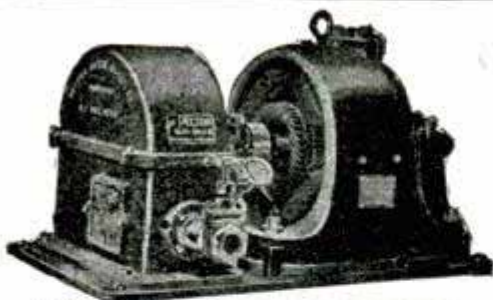

PELTON MOTOR AND DYNAMO DIRECT CONNECTED.

The PELTON MOTOR possesses all the advantages of the famous PELTON WATER WHEEL. It is essentially a high grade machine of the best mechanical construction, and is guaranteed to develop a maximum power using a minimum quantity of water. Tests at Cornell University show the remarkable efficiency of 88 per cent. Adapted for running from city mains or independent water supply, and can be used for any purpose requiring power. For example, dynamos, dairy and farm machinery, fans and blowers, printing presses, etc., etc. Send for catalogue giving capacity and prices of various sizes.

THE PELTON WATER WHEEL CO.,

138 Main St., SAN FRANCISCO.
145 Liberty St., NEW YORK.



Our No. 40 Bench

Teach The Boys to Use Their Hands

Every boy ought to have a little carpenter shop of his own. He can earn money doing carpenter work for his family and friends and have lots of fun besides.

Our Youth's Manual Training Bench is a whole carpenter shop in itself for a bright boy. It is used in the best manual training schools in the country.

Bench $4\frac{1}{2}$ ft. long, 32 inches high, 20 inches wide—fitted with a 13-inch glued up maple top $1\frac{1}{2}$ inches thick, with 7-inch well for tools, fitted with two vices. Back board and tool rack as shown in illustration. Frame, glued up top, vices and tool rack all made of hard maple.

Our catalog gives complete information in regard to this and other manual training benches, and it shows a number of styles especially designed for manual training school use. Write for a copy.

GRAND RAPIDS HAND SCREW CO.

146 S. Ionia Street

GRAND RAPIDS, - - - MICH.

POPULAR MECHANICS

Vol. 7. No. 9.

CHICAGO, SEPTEMBER, 1905.

10 Cents a copy.
\$1.00 a year

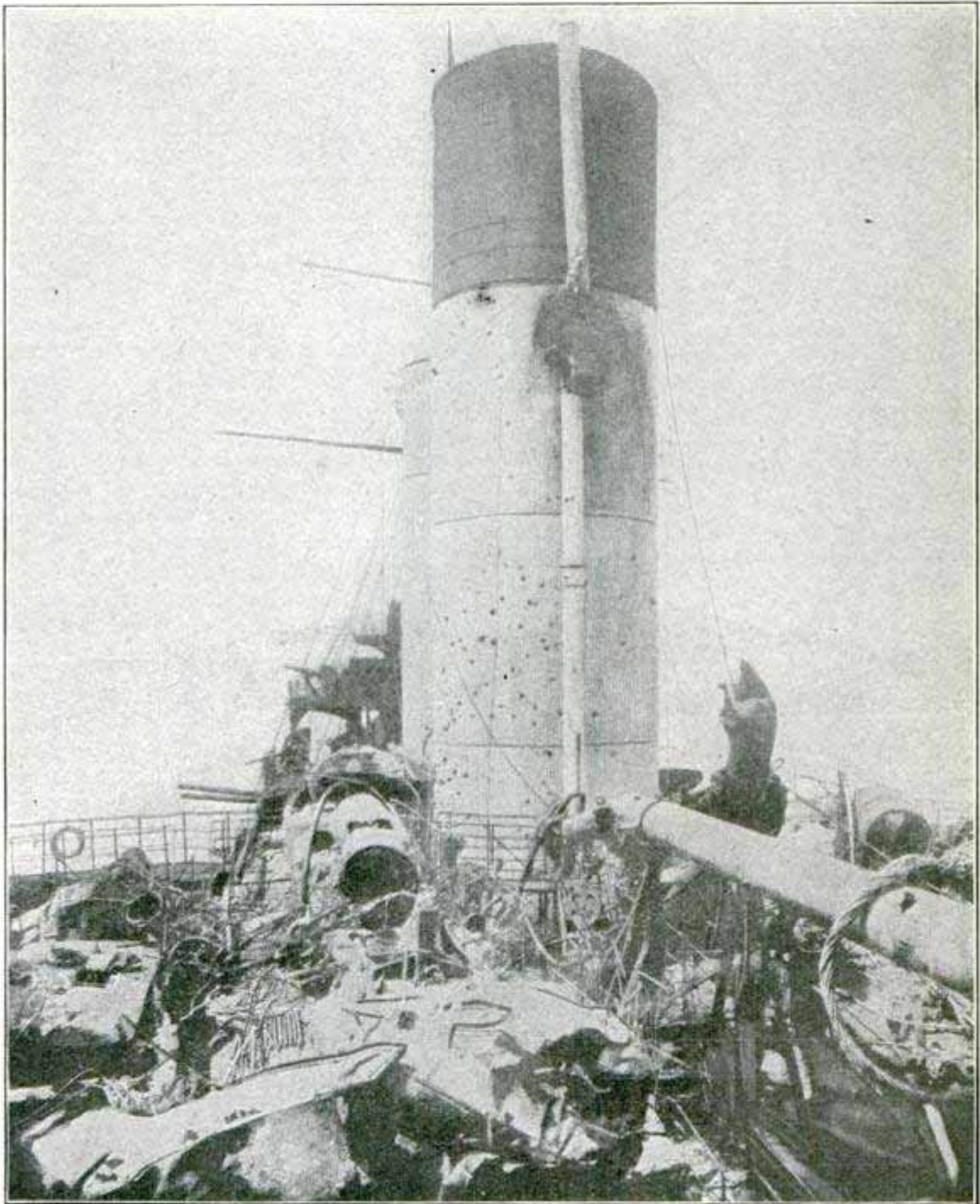

The Russian Battleship "Orel," Riddled by Japanese Fire in the Great Naval Battle of the Sea of Japan

FINEST GUNPOWDER PLANT IS IN JAPAN

The most complete, modern, convenient and practical gunpowder plant in the world belongs to the Japanese government and is located at Meguro, near Tokio. All kinds of ordnance and blasting powders are manufactured at this plant and 500 men are employed. Every department has its allotment of space, but not a foot is wasted, nor is there anything superfluous about the massive buildings and their equipment. A narrow gauge railroad runs along the main street for the full length of the factory grounds and overhead a wire-rope power-transmission connects all departments. Though modern in every respect, the plant is none the less Japanese in appearance. The corners of the roofs of the buildings turn up and there are many details in every department carried out in Japanese fashion.

Five to six thousand pounds of finished material is turned out daily, yet grounds and buildings are kept neat and clean. A detachment of soldiers patrol the plant and military precision and discipline govern.

STEEL STREET CARS

The growing tendency to build cars out of non-combustible materials has entered a new field, and the first steel street car has been finished and is running in the streets of New York. No wood is used in the construction of the car except the little required for the window sash, parts of the roof and the strips on the floor, and all these have been fireproofed. There is not the same necessity for a fireproof street car that there is for a steam car, as the passengers could always escape, but the street car, when stored in car barns, is one of

the most combustible of all things, and when a car barn takes fire the loss is always heavy and usually total.

TELEGRAPHING PHOTOGRAPHS

Photographs can now be sent to a distance by telegraph. This means that a disaster occurring in New York tonight may be illustrated from actual photographs of the scene in the San Francisco papers tomorrow morning, instead of from the artist's imaginary pen pictures.

The instrument by which the telegraphic transmission of photographs, handwriting and photo-engravings is possible is the invention of Professor Arthur Korn, of Munich, and involves the use of a selenium cell, the electrical resistance of which varies according to the action of the light upon it. When an image from a photographic film is thrown upon this selenium cell the variable resistances are set up and transmitted to the receiving end of the apparatus. Here they vary the light of a Geissler tube which acts upon a sensitive tube as explained in the illustration, which we reproduce by courtesy of the Illustrated London News. The French telegraph service has been testing the photographic powers of the apparatus on a line between Paris and Rouen, for several weeks past and the illustration shows facsimiles of photographs actually sent by telegraph.

A special course of instruction for fitting boys to become apprentices in the shops of the Pennsylvania R. R. has been adopted by the board of education of Altoona, Pa., and will be taught in the high school of that city. Railway officials assisted in preparing the course.

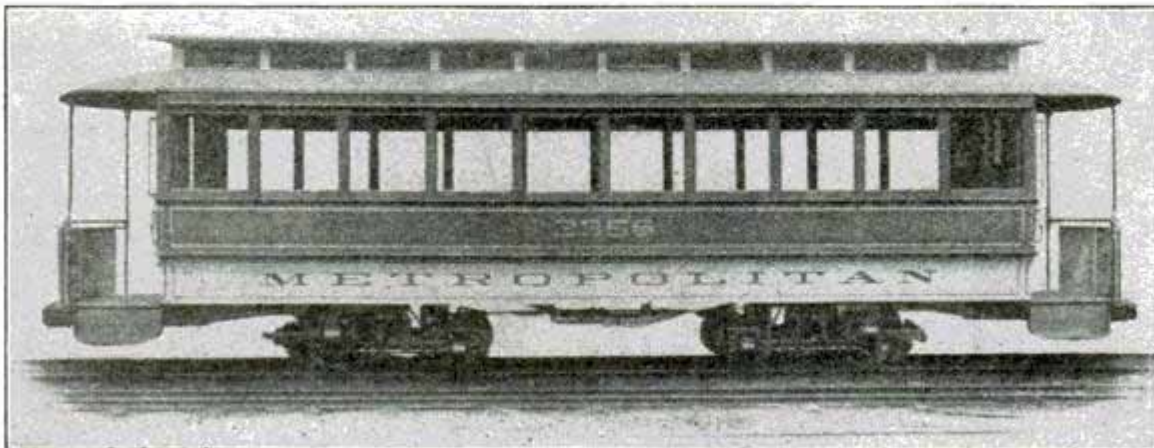

First Steel Street Car Ever Built

APPARATUS, BY WHICH PHOTOGRAPHS ARE ACTUALLY TELEGRAPHED

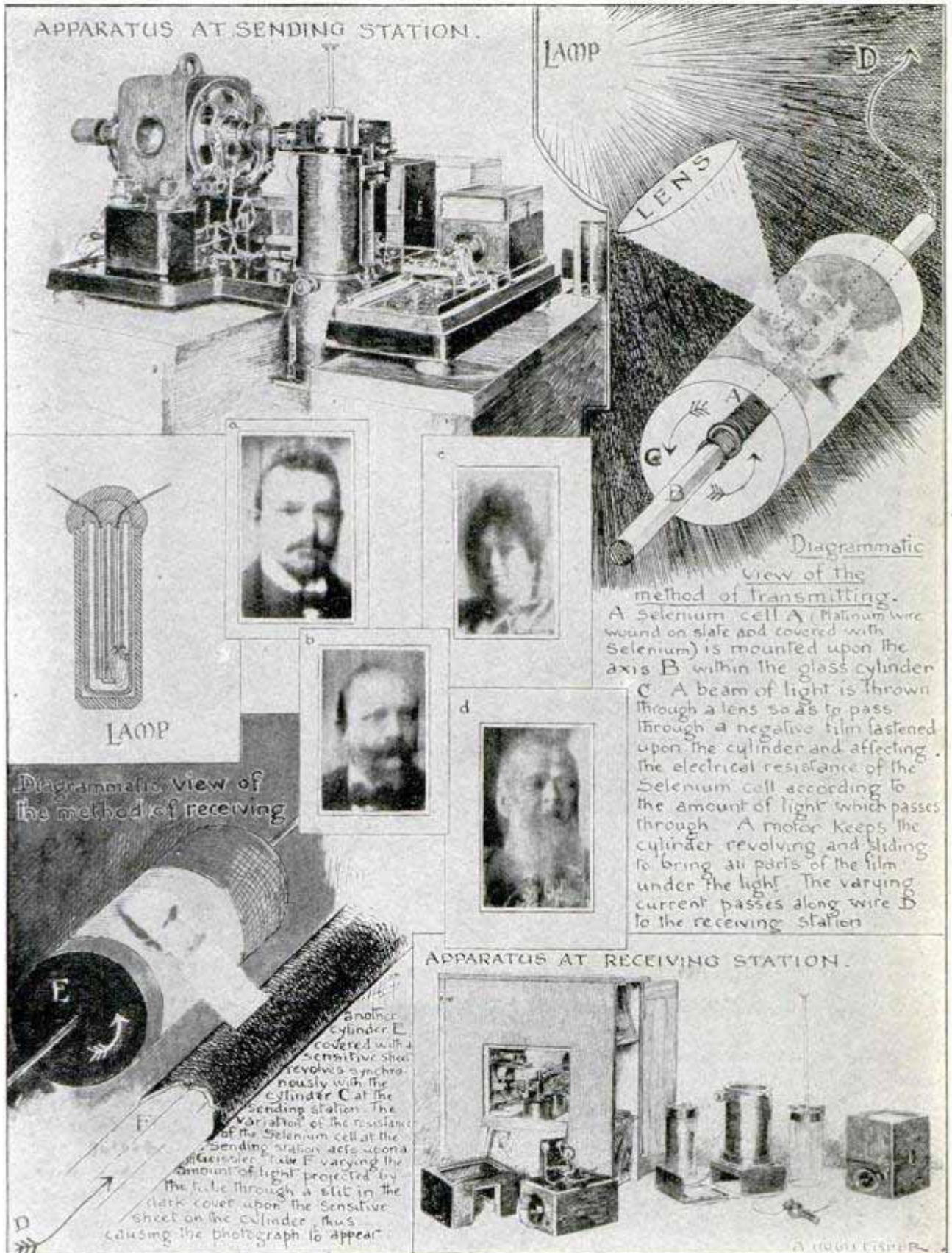

Portraits a, b, c and d are Reproductions of Photographs Sent Over the Wire of the French Telegraph Co.

OCEAN TURBINES DECLARED TOO SLOW

The steam turbine has made such rapid progress considerable surprise will be occasioned at the report of Herr Struver, the chief constructing engineer of the North German Lloyd line. He declares as a result of test voyages he made on the Allan liner "Victorian" that: "It may do for small vessels, but it is not the thing for big ones. It does not save space or weight, and I did not discover that it saved anything in coal.

MOSLEMS SACRIFICE EYES AT PROPHET'S TOMB

The pilgrim Moslem traveling toward Mecca has one supreme objective—the Prophet's tomb. When he has gazed on that he has, by some strange frenzy of belief, exhausted the delights of vision. He would insure that Mohammed's resting place be his last earthly sight.

Near the Ka-baah are men heating bricks white-hot in pans of coals. When the pilgrim has feasted his eyes on the (to him)

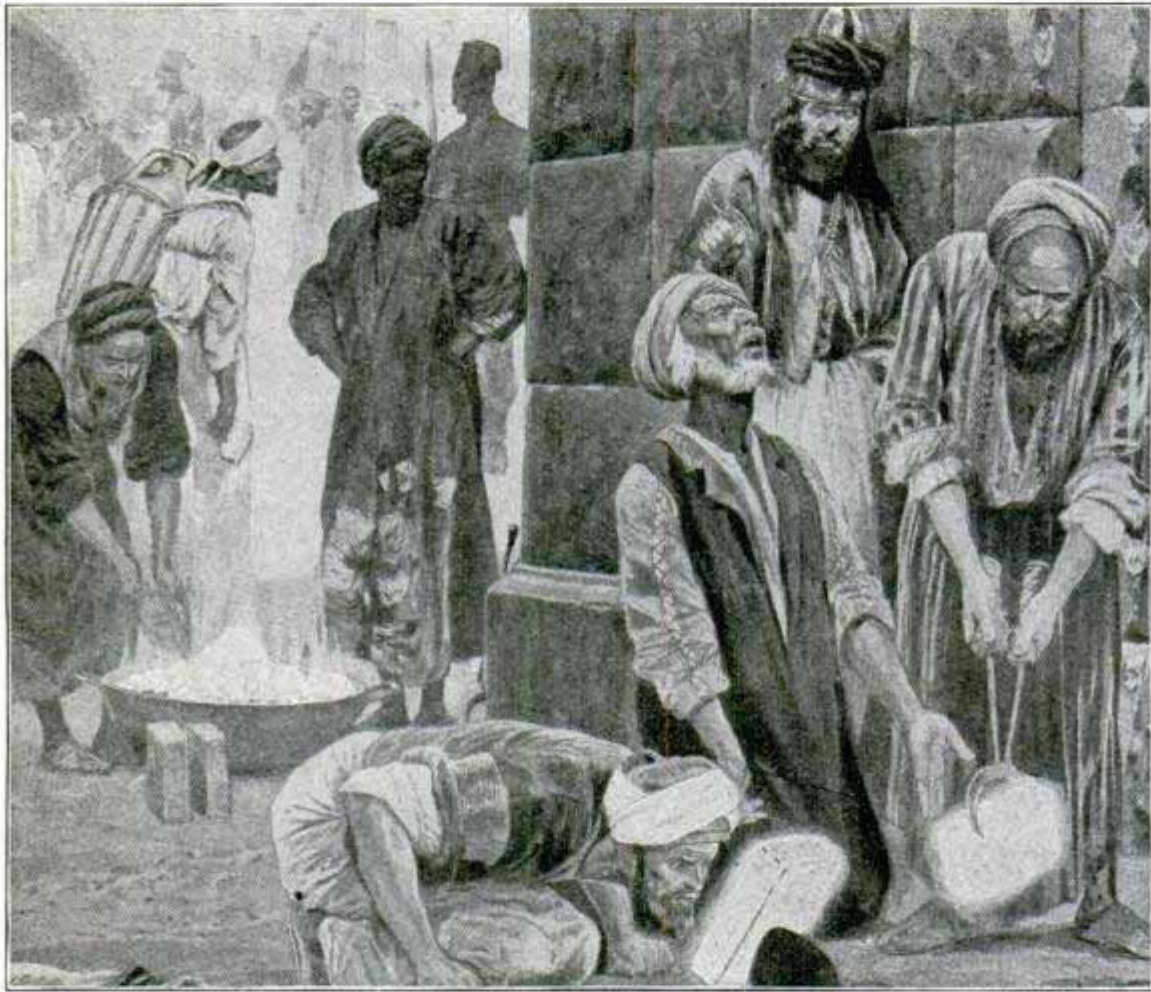

"They Gaze at White-Hot Bricks Until Their Sight is Destroyed."

The one advantage that can be claimed for it is that it has little or no vibration. But that does not offset the other disadvantages."

The difficulty of reversing is emphasized, the expert stating that it takes more than five times as long to reverse a turbine as a reciprocating engine.

However, the Cunard line have under construction two immense turbines which are expected to have a sustained speed of 24 knots an hour. It is said important improvements have been made which are guarded secrets.

blessed sight, he buys one of these white-hot bricks and with his face still turned toward the tomb, brings his eyes near the terrible heat of the brick and holds them there until his sight is destroyed. His agony is fearful, but he bears it till his object is accomplished. Then his sufferings stupefy him; the white-heat of the brick dies out. In an hour or two he rises and takes his way—a blind man.

France has electric lighthouses with lights of 30,000,000 candle power.

GERMANY TO SELL PNEUMATIC TOOLS HERE

German manufacturers are reported to have made a marked advance in their manufacture of pneumatic tools and compressors on account of recent important inventions. These tools have been introduced in the great Krupp works with success and a well-known firm in Frankfort insists its tools are now superior to the American, and considerably less expensive. A branch factory will probably be established in the United States, and the improved German tools put in competition with the American.

WORLD'S LARGEST STEAM TURBINES

The largest steam turbines ever built are under construction for the power house of the Brooklyn Heights Railroad. There will be two of them with a guaranteed output each of 16,000 brake hp., with dry steam at 175 lbs. and a vacuum of 28 in.

EDISON STORAGE BATTERY AGAIN PERFECTED

Two years have passed since the extravagant claims for a new storage battery were heralded by the daily press. Edison now announces that he has perfected the battery and that the problem of vehicle traction is surely solved. He claims his battery will store sufficient power to run

DETECTING FORGERIES BY THE MICROSCOPE

One of the surest means of detecting fraudulent additions to or changes in documents is by the use of the microscope. Mysteries in crime that have baffled detectives for months have at times been laid bare by the intelligent use of this instrument. The guilty fears this mechanical witness against him, as he fears no spoken evidence. A skillful lawyer can confuse and discon-

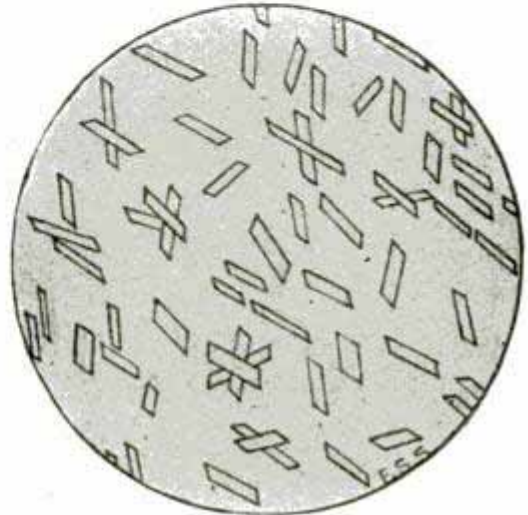

Fig 1

cert a human witness and tear to shreds the most damning testimony; but when the microscope, silent, infallible witness, lays bare to the vision the immutable fact, he can only hold his peace.

Suspected blood-stains on clothing may be examined under the microscope, and their nature established beyond doubt. The stains

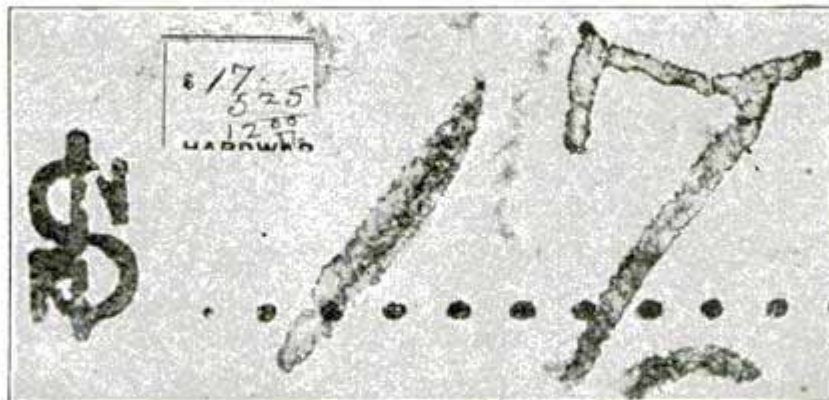

Fig 2.—\$11 Converted into \$17

a pleasure vehicle 100 to 150 miles an hour over good roads. The expectation is to operate a one-horse delivery wagon for 58 per cent of what it costs to do the work with a horse.

are treated with a little alkali, evaporated to dryness and then heated with acetic acid, and a minute amount of sodium chloride, says Knowledge and Scientific News, London. If the stain is from human blood,

small but characteristic crystals (haemin crystals) will appear. These crystals, much magnified, are illustrated in Fig. 1.

In forgeries the investigation resolves itself to the microscope and the trained ob-

servers by imperfections that may not be doubted.

For work of this nature a 1/6 in. is a sufficiently high power. A good substage illumination by means of a condenser is re-

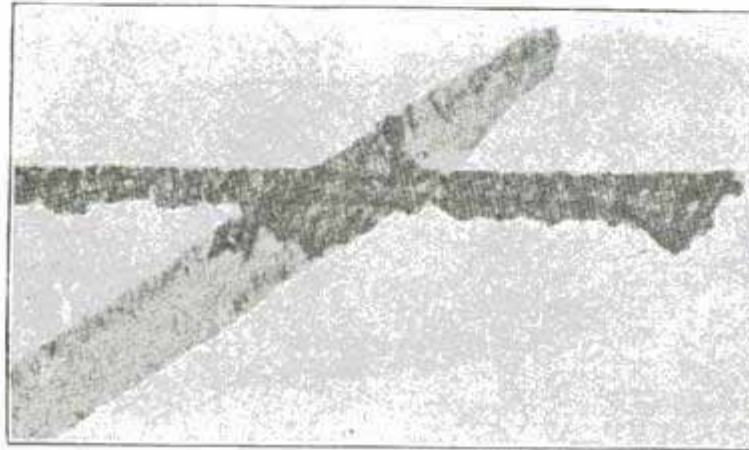
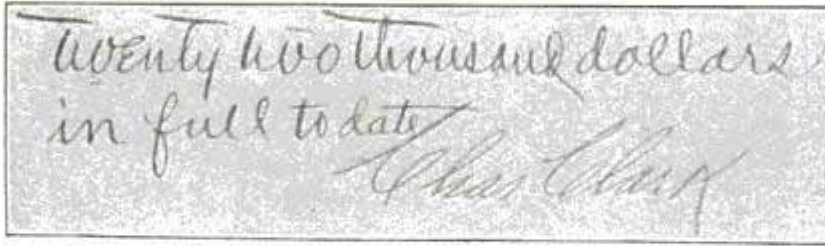

Fig. 3

The Stroke That Betrayed the Forger

Fig. 4

server. If a paper has been folded and afterward opened and an addition, change, interlineation, etc., made in it, a minute quantity of ink would follow the fold, did a single stroke of the pen cross it. A difference in the pen used by the forger is brought out under the microscope, or the strokes may be measured up to the ten-thousandth of an inch. The color of the ink may not be the exact shade, or may vary because of difference in the age of the writing.

Where figures or letters have been changed the joining of the new strokes with the old is certain to be imperfect. This is illustrated in Fig. 2, where in the numeral II one of the I's has been changed to a 7.

In Fig. 3 the words "in full to date" have been added and the fatal error made of allowing the cross of the "t" in the word "date" to pass over a letter in the signature. This, under the microscope, is incontrovertible evidence, no matter how well otherwise the forgery may have been executed.

The most painstaking forgeries are the most apparent when viewed through the microscope. In tracing the additions the pen has been lifted many times, perhaps; or the words or signature has been first traced in with a pencil, and these things proclaim

themselves, however, and opaque objects must be illuminated by means of a bull's-eye or in some other way. Micro-photography was explained in the June number of Popular Mechanics.

HOW AUTO SCORCHERS ARE CAUGHT

The suburban towns along Lake Michigan, north of Chicago, afford some of the finest automobile courses in the world. The local authorities have recently limited speed through their towns to about 15 miles an hour. Offenders are detected in this way: Two stations are established 1,000 ft. apart, connected by a wire. At each station an officer is concealed behind shrubbery. As a flyer passes the first station the signal is telegraphed to the other where a stop watch is started. When the offender passes the second station the time is taken and if the speed is too high a signal is passed to a third officer who makes the arrest.

Another scheme tried by villages is to build obstructions or bumps at street crossings. Spectators greatly enjoy watching unsuspecting motorists "bump the bumps."

THE MODERN QUICK-FIRING FIELD GUN

Stationary Carriage and Efficient Recoil Apparatus Essential Features---Types of Guns Used by Several Nations

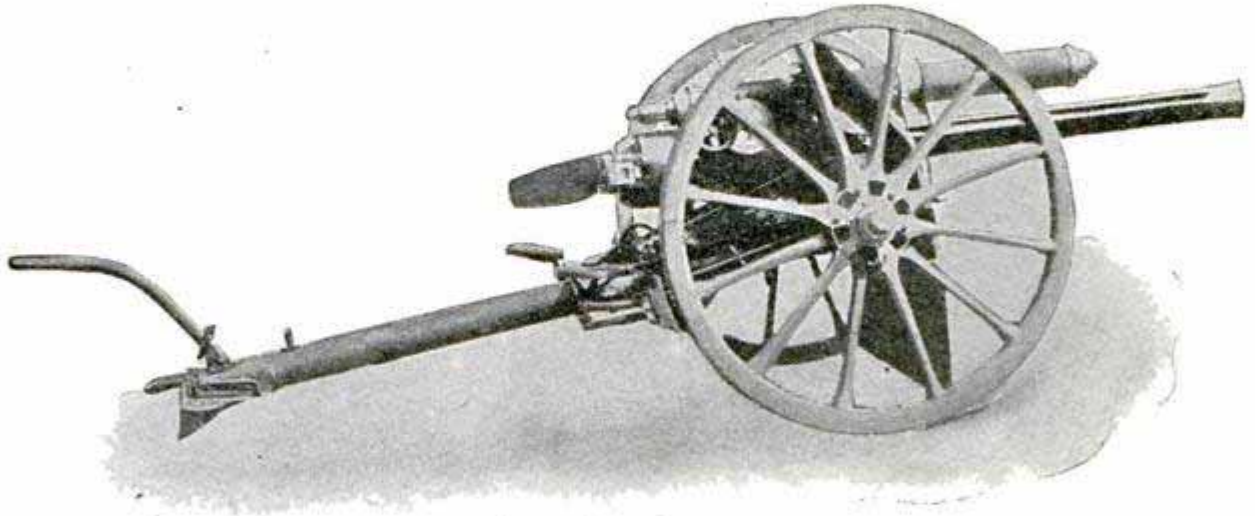

British 18-pr. Quick-Firing Gun for Horse and Field Artillery

The great advantage afforded by the modern quick-firing gun is that, on firing, the carriage remains perfectly stationary, while a recoil apparatus handles the gun in recoil, and returns it to position with sights still aligned on the target. In the old equipment, gun and carriage were carried back several yards by the force of the recoil when the gun was fired, and the gunners were obliged to step aside to save themselves from injury. Then the gun and carriage had to be man-handled up to its former position and laid again on the target. Delay, fatigue, exposure, three elements that the improved army equipment tends always to eliminate wherever possible.

In the new type of field gun a buffer or cushion between the gun and the carriage places the shock of the discharge low down in the carriage with a great increase in steadiness of the gun. The gun itself when fired recoils on a slide and a flow of liquid,

usually oil, past the piston-head checks its force. The compression of powerful springs also checks it, and when the force of recoil is expended, these springs, expanding, return the gun to position with its sights aligned on the target. On the end of the

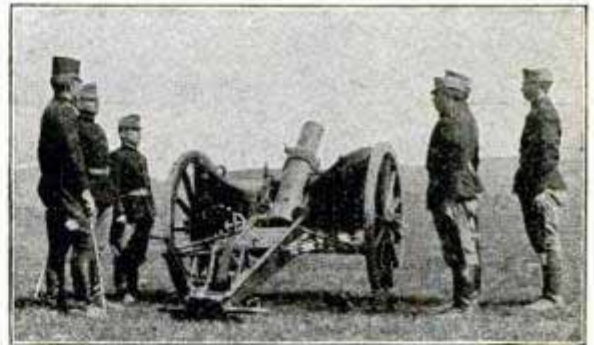

Austrian Field Howitzer

trail is a "spade" or triangular plate of steel, which is forced into the ground with the first discharge of the gun and holds the main part of the carriage stationary.

Telescopic sights, which are of great assistance to the gun layer, are used on the modern field gun, and it also has a nickel shield of great resisting power.

The British 18-pr. quick-firing gun is provided with a limber which enables the firing of as much as twenty-nine rounds per minute. The interior of this limber has circular pigeon holes each of which contains a shell and cartridge in one piece. The shell contains 364 bullets and is used with most deadly effect.

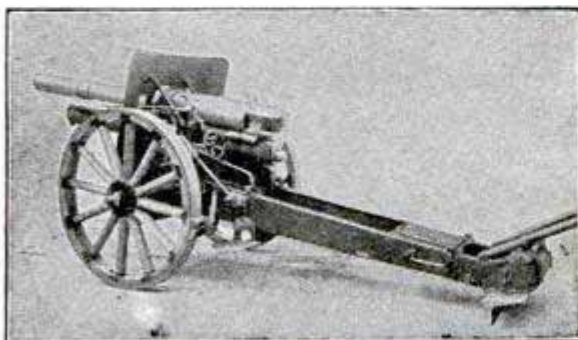

German Siege Gun

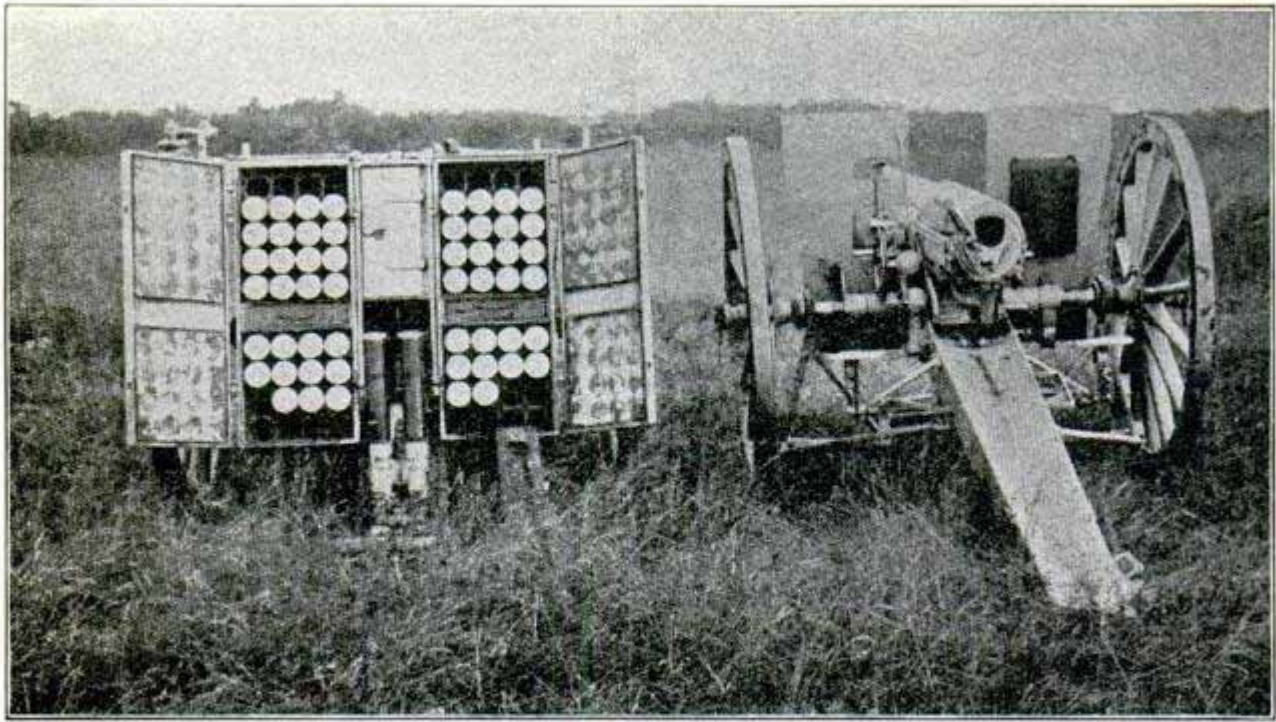

French Quick-Firing Gun Unlimbered and Ready for Action

The quick-firing gun in use by the various European powers differs but little in its essential features, though the artillerists of one nation do not always agree with those of another as to the most important advantages to be embodied in a weapon.

The German siege gun mounted upon a traveling carriage greatly resembles in

appearance the modern field gun. When being drawn over the road, the gun is run back on the trail. The limber used with this gun is exceedingly small.

The French artillerists consider high velocity and long range essential, therefore their quick-firing guns are of great length. The gun after recoil is returned to firing



German Field Artillery and Big Naval Guns from the Krupp Works at Essen

position by compressed air. The details of this arrangement are a carefully guarded secret. The limber and wagon used by the French carry the ammunition in pigeon-holes and during the firing one body of the wagon is up-ended and the lids opened outward to form a protection for the gunners preparing the shell.

The Austrian government has adopted the field howitzer, which is useful for indirect firing. The Austrian quick-firing gun is of wrought bronze with recoil tube mechanism and a detachable shield for protecting the gunners.

FRENCH TANDEM COMPOUND SUB-URBAN LOCOMOTIVE

The illustration shows the new tandem compound tank locomotives for suburban work on the Paris Ceinture railway. These engines weigh 62 tons and require no tender. The drivers are 5 ft. 2.9 in. diameter. The high pressure cylinder is placed first in front of the leading driver, and is 12.9 in. diameter; low pressure cylinder 21.26 in. diameter; stroke 23.6 in. In starting, both cylinders can be made to work on live steam by moving a lever. Other details are: Fire

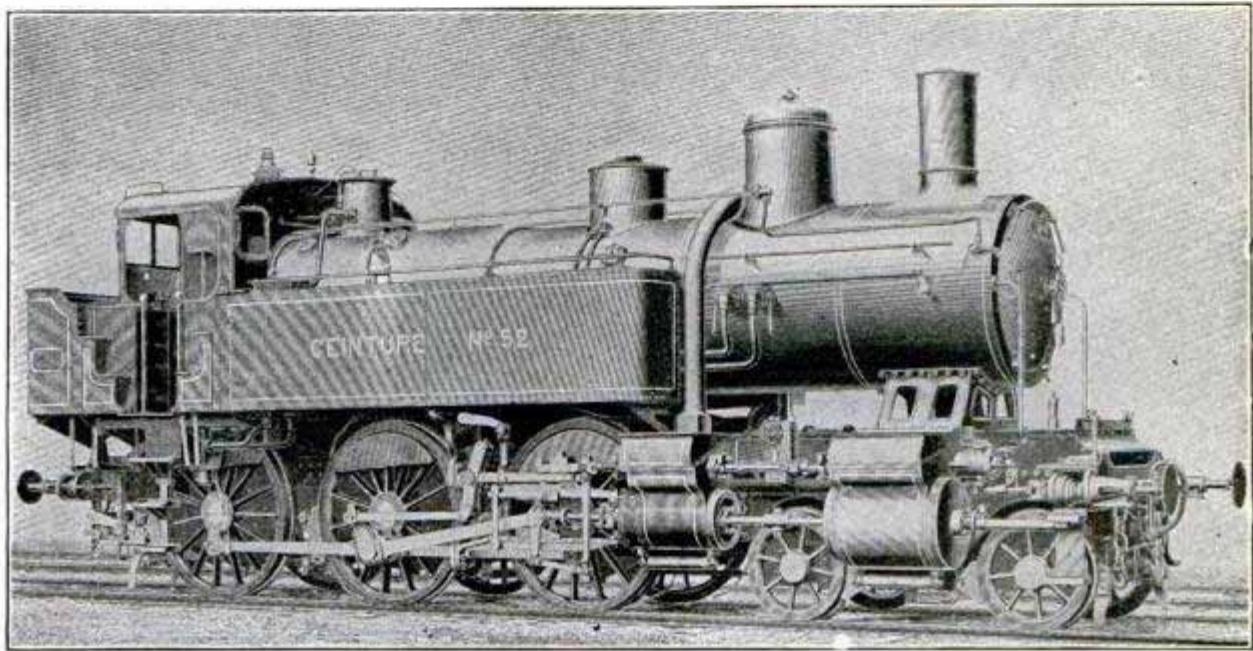

New French Compound Suburban Engine

When the British entered on the Boer war their field guns were out-of-date. New guns were supplied by the German firm of Ehrhardt, on short notice, and these guns have proven so serviceable that the British army has adopted them extensively into service. Ehrhardt steel, of which these guns are made, is said to offer great resistance to the strain of rapid firing.

HILLS TO STOP TRAINS

One of the elevated roads in Chicago is rebuilding its track and will raise the rails at stations to make a "hump" 3 ft. high. This will not only assist in bringing the train to a stop, but the down-grade assists in starting again.

Fifty thousand tons of welded chain were made in this country last year, making it the largest producer in the world.

grate area, 24 sq. ft.; tank capacity, 1,100 gallons; fuel, 3 tons; working pressure 227 lbs.

SIDE LIGHTS ON VESSELS

Red and green side lights on steamers were first required to be carried by the British Admiralty by act of Parliament, January 1, 1847, and the regulation was adopted by the United States navy in 1848. British sailing vessels, however, were not required to carry these lights until 1852. The British shipping act or rule of the road went into effect for British shipping in 1862 and was adopted by the United States in 1864 and is in substance the recognized rule of the road at sea throughout the commercial world. Act of Congress of March 3, 1849, provides that steam vessels under way at night on the Great Lakes shall show the white, green and red lights substantially as at present.

EXPERIMENTS WITH ARTIFICIAL WINGS

English Scientists' Feathered Craft Has Lifting Power of 100 lbs. in Each Wing

Several English scientists are conducting some interesting and promising experiments with a pair of artificial wings operated by a $3\frac{1}{2}$ -hp. gasoline engine. It has been found that in a bird the wings are so shaped, and the feathers in the wing so shaped and located, that during the upward movement of the wing there is the least possible resistance to the air, and even that considerable air actually passes through the wing. On the downward stroke the reverse is true, as the feathers close and



Ready to Be Launched on the Air--Ohio

not only afford a lifting motion but a forward one as well.

As a result of these observations they constructed a pair of mammoth wings as nearly approaching those of a crow as possible. These wings were hung from a frame in such a way that a rise of 2 ft. was possible. To the wings was attached the engine and machinery for wagging, and the whole was mounted on four wheels to permit a forward motion. The wings measured 20 ft. from tip to tip and had 60 sq. ft. of surface, and were operated at 100 flaps per minute. It was found that at this speed the wings lifted bodily the engine and machinery, weighing 232 lbs., the limit of the confined space—2 ft. In other words, each wing was estimated to have a lifting power of more than 100 lbs., together with a considerable forward movement.

An Ohio inventor is working along somewhat similar lines, except that his wings are made of real feathers, while in the English experiments the "feathers" were artificial.

The American inventor, C. E. Irish, used strong turkey wing feathers in constructing his flying-machine. Altogether the machine has 26 pairs of wings and thou-

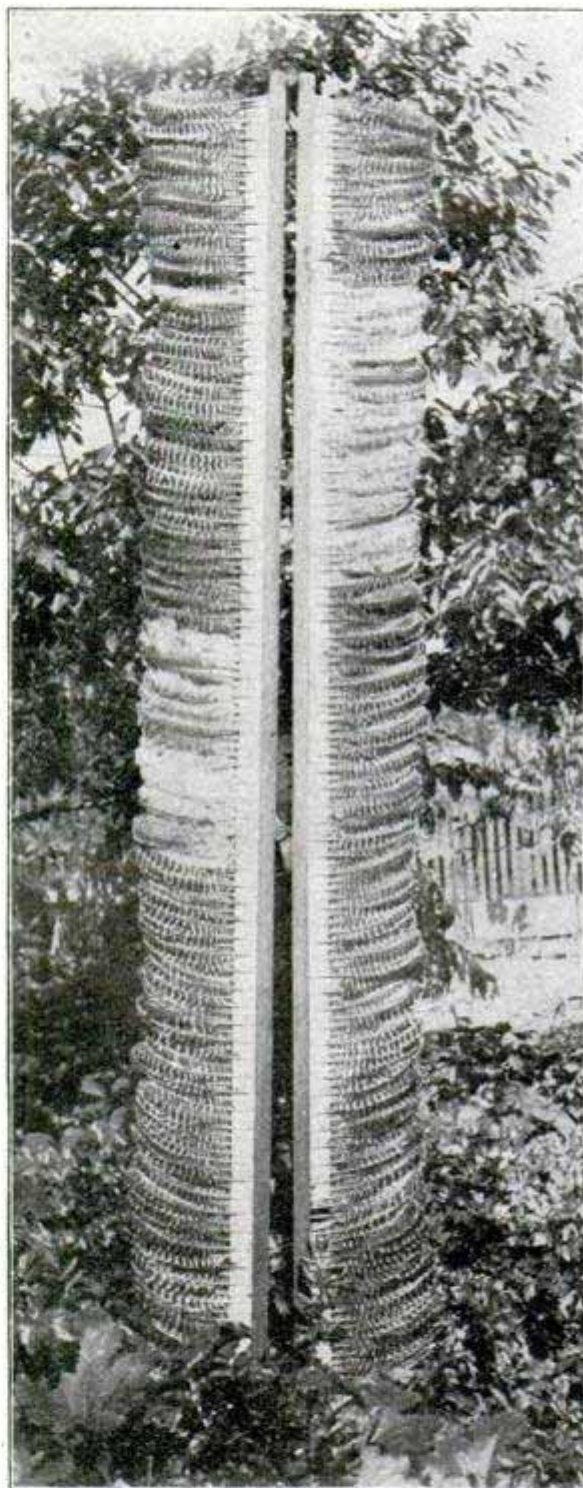

One of the 26 Pairs of Wings--Ohio

sands of feathers were required for them, every feather being glued into place separately. The wings are attached to a light framework, shaped somewhat like the breastbone of a bird. The machine is mounted on wheels and to start it must first be run down an incline, then launched on the air by taking an upward tack.

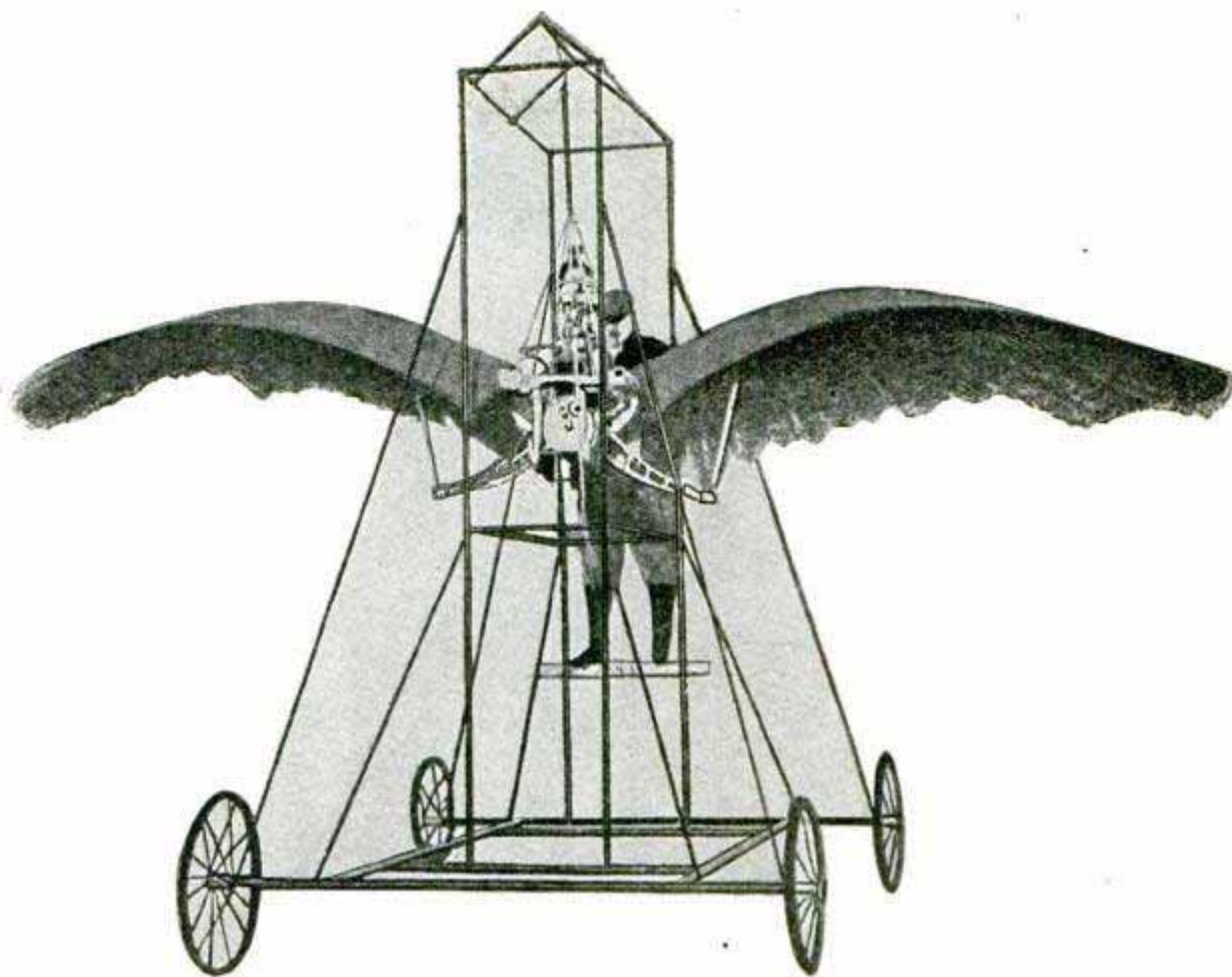

"They Constructed a Pair of Mammoth Wings."---English Flying-Machine

No engine is provided for propelling this craft, the inventor declaring that by a scientific study of birds and application of their principle of flight, he will eventually accomplish with his machine what every one else has fallen short of: The free, untrammelled navigation of the air. In flight, the control of the machine will depend

entirely on manipulation of the wings.

Mr. Irish proposes to utilize gravity by making a sudden upward tack every time the machine gains a certain degree of acceleration by downward flight. His project, though still a dream, forms a unique chapter in the certain evolution of aerial navigation.

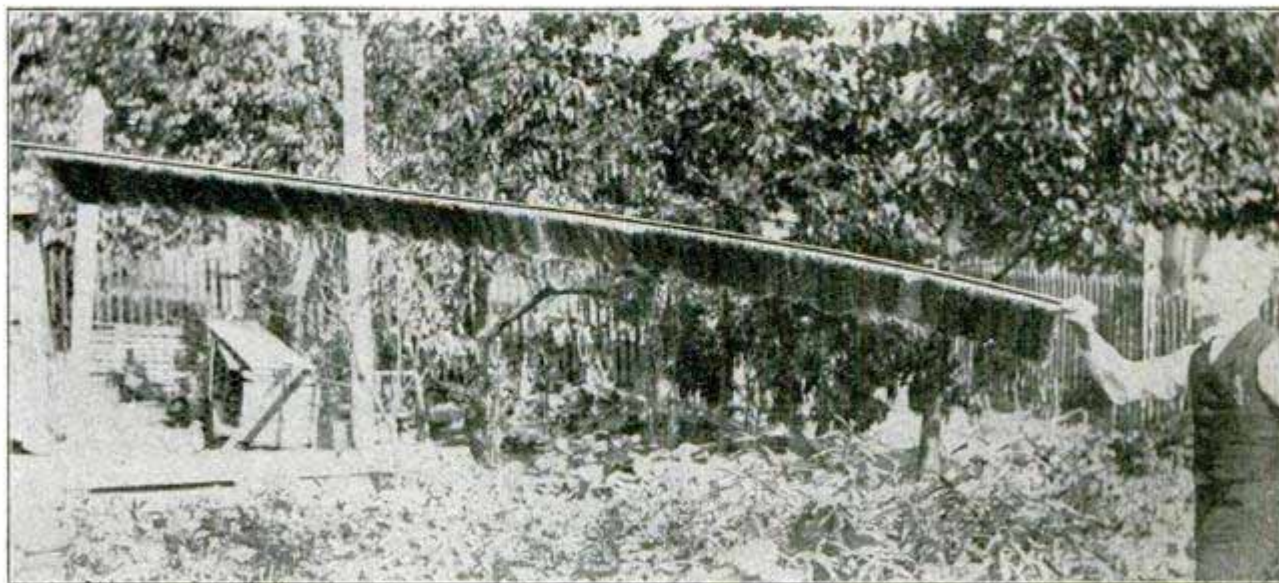

A Single Wing--American Experiment

DEVICE TO RESCUE SUNKEN SUBMARINES

Submarine Sailing Most Perilous of All Work Undertaken by Army or Navy

The operating of a submarine boat is today the most perilous of all duties required of soldiers or marines. Every time the

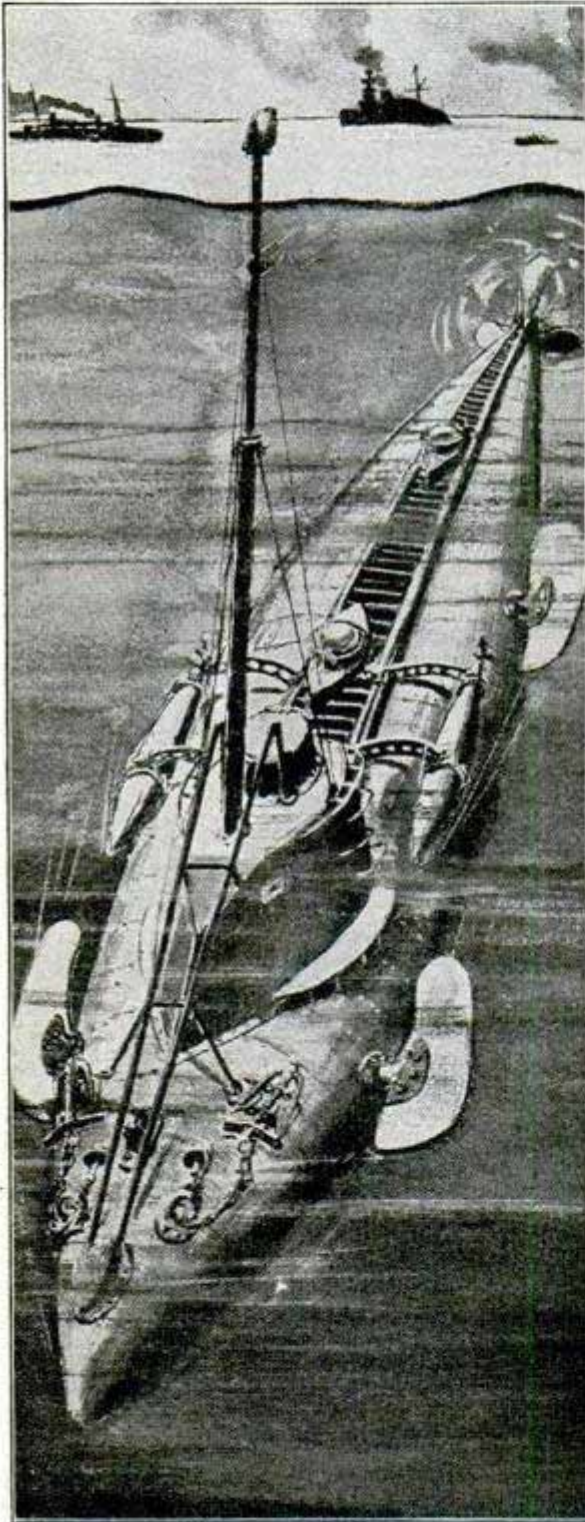

The Lost "Farfadet"

officers and engineers enter one of these craft and hear the hatches close above them, they do so with the full knowledge that they may never return alive. The service requires not only men who are highly proficient in the operation of the delicate machinery which operates the craft, but men who do not know what fear of danger is. The failure of any one of a hundred parts of machinery means death in its most terrible form. Not annihilation in an instant, as with the bursting of a shell, or a magazine, but death painful in the extreme, and extending over several hours, as inch by inch the supply of air is steadily consumed, until finally the last vestige of vitality is exhausted and the victim who has lain helpless through an eternity of torture sinks into a grateful unconsciousness.

The four disasters to submarine boats during the past few months, with the accompanying terrible loss of life, is causing engineers to seek some method of relief. The accident to the French submarine "Farfadet," in which the 13 occupants died, was especially heartrending. When the dive was made one of the hatches was poorly secured and water poured into the vessel, which sank to the bottom in deep water. Divers who were sent down reported signals from the men confined for two days, showing they lived until the supply of compressed air was entirely exhausted. Time and again the boat was brought to the surface, only to slip from the hoisting ropes and chains before the prisoners could escape. Meanwhile the agonized members of their families stood on the docks day and night, watching the efforts of the wrecking crews.

The "Farfadet" was maneuvering in the harbor of Sidi Abdallah, Tunis, and descended at 9 a. m. on July 6, and was finally recovered on July 15. Every attempt at hoisting with ropes and chains failed owing to the inability to securely attach them. A floating dock was finally sunk, the submarine pulled onto the dock, and the dock inflated with air, when it came to the surface with its burden.

An English naval architect, S. H. Terry, now suggests the use of two steel buoys, one to be carried in a recess in each end of the boat. These buoys to be 3 ft. diameter by 2 ft. 6 in. deep, with a lifting power of 500 lbs. each. To each buoy would be attached a steel rope with a breaking strain of 120 tons, the rope wound around a drum. When a submarine becomes disabled and unable to rise, levers within the boat would release the buoys which would immediately rise to the surface,

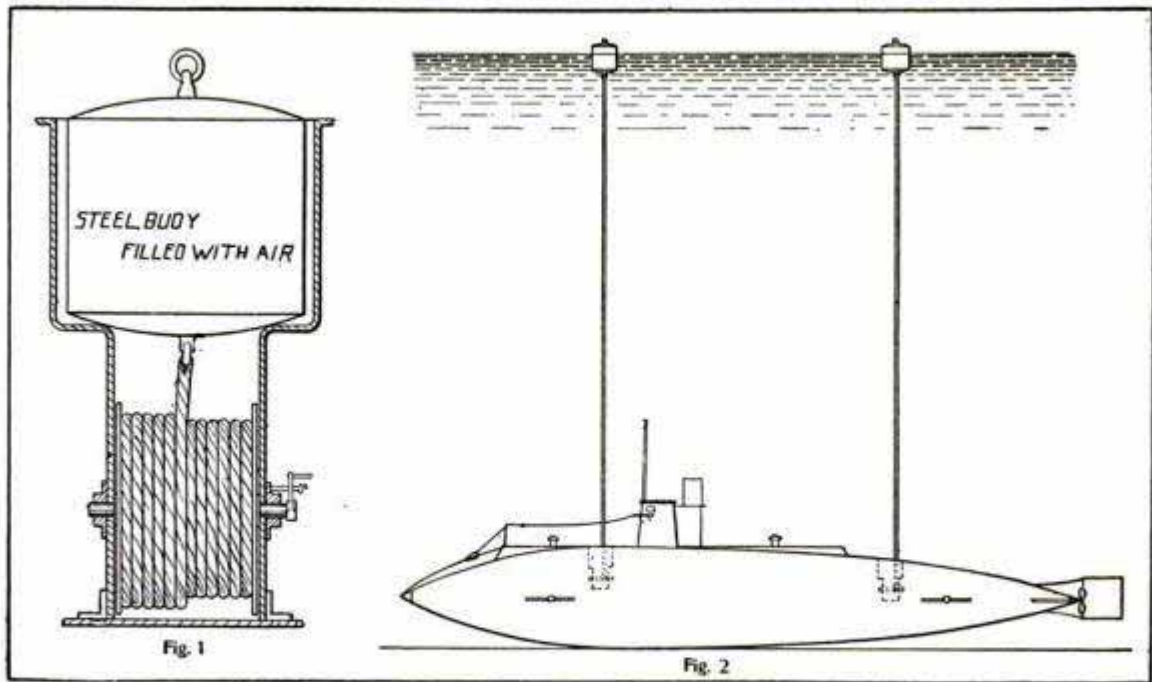

Proposed Plan to Rescue Sunken Submarines

taking the ropes with them. By means of these ropes almost any other boat could raise the submarine without loss of time. The buoys would also greatly facilitate the location of the boat. Mr. Terry says:

"As it seems scarcely likely that the field of work of submarines will ever be in deep water—deeper than, say, 120 ft. to 150 ft.—and as, if they work in water deeper than this they may possibly collapse, I have only provided for salving them from a moderate,

reasonable and workable depth—such a depth, in fact, as that in which those lamentable disasters usually take place. Had such lifting powers been available in the case of the A 1, near the Warner lightship, or in the A 8, the vessels could have been at once within half an hour, brought to the surface, and all lives saved.

"I abstain from all comments on the structure of the boats which renders the opening of a hatch nearly awash a necessity

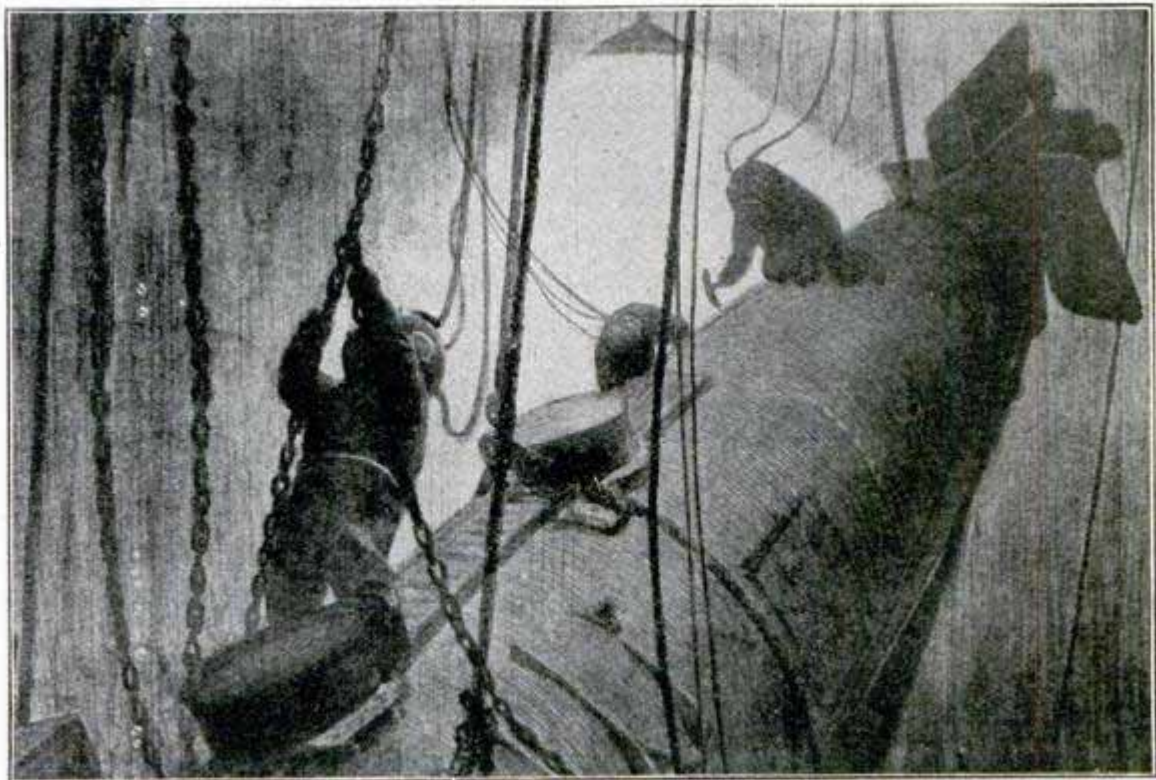

Divers Trying to Communicate with the Imprisoned Crew---Placing Slings for Raising the Vessel

when men have to pass in and out, and on the regulation which compels them to wear a dress in which it is next to impossible to swim.

"It is evident that when submarine boat drill takes place, a salvage vessel, with all diving apparatus, and with lifting apparatus should accompany the boats."

LEARNING TO RUN A TROLLEY CAR

Less skill is actually required to run a trolley car than to drive a horse car, especially if the trolley car has air brakes, as most of them have in these days. At the same time there are certain essentials without which a man is not safe to trust out on a busy street with such a forcible affair as an electric car with full power turned on.

The horse car drivers used to learn on a little piece of unused track kept for the purpose back of the street car barns; the motormen on the large city lines learn in a school provided for the purpose by the company. In this school a row of controllers such as are found on the street cars, are set up on a platform and here the students, 10 at one time, are instructed in the arts of starting and stopping a car and working the hand and air brakes. The instructor also stands on a platform where he can watch the work of the men as he gives the bell signals again and again until the good



Courtesy St. Ry. Journal

Teaching Motormen

ones are retained and the dull ones rejected. The most difficult part is to teach the men how to operate their cars without using more power than is necessary.

All electric arc lamps in London will be replaced with incandescent gas lights for street lighting. With the improved gas lamp, it is said, ten times as much light is procured as with the electric arc light, at the same cost.

PORTABLE SUCTION GAS PRODUCER AND ENGINE

The success of the suction gas producer in connection with stationary engines in England has led to the manufacture of a portable type. The outfit illustrated is 12½ h. p. and weighs 5 tons. The truck frame

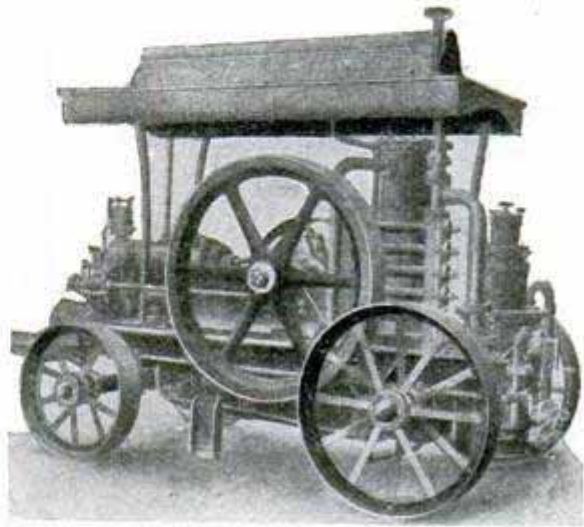

Portable Gas Producer

is steel with as much of the machinery as possible carried close to the ground. The gas producer is air cooled, thus greatly reducing the amount of water required. A small quantity of water from the canopy is allowed to flow into the coke scrubber, so as to keep the coke moist, and more thoroughly to cleanse the gas before passing to the engine.

TUNNELS TO REPLACE SNOW SHEDS

Millions of dollars will be spent by the Central Pacific railroad in constructing tunnels through the Sierra Nevada mountains. This will be done to save the great sums annually required to maintain the present snow sheds and at the same time secure shorter routes and reduced grades. Five great tunnels are already decided on, one of them five miles long. The snow shed was considered a marvel of engineering when first established, but will soon become a thing of history.

In 1904 this country produced 27,644,330 tons of iron and consumed in manufactures 30,224,910 tons. In 1902 we consumed 35,886,921 tons (highest record ever made); and in 1903, 34,232,399 tons.

WIRELESS TELEGRAPHY IN THE AMERICAN NAVY

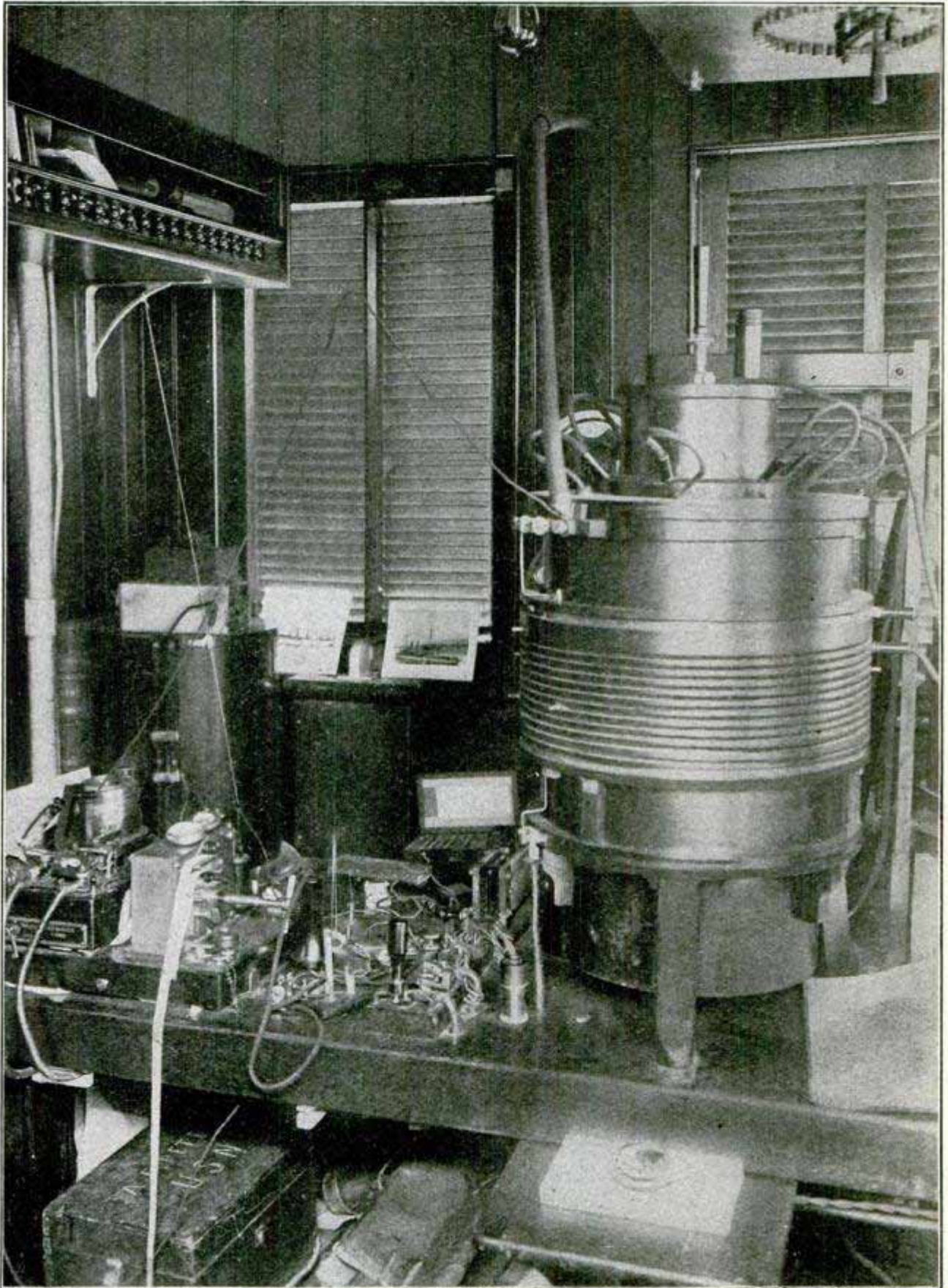

Copyright, 1906, by Walden Fawcett

The Wireless Telegraph Station installed on Board the "Chicago"

CURING OF CEMENT BLOCKS

[Excerpts from paper by James Wimmer, read before the Iowa Cement Users' Association]

I, of course, consider nothing but the perfect block. This means sharp, clean sand, good cement, proper proportions, thoroughly mixed, thoroughly tamped, and placed in the shade. A block well made but badly cured, is worthless, and a block poorly made and well cured is worthless, so great care must be taken in all stages of block manufacture.

One of the most important features of block manufacturing is the curing process. A block must cure uniformly. The primal requisite in proper curing is water, and plenty of it. No stated time can be given for beginning the sprinkling, as all depends on the atmospheric conditions. Some days you can begin sprinkling three hours after the block is molded, while at other times five to eight hours will elapse before you can apply water with safety. The moment you

We hear of some people who advocate the process of curing blocks under water. My actual experience tells me this is a failure, for two reasons: First, it is not practical; second, it means extra labor and expense. Imagine what an area it would require to submerge the product of five days' labor, which means about 600 blocks from the average machine.

COMBINED LOCOMOTIVE AND CAR

An English firm is building some novel combination locomotive-cars for the Hungarian State Railways, with the prospect that the same type will be adopted on English roads for light service. The car weighs 14 tons, of which one-half is on the drivers, and carries 33 passengers in two compartments. The engineer and machinery occupy a third compartment, while a fourth is used by the conductor and "guard."

The engine is a high speed horizontal

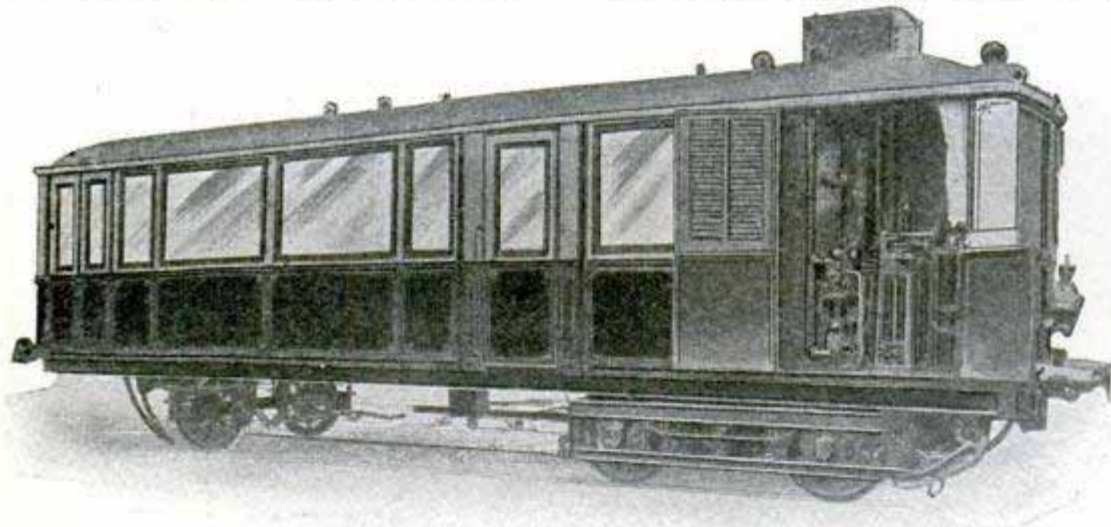

Weight 14 Tons; Speed 30 Miles; Carries 33 Passengers

detect the face of outer surface turning light, it is a sure sign the blocks need water, and they must be sprinkled as often as this is noticed. You can not make them too wet. This process should continue for at least forty-eight hours, or until the block can be removed from the pallets, lathed and piled. By lathing each tier the blocks dry uniformly. This water cure continues from five to eight days. All of our sprinkling is done with hose and spray, and this is carefully attended to by one man. We have found that blocks can only be successfully cured by one experienced man. What is everybody's business is nobody's business, and the blocks can not and must not be neglected.

compound with cylinders 4.7 in. and 7 in. diameter with 5½-in. stroke, and runs at 600 r. p. m., producing 35 h. p. The engine is suspended from the truck and drives by means of a spur gear, of which there are two for securing power in starting, or speed when running, as required. The gears are thrown in or out by a friction clutch. The boiler is vertical 32 in. diameter, 45 in. high, and fired from the top through a central tube; it carries 270 lbs. steam. The car makes 30 miles an hour, using 6½ lbs. coal and 4½ gal. water per mile, and is intended for short or branch lines or for late service where it would not pay to operate a train. Cost of operation is 15 cents per mile.

EFFECT OF IRON AND PNEUMATIC TIRES ON ROADWAY

Dust on roadways is largely caused by the chopping action of the sharp pointed steel shoes worn by horses. If the horses could be removed and all wheels rubber-tired there would be comparatively little dust. The effect of an iron tire is to dig into the softer portions of the road surface, and to crush uneven portions.

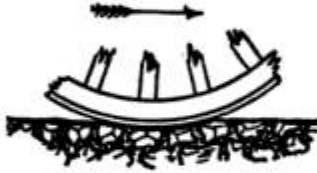

Iron Tire Crushes

Technics, London, illustrates the effect of the two tires. The pneumatic tire flattens

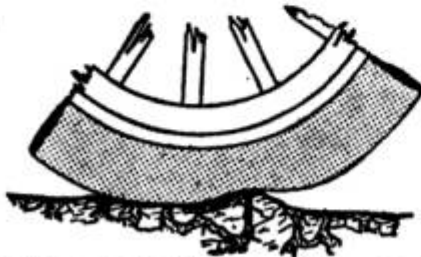

How a Pneumatic Tire Absorbs an Obstacle

like a ribbon, and adjusts itself to the inequalities of the surface, but in resuming

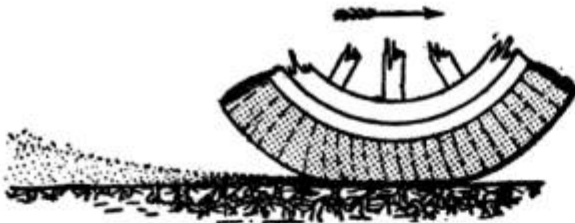

How a Pneumatic Tire Throws Up Dust Without Pulverizing the Road

its shape throws off the particles which have been raised by the vacuum it produces.

An old man at Mirror Lake, Wis., employs a unique method of propelling his boat and fishing at the same time. At the stern of the boat is a paddle wheel like those used on river steamers. A chain runs on cogs from the wheel to a crank, which the old man turns with one hand while he handles his lines with the other.

The structural steel business is lively this year, and it is said that the demand for material for railroad bridges exceeds former years considerably. Other branches are likewise rushed. There is much new railroad work and the orders for equipment and track supplies are pouring in.

JAPANESE TEACHING RUSSIAN TO RUSSIANS

One of the most unexpected things that has ever occurred in connection with any war is now being successfully done at Himeji, Japan. At this town are confined the 70,000 Russian prisoners of war, mostly from Port Arthur, nine-tenths of whom are illiterate. With a desire to improve their minds the Japanese government has established in the prison a school to teach the illiterate Russians *their own language*. The Japan Daily Times says: "Thanks to the teaching, those soldiers who were totally illiterate are now able to write letters to their homes. It is stated that the authorities of the quarters are receiving inquiries from Russia asking if the letters were really written by the senders."

This certainly is one of the most unusual events ever produced by any war, and is as creditable to the Japs as it is valuable to the Russians. The Kobe Daily News now issues an illustrated weekly called "Japan and Russia" for the prisoners. "The magazine is to keep the 70,000 Russian prisoners now in this country informed about the general situation at the front and the attitude of the various powers in connection with the war, as well as to acquaint the prisoners with the characteristics of our people, thus preparing the way for mutual friendship and confidence between the two nations after the restoration of peace. The first number contains nearly twenty beautiful illustrations in half tone."

No wonder the Russians are not over anxious about being released.

SAULT SAINTE MARIE CANAL

With suitable honors in which high government officials of the United States and Canada participated, the fiftieth anniversary of the canal was celebrated on August 3. This canal is the gateway to Lake Superior. The first canal was projected by S. T. Mason, the first governor of Michigan, in 1839; work was begun in 1852 under government control, and completed in 1855. The locks have been twice reconstructed and enlarged. The American lock is 800 ft. long and 100 ft. wide; the Canadian lock 1,000 ft. long. No tolls are charged. During the past 10 years 253,000,000 tons passed through the canal, a much larger traffic than passes through any other canal in the world.

QUEER STREET CARS FOR AFRICA

An American firm of street car builders are shipping some odd street cars to Cape Town, South Africa. These cars are divided into three compartments, one for first-class

hundreds of offices hot water and ice water are supplied. Filtered ice water flows day and night throughout the year by the simple opening of a faucet. But not a pound of ice is ever taken into the building; the cold water, like the hot water and the elec-

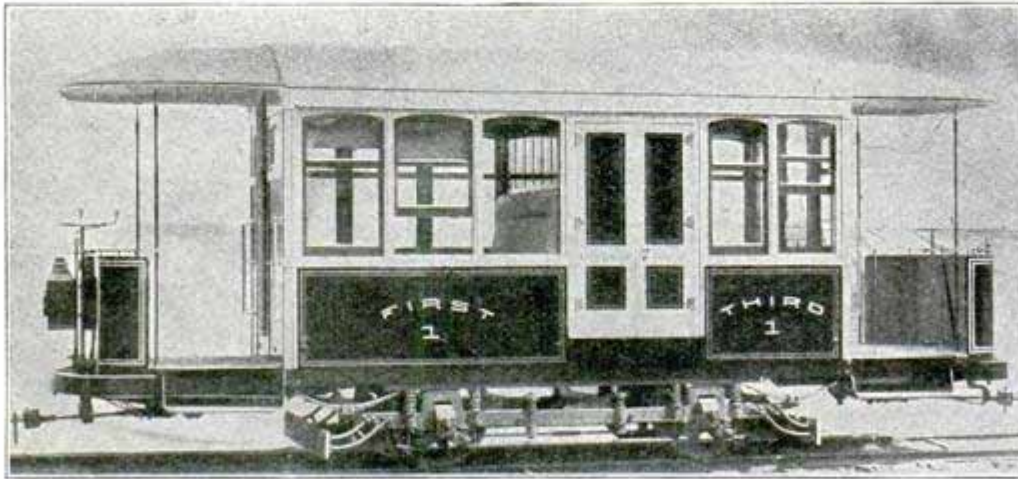

Courtesy Brill Car Co

Cape Town, Africa, Street Car

passengers, seating four people, and making a room about 6 ft. by 7 ft.; another compartment for baggage; and a third for third-class passengers. What happens to the second-class passengers is not stated; perhaps they get out and push. The body of the car is 15 ft. long, with windows that can be pushed out of the way, making a semi-open car in pleasant weather.

REFRIGERATION FOR OFFICE BUILDINGS

The modern sky-scraper office building, with as many acres of floor space as a good-sized pasture, is not only heated and lighted with its own plant, but in each of the

tric light, has its own individual "plant."

The refrigerating plant is similar to those used in cold storage houses. Such a plant in one of the new buildings in Chicago has a capacity of 800 gallons of filtered drinking water per hour at a temperature of 35 deg. The temperature of the water on the 20th story is 45 deg. The refrigerating machinery is operated by electric motors, and after the water is cooled it is pumped by electric pumps through pipes to all parts of building.

From drinking warm water from a jug brought out to the harvest field by a bare-footed boy, to imbibing filtered ice water at 40 deg. in the palatial office of the up-to-date building is a long step, but many of the best men now occupying luxurious quarters have made the trip.

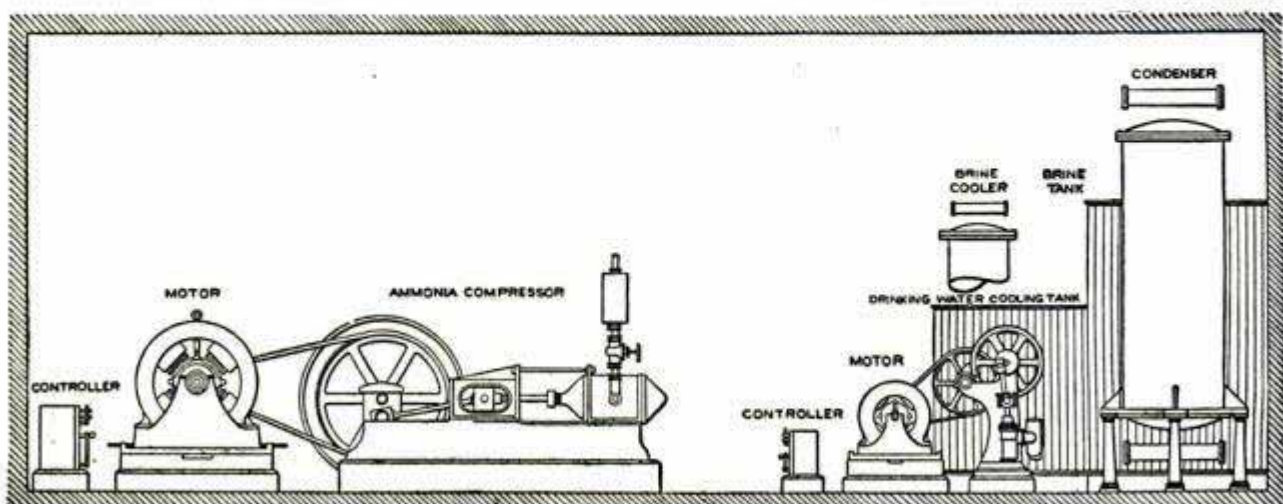

Water Cooling Plant in the Largest Office Building in the World; Chicago

WHY RAILS FAIL IN SERVICE

A good rail is of the utmost importance, but very few of the millions who ride in safety over the thousands of miles of steel have any conception of the skill and care required to produce a first quality rail. When rail is being rolled a careful selection is made not only of the steel itself but any rails which show imperfections are either thrown out or sold as "seconds", and used for laying side tracks or on lines where the traffic is light or infrequent.

Notwithstanding the rigid inspection through all the process of making, shipping and laying, a rail may be perfect to all appearances, and yet be unsound within. This condition can only be discovered by sawing up the rail, making it unfit for use, or by demonstration under actual service. Fortunately unsound rails rarely ever give way all at once, but show their unfitness by a gradual breaking down, so that there is opportunity to take them up before a condition of serious danger occurs.

An eastern road, which has made unusual records, covering a period of many years, gives the following as the chief causes of rail failure in service: (1) Pipes in the steel; (2) Presence of a considerable proportion of blowholes; (3) Excessive segregation; (4) Coarse granular structure; (5) Rough handling.

Robert Job, chemist for the Philadelphia & Reading Ry., says: "To sum up, the results of our investigation indicate that the greater part of the difficulty which occurs today with rails under heavy traffic is due to unsound condition of the steel, a condition which existed in comparatively slight degree in the earlier rails."

BIGGEST AIR-SHIP EVER BUILT

The biggest air-ship ever built made a successful ascent to 2,400 ft. from the Alexandra Palace, on July 22. The ship has a cigar-shaped gas bag 150 ft. long, beneath which is a bamboo frame and deck 123 ft. in length. It is propelled by two 50-hp.

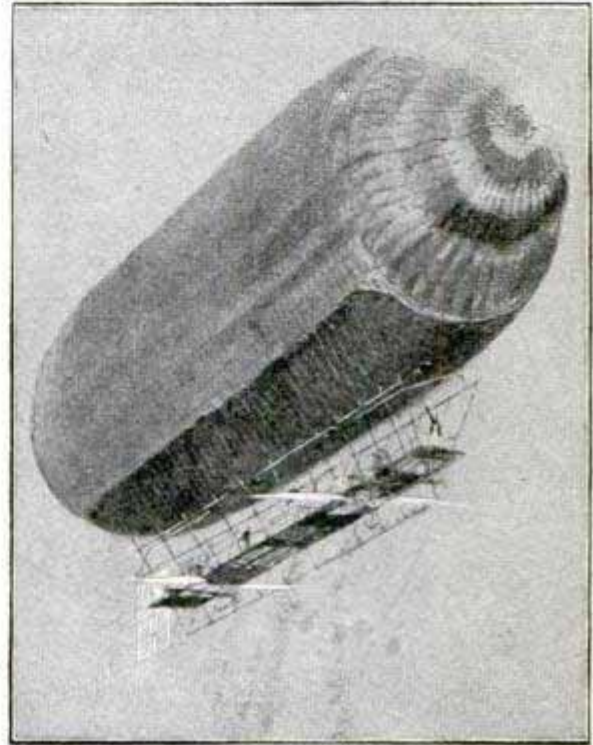

100-hp. Air Ship

gasoline engines, which drive four propellers. The ship was built for the English War Department. Four aeronauts made the ascent, the ship having the greatest lifting power of any yet built. The descent was successfully accomplished, but, owing to an accident while landing, the balloon had to be cut open and the car was wrecked.

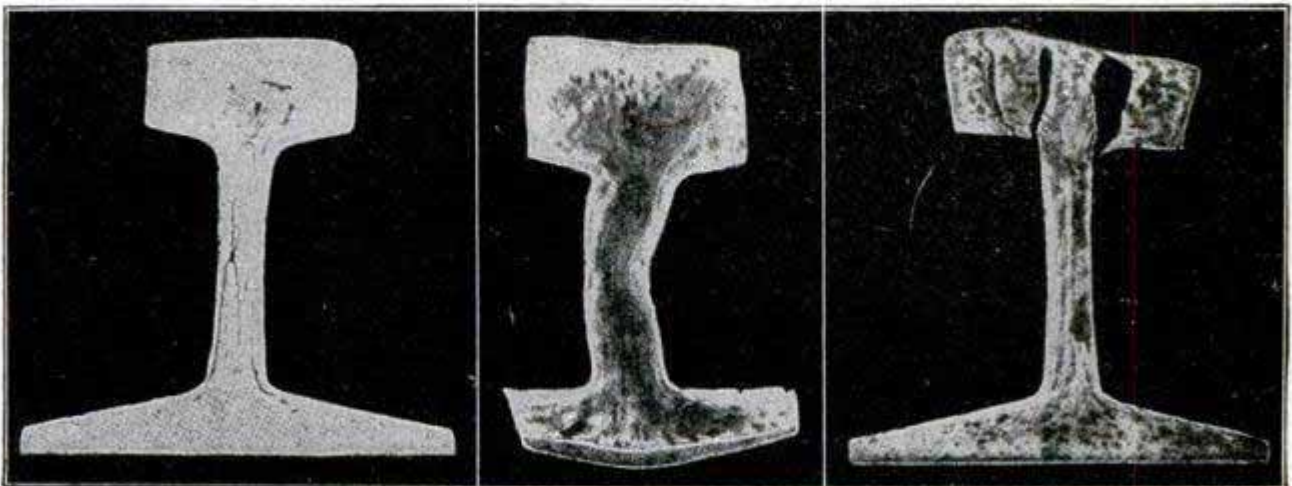

Pipe in Steel

Unsound Steel--Service
Five Weeks

Unsound Steel--Service
Five Months

HOW TO BUILD A MODEL YACHT

By Alex. E. Quinn, of San Francisco

Within the past few years the interesting and instructive sport of model yachting has become very popular in the sporting circles of San Francisco. This popularity has been caused principally by the efforts of a lately formed model yacht club, in the affairs of which some of the foremost citizens of San Francisco have taken a great interest. Quite a few of these men are naval architects, marine engineers, etc. Another vital reason for the great hold this sport has taken upon the San Francisco public, is the donation to the city of a fine lake, especially for the model yachting, by one of

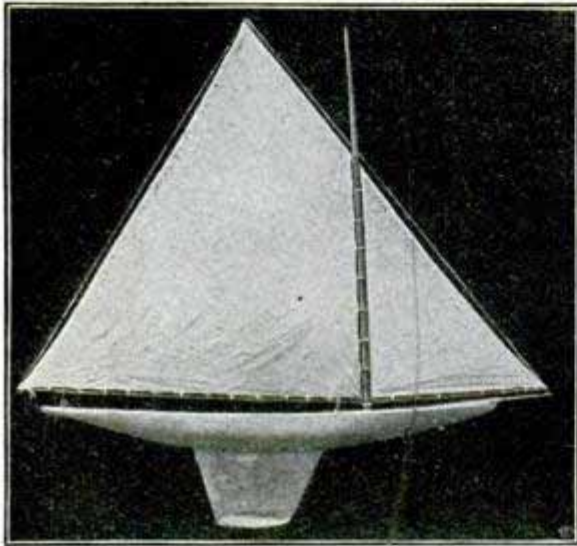

The Finished Model Yacht

our most public-spirited men, Mr. Spreckles, whose name the lake now bears. Lake Spreckles is situated in the beautiful Golden Gate Park, is about 250 ft. in diameter at its widest part, and around a portion of its edge a stone walk is laid, upon which the yachtsmen can easily go around from one side to the other.

On a Sunday or holiday morning you can see nearly half a hundred yachts of all sizes, shapes and rigs, sailing upon this lake, and the close contests between the different yachts furnish excitement and amusement for the large crowd of interested spectators.

Mr. Geo. W. Gickie, formerly manager of the Union Iron Works, presented a trophy cup to the San Francisco model yacht club, and this cup is held by the owner of the speediest boat in each special race; besides this cup many other prizes of all descriptions are won or held by the different competitors.

The yachts permitted to enter these races must not be over 50 in. on the load waterline, with a corresponding sail area of generally not more than 2,500 sq. in., being classified according to size, etc., in three classes.

The following will give an outline of how to construct one of these yachts. The first step is to build the hull, the best wood for this being cedar, and the best metal aluminum, the cedar boat (which will be described) is cheaper, but takes a longer time to build, as the wood has to be thoroughly seasoned, then shaped exactly on the outside to template taken from the lines of the plan; after which the inside must be hollowed out until the shell is about $\frac{1}{8}$ -in. thick, except along the keel, where it is advisable to leave $\frac{1}{2}$ in. of wood for fastening the aluminum fin which takes the lead, and along the deck line where it is best to leave $\frac{1}{4}$ in. thickness for fastening the deck to the hull. In order to make the hull perfectly watertight, it is best to first give it three coats of shellac on the inside, then to glue strips of light canvas or linen upon this and then give two or more coats overall. For a boat of 70-in. overall, 50-in. on the load waterline and a beam of 10 in., the hull must not weigh more than 7 lb. after the aluminum fin, Fig. 1, is fitted; the boat complete must not weigh more than 27 lb.

For ease in transportation the mast should be made portable, at the same time, however, the opening in the deck for the mast must be watertight, and this result is best

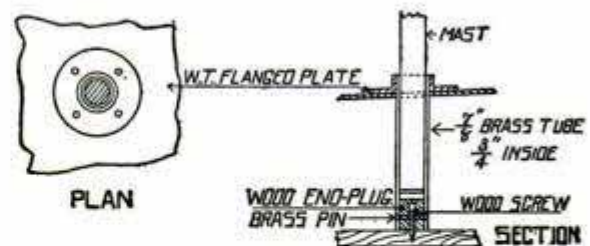

Fig. 2

obtained by placing a piece of $\frac{3}{8}$ -in. brass tubing over a plug secured to the keel by a wood screw (See Fig. 2). This tube is made long enough to project through the deck. To prevent turning, a pin is put through tube and plug. The mast may then be put in place or removed very easily. An aluminum flanged plate bedded in white lead is placed on the deck where the tube comes through in order to make it watertight.

The bow-sprit, (Fig. 1) is best made portable also, and the most suitable wood for this part is oak. The bow-sprit can be fitted to the deck of the boat by means of two brackets, the one at the end of the bow-sprit made with three legs, the other bracket need only be a common strap bracket. The material most suitable for these brackets is aluminum, as this metal is lightest and is not affected by water.

All the rigging fittings, such as rings, screw eyes, pins, etc., had best be made of aluminum also. Two aluminum travelers one for the gib and one for the mainsail,

must be about 2 in. or more forward of the center of buoyancy of the hull, because these model yachts are fitted without rudders and this is necessary for them to sail straight.

The lead for the size of boat mentioned is best cast in cigar shape and must have its center of buoyancy directly under the center of buoyancy of the hull, because if these two are not in correct relation with each other, the waterline of the boat will change, making the hull dip either forward or aft.

The aluminum fin on which the lead is fastened is best attached to the hull of the boat (if boat is finished natural wood) by

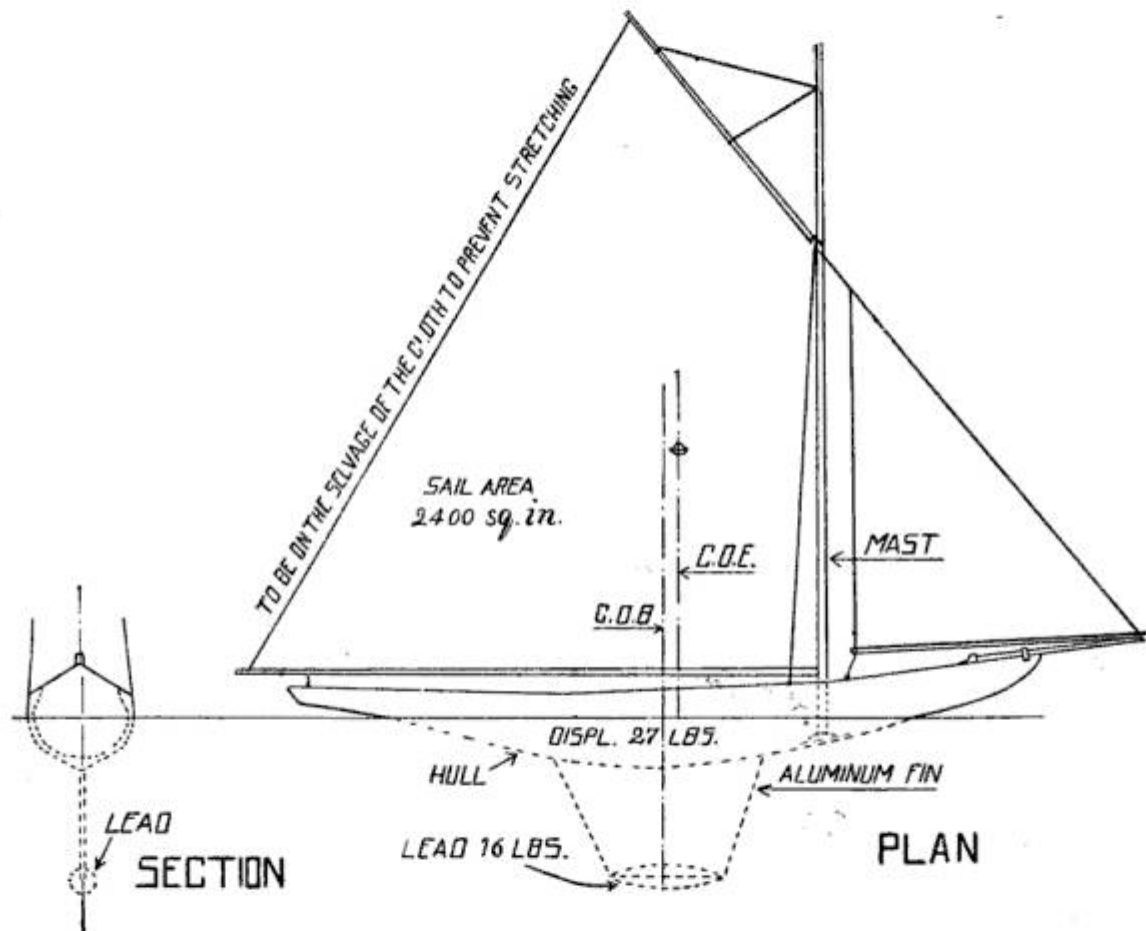

Fig. 1

must be fitted to the deck, so as to give the booms enough play. Both should be the same length, so the mainsail and gib will be on the same angle. This angle depends on the strength of the wind and can be found by experience in sailing boom stays to be fitted, so that they can be adjusted accordingly.

The best material for the sails is Lonsdale cambric. If care is taken to have the edge of the sail running from the gaff to the end of the boom, in the selvage, no trouble will be experienced on account of slack or baggy sails.

The center of effort of the entire sail area

means of two aluminum angles $\frac{3}{4}$ in. x $\frac{3}{4}$ in., or if the boat is to be painted or enameled, by cutting slots 1 in. deep and 1 in. apart, or as wide apart as will come out even, in the upper edge of the fin and then bending the squares alternately to right and left. The hull can then be recessed in way of these squares, in each of which three wood screws fastening it to the hull had best be put; in this way a very smooth job can be done. The lead may be fastened to the aluminum fin by slotting it lengthwise about half the diameter deep, then boring two or more holes through lead and fin, and fastening the lead to the fin by either bolts or

wood screws whichever you may prefer. In this manner the lead is easily made portable and its absence often prevents injuring the boat when not in use.

After your boat is complete it should get three or more coats of schellac, and the same number of coats of varnish, leaving at least an interval of two days between each coat. Before the last coat the boat should be rubbed down thoroughly with pumice stone so as to get a smooth and glossy surface.

HOW LIONS ARE CARRIED

For some reason, not stated, the express companies object to carrying lions as they do large dogs with simply a tag attached and the charges guaranteed. Each spring and fall a large number of these fierce animals have to be carried to or from winter quarters.



The King of Beasts Powerless

The moving of these ferocious beasts from railroad cars to dens would be a dangerous and difficult job were it not for the use of what is known as a "carrying cage," and also the skill of the workmen. This carrying cage is so built that the lion, if he be a large one, once inside has no room to move

either forward or back. The sides are of heavy planks which are reinforced with iron. The front is barred and the door at the rear is made simply of strong timbers. The cage is carried by means of cleats or handles along each side.

When a lion is to be transferred from his traveling den to the carrying cage, the two cages are placed end to end and then the doors are opened. In the front end of the carrying cage a piece of meat is placed, whereupon the lion leaps wildly toward it. As soon as he has passed the threshold the door of the carrying cage is closed behind him and he finds himself unable to back up, go ahead or turn around. Several men sit on top of the cage as the lion makes the leap forward. This keeps the cage from tipping over. For a very large lion it is sometimes necessary to employ a half dozen men in carrying the cage.

NEW SUGAR BEET HARVESTER

A new beet harvester which saves from \$5 to \$12 per acre over the old way of gathering sugar beets is now on the market. It consists of a knife something like a plow-

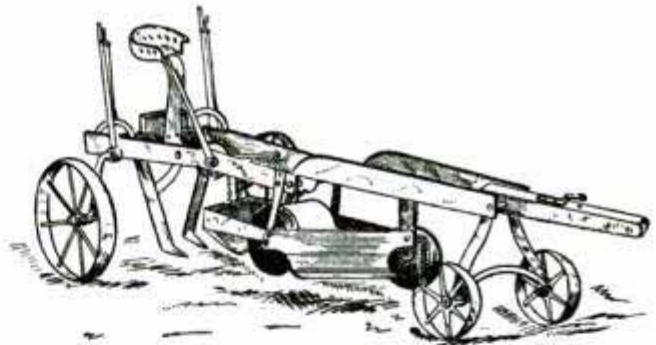

Beet Digger

share, which cuts off most of the foliage. This is followed by a roller which carries a topping knife, and conforms closely to the unevenness of the ground, and cuts off the stems close to the beet. The diggers which in turn follow remove the beets and throw them out upon the ground. These several operations are all performed by the one machine drawn by a team of horses at an ordinary walk.

GREAT LAKES SHIPYARDS BUSY

All the large ship building yards on the great lakes are full of work and their capacity engaged for eighteen months to come. Sixteen mammoth vessels are under contract besides many smaller craft.

THE FIRST SUBMARINE

Invented by an American 100 Years Ago--Called the "Plunging Boat" and Declared Impossible

A full century ago an ingenious American, Bushnell by name, conceived the idea of a submarine boat. Instead of the modern firing torpedo he planned to bore a hole in the wooden bottom of a vessel and so attach a charge of powder which was to be fired by means of a clockwork mechanism.

Bushnell's "plunging boat" bears little resemblance in shape to the submarine of today, but did embody all its main conditions. It was egg-shaped, resembling two large tortoise shells joined at the edges.

Propulsion was secured by means of two crude propellers worked by hand, intended to give either a vertical or horizontal movement to the boat. The "torpedo" consisted of a magazine of 150 lbs. of powder to be exploded when the clockwork reached a certain point. This exploding machine had to be set going before the boat started on its errand, hence the obvious necessity of the operator losing no time in placing it in position and making his escape. A trial was actually made in New York harbor in 1776, but Bushnell experienced the same difficulty his more modern successors have found—that of finding the enemy after his boat was submerged. While he was still searching, the clock ran down and the magazine went up, but strange to relate he escaped. The boat had a lead ballast which could be released when the operator desired to come quickly to the surface. Water ballast was employed, with a hand force pump for ejecting it when desired.

In 1800 Fulton, also an American, built a submarine in France, with money furnished by Napoleon, which, although

declared a success, was not actually used in warfare. Not until 100 years after the efforts of these two daring inventors did the hornet of the deep become a recognized means of warfare.

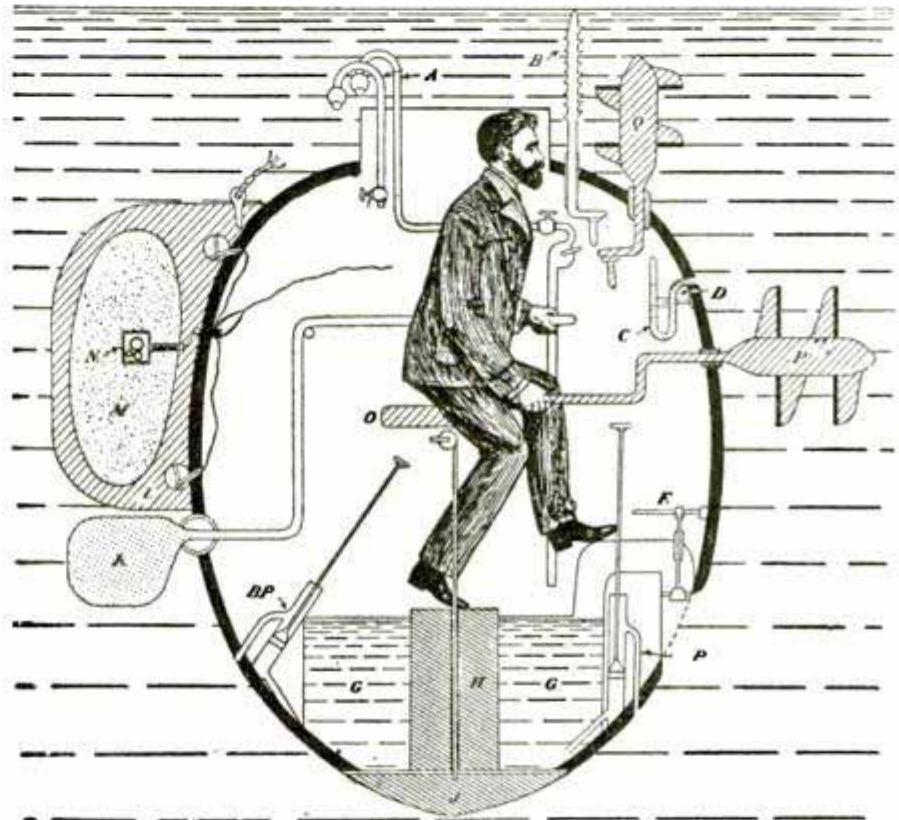

SECTION OF BUSHNELL'S SUBMARINE.

- | | |
|--|--|
| A. Air pipes. | G. Water tanks for adjusting buoyancy of vessel. |
| B. Wood screw. | H. Lead ballasting weight. |
| C. Pressure gauge, indicating depth of submarine below surface of sea. | J. Detachable lead weight. |
| D. Compass. | K. Steering rudder. |
| E. Valve for introducing water into tanks. | L. Magazine. |
| F.P. Force pump for removing water from tanks. | M. 150 lbs. percussion powder. |
| B.P. Bilge force pump for ejecting leakage water. | N. Clockwork for exploding powder. |
| | O. Strut. |
| | P. Propeller for horizontal propulsion. |
| | Q. Propeller for vertical propulsion. |

CLEANING THE GOVERNMENT MINT

Last year \$21,240 worth of gold dust was scraped from the nineteen chimneys of the United States mint during the annual cleaning. During the year \$50,000 of gold and silver dust were swept from the floors of the mint, while thousands of dollars were recovered by burning the work clothes of employes. The mint cleaning for this year is now in progress, every precaution being taken against loss of any of the dust.

JAPANESE BATTLESHIP "KATORI" LAUNCHED

The "Katori," the first of the two big first-class battleships now under construction in England for the Japanese navy was recently launched and in a few months will be ready to help uphold the dignity of Japan upon the high seas. The vessel was launched according to Japanese custom and was christened by a member of Japan's royalty—Princess Arisugawa. Instead of breaking a bottle of wine over the stem, when the vessel was released a cage of red and white cloth hung over the stem was opened and out fluttered a

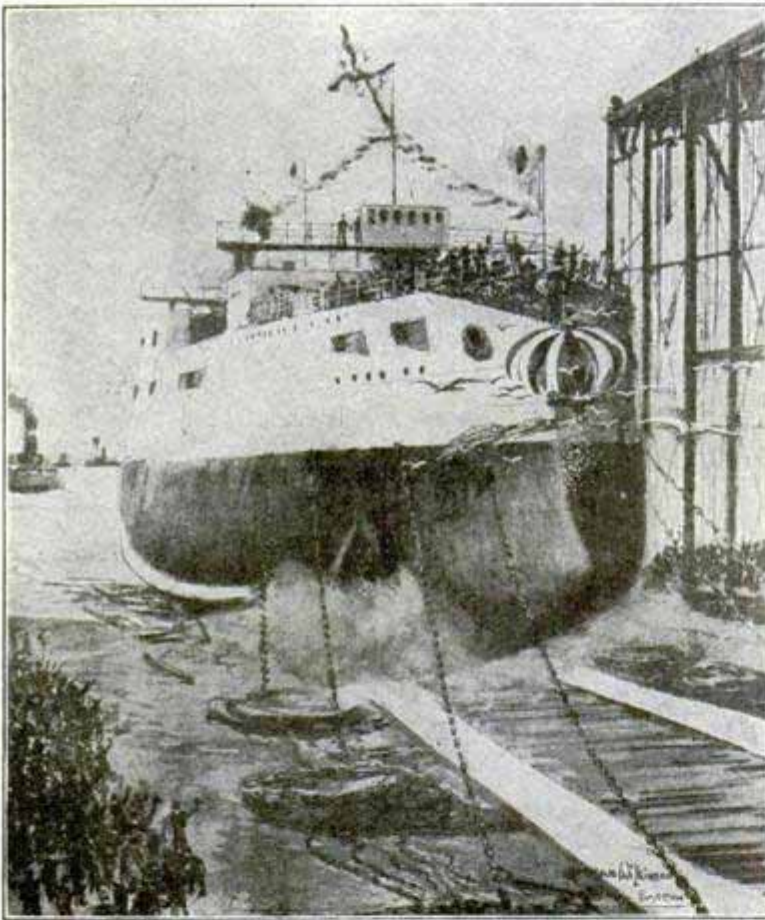

The New Japanese Battleship "Katori"

flock of pigeons and a shower of confetti—a Japanese ritual to their war god Kashima.

The "Katori" had the heaviest launching weight, 9,400 tons, of any vessel ever put into the water. When completed she will have a displacement of 15,950 tons. Her dimensions are: Length between perpendiculars, 420 ft.; beam, 78 ft.; draught, 20 ft. She is designed for a speed of 18½ knots. Her armament will comprise four 12-in. guns, four 10-in. guns, twelve 6-in. guns, twelve 12½ pounders, three 3 pounders, six Maxims and five 18-in. submerged torpedo

tubes. Her total ordnance is capable of discharging 24,800 pounds of shot per minute. The total coal capacity of the "Katori" is 2,100 tons. Her engines will develop 16,000 hp. There are 20 Niclausse watertube boilers in three separate rooms. The heating surface is 44,000 sq. ft.; grate area, 1,334 sq. ft. The vessel will carry 980 officers and men.

TIME-RECORDING CAMERA FOR TRAPPING MOTORISTS

A time-recording camera has been patented in England with which it is proposed to trap motorists who exceed the speed limit. The camera will take a photograph of any rapidly passing object and at the same instant photographs a watch also. The watch is in a special case which has an opening for inserting a card bearing the date.

To trap motorists, the over-speedy car is photographed by an officer with a time-camera at each end of a pre-determined stretch of boulevard and on the difference in the recorded time and the distance traversed the speed is determined, while the occupants of the car may be identified by photograph, also.

Each watch has a registered number, and is sealed in its case, making a trustworthy record for court use.

FOOD DEPOTS ON DESERT ISLANDS

The New Zealand government has provided for castaway crews by establishing depots where food and clothing may be obtained on several islands off the coast. Not long ago a French crew, shipwrecked and cast upon the Auckland islands, were sustained for a considerable period by this thoughtful provision. At most of the islands a boat is left, also, while finger posts point out the way to the depots. The government steamer visits most of the islands twice a year, and no island is visited less than once a year.

The policemen of Chicago have discovered a new method of dealing with auto scorcherers. A bullet hole in one tire brings them to a stop every time.

THE HARNESSING OF HEAT

PART IV.—The Steam Engine

Having now traced the evolution of heat up to the point where it has imparted its energy to a mass of water, changing the latter into steam, it remains for us to see how this energy is made to do useful work. That a mass of heated steam is capable of doing work is shown by the fact that it exerts a pressure, tending to move the confining walls of the boiler outward. The problem before the engineer then, is to so apply this steam that the greatest amount of useful work may be accomplished, with the least amount of waste.

The accompanying diagram shows the common arrangement of boiler and engine, so familiar to every one. Let us trace the transformations of energy which take place. Underneath the boiler is the coal, with its store of energy which we wish to make use of. We burn the coal, and its stored up energy is changed to heat energy; the heat gives its energy to the water in the boiler, changing it into steam, whose energy is shown by the pressure it exerts. Conducted through the pipe P to the valve chamber V, it is led into the cylinder C, in such a way as to push the piston H, and its connected rod R, first in the one direction and then in the other, producing rotation of the wheel W. Thus our transformation from the energy in the coal to the energy of the rotating wheel is complete. But notice this—there has been no energy created at any stage of the process. All that we have done is to take the energy given us by nature, and to transform that energy as best we can into the form which we wish it to take. Note this also—that such a transformation is not a perfect one. That is, do what we will, all the heat energy will not be transformed into mechanical energy. Not that any energy can ever be destroyed, but that some of the heat refuses to enter into the process, and persists in escaping into surrounding space at every available point. Thus there is loss by radiation from the boiler and its settings, by radiation from the connecting pipes and from the engine itself, and last of all there is a loss in the heat generated by the friction of the engine.

One point of great importance in regard to the engine is this—that the expansion of the steam when it pushes the piston this way and that, is done at the expense of its own heat. In other words, expansion lowers its

temperature, and the useful work which we get out of the steam robs it of its heat energy. Obviously then, we desire to allow a given mass of steam its fullest possible expansion in the cylinder. So, if a simple engine were used as in the figure, the cylinder ought to be very large and long. For mechanical, as well as for other reasons, this is undesirable; so instead, we use two or three or even four cylinders, sending the steam through them in succession, allowing it to expand a little in each one, instead of attempting to perform the expansion in one cylinder. But in any case, the more the steam expands, the lower its temperature,

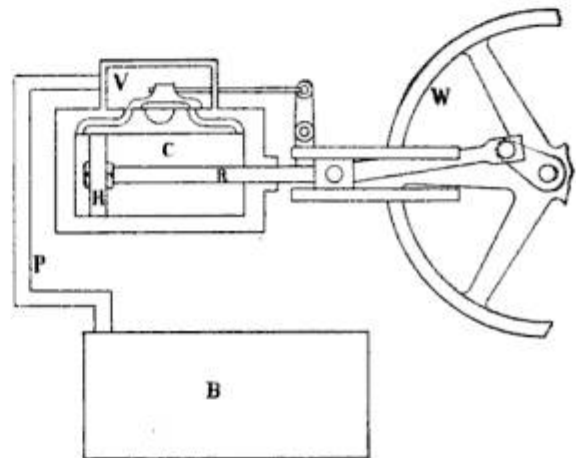

and finally, having given up all the heat which we can extract from it, the steam is rejected through the exhaust pipe. Thus the steam serves simply as a medium for the conveyance of heat. It is not the steam, primarily, that does the work, but it is the heat that is contained in the steam.

It must not be supposed that the cylinder is filled and emptied with steam at boiler pressure, at each stroke. There would be little expansion if this were the case, and consequently only a little of our available energy would be realized. As every engineer knows, the supply of steam is cut off when the engine has made a fraction of each stroke, and during the remainder of that stroke the work performed is done by the expansion of the steam already admitted.

Theory shows that the efficiency of a steam engine depends upon two things—first, upon the temperature of the entering steam; second, upon the temperature of the exhaust steam. The higher the temperature of the former and the lower the temperature of the latter, the greater will be the efficiency. The

natural way of increasing the initial temperature is to increase the pressure, and the last fifty years has seen a steady rise in boiler pressures. The natural way of lowering the temperature of the exhaust is to allow the steam every possible chance for expansion, thus extracting every bit of heat which it is possible to extract. Taking as a fair value for the maximum safe pressure, 175 lbs. per square inch, the theoretical efficiency of a perfect steam engine is about 31 per cent, that is, only this percentage of the energy given to the engine in the form of heat would be available for useful work. Since every engine must waste a great deal of energy in friction, and since heat is constantly leaking out into the surrounding air, the practical efficiency of an engine is much less than the above figure.

HAUL RAILROAD TRAIN BY ROPES

On a grade of 1 in 42 out of the Queen Street Terminus, Glasgow, on the main line to Edinburgh, the trains are assisted by being hauled by a rope. When the line was first opened in 1842 it was considered that this incline, which is $1\frac{1}{4}$ miles long, would be too steep for ordinary locomotive power. A pair of 80 h. p. beam engines were placed at the head of the incline to work a large drum round which an endless wire rope (when first installed the rope was of hemp) went down one line, round a horizontal grooved wheel, and back up the other line. These engines have been almost continually at work since 1842. The wire ropes

weigh about 24 tons and last about 15 months. They pass over grooved pulleys between the rails to keep them from rubbing on the sleepers or ballast, also to preserve their proper course.

INSTANTANEOUS X-RAY PHOTOGRAPHS

The long exposures required in X-ray photography have been a great disadvantage in its use for practical purposes. After many experiments, however, Prof. Rieder and Dr. Joseph Rosenthal of Munich have succeeded in taking instantaneous X-ray photographs. The apparatus used includes strong electric currents, especially good X-ray tubes, very sensitive photographic films and intensifying screens. Photographs of the human chest were taken in less than a second, the patient ceasing to breathe in the meantime.

Taking photographs between heart-beats was another important experiment tried. The period of exposure required was measured by a contrivance consisting of a wooden disk, 39 in. in diameter and covered with lead. A sector, one-seventh of the entire surface, was cut from the disk. The object to be photographed and the sensitive plate were placed behind the disk and the X-ray apparatus in front of it. The disk was revolved on its center once in a second, and the open place in it exposed the plate to the rays just one-seventh of that period.



Wire Cable Hauls Railroad Train

THE AMERICAN DIESEL ENGINE

By Geo. W. Richardson, Consulting Engineer, Chicago

Forty years marks an important "epoch" in most men's lives. To the man of reflective mind, who reaches this age, life takes on new aspects. Thenceforward the future grows more and more uncertain. The longer part of life's road now lies behind, and the

accomplished in the past with the steam engine as a prime mover.

Prior to 1848 the leading prime mover was the simple slide valve throttling governor steam engine. This engine was very uneconomical due to the fact that the steam in the

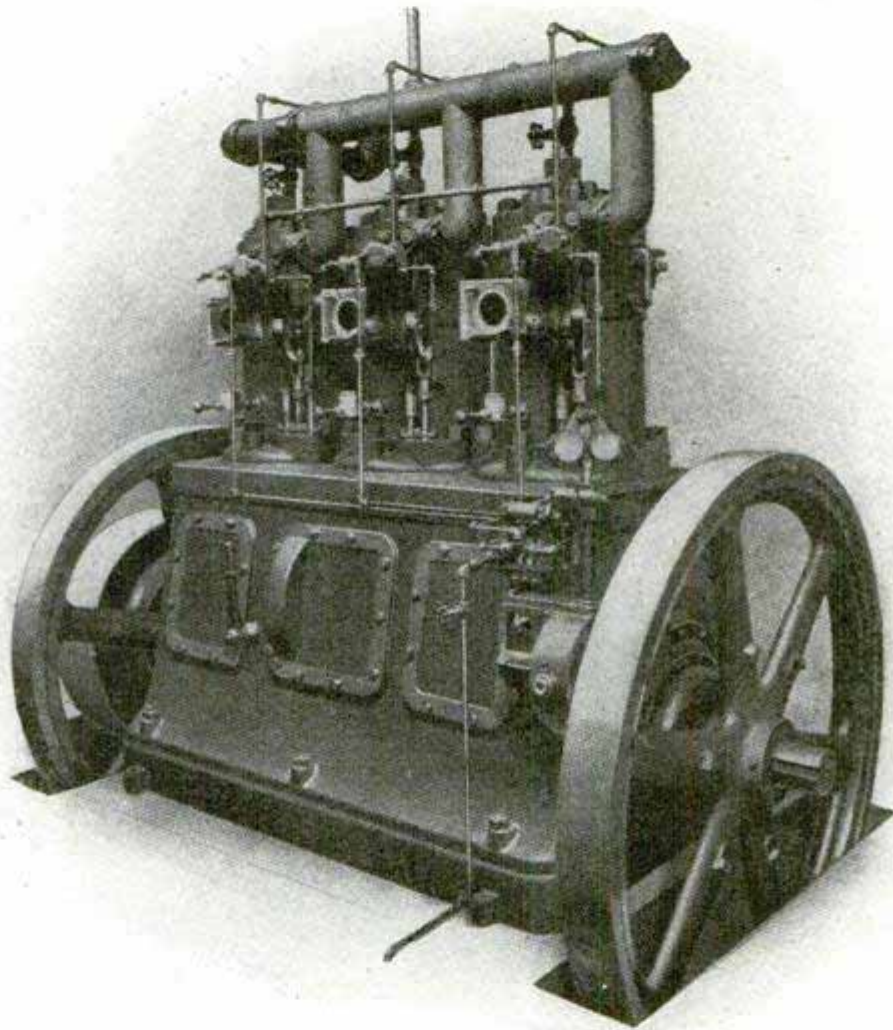

Triple Cylinder--225 H. P.

man gradually comes to realize, whether he likes to acknowledge it or not, that he is to some extent at least on the down grade. Naturally the past becomes more and more the subject of his thoughts, and he finds pleasure in recalling and recounting the deeds of the years gone by.

Something of this pleasure of retrospection has been mine in preparing, in response to the invitation of the editor of this magazine, a description of the American Diesel engine and a statement of the remarkable economy achieved by it.

Before describing this engine it is best to give a brief outline of what has been

accomplished in the past with the steam engine as a prime mover. Prior to 1848 the leading prime mover was the simple slide valve throttling governor steam engine. This engine was very uneconomical due to the fact that the steam in the cylinder was not cut off until three-fourths of its stroke was passed, thereby losing the benefits of the expansion of the steam after cut-off.

Later this loss was reduced by cutting off the steam earlier in the stroke, say at $\frac{1}{4}$ th, thus allowing $\frac{3}{4}$ ths of the remaining stroke for the steam to expand. Below is a table showing the effective pressures at different points of cut-off:

Steam cut-off at full stroke equals	100 lbs	effective pressure
.....	90
.....	80
.....	60
.....	50
.....	40

From the above it is evident that if you

only get 100 lb. effective pressure with a full cylinder of steam, and you get 40 lb. effective pressure with only $\frac{1}{4}$ th of a cylin-

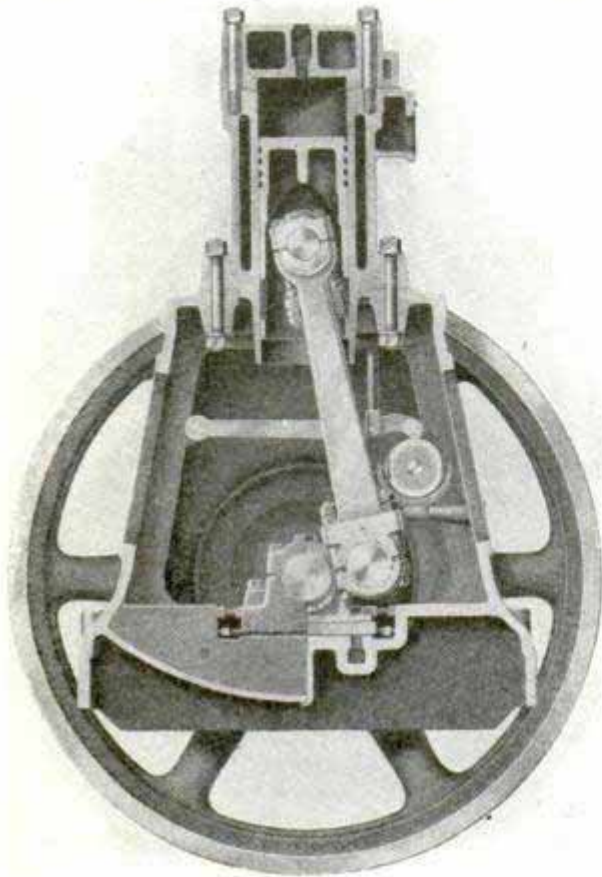

Sectional View Diesel Engine

der full of steam the quarter cut-off is by far the most economical to use. It was Geo. H. Corliss who first brought out this automatic cut-off gear.

But, as was the case with the Diesel engines, Corliss had a hard time to introduce his engines as the public was then, as now, skeptical about adopting new and modern methods. In his effort to secure business and introduce his engines Mr. Corliss, in the early days, resorted to the making of unusual guarantees, often agreeing to take as the price of the engine, the saving of the fuel in a specified time.

In 1852 Corliss put a new engine in the rolling mill of Crocker Brothers & Co., in Taunton, Mass., guaranteeing to do one-third more work than the old engine was doing, and where five tons of coal had been used per day but two tons should be used to do the same work; and further guaranteed to forfeit \$1 per pound for every pound per day used in excess of the two tons.

Since then there have been numerous engines on the market, notably the shaft governor type of automatic cut-off gear, claiming the same economy and in some cases higher, and most recently the steam turbine;

but they all want to guarantee the steam per horsepower per hour. None of them will guarantee the cost of the fuel to make this steam.

Now at this late date comes the Diesel engine showing as remarkable an economy over the Corliss engine as the Corliss engine showed over the old throttling governor; and with the equivalent guarantee, viz.:

This engine being an oil engine, or what is known as the internal combustion engine, it is possible to guarantee the cost of fuel.

It is guaranteed that the cost of, or the saving made in the fire room of a steam plant, i. e., fireman's wages, and labor of handling coal, repairs to boilers, setting and grate bar repairs, etc., will pay for the oil this engine will consume. So the saving in operation, as compared with the steam plant, would equal the total value of the coal the steam plant would have consumed.

In describing this engine it may be well to state that there is no other engine in the world that works on the same principle. Its cycle is the same as the gas engine, such as the well known Otto cycle. There its similarity to the gas engine ends absolutely; in everything else it follows the lines of the steam engine.

The first stroke is a suction stroke, drawing in a cylinder full of pure, clean air; on the second stroke it compresses this to a tension and consequent temperature sufficient to ignite any fuel which may be injected into it; therefore no igniters are necessary, doing away with this evil. At the beginning of the third stroke, a small quantity of fuel oil is injected into this red hot air in the form of spray, by means of a jet of highly compressed air, and thus in a completely atomized state the fuel meets and mixes with the hot compressed air in the cylinder, burning (due to the pure air) to complete combustion, and during a period of time exactly regulated by the governing mechanism of the engine, generally through 1-10 part of the stroke; subsequent to which the stroke is finished by the expansion of the burnt products. The fourth stroke discharges the products of combustion, and leaves the cylinder empty and ready for another suction stroke.

It should be borne in mind that the air in the cylinder at the commencement of the working stroke is more than sufficient to burn all the fuel that can be introduced while the fuel valve is open, and as it is at extremely high temperature, and the oil is injected in a finely divided condition, complete and perfect combustion is the result.

A great many people think that the power expended to compress this air is lost, which is not true, for if you drop a rubber ball on the floor it will rebound, so it is evident that the power expended in compressing the cylinder volume of pure air is given off again to the shaft of the engine during the combustion or motor stroke.

This simple process, absolutely new and original with Diesel, has enabled him to accomplish with one-half pint of common crude or fuel oil as much as the explosive engine does with a full pint of the much more expensive gasoline. There are no explosions in the cylinder of this engine, as in a gas or gasoline engine; instead the oil burns gradually to complete combustion. A white handkerchief held over the exhaust of this engine will not become soiled.

It may be well to state that the oil, called

of steam engine it only utilizes 6 per cent of the fuel expended. Below is a table of the efficiencies of the different types of (prime movers) engines:

	Per cent.
A good slide valve steam engine utilizes only...	5
A plain Corliss engine utilizes only.....	6
A compound condensing engine utilizes only...	8
A reheating compound or triple expansion or turbine utilizes only	12
The best oil engine (explosive type), utilizes only	16
The best gas engine (explosion type) utilizes only	15
The Diesel Engine oil (non-explosive), utilizes fully	40

For New York or Chicago conditions, with coal at \$3 per ton, and fuel oil at 4 cents per gallon delivered, 100 actual horsepower hours cost only 36 cents for fuel in a Diesel engine as against 60 cents in a large Corliss engine; or \$1.10 in the slide valve engine generally used in small plants.

The following table shows the saving in

PRICE COAL PER TON.

OIL AT	\$2.00	\$2.25	\$2.50	\$2.75	\$3.00	\$3.50
3 cents.....	\$12.16	\$14.69	\$17.22	\$19.76	\$22.30	\$27.35
3½ "	10.81	13.34	15.87	18.41	20.95	26.00
4 "	9.46	11.99	14.52	17.06	19.60	24.65
4½ "	8.11	10.64	13.17	15.71	18.25	23.30
5 "	6.76	9.29	11.82	14.46	16.90	21.95
5½ "	5.41	7.94	10.47	13.11	15.55	20.60
6 "	4.06	6.59	9.12	11.76	14.20	19.25
6½ "	2.71	5.24	7.77	10.41	12.85	17.90

fuel oil, is a by-product of the oil refineries. That is, it is the refuse after the kerosene, naphtha and gasoline have been extracted, and as this engine will burn any kind of oil, and all oils have the same caloric value, the cheapest is the best for the purpose intended. Fuel oil is generally sold at from 3 to 4 cents per gallon.

The Diesel people guarantee 100 horsepower for one hour, under your own operating conditions, with not to exceed 8 gallons of oil, or 150 horsepower hours, which is equivalent to 100 kilowatts on the switchboard, on 12½ gallons of oil; and will pay for all oil used in excess of this. In actual practice this amount is reduced 25 per cent. Consequently with this large margin of 25 per cent they would be safe in paying \$1 per gallon for all oil or fuel one can burn in excess of their guarantee.

The reason that this engine is able to show such a high economy is due to the fact that its heat efficiency is 40 per cent of the fuel expended and works on the cheapest grades of fuel oil.

While the Corliss engine is the best type

Diesel engine over slide valve engine, for each B. H. P. 3,000 hours per year, 50 H. P. to 100 H. P.

The fuel consumption in the Diesel engine is proportional to the load. Therefore, on variable load from half to full power add 50 per cent to the above saving. No fireman needed.

It will interest some readers to compare the relative features as to space occupied, weight and attendance required by the steam and Diesel engines respectively. For illustration take a 100-hp. plain horizontal Corliss engine. Such an engine will occupy about 5 ft. by 25 ft. of floor space, to which must be added floor space for flywheel and in the boiler room for boilers, feed water heaters, and pumps of not less than 16 ft. by 40 ft. or a total of 765 sq. ft. A Diesel engine of 100 hp. occupies 5 ft. by 12 ft. or a total area of 60 sq. ft. There are the further economies of stack, piping, valves, etc., which are inevitable in the use of a steam engine.

A natural query to make is one regarding the method of starting this engine. This is

done by compressed air from the auxiliary reservoir. A handle (not shown) throws the fork (see illustration) so as to move the valve cams of the first cylinder along the

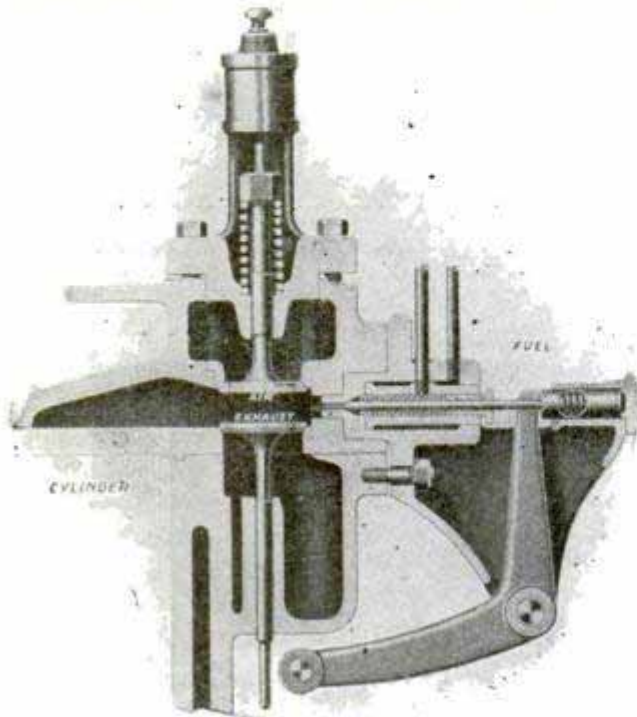

Sectional View of Valves

cam shaft, and brings into operation a starting cam operating a starting valve. This valve simply admits compressed air to drive the piston for one or two revolutions and the compression is then sufficient in the other cylinders to ignite the charge in these cylinders. The starting cam is automatically thrown out of action and the admission and exhaust cams thrown in when the handle is let go.

FIRE ALARM BOX THAT HAND- CUFFS TRICKSTERS

When the new fire alarm box recently patented is installed, fire companies will no longer be called out by false alarms—or, if they are, the miscreant will receive his due. The box has a small door in front, and immediately this is opened a large gong in the box begins sounding, attracting attention to that place. On the inside are two small doors, having a slot through which the hand must be thrust to send in an alarm. As the party sounds the alarm a rubber-lined aluminum handcuff snaps around his wrist, the slotted doors fly open, releasing the handcuff and three feet of chain, and the party is a prisoner until the fire company arrives to find out where the fire is and release him. He can, however, close the large doors of the box and cause the large gong to cease ringing.

WHY MOTOR BUSES WILL NOT DISPLACE STREET CARS

Motor buses are coming into common use in European cities, and to a limited extent in this country, but are not calculated to replace street cars, at least until several economies can be effected.

The cost for power is less per passenger in the case of the street car, as metal wheels on steel rails cause less resistance than rubber tires on even the best pavement. The cost of the rubber tires is another reason, as records show the expense for tires to be about 4 cents per mile, against 2½ cents per car for rails. The power cost is 24 cents per ton for electric cars and 80 cents for gasoline.

TIN PRODUCTION IN 1904

The world's production of tin in 1904 was 92,243 tons, of which 159 tons was mined in the United States. This country imported 40,382 tons, valued at \$21,486,311. The world's consumption exceeded the production by 2,512 tons.

PARIS MOTOR BUS

The pavements of Paris are unusually good, being chiefly asphalt. The conditions therefore for vehicle travel are excellent. The extensive omnibus system by means of

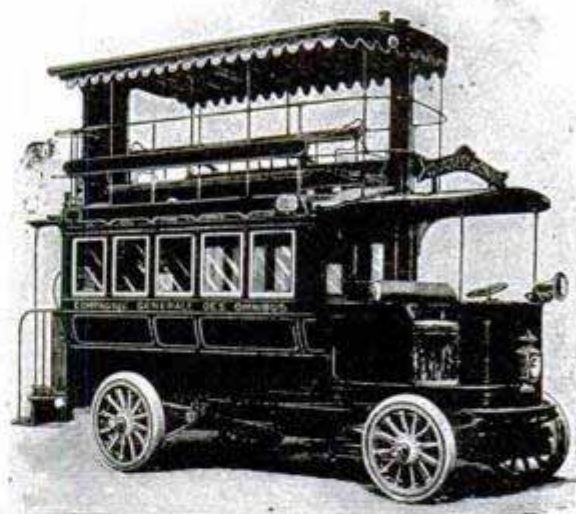

Bus Used in Paris

which the citizens largely travel is to be changed from animal to motive power. The illustration shows the bus which has been adopted, gasoline engines, air cooled, being used.

FATAL ACCIDENT WITH AEROPLANE

Aeronaut Maloney Falls 2,200 Feet--Did Not Know Mast Had Broken--Experimental Flights With Machine To Continue

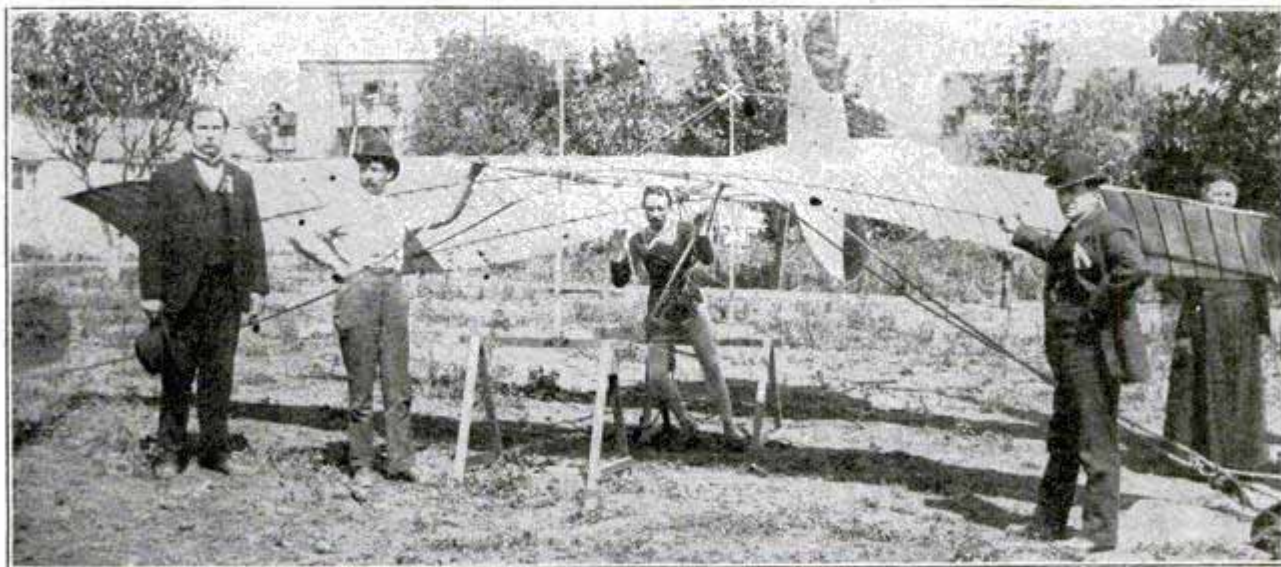

White Cross Shows Where Mast Was Broken--Aeronaut Maloney in Saddle--Prof. Montgomery, the Inventor, at the Right

The promising experiments at Santa Clara College, California, illustrated in July, and which attracted world-wide attention, are temporarily delayed through the fatal accident to the daring operator, John Maloney.

The aeroplane has no direct means of ascent or propulsion as yet, and a balloon has been used to tow it up. When the ascent was made one of the ropes failed to release properly, and it is believed, broke one of the two masts on the aeroplane. Maloney evidently was unaware of this, or else took chances he should not have done. At a height of 2,200 ft. he cut loose from the balloon and glided downwards for over 1,200 feet. He then undertook a dive at an angle of 60 degrees through a distance of 100 ft. Ordinarily the machine could stand the necessary strain, but this time the back wings collapsed and the aeronaut lost control. Clinging to the aeroplane he fell to the ground through from 1,000 to 800 feet and died twenty minutes afterwards. The accident was witnessed by hundreds of spectators and when the aeronaut was falling and seen to be doomed, Rev. Father Bell, one of the professors and a close friend of Maloney, uncovered his head, raised his hand and administered the final blessing to the unfortunate man.

Maloney made desperate attempts all the way down to control the machine, but without success.

Prof. Kavanagh writes: "In the accompanying picture I have marked a portion of the machine called the mast. The balloonist testified, at the coroner's inquest, that when the balloon made its first leap from the earth, this mast was broken by one of the ropes that were used to liberate the balloon. A break in that part of the aeroplane would not be dangerous in slight dips and curves. It would, however, account for the mishap after the deep plunge mentioned above, for at the sudden turn there would be more pressure above than below the wing surface and the back wings which, on account of the break, were free to move down, would naturally sink in and cause a backward somersault, which was in fact observed.

"Several aeronauts have already applied for leave to operate the machine, one of them after having witnessed the disaster. They seem to attribute the accident to excessive boldness on the part of Mr. Maloney, and in all truth he was extremely bold."

A new type of milk car used on the Great Northern Railroad of England is fitted with a special adjustable ventilating apparatus. The milk is no longer nearly churned into butter by the oscillation. Even on sharp curves at rapid speed the oscillation is scarcely noticeable. The milk vans are 45 ft. long.

THE MANUFACTURE OF CEMENT POSTS

By H. A. Low, in Concrete.

The growing scarcity of suitable timber for posts, and the increasing cost, have caused a strong demand for a substitute which will at the same time be cheaper and durable. To meet this urgent demand engineers and inventors have brought forward steel posts, cast iron posts, cut stone posts and finally concrete or artificial stone posts. These latter have been tried and not found wanting. The principal materials for their manufacture, sand or gravel and cement, are easily obtainable in every locality, and what is a determining factor, are remarkably cheap. The third element necessary in the manufacture is a steel reinforcement.

After all experiments and ventures have been tried, it is now a known fact that the best and cheapest reinforcement is steel wire, cabled tightly. This great value of steel wire reinforcement is obtained from the well-known principle and scientific fact that steel in tension and concrete in compression are the best materials used in their strongest way. The reinforcement being decided upon, the next step is the position of this and the method of making the post.

The best place to have the reinforcement is in the corners of the post, because the greatest strength is obtained by so placing, and the nearer to the edge they can be placed, without danger of the concrete breaking out under the strain, the better. I have found that in an ordinary line post the wires should be placed within a half inch of the edges. By placing the reinforcement in each corner of the post, two wires in tension are always secured no matter from what direction the strain comes.

The next consideration is the method or process of making the concrete. I have found that the tamped or dry process has not been as successful in tests as the wet process product. The latter uses less cement, makes a denser post and gives the cement enough water to make nearly perfect crystallization, at the time when it needs it, and not after the initial set has taken place. The tamped post is more subject to the action of the elements, and water penetrating it readily makes it liable to injury from the frost. The wet process post has a glaze on the surface that makes

it nearly impervious. Furthermore, there can be no accurate placing of the reinforcing wires with the tamped post, for the reason that the tamper will displace the wire, and the concrete will not form around and unite with the wire, sinking into the shoulder of the twist and not allowing the wire to stretch as it will when wet enough to pour. All in all, I believe that the most successful way to make a fence post is to pour it.

After posts have been molded and the concrete has set, they are ready for the curing, which should be done in the manner of other concrete products, keeping them well sprinkled. The posts can be used in thirty or even twenty days after they are made, but it is advisable to keep them at least sixty days previous to setting out.

The posts, being made of true concrete, grow constantly harder and better by exposure to the weather. I have observed posts that have been allowed to freeze in a river and thaw out that were apparently stronger than before. The farmers of today are alive to every meritorious article. They read their farm journals carefully, and they are aware of the fact that there are some posts better than wooden ones. They have the money to invest in a post that offers durability and they are willing to invest it. The field for making the posts is unlimited and the demands are immense. To fence the United States farm lands, properly, would require the enormous number of over three and one half billions of fence posts. The possibilities of the business are simply enormous. The consumption of fence posts in this country today touches so high a figure as to stagger the mind. A conservative estimate shows that the number of posts in use at the present time in the United States is 3,446,345,528. The field is an especially alluring one and is sure to bring financial success to the progressive business man who enters it promptly.

A speed of 130 miles an hour is declared by a French automobile engineer to be the maximum attainment possible to automobiles, while maintained at the present weight. M. Serpollet has determined to approach this limit as nearly as possible, and is now building a machine designed for a speed of 125 miles per hour. The weight of the engine, without steam generator or boiler, will be 330 lbs. and the motor will develop over 200 hp.

All the articles appearing in this department are reprinted in book form at the end of each year.

SHOP NOTES

Contributions to this department are invited. If you have worked out a good idea or know of one, please send it in.

CHEAP PAINT FOR ROUGH WALL SIGNS

A solution consisting of green vitriol stirred into lime milk makes an excellent cheap yellow coating for large signs on rough dead walls, rocks, cliffs, etc., says the Master Painter. The paste will be green at first from the separating protoxide of iron, but after it is applied and dry will become yellow by oxidation in the air. It adheres firmly to any surface and will not wash off. The color is darker or lighter, according to the amount of green vitriol used.

HOW TO FASTEN A RING TO A ROPE



The writer has used the method shown in the accompanying drawing in fastening a halter rope to the ring of the halter, but it is apparent that the method applies to any similar case where ropes and rings are used.

The advantage is that the ring has two thicknesses of rope to wear through before a break can occur. The free end of the rope is fastened down to the other with a cord or wire. If heavy wire must be used, it may be wrapped as tightly as possible and then hammered flat.—

Contributed by Joseph B. Kell, Marion, Ohio.

PIERCING PUNCH OF PIANO WIRE

Piano wire makes an excellent piercing punch for piercing holes in sheet metal, says a correspondent of the American Machinist. The punch is rather difficult to make, but is good for piercing holes of the same diameter as the thickness of the metal, or when the metal is unusually tough.

HOW TO MAKE SIX-SIDED NUTS

Good iron will be required for this purpose as poor iron will not stand the thread cutting. Take a piece the size the nut is to be and cut the nut. Do not cut from the

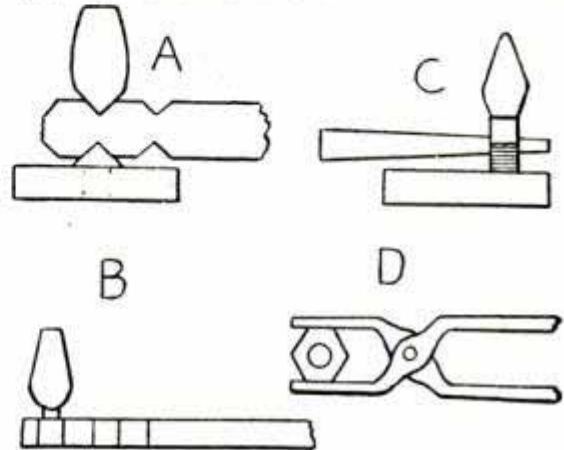

Making a Six-Sided Nut

flat side, says the American Blacksmith, but hold the iron on the hardy as shown in the illustration at A. B shows the punching operation, C finishing the shape and D shows a pair of tongs for holding the nut, which must be made thinner, as $\frac{1}{4}$ in. is a little too thick. Finish the nut on a pin from 16 to 18 in. long.

EMPTYING AN OIL-BARREL

The illustration shows a method of emptying oil from the barrel that will do the

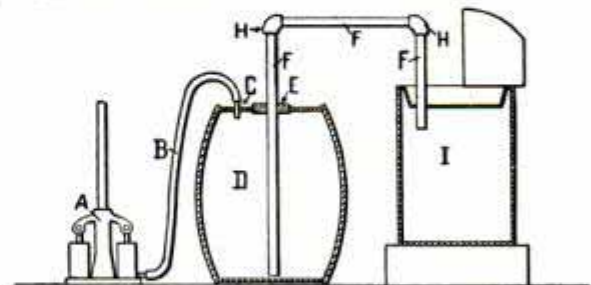

Emptying An Oil Barrel

work in from ten to fifteen minutes. The apparatus includes the following parts:

A, pump (any old pump will do); B, hose; C, bush on hose; D, oil barrel; E, large bushing; F, $\frac{3}{4}$ -in. pipe; H, $\frac{3}{4}$ -in. elbow; I, oil tank. The oil is forced out by air.—Contributed by Alex Mattley, Menominee, Wis.

PIPE CLAMP THAT WILL NOT CRUSH OR MAR PIPE

Having occasion to do some pipe fitting with brass and nickel pipe I made use of the following kink to hold same in an ordinary pipe vise, the object being to grip the pipe

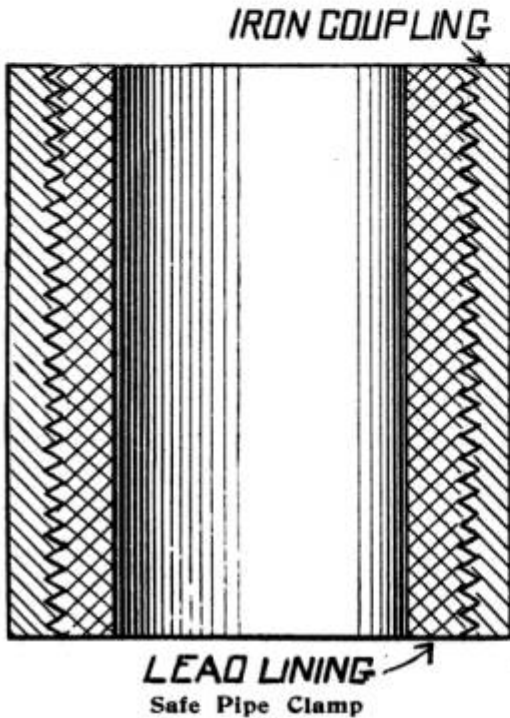

tightly, but not mar or scratch or even crush it, as an ordinary pipe vise would:

The clamp is made of a common iron coupling one size larger than the pipe to be held, i. e., for $\frac{3}{4}$ -in. pipe use a 1-in. coupling. Slip the coupling over the short piece of pipe, and using the pipe as a mandrel, pour melted lead around it, filling up the coupling. When cool, slip the coupling off the pipe and saw it in halves, using a back saw. You will now have a clamp made of two halves, one of which is shown in the illustration. When using sprinkle the clamp with plaster of paris and you will get a never-slip grip. The threads of the coupling are all that is required to hold the lining. It is cheaper to make a whole set of these clamps than it is to buy a special machine.—Contributed by John Weldon, 433 Columbia St., Brooklyn, N. Y.

SIZE FOR PLASTER WALL

Boil flaxseed in water and apply to the wall, or it may be applied over a first coating of paint. This size is useful on wood, also.

HOW TO ESTIMATE WEIGHT OF WROUGHT IRON AND OTHER METAL BARS

The weight of a bar of iron, steel, copper, lead or brass may be very quickly and quite accurately estimated by the following formula. Multiply the dimensions and add one cipher to the result. Then divide by 3 and the final result is the weight in pounds.

For example: Take a bar of wrought iron 20 ft. long by 2 in. thick by 4 in. wide, and we have $20 \times 2 \times 4 = 160$. Add a cipher, which gives 1,600 and this divided by 3 gives $533\frac{1}{3}$, which is the weight in pounds.

For cast iron deduct $\frac{1}{8}$ from the weight of wrought iron.

For steel add 1-48 to the weight of wrought iron.

For copper add 1-7 to the weight of wrought iron.

For lead add $\frac{1}{2}$ to the weight of wrought iron.

For brass add $\frac{1}{3}$ to the weight of wrought iron.

Contributed by Anthony Haselman, Newark, N. J.

A HOOK KINK

Fig. 1 shows a common hook whose bad feature is that when hoisting, point A catches on any projection it may encounter. If the eye is turned around as shown in the side view, Fig. 2, point B will strike a projection

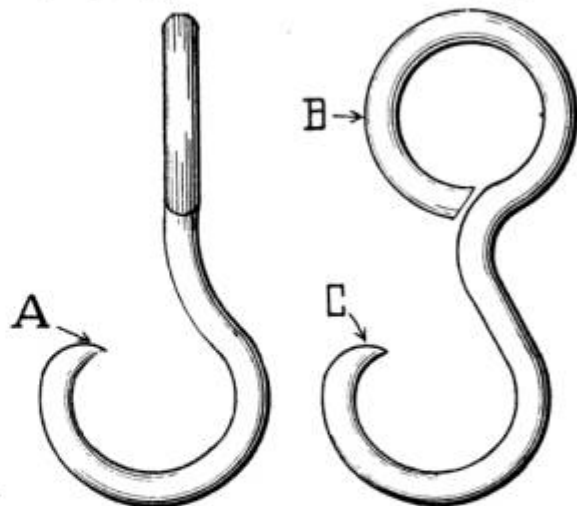

Fig. 1

Fig. 2

first. This will cause the hook to bounce off and point C will safely pass by the projection.—Contributed by John Weldon, 433 Columbia St. Brooklyn, N. Y.

A gill of shellac varnish added to a gallon of asphaltum is a good hardening agent.

HANDY BURR REAMER

When rolled steel plates have been drilled, especially ones $1\frac{1}{2}$ in. or more in thickness, they have a burr around the upper and lower edge of the hole. A reamer that will quickly cut these off and save a lot of chiseling may be made as follows:

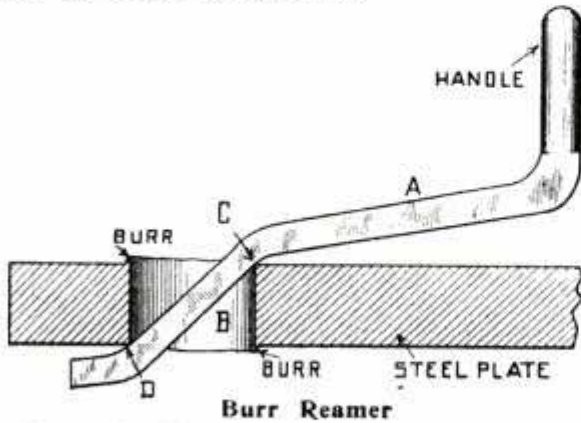

Have the blacksmith bend a piece of $\frac{1}{2}$ -in. square tool steel, about 15 in. long, to the shape shown in the illustration at A. Temper this device, grind it square and sharpen at the points C and D, where it is to cut the burrs. Place this reamer in the drilled hole (B in the sketch) and turn it round and round a few times until it has cut the top and bottom edges of the hole smooth.—Contributed by W. J. Slattery, Emsworth, Pa.

DRESSING OIL OR WHETSTONES

When it is necessary to dress oil or whetstones, level them on the emery wheel, holding them on the flat face. This requires from three to five minutes and makes them like new stones.—Contributed by J. W. Brown, Rensselaer, Ind.

ADVANTAGES OF ZINC ROOFING

The advantages of zinc roofing over other roofing materials is receiving more or less attention in this country of late. The claims for the superiority of zinc for this purpose is based on its tenacity, its density, its durability, the fact that it is not inflammable and that a thin coating of oxide forms upon the zinc when exposed, this coating being insoluble in water and becoming a permanent protection, preventing further corrosion and doing away with the necessity of painting the roof.

Zinc is one and one-half times lighter and four times stronger than the same substance of lead. Old zinc when stripped from a roof is said to be worth one-half its original value.

The largest zinc sheets used for roofing are 8x3 ft. in size, 0.053 in. thick, and weigh 1 lb. 14 oz. per square ft. The roof must be laid so as to give the material plenty of play, as the expansion and contraction of zinc is greater than that of any other metal. Under extremely high temperatures zinc gives off a bright green flame, which fact has given rise to the belief that it is inflammable.

CONVENIENT CENTER GAUGE

The sketch shows a method I have found very convenient, and which will be understood from the drawing, for truing or lining

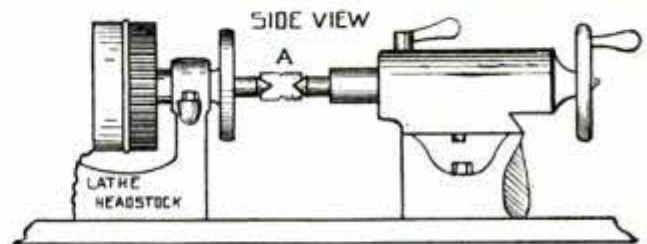

Fig. 1 SHOWING GAUGE ON LATHE CENTERS AT A.

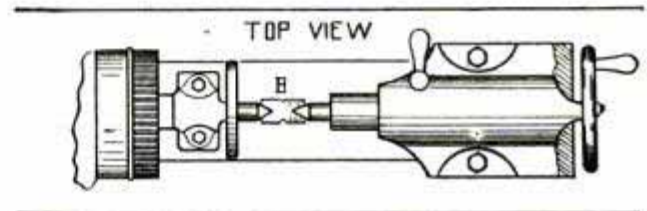

Fig. 2 WITH GAUGE ON CENTERS AT B.

up the centers in an iron turning lathe. By taking a piece of sheet steel $\frac{3}{64}$ in. in thickness any skilled machinist can make one in a short time. This device can be used for thread tool centering as well as lathe centers at 60 deg., graduated pitch. This gauge

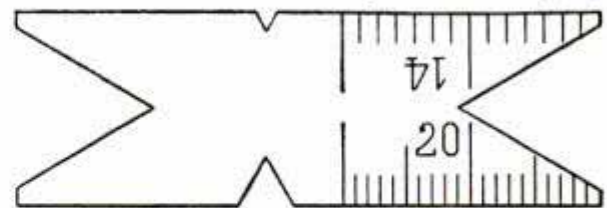

Fig. 3 FULL SIZE

can be graduated the same as any other center gauge; on one side 14ths and 20ths, and on the other 24ths and 32nds in fractions of an inch.—Contributed by F. M. D., Rock Falls, Illinois.

Rubbing a window pane with fine sand and water will make it obscure, yet diaphanous, says the Master Painter. Another method is to cleanse the glass thoroughly, then moisten it with hydro-fluoric acid. When the acid has eaten the glass enough, wash it off with plenty of clean water.

FIRING A GAS ENGINE WITH A TELEPHONE MAGNETO

The magneto out of an old broken telephone can easily be used instead of batteries, for running a gas engine. The batteries are usually a source of trouble, especially if the engine is used very much.

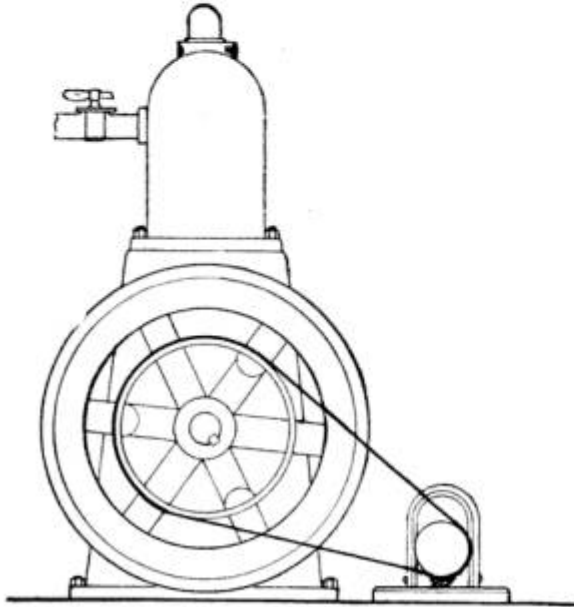

Magneto Connected to Engine

To connect the magneto, saw out a pulley a little narrower than the large cog-wheel on the machine and $\frac{3}{4}$ in. thick. Then screw off the handle and bore a hole in the center of the pulley large enough to fit the screw from which the handle was taken. Now screw on the pulley and you will find it will hold very securely. Fasten the magneto to a block of wood and nail the block to the floor. Take an ordinary sewing machine belt and connect it around the main pulley on the engine, and a V-groove on the wooden one of the magneto.

To make connections take the two wires from the magneto and join them to a spark coil and from there to the engine.—Contributed by E. H. Klipstein, 116 Prospect St., East Orange, N. J.

SOLDER FOR ALUMINUM

What is reported to be the most successful solder for aluminum yet secured, consists of tin 64 parts by weight, zinc 30 parts, lead 1 part and aluminum 1 part, to which add a small portion of resin. To solder, clean the surfaces and face with the solder. No chemical is used, but the surfaces of the parts to be soldered should be gently heated to assist in making a good adhesion.

USE OF THE COMPASS IN LOCATING POLES OF A GENERATOR

Numerous letters have reached us asking if the following statement, which recently appeared in this magazine is not a mistake. The statement was:

"While the dynamo is in service, bring the north-seeker end of a compass needle near each of the poles. Those that attract this end are north poles and those repelling it are south poles."

What has misled is the common mistake of calling the north-seeking end of the compass needle a "north pole." In reality that end of a compass needle is the south pole of the compass; otherwise it would not seek the north magnetic pole of the earth, because like poles repel. Hence when a compass is brought within the influence of a generator that is the north or positive pole of the generator which attracts the north-pointing end of the compass needle.

HOW TO MAKE A LEAD HAMMER

Lead hammers are useful when assembling parts which it is important not to mar. Such a hammer can be made in the shop, says a correspondent of the Model Engineer, London.

In the center of a piece of 2-in. tube, 3 or 4 in. long, drill a $\frac{3}{4}$ -in. hole and then, cutting through the center of this hole, saw the tube in two. Through a foot-length of $\frac{3}{4}$ -in. tube, drill two $\frac{3}{8}$ -in. holes at right angles to

FIG. 1.

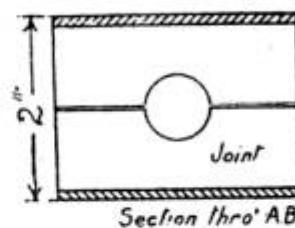

FIG. 2.

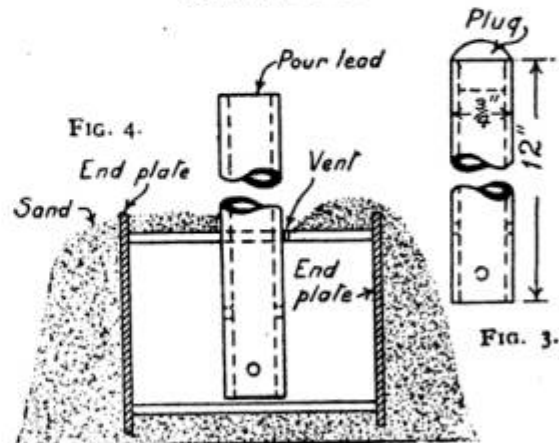
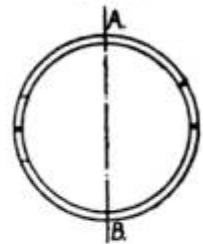

FIG. 3.

Details of Lead Hammer

each other, one $\frac{3}{4}$ in. from one end of the tube and the other $1\frac{1}{2}$ in. from the same end. This last tube is for the handle.

Procure some ordinary moulder's sand and bed the two halves of the large tube in it, so that the sand holds the two parts together. Into the $\frac{3}{4}$ -in. hole in the large tube insert that end of the handle tube that has the two holes. Against each end of the 2-in. tube, place a piece of tin to keep the molten lead from running out. Bank up the tube and ends well with sand, leaving a vent hole on top for air to escape. Pour molten lead down the inside of the handle until the large tube is full. When cold remove the halves of the large tube and the lead head will be secured to the handle by the two $\frac{3}{8}$ -in. holes in the handle. Fig. 1 is a sectional view of the 2-in. tube; Fig. 2 is an end view of the same; Fig. 3 shows the handle, and Fig. 4 shows mould with handle, ready for casting. File around the edges of the outer end of the handle.

INTERCHANGEABLE SCRIBER POINTS FOR PRICK PUNCHES

The prick-punch shown in the illustration is made so that a number of interchangeable scriber points may be substituted as required. This is a handy tool for the portable kit of a traveling mechanic. Its principal advantage, says a correspondent of Machinery, is that the point can be kept sharp easily, since the cross-section does not increase in size much up to the holder. A

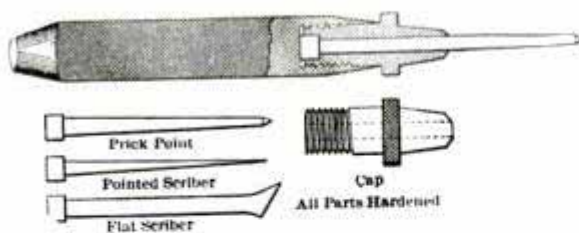

Prick Punch With Interchangeable Points

point can be substituted for one that has been ground away without going to the tool dresser.

FILLING FOR CRACKS IN FLOOR

Cracks in a new floor that is to be stained and varnished may be filled with a putty made as follows. Dissolve 2 parts common glue in 14 parts water, then mix in 4 parts plaster of paris and 2 parts litharge.—Master Painter.

HOW TO MAKE A WHISTLE FOR A STEAM PLANT

In a plant where there is no whistle this convenience can be contrived out of a piece of 4-in. brass pipe 1 ft. long. A correspondent of the Engineer's Review tells how to make such a whistle.

Make a center piece, A in the sketch, out of a piece of brass and drill three holes in it.

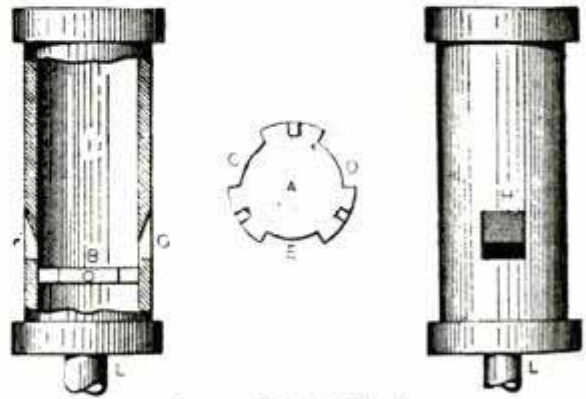

Home-Made Whistle

File away three sides of this disk, C, D and E to provide for steam passages. Make holes in the tube to correspond to those in the disk, fit the disk in the tube as at B, Fig. 1, and run pins through the holes in the tube to those in the disk. Cut the pins off even with the outside of the pipe and solder firmly.

Above the steam passage in the disk and in line with them file three rectangular holes, F, G, in the brass pipe. On the upper side file the edges down to form a sharp lip (H, Fig. 2). Fit round disks to the top and bottom of the whistle having the lower one drilled and tapped for a steam pipe, L. This whistle makes a sound that can be heard all over the plant.

STEEL-BLUE ENAMEL FOR ANY METAL

An enamel for use on any metal and which will keep so long as it is tightly corked is made as follows:

Dissolve 1 part of borax in 4 parts of water. Macerate 5 parts bleached shellac in 5 parts of alcohol, saving out a small portion of the alcohol for dissolving methylene blue of sufficient amount to give the color desired. Heat the watery solution to boiling and, constantly stirring, add the alcoholic solution. Stir out all lumps and add the blue solution. Before applying, clean the metal bright with an emery cloth. Apply enamel with a soft brush.

TOOLS AND DEVICES FOR BENDING PIPE

A corner fitted up with tools and devices for working with and bending pipe will be found a convenient and profitable department in many shops. Very little space would be required, and with the proper apparatus the difficult task is rendered light and easy.

The result of trying to bend tubes or pipes with a section of steel rod is shown in Fig. 1. The tube wall is crushed in and when further doubled over is completely ruined (Fig. 2). Sometimes, where it is attempted to bend the metal back to restore the fractured place, it splits as in Fig. 3. At this point the workman probably tries to

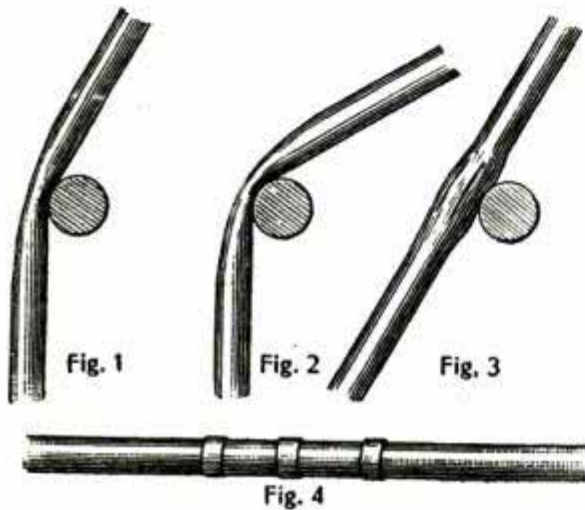

remedy the matter by brazing on metal rings, as in Fig. 4.

All this trouble could be avoided by melting rosin in a good-sized glue pot and then with a ladle pouring it into the hollow of the pipe or tube, as in Fig. 5. When the pipe is filled, plug the other end with a wooden stopper and you have a solid wall as at F. Fig. 6, a sectional view. Or, if preferred, or more convenient, the tube may be packed with clay, as at G. The spiral spring method is shown in Fig. 8 and a set of springs for this purpose ranging in size from $\frac{1}{4}$ in. to

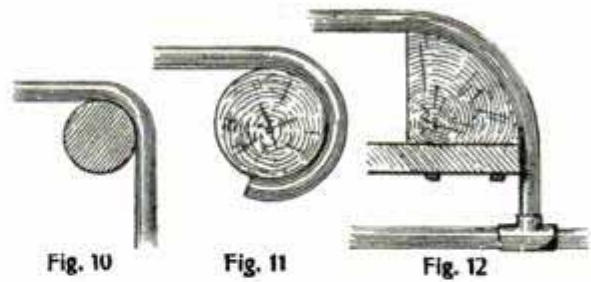
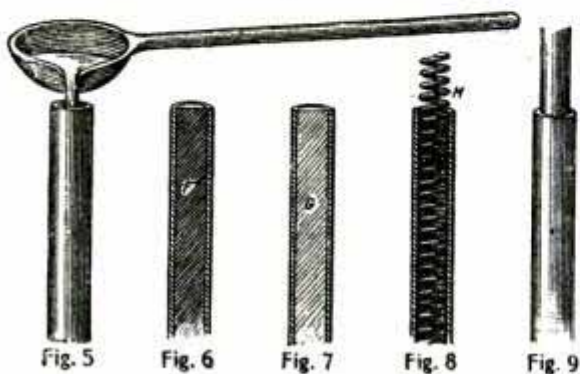

1 in. in diameter could be made from common steel wire and hung up in order in the pipe-bending corner. The method shown in Fig. 9 involves the use of a piece of wire to fit the inside of the tube. This is a good method for bending tubes of small diameter. By all these methods the pipe can be bent cold.

Pipe-bending forms are shown in Figs. 10,

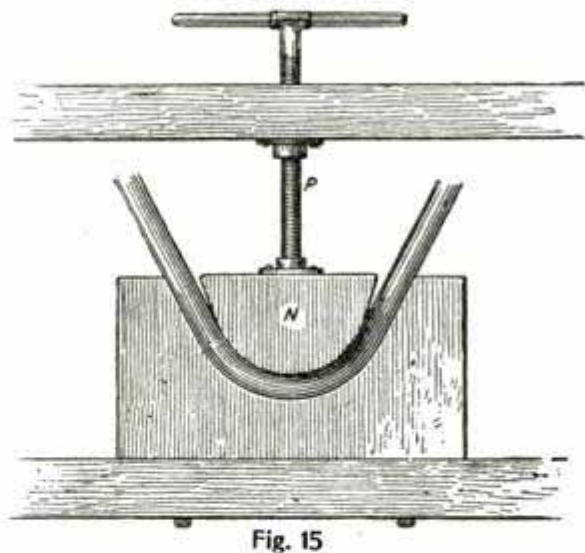
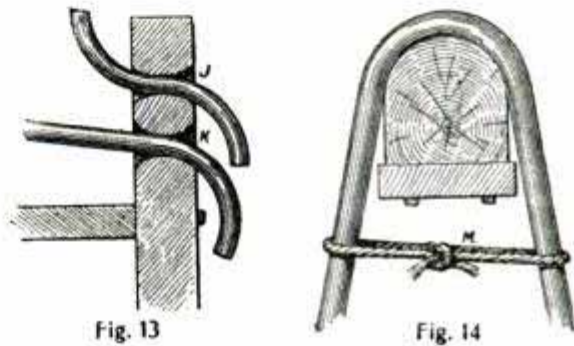

11 and 12. The small round forms are metal, but others may be made of common hardwood stock. Shaft stock, 2 or 3 in. in diameter, may be used for a form like Fig. 10. Secure the shaft to a firm base of wood and effect the bending much as in bending over the point of the anvil. Hardwood is used for bends of large diameter, as in Fig. 11.

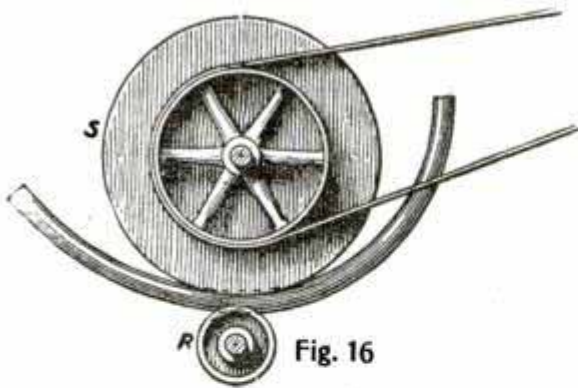

Fig. 16

The bending device shown in Fig. 13 is made of wood and is very handy. To make it select a piece of hardwood 4 in. square and 3 ft. long. Bore straight through one side, using an inch bit, and then shape the beveled places by working down the tapers of the two holes. Fasten it securely to the work bench by means of bolts. This is for light service, says the Blacksmith and Wheelwright. For heavier pipes and tubing a wooden form like Fig. 14 is useful, and may be bolted to a projection of the bench. Bend the pipe over as far as possible with the hands and then drop a loop of rope, M, over to hold it in place.

A set form bending device is shown at Fig. 15. The block for the base is cut out in the desired curve and a piece of hardwood, N, is shaped to correspond with the curve in the base and is fitted to the shaft P. The shaft can be raised and lowered, turning the crossbar as it is threaded.

Fig. 16 shows a revolving disk bending device. This consists of a small lower wheel of iron or steel having a shallow groove (just deep enough to grip the pipe) and a larger upper wheel, S, driven by a wheel for a belt as shown. Both the upper and lower wheels revolve in substantial wooden bearings on metal shafts. Pipe sleeves are used to line the bearings in which the shafts turn. The curve is made by running the pipe between the grooved wheels.

A grip form for pipe-bending is shown in Fig. 17. It is made of two pieces of hardwood, jointed at T, and having a series of holes of various sizes bored for receiving

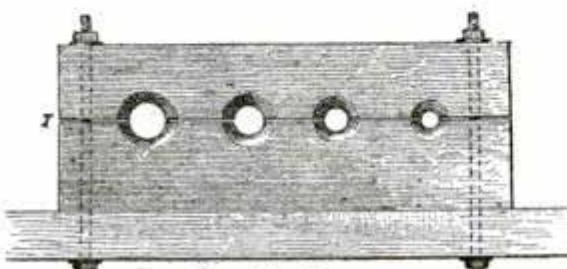

Fig. 17

the tubing to be bent. The clamping arrangement is bolted to the bench and the pipe is held firm while being bent.

TO STOP HUMMING OF TELEPHONE WIRES

The following is recommended as a positive cure for the humming of telephone wires.

Procure a porcelain spool insulator with a deep groove and place in the groove a rubber band (a piece of inner tube from a bicycle will do); then place around the rubber and in the groove the line wire, preferably insulated. Pass another piece of insulated wire through the hole in the insulator and make a connection as shown

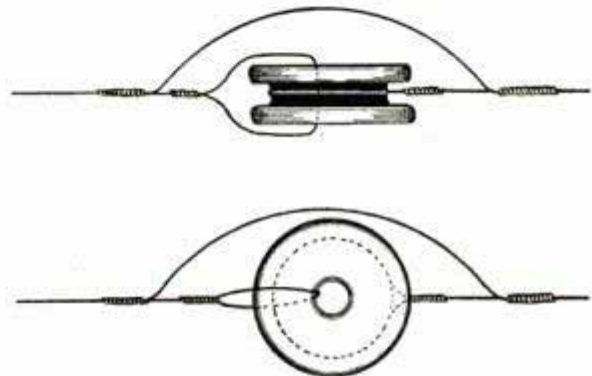

Anti-Hum Device

in the sketch. With another piece of wire bridge around the connection so as to complete the circuit. The device is cheap and efficient.—Contributed by Walter La Homa-due, Cherry Valley, N. Y.

UNITED STATES STANDARD BOILER IRON THICKNESS

The following table gives the thickness of boiler iron required by the laws of the United States, for the various pressures given in each case. The Practical Engineer states these figures are for pressure equivalent to the standard for a boiler 42 in. diameter and one-quarter inch thick.

Thickness in Sixteenths	DIAMETER.						
	42 Inches.	48 Inches.	54 Inches.	60 Inches.	66 Inches.	72 Inches.	78 Inches.
5	169.9	160.4	152.0	144.4	137.5	131.2	125.5
4½	158.5	149.7	141.8	134.7	128.3	122.5	117.2
4¼	147.2	139.1	131.8	125.1	119.2	113.7	108.8
4	135.9	128.3	121.6	115.5	110.0	105.0	100.0
3½	124.5	117.6	111.4	105.9	100.8	96.2	92.0
3¼	113.7	106.9	101.3	96.2	91.7	87.5	83.0
3	101.9	96.2	91.2	82.6	82.5	78.7	75.0

SAFE BUSHING FOR A WOOD SPLIT PULLEY

Oftentimes when a large wood pulley is tightened on a small shaft, it is a hard matter to keep it from slipping, especially a new pulley, where it would only take a few minutes work to cut a keyway in the shaft

HOT BLAST STOVE FOR SKIN-DRYING MOLD

A hot-blast stove used for skin-drying molds for large pipe castings is described by a correspondent of the American Machinist, who recommends it on the grounds of cheapness and high efficiency.

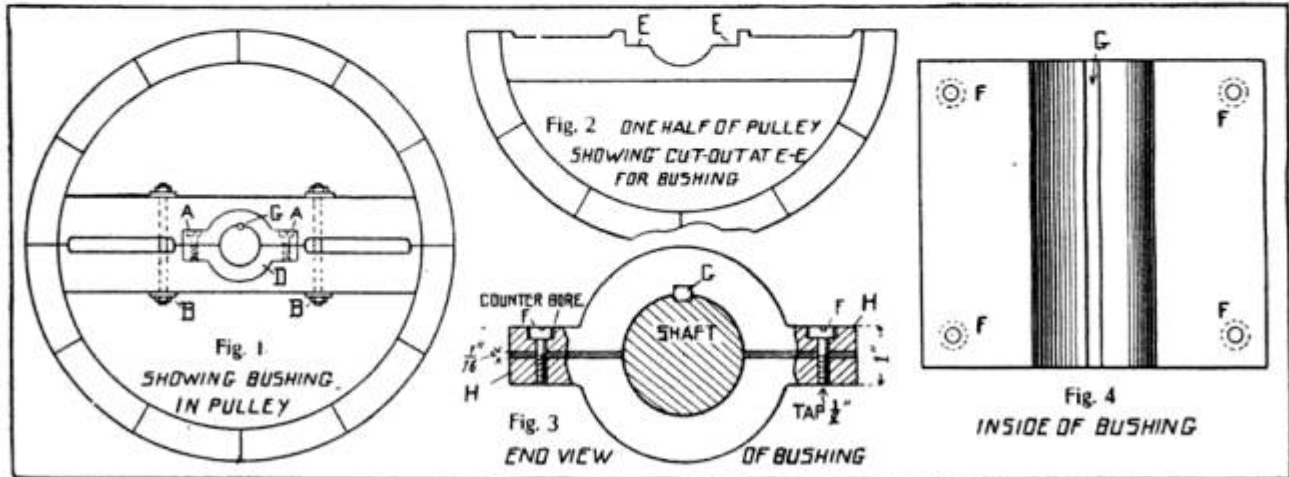

with a cold chisel without taking down a section of shafting.

Make an iron bushing of forged or cast steel to fit the hole for the former wood bushing, with two projecting lugs as at H H, Fig. 3. Cut out the pulley on each side of the hole as at E E, Fig. 2, to make a place into which the bushing will fit.

Drill four holes in the bushing, two at each side as at F F, Fig. 4, and tap 1/2 in. or larger in one-half of the bushing for blind cap screws.

Bolt the two halves of the bushing together and bore them out the size of the shaft. Put pasteboard between the halves before boring. Then keyseat and put on shaft over key at G, Fig. 3.

This bushing can be made from a pattern, cast iron or steel, and as long as the web of the pulley it is used with. This is a good method where a large pulley has to transmit power to a heavy load.

Fig. 1 shows bushing in pulley at D, keyed on to shaft and bolts, B. B., all set.—Contributed by F. M. D., Rocks Falls, Ill.

Use a very soft iron for brass molds, as the best iron for the purpose is one that cuts easily. Common machinery iron is not at all adapted to the purpose, as it soon develops cracks on the surface of the mold casting.

An ordinary coke stove (four gray-iron rings set up on a circular grate with four legs) is surrounded by a cylinder of No. 16 steel, 33 in. diameter, 48 in. high and fitted with a cover. The cylinder fits the grate casting. The stove has a Y inlet, each branch fitted with a butterfly damper, and at the top one outlet. Air is supplied to the heater by a small blower mounted on a plank and driven by a motor. The hot air is driven into the mold, as shown in the sketch. The combustion of the coke is controlled by means of the damper in the inlet under the grate. The half-mold shown in the sketch is covered with boards, sacking and sheet iron. The temperature in the

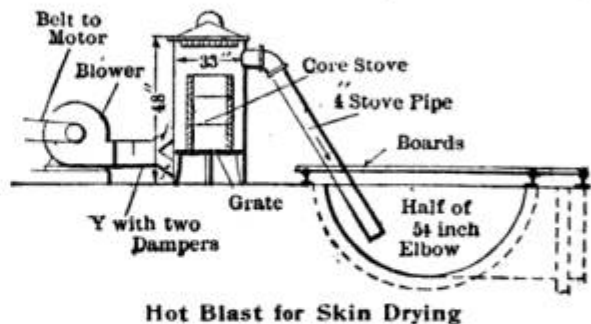

mold will register 300 degrees F., and a bushel of coke will last ten hours, continuous run.

Many of the parts required for this stove will be found lying unused about the shop.

POPULAR MECHANICS balance of your life for - - - - - \$10.00
 POPULAR MECHANICS five years, only - - - - - \$3.00

FENCE POSTS BOTTOM UPWARDS

Many years ago while engaged in running a saw mill in eastern Connecticut I had a lot of fence posts to saw from small chestnut logs. The posts were to be sawed tapering and to economize in lumber the logs were

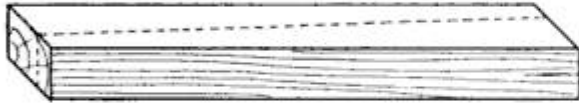

Post Economy

first sawed square and then split diagonally like the accompanying diagram. Of course they were to be set in the ground large end down, which would bring one-half of them bottom up in regard to the position in which they grew.

I remembered hearing an old farmer say that posts set that way would outlast those set "right end up" and I determined to improve the opportunity at hand to test the matter. So I marked all the inverted ones and as the fence was to be built in the neighborhood I watched the result.

Examining the fence about nine years after it was built convinced me, as the inverted ones were practically sound while the others showed very much more decay.—Contributed by Andrew Whiton, Hartford, Conn.

LINOLEUM COVERS FOR WORK BENCHES

Heavy linoleum makes a fine covering for the tops of work benches, says a correspondent of the American Machinist. The bench may have a pine top instead of one of hardwood, but should be constructed quite as usual. Use tongued and grooved pieces for the top and fill all holes with plaster of paris. The linoleum costs about \$1 per yard.

To fasten it to the bench glue the edge next the workman for about 3 in. and secure over night. Then trim the edge flush with the bench and hold the other edges in place with wooden strips arranged so the linoleum will move under them as the top of the bench shrinks. The linoleum is so stiff it will always lie flat and it will last for years. Two benches covered with it have been in use five years and though the covers are marred some, they are still in good order for work.

Is there anything you want but don't know where to get it? Write Popular Mechanics. Information free.

APPARATUS FOR THAWING OUT PUMPS

For thawing out frozen pumps, the handy portable apparatus shown in the illustration was contrived by a correspondent of the Metal Worker. It consists of an ordinary gas firepot with a galvanized iron can of suitable size, the top of which is provided with two outlets, made from small pieces of galvanized iron pipe soldered securely in place. One outlet stands vertically from the

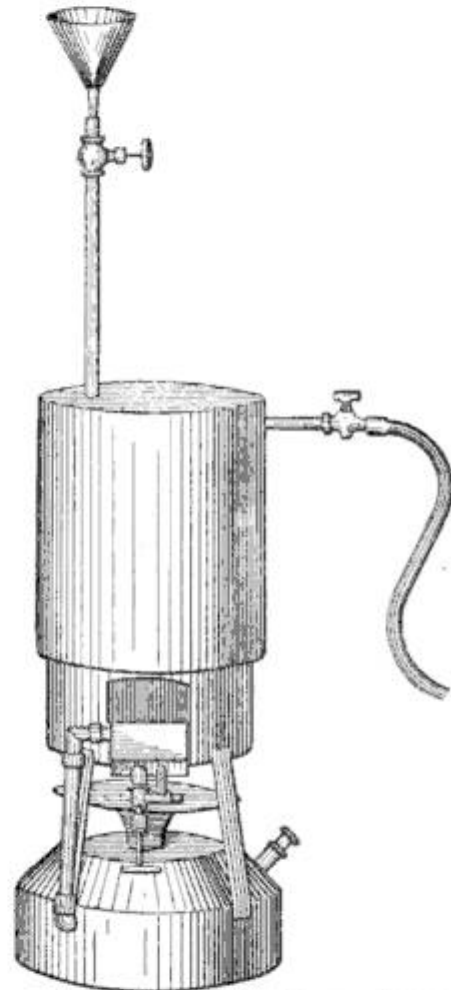

Thaws Ice 60 Feet Distant from Apparatus

top of the can and has a small globe valve on it, just above a T arranged to receive a safety valve. Above the globe valve is soldered a small funnel.

The other outlet is connected from the side of the boiler into a small valve, or petcock, which receives a rubber hose. To use the apparatus the boiler is heated until sufficient steam pressure is generated, when the hose is inserted in the pump, finds its way readily to the ice and the steam speedily thaws it. Ice 60 ft. distance from the boiler can be thawed in this way. Most shops contain all the materials required for such an apparatus.

AIR WHITEWASHER

A whitewasher operated by compressed air, says a correspondent of Locomotive Engineering, accomplishes in two hours an

amount of work that would keep one man busy a month. The construction of the machine is fully explained in the illustration.

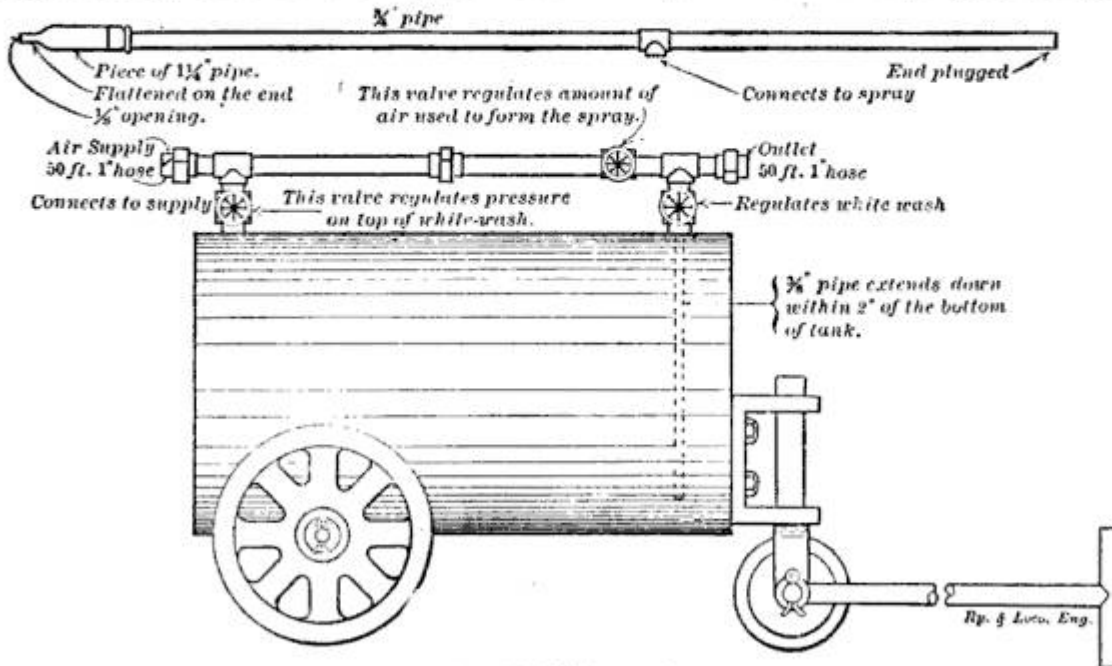

An Air Whitewasher

amount of work that would keep one man busy a month. The construction of the machine is fully explained in the illustration.

end of the lever acts as a center and can have any number of holes drilled in it. It is very easy to straighten 2-in. pipe in such a press.

MACHINE FOR STRAIGHTENING PIPE AND SHAFTING

The press shown in the illustration can be used for straightening pipe and shafting or for bending pipe. The device was contrived by a correspondent of the American Machinist and in construction is very simple.

Rubbing with a piece of chamois leather or cotton flannel moistened with alcohol will readily reduce a too strong high light in a negative.

Shop Notes for 1905; 200 pages; 385 illustrations; price, 50 cents.

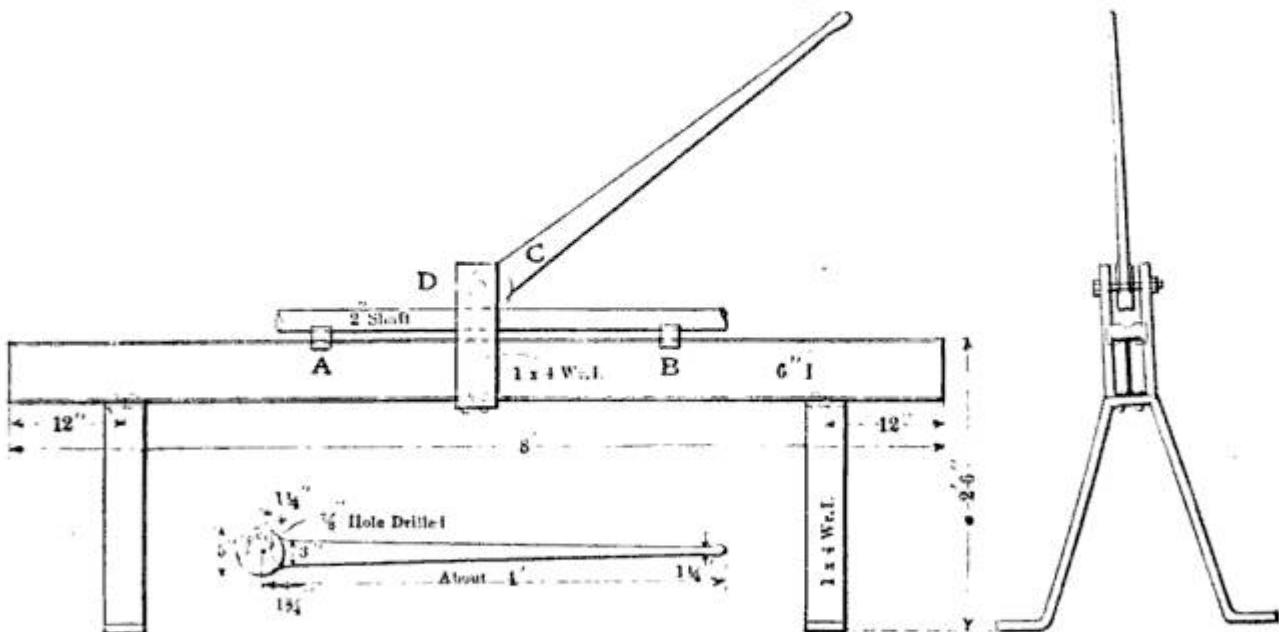

Pipe and Shaft Straightening Device

DEVICE FOR BENDING ELECTRIC CONDUIT

A device for bending the smaller sizes of electric conduit is made by screwing a piece of pipe into a tee, A. To use slip the tee over the conduit till it reaches the point where the bend is to be made. Then stand

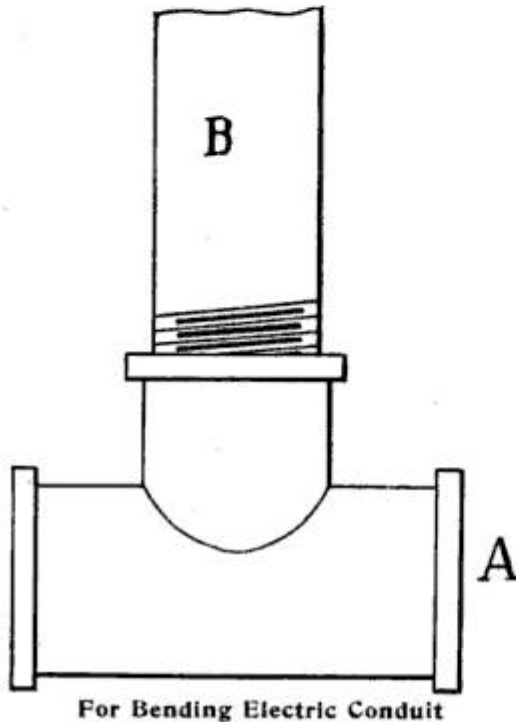

on the conduit and pull or push handle B. Any curve can be bent in this way and different sized tees may be used for different sizes of conduits.—Contributed by John Weldon, 433 Columbia St., Brooklyn, N. Y.

HINTS ON GLUE

It requires more water to dissolve good glue than to dissolve poor glue. The best glue, says the Wood-Worker, will require from one-half to more than double the water required for poor glue.

Good glue breaks hard and tough, with a splintered edge.

Cleanse the glue kettle often.

Frozen glue is so porous that it can be made up at once.

IMPROVING A WASHER

A thick washer can be made out of an old nut or a thinner one can be made of a piece of sheet iron or a metal button, says Gas Power. A very simple and easily made washer is a ring made from a piece of wire of suitable thickness.

A GOOD FLUID PASTE

Dissolve 10 lb. gum arabic and 2 lb. sugar in the amount of water required. Then add 1¾ oz. nitric acid and heat to the boiling point. This liquid paste will not mould and dries to a transparent layer on the paper. The Western Painter says it is well adapted for the flaps of envelopes, fine bookbinders' work, etc.

TO FIND CENTER OF SHAFT WITHOUT CENTER PUNCH

Procure a block of wood 1 in. thick and with an auger bit bore a hole in the block until just the point of the bit shows through

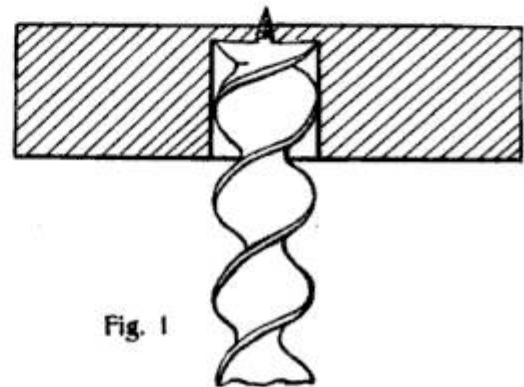

Fig. 1

the block as in Fig. 1. Then place block over the end of the shaft, Fig. 2, and with a sharp pointed punch and a hammer the center can

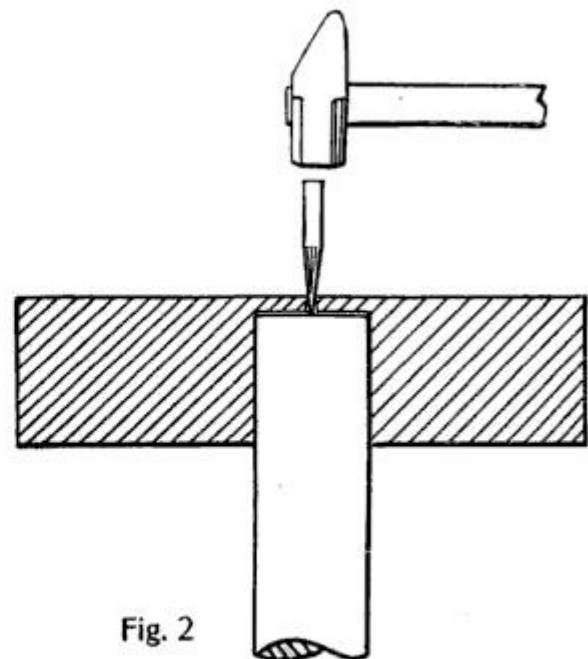
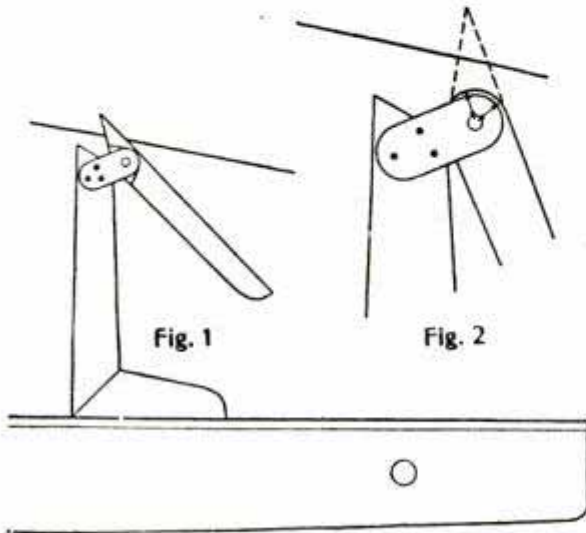

Fig. 2

be marked slightly. Then use a drill and drill out. The hole in the block must be the same size as the shaft.—Contributed by Eli Tolliver.

IMPROVING THE CLINOGRAPH

The clinograph is a set square used by draughtsmen for drawing inclined lines, section lines, and for shading, etc. It comprises two parts, one having two rectangular edges and another part, termed the "blade," which



Two Forms of Clinograph

is hinged to the first part. In using the appliance, one of the fixed edges is placed against the T-square and the blade adjusted to any position desired, where it is held by friction.

The instrument is slid along the T-square to any part of the drawing paper, for drawing parallel lines, says *Technics*, London, or for perpendicular lines, it is set and then turned with its other edge against the T-square. The illustration shows two forms of the clinograph. Fig. 1 shows a form in common usage, but the form shown at Fig. 2 is an improvement upon the first form, in which the edge can only be brought to coincide with a line by trial. In the second form the concentric portion is brought to the line and the blade swung around to coincide with the line without a trial. The alteration can be made with a pocket knife.

Has your boy a copy of *Mechanics for Young America*? Paper covers, 25 cents.

A GOOD STAPLE PULLER

A good staple puller that will do the work quickly and easily and leave the staples in better condition than such tools do ordi-



Fig. 1.

narily, is made of 1/2x1/2-in. steel; a correspondent of the *Blacksmith and Wheelwright* says he uses old harrow teeth for the purpose. The steel is first shaped as

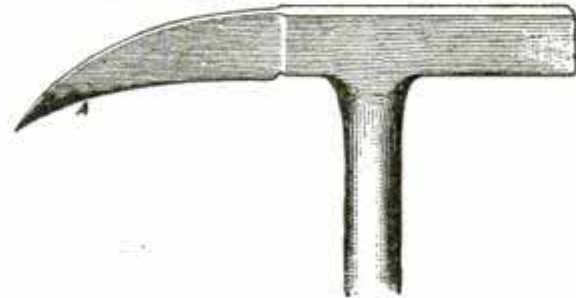

Fig. 2.

in Fig. 1, a bottom view, and then as in Fig. 2. The edges at A, Fig. 2, are rounded a little so they will not injure the wire. The handle may be of any length desired.

A sewing-machine that will sew directly from two reels of thread instead of using a spool of thread and a shuttle is the reputed invention of an Irishman. The machine is of simple mechanism and can be manufactured and sold at a greatly reduced price. Experts say the machine will revolutionize the sewing-machine trade of the world.

STRAINER FOR AIR PUMP

A strainer for the air cylinder of an air pump consists of curled hair held between two strainers. The device is screwed on the air cylinder and strains the dirt out of the air. A correspondent of *Locomotive Engineering* has used this strainer with excellent results.

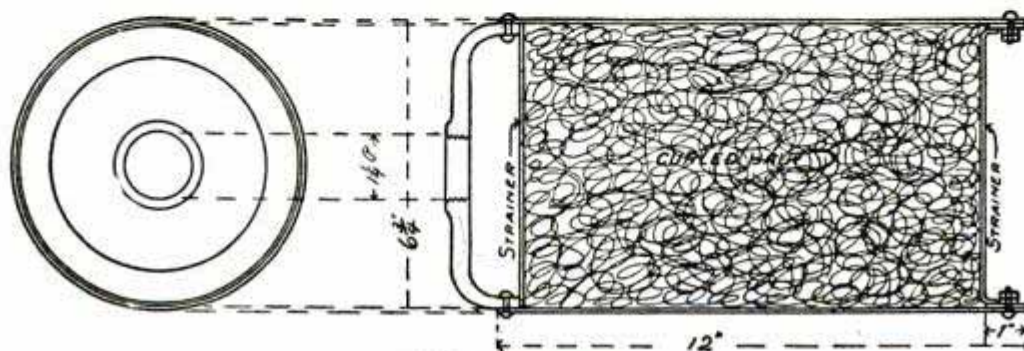

Air Pump Strainer

DRIVING STAKES BY COMPRESSED AIR

A unique stake-driver and one that saves considerable hand labor is used by the Barnum and Bailey circus, says Air-Power. The apparatus consists of a rock drill suspended between two vertical guides. The two side rods of the drill are continued below the lower head and support a round anvil. This anvil rests on the head of the stake to be driven and holds it firmly by means of spring clasps. As the stake is driven into the ground the driver is lowered by means of a cylindrical hoist and follows the stake downward until it is driven in securely.

CROW BRIDGES FOR DRILLING HOLES IN DIFFICULT PLACES

For drilling holes in difficult places, the crow bridge can be used to advantage many times.

Fig. 1 shows how a crow or brace may be used. It is made of 1x1½ in. iron. The arms may be extended if required by two extension pieces, B.

When it is possible to pass a chain around the casting, cylinder, or material to be drilled, the crow may be used on work as in Fig. 2. Two holes are drilled at C C and the end link of a small chain passed through one, and a small bolt D pushed through the link to hold the chain. The chain is then passed around the work and pulled through the other hole until taut and fastened there with a small bolt.

The beauty of these crows, says a correspondent of the Engineer's Review, is that it is only necessary for an engineer to get hold of the bar iron. He can then shove it into his furnace fire, get a red heat on it

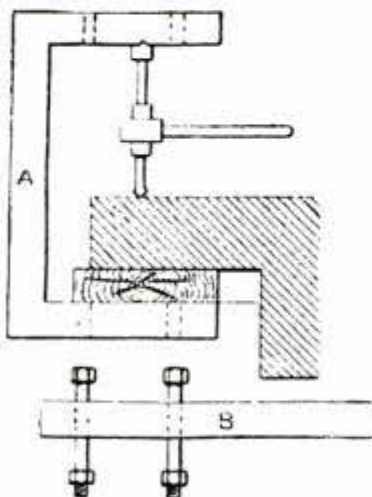

Fig. 1

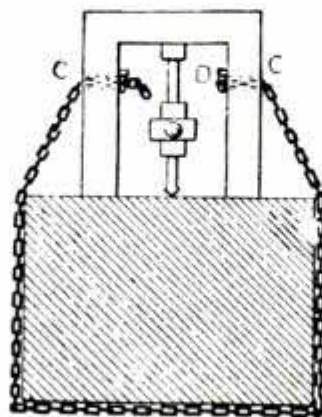

Fig. 2

and bend it as required. A couple of holes drilled completes the job and he has two handy tools.

HOW TO MAKE A SPARK PLUG FOR A SMALL GAS ENGINE

For a small gas engine ($\frac{1}{8}$ h. p.) a spark plug may be made and substituted for the ignition tube. A correspondent of the Model Engineer, London, tells how to make such a spark plug.

FIG. 1.—SPARK PLUG.

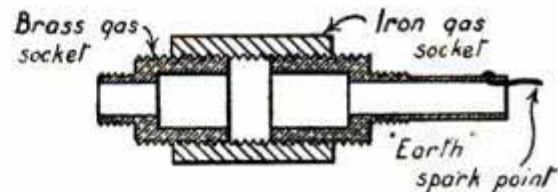

FIG. 2.—SECTION.

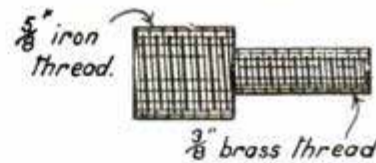

FIG. 3.—BRASS SOCKET

Make a stuffing-box of three ordinary gas sockets, packing them with asbestos string moistened with paint. Insulate the "live" wire by a glass tube (Fig. 1), passing it through the stuffing-box. Connect the outer end of the "live" wire to a short piece of thin platinum wire and then hermetically seal this wire through the end of the glass tube. Pack the wire tightly in the tube with paint-moistened asbestos.

Rivet the "earth" spark point through a hole in the brass tube, which hole may be made by filing or turning off the lower part of the thread of the bottom brass gas socket (Fig. 3). Then bake the whole plug in the oven.

The spark plug screws into the $\frac{3}{8}$ -in. hole previously occupied by the ignition tube.

The mechanic with a just appreciation of economics will send \$10 for a "Pop" life subscription.

HOT WATER FOR OFFICE USE

A system for heating water for office use was planned by a correspondent of Power. An old feed-water heater of the enclosed type, that had become too small for its original purpose was moved from the engine room to the second floor of the building and placed near the main exhaust pipe of the engine.

A 2-in. hole was tapped in the exhaust

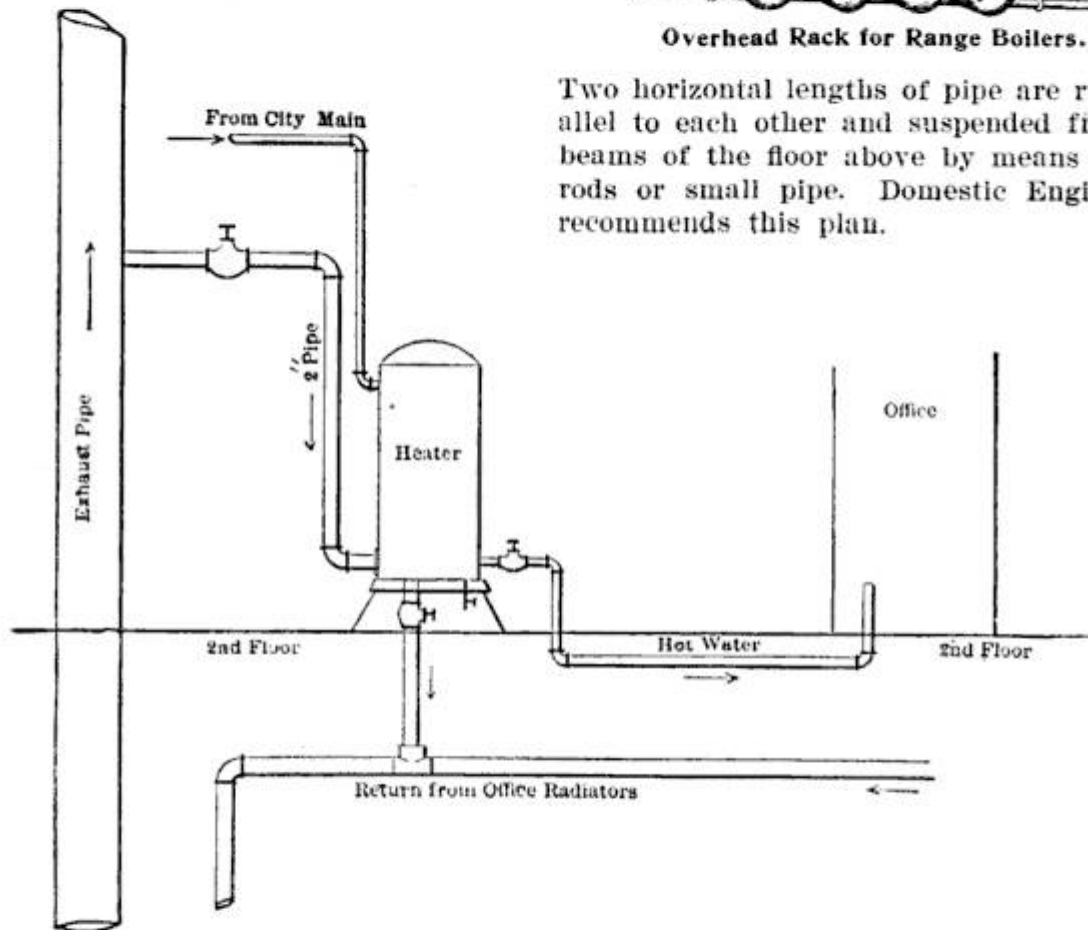

For Providing Hot Water for Office Use.

pipe and a pipe run from this hole to the heater. The outlet of the heater was connected to the return pipe of the radiators from the office. The cold water entered the heater from the city main at the top and the delivery was piped under the floor to the office, as shown.

HOW TO REVIVE BURNT STEEL

A burnt tool may be revived so that it can be used in nearly every case, and if not the experiment has cost nothing, writes a correspondent of the Model Engineer.

Harden the tool in the usual way three times and then temper to the desired degree. This method can be used on hand tools, drills and small chisels with advantage.

STORING RANGE BOILERS

Range boilers not only take up considerable space in the shop, but are apt to suffer damage by being tipped over. The sketch shows a convenient means of storing them.

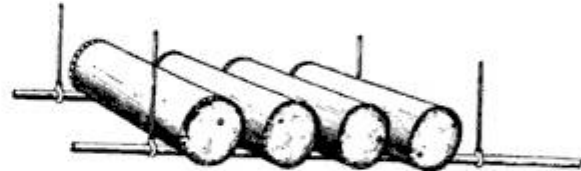

Overhead Rack for Range Boilers.

Two horizontal lengths of pipe are run parallel to each other and suspended from the beams of the floor above by means of iron rods or small pipe. Domestic Engineering recommends this plan.

TO APPLY ASBESTOS NEATLY

In applying asbestos about the steam plant a neat, quick method pays. The following is given by Machinery as such:

Make the asbestos plastic by mixing it thoroughly with water. Apply the first coat rough and about $\frac{1}{2}$ in. thick, using a pointed trowel. Let dry and apply a second coat $\frac{3}{4}$ in. thick, and straighten down with a large trowel. Wind the second coat with No. 16 annealed wire, having the coils about 3 in. apart at all points. In case of a flat surface, bind it with horizontal wiring. Apply a third coat of asbestos to cover the wire and make a smooth surface. A 100-lb. bag of the material will cover about 40 sq. ft. of surface in this way.

SHARPENING DIGGING BARS

The method of sharpening the digging bars used for digging post holes, commonly is to give the point a bevel like a chopping or cold

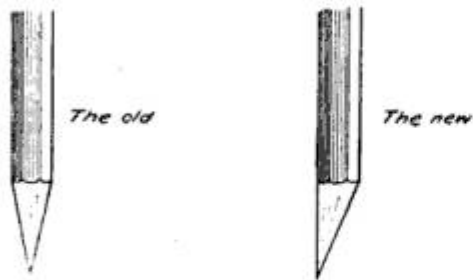

Two Ways of Sharpening Digging Tools

chisel. In hard or gravelly soil this shaped tool is apt to make a funnel-shaped hole and it is difficult to get the workmen to do any better with it.

A correspondent of the American Telephone Journal says that if the bar is beveled all on one side and the other side is left straight like a wood chisel this difficulty of funneled holes will be greatly overcome and that the men can make better time using this shaped tool.

HANDY BELT CLAMP

This simple and convenient clamp is made of $\frac{1}{2}$ -in. by 2-in. iron and is intended for belts not larger than 12 in. wide and $\frac{3}{8}$ in. thick. The dimensions of the clamp can be increased in proportion for larger belts, however, says the Engineer's Review. The side

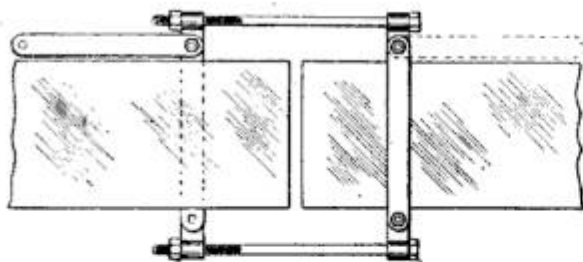

Belt Clamp

bolts of the clamp are of $\frac{7}{8}$ -in. stock, 24 in. long and the bolts clamping the crosspieces are of $\frac{1}{2}$ -in. stock, $2\frac{1}{2}$ in. long with square heads.

In taking the clamp off, first slacken up on the long bolts, then on the small bolts and take two of them out.

To make new tin roofs hold paint well, give them a good rubbing with No. 1 sandpaper before applying the paint.

When paint is "tacky" try rubbing it with a cloth wet with ammonia.

SPRINGING PACKING RINGS OVER PISTON

In putting a snap ring on the piston of the high pressure cylinder of a tandem compound engine a correspondent of the Engineer's Review made use of the following kink. This job is very difficult for as soon as the ring is started on one side it slips off the other, and yet, for fear of breaking the ring the engineer must proceed cautiously.

Four pieces of square iron were cut off in 3-in. lengths and threaded to a depth of $2\frac{1}{2}$ in. One end of each block was made tapering, coming down to a sharp point to prevent slipping of the ring surface.

Four bolts were threaded and screwed into these four blocks, which were placed in position as shown in the illustration. To put the

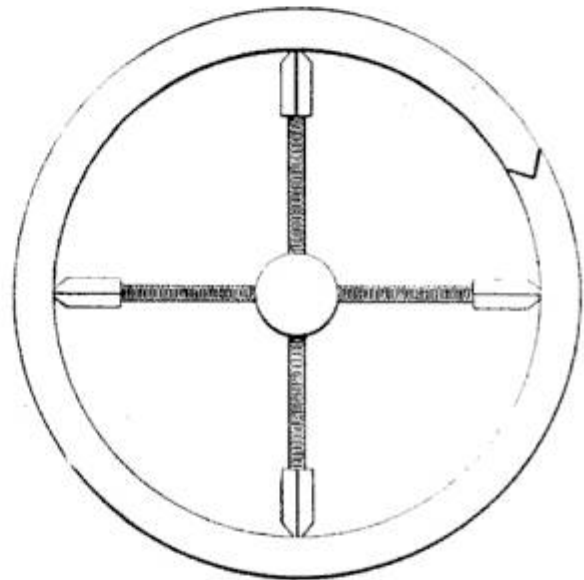

Method of Springing Packing Ring Over Piston

ring on the piston, the bolts and blocks were put in place and tightened up so as to spring the ring evenly until it was large enough to slip on over the piston.

MIXING CONCRETE

A concrete mixture of the following proportions is recommended by engineers.

To 1 bbl. Portland cement add 3 bbl. clean, sharp sand. Mix the two intimately, either manually or by a mechanical mixer. Add enough water to bring it to the proper consistency, the amount required being judged by one of experience in the work. Add 5 bbl. of broken stone and intermix the whole, which is then ready for use. This is known as a "1-3-5 mixture." The nature of the ingredients and the purpose for which the concrete is intended make the proportions variable, however.

HOW TO MAKE AN ELECTRIC ILLUMINATED FOUNTAIN

One of the prettiest and most attractive displays for a show window is an electric illuminated fountain. The Keystone tells how such a fountain may be constructed.

Have a tinsmith make the center bowl A of tin, of any size desired, according to the size of your window. This center bowl should be shaped like a large cake tin, hollow in the center. Cut a hole in the center

Make a skeleton pulley, D, with a piece of colored glass in each of its openings. Use red, green, yellow and blue glass and fasten it in position with tacks. Arrange this pulley so that half of it is in the center of the fountain.

Place a strong electric light with a reflector in the position shown at F, so that it sends its rays upward through the colored glass and through the center cone on the water. The effect will be most beautiful. The changing of the colors can be reduced

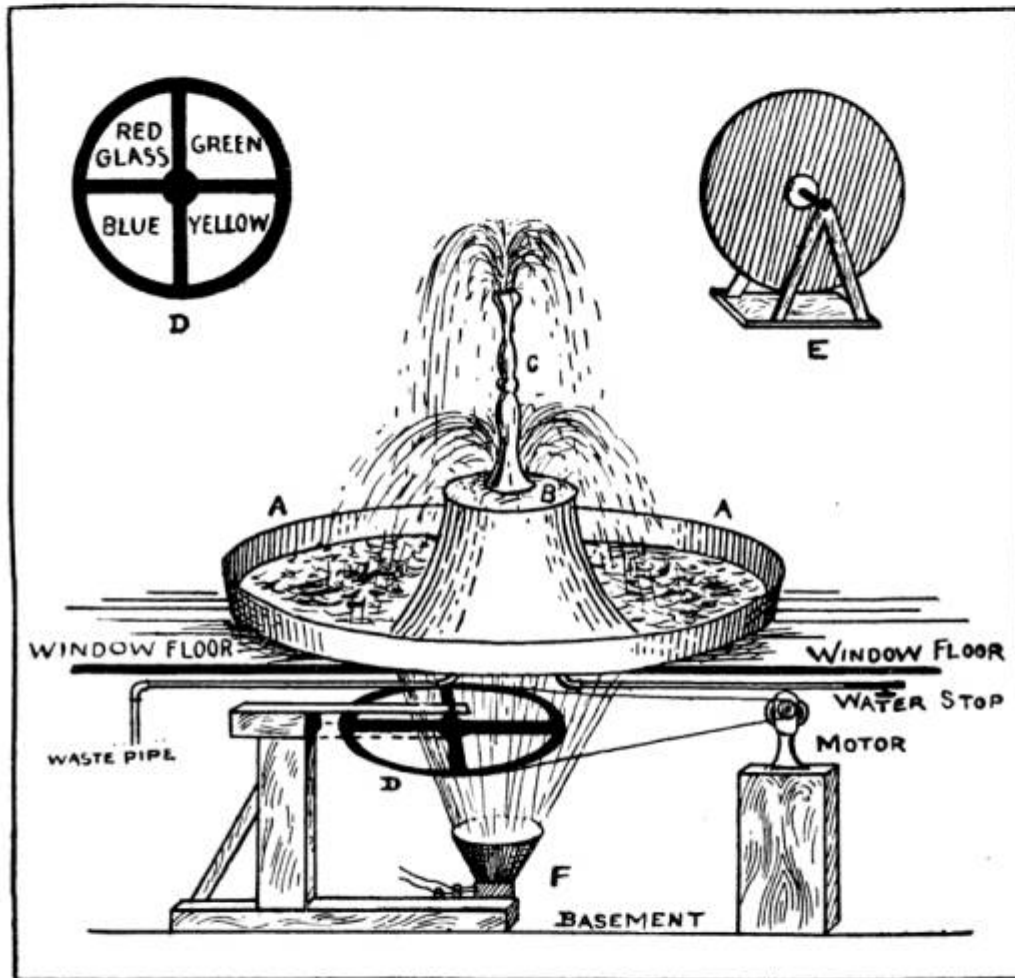

Electric Illuminated Fountain

of the window floor and place the tin bowl over it. Put a large rubber band around the center tin cone. Secure a circular glass shelf, B, having a hole in the center, and rest it upon the cone.

Have the tinsmith make a fancy stem, C, enamel it white, punch fine holes in it at the top and bottom and solder it to the water pipe, which passes through the hole in the center of the glass shelf and which is attached to the main pipe in the basement. Put a rubber washer on the glass shelf to make it watertight. The waterflow is regulated by water stop and the surplus is carried off through the waste pipe.

to speed by means of the reducer E. In the lower bowl lay three electric bulbs colored green, with wires made waterproof, well insulated and enameled. Pond lilies and gold fish may be added and a magnificent display created.

A good cement for metal joints consists of ground white lead worked up with enough powdered red lead to bring it to the consistency of putty. Then add boiled linseed oil.

Our premium list is worthy of your attention. Write for it.

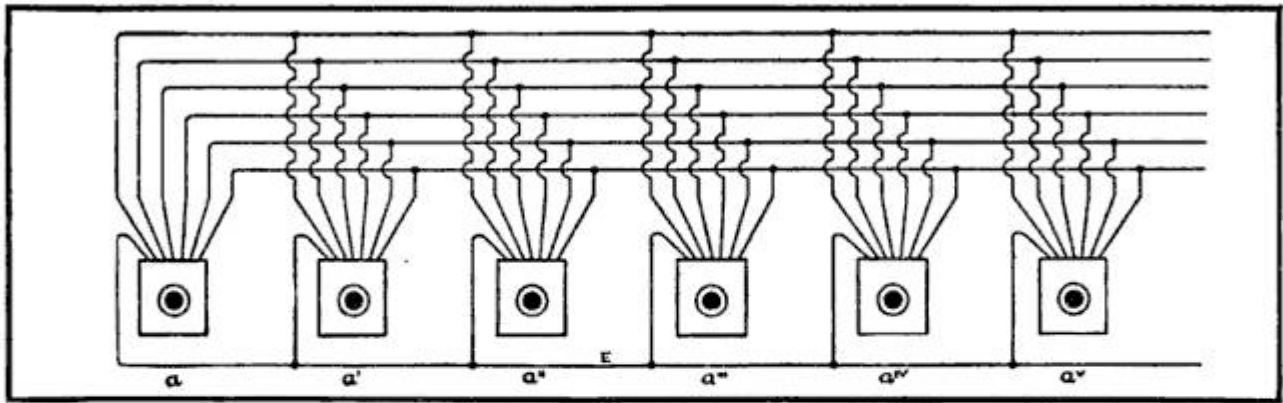

Plan of Wiring for Intercommunicating Telephone System

INSTALLING INTERCOMMUNICATING TELEPHONES--PLAN FOR SIX TELEPHONES

The approved plan of wiring for intercommunicating systems is shown in the accompanying diagram, which we reproduce by courtesy of the American Telephone Journal. The diagram shows six telephones, a, a', a'', etc., to each of which six wires are run. The circuits are completed from the other terminals of each telephone, through the common return wire. The diameter of this return wire should equal the sum of the diameters of the separate wires, where the lines average over 1,000 ft. in length.

Switch board cable should not be used on the intercommunicating system because of creating mutual induction between two circuits, being twisted in pairs. Ordinary house wire, No. 19 B. & S. gauge, with a rubber insulation and a covering to match the woodwork along which it is run is recommended as best. Each separate wire should have a distinct color or combination.

ANOTHER METHOD OF REVERSING COUNTERSHAFT WITHOUT CROSSING BELT

Commenting on the article on reversing a countershaft without crossing the belt by means of two idlers, which appeared in the July Popular Mechanics, W. B. Burrows, of Minneapolis, Minn., says:

"The use of the two idlers for this purpose is all right, but according to my way of figuring they are not used correctly for the reason that the strain of the full load is brought on one of the idlers. I herewith submit a sketch of what I consider the better method for this kind of a drive, as it brings all the strain on the main shafts (where it belongs), leaving the idlers to simply guide the belt and carry the weight of the slack side, as well as allowing lighter shafts and bearings to be used for the idlers. I have used both ways, the latter up to 600 r. p. m., carrying a heavy, uneven load, and find that it gives a great deal better satisfaction all around."

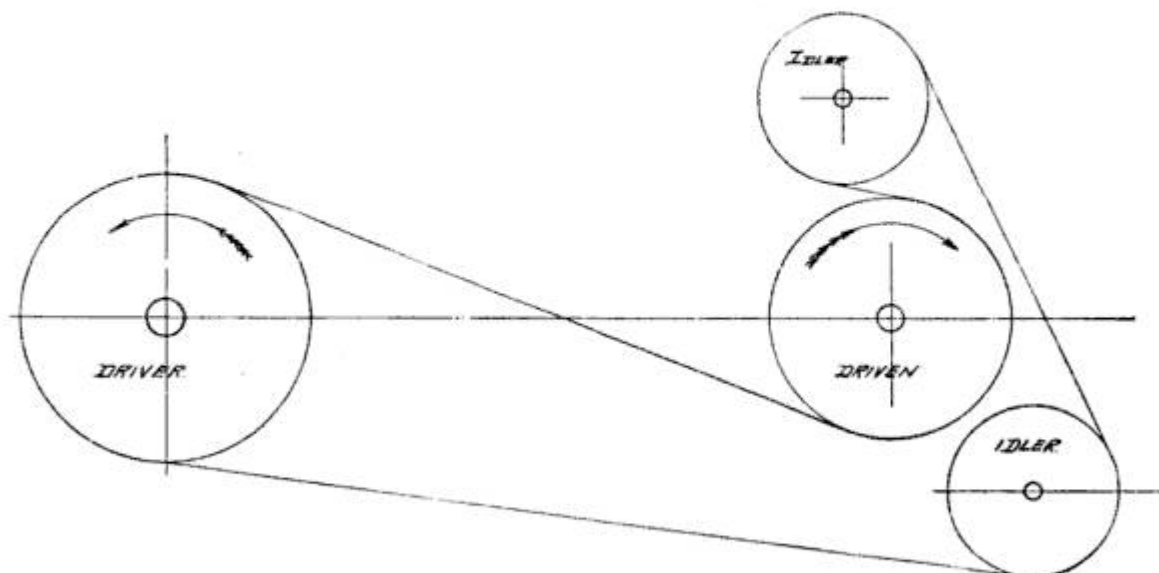

"All the Strain Comes on the Main Shaft, the Idlers Merely Guide the Belt"

MECHANICS FOR YOUNG AMERICA

A PRACTICAL CAMERA FOR FIFTY CENTS

By C. H. Claudy

I say for fifty cents, but really this is an outside estimate. If you possess a few tools and the rudiments of a shop, by which is meant a few odds and ends of screws, brass and nails, you can really make this camera for nothing.

The camera box is the first consideration, and for this a cigar box answers every purpose. It is better to use one of the long boxes which contain a hundred cigars and which have square ends. This box should be cut down, by means of a saw and a plate, until the ends are four inches square. Leave the lid hinged as it is when it comes.

Commercially, plates come three and one-half by three and one-half, or, in the lantern slide plate, three and one-quarter by four inches. If it is desired to use the three and one-half by three and one-half, which is advised, the box should measure that size in its internal dimensions.

We now come to the construction of the most essential part of the camera—the pin hole and the shutter, which take the place of the lens and shutter used in more expensive outfits. This construction is illustrated in Fig. 4. Take a piece of brass, about a sixteenth of an inch thick and one and one-half inches square. Bore a hole in each corner, to take a small screw, which will fasten it to the front of the camera. With a quarter inch drill bore nearly through the plate in the center, but be care-

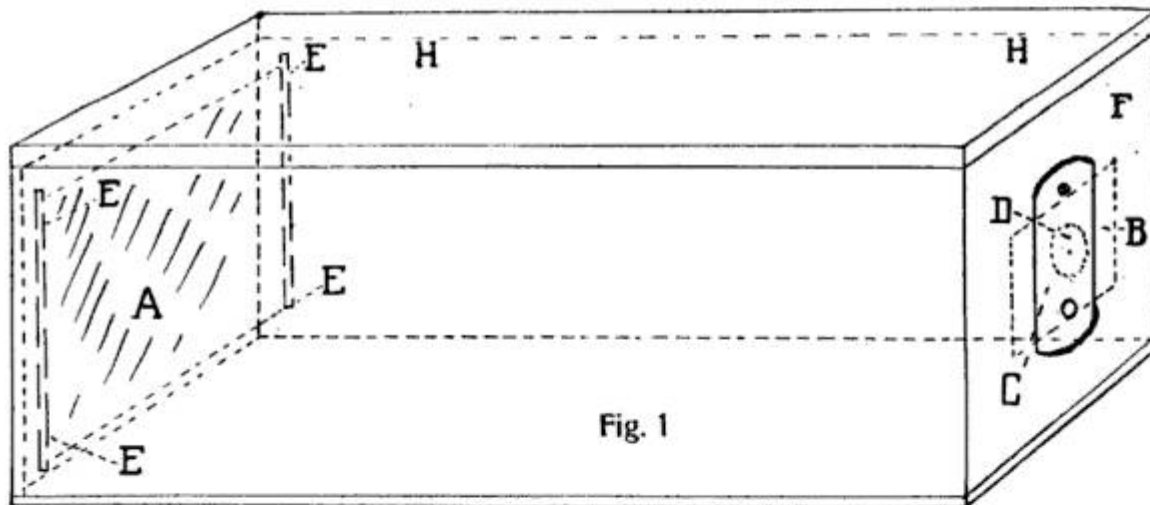

Fig. 1

Clean all the paper from the outside and inside of the box—which may be readily done with a piece of glass for a scraper and a damp cloth—and paint the interior of the box a dead black, either with carriage makers' black or black ink.

Now bore in the center of one end a small hole, a quarter of an inch or less in diameter. Finally insert on the inside of the box, on the sides, two small strips of wood, an eighth of an inch by a quarter and fasten them with glue, an eighth of an inch from the other end of the box. Examine Fig. 1, and see the location of these strips, which are lettered EE. Their purpose is to hold the plate, which may be any size desired up to four inches square,

ful that the point of the drill does not come through. This will produce the recess shown in the first section in Fig. 4. Now take a No. 10 needle, insert the eye end in a piece of wood and very carefully and gently twirl it in the center of the brass where it is the thinnest, until it goes through. This pin hole, as it is called, is what produces the image on the sensitive plate, in a manner which I shall presently describe. The shutter consists of a little swinging piece of brass completely covering the recess and pin hole, and provided with a little knob at its lower end. See Fig. 3, in which F is the front of the camera, B the brass plate and C the shutter. This is also illustrated in the second cross section in Fig. 4. In the

latter I have depicted it as swung from a pivot in the brass, and in Fig. 3 as hung from a screw in the wood of the front board; either construction will be effective.

Lastly, it is necessary to provide a finder for this camera in order to know what picture you are taking. Make a little frame of wire, the size of the plate you are using,

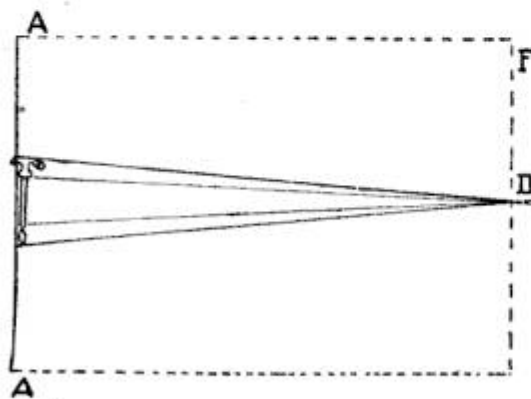

Fig. 2

and mount it upright (see Fig. 5) on top of the camera as close to the end where the pin hole is as you can. At the other end, in the center, erect a little pole of wire half the height of the plate. If now you look along the top of this little pole, through the wire frame and see that the top of the little pole appears in the center of the frame, everything that you see beyond will be taken on the plate, as will be made plain by looking at the dotted lines in Fig. 5, which represents the outer limits of your vision when confined within the little frame.

When you want to use this camera, take it into an absolutely dark room and insert a plate (which you can buy at any supply store for photographers) in the end where the slides of wood are, and between them and the back of the box. Close the lid and secure it with a couple of rubber bands. See that the little shutter covers the hole. Now take the camera to where you wish

into place. It is important that the camera be held rigid during the exposure, and that it does not move and is not jarred—otherwise the picture will be blurred. Remove the plate in the dark room and pack it carefully in a pasteboard box and several wrappings of paper to protect it absolutely from the light. It is now ready to be carried to some one who knows how for development and printing.

To explain the action of the pin hole I would direct attention to Fig. 2. Here F represents the front of the camera, D the pin hole, AA the plate and the letters RR, rays from a lighted candle. These rays of course, radiate in all directions, an infinite multitude of them. Similar rays radiate from every point of the object, from light reflected from these points. Certain of these rays strike the pin hole in the front of the camera, represented here by RRRR. These rays pass through the pin hole, and as light travels only in straight lines, reach the plate AA, forming an inverted image of the object, in this case a candle in a candlestick. Millions of rays are given off by every point in every object which is lighted by either direct or reflected light. To all practical purposes only one of these rays from each point in an object can pass through a minute opening, like a pin hole. This being so, any screen which interrupts these selected rays of light will show upon it a picture of the object, only inverted. If that screen happens to be a photographically sensitive plate, which is protected from all other

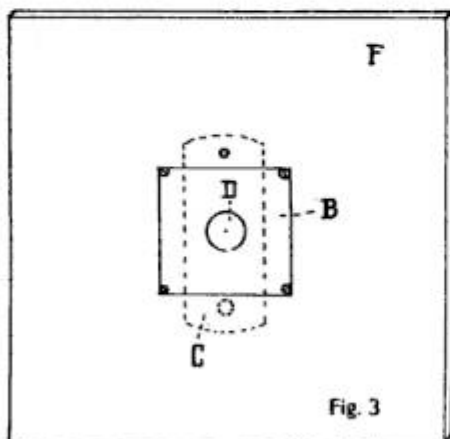

Fig. 3

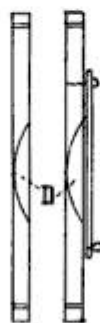

Fig. 4

light by being in a dark box, upon it will be imprinted a photographic image which can be made visible by the application of certain chemicals, when it becomes a negative, from which may be printed positives. This camera is not a theoretical possibility, but

pin in each side to serve as a shaft. For the supports of the wheel use pieces of tin, bent into L-shape and soldered fast to the can. Place them in such position, with respect to the small hole punched, that the spurt of steam from the hole will strike the

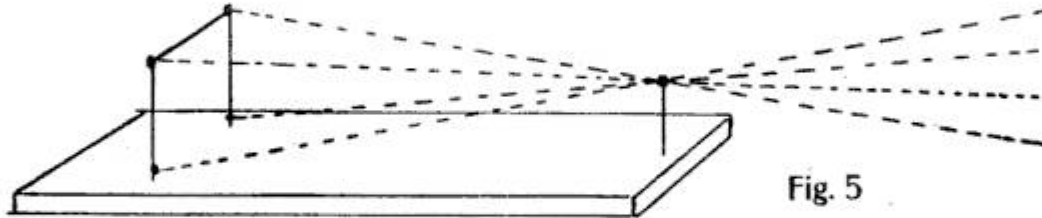

Fig. 5

an actual fact. I have made and used one successfully, as a demonstration of pin hole photography.

HOW TO MAKE A VERY SIMPLE STEAM TURBINE

By A. L. Burkhardt

A miniature steam turbine which is simpler in construction than the one described in the July issue of Popular Mechanics may be made as follows:

A tin can of quart size or larger may serve for the boiler. The can must have a good lid, so that it will not leak. In the top of the can, near one edge, punch a small hole. Through this hole the steam is to come out and strike the paddles of a small wheel. Make the wheel of two pieces of wood, fastened together by cutting halfway through the middle of each and then fitting each into the other, as every boy knows how to do to form a four-paddle water wheel. Drive a

ends of the paddles of the wheel squarely. Fill the boiler three-fourths full of water, set it on a hot stove and as soon as steam is generated fast enough to come out the escape hole with slight force the wheel will start to revolve.

POWER OF SMALL COILS FOR SENDING WIRELESS MESSAGES

By O. F. Dame of the New England Coil Winding Company

Hundreds of amateurs interested in wireless telegraph experiments are seeking definite information as to the sending power of small coils giving 1, 2, 3 and 4 in. sparks. As the successful operation of wireless apparatus depends considerably upon the efficiency of the receiving apparatus, there is absolutely no rule that can be laid down specifically, each man's experience differing from that of nearly everyone else.

Calculations based on recent experiments made by ourselves between two points three miles apart, over an uninterrupted stretch of water, and later from one hill to another, a mile distant, tend to show that one can send twice the distance over water that he can over land. In tests made at Atlantic, Mass., the minimum sending power required for one mile was $\frac{1}{2}$ -in. spark, and it was found that the maximum sending distance of an ordinary 2-in. spark coil operated by six cells of dry battery with no intensifying jars attached, was three miles. In these tests a glass tube coherer of the Marconi type was used. Each station was provided with a short pole, 15 ft. high, and a ground wire buried in moist earth. By the addition of Leyden jars and a more sensitive receiving device the same coil was used successfully a distance of eight miles over water.

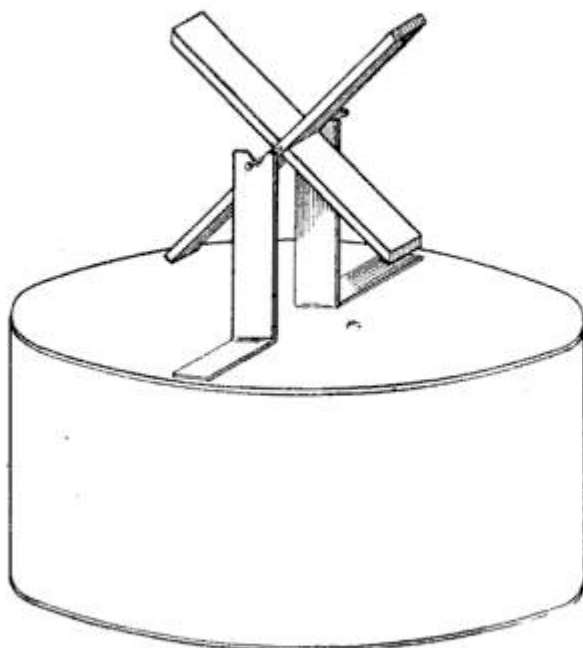

A Simple Turbine Engine

It will therefore be seen that it is impossible for a coil manufacturer to state how much of a spark a customer will require for an estimated distance, without a thorough knowledge of the apparatus to be used at the receiving end, the location of the stations, and what is undoubtedly of more importance than anything else, the natural cleverness of the amateur in handling the subject. Wireless experiments furnish excellent opportunities for a man to exercise his ingenuity to the fullest extent. While it is true, that the induction coil is one-half of the outfit, a sensitive receiving device is equally necessary. The glass tube coherer was the first successful receiver and is used today by the United States government at some stations, and in locations where the stations are not thickly established will serve admirably for years to come. Wireless enthusiasts who have advanced in their experiments to a point where the coherer is discarded for the electrolytic or magnetic receivers, find small sparks rightly operated very successful over distances double that of the coherer period. It is safe, therefore, to assume that a 2-in. coil properly established is a suitable transmitter within the limits of a township, and a 3 or 4-in. coil sufficient for wireless communication of a more advanced character. The literature on wireless telegraphy, owing to the newness of the subject, overflows with questionable theories advanced by experimentalists whose researches lead them to think such and such things are so because certain experiments resulted that way. The future has in store so many undreamed-of discoveries that there seem to us to be very bright futures for the young students who master the principles while the thing is new.

THE "BENNINGTON" DISASTER

The explosion of the boilers of the U. S. S. "Bennington" while in port at San Diego, Cal., has caused general adverse criticism by engineers and the public. Sixty-five sailors were killed or died from injuries. Had the explosion occurred a day later, when the vessel would have been at sea, her loss would doubtless have been one more of the "mysteries."

The generally accepted explanation is that the boilers were not only unsafe, but had been known to be in that condition for months past. It is far from creditable that the same critical boiler inspection which another branch of government so rigidly enforced against merchantmen could and

RINGING A BELL BY TOUCHING A GAS JET

The experiment of scuffing the feet over a carpet and then producing a spark which will light the gas by touching the chandelier was given in the April Popular Mechanics. One of our correspondents, Frank C. Osborn, of New York City, says that if a wire is connected to the chandelier and led to one terminal of the coherer of a wireless tele-

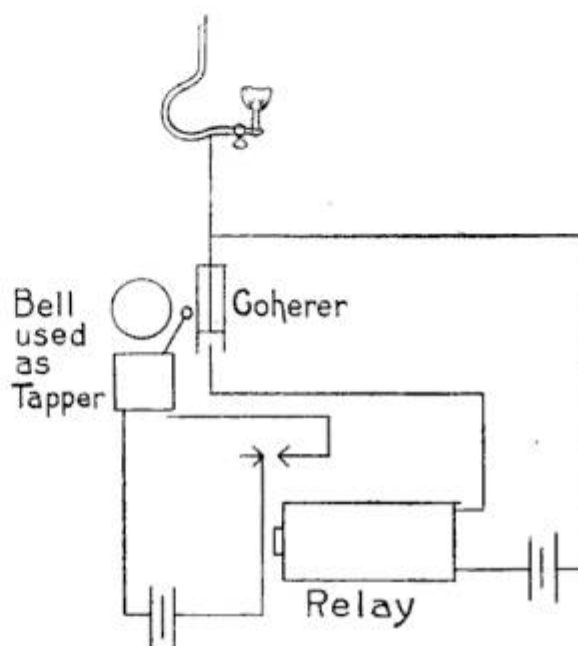

Touch the Gas Jet and Ring the Bell

graph outfit the bell will ring every time the spark is produced by touching the chandelier, and that, as the chandeliers are all connected by the gas-pipe, the bell will ring, no matter in which room the spark is produced.

should not prevail in its navy. Admiral Geo. W. Melville, chief of the bureau of steam engineering, says:

"It is passing strange that while we are wasting time and money on the boiler question, Great Britain is installing 23,000 horsepower of American boilers in their latest and greatest battleship that has been laid down by any navy in the world, the "Dreadnought." Great Britain has fought the "battle of the boiler" very much to her cost, and this greatest and most conservative navy in the world has selected an American boiler because in their service they have proved it to be the most economical, most reliable, smokeless and easiest kept in repair of any marine boiler in the world. Why should we not do likewise?"

CHEMISTRY FOR MECHANICS

By M. G. KOPF

This is the first of a series of short lessons on practical chemistry, particularly adapted to the mechanic. The professional chemist is now considered indispensable in the larger manufacturing industries. We have the iron smelter sending samples of iron to the chemist, to be analyzed, so that he will be able to grade it as regards strength and purity. We have the food chemist, constantly in watch of our health. There is the agricultural chemist transforming arid deserts and wastes into productive farms and fields. In the shops we wonder why one tool breaks sooner than another, why some oils are better than others. We cannot all be chemists, but every one may easily obtain some knowledge of the science in its immediate relation to the things which are closely connected with his every-day work. These articles will all be written in plain simple language "so you can understand it."—Editor's Note.

PART I.

Before entering into details it would be well for one to know something about the history of chemistry. The word chemistry is probably derived from the word *chemia*, which is an old name for Egypt. The word simply signifies the Egyptian art; it was so called because chemistry was first practiced in Egypt. The development of chemistry has been through a series of long and tedious experiments. The Egyptians possessed, through their knowledge of chemistry, considerable skill in the arts of dyeing, painting and glass making; also in metallurgy. When the Arabs, in 640 A. D., invaded Egypt they became acquainted with the Egyptian sciences. A man called Geber wrote the first book on chemistry. He discovered a solvent for gold. After this chemistry advanced step by step until we now have a practical science.

For the first work the following articles will be needed. One may think there will be some difficulty in obtaining these, but on applying to a druggist he will give information as to the location of dealers in chemicals and chemical apparatus. Obtain five feet of $\frac{3}{16}$ in. soft glass tubing; three inches of platinum wire; one 2-in. evaporating dish; one bunsen burner; one-half dozen small test tubes; one pair of tongs; three feet of $\frac{1}{4}$ -in. pressure tubing; six inches of $\frac{1}{4}$, or preferably, $\frac{3}{16}$ in. rubber connecting tubing; a small quantity of sulphur; some sugar; a small quantity of alcohol; some potassium sulphate; a piece of magnesium ribbon, and a test tube holder. All of these articles will come to about \$1.50, but most of them will be needed in subsequent work. After obtaining all the above things provide a bench, which must be painted over with a thick coating of tar paint and located near a gas jet. Connect the burner with the jet by means of the

three feet of $\frac{1}{4}$ -in. pressure tubing. Turn on the gas and light it at the burner and it will be noticed that on admitting air, by means of the draft at the bottom of the burner, a blue, non-luminous flame will be produced, and that on turning the draft off, a luminous, white and smoky flame will result.

Now take a piece of glass tubing a foot long and cut it up into lengths of 4 inches. To do this procure a three-cornered file and with it make scratches at the places the tube is to be cut. Then place the thumbs on the side opposite the scratch and break the tube just as a stick is broken. Having cut the tubing into the proper lengths, and

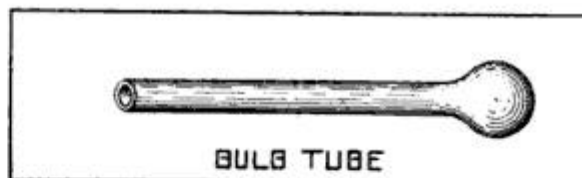

BULB TUBE

adjusted the bunsen burner to give a non-luminous flame proceed to make a holder for the platinum wire and two bulb tubes. (See drawing.) Begin by rounding off the rough edges of the ends of the tubes. To do this hold the end of one of the tubes in the flame and watch closely until the edges melt, but do not hold long enough to make the bore of the tube smaller. Then on two of the tubes make bulbs. This is accomplished by holding the tube in the flame, as before, and rotating constantly until a lump of glass forms on the end. When the lump of glass is very hot withdraw the tube quickly from the flame and, rotating it at the same time, blow gently in the cool rounded end, until a bulb is formed from $\frac{3}{8}$ to $\frac{1}{4}$ in. in diameter. In the next chapter directions will be given for making "U" tubes of various shapes and also how to bend glass tubing.

Fuse the platinum wire in the remaining tube by holding the tube in the flame, and rotating, until the end is nearly closed. Then insert the platinum wire a quarter of an inch or so into the tube and heat, rotating at the same time until the glass has fused around the wire (See drawing).



By means of the glass handle hold the wire in a non-luminous flame. It gets white hot. Now withdraw it. It cools and is the same as before. Take a piece of magnesium ribbon and by means of the tongs hold it in the flame. It ignites and burns with a brilliant flame of a white color. A white powder is left, in no way resembling the magnesium ribbon. On heating the platinum wire we have a physical change; on heating the ribbon we have a chemical change. In a physical change we get back what we started with. In a chemical change we get a new substance.

Heat up some sugar in a bulb tube. The sugar gives off sweet smelling vapors turning black at the same time. Is this a chemical or physical change? This is a chemical change because a new substance carbon (C) is formed.

Place a teaspoon half full of powdered potassium sulphate (K_2SO_4) in a test tube and add about enough water (H_2O) to fill

(To be continued next month.)

half way. When the K_2SO_4 is dissolved, add some alcohol (C_2H_5OH) drop by drop until a thick, white precipitate is formed. Drain off the H_2O and compare the precipitate with the original K_2SO_4 . What kind of change has taken place? The precipitate tastes like the original K_2SO_4 , therefore, to all appearances, a physical change has taken place.

Into the evaporating dish, partly full of water (H_2O), put a small piece of camphor (do not use moth balls); light it with a match. It burns into light, heat and smoke. These we cannot get back. Therefore a chemical change took place. Obtain some fine iron filings. To an equal amount of this add some sulphur. Mix thoroughly. Look at the gray mass with a lens. Put some of the powder into a test tube with H_2O , shake and allow to settle. Try the action of a magnet on the mass. Has a chemical change taken place? No, because in all cases there is still some iron and sulphur. Now cautiously heat some of the mixture in a test tube until the sulphur melts. Observe all the changes. While hot pour on some H_2O . The test tube will shatter and you will be able to get out the substance inside. Has a chemical change taken place? Yes, because the remaining substance is not acted upon by the magnet. You can see no more iron or sulphur. A new substance is formed, iron sulphide (FeS). So now we know what constitutes a chemical and physical change. Next we will take up elements, mixtures, compounds and the three states of matter.

PORTABLE ELECTRIC CONVEYER

A portable electric conveyer is used on a New York wharf where a great deal of perishable freight—fruits, vegetables, tobacco, etc.—is handled and is considered one of the most efficient aids to rapid handling of these cargoes. The conveyer is attached to a convenient socket and may be used either in the hold of the vessel or on the wharf. This machine handles freight with twice the dispatch of ordinary methods, says the Bulletin of the New York Edison Company. The illustration shows it on "the farm," or the place where garden truck is loaded on market wagons.

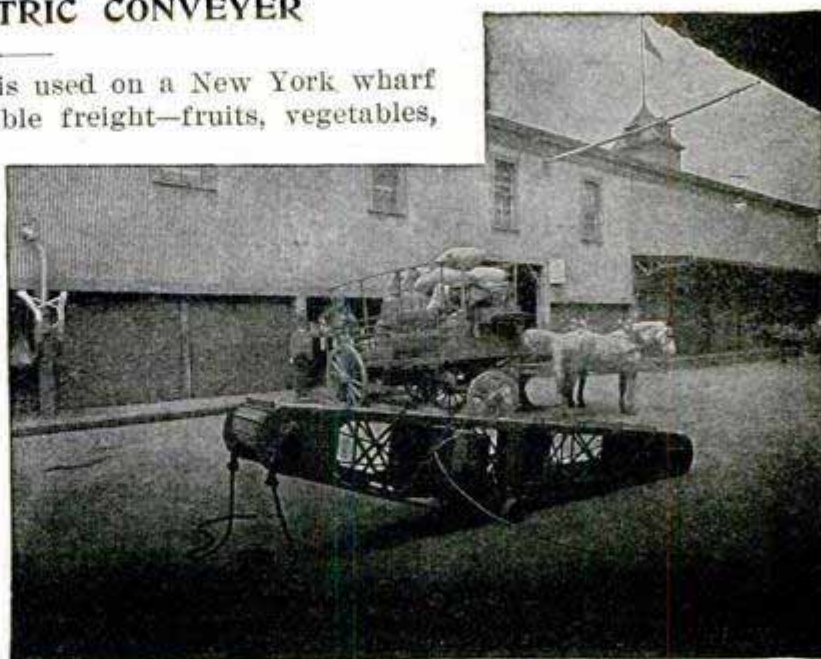

Portable Electric Conveyer

**WE MANUFACTURE TO ORDER
DIES, TOOLS AND
AUTOMATIC MACHINES**

**ALSO HARDWARE SPECIALTIES
AND PATENTED NOVELTIES**

**ESTIMATES FURNISHED ON EXPERT
MODEL WORK, SEND DRAWING OR
SAMPLE.**

BOOKLET FREE. WRITE TODAY.

Stamping & Tool Co.

DEP. C

LA CROSSE, WIS.

COMPLETE DESIGNS of various size
GAS ENGINES

3 in. x 3 in. Water Cooled - \$1.00
4 in. x 5 in. Water Cooled (2 Cylinder) 1.50
4 in. x 5 in. Water Cooled (4 Cylinder) 2.00

These blue prints contain all details and dimensions necessary
for the factory.

Address **MUNROE & CO.**
361 Houseman Bldg., - GRAND RAPIDS, Mich.

AUTO FOR RURAL FREE DELIVERY

Some of the 33,000 rural free delivery carriers are using automobiles instead of horses. They find that they can cover a 25-mile

route, having the usual 150 boxes, in about two hours. To do the same work with a mail wagon drawn by horses takes about eight hours. The patrons along the route naturally like the more rapid service, as it brings them the daily market reports just that much earlier.

The illustration shows the auto free delivery on Route No. 2 out of Groton, S. D. It has been in service one year, except a short time in mid-winter when the regulation mail wagon and horses were substituted. The route is 32 miles long.



THE IDEAL SIGHT RESTORER

Is Your Sight Failing ?

All refractive errors, muscular trouble and chronic diseases of the Eye successfully treated by scientific MASSAGE.

"I am in my seventy-ninth year, and have the Sight Restorer and yourselves to thank for renewed eye-sight." (Testimonial 177)

"I wish I could impress every one afflicted so they would give the Restorer a trial." (Testimonial 244)

English, German or Spanish pamphlet mailed free. Address
THE IDEAL COMPANY, 239 M Broadway, New York.

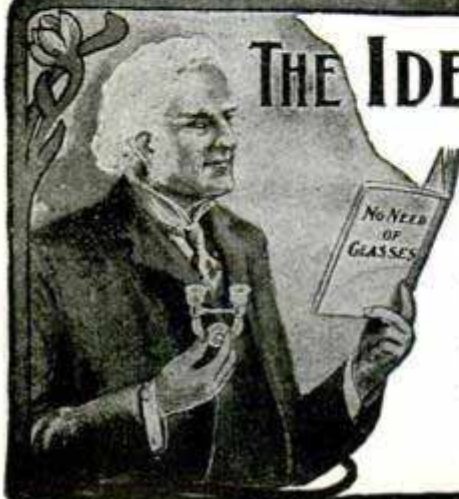

MYERS CONVERTIBLE MACHINE TOOLS

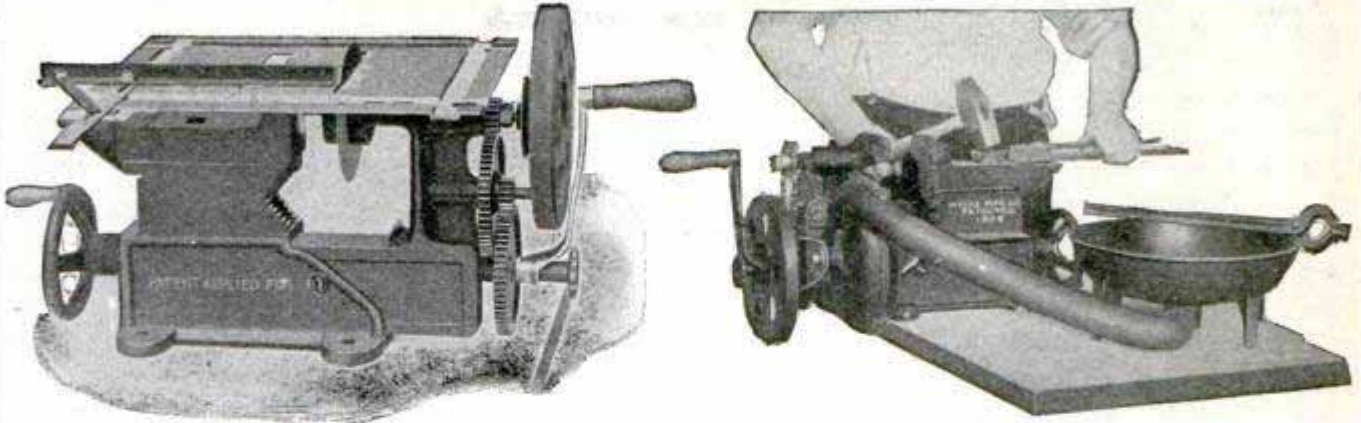

Height, over all, 14 inches; Length, exclusive of handles, 18 inches; Weight, boxed, 100 lbs.

A newly invented machine that enables a carpenter, machinist, blacksmith or any "handy man" to do, at home, practically all kinds of work that can be done in regular shops. With its numerous attachments it may be used in Forging, Drilling, Boring, Grinding, Sawing (wood or metal), Grooving, Buffing, Sand-papering, Thread-cutting and in many other ways. A tool-steel hardie goes with the anvil. Has vise with 4-inch face, pipe-vise, saw-table and gauge adjusted to mitering. Our smallest size circular saw (8-inch) saws inch lumber.

Has cut gears, and may be operated by hand, foot or motor power. The 9-pound fly-wheel imparts wonderful speed and momentum. Not an ordinary, cheap "repair kit," but a real machine, made from the best of materials, and does absolutely true work. All of our attachments such as saws, emery-wheels and drills are the best standard makes. Our Machine-Tools are guaranteed both as to materials and workmanship. Big demand for them in towns and cities as well as in the country. Sold direct by the manufacturers to users at reasonable prices with liberal discounts to Manual Training Schools. Write for descriptive circular.

MYERS MANUFACTURING CO., 65 Wabash Avenue, CHICAGO

LETTERS TO THE EDITOR

HOW ABOUT THIS? I am a machinist and have been a subscriber to "Pop" for about two years. I have just recently handed in my name for five years. I would not like to do without "Pop." It keeps me posted on what is going on in the mechanical world. If I want to buy anything in the mechanical line that I cannot get at home, I can get it by the aid of "Pop," or if I have something for sale or trade, a little ad. will bring the desired result. There is yet one thing I seriously need. A good wife. What can "Pop" do for me in this line?—K. Y. Subscriber.

WANTS POP BY WIRELESS

Dawson, Yukon Ter., July 15, 1905.
The sample copy of Popular Mechanics of May, 1905, Mailed to the Standard Oil Co., Dawson, Y. T., arrived safely. This is the finest work of this kind I have ever seen, and I wonder now how I escaped all these years without it.

Enclosed find \$1, for which add my name to your list as per date stated and forward to me by wireless or the most rapid method you may be using at the present time for distribution. Chester W. Tennant.

PAPER CLOTHING

Paper fabrics are manufactured in several European countries, notably Saxony, where narrow strips of paper are spun into cloth. Paper and cotton spun together form a fabric suitable for summer garments, while paper and woolen yarns are woven into heavier materials. The fabric is cream colored, may be laundered without injury, offers remarkable resistance to water and is said to be low in cost. It is used chiefly for men's garments.

Please mention Popular Mechanics when writing Advertisers.

Do you ever Think?

Do you ever think of how you are going to get along in life? Knowing little, means constant struggle, poor salary. Knowing a great deal, brings to you satisfactory work and high pay. We have helped thousands. In your spare time we qualify you for an Electrical, Steam or Mechanical Engineer, Mechanical Drawing,

Machine Design, Electric Lighting, Motorman, Dynamo Tender, Short Electrical Course, Algebra, Arithmetic.

Special Offer: New students enrolling now will be provided, FREE OF CHARGE, with our reference library and electrical instruments to help them in their studies. Write for our free 80-page book and testimonials.

ELECTRICAL ENGINEER INSTITUTE OF CORRESPONDENCE INSTRUCTION
Dept. 6, 240 West 23d Street, - New York

This Shows Our

"Vim" Butt Spark Magneto

We make other Types for

Butt and Jump Spark Ignition

Also

COILS

of all kinds. Write for prices and full information

THE TRITT ELECTRIC CO. South Bend, Indiana



TELEGRAPHY LEADS TO

TELEGRAPHY

Is undoubtedly the best and most remunerative trade or profession for a young person with limited means and an ordinary education to undertake. It not only affords continuous employment and excellent wages, but it is a stepping-stone to some of the best positions in life. Many of the country's leading financiers, statesmen and men of fame have begun as telegraph operators. It is an excellent "university of business experience," and through the opportunities offered in its training the best possibilities are offered to one following it.

To the uninitiated the clicking of the sounder seems incomprehensible, but with only a few hours' study its principles are readily understood, and with proper effort anyone possessing some aptitude and talent can successfully master it. There is nothing difficult to be confronted.

THE NATIONAL AUTOMATIC TELEGRAPH TRANSMITTER

is a successful self-instructing teacher of telegraphy. It is simple of mechanism and a child can operate it, and it is of great value both to the student who knows nothing of telegraphy as well as to one who is well advanced in the work. A simple governor upon the transmitter, which is easily regulated by the hand, permits of the records being reproduced at a speed of from 5 to 40 words per minute. All records are exact reproductions of characters as made by an expert telegraph operator, and *are not mechanical.*

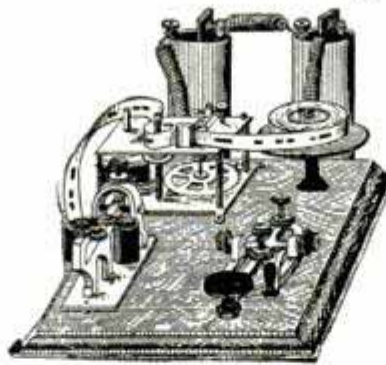

POPULAR MECHANICS believes this self-teacher to be the best upon the market, and the most successful way for one to learn telegraphy thoroughly and quickly. The price of a complete outfit, including the best telegraph instruments, motor and tape reel, all mounted on a polished

oak base, two cells of batteries and an entire series of records (10,000 words) and THE TELEGRAPH INSTRUCTOR, a practical and complete telegraphic textbook, is \$20, or given for a club of 35 new subscribers. The same outfit without key, sounder and batteries, \$16.50 or 28 new subscribers. All outfits sold upon 15 days' approval.

Send for our special catalogue regarding this, containing full explanation in detail

Address **POPULAR MECHANICS JOURNAL BUILDING** CHICAGO, ILLINOIS

THE HIGHEST POSITIONS

O P E R A T O R S I N G R E A T D E M A N D

D E A S I L Y L E A R N E D

MANUFACTURERS FOR INVENTORS

We have the best equipped plant in the United States for EXPERIMENTAL WORK, MODELS, METAL SPECIALTIES of all kinds.

Our line of work is essentially special, as we

MANUFACTURE TO ORDER FOR OTHERS

Shipments made direct to customers of our clients. Use of sales department lent, if desired. All facilities for boxing, shipping, etc.

SEND FOR BOOKLET containing full information of our method of doing business.

The **AMERICAN SPECIALTY CO., Harvard, Ill.**

MACON'S MAGIC WHISTLE

Macon, Mo.—The first night the screech-owl whistle was unbinged here it broke up a colored revival meeting. Dogs howled lugubriously and rolled over in the streets. Horses butted their heads against the walls of their stalls. As the days went by and the engineer increased in proficiency, temperance men took to hard drink and preachers quit damning cards and dancing in order to devote all their time to the greater evil.

To describe that whistle is beyond the ken of mortal man. The strongest work of pen and ink would be as thin air compared to the thing itself. It started with a mournful cadence like Rachel weeping for her loved and lost. Then it would roll up its sleeves moisten its hands and send aloft a twisted wail that would shake the stars and bend the handle of the dipper. It wasn't exactly a whistle nor was it a screech. It was a sort of mixed melody like somebody had up-ended a vat of boiling water on a roomful of tomcats and the cats immediately began talking about it.

That awful blast has been known to make a red-headed girl's hair turn golden and to cause premature baldness where raven locks had flourished.

The citizens stood it for a week. Then they rose up as one man. The whistle was sent out of town in disgrace. It was coupled to the steam pipe over the waterworks plant down on the river, since which time no fish have come nearer than five miles of the reservoir and the real screech owl has gone out of business before its sinister mechanical rival.

And now the council is going to bring it back to town and limit its use to fire alarm. The code agreed on is: One blast, first ward; two blasts, second ward; three blasts, third ward; four blasts, fourth ward; five blasts, fifth ward, and six blasts means that Missouri has returned to democracy.



Bargains IN MOTORS

Electrical Repairing and Construction
SEND FOR BARGAIN SHEET

PEERLESS ELECTRIC CO.,
141-143 So. Clinton St.,
Phone Main 1025 Chicago

Your Ideas Developed

PATENTS PERFECTED EXPERIMENTAL WORK
EXPERT MODEL AND DIE MAKING

METAL SPECIALTIES MANUFACTURED

Punch, Press and Screw Machine Work, Brass Finishing, Oxidizing, Nickel Plating, Enameling. Thirty years' experience.

JOHN OLDFIELD, 937 North 41st Court, CHICAGO

Write for Our
Great Offer

To One Man
In Every Shop

..Popular Mechanics..

The Largest Factory in the United States for Manufacturing Metal Specialties IS AT YOUR SERVICE

Write us for estimate on any article you want manufactured.

Prompt and careful attention given all correspondence

FORT DEARBORN MFG. CO.

Manufacturers of

Incorporated 1895.

SPECIAL MACHINERY DIES, TOOLS, Etc.

Also Blanking, Forming and Drawing of Sheet Metal

63-65 Crossing Street - CHICAGO

Gear and Cam Cutting

Surface and Circular Grinding

Screw Machine Work

Going to Put It on the Market?

You have the article; we have the brains and the equipment for making it at the lowest cost.
We manufacture and ship all kinds of Special machinery on contract.

LET US ACT AS YOUR FACTORY

JOHN WISHART MACHINE WORKS, Engineers and Machinery Mfrs. (Inc.) 43 to 45 S. Canal Street, Chicago.
LONG DISTANCE 'PHONE. MAIN 889.

Please mention Popular Mechanics when writing Advertisers.

GASOLINE SOLDERING IRON AND BLOW TORCH



Furnished with two coppers drop forged from bar, one for regular work and one for heavy work. Nothing complicated. No pump to get out of order. No platinum coil to burn out. Never too hot and never too cold. No wind will blow it out. Can be changed to blow torch instantly. Can be carried in any tool kit, or lineman's belt. Will last for years. Used by tanners, plumbers, painters and electricians. Guaranteed to give satisfaction. If your jobber does not handle them, write us for illustrated booklet and price.

EMMELMANN BROS. MFG. COMPANY, Indianapolis, Ind., U. S. A.

WE WILL SEND YOU

One Pipe Cutter,
One Wrench. All for handling pipe from $\frac{1}{4}$ to 1 inch.
ON RECEIPT OF \$10.50

Send for Catalogue of Complete Line,
ARMSTRONG MFG. CO., Bridgeport, Conn.

One Vice,
One Set GENUINE
Armstrong Stocks
and Dies.

WE MANUFACTURE

Metal Specialties, Dies, Tools, Metal Stampings of all kinds, Screw Machine Work, Novelties, etc. Estimates cheerfully given. Send drawing or models.

Metal Specialty Mfg. Co.,
18-24 W. Randolph St., Chicago

Wanted Toys and Novelties

We want Small Novelties and Toys to manufacture and sell on royalty. If you have Small, Useful Novelty, Toy or Advertising Article, send us sample or model and we will make you an offer. We have ample means and well equipped factory.

KUBEC MANUFACTURING CO.

666 W. Lake Street, - - - Chicago

UNPARALLELED FACILITIES FOR MANUFACTURING

Metal Specialties

OF ALL KINDS PROMPTLY AND REASONABLY WILL MANUFACTURE DIRECT OR ON ROYALTY
Crescent Mfg. Co., Valparaiso, Ind.

Farmer Skidmore (reading signs in a city hotel room)—"Gas burned all night charged extra. Don't blow out the gas." These fellows is bound to catch you one way or the other.—Cleveland Leader.

NEW MECHANICAL IDEAS

CHANGEABLE ELECTRIC SIGNS:—Any letter can be made by inserting the incandescent bulbs in the box frame to form whatever style letter is desired. There are no wires except those attached to the bottom of the box which connect with the metal

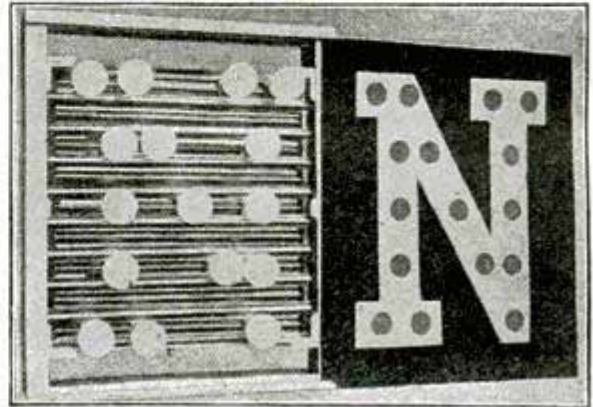

bars holding the bulbs. If the sign is hung across the sidewalk it may have different reading on the two sides. Steel face plates cut for the various letters cover the boxes to conceal the metal bars. The manipulation of the letters can be done without any knowledge of electricity.

POSTOFFICE SIGNALS:—This is a box sign to be hung in front of postoffices where there is no free delivery. The box contains several signs indi-



cating that the mail is being distributed, about to close, mail's late, etc. The signs are manipulated from within the office by means of wires.

J. H. Eddleman, of 2053 N. Franklin St., Philadelphia, Pa., wishes to correspond with anyone having a "Pop." for January, 1904, to dispose of.



Platinum, Gold, Silver, Etc., without the use of solder or acids. Solderene solders anything and everything that the old method of using bar or wire solder, acids, rosin and paste accomplished.

AGENTS WANTED. SEND TEN CENTS FOR A SAMPLE STICK.

THE CHAS. A. THOMPSON CO., - 41 Cortlandt Street, New York, N. Y.

Please mention Popular Mechanics when writing Advertisers.

SOLDERENE

A new rapid flux and tin combined for soldering and mending iron. Copper, Brass, Lead, Zinc, Tin. Solderene solders anything and everything that the



BUY A CAPITAL GAS ENGINE

And you will not sit up nights worrying about expensive power.

Our engines are beyond the standard set by older gas engine builders and no one who is looking for the best and most economical power should buy any engine without first investigating the merits of the Capital Engine. Write for Catalog P.

CAPITAL GAS ENGINE CO., - Indianapolis, Ind.

POCKET KNIFE TOOL KIT:—This extremely useful kit includes six tools all of which except the cutting blade, are removable from the handle. The kit contains: knife blade $3\frac{3}{8}$ in., reamer $3\frac{1}{8}$ in., file 4 in., saw 4 in., chisel $3\frac{3}{8}$ in., and screw driver $3\frac{3}{4}$ in. Any tool can be firmly attached as indicated by the arrow in one second of time by a simple backward wrist movement, and as quickly removed by a



forward wrist movement. The tools are all made of the best material, and are calculated to provide for all ordinary emergencies. The knife and tools are carried in a neat leather pocket book only $4\frac{1}{2}$ in. long, $3\frac{3}{8}$ in. wide and $\frac{3}{4}$ in. thick, and will commend itself as just the thing for every day use; while for hunters, sailors, campers, etc., it is almost indispensable.

GOOD REPAIR SHOP CARD

One of our readers who runs a general repair shop in Lancaster, Ohio, sends us his card, which may serve as a suggestion to others:

IF YOU HAVE ANYTHING BROKE,
EXCEPT YOURSELF,
BRING IT TO ME AND I WILL FIX IT

ALL KINDS OF LIGHT REPAIRS
NEATLY AND CHEAPLY DONE

"Mr. Dip, the famous dyer,
Was trying to dry-clean;
Suddenly he caught fire,
And hasn't since benzine."

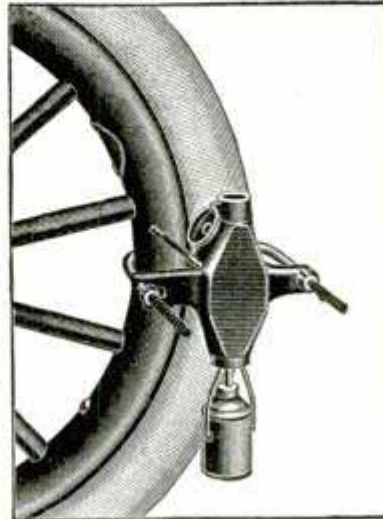

We Know
— AND —
You Know

Those cement patches are constantly coming off this hot weather. Our Vulcanizers not only make patches stay, but will mend cuts and holes in outer casings of auto tires good as new.

GUARANTEED

Let us tell you. Ask for circular "R."

"STITCH-IN-TIME"
VULCANIZER CO.

TOPEKA, KAN., U. S. A.

The CLIMAX BLOW TORCH

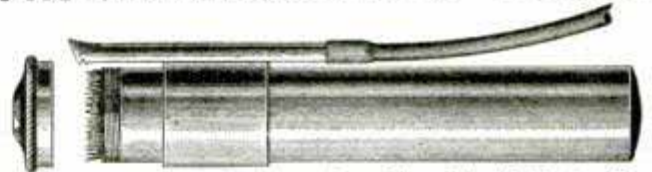

An improvement over every good quality of the Soldering Iron. Carries its own heat supply. This torch is used by jewelers and electricians everywhere and every professional and amateur worker should have one. Price only 55 Cents postpaid.

CLIMAX MANUFACTURING CO., - 1 Hartford Street, Boston

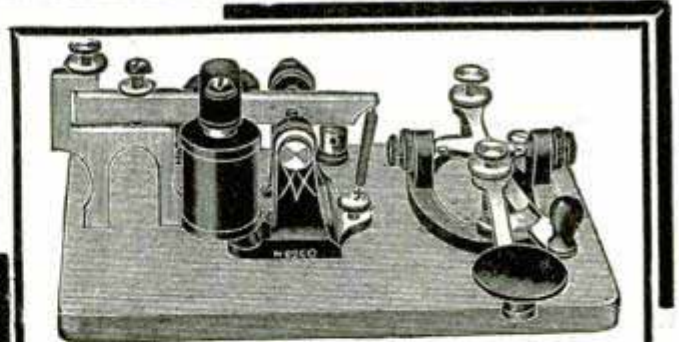

CATALOGUE FREE **PRICES RIGHT**

Telegraph Instruments, Telephones
Burglar Alarms, Bells, Push Buttons, Batteries, Electric
Clocks, Medical Apparatus, Motors, Etc., Etc.

MANHATTAN ELECTRICAL SUPPLY CO.

32 Cortland St., New York

188 Fifth Ave., Chicago

CRANE VALVES

ESTABLISHED 1855

CHEAP PARTS For **WIRELESS TELEGRAPH APPARATUS**
Coils, Coherers, Relays, Sounders, Keys, Secondary Windings, Primaries, Interrupters
Condensers, Leyden Jars—in fact about everything in materials for "wireless" work.

Don't take it for granted that we do not sell such and such a thing. Ask us—the chances are we can save you dollars.

NEW ENGLAND COIL WINDING CO., Atlantic, Mass.

Please mention Popular Mechanics when writing Advertisers.

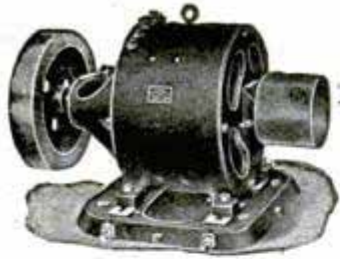

SPECIAL GAS ENGINE GENERATOR

Steady light from an ordinary Gas or
Gasoline Engine. Write for Bulletin.

Rochester Electric Motor Co.
23 FRANK STREET - ROCHESTER, N. Y., U. S. A.

AUTOMATIC JACK:—This machine will raise all four wheels of an auto from the floor at one time. It consists of a light but strong metal framework, onto which the machine is run, the momentum causing four rockers to rise until they raise the

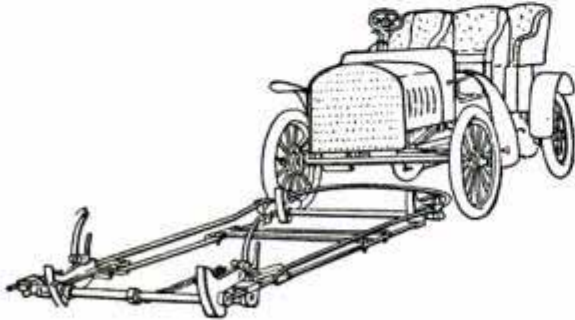

"Will Raise All Four Wheels at One Time"

wheels one inch clear from the floor. A spring is at the same time compressed, which can be released by a lever and return the car to the floor when desired.

BENCH DRILL PRESS.—A neat labor saving device which has frequent use even in shops having



Handy Bench Drill Press

power drills. In this tool the distance from chuck to table is $6\frac{1}{2}$ in.; weight $6\frac{1}{2}$ lbs.; height over all $15\frac{1}{2}$ in.

BAKER'S BREAD RECORD:—English bakers keep a record of the size of the loaves secured from different purchases of flour. At a certain period after baking the bread is cut, a slice laid on the leaf of a blank book kept for the purpose, and the outline carefully marked with a pencil. In each of the diagrams thus made are written the various facts of interest in connection with the loaf, materials, quantities, time, temperatures, color, yield, etc. In this way comparisons are made to show whether any certain grade of flour maintains its quality. In the cut the heavy line shows the flour at its best and the dotted line results that were obtained some months later, and not nearly as good.

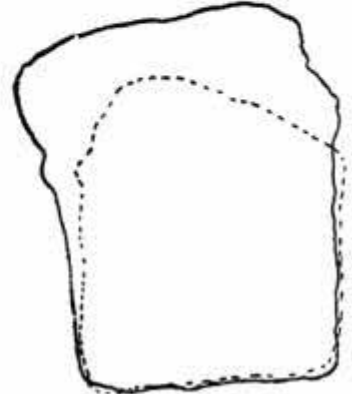

SPEEDISTMETER:—This new instrument for automobiles combines an 8-day clock, shows at what speed the car is moving at all times, and records

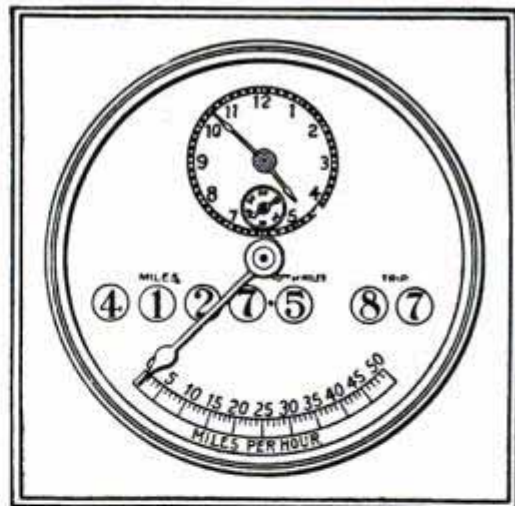

both the number of miles made on each trip and the total miles travelled to date. The trip record reads up to 100 miles, and the total up to 100,000.



"Quick Action"
IGNITING DYNAMOS and
MAGNETOS

The most Reliable Sparkers on the
Market.

Take the Place of Batteries.



Jump Spark Coils

FOR ALL PURPOSES

Single, Double, Triple and Quad-
ruple for Stationary Engines and
Automobiles. Guaranteed in every
particular. Fine Vibrator.

SEND FOR CATALOGUE D.

THE KNOBLOCK HEIDEMAN MFG. COMPANY
SOUTH BEND, IND.

Please mention Popular Mechanics when writing Advertisers.

ENGINEERS— A MONEY MAKING PROPOSITION —ELECTRICIANS

Is open to you if you have charge of a motor or generator. **FREE** a regular 50c stick just to prove to you how good it really is and we will explain our profit-sharing plan on trial orders. Send two green stamps to cover postage.



50c Per Stick

STOPS SPARKING, PREVENTS HEATING AND CUTTING

\$5.00 Per Doz.

SLUSSER BROTHERS, Manufacturers of Mechanical and Electrical Specialties,

Bradford Building, Charleston, W. Va.

THE LOST SNAP SHOT

The Explosion Happened but the Picture Didn't

An amateur photographer relates in the American Amateur Photographer how he missed the picture of his life. He was traveling in the mountains of Oregon and came upon a party of workmen, 100 in number, who were blasting out the side of a mountain for a railroad. For days the men drilled making ready for a blast which was to alter the appearance of the whole canyon.

"I expect to fire the shot at noon," said the foreman, and even as he spoke there was a quick, smothered report from the drill hole, which was being "sprung" by small charges of dynamite to make the bottom large enough to hold the twenty kegs of black powder. It would be the last big "shot" of the season, and the amateur determined to make a picture of it.

He went at once to the hillside, about a hundred yards away, and chose a place to stand the camera. There was a large log convenient for shelter from flying stones. He was the more careful about this, for a young fellow on a similar job the summer before had been killed and his camera demolished by a falling stone.

The camera had no kind of automatic shutter, but after considerable planning and eager work he improvised one that did very well. This done, he cleaned and dusted the camera thoroughly, taking out the lens and wiping it thoroughly with an old linen handkerchief. While thus engaged, he was startled by the loud call of the timekeeper announcing 12 o'clock. As soon as all the men should get to a safe distance the fuses would be lighted, so there was no time to lose.

Hastily gathering up his outfit, the amateur sought the dankish gloom of the root cellar and there loaded the plate holder. A moment later as he hurried along the track he met numbers of laborers walking rapidly towards camp. Joe Martin was out in the channel going from one fuse to another with a lighted taper, and calling loudly, "Fire! Fire!" The amateur dashed up the hillside, stood the machine

(Continued on page 966.)

Eldredge Battery Volt-Meter

Reading 0 to 3 Volts in $\frac{1}{10}$ Divisions

A convenient and practical instrument for those who use Primary and Storage Batteries. Its range will cover two cells of primary or one cell of Storage Battery, in Dead Bear in its readings. Non-removable nuts on strong contact posts. . . Price \$4.

ELDREDGE ELECTRIC MFG. CO., Springfield, Mass.



Robert Battery Volt-Ammeter

Guaranteed

Forwarded prepaid, including case, upon receipt of \$4.50

3 VOLTS | SEND FOR CATALOGUE
30 AMPERES

THE ROBERT INSTRUMENT CO.
60 Shelby St. Detroit, Mich.



DYNAMO CASTINGS

Sets of Material or Finished Parts for the **FRANKLIN MODEL DYNAMO**
PRICE \$3.50 AND UP

Will light six 6 c. p. lamps
Write for illustrated booklet 8

PARSELL & WEED,
129-131 West 31st Street, - NEW YORK CITY

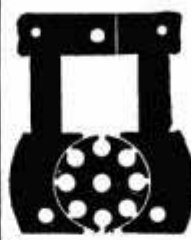

A NEW CURE FOR MOTORPHOBIA

FOUND IN OUR NEW CATALOG OF
"EVERYTHING FOR YOU AND YOUR AUTO"

THE MOTOR CAR SUPPLY CO.

1427 MICHIGAN AVENUE CHICAGO, ILL.

The Wonder Gasoline Motors

MOST SIMPLE AND EFFICIENT OUTFITS ON THE MARKET

NO valves, gears, etc., to get out of order. So simple that a child can operate them. Just the thing for the farm, shop, cottage, electric light plant, or wherever a steady and reliable power is required. Our $\frac{1}{2}$ H. P. marine outfit is without an equal. Parties are getting better than 8 miles per hour from them. They furnish more power for less money than any other motor on the market. Prices will surprise. Write today. Tell us what you want to operate and we can save you money. Outfits up to 5 H. P. Descriptive catalogue free.

The R. M. CORNWELL COMPANY, - 408 S. Salina Street, - SYRACUSE, N. Y.
Please mention Popular Mechanics when writing Advertisers.

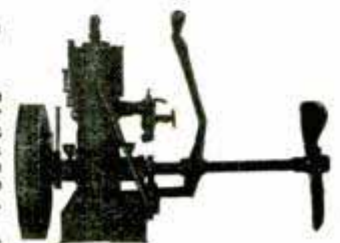
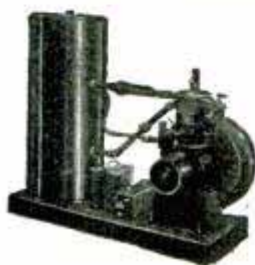

\$100 The New Pierce Gasoline Motor

IS A WONDER

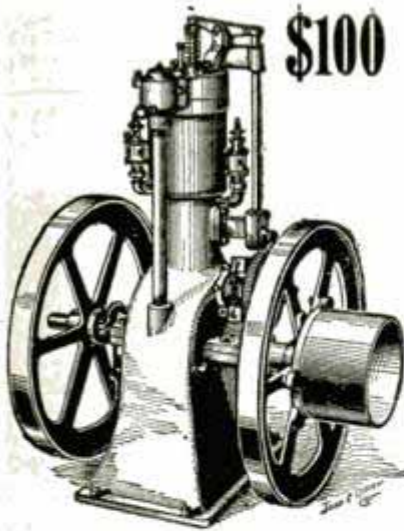

It will develop more power on less fuel than any other make in the world....

Built on modern lines and up to the very latest practice; made from the best material, and with ordinary care will last a life-time.

We have been building Gasoline Motors for over twenty years. More than 12,000 PIERCE MOTORS are in use in all parts of the world. We know how to, and do, build them right, in fact, we

Guarantee Them to Give Satisfaction.
If they do not, send them back and we will refund your money in full. . . .

The PIERCE MOTORS are the best in the world and cost less than the poorest. We guarantee them against defective material for life. If you want power for any purpose, write for our printed matter, stating your needs. We also build other sizes up to 100 H. P., also Marine Motors, Launches and Auto Boats. Be sure and address

PIERCE ENGINE COMPANY, - Dept. 2, Racine, Wis.

3 1-2 Actual Horse Power

Gasolene Motors ^A/_D Castings



A complete line from 1 1/4 to 10 h. p., for Bicycle, Automobile, Marine or Stationary. Also attachable motor outfits and Complete MOTOR-CYCLES. Send stamp for catalogue.

STEFFEY MFG. CO.,

Brown and Fenwick Sts., Philadelphia, Pa.



Convert Your Bicycle Into a Motorcycle

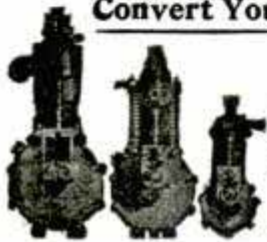

We have a 1 1/4 H. P. B'ke Motor. We sell the set of castings & drawings for **\$7.50**

We also have a 2 1/2 H. P. set of castings. Send stamp for catalogue and full particulars.

EUREKA MFG. & SUPPLY CO.,
ST. PAUL MINN.



Gasoline Engines

Three Styles—All Sizes.
Feed Mills, Saw Machines, etc.
LOWEST PRICES
Write for descriptive circulars and price list. Agents Wanted.
GILSON MFG. CO.
26 Park St., Port Washington, Wis.

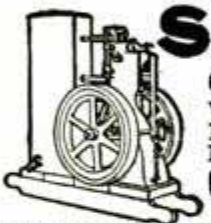

SIMPLICITY

GASOLINE ENGINES
Vertical and Horizontal, 1 1/4 to 15 h. p. Stationaries, Portables, Pumping Outfits and Sawing Rigs.
GET OUR PROPOSITION
and 1905 catalogue.

Western Malleable & Grey Iron Mfg. Co.
134 Chase Street, Milwaukee, Wis.

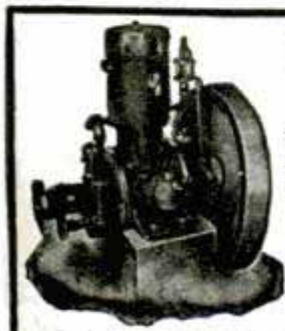

15 Days' Trial on this Engine

No cash payment required. We pay freight to any point within 1,000 miles of Chicago. Spark Plugs guaranteed for 365 days, \$1.50 each.

Second-Hand Engines all Sizes
McDONALD & ERICKSON,
36 West Randolph St., Chicago.

close to the log and drew the cloth over his head. A few stragglers hurrying toward camp paused a second, and one of them called, "Hey there Youse'll get the glass smashed in that thing!" Then they scurried away, for now a score of "block holes" began going off like a fusillade of artillery, with occasionally a "coyote hole" which threw the boulders like canister.

Drawing the plate-holder from his pocket with one hand, the amateur turned the focusing screw rapidly with the other. A queer circle of light appeared on the ground glass. But no landscape with its living colors and sunlit foliage, and trees and hills upside down. Fragments of stone were now falling all about, striking the rails or clipping through the tree tops. Heedless of any danger the "spec" twirled the screw desperately. Backward and forward and back again, but always that hazy disc of light, now large, now small. It was maddening, and withal, most strange. The amateur popped his head out quickly and looked the machine over. Then glancing at the channel he saw a tiny wreath of smoke curling away from the ridge, and he knew the long fuse was nearly gone. Now trembling and furious, the amateur dropped the plate-holder, and with both hands worked the focusing frame back and forth, watching the glass.

Suddenly the air quivered violently, the ground rocked under his feet and a muffled, thundering roar filled the canyon. The amateur dodged under the log and looked quickly at the channel. The whole ridge, lifted bodily, hung in midair, surrounded by a cloud of smoke and dust, shot through by heavy, tumbling stones or sharp fragments that whizzed like bullets. A brief moment it seemed to hover, then the huge mass settled back with the groaning of thousands of tons of rock grinding together. The smoke floated lightly away on the breeze, a deep rumbling echo rolled like a tidal wave among the mountains, and the big blast was over.

While waiting a moment for any belated block hole to shoot, the "spec" nursed his wounded pride and fondly wished that a thousand pound boulder might settle on that miserable old camera. Soon the foreman, who had kept count of the shots, cried, "All over." And the men came out from behind trees and under bridges and quietly surrounded the mess-house. The amateur snatched the camera and hastened into camp. He brushed suddenly past the stable boss who wanted to order a dozen copies of the picture. That simple soul knew every slip 'twixt the bottle and the lip, but the vastly more numerous uncertainties between the exposure and a picture how could he know? Bursting into the tent the "spec" threw the treacherous machine into an empty bunk and sat down, full of disgust and a dull sense of amazement. Pulling himself together a moment later to get ready for lunch, his eye fell upon the table. There lay the old linen handkerchief, and close by it the lens.

Please mention Popular Mechanics when writing Advertisers.

OTTO ENGINES

Running Steadily Since '79

Ritter & Co., Publishers, Reading, Pa., write: We have had this engine (Otto No. 54) in use for nearly 30 years and it now needs some repairs." Is it any wonder after all these years of service? Any other make would have found its way to the scrap pile long ago, but **Otto Workmanship** and **Otto Materials** seem to be well nigh proof against wear. The "Otto" costs a little more and is worth a great deal more.



OTTO GAS ENGINE WORKS, Phila., Pa.

STANDARD OF THE WORLD

HE WAS NOT DISTURBED

Island resorts were just coming into popularity when Captain Coomers took charge of the "Belle," plying between the mainland and the island. Captain Coomers was a sailor of long experience.

On one passage across the bay she fell foul of a current that pushed her upon a sand bank. The passengers began to run for the boats and hunt in impossible places for life preservers. Captain Coomers sat on deck, his big frame supported by a camp stool and his "game leg" stretched out on another camp stool.

A passenger ran up to him and cried, "O, captain, we are wrecked!"

"Hum?"

"We are wrecked!"

"Be we?"

"Is there any danger?"

"Hum?"

"Are we going to sink?"

"Not fur in this water."

"Are you sure? I'm afraid we—we shall all be drowned!"

"Not if you're more'n four feet high."

The passenger seemed satisfied at last, and went away. Captain Coomers resumed his gaze at the deck. Presently another passenger saw him.

"O captain, I'm so glad you're here."

"So be I."

"Think there's any danger?"

"I ain't seen any."

"Of course we—we aren't far from shore?"

"No. We're as nigh as two lovers on a slopin' sofa."

"You take it coolly!"

"Well, you see I've been wrecked off Cape Horn and I was in a boat that was chawed up by a whale. I don't puppus to get my boots wet out o' any sech land vehicle as this here."

Harlow's Perfect Canopy

THE MOST DESIRABLE LAUNCH CANOPY AND STORM COVER EVER MANUFACTURED.

Adjustable and disappearing. Send for Catalog.

HARLOW CANOPY CO., Janesville, Wisconsin

Gasoline Engines and

CASTINGS

AUTO, MARINE and STATIONARY

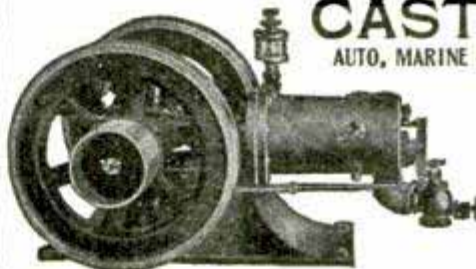

ARE you in the market for Gasoline Engines or Accessories? We conduct a real Bargain Place on these lines. Write us.

Booklet on Request.

L. W. GILLESPIE & COMPANY, MARION, IND.

The MIETZ & WEISS

OIL ENGINE, Stationary and Marine

1 to 75 H. P.

128-138 Mott St. - New York

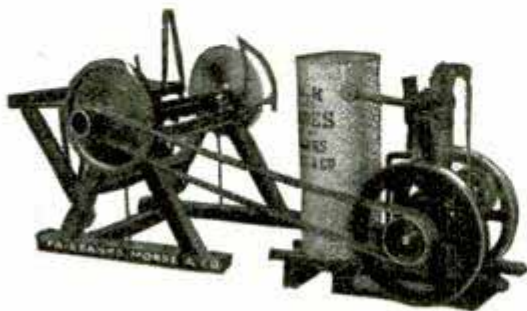

Fairbanks-Morse Jack-of-all-Trades

Gasoline Engine will saw more wood than any other 2 H. P. Gasoline Engine.

It is sent all set up and ready to run.

Awarded Gold Medals at World's Fair, 1904

Cut out complete advertisement and send to

FAIRBANKS, MORSE & CO., Monroe St., Chicago, Ill.

Please send me illustrated Catalogue No. H449 Gasoline Engines. I may want.....H. P. Engine to run.....

Name..... Street No.....

Town..... State.....

A Roth Motor will Drive Any Kind of a Machine Tool

No shafting, pulleys or belting to maintain. The motor running any machine not in use can be shut off.

Considering Economy, Efficiency and Design, the
ROTH MOTOR is beyond reach of competitors.

Self-oiling, noiseless in operation, free from sparking and automatic in its speed regulation at variable loads.

Write us of your motor wants and we will send illustrated catalogue free.

ROTH BROS. & CO., Manufacturers,
27-31 So. Clinton Street, CHICAGO



SEND FOR IT

MY revised list of machinery and contractors' equipment July issue, is now ready, and covers eleven printed pages with location and prices. I will be very pleased to send a copy to you if you will let me have your address.

Willis Shaw, Machinery

171 La Salle St CHICAGO, ILL.

SPECIAL MANUFACTURING

Dies and Stamping

-- TO ORDER --

SPECIAL MACHINERY, MODELS EXPERIMENTAL WORK

DROP FORGING DIES AND DROP FORGINGS

Hardware Specialties, etc., Man'd to Order. Send Samples or Drawings for Estimates. Write for Our Booklet.

THE GLOBE MACHINE & STAMPING CO.
973 Hamilton St., - Cleveland, Ohio

NEW BOOKS

PAINTERS' OILS, COLORS AND VARNISHES.

Edited by Paul N. Hasluck. Numerous illustrations; 160 pages; crown, 8vo.; cloth, \$1.00. David McKay, Philadelphia.

A comprehensive digest of information in the subject mentioned, drawn from the experience of chemists and color manufacturers. Concise in its treatment and always clear. A chapter on Oils and Vehicles contains information that every painter should have at his finger ends. The various classes of pigments are treated in chapters, as are also Paint Grinding and Mixing; Gums, Oils and Solvents for Varnishes, and Varnish Manufacture. The illustrations show machines and apparatus used in preparing oils and paint.

PHOTOGRAPHIC REFERENCE BOOK.

Edited by J. McIntosh. Illustrated; 340 pages; paper covers; 75 cents. Tennant & Ward, New York.

The second edition of this work has been largely added to and rewritten. Its aim is to tell how to do anything and everything in connection with photography. Its pages are crammed full of handy, practical information, further elucidated by diagrams and tables.

ELECTRO-PLATING.

Edited by Paul N. Hasluck. Numerous engravings and diagrams; 160 pages; Cloth, 50 cents. David McKay, Philadelphia.

A handbook full of concise, practical information on electro-plating. A book that may be referred to at any stage of the work. Treats of Tanks, Vats and Other Apparatus, Batteries, Dynamos and Electrical Accessories, Appliances for Preparing and Finishing Work; Silver-Plating; Copper-Plating; Gold-Plating; Nickel-Plating and Cycle-Plating; Finishing Electro-Plated Goods; Electro-Plating with Various Metals and Alloys. All the apparatus required is illustrated and clearly explained. The book also contains several valuable tables.

YOUR INTERESTS AND OURS ARE IDENTICAL.

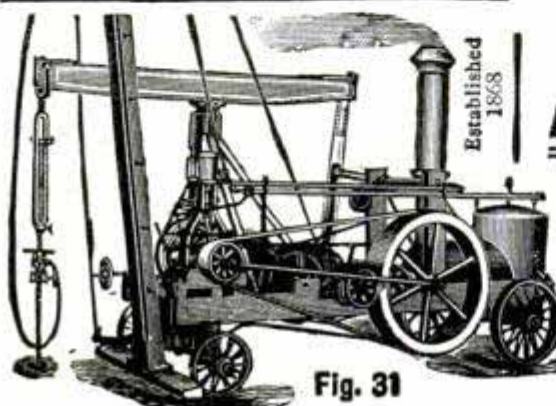

Fig. 31

You Want Practical

WELL DRILLING MACHINERY

to develop that

Mineral, Oil or Water

proposition; we have it. Guarantee it to work satisfactorily.

Tell us about the formations, depth, diameter holes; will send printed matter and can save you money.

THE AMERICAN WELL WORKS,

AURORA, ILL., U. S. A.
CHICAGO, ILL. DALLAS, TEXAS.

"Star" Lathes Foot or Power

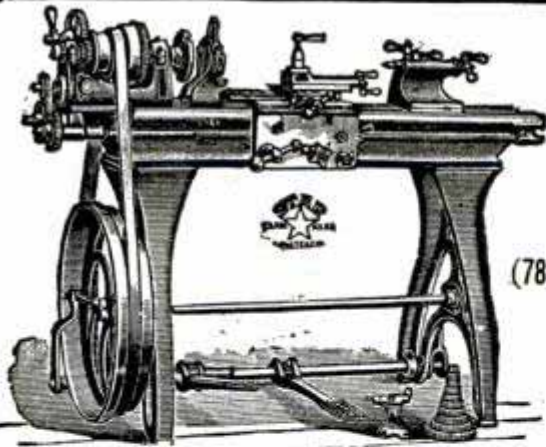

Engine Lathes, Bench Lathes, Foot Power Lathes, Speed Lathes, Wood-Turning Lathes.

High-grade screw-cutting engine Lathes, with forged crucible steel hollow spindles, phosphor bronze bearings, gear-driven reversible feeds with strong friction drive in apron, our patented spring nuts which allow quick shifts of change gears, also Draw-in Chuck, Gear-cutting, Milling and Taper Attachments if desired.

Suitable for electrical and repair work, model makers, gunsmiths, technical schools and fine, accurate machine-shop and tool-room service. Ask for COMPLETE DESCRIPTIONS.

THE SENECA FALLS MFG. CO.
102 Water Street, Seneca Falls, N. Y., U. S. A.

PRACTICAL PERSPECTIVE. By Frank Richards and Fred H. Colvin. Illustrated; 60 pages. Cloth, 50 cents. The Derry-Collard Co., New York.

In this work the author makes clear the principles of isometric perspective—the only practical perspective for mechanical work—and shows its application to some of the kinds of work for which it is adapted. The examples include architectural details, jigs and fixtures, pattern work, locomotive details, structural steel work, concrete piping, blacksmithing and carpentry. The drawings are made on isometric paper, two pads of which will be sent with the book for \$1.00.

NEW PUBLICATIONS.

THE DULUTH AERIAL FERRY BRIDGE has attracted such world-wide interest that a handsomely illustrated booklet on the bridge and its construction, prepared by Norman Mattocks, will be sent free to all those sending a 2-cent stamp to the Engineer Dept., City of Duluth, Minn., requesting a copy.

MINNESOTA LAKES as described and illustrated from photographs in a beautiful booklet mailed on request to A. M. Cleland, Gen'l Passenger Agent, Northern Pacific Railway, St. Paul, Minn., are certainly alluring to the lover of out-door life. The booklet contains considerable pertinent information, including the fish and game laws of the state.

ON THE LEWIS AND CLARK TRAIL is an illustrated booklet sent out with the compliments of the citizens of Spokane, Wash., and depicting the beauties of that city. A copy of the pamphlet may be had by addressing F. E. Goodall, President Spokane Chamber of Commerce. The editor's copy contained a pass good for a 30-mile round trip on the "Seeing Spokane Electric Car."

A CAMERA JOURNEY TO THE LEWIS AND CLARK CENTENNIAL EXPOSITION, published by the Great Northern Railway and sent free on request to F. I. Whitney, Passenger Traffic Manager, St. Paul, Minn., portrays in illustrations from photographs the beautiful scenery that the northern route passes through or near. The book is a guide for observant eyes and anyone going this way should procure a copy.

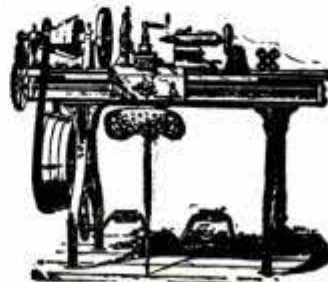

LATHES

9 to 13 inch Swing

List price, \$65.00 and up according to size. When ready to buy send for Lathe Catalog and prices

W. F. & John Barnes Co.
100 Ruby St., : : Rockford, Ill.

FOOT and POWER

AND TURRET LATHES, PLANERS
SHAPERS AND DRILL PRESSES : : :

SHEPARD LATHE CO.

A131 W. 2d St., Cincinnati, Ohio

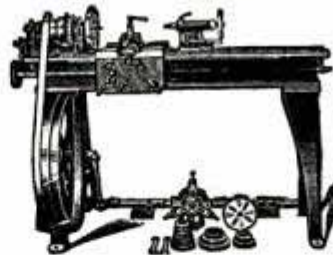

B. F. BARNES' ELEVEN-INCH SCREW CUTTING LATHE

For foot or power as wanted. Has power cross feed and compound rest. A strictly high-grade modern tool. We also build a 9-inch lathe. Descriptive circulars of each lathe upon request.

B. F. BARNES CO., Rockford, Ill.

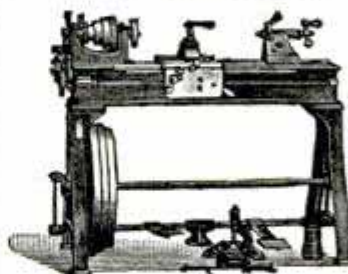

FOOT and POWER LATHES

9 to 15 inch swing.
Built for service.

High Grade, Low Price
Accurate Tools

CATALOGUE FREE.

SEBASTIAN LATHE CO.

107-109 Culvert Street
CINCINNATI, O.



A Reliable Work Bench

This Bench is made of hard Maple; the top consists of strips glued together to avoid warping; has 2 1/2 inches thick Bench Screws; the Bench is 6 1/2 ft. long, 2 ft. wide and 34 in. high; stand bolted, weight 200 lbs. ASK YOUR DEALER FOR IT.

C. CHRISTIANSEN, 86-90 Pratt St., Chicago

STARRETT TOOLS

are the recognized standard for accuracy, workmanship, design and finish. Whether you use tools to earn your daily bread or for amusement and relaxation from a different vocation, it pays to use GOOD tools. You get a better quality of bread and a good deal more pleasure.



L. S. STARRETT

USE STARRETT TOOLS

We make hundreds of different tools. Ours is the largest plant in the world where nothing but fine mechanical tools are made. All these tools are fully described and illustrated in our Catalogue No. 17AP, which you may have by sending us your address. There is a good deal of valuable information in its 176 pages which it will pay anyone who uses tools to have.

THE L. S. STARRETT COMPANY
ATHOL, MASS., U. S. A.

Dynamo and Motor Bargains

We carry in stock over 600 machines in all sizes from $\frac{1}{8}$ to 100 horse power, both new and second hand, *all guaranteed*. Small factory equipments our specialty

NO ONE

Can sell you a first-class machine for less money. We repair all makes. Send us your inquiries.

Guarantee Electric Co.

CHAS. E. GREGORY, Pres.

153 to 159 S. Clinton St.,

CHICAGO

STARTING A LARGE STEAM TURBINE

Interesting Account of How It Is Brought From Cold to Speed in 2 1-2 Minutes.

In a paper read before the American Society of Engineers, A. S. Mann gives a vivid picture of how a big steam turbine in an electric plant is brought into action. He said:

If a large steam turbine is cold and at rest, how quickly can it be started? Can it be brought up to speed as readily as can a good cross-compound engine that is cold all over? Most station men would have doubts as to the adaptability of the large turbine, say 1,500 kilowatts, or 2,250 horsepower, for emergency work. So much has been written about the sensitiveness of a rotating disc to the changes of temperature and the effects of unequal expansion that it is easy to imagine difficulties in the rapid start. The possibilities of an engine with a 62-inch low-pressure cylinder in starting practically cold and coming up to synchronous speed are well understood. A station manager would criticize an engineer who would open his throttle as fast as he dared without wrecking his piping system and let his machine jump into her work. One turn at a time on the throttle is about all that is considered safe, and even then a close watch is kept for groaning valves and cold back bonnets.

Every time the starting valve is moved to increase the steam flow, the engine is allowed to take its full increment of speed, due to that particular throttle position before the supply valve is moved a second time. There are ten large oil cups, and frequently more, that must be opened and adjusted before the machine moves at all, besides whatever oiling is to be done about the air pumps and other auxiliary apparatus.

IT WILL PAY YOU! THE BOWSER

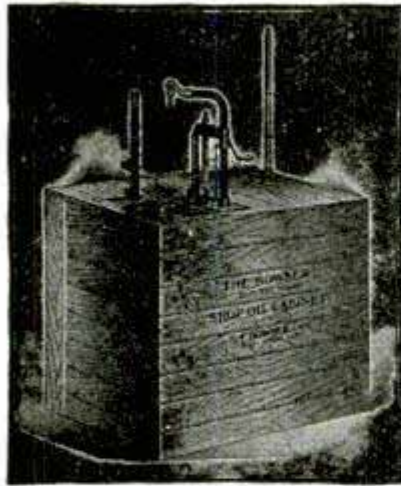

Handles
All
Grades
and
Kinds
of
Lubricating
Oils

SINGLE SQUARE CABINET

NO WASTE, NO OIL-SOAKED FLOORS

The "OILER" is exactly filled
AT ONE STROKE; there is no
overflow.

Fifty Different Styles. Send for Catalog XII

S. F. BOWSER & CO., Ft. Wayne, Ind.

Most engineers would consider ten minutes as rather a fast start and fifteen minutes as a more usual starting period, including time taken for warming up; in fact, it may not be overstating the case to say that if it were known that an engine-driven plant were to be called upon in emergency for power and it were essential that the briefest possible time were to elapse between the call and the taking of the load, one or more engines would be kept in motion all the time, turning slowly and hot all over.

This question makes itself very prominent when the steam station is operated as an auxiliary to a large source of high-tension power, which is itself in the construction stage and has a large overload capacity of its own to carry, supplying all sorts of apparatus that use electric power, railway, lighting, and power circuits, simultaneously. At such a time all sorts of accidents will happen to the high-tension water-driven plant, most of them due to the necessarily temporary character of many of the electrical connections. It takes months before an intricate system of wiring can be thoroughly relied upon, for it takes months before the temporary work of construction can be replaced.

The station at present under consideration is equipped with three Curtis turbine-driven alternators, 40 cycle, 10,000 volts, each of 1,500 kilowatts normal capacity. During the summer months the station is operated as an auxiliary to a water power plant, taking all sudden overloads. A signal has been arranged, a $\frac{3}{4}$ -inch whistle, so that it can be blown instantly should the power fail. A blast of that whistle means cut in two turbines and bring the third up to speed. The load will be heavy, and all auxiliary apparatus must be in regular operation.

Each turbine has a surface condenser and there are three or four pumps to be started for each pair of turbines; one circulating pump, one pressure pump for the step bearings and one dry-air pump, all of

(Continued on page 972.)

Please mention Popular Mechanics when writing Advertisers.

TECHNIC OF Mechanical Drafting

BY CHAS. W. REINHARDT

Chief Draftsman, Engineering News

Author of "Lettering for Draftsmen, Engineers and Students."

"SHOWS HOW TO DO IT"

Contains chapters on outlining, lettering, outline shading, section lining, curved surface shading, shading of inclined surfaces, topographical drawing, character and finish, etc. Boards 11x8 ins. 42 pp. 90 text illustrations and 11 full page plates. Plates I to IV contain 69 distinct conventions for section lining.

Prof. Jacoby of Cornell, says: "Each of the chapters on 'outline shading' and on 'section lining' are alone worth the price of the book."

Most Popular Book on Mechanical Drafting Ever Published

Adopted as Standard in many Technical Schools
PRICE, \$1.00

MECHANICS

PROBLEMS FOR ENGINEERING STUDENTS

By Prof. Frank B. Sanborn

500 problems, many being examples in engineering practice.

Contents: I, Work (Problems 1 to 172); II, Force (Problems 173 to 406); III, Motion (Problems 406 to 500) answers and complete index. A practical, elementary book of problems for the use of practicing mechanics, engineers and students.

PRICE, \$1.50

Send for descriptive catalog M. P. and a sample copy of Engineering News

THE ENGINEERING NEWS PUBLISHING CO.

220 BROADWAY, NEW YORK

HENRY & HORA'S Modern Electricity

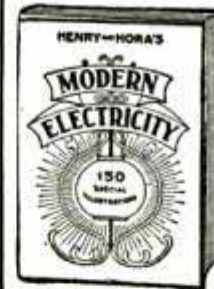

Explains X-Rays, Wireless Telegraphy, Radium, Transmission & Distribution, Power Stations, Wiring, etc. Written in plain English.

All Problems Solved

Practical—Accurate—Scientific
150 illustrations.
355 pages. Cross index.

"A practical handbook for students, apprentices, and electrical engineers."—Scientific American.

Silk Cloth, decorative cover, silver stamping, . . . \$1.50
Seal Leather, marbled edges, gold stamping, . . . 1.00

LAIRD & LEE, PUBLISHERS
263 Wabash Ave. CHICAGO

"SHOP NOTES."

200 Pages,
386 Illustrations.

PRICE - - - 50 CENTS

POPULAR MECHANICS

Manufacturers of Various Styles and Sizes of Draughting Tables, Drawing Boards, Blue Print Filing Cabinets, Blue Print Frames, Etc. Send for Illustrated Catalogue or ask your jobber.



FRITZ & GOELDEL MFG. CO.,
99 Alabama Street, Grand Rapids, Mich.

Send for THE MONTHLY "CONCRETE" JOURNAL

One Dollar a Year. Sample Copy Free

Concrete Publishing Co., = 20 Congress St. DETROIT, MICH.

Cement Fence Posts

Cheap as wood, and will last forever. Made with simple and inexpensive tools. Fire proof, frost proof, wind proof.

Material used: Cement & Sand or Gravel. Will supplant Wood and Iron entirely. For part's write with stamp.

A. D. MACKAY & CO.
Chamber of Commerce, Chicago



GOVERNMENT POSITIONS

Opportunity to prepare for U. S. Civil Service Examinations by mail. Salary to start \$600.00 to \$2500.00 per year; 60,000 appointments last year; many more next year. Manual of information and sample questions, 160 pages 50 cts. Catalogue FREE. Dept. 30.

AMERICAN COLLEGE OF CIVIL SERVICE,
Valparaiso, - Ind.



Typewriters all makes

All the Standard Machines SOLD or RENTED ANYWHERE at HALF MANUFACTURERS' PRICES allowing rental to apply on price. Shipped with privilege of examination. Write for Catalogue TYPEWRITER EMPORIUM, 202 LaSalle St. Chicago

Andrews Office Desks



Have a name to their credit and are a CREDIT to their name, for they are made by

Specialists who know how.

STEEL TYPEWRITER

CHAIRS \$4, DELIVERED

The A. H. Andrews Co.

174 Wabash Ave., Chicago



IF

you are in the market for any kind of machinery and don't know where to get it, write :: :: :: :: ::

POPULAR MECHANICS

Please mention Popular Mechanics when writing Advertisers.

which are motor driven. The exciter is driven by a steam engine and must be started also, for it supplies current to a portion of the auxiliary apparatus.

The boiler room has steam up at all times, supplying a system for manufacturing purposes other than power, and slow fires are kept in enough boilers to make steam needed for the normal load. Forced load means forced fires. The boilers have under-feed stokers, equipped with pressure blast, and will respond quickly to a 50 per cent excess call for steam. The operating force for this is about equivalent to a force for an engine-driven plant. Engineers and oilers, however, are busy about the building on construction work, installing new apparatus and taking such work as their regular occupation, when the turbines are not running.

At the sound of the whistle the water tender starts a blower on the extra row of boilers; all blast

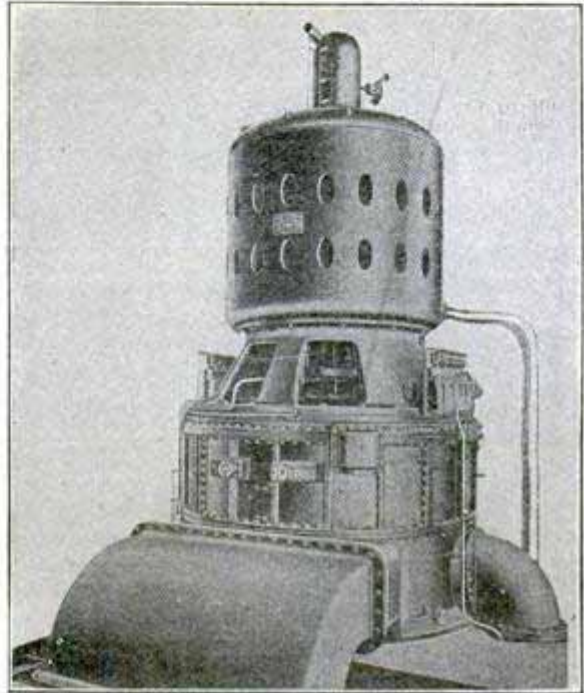

2000 K. W. Curtis Steam Turbine

dampers are opened up and all stokers are allowed to feed at the maximum rate. Each fireman dumps his free ash and bars over his red fire. The man in charge of the coal and ash conveyor starts the pressure pump for step bearings. One of the turbine men starts the exciter which supplies current to the auxiliaries besides its field current; a second turbine man starts the circulating pump and then his turbine. The hot-well pump and the air-pump are started by the oiler. These movements take place simultaneously. The force is organized upon the lines that obtain in a fire station; each man has his specific duty, and after performing it looks to see that there is nothing more for him to do. Only a few seconds elapse between starting the first pump and starting the first turbine.

The turbine throttle is opened as fast as an 8-inch steam valve can be opened without endangering the steam piping system. It is not considered advisable to open the throttle valve as fast as a man's strength will permit, but if nothing unusual occurs in the pipe line, sentiment does not spare the turbine.

One electrician attends to the switchboard and telephone. As soon as the machine approaches speed, the synchronizing system is cut in and the main switches are got ready. One and one-half minutes will do all the work here outlined, including the considerable time taken in mustering the crew from various parts of the building.

Manipulating an engine regulator so that it shall be at a precise speed and at an exact phase relation-

(Continued on page 974.)

You Can Make
BIG MONEY

With My New **PRIZE VENDING MACHINES**

Best Novelty and Money Maker ever placed on the market. Operated with nickels. Also six other new style Vending Machines now ready. Write to Manufacturer for full particulars and prices.
THOS. H. SHERBORNE, 29 South 3rd Street, PHILA, PA

The New
Popular Mechanics
PREMIUM LIST

**Fully Illustrated
Is Now Ready**

**BOOKS FOR MECHANICS,
ELECTRICIANS, ENGINEERS
SHOP TOOLS OF ALL KINDS
SPORTING GOODS, WATCHES, ETC.**

Something for everybody given for
one or more new subscribers.

ADDRESS

**Popular Mechanics
JOURNAL BUILDING, CHICAGO**

\$13 SAVE YOUR STENOGRAPHER'S TIME \$13
Dearborn Jr. Typewriter Cabinet \$13

42 in. long
24 in. deep
38 in. high

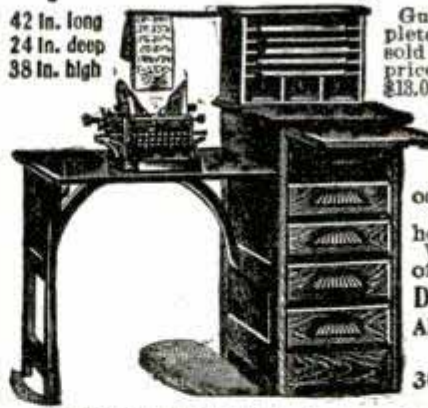

Guaranteed the most complete and perfect desk ever sold at any where near the price. We ship on approval. \$13.00. Freight Prepaid

East of Rocky Mountains. Without roll curtain to paper cabinet, price \$12.00. Made of solid golden oak, beautifully finished. Invaluable note book holder free with Cabinet. Write for FREE catalog of this and other styles.

DEARBORN DESK CO
ALEXANDER A. SAMUEL

Gen. Mgr.
**304 Fisher Building
CHICAGO, U. S. A.**

IF YOU WANT A DESK ASK "DEARBORN"

What Is Daus' Tip-Top?



TO PROVE that Daus' "Tip Top" is the best and simplest device for making 100 copies from pen-written and 50 copies from typewritten original, we will ship complete duplicator, cap size, without deposit on ten (10) days' trial.

Price \$7.50 less trade discount of 33 1/3%, or **\$5 net**

THE FELIX S. K. DAUS DUPLICATOR CO.
Daus Building, 111 John St., New York City

WANTED

men to post signs, advertise, and distribute samples. Salary \$18.00 weekly. \$3.00 per day for expenses. State age and present employment.
KUHLMAN CO., Dept. A. - - - ATLAS BLOCK, CHICAGO

**BE A
WATCHMAKER.**

EARN WHILE YOU LEARN. Send for our Book Free. "How to be a Watchmaker." Postal will do. Stone's School of Watchmaking, Globe Bldg., St. Paul, Minnesota.
Please Mention Popular Mechanics.

Surprise Yourself

by finding out at how low prices you can buy everything you use in your trade and in your home, all of highest quality. Montgomery Ward & Co.'s Big New Catalogue No. 74 for 1905-6 tells you all about it.

One Copy Sent Free

and postpaid to every grown person residing in the rural districts who will write for it and mention Popular Mechanics. We must positively decline to fill orders for our catalogue from large cities, or from Cook Co., Ill. All others are invited to send their name and address, carefully written on a postal card, or fill out and mail us this coupon. Just say "Send me free and prepaid one copy of your New No. 74 Catalog." Do this now

Cut here, fill in carefully and send to Montgomery Ward & Co., Chicago.

COUPON

Send me FREE and prepaid one copy of your New No. 74 Catalogue for 1905-6. I saw your ad in Popular Mechanics.

Name _____ R. F. D. No. _____

Post Office _____ County _____ State _____

MONTGOMERY WARD & CO., Michigan Ave., Madison and Washington Sts., Chicago

Please mention Popular Mechanics when writing Advertisers.

Nature's Coffee Pot

'Makes Coffee Harmless.'

We have at last discovered the active principles of separating the pure Coffee extract from the bitter and poisonous matter of the Coffee Bean.

Like all great inventions—it is simple; so simple indeed that it seems impossible that it was not thought of before. We want to tell you more about this Coffee Pot—it's wonderful workings and the clever way it transposes Coffee into a drink—as healthy and harmless—as a glass of water.

Try This Coffee Pot at Our Expense

Talk is cheap—let us show you the proof by sending you a Nature's Coffee Pot. We want you to test it for yourself in your own home. Send us no money until you are satisfied—then mail us a dollar or send us back the Pot. This is our way of doing business.

THE POILLON POTTERIES, Branch No. 3, Woodridge, N.J.

GENUINE
CASE
GENTS
OR
LADIES
SIZE



This ELEGANT Watch \$3.75

Before you buy a watch cut this out and send to us with your name and address, and we will send you by express for examination a handsome WATCH AND CHAIN C. O. D. \$3.75. Double hunting case beautifully engraved, stem wind and stem set, fitted with richly jeweled movement and guaranteed a correct timekeeper; with long Gold plated chain for Ladies or vest chain for Gents. If you consider it equal to any \$35.00 GOLD FILLED WATCH Warranted 20 YEARS pay the express agent \$3.75 and it is yours. Our 20 year guarantee sent with each watch. Mention if you want Gents' or Ladies' size. Address J. FARBER & CO., 331, 33 Quincey St., CHICAGO.

LETTERING

A neat booklet, now ready, contains many good things for students

PRICE, 25 CENTS

DRAFTSMEN, DESIGNERS, ARCHITECTS,

need our new book on dimensions of

Pipe, Fittings and Valves

NO BOOK LIKE IT

FLEXIBLE CLOTH BACKS, 50 CENTS.

HAVE YOU SEEN A COPY OF

THE DRAFTSMAN?

It is a neat monthly magazine on DRAFTING and Home Study.

\$1.00 PER YEAR. 4 MONTHS TRIAL, 25c.
or the Magazine and "Lettering" for \$1.00

ADDRESS _____

THE DRAFTSMAN, Cleveland, O.

ship from some other machine, not more than 1-1500 part of second removed from it, is no matter that can be hurried, and one minute is fast time on such work. But the whole thing, phasing-in and all, has been done in 2½ minutes, including full load on the turbine, which started from a standstill.

This performance has been gone through a great many times, and our record book shows that out of 43 such calls 10 starts were made in 2½ minutes, 18 in 3 minutes, and 15 in 3½ minutes. We have taken the time in a number of instances when all the auxiliaries have been in motion, and it only remained to start the turbine and phase it in on the line; the only valves to open on such cases are the throttle and one small oil valve. The two quickest starts have been made in 45 seconds and 70 seconds, respectively, including phasing-in. Others range between 1 minute 10 seconds and 1½ minutes. These two quickest starts were made on a turbine which had stood for 24 hours with the throttle valve shut tight, though there was a slight leakage past the seat. After the throttle valve is off its seat it is not more than 30 seconds before the turbine is up to speed. A cross-compound reciprocating engine of the four-valve type, 2,250 horsepower capacity, can be brought up to speed from a standstill in five minutes if it is hot all over. This five minutes is to be compared with the seventy seconds required for the similar turbine operation.

A reciprocating engine, which is turning over slowly with the throttle valve just off its seat or with by-pass open and having all its oil cups open and regulated, can be brought up to speed, say 75 turns, in 2½ minutes. This can be compared with the 30 seconds necessary for bringing the turbine up under the same conditions; that is, about one-fifth the time necessary for bringing up the engine.

If the engine is cold all over and has all its oil cups shut tight, all its auxiliaries quiet, 15 minutes is called a rapid start. Starts have been made under such conditions in 12 minutes. When we start a cold turbine we open up the valve and let her turn, and in two minutes we are ready to bring her up to speed and she will be at speed in 2½ minutes, dividing the engine's time by more than four.

GENUINE CASE OF "LONG FELT WANT"

"While I was looking over the magazines on a news stand today, the attractive cover of your periodical caught my eye. I investigated it and found to my great joy that it was a book I have been in search of for a long time. I came to the conclusion right there that I would become a subscriber to such an excellent publication, and the result is I am enclosing \$1 in payment of a year's subscription."
—W. A. Brooks, Jr., 2642 Brown St., Philadelphia.

THE NORTHWESTERN LINE CHICAGO TERMINALS

A descriptive pamphlet with large scale map of its extensive and complete terminal facilities at Chicago has been prepared by the Chicago & Northwestern Ry. This will be of interest to industrial concerns located on these terminal lines, and more especially to those seeking new sites with adequate railway conveniences. Send for free copy to Industrial Department, C. & N. W. Ry., Chicago, Ill.

If you want anything and don't know where to get it write us.

If you have a new idea or invention ask our Patent Bureau what you want to know and they will answer promptly and fully without charge.

We want a mechanic in every shop to act as our agent. Write for particulars.

POPULAR MECHANICS CO.

FREE OUTFIT TO AGENTS

Fruit Jar Wrench and Holder

So simple, so handy, never fails in tightly sealing or easily opening fruit cans.

Price 25 Cents per Set

Very liberal offer to agents. Other specialties. Write for free descriptive matter.

BENJAMIN P. FORBES, 137 Perkin's Power Block, Cleveland, O.



TIZ-IT
Trade Mark
(Cut 1/2 Size)

SEE THAT BALL?

This New All-Metal-Ball-and-Socket-Swivel-Joint HORN CONNECTION will positively improve your PHONOGRAPH or GRAPHOPHONE. Fits all Edisons and new Columbias. Price 50 C's Postpaid.—KREILING & COMPANY—Inventors and Sole M'frs.—855 N. 40th Ave., CHICAGO.

BURN AIR-IT'S CHEAP NO STOVE LIKE IT!

Consumes \$95 Barrels of Air to one gallon of Kerosene. Penny fuel, burns like gas, hottest fire, won't explode, saves work and fuel bills. No coal, wood, dirt, ashes—no wick, no valves, easy operated, handsome, durable. Grand cooker, baker, quick work, cool kitchens. 18000 Harrison Wickless, Valveless Oil-Gas and Air Burners sold 1 month. AGENTS WANTED—\$40 Weekly. Greatest MONEY MAKER. Guaranteed, all sizes, sent anywhere, \$8 up. Write, FREE proposition, 30 day trial offer.

World Mfg. Co., 5909 World B'ld'g, Cincinnati, Ohio.



You Can Make Gas

100 Candle Power Strong at

15 CENTS A MONTH

by using our

Brilliant Gas Lamps

We Guarantee Every Lamp

Write for our P. M. Catalogue. It tells all about them and our gasoline system.

Brilliant Gas Lamp Co.

42 State Street, CHICAGO, ILL.



BE THE BOSS

Make \$100 per month. Others do it. You have same chance. Start a mail order business at home. Write for our "Starter" and free particulars. Mgr. W. C. Co., 956 E. 23rd St., Los Angeles, Cal.

LOW PLUMBING BILLS

Get them by paying right prices for supplies. We sell

SUPPLIES AT WHOLESALE

You save 20% to 40% on every article. Highest grade goods and line complete. Free illustrated catalog gives all particulars. Write for it.

B. P. KAROL,
229 W. Harrison St., Chicago.



BE YOUR OWN BOSS

MANY MAKE \$2,000 A YEAR

You have the same chance. Start a Mail Order Business at home. We tell you how. Money coming in daily. Enormous profits. Everything furnished. Write at once for our "Starter" and FREE particulars.

P. M. Krueger Co., 155 Washington St., Chicago, Ill

Please mention Popular Mechanics when writing Advertisers.

\$20 to \$50 Weekly made

selling this new invention, the

STANDARD Self-Filling Self-Cleaning FOUNTAIN PEN

No ink dropper. No smeared fingers. No twisted rubber

Fills itself instantly at any ink-well, THIS WAY.



\$178.90 earned in 32 days by retir-

\$48.00 earned in first four weeks by

\$35.80 for a month's odd hours by

\$5.40 made in First Two Hours by

Our free lessons in successful salesmanship

make experience unnecessary. We send all

particulars and figures to prove above and many other records.

Write today. Energetic Agents and District Managers Wanted.

STANDARD PEN CO., 956 Baker Bldg., TOLEDO, O.

\$15.00 LIST REFRIGERATORS \$6.21



Factory Closing Out SALE

Price less than cost to manufacture

White Enamel Lined, Zinc Lined Galvanized Steel Lined Charcoal, Granite Rock Filling Cold Air Space

Our prices \$5.00 to \$8.00 Less than Department Stores

SENT ANYWHERE C. O. D. SUBJECT TO APPROVAL

Tolman Steel Range Co. 66 Lake Street, Chicago

I Turned Out \$301.27

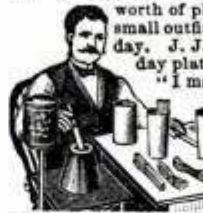

worth of plating in 2 weeks, writes M. L. Smith of Pa. (used small outfit). Rev. Geo. P. Crawford writes, made \$7.00 first day. J. J. S. Mills, a farmer, writes, can easily make \$5.00 day plating. Thos. Parker, school teacher 21 years, writes, "I made \$9.80 profit one day, \$9.35 another." Plating Business easily learned. We Teach You

Free—No Experience Required. Everybody has tableware, watches, jewelry and metal goods to be plated with Gold, Silver, Nickel and Tin plating. Heavy Plate—latest process. No toy or humbug. Outfits all sizes. Everything guaranteed. LET US START YOU.

Write today for Catalogue, Agency and Offer. Address, F. Gray & Co., Plating Works, Cincinnati, O.



The season is here to

MAKE MONEY

Get started early.

\$40 to \$75 A WEEK

Can be made with one of these

Steam Peanut Roasters and Corn Poppers

S. DUNBAR & CO.

16-18 No. Desplaines St. CHICAGO.

Catalog Free.

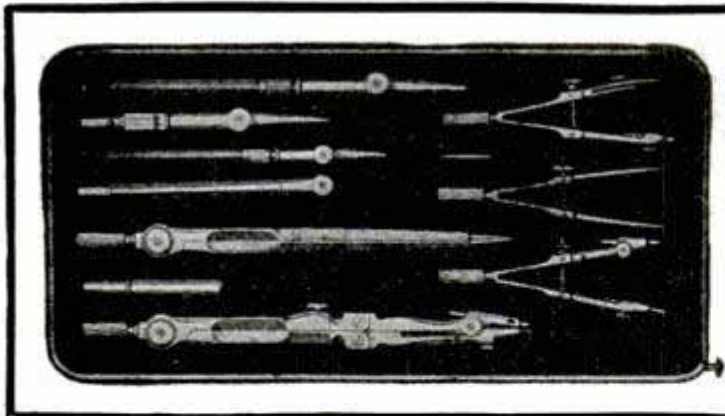

KEUFFEL & ESSER COMPANY OF NEW YORK

111 East Madison Street

Chicago

DRAWING MATERIALSSURVEYING INSTRUMENTSWrite for particulars about our new Mechanics
Steel Tape Rule.

Grand Rapids School of Mechanical Drawing

361-362-363 Houseman Bldg., Grand Rapids, Mich.

INSTRUCTIONS BY MAIL

In MECHANICAL DRAWING, NAVAL or MARINE ARCHITECTURE,
BOAT DESIGNING, LANDSCAPE GARDENING.

SEND FOR OUR CATALOGUE OF FULL INFORMATION.

LEARN TELEGRAPHY AND R. R. ACCOUNTING

Operators Always in Great Demand

\$50 to \$100 per month salary assured our graduates under bond.
Our schools are endorsed by every railway official in the U.S.
Ladies also admitted. Write for catalogue.

MORSE SCHOOL OF TELEGRAPHY

Cincinnati, O. Buffalo, N. Y. Atlanta, Ga. La Crosse, Wis.
Texarkana, Tex. San Francisco, Cal.

A NEW CARD GAME FOR THE PARLOR

Effect.—Performer lets anyone choose a card from a pack. Card is returned to same and pack given a quick flip. Upon fanning the pack, selected card is found to have turned over, and is in a position directly opposite to the rest of cards in pack.

Modus Operandi:—Any pack may be used. Have some one shuffle them well and then give anyone a free choice. While he is looking at the card, and you are telling him not to forget it quickly turn over bottom card of pack, and then turn pack over. To all appearances, the cards are as before, but in reality, only the top card faces downwards. Next let the selected card be returned to pack by being pushed in. To open the pack would be to give away the deception. Give the pack a quick snap, turning it over again. Fan it and the chosen card will be seen facing in an opposite direction to the rest of the pack. Do not fan too much, or the reversed bottom card will be seen.—Albert Laudette.

HOW TO "CURE" FRAYED CUFFS

There is a better way to make one's frayed cuffs presentable than to pare them with the scissors. Says a writer: "With the first touch of steel the cuff is ruined. Light a match and pass it round the frayed edge (do not burn your wrist). The cleansing fire will remove the dross and leave intact the pure gloss of the cuff. A cuff treated with fire will last laundry generations longer than the cuff treated with steel."

ENORMOUS PRODUCTION OF CANS

Previous to 1850 few tin cans were made in the United States, but the civil war created a great demand for canned goods. When the war ceased emigration to the West furnished another large market for canned goods, and now there are few families in all this land that do not use from one to a dozen cans each week.

There are more than 2,000 canning factories in this country, including meats, fish and vegetables, requiring 1,200,000,000 cans a year.

DRAWING STUDENTS NEED THE DRAFTSMAN

25c for 4 months—Cleveland, Ohio

FREE TO ALL SHORTHAND

FIRST LESSON MARVELOUS SYSTEM

So cheap and simple, anyone can now learn in 20 lessons by mail. No interference to regular work. Greatest educational offer of the age. Endorsed by leading papers and eminent educators as the greatest work in the history of education. Thousands of testimonials and graduates. Campaign of Education. 815 Broadway, New York City

Please mention Popular Mechanics when writing Advertisers.

EUGENE DIETZGEN COMPANY

181 Monroe Street, CHICAGO
119-121 W. 23d St., NEW YORK

SAN FRANCISCO



NEW ORLEANS

Most complete line of

Drawing Materials and Surveying Instruments

Our Rapid Printing Blue Print Paper has no equal.
The Celebrated Vandyke Solar Paper for Blue and
Black line prints. Send for sample prints.

ALL GOODS WARRANTED

WRITE FOR CATALOG "P"—416-pp, PROFUSELY ILLUSTR'D.

AUTOMOBILE DRIVERS, REPAIRMEN, CHAUFFEURS,

and others wanted all over the country; 50,000 machines built this year in United States, affording great opportunities for our students; 6 cents a day will qualify you for good wages in this growing field. For full particulars, address Dept. B147.

The Correspondence School
of Automobile Engineering

AKRON, Ohio

Engineering

MECHANICAL,
ELECTRICAL,
STEAM,
CIVIL.

Complete and short courses. Thoroughly equipped engineering shops. Shop work from the beginning. Short courses in Steam and Electrical Engineering. Expenses low. Accommodations the best. School all year. Students may enter any time. Correspondence steam and electrical courses. Send for catalogue. Mention course in which interested.
HIGHLAND PARK COLLEGE, Des Moines, Ia.

Multiply This in Your Head

Wouldn't you like to be able to figure this and hundreds of other similar problems in your head? Wouldn't you like to be able to add, subtract, multiply, and divide any problem almost instantly without writing any partial product—to be able to simply write the answer?

Our Free Book, "Rapid Calculation"

tells you all about a method which will make you a master of figures. It tells of a system by which you can figure instantly the most intricate sums in your head; handle groups of figures and fractions as easily as single whole figures; in fact, cut the work of figuring in two.

A better position and a large salary have come to hundreds who have read this book. If you want to better your position, to increase your salary, to make yourself worth more to yourself and your employer, to hold the whip-hand in financial transactions, to make your work easy and interesting instead of tiresome, you should write for this book at once. It will cost you nothing but the trouble of asking for it. A postal will bring it to your very door. It may cost you a good position or a valuable promotion to neglect this opportunity. Write for it to-day before you forget it. Address

COMMERCIAL CORRESPONDENCE SCHOOLS, 147 A, COM'L BUILDING, ROCHESTER, N. Y.



TWO YOUNG MEN WHO WILL LOSE THEIR POSITIONS

Some young men depend upon the direct personal influence of friends in official position for securing advancement, says the Electric Journal. This method seems to them the only method, not only for themselves but for others—as they are apt to suspect that some particular favoritism underlies each advancement.

Some young men, on the other hand, seem to think that the only way to get on in the world is by vigorous activity on their own part in applying for new jobs or asking for an increase in their pay. They are sure they will be side-tracked unless they are insistent and persistent in urging their claims for something better.

There is a right and proper indorsement of a man's ability and fitness by those who know him, but it is quite different from pull. A measure of tactful aggressiveness is commendable in an ambitious young man, but it is quite different from discontented, restless, impertinent push.

Did you ever observe how many of the men about you—particularly those having positions of responsibility—are in their places because of their fitness for them? When a man is advanced, is it not usually because he has given promise of his ability by his past work?

There are two men who will probably not hold their jobs very long—one is the man who does not *make good*, the other is the man who does his work so well that he shows his capability for something more. Observe for yourself. Note the men about you and study their characteristics and see how efficiently they are doing their work. You can predict fairly well whether they will be doing exactly the same thing in a year, or something larger or smaller.



Half a Man Half a Salary

The half-sized salary goes to the man who has but half developed his abilities. If you are earning but half what you need, we can qualify you for promotion in your present work or prepare you for a more congenial position and better salary. We are doing it right in your own district every day for others, to whom we can refer you. The accounts of the rise of some of our students read like romance. Many have risen from the lowest to the highest positions in their calling.

We teach Engineering in all its branches; Architecture; Mechanical Drafting; Ad Writing; Show-Card Writing; Window Dressing; Illustrating; Ornamental Designing; Bookkeeping; Steatography; Etc.

Write today, stating which Course interests you.

International Correspondence Schools
Box 872, Scranton, Pa.



Earn from \$80 to \$125 Per Month

WE WANT YOUNG MEN for Firemen and Brakemen, experience unnecessary. High Wages, Promotion. Positions secured as soon as competent. Instructions by mail. Cut out Coupon and send with stamp for full particulars to-day . . .

National Railway Training School, 224 Boston Blk. MINNEAPOLIS, MINN.

Name _____
Town _____
State _____
R. F. D. No. _____
Age _____

EVERY INVENTOR

Who Wants to know

1. What are the most profitable inventions,
2. How to perfect inventions,
3. The first step to take in getting a patent,
4. How to protect himself from parties who might steal his invention before he can get a patent,
5. How to find out what patents have been granted on inventions like his, or intended for the same purpose,
6. How much it costs to get a patent,
7. How long it takes to get a patent,
8. What protection a patent is,
9. How he can sell his patent after he obtains it,
10. How to handle his patent to get the most money out of it,
11. Where and at what expense he can have working drawings made of his invention,
12. Where and at what expense he can have models or experimental machines made,

should send his questions to

**POPULAR MECHANICS PATENT
BUREAU,**

Journal Bldg. - - Chicago, Ill.



I SELL PATENTS

If you wish to buy or lease on
royalty, patents on hardware or
mail order specialties, machinery, in fact anything, write me.

INVENTORS desirous of selling their patents
quickly and to the best advantage should register with
me. I can save you time and money.

Charles A. Scott 796 Mutual Life Bldg.
Buffalo, N. Y.

REVERSING A MARINE TURBINE

Since the article on page 906, this issue, was printed, an article has appeared in the *Shipping World*, London, which indicates that ocean turbines are not as clumsy as stated by the expert whom we quoted. It says:

The steam turbine is being gradually accepted as a reliable and economical marine motor, but there is still a belief in some circles that a turbine-propelled vessel is not handy in maneuvering through tortuous channels or in going alongside. Why such an idea should have gained currency it is difficult to say; for all turbine ships are fitted with powerful reversing machinery, and they have the advantage almost without exception of possessing three shafts. Certainly the rotary inertia of a turbine spindle and shaft is large and offers great resistance to a reversal of the direction of turning; but, unlike a reciprocating engine, a turbine allows of steam being turned on for going astern before the ahead rotation is stopped, and consequently the change can be effected very quickly. This rapidity of reversal was well demonstrated during the trials of the new L. B. & S. C. Railway turbine steamer "Dieppe," built by the Fairfield Shipbuilding Company. She is a steamer 282 ft. over all by 34 ft. 8 in. beam by 14 ft. 6 in. deep, and of 1,360 tons displacement. There are three propeller shafts, each fitted with one screw and each driven by a separate turbine. The contract required that when running at a speed of 12 knots she was to stop within 100 metres. Two boats were moored to mark this distance, and for two miles in advance of the first boat the "Dieppe's" turbines ran at the rate of revolution which previous performance on the measured mile had determined as necessary to give a speed of 12 knots; within six seconds of the order, "Full speed astern," the turbines were running astern, and in 41 seconds the ship herself was moving astern; the distance traversed from the time the order was given to reverse until the ship began to go astern being 100 yards. During a double voyage across the Channel, which means a trip of about 130 knots, the "Dieppe" made an average speed of 21.5 knots, and she also negotiated the tortuous entrance channel at Dieppe at a fair speed.

A 70-foot camera will be used to photograph the eclipse of the sun August 30. Expeditions from this country have been sent to Spain, Labrador, Egypt and Arabia, as it will be the most important eclipse taking place in a period of 50 years.

A Cologne engineer claims that dead bodies can be successfully petrified by encasing them in plaster of paris immediately after death. The body is placed in a box and the liquid plaster is poured in upon it through a hole. With the beginning of decomposition the body absorbs the salicylic acid from the cement and in time petrifies.

PATENTS

Valuable and Salable Patents Secured.
Advice as to Patentability and Commercial
Value Free Write for Inventors' Hand Book.

SHEPHERD & PARKER, PATENT LAWYERS

"During the past 10 years Mr. Shepherd, of Shepherd & Parker, has obtained for us a great many important patents. We have no hesitation in heartily recommending him to anyone having need of the services of a patent attorney.

HALLWOOD CASH REGISTER CO.

Mr. Parker on Nov. 1, 1903, resigned his position as an examiner in the U. S. Patent Office to enter this firm. Address

210 Dietz Building . . . WASHINGTON, D. C.

PATENT LAW DECISION

The United States Court of Appeals of the District of Columbia has recently rendered an important decision on the law applying to public use of an invention before a patent is applied for. The statutes provide that if an invention is used by the public or on public sale for more than two years before a patent is applied for on such invention a valid patent cannot be obtained thereon, and every applicant for a patent must make an oath that his invention has not been on sale or in public use for more than two years prior to the date of his application. There have been many decisions by the United States Courts as to what constitutes "public use" or "on sale" within the meaning and intent of the statutes, and while the decision above referred to is in harmony with most of the decisions it bears upon a point that has not been very fully passed upon heretofore.

In the case before the court, the applicant for a patent secured an order for a machine embodying his invention in December, 1898, and a machine was made and delivered before April 23, 1899, and a catalogue showing the invention was published by a company representing the inventor in March, 1899. The inventor did not apply for a patent until April 23, 1901, more than two years from the time he sold his machine. It also appeared that the inventor's circumstances were such that he could not at his own expense build and test the machine and that the machine sold by him was the first machine built covering his invention, and that it was understood to be an experimental machine and the purchaser was at liberty to return it if it was unsatisfactory.

The court decided as follows:

1. That a single unrestricted sale by an inventor of his machine is a public sale or puts it "on sale" within the meaning of the statutes.

2. That a single sale of the invention by the inventor for experimental purposes, where he is unable otherwise to make proper test, does not put the invention "on sale" within the meaning of the statutes.

3. That where a clear case of "on sale" is established the burden is on the inventor to prove that the sale was for the purpose of having proper test made, and that it was at least to that extent restricted sale.

The court quoted a decision of a co-ordinate court as follows:

"Public use in good faith for experimental purposes and for a reasonable period even before the beginning of the two years of limitation, cannot affect the rights of the inventor."

It will thus be seen that an inventor has a right to build an experimental machine and exhibit it publicly, and that if he does so more than two years before he applies for a patent on such machine, it will not forfeit his right to a patent. Every inventor should, however, be extremely cautious about offering his invention for sale before he has applied for a patent, for aside from the bar of public use provided by law, there is always the possibility of some one seeing the invention, making changes in it which may or may not be improvements, and applying for a patent in his own name. This has been done many times and if the invention is valuable nearly always results in an expensive lawsuit and usually in the loss of the invention to the real or bona fide inventor.

PATENTS

Save time and money
by employing a Wash-
ington attorney.

WATSON E. COLEMAN,

Registered Patent Attorney

COLUMBIAN BUILDING, WASHINGTON, D. C.

Advice Free; Terms Low; Highest References; Best Service

"We Analyze Everything"

At Reasonable Rates. We Devise New and Original

Address **Formulae**

The Ellsworth Laboratories

MAX D. SLIMMER, Ph. D.

857 Dearborn Street. . . . Chicago

PATENTS

SECURED OR FEE RETURNED

FREE opinion as to patentability. Send for Guide Book and What To Invent, finest publication issued for free distribution. Patents secured by us advertised free.

EVANS, WILKENS & Co.,

No. 717 F Street N. W. Washington, D. C.
New York Offices, 132 Nassau Street, N. Y. City

Established Over 30 Years

EXPERIMENTAL

AND MODEL WORK

Inventors' Ideas Developed. Circulars Free.

WM. GARDAM & SON, (Inc.)

45-51 Rose St. New York

PATENTS

Valuable Book on Patents FREE. Tells how to secure them at low cost. How to sell a Patent and What to Invent for Profit. Gives Mechanical Movements invaluable to Inventors. Full of Money-Making Patent Information. NEW BOOK FREE to all who write.

O'MEARA & BROCK, Patent Attys., 918 F. Street, Washington, D. C.

NEW YORK OFFICE, 288 Broadway, New York City

MODELS CHICAGO MODEL WORKS

179 E MADISON ST., CHICAGO, ILL.

ESTABLISHED 1867 WRITE FOR CATALOGUE OF MODEL SUPPLIES

Send three one-cent stamps for 5-color
PICTURE OF LINCOLN PARK BRIDGE

W. L. STEBBINGS

Civil and Consulting Engineer

LICENSED ARCHITECT

Monadnock Block, Chicago

Tel. Harrison 1104

Cable Address "Stebbing" Directory Code

The National Lines of Mexico

NATIONAL RAILROAD OF MEXICO
MEXICAN INTERNATIONAL RAILROAD
INTEROCEANIC RAILWAY OF MEXICO

MEXICO'S GREATEST RAILWAY SYSTEM

All Year Tourist Rates
and Homeseekers'
Excursion Rates

Daily Pullman Service
between St. Louis, Mo.
and City of Mexico

VIA

LAREDO ROUTE

578 Miles Shortest 22 Hours Quickest

—Affording—

The Only Through Pullman Service

The Republic of Mexico abounds in attractions for
Tourist, Prospector and Investor, and the Capital

MEXICO CITY

The Paris of America

is an all-year resort unsurpassed.

Average temperature:

Summer 68 deg., winter 53 deg. Fahr.

Only line affording diverse route without extra charge.

For illustrated descriptive literature, rates, sleeping car
reservations, etc., call on or address

GEO. W. HIBBARD,
General Passenger Agent,
Apartado No. 322
Mexico City, Mexico

G. R. HACKLEY,
General Western Agent,
Suite 230-240 Quincy Bldg.,
Chicago, Ill.



**"FOLLOW
THE FLAG"**

WABASH Summer Tours

Write today for a Free copy
of **WABASH Summer Tour
Book—1905**, outlining many
very attractive summer vaca-
tion trips, with rates, etc.

Write us about any tour you
may have in contemplation.
We shall be glad to assist you.

C. S. CRANE,
G. P. & T. Agent,
ST. LOUIS.

F. A. PALMER,
A. G. P. Agent,
CHICAGO.

INDUSTRIES

ARE

OFFERED

LOCATIONS

WITH

Satisfactory Inducements
Favorable Freight Rates
Good Labor Conditions
Healthful Communities

ON THE LINES OF

THE ILLINOIS CENTRAL R. R.

AND THE

YAZOO & MISSISSIPPI VALLEY R. R.

For full information and descriptive pamphlet, address

J. C. CLAIR

Industrial Commissioner

1 Park Row, - - - Chicago, Ill.

The Overland Limited California

the most luxurious train in the world,
leaves Chicago 8:00 p. m. daily. Less
than three days to San Francisco,
Magnificent equipment. Electric lighted
throughout.

THE BEST of EVERYTHING

Two other fast trains leave Chicago 10
a. m. and 11:35 p. m. daily, with through
service to San Francisco, Los Angeles
and Portland via the

**Chicago & North-Western,
Union Pacific and
Southern Pacific Railways**

All agents sell tickets via
this route.

Illustrated booklets on
application to
W. B. KNISKERN,
CHICAGO, ILL.
or **E. L. LOMAX,**
OMAHA, NEB.

OL16

Great is Texas!

The Eyes of the World Are Upon Her

THE HOME-SEEKER wants to know about her "Matchless" Climate and Her Cheap Lands.

THE INVESTOR wants to know about not only Her Cheap Land and Low Taxes, but as well, Her Wealth of Mine and Forest, and this is to let you know that

**The International & Great Northern
Texas' Greatest Railroad**

traverses more than a thousand miles of the Cream of Texas' Resources, latent and developed, and that you may learn more about the GREAT I. & G. N. COUNTRY by sending a 2-cent stamp for a copy of the ILLUSTRATOR AND GENERAL NARRATOR, or 25 cents for a year's file of same, or by writing

**D. J. PRICE, G. P. & T. A., I. & G. N. R. R.
Palestine, Texas**

THE TRACKLESS SEA

Great and ungovernable is the sea. We blast granite, tunnel mountains, dig mines and lay down jealous lines between this and that possession, but the sea submits itself to no boundary besides the beach and cliff. The moment we reach the limit of these, we encounter wholly new conditions of life and performance. The continent has its kingdoms and revolutions. The ocean has none. We give it names, we divide it by latitudes and longitudes. We map it, but prick our course upon its chart without making a dent or drawing a line upon its skin. We sound it without leaving behind us a well into its depth or a pinhole in its surface. Nothing is more permanent than a mound of "earth." That which was raised by prehistoric mourners on the sky-line of the windy downs is seen as clearly as the last in the churchyard below. Let a child make a heap of only a dozen spadefuls on a level sward, and, if let alone, it will assert itself for centuries.

But there is no "water heap" beside the wave, which no sooner rises than it sinks, and which refuses to rise at all by aid of any tool, however man may try to pile it up. As, indeed, we approach the sea the earth itself loses its retentive power, and the waves which quickly flatten down the children's hillocks of sand are only hints of their refusal to retain any impression made by the hand of man upon the ocean which they fringe. True, we read of billows "mountains high," and may see valleys of waters in Atlantic gales; but while the Alpine ranges of the land are fixed, these mountains and hills of the sea are incessantly brought low, and level plains soon take the place of ocean height. Then, too, however continuously men make their tracks from one great seaport to another, there is no beaten highway on the sea. It lies the same before the hindmost ship in the procession of thousands which have followed one another. There is no recovery of his lost path for the ocean traveler by seeking for the footsteps of those who have gone before. Each must use the same process for a discovery of his road. He must ask the sun in the sky above his head, not the signs beneath his feet, in order to find out where he is. He must consult the metal compass, not the guidance of the pointed waves, to know in which direction he shall go that he may be at the haven where he would be. The land voyager follows the trodden road, the last seaman who seeks his is no better guided than the first.

"POP" A WHOLE SCHOOL

I cannot find words enough to describe the merits of your magazine; it is a whole school in itself; so plain and easily understood, by the layman. For him it is a godsend.—C. C. Dollison, Lancaster, O.

Please mention Popular Mechanics when writing Advertisers.

12 O'Clock

LECTURES
TO
EMPLOYEES

- Do your men ever spoil material?
- Do they sometimes break valuable machinery?
- Do they waste time by poor methods?
- Do they fully appreciate the cost of carelessness?
- Could their effort be more intelligent?
- Do they realize the value of accuracy?
- Do they understand the theory of saving?
- Do they know how to keep well?

These are only a few of the suggestive subjects which are treated in the

"Lunch Hour Talks"

to employes, and which bring to the men, in language they can understand, every day helps personally useful to them and profitable to you. It pays to educate your men along these lines. The talks have been delivered more than 200 times with highly gratifying results, in many of the largest shops in Chicago.

The lecturer, Dr. Earl M. Pratt, has for years made these subjects a study in connection with his own personal experience in actual shop work. It takes a mechanic to talk to a mechanic.

Dates are now being booked for single lectures, or a series in any number desired.

Our plan is that the employer should pay for the lectures, though in some cases the men have themselves contributed a fund to secure the talks. Terms are very reasonable, as it is not our aim to make money out of this work.

It will at least pay every employer who reads this to write us for details of the plan and secure full particulars which cannot be given in this limited space. The idea is new; has proved very successful in every instance; the talks are greatly enjoyed by the men; and the work is along broad practical lines calculated to produce immediate and valuable results. Ordinary subjects of controversy are cut out; the aim is to illustrate the importance of doing little things right, and to quicken men's minds to better work. The lecture on "Accuracy" should be heard by every mechanic in the land.

In writing for terms—which are very reasonable—and details, please indicate what special subjects you prefer.

ADDRESS

Popular Mechanics Lecture Course
Journal Bldg., Chicago.

25
Cents**BOOK**
— FOR —
BOYS25
Cents**"Mechanics for
Young America"****Tells How to Make Things**Reprinted from the Boys' Department of Popular
Mechanics. Fully Illustrated. Instructions are
"Written so you can understand it."**CONTENTS**

How to Make a Paper Boat.....
How to Make a Barrel Boat.....
How to Make a Water Wheel.....
How to Make Your Own Fishing Tackle.....
Temporary Camps and How to Build Them.....
Permanent Camps and How to Build Them.....
How to Build an Imitation Street Car Line.....
How to Make a Water Bicycle.....
How to Make a Miniature Windmill.....
How to Build an Ice Boat.....
A Novel Burglar Alarm.....
A Mechanical Ventriloquist and How to Make It.....
How to Make a Boot-Blackening Cabinet.....
Renewing Dry Batteries.....
How to Make Water Motors.....
How to Make "Antique" Clocks from Up-to-Date Materials.....
Lettering a Clock Dial.....
How to Make a Windmill of One or Two Horse- power.....
How to Make a Trap for Rabbits, Rats and Mice.....
How to Make a Small Searchlight.....
Kites of Many Kinds and How to Make Them— Jug Fishing.....
How to Do Ornamental Iron Work.....
Ornamental Metal Guards for Open Fireplaces.....
How to Make a Propelling Vehicle.....
How to Make a Water Telescope.....
How to Make Paper Balloons.....
How to Make a Hectograph.....
Useful Articles and Ornaments Made of Old Bicycle Parts.....
Devices for Winter Sports—How to Make and Use Them.....
Coasting Sleds, Chair Sleighs, Toboggan Slides and Skis.....
How to Make Rubber Stamps.....
How to Make a Baggage Carrier for Bicycles.....
A Water Candlestick.....
Boys' Hand-Power Auto—How Made.....
How to Make a Pair of Dumb-Bells.....
How to Rid Your Yard of Cats.....
How to Make an Easel.....
To Light a Gaslight Without Matches.....
Things a Boy Can Make Out of old Bicycle Parts.....
How to Make a Wind Propeller.....
Photographing from a Captive Balloon.....
How to Make a Simple Burglar Alarm.....

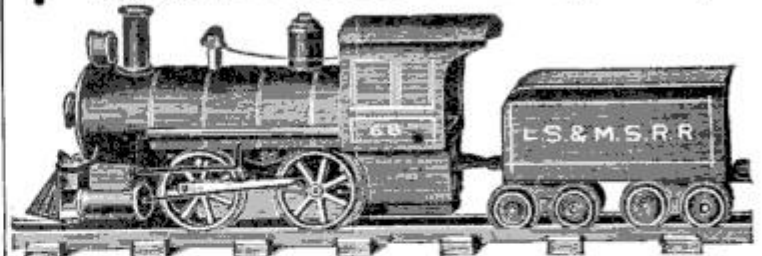
Sent postpaid on receipt of 25 cents, or order
from your newsdealer.**Popular Mechanics,**
Journal Building, - - Chicago**ELECTRIC RAILWAYS****Dynamos : Motors : Gas Engines**Complete Working Models, also Castings and Parts. Every-
thing for the Amateur Electrician. Send for Catalogue B**The CARLISLE & FINCH CO.,**
262 E. Clifton Ave. Cincinnati, Ohio**EVERY INVENTOR**

Should write to us before incurring much expense in connection with his invention. We are frequently able to save inventors a great deal of money and trouble by showing them that their inventions have already been patented, or are not practical, and many times we assist in perfecting or completing crude devices or mechanisms which are submitted for our expert opinion.

No inventor should make an expensive model of his invention until he has had us find out if his ideas are new in whole or in part. No one can tell whether any invention is new or not until he has had looked up all the patents on similar inventions. Every inventor thinks his invention is new because he never saw anything like it though he has diligently looked in catalogues and stores and has inquired of others who ought to know about such things. No inventor can depend on such information when it comes to a patent. The very thing he has invented may have been patented, manufactured and sold fifty years ago, or it may be on the market in a small way in some remote section of the country. No one in buying a piece of land depends on what he or Tom, Dick or Harry knows about the title—he has the records searched. This is the first thing to do before applying for a patent. If a patent has ever been granted on a particular invention, we will find it and send the inventor for whom we are making the examination a copy of the drawings and specifications so he can see just what has been done along that line. The patent or patents found may not show exactly his idea, but may contain some feature or features that if combined with his invention would improve it. With the patents before him the inventor can satisfy himself as to the desirability of applying for a patent on his own invention. If we should find a patent showing his exact invention he will be saved the cost of applying for a patent, which is never less than \$45.

The expense of making this search, including copies of the patents found, and our opinion, is Five Dollars. We do not require a model, but a pencil drawing and a brief description of the construction and operation of the invention is all that is needed in most cases.

Inventors should be careful how they show their inventions to others until they have consulted a patent attorney or taken steps to protect their ideas. The attorney who has charge of our patent bureau has had over 25 years' experience in the business and was among the first to be registered in the U. S. Patent Office as an attorney. We have among our clients inventors in every section of the country from Maine to California and will be pleased to furnish their names and addresses as references. We have a corps of mechanical draftsmen who can ex-

THE WORLD'S HEADQUARTERS FOR ELECTRIC NOVELTIES & SUPPLIES

If It's Electric We Have It.

We Undersell All.



Fan Motors.....	\$2.00 to \$15.00
Battery Table Lamp.....	3.00
Battery Hanging Lamp.....	10.00
Telephone, complete.....	2.00, 5.95
Electric Door Bells.....	1.00
Electric Carriage Lamps.....	6.00
Electric Lanterns.....	2.00, 3.00
\$8.00 Medical Batteries.....	3.95
\$12.00 Belt with Suspensory.....	2.50
Telegraph Outfits.....	2.00
Battery Motors.....	.75c to 12.00
Battery Fan Motor.....	6.50
Bicycle Electric Lights.....	3.50
Electric Railway.....	3.25
Pocket Flash Lights.....	1.00 to 2.50
Necktie Lights.....	.90c, 1.00, 1.25
Dynamos.....	2.00 to 900.00

OHIO ELECTRIC WORKS, Cleveland, Ohio

Agents Wanted. Send for New Catalogue Just Out.
Our Battery Fan Motors are most economical.

cute working drawings as well as patent drawings. We assist our clients in placing their inventions or patents with manufacturers.

We will furnish freely any information about patents upon receipt of request.

Popular Mechanics' Patent Bureau,
Journal Bldg., Chicago, Ill.

USE INTELLIGENT EFFORT

Energy is a good thing, but it should be well directed. The writer was in an office the other day where a business inquiry had been received, calling for an immediate reply by mail.

The clerk who opened the letter spent ten minutes trying to decipher the address. He then rushed to the bookkeeper who spent another ten minutes reading and rereading the letter. Five minutes more was consumed trying to find an account in the ledger which might identify the name.

The letter then went the rounds of the office, during which time six clerks spent a total of thirty minutes and the signature was decided to be any one of four names.

This performance had consumed fifty-five minutes and produced four different addresses.

Then the energetic clerk returned to his desk and discovered a self-addressed, stamped envelope from the writer of the letter. In offices and shops many an otherwise good man wastes hours of valuable time through the sheer impetuosity of doing things.

WEEDLESS FISH HOOK.—This is a new patent hook, so arranged that it is a perfect weedless hook, and that a fish once hooked on it can not get off. It

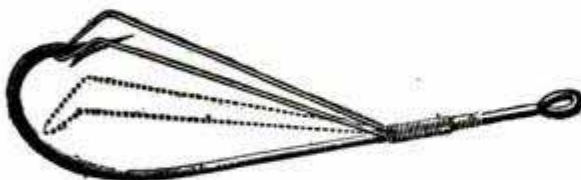

Fish Hook

is very simple in construction and will stand considerable misuse. The business part is always ready for business. The spring is of the best music steel.

A valuable mineral fertilizer, phosphate rock, has been discovered to abound in California. Hitherto the entire supply for the United States was confined to North Carolina, South Carolina and Florida. Two years ago the product for this country amounted to 1,570,288 long tons, valued at \$4,993,912.

Please mention Popular Mechanics when writing Advertisers.

EVERY BOY His Own Toy-Maker



It tells you how to make a Steam Engine, a Photographic Camera, a Windmill, a Microscope, an Electrical machine, a Galvanic Battery, an Electric Telegraph, an Electrotyping Apparatus, a Telephone, a Kaleidoscope, a Magic Lantern, an Aeolian Harp, Boats of every kind, from a little rowboat to a full-rigged schooner; how to make Kites, Balloons, Paper Toys, Masks, Card Racks, Wagons, Carts, Toy Houses, Bows and Arrows, Pop Guns, Slings, Stilts, Fishing Tackle, Rabbit and Bird Traps, and many other things, and all is made so plain and simple that any boy can easily make anything described. The whole is illustrated with more than 200 handsome illustrations. This is a great book and you should not be without it. Price only 10 cents, postpaid, 3 for 25 cents. Address

WESTERN SPECIALTY CO., 336 Jackson Street, St. Paul, Minn.

ELECTRIC MOTOR, 75c.

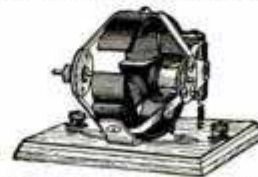

An entirely new design. Runs with a wet or dry battery. Has 2-inch armature, wrought iron field magnet, pulley, etc. 75 cents; packing and postage, 15 cents. Catalogue Free.

Electro magnets for experimenting, 15 cents each.

Send 10 cents for 20 feet of magnet wire for experimenting and making small magnets.

ARTESIAN ELECTRIC CO., 744 Artesian Ave., Chicago

50c

50c

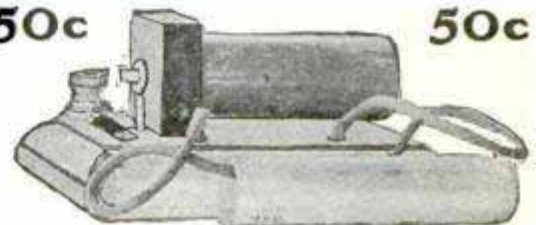

B-B INDUCTION COIL

A very powerful instrument. The current can be regulated from the mildest to a power that few can endure. Price 50c, postage and packing 10c. Send your order now.
Ithaca Electric Novelty Co., Inc., Box 64, Ithaca N.Y.

MOTORS

1/2 H. P. BATTERY MOTOR

A PRACTICAL MACHINE—NOT A TOY

\$5.00 each

SEND FOR PARTICULARS

WALSH'S SONS & CO., Newark, N. J.

How To Make Mirrors

We have for years sold our renowned Mirror Formulas, and hundreds of them at \$1.00, and a large number at \$2.00, and they are worth the money.

For a short time will make a SPECIAL PRICE of 25 cents and give you exactly the identical formulas sold at \$1.00 to \$2.00, provided you cut out and return this adv. with your order. We also tell you FREE OF CHARGE how to Emboss, Etch, Grind, Foil, Gold Leaf, Frost, Chip, and make Imitation Stained Glass. How to transfer Photos onto Glass. How to Bore Holes in Glass and Cut Sky Lights. All the above and more for the small sum of 25 cents. Money back if you are not pleased.

G. L. PATTERSON & CO., Chicago, Ill.

LIGHTING A FIRE.

When the chimney is cold it is often difficult to light a fire without making a great deal of smoke. To prevent this, burn a few pieces of paper in the chimney or smoke flue and thus start an upward current. The fire will then burn without any more trouble.

POPULAR MECHANICS SHOP NOTES FOR 1905

Second 10,000 Edition

Easy ways to do hard things.
Of daily use to every mechanic.

"Worth it's weight in gold,"

—writes one

"Best book I ever had,"

—says another.

REVISED AND ENLARGED
FOR 1905

Compiled from the "Shop Notes"
Department of Popular Mechanics
up to and including Volume VI.

200 Pages--385 Illust's

"INDEXED SO YOU CAN FIND IT"

For Sale by all Newsdealers

Price Postpaid 50 cents

POPULAR MECHANICS

JOURNAL BUILDING
CHICAGO



SENT ON APPROVAL

to responsible people

Laughlin

Fountain Pen.

Guaranteed finest grade 14k

SOLID GOLD PEN

To test the merits of this publication as an advertising medium we offer you your choice of

These **\$1.00**
Two Popular Styles For Only
Postpaid to any address

(By registered mail 8c extra)

Holder is made of finest quality hard rubber, in four simple parts, fitted with very highest grade large size 14k. gold pen, any flexibility desired—ink-feeding device perfect

You may try the pen a week; if you do not find it as represented, a better value than you can secure for three times the price in any other make, if not entirely satisfactory in every respect, return it, and we will send you \$1.10 for it, the extra 10 cents being for your trouble in writing us and to show our confidence in the Laughlin Pen—(Not one customer in 5,000 has asked for his money back.)

Either style—Richly Gold Mounted, including a handsome extra fine leather case for presentation purposes, \$1.50 extra.

Grand Special Offer

For an investment of \$2.50 we send you a Fountain Pen Outfit, including richly gold mounted fountain pen and extra fine leather case, that you cannot duplicate elsewhere for \$10.00—and refund your money if you are not enthusiastic with your purchase.

Lay this "Publication" down and write NOW.

Safety Pocket Pen Holder sent free of charge with each pen

ADDRESS

LAUGHLIN MFG. CO.

926 Griswold Street
DETROIT, MICH.



When You Want Anything
And Don't Know Where to Find It
Write Popular Mechanics

RHEUMATISM

Cured Without Medicine

We Want to Send Our Great New External Remedy to Every Sufferer TO
TRY FREE.

SEND YOUR NAME TODAY.

Don't take medicine for rheumatism—Nature provided millions of pores for carrying off impurities, and our new external remedy, **MAGIC FOOT DRAFTS**, possesses the power of absorbing through the largest of these pores the uric acid and other poisons which cause rheumatism. Already over 100,000 persons have found relief through this simple,

harmless appliance, which it costs you nothing to try if you write at once. Send your name today. The Drafts come by return mail. Then if you are satisfied with the benefit received, send us One Dollar. If not, they cost you nothing. The risk is ours. A valuable book on Rheumatism (illustrated in colors) comes free with the trial Drafts. Magic Foot Draft Co., 951 Oliver Bldg., Jackson, Mich.



ELECTRICITY ON A DUCK FARM.

That electricity may be utilized to advantage even in the raising of ducks is demonstrated in a large farm in New Jersey devoted to the raising of these fowls. Current is furnished to this farm by the Public Service Corporation of New Jersey and is used in a great variety of ways. First of all, the eggs are examined in an electric egg tester. Then the incubators are ventilated by electrically driven exhaust fans and it is said that since this application healthier and livelier ducklings are hatched than before. An electric motor mixes the feed (somewhere more than a ton a day) for the full-grown fowls. Electricity also assists in a novel way in the fattening of the ducks for market. In the words of the owner: "Frequently during the night one duck would become frightened at something and set up a quack. Before long the whole 5,000 would be at it and keep on scurrying about in their coops all night. This would materially reduce their weight, even in one night, and was also decidedly unpleasant. I put a small electric light in each coop and kept it burning all night. Ever since then the ducks have been getting a good night's rest, and their market value has been considerably increased."

RAT SHORT-CIRCUITED ELECTRIC SYSTEM.

Not long since a little long-tailed rat put the entire lighting and electric power service of Vancouver, B. C., temporarily out of business. The rat climbed on to one of the wires at the Barnet Crossing station and its tail touched a section of the iron frame work. In an instant the rat was burned to a crisp and the electric system was short circuited.

FINE GUNS, given for small clubs of new subscribers to Popular Mechanics. Send for catalogue.

Please mention Popular Mechanics when writing Advertisers.

FREE

HAIR
FOOD

FALLING HAIR AND BALDNESS ABSOLUTELY CURED

There is but one way to tell the reason of baldness and falling hair, and that is by a microscopic examination of the hair itself. The particular disease with which your scalp is afflicted must be known before it can be intelligently treated. The use of dandruff cures and hair tonics, without knowing the specific cause of your disease, is like taking medicine without knowing what you are trying to cure. Send a few fallen hairs from your combings, to Prof. J. H. Austin, the celebrated Bacteriologist, who will send you absolutely free a diagnosis of your case, a booklet on care of the hair and scalp, and a sample box of the remedy which he will prepare specially for you. Enclose no postage and write to-day.

PROF. J. H. AUSTIN
456 McVicker's Theatre Bldg., Chicago.

AGENTS WANTED Sell \$1 bottle Sarsaparilla for 35c; best seller; 200 per cent profit. Write today for terms. F. B. Greene, 115 Lake St., Chicago

ECZEMA Tetter and all itching Skin Torture CURED. **Free Trial** Send for **Free Trial** HALE CHEMIC CO., - - - Kirksville, Mo.

WHEN IN SAN FRANCISCO

YOU CAN ALWAYS GET

Popular Mechanics

and its books, as well as back numbers, and any other book or periodical you want.

ROBERT C. ROSS, 1203 Market Street, Frisco

DESIRABLE
Factory Location

A rapidly growing town in Southern Wisconsin offers inducements to desirable industries. Two lines of railroad, power, electric light, no saloons, no unions. Address

Factory Location, - care Popular Mechanics

"Want" and "For Sale" Ads. 2 cents per word, payable in advance. Replies may be sent to a number, care Popular Mechanics, and will be forwarded promptly without extra charge.

"SHOP NOTES"—Paper covers 50 cents. Popular Mechanics.

AUTOMOBILES.

FOR SALE—Loomis runabout, \$200; double opposed air cooled motor; photo on request. Lock Box 323, Batre, Vt.

FOR SALE—Michigan runabout, gasoline, little used, everything first-class, \$300. Address A. W., care Popular Mechanics.

FOR SALE—One tandem Motor Cycle, frame complete. One Merkel Motor Cycle, A-1 shape. Also 2½x3 in. pipe die and stock. B. G. Raymond, St. Cloud, Minn.

STAMP BRINGS great Bargain. Save 50 per cent on new and second-hand Automobiles, Motor Bicycles, Gears, Machinery parts, and Stationary Engines. T. S. Culp, Canton, Ohio.

FOR SALE—Runabouts and Touring Cars which we have in trade, will be sold at less than half cost. Popular makes and guaranteed condition. Don't fail to write if interested. They're snaps. The Starin Co., North Tonawanda, N. Y.

FOR SALE—Merkel Motor Cycle, 2¼ horse-power. Machine carefully used and in fine condition. Cost \$150. Will sell for \$65. Big Bargain. The Starin Co., North Tonawanda, N. Y.

FOR SALE—One pair leather covered automobile baskets, one umbrella holder, one pair oil lamps, one acetylene lamp with generator. All practically new, having been used but a few times. All or any part of the above can be bought cheap. Address G. F. L., care Popular Mechanics.

YOU WILL find them in France, Germany, Australia, England, Canada and all of the leading factories in the United States. We mean Diamo-Carbo Emery Wheel Dressers. Our booklet for the asking. Stephan Brothers, Urbana, Ohio.

FOR SALE OR EXCHANGE—Automobile gear. Address C. C. H., 18 North Front St., Columbus, O.

FOR SALE OR EXCHANGE—4 h. p. automobile or boat 4 cycle gasoline engine. Address A. P. C., 18 North Front St., Columbus, O.

BLACKSMITHS.

EVERY USER of emery wheels should have our booklet on Diamo-Carbo Emery Wheel Dresser. A postal card will bring it to you. Address Stephan Bros., Urbana, Ohio.

GOOD BLACKSMITHS ARE SCARCE AND BUT FEW LEARNING THE TRADE.

And the smith comes first of all professions or trades. The smith must make the tools first for all from the surgeon to the safe blower, by using Toy's Treatise on new steels explaining how to work them with 75 new methods for working all difficult jobs. Ten receipts for making your own compounds for welding different kinds of steel solid. Thermite welding fully explained; also two colored tool tempering charts; chart A explains all annealing and hardening; Chart B explains both scientific and plain tempering to a standard. All the above for \$1.00. Valuable samples free. W. M. Toy, Sidney, Ohio.

BUSINESS CHANCES.

FOR SALE—Eleven hundred and fifty acres pine timber. Double circular saw mill, twenty thousand capacity; cable feed, live rolls, gang edger, log turner and log haul, steel head blocks, shingle mill and planer. Good buildings, all new and modern. Big Bargain. For particulars apply to J. J. Patterson, Eagleville, Modoc Co., California.

FOR SALE—Complete first-class Steam Laundry in growing town of 2,000 population. Wood plentiful; water good; prices cheap. Proprietor going into another business. Particulars given on application to N-184, Popular Mechanics.

FOR SALE—Best equipped machine shop in California, doing fine business. 5 h. p. gasoline engine, and good stock of all necessary tools. Address, Geo. E. Henton, Mountain View, California.

DIAMO-CARBO EMERY WHEEL DRESSER: better than black diamond. Booklet and testimonies free. Stephan Bros., Urbana, Ohio.

FOR SALE—A well equiped machine shop in southern Michigan, doing a good business. Price, \$3,000. Splendid opportunity for a good business mechanic. Address No. 987, care Popular Mechanics.

IF YOU wish to help the company you are working for, get our booklet and testimonies on Diamo-Carbo Emery Wheel Dresser. Stephan Bros., Urbana, Ohio.

Six Thousand acres of fine timber land in Idaho (deeded) for sale cheap if taken soon. Address W. J. Ramey, Nezperce, Idaho.

FOR SALE

MAKE AN emery wheel any shape you wish with a Diamo-Carbo Emery Wheel Dresser. Send for booklet and testimonies. Stephan Bros., Urbana, O.

FOR SALE—One horse power gasoline engine in good condition. Address J. M. Doll, 528 Fannin St., Shreveport, La.

FOR SALE—High grade marine and automobile gasoline engines, all sizes. State your want. Lowest prices. Houle & Co., 580 East St., Holyoke, Mass.

FOR SALE—A two-light d. c. dynamo, or ½ h. p. motor, 110 volts, equipped with four slip rings giving 85-volt single-phase and 70 volt three-phase, a. c. current, either as a rotary converter or self-exciting generator. A fine experimental machine. Speed 2,000; price \$18. Address A. B., care Popular Mechanics.

GET A Desmond Injector if you wish to be sure of your water supply. Write for booklet. Desmond-Stephan Mfg. Co., Urbana, Ohio.

FOR SALE OR TRADE—10 h. p. steam engine in good condition, one boiler feed pump. Will trade for a six or eight h. p. gas or gasoline engine. M. A. Hyatt, Eaton, Ind.

FOR SALE—One fine 18-in. lathe, 8 ft. bed, \$200; one Hendey friction shaper, 18-in. stroke, \$100; one Fox milling machine No. 2, with 18 cutters, \$100. All the above guaranteed in perfect condition. R. C. Bradley & Co., 413 Market St., Shreveport, La.

FOR SALE—Foot power lathe, 9x25, screw cutting, with all fixtures, full set taps and dies, 9 sizes, ¼ to 1 in. U. S. S. thread. This outfit is almost new. Write me for particulars. George Nein, 491 Van St. Barberton, Ohio.

FOR SALE OR EXCHANGE—Power plant of steam automobile, boiler, engine, pumps, gauges, tanks, burner regulator, etc. Will exchange for motorcycle not less than 2 h. p. For particulars address M. W. Cameron, Linwood, N. Y.

A PRACTICAL BOOK, "Dies and Diemaking." Postpaid \$1. J. L. Lucas, Bridgeport, Conn.

FOR SALE.—Chain drive, reading standard, motorcycle, with large motorcycle lamp, tool bag with tools and cyclometer, enameled light blue; is a first-class hill-climber, ridden 350 miles. Price \$125. J. Bentell, 838 McLaren Ave., St. Louis, Mo.

HELP WANTED.

WANTED SALESMEN—The Tropical Oil Company, Cleveland, O., will arrange on salaried basis with lubricating oil salesmen for territory not covered; can also use on attractive commission proposition few good salesmen without previous experience in this line, which is easily learned. Communicate with us.

WANTED—Every user of emery wheels to have our booklet on Diamo-Carbo Emery Wheel Dressers, a postal card will get it for you. Stephan Bros., Urbana, Ohio.

WANTED.

THE WONDERFUL DESMOND Injector should be on every boiler. Send for booklet and testimonials. Desmond-Stephan Mfg. Co., Urbana, Ohio.

AGENTS WANTED for Farmers Stand-by, Eight tools in one. Fastest seller ever put on the market. Write for descriptive circular and agents' terms to B. W. Tucker, Chickasha, Indian Territory.

AGENTS TO SELL my Calipers and Levels; good pay. Ernst G. Smith, Columbia, Pa.

WANTED—GOOD Bb Cornet in exchange for half-size Violin and new six-keyed Eb Piccolo, with German silver head and tuning slide. Also want to buy good Bb Clarinet and Edison or Columbia Phonograph and records. Cash or exchange. Write, enclosing stamp, to John A. Nelson, Craig, Neb.

MISCELLANEOUS.

THE WONDER OF THE AGE—Diamo-Carbo Emery Wheel Dresser, booklet and testimonials free. Stephan Bros., Urbana, Ohio.

BRAINS FOR SALE—Do you want a prospectus written and illustrated for your new company or syndicate? Do you want one that will command attention and sell shares? Do you need a catalogue or booklet that will not be thrown in the waste basket? If so write to Expert, care of Popular Mechanics, Journal building, Chicago.

WHEN YOU WANT anything and don't know where to get it, write Popular Mechanics.

WANTED—If you have anything in light metal manufacturing, job or experimental work, write me. Lowest prices. Schwabe & Son, 55 W. Washington St., Chicago.

A PRACTICAL BOOK, "Dies and Diemaking." Postpaid \$1. J. L. Lucas, Bridgeport, Conn.

TRUE OR SHAPE emery wheels in any shape you wish with a Diamo-Carbo Emery Wheel Dresser; booklet and testimonials free. Stephan Bros., Urbana, Ohio.

FOR SALE—Civil Engineering Scholarship in the International Correspondence Schools. Complete set of books A Bargain. N-183, Popular Mechanics.

DON'T FORGET to get our price on our medical batteries this month; all sizes and prices. Get our price first. Smith Electric Supply House, 207 and 213 E. Van Buren St., Chicago, Ill.

STEEL, BRASS, Wood Stamps, 8c a letter; Seals, Door Plates, 50c; Embossing, Stationery Dies, \$1.50; Presses, \$2.50. Postal brings price circular. J. Kiola, Engraver, 155 W. Madison St., Chicago, Ill.

FOR SALE—Mechanical Refrigeration Course, International Correspondence Schools, \$15. Address J. H. P., care Popular Mechanics.

WILL MANUFACTURE and place on the market any machine or device. Machinery, etc., to be designed or developed will receive my prompt and careful consideration. Let us figure on your work. Edward Lindmueller, Williamson Bldg., Cleveland, O.

FOR SALE—Encyclopedia Applied Electricity, five volumes, new, \$12.50. Also Blickensderfer Typewriter in good condition, \$12. Edwin Trube, Galveston, Tex.

SOMETHING NEW!—Our Magic Engraving Fluid is used with a rubber stamp. Marks all tools and metal articles permanently. Best seller on earth. Sample package and agent's terms, 25 cents. Address Gem Specialty Co., St. Cloud, Minn.

ANYONE WISHING TO SELL missing numbers of Horseless Age, 1905; Popular Mechanics, 1905; Power, 1903; Automobile, 1903; Motor World, 1904; Motor Age, 1903. Mrs. C. F. MacDermot, Hotel Wentworth, New Castle, N. H.

500 BOOKS

Our new catalog of latest mechanical and technical books, now ready. Write for a copy.

Want a

Typewriter Free?

It takes no money and very little effort to earn A FINE TYPEWRITER. This is certainly the greatest offer we have ever made. Write at once for "How To Get It."

Popular Mechanics,
JOURNAL BUILDING, CHICAGO

WANTS MOTOR FOR WHEEL CHAIR.—Reading your Popular Mechanics for July and not seeing anything that I really need I decided to write to you. I am in a very unfortunate position. I have been living at this hospital for the last eight years at the expense of the good Sisters here. I have not been able to work to earn my living, as I have my two legs taken off close to the thigh and also one arm; so you see what a position I am in.

But I have saved up a little money and I would like to get a small motor to put on my wheel chair, as I have only a few more years to live and I would like to enjoy life.

If there is anything that you can do for me and know of anything I wish you would let me know. I don't want anything without paying for it, but I can't afford to pay a big price. I remain,

W. RUZENSKI.

St. Joseph's Hospital, South Bend, Ind.

A new test to ascertain absolutely whether a being is dead or not consists in injecting a solution of fluoresceine deep into the tissues. If the blood still circulates, the skin and mucous membranes will become very yellow and the eyes of an emerald shade. If life remains the injection does no harm and the coloring disappears, but if extinct the coloring does not appear at all.

MANUFACTURERS Why not locate where intelligent labor, raw material and demand

for your product obtains. All these and more found on the **BURLINGTON ROUTE**. For information write to



W. H. MANSS, Industrial Commissioner
209 Adams Street - - - - - Chicago

Please mention Popular Mechanics when writing Advertisers.

Hot Air Engine

FOR RUNNING FANS, WINDOW DISPLAYS,
MODEL MACHINERY, PEANUT ROASTERS,
∴ ∴ SEWING MACHINES, ETC. ∴ ∴

Runs with Gas, Alcohol or Gasoline

These engines are practical in use and require no attention when running beyond an occasional drop of oil. The small size for running a fan or several revolving window displays uses only 3 cents worth of gas in 10 hours with gas at \$1 per thousand feet. The engine is perfectly safe, cannot explode and is far superior to any other small power yet perfected. The No. 1 weighs 18 lbs., has a speed of 500 revolutions per minute, grooved fly wheel $6\frac{3}{4}$ in. diameter, and furnishes 1-40th horsepower.

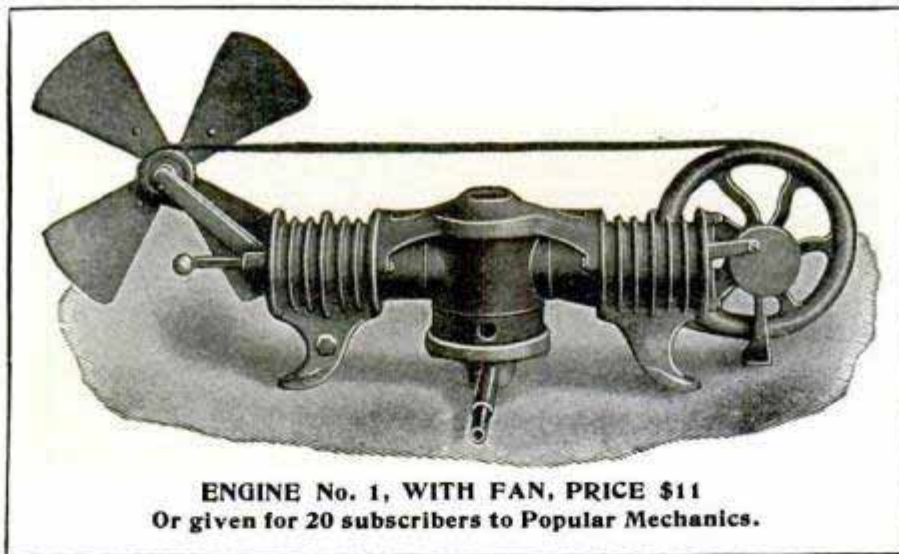

ENGINE No. 1, WITH FAN, PRICE \$11
Or given for 20 subscribers to Popular Mechanics.

ENGINE No. 2

This engine has two cylinders, has twice the power of No. 1, and will run sewing machines and do other work of equal power. Burns gas only. Weight 30 lbs., 500 revolutions, uses 6 cents worth of gas per day. When used on sewing machines a speed controller to start, stop and regulate speed of sewing machine is required. Controller \$2 extra. Controller not needed for continuous work.

Price of this Engine \$18 or given with 35 subscribers to Popular Mechanics

POPULAR MECHANICS

Journal Building

CHICAGO, ILL.

DON'T SPECULATE

TAKE A CERTAINTY

Would you be open for an investment which will yield, with reasonable assurance, from 50 to 100 per cent each year?

An investment that will enable your surplus earnings to work with you and shorten the road to wealth. Not a get-rich-quick scheme, but a get-rich-sure investment, that is sure as the seasons, and increases as they roll by.

Study it out for yourself: A rubber plantation in the finest rubber zone in the tropics: 200 to 250 trees per acre; two pounds of rubber and upwards to the tree, worth now \$1.40 per pound, gold. No speculation in that. Rubber is worth the money, and we have the rubber.

Our rubber plantation consists of 6,000 acres; enough developed to insure its success, making a certainty of an enterprise that is within the reach of any prudent working man that can save from \$2.50 to \$12.50 per month from his earnings.

The contract protects you in misfortune, sickness or death.

Send today for our prospectus and further detailed information.

MONTEZUMA AGENCY

1107 Ashland Block,

- - -

Chicago

MAKE YOUR OWN LIGHT

A complete equipment for making your own Electric Light. A boy can start it.
Requires no attention

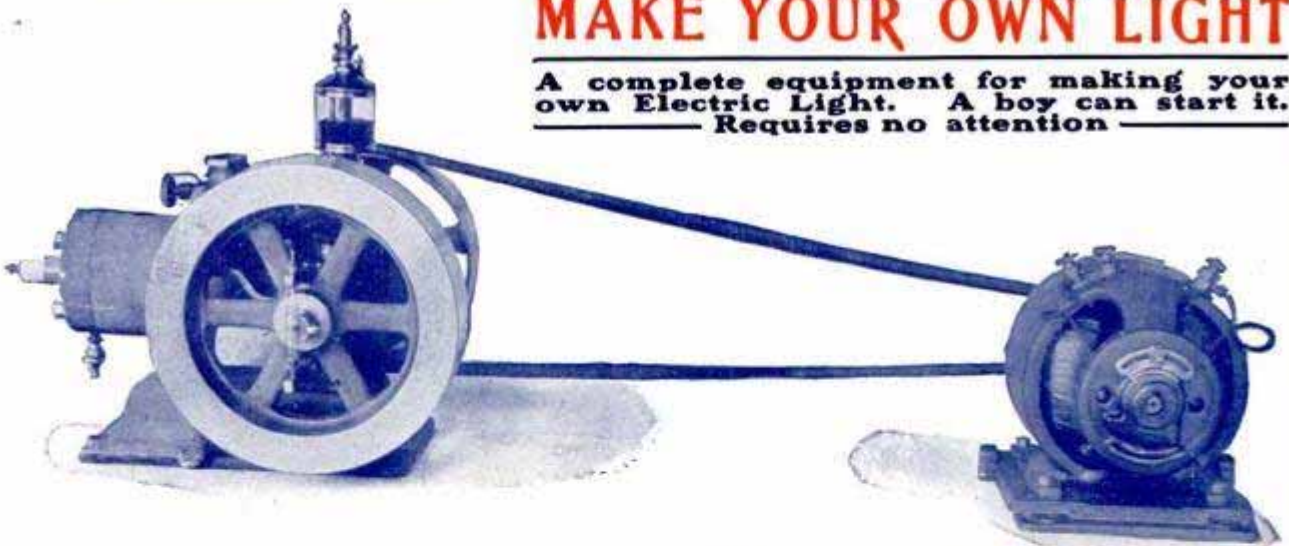

$\frac{1}{4}$ -h. p. Gasoline Engine, 6 Light Generator, 200 feet Covered Wire, 36 feet Lamp Cord, 6 16-Candle Power Lamps, 6 Sockets, 6 Rosettes, 6 Porcelain Tubes, 50 Porcelain Knobs, 2 feet Cir. Loom, 1 Switch Fuse, Solder and Tape. The above complete and perfect outfit is offered at a price so low you cannot afford to burn oil. Send for descriptive circulars.

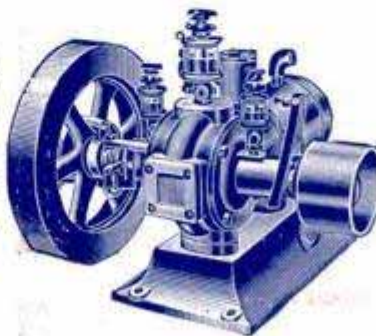

The most Perfect Small Engine Ever Built.....

STRONG DURABLE
SIMPLE POWERFUL

Mounted on solid wood base. All connections made and ready to run.

JUNIOR ENGINE WORKS,

- 907, 160 Washington Street,

- Chicago

THIS MACHINE MADE

\$12.⁶⁵ in One Day

Small Investment. Quick and Sure Profit. We Prove It



This is one of 200 different coin-operated Mills Machines, daily earning big money for their owners.

Whether you live in a small town or a big city, an investment of \$15 up will earn you a large, honest, independent income without work or worry. You just count the profits.

Others Make Money Fast

Your opportunity is just as good as C. L. Anderson's, Peoria, Ill. He says: "Punching Bag arrived 4 o'clock yesterday afternoon, opened it this morning at 9 o'clock and took out \$12.65."

John Fuller, Mt. Airy, N. C., says: "I have taken 39,000 pennies out of one of your Mills Bag Punching Machines in the past 13 months." He DOUBLED his MONEY every 60 days.

Why Not You?

Just think what several such machines would do for YOU. Mills Machines often pay for themselves in 10 days,—after that it is ALL PROFIT. Everybody patronizes a Mills Amusement Machine—men, women and children. They are regular MINTS at picnics, parks, county fairs, carnivals, stores of all kinds or wherever people are to be found.

After 90 days' use, Julius Siegle, of Hannibal, Mo., says he would not take \$500 for his Bag Punching Machine.

If you have any sum of money—\$15 or more—to invest in a sure money-maker, don't fail to write to-day for our Booklet No. 48, "How to Make Money Fast." It's Free.

MILLS NOVELTY CO.

11 to 23 S. Jefferson St., - CHICAGO, ILL.

The WARNER "LITTLE WONDER" WATER MOTOR



A Complete Grinding and Polishing Outfit

Indispensable for home and general use. Saves hours of time and makes silverware and cutlery shine like new. Sharpens edged tools of every description, shears, knives, hatchets, etc. Will run a small dynamo, sewing machine or other light machinery. In every home this motor will fill a long felt want. Dentists, doctors, butchers, cooks, jewelers, carpenters, plumbers and mechanics generally will find this machine of immense value. Price complete, including emery wheel, pulley wheel (for power transmission), 2 buffing and polishing wheels, and sticks of silver and steel polishing composition..... \$4.00

Motor attaches directly to standard threaded faucet or by means of our "universal connection" to any smooth faucet. Absolutely practical. Universally successful. This is not a toy and we will cheerfully refund your money if unsatisfactory as you take no chances. Booklet giving full description sent free. Correspondence with dealers solicited. Send check, money order or U. S. D. order to

WARNER MOTOR CO., Flatiron Bldg. Dept. 14 New York City

COMBINATION PLIER

SIX USEFUL TOOLS IN ONE

- Wire Cutter
- Side Cutter
- Pipe Grip
- Reamer
- Screw Driver
- Flat Nose Plier

Drop forged from an extra fine grade of steel.

The handles are so designed that they fit perfectly the palm and will not tire the hand.

This also makes it an easy cutting tool.

80c



A household tool that is constantly needed in all trades and professions

Ask your dealer for UTICA tools if he has not got them write us.

No. 700—
7-inch sent to any address in the United States on receipt of 80 cents. Write for the green book—FREE.

Every Tool GUARANTEED

Only the Genuine Bear This Mark



Utica Drop Forge & Tool Co.,
73 Genesee Street, UTICA, N. Y.

BUILD YOUR OWN BOAT

By the Brooks System

If you can drive a nail and cut out a piece of material from a full-sized pattern—you can build a canoe—row-boat—sail-boat—or launch—in your leisure time—at home, and the building will be a source of profit and pleasure.

All you need is the pattern, costing from \$2.50 up, and materials, from \$5.00 up. The tools are common in every household. Patterns of over 40 styles and sizes—all lengths from 12 to 55 feet.

The Brooks System consists of exact-size printed paper patterns of every part of the boat—with detailed instructions and working illustrations showing each step of the work—an itemized bill of material required and how to secure it.

Over six thousand amateurs successfully built boats by the Brooks System last year. Fifty per cent. of them have built their second boat. Many have established themselves in the boat-manufacturing business.

Catalogue and particulars free. For 25 cents 100-page catalogue containing valuable information for the amateur yachtsman, showing several working illustrations of each boat and a full set for one boat. Full line in knock-down and completed boats. When so ordered, patterns are expressed, charges prepaid, C. O. D., to allow examination.

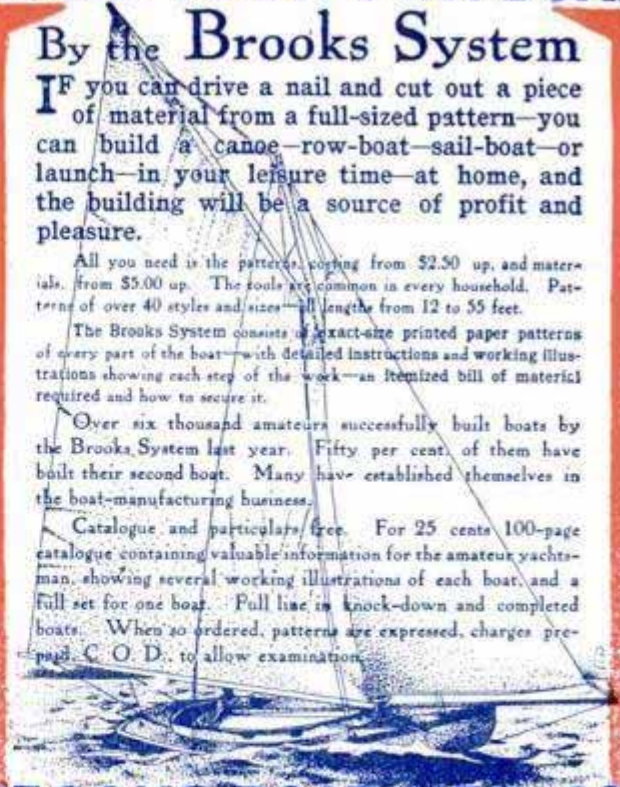

BROOKS BOAT MFG., CO.

Originators of the Pattern System of Boat Building
3709 Ship St. Bay City, Mich. U.S.A.