

MAKING YOUR OWN WEB SITE

February 1998

Popular Electronics[®]

A Hands-On Approach to **Op-Amps**

Discover how op-amps operate and how to use them—then build one or more of these three op-amp-based circuits

Build this **Heated Pet Pad**

Keep your pet warm during these cold winter months

Experimenting with the **4093 NAND Schmitt Trigger**

Everything you wanted to know about this useful integrated circuit

Plus:

- Gizmo—Building Your Home Theater
- CD-ROMS and Stuff
- VSWR and Transmission Lines

PLUS!
Alarming Circuits
and Keyboards

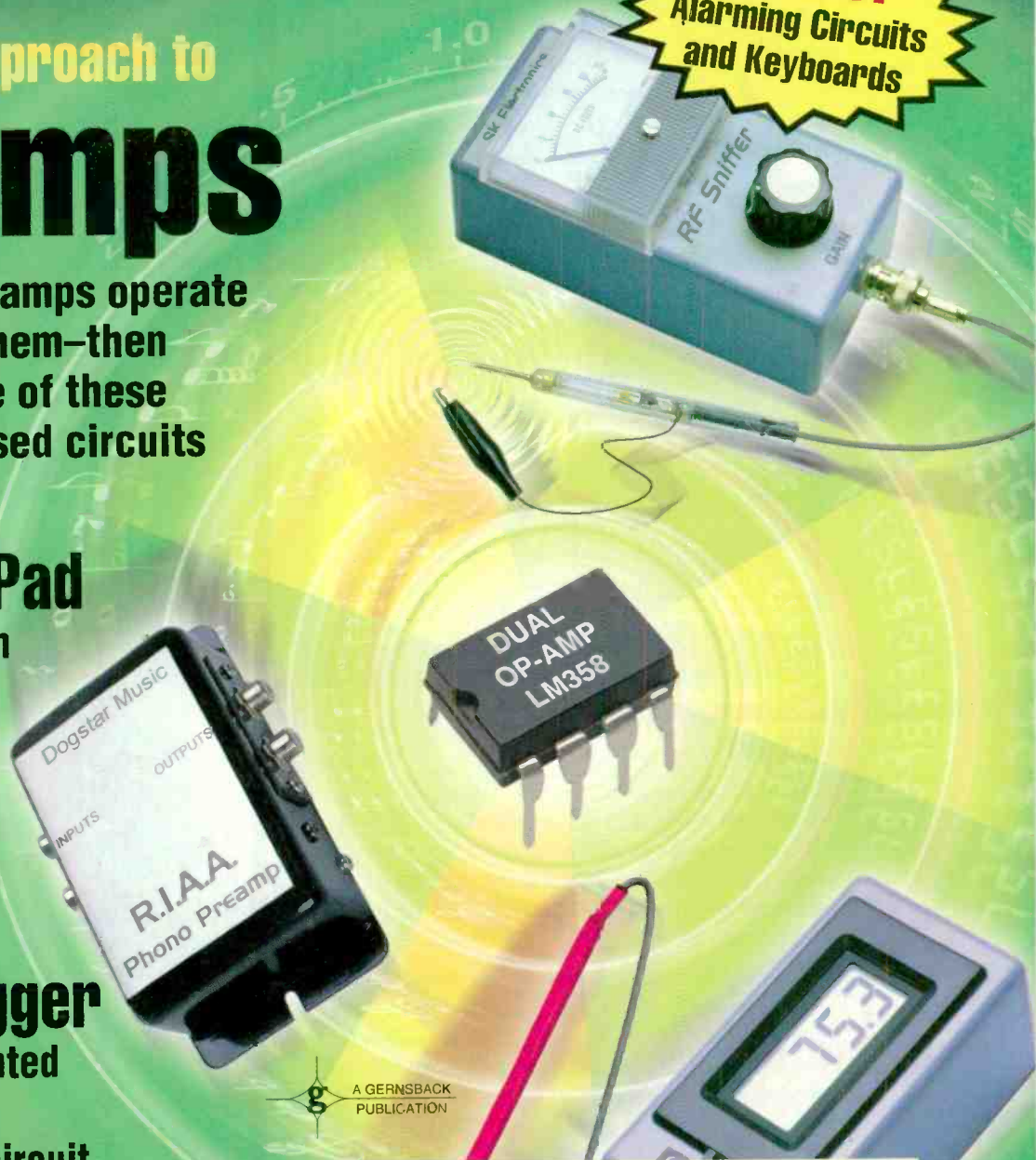

 A GERNSBACK PUBLICATION

\$4.50 U.S.
\$4.99 CAN.

#BXBDCCCH***** 5-DIGIT 55414
#55414LNE108AE007# SEP98 P53

KENNETH LYNES RESP

1088 22ND AVE SE 147
MINNEAPOLIS MN 55414-2542

Better Designs -Faster

\$299

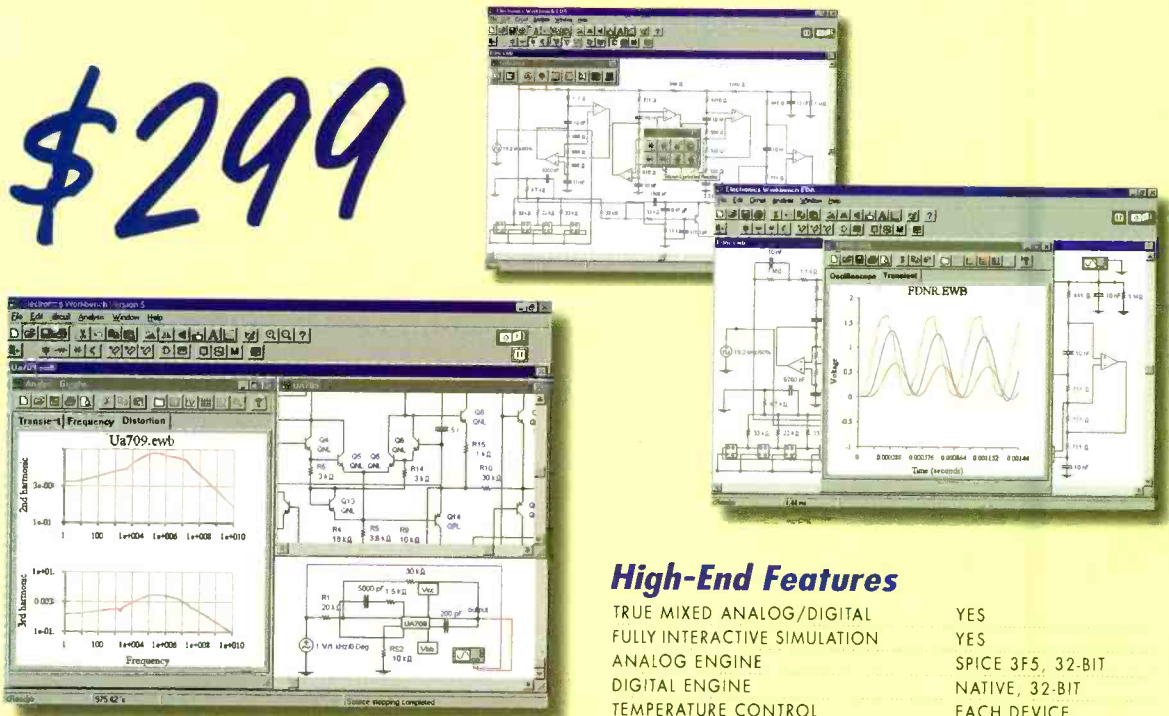

NEW!

Electronics Workbench Version 5 with analog, digital and mixed A/D SPICE simulation, a full suite of analyses and over 4,000 devices. Imports SPICE netlists. Exports to PCB layout programs. Still the standard for power and ease of use. Still the same low price.

Join over 75,000 customers and find out why more engineers and hobbyists buy Electronics Workbench than any other SPICE simulator. You'll be working productively in 20 minutes, and creating better designs faster. We guarantee it!

Check our web site at
<http://www.interactiv.com>
for a free demo

30-DAY MONEY-BACK GUARANTEE

VERSION 5.0 FOR WINDOWS 95/NT/3.1. Upgrades from previous versions \$79.

CALL 800-263-5552



INTERACTIV

Fax: 416-977-1818 Internet: <http://www.interactiv.com> CompuServe: 71333,3435/BBS: 416-977-3540/E-mail: ewb@interactiv.com

High-End Features

TRUE MIXED ANALOG/DIGITAL	YES
FULLY INTERACTIVE SIMULATION	YES
ANALOG ENGINE	SPICE 3F5, 32-BIT
DIGITAL ENGINE	NATIVE, 32-BIT
TEMPERATURE CONTROL	EACH DEVICE
PRO SCHEMATIC EDITOR	YES
HIERARCHICAL CIRCUITS	YES
VIRTUAL INSTRUMENTS	YES
ON-SCREEN GRAPHS	YES
ANALOG COMPONENTS	OVER 100
DIGITAL COMPONENTS	OVER 200
DEVICE MODELS	OVER 4,000
MONEY-BACK GUARANTEE	30-DAY
TECHNICAL SUPPORT	FREE

Powerful Analyses

DC OPERATING POINT	YES
AC FREQUENCY	YES
TRANSIENT	YES
FOURIER	YES
NOISE	YES
DISTORTION	YES

Electronics Workbench[®]

VERSION 5

INTERACTIVE IMAGE TECHNOLOGIES LTD., 908 Niagara Falls Boulevard, #068,
North Tonawanda, New York 14120-2060/ Telephone 416-977-5550

TRADEMARKS ARE PROPERTY OF THEIR RESPECTIVE HOLDERS. OFFER IS IN U.S. DOLLARS AND VALID ONLY IN THE
UNITED STATES AND CANADA. ALL ORDERS SUBJECT TO \$15 SHIPPING AND HANDLING CHARGE

CIRCLE 14 ON FREE INFORMATION CARD

www.americanradiohistory.com

Popular Electronics®

FEBRUARY 1998

Vol. 15, No. 2

g

A GERNSBACK
PUBLICATION

COVER STORY

31 A Hands-on Approach to Op-Amp Basics

Learn how op-amps operate and how to use them in your own design, while building one or more of this trio of op-amp-based circuits

—Fred Nachbaur

CONSTRUCTION

45 Heated Pet Pad

Be kind to your four-footed friend by furnishing it with a warm spot to rest on those cold winter nights—Walter W. Schopp

FEATURES

19 Gizmo

Home-theater design continues. In this issue, we take a look at the latest in receivers, large-screen TVs, video projectors, DVD players, and more!

50 Experimenting with the 4093 NAND Schmitt Trigger

Explore some of the possibilities offered by the 4093 CMOS NAND Schmitt trigger. The circuits outlined in this article are not only educational, but fun to build—Newton C. Braga



Page 31

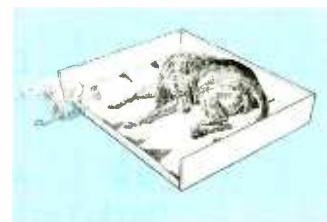

Page 45



Page 19

POPULAR ELECTRONICS (ISSN 1042-170-X) Published monthly by Gernsback Publications, Inc. 500 Bi-County Boulevard, Farmingdale, NY 11735. Periodicals postage paid at Farmingdale, NY and at additional mailing offices. One-year, twelve issues, subscription rate U.S. and possessions \$21.95. Canada \$28.84 (includes G.S.T. Canadian Goods and Services Tax Registration No. R125166280), all other countries \$29.45. Subscription orders payable in U.S. funds only. International Postal Money Order or check drawn on a U.S. bank. U.S. single copy price \$4.50. Copyright 1997 by Gernsback Publications, Inc. All rights reserved. Hands-on Electronics and Gizmo trademarks are registered in U.S. and Canada by Gernsback Publications, Inc. Popular Electronics trademark is registered in U.S. and Canada by Electronics Technology Today, Inc. and is licensed to Gernsback Publications, Inc. Printed in U.S.A.

Postmaster: Please send address changes to Popular Electronics, Subscription Dept., P.O. Box 338, Mount Morris, IL 61054-9932

A stamped self-addressed envelope must accompany all submitted manuscripts and/or artwork or photographs if their return is desired should they be rejected. We disclaim any responsibility for the loss or damage of manuscripts and/or artwork or photographs while in our possession or otherwise.

As a service to readers, Popular Electronics publishes available plans or information relating to newsworthy products, techniques, and scientific and technological developments. Because of possible variances in the quality and condition of materials and workmanship used by readers, Popular Electronics disclaims any responsibility for the safe and proper functioning of reader-built projects based upon or from plans or information published in this magazine.

PRODUCT REVIEWS

58 Hands-on Report
Wireless Radio Surveillance System—a complete camera/
transmitter/receiver monitor

COLUMNS

8 Multimedia Watch
CD-ROMs and Stuff—*Marc Spiwak*

12 Net Watch
Making Your Own Web Site—*Konstantinos Karagiannis*

14 Computer Bits
Telephone Talk II—*Jeff Holtzman*

15 Scanner Scene
No Duplicate Frequencies!—*Marc Saxon*

60 DX Listening
BBC's Empire Service—*Don Jensen*

62 Antique Radio
Smoke Test for the NR-5—*Marc Ellis*

64 Think Tank
Alarming Circuits and Keypads—*John Yacono*

67 Circuit Circus
Circuit Potpourri—*Charles D. Rakes*

69 Ham Radio
VSWR and Transmission Lines—*Joseph J. Carr*

DEPARTMENTS

4 Editorial
5 Letters
29 New Products
30 Electronics Library
73 Popular Electronics Market Center
102 Advertising Index
102A Free Information Card

Popular Electronics

Larry Steckler, B.S., C.E.T.,
editor-in-chief and publisher

EDITORIAL DEPARTMENT

Edward Whitman, managing editor
Julian Martin, editorial advisor
Robert Young, technical editor
Evelyn Rose, assistant editor
Teri Scaduto, assistant editor
Debbie Cybula, editorial assistant
Joseph J. Carr, K4IPV,
contributing editor
Marc Ellis, contributing editor
Jeffrey K. Holtzman,
contributing editor
Don Jensen, contributing editor
Konstantinos Karagiannis,
contributing editor
Charles D. Rakes, contributing editor
Marc Saxon, contributing editor
Marc Spiwak, contributing editor
John Yacono, contributing editor

PRODUCTION DEPARTMENT

Ruby M. Yee, production director
Ken Coren, desktop production director
Lisa Baynon, desktop production
Melissa Giordano, desktop production
Kathy Campbell, production assistant

ART DEPARTMENT

Andre Duzant, art director
Russell C. Truelson, illustrator

CIRCULATION DEPARTMENT

Theresa Lombardo,
circulation manager
Gina L. Gallo, circulation assistant

REPRINT DEPARTMENT

Marie Falcon, Reprint Bookstore

BUSINESS AND EDITORIAL OFFICES

Gernsback Publications, Inc.
500 Bi-County Blvd.
Farmingdale, NY 11735
1-516-293-3000
FAX: 1-516-293-3115
President: **Larry Steckler**
Vice-President: **Adria Coren**
Vice-President: **Ken Coren**

SUBSCRIPTION

**CUSTOMER SERVICE/
ORDER ENTRY**
1-800-827-0383
7:30 AM - 8:30 PM EST

Advertising Sales Offices
listed on page 102

Composition by Mates Graphics
Cover by Loewy Design



Since some of the equipment and circuitry described in POPULAR ELECTRONICS may relate to or be covered by U.S. patents, POPULAR ELECTRONICS disclaims any liability for the infringement of such patents by the making, using, or selling of such equipment or circuitry, and suggests that anyone interested in such projects consult a patent attorney.



Revolutionary data transmitter turns your TV into a video phone

C-Phone Home™ uses a digital camera and the latest in data transmission to provide high quality, affordable video phone calling.

by Dexter Mulligan

Have you ever watched an episode of the Jetsons and wondered what it would be like to live in a technological "World of the Future?" I have, and of all of the amazing innovations featured on the show, my favorite is the video phone. Wouldn't it be great to be able to talk to someone in another city and be able to see their expressions, so that you could interact just as though you were standing in the same room? Imagine calling your children, or grandchildren, and being able to look at them as you converse, without the time and expense associated with travel. Now you can, thanks to a revolutionary product that turns your TV and phone line into a full-color video phone system: the C-Phone Home.

Face to face. Ever since the 1964 World's Fair, when a video phone prototype was first demonstrated, researchers have attempted to develop a way to make the concept available for mass-market use. Unfortunately, the resulting products were either prohibitively expensive or suffered from poor picture quality. Small, computer-based display screens and relatively slow transmission speeds resulted in little more than a fuzzy still image that changed sporadically.

What's more, these products seemed to be designed for only the most knowledgeable electronic engineers, because they relied on a computer program and involved complicated installation and operation. That all changed at the latest Computer Electronics Show in Las Vegas, where everyone from industry experts to the general public was astounded to see the level of quality, accessibility and affordability of the C-Phone Home system.



The C-Phone Home is about the size and shape of a cable TV converter box, and hooks up to the TV just like a VCR. Your television set is used to present the audio and video of the person being called.



The C-Phone's high resolution means the image that's displayed is vibrant and life-like, so you can see, hear and interact with the other party in a manner never before possible.

Seeing is believing.

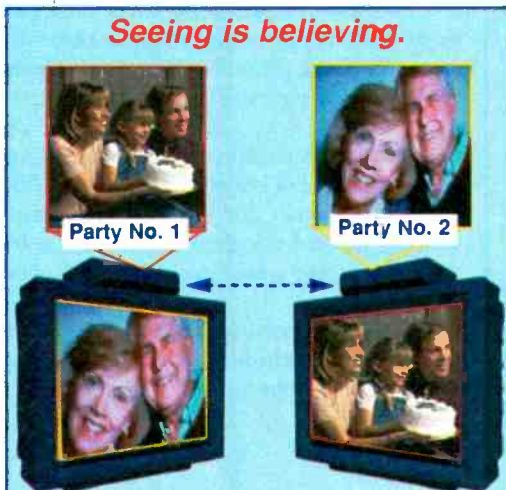

The key to the C-Phone Home is a data compression system that allows the video images to be transmitted quickly over your existing phone line using a 33.6 Kbps modem. This creates a higher resolution image that is displayed at speeds up to 16 frames per second.

See what you're missing. The key to the C-Phone Home is a data compression system that allows the video images to be transmitted quickly over normal bandwidth phone lines using a 33.6 Kbps modem. This creates a higher resolution image that is displayed at speeds up to 16 frames per second. This means the image that's displayed is vibrant and life-like, so you can see, hear and interact with the other party in a manner never before possible. Imagine the joy and pride on grandparents faces as they see a new grandchild for the first time...from thousands of miles away.

Seeing is believing. The C-Phone Home is about the size and shape of a cable TV converter box, and hooks up to the TV just like a VCR. Your television set is used to present the audio and video of the person being called, as well as all text menus used to operate and configure the system. If your TV has a picture-in-picture feature, the system lets you view calls and programs simultaneously.

The amazing remote control provides the user with the ultimate in convenience. Two omni-directional microphones strategically positioned in the top of the C-Phone Home unit provide a built-in full duplex speakerphone. This allows everyone to speak freely as if you were all together in the same room. The speakerphone can be used for standard phone calls as well as video phone calls. You can use the remote, which has a 20-number memory, to speed dial a video call when the TV's on or to answer the phone with the push of a button. When answering a video call, you push a button to determine when the video transmission begins, so your privacy will never be invaded. The built-in digital camera is recessed and de-emphasized, so the subjects will simply look at the screen, without acting self-consciously.

Try it at home. The world has waited decades for video phone technology, but you can order yours today. It comes with a one-year manufacturer's limited warranty and Comtrad's exclusive home trial. If for whatever reason you are not completely satisfied, return it within 30 days for a full refund "No Questions Asked."*

Both parties need a C-Phone or any H.324 compatible system to see and to be seen.

System includes set-top box with built-in camera and modem, wireless remote, AC adapter, cables, adapters and installation instructions. Video phone service package is \$9.95 per month and 29¢ per minute, 12-month contract required. *Service package is non-refundable.

Video Phone System. \$349.95 \$12 S&H
Buy two or more systems \$299.95 each

Please mention promotional code 3041-12025.

For fastest service call toll-free 24 hours a day

800-992-2966



Accredited B.S. Degree in Computers or Electronics

by studying at Home

Grantham College of Engineering
offers 3 distance education programs:

- B.S.E.T. emphasis in Electronics
- B.S.E.T. emphasis in Computers
- B.S. in Computer Science

NEW!
-Electronics Workbench Professional 5.0
included in our B.S.E.T. curriculums
-Approved by more than 200 Companies,
VA and Dantes, (tuition assistance avail.)

For your free catalog of our programs dial

1-800-955-2527

<http://www.grantham.edu>

GCE

Your first step
to help yourself
better your future!



Grantham College of Engineering
34641 Grantham College Road
Slidell, LA 70460-6815

Some Say Watching Tropical
Fish Lowers Blood Pressure
& Relieves Stress...



They Could Be On To
Something.



Discover the Caribbean aboard a Tall Ship.
6 & 13 day adventures from \$650.
For more information call your travel agent
or 1-800-327-2601.

 **Windjammer**
Barefoot Cruises.inc.

P.O. Box 190120, Dept. 5568, Miami Beach, FL 33119

CIRCLE 172 ON FREE INFORMATION CARD

EDITORIAL

Is Big Brother Listening to You?

While listening to the radio on my drive to work a few days ago, I heard a discussion that was very relevant to our personal communications society. A commentator mentioned that he recently set up his wireless "baby-sitter" to monitor his newborn's room from a remote point in the house. After everything was set properly, he went downstairs for a quiet evening with his wife. All of a sudden, he started to hear voices coming from the remote monitor receiver. He knew that his three-month-old could not be talking yet, so he listened carefully to the conversation. He realized that what he was overhearing was coming from his neighbor's house. Apparently, they also had a wireless intercom in their baby's room that was being picked up by this commentator's receiver. Interesting!



In Tom Clancy's novel *Clear and Present Danger*, the CIA was able to listen in to cellular telephone conversations that were going on between the various Colombian drug lords. Somehow they tapped into a cellular repeater and/or satellite network that was relaying information over the air. The information the CIA obtained was key in heading off certain illegal operations. About two years ago, I recall, some real-live individuals owning a scanner were eavesdropping on cellular telephone conversations from a famous Congressman. The matter became public knowledge, and there were all sorts of repercussions. (Speaking of politics, in the midst of the Cold War, people were amazed that, with my 100-watt ham radio station, I was able to converse with amateurs in the Communist countries. I responded that there is no "Iron Curtain" around your ham station.)

Just look at our *Scanner Scene* columns: frequencies for most type of wireless transmission—whether they be communications between performers in a concert hall using wireless microphones, conversations held in the drive-thru order line of a fast-food restaurant, the sound track in a movie drive-in, or just plain wireless telephony frequencies—are common knowledge and readily accessible for those with the proper equipment. I know of people who refuse to conduct business over a cell phone, since they are paranoid about their conversations being monitored and recorded.

Wireless communication is just another form of broadcasting—recall that the classic example of radiation from a point source transmitter is shown as pebbles dropped in a pond, and that the radio waves formed are but ripples in the pool, flowing outward in ever-widening circles from the source. Any object that is in the path of these waves intercepts the motion and receives the energy.

In Orwell's famous novel, *1984*, the expression "Big Brother is watching you" was coined. Perhaps in the late nineties, the term "Big Brother is listening to you" might be more appropriate.

Ed Whitman
Managing Editor

LETTERS

SORRY, WRONG NUMBERS

In the *Multimedia Watch* column (**Popular Electronics**, January 1998), the incorrect telephone number was listed on page 10 for GNT Electronics. The fax number was published, instead of the telephone number. Their telephone number is 888-858-0626 or 408-727-3856.—Editor

In the *New Products* column (**Popular Electronics**, December 1997), page 20, the telephone/fax number for Alphalab Inc. is wrong. Since publication, it has changed to 808-874-9126.—Editor

DTMF WIRE TRACER CORRECTIONS

Thank you for printing my correction ("Letters," **Popular Electronics**, January 1998) for the article "DTMF Wire Tracer" in the July issue. I have since built a working unit; however, I found some additional changes were needed to get this project up and running. The unit's display was on at all times and was not blanking between the signal input interval. I found that removing the 5V-supply line to pin 14 of the display and feeding the collector of Q3 to this pin solved the problem. The collector of Q3 does not need to be connected to pin 1 of the display; this pin is left unconnected.

For people who like to etch their own boards, please note that due to ink bleed in the magazine, some traces on the foil pattern appear to be connected when they are not. Pins 1 and 2 of the display do not get connected. The trace that runs near pin 8 should not be touching. The trace that runs between pins 2 and 3 of IC1 should not connect to pins 2 or 3. The trace on IC2 should run between pins 5 and 6 and not connect to either. The dot matrix display has a notch on one corner of it; this is nearest to the display's pin 1 connection. I modified the original design slightly and have enclosed a new foil pattern. Happy decoding to all!

M.K.

LaPorte, IN

Thanks for all your inputs and new

pattern diagram. At least you finally got the satisfaction of building a working unit. By the way, some readers indicated that the unique telecom ICs needed in this construction may now be difficult to obtain. In particular the DTMF decoder IC is listed as a SSI1204 (TDK/Silicon Systems—Tel. 714-573-6000), equivalent to a CD22204 (Harris Semiconductor), or a MC145436 (Motorola device distributed by Future Active—Tel. 800-655-0006).

The other unique IC is the DTMF generator specified as a National Semiconductor TP5088. It appears that Digi-Key no longer stocks this device. National informed us that at one point they obsoleted the item, but recently brought it back. They said that their distributors (Hamilton, Pioneer, Future, Newark, etc.) may not have the IC on the shelf, but it can be obtained from National under special order.—Editor

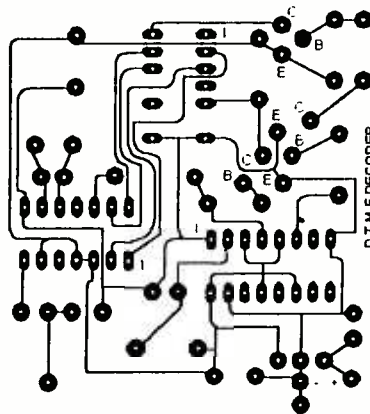

Here is a cleaned-up version (less the ink bleed runovers) of the tone-decoder foil pattern of Fig. 5, page 41 (**Popular Electronics**, July 1997).

FIX FOR A KEYPAD PROBLEM

There's an error in the schematic in the article "The Electronic Garage Door Opener" (**Popular Electronics**, September 1997). It has to do with connections to the keypad. Presumably, if one used the membrane-type keypad made by AMP, mentioned in the caption on page 58, you would connect it according to the pin numbers in the main schematic—see Fig. 1 on page 51 of that article. Maybe it would work; I don't know—I didn't try it.

However, if one could not find an AMP unit and used a different keypad, as I did, you would probably ignore the pin numbers and use function names: R1, R2, etc. The function names are wrong! What is shown as R1 is really Row 4, R2 is really Row 3, etc. The result is that the default key code becomes 0, 9, 5, 7 instead of the stated 2, 6, 4, 8. The "#" key becomes "3," and so on. Figure 2 on page 52, the keyboard schematic, is drawn correctly.

I noticed one other error. Figure 4, the parts placement diagram on page 57, does not show resistor R7. In the position below R8, where R7 should be, is what appears to be a jumper. After solving these problems and reversing the four row connections, my opener now works fine.

B.O.

via e-mail

Good observation. In some construction articles, the author uses parts that he or she has available. Unfortunately when the issue gets printed, these parts may no longer be available, or may have been replaced by the manufacturer with a different part. In the case of ICs, we try to cross-reference with NTE or Thomson SK equivalents, where possible.—Editor

SPEED CONTROLLER FOR REMOTE-CONTROL MODELS

I'm writing in response to the letter from Mike Criswell ("Haves & Needs," **Popular Electronics**, April 1997), requesting information on inexpensive speed controls for remote-controlled model airplanes. I wrote the "Scale Electric" column for *Scale R/C Modeler* for 10 years.

I wonder if Mr. Criswell ever looks at the model magazines and electronics magazines—the advertisements as well as the projects. There are more than 50 different speed controls available from a large number of manufacturers, including Cermark, Astro-Flight, Novak, Jomar, Cannon, Tamiga, Futaba, Airtronics, ACE R/C, and Hi-Tech, to name just a few that come immediately to mind. Many of the controls are priced in the \$35 to \$75

bracket. In addition, I've seen many published designs for speed controls. *RCM, Model Builder, Electron Electronics, and RCM World* have all published good designs.

I manufacture many different types of electronic devices for radio control, free flight, and U-control—including a speed control. The microprocessor, two MOSFETS, and Schottky diode will cost about \$18 when ordered in small quantities. I charge \$10 to program the microprocessor. When you consider that you have to make your own board and be responsible for all errors, \$35 seems very affordable.

B.Y.
Bill Young Designs
4403 East Rustic Knolls Lane
Flagstaff, AZ 86004

HAVES & NEEDS

I've been searching for a five tube radio kit or circuit for some time. All I can find are radio kits using solid-state devices. I was hoping you could help me out.

Robert F. Terry
133 Sutton Road
Ardsmore, PA 19003

I need an instruction manual for my Commodore 128D computer. I also need a programmer's reference guide. Although I get the computer to boot and the welcome screen comes up, I don't know what to do next. I have tried everything, but I can't get it to store basic programs, etc.

Any help or manuals would be greatly appreciated.
Joseph W. Baldwin
2132 Jeannie Court
Warren, MI 48091

I am looking for an owner's manual and a service manual for a Realistic Model #43-205 Interphone Plug N Talk (intercom), or parts for it. Can anyone out there help?

Kenneth L. Wamsley
10914 E. Maple Grove Road
Mt. Hope, KS 67108

I am trying to get a Micro 900 ES cordless telephone manufactured by Bel-Tronics Inc. I contacted the company, but they have discontinued their telecommunications line. If there is any reader who has this model telephone, I would be happy to pay for it even if it

is a non-working unit. Thanks.
W. Daniel
Kitson Town P.A.
St. Catherine
Jamaica, West Indies

I am looking for a Heathkit IM-17 VOM, preferably solid-state or similar at a reasonable price. Now that Heathkit is out of the kit business, I thought you might help me again. I appreciate it.

Larry Cook
362 East South Street
Richland Center, WI 53581-2971

ELECTRONIC GAMES

BP69—A number of interesting electronic game projects using IC's are presented. Includes 19 different projects ranging from a simple coin flipper, to a competitive reaction game, to electronic roulette, a combination lock game, a game timer and more. To order BP69 send **\$8.00 (includes s&h)** in the US and Canada to **Electronic Technology Today Inc., P.O. Box 240, Massapequa Park, NY 11762-0240.** US funds only. Use US bank check or International Money Order. Allow 6-8 weeks for delivery. MA07

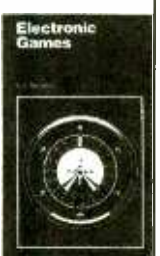

SCANNER USERS • COMMUNICATIONS PROFESSIONALS

We've Got Your Numbers!

POLICE CALL PLUS

1998 EDITION

COMPLETELY REVISED

CURRENT THROUGH OCTOBER, 1997

- 17,000 Codes and Signals.
- FCC and Federal Frequency Allocations 25-941 MHz.
- Includes Glossary of Slang and Terms.
- Illustrated Listener's Guide Book.

GOT A SCANNER? GET POLICE CALL PLUS

At your scanner dealer and all Radio Shack stores.

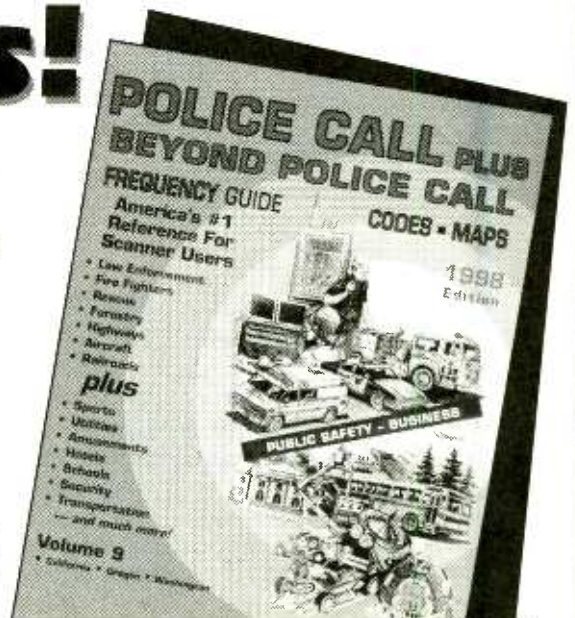

More People Buy **POLICE CALL** Than All Other Frequency Guides (VHF/UHF) Combined.

CIRCLE 173 ON FREE INFORMATION CARD

Budget Project and Computer Books

BP317—Practical Electronic Timing \$6.95. Time measurement projects are among the most constructed gadgets by hobbyists. This book provides the theory and backs it with a wide range of practical construction projects. Each project has how-it-works theory and how to check it for correct operation.

BP415—Using Net-scape on the Internet **BRAND NEW**
\$7.95. Get with the Internet and with surfing, or browsing, the World Wide Web, and with the Netscape Navigator in particular. The book explains: The Internet and how the World Wide Web fits into the general scenario; how do you go about getting an Internet connection of your own; how to download and install the various versions of Netscape browsing software that are available; and how to use Netscape Navigator to surf the Web, and to find and maintain lists of useful sites. There's a heck of a lot more, too!

BP325—A Concise User's Guide to Windows 3.1 \$7.95. Now you can manage Microsoft's Windows with confidence. Understand what hardware specification you need to run Windows 3.1 successfully, and how to install, customize, fine-tune and optimize your system. Then you'll get into understanding the Program Manager, File Manager and Print Manager. Next follows tips on the word processor, plus how to use Paintbrush. There's more on the Cardfile database with its auto-dial feature, Windows Calendar, Terminal, Notepad, etc.

BP327—DOS: One Step at a Time \$5.95. Although you spend most of your time working with a word processor, spreadsheet or database, and are probably quite happy using its file management facilities, there will be times when you absolutely need to use DOS to carry out 'house-keeping' functions. The book starts with an overview of DOS, and later chapters cover the commands for handling disks, directories and files.

PCP119—Electronic Music and Midi Projects \$14.95. Save cash by building the MIDI gadgets you need. Want a MIDI THRU box, program change pedal, Metronome, analog echo unit, MIDI patchbay or switcher? Over 16 practical and very useful music and MIDI projects—all in this book! The projects are explained in detail with full instructions on assembly.

PCP120—Multimedia on the PC! \$14.95. What is Multimedia? What can it do for you? It can do lots of nice things! This 184-page book helps you create your own multimedia presentation. Multimedia applications by people like you can revolutionize educational and business applications as well bring more fun, fun, fun into your leisure computer activities.

BP404—How To Create Pages for the Web Using HTML \$6.95. Companies around the world, as well as PC users, are fast becoming aware of the World Wide Web as a means of publishing information over the Internet. HTML is the language used to create documents for Web browsers such as Mosaic, Net-scape and the Internet Explorer. These programs recognize this language as the method used to format the text, insert images, create hypertext and fill-in forms. HTML is easy to learn and use. This book explains the main features of the language and suggests some principles of style and design. Within a few hours, you can create a personal Home Page, research paper, company profile, questionnaire, etc., for world-wide publication on the Web.



BP377—Practical Electronic Control Projects \$6.95. Electronic control theory is presented in simple, non-mathematical terms and is illustrated by many practical projects suitable for the student or hobbyist to build. Discover how to use sensors as an input to the control system, and how to provide output to lamps, heaters, solenoids, relays and motors. Also the text reveals how to use control circuits to link input to output including signal processing, control loops, and feedback. Computer-based control is explained by practical examples.

BP411—A Practical Introduction to Surface Mount Devices \$5.95. This book takes you from the simplest possible starting point to a high level of competence in working with Surface Mount Devices (SMD's). Surface mount hobby-type construction is ideal for constructing small projects. Subjects such as PCB design, chip control, soldering techniques and specialist tools for SMD are fully explained. Some useful constructional projects are included.

BP136—25 Simple Indoor and Window Aerials \$5.50. Many people live in flats and apartments where outdoor antennas are prohibited. This does not mean you have to forgo shortwave listening, for even a 20-foot length of wire stretched out under a rug in a room can produce acceptable results. However, with experimentation and some tips, you may well be able to improve further your radio's reception. Included are 25 indoor and window antennas that are proven performers. Much information is also given on shortwave bands, antenna directivity, time zones, dimensions, etc. A must book for all amateur radio enthusiasts.

BP336—A Concise User's Guide to Lotus 1-2-3 Release 3.4 \$7.25. Discover how to use a three-dimensional Lotus spreadsheet in the shortest and most effective way. The book explains how: to generate and manipulate 3-dimensional worksheets and how to link different files together; to generate and add graphs to a worksheet, edit them, and then preview and print the worksheet; to use the SmartIcons and become more productive with your time; to use the WYSIWYG add-in to produce top quality screen and printed displays; and much more.

BP379—30 Simple IC Terminal Block Projects \$6.50. Here are 30 easy-to-build IC projects almost anyone can build. Requiring an IC and a few additional components, the book's 'black-box' building technique enables and encourages the constructor to progress to more advanced projects. Some of which are: timer projects, op-amp projects, counter projects, NAND-gate projects, and more.

BP401—Transistor Data Tables \$6.95. The tables in this book contain information about the package shape, pin connections and basic electrical data for each of the many thousands of transistors listed. The data includes maximum reverse voltage, forward current and power dissipation, current gain and forward transadmittance and resistance, cut-off frequency and details of applications.

BP403—The Internet and World Wide Web Explained \$6.95. You've heard about the Information Superhighway. Sort of makes you feel timid about getting on the Web. Put your fears aside! This book eliminates the mystery and presents clear, concise information to build your confidence. The jargon used is explained in simple English. Once the tech-talk is understood, and with an hour or two of Web time under your belt, your friends will call you an Internet guru!

BP92—Electronics Simplified: Crystal Set Construction \$2.69. This book is written for those who wish to participate in electronics more through practical construction than by theoretical study. It is designed for all ages upwards from the day when one can read intelligently and handle simple tools. The crystal set projects are designed to use modern inexpensive components and home-wound coils. A book highly recommended for all newcomers.

ETT1—Wireless & Electrical Cyclopaedia \$5.75. Step back to the 1920's with this reprinted catalog from the Electro Importing Company. Antiquity displayed on every page with items priced as low as 3 cents. Product descriptions include: Radio components, kits, motors and dynamos, Leyden jars, hot-wire meters, carbon mikes and more. The perfect gift for a radio antique collector.

ELECTRONIC TECHNOLOGY TODAY INC.
 P.O. BOX 240, Massapequa, NY 11762-0240

Name _____
 Address _____
 City _____ State _____ Zip _____

SHIPPING CHARGES IN USA AND CANADA

\$0.01 to \$5.00.....	\$2.00
\$5.01 to \$10.00.....	\$3.00
\$10.01 to \$20.00.....	\$4.00
\$20.01 to \$30.00.....	\$5.00
\$30.01 to \$40.00.....	\$6.00
\$40.01 to \$50.00.....	\$7.00
\$50.01 and above.....	\$8.50

SORRY No orders accepted outside of USA & Canada

Total price of books	\$ _____	No. of Books Ordered <input type="checkbox"/>
Shipping (see chart)	\$ _____	
Subtotal	\$ _____	
Sales Tax (NYS only)	\$ _____	
Amount Enclosed	\$ _____	

All payments must be in U.S. funds!

NW2

Allow 6-8 weeks for delivery

MULTIMEDIA WATCH

CD-ROMs and Stuff

MARC SPIWAK
ASSOCIATE TECHNICAL EDITOR
COMPUTER RESELLER NEWS

I remember that when I first started writing this column most CD-ROM drives were 13, and the first one I got my hands on was a \$500 23 NEC unit. That drive transferred data at the rather slow rate of 300 kilobytes per second. I don't remember for sure, but I think the average seek time was somewhere around 300 milliseconds—much faster than the 500 milliseconds or so (half a second!) that the first CD-ROM drives took. Well a lot has changed over the years, and now CD-ROM drives are up to 12 times as fast as that old 23, and average seek times are often less than 100 milliseconds. I might have mentioned 63 or 83 drives, or maybe even a 123 in this column in recent years, but I haven't talked about them for a while and it's time. I recently tested a 243 drive from Teac and it really flies. But I don't think the drives can get much faster.

The first CD-ROM drives ran at the same speed as music CD players, transferring data at 150 kilobytes per second (kbps). Soon after that, 23 drives came out that transferred data at 300 kbps. Oddball 33 drives made a brief appearance in stores because 43 drives were just around the corner. But so were 63 and even 83 drives, the first ones capable of transferring over a megabyte per second—1200 kbps, or 1.2Mbps for an 83 to be exact. At that point poorly designed drives (slower drives hopped up to run faster) would break down because discs became unbalanced from spinning so fast. The drives literally shook apart after extended use.

Disc irregularities, or even an off-center silk screen, can cause a CD-ROM to vibrate at high RPM. In fact it's hard to avoid wobble in a disc that is designed to be removable and handheld. Hard-drive components are made to exact tolerances, and the drives are factory sealed to prevent contamination. The tolerances just aren't there for CD-ROM drives. A physical barrier has been reached, and we're never going to get more than a few megabytes per

second from a CD, no matter how fast we spin them. And let me stray for a moment, that's why it makes no difference whether a CD-ROM drive is IDE or SCSI—either interface can easily handle the throughput. In fact, if you put a "regular" SCSI CD-ROM drive (narrow, or 8-bit) on an ultra-wide SCSI chain (16-bit), the whole chain drops down to narrow performance. That's why workstations with fast SCSI hard drives usually have an IDE CD-ROM drive—either that or a separate SCSI controller for peripherals other than the hard drive(s). But let me get back to my original discussion.

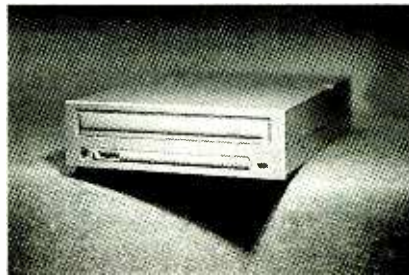

Teac's CD-524E 24X CD-ROM drive is fast and very affordable with a street price of only \$149.

Manufacturers have continued to up the CD-ROM 3-factor, but now the rating often refers to the peak rate and not the average. Very few drives live up completely to their 3-factor, but some come very close. Teac's new 243 CD-ROM drive, the *CD-524E*, is very fast. Teac states that the 243 rating is a maximum, and that the drive's average speed is 19.33. They also claim a 95 millisecond average access time.

A CD-ROM benchmarking program that I use, Quarterdeck's *CD-Certify Pro* (included within their *WINProbe 4* toolbox program—\$49.95), rated the *CD-524E* at 233, with a data transfer rate of 3468 kbps and average access time of 102 milliseconds. But a more real-world test I do, copying a 30 megabyte file (the Weezer video off the Win95 CD) from CD to hard disk took only 15 seconds—that works out to a transfer rate of about two megabytes per second or just under the 163 specification. But

you have to understand that this is blazing speed in terms of sustained performance for a CD-ROM drive. Most 163 drives couldn't sustain a 163 rate—that's usually just their peak speed. Try my file-copy test with your CD-ROM drive, and you'll see what I mean.

Regardless of its speed designation, though, Teac's *CD-524E* is the fastest CD-ROM drive I've ever tested. I have yet to see a true 243 CD-ROM drive—one that can sustain a 3600-kilobyte per second transfer rate. There are caching programs that can speed up CD-ROM data by guessing what you might want to do next and caching it to memory or hard disk, or they even temporarily copy large chunks of a disc onto a hard drive. However, the CD-ROM drive itself never runs any faster. At any rate, even though CD-ROM drive performance seems to have reached a peak, prices have plummeted. You can get a state-of-the-art *CD-524E* for an estimated street price (ESP) of only \$149.

NEW MONITOR SIZE

Everyone likes a big computer monitor—the bigger, the better. But not everyone can afford anything larger than a 17-inch unit, which can now be gotten for around \$600 for a decent one. The 20- and 21-inch monitors usually cost upwards of \$1000, and they are physically huge. But now there's a slightly smaller alternative: the 19-inch monitor. KDS USA is now manufacturing one of the first 19-inch monitors available on the market, the *Visual Sensations VS-19*. There's 18.8 inches of viewable space on the CRT, so it's not just a big 17-inch in disguise. It looks like a 20-inch monitor when it's sitting in front of you, and it has pretty much the same amount of screen real estate. It also has a good picture. The best thing about the *Visual Sensations VS-19*, though, is its price—with a manufacturer's suggested retail price (MSRP) of \$999. It's available in stores for about \$900 ESP.

In close contention with the *VS-19*,

How to make your car invisible to radar and laser...legally!

Rocky Mountain Radar introduces a device guaranteed to make your car electronically "invisible" to speed traps—if you get a ticket while using the product, the manufacturer will pay your fine!

by Phil Jones



If your heart doesn't skip a beat when you drive past a speed trap—even if you aren't speeding—don't bother reading this. I can't tell you how many times that has happened to me. Driving down the interstate with my cruise control set at eight miles over the limit, I catch a glimpse of a police car parked on the side of the road. My heart skips a beat and for some reason I look at my speedometer. After I have passed the trap, my eyes stay glued to my rear view mirror, praying the police officer will pass me up for a "bigger fish."

The Phazer will "jam" both radar and laser guns, preventing police from measuring your speed.

It seems that as speed-detection technology has gotten more and more advanced, speeding tickets have become virtually unavoidable. And although devices exist that enable motorists to detect these speed traps, they are outlawed in many states... including mine.

The solution. Today, Rocky Mountain Radar offers drivers like me a perfect solution—the Phazer. Combining a passive radar scrambler with an active laser scrambler, the Phazer makes your automobile electronically "invisible" to police speed-detecting equipment.

The radar component works by mixing an X, K or Ka radar signal with an FM "chirp" and bouncing it back at the squad car by way of a

waveguide antenna, effectively confusing the computer inside the radar gun. The laser component transmits an infrared beam that has the same effect on laser Lidar units.



Perfectly legal. Some radar devices have been outlawed because they transmit scrambling radar beams back to the waiting law enforcement vehicle. The Phazer, however, reflects a portion of the signal plus an added FM signal back to the police car. This, in effect, gives the waiting radar unit an electronic "lobotomy."

Best of all, unless you are a resident of Minnesota, Oklahoma or Washington, D.C., using the Phazer is completely within your legal rights.

HOW TO MAKE YOUR CAR DISAPPEAR

Radar and laser scramblers are devices that foil speed traps by making vehicles electronically "invisible" to police radar. Radar scramblers mix a portion of the radar signal with background clutter and reflect it back to the squad car. This technique, pioneered by Rocky Mountain Radar, creates an unreadable signal that confuses the computer inside the radar gun.

The laser scrambler in the Phazer works in a similar manner. It transmits a special infrared beam with information designed to scramble the laser signal. The result? Readouts on police radar and laser guns remain blank. As far as the police officer is concerned, your vehicle is not even on the road.

The Phazer makes your car invisible to police radar and lasers or the manufacturer will pay your speeding ticket!



How it scrambles radar.

Police radar takes five to 10 measurements of a vehicle's speed in about one second. The Phazer sends one signal that tells the radar the car is going 15 m.p.h. and another signal that the car is going 312 m.p.h. Because police radar can't verify the speed, it displays no speed at all. To the radar gun, your car isn't even on the road.

Works with laser, too! The Phazer also protects your vehicle from Lidar guns that use the change in distance over time to detect a vehicle's speed. The Phazer uses light-emitting diodes (LEDs) to fire invisible infrared pulses through the windshield. Laser guns interpret those pulses as a false indication of the car's distance, blocking measurement of your speed. Again, it's as if your car isn't even on the road.

Range up to three miles.

The Phazer begins to scramble both radar and laser signals as far as three miles away from the speed trap. Its range of effectiveness extends to almost 100 feet away from the police car, at which point you should be able to make visual contact and reduce your speed accordingly.

Encourage responsible driving.

While the Phazer is designed to help you (and me) avoid speed traps, it is not intended to condone excessive speeding. For that reason, within the first year, the manufacturer will pay tickets where the speed limit was not exceeded by more than 30%, or 15 miles per hour, whichever is less.

Double protection from speed traps.

If the Phazer sounds good, but you prefer to be notified when you are in range of a police radar, the Phantom is for you. The Phantom combines the Phazer (including the Ticket Rebate Program) with a radar detector. It's legal in every state except Minnesota, Oklahoma, Virginia and Washington, D.C. Ask your representative for more details!

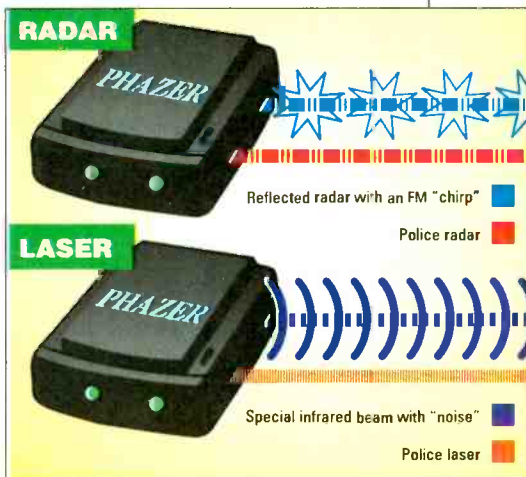

Risk-free. Thanks to Rocky Mountain Radar, speed traps don't make my heart skip a beat anymore. Try the Phazer or the Phantom yourself. They're both backed by our risk-free trial and three-year manufacturer's warranty. If you're not satisfied, return them within 90 days for a full "No Questions Asked" refund.

The Phazer \$199 \$14 S&H
The Phantom \$349 \$18 S&H
 Please mention promotional code 2541-12105

For fastest service call toll-free 24 hours a day
800-399-7863

comtradindustries
 2820 Waterford Lake Drive, Suite 102 Midlothian, VA 23113

is the ViewSonic Corporation's graphics series monitor, model G790. Their first 19-inch monitor features an 18.0 viewable area with flat-square display. Flicker-free performance is assured with 1280 × 1024 resolution at a high 88-Hz refresh rate, and a maximum resolution of 1600 × 1280. The vertical scan rate of 180 Hz is one of the highest available and provides flawless 3-D application displays. The ViewSonic G790 also boasts user-friendly push-button controls that allow viewers to adjust image quality, size, position and geometry for optimal viewing. Also, a special anti-reflection, anti-glare screen treatment is utilized to refract unwanted light away from the user. Competitively priced, the monitor can be found with an ESP of \$949.

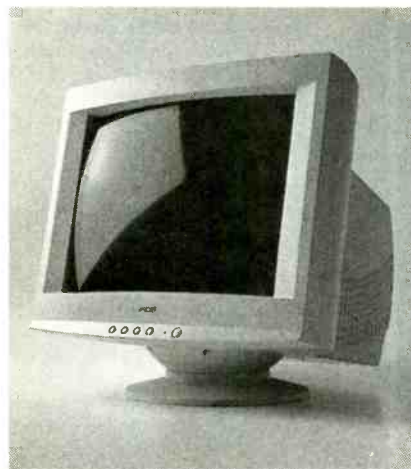

KDS USA's new Visual Sensations VS-19 is one of the first 19-inch monitors on the market.

MORE GREAT SPEAKERS

I know I cover multimedia speakers here quite often. But good speakers are at the heart of every multimedia system, and lot's of speaker manufacturers want me to try out their speakers. So the least I can do is tell all my readers about them. This month I have new ACS48 speakers from Altec Lansing. It's the new high-end model in their PowerCube speaker system lineup. I love Altec's older ACS45 speaker system for its compact, innovative design, and great sound. The new ACS48 builds on the older design, basically adding more power and a bit more bulk to the components.

This new design features multiple speaker drivers in the satellites—each one contains a 3-inch midrange and a ¾-inch tweeter. The ACS48's 6-inch subwoofer has a wood enclosure, pro-

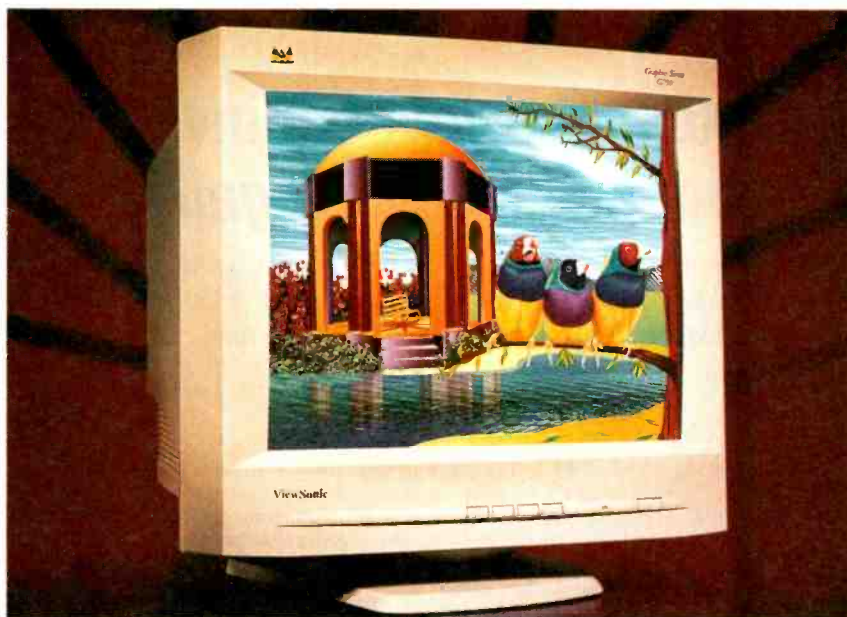

ViewSonic's entry into the 19-inch monitor arena with their new model G790 Graphic Series Monitor.

viding deeper, richer bass than plastic subwoofer cabinets. The PowerCube system has electronic controls to adjust the volume of the satellite speakers and the subwoofer simultaneously. There's no power switch—the speakers automatically turn on with your PC, power down when not in use, and automatically shut down when you turn off your PC. The system has 80 watts of total power output—20 watts per channel for the satellite speakers and 40 watts for the subwoofer. I like the ACS48 speaker system. It's well worth its suggested retail price of \$149.95.

More speakers this month come from Labtec. The new LCS-2420 three-piece speaker system puts decent sound in a relatively small package for a very reasonable price of \$79. The system is a nice step up from the giveaway speakers that come with a lot of computer systems. The LCS-2420 has 20 watts total power—3.5 watts for each driver and 10 watts for the subwoofer. If you have stereo speakers but no subwoofer, then you might want to consider Labtec's LCS-2408 universal subwoofer. The unit contains a single 5¼-inch woofer and 14-watt amplifier. The universal subwoofer plugs into your sound card, and your satellite speakers plug into the subwoofer. The unit has a built-in 150Hz crossover circuit. The LCS-2408 universal subwoofer sells for \$59.99.

NEW SOFTWARE

Links LS, a really neat golf simulator from Access Software, is now being released for Mac owners. *Links LS* features Arnold Palmer as a movie-quality, 30-frame-per-second animation and it includes the Kapalua Plantation and Village courses on Maui, along with Palmer's home course, Latrobe Country Club. Access Software also has a new course available for the *Links LS* golf engine: Congressional Country Club. Just outside Washington, DC rests the site of the 1997 U.S. Open, the Congressional Country Club, which includes the Blue Course, featuring 7219 yards of Maryland charm. The prestigious golf course comes to life on your PC. Green's fee for this program will run \$44.95.

The Eurofighter is being constructed by a European consortium consisting of Britain, Spain, Italy, and Germany. The aircraft should be completed by the turn of the millennium with all four nations



Labtec's LCS-2420 three-piece speaker system sounds good with 3.5 watts for each driver and 10 watts for the subwoofer.

WHERE TO GET IT

Access Software

4750 Wiley Post Way
Building 1, Suite 200
Salt Lake City, UT 84116
801-359-2900

www.accesssoftware.com

**CIRCLE 60 ON FREE
INFORMATION CARD**

Altec Lansing Technologies, Inc.

Route 6 and Route 209
Milford, PA 18337
800-ALTEC-88

www.altecomm.com

**CIRCLE 61 ON FREE
INFORMATION CARD**

Digital Image Design Ltd. and Ocean of America Inc.

333 West Santa Clara Street, Suite 820
San Jose, CA 95113
408-289-1200

www.did.com

**CIRCLE 62 ON FREE
INFORMATION CARD**

Dr. Solomon's Software, Inc.

1 New England Executive Park
Burlington, MA 01803
888-377-6566

www.drsolemon.com

**CIRCLE 63 ON FREE
INFORMATION CARD**

KDS USA

12300 Edison Way
Garden Grove, CA 92841
714-379-5599

www.kdsusa.com

**CIRCLE 64 ON FREE
INFORMATION CARD**

having active Eurofighter squadrons by 2004. But Digital Image Design and Ocean of America are offering PC-users the opportunity to fly this incredible aircraft now with *EF2000 V2.0*, years before actual pilots fly it. Parameters include the number of aircraft in your flight, composition of enemy flights, altitude of each flight, weapons used, starting positions, weather conditions, time of day, and skill level—at a MSRP of only \$49.95. *EF2000 V2.0* supports graphics cards featuring either 3DFX or Rendition chipsets.

Microsoft has updated one of its most popular CDs—*Bookshelf 98* has arrived. This single CD contains 10 essential reference tools—*The American Heritage Dictionary of the English*

Labtec Inc.

1499 SE Tech Center Drive, Suite 350
Vancouver, WA 98683
360-896-2000

www.labtec.com

**CIRCLE 65 ON FREE
INFORMATION CARD**

Microsoft Corporation

One Microsoft Way
Redmond, WA 98052
206-882-8080

www.microsoft.com

**CIRCLE 66 ON FREE
INFORMATION CARD**

Quarterdeck Corp.

13160 Mindanao Way
Marina del Rey, CA 90292-9705
800-683-6696

www.qdeck.com

**CIRCLE 67 ON FREE
INFORMATION CARD**

Teac America, Inc.

7733 Telegraph Road
Montebello, CA 90640
213-726-0303

www.teac.com

**CIRCLE 68 ON FREE
INFORMATION CARD**

ViewSonic Corporation

381 Brea Canyon Road
Walnut, CA 91789
800-888-8583

909-869-7976

www.viewsonic.com

**CIRCLE 69 ON FREE
INFORMATION CARD**

Vivid Interactive

15127 Califa Street
Van Nuys, CA 91411
818-908-9663

www.vividplaytime.com

**CIRCLE 70 ON FREE
INFORMATION CARD**

Language, Third Edition; The Microsoft Bookshelf Internet Directory 98; The new Encarta 98 Desk Encyclopedia, a condensed version of the Encarta multimedia encyclopedia; The Encarta 98 Desk World Atlas; The Original Roget's Thesaurus of English Words and Phrases; The World Almanac and Book of Facts 1997; The Columbia Dictionary of Quotations; The People's Chronology; The National Five-Digit Zip Code and Postal Office Directory; and the new Microsoft Bookshelf Computer and Internet Dictionary. The QuickShelf information retrieval tool puts an icon in the lower right corner of the Windows 95 screen that provides instant access to all Bookshelf 98 information. The set is available for approx-

imately \$54.95.

Also from Microsoft comes *Microsoft Plus! for Kids*. This software accessory kit makes Windows 95 more secure and more fun for kids. Parents can set limits on desktop and Internet access, while kids have fun with 10 desktop themes, 3 creativity applications, clip art, and special fonts. Kids can also make the PC speak in 20 funny voices with a text-to-speech application or play music and record tunes with an electronic keyboard application. Cost is approximately \$24.95. Also from Microsoft for kids comes *The Magic School Bus Explores the Rainforest*—where kids can hop aboard The Magic School Bus and travel to the Costa Rican rainforest. There they can explore all the rainforest layers and eco-zones. The disc comes to life with animation, sound, video, photography, and narration. Hop on this magic bus for \$49.95.

Last month I talked about the DVD-ROM drive I've installed in one of my computers. I had mentioned that I watched a couple of DVD movies, where the discs featured the wide-screen version on one side and the panned-and-scanned version on the other. That feature wasn't available until DVD arrived, but otherwise those movies don't take advantage of any of DVD's more interesting features. One such feature, being able to watch scenes of a movie from different camera angles, requires that a movie be filmed from multiple angles in the first place. So wouldn't you know it, the first DVD movie I've been able to find that offers multiple viewing angles is a full-length adult film called *Bobby Sox* from Vivid Interactive. Admission price for this movie is at a MSRP of \$29.95. Vivid Interactive has other adult movies and games available on CD-ROM. One good game is the interactive video poker *Pandora's Poker Palace* (\$39.99). It's real good stuff if you like this kind of fun.

If computer viruses have plagued your PC, then consider trying *Dr. Solomon's Anti-Virus*—it detects and destroys viruses automatically. Anti-Virus includes an SOS disk that lets you boot clean from a diskette if your operating system won't load. *Dr. Solomon's Anti-Virus* (\$49.95) combats more than 11,000 known viruses and specializes in virus protection for Microsoft Office 97.

NET WATCH

Making Your Own Web Site

KONSTANTINOS KARAGIANNIS

Okay, so we've been visiting them for some time now. If you've been reading this column, or if you just spent a few hours online, countless numbers of Web sites are already in your mind. Need a book? Check out www.amazon.com. Planning a road trip? Visit www.mapquest.com. Want to promote your own business or just post some of your favorite musings on the Web? Head over to....

Where? Do you have a Web site yet?

If the answer is no, then I have a treat for you this month. Despite how mysterious well-done Web pages might look to newbies, they shouldn't cause any fear in the hearts of those who want to publish online. All those wonderful-to-look-at sites are created using hypertext markup language or HTML. Chances are you've come across this acronym dozens of times but never had the desire to learn its syntax. This month, we'll take a look at a method of creating Web sites that doesn't require you to know a single HTML tag. And then we'll go on to examine how you can post your page for free!

HOTMETAL PRO 4.0

As I just hinted, there's a very good reason I chose SoftQuad's *HoTMetal Pro 4.0* as the HTML editor described in this month's column—it is easy to use and requires no previous knowledge of HTML. Before we look into its features, let's get a few basics out of the way.

You don't need a supercomputer by any means to work with the program. However, you will need at least a 486/33 (Pentium recommended) with 16-MB of RAM, a CD-ROM, VGA display, and, of course, the OS of choice in this day and age—Windows 95 (it will also run on NT). If your machine doesn't meet at least these criteria, it's time to seriously consider upgrading (check out last month's *Net Watch* for how to do so online).

To get a trial version of the software, you can visit SoftQuad's Web

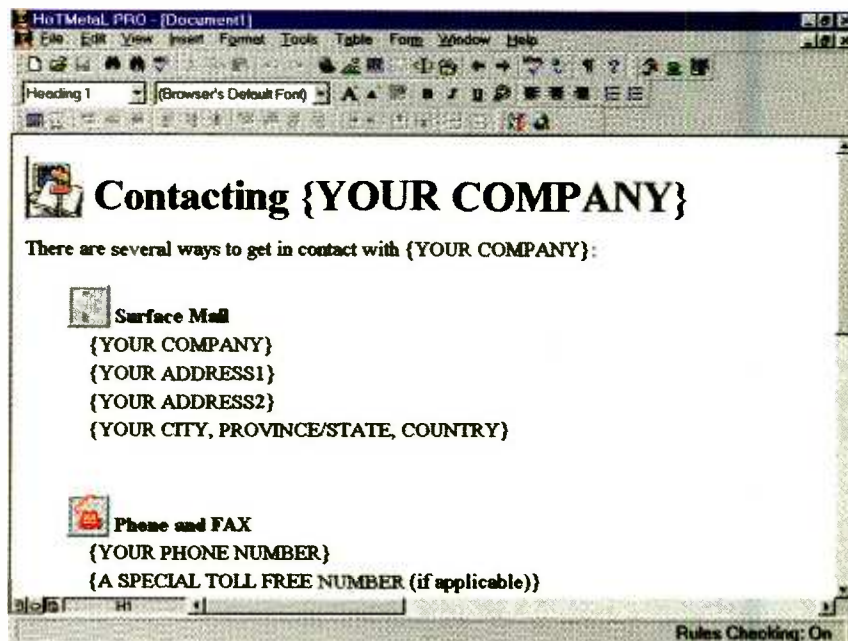

If you're new to HTML, *HoTMetal Pro 4.0* makes Web design easy for you by hiding all the codes and letting you work in a "what you see is what you get" environment. The program even provides templates like this one that you can customize.

site and download it. The site will have the latest ordering options as well. At the time of this writing, *HoTMetal Pro 4.0* retails for about \$129, (with a street price of \$90) and it's worth every penny. One of the best things about *HoTMetal Pro 4.0* is that it allows you to edit in one of three modes: WYSIWYG, Intermediate, and Expert.

The first mode, whose acronym stands for "what you see is what you get," lets you work in exactly the way that its name implies. Using word-processor-like pull-down menus and toolbars, you can create a graphically pleasing page just as if you were playing around with the desktop publishing features of, say, *Microsoft Word*. This is the mode I strongly recommend you use, especially at first.

For those more advanced users, the Intermediate mode allows you to work in a WYSIWYG view, but with HTML tags showing. These are the bracketed commands that tell a Web browser how to display text, where to link it, etc. Finally, adept HTML users will find Expert to be the perfect environment for maintaining complete con-

trol of raw HTML, while still having access to all of *HoTMetal Pro 4.0*'s features.

It's really easy to get started, as there is a built-in "Site Maker." This application contains a sophisticated creation wizard that takes you through the process of creating a great site, step by step. All you have to do is specify your preferences for the page's purpose, décor or theme, layout, and type of content, and "Site Maker" does the rest. If you have one or two graphics you'd like to use and a handful of paragraphs of content, you're all set.

To increase the potency of the site, you can access "HoTMetal FX." These

FOR MORE INFORMATION

SoftQuad Inc.
20 Eglinton Ave. West
12th Floor
P.O. Box 2025
Toronto, Ontario
Canada M4R 1K8
Tel. 416-544-9000
Fax: 416-544-0300

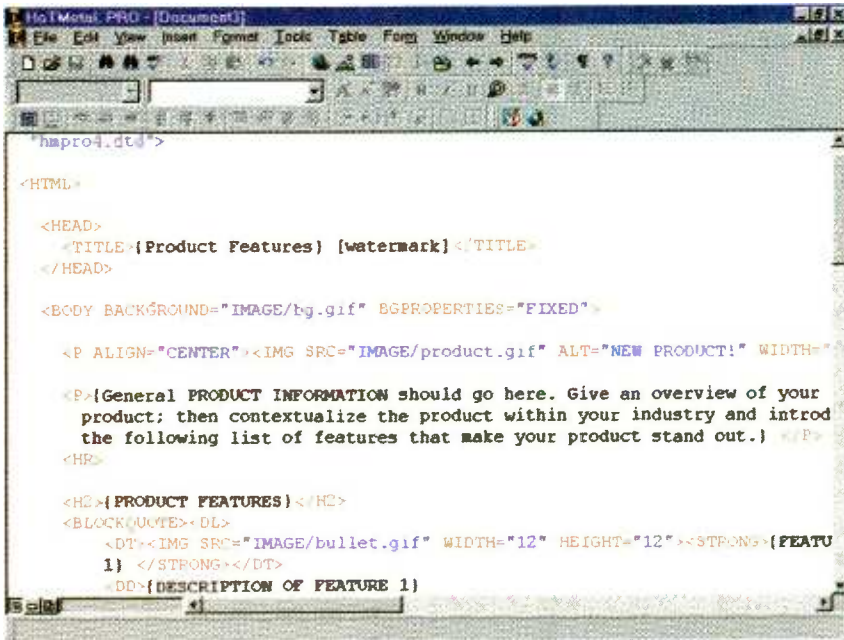

For the ultra-advanced Web designer, HoTMetal's Expert mode lets you work in raw HTML, while still maintaining point-and-click access to all the great features of the software.

are enhancements to your HTML pages that you can just drag-and-drop right in. Forget about spending hours trying to write a script that lets you have a window with information pop up on your site—"HoTMetal FX" includes Java applets and JavaScripts that make such embellishments a cinch. FX enhancements also include coordinated page designs, backgrounds, buttons, rulers, animated GIF images, clip art, dynamic HTML, and standard CGI scripts.

We mentioned graphics a few lines above. Not all images are ready for use on a Web site when you load them or scan them into your computer. To help you touch up those shots, SoftQuad has included *PhotoImpact* on the CD-ROM, which is an advanced graphics-editing package. In addition to using several retouch features, you can create thumbnail catalogs as you browse through the images on your disk. Then, choose the shot you want and drag it onto your page. With the "GIF Animator" feature, you can create those moving little icons and buttons that make many pages look so advanced.

When you have some HTML pages saved on your hard drive, access the "Information Manager." This lets you manage your site, visualizing its structure with a unique "Web View" display. Move, delete, or rename files; and the "Site Doctor" updates your links automatically. Add new links by dragging

and dropping pages onto the "Web View." These automatic features keep your site from having "dead links" that go nowhere.

You can test your site with a single mouse click that lets you select a browser on your system to view the pages as others around the world will see them. Make sure you at least test with *Netscape Navigator* and *Internet Explorer*, as these are the most commonly used browsers. Then, when

you're at the point where you feel your new creation is ready for the eyes of the world, a mouse click will publish your whole site, selected files, or only those pages that have changed since your last publish.

"Hold on," you say? "Publish my site," you ask? "Where?"

If your Internet Service Provider (ISP) doesn't provide space for you online (many do—you should ask), there is a site you can go to and get a free Web presence. So don't click the "Publish" button just yet.

GEOCITIES

If your ISP hasn't provided any room on the Web for you, and if you don't feel like adding to your monthly Net costs by paying a host, there is an option out there. Access *GeoCities*, become a member for free, and get ready to load as much as two megabytes of Web data for the whole Net to see (two megs is plenty if you watch the size of your graphics).

This innovative site lets you choose a "Neighborhood" for storing your site. Just make sure your site matches the theme of the name of the "Neighborhood". For example, the site tells you that "If your page is about the entertainment industry, you should be located in Hollywood. If it's about your favorite sports team, then choose 'Colosseum'."

(Continued on page 16)

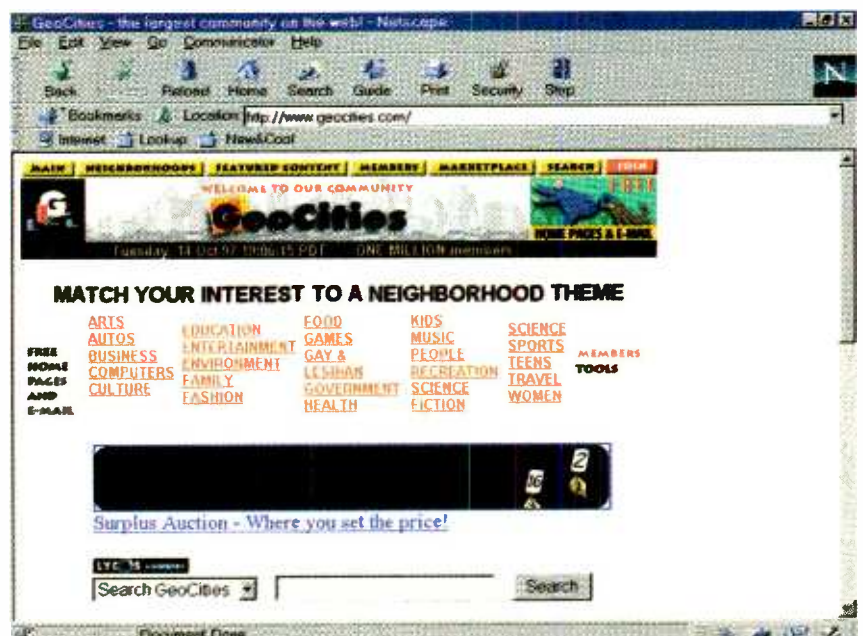

Spend a few minutes choosing the right "Neighborhood" for your Web site at GeoCities and then post it for free! Just keep it under two megabytes.

COMPUTER BITS

Telephone Talk II

JEFF HOLTZMAN

Last month we began a discussion of computer-telephone integration. The way that telephone technology has evolved (or failed to evolve) during the past two decades is a travesty. What we should have are smart phones attached to a high-speed digital (bus) network. These phones should be available with a range of features so that we can choose what we want and pay accordingly. The bus should connect to a network controller that, on the other side, connects to the telco's local office via a big fat bit pipe.

I'd like to be able to do things like the following with this intelligent phone system:

Intercom groups. I would create one master group that included all phones in the house. I'd create another that would include all phones except those in the kids' rooms. This second group would respond to the doorbell button, gently ringing a chime on all phones that belonged to the group. In fact, I'd have one group for the front door and one for the back door.

Selective monitoring. From wherever I happened to be in the house, I'd like to be able to monitor what's happening anywhere else.

Security. There would be security levels, so "users" would have basic capabilities, and "administrators" would have more capabilities. In addition, there would be smart connections between my system and those of my selected security partners, such as the local fire and police. If a fire alarm goes off and is not canceled in a specified time, the fire department would be notified automatically.

Home monitoring and control. I'd want sensors installed in all the major subsystems of my house, including plumbing, electrical, video, and data (ideally these sensors would also have a built-in-test capability and notify the system in the event of their malfunction). I'd let the system know when my family and I went on vacation, so that if it saw a sudden increase in water use, indicating a possible leak, it could shut off water at the main and notify my des-

ignated plumbing supplier. The system would also be able to automatically start the in-ground sprinkler system, if it had not rained that day.

Device sensing and control. I should be able to arbitrarily install and remove sensing and control devices from the bus at any time. I would install a rain detector outside as an input to the sprinkler control subsystem. I would install motion detectors in key locations. I would program the system to turn on the air-conditioning 20 minutes before I got home from work. Of course, I could override that setting remotely if I decided to come home early one day. I want to be able to control lighting in every room, so I can simulate a "lived-in" look when we're on vacation. I want control over audio and video devices connected to the system, so that I can turn down the kids' stereo when it gets too loud, and prevent them from watching objectionable video programming. I want my toaster to know that I like my toast crunchy, and that my wife likes hers soft.

Remote access. I want to be able to dial in to my home from anywhere and access all features just as if I were local. And I don't want to have to remember obscure touch-tone codes to do so. There should be a clean and simple computer interface using a GUI with menus and all the rest. For example, I should be able to "connect" the sound card in my remote PC (or laptop) to the monitoring function and selectively listen to what's going on at any phone on the system. All monitoring and control functions would be available (on a security clearance basis, of course) to me transparently, whether I'm lounging in my study or on safari in Africa.

With this type of system, I'd put a phone in every room in the house!

A PATTERN EMERGES

When you start thinking about things in this way, the "phone system" as an entity begins to shrink, and becomes just another element in a larger system of integrated components, of which

(Continued on page 16)

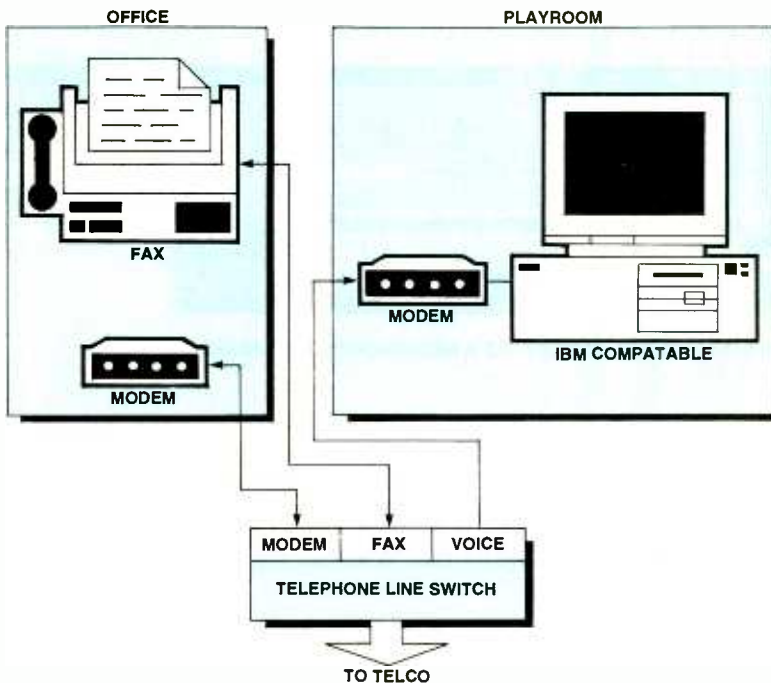

Use a telephone-line switch "backwards" to avoid outgoing line contention.

SCANNER SCENE

No Duplicate Frequencies!

MARC SAXON

There's always something new under the sun, and the *RadioShack PRO-64* handheld scanner wants to prove this point. Here's an attractive new unit with features you will certainly want to look at seriously.

The PRO-64 has 400 memory banks (10 banks of 40 channels each), plus 40 additional monitor memories for the temporary storage of new frequencies that you discover during a band search. You can later move those stored frequencies into the permanent memory banks. To help you quickly and easily search for new frequencies, the PRO-64 has 17 preprogrammed search bands, but you can also set up ten additional search bands of your own using your choice of lower/upper limits. There are 11 preprogrammed weather channels, as well as 10 selectable priority channels.

A great feature is the set's ability to notify you automatically that you are duplicating a frequency already stored in its memory. Other features are auto-store and sorting. Auto-store quickly finds available unused memory slots and stores your new frequencies there. Sorting automatically rearranges all frequencies in a bank into consecutive order. This makes it easy for you to step through any storage bank and survey the frequencies you've placed there.

Frequency coverage is ample, including 29–54, 137–174, 380–512, and 806–960 MHz (minus the cellular bands). In addition, there's the VHF aeronautical band (108–137 MHz). The PRO-64 scans at up to 25 channels per second, and searches at up to 50 steps/second.

It's a triple-conversion job. The three IF stages are 257.5 MHz, 21.4 MHz, and 455 kHz. First IF stage rejection at 154 MHz is 50 dB, and the second IF stage rejection is 100 dB. Spurious rejection (FM) at 154 MHz is 40 cB. Selectivity at -6dB is ± 10 kHz, and at -50 dB it is ± 25 kHz. FM sensitivity is 1 μ V from 29–512 MHz and 2 μ V in the 800-MHz band. In the VHF aeronautical band, AM sensitivity is 2 μ V.

The PRO-64 operates for 18.5 hours from six AA alkaline batteries. It can also be used with optional AC or DC adapters. An optional rechargeable battery pack is also available and is



The PRO-64 from RadioShack is a handheld scanner with a special duplication feature—it notifies you automatically if you are attempting to store a frequency that's already stored in memory.

recommended. As you can see, they're packing lots of great new features into the new equipment. Check out the PRO-64 at any RadioShack store (currently on sale for \$200).

AR-5000: DOUBLE THE CHANNELS

We frequently hear about clever pro-

gramming tricks that enable all sorts of enhanced operating features in scanners. One we recently learned about relates to the *AOR AR-5000* desktop scanner, which has traditionally been advertised, represented, and sold as a scanner with 1000 memories. In fact, you can easily get it to operate on an additional 1000 memory channels! That's because it turns out that the AR-5000 has two individual 1000 channel memory banks, known as Bank 0 and Bank 1. Bank 0 is preprogrammed with frequencies at the factory.

To implement the dual bank feature in the AR-5000, all the user needs to do is hold in either the SRCH or SCAN button while powering up the unit. The SRCH button calls up Bank 0, while the SCAN button calls up Bank 1. The selected bank is visually indicated by the presence or absence of the decimal point at the 1-Hz position. When the decimal point is present, then Bank 1 (the factory default position) is being received. No decimal point means it's working with Bank 0. Each bank may be programmed independently of each other, including the alpha-numeric text comment.

This innovation is courtesy of Computer Aided Technologies, P.O. Box 18285, Shreveport, LA 71138. Their telephone number is 318-687-2555, and on the web they can be found at www.scanat.com. They produce excellent computer software for scanner owners.

FREQUENCIES FROM OUR MAILBAG

Paul A. of Montreal writes to say that the famous *Cirque du Soleil* (Circus of the Sun) entertainment tours across Canada and the U.S.A. make extensive use of radio communications to coordinate its performances. If you bring a scanner to a performance (with an earpiece so as not to annoy other patrons), you can listen in. One other point—much of the chatter is in French, so it helps a lot if you speak or understand French.

Among the frequencies Paul discov-

ered are: 418.075, 418.575, 476.00, 476.20, 477.20, 523.30, 591.30, 601.90, 604.70, 798.30, and 805.90 MHz. Several of these look to be out of the range of most scanners. The frequency at 601.90 MHz may be the show's director, while 418.075 MHz is used by the ushers.

Speaking of being in the audience, several letters have come in noting that many churches, lecture halls, and both movie and legitimate theaters, etc., are now equipped with radio facilities to assist hearing-impaired audience members who are using the facility's special receivers. But what are the frequencies? According to the folks at CRB Research Books Inc., there is one unit that operates on the following frequencies: 72.05–72.95 MHz in 5 kHz steps, also 74.70 MHz, 74.75 MHz, plus 75.25–75.95 MHz in 5 kHz steps. Most likely these are all of the frequencies available in the U.S. for such services. Certainly such transmissions are made with very low power and probably aren't intended to carry more than 1000 feet or so. However that's what they said about cordless telephones, and those things can be heard from much further away than that. That is to say, if you parked outside the movie theater, you could hear the film's entire sound track right on your scanner. It's half as good as when they had drive-in theaters.

CRB Research Books is a leading publisher of scanner frequency guides and equipment modification guides. Their address is P.O. Box 56, Commack, NY 11725. Tel. 516-543-9169; Web: www.crbbooks.com. A free catalog is available upon request.

RECOMMENDED READING

We have seen a couple of issues of Alex Blaha's new magazine *Scanning USA*, and it looks quite good. Comes out monthly and should appeal to beginners as well as newbies. A dozen issues cost \$19.95, sample copy \$3, from *Scanning USA*, 2054 Hawthorne Avenue, Joliet, IL 60435; Tel. 800-651-0922. Another good source of info is the *Radio Monitors Newsletter of Maryland*, P.O. Box 394, Hampstead, MD 21074. One year membership is \$15, with a sample copy for \$2. Another somewhat localized publication is the *American Scannergram* (serving Ohio plus the surrounding and northeastern states). It is published bimonthly by the All Ohio

Scanner Club, 20 Philip Drive, New Carlisle, OH 45344. They can also be contacted by e-mail at n8oay@sprint-mail.com or visit their Web site: www.aosc.rpmdp.com. We also find useful information in the publication of *The Scanner Club*, P.O. Box 62, Gibbstown, NJ 08027. Rates are \$24.95 for six issues of their publication, with a sample copy being \$4.

Please keep in touch with your ideas, questions, frequencies, and scanner-related news. Our e-mail address is: Sigintt@aol.com, or write to us at *Scanner Scene*, **Popular Electronics**, 500 Bi-County Blvd., Farmingdale, NY 11735. ■

NET WATCH

(continued from page 13)

In your "Neighborhood," you then have to find a vacancy for your site. The easiest way to do so is to go to the main page of the neighborhood and click "Join this Neighborhood." This will transfer you to a page of step-by-step instructions. Or, you can click "Browse Great Pages" here and search through numbered address blocks in the "Neighborhood," looking for a graphical house that says "vacant" next to it. Once you click on a house, you'll get an application form with the address portion of the form already filled out, based on your selection. Complete the rest of the form and wait for your password to be sent to you via e-mail once the application is accepted.



Now back to the "Publish" window in *HoTMetaL Pro 4.0*. This asks you for a Web address, user name, and password. Once you have a *GeoCities* address, you'll have everything you need to type into the "Publish" fields. Then click that button and watch the progress indicator. When it's finished, your site is up, almost as if by magic.

That's all the space we've got for now. Until next time—get to work on those Web pages! I can be reached at net-watch@compports.com and *Net Watch*, **Popular Electronics**, 500 Bi-County Blvd., Farmingdale, NY 11735. ■

COMPUTER BITS

(continued from page 14)

voice communication is just one small part. Obviously, we're a long way away from that type of total integration. What's ironic is that the phone companies have so utterly failed to take advantage of technical advances during the past two decades.

The writing is on the wall. With deregulation under way and competition on the rise, the phone companies are finally going to have to put up or shut up. And based on the way micro-computer technology has steam-rolled every industry it has touched—typography and graphic design, product modeling and design, business planning and operation, manufacturing, knowledge and entertainment production—it is not at all difficult to imagine a different kind of future. This emerging future is not about preserving the *status quo*. It is about a vibrant, intensely competitive, service- and feature-oriented environment in which companies strive to earn our loyalty, not legislate it.

IN THE MEANTIME

Last month I promised I would show you how I solved a more immediate problem. My kids and I share a modem line at home, and we were running into contention problems. Occasionally they would try to dial out when I was already on-line, or vice-versa. The solution was one of those telephone-line switching devices. Normally we think of those devices as being used for routing inbound calls to phone, fax, modem, and answering machine. However, they can also be used as out-bound contention managers. The trick is to realize that whenever any one channel is in use, the other channels respond with a busy signal if you try to use them.

The figure shows how it works. From an incoming point of view, the device switches between the fax and modem in my office. From an outgoing point of view, the device prevents me from interrupting their calls, and vice versa. The unusual thing about the setup is that their modem is attached to the voice port of the switch. Thus, in-bound voice calls, of which there should never be any, are routed to the kids' modem. And outbound, we can't interfere with each other. *Fait accompli*. See you next time; stay in touch at jkh@acm.org. ■

Electrify Your Library

It's as Easy as 1-2-3 With EBC

Choose any

5 Books for only **\$4.95**

Values to **\$272.40**

with membership

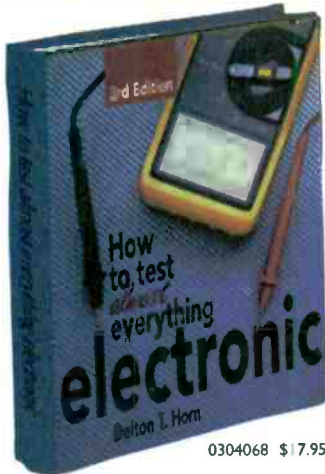

0304068 \$17.95

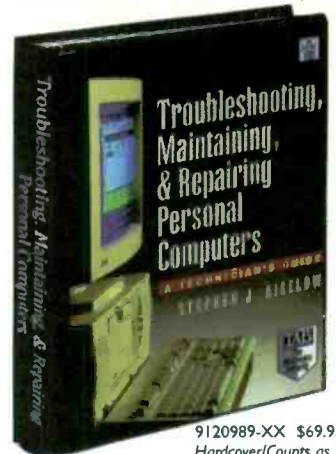

9120989-XX \$69.95
Hardcover/Counts as 2

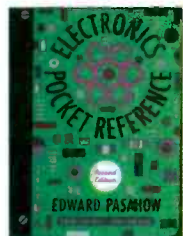

0487375 \$24.95

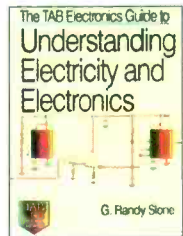

0582165 \$19.95

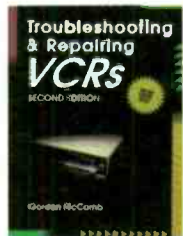

1550178 \$22.95

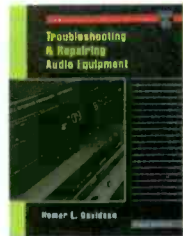

0157561 \$24.95

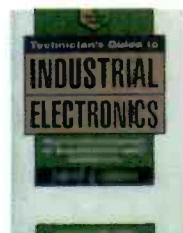

0112738 \$47.95
Hardcover

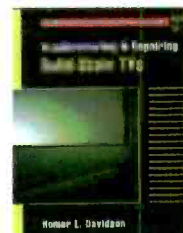

0157537 \$44.95
Hardcover

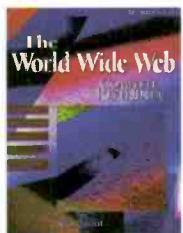

8821428 \$29.95

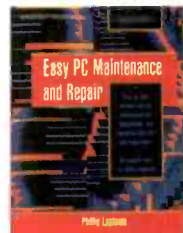

036432X \$29.95
Hardcover

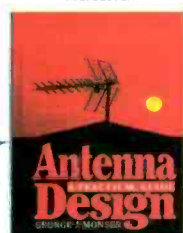

0428433 \$60.00



0717753 \$19.95

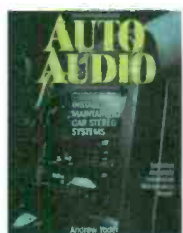

0765359 \$34.95

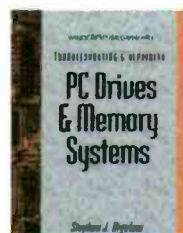

0053146 \$24.95

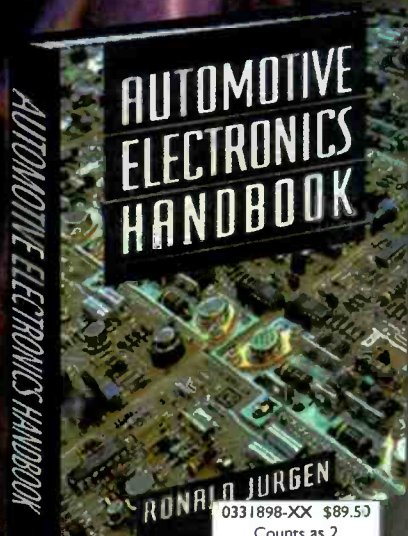

0331898-XX \$89.50
Counts as 2

Electronics Book Club®

YES! Please send me the books listed below, billing me just \$4.95, plus shipping/handling & tax. Enroll me as a member of the **Electronics Book Club®** according to the terms outlined in this ad. If not satisfied, I may return the books within 10 days without obligation and my membership will be cancelled. I agree to purchase just 2 more selections at regular club prices during the next 12 months and may resign anytime thereafter.

If you select a book that counts as 2 choices, write the book number in one box and XX in the next.

- Please bill me
- Check or money order enclosed payable to: The McGraw-Hill Companies
- Charge my Visa MasterCard AMEX Discover

Acct.# _____ Exp. Date ____/____/____
 Name _____ Signature _____
(required on all orders)
 Address/Apt.# _____
 City/State _____
 Zip _____ Phone _____

See other side for more great selections! ➔

Valid for new members only, subject to acceptance by Electronics Book Club. Canada must remit in U.S. funds drawn on U.S. banks. Applicants outside the U.S. and Canada will receive special ordering instructions. A shipping/handling charge & sales tax will be added to all orders. © 1997 EBC



024247X \$49.00



0157626 \$24.95



1574875 \$19.95



0052387 \$28.95

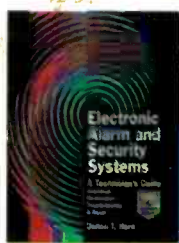

0305285 \$39.95



0236143 \$24.95



0116113 \$40.00



0057311 \$44.95



0242054 \$24.95



0535469 \$29.95

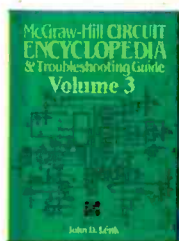

0376115 \$39.95

Choose any 5 Books for only \$4.95 with membership



157154X \$21.95



0317917-XX \$60.00
Counts as 2



0242003 \$24.95

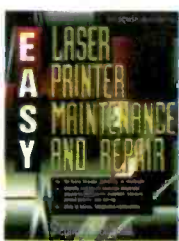

0359768 \$19.95

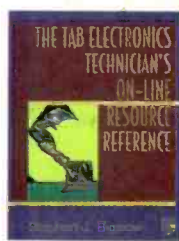

036219X \$44.95
Hardcover



0155593 \$22.95



0699208 \$65.50



0707618 \$21.95



0650780 \$27.95



0116725 \$49.95

FOR FASTER SERVICE CALL: 1-614-759-3666 (Monday-Friday 8:30 am - 5:00 pm EST)
OR FAX: 1-614-759-3749 (24 hrs a day—7 days a week)

If card is missing, Write to: Electronics Book Club, A Division of the McGraw-Hill Companies, P.O. Box 549, Blacklick, OH 43004-0549



NO POSTAGE
NECESSARY
IF MAILED
IN THE
UNITED STATES



BUSINESS REPLY MAIL

FIRST-CLASS MAIL PERMIT NO 4474 COLUMBUS OH

POSTAGE WILL BE PAID BY ADDRESSEE

ELECTRONICS BOOK CLUB®

A Division of The McGraw-Hill Companies

PO BOX 182600
COLUMBUS OH 43272-3027



JOIN NOW TO GET THESE GREAT CLUB BENEFITS:

The largest selection of electronics books available anywhere – at up to 50% off publishers' prices.

Free 10-day trial on every book you order. You must be satisfied – or you may return any book within 10 days with no obligation.

Free Bonus Book Program that lets you earn points for bigger book buying power!

Great Club Terms: simply buy 2 more books at exclusive member savings within the next 12 months with no further obligation.

Dependable Service and Delivery: you're guaranteed to get the best choice of books from all publishers. Every 3-4 weeks, you'll receive the Club Bulletin, packed with the newest and best electronics books. When the Bulletin arrives, if you want the Main Selection, do nothing – it will be shipped automatically. If you want another book or no book at all, just indicate your choice on the Reply Form and return it by the date specified. If you ever receive a book you don't want due to late delivery of the Club Bulletin you may return it at our expense.

All books are paperback unless otherwise indicated. Publishers' prices shown.

GIZMO®

HOME THEATER PART II

Last month's Gizmo was a home-theater backgrounder. This month, we take a close look at some home-theater gear: a Dolby Digital A/V receiver, two different large-screen video options, a device for improving your video signal, a second-generation DVD player, and a VCR that skips through the previews on your tapes. Next month, the home-theater action continues, with a look at a home-theater speaker package, a test-pattern disc that can help you tweak your setup for peak performance, and a laserdisc/DVD/CD combo player.

FORWARD- LOOKING RECEIVER

MODEL 1090VR AUDIO-VIDEO SURROUND RECEIVER. From Kenwood USA Corp., P.O. Box 22745, Long Beach, CA 90801; Web: <http://www.kenwoodusa.com>. Price: \$1200.

Looking for an A/V receiver that will serve you well into the next century? Look for one that's equipped with a Dolby Digital surround-sound decoder—to keep up with emerging digital formats including DVD, digital satellite TV, digital TV (DTV), and high-definition TV (HDTV). Look for one with multi-room capability, so that your home theater isn't confined to the family room—you can retreat to your bedroom with a movie while the kids commandeer the big-screen multimedia set for their computer-gaming. Look for one that's designed to accommodate tomorrow's electronic equipment, with sufficient inputs and the ability to control new models.

Look no further. Kenwood's 1090VR A/V receiver can do all that, and more. It's

so versatile, in fact, that we'll just be able to touch on some of its features here—after a couple of week's use, we're still learning all that it can do.

In a nutshell, the 1090VR offers 120 watts-per-front-channel in surround and stereo modes and 120-watts-per-surround-channel; Dolby Digital and Dolby Pro Logic decoding; five DSP modes; dual-source, dual-room capability; a universal remote control that can be upgraded via telephone to operate new components as they are added to your system; a Radio Data System (RDS) tuner that can display the station name and other text from stations that transmit RDS information; and on-screen displays to simplify home-theater setup.

The rear panel gives you a good idea of the receiver's capability. It's home to seven audio inputs as well as a tape monitor and A/V aux input; four audio outputs; four video inputs and three video outputs (all support S-Video and composite video); six individual pre-amp outputs; left and right speaker outputs and video and stereo outputs for a second room; and a "TRAITR" transistor in the final stage to stabilize temperature and minimize the distortion caused

by temperature variations. Whew!

The 1090VR is larger than your average A/V receiver, standing 6-3/8 inches tall and weighing in at close to 30 pounds. This isn't one of those typical display-and-a-couple-of-knobs jobs, either. The front panel is chock full of controls and indicators—even more so than the remote control. From the looks of things, you'd expect to be able to operate all of the receiver's functions from either the front panel or the remote. In reality, while there are some duplicate controls, each has some exclusive functionality, and many operations require the use of both front-panel and remote-control buttons.

The remote control is a story in and of itself. Developed with Ziba Design and Universal Electronics Inc., the FutureSet remote is ergonomically designed, can control a wide range of today's—and tomorrow's—A/V equipment, and offers macro capability that allows you to perform multiple operations on multiple components with a single button push. Its arched, curved shape fits any size hand and accommodates people who tend to hold the remote in one hand, as well as two-handed users. For those who prefer to leave the remote sitting on the coffee table, the FutureSet's four cor-





The FutureSet remote control can be updated via phone to operate components you buy in the future. Macro capability lets you program a series of multi-component operations into one press of a button.

ner supports give it stability on a flat surface, and its IR emitter is placed high for good aim. The buttons light up bright red for use in the dark and blink to let you know that a button has been pushed. Color-coded labels show the secondary functions of buttons, but, unfortunately, those labels are printed on the remote instead of on the illuminated buttons, so they cannot be seen in the dark.

The 1090VR's manual contains a full library of control codes for most video and audio components, including DVD players. When you upgrade your system in a few years, you can call a toll-free number to request an update. Control codes for the new components can be magnetically transferred by holding the FutureSet up to the phone's receiver.

The FutureSet offers several advanced features. Three macros each allow you to program as many as 20 operations into a single command. You might want to have

Gizmo is published by Gernsback Publications, Inc., 500 Bi-County Blvd., Farmingdale, NY 11735. Senior Writers: Christopher Scott and Teri Scaduto. Copyright 1997 by Gernsback Publications, Inc. Gizmo is a registered trademark. All rights reserved.

your DSS IRD, TV, and the 1090VR come on with just the two button presses. The remote can be used to operate components in a second room, and two independent on-screen displays show the status of equipment in each room. (Kenwood offers as an option an additional remote designed specifically for use in the second room.) The FutureSet allows you to control more than one component at a time; you can use it to have the VCR rewind a videotape while you're listening to a CD. So that you don't get confused as to which devices are being controlled, the FutureSet automatically names active inputs with the device it's programmed to control. If you program the remote to operate an RCA DSS receiver, the input will be labeled "DSS." If you program it to control a JVC VCR, another input will be labeled "VCR." There is no other way to label the inputs—no simple "video 1, video 2, video 3."

Hooking up the 1090VR is straightforward, although it can get a bit complex if you take full advantage of all the receiver's many inputs. The 1090VR also offers a feature called "System Control," a proprietary control bus that allows you to link multiple Kenwood products together.

After you've connected all your components to the receiver, there are still a few more adjustments to make. The 1090VR's on-screen display helps you set up your surround-sound speakers. The displays prompt you to enter information about room size and acoustics; the number, size, and placement of your speakers; and whether or not a subwoofer is being used. A test tone makes it easy to determine the proper volume level for each speaker, and the level indicator lets you know if the signal needs attenuating.

The 1090VR has a Radio Data System (RDS) tuner. RDS, which has seen widespread use in Europe for some time now, is a system that transmits digital data along with the FM broadcast signal. RDS tuners can extract that information and use it for various purposes, such as displaying the station's name and format, for traffic or weather advisories, or for advertisements.

The 1090VR's tuner can locate any local RDS stations and automatically program them into preset memory positions. Up to 40 RDS stations can be stored simply by pressing and holding the front-panel MEMORY button for more than two seconds. (Those stations are automatically stored beginning in preset position 1 and will overwrite any manually stored stations, so it's best to use RDS auto memory first.)

The stations that are stored using RDS auto memory can then be tuned according to program type, using the PTY search function. RDS's program type table contains 22 different categories, including talk, public, country, top 40, news, classical, jazz, rock, sports, and oldies. Press the PTY button, and then use the tuning up and down keys to scroll through the choices. Make your selection and press PTY search. The radio will tune to the first station belonging to that category, displaying its name.

The RDS tuner also allows you to search for traffic information, using the front-panel TP (traffic program) key. The radio will look for an RDS station that is currently broadcasting traffic information and will switch to that station. True, traffic information might not be important in a home theater, but it does allow you to check the situation on the roads before you set out to work or on a trip.

The 1090VR offers several different ambiance effects: Dolby Digital, Dolby Pro Logic, Dolby 3 Stereo, a number of DSP modes, straight two-channel stereo mode, and "source direct." The amplifier drives all five surround channels plus the ".1" low-frequency effects channel required for Dolby Digital. Both Dolby Digital and

Dolby Pro Logic surround-sound decoders are built in to the receiver. If you don't have surround speakers installed, you can use the Dolby 3 Stereo mode (with Dolby and non-Dolby sources) to create a panoramic frontal sound field while keeping the dialog localized on screen. The DSP modes simulate the sonic ambiance of an arena, jazz club, church, theater, or stadium. In addition, the "wall," "room," and "effect" parameters let you adjust the "brightness," "size," and "presence" of the sonic environment according to your personal preferences. Source-direct mode bypasses all audio processing, feeding the signal straight from the source to the amplifier.

If you tend to do your movie watching after the kids are in bed, and you don't want to wake them with loud soundtracks, you'll appreciate the 1090VR's "midnight mode." Available only in the Dolby Digital mode, it compresses the dynamic range of previously specified parts of the AC-3 soundtrack (usually, scenes with sudden increases in volume) to minimize the difference in volume levels between different scenes. Not all Dolby Digital software is compatible with the Midnight Mode.

It takes a while to become familiar with the 1090VR—there's just so much to learn. But with this receiver installed at the heart of your home-theater, you'll be able to integrate and control all the various pieces, creating one seamless, convenient system.

FINE TUNING

MODEL VP100 TV ENHANCER. Manufactured by Faroudja Laboratories Inc., 750 Palomar Avenue, Sunnyvale, CA 94086; Tel. 408-735-1492; Fax: 408-735-8571. Price: \$799.

It's taken a few years, but, finally, your home theater is complete. That large-screen TV you splurged on a few years back is now flanked by three matched speakers; the surround speakers and powered subwoofer are in place. You've switched from cable to satellite reception. And you've just replaced your old receiver with one that can handle the Dolby Digital soundtracks found on the films you load into your new DVD player.

What is wrong with this picture? Probably nothing—except, perhaps, the picture.

There have been some big improvements in front- and rear-projection sets—and even in direct-view TVs—in



recent years. If your large-screen set has a few years under its belt, it might not be up to the task of delivering the high-quality signals produced by today's digital sources.

You could go out and replace the set with a bigger, better, newer model for a few grand. But if your old TV is still working well, that might not be practical—particularly with digital TV looming on the near horizon. It would make sense to delay such a major purchase until you could replace your old faithful model with a set that's truly "new and improved."

In the meantime, however, you don't have to settle for just-okay video. Your state-of-the-art home theater can look amazing, not mediocre, despite your older model television, thanks to Faroudja Laboratories' VP100 Video Processor. It provides a quick (though not cheap) fix to many image problems plaguing front- and rear projection sets, large-screen CRT TVs, and computer monitors. To be useful, your set must have an S-Video input, and your source must have a composite-video output.

Faroudja is well-known and -respected in the video industry and among the videophile community. The company holds dozens of patents in the field of video processing, though it is perhaps best known for its lines of professional, very high-priced, line-doublers and line-quadruplers.

Aimed at home-theater enthusiasts, the VP100 uses some of the same patented techniques as those professional products, although it does not add lines to the image. Instead, it provides three types of image enhancement. It separates the black-and-white (luminance) and color (chrominance) information within the signal, provides detail enhancements, and allows the user to correct luminance/chrominance (Y/C) delay.

The VP100 is a small (approximately 6×6×2 inch) set-top (or shelf-top) box with a bowed top. It weighs just 1.5 pounds, but is no lightweight; an all-metal chassis with a heavy-gauge, extruded-aluminum case gives the processor a rugged, professional feel. The front panel holds two dials,

labeled "detail" and "delay," each marked with 16-numbered positions. An external wall-mount 9-volt DC adapter plugs into the only rear-panel connector that is not gold-plated. The rear panel also hosts a composite video input, composite video loop output, and side-by-side S-Video outputs that allow the VP100 to act as a composite-to-S-Video adapter (a Y/C splitter) and a two-output distribution amplifier.

Installation is straightforward. The composite-video output of a laserdisc player, A/V receiver, preamp, or switcher is connected to the processor's composite-video input. The dual S-Video outputs can serve two monitors—handy if your setup includes both a projector and a direct-view TV, or a monitor and an S-Video recorder.

One of the nicest things about the VP100 is that, in most cases, you can set it once and forget about it. Its factory-preset positions are "set to broadcast television standards and represent the optimum settings for most installations." If your home theater falls into that category, you can install the VP100, pop in a film, and immediately enjoy noticeably improved picture quality.

Should your setup require some manual adjustments, the process won't give you much trouble. Find a laserdisc, DVD, or high-quality VHS tape with a lot of bright and colorful scenes (some of the kids' animated movies come to mind). Even better, try to get your hands on the type of disc used by professionals to fine-tune audio/video systems. (We used the DVD version of *Joe Kane's Video Essentials*, which we'll review next month).

Set the detail knob to "0" and reduce the sharpness on the TV and VCR by 50% from its usual position. Then locate a well-lit scene in the movie, and turn the detail knob until the horizontal and vertical edges of the image appear sharp, but not so far that thin white lines appear next to the edges, giving the image an artificial look.

Incorrect color alignment is visible as a shifting of the color off to one side of the object, resulting in a smearing on one side

and a gray line on the other. Again using a brightly-colored source, freeze a frame with the pause control, locate something in the picture that has well-defined edges on both sides, and turn the delay control clockwise to shift the color back to its proper position.

The results are dramatic. We did a simple A/B comparison test by feeding the loop output to one of the Sharp projector's inputs, and feeding the processed S-Video output to another input. The detail and sharpness of the image noticeably increased.

The reason it's so simple for you to use the VP100 is that all the hard work is going on invisibly inside the unit. Let's take a look at how it works. Faroudja's patented adaptive comb filter separates the luminance (brightness) from the chrominance (color) information and strives successfully to eliminate "dot crawl," those squirming dots that you'll typically see at the boundary where different colors meet. Its Detail control determines how the VP100 processes the image. While similar in some respects to the sharpness control found on most TVs, Faroudja's processing boosts selective frequencies and avoids the production of hard, noisy, white edges in the image.

Despite its impressive performance, it's important to remember that the VP100 won't do much to improve a poor source signal. If your TV or projector has an S-Video input, use it, and forget about the VP100. If your picture-quality problems are caused by worn-out VHS tapes or weak broadcast signals, you'd be better off upgrading to laserdisc, DVD, or satellite TV. If you've got good source components, and your image is being compromised by long video-cable runs, try the VP100.

VISIONARY VIDEO

Digital Home Theater. From Projectavision, Inc., 2 Penn Plaza, Suite 640, New York, NY 10121; Tel. 212-971-3000; Web: <http://www.projectavision.com>. Price: \$7999.

True or False: For large-screen television, you must choose between a front-projection and a rear-projection set.

The correct answer is ... False. There is a third choice available in *Projectavision's Digital Home Theater* (DHT), which combines a portable front-projection unit that can throw an image as large as 260 inches

(diagonal) with a 60-inch (diagonal) rear-projection set, and does triple-duty as a large-screen SVGA computer monitor. The fully digital system's modular design adds to its versatility, and its use of Texas Instruments' Digital Light Processing (DLP) technology creates a life-like image.

The Digital Home Theater is a truly innovative product in terms of design as well as technology. It arrives in three boxes. Two quite large (56×27×30 and 56×19×44 inches) boxes hold the cabinet base and the cabinet top (the screen), respectively, and a smaller (29×23×15 inches) one contains the projector, instructions, and accessories. Though large, the boxes are not unmanageable. Each fits easily through a standard doorway, and the heaviest (the base) weighs in at just 80 pounds.

The two large boxes have lift-off lids on both top and bottom, allowing you the option of lifting the DHT pieces out of the box, or lifting the box off the DHT (clever,

huh?). That design also allows the box to fold flat for storage. Once the base unit is unwrapped, it rolls about on casters for easy positioning. The front wheels can be locked in place when setup is complete.

The 42-pound screen unit connects to the base with four large knobbed screws. The rear of the cabinet is set at the proper angle for alignment with the reflector mirror and projector optics by tightening four pairs of "locks" on the top cabinet. The four locks are round, almost flat knobs, with a groove down the center of each. A quarter or other coin can be used to turn them and lock them into place.

The projector slides into a locked compartment in the base unit. A portable "docking station," which contains all necessary inputs and outputs for audio, video, and computer connections, comes installed in the projector for front-projection use. Because there's a permanent one in the DHT base, the portable docking station must be removed before the projector is installed in the cabinet. The docking sta-



tion simply pulls out of the projector and can be safely stored in a special compartment built into the lower cabinet. The rear-projection lens is inserted and locked into position, and then the projector can be slid down into the cabinet and seated on the permanent docking station. The cabinet also has a special place for storing the front-projection lens.

Fully assembled, the Digital Home Theater is surprisingly compact. It stands 64 inches tall, is 51 inches wide, and projects a mere 23 inches from the wall. The Projectavision set is a sleekly-attractive addition to any modern decorating scheme, yet unobtrusive enough to fit in more traditional homes.

Thanks to its sensible, modular design, the Digital Home Theater can be assembled and unpacked by two adults in a matter of minutes. A large, one-page instruction sheet—the first thing you see when you open the box labeled “Open Me First”—makes it easy to see each step of the assembly process without having to flip through the manual (where the same directions appear). Photos of each step accompany the written instructions. At one or two stages, line drawings might have more clearly illustrated the required actions, but the photos were sufficient. All in all, it was *much* easier than putting together any piece of IKEA furniture we’ve ever bought!

The Digital Home Theater is a stand-alone unit, equipped with television tuner, one internal and two external full-range speakers, and a two-channel 20-watt audio amplifier. For integration with the rest of your home theater—and possibly your home office—audio and video connections are made via the docking station’s rear panel, easily accessible on the back of the lower cabinet. The DHT provides three composite video inputs and outputs, two S-Video inputs and one output, audio and speaker jacks, two antenna/cable inputs, and computer SVGA and audio connections. The manual illustrates several possible home-theater installations, providing connection details for cable, antenna, satellite, VCR, laserdisc, DVD, camcorder, audio gear, video games, and personal computer.

Once you have all your audio/video equipment connected to the DHT, you can program its remote control to operate most brands of VCR and cable boxes, as well as a second television, using the manufacturer code numbers listed in the manual. The remote control is thoughtfully designed and relatively streamlined. Source-selection and sleep buttons are arrayed across



The DHT projector can be used solo as a front-projection TV.

the top, with VCR controls directly below. A numeric keypad holds center court; the middle vertical row of numbers—2, 4, 8, and 0—each have a second function: FLIP, TIME, DISPLAY, and FREEZE, respectively. The FLIP function is used to invert or reverse the image when the projector is removed from the cabinet and mounted on the ceiling. The TIME function displays the current time; DISPLAY calls up the date, time, and current function; and FREEZE releases an image that has been stopped (using one of the on-screen menus). Below the keypad are found TV/VCR, ENTER, MUTE, and MENU buttons. The most-frequently used controls are closest to the bottom where they are most accessible. Large, wedge-shaped volume and channel controls are arranged in a circle, with the POWER button directly below them. The lowermost button, adorned with a light-bulb icon, is used to illuminate the keys on the remote.

We were happy with the well-designed, common-sense Digital Home Theater before we even turned it on. The pleasant surprises continued.

The 60-inch diagonal rear-projection image was crystal clear, consistently sharp and bright, even in a well-lit room. The Digital Home Theater is the first U.S. product to use Texas Instruments’ digital light-processing (DLP) projection technology. DLP uses 960,000 digital light-switch micromirrors to reflect beams of light to form an image directly onto the screen. (The two-chip system, unique in the world

of consumer electronics, places 480,000 micromirrors on each of the chips.) The entirely digital process allows both video and computer-generated images to be displayed in accurate, full-spectrum color. The projector also features a lamp life of 6000 to 8000 hours. And the unit’s convergence never needs adjusting.

Projectavision added its own technological innovations to the mix. The first technology developed by the company was called “depixelization.” As the name implies, it was a method for smoothing out the dots (pixel effect) that plague LCD projection images.

We used the Digital Home Theater’s on-screen menu system to make some image adjustments, using Joe King’s *Video Essential’s* test-pattern DVD as a guide. The resulting image showed no visible scan lines or distortion. Colors were true to life, and edges were clearly defined but not harsh. We saw not only a bigger picture, but more of a picture, thanks to virtually zero overscan.

Next, we hooked up the Faroudja VP100, not because we felt the image needed improvement, but out of curiosity. The TV enhancer that made such a big difference in picture quality on our old TV was definitely not needed with the Digital Home Theater.

Besides video adjustments, the DHT menu system is used for channel setup, selecting video sources, choosing which speakers to use, and entering time and date (which must be manually reprogrammed

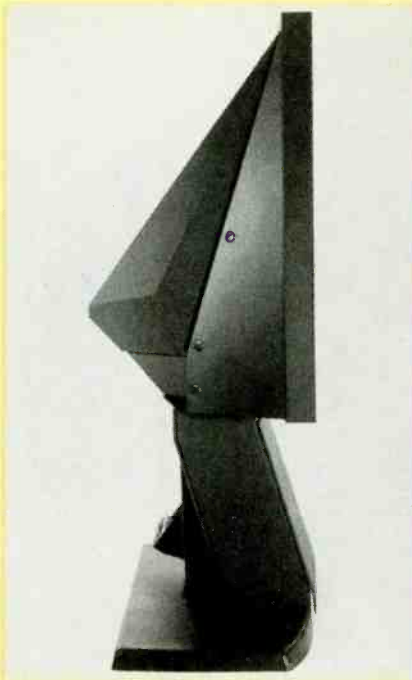

Viewed from the side, the Digital Home Theater presents a slim profile.

for Daylight Savings Time and leap year changes). It also activates closed captioning or video mask, which “masks off” the top and bottom of the screen for viewing widescreen images.

We watched several DVDs on the Digital Home Theater, along with some of the baseball playoff games (via satellite). During most of our viewing time, the overhead light remained on—in a few cases, we watched during the day, curtains open. In all cases, the DHT provided an exceptionally sharp image. The picture remained clear and easy to see from a variety of viewing angles. The DHT’s brightness is rated at 350 ANSI lumens. It offers 800 lines of horizontal resolution in video mode, and 800×600 lines in SVGA mode.

To use the DHT as a front projector, you simply slide the projector out of the base unit, switch lenses, and insert the portable docking station. If you want to mount the projector on the ceiling, you’ll have to make image adjustments (flipping it upside down). If your room is at least 30 feet long, you can throw an image that measures 260 inches in diameter. (Our setup precluded anything larger than about 120 inches.) Even the large front-projection pictures were sharp and detailed.

As a computer monitor, the Digital Home Theater is larger than we’d like to use on a regular basis, but we can’t imagine a more convincing presentation tool.

Granted, almost eight grand is a lot to spend on a TV. Other 60-inch diagonal sets

can be purchased for far less. But the Digital Home Theater is not just a rear-projection set. For your money, you also get a portable projector for super-large viewing and a large-screen computer monitor that will allow all you mouse potatoes to become couch potatoes as well. You might keep the projector in the base unit all year long, and then pull it out and use it as a front-projector for your annual Super Bowl Party. If you can pry your family away from the Digital Home Theater, you can take the projector on a business trip and hook it up to a PC for large-screen sales presentations.

The Digital Home Theater is a lot of TV, even if you choose to use it strictly as a 60-inch rear-projection set. Its modular design, slim profile, and, most important, superb picture quality place it far ahead of the pack.

DIGITAL VIDEO DELIGHT

MODEL DVD905 DVD PLAYER. Manufactured by Samsung Electronics America, Inc., 105 Challenger Road, Ridgefield Park, NJ 07660-0511; Tel. 201-229-4000; Web: <http://www.sosimple.com>. Price: \$749.

When the first wave of DVD decks hit the market last year, they represented a truly new and improved way to watch (and listen to) video. Now, as the second-generation decks are being introduced, it’s easy to say that they offer only slight design/cosmetic improvements over last year’s crop—and that might be true, in some cases. But most of the American public has yet to experience DVD, so we’re going to treat the second round of DVD decks for what they are—slightly new and improved versions of a superior video format. For those of you who are not familiar with DVD, we’ll review some of the basics as we take a look at the *DVD905*, Samsung’s high-end, second-generation DVD deck.

The DVD905 resembles—and serves as—a CD player. Its silver-toned front panel has a center disc tray that slides out to accept a five-inch DVD, CD, or Video-CD disc. The OPEN/CLOSE button is just to its right. Above the disc tray is a vacuum-tube fluorescent display and a button to control its brightness level. When a disc is inserted, the title scrolls across the display that informs you during play of title, chapter (or track) numbers, of total, and of remaining

play time. Other information, such as the selected angle of view, is also shown. At the left of the front panel is a rectangular POWER button. The right side is home to one large circular button used to control play/pause, stop, and skip/search functions.

The rear panel is equally pared down—although its terminals are indicative of some of the DVD905’s potential. It provides both optical and coaxial digital-audio output terminals; RGB, composite, and S-Video outputs; and a two-channel audio output for listening to stereo CDs. The optical and digital audio outputs are for connection to an audio system that has a built-in AC-3 decoder (they can also output digital PCM data from a CD). There are also six discrete audio outputs—this DVD deck has its own built-in Dolby Digital decoder.

That’s a big plus. The DVD905 can be used with a Dolby Digital-ready receiver (one that offers a 5.1-channel amplifier), which costs less than one with the Dolby Digital decoder built in, and which you might already own.

In contrast to the sparsely-populated front and rear panels, the remote control is home to close to 50 different buttons. Granted, some of those are for operating a television; the remote can be programmed (with manufacturer codes found in the user’s guide) to control most models of TVs. But it still takes a while to find your way around the remote.

In addition to the numeric keypad, device-select buttons, device power buttons, and basic DVD/CD controls (PLAY/PAUSE, STOP, and SKIP), you’ll find buttons labeled TIME, SEARCH, ANGLE, STEP, TITLE, and SUBTITLE—all of which we’ll explain later. The only buttons that really stand out are four curved ones, labeled UP, DOWN, LEFT, and RIGHT, that are centered around a circular ENTER button. Those are used for moving through, and selecting options from, the on-screen menus. Unfortunately, the VOLUME and CHANNEL UP/DOWN buttons are not particularly distinctive, nor is the MUTE button.

The deceptively thick user’s manual walks you through the installation process, illustrating both simple and complex audio video setups. Using more pictures than words, the manual makes it easy to add the DVD player to your home-theater system. It also clearly explains how to use it once it’s all hooked up.

Just like playing an audio CD, you can place a disc in the tray, close it, and hit PLAY. The DVD format, however, offers the potential for software producers to provide several viewer options. To take

advantage of them, you'll have to use many of those remote-control buttons. DVD discs can hold a tremendous amount of data; they can store not only a movie and its soundtrack, but also alternate viewing angles or aspect ratios, as many as eight audio language soundtracks and 32 different subtitles, and additional information such as biographies of the actors. Like the tracks on a CD, the data on a DVD is divided, in this case, into titles and chapters. An on-screen table of contents allows you to move directly to the beginning of a title or chapter; FAST-FORWARD and REWIND keys let you skip ahead or back.

To select the language of the soundtrack, press the AUDIO button. All available soundtrack languages are displayed, and you can use the direction buttons, and then ENTER, to make a selection. The subtitle button works in the same manner, displaying and allowing you to choose the language in which you'd like to see the subtitles displayed. (The STO button is used to turn the subtitles on or off.) The ANGLE button lets you select the angle of view, if different ones have been included on the disc. So far, few DVD titles have been produced to take advantage of this feature. In fact, we know of just one, an X-rated film—use your imagination. It's also possible to make soundtrack, subtitle, and angle selections by pressing the menu button while in play mode, and then using the direction buttons and ENTER to choose from the options displayed.

It isn't necessary to make all of those selections every time you watch a disc. For the most part, you'll probably want to hear the same language spoken and do without subtitles. However, you can change the DVD905's default settings to reflect your personal tastes on every disc played—and even to change the language of the menus themselves—using the SETUP/MUTE button. If, for instance, Spanish is your first language, but you are trying to improve your English, you might want to set the deck to play the English soundtrack while it is playing Spanish subtitles. To do so, you would press the SETUP button while in stop mode, and then select the category you'd like to change. Again, you'd use the direction buttons and ENTER to make your choices. You'd then hear every movie in Spanish with English subtitles (as long as those options were offered on the disc).

The SETUP/MUTE button can be used to select one of three aspect ratios—16:9 widescreen, 4:3 pan-scan (which shows only the center portion of a 16:9 image), and 4:3 letter box (which adds black bars at



the top and bottom of your standard TV when you're watching a 16:9 aspect-ratio movie). Of course, not all discs support multiple aspect ratios. The SETUP button is also used to customize the DVD905's outputs to your home-theater system. The setup menu asks you to input such information as the aspect ratio of your TV, whether it accepts composite or S-Video, and whether you want the deck to output AC-3 (Dolby Digital) audio to your receiver. For configuring your surround-sound system, the menu will ask if you have center-and surround-speakers and a subwoofer.

Phew! If all that sounds a bit complex, try to keep it in perspective. The DVD format provides so many features that setup is bound to be a bit thought-provoking, but not all too time-consuming. Once all that's out of the way, however, a DVD player is as easy to use as a CD player—in fact, one of DVD's virtues is its similarity to the CD format, making it less "frightening" to consumers.

Most of the time, you'll probably just put in a DVD and watch a movie from start to finish. If the phone rings, you can press PAUSE and resume play when you hang up, just as you'd do with a videotape. There's not much difference—except in quality.

DVD represents a tremendous step up from VHS videotape, and a noticeably better picture than laserdisc can deliver. As for sound, Dolby Digital is an integral part of the DVD standard.

To hear a soundtrack in Dolby Digital surround sound, you need both the decoding circuitry and an amplifier capable of driving 5.1 discrete channels. The DVD905 provides the necessary decoding circuitry, allowing you to hook up a Dolby-Digital-ready receiver or amp. Conversely, if your home theater already includes a DD decoder, you can hook the DVD905 to it

with a single optical or coaxial digital cable.

We played several movies on the DVD905. While the player worked flawlessly, we did find a few disappointments on the discs themselves. *Woodstock: The Director's Cut*, had a few very choppy scene changes, so abrupt that they appeared to be mistakes. *Woodstock* ran 225 minutes; rather than put the movie on a dual-layer disc, the manufacturer chose to use a dual-side disc. We had to get up and flip it over—an unforgivable flaw, in our eyes. Of lesser import, after scanning the manual's list of possible audio and subtitle languages (which included Bihari, Inupiak, Kirghiz, Urdu), we'd hoped (somewhat unrealistically, we suppose) that *Michael Collins* might include an Irish soundtrack (or at least Irish subtitles). But, like all the other DVDs that we've seen so far, it was limited to English, French, and Spanish—not quite living up to its potential, so far.

DVD as a format, however, is full of potential, and the DVD905 has the ability to take advantage of every bit of it when the disc producers are ready to do the same.

THE BIG PICTURE

SHARPVISION XV-S96U LCD PROJECTOR. From Sharp Electronics Corporation, Sharp Plaza, Mahwah, NJ 07430-2135; Tel. 800-BE-SHARP; Web: <http://www.sharp-usa.com>. Price: \$6995.

You can't get a true home-theater experience without a good-sized picture. If your media room is big, and you like the up-close-and-personal feel that a really big picture provides, a front-projection TV is for you. And if your home-theater setup includes a personal computer for game playing or 'Net surfing, the *SharpVision* 25

XV-S96U, which throws an image that measures up to a whopping 40-feet (measured diagonally), just might be the projection TV (P-TV) for you.

Sharp's multimedia LCD projector not only has composite-video and S-video inputs, it adds component video input for DVD and DSS and an RGB input for computer video. Component video is the professional-style signal currently output by high-end DVD players, and it's likely to be output by tomorrow's Digital TV (DTV) and HDTV televisions and converter boxes. A subtle step up from S-Video, component video is poised to replace it as the best-possible video signal available to consumers.

Whereas S-Video separates the chrominance (color) information from the luminance (brightness) information, component video breaks the video signal into three parts: Y (the luminance signal), B×Y (a chrominance or color-difference signal equal to the difference between the blue signal and the luminance signal), and R×Y (a second chrominance signal equal to the difference between the red signal and the luminance signal). What about green? The level of the green signal can be determined from the equation $Y \times 0.3R \times 0.59G \times 0.1B$.

Theoretically, component video can provide superior color and image quality. To our eyes, it's tough to tell the difference between S- and component-video signals. Component video is, however, the format of choice of pro gear, and it's what you'll see on a vectorscope display.

The XV-S96U also provides a direct input for computers. It accepts a PC's VGA output directly or a Macintosh RGB input, 640×480 maximum, via a supplied adapter. It's easy to view PC applications, Web pages, and video-game images without the need for a separate scan converter or any other add-on adapter.

Projection televisions gained a bad reputation for creating poor-quality images—lackluster colors, a low level of brightness such that a darkened room was required, and low resolution that resulted in obvious pixelation (at large image sizes, the picture resembled a comic strip, obviously made up of different colored dots). The SharpVision XV-S96U addresses all of those problems, with a high degree of success.

The primary improvement over previous models and other brands stems from the use of Sharp's Ultra High-Brightness Technology. The projector creates an image with 600 ANSI Lumens—a figure which probably means nothing to you, but is quite impressive to those in the industry. The



SharpVision's brightness level is almost two-and-a-half times that of even the brightest CRT projectors (which, by the way, cost at least double what you'll pay for the XV-S96U). In real-life terms, 600 ANSI Lumens will allow you to watch a movie—without drawing the curtains and turning out all the lights—and to take the image to its maximum size while retaining picture quality.

Improvements to the projector's optical system helped tweak the brightness to its maximum level, while ensuring uniformity. The XV-S96U's "3D-Y/C" digital comb filter circuitry ensures minimal dot crawl and cross-color noise. Each of the projector's three LCD panels contains 309,120 pixels. Further image improvements can be attributed to a super-high aperture LCD with micro-lens technology that allows the passage of 45% more light, a 350-watt metal halide lamp, and built-in quad-speed line doubling. The projector produces video images with up to 500 scan-doubled TV lines of resolution.

We've used previous SharpVision models and been moderately pleased with the results. This one, however, draws raves.

Although it's not quite as small and portable as some earlier models, at 31 pounds and measuring approximately 9×21×21 inches, the XV-S96U still is easy to carry. The projector can be ceiling mounted, placed on a shelf or table across the room from a screen, or even placed behind a screen to serve as a rear projector. (The image can be reversed for rear projection and inverted for ceiling mounts.)

The projector's front panel features the lens on the left side; a small built-in speak-

er in the center; and temperature, lamp replacement, power indicators, and the POWER button, on the right. An exhaust fan (which, unfortunately, is loud enough to be heard during quiet scenes in some films) is on the right side panel. The left side panel hosts an operation panel with controls for adjusting video parameters, the lens, and the volume, as well as an INPUT-selection button, and a MUTE button. For making adjustments in a darkened room, the controls use a phosphorescent display that, after being exposed to light, will glow in the dark. The rear panel offers an RGB input connector, two composite video inputs, one composite video output, an analog component input, an S-Video input, an RGB audio input, a 12-volt DC output, and a jack for a wired remote control.

Interestingly, the manual made no reference to the wired-remote input. However, although a Sharp spokesperson was unable to confirm this by press time, we assume that it's intended for use as a trigger input to allow the projector to be turned on automatically by another piece of home-theater gear. An infrared remote control supplied with the projector provides the same operation controls that can be found on the projector's side panel, along with a menu button for activating the on-screen menu system.

Unlike a direct-view TV, which can be used straight out of the box, the projector requires a bit of setup. The first consideration is the distance from the projector to the screen and its relationship to the picture size. You can place the projector anywhere from 4.3 feet to 58.4 feet from the screen, depending upon your room size and how big an image you want. To get the largest

possible image (500 inches diagonal), you'd have to place the projector the full 58.4 feet away—which, in our case, would be in our next-door neighbor's dining room. A 40-inch image can be generated with the projector up to 7.2 feet away. A more typical scenario would be to place the XV-S96U between 11.5 and 18.4 feet away from the screen to get a 100-inch image.

Our test room allowed a maximum distance of 15 feet from projector to screen, with the projector resting upon a fireplace mantel—which was possible thanks to its closely spaced feet. To avoid picture distortion, the projector and screen should be perpendicular to each other, and the center of the lens should be even with the center of the screen. The projector's feet can be used to make gross adjustments (up to five inches) to the level and height of the projector position. Minor adjustments can be done electronically, using the power lens shift feature—a big improvement over some of the older models, and one which custom A/V installers will love for the time it will save. (For ceiling mounts, an installation kit and installation adaptor are sold separately.)

The LENS button is used to not only to shift the image, but also to zoom in or out and to adjust the focus, depending upon the mode selected via the on-screen menu. It is also used to invert the image for ceiling installations (in which the projector is mounted upside-down).

One of the drawbacks of a projection television is that it is not a self-contained unit. We're not talking about the need for a screen—in a pinch, you can watch the movie on a blank white wall. But the projector does not have a tuner, so you must add a source component—VCR, satellite receiver, DVD—player before you can get any video at all. And, while the XV-S96U's small speaker might be sufficient for a sales presentation, you'll have to add speakers and an A/V receiver for home-theater sound. All of this can become complex if the projector is located some 15 or 20 feet away from the rest of your gear (which is why custom installers are there in the first place!).

With all your equipment in place, you're ready to adjust the picture. Unlike cathode-ray-tube projectors, which have to be professionally aligned for proper convergence of the output from the red, green, and blue CRTs (and frequently realigned), the XV-S96U LCD projector is factory preset. However, there is an array of standard picture adjustments available. The projector's on-screen menus walk you

through adjustments for contrast, brightness, color intensity, tint, sharpness, and the like. At any time, you can call up the status screen to see line-graph representations of all the settings. A "reset" option allows you to return to the factory preset levels.

When you watch widescreen movies, the projector's masking function blacks out the top and bottom segments of the screen. Three modes are available: normal, vista, and CinemaScope/Letterbox.

We used the SharpVision XV-S96U in a less-than ideal setting—a 13×16-foot living room with curtainless windows admitting ample sunlight. We had a high-reflectivity video screen that measured six feet diagonally. Unfortunately, it was a couple of inches smaller than the smallest image we could project, given room size and the location of the screen and the projector. Interestingly, because the image on the screen had virtually zero overscan, we could see more of the image than we could on our other TVs, despite losing the two or three inches. Nevertheless, even during daylight hours, the SharpVision produced a bright, clear image.

The XV-S96U produced a vibrant, consistent sharp image. Darkly-lit indoor scenes didn't lose details, and outdoor, sunlit scenes weren't harsh. From a distance of more than eight feet from the six-foot screen, pixels seemed to disappear. Edges were clean-cut, and there was very little "blooming"—only very bright reds tended to bleed a bit. The large image size and true-to-life colors created an engrossing video experience—just like being at the movies.

PREVIEW PASSER

ULTRAVISION VT-UX625A VCR WITH MOVIE-PASS. From Hitachi Home Electronics (America), Inc., 3890 Steve Reynolds Blvd. Norcross, GA 30093-3012; Tel. 770-279-5600; Web: <http://www.hitachi.com>. Price: \$299.

When we were kids, we could spend an entire Saturday afternoon at the movies watching a double feature, some cartoons, previews, and even an occasional newsreel. These days, when we go to a theater to see a film (no more double features), we're bombarded not only with previews of upcoming features, but also with commercials for products and local shops and restaurants. It gives us a few extra

minutes to buy popcorn and soda without missing the beginning of the film we've paid (big bucks) to see. Besides, we can just imagine how much tickets would cost if theater owners didn't have that source of revenue.

Where we really do mind commercials and previews, however, is on home videos. We've already paid our money to buy or rent the tape—why should we be subjected to commercials or previews? The previews always seem to be of gory shoot-'em-up flicks. Our time is limited; we don't want to waste it watching previews of films we'd never go see. Most offensive are the ads on children's tapes—we certainly don't want our little boy to be asking for a video (or tie-in toy) before he's even watched the movie we just brought home!

In the past, we've had two options—fast-forward through the previews, or use that time to pop some corn or get a drink. Now, however, we can sit down, pop in a tape, press two remote-control buttons, and the Hitachi Ultravision VT-UX625A VCR will automatically fast-forward to the start of the movie.

That convenient feature is called *Movie Advance* or, more familiarly, MA Skip. When a prerecorded tape is inserted into the VT-UX625A, the deck powers up and playback starts automatically. A press of the MA SKIP button on the remote control calls up the Movie Advance menu. Select 1 on the remote's numeric keypad to choose "go to start of movie," and the VCR will find the beginning of the film and fast-forward right to that point on the tape. A blue-background screen displays the message "searching for start of movie" and offers the option to cancel MA Skip. When it's reached the start of the movie, it prompts you to press the PLAY button with the on-screen message: "Movie is ready. Start—play."

What if I like watching some of the previews? The second option on the MA menu—"Go to first preview"—is for you. Press the 2 button, as prompted, and the VCR will fast-forward to the beginning of the first preview. If you don't want that one, press the MA SKIP button to advance to the next preview.

We first tried the MA skip feature on a much-played copy of *The Land Before Time II*. Following the instructions to the letter, it took the VT-UX625A exactly 80 seconds to locate the start of ... the preview for *The Adventures of Timmy the Tooth*. We rewound, ejected, and reinserted the tape, because Movie Advance won't work with

tapes that have been played part way. Once again, we pressed MA SKIP, selected “go to start of movie,” and pressed 1. Once again, it took 80 seconds to locate the start of the *Timmy the Tooth* preview. Next, we rewound, pressed PLAY, and manually fast-forwarded through the preview (as we’ve done 100 times before), and in just under 30 seconds, we reached the start of the feature.

The manual includes a couple of caveats besides the “played part way” one. Movie Advance will not operate with damaged tapes, although we hadn’t had any trouble with this one. And it warns that the VCR may not be able to locate the starts of specific movies or previews (it didn’t seem to have any trouble locating the beginning of this preview). We tried ignoring the “part-way” rule, and pressed MA SKIP in the middle of the preview. The VCR took about a minute to fast-forward to another part of the same preview.

We were stumped. We tried another video: *Land Before Time IV* (okay, so the kid loves dinosaurs!). This time, the VCR took 75 seconds to reach the start of the film, and did so perfectly ... at least to our way of thinking. The VT-UX625A brought the tape right to the title scene. But, it skipped one of our son’s favorite parts—the Universal Cartoon Studios logo, which features a cute little cartoon airplane circling the earth. He made a fuss, as only a two-year-old can, until we rewound to the airplane part.

Next, we tried MA Skip on *The Little Mermaid*. (Quite a tape library we own, isn’t it?) One minute, 30 seconds, and it was right on the money once again. We’re still not sure what happened with *The Land Before Time II*, but we suspect that the tape might be a bit too well worn.

Movie Advance is actually one of three features that comprise “Movie Pass.” The other two, Movie Return and Movie Rewind, while convenient, are nothing to write home about. Movie Return does not take the tape back to Blockbuster for you. Instead, it automatically rewinds any tape with the safety tab removed, ejects it, and turns off the power. Movie Rewind is a high-speed rewind, which takes less than a minute and a half to rewind the average T-120 tape.

Aside from Movie Pass, the Ultravision VT-UX625A boasts an array of features that are becoming standard fare on today’s VCRs. The Hi-Fi deck has dual azimuth heads and an automatic head-cleaning system. It offers eight-program/one-year preset recording with several different methods of programming, including VCR



Plus+. Convenience features include front-panel A/V inputs and automatic clock set.

The auto-clock-set function is not entirely automatic; at initial setup, you must manually input the time, date, time zone, and if Daylight Saving Time is in effect. In the event of a power interruption of less than an hour’s duration, auto clock set will use the time signals that are transmitted along with TV shows by several cable and broadcast stations (mainly, PBS stations) to reset the clock to the correct time—no more flashing “12:00.” The feature also automatically changes the time during Daylight Saving Time. According to the manual, the displayed time might drift from the correct time by up to one minute—which could cause you to miss the last crucial minute of the programs you tape.

Time-shifted recording couldn’t be easier than it is with the VT-UX625A. One press of the remote-control program button brings up the on-screen VCR Plus+ menu, which requires simply that you input the code for the program you want to record and turn off the deck. Those codes can be found in TV Guide and most newspaper TV listings. VCR Plus+ automatically begins recording at the proper time.

To bypass VCR Plus+, press the PROGRAM button two times. That brings up another on-screen menu, which prompts you to input the channel, start and stop times, tape speed, date, and if you want to record the program once, daily, or weekly.

Same-time recording can be done by pressing the REC button on the remote or the REC/IRT button on the front panel. The “IRT” stands for Instant Recording Timer, and subsequent presses of the front-panel REC/IRT button sets a timer in 30-minute increments.

The VCR offers several playback effects. Variable-speed playback options include still playback (with a press of the PAUSE button), slow motion (with the SLOW button in play mode), and frame-by-frame advance using the SKIP button in pause mode. You can also attempt to fast-forward through commercial breaks using the SKIP button in play mode. Each press moves the tape forward for about one minute; ads generally run for either 30 or

60 seconds, so this method works, but not very accurately. Finally, the shuttle ring on either the front panel or the remote control can be used in play or pause mode to achieve different playback speeds, and also in stop mode to fast-forward or rewind the tape.

The VT-UX625A offers an index mark feature that helps you locate specific sections on a tape that contains several recordings. Whenever you press the REC or REC/IRT button to record a program, an index mark is automatically created. In index search mode, the VCR fast-forwards or rewinds until it finds an index mark, then plays 15 seconds of the program that starts at that spot on the tape. Press PLAY to watch that program, or else the VCR continues its index mark search.

The remote control is thoughtfully designed, and can be programmed to control a television from just about any major manufacturer (programming codes appear in the manual). Its top portion contains a red POWER button and several less-used buttons (including the numeric keypad) that are smaller and darker than those on the lower portion. Besides being larger and easier to reach, those buttons are backlit (with a press of the LIGHT button) for use in darkened rooms. We found the larger buttons took some getting used to—they had a mushy feel and required a hard push to the center of the button to activate them. The shuttle dial is found at the bottom of the remote control.

Besides the glitch that we unfortunately experienced with the very first tape on which we tried the Movie Advance feature, we had no other trouble on any of the Ultravision VT-UX625A’s operations. Setup and recorder timing were easy, and the on-screen menus were easy to follow. Our number one complaint, however, is that the deck does not offer Commercial Advance in addition to Movie Advance. It stands to reason that folks who dislike previews and ads on recorded tapes would also be annoyed by commercials in the programs they record off the TV. Why not eliminate such interruptions altogether? We hope that Hitachi will do so with a future model. ■

NEW PRODUCTS

LIGHTWEIGHT ANTENNAS

MFJ's lightweight antennas, the MFJ-1721 2-Meter UltraLite and MFJ-1722 2-Meter/440 MHz UltraLite, are built for mobile use. They eliminate the shielding effect of your car and produce significant gain, especially compared to a handheld rubber duck that radiates poorly in a car. Place one of these magnet-mount antennas on the roof of your car, and its full-length radiator will significantly extend the range of your handheld.

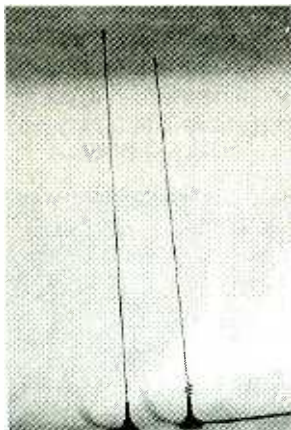

The MFJ-1721 and MFJ-1722 antennas both handle 50 watts on two meters, and their SWR is typically less than 1.5:1. The MFJ-1721 is nominally $\frac{1}{4}$ wave on two meters and can be adjusted for any frequency to 500 MHz. Only the dual-band antenna, the MFJ-1722, covers the 440 MHz-range as well, with a power rating of 25 watts. It is a full $\frac{1}{4}$ wave on 144 MHz.

Weighing less than two ounces each, the antennas include nine feet of flexible RG-174U coax cable with a BNC connector. Take these antennas anywhere—their sleek black finish blends with any vehicle. Built for rugged, mobile use, the UltraLites' 20-inch stainless-steel whip will curve to fit any briefcase, bag, or glove compartment, giving extra protection for your rig or handheld. Each magnet-mount antenna comes with a tiny, powerful 1- $\frac{1}{8}$ -inch diameter earth magnet and an adapter for mobile rigs.

The MFJ-1721 antenna costs \$14.95 and the MFJ-1722 costs \$18.95. For more information, contact MFJ Enterprises Inc., P.O. Box 494, Mississippi

State, MS 39762; Tel. 800-647-1800; Web: www.mfjenterprises.com.

CIRCLE 80 ON FREE INFORMATION CARD

SOCCER ROBOT

This easy-to-build interactive Soccer Robot (MV-982) from OWI Incorporated, brightly-colored in red, is an eye-catching project. Designed for beginning builders (10 years old and above), it comes with complete step-by-step instructions that make construction a snap.



The robot (measuring 5 $\frac{1}{2}$ -x3 $\frac{1}{2}$ -x5-inches) has six operational kicking mechanisms, and it includes a control box and a red and yellow soccer ball. With its ability to run forward, backward, to turn left or right, and to make 360(turns, the Soccer Robot makes for both an educational project and an entertaining toy. Children of all ages will have hours of fun playing games and tournaments. Not only will they surprise their friends with the great moves they can make with the robot, they will be developing hand/eye coordination skills at the same time.

As part of building this project, the hobbyist or student will learn the basics of robotics, soldering, and electronics. Every robot-builder will gain a knowledge of sensors and gear drives, as well as a familiarity with block diagrams and schematics.

The MV-982 Soccer Robot has a suggested retail price of \$34.95. Contact OWI Incorporated, 1160 Mahalo Place, Compton, CA 90220-5443; Tel. 310-638-4732; Fax: 310-638-8437.

CIRCLE 81 ON FREE INFORMATION CARD

SURGE PROTECTOR

American Power Conversion (APC) has introduced the SurgeArrest SurgeStation series, providing surge protection for computer peripherals, PCs with

modems, cable TV, and other electronic equipment. It is offered in three product families—professional, performance, and the network series.

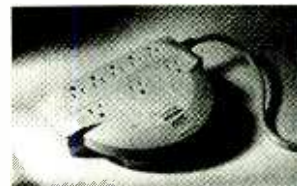

The SurgeStation is available in models which feature eight outlets, three of which are spaced to handle transformer blocks and two of which are "always on" outlets for constant power devices. It provides a building wiring-fault indicator, which allows users to diagnose wiring problems as soon as the unit is plugged in. The surge protector comes with a right-angle plug that maximizes work space and a foot-operated switch that's recessed enough to prevent accidental turn-off. It is available in models with protection built-in for multiple telephone lines, telephone and cable/DSS/cable modems, or networks (100BaseT, 10BaseT, and Token Ring).

Its compact design enables it to be wall-mounted or to fit on or under your desk or workspace. The eight-outlet models measure 1.75-x8.0-x5.74-inches. Cord-management straps that can be used to wrap up and organize power cords are an option on selected models.

The SurgeArrest SurgeStation series starts at \$59.99. Contact American Power Conversion, P.O. Box 278, 132 Fairgrounds Road, W. Kingston, RI 02892; Tel. 800-877-4080 or 401-789-5735; Fax: 401-789-3710; Web: www.apcc.com.

CIRCLE 82 ON FREE INFORMATION CARD

BOSE RADIO

Bose Corporation announces the Connoisseur Edition Wave Radio. With its special rich platinum finish and taupe and burgundy accents, it makes an ideal gift for the holidays, Valentine's Day, or any special occasion.

The Connoisseur Edition offers the
(Continued on page 59)

ELECTRONICS LIBRARY

SECRETS OF RF CIRCUIT DESIGN: 2nd EDITION

by Joseph J. Carr

The revised and updated intermediate-level handbook gives readers the best ways to design, build, and test today's radio frequency (RF) circuits. It's filled with projects and experiments that make it easy to apply RF principles to real-life applications.

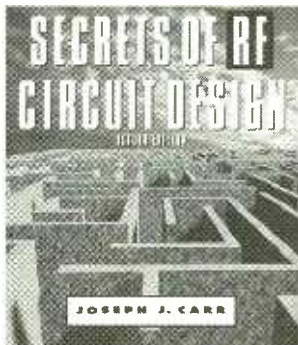

Joe Carr, the author, is a regular columnist for **Popular Electronics**. He takes you step-by-step through functional projects, such as designing and building radio receiver circuits, RF bridges, amplifiers, receiver preselectors, simplified spectrum analyzers, and time-domain reflectometers. Parts lists and component sources are provided for every project.

With this reference book, readers will learn how to select, use, maintain, and repair variable capacitors. They will also learn how to design and wind inductor coils, and construct and ground simple wire antennas. There is detailed coverage of simple RF instruments, as well as UHF and microwave components. In response to reader feedback, the second edition now has material on Very Low Frequency (VLF); building inductance-capacitance (LC) RF filters—high-pass, low-pass, bandpass, and notch; and double-balanced mixers.

Secrets of RF Design: 2nd Edition costs \$24.95 and is published by TAB Books, Division of McGraw-Hill, Inc., 11 West 19th Street, New York, NY 10022; Tel. 800-2MCGRAW or 212-337-5951; Fax: 212-337-4092; Web: www.ee.mcgraw-hill.com.

CIRCLE 91 ON FREE INFORMATION CARD

THE NO B.S. GUIDE TO WINDOWS NT 4.0

by Jim Forkner

Aimed at readers who already know how to launch programs and print files from Windows NT4.0, this book covers what every Windows NT 4 user needs to know. There are thorough instructions on installing your system—how to get it ready or uninstall it if you change your mind, and how to install both Windows NT Workstation and Server.

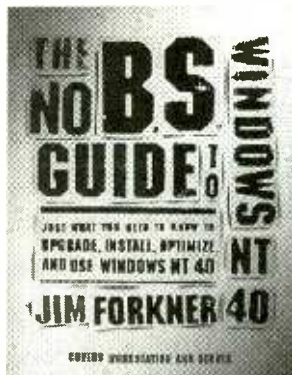

Tips are given on customizing NT and using NTFS file access controls. Free productivity aids that are available from Microsoft are covered, as well as upgrading the system with the latest service packs and "hotfixes." Users are taught how to upgrade to the latest free version of Microsoft's Web browser, Internet Explorer, and install fax software for Windows NT Workstation.

The author explains how to administer an NT system, and use an NT domain—a virtual computer spanning all the resources of the user's network. Also covered is connecting the NT system to a LAN or the Internet, and installing the Web server, NT Server. NT Server comes with FrontPage, a product that can be used to create the basis of an entire Web site. Readers are shown how to use FrontPage to start building a Web site in less than 30 minutes.

The No B.S. Guide to Windows NT 4.0 costs \$21.00 and is published by No Starch Press, 401 China Basin Street, Suite 108, San Francisco, CA 94107-2192; Tel. 415-284-9900; Fax: 415-284-9955; Web: www.nostarch.com.

CIRCLE 92 ON FREE INFORMATION CARD

GENERAL CATALOG

from Contact East, Inc.

The most recent catalog from Contact East is a 268-page full-line catalog packed with hundreds of new test instruments and tools for engineers, technicians, and hobbyists. Featured are products from brand-name manufacturers for testing, repairing, and assembling electronic equipment. Highlights include: Fluke's 123 20-MHz-Scopemeter, Tektronix' TDS 200 series compact digital scopes, and Hewlett Packard's Basic instruments line, B&K Precision power supplies and Leader function generators and counters, as well as portable and bench-top digital-storage scopes and DMMs.



There is a full selection of EPROM programmers, soldering/desoldering equipment, tool kits, power supplies, breadboards, heat guns, measuring and precision hand tools, and adhesives. Reference books are included as well. Inspection and communication test equipment, PCB assembly devices, ESD protection products, ozone-safe cleaners, magnifiers, workbenches and tool cases are among the other products also covered. A handy index, which lists product manufacturers as well as product types, makes it easy to find the item you are looking for.

The General Catalog is free upon request from Contact East, Inc., 335 Willow Street, North Andover, MA 01845; Tel. 508-682-2000; Fax: 508-688-7829; Web: <http://www.contacteast.com>.

(Continued on page 96)

A HANDS-ON APPROACH TO OP-AMP BASICS

Operational amplifiers have infiltrated nearly every aspect of our lives, finding application in everything from TVs and VCRs to computers and transportation. In this article, we'll show you how these little globs of grease operate, and then we present three op-amp-based projects to help further your understanding of this extremely adaptable device.

FRED NACHBAUR

The operational amplifier (op-amp) is perhaps the single most useful component in linear electronics. This article covers some op-amp basics, and it details three interesting and useful "one-evening" circuits built around the LM358 dual op-amp: a phono pre-amp, an RF probe, and a digital thermometer. All three projects are battery powered, and they contain no exotic parts. But before we get into the actual projects, let's cover basic op-amp theory.

The operational amplifier derives its name from the early days of analog computing. In its original application, it was used to perform mathematical operations such as addition, subtraction, and so on. Even today, there is considerable interest in the op-amp's ability to perform arithmetic and calculus operations to simulate complex systems in real time, using voltages or currents as analogs of real-life situations.

It was not long, however, before it was realized that the op-amp could be used in a much greater range of applications than originally anticipated. Today, virtually all analog electronic gear uses at least one op-amp.

What Is An Op-Amp? Figure 1A shows the commonly accepted schematic symbol for the op-amp. Note that unlike most traditional



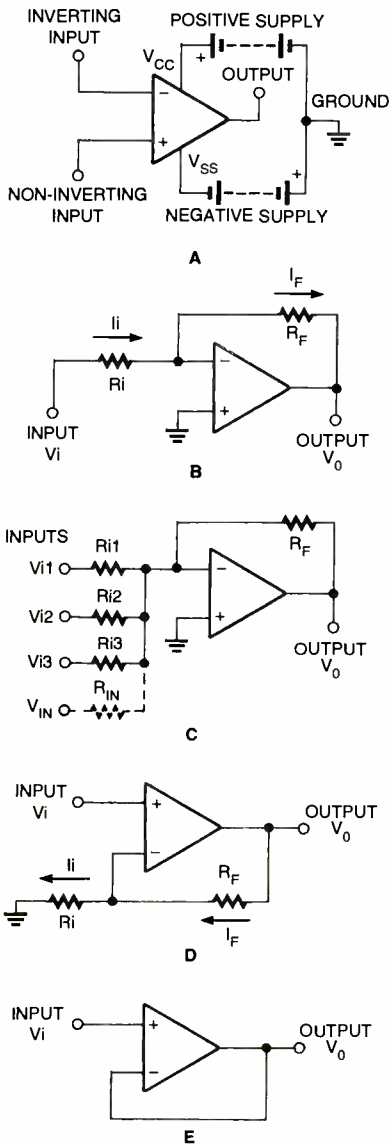

Fig. 1. The commonly accepted schematic symbol for the operational amplifier is shown in A. The op-amp's inverting configuration is shown in B, a summing amplifier is shown in C, the non-inverting configuration is shown in D, and E shows a non-inverting voltage follower configuration.

amplifiers, which have only a single input and a single output, the op-amp has two inputs: One input, marked "+," is called the non-inverting input, and the other, marked "-", is called the inverting input. Having two separate inputs allows for an incredible degree of flexibility in application.

The input signal can be applied to either input, thereby giving a choice of inverting or non-inverting amplification. In a non-inverting amplifier (signal applied to the + input), the output phase is identical

to the input phase; *i.e.*, as the input goes positive, the output also goes positive, and vice versa. Conversely, in an inverting amplifier (signal applied to the - input), the output phase is inverted from the input phase; *i.e.*, as the input goes positive, the output goes negative.

Another way of looking at that is to view the inputs as *differential* inputs. That is, the output responds not to an absolute voltage value at either input, but rather to the *difference* between the voltages presented to its two inputs. A second mode of operation, often called an "instrumentation amplifier," takes advantage of that characteristic, wherein both inputs are used in a differential, or *push-pull* configuration.

The third mode, *common mode*, represents the same signal simultaneously applied to both inputs. In a perfect op-amp, the common-mode gain would of course be zero, since the effects on the two inputs would exactly cancel. However, in the real world, there's always some slight difference in voltage gain between the two inputs, resulting in some output signal under the common-mode condition.

Originally, op-amps were designed to operate from "bi-polar" power supplies, thereby allowing the op-amp's inputs and outputs to swing either above or below the ground reference. However, op-amps can be operated from conventional single-end supplies if appropriate design measures are taken. We'll explore a couple of different options as we discuss each circuit.

The Ideal Op-Amp. Let's digress briefly to examine the characteristics of what we'll call the "ideal" op-amp. If such a critter existed, it would have the following properties:

- 1) Infinite differential voltage gain
- 2) Zero common-mode voltage gain
- 3) Infinite input impedance (zero current into inputs)
- 4) Zero output impedance (output voltage independent of output current)

Lest anyone think that we're engaging on some quest for the

PARTS LIST-THE RIAA PHONO PREAMPLIFIER

RESISTORS

(All resistors are 1/4 or 1/8 watt, 5% metal film units.)

- R1, R10—430,000-ohm
- R2, R3, R4, R11, R12, R13—51,000-ohm
- R5, R6, R14, R15—510-ohm
- R7, R16—15,000-ohm
- R8, R17—1000-ohm
- R9, R18, R19—10,000-ohm

CAPACITORS

- C1, C6—1- μ F, 16-WVDC, electrolytic or tantalum
- C2, C7—0.3- μ F, 16-WVDC, tantalum or Mylar
- C3, C8—33- μ F, 16-WVDC, electrolytic
- C4, C9—1500-pF, ceramic-disc or Mylar
- C5, C10—0.47- or 0.5- μ F, 16-WVDC, electrolytic, tantalum or Mylar
- C11—100- μ F, 16-WVDC, electrolytic
- C12—22- μ F, 16-WVDC, electrolytic

ADDITIONAL PARTS AND MATERIALS

- B1—9-volt, alkaline (or 8.4-volt NiCd) transistor-radio battery (see text)
- IC1—LM358 or LM1458 dual op-amp, integrated circuit (see text)
- J1-J4—RCA female chassis-mount (preferably isolated from chassis)
- S1—SPST slide, rocker, or toggle switch
- Printed-circuit board, metal enclosure, stereo patch cord, battery clip, IC socket, wire, solder, hardware, *etc.*

unattainable, it should be mentioned that real-life op-amps actually approach the ideal in most applications. So exploring the characteristics of the ideal op-amp is not a wistful exercise, it is, instead, a useful tool to get a handle on the non-ideal devices in this all-too-imperfect "real world."

While we're at it, let's add a couple more characteristics to our wish list for the ideal op-amp:

- 5) Infinite bandwidth (flat frequency response from DC to infinity)
- 6) Inputs and outputs capable of swings to power supply limits
- 7) No output phase shift at any frequency

The Inverting Amplifier. Figure 1B shows a basic inverting amplifier, consisting of an op-amp and two resistors; R_i (input) and R_f (feed-

back). Our input signal is applied to R_i and referenced to the non-inverting input (ground). Note: For the sake of discussion, we're assuming the traditional bi-polar supply.

What can we deduce from this circuit? Well, let's start with Condition 1, infinite differential gain. That means that regardless of the output voltage, the differential voltage between the inverting and non-inverting inputs must be zero. Since the non-inverting input is at ground potential, it follows that the inverting input must also be at ground potential. That situation is called a *virtual ground point*. It, therefore, follows that the input resistance of the amplifier is exactly equal to R_i . Another way of stating this is that our input current (I_i) is equal to input voltage V_i divided by R_i . A surprising conclusion is that the signal voltage at the inverting input is zero, even though there is no current flowing into it!

Condition 3, infinite input impedance, implies that current into either input must be zero. By Norton's Current Law, which states that the sum of all currents entering a node must equal zero, we can deduce that since there is current I_i entering the node at the inverting input, that same magnitude of current must be leaving the node via R_f . In other words, $I_f = -I_i$.

By Ohm's Law, our output voltage V_o must equal I_f multiplied by R_f , since the left side of R_f is at zero volts. A little algebraic manipulation gives the following simple (and perhaps surprising) result:

$$\text{Voltage Gain} = A_v = V_o/V_i = -R_f/R_i$$

The minus sign tells us that the output phase is inverted, since we're applying our signal to the inverting input. Note that overall *open-loop* gain (assumed infinite) plays no part in this relationship, nor does output impedance (assumed to be zero by Condition 4), or input impedance (assumed infinite by Condition 3). That sounds too good to be true.

The amazing thing is that in a great many circuits, our set of assumptions describing the ideal op-amp is entirely reasonable. Typically, the open-loop voltage

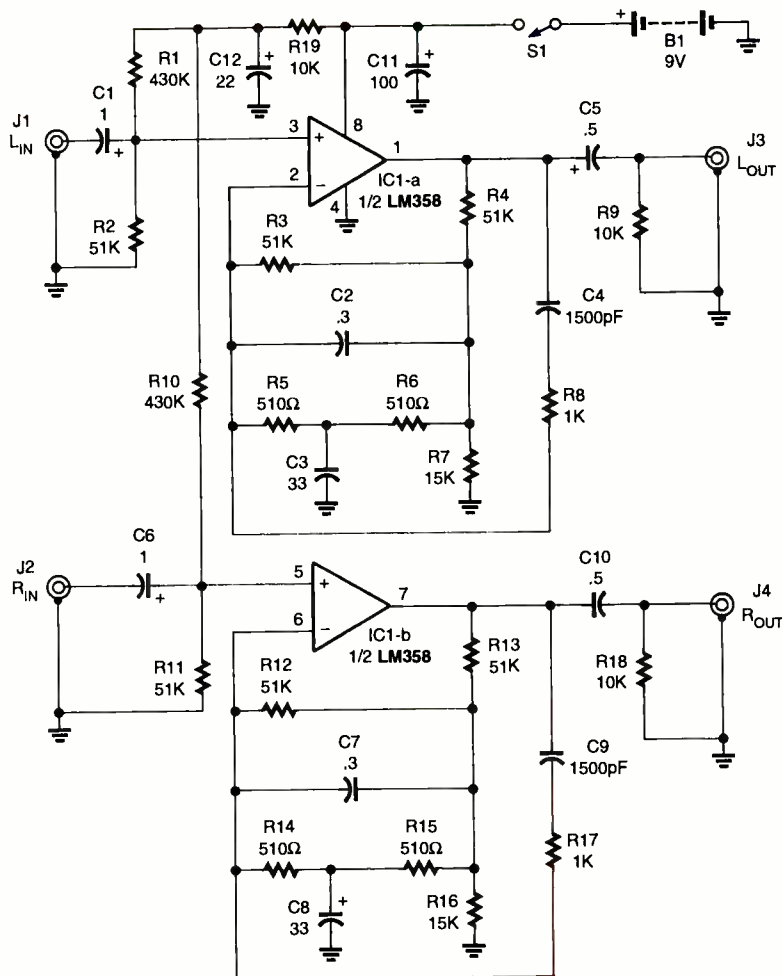

Fig. 2. The RIAA Magnetic Phono Preamp can be used to boost the level of any magnetic cartridge to the line level required to drive the AUX, CD, VCR or TAPE IN inputs, of your stereo, while simultaneously equalizing the frequency response to the RIAA standard used on vinyl records.

gain of an op-amp is on the order of 100,000. Provided that our closed-loop gain (set by the ratio of R_f to R_i) is much less than the open-loop gain, our calculations based on the ideal op-amp will be so close to the actual value that we would be hard pressed to even measure the deviation.

For instance, plugging real numbers into our circuit, if $R_i = 1000$ ohms and $R_f = 100,000$ ohms, our "theoretical" gain would be 100. Assuming an open-loop gain of 100,000, our actual gain will be only 99.99. Given that component tolerances on even precision resistors rarely are better than 0.5 percent, the 0.01 percent deviation in calculated gain versus actual gain is negligible. Similarly, the other assumptions (infinite input impedance and zero out-

put impedance) are entirely reasonable and therefore valid, when using op-amps in a closed-loop configuration.

So far we haven't mentioned Condition 2. That one essentially states, together with Condition 6, that we can choose any voltage as our reference without any effect on our signal gain. Conditions 5 and 7 tell us that our frequency and phase response will be flat (constant gain vs. frequency), regardless of signal levels. While those assumptions can be reasonable over a given range (e.g., the audio range from DC to 20 kHz), we have to be careful when going beyond that range, modifying Condition 5 as needed. Deviation from the ideal set forth in Condition 7 can also get us in trouble when using low closed-loop gain (low ratio

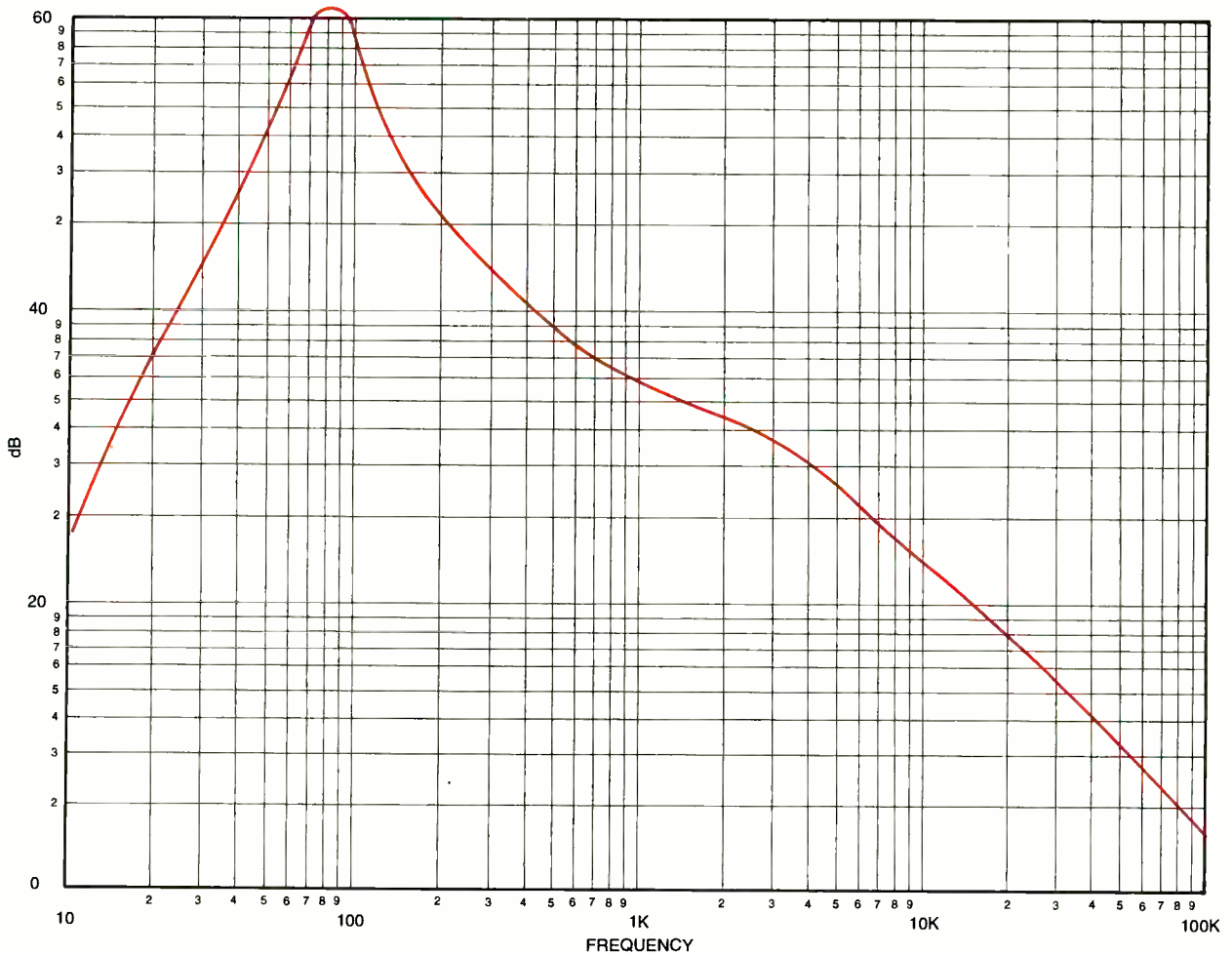

Fig. 3. Seen here is the measured frequency response of this design of the RIAA Magnetic Phono Preamp.

of R_f to R_i) because of phase shifts that can result in oscillation.

The LM358 dual op-amp is unconditionally compensated, meaning that its frequency response is internally limited to prevent oscillation at low gains. The price is a more limited bandwidth (Condition 5) at higher gains. Still, for the frequencies of interest in our projects (essentially the audio range), assumptions 5 and 7 are still reasonable.

The last assumption we have to modify (or at least take into account) is 6. Real op-amps can get quite close to either supply rail (typically within a volt or less), but we still have to be careful when using low supply voltages to prevent unplanned-for clipping distortion. An interesting feature of the LM358 (and similar op-amps) is that, for the inputs, we actually encounter that condition as regards the negative supply rail (though not as regards

the positive rail). That means that inputs can go to the negative supply or even slightly below, and the op-amp will still work properly. Similarly, the output can go very low (to within less than 0.05 volts of the negative supply), making it well suited for single-supply battery applications.

A special case is the inverting voltage follower, or just plain "inverter." If the two resistors have the same value, gain will be 1 (unity), but the output will be inverted from the input.

Addition and Subtraction (Mixing).

Any number of input resistors (R_i) can be added to make active mixers. See Fig. 1C. Mathematically, such circuits perform addition, or (if preceded by inverting voltage followers) subtraction operations. Since the inverting input of the op-amp is at virtual ground, there's no interaction between input sources

as is always the case to some degree with passive mixers.

By choosing different values for the input resistors, each input can be appropriately *weighted* (which, in mathematical terms, would correspond to multiplication by a constant). So you could combine microphone- and line-level inputs in audio mixer applications within a single mixer (analog adder) stage.

Other Inverting Operations. If the resistors in Fig. 1B are replaced by other components, a variety of other operations are possible. Table 1 lists some of the options that are possible. Since we won't be using any of those options in our projects, we won't pursue them any further than to give a summary of the possibilities. Other combinations (networks) give even more complex options, such as filters (notch, band-pass, low-pass, high-pass) and other

Studies show that jobs for computer service technicians will be up by 38% in the next 10 years!

Prepare for today's opportunities in computer service with NRI's flexible, state-of-the-art training

As an NRI student, you're in charge. You decide when and where to study. You set your own pace. You even build a computer system that suits your needs and budget. Only NRI training gives you the control you want, the expertise you need!



You prepare for A+ Certification with one-on-one instruction and NRI's CD-ROM tutorial

Throughout your course, your work is reviewed and evaluated by your experienced instructor. So even though you're studying at home, you're never alone. You can reach your instructor by mail, phone, fax, or modem.

That's right! With NRI's exclusive Online Connection you can chat with your instructor, attend online seminars, get the answers to

frequently asked questions, download supplemental materials, find out about changes in technology, and more.

As the culmination of your training, you receive NRI's interactive CD-ROM with tutorials related to the A+ Certification exam. In no time at all, you'll have the skills, experience, and confidence you need to sit for the A+ exam and take advantage of the booming opportunities in computer service. Just think — everyone with a computer is a potential client!



YOU GET EVERYTHING YOU NEED FOR SUCCESS

- **PENTIUM® 200 MMX™ PC** Features 16 meg RAM, 256K cache memory, and 1.6 gigabyte hard drive for exceptional data storage capacity and data access speed
- **SUPER VGA COLOR MONITOR** Plus 1 meg video memory
- **EXCITING MULTIMEDIA PERIPHERALS** 8X CD-ROM drive, 16-bit sound card, and stereo speakers
- **FAX/MODEM** 33,600 baud for fast communications, plus Netscape Navigator™ Web browser and ten free hours of America Online
- **DIAGNOSTIC PACKAGE** The portable ForeFront Troubleshooter™ software and CD-ROM for quick detection of system and multimedia failures
- **NRI DISCOVERY LAB** Complete breadboarding system to design and modify circuits, diagnose and repair faults
- **COMPUTER-BASED ELECTRONICS TROUBLESHOOTING** Interactive diskettes help you solve common component problems
- **WINDOWS 95/98 UPGRADE** Today's popular, time-saving operating system
- **CD-ROM TUTORIAL** Easy prep for A+ Certification!

With a combination of step-by-step lessons and hands-on training projects, NRI builds your skills and confidence quickly. You begin with an exploration of electronics and move on to such cutting-edge subjects as virus protection, multimedia troubleshooting, PC communications, Local Area Networks, and more.

Best of all, you get the top-notch computer and diagnostics you need to put theory into practice — and start earning while you learn!

You train with and keep the exact computer you want

Understanding that technology changes rapidly, NRI has just created its unique PC Options Plan. When you're due to receive your Pentium® processor-based system, you're given options based on future developments in technology. You may choose the Pentium® 200 MMX™ system described here or purchase selected upgrades at special student rates. It's our state-of-the-art guarantee!

No matter what PC features you prefer, you'll get the software and diagnostics respected throughout the industry: Windows 95 (with a guaranteed upgrade to Windows 98), Netscape Navigator™, and the self-booting ForeFront Troubleshooter™ diagnostic package. No school gives you more!

FREE CATALOG!
1-800-321-4634, Ext. 2862
Visit our Home Page at <http://www.mhcec.com>

SEND TODAY FOR FREE NRI CATALOG!

NRI Schools 4401 Connecticut Avenue, NW
Washington, DC 20008

Check one FREE catalog only.

- | | |
|--|---|
| <input type="checkbox"/> PC SERVICING | <input type="checkbox"/> PC Applications Specialist |
| <input type="checkbox"/> Computer Programming | <input type="checkbox"/> Networking with Windows NT |
| <input type="checkbox"/> TV/Video/Audio Servicing | <input type="checkbox"/> Bookkeeping and Accounting |
| <input type="checkbox"/> Desktop Publishing with PageMaker | <input type="checkbox"/> Mastering Microsoft Office |

OR GET YOUR AAS DEGREE!

- | |
|--|
| <input type="checkbox"/> Accounting |
| <input type="checkbox"/> Business Management |
| <input type="checkbox"/> Computer Science |
| <input type="checkbox"/> General Studies |

Name _____ (please print) _____ Age _____

Address _____

City _____ State _____ Zip _____

A Division of The McGraw-Hill Companies



Accredited Member, Distance Education and Training Council 0018-0298

specialized signal-processing operations. (Note: The transistor referred to in Table 1 is an ordinary bipolar unit with its base and collector tied together.)

By cascading various operators, more complex functions can be achieved. For instance, the outputs of two or more logarithmic amplifiers can be added or subtracted (mixed), then fed to an exponential (*anti-log*) amplifier to achieve multiplication and division operations.

The Non-Inverting Amplifier. Figure 1D shows the basic non-inverting configuration. In that case, the signal is applied to the non-inverting input, and negative feedback is applied from the output to the inverting input via resistors R_f and R_i . Again following the ideal model, an analysis of the circuit (and again using the reverse logic used for the first analysis) reveals these characteristics:

- 1) Since the signal is applied directly to the non-inverting input, the input resistance is infinite. (In real op-amps, we have to modify that statement to *practically infinite*.)
- 2) Assuming infinite gain, it follows that the input signal will also appear at the inverting input, since again there must be zero differential voltage (in reality, practically zero.)
- 3) Once again, current into the inverting input will be zero, so we can conclude that the current flowing in R_i equals the current through R_f .

Putting that all together using the voltage divider rule, we arrive at the conclusion that $V_o/V_i = A_v = (R_f + R_i)/R_i$ or $A_v = (R_f/R_i) + 1$. Note that the present equation differs from the one arrived at for the inverting amplifier. For instance, with R_f equaling R_i , the inverting amplifier would have a gain of 1 (unity), whereas the non-inverting amplifier would have a gain of 2. At higher voltage gains, however (greater than, say, 20 or so), you can safely use the simpler formula $A_v = R_f/R_i$ without too much error.

A special case of the non-inverting amplifier is shown in Fig. 1E. In

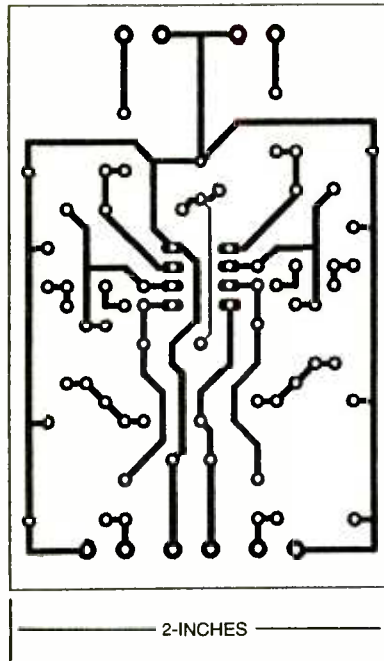

Fig. 4. The Magnetic RIAA Phono Preamp was assembled on a small printed-circuit board. A template of the printed-circuit artwork is shown here full-size.

that case, R_f equals zero, and R_i is indeterminate (i.e., R_i could equal any value, as you can verify by plugging values into the equation in the previous paragraph). That circuit is called a *voltage follower*, since the output voltage tracks the input voltage. Although there is no voltage gain in such a circuit, there is a phenomenal current gain, since the input resistance is near-infinite, and the output impedance is near-zero.

You may have noticed in our discussion of the inverting amplifier that its input impedance is definitely finite, being equal to R_i . In actual circuits, it is rarely practical to use values for R_i much greater than 100k or thereabouts. However, by preceding the inverting amplifier stage with a voltage follower, near-

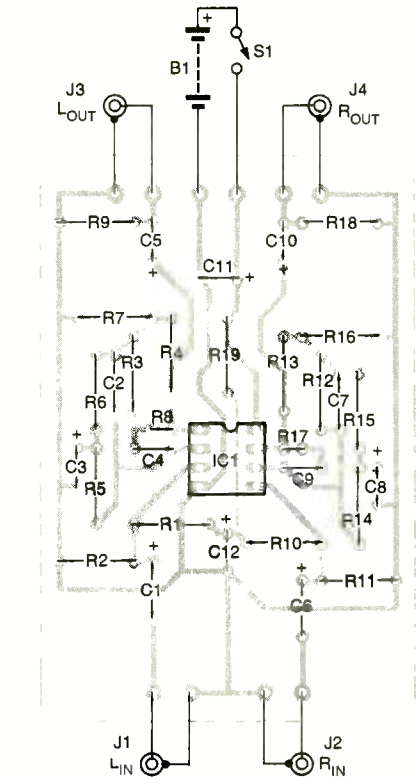

Fig. 5. Assemble the printed-circuit board for the preamp guided by this parts-placement diagram. Be sure to use shielded cable to make the connections between the circuit board and the input/output jacks.

infinite input impedance can be achieved. That's a very common use for dual op-amps. Without increasing the parts count, you can make inverting amplifiers (or other inverting operators) with a very high input resistance. Using that technique, you can avoid the problems that arise due to loading effects on the signal source.

Other Non-Inverting Operators.

Unfortunately, the non-inverting configuration does not lend itself as easily to other tasks such as summing, or the calculus operations of integration and differentiation. Common

TABLE 1—ALTERNATE OPERATIONS

INPUT ELEMENT	FEEDBACK ELEMENT	OPERATION
Resistor	Resistor	Amplifier
Capacitor	Capacitor	Amplifier
Resistor	Capacitor	Integrator
Capacitor	Resistor	Differentiator
Resistor	Transistor*	Logarithmic amp
Transistor*	Resistor	Exponential amp

*See Text

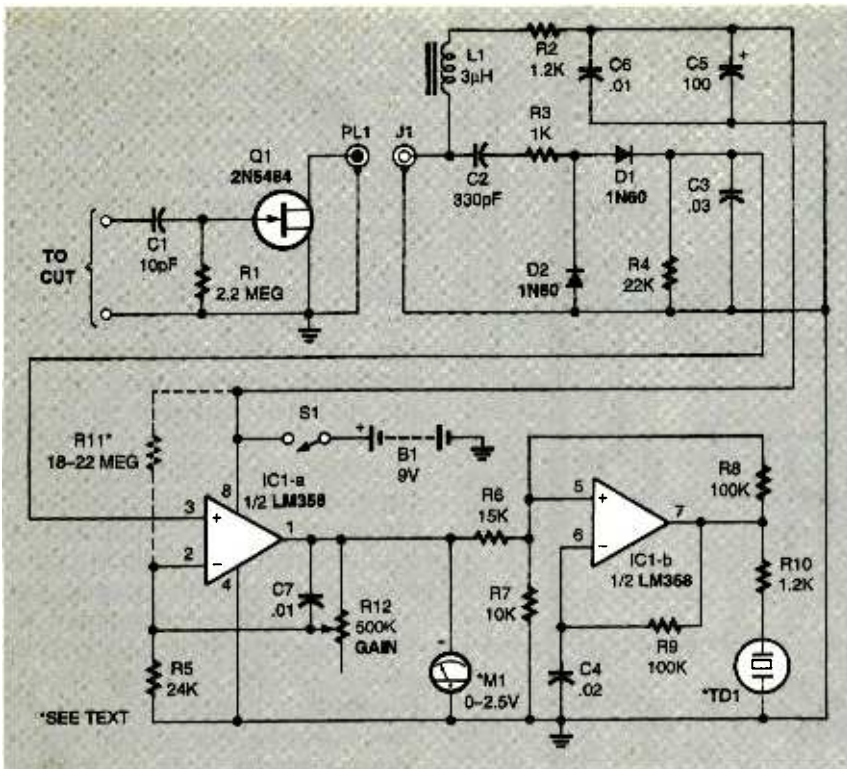

Fig. 6. The RF Sniffer can be broken down into two main sections: an active probe and a DC amplifier. Unlike conventional probes that can severely affect the resonant point of the circuit under test, the active probe reduces loading effects.

practice, in such instances, is to use the inverting configuration, and either precede or follow it with an inverting voltage follower. Again, the dual op-amp lends itself ideally to such applications.

However, there is a virtually unlimited range of possibilities for designing active-filter networks around the non-inverting amplifier. As an example, the phono preamp uses non-inverting amplifier to build an amplifying filter customized to produce the RIAA response curve of the magnetic phono cartridge.

RIAA Magnetic Phono Preamp.

With the resurgence of interest in vinyl records, it seems that many people are looking for preamps that allow using magnetic phonograph cartridges with modern stereos that lack phono inputs. Our phono preamp can be used to boost the level of any magnetic cartridge to the line level required by your stereo's AUX, CD, VCR or TAPE IN inputs, while simultaneously equalizing the frequency response to the RIAA standard used on vinyl records.

Figure 2 shows the schematic diagram of the *RIAA Magnetic*

Phono Preamp. In that circuit, the two halves of the LM358 (IC1-a and IC1-b) are used as left- and right-channel stereo amplifiers. The non-inverting configuration is used to satisfy purists who insist that the phase be consistent throughout the audio chain. However, the actual circuit is a bit more complex than the simple examples presented in our tutorial. So, let's dive right in, and use what we've learned so far to figure out the basic operation of our preamp. For our discussion, we'll refer only to the parts' designations for the left-channel of the circuit; the right channel is, of course, identical.

We'll start with a DC analysis. For our purpose, imagine that all the capacitors are missing from the circuit, since they act as open circuits for DC (and sufficiently low frequency AC signals). Using the voltage divider rule, and given that the current drawn by the op-amp inputs can be neglected, the DC voltage at the non-inverting input is 9 volts; so $R2/(R1 + R2) = 9 \times 51/(51 + 430) = 0.95$ volts. Because the AC input signal is on the order of hundreds of microvolts, and the LM358 inputs can operate down to the

negative supply rail, there is plenty of input headroom.

Because the differential voltage across the inputs is approximately zero and the inverting input draws zero current, we can conclude that there must be 0.95 volts DC at the junction of R4 and R7. Therefore, the op-amp output voltage must be 0.95 volts: so $(R4 + R7)/R7 = 0.95$ volts $\times (51 + 15)/15 = 4.2$ volts. Again, we have plenty of output headroom, since the maximum voltage expected at the output is around 2 volts peak. If the calculations were repeated for a 6-volt supply, you'd find that the input DC bias voltage would be 0.64 volts and the output bias voltage would be 2.8 volts—still quite reasonable.

For AC signals, the capacitors are, of course, not negligible. In fact, using capacitors C2, C3, and C4 within the feedback loop makes the circuit an amplifier with RIAA equalization. A full AC analysis is beyond the scope of this article. But suffice it to say, the result of frequency equalization is to give a smooth high-frequency roll-off over most of the audible range, within the time constants specified for the RIAA standard. The measured frequency response of this design is shown in Fig. 3.

The overall circuit is essentially a modified integrator. It might help your understanding to recognize that the output of a magnetic cartridge is proportional to the *velocity* of the stylus, not its position. In other words, the cartridge's signal is an analog of the *derivative* of stylus position, so we have to *integrate* that signal to reclaim the original frequency's characteristics.

The equivalent input resistance to the preamp is about 47k, as expected by typical magnetic cartridges. Capacitor C1 is chosen to give a 3dB corner at 30 Hz to help roll-off subsonics. Similarly, C5 and R8 form another pole at 30 Hz for a total of 12dB per octave rolloff below 30 Hz. (That constitutes a "rumble filter.") If you don't want the rumble filter, increase C1 and C5 to 1 µF, and omit R8 (as well as corresponding parts in the right channel). That gives input and output corners of 3 Hz, assuming an amplifier line input resistance of about 50k.

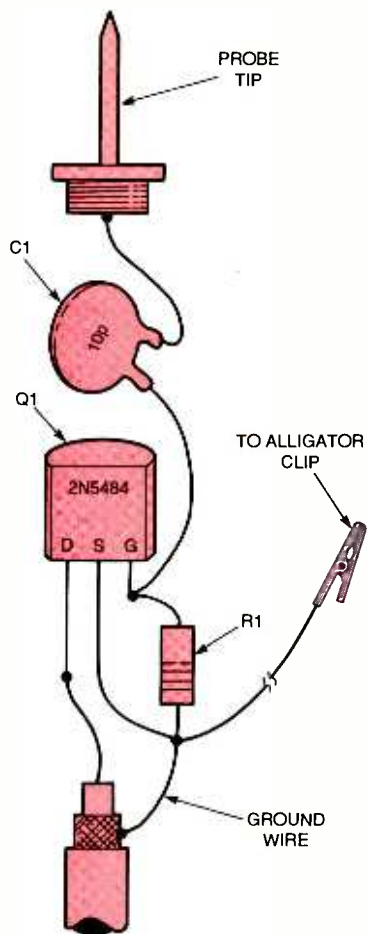

Fig. 7. The RF Sniffer was assembled in two sections—the probe and the amplifier/annunciator. Details on building the probe, which was built into the body of an old BIC pen, are shown here.

Preamp Construction. The prototype of the Magnetic RIAA Phono Preamp was assembled on a small printed-circuit board, measuring 2 by 3 inches. A template of the author's printed-circuit artwork is shown in Fig. 4. A parts-placement diagram for the preamp's printed-circuit board is shown in Fig. 5. In order to minimize AC hum, the circuit should be housed in a metal enclosure. Use shielded cable to make connections between the circuit board and the input/output jacks, and connect the grounds of the output jacks to the chassis. Do not connect the grounds of the input jacks to the chassis ground. If your turntable has a separate ground wire, make provision to connect it to the preamp chassis with a bolt and a couple of nuts.

Be sure to pay close attention to

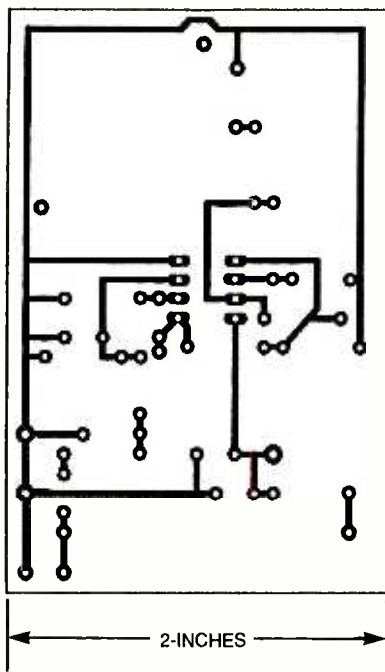

Fig. 8. The second half of the RF Sniffer, the amplifier/annunciator, was assembled on a small printed-circuit board. A template of that board layout is shown here full-scale.

the orientation of the polarized capacitors (tantalum and electrolytic). Use a low-profile socket for IC1 (the LM358). Note: The LM358 can be replaced by an LM1458, which is essentially the same part, except that it consumes slightly more power. Using a wall power supply with the preamp is not recommended, because of the low input signal levels and high gain of the circuit, especially at low frequencies.

RF Sniffer. If you do any work with radio frequencies (RF), the RF Sniffer is sure to be indispensable on your test bench. It can be used to tune and troubleshoot radio gear at frequencies ranging from the medium-wave broadcast band to well within the UHF region. Unlike most RF probes, which simply use a passive rectifier (detector) to feed a signal into a DC voltmeter, our unit has a FET broadband amplifier built into the probe tip, and a variable-gain DC amplifier after the detector. That allows for greater sensitivity and lower loading (thereby giving greater accuracy). The circuit can be used as a relative field-strength meter for comparing transmitter antennas, etc., by connecting a

short whip antenna to the end of the probe. Through its continuously variable gain, the circuit's sensitivity can be adjusted as required. The RF Sniffer also includes an audible level indicator, allowing you to tune transmitter multiplier chains without looking at the meter.

A schematic diagram of the RF Sniffer is shown in Fig. 6. The circuit can be broken down into two sections: an active probe and a DC amplifier. The probe's main function is to reduce RF loading on the circuit of interest. Conventional probes are of limited use in tuning, because capacitive loading affects the resonant point of the circuit under test (CUT). The secondary purpose of the probe is to provide broad-band gain. Most service monitor-generators are capable of outputting up to about 10,000 μV (0.01 volts). Because of that, it is difficult to directly test the front-end (RF amplifier) of receivers. That's not a problem with the active probe! The output can be compared with the input for a relative indication of the gain of the RF amp.

The probe is comprised of a 2N5484 high-frequency junction FET (Q1), a 2.2-megohm resistor (R1), and a 10-pF capacitor. Resistor R1 is used to bias the gate of Q1 at ground potential, while bleeding off static charges that might otherwise accumulate on Q1's gate. Capacitor C1 couples RF signals to Q1, while blocking DC and low frequencies, including 60-Hz AC hum. The output of Q1 (at its drain) is fed via a short length of coaxial cable to a male BNC connector (PL1). Any signal picked up by the probe is fed through PL1 to J1 (a female BNC connector) for application to the RF Sniffer. The same cable is used to feed DC power to Q1 to operate it.

In the RF Sniffer, a series circuit, comprised of a small ferrite coil (L1) and a resistor (R2), which provides a load for the JFET, is connected (via the BNC connectors) to the drain of Q1. The L1/R2 combination also supplies DC power to the probe. The network is designed to present a larger load (allowing greater gain) at higher frequencies. Components C2 and R3 are used to couple the RF signal to the detector (comprised of D1 and

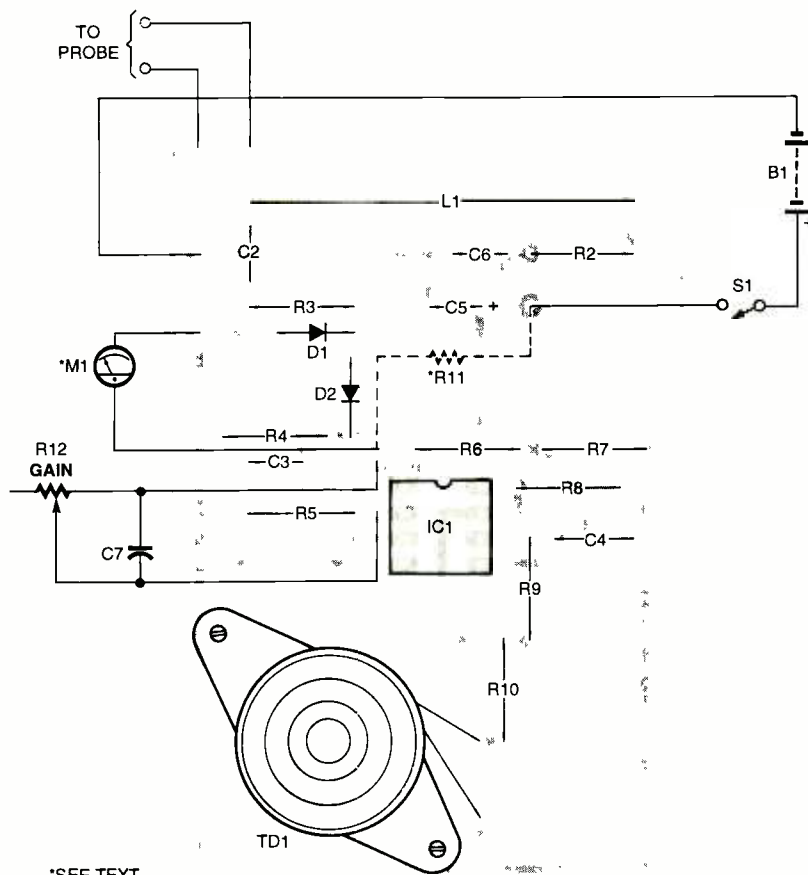

*SEE TEXT

Fig. 9. The parts-placement diagram for the RF Sniffer is shown here. Note that capacitor C7 is not mounted to the printed-circuit board, but is instead wired directly across the active terminals of R12 (the gain control).

D2). The detector converts the RF signal to a DC voltage. A pair of resistors connected in series with L1 and C2 (R2 and R3, respectively) helps to reduce the circuit's Q to prevent a large increase in response at the resonant frequency of C2 and L1.

During positive half-cycles of the input signal, C3 is charged through C2, R3, and D1. During negative half-cycles, current is diverted through D2, allowing C3 to discharge through R4. The DC output of the detector is fed to the non-inverting input of IC1-a, which is configured as a non-inverting amplifier. Note that the DC reference (ground) for the op-amp is the negative supply line and that no provision was made for "offset nulling." That means at higher gains, the output voltage remains slightly above zero. If that bothers you, install optional resistor R11; R11 should have a value ranging between 18 and 22 megohms.

Resistor values lower than 18 megohms can cause the circuit to have too much of a threshold before any voltage is registered.

The output of IC1-a is fed directly to a 0-25-volt, analog, panel-type, DC voltmeter. The voltmeter was re-scaled for 0-2.5 volt operation by changing its internal series resistor. There is some flexibility in meter selection. A 5-volt full-scale meter would be the practical upper limit, and it allows the circuit to read higher RF voltages without pinning. A 1-volt full-scale meter would be the practical choice for reading the lower limit, but would limit the maximum voltage reading.

You needn't use a dedicated meter. You can feed the output of IC1-a to a pair of jacks, allowing the circuit to feed a bench or field VOM or DVM. The 2-volt VOM range would be ideal. A small bypass capacitor (say, about 0.01 μ F or so) at the jacks would help prevent

false readings, if the RF Sniffer is used in areas near strong RF fields.

The gain of the amplifier is set by the ratio of $(R12 + R5)/R5$. Note that the lowest gain that can be achieved with the circuit is unity, whereas maximum gain can be increased by lowering the value of R5. A practical lower limit for R5 is about 5k (corresponding to a maximum gain of 100). Be aware that at less than a volt or so, the actual readings can't be trusted because of the non-ideal nature of our rectifier diodes. However, for most applications, that's not a problem. The Sniffer's most useful as a relative-RF indicator. So, it's pointless to calibrate the gain control or use a multipole switch and precision resistors to define various gain settings.

The audible indicator of the RF Sniffer is built around IC1-b, which functions as a comparator. The positive feedback path through R8 between the output and non-inverting input, produces a hysteresis voltage, allowing the amplifier's output to alternate between fully on (saturated) and fully off (cut off). A second feedback loop is formed via R9 and C4, connected between the output of IC1-b and its inverting input.

To understand how that portion of the circuit works, imagine that IC1-b has just gone high. That causes C4 to charge through R9 until the voltage on it (and at the inverting input of IC1-b) exceeds the voltage at the non-inverting input. That causes IC1-b's output to toggle low, bringing pin 5 to the lower hysteresis voltage. Capacitor C4 begins to discharge, until the voltage on pin 6 drops to the level at pin 5, and the cycle repeats. In essence, IC1-b functions as a free-running pulse generator.

As the DC input bias to the circuit increases, the width of the gap between the two trip points (hysteresis voltages) narrows, and the frequency of the pulse-generator increases. The output pulses are fed to a piezo electric transducer, TD1, which provides an audible indication of RF level!

Sniffer Construction. The RF Sniffer was assembled in two sections—the probe and the amplifier. Details on

PARTS LIST FOR THE RF SNIFFER

SEMICONDUCTORS

D1, D2—1N60 (or equivalent) germanium diode
 Q1—2N5484 (or equivalent) JFET
 IC1—LM358 low-power, dual op-amp, integrated circuit

RESISTORS

(All resistors are 1/4- or 1/8-watt, 5% metal film units.)

R1—2.2 megohm
 R2, R10—1200-ohm
 R3—1000-ohm
 R4—22,000-ohm
 R5—24,000-ohm
 R6—15,000-ohm
 R7—10,000-ohm
 R8, R9—100,000-ohm
 R11—18—22-megohms (optional, see text)

CAPACITORS

C1—10-pF, ceramic-disc
 C2—330-pF, disc-ceramic
 C3—0.03–0.033- μ F, ceramic disc
 C4—0.02–0.03- μ F, ceramic-disc or plastic-film
 C5—47–100- μ F, 16-WVDC electrolytic
 C6—0.01- μ F, ceramic-disc

ADDITIONAL PARTS AND MATERIALS

B1—9-volt, alkaline (or 8.4-volt NiCd) transistor-radio battery
 J1—BNC female chassis-mount connector
 L1—3-mH (nominal), slug-wound RF choke (see text)
 M1—0–1/10–5-volt DC panel meter (see text)
 PL1—BNC inline male plug
 S1—SPST slide, rocker, or toggle switch
 Printed-circuit-board materials, enclosure, RG174/U cable, battery clip, IC socket, wire, solder, hardware, etc.

building the probe are shown in Fig. 7. The probe was built into the body of an old BIC pen; the three parts were wired to the end of a length of RG174U cable and pushed through the pen barrel. The free end of C1 was soldered to a probe tip from a worn-out VOM cable. A 6-inch length of flexible black wire small enough to squeeze through the hole in the pen barrel was used as the ground wire. After the assembly was installed in the barrel, a small

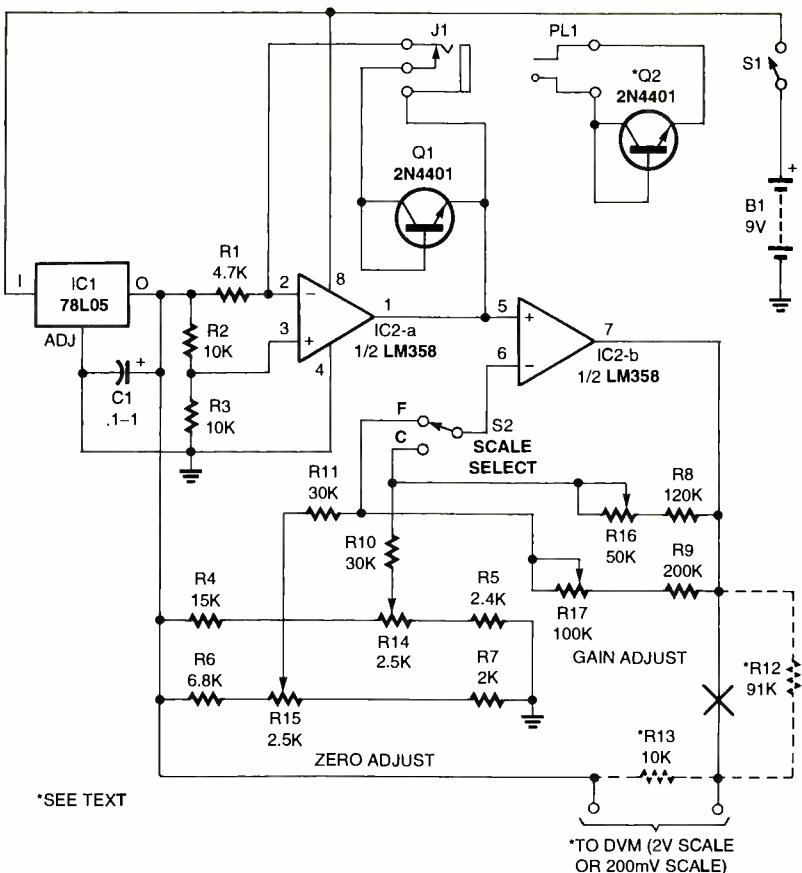

Fig. 10. The Electronic Thermometer can be used to convert any digital voltmeter (DVM) into a reasonably accurate thermometer capable of measuring from about -40°C (or F) to over 150°C (302°F). Or, if desired, a dedicated digital voltmeter module can be permanently connected to the circuit.

alligator clip was connected to the free end of the ground wire.

To seat the pin plug, heat the plug with a soldering iron and slowly push it into the pen barrel. Once cooled, the plastic hardens around the threaded portion of the probe tip. For added strength, apply a bit of "Krazy glue" around the perimeter of the tip and squeeze a bit of silicone cement around the cable where it enters the pen body. That insures that the probe won't be accidentally pulled apart. The free end of the probe's main wire can be connected to a male BNC connector. The mating female BNC connector can then be attached to the project's enclosure.

The second half of the RF Sniffer was assembled on a small printed-circuit board. A template of that board layout is shown in Fig. 8, and its corresponding parts-placement diagram is shown in Fig. 9. Note that

capacitor C7 is wired directly across the active terminals of R12 (the gain control). The RF choke, L1, can be salvaged from an old piece of equipment or you can wind your own by winding about 16 turns of 22-gauge wire on a 3/4-inch long, 3/16-inch ferrite slug. A suitable coil form is available from RadioShack (part number 273-102B). However, its inductance is far too high for our purposes (100 μ H), so remove all but 10–16 turns.

The rest of the project is pretty straightforward. As for the piezo transducer, which should be a non-oscillating type, it can be any unit that you happen to have on hand. However, if you just happen to have a self-oscillating unit, the oscillator circuit (usually a single transistor and a few resistors) can be removed from the transducer. Otherwise you can purchase one from any electronics outlet. If desired, you can

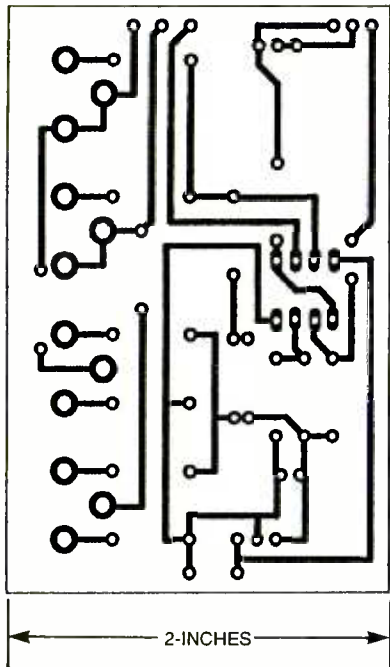

Fig. 11. The Electronic Thermometer was assembled on a small printed-circuit board, measuring 2 by 3 inches. A template of the printed-circuit-board artwork is shown here full-scale.

install a switch in series with the output transducer so that it can be turned off when not needed. If your buzzer produces a low-pitched growl at higher gain settings even when no input is applied, install R11 at the point indicated in the parts-placement diagram.

Electronic Thermometer. The final project—an *Electronic Thermometer*—can be used to convert any DVM into a reasonably accurate thermometer capable of measuring from about -40° (C or F) to over 150°C (302°F). If desired, a dedicated digital voltmeter module can be permanently connected to the circuit. A double-throw switch allows the circuit to measure Celsius or Fahrenheit.

A schematic diagram of the circuit is shown in Fig. 10. The circuit is powered from a 9-volt battery, whose voltage is stabilized by a 78L05 low-power, fixed 5-volt, voltage regulator. The output of the regulator divides along several paths, one of which leads to IC2-a (half of an LM358 dual op-amp). In that path, the output of IC1 is fed through R1 to the inverting input of IC2-a and across a voltage divider,

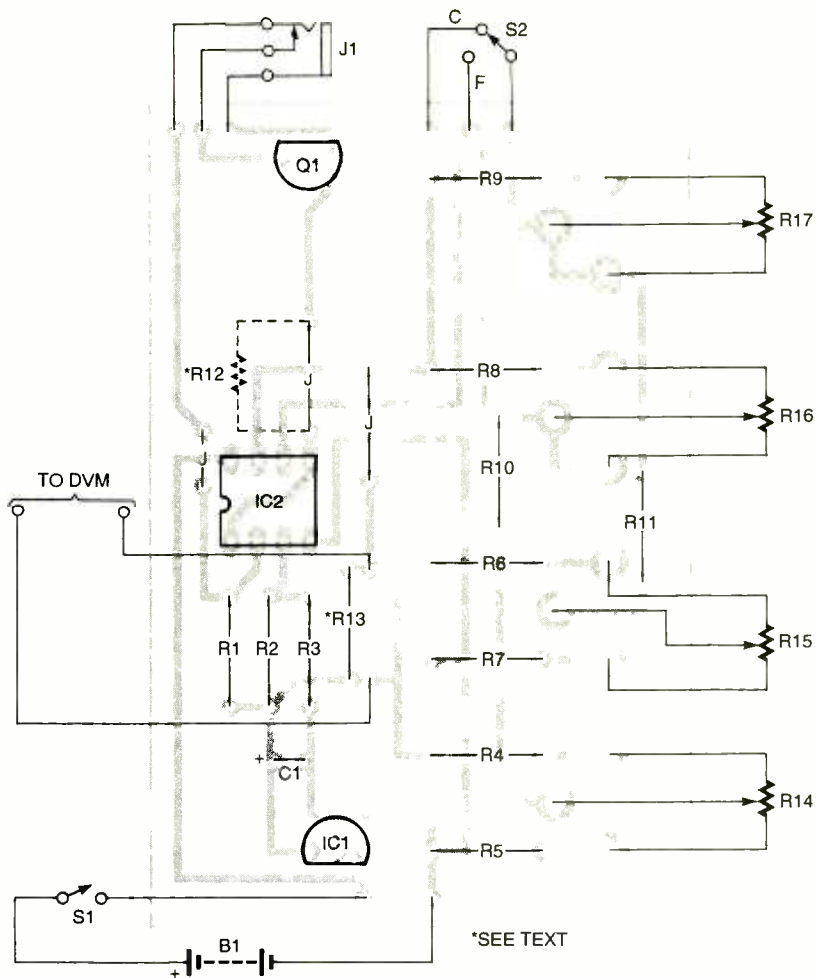

Fig. 12. Assemble the Electronic Thermometer, guided by this parts-placement diagram. Once the board is fully assembled, it can be housed in an enclosure of your choice.

consisting of R2 and R3. The voltage divider applies a 2.5-volt reference to the non-inverting input of IC2-a at pin 3.

The 5-volt reference is therefore exactly 2.5 volts above the voltage at the non-inverting input. The result is that a current of about $530\ \mu\text{A}$ flows into input resistor R1. Remembering our inverting amplifier theory, that means that the constant current also flows through our sensing transistor Q1 (or Q2, if the external probe is plugged into J1). In other words, we are simply using the first op-amp section as a precision current source.

That causes the output of IC1-a to be about 0.6 volts below the non-inverting input, or at about 1.9 volts at room temperature. Furthermore, that voltage will vary in direct proportion with temperature. Note that while the transistor has a *negative*

temperature coefficient, the output from the constant-current source will have a *positive* temperature coefficient because we are using the inverting configuration. The second half of the LM358 is used as a non-inverting, scaling amplifier. Remember that equation for a straight line, $y=mx+b$? Our circuit essentially adjusts the two constants— m (slope) and b (y-intercept)—by adjusting the op-amp's gain and input offset at two known temperatures.

The non-inverting input of IC2-b at pin 5 is connected to the signal voltage, while the inverting input at pin 6 is switched between two feedback networks: one for Fahrenheit, and one for Celsius. The voltage divider at the input element is used to set one known point for either scale, and the feedback element defines the other.

Although the networks might seem like overkill (theoretically, the job could have been done with just four potentiometers), the additional resistors make the circuit a lot easier to calibrate. The two adjustments are still somewhat interactive. The good news is that the calibration procedure outlined below converges quite rapidly nonetheless.

Note that the meter's negative lead is referenced to the +5 volt line. That is so it will indicate temperatures below zero (in either system). Thus, if the positive lead (connected to the output of IC2-b) goes above 5 volts, the reading is positive; below 5 volts, the reading is negative.

Thermometer Construction. The Electronic Thermometer was assembled on a printed-circuit board, measuring 2 by 3 inches. A template of the printed-circuit-board artwork is shown in Fig. 11 at full scale. The Electronic Thermometer is the least critical of our three projects, and is therefore most suitable for beginning hobbyists. A parts-placement diagram for the printed-circuit board is shown in Fig. 12. Once the board is fully assembled, it can be housed in an enclosure of your choice.

Note that both of the zero-adjust trimmer potentiometers are 2.5k units, while the gain-adjust controls are 50k (R16) and 100k (R17) trimmer units. If you can't find the right value for one or more of the trimmers, you can get away with using the next higher value and paralleling it with the required fixed resistor to produce an equivalent value.

When used with a DVM, the design of the Thermometer is such that 2 volts represents 200 degrees, allowing the circuit to be used with inexpensive DC voltmeters whose lowest range is 2 volts. However, the decimal point will be out of place; *i.e.*, 50.0 degrees will be displayed as 0.500 volts.

If the meter has a 200 millivolt range, placing a 10:1 voltage divider between the circuit and the meter allows that range to be used, thereby putting the decimal point in the correct position—*i.e.*, 50.0 degrees displayed as 50.0 millivolts. To use the 200 mV DVM scale, include R12 and R13 in the circuit.

Note from the parts-placement diagram that R12 replaces a jumper that would otherwise be installed in the circuit.

Alternately, you can use a dedicated LCD panel-meter, as in the prototype. The panel-meter used in the prototype accepts a full 2-volt output and allows you to set the decimal point to wherever you want it. On most such DVM modules, the decimal place is set via jumper connections.

If you decide to use an analog VOM or other meter movement with a low input impedance (*i.e.*, 1000 ohms-per-volt), install a 2.2k resistor across the regulator output (between the negative terminal of the meter and the low side of the battery). The resistor is needed because the 78L05 cannot sink current and maintain regulation. For any meter that draws more than 500 microamps or so, increase the load on the regulator to insure that the meter doesn't pull its voltage above 5 volts.

Where the probe is concerned, virtually any small-signal transistor can be used as the sensor, including PNP units. For a PNP transistor, simply reverse the two connections to the circuit. If a PNP unit (*e.g.*, 2N4403, 2N3906, *etc.*) is used for the on-board sensor, bend the base lead towards the collector and solder the two together. Cut off the excess, and install the transistor backwards. The center hole in the printed-circuit board is not used in this situation.

Nonetheless, use a matched pair of conventional TO-92 transistors. The probe was fabricated by gluing the transistor to the end of a narrow strip of glass-epoxy printed-circuit board material using a slow-curing epoxy with a steel powder binder. That kind of epoxy tends to be more tolerant of high temperatures than the quick-setting type, and the steel binder improves its strength. A length of nylon-coated two-conductor cable taken from a cheap headset was used to connect the probe to the circuit through a 3.5mm ($1/8$ -inch) phone plug. The phone plug and Jack allows the probe to be disconnected or connected at will. Be sure that your probe is well sealed against moisture by coating all exposed connections with epoxy—

PARTS LIST FOR THE ELECTRONIC THERMOMETER

SEMICONDUCTORS

- Q1, Q2—2N4401 low-power, general-purpose, NPN silicon transistor
- IC1—78L05 low-power, fixed, 5-volt regulator, integrated circuit
- IC2—LM358 low-power dual op amp, integrated circuit (see text)

RESISTORS

(All fixed resistors are $1/4$ - or $1/8$ -watt, 5% metal-film units.)

- R1—4700-ohm
- R2, R3—10,000-ohm
- R4—15,000-ohm
- R5—2400-ohm
- R6—6800-ohm
- R7—2000-ohm
- R8—120,000-ohm
- R9—200,000-ohm
- R10, R11—30,000-ohm
- R12—91,000-ohm (optional, see text)
- R13—10,000-ohm (optional, see text)
- R14, R15—2500-ohm, $5/8$ -inch diameter, thumbwheel, trimmer potentiometer
- R16—50,000-ohm, $5/8$ -inch diameter, thumbwheel, trimmer potentiometer
- R17—100,000-ohm, $5/8$ -inch diameter, thumbwheel, trimmer potentiometer

ADDITIONAL PARTS AND MATERIALS

- B1—9-volt alkaline (or 8.4-volt NiCd) transistor-radio battery
- C1—0.1–1- μ F (any type)
- J1— $1/8$ -inch (3.5mm), normally-closed, switching phone jack
- PL1— $1/8$ -inch (3.5mm) phone plug
- S1—SPST slide, rocker, or toggle switch
- S2—SPDT slide, rocker, or toggle switch
- Printed-circuit board, DVM or panel meter (see text), 9-battery clip, high-temperature epoxy, heat-resistant wire, IC socket, wire, solder, hardware, *etc.*

the calibration procedure requires that the probe be fully immersed in water.

Calibrating The Thermometer. The easiest way to calibrate the probe is to use the freezing point (0° Celsius) and boiling point (100° Celsius) of water. To calibrate the Thermometer, boil water and adjust the heat so

(Continued on page 72)

HEATED PET PAD

Now you can be kind to your four-footed friend by furnishing your pet with a warm spot to rest on those cold winter nights

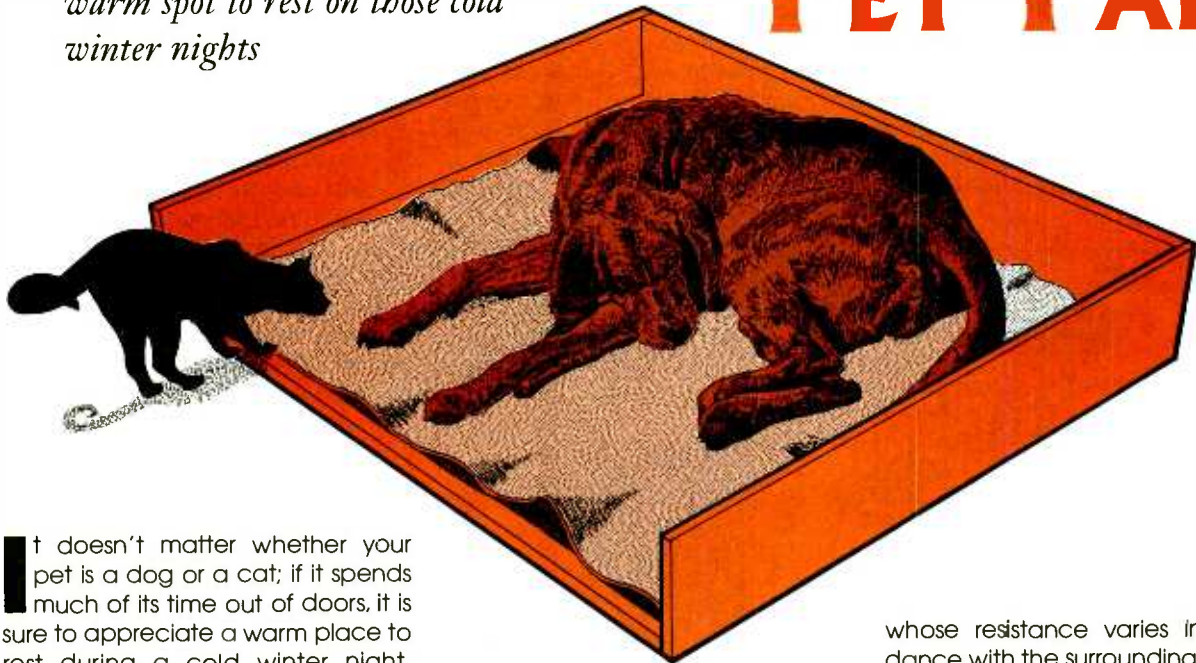

WALTER W. SCHOPP

It doesn't matter whether your pet is a dog or a cat; if it spends much of its time out of doors, it is sure to appreciate a warm place to rest during a cold winter night. Considering that your animal spends a good part of the day laying around, you can imagine how much it would treasure a heated lounging area. One approach to providing such an area is to supply your pet with an electric blanket. But that is not a wise thing to do, given the nature of most animals—their propensity toward scratching, biting, and clawing at nearly everything with which they come in contact—and the hazard that liquids spilled on the blanket would create.

Another possibility is to build the safe and inexpensive *Heated Pet Pad* described in this article. The Heated Pet Pad was originally designed to replace a very expensive commercial unit that had a nasty habit of producing huge amounts of RFI. The RFI problem was caused by a bi-metal thermal switch that was used to control the cycling on and off of the unit. As the unit cycled on and off, arcing across its contacts would occur, which translated into RF hash. Since the unit was designed to produce very little heat, it frequently toggled on for very short durations—often five to six times a minute. That type

of operation is extremely hard on mechanical contacts.

An alternative to the problem-plagued, bi-metal thermal switch is to use a zero-crossing switch. A zero-crossing switch is an electronic device that turns on and applies AC voltage to a load just as the AC waveform passes the zero-voltage point of the input sinewave. With that arrangement, there are no arcing contacts; thus, no RFI is generated when the heater is turned on and off.

About the Circuit. A schematic diagram of the Heated Pet Pad is shown in Fig. 1. The circuit is comprised of three ICs, a negative-temperature-coefficient (NTC) thermistor (R13), a Triac (TR1), Nichrome heating wire; five 1N4004 1-amp, 400-PIV rectifier diodes (D1–D5); and a few additional components. For those not familiar with thermistors, it is a resistive semiconductor device,

whose resistance varies in accordance with the surrounding temperature. A negative-temperature-coefficient thermistor's resistance varies inversely to temperature changes. That is, as temperature increases, its resistance decreases, and vice versa.

Power is fed to the Heated Pet Pad through a common 117-volt AC plug and line cord (PL1). The AC voltage that's delivered to the circuit through PL1 is fed through fuse F1. The voltage then divides along two paths. In one path, the 117-volt AC voltage is applied directly to one end of the Nichrome wire heating element. Then it goes to Triac TR1 and the output section of the optoisolator/coupler (a zero-crossing, Triac-driver, switching network) that's used to control the operation of the Nichrome wire heating element.

In the second path, the AC line voltage is applied to a full-wave, bridge rectifier comprised of D1 through D4 and a series-parallel-connected resistor network (R1–R4). Together, those resistors function as a single unit with a value of 10k and a tolerance of 20 watts, which allows the resistor bank to run quite cool during oper-

ation. The purpose of those resistors is to drop the AC line voltage to 15 volts prior to rectification by the diode bridge.

The DC output of the diode bridge is filtered by C1 and C3, and then it's fed to IC1 (the 12-volt regulator), the output of which is filtered by C2 and C4. The output of the regulator is used to power op-amp IC2, which is set up as a comparator. The DC source voltage is also applied to a pair of voltage-divider networks: One network is

As long as the temperature sensed by R13 remains above the preset level, the voltage applied to pin 3 of IC2 remains equal to that at pin 2, so the output of IC2 remains low and no heating occurs. However, as the temperature sensed by R13 decreases, its resistance increases, forcing the voltages applied to IC2's two inputs out of balance. When the voltage at pin 3 has risen sufficiently, the output of IC2 goes high. That high, applied to IC3's internal LED via pin 1, causes

Construction. The author's prototype was assembled in a two-step operation. The first operation involves assembling the heated pad (with heating element) and its enclosure. The other step has to do with the assembly of the printed-circuit board.

Begin assembly with the pad/enclosure construction. Start with two pieces of ABS plastic sheeting (available from your local "do-it-yourself" plastic supply house); one piece 0.098-inch thick for the top and the other 1/8-inch thick. Cut both plastic sheets to 2-1/2 by 18-1/2 inches.

As shown in Fig. 2, using 3/4-inch masking tape, cover the edge of the top piece, which will become the inside surface. Also mask off an area of 2-1/2 by 4 inches in one corner. That 2-1/2 by 4-inch area will be used to mount the unit's printed-circuit board. When the masking is completed, you are ready for the next step.

Spray the exposed area of the underside (the tape side) of the top with 3M's SUPER 77 spray adhesive (available from the supplier listed in the Parts List). After spraying the adhesive, cover the area completely with heavy-duty aluminum foil. Firmly press down the foil, and remove any air bubbles by poking pin holes in them and then flattening the foil. Next, trim the aluminum foil up to the edge of the masking tape and remove the excess. Also trim and remove the aluminum foil from the 2-1/2 by 4-inch printed-circuit-board mounting area.

Remove the masking tape. Then complete the edges by gluing 1/2-inch square acrylic bar stock around the edges that were covered with masking tape, using a thickened clear acrylic cement (also available from plastic supply houses). Miter the bar stock to 45° in the corners to make a good solid frame (see Fig. 3). The frame, which will be glued to the top piece, will serve as the outer sides of the pad; the bottom cover will be mounted and held with 4-40 x 1/4-inch flat-head screws.

Next, lay out the location of the heater wire by measuring and marking on the foil with a flow-ball

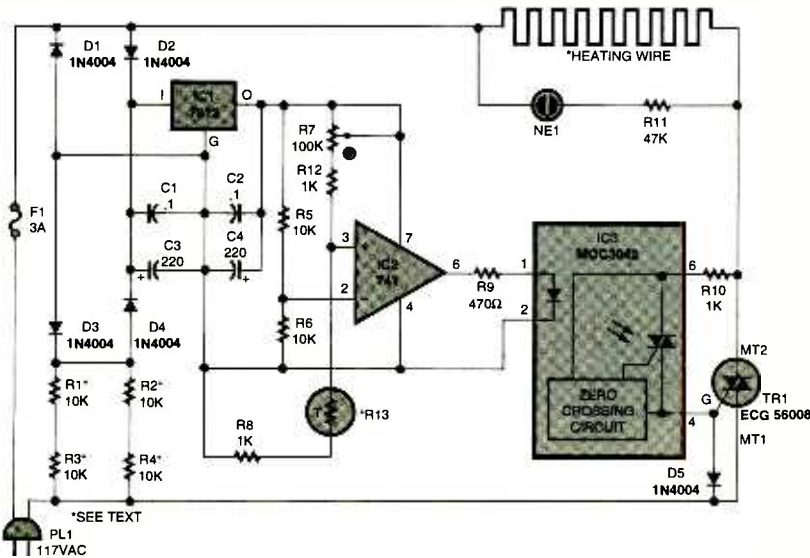

Fig. 1. The Heated Pet Pad is comprised of a 7812 12-volt, 1-amp, voltage regulator (IC1); a 741 op-amp (IC2); and an MOC3042 zero-crossing, Triac-driver, optoisolator/coupler (IC3); a negative-temperature-coefficient (NTC) thermistor (R13); a 15-amp, 600-volt Triac (TR1); 19 feet of Nichrome heating wire; five 1N4004, 1-amp, 400-PIV rectifier diodes (D1-D5); and a few additional components.

comprised of R5 and R6, and the other is composed of R7, R8, R12, and R13 (the thermistor). The first divider network, R5/R6, is used to provide a voltage (approximately 6 volts) to the inverting input of IC2, thereby establishing a reference voltage at pin 2. The other voltage-divider network supplies a voltage to the non-inverting input of op-amp IC2 at pin 3. Potentiometer R7 is used to set the temperature at which the output of IC2 toggles high, and by extension, the temperature at which the Heated Pet Pad turns on. The two inputs to the op-amp must remain in a *balanced* condition in order to prevent Triac TR1 from turning on. As long as both inputs to the op-amp are equal, the op-amp's output remains low.

the LED to illuminate. Light radiation from the LED striking the light-sensitive, zero-crossing/Triac-driver output of IC3 turns it on. That sequence, in turn, triggers the gate of Triac TR1, causing it to turn on, energizing the wire heating element.

As the ambient air temperature rises, the resistance of R13 decreases. When R13's resistance has sufficiently decreased, the voltages at the two inputs of IC2 return to a balanced condition, causing the output of IC2 to again go low. That turns off IC3, which, in turn, shuts the Triac off. The heating element now cools down, until the temperature sensed by R13 has decreased below the set threshold; at that point, the cycle repeats.

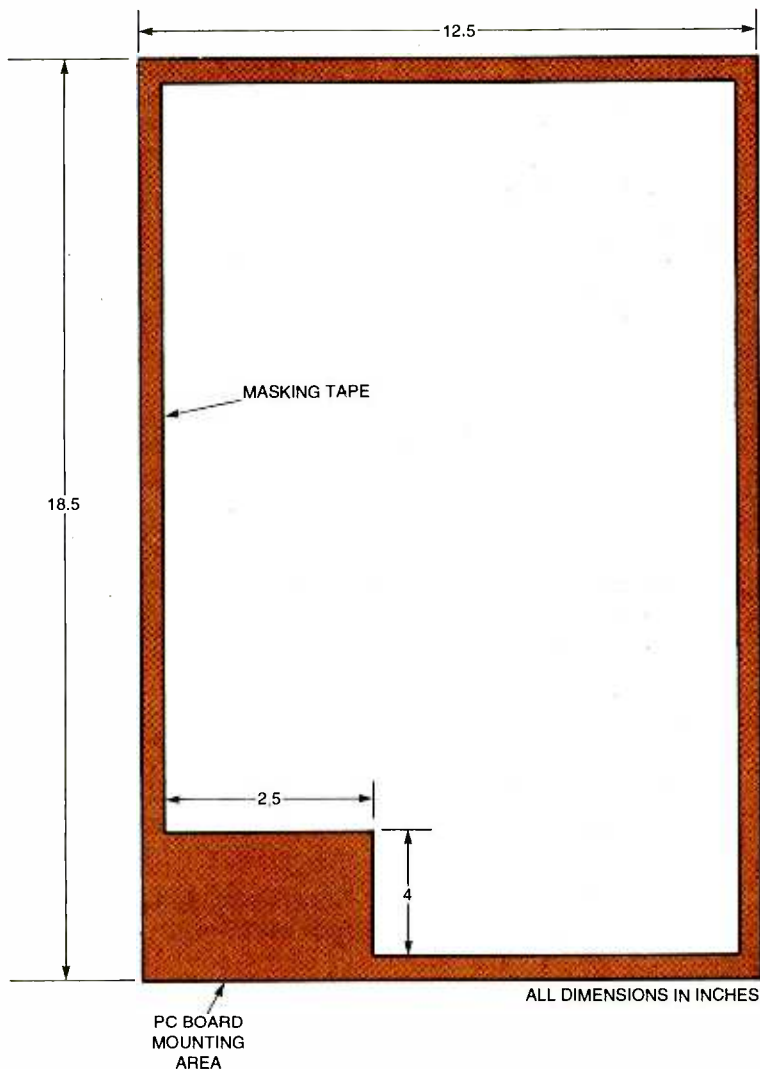

Fig. 2. The Heated Pet Pad was assembled in two steps. Outlined in this illustration is the beginning of the heated pad (with heating element) and its enclosure. Start by cutting two pieces of ABS plastic sheeting (one piece 0.098-inch thick for the top and the other $\frac{1}{8}$ -inch thick for the bottom) to $12\text{-}\frac{1}{2}$ by $18\text{-}\frac{1}{2}$ inches. Then cover the edges of the 0.098-inch piece with $\frac{3}{4}$ -inch masking tape. Also mask an area of $2\text{-}\frac{1}{2}$ by 4 inches in one corner, for the unit's printed-circuit board.

type marking pen, following the pattern shown in Fig. 3. After the marking is completed, follow the line from one end to the other laying down the #30 enamel insulated Nichrome wire heating element. Tape it in place with #69 Scotch glass-cloth electrical tape (made by 3M), which can withstand temperatures up to 366°F.

Warning: Do not attempt to make square corners with the wire. Nichrome wire is coated with a high-temperature, enamel insulation. Attempting to make square corners could cause the wire's enamel coating to chip, creating a

shock hazard or possibly causing a short. Therefore, care must be taken when laying out the wire that no chipping occurs or that the coating is not accidentally scraped or kinked during the layout process. If wire does become kinked, cut the wire at each side of the kink and scrape about $\frac{3}{8}$ -inch of the enamel off the ends of both wires with a sharp knife. Tightly twist the wires together and cover the joint with a single layer of glass tape.

After you have taped down the wire heating element, scrape the enamel off the two free ends with a sharp knife. Connect a short length

of heavy wire (AC line cord is best) to each end of the wire heating element by tightly twisting and then taping or using wire nuts (twist caps) on the connections. Make sure that there are no exposed bare wires at the joints; then tape them down to the aluminum-foil surface. Finally, using an ohmmeter, check the heater wire for continuity and shorts to the aluminum foil. If you have a complete circuit from one end to the other without any shorts to the aluminum foil, you are ready for the next step.

Cut a piece of stiff paper to $2\text{-}\frac{1}{2}$ by 4 inches and tape it over the printed-circuit-board mounting area. Spray the complete heater surface with another coat of adhesive and put another layer of aluminum foil over the wire heating element, so that it is sandwiched between the two layers of foil on the inside surface of the top of the enclosure. Smooth down the aluminum foil, as before, to remove any air bubbles. Trim the aluminum around the edges up to the $\frac{1}{2}$ × $\frac{1}{2}$ -inch edge pieces. Trim around the board-mounting area and remove the paper shield that you placed over it.

The pattern shown in Fig. 3 calls for about 19 feet of #30 Nichrome resistance wire. That wire has a resistance of about 6.75 ohms per foot, giving a total resistance of 128 ohms (found by multiplying 6.75 ohms × 19 feet). Using Ohm's law— $I = E/R$ — $117\text{ volts AC}/128\text{ ohms}=0.9\text{ amps}$.

If your pet is a large dog, you might want to build a larger pad. Using larger and longer lengths of Nichrome wire, you can create almost any size pet pad. But try to limit the total heater current to around 1 or 2 amps, so that the unit will have a slow heating and cooling cycle. Some of the basic resistances of type 60 Nichrome resistance wire used for heaters are shown in Table 1.

Whether you build your unit to the dimensions outlined here or to your own specifications, keep the spacing between the wire heating element in the $\frac{3}{4}$ -to 1-inch range to obtain a smooth heat dispersion pattern. Using the PC-board pattern of the controller (see Fig. 4), drill

PARTS LIST FOR THE HEATED PET PAD

SEMICONDUCTORS

- IC1—7812 12-volt, 1-amp, voltage regulator, integrated circuit
 IC2—741 op-amp, integrated circuit
 IC3—MOC3042 zero-crossing, Triac driver, optoisolator/coupler, integrated circuit
 TR1—ECG56008, NTE56008, SK3660, or similar, 15-amp, 600-volt, Triac
 D1—D5—1N4004 1-amp, 400-PIV rectifier diodes

RESISTORS

- (All fixed resistors are $\frac{1}{4}$ -watt, 5% units, unless otherwise noted.)
 R1—R4—10,000-ohm, 5-watt, 5%, ceramic power
 R5, R6—10,000-ohm
 R7—100,000-ohm micro-miniature, trimmer potentiometer (RadioShack #271-284, or similar)
 R8, R10, R12—1000-ohm
 R9—470-ohm
 R11—47,000-ohm
 R13—Precision Thermistor, -50 to +110°C (RadioShack #271-110A)

CAPACITORS

- C1, C2—0.1- μ F, ceramic-disc
 C3, C4—220- μ F, 35-WVDC, electrolytic

ADDITIONAL PARTS AND MATERIALS

- NE1—NE-2A, low-profile neon lamp
 F1—3-amp miniature fuse (RadioShack #RSU 11322823)
 PL1—AC line cord with molded plug
 Heater wire, Fiberglass tape, spray adhesive, ABS plastic sheeting (see text)
 $\frac{1}{2}$ - \times $\frac{1}{2}$ -inch acrylic bar (see text), wire, solder hardware, etc.

Note: Heater wire is available by mail-order from Pelican Wire Company, 6266 Taylor Road, Naples, FL 34109-1896, Tel. 941-597-8555; Request sample of #30 Enameled Nichrome heater wire for \$15.00 postpaid. Sample contains 20 to 25 feet of wire. Fiberglass tape (3M #69 $\frac{3}{4}$ -inch glass cloth tape, part #95F6313) and spray adhesive (3M type SUPER 77 aerosol) is available from Newark Electronics, Tel. 312-784-5100.

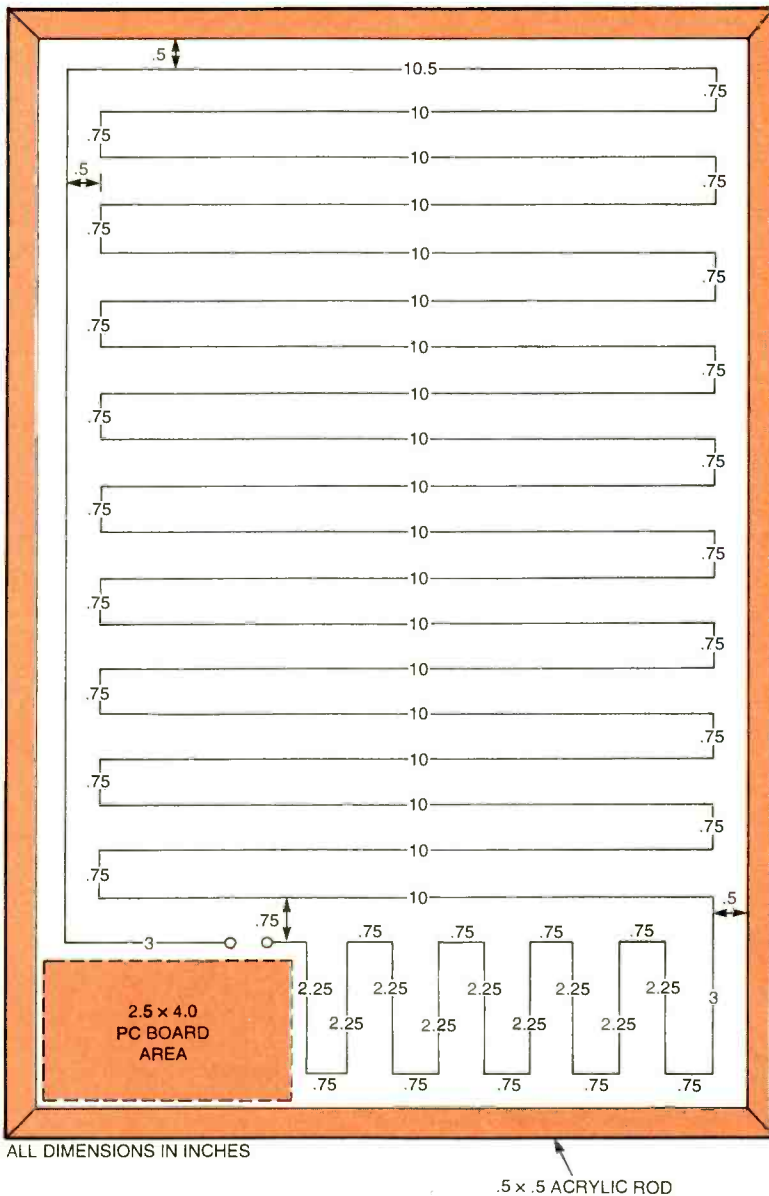

Fig. 3. Glue four lengths of $\frac{1}{2}$ -inch square acrylic bar stock (mitered to 45° to form good 90° corners, as shown) around the edges, using a thickened clear acrylic cement. Following the pattern shown, lay down the #30 enamel insulated Nichrome wire heating element, and tape it in place with #69 Scotch glass-cloth electrical tape.

the four mounting holes in the board-mounting area. Then drill a $\frac{5}{16}$ -inch hole in the plastic top so that it will be located directly above R7 when the board is mounted in position. That hole is required to allow adjustment of the unit's trip point. Also drill a $\frac{5}{8}$ -inch hole where the neon lamp, NE1, will be located. This hole allows you to view the neon lamp so that you can determine when the heater is turning on and off. When laying out the holes, make sure you are look-

ing at the bottom of the board, and that it is oriented in the correct top and bottom direction.

Use masking tape around the edges of the bottom cover so that hole locations can be marked. Mark about five evenly-spaced holes across the bottom and top and about seven evenly-spaced holes on both sides. Make the marks $\frac{1}{4}$ -inch from the outside edges of the bottom cover. After marking the hole locations, clamp the bottom cover in place. Using a

#43 bit, drill the mounting holes around the edge through the cover and into the $\frac{1}{2} \times \frac{1}{2}$ -inch frame at least $\frac{3}{8}$ -inch deep. Next, remove the cover and tap all the holes in the frame $\frac{1}{8}$ -inch deep using a 4-40 tap. Enlarge the holes in the cover sheet with a #31 bit and countersink the holes on the

outside for 4-40×1/4-inch flat head screws.

Now let's turn our attention to assembling the printed-circuit board. A full-scale template of the author's printed-circuit artwork, which measures 3 by 4 inches, is shown in Fig. 4. Assemble the printed-circuit board according to the parts-placement diagram shown in Fig. 5, saving the heating element for last. Connect the thermistor to the board via a pair of 6-8-inch lengths of insulated hookup wire. Cover the solder joints at the thermistor with heat-shrink tubing or wrap some glass tape around the joint, so that the joint does not short to the aluminum foil when the leads are taped down.

TABLE 1— NICHROME WIRE RESISTANCE

AWG GAUGE	DIAMETER INCHES	V/FT @68°F
25	0.0179	2.1C7
26	0.0159	2.670
27	0.0142	3.348
28	0.0126	4.251
29	0.0113	5.286

Temporarily connect the heater wires to the two heater terminals. Attach a cord for the line voltage to the line input terminals. Next, rotate R7 fully counterclockwise. Plug the controller's line cord into an AC outlet. The neon lamp should be off indicating no power is being delivered to the heater. Slowly turn R7 clockwise; the heater (as indicated by NE1) should come on somewhere within the range of R7. If you are able to turn the heater on and off via R7, the control is working properly. Turn R7 slowly clockwise until the heater just comes on and stays on. When the neon lamp is on, touch the thermistor, R13, with a hot soldering iron. The neon lamp should go off.

If, on the other hand, the neon lamp cannot be turned on and off via R7, check for the usual poor solder joints and/or misplaced components. If the neon lamp can not be turned off, it usually indicates a bad IC3 or Triac. Once you get the project operating properly, you are ready to finish up the basic construction.

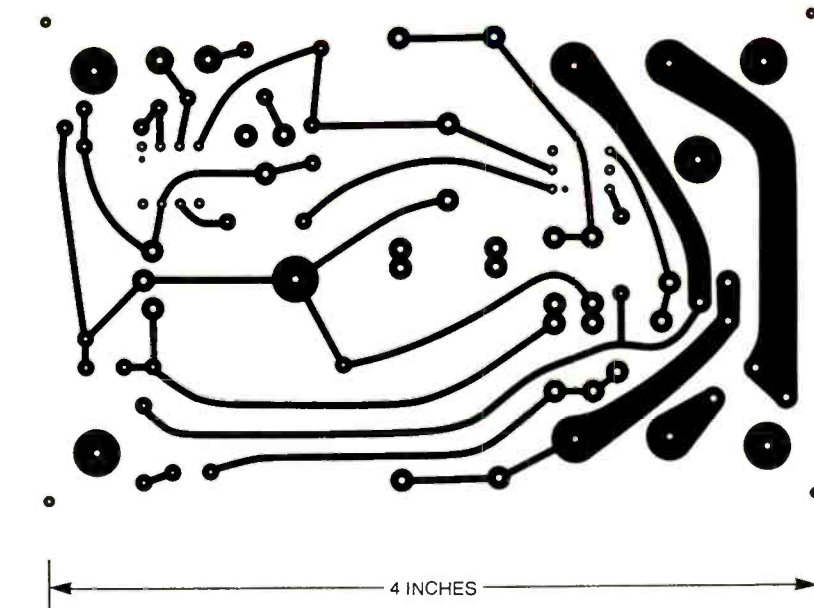

Fig. 4. Most of the electronics for the Heated Pet Pad were assembled on a printed-circuit board, measuring 2-1/2 by 4 inches. A template for the printed-circuit layout is shown here full size.

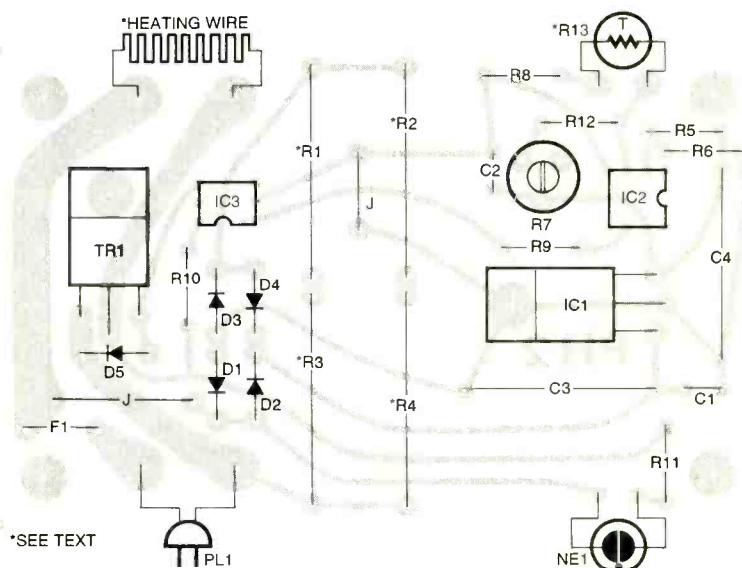
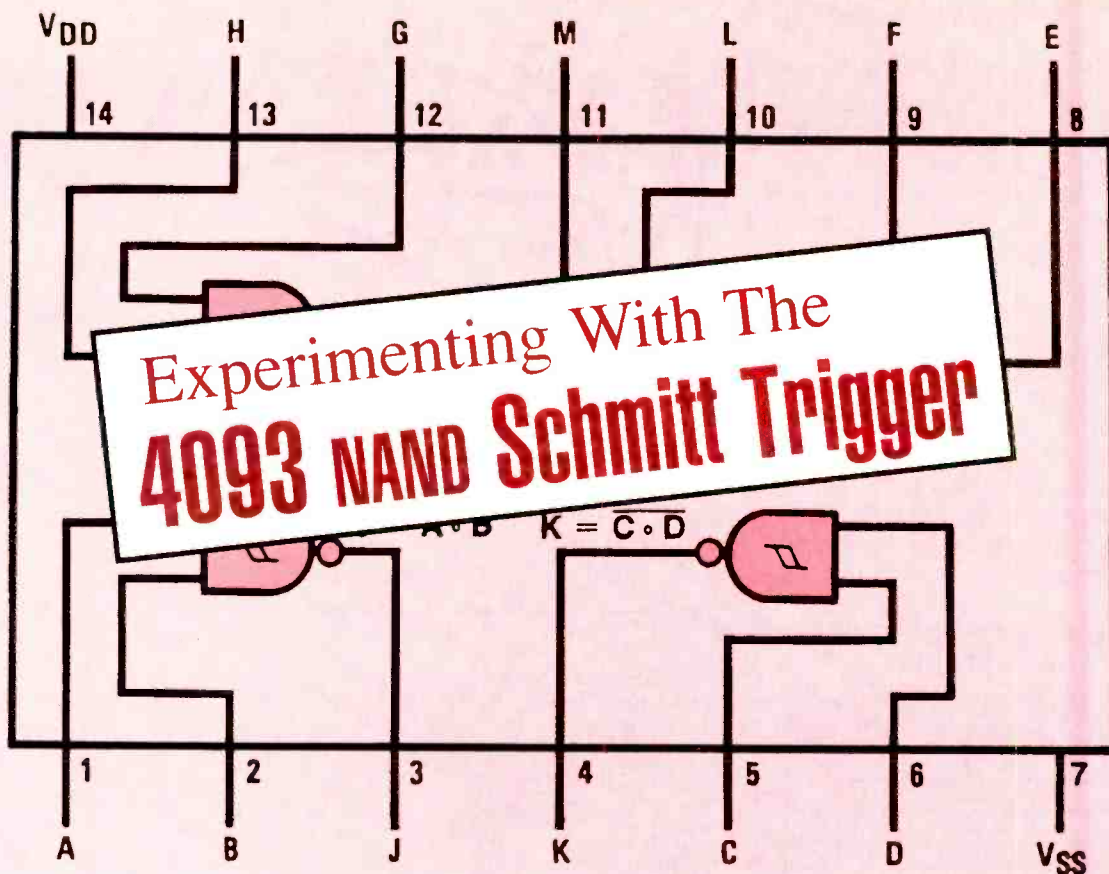

Fig. 5. Assemble the printed-circuit board according to this parts-placement diagram, saving the heating element for last. Connect the thermistor to the board via a pair of 6-8-inch lengths of insulated hookup wire and cover the solder joints at the thermistor with heat-shrink tubing or some glass tape.

Feed the line cord into the edge hole and pull about six inches of the cord inside the pad. Connect the line cord to the printed-circuit terminals and also connect the heater wires to the heater terminals across from the line cord terminals. Mount the board on 3/8-inch threaded standoffs using 4/40×1/8-inch flat head screws in the previ-

ously drilled holes. Fold a small piece of aluminum foil, about 1-inch square, in half and put the thermistor in the fold. Stretch the thermistor leads out toward the center as far as they will go and tape the aluminum foil packet containing the thermistor down tightly to the space between the heater

(Continued on page 72)



The circuits shown in this article, based on the 4093, are not only fun to build, but can also teach the builder about these devices and their practical use.

Steadily declining prices and low-power requirements are the driving forces behind the growing popularity of CMOS integrated circuits. Like their relatively high-power TTL cousins, CMOS devices are available in a wide variety of configurations to suit the many applications in which they can be used.

In this article, we'll explore some of the possibilities offered by the 4093 CMOS quad 2-input, NAND Schmitt trigger, by presenting several circuits that you can build and toy around with in your spare time. All you'll need is a solderless breadboard and a suitable power source.

The 4093. The 4093 is comprised of four positive-logic, 2-input, NAND Schmitt triggers (as shown in Fig. 1A) housed in a 14-pin package. The

NEWTON C. BRAGA

four NAND gates can be operated independently of one another or in concert. Figure 1B shows the transfer characteristic of the 4093 quad NAND Schmitt Trigger. The general shape of the transfer characteristic is the same for all positive supply voltage (V_{DD}) levels. But what are Schmitt triggers?

Schmitt triggers are a special breed of NAND circuits, whose snap-action in response to an input signal is one of its most attractive qualities. Another important characteristic of the Schmitt trigger is that it provides hysteresis (typically 2.0 volts with a 10-volt supply). To get a better understanding of hysteresis, let's take a brief look at the oscillator circuit shown in Fig. 2A. A comparison of the oscillator's input/output

waveforms is shown in Fig. 2B.

Oscillators. Note that the pin 1 input to the gate in Fig. 2A is tied to the positive supply rail, while the pin 2 input is connected to the junction formed by the capacitor (C) and the feedback resistor (R). Before power is applied to the circuit, both inputs and output are at ground potential (logic 0) and the capacitor is discharged. When power first is applied to the oscillator circuit, pin 1 of the gate immediately goes high, while its pin 2 input remains low. Under that input condition, the output of the NAND gate goes high (see time t_0 in Fig. 2B). That causes capacitor C to begin charging through resistor R until V_p is reached. When the charge on the capacitor reaches V_p , pin 2 goes high. Now that both inputs of the gate are high (time t_1), the gate's output snaps

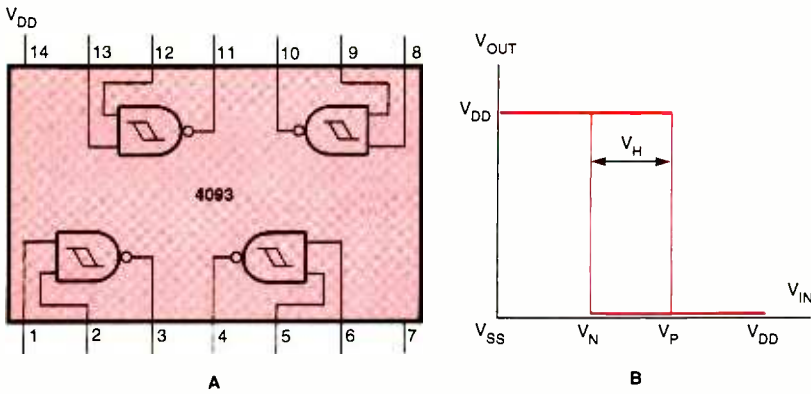

Fig. 1. The 4093, which is housed in a 14-pin package, is comprised of four 2-input NAND Schmitt triggers (as shown in A) that can be used independently. Transfer characteristics for the 4093 quad NAND Schmitt Trigger are shown in B.

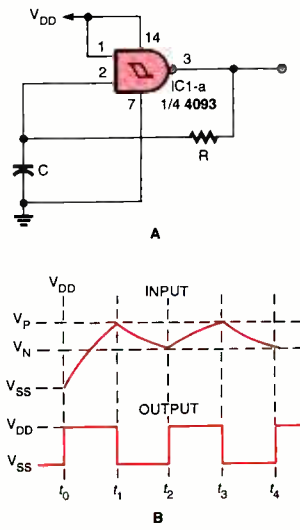

Fig. 2. A single gate from the 4093 can easily be configured as an oscillator as shown in A. The input/output characteristic waveforms for that circuit are shown in B.

low, causing C to begin discharging through R until V_N is reached. When the signal applied to pin 2 decreases to the V_N level, the output of the gate goes high once more, and the sequence of events repeats until power is removed from the circuit.

Note from Fig. 2B that the output of the gate remains high until the minimum, positive-trigger voltage (V_P) level is reached. At that point, the output goes low and remains low as the input voltage continues to rise toward V_{DD} . Even as the input voltage is reduced, the output remains low until the maximum negative trigger voltage (V_N) level is reached. At that point, the output toggles high and remains high as the input voltage approaches zero.

The lag between the change in the input voltage and the output signal is called the hysteresis. The hysteresis voltage is typically 0.6 volt for a 5-volt supply and 2.0 volts for a 10-volt supply.

One of the major advantages of that circuit is that the oscillator is self-starting at power up. The operating frequency of the circuit is governed by the supply voltage—which is around 1.2 MHz for a 12-volt supply, and decreases with lower voltage supplies. The minimum value recommended for C is 100 pF; for R the recommended value is 4.7k.

Signal Injector. If you've tried repairing your own audio equipment, you no doubt are well aware of what magic can be accomplished with a signal injector. For the uninitiated, a signal injector is a simple square-wave generator that is designed to feed a signal through a circuit in order to determine the general location of, and finally to isolate, the malfunctioning component in a circuit. Such devices are also useful in troubleshooting the RF stages of AM/FM receivers.

A schematic diagram of the *Signal Injector* is shown in Fig. 3. The oscillator or square-wave generator portion of the circuit is built around a single gate (IC1-a). The oscillator operates at a frequency of 1kHz, as determined by the values of capacitor C1 and resistor R1. The operating frequency of the circuit can be altered by selecting various resistor and/or capacitor value combinations for the oscillator stage. The square-wave output

of the circuit swings the full supply rail. The circuit can be powered from source voltages ranging from 6 to 15 volts (9 volts is recommended). The other three gates of IC1 are connected in series with the output of IC1-a and in parallel with each other. That configuration is used to buffer and amplify the oscillator output to a level sufficient to drive the circuit-under-test (CUT).

A signal injector is used from the "back" to the "front" of an audio (or RF) circuit. For instance, to use the signal injector with an AM-receiver, the injector's output signal is applied to the base of the output transistor. If the transistor and everything after it is operating correctly, the signal will be heard in the speaker. If no signal is heard, the injector signal is moved progressively toward the speaker, until a sound is emitted from the speaker. The component just prior to that point is the likely malfunctioning component.

On the other hand, if the output stage proves to be okay, the probe is then moved to the next previous stage and the signal is applied to the base of the driver transistor. The output signal will be higher if everything is working. Assuming that everything is functioning properly to this point, the injector signal is progressively moved toward the front end of the circuit, applying the signal to the volume control, detector stage, IF stages, mixer, and so on, until the malfunctioning stage is located. Then using the same technique within that stage, the malfunctioning components can be isolated and the fault located.

Fluorescent-Light Inverter. The schematic diagram of the *Fluorescent-Light Inverter* is shown in Fig. 4. The circuit can be used to light a fluorescent tube from a 12-volt auto battery or two 6-volt rechargeable wet-cells. That circuit is essentially the same as the previous one with a few minor changes—e.g., C2 of Fig. 3 has been replaced by resistor R2, and the output of the previous circuit is now being fed to the base of a transistor (Q1).

In its present incarnation, the buffered oscillator output is used to alternately drive Q1 between saturation and cut-off. The collector of

Q1, which is connected to one end of a step-up transformer, produces a rising and collapsing field in the primary of T1. That, in turn, causes a much higher varying voltage to be induced in the secondary winding of T1. The voltage induced in the secondary of T1 is applied to the fluorescent tube, causing the tube to instantly light without flickering.

The circuit is capable of driving a 6-watt fluorescent lamp from a 12-volt source. Since the circuit draws a mere 500 mA, quite a few hours of operation can be obtained from a single charge when using two 6-volt rechargeable wet-cells. The tube's operation will be somewhat different than when operated from the 117-volt AC mains. Because it is powered by high-voltage pulses, there is no need for a starter or pre-heater. When building the circuit, the output transistor should be mounted on a heatsink. The transformer can be a mini-type with a 117-volt primary and a 12.6-volt, 450-mA secondary.

Fluorescent Flasher. The *Fluorescent Flasher*, shown in Fig. 5, combines elements of both the original oscillator circuit and the Fluorescent-Light Inverter. The circuit, comprised of a pair of oscillators and an amplifier/buffer stage, can be used as a roadside flashing warning light.

In this circuit, the output of the first oscillator, IC1-a, is fed to one leg of the amplifier/buffer stage (IC1-c). The input to the other leg of the amplifier/buffer is derived from the second oscillator (IC1-b). The two oscillators operate at different frequencies, as determined by their respective RC networks.

That arrangement produces a frequency-modulated output that is fed to the transformer through transistor Q1 to induce a high-voltage spike in T1's secondary winding. Only when both the signals applied to the IC1-c are high does its output go low. That low turns off Q1, causing a high-voltage spike to be induced in T1's secondary winding. That, in turn, causes the lamp to flash.

Light-Triggered Fluorescent Flasher. The *Light-Triggered Fluorescent Flasher* (see Fig. 6) is an improvement on the previous circuit.

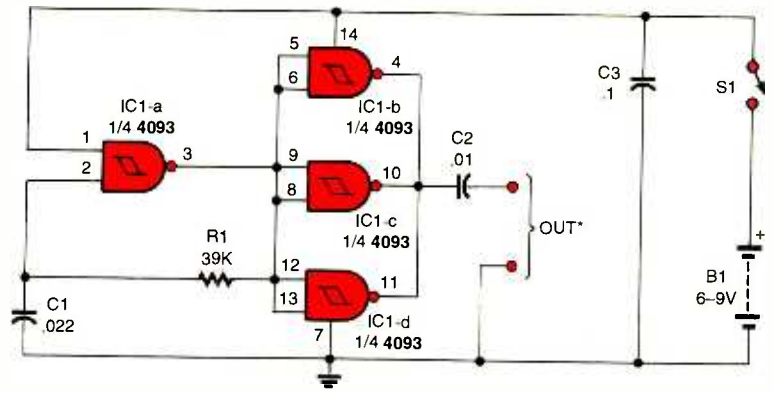

Fig. 3. The oscillator circuit shown in Fig. 2 can be used to form the basis of a simple Signal Injector. The oscillator portion of the circuit is built around IC1-a, which produces a square-wave output. The other three gates are used to boost the output current to a level sufficient to drive the input of the circuit to be tested.

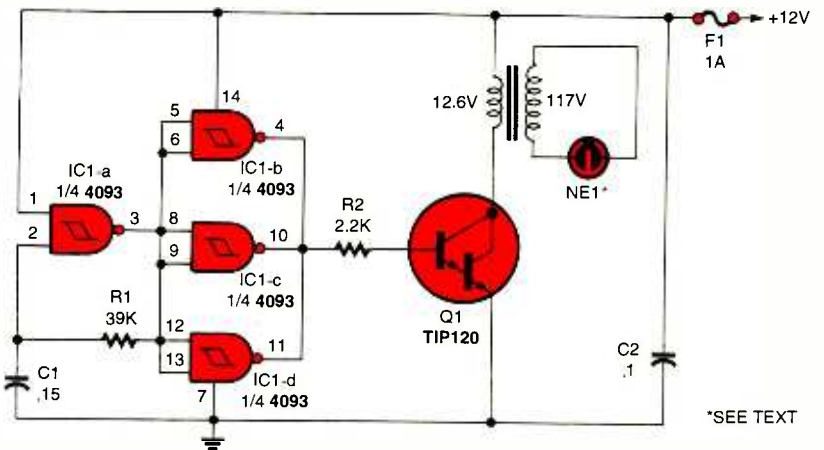

Fig. 4. The Schmitt trigger portion of the Fluorescent-Light Inverter is nearly identical to that used in the previous circuit. In this case, the output of the oscillator is used to drive a Darlington transistor, which in turn is used to pulse the DC current across T1, setting up a fluctuating magnetic field. That rising and collapsing field induces a magnified copy of the primary current in the transformer's secondary, which is used to drive the fluorescent tube.

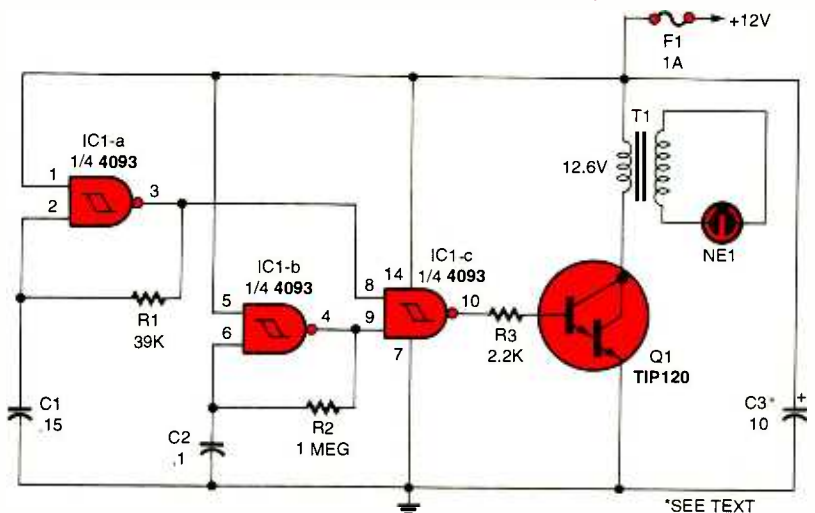

Fig. 5. The Fluorescent Flasher, which combines elements of both the original oscillator and the inverter circuits, can be used as roadside flashing warning light.

It's Not Just Training...

"I needed a refresher in fundamentals and a piece of paper that said I had a degree. CIE gave me both."

Louis P. Briant
Senior Engineer
Sentel Corp.

"CIE allowed me to use my G.I. Bill benefits and independent-study allowed me to continue my studies while deployed."

Charles Hepper
Electronics Senior Chief
U.S. Navy

"The fact that I intended to continue pursuing my Associate Degree with CIE was a key factor in being considered for my current position."

Annamarie Webster
Project Engineer -
Instrumentation
Ketchikan Pulp

"My associates at work recommended CIE... The lessons were structured so they were easy to comprehend."

Vincent R. Buescher
Communications Technician
AT&T

"I reenrolled and received my A.A.S. degree from CIE because of the good experiences I had in one of CIE's career courses."

Maurice M. Henthorn, Jr.
Electronic Technician
The Denver Post

Independent study from CIE will give you the skills you need to win your own independence in a successful career.

At CIE, we pride ourselves in keeping pace with the latest developing technologies. In turn, this assures our students that upon graduation they can mesh seamlessly into a variety of exciting and rewarding technology-based careers.

Back in the 1930's, we specialized in teaching radio and television sciences. Today, it's computer technology, programming, robotics, broadcast engineering, information systems management, and the electronics behind it all.

But some things have not changed, like the desire of CIE's faculty and staff to see their graduates succeed.

That is why at CIE we teach not only the hands-on, practical aspects of electronics technology, but also delve into the "why" behind today's technology. Why does it work the way it does?

The insights to be gained from such a broad, rich and comprehensive

education at CIE matches or exceeds those gained through

traditional commuter institutes while providing an education schedule to match your commitments and lifestyle.

Our patented learning program is specifically tailored for independent study and backed up by a caring team of professional educators who are at your call whenever you need their help.

At CIE, we'll match our training with your background and career goals and help you decide which of the many career courses that we offer suits you best. We offer an Associate Degree Program and through our affiliation with World College a Bachelor Degree

Program.

If you have the sincerity, the smarts and the desire, CIE can make it happen. CIE is already the institute of choice for many Fortune 1000 companies. Why shouldn't you be next?



Computer Programming



Electronics Technician

...It's an Education.



1776 East 17th Street
Cleveland, OH 44114
(216) 781-9400 • 1-800-243-6446

YES! Please send me more information on:

- CIE's Associate Degree Program
- CIE's Career Courses
- World College's Bachelor Degree Program

Name _____

Address _____

City _____ State _____ Zip _____

Phone: _____

Check for G.I. Bill Active Duty Veteran

AH 110

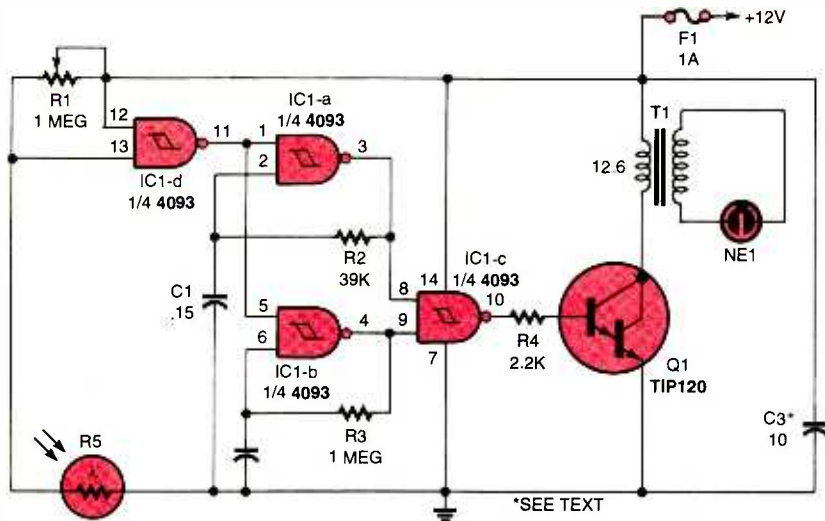
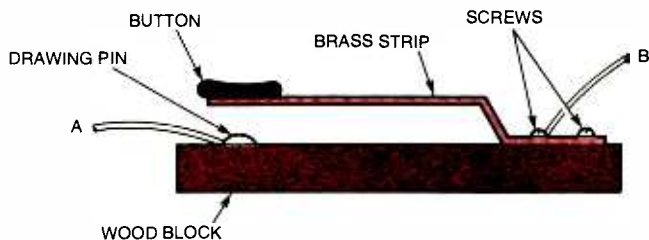
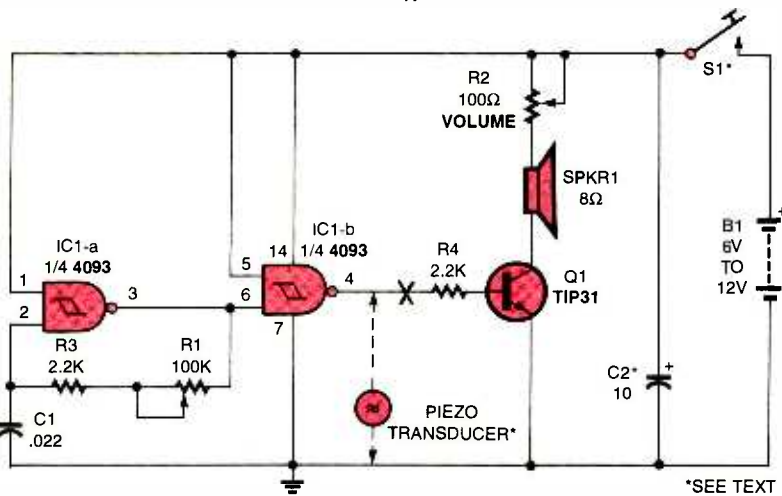

Fig. 6. The Light-Triggered Fluorescent Flasher is a variation of the previous circuit. With only a few slight modifications, the flasher has been redesigned to automatically begin flashing when the headlights of an oncoming vehicle illuminate its sensor.



A



B

Fig. 7. This circuit was designed with the aspiring ham or Boy Scout working toward an award in communications in mind. The circuit is comprised of the homebrew sending key shown in A and the variable-frequency oscillator shown in B. Switch S1 represents the sending key.

With only a few slight modifications, the Fig. 5 circuit has been redesigned to automatically begin flashing when an incoming vehicle illuminates a sensor with its headlights. The circuit uses a light-dependent resistor, R5, as the sensing

device.

Potentiometer R1 sets the sensitivity of the circuit and should be adjusted so that the fluorescent tube starts flashing when a flashlight beam is swept across the lens from a distance of 10 to 12 feet.

Potentiometer R1 is also set so that the flasher turns off by itself when the light source no longer strikes the sensor.

Morse Code Sender. If you're an aspiring ham or Boy Scout working toward an award in communications, our next circuit may be just what you need. The circuit is comprised of a homebrew sending key (see Fig. 7A) and a variable frequency oscillator.

The key is composed of a strip of springy brass that is bent twice—upwards at about a 30–45 degree angle and back as shown—giving the strip a crank shape. The crank-shaped brass strip is then mounted to a wooden block with two wood screws. At the other end of the wooden block, directly beneath the free end of the brass strip, a large brass drawing pin or a round-headed brass screw is installed in the block. A plastic button was glued to the free end of the brass strip to form a knob. Wire leads are then connected to each end of the key, as shown, to allow the unit to be easily connected to the rest of the circuit.

Figure 7B is a schematic diagram showing the entire sending circuit. Switch S1 represents the sending key. The tone (frequency) of the output can be adjusted via potentiometer R1, while potentiometer R2 governs the volume level. The frequency of the free-running oscillator can be varied over a fairly wide range; however, output tones between 500 and 1000 Hz are the most pleasant and the least tiring.

A piezoelectric transducer can be added to the circuit, and the speaker along with its driver transistor (Q1) eliminated. The circuit can be powered from sources ranging from 6 to 12 volts. When powered from a 12-volt source, the output transistor should be mounted on a heatsink.

Beep-Tone Generator. The Beep-Tone Generator is nearly a carbon copy of the circuit that appears in Fig. 5, except that the transformer and fluorescent tube have been replaced by a speaker. Figure 8 shows a schematic diagram of the Beep-Tone Generator circuit. The

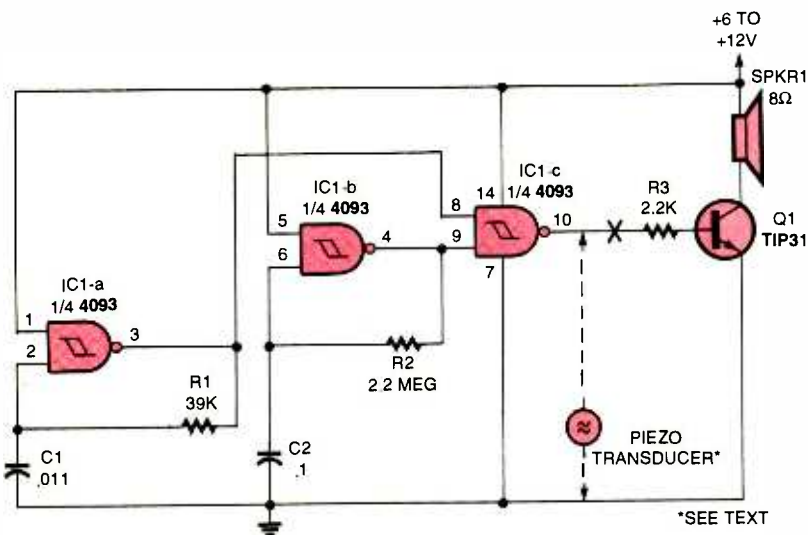

Fig. 8. The Beep-Tone Generator is nearly a carbon copy of the flasher circuit in Fig. 5, except that the transformer and fluorescent tube are replaced by a speaker.

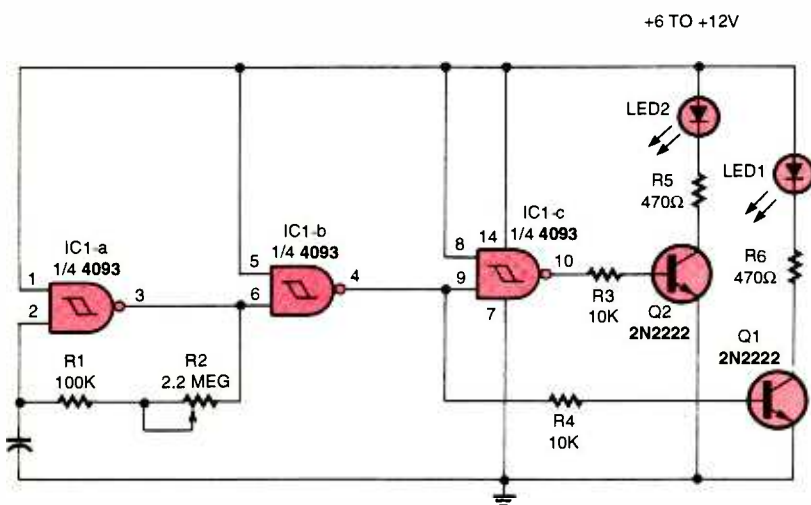

Fig. 9. The LED Flasher is another simple circuit based, in part, on the variable-frequency oscillator outlined in Fig. 7.

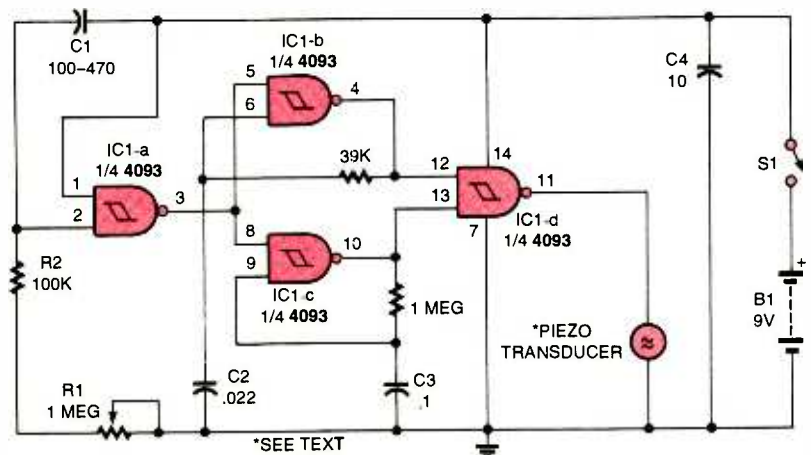

Fig. 10. The Timer circuit, with its adjustable-trigger output, can be made to sound after 10 seconds to 15 minutes have elapsed.

heart of the circuit is a pair of simple oscillators, one comprised of IC1-a, and R1 and C1 (which form the oscillator's RC time constant), and the second one composed of IC1-b, along with R2 and C2. The first oscillator operates as a 1-kHz, free-running, oscillator, while the second operates as an 1-Hz modulation oscillator. The basic tone frequency is determined by C1 and R1 in the first oscillator, and the modulation frequency is determined by C2 and R2 in the second oscillator.

A third gate (IC1-c) is used to combine the two oscillator outputs to produce a modulated 1 kHz signal. That signal is then applied to the base of a power transistor, which is used to drive a small loudspeaker. The speaker can be scrapped in favor of a piezoelectric transducer. The fixed-value resistors in the two oscillator circuits can be replaced by 100k (for IC1-a) and 2.2-megohm (for IC1-b) potentiometers.

With a 6-volt power supply, a common 2N2222 transistor can be used in the output stage. But when powered from 9- or 12-volt sources, a powerful transistor such as a TIP31 is needed. If the TIP31 is used for Q1, it is recommended that the transistor be mounted on a heatsink.

LED Flasher. The LED Flasher, see Fig. 9, is another simple circuit based, in part, on the variable-frequency oscillator outlined in Fig. 7. The circuit is suitable for use in games and timers, or can be used to indicate power. If powered from a common 6- to 12-volt battery, the circuit will flash at a frequency of about 1 Hz for several days.

The two LEDs alternately flash at a rate determined by the setting of potentiometer R2. In the flasher circuit, one gate (IC1-a) is configured as an astable multivibrator (oscillator), with its frequency range governed by C1, R1, and R2. The output of the oscillator is applied to a second gate (IC1-b), which functions as an amplifier.

The output of the amplifier stage is then fed along two paths. In the first path, the signal is applied to transistor Q1, which is used as an LED driver. In the other path, the amplifier output is fed to a third gate (IC1-c).

(Continued on page 72) 57



American Innovations WSS-300 Portable Radio Color Wireless Surveillance System

No need for eyes in the back of your head with this complete TV-camera/transmitter/receiver system.

For people who need to observe two places at the same time, either in the home or at work, American Innovations' WSS-300 Portable Radio Color Wireless Surveillance System is the answer. While you watch one area personally, you can use this system as a play area monitor. At home or at work, use it as a security system. You can also monitor on-the-job activities performed by people and/or automated machinery. The applications are many; after discovering how inexpensive the system is and how easy it is to use, the possibilities of applying it to your personal needs will appear to be limitless.

The System. The WSS-300 System has a 300-foot range that includes a complete TV-camera/transmitter/receiver, unobstructed by ordinary walls, floors or ceilings. The shell of a compact AM/FM cassette-radio cabinet (11-inches wide by 6-inches high, and 3-1/2-inches deep) incorporates the camera, transmitter and antenna. Due to the camera's placement within the cabinet, the internal electronics of the cassette player was not installed. Albeit, the AM/FM radio does function normally.

From outward appearance, the unit appears deceptively genuine. The separate receiver unit is housed in a small cassette-like enclosure. Its antenna is external and may be adjusted for optimum reception from the remote transmitter unit.

With excellent sensitivity, as well as built-in backlight compensation, the high-resolution (380 lines) color-TV camera and the FCC-approved transmitter deliver consistently sharp

video images to the system's receiver. In addition, the receiver's circular polarized directional transmitting and receiving antennas maximize the signal range and minimize signal interference.

The Test. After opening the WSS-300 System package, installation and operation was performed by a neophyte whose electronic experience is limited to connecting TVs, audio components, and tape recorders—similar to most of the population in North America.

The test hookup took less than 15 minutes due to painstakingly reading the instructions (always recommended) and rechecking the connections. The receiver was connected directly to a TV monitor through an A/B coaxial switch. The receiver's output is set to either TV-channel 3 or 4; so preset the monitor's channel to match it correctly. The power switches were turned on and, *voilà*, instant color-TV surveil-

lance. The color was so natural that with the camera aimed at a dull corner of a room, the TV picture appeared to lack color unlike other systems where the color blooms excessively harshly. However, when it viewed children's toys, the full-color fidelity capacity of the system was totally revealed with true colors displayed.

The unit's high sensitivity rating, specified by a low 2 lux rating for the camera, was verified in a room illuminated with a shaded 40-watt bulb. The bed and sleeping child were clearly discernible on the screen, and the colors even remained true. In another viewing test, the driveway was scanned in bright sunlight with excellent screen images produced.

Caution: Do not aim the camera at the sun or allow its rays to strike the front of the cassette cabinet. This holds true for all TV cameras and camcorders.

The optics include two important



CIRCLE 120 ON FREE INFORMATION CARD

features—auto-iris and auto-focus. As the available light increases and decreases, the lens' iris closes and opens providing uninterrupted impeccable viewing. Likewise, the lens focuses on objects from about one foot or less to infinity without loss of clarity.

The system comes with four built-in selectable channels for TV transmission. When the system is first turned on, both the receiver and the transmitter lock on to channel 1. Should the picture be degraded, the user has the option to manually switch to one of the other channels. At no time during our test period, and the eventual play period thereafter, was there any loss of picture quality on any of the four channels. We believe that channel selection is most important only when other similar TV transmitting systems are in the vicinity.

Due to the laws governing the use of concealed microphones, the system has no audio capability to go with the video. The system is designed for security and protection of individuals and property.

What You Get. The WSS-300 system comes complete with a color camera and four-channel transmitter in an AM/FM radio/cassette case, along with a four-channel FCC-approved receiver. Also included is a video cable to connect to your VCR or TV-monitor, an A/B coaxial switch to select between receiver and cable/antenna reception, coax cable, and a power adapter to provide 12 VDC power to the receiver, as well as an easy-to-follow instruction booklet. The transmitter works off the AC line.

The WSS-300 Portable Radio Color Wireless Surveillance System has an introductory price of \$895. For more information, contact American Innovations, Inc., 119 Rockland Center, Suite 315, Nanuet, NY 10954; Tel. 914-735-6127; Fax: 914-735-3560; Web: www.spsite.com. ■

ANTIQUE RADIO CLASSIFIED Free Sample!

Antique Radio's
Largest Circulation Monthly
Articles, Ads & Classifieds.
6-Month Trial: \$18.95. 1-Yr: \$38.95 (\$55.95-1st Class).
A.R.C., P.O. Box 802-L18, Carlisle, MA 01741
Phone: (508) 371-0512 VISA/MC Fax: (508) 371-7129

NEW PRODUCTS

(continued from page 29)

same outstanding sound quality and user-friendly features as the popular white or dark gray model. It features full, rich sound that comes from the 34-inch single-ended "waveguide" inside the unit, excellent sound reproduction at any volume, and simple touch controls on both the front of the unit and on the palm-sized remote. The AM/FM radio provides 12 presets, mute and scan functions, and an automatic sleep function that enables listeners to fall asleep to one station and wake to another.



It will be produced on a limited basis and will be sold through February in Bose stores throughout the U.S., while supplies last. Buyers will also receive, a complimentary book, *Where Music Comes From* by noted photographer Nubar Alexanian, which retails for \$39.95.

The Connoisseur Edition Wave Radio has a MSRP of \$379. Contact Bose Corporation, The Mountain, Framingham, MA 01701-9168; Tel. 800-444-BOSE; Web: www.bose.com.

**CIRCLE 83 ON FREE
INFORMATION CARD**

ALL-IN-ONE DIGITAL POWER METER

Designed to meet the needs of instrument manufacturers, the CP-210A is a digital power meter from Eldan Instrumentation Power, a division of Mid-Eastern Industries. This high-precision, low-cost, all-in-one meter is suitable for power factor and efficiency measurements, for testing of UPS and for switching power supplies.

At one glance, technicians can read voltage, watts, current, and frequency, eliminating the need for four separate instruments. The CP-210A (10.2-x4.3-x13.7-inches) provides a simultaneous, bright LED display of all four parameters on auto-ranging 3½-digit LED dials. The unit measures 50 Hz, 60 Hz, and all input frequencies up to 1000 Hz.

The CP-210A costs \$615. Contact



Eldan Instrumentation Power, division of Mid-Eastern Industries, 100 School Street, Bergenfield, NJ 07621-2915; Tel. 201-385-0500; Fax: 201-385-0702.

**CIRCLE 84 ON FREE
INFORMATION CARD**

FAX FOR WINDOWS

PC HF Facsimile 8.0 for Windows, recently released by SSC Corp., allows PCs with Windows users to receive weather faxes. Charts, weather satellite photos, radio teletype, NAVTEX, FEC, SITOR, ASCII, and Morse code digital news and weather broadcasts can be downloaded with this software.



Connecting the demodulator between the computer's serial port and a SSB shortwave communications receiver, enables digital radio transmissions to be received, displayed, printed, or recorded on to disk. SSC's Windows FSK demodulator allows the program to operate in the background.

The package includes image and text-decoding software, miniature demodulator, world-wide frequency list, a manual, and broadcast schedules. Systems requirements are Windows 3.1X, Windows 95, or Windows NT; 4-8Mb RAM; and 6Mb of disk space.

The PC HF Facsimile 8.0 for Windows has a MSRP of \$179.95. Contact SSC, 615 S. El Camino Real, San Clemente, CA 92672; Tel. 714-498-5784; Web: www.sscorp.com. ■

**CIRCLE 85 ON FREE
INFORMATION CARD**

DX LISTENING

BBC's Empire Service

DON JENSEN

Grandpa's atlas in the 1930s was a world of pink—Aden to Zanzibar, A to Z, the map was marked with patches of that pastel color, signifying the vast extent of the British Empire. The sun, quite literally, never set on the Union Jack.

The pre-World War II Empire included commonwealth nations, crown colonies, territories, possessions, and protectorates. There were nearly 60 countries and islands that looked toward England as their historic, if not literal, motherland. Among the larger ones, mostly with looser ties, were Australia, Canada, and South Africa. But there also the smaller ones, including all manner of islands from the West Indies: Trinidad and Tobago, the Windwards, and the Leewards, for instance—to the Pacific islands: Tonga, Tokelau, and Christmas Island among them. Today, that has all changed. The British Empire is but a shadow of its old self. One of the last crown jewels was lost only last July, when England turned Hong Kong over to Chinese authorities. Fewer than 20 of the dots on Grandpa's old map remain pink.

Over those decades, the British Broadcasting Corporation's World Service—once actually called the Empire Service—helped link all those little bits of Britain around the world. Some of them became the sites of shortwave relay stations.

The BBC's East Asian SW relay at Hong Kong disappeared before the Chinese takeover; it was dismantled and shipped out. But when Singapore, another Asian jewel in the imperial crown, became an independent republic in 1965, the BBC relay station stayed on, and it remains today. The schedule for the Far Eastern Relay site at

Singapore includes 0500-1600 UTC on 9,740 kHz; and at 0500-0900 UTC, 1100-1300 UTC, and 2000-0300 UTC, on 11,955 and 15,360 kHz.

Another British Broadcasting Corporation shortwave relay site is located at Victoria on the island of Mahe in the

special treaty status. Here, on offshore Masirah, is the BBC's Eastern Relay shortwave station. Its broadcast schedule includes 0000-0200 UTC on 5,965 kHz; 1630-1830 UTC on 9,510 kHz; and 0300-1400 UTC on 11,760 kHz and 15,310 kHz.



A chain of shortwave relays around the world still sends the British Broadcasting Corporation signals to many a remote dot in the ocean, once part of England's far-flung Empire.

Seychelles, an Indian Ocean island group that gained its independence from Great Britain in June 1976 and then became part of the loosely-knit British Commonwealth. A partial schedule for this Indian Ocean relay station is 1700-2130 UTC on 9,630 kHz; 0330-0430 UTC on 11,730 kHz; and 0430-0600 UTC on 15,420 kHz.

To the northwest, at the tip of the Arabian peninsula in the Persian Gulf is Oman. Though an independent sultanate, this oil-rich country was long a virtual political and economic dependency of Great Britain, and still retains

BBC CYPRUS SITE

Though now politically split between its ethnic Greek and Turkish communities, the Mediterranean island of Cyprus formerly was one of Britain's imperial dots on the map. Captured from the Turks during WWI, Cyprus became a British crown colony in 1925 and remained so until 1960, when an independent Cypriot nation was born. After a civil struggle, a portion of the island declared itself the Turkish Federated State of Cyprus in 1975.

Near Limassol in the Greek-influenced part of Cyprus, the BBC main-

(CREDITS—David Clark, ONT; Mark Humenyk, ONT; Harold Levison, PA; Gigi Lytle, TX; William McGuire, MD; Mark Mohrmann, VT; Jay Novello, NC; Giovanni Serra, ITALY; World DX Club, c/o Richard D'Angelo, 2216 Burkey Drive, Wyomissing, PA 19610; North American SW Association, 45 Wildflower Road, Levittown, PA 19057)

tains its East Mediterranean SW relay. It can be heard signing on at 2359 UTC on 9,410 kHz, with identification and a clear mention of the specific site, followed by tuning and time signals and English news. Other bits of schedule are found at 0200-0500 UTC on 12,095 kHz; and 0400-0600 UTC and 0930-1500 UTC on 15,575 kHz.

In the Western Hemisphere, the BBC's Caribbean Relay station is located near St. John's on the island of Antigua in the Leewards. Independent from Great Britain since 1981, this tiny country, a mere 108 square miles, is part of the state of Antigua and Barbuda.

One of the remaining bits of the old British Empire is Ascension Island, a remote and tiny island in the South Atlantic. Only six by nine miles in size, it is home to the BBC Atlantic Relay Station at English Bay. This World Service relay station schedule is from 0000 to 0800 UTC on 5,970 kHz, 6,005 kHz, 6,190 kHz and 9,600 kHz; and 1500 to 2300 UTC on 11,750 kHz, 15,400 kHz, and 17,830 kHz.

Much of the BBC World Service program stream to the Americas is rebroadcast from these SW transmitters. The best time to tune is between 0000 and 0700 UTC during our evening hours. Frequencies to try include 5,975 kHz, 6,175 kHz, or 9,590 kHz. Or, during the mornings, from 1100-1400 UTC, try 15,220 kHz or 17,840 kHz.

The imperial sun may be sinking fast, but SWLs can still enjoy familiar BBC shortwave programming relayed from some of these former global outposts of the old British Empire.

HELP WANTED—HARPIES

Lest I be accused of thumping the drum too vigorously for ol' Auntie Beeb, the venerable British Broadcasting Corporation, let me quote a "discouraging word" from Harold Kerrison, an Englishman from Suffolk, commenting in a recent issue of the World DX Club's publication, *CONTACT*.

Kerrison began by waxing enthusiastic about the BBC announcers of years past who were renowned for their direct delivery and perfect pronunciation. Back then, Harold wrote, we listeners probably failed to fully appreciate the aural treasures of such radio voices as "Alvar Lidell or Bruce Belfrage in full diction!" The last survivor of that gifted gang is Raymond Baxter, whose deliv-

ery in measured phrases is like blank verse spoken off the cuff....

"Out of all the murderers of the English (language—*Editor*) who infest our BBC (today), the most outstanding is the typical female with a voice like a bugle band who interrogates and showers her victim with PC dogma.

Where does the BBC get them from? Is the old Greek legend of the Harpies actually alive and well? Is there perhaps a discrete island out there somewhere filled with fierce Amazons and latter-day Furies, and does personnel at the Beeb have a direct line?"

Wow, that Harold is no shy guy when it comes to speaking his chauvinistic piece!

GEORGIA ON MY MIND

No, not *that* Georgia. I'm not talking Dixie, south of the Mason-Dixon Line, but rather south of the Caucasus, the now independent country carved out of the former Soviet Union. Today's Georgian Radio, a survivor of the USSR broadcasting monopoly, with broadcasting studios in the capital, Tbilisi, has an external SW service called, in Russian, *Radiostantsiya Gruziya*, and, in English, "Program Georgia". Broadcasting, reportedly, is still irregular, but here are some times and frequencies reported for English programming: 0630-0700 UTC on 11,805 kHz; 0830-0900 and 0930-1000 UTC on 11,910 kHz; 1730-1800 UTC on 6,080 kHz; 1830-1900 UTC on 11,910 kHz; and 1930-2000 UTC on 11,760 kHz.

MORE POWER

In the mailbox is a letter from Chad Tyler, Emporia, KS, who says he heard a news item about the Zambia National Broadcasting Co. in southern Africa.

ZNBC is supposed to have two new 100-kW American-made continental transmitters operating on shortwave. What struck me as curious, though is the fact that they are being paid for by China, replacing a pair of obsolete units, which also had been a Chinese gift more than 20 years ago. Three new antennas, called 'Lazy H' types, have been installed for 60-, 49- and 41-meter band transmissions with the new transmitters. This should provide better reception of Zambia broadcasting.

Thanks, Chad. Next a question from a university student at Duke University in North Carolina. Our reader says he would prefer not to have his name pub-

lished in the column, but he says he is a native of India.

Why is it so hard for me to hear All India Radio on shortwave? Have you any suggestions?

While AIR's new high-powered 500-kilowatt SW transmitters are often heard in North America, admittedly it can be tough to hear them with an inexpensive shortwave receiver and just a small whip antenna. At this writing, however, All India Radio is said to be negotiating for a SW relay of its programming from a high power station in either the Caribbean area or in West Africa, a lot closer to us. It may be reality by the time you read this.

DOWN THE DIAL

With the sunspot numbers starting to rise, look for good openings on the higher frequencies. Here are some tuning targets for you:

ASCENSION ISLAND—1,660 kHz, BBC broadcasting in English is relayed from this South Atlantic transmitting site. It was logged at 1430 UTC with play-by-play of a soccer match.

CAMBODIA—11,940 kHz, National Voice of Cambodia is reported with possible Thai language programming at 1232 UTC. Loud woman announcer and a variety of Asian music.

COLOMBIA—4,975 kHz, Ondas del Orteguzaza is heard at 2300 UTC in Spanish with a promo for the Todelar radio network, ID, and newscast.

ICELAND—9,275 kHz, Rikisutvarpid, the shortwave outlet at the Icelandic capital of Reykjavik, has been noted here, parallel to 11,402 kHz, at 2300 UTC with news in Icelandic.

INDIA—11,620 kHz, All India Radio, Bangalore, operates in English on this frequency and parallel 9,950 kHz, around 2250 UTC with music of the subcontinent and commentary.

MALAWI—3,380 kHz, Malawi Broadcasting Corporation broadcasts from southern Africa on this frequency, noted at 0340 UTC with African music and announcements in the local Chichewa language, but with some English advertisements and an identification or two.

VIETNAM—15,098 kHz, Voice of Vietnam from Hanoi has been heard around 1330 UTC in English with news, identification, and commentary. Vietnamese patriotic songs continue to final announcements and sign-off at 1457 UTC. ■

ANTIQUE Radio

Smoke Test for the NR-5

MARC ELLIS

As I pick up the restoration of the *Freed-Eisemann NR-5* once more, it will be helpful to readers who may have just joined me to review what I've done so far. This series began with last June's issue, when I discussed the rise in popularity of the TRF (tuned radio frequency) circuit in the early '20s. In that column, I explained why the design held its own for so many years, even though it required three tubes and three tuning dials to do what most regenerative sets could do with one of each. Following up in July, I introduced the Neutrodyne circuit, which was the best-known and most effective of the TRF designs. Explaining Freed-Eisemann's very early identification with this circuit, I took a detailed look at that company's classic five-tube, three-dial, Model NR-5 Neutrodyne. In the September issue, I examined an actual NR-5, recently added to my collection with the idea of restoring it for this column. A list was made of all the physical and electrical problems requiring attention.

The NR5, like most "three-dialers," is a battery-operated radio, and I could have powered it with batteries. However, I thought that readers would be interested in looking at some circuits for powering battery sets from the AC line. So in the November and December columns, I discussed how I built simple versions of the "A," "B," and "C" battery-eliminators described by Dr. Fred Archibald in *The Old-Timer's Bulletin of The Antique Wireless Association* (November, 1989).

Now, in this column, I'm taking up the restoration where I left off. My practice ordinarily is to carefully clean a set and correct all of its obvious physical and electrical problems (remember that list I made) before applying power for the first time.

However, this time I ignored my own good advice. The "A," "B" and "C" (filament, plate and grid bias, respectively) supplies were built; the series of articles had been running for a number of months; I was getting impatient and was sure you readers were too. I was

going to fire up the NR-5 after doing only the few things absolutely necessary to put it in running condition.

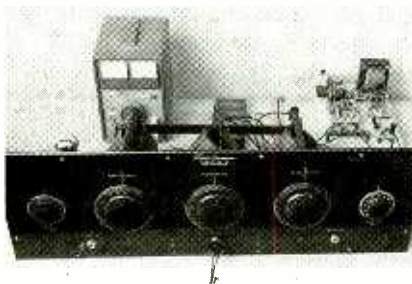

The NR-5 laid out on my bench for its smoke test. At right rear is the breadboard-mounted "A," "B," and "C" supply. At left is the Eico battery-eliminator/charger temporarily pressed into service to supply bias.

FIRST THINGS FIRST

Of course I couldn't get anywhere until I repaired the "A" supply that had suddenly quit working after passing its preliminary tests with flying colors (December, 1997 column). I thought that perhaps the 2N3055 regulator had given up the ghost. I wasn't sure that I had provided an adequate heat sink, and it was running quite hot. However, that didn't turn out to be the case.

A little troubleshooting with a voltmeter and ohmmeter soon isolated the trouble—a PC board foil had opened up because it was carrying too much current. I had intended to hard-wire all high-current connections, but had absent-mindedly made this connection through the foil. Fixing that was the work of a moment, and the supply was once more delivering its rated 5.2 volts.

My next move was to temporarily replace the 1- μ F plate bypass capacitor with a modern unit. I know from experience that these 70-odd-year-old flat-can paper capacitors invariably open or are reduced to a fraction of their capacity. Later, I'll find a ceramic cap that will fit inside the can in place of the old "guts," but for now I just took it out of the circuit and tack-soldered a 1- μ F junk box unit in its place.

Incidentally, dismantling solder con-

nections made with that old-time heavy flat bus bar is no joke. I was very glad to have the American Beauty iron I'd recently picked up at a garage sale, though I wish it were 100 watts or more instead of 60! I used copper desoldering braid, sucking up enough old solder so that I could pry the bus bar away from its connection to the capacitor lug.

Another problem mentioned during our initial survey of the set was the grid-leak resistor which, over seven decades, had changed in value from 2 megohms to about 500k-ohms. Long-term, I'd like to dismantle this grid leak and rebuild it with a new 2-megohm resistor inside. But for this test I just removed it and tack-soldered a 2-megohm resistor in its place.

HOOKING UP TO THE SUPPLY

At last, I was ready to apply power and try out the battery eliminators and the set. But there was one small problem. Without the set's hook-up diagram (normally tacked to the inside of the lid, but missing on this set), I didn't know which power binding posts were which. Though I have the schematic, the NR-5's maze of bus-bar wiring is virtually impossible to trace by inspection. Of course, I was quickly able to identify the posts by connecting my ohmmeter between each one and a key circuit point.

While I was at it, I verified that all the normally-closed switches associated with the various phone jacks were making electrical contact. When phones or speaker are plugged into the "Detector" or "First Audio" jacks, built-in switching breaks the circuit to the audio-coupling-transformer primary—placing the phones or speaker in the circuit instead. I also plugged an appropriate speaker into the "Second Audio" jack (which has a set of contacts that energize the filament of the second audio tube when a plug is inserted).

Deciding to start with just filament power, I hooked up the "A" supply, turned out the lights, and plugged in the power supply. I was really gratified

to see a golden warm glow appear at the base of each of the five 01-As. (Readers who followed my earlier 1930 ham receiver project will remember the difficulty I had getting even to this step, using friction-contact tube sockets that I had not thought of cleaning in advance. I had to disconnect both sockets to clean them, and even then had problems with intermittent contact.) But these push-and-twist bayonet-lock jobs made wonderful contact the first time without any attention at all!

Now I was ready to try out the "B" and "C" supplies. Readers who have been following this story know that the "B" supply has two resistors, controlling the 90- and 22½-volt B+ outputs, respectively, whose values need to be determined by experimentation because they depend on the load drawn by the set. I had already put in a value for the 90-volt output (it happened to be 1500 ohms), calculated according to the estimated load.

I decided to start by hooking up just that "B" output to the set—thus energizing the plates of four of the five 01-As (two RF amplifiers and two audio amplifiers). I would also hook up the grid bias ("C") supply, after adjusting it to deliver the proper voltage (4.5 volts) with the built-in potentiometer provided. I'd adjust and connect the 22½-volt output in a later step.

After carefully checking all my connections twice (many a set of 0-1As has had its filaments blown through being accidentally connected across the "B" supply), I turned off the lights so I could watch the tubes and turned on the supplies. The tubes remained stone cold, but I saw a tiny spark come from the fuse of the "A" supply! My first thought was that the 2N3055 regulator had indeed finally given up the ghost. But luckily I decided to check the wiring from the radio to the supplies one more time before dismantling the supply for troubleshooting.

I had indeed connected the wires according to "the book," but there was a problem with the configuration of the "B" and "C" supplies that I hadn't foreseen. If you look at the schematic (December, 1997), you'll note that the "C" supply's plus output terminal is also the "B" supply's minus output terminal. The NR-5 hookup (as is frequently the case with early battery sets) calls for the "C" plus lead to be connected to the set's "A" minus termi-

nal. Fine. However, again as is usual, the "B" minus lead from the power source is to be connected to the set's "A" plus terminal.

If you see what has happened here, you are quicker than I was when I made the hookup. What it boils down to is that both the plus and minus terminals of the "A" supply were connected to the same point (the "B" supply minus terminal). The result—a dead short and a blown fuse. So giving up the idea of using the built-in "C" supply for the moment, I brought in my old Eico battery eliminator/charger (purchased years ago for firing up 01-As), adjusted it for 4½ volts, and hooked it up as a temporary "C" supply.

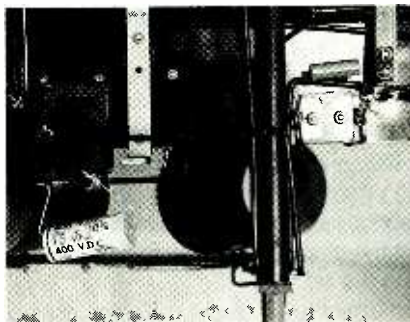

Under-chassis view showing temporary lash-ups used to make the set playable (see text). At left is a 1-μF capacitor substituting for flat-can unit above it. Just to the right of the post is a modern 2-megohm resistor tack-soldered across the grid leak clips.

Putting in a new fuse, I turned on the supplies again. Now I saw the golden glow of properly energized 01-As and heard a hum signifying that the speaker had come to life. But my DVM showed that only about 50 volts was being delivered to the set's 90-volt terminal. Trying successively smaller resistors, I was still unable to obtain the proper value. Finally I eliminated the resistor entirely, shorting across its binding posts with a length of wire. Now the voltage rose to about 70 volts, which I would have to be happy with.

Hooking up the 22½-volt terminal of the supply to the proper binding post on the NR-5, I began experimenting with its voltage setting resistor. A 50k-ohm resistor hit the required voltage almost on the nose, and the set was ready to fly! I've heated up many long-disused radios in my time, but the excitement of the final moment of truth never seems to go away! Would it perform or not?

THE RESULTS

Using no ground and an antenna consisting only of a 10-foot wire strung out on the floor of my study, I began picking up stations at once. They were reasonably hum-free, but loud and distorted. Apparently they were strong enough to overload the final audio tube and/or the loudspeaker. I unplugged the speaker from the "Second Audio" jack and inserted it into "First Audio." This did the trick. Cutting out one stage of amplification made the signals clear and undistorted. They were also remarkably free of hum.

Now I began hunting up and down the dial (or should I say "dials") looking for other stations. I don't know how many of you have tuned a 3-dialer before, but it is an interesting experience. You adjust all three dials close to the same setting, and then hunt with one of them to see if you can tune in a station. It might come in as a faint whisper—but after you peak the other two dials, the volume usually rises dramatically, perhaps even becoming too loud. Using this technique, I could pick up signals throughout the entire broadcast band. They tuned in and out with velvet smoothness, only occasionally becoming unstable or hard to separate. And would you believe the first solid broadcast I picked up was "The Jack Benny Show," with special guest Groucho Marx! Hmmm....

By the way, the filament rheostats have no effect on volume. They were put there to keep the filaments at the correct voltage as the "A" batteries powering them became discharged. Set the voltage too low, and there will be no sound. But, after reaching the point where sound comes on, there is no further change in sound level with rheostat setting. If a signal is too loud at the second audio stage, you can plug your speaker into the first audio stage as I did. If still too loud, you can cut out that stage by plugging your speaker or headset into the "Detector" jack. No other adjustment is possible.

All in all, awakened from its decades-long sleep with hardly any preparation or maintenance and without even a decent antenna provided, this radio has turned in an amazing performance! Plans are now to go back and do the right thing by the NR-5, cleaning up all the loose ends. I'll also see what can be done to deal with the bias supply problem. So long for now! ■

Think Tank

Alarming Circuits and Keypads

JOHN J. YACONO
TECHNICAL EDITOR
COMPUTER RESELLER NEWS, IEEE

This month's circuits feature alarm projects and keypad interfaces. But last month I promised to describe how to use adjustable or programmable power supply regulators, so let's get to that first.

In the previous *Think Tank* column, it was mentioned that the XX7 family of adjustable regulators consists of positive and negative voltage regulators, denoted X17 and X37, respectively. Recall that the first digit in the part number indicates the grade or quality of the component. The positive and negative regulators function in the same manner, so we need only discuss one type (either positive or negative) to understand how to use anything in the family.

For the sake of discussion, let us examine positive-voltage adjustable regulators. Keep in mind that the exact same rules apply for negative regulators; they just require a negative input voltage and provide a negative output voltage.

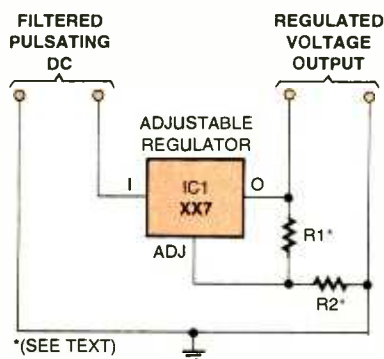

Fig. 1. Changing the ratio of R2 to R1 allows the adjustable voltage regulator to be used to provide output voltages between 1.25 and 37 volts DC when a 40-volt input is supplied.

Figure 1 shows a positive adjustable regulator with its two programming resistors R1 and R2. No pin numbers are shown, because they depend on the gender (positive or negative) and case style (TO-220, TO3, etc.) of each unit.

Resistor R1 is usually fixed at 240 ohms to provide optimal performance. The value of R2 then determines the

output voltage, V_{OUT} , of the positive adjustable regulator according to the following equation

$$V_{OUT} = 1.25 \times (1 + R2/R1) + R2 \times I_{ADJ}$$

where I_{ADJ} (the "adjustment current") is dependent on the regulator and is typically between 40 and 50 μA . That current is so small you can assume it is zero, simplifying the equation to

$$V_{OUT} = 1.25 \times (1 + R2/R1)$$

For example, with a 40-volt input voltage applied to the regulator and fixing the value for R1, any voltage from about 1.25 to 37 volts can be obtained at the output of the regulator by selecting the resistor, R2.

There are a couple of design considerations to keep in mind when using programmable voltage regulators. At lower output voltages, the available current is limited by the power dissipation of the regulator. If more than a 1/4-amp of current is to be drawn from the device, then use a heatsink. You should also use a heatsink if the input voltage will be more than 6 volts higher than the output voltage. The waveform into the regulator should be filtered to supply at least 3 volts RMS more voltage than the desired output voltage. Also, a 0.1- μF ceramic-disc or a 1- μF tantalum bypass capacitor is recommended at both the input and output of the regulator to increase stability and improve transient response. The capacitors should be connected as close to the regulator leads as possible. Next month, I'll describe how to use these neat ICs to control current instead of voltage. Now, it's time for the letters.

ISOLATED WARNING SYSTEM

While working on a project recently, I needed to add a simple warning system that was isolated from the main power source. After experimenting with several different circuits, I made this one (Fig. 2) that is isolated from the

main circuit by the phototransistor and operated by its own supply. The device being monitored illuminates phototransistor Q1, keeping the rest of the circuit (an oscillator) from operating. By the way, the RadioShack phototransistor is an infrared (IR) phototransistor, so the illumination device you are monitoring must emit some spectral response in

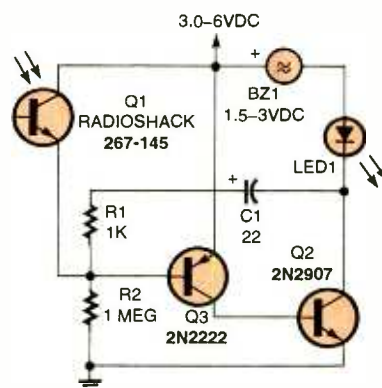

Fig. 2. This warning system is isolated from the main circuit by using a phototransistor. Absence of light at Q1 sets off the buzzer.

the IR range of Q1. If you use other phototransistors, keep in mind that their spectral characteristics should be consistent with the light to be monitored.

With some adjustments, this simple oscillator circuit can have many applications. I found the buzzer or LED can be removed if only one of those components is desired. I wanted both in my application, so I used both. Also, the phototransistor can be replaced by another component such as a relay.

Power for the circuit needs to be between 3 and 6 volts DC. I chose to use two D-cells to operate the circuit, which I found would only draw about 11-mA every 12 to 15 seconds. Therefore these batteries are sufficient to keep the circuit going a long time.

—John M. Kuzio, Trenton, NJ

I can see lots of uses for your nice circuit. Placed near the power-on incandescent lamp of most devices, it

can alert you if the unit under scrutiny shuts off or even loses AC power. An equivalent part for the 2N2907 transistor is an NTE159M, while the 2N2222 can be replaced with a NTE123A.

SYSTEM-TRIPPED INDICATOR

I use the circuit in Fig. 3 to keep an "eye" on a remote storage facility. No one is in close enough proximity to see or hear any attempt to enter the premises. Upon my return, I simply press S2 to see if the system has been tripped. The motion detector used is a low-cost unit with both lamps removed and the photocell disabled so that the detector operates in the daytime. An AC plug adapter is screwed into one of its 117-volt AC sockets, and a 9-volt DC power supply is then plugged into this socket adapter.

When the detector is tripped, AC is applied to energize the supply where 9-

volts DC is generated to latch or set the SPDT 2-coil latching relay, RY1. Pushing S2 will light the LED if the motion detector has been tripped. Releasing S2 and pushing S1 resets the system. Diode D1 separates both battery supplies.

The value of R1 should be chosen so the latching relay RY1 operates reliably with both power supplies. The motion-detector's "on-time" can typically be adjusted to your preference—usually over a 3-to 15-minute range. The voltage adapter can also power a *Sonalert* buzzer and/or strobe light. That usually encourages an intruder not to hang around long. An optional keyed switch for the owner's use, S3, could stop the alarm.

Give some thought as to where the motion detector is to be mounted. Large dogs could set it off. Also try to make it inaccessible to anyone who could unplug or tear wires loose. The

motion detector can be used in- or outdoors, but all other components are best mounted indoors. The system as described is quite low in cost. It is not intended to be a first-class protective system with all the bells and whistles, but it does work and is easy to install.

The latching relay is available from *Hosfelt Electronics* (800-524-6464) as part number 45-249. Equivalent or similar relays are available from *All Electronics* (800-826-5432).

—Roger W. Hamel, Cedarville, MI

Very nice, Roger! For outdoor mounting, I'd also recommend sealing both ends of the AC adapter plug with silicon caulk or petroleum jelly to protect it from the elements. An interesting addition would be another latching circuit to indicate that the power adapter was pulled from the socket.

MEDICAL ALERT

I use an alarm to remind me to take my medicine on schedule. One such alarm circuit (widely used in industrial plants) is shown in Fig. 4A. The circuit is popular because it is simple, economical, and immune to the electrical noise typically found in industry.

When the timer contacts close, the light comes on and the alarm sounds. When the push-button switch, S1, is operated, relay RY1 is activated. The relay also opens the contacts in series with the audible alarm and silences the buzzer. When the timer contacts open, the relay resets for the next alarm cycle, and the light goes out.

The circuit can be expanded to operate any number of devices by simply adding more relays. A light may be added for each contact pair to indicate when the contact is still closed after the alarm is silenced. If you build this circuit, take the usual precautions when handling 117VAC power. *The life saved may be your own.*

To get away from using AC power, I rigged up the circuit shown in Fig. 4B. When the timer contacts close, the buzzer sounds. When the push-button is closed, the gate circuit on the SCR is energized, the SCR conducts, and the buzzer is short-circuited—silencing it. The SCR continues to conduct until the timer contacts open, setting the circuit up for the next alarm cycle.

I used parts I had in my junk box. The SCR I happened to have completely silences the solid-state buzzer. The parts you have on hand may differ.

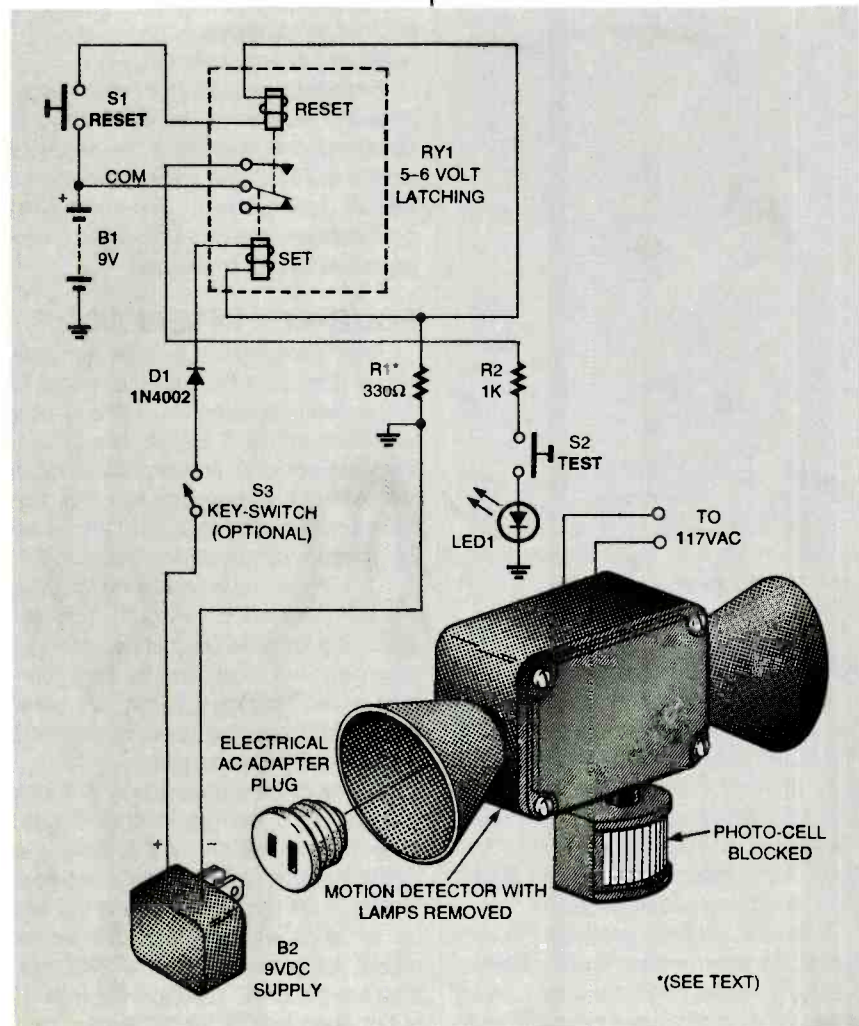

Fig. 3. This handy system-tripped indicator circuit will notify you if the alarm has been tripped. Use an external buzzer or strobe light to startle any prowler.

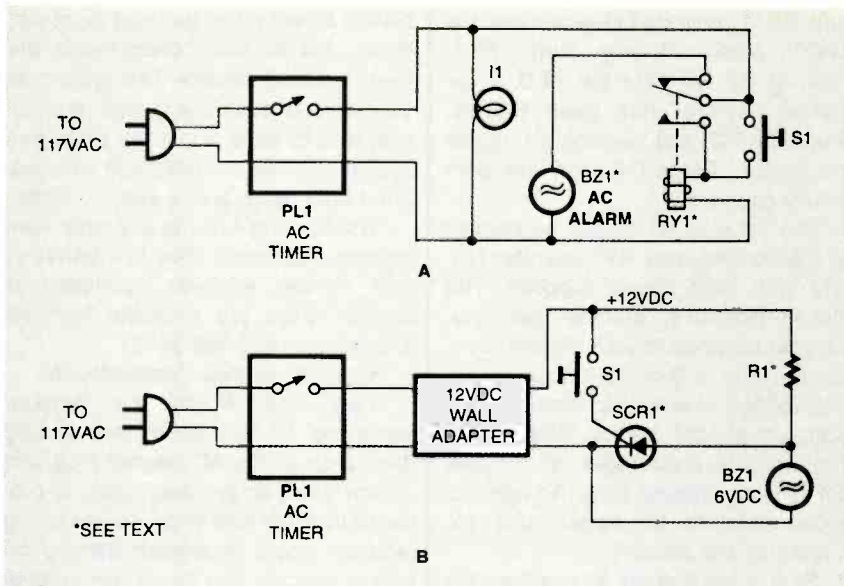

Fig. 4. The circuit in (A) uses the programmed AC timer to set the buzzer/relay after a known amount of time. A similar circuit in (B) uses a 12-volt adapter to supply the power to the low voltage components.

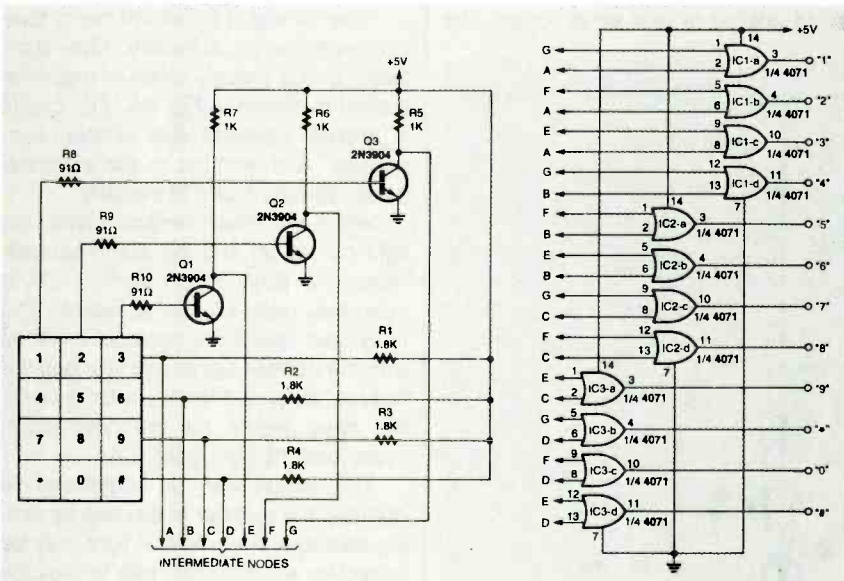

Fig. 5. This circuit is a neat interface for low-cost telephone-like keypads. The switches in the keypad select a specific row and column line when pressed. The 4071 IC provides the proper logic to identify the designated numerical keypad reference.

and the other for its column—change to a low voltage. The low voltage corresponding to the column is the saturation voltage for its transistor. The low voltage for the row is produced by the row's voltage divider, consisting of a 1.8k- and a 91 ohm resistor.

In practice, the low voltage is found to be around 1 volt, low enough to be considered a logic zero by the OR gates connected to the intermediate nodes. Only the gate corresponding to the depressed key will have two logic-low inputs, so that gate will be the only one with a low output. The 4071 ICs are CMOS, quad 2-input OR gates, and are equivalent to NTE4071B devices.

The circuit has been tested using 2N3904 transistors (equivalent to NTE123AP, but any general-purpose transistor will do. Also, the circuit has been proven to work for a range of resistor values, as well as the ones in the schematic. If other logic is needed, the OR gates can easily be replaced by another set of gates.

—Albert Lozano, Lehman, PA

Definitely versatile and smart. I suppose the resistor values would have to be changed to guarantee the circuit will work if a TTL chip is substituted for the CMOS unit shown. Experimenters, note that you can use NOR gates if normally low output is desired.

FOUR-KEY INTERFACE

After using my last keypad with individual outputs, I tried to find a way to use a standard numeric telephone-type keyboard with a 7-lead matrix output. They are easier to find and priced quite low. What I came up with is a four-digit code device (see Fig. 6) that allows for 24 possible combinations (i.e. $4 \times 3 \times 2 \times 1$). The jumpers shown in Fig. 6 set the combination to 5-0-2-8. The circuit's only limitation is that you can use only *one vertical column* for your four-digit code. The keys in the two other columns that are not used for the code are wired to cause a reset.

At any given moment, only one row (horizontal) is hot (positive). If a non-code digit is entered at this time, the circuit resets to an initial start condition. That is, if Q1 (row 4) is hot and the key "S" or "#" is entered, then the circuit resets. Likewise, if Q0 (row 2) is hot, then key "4" or "6" resets; if Q2 (row 1) is hot, then key "1" or "3" resets; or if Q3 (row 3) is hot, then "7" or "9" resets.

(Continued on page 71)

KEYPAD INTERFACE

The circuit in Fig. 5 is an interface for low-cost telephone-like keypads. The circuit produces a logic output that identifies the key that has been pressed. The switches in the keypads provide a low-resistance path between their row and column lines when pressed, and a high-resistance path if left alone.

If no key has been pressed, the voltage at the intermediate nodes (labeled A to G) is 5 volts (logic 1 or high). So all of the gates outputs are normally high. When a key is pressed, two of the intermediate nodes—one for the key's row

Circuit Circus

Circuit Potpourri

CHARLES D. RAKES

This time we're going to stir the potpourri pot and dip out a few simple unrelated circuits for you to consider using in a present or upcoming project.

Our first entry in Fig. 1 is a handy ultra-simple circuit that uses a single DPDT switch to turn your digital multimeter (DMM) into a capacitor tester. With a little practice, you can tell if a capacitor has leakage, is open, or shorted, and if its true capacitance is close to its marked value. I'm sure all of the old-timers reading this remember using their favorite analog volt ohmmeter, set on its highest ohm range, to check out questionable capacitors. The better meters, like the Simpson Model 260, had a built-in polarity reversal switch that made the job a snap. The majority of modern DMMs does not offer a polarity-reversal switch. The circuit in Fig. 1 allows the modern DMM to perform the same function by using the external switch, S1.

All capacitors smaller than 1- μ F can best be checked on the highest ohm range. Larger values, including most all electrolytic capacitors, should be checked on a lower ohm range. Since meters vary greatly, you will have to experiment to determine the best range to use. The majority of the

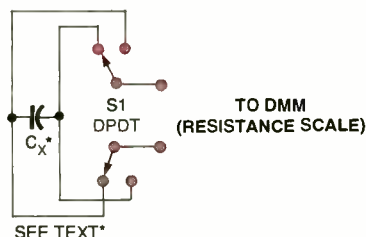

Fig. 1. Use this simple circuit with your present DMM to check unknown capacitors for shorts, leakage, etc.

PARTS LIST FOR DMM CAPACITOR TESTER (FIG. 1)

- C_x—Capacitor under test (see text)
- S1—Any DPDT toggle, slide, or push-button switch

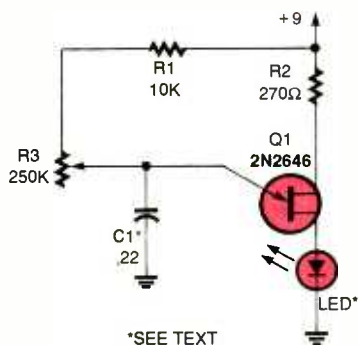

Fig. 2. This circuit is the perfect driver for IR devices or visible LEDs.

PARTS LIST FOR IR/LED DRIVER (FIG. 2)

- C1—0.22- μ F, 50-WVDC, mylar capacitor
- LED1—Infrared light-emitting diode (LED), or visible LED (see text)
- Q1—2N2646 unijunction transistor (NTE640¹, or equivalent)
- R1—10,000-ohm, 1/4-watt, 5% resistor
- R2—270-ohm, 1/4-watt, 5% resistor
- R3—250,000-ohm potentiometer

DMMs offered today will automatically change ranges or autorange, and if this is the type you are going to use—just set it on OHMS and check away. Capacitors smaller than 0.01- μ F can only be checked for shorts or leakage, as the charge and discharge time is too quick to compare for capacitance value.

Here's how most modern digital multimeters react to our method of capacitor checking. When a good capacitor, 0.01- μ F or larger, is first connected to the test circuit, the meter will instantly show a low resistance reading and then rapidly increase in value to infinity—or to the meter's maximum resistance reading. Switching S1 to the other position will cause the meter to read a negative resistance, then rapidly swing through zero and increase again toward infinity. If the meter reading stops short of its maximum resistance reading, this will be the capacitor's internal leakage resistance figure. In all non-electrolytics, this read-

ing should approach infinity for good capacitors. The charge/discharge time depends on the capacitor's value. Larger capacitors take more time to charge and discharge than smaller capacitors, and after some experience using this method, you will be able to judge the approximate value of the capacitor under test. Another method is to compare the questionable capacitor with a known unit of the same value.

If you work with infrared (IR) remote controls, or just like to play with IR circuits, this driver circuit (Fig. 2) is for you. The unijunction transistor is a natural when it comes to generating the fast narrow pulses required to drive IR devices or visible LEDs. The pulse rate of the oscillator circuit derived from the 2N2646 unijunction transistor is variable and controlled by potentiometer R3. Using the component values shown, you may vary the pulse rate from a few pulses per second to several thousand per second. To lower the frequency range, increase the value of

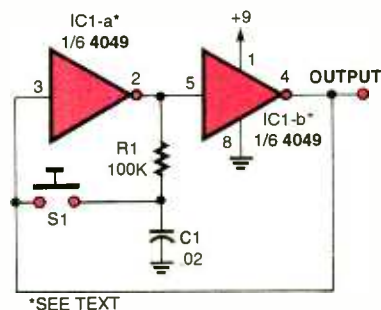

Fig. 3. The output level of this circuit will change state each time switch S1 is pushed. I'm sure you can find numerous applications for this simple configuration.

PARTS LIST FOR STATE-CHANGER CIRCUIT (FIG. 3)

- IC1—4049 hex-inverting buffer IC (NTE4049, or equivalent)
- C1—0.02- μ F, 50-WVDC, mylar or similar capacitor
- R1—100,000-ohm, 1/4-watt, 5% resistor
- S1—Normally open push-button switch

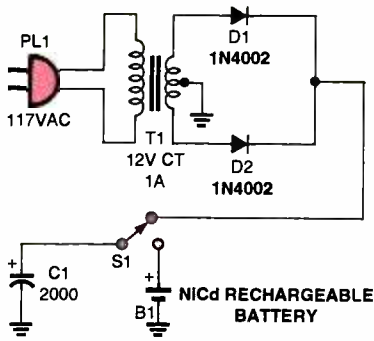

Fig. 4. Here's a handy circuit to zap NiCd batteries back to life after a memory loss. In most cases, the zapped cells can be recharged again.

PARTS LIST FOR NiCd BATTERY ZAPPER (FIG. 4)

- B1—Nickel-cadmium rechargeable battery
- C1—2000- μ F, 25-WVDC, electrolytic capacitor
- D1, D2—1N4002 silicon diode
- S1—15-amp, heavy-duty SPDT toggle switch
- T1—12-volt, 1-amp, center-tap transformer

C1; to raise the frequency range, decrease C1's value.

The next entry (Fig. 3) uses a 4049 hex-inverting buffer IC. The circuit turns two of the CMOS inverters into a handy debouncing alternate output switch. Each time switch S1 is pushed, the output changes state. The circuit can be used to latch power on to another circuit, or to drive a stepping circuit, or to...(put your application here).

When you build this circuit, make sure you tie the remaining four unused

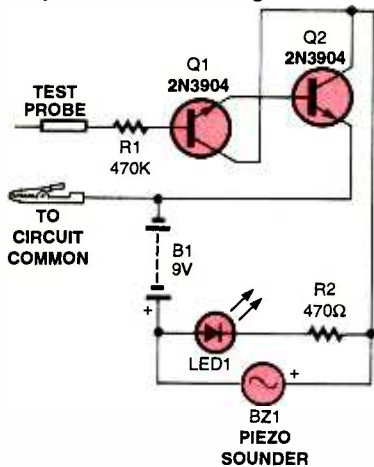

Fig. 5. There are numerous applications for this tester—when the probe senses any voltage greater than 1.5 volts, the buzzer will sound and the LED will light.

PARTS LIST FOR LOGIC PROBE (FIG. 5)

- B1—9-volt battery
- BZ1—Piezo sounder (RadioShack 273-073, or equivalent)
- LED1—Light-emitting diode, any color
- Q1, Q2—2N3904 NPN transistor (NTE123AP, or equivalent)
- R1—470,000-ohm, $\frac{1}{4}$ -watt, 5% resistor
- R2—470-ohm, $\frac{1}{4}$ -watt, 5% resistor

inverter inputs to ground (namely pins 7, 9, 11, and 14). There should never be a CMOS input or gate left open in any application where all gates and inputs are not used in a circuit function. Leaving an input or gate open will allow Murphy to rain on your parade!

Moving right along to the nickel-cadmium battery zapper circuit shown in Fig. 4, we have a simple circuit that can often shock a naughty NiCd into taking a charge and being useful once again. This method of shock therapy will work on a number of NiCds that have acquired a bad memory habit. If the NiCd in question won't take a charge—this method is worth a try. The zapper circuit is no more than a DC power supply that charges a large electrolytic capacitor up and dis-

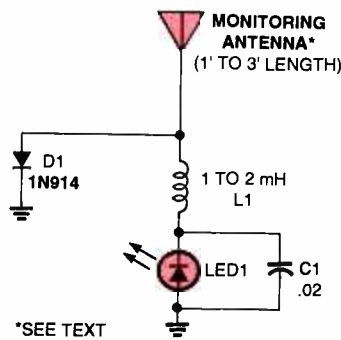

Fig. 6. Want to find out if your ham or CB transmitter is generating any RF output? Then bring the monitoring antenna close to your transmitter and key-down the rig—wait and see the LED lights.

PARTS LIST FOR TRANSMITTER-OUTPUT SENSOR (FIG. 6)

- C1—0.02- μ F, 50-WVDC, mylar or similar capacitor
- D1—1N914 silicon signal diode
- LED1—Light emitting diode, any color
- L1—1 to 2-mH RF choke

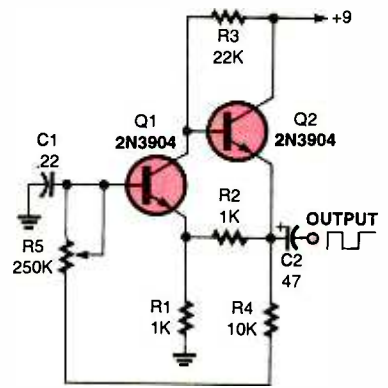

Fig. 7. Here's a neat circuit to generate square-waves in the audio range. Try using this output to clock other circuits.

PARTS LIST FOR SQUARE-WAVE OSCILLATOR (FIG. 7)

- C1—0.22- μ F, 50-WVDC, mylar capacitor
- C2—47- μ F, 25-WVDC, electrolytic capacitor
- Q1, Q2—2N3904 NPN transistor (NTE123AP, or equivalent)
- R1, R2—1000-ohm, $\frac{1}{4}$ -watt, 5% resistor
- R3—22,000-ohm, $\frac{1}{4}$ -watt, 5% resistor
- R4—10,000-ohm, $\frac{1}{4}$ -watt, 5% resistor
- R5—250,000-ohm potentiometer

charges it through the selected cell. Be extremely careful using the zapper, and don't pulse the cell too many times as the internal heating could cause the NiCd to explode! Cover the cell and then zap it!

Our next entry (Fig. 5) is a two-transistor logic probe, or positive voltage sensor, that lights up and sounds off when connected to a live circuit. Transistors Q1 and Q2 are connected in a Darlington configuration that gives the circuit a very high input impedance. The transistors' common collector output drives the piezo sounder and LED. When the probe senses a positive voltage greater than approximately 1.5-volts (logic high), the transistors turn on, resulting in visual and audible output signals. The probe's negative lead must be connected to the negative or common circuit under test for the tester to operate.

Our next churn of the pot brings out the circuit shown in Fig. 6, which is useful in checking out RF transmitters for RF output. If an amateur radio or CB transmitter is in question, bring the monitoring antenna of this circuit close

(Continued on page 71)

HAM Radio

VSWR and Transmission Lines

JOSEPH J. CARR, K4IPV

I always make sure that the key equipment used in my ham station is operating perfectly. When it comes to antennas, rotors and transmission lines, I pull out all the stops. These items are not easy to replace and Murphy will always try to take them down right in the middle of a harsh winter storm. To head off any potential problems, antenna and transmission line measurements should be made when the antenna is first installed (and periodically thereafter). At that time, I like to record certain measurements such as VSWR (Voltage Standing Wave Ratio or simply SWR), feedpoint impedance, etc. Should a problem arise, I pull the information out, and repeat the same measurements—and hopefully get a clue for solving the problem.

Many antenna measurements are difficult to make with any degree of accuracy. There are some things about antennas that can and should be measured, however, regardless of the difficulty. For example, VSWR and the resonant frequency of the antenna are readily obtainable. It is also possible to measure the impedance of the antenna feedpoint.

You can measure the VSWR either with a special VSWR meter (often built into transmitters or antenna tuning units) or by using an RF wattmeter. As you frequency-step through the band of interest, determine the VSWR at various frequencies. Then draw a VSWR curve of how the antenna performs across the band (an ideal curve is shown in Fig. 1). The resonant frequency (f_D) is the point where the VSWR dips to a minimum (which may or may not be the much-sought-after 1:1 VSWR point).

You can use this resonant frequency to figure out whether your antenna is too long (resonant frequency lower than the hoped-for design frequency), or too short (resonant frequency above the hoped-for design frequency). Figure 2 shows all three situations. Curve A represents the desired or ideal curve that is centered on the desired

frequency (f_D). If the antenna is too long, however, the resonant frequency will be shifted downwards towards f_1 and curve B will result. Similarly, if the antenna is too short, curve C will be found as the resonant frequency shifts up the band to f_2 .

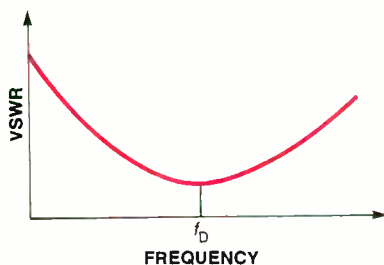

Fig. 1. VSWR-vs.-frequency curve.

But resonant frequency and VSWR curves are not the entire story, because they don't tell us anything about the impedance presented by the antenna. One cannot get the VSWR to be 1:1 unless the antenna impedance and transmission line impedance are the same. For example, an ideal half-wave ($\lambda/2$) dipole antenna in free space has a nominal textbook impedance of 73 ohms, which makes it a very good match to 75-ohm coaxial cable. But the actual impedance of a real dipole, with finite thickness above a typical ground, may vary from a few ohms to more than 100 ohms. For example, if your antenna really has a feedpoint impedance of (say) 25

ohms, using 75-ohm coaxial cable to feed it produces a $VSWR = 75/25 = 3:1$. Not too great! Measuring the feedpoint impedance is therefore essential to making the antenna work properly.

There are any number of instruments that aid in making antenna measurements. Some of them are quite reasonably priced (or can be built), while others are beyond the reach of all but the most ardent and free-spending enthusiasts. I use the MFJ SWR Analyzer Model MFJ-259 device (available from MFJ Enterprises, P.O. Box 494, Mississippi State, MS 39762; Tel. 800-647-1800; Web: www.mfjenterprises.com). They make several different models from HF through UHF. Another professional-operating unit is the AEA Graphical Antenna Analyst (sold by Tempo Research Corp., 1221 Liberty Way, Vista, CA 92083; Tel. 760-598-9677; Web: www.aea-wireless.com). Their model SWR 121 HF covers the 1–30 MHz range, while model 121 V/U covers 120–175 MHz, 200–225 MHz, and 400–475 MHz frequency ranges.

DOPING OUT COAXIAL CABLE

When you either install an antenna or do a bit of preventative maintenance, or even find that the antenna is not working properly, one thing to check is the transmission line. Two basic measurements are popular. Figure 3 shows how to make simple resistance checks. The coax cable consists of an inner conductor and an outer conductor

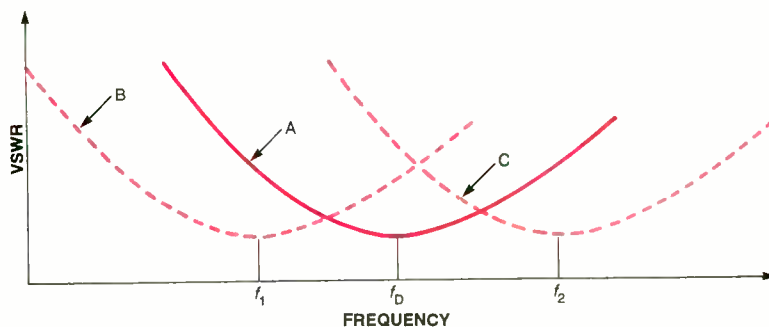

Fig. 2. Family of VSWR-vs.-frequency curves illustrating off-resonance conditions.

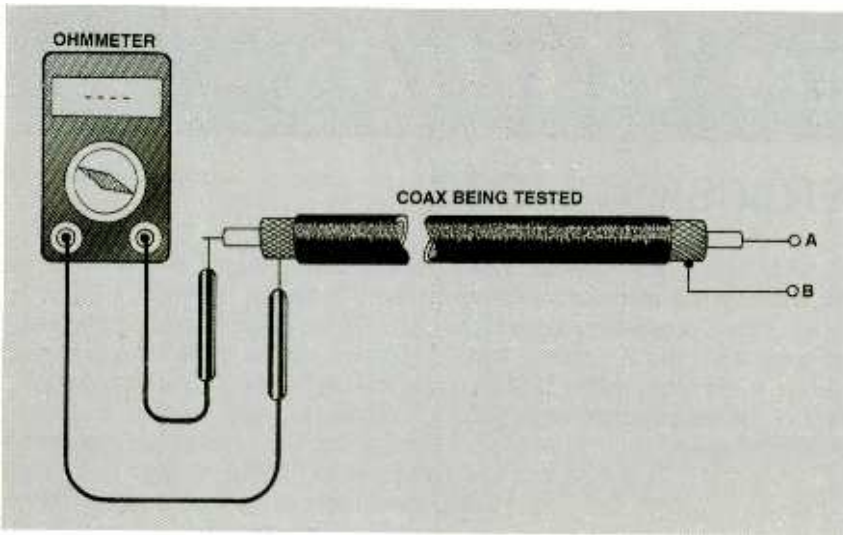

Fig. 3. Resistance checks of a coaxial cable.

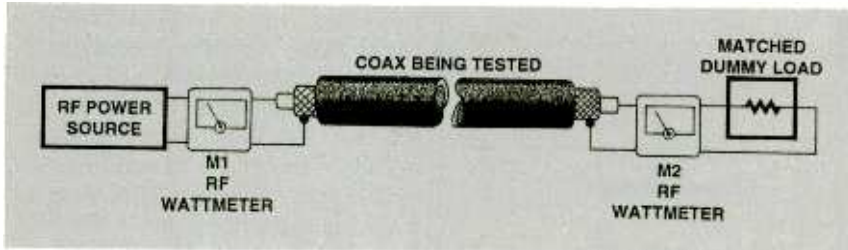

Fig. 4. Loss measurement setup for coaxial cable.

(shield). With terminals A and B open (leads disconnected at the antenna), there should not be any resistive path across the input terminals (as shown). If a high resistance is seen, then there might be some contamination in the system, or else the insulation has failed—permitting a current path. A low resistance indicates a short circuit. If the cable has been cut, or crushed, or the connector is messed up, then a short can result. If terminals A-B are shorted together, a low resistance should be noted. If not, then it is likely that the center conductor is open. Of course, if connectors are on the line, either the shield or center conductor could be at fault. Another good idea is to disconnect your antenna from the line, and then to connect a dummy load at the end of the line (with the same impedance of the transmission line). Measure the VSWR at the input (transmitter end). Your VSWR should be pretty close to 1:1 for all operating frequencies.

The other issue is loss or attenuation of the transmission line. Cable losses get higher as they age, so low loss on installation does not guarantee low loss later on. Losses in new cables run from 0.2 dB/100 ft at 4 MHz. At 30

MHz, the losses are 0.7 dB/100 ft to 2.6 dB/100 ft. At VHF/UHF frequencies, the losses rise considerably. Figure 4 shows a test set-up for coaxial cable loss. It is necessary to know the length of the piece of coax under test. For ease of calculation, a 100-foot section should be used. Two RF power meters (M1 and M2) are used to measure the input power to the line (M1) and the delivered power (M2). The difference in power determines the loss. The loss is:

$$\text{LOSS}_{\text{dB}} = 10 \times \log (P_{\text{M2}}/P_{\text{M1}})$$

where

LOSS is the loss in the cable in dB (decibel), PM1 is the power reading on M1 (watts), PM2 is the power reading on M2 (watts).

If the cable length is 100 feet, then you already have the loss in dB/100 ft. But if length (L_{FT}) is anything other than 100 feet, then you need to make the following calculation:

$$\text{LOSS}_{\text{dB}/100\text{-FT}} = (\text{LOSS}_{\text{dB}}/L_{\text{FT}}) \times 100$$

When the winter weather breaks (I know that California and the South-

west don't know the term!), it might be a good idea to haul down the antenna and transmission line to make a few measurements. You may find that poor weather undermines the quality of your system!

A QUESTION ABOUT LOOPS

A lot of my articles, columns and books have dealt with loop antennas. I like them, and I am writing a book on loop antennas (slowly, however, because I build each basic design before writing it up). I am working with both large loops ($>0.5\lambda$) and small loops ($<0.15\lambda$).

A reader wrote to me asking about the radiation patterns of the two types of loops. Both of them have a "figure-8" pattern, but they are oriented in different directions. The large loop antenna, say 1λ overall, or $\lambda/4$ on each side, projects the maxima (or "main lobe") azimuthal (horizontal) pattern perpendicular to the plane of the loop. The nulls are off the edges of the loop. The small loop, on the other hand, places the main lobe off the edges, and the nulls are perpendicular to the plane of the loop. It seems contradictory, but it's the way it is. See my books *Receiving Antenna Handbook* or *Practical Antenna Handbook - 2nd Edition*, for more information about both styles of antenna (available from Bookmasters on 800-247-6553 or via Amazon Books at www.amazon.com).

Another reader built a small loop and was trying to do some "fox hunting" (hidden transmitter hunting). He misunderstood that the small loop nulls were 90 degrees out from those of his 1λ quad loop...and apparently ran all over town looking for the hidden transmitter. Oh, well, he enjoyed a good late lunch and some brew with the guys afterwards!

I can be reached by snail-mail at P.O. Box 1099, Falls Church, VA, 22041, or by e-mail at carrjj@aol.com. ■

POPTRONIX

Online Edition

We're on the web **FREE**

<http://www.poptronix.com>

THINK TANK

(continued from page 66)

I used a 4017 IC, CMOS decade counter with decoded output as the counter (equivalent NTE4017B). At any given moment, only one row is held high by the Q output of 4017. If you press the key connected to that row, it will send a clock signal back to the 4017. Pressing a key from another row resets the IC.

(available from Gateway Products for 15 cents each) with no problems. As you suggested, John, I wired a manual switch across the relay contacts. By the way, I recommend the relay contacts be rated no lower than 5 amps minimum.

—Roger W. Hamel, Cedarville, MI

For circuits where jumpers are required, I sometimes use IC sockets as receptacles for small jumper wires. The jumpers between the keypad and Q outputs are good candidates for this

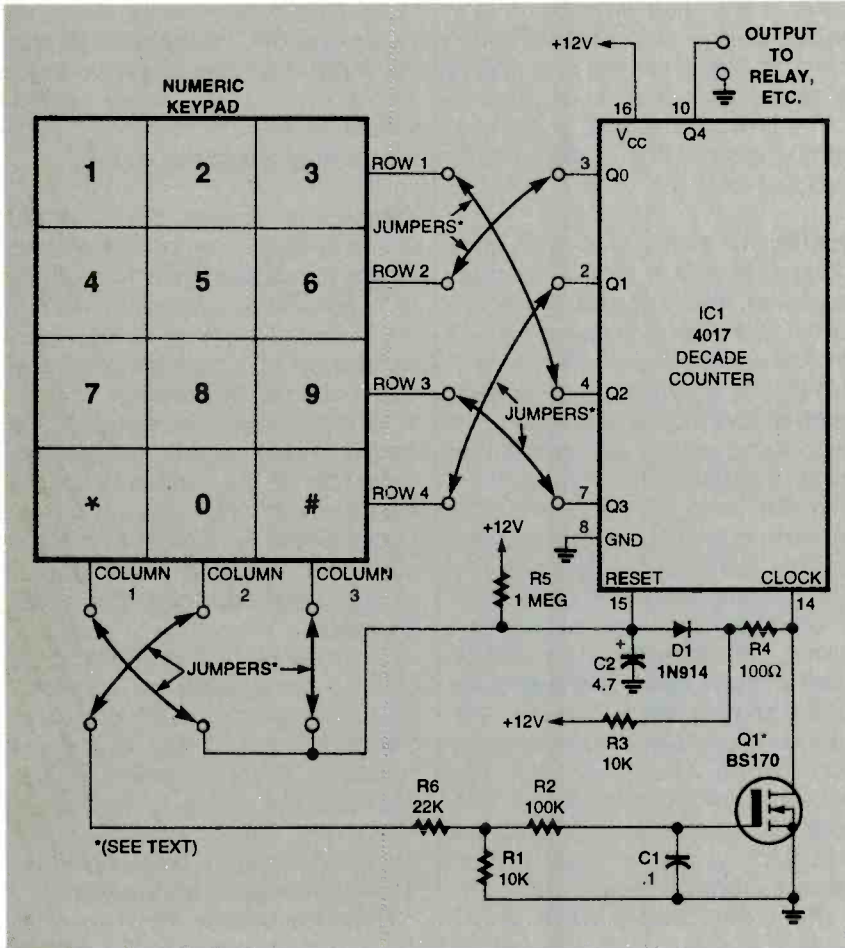

Fig. 6. In this circuit, a standard telephone-type keypad is used to provide a digital lock. The relay will not operate unless it receives the correct four-digit code.

Entering a sequence too slowly forces the circuit to reset itself. If a 1- μ F capacitor is substituted for C2, then the correct code sequence must be entered in a very short time before a reset occurs.

I would like to add that I just finished building the water-detector bilge-pump controller by Dick Foster (seen *Popular Electronics*, February 1996, page 68). It works just fine. For those of you that may have trouble locating Q1 (a 2N5305), I used an MPSA-13

kind of treatment as a simple jumper block (like the kind used in computers) probably won't do. By the way, the BS170 MOSFET, Q1, is an N-channel enhanced mode device, equivalent to an NTE490.

Well, we've run out of room again. Remember if you've got a great circuit or two, send a neat schematic, full description of its operation, and key construction details to: *Think Tank*, *Popular Electronics*, 500 Bi-County Blvd., Farmingdale, NY 11735.

For each of your circuits that appear, you'll receive a book from our library. Send enough circuits to fill a whole column and you'll also get a classic MC1010L chip from 1967 and a kit. Happy soldering!

CIRCUIT CIRCUS

(continued from page 68)

to the RF transmitter, then key-down the transmitter. If it is putting out RF, the LED will light. The circuit may be built in a small plastic or metal case. The antenna can be anything from a piece of wire to one of the pull-up replacement antennas made for CB rigs or TVs.

In our last circuit, Fig. 7, we see a great square-wave oscillator circuit. Here we have two generic NPN transistors direct coupled in a variable frequency-oscillator configuration that covers a frequency range of a few hertz to several thousand hertz. The output is a fast-rising and -falling waveform that is suitable for clock work or other circuit applications where a clean waveform is required. The oscillator's frequency range may be increased by decreasing the value of C1, or the range may be lowered by increasing the capacitor value.

Here's hoping at least one of these circuits will be useful. Until the next *Circus*, may all of your circuits work the first time.

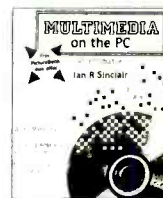

MULTIMEDIA on the PC!

What is Multimedia? What can it do for you? It can do lots of nice things! This 184-page book helps you create your own multimedia presentation. Multimedia applications by people like you can revolutionize educational and business applications as well as bring more FUN, FUN, FUN into your leisure computer activities.

Mail coupon to:

Electronics Technology Today, Inc.
P.O. Box 240
Massapequa Park, NY 11762-0240

Please send me my copy of *Multimedia on the PC* (PCP120). I enclose a check or money order for \$18.95 to cover the book's cost and shipping and handling expenses. NY state resident must add local sales tax.

Name _____

Address _____

City _____ State _____ Zip _____

All orders must be paid in U.S. funds only. Sorry, no orders accepted outside of USA and Canada. Please allow 6-8 weeks for delivery. MA02

OP-AMP BASICS

(continued from page 44)

that it maintains a slow boil. Also fill a good-sized container with crushed ice, and add just enough water to make a thick slurry. Set all of the trimmer potentiometers to the center of their rotation. Put the probe in the ice-water slurry, and stir it around until the reading on your DVM stabilizes. With switch S2 in the Celsius (C) position, adjust R14 to read exactly zero. Flip the switch to the "Fahrenheit" position, and adjust R15 to read 32.0 degrees (0.320 volts).

Then switch S2 back to the Celsius position, put your probe into the boiling water, and again continuously stir it around. After the reading has stabilized, adjust R16 to read 100.0 degrees (1 volt), $\pm 1/2$ of the initial error. For example, if the reading is 108.0°, adjust R16 to a reading of 96.0. Similarly, if the reading is 92.0, adjust R16 to a reading of 104.0. That overshooting technique makes the adjustments converge more quickly. Afterwards switch S2 to Fahrenheit, and adjust R17 to read 212.0 $\pm 1/2$ the initial error. (You may have to set the meter to a higher range).

Go back into the ice slurry, and repeat the zero settings (R14 and R15 for Celsius and Fahrenheit, respectively). Again, overshoot the value by $1/2$ of the error. Then go back to the boiling water, and adjust R16 and R17. The two pairs of adjustments should converge quite rapidly, say after five or six cycles. Repeat until you're satisfied that the adjustments are close enough.

Button up your project to prevent accidentally undoing your calibration efforts, and you're done. It is a good idea to place a drop on two of enamel or other sealant on each potentiometer to ensure that your calibration efforts are not accidentally undone. If you used matched transistors, the two sensors should collaborate within a few tenths of a degree. The thermometer is not limited to simple temperature measurements. For example it might be incorporated in to some other project such as the Heated Pet Pad project on page 45 of this issue.

HEATED PET PAD

(continued from page 49)

wires. Make sure the thermistor packet makes good contact against the foil. That allows the thermistor to monitor the temperature of the aluminum foil between the wires instead of the hot wire itself.

Glue a 2-inch long piece of $1/2$ - $\times 1/2$ -inch acrylic bar about in the middle of the inside of the bottom cover. It will serve to support any heavy weight put on the center of the pad. Check the unit's operation again before putting in all the bottom screws. If it works as before, unplug it, screw the bottom lid on, and turn it over.

Operation. With the power cord plugged in, and R7 set fully counter-clockwise, slowly rotate R7 clockwise until the neon lamp just comes on. Allow a few minutes for the aluminum foil to reach the correct temperature, at which time the neon lamp will go off. After a few minutes, check the temperature with the palm of your hand. The plastic surface should just be comfortably warm to the touch. If the pad needs more heat, turn R7 slightly clockwise until the neon lamp comes on. Each time an adjustment is made, allow a few minutes for the sensing unit to adjust to the new heat level before checking the pad surface. After R7 is set to the desired temperature, cover the hole with a small square of black electrician's tape to keep dirt from falling through the hole.

When the correct point is set, cycling frequency will depend on the outside temperature. You must remember that it is maintaining the temperature on a large heat loss at a slightly elevated level. If the outdoor temperature is very cold, the unit will cycle more frequently and for longer periods of time.

It really doesn't take much effort to give him or her a warm spot to lay on during a cold winter night. In the process, you'll learn all about AC-direct resistance heating. You may very well use this knowledge to construct direct-resistance heaters for plastic forming and many other projects in the future.

SCHMITT TRIGGER

(continued from page 57)

Its output is used to drive a second LED via transistor Q2. That arrangement places LED1 and LED2 in an alternating pattern.

The capacity of the output driver can easily be increased by replacing the general-purpose 2N2222 transistors with a pair of Darlington units. That would allow the circuit to drive high-current loads, such as lamps or relays. The values of R5 and R6 depend on the supply voltage. With a 6-volt source, those resistors should be 470 ohms. With a 12-volt supply, they should be 1k units.

Timer. The simple *Timer* circuit, shown in Fig. 10, can be adjusted to trigger its output in from 10 seconds to 15 minutes via potentiometer R1. The output of the Timer can be used to drive either a piezoelectric transducer or an 8-ohm speaker.

In that circuit, two gates (IC1-b and IC1-c) are used as oscillators. The operation of the oscillators is controlled by a third gate (IC1-a). Before power is applied to the circuit, both inputs to IC1-a are at ground and capacitor C1 is discharged.

At power up, both pin 1 and pin 2 of IC1-a immediately go high, forcing its output low, as C1 begins to charge through R1 and R2. The low output of IC1-a is applied to the dual-oscillator stage (consisting of IC1-b and IC1-c), keeping them turned off. Therefore, no sound is produced in the piezo transducer.

When the charge on C1 reaches the supply rail, pin 2 of IC1-a goes low, causing its output to go high, turning on the dual-oscillator stage. The outputs of the two oscillators are fed to IC1-d, producing a modulated output.

The modulated output of IC1-d is used to drive a piezoelectric transducer (buzzer). The delay time provided by IC1-a is determined by the values of R1, R2, C1, and the internal characteristics of the integrated circuit. The values shown provide time intervals ranging from 10 seconds to 15 minutes. That time frame can easily be altered by changing the value of C1.

Market Center™

ROBOTIC MACHINING

ROUTE, MILL, DRILL, CARVE, ENGRAVE, PAINT
IN WOOD, PLASTIC, VINYL, PC BOARD, & LIGHT METALS!

STARTING AT
\$695.00

- 4 MOTOR GANTRY MILL CONFIGURATIONS
- PC COMPUTER CONTROLLED CNC/DNC
- IMPORT/ EXPORT FILES TO OTHER CADS
- AUTO-BACKLASH COMPENSATION
- PRE-MACHINED HEAVY CASTINGS
- SIMULTANEOUS 3 AXIS MOTION
- FREE 3D CAD/CAM SOFTWARE
- AVAILABLE IN KITS OR ASSEMBLED
- EXPEDITE SERVICE ALSO AVAILABLE
- OPTIONAL ALUMINUM WAY COVERS
- .001" RESOLUTION / AMERICAN MADE

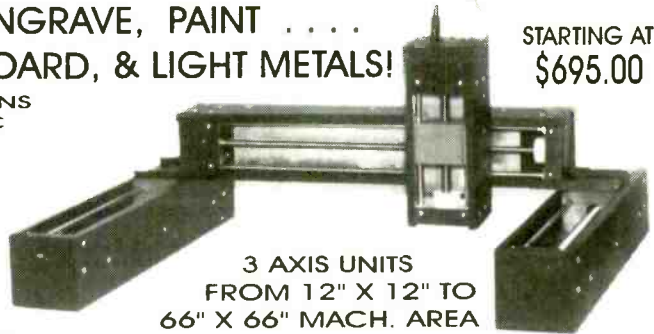

3 AXIS UNITS
FROM 12" X 12" TO
66" X 66" MACH. AREA

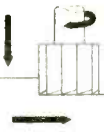

<http://www.uscyberlab.com>

U.S. CYBERLAB, INC. 14786 SLATE GAP RD., WEST FORK, AR 72774

CALL NOW FOR INSTANT SPECS 501-839-8293 24 HR. FAX-BACK

Weeder Technologies

Add \$4
Ship/Hand
US & Canada

FREE
CATALOG!



Pro-Kit

PO Box 2426, Ft. Walton Beach, FL 32549

850-863-5723

Stackable RS-232 Kits

Digital I/O - 12 I/O pins individually configurable for input or output. DIP switch addressable; stack up to 16 modules on same port for 192 I/O points. Turn on/off relays. Sense switch transitions, button presses, 4x4 matrix decoding using auto-debounce and repeat. **\$32.00**

Analog Input - 8 input pins. 12-bit plus sign self-calibrating ADC. Returns results in 1mV steps from 0 to 4095. Software programmable alarm trip-points for each input. DIP switch addressable; stack up to 16 modules on same port for 128 single-ended or 64 differential inputs. **\$49.00**

Home Automation (X-10) - Connects between a TW523 and your serial port. Receive and transmit all X-10 commands with your home-brewed programs. Full collision detection and auto re-transmission. **\$38.50**

Caller ID - Decodes the caller ID data and sends it to your serial port in a pre-formatted ascii character string. Example *12/31 08:45 850-863-5723 Weeder, Terry <CR>*. Keep a log of all incoming calls. Block out unwanted callers to your BBS or other modem applications. **\$34.50**

Touch-Tone Input - Decodes DTMF tones used to dial telephones and sends them to your serial port. Keep a log of all outgoing calls. Use with the Caller ID kit for a complete in/out logging system. Send commands to the Home Automation or Digital I/O kits using a remote telephone. **\$33.50**

Telephone Call Restrictors

Two modes of operation; either prevent receiving or placing telephone calls (or call prefixes) which have been entered into memory, or prevent those calls (or call prefixes) which have *not* been entered.

Block out selected outgoing calls. Bypass at any time using your password. **\$35.00**

Block out selected incoming calls. Calls identified using Caller ID data. **\$48.00**

Phone Line Transponder

7 individual output pins are controlled with buttons 1-7 on your touch-tone phone. Automatically answers telephone and waits for commands. Monitor room noises with built in mic. "Dial-Out" pin instructs unit to pick up phone and dial user entered number(s). Password protected. **\$49.00**

IR Remote Control Receiver

Learns and records the data patterns emitted by standard infrared remote controls used by TVs, VCRs, Stereos, etc. Lets you control all your electronic projects with your TV remote. 7 individual output pins can be assigned to any button on your remote, and can be configured for either "toggle" or "momentary" action. **\$32.00**

DTMF Decoder/Logger

Keep track of all numbers dialed or entered from any phone on your line. Decodes all touch-tones and displays them on a 16 character LCD. Holds the last 240 digits in a non-volatile memory which can be scrolled through. Connect directly to radio receiver's speaker terminals for off-air decoding of repeater codes, or numbers dialed on a radio program. **\$54.50**

SPECIAL PROJECTS

We design/build/modify/repair/consult on any device/system/process/project electronic/computer/mechanical/optical (eg: phone/auto/security/Radionic/lab/energy/HV/EM/RF/radar/ultrasonic/IR/UV/commo) for business and personal/invention needs. Describe & include nonrefundable \$30 pre-engineering fee. Time & cost estimates 7-10 days. Confidentiality guaranteed.

10% OFF
Orders Over
\$100!!

TOP SECRET

NOW
BIGGER AND
BETTER!

CONSUMERTRONICS

P.O. Box 23097 ABQ, NM 87192-1097

ORDER TODAY! 505-237-2073

Fax: 505-292-4078

Web Adventure: www.tsc-global.com

Established in 1971. Featured on CBS "60 Minutes," Forbes, New York Times. Add \$5 total S/H (US, Canada). Sold for educational purposes only. Postal M.O. is fastest. VISA, MC OK. COD (\$49-\$999), add \$7.

STOPPING POWER METERS

STOPPING POWER METERS

As reported on "60 MINUTES" All-new 6th Edition!! Over 45 pages jam-packed with how devices can slow down (even stop) watt-hour meters - while loads draw full power! Device plugs into one outlet and normal loads into other outlets. Describes meter creep, overload droop, etc. Plans only!

THE I.G. MANUAL: External magnetic ways (applied to meter) to slow down and stop power meters while drawing full loads. Plans \$25.

KW-HR METERS: How watt-hour meters work, calibration, error modes (many), ANSI Standards, etc. Demand and Polyphase Meters. Experimental results to slow and stop meters by others. \$25.

Special! All 3 (above), Only \$59!

OFF-THE-SHELF

HARDWARE

See our Catalog for Limited Warranty and all other Policies.

THE SLOT MACHINE MASTER II

Small, battery-operated. Range of about 15 feet. Originally invented by a slot machine mechanic. \$522 (1lb). User Manual Only: \$98 (read below)

2-TRACK CARD READER/SLAVE-WRITER

Copy the magnetic stripe data from one data card to another! Options are available. Battery operated/portable. \$1495 (2lb). User Manual Only: \$98

THE VIDEO POKER MASTER

Small, battery-operated. \$625 (1lb). User Manual Only: \$95

S.P.M. EDUCATIONAL MODULE

See our "STOPPING POWER METERS" Manual + Video. \$425 (3lb). User Manual Only: \$90

WILLIAMS' VAN ECK SYSTEM

Range up to 1 KM. MULTISYNC VERSION: Ideal for monitoring high-resolution monitors (VGA - SVGA). Includes our proprietary SYNREST II Module (with built-in microwave amp, tuner and Williams' NTS Co-RGB Converter), quality multisync monitor, nominal antenna and hookups. \$3295 (60 lb) User Manual Only: \$195

◆ WYES DEMONSTRATION VIDEO TAPE: 18 minutes. \$39 (1 lb).

HI-PULSE JAMMER/ZAPPER

Jams and possibly physically wipes out EM surveillance, harassment and weapons devices (external and internal), etc. - even the newest EM devices, including implants. Portable and powerful. \$1242 (3 lb). User Manual Only: \$100

*User Manuals: Instruction booklets that come with these popular items. (Do not contain schematics). If you purchase the device within 30 days of purchasing the User Manual we will deduct the full price of the User Manual from the Actual Price! There are no refunds or discounts given on User Manuals. Only Money Order, Check, or Cash accepted.

MORE! MORE! MORE!

RF/EM/μWave/Radar/Ultrasonic/IR/Light/Sound Detectors/Xmitters/Jammers/Blasters ★ Security/Surveillance ★ EM Weaponry/Countermeasures ★ Neurophone/Rife/Resonant Crystal Radionics ★ Bug & Tap Detectors/Blasters ★ Lineman's Handsets ★ Phone Color Boxes ★ Voice Disguisers ★ DTMF Decoders ★ Child Finders ★ Subliminal Mixer/Amps (Ultrasonic/Infrasonic) ★ Alien Brainblasters ★ Electronic Dowzers ★ Shriek Modules ★ Ghost Detectors ★ Vortex Generators ★ Blackjack Devices ★ 6th Sense Communicators ★ More! Order Catalog Today!!

NEW

S.P.M. THE VIDEO!!

Now its easier to learn about KW-HR Power Meters than ever before! This educational video shows you how they work and their anatomy. Demonstrates SPM device and external magnetic methods used to slow and stop meters! Hosted by a top expert in the field. From the novice to the pro, an excellent source of info on these exciting devices! Great in combo with our SPM related manuals! Only \$59 for SPM video + SPM manual!!

ATMs \$39

ATM crimes, abuses, vulnerabilities and defeats exposed! 100+ methods detailed, includes: Physical, Reg. E, cipher, PIN compromise, card counterfeiting, magnetic stripe, false front, TEMPEST, tapping, spoofing, inside job, vibration, pulse, high voltage - others. Histories, law, detailed security checklist, labeled internal photos, figures. More!

CELLPHONE MOD GUIDE

How cellphones operate and are modified. Vulnerabilities to hack attack and countermeasures. Details on programming NAMs, ESNs, etc (cloning), control data formats, computing encoded MINs, ESNs, SIDHS, operating systems, PROM programming, forcing ACK, test mode and resets, cable diagrams, scanning, tracking, scanner restorations, freq allocations, roaming, Step-by-steps to keypad-reprogram 100+ popular cellphones. More! \$59

PAGER MANUAL \$29

How Pagers work, different types and uses, freqs, advantages over and uses with cellphones, and tips and tricks. How Pagers are hacked/countermeasures. And plans for a Personal Pocket Paging System (xmitter and receiver).

PHREAKING CALLER ID & ANI

How they work and dozens of ways of defeating Caller ID, ANI, *69, *57, Call Blocking, *67 etc. Also describes ESS, 557, CN/A, CMA, DNR, Diverters, LID Extenders, Centrex - more! \$19.

BEYOND VAN ECK PHREAKING

Eavesdropping on TV and computer video signals using an ordinary TV described in detail. Includes security industry reports. Range up to 1 KM. Plans include both the ours and the original Top Secret Van Eck designs! \$29.

HACKING THE INTERNET \$24

The absolute latest tricks and methods being used on the Net to pirate software (warez) and the newest hacking websites. Updated every two months. Includes examples, countermeasures, password defeats, UNIX, Sprintnet, brute force methods, lots of tips, and more!

COMPUTER PHREAKING \$39

Describes in detail how computers penetrate each other, and how VIRUSES, TROJAN HORSES, WORMS, etc are implemented. Dozens of computer crime and abuse methods and countermeasures. Includes disk filled with hacker text files and utilities, and the legendary FLUSHOT+ protection system. Internet advice, password defeats, glossary - much more! Manual + PC Disk!

OTHER EXCITING TITLES

Call for Descriptions

- Hacking Fax Machines - \$29
 - PBX Hacking - \$19
 - Voice Mail Hacking - \$29
 - Beyond Phone Color Boxes - \$29
 - Hacking Answering Machines - \$19
 - By an Order of the Magnitude - \$49
 - Ultimate Success Manual - \$15
 - Internet Cons & Scams - \$19
 - Internet Tracking & Tracing - \$29
 - Cookie Terminator - \$19
 - Casino Hacking - \$18
 - Credit Card Scams - \$29
 - Radionics Manual - \$29
 - Heal Thyself - \$19
 - Stealth Technology - \$24
 - High Voltage Devices - \$29
 - The Hacker Files - \$39
 - Cons & Scams - \$29
 - Mugger, Rapist - Die! - \$8.95
 - Cryptanalysis Techniques - \$29
 - Secret & Survival Radio - \$24
 - Secret & Alternate IDs - \$15
 - Rocket's Red Glare - \$29
 - Mind Control - \$29
 - EM Brainblaster - \$29
 - The Placak Report - \$29
- More in Catalog!**

THE REBEL !!

IF YOU ORDER ANY CATALOG THIS YEAR, THIS MUST BE IT!

THE ALL-NEW TOP SECRET CATALOG FEATURES 200+ HI-TECH PRODUCTS! WILL ROCK YOUR WORLD!

MAIL \$3, OR \$1 WITH ORDER!
ORDER NOW!

AMAZING PRODUCTS!



ELECTRONIC & SCIENTIFIC DEVICES

ALL NEW LASER WINDOW BOUNCE SCIENCE PROJECTS

USES SCATTERED AND DIRECT REFLECTIONS

Remarkable concept allows user to hear sounds within a premise over a beam of laser light reflected from a window or similar surface. Experimental device provides hours of interesting and educational use. Utilizes a visible red laser that simplifies alignment and discourages illegal use. Usable range will vary expect about 20 to 50 meters. Optional lens will increase range 200 to 400 meters! Further range requires expensive optics. Requires a sturdy video tripod (not Incl.) Caution-check local law in your state if planning to use for accessing oral communication.



- LWB5** Plans.....\$20.00 **LWB5K KIT/PLANS**.....\$149.50
LWB50 Ready to Use With Selected Laser Pointer.....\$199.50
LWB70 Above With High Performance Laser Gun Sight, Long Range
 Extender Lens and Cushioned Headsets.....\$299.50

\$59.95 6 TRANSMITTER Projects

CAUTION: Check Public Law 90-352

- 1 Super Sensitive Ultra Clear 1 Mile+ Voice Transmitter
 - 2 1 Mile + Telephone Transmitter
 - 3 Telephone 'DRC' IN' Transmitter Line Powered: Needs No Batteries!!
 - 4 Tracking, Homing Beacon "Beeping" transmitter
 - 5 Transmitter Rebroadcasts Video or Audio Outputs
 - 6 Short Range TV/FM Disrupter NEAT FRANKIE! Discretion Advised
- All 6 Above Kits Plus FREE Info Data Pack on "HELPFUL HINTS" Using Wireless Devices
COMBOX Kits and Plans.....\$59.50

ULTRA BRIGHT LASERS

4 to 7x brighter 650-630 nm Radiation

ALL METAL CONSTRUCTION
 1 YEAR WARRANTY



- LAPN65** 15mw equiv 2000 ft.....\$29.95
LAPN63 30mw equiv 3000 ft.....\$69.95

FOCUSABLE LASER POINTER

From a Small Dot to a Large Spot

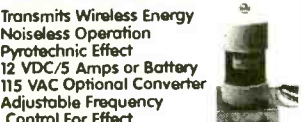

- LAPN65F** Focusable Above **LAPN65**...\$59.95

TRANSISTORIZED TESLA COIL

Turns a Light Bulb Into a Spectacular Plasma Display

Transmits Wireless Energy
 Noiseless Operation
 Pyrotechnic Effect
 12 VDC/5 Amps or Battery
 115 VAC Optional Converter
 Adjustable Frequency
 Control For Effect

- TCL5** Plans.....\$8.00
TCL5K Kit/Plans.....\$59.50
TCL50 Ready to Use.....\$99.50
12DC/7 12VDC@7Amps.....\$39.50

NEW CYBERNETIC EAR!

Use For Courtesy Lowering of TV Volume Control etc. Deflect Rattles and Other Mechanical Abnormalities, Leaking Gases, A/c, or Corona. Great Safety Aid for Shop

Enhances Most Hearing 3 to 4 Times!
 Adjustable Volume Control, Fits Easily into Either Ear. Many Many Uses!

CYBEREAR Ready to use...\$19.95

3 MI TELEPHONE TRANSMITTER

Tunable On FM Broadcast. Excellent Telephone Project. Only Transmits When Phone is Used

- VWPM7K** Kit/Plans.....\$39.50
BEEP1K BEEPER ALERT KIT.....\$19.95

ELECTRIC CHARGE GUN WITH 15 FOOT RANGE!!

Stuns and Immobilizes Attackers From a Distance. More Knockdown Power than a Handgun!!
 Check Your State Legality
FREE!!! 100KV Stun Gun

- ECG10** With STUN100.....\$249.50
STUNGUNS SOLD SEPARATELY
STUN200 200KV StunGun.....\$49.50
STUN300 300KV StunGun.....\$69.50

JACOBS LADDER

Observe a pyrotechnical display of "traveling" fiery plasma. Starts off as 1/2" arc and expands to over 3" before evaporating into space. This is an excellent attention getting display as well as a winning science project!! With arc control.

- JACK1** Plans.....\$8.00
JACK1K Kit Minus Case.....\$129.50
JACK10 Ready to Use.....\$249.50
12KVGEN20 Pwr Supply Only.....\$99.50
12KVGEN2K Kit of Pwr Supply.....\$79.50

250KV TESLA COIL

10-14" of Explosive Bolts of Lightning

Transmit Wireless Energy
 Strange and Bizarre pyrotechnical effects.
 Ion Motors Anti-Gravity
 Size 20" H x 8" Sq
 Weight - 25 Pounds
 115 Volts/2 Amps AC
 Labeled "Use Caution"

- BTC3** Plans.....\$15.00
BTC3K Kit/Plans.....\$349.50
BTC30 Ready to Use.....\$449.50
BTC4 Plans, 500kv Unit.....\$20.00

HIGH CRIME AREA SECURITY!

INFINITY+ TRANSMITTER

ROOM MONITOR/ LINE GRABBER/CONTROLLER

- MONITOR YOUR PREMISES: Avoid ambushes and break ins.
- ACCESS ON GOING CALLS: Longwinded teenagers!
- CONTROL 8 APPLIANCES: Remote control your home!!!
- EXTRA ADDED FEATURE!!!: Intercept those "CON-HUNGRY" Toll Calls Made From PAY Phones!

- TELCON3** Plans.....\$10.00
TELCON3K Kit/Plans.....\$99.50
TELCON30 Ready to Use.....\$149.50
 Programmed With built in BEEPER ALERT

PHASOR BLAST WAVE PISTOL

130 db of Directional Sonic Shock Waves Energy
 Handheld and Battery Operated

- PPP1** Plans.....\$8.00
PPP1K Kit/Plans.....\$49.50
PPP10 Ready to Use.....\$79.50

ATTENTION! HIGH VOLTAGE EXPERIMENTERS

Battery Powered Mini Sized Modules for research in: HOVERCRAFT, ION GUNS, FORCE FIELDS, SHOCKERS etc

- MINIMAX4** 4KV@10ma.....\$19.50

BURNING LASER RAY GUN

UTILIZES LOSSLESS ENERGY CHARGING

All Parts Available
 A FUTURISTIC CONCEPT!!

- LAGUN2** Plans.....\$20.00

BURNING CO2 BENCH LASER

HOTTER THAN MOST TORCHES!
 All Parts Available

- LC7** Plans.....\$20.00

KINETIC ELECTRIC GUN

PIONEER A FUTURISTIC WEAPON!
 DANGER HIGH VOLTAGE

500 Joules Energy Storage
 Constant Current Charging
 Triggered Spark Switch
 Bolitic Velocities
 Handheld Battery Operated
 Labeled A Dangers product

- EGUN1** Plans with Parts List.....\$20.00
 All Parts are Individually Available

3MI FM BC TRANSMITTER

Safety Product Allows Listening to Children or Invalids in Hazardous Areas, Pools, Ponds etc. Great Security Intrusion Alert! Uses FM Table Top Radio.

- FMV7K** Kit/Plans.....\$39.50

ION RAY GUN PROJECTS ENERGY!

Star Wars Technology
 Demonstrates Weapons Potential!

- IOG7K** Kit/Plans.....\$99.50

GRAVITY GENERATOR

Demonstrates a unique phenomena of electrical reactions that produce the effect of "anti-gravity". You build and levitate a small mock space ship from simple materials. Excellent scientific demonstration of a fascinating method of levitation. Levitate an Object!

- GRA1** Plans and Book.....\$20.00
GRA1K Pwr Sup Kit/Plans.....\$99.50
GRA10 Assbl'd Pwr Sup.....\$149.50

ELECTRONIC HYPNOSIS AND MIND CONTROL

Generates Highly Effective Audible and Visual Stimuli With Bio-Feedback That Can Induce Hypnotic as Well as ALPHA Relaxed States of the Mind. Place Subjects "Under" Your Control. Enhances Hidden PSYCHIC Ability in Many People!

- MIND** Plans.....\$15.00
MIND2K Kit and Plans.....\$49.50
MIND20 Assembled.....\$79.50

TELEPHONE TAPING SYSTEM EXTENDED X4 PLAY

Tapes Phone Conversation 20 Mins Input 2! Check Laws!

- TAP30X** Ready to Use.....\$84.50
BEEP10 Beeper Alert.....\$29.95

SHOCK FORCE FIELD/ VEHICLE OBJECT ELECTRIFIER

Hard Shock Balls, Wanda, Electrify Objects. Great Payback for Those Wassguy!!

- SHK1K** Kit of Pwr Module.....\$19.50

ATTENTION!! RAILGUN EXPERIMENTERS HIGH ENERGY PULSER

RAIL GUN, COIL GUN, EXPLODING WATER, ANTIGRAVITY, MASS WARPING, LEVITATION, PLASMA PROPULSION, LATTICE SHAPPING, EMP etc

- Lossless Energy Charging
- Programmable Voltage to 2 KV and Energy Control to 3 KJ
- Triggered Spark Switch [IKJ]
- Universal 12 VDC or 115 VAC
- 7.5 X 7.5 X 7" Light weight

- HEP3** Plans High Energy Pulser/Ignitor.....\$15.00
HEP3K Kit/Plans (Minus Energy Storage).....\$199.50
HEP30 Assembled (Minus Energy Storage).....\$299.50
HEPCAP 800 Joules Energy Storage.....\$199.50

We Accept MC, VISA, Cash, MO, Checks. Please add \$5.00 Shipping. COD Orders Add Additional \$4.75. REQUEST A FREE CATALOG!!

INFORMATION UNLIMITED DEPT PE1097
 BOX 716 AMHERST, N.H. 03031

24 Hr Toll FREE "Orders Only" Line 1-800-221-1705
 Fax Your Order to 1-603-672-5406
 9 to 5 pm EST Information Line 1-603-673-4730
 See Our Web Site at <http://www.amazing1.com>

WORLD'S SMALLEST

Wireless Video Transmitters

Used by hundreds of hobbyists and professionals alike in R/C models, Robots, Surveillance Video, movie Special Effects, and Law Enforcement.

"... previously, I used expensive wireless units from Pelco, MVP, and Supercircuits. Nothing approaches the VidLinks in power, picture quality, size, and value. Thank you." *R. Leslie, CCTV Installer, NY.*
 "The best... Incredible color, resolution... very easy to use... cool." *P. Davis, Movie Props, CA.*

Actual Size!!!



Live Remote Video From \$99.00

- Full 100 mW RF Power. Range 500ft. to 1/2mile •
 - Crystal Controlled •
- High-Resolution Full Color/ B&W video •
- Fully epoxy encased- no exposed components •
- Fully assembled- only two wires to attach •
 - MONEY BACK GUARANTEE. •

VidLink 100: 100mW Power- upto 1/4 Mile
\$199.00 New! High-Power!

VidLink 15: 15mW Power- upto 150 Feet
\$99.00 New! Low Price- Same Size!

Covert Camera: 1 1/4" sq. Pinhole Lens
\$169.00 Pro Grade Japanese Quality!

*** Audio Module Now Available. Call. ***
 Check/MO, COD +\$5.00, S&H \$5.50

**AEGIS
RESEARCH**

#671-1225 E. Sunset Dr.
 Bellingham, WA
 98226-3529 USA

1-604-224-0416

Visit our virtual catalog on the INTERNET at:
<http://www.lynx.bc.ca/virtualspys>

Electronic Training Videos



Learn electronics quickly and easily with UCANDO's computer-animated training videos. Students can learn at their own pace and professionals will find the UCANDO videos to be a valuable source of reference material. If these videos aren't the best learning tools you've ever seen, return them within 30 days for a

complete refund. These videos are being used by Tech-Schools, CET's, Military Branches, Ham Operators, Industries, and more, across the United States and around the world. Order today and see how UCANDO is ...

"Changing The Way The World Learns Electronics."

VCR Maintenance & Repair ... \$29.95 All others ... \$44.95 each
 • Intro to VCR Repair • Direct Current • Alternating Current •
 Semiconductors • Power Supplies • Amplifiers • Oscillators • Digital 1 •
 Digital 2 • Digital 3 • Digital 4 • Digital 5 • Digital 6 • AM Radio • FM
 Radio Part 1 • FM Radio Part 2 • TV Part 1 "Intro to TV" • TV Part 2
 "The Front End" • TV Part 3 "Audio" • Fiber Optics • Laser Technology •

SAVE!!! 6 videos for only \$240 or 12 videos for only \$450



1-800-678-6113

or mail check or money order to:

UCANDO Videos

P.O. Box 928

Greenville, OH 45331



FREE Shipping ... FREE Catalog

CIRCLE 136 ON FREE INFORMATION CARD



Are you overpaying . . .

. . . your cable company?

You are if . . .

**. . . you are leasing their
equipment.**

- Forest Electronics, Inc. offers a complete line of New Cable Decoders and Converters that are fully Compatible with your cable system.
- All systems come with: Remote Control, & Parental Guidance Feature. Volume Control is also available.
- All Equipment is fully guaranteed & comes with a 30 day money back option.

For More Information Call Us 24 Hours a Day At:

800-332-1996

FAX: 813-376-7801

Our Complete Catalog is now online  www.csi.com

Circuit Specialists Inc.

SINCE 1971

Check Out What We Have To Offer:

Fantastic DMM Offer!!!

Don't let the price fool you. This meter is a digital multimeter designed for engineers and hobbyists. Equipped with 5 functions and 19 ranges. Each test position is quickly and easily selected with a simple turn of the FUNCTION/RANGE selector rotary switch.

General Rubber Boot Included

Display: 3-1/2 Digit LCD, 21mm Figure Height with Automatic Polarity
Overrange Indication: 3 Least Significant Digits Blank

Temperature for Guaranteed Accuracy: 23°C±5°C RH<75%

Temperature Ranges:
Operating: 0°C to 40°C (32°F to 104°F)
Storage: -10°C to 50°C (14°F to 122°F)

Power: 9V Alkaline or Carbon-Zinc Battery (NEDA1604)

Low Battery Indication: BAT on Left of LCD Display

Dimensions: 188mm long x 87mm wide x 33mm thick

Net Weight: 400g

DC Voltage (DCV)
Range: Resolution: Accuracy:
200mV 100µV ±(1%rdg+2dgt)

2000mV 1mV ±(1%rdg+2dgt)

20V 10mV

200V 100mV

1000V 1V

Maximum Allowable Input: 1000V DC or Peak AC.

DC Current (DCA)
Range: Resolution: Accuracy:
200µA 100nA ±(1.2%rdg+2dgt)

2000µA 1µA ±(1.2%rdg+2dgt)

20mA 10µA ±(1.2%rdg+2dgt)

200mA 100µA ±(1.2%rdg+2dgt)

10A 10mA

Overload Protection: mA Input: 2A/250V fuse.



Our Best Offer Ever on a

High Quality Full Sized DMM

\$19.00 any qty

Resistance (Ω)
Range: Resolution: Accuracy:
200Ω 100mΩ ±(1.2%rdg+2dgt)

2000Ω 1Ω ±(1.2%rdg+2dgt)

20KΩ 10Ω ±(1.2%rdg+2dgt)

200KΩ 100Ω ±(1.2%rdg+2dgt)

2000K±2 1KΩ ±(2%rdg+10dgt)

20MΩ 10KΩ ±(2%rdg+10dgt)

Maximum Open Circuit Voltage: 2.8V

Diode Test
Measures forward voltage drop of a semiconductor junction in mV test current of 1.5mA Max.

ohFE Test
Measures transistor hFE.
Frequency Range: 45Hz-450Hz
Maximum Allowable Input: 750V rms
Response: Average Responding. Calibrated in rms of a Sine Wave.

AC Voltage (ACV)
Range: Resolution: Accuracy:
200V 100mV ±(1.2%rdg+10dgt)

750V 1V

CAT NO	DESCRIPTION	PRICE
9300G	Rugged High Quality DMM with Rubber Boot	\$19.00

Special Offer! The next generation of Digital Multimeters with 3-3/4 digits, 4000 count, auto-ranging and analog bargraph, 10MHz frequency counter, True RMS mode and RS-232C interface. **LIMITED TIME OFFER!** You MUST enter your order by December 31st, 1997 to receive this special price! Regular C.S.I. price \$169.00. Plus we'll even include the optional temperature adaptor and K-type thermocouple probe! We even include the holster!

CAT NO	DESCRIPTION	PRICE
PROTEK506	Digital Multimeter	\$139.00

Developer This product is used as the developer on our positive photo-resist printed circuit boards. Includes instructions, 50 gram package, mixes with water, makes 1 quart. **PRICE EACH**

CAT NO	DESCRIPTION	1	10	25
POSDEV	Positive Developer	\$.95	\$.80	\$.50

Etching Chemicals/Ferric Chloride
A dry concentrate that mixes with water to make 1 pint of etchant, enough to etch 400 sq. inches of 1oz board. **PRICE EACH**

CAT NO	DESCRIPTION	1	5
ER-3	Makes 1 pint	\$3.50	\$2.75

Positive Photo Resist Pre-Sensitized Printed Circuit Boards
These pre-sensitized printed circuit boards are ideal for small production runs. They provide high resolution and excellent line width control. High sensitive positive resist coated on 1oz. copper foil allows you to go direct from your computer plot or art work layout. No need to reverse art.

Single-Sided, 1oz. Copper Foil on Paper Phenolic Substrate			
CAT NO	DESCRIPTION	1	PRICE EACH
		10	50
PP101	100mm x 150mm/3.91" x 5.91"	\$2.55	\$1.90 \$1.70
PP114	114mm x 165mm/4.6" x 6.6"	2.98	2.45 1.98
PP152	150mm x 250mm/5.91" x 9.84"	5.40	3.98 3.60
PP153	150mm x 300mm/5.91" x 11.81"	6.15	4.48 4.10
PP1212	305mm x 305mm/12" x 12"	12.78	10.65 8.52

Single-Sided, 1oz. Copper Foil on Fiberglass Substrate			
CAT NO	DESCRIPTION	1	PRICE EACH
		10	50
GS101	100mm x 150mm/3.91" x 5.91"	\$ 3.90	\$2.98 \$2.60
GS114	114mm x 165mm/4.6" x 6.6"	4.80	3.49 3.20
GS152	150mm x 250mm/5.91" x 9.84"	8.69	5.98 5.78
GS153	150mm x 300mm/5.91" x 11.81"	10.20	7.20 6.80
GS1212	305mm x 305mm/12" x 12"	18.88	15.73 12.59

Double-Sided, 1oz. Copper Foil on Fiberglass Substrate			
CAT NO	DESCRIPTION	1	PRICE EACH
		10	50
GD101	100mm x 150mm/3.91" x 5.91"	\$ 5.07	\$3.68 \$3.38
GD114	114mm x 165mm/4.6" x 6.6"	5.95	4.29 3.99
GD152	150mm x 250mm/5.91" x 9.84"	10.47	7.39 6.98
GD153	150mm x 300mm/5.91" x 11.81"	11.95	8.69 8.30
GD1212	305mm x 305mm/12" x 12"	22.09	18.35 14.68

Etching Tank This handy etching system will handle PC boards up to 8" x 9", two at a time. Ideal for etching your PCB's! System includes an air pump for etchant agitation, a thermostatically controlled heater for keeping etchant at optimum temperature and a tank that holds 1.35 gallons of etchant. A tight fitting lid is also supplied to prevent evaporation when system is not being used. Typical etching time is reduced to 4 minutes on 1oz. copper board!

REDUCES ETCHING TIME!	CAT NO	DESCRIPTION	PRICE
	12-700	Etch Tank System	\$37.95

1/3" CCD Board Cameras
Available with PINHOLE LENS with AUDIO: STANDARD LENS with AUDIO: and STANDARD LENS with INFRA-RED. These are the world's smallest commercially available CCD board cameras!

World's Smallest B&W Board Cameras			
Specifications			
Image Pick-Up Device	1/3" CCD area Sensor		
Picture Elements	EIA=512(H) x 492(V)		
Pixel Pitch	EIA=9.6UM (H) x 7.5UM (V)		
Scanning System	2: 1 Interlace		
Scanning Frequency	EIA=525 lines, 60 field/sec (II) 15.750 KHz x 60 HK		
Resolution	430 Lines		
Minimum Illumination	0.03 LUX		
S/N Ratio	45DB		
Lens Mounting	4.3mm standard, 5mm pinhole		
Video Output	1.0 VP-P/750OHM composite signal		
Power Requirement	8-12 VDC (9VDC standard)		
Power Consumption	100mA		
Operating Temperature	-20C + 70 C RH 95% Max		
Storage Temperature	-40C - 85 C RH 95% Max		
Audio Pick-Up Sensitivity	-60 DB (ODB = 1B/UBAR, 1KNZ)		
Audio Frequency Range	20 Hz to 20KHz		
Audio S/N Ratio	More than 35DB		
Audio Output Level	1VP-P/600 OHM		
Dimensions			
WDP-2000	30mm (H) x 30mm (W)		
WDS-2005	30mm (H) x 30mm (W)		
WDI-4000	44mm (H) x 30mm (W)		

World's Smallest B&W Board Cameras			
CAT NO	DESCRIPTION	1	PRICE EACH
		5	
WDP-2000	1/3" B&W Pinhole Lens with Audio	\$89.00	\$77.00
WDS-2005	1/3" B&W Standard Lens with Audio	89.00	77.00
WDI-4000	1/3" B&W Infra-RED (no audio)	89.00	77.00
WDPH-55BW	Plastic Housing Option for B&W Board Cameras	13.00	12.00

CIRCUIT SPECIALISTS, INC.
SINCE 1971
800-811-5203
602-464-2485
602-464-5824(FAX)
WE ACCEPT:   

RECEIVE OUR LATEST 132 PAGE CATALOG!
It's chock full of all types of electronic equipment and supplies. We've got I.C.'s, capacitors, resistors, pots, inductors, test equipment, breadboarding supplies, PC supplies, industrial computers, data acquisition products, personal computers and computer parts, plus much, much more. FAX us your name and address or call **800-811-5203, ext. 5**, to leave a message on our catalog request line.

February 1998, Popular Electronics

EARN MORE MONEY!

Be an FCC LICENSED ELECTRONIC TECHNICIAN!



No costly school. No commuting to class. The Original Home-Study course prepares you for the "FCC Commercial Radiotelephone License." This valuable license is your professional "ticket" to thousands of exciting jobs in Communications, Radio-TV, Microwave, Maritime, Radar, Avionics and more...even start your own business! You don't need a college degree to qualify, but you do need an FCC License.

No Need to Quit Your Job or Go To School
This proven course is easy, fast and low cost! **GUARANTEED PASS**—You get your FCC License or money refunded. **Send for FREE facts now. MAIL COUPON TODAY!**

Or, Call 1-800-932-4268 Ext. 240

COMMAND PRODUCTIONS

FCC LICENSE TRAINING, Dept. 240
P.O. Box 2824, San Francisco, CA 94126
Please rush **FREE** details immediately!

NAME _____
ADDRESS _____
CITY _____ STATE _____ ZIP _____



CABLE TV Converters & Descramblers

Compatible with
**Jerrold, Scientific Atlanta,
Pioneer, Oak, & Hamlin
Equipment**

BRAND NEW!

6-MONTH GUARANTEE

LOWEST PRICES

Volume Control & Parental Lockout Available

Greenleaf Electronics

1-800-742-2567

NO ILLINOIS SALES

It is not the intent of Greenleaf Electronics to defraud any pay television operator and we will not assist any company or individual in doing the same.

TURN YOUR PC INTO A DIGITAL STORAGE OSCILLOSCOPE!

The all new
PC-
MultiScope
2

10Mhz
analog
bandwidth!

At right:
Actual
scope
screen as
seen on
your PC
monitor

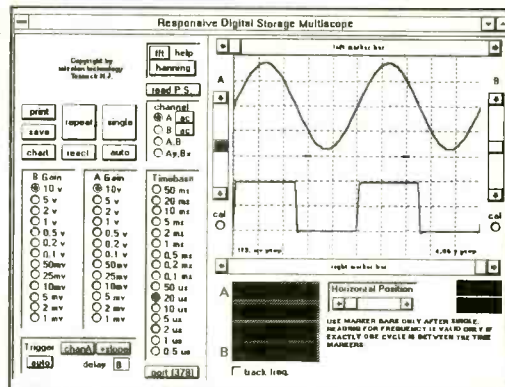

FEATURES:

1. Dual channel; external triggered
2. Digital storage; Windows based
3. Connects to PC parallel port
4. 20Megasamples/sec sampling; 10Mhz max. analog bandwidth
5. 8 bit resolution/ 8K RAM buffer
6. Prog. gain: 10v/div to 1mv/div
7. Spectrum analyzer (fft) function
8. Strip chart recorder function
9. TTL output for control apps
10. Visual Basic source code avail.



For industrial, educational, hobbyist, auto, and audio test & measurement

\$399 + S/H. Visa/MC/Check OK
Add \$99 for source code option

The top choice of corporations, universities and scientists worldwide!

AMAZE ELECTRONICS CORPORATION

amaze@hooked.net www.hooked.net/users/amaze

Phone: 800-996-2008 Fax: 408-374-1737

WE'VE GOT IT!

MCM ELECTRONICS®

Prices Effective
December 16, 1997
through
February 27, 1998

To take advantage of special pricing on the items listed, you must provide this code: ▼

SOURCE CODE: POP49



#72-7051

Your Choice \$19.95



#72-7043

Current Meters
Inexpensive ammeters are ideal for any DC current measuring application including charging systems.

Induction type sensing only requires cable to be placed in slot frame on the rear of meter case, no electrical connections or leads to hook up.

Order #	Current range
72-7051	-100-0-100 Amp
72-7043	-30-0-30 Amp



Round Analog Panel Meters

These meters feature rugged steel backs, U-clamp flush mounting, fade proof lithographed metal dials and glass fronts. Dimensions: 2" (D) x 1.5" (D). Accuracy 5%

Order #	Range
72-7047	0-15VDC
72-7048	0-50VDC
72-7049	0-5mADC

Your Choice \$19.95



New Low Price

TENMA® Manual Ranging DMM

Features 3 1/2 digit LCD display, DC voltage measurement up to 600V, transistor, diode and battery test. Also measures AC voltage to 500V, DC current to 2A, and resistance to 2000Kohm. Holster, manual and test leads included. Requires one 9V battery not included (#290-080)

Order #	(ea.)
72-2055	\$24.95



SAVE \$2

MCM AUDIO SELECT™ Shielded Woofer

This high quality polypropylene cone woofer features rubber surround and shielded magnet, making it ideal for home theater applications. Great for cabinet upgrade or original design, this woofer will meet all of your needs.

Order #	Reg.	\$13.95
55-1191	\$15.95	

MCM is the leading supplier to the consumer electronics service industry. Additionally, hobbyists, educators and even manufacturers have looked to MCM for all of their component needs. Call today for your free catalog!



New Low Price

2 Meter, 50 Watt Ham Radio Amplifier

Rated output is easily obtained with 5W in. Requires only 1W to drive. 18dB GaAs FET switchable pre-amp. 144-148MHz operation only.

Order #	(ea.)
111-2100	\$99.00

Alinco magnet speakers commonly used in portable radios, tape recorders or projects. All have 8ohm coil. Many other sizes and ferrite magnet versions available.



Order #	Size	(ea.)
52-085	1 1/2"	\$1.59
52-095	2"	\$1.59
52-105	2 1/2"	\$1.69
52-115	3"	\$1.89
52-120	3 1/2"	\$2.29



FREE Catalog!

1-800-543-4330

www.mcmelectronics.com

Hours: M-F 7 a.m.-9 p.m., Sat. 9 a.m.-6 p.m., EST.



Computer Monitor Repair Tech Disk

Software easily installs on PC compatible computers. Simply key in monitor model or chassis number and case histories with problems and solutions are displayed. Your own problems/solutions can be added.

Order #	Reg.	\$24.95
81-2475	\$29.95	

SAVE \$5



The Modem Guide

Comprehensive list of over 170 different modems and their complete settings. Also lists all major manufacturers, with U.S. offices, and phone, fax, Internet and E-mail addresses for each.

Order #	Reg.	\$9.95
81-2418	\$12.95	

SAVE \$3

Same Day Shipping!

In stock orders received by 5:00 p.m. (YOUR TIME), are shipped the same day.



MCM ELECTRONICS®
650 CONGRESS PARK DR.
CENTERVILLE, OH 45459
A PREMIER FARNELL Company

SOURCE CODE: POP49

New and Pre-Owned Test Equipment

Goldstar

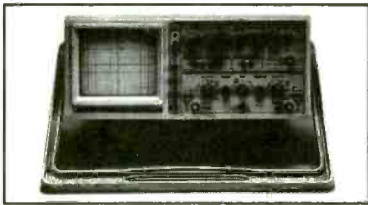

Model OS-9100P → **\$899.00**

Full 100 MHz Bandwidth!

- Dual-Channel, High Sensitivity
- TV Synchronization Trigger
- Calibrated Delayed Sweep
- Includes Two Probes, 2 Year Warranty

FREE SHIPPING!
ON GOLDSTAR EQUIPMENT
ANYWHERE IN THE U.S.
Excluding AK & HI

BK PRECISION
MAXTEC INTERNATIONAL CORP. Model 4040 \$499.00
20 MHz Sweep/Function Generator

Pre-Owned Oscilloscope Specials

Tektronix 2215	60 MHz	\$549.00
Tektronix 465	100 MHz	\$579.00
Tektronix 465B	100 MHz	\$729.00
Tektronix 475	200 MHz	\$829.00
Tektronix 475A	250 MHz	\$929.00
Tektronix 2465	300 MHz	\$2,499.00

- Professionally Refurbished
- Aligned & Calibrated to Original Specifications
- The Industry Standard of Oscilloscopes
- 6 Month Warranty - The Longest Available!

See us on the Web!
www.fotronic.com

LOWEST PRICES EVER!

NEW FLUKE MULTIMETERS & TEKTRONIX OSCILLOSCOPES
The Industry Standard in Multimeters

Fluke Model 87 \$285.00 !!!

**We Buy Surplus
Test Equipment**

1-800-996-3837

Test Equipment Depot

A FOTRONIC CORPORATION COMPANY
P.O. BOX 708 Medford, MA 02155
(617) 665-1400 • FAX (617) 665-0780

email: afoti@fotronic.com



TOLL FREE 1-800-99-METER

BEST DEALER PRICING!

CABLE DIRECT

CONVERTERS • FILTERS
DESCRAMBLERS

IMPROVE YOUR IMAGE WITH
VIDEO STABILIZERS

**FREE
CABLE TV
CATALOG!**

**100%
MONEY BACK
GUARANTEE!**

Now you can tune-in your favorite
cable TV programming
and **SAVE \$100'S -
EVEN \$1000'S** on premium
CABLE TV EQUIPMENT.



**MODERN
ELECTRONICS**
1-800-906-6664

2609 S. 156TH CIRCLE • OMAHA, NE 68130
<http://www.modernelectronics.com>

Smithy 3-in-1 Lathe-Mill-Drill

**Own your own
machine shop**

Now you can make your
own repairs and
build things you've
only imagined.

• Easy to use—no
experience required.

Toll-free machining help by phone.

• Versatile—fix or make most anything out of metal,
wood, or plastic. Do quality work right away.

• Affordable—Three models starting at \$995.

GUARANTEED to pay for itself in six months.

**Smithys are used by professionals
and hobbyists worldwide for:**

- Auto restoration
- Maintenance
- Gun work
- Light manufacturing
- Equipment repair
- Education
- Model building
- Prototyping



*"I can fix most
anything. Now I don't
know how I lived
without it. It paid for
itself in no time."*

Call today for your **FREE**
benchtop machine shop
Information pak!
(800) 345-6342

or write: **POWERHOUSE** Dept. PE PO Box 1517
Ann Arbor, MI 48106-1517

FREE 30-day IN-YOUR-SHOP trial

Enjoy the freedom
& cost savings of
owning a benchtop
machine shop. Call
or write today!!

PROGRAMMERS OVER 50 MODELS

ADVANTECH EETOOLS NEEDHAMS DATA I/O ICE TECHNOLOGY HILO
SYSTEM GENERAL CHROMA MODULAR CIRCUIT TECHNOLOGY XELTEK



PROMAX EMP-20 MEGAMAX MEGAMAX4 SIMM/SP TESTER EMUPA

CALL ADVANTECH LABTOOL	599 EETOOLS SIMMAX
629 ICE TECH MICROV	795 CHROMA SIMM/SP
650 EETOOLS ALLMAX +	359 MOD-MCT-EMUPA/R
409 EETOOLS MEGAMAX	279 MOD-MCT-EMUP/R
509 EETOOLS MEGAMAX4	49 EPROM 1G TO 512K
369 XELTEK SUPERPRO II	69 EPROM 1G TO 1MEG
409 XELTEK SUPERPRO II P	99 EPROM 4G TO 1MEG
249 XELTEK SUPERPRO II	199 EPROM 16G TO 1 MEG
165 XELTEK ROMMASTER II	89 EPROM 1G TO 8MEG
479 MOD-MCT-EMUPA	129 EPROM 4G TO 8MEG
739 STAG ORBIT-32	250 EPROM 8G TO 8MEG



LABTOOL48 MICROMASTER SUPERPRO ALLMAX PLUS ROMMASTER2

General Device Instruments

Sales 408-241-7376 Fax 241-6375 BBS 983-1234

Web www.generaldevice.com E-Mail icdevice@best.com

Quality Microwave TV Systems

**WIRELESS CABLE - ITFS - MMDS
ATV - INTERNATIONAL - S-BAND**
Amplifiers • Antennas • Books • Components
Filters • Systems • Video Products

• RF Frequency 1990 - 2700 MHz

• Cable Ready - VHF - UHF Outputs

• SASE For "FREE" Catalog or Send \$1

PHILLIPS-TECH ELECTRONICS

PO Box 8533 • Scottsdale, AZ 85252

ORDER LINE 800-880-MMDS

CATALOG/INFO 602-947-7700

FAX LINE 602-947-7799

FREE SHIPPING Visa • MC • Amx • Disc • COD's • Qty Pricing

CHALLENGER SYSTEM

33-Channel 520B-Gain

Complete Grid 5265

Five Year Warranty

CIRCLE 154 ON FREE INFORMATION CARD

**OVER
30,000
ITEMS
IN STOCK**

Dalbani®

The Ultimate Saving Source

**LARGE VARIETY
SAME DAY SHIPPING**

SHIP UP TO
5lbs
FOR ONLY

\$3.95



2nd Day Air



Plus handling & C.O.D. charge if it applies

Over 6,000 new items

Audio/Video Service Parts
Audio/Video Accessories
Professional Audio
Security Products
Connectors
Technician Aids
Chemicals
Test Equipments
Soldering Equipment
Automotive Products
Automotive Installation Kits

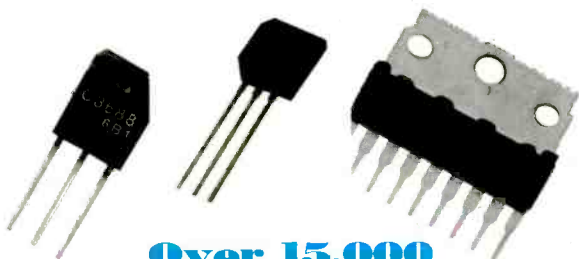

**Over 15,000
Original SEMI in stock.**



Dalbani®

4225 NW 72ND AVE. MIAMI, FLORIDA 33166
TEL : (305) 716-1016 ----- FAX : (305) 594-6588

TO ORDER A CATALOG CALL "258"

1-800-325-2264

CIRCLE 48 ON FREE INFORMATION CARD

LEADER

For Professionals Who Know The Difference

- Oscilloscopes
- Video Sync/Test Generators
- Waveform Monitors/Vectorscopes
- EFP/ENG Instruments
- RF Signal Level Meters
- Audio Generators & Meters
- Frequency Counters
- Meters & Bridges
- Power Supplies
- Function Generators
- RF Generators

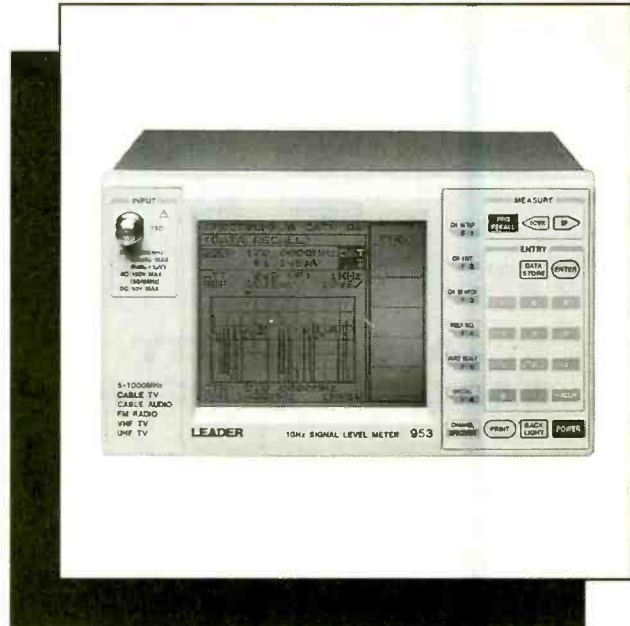

Call, fax or email for your free test and measurement instrument catalog today!
 800-638-2020 * Fax 800-545-0058
 Email: SMPRODINTL@aol.com



Test Instruments, Equipment, Tools & Supplies For Electronic Production, Maintenance & Service
 8931 Brookville Road, Silver Spring, MD, 20910 * 800-638-2020 * Fax 800-545-0058

CIRCLE 47 ON FREE INFORMATION CARD

ELECTRONIC COMPONENTS

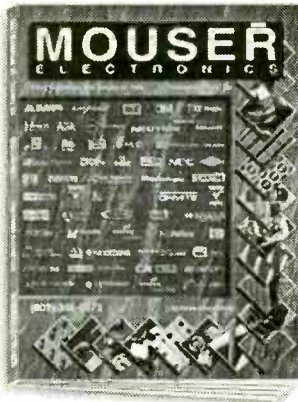

Call for your **FREE** 364 page catalog TODAY!

- 69,000+ Products
- 135 Manufacturers
- Same Day Shipping
- No Minimum Order

800-992-9943

817-483-6828 Fax: 817-483-0931
 www.mouser.com catalog@mouser.com

958 North Main St., Mansfield, TX 76063

CIRCLE 152 ON FREE INFORMATION CARD

Call Today And **SAVE!** **Unbeatable PRICES!**

CABLE TV

**DESCRAMBLERS
 CONVERTERS · FILTERS
 VIDEO STABILIZERS**

FREE ➤ 30 Day Trial
FREE ➤ Product Catalog
FREE ➤ 1 Year Warranty

100% MONEY BACK GUARANTEE



Let us point you in the right direction ...



TOLL FREE
888-554-ARROW
888-554-2776

VIDEO INVERTER

Create & Restore Inverted Video

R.C. Distributing
 PO Box 552 · South Bend, IN 46624
 Website: www.south-bend.net/rcd

For Free Information Package on Completed Units and Pricing
Call 219-236-5776

!!!BROADCAST FARTHER!!!

The model 320 is an 80-110 MHz RF amplifier that connects to mono or stereo FM transmitters and produces a powerful 2-15 watt signal which could broadcast up to 5 miles or more! Requires 50-150 mW drive. Step by step plans complete with part source information and antenna designs. **ONLY \$14 PLUS \$2 S&H NO C.O.D.'S**

Progressive Concepts
 BOX 586 STREAMWOOD, IL 60107
 (630)736-9822 FAX: (630)736-0353

BUGGED??

EAVESDROPPING is unbelievably widespread! Electronic Devices with amazing capabilities can be monitoring your telephone and room conversations RIGHT NOW! Are you sure you're safe? **FREE CATALOG tells you fast!** Includes Free Bonus details on fantastic opportunities now open in Counter-Surveillance field. Exciting, immensely interesting and **EXTREMELY** profitable (up to \$250/hr) full/part-time income. Call Now!



1-800-732-5000

ALFA ELECTRONICS, INC.

- HIGH QUALITY TEST EQUIPMENT PROVIDER

1-800-526-2532 (526-ALFA)

15 Days Money Back Guarantee!

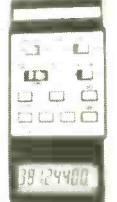
	<p>DMM</p> <p>DMM-10 (\$19.95): 3 1/2 digit, DC/AC V, Ω, hFE, diode, signal output(+3V, -0.5Vsq, 50% duty)</p> <p>DMM-17B (\$39.95): 3 1/2 digit, DC/ACV, contin., DC/ACA, Ω, Capacitance, hFE, diode, Freq</p> <p>DMM-20 (\$74.95): AC/DC (V, A), Freq, cont., Capac, induct., Ω, hFE, diode, duty cycle</p> <p>DMM-22 (\$89.95): 4000 counts, bar graph, Freq, AC/DC(V,A), Ω, Capacitance, diode, contin.</p> <p>DMM-23T (\$99.95): 4 1/2 digit, high resol. (10uV, 10nA, 10mΩ), hFE, diode, contin., true rms</p> <p>DMM-89S (\$179.00): true rms, AC/DC (V,A), Ω, bar graph, freq, capac., dBm, logic, diode</p>		<p>LCR METER</p> <p>CAP-15 (\$49.95): 3 1/2 digit, 0.1pF-20mF, 9 Ranges, 0.1pF resolution zero adjustment</p> <p>LCR-195 (\$89.95): 1uH-200H (induct.), 0.1pF-200uF(Capac.), 0.01Ω-20MΩ(resistance)</p> <p>LCR-814 (\$189.95): 0.1uH-200H, 0.1pF-20mF, 0.1Ω-20MΩ, Q Factor, dissipation, zero adjust</p> <p>LCR-131D (\$229.95): autorange, 0.1uH-10kH, 0.1pF-10mF, 1mΩ-10MΩ, Q Factor, serial/parallel, 120Hz/1kHz testing mode</p>	<p>FREQ. COUNTER</p> <p>FC-1200 (\$129.95): 1.25GHz Handheld, 8 digits display, 10ppm accuracy, sensitivity 5mV (130-350MHz), 30mV (440MHz), 22m (800MHz), batteries or 9V adapter.</p> <p>FC-2500 (\$179.95): 2.5GHz Handheld, 8 digits display, 4ppm accuracy, sensitivity <50mV, batteries or 9V adapter.</p> <p>FC-5270A (\$149.95) 1.2 GHz bench type, 8 digit, 10 ppm, 35mV sensitivity, 10Vp-p max input, power by 9V adapter.</p> <p>FC-5700 (\$329.95) 1.3GHz bench type, 8 digit, 1 ppm accuracy, 20mV sensitivity, period 0.1us to 100ms. Ideal for test & repair of audio instrument.</p>																		
	<p>DMM-113 (\$24.95): Pocket Size, DC/ACV, Ω, diode, Continuity beeper</p> <p>DMM-120 (\$24.95): economy type, DCV, ACV, DCA, Ω, hFE, diode</p> <p>DMM-122 (\$59.95): DC/AC(V,A), Ω, hFE, diode, capacitance, freq, logic, continuity</p> <p>DMM-123 (\$44.95): DMM + capacitance, DC/AC(V,A), Ω, hFE, diode, continuity</p> <p>DMM-124 (\$69.95): Electrical+Temp, DC/ACV, capacitance, freq, 3 phase, diode, contin.</p> <p>DMM-125C (\$54.95): Autorange + bar graph, DC/ACV, Cap, Ω, diode, continuity beeper</p>		<p>FLUKE DMM</p> <table border="1"> <tr> <th>HandHeld</th> <th>Scope Meter</th> </tr> <tr> <td>70-II \$ 84.95</td> <td>92B \$1,399</td> </tr> <tr> <td>12-II \$ 75.95</td> <td>96B \$1,699</td> </tr> <tr> <td>73-II \$ 97.95</td> <td>99B \$1,999</td> </tr> <tr> <td>75-II \$129.00</td> <td>105B \$2,499</td> </tr> <tr> <td>76-II \$175.00</td> <td>863E \$469</td> </tr> <tr> <td>77-II \$155.00</td> <td>867E \$659</td> </tr> <tr> <td>79/29-II \$175.00</td> <td></td> </tr> <tr> <td>87 \$287.00</td> <td></td> </tr> </table>	HandHeld	Scope Meter	70-II \$ 84.95	92B \$1,399	12-II \$ 75.95	96B \$1,699	73-II \$ 97.95	99B \$1,999	75-II \$129.00	105B \$2,499	76-II \$175.00	863E \$469	77-II \$155.00	867E \$659	79/29-II \$175.00		87 \$287.00		<p>SPECIALTY</p> <ul style="list-style-type: none"> • Sound meter \$169.95 • EMF Tester \$69.95 • Conductivity \$169.95 • Thermometer \$69.95-\$89.95 • Humid./Temp meter \$169.95 • Press. meter \$299.95 • Electr. scale \$89.95 • Watt Meter \$129.95 • High Voltgae Probe \$59.95 • pH Meter \$79.95 • Light Meter \$80-\$90 • Light Adapter \$49.95 • Anemometer \$179.95 • Anemometer adapter (And More) \$89.95
HandHeld	Scope Meter																					
70-II \$ 84.95	92B \$1,399																					
12-II \$ 75.95	96B \$1,699																					
73-II \$ 97.95	99B \$1,999																					
75-II \$129.00	105B \$2,499																					
76-II \$175.00	863E \$469																					
77-II \$155.00	867E \$659																					
79/29-II \$175.00																						
87 \$287.00																						

OSCILLOSCOPE

Dual Trace, Component Test, 6" CRT, X-Y Operation, TV Sync, CH2 Output, Graticule Illum, 2 Probes(x1;x10)

- PS-200 20 MHz Dual Trace \$339.95
- PS-205 20 MHz Dual w/ Delay Sweep \$429.95
- PS-400 40 MHz Dual Trace \$494.95
- PS-405 40 MHz Dual w/ Delay Sweep \$569.95
- PS-605 60 MHz Dual w/ Delay Sweep \$769.95
- PS-1000 100MHz Dual Trace \$999.95

Digital Scope

- DS-303 30MHz Digital, 20 Samples/sec \$849.95
- DS-303P RS-232 interface, 30Mhz \$1,049.95

Scope Probe

- HP-9060 (60MHz) \$15, HP-9150 (150MHz) \$22, HP-9250 (250MHz)\$29, HP-9258 (250MHz,100:1)\$39

AUDIO/RF/FUNCT. GENERATOR

RF Generator

- SG-4160 (\$124.95) 100kHz-150MHz sinewaves in 8 ranges, 100mV at 35MHz
- SG-4162 (\$229.95): Generate same signal as SG-4160, but with int. counter (150MHz).

Audio Generator

- AG-2601 (\$124.95) 10Hz-1MHz, 0-8Vpp sine, 0-10Vpp squarewave
- AG-2603 (\$229.95): Same as AG-2601, but with additional counter and digital display.

Function Generator

- FG-2100A (\$169.95) 2Hz-2MHz, 5mV-20Vpp
- FG-2102AD (\$229.95) same as FG-2100A, but with int. counter and TTL, CMOS output.
- FG-2103 (\$329.95) Sweep 0.5Hz-5MHz, linear/log VCG, GCV, and int. counter

POWER SUPPLIES

Single Output DC Power Supplies

- Short Circuit and overload protected
- Constant current, constant voltage mode
- 0.02%+2mV line regulation; 0.02%+2mV load regulate

Analog Meters Display

- PS-303 (\$159.00) 30V/3A
- PS-305 (\$219.95) 30V/5A
- PS-8110 (\$289.95) 60V/5A
- PS-8112 (\$399.95) 60V/5A
- PS-1610 (\$289.00) 16V/10A
- PS-8107 (\$399.95) 30V/10A

Digital Voltage, Analog Current

- PS-8200 (\$179.95) 30V/3A
- PS-8201 (\$239.95) 30V/5A

Digital Volt & Current Display

- PS-8300 (\$199.95) 30V/3A
- PS-8301 (\$239.95) 30V/5A

Dual Tracking

- Short Circuit & overload protected
- Constant current & constant mode
- Independent or Tracking

Dual Tracking (Analog V & I Displays)

- PS-303D (\$314.95) 30V/3A/30V/3A
- PS-305D (\$399.95) 30V/5A/30V/5A
- PS-8108 (\$549.95) 60V/3A/60V/3A
- PS-8109 (\$699.95) 60V/5A/60V/5A

Triple Output

- One fixed 5VDC, 3 Amp output
- Parallel to double current output (PS-8102 & PS-8103 only)



Triple Output (Analog display)

- PS-8102 (\$399.95) 30V/3A/30V/3A
- PS-8103 (\$489.95) 30V/5A/30V/5A

Digital Displays

- PS-8202 (\$499.95) 30V/3A/30V/3A
- PS-8203 (\$549.95) 30V/5A/30V/5A

INSTEK® Test & Measuring Instrument ISO 9002 Cert. #934163 (2 Years Warranty)

<p>OSCILLOSCOPE</p> <p>OS-653 \$699.95 50MHz Triggering</p> <p>OS-622B \$399.95 20 MHz Oscilloscope</p>   <ul style="list-style-type: none"> • Dual CH / Delay sweep • ALT trigger, trigger lock • 1mV/div sen., delay line • Zaxis input, CH1 output • Hold off, TV syn. • 2 probes (x1, x10) <p>OS-305 (\$209.95) - 5 MHz One Channel</p> <p>OS-310 (\$324.95) - 10 MHz One channel</p>	<p>DC POWER SUPPLIES</p> <p>Triple Output</p> <ul style="list-style-type: none"> • 2 variable out 0-30V, 0-3A • One fixed 5V, 3A output • Auto track, serial, parallel • Const. volt, current mode • 4 analog or 2 digital display <p>PC-3030 (\$499.95)</p> <p>PC-3030D (\$549.95)</p> <p>Single Output</p> <ul style="list-style-type: none"> • Const voltage, current mod • Voltage regulation <math>\leq 0.01\%</math> • Current regulation <math>\leq 0.2\%</math> • PS: 2 analog or 1 digital dis • PR: 2 analog or 2 digital dis <p>Analog Meters Display</p> <p>PS-1830 (\$209.95) 18V/3A</p> <p>PS-1850 (\$219.95) 18V/5A</p> <p>PS-3030 (\$224.95) 30V/3A</p> <p>PS-6010 (\$209.95) 60V/10A</p> <p>PR-3060 (\$314.95) 30V/6A</p> <p>PR-6030 (\$314.95) 60V/3A</p> <p>Programmable</p> <ul style="list-style-type: none"> • High stability, low drift • One fixed 5V, 3A output • 100point program (PPS ser) • 50point program (PPT ser) • Auto serial/parall. (PPT ser) • Auto track (PPT series), IEEE-488.2 and SCPI compatible command set (optional) <p>PPS-1860G (\$1,099.95)</p> <p>PPS-3635G (\$1,099.95)</p> <p>PPS-6020G (\$1,099.95)</p> <p>PPT-1830G (\$1,399.95)</p> <p>PPT-3615G (\$1,399.95)</p> <p>FG-830 (\$1,499.95) 30MHz Synthesized Function Gen.</p> <ul style="list-style-type: none"> • Output: sine, tri, square, sync out, arb. waveform 	<p>FUNCTION GENERATOR</p> <p>FC-8015G (\$189.95) Sweep 0.02Hz-2MHz, no counter</p> <p>FC-8016C (\$239.95) 0.02Hz-2MHz w/ counter</p> <p>FC-8017G (\$249.95) Sweep 0.02Hz-2MHz w/counter</p> <p>FC-8019 (\$399.95) Sweep 0.02Hz-2MHz w/counter</p> <p>FC-8019 (\$209.95) 0.02Hz-2MHz w/counter</p> <p>FC-8050 (\$499.95) Sweep 0.05Hz-5MHz w/counter</p> <p>FC-8270 (\$629.95) 2.7GHz</p> <p>FC-2010G (\$294.95)</p>	<p>BENCHTOP DMM</p> <p>DM-8034 (\$179.95) 3 1/2 digit</p> <p>DM-8040 (\$339.95) 3 1/2 digit</p> <p>DM-8055 (\$649.95) 5 1/2 digit</p> <p>DM-8055C (\$889.95) GPIB</p> <p>Frequency Counters</p> <p>FC-8131 (\$469.95) 1.3GHz</p> <p>FC-8270 (\$629.95) 2.7GHz</p> <p>FC-2010G (\$294.95)</p> 
---	---	--	--

ALFA ELECTRONICS P.O. BOX 8089 PRINCETON, NJ 08543

TEL: (800)526-ALFA(2532) / (609)897-1135 FAX: 609-897-0206 Email: alfa0168@aol.com

Call/Write/Fax/Email for **FREE CATALOG** Visa, MC, AMEX, COD, PO Accepted. OEM Welcome. 1 Year Warranty (2 Years for Instek)

CIRCLE 26 ON FREE INFORMATION CARD

February 1998, Popular Electronics

Buyers' Budget Books Better Buys

BP294-A Concise Introduction to Microsoft Works \$6.95. In the shortest and most effective way, you can use the word processor to advantage to type, edit, print and save documents. It goes on to explain how Works can be used to build up simple spreadsheet examples, edit them, save them, print them and retrieve them. It informs you how to create simple macros, and enables you to simplify long repetitive tasks and to customize the program to your own needs.

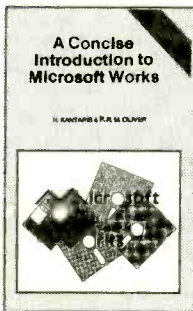

BP349-Practical Opto-Electronic Projects \$5.95. If you shun opto-electronic projects for lack of knowledge, this is the book for you. A bit of introductory theory comes first and then a number of practical projects which utilize a range of opto devices, from a filament bulb to modern infrared sensors and emitters.

BP350-Electronic Board Games \$6.00. Twenty novel electronic board games that you can build from the plans in this book. Whether you are interested in motor racing, searching for buried treasure on a barren island or for gold in Fort Knox, spinning the wheel of fortune, or doing a musical quiz—there is something for you to build and enjoy!

BP351-WordPerfect 6 Explained \$6.95. This is a practical, hands-on, book and the routines described will help you get the most out of WordPerfect 6. The book explains the hardware requirements for the package and steps you through a standard installation. It guides you through the WordPerfect program environment to enter, edit and enhance text and shows how to get the best from the three different operating modes, depending on the type of PC you are using. The formatting codes, button bars, ribbon, tabs, graphic manipulation and styles will no longer be a mystery.

BP388-Why Not Personalize Your PC? \$6.95. Find out how to: Set up and organize groups of programs and data files, and change the opening logo; use the Control Panel to personalize your working environment; use screen savers and wallpaper files; manage the DOS prompt; and transfer your customization files to a new Windows installation. In DOS, you discover how to: Write batch files and create specialist programs using the debug program, design professional looking menus, and more.

BP367-Electronic Projects for the Garden \$6.95. Electronics enters the Garden! New exciting book points out how gardeners can build simple gadgets to promote success where the elements work against you. Some of the projects are: over/under temperature monitoring, dusk/dawn switching, automatic plant watering, warming cables, etc.

BP368-Practical Electronics Musical Effect Units \$5.95. There is a constant hullabaloo for musical effects projects by the hobbyist community. This book provides practical circuits for several projects that range in complexity and are sure to work. All the circuits are easy to build and use readily-available parts.

BP363-Practical Electronic Music Projects \$5.95. The text contains a goodly number of practical music projects most often requested by musicians. All the projects are relatively low-in-cost to build, and all use standard, readily-available components. The project categories are guitar, general music and MIDI.

100% NEW TITLES LISTED EACH MONTH—CHECK US OUT!

BP385-Easy PC Interfacing \$6.95. The built-in ports in your PC provide an easy and hassle-free way of interfacing your circuits. This book provides useful PC add-on circuits including the following: Digital input/output ports; analog-to-digital and digital-to-analog converters; voltage and current measurement circuits; resistance and capacitance meters, temperature measurement interface, biofeedback monitor, and many other useful interfaces.

BP393-Practical Concise Introduction to UNIX \$5.95. If you are using or intend to use the UNIX multi-user operating system and want to get the most out of your computer system in terms of efficiency and productivity, then you must learn its operating system. The book explains how the UNIX operating system is structured so that you understand what happens when you first approach your computer.

BP396-Electronic Hobbyists Data Book \$5.95. This book provides a wide range of data. If, for example, you require details of a modern five-band resistor code or an old color code for a ceramic capacitor, the formula for parallel resistance, or basic data on an NE5534AN operational amplifier, it is contained within these pages. The subjects covered are numerous and widespread to cover all hobbyist interests.

BP343-A Concise Introduction to Microsoft Works for Windows \$7.95. The book explains and details: How the Works for Windows package fits into the general Microsoft Windows environment; how to use the word processor to advantage; how to use Microsoft Draw to create and edit graphics and place them in your documents; how to build up simple spreadsheet examples; and how single, and multiple charts, or graphs, of different types can be generated. And there's much more!

BP282-Understanding PC Specifications \$7.25. This book explains PC specifications in detail, and the subjects covered include the following: Differences between types of PC (XT, AT, 80386, 80486, Pentium etc.); math co-processors; input devices (keyboards, mice, and digitizers); memory, including both expanded (EMS) and extended RAM; RAM disks and disk caches; floppy disk drive formats and compatibility; hard disk drives; and display adapters (CGA, Hercules, super VGA, etc.).

BP298-Concise Intro to the Macintosh System and Finder \$6.25. Although the Mac's WIMP user interface is designed to be easy to use, much of it only becomes clear when it is explained in simple terms. The book explains: The System and Finder, what they are and what they do; how to use the System and Finder to manipulate disks, files and folders; configuring and printing files from the Finder; getting the most from the system utility programs; and running MultiFinder.

BP301-ANTENNAS FOR VHF AND UHF \$6.00. From installing a TV or FM antenna to setting up a multi-antenna array for shortwave listening or amateur radio, this book explains the essential basics of VHF and UHF antenna operation and installation. In easy-to-understand terms it helps you understand how antennas work, the advantages of different antenna types, and how to get the best performance out of an antenna.

BP316-Practical Electric Design Data \$7.95. A builder's bargain book—a comprehensive ready-reference manual for electronic enthusiasts with over 150 practical circuits. It covers the main kinds of components (from pig-tail leads to surface mount), pin-outs, specs and type selection. Basic units are defined and most used formulae explained. Five additional sections are devoted to circuit design, covering analog, digital, display, radio and power supply circuits.

BP319-Making MS-DOS Work For You \$6.50. This book could help you improve your system set-up and provide you with a simple-to-use, but professional looking, menu system. The routines described will help you understand more of the workings of MS-DOS and help you get the most out of your computer in terms of efficiency, productivity and enjoyment.

BP341-MS-DOS 6 Explained \$7.95. The book covers: How the DOS operating system of your computer is structured so that you can understand what happens when you first switch on your computer; How directories and subdirectories can be employed to structure your hard disk for maximum efficiency; how to use the DOS Shell program, and much, much more.

BP345-Getting Started In Practical Electronics \$5.95. If you are looking into launching an exciting hobby activity, this text provides basic essentials for the builder and 30 easy-to-build fun projects with which every experimenter should toy. Printed-circuit designs are included to give your project the professional touch.

ELECTRONIC TECHNOLOGY TODAY INC.
P.O. BOX 240, Massapequa, NY 11762-0240

Name _____
Address _____
City _____ State _____ Zip _____

SHIPPING CHARGES IN USA AND CANADA

\$0.01 to \$5.00.....	\$2.00
\$5.01 to \$10.00.....	\$3.00
\$10.01 to \$20.00.....	\$4.00
\$20.01 to \$30.00.....	\$5.00
\$30.01 to \$40.00.....	\$6.00
\$40.01 to \$50.00.....	\$7.00
\$50.01 and above.....	\$8.50

SORRY No orders accepted outside of USA & Canada

Total price of books.....	\$	No. of Books Ordered <input type="text"/>
Shipping (see chart).....	\$	
Subtotal.....	\$	
Sales Tax (NYS only).....	\$	
Amount Enclosed	\$	

All payments must be in U.S. funds!

PARTS EXPRESS

ELECTRONICS & MORE

FREE 244 PAGE CATALOG



UNBELIEVABLE VALUE!

4 Way Speaker Switch

Control up to 4 pairs of speakers with this compact speaker selector switch. Features circuit protector, heavy duty rocker switches, spring loaded terminals, and silver plated switch connectors. Includes one pair of amplifier inputs. Load to amplifier is minimum 4 ohms (with 8 ohm speakers) or 220 ohms with all speakers switched off. Net weight: 1 lb.

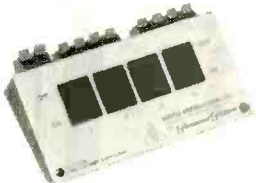

#PO-309-030 WAS \$22⁵⁰ EACH NOW \$15⁰⁰ EACH

"The Sound Bridge" FM Stereo Wireless Transmitter

The Sound Bridge is a mini FM wireless transmitter that can be used to broadcast stereo sound from any audio source like portable CD players, TVs, electronic games, CD-ROM, even computer soundcards, to your home stereo receiver! Adjustable from 89 to 95.5 MHz.



HOT NEW ITEM!

#PO-249-220 \$14⁹⁵ EACH

Weller Professional Irons

Weller



Perfect for a variety of electronic soldering work, this top quality iron features a long life, double coated tip and a quick change, plug-in heater element. Lightweight handle includes a comfortable cushioned grip. Net weight: 1/2 lb.

#PO-372-110 (25 Watt) \$30⁹⁰ (1-3) \$28⁵⁰ (4-UP)
#PO-372-112 (35 Watt) \$38⁹⁰ (1-3) \$34⁹⁵ (4-UP)

Peak Instrument Co.

"The Woofer Tester"

Peak Instrument Co. proudly introduces "The Woofer Tester". Just ask any loudspeaker engineer, and they will tell that the only way to design enclosures of the correct size and tuning is to measure the Thiele-Small parameters for the actual drivers to be used. The reason? Manufacturers published specs can be off by as much as 50%! But until now, measuring the parameters yourself required expensive test equipment and tedious calculations, or super expensive measurement systems (\$1,200 to \$20,000). The Woofer Tester changes all that. Finally, a cost effective, yet extremely accurate way to derive Thiele-Small parameters, in only minutes! The Woofer Tester is a combination hardware and software system that will run on any IBM compatible computer that has EGA or better graphics capability and an RS232 serial port. The Woofer Tester will generate the following parameters: Fs, Qms, Qes, Dts, Vas, BL, Re, Le, SPL @ 1W/1m, Mmd, Cm, and Rm. Sealed box data: Fsb and system Q. Vented box data: Fsb, ha, alpha, and Q loss. The Woofer Tester system includes hardware, test leads, serial cable, AC wall adaptor, detailed instructions, and software.



QUICKLY AND ACCURATELY MEASURES:
Fs, Qms, Qes, Dts, Vas, BL, Re, Le, SPL @ 1W/1m, Mmd, Cm, and Rm IN MINUTES!

30 DAY MONEY BACK GUARANTEE

1 YEAR WARRANTY 1 DAY SHIPPING

#PO-390-800 \$249⁰⁰ EACH

900 MHz Wireless Speaker System

- ◆ 900 MHz technology sends signal up to 180 ft., through walls, floors and ceilings.
- ◆ Ideal for use as rear surround speakers or for adding wireless sound to every room in the house!
- ◆ Full range, bass reflex design with built-in high power, low distortion amplifier.
- ◆ Weather resistant cabinet for outdoor use.
- ◆ Selectable battery (six C size for each speaker) or AC operation, adaptor included. Built-in recharging circuitry. Ni-cad batteries.
- ◆ System includes: 900 MHz transmitter, wireless speaker pair, AC adaptors, and all cables necessary to hook up system.
- ◆ Limited availability. ◆ Net weight 9 lbs.
- ◆ Frequency response: 20-18KHz.



#PO-319-030 \$169⁹⁵ EACH

Home Theatre In-Floor Subwoofer

To fully appreciate the potential of movie soundtracks, a dual voice coil subwoofer is a must! Many film special effects are extremely demanding in the low frequency range and require a subwoofer that can duplicate explosions, earthquakes, even the footsteps of Tyrannosaurus Rex! This subwoofer fits the bill by featuring a 10" dual voice coil woofer for true stereo operation and high pass filters for your main speakers. The most unique feature of this subwoofer is the fact that it is designed to be mounted in between the floor joists in new and existing home constructions. Simply mount the in-floor sub to the joists and mount a heat register grill above opening in subwoofer front enclosure. The subwoofer is now totally out of view and ready to rumble! Includes detailed installation manual.



Specifications: 10" dual voice coil treated paper cone woofer with poly foam surround ◆ Frequency response: 30-100 Hz ◆ Nominal impedance: 8 ohms per coil ◆ Power handling: 100 watts RMS channel/140 watts max ◆ SPL: 89 dB 1W/1m ◆ Dimensions: 27" D x 14-5/8" W x 9" H ◆ Net weight: 29 lbs.

#PO-300-445 \$139⁹⁵ EACH

Dayton Loudspeaker Co.®

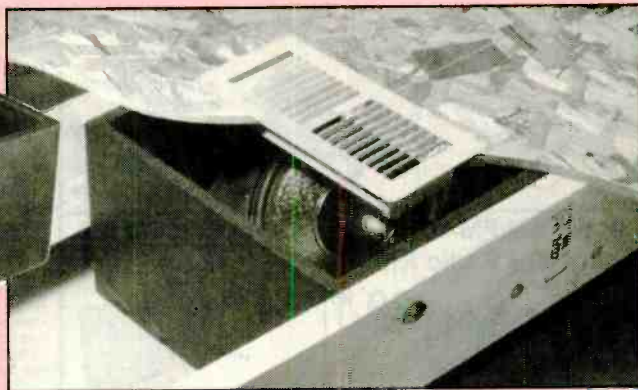

◆ 30 day money back guarantee ◆ \$20.00 minimum order
◆ We accept: Mastercard, Visa, Discover, and company C.O.D. orders ◆ 24 hour shipping ◆ Shipping charge = UPS chart rate + \$1.90 (\$5.00 minimum charge) ◆ Hours 8:00 am - 8:00 pm ET, Monday - Friday ◆ 9:00 am - 5:00 pm Saturday. Mail order customers, please call for shipping estimate on orders exceeding 5 lbs. ◆ Foreign destination customers please send \$5.00 U.S. funds for catalog. ◆ Quantity pricing available.

1-800-338-0531

340 E. First St., Dayton, OH 45402-1257
Phone: 937-222-0173 ◆ Fax: 937-222-4644
E-Mail: sales@parts-express.com

CIRCLE 146 ON FREE INFORMATION CARD

CALL TOLL FREE
(800) 292-7711 orders only
Se Habla Español

C&S SALES

EXCELLENCE IN SERVICE

LOOK FOR OTHER
MONTHLY SPECIALS
ON OUR WEBSITE

NEW **XK-700 Digital / Analog Trainer**
Elenco's newest advanced designed Digital / Analog Trainer is specially designed for school projects. It is built on a single PC board for maximum reliability. It includes 5 built-in power supplies, a function generator with continuously sine, triangular and square waveforms and a 1560 tie point breadboard area. Tools and meter shown optional. (Mounted in a professional tool case made of reinforced metal).

XK-700
Assembled and Tested
\$189.95

XK-700 - SEMI KIT
w/ Fully Assembled PC Board
\$174.95

XK-700K - Kit
\$159.95



Made in the USA

Volt Alert™ By FLUKE

Volt Alert™ is the new pocket-sized AC line voltage detector from Fluke. Easy to use - just touch the tip to an outlet or cord. When it glows red, you know there's voltage in the line.

Electrician's, maintenance, service, and safety personnel can quickly test for energized circuits and defective grounds on the factory floor, in the shop, or at home.

- Fits in shirt pocket for convenience.
- All outer surfaces are uncondusive for safety.
- Detects voltage metallic contact.



#1AC **\$19.50**

DIGITAL LCR METER

Model LCR-1810 **NEW**



\$99.95

- Capacitance 1pF to 20µF
- Inductance 1µH to 20H
- Resistance .01Ω to 2000MΩ
- Temperature -20°C to 750°C
- DC Volts 0 - 20V
- Frequency up to 15MHz
- Diode/Audible Continuity Test
- Signal Output Function
- 3 1/2 Digit Display

20MHz Sweep / Function Generator with Freq Counter

B&K 4040

- 0.2Hz to 20MHz
- AM & FM modulation
- Burst Operation
- External Frequency counter to 30MHz
- Linear and Log sweep

10MHz B&K 4017 **\$309**
5MHz B&K 4011 **\$239**



\$399



Model M-6100

The M-6100 is Elenco's most sophisticated meter with almost every possible feature available. The M-6100 even has a computer interface for viewing and storing data on a personal computer. It comes complete with software, RS-232 cable, test leads and manual.

\$125

Model XP-581

4 Fully Regulated DC Power Supplies in One Unit
4 DC voltages: 3 fixed - +5V @ 3A, +12V @ 1A, -12V @ 1A
1 Variable - 2.5 - 20V @ 2A

\$89.95



SATELLITE FINDER

Model SF-100A

- Aligns Satellite Dishes
- Range 950-2050MHz
- Audio Tone
- Compact Size
- Self Power Check

\$39.95



Digital Multimeter

Model M-1700

\$39.95

11 functions including freq to 20MHz, cap to 20µF. Meets UL-1244 safety specs.



Technician Tool Kit

TK-1500

28 tools plus a DMM contained in a large flexible tool case with handles ideal for everyone on the go.

\$49.95

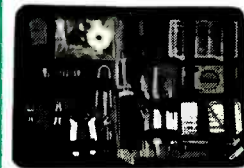

Kit Corner

over 100 kits available

AK-700

\$14.95

Phone kit with training course.



RADIO CONTROL CAR KIT

MODEL AK-870

- 7 functions
- Remote control included

\$24.95



No Soldering Required

Model AM/FM-108K

Transistor Radio Kit with training course

\$29.95



35mm Camera Kit

Learn all about photography

AK-540

\$14.95



No Soldering Required

The New DMM900 Series Handheld Digital Multimeters

For high-performance digital multimeters that are accurate, reliable, and rugged, the DMM900 Series extends the Tektronix line of already affordable DMMs. Twice the accuracy. Up to 10 times the resolution. And a full range of capability that spans voltage, current, digital multimeters features a dual numeric display, 3-year warranty, and autoranging capability. All backed by the reliability of the Tektronix brand.

Features

DMM912, DMM914, DMM916

- 40,000 Count Display
- 0.06% Basic DC Volts Accuracy (DMM916)
- DC Voltage Ranges from 400mV to 1,000V
- AC Voltage Ranges from 4V to 750V (True RMS)
- AC and DC Current Ranges from 10,000µA to 10A
- Resistance Ranges from 400Ω to 40MΩ
- Capacitance Ranges from 4nF to 40µF
- Frequency Ranges from 400Hz to 2MHz
- Temperature Measurements from -50°C to +980°C (DMM916, DMM914)
- 3 Year Warranty
- CE Marking



DMM 912
\$189

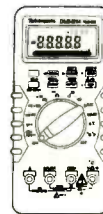

DMM 914
\$235



DMM 916
\$275

GUARANTEED LOWEST PRICES ON TEK DMMs

WE WILL NOT BE UNDERSOLD C&S SALES, INC.

UPS SHIPPING - 48 STATES 5%
OTHERS CALL FOR DETAILS
IL Residents add 8.25% Sales Tax

150 W. CARPENTER AVENUE
WHEELING, IL 60090
FAX: (847) 541-9904 (847) 541-0710
http://www.elenco.com/cs_sales/



15 DAY MONEY BACK
GUARANTEE

FULL FACTORY WARRANTY

PRICES SUBJECT TO CHANGE WITHOUT NOTICE

CIRCLE 127 ON FREE INFORMATION CARD

www.americanradiohistory.com

Same Day
Shipping

C & S SALES
Your one stop source for
all your electronic needs!

CALL OR WRITE FOR OUR
**NEW FREE 64 PAGE
CATALOG!**
(800) 445-3201

Fluke Scopemeters



- 123...NEW.....\$950
- 92B.....\$1445
- 96B.....\$1695
- 99B...NEW.....\$2095
- 105B.....\$2495

**ALL FLUKE
PRODUCTS
ON SALE**

**B & K PRECISION
SCOPES**

100MHz THREE-TRACE

Model 2190A



- 1mV/division sensitivity
- Sweeps to 5ns/division
- Dual time base
- Signal delay line
- 15KV accelerating voltage

\$1295.00

60MHz DUAL-TRACE

Model 2160



- 1mV/division sensitivity
- Sweeps to 5ns/division
- Dual time base
- Signal delay line
- V mode displays two signals unrelated in frequency.
- Component tester

\$895.00

40MHz DUAL-TRACE

Model 1541C

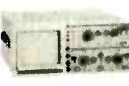

- 1mV/division sensitivity
- Video sync separators
- Z-axis input
- Single Sweep
- V mode displays two signals unrelated in frequency
- Component tester

\$695

60MHz, CURSORS & READOUTS, DUAL TIME BASE

Model 2260



- Cursors and readouts
- 1mV/div sensitivity
- 23 calibrated ranges - main time base
- 19 calibrated ranges - delayed time base
- Signal delay time
- V-mode - displays 2 signals unrelated in frequency.
- Component tester
- Z-axis input
- Single Sweep

\$1225

20MHz DUAL-TRACE

Model 2120B - 2 Year Warranty

Special \$375

Model 2125A with delayed sweep

\$539.95



- 1mV/division sensitivity
- AUTO-NORM triggered sweep operation
- AC, TVH, TVV and line coupling
- Calibrated 19 step time-base with x10 magnifier
- Compact low-profile design

**Affordable Spectrum
Analyzers by B&K**

500MHz Series
Model 2615 - \$1595
Model 2620 w/ tracking generator - \$1895

1.05GHz Series
Model 2625 - \$2395
Model 2630 w/ tracking generator - \$2995

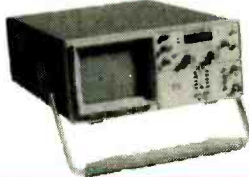

Quality Scopes by Elenco
Lowest Prices of the Year!



60MHz

DS-603 \$1350

- Analog / Digital Storage
- 20MS/s Sampling Rate

S-1360 \$749

- Analog with Delayed Sweep

100MHz

S-1390 \$995

- Analog

**Includes
Free Dust
Cover and
Probes**

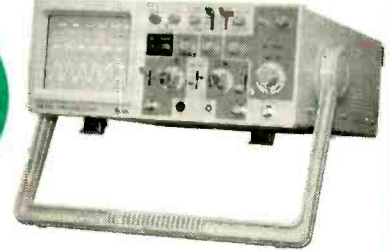

25/30MHz

DS-303 30MHz \$1095

DS-203 20MHz \$725

- Analog / Digital Storage

S-1330 \$439

- 25MHz Analog
- Delayed Sweep

S-1325 \$325

- 25MHz Analog

**2 Year
Warranty**

SIMM MODULE TESTER

B & K 898

\$625

- Tests 72 and 30-pin SIMMs to 36 bits.
- Stand alone and portable. No other equipment required.
- Automatically identifies width, depth and speed of SIMMs.
- 10 built-in tests identify most memory defects. Preheat cycle prior to test.



PORTABLE SEMICONDUCTOR TESTER

B&K 510

- In or out-of-order circuit tests for transistor, FETs, SCRs and darlington.

\$199.00



Fluke Multimeters

Model 70III	\$85	Model 83	\$235
Model 73III	\$115	Model 85	\$269
Model 75III	\$139	Model 87	\$289
Model 77III	\$154	Model 863E	\$475
Model 79III	\$175	Model 867BE	\$650

B&K Precision Multimeters

Model 391	\$143	Model 388A	\$99
Model 390	\$127	Model 2707	\$75
Model 389	\$109	Model 2860A	\$79
Model 5390	\$295	Model 5370	\$219
Model 5380	\$265	Model 5360	\$195

MX-9300

Four Functions in One Instrument

Features:

- One instrument with four test and measuring systems:
 - 1.3GHz Frequency Counter
 - 2MHz Sweep Function Generator
 - Digital Multimeter
 - Digital Triple Power Supply
- 0-30V @ 3A, 15V @ 1A, 5V @ 2A



\$459⁹⁵

GUARANTEED LOWEST PRICES

C&S SALES, INC.

150 W. CARPENTER AVENUE
WHEELING, IL 60090
FAX: (847) 541-9904 (847) 541-0710
http://www.elenco.com/cs_sales/



**15 DAY MONEY BACK
GUARANTEE**

FULL FACTORY WARRANTY
PRICES SUBJECT TO CHANGE WITHOUT NOTICE

UPS SHIPPING: 48 STATES 5%
OTHERS CALL FOR DETAILS
IL Residents add 8.25% Sales Tax

February 1998, Popular Electronics

Modern computing and standard surge suppressors...a recipe for disaster.

Almost all surge protection devices use MOV's (metal oxide varistors) as their active element. MOV's are sacrificial/wear/limited life components. Surge suppressors based on this technology are doomed to failure. These surge "suppressors" also don't suppress a thing. They divert powerline surges equally to the ground and neutral wire. When you put current on the common ground wire of interconnected equipment some of that current will flow (through the inherent ground loops) to the data lines. This is a major cause of lock-ups and misoperations that plague today's computer environments. Another fact; all modern computers use switch mode power supplies. During surges the power supply capacitors must charge to the clamping level of the MOV before the MOV turns on. A recent study has shown that it takes a 3000A surge 15 microseconds (15,000 nanoseconds) to charge the typical capacitors of these power supplies to that level. The surge is virtually over before the MOV reacts. (See five things you probably don't know about your surge suppressor at www.fivethings.com.)

THE POINT: Standard surge suppressors allow too much current to hit the computer. Standard surge suppressors divert surge current to the ground wire and disrupt data transfer. Standard surge suppressors eventually fail without warning. Modern computers have logic voltage levels (the signals that transmit the data) and power supply voltages that are dramatically lower than that of their recent predecessors. Modern computers use integrated circuits with transistors of ever decreasing physical geometries. Modern computers are virtually always interconnected to other computers or peripheral equipment. The bottom line; *modern computers are much more sensitive and susceptible to powerline anomalies.*

INTRODUCING BRICK WALL SURGE FILTERS. . . The World's Best Surge Suppressor

Initially engineered for critical, non-fail industrial applications, this patented device protects indefinitely and sets a new standard for every measure of surge suppressor and powerline filtering performance.

A Brick Wall 1) Utilizes NO MOV'S or Any Other Sacrificial Components (a two pound inductor and nine capacitors are the heart of the unit) 2) Has No Joule Rating or Surge Current Limitations 3) *HAS BEEN TESTED AND CERTIFIED BY UL TO THE MOST DEMANDING CLASSIFICATION OF A NEW GOVERNMENT SPECIFICATION; CLASS I, GRADE A. Which Means: UL PUT ONE THOUSAND 3000A, 6000V SURGES (this is the largest surge an interior environment can experience) THROUGH A UNIT (at 60 second intervals) AND DOCUMENTED NO FAILURE OR PERFORMANCE DEGRADATION OF ANY KIND WHATSOEVER.*

i.e.: A Brick Wall Will Not Fail.

We know of no cord connected, MOV based surge protection device that has, or can pass this test.

A Brick Wall possesses UL's lowest Suppressed Voltage Rating (let-through voltage) of 330V. This is the lowest rating they will grant. In that test of one thousand 6000V, 3000A surges, *UL NEVER SAW THE LET-THROUGH VOLTAGE EXCEED 290V. YOU CANNOT DO BETTER THAN THIS FOR A POINT-OF-USE SURGE PROTECTION DEVICE.* Once again, we know of no other surge protection device that could come close to this performance level.

A Brick Wall is a current activated *Series Mode* device. *Since it is not wired in parallel, nor voltage activated, it does not have to wait for the capacitors of the power supply to charge before it becomes effective. YOUR EQUIPMENT IS PROTECTED INSTANTANEOUSLY (and indefinitely).*

These devices were engineered utilizing a current limiting/surge filtering technology. *THEY DO NOT DIVERT ANY SURGE CURRENT TO THE GROUND WIRE. They Will Not Cause Your Computer System To LOCK-UP, CRASH OR MISOPERATE as a consequence of surge diversion. Your current surge "suppressor" will.*

Powerline Filtering

In addition to all this, Brick Wall Surge FILTERS are the best AC powerline filters you can buy (that we have been able to find anyway). Industrial machinery, copiers, coffee makers, laser printers, fluorescent lights, refrigerators, etc., all cause powerline noise that can cause your computer to misoperate. A Brick Wall Surge Filter will make powerline noise related problems disappear.

You Can't Buy a Better Surge Protection/Powerline Filtering Device...Anywhere.



**BRICK WALL DIV.,
PRICE WHEELER CORP.
1-800-528-0313**

Fax: 1-800-528-6623 E-Mail: info@brickwall.com

Web: www.brickwall.com

Visa - MC - AMEX

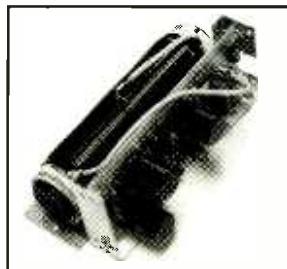
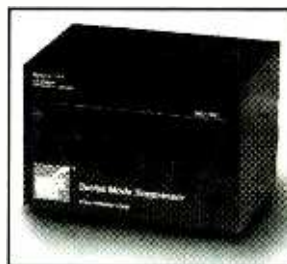

Available in Modular Form

ASK ABOUT OUR NEW IN-LINE UPS/SERVER PROTECTOR



One tree can make
3,000,000 matches.



One match can burn
3,000,000 trees.



UL Part 1 Series of The Voltage
1 The Voltage and

Whaddya Say To
A Guy Who's Had
The Same Job
For 50 Years,
Has Never Called
In Sick Or
Showed Up Late,
Never Taken A
Vacation Or A
Holiday, Never
Asked For A
Raise Or Griped
About His Bonus
And, Believe It Or
Not, Has No
Plans For
Retirement?



Thanks.

Remember - only you can prevent forest fires.

Xcelite Wheeled Tool Case!!!

- Super tough, black polyethylene rotationally molded for maximum strength.
- 53 individual hand tools, 31 Series 99 interchangeable screwdriver/nutdriver blades and handles, and two specialized screwdriver/nutdriver kits.
- Extra large (3-5/8") roller bearing wheels with wide base for maximum stability and easy transport over rough pavement or stairs.
- Extra wide, comfortable extension handle is molded into case to prevent wear.
- Dimensions: 18" x 15" x 8" deep.
- Extension handle locks into place automatically when extended and retracted. Easy one-handed release.
- Two spring loaded tote handles for convenience.
- "D" ring provided for Bunji cords to carry other cases on top.
- 3-panel hinged tool pallet in lid plus additional pallet in bottom.
- Extra large all new screen mesh literature/utility pocket.
- Extra large storage space for additional equipment.



Xcelite

MODEL TCMB-100/STW
Suggested Price \$1109.80
SUPER SPECIAL \$ 695.00!!!



8931 Brookville Rd * Silver Spring, MD, 20910 * 800-638-2020 * Fx 800-545-0058
Email: SMPRODINTL@aol.com

CIRCLE 46 ON FREE INFORMATION CARD

CONTROL MEASUREMENT INPUT

RELAYS • LIGHTS • MOTORS
TEMPERATURE • PRESSURE • LIGHT LEVELS • HUMIDITY
SWITCH POSITIONS • THERMOSTATS • LIQUID LEVELS

MODEL 30 \$79



- PLUGS INTO PC BUS
- 24 LINES DIGITAL I/O
- 8 CHANNEL
- 8 BIT A/D IN
- 12 BIT COUNTER
- UP TO 148 SMP/SEC

MODEL 45 \$189



- RS-232 INTERFACE
- 8 DIGITAL I/O
- 8 ANALOG INPUTS
- 2 ANALOG OUTPUTS
- 2 COUNTERS-24 BIT

MODEL 100 \$279



- 12 BIT 100 KHZ A/D
- 4 ANALOG OUTPUTS
- 3 TIMER COUNTERS
- 24 DIGITAL I/O

MODEL 60 \$179

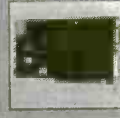

- 8 2-AMP RELAYS
- 16 DIGITAL I/O
- 1 8-BIT ANALOG INPUT

MODEL 40 \$109



- RS-232 INTERFACE
- 28 LINES DIGITAL I/O
- 8 ANALOG INPUTS
- PWM OUTPUT
- OPTIONAL 12 BIT A/D

MODEL 70 \$239



- RS-232 INTERFACE
- 18 BIT A/D
- 5.5 DIGIT
- UP TO 60 SMP/SEC

NEED A CUSTOM PCB? TRY US.
PRAIRIE DIGITAL, INC.
PHONE 608-643-8599 • FAX 608-643-6754
920 SEVENTEENTH STREET • PRAIRIE DU SAC, WISCONSIN 53578

CIRCLE 45 ON FREE INFORMATION CARD

Learn by Example!

The PRIMER 8085 Based Microprocessor Training and Control System shows you how to program by example. Examples & exercises in the Self Instruction manual take you from writing simple programs to controlling motors. Start out in Machine language, then move on to Assembler, & then continue on with optional C, Basic, or FortH Compilers. This trainer can be used stand alone via the keypad and display or connected to a PC with the optional upgrade (\$49.95). The Upgrade includes: an RS232 serial port & cable, 32K of battery backed RAM, & Assembler/Terminal software.

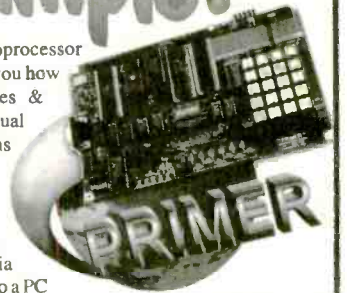

Examples Include:

- Measuring Temperature
- Using a Photocell to Detect Light Levels
- Making a Waveform Generator
- Constructing a Capacitance Meter
- Motor Speed Control Using Back EMF
- Interfacing and Controlling Stepper Motors
- Scanning Keypads and Writing to LCD/LED Displays
- Bus Interfacing an 8255 PPI (new)
- Using the Primer as an EPROM Programmer

The PRIMER is only \$119.95 in kit form. The PRIMER Assembled & Tested is \$169.95. Please add \$5.00 for shipping within the U.S. Picture shown with upgrade option and optional heavy-duty keypad (\$29.95) installed.

EMAC, inc.

11 EMAC WAY, CARBONDALE, IL 62901
618-529-4525 Fax 457-0110 BBS 529-5703
World Wide Web: <http://www.emacinc.com>

1985 - 1997
OVER
12
YEARS
OF SERVICE

Radiotelephone - Radiotelegraph
FCC Commercial License

Why Take Chances?

Discover how easy it is to pass the exams. Study with the most current materials available. Our **Homestudy Guides, Audio, Video or PC "Q&A"** pools make it so fast, easy and inexpensive. No college or experience needed. The new commercial FCC exams have been revised, covering updated Aviation, Marine, Radar, Microwave, New Rules & Regs, Digital Circuitry & more. We feature the Popular "Complete Electronic Career Guide" 1000's of satisfied customers

Guarantee to pass or money back. Send for **FREE DETAILS** or call **1-800-800-7555**

WPT Publications
 4701 N.E. 47th Street
 Vancouver, WA 98661

Name _____

Address _____

City _____ St. _____ Zip _____

1-800-800-7555

**Low Cost CAD Software
 Now In Windows™95**

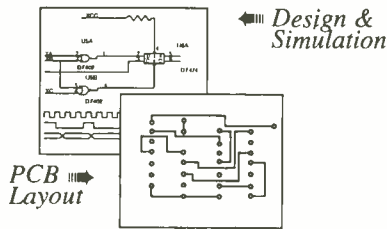

- Easy to use schematic entry program (**SuperCAD**) for circuit diagrams, only \$149. Includes netlisting, bill of materials, extensive parts libraries.
- Digital simulator (**SuperSIM**) allows you to check logic circuitry quickly before actually wiring it up. Works directly within SuperCAD and displays results in "logic analyzer" display window. Starting at \$149 this is the lowest cost simulator on the market. Library parts include TTL, and CMOS devices.
- Analog simulator (**mentalSPICE**) for \$199. Allows AC, DC and transient circuit analysis. Includes models of transistors, discretes, and op amps.
- Circuit board artwork editor and autorouter program (**SuperPCB**), starting at \$149. Produce high quality artwork directly on dot matrix or laser printers. You can do boards up to 16 layers including surface mount. Includes Gerber and Excellon file output. Autorouter accepts netlists and placement data directly from the SuperCAD schematic editor.
- **New!**—Complete electronic design package (**mentalMAX**) including schematic editor, analog and digital circuit simulation, and printed circuit board layout with autorouter for only \$549!

Write or call for free demo disks:
MENTAL AUTOMATION, INC.

5415 - 136th Place S.E.
 Bellevue, WA 98006
 (425) 641-2141

Internet: <http://www.mentala.com>

BREAST CANCER BEGINS EVEN SMALLER THAN THIS. THAT'S WHY YOU NEED A YEARLY MAMMOGRAM, ESPECIALLY AS YOU GET OLDER. MAMMOGRAMS CAN DETECT LUMPS TOO SMALL FOR YOU TO FEEL AND EARLY DETECTION MAY SAVE YOUR LIFE, SO CALL **1-800-ACS 2345.**

GET A MAMMOGRAM. EARLY DETECTION IS THE BEST PROTECTION.



**EARN \$1000⁰⁰ WEEKLY
 BECOME A CABLE INSTALLER**

No Exp. Nec. No Selling or Gimmicks. A Real Trade Big Demand—Big Pay. Powerful. Inside Info by Pro Installers Low Cost - One Day Setup. Get the Edge! PINTO, Box 5395, Phila. PA 19142

24 HRS FREE INFO 1-800-450-5671

CABLE TV CONVERTERS

Equipment & Accessories
 Wholesalers Welcome

Call **C&D ELECTRONICS**
 1-888-615-5757 M-F 10a-6p

**START A CAREER
 IN ELECTRONICS!**

Accredited home study. Repair, install, and service audio equipment, microwave ovens, alarm systems, small appliances, and more. For free career literature, send or call. **CALL 800-223-4542**



Name _____
 Address _____
 City/State _____ Zip _____
 Age _____ Phone (____) _____
The School of Electronics, Dept ELB341
 PCDI, 6065 Roswell Road, Atlanta, GA 30328

The Pocket Programmer

\$129.95



The portable programmer that uses the printer port of your PC instead of an internal card.

Easy to use software that programs E(E)prom, Flash & Dallas Ram. 27(C)/28(C)(F)/29(C)(F)/25 series from 16K to 8 Megabit with a 32 pin socket. Adapters available for MCU's 874X, 875X, Pic, 40-Pin X 16 & Serial Eprom's, PLCC, 5-Gang and Eprom Emulator to 32K X 8.

Same Name, Address & Phone # for 13 Years.... Isn't it Amazing ?

Intronics, Inc.
 Box 13723 / 612 Newton St.
 Edwardsville, KS 66113 Add \$4.75 COD
 Tel. (913) 422-2094 Add \$4.00 Shipping
 Fax (913) 441-1623 Visa / Master Charge

SURVEILLANCE

The Latest High Tech Professional Electronic Devices
 Our latest catalog offers a HUGE selection of surveillance, counter-surveillance/privacy devices; hidden video equipment, pinhole cameras \$159⁰⁰, telephone recording systems: 7-Hour \$125⁰⁰—10-Hour \$139⁰⁰—16-Hour \$199⁰⁰ touch tone decoders, scanners, bug/phone tap detectors, voice disguisers, telephone scramblers, locksmithing tools, and more.
 Catalog \$5.00

SPY OUTLET

P.O. Box 337, Buffalo, NY 14226
 (716) 695-8660/(716) 691-3476

BE A LOCKSMITH!

Home study. Learn locksmithing for a great career, or to start your own at-home business. **FREE LITERATURE: 800-223-4542**

Name _____ Age _____
 Address _____ Phone _____
 City _____ State _____ Zip _____
The School of Locksmithing, Dept. LKB341
 PCDI, 6065 Roswell Rd., Atlanta, GA 30328

Debco is a Kit Builders Paradise
 Electronic Kits - Plans - Parts - Computers - Amateur Radio

Call Debco today for your **FREE** copy of **The Electronic Experimenter's Journal**

1 800 423 - 4499
 Debco Electronics 4025 Edwards Rd. Cincinnati, OH 45209

NOW MAKE AN EXTRA \$600 PART TIME WEEKENDS -- UP TO \$2,000 A WEEK FULL TIME IN Explosive SATELLITE DISH TV/ELECTRONICS FIELD!

Hottest Career Opportunity Since Invention of the VCR!

See How Fast The Money Rolls In!

Part time: Here's what you can earn
over a typical weekend:

Install 2 Satellite dish systems at \$200	= \$400
Repair 4 TV's at \$50 each	= \$200

Total Weekend Income = \$600

Full time: Working just five days a week
you could easily earn:

Install 5 Satellite dish systems at \$200	= \$1,000
Repair 10 TV's, average \$50 each	= \$500
Clean and adjust 10 CD players, average \$35 each	= \$350
Service 2 Home entertainment centers at \$75	= \$150

Total Weekly Income = \$2,000

**In addition you can make big extra profits
on other supplies you furnish!**

Get in THE FAST LANE on the NEW "INFORMATION SUPERHIGHWAY" Everyone's Talking About!

It's exciting! It's gigantic! The technology of tomorrow is here today! You've been reading and hearing about the amazing Information Superhighway. It's so new that few technicians are equipped to service

this fast emerging field! Foley-Belsaw gives you Satellite dish technology (including new mini-dish) along with the electronic expertise you need to make big money servicing TVs and other electronic equipment.

Be your own boss! It's quick and easy to become an expert at home in your spare time. Earn really BIG money adjusting, installing and repairing • **Satellite dish systems** • **TV's** • **Amplifiers** • **CD players** • **AM/FM tuners** • **Home entertainment centers**. Every home, every business, every office in your area desperately needs your expertise!

Your timing just couldn't be better! Never before and probably never again will you have a ground-floor opportunity like this to get into a booming business of your own, make really big money starting right away, be your own boss and enjoy financial freedom and security. The fact you're reading this message shows you're smart enough to realize this!

Satellite dish/TV/Electronics is easy

to learn in your spare time at home. This modern, practical hands-on course combines simple step-by-step lessons with easy-to-follow video cassette guidance. No special experience or electronics background is necessary. Just average mechanical aptitude and the ability to follow simple A-B-C repair procedures that are clearly outlined for you.

And when you complete the course you will receive Foley-Belsaw's official diploma attesting to your expertise.

**30-DAY
NO RISK TRIAL**
Send for details



Send coupon today for FREE Fact Kit. No obligation.

Don't miss out on this once-in-a-lifetime opportunity. Send in the coupon NOW. Get all the facts and study them in the privacy of your own home. There's absolutely no obligation and no salesman will call on you. So don't delay. Mail the coupon today!

MAIL TODAY FOR FREE INFORMATION PACKAGE

Foley-Belsaw Institute
6301 Equitable Road
Kansas City, MO 64120-1395



- YES!** Without obligation send free information kit so I can learn how to become a professional Satellite Dish/TV/Electronics Specialist, in order to earn high extra income. Dept. 31505
- VCR Repair**-Unlimited profits in this growing field. Dept. 62733
- Interested in an exciting, money making career in **Computer Repair, Maintenance and Upgrade?** Dept. 64634
- Personal Computer Programming**-Learn fast at low cost for big earnings. Dept. 35452

Name _____

Address _____

City _____ State _____ Zip _____

Call toll-free 1-800-487-2100

PC-based Front Panel Access Computer

7-11 PC --- 24-hour Working Computer from \$600

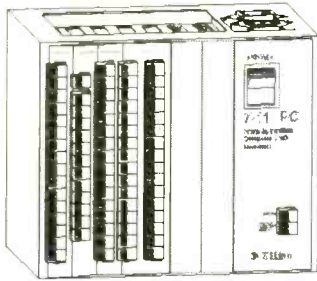

For Computer
Telephony Server or
Home Automation or
Network Computer
Fanless, compact size
9.0"W 7.5"H 6.5"D

**Handy PC --- Field
Computer** from \$700
In between of Laptop
& Desktop for the size,

Using regular CD-ROM, HD, FD and mini keyboard
Easy to carry around, 10.5"W 11"H 6.5"D

PLC PC --- Industrial Computer from \$900
Accessibility like PLC (Programmable Logic Controller)

Euro Bus and PCI
Bus for higher
reliability & better
performance.
17"W 11"H 6.5"D

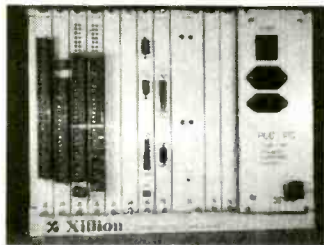

All above 3 models
accept ISA or PCI
interface cards, and
proprietary front panel
connecting cards: I/O, A/D, D/A, X-10, up to 10A/220V

NETWORK your phones !

Boost your telecommunication performance.
Make small business sounds big & professional.
FX207 is easy to use and very low cost.

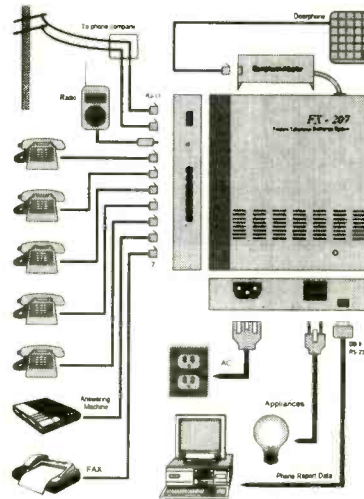

This small device provides same functions found in big, expensive PBX units; call transfer, conference, intercom, do not disturb, call restriction (blocking) call pickup, call waiting,.... Plus some extras you don't normally find in most regular PBX units such as: Voice direct incoming calls with your own message, transfer fax automatically, Tele-remote control your appliances or computer, Record and manage call numbers & time usage through your computer. You might even use it for phone projects - control phone operation with PC,

For home, For office, For home office.

FX207 handles two phone lines expanding to seven extensions using standard tone or rotary phones, FAX and answer machines. Plug in with regular phone plugs. Easy to install. Do it yourself.

\$298 limited time special !

(Plus S&H, California add sales tax, Discount Code X4PE, MSRP\$399)

XILLION Co. <http://www.xillion.com> 15447 Proctor Av. City of Industry, CA91745, Tel: (818)336-1890, Fax:(818)336-2061

• The world's largest & most varied surplus company - 1 liquidating & 1 retail-tech
• Mobile items - 1 liquidating & 1 retail-tech
• Large quantities - 1 liquidating & 1 retail-tech
• Overstocks - 1 liquidating & 1 retail-tech
• Save! Save! Save! Save!

If you are not getting this catalog you are missing out on some of the best deals in electronics today! We have thousands of items ranging from unique, hard-to-find parts to standard production components. Call, write, or fax today to start your free subscription to the most unique catalog in the industry, filled with super values on surplus electronic and hobbyist type items. If you have a friend who would like to receive our catalog, send us their name and address and we will gladly forward them a complimentary 100 page catalog.

Why pay more? Call today.



340 East First Street Fax Order Line
Dayton, Ohio 45402 1-800-344-6324

Order Toll-Free
1-800-344-4465

CIRCLE 151 ON FREE INFORMATION CARD

COPY RENTAL TAPES

WITH OUR VIDEO STABILIZERS

BEFORE



AFTER



FREE CABLE TV CATALOG!

The clearest picture possible playing back movies. **GUARANTEED** to eliminate copy protection.

- No Rolls/Jitters/Flickers/Fading
- Works on all TV's, VCR's Beta & Cable
- Gold Video Connectors & Cables Included
- 1 Year Warranty
- Money Back Guarantee



VISION ELECTRONICS
1-800-562-2252

2609 S. 156TH CIRCLE • OMAHA, NE 68130
<http://www.modernelectronics.com>

BUILD YOUR OWN COMPUTER!

- Complete Kits Available
- Step-by-step Video
- Learn the Computer Inside and Out!



Computer Kits

(888) 840-8840

<http://www.computerkits.com>

"Building Quality Computers Since 1987"

CABLE TV CONVERTERS

Equipment & Accessories
Wholesalers Welcome

Call C&D ELECTRONICS
1-888-615-5757 M-F 10a-6p



A public service of this magazine

Any waveform you want!



Starting at
\$795

Quantity 1

Money back
guarantee

● Synthesized Signal Generator

Clean sinewaves DC-20 MHz with .001% accuracy!
.1 Hz steps. DC Offset. RS232 remote control.

● Arbitrary Waveform Generator

40 Megasamples/Second. 32,768 points. 12 bit DAC

● Function Generator

Ramps, Triangles, Exponentials & more to 2 MHz!

● Pulse Generator

Digital waveforms with adjustable duty cycle

Telulex Inc. model SG-100

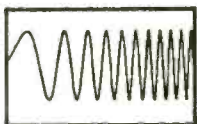

DC to 20 MHz linear
and log sweeps



Int/Ext AM, SSB,
Dualtone Gen.

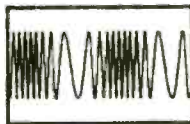

Int/Ext FM, PM,
BPSK, Burst

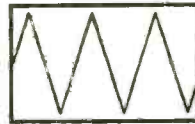

Ramps, Triangles,
Exponentials



Pulse Generator



Noise

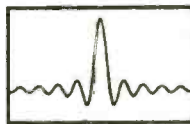

Arbitrary Waveforms

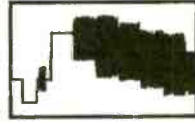

Unlimited Possibilities!

Telulex Inc.

2455 Old Middlefield Way S Tel (415) 938-0240 <http://www.Telulex.com>
Mountain View, CA 94043 Fax (415) 938-0241 Email: sales@Telulex.com

CIRCLE 142 ON FREE INFORMATION CARD

❖ ATTENTION CABLE VIEWERS ❖

CABLE VIEWERS. . .get back to your BASIC Cable Needs

Call 800-577-8775

For information regarding all of your BASIC cable needs.



**BASIC
ELECTRICAL
SUPPLY &
WAREHOUSING
CORPORATION**

5 GOOD REASONS TO BUY OUR FAR SUPERIOR PRODUCT

- ❖ PRICE
- ❖ EFFICIENT SALES AND SERVICE
- ❖ WE SPECIALIZE IN 5, 10 LOT PRICING
- ❖ ALL FUNCTIONS (COMPATIBLE WITH ALL MAJOR BRANDS)
- ❖ **ANY SIZE ORDER FILLED WITH SAME DAY SHIPPING**

We handle NEW equipment ONLY - Don't trust last year's OBSOLETE and UNSOLD stock!
COMPETITIVE PRICING—DEALERS WELCOME

HOURS: Monday-Saturday 9-5 C.S.T.

It is not the intent of B.E.S.W. to defraud any pay television operator and we will not assist any company or individual in doing the same.
*Refer to sales personnel for specifications.

P.O. Box 8180 ■ Bartlett, IL 60103 ■ 800-577-8775

NEW! ELECTRONICS CD-ROM

The most effective way of learning electronics

Two Courses on one CD-ROM!
Only \$49.00

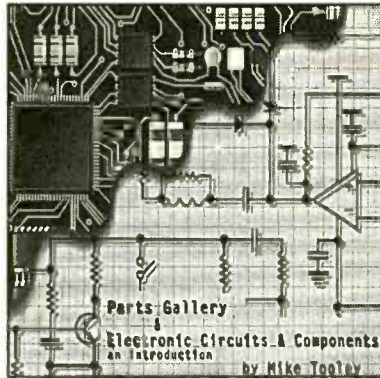

Electronic Circuits and Components

Discover the standards and application of common types of electronic components and how they are used to form complete circuits in **Electronic Circuits & Components**. Sections on the disc include: Fundamental Electronic Theory, Active Components, Passive Components, Analog Circuits, and Digital Circuits. The CD-ROM includes:

- Interactive laboratories • Supervisor notes
- Full audio commentary • Editable worksheets
- About 20 links to pre-designed Electronics Workbench circuits

The Parts Gallery

Many students have a good understanding of electronic theory but still have difficulty in recognizing the vast number of different types and makes of electronic components. **The Parts Gallery** has been designed to help overcome this problem; it will help students recognize common electronic components and their corresponding symbols in circuit diagrams. This CD ROM incorporates a quiz so that students can check their knowledge of electronic components and symbols. The CD-ROM includes:

- Over 150 component and circuit photographs • Supervisor notes
- Self-test component and symbol quizzes • Hundreds of electronic symbols

To Be Released Soon!

A series of interactive CD-ROMs provides a comprehensive and up-to-date introduction to the world of electronics. The series provides a sound understanding of the principles and behavior of electronic components and the circuits to which they are connected. Two new CD ROM discs are to be released in the very near future. They are **Analog Electronics** and **Digital Electronics**. As soon as they are released, information on their contents and availability will be published.

Clagg Inc., PO Box 4099
Farmingdale NY 11735-0792
e-mail: claggk@poptronix.com

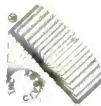

Name _____ Phone _____

Address _____

City _____ State _____ Zip _____

Enclosed is \$49 for each Student version (single user) of **The Parts Gallery** and **Electronic Circuits & Components** on a single CD-ROM, shipping included inside the U.S.

I am ordering (....) copies at \$49 each. NY State residents must include sales tax.

I have enclosed my check for \$ _____

Please charge my credit card for \$ _____

Visa MasterCard Discover Expiration Date: ___/___

Card Number _____ Signature _____

(Name on order and signature must be same as on Credit Card.)

ADAPT-11 68HC11 Modules for Solderless Breadboards

- miniature 2.0" by 2.8" module
 - plugs vertically into solderless breadboard for easy development
 - BOOT/RUN switch for easy programming via PC serial port
 - all I/O lines on dual row connector
- Complete modular prototyping system!
Expansion accessories available!

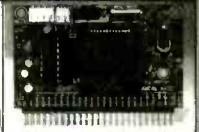

For just US\$74.95, our Starter Package (AD11SP) provides everything you need to get going fast! Now you can harness the power of the popular 68HC11 in your projects! Includes ADAPT-11 with 68HC11E2, providing 2K EEPROM (re-programmable), 8 channel 8-bit Analog-to-Digital Converter (ADC), hardware timers, counters, interrupts, Serial Peripheral Interface (SPI), Serial Communications Interface (SCI), & more! On-board RS-232 interface (cable included), 5-volt regulator, 8MHz crystal, reset circuit, and convenient program/run switch. Comes with non-commercial versions of HC11 Assembler, BASIC, & C, as well as handy utilities & example code. Includes Motorola 68HC11 Pocket Programming Reference Guide and manual with schematic. All you need is a PC to write & program your software, a DC power supply, and a solderless breadboard (or protoboard) to build your application circuits on (or use our modular accessories).

Visa • MasterCard • AmericanExpress • Discover

TECHNOLOGICAL ARTS

309 Aragona Blvd., Suite 102, Box 418, Va. Beach, VA 23462
1644 Bayview Avenue, Box 1704, Toronto, ON M4G 3C2
voice/fax: (416) 963-8996 www.interlog.com/~techart

Slot Machines \$ 599.00

Free Shipping

Slot Machine Demo
Video \$ 5.99
40 - Minutes

33" High 20" Wide 14" Deep

Brochure \$ 1.00

Magic Box

Test Chips

Filter Kits



Notch Filters

Video Media www.nutnet.com

P.O. Box 93/6025

Margate, Fl. 33093

(954)-752-9202



BUY BONDS

**C
COMPILER \$49.00**

for **PIC microcontrollers**

Supports PIC16C55x, 16C6x, 16C62x, 16C8x, 16C92x microcontroller families. Based on ANSI C standard. Supports arrays, unions, structures, pointers, strings, function calls, if, for, switch, while, interrupt vectors, in-line assembler code, 8 & 16 bit variables, etc. Outputs Intel Hex format and assembly code. Code optimizer included. Excellent development tool!

732-873-1519 fax: 732-873-1582 e: grichrc@aol.com
Grich RC Inc. 120 Cedar Grove Ln, Ste 340, Somerset NJ 08873

ALL ELECTRONICS

C O R P O R A T I O N

ELECTRET MIKE

Panasonic # WM 54BT-D
Electret condenser microphone
cartridge. Low impedance,
omnidirectional mike. 20 - 12,000 HZ.
0.38" dia. x 0.175" high.



CAT #MIKE-36

60¢ each

10 for \$5.50
100 for \$45.00

Low Power Audio Amp

Motorola MC34119P

Low power audio amplifier suitable
for speaker phones or talking picture
frames. The 8 pin DIP package requires
only a few additional parts, operates on 2 - 16
volts and drives speakers of 8 ohms or greater.
Output power exceeds 250 mW with 32 ohm
speaker. Power-down option saves power in
battery driven applications. Hook-up sheet.



Large quantity available.

CAT # MC34119P

50¢ each

50 for \$20.00
500 for \$150.00

SUPER SAVINGS ON S-VHS TAPES (USED)



Super VHS tape users! Save a bundle
on name-brand S-VHS, T-120 tapes.
These tapes were used for a brief period,
then bulk erased.

The record-protect tabs
have been broken out, so you
will have to cover the notch with a
piece of tape, but they work great and
cost a fraction of the "new" price. Try some,
you'll be back for more.

CAT #S-VHS

\$3.00
each

10 for \$28.00 • 100 for \$250.00

Ultrabright LED

PAINFULLY BRIGHT RED LED

2500 to 4000 mcd @ 20 ma. These
T 1 3/4 (5 mm diameter) red LEDs are
significantly brighter than conventional
LEDs. At close range, they are painful
to look at. They are great for attention getting
displays that can be seen from a distance.



Water clear in off-state.

CAT # LED-42 **2 for \$1.20**

10 for \$ 5.00 • 100 for \$ 45.00
1000 for \$ 400.00

3 Volt Lithium Coin Cell with PC Leads

Panasonic # BR2330-1GU

3 volt, 255 mAh coin cell. Lithium
batteries have a very long shelf life
and are great for memory back-up
protection. 0.9" diameter x 0.12" thick. 0.7"
between positive and negative pc leads.



VERY SPECIAL PRICE
LARGE QUANTITY AVAILABLE

75¢ each

CAT #LBAT-16

20 for \$12.00
100 for \$45.00
1000 for \$300.00

2 1/2" 8 ohm Speaker

Panasonic # EAS65P76A3

8 ohm 0.4 watt speaker with
soft-edge paper cone for good
frequency response. 0.93" over-
all depth. 2.25" wire leads with
2 prong (0.1" spacing)
socket connector.



Large quantity available.

CAT# SK-255

\$1.00
each

10 for \$8.50
100 for \$70.00

QUALITY
PARTS

FAST
SHIPPING

DISCOUNT
PRICING

CALL, WRITE, FAX
or E-MAIL For A
Free 96 Page
CATALOG.
Outside the U.S.A.
send \$3.00 postage.

Tamper Resistant Electrical Outlet Cover

Leviton # 830-36022

"Kiddy Cop"
Prevents children from
playing with electrical outlets
and risking electrical shock.
Beige spring loaded outlet
cover closes automatically
when outlets are not in use.
Fits all standard dual wall out-
lets. Easy to install. Remove
existing wall plate and replace with
outlet guard. Individual display pack-
aging with screw. CAT # OG-022



\$1.50
each

10 for \$12.50

Light Activated Intrusion Alarm

Leviton "Snapit-Alert"

830-51031

This handy light activated
alarm buzzes intermittantly
when exposed to light. Use it in desk draw-
er, gun rack, medicine cabinet, refrigerator,
school locker or file cabinet to prevent chil-
dren or unwanted intruders from being
where they don't belong. Red plastic case
with self-adhesive Velcro backing. 2.5" x 3"
x 0.84". Operates on 9 volt battery (not
included). Good-looking retail packaging.



\$2.50
each

CAT# SNA-2

10 for \$20.00

Twist-On F-56 Connector



Twist-on co-ax connector
for RG-6 cable.

CAT #FTO-56R

100 for \$15.00

500 for \$50.00 • 1000 for \$70.00

ORDER TOLL FREE

1-800-826-5432

MAIL ORDERS TO:
ALL ELECTRONICS CORP.
P.O. BOX 567
VAN NUYS, CA 91408-0567

FAX (818) 781-2653 • INFO (818) 904-0524
INTERNET <http://www.allcorp.com/>
E-MAIL allcorp@allcorp.com

NO MINIMUM ORDER • All Orders Can Be Charged to Visa, Mastercard, American Express or Discover • Checks and Money Orders Accepted by Mail • Orders
Delivered in the State of California must include California State Sales Tax • NO C.O.D. • Shipping and Handling \$5.00 for the 48 Continental United States • ALL
OTHERS including Alaska, Hawaii, P.R. and Canada Must Pay Full Shipping • Quantities Limited • Prices Subject to change without notice.

MANUFACTURERS - We Purchase EXCESS INVENTORIES... Call, Write, E-MAIL or Fax YOUR LIST.

CIRCLE 28 ON FREE INFORMATION CARD

www.americanradiohistory.com

CABLE T.V. EQUIPMENT

Friendly, Knowledgeable Service



**ORDERS CALL:
1-800-361-4586**



- All Equipment New
- Convertors & Descramblers
- 30 Day Money Back Guarantee
- 6 Month Warranty
- Visa, MC, C.O.D. Welcome

KDE ELECTRONICS, INC.

P.O. Box 1494
Addison, IL 60101

Info. 630-889-0281 HRS: Mon-Fri, 9-6 CST
Fax 630-889-0283 Sat, 10-2 CST

Hexapod Walker Kit \$150.00



Build your own functional Hexapod Robot

The kit comes complete with all hardware, structural components, 3 Hitec servos, Counterfeit Basic Stamp kit, software and an illustrated assembly manual. This robot can walk forward, reverse and turn on a dime using the alternating tripod walking gait. It is an excellent foundation for many artificial intelligence and behavioural based experiments. It is a lot of fun to build and even more fun to operate. Check out our web site for more information and other robot kits.

• 12 Servo Hexapod \$375.00 • Infrared Proximity Det \$30.00 • Mobile Robots Book \$48.00

Quantity discounts available. \$7.50 Shipping & Handling for USA, call for international and quantity shipping charges. IL residents add 6.25% sales tax to total.

Many more robot kits, ask for our free catalog!

Technical Service & Solutions
104 Partridge Road
Pekin, IL 61554-1403 USA

Tel: 309-382-1816

Fax: 309-382-1254

www.lynxmotion.com

jfrye@lynxmotion.com

Digital Entertainment GREAT VALUES ON:



SAVE Compare to Cable
30%-50%



MORE ENTERTAINMENT OPTIONS
ALL THE HOT ACCESSORIES
PAY LESS

Fax: 218-739-4879
Int'l: 218-739-5231

1010 Frontier Dr.
Fergus Falls, MN 56537

Call Now 800-500-9275
www.skyvision.com

Skyvision

ELECTRONICS LIBRARY

(continued from page 30)

ACCESS TO THE AIRWAVES

by Allan H. Weiner (as told to Anita Louise McCormick)

A firm believer that the airwaves are free and rightfully belong to the people, the author has devoted himself ever since his childhood to the development of "pirate" radio broadcasting. The film *Pump Up the Volume* appears to be loosely based on Weiner's radio adventures when he was a teenager. The trials and tribulations that he experienced in creating Radio New York International are legendary. When the FCC illegally seized Weiner's radio ship in 1987, it made headlines around the world.

This book, an autobiographical account told to Anita Louise McCormick, presents Weiner's story as a heart-warming tale of an electronics genius at work. It's also a chilling indictment of government disregard for free speech and personal liberties. In spite of the

FCC's attempts to shut him down, Weiner has persevered and continues to work towards a future in which the airwaves are open to all who choose to use them.

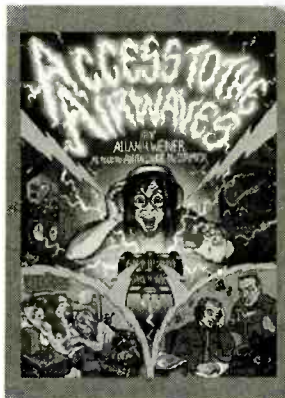

Access to the Airwaves: My Fight for Free Radio costs \$17.95 plus \$4.95 S & H and is published by Loompanics Unlimited, P.O. Box 1197, Port Townsend, WA 98368-0243; Tel. 800-380-2230.

CIRCLE 93 ON FREE INFORMATION CARD

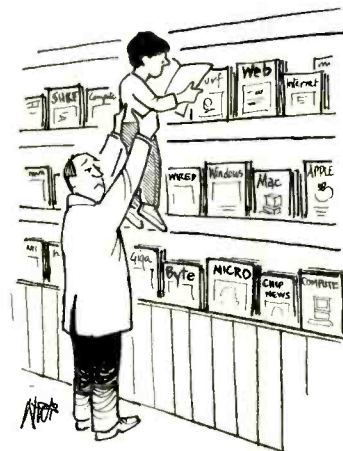

POPTRONIX®

Online Edition

We're on the web **FREE**

<http://www.poptronix.com>

Learn MICROCONTROLLERS EMBEDDED SYSTEMS and PROGRAMMING...

...with the AES learning system/
embedded control system.
Extensive manuals guide you
through your development
project. All programming and
hardware details explained.
Complete schematics. Learn to
program the LCD, keypad digital,
analog, and serial I/O. for your applications.

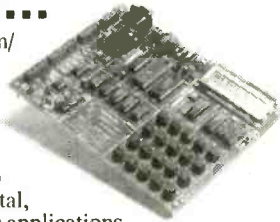

**THREE MODELS AVAILABLE. Choose from an
Intel 8051, Intel 8088, or Motorola 68HC11
based system. All models come with:**

- 32K Byte ROM, 32K Byte RAM • 2 by 16 Liquid Crystal Display • 4 by 5 Keypad • Digital, Analog, and Serial I/O • Interrupts, timers, chip-selects • 26 pin expansion connector • Built-in Logic Probe • Power Supply (can also be battery operated) • Powerful ROM MONITOR to help you program • Connects to your PC for programming or data logging (cable included) • Assembly, BASIC, and C programming (varies with model) • Program disks with Cross Assembler and many, well documented, program examples • User's Manuals: cover all details (over 500 pages) • Completely assembled and ready to use • Source code for all drivers and MONITOR • Optional Text Book

Everything you need. From \$279.
Money Back Guarantee

Call for Free Info Pack, or see
WEB at <http://www.aesmicro.com>
714-550-8094, FAX 714-550-9941

AES
Advanced Educational Systems

Call 1-800-730-3232

AES 575 ANTON BLVD., SUITE 300, COSTA MESA, CA 92626, USA

OSCILLOSCOPES from \$169 !!!

ATC O-Scope uses printer port to turn PC-AT into
Digital Storage Oscilloscope, Spectrum Analyzer,
Freq. Counter, Logger, DVM. DC-500KHz

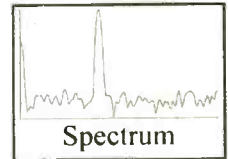
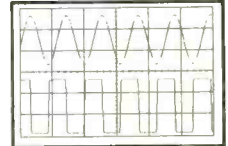

- Print, log to disk, or export data
- Accepts standard scope probes
- Uses standard printer port
- Small and portable
- Works with laptops
- Same day shipping
- Made in U.S.A.
- Single channel units from \$169
- Dual channel units from \$349

Options:

- Probe sets
- Automotive probes
- Battery packs

Order yours today.

800 980 9806

MC/Visa/Amex

Allison Technology Corporation

8343 Carvel, Houston, TX 77036 USA

PH: 713 777 0401, FAX: 713 777 4746, BBS: 713 777 4746

<http://www.atcweb.com>

CIRCLE 137 ON FREE INFORMATION CARD

Since 1965, we've worked to make sure all children have the opportunity to
learn valuable lessons during the years when it's easiest for them to learn.
To find out how you can help, call your local Head Start.



Nurture the future
BE A HEAD START VOLUNTEER



SURVEILLANCE HIDDEN CAMERAS
DIRECT FROM MANUFACTURER - BEST PRICE IN THE MARKET

Ultra miniature hidden camera, in dome, smoke or motion detector w/ mic. B/W or Color. Wide view angle. Low light sensitivity + super sharp images, plus video and audio output. From \$159.00. Also 1/2" B/W covert camera w/mic. only \$99.00 USD. Wireless hidden camera, start of only \$5.49 USD. Plus \$5.95 for SH. Wholesale Welcome. C=O. Check, Money Order or Visa/MC.

BOLIDE INTERNATIONAL CORPORATION
PH: (800) 355-0895 or (818) 575-8178
9660 Fial Drive #318, El Monte, CA 91731
<http://www.bolideinternational.com>

Cable TV Outlet



Factory
Direct!

Get the Clearest Coverage
of Sports, Movies, News,
Main Events and Adult!

- Unbeatable Wholesale Pricing-
- Converters/Descramblers-
- Filters and Accessories-
- Premium Channel Coverage-
- Full Satisfaction Guaranteed-

QB VIDEO

Open M-F 9a to 5p (CT)

1-800-249-3025

Visa, MC & C.O.D.'s Welcome

\$139* Laser LightShow

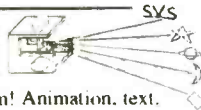

Draw with a laser beam! Animation, text,
music & more! Includes galvanos, mirrors,
servo amp, demo software disk, analog and
digital computer interface. Use an inexpen-
sive pen pointer or high power gas laser.

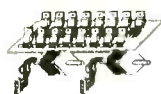

Computerized Motors \$39*

Includes: 2 Stepper motors,
2 DC motors, computer interface, training
manual, & demo software disk. Expandable!
Up to 12 motors, up to 3 amps per phase.

Now with 4 Axis Linear Interpolation
* Add \$6 for shipping. Computer with parallel printer port
& cable, assembly, power supply, & laser are required

FREE FLYER

Voice 510-582-6602 Fax 510-582-6603

SVS

1273 Industrial Pkwy West Bldg. 460
PO Box 55125 Hayward CA 94545-0125

<http://www.xtronics.com/kits.htm>

Join the exciting and profitable world of factory
automation via PLCs. First, buy the PLC Primer,
a great intro to PLCs & ladder logic programming.
It ships with student PLC software and a PLC
manual for \$37.94. Next, get our PLC starter kit.
It comes with an 8(+2 Pot)in 8 out Toshiba PLC,
cable, software (Win95 & 3.1 w/o support) for \$295.00!!

Electronic Kits!

See these and more on
our WEB site!



Crystal radio	\$5.75	Glitter-Globe Buckminster Fuller	
Function Gen w/FM	\$28.00	sphere 64 LEDs EN1292	\$45.00
Function Generator	\$14.95	Deluxe IC Radio	\$11.95
Pulse Generator	\$28.00	World Radio	\$25.95
RF Sig Generator	\$28.00	Train Sound Module	\$3.80
FM Microphone	\$6.95	IR Receiver or Xmitter	\$3.90
Ultrasonic Translator - Hear		Assembled Metal	
ultrasonic-sound	\$18.50	Detectors from	\$18.50!!

Transtronics

Free catalog

3209 W. 9th Street
Lawrence, KS 66049
Minimum Order \$20.00 +
Shipping - up to 4 lb \$5.00
We ship over seas!

ph 785 841 3089
FAX 785 841 0434

USE POPULAR ELECTRONICS

READ BY BUYERS OF ELECTRONIC EQUIPMENT ACCESSORIES AND PARTS

INSTRUCTIONS FOR PLACING YOUR AD!

HOW TO WRITE YOUR AD

TYPE or **PRINT** your classified ad copy **CLEARLY** (not in all capitals) using the form below. If you wish to place more than one ad, use a separate sheet for each additional one (a photo copy of this form will work as well). Place a category number in the space at the top of the order form (special categories are available). If you do not specify a category, we will place your ad under miscellaneous or whatever section we deem most appropriate.

We cannot bill for classified ads. **PAYMENT IN FULL MUST ACCOMPANY YOUR ORDER.** We do permit repeat ads or multiple ads in the same issue, but, in all cases, full payment must accompany your order.

WHAT WE DO

The first word and company name of each ad are set in bold caps at no extra charge. No special positioning, centering, dots, extra space, etc. can be accommodated.

RATES

Our classified ad rate is \$1.75 per word. Minimum charge is \$26.25 per ad per insertion (15 words). Any words that you want set in bold are each .40 extra. Indicate bold words by underlining. Words normally written in all caps and accepted abbreviations are not charged anything additional. State abbreviations must be post office 2-letter abbreviations. A phone number is one word.

If you use a **Box** number you must include your permanent address and phone number for our files. **ADS SUBMITTED WITHOUT THIS INFORMATION WILL NOT BE ACCEPTED.**

For firms or individuals offering Commercial products or Services. **Minimum 15 Words.** 5% discount for same ad in 6 issues within one year; 10% discount for same ad in 12 issues. **Sorry, no discounts on credit-card orders.** **Boldface** (not available as all caps), add .40 per word additional. **Entire ad in boldface**, add 20%. **Tint screen behind entire ad**, add 25%. **Tint screen plus all boldface ad**, add 45%. **Expanded type ad**, add \$2.25 per word.

General Information: A copy of your ad must be in our hands by the 13th of the fourth month preceding the date of issue (i.e. Sept issue copy must be received by May 13th). When normal closing date falls on Saturday, Sunday or Holiday, issue closes on preceding work day. Send for the classified brochure.

DEADLINES

Ads not received by our closing date will run in the next issue. For example, ads received by November 13 will appear in the March issue that is on sale January 17. **POPULAR ELECTRONICS** is published monthly. No cancellations permitted after the closing date. No copy changes can be made after we have typeset your ad. **NO REFUNDS**, advertising credit only. No phone orders.

CONTENT

All classified advertising in **POPULAR ELECTRONICS** is limited to electronics items only. All ads are subject to the publishers approval. **WE RESERVE THE RIGHT TO REJECT OR EDIT ALL ADS.**

AD RATES: \$1.75 per word. Minimum \$26.25

Send you ad payments to:

POPULAR ELECTRONICS 500 Bi-County Blvd, Farmingdale, NY 11735-3931

CATEGORIES

100 - Antique Electronics	270 - Computer Equipment Wanted	450 - Ham Gear Wanted	630 - Repairs-Services
130 - Audio-Video Lasers	300 - Computer Hardware	480 - Miscellaneous Electronics For Sale	660 - Satellite Equipment
160 - Business Opportunities	330 - Computer Software	510 - Miscellaneous Electronics Wanted	690 - Security
190 - Cable TV	360 - Education	540 - Music & Accessories	710 - Telephone
210 - CB-Scanners	390 - FAX	570 - Plans-Kits-Schematics	720 - Test Equipment

CLASSIFIED AD COPY ORDER FORM

Place this ad in Category # _____ Special Category \$20.00 Additional _____

1 - \$26.25	2 - \$26.25	3 - \$26.25	4 - \$26.25	29 - \$50.75	30 - \$52.50	31 - \$54.25	32 - \$56.00
5 - \$26.25	6 - \$26.25	7 - \$26.25	8 - \$26.25	33 - \$57.75	34 - \$59.50	35 - \$61.25	36 - \$63.00
9 - \$26.25	10 - \$26.25	11 - \$26.25	12 - \$26.25	37 - \$64.75	38 - \$66.50	39 - \$68.25	40 - \$70.00
13 - \$26.25	14 - \$26.25	15 - \$26.25	16 - \$28.00	Total words _____		\$1.75 per word = \$ _____	
17 - \$29.75	18 - \$31.50	19 - \$33.25	20 - \$35.00	Bold Face _____		\$0.40 per word = \$ _____	
21 - \$36.75	22 - \$38.50	23 - \$40.25	24 - \$42.00	Special Heading _____		\$20.00 = \$ _____	
25 - \$43.75	26 - \$45.50	27 - \$47.25	28 - \$49.00	Other _____		= \$ _____	

Total classified ad payment \$ _____ enclosed **TOTAL COST OF AD \$ _____**

Check Mastercard Visa Discover Card # _____ Expiration Date ____/____/____

Signature _____

Name _____ Phone _____

Address _____ City State Zip _____

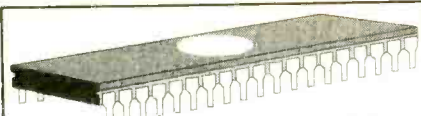

CABLE CONVERTER DIAGNOSTIC TEST CHIP

LOAD FULL ACTIVATION OF CABLE CONVERTER

WE STOCK A COMPLETE LINE OF CHIPS, TOOLS,
WIRELESS QUICK INSTALL TEST BOARDS AND
DIAGNOSTIC CUBES FOR ALL CONVERTERS!

***ANYONE IMPLYING ILLEGAL USE WILL BE ***
DENIED SALE. WE SELL PRODUCTS ONLY!! TO
TECHNICIANS OR CABLE REPAIR FACILITIES!!

#1 IN CUSTOMER SERVICE & TECH. SUPPORT!

*ALL ORDERS SHIP WITHIN 24HRS, UPS/ FED-X.

*PRIORITY NEXT DAY SHIPPING AVAILABLE!

*SALE= BUY 5 TEST BOARDS AND GET 1 FREE.

*MON-FRI - 8AM-7PM - SAT 10AM-2PM EST.

*WEB PAGE HTTP://WWW.800-GOCABLE.COM

VISUAL
COMMUNICATIONS INC.
ORDERS/CATALOG 1-800-GO-CABLE
TOLL FREE TECH. DEPT. 1-888-519-TECH EST. 1976

NOW HEAR THIS! ELECTRONIC EAVESDROPPING EQUIPMENT DESIGN

By Winston Arrington

This 126-page revised edition contains 117 schematic diagrams and text of our production equipment. 29 Crystal, 35 Room, 32 Telephone, 15 Phantom Zero, Infrared, Countermeasures equipment, and more. Request a free detailed explanation sheet of contents. **PRICE:** \$150.00 + S&H. U.S. \$6.00, Canada \$8.00.

SHEFFIELD ELECTRONICS CO.
P.O. Box 377940-C, CHICAGO, IL 60637-7940
Tel. (773) 324-2196

Code: 377940-B

Turn Your Multimedia PC into a Powerful Real-Time Audio Spectrum Analyzer

Features

- 20 kHz real-time bandwidth
- Fast 32 bit executable
- Dual channel analysis
- High Resolution FFT
- Octave Analysis
- THD, THD+N, SNR measurements
- Signal Generation
- Digital Filtering
- Triggering, Decimation
- Transfer Functions, Coherence
- Dynamic Data Exchange (DDE)
- Time Series, Spectrum Phase, Spectrogram and 3-D Surface plots
- Real-Time Recording and Post-Processing modes

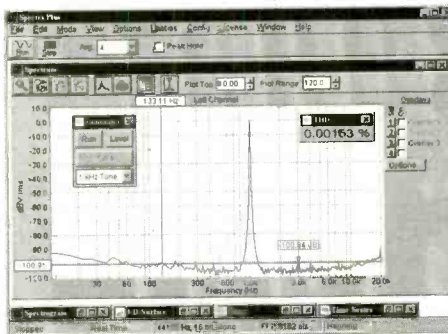

Applications

- Distortion Analysis
- Frequency Response Testing
- Vibration Measurements
- Acoustic Research

System Requirements

- 486 CPU or greater
- 8 MB RAM minimum
- Win. 95, NT, or Win. 3.1 + Win.32s
- Mouse and Math coprocessor
- 16 bit sound card

PHS Pioneer Hill Software
24460 Mason Rd. N.W.
Poulsbo, WA 98370

Sales: (360) 697-3472

Fax: (360) 697-7717

e-mail: pioneer@telebyte.com

Priced from \$299

(U.S. sales only - not for export/resale)

Professional Quality Sound Cards Available...Call

DOWNLOAD FREE 30 DAY TRIAL!

www.telebyte.com/pioneer

Spectra Plus 4.0

Affordable Signal Processing Software

ATTENTION DEALERS: WHOLESALE ONLY!



Formerly JES, Inc.

EXCLUSIVE:



NEW!

Wavemaster 99 Channel

• Sleep Timer • Std./HRC Switch • Parental Control

10+	20 +	50+
\$57	52	45

	5+	10+	20+
Panasonic 145	\$72	65	60
Refurb. Panasonic 145	57	55	52
Panasonic 100	52	49	--
Panasonic 175	--	CALL!	--
Starcomm DQN	49	45	39
(99 ch, Refurb.)			

TOLL FREE:
800-322-9690



FAX:
516-246-5634

**WHOLESALE PRICES
STARTING AS LOW AS \$99.00**

CABLE TV DESCRAMBLERS CONVERTERS FILTERS • VIDEO STABILIZERS

1 Year Warranty on All Products.
Affordable Extended Warranty.
FREE CATALOG!

**30 Day
FREE
TRIAL**

Call the Cable Professionals 24 Hours A Day!

1-800-379-3976
HTTP://WWW.ORION-ELECTRONICS.COM



MONDO • TRONICS

ROBOT STORE

* KITS *

Your

* BOOKS *

Mailorder

* PARTS *

Source

* VIDEOS *

For

* MODELS *

Robots!

* MORE! *

(REQUEST OUR FREE CATALOG)

www.robotstore.com

800-374-5764

Or write to us:

4286 Redwood Hwy #226-101
San Rafael CA 94903

Phone 415-491-4600 • Fax 415-491-4696

Email info@mondo.com

REAL ESTATE

GOV'T FORECLOSED homes from pennies on \$1.00. Delinquent Tax, Repo's, REO's. Your Area. Toll Free (1)800-218-9000 Ext.H-14087 for current listings.

AUDIO-VIDEO-LASERS

VIDEO Stabilizer. Works with all videotapes. \$45.95 + \$6.00 S&H. Free brochure. 30 day moneyback. **STAR DEVELOPMENT**, Box 92457, Milwaukee, WI 53202. (414) 860-1471.

CABLE TV

CABLE TV EQUIPMENT & ACCESSORIES. Wholesalers Welcome! 30 day Moneyback Guarantee! Free Catalog! **PROFORMANCE ELECTRONICS, INC.** 1-(800) 815-1512.

CABLE TV Descramblers. One Piece Units. Pioneer 6310's, Scientific Atlanta 8580's; DPV7's and others. Lowest prices. Money back guarantee. **Precision Electronics**, Houston, TX 1-(888) 691-4610.

CONFUSED Descramblers will explain all your options, all makes and models wholesale and retail, Open 6 days wk 9AM - 8 PM Est. Best tech support and friendly service. Toll free 1 (888) 238-0967 **ROYAL ENGINEERING INC.**

CABLE Descrambling, New secret manual. Build your own descramblers for cable and subscription TV. Instructions, schematics for SSAVI, Gated Sync, Sinewave, some free methods \$12.95, \$2.00 postage. **CABLETRONICS**, Box 30502PE, Bethesda, MD 20824.

CABLE Descramblers and Converters. 10 lot decoders \$38.00 ea. 10 lot converters \$57.00 ea. Visa and Mastercard accepted. (304) 337-8027.

MAESTRO latest technology. Compatible with all major systems: Pioneer, Jerrold, Scientific Atlanta, Zenith. Universal descramblind capabilities. Dealers wanted. Money back guarantee. 1 (800) 676-7966.

DESCRAMBLE cable with simple circuit added to Radio Shack RF modulator and using VCR as tuner. Instructions \$10.00. **TELCOM**, Box 832P 2, Brusly, LA 70719.

FREE Cable Descrambler Plans. For Details Write: SIERRA PUBLISHING, 909 E. Yorba Linda Blvd., Suite H-181, Dept. PEN, Placentia, CA 92870.

CABLE Descramblers, External activators for Jerrold or Scientific Atlanta Systems. 24 hours Just call 1(800)218-7192.

Wholesale Cable Warehouse Decoders for all systems **Best Prices Guaranteed** Helpful, friendly service and support ready to help. 30 day money back guarantee and full 1 year warranty call mow 1-800-387-0349 Dealers Welcome Call for free price quote.

CABLE Descrambler!! Anyone can build in seven steps **Radio Shack** parts. **Plans/Kit** from \$5.00 plus **Free Bonus!!** 1-800-818-9103

CABLE "Bullet Terminator and I.D. Blocker" Electronically shields yourself and your box. Free Hackers Guide included. **Lifetime** guarantee **Wholesale** prices. 1-800-820-9024

BIG SALE!! NOTCH FILTERS \$18.00 EXTERNAL ACTIVATORS \$125.00 DESCRAMBLERS FROM \$99.00 Test chips from \$5.00. **Bullet/ I.D \$135.00** Name Brand **Cable Descramblers** from \$135.00 Let us Beat Your Best Price. 1-800-449-9189 ANYTIME.

RFT-Dam (Digital Auto Mode) The only answer for dpb x = >CFT 20xx. **Best Prices** 1-800-627-2339

Signal Eliminator can block severe TV interference or unwanted channels! Visit us on the web today at <http://members.aol.com/tvfilter>. Request a free brochure by mail or voicemail. **Star Circuits**, PO Box 94917, Las Vegas, NV 89193. 1-800-433-6319

CABLE DESCRAMBLER/VIDEO OUTLET ORDER TODAY and HAVE IT TOMMOROW Guaranteed lowest price. Don't pay more. 24 Hr. Tech Support Group. Open 7 days-24hrs. Daily. We will not be undersold. C.O.D. & Credit Cards. **LIFETIME WARRANTY** 1-800-586-9920

PLANS-KITS-SCHEMATICS

ELECTRONIC Project Kits. www.qkits.com. 1 (888) GO-4-KITS, 292 Queen St., Kingston, ON, K7K 1B8. **QUALITY KITS.**

ALL-In-One Catalog, 60 mouth-watering pages. CB/HAM/audio/TV/spy/broadcast/science projects, **multipower broadcasting**, broadcast transmitters, amplifiers, antennas, "secret books", start your own radio station and more. Send \$1.00 to **PAN-COM INTERNATIONAL**, PO Box 130-P02, Paradise, CA 95967.

FM MICRO/LOW POWER BROADCASTING 88-108MHZ. Assembled PLL transmitters and rf amps, mono/stereo 20mW's 110 Watts. Photo catalog/info call (250)642-2859. **R. Scott Communications Ltd.** We ship world wide from Canada.

UNDERGROUND ELECTRONIC DEVICES AND MORE. FREE CATALOG INFORMATION CENTER P.O. BOX 876PE HURST, TEXAS 76053. WWW.THEINFORMATIONCENTER.COM

Automation via phone, no computers furnace, ect, on remotely. Components, from local stores plans \$12.95. **AMR Automate Ctr.**, Box 1176 Waltham, MA 02254-1176

SATELLITE EQUIPMENT

VIDEOCYpher II descrambling manual. Schematics, video and audio. Explains DES, EPROM, CloneMaster, Pay-per-view \$16.95, \$2.00 postage. Schematics for Videocypher Plus, \$20.00. Schematics for Videocypher 032, \$15.00. Collection of software to copy and alter EPROM codes, \$25.00. VCII Plus EPROM, binary and source code, \$30.00. **CABLETRONICS**, Box 30502PE, Bethesda, MD 20824.

DSS Hacking: How to construct and program smart cards, w/pic16C84, software. Complete DSS system schematics. \$16.95. **CABLETRONICS**, Box 30502PE, Bethesda, MD 20824.

SKYVISION! Your Satellite Home Entertainment Source. **Best values:** DBS and C/Ku-band equipment, including 4DTV. Most complete selection: Parts-Tools-Upgrades-Accessories!! **Free** Discount Buyer's Guide. Call (800)543-3025. International (218)739-5231. www.skyvision.com

FREE DSS TEST CARD information package. Works on new system and turns on all channels including PPV, adult and sport channels. Write **SIGNAL SOLUTIONS**, 2711 Buford Rd., Suite 180, Richmond VA 23235.

SECURITY

ELECTRONIC sales of security systems for home, apartment, or business. Stop burglars now. call (812)295-4240.

BUSINESS OPPORTUNITIES

SATELLITE Television Pays! 18" minidish sales force needed. **STAR VISION DIRECT:** (800) 899-9707, 8am-10pm Pacific.

\$\$\$ Millions in scrap gold from old electronics, computers, circuit boards, jewelry, 24 hours: (603) 645-4767.

ELECTRONICS Enterprises, Home based. Part/Full time. 250pg Comprehensive Guidebook, insider information, 24hr recording (800) 326-4560 x145.

EASY WORK! EXCELLENT PAY! Assemble Products At Home: Call Toll Free 1-800-467-5566 EXT. 5730

CB- SCANNERS

CB Radio Modifications! Books, plans, frequencies, sliders, 10-Meter, amplifiers, repairs, high-performance accessories. Catalog \$3.00, **CBCI** Box 31500PE, Phoenix AZ 85046. (888)643-1800.

COMPUTER SOFTWARE

Brainteasing Great Fun. Easy set-up program installs 10 shareware working game icons to your **Windows or Win 95** Program Manager. Only \$17.95 to: Alisha, POB 377, Dept. 3, Old Bethpage, NY 11804

EPROM+ *The Professionals Choice!*

A DEVICE PROGRAMMER FOR BENCH AND FIELD

Uses parallel printer port!

Excellent software!

Supports all standard parts!



FIRST GENERATION EPROMS 2708, TMS2716*, 25XX
SECOND GENERATION EPROMS (24, 28, 32 PIN) 2716 - 27C080 (8 MEG) *ADAPTER REQUIRED, DIAGRAMS INCLUDED
16 BIT EPROMS (40, 42 PIN) 27C1024 - 27C160 (16 MEG)
FLASH EPROMS (28, 32 PIN) 28F, 29C, 29EE, 29F FAMILIES PLUS BOOT BLOCK DEVICES
EPROMS/NYRAMS (24, 28, 32 PIN) 28C04 - 28C010, X2210/12, ER5901, PLUS DALLAS 12XX
SERIAL EPROMS* (8, 14 PIN) 17XX, 24XX, 25XX, 35XXX, 59XX, 85XX, 93XX, 95XX+ER1400
BIPOLAR PROMS* (16 - 24 PIN) 74SXXX AND 82SXXX FAMILIES
MICROCONTROLLERS* (ALL FAMILIES) 874X, 875X, 87C5XX, 87C75X, 89C5X, 89C051, 68705, 68711, PIC12XXX - 16CXXX, 17C4X PLUS FLASH AND 14000

• READ, PROGRAM, COPY, COMPARE FILE LOAD/SAVE (PLUS MUCH MORE!)
 • FULL SCREEN EDITOR W/25 CMDS + BYTE/WORD MODES
 • RUNS UNDER DOS, WIN3.1/95 ON ANY SPEED MACHINE
 • SUPPORTS INTEL HEX, S-RECORD AND BINARY FILES
 • MADE IN USA • 30 DAY MONEY BACK GUARANTEE

\$289

SYSTEM INCLUDES: PROGRAMMING UNIT, PRINTER PORT CABLE, POWER PACK, SOFTWARE & MANUAL \$55.00 SHIPPING • \$5.00 C.O.D. VISA • MASTERCARD • AMEX

ANDROMEDA RESEARCH, P.O. BOX 222, MILFORD, OH 45150 (513) 831-9708 FAX (513) 831-7562

HOME AUTOMATION

World's Largest Selection!

Widest Selection of X-10 Devices Available

Thousands of hard-to-find automation, X-10 and wireless control products. Computer interfaces, software, development tools, lighting control, telephone systems, security systems, surveillance cameras, infra-red audio/video control, HVAC, pet care automation, wiring supplies, books and videos and much more!



Packed with Pictures & Diagrams

HOME AUTOMATION SYSTEMS, Inc.

Questions: 714-708-0610 Fax: 714-708-0614

e-mail: catalog@smarthome.com
 website: smarthome.com

Lowest Prices Guaranteed!

24 Hours **Call 800-SMART-HOME** 800-762-7846

Super Savings!!! Super Savings!!!



10 Watt Multimedia Speakers
 Amplified speaker system features 10 watt max. power

output, 80Hz-20KHz frequency response, 0.5% THD, 40dB signal-to-noise, 2" x 4" full range speaker. Separate controls for volume and power. Includes cables and wall transformer. Size: 3-7/8" (D) x 3-1/2" (W) x 5-1/2" (H).

Retail Price: \$34.95

No. 220-0201.....\$9.95 (per pair)



50 Watt Multimedia Speakers
 Amplified speaker system features 50 watt max. power

output, 80Hz-20KHz frequency response, 3" magnetically shielded full range speaker. Separate controls for power, volume and tone. Includes LED power indicator and front headphone jack. Includes cables and wall transformer. Size: 5-1/8" (D) x 4-1/2" (W) x 7" (H).

Retail Price: \$79.95

No. 220-0203.....\$29.95 (per pair)



20 Watt Multimedia Speakers
 Amplified speaker system features 20 watt max. power

output, 80Hz-20KHz frequency response, 0.3% THD, 45dB signal-to-noise, 3" full range speaker. Separate controls for volume, power and tone. LED power ON indicator. Includes cables and wall transformer. Size: 5-1/2" (D) x 3-3/4" (W) x 7-1/8" (H). Retail Price: \$59.95

No. 220-0202.....\$19.95 (per pair)

Super CHARGER™

Alkaline and Ni-Cd Charger for AAA, AA, C and D Cell batteries. Incredible space-age technology automatically and safely recharges regular alkaline (1.5V) and nickel cadmium (1.2V) batteries. Mfg: Buddy L. Model #8000.

Repackaged

No. 140-0140.....\$7.95 (ea)



340 E. 1st St.
 Dayton, Ohio
 45402
 Call for a free catalog

Order Toll-Free
 1-800-344-4465
 Fax Order Line
 1-800-344-6324

CIRCLE 150 ON FREE INFORMATION CARD

MISCELLANEOUS ELECTRONICS FOR SALE

TUBES for sale. Large stock on hand. Call 1-800-370-3390 or dwarders@telepath.com.

Call for a free electronics catalog or visit our web site at www.bgmicro.com/. B.G. Micro - PO Box 280298 Dallas, TX 75228. Order line 800-276-2206

AUTOS FOR SALE

SEIZED CARS from \$175. Porsches, Cadillacs, Chevys, BMW's, Corvettes. Also, Jeeps, 4WD's Your Area. Toll Free 1(800)218-9000 Ext.A-14087 for current listings.

BEST BY MAIL

Rates: Write National, Box 5, Sarasota, FL 34230

BUSINESS OPPORTUNITIES

FREE GAS EARN CASH DAILY. Free Gas, 24813 N.E. Steger Drive, Battle Ground, WA 98604. Call 1-888-742-5541.

FREE ADVERTISING! 1,000 Internet Sites that Accept FREE Ads! (603) 645-4796

EDUCATION

HIGH SCHOOL DIPLOMA At Home, Accredited, Fast, "Failure-Proof" 1-800-470-4723; American Academy, 12651 S. Dixie Highway, Miami, FL 33156.

HIGH SCHOOL DIPLOMA!!! FREE brochure. Call NOW! 1-800-532-6546 Ext. 90.

FINANCIAL

FREE CASH GRANTS! Never Repay. Any Purpose. Call FREE 1-800-375-1098.

CASH NOW FOR FUTURE PAYMENTS! We buy payments from Insurance Settlements, Annuities, or Mortgage Notes. We also buy Military Annuities (VSIs). Call R&P Capital Resources at 1-800-338-5815 ext. 500.

BAD CREDIT! SECOND Social Security Number! Credit Cards. \$104.00. SFS, 5126 W. Olive #238, Glendale, AZ 85302. 1-888-971-7661.

OF INTEREST TO ALL

100 INCH HOME Theater Projection Unit Under \$40.00! For information write to: TNT, 90 Luke St., #101B, Lafayette, LA 70506.

CABLE TV CHANNELS

EQUIPMENT Direct! **FREE 30 DAY TRIAL!**

GUARANTEED

SAVE \$1000's
 The Nationwide source for cable TV equipment.
 "BUY WHERE THE DEALERS BUY."

FREE TV Cable Descramblers, Converters and Magic Box Catalog. Open Every Day!

Your VCR TAPES CAN PLAY AS CLEAR AS DAY!
 Eliminates copy protection on any tape

UNJAM NOW WITH Video Decoder
 • Copy any rental/bought tape
 • Power Cord and HiC Plugs Included

2 Year Warranty
CALL NOW!
 Member Better Business Bureau
MEGA ELECTRONICS!
 1-800-676-6342 VISA • MC • CDD

FREE 30 Day Trial!

ADVERTISING INDEX

Popular Electronics does not assume any responsibility for errors that may appear in the index below.

Free Information Number	Page	Free Information Number	Page
— Aegis Research, Canada	76	150 Mendelson's.....	101
— AES	97	151 Mendelson's.....	92
26 Alfa Electronics.....	83	— Mental Automation	90
28 All Electronics.....	95	13 MicroCode Engineering	CV4
137 Allison Technology.....	97	— Modern Electronics	80
— Amaze Electronics	78	— Mondo-tronics.....	100
— Andromeda Research.....	101	152 Mouser	82
— Arrow Electronics.....	82	— NRI Schools.....	37
— Basic Electrical Supply	93	— Orion Electronics.....	99
127 C&S Sales, Inc.	86	156 Parallax	CV3
— Circuit Specialists.....	77	146 Parts Express	85
— CLAGGK, Inc.....	94	— Pioneer Hill Software	99
— Cleveland Inst. of Electronics.....	55	45 Prairie Digital Inc.	89
— Command Productions	78	— Price Wheeler.....	88
— Computer Kits	92	47 Print	82
— Comtrad Industries.....	3, 9	46 Print.....	89
— Consumertronics.....	74	— QB Video	97
48 Dalbani	81	— RC Distributing	82
— EDE Spy Outlet	90	— Sheffield Electronics.....	99
— Electronic Tech. Today	7, 84	— Silicon Valley Surplus	97
— EMAC.....	89	— Smithy Company	80
— Foley-Belsaw	91	— Tab Books.....	17
— Forest Electronics	76	— Tech Services & Solutions.....	96
— Fotronic Corporation	80	— Technological Arts	94
— General Device Instruments.....	80	142 Telulex.....	93
— Grantham College of Eng.....	4	— Transtronics	97
— Greenleaf Electronics Inc.	78	136 UCANDO Videos.....	76
173 Hollins Radio Data	6	— US Cyberlab.....	73
— Home Automation Systems.....	101	— Video Media	94
— Information Unlimited	75	— Vision Electronics	92
14 Interactive Image Technologies	CV2	— Visual Communications	99
— Intronics, Inc.....	90	— Weeder Technologies	73
— James Electronic Services.....	99	172 Windjammer Barefoot Cruises	4
— KDE Electronics	96	— WPT Publications.....	90
155 MCM Electronics	79	— Xillion	92
— Mega Electronics	101		

ADVERTISING SALES OFFICES

Gernsback Publications, Inc.
500 Bi-County Blvd.
Farmingdale, NY 11735-3931
1-(516) 293-3000
Fax 1-(516) 293-3115

Larry Steckler, EHF/CET
President (ext. 201)
e-mail advertising@gernsback

Adria Coren
Vice-President (ext. 208)

Ken Coren
Vice-President (ext. 267)

Christina Estrada
Assistant to the President (ext. 209)

For Advertising ONLY
1-516-293-3000
Fax 1-516-293-3115

Larry Steckler
publisher

Arline Fishman
advertising director (ext. 206)

Marie Falcon
advertising assistant (ext. 211)

Adria Coren
credit manager (ext. 208)

**Subscription/
Customer Service/
Order Entry**
1-800-827-0383
7:30 AM - 8:30 PM EST

ADVERTISING SALES OFFICES

EAST/SOUTHEAST

Stanley Levitan
Eastern Sales
1 Overlook Ave.
Great Neck, NY 11021-3750
1-516-487-9357, 1-516-293-3000
Fax 1-516-487-8402
slevitan26@aol.com

MIDWEST/Texas/Arkansas/ Oklahoma, Colorado, Arizona

Ralph Bergen
Midwest Sales
One Northfield Plaza, Suite 300
Northfield, IL 60093-1214
1-847-559-0555
Fax 1-847-559-0562
bergenrj@aol.com

PACIFIC COAST/Mountain States

Anita Bartman
Hutch Looney & Assoc., Inc.
6310 San Vicente Blvd.
Suite 360
Los Angeles, CA 90048-5426
1-213-931-3444 (ext. 227)
Fax 1-213-931-7309

BASIC Stamp[®] computers

Tiny computers run PBASIC programs

BASIC Stamps answer the request for small, low-cost, easily programmable computers. BASIC Stamps are programmed in Parallax BASIC (PBASIC), a simple language with powerful I/O instructions. BASIC Stamps have their own PBASIC interpreter, non-volatile EEPROM, and 5-volt regulator. Because of their reliability and ease of programming, BASIC Stamps are the microcontroller of choice for hobby projects and industrial control.



Mechanical insect controlled by BASIC Stamp

Parallax's United Kingdom distributor Milford Instruments (www.milinst.demon.co.uk) uses the BASIC Stamp I to control servos, LEDs and antennae switches in their BASIC Stamp Bug kit. The popular bug survived a week of booth crawling at the Spring 1997 COMDEX show in Atlanta, Georgia and is now.



Plastic extrusion machine industrial application

Fisher Automation of Whitestone, New York uses BASIC Stamps in their plastic extrusion machines to sense the appropriate time to start a cut cycle and sequence several pneumatic valves. Fisher Automation reports that "the BASIC Stamp has proven extremely reliable in our applications, running 24 hours per day, seven days a week, and performing up to 70 cuts per minute."

BASIC Stamp[®] modules

BS1-IC Module (part #BS1-IC)

- 8 I/O lines
- 80 PBASIC instructions max.
- 2000 instructions/sec.
- 2400 baud serial I/O
- 14-pin SIP module



\$34

Familiar PBASIC language with I/O instructions including BUTTON, HIGH, INPUT, LOW, OUTPUT, POT, PULSIN, PULSOUT, PWM, REVERSE, SERIN, SEROUT, SOUND, and TOGGLE.

BS2-IC Module (part #BS2-IC)

- 16 I/O lines
- 500 PBASIC instructions max.
- 4000 instructions/sec.
- 50k baud serial I/O
- 24-pin DIP module



\$49

Similar language as BS1-IC, plus DTMF, FREQOUT, SHIFTIN and SHIFTOUT, XOUT (X-10 powerline control), etc. I/O functions common to both modules have a higher resolution on the BS2-IC, due to its faster clock speed. Larger EEPROM, high speed, and diversity of instructions make the BS2-IC our most popular product.

BASIC Stamp[®] Starter Kits

BASIC Stamp I Starter Kit (part #27205)

\$99

BASIC Stamp II Starter Kit (part #27203)

\$149

BASIC Stamp Starter Kits include the BS1-IC or BS2-IC modules shown above, carrier board with prototype area with 9-volt battery clip, manual, application notes, and software. Free technical support is also included.



BASIC Stamp II Starter Kit shown with BS2-IC module on carrier board

Serial LCD Displays

2-line x 16 character LCD display (part #27910)

\$54

4-line x 20 character (part #27919)

\$109

Serial LCD modules from Scott Edwards Electronics take one BASIC Stamp I/O line and ground, and are controlled with simple SEROUT instructions. For example, to print "Popular Electronics" on the LCD, your PBASIC program would execute the following instruction:

SEROUT 0,N2400,("Popular Electronics")



BASIC Stamp[®] AppKits

MAX7219 8-digit LED display driver (part #27914)

\$26

LTC1298 12-bit A/D convertor (part #27916)

\$26

DS1620 digital thermometer / thermostat (part #27917)

\$26

RS-485 long-distance communication (part #27921)

\$26

Xicor X25640 8k serial EEPROM (part #27918)

\$26

AppKits include all the materials you need to learn about interfacing electronic parts to the BASIC Stamp. Each AppKit contains a sample device and supporting components, easy to read documentation, and source code.

Visit Parallax at Fall 1997 COMDEX



Las Vegas, Nevada, November 17 to 21, 1997.

BASIC Stamps are shown in applications submitted by our customers. BASIC Stamp Starter Kits are promoted at show-special prices. Watch our web site for free guest passes to COMDEX.



PARALLAX (888) 512-1024

3805 Atherton Road, #102 • Rocklin, CA 95765 • USA

Office / Technical Support: (916) 624-8333 • Fax: (916) 624-8003 • FaxBack: (916) 624-1869
info@parallaxinc.com • stamptech@parallaxinc.com • <http://www.parallaxinc.com>

Australia and New Zealand +61 39 720 5344, +61 67 722 777 • Austria +49 241 918 90 0 • Belgium +32 4 377 5151 • Bulgaria +359 2 72 77 50 • Brazil +55 11 453 5588 • +55 11 801 0045 • Canada (514) 336-9426 • Czech Republic +42 49 5813 252 • Finland +358 31 266 1885 • France +33 328 550 328 • Germany +49 241 918 90 0 • Greece +30 1 902 0115 • Hungary +36 1270 7680 • India +91 422 232 561 • Ireland +44 1 977 683 665 • Israel +972 3 498 543 • Italy +39 0542 55400 • Japan +81 3 3251 1779 • Netherlands +31 10 450 4949 • Poland +48 34 648 882 • Singapore +65 296 3995 • Slovak Republic +42 7 580 2574 • South Africa +27 11 493 6242 • Sweden +46 431 41 00 88 • Switzerland +49 241 918 900 • Taiwan +886 2 647 1978 • United Kingdom +44 1 977 683 665 • United States 800 344-5339 (Digi-Key), 800 831-4242 (Jameco), 800 538-5000 (JDR), 800 552-6733 (Martin P. Jones), 800 467-7736 (DC Electronics), 415 491-4600 (Mondo-Tronics) 800 843-7422 (Radio Shack Unlimited) 303 512-2060 (TechAmerica)
 PBASIC, BS1-IC, and BS2-IC are trademarks and BASIC Stamp[®] & the Parallax logo are registered trademarks of Parallax, Inc. • Prices do not include shipping and sales tax • Features and prices subject to change without notice. Prices are U.S. prices only, prices in other countries may vary.
 COMDEX is a registered trademark of Softbank COMDEX.

CIRCLE 156 ON FREE INFORMATION CARD

Professional Power

at a hobbyist price.

That has been our philosophy at MicroCode Engineering since 1987. So it's no surprise that **CircuitMaker** and **TraxMaker** are the leading software tools for affordable, easy-to-use circuit design, simulation and PCB layout.

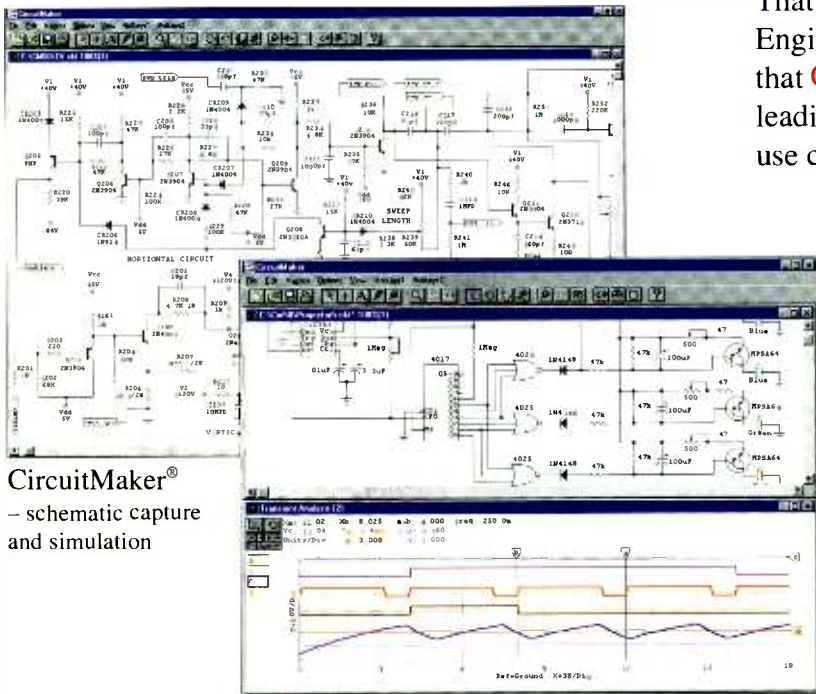

CircuitMaker®
– schematic capture and simulation

QUICKLY DESIGN analog, digital or mixed analog/digital circuits with CircuitMaker's advanced schematic features. You fully control the wiring, device placement, annotation and colors. And the Symbol Editor and macro features let you create unlimited custom devices and symbols.

SIMULATE and **ANALYZE** what you create – try all the “what if” scenarios with:

- Fast, proven 32-bit SPICE 3f5/XSpice simulator
- True mixed analog/digital simulation
- Fully interactive digital logic simulation
- 4,000-device library
- AC Frequency Analysis
- DC Operating Point Analysis
- DC Transfer Function
- Transient Analysis
- Step Function – step component values and sources over a user-definable range

TraxMaker® – PCB layout and autorouting

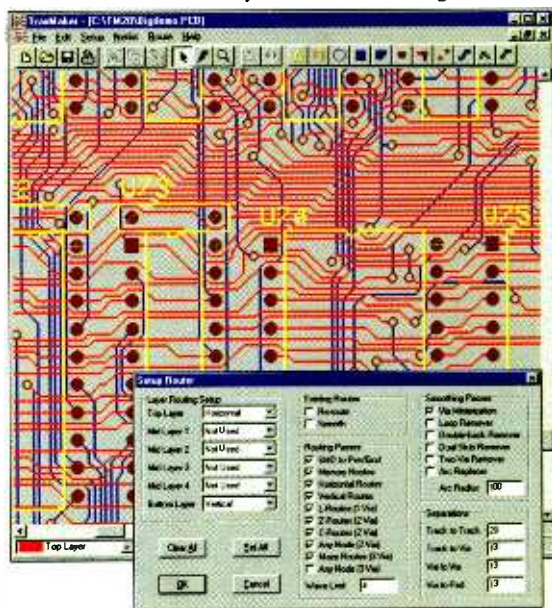

TAKE MEASUREMENTS at any point in the circuit with a click of the Probe tool. Results appear immediately on virtual instruments like the Digital Oscilloscope, Curve Tracer, Digital Multimeter and Bode Plotter. No other simulator lets you take measurements as quickly and easily as CircuitMaker.

COMPLETE the design process with TraxMaker, a professional printed circuit board layout program with built-in autorouter. Import netlists from CircuitMaker and other schematic programs, or design boards from scratch.

- Includes autorouter, auto component placement and Design Rules Check
- Supports up to 8 copper layers, board sizes up to 32 x 32 inches
- Surface mount and through-hole components from a customizable library
- Outputs your PCB as a Gerber file, Excellon N/C drill file, and prints to any Windows-selectable printer or plotter

RELY ON free technical support from qualified engineers. And every MicroCode product is backed by our **30-day Money-Back Guarantee** if it does not live up to your expectations.

Call 800-419-4242 for more information and free demos

(or download from www.microcode.com)

CIRCLE 171 ON FREE INFORMATION CARD

CircuitMaker Version 5	\$299
TraxMaker Version 2	\$299
CircuitMaker Design Suite™	\$549
<small>(CircuitMaker and TraxMaker)</small>	