

ELECTRONIC SENSORS YOU CAN BUILD

February 1997

Popular Electronics®

Build a 22-Watt Amplifier

**Dramatically improve
the sound of your
car stereo for less than \$20**

The Mobile Assistant

**This belt-worn computer is
the world's most portable PC**

Build an Automatic Headlight Control

**Turn on your car's windshield wipers
and this circuit will do the rest**

Cruising the Lowest Ham Bands

**Learn what signals lurk in these
unusual frequencies**



GERNSBACK
PUBLICATION

\$3.99 U.S.
\$4.50 CAN.



NEW VERSION!

Electronics Workbench Version 5 with analog, digital and mixed A/D SPICE simulation, a full suite of analyses and over 4,000 devices. Still the standard for power and ease of use. Now ten times faster. Still the same low price.

Join over 75,000 customers and find out why more engineers and hobbyists buy Electronics Workbench than any other SPICE simulator. You'll be working productively in 20 minutes, and creating better designs faster. We guarantee it!

\$299

SAME GREAT PRICE!

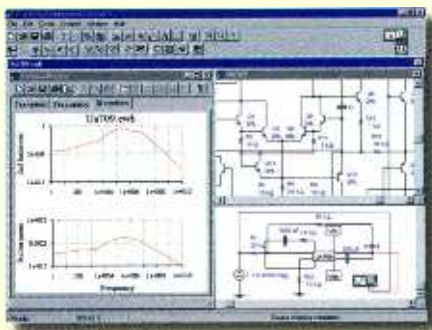

High-End Features

TRUE MIXED ANALOG/DIGITAL	YES
FULLY INTERACTIVE SIMULATION	YES
ANALOG ENGINE	SPICE 3F5, 32-BIT
DIGITAL ENGINE	NATIVE, 32-BIT
GMIN STEPPING	YES
TEMPERATURE CONTROL	EACH DEVICE
PRO SCHEMATIC EDITOR	YES
HIERARCHICAL CIRCUITS	YES
VIRTUAL INSTRUMENTS	YES
ON-SCREEN GRAPHS	YES
ANALOG COMPONENTS	OVER 100
DIGITAL COMPONENTS	OVER 200
DEVICE MODELS	OVER 4,000
MONEY-BACK GUARANTEE	30-DAY
TECHNICAL SUPPORT	FREE

Powerful Analyses

DC OPERATING POINT	YES
AC FREQUENCY	YES
TRANSIENT	YES
FOURIER	YES
NOISE	YES
DISTORTION	YES

30-DAY MONEY-BACK GUARANTEE
VERSION 5.0 FOR WINDOWS 95/NT/3.1.
Upgrades from previous versions \$79.

FEATURES OF ELECTRONICS WORKBENCH VERSION 5

WHAT'S NEW

Now 10 times faster! Handles 4 times larger circuits. More and better device models. New thermal modeling. New on-screen graphs. New analyses (Fourier, Noise and Distortion). 25 new components including vacuum tubes, diodes, solenoids, 50 new ICs. Improved accuracy, improved schematic editor with zoom and grouping, pages, interactive wiring, improved filter, improved waveform, redesigned word generator and logic analyzer.

GENERAL

Integrated Tool: Fully integrated schematic editing, SPICE simulation and waveform generation and analysis. Supports modifications to the circuit during simulation. Circuit analysis through virtual test instruments. Six analyses listed below.

Simulation Engine: Interactive, 32 bit SPICE 3F5 enhanced with true mixed digital and mixed analog/digital support. Automatic interior of signal transition interface. Supports multiple usage of hierarchical blocks. GMIN stepping for better convergence. No power limitation circuit size or complexity.

Schematic Capture: Click and drag interface. Hierarchical workspaces. Automatic wire routing with automatic reference designations. Schematic size independent instrument for quick and simple analysis. Six analyses for on-screen graphs and more (see table below).

Simulation: All design information, including simulation SPICE parameters setup and execution of all models, saved in a design file to be reloaded into a new simulation.

Post-processor: SPICE post-processor with other simulators or to create timing diagrams. Imports manufacturers' models and creates interchangeable Electronics Workbench components. Exports to standard PCB layout packages such as OrCAD, Protel and Tango.

ANALYSES

DC Operating Point: Calculates DC operating point and assigns voltage and current mode.

Transient: Circuit voltages and currents over time at any number of nodes. Specify start and stop times.

AC Frequency Sweep: Small signal gain and phase over range of AC frequencies at any number of nodes. Sweep range, type, decade, octave or linear and resolution (number of steps) of frequency sweep.

Fourier: Magnitude and phase of DC and Fourier spectral components of transient response. Specify fundamental frequency and an unlimited number of harmonics.

Noise: Resistor and semiconductor noise distribution reported as RMS sum. Specify device of interest and reference nodes, start and stop time and resolution of frequency sweep.

Distortion: Small signal of steady-state harmonic and intermodulation products over a range of frequencies. Specify any number of nodes and sweep range, type and resolution. Operates on individual devices on an individual basis.

VIRTUAL TEST INSTRUMENTS

Digital: 1-bit, 2-bit, 3-bit, 4-bit, 8-bit, 16-bit, 32-bit, 48-bit, 64-bit, 80-bit, 96-bit, 112-bit, 128-bit, 144-bit, 160-bit, 176-bit, 192-bit, 208-bit, 224-bit, 240-bit, 256-bit, 272-bit, 288-bit, 304-bit, 320-bit, 336-bit, 352-bit, 368-bit, 384-bit, 400-bit, 416-bit, 432-bit, 448-bit, 464-bit, 480-bit, 496-bit, 512-bit, 528-bit, 544-bit, 560-bit, 576-bit, 592-bit, 608-bit, 624-bit, 640-bit, 656-bit, 672-bit, 688-bit, 704-bit, 720-bit, 736-bit, 752-bit, 768-bit, 784-bit, 800-bit, 816-bit, 832-bit, 848-bit, 864-bit, 880-bit, 896-bit, 912-bit, 928-bit, 944-bit, 960-bit, 976-bit, 992-bit, 1008-bit, 1024-bit, 1040-bit, 1056-bit, 1072-bit, 1088-bit, 1104-bit, 1120-bit, 1136-bit, 1152-bit, 1168-bit, 1184-bit, 1200-bit, 1216-bit, 1232-bit, 1248-bit, 1264-bit, 1280-bit, 1296-bit, 1312-bit, 1328-bit, 1344-bit, 1360-bit, 1376-bit, 1392-bit, 1408-bit, 1424-bit, 1440-bit, 1456-bit, 1472-bit, 1488-bit, 1504-bit, 1520-bit, 1536-bit, 1552-bit, 1568-bit, 1584-bit, 1600-bit, 1616-bit, 1632-bit, 1648-bit, 1664-bit, 1680-bit, 1696-bit, 1712-bit, 1728-bit, 1744-bit, 1760-bit, 1776-bit, 1792-bit, 1808-bit, 1824-bit, 1840-bit, 1856-bit, 1872-bit, 1888-bit, 1904-bit, 1920-bit, 1936-bit, 1952-bit, 1968-bit, 1984-bit, 2000-bit, 2016-bit, 2032-bit, 2048-bit, 2064-bit, 2080-bit, 2096-bit, 2112-bit, 2128-bit, 2144-bit, 2160-bit, 2176-bit, 2192-bit, 2208-bit, 2224-bit, 2240-bit, 2256-bit, 2272-bit, 2288-bit, 2304-bit, 2320-bit, 2336-bit, 2352-bit, 2368-bit, 2384-bit, 2400-bit, 2416-bit, 2432-bit, 2448-bit, 2464-bit, 2480-bit, 2496-bit, 2512-bit, 2528-bit, 2544-bit, 2560-bit, 2576-bit, 2592-bit, 2608-bit, 2624-bit, 2640-bit, 2656-bit, 2672-bit, 2688-bit, 2704-bit, 2720-bit, 2736-bit, 2752-bit, 2768-bit, 2784-bit, 2800-bit, 2816-bit, 2832-bit, 2848-bit, 2864-bit, 2880-bit, 2896-bit, 2912-bit, 2928-bit, 2944-bit, 2960-bit, 2976-bit, 2992-bit, 3008-bit, 3024-bit, 3040-bit, 3056-bit, 3072-bit, 3088-bit, 3104-bit, 3120-bit, 3136-bit, 3152-bit, 3168-bit, 3184-bit, 3200-bit, 3216-bit, 3232-bit, 3248-bit, 3264-bit, 3280-bit, 3296-bit, 3312-bit, 3328-bit, 3344-bit, 3360-bit, 3376-bit, 3392-bit, 3408-bit, 3424-bit, 3440-bit, 3456-bit, 3472-bit, 3488-bit, 3504-bit, 3520-bit, 3536-bit, 3552-bit, 3568-bit, 3584-bit, 3600-bit, 3616-bit, 3632-bit, 3648-bit, 3664-bit, 3680-bit, 3696-bit, 3712-bit, 3728-bit, 3744-bit, 3760-bit, 3776-bit, 3792-bit, 3808-bit, 3824-bit, 3840-bit, 3856-bit, 3872-bit, 3888-bit, 3904-bit, 3920-bit, 3936-bit, 3952-bit, 3968-bit, 3984-bit, 4000-bit, 4016-bit, 4032-bit, 4048-bit, 4064-bit, 4080-bit, 4096-bit, 4112-bit, 4128-bit, 4144-bit, 4160-bit, 4176-bit, 4192-bit, 4208-bit, 4224-bit, 4240-bit, 4256-bit, 4272-bit, 4288-bit, 4304-bit, 4320-bit, 4336-bit, 4352-bit, 4368-bit, 4384-bit, 4400-bit, 4416-bit, 4432-bit, 4448-bit, 4464-bit, 4480-bit, 4496-bit, 4512-bit, 4528-bit, 4544-bit, 4560-bit, 4576-bit, 4592-bit, 4608-bit, 4624-bit, 4640-bit, 4656-bit, 4672-bit, 4688-bit, 4704-bit, 4720-bit, 4736-bit, 4752-bit, 4768-bit, 4784-bit, 4800-bit, 4816-bit, 4832-bit, 4848-bit, 4864-bit, 4880-bit, 4896-bit, 4912-bit, 4928-bit, 4944-bit, 4960-bit, 4976-bit, 4992-bit, 5008-bit, 5024-bit, 5040-bit, 5056-bit, 5072-bit, 5088-bit, 5104-bit, 5120-bit, 5136-bit, 5152-bit, 5168-bit, 5184-bit, 5200-bit, 5216-bit, 5232-bit, 5248-bit, 5264-bit, 5280-bit, 5296-bit, 5312-bit, 5328-bit, 5344-bit, 5360-bit, 5376-bit, 5392-bit, 5408-bit, 5424-bit, 5440-bit, 5456-bit, 5472-bit, 5488-bit, 5504-bit, 5520-bit, 5536-bit, 5552-bit, 5568-bit, 5584-bit, 5600-bit, 5616-bit, 5632-bit, 5648-bit, 5664-bit, 5680-bit, 5696-bit, 5712-bit, 5728-bit, 5744-bit, 5760-bit, 5776-bit, 5792-bit, 5808-bit, 5824-bit, 5840-bit, 5856-bit, 5872-bit, 5888-bit, 5904-bit, 5920-bit, 5936-bit, 5952-bit, 5968-bit, 5984-bit, 6000-bit, 6016-bit, 6032-bit, 6048-bit, 6064-bit, 6080-bit, 6096-bit, 6112-bit, 6128-bit, 6144-bit, 6160-bit, 6176-bit, 6192-bit, 6208-bit, 6224-bit, 6240-bit, 6256-bit, 6272-bit, 6288-bit, 6304-bit, 6320-bit, 6336-bit, 6352-bit, 6368-bit, 6384-bit, 6400-bit, 6416-bit, 6432-bit, 6448-bit, 6464-bit, 6480-bit, 6496-bit, 6512-bit, 6528-bit, 6544-bit, 6560-bit, 6576-bit, 6592-bit, 6608-bit, 6624-bit, 6640-bit, 6656-bit, 6672-bit, 6688-bit, 6704-bit, 6720-bit, 6736-bit, 6752-bit, 6768-bit, 6784-bit, 6800-bit, 6816-bit, 6832-bit, 6848-bit, 6864-bit, 6880-bit, 6896-bit, 6912-bit, 6928-bit, 6944-bit, 6960-bit, 6976-bit, 6992-bit, 7008-bit, 7024-bit, 7040-bit, 7056-bit, 7072-bit, 7088-bit, 7104-bit, 7120-bit, 7136-bit, 7152-bit, 7168-bit, 7184-bit, 7200-bit, 7216-bit, 7232-bit, 7248-bit, 7264-bit, 7280-bit, 7296-bit, 7312-bit, 7328-bit, 7344-bit, 7360-bit, 7376-bit, 7392-bit, 7408-bit, 7424-bit, 7440-bit, 7456-bit, 7472-bit, 7488-bit, 7504-bit, 7520-bit, 7536-bit, 7552-bit, 7568-bit, 7584-bit, 7600-bit, 7616-bit, 7632-bit, 7648-bit, 7664-bit, 7680-bit, 7696-bit, 7712-bit, 7728-bit, 7744-bit, 7760-bit, 7776-bit, 7792-bit, 7808-bit, 7824-bit, 7840-bit, 7856-bit, 7872-bit, 7888-bit, 7904-bit, 7920-bit, 7936-bit, 7952-bit, 7968-bit, 7984-bit, 8000-bit, 8016-bit, 8032-bit, 8048-bit, 8064-bit, 8080-bit, 8096-bit, 8112-bit, 8128-bit, 8144-bit, 8160-bit, 8176-bit, 8192-bit, 8208-bit, 8224-bit, 8240-bit, 8256-bit, 8272-bit, 8288-bit, 8304-bit, 8320-bit, 8336-bit, 8352-bit, 8368-bit, 8384-bit, 8400-bit, 8416-bit, 8432-bit, 8448-bit, 8464-bit, 8480-bit, 8496-bit, 8512-bit, 8528-bit, 8544-bit, 8560-bit, 8576-bit, 8592-bit, 8608-bit, 8624-bit, 8640-bit, 8656-bit, 8672-bit, 8688-bit, 8704-bit, 8720-bit, 8736-bit, 8752-bit, 8768-bit, 8784-bit, 8800-bit, 8816-bit, 8832-bit, 8848-bit, 8864-bit, 8880-bit, 8896-bit, 8912-bit, 8928-bit, 8944-bit, 8960-bit, 8976-bit, 8992-bit, 9008-bit, 9024-bit, 9040-bit, 9056-bit, 9072-bit, 9088-bit, 9104-bit, 9120-bit, 9136-bit, 9152-bit, 9168-bit, 9184-bit, 9200-bit, 9216-bit, 9232-bit, 9248-bit, 9264-bit, 9280-bit, 9296-bit, 9312-bit, 9328-bit, 9344-bit, 9360-bit, 9376-bit, 9392-bit, 9408-bit, 9424-bit, 9440-bit, 9456-bit, 9472-bit, 9488-bit, 9504-bit, 9520-bit, 9536-bit, 9552-bit, 9568-bit, 9584-bit, 9600-bit, 9616-bit, 9632-bit, 9648-bit, 9664-bit, 9680-bit, 9696-bit, 9712-bit, 9728-bit, 9744-bit, 9760-bit, 9776-bit, 9792-bit, 9808-bit, 9824-bit, 9840-bit, 9856-bit, 9872-bit, 9888-bit, 9904-bit, 9920-bit, 9936-bit, 9952-bit, 9968-bit, 9984-bit, 10000-bit.

POWERFUL NEW VERSION!

COMPONENTS

Sources: DC Voltage, DC Current, AC Voltage, AC Current, Voltage-Controlled Voltage, Voltage-Controlled Current, Current-Controlled Voltage, Current-Controlled Current, AM, FM, Vcc, Clock, Pulse-Width Modulated, Frequency Shift Keying, Polynomial, Piece-Wise Linear, Controlled Voltage, Controlled Oscillator and Nonlinear, Dependent Basic Resistor, Capacitor, Inductor, Transformer, Relay, Switch, Time-Delay Switch, Voltage-Controlled Switch, Current-Controlled Switch, Pull-Up Resistor, Variable Resistor, Resistor Pack, Polarized Capacitor, Variable Capacitor, Variable Inductor, Coupled Inductor and Nonlinear Transformer.

Diodes: Diode, Zener Diode, LED, Shockley Diode, Diac, SCR, Triac and Full Wave Bridge Rectifier.

Transistors: NPN and PNP BJT, N- and P-Channel JFET, 3 and 4 Terminal Enhancement and Depletion N- and P-Channel MOSFET.

Analog ICs: 3 and 4 Terminal Opamps, Comparators and Voltage Regulators.

Mixed ICs: 4-to-D, Luenver, 10-A Voltage and Current Converters, 555 Timer and Monostable.

Logic Gates: AND, OR, NOT, NOR, NAND, XOR, MUX, Tri-State Buffer, Buffer and Schmitt Trigger.

Digital: 45, 74, 74C, 74D and D Flip-Flops, Half and Full Adders, Multiplexers, Demultiplexer, Encoder and Decoder.

Indicators: Bulb, Indicator, Ammeter, Probe, Pass and Decoded 7 Segment Display, Buzzer and Raw and Decoded Bargraph.

Control: Differential Integrator, Gain Block, Transfer Function Limiter, Multiplex Divides and Summer.

Other: Fuse, Locus and Locusless Transmissor Limiter, Virtual DC motor, Vacuum Tube and Buck and Boost Converter.

74xx ICs: 7400, 7401, 7402, 7403, 7404, 7405, 7406, 7407, 7408, 7409, 7410, 7411, 7412, 7413, 7414, 7415, 7420, 7421, 7422, 7423, 7424, 7425, 7426, 7427, 7428, 7430, 7431, 7432, 7433, 7434, 7435, 7436, 7437, 7438, 7439, 7440, 7442, 7445, 7447, 7448, 7449, 7450, 7451, 7454, 7455, 7469, 7472, 7473, 7474, 7475, 7476, 7477, 7478, 7486, 7490, 7491, 7492, 7493.

74xxx ICs: 74107, 74109, 74112, 74113, 74114, 74115, 74116, 74118, 74119, 74120, 74130, 74134, 74137, 74138, 74139, 74140, 74141, 74142, 74143, 74144, 74145, 74153, 74154, 74155, 74156, 74157, 74158, 74159, 74160, 74161, 74163, 74164, 74165, 74166, 74169, 4173, 74174, 74175, 74181, 74190, 74191, 74192, 74194, 74195, 74196, 74199, 74208, 74240, 74241, 74242, 74243, 74253, 74257, 74258, 74275, 74280, 74290, 74293, 74297, 74350, 74352, 74353, 74365, 74367, 74368, 74373, 74374, 74375, 74377, 74378, 74379, 74393, 74395, 74445, 74465.

Digital: Models for ICs: Gates and Flip-Flops in HDL, 15-bit pole HDL buffer, HDL operational 15 kilohm pole 15 buffer, 15 pin collector and 15 pin open collector buffer configurations.

Diodes: Over 1,300 models for Diodes, Zener Diodes, LEDs, Shockley Diodes, and Diacs from Motorola.

Terminal Instruments: International Rectifier, Zetex, and Philips.

Transistors: Over 1,400 models for NPN and PNP BJTs, JFETs, MOSFETs, SCRs, Triacs and IGBTs from Motorola, National Semiconductor, International Rectifier, Toshiba, Harris and Philips.

Analogs ICs: Over 1,200 models for Opamps, Comparators and Voltage Regulators from Motorola, Texas Instruments, Maxim, Elance, Analog Devices, Zetex, Burr-Brown and Linear Technology.

Other Models: a variety of Relays, Transformers, Vacuum Tubes, Transmissors (any) and Crystals.

CALL 800-263-5552



Fax: 416-977-1818 Internet: <http://www.interactiv.com> CompuServe: 71333,3435/BBS: 416-977-3540/E-mail: ewb@interactiv.com

CIRCLE 13 ON FREE INFORMATION CARD

www.americanradiohistory.com

Electronics Workbench

VERSION 5

INTERACTIVE IMAGE TECHNOLOGIES LTD., 908 Niagara Falls Boulevard, #068, North Tonawanda, New York 14120-2060/Telephone 416-977-5550

TRADEMARKS ARE PROPERTY OF THEIR RESPECTIVE HOLDERS. OFFER IN U.S. DOLLARS AND VALID ONLY IN THE UNITED STATES AND CANADA. ALL ORDERS SUBJECT TO \$15 SHIPPING AND HANDLING CHARGE.

Popular Electronics[®]

FEBRUARY 1997

Vol. 14, No. 2



A GERNSBACK
PUBLICATION

COVER STORY

27 Build a 22-Watt Amplifier

Is the performance of your car stereo lacking in some areas? Are your road trips just not as entertaining as they could be? Put some real power into your vehicular audio system with this amplifier that looks small but actually sounds big. Best of all, it costs less than \$20 to build—*Gary Clifton*

CONSTRUCTION

32 Build an Automatic Headlamp Control

In many states, if your car's windshield wipers are on, the law requires you to turn on the vehicle's headlamps too. With this circuit you'll never have to remember to do that again. Just switch on your vehicle's wipers and let the Control module do the rest for you—*Anthony J. Caristi*

49 Build an Infrared Remote Decoder

Use it to operate your computer from across the room with any TV or VCR remote control—*Stuart Ball*

FEATURES

30 The Mobile Assistant

Forget about laptops if you're looking for a computer that's truly portable. Learn about a belt-worn PC that leaves your hands free to do repairs and other tasks—*Bill Siuru*

39 Cruising the Lowest Ham Bands

Join us for a look at LowFERS and MedFERS, the most unusual ham frequencies that you can explore. Learn what signals lurk in those regions of the spectrum, and what equipment you can use to hear them —*Karl T. Thurber, Jr.*



Page 27



Page 30

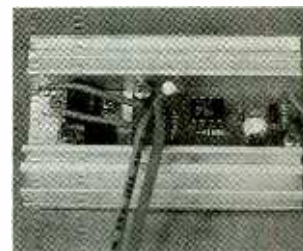

Page 32

POPULAR ELECTRONICS (ISSN 1042-170-X) Published monthly by Gernsback Publications, Inc. 500 Bi-County Boulevard, Farmingdale, NY 11735. Periodicals postage paid at Farmingdale, NY and at additional mailing offices. One-year, twelve issues, subscription rate U.S. and possessions \$21.95, Canada \$28.84 (includes G.S.T. Canadian Goods and Services Tax Registration No. R125166280), all other countries \$29.45. Subscription orders payable in U.S. funds only. International Postal Money Order or check drawn on a U.S. bank; U.S. single copy price \$3.50. Copyright 1996 by Gernsback Publications, Inc. All rights reserved. Hands-on Electronics and Gizmo trademarks are registered in U.S. and Canada by Gernsback Publications, Inc. Popular Electronics trademark is registered in U.S. and Canada by Electronics Technology Today, Inc. and is licensed to Gernsback Publications, Inc. Printed in U.S.A.

Postmaster: Please send address changes to Popular Electronics, Subscription Dept., P.O. Box 338, Mount Morris, IL 61054-9932

A stamped self-addressed envelope must accompany all submitted manuscripts and/or artwork or photographs if their return is desired should they be rejected. We disclaim any responsibility for the loss or damage of manuscripts and/or artwork or photographs while in our possession or otherwise.

As a service to readers, Popular Electronics publishes available plans or information relating to newsworthy products, techniques, and scientific and technological developments. Because of possible variances in the quality and condition of materials and workmanship used by reader, Popular Electronics disclaims any responsibility for the safe and proper functioning of reader-built projects based upon or from plans or information published in this magazine.

P R O D U C T R E V I E W S

8 Hands-On Report

Dycam 10-C digital camera

12 Product Test Report

AudioSource MCSW 1 powered subwoofer

C O L U M N S

16 Net Watch

The State of Digital Audio—*Dan Karagiannis*

21 Multimedia Watch

My New Favorite PC—*Marc Spiwak*

61 Computer Bits

DOS or Windows or Both?—*Jeff Holtzman*

62 Ham Radio

Winter Ham Activities—*Joseph J. Carr*

64 Antique Radio

A Spate of New Books—*Marc Ellis*

66 DX Listening

Farewell, ANDEX—*Don Jensen*

71 Scanner Scene

When Disaster Strikes—*Marc Saxon*

73 Circuit Circus

More Electronic Sensors—*Charles D. Rakes*

76 Think Tank

Benchtop Stuffing—*John Yacono*

D E P A R T M E N T S

4 Editorial

6 Letters

24 New Products

58 Electronics Library

81 Popular Electronics Market Center

112 Advertiser's Index

112A Free Information Card

Larry Steckler, EHF-CET
editor-in-chief and publisher

EDITORIAL DEPARTMENT

Dan Karagiannis, editor

Teri Scaduto, assistant editor

Evelyn Rose, editorial assistant

Joseph J. Carr, K4IPV,
contributing editor

Marc Ellis, contributing editor

Jeffrey K. Holtzman,
contributing editor

Don Jensen, contributing editor

Charles D. Rakes,
contributing editor

Marc Saxon, contributing editor

Marc Spiwak, contributing editor

John Yacono, contributing editor

PRODUCTION DEPARTMENT

Ruby M. Yee, production director

Ken Coren,
desktop production director

Lisa Baynon, desktop production

Kathy Campbell,
production assistant

ART DEPARTMENT

Andre Duzant, art director

Russell C. Truelson, illustrator

CIRCULATION DEPARTMENT

Jacqueline P. Cheeseboro,
circulation director

Theresa Lombardo,
circulation assistant

Michele Torriolo,
POPULAR ELECTRONICS bookstore

**BUSINESS AND EDITORIAL
OFFICES**

Gernsback Publications, Inc.

500 Bi-County Blvd.

Farmingdale, NY 11735

1-516-293-3000

FAX: 1-516-293-3115

Web: <http://www.gernsback.com>

President: **Larry Steckler**

**SUBSCRIPTION
CUSTOMER SERVICE/
ORDER ENTRY**

1-800-827-0383

7:30 AM - 8:30 PM EST

**Advertising Sales Offices
listed on page 112**

Composition by Mates Graphics

Cover by Loewy Design

Cover Illustration by Chris Gould



Since some of the equipment and circuitry described in POPULAR ELECTRONICS may relate to or be covered by U.S. patents, POPULAR ELECTRONICS disclaims any liability for the infringement of such patents by the making, using, or selling of such equipment or circuitry, and suggests that anyone interested in such projects consult a patent attorney.

TraxMaker[®]

A Virtual Environment For
Growing Printed Circuit Boards

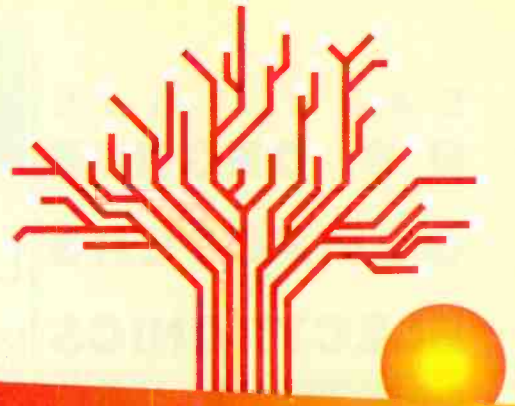

“Finally, a low cost, easy to use, professional quality, PCB design tool”

TraxMaker is a Printed Circuit Board (PCB) layout program that supports multiple layers along with full auto placement of components and autorouting of tracks. TraxMaker makes good design practice easy, according to user definable “Design Rules”. It has a familiar, easy to learn Windows interface. TraxMaker is a truly cost effective package which is sure to handle your most demanding PCB design tasks. TraxMaker can be used as a standalone product or with compatible schematic capture products. When used in conjunction with CircuitMaker, TraxMaker completes a powerful beginning to end circuit design system.

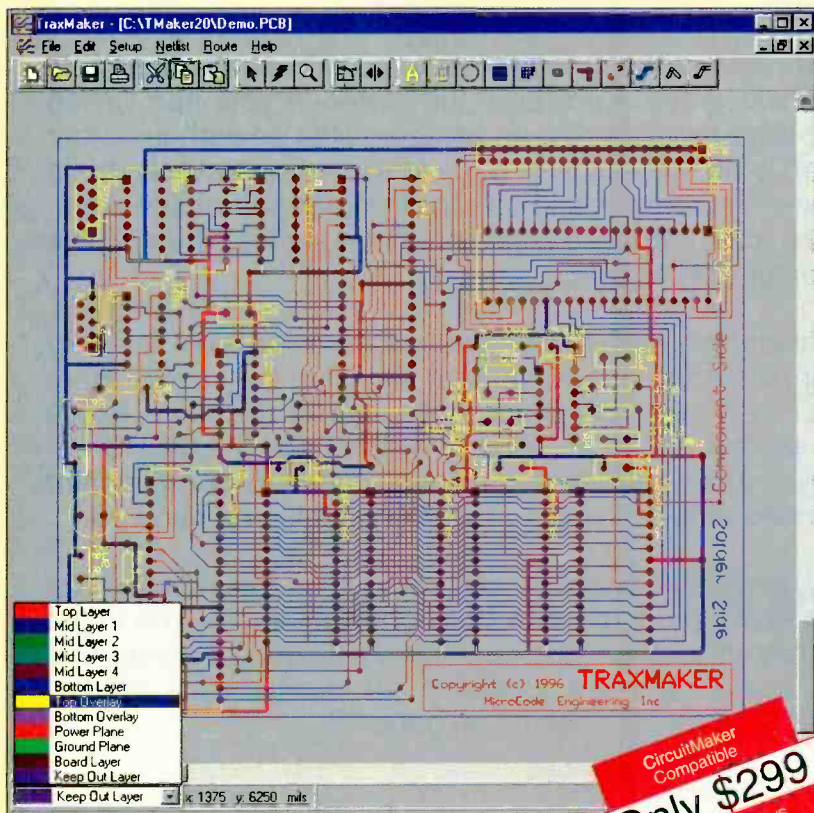

TraxMaker Features

- Exceptionally easy to learn and operate
- 6 signal layers plus power and ground planes, top and bottom overlays, and solder and paste masks
- Built-in autorouter which provides routing of entire board, individual nets, pad to pad (without net), or interactive (using ratsnest)
- Automatic component placement with user definable placement grid and keep-out areas
- Full support for both through-hole and surface mount components
- Output to any Windows compatible printing device, Gerber files, and Excellon N/C drill file
- Import CircuitMaker, Protel, and Tango netlists
- Orthogonal, curved, and any angle tracks
- Design objects include tracks, pads, vias, arcs, free text, rectangular and polygon fills
- Includes a wide selection of component patterns and new patterns can be quickly and easily created
- Choose either Metric or English units
- Maximum resolution of .001 inches (1 mil)
- Maximum board size of 32 x 32 inches

FREE Functional Demo

Product literature and a free functional TraxMaker demo are available on the Internet at <http://www.microcode.com>, on CompuServe (GO MICROCODE) and on America Online by doing a file search for TraxMaker

Call Now to Order or
Request Additional Information

800-419-4242



EARN YOUR
B.S. DEGREE
IN
COMPUTERS
OR
ELECTRONICS



By Studying at Home

Grantham College of Engineering, now in our 46th year, is highly experienced in "distance education"—teaching by correspondence—through printed materials, computer materials, fax, modem, and phone.

No commuting to class. Study at your own pace, while continuing on your present job. Learn from easy-to-understand but complete and thorough lesson materials, with additional help from our instructors.

Grantham offers three separate distance-education programs, leading to the following accredited degrees:

- (1) The B.S.E.T. with Major Emphasis in Electronics.
- (2) The B.S.E.T. with Major Emphasis in Computers.
- (3) The B.S.C.S. — the Bachelor of Science in Computer Science.

An important part of being prepared to *move up* is holding the right college degree, and the absolutely necessary part is knowing your field. Grantham can help you both ways—to learn more and to earn your degree in the process.

Write or phone for our free catalog. Toll free, 1-800-955-2527, or see mailing address below.

Accredited by
the Accrediting Commission of the
Distance Education and
Training Council

GRANTHAM
College of Engineering
Grantham College Road
Slidell, LA 70460

EDITORIAL

Listening Pleasure

Let's face it, most of us spend a lot of time driving. Whether you travel to work or school, or live a good distance from your sweetheart, you might be spending an hour or more in your car each day. Shouldn't that experience be a pleasant one?

To make road travel more enjoyable, a lot of drivers turn to (or turn on) their car stereos. But if the sound system within your car isn't quite up to par, you won't be all that happy with those hours spent behind the wheel. Instead, you'll probably find yourself wishing you were home listening to music the right way.

This month we're happy to present you with a truly affordable way of boosting the power of the stereo in your car. Called the 22-Watt Amplifier, it's an amazing little powerhouse that you can build for less than \$20. At that price, you can build two, one for the front and one for the rear pair of speakers. You'll be quite surprised at just how loud such a setup is! The story begins on page 27.

Also this month, we've got some great non-musical listening tips for all of our ham readers. In "Cruising the Lowest Ham Bands" we'll give you an idea of some of the more exotic things there are to hear in the LowFERS and MedFERS frequency ranges, and even show you the kind of equipment you'll need to tune them in. The story begins on page 39.

Finally, for any audiophiles with computers, this month's *Net Watch* explores the current state of digital audio. You might be surprised to learn just how many CD-quality songs and movie audio clips are available for downloading off the Internet. The column begins on page 16.

Happy listening!

Dan Karagiannis
Editor

Why pay for cellular phone service if you only want it for emergency use?

The SOS Phone offers a 24-hour call center to connect you with your emergency roadside service, 911 service or family members in the event of an emergency.



Press the Tow button and your emergency road service will be dispatched to tow your automobile.

To tell you the truth, I am not interested in owning a cellular phone...except for use in an emergency. What would I do if my car broke down on the interstate or ran out of gas on some deserted back road? How would I get help? Like most women, I have the safety of my children to consider.

Last month, I inquired about cellular phone service. I was surprised to find out how expensive it was, even for the most basic calling plans! I just couldn't justify spending that much for something I may never need. Then a good friend told about a product she thought would solve my problem. It's the SOS Phone—a cellular phone service designed exclusively for emergency use!

What does it do? With the touch of a button, the SOS Phone will connect me to a roadside emergency service, a 911 service or a trained SOS operator, 24 hours a day. If I ever need help, I know it's just a phone call away.

Emergency assistance. By pressing the "tow" button, I'll be connected with my emergency roadside service provider. Or, if I don't have one, the SOS operator can recommend one to me and dispatch them immediately.



The 911 button will connect you to 911 police or other emergency services, and the call is absolutely free!

The "911" button will connect me to the 911 emergency service in my area—best of all, the call is absolutely free!

Personalized service. Each SOS Phone has a serial number that is recorded at the Call Center, so each time I use my phone, the operators will know that it is me calling, and will greet me by name. Plus, my SOS Emergency Record will appear instantly on the computer screen and the operator will connect me with the person or emergency service I need.

Not just for emergencies. If I just want to call home to tell

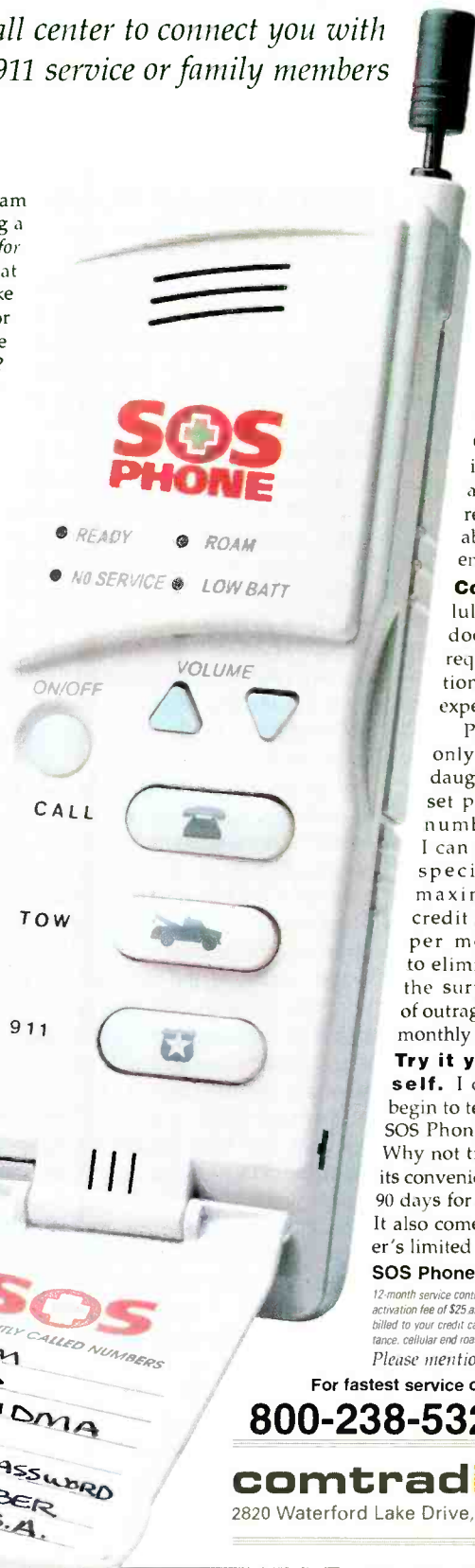

my husband that the kids and I are running late, I can! By pressing the "call" button, I'll reach an operator. When I ask the operator to call home, I'll be connected automatically. And because the Call Center has my list of 10 most-used phone numbers, I don't even have to recite the number!

Great for teens. The SOS Phone is also a great thing to have around for my stepdaughter. I can rest assured that she'll always be able to get in touch with us (or an emergency service) if she needs to.

Cost control. Unlike ordinary cellular phone plans, the SOS Phone doesn't have any minimum usage requirements or any other stipulations that could change the price I expect to pay each month.

Plus, without my password, the only non-emergency calls my stepdaughter can make are to our 10 pre-

set phone numbers. I can even specify a maximum credit limit per month to eliminate the surprise of outrageous monthly bills! **Try it yourself.** I can't







Use the Call button to talk to an SOS operator or be connected to someone on your preset list of numbers.

begin to tell you how much confidence the SOS Phone has given me and my family. Why not try it yourself? If you don't enjoy its convenience and security, return it within 90 days for a "No Questions Asked" refund. It also comes with a three-year manufacturer's limited repair or replacement warranty.

SOS Phone \$99 \$12 S&H
12-month service contract required for this price. Requires a one-time non-refundable activation fee of \$25 and a monthly charge of \$9.95. Calls made on the Call button are billed to your credit card at \$1.45 per minute. (That rate includes all local, long-distance, cellular and roaming fees.) For outgoing calls only.
 Please mention promotional code 1788-PL-10005.

For fastest service call toll-free 24 hours a day

800-238-5322    

comtradindustries

2820 Waterford Lake Drive, Suite 102 Midlothian, VA 23113

LETTERS

Thanks for the Info!

I NEEDED THAT

Just a quick note to thank you for Lyle Russell Williams' article, "Becoming an Electronics Engineer," which ran in the November 1996 issue of **Popular Electronics**. This is just the sort of information that I am looking for as I make the transition from technician level to engineering. It was very interesting to see what could be waiting for me on the other side of graduation from engineering school.

How about printing similar articles in the future on how to use our electronics skills to make money. The "hobby" end of electronics is great, but one can only have so many home-made gadgets cluttering up the home!

B.L.M.

Albuquerque, NM

Thank you for writing. While we are primarily a hobbyist magazine, we would be open to publishing more articles on how to make money using electronics skills. After all, who wouldn't love to make money doing what he or she likes?—Editor

NEW TESTING POLICIES

The readers of **Popular Electronics** might be interested to hear about some sweeping policy changes announced recently by the International Society of Certified Electronics Technicians (ISCET). The changes allow other organizations to administer ISCET tests, and allow the ISCET-issued test and certificate to bear the name and logo of the participating organization. A portion of the test fee will go to the certifying organization.

In addition, ISCET has agreed to accept the Electronics Technicians Association (ETA) Associate Test in lieu of the ISCET Associate Test requirement to qualify to take any one of the ISCET Journeyman exams. ISCET would also be willing to work with ETA to develop a common Associate exam question pool.

ISCET is recognized as the leading electronics and appliance technician-certification agency, having certified

more than 41,000 technicians, most of whom hold Associate certification.

B.R.

ISCET

Fort Worth, TX

PARTS POLICY, PLEASE!

I have read **Popular Electronics** for about 45 years. Lately, however, I have been disappointed to see companies writing articles and then offering to sell the key part at *extremely* high prices. In the November issue, for instance, the PIC CPU for the "Easyscope" costs about \$2; they are selling it for \$50. That's quite a markup!

Popular Electronics has held my attention over the years because it offered projects that hobbyists could build. I now look at the parts list before reading any construction article. Today, when the average electronics engineer or technician (let alone experimenter) doesn't own a PIC programmer, I believe the magazine should establish a policy to keep its projects accessible to its readers.

I would like to suggest that all construction articles use parts that are readily available from more than one source. All source code should be available through **Popular Electronics** for anyone to use with no royalty of other charge. If a printed-circuit board is made available, the magazine should print the film with drill centers. If a PC board is mandatory for the project to work properly, the article should explain how to make the board.

I am an electronics engineer who got into the field largely because of **Popular Electronics** and Don Lancaster. I credit my good grades in college to my experience building the projects presented each month in the pages of your magazine.

Years ago, I wrote an article that **Popular Electronics** published (and reprinted). I could write a construction article every month that would use a programmed microcontroller, offer to sell the chip for \$50, and make a lot of money—but I feel that is wrong. It prohibits other young experimenters from

building projects that would help them learn more about electronics.

Thanks for listening!

A.M.

We received a reply from Robert G. Brown in which he states that at the time he prepared the article, the unprogrammed PIC he uses was over \$20. He and many readers still feel, however, that the cost of the complete kit—\$85—is a great value.

*I have to add, in response to your other comments, that we do provide source code, free of charge, for every PIC project we run in **Popular Electronics**. The files were posted in the past to our BBS, and will now be posted to our FTP side (<ftp.gernsback.com>). Also, we always provide PC-board templates when a project uses them, as well as any special assembly procedures necessary to make the boards.*

Hope this answers your concerns; thanks for writing.—Editor

HAVES & NEEDS

I am seeking a manual for an oscilloscope: Model Conar 255, manufactured by Conar Instruments in Washington D.C. Thank you for your help.

DUKE HOLY

1125 Shoreview

Englewood, FL 34223

Popular Electronics is a unique magazine. When my copy arrives each month, I can't wait to turn to my favorite columns (*Circuit Circus* and *Think Tank*). I love building projects and servicing television, audio, and VCR equipment—which, fortunately, is my profession.

I am interested in corresponding with other people around the world who share my interest in electronics, and who would like to exchange ideas on this important field.

JOSEPH ANIE

Port Fire Service

Box 383, Tema Ghana

West Africa

FLUKE®



Some
things
come
and go.

Introducing The Fluke Lifetime Limited Warranty For Multimeters.

Some things you buy on a whim. And regret later. But now we have something you'll never regret: genuine Fluke Digital Multimeters, backed by our new lifetime limited warranty.

Every member of our rugged and reliable Fluke 20, 70, and 80 Series DMMs now comes with our new lifetime warranty. That's a lifetime longer than standard warranties on the other bargain-basement meters.

Which is reassuring. As is knowing that you've already purchased the DMM known for its unsurpassed

quality, reliability, accuracy, and ruggedness.

Every Fluke multimeter is built in the United States, under a quality system certified to meet ISO 9001 requirements. They're easy to use, with faster response times that give you readings in seconds, and at a glance.

It's no wonder millions of professionals have chosen Fluke DMMs as the only name they trust.

For more information on the DMMs that last a lifetime, call Fluke today at 1-800-44-FLUKE. Or visit our website at www.fluke.com. It's one move you won't live to regret.

Others last a lifetime.



20 Series

70 Series

80 Series



DYCAM 10-C DIGITAL CAMERA



*Forget film and developing;
take still pictures electronically
with this digital camera.*

The principles behind photography haven't changed much in the past hundred years or so. Basically a light-sensitive substance, usually some compound of silver on a flat surface, is exposed to a scene of interest through the aperture of a pinhole or lens. From that point on it's all chemical, not electronics. Color photography adds fancier chemicals to the mix, but the principles are the same.

Now photographic chemicals and related products are relatively expensive, so that's why you can pay a lot for film and its developing. One way around this is the charge-coupled device, or CCD. A CCD is a solid-state device that "sees" light and outputs an electronic representation of what it sees. There are CCDs of varying quality and sensitivity, and of course, price.

Video cameras contain a CCD. These cameras convert an image—actually a series of them—into an electronic signal that is transferred to video tape. When the tape is played back, the recorded signal is converted into the type of signal that a television set requires. NTSC is the TV signal format used in the United States and many other countries. The problem is, the resolution of an NTSC TV picture is rather poor compared to a pho-

tograph. If you've ever seen an image captured from NTSC video you can see how much detail is missing. You don't really notice the lack of detail while watching TV, but if you get up close to the screen you can actually see the spaces between color pixels. This is why people are anxious for HDTV to become available, because it will have at least double the resolution of NTSC, and a wider picture as well.

Clearly then, CCDs of much better quality must be used in still cameras. This is one reason why electronic still cameras have been high in price. Another problem is that images from an electronic still camera must be viewed on a monitor, or printed. And affordable color printers just didn't exist only a few years ago. But thanks to advancements in technology, home computers, and color printers, electronic still cameras are breaking new ground, and fairly advanced ones can now be purchased for under \$1000.

The advantages to a digital camera are many. There's no expensive film involved, no development costs, and your PC becomes your own personal photo studio. Pictures in electronic form can instantly be e-mailed anywhere in the world. A photographer/reporter up in a helicopter

documenting some sort of disaster can send pictures via wireless e-mail or modem to a publisher as the pictures are taken. Internet users can upload pictures immediately after taking them without having to scan them in first.

Dycam 10-C Digital Camera. The Dycam model 10-C truly is a camera of the '90s. This digital color zoom camera features a power zoom with a close-up mode, automatic focus, automatic flash, virtually unlimited storage with add-on memory cards, and outputs pictures in a maximum 640 x 480 resolution.

The 10-C is nearly identical to a handful of other digital cameras, as well it should be; all of them are made by Chinon. The unique thing about the Dycam 10-C is that this is the only one with a threaded collar around the lens, so you can attach accessory lenses and filters. The 10-C also sells for a bit less than the others, with a list price of \$998. That price includes the camera, a serial adapter cable, four AA batteries, user's guides, and software on diskette. The camera is powered from four AA batteries—lithium, alkaline, or Ni-Cd batteries can be used. A battery-level indicator tells you when you should change the batteries. Images are retained even

Fifteen years of micro-electronic research makes a thing of the past!

This little box uses your home's electrical wiring to give non-subscribers, cable subscribers and satellite users better TV reception on local broadcast networks!

Technology corner

Why don't conventional antennas work as well as the Spectrum?

Bandwidth of TV Signal

1 2 3 4 5 6



Spectrum system:
Precision tuning

Other systems:
Non-precision tuning

■ When TV signals are tuned at the TV channel's center frequency, optimum tuning has been achieved.

■ Other antennas can't offer center frequency tuning like the Spectrum Antenna can. They only offer such tuning up to the edge of the center frequency. As a result, your TV picture remains snowy.

How does Spectrum use a home's electrical wiring as an antenna?

Believe it or not, the Spectrum Antenna simply "activates" the giant antenna that already exists in your home. Essentially, it uses all of the wiring throughout your home's walls and ceilings to make an antenna as large as your house for unbelievably clear reception of local broadcasting.

Acting Antenna



Before

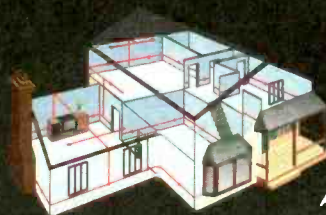

After

Until recently, the only convenient way to guarantee great TV reception was to have cable installed or place an antenna on top of your TV. But who wants to pay a monthly cable fee just to get clear reception, or have rabbit-ear antennas that just don't work on all stations? Some people just aren't interested in subscribing to cable. Or they may live in an area where they can't get cable and TV-top antennas aren't powerful enough. And what about those people who have cable or satellite systems but still can't get certain local stations in clearly?

Now, thanks to fifteen years of microelectronics research, a new device has been developed that is so advanced, it actually makes conventional antennas a thing of the past. It's called the Spectrum Universal Antenna/Tuner.

Advanced technology. Just imagine watching TV and seeing a picture so clear that you'd almost swear you were there live. Just plug the Spectrum Antenna into a standard AC outlet and plug your TV into the Spectrum. You can remove the unsightly clutter of traditional TV-top devices gathering more dust than television signals. Get ready for great reception. Your TV will display a sharp, focused picture thanks to Spectrum's advanced "Signal Search" and "Fine Tuner" controls.

Uses your home's electrical wiring. The Spectrum Antenna is a highly sophisticated electronic device that connects into a standard wall outlet. The outlet interfaces the Spectrum Antenna with the huge antenna that is your home wiring network. It takes the electrical wiring in your house or apartment and turns it into a multi-tunable, giant TV reception station which will improve your TV's overall tuning capability. The results are incredible. Just think how much power runs through your home's AC wiring system—all that power will be used to receive your local broadcasting signals.

How it works. Broadcast TV signals are sent out from the local broadcast station (ABC, CBS, NBC, etc.). They interface with your home's AC power line system, a huge aerial antenna network of wiring as large as your home itself. When the Spectrum Antenna interfaces with the AC line, the signal is sent to its signal processing circuit. It then processes and separates the signal into 12 of the best antenna configurations. These specially-processed signals route themselves into 12 separate circuits. The Spectrum Antenna includes a 12-position rotary tapping switch, the "Signal Switch" control, which gathers 12 of the best antenna configurations.

Parallel 75 ohm resistance
For minimum loss of signal

Signal search control
For selecting multiple antenna configurations

Resonant fine tuner control
For dialing in crisp, clear TV/stereo reception, eliminates ghosting

Dual outlets with surge protection

For plugging in additional TV/stereo equipment, guarding against damage and surges

The "Signal Search" offers varying antenna configurations for the user to select from the best signals of all those being sent. The signal then passes through the Spectrum Antenna's special "Fine Tuner" circuit for producing crisp, clear reception.

Rural areas. If you live in a rural area you may need to enhance the incoming signal—most rural areas signals are weak, making them harder to fine tune. The "Gain Booster" is a high-frequency signal booster designed to increase the output level of the signal entering your television. It delivers a 10-fold greater signal which will bring richer color and a noise-free picture. By using the "Gain Booster," all of the Spectrum's fine tuning controls will function better, giving the Spectrum Antenna a stronger signal to fine tune. It also works in conjunction with your outdoor antenna.

Risk-free offer. The Spectrum Universal Antenna/Tuner comes with our exclusive 90-day risk-free home trial and a 90-day manufacturer's warranty. Try it, and if you're not satisfied, return it for a full "No Questions Asked" refund.

Limited time offer! We realize that most people have more than one TV in their home. We are offering a special discount on additional Spectrum Antennas so you can get great reception on all your TVs!

Spectrum Antenna \$39 \$4 S&H
Additional antennas just . . . \$34 S&H free
Gain Booster \$19 \$2 S&H

Please mention promotional code 1495-PL-10006.

For fastest service, call toll-free 24 hours day

800-230-5023



To order by mail, send check or money order for the total amount including S&H.. To charge it, enclose your account number and expiration date.

Virginia residents only—please add 4.5% sales tax.

comtrad industries

2820 Waterford Lake Dr., Suite 102
Midlothian, Virginia 23113

ELECTRONIC COMPONENTS

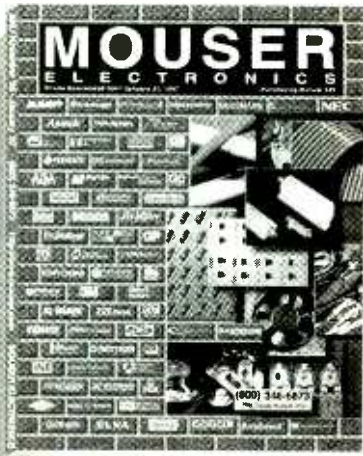

Call for your **FREE 332**
page catalog **TODAY!**

- 68,138 Products
- 128 Manufacturers
- All Orders Ship Same Day
- No Minimum Order

800-992-9943 FAX: 817-483-0931
http://www.mouser.com sales@mouser.com

958 North Main St., Mansfield, TX 76063

CIRCLE 164 ON FREE INFORMATION CARD

The professional weather
station for people curious
about the weather.



★★★★
The Best™
(Alan Fields,
Partly Sunny)

Haven't you always wanted a weather station? The Weather Monitor II makes a state-of-the-art weather monitoring system affordable enough for home use!

FEATURES INCLUDE:

- Inside & Outside Temps
- Wind Speed & Direction
- Barometer
- Time & Date
- Inside Humidity
- Wind Chill
- Alarms
- Highs & Lows
- Rainfall Option
- Instant Metric Conversions
- Outside Hum. & Dew Point Option
- PC Interface Option

1-800-678-3669

M-F 7 a.m. to 5:30 p.m. Pacific Time • PE674E
FAX 1-510-670-0589 • M/C and VISA
One-year warranty • 30-day money-back guarantee

DAVIS INSTRUMENTS

3485 Diablo Ave., Hayward, CA 94545

CIRCLE 162 ON FREE INFORMATION CARD



One year old Daniel doesn't mind having his picture taken with the Dycam 10-C digital camera. This shot shows the best resolution the camera can provide.

with the batteries removed, but the camera's built-in clock will fail three minutes after removing them.

An AC adapter is available from Dycam for \$79, and this eliminates the need for batteries, but it also ties you to an AC outlet. The AC adapter is fine for studio work, and useful when transferring pictures from the camera to computer, as this operation consumes a lot of power. The camera turns on when the flash is pulled out to the side, and it shuts itself off after 60 seconds to conserve power if it's not being used.

You don't need a computer to use the camera, although you do need one to import the pictures and view them on. The camera can be used with a PC or Mac. A PC must be a 486 or better, running Win 3.1 or higher, have at least 8 MB RAM, a high-density floppy drive, and about 10 MB of free hard-disk space. A Mac must have a 68020 processor or higher, System 7.0.1 or later, 8 MB of RAM, a high-density floppy drive, and about 10 MB of free hard-disk space.

Using the 10-C. The Dycam 10-C is very easy to use. Its internal memory can hold 40 pictures in the normal resolution, 10 pictures in fine resolution, and 5 pictures in super-fine resolution. The normal resolution consists of 320 X 240 pixels stored in a compressed form that has some loss of

detail associated with it. The fine resolution pictures contain basically the same level of picture detail with the same lossy compression scheme, but at 640 X 480 pixels—double the size of the normal-resolution pictures. The super fine pictures are also 640 X 480, but these are stored using a lossless compression scheme that retains as much detail as possible.

In actual use, however, you'll see very little difference between the fine and super-fine pictures. Resolution modes can be "mixed and matched," so that you can select the resolution that best suits a particular image, while still squeezing the most out of the camera's memory.

The Dycam 10-C also accepts standard PCMCIA add-on memory cards to increase the number of pictures you can take before downloading them to a PC. Dycam sent us a 4-megabyte card that increases the camera's capacity to 172 normal-resolution pictures, 43 fine-resolution pictures, or 21 super-fine-resolution pictures. Dycam sells this card for \$349. Cards with larger and smaller capacity are also available. While a reporter might need more memory in the camera, most users will be fine without one.

Seasoned photographers will feel comfortable with the Dycam 10-C in their hands. It looks and feels like

(Continued on page 57)

**NEW
Xplorer**

It's a receiver a counter, a recorder, a decoder...



•Two-Line LCD display. First line displays frequency. Second line switches between either CTCSS, DCS, DTMF, Signal Strength, or Numerical Deviation.

NMEA-0183 GPS Interface, -Connect your GPS to the Xplorer for Mapping applications. (GPS and Mapping Software not included)

The New Xplorer Test Receiver. Ideal for any two-way communications testing or monitoring. The Xplorer is a value packed performer integrating the functions of a CTCSS, DCS, and DTMF Decoder, Frequency Recorder, Nearfield Receiver and more into one hand-held unit. No more guessing when programming a frequency for monitoring-the Xplorer captures nearfield frequencies off the air from 30MHz - 2GHz in less than 1 second. The New Xplorer; providing the power of handheld portability with state of the art functionality and performance.



•Built-in Speaker. All frequencies received are demodulated for instant monitoring.

and the last instrument you will ever NEED.

Features & Specifications

- Frequency Lock Out, Manual Skip, and Auto or Manual Hold
- Internal Speaker, Audio Earphone/Headphone Jack
- Built-in PC Interface, PC Connection Cable and Download Software included
- Relative ten segment Signal Strength Bargraph
- Optimum Maximized Sensitivity for increased nearfield distance reception
- Tape Control Output with Tape Recorder Pause control relay and DTMF Encoder for audio data recording
- High speed FM Communications Nearfield Receiver, sweeps 30MHz - 2GHz in less than 1 second
- Two line LCD displays Frequency and either CTCSS, DCS, DTMF, Deviation or Signal Strength
- NMEA-0183 GPS Interface provides tagging data with location for mapping applications
- Frequency Recording Memory Register logs 500 frequencies with Time, Date, Number of Hits and Latitude/Longitude. (Latitude & Longitude coordinates are only displayed in memory when used with GPS)
- Real-Time Clock/Calendar with lithium battery back-up
- Built-in Rapid Charge NiCad Batteries with 5 hour discharge time and Power Supply included
- Numerical Deviation Display with 1-10kHz and 10-100kHz ranges
- Telescoping Whip full range Antenna included



•Easy touch control pad. F1 & F2 keys control all Xplorer functions. Hold, Skip, Store and Lockout all enabled through the keypad.

Introductory Price
\$899

FACTORY DIRECT ORDER LINE 800-327-5912

OPTOELECTRONICS®

5821 NE 14th Avenue • Ft Lauderdale, FL • 33334 • Tel: 954-771-2050 • Fax: 954-771-2052
Visa • MasterCard • C.O.D.

Prices and Specifications are subject to change without notice or obligation
* Contact Optoelectronics for mapping software available

CIRCLE 43 ON FREE INFORMATION CARD

Check Out Our
Web Site:
www.optoelectronics.com

U.S. Patent No. 5,471,402

PRODUCT TEST REPORT

AudioSource MCSW 1 Powered Subwoofer

BY STEPHEN A. BOOTH

Bass—the lower frequencies of the audio spectrum—is the underlying foundation for most music. Yet it's the place where many loudspeakers reveal their shortcomings.

To sound these deep registers with accuracy and volume, a loudspeaker must push large volumes of air that recreate the long waveforms in the 20- to 200-cycles-per-second range. Most speakers carry the melody fine through the mid-range and treble frequencies, but begin to "roll off" or attenuate the bass signals long before plumbing their depths.

The size of the woofer or bass-speaker driver, cabinet volume and style, and available wattage all play a role in low-frequency response. Typically, small speakers of the bookshelf type, those bundled with mini-stereo systems or built into TVs, just run out of gas. It's not that they don't deliver bass below their stated cutoff—but they don't reproduce it accurately. If, for example, the speaker promises flat frequency response down to 100 Hz, the vibes below that point will be muddy, from distortion. Instead of a tight, distinct kettle-drum roll, you'll hear a tubby sort of rumble.

A dedicated subwoofer can restore the bottom to music or special effects. It's a speaker whose only job is to handle the lowest bass. A crossover in the subwoofer or elsewhere routes sounds above a given frequency to the main stereo speakers. Often, the subwoofer has its own source of amplification, sometimes built-in. That's the case with the MCSW 1 from AudioSource.

The Burlingame, California-based manufacturer offers this compact, powered subwoofer as an affordable add-on to sound systems that might be a bit anemic in the range below 180 Hz. This is frequently true of today's popular "shelftop" or mini-stereo systems. Though they have nice features and performance otherwise, and usually some kind of electronic bass-boost circuitry, their necessarily small speakers

can't reproduce the deepest notes of a pipe-organ or the earth-shaking sound effects found in many movies.

With amplification up to 50 watts and a variable crossover that may be adjusted to work smoothly with a wide variety of speakers, the MCSW 1 complements a shelftop stereo nicely. Size-wise, it's also a nice match. The 8-inch speaker is housed in a 12-inch black cube that won't overpower a room or the main system.

TEST RESULTS

Except for one *peccadillo*, the MCSW 1 got passing grades in electrical measurements performed at the Advanced Product Evaluation Laboratory (APEL), an independent testing facility in Bethel, Connecticut.

Actually, the one slip-up the lab detected has more to do with the manufacturer's claims than the subwoofer's performance.

Although AudioSource rates the power output of the MCSW 1's amp at 50 watts, this maximum is achieved only at the 50 Hz frequency. So, if the subwoofer's crossover were set to operate at higher frequencies (up to its 180 Hz limit), power output would not be as great at these points. This is not a bad thing—the horsepower is most needed at the lower point—merely a clarification of the builder's specs.

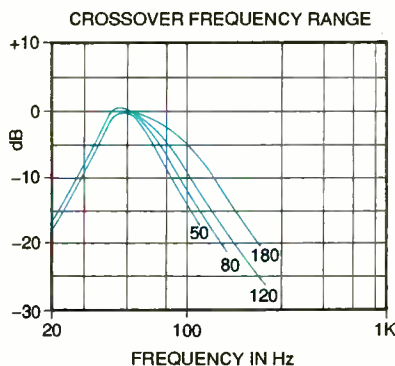

Fig. 1. This diagram shows how the MCSW 1 subwoofer performs in its four crossover frequency ranges.

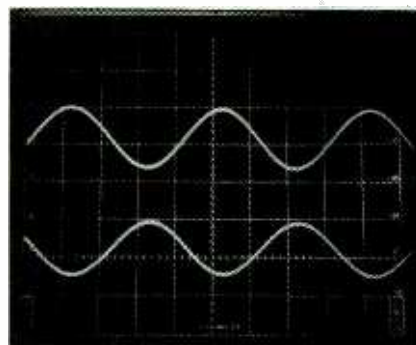
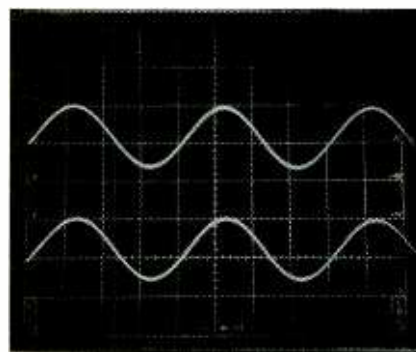

Fig. 2. As you can see from these scope screenshots, the subwoofer is capable of both accurately reproducing (top) and reversing (bottom) the phase of an audio signal. The original input signal in each screenshot is shown as the top wave, and the subwoofer's is shown as the bottom wave.

Otherwise, the MCSW 1 performs as advertised. As shown in Table 1, signal-to-noise ratio (92.5 dB) is very decent at maximum output. Also at top-power, distortion is inaudible at the low 50-Hz point. In fact, distortion is not a factor at any of the four crossover frequencies (see Fig. 1).

Regarding phase (see Fig. 2) the MCSW 1 replicates an input signal accurately—and can reverse it accurately. Why would you want to? This is a matter of speaker placement and your hearing.

IN-USE EVALUATION

Normally, you should operate the MCSW 1 with its rear-mounted Phase switch in the "0-degrees" mode—that is in-phase with the main stereo speakers. But because the subwoofer

is not in the same cabinet as these, and might be located quite differently, AudioSource notes that it's possible the subwoofer frequencies will arrive at your listening position "out of phase" from the other speakers.

If this were the case, some sound-waves in the upper bass and lower midrange might be canceled, making the music seem audibly hollow. Raising the subwoofer's volume (through its level-control) would not improve the sound. AudioSource suggests setting the Phase switch to the "180-degrees" position (and thereby reversing) to compensate for the cancellation effect, and restore balanced sound.

The Phase reversal switch is a very useful and thoughtful feature, so the very minor annoyance it raises will seem petty: The MCSW 1 has no remote control for those rear-mounted switches and dials.

It's no big deal when adjusting the crossover frequency, which should be a one-time operation. If a check of your main speakers shows that they're flat down to, say, 70 Hertz, you'd set the crossover around 80 Hz to let the sub

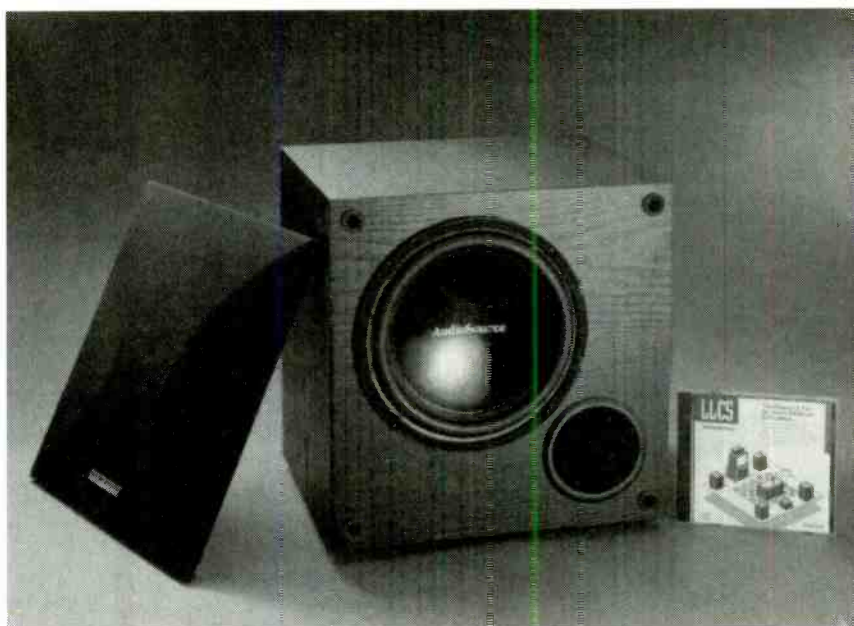

Don't put up with a lack of bass reproduction from your sound system. Add the AudioSource MCSW 1 powered subwoofer shown here and really experience music and movies.

handle the bass from that point down. But it would be convenient, for example, to be able to adjust subwoofer volume and phase from your listening position. Ditto for turning the subwoofer

on and off—just to hear the difference.

And what a difference the MCSW 1 does make. For a listening evaluation, the powered subwoofer was added to a typical shelftop mini-stereo, with the

SCANNER USERS • COMMUNICATIONS PROFESSIONALS

We've Got Your Numbers!

POLICE CALL PLUS

1997 EDITION

COMPLETELY REVISED

CURRENT THROUGH OCTOBER, 1996

- 17,000 Codes and Signals.
- FCC and Federal Frequency Allocations 25-941 MHz.
- Includes Glossary of Slang and Terms.
- Illustrated Listener's Guide Book.

GOT A SCANNER? GET POLICE CALL PLUS

At your scanner dealer and all Radio Shack stores.



More People Buy **POLICE CALL** Than All Other Frequency Guides (VHF/UHF) Combined.

Buy One Get One

50%
off!



Explore the Caribbean
on a 6 or 13 day
sailing adventure.

Call your travel agent or
1-800-327-2601
<http://www.windjammer.com>



P.O. Box 190120, Dept. 5568,
Miami Beach, FL 33139-0120

June - mid Dec. sailings only. Restrictions apply.

CIRCLE 172 ON FREE INFORMATION CARD

ANTIQUE RADIO CLASSIFIED Free Sample!

Antique Radio's
Largest Circulation Monthly
Articles, Ads & Classifieds.



6-Month Trial: \$18.95. 1-Yr: \$36.95 (\$53.95-1st Class).
A.R.C., P.O. Box 802-L16, Carlisle, MA 01741
Phone:(508) 371-0512 VISA/MC Fax:(508) 371-7129

HIGH POWER AUDIO AMPLIFIER CONSTRUCTION

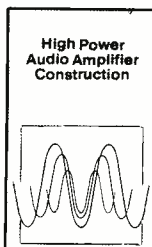

High Power
Audio Amplifier
Construction

BP277—Here's background and practical design information on high power audio amplifiers capable of 300±400 watts r.m.s. You'll find MOSFET and bipolar output transistors in inverting and non-inverting circuits. To order your copy send **\$6.25 plus \$3.00** for shipping in the U.S. and Canada to **Electronic Technology Today Inc., P.O. Box 240, Massapequa Park, NY 11762-0240**. U.S. and Canada only. Payment in U.S. funds by US bank check or International Money Order. Please allow 6-8 weeks for delivery. MA03

TABLE 1—TEST RESULTS

The following test results were furnished by the Advanced Product Evaluation Laboratory, an independent testing facility located in Bethel, CT.

Brand: AudioSource
Model: MCSW 1 Powered Subwoofer
Price: \$250

Maximum Power Output (@ 50 Hz): 50 watts
Distortion (@ 50 Hz): 0.18%
Signal-to-Noise Ratio: 92.5 dB

Crossover Network:
Frequencies (@ 1 watt)
50 Hz
80 Hz
120 Hz
180 Hz

Distortion
0.16%
0.90%
0.005%
0.005%

Crossover Frequency Range: See Fig. 1

Phase Shift (0-deg./180-deg.): See Figs. 2 and 3

Other Measurements:
Speaker Size: 8-inch Round
Speaker Impedance: 8 ohms
Dimensions (inches): 12.125 × 12 × 11.25
Weight: 19.75 pounds

very demanding Pierre Verany "Digital Test" CD set (PV.788031/788032) played as source material.

On a recording of fireworks, the MCSW 1 clearly reproduced the receding echoes or reverberation of the explosions. Without it, you could hear only the boom of the initial reports—even with the mini-stereo's bass-boost at the maximum level. Likewise, during a performance by a Dixieland band, you'd never know there was a bull-fiddle (a.k.a., double bass, bass viol, contrabass) on stage until the MCSW 1 kicked in. Ditto for the lowest pipes in Louis Vierne's "1st Organ Symphony."

More important, the difference between accurate bass reproduction and mush was most clearly audible during the fourth movement of Rimsky-Korsakov's "Scheherazade." Whereas a volley on the kettle drums had a fuzzy, tubby quality when heard through the mini-stereo alone, with the MCSW 1 the individual baton strokes were distinct against their ascending rumble.

When it was connected to a more sophisticated stereo system and speakers, the effect of the MCSW 1 was less dramatic, but still a profound improvement. You could expect similar results by adding the bass cube to a surround-sound home theater setup. Just hooking it up to a stereo TV did wonders for the boob-tube's under-achieving full range speakers.

The MCSW 1 might not have remote control convenience, but it operates in a standby mode where it powers up automatically when it senses an input signal from the connected source unit. And, conveniently, versatile inputs and outputs enable connection to different types of equipment. These include line-level RCA jacks, which you'd use to route an unamplified signal through the crossover from audio equipment with a preamp-out or a dedicated subwoofer output.

For audio gear that lacks a preamp out (for example, many mini-stereos), the MCSW 1 also has high-level inputs and outputs of the speaker-terminal clamp type. You'd use these to receive an amplified signal from an audio component's speaker output terminals, and relay the signal on through the subwoofer's crossover to the input terminals of the stereo speakers.

Overall, the MCSW 1 provides a satisfying way to make an existing sound system more satisfying—and it's a less expensive upgrade compared to replacing amps and speakers. ■

FOR MORE INFORMATION

AudioSource
1327 North Carolan Avenue
Burlingame, CA 94010
Tel. 415-348-8114

CIRCLE 72 ON FREE
INFORMATION CARD

How to make your car invisible to radar and laser...legally!

Rocky Mountain Radar introduces a device guaranteed to make your car electronically "invisible" to speed traps—if you get a ticket while using the product, the manufacturer will pay your fine!



■ **The Phazer will "jam" both radar and laser guns, preventing police from measuring your speed.**

If your heart doesn't skip a beat when you drive past a speed trap—even if you aren't speeding—don't bother reading this. I can't tell you how many times that has happened to me. Driving down the interstate with my cruise control set at eight miles over the limit, I catch a glimpse of a police car parked on the side of the road. My heart skips a

beat and for some reason I look at my speedometer. After I've passed the trap, my eyes stay glued to my rear view mirror, praying the officer will pass me up for a "bigger fish."

It seems that as speed-detection technology has gotten more and more advanced, speeding tickets have become virtually unavoidable. And although devices exist that enable motorists to detect these speed traps, they are outlawed in many states... including mine.

The solution. Today, Rocky Mountain Radar offers drivers like me a perfect solution—the Phazer. Combining a passive radar scrambler with an active laser scrambler, the Phazer makes your automobile electronically "invisible" to police speed-detecting equipment.

The radar component works by mixing an X, K or Ka radar signal with an FM "chirp" and bouncing it back at the squad car by way of a

waveguide antenna, effectively confusing the computer inside the radar gun. The laser component transmits an infrared beam that has the same effect on laser Lidar units.

Shown actual size, the Phazer is only 3"W x 4"L x 1.5"H!

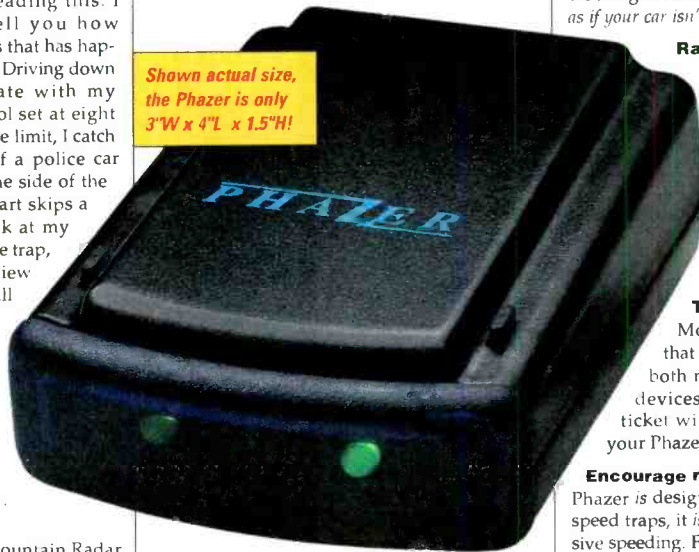

Perfectly legal.

Some radar devices have been outlawed because they *transmit* scrambling radar beams back to the waiting law enforcement vehicle. The Phazer, however, *reflects* a portion of the signal plus an added FM signal back to the police car. This, in effect, gives the waiting radar unit an electronic "lobotomy."

Best of all, unless you are a resident of Minnesota, Oklahoma or Washington, D.C., using the Phazer is completely within your legal rights.

HOW TO MAKE YOUR CAR DISAPPEAR

Radar and laser scramblers are devices that foil speed traps by making vehicles electronically "invisible" to police radar. Radar scramblers mix a portion of the radar signal with background clutter and reflect it back to the squad car. This technique, pioneered by Rocky Mountain Radar, creates an unreadable signal that confuses the computer inside the radar gun.

The laser scrambler in the Phazer works in a similar manner. It transmits a special infrared beam with information designed to scramble the laser signal. The result? Readouts on police radar and laser guns remain blank. As far as the police officer is concerned, your vehicle is not even on the road.

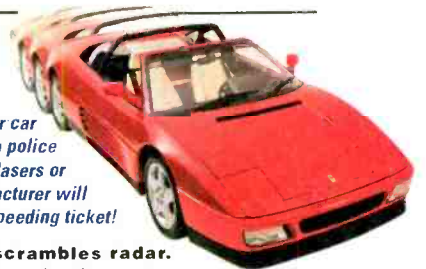

■ **The Phazer makes your car invisible to police radar and lasers or the manufacturer will pay your speeding ticket!**

How it scrambles radar.

Police radar takes five to 10 measurements of a vehicle's speed in about one second. The Phazer sends one signal that tells the radar the car is going 15 m.p.h. and another signal that the car is going 312 m.p.h. Because police radar can't verify the speed, it displays no speed at all. *To the radar gun, your car isn't even on the road.*

Works with laser, too! The Phazer also protects your vehicle from Lidar guns that use the change in distance over time to detect a vehicle's speed. The Phazer uses light-emitting diodes (LEDs) to fire invisible infrared pulses through the windshield. Laser guns interpret those pulses as a false indication of the car's distance, blocking measurement of your speed. *Again, it's as if your car isn't even on the road.*

Range up to three miles.

The Phazer begins to scramble both radar and laser signals as far as three miles away from the speed trap. Its range of effectiveness extends to almost 100 feet away from the police car, at which point you should be able to make visual contact and reduce your speed accordingly.

Ticket rebate program. Rocky Mountain Radar is so confident that the Phazer will protect you from both radar and laser speed-detection devices that if you do get a speeding ticket within the first year while using your Phazer, they will pay your fine!

Encourage responsible driving. While the Phazer is designed to help you (and me) avoid speed traps, it is *not* intended to condone excessive speeding. For that reason, the manufacturer will only pay tickets where the speed limit was not exceeded by more than 30%, or 15 miles per hour, whichever is less.

Risk-free. Thanks to the ticket rebate program, speed traps don't make my heart skip a beat anymore.

Try it. Your car will be invisible to police radar and laser, or the manufacturer will pay your fine! It's backed by our risk-free trial and three-year manufacturer's warranty. If you're not satisfied, return it within 90 days for a full "No Questions Asked" refund.



■ **The Phazer is a completely legal way to protect yourself from speed traps (except in OK, MN and Washington DC).**

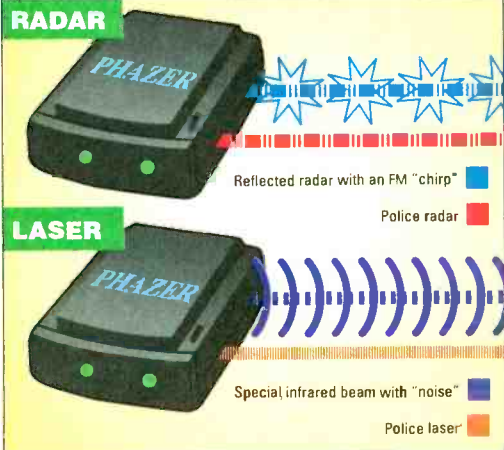

The Phazer \$199 \$14 S&H
Please mention promotional code 1901-PL-10007.

For fastest service call toll-free 24 hours a day

800-992-2966



comtradindustries

2820 Waterford Lake Drive, Suite 102 Midlothian, VA 23113

NET WATCH

The State of Digital Audio

BY DAN KARAGIANNIS

Every little corner of cyberspace shouldn't look and sound the same. That's been the unwritten motto of most Net-site creators, and for this reason multimedia on the Net was born. In fact, cyberspace sights and sounds are so common now that I'm sure anyone with a SLIP/PPP connection who has been to even a handful of sites with a graphical Web browser has experienced them.

Even in its simplest forms, multime-

dia adds a lot to cyberspace. Pages with animated burning torches, or moving little cartoon characters are always more interesting to look at than the usual gray pages with a picture here or there. The same goes for sound—clicking on something and hearing a bit of digital audio only enhances one's experience as well. It's this latter type of digital technology we'll be looking at this month.

With the information in the column, and a few minutes of download time, you'll be equipped to hear some amazing sounds, all right off the Net. And for the audiophiles out there, yes I do mean CD quality!

files as you download them. But anyone who's tried version 2.0 of the software knows that RealAudio files are not all that clean. Forget about CD, tape, or even FM-radio quality. The files tend to sound more like a weak AM station at best. (RealAudio 3.0 is better, but you need an ISDN connection to hear CD quality audio.) Currently, the most practical way to hear good-sounding audio is to download it first. But those files tend to be large.

when the transfer and playback is completed. Now to make things worse...

Due to the fact that most simple compression techniques can only do so much (read "very little") to a sound file, most digital audio has to be made smaller in other ways. That's where the other three factors come in to play.

The sample rate is one of the biggest factors to determine a file's clarity and timbre. Audio CDs use a 44.1-kHz rate, which is the industry standard (although DAT recorders now record up to 48 kHz). Files of this quality tend to get large real fast (we'll look at just how large in a moment), so 22- or 11-kHz (or lower) rates are often used. The result? While dividing the rate also divides the size of the audio file, you often end up with a sound that resembles a transistor radio playing in a tin can.

The sample size of digital audio is also an important quality-determining factor. The best available in high-end audio samplers is 18 bits. In sound cards, you probably won't find a size that's higher than 16 bits (no, any sound card with the number "32" in its name does not work with 32-bit samples; that number refers to "voices," which is out of the scope of this column). Audio CDs use 16-bit audio, which sounds great. But, just like a high sampling rate, a high sampling size also adds up those megabytes quite quickly. As a result, a lot of files are 8-bit, which makes the file half as large and sound only half as good.

So far, to keep the size of a file down, we end up with a tinny bit of audio that sounds almost full of static. Now let's consider stereo vs. mono. Stereo means you have two separate tracks of audio in a file. As you might have guessed, stereo therefore means you have a file that's twice as large. Therefore, most .wav files on the Net are mono, which takes out any bit of life left in an already horrible file.

Now that we've looked at all the factors, let's get an idea of what the term "large" meant in all the paragraphs you just read. If you record a standard-length pop song, which is about three-



Winplay3 seems to be the best .mp3-file player available. You'll swear you were listening to a CD!

Why? The reason for that lies in four factors of digital audio: the compression, sample rate, and sample size used in a file, and whether it is stereo or mono.

The first one, compression, is a factor in the computer world that no one should be a stranger to by now. The most common use of compression is in the creation of .zip files, which allow several regular files to be grouped into one file and shrunk to a percentage of their size. But when it comes to digital audio files, this type of compression doesn't do much (try zipping up a .wav file and you'll see what I mean).

The type of sound-file altering done by programs like RealAudio tends to be a bit "lossy." In other words, the file gets damaged by compression. Because of that, no matter how good the file is to begin with, it won't sound quite so good

COMPRESSION, SAMPLING, AND STEREO

In the past we've explored RealAudio, which lets you listen to audio

25 REASONS WHY NRI TRAINING IN COMPUTER SERVICING IS YOUR BEST CHOICE FOR CAREER SUCCESS

According to the Department of Labor, jobs for computer service technicians will be up by 38% in the next 10 years. Isn't it about time that you looked into NRI training?

- 1** You don't need any experience to get started.
- 2** You can depend on NRI, a division of The McGraw-Hill Companies.
- 3** You study at home, at your own pace.
- 4** You put theory into practice with hands-on projects.
- 5** You work one-on-one with an experienced instructor.
- 6** You establish a solid foundation with a review of basic electronics.
- 7** You train with the NRI Discovery Lab to experience circuit design and modification.
- 8** You train with a digital multimeter, for quick and easy testing.
- 9** You get a customized Pentium® 166 or better PC to train with and keep!
- 10** You learn how to troubleshoot and maintain today's sophisticated PCs.
- 11** You explore the features you've chosen for your computer, from the memory chips to the high-speed CD-ROM drive.
- 12** You learn how to take advantage of PC communications and the Internet.
- 13** You use your new computer's 28,800 baud or faster fax/modem in conjunction with Netscape Navigator™ Web browser software.
- 14** You explore the applications and accessories of Windows 95, today's hottest graphical user interface.

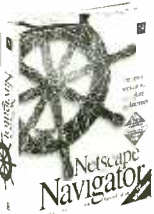

15 You train with and keep the self-booting ForeFront Troubleshooter™ software and CD-ROM, comprehensive diagnostics you can trust.



16 With NRI's new PC Options Plan, you can purchase low-cost computer upgrades and peripherals for your customized PC.

17 You have access to NRI's brand-new "cyberschool" to contact your instructor, download supplemental materials, participate in online seminars, and more!

18 You can call NRI's TeleService hotline, for 24-hour answers to your questions.



19 You get immediate feedback with NRI's TeleGrading service, featuring 24-hour exam grading.

20 Your company may pay for all or part of your tuition. (Hundreds of companies do!)

21 You can prepare for the A+ Certification exam with NRI's exclusive CD-ROM!



22 You can continue receiving advice and feedback from your instructor after you graduate.

23 You can turn to NRI for letters of recommendation, transcripts, tips on resume writing, and more.

24 You get the skills and confidence to move up on the job, start a new career, or open your own business.

25 You can call our toll-free number for a free catalog. Or, visit us at <http://www.mhcec.com> on the Web!

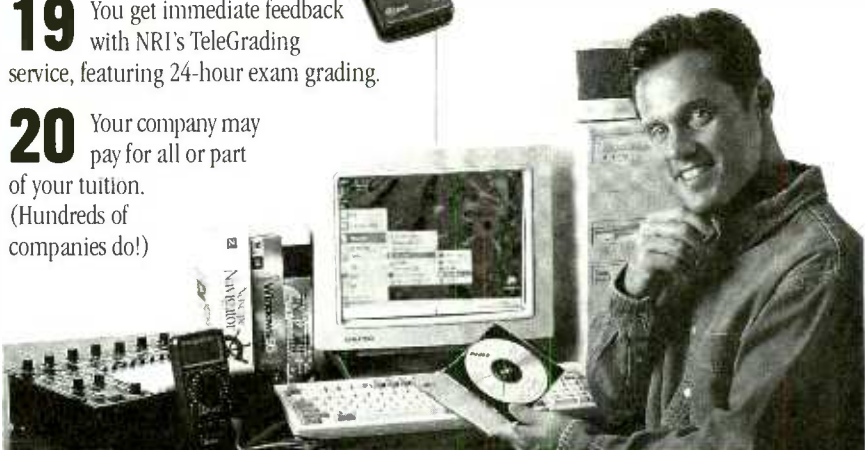

CALL 1-800-321-4634 FOR FREE CATALOG!

NRI Schools

4401 Connecticut Avenue, NW, Washington, DC 20008

Ask for Ext. 2132

✓ Check one FREE catalog only. High school diploma or GED recommended for all courses, required for degree programs.

- | | |
|--|---|
| <input type="checkbox"/> MICROCOMPUTER SERVICING | <input type="checkbox"/> Networking with Windows NT |
| <input type="checkbox"/> Computer Programming | <input type="checkbox"/> Bookkeeping and Accounting |
| <input type="checkbox"/> TV/Video/Audio Servicing | <input type="checkbox"/> Visual Programming in C++ |
| <input type="checkbox"/> Desktop Publishing with PageMaker | <input type="checkbox"/> Mastering Microsoft Office |
| | <input type="checkbox"/> Webmaster |

OR GET YOUR DEGREE!

- AAS Degree in Accounting
- AAS Degree in Business Management

Name _____ (please print) Age _____

Address _____

City _____ State _____ Zip _____

A Division of The McGraw-Hill Companies



Accredited Member, Distance Education and Training Council

0018-0297



Bongo's Big Site O' Hell holds more great-sounding digital audio files than you'll ever have time to download.

and-a-half-minutes long, at CD quality (44.1 kHz, 16 bit, stereo), you'll eat up 36 megabytes of space! That's one large .wav file, and one which would take you so long to transfer that your connection would probably disconnect (ever notice how connections seem to go down only when you're more than halfway through downloading a file?).

So it's pretty clear that .wav files, which are mostly uncompressed, will never provide a good way of putting digital audio on the Net. But what if there was a format that let you take a three-and-a-half-minute song, record it at CD quality, and have it take up less than 3 megabytes?

LAYER-3 AUDIO

The need for data reduction of video pictures and sound has been recognized for some time, and as a result a standard for compression was developed: MPEG. Using the latest level of MPEG audio coding—layer-3—you can shrink down CD audio by a factor of 12, without losing any timbre, clarity, or overall clarity.

Our first site this month is probably the best place to visit to get started with layer-3 audio, or .mp3 files. It's name is a bit deceiving, as it's called MPEG Layer 3 Sounds. Actually it contains sounds *and* teaches you .mp3 basics.

You'll find a few useful section links at the top of the page. What is MP3? teaches you in a non-technical way

about the technology. There are links to an FAQ if you want more information.

How Do I Play the MP3 Sounds Archived Here? is probably the most useful section. Here you'll find links to software that lets you listen to .mp3 files on your computer. The best seems to be Winplay3. There's a link to a version with a 20-second limit, and one to a version without limits.

How Do I Encode My Own MP3 Files? gets you started on the slightly annoying process of making your own digital-audio files. I call it annoying because it's not a graphical-interface procedure, and let's face it: Windows has spoiled all of us!

Links to Other People's Pages is definitely worth checking out too. Here you'll find an assortment of places to go if you're looking for song files, movie sound clips, etc. Speaking of movie clips, though, there are plenty right at the MPEG Layer 3 Sounds page.

The files at this site are pretty neat. There are high-quality *Star Wars*

HOT SITES

MPEG Layer 3 Sounds

<http://www.eskimo.com/~miyaguch/mp3.html>

Bongo's Big Site O' Hell

<http://bongo.dorms.tamu.edu/>

Digital-Audio Newsgroups

alt.binaries.sounds
alt.binaries.sounds.music

Trilogy, *Jurassic Park*, and even *Simpsons* clips.

Another site worth mentioning is Bongo's Big Site O' Hell. Despite its non-serious-sounding name, this large hot spot is actually a major archive of .mp3 and other multimedia files. It's even configured to play .mp3 audio right over the Net, but you'll need a 128-kbps ISDN connection to listen to it. Considering most of us don't have that, we'll have to download the files first and hear them.

What kind of files? Well, in addition to movie audio you'll find all types of music, including quite a few popular songs. We won't even get into whether this is legal or not; just think of it as listening to a *powerful* radio station, with a digital tape recorder running.

Before we leave the topic of .mp3, let me just mention one other resource on the Net for obtaining files of this type. Use your USENET news reader to access any of the alt.binaries.sounds newsgroups (especially alt.binaries.sounds.music). Most of the files posted there are layer-3 audio. Here's where you'll learn firsthand about another great feature of layer-3 files. If you want to, you can download just one part of a multipart .mp3 file, decode it, and take a listen. Then, if you like what you hear, download the rest. This isn't possible with multipart, posted .wav files.

REALAUDIO 3.0

In the spirit of fairness, I just want to give a brief update to the current status of RealAudio software. The latest version of the software, 3.0, gets a bit closer to broadcast quality than 2.0 did. But keep in mind, this isn't really supposed to compete with .mp3 for quality. After all, RealAudio does something unique. It lets you hear audio as it downloads, and not after.

If you have an ISDN connection, you can take advantage of this software (just like you could with streaming layer-3 files) by having it provide you with almost-CD-quality sound as it comes off the Net. I won't go any deeper into the product again, but do want to stress that for what it does it's probably the best available.

That just about does it for this month. If you'd like to drop me a line, send e-mail to peeditor@gernsback.com, and snail-mail to *Net Watch*, Popular Electronics, 500 Bi-County Blvd., Farmingdale, NY 11735.

MULTIMEDIA WATCH

My New Favorite PC

BY MARC SPIWAK
TECHNICAL EDITOR
WINDOWS MAGAZINE

I've got a new favorite PC—for the next month or so, anyway. That's how often newer and faster systems seem to come out. It's hard to believe the kind of PC the average guy can buy these days, and not for an astronomical figure, either. Micron's new Millennium Pro Plus is fueled by two Pentium Pro 200 MHz CPUs. It comes with 64 MB of RAM and a 512K pipeline burst secondary cache. While I'm talking about a Micron system, you

SCSI adapter card features an external connector for hooking up external SCSI peripherals. That's the fastest way to connect an extra CD-ROM drive, a CD-R drive, a tape backup, and so on. And any portable SCSI device will absolutely blow away a parallel-port based cousin in performance. The system also came with a Sound Blaster 16 sound card.

Naturally the system includes a 17-inch monitor. But it also comes with the

any version of Windows will run at warp speed on a Pro. However, you absolutely need NT to take any advantage of having two CPUs. Windows 95 really can't do anything with two CPUs, and for that matter it doesn't even know there are two CPUs.

I don't have a problem with NT being different than Win 95. As a matter of fact, NT 4.0 has the Win 95 front end, so anyone familiar with Win 95 will have no trouble navigating through NT 4.0. For that matter, anyone familiar with Win 3.1 wouldn't have any trouble using NT 3.51. The real difference is that any flavor of NT has a lot more features built in than Win 95 or Win 3.1, especially in the security department. My problem is that NT is not what I want for multimedia.

Any software designed to run under Win 95 was supposed to work in NT as well, but it just didn't turn out that way. Many programs just don't work right, and NT 4.0 is an entirely new animal with entirely new incompatibilities. I actually wiped out the NT 4.0 installation on my hard drive by trying to install CD Creator 2.0, which supposedly runs fine under NT 3.51. Fortunately I had already tested the system. I later found out that there is a known incompatibility with CD Creator under NT 4.0. That's some incompatibility! But none of that really matters because Win 95 is definitely the preferred platform for multimedia, and that's what this column is all about.

The problem is that Win 95 contains some 16-bit legacy code for backward compatibility, and that's not really what you want for NT. There is some performance penalty when running Win 95 on a Pentium Pro, but the penalty really goes to the processor rather than the software. Pros run best when they don't have to stumble across 16-bit code. But the truth is that Win 95 runs great on a Pentium Pro, and it seems to run faster on a Pro 200 than on any Pentium. It's a fact, though, that Win 95 can't take advantage of two processors, period.

Software that can take advantage 21



My dual-processor Pentium Pro 200 is more than twice as fast as a Pentium 200, but only with software that can take advantage of the two processors.

can be sure that any dual Pentium Pro system is going to be radically powerful. One thing I noticed is that a dual-processor system generates a lot of heat. The system is cooled by a total of four fans, and it heats up my office in no time.

The Millennium Pro Plus uses all SCSI components: a Seagate 2GB Ultra SCSI hard drive, a Plexstor 8× CD-ROM drive, and an Iomega 1 GB jaz drive. A jaz drive is basically a hard drive with removable cartridges. It's nearly as fast as a conventional hard drive, and each cartridge holds a gigabyte. The cartridges are great for transporting tons of data or for use as an ultra-fast backup system. One nice thing about a SCSI system is that the

fastest graphics accelerator I've ever tested—Number Nine's Imagine 128 Series 2. I can play Video CD movies using software MPEG alone, and play them at full-screen size without dropping any frames. That card will allow any reasonably fast Pentium to do that, and I'm not even sure yet what it can do with two Pentium Pro CPUs. The fact is, there's not much you can do yet with two processors, as not much software can take advantage of them. Let me explain:

The system came loaded with Windows NT Workstation 4.0 and a Microsoft Office CD—you need 32-bit software for NT, so Office fits the bill. You also need NT to take full advantage of a Pentium Pro CPU, although



Kurzweil Voice 2.0 voice-recognition software lets you control Windows and many Windows-based programs by voice and type by voice.

of the two processors better watch out, though. According to a Wintune benchmarking score, a program free for anyone to download from the *Windows Magazine* Web site (www.winmag.com), the dual Pentium Pro system burned through 833 million instructions per second (MIPS). A single-processor Pentium 200 system (not a Pro) recently scored 361 MIPS, so you can see how fast this system really is. An Access database benchmark test that I have used was completed in 1 minute 7 seconds on the dual-processor system. For that to be impressive you must understand that the same test took nearly 2-1/2 minutes on a single-processor Pentium Pro 200, and about 26 minutes (!) on a 486 DX2/66. My guess is that it would take about 3 minutes on a regular Pentium 200, although I haven't tried it yet.

If I were buying a system today, I would buy a dual-processor Pentium Pro—if I could afford one. The Micron system comes to a total of about \$5500. If I couldn't afford it, I'd make it a single-processor Pro. That alone subtracts around \$700 from the price. I could certainly do with half the memory for another few hundred dollars saved. Doing away with the jaz drive chops off another \$500 or so, as does settling for a less luxurious graphics accelerator. Then you're looking at a \$3500 barnstorming system, and probably well under \$3000 by the time you read this.

NEW STUFF

I recently felt like Scotty in the movie, *Star Trek: The Voyage Home*, when he's in the acrylics factory giving away the formula for transparent aluminum. He picks up the mouse like a microphone and says "Computer." I feel the same way when I use *Kurzweil Voice 2.0*. That's a voice-recognition software which lets you control Windows and many Windows-based programs by voice. You can also type by voice. Typing by voice is easy, and you never have to worry about spelling errors. The software will run on a 486 DX4/75 or faster, although a Pentium is recommended. Anyone who can't type can now, although fast typists still beat the software. In addition to recommending a Pentium, the program requires 35 MB of disk space and 16 MB of RAM for a 30,000-word vocabulary or 24 MB of RAM for a 60,000-word vocabulary. A Telex Nomad microphone is included with the software.

You have to train the program to recognize your speech. You do that by pronouncing lots of words and numbers in a process that takes about half an hour. The software then learns more and more as you go. You give system commands using continuous dictation, speaking without pauses between words—"Filemenu," "Saveas," and so on. You dictate with a sharp pause between each word as if you were reading words separated by periods. Punctuation marks and numbers are spoken in as you would say them, and letters are entered in a special mode (Alpha, Bravo, Charlie, etc.). The program also recognizes spoken letter combinations and acronyms such as AC, DC, and SCSI.

Kurzweil Voice displays your words as you speak. If it gets something wrong, or if you say something wrong, you say "Correct That" or "Delete That." You can also pick words from a list of numbered suggestions by saying "Take 1" to accept the first word, "Take 2" for the second, and so on. You can always type it in yourself whether it's on the list or not, but it's best if you do everything by voice so that you train the software as much as possible. It seems that Kurzweil Voice 2.0 lets you dictate as fast as you can speak, as long as there's the pause between each word. You just have to shell out \$695 for the software. But if you can make money by typing, and can't real-

WHERE TO GET IT

Activision Los Angeles
11601 Wilshire Boulevard, Suite 1000
Los Angeles, CA 90025
CIRCLE 60 ON FREE
INFORMATION CARD

Broderbund Software
500 Redwood Blvd., PO Box 6121
Novato, CA 94948
CIRCLE 61 ON FREE
INFORMATION CARD

Discovery Channel Multimedia
7700 Wisconsin Avenue
Bethesda, MD 20814
CIRCLE 62 ON FREE
INFORMATION CARD

E.M.M.E. Interactive
1200 Summer Street
Stamford, CT 06905
CIRCLE 63 ON FREE
INFORMATION CARD

Kurzweil Applied Intelligence, Inc.
411 Waverly Oaks Road
Waltham, MA 02154
CIRCLE 64 ON FREE
INFORMATION CARD

Maris Multimedia
4040 Civic Center Dr., Suite. 200
San Rafael, CA 94903
CIRCLE 65 ON FREE
INFORMATION CARD

Micron Electronics, Inc.
900 East Karcher Road
Nampa, Idaho 83687
CIRCLE 66 ON FREE
INFORMATION CARD

Now What Software
500 Sansome Street, Suite 501
San Francisco, CA 94111
CIRCLE 67 ON FREE
INFORMATION CARD

Psygnosis, Inc.
919 East Hillsdale Blvd.
Foster City, CA 94404
CIRCLE 68 ON FREE
INFORMATION CARD

Simon & Schuster Interactive
1230 Avenue of the Americas
New York, NY 10020
CIRCLE 69 ON FREE
INFORMATION CARD

Splash Studios
8573 154 Avenue NE
Redmond, WA 98052
CIRCLE 70 ON FREE
INFORMATION CARD

The Voyager Company
578 Broadway, Suite 406
New York, NY 10012
CIRCLE 71 ON FREE
INFORMATION CARD

ly type, Kurzweil will pay for itself.

I've got a bunch of new software from Activision this month. MechWarrior 2 fans will certainly like the Win 95 version of the *MechWarrior 2 Expansion Pack: Ghost Bear's Legacy* (\$29.95), with 15 new 'Mechs, 30 new missions, and a dozen new weapons. As out of place as it might seem, Now is the time that Activision also releases *NetMech* for MS-DOS (\$14.95), which allows eight MechWarriors to compete in battle with modem or network connections. *The Elk Moon Murder* is a live-action game that turns you into a detective investigating a brutal murder. You must visit the crime scene, question people, gather evidence, and search the town for clues and suspects before it's too late.

If you like to drink exotic beers from around the world or just are interested in beer, then take a look at the *World Beer Hunter* CD-ROM from Discovery Channel Multimedia. Renowned British beer connoisseur Michael Jackson (not the singer) takes you around the world on a beer run. You'll find maps, audio, video, profiles on pubs and breweries, and plenty of information on hundreds of beers. This one sells for \$34.95.

Origins of Mankind, from Maris Multimedia, is a study of man's past and how we got where we are today. Rich animations, 3D graphics, computer-generated landscapes, and more, show the path that life has taken over the past 70 million years or so. Morphing technology even lets you watch evolution in action. This interactive textbook on human evolution costs \$39.95.

Thor Heyerdahl is a legendary explorer who believes that the Pacific Islands were populated by ancient Peruvians, Egyptians, and Sumerians; and years ago he set out to prove it. *Kon-Tiki Interactive* details how, nearly 50 years ago, Dr. Heyerdahl sailed from Peru to Polynesia in 101 days on a waterlogged balsa raft named Kon-Tiki. The disc also covers the Ra I and II Expeditions across the Atlantic, and many of Dr. Heyerdahl's other expeditions as well. You can get this one from The Voyager Company for \$39.95.

The *3D Talking Globe* from Now What Software is an interesting disc that presents you with a global atlas that you can quickly move around on. It's much like moving a real globe except that you do it with a hand-shaped mouse pointer. Three-million

place names are stored in a look-up database and you can hear 3000 of them spoken in the native language. Among many other neat features there's an adjustable magnifying glass and a tape-measure-like mileage meter that tells you how far it is from one point to another. This disc sells for \$34.95.

If you enjoy shooting paintballs at your friends, then you'll enjoy the CD-ROM game *Lemmings Paintball* for Windows 95 from Psygnosis. This game puts you in charge of a Lemmings tribe on a weekend mission to capture the other team's flags. You're armed with a pump-action paint gun and tons of paint balls.

People who enjoy solving puzzles will probably be interested in *Brainstorm!* from Simon & Schuster Interactive. Your powers of spatial relations and abstract visuals are tested to the limits with 3D animations, brain teasers, strategy games, puzzles, and more. This title has a suggested retail price of \$34.95.

E.M.M.E. Interactive is an international developer of education/entertainment CD-ROMs, with something interesting for everybody. I recently had the pleasure of sampling such titles as *Voyage in France*, *Greatest Moments of Our Time*, *Michelangelo*, and *The Great Myths and Legends*. If any of these titles interest you, contact E.M.M.E. for a complete list of them.

I have four new children's titles from Broderbund Software for this month. Intended for ages 4-7, *Gregory and the Hot Air Balloon* is an animated storybook adventure featuring Gregory Chuckwood and his pet Lizard, Newt. *Darby the Dragon* takes kids ages 5-8 on a multimedia adventure with Darby, the friendly Dragon Prince. Two other animated multimedia titles are for kids ages 8-12. *Write, Camera, Action* teaches reading and writing in a fun way, and *Reading Galaxy* builds comprehension and problem-solving skills with excerpts from many kids' books.

Kids of all ages will want to play *Piper* from Splash Studios. The game features Jason David Frank from the *Mighty Morphin Power Rangers* TV show. Piper battles Mephisto, King of the Rats, in a race to discover the Lost Cavern of Gold. There are different levels for different age groups, as well as puzzles, jokes, hidden treasures, songs, videos, and four rat-whacking games.

You can Build Gadgets! Here are 3 reasons why!



BP345—GETTING STARTED IN PRACTICAL ELECTRONICS \$5.95

If you are looking into launching an exciting hobby activity, this text provides minimum essentials for the builder and 30 easy-to-build fun projects every experimenter should toy with. Printed-circuit board designs are included to give your project a professional appearance.

BP349—PRACTICAL OPTO-ELECTRONIC PROJECTS \$5.95

If you shun opto-electronic projects for lack of knowledge, this is the book for you. A bit of introductory theory comes first and then a number of practical projects which utilize a range of opto devices, from a filament bulb to modern infrared sensors and emitters—all are easy to build.

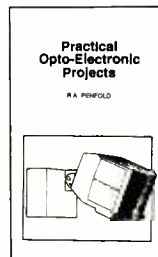

Practical Electronic Music Projects

BP363—PRACTICAL ELECTRONIC MUSIC PROJECTS \$5.95

The text contains a goodly number of practical music projects most often requested by musicians. All the projects are relatively low-in-cost to build and all use standard, readily-available components that you can buy. The project categories are guitar, general music and MIDI.

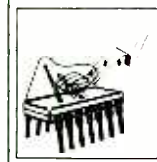

Mail to:
Electronic Technology Today, Inc.
P.O. Box 240
Massapequa Park, NY 11762-0240

Shipping Charges in USA & Canada

\$0.01 to \$5.00.....	\$2.00	\$30.01 to \$40.00.....	\$6.00
\$5.01 to \$10.00.....	\$3.00	\$40.01 to \$50.00.....	\$7.00
\$10.01 to \$20.00.....	\$4.00	\$50.01 and above.....	\$8.50
\$20.01 to \$30.00.....	\$5.00		

Sorry, no orders accepted outside of USA and Canada. All payments must be in U.S. funds only.

Number of books ordered.

Total price of books.....	\$ _____
Shipping (see chart).....	\$ _____
Subtotal.....	\$ _____
Sales Tax (NYS only).....	\$ _____
Total enclosed.....	\$ _____

Name _____
Address _____
City _____ State _____ ZIP _____

Please allow 6-8 weeks for delivery.

NEW PRODUCTS

NOTEBOOK SURGE PROTECTOR

Aimed at mobile computer users who rely on notebook PCs for critical tasks while on the road, *American Power Conversion's SurgeArrest Notebook* is a compact, travel-size device that provides telephone-line and AC-power line protection against damaging power surges and spikes. A thermal fuse disconnects the AC line in the event of a sustained overvoltage. Also the device carries a lifetime warranty and a \$3500, three-year equipment-protection policy.

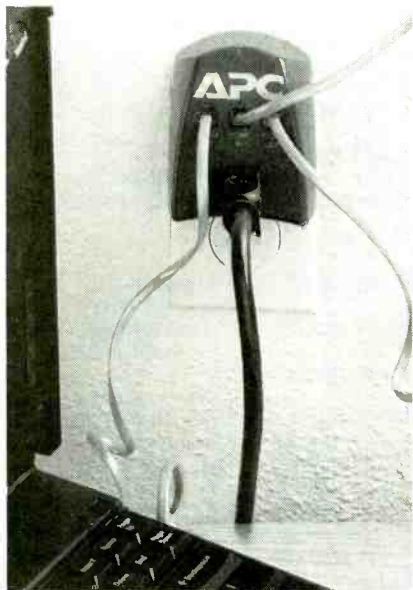

With three phone jacks, the SurgeArrest Notebook protector makes hotel-room laptop use more convenient than ever. Users no longer have to climb behind or around furniture to unplug the telephone line from the phone and the wall to link to the notebook computer. One telephone line can be plugged into the notebook PC while still retaining the use of the telephone. The surge protector can also be used to protect fax machines.

The SurgeArrest Notebook protector costs \$29.95. For additional information, contact American Power Conversion, P.O. Box 278, 132 Fairgrounds Road, West Kingston, RI 02892; Tel. 800-877-4080; Web: <http://www.apcc.com>.

CIRCLE 80 ON FREE INFORMATION CARD

DIGITAL DICTAPHONE

The *Voice It Manager* is a cross between a dictation machine and a personal organizer. The pocket-sized, digital device is available in two models with recording capacities of 22 or 45 minutes. Voice data is stored directly onto a computer chip, allowing individual messages to be instantly accessed and played or erased. Messages are stored in memory until purposely erased, so there is no danger of inadvertently recording over important notes. The Voice It Manager's "flash" memory chip is designed to retain messages even when battery power is lost.

Digital recording technology also allows messages to be sorted and organized. Notes can be categorized into any of five channels or "files." A library of 20 icons allows users to customize files by popular subject headers such as "things to do," "expenses," "memos," and "meetings."



A calendar and scheduling feature allows users to program certain messages to play automatically as audible reminders. Recurrent reminders can be recorded once and scheduled to play back regularly by day, week, month, or year. An LCD readout furnishes information on which channel is in use; the number of notes in the channel; and the time, day, and date of recording.

The Voice It Manager's contact file can store up to 100 names with three phone numbers per name. Voice notes

with addresses or other information can be appended to the names in the contact file. Phone numbers appearing on the LCD can be automatically dialed by holding the unit's speaker next to a telephone mouthpiece.

The *Models VM-15* (with 22 minutes of recording time) and *VM-30* (45 minutes) have suggested retail prices of \$129.95 and \$169.95, respectively. For more information, contact Voice It Worldwide, 2643 Midpoint Drive, Suite A, Fort Collins, CO 80545; Tel. 970-221-1705; Fax: 970-221-2058.

CIRCLE 81 ON FREE INFORMATION CARD

DIGITAL MULTIMETER

Extech's Model 380760 digital multimeter provides 30 ranges and eight functions, including DC/AC voltage, DC/AC current, resistance, diode test, and audible continuity test. Designed to meet IEC-1010 standards, the DMM provides $\pm 0.5\%$ basic DC voltage accuracy. An oversized one-inch LCD readout offers 1999 counts with two or three updates per second. Over-range, polarity, and low-battery indications are featured, along with auto power off and data-hold functions. Four input jacks with overload protection are provided. The multimeter comes complete with test leads,



a 9-volt battery, and a protective holster with a dual-position tilt stand.

The Model 380760 digital multimeter costs \$39. For additional information, contact Extech Instruments Corporation, 335 Bear Hill Road, Waltham, MA 02154; Tel. 617-890-7440; Fax: 617-890-7864; e-mail: extech@extech.com; Web: <http://www.extech.com>.

CIRCLE 82 ON FREE INFORMATION CARD

FIELD-SERVICE SOLDERING IRONS

Two soldering irons from *M.M. Newman* are designed for industrial and electronic field service, as well as automotive, marine, and hobby applications. The *Antex Model G/3U* miniature soldering iron heats up and recovers instantly and operates from 115 volts AC for in-plant or field-service use. The *Model MLXS* soldering iron is powered by any standard 12-volt automotive or marine battery. For optimal thermal efficiency, both irons feature heating elements placed directly under their tips.



Both models are available with a variety of specialized, interchangeable slide-on tips. The Model G/3U heats up to 800°F in 45 seconds, while the MLXS takes two minutes to reach that temperature. The Model G/3U has a six-foot cord and a three-prong plug, while the 12-volt iron has a 15-foot cord with two alligator clips for mobility.

The *Antex Model G/3U* miniature soldering iron has a list price of \$19.95, and the *Model MLXS* 12-volt iron costs

\$34.65. For further information, contact M.M. Newman Corporation, 24 Tioga Way, Marblehead, MA 01945; Tel. 617-631-7100; Fax: 617-631-8887.

CIRCLE 83 ON FREE INFORMATION CARD

PC-BASED PROGRAMMERS

ICE Technology's PC-based programmers offer low-cost solutions for a wide range of programmable devices. Varying in levels of device support, the programmers are all-inclusive, requiring no add-on modules or adapters to support any parts up to and including 40-pin dual in-line packages. Socket adapters available optionally expand support to SOIC, PLCC, PGA, QFP, and TSOP packages.

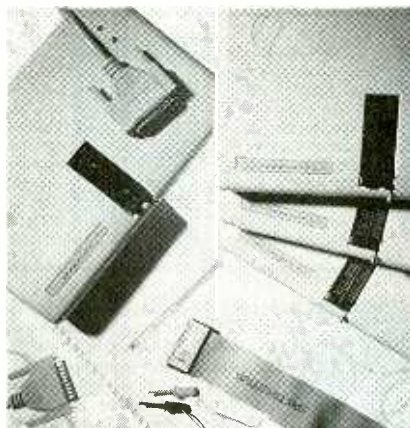

The *Speedmaster 1000+* supports EPROMs, EEPROMs, Flash, Serial PROMs, BPROMs, 8748/51 micros, GALs, and erasable PALs. The *Speedmaster LV* adds support for Bipolar PALs and complex programmable logic, as well as for low-voltage devices. The *Micromaster 1000+* is a universal programmer that can also program more than 180 microcontrollers, including PICs, COP8 series, Motorola 68HCxxx series, TMS370, Z8, 87Cxxx, and more, all without any additional software or modules.

The *Speedmaster 1000+* costs \$495; the *Speedmaster LV* costs \$595; and the *Micromaster 1000+* costs \$695. All three models are compatible with ICE's built-in ROM/RAM emulator upgrade options, priced starting at \$175, which feature built-in 8- or 16-bit ROM/RAM and chip testing for TTL, CMOS, DRAM, and SRAM. Free software upgrades on all programmers are available on ICE Technology's ftp site. For more information, contact ICE Technology, Inc., P.O. Box 1438,

Henderson, NC 27536; Tel. 800-624-8949 or 919-693-0678; Fax: 919-693-0681; Faxback: 919-693-1509; Web: <http://www.icetech.com>.

CIRCLE 84 ON FREE INFORMATION CARD

MOBILE MUSIC STORAGE

With car CD players becoming increasingly popular, more drivers are discovering a need for safe and convenient disc storage space in their vehicles. Case Logic's CDV-12 CD Visor meets that need: neatly organizing CDs, keeping them at the driver's fingertips and yet safely out of sight—behind the sun visor.

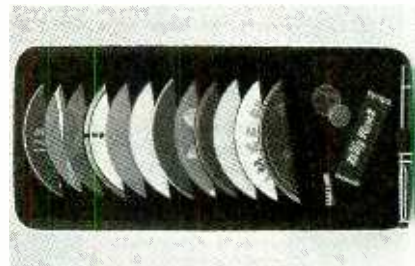

The CD Visor holds 12 compact discs securely in soft protective slots. Hook-and-loop straps adjust to fit any car or truck visor, and allow the CD holder to be easily moved to provide access to the vanity mirror, without detaching the unit. A mesh accessory pocket and elastic pen loop allow drivers to also store pocket change, gas cards, tire gauges and the like behind the visor.

The CDV-12 CD Visor costs \$9.95. For additional information, contact Case Logic, 6303 Dry Creek Parkway, Longmont, CO 80503; Tel. 800-447-4848 or 303-530-3800; Fax: 303-652-1091; Web: <http://www.caselogic.com>.

CIRCLE 85 ON FREE INFORMATION CARD

PIC MICROPROCESSOR DEVELOPMENT SYSTEM

Sirius microSystems' PIC-MDS is a complete development system for the inexpensive Microchip PIC family of RISC microcontrollers. It consists of a development board, a programmer, a cross-assembler, and a detailed training text. Specifically designed to make it easy to learn how to program and use microcontrollers, the PIC-MDS provides step-by-step examples to guide users from writing and testing simple programs to keypad, LCD, A/D, serial I/O,

continued on page 72

Hobbyist's Paperback Budget Books



BP80/98—Popular Electronic Circuits—Books 1 and 2...\$11.90. Contains a wide range of circuits which are accompanied by text giving a brief introduction, circuit description and special notes on construction and setting-up that may be necessary.



#160—Coil Design and Construction Manual...\$5.95. A complete book for the home builder on how to make RF, IF, audio and power chokes and transformers. Practically every possible type is discussed and calculations are explained in detail.



BP271—How to Expand, Modernize and Repair PC's and Compatibles...\$7.75. All the practical information you are likely to need to upgrade your PC and compatible. Also contains useful information and illustrations to help you with repairs.



BP276—Shortwave Superhet Receiver Construction...\$6.95. Provides construction details, including coil winding, of a number of advanced-design receivers which should have performance levels at least equal to commercial sets of similar complexity.



#223—50 Projects Using IC CA3130...\$5.00. One of the more practical and useful operational amplifiers (opamp), the CA3130 integrated circuit chip is the heart of several easy-to-assemble projects covered in the book. The projects are divided into five categories: audio projects, RF projects, test equipment, household projects and a catch-all miscellaneous group. Ideal for all skill levels.



BP122—Audio Amplifier Construction...\$5.75. Practical designs are featured and include circuit diagram and description, Veroboard or printed-circuit board layout and construction notes. The text is divided into two parts. The first deals with many types of preamplifiers. The second covers power amplifiers from a simple low-power battery type to a 100-watt DC-coupled amplifier using four MOSFETs in the output stage.



BP107—30 Solderless Breadboard Projects—Book 1...\$5.95. Each project is designed to be built on a "Verobloc" breadboard and is presented with a brief circuit description, circuit diagram, component layout diagram and components list. Notes on construction and applications are provided. Wherever possible, the components are common to several projects to keep project costs down.



BP266—Electronic Modules and Systems for Beginners...\$7.25. Shows the reader how to build a number of simple analog and digital circuit modules, all suitable for battery operation, and all based on only 1 or 2 transistors or ICs.



BP329—Electronic Music Learning Projects...\$6.25. A beginner's book that will assist you in assembling such projects as the Elexylophone, Gildaphone, Melody Ranger, Cordmaker, Appealing Handbells, Electronic Sol-Fa, Tune-up Box and more.



BP319—Making MS-DOS Work For You...\$6.50. What you need to know first, comes first, however the text is written in a circular style so that the reader can start anywhere in the text. This book is relevant to all versions of both MS-DOS and PC-DOS.



BP303—Understanding PC Software...\$6.95. Covers main types of PC software, giving details of typical uses, the basics of how they are used and their limitations. Each chapter covers popular software and programs of a similar type.



BP105 Aerial (Antenna) Projects...\$5.50. In this book the author has considered practical antenna designs, including active, loop and ferrite antennas which perform well and are relatively simple and inexpensive to build. The complex theory and mathematics of antenna design have been avoided. Also included are construction details of a number of antenna accessories including a pre-selector, attenuator and filters.



BP33—Electronic Calculator Users Handbook...\$5.75. The book eliminates the mysteries of the calculator and offers unique ideas for the simplest to most complex calculators. Covers the basic functions plus trigonometric, hyperbolic, logarithms, square roots and powers. Included are formulas and data for VAT, discounts, and mark up, currency conversion, interest, binary and octal numbers, and much more!



BP125—25 Simple Amateur Band Antennas...\$5.50. Plans to build antennas that are simple and inexpensive to construct and perform well. From the simple dipole to beam, triangle and even mini-rhombic types made from four TV masts and about 400 feet of wire. After the antenna discussion you will find a complete set of dimension tables that will help you "tune" an antenna on a particular frequency.



BP263—A Concise Introduction to dBASE...\$6.95. The most popular data-base program, dBASE, is difficult to master without help. This book helps you spend your time using dBase, not setting it up. A user's guide that covers all the basics up to dBase IV.



PCP104—Electronics—Build and Learn...\$9.95. Construction details are given to build a circuit demonstrator that is used throughout the book to introduce common electronic components and how these components are built up to useful circuits.



BP302—A Concise Users Guide to Lotus 1-2-3 Release 3.1...\$6.25. Written to help existing spreadsheet users upgrade to 1-2-3 Release 3.1, which has the ability to work 3-dimensionally with both multiple worksheets and files.

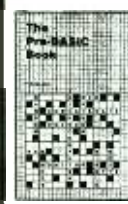

BP146—The Pre-BASIC Book...\$6.95. Another book on BASIC but with a difference. It concentrates on introducing technique by looking in depth at the most frequently used and more easily understood computer instructions.

Just What the Project Builder Is Looking For!

- | | |
|---|--|
| <input type="checkbox"/> #160—Coil Design and Construction Manual\$5.95 | <input type="checkbox"/> 1596T—24 Silicon-Controlled Rectifier Projects.....\$9.95 |
| <input type="checkbox"/> #219—Solid State Novelty Projects\$4.95 | <input type="checkbox"/> BP58—50 Circuits Using 7400 Series ICs\$5.50 |
| <input type="checkbox"/> #222—Solids State Shortwave Receivers for Beginners.....\$5.50 | <input type="checkbox"/> BP69—Electronic Games.....\$5.50 |
| <input type="checkbox"/> #223—50 Projects Using IC CA3130.....\$5.00 | <input type="checkbox"/> BP71—Electronic House Projects\$5.00 |
| <input type="checkbox"/> #225—Practical Introduction to Digital ICs.....\$5.25 | <input type="checkbox"/> BP84—Digital IC Projects.....\$5.50 |
| <input type="checkbox"/> PCP111—Electronic Test Equipment Handbook.....\$13.95 | <input type="checkbox"/> BP93—Electronic Timer Projects.....\$5.50 |

ELECTRONIC TECHNOLOGY TODAY INC.
P.O. BOX 240, Massapequa, NY 11762-0240

Name _____
Address _____
City _____ State _____ Zip _____
PE5

Allow 6-8 weeks for delivery

SHIPPING CHARGES IN USA AND CANADA

\$0.01 to \$5.00	\$2.00
\$5.01 to \$10.00	\$3.00
\$10.01 to 20.00	\$4.00
\$20.01 to 30.00	\$5.00
\$30.01 to 40.00	\$6.00
\$40.01 to 50.00	\$7.00
\$50.01 and above	\$8.50

SORRY No orders accepted outside of USA & Canada

Total price of merchandise \$ _____
Shipping (see chart) \$ _____
Subtotal \$ _____
Sales Tax (NYS only) \$ _____
Total Enclosed \$ _____

Number of books ordered

All payments must be in U.S. funds!

Add big stereo sound to your car's audio system without spending big bucks.

BY GARY CLIFTON

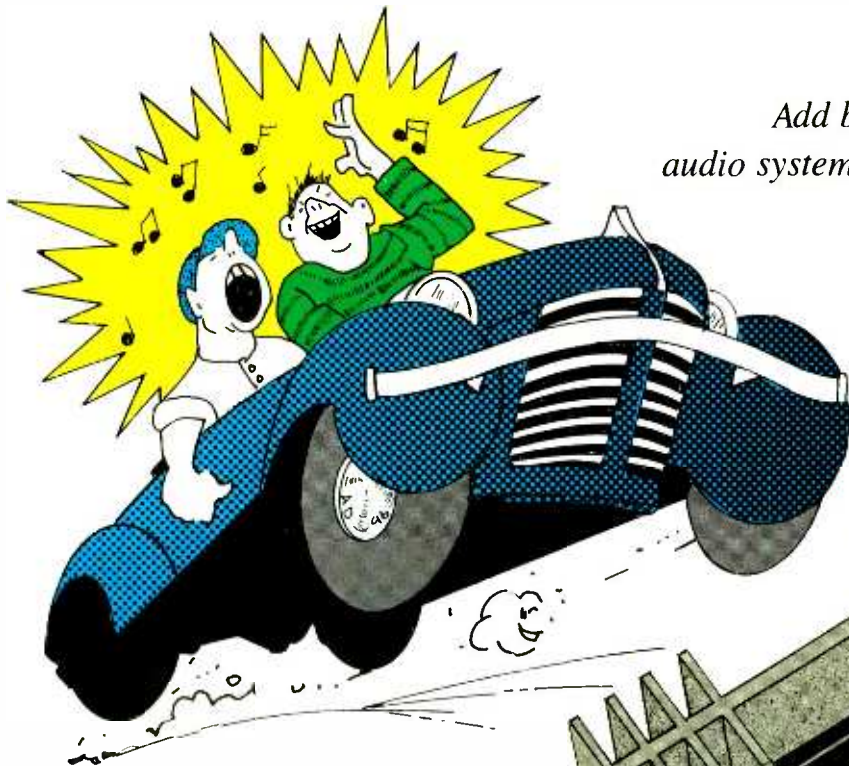

BUILD A 22-WATT AMPLIFIER

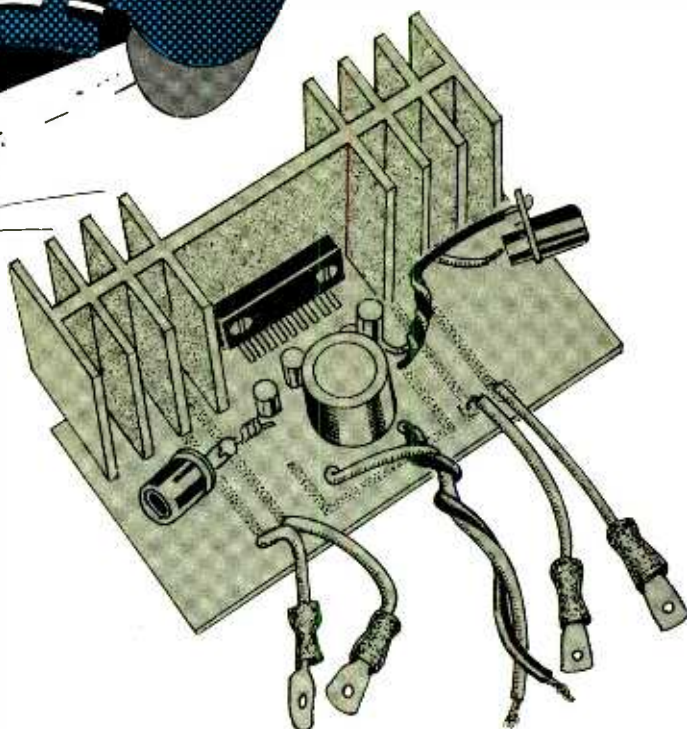

Is your car stereo missing something? Do the speakers that accompany you to and from work each day really put out all that they can? Let's face it; our car audio systems are the only entertainment we have while on the road. And if those systems aren't up to par, you'll feel it. So why not breathe some new life into your car's sound system?

The 22-Watt Amplifier described in this article will deliver up to 22 watts-per-channel into a pair of four-ohm loudspeakers. Best of all, you can build it for under \$20. That means you can build one Amplifier for the front speakers in your car, a second one for the rear speakers, and have 44 watts of pure audio power, all without breaking the bank.

The TDA1554. Whether you're a beginner at electronics or an experi-

enced hobbyist, be prepared for a pleasant surprise: The low parts count of this project means you can easily assemble the Amplifier in an evening. Such a low parts count is possible because of the TDA1554 integrated amplifier, which is found at the heart of the circuit (see Fig. 1; the amplifier chip is IC1).

A number of factors made the TDA1554 IC an ideal choice for this project. First of all was the cost—the chip is relatively inexpensive for what it does. Second, the TDA1554 was designed primarily for automotive applications. It runs on a +12- to +15-volt supply capable of delivering up to 5–10 amperes. Therefore, using the chip eliminates the need for a separate power supply.

The TDA1554's other features include a mute/delay circuit to eliminate turn-on pop; and thermal, ESD

(electro-static discharge), and load-dump protection. Input impedance is typically 30,000 ohms in BTL (bridge-tied-load) applications, with gain typically at 26 dB. The power bandwidth runs from about 20 Hz to 20 kHz. Output power is typically 17 watts at 0.5% THD (total harmonic distortion) and 22 watts with up to 10% THD in the BTL configuration.

Inside the TDA1554 are four independent amplifiers, a mute/standby switch, and some protective circuitry. Each amplifier can drive up to 11 watts into a 2-ohm load, or amplifiers can be paired to drive up to 22 watts into 4-ohms using the BTL configuration; the latter is used in the Amplifier project. The mute/standby switching circuit is used to eliminate loudspeaker turn-on pop by providing a slight delay and a gradual turn-on. Both the inverting and non-inverting inputs are

available for each of the four amplifier sections.

As just mentioned, the chip uses a BTL output configuration to get 22 watts out of a nominal 12-volt DC system. This circuit is sometimes referred to as a "bridge" or "bridged output" where neither side of the load (in this case loudspeaker) is tied to ground. Instead, two amplifiers operated 180° out-of-phase are tied together or bridged at the load. While one side is moving high, the other side is moving low. No phase-shifting circuitry is involved to obtain the 180° shift. The audio inputs are fed to the inverting input of one amp and the non-inverting input for the other amp in each stereo pair. The result is typically twice the power (into the load) either amplifier could deliver into a single-ended load (which is when one side of the loudspeaker is connected to the amplifier and the other side is connected to ground).

Circuit Description. The schematic for the 22-Watt Amplifier is shown in Fig. 1. Power for the circuit (+12 volts) is provided by a connection to the host vehicle's battery. A connection is also provided for the vehicle's ground. Capacitors C1 and C2 provide decoupling of any signal riding on the supply voltage, while capacitor C3, working in conjunction with IC1, provides ripple rejection.

The incoming audio signal is coupled to IC1 by capacitors C4 and C5. Those 10- μ F capacitors are used to avoid rolling off of the low audio frequencies. Resistor R1 and capacitor C6 feed the mute switch circuit (included in IC1), providing the delay that eliminates turn-on pop. Their R/C time constant is about 1.4 seconds. None of the component values external to IC1 are critical, but major value substitutions should not be made.

Pin 14 (the mute switch) of IC1 must have at least 8.5 volts for the amplifier to be on, or be held below 3.3 volts to ensure the chip stays in the mute condition. Current requirements at this pin are on the order of 40 μ A in the on condition, and 100 μ A for standby. The R1/C6 combination used here (47 μ F and 39,000 ohms) provides enough delay to eliminate turn-on pop without having an excessive wait for normal operation. In addition to this slight delay, pin 14 gradually comes up

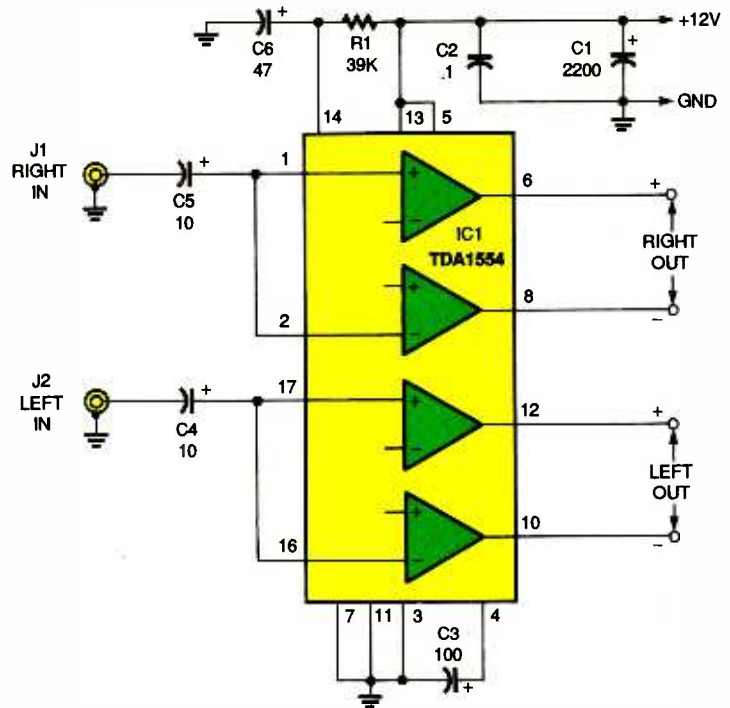

Fig. 1. The heart of this 22-Watt Amplifier is the TDA1554 IC. Four internal amplifiers in that chip can be connected as two bridges to drive two four-ohm speakers.

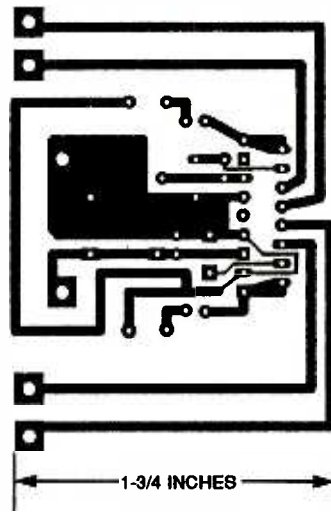

Fig. 2. Here's a full-size foil pattern that you can use to make your own PC board.

above the 8.5-volt threshold as C6 charges up, rather than coming on instantly as it would if a simple switch were used.

Values for C6 and R1 aren't critical, but R1 should be no larger than 100,000 ohms and the R1/C6 time constant should be on the order of a second or two. Too short a time constant may not eliminate the turn-on pop; too long a time constant does no harm except causing an irritating delay.

Power and Heat. Before we get to how to actually build the Amplifier, a few things about its power consumption and heat production need to be brought up. If it's driven to the full 22-watts-per-channel output with a continuous 1-kHz sine wave, total current consumption for this project is on the order of five amperes. However, if you're listening to music with the volume turned up until the peaks just begin to clip, the Amplifier will consume about two amperes or less. This is due to the dynamic range inherent in music—not every sound is at peak volume and there are slight pauses, often between beats.

Consider the difference between a softly strummed harp and a bass drum, for instance. Most of the power peaks are also short transients rather than continuous tones. For that reason current consumption isn't really an issue if you use one of these amplifiers in an automotive applications. However, using two or more amplifiers at high volume may drain the battery if your car's engine isn't running. For in-home use, each Amplifier should have at least a three-ampere supply available to handle transitory peaks adequately.

Now, on to heat production. The TDA1554 IC has a worst-case power

dissipation of around 25 watts. This represents heat that has to be carried away from the die inside the IC package. There is a thermal resistance between the die and the IC package itself, between the IC package and the heatsink, and finally between the heatsink and the surrounding air. The end result is that this amplifier requires a heatsink with a thermal resistance of 2.8° C/W or lower. Inadequate heat-sinking results in thermal shutdown or intermittent, erratic operation as the die heats and cools.

For this reason, use a thermalloy extrusion #11096 heatsink; it has a thermal resistance of 2.1° C/W for a 3-inch-long section, which is better than the calculated requirement. The prototype circuit was tested with a 2-inch

PARTS LIST FOR THE 22-WATT AMPLIFIER

CAPACITORS

- C1—2200- μ F, 25-WVDC, electrolytic
 C2—0.1- μ F, ceramic monolithic
 C3—100- μ F, 25-WVDC, electrolytic capacitor
 C4, C5—10- μ F, 16-WVDC, electrolytic
 C6—47- μ F, 25-WVDC, electrolytic

ADDITIONAL PARTS AND MATERIALS

- IC1—TDA1554 two-channel audio amplifier, integrated circuit
 R1—39,000-ohm, 1/4-watt, 5% resistor

- J1, J2—RCA jacks, panel mount
 Printed-circuit materials, metal or plastic enclosure (minimum 3 x 3 x 4 inches) with ventilation holes, 2-inch heatsink (thermal extrusion 11096 or equivalent; see text), heatsink compound, two 6-32 screws and nuts, 7/16- to 10-ampere in-line fuse and holder, shielded audio cable, 18- and 20-gauge insulated stranded wire, solder, hardware, etc.

Note: The following is available from DC Electronics (2334 N. Scottsdale Rd, Scottsdale, AZ 85257; Tel. 800-467-7736): complete kit of parts (S1554 Kit) including the heatsink, TDA1554 IC, etched and drilled PC board, and all on-board components—\$19.95; TDA1554 IC—\$8.95; heatsink (11096-2)—\$3.49; PC board—\$10.95. Shipping and handling is \$4.00; Arizona residents please add applicable sales tax.

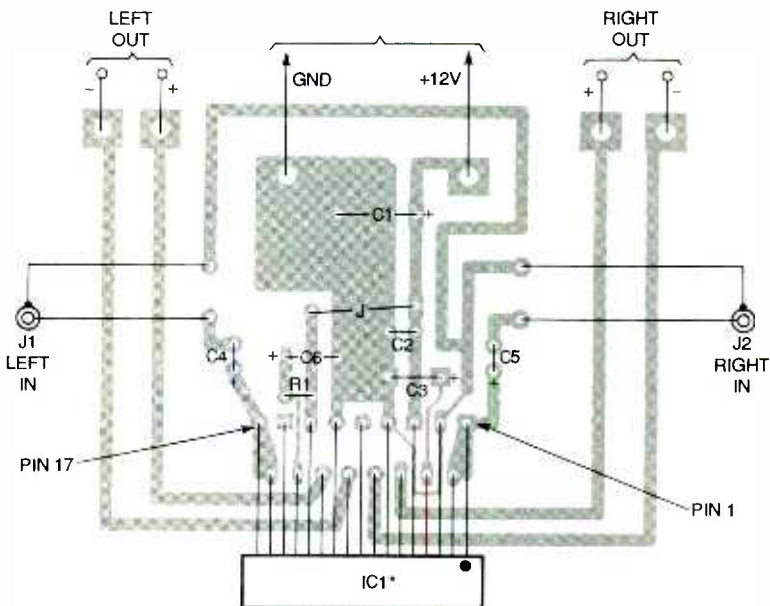
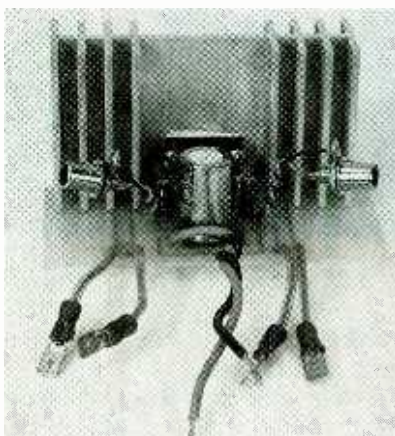

Fig. 3. Use this parts-placement diagram as a guide when building the Amplifier. Note that IC1 is an in-line SIP; therefore its pin numbers are numbered consecutively from pin 1 at the marking to pin 17 at the other unmarked end of the IC.



As you can see, the assembled 22-Watt Amplifier is dwarfed by the aluminum heatsink.

length of this extrusion, and it was found that a 2-inch piece is adequate for a music load, but only marginally acceptable for continuous operation at 5 amperes. If the Amplifier is going to be installed in the trunk of a car in a warm climate (like the desert), a bigger heatsink will be required to cope with the higher ambient temperature that can build up in such enclosed, unventilated volumes.

Construction. The prototype for the 22-Watt Amplifier was built on a printed-circuit board. If you'd like to do the same you can either make your own PC board using the foil pattern shown in Fig. 2, or order one from

the source mentioned in the Parts List. PC-board assembly is recommended for most audio projects.

If you're using a PC board, use the parts-placement diagram shown in Fig. 3 as a guide. Begin assembly by installing C1. Solder it into place and save one of the snipped leads to use for the jumper, which should be installed next. Install R1 (standing up) by doubling back one lead so both leads are parallel. Next, install the remaining capacitors and check polarity before soldering.

Attach to the circuit board wire leads of ample length for the speaker, power, and ground connections shown. For power and ground leads an 18-gauge, or heavier, insulated, stranded wire should be used. Stranded 20-gauge wire is fine for speaker leads. Select different-colored leads to avoid confusion.

Audio input signals should be routed in through shielded cables to minimize hum, alternator whine, and other extraneous noises. Attach those cables at this time; then connect standard RCA phono jacks (J1 and J2) to them.

After everything else is soldered into place, install IC1 onto a heatsink before soldering the IC onto the PC board. As we mentioned earlier, use a thermalloy extrusion #11096 heatsink or its equivalent (one is available from
(Continued on page 56)

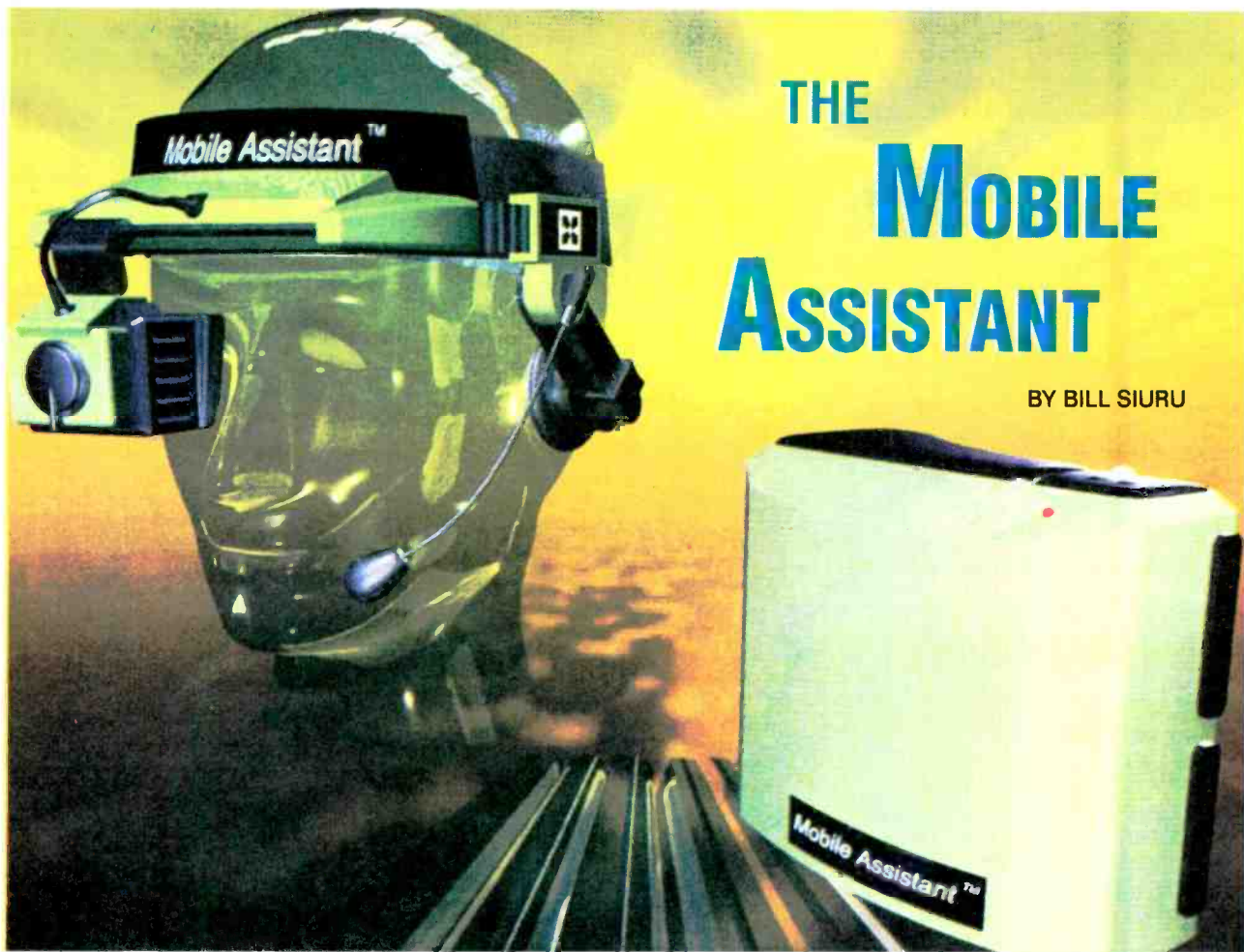

THE MOBILE ASSISTANT

BY BILL SIURU

Here's a look at an advanced portable computer that you can wear!

Computers are an integral part of an ever increasing number of occupations. This includes not only white-collar office workers, but also blue-collar technicians who use computers while troubleshooting and repairing complex equipment like aircraft, computers, power-generation systems, and automobiles, to name a few.

More and more technical data used for diagnosis and service is being transferred from bookshelves full of manuals to much more compact computer databases, which are accessed via laptop or notebook computers. While this trend reduces the time required in looking up the needed information, schematic diagrams, troubleshooting test points, visual inspection hints, and other data, there is still a lot of wasted effort. For instance, the technician has to move to the computer, use a keyboard or mouse to search for and retrieve the information they need,

perhaps print it out, and then move back to the job site.

Unlike office employees who work in computer-friendly environments, technicians often have to work in cramped quarters, outdoors in all types of weather, and perhaps 30 to 40 feet above ground on a wooden utility pole. Even small notebook computers are too cumbersome in such environments. What then is a tech to do?

A Mobile Solution. One answer is for the technician to wear a computer that has input/output peripherals, which can be used hands-free. This is the whole idea behind the *Mobile Assistant* now offered by *Computer Products and Service Inc.*, an information and systems integrator located in Fairfax, VA. Indeed, the inspiration for the *Mobile Assistant* came while watching Army technicians juggling technical manuals and simultaneously trying to make repairs.

The patented *Mobile Assistant* took six years to develop. It's a 6- x 5- x 3-inch IBM-compatible, belt-worn computer that looks a bit like a canteen and weighs 2.75 pounds. The specifications on the preliminary basic computer include a 486 processor operating at 50 MHz with clock doubling, a 340-MB internal hard drive, internal analog/digital conversion, 4 MB of RAM, and a PCMCIA reader.

The computer is pre-loaded with MS-DOS 6.2 or Microsoft Windows 3.1 software plus speech recognition and synthesis hardware and software. Windows 95 or SCO/UNIX can be loaded as an option. There are I/O ports for standard serial, parallel, and keyboard peripherals, including external disc drives, printers, and CD-ROMs.

Cards for cellular phones, FAX/modems, RF communication devices, and interfaces with equipment-specific diagnostic setups can be plugged into the dual PCMCIA slots. For video conferencing there is an op-



With more accessories than a Japanese camera, the Mobile Assistant can be adapted to virtually all kinds of tasks in the field as well as in workshops.

tional Integrated Video Kit that includes a miniature head-mounted camera with 24-bit capture, plus associated image processing, JPEG compression, and basic voice-control capability. Expansion upgrades available include additional RAM (4 MB, 8 MB, 16 MB or 32 MB) and an 810-MB hard drive. The computer is designed to withstand a 3-foot drop, has passed FCC class A certifications, and is even splash-proof.

The Mobile Assistant uses a miniature monochrome VGA heads-up display mounted on a sliding frame so it can be moved and viewed by either the right or left eye. Located a few inches in front of the eye, it can be used with eyeglasses and can be tilted and rotated. Unlike an occlusive display used in virtual-reality applications, the monocular, single-active matrix liquid crystal display (AMLCD) fills only a small portion of the field of view.

Called an *augmented reality display*, the AMLCD allows users to see both the computer image and the outside world simultaneously without distortion. The image actually appears to float in front of the user, filling a viewing area that is equivalent to a 15-inch desktop monitor with comparable resolution. The 0.7-inch diagonal VGA, supplied by Kopin of Taunton, MA, has 640- × 480-pixel resolution and weighs about 8 ounces. There are controls for focusing and adjusting brightness for viewing in even bright sunlight. For safety's sake, there is no high voltage near the user's head.



The Mobile Assistant is currently in use in the military, where critical field work must be performed without the availability of volumes of technical manuals. Data can be called up and viewed on a miniature heads-up display that can be slid over either eye



The Mobile Assistant allows for complete "hands-off" operation as this technician follows a visual test/repair procedure on complicated military equipment.

Power Packed. The system is powered by a rechargeable lithium-ion battery that weighs 1.8 pounds and is also worn on the belt. It has a 3- to 4-hour capacity between recharges. There is an optional AC power supply, or a disposable lithium-battery pack that offers 14 hours of operational life.

Users can access the system and navigate through the various databases using several options. First, there is a mouse built into the computer. Both a miniature keyboard or a wrist-worn keyboard are optional. However, for complete hands-off operation, there is headset-mounted microphone for the speech-recognition system. Voice-recognition hardware and software is now rapidly maturing, and is expected to become a mainstream technology over the next few years. In all fairness, current voice-recognition systems still require very precise and clear verbal commands—no mumbling or thick accents allowed.

Applications. Computer Products and Service Inc. envisions many uses for the Mobile Assistant. For instance, technicians can work while viewing a needed schematic, or even watch a video clip showing how to complete the repair at hand. A novice or apprentice technician could communicate with an experienced expert who could not only talk, but visually guide him or her through a complicated procedure.

The Army is now testing the Mobile Assistant in conjunction with the Intelligent Fault Locator used to diagnose and repair subsystems on the AH-64A Apache helicopter. Here the belt-worn computer is used to read trouble codes and perform diagnostic tests, as well as to access the Interactive Electronic Technical Manual (IETM). The IETM replaces hard-copy manuals that take no less than three trucks to transport!

In the civilian world, AIL Eaton Corporation has adapted the Mobile Assistant for use in servicing gas burners and power plants. Other applications include law enforcement, firefighting, medical diagnostics and treatment, and more.

Another example is in the routine inspection of incoming materials. The
(Continued on page 52)

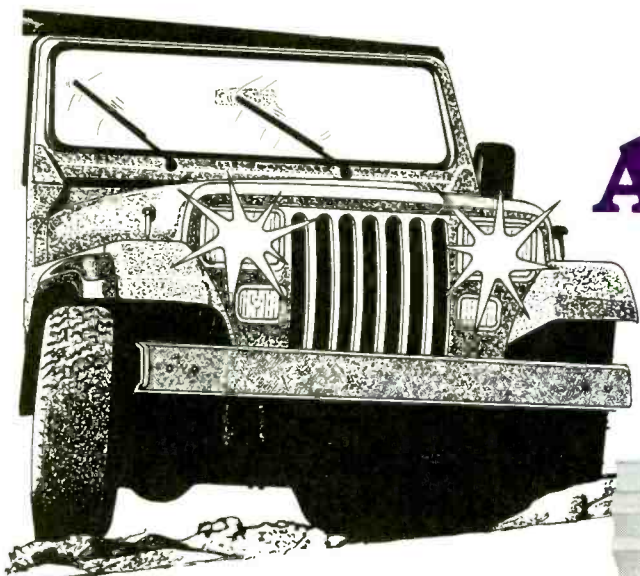

BUILD AN AUTOMATIC HEADLAMP CONTROL

BY ANTHONY J. CARISTI

Let this circuit switch on your vehicle's headlamps whenever you turn on your windshield wipers. Use it to help prevent accidents, and, in some places, to obey the law.

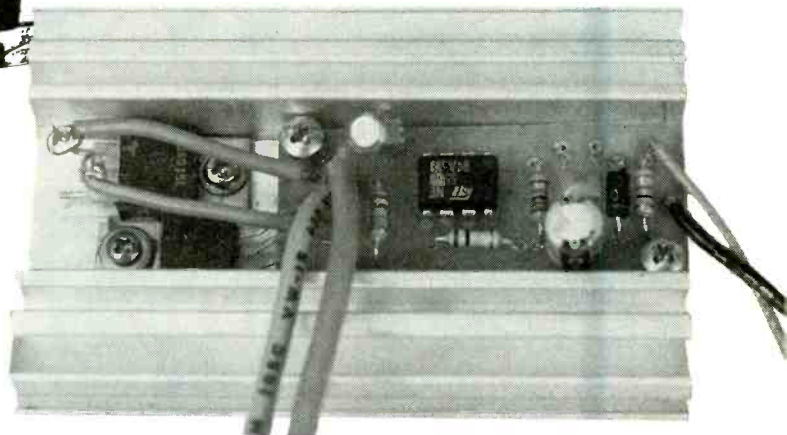

Circuits like the *Automatic Headlamp Control* described in this article will eventually be part of many vehicles manufactured in the United States. In fact, this type of system is already standard equipment on at least one line of domestic luxury cars. The purpose of such units is to ensure that the headlamps of a vehicle are automatically lighted whenever the windshield wipers are operating.

About 16 states already have a law on the books that requires drivers to have their vehicle's headlamps on during inclement weather, and other states are sure to follow. Also, studies have shown that the accident rate is substantially reduced when automatic headlamps are on during daylight hours.

Of course, it is easy for the driver to turn on the headlamps when required, but there are several important reasons to build and install this electronic module. First, it is completely automatic. There is no need to remember to manually turn on or off any switch. As a result, the driver al-

ways obeys the law, and there will never be an occasion where the battery goes dead when the headlamps are inadvertently left on after parking the vehicle.

Second, the Control circuit provides enough current to the headlamps to make them visible to other drivers, but does not deliver full power. This is accomplished without the use of bulky, heat-producing power resistors. Using pulse modulation, the circuit operates the headlamps at about a 30% duty cycle, which minimizes the load on the alternator and battery, and has virtually no effect on headlamp filament life.

With the Automatic Headlamp Control, you will never be given a summons when you forget to turn on your lights, and its automatic feature can help avoid an accident. Those reasons alone should prompt you to build and install this low-cost circuit.

Some other features of the Control circuit are its relatively small size (which allows you to place it anywhere in the engine compartment of your vehicle), and the fact that it has

no operating controls or adjustments. Once installed, the Control has no effect on normal headlamp operation except to automatically illuminate the lamps whenever your windshield wipers are on.

Circuit Description. The schematic for the Automatic Headlamp Control is shown in Fig. 1. At the heart of the circuit is IC1, a 555 timer chip that is operated as an astable or free-running multivibrator. The frequency of operation, about 40 Hz, is determined by the values of R2, R3, and C2. The duty cycle of the oscillator is set to about 70% by the ratio of R2 to R3.

The 555 is operated by the 12-volt DC power source that appears across the windshield-wiper motor assembly. Thus, the circuit oscillates only when the windshield wipers are turned on. Components R1, D1, and C1 protect the circuit from voltage transients that may appear on the power line of the vehicle.

A P-channel power MOSFET transistor, Q1, is used to deliver current to the headlamps. Power-diode D3 iso-

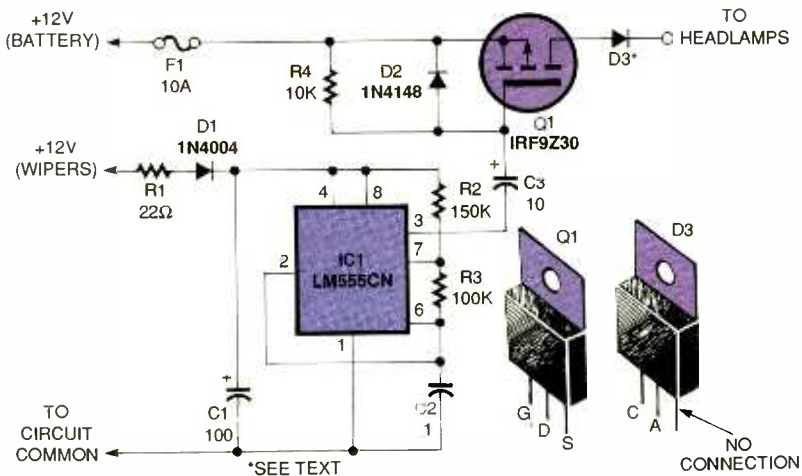

Fig. 1. Here's the schematic for the Automatic Headlamp Control circuit. Note the pinouts of MOSFET Q1 and power-diode D3.

lates the Control module from the normal headlamp circuit of the vehicle. As we'll see later, both Q1 and D3 need to be placed on a small heatsink to dissipate the amounts of heat that they generate.

When the windshield-wiper motor is at rest, the oscillator circuit is dormant, and Q1 is biased off by R4. Once the wiper motor is turned on, IC1 oscillates producing a waveform that is coupled to the base of Q1 through C3. As a result, Q1 turns on with a 30% duty cycle. During the time Q1 is forward biased, battery voltage is present at the anode of D3. Pulses of current then flow into the low-beam headlamps, illuminating them to somewhat less than full brightness.

A 10-ampere fuse, F1, protects Q1 and D3 from any possible excessive current. Such conditions can arise as a result of short circuits or malfunctions in the vehicle's electrical system.

Construction. The author's prototype for the Automatic Headlamp Control consists of a single-sided printed-circuit board mounted to a small heatsink. Any heatsink may be used as long as it contains a flat mounting area that's large enough to accommodate the PC board and the two TO-220AB-size semiconductor components, Q1 and D3.

If you wish to build the circuit on a PC board, you can either etch your own using the full-size template shown in Fig. 2, or order an etched and drilled board from the source mentioned in the Parts List. Alternatively, you can hard wire the circuit on a perforated board, making sure

you keep the board compact enough to fit on your chosen heatsink. Excellent project-building techniques must be used, though; it's a harsh environment under the hood of a vehicle.

For those building the circuit on a PC board, a parts-placement diagram is shown in Fig. 3. Before starting, clean the copper side of the PC board with steel wool to remove any

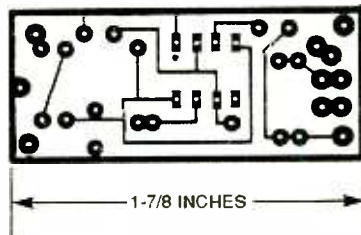

Fig. 2. If you'd like to etch your own PC board for the Control module, use this full-size template.

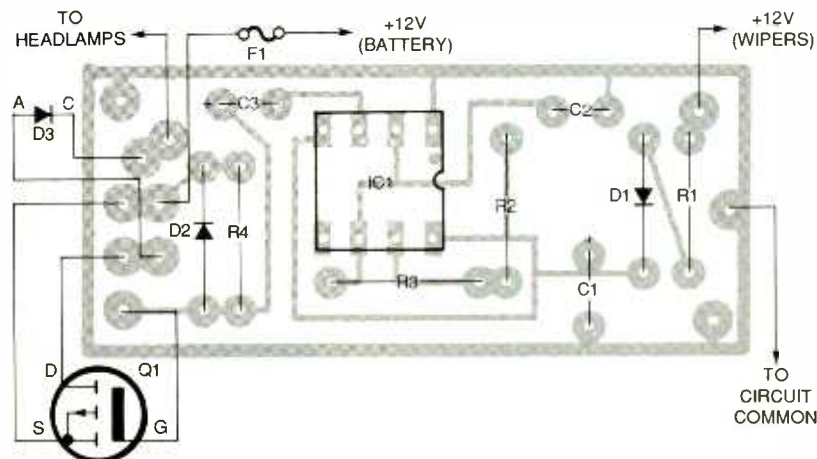

Fig. 3. Use this parts-placement diagram as a guide when assembling the Control board. The pins of Q1 and D3 are labeled to make off-board assembly easy.

dirt, oxidation, etc. When the board's thoroughly clean, begin by installing the resistors. Then solder the capacitors to the board, observing correct placement of the electrolytic units.

Solder four insulated, 18-gauge stranded wires (about 12-inches long) to the board next to facilitate connections to the vehicle (the wires will also make bench testing easier). You should use different-colored wires to prevent confusion.

Mount diodes D1 and D2 next, as shown in the diagram. Then connect D3 and Q1 to the board, using the pinouts shown in Fig. 1 and the labeled points shown in Fig. 3, as guides. You can simply bend the leads of Q1 and solder them to the board, but you will need to use short, insulated, 18-gauge stranded wire leads to connect D3 (as you can see in Fig. 3, the pads are not adjacent). Carefully bend up the anode and cathode wire terminals of the diode before soldering them to the leads. Be sure the wires and solder connections do not short out each other or anything else.

The last component to install is IC1. Do not use a socket for this part. Instead, solder it directly to the board for reliability, because the circuit will be subjected to the vibration and harsh environment of the engine compartment of your vehicle. Before soldering the IC, be absolutely sure it is properly oriented as shown in Fig. 3. Be careful; it is difficult to remove a multi-pin IC from the board once it has been soldered in place.

When the printed-circuit board is completed, examine it very carefully for opens, short circuits, and bad sol-

der connections, which may appear as dull blobs of solder. Any solder joint that is suspect should be redone by removing the old solder with desoldering braid, cleaning the joint, and carefully applying new solder. It is far easier to correct problems at this stage rather than later on if you discover that the circuit does not work.

Figure 4 provides drilling information for the heatsink used in the author's prototype. Two holes are used to mount the printed-circuit board, and the other two are used to mount Q1 and D2. The location of mounting holes, used to secure the heatsink to the vehicle's chassis or sheet metal, are left up to the discretion of the builder.

PARTS LIST FOR THE AUTOMATIC HEADLAMP CONTROL

SEMICONDUCTORS

- IC1—LM555CN or equivalent timer, integrated circuit
- Q1—IRF9Z30 P-channel MOSFET
- D1—1N4004 or equivalent silicon diode
- D2—1N4148 or equivalent silicon diode
- D3—Silicon power diode, 15-ampere, 200-volt (Mouser 519-D2015L or equivalent)

RESISTORS

- (All resistors are 1/4-watt, 5% units.)
- R1—22-ohm
- R2—150,000-ohm
- R3—100,000-ohm
- R4—10,000-ohm

CAPACITORS

- C1—100- μ F, 25-WVDC, radial electrolytic
- C2—0.1- μ F, ceramic-disc
- C3—10- μ F, 25-WVDC, radial electrolytic

ADDITIONAL PARTS AND MATERIALS

- F1—10-ampere slow-blow fuse
- Printed-circuit materials, heatsink, fuse holder, machine screws and matching hex nuts, fiber shoulder washer, mica insulator, wire nuts, test lamp, electrical tape, 18-gauge stranded hookup wire, solder, hardware, etc.

Note: The following parts are available from A. Caristi (69 White Pond Road, Waldwick NJ 07463): etched and drilled PC board—\$9.95; IC1—\$2.50; Q1—\$9.50; D3—\$4.75. Please add \$5.00 postage and handling.

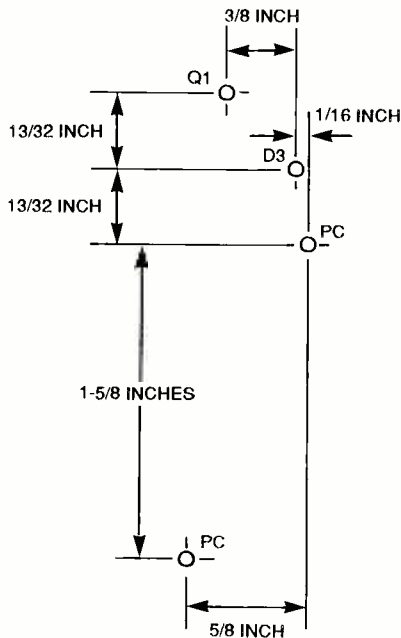

Fig. 4. This heatsink drilling template was used to make the author's prototype.

Make sure the transistor and power diode will lie flat on the heatsink. Then mount the PC board to the heatsink using suitable hardware and two plastic spacers, about 1/16- to 1/8-inch thick to prevent the circuit from shorting out to the metal. Small spacers can be fabricated by cutting a 1/4-inch-long spacer in half.

It is important that proper mounting hardware, including plastic spacers and a mica insulator, be used to mount Q1. Figure 5 illustrates how the insulating shoulder washer, mica, and transistor are assembled. Power-diode D3 is an isolated component and no insulation is required. However, heatsink compound should be used on both semiconductor parts to maximize heat transfer to the metal.

Do not attempt to install the circuit board in the vehicle at this time. It must first be tested to ensure that it is working properly.

Preliminary Test. To perform the ini-

tial test a 12-volt DC source is required. You'll also need a DMM. If available, an oscilloscope may be used to display waveforms. A small 12-volt automotive-type lamp such as a number-1157 unit can be used as a test load to simulate the headlamps of the vehicle. Be sure the DC power source is capable of driving the required lamp current. Figure 6 illustrates the preliminary test setup you need to assemble.

Before applying power, take a resistance reading between the metal tab of Q1 and the heatsink to verify that the resistance reading is infinite. If not, check and correct the assembly according to Fig. 5.

Connect the negative side of the power supply to circuit common. Then attach the positive side of the supply to both the +12-volt battery and wiper connections. Finally, connect the test lamp between the cathode of D3 and circuit common. Turn the power supply on.

The lamp should be lighted with less than normal brightness. This can be verified with a DMM, which will indicate an average voltage of about 3 volts across the lamp.

Disconnect power from the +12-volt wiper wire only. The lamp should be extinguished.

If the circuit performs as indicated, the preliminary test is completed. Otherwise, troubleshoot the circuit to locate and repair the fault. Visually inspect the board for shorts again, then double-check the orientation of all semiconductor components, and of C1 and C3.

If no fault is found with the assembly, connect an oscilloscope probe to pin 3 of IC1 to ascertain that it is oscillating. If not, try a new chip. If IC1 is operating, replace Q1.

When the board is operational as described, it is ready to be installed into the vehicle. Let's take a look at how to do that.

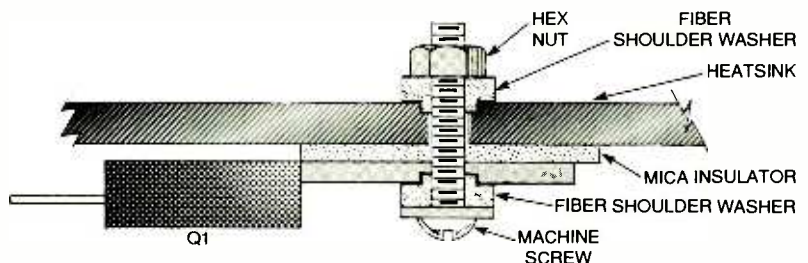

Fig. 5. MOSFET Q1 must be mounted to the heatsink as shown here.

It's Not Just Training...

"I needed a refresher in fundamentals and a piece of paper that said I had a degree. CIE gave me both."

Louis P. Briant
Senior Engineer
Sentel Corp.

"CIE allowed me to use my G.I. Bill benefits and independent-study allowed me to continue my studies while deployed."

Charles Hopper
Electronics Senior Chief
U.S. Navy

"The fact that I intended to continue pursuing my Associate Degree with CIE was a key factor in being considered for my current position."

Annamarie Webster
Project Engineer -
Instrumentation
Ketchikan Pulp

"My associates at work recommended CIE... The lessons were structured so they were easy to comprehend."

Vincent R. Buescher
Communications Technician
AT&T

"I reenrolled and received my A.A.S. degree from CIE because of the good experiences I had in one of CIE's career courses."

Maurice M. Henthorn, Jr.
Electronic Technician
The Denver Post

Independent study from CIE will give you the skills you need to win your own independence in a successful career.

At CIE, we pride ourselves in keeping pace with the latest developing technologies. In turn, this assures our students that upon graduation they can mesh seamlessly into a variety of exciting and rewarding technology-based careers.

Back in the 1930's, we specialized in teaching radio and television sciences. Today, it's computer technology, programming, robotics, broadcast engineering, information systems management, and the electronics behind it all.

But some things have not changed, like the desire of CIE's faculty and staff to see their graduates succeed.

That is why at CIE we teach not only the hands-on, practical aspects of electronics-technology, but also delve into the "why" behind today's technology. Why does it work the way it does?

The insights to be gained from such a broad, rich and comprehensive

education at CIE matches or exceeds those gained through traditional commuter institutes while providing an education schedule to match your commitments and lifestyle.

Our patented learning program is specifically tailored for independent study and backed up by a caring team of professional educators who are at your call whenever you need their help.

At CIE, we'll match our training with your background and career goals and help you decide which of the many career courses that we offer suits you best. We offer an Associate Degree Program and through our affiliation with World College a Bachelor Degree

Program.

If you have the sincerity, the smarts and the desire, CIE can make it happen. CIE is already the institute of choice for many Fortune 1000 companies. Why shouldn't you be next?



Computer Programming



Electronics Technician

...It's an Education.



1776 East 17th Street
Cleveland, OH 44114
(216) 781-9400 • 1-800-243-6446

YES! Please send me more information on:

- CIE's Associate Degree Program
- CIE's Career Courses
- World College's Bachelor Degree Program

Name _____

Address _____

City _____ State _____ Zip _____

Phone: _____

Check for G.I. Bill Active Duty Veteran

AH86

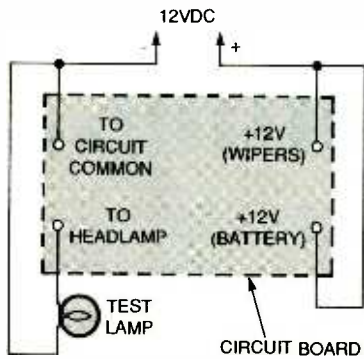

Fig. 6. Here's how to wire up the Control board so that you can perform a preliminary test without connecting the circuit to your vehicle.

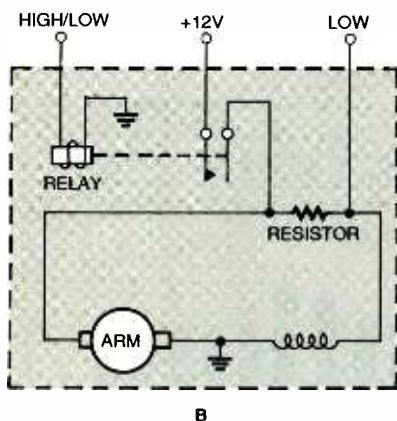
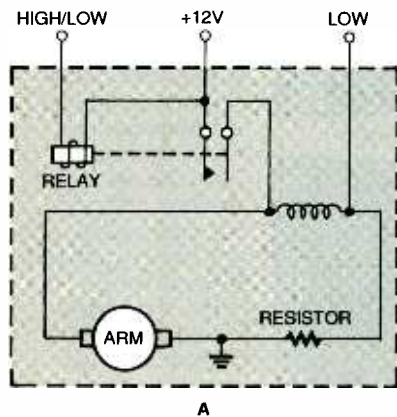

Fig. 7. Your vehicle's windshield-wiper circuit could work either by ground-control (A) or +12-volt switching (B).

Installation. You will need some more 18-gauge wire, preferably of matching colors to the leads you already attached, to make the connections between the Control module and your vehicle's electrical system. Wire nuts may be used if desired.

A fuse holder should be soldered to the wire that leads to the +12-volt battery connection. You can obtain

an inline fuse holder, as well as a 10-ampere slow-blow fuse, from an electronics supply house or automotive parts dealer. Insert the fuse at this time.

In order to accommodate all vehicles with electric windshield wipers the installation wiring is accomplished in either of two ways. The method you use will depend upon whether the dashboard switch in your vehicle controls the ground return for the wiper-motor relay coil or if it controls +12 volts.

Figure 7A illustrates a typical wiper

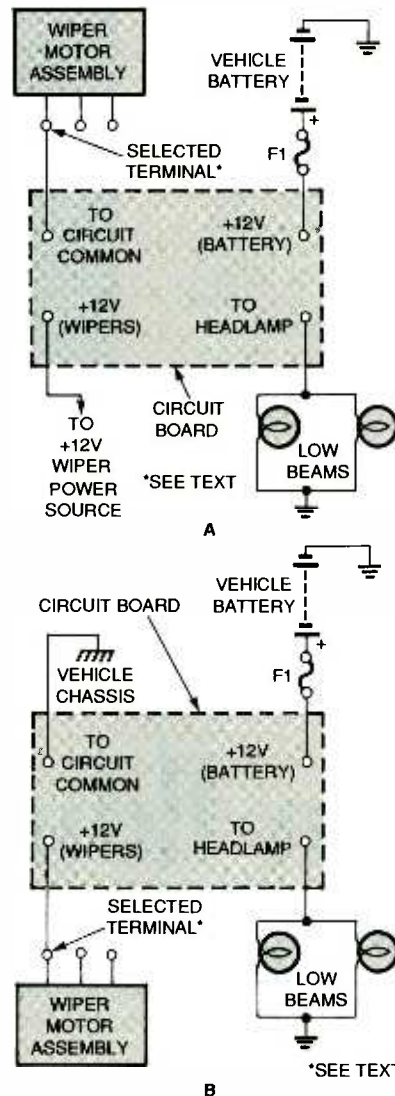

Fig. 8. If the wire you choose for connecting the wiper assembly (see text) is at +12 volts potential with the motor off, and zero volts when it is on, use the connection diagram shown in A to install the Control module. If the selected wire is at zero volts with the wipers off, and at +12 volts when they are on, use the diagram shown in B.

circuit that uses ground-return control. The dashboard panel switch provides the ground return for the relay coil, and a second pair of contacts shorts out the high-speed resistor that is placed in series with the shunt field of the motor.

Figure 7B illustrates a +12-volt switching system. Here the panel switch controls power to the relay coil, and a second pair of contacts is used to short out the high-speed resistor when low speed is selected.

Notice that in both circuits the relay coil wire changes voltage level when the wiper motor is operated at either speed. This is the wire that must be identified.

To determine which circuit is applicable to your vehicle, take a DC voltmeter and check the potential of all wires leading to the wiper motor assembly. Make sure the ignition is on, and set the dashboard wiper switch to each position, including off.

Figure 8A should be used as a guide when installing the Control module if the selected wire is at +12 volts potential with the motor off, and zero volts when it is on. Figure 8B should be used if the selected wire is at zero volts with the wipers off, and at +12 volts when they are on.

If necessary, refer to a shop manual or ask a qualified automotive technician or the dealer to determine which circuit is applicable to your vehicle. That could save you some trouble if you're not sure.

Before starting the actual installation, disconnect the negative (chassis) wire from the vehicle's battery. This will ensure that no inadvertent short circuit occurring during installation will cause damage.

The module should be placed at a location in the engine compartment of the vehicle where it will be protected against damage and dirt. Extra heat dissipation may be obtained by securely mounting the heatsink to any metal part of the vehicle, using heatsink compound to attain maximum heat transfer. If desired, a plastic cover may be placed over the assembly to protect it against grime and grease. It is preferable that the assembly be mounted near the front of the vehicle where it is close to the headlamps. Be sure to choose a location for the project that is protected
(Continued on page 56)

CRUISING THE LOWEST HAM BANDS

BY KARL T. THURBER, JR.

Must the higher frequencies always be "better" frequencies? While technology dictates the exploration and use of ever-higher frequencies, there still is considerable interest in the other end of the electromagnetic spectrum. By the "other end," we mean the basement: longwave (LW) and mediumwave (MW).

In this article, we'll explore the two lowest ham bands: the Federal Communications Commission (FCC) "Part 15" no-license frequency allocations of 160 to 190 kHz and 510 to 1705 kHz. Allocations in those ranges are referred to as LowFERS (Low Frequency Experimental Radio Station) and MedFERS (Medium Frequency Experimental Radio Station). Sometimes, you'll see hobbyists who focus on those bands referred to as LowFERS or MedFERS (both with a lowercase "s"). The terms were coined by Ken Cornell, W2IMB, who for years operated the LW beacon "KEN" on 187.5 kHz, and who now operates the MW beacon with the same ID on 1652 kHz.

You'll find LowFERS and MedFERS pursuits fun and technically rewarding. And, if you keep emissions within the band, you can try all sorts of modulation methods and transmission modes. Has this been a limited area of exploration? Not exactly. While many experimenters also are licensed hams, many others are not.

But before we get to the exploring of the bands, let's examine the rich history in LW and MW for LowFERS and MedFERS. We'll begin with a look at LW in the "good old days" of radio.

Longwaves. Much radio pioneering was on LW. That spectrum below the AM broadcast band is where wireless

originated. For a long time, the view was that higher frequencies, the so-called shortwaves (SW) lying above the AM standard broadcast band (BCB), were useless terra incognita (see the "Electromagnetic Spectrum" box). This is explained largely by technology—it then was much easier to generate radio frequency (RF) energy at longer wavelengths than at shorter ones.

LW frequencies were the place to be until the early 1920s, when radio amateurs moved ever-higher to escape interference from commercial stations. Amateurs made an important discovery: the higher the frequency, the greater the communications range. When that word got out, most hams rushed to the higher frequencies.

Then, LW went into a decline that only began to be reversed after World War II; even today, LW is largely neglected by shortwave listeners (SWLs). LW's renaissance is due in part to recognition of propagation charac-

teristics that actually make LW superior to SW for some tasks such as radio determination, military emergency communications, and time-keeping and frequency transmissions.

Longwave Inhabitants. You're probably familiar with MW, especially the AM BCB, now 535–1705 kHz. But LW, from 30 to 300 kHz, offers listening largely unknown to SWLs. The heart of the LW region has plenty of activity. There you'll find signals from time and frequency stations, broadcasters, military and emergency communications, unlicensed but legal experimenters (more on them later), radioteletype stations, radio determination (radiolocation and radionavigation), and some unusual signals (see Table 1 for both LW and MW frequency allocations).

The 150-285 kHz band is a popular broadcast band in Europe, North Africa, the Middle East, and Asia, where LW broadcasters use high-power transmitters and large antennas to

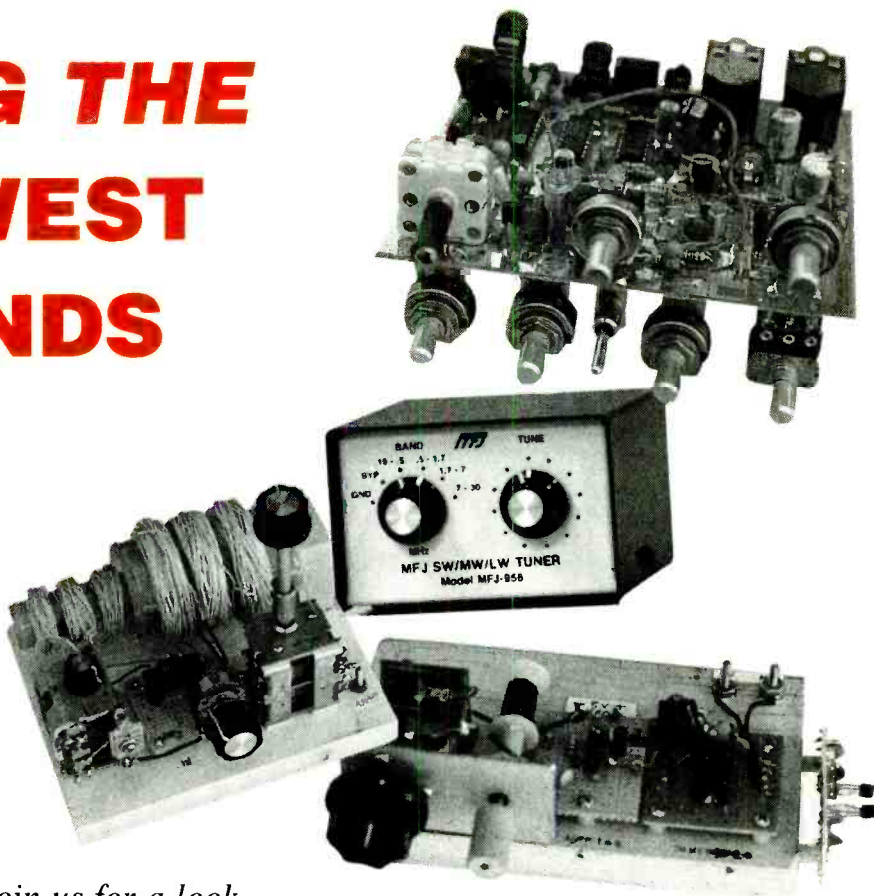

*Join us for a look
at the most unusual ham bands—LowFERS and
MedFERS—and the equipment used to explore them.*

TABLE—1

Band (kHz)	Service
30-70	Fixed stations and maritime mobile
59-61	Standard frequency stations (WWVB at 60 kHz)
70-90	Fixed stations/radiolocation/radionavigation
90-110	Radionavigation (LORAN-C at 100 kHz)
110-130	Fixed stations/maritime mobile/radiolocation
130-150	Fixed stations/maritime mobile
150-285	Foreign broadcasting (but not in the U.S.)
160-190	Fixed and 1750-meter "Part 15" band (U.S.)
190-435	Aeronautical and marine beacons (radionavigation)
200-285	Aeronautical mobile stations
285-325	Marine radionavigation
325-405	Aeronautical and marine radionavigation/aeronautical mobile
405-415	Marine radionavigation (including 410-kHz radio directionfinding)
415-490	Maritime mobile (maritime coast and ship telegraphy)
490-510	Mobile (500-kHz distress and calling frequency)
510-525	Aeronautical radionavigation/marine radionavigation/512-kHz ship calling/coastal stations/beacons/NAVTEX
510-1705	Experimenters' Part 15 "Top End" band in U.S.
525-535	Traveler's Information Service (TIS)/Highway Advisory Radio (HAR) on 530 kHz
535-1605	Standard AM Broadcast Band (in the U.S.)
1605-1635	Traveler's Information Service/Highway Advisory Radio stations
1605-1705	Extended AM Broadcast Band (in the U.S.)
1705-1800	Radiolocation
1800-2000	160-meter amateur-radio band

make their signals as strong as possible. As a result, station range is much greater than on the MW BCB, which tends to be almost useless at night because of mutual interference.

There are few LW broadcast enthusiasts in the United States. This is primarily because relatively few receivers cover LW, and it's hard for U.S. listeners to pull overseas broadcasters through the interference from the radio beacons in our hemisphere.

LW Stations. Some of the most common LW stations are radio-navigational aids, or radio beacons. You'll find them between about 190 and 405 kHz and also 510 through 525 kHz (anything above 300 kHz technically is MW, but we won't split hairs).

Some are aeronautical beacons, others are marine. Both employ slow amplitude modulated Morse code, making them easy to ID. Both are sources of DX, especially at night, although the majority are low powered with a daytime range of about 200 miles. While signals from radio beacons, which may run several hundred watts, have been received out to 1000 miles or so, DX contacts on 1750 meters of 150 miles are fairly un-

usual. But beacons are thinning out, as Global Positioning System (GPS) satellites and VHF/UHF airport equipment are used increasingly.

Around 100 kHz, you'll find LORAN-C, which is a radio-navigation system used by ships and planes to accurately determine their position. Special receivers pick up the signals from the network of 100-kHz transmitters at various points throughout the world, and analyze minute signal time-of-arrival differences from multiple sites to calculate position. However, this system slowly is going out of favor as GPS usage increases.

You'll also come across the Ground Wave Emergency Network (GWEN), which is a system of LW sites that form an emergency network to provide command and control communications in the event of nuclear attack. GWEN is designed to overcome nuclear-caused electromagnetic pulse (EMP), relaying teletype messages and linking strategic alerting sensors and warning radars. The 2- to 3-KW stations operate between 150 and 175 kHz. The signals are short bursts of encrypted digital information that many listeners describe as ear-shattering.

There are, of course, many other military, government, and commercial stations on LW that you'll likely hear. You will also come across several standard time and frequency stations, notably on 60 kHz, such as WWVB in Colorado. Besides 1750-meter stations, there are other fixed, mobile, aeronautical, marine, radiolocation, and radionavigation signals you may hear. Too, there are "strange long-wave bedfellows" using Morse, RTTY, and digital modes only the military could tell us about—if they wanted to do so.

Longwave Propagation. How do signals propagate at LW? Much depends on just how low the frequency is. At the high end of LW, propagation isn't much different from the familiar AM BCB. Daytime propagation there is limited mostly to groundwave, but nightfall can extend coverage by thousands of miles. Medium- and high-frequency signals are absorbed by the lower layers of the ionosphere and the earth, while LW signals are absorbed less.

The reflectivity of the ionosphere on LW tends to remain fairly constant, making long-distance LW communications much more stable than communications on SW. This is one reason

THE LONGWAVE CLUB OF AMERICA

Since 1974, LW enthusiasts have had a "just for us" style forum in the Longwave Club of America (LWCA). It was organized to promote LW DXing, experimentation on frequencies below 530 kHz, and activity on the 1750-meter band.

The LWCA publishes *The LOWDOWN*, a monthly newsletter that contains loggings, beacon-station information, LowFERS and MedFERS activities, and equipment designs for both reception and transmission. There are several columns and features that cover beacons, LW loggings, the 1750-meter band, and special interests such as earthquake and geophysical monitoring. *The LOWDOWN* is the best single source for LowFERS and MedFERS activities: it contains up-to-date listings of enthusiasts, their callsigns, frequency of operation, and other operational characteristics.

Membership in the LWCA and a one-year subscription to *The LOWDOWN* is \$18 in the U.S., \$19 in Canada, and \$26 overseas. Information is available from publisher Bill Oliver at LWCA.

why LW broadcasting is so popular in many parts of the world: stations operating on LW can be heard coming through day or night, every day. LW also is ready-made for time and frequency stations, where the stable propagation doesn't introduce many anomalies in received signals.

For a given power, groundwave range is much greater on LW than on MW or SW; at the lowest frequencies, range can be global. In fact, the lowest frequencies, ELF and VLF, can travel halfway around the world and penetrate a short distance beneath the surface.

During the day, LW propagation is mostly by groundwave. As frequency decreases, signals propagate in duct-like or waveguide fashion. The groundwave travels over extended distances because it hugs the earth and follows its curvature.

There is some skywave propagation on LW. As frequency approaches MW frequencies (300 kHz), skywaves become common, especially at night. During the day, the low frequencies tend to be slightly reflected from the D or lowest ionosphere layer. At night, the D and E layers mostly disappear and signal absorption decreases. Signals then can be reflected back to the earth from the highest ionospheric F layers as skywave (skip) signals.

The 1750-meter band enjoys fairly stable propagation characteristics but suffers from high noise. There are relatively few users, so there's little propagation forecasting in the amateur radio press for 1750-meter LowFERS. However, MW propagation is comparable to the 80- and 160-meter propagation forecasts in the ham magazines.

In all types of LW communications, however, atmospheric noise is a limiting factor. High noise levels plague LW, with the tropical regions being the worst. Here, thunderstorm static indeed can be terrible. Manmade noise from household and industrial appliances, light dimmers, and motors, also affects LW reception greatly.

Other than using a good noise limiter or blanker, about the only receiving-end fix you can apply to the noise problem (other than locating antennas away from power lines and buildings) is to boost the signal-to-noise

ratio at the receiver by using a directive, noise-canceling antenna such as a loop, or an "active gain antenna" with a preamp right at the antenna. More on them, and some other ways to help resolve the noise problem, later.

The 1750-Meter Band. The FCC allows for some types of RF devices that don't fall under its other rules in its Part 15 regulations, "Radio Frequency Devices." Part 15 covers both unintentional limited-radiation devices, such as radios and TV sets, computers, TV receivers, etc., all of which may generate radio signals as part of their op-

eration; and intentional radiators, such as garage-door openers, cordless telephones, wireless microphones, and highway and tunnel radio systems, etc., which deliberately radiate signals. (Part 15 also prohibits radiation at certain critical frequencies, such as 100 kHz, where LORAN-C is used, and 500 kHz, a ship emergency frequency.)

You'll find several interesting provisions tucked away in Part 15. One section permits the no-license-needed use of up to 1 watt RF power input and a 15-meter (50-ft.) long antenna, including the transmission line and ground lead, between 160 and 190

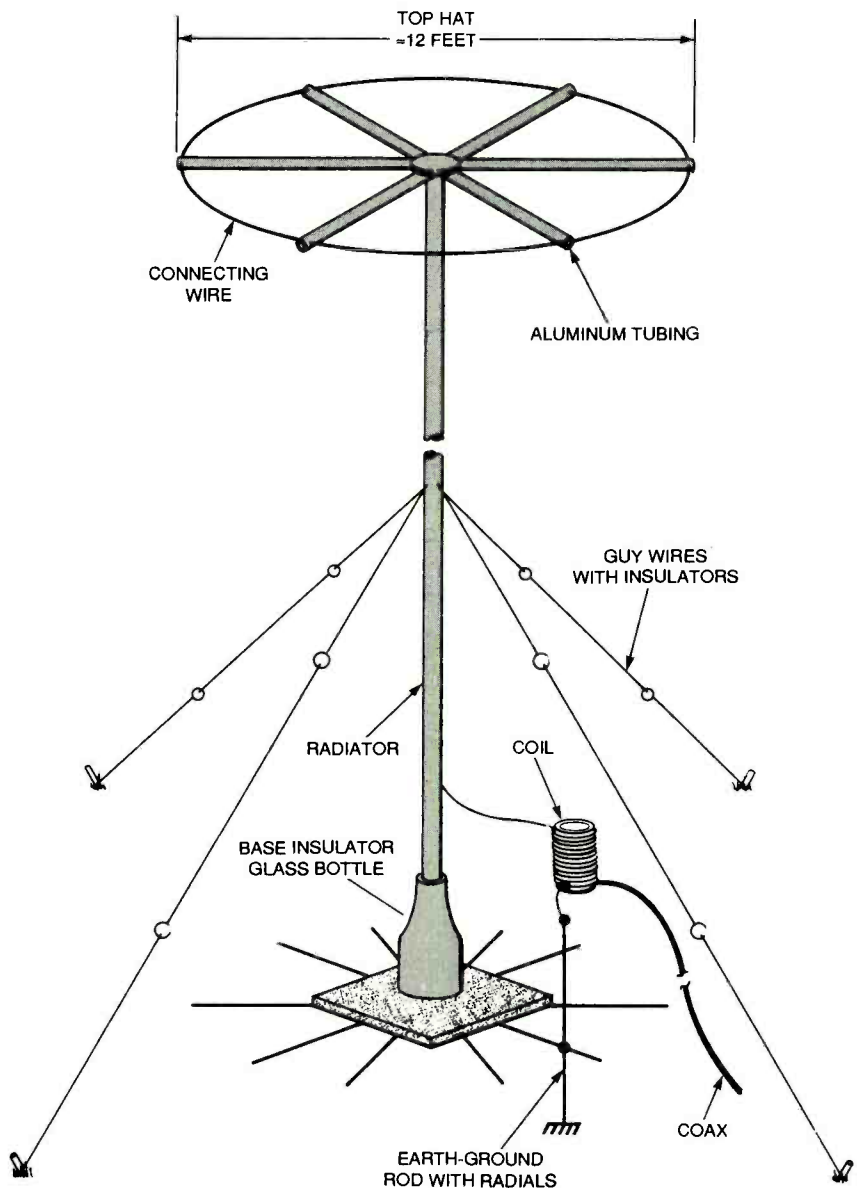

Fig. 1. Here's a typical 1750-meter LowFERS transmitting antenna. Note that the total length of the antenna, transmission line, and ground lead legally can't exceed 15 meters.

kHz. Another section permits similar MW operation from 510–1705 kHz with 100 milliwatts and a short, 3-meter (about 10 feet) antenna, again including the transmission line and ground lead. A third Part 15 section, which we won't be concerned with, governs other operation in the 535- to 1705-kHz range. This section is mainly for "carrier current" and "leaky coax" systems as used on college campuses, at entertainment parks, and along roadways.

Some hobbyist experimental stations operating under Part 15 call their stations LowFERS (or MedFERS, if on MW). For years, a small but enthusiastic group of experimenters has been communicating on the so-called "1750-meter band," running from 1874 to 1578 meters (160 to 190

THE ELECTROMAGNETIC SPECTRUM

To see clearly where LW and MW fit into the electromagnetic spectrum, let's take a brief look at the spectrum as a whole, in terms of frequency.

The total usable spectrum generally is considered to extend from a few Hz to approximately 300 GHz. This truly immense range of frequencies is broken up into smaller groupings that are easier to understand and deal with conceptually.

In the lowest range are the frequencies known as the ultra low frequencies (ULF), from zero to 3 Hz. Just above ULF lie the extremely low frequencies (ELF); they cover 3 Hz to 3 kHz. Above that, from 3 to 30 kHz, are the very low frequencies (VLF). Next come the low frequencies (LF), from 30 to 300 kHz. This is the upper limit of LW, although some consider anything below the AM broadcast band (BCB) to be LW. The medium frequencies (MF), or MW, extend from 300 to 3000 kHz (3 MHz).

From 3 MHz to 30 MHz are the high frequencies (HF). Above them are the very high frequencies (VHF), from 30 to 300 MHz. The ultra high frequencies (UHF) extend from 300 to 3000 MHz, or 3 GHz. From 3 GHz to 30 GHz are the super high frequencies (SHF), and from 30 GHz to 300 GHz, the extremely high frequencies (EHF).

Of course, people aren't always consistent in labeling frequency or wavelength. Often, anything below about 500 kHz is referred to as LW, when 300 kHz actually is the dividing line between MW and LW. On the high end, too, there's blurring. MW ends and SW starts at 3000 kHz (3 MHz), but many consider MW as stopping just above the AM broadcast band, or around 1705 kHz. ■

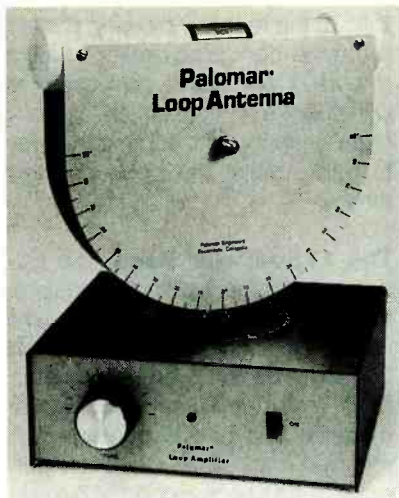

The LA-1 Loop Amplifier made by Palomar Engineers can be used with any of six plug-in accessory loops to cover LW, 10–40 kHz (for OMEGA), 40–150 kHz (for WWVB), 150–550 kHz, AM BCB, 160 and 80 meters (including the MW "top end,") and HF to 16 MHz.

kHz). As we've seen, 1750 really isn't a ham band at all: no operator or station license is required. And, as we have also seen, the FCC rules governing operation there set forth some tough requirements, including one that says that all emissions below 160 kHz or above 190 kHz (in other words, outside the 1750-meter band) must be suppressed by at least 20 dB.

The FCC restrictions do make LowFERS operation challenging. Fortunately, there are no stipulations as to emission type: you can use SSB, AM, FM, RTTY, CW, and other modes. There are, of course, no restrictions on receiving antennas or equipment.

Even with the power and antenna limits, experimenters sometimes span 100, 300, and—very rarely—1000 miles or more, mostly with automatic, one-way beacon transmissions. From time to time, two-way LowFERS QSOs take place over moderate distances.

Then, there's GWEN. Its presence over most of the 1750-meter band has forced activity above 175 kHz; much 1750-meter action, especially beacons, has been centered near 189.5 kHz. Most work has been on CW, though advanced digital modes are being tried.

Since the FCC frowns on amateur call signs on non-amateur frequencies, many operators use either their initials, old-style telegraphers' "sines," or nicknames as IDs for their two-way

communications or beacon stations. The Longwave Club of America (LWCA's) monthly journal (see the "Longwave Club of America" box) lists these beacons.

Is an LW amateur band on the horizon? Well, with the increasing interest in the 1750-meter band, the American Radio Relay League (ARRL) in June 1992 approached the government regarding a shared amateur radio band in the LW region. The proposal has been favorably received, at least initially, by the FCC and other government agencies, such as the National Telecommunications and Information Administration (NTIA). A government study even concluded that amateurs could indeed use an additional 2180 kHz of spectrum space—including a 30 kHz-wide ham band at 160–190 kHz, but don't hold your breath waiting for it to materialize.

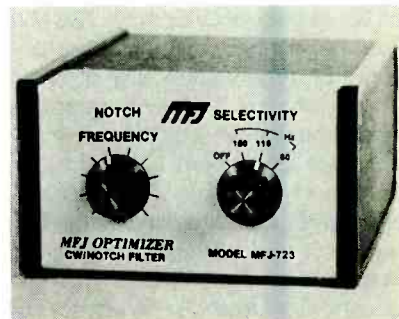

The LW bands are replete with annoying interference. This low-cost MFJ "Optimizer" filter helps you pull out signals of interest and notch out interference.

Most countries that use the LW broadcast band (about 150–285 kHz) aren't particularly interested in allowing amateur operation on 1750 meters. However, the German Department of Communications reportedly will create a ham band around 140–150 kHz in the near future. Many LowFERS believe this is actually a better choice for a new ham band than 160–190 kHz since it's below the overseas LW broadcasting band and thus offers more opportunities for DX, especially transatlantic amateur LW communications.

LW Receiving Equipment. To most radio listeners, LW indeed is terra incognita, unknown territory. One reason has been the lack of high-performance receivers covering LW.

By the time you tune down to 500 kHz, most receivers are far less sensitive than they are on SW. The assumption apparently is, at LW, you won't be able to hear anything but the strongest signals over the noise. However, today several suppliers sell receivers, receiving converters, filters, antenna tuners, loops, and active gain antennas that make good LW reception possible.

For communications equipment capable of tuning below the AM BCB, you can buy a military-surplus receiver, new or used commercial set, or a receiving converter. You can even build your own LW radio. Let's look at some of these possibilities:

You can find surplus receivers that tune down to 150 kHz, or so. Unfortunately, many such radios require restoration, and most need modification for 120-volt, 60-cycle AC. Actually, most tube-type surplus sets are pretty old and tired, halfway through the 1990s, so results may be disappointing if you use them for LW reception.

Possible surplus LW receivers include the BC-453, BC-1206-A, BC-348, BC-779, ARB, RAK-7, R-439, URM-41, RBA, RBL, and R-389 URR. The latter set, made for the government by Collins Radio in the 1950s, is a very good radio whose coverage extends to VLF.

The LW bands are covered by a few older commercial communications receivers that you might find at used equipment dealers or at hamfests, but in view of their age and older technology, it's best to avoid them. These radios include the Heathkit DF-2, Hammarlund RDF-10, National NC-66, Drake SPR-4, Kenwood R-300, and Realistic DX-300.

Moving upscale, the 1950s-vintage National HR0-60 still is a good general-coverage receiver. With its accessory G, H, and J plug-in coil sets, it tunes down to 50 kHz. The Hammarlund VLF Super Pro, known as the SP-600-VLF, also is a well-regarded set.

There are some excellent, newer, LW-capable communications receivers on the market, too, though most are expensive. These include the Watkins-Johnson HF1000 (about \$3800); Drake R-8A (\$1060); Japan Radio NRD-535D (\$1200); Kenwood R-5000 (\$1040); ICOM R-71A (\$1250); AOR3000A (\$1050); and Yaesu FRG-100B (\$590). Others include the Lowe HF-150 (\$600) and HF-225 (\$970). All of these radios tune the

1750-meter and MW bands; most tune as low as 50 or 100 kHz and some go much lower.

Several good, lower-priced "world band" radios also tune LW. These include the Grundig YB-400 (\$200) and Satellit 700 (\$500); Sangean ATS-808 (\$170) and ATS-606 (\$160); Sony ICF-2010 (\$350), ICF-SW55 (\$350), and ICF-SW7600G (\$200); and Panasonic RFB-45 (\$170). However, not all world-band radios have a beat frequency oscillator (BFO), needed to receive CW signals.

Most of these radios are available

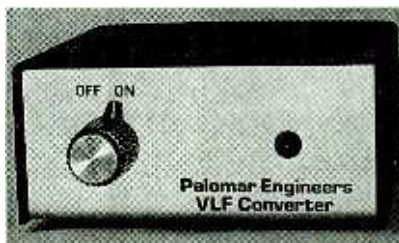

This Palomar Engineers VLF Converter lets you receive the low bands for about \$80; all you need is a communications receiver and an antenna.

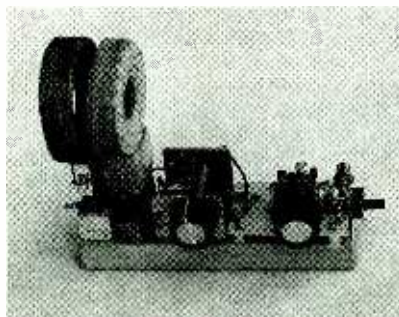

Obtaining good receiver sensitivity on LW is often a problem, but you can use a preamplifier to boost reception. Shown here is a homebrew, regenerative RF preamp with LowFERS coils.

through dealers. These include Amateur Electronic Supply, Associated Radio, C. Crane Co., Electronic Distributors Co. (EDCO), Electronic Equipment Bank (EEB), Grove Enterprises, Ham Radio Outlet, Lentini Communications, Universal Radio, and several other firms.

One of the least expensive ways to listen to LW, though, is to buy a VLF/LF frequency converter and hook it up to your present communications receiver. Converters are available from several suppliers, including Palomar Engineers.

The Palomar Engineers VLF-A Converter is \$79.95. It uses a crystal-con-

trolled local oscillator and a mixer to translate the 10- to 500-kHz range to the 80-meter amateur band, from 3510 to 4000 kHz. A similar unit, the VLF-S, converts VLF to 4010-4500 kHz for general coverage (rather than ham-bands-only) receivers.

At least two firms, Curry Communications and LF Engineering Co., offer accessories for LW. These include equipment for LF and VLF reception, 1750-meter band operation, and VLF/ELF natural-radio-phenomena detection. Products include VLF/LF converters and preamplifiers, active-gain antenna systems, and wire and loop receiving antennas, as well as some esoteric accessories for both VLF and ELF.

As mentioned earlier, one of the LW reception problems you'll encounter is noise. Static levels increase greatly as you go down the dial, so LW reception is marred by natural and man-made noise. But some accessories can help in coping with static. Both automatic noise limiters (ANLs) and automatic noise blankers (ANBs) can be effective against certain types of noise.

The ANL is the older and simpler circuit, one that merely whacks off noise pulse peaks, reducing them to tolerable levels. The ANL usually degrades the receiver's audio. A noise blanker is more complex; it effectively silences the receiver during the noise pulse. The ANB often is adjustable whereas the noise limiter normally is an on-off device. The ANB doesn't degrade audio nearly as much as does the limiter.

A newer technology involves Digital Signal Processing (DSP) filters, which can make real improvements in 1750-meter communications. They simulate analog filters, varying their characteristics to react to changing conditions. They offer superior performance in reducing interference on voice, CW, and RTTY by converting the received audio, both signal and noise, to digital data and processing it. Several firms offer DSP-based filters. One is JPS Communications, which offers the NIR series noise and interference reduction units.

DSP also offers the ANC-4 Antenna Noise Canceller. Installed at the antenna connector, it cancels locally generated noise, such as power-line, computer, and TV noise. This is done

SUGGESTED READING

Are you interested in reading and learning more about LW, MW, LowFERS and MedFERS? Check out these books, guides, newsletters, and other specialized publications.

The Low and Medium Frequency Radio Scrapbook: The "dean" of radio hobbyists who focus on FCC "Part 15" bands is Ken Cornell, W2IMB, of Point Pleasant Beach, NJ. He has self-published the *Scrapbook* for over 20 years. The latest, 9th edition is a 93-page, how-to-do-it compendium that offers you LW information and equipment designs for receiving and transmitting. It has a general introduction to the 1750-meter band, details on operating LW and MW beacons, and an introduction to LW earthquake and geophysical monitoring. The book is \$17.50, postpaid book rate, or \$18.75 first-class mail. Checks should be payable to Ken Cornell.

The Active Antenna Scrapbook: A second, new scrapbook also is available from Ken Cornell. It's the Active Antenna Scrapbook, a 29-page booklet that has more than you ever wanted to know about active-gain antennas—short verticals that have a built-in preamplifier for increasing the signal-to-noise ratio. The booklet has circuits for several broadband and remotely tunable, LW and MW active-antenna designs. Included are designs for regenerative preamplifiers, which Ken claims are capable of excellent LW and MW performance. The scrapbook also includes reprints of articles from *The LOWDOWN* that deal with active antennas and ferrite loops. The booklet is \$10 postpaid in the U.S. via first class mail, or \$13.00 for foreign airmail.

The World Below 500 Kilohertz: If you want to learn more about this part of the spectrum, this is a good, one-stop tutorial on LW, by L. Peter Carron, Jr., W3DKV. The 64-page booklet, probably the only available beginner's book on LW, offers a nice overview of LW and introduces many of the "strange bedfellows" that reside there. It's available from Universal Radio for \$4.95, plus \$2 shipping and handling.

Shortwave Receivers Past and Present: Don't let the word "shortwave" in the title fool you. This 1993 blue book, by Fred J. Osterman, also includes some excellent LW and MW receivers. It's a 106-page directory of the vital statistics of more than 200 communications receivers, tube-type and solid-state, marketed over the past 20 years. It provides specifications and photos of most of the

receivers. Also included in the book is a chart showing the new and approximate used cost of each set. It's \$8.95 plus \$2 shipping and handling from Universal Radio.

BBS Radio: The National Directory of Radio Hobby Bulletin Board Services: This Tiare book by Mike Witkowski lists several hundred BBSes devoted to the radio-communications hobby. The BBS listings show the board's name, area code, and telephone number. A location also is shown for most listings. It's \$9.95.

The NRC AM Radio Logbook, 13th Edition: For North American MW AM stations, this is one tool you'll want. It includes day and night antenna and power information, format, hours of operation, address, network affiliations, etc. Price is \$19.95 for U.S. readers and \$20.95 for Canadians; it's \$3 less for National Radio Club (NRC) members. The Logbook is available from NRC Publications. (NRC membership is \$24.00 for U.S. listeners, \$25.00 for Canadians. For particulars and information on their DX News newsletter, contact the NRC Subscription Center.)

A DXer's Technical Guide: Now in its second edition, this 120-page International Radio Club of America (IRCA) book answers questions on MW receiver and antenna theory and performance improvement, receiver accessories, receiver modifications, and more. It's available from the IRCA Bookstore for \$6 to members, \$8 to others. An introductory brochure, *An Introduction to Broadcast Band DXing*, also is available for 35 cents. (IRCA membership is \$25.00 for U.S. listeners, \$27.00 for Canadians. For particulars and information on their DX Monitor newsletter, contact the IRCA.)

Transmitting Antennas And Ground Systems For 1750 Meters: For a comprehensive background on LowFERS antennas, order a copy of this book, edited by Michael Mideke. This is a 60-page, 1987 collection of articles from various LowFERS publications. It's \$5.00 postpaid from Max Carter, 46 14th St., Wheatland, WY 82201.

Radio Electronics Series of Articles: You'll find detailed discussion and construction details on VLF through HF active antennas, loops, and antenna tuners in a series of articles by R. W. Burhans. The series appeared in our sister publication, *Radio Electronics* (now *Electronics Now*), in the February through June 1983 issues. Check your local library for these issues.

LowFERS 1750-Meter Transmitters. There are few, if any, commercial LowFERS transmitters and transceivers on the market today. But it's not too difficult to build LW equipment—most designs use a simple, solid-state,

crystal-controlled exciter and power-type FET final amplifier. Over the years, various do-it-yourself LW construction projects have been described in the amateur press.

A bibliography of VLF/LF construction projects (1750-meter band transmitters and transceivers, receivers, converters, etc.) is available from the ARRL Technical Department; or you can download it from the ARRL BBS (filename VLFTXT) or the Long-wave BBS (see below). You'll also find that several RF circuits are in Ken Cornell, W2IMB's *The Low and Medium Frequency Radio Scrapbook* (see the "Suggested Reading" box). Other designs appear in the LWCA's journal, *The LOWDOWN*.

An important construction article is "Build Your Own Lowfer Transceiver," by David Curry, WD4PLI, of Curry Communications, in the April 1994 *QST*. He described a 1750-meter LowFERS CW transceiver, the CW-893. The receiver portion is similar to the military RBL LW receiver. The transmitter section generates 1 watt of power input, and it's VFO (variable frequency oscillator) controlled.

Curry Communications also offers a 1750-meter transverter kit, the SAM-1, which allows any radio amateur with 80-meter capability to operate on 1750. The unit includes both a receiver upconverter and a transmitter downconverter that takes an 80-meter signal from a conventional amateur transceiver and converts it to a 1750-meter signal; it also receives on 1750 and converts the signals to ham-band frequencies. The firm also expects to have a 1750-meter SSB transceiver, a LF synthesizer, and an audio-receiving processor available in the near future.

LW Receiving Antennas. There are many types of horizontal and dual-polarized wire antennas you can adapt for LW. LW receiving antennas are much like those for the 160-meter amateur band or for MW AM BCB DXing, only on a larger scale. The *ARRL Antenna Book* is a good place to start for antenna basics.

You'll find in antenna books all sorts of variations on singlewires, longwires, end-feds, Marconis, and combination vertical and horizontal L's for LW reception. As a rule, you should get as much wire as possible in the air and

before the noise gets into the set. Front-panel controls let you adjust the phase and magnitude of the local interference, leading to deep noise cancellation. The \$175 product works down to 100 kHz.

run it well clear of all surrounding objects and noise sources. Best reception results on LW usually are achieved with an antenna that's tuned or trapped to keep out strong local AM BCB stations.

One classic receiving antenna for LW and MW is the Beverage, with its gain and directional characteristics. It consists of a horizontal wire a wavelength or more long, sometimes 1000 feet or more, suspended 10 to 20 feet above the ground and supported at intervals. The Beverage normally is terminated at the far end with a resistor which is connected to a metal stake that is driven into the ground. It's pointed in the direction of the desired signals.

Any discussion of LW antennas wouldn't be complete without a discussion of receiving loops. Loops are enjoying renewed popularity on LW because they can be physically small yet work well, they can be resonated or tuned to a particular frequency, and they can be rotated to take advantage of their directionality. Most loops are built to have a figure-eight pattern.

You'll find loops are quieter than single-wire outdoor antennas, are less prone to swamping by strong local BCB stations, and can be used effectively to null out noise and interference. Some loops allow for greater noise reduction by enclosing the loop wires in a special, nonmagnetic shield. This technique can markedly improve the overall signal-to-noise ratio of the received signal. However, you may find poor results with indoor loops due to noise radiated from household wiring. Palomar Engineers and Kiwa Electronics are two really good sources for various loop antennas.

Another option is an active-gain antenna. Such an antenna popular on LW consists of three main parts: a physically short, vertical steel whip or wound coil element; an antenna-mounted preamplifier; and a receiver coupler. Some LW buffs assert that active-gain antennas they make the best overall LW receiving antennas, at least for modest-space, urban locations. Such antennas can improve receiver performance by reducing overall sensitivity to various local noise sources.

You can mount these antennas



Shown here is a crystal-controlled MedFERS transmitter, circa 1975. It uses an enameled wire tank coil and is ferrite-rod tuned. You can substitute a slug-tuned VFO coil for the crystal.

easily outdoors, away from noise and distracting objects; the amplified signal is routed to the LW receiver through a length of coaxial cable whose shielding minimizes noise pickup. Curry Communications, LW Engineering, MFJ Enterprises, and several others make this type of antenna system.

LW Transmitting Antennas.

Designing an efficient antenna for the 1750-meter band is a challenge because of the FCC's 15-meter length restriction. These antennas are very short, electrically speaking, and they also have very low radiation resistance.

The best LowFERS antennas probably have efficiencies below one percent, and most will be even less efficient than that. Despite these limitations, if you're resourceful in reducing loss in the antenna system and maximizing efficiency in the transmitter, your signals can be detected over much longer ranges, especially when using CW.

For transmitting on 1750 meters, almost any antenna will do for casual experimentation, out to a mile or two. However, for best results you should use a short, loading-coil resonated vertical antenna, topped with a large, horizontal "capacitance top hat," and secured with guy wires (see Fig. 1). A glass bottle insulates the base of the antenna, with the loading coil being connected between the radiator and the ground system. The center con-

ductor of the coax feedline is connected to the coil tap. A ground rod and a 25- to 30-foot or greater radial system are used. The total length of the antenna, transmission line, and ground lead legally can't exceed 15 meters.

The essential components of a LowFERS antenna system are the ground system, a loading network, a vertical radiator, and a top hat. The vertical radiator is used in conjunction with a substantial ground rod and a 25- to 30-foot radial system. Typically, a separate vertical active-gain whip antenna is used for receiving.

The simplest loading network is a low-loss, high-Q (quality factor) coil in series with the antenna, preferably above the center of the antenna for optimum efficiency. It tunes out the capacitive reactance of the antenna and brings the feedpoint impedance down to a reasonable level. Although the radiating section can be sloping or bent, the height above ground is actually more important in securing good performance than is the total length.

A top hat improves the antenna's current distribution. When you add a top hat to a vertical, the top hat doesn't radiate, but it increases the effective height of the vertical portion.

A good, low-resistance ground is also very important for a LowFERS transmitting antenna. Some LowFERS get good results with lengths of chicken wire forming a ground screen 50

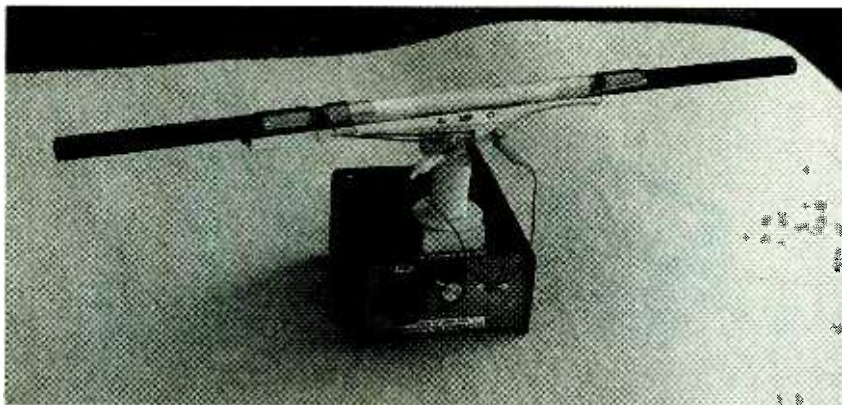

One of the most popular antennas for MW DX is the loop; loops are small and can sit on a desk or table where they can be turned for optimum peak or null. Shown is an experimental MedFERS dual-rod, ferrite-loop antenna with regeneration.

feet square or larger. Another approach is to put out a number of radials, each at least as long as the antenna height, with several of them terminated at their outer ends in an earth ground. When a sophisticated ground system isn't practical, you can run connecting wires from the base of the antenna to all available grounds—water pipes, metal buildings, or wire fences.

Mediumwaves and MedFERS. The easiest parts of the radio spectrum for you to explore include the MW AM BCB. DXing the BCB is an exciting way to enter the listening hobby, and it doesn't require a major investment in equipment or antennas. All that's required is time, patience, and knowledge. The immense popularity of the BCB helps to explain why many people like to transmit in or adjacent to the BCB.

The U.S. MW AM BCB currently extends from 535 to 1605 kHz (down to 525 kHz in Canada). To complicate things for MedFERS, the FCC has released a list of allotments for the expanded BCB, 1605–1705 kHz. Stations that are experiencing high levels of interference will begin appearing on 1605-1705 kHz soon. The FCC's objective in expanding the band was not to increase the number of AM stations on the BCB, but to decrease congestion.

This is good news for AM DXers, but how this expansion will affect MedFERS isn't clear. MedFERS have taken advantage of the relative quiet in this segment to accomplish amazing DX with 100-milliwatt transmitters and 10-foot antennas, under FCC Part 15.

There's no lack of signals below the BCB. Up to 405 kHz, there are aeronautical and marine beacons aplenty. Other signals include mobile stations, 410-kHz direction finding, the 500-kHz distress and calling frequency, the 512-kHz ship-calling frequency, and more beacons from 510-525 kHz. The main MW inhabitant, of course, is the 535- to 1605-kHz standard AM BCB and its extension to 1705 kHz in the U.S.

Travelers' Information Service (TIS)/ Highway Advisory Radio (HAR) stations and some licensed experimental stations presently are found in the 1605- to 1705-kHz "top end" area in the U.S., along with unlicensed MedFERS Part 15 stations. But they all may be squeezed by new BCB stations and will have to try to find frequencies with the least interference.

The DX stations, including MedFERS, that you're able to receive depend largely upon MW propagation conditions. Those vary depending upon the time of day, the season, and other factors. On MW, the single most important factor for good DX is time of day. MW signals almost always get absorbed by the D Layer during daytime. As a result, most MW signals received during daytime will arrive by ground-wave, making reception of signals over a few hundred miles away unusual.

At night, however, the ionosphere reflects MW signals, making it possible for signals to be heard at much greater distances, up to a few thousand miles, via skywave. DX reception also tends to be better in winter than in summer, due to the season's lower atmospheric noise and longer hours of darkness.

You also can work MW DX when your receiving station and/or the transmitter are in partial darkness; it's possible to hear distant stations using "grayline" or "terminator" propagation. Most MW DXers log the greatest number of stations in the hour or two around sunrise and sunset, especially in the fall and winter. Most anything can happen in these turbulent periods; such times can offer flea-powered MedFERS transmitters a chance to come through, at least momentarily.

You should keep in mind that MedFERS activities are constrained by the FCC even more than LowFERS activities. The FCC's rules in Section 15.218 permit MW operation from 510–1705 kHz with 100 milliwatts and a 3-meter (about 10 ft.) antenna. This contrasts with the 1-watt power and 15-meter antenna allowed LowFERS. These constraints make it difficult to be heard at distant locations. Consequently, there are relatively few MedFERS stations, probably only about 30–60 of them. Most of the active stations employ low-power (100-milliwatt) CW beacons from 1605–1705 kHz in the top-end area. Other beacons tend to cluster around 510–515 kHz. There's little MedFERS two-way work.

Of course, MW is popular with frustrated radio disk jockeys and others using home-type AM "wireless mikes" or "wireless broadcasters," but their signals usually don't get very far. Pirate radio stations pop up from time to time in and adjacent to the AM BCB, although this type of MW activity has decreased in recent years. Most of the pirates appear to have migrated to around 6950 or 7400 kHz, just below and above the 40-meter amateur band, where it's easier to radiate more of the power they generate. But we really shouldn't call these stations MedFERS in that pirates don't operate under Part 15 or any other FCC rules.

MW Receivers and Transmitters.

Almost any radio capable of AM BCB DXing can be used in a MedFERS set-up. However, many radios, even those designed for quality SW reception, aren't great BCB performers. Some features you should seek in a BCB/MedFERS receiver include provisions for an external antenna, high selectivity, digital frequency display, and a

BFO. Most communications receivers and world-band radios cover MW and meet most of these requirements.

MedFERS transmitters are homebrew—no commercial MedFERS transmitters are offered today. However, some well-constructed wireless broadcasters can be pressed into service as MedFERS transmitters, especially if they are modified for crystal control, and a few homebrew designs have been advanced by MedFERS enthusiasts like Ken Cornell.

At least one firm offers a Part 15-compatible AM transmitter that could be adapted for MedFERS work. Ramsey Electronics offers the AM-1, a \$34.95, 100-milliwatt kit that operates in and adjacent to the standard broadcast band; its range is up to ¼ mile, depending on antenna and conditions. (Ramsey also offers several low-power, quality FM, FM stereo, and TV transmitters.)

MedFERS Receiving Antennas.

MedFERS receiving antennas are basically what you'd use for AM BCB reception. Most MW receivers have a short internal ferrite rod, but suitable mainly for receiving high-power distant stations. For more advanced DX-ing, external antennas offer advantages.

The most common external antenna is a randomwire, 50 feet or more in length. A more advanced wire antenna is the Beverage, mentioned previously. One problem with your using a wire antenna for MW is the wire's inability to reject strong local signals. Most receivers lack the dynamic range to effectively deal with very strong signals from a local AM BCB broadcaster as picked up by a randomwire. Thus, some sort of tuned antenna is best for all but the most isolated, rural locations.

Much as on LW, one of the most popular antennas for MW DX is the loop antenna, and it can be either of two types: ferrite rod or air-core wound wire loop. These antennas are small (1 to 3 feet in diameter) and sit on a desk or table where they can be turned to peak or null received signals as needed.

Plans for building MW loops are available through International Radio Club of America (IRCA) and National Radio Club (NRC) publications. Also, Palomar Engineers offers a handy

"Loop Coupler" that facilitates connecting an outboard loop to radios with built-in antennas that don't have an external antenna jack. Active-gain antennas also are popular at MW.

MedFERS Transmitting Antennas.

Since there are no restrictions on MedFERS receiving antennas, separate receiving and transmitting antennas generally are used. Unfortunately, the FCC's 10-foot antenna limit doesn't leave room for flexibility.

Designing a satisfactory transmitting antenna will take some headscratching and trial and error. One

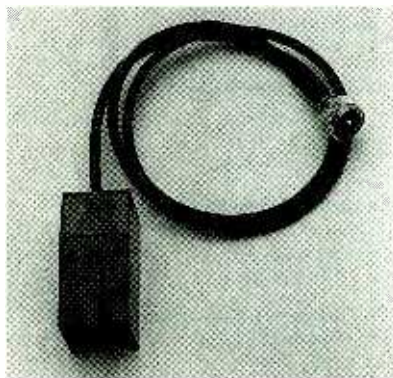

Many BCB radios have built-in loop antennas, but no connector for an external antenna. This Palomar Engineers Loop Coupler will magnetically couple an antenna to a radio's built-in antenna.

simple option is to attach a 10-foot window-mounted wire to the MedFERS transmitter, located on a desk near the window. A few operators have reported success with transmitting loops, but these haven't caught on.

Roof-mounted vertical pipe antennas, usually with a top hat of stiff wire or metal tubing, and often with a loading coil, and with ground radials laid out over roof shingles, are popular. You can install the transmitter in an outdoor shed (preferably metal) and mount the antenna on its roof, feeding audio, power, and control cables to the transmitter for remote operation from your home. Often antennas are placed in the clearest part of the yard.

Low-Band Web Sites. Several features of the Internet are of interest to LW and MW radio hobbyists. Most interesting of these is the World-Wide Web. The Web has become an

organizing system that makes it easy to find information and move among various Internet resources. (See the monthly *Net Watch* column in this magazine.)

Here are a few Web pages featuring amateur-radio and listener topics. Though the focus of most sites is on amateur radio and SW listening, some of the sites we list have items of interest to LowFERS and MedFERS.

Radio Resources on the Internet is found at <http://www.wave-rider.co.uk/~paulj/radio.html>. This is a very good place to begin your search for Web-based radio information.

The Radio Netherlands Receiver Data Bank is at the URL <http://www.rnw.nl/rnw/en/pub/receiver.html>.

Gilfer Shortwave is at <http://www.pics.com/gilfer/>.

The Shortwave Radio Catalog is found at <http://itre.ncsu.edu/radio/>.

Kenwood Communications can be found at the URL <http://www.accessnv.com/kenwood/amateur.html>.

Kiwa Electronics is found at the Web URL <http://www.wolfe.net/kiwa/>.

The ARRL operates the ARRL Web page, which you can find at the URL <http://www.arrl.org/>.

Lowe Technical Services USA is yours for the browsing at <http://www.exchange.com/lowe/zts1.htm>. Their UK home page is found at <http://www.demon.co.uk/lowe/>.

USENET Newsgroups. There also are considerable radio hobbyist resources you'll find in USENET newsgroups. These are discussion groups that focus on specific subjects that are the Internet equivalent of online service and BBS forums.

To my knowledge, there's no specific forum dedicated exclusively to LW or MW. But you may find the discussions and information postings on several radio-related newsgroups to be useful. Some of the more promising USENET newsgroups are the following—their names are fairly descriptive of their contents:

- alt.radio.pirate
- rec.radio.amateur.antenna
- rec.radio.amateur.equipment
- rec.radio.amateur.homebrew
- rec.radio.broadcasting
- rec.radio.info
- rec.radio.shortwave
- rec.radio.swap

FOR MORE INFORMATION

American Radio Relay League

225 Main St.
Newington, CT 06111-1494
Tel. 203-594-0200
BBS: 203-594-0306

Associated Radio

8012 Conser
Box 4327
Overland Park, KS 66204
Tel. 913-381-5900

CQ Communications, Inc.

76 N. Broadway
Hicksville, NY 11801-2953
Tel. 800-853-9797

C. Crane Company

558-10th St.
Fortuna, CA 95540
Tel. 800-522-8863

Carter, Max

46 14th St.
Wheatland, WY 82201

Cornell, Ken

225 Baltimore Ave.
Point Pleasant Beach, NJ 08742
Tel. 908-899-1664

Curry Communications

737 North Fairview St.
Burbank, CA 91507
Tel. 818-846-0617

Davis, John H.

P.O. Box 367
Warm Springs, GA 31830
Tel. 706-672-0964
Longwave/Part 15 BBS: 706-672-0360

Electronic Distributors Co. (EDCO)

325 Mill Street, N.E.
Vienna, VA 22180
Tel. 703-938-8105

Electronic Equipment Bank (EEB)

323 Mill Street, N.E.
Vienna, VA 22180
Tel. 800-368-3270

Gilfer Shortwave

52 Park Avenue
Park Ridge, NJ 07656
Tel. 800-445-3371

Grove Enterprises

P.O. Box 98
300 South Highway 64 West
Brasstown, NC 28902-0098
Tel. 800-438-8155

Ham Radio Outlet

933 N. Euclid St.
Anaheim, CA 92801
Tel. 800-854-6046

International Radio Club of America (IRCA)

P.O. Box 1831
Perris, CA 92572-1831

IRCA Bookstore

Attn: Phil Bytheway
9705 Mary N.W.
Seattle, WA 98117-2334

JPS Communications, Inc.

P.O. Box 97757
Raleigh, NC 27624-7757
Tel. 800-533-3819

Kiwa Electronics

612 S. 14th Ave.
Yakima, WA 98902
Tel. 800-398-1146

LF Engineering Co., Inc.

17 Jeffry Road
East Haven, CT 06513
Tel. 203-248-8851

Lentini Communications, Inc.

21 Garfield St.
Newington, CT 06111
Tel. 800-666-0908

The Longwave Club of America (LWCA)

Bill Oliver, Publisher
45 Wildflower Rd.
Levittown, PA 19057
Tel. 215-945-0543

National Radio Club, Inc.

And NRC Publications
P.O. Box 164
Mannsville, NY 13661-0164

NRC Subscription Center

Box 118
Poquonock, CT 06064-0118

Palomar Engineers

P.O. Box 462222
Escondido, CA 92046
Tel. 619-747-3343

Ramsey Electronics, Inc.

793 Canning Parkway
Victor, NY 14564
Tel. 800-446-2295

Tiare Publications

P.O. Box 493
Lake Geneva, WI 53147
Tel. 800-420-0579

Universal Radio, Inc.

6830 Americana Parkway
Reynoldsburg, OH 43068-4113
Tel. 800-431-3939

Bulletin Board Systems. The Longwave/Part 15 BBS System is a hotbed of online activity. It's operated by LowFERS and MedFERS hobbyist and *LOWDOWN* columnist John H. Davis, KD4IDY. The BBS has a great deal of information on LW, MW, and FCC Part

15 activity. It's free and can be reached at 706-672-0360; log-on parameters are 8-N-1. You may also wish to peruse the Tiare publication, *BBS Radio: The National Directory of Radio Hobby Bulletin Board Services*, by Mike Witkowski, or the *CQ Amateur Radio*

Almanac, for other radio-oriented BBSes.

Another great BBS is the ARRL Technical Information Service (TIS). You'll find that the ARRL has several downloadable text files that deal with LW issues. You can access them and other amateur-radio- and electronics-related information via BBS at 860-594-0306, or in the ARRL area in America Online's Ham Radio Club (Keyword HAM or HAM RADIO). If you have Internet FTP access, connect to the oak.oakland.edu FTP site; you'll find the ARRL files in the "/pub/hamradio/arrl" directories. ARRL files also can be reached at the ftp addresses: ftp.cs.buffalo.edu in the "/pub/ham-radio/qex" directories; and at mgate.arrl.org.

We think you'll find the low bands to be an interesting complement to the more conventional aspects of radio communications. The microwaves may be more exotic, but there's still a great deal to learn about LW. Twist your dial as low as it will go, and enjoy a challenging form of radio you may not even have known existed. Give LW and MW a listen: with a bit of care, there's no telling what you may pull out from underneath the static! ■

BUY BONDS

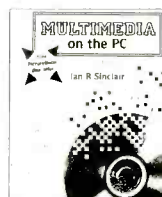

MULTIMEDIA on the PC!

What is Multimedia? What can it do for you? It can do lots of nice things! This 184-page book helps you create your own multimedia presentation.

Multimedia applications by people like you can revolutionize educational and business applications as well as bring more FUN, FUN, FUN into your leisure computer activities.

Mail coupon to:

Electronics Technology Today, Inc.
P.O. Box 240
Massapequa Park, NY 11762-0240

Please send me my copy of *Multimedia on the PC* (PCP120). I enclose a check or money order for **\$18.95** to cover the book's cost and shipping-and-handling expenses. NY state resident must add local sales tax.

Name _____

Address _____

City _____ State _____ Zip _____

All orders must be paid in U.S. funds only. Sorry, no orders accepted outside of USA and Canada. Please allow 6-8 weeks for delivery. MA02



Build a Remote-Control Interface for your Computer

BY STUART BALL

Sitting in front of a keyboard is not always the most practical way to control your computer. For example, if you tried to run a computer slideshow for a business presentation, more than a few of those present might have a hard time seeing over your head! Or perhaps you would like to play a simple game with a few friends, and would prefer not to have to crowd around the keyboard. In either case, being able to sit away from the computer while controlling it is desirable. If you build the *Remote-Control Interface* described in this article, you'll be able to do just that. The unit receives the infrared signal from your TV or VCR remote controller and transmits the data serially to your computer.

IR Remote-Control Basics. A wireless infrared remote uses an infrared LED to transmit information to a receiver. That receiver has a matching IR-detector diode and circuitry that extracts the digital information from the IR pattern.

The IR signal that is transmitted is a modulated carrier. That means that a base frequency is turned on and off to transmit the digital information. The standard carrier frequency for IR remotes is 40 kHz. While there is a single standard carrier frequency, the transmission bit timings and word lengths vary. All have the following characteristics in common, though:

For starters, the carrier is frequency modulated. That is, a one bit takes longer to transmit than a zero bit. Also, all carriers transmit a sync bit at the start of each word. All words are the same length, and each key that you

Operate your computer from across the room with any TV or VCR remote controller.

press on the remote will cause a unique pattern, with a known number of bits, to be transmitted.

The sync bit is longer than an ordinary bit; the transmitted carrier is on for an extended period, then off for an extended period. That is followed by the bits of the digital word. The Remote-Control Interface decodes two common formats: The first format uses 22 bits, each 1.6- to 3.3-microseconds long. The second format uses 32 bits, each 1.2- to 2.2-microseconds long. Another mode in the Interface analyzes the bit pattern transmitted by a remote (that will be described later).

Circuit Description. The schematic diagram of the circuit is shown in Fig. 1. IR-detector module MOD1 (available from Radio Shack as part no. 276-137) contains an IR detector, a 40-kHz filter, and waveshaping circuitry (all enclosed in a shielded box). The module has excellent sensitivity and the ability to reject unwanted signals. The module provides a TTL-compatible output that is fed to one of the inputs of an 8031 processor, U1, which has a multiplexed data bus.

Processor U1 decodes the IR data, which is then captured during the first half of the data transmission cycle of the 74LS373 octal latch, U2. During the second half of the cycle, the data is transmitted to the 27256-2 EPROM, U3, where it is affected by one of three operating modes (more on that later on when we discuss the Firmware

later on) and retransmitted to the Interface's output driver—a MAX232. That IC, U4, translates TTL signals to RS-232 levels for the computer. The connection between the Interface and the computer is made with SO1, a DB25S connector.

Power for the circuit is provided by a 9-volt AC adapter. That voltage is regulated to 5 volts by a 7805 regulator, U5. Because the voltage is insufficient to drive the RS-232 line; however, the MAX232 contains an internal DC-to-DC converter that generates the +12 volts needed to take care of that.

Construction. The author's prototype was built on a perforated board and was wired point-to-point. However, if you are interested in using a PC board, send an SASE to the address given in the Parts List. If there is sufficient interest, a printed-circuit board will be made available, and ordering information will be forwarded.

If you build the circuit using a perf-board you can either connect the DB25 connector (SO1) to the board using a 26-pin header, a matching IDC connector, and a 26-conductor ribbon cable (wire 26 would have to be clipped), or you can connect SO1 directly to the board. Either way, there are only four connections made to or on the DB25 connector: Pins 4 and 5 of SO1 should be connected to each other, pin 3 of SO1 should be connected to pin 14 of U4, and pin 7 of

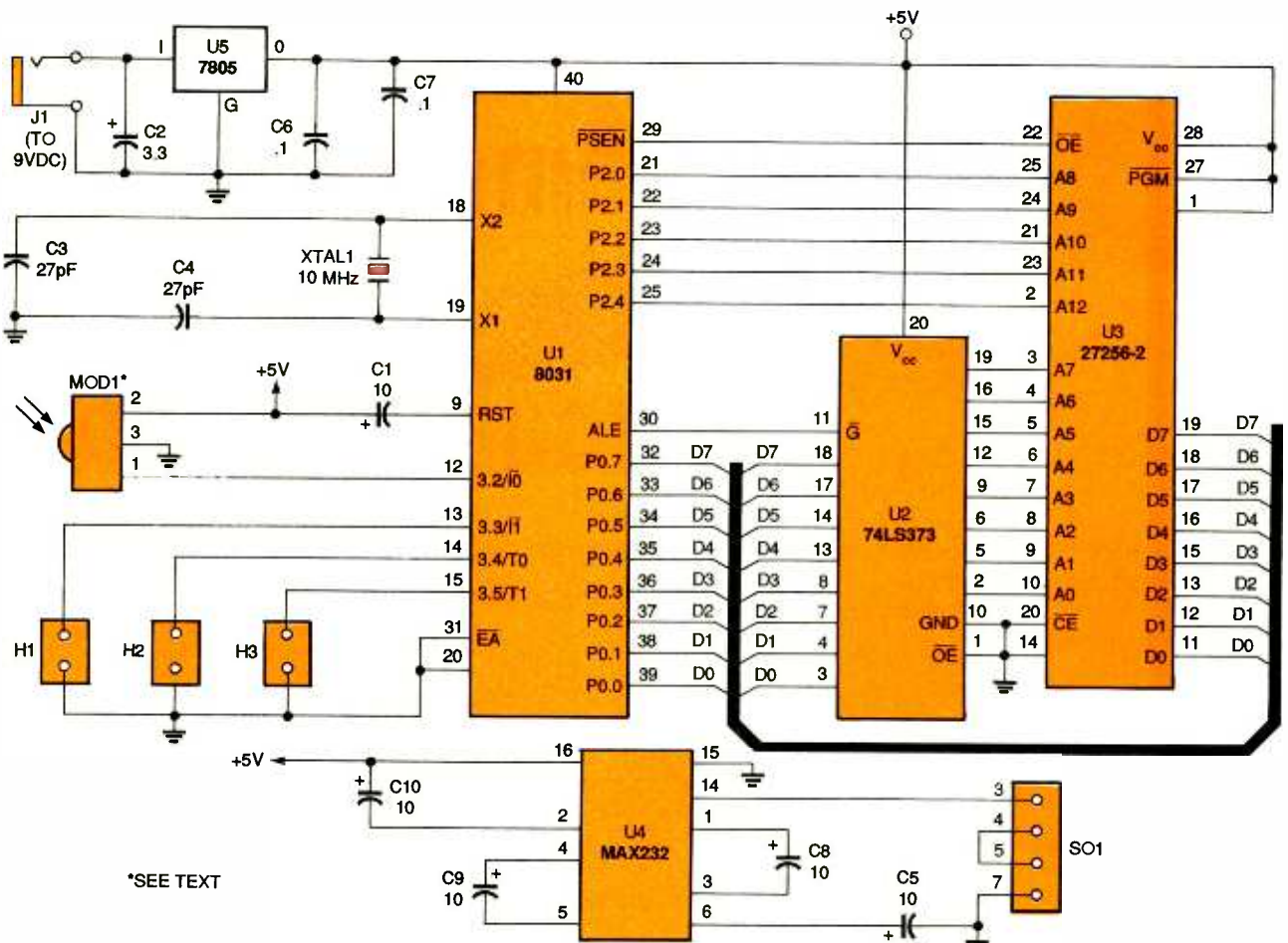

Fig. 1. As this schematic shows, the Remote-Control Interface has a relatively low parts count. That is made possible by the configuration of the 8031 processor (U1) and the EPROM (U3), which allows for efficient processing of IR signals that are received by the IR module, MOD1.

```

REMOTE
00000000 00000000 00000000 00000000 00000000 00000000 00000000 00000011
11111111 11111111 11111111 11000001 11000001 10000011 10000011 00000111
00000110 00001111 11111100 00011100 00111111 11111000 01111111 11110000
11111111 11100001 11111111 10000011 11111111 00000111 11111110 00001110
00001111 11111100 00011000 00111111 11110000 01110000 11100000 11111111
11000001 11000011 10000011 10000111 11111111 00001110 00001111 11111100
00011111 11111000 00111000 01111111 11100000 11111111 11000001 11111111
10000011 11111111 11111111 11111111 11111111 11111111 11111111 11111111
11111111 11111111 11111111 11111111 11111111 11111111 11111111 11111111
11111111 11111111 11111111 11111111 11111111 11111111 11111111 11111111
11111111 11111111 11111111
LOCAL
Power key - Toshiba TV remote

Chat Mode - Press ESC to end

```

Fig. 2. Here's a typical analyzer-mode data block. It was captured on a PC, using PROCOMM in chat mode. Zeros represent the "ON" carrier condition and ones represent carrier "OFF," or no signal. Each character position represents 150 microseconds of time.

SO1 connects to ground.

The IR-detector module should be mounted at the edge of the board, so that it can be exposed to IR signals

through a hole in the project case. The Radio Shack detector module specified for MOD1 is readily available, but you could remove the re-

mote detector from a junked VCR or television and use it on the board instead. Of course, figuring out the wiring for that approach is up to you.

The 7805 regulator, U5, needs to be mounted on a small heat sink. Use IC sockets for the other four integrated circuits. Also, when laying out the placement of the components, make sure that the 10-MHz crystal, XTAL1, is located near U1 (in other words, the amount of wire connecting the two should be kept to a minimum).

Power-jack J1 should be mounted to the side of the project enclosure. Make sure that the jack you use for J1 matches the plug on your AC adapter. Any adapter that produces 9-volts DC at 500 mA will work fine.

When installing the three 2-pin headers, H1-H3, you might want to label them to make it easy to tell which is which. That is important because to use the different modes of the Remote-Control Interface, you will have to use certain jumper configurations

on each of the headers. Mistaking one header for another will result in the unit being set improperly.

Firmware Operation. The EPROM (U3) in the Remote-Control Interface uses firmware with three modes of operation for interpreting the data stream. The firmware was written in 8031 assembly language, using the CROSS-16 meta assembler from Universal Cross Assemblers, and can be obtained on disk from the source

PARTS LIST FOR THE REMOTE-CONTROL INTERFACE

SEMICONDUCTORS

- U1—8031 microprocessor, integrated circuit
- U2—74LS373 octal latch, integrated circuit
- U3—27256-2 EPROM, integrated circuit
- U4—MAX232 TTL to RS-232 converter, integrated circuit
- U5—7805, 5-volt regulator, integrated circuit

CAPACITORS

- C1—10- μ F, 16-WVDC, electrolytic
- C2—3.3- μ F, 25-WVDC, electrolytic
- C3, C4—27-pF, ceramic-disc
- C5, C8—C10—10- μ F, 35-WVDC, electrolytic
- C6, C7—0.1- μ F, ceramic-disc

ADDITIONAL PARTS AND MATERIALS

- MOD1—Infrared-detector module (Radio Shack #276-137 or equivalent)
- XTAL1—10-MHz crystal
- H1—H3—2-pin header
- SO1—DB25S connector
- J1—Power jack (should match AC-adaptor plug)
- Perfboard materials, enclosure, 26-pin board-mount header with matching IDC connector (optional), 26-conductor ribbon cable (optional), AC adapter (9-volts DC, 500 mA), wire, solder, hardware, etc.

Note: The following are available from Stuart Ball (741 Okie Ridge, Yukon, OK 73099): a 5.25- or 3.5-inch disk (please specify which) containing the firmware source code and hex files for the Interface—\$11.50; U3, programmed with the code, is available for \$15.00. Oklahoma residents, please add appropriate sales tax.

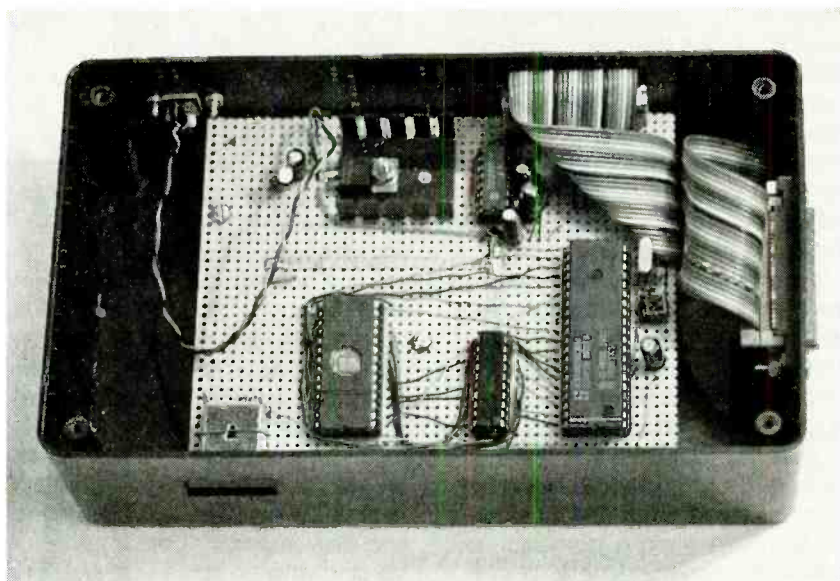

The author's prototype was built on a perforated board, using point to point wiring. As you can see, the DB25S connector is attached to the board with a ribbon cable.

mentioned in the Parts List, or can be downloaded from the Gernsback BBS (516-293-2283). A pre-programmed EPROM is also available from the source in the Parts List.

The first mode of operation is called the "analyzer mode." In that mode, the firmware waits for a signal from the remote unit, then begins sampling the data stream every 150 microseconds. After 100 milliseconds of data has been sampled and stored, it is converted to ASCII for transmission to the PC. Spaces are inserted every eight characters, and a carriage return/linefeed sequence is sent after 72 characters. That mode is intended for use in decoding the format of an unknown remote.

Figure 2 shows a typical analyzer-mode data block. That data was captured on an IBM-compatible PC, using PROCOMM (a communications program) in chat mode, then printed with the "print screen" function. In Fig. 2, zeros represent the "on" carrier condition and ones represent carrier "off," or no signal. Each character position represents 150 microseconds. The sync signal is on for 9.3 microseconds (61 continuous on samples) then off for 4.5 microseconds (30 continuous off samples). That is followed by a 1-microsecond zero bit (five on samples, three off samples), then another zero, then a 2.2-microsecond one bit (five on samples, ten off samples). The complete data pattern for that example is as follows:

```
Sync 0000 0100 1111 1101 0100 1000
1011 0111
```

When interpreting data in analyzer mode, remember that the Interface samples at 150-microsecond intervals. Therefore, the data has a resolution of 150 microseconds. In the example shown, some of the zero bits have an off/on pattern of 5/3, others have a pattern of 5/2, 4/3, etc. The one bits have a similar ambiguity. To find the actual bit timing of an unknown remote, average the patterns over several bits.

The second mode, the "encode mode," receives IR data and parses it into a single data byte for the PC. The IR format has 22 bits, with 1.6- to 3.3-microsecond bit times. A single output byte is generated by exclusive-OR'ing the incoming data bytes. The data is not an even multiple of eight bits, so the trailing bits are padded with zeros for inclusion in the final sum.

The third mode, the "decode mode," receives IR data and parses it into four bytes to the PC. That data format is 32 bits, with a 1.2- to 2.2-microsecond bit time. That is the format illustrated (in the analyzer mode) in Fig. 2. In decode mode, the example shown in Fig. 2 would result in the sequence 02FD48B7 (h) being transmitted to the host computer.

In the first two modes, the Interface looks for a valid sync bit to begin the data stream. Each received bit generates an interrupt to the 8031 pro-

cessor, U1. The first bit, presumably the sync bit, causes the internal timers to start. If the time to the next interrupt is correct for a sync bit, then the time between the following interrupts is measured. The one/zero threshold is determined by the time between bit edges. Time is measured using one of the 8031's internal timers.

In all three modes, data is sent to the PC at 1200 baud. The baud rate is controlled by one of the internal 8031 timers, and can be adjusted by changing the firmware. In a typical application, software in the PC would receive the ASCII data from the Interface, and perform some operation (change screens in a VGA slide show, for example) when a particular key was pressed on the remote.

The Remote-Control Interface can be switched between operation modes by changing the jumper configuration on two of the two-pin headers, H1 and H2. Header H3 is unused in the present version of firmware. However, if you obtain the source code on disk, you could change the setup of EPROM U3 to have H3 accommodate another mode. The first two headers are encoded as follows:

When H1 is shorted with a jumper, the Interface is set in analyzer mode and H2 is ignored. If H1 is open, the unit is set into either the second (encode) or third (decode) mode, depending upon the jumper configuration of H2. If H2 is shorted, the unit will have a data format of 22 bits, with a 1.6- to 3.3-microsecond bit time (which is the second mode). If H2 is open, the Interface has a 32-bit data format, with a 1.2- to 2.2-microsecond bit time (the third mode).

Use and Setup. To use the Interface, first determine which data format is used by your remote controller, using the Interface's analyzer mode. Use a serial cable to connect the Interface to a serial port on your computer. The Interface will send either a single hex byte (two ASCII characters) or four hex bytes (eight ASCII characters) for each key that is pressed on the remote controller.

Note that the Interface only sends data to your serial port. To interpret that data and have it actually do something, you will need to either write or acquire software that will do so. With a little trial and error, you

should be able to figure out what key sends what codes to the PC. Once you have that figured out, assigning software functions to each key becomes easier. Because the Interface does no error-checking on the data it receives and sends, you must make sure that your software rejects any unknown codes it receives.

Once you have determined what key does what on your remote, you will have to label the remote so that you can remember the functions. Obviously, this project is meant for use with an off-the-shelf remote. Many remotes use a sheetmetal cover with the key descriptions. If that is carefully removed, the cover can be repainted and new legends applied with dry-transfer lettering. Or, if you are very careful about masking the keys, you might be able to paint and re-label the panel without removing it.

Applications. Remote control of a multimedia presentation or a software demo is probably the most practical use of the Interface. Normally, when a piece of software is demonstrated to a large group, everyone wants to crowd around the screen but the person demonstrating it must be near the PC and the keyboard. With an IR remote controller and the Interface, software demos, as well as multimedia presentations and slide shows, can be controlled.

Here's a possible application of the Interface in education: If you have a remote controller with a 0-9 keypad, you could use the Interface and an on-screen calculator program to demonstrate math problems to a classroom of elementary students. Of course, the keys which perform mathematical functions will have to be marked as such; for example, the STOP button could be the one that performs addition (if no key on the remote creates the code for a "+" sign, then the calculator program would have to be altered to accept another character to cause it to perform addition). If the numbers displayed and the monitor are large enough, an entire class should be able to see.

You can use almost any piece of software with the Interface, as long as the software has a reasonable number of possible commands (the remote should have enough buttons to accommodate them). ■

MOBILE ASSISTANT

(Continued from page 31)

Mobile Assistant could replace labor-intensive procedures that now use handwritten entries on a clipboard, which must be then manually key-punched into a remote computer. Instead an inspector could speak information into a microphone that is connected directly to the belt-mounted computer.

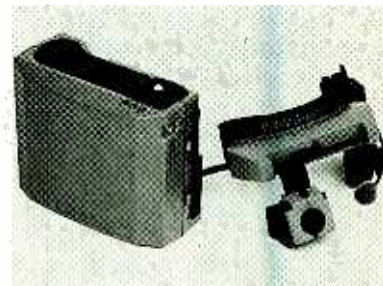

The canteen-size, IBM-compatible, belt-worn computer weighs only 2¾ pounds. It currently packages a 486-50 MHz processor, and a 340-MB internal hard drive.

The Future. Computer Products and Service Inc. is already working on a second-generation Mobile Assistant that has increased computing power, weighs less, has improved battery life, and is less costly. Currently, the basic Mobile Assistant system costs \$10,000. With peripherals and options, it can have a bottom line of \$17,000 or more.

Due in late 1996, the new system is expected to feature a faster CPU running at from 75 to 120 MHz, plus built-in multimedia and communications capabilities. More PCMCIA slots and special communication antenna ports will be added. Increased storage on hard drives is planned, with up to 1.5 GB anticipated. Weight and size will decrease by 40 percent. A full-color VGA display is also being planned. ■

FOR MORE INFORMATION

Computer Products & Services, Inc.
12701 Fair Lakes Circle
Fairfax, VA 22033
Tel. 703-631-6925
Fax: 703-631-6734

Learn Valuable Skills At Home In Your Spare Time...

Earn \$\$\$ As A PC Repair Technician!

Train with the world's acknowledged leader in home education to enter a fast-growing, high-paying computer career!

Now you can train quickly and easily to begin a successful career as a PC Repair Technician. ICS at-home training offers you complete, comprehensive, and affordable instruction that will prepare you for promotions, pay raises — even a new career — in less time than you ever thought possible!

Why pay more for an outdated PC? ICS shows you how to get the computer you want — at a price you can afford!

Unlike other schools, which include a generic, outdated PC with their PC repair training — and add as much as \$1,500 to their tuition fees — ICS lets you make your own decision. That's why our training is so much more affordable than theirs. Take advantage of the savings to buy a PC that suits your individual needs — or pocket the cash if you already own a computer.

What's more, ICS gives you invaluable instruction on how to make the best PC purchase. Your lessons teach you how to get the computer you want and give you tips on getting the best price and warranty.

PC Repair Technicians are in demand!

The U.S. Department of Labor forecasts phenomenal growth in this field in the years to come. With millions of PCs going online every year, the world needs men and women with the skills to keep them running. ICS will give you the skills to take advantage!

Only ICS — the world leader in distance education — offers you all these outstanding benefits:

- **Experience.** In our 100 years of existence, ICS has trained more than 10,000,000 students!
- **Recognition.** ICS training has been used by the employees of more than 2,000 leading companies, including IBM, AT&T, Xerox and Ford.
- **Accreditation.** ICS is nationally accredited by the Accrediting Commission of the Distance Education and Training Council in Washington D.C.



Call or send for FREE information — and start toward your bright future today!

Get the facts about ICS PC repair training. We'll send you a free information package that tells you how you can start toward an exciting, successful career as a PC Repair Technician.

Mail the post-paid card at left today!

If card is missing, send coupon, or

CALL TOLL FREE:

1-800-596-5505 EXT. 2166

CALL ANYTIME —

24 hours a day, 7 days a week.

<http://www.icsearn.com>



ADVANCE YOUR CAREER WITH A+ CERTIFICATION! ICS HAS THE TEST PREPARATION MATERIALS YOU NEED!

A+ Certification is fast becoming the standard by which PC Repair Technicians are measured. In fact, many computer manufacturers and servicing companies won't hire you without it! ICS provides a valuable A+ Certification Test Preparation Kit along with our complete PC Repair Program, as well as making it available as a separate program. We want to make sure you get the credentials that will get you the job!



Sponsor

A+ Certification Program is an industry-wide, vendor-neutral program developed and sponsored by The Computing Technology Industry Association®. The Computing Technology Industry Association® and A+ are registered trademarks. All rights reserved.



School of Computer Training

Dept. PEMS17S

925 Oak Street, Scranton, PA 18515

YES! Please send me FREE information about how I can

learn PC repair skills at home. *No obligation. Please check one of the following:*

27 Send me information about the complete ICS PC Repair Program

(includes A+ Certification Test Prep materials).

44 Send me information about the A+ Certification Test Preparation (materials only).

Name _____ Age _____

Address _____ Apt. # _____

City/State _____ Zip _____

Phone (_____) _____

22-WATT AMPLIFIER

(Continued from page 29)

the source mentioned in the Parts List). Though it might get tedious trying to line up and insert the IC1 pins in the PC board with the heatsink attached, this is easier than trying to align the mounting holes in the heatsink for mounting to IC1 with the latter already soldered to the PC board. Pre-drill the mounting holes in the heatsink to match those on IC1.

Apply a thin layer of heatsink compound to the back of IC1; then use two #6 screws and nuts to attach the heatsink. Screws should be snug but not over-tightened as this can damage the IC. Clean away any excess heatsink compound; then install and solder the IC1 pins into the PC board. Note the placement of pins 1 and 17.

Visually inspect for and remove any solder bridges, cold-solder joints, etc. Tight places to watch for solder bridging are around pins 2-5 and 13-15 on the IC. Refer to Figs. 2 and 3 if in doubt as to whether foils and parts should be touching or not. After the circuit passes a strict visual inspection, you can proceed to put the circuit in an enclosure.

While either a metal or plastic enclosure can be used to house the Amplifier, you should be sure that it is well ventilated to allow the heatsink to do its job. Keep in mind that even though plastic boxes are usually cheaper, metal boxes offer better shielding and durability in harsh environments. An LED in series with a 1000-ohm resistor can be added into the circuit (tack soldered onto the V+ foil trace and ground) to serve as a pilot light indicating when the unit is powered up. There is no provision on-board for a fuse, but a 7½ to 5- to 10-ampere fuse in the power line to the Amplifier is highly recommended.

Connections. Attach the Amplifier to your car stereo as follows. First attach the line-level signal source from the stereo to the inputs on the board. Speaker-level signals from car radios will work if they are single-ended rather than bridged. The way to determine this is by checking the loudspeaker outputs at the back of the radio. If there is a common ground

and one lead per loudspeaker, it is a single-ended output. If there are two leads per loudspeaker coming out of the radio and neither lead is common to ground, it is a bridged output and should not be connected directly to the Amplifier. If you do, you will effectively short half the bridge out and probably damage the radio.

Next connect one pair of your car's speakers to the Amplifier. As we mentioned earlier, for two pairs of speakers, you should build two Amplifiers. Heavy-duty, 6- x 9-inch, three-way, four-ohm, oval loudspeakers are a good match for the amplifier. While it may be tempting to use existing, factory-installed loudspeakers, there are two things that require caution. First, many systems do not use the BTL output configuration and may therefore have only one lead going from the radio to the loudspeaker. The other loudspeaker lead may be grounded to the loudspeaker frame.

Another concern is the power-handling capability of the existing loudspeakers; they need to be rated for at least 20-watts RMS. In spite of the rating (in watts), small loudspeakers can only generate a limited amount of sound. Within reason, bigger is usually better, especially for bass response (bass response falls off sharply as loudspeaker size decreases, particularly at higher listening levels). This amplifier will drive a pair of bookshelf loudspeaker boxes (10-inch woofer, 4-inch mid-range, and a dome tweeter, for instance) just fine, but that type of loudspeaker box is usually impossible to mount in a car. The amplifier will drive eight-ohm loudspeakers, but will deliver more power into four-ohm loudspeakers. Most automotive loudspeakers are four-ohm, but check yours to be sure.

Finally, make the +12-volt power and ground connections between the Amplifier and your car's electrical system. Test the sound system to make sure it works, and then secure the Amplifier in place. The location of the unit is entirely up to you, but most people like to keep amplifiers in the trunk.

With good front and rear speakers, two of these Amplifiers will provide excellent sound and lots of power. Performance will be as good as commercial units in this power range and better than cheap units rated at "peak" power. ■

AUTOMATIC HEADLAMP

(Continued from page 38)

against engine heat, rain, snow, and road hazards.

Splice the wire connected to the cathode of D3 to the low-beam wire of either headlamp. Do that by removing a small amount of insulation from the low-beam wire and wrapping the other wire around it. Apply solder for a good connection and then insulate it thoroughly with plastic electrical tape. The lamp has three wires for either high beam, low beam, or ground. Be sure to properly identify the low-beam wire. If in doubt, use a voltmeter to check which wire is hot when the low beams are operated by the instrument panel switch.

The free connection of the fuse holder (the side not connected to the source of Q1) should be connected to the positive side of the car battery. Many vehicles have two wires at this location, one for the starter and the other for the electrical system. Choose the smaller of the two wires. Solder and insulate the connection with tape.

Locate the selected windshield wiper lead as described earlier, connect it to the Control module as shown in Fig. 8A or Fig. 8B, depending on which configuration applies (again, as described earlier). Then connect the remaining wire of the module, +12V wipers or circuit common, to either the windshield-wiper-motor +12-volt source (which is switched off with the ignition key) or the vehicle chassis (ground) as required.

Replace the ground connection on the vehicle's battery. Tighten the screws or nuts securely. This completes installation of the control module.

Final Checkout. Testing the circuit at this point is simple. Start the engine of your vehicle and turn on the windshield wipers. Check the headlamps to verify that they are illuminated, but not at full brightness. Verify that the headlamps stay lit for each of the speeds of the wipers.

Turn off the windshield wipers. The headlamps should be extinguished. This completes the final checkout. You and your vehicle are now ready to go! ■

DIGITAL CAMERA

(Continued from page 10)

many other "regular" cameras, and many of the same old familiar features are still there. An LCD panel on the back of the camera indicates the resolution setting, flash mode, auto-focus mode, battery level, zoom mode, number of pictures taken, number of pictures remaining, timer status, erase mode, data copy mode, and whether a memory card is installed or not. The number of pictures taken and remaining also reflects whether or not a memory card is installed.

The viewfinder of the 10-C looks much like any other modern camera. Looking through the viewfinder you'll see close-up compensation brackets for different types of pictures and the auto-focus target mark (the spot that the camera will normally focus on). When the shutter button is pressed halfway down, the camera will auto-focus; the picture is taken when it's pressed all the way down.

The 10-C has different auto-focus (AF) modes for different situations. A multi-AF mode is used when the subject is not in the center of the picture. In this mode the camera uses multiple infrared beams to focus the lens. A spot AF mode is used when the subject is smaller than its surroundings; in this mode the camera will focus on the "spot" at the center of the lens. A focus lock feature allows you to focus on something and have the camera hold that focus as you reposition it.

The camera's 3x zoom lens can be used manually to move in and out as you prefer, or it can be set to work automatically in the program zoom mode. In this mode the camera zooms in automatically depending on the size of the subject and the distance to it. A macro mode lets you position the camera about 19 inches from the subject for close-up work.

The flash also has three modes. In the auto-flash mode, the flash will come on when it's necessary. The fill-flash mode is best used when the camera needs additional lighting, like when the subject is darker than its surroundings. A no-flash mode can be used when you don't want the flash at all. One last neat feature is the camera's built-in timer. This lets you set up a

picture and have enough time to get in the picture yourself before the shutter clicks.

Software. The Dycam 10-C comes with all the software you need to import, view, manipulate, and save images. A supplied cable connects the camera to a serial port on the computer. The software first imports data from the camera and then shows you thumbnails of the pictures. You then select images you want to load. Images can be saved in many different formats, including BMP, TIFF, JPEG, and more.

The software also lets you adjust the images to correct for various problems. Images can be sharpened, resized, cropped, color adjusted, and more. Of course you can also manipulate the images to your heart's content with your favorite photo-retouching software. The Dycam software also lets you control the camera from the computer if you need to.

Accessories and Limitations. As mentioned before, the 10-C camera has a threaded collar around the lens that lets you add on other lenses and filters. However, the camera is a viewfinder type, and not an SLR (single-lens reflex). This means that you look through a different lens than the picture is taken through. Therefore, the effect of any add-on lens or filter can only be seen in the final picture. However, pictures taken with this camera are essentially free, so you can experiment all you want without spending any money on bad pictures.

We tested out two accessory lenses, a close-up set and a wide-angle lens. Both are available from Dycam for \$89 each. The wide-angle lens gives nearly a fish-eye view of the world, and allows you to get a large scene in view without being too far away. The fish-eye effect can be removed by cropping and manipulating the final image. The close-up set is a series of three lenses that can be stacked to create the desired effect.

Unfortunately, the Dycam 10-C is not ideally suited for close-up work. Detail level in the electronic image is not equal to a conventional photograph, and detail is usually what you want to see in a close up. For example, the pictures you see in this magazine of PC boards and ICs close up could

not be taken with the 10-C. Actually they could be taken, but they wouldn't be clear enough to be reproduced here. For the most part, any picture you could take with a non-professional 35-millimeter camera could also be taken with the 10-C.

If you already own a computer and happen to take a lot of photographs, then the Dycam 10-C will be a handy investment. Even if you are not interested in a digital camera now, you soon will be—you'll have no choice. At some point the quality and prices of electronic cameras will be close enough to conventional ones so that the savings on developing and film will be more than enough to make the purchase worthwhile. In the meantime, owning an electronic camera will allow you to do things that are impossible with a regular camera. ■

FOR MORE INFORMATION

Dycam, Inc.
9414 Eton Ave.
Chatsworth, CA 91311
Tel. 818-998-8008

AMERICAN HEART
ASSOCIATION
MEMORIALS & TRIBUTES



1-800-AHA-USA1

American Heart Association

Timid about getting on the . . . World Wide Web?

You've heard about the *Information Superhighway* and all the hype that goes with it! Sort of makes you feel timid about getting on the Web. Put your fears aside! A new book, *The Internet and World Wide Web Explained*, eliminates all the mystery and presents clear, concise information to build your confidence. The jargon used is explained in simple English. Once the tech-talk is understood, and with an hour or two of Web time under your belt, your friends will believe you are an Internet guru!

To order Book #403 send \$6.95 plus \$3.00 for shipping in the U.S. and Canada only to Electronics Technology Today Inc., P.O. Box 240, Massapequa Park, NY 11762-0240. Payment in U.S. funds by U.S. bank check or International Money Order. Please allow 6-8 weeks for delivery.

ELECTRONICS LIBRARY

CABLE COMMUNICATIONS: Building the Information Infrastructure

by Eugene R. Bartlett

This book explores the many technologies now merging into the "information superhighway," with a focus on the cable systems that will form the backbone of the highway. The book not only analyzes the systems that are currently in place, but also reports on those in development. It provides in-depth discussions of the work required to interconnect and bridge the many systems into a complete information network.

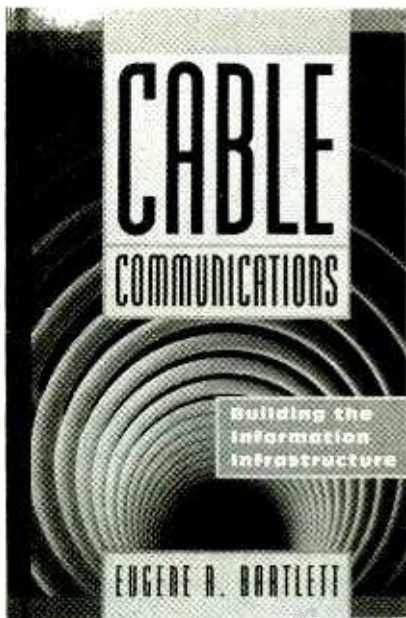

Written in easy-to-understand language with a minimum of technical jargon, the book covers both video and audio technology in detail. It examines a wide range of important considerations, describing the types of cables and wires being used, demonstrating cable-system transmission and control methods, investigating cable-system signals sources, and showing how to maintain and improve the information highway. The book also explores the role played by the information highway in global telecommunications.

The book features full coverage of everything from non-conductive cables to coaxial cable systems, from tele-

phone signals and message traffic to hard-wire controls, from fiber-optic computer data systems to commercial applications, and from personnel education and training to the present status of the information highway in the world marketplace. A number of helpful appendixes cover such aspects as wire-loop resistance, the velocity of propagation, broadband noise combining, frequency testing, satellite ground-station pointing, and SONET networks and testing techniques.

Cable Communications: Building the Information Infrastructure costs \$50 and is published by McGraw-Hill Book Company, 11 West 19th Street, New York, NY 10011; Tel. 800-2-MCGRAW. **CIRCLE 90 ON FREE INFORMATION CARD**

THE ARRL REPEATER DIRECTORY 1996-1997

from the American Radio
Relay League

Amateur-radio enthusiasts will be hard-pressed to find more information packed into a pocket-sized source than the over 20,000 listings contained in this book. The 25th Anniversary Edition of the Repeater Directory features many more coordinated repeaters than were found in previous editions and more FM listings as FM has become an increasingly popular mode of operation for the amateur-radio operator of the 90s.

The handy reference manual includes repeater locations, frequencies, and other pertinent data for the United States, Canada, and (where available) the Caribbean, Central and South America, Pacific Islands under U.S. jurisdiction, and parts of Europe. It provides readers with the information they need to contact Frequency Coordinators and regional members of the American Radio Relay League (ARRL) Spectrum Management Committee and Digital and Future Systems Committees. In addition, it features listings of packet radio systems and worldwide propagation beacons. A national listing of ARRL Special Service Clubs includes their meeting times, locations, and contact persons.

The ARRL Repeater Directory

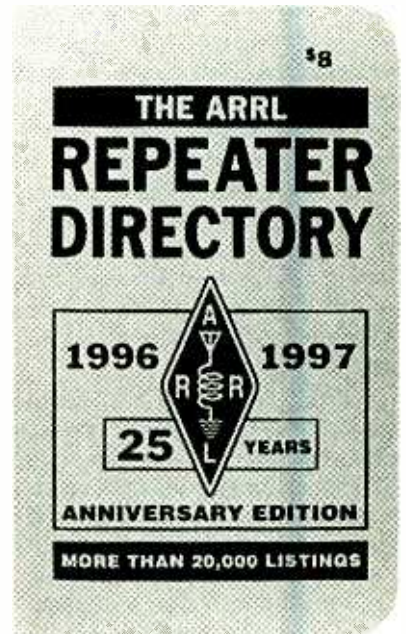

1996-1997 costs \$8 and is published by The American Radio Relay League, 225 Main Street, Newington, CT 06111-1494; Tel. 860-594-0200; Fax: 860-594-0303; e-mail: pubsales@arrl.org; Web: <http://www.arrl.org/>.

CIRCLE 91 ON FREE INFORMATION CARD

BUILDING A 3D GAME ENGINE IN C++

by Brian Hook

Most game-programming books hand you a finished game engine—locking you into someone else's design from the beginning—and then tell you how to add on a few features. It's easier to present a finished product than to explain everything that developers need to understand about game programming.

This book takes the opposite approach. It gives you all the technical details and know-how, along with insider's shortcuts and tricks-of-the-trade. It shows you how to build your own custom engine from scratch, using AST3D, a powerful 3D graphics library that is included on the companion disk. The disk also includes source code for Borland and Watcom C++ compilers and an original 3D game engine that you can use to create your own games.

Together, the book and disk allow



you to build the game you want, without having to pay a licensing fee. You'll learn how to design and develop professional-quality games, including 3D graphics games; implement collision and boundary detection; and create "intelligent" entities using artificial-intelligence algorithms.

Building a 3D Game Engine in C++ costs \$34.95, including disk, and is published by John Wiley & Sons, Inc., 605 Third Avenue, New York, NY 10158-0012; Tel. 800-CALL-WILEY; Web: <http://www.wiley.com/cobooks/>.

CIRCLE 92 ON FREE INFORMATION CARD

INTERNET SECURITY FOR BUSINESS

by Terry Bernstein, Anish B. Bhimani, Eugene Schultz, and Carol A. Seigel

Businesses set up Web sites specifically to encourage people from around the world to visit, browse, and retrieve product information. But by creating an Internet presence, they also open the door to some unwanted visitors—some with mischievous or malicious intentions. How can potential troublemakers be weeded out?

This book provides business and managerial perspectives on why, when, and how to implement Internet security controls. Written for the manager who needs to understand the dangers that lurk online, the book outlines a complete program for securing a full range of Internet and Intranet services, including firewalls, electronic commerce, encryption and digital signatures, e-mail, and Internet news service. It also contains easy-to-follow

guidelines on how to educate and train employees to identify and respond to almost any breach of security, both internal and external.

Internet Security for Business costs

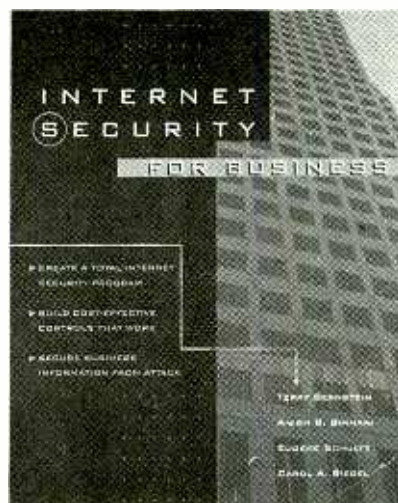

\$34.95 and is published by John Wiley & Sons, Inc., 605 Third Avenue, New York, NY 10158-0012; Tel. 800-CALL-WILEY; Web: <http://www.wiley.com/compbooks/>.

CIRCLE 93 ON FREE INFORMATION CARD

GETTING STARTED IN PRACTICAL ELECTRONICS

by Owen Bishop

Electronics can be a fascinating hobby and a good career choice—but its technical nature and jargon makes it intimidating for newcomers. This book strives to answer all of the questions that beset beginners, from defining the terminology to explaining how to use a soldering iron. Rather than discussing electronics theory and application in cut-and-dried text, the book uses hands-on projects and experiments to illustrate electronics concepts. Readers learn while doing.

The book is divided into two parts. The first part, aimed at absolute beginners, explains everything needed to build the 30 projects presented in the second part of the book. The opening section describes what electronic components look like, how to handle them, what to ask for when buying them, and what they do. It shows readers how to understand circuit diagrams, how some simple circuits work, and how to perform simple calculations needed to make circuits work as you want them to.

It also describes several different construction and troubleshooting techniques.

The 30 projects in the second section of the book are divided by degree of difficulty into three chapters. All of the projects are powered by battery, so the beginner is in no danger from electric shock. Printed-circuit designs are included.

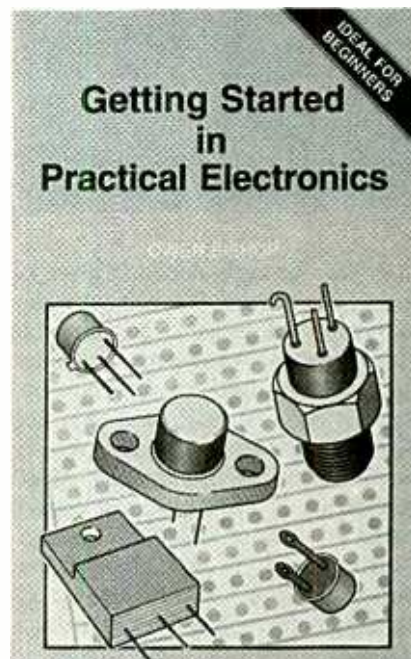

Getting Started in Practical Electronics (Order No. BP345) costs \$5.95 plus \$3 shipping and handling and is published by Electronics Technology Today Inc., P.O. Box 240, Massapequa Park, NY 11762-0240.

CIRCLE 94 ON FREE INFORMATION CARD

QRP POWER!

compiled by Joel Kleinman, N1BKE, and Zack Lau, KH6CP/1

A QRP station, by definition, is one that runs on 5 watts or less. Thousands of ham-radio enthusiasts know that it really isn't that hard to work the world on 5 watts—or 200 milliwatts, for that matter. Although it's a challenge to run on low power, QRPers gladly embrace the task. They enjoy the feeling of accomplishment attained when they make worldwide contacts using less power than it takes to light a tiny bulb. Operating savvy, antenna efficiency, and patience take the place of raw power.

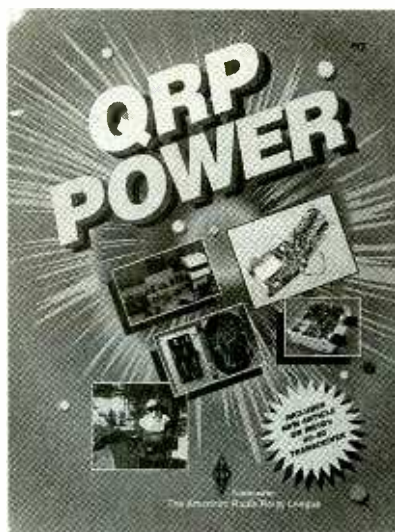

Written for experienced QRPers as well as newcomers, this book provides everything you need to get the most out of low-power operating. It contains the best recent QRP articles from publications such as *QST*, *QEX*, and *The ARRL Handbook*, as well as a new, in-depth article on the popular 40-40 transceiver. The articles cover current trends in amateur low-power communications, and present projects that readers can build themselves, including a 40-meter regenerative receiver, a one-watt transmitter, and circuits to modify existing rigs.

QRP Power costs \$12 and is published by The American Radio Relay League, 225 Main Street, Newington, CT 06111-1494; Tel. 860-594-0200; Fax: 860-594-0303; e-mail: pub-sales@arrl.org; Web: <http://www.arrl.org/>.

CIRCLE 95 ON FREE INFORMATION CARD

THE INTERNET COMPLETE REFERENCE: Second Edition
by Harley Hahn

This book is intended to serve as a guide and a companion on your every journey into the Internet. Written in a friendly, first-person style, the book reassures and entertains readers, without insulting their intelligence. By learning how the Internet and its visual component, the World-Wide Web, work together, readers learn how to navigate both with confidence.

The book is organized to make mastering the Internet and the Web a

logical, comfortable process. It explains what is needed to connect to the Internet, how to communicate with people around the world using e-mail, chat rooms, IRC, and MUDs; and how to use browsers to access a variety of Internet resources, such as gopher, FTP, Usenet, telnet, and e-mail. Extensive Web coverage describes what the WWW really is and how to use it; Web Pages and Home Pages; URLs; links, forms, and image maps; and Web directories and Search Engines. A 200-page directory to Internet resources is included. Throughout the book, icons alert readers to pertinent information that can be quickly referenced in catalog listings.

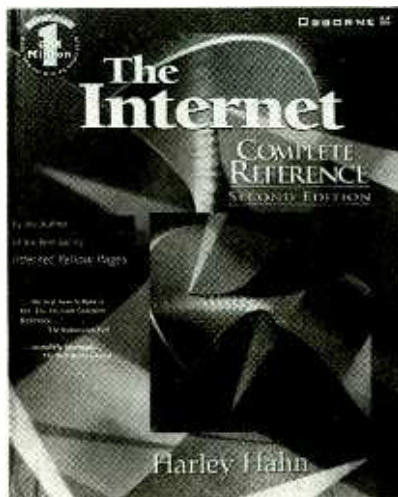

The Internet Complete Reference, Second Edition costs \$32.95 and is published by Osborne/McGraw-Hill, 2600 Tenth Street, Berkeley, CA 94710; Tel. 800-227-0900.

CIRCLE 96 ON FREE INFORMATION CARD

POWER ELECTRONICS: Second Edition
by D. A. Bradley

Although power electronics is a rapidly expanding field, it is often not given in-depth coverage in engineering classes. This tutorial guide to power electronics is designed to fill that gap for undergraduate students at the first- or second-year level.

The book provides complete coverage of the field of power electronics, beginning with a discussion of the operational characteristics of various devices and ending with a summary of

complete power-electronics systems. It reviews the design and operations of both AC converters and DC systems. Numerous worked examples, exercises, marginal notes, and references reinforce the main text.

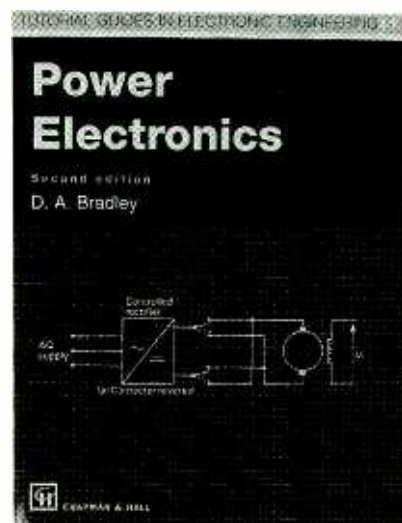

The second edition contains an extensive update of the original book, along with a new chapter on power supplies. The worked examples have also been revised and updated. The book offers a timely analysis of micro-computer applications, coverage of control algorithms, and case studies obtained from a number of manufacturers.

Power Electronics costs \$25.95 and is published by Chapman & Hall, One Penn Plaza, 41st Floor, New York, NY 10119.

CIRCLE 97 ON FREE INFORMATION CARD

THE REVOLUTIONARY GUIDE TO VISUAL BASIC 4 PROFESSIONAL
by Larry Roof

Written for experienced programmers who are moving to Visual Basic 4.0 (VB4) Professional release (32- or 64-bit) from either 3.0 or another development tool, this book assumes a good knowledge of the fundamentals of Visual Basic and of programming in general. The book focuses on four key areas for developers using VB4: the Win32 API, Objects and OLE, Databases, and the VB development cycle. Each area receives in-depth

continued on page 63

DOS or Windows or Both?

BY JEFF HOLTZMAN

Windows 95 was supposed to solve the problem of running DOS applications and games under Windows. In my experience, it hasn't. So here's how you can have your cake and eat it too. Even though there is no DOS in Win95 (wink, wink), Win95 still responds to most of the commands used by DOS 6 to customize the way a given machine boots.

By using those commands, you can simultaneously: Set up your machine to run either "DOS" or Win95, and optimize usage either way. The benefits will be better system stability and more efficient operation. Another benefit is that you'll be able to run Win95 from the command line, and return to the command line to do something else if necessary.

What we'll do is set up your system so that it boots to a "DOS" prompt. Of course, if you issue the VER command at that prompt, you'll see something like the following:

```
C:\>ver  
Windows 95. [Version 4.00.950]
```

Actually, we won't necessarily boot to a DOS prompt. We'll use the CONFIG.SYS menu system supported in DOS6 and Win95 to create machine configurations optimized for different environments (for example, running DOS games or running Win95). And best of all, you can extend the techniques shown here to add other configurations.

OVERVIEW

What we're going to do is edit several of Win95's system-configuration files. There are numerous ways to make your system non-bootable if you're not careful, so carefully follow these steps before doing anything else.

Within Win95, create a boot diskette using Win95's My Computer, Control Panel, Add/Remove Programs, Start-Up Disk.

Still within Win95, start a DOS box. Copy the following files from C:\ to the boot diskette: CONFIG.SYS, AUTOEXEC.BAT, MSDOS.SYS. Note

that all three are text files. However, MSDOS.SYS may not show up in a normal directory listing, because it's normally a hidden file. Therefore, you can issue the command:

```
C:\>dir /a
```

to see all the files in a directory. Then you can use the ATTRIB command to make MSDOS.SYS accessible as follows:

```
C:\>attrib -r -h -s msdos.sys
```

Copy the file to the boot diskette; then add or edit the Options section of the file to include the following, making sure you don't delete anything, especially all those lines full of x's.

```
[Options]  
BootGUI=0  
Logo=0
```

Save the file. Now rename CONFIG.SYS and AUTOEXEC.BAT to anything you want. Close the DOS box, and shut down Win95, forcing it to restart the computer.

After the computer reboots, you'll see the usual "Starting Windows 95..." message, and then find yourself at a pure "DOS" prompt. Since you booted with no AUTOEXEC.BAT, you won't have much of a path, and obviously there will be no device drivers.

Now create a new CONFIG.SYS with contents as follows:

```
[menu]  
menulitem=DOS, DOS (games)  
menulitem=Windows, Windows 95  
menuDefault=DOS, 10
```

```
[Common]
```

```
[DOS]
```

```
[Windows]
```

Yes, the [DOS] and [Windows] sections are empty for now. We just need them there so the menu system will work

properly. Later on, we'll add real-mode device drivers to the DOS section, and anything else you might require to the Windows section. Items listed in the [Common] section will be executed by all defined configurations.

Now create a new AUTOEXEC.BAT as follows:

```
@ECHO OFF  
Echo Processed by both DOS and  
Windows!  
goto %config%  
  
:DOS  
Echo DOS!  
goto END  
  
:Windows  
echo Windows  
  
:END
```

Note the environment variable %config%. It contains a text string corresponding to the choice you made at boot time. Anything in AUTOEXEC.BAT before the GOTO %config% will be executed by both configurations. Note the GOTO in the DOS section. It is required to skip over the commands in the Windows section. Otherwise those commands would get executed too. Most people deplore the use of GOTO statements in any type of programming, but DOS's (oops—I mean Win95's) batch language is so wimpy that there's no choice.

Now reboot. If you've typed everything correctly, you should see a menu that allows you to select DOS or Windows. Then, by inserting the appropriate device drivers and utility programs in the corresponding sections of the new CONFIG.SYS and AUTOEXEC.BAT files, you'll have an optimized multi-boot setup.

For example, the files I use on my kids' machine appear in Listing 1 and Listing 2. In CONFIG.SYS, note that the DOS sections load real-mode (DOS only) drivers for a sound card and a CD-ROM. The Windows sections load

continued on page 79

HAM Radio

Winter Ham Activities

BY JOSEPH J. CARR, K4IPV

Now that it's the dead of winter, what do you do? Of course, if you live in southern California or around Tucson, Arizona you can snicker at the idea that summer and winter are substantially different. For most of the nation, however, winter brings a deep freeze.

Speaking of cold weather, our cars (or mobile rig transportation units) are often difficult to start. I had a ham uncle, now deceased, who lived in the Midwest in an area where temperatures of -30 degrees were not uncommon. Car batteries don't crank well at very cold temperatures. Add to that the problem of the thick, viscous oil in the engine requiring more current to overcome, and the result is a deeply disappointing attempt to get moving (*rah-rah-rah-splutzz* is not exactly the sound that I want to hear from my car's starter).

Uncle Julian taught me a little trick that seems to work well in cranking a cold automobile engine. Turn on the headlights on high beam, as well as the interior lamps and the radio, for about five minutes prior to starting the engine. Right before you crank, turn all that stuff off and then turn the key. The reason batteries don't work so well cold is that their internal resistance goes up at those temps. But turning on the lights and a few other things for a few minutes draws enough current to take the edge off the battery's deep freeze. While it may not be up to April efficiency, it's a lot better than cold cranking that darn battery. I've tried it a few times, and it seems to work quite well.

Of course, one way to keep warm and enjoy hamming in winter is to operate a bunch. You will find that the HF bands get real interesting this time of year. Go tune around 40-meters between 0000L and 0500L and see what's there (or hear what's there as the case may be). A lot of far eastern stuff rolls in during those hours. It is relatively easy for you to hear Japanese, Australian, and New Zealand stations during the wee hours.

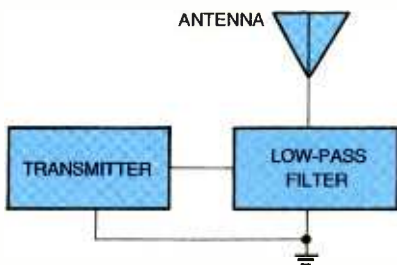

Fig. 1. Here's how to insert a low-pass filter to kill harmonics from your transmitter.

But winter storms bring down antennas, and the climate isn't well suited to putting them back up, so operating may be terminated. For those nights, you might want to try something else. One thing, of course, is reading back issues of **Popular Electronics**, or one of my books. Or how about studying for the next higher class of amateur-radio license. Even if your antenna is not up, a few feet of wire will allow the receiver to operate, and that means you can copy the W1AW ARRL code practice sessions. Write ARRL at 225 Main Street, Newington, CT, 06111 for a copy of their schedule. Or, if you have Internet access, try e-mailing them at hq@arrl.or.

Another thing to do is build something. Although some people are fond of saying that hams "don't build anything anymore," my own experience tells me this is not so. While fewer hams, or a lower percentage, might be building, I get a strong response from readers whenever I do anything on simple, low-cost construction projects. This time, let's look at a classic TVI filter that is a bit different from the normal sort of filter found in ham radio.

LOW-PASS FILTERS

Television interference (TVI) is nobody's friend. When it rears its ugly head, you get mad, your neighbor gets mad (or your spouse!), and no one wins. In really severe cases, when it is your fault, you might even get tossed off the air with "quiet hours" imposed. Not fun.

The solution to TVI for HF transmitters is to insert a low-pass filter between

the transmitter output and the antenna feedline. Figure 1 is a simple block diagram that shows how to do it. Even some antenna tuners don't help because they are designed as simple "line flatteners," some of which are actually high-pass filters (great!). Most of the time, the usual low-pass filter that you can obtain from ham supply stores works well.

However, there are times when the simple filters are not terribly effective. One of those times is when the affected stations are on TV Channel 2 (54-60 MHz). That channel has some special problems because it is harmonically related to several ham bands, and receives some of the lower-order harmonics (2nd, 3rd, 4th, etc.).

Another problem is that the effectiveness of simple pi-section and tee-section low-pass filters depends on the load and source impedances being constant and resistive. If a complex or varying impedance is presented, then all bets are off. Not only will the suppression of harmonics be reduced, but there are some malignant little situations where the reactance of the load impedance tunes the reactance of the filter, creating resonances that increases, not reduces, the harmonic. Wonderful! Talk about getting a false sense of security!

ABSORPTIVE FILTERS

Figure 2 shows the block diagram of a simple absorptive filter. Traditional low-pass filters are reflective. They reflect the unwanted harmonic energy

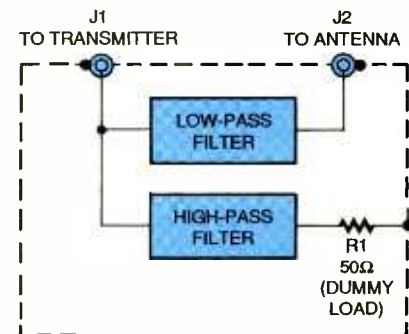

Fig. 2. Use this block diagram of an absorptive filter if you get interference complaints.

back toward your transmitter. The filter in Fig. 2 doesn't do that mean little trick. The low-pass filter section passes the desired HF signals to the antenna at J2, while the high-pass filter section, on the other hand, passes the harmonic energy through a high-pass filter to a dummy load, where it is absorbed. The energy of the harmonics is basically converted to harmless heat.

output capacitor of the low-pass filter, leading to the antenna, is series-resonant tuned by an additional inductor. This series trap is tuned to 52 MHz, so will provide an extra measure of TV channel 2 suppression. It will also add some more attenuation at odd integer multiples of 52 MHz, although not as much.

The dummy load must—repeat

The book covers the new object extensions to VB and shows how encapsulating code and data makes life easier, safer, and much more efficient.

The Win32 API is examined from the Visual Basic programmer's perspective, including a detailed look at Registry manipulation and Windows messages. A complete run-down of developing multimedia applications rounds off the first part of this useful guide.

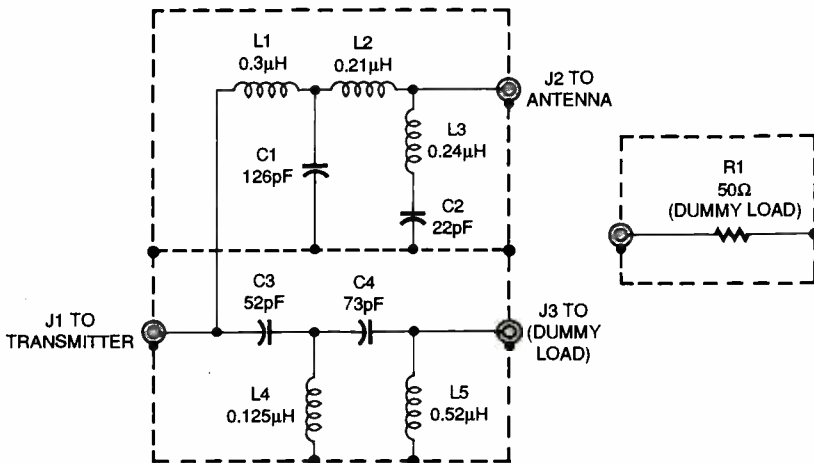

Fig. 3. Here's an absorptive-filter circuit that is effective and easy to build.

The absorptive filter in Fig. 3 is based on the classic design by Weinreich and Carroll from 1968. The high-pass and low-pass sections are shielded from each other (even though in the same shielded box) to prevent interaction.

If you want to try building this filter, wind the coils on high-powered toroids. The instructions that come with the toroids will tell you how many turns will equal what value (it varies with the type of material and size of the core). Alternatively, you could wind an air-core coil using the nomograms in *The ARRL Handbook for Radio Amateurs*.

I built one for QRP rigs (5-watt CW). It used the Amidon T-50-2 toroidal cores. For those cores, the coils are wound as follows:

- L1 = 8 turns
- L2 = 7 turns
- L3 = 7.5 turns
- L4 = 5 turns
- L5 = 11 turns

For the QRP rig, the coils could be wound using 22-gauge hook-up wire, although for any higher power that wire is unsuitable.

One feature of this circuit is that the

MUST—be noninductive, and have a value of 50 ohms. For high-power transmitters, at least a 250-watt dummy load should be used, although higher power ratings won't hurt anything. It is prudent for ham operators to keep a dummy load handy for off-the-air testing.

I have two: a 3000-watt unit and a 250-watt unit. If you want to use the regular station dummy load, rather than trying to find the correct resistor, then build it like the diagram: J3 leads to the dummy load through a very short length of coaxial cable, or via a double-male coaxial connector if that proves mechanically sound.

That's all for this issue. I can be reached by snail mail at P.O. Box 1099, Falls Church, VA, 22041, or by e-mail at carrij@aol.com.

ELECTRONICS LIBRARY

(continued from page 60)

coverage, and techniques are illustrated using complex example projects that bring out the real issues involved in all aspects of commercial Visual Basic development.

The included CD-ROM contains all the source code from the book. It also has a hypertext version of the book.

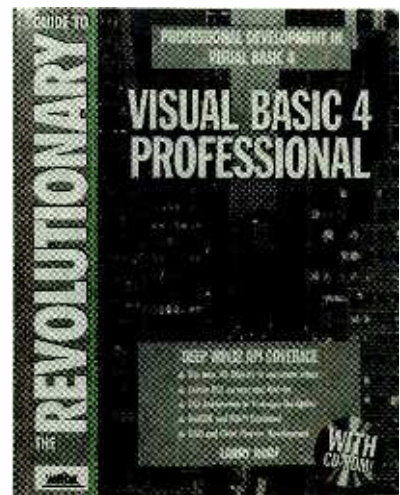

The book's next section is devoted to OLE—what it is and how to put it to work in useful applications, including a help-file creator that uses the Word OLE object. Readers are shown how to use OLE automation to create custom Internet applications using Netscape Navigator.

Database coverage starts with the data controls and goes on to present a detailed analysis of creating networked multi-user and client/server database systems. The final four chapters describe the process of creating a real-world Visual Basic application—a Workflow automation tool. Bringing together all the techniques from the book, it shows how to design, code, optimize, and distribute the application, including the creation of professional online help.

The Revolutionary Guide to Visual Basic 4 Professional costs \$44.95, including CD-ROM, and is published by WROX Press, 2710 West Touhy Avenue, Chicago, IL 60645-9911; Tel. 800-814-4527; Fax: 312-465-4063.

CIRCLE 101 ON FREE INFORMATION CARD

ANTIQUE Radio

A Spate of New Books

BY MARC ELLIS

Work on the project I had intended to continue talking about these last few months, *The Knight Kit Star Roamer*, is still at a virtual standstill! First, I was stopped by the arrival of summer, with its attendant yard work and home-maintenance chores. Then we moved into the radio-show season, when I spent one week each at RadioFest (Elgin, IL) and the Antique Wireless Association Rochester Conference (upstate New York). Following Rochester, I took another week off to vacation in Boston.

Luckily, although your faithful columnist hasn't been able to put in much workbench time, a number of interesting new books have appeared in his mailbox or been slipped to him at the conferences. And they are a ready-made subject for this month's column!

TUBE LORE by Ludwell A. Sibley

This is nothing less than a compilation of virtually every tube type manufactured in this country from 1920 to the present. Included are not only the receiving tubes that most of us antique-broadcast-set buffs are familiar with, but also special-purpose, transmitting, military, and unique types produced by individual manufacturers.

As the author points out in his Fore-

word, this is not a tube manual. You won't find basing diagrams or extended documentation of operating parameters. You also won't find many pretty pictures. What you will find is a short "bio" on each tube (ranging from a few lines to a few paragraphs) that provides information on the main application(s) and key operating characteristics.

With this book on your shelf, you'll never have to wonder whether the odd-ball tube you found in that flea-market grab bag is a rare and useful device to be kept and treasured—or something so peripheral that you'll want to fob it off on someone else at the next club event. And many other features of the book are worth the price of admission all by themselves.

One of them is the six-page "Tube User's Guide," which is crammed with street-smart information on using, testing, identifying, repairing, reactivating, and dating your vintage bottles. For example, did you ever realize that you could save time when testing a batch of tubes by setting up the filament pin connections and filament voltage first, and then letting the tube warm up while you make the other settings on the tester? Sibley points out that this is perfectly safe because no known tester applies plate voltage before the "test" button is pushed.

Another section I enjoyed browsing through is "Trends in Tube Design." Starting in the 1930s, when innovative designs began to replace "electric lamp" style tubes, this chapter takes the reader through the development of acorn, metal, Loktal, miniature, sub-miniature, lighthouse, button-stem octal, Nuvistor, Compactron, Novar, "9-T9," and high-reliability tubes. It's a truly invaluable perspective on the history of the vacuum tube.

Also of more than passing interest is the section on military tubes, which contains a very thorough "ID" list that includes U.S. and Canadian types. Many little-known tubes not found on most such lists have been researched and included by Sibley. Wondering if that tube with a "VT," "CG," or other

armed-forces prefix is something you can use to fix Grandma's cathedral? Look it up here and find out!

One feature I might argue with is the list of auction prices (mostly 1993–1995 vintage) at the conclusion of this book. For one thing, prices seem too ephemeral to be included in a volume of such permanent and lasting value. For another (to my mind), there is not a big enough collector base to stabilize the prices of radio items to the point where they should be valued in the manner of vintage artifacts such as cameras, glass ware, dolls, furniture, and the like.

Having folks around who, rightly or wrongly, consider price lists to be gospel tends to take the serendipity (and fun) out of collecting. To quote from the author's Foreword: "As with all auction 'actuals,' these are snapshots of single transactions and should be used with caution."

Tube Lore is a highly recommended addition to any radio collector's library. It is a 1996 self-published, 8-1/2" × 11-inch, softbound, 186-page book. You can get it for \$19.95 postpaid in North America, and for \$24.95 elsewhere. Contact Ludwell Sibley, 44 East Main Street, Flemington, NJ 08822.

THE AWA REVIEW: Volume 10, Edited by William B. Fizette, K3ZJW

Beginning with *Volume 1* in 1986, the Antique Wireless Association has sought and published authoritative papers on the history of wireless communications. Eleven years later, *Volume 10* continues this tradition by presenting six papers by experts in their respective subjects.

"Atwater Kent—Master of Marketing," by noted AK authority Ralph Williams, looks at Atwater Kent in his role as marketer and promoter of his products. "The Race for Radiotelephone: 1900–1920," by radio researcher/professor Mike Adams, discusses the five key individuals responsible for

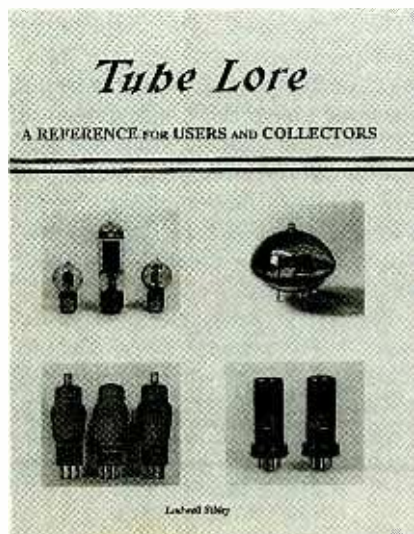

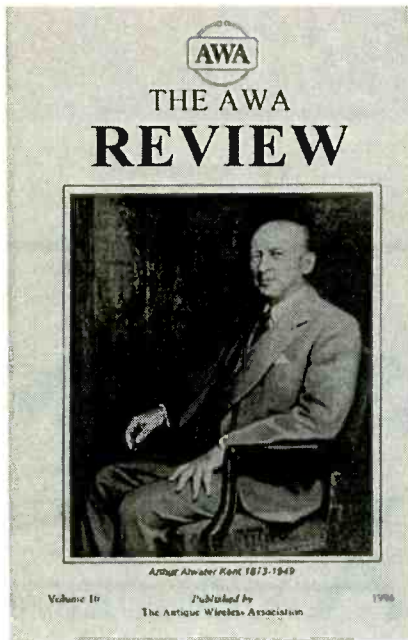

the development of radiotelephone technology. Christopher Bacon's "Commemorating the 75th Anniversary of Radio Central" recounts the history of RCA's huge radio-transmission facility at Rocky Point, New York.

"Defiance in the West—The Heintz and Kaufman Story," by tube experts Hank Olson and Al Jones, tells the story of a well-known tube manufacturer's legal battle with David Sarnoff and The Radio Trust. "The Collins Radio Company—Ingredients of Success," by F. Parker Heinemann, describes the formation and early years of the Collins Radio Company and includes some superb photos of early Collins transmitters. Floyd Paul's "Gilfillan Bros. Inc., Early Records" covers the early years of The Gilfillan Radio Company and includes photos of some desirable collectibles.

Like all of its predecessors in this series, *Volume 10* is authoritatively written and tightly edited. It was published in 1996 by the Antique Wireless Association. The softbound book measures 6 × 9 inches, is 261-pages long, and contains approximately 190 illustrations. You can get it in the U.S. for \$20 postpaid (write for foreign pricing). Contact Dex Deeley, Antique Wireless Association, 8 Briar Circle, Rochester, NY 14618.

For those who would like to start a collection of *AWA Reviews*, back issues are available going back at least to *Volume 6*. For information write to

The American Wireless Association, 2 Walnut Place, Apalachin, NY 13732.

RADIO DIAGRAM SOURCEBOOK

by Richard Gray

This book grew out of author Gray's frustration in locating reliable sources of service information and in identifying unmarked sets. He spent many hours in libraries searching through old advertisements and service manuals to identify the major information sources and pinpoint the strengths and weaknesses of each one. The results of that research, originally published as a

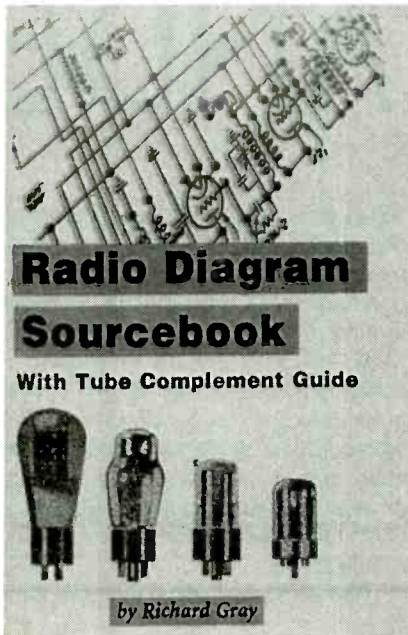

series of articles in the *Gazette* of the Southern California Antique Radio Society, form the basis for Part 1 of this book.

Titled "Early Service Information," the 28-page section is a useful review of vintage-radio documentation, including the Rider, Gernsback, Beitman, and Sams collections, as well as original manufacturer's service literature. The section concludes with some very helpful suggestions on how to identify a radio chassis when the manufacturer and/or model number is not known.

Gray's best source for identifying "mystery radios" was the very rare *Sylvania Tube Complement Book* (1944). The fact that it was far too big to reprint in a club newsletter, even in sections, led Gray to publish his book. The *Sylvania* book appears, in its entirety, as Part 2 of the *Radio Diagram*

Sourcebook. This excellent reference covers 10,000 pre-WWII radios, giving the make, model, tube complement, dial-lamp number, and IF frequency for each. It also contains alignment, tube-testing, and tube-substitution information; a trade-name-to-manufacturer cross reference; and a dial-lamp characteristic chart.

This "one-stop" source of identification and service information should be a welcome companion in your workshop! Published by Sonoran Publishing, LLC. in 1996, this softbound book measures 6 × 9 inches, and is 270-pages long. Its suggested retail price is \$18.95; it's available from most antique-radio sources.

CRYSTAL RADIO: History, Fundamentals and Design

By P.A. Kinzie

This latest addition to the books published by the Xtal Set Society neatly bridges a gap in the literature of the crystal set. Though in vogue for only a short time, the crystal set was, for many, the key that opened the door to a whole world of point-to-point and broadcast communications. *Crystal Radio* provides the reader with concise but comprehensive information about the development of crystal radios, and also provides what he or she needs to know to make them work.

In the book's three major sections,

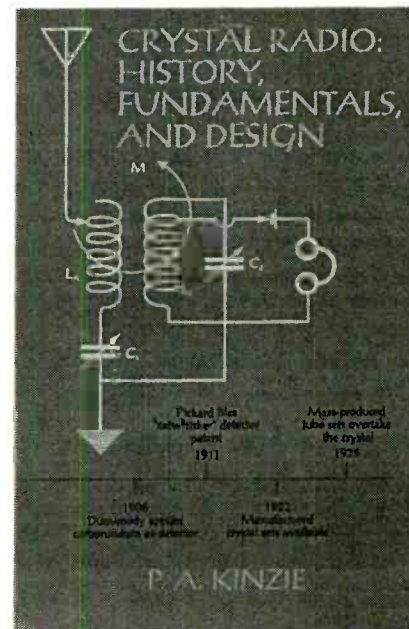

continued on page 70 65

DX LISTENING

Farewell, ANDEX

BY DON JENSEN

For 22 years, Andes DXers International was the listeners' club sponsored by HCJB, the Voice of the Andes shortwave station in Quito, Ecuador. Some months ago, its several-thousand members, worldwide, learned that this era was ending.

ANDEX, as the club's name was usually abbreviated, was operated as the off-the-air counterpart to the long running "DX Partyline" broadcast aired by this popular and easy-to-tune South American religious SW station. Under a series of managing editors, from the now-retired Clayton Howard to Ken MacHarg, its publication, *Andex International*, went out regularly, gratis, to thousands of club members all around the world.

But, announced MacHarg, "Times change, and the interest in the publication has dropped through the years. Reading material has changed and is much more available than it was in the past. So we put ANDEX to rest."

Nonetheless, ANDEX and its SWL's newsletter had a good run! "Before I ever came to Ecuador to live and work, ANDEX was part of my window on South America," MacHarg wrote in the bulletin's final issue. "In fact, I have fond memories of reading ANDEX from issue number one.... And I'm proud to say that I have a complete collection of every issue ever published." It was in the ANDEX newsletter that many shortwave listeners learned about the people and culture of Ecuador, unique customs such as the "old men" (stuffed dummies set on fire on New Year's Eve to mark the arrival of the new year), and the Andean tradition of raising guinea pigs, not as pets, but for food!

The bulletin contained capsule profiles about shortwave stations in Ecuador and elsewhere in South America—other broadcasters that

CREDITS — Jerry Berg, MA. Peter Card, RI. Peter Costello, NJ. Don Dacus, AR. William Flynn, OR. Harold Levison, PA. Mark Mohrmann, NY. Bob Pierce, MA. Dan Ziolkowski, NY. North American SW Association, 45 Wildflower Road, Levittown, PA 19057. World DX Club, c/o Richard D'Angelo, 2216 Burkey Drive, Wyomissing, PA 19610.



Here's the longtime logo of HCJB's Andes DXers International newsletter.

SWLs could hear, or hope to log someday. There were technical tips on signal propagation, building antennas, and how to use receivers. ANDEX members around the world were profiled, as were, frequently, HCJB on-the-air personalities, giving faces and backgrounds to some of the station's familiar voices. Once, years ago, *Andex International* even published my photo and an interview recorded when I visited the Quito broadcast facilities during a Latin American trip.

This slim publication featured illustrations of members' favorite QSL cards from stations around the world. And there were "soft sell" inspirational messages tucked in the bulletin as well; for that, after all, is HCJB's mission in the world.

"Familiar names crop up," said MacHarg, nostalgically paging through more than two decades of back issues, "names of people on and off the air through the years...Clayton and Helen Howard, Ruth Stanley, Bob Beukema, Dee Baklenko, Brent Allred, John Beck and more...at the Voice of the Andes."

Its last managing editor saluted, too, the member-readers of *Andex International* who sent in to the station "loads of correspondence." ANDEX and its news bulletin now are part of the past, but HCJB, the popular Voice of the Andes, goes on. And its non-broadcasting outreach to regular listeners is not over.

"Even as the decision to close

ANDEX was made," said Rich McVicar, a former director of HCJB's listener club and now programmer and frequency manager for the station, "discussion began on how to bring the club back in the future on the Internet. That will depend on available personnel."

For now, though, shortwave listeners who also have access to e-mail can get the *Andean Herald*, which is sent out twice-weekly by computer from HCJB's English Language Service. It contains information on upcoming programs—data that's more detailed and timely than that in the station's regular program schedule. There's no charge for subscribing to this electronic newsletter. You can post your request to english@hcjb.org.ec.

SECRET RADIO VOICES

One of the more interesting aspects of shortwave listening has always been the clandestine broadcasters that populate the airwaves. Wherever and whenever there is some politically "hot" spot in the world, you will usually find one or more of these illicit radio stations. Whatever their locations—often secret—or languages broadcast, they usually represent the "outs" trying to counter the authorized programming of the "ins." Often they are the voices of exiled elements, fomenting trouble, or trying to, for the governments they oppose.

Mathias Kropf, a German listener and expert on listening to these clan-

5 BOOKS FOR ONLY \$4.95

WHEN YOU JOIN THE

Electronics Book Club®

VALUES TO \$182.80

The leading source of information for electronics hobbyists for over 30 years!



0350787-XX \$44.95
Counts as 2/Hardcover

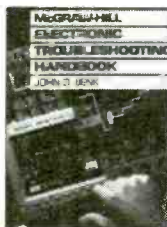

0376511-XX \$39.50
Counts as 2/Hardcover



024247X \$49.00

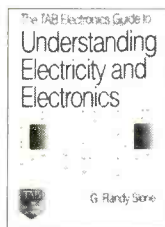

0582157 \$26.95
Hardcover

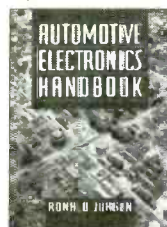

C331896-XX \$89.50
Counts as 2



1570519 \$17.95



0156786-XX \$24.95
Counts as 2



036432X \$29.95
Hardcover

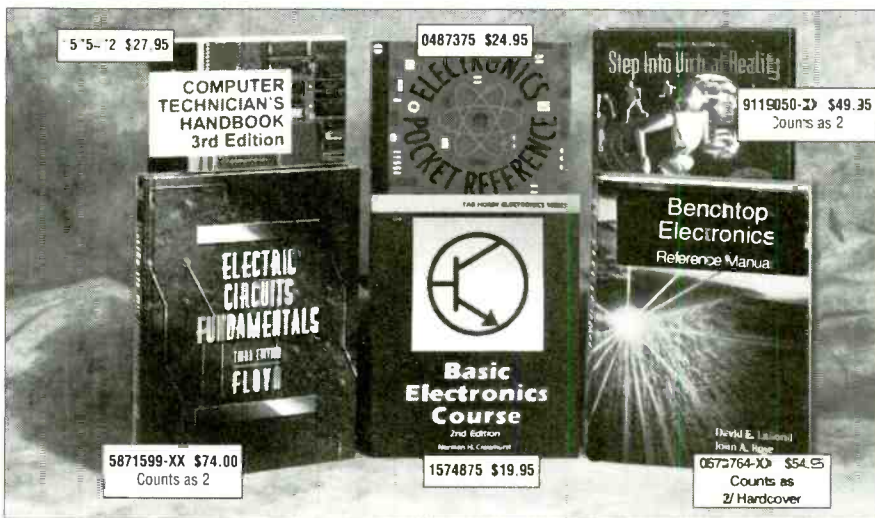

5-5-72 \$27.95

COMPUTER
TECHNICIAN'S
HANDBOOK
3rd Edition

0487375 \$24.95



9119050-2D \$49.35
Counts as 2



Benchtop
Electronics
Reference Manual

5871599-XX \$74.00
Counts as 2

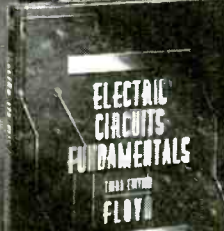

Basic
Electronics
Course

1574875 \$19.95

0672764-XX \$54.55
Counts as 2/Hardcover



5872625-XX \$30.00
Counts as 2/Hardcover



0053146 \$24.95



9122264-XX \$39.95
Counts as 2



0052387 \$28.95
Hardcover

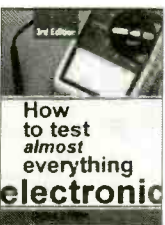

0304068 \$15.95

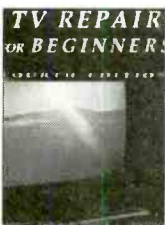

073092X \$19.95

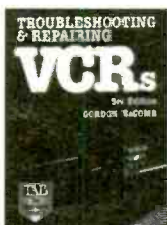

1550166-XX \$34.95
Counts as 2

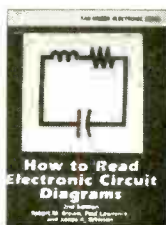

1554637 \$16.95

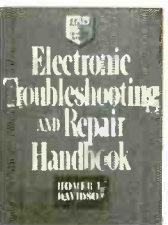

015676-XX \$69.00
Counts as 2/Hardcover



0717753 \$19.95



1577564 \$22.95

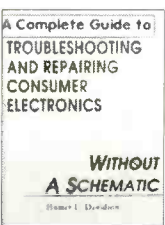

0156492 \$34.95
Hardcover

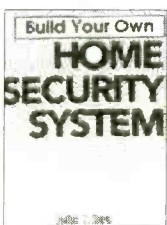

0303932 \$17.95



0305285 \$39.95

As a member of the ELECTRONICS BOOK CLUB®...you'll enjoy receiving Club bulletins every 3-4 weeks containing exciting offers on the latest books in the field at savings of up to 50% off the regular publishers' prices. If you want the Main selection, do nothing and it will be shipped automatically. If you want another book, or no book at all, simply return the reply form to us by the date specified. You'll have at least 10 days to decide. If you ever receive a book you don't want due to late delivery of the bulletin, you can return it at our expense. Your only obligation is to purchase 3 more books during the next 12 months, after which you may cancel your membership at any time. And you'll be eligible for FREE BOOKS through our Bonus Book Program.

A shipping/handling charge and sales tax will be added to all orders. All books are softcover unless otherwise noted. If you select a book that counts as 2 choices, write the book number in one box and XX in the next. (Publishers' Prices Shown) ©1996 EBC

PE297

If card is missing, write to: Electronics Book Club®, A Division of the McGraw-Hill Companies, P.O. Box 549, Blacklick, OH 43004-9918

destine SW stations, regularly writes about them in *Contact*, the monthly bulletin of the World DX Club in England. Clandestine stations come and go, as the winds of domestic and international politics shift around the world. But some stay on the air for surprisingly long periods of time; in some rare instances, for decades!

Currently, says Kropf, the average number of years of service by active clandestine stations is 8.4 years. For comparison, the figure was 8.1 years in 1995, and 5.9 years in 1991.

Let's now take a look at some of the oldest shortwave clandestine voices that are still found on the air today (their names are shown in English, but are actually translated from their native tongues):

Voice of National Salvation, a North Korean clandestine whose programs are aimed at South Korea, began life in 1970 as the Voice of the Revolutionary Party for Reunification. Look for it broadcasting in Korean around 4,120 kHz at about sunrise at your location.

Radio Echo of Hope is South Korea's answer to the above, directing its programming to listeners north of the 38th Parallel. It has been on the air since 1973, and currently is said to be operating on 3,985 kHz about 1100 UTC.

Voice of the Resistance of the Black Cockerel is a clandestine station that has aired anti-government broadcasts in Angola in southern Africa since 1979.

Voice of Iranian Kurdistan and Voice of Iraqi Kurdistan are the twin clandestine voices of the opposition to the established regimes of Iran and Iraq as the Kurdish minority struggles for its own political identity. They have been on shortwave since 1980. The former has been reported as operating on variable frequencies around 4,000 and 7,300 kHz at 1400 UTC; the latter on approximately 4,075 kHz at 0500 UTC.

BBC QSL'S

The British Broadcasting Corp., as many SWLs know, responds to listeners' reports of reception with acknowledgments that do not include as extensive details as many DX fans would wish. It is disappointing to QSL collectors that Auntie Beeb in London will not note on those acknowledgment cards the location of the particular relay station, wherever it is in the world, airing a particular transmission. For those

SWLs trying to log stations in as many different countries as possible, it is important to have the transmitter site, be it Antigua or Singapore, Seychelles or Lesotho, noted on the QSL.

You can come out ahead, notes Dan Smith, Daventry, England, in a recent issue of the World DX Club bulletin, by sending your BBC reception report directly to the overseas relay station. Here are some of them:

BBC East Mediterranean Relay Station (P.O. Box 219, Limassol, Cyprus) replies directly with a data specific QSL card.

BBC Far Eastern Relay Station (P.O. Box 434, Singapore) does the same.

BBC, via Caribbean Relay Co. Ltd., (P.O. Box 1203, St. John's, Antigua and Barbuda) often responds to reception reports by letter.

BBC Atlantic Relay Station (English Bay, Ascension Island) verifies by letter.

BBC Indian Ocean Relay Station (P.O. Box 448, Victoria, Seychelles) also responds by letter to reports.

BBC Lesotho Relay Station, Senior Engineer (c/o British High Commission, P.O. Box 521, Maseru, Lesotho) has replied to reports with a detailed letter.

DOWN THE DIAL

Looking for some new loggings? Try these.

ALGERIA—17,448 kHz. Radio TV Algerienne has French-language programs around 1800 UTC, but there is interference from WYFR.

BELGIUM—9,925 kHz. Radio Vlaanderen airs English news, a DXers program and press review, beginning at 2330 UTC.

CHILE—6,090 kHz. Radio Esperanza has been heard around 0745 UTC with a recorded religious program in English. Later, Spanish programming resumes, with station identification and religious music.

GUYANA—3,290 kHz. Guyana Broadcasting Corp. is noted around 0330 UTC playing pop music with English lyrics. And, during the early morning hours around 0830 UTC, the station again was heard with instrumentals and Hindi music.

HUNGARY—11,870 kHz. Radio Budapest is noted beginning at 0100 UTC with English news and identification.

KUWAIT—11,990 kHz. Radio Kuwait's English transmission at 1930 UTC apparently includes a relay of the station's local FM outlet, since it identifies

as "Super Station 99.7, Radio Kuwait." It switches to Arabic programming at 2100 UTC.

LESOTHO—3,255 kHz. BBC's Lesotho relay station is heard shortly before 0500 UTC with the program, "Network Africa," with identification on the hour. This transmission is paralleled on 9,600 kHz as aired by the BBC Atlantic relay on Ascension Island. ■

ANTIQUÉ RADIO

(continued from page 65)

Kinzie covers the historical development of the crystal detector, the fundamentals of receiver design, and of crystal-set design. A fourth section deals with the crystal material itself. Each section includes a bibliography of related current and historical books and articles for further reference. If you enjoy working with crystal sets, you'll find the collected reference material presented in this volume to be invaluable.

Published by the Xtal Set Society (P.O. Box 3026, St. Louis, MO 63130), this 5-1/4" × 8-1/4"-inch, softbound, 119-page book is available for \$10.95 plus \$2.50 shipping and handling.

Another recent publication of the Xtal Set Society is also worthy of note: *Crystal Sets: Volume V* (85 pages, 5-1/4" × 8-1/4" inches, softcover). The book includes the six issues of the society's newsletter ending November 1995. It costs \$9.95 plus \$2.50 shipping and handling if ordered alone. However, there is no additional shipping and handling charge if it is ordered along with *Crystal Radio: History, Fundamentals and Design*.

See you again next month, when, maybe, at long last we'll get back to that Star Roamer. Until then, I'd sure like to hear from you! Please feel free to send your comments and questions to *Antique Radio*, **Popular Electronics**, 500 Bi-County Blvd., Farmingdale, NY 11735. ■



"How about making a switch to turn off the light so I can get some sleep?"

SCANNER SCENE

When Disaster Strikes

BY MARC SAXON

Here's a clever piece of hardware. It's called the *Xplorer Test Receiver*, and it is another one of those intriguing products from *Optoelectronics*. The *Xplorer* is a handheld near-field surveillance (and, if you will, test) receiver that automatically sweeps through the range of 30 to 2000 MHz (2 GHz) in less than one second.

As it sweeps, the *Xplorer* will lock in on any active frequency being transmitted from its local area, reproducing the FM audio for monitoring on its internal speaker. There are more than a dozen operating modes.

A two-line backlit LCD readout displays the transmitted signal on the top line. The second line can be switched to show decoding of CTCSS, DCS, and DTMF tones, LTR trunking, relative trunking, FM deviation, and even latitude and longitude.

The receiver's operation permits manual skip, frequency lock-out, auto or manual hold, and the recording of 500 frequencies. The frequency-recorder memory register might include such information as frequency, time, date, latitude, and longitude.

The *Xplorer* has a serial data interface that provides for TTL and RS-232C formats, and an NMEA-0183 interface for providing Global Positioning System (GPS) information, including altitude. A headphone jack is provided, as well as an auxiliary jack that can be used to control a tape recorder. The receiver's internal rechargeable battery pack takes a full charge in less than an hour, using the included AC charger. An LED on the *Xplorer's* panel advises when it's time for a recharge.

Operation is really quite simple (the *Xplorer* has only five buttons on its panel.) For all that it can do, that's minimal. It has unlimited potential for a wide variety of hobby, law-enforcement, private-security, and test purposes. Its versatility allows the *Xplorer* to cross over into many different applications. Take it to any location where there are some communications, turn it on, and you can listen in while also getting a

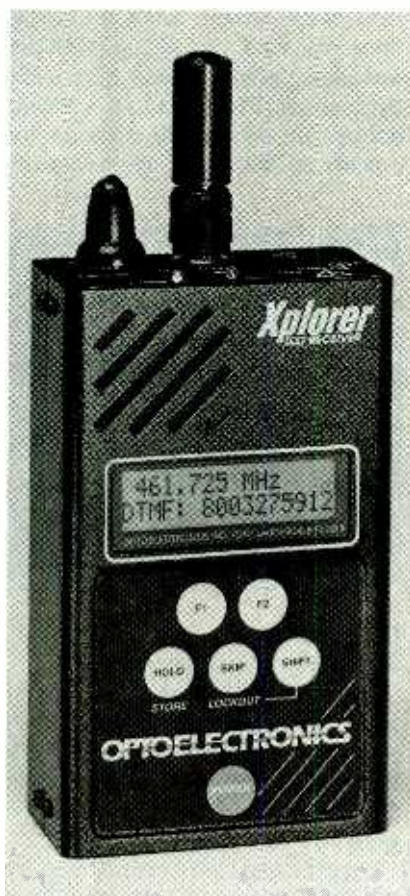

Optoelectronics' Xplorer nearfield surveillance receiver has hobby, law-enforcement, security, and test applications.

listing of the actual frequencies that are being used. Think of the possibilities!

The *Xplorer* costs approximately \$900. For more information, contact Optoelectronics, 5821 N.E. 14th Avenue, Fort Lauderdale, FL 33334. You can call 954-771-2050, or send e-mail to opto@igc.net.

WHEN THINGS GO AWRY

The Federal Emergency Management Agency (FEMA) is the organization that participates in the aftermath of all large-scale disasters in the United States. That category includes those wrought by nature (earthquakes, floods, tornadoes, hurricanes), ecological threats (such as accidents at nuclear plants), and acts of terrorism or enemy attack.

Although FEMA has an extensive HF network, the agency also makes heavy use of frequencies that can be tuned in on scanners. While FEMA stations would, of course, be expected to be most active during actual disasters, they can often be monitored at other times, both during practice drills and with routine traffic.

That being the case, you'll want to know FEMA's reported national simplex and repeater output frequencies. The primary emergency repeater frequency is 138.225 MHz; the primary emergency simplex frequency is 141.725 MHz. The National Civil Radio System simplex channels are 164.8625 and 165.6625 MHz. FEMA portable repeaters operate on 142.975, 143.35, 143.375, 143.425, 143.975, 168.40, 168.075, 168.10, and 168.70 MHz. The National Warning System uses 167.925, 167.975, and 169.875 MHz. The Urban Search and Rescue Team Simplex frequencies are 408.5125, 409.4875, 410.4875, 410.5125, 413.2125, 416.0375, 416.8125, 416.9375, 417.5875, and 417.6625 MHz. The Federal Executive Board Emergency Net is on 170.20 MHz. Coordination with USAF (Wideband FM mode) is on 266.05, 273.8, 305.55, 322.75, 336.8, 382.35, 397.05, and 399.75 MHz. Other frequencies include 138.575, 139.10, 139.225, 139.45, 139.95, 140.025, 140.90, 141.95, 142.025, 142.40, 142.925, 142.95, 143.05, 143.25, 143.60, 143.625, 148.575, 163.10, 169.25, 409.125, 418.05, 418.075, and 418.575 MHz.

Depending on how many spare memory slots you have available, it might be worth programming all, or at least some, of those frequencies into your scanner. If you can't program any right now, at least keep this list handy. In the event that FEMA ever needs to swing into action in your area, these channels will be the ones to monitor.

ANOTHER NEW RADIO SERVICE

The Low Power Radio Service 71

(LPRS) was created by the FCC in the 216- to 217-MHz band. It is considered a Personal Radio Service for short-range use, authorized on a secondary non-interference basis for low-power users. The FCC suggested that it is also suited to law-enforcement tracking systems, auditory assistance devices for persons with hearing disabilities, health-care assistance for persons with illnesses, and point-to-point network control communications for Automated Maritime Telecommunications Systems (ATMs).

Transmitters will need to be FCC-type accepted before they can be marketed, and must meet the agency's technical standards. Under the LPRS technical standards, a transmitter must be produced in a manufacturer's choice of any one of three possible bandwidths (5, 25, or 50 kHz), and is limited to 100 milliwatts of effective radiated power (ERP).

Individuals will not be required to get licenses for LPRS operation. The FCC feels that using any agency-type accepted transmitter should be sufficient to meet the needs of the service and the agency.

Now you know where to monitor for the next generation of police bumper-beepers.

CLARIFICATION, PLEASE

Bill Intelisano, of Altamonte Springs, Florida, is new at scanning. He recently acquired a RadioShack PRO-34 but has become confused about terms used for modes such as *WFM*, *NFM*, *SSB*, *Digital*, *AM*, and *FM*.

In a nutshell, aircraft communications are in AM mode, the same as your local medium-wave broadcasters. Virtually all other two-way VHF/UHF scanner communications are FM (more specifically, NFM, which means narrow FM.) WFM means wide FM, which is the mode used by FM and TV broadcasters, plus some specialized UHF stations. SSB stands for Single Sideband, which is used primarily on HF (shortwave). Digital modes are voice or non-voice systems that cannot be monitored on present-era scanners.

That's a wrap. We're looking forward to having you back with us next time. Please share with us your frequency lists, questions, and ideas. Write to *Scanner Scene*, **Popular Electronics**, 500 Bi-County Blvd., 72 Farmingdale, NY 11735. ■

NEW PRODUCTS

(continued from page 25)

data-logging, and interrupt routines.

The PIC-MDS development board includes both PIC16C71 and PIC16C84 microcontrollers, a 16-key matrix keypad, a 2-line by 16-character LCD, a ZIF socket, buffered LED port state indicators, an RS-232 serial port, two analog input potentiometers, a 256-byte serial EEPROM, an oscillator socket for crystals or ceramic resonators, on-board +5-volt and variable

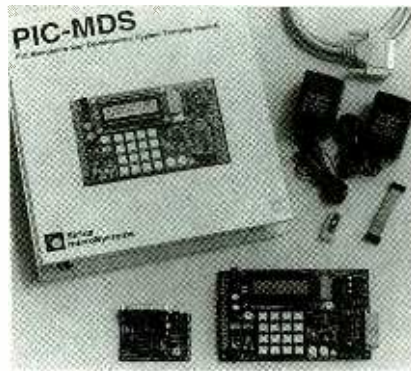

DC power supply, and screw terminal and header connections to all pins.

Microcontroller applications are created and assembled on an IBM PC using the PM Macro Assembler. The training text fully explains each example and its operation. Users can then write their own applications.

Applications are programmed into the PIC16C71 or PIC16C84 using the included EPIC programmer, which is capable of programming all mid-range 18-pin PICs. Optional 28- and 40-pin socket adapters are available.

The PIC-MDS development system costs \$299. Hobbyist and student versions are also available. For more information, contact Sirius microSystems at 172 Harvard Road, Waterloo, Ontario N2J 3V3, Canada; Tel. 519-886-4462; Fax: 519-886-4253; Web: <http://www.siriusmicro.com>.

CIRCLE 86 ON FREE INFORMATION CARD

1.3-GHz HANDHELD FREQUENCY COUNTER

Global Specialties' Model 5003 is a compact, battery-powered 1.3-GHz frequency counter that offers handheld convenience combined with the features and performance normally found only with higher priced benchtop mod-

els. Its sensitivity is high across the whole frequency range, with no dead spots. A low-pass filter can be selected to reduce noise and ensure stable readings at lower frequencies.

The Model 5003 features a 0.45-inch high, 8-digit LCD readout with a full range of indicators to depict measurement function, time, overflow, trigger activity, hold, input A, input B, low battery, and all measurement units. Only five large buttons are needed to select all functions and ranges. A special hold function allows readings to be frozen on the display for measuring non-continuous signals or recording results later. A unique "push to measure" feature gives a virtually instantaneous reading followed by an automatic power-down after 15 seconds.

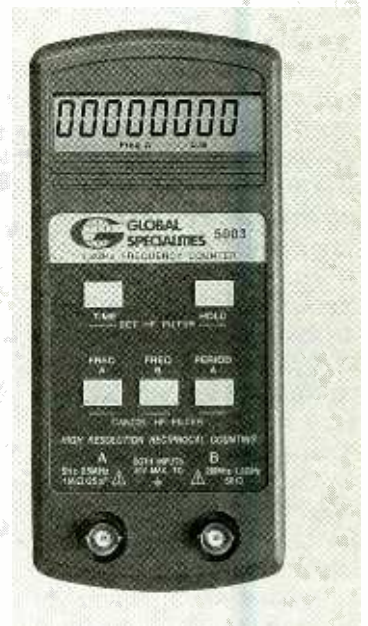

The Model 5003 hand-held frequency counter costs \$250. For further information, contact Global Specialties, 70 Fulton Terrace, New Haven, CT 06512; Tel. 203-466-6103; Fax: 203-468-0060.

CIRCLE 87 ON FREE INFORMATION CARD ■



"Sam, haven't you learned how to exit the Internet yet?"

Circuit Circus

More Electronic Sensors

BY CHARLES D. RAKES

Let's see now, last month we started on a sensor odyssey and looked at several light- and touch-activated sensor circuits. With sensors abound, we're going to continue on course and look over a few not-so-common sensor circuits.

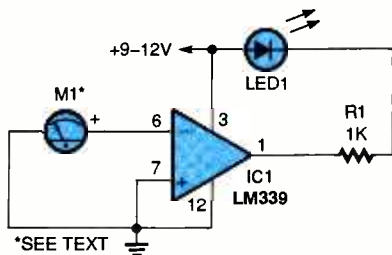

Fig. 1. This vibration detector uses an analog meter as its sensor.

PARTS LIST FOR THE VIBRATION DETECTOR (Fig. 1)

IC1—LM339 comparator, integrated circuit
LED1—Light-emitting diode, any color
R1—1000-ohm, 1/4-watt, 5% resistor
M1—Analog meter, 0-50 μ A, 0-1 mA (see text)
Power source, wire, solder, etc.

VIBRATION DETECTOR

Our first entry, see Fig. 1, uses a basic electrical instrument as a sensing device. The instrument, which has been around for ages, is the D'Arsonval analog meter. For all you digital circuiters, that's the meter with a needle instead of glowing digits. The meter used in my test circuit was a new-model Simpson 260 VOM.

It does look a little unusual having a meter connected to the input circuit of a comparator and not to its output. But we're not using the meter in this circuit to display an output. You see, the needle in an analog meter happens to be very sensitive to external movement and vibration. For this reason, we'll use the meter to generate an output.

An analog meter is built like a miniature generator. A multi-turn armature, which connects to the meter's needle, is positioned between the poles of a powerful permanent magnet. Any need-

le movement causes the armature to move in this strong magnetic field, which produces a minute voltage across the armature's winding.

In this circuit, any movement or vibration will cause the armature to produce a small electrical signal. An LM339 comparator (IC1) amplifies the armature's signal, causing LED1 to flicker on and off as the needle moves back and forth. (Note that in all the circuits that use it, the LM339's unused pins should be tied to ground.)

Maximum sensitivity occurs when the meter's needle is in the same plane as the external moving force. Also the sensitivity may be maximized by adjusting the meter's mechanical zero scale up and away from the end peg.

The choice of meter also plays an important part in the circuit's sensitivity. The Simpson's 0- to 50-microampere range is by far more sensitive to weak movements or vibrations than the 0- to 1-milliamperere range.

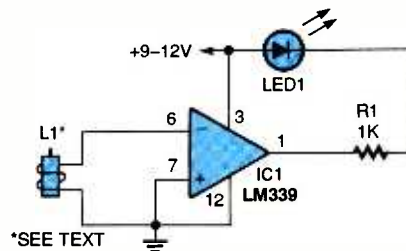

Fig. 2. A relay coil makes a great magnetic-field detector.

PARTS LIST FOR THE MAGNETIC-FIELD DETECTOR (Fig. 2)

IC1—LM339 comparator, integrated circuit
LED1—Light-emitting diode, any color
R1—1000-ohm, 1/4-watt, 5% resistor
L1—110-volt AC relay coil (see text)
Power source, wire, solder, etc.

MAGNETIC-FIELD DETECTOR

Our second sensor circuit, shown in Fig. 2, replaces the meter, as the sensing element, with a relay coil, L1. This arrangement is very sensitive to varying magnetic fields. Move a small per-

manent magnet past the relay coil and LED1 will respond.

The sensor's operation is similar to the previous circuit with the coil located in a fixed position and the magnet in motion. Just about any relay coil will work, but for maximum sensitivity select a coil with the most inductance that will also have the greatest resistance.

Placing a permanent magnet a few inches away from, but in line with, the coil's pole piece turns the circuit into a sensor that can detect a ferrous object passing between the magnet and coil. Any time the magnetic field changes, a small AC voltage is generated across the coil. The voltage causes LED1 to flicker on and off.

TILT SENSOR

Our next entry is an unusual tilt sensor with LED position indicators. Figure 3A shows the basic components used in the sensor. A metal ball sits on top of a metal plate that is mounted on an insulated stand. Four metal pins are located at each corner. The metal plate is connected to +12 volts, and the four insulated pins go to the sensor's input circuitry (we'll get to that in a moment).

When the ball is centered (in a non-tilt position), it does not come into contact with any of the pins. That means that no electrical connection is made between the ball and the pins. If the sensor tilts towards the north (as shown in the diagram) the ball will roll between pins A and B. That will complete an electrical circuit, placing +12 volts on both those pins. The table in Fig. 3B shows which pins will be contacted when the sensor tilts in each direction.

So what do you do with the information the sensor provides? It should be fed to the tilt-sensor decoder shown in Fig. 4. As you can see, pins A through D are connected to the inputs of several 4011 NAND gates (IC1-IC2). When both inputs of one of the NAND gates goes high, its output goes low lighting the LED connected to it.

In our previous example of a north tilt, both pins A and B will cause input

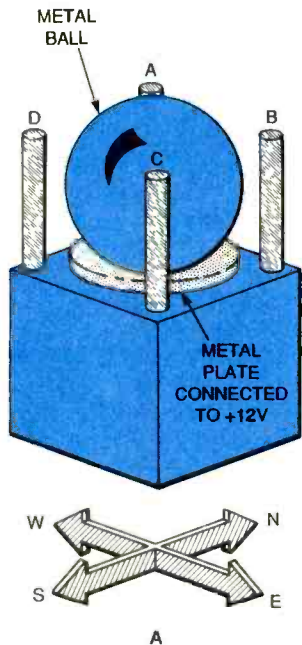

DIRECTION	BALL POSITION
N	A,B
S	C,D
E	B,C
W	A,D
NE	B
NW	A
SE	C
SW	D

Fig. 3. When the sensor in A tilts, a current is applied through the metal ball to one or two of the pins, indicating one of the directions shown in B.

PARTS AND MATERIALS LIST FOR THE TILT SENSOR (Fig. 3A)

- Metal ball (e.g. a ball bearing)
- Metal pins (4)
- Metal plate
- Insulated block
- Note:** Sizes of all components will depend on the overall size of the device.

pins 1 and 2 of IC1-a to go high. As a result, LED1, the "north" indicator, will light. All other gate inputs of IC1 and IC2 are pulled to ground with 47,000-ohm resistors. That leaves the remaining LEDs dark.

Note that each of the IC2 gates have both their input pins tied together and to one directional pin. That's to accommodate for tilting in directions between the four cardinal points. For example, if the sensor tilts to the northwest position, the ball only touches the A pin. That means that IC2-b's output

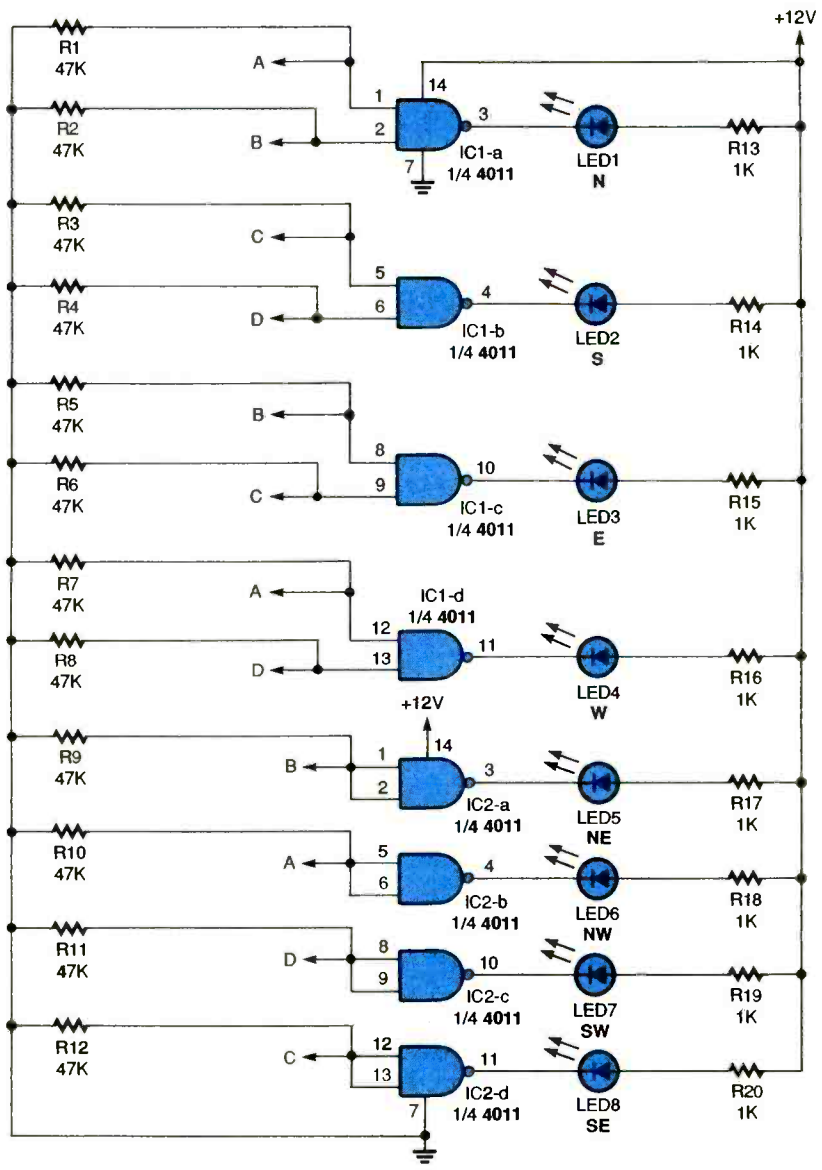

Fig. 4. This circuit decodes the information provided by the tilt sensor of Fig. 3, and provides a visual indication of direction with one of eight LEDs.

PARTS LIST FOR THE TILT-SENSOR DECODER (Fig. 4)

- IC1, IC2—4011 quad two-input NAND gate, integrated circuit
- LED1-LED8—Light-emitting diode, any color
- R1-R12—47,000-ohm, 1/4-watt, 5% resistor
- R13-R20—1000-ohm, 1/4-watt, 5% resistor
- Power source, IC sockets, wire, solder, etc.

will go low lighting LED6 (the "northwest" indicator). All other directions operate in a like manner.

WIND-DIRECTION SENSOR

Now let's take a look at another sensor-and-decoder-circuit combination (see Figs. 5 and 6). This one senses

wind direction and gives an output with last-position memory.

You'll need to build a wind vane like the one shown in Fig. 5. It should have a weighted front end and an air paddle in the rear. Attach a small, strong magnet to the front part of the wind-vane arm. Then, position eight reed magnetic switches in a circle around a piece of plastic pipe, and electrically connect them as shown.

Keep in mind that the drawing in Fig. 5 is not meant to serve as a blueprint for construction. Rather, it is offered as a general guide to use in building your own version. That's because the size or type of wind vane used is not critical. Only the placement of the sensors is important.

Note that the reed switches each

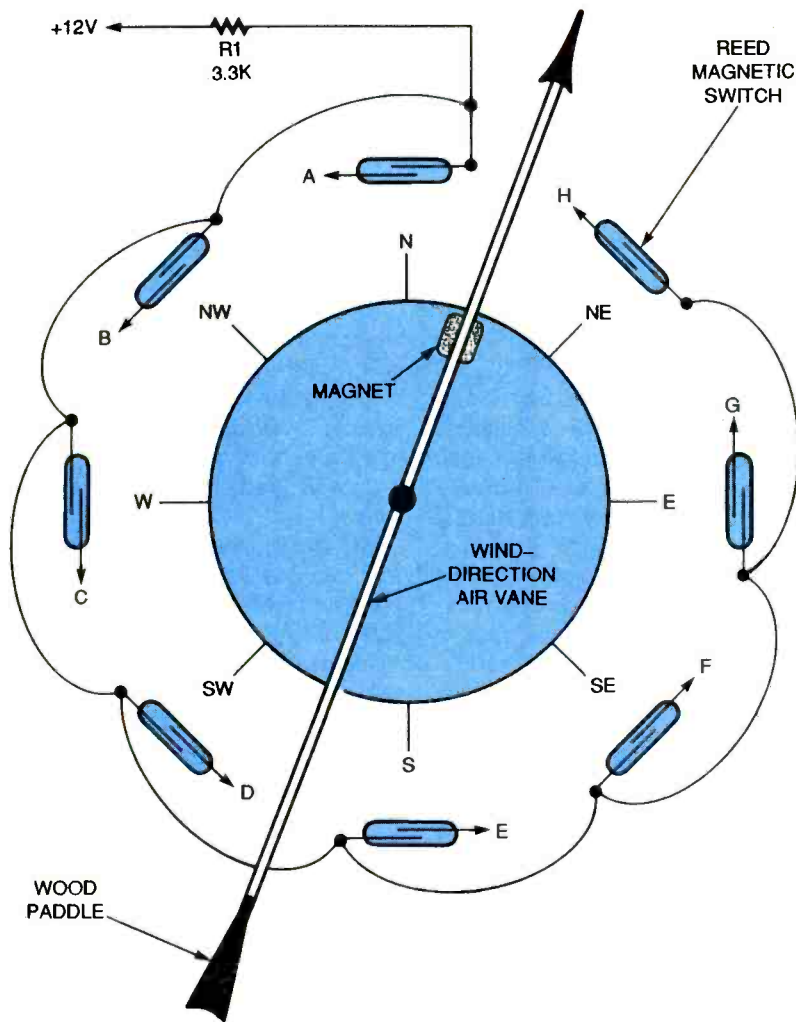

Fig. 5. The wind vane shown here will activate one of eight reed switches using a magnet on its arm.

PARTS AND MATERIALS LIST FOR THE WIND-DIRECTION SENSOR (Fig. 5)

- R1—1000-ohm, 1/4-watt, 5% resistor
- Reed magnetic switches (8)
- Magnet
- Plastic pipe
- Wood
- Power source, wire, solder, etc.

PARTS LIST FOR THE WIND-DIRECTION-SENSOR DECODER (Fig. 6)

- SCR1-SCR8—2N5061, ECG5401, or similar low-current silicon-controlled rectifier
- LED1-LED8—Light-emitting diode, any color
- R1-R8—1000-ohm, 1/4-watt, 5% resistor
- R9-R16—10,000-ohm, 1/4-watt, 5% resistor
- C1-C8—0.1- μ F, ceramic-disc capacitor
- S1—SPST switch
- Power source, wire, solder, etc.

electrically connect to points labeled A through H. Those points correspond to points A-H in the wind-direction decoder circuit shown in Fig. 6.

The decoder uses eight low-current 2N5061 SCRs and eight LEDs to latch and display the wind vane's position. If the wind vane is pointing due north, reed switch A is closed sending current into the gate of SCR1. That current turns the thyristor on, causing it to light LED1. If the wind shifts slightly to a position in between north and northwest or north and northeast, without activating any of the reed switches, LED1 will remain on indicating that the

last wind direction was north.

With SCR1 turned on, one end of capacitors C8 and C1 is pulled to ground. The other end of both capacitors is tied to the +12-volt buss through a resistor and LED; that means both capacitors are charged to near 12 volts. All other capacitors are not charged because both ends of each capacitor are returned to the +12-volt buss through a resistor and LED at each end. When the wind direction shifts to the northwest, the B reed switch turns

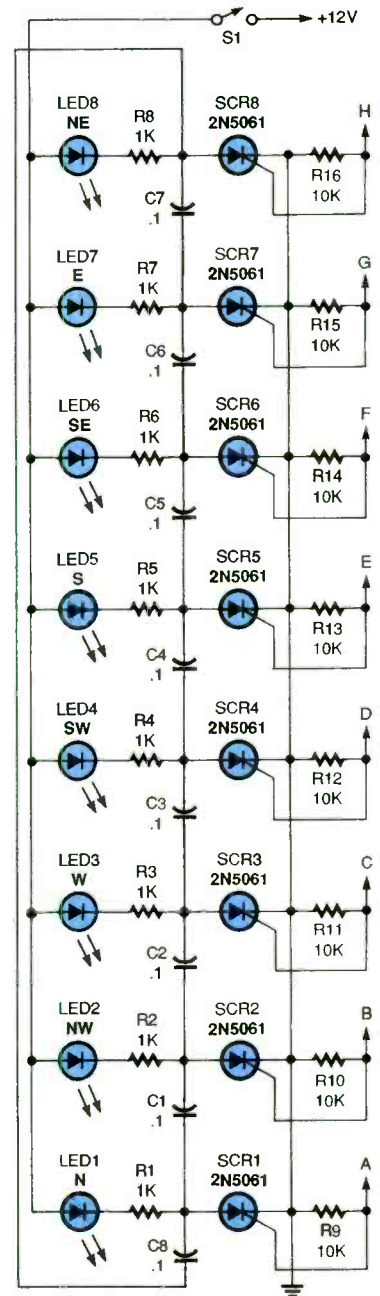

Fig. 6. This circuit decodes the wind vane from Fig. 5 and give a visual indication of which way the wind is blowing.

SCR2 on, thereby "taking" the positive end of C1, which is connected to its anode, to ground. This negative pulse turns SCR1 off as SCR2 turns on, lighting LED2 as a result.

REED-SWITCH REPLACEMENT

If you want to get fancy and do away with the eight reed switches used in Fig. 5, take a look at the reed-replacement circuit shown in Fig. 7. A Hall-effect integrated circuit (IC1) and a few components connected as shown replace

continued on page 78

Think Tank

Benchtop Stuffing

BY JOHN J. YACONO
TECHNICAL EDITOR
WINDOWS MAGAZINE

This month's circuits are all pieces of test equipment. As usual, the authors will be rewarded with a book from our library. If you'd like to participate, send in a schematic of a working circuit with a complete explanation of how it works to *Think Tank*, **Popular Electronics**, 500 Bi-County Blvd., Farmingdale, NY 11735. If you send in enough quality circuits to fill a column, you'll receive a free kit and individually packaged MCL1010 chip from 1967 (see my first *Think Tank*, April 1991 for data).

To continue our discussion on semiconductors, I'll answer the questions I posed last month. To make a P-type semiconductor, you combine a tetravalent substrate material (with four outer or "valence" electrons) and a dopant with three valence electrons. The dopant is a "trivalent" material. When it combines with the substrate it provides one less electron than the substrate material needs to reach the magic number of eight shared electrons. That leaves a hole in the outer shells of all the pairs formed by doping. It's as though the dopant was a hole donor and the substrate was a hole acceptor. The absence of the appropriate number of electrons gives the P-material a characteristic positive charge, thus the name "P-type."

If you pass a current through a P-type material, electrons do move, but they don't completely fill the holes. The number of holes in the material remains fairly constant. When electrons flow into the material, they jump from hole to hole. This makes it appear as though the holes are jumping from place to place in the opposite direction. For that reason the holes are called the "majority charge carrier," and are considered responsible for current flow.

Now, what happens when you take an electron-glutted N-type material and put it in physical contact with an electron-poor P-type material? Where the materials touch forms what's called a "PN junction," and as you might guess, some electrons flow across the

junction from the N material into the P material, while holes flow from the P material to the N material. But after a short while the electrons and holes stop flowing.

The electrons that have flowed into the P material form a barrier of negative charge that dissuades further electrons from crossing the junction. The holes that flow into the N material also form a barrier that prevents further holes from migrating. This situation forms a region of potential near the junction that's positive in the N material and negative in the P material. The actual potential across the region is called the barrier potential.

The simple PN junction is the heart of the simplest semiconductor. Can you determine which one? Next time, we'll discuss how the barrier potential affects the component's behavior and how it works overall. Now, let's check out some letters.

SWITCHABLE REGULATOR

By connecting three Zener diodes in series with a switch and commonly available parts, you can make a three-voltage regulated supply (see Fig. 1). You should use 15-volts DC as the power source.

With switch S1 in the 6-volt position, the current from the supply through resistor R1 biases Q1 with a 6-volt input signal, which is reproduced

at the circuit output. With the switch set to the 9-volt position, a 3-volt Zener (D2) is added to the circuit boosting the output another 3 volts. Placing the switch in the 12-volt position will bias the transistor at 12-volts by adding another 3-volt Zener. Capacitor C1 filters the circuit's output.

—Joseph Anie, Tema Ghana, West Africa

Real nice. The circuit is extendible, too. You can boost the input voltage, number of diodes, transistor current rating, and number of switch positions to increase the range or granularity of the output voltage. Equipped with a cigarette-lighter plug, the circuit would make a great voltage adapter to power CD-players and other such devices in the car.

RS-232 PROBE

Up until now, I have held back from submitting any ideas because I didn't feel that any of my simplistic and very dedicated (single-use) circuits would be of general use. Recently, though, after having pegged my DMM, I needed to test the active inputs and output of an online RS-232 cable on my computer. I found these two circuits (see Figs. 2A and 2B) to be extremely useful for this and several other tests, so I thought I'd pass them along to **Think Tank** readers.

Basically, the testers are window comparators, with the windows being ± 3 volts wide. (Window comparators are very useful instruments, at least, in my workshop; so I have several.) The LM339 was chosen because of its open-collector output. In Fig. 2A resistors R1, R4, and R5 set the voltage-reference levels. When testing a wire, if it is driven by an RS-232 output, the test circuit's input will be driven high or low. In either case, one or the other of the comparators' outputs will go low, turning on the LED.

The circuit in Fig. 2A is very susceptible to changes in the supply. The circuit in Fig. 2B corrects that by incorporating the forward voltage drop of a 1N4001 diode to the threshold volt-

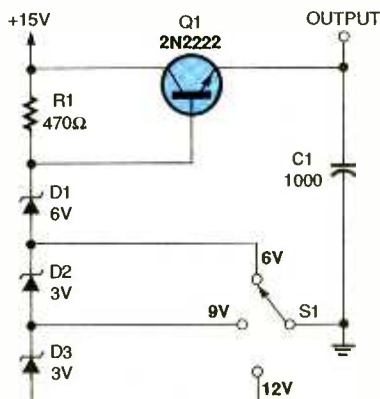

Fig. 1. This three-voltage regulated supply can be added to for more voltage ranges.

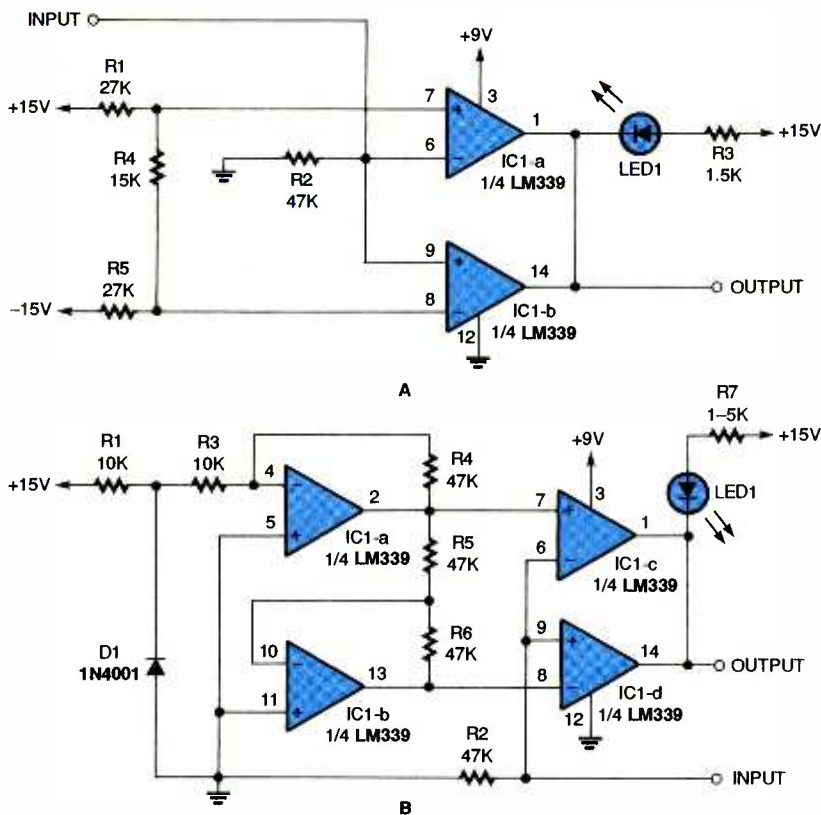

Fig. 2. These RS-232 probes work using a 3-volt window comparator.

ages at both of the op-amp's reference inputs.

The biggest advantage of this one over others I have is that it can be slipped into my shirt pocket for use on the road. I hope this is of some use to someone else.

—Michael E. Keller, Lancaster, PA

By adjusting the values of the threshold voltages, and connecting a buzzer to the output, you can use the circuit as an over-voltage alarm. Also, it's worth noting that a really simple RS232-tester can be made by placing a resistor and bi-directional LED in series. Add some probes and you will have a tester that can indicate the polarity of the signal, too.

LOGIC PROBE

The price of a logic probe knocked me out when I shopped around for one. So I put together some parts and pocketed the difference. The circuit (shown in Fig. 3) did just what other logic probes do. It uses a 4N35 optocoupler (IC1) and a C9013G transistor (Q1). A positive pulse at the base of Q1, turns on the transistor. The 10,000-ohm resistor (R2) limits the incoming pulse so as not to feed too much current to the base of Q1, pre-

venting the transistor from being damaged.

With the base of Q1 at a positive potential, electron current flows from the emitter to the collector junction. The incoming pulse also pulls pin 6 high, lighting up LED1 by allowing current to flow between pins 4 and 5. The 330-ohm resistor (R3) provides current-limiting for pin 6, while the R4 is the current limiter for pin 4.

When testing a digital circuit, if the LED lights up, that portion of the circuit is in a high state, and if the LED remains off, a low is present. The circuit

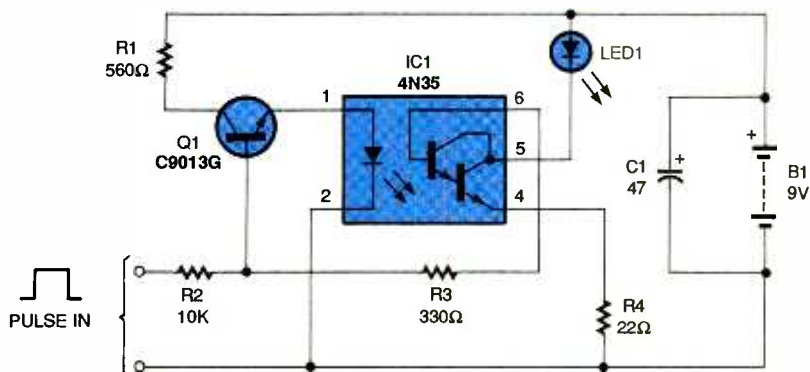

Fig. 3. Why buy a commercially available logic probe when you can build this simple one and save a lot of money?

can be placed inside a small enclosure if its connections are made as short as possible.

—Jose Ignatius A. Alea, Cebu, Philippines

A 555 monostable timer circuit would be a nice addition to stretch fast in-coming signals for detection. Switching the 555 circuit in and out of the signal path would permit the circuit to differentiate steady-state levels from pulses.

RF SIGNAL-STRENGTH CIRCUIT

I have enclosed information on a small project I completed last summer that I have found of much use in evaluating RF/IF filters for ham-radio projects. It is a detector based on the RSSI (received signal-strength indicator) output of a line of Motorola integrated circuits.

I used the MC3356 IC (See Fig. 4A for the schematic) but others that have the RSSI output can be used. My circuit uses only part of the IC's functions, namely the IF (logarithmic) amplifier and RSSI output circuit. A 9-volt battery is needed for operation. Components R2, C4, and C6 filter that supply. The other components surrounding the IC bias it, bypass high-frequency RF to ground, or couple the RF signals into the IC. A 40-dB attenuator is attached to the IC's input to handle large signals. (The RSSI voltage output will vary almost linearly with a 60-dB change in input power.) If vacuum-tube circuits are to be swept, then a 600-volt, 0.01- μ F capacitor should be used at the attenuator's input to isolate the higher DC potential they generate.

To use the circuit, an oscilloscope

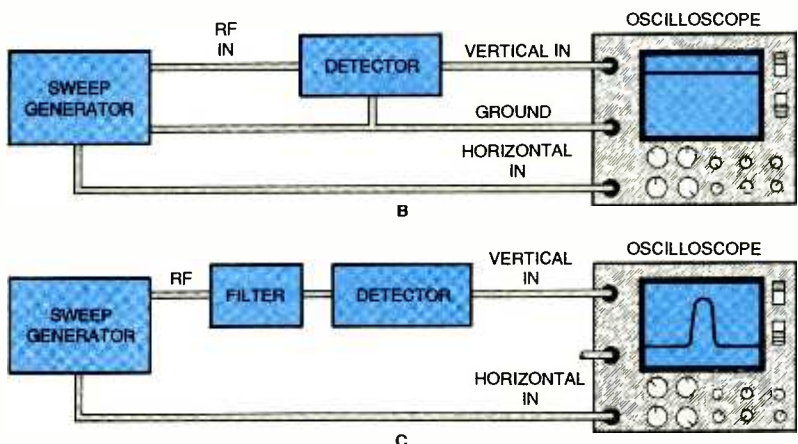
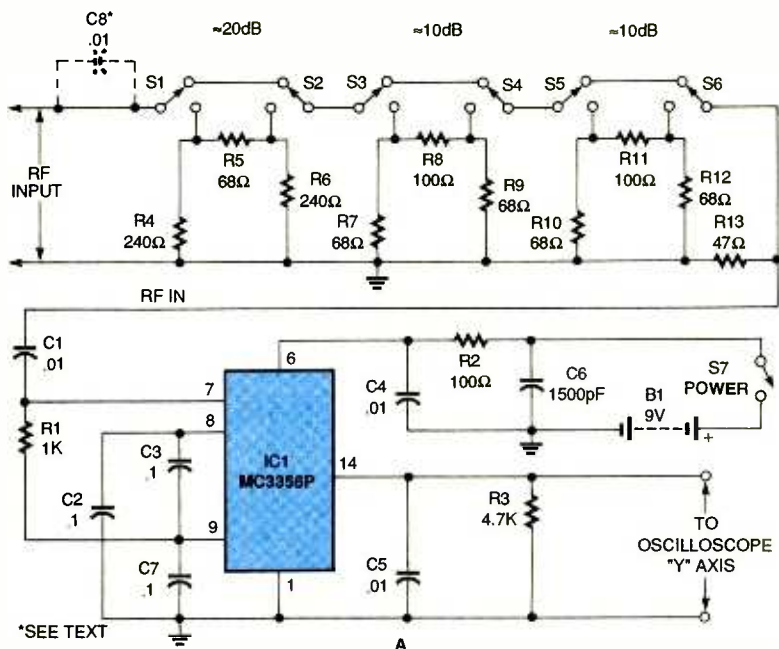

Fig. 4. Here's something not everyone has on their bench. It's an RF signal-strength circuit that works with an oscilloscope.

and a sweep generator are needed. The old sweep generators that were once used for radio/TV alignment will work if the sweep width needed isn't too small. Connect the circuit as shown in Fig. 4B, and adjust the signal level and attenuator until a flat line is seen across the top of the scope screen.

The next step is to insert the circuit to be adjusted or evaluated in between the sweeper output and the detector input (as shown in Fig. 4C). If the circuit has gain, you will have to switch on some attenuation using switches S1-S6. (Note that S1 and S2, S3 and S4, and S5 and S6 are paired up, and should be switched together. You can, of course, replace them with DPDT switches.) A pattern of frequency response for the circuit will be swept across the oscilloscope screen.

Changing any variable inductors or capacitors will allow you to adjust the frequency response as desired.

I have used this circuit to evaluate homemade crystal filters for insertion loss, and shape factor, as well as looking at the frequency response of RF pre-selector filters. As long as the filter to be swept is less than 1- to 2-MHz wide, and the center frequency is less than 20 MHz or so, the detector will work up to its full specification. Above 20 MHz, the frequency response starts to drop off, and the 60-dB range starts to shrink.

—Douglas Ripka, Rebersburg, PA
Very nice circuit indeed. I recommend using a shielded enclosure and coaxial cable for both the circuit's input and output. A switch for the optional capacitor would be a good idea, too.

CIRCUIT CIRCUS

(continued from page 75)

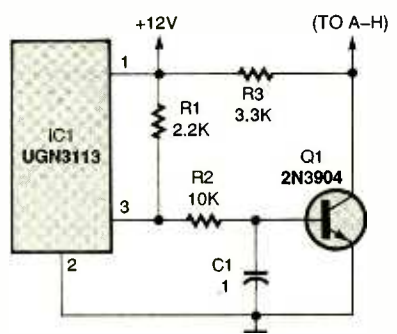

Fig. 7. This circuit can be used to replace one of the reed switches in Fig. 5.

PARTS LIST FOR THE REED-SWITCH REPLACEMENT (Fig. 7)

- IC1—UGN3113 Hall effect, integrated circuit
- Q1—2N3904 NPN transistor
- R1—2200-ohm, 1/4-watt, 5% resistor
- R2—10,000-ohm, 1/4-watt, 5% resistor
- R3—3300-ohm, 1/4-watt, 5% resistor
- C1—0.1-μF, ceramic-disc capacitor
- Power source, wire, solder, etc.

the reed switch. Of course you'll need eight circuits to replace all of the reed switches in the wind-direction sensor.

With no strong magnetic field near IC1, pin 3 is high, allowing base current to reach Q1. That current turns on the transistor and lowers its collector voltage to near zero. In this state, no gate current is sent out to the SCRs. When a magnet is positioned near the Hall effect IC, however, the output at pin 3 goes low, turning Q1 off and allowing gate current to flow to the decoder circuit, and thereby the connected SCR.

Here's hoping that one of these unusual sensor circuits will find a home in one of your future projects. Good circuitry until we meet here again next month.



"Remember when you made contact with the guys with the strange accent?"

COMPUTER BITS

(continued from page 69)

almost nothing, because Win95 does all that internally. In AUTOEXEC.BAT, the DOS section launches a separate batch file that allows the kids to select from a menu of games. Even my three-year-old knows how to get to his favorite piece of software. And the Windows section simply (you guessed it) launches Win95.

DEBUGGING AND CUSTOMIZING

If you have any problems, remember you can always boot from the floppy, restore all three of the files to the root of your C drive, and live happily ever after.

If you've got a multi-boot system that works at the boot-sector level, the new menu system described here will only come into play after you select Windows 95 from the boot-loader menu. In other words, you'll have to make two levels of choices: First, Win95 vs. your other multi-boot OS(es), followed by the appropriate choice from the new menu. This system works just fine on a dual-boot Win95/WinNT system, for example.

There are several other commands you can use in the CONFIG.SYS menus; see the MS-DOS 6 User's Guide (pp. 105-12) or online help for details. There are also several other settings you can add to MSDOS.SYS to customize its behavior. See the Windows 95 Resource Kit (p. 204-5) for details.

One particularly useful command allows you to specify a default menu choice and a time-out value. For example, add:

```
menuDefault=DOS, 10
```

to the Menu section of CONFIG.SYS. That will cause the DOS choice to be selected after a period of ten seconds, provided the user hasn't already made another selection.

To return to the command line from Win95, do a normal shutdown (Start menu, Shutdown..., Shutdown the computer). After you click OK, you'll be back in "DOS." This will not be the "DOS" with all the DOS-specific device drivers; it's just Win95's "DOS" mode. By the way, you won't have long file-

LISTING 1 CONFIG.SYS

```
[menu]
menuItem=DOS, DOS (games)
menuItem=Windows, Windows 95
menuDefault=DOS, 10

[Common]
numlock=off

[DOS]
DOS=HIGH,UMB
DeviceHigh=C:\WINDOWS\HIMEM.SYS
DeviceHigh=C:\WINDOWS\EMM386.EXE X=A000-CbFF frame=cc00 i=dc00-eff
2080 Verbose RAM
FILES=75
BUFFERS=32
LASTDRIVE=Z

REM SCSI CD drivers
DeviceHigh=C:\ADAPTEC\ASPI4DOS.SYS /D /P230
DeviceHigh=C:\ADAPTEC\ASPICD.SYS /D:ASPICD0

REM Sound card driver
DeviceHigh=C:\PROAUDIO\MV SOUND.SYS D:1 Q:7

[Windows]
REM Don't do anything special; Win95 does it all.
```

LISTING 2 AUTOEXEC.BAT

```
@ECHO OFF

:Common
prompt $P$G
path C:\BAT;C:\utl;C:\WINDOWS;C:\WINDOWS\COMMAND;C:\dos;
set TEMP=C:\WINDOWS\TEMP
set TMP=C:\WINDOWS\TEMP
set DIRCMD=/OE

goto %config%

:DOS
mscdex /D:ASPICD0 /L:Z
rem set audio card to max volume
\proaudio\pas set speaker to 100
set blaster=A220 i7 d1
lh mouse
mode con rate=30 delay=1
doskey
kids
goto END

:Windows
win

:END
```

name support in this mode, nor will networking work, nor will you have access to a CD-ROM drive or any other hardware controlled by a device driver.

My setup is actually a little more complicated, because some games need EMS memory, even though most won't function with a memory manager loaded. The point is that you can add

as many sections as you want to either or both files, and customize things to your heart's content. A common use is to load or not load network drivers. Another common use is to customize at-home and at-work settings. You could also create per-user environments, although you'd probably be better off using Win95's User Profiles for that task. But that's another story. ■

Skyvision, Inc.[®]
 1048 N. Frontier Dr. • Fergus Falls MN. 56537

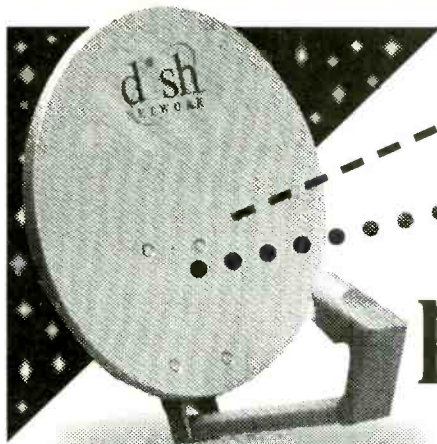

Small dish,
BIG
 programming!

PLUS:

- ▼ Multi-room TV viewing options & accessories
 - ▼ Mobile systems for RV's & vacation homes
- AND MORE!**

800-500-9264
 **Skyvision**[®]
 www.skyvision.com

40 of America's Most Popular TV Channels includes DISNEY

- ▼ Makes cable & other 18" dish options obsolete.
- ▼ The HOTTEST digital programming available!



The Best Television Comes on a DISHSM

DISH Network is a registered Service Mark of EchoStar Comm. Corp.

FREE DISCOUNT BUYER'S GUIDE

KEEP YOUR SYSTEM RUNNING STRONG!

MOST COMPLETE SELECTION OF:

- ✓ System Upgrades
- ✓ Parts & Accessories
- ✓ Tune-up Tools & Kits
- ✓ Complete Systems
- ✓ Technical Support Hotline
- ✓ Discount SKYPAC™ Programming

GET YOUR FREE ISSUE NOW!

800-334-6455
 NEED A REPAIR ITEM FAST? WE'LL GET IT OUT TODAY!

 **Skyvision**[®]
 www.skyvision.com



Market Center™

Weeder Technologies

Add \$4
Ship/Hand
US & Canada

FREE CATALOG!



Pro-Kit™

PO Box 421, Batavia, OH 45103

weedtech@iglou.com

513-752-0279

Home Automation

Connects between a TW523 and an RS-232 serial port. Use your PC/Mac to receive and transmit all X-10 commands. Create your own program to control your home automation system, turning on/off any device plugged into an electrical outlet with response to time/date, other X-10 transmissions or any other computer input stimuli. **\$38.50**

Caller ID / RS-232

Connects between a telephone wall jack and an RS-232 serial port. Decodes the caller ID data sent over the phone line and sends it to your PC/Mac. In a pre-formatted ASCII character string. Create your own program to log the name, number, date, and time of all incoming calls. Block out unwanted callers to your BBS/modem. **\$34.50**

Telephone Call Restrictor

Connects to telephone wall jack. Disables all phones on the line if attempting to either: dial a number that has been stored in memory "Block" mode or, dial a number that has not been stored in memory "Allow" mode. Use touch-tone phone to enter telephone numbers into memory, and choose mode. Program from any phone on the line using your password. **\$35.00**

50 MHz Frequency Counter

Reads frequency from 1Hz to 50MHz and displays up to 7 digits on a 16x1 character LCD display. Auto-range feature provides floating decimal point and automatic placement of suffix (Hz, KHz, or MHz). Microcontroller based provides for very small parts count, only 2" x 3" big. **\$48.50**

Telephone Scrambler

Scrambles your voice before sending it over the telephone line. Prevent eavesdropping from an extension or tap. Connects between your telephone and wall jack. No modifications are required to your telephone. Full duplex operation. **\$43.00**

IR Remote Control Receiver

Learns and records the data patterns emitted by standard infrared remote controls used by TVs, VCRs, Stereos, etc. Lets you control all your electronic projects with your TV remote. Seven individual I/O pins can be assigned to any button on your remote, and can be configured for either "toggle" or "momentary" action. **\$32.00**

RS-232 Digital I/O

Give your home-brewed PC/Mac programs a link to the outside world! 12 I/O pins can be configured individually for input or output. Turn on/off relays, triacs, etc. Respond to button presses, switch changes, 4x4 matrix decoding with auto-debounce. Stack up to 16 units on the same serial port for a total of 192 I/O points. **\$32.00**

DTMF Decoder/Logger

Keep track of all numbers dialed or entered from any phone on your line. Connects to your telephone wall jack. Decodes all 16 touch-tones and displays them on an LCD display. Holds the last 240 digits in a non-volatile memory. Scroll through and view all telephone numbers dialed, credit card numbers entered, etc. **\$54.50**



PUT YOUR PC TO WORK

THIS IS THE DREAM MACHINE YOU'VE BEEN WAITING FOR

2.5, 3, & 4 AXIS CNC/DNC DESKTOP MANUFACTURING UNITS

- AUTOMATICALLY PROTOTYPE PC BOARDS & MACHINE 3D PARTS FROM CAD
- CARVE, ROUTE, MILL, & DRILL WOOD, PLASTICS, & LIGHT METALS
- FREE POWERFUL 3D CAD/CAM SOFTWARE WITH EACH UNIT
- INEXPENSIVE CNC KITS AND ASSEMBLED CNC UNITS
- NOW OVER 20 DIFFERENT MODEL-OPTIONS
- EXPEDITE & SUPER-EXPEDITE AVAILABLE



SIZES FROM 12"x 12"
TO HUGE 6'x 6' UNITS

ORDER NOW! 501-839-8293 U.S. CYBERLAB, INC., 14786 SLATE GAP ROAD, WEST FORK, AR 72774

CALL NOW FOR INSTANT SPECS 501-839-8293 24 HR. FAX-BACK SERVICE

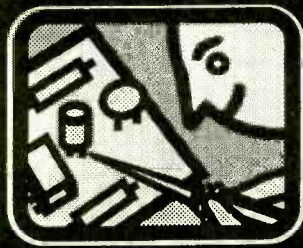

RAINBOW KITS

Many of our kits are available completely built!



TEMPERATURE GENIE

Ever lost frozen food because your freezer stopped? The TC-2 kit would have saved you money. An alarm activates when the temperature reaches a critical point. Turn ceiling fans on automatically when it gets too hot. This kit gives you 100mA of output. SIZE: 2" x 1.4" Power requirement 6 to 15V DC. If you want to switch more power see our Tnac (TP-1) or Relay (RP-1) Power kit. **KIT \$7.95**



WIRELESS FM MICROPHONE

Small but mighty this little jewel will out perform most units many times its price. It really stomps out a signal. The WM-2 kit is a buffered wireless mike that operates from 80MHz to 120MHz FM, the frequency of any broadcast FM radio. Includes a mini-electret mike. 6 to 12v DC. SIZE: 1.25" x 1" **KIT \$14.95**

TV NOTCH FILTERS FOR CHANNELS 2 thru 22 ONLY

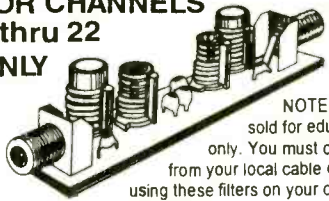

Our TV filters eliminate unwanted TV channels or interference that alters both sound and video with a beep beep beep. Works on cable channels (2 thru 22) only. **KIT \$14.95**

NOTE: All TV Filter Kits are sold for educational purposes only. You must obtain permission from your local cable company before using these filters on your cable system.



PHONE TRANSMITTER

Small but mighty, it fits anywhere. Phone line powered, never needs batteries. Transmits both sides of a phone conversation loud and clear, wireless, to any FM radio at great distances. Variable tunes from 70MHz to 130MHz FM. You can also use it as a speaker phone. SIZE: 1.25" x 6". **KIT \$12.95**



MICRO-MINIATURE PHONE TRANSMITTER

We haven't seen a smaller phone transmitter than the MMPT2 kit. Powered by the phone, it requires no battery. Transmits both sides of a phone conversation to an FM radio up to a 1/4 mile away. Tunable from 88 to 108MHz FM. Attach it to one phone or add it to the line to pick up all incoming calls. The MMPT2 is undetectable if properly installed. Unit has surface mounted parts, you install the leaded parts. Size .45" x 6" **KIT \$29.95**

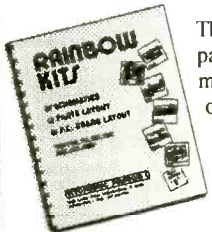

This Manual contains schematics, parts lists & P.C. board layouts for many of the Rainbow Kits. Use your own parts to construct our kits. **KIT BOOK \$14.95 \$9.95 with the purchase of any kit.**

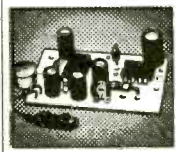

SUPER SNOOPER BIG EAR

Listen through walls, hear conversations across the room. Add a parabolic reflector and hear blocks away. The BIG EAR can be hidden about anywhere. Makes an ultra sensitive intercom. Can be used as a 1.5W AMP. We supply a mini-electret mike in the kit. Power requirement 6 to 12v DC. SIZE: 1.75" x 1" **KIT \$10.95**



MICRO-MINIATURE WIRELESS MIKE

So small you could hide this one on some real bugs! It's the smallest we've ever seen. With it's super sensitive mike it transmits a whisper or a room of conversation to an FM radio, tunable from 88 to 108MHz FM. With a proper antenna it transmits about 1/2 mile. The kit is made with surface mounted parts, we have already mounted these parts. You install the leaded parts. Power requirement 6 to 12v DC. SIZE: .35" x .9" **KIT \$34.95**

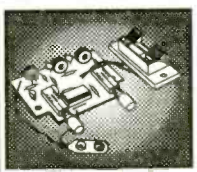

INDUCTANCE METER

This is the kit everyone has been asking for. Turn your digital volt ohm meter into an inductance meter. It will read inductors 3uH to 7MH. Power requirement 9v DC. SIZE: 1.75" x 2.5" **KIT \$14.95 \$8.95**

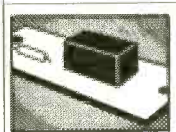

RELAY POWER KIT

Increase the output of any kit from 100mA to 3 Amps If you need to switch more power, up to 300 Watts, with the Light Genie, Temperature Genie, Timer or Vox kits, use the Relay Kit. We supply a two pole relay 1.5 Amps ea., tie both poles together and get 3 Amps. Size .75" x 2" **KIT \$9.95**

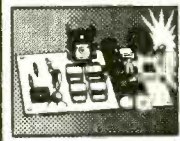

STROBE LIGHT

Do you need an attention getter, warning light, or flashing light for model airplanes? Then this kit is for you. Use it as an emergency light for your auto, radio tower, even use it on your bicycle. Has a variable flash rate. Power requirement 6 or 12v DC. SIZE: 3.5" x 1.9" **KIT \$11.95**



DIGITAL THERMOMETER

The DT-3 kit will turn your digital volt ohm meter into an accurate digital thermometer with .1 degree resolution. Measure temperatures from -40° to 250F° The remote sensor is .25" sq. and can be mounted many feet from the meter. Power requirement 9V DC. SIZE: 2" x 1.35" **KIT \$8.95**

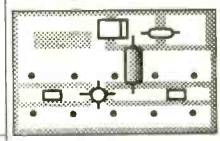

WIDE BAND PRE-AMP

Uses PCB and surface mount technology for better performance. Use for scanners, HT's, Frequency counters, Satellite Receivers. It amplifies low-level (weak) signals. If the signal is extremely low, two amplifiers can be used in a series. **KIT \$19.95**

- 1MHz to 2.5 GHz 2.8dB NF
- 1dB compression=OdBm
- Gain: 1MHz- 20dB to 2.5GHz-6dB
- Power requirement: 12v @ 6Ma



FM STEREO TRANSMITTER

Own your own FM radio station. Any stereo signal you plug into the FMST-100 will be transmitted to any FM radio tuneable from 76 to 108MHz FM. Transmit a wireless link through an auditorium, from your car to your camper, listen to your CD's while mowing the lawn. Play music on one channel sing on the other. Clarity is excellent, approx. 40dB stereo separation. Length of antenna determines the distance of transmission. Complete with stereo input level controls & crystal for stereo separation. 9v battery operation. SIZE: 1.5" x 2.5" x 3" **KIT \$29.95**

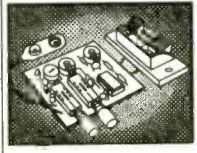

CAPACITANCE METER

This kit will turn your digital volt meter into a capacitance meter. Turn that junk box of unmarked capacitors into a fortune of usable parts. Measure capacitors from 2.2pF to 2.2uF. Power requirement 9v DC. SIZE: 1.80" x 2" **KIT \$12.95**



ELECTRONIC RAINBOW

Please add sufficient postage First lb \$5.00 Canada \$7.00 Additional LB. Add \$1.00 US FUNDS ONLY We will accept telephone orders for Visa or Mastercard

Electronic Rainbow Ind., Inc.
6227 Coffman Rd. Indianapolis, IN 46268

CALL 317-291-7262 FAX 317-291-7269
INTERNET: www.rainbowkits.com



DALBANI

UNIQUE REALTIME
OSCILLOSCOPE
BUILT-IN FUNCTION
GENERATOR



20MHz

Manuf # OS-9020G

2-CH
DUAL TRACE



\$498.00

Order N° 50-820

1 MHZ FUNCTION
GENERATOR

Features

- Wider than specified frequency response
- High deflection factor of 1mV/div.
- Wide dynamic range up to 30MHz without waveform distortion
- Algebraic sum of CH1 and CH2
- Low drift with compensation circuit
- Superb trigger sensitivity
- Maximum sweep rate of video signals with internal TV sync. separator
- Jitterless trigger circuitry
- CH1 signal output terminal available
- Variable trigger hold-off
- High precision X-Y phase difference measurement up to 50kHz
- Built-in function generator with BNC output of 50Ω and TTL
- Three kinds of waveform are available with 50Ω output
- Flat output waveform frequency up to 1MHz

Specifications:

Vertical deflection: • Bandwidth :DC coupled (DC to 20MHz normal), AC coupled :(10Hz to 20MHz normal) • Deflection factor: 5mV/div to 5V/div in 10 calibrated steps of 1-2-5 sequence • Rise time: 17.5nS or less

Horizontal deflection: • Time Base A: 0.2μs to 0.2S/div in 19 calibrated steps. 1-2-5 sequence • Uncalibrated continuous control between steps of at least 1: 2.5.



CODE PE96

PLEASE MENTION
WHEN ORDERING

Items are subject to availability.
Prices are subject to change without
any prior notice.

FLYBACK
TRANSFORMERS



\$12.50

Replaces
GOLDSTAR 154-074R
ORDER N° 63-0189

\$20 MINIMUM ORDER
CALL NOW FOR YOUR
232 PAGE FREE CATALOG
1-800-325-2264

HOT PRICES ON POPULAR SEMI'S

Order N°	Brand	Min	Price
BU-208	TESLA	10	\$1.49
BU-208/O	TOSHIBA	1	4.50
2N-3055	TESLA	10	0.60
2N-3773	TESLA	5	1.20
2SD-1398	SANYO	10	1.49
2SD-1650	SANYO	5	1.69
STRD-1005	SANKEN	1	4.15
STR-30130	SANKEN	1	2.66
STRS-6301	SANKEN	1	8.50
TA-7777N	TOSHIBA	1	6.96
TDA-2005	SGS	5	1.49



TUN-O-WASH®
ORDER N° 30-0100

\$7.50

(CFC Free)

Fast drying electronics
grade cleaner for tuners,
controls and PC boards.

TUN-O-WASH is excellent cleaner and
degreaser for tuners, controllers and PC boards.

- Designed for cleaning and degreasing consumer electronics
- Cleans in one step, no rinsing required
- Contains no ozone depleting compounds
- CFC and HCFC free
- Not for use on energized equipment
- 12.5 Oz aerosol (12 cans per case)



DIGITAL MULTIMETERS
NEW! Digital

- Overload protect 1000VDC or peak AC on all other ranges
- Input impedance 10M Ohm on all ranges
- Base accuracy range ± 0.5 % to ± 1.0 %
- Resistance 200Ω, 2K, 20K, 200K, 2M, 20M
- Audible continuity response lower than 50Ω
- DC Voltage 200mV, 2V, 20V, 200V, 1000V
- AC Voltage 200mV, 2V, 20V, 200V, 700V

ORDER N° 50-815

DALCO



\$19.95

LOGIC Probe
ORDER N° 51-1015

- Length: 8 inches
- Range: 4.5 To 15 VDC
- Includes Test Leads
- Compatible With TTL, DTL, RTL, HTL, CMOS, NMOS Logic

\$8.99

SOLDER ROLL

- 1 LB Spool
- 370 deg F melting point
- Fastest solder
- Alloy 60/40, tin lead, non corrosive flux, Diam. 1.2mm

ORDER N° 51-1005

\$3.95

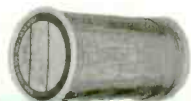

COLOR CODED
LEADS HEAVY DUTY
ORDER N° 56-500

\$2.82

- 11" Long Wire Lead
- Insulated 1/16" Alligator Clips
- 20 Gauge Wire Size • 10 Leads
- BLACK, GREEN, RED, YELLOW, WHITE



SOLDER WICK

- Solder Remover
- Length 5 Feet

85¢

Min. 2 pcs.



VCR ALIGNMENT TOOL KIT

ORDER # 50-888

The most popular

\$24.99

- VCR Head puller
- Retaining ring remover
- Spring hook
- Micro screwdriver
- Hex key set • Fitted vinyl • Soft zippered case
- Dimensions: 9 1/2"(W) X 12 1/4"(L)
- 7 Assorted head & guide aligners
- 3 Reverseable screwdrivers (Small-Flat-Philips)



TEMPERATURE CONTROLLED
SOLDERING STATION

\$64.00

- Adjustable Temp.: 300°F - 790°F - 150°C - 480°C
- Grounded Tip for Soldering: Static Sensitive Devices, Heater Aid.
- Led Power Temperature Indicator
- Overheat Protection W/ Temperature Control
- Auxiliary Grounded Terminal
- Comes in digital LED display
- 48 Watts soldering iron

ORDER N° 51-1035



Universal Audio/video Remote
ORDER N° 82-1055

- Controls basic functions of TV, VCR, cable box, and CD or laser player
- Ergonomic design! Main buttons are in line with natural thumb motion
- Two-minute memory allows time to replace batteries without re-programming
- Programming reminder sticker inside battery compartment
- Sleep time for 60, 30, or 15 minutes (according to your TV)
- Set key recessed to prevent accidental deprogramming
- Spanish instruction included
- Requires four AAA Batteries (not included)



MAGNAVOX
Smart. Very smart.

\$9.95

- Cable (11 brands)
- VCR (68 brands)
- TV (77 brands)
- Compact disc and Laser Disc (94 brands)

4225 N.W. 72nd AVE MIAMI, FLORIDA 33166 TEL : (305) 716-1016 FAX : (305) 594-6588

CIRCLE 150 ON FREE INFORMATION CARD

SEE US
NOW AT
<http://www.cir.com>

**CIRCUIT
SPECIALISTS
INC.**

**Check Out
What
We
Have
To Offer:**

Fantastic DMM Offer!!!

Don't let the price fool you. This meter is a digital multimeter designed for engineers and hobbyists. Equipped with 5 functions and 19 ranges. Each test position is quickly and easily selected with a simple turn of the FUNCTION/RANGE selector rotary switch.

Rubber Boot Included

General
Display: 3-1/2 Digit LCD, 21mm Figure Height with Automatic Polarity

Overrange Indication: 3 Least Significant Digits Blank

Temperature for Guaranteed Accuracy:
23°C±5°C RH<75%

Temperature Ranges:
Operating: 0°C to 40°C (32°F to 104°F)
Storage: -10°C to 50°C (14°F to 122°F)

Power: 9V Alkaline or Carbon-Zinc Battery (NEDA1604)
Low Battery Indication: BAT on Left of LCD Display

Dimensions: 188mm long x 87mm wide x 33mm thick
Net Weight: 400g

DC Voltage (DCV)

Range: Resolution: Accuracy:

200mV 100µV
2000mV 1mV
20V 10mV ±(1%rdg+2dgts)
200V 100mV
1000V 1V

Maximum Allowable Input: 1000V DC or Peak AC

DC Current (DCA)

Range: Resolution: Accuracy:

200µA 100nA
2000µA 1µA ±(1.2%rdg+2dgts)
20mA 10µA
200mA 100µA
10A 10mA ±(1.2%rdg+2dgts)

Overload Protection: mA Input, 2A/250V fuse.

AC Voltage (ACV)

Range: Resolution: Accuracy:

200V 100mV ±(1.2%rdg+10dgts)
750V 1V

Frequency Range: 45Hz-450Hz

Maximum Allowable Input: 750V rms

Response: Average Responding. Calibrated in rms of a Sine Wave.

CAT NO	DESCRIPTION	PRICE
9300G	Rugged High Quality DMM with Rubber Boot	\$19.00



Our Best Offer Ever on a

High Quality Full Sized DMM

\$19.00 any qty

Resistance (Ω)

Range: Resolution: Accuracy:

200Ω 100mΩ
2000Ω 1Ω
20KΩ 10Ω ±(1.2%rdg+2dgts)
200KΩ 100Ω
2000KΩ 1KΩ
20MΩ 10KΩ ±(2%rdg+10dgts)

Maximum Open Circuit Voltage: 2.8V

Diode Test

Measures forward voltage drop of a semiconductor junction in mV test current of 1.5mA Max.

hFE Test

Measures transistor hFE.

Switchable Scope Probe Sets

(Selectable X1/Rel/X10) These high quality scope probe sets are for oscilloscopes up to 60MHz (model HP 9060) or 150MHz (model HP9150). Both sets include a handy storage pouch and include an IC test-hook adapter for the probe. The BNC connector rotates to avoid cable tangle or kink. Cable length is 1.4 meters.

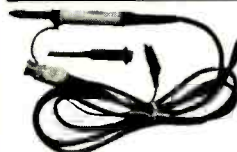

CAT NO	DESCRIPTION	1	10	100
HP-9060	Scope Probe Set DC~60MHz	\$16.49	\$14.49	\$11.58
HP-9150	Scope Probe Set DC~150MHz	24.95	21.95	18.62



Positive Photo Resist Pre-Sensitized Printed Circuit Boards

These pre-sensitized printed circuit boards are ideal for small production runs. They provide high resolution and excellent line width control. High sensitive positive resist coated on 1oz. copper foil allows you to go direct from your computer plot or art work layout. No need to reverse art.

Single-Sided, 1oz. Copper Foil on Paper Phenolic Substrate

CAT NO	DESCRIPTION	PRICE EACH		
		1	10	50
PP101	100mm x 150mm/3.91" x 5.91"	\$2.55	\$1.90	\$1.70
PP114	114mm x 185mm/4.6" x 6.6"	2.98	2.45	1.98
PP152	150mm x 250mm/5.91" x 9.84"	5.40	3.98	3.60
PP153	150mm x 300mm/5.91" x 11.81"	6.15	4.48	4.10

Single-Sided, 1oz. Copper Foil on Fiberglass Substrate

CAT NO	DESCRIPTION	PRICE EACH		
		1	10	50
GS101	100mm x 150mm/3.91" x 5.91"	\$ 3.90	\$2.98	\$2.60
GS114	114mm x 185mm/4.6" x 6.6"	4.80	3.49	3.20
GS152	150mm x 250mm/5.91" x 9.84"	8.69	5.98	5.78
GS153	150mm x 300mm/5.91" x 11.81"	10.20	7.20	6.80

Double-Sided, 1oz. Copper Foil on Fiberglass Substrate

CAT NO	DESCRIPTION	PRICE EACH		
		1	10	50
GD101	100mm x 150mm/3.91" x 5.91"	\$ 5.07	\$3.68	\$3.38
GD114	114mm x 185mm/4.6" x 6.6"	5.95	4.29	3.99
GD152	150mm x 250mm/5.91" x 9.84"	10.47	7.39	6.98
GD153	150mm x 300mm/5.91" x 11.81"	11.95	8.69	8.30

Etching Chemicals/Ferric Chloride

A dry concentrate that mixes with water to make 1 pint of etchant, enough to etch 400 sq. inches of 1oz board.

CAT NO	DESCRIPTION	PRICE EACH	
		1	5
ER-3	Makes 1 pint	\$3.50	\$2.75



Developer This product is used as the developer on our positive photo-resist printed circuit boards. Includes instructions. 50 gram package, mixes with water.

CAT NO	DESCRIPTION	PRICE EACH		
		1	10	25
POSDEV	Positive Developer	\$.95	\$.80	\$.50



Etching Tank This handy etching system will handle PC boards up to 8" x 9", two at a time. Ideal for etching your PCB's! System includes an air pump for etchant agitation, a thermostatically controlled heater for keeping etchant at optimum temperature and a tank that holds 1.35 gallons of etchant. A tight fitting lid is also supplied to prevent evaporation when system is not being used. Typical etching time is reduced to 4 minutes on 1oz. copper board!

REDUCES ETCHING TIME!

CAT NO	DESCRIPTION	PRICE
12-700	Etch Tank System	\$37.95

Desoldering Pumps

These powerful plastic body desoldering pumps are designed for easy one hand operation for fast, efficient desoldering. Double O-ring piston seals for maximum suction.



CAT NO	DESCRIPTION	PRICE EACH		
		1	5	10
08-366S	Large Desoldering Pump	\$15.89	\$13.49	\$11.95
08-366E	Regular Desoldering Pump	10.89	8.59	7.39
08-366TIP	Replacement Tip	1.95	1.95	1.95

SEE OUR ON-LINE CATALOG AT
<http://www.cir.com>

Electronic Soldering System Here's the ideal solution when **Temperature Control** is required. Easy to use slide control allows user to set system from 300°F to 840°F. Voltage to iron from control unit is 24V Iron heating power is 48W. Replaceable 5.3mm tip is standard. Replacement irons and tips are available.

CAT NO	DESCRIPTION	PRICE EACH	
		1	5
SL10	Temp Controlled Soldering Iron	\$56.00	\$50.00
SL24V	Spare 24V Soldering Iron	10.50	7.50



Electronic Soldering System with LED Display Deluxe temperature controlled system with LED display for maximum accuracy. Temperature is adjustable from 160°-480°C (320°-900°F). Iron heating power is 48 Watts. Runs on 24V from controller unit. Replacement irons and tips are available. Tip size is 5.3mm.

CAT NO	DESCRIPTION	PRICE EACH	
		1	5
SL30	Deluxe Soldering System w/LED	\$86.00	\$75.00
SL24V	Spare 24V Soldering Iron for SL10 or SL30	10.50	7.50



Replacement Tips for SL10/SL30

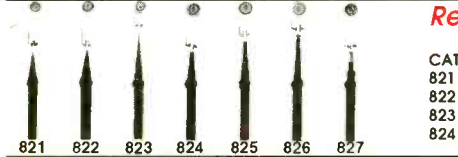

CAT NO	DESCRIPTION	PRICE EACH	
		1	5
821	1/32" Pencil Tip	\$1.39	\$1.19
822	1/32" Pencil Tip	1.39	1.19
823	1/64" Pencil Tip	1.39	1.19
824	1/16" Chisel Tip	1.49	1.29

We now offer a variety of replacement tips for the SL10/SL30 soldering stations.

CAT NO	DESCRIPTION	PRICE EACH	
		1	5
825	1/8" Chisel Tip	\$1.49	\$1.29
826	3/64" Chisel Tip	1.49	1.29
827	3/64" Pencil Tip	1.59	1.39

Ball Bearing 12V DC Fans



These High Quality Fans feature Ball Bearings and Brushless DC Motors. All of them are designed to meet UL, CSA & VDE Standards. Design these fans into power supplies, computers or other equipment requiring additional air flows for heat removal. These fans are regular Circuit Specialists stock items — they are not surplus.

CAT NO	PRICE EACH			
	1	10	25	100
CSD 4010-12	\$ 9.88	\$ 6.38	\$5.48	\$4.87
CSD 6025-12	9.38	5.91	5.41	4.71
CSD 8025-12	8.88	5.85	5.19	4.49
CSD 9225-12	8.95	6.14	5.29	4.59
CSD 1225-12	11.45	8.96	7.82	6.85

Specifications

CAT NO	DIMENSIONS (MM)	RATED VOLTAGE (V)	START VOLTAGE (V)	INPUT CURRENT (A)	AIR FLOW (CFM)	STATIC PRESSURE (INCH-H ₂ O)	SPEED (RPM)	NOISE LEVEL (dB)	WEIGHT (g)
CSD 4010-12	40x40x10mm	12	7	0.06	5.1	0.19	5,500	26	20
CSD 6025-12	60x60x25mm	12	5	0.13	13.7	0.165	4,500	28	65
CSD 8025-12	80x80x25mm	12	5	0.16	37.8	0.177	3,000	31	80
CSD 9225-12	92x92x25mm	12	5	0.32	42	0.18	2,800	37	95
CSD 1225-12	120x120x25mm	12	5	0.35	62	0.180	2,500	42	135

INDUSTRY BEST PRICING!

- SOLDER • SOLDER • SOLDER •
- SOLDER • SOLDER • SOLDER •

We stock high quality 60/40(Sn%/Pb%), .031" and 63/37, .031" diameter. This is prime JIS certified solder that we maintain as a regular stock item (It is not "Left-overs, Rejects or Surplus") and you can buy it from us at a fraction of the price that you are used to.



Tired of Paying Inflated Prices for Solder?

CAT NO	DESCRIPTION	PRICE EACH		
		1	10	25
RH60-1	1-lb. Spool, .031", 60/40	\$ 6.90	\$ 5.96	\$ 5.30
RH63-1	1-lb. Spool, .031", 63/37	6.95	6.10	5.41
RH60-4	4.4-lb. Spool, .031", 60/40	24.00	21.90	17.92
RH60-TUBE	6-oz. Tube, .031", 60/40	.99	.89	.79

CCD Camera - IR Responsive As Low As \$109!!

This black and white monochrome CCD Camera is totally contained on a PCB (70mm x 46mm). The lens is the tallest component on the board (27mm high from the back of the PCB) and it works with light as low as 0.1 lux. It is IR Responsive for use in total darkness. It comes with six IR LED's on board. It connects to any standard monitor. AUX or video input on a VCR or through a video modulator to a TV. Works with a REGULATED 12V power supply (11V-13V). Hooks up by connecting three wires: red to 12V, black to ground (power & video) and brown to video signal output.

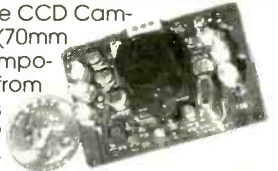

CAT NO	DESCRIPTION	1	5
CA-H34A	PCB Mounted IRCCD Camera	\$125.00	\$109.00

SEE OUR ON-LINE CATALOG AT <http://www.cir.com>

CIRCUIT SPECIALISTS, INC. SINCE 1971

**800-811-5203
602-464-2485
602-464-5824(FAX)**

WE ACCEPT:



RECEIVE OUR LATEST 132 PAGE CATALOG!

It's chock full of all types of electronic equipment and supplies. We've got I.C.'s, capacitors, resistors, pots, inductors, test equipment, breadboarding supplies, PC supplies, industrial computers, data acquisition products, personal computers and computer parts, plus much, much more. FAX us your name and address or call **800-811-5203, ext. 5**, to leave a message on our catalog request line.



AMAZING ELECTRONIC & SCIENTIFIC DEVICES

Lasers, Tesla, Ions, Anti-Gravity, Magnetics & More!

Plans • Ready-to-Use • Easy-to-Build Kits



Laser Ray Gun
Handheld, battery operated. Produces an intense burst of light capable of burning holes.
LAGUN2 Plans \$20.00
LAGUN2K Kit/Plans Price on Req



250KV Tesla Coil
10-14" of Explosive Bolts of Lightning!
• Transmit Wireless Energy
• Ion Motors
• Anti-Gravity
• Strange and bizarre pyrotechnical effects
• Many other experiments shown in detail
• Award winning science project!
BTC3 Plans \$15.00
BTC3K Kit/Plans with coil \$299.50
BTC30 Assbld Ready to Use \$399.50
BTC4 Plans, 500KV unit \$20.00

ATTENTION: Experimenters & Researchers!
Anti-Gravity, Rail & Coil Guns, Mass Warping, Levitation Research, Exploding Water, Propulsion Drivers, Lattice Snapping, EMP etc. Loss-less Energy Charger with triggered spark switch. • Adjustable 500 to 3KV out
• Charges up to 25KJ • Programmable Output
HEP1 Plans \$15.00
HEP1K Kit/Plans with 500J \$399.50
HEP10 Lab Assembled - to your specs.
Write, call or fax for price & delivery
...shown connected to potential rail gun system



Visible Beam Gas Lasers
Millions degree temp equiv. Illuminates low level clouds
• Light Shows
• Window Listener
• Optical Projects
• 12/115V
• Science Project
LAS1KM 1 mw, low cost Kit \$69.50
LGU6K 2-3mw Kit \$119.50
HNE70 5-7mw, ready to use \$299.50



Gravity Generator
Levitate an object!
Great science fair project!
GRA1 Plans \$15.00
GRA1K Power Supply Kit/Plans ... \$99.50
GRA10 Assbld Kit/Plans \$149.50
Includes text book on Anti-Gravity theory!



Solid State Tesla Coil
• Generate fiery electrical plasma discharge
• Powers light and objects without contact
• Experiment with electrical and mechanical fields
TCL5 Plans \$8.00
TCL5K Kit/Plans 12VDC \$49.50

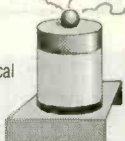

Pioneer a Futuristic Weapon!
Electric Gun - prototype designed in our lab - Join the research!
• Ballistic Velocities
• Handheld • Battery Operated
• Labelled as DANGEROUS Product
Experiment now before it is classified as a firearm! EGUN1 Plans \$20.00
(Must be 21 for purchase of hardware)



Ion Ray Gun
Project Energy!
Star Wars technology demonstrates weapons potential. IOG7K Kit/Plans \$99.50



4000 Volts 10ma High Voltage Module - Ready to use - for many projects from hoverboards to pyrotechnics.
MINMAX4 While they last! \$19.50

"Talking" Plasma Globe
Spectacular color. Pulsates to music, sounds! 8-9", with intensity and sound controls. PLASMA1 Ready to Use \$79.50



Electronic Hypnotizer *Caution Required*
Control their minds! Programmable audible and visual stimuli induces hypnotic trances. HYP2K Kit with Book \$39.95
EH2 Hypnosis Book & Plans \$14.95



We can design and build high voltage systems - to your specs!
Call or fax us with your requirements!

TACTICAL ELECTRONICS

Cybernetic Ear!
Enhances normal hearing 3-4 times!
Adjustable volume control, fits easily into either ear. Many, many uses.
Ready to Use!
CYBEREAR \$19.95



ALL NEW Telephone Line Grabber/Infinity Transmitter
Use tone phone anywhere in the world to:
• Monitor your premises - avoid break-ins
• Access ongoing calls - longwinded kids
• Control up to 8 appliances in your home!
• Re-direct costly toll calls from pay phones!
TELCON3 Plans (credit to purch) .. \$ 10.00
TELCON3K Plans/Kit \$99.50
TELCON30 Ready to Use \$149.50



Long Range "Ultra-Ear" Parabolic Mic can hear a distant whisper! BUG Mother Nature!
20" dish uses satellite technology to capture distant sounds. PM5 Plans \$ 8.00
PM5K Kit/Plans \$149.50
• Optional Wireless Retrofit transmits captured sounds to an FM radio.
WM5K Kit for Wireless Option \$29.50



Phasor Sonic Blast Pistol
Rids areas of unwanted pests. Trains and conditions wild and domestic animals. Great for barns, attics, cellars, gardens.
PPP1K Kit/Plans \$39.50



3 Mi Telephone Xmitter
• Tune-able 80-130 Mhz • Undetectable
• Only transmits when phone is used
VWPM7K Kit/Plans \$39.50

3 Mi Voice Transmitter
• Ultra-Sensitive Mike
• Crystal Clear
• Tunes 80-130 MHz.
FMV1K Kit/Plans \$39.50



FireBall Gun
Shoots flaming ball - two shot capacity. Great for special effects and remote fire starting. CAUTION REQUIRED!
FIREBALL Plans (dangerous product). \$10.00



Shocker Force Field/Vehicle Electrifier
Make hand and shock balls, shock wands and electrify objects. Great payback for those wise guys!
SHK1K Easy to Assemble Kit \$19.50



Extended Play Telephone Taping System
• Tapes Phone Conversation • Extends Tape X4 • Check Local Laws before using!
TAP30X Ready to Use \$84.50



"Drop-In" (Imi) Telephone Transmitter
Easily tunable over FM radio. Never needs battery! #DROPIN Kit/Plans \$ 19.95



See In Total DARKNESS!
• High Quality IR Night Vision
Scope with IR illuminator.
SD10 Ready to Use \$199.50



Electric Charge Gun
Life is Precious - PROTECT IT!
Stuns & immobilizes attackers 15 feet away! Check your state laws for legality. More knockdown power than most handguns. No permanent injury. ID coded.
ECG1 Data (Creditable to purch) \$10.00
ECG10 Charge Gun, Ready to Use, includes FREE Stun Gun! \$249.50
STUN GUNS - sold separately:
STUN100 100,000 Volts \$34.50
STUN200 200,000 Volts \$49.50



3 Mi Tracker Transmitter
• Tunable Output
• Uses FM Radio
• Excellent Signal Beacon
HOD1K Kit/Plans \$39.50



MIND CONTROL!
Places subjects under your control. Programmable audible & visual stimuli with biofeedback. Induces strange & bizarre hallucinations without drugs. Caution - not FDA approved.
MIND2 Plans \$15.00
MIND2K Kit and Plans \$49.50
MIND20 Assembled Unit \$69.50



FANTASTIC BRIGHTNESS!
High Quality Laser Pointer
LAPN64 15mw equiv, 2000' \$39.50
LAPN61 50mw equiv, 4000' \$84.50



Window Bounce Laser Listener
Aim at window and listen to sounds from reflected light. CAUTION - Not for illegal use. LWB3 Plans \$10.00
LWB3K Kit/Plans (req's vid tripod) \$149.50



1000' Potato Cannon
Not a Toy! Uses electronic or piezo ignition. CAUTION REQUIRED!
POT1 Plans (dangerous product) ... \$10.00



VISIT US ON THE WEB!
<http://www.amazing1.com>

INFORMATION UNLIMITED

Dept PEM-7, Box 716, Amherst, NH 03031
Phone: 603-673-4730 FAX: 603-672-5406
MC, VISA, COD, Checks accepted Please add \$5.00 S & H

CATALOG!
FREE with Order or send \$1 P&H

24 Hour Phone
800-221-1705
Orders Only Please!



#72-2035 ... Reg. \$149
only **\$129**

#72-2040 ... Reg. \$179
only **\$159**

Quality you can afford.

TENMA® Test Equipment

Compact, rugged, and autoranging, this line of high-performance DMMs are perfect for troubleshooting electronic circuitry, adjusting and calibrating products and testing components. The "High Tech Series" offer performance and 5,000 count for greater resolution and repeatability. So whether you are solving problems in the field, at home, or at the workbench, Tenma digital multimeters give you all the measurement capability you need for today's technology.

Why should you buy Tenma DMMs?

- 30 day satisfaction guarantee
- Best price/performance
- One year warranty
- NIST calibration available
- 5000 count
- Feature packed

The complete Tenma line can be found at MCM Electronics. MCM stocks over 30,000 items... serving every need of the electronics repair industry. Test equipment, semiconductors, audio/video parts, tools, computer parts and more. Request your FREE catalog today!

Prices effective from December 19, 1996 through February 28, 1997

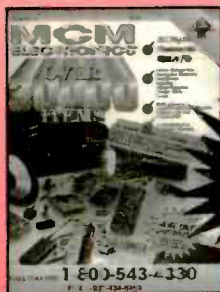

FREE Catalog

20th
Anniversary
1996

Authorized
Panasonic

Quasar/Technics
Original Parts Distributor

RCA/GE
Premier
Distributor

To order a FREE catalog, Call...

1-800-543-4330

Hours: M-F 7 a.m.-9 p.m., Sat. 9 a.m.-6 p.m., EST.



MCM ELECTRONICS®

650 CONGRESS PARK DR.
CENTERVILLE, OH 45459
A PREMIER FARNELL Company

Fast delivery from distribution centers near Reno, NV and Dayton, OH.

CODE:POP37

CIRCLE 151 ON FREE INFORMATION CARD

www.americanradiohistory.com

CALL TOLL FREE
(800) 292-7711 orders only
Se Habla Español

C&S SALES
EXCELLENCE IN SERVICE

CALL OR WRITE FOR
A FREE 60 PAGE
CATALOG!
(800) 445-3201

XK-550 Digital / Analog Trainer

Elenco's advanced designed Digital / Analog Trainer is specially designed for school projects. It is built on a single PC board for maximum reliability. It includes 5 built-in power supplies, a function generator with continuously sine, triangular and square wave forms. 1560 tile point breadboard area.

XK-550
Assembled and Tested
\$169.95

XK-550K - Kit
\$139.95

Tools and meter shown optional



TK-3000
\$89.95

Tools Included:

- SR-2 - Deluxe Soldering Iron
- SH-1 - Soldering Iron Stand
- ST-1 - Diagonal Pliers
- ST-2 - Long Nose Pliers
- ST-30 - Deluxe Wire Stripper
- SE-1 - Solder Ease Kit
- ND-3 - 3 pc. Nut Driver Set
- TL-8 - Precision Screw Drivers
- ST-5 - Screw Driver Slotted 3/16"
- ST-6 - Screw Driver #1 Phillips
- ET-10 - IC Puller
- SP-2 - Solder Pump
- ST-20 - Safety Goggles
- ST-9 - Pocket Screw Driver
- ST-4 - Solder Tube
- SW-3 - Solder Wick

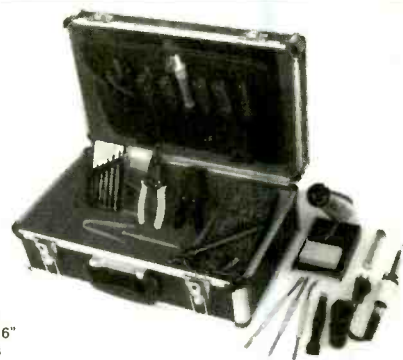

A professional technician service tool kit in a metal reinforced tool case with heavy-duty handle and locks. A removable pallet handles most of the tools listed with more room for tools and parts in the lower half.

GF-8026 w/ Frequency

- Linear and Log Sweep
- .02Hz to 2MHz
- Counter Range 1Hz to 10MHz
- 4 Digit Display

\$225



MX-9300 Four Functions in One

• One instrument with four test and measuring systems:
 1.3GHz Frequency Counter • 2MHz Sweep Function Generator
 Digital Multimeter • Digital Triple Power Supply
 (0-30V @ 3A, 15V @ 1A, 5V @ 2A)

\$479.95



Model XP-581

4 Fully Regulated DC Power Supplies in One Unit
 4 DC voltages: 3 fixed - +5V @ 3A, +12V @ 1A, -12V @ 1A
 1 Variable - 2.5 - 20V @ 2A

\$85



**Auto Ranging Hand-Held
 DMM w/ Bar Graph
 Model EDM-163**

\$99.95

7 Functions with data hold
 Compares to Fluke Model 77II

**Digital Multimeter
 Model M-1700**

\$39.95

11 functions including freq to 20MHz,
 cap to 20µF. Meets UL-1244 safety
 specs.



Fluke Multimeters

70 Series	80 Series
Model 70II\$69.95	Model 83\$235.00
Model 73II\$97.50	Model 85\$269.00
Model 75II\$135.00	Model 87\$289.00
Model 77II\$154.95	
Model 79II\$175.00	

B&K Precision Multimeters

Model 391\$159.00	Model 388A\$99.00
Model 390\$139.00	Model 2707\$79.00
Model 389\$109.00	Model 2860A\$85.00

Kit Corner

over 100 kits available

PT-223K
\$15.95

Phone kit with training course.



Fiber Optics Technology
with training course
Model FO-30K

\$19.95



**Model AM/FM-108K
 Transistor Radio Kit**

with training course

\$29.95

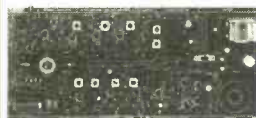

**M-1005K
 Compact Multimeter
 Kit**

\$19.95
 6 Functions & Transistor Test



Model M-6100

Programmable DMM
**Includes FREE Computer Interface
 and FREE Software**

- Analog Bar Graph
- Large 3 3/4" LCD Display
- Menu Driven
- Triple Display
- RS-232 Interface
- True RMS
- 9 Basic Functions including cap. & freq.
- Auto Power Off
- Easy-to-use

\$125



WE WILL NOT BE UNDERSOLD

C&S SALES, INC.

**15 DAY MONEY BACK
 GUARANTEE**

UPS SHIPPING: 48 STATES 5%
 OTHERS CALL FOR DETAILS
 IL Residents add 8% Sales Tax

150 W. CARPENTER AVENUE
 WHEELING, IL 60090
 FAX: (847) 520-9904 (847) 541-0710
http://www.elenco.com/cs_sales/



FULL FACTORY WARRANTY

PRICES SUBJECT TO CHANGE WITHOUT NOTICE

CIRCLE 32 ON FREE INFORMATION CARD

**FREE PROBES
WITH ALL
SCOPES**

OSCILLOSCOPES
Lowest Prices of the Year!

**CALL OR WRITE FOR
A FREE 60 PAGE
CATALOG!
(800) 445-3201**

**B&K Precision
Scopes**

60MHz ANALOG WITH DIGITAL STORAGE

Model 2560
• Cursors and readouts
• RS-232 port
• 20MS/s real time sampling
• 1GHz equivalent time sampling (at 0.1µs/div.)
• Prints via RS-232 port to any HP-GL plotter
\$1995

20MHz ANALOG WITH DIGITAL STORAGE

Model 2522A
• 20MHz analog bandwidth
• 20MS/s sampling rate
• 2K memory per channel
• 300MHz equivalent time sampling
• Pre-trigger capture
\$869.95

100MHz THREE-TRACE

Model 2190A
• 1mV/division sensitivity
• Sweeps to 5ns/division
• Dual time base
• Signal delay line
• 13kV accelerating voltage
\$1379.95

60MHz DUAL-TRACE

Model 2160A
• 1mV/division sensitivity
• Sweeps to 5ns/division
• Dual time base
• Signal delay line
• V mode-displays two signals unrelated in frequency.
• Component tester
\$949.95

40MHz DUAL-TRACE

Model 1541C
• 1mV/division sensitivity
• Video sync separators
• 2-axis input
• Single Sweep
• V mode displays two signals unrelated in frequency.
• Component tester
\$695

60MHz, CURSORS & READOUTS, DUAL TIME BASE

Model 2260
• Cursors and readouts
• 1mV/div sensitivity
• 23 calibrated ranges - main time base
• 19 calibrated ranges - delayed time base
• Signal delay time
• V-mode - displays 2 signals unrelated in frequency.
• Component tester
• 2-axis input
• Single sweep
\$1225

20MHz DUAL TRACE

**Model 2120 - 2 Year Warranty
Special \$389.95**

**Model 2125 with delayed sweep
\$539.95**

• 1mV/division sensitivity
• AUTOCORRECT triggered sweep operation
• AC, TVM, TVM and line coupling
• Calibrated 19 step time-base with x10 magnifier
• Compact low-profile design

Quality Scopes by Elenco



60MHz

40MHz

25/30MHz

DS-603 \$1350

S-1345 \$569

DS-303 \$1095

- Analog / Digital Storage
- 20MS/s Sampling Rate

- Analog with Delayed Sweep

- Analog / Digital Storage

S-1360 \$749

S-1340 \$475

S-1330 \$439

- Analog with Delayed Sweep

**2 Year
Warranty**

- 25MHz Analog
- Delayed Sweep

S-1325 \$325
• 25MHz Analog

OSCILLOSCOPE SELECTION CHART

ANALOG		Sensitivity (max)	No. of Channels	Sweep Rate Max ns/div	Delayed Sweep	Video Sync	Component Tester	Beam Find	Time Base
Model	Bandwidth MHz								
S-1360	60	1mV/div	2	10ns/div	Yes	Yes	Yes	Yes	2
S-1345	40	1mV/div	2	10ns/div	Yes	Yes	Yes	Yes	2
S-1340	40	1mV/div	2	10ns/div	No	Yes	No	No	1
S-1330	25	1mV/div	2	10ns/div	Yes	Yes	Yes	Yes	2
S-1325	25	1mV/div	2	10ns/div	No	Yes	No	No	1
DIGITAL STORAGE		Analog Sen (max)	No. of Channels	Sampling Rate	Memory Channel	Internally Backed Up	Pretrigger %	Output	
Model	Bandwidth MHz								
DS-303	30	1mV/div	2	20MS/S	2K	Yes	0, 25, 50, 75	RS232	
DS-603	60	1mV/div	2	20MS/S	2K	Yes	0, 25, 50, 75	RS232	

**Affordable Spectrum
Analyzers by B&K**

500MHz Series

Model 2615 - \$1595
Model 2620 w/ tracking generator - \$1895

1.05GHz Series

Model 2625 - \$2395
Model 2630 w/ tracking generator - \$2995



HITACHI SCOPES

**Inventory Reduction Sale
Lowest Prices of the Decade!**

V-209 - 20MHz Battery Operated Was \$1505, NOW \$1095 Save \$410
V-695 - 60MHz w/ Cursors Was \$1815, NOW \$1395 Save \$420
V-422 - 40MHz Was \$965, NOW \$765 Save \$200
V-1065A - 100MHz w/ Cursors Was \$2139, NOW \$1565 Save \$574
V-525 - 10MHz w/ Cursors Was \$1355, NOW \$955 Save \$400
V-1560 - 100MHz Was \$1790, NOW \$1490 Save \$300
V-552 - 50MHz Was \$1195, NOW \$850 Save \$345
V-1565 - 100MHz w/ Cursors Was \$1960, NOW \$1595 Save \$365
V-555 - 50MHz w/ Cursors Was \$1375, NOW \$975 Save \$400
V-252 - 20MHz **\$419**

Fluke Scopemeters



91 \$1225
92B \$1445
96B \$1695
97 \$1795
97A \$2945
99B \$2095

Call or write for complete specs.

WE WILL NOT BE UNDERSOLD

C&S SALES, INC.

150 W. CARPENTER AVENUE
WHEELING, IL 60090

FAX: (847) 520-9904 (847) 541-0710
http://www.elenco.com/cs_sales/

CIRCLE 32 ON FREE INFORMATION CARD

**15 DAY MONEY BACK
GUARANTEE**

FULL FACTORY WARRANTY

PRICES SUBJECT TO CHANGE WITHOUT NOTICE

UPS SHIPPING: 48 STATES 5%
OTHERS CALL FOR DETAILS
IL Residents Add 8% Tax

ALL ELECTRONICS

C O R P O R A T I O N

QUALITY PARTS

FAST SHIPPING

DISCOUNT PRICING

CALL, WRITE, FAX
or E-MAIL For A
Free 64 Page
CATALOG.
Outside the U.S.A.
send \$2.00 postage.



PC MOUNT POWER RELAY 24 Vdc

Potter & Brumfield # T90N5D12-24
24 Vdc, 675 ohm coil. SPDT con-
tacts rated 20 amps (N.O.), 10 amps (N.C.) @
240 Vac. 1.15" X 0.09" X 0.65". PC terminals.
UL and CSA listed.

CAT# RLY-55 **\$2⁰⁰**
each

10 for \$18.50 • 100 for \$150.00

SPECIAL PRICE! TWIST ON F-56 CONNECTOR

We recently made a large
purchase of this twist-on co-ax
connector for RG-6 cable.



Special pricing while
the supply lasts.

100 for \$15.00
500 for \$50.00
1000 for \$70.00

CAT #FTO-56R

SPECIAL PRICE BI-COLOR LED



RED/ GREEN diffused.
T 1 3/4 (5mm) Three Legs
Center cathode.

CAT# LED-63

35¢
each

100 for \$29.00 • 1000 for \$250.00

(USED) "HI-8" VIDEO CASSETTE

SONY Hi-8
Top quality, metal
particle 120 minute video
cassettes. Used for a short
time, then bulk-erased.
Each cassette has its own
plastic storage box.
Satisfaction Guaranteed.



\$3⁰⁰
each

CAT # VCU-8

10 for \$28.00 • 100 for \$250.00

PADDED CARRYING CASE

Good-looking pro-
tective carrying case for Zip drives,
Walkman
players,
tools, guns,
photographic or
electronic equipment. This
well-made black canvas bag has
0.5" thick padding all around and a nylon
inner liner. 1.5" wide webbed handle and detach-
able shoulder strap. Heavy-duty zipper. Interior
pocket and adjustable velcro compartment.
Interior area: 16" X 6" X 2.5". These are new
bags with a company logo (Interactive Network)
on a patch on one side.



\$5⁰⁰
each

CAT # CSE-10

DRIVE CABINET W/ SUPPLY

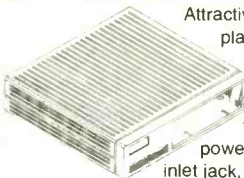

Attractive, heavy-gauge gray
plastic cabinet designed
to hold a 1/2 height
CD ROM drive.

Contains a 5 Vdc /
12 vdc switching
power supply, IEC power
inlet jack, on/off switch, cooling
fan, LED indicator, DB-15 connector and two RCA
jacks. 10.43" X 9.75" X 2.2" overall size. Drive
opening in front of case is 5.87" X 1.68". IEC
power cord not included.

\$15⁰⁰
each

CAT# MB-53

SPST, N.C. SWITCH

SPECIAL
PURCHASE!

Marquardt # 1050.0141A
Small, normally-closed switch rated 2 amps @
125/250 Vac. Prepped with 5" long wire leads
and 2 contact socket connector. Body
size: 0.78" X 0.4" X 0.25". UL and
CSA listed. Large quantity available.



4 FOR \$1⁰⁰

CAT# SMS-140

250 for \$50.00
1000 for \$150.00

12 Vdc, MINI BLOWER

Nidec, Gamma 28 # A34342-55APP
12 Vdc, 0.18 amp brushless cen-
trifugal blower designed for
applications with space limita-
tions. This small, lightweight
blower features permanently
lubricated ball bearings and a
quiet thermoplastic housing. 3"
diameter X 1.18" thick.
Output port is 1.4" X 1".
5" leads.

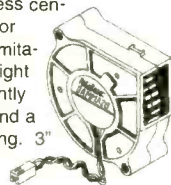

\$7⁰⁰
each

CAT# CF-39

THERMOELECTRIC COOLER PELTIER JUNCTIONS



These incredible miniature solid state heat
pumps raise or lower temperature in a small
area almost instantly. Utilizing the Peltier
effect these modules perform the same cooling or
heating functions as freon based refrigera-
tors but they do it with no moving parts, and
are very reliable. Current applied to the device
will produce heat on one side and cold on the
other side, up to 68° C difference between the
two sides. Modules can be mounted in parallel
to increase the heat transfer effect or can be
stacked to achieve high differential tempera-
tures. 127 thermocouples per device. Operates
on 3-12 Vdc. Requires a heatsink to prevent
overheating.

1.18" (30 mm) square
X 0.15" (3.8 mm) thick.

\$17⁰⁰ CAT# PJT-1
each 5 for \$75.00

1.57" (40 mm) square
X 0.15" (3.8 mm) thick.

\$26⁰⁰ CAT# PJT-2
each 5 for \$110.00

Quantity Pricing Available!

ORDER TOLL FREE

1-800-826-5432

MAIL ORDERS TO:
ALL ELECTRONICS CORP.
P.O. BOX 567
VAN NUYS, CA 91408-0567

FAX (818) 781-2653 • INFO (818) 904-0524
INTERNET <http://www.allcorp.com/>
E-MAIL allcorp@allcorp.com

NO MINIMUM ORDER • All Orders Can Be Charged to Visa, Mastercard, American Express or Discover • Checks and Money Orders Accepted by Mail • Orders
Delivered in the State of California must include California State Sales Tax • NO C.O.D. • Shipping and Handling \$5.00 for the 48 Continental United States • ALL
OTHERS including Alaska, Hawaii, P.R. and Canada Must Pay Full Shipping • Quantities Limited • Prices Subject to change without notice.

MANUFACTURERS - We Purchase EXCESS INVENTORIES... Call, Write, E-MAIL or Fax YOUR LIST.



AMERICAN RELIANCE

AMREL Offers Lowest Prices & Best Warranties on DC Power Supplies ANYWHERE!

3 YEAR WARRANTY



3 YEAR WARRANTY

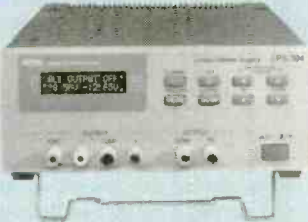

AMREL Offers Superior Analog Power Supplies Starting as Low as \$149.00

- Low Output noise rating less than 0.3mV.
- Line/load regulation rated at low 0.01% + 1mV.
- Transient response time of 50µ Sec.
- Overload protection, and Output enable/disable.
- Coarse and fine voltage/current adjustment.
- Auto series/parallel operations for triple output supplies.

AMREL Offers Features And Prices on Digital Power Supplies That The Competition Can't Beat!

- Microprocessor controlled.
- User friendly keypad data entry.
- Low output noise rating less than 1mV.
- Line/Load regulation rated less than 2mV.
- Output enable/disable and Power off memory.
- Optional RS-232 interface capability.

Model	LPS-101	LPS-102	LPS-103	LPS-104	LPS-105	LPS-106	LPS-301	LPS-302	LPS-303	LPS-304	LPS-305
Rating	30V/1A	30V/2A	30V/3A	+30V/1A -30V/1A 3-6.5V/3A	+30V/3A -30V/3A 3-6.5V/3A	60V/1A	15V/2A(H) 30V/1A(L)	15V/4A(H) 30V/2A(L)	30V/3A	+30V/1A -30V/1A 5V/2A	+30V/2.5A -30V/2.5A 3.3-5V/3A
List Price	\$195	\$225	\$295	\$395	\$495	\$245	\$249	\$299	\$369	\$399	\$599
Sale Price	\$149	\$179	\$199	\$375	\$469	\$219	\$199	\$285	\$350	\$379	\$569

PR INT



Products International Inc.

8901 Brookville Road • Silver Spring, Maryland 20910 • Fax: 800-545-0058 •

Call: **1-800-638-2020**



CIRCLE 46 ON FREE INFORMATION CARD

CONTROL MEASURE INPUT

RELAYS • LIGHTS • MOTORS
TEMPERATURE • PRESSURE • LIGHT LEVELS • HUMIDITY
SWITCH POSITIONS • THERMOSTATS • LIQUID LEVELS

MODEL 30 \$79



- PLUGS INTO PC BUS
- 24 LINES DIGITAL I/O
- 8 CHANNEL
- 8 BIT A/D IN
- 12 BIT COUNTER
- UP TO 14K SMP/SEC

MODEL 45 \$189



- RS-232 INTERFACE
- 8 DIGITAL I/O
- 8 ANALOG INPUTS
- 2 ANALOG OUTPUTS
- 2 COUNTERS-24 BIT

MODEL 100 \$279



- 12 BIT 100 KHZ A/D
- 4 ANALOG OUTPUTS
- 3 TIMER COUNTERS
- 24 DIGITAL I/O

MODEL 60 \$179



- 8 2-AMP RELAYS
- 16 DIGITAL I/O
- 1 8-BIT ANALOG INPUT

MODEL 40 \$99



- RS-232 INTERFACE
- 28 LINES DIGITAL I/O
- 8 ANALOG INPUTS
- PWM OUTPUT
- OPTIONAL 12 BIT A/D

MODEL 70 \$239



- RS-232 INTERFACE
- 18 BIT A/D
- 5.5 DIGIT
- UP TO 60 BMP/SEC

NEED A CUSTOM PCB? TRY US.

PRAIRIE DIGITAL, INC.

PHONE 608-643-8599 • FAX 608-643-6754

846 SEVENTEENTH STREET • PRAIRIE DU SAC, WISCONSIN 53578

CIRCLE 47 ON FREE INFORMATION CARD

Electronic Training Videos



Learn electronics quickly and easily with UCANDO's computer-animated training videos. Students can learn at their own pace and professionals will find the UCANDO videos to be a valuable source of reference material. If these videos aren't the best learning tools you've ever seen, return them within 30 days for a

complete refund. These videos are being used by Tech-Schools, CET's, Military Branches, Ham Operators, Industries, and more, across the United States and around the world. Order today and see how UCANDO is ...

"Changing The Way The World Learns Electronics."

VCR Maintenance & Repair ... \$29.95 All others ... \$44.95 each
 • Intro to VCR Repair • Direct Current • Alternating Current • Semiconductors • Power Supplies • Amplifiers • Oscillators • Digital 1 • Digital 2 • Digital 3 • Digital 4 • Digital 5 • Digital 6 • AM Radio • FM Radio Part 1 • FM Radio Part 2 • TV Part 1 "Intro to TV" • TV Part 2 "The Front End" • TV Part 3 "Audio" • Fiber Optics • Laser Technology •

SAVE!!! 6 videos for only \$240 or 12 videos for only \$450



1-800-678-6113

or mail check or money order to:

UCANDO Videos

P.O. Box 928

Greenville, OH 45331



FREE Shipping ... FREE Catalog

CIRCLE 136 ON FREE INFORMATION CARD

February 1997, Popular Electronics

TOP SECRET

CONSUMERTRONICS
P.O. Drawer 537 Alamogordo, NM 88311

Orders: 505-439-1776

Fax Orders: 505-434-0234

users.aol.com/wizguru/hi-tech.html

Add \$5 S/H (US, Can.) 10% Off orders \$100+
Postal M.O. is best. VISA, MCO, COD add \$6.
Since 1971! Sold for educational purposes only.

OFF-THE-SHELF HARDWARE

Van Eck Systems * Data Card Reader/Writers * Security/Surveillance * RF/EM/uWave/Radar * Carjack/Poiler * Child Finder * Panic Button * Shriek Module * TENS * Subliminal Mixer/Amp (Ultra-sound & Infrasonic) * Electronic Dowsers * Ghost Busters * Hearing Assistor * Vortex Generator * 6th Sense Communicator * Buy Catalog Today!

SPECIAL PROJECTS

We design/build/repair/modify/consult on any device/system/project - electronic/computer/mechanical/optical (eg: phone/auto/security/radionic/lab/energy/HV/EM/RF/radar/ultrasonic/IR/UV) for business and personal invention needs. Describe & include nonrefundable \$30 pre-engineering fee. Time & cost estimates 7-10 days. Confidentiality guaranteed.

CELLPHONE MODS

See our Catalog for our infamous cellphone modification guide (\$59) - detailed, comprehensive, covers all makes - 10 times more info than competitor's "guide". Free Data Search: As a special service to our Cellphone Mods customers, we will perform one FREE search of our massive cellphone database. Request by mail (don't fax); include a #10 SASE.

PAGER (BEEPER) \$39

Describes in detail how Pagers work, different types and uses, frequencies, advantages over and uses with cellphones, and tips and tricks. And how Pagers are hacked and countermeasures. Includes the plans for your own Personal Pocket Paging System (transmitter and receiver).

HACKING FAX MACHINES \$39

Describes in detail how Faxes are hacked and countermeasures. Includes Fax protocols, commo parameters, compression, commands, spy switch. And insights into designing Fax interception devices and modifying existing Faxes into Stealth Faxes.

PBX HACKING

Exposes ALL issues relating to PBX hacking, including countermeasures! Can you afford a \$90,000 phone fraud loss (avg. loss of hacked PBXs)? Featured in Forbes. \$29.

VOICE MAIL HACKING

How VM Box systems are used and ways they are hacked. Includes ASPEN, MESSAGE CENTER, BIX, GENESIS, EZ, SYDNEY, PHONE MAIL, CENTAGRAM, CINDY, AUDIX, SPERRY, more! A must for security types! \$29.

CREDIT CARD SCAMS

Details every known means of credit card fraud and scams. Protect yourself! \$29.

INTERNET CONS & SCAMS \$29

Net fraud rakes in \$2+ Billion annually! Most are done anonymously and with little fear of prosecution. Described in detail, includes countermeasures!

INTERNET TRACKING AND TRACING

The Net is infected with spammers, stalkers, scammers, infectors, and other wrongdoers who hide behind its anonymity. Learn how to trace them down in this comprehensive manual! \$39

AUTOMATIC TELLER MACHINES

ATM crimes, abuses, and vulnerabilities exposed! 100+ methods detailed, include: Physical, Reg. E, cipher, PIN compromise, card counterfeiting, magnetic stripe, false front, TEMPEST, Van Eck, tapping, spoofing, inside job, super-cool, Much more! Case histories, law, counter-measures, security checklist, labeled internal photos, figures. \$39

COMPUTER PHREAKING \$39

Describes in detail how computers penetrate each other, and how VIRUSES, TROJAN HORSES, WORMS, etc. are implemented. Dozens of computer crime and abuse methods and countermeasures. Includes IBM disk filled with hacker text files and utilities, and the legendary FLUSHOT+ protection system. BBS advice, password defeats, glossary - much more! Invaluable!

PHREAKING CALLER ID & ANI \$29

Details on how they work and dozens of ways of defeating Caller ID, ANI, *69, *57, and Call Blocking & *67. Describes Caller ID, Orange, Beige, Cheese and CF Boxes, ESS, SS7, E-911, various CLASS services, Diverters, Extenders, Centrex - much more!

HACKING ANSWERING MACHINES \$29

How answering machines are hacked to listen to - even erase - messages, and to convert them into mini-VMBs, and countermeasures!

HIGH VOLTAGE DEVICES \$29

Plans for: Stun Gun, Taser, Prod, Cane, Blaster, Flasher, Zapper, Audio/RF/Radar Jammer, Fence Charger, Plasma & Van de Graaff Guns, Jacob's Ladder, Geiger Counter, Fish Stunner, Plant Stim., Kirlian, Ozone Gen., much more!

BEYOND PHONE COLOR BOXES

Dozens described - many circuits. Plus Call Forwarding, Conferencing, Phreak History, Diverters, Extenders, Loops, REMOBS, Bridging Heads & Cans, Optocom, 3rd Party and other methods - more! \$29.

Beyond VAN ECK PHREAKING

Eavesdropping on TV and computer video signals using an ordinary TV described in detail. Range up to 1 KM. Plans include our and original Top Secret Van Eck designs! \$29.

STOPPING POWER METERS \$29

As reported on CBS "60 Minutes"! How certain devices can slow down - even stop - watt-hour meters - while loads draw full power! Device simply plugs into one outlet and normal loads into other outlets. Also describes meter creep, overload droop, etc. Plans.

SHOCKING!
ALL-NEW TOP SECRET CATALOG. FEATURES 200+ SURVIVAL PRODUCTS! WILL BLOW YOUR MIND! MAIL \$3, OR \$1 WITH ORDER!

Learn by Example!

The PRIMER 8085 Based Microprocessor Training and Control System shows you how to program by example. Program examples take you from writing simple programs to controlling motors. This trainer can be used stand alone via the keypad and display or connected to a PC with the optional upgrade (\$49.95). The Upgrade includes: an RS232 serial port, a serial cable, 32K of battery backed RAM and Assembler/Terminal software.

EXPERIMENTS USING THE PRIMER INCLUDE:

- Measuring Temperature
- Using a Photocell to Detect Light Levels
- Making a Waveform Generator
- Constructing a Capacitance Meter
- Motor Speed Control Using Back EMF
- Interfacing and Controlling Stepper Motors
- Scanning Keypads and Writing to LCD/LED Displays
- Using the Primer as an EPROM Programmer

The PRIMER is only \$119.95 in kit form. The PRIMER Assembled & Tested is \$169.95. Please add \$5.00 for shipping within the U.S. Picture shown with upgrade option and optional heavy-duty keypad (\$29.95) installed.

ENAC, inc.

P.O. BOX 2042, CARBONDALE, IL 62902
618-529-4525 Fax 457-0110 BBS 529-5708

1985 - 1996
OVER
10
YEARS
OF SERVICE

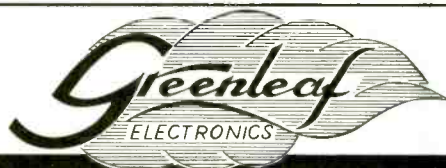

CABLE TV Converters & Descramblers

Compatible with
**Jerrold, Scientific Atlanta,
Pioneer, Oak, & Hamlin
Equipment**

BRAND NEW!

6-MONTH GUARANTEE

LOWEST PRICES

Volume Control & Parental Lockout Available

Greenleaf Electronics

1-800-742-2567

NO ILLINOIS SALES

It is not the intent of Greenleaf Electronics to defraud any pay television operator and we will not assist any company or individual in doing the same.

I DOUBLED MY INCOME...

WORK ONLY HALF THE HOURS!

I covered a lot of miles driving a cab for 13 years... but I sure didn't get anywhere! I mean the hours were long. The pay was short. My boss pushed, pushed, pushed all the time. In the meantime bills were piling up. Medical bills. House repairs. Charge cards. Just the everyday things. I was not just behind the wheel. I was behind the eight ball.

That's when I saw a magazine article that talked about the hottest big money-making career opportunities of the 90's. The one that interested me the most pertained to the **NEW explosive SATELLITE DISH/TV/ELECTRONICS field.**

I mailed the coupon for the FREE information kit they offered. I liked what I saw when the information packet came in the mail. What really caught my eye, however, was the idea I could gain all the knowledge I needed to make a success of this business studying in my spare time at home. **Foley-Belsaw's modern, practical hands on course combines simple step-by-step lessons with easy-to-follow video cassette guidance.** No special experience, education or electronics background is necessary. Just average mechanical aptitude to follow simple A-B-C repair procedures that are clearly outlined for you.

I decided to get in on the action... and just look at me now! Now I'm really in the driver's seat. I'm doing what I want to do. I'm my own boss. I set my own hours. I'm making more money than my wife and I ever dreamed possible. **Would you believe I'm making twice what I made driving a cab...and I work only half as many hours.**

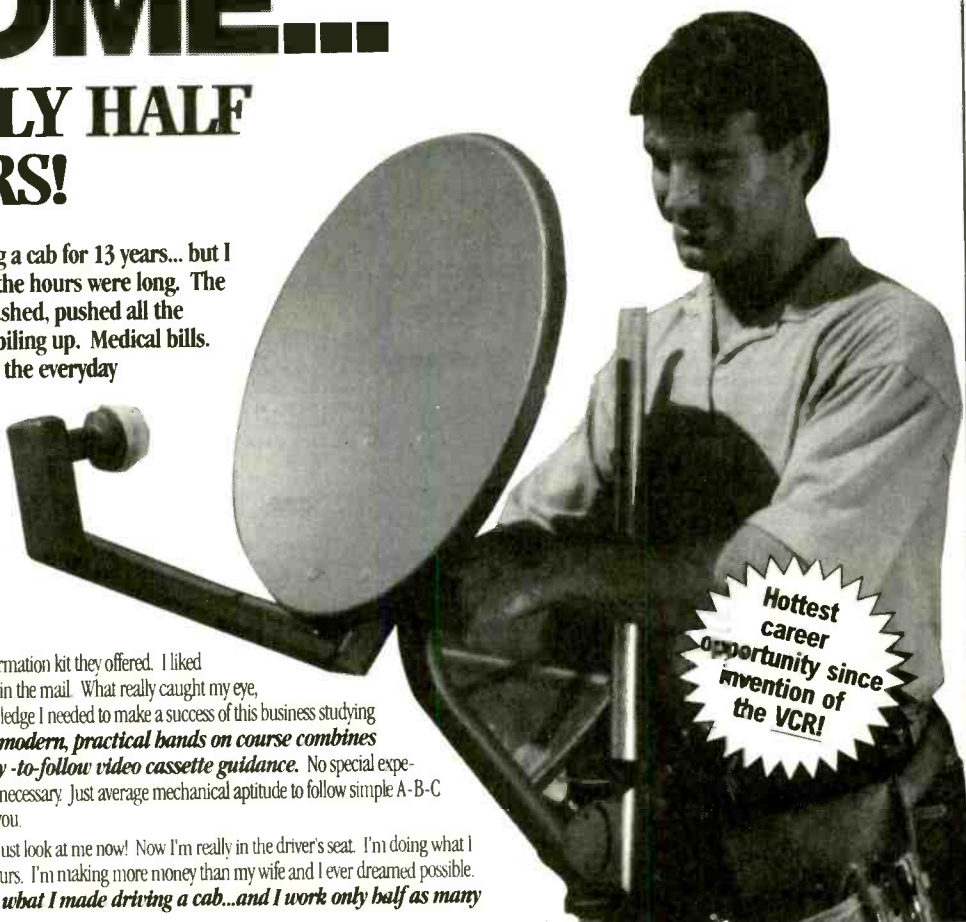

Hottest career opportunity since invention of the VCR!

Get in the FAST LANE on the New "INFORMATION SUPERHIGHWAY" Everyone's Talking About!

It's exciting! It's gigantic! The technology of tomorrow is here today! You've been reading and hearing about the amazing INFORMATION SUPERHIGHWAY. **It's so NEW that few technicians are equipped to service this fast emerging field! Foley-Belsaw gives you SATELLITE DISH technology (including New MINI-DISH)...** along with the electronics expertise you need to make BIG MONEY servicing TVs and other electronics equipment.

Be Your Own Boss!

It's quick and easy to become an expert at home in your spare time. Earn really BIG money adjusting, installing and repairing Satellite Dish Systems, TVs, Amplifiers, CD Players, AM/FM Tuners, Home Entertainment Centers. Every home, every business, every office in your area desperately needs your expertise!

Your Timing Couldn't Be Better!

Never before and probably never again will you have a ground-floor opportunity like this to get into a

booming business of your own, make really big money, be your own boss and enjoy financial freedom and security. The fact you're reading this message shows you're smart enough to realize this!

Learn In Spare Time At Home!

It's easy to learn in your spare time at home. And when you complete the course you will receive Foley-Belsaw's official diploma acknowledging your accomplishment

Send Coupon Today for FREE Kit. No Obligation.

Don't miss out on this once-in-a-lifetime opportunity. Send in the coupon NOW! Get all the facts and study them in the privacy of your own home. There's absolutely no obligation and no salesman will call on you. So don't delay. Mail the coupon today.

"Took in over \$3,200 in the past 10 days!"
H.H., Denver, CO

"Doubled my income within 6 weeks."
R.B., Bakersfield, CA

Mail for FREE Information Package

Foley-Belsaw Institute
6301 Equitable Road
Kansas City, MO 64120-1395



Please Check Only ONE of the Following:

- | | |
|---|---|
| <input type="checkbox"/> Satellite Dish, Dept. 31335 | <input type="checkbox"/> Locksmithing, Dept. 12892 |
| <input type="checkbox"/> Computer Repair, Dept. 64430 | <input type="checkbox"/> Small Engine Repair, Dept. 52769 |
| <input type="checkbox"/> Gunsmithing, Dept. 92385 | <input type="checkbox"/> Woodworking, Dept. 43640 |
| <input type="checkbox"/> PC Programming, Dept. 35303 | <input type="checkbox"/> Upholstery, Dept. 81309 |
| <input type="checkbox"/> VCR Repair, Dept. 62583 | <input type="checkbox"/> Saw & Tool Sharpening, Dept. 21708 |
| <input type="checkbox"/> Vinyl Repair, Dept. 71242 | |

Name _____

Address _____

City _____

State _____ Zip _____

Call Toll-FREE **1-800-487-2100**

ALFA ELECTRONICS

HIGH QUALITY TEST EQUIPMENT
BEST PRICE



DMM 89 \$179.00

Most Advanced DMM

-80.7 to 81.4 dBm with 4Ω-1200Ω
20 reference impedances
True RMS
Frequency counter: 100 Hz -10MHz
Capacitance: 5nF-50mF
Measure AC volt to 20kHz
5000 counts, 0.1% basic accuracy
Auto/manual range, fast bar graph
Min/Max/Ave/DH/Relative/Zoom
Auto power off
Input warning
Splash proof
Volt, amp, ohm, logic, diode, continuity
Ruggedized case
Rubber holster included



DMM A91 \$49.95

NOW \$39.00

Plus Free Case
Solar Cell Powered
Large Display

Diode, Continuity
Volt, Amp, Ohm
Data Hold
Auto power off
7 functions, 19 ranges
3.5 Digit, 0.6% accuracy
Auto/Manual ranging
Energy saver
Student & hobbyist's favor



DMM 20 \$74.95

Inductance: 2mH-20H
Capacitance: 2nF-200μF
Resistance: 200-200MΩ
Frequency: 2kHz-20MHz
3.5 Digit, 0.5% accuracy
DC/AC Current and Volts
Transistor hFE, diode test
Continuity, Duty %
Peak hold/Max
Ruggedized case
Rubber holster \$8.00

Full line of DMMs,
economy, compact,
ruggedized, solar cell,
automotive, heavy duty,
industrial, electrical
starts from \$19.95

Fliuke Multimeter
Fliuke 12 \$84.95
Holster C-10 10
Fliuke 70 II \$75.95
Fliuke 73 II \$97.50
Fliuke 75 II \$129
Holster C70 \$16
Fliuke 77 II \$155
Fliuke 79 II \$175
Fliuke 29 II \$175
Fliuke 76 \$175
Fliuke 87 \$287
Fliuke 867 \$1199

Scope Meter
Fliuke 97 \$1785
Fliuke 105 \$2799



LCR Meter 131D \$229.95

Most Advanced LCR
Dual display: L/Q or C/D
Inductance: 10mH-10.000H
Capacitance: 10nF-10mF
Resistance: 10Ω-10MΩ
Auto/manual range
Dissipation factor & Q factor
Serial & parallel mode
Relative mode for comparison
and to remove parasitics
Statistics, tolerance,
Best for design, incoming
testing & production
SMD and chip component
test probe \$25.00



LCR Meter 814 \$189.95

Best Resolution LCR

Inductance: 200μH-200H
Capacitance: 200pF-20,000μF
Resistance: 2Ω-20MΩ
Resolution of 0.1μF, 0.1pF, and
1mΩ are useful for high frequency
and SMD
Dissipation factor indicates leakage
in capacitor and Q factor in inductor
Zero adjustment to reduce parasitics
Best for high frequency RF
SMD and chip component test probe
\$25.00
Padded deluxe case \$8.00

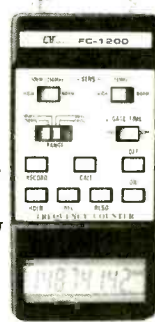

Frequency Counter FC-1200 \$129.95

Frequency 10Hz-1.25GHz
Display: 8 digit LCD
Period: 0.1us-0.1s
Records: Max/Min/Average
Data hold, relative mode
Telescoping antenna \$8.00
Deluxe case \$5.00

Also Available:
AC/DC clamp meter, Light meter,
Thermometer, pH meter, High voltage
Probe, Digital Caliper, Anemometer,
Electronic scale, Force Gauge,
Tachometer, Stroboscope, Humidity
& EMF adapter, Sound level meter,
Frequency counter, SWR/field
strength/power meter, Dip meter

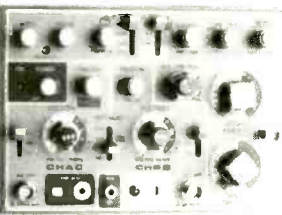

20 MHz Oscilloscope with Delay Sweep PS-205 \$429.95

Dual Trace, Component test, 8" CRT, X-Y Operation, TV Sync, Z-Modulation, CH2 Output, Graticule Illum, 2 probes each has x1, x10 switch. Best price with delay sweep
PS-200 20 MHz DUAL TRACE \$339.95
PS-400 40 MHz DUAL TRACE \$494.95
PS-405 40 MHz DELAY SWEEP \$589.95
PS-605 80 MHz DELAY SWEEP \$789.95
PS-1000 100 MHz DUAL TRACE \$999.95
Scope Probe: 60MHz x1, x10 \$15, 100MHz x1, x10 \$22
250MHz x1, x10 \$29, 250MHz x100 \$39

Digital Storage Scope

DS-303 30MHz, 20M Sample/sec \$849.95
DS-303P w/ RS-232 Interface \$1,049.95
Switchable between digital and analog modes
2 K word per channel storage
8 bit vertical resolution (25 Level/div)
Expanded Timebase 10ms/div - 0.5 s/div
Refresh, Roll, Save all, Save CH2, Pre-Trig
Plotter control

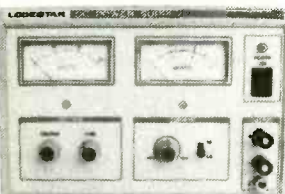

DC Power Supply PS-303 \$159.00

0-30 VDC, 0-3A output
Constant voltage & constant current mode
0.02% + 2mV line regulation
0.02% + 3mV load regulation
1 mVrms noise and ripple
Short circuit and overload protected
PS-8200 with digital voltmeter \$179.00
Also available: 30V/5A, 60V/3A, 60V/5A
16V/10A, 30V/10A

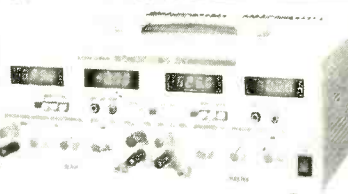

DC Power Supply Triple Output PS-8202 \$499.95

Two 0-30 VDC, 0-3A outputs
One fixed 5VDC, 3A output
Capable of independent or tracking operation
Constant voltage and constant current mode
Four digital meters for volt and current display
Excellent regulation and low ripple
Short circuit and overload protected
Also available: 30V/5A, triple output \$549.95
Dual tracking 30V/3A, 30V/5A, 60V/3A, 60V/5A

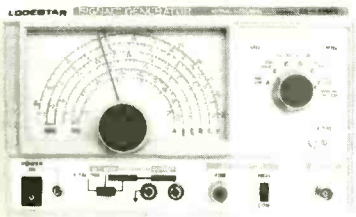

RF Signal Generator SG-4160B \$124.95

100 kHz-150MHz sinewave in 8 ranges
RF Output 100mVrms to 35 MHz
Internal 1kHz, External 50Hz-20kHz
AM modulation
Audio output 1 kHz, 1 Vrms
Output Impedance: 50 Ohm
Size: 5.9"H x 9.8"W x 8.1"D

Audio Generator AG-2601A \$124.95

10Hz - 1MHz in 5 ranges
Output: 0-8Vrms sinewave
0-10Vp-p squarewave
Synchronization: ±3% of oscillation frequency per Vrms
Output distortion:
0.05% 500Hz - 50kHz
0.5% 50Hz - 500kHz
Output impedance: 600 ohm

Function Generator FG-2100A \$169.95

0.2 Hz -2 MHz in 7 ranges
Sine/square/triangle/pulse/ramp
Output: 5mV-20Vp-p
1% distortion, DC offset ± 10V
VCF: 0-10V control freq. to 1000:1

Function Gen./Counter FG-2102AD \$229.95

Generates signal same as FG-2100A
Frequency counter 4 digits
Feature TTL and CMOS output



RF Signal Generator Counter SG-4162AD \$229.95

Generates RF signal same as SG-4160B
8 digit frequency counter 1Hz - 150 MHz for internal and external source Sensitivity <50mV

Audio Generator/Counter AG-2603AD \$229.95

Generates audio signal same as AG-2601A
8 digit frequency counter 10Hz-150MHz for internal and external sources Sensitivity <50mV

Sweep Function Gen./Counter \$329.95

0.5Hz to 5 MHz in 7 ranges
Sweep: Linear 10:1/Log 10:1 20ms-2s
AM Modulation
Gated Burst, Voltage Control Gen.
Generator Control Voltage & 8 digit counter 1Hz-10MHz for internal & external sources

ALFA ELECTRONICS

P.O. BOX 8089, Princeton, NJ 08543-8089

(800) 526-2532/(609) 897-1135

FAX:(609) 897-0206

Visa, Master Card, American Express, COD, Purchase Order Welcome

1 YEAR PARTS AND LABOR WARRANTY

CALL / WRITE / FAX FOR FREE CATALOG

CIRCLE 26 ON FREE INFORMATION CARD

**FREE CATALOG
CALL TOLL FREE
1-800-338-0531**

E-Mail: xpress@parts-express.com



**Parts
Express™**

**30 DAY MONEY
BACK GUARANTEE!**

340 E. First St., Dayton, OH 45402-1257
Phone: 937-222-0173 ♦ Fax: 937-222-4644

**Amplified Indoor
FM Antenna**

17" tall, amplified FM antenna. Improves reception with weak FM signals. 18 dB of gain. Includes AC adaptor, gain control, and 75 ohm coaxial cable terminated with an "F" connector.

**HOT
NEW
ITEM!**



#PO-219-055 **\$12⁹⁰**

Cable TV Stereo Decoder

When used in conjunction with a cable TV converter or cable ready VCR, this handy device allows you to feed the cable TV stereo signal into your home sound system for superb audio reproduction of your favorite shows, movies, and sporting events.



#PO-189-110 **\$19⁹⁰**

Digital Video Stabilizer

The digital video stabilizer will eliminate the constant picture distortion caused by the copyright protection on movie videotapes. This unit is fully automatic and operates on one 9V battery which is included.

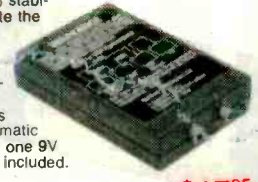

#PO-180-320 **\$17⁹⁵**

Decoy Cameras

These 1/3" CCD cameras offer a clever means of disguise. Both feature a 3.6mm wide angle lens, built-in electronic shutter, and a 12 VDC power supply. Minimum illumination: 0.3 lux. 400 line resolution. Smoke detector decoy camera includes an audio output.

**AFFORDABLE
HIGH TECH
SURVEILLANCE!**

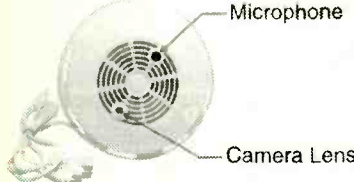

Part #	Description	Price
PO-335-535	Smoke detector decoy	\$249.50
PO-335-540	Decoy clock camera	299.95



**"The Sound Bridge"
FM Stereo Wireless Transmitter**

The Sound Bridge is a mini FM wireless transmitter that can be used to broadcast stereo sound from any audio source like portable CD players, TVs, electronic games, CD-ROM, even computer soundcards, to your home stereo receiver! Adjustable from 89 to 95.5 MHz.



**HOT
NEW
ITEM!**

#PO-249-220 **\$14⁹⁵**

**Portasol/Weller Butane
Soldering Tool**

**NO CORDS,
NO BATTERIES!**

This cordless, refillable, butane powered soldering tool is ideal for any on-site soldering job. Provides up to 35 watts with a temperature range up to 700 degrees F. Includes flint ignitor in plastic case, safety cut off switch, and C-2 chisel tip.

#PO-372-150 **\$25⁹⁵**

**150 MHz Oscilloscope Probe
Kit**

Deluxe probe kit features a modular design for longer life, switchable 10:1 probe with 150 MHz bandwidth, 2.8 ns rise time, and adjustable capacitance from 10-35 pF. 60" in length.



**GREAT
VALUE!**

#PO-390-100 **\$29⁹⁵**

**Memorex CD Repair And
Maintenance Kit**

Don't throw away expensive CDs because of annoying mistracking and skipping errors! The Memorex CD Repair kit contains enough solution and materials to clean and repair 12 compact discs.

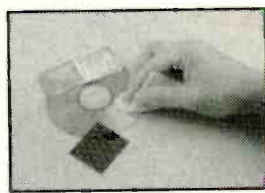

#PO-249-032 **\$1⁹⁵**

5" Sealed Back Midrange

5" heavy duty sealed back midrange with deluxe mesh grill. 1" aluminum voice coil. Popular midrange for auto sound installations. ♦Power handling: 35 watts RMS/50 watts max ♦Voice coil diameter: 1 inch ♦Impedance: 8 ohms ♦Frequency response: 800-10,000 Hz.



#PO-280-030 **\$7⁵⁰**

3 Channel Color Organ Kit

This sound to light unit features three separate outputs, which can be controlled independently. Each output reacts to three different bands of the musical spectrum: bass, midrange, and treble. Has built-in microphone, so no connection is required to music source, but a line input is provided.



**SUPER
QUALITY
KIT!**

#PO-320-210 **\$59⁹⁵**

1", Titanium Dome Tweeter

Features a ferro fluid cooled Kapton voice coil and a rubber surround. Very natural sounding high frequency reproduction with extended response to 30KHz. ♦Power handling: 50 watts RMS/75 watts max ♦Voice coil diameter: 1" ♦Impedance: 8 ohms ♦Frequency response: 2500-30,000 Hz.



**RESPONSE
TO 30KHz!** **Dayton Loudspeaker Co.®** **\$16⁵⁰**

#PO-275-050

6-1/2" Woofer

Polymer resin treated paper cone with poly foam surround. Long throw voice coil design helps to deliver powerful bass output. Perfect for bookshelf type speakers. Mfg. #C16L020-51F. ♦Power handling: 60 watts RMS/120 watts max. ♦Voice coil diameter: 1-1/4 inches ♦Impedance: 8 ohms ♦Frequency response: 57-7000 Hz.



#PO-290-023 **\$19⁹⁵**



♦30 day money back guarantee ♦\$20.00 minimum order ♦We accept Mastercard, Visa, Discover, and company C.O.D. orders ♦24 hour shipping ♦Shipping charge = UPS chart rate + \$1.90 (\$5.00 minimum charge) ♦Hours 8:00 am - 8:00 pm ET, Monday - Friday ♦9:00 am - 5:00 pm Saturday. Mail order customers, please call for shipping estimate on orders exceeding 5 lbs. ♦Foreign destination customers please send \$5.00 U.S. funds for catalog. ♦Quantity pricing available.

CIRCLE 146 ON FREE INFORMATION CARD

1-800-338-0531

❖ ATTENTION CABLE VIEWERS ❖

CABLE VIEWERS... get back to your **BASIC** Cable Needs

Call 800-577-8775

For information regarding all of your **BASIC** cable needs.



5 GOOD REASONS TO BUY OUR FAR SUPERIOR PRODUCT

- ❖ **PRICE**
- ❖ **EFFICIENT SALES AND SERVICE**
- ❖ **WE SPECIALIZE IN 5, 10 LOT PRICING**
- ❖ **ALL FUNCTIONS (COMPATIBLE WITH ALL MAJOR BRANDS)**
- ❖ **ANY SIZE ORDER FILLED WITH SAME DAY SHIPPING**

**BASIC
ELECTRICAL
SUPPLY &
WAREHOUSING
CORPORATION**

We handle **NEW** equipment **ONLY** - Don't trust last year's **OBSOLETE** and **UNSOLD** stock!
COMPETITIVE PRICING—DEALERS WELCOME

HOURS: Monday-Saturday 9-5 C.S.T.

It is not the intent of B.E.S.W. to defraud any pay television operator and we will not assist any company or individual in doing the same.
*Refer to sales personnel for specifications.

P.O. Box 8180 ■ Bartlett, IL 60103 ■ 800-577-8775

TRIDENT



\$699⁰⁰
SV150

**1000KHz to 1.00GHz
Spectrum Analyzer System
Up to 500MHz Span. Two bands.**

All the advantages of a Spectrum Analyzer at a very affordable price. Great for interference and signal hunting. RS232 connect for logging signals to disk. Real time display sweep outputs on any X,Y scope. Variable span and sweep rate. Marker function and selectable bandwidth. Demods in AM/NFM/WFM plus BFO for CW/SSB modes. For instant information use our fax back service at 317 849 8683, #405. Or, email Scanns@www.acecomms.com . http://www.acecomms.com/Scanns.



Order Line: 1 888 445 7717

10707 E. 106th, Fishers, IN 46038 International: 317 842 7115
Fax 317 849 8794 Email: Scanns@www.acecomms.com

CIRCLE 25 ON FREE INFORMATION CARD

**ARE YOU LOOKING FOR
NEW AND MOST
INNOVATIVE PRODUCTS?
hard to find**

world wide products unique

IF SO, WE HAVE JUST THE RIGHT PRODUCTS FOR YOU! PRODUCTS FOR ALL AGES CAN BE FOUND IN OUR CATALOGS THE BEST KNOWN BRANDS SUCH AS IBM, ACER, ARMNOTE, TOSHIBA, NUREALITY, QUORUM, FUJI, PANASONIC AND SO MUCH MORE! WE ALSO CARRY A WIDE RANGE OF PRODUCTS LIKE COMPUTERS, KEYBOARDS, MODEMS, MONITORS, MOTHERBOARDS, CHIPS

ELECTRONIC COMPONENTS
CABLES PLUGS ADAPTERS
CD ROMS HARD DRIVES LAPTOPS
FAXES SCANNERS BUSINESS OPPORTUNITIES
TOYS SECURITY ALARM SYSTEMS

ALL YOU HAVE TO DO IS SEND \$9.00 U.S. \$15.00 CND TO BECOME A LIFETIME MEMBER OF THE GREAT SELECTION OF PRODUCTS THAT MANA ELECTRONICS HAS TO OFFER! INSTEAD OF SEARCHING, WE SEND IT RIGHT TO YOUR HOME! PRODUCTS ARE FACTORY FRESH, WARRANTED AND REFUNDABLE. WE OFFER DEALS, DISCOUNTS, PROMOTIONAL GIFT ITEMS TO OUR MEMBERS WHILE YOU ARE CURRENTLY UPDATED WITH CATALOGS OF THE NEWEST AND MOST INNOVATIVE ELECTRONIC PRODUCTS AVAILABLE TODAY!

only \$9.00us \$15.00cnd 30 DAY REFUND.

order now! AND GET A FREE PEN!



SEND CHECK OR MONEY ORDER TO

MANA ELECTRONICS

P.O. Box 67002 RPO Maples
Winnipeg MB R2P 2T3
(204)-697-3488



The Pocket Programmer

\$129.95



The portable programmer that uses the printer port of your PC instead of an internal card.

Easy to use software that programs E(E)prom, Flash & Dallas Ram. 27(C)/28(C)(F)/29(C)(F)/25 series from 16K to 8 Megabit with a 32 pin socket. Adapters available for MCU's 874X, 875X, Pic, 40-Pin X 16 & Serial Eprom's, PLCC, 5-Gang and Eprom Emulator to 32K X 8.

Same Name, Address & Phone # for 13 Years.... Isn't it Amazing ?

Intronics, Inc.
Box 13723 / 612 Newton St.
Edwardsville, KS 66113 Add \$4.75 COD
Tel. (913) 422-2094 Add \$4.00 Shipping
Fax (913) 441-1623 Visa / Master Charge

PROGRAMMERS OVER 50 MODELS

ADVANTECH EETOOLS NEEDHAMS DATA I/O ICE TECHNOLOGY HILO SYSTEM GENERAL CHROMA MODULAR CIRCUIT TECHNOLOGY XELTEK



PROMAX EMP-20 MEGAMAX MEGAMAX4 SIMM/SIP TESTER EMUPA
 CALL ADVANTECH LABTOOL 599 EETOOLS SIMMAX
 629 ICE TECH MICROV 795 CHROMA SIMM/SIP
 650 EETOOLS ALLMAX + 359 MOD-MCT-EMUPA/R
 409 EETOOLS MEGAMAX 279 MOD-MCT-EMUP/R
 509 EETOOLS MEGAMAX4 49 EPROM 1G TO 512K
 369 XELTEK SUPERPRO II 69 EPROM 1G TO 1MEG
 409 XELTEK SUPERPRO II P 99 EPROM 4G TO 1MEG
 249 XELTEK SUPERPRO L 199 EPROM 16G TO 1 MEG
 165 XELTEK ROMMASTER II 89 EPROM 1G TO 8MEG
 479 MOD-MCT-EMUPA 129 EPROM 4G TO 8MEG
 739 STAG ORBIT-32 250 EPROM 8G TO 8MEG



LABTOOL4B MICROMASTER SUPERPRO ALLMAX PLUS ROMMASTER2

General Device Instruments

Sales 408-241-7376 Fax 241-6375 BBS 983-1234
 Web www.generaldevice.com E-Mail icdevice@best.com

WINDOWS 95 —One Step at a Time

Don't know what to do when confronted with Microsoft's Windows 95 screen? Then you need a copy of *Windows 95—One Step at a Time*. Develop your expertise with the straight-forward presentation of the frequently-used features that make Windows 95 so valuable to the PC user.



To order Book BP399 send \$6.95 plus \$3.00 for shipping in the U.S. and Canada only to **Electronics Technology Today Inc.**, P.O. Box 240, Massapequa Park, NY 11762-0240. Payment in U.S. funds by U.S. bank check or International Money Order. Please allow 6-8 weeks for delivery.

Learn MICROCONTROLLERS EMBEDDED SYSTEMS and PROGRAMMING...

...with the AES learning system/ embedded control system. Extensive manuals guide you through your development project. All programming and hardware details explained. Complete schematics. Learn to program the LCD, keypad digital, analog, and serial I/O. for your applications.

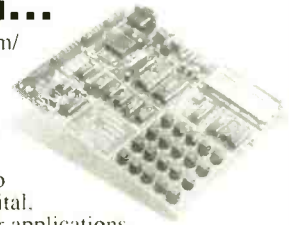

THREE MODELS AVAILABLE. Choose from an Intel 8051, Intel 8088, or Motorola 68HC11 based system. All models come with:

- 32K Byte ROM, 32K Byte RAM • 2 by 16 Liquid Crystal Display • 4 by 5 Keypad • Digital, Analog, and Serial I/O • Interrupts, timers, chip-selects • 26 pin expansion connector • Built-in Logic Probe • Power Supply (can also be battery operated) • Powerful ROM MONITOR to help you program • Connects to your PC for programming or data logging (cable included) • Assembly, BASIC, and C programming (varies with model) • Program disks with Cross Assembler and many, well documented, program examples • User's Manuals: cover all details (over 500 pages) • Completely assembled and ready to use • Source code for all drivers and MONITOR • Optional Text Book

Everything you need. From \$279. Money Back Guarantee

Call for Free Info Pack, or see WEB at <http://www.aesmicro.com> 714-550-8094, FAX 714-550-9941



Call 1-800-730-3232

AES 970 W. 17TH STREET, SANTA ANA, CA 92706, USA

EPROM+ PROGRAMMING SYSTEM USES PARALLEL PORT

EPROMS (24, 28, 32 & 40 PIN*) +27C AND 25XX 1702*, 2708, TMS2716*, 32, 32A, 64, 64A, 128, 128A 256, 512, 513, 011, 010, 101, 1001, 1000, 1024, 210, 020 2001, 220, 2048, 4001, 2, 040, 080, 240, 4096, 68764/66
FLASH EPROMS 28F256, 28F512, 28F010, 28F020, 29C257, 29C010, 29C040, 29F010, 29F040
EEPROMS & NVRAMS (18, 24 & 28 PIN +CXX) 2210, 2212, 2804, 2816, 2816A, 2817, 2864, 2865 28256, 28C010, DS1220, DS1225, DS1230
SERIAL EEPROMS* (8 & 14 PIN PLUS CXX) ER 1400, M58657, 2401, 02, 04, 08, 16, 32, 65, 2444 59C11, 80011A, 9306, 46, 56, 66, 85, 72, 82, 92, 168/9XX
BIPOLAR PROMS* (16 THROUGH 24 PINS) 74SXXX AND 82SXXX FAMILY
MICROCONTROLLERS* 8741, 42, 48, 49, 8751 C51, 52, C52, 87C5XXX, 87C75X, 89C5X, 68705 68HC705, 68HC711E9, PIC16CXX, TMS7742
 *ADAPTER REQUIRED - DIAGRAMS INCLUDED



SYSTEM INCLUDES: PROGRAMMING UNIT, PRINTER PORT CABLE, POWER PACK, MANUAL AND SOFTWARE.

\$289

ADD \$5.00 SHIPPING \$5.00 C.O.D. VISA/MASTERCARD

ANDROMEDA RESEARCH, P.O. BOX 222, MILFORD, OH 45150 (513) 831-9708 FAX (513) 831-7562

Be a PC repair expert!

Approved home study. Learn to troubleshoot, repair, install, upgrade, and service computers. **Free literature: 800-223-4542**

Name _____ Age _____
 Address _____ Phone (____) _____
 City/State _____ Zip _____
School of PC Repair, DEPT. JJB341, PCDI
 6065 Roswell Road, Atlanta, Georgia 30328



COUNTERSURVEILLANCE MANUFACTURER

AI-6600 PHONE TAP DETECTOR

- DETECTS:**
- Radio Frequency Taps
 - Series and Parallel Taps
 - Line Impedance Taps
 - Extension Phone Listeners

\$149⁹⁵



AI-2100 VIBRATING TRANSMITTER DETECTOR

- DETECTS:**
- Body Wires
 - FM Wireless Mics
 - AM Transmitters
 - UHF Transmitters

\$189⁹⁵



AI-5500 COMPLETE SAFETY SYSTEM

- DETECTS:**
- All Phone Taps and Extension Phone Listeners
 - All Body Wires, Wireless Mics, AM/FM and UHF Transmitters
- DEFEATS:**
- All Body Wires, Transmitters and Distance Microphones with its built-in white noise generator

\$379⁹⁵



TRVD-900 TRANSMITTER / TAPE RECORDER & VIDEO DETECTION SYSTEM

- DETECTS:**
- Body Wires
 - FM Wireless Mics • AM Transmitters • UHF Transmitters
 - Tape Recorders • Video Equipment

Alerts User By Vibrating and/or Illuminated LEDs

\$495⁰⁰

WSS-100 WIRELESS SURVEILLANCE SYSTEM SEES & HEARS EVERYTHING!

- FEATURES:**
- 2.4 GHz Video / Audio Transmitter
 - 4 Channel Receiver • 300' Transmission Range
 - Black & White CCD w/ Auto-Iris Lens • 410(H) TV Line Resolution
 - FCC Approved Frequency

\$649⁹⁵



Send \$6.00 for 32-Page Catalog (FREE w/ Purchase)

Items May Be Purchased by Certified Check, Money Order or C.O.D.

AMERICAN INNOVATIONS, INC.

119 ROCKLAND CENTER ~ SUITE 315 • NANUET, NY 10954

VOICE: (914) 735-6127 • FAX: (914) 735-3560

HTTP://WWW.SPYSITE.COM • E-MAIL: AMERICAN@SPYSITE.COM

Quantity Discounts Available

OWN A MACHINE SHOP

The Smithy 3-in-1 lathe-mill-drill gives you all 3 basic machine

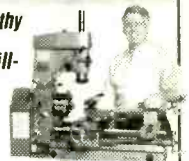

tools in one easy-to-use benchtop machine. Save time & money. For home or business.

Call for your FREE Info Pak & instructional video.

1-800-345-6342

FREE Machining Basics video

Ask for Operator PE12

or write

Dept. PE12
PO Box 1517
Ann Arbor, MI
48106-1517

Smithy

Mini-Mods

Miniature Engineering Modules

Pocket Watch Real time clock w/alarm & leap year compensation

\$19.⁹⁵ Each

RamPack

8Kx8 serially addressable SRAM

Motor Mind

Serially controlled H-Bridge driver

Mini-Watt

5V@200mA battery power supply w/charger. Add \$10 for power cube and NICads

First three products use serial com. and have auto baud detect.

All products perfect for Basic Stamp and micro-controllers



SOLUTIONS CUBED

3029 F Esplanade

Chico, CA 95973

(916) 891-8045

www.solutions-cubed.com

WHOLESALE PRICES STARTING AS LOW AS \$99.00

CABLE TV DESCRAMBLERS CONVERTERS FILTERS • VIDEO STABILIZERS

1 Year Warranty on All Products. Affordable Extended Warranty. **FREE CATALOG!**

30 Day FREE TRIAL

Call the Cable Professionals 24 Hours A Day!

Orion Electronics

1-800-379-3976

HTTP://WWW.ORION-ELECTRONICS.COM



START A CAREER IN ELECTRONICS!

Accredited home study course. Train now for a great career or sideline.

You'll understand how electronics devices work so you can repair, install, and service audio equipment, microwave ovens, small appliances, alarms, and more.

Earn good money as a technician in an electronics company—or open your own at-home business. For your free career literature, send or call 24 hours a day.

CALL 800-223-4542

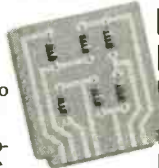

Name _____
Address _____
City/State _____ Zip _____
Phone (____) _____ Age _____

The School of Electronics, Dept. ELB341
PCDI, 6065 Roswell Road, Atlanta, GA 30328

TERK OUTLET STORE SAVINGS

POWERED AM/FM AND TV ANTENNAS

The world's leading manufacturer of antennas has slightly imperfect inventory, fully refurbished and available factory-direct at reduced prices. Call now for availability and pricing.

1.800.942.8375



TERK TECHNOLOGIES



MASTERCARD & VISA CHEERFULLY ACCEPTED. CALL TERK TODAY

PLAINVIEW, NEW YORK

ELECTRONIC KITS! VOICE CHANGERS! AND MORE!

PRICES SUBJECT TO CHANGE WITHOUT NOTICE



TOLL FREE ORDER LINE: 1-800-336-7389
FAX LINE: 1-602-731-4748
TECH SUPPORT NUMBER: 1-602-894-0992

XANDI ELECTRONICS, INC.
MANUFACTURER OF HIGH QUALITY KITS

143.775 MHz CRYSTAL CONTROLLED TRANSMITTER KITS



XTR300EZ \$79.95
XTL3000EZ \$99.95
XTL1000EZ \$69.95

XTR300

TRACKING TRANSMITTER KIT
Transmits continuous beep-beep-beep
Ideal for locating lost or stolen items
Range up to 1/2 mile

XTL3000

LONG RANGE TRANSMITTER KIT
Sensitive built in microphone
Range up to 1 mile
Custom frequencies available

XTL1000

TRANSMITTER KIT
Sensitive built in microphone
Range up to 1/2 mile
Custom frequencies available

CRYSTAL TRANSMITTER KITS

- Ultra-miniature surface mount construction.
- E-Z kit approach makes assembly a snap.
- Miniature battery and holder mounted directly to the circuit board.
- Transmit to any scanner type receiver

BUG DETECTOR

XBD500
\$149.95

- Professional quality.
- Not a kit, ready to use.
- Covers 1 to 2,000MHz.
- Uses new Microwave Integrated Circuit amplifier.
- Adjustable sensitivity.
- Audio jack for privacy ear phone.



Any intercepted signal causes an audio tone that increases from a low pitched growl to a high pitched squeal as the signal strength increases.

88-108 MHz FM RECEIVER

XMR2000
\$29.95

- Worlds smallest FM radio.
- As small as a hearing aid.
- Weighs less than 1/4 oz.
- Digital touch tuning.
- Ideal for use with our 88-108MHz FM transmitters



88-108 MHz FM TRANSMITTER KITS



XST 500EZ \$49.95
XWB 1000EZ \$46.95
XFM 100C \$21.95



XSP 250EZ \$34.95
XTR 100C \$29.95
XTT 100C \$19.95

XST 500 Voice transmitter. Range up to 1 mile. Supersensitive mic. Uses 9 volt battery. Uses surface mount components.

XWB 1000 Voice transmitter. Range up to 1/2 mile. Includes mic and battery on circuit board. Uses surface mount components.

XFM 100 Voice transmitter. Range up to 1 mile. 9 v battery and leaded components.

XSP 250 Super-miniature telephone transmitter. Range 1/4 mile. Powered by phone line. Uses surface mount component.

XTR 100 Tracking transmitter. Range up to 1 mile. Uses 9 volt battery. Transmits a BEEP - BEEP - BEEP tone

XTT 100 Telephone transmitter. Range up to 1 mile. Uses 9 volt battery.



XPC 400
TV CAMERA
400 LINES OF RES

- Use any TV or VCR with a video input connector.
- Includes power cube.
- About half the size of a pack of cigarettes.
- See entire room through pin sized hole.

Assembled \$269.95



XVS100
TV TRANSMITTER

- Use with XPC400, VCR, Camcorder, etc.
- Power cube included.
- Uses the UHF TV band.
- Transmits video and audio.
- Up to 100 foot range.

E-Z Kit \$29.95

PHONE VOICE CHANGER

16 levels of digital voice changing. Sound tougher, older or younger, female or male. Powered by 4 AA batteries. (Batteries not included).

Works with regular or multi-line phones. Connects between handset and phone. Note will not work with cordless or handset type telephones.



T-2001
Assembled
\$69.95



XLB-9 \$8.95
9V LITHIUM BATTERY

Worlds most powerful 9V battery! Twice the life of alkaline batteries.



XLB-3 \$3.95
3V CAMERA BATTERY

Small 3V Lithium battery. For use with XTL3000, XTL1000, XTR300, and XWB1000.

PROJECT BOX
\$14.95

Ideal project box to give your kits that professional look. Available custom drilled for the following kits: XFS108, XPS1000, XLC900, and XVA250.

XANDI ADVANCED HOBBY KITS



XPS 1000C
\$55.95

TELEPHONE SNOOP KIT

- Dial home from anywhere and hear inside your home.
- TouchTone coded for secure operation.
- Stop burglars and intruders.
- Reliable 24 hour protection.



XLC 900C
\$49.95

SCANNER CONVERTER KIT(800-950MHZ)

- Uninterrupted coverage of the 800 to 950 MHz band!
- Works with any 400-550MHz scanner.
- Gain: 6 dB typical.
- Noise figure: 3 dB typical.



XVA 250C
\$49.95

VOICE-STRESS ANALYZER KIT

- See at a glance if your being lied to!
- Subject need not be present. Works with voices from recordings, TV or radio.
- Has built-in microphone.
- Easy to use LED display output.



XFS 108C
\$39.95

88-108 MHz FM STEREO TRANSMITTER KIT

- Separate level control for both left and right channels.
- Output level circuit with test points for quick and easy tuning.
- Transmit from any stereo audio source to most any FM stereo receiver.

Serving the public since 1981
XANDI ELECTRONICS, INC.
1270 E Broadway Rd. # 113
Tempe AZ 85282

WE ACCEPT CHECK, VISA, MC, MO, COD
SHIPPING & HANDLING EXTRA



SEND \$2.00 FOR COMPLETE CATALOG

REFUNDABLE ON FIRST ORDER

SEND MAIL ORDERS TO:
XANDI ELECTRONICS
BOX 25647
TEMPE, AZ 85285-5647

CIRCLE 134 ON FREE INFORMATION CARD

Fix It Yourself!



It's easy, fast, and rewarding to repair it yourself with the Electronics Repair Manual!

- Hands-on, detailed, troubleshooting instructions
- "How to" primer for test equipment: oscilloscope, frequency counters, video analyzers, etc.
- Schematic diagrams
- Trouble analysis flowcharts
- Preventive maintenance techniques
- Safety precaution checklists
- Comprehensive replacement parts list
- Directory of manufacturers

Leading Manufacturers Represented...

- Emerson • Nintendo • RCA • Technics
- Hitachi • Panasonic • Sanyo • Toshiba
- IBM • Pioneer • Sharp • Zenith
- NEC • Quasar • Sony and others!

✓ Dozens of Fix-It-Yourself Projects for...

- CD Players
 - VCRs
 - Televisions
 - Camcorders
 - Computer Equipment
 - Fax Machines
 - Telephones
 - Amplifiers
 - Car Radios
 - Home Appliances
 - AM/FM Tuners
 - Thermostats
- ...and more!**

30-Day Free Trial!



Keep Your Skills Up-to-Date!

The Electronics Repair Manual and the Modern Manual Electronics Manual will be a valuable reference for years to come. Supplements, each containing over 125 pages, add new repair projects, valuable insights into new technologies, diagnostic and repair techniques, electronics projects, and more schematic diagrams into your manual. Just \$35 each for Electronics Repair and \$49.50 each for Modern Electronics plus shipping and handling. Supplements are sent 4-5 times a year and are fully guaranteed. Return any supplements you don't want within 30-days and owe nothing. Cancel anytime.

INSTEK Test & Measuring Instruments

20 MHz, 2-Channel, OSCILLOSCOPE

- ▣ model #OS-622B
- ▣ 20MHz, Dual Channel
- ▣ High Sensitivity 1mV/DIV
- ▣ TV Synchronization
- ▣ Z axis input
- ▣ ALT Triggering Function
- ▣ Hold Off Function
- ▣ Trigger Level Lock Function
- ▣ CH 1 Output
- ▣ Includes Probes (x1, x10)
- ▣ 2 Year Warranty

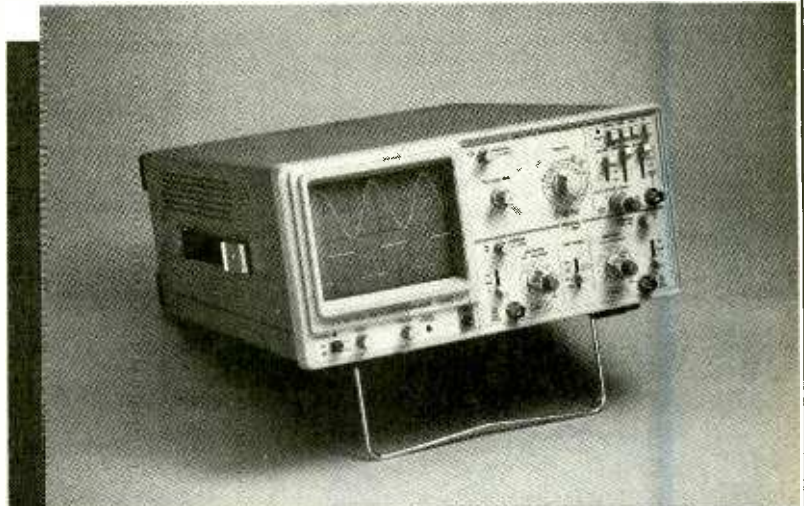

Regular \$499.00 Sale \$389.95

PRINT™ 
Products International



800-638-2020



Test Instruments, Equipment, Tools & Supplies For Electronic Production, Maintenance & Service
8931 Brookville Road, Silver Spring, MD, 20910 * 800-638-2020 * Fax 800-545-0058

CIRCLE 45 ON FREE INFORMATION CARD

TAKE A BITE OUT OF YOUR CABLE BILL !!!

CABLE BOXES & DESCRAMBLERS



1(800) 72-BOXES

AT LAST! DC-20 MHz SYNTHESIZED PERFORMANCE FOR ONLY \$795!

- DC-20 MHz, .1 Hz resolution, DC offset
- Linear/Log Sweep
- Internal/External AM
- Internal/External FM
- Internal/External PM
- Internal/External SSB
- Internal/External BPSK
- Dualtone Generation
- Internal/External FSK
- Burst
- DTMF Generation
- DTMF Detection
- Power Level Measmt

\$795

Quantity 1
Made in U.S.A.

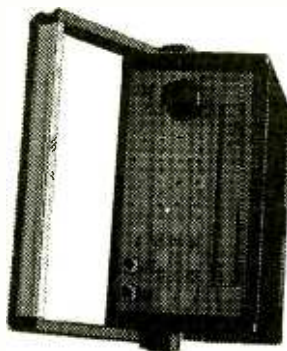

The SG-100 gives you .1 Hz synthesized precision and a wide diversity of modulation functions all of which can be performed using an internally generated or externally applied signal. You also get signal analysis functions that are just not offered on any other signal source such as DTMF Detection and Power Level Measurement. And because you can download new instrument functions to Flash memory, you can ensure that your SG-100 will never become obsolete.

The SG-100 is available NOW and is ready to turn your engineering bench into a real powerhouse!

Telulex Inc.

2455 Old Middlefield Way S, Mountain View, Ca. 94043 (415) 938-0240
Fax: (415) 938-0241 <http://www.telulex.com> email: sales@telulex.com



C.O.D. P.O.



**Are you overpaying . . .
 . . . your cable company?**

You are if . . . 
 . . . **you are leasing their
 equipment.**

- Forest Electronics, Inc. offers a complete line of New Cable Decoders and Converters that are fully Compatible with your cable system.
- All systems come with: Remote Control, & Parental Guidance Feature. Volume Control is also available.
- All Equipment is fully guaranteed & comes with a 30 day money back option.

For More Information Call Us 24 Hours a Day At:

800-332-1996

FAX: 813-376-7801

CABLE T.V. EQUIPMENT

Friendly, Knowledgeable Service



**ORDERS CALL:
 1-800-361-4586**

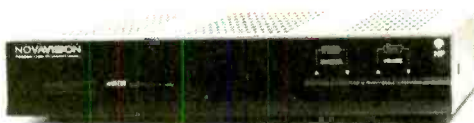

- All Equipment New
- Convertors & Descramblers
- 30 Day Money Back Guarantee
- 6 Month Warranty
- Visa, MC, C.O.D. Welcome

KDE ELECTRONICS, INC.

P.O. Box 1494

Addison, IL 60101

Info. 630-889-0281

HRS: Mon-Fri, 9-6 CST

Fax 630-889-0283

Sat, 9-3 CST

CABLE DIRECT

CONVERTERS
 DESCRAMBLERS
 VIDEO STABILIZERS
 FILTERS



**100%
 MONEY BACK
 GUARANTEE!**

**30 DAY
 FREE
 TRIAL!**

FREE Cable TV Catalog.



Now you can tune-in your favorite cable TV programming and **SAVE \$100'S - EVEN \$1000'S** on premium CABLE TV EQUIPMENT.

**MODERN
 ELECTRONICS**

1-800-906-6664

2125 S. 156TH CIRCLE • OMAHA, NE 68130

THE GREATEST SPY BOOK EVER!!

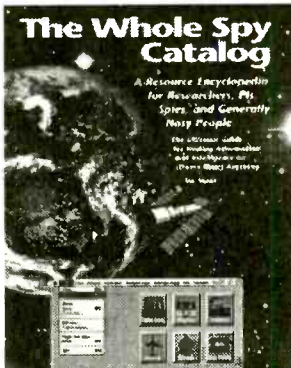

How to Locate and: Bug Anyone — Tap Any Phone — Conduct Video Surveillance — Install Latest Counter Measures — Research Anyone — Track Anyone's Assets — Hire Ex-CIA/KGB Agents. Real Inside Secrets.

Plus, latest in night vision, order satellite photographs of anywhere on earth, best book sources for CIA publications, ID changing, private detective schools, newsletters, courses, and associations, latest B & E tricks. "Recommended (or hated) by CIA directors, the world's most famous private detective, KGB officers . . . Lee Lapin does it again! **THE WHOLE SPY CATALOG** (440 pages) \$49.95 PP, orders 1-4115-513-5549, or Intelligence Inc., Dept K, 2228 S. El Camino Real, San Mateo, CA 94403.

Top 50 surveillance product catalog FREE w/order.

**INTELLIGENCE
 INCORPORATED**

Radiotelephone - Radiotelegraph

FCC Commercial License

Why Take Chances?

Discover how easy it is to pass the exams. Study with the most current materials available. Our Homestudy Guides, Audio, Video or PC "Q&A" pools make it so fast, easy and inexpensive. No college or experience needed. The new

commercial FCC exams have been revised, covering updated Aviation, Marine, Radar, Microwave, New Rules & Regs, Digital Circuitry & more. We feature the Popular

"Complete Electronic Career Guide" 1000's of satisfied customers

Guarantee to pass or money back.

Send for **FREE DETAILS** or call

1-800-800-7588

WPT Publications
 4701 N.E. 47th Street
 Vancouver, WA 98661

Name _____

Address _____

City _____ St. _____ Zip _____

1-800-800-7588

HOME AUTOMATION

World's Largest Selection!

*Widest Selection of
X-10 Devices Available*

Hundreds of hard-to-find automation, X-10 and wireless control products. Computer interfaces, software, development tools, lighting control, telephone systems, security systems, surveillance cameras, infra-red audio/video control, HVAC, pet care automation, wiring supplies, books and videos and much more!

*Loaded with Pictures
& Diagrams*



HOME AUTOMATION SYSTEMS, Inc.

Questions: 714-708-0610 Fax: 714-708-0614

e-mail: catalog@smarthome.com

<http://www.smarthome.com/smarthome>

**Lowest Prices
Guaranteed!**

24 Hours

Call 800-SMART-HOME 800-782-7340

Don't rent own! Cable TV Descramblers

We'll beat Any Price!

- Same Day Shipping!
- 30 Day Money Back Guarantee!
- Credit Cards/C.O.D.

Have make and model number of equipment used in your area

REPLACEMENTS FOR MOST SYSTEMS

CALL TOLL FREE

CABLE DISCOUNT

1-800-684-9135

NO NEW JERSEY SALES!

Anyone implying theft of service will be denied assistance.

Quality Microwave TV Systems
WIRELESS CABLE - ITFS - MMDS
ATV - INTERNATIONAL - S-BAND
Amplifiers - Antennas - Books - Components
Filters - Systems - Video Products
 • RF Frequency 1990 - 2700 MHz
 • Cable Ready - VHF - UHF Outputs
 • SASE For "FREE" Catalog or Send \$1

PHILLIPS-TECH ELECTRONICS
 PO Box 8533 • Scottsdale, AZ 85252

ORDER LINE 800-880-MMDS
CATALOG/INFO 602-947-7700
FAX LINE 602-947-7799

CHALLENGER SYSTEM
 33-Channel 52dB+ Gain
 Complete Grid \$265
 Five Year Warranty
FREE SHIPPING Visa • MC • Amx • Disc • COD's • Qty Pricing

CIRCLE 145 ON FREE INFORMATION CARD

PROTOTYPES

Or large runs. PCBs, wave soldering, cabinets and other metal parts, silk screen printing, plastic injection, xformer/coil winding, etc. Assembly, wiring. Very low prices! Twin plant in Mexico. We ship to your door. V&V. PH. (713) 537-7518 Fax. 011 (525) 361-5996.

CONTROL YOUR WORLD
32K HC11
ModCon
 Low Cost Microcontroller boards & kits + Applications

ZORIN <http://ZORINco.com>
 or call (206) 262-6061

Low Cost CAD Software for the IBM PC and Compatibles Now In Windows™

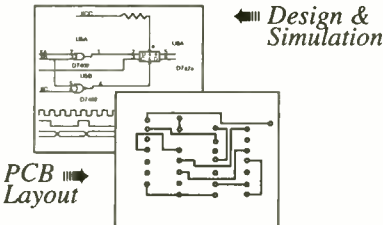

- Easy to use schematic entry program (SuperCAD) for circuit diagrams, only \$149. Includes netlisting, bill of materials, extensive parts libraries, More parts, and automatic wiring available in enhanced CAD package (SuperCAD+) for only \$249.
- Powerful, event-driven digital simulator (SuperSIM) allows you to check logic circuitry quickly before actually wiring it up. Works directly within the SuperCAD editor from a pulldown menu and displays results in "logic analyzer" display window. Starting at \$149 this is the lowest cost simulator on the market. Support for PALS, a larger library, and a separate interactive logic viewer are available in full-featured SuperSIM+ for only \$399. Library parts include TTL, CMOS and ECL devices.
- Circuit board artwork editor and autorouter programs (SuperPCB), starting at \$149. Produce high quality artwork directly on dot matrix or laser printers. You can do boards up to 16 layers including surface mount. Includes Gerber and Excellon file output. Autorouter accepts netlists and placement data directly from the SuperCAD schematic editor.
- Low cost combination packages with schematics and PCB design: 2-layer for \$399, 16-layer for \$649.
- DOS version available.

Write or call for free demo disks:

MENTAL AUTOMATION
 5415 - 136th Place S.E.
 Bellevue, WA 98006
 (206) 641-2141 • BBS (206) 641-2846
<http://www.mentala.com>

CABLE BOX DISCOUNT

We'll Meet or Beat The Competition!

ORIGINAL EQUIPMENT, DESCRAMBLERS,
CONVERTERS, SUPER-Q

***** Same day Shipping! *****

Have make and model number used in your area

REPLACEMENT FOR MOST SYSTEMS

\$\$ SAVE BIG BUCKS\$\$

DON'T WAIT CALL TOLL FREE

1-888-561-4796

VOID WHERE PROHIBITED

Anyone implying theft will be denied assistance.

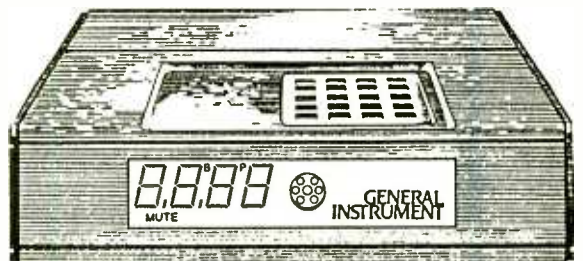

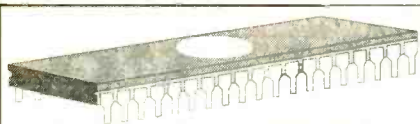

CABLE CONVERTER DIAGNOSTIC TEST CHIP

LOAD FULL ACTIVATION OF CABLE CONVERTER

WE STOCK A COMPLETE LINE OF CHIPS, TOOLS, WIRELESS QUICK INSTALL TEST BOARDS AND DIAGNOSTIC CUBES FOR ALL CONVERTERS!

*****ANYONE IMPLYING ILLEGAL USE WILL BE DENIED SALE. WE SELL PRODUCTS ONLY!! TO TECHNICIANS OR CABLE REPAIR FACILITIES!!**

#1 IN CUSTOMER SERVICE & TECH. SUPPORT!

***ALL ORDERS SHIP WITHIN 24HRS, UPS/ FED-X.**

***PRIORITY NEXT DAY SHIPPING AVAILABLE!**

***SALE- BUY 5 TEST BOARDS AND GET 1 FREE.**

MONDAY THRU FRIDAY - 8AM-7PM EST.

HTTP://WWW.AMERICANINTERNET.COM/GOCABLE



COMMUNICATIONS INC.

FOR ORDERS 1-800-GO-CABLE

CATALOG & TECH. SUPPORT 717-620-4363 EST. 1976

WE HAVE IT ALL! Surveillance

- Infinity Transmitters
 - FM Wireless Transmitter Kits
 - Vehicle Tracking Systems
 - Bug Detectors
 - Caller I.D.
 - Wired Mikes
 - Telephone Register with Printer
 - Long-play Recorders
 - Shotgun Mikes
 - Telephone Recording Adapters
 - Alcohol Testers
 - Telephone Scramblers
 - Hidden Video Cameras
 - Telephone Tap Detectors
 - Drug Testers
- MUCH, MUCH, MUCH MORE.**

Our 27th Year!
Small catalog FREE.
Larger catalog send \$5.

Mail Order only. Visa, MasterCard and C.O.D. accepted for equipment only.

Inquire for dealers' prices.

A.M.C. SALES, INC.

193 Vaquero Dr. • Boulder, CO 80303

Mon.-Fri. 8 a.m.-5 p.m. Mtn. Time

800-926-2488

(303) 499-5405 • Fax (303) 494-4924

Internet: <http://www.siteleader.com/catalogdepot/AMCSC-home.html>

E-mail: amc-sales@siteleader.com

**K
A
B
L
E
W
O
R
K
S**

Zenith ST 1000's \$25.00

Screened & Cleaned

Also:

SA-8580

SA-8550

SA-8590

DPBB-7

DPV-5

DPV-7

Basics

Pioneers

& more!

All converters unmodified

800-899-5000

\$139* Laser LightShow



Draw with a laser beam! Animation, text, music & more! Includes galvos, mirrors, servo amp, demo software disk, analog and digital computer interface. Use an inexpensive pen pointer or high power gas laser.



Computerized Motors \$39*

Includes: 2 Stepper motors, 2 DC motors, computer interface, training manual, & demo software disk. Expandable! Up to 12 motors, up to 3 amps per phase.

Now with 4 Axis Linear Interpolation

* Add \$6 for shipping. Computer with parallel printer port & cable, assembly, power supply, & laser are required

FREE FLYER

Voice 510-582-6602 Fax 510-582-6603

SVS

1273 Industrial Pkwy. West Bldg. 460
PO Box 55125 Hayward CA 94545-0125

CABLE TV CONVERTERS AND DESCRABLERS



WE CARRY A FULL LINE OF CONVERTERS AND DESCRABLERS COMPATIBLE WITH MOST MAJOR BRANDS INCLUDING:

- Scientific Atlanta™
- Jerrold™
- Tocom™
- Zenith™
- Pioneer™

30 DAY MONEY BACK GUARANTEE BEST PRICES FREE CATALOG

Please have the MAKE & MODEL # of your full premium service cable box ready when you call!

ALLSTAR ELECTRONICS 800-782-7214

HOURS: 9-6 M-F 10-3 Sat EST

It is not the intent of Allstar Electronics to defraud any pay TV operator. Anyone implying theft of service will be denied assistance. All brand names are registered trademarks of their respective owners & are used for reference only. 110-64 Queens Blvd., #466, Forest Hills, NY 11375. NO NYS SALES.



If you are not getting this catalog you are missing out on some of the best deals in

electronics today! We have thousands of items ranging from unique, hard-to-find parts to standard production components. Call, write, or fax today to start your free subscription to the most unique catalog in the industry, filled with super values on surplus electronic and hobbyist type items. If you have a friend who would like to receive our catalog, send us their name and address and we will gladly forward them a complimentary 100 page catalog.

Why pay more? Call today.

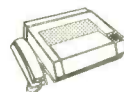

340 East First Street Fax Order Line
Dayton, Ohio 45402 1-800-344-6324

Order Toll-Free 1-800-344-4465

CIRCLE 147 ON FREE INFORMATION CARD

SURVEILLANCE & COUNTERSURVEILLANCE Electronic Devices

Discreet audio & video systems
• High performance recording devices • Voice encryption devices
• Personal protection • Bug detection • How-to books from the Spytch™ library...and more!

CALL TOLL-FREE: 1-888-SPY-TECH
(1-888-779-8324) 24 hrs a day 7 days a week

Exclusive Spytch™ Catalogue — over 100 pages of the latest security & surveillance products in the world. See it for yourself!



\$29.95 incl. S/H plus appl. taxes

James Bond shops here!

EARN MORE MONEY!

Be an FCC LICENSED ELECTRONIC TECHNICIAN!



No costly school. No commuting to class. The Original Home-Study course prepares you for the "FCC Commercial Radiotelephone License." This valuable license is your professional "ticket" to thousands of exciting jobs in Communications, Radio-TV, Microwave, Maritime, Radar, Avionics and more... even start your own business! You don't need a college degree to qualify, but you do need an FCC License.

No Need to Quit Your Job or Go To School
This proven course is easy, fast and low cost! **GUARANTEED PASS**—You get your FCC License or money refunded. **Send for FREE facts now. MAIL COUPON TODAY!**

Or, Call 1-800-932-4268 Ext. 240

COMMAND PRODUCTIONS

FCC LICENSE TRAINING, Dept. 240
P.O. Box 2824, San Francisco, CA 94126
Please rush FREE details immediately!

NAME _____
ADDRESS _____
CITY _____ STATE _____ ZIP _____

WORLD'S SMALLEST

Wireless Video Transmitters

Used by hundreds of hobbyists and professionals alike in R/C models, Robots, Surveillance Video, movie Special Effects, and Law Enforcement.

"... previously, I used expensive wireless units from Pelco, MVP, and Supercircuits. Nothing approaches the VidLinks in power, picture quality, size, and value. Thank you." *R. Leslie, CCTV Installer, NY.*
"The best... Incredible color, resolution... very easy to use... cool." *P. Davis, Movie Props, CA.*

Actual Size!!!



Live Remote Video From \$99.00

- Full 100 mW RF Power. Range 500ft. to 1/2mile •
- Crystal Controlled •
- High-Resolution Full Color/ B&W video •
- Fully epoxy encased- no exposed components •
- Fully assembled- only two wires to attach •
- **MONEY BACK GUARANTEE.** •

VidLink 100: 100mW Power- upto 1/4 Mile
\$199.00 New! High-Power!

VidLink 15: 15mW Power- upto 150 Feet
\$99.00 New! Low Price- Same Size!

Covert Camera: 1 1/4" sq. Pinhole Lens
\$169.00 Pro Grade Japanese Quality!

*** Audio Module Now Available. Call. ***
Check/MO, COD +\$5.00, S&H \$5.50

AEGIS RESEARCH

#671-1225 E. Sunset Dr.
Bellingham, WA
98226-3529 USA

1-604-224-0416

Visit our virtual catalog on the INTERNET at:
<http://www.lynx.bc.ca/virtualspy>

One tree can make
3,000,000 matches.

One match can burn
3,000,000 trees.



A Public Service of This Magazine
& The Advertising Council

Converters & Descramblers Call 1-800-715-6789

30 Day Money Back Guarantee

FREE Catalog



illumium
ENTERPRISES

...It's Full of Stars

- Panasonic
- Jerrold
- Pioneer
- Zenith
- Scientific Atlanta

ALL MAJOR CREDIT CARDS ACCEPTED

13492 Research Blvd • Suite 120-113 • Austin, TX 78750

BIG PROGRAMMING!
COMPARE TO CABLE & OTHER 18" DISHES

SAVE 30 TO 50%

dish NETWORK

Nothing Else Compares™
©1997 Network & Service Corp. or Satellite Choice Corp.

Skyvision, Inc. 1038 Frontier Dr. Fergus Falls, MN 56537
VISIT OUR WEB SITE! www.skyvision.com

CALL NOW! 800-500-9264

OSCILLOSCOPES

from \$169 !!!

ATC O-Scope uses printer port to turn PC-AT into
Digital Storage Oscilloscope, Spectrum Analyzer,
Freq. Counter, Logger, DVM. DC-500KHz

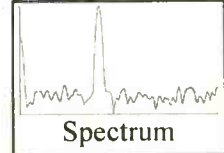
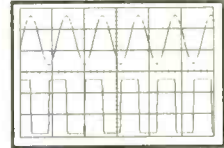

- Print, log to disk, or export data
 - Accepts standard scope probes
 - Uses standard printer port
 - Small and portable
 - Works with laptops
 - Same day shipping
 - Made in U.S.A.
 - Single channel units from \$169
 - Dual channel units from \$349
- Options:**
- Probe sets
 - Automotive probes
 - Battery packs

Order yours today.

800 980 9806

MC/Visa/Amex

Allison Technology Corporation

8343 Carvel, Houston, TX 77036 USA

PH: 713 777 0401, FAX: 713 777 4746, BBS: 713 777 4746

<http://www.atcweb.com>

CIRCLE 137 ON FREE INFORMATION CARD

New and Pre-Owned Test Equipment

Goldstar

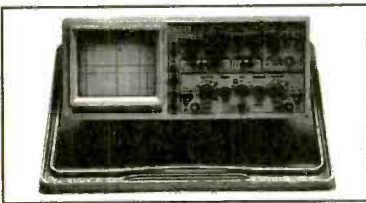

Model OS-9100P → **\$899.00**

Full 100 MHz Bandwidth!

- Dual-Channel, High Sensitivity
- TV Synchronization Trigger
- Calibrated Delayed Sweep
- Includes Two Probes, 2 Year Warranty

FREE SHIPPING!

ON GOLDSTAR EQUIPMENT
ANYWHERE IN THE U.S.
Excluding AK & HI



BK PRECISION

MAXTEC INTERNATIONAL CORP. Model 4040 \$499.00

20 MHz Sweep/Function Generator

- 0.2 Hz to 20 MHz, 5 digit LED Display
- AM & FM Internal or External Modulation
- Sine, Square, Triangle, TTL, CMOS Outputs
- Burst Operation
- External 30 MHz Frequency Counter

NEW!

Pre-Owned Oscilloscope Specials

B + K Precision 1476 10 MHz \$229.00
Great Starter Scope!

Tektronix 465	100 MHz	\$599.00
Tektronix 465B	100 MHz	\$699.00
Tektronix 475	200 MHz	\$799.00
Tektronix 475A	250 MHz	\$899.00

- The Industry Standard of Oscilloscopes
- Dual Channel, Calibrated Delayed Sweep
- Professionally Refurbished
- Aligned & Calibrated to Original Specifications
- 6 Month Warranty - The Longest Available!

LOWEST PRICES EVER!

NEW FLUKE MULTIMETERS & TEKTRONIX OSCILLOSCOPES

The Industry Standard in Multimeters

NEW!

Model 79 II ..\$172.00

Model 87 ..\$285.00

TEKTRONIX TDS SERIES
ON SALE!

Test Equipment Depot

A FOTRONIC CORPORATION COMPANY

P.O. BOX 708 Medford, MA 02155

(617) 665-1400 • FAX (617) 665-0780

1-800-996-3837



TOLL FREE 1-800-99-METER

CIRCLE 318 ON FREE INFORMATION CARD

JENSEN®

everything you need for servicing electronics

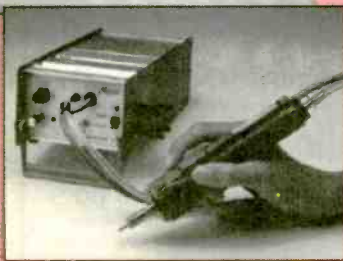
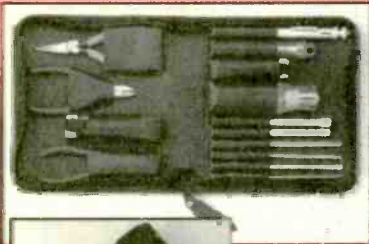

Just a small sampling of the many thousands of new, unique or hard-to-find quality items you'll discover in every Jensen catalog.

Call 800 426-1194 today
for your FREE catalog!



JENSEN TOOLS INC.

7815 S. 46th St., Phoenix, AZ 85044
Ph: 602 968-6231
FAX: 800 366-9662

<http://www.jensentools.com>

CIRCLE 149 ON FREE INFORMATION CARD

New Surveillance Devices!

Smoke Alarm and Table Clock Video Cameras
Ultra miniature video cameras hidden in smoke alarm or alarm clock - your choice. Wide field of view and super .1 lux low light sensitivity! Undetectable!
SC-600 TC-70 High quality B/W with 420 lines of resolution for ultra sharp images. Direct output of video and audio. \$219.95 ea.
Best price on surveillance cameras anywhere!

Telephone Transmitter Kit hidden in dual modular adaptor
Transmits both sides of conversation to any FM radio up to 1/4 mile. "SnapKit" technology. Uses phone line for power and antenna. Goes completely unnoticed. MA-100 \$25.95

High quality cassette deck plugs directly into telephone jack! Records up to 12 hours of conversations on a single cassette. Recording starts and stops automatically when phone is used!
THR-12 12 Hour Telephone Recorder \$99.95
Seymour-Radix Inc. Box 166055-E Irving, TX 75016
Now you can visit us on the Internet at: <http://www.why.net/home/sr/>

BROADCAST FARTHER !!!

The model 220 is a 80-110MHz FM amplifier that connects to mono or stereo FM transmitters and produces a powerful 2-15 watt signal which could broadcast up to 5 miles or more! Requires 50-150 mW drive.
Step by step plans complete with part source information and antenna designs... ONLY \$14 PLUS \$2 S&H NO C.O.D.s
Progressive Concepts
BOX 586 STREAMWOOD, IL 60107
(630)736-9822 FAX:(630)736-0353

CABLE TV CONVERTERS

Equipment & Accessories
Wholesalers Welcome
Call C&D ELECTRONICS
1-800-310-1153 M-F 10a-6p

Prototype it FAST!
with Prototronics 8051 or 28
Fully assembled 8051 or 28 SBC
4.3 x 8 inch board w/ large proto area
Supports up to 32K EPROM - 32K RAM
Chips in sockets - 8 volt operation
On-eye EPROM w/ accurate and s-dam
Full scope w/ automatic no probe
Ready to run... \$99.00 ea.
Software Science
3750 Roundbottom Rd.
Cincinnati, Ohio 45244
1 888 561-2060

It could be a best seller. But it's free.

To get your free catalog, write:
**Consumer Information Center
Dept. BEST, Pueblo, CO 81069**

CABLE T.V.
Buy Direct From the Wholesaler
We will match or beat any advertising
Save \$\$\$
Dealers Welcome
• Tocom • Pioneer • Jerrold
• Zenith • Century • Panasonic
and more
1 Year Warranty 30 days money back
Visual Concepts 1-888-838-4444

BE A LOCKSMITH!
Home study. Learn locksmithing for a great career, or to start your own at-home business.
FREE LITERATURE: 800-223-4542
Name _____ Age _____
Address _____ Phone _____
City _____ State _____ Zip _____
The School of Locksmithing, Dept. LK8341
PO-1, 6065 Roswell Rd., Atlanta, GA 30328

Education? Retirement? Peace of Mind?

You have your reasons.



No matter what you're saving money for, U.S. Savings Bonds make sense. They're backed by the full faith and credit of the United States. They earn interest for up to 30 years. And their value is guaranteed to grow at market-based rates.

Ask your employer or banker about saving with U.S. Savings Bonds.

Or for a recorded message of current rate information, call 1-800-4US-BOND
1-800-487-2663



A public service of this magazine

SURVEILLANCE

The Latest High Tech Professional Electronic Devices

Our latest catalog offers a **HUGE** selection of surveillance, counter-surveillance/privacy devices: pinhole camera w/audio \$199⁰⁰, hidden video, electronic kits, telephone recording systems: 7-Hour \$125⁰⁰ - 16-Hour \$199⁰⁰ touch tone decoders, scanners, bug/phone tap detectors, voice disguisers, telephone scramblers, locksmithing tools, and more.

Catalog \$5.00

SPY OUTLET

PO Box 337, Buffalo NY 14226
(716) 691-3476/(716) 695-8660

INSIDE CRYSTAL SETS

An easy-to-read book on crystal set theory and construction opens vistas for novices and pros alike. Build radios like Grandpa did, do it better, and know what you are doing. *The Crystal Set Handbook*, published by The Crystal Set Society, is an authentic guide on the topic.

THE CRYSTAL SET HANDBOOK

2nd Volume in the *How to Build a Crystal Set* Series

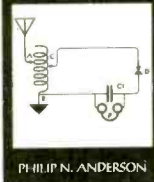

PHILIP N. ANDERSON

To order *The Crystal Set Handbook*, send \$10.95 plus \$4.00 for shipping in the U.S. and Canada only to **Electronics Technology Today Inc.**, P.O. Box 240, Massapequa Park, NY 11762-0240. Payment in U.S. funds by U.S. bank check or International Money Order. Please allow 6-8 weeks for delivery.

BEST BY MAIL

Rates: Write National, Box 5, Sarasota, FL 34230

OF INTEREST TO ALL

PINBALL MACHINES! BOOKS, Parts, Catalog \$2.00. 5290-(PE) Platt Springs, Lexington, SC 29083-9252.

ACCREDITED COLLEGE DEGREES from home. Complete list \$7.50 or SASE for more information. The Letter Boutique, Box 228-(PE), Wagontown, PA 19376.

HIGH SCHOOL DIPLOMA At Home, Accredited, Fast, "Failure-Proof" 1-800-470-4723, American Academy, 12651 S. Dixie Highway, Miami, FL 33156.

INTERSTELLAR TRAVEL BREAKTHROUGH! Secret Alien Technology, Reactionless Dipole Antigravity Drive, Wormhole Engineering, Gravitational Free Energy, Nostradamus Prophecy Revelation First Edition \$9.50 + \$1.50 S&H: JMSA, POB 160725, Austin, TX 78716.

FREE VIDEO REVEALS #1 INCOME SECRETS 1-800-995-0796 X6340.

BUGGED??

EAVESDROPPING is unbelievably widespread! Electronic Devices with amazing capabilities can be monitoring your telephone and room conversations **RIGHT NOW!** Are you sure you're safe? **FREE CATALOG** tells you fast! Includes Free Bonus details on fantastic opportunities now open in Counter-Surveillance field. Exciting, immensely interesting and **EXTREMELY** profitable (up to \$250/hr) full/part-time income. Call Now! **1-800-732-5000**

BROADCAST TRANSMITTER

The FMS2 studio quality transmitter is FULLY crystal controlled and programmable to any FM broadcast frequency.

Unit features: ALC, 2:1 compressor, audio buffer / amplifier, pre-emphasis, roll off filter, stereo generator, digital PLL tuning, 75 MHz-125MHz bandwidth, 500mW power output and a special introductory price of only \$295.00 US.

SCHEMATICS FOR UNIT S27 CATALOG 800-504-1178
FAX POLL INFO 416-243-1087 TEK LINE 416-243-2260



WAVEMACH

Decco is a Kit Builders Paradise

Electronic Kits - Plans - Parts - Computers - Amateur Radio



Call Decco today for your **FREE** copy of

The Electronic Experimenter's Journal

1 800 423 - 4499

Decco Electronics 4025 Edwards Rd. Cincinnati, OH 45209

CABLE TV CONVERTERS

Equipment & Accessories
Wholesalers Welcome

Call **C&D ELECTRONICS**
1-800-310-1153 M-F 10a-6p

"FULL VIEWING" CABLE BOXES



LOWER YOUR CABLE BILL NOW!
CHANNEL SURFERS

1-800-447-7634

Remote Automotive Engine Starters

Warm up your car in the winter. Cool it off in the summer.
SmartStart™ Real Time clock based. Programs like a VCR. The engine starts at the times you set, up to 4 start times per day. Also set the run time, day and time.

TouchStart™ Start and stop the engine, and honk the horn with a 2 channel key chain transmitter up to 300 ft. away.

Plans and parts list only... \$14.00 each + \$3 S&H.
Send check or M.O. to: Modern Circuit Solutions Corporation
P.O. Box 212 Cedarburg, WI 53912-212

CONVERTERS & DESCRABLERS



TARGET ELECTRONICS

(800) 995-1749

We sell Test Chips!
MC, VISA, AE, C.O.D

DEALERS WELCOME!

CABLE TV CHANNELS

EQUIPMENT Direct! **FREE 30 DAY TRIAL!**

GUARANTEED

SAVE \$1000's
The Nationwide source for cable TV equipment.
"BUY WHERE THE DEALERS BUY!"

FREE TV Cable Descramblers, Converters and Magic Box Catalog. Open Every Day!

FREE YOUR VCR TAPES CAN PLAY AS CLEAR AS DAY!
Eliminates copy protection on any tape.

UNJAM NOW WITH Video Decoder
• Copy any rental/bought tape
• Power Cord and RC Plugs Included

2 Year Warranty
CALL NOW! Member Better Business Bureau
MEGA SURFERS! **1-800-676-6342** VISA • MC • C.O.D. **FREE 30 Day Trial!**

NEW!

PIC microcontroller & Surveillance KITS.

Many kits use Surface Mount Technology. Among the kits are an ultra small wireless FM mic, and our new phone transmitter SLeach™. PIC kits include security products such as secure remote keyless entry. SMT kits include our exclusive surface mount soldering guide. Many kits under \$20. Call for a catalog of available kits. All kits are designed and manufactured by IEC.

Pager Decoder Interface kit for PC Only \$19.95 + S&H

uses the popular PD shareware software available on our BBS.

Order 1-800-417-6689

Mon. - Fri. 9AM-5PM ET.
Visa, MC, Money Orders
IEC, P O Box 52347, Knoxville, TN 37950-2347

Sorry, no refund for used kits.
Do not use these devices without authorization from your local officials.
Prices subject to change.
Returns are subject to a restocking fee.
©1997 IEC

BE AN ELECTRICIAN!

Home study. Maintain and install electrical systems, wiring, utilities, phones, and more.
FREE LITERATURE: 800-223-4542

Name _____ Age _____
Address _____ Phone (____) _____
City/State _____ Zip _____
The Electrician School, PCDI, DEPT TEB341
6065 Roswell Road, Atlanta, Georgia 30328



MONDO • TRONICS

ROBOT STORE

* KITS *

Your

* BOOKS *

Mailorder

* PARTS *

Source

* VIDEOS *

For

* MODELS *

Robots!

* MORE! *

(REQUEST OUR FREE CATALOG)

www.robotstore.com

800-374-5764

Or write to us:

524 San Anselmo Ave #107-124

San Anselmo CA 94960

Phone 415-455-9330

Fax 415-455-9333

Email info@mondo.com

CLASSIFIED

MISCELLANEOUS ELECTRONICS FOR SALE

THE Case Against Patents. Thoroughly tested and proven alternatives that work in the real world. \$28.50. **SYNERGETICS PRESS**, Box 809-C, Thatcher, AZ 85552. (520) 428-4073. Visa/MC.

57 Electronic Journals. How to get free subscriptions. \$5.00. **CABLETRONICS**, Box 30502PE, Bethesda, MD 20824.

POOR reception on your A.M. radio? Our signal booster will help. Guaranteed! Send \$2.00 for details (refundable with order). **FALA ELECTRONICS**, PO Box 1376, Dept. 4, Milwaukee, WI 53201.

SOLAR cells, panels, nicad chargers. List \$1.00. **SYMBIANCE, INC.** P.O. Box 2965, Tempe, AZ 85280-2965.

PLANS-KITS-SCHEMATICS

TRANSISTOR Data Tables — Given are the basic electronic parameters for the worlds popular transistors in one volume. A must for servicemen, hobbyists and engineers. Order "Transistor Data Tables" (BP401) for only \$9.95 (price includes shipping) from **ELECTRONIC TECHNOLOGY TODAY, INC.**, PO Box 240, Massapequa Park, NY 11762-0240. USA and Canada only. US funds.

CRYSTAL Set Handbook — Visit antiquity by building the radios your grandfather built. Assemble a "Quaker Oats" rig, wind coils that work and make it look like the 1920's! Only \$10.95 plus \$4.00 for shipping and handling. **CLAGGK INC.**, PO Box 4099, Farmingdale, NY 11735. US funds only! USA and Canada — no foreign orders.

HEATH COMPANY is selling photocopies of most Heathkit manuals. Only authorized source for copyright manuals. Phone: (616) 925-5899, 8-4 ET.

HOME automation via phone. No expensive computers. Furnace, air conditioner, on remotely. Plans, \$10.95. **AMR CTR.**, PO Box 1176, Walham, MA 02254-1176.

HACKERS catalog. **Hard-To-Find** kits and assembled equipment (**Red box, spy, cable** etc.). **Low prices.** \$1.00. **SMITH-05**, Box 371, Cedar Grove, NJ 07009.

ELECTRONIC Project Kits. www.qkits.com. 1 (888) GO-4-KITS, 292 Queen St., Kingston, ON, K7K 1B8. **QUALITY KITS.**

MONITORS made simple. Learn to repair computer monitors! Case studies, illustrations, parts sources, manufacturers included! 136 pages, softcover. \$19.95 + \$2.50 shipping. Order today! Send check or money order to **PIKES PEAK PRESS**, 321 W. Henrietta Ave., P.O. Box 1801, Woodland Park, CO 80866. (719) 687-1499.

BIO-Stimulator featured in PE June issue. Tone muscles, relieve aches and pains with electronic acupuncture. Updated kit with enclosure \$40.00 plus \$2.50 S&H. **RAH PROJECTS**, P.O. Box 15904, N.B. California 92659.

TRANSFER paper for printed circuits with laser or copier, excellent quality. 30 sheets 8X10 with instructions \$24.00, send check or money order to **G. SANTA MARIA**, 1602-A Washington Ave., Suite #915, Miami Beach, FL 33139.

<http://www.users.interport.net/~zebra/ts> is our TimeX/Sinclair web site. **ZX81 Computer kits** \$30.00 plus shipping. **ZEBRA SYSTEMS INC.**, 131 Joralemon St. #52, Brooklyn, NY 11201.

COMPUTER SOFTWARE

ZSORT. Sort huge files fast. Disk \$5.00. Manual \$10.00. Box 12238, Lexington, KY 40581-2238.

BUSINESS OPPORTUNITIES

START your own technical venture! Don Lancaster's newly updated **Incredible Secret Money Machine II** tells how. We now have autographed copies of the Guru's underground classic for \$18.50. **SYNERGETICS PRESS**, Box 809-C, Thatcher, AZ 85552. (520) 428-4073. Visa/MC.

INVENTIONS, ideas, new products! Presentation to industry/exhibition at national innovation exposition. Patent services. 1 (800)-288-IDEA.

TELEVISION pays! Join us marketing the fastest selling, most advanced digital minidish satellite home entertainment system. Discount prices. You profit! Call **STAR VISION DIRECT** for free information: (800) 899-9707, 8am-10pm Pacific.

HOME based electronics work. Part/Full time. Comprehensive Guidebook, 250+ pages. \$17.00, 24hr recording (714) 425-0261 x132.

EASY work! Excellent pay! Assemble products at home. Call toll free 1 (800) 467-5566 Ext. 5192.

EDUCATION

LEARN IBM PC Assembly Language. Disk \$5.00, Book \$18.00. **ZIPFAST**, Box 12238, Lexington, KY 40581-2238.

WINDOWS 95 Kickoff — Staring at Windows 95 and not knowing what to do? Then get your personal copy of "Windows 95-One Step at a Time" (BP399). Only \$9.95 (price includes shipping) from **ELECTRONIC TECHNOLOGY TODAY, INC.**, PO Box 240, Massapequa Park, NY 11762-0240. USA and Canada only. US funds.

FCC/CET software. General Radiotelephone, CET preparation. Five 3.5 inch diskettes. Q/A format: interactive, comprehensive. EGA/VGA. Complete program, \$35.00. **TUTOR-TECH**, 170 Locksunat Way, #2, Sunnyvale, CA 94087. (408) 481-9543.

RECEIVE your certified electronics technician license guaranteed or money back. Manual, simulated exams, and tutoring \$24.95 covers all costs. Check or money order to: **MASS. INSTITUTE OF ELECTRONICS**, Box 111, 351 Pleasant St., Northampton, MA 01060.

CELLULAR TELEPHONES

No second line charge! Enjoy convenience of multiple phones on one number. 1 (800) 227-8290. ohntnd@aol.com

CABLE TV

ATTN. CABLE box owners! Order your ID signal stopper now. Send \$23.00 to **R.R. ENTERPRISE**, Box 3532, Easton, PA 18043.

CABLE descrambling, new secret manual. Build your own descramblers for cable and subscription TV. Instructions, schematics for **SSAVI**, gated sync, sinewave, some free methods (HBO, Cinemax, Showtime, UHF, Adult)\$12.95, \$2.00 postage. **CABLETRONICS**, Box 30502PE, Bethesda, MD 20824.

CABLE TV equipment & accessories. Wholesalers welcome! 30 day moneyback guarantee! Free catalog! **PROFORMANCE ELECTRONICS, INC.**, 1 (800) 815-1512.

CABLE descrambler! Anyone can build in seven steps with **Radio Shack** parts. Plans/kit from \$5.00. plus free bonus. 1 (800) 818-9103.

DESCRAMBLE cable using simple circuit. E-Z to follow instructions \$10.00. Complete kit with free "Bullet Stopper". \$20.00. 1 (800) 522-8053.

CLASSIFIED

CABLE "Bullet Terminator/I.D. Blocker". Electronic shields yourself and your box. Free Hackers Guide included. Lifetime guarantee. Wholesale prices. 1 (800) 820-9024.

CABLE converters and test modules. Money back guarantee. New J. Automultimode, and new custom CFT 22XX modules. Extremely competitive. Wholesale pricing. Catalog. Credit cards. 1 (888) 443-9185.

CABLE box discount, original equipment, descramblers, converters, Super-Q, quantity discount, call now. We'll meet or beat the competition. **TC TRONICS, 1 (718) 349-6506.**

CABLE TV, descramblers, converters. Quantity discounts. 30 day free trial. Competitive prices. Call now! 1 (800) 322-0921 **REGAL SALES, INC.**

CABLE TV descramblers. One piece units. Pioneer 8310's. Scientific Atlanta 8580's, DPV's and others. Lowest prices. Money back guarantee. Houston, TX (713) 691-4610.

ATTENTION P2-1-2 cable box owners. Schematic for simple turn-on circuit. Send \$24.95 + \$3.00 shipping to **W.A.W.G.L. 78 Satinwood, Cheektowaga, NY 14225.**

FULL line of cable descramblers and accessories for all types of systems. Test kits. Multimode, chips, much more. Everything you need. Just call (808) 735-9988. Best price guaranteed.

CABLE - test chips; Jerrold; Pioneer; Tocom; Scientific Atlanta, Zenith, Jerrold cubes; Pioneer programmable cubes; HUDSON, 1 (800) 863-3237.

BIG sale!!! Large selection of notch filters as low as \$6.00 each. Descramblers \$99.00. Test chips from \$5.00. Bullet/I.D. \$10.00. Name brand cable descramblers from \$135.00. The best dealer pricing anywhere. 1-800-449-9189.

COMPONENTS

RESISTORS 20 for \$1.00. LEDS 4 for \$1.00. Catalog \$1.00. **ZIPFAST, Box 12238, Lexington, KY 40581-2238.**

ANTIQUÉ ELECTRONICS

MODERN RADIO LABORATORIES. Since 1932. MRL Handbooks. More. \$2.00 catalog. P.O. Box 14902, Minneapolis, MN 55414-0902.

RADIO Dial Scales. SASE for catalog. **RSE, 323 E. Matilija #110-241, Ojai, CA 93023.**

AUDIO-VIDEO-LASERS

LASER projectors - complete professional systems starting at \$695.00. BeamScan by **RED LINE LASER PRODUCTS.** (314) 831-3014.

TEST EQUIPMENT

TECHNICIANS: Electronic component tester for use with oscilloscope. Satisfaction guaranteed. \$29.95 plus S&H. Info.: **ELECTROHM, 529 Brentwood, Lawrence, KS, 66049.** Fax: (913) 832-2481.

LARGE assortment of used test equipment. Most instruments are priced at 10% of original cost or less. Request list. **JIM STEVENSON, 3401 Sunny Slope Road, Bridgewater, NJ 08807.** (908) 722-6157 Fax: (908) 722-6391.

SATELLITE EQUIPMENT

VIDEOCYEPHER II descrambling manual. Schematics, video and audio. Explains **DES, EPROM, CloneMaster, Pay-per-view (HBO, Cinemax, Showtime, Adult, etc.) \$16.95, \$2.00 postage.** Schematics for Videocypher Plus, \$20.00. Schematics for Videocypher 032, \$15.00. Collection of Software to copy and alter EPROM codes, \$25.00. **VCII Plus EPROM, binary and source code, \$30.00. CABLETRONICS, Box 30502PE, Bethesda, MD 20824.**

OBTAINING Sound for your VCII and VCII Plus is easy. No codes needed. Also **DSS Test Card** information. Details: 1 (800) 211-5635.

IMPROVE your satellite picture. Focus Maximizer is a diagnostic tool that optimizes feedhorn spacings. \$26.50. Free brochure. **WATERSHED ELECTRONIC DEVELOPMENT (800) 756-7854.**

SOUND for Videocypher-II and plus without codes. Free details. **SASE. NASSIRIAN, Box 382-P, Rio Linda, CA 95673.**

MINDISH satellite systems, surround sound, big TVs, total home entertainment systems. Call **STAR VISION DIRECT** for free information and our discount prices: (800) 899-9707, 8am - 10pm Pacific.

STAY informed on the satellite TV underground. Subscribe to the North Star Gazer! Published monthly. \$48.00 year. **NORTH STAR, P.O. Box 1023, Lapeer, MI 48446.** (810) 664-4022.

SECURITY

ELECTRONIC sales of security systems for home, apartment, or business, will send information, call (812) 295-4240.

REPAIRS-SERVICES

COMPUTER repairs only \$59.95!! Parts extra! Sales, service, upgrades and more. **BEACH RADIO, Quincy, MA.** (617) 823-2985 or (617) 928-0626.



www.pueblo.gsa.gov

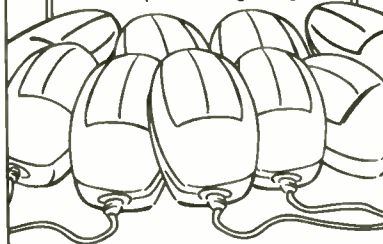

9 out of 10 mice prefer the Consumer Information Catalog online. Catch it at www.pueblo.gsa.gov.

U.S. General Services Administration

Create Your Own Virtual Worlds and Share Them with 10 Million People!

- Learn How to Build Your Own Virtual Reality "Virtual Worlds" Quickly and Easily!
- Explore your Virtual Worlds on Your PC or put them on the Internet for Others to Explore!
- Explore your Worlds with your PC monitor and keyboard, or with Greater Immersion using Low-cost Homebrew Virtual Reality Equipment!

Convert this \$69 Mattel Powerglove into a VR Glove! Save \$Thousands! We show you how, and where you can buy Powergloves!



VR Goggles with head tracking cost over \$4,000 only a few years ago. Now they're under \$500! And 3-D VR Shutter Glasses are under \$100! Now Immersive VR is affordable!

"A Smorgasborg of info on VR!" -Sid Mirzad

"I love it! At under \$5 per book, don't miss out on this Incredible Value!" -Pam Eifert

Desktop VR contains a complete primer on using VR on your PC, plus:

- Where to get low cost HMDs (head mounted displays) & other equip
- The famous Mattel Powerglove hack (converting a \$69 Powerglove for use with VR)
- Powerglove sources
- Listings of virtual world building software
- Comprehensive listings of HMD compatibility with popular games & software
- Plus much more!

VRML Primer explains VRML (Internet's "VR Modeling Language"), plus:

- Building virtual worlds on the Internet
- Virtual world authoring software & where to get it
- Great VR worlds to visit on the Internet
- Putting your virtual world on the Internet
- More!

Special Report: Virtual Reality an Exploding Technology Exclusive report on the explosion of VR in medical, amusement, consumer & other arenas

- News blurbs on market entry by heavyweights & Fortune 500's
- The VR marketplace
- 28 pp.

VR InfoMania Time saving valuable resources including Listings of Internet websites devoted to VR

- Listings of VR books
- Listings of VR magazine articles & research papers
- Listings of Internet FTP download sites & VR-related newsgroups
- Article listings from back issues of VR magazines
- Where to go to experience real VR
- Reviews of popular VR books
- Glossary of VR terms
- Great VR applications
- The future of virtual sex
- Plus Much More!
- 88 pp.

FREE DOUBLE BONUS!

FREE! **VR Resource Directory** is your guide to over 600 companies involved with VR products, software, R&D & consulting, plus professional trade organizations, clubs, more! 80 pp. Yours absolutely **FREE!**

FREE! **VR Cartoons** featuring dozens of funny cartoons about VR! Yours absolutely **FREE!** Limited printing, don't miss out! Order today!

Order \$5 Plus Postage **You Get All 6 Publications!**

ONLY \$49! Calif. residents add sales tax

ONLY \$29! Plus \$3.95 S&H

Special Introductory Price! Includes All 6 Publications!

2-3 Day Delivery \$7.50 Fedex Overnight Air \$14.95

30-Day 100% Satisfaction Money-Back Guarantee!

24 HOUR TOLL FREE ORDER LINE

1-800-951-7100 FAX ORDERS 619-485-8968

Send Check or Money Order to: Virtual Reality Publishing 16486 Bernardo Center Drive, Suite 378, San Diego CA 92128

©1997 VR Publications. All rights reserved. VR Publications is a registered trademark of VR Publications. All other trademarks are the property of their respective owners.

VR Publications is a participant in the Amazon.com Associates Program, an affiliate advertising program designed to provide a means for sites to earn advertising fees by advertising and linking to Amazon.com.

ORDER TODAY... HAVE IT TOMORROW!

BUY BONDS

ADVERTISING INDEX

Popular Electronics does not assume any responsibility for errors that may appear in the index below.

Free Information Number	Page	Free Information Number	Page
25	Ace Communications	—	KDE Electronics
—	Aegis Research, Canada	—	Mana
—	AES	151	MCM Electronics
26	Alfa Electronics	—	Mega Electronics
28	All Electronics	147	Mendelson's
137	Allison Technology	—	Mental Automation
—	Allstar Electronics	157	MicroCode Engineering
—	AMC Sales	171	MicroCode Engineering
—	American Innovations	—	Millennium Enterprises
—	Andromeda Research	—	Modern Electronics
—	Basic Electrical Supply	—	Mondo-tronics
32	C&S Sales, Inc.	164	Mouser Electronics
—	Cable Discount	—	NRI Schools
—	Circuit Specialists	43	Optoelectronics
—	Cleveland Institute of Electronics	—	Orion Electronics
—	Command Productions	156	Parallax
—	Comtrad Industries	146	Parts Express
—	Consumertronics	47	Prairie Digital Inc.
150	Dalbani	46	Print
162	Davis Instruments	45	Print
—	EDE Spy Outlet	—	Quality Entertainment
148	Electronic Rainbow	—	School of Electronics
—	Electronic Technology Today	—	Silicon Valley Surplus
—	EMAC	—	Skyvision Inc.
158	Fluke	—	Smithy Company
—	Foley-Belsaw	—	Solutions Cubed
—	Forest Electronics	—	Spy Tech
—	Fotronic Corporation	—	Tab Books
—	General Device Instruments	—	T.C. Tronics
—	Grantham College of Engineering	144	Telulex
—	Greenleaf Electronics Inc.	—	Terk Technologies
—	Hollins Radio Data	136	UCANDO Videos
—	Home Automation	—	US Cyberlab
—	ICS Computer Training	—	Virtual Reality Publishing
—	I.E.C.	—	Visual Communications
—	Information Unlimited	—	Weeder Technologies
—	Intelligence Incomp.	—	Weka Publishing
13	Interactive Image Technologies	172	Windjammer Barefoot Cruises
—	Intronics, Inc.	—	WPT Publications
149	Jensen Tools	134	Xandi Electronics
—	Kableworks		

ADVERTISING SALES OFFICES

Gernsback Publications, Inc.
500 Bi-County Blvd.
Farmingdale, NY 11735-3931
1-(516) 293-3000
Fax 1-(516) 293-3115

Larry Steckler, EHF/CET
President (ext. 201)

Christina Estrada
Assistant to the President (ext. 209)

For Advertising ONLY
1-516-293-3000
Fax 1-516-293-3115

Larry Steckler
publisher

Arline Fishman
advertising director (ext. 206)

Michele Torriolo
advertising assistant (ext. 211)

Adria Coren
credit manager (ext. 208)

**Subscription/
Customer Service/
Order Entry**
1-800-827-0383
7:30 AM - 8:30 PM EST

ADVERTISING SALES OFFICES EAST/SOUTHEAST

Stanley Levitan
Eastern Sales
1 Overlook Ave.
Great Neck, NY 11021-3750
1-516-487-9357, 1-516-293-3000
Fax 1-516-487-8402

MIDWEST/Texas/Arkansas/ Oklahoma, Colorado, Arizona

Ralph Bergen
Midwest Sales
One Northfield Plaza, Suite 300
Northfield, IL 60093-1214
1-847-559-0555
Fax 1-847-559-0562
bergenrj@aol.com

PACIFIC COAST/Mountain States

Anita Bartman
Hutch Looney & Assoc., Inc.
6310 San Vicente Blvd.
Suite 360
Los Angeles, CA 90048-5426
1-213-931-3444 (ext. 227)
Fax 1-213-931-7309

Reader Service Card

MAIL-FAX OR E-MAIL YOUR REQUEST

Now you have 3 ways to request free information on products and services featured in this issue

To insure a prompt reply, please furnish all requested information

To Receive
Information on
Products and
Services In
This Issue

Circle the numbers
corresponding to the
advertised products
or editorial items that
interest you.

Mail Card
or Fax To: (413) 637-4343
or E-Mail your request to:
BERKCOMP@AOL.COM.

For E-Mail users,
your subject is
Popular Electronics
2/97
Format your message:

- Name and Address information
- Telephone and Fax numbers
- Requested item numbers separated by commas

BUSINESS PROFESSIONAL FREE INFORMATION CARD							
Popular Electronics							
Name _____	Title _____	26	52	78	104	130	156
Company _____		27	53	79	105	131	157
Dept. MS _____		28	54	80	106	132	158
Daytime Business Phone _____		29	55	81	107	133	159
Company Address _____		30	56	82	108	134	160
City _____ State _____ Zip +4 _____		31	57	83	109	135	161
		32	58	84	110	136	162
		33	59	85	111	137	163
		34	60	86	112	138	164
		35	61	87	113	139	165
		36	62	88	114	140	166
		37	63	89	115	141	167
		38	64	90	116	142	168
		39	65	91	117	143	169
		40	66	92	118	144	170
		41	67	93	119	145	171
		42	68	94	120	146	172
		43	69	95	121	147	173
		44	70	96	122	148	174
		45	71	97	123	149	175
		46	72	98	124	150	176
		47	73	99	125	151	177
		48	74	100	126	152	178
		49	75	101	127	153	179
		50	76	102	128	154	180
		51	77	103	129	155	181

Unclear or incomplete mailing info will prevent our processing this request.

1 Please send me 12 issues (1 year) of POPULAR ELECTRONICS for \$18.95 and bill me. (Canada \$25.63 — US Funds only — Includes G.S.T.)

2 Please send me 12 issues (1 year) of ELECTRONICS NOW for \$17.97 and bill me. (Canada \$25.65 — US Funds only — Includes G.S.T.)

Do you own a computer? 5 Yes 6 No

Do you plan to buy a computer sometime this year? 7 Yes 8 No

VOID after April 30, 1997 Allow 6-8 weeks for delivery of first issue

**To Order a New Subscription or
To Renew an Existing Subscription
Call 1-800-827-0383**

.20¢ POSTAGE
REQUIRED IN
U.S.A.

Popular Electronics

**READER SERVICE MANAGEMENT DEPT.
P.O. BOX 5192
PITTSFIELD, MA 01203-9989**

BASIC STAMP[®] COMPUTERS

Tiny computers run PBASIC[™] programs

BASIC Stamps are component-sized computers that run PBASIC programs. They have 8 or 16 I/O lines, which can be used for a variety of digital and analog purposes. And their language is both familiar and extensive; the language includes FOR...NEXT, IF...THEN, and GOTO, as well as XOUT, SHIFTOUT, DTMFOUT, and other special commands.

If you've heard about BASIC Stamps, but never took the plunge, now you can do so for less. We now offer a "Starter Kit" for just \$79. The kit contains everything you need to get your feet wet.

**New
BASIC Stamp
Starter Kit for \$79!**
Contains our original
BASIC Stamp rev. D,
plus software, cable,
and manual.



John McLean uses BASIC Stamps to gather data in Lechuguilla Cave (America's deepest cave, located in Carlsbad Caverns National Park).



Charles Walsh and his students in Great Falls, Montana, use BASIC Stamps in robotics projects.



Although it may be difficult to see here, that's a BS1-IC next to the white wires.

Issac Kurtz and John Bishop use BASIC Stamps in artificial hands at the Bloorview MacMillan Centre in Toronto, Canada.

BS1-IC Module [™] **\$34**
8 I/O lines
80 instructions max.
2000 instructions/sec.
2400 baud serial I/O
14-pin SIP module

FaxBack
#6002



I/O instructions for pushbuttons, potentiometers, pulse measurement, PWM, serial I/O, sound, etc.

BS2-IC Module [™] **\$49**
16 I/O lines
500 instructions max.
4000 instructions/sec.
50k baud serial I/O
24-pin DIP module

Same I/O instructions as BS1, plus touch-tones, frequency generation, pulse counting, serial shift registers, X-10 powerline control, etc. I/O functions common to both modules have a higher resolution on the BS2-IC, due to its faster clock speed.

Programming Package **\$99**
Contains programming materials needed to program BASIC Stamps; includes cables, PC software, manuals, and free technical support.

Carrier Boards **\$15-\$20**
Provide small prototyping area, 9-volt battery clips, and programming connector. Not absolutely necessary, but recommended to make programming and experimentation easy.

New! 4-line Serial LCD **\$109**

New 4-line serial LCD display is fun and useful for projects that require interaction with people. The display only takes one I/O line to operate, and can be controlled using simple SEROUT instructions in your program.



FaxBack #6004

PARALLAX [®] **INC.**

3805 Atherton Road, #102 • Rocklin, CA 95765 • USA • Toll-Free Sales: (888) 512-1024 • Office/tech. support: (916) 624-8333
Fax: 624-8003 • FaxBack: 624-1869 • E-mail: info@parallaxinc.com • Ftp: ftp.parallaxinc.com • http://www.parallaxinc.com

Australia +61 39 720 5344, +61 67 722 777 • Austria +49 241 918 90 0 • Belgium +32 4 377 5151 • Bulgaria +359 2 72 77 50 • Brazil +55 11 453 5588, +55 11 801 0045 • Canada (514) 336-9426 • Czech Republic +42 49 5813 252 • Finland +358 31 266 1885 • France +33 3 20 52 98 52 • Germany +49 241 918 90 0 • Greece +30 1 902 0115 • Hong Kong +852 2720 0255 • Hungary +36 1163 2879 • India +91 422 232 561 • Ireland +44 1 977 683 665 • Israel +972 3 498 543 • Italy +39 0542 55400 • Japan +81 3 3251 1779 • Netherlands +31 10 450 4949 • New Zealand +61 39 720 5344, +61 67 722 777 • Poland +48 34 648 882 • Singapore +65 746 8182 • Slovak Republic +42 7 580 2574 • South Africa +27 11 493 6242 • Sweden +46 70 576 14 54, +46 431 41 30 88 • Switzerland +49 241 918 900 • Taiwan +886 2 647 1978 • United Kingdom +44 1 977 683 665 • United States (800) 344-4539 (Cigi-Key), (800) 831-4242 (Jameco), (800) 538-5000 (JDR)

PBASIC, BS1-IC, and BS2-IC are trademarks and BASIC Stamp & the Parallax logo are registered trademarks of Parallax, Inc. Prices do not include shipping and applicable sales tax • Features and prices subject to change without notice • Prices are U.S. prices only; prices in other countries may vary

0996PESR

CIRCLE 156 ON FREE INFORMATION CARD

www.americanradiohistory.com

CircuitMaker[®]

The Virtual Electronics Lab[™]

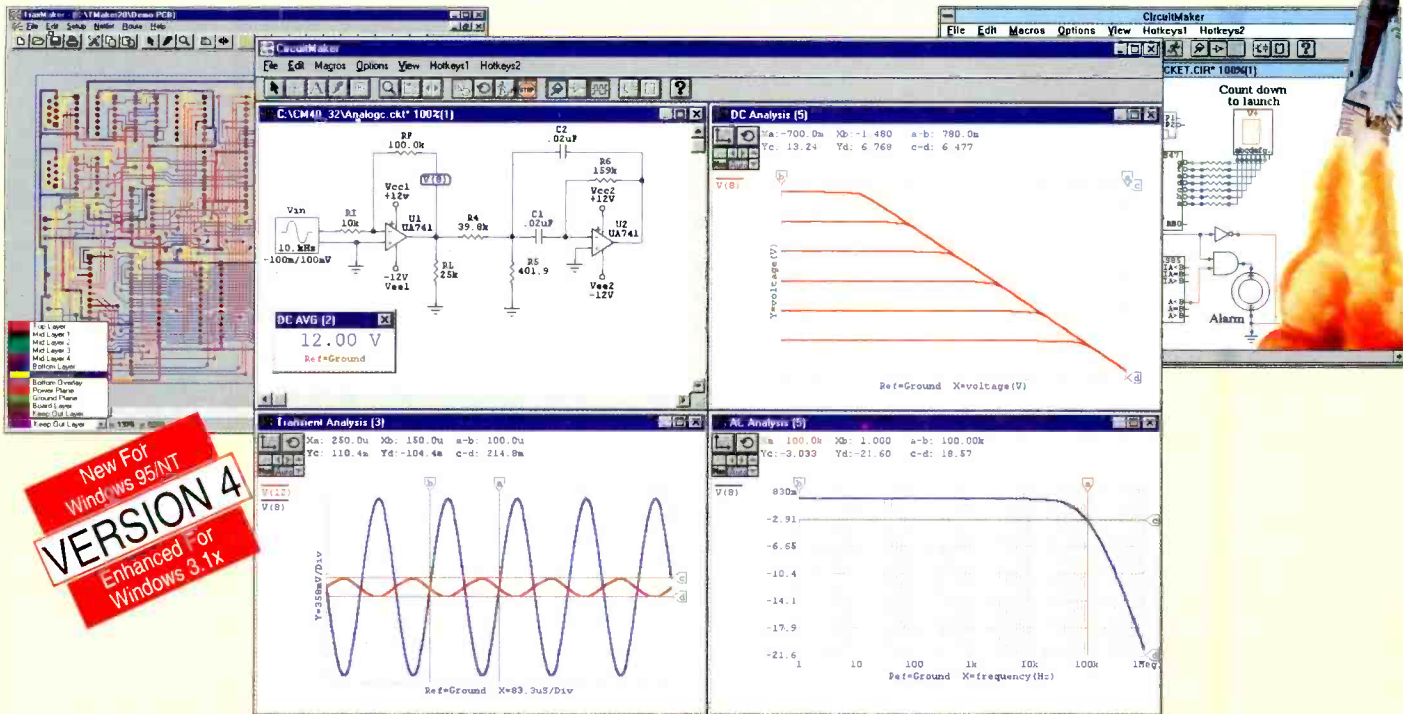

New For
Windows 95/NT
VERSION 4
Enhanced for
Windows 3.1x

Professional Schematic Layout

CircuitMaker's schematic capabilities are unmatched and include many advanced editing features not found in similar programs. These powerful features minimize the time and task associated with drawing a schematic and insure a professional looking final product. Printout and export options are numerous and results are of the highest quality. But that's what people have come to expect from CircuitMaker.

Unlimited, Indestructible Devices

CircuitMaker ships with over 1500 devices. That's more (at no additional cost) than any competing product. If you need a device that is not included, CircuitMaker provides industry standard SPICE import and a powerful macro capability. These indestructible devices accurately emulate actual devices and enable the user to try all those "what if" scenarios with no risk and at no additional cost.

Accurate Simulation & Advanced Analysis

CircuitMaker features analog, digital and mixed-mode simulation. Obviously, simulation is of no value if the results are not accurate. CircuitMaker's simulation engine is based on Berkeley SPICE3, which is renowned for it's accuracy. That's why we can factually state that CircuitMaker provides it's user with the most accurate simulation available. Furthermore, CircuitMaker provides a wealth of analysis capabilities not found in other products in it's class. No other product offers this much simulation muscle at such a reasonable price.

Printed Circuit Board Output

CircuitMaker's PCB output capability helps you complete your design cycle, by generating a netlist that can be imported into any compatible PCB program. This is not a costly "add-on module", it comes standard with every copy of CircuitMaker. MicroCode Engineering also offers TraxMaker, a professional level, PCB layout and autorouting program for just \$299. Used in conjunction with CircuitMaker, TraxMaker completes a powerful end-to-end circuit design system.

SPICE Export/Import
PCB Export
Retail Price
Full SPICE Compatibility
Digital, Analog, and
Mixed-Mode Simulation
Advanced Schematic Features
Schematic Capture

CircuitMaker	YES	YES	YES	YES	YES	YES	\$299
Electronics Workbench version 4	YES	NO	YES	NO	NO	NO	\$299
Electronics Workbench Engineer's Pack	YES	NO	YES	NO	YES	YES	\$599

"CircuitMaker Shocks The Competition, With An Unbeatable Bottom-line"

Total Customer Satisfaction

At MicroCode Engineering we are committed to total customer satisfaction. When you purchase CircuitMaker you have the confidence of knowing that a trained staff of professionals is available to serve you after the sale. Our free unlimited customer service is second to none! Whether you have general or technical questions they will be answered promptly by a knowledgeable representative.

FREE Functional Demo

A free functional demo is available on the Internet at <http://www.microcode.com> on CompuServe (GO MICROCODE) and on America Online by doing a file search for CircuitMaker.

Call now to order or
request additional information
800-419-4242

