

March 1994

# Popular Electronics®

## PERSONAL DIGITAL ASSISTANTS

The Zoomer, Newton, and EO face off in our head-to-head evaluation



## Build a World-Band Regenerative Radio

Our nine-band receiver gives you a window on historic events around the world



## Build an Electrical-System Analyzer for your Car

A useful and inexpensive test accessory



## Hamming in the Fabulous Fifties

A look back at the great gear and good times from the golden age of amateur radio

A GERNSBACK PUBLICATION

#BXBDCCCH\*\*\*\*\*3-DIGIT 605  
FEB 1995  
#60506DHM997GA006# RESP 100  
ROBERT DAHM  
997 GRAND AVE  
AURORA IL 60506-2513  
BDZ

Build an...  
All...  
craps, and slots—without the financial risk

# A DAY IN THE LIFE OF SCOPEMETER<sup>®</sup>

6:42 AM, Motor in #2 shaft overheating. Dual channel shows incorrect drive signal.

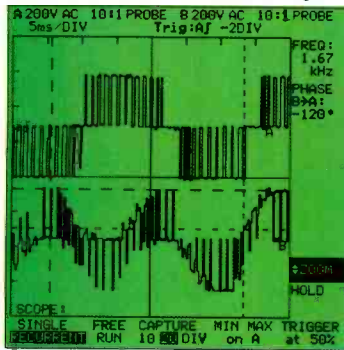

10:57 AM, Intermittent Auditorium lighting. Waveform shows too much noise.

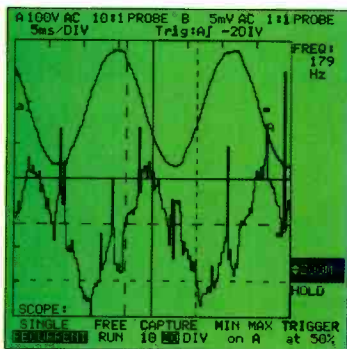

1:22 PM, Copier toning uneven. Counter finds clock off frequency.

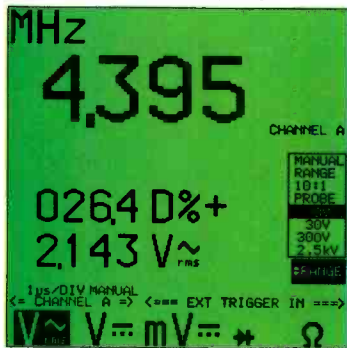

4:05 PM, Salesman presents demo board. 25MS/s finds 40ns glitches.

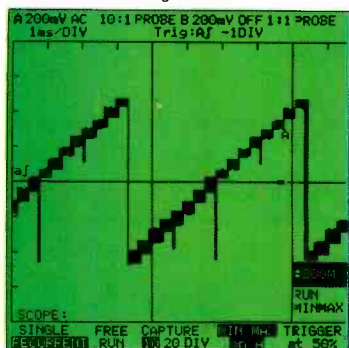

8:23 AM, Security Monitor not working. 3-1/2-digit DMM indicates bad ground.

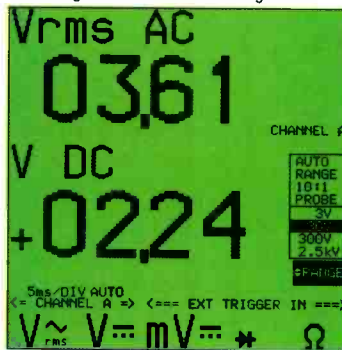

11:17 AM, 5V Control Signal is bad. Scope display reveals -DC offset.

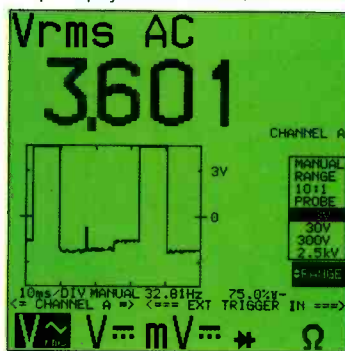

9:25 AM, Conveyor Stepper Control fails. Cursors help find broken sync connection.

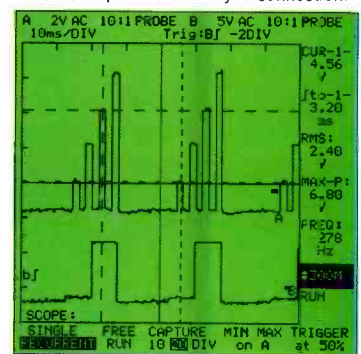

12:58 PM, Air Conditioner overheating. Resistance shows corroded connection.

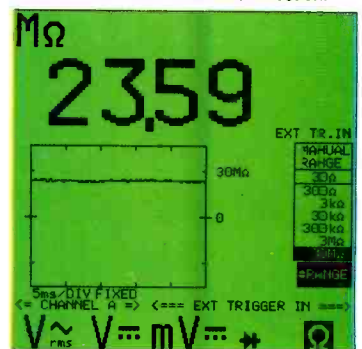

2:14 PM, Testing Power Inverter loads. Save reference waveform to memory.

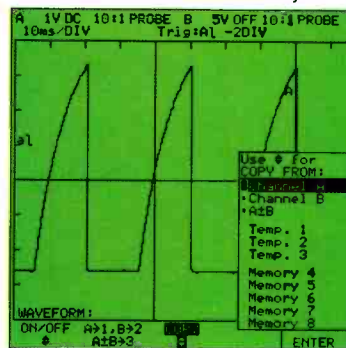

3:12 PM, Copier fails, again! The ns rise time helps find broken shield.

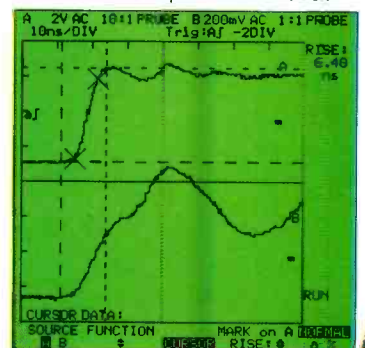

From the roof top to the basement, indoors and out, the ScopeMeter test tool works wherever you work. The sealed, ruggedized case is designed for hand-held use. The backlit screen works in both bright sun and low light conditions. And the logical control panel makes operation simple. So, make your day a little easier. Call 1-800-44-FLUKE and ask how the ScopeMeter test tool can help you save time and frustration with electrical problems, on the go.

©1993, John Fluke Mfg. Co., Inc., P.O. Box 9090, M/S 250C, Everett, WA 98206-9090. U.S. (206) 356-5400. Canada (416) 890-7600. Other countries (206) 356-5500. All rights reserved. ScopeMeter is a registered trademark of John Fluke Mfg. Co., Inc. Ad No. 00387

## FLUKE<sup>®</sup>

CIRCLE 153 ON FREE INFORMATION CARD

[www.americanradiohistory.com](http://www.americanradiohistory.com)





# Popular Electronics®

THE MAGAZINE FOR THE ELECTRONICS ACTIVIST!

## CONSTRUCTION ARTICLES

- BUILD A WORLD-BAND REGENERATIVE RADIO** ..... Lyle Russell Williams 33  
*Tune in the world with a solid-state version of the classic regenerative receiver*
- BUILD THIS ELECTRONIC CASINO** ..... Jay Kirschenbaum 47  
*Play three of the most popular casino games with this handheld project*
- AN ELECTRICAL-SYSTEM ANALYZER FOR YOUR CAR** ..... Anthony J. Caristi 66  
*Avoid expensive road-service calls with a monitor that alerts you to any of several potential problems*

## FEATURE ARTICLES

- HAMMING IN THE FABULOUS FIFTIES** ..... Karl T. Thurber, Jr. 41  
*Take a nostalgic trip to the golden days of ham radio*
- ALL ABOUT PIEZOELECTRIC ELEMENTS** ..... A. Singmin 69  
*Explore the basic principles of piezoelectric-transducer operations*
- SAVE A BUNDLE WITH TONER CARTRIDGE RECYCLING** ..... Fred Blechman 71  
*Recycling toner cartridges can save more than dollars and cents*

## PRODUCT REVIEWS

- HANDS-ON REPORT** ..... 16  
*Microcode Engineering Circuit Maker software*
- PRODUCT TEST REPORT** ..... Len Feldman 22  
*Yamaha RX-V870 Audio/Video surround-sound receiver*
- GIZMO** ..... 51  
*Special report: personal digital assistants*

## COLUMNS

- THINK TANK** ..... John Yacono 26  
*Pinouts and tools*
- ANTIQUÉ RADIO** ..... Marc Ellis 75  
*The mother of all radio museums*
- COMPUTER BITS** ..... Jeff Holtzman 80  
*ClarisWorks for Windows*
- CIRCUIT CIRCUS** ..... Charles D. Rakes 82  
*Oscillators and bridge circuits*
- DX LISTENING** ..... Don Jensen 84  
*The broadcasters SWL's love to hate*
- HAM RADIO** ..... Joseph J. Carr 86  
*Want to operate W1AW?*
- SCANNER SCENE** ..... Marc Saxon 88  
*Tracking Smokey Bear*

## DEPARTMENTS

- EDITORIAL** ..... Larry Steckler CET/EHF 2
- LETTERS** ..... 4
- ELECTRONICS LIBRARY** ..... 6
- NEW PRODUCTS** ..... 12
- ELECTRONICS MARKET PLACE** ..... 77
- POPULAR ELECTRONICS MARKET CENTER** ..... 97
- ADVERTISER'S INDEX** ..... 128
- FREE INFORMATION CARD** ..... 129

Popular Electronics (ISSN 1042-170X) Published monthly by Gernsback Publications, Inc., 500-B B-Country Boulevard, Farmingdale, NY 11735. Second-Class postage paid at Farmingdale, NY and at additional mailing offices. One-year, twelve issues, subscription rate U.S. and possessions \$21.95, Canada \$28.84 (includes G.S.T. Canadian Goods and Services Tax Registration No. R125166280), all other countries \$29.45. Subscription orders payable in U.S. funds only. International Postal Money Order, or check drawn on a U.S. bank. U.S. single copy price \$3.50. © 1994 by Gernsback Publications, Inc. All rights reserved. Hands-on Electronics and Gizmo trademarks are registered in U.S. and Canada by Gernsback Publications, Inc. Popular Electronics trademark is registered in U.S. and Canada by Electronics Technology Today, Inc. and is licensed to Gernsback Publications, Inc. Printed in U.S.A.

Postmaster: Please send address changes to Popular Electronics, Subscription Dept., P.O. Box 338, Mount Morris, IL 61054-9932.

A stamped self-addressed envelope must accompany all submitted manuscripts and/or artwork or photographs if their return is desired should they be rejected. We disclaim any responsibility for the loss or damage of manuscripts and/or artwork or photographs while in our possession or otherwise.

As a service to readers, Popular Electronics publishes available plans or information relating to newsworthy products, techniques, and scientific and technological developments. Because of possible variances in the quality and condition of materials and workmanship used by readers, Popular Electronics disclaims any responsibility for the safe and proper functioning of reader-built projects based upon or from plans or information published in this magazine.

**Larry Steckler**

*EHF, CET*

*Editor-in-Chief and Publisher*

## EDITORIAL DEPARTMENT

**Carl Laron**

*Editor*

**Robert A. Young**

*Associate Editor*

**John J. Yacono**

*Associate Editor*

**Teri Scaduto**

*Assistant Editor*

**Evelyn Rose**

*Editorial Assistant*

**Marc Spiwak**

*Editorial Associate*

**Joseph J. Carr, K4IPV**

**Marc Ellis**

**Len Feldman**

**Jeffrey K. Holtzman**

**Don Jensen**

**Charles D. Rakes**

**Marc Saxon**

*Contributing Editors*

## PRODUCTION DEPARTMENT

**Ruby M. Yee**

*Production Director*

**Karen S. Brown**

*Production Manager*

**Kathy Campbell**

*Production Assistant*

**Lisa Rachowitz**

*Editorial Production*

## ART DEPARTMENT

**Andre Duzant**

*Art Director*

**Injae Lee**

*Illustrator*

**Russell C. Truelson**

*Illustrator*

**Jacqueline P. Cheeseboro**

*Circulation Director*

**Michele Torrillo**

*P-E Bookstore*

## BUSINESS AND EDITORIAL OFFICES

Gernsback Publications, Inc.

500-B Bi-County Blvd.

Farmingdale, NY 11735

1-516-293-3000

Fax: 1-516-293-3115

President: **Larry Steckler**

**Subscription**

**Customer Service/Order Entry**

1-800-827-0383

7:30 AM – 8:30 PM EST

Advertising Sales offices listed on page 128

Cover by Lowey Design,

Cover Photography by Dan Wilby Productions

Composition by

Mates Graphics



Since some of the equipment and circuitry described in POPULAR ELECTRONICS may relate to or be covered by U.S. patents, POPULAR ELECTRONICS disclaims any liability for the infringement of such patents by the making, using, or selling of any such equipment or circuitry, and suggests that anyone interested in such projects consult a patent attorney.

## COLORIZING MOVIES—MUCH ADO ABOUT NOTHING

I know, you're already mad at me! How could I possibly defend colorizing old black-and-white movies? Well I can! It's all a matter of personal choice. And if I don't like seeing an old movie in color, all I need to do is use my remote to turn off the color. So why all the excitement?

What I would like you, our reader, to do is to take a favorite monochrome movie that has been colorized and watch it. While you are watching, turn the color on and then off every 15 minutes, or so. Now you're watching segments of the same movie, some in color, some in monochrome. When you're done, drop me a note; a postcard will do. Give me the name of the movie you watched, and tell me if it was better or worse in color. Don't bother protesting the colorization; I don't intend to debate that subject. Just tell me if the movie was better or not better after being colorized.

In a couple of months, I'll let you know how you rated colorization, and list the movies you rated.

If you want to have even more fun, do the same thing with a recent, color movie. Turn the color off and on every 15 minutes and then tell me which version you liked better.

Again, give me the name of the movie as well as your opinion.

I'll be looking for your responses.

Larry Steckler, EHF, CET  
Editor-in-Chief and Publisher



## Introducing a New Era In Technical Training.

World College, an affiliate of the Cleveland Institute of Electronics, was created to provide a four year, independent study, technical degree program to individuals seeking a higher education. The Bachelor of Electronics Engineering Technology Degree, offered by World College, prepares students for high-paying careers in electronics, telecommunications, electrical power, computer and control systems. World College's curriculum is taught in an effective, time-proven, independent study environment. With World College's flexible study schedule, students have the opportunity to work or spend time with their family without having to worry about rigid scheduling residential colleges offer.

## A Quality Education with a Flexible Schedule.

In a world heavily dependent on electronic equipment, people who understand electronics will have no problem putting their knowledge to work... in high-paying careers. The staff and faculty of World College have invested over ten years developing, what we believe to be, the finest independent-study, baccalaureate degree program available. World College's mission is to instill in each student the knowledge, education, and training that employers are seeking for the many technical positions available today. It's a program created to provide the best education and training possible with a flexible schedule to match your busy lifestyle.



World College is currently seeking approval to confer the Bachelor Degree from the Virginia Council of Higher Education.

# Earn A Bachelor of Electronic Engineering Technology Degree from



**WORLD  
COLLEGE**  
*Bringing Technology Home!*

Lake Shores Plaza  
5193 Shore Drive, Suite 113  
Virginia Beach, VA 23455-2500

## Send For Your Free Course Catalog.

Take the first step towards a new start  
in life. Send for World College's Free  
Independent Course Catalog today and  
discover how easy and affordable it is  
to get started on your **Bachelor Degree.**

World College is affiliated with



## Complete the Entire Degree Program Under One Roof. Yours!

Only World College offers an independent study, four year technical degree which can be completed through one school. All lab equipment\*, parts, and software are included in your tuition and the program's 300-plus laboratory experiments can be completed in your own home.

## You Pay Only For Time Actually Used.

World College not only provides a means to earn a Bachelor Degree while fulfilling current obligations, but there are no restrictions on how fast you can complete the program. At World College, you pay tuition only for the actual upper-level semesters it takes to graduate. The quicker you complete the program, the less you pay in tuition. It's an effective way to keep you motivated in order to complete the course and move on to a better paying position as quickly as possible.

Currently not available in Ohio.

\* Student must have access to a personal computer system.

**YES!** Please send me  
World College's Free Course  
Catalog detailing the full  
curriculum.

Name: \_\_\_\_\_

Address: \_\_\_\_\_

Apt: \_\_\_\_\_

City: \_\_\_\_\_

State: \_\_\_\_\_ Zip: \_\_\_\_\_

Phone: ( \_\_\_\_\_ ) \_\_\_\_\_

Age: \_\_\_\_\_

Return to: **WAH06**

World College  
Lake Shores Plaza  
5193 Shore Drive, Suite 113  
Virginia Beach, VA 23455-2500

## SORRY, WRONG NUMBER

In the article, "Build a Relative Humidity Indicator" (**Popular Electronics**, January 1994), the telephone number of Hy-Cal Engineering is mistakenly listed as 800-444-4000. That number is answered by an MCI Information operator. The correct number is 818-444-4000.

Other than that, the article was very good. Keep up the good work.

P.B.  
Kalamazoo, MI

## RELOCATED SUPPLIERS

The company referred to as "KA7QJY Components" in the article "Where to Find Electronics Parts" (**Popular Electronics**, November 1993) has moved and changed its name. The company is now known as Dan's Small Parts and Kits. It is located at 1935 South 3rd West #1, Missoula, MT 59801. The phone/fax number is 406-543-2872.—Editor

Oak Ridge Engineering, mentioned in "Where to Find Electronics Parts," has moved. The new address is 477 Ann Street, Pigott, AR 72454. The new phone number is 501-598-3459.

LINDEL CLARK, OWNER  
Oak Ridge Engineering  
Pigott, AR

## MISSING TRADEMARK

Thanks for the review of our company's Robix Robot-Construction Set (**Popular Electronics**, January 1994). I hope you readers enjoyed it.

I'd like to correct one omission. "Robix" is indeed a trademark of Advanced Design, Inc.

EVAN ROSEN, PRESIDENT  
Advanced Design, Inc.  
Tuscon, AZ

## WE ASKED—YOU ANSWERED

In response to your request ("What's Next?," **Popular Electronics**, December 1993) for input on your good magazine's

content for the upcoming year, I would like to make a couple of comments.

First, I'd like to say that I do enjoy the content of your magazine. I am an Electrical Engineer both by training and practice. I'm also an electronic and computer hobbyist. Your level of electronics coverage is more than adequate for my appreciation—I get enough of the theoretical stuff at work.

I do thoroughly enjoy the articles on simple basic transistor and IC application "whatever's" (oscillators, amplifiers, etc.). I see so many projects that use micro's that it is relaxing to review some very fundamental control ideas. It also makes one realize that in some applications, a bunch of transistors can do the same job. It might not be as precise, but then sometimes we tend to be too exacting.

I would enjoy seeing more articles on linear devices interfacing with some type of transducer (temperature, humidity, acceleration, etc.). It would also be nice to see items on magnetic compasses using a fluxgate magnetometer, and on the use of transistors instead of IC's as basic integrators and differentiators. Then there is the subject of home automation: What sort of bus structure is going to be used, and how do we interconnect to it?

Also in the wings, is low-power RF to be used as a control feature? Note the computer industry and the extent to which it is being promoted for printer and peer-to-peer communications. The cost of RF communication devices is decreasing rather rapidly, more so than the apparent cost of using fiber-optic and/or copper lines in the home.

I also like the articles and/or reviews of new electronic devices that are being introduced to the market, and items that are on the forefront of their respective areas, be it stereos, computers, photography, blenders, or robotics. The short reviews keep one informed that

a lot of progress is being made to make us live better and enjoy what we have that much more.

It would also be nice to have more articles on adding new functions to our cars. And then there are remote-controlled electric lawn mowers . . . I could keep going, but I think you get the idea that what you are doing is what you should be doing. Just continue to do it and keep up with the times.

R.B.  
Cortland, OH

I'd like to commend you on a very fine magazine. I've read **Popular Electronics** for many years.

As an electronics hobbyist, I really appreciate the construction articles, and the articles that deal with the new and upcoming electronic "gizmo's." I feel as if the magazine is just about right in the balance of articles.

Even though I am not personally interested in every area covered, the areas you do cover are about right for electronic hobbyists and professionals (of course, this is only my "2-volts worth"). Since you did ask, however, I would like to see more construction articles in the computer/digital area.

Please keep up the good work.

R.R.  
Bedford, IN

## RECALCULATING ELECTRIC CAR COSTS

After reading the letter titled "Electric Car Costs" (**Popular Electronics**, December, 1993), I think that R.D.C. must have spend most of his time at the ballpark and not in mathematics class. His attempt to prove that operating battery-powered electric vehicles (BPEV's) will cost more than operating internal-combustion engine vehicles (ICEV's) is seriously flawed with basic arithmetic errors. Those errors, when corrected, paint a completely different picture.

First, in the BPEV calcula-

tions, R.D.C. failed to convert 547.5 billion *pounds* of coal per year to *tons* before multiplying by \$52 per ton to get the annual cost of coal. The correct annual cost, using R.D.C.'s assumptions, would be \$14.235 billion. How he arrived at \$28.47 billion is a mystery.

Second, gasoline weighs six pounds per gallon. All airline pilots (such as myself) rely on this number to calculate critical weight and balance of an aircraft prior to every flight. Why R.D.C. is concerned about the weight of gasoline is another mystery.

Third, the annual cost of gasoline (73 billion gallons per year multiplied by \$1.23 per gallon at the pump) would be \$89.75 billion. How R.D.C. arrived at \$12.82 billion is yet another mystery.

Using the corrected numbers, ICEV's are 6.3 times more expensive than BPEV's. If you add the hidden cost of the various oil subsidies paid to oil companies (estimated to be \$3 per gallon) you add another \$219 billion to the annual ICEV fuel costs. The 6.3 factor now becomes a whopping 21.7.

As for pollution, 100 million ICEV's would emit about 869 tons (360 grams per mile) of carbon dioxide versus 580 tons (240 grams per mile) for BPEV's, providing even more justification for making the transition to electric vehicles as soon as possible.

To carry this thinking further, development of fuel-cell electric vehicles (FCEV's), using hydrogen as a fuel, should be considered. The hydrogen could be produced from solar-powered photovoltaic cells and could eliminate the use of fossil fuels completely. FCEV technology could provide a renewable energy source that could be stored and distributed like gasoline. It would result in zero pollution and provide a solution to short- and long-distance transportation.

D.E.M.  
Gilbert, AZ



# Turn a Faulty VCR Into a Profit

Newly revised, **MAINTAINING AND REPAIRING VCRs** is the ONE book you need to quickly pinpoint any malfunction and fix it right down to the component level.

## See how easy it is to make successful VCR repairs

Packed with hundreds of helpful pinout diagrams and exploded-view illustrations, **MAINTAINING AND REPAIRING VCRs** gives you the

“... gives all the necessary information for learning the art of troubleshooting popular brands.”

—*Electronics For You*

how-tos to tackle even the trickiest VCR, Beta, or camcorder repairs. Don't spend your time looking through service literature, and using trial and error.

Everything you need to turn a broken VCR into cash in your pocket is here in **MAINTAINING AND REPAIRING VCRs**.

## Turn to Bob Goodman for expert advice

Bob Goodman walks you through every service, maintenance and repair you make, giving you actual case problems, symptoms to watch for, and solutions for each.

**MAINTAINING AND REPAIRING VCRs** will help you master maintenance and repair procedures, including how to:

- Adjust belt and drive wheels
- Replace audio and video heads
- Fix damaged or weak control functions
- Minimize damage caused by contaminants
- Repair and replace dirty switch contacts
- Troubleshoot electronic or mechanical servo malfunctions
- Identify and correct video head sticking and friction
- Turn a snowy, weak picture into a crisp, strong picture
- Adjust an improperly running tape path
- And much more.

“... fully explains the mechanical systems and electronic circuitry ... also details servicing data on all popular brands of VCRs.”

—*VIDEO Magazine*

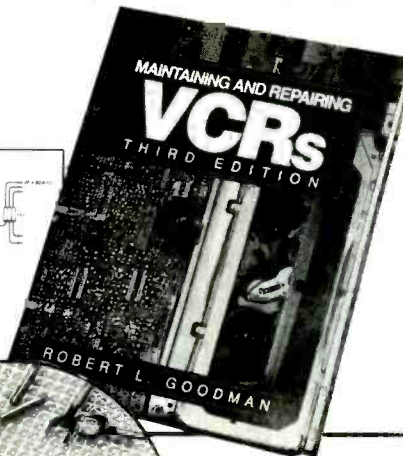
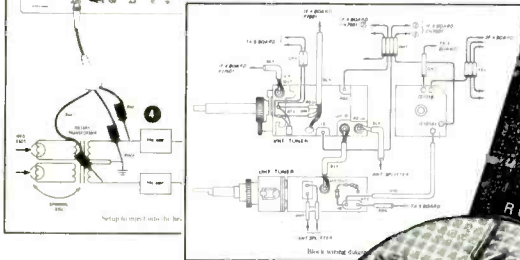
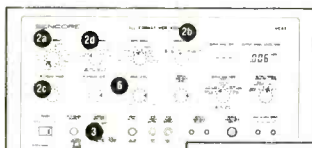

**FREE UNIVERSAL TEST LEAD KIT WITH EACH ORDER!**

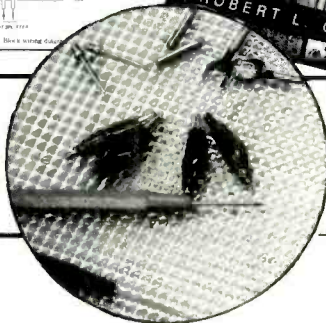

*Includes 14 electronic tools that you can use to test and measure equipment.*

Please cut along dotted line

## 3 Easy Ways to Order:

**CALL 1-800-822-8158**

**FAX: 1-717-794-5291**

**Mail: TAB/McGraw-Hill Inc.**  
Blue Ridge Summit, PA 17294-0840

**YES**, send me **MAINTAINING AND REPAIRING VCRs—3rd Ed. (#023969-XH)** to examine **FREE** for 30 days. After 30 days, I will pay \$39.95 plus postage, handling and applicable state and local sales tax. If I am not completely satisfied, I can return the guide and owe nothing.

Name \_\_\_\_\_

Address \_\_\_\_\_

City \_\_\_\_\_ State \_\_\_\_\_ Zip \_\_\_\_\_

Telephone \_\_\_\_\_

Signature **X** \_\_\_\_\_

order invalid without signature

Order subject to credit approval and acceptance by McGraw-Hill. Prices subject to change. Orders made outside the U.S. and Canada must be prepaid in U.S. dollars drawn on U.S. banks, and include an additional \$5.00 postage and handling.

SP34PV2

# ELECTRONICS LIBRARY

## Radio Receiver Projects You Can Build

by Homer L. Davidson

The 33 projects in this book are sure to appeal to radio buffs, students, and hobbyists who enjoy working with electronics. No experience is necessary to build all types of inexpensive, useful radio receivers from scratch, following the common-sense, hands-on directions offered in the book. More than 200 helpful circuit diagrams and photographs accompany the plain-English text.

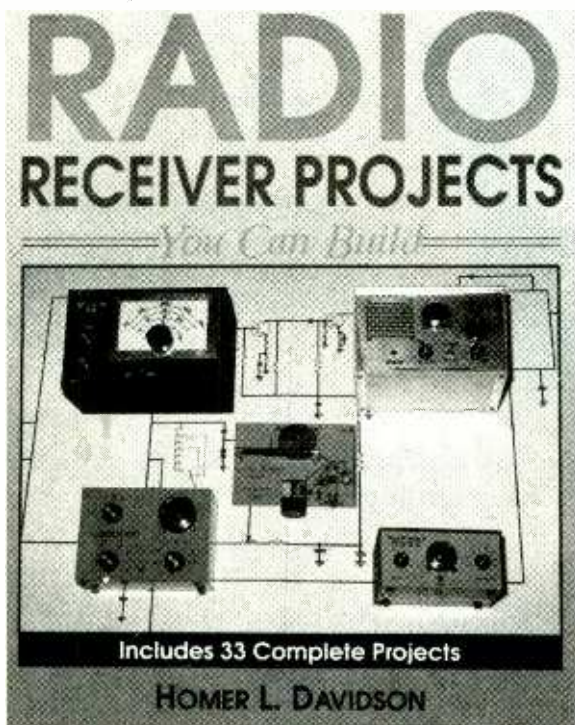

Some of the projects include a simple crystal radio, an integrated AM radio, an antique-tube regenerative radio, a two-tube regenerative battery-powered radio, an integrated tube radio, a one-tube shortwave radio, a toroidal-coil shortwave radio, a solar-powered radio, and a direct-conversion shortwave receiver that uses the TDA7000 IC chip.

The book also covers PC-board, chassis, and cabinet construction. Sources for parts and components are included.

*Radio Receiver Projects You Can Build* costs \$18.95 and is published by Tab Books Inc., Blue Ridge Summit, PA 17294-0850; Tel. 800-233-1128.

**CIRCLE 98 ON FREE INFORMATION CARD**

## HIGH-TECHNOLOGY DEGREE ALTERNATIVES: Earning a High-Tech Degree While Working Full Time

by Joel Butler

If there's one thing that's certain in today's economy it's that everything changes. Advanced education can help you cope with the changing job market, and advance your career in a positive direction. Whether you have no credits or are only a semester short of graduation, this book shows you how to get a college degree without leaving your full-time job.

There are more than 50 accredited undergraduate and graduate programs across the country that offer non-traditional methods of obtaining a college degree in technical fields such as engineering, computer science, information systems, electronics, and technology-oriented management. Many of those offer "external" degree programs that you can complete no matter where you live, without ever entering a traditional classroom.

This book reveals time- and money-saving techniques that can get your college education on track. It offers three steps to help you discover which high-tech degree will help you move up the ladder in your chosen field, and how to select the right school. Cost-cutting pointers in-

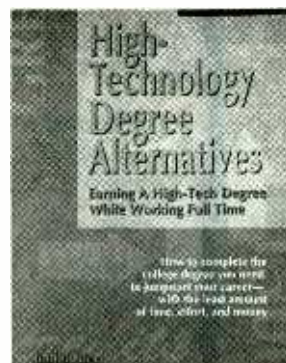

clude earning college credit for work and military experience, turning what you know into college credits, sure-fire credit transfers, and using exams to build credits and cut your degree completion time. The book also covers how to personalize a degree program to fit your goals, schedule, and budget by creating your own college courses and individualized majors, and by taking independent-study courses by mail.

*High-Technology Degree Alternatives* costs \$21.95 and is published by Professional Publications, Inc., 1250 Fifth Avenue, Belmont, CA 94002; Tel. 800-426-1178.

**CIRCLE 85 ON FREE INFORMATION CARD**

## A CONCISE INTRODUCTION TO WORDPERFECT 5.2 FOR WINDOWS

by P.R.M. Oliver and N. Kantaris

The routines described in this book will help you get the most out of WordPerfect 5.2 for Windows. Written with busy beginners in mind, the book assumes no prior knowledge of WordPerfect and has an underlying structure based on the philosophy "what you need to know first appears first."

The book outlines the hard-



**A Concise Introduction to WordPerfect 5.2 for Windows**

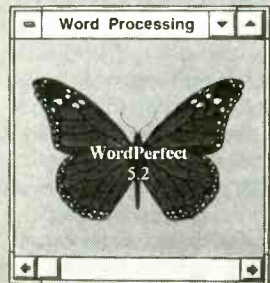

ware requirements for WordPerfect 5.2 for Windows, and walks you through a standard installation on a PC. It familiarizes you with the basics of WordPerfect and the Windows environment, and explains how to benefit from the built-in Help system and the different operating modes and screen views. The book covers how to enter, edit, and enhance text; how to work with formatting codes, button icons, the ruler,

tabs, graphic boxes, and styles; and how to use advanced features such as document checking, columns, outlining, tables, file and data management, transfers, and creating and running simple recorded Macros. A brief introduction to the Macro Programming Language is included. The book also shows how to come to terms with the program's ability to use two sets of printer drivers, and still produce good-looking printed output.

*A Concise Introduction to WordPerfect 5.2 for Windows (order No. BP339) is available for \$7.25 plus \$2.50 shipping and handling from Electronics Technology Today Inc., P.O. Box 240, Massapequa Park, NY 11762-0240.*

**CIRCLE 97 ON FREE INFORMATION CARD**

**GORDON WEST'S NEW ADVANCED CLASS FCC LICENSE PREPARATION**  
by Gordon West, WB6NOA

By taking the step to the next-

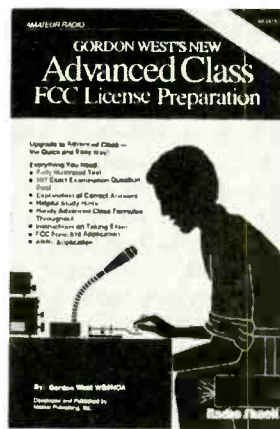

to-highest amateur-operator/primary-station license—the Advanced Class—you can enjoy increased privileges on world-wide bands and can become a part of the VE system for conducting amateur license examinations. This book makes it easier to take that step, by providing everything you need to learn about, prepare for, and pass the exam. It contains the exact 507 FCC Element 4A questions with their multiple-choice answers, that are valid

until July 1, 1995. Fifty of those questions will appear on each exam given. The correct answer each of the questions is identified, and an explanation as to why that answer is correct is provided. The fully-illustrated text also includes study pointers and instructions for successfully taking the exam, along with charts, diagrams, and formulas for an easy-to-understand approach to learning.

*Gordon West's New Advanced Class FCC License Preparation is published by Master Publishing Inc. and is available for \$9.90 at Radio Shack (Cat. no. 62-2415).*

**CIRCLE 86 ON FREE INFORMATION CARD**

**MAINSTREAM MULTIMEDIA: Applying Multimedia in Business**

by Roger L. Fetterman and Satish K. Gupta

As multimedia computing based on desktop platforms begins to

SCANNER USERS • COMMUNICATIONS PROFESSIONALS

# We've Got Your Numbers!

(319,000 FREQUENCIES)

## POLICE CALL 1994 EDITION

**COMPLETELY REVISED  
CURRENT THROUGH OCTOBER, 1993**

- 14,000 Codes and Signals.
- All Inclusive Frequency List.
- Illustrated Listener's Guide Book.

**GOT A SCANNER? GET POLICE CALL.**

At your scanner dealer and all Radio Shack stores.

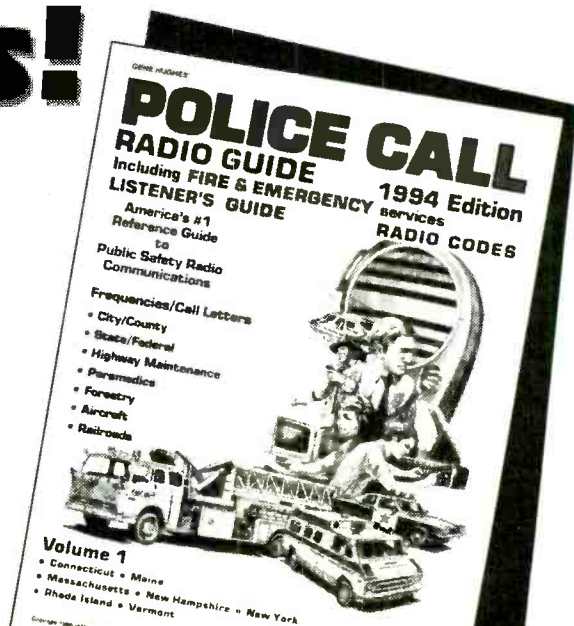

More People Buy **POLICE CALL** Than All Other Frequency Guides (VHF/UHF) Combined.

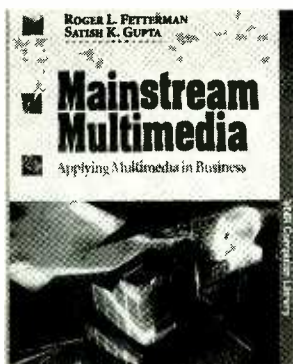

gain acceptance in the business world, this book describes how, when, where, and why multimedia capabilities can and should be used in different business environments. It can help business managers make informed decisions about multimedia applications.

The book explores the transformation of personal computers from "compute-intensive" to "communications-intensive" device, and explains how advances in desktop platforms, operating systems, authoring systems and applications software can provide seamless integration of audio, images, and video with text, graphics, and animation.

Taking a structured-analysis approach, the book shows how to match multimedia computing and networking solutions to application requirements to ensure success. The technology infrastructure is revealed in discussions of the components needed to implement desktop applications and multimedia-capable networks, with separate sections covering computing platforms, operating systems, storage devices, compression technologies, and networking solutions. Methods for analyzing costs and value are also provided.

*Mainstream Multimedia* is published by Van Nostrand Reinhold, 115 Fifth Avenue, New York, NY 10003.

**CIRCLE 87 ON FREE INFORMATION CARD**

### IN PLAIN ENGLISH: WINDOWS 3.1

by Jack Nimersheim

Windows 3.1 is a graphic interface designed to simplify using an IBM PC or compatible com-

puter, but at first glance it can seem anything but simple to new users. Because most of today's most powerful and useful programs operate in the Windows environment, it's worth learning to use the program. With a minimal amount of "computerese," this book helps you have fun while mastering Windows, instead of getting lost in a frustrating technical puzzle. It doesn't get bogged down explaining absolutely everything there is to know about Windows—the Windows manual does that. Instead, this book provides a full explanation of everything you need to know to effectively use Windows on an everyday basis.

In Plain English™

# WINDOWS 3.1

Jack Nimersheim

Computer Books in Language You Can Understand and Use

The book begins with a look at Windows basics and a step-by-step installation guide. It goes on to explain how to use Windows' standard mode and the enhanced 386 mode; select icons; open and change windows; use the control panel, work with different fonts; personalize your Windows desktop; use the Program Manager and the File Manager; manipulate data; work with directories and files; modify program groups; and deal with memory. Plenty of screen shots accompany the text, and each chapter includes a glossary of new terms that have been introduced in its pages.

In Plain English: Windows 3.1 costs \$9.95 and is published by WorldComm, Division of Creativity, Inc., 65 Macedonia Road, Alexander, NC 28701; Tel. 704-252-9515.

**CIRCLE 88 ON FREE INFORMATION CARD**

### ALL THUMBS GUIDE TO TELEPHONES & ANSWERING MACHINES

by Gene B. Williams

No experience (or repair shop) is necessary to keep your telephone gear running smoothly. You can save money by doing the job yourself, by following the clear, step-by-step instructions in this book. It explains how to safely and easily troubleshoot, test, and repair problems with virtually every type of telephone, including cordless phones, and answering machines.

The book explains how to install wiring inside and outside your house; take apart, repair, and put back together telephones and answering machines; disassemble, install, and modify telephone jacks; and clean the heads in your answering machine. Also included are pointers on performing tests with a voltmeter, and instructions for building a simple signal generator to test the wires inside walls.

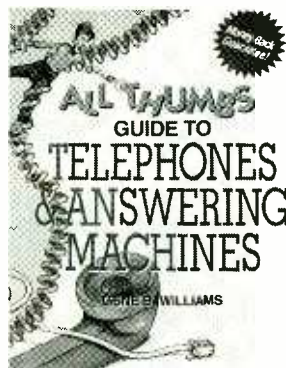

Written for complete novices, the book explains the basics of safety and describes the tools necessary and shows how to use them. The text is heavily illustrated with detailed drawings. Finally, a money-back guarantee is offered if you find yourself unable to follow the book's instructions.

*All Thumbs Guide to Telephones & Answering Machines* costs \$9.95 and is published by Tab Books Inc., Blue Ridge Summit, PA 17294-0850; Tel. 800-233-1128.

**CIRCLE 98 ON FREE INFORMATION CARD**

### THE PRESENTATION DESIGN BOOK: Second Edition

by Margaret Y. Rabb

You can spend a fortune on desktop-publishing hardware and software and still turn out boring presentations, if you don't know how to use those tools creatively and effectively. The bottom line is communication, and this book shows you how to get your message across to your audience with polished computer graphics and screen shows that lend power and appeal to presentations.

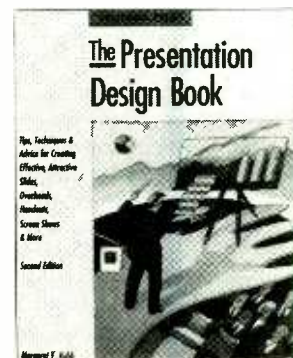

The book provides sound advice, insightful how-to examples, and easy-to-follow guidelines for designing persuasive slides, overheads, and handouts. The updated second edition adds material on using sound, video, animation, and interactivity in presentations, without sacrificing clarity or impact. A four-color section explores the use of color to create depth and set the tone. The book shows how to analyze the audience and environment to determine to optimal presentation media; understand the subtle effects of typeface on audience perceptions; create the best layout and design; integrate various multimedia elements into a cohesive, balanced presentation; and determine hardware and software requirements for multimedia presentations.

*The Presentation Design Book: Second Edition* costs \$24.95 and is published by Ventana Press, P. O. Box 2468, Chapel Hill, NC 27515; Tel. 919-942-0220; Fax: 919-942-1140.

**CIRCLE 89 ON FREE INFORMATION CARD**



# NRI knows: The best way to learn to service today's computers is to actually build a state-of-the-art computer from the keyboard up.

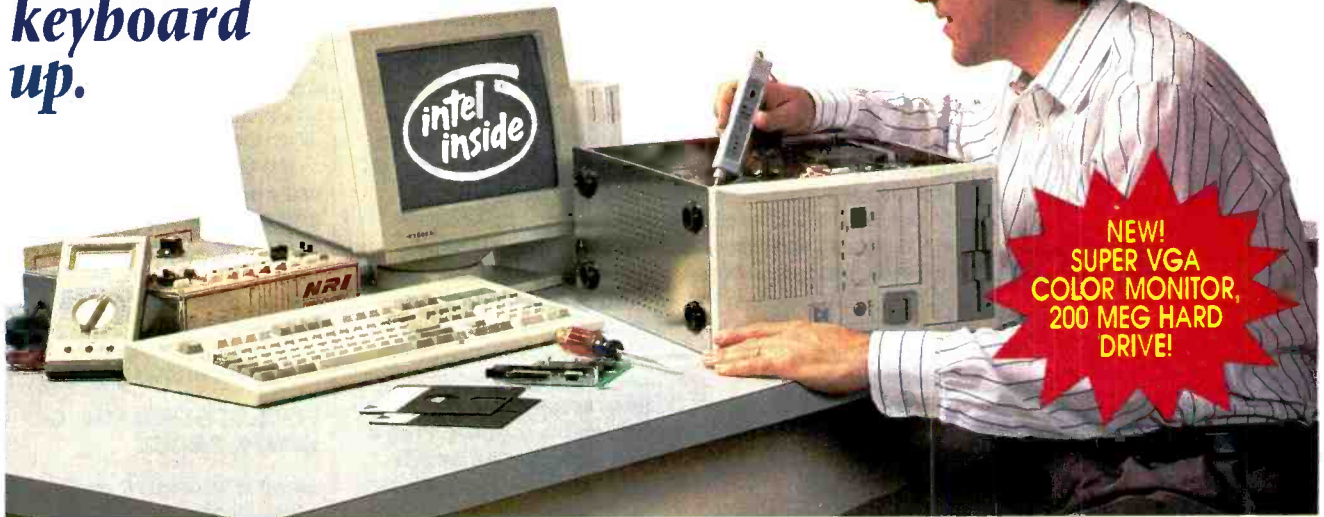

## TRAIN WITH THE LEADER - NRI

The Department of Labor forecasts over 220,000 jobs for computer service technicians by the year 2005 — a full 38% increase over today's level. With NRI's easy, effective training, you can cash in on this wide-open opportunity and become a high-paid computer service technician.

NRI is the best way to prepare for a profitable new career, even a business of your own. A leader in at-home training for 80 years, NRI knows how to help you break into this high-demand field — regardless of your background in electronics! That's because you start with the basis, moving on step-by-step to master advanced computer concepts — all the while reinforcing theory with hands-on training that ensures success.

## LEARN BY DOING

NRI's highly acclaimed learn-by-doing approach gives you a complete understanding of the intricate electronics behind the 1 meg RAM, 32-bit CPU computer included in your course. You perform hands-on electronics experiments with your NRI Discovery Lab and digital multimeter, then build and test the powerful 486sx/25 MHz computer you train with and keep. You install the floppy drive and, to give you maximum storage capacity, the 200 meg hard disk drive. And you go on to interface the Super VGA color monitor now included in your course. You even learn to recognize and service virtually any computer problem with the extraordinary R.A.C.E.R. plug-in card and QuickTech diagnostic software.

## STUDY AT YOUR OWN PACE

With NRI, you study in the privacy and convenience of your own home — with your personal instructor and NRI's team of technical professionals behind you every step of the way. You learn at your own pace — no classroom pressures, no night school, no point in quitting your present job until you're ready to make your move!

Everything you need, for your training and your future, is included in the course...from the NRI Discovery Lab you use to build up and test prototype circuits to the mini-tower 486sx IBM-compatible computer with color monitor, 200 meg hard drive, 3.5" floppy drive, DOS, QBasic, and Microsoft Works, with its many utilities.

What's more, NRI's expanded and updated lessons give you a thorough understanding of computer operation, troubleshooting, and servicing. Your broad-based knowledge will come from detailed, easy-

to-understand explanations of everything from batch file applications to recovering lost data to printer servicing. You'll be on top of the latest trends and techniques, and by practicing what you read, you'll quickly acquire lasting, real-world knowledge that you can put to use right away!

It's a fact: Only NRI gives you such thorough, effective training in computer servicing because only NRI has you assemble and test one yourself!

## LEARN MORE ABOUT NRI TODAY

Send today for NRI's free, full-color catalog that describes every aspect of NRI's innovative computer training, as well as hands-on training in other growing high-tech career fields. If coupon is missing write to: NRI Schools, McGraw-Hill Continuing Education Center, 4401 Connecticut Avenue, NW, Washington, DC 20008.

IBM is a registered trademark of International Business Machines Corp. R.A.C.E.R. and QuickTech are registered trademarks of Ultra-X, Inc. Intel Inside is a trademark of the Intel Corp.

## SEND CARD TODAY FOR FREE NRI CATALOG

**NRI Schools** McGraw-Hill Continuing Education Center  
4401 Connecticut Avenue, NW, Washington, DC 20008



Check one FREE catalog only

- MICROCOMPUTER SERVICING
- TV/Video/Audio Servicing
- Telecommunications
- Industrial Electronics & Robotics
- Security Electronics
- Electronic Music Technology
- Basic Electronics

- Computer Programming
- Programming in C++ with Windows
- Desktop Publishing & Design
- Word Processing Home Business
- Bookkeeping & Accounting
- Home Inspection
- Building Construction
- Small Engine Repair
- Automotive Servicing

For career courses approved under GI Bill, check for details.



Name \_\_\_\_\_ (please print) \_\_\_\_\_ Age \_\_\_\_\_

Address \_\_\_\_\_

City/State/Zip \_\_\_\_\_ Accredited Member, National Home Study Council 18-0394

# NEW PRODUCTS

## Hi8 VCR



For playing back and editing Hi8 and standard 8mm videotapes, Sony's EV-C100 Hi8 player/recorder delivers crystal-clear images and hi-fi stereo. The deck's Hi8 recording system captures more than 400 horizontal lines of resolution (versus 250 lines for VHS), to reveal image details without jitter or noise, even in still, slow-motion, or frame-by-frame modes. The EV-C100 also provides up to two hours recording in SP (best-picture) mode.

The AFM sound-recording

feature provides hi-fi stereo audio with wide dynamic range and minimum distortion. Sony's "Voice Boost" system minimizes background noises by boosting the frequency of the human voice.

For editing, the EV-C100's offers a dual-mode shuttle dial, which lets the user operate slow-motion and picture search in both forward and reverse. Other features include frame-by-frame advance/reverse buttons, a flying erase head, 2-times fast play, a Control L (LANC) editing interface, one-touch synchronized editing, and an edit switch to maintain maximum picture quality during editing.

The EV-C100 Hi8 VCR has a suggested retail price of \$650. For more information, contact Sony, 1 Sony Drive, Park Ridge, NJ 07656.

**CIRCLE 101 ON FREE INFORMATION CARD**

## LONG-LIFE SMOKE DETECTOR

Safety studies have shown that between 30% and 50% of all installed smoke detectors are not doing their job because of missing or dead batteries. *Ultralife Batteries* addresses that problem in its *Ultralife Smoke Detector*, which is powered by a unique 9-volt lithium battery that lasts up to four times longer than an alkaline battery and up to ten times longer than a carbon-zinc battery. The company offers a six-year limited warranty for both the battery and the detector. The detector senses fires in their earliest stages, responding with a powerful 85-dB horn.

To let the homeowner know when the battery finally does die, a "low-battery" chirp will sound for 30 days. When the battery is working properly, a red operating light flashes at 45-second intervals to indicate that the unit is receiving power. In addition, the smoke detector has a battery-test button.

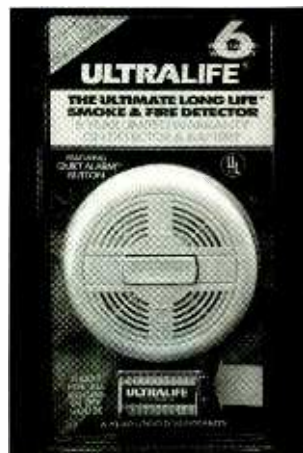

The main cause for missing batteries is false alarms: Consumers remove the batteries when the smoke alarm goes off due to fireplace, cigarette, or cooking fumes, and then forget to replace them. The Ultralife detector has a "quiet-alarm" button that can be used to quickly silence those nuisance

alarms, without removing the batteries. The unit re-arms itself in ten minutes. In addition, the detector cover will not close unless a battery is in place within the unit.

The Ultralife Smoke Detector has a suggested retail price of \$19.95. For further information, contact Ultralife Batteries, Inc., 1350 Route 88 South, P. O. Box 622, Newark, NY 14513; Tel. 800-332-5000.

**CIRCLE 102 ON FREE INFORMATION CARD**

## POCKET-SIZED LOGIC-SCOPE PROBE

Aimed at technicians, engineers, students, or hobbyists, for use in the lab or as a cost-effective enhancement to field-service equipment, the *MX9100* logic-scope probe converts an ordinary analog oscilloscope into a logic-analysis instrument suitable for examining and analyzing single-shot and repetitive digital phenomena. The portable 8-channel unit can be used independently or can be daisy-chained to provide 16- or 24-channel reading capability. The probe offers a full complement of grabber test leads and a BNC scope interface. It will work with any scope with a bandwidth of 5 MHz or higher, sensitivity of 200 mV/div or better, and external-triggering capabilities.

The *MX9100* has three operating modes. In the logic-analyzer mode, the usual analog scope becomes an 8-channel logic analyzer with a memory input depth of 16 bits. Each channel is displayed as a horizontal line in a "timing diagram" manner. In the trigger-probe mode, a real-time trigger signal is generated whenever an 8-bit user selected condition is met. Analog signals can be viewed while triggering the scope externally using a digital combination. The MUX mode allows eight digital signals in real time to be simultaneously displayed on the screen.





The MX9100 logic scope probe kit, including 11 test leads, 8 gray signal leads, one clock lead (yellow), a red power lead, and a black ground lead, costs \$330. For more information, contact ITT Pomona, 1500 East Ninth Street, Pomona, CA 91766-3835; Tel. 909-469-2900; Fax: 909-629-3317.

**CIRCLE 103 ON FREE INFORMATION CARD**

### MULTIMETER WITH THERMOMETER

Extech's Model 380505 hand-held multimeter offers seven functions, including a Type-K thermocouple input for temperature measurements from 0°-1999°F. The multimeter also monitors five ranges in both DC and AC voltage, DC amps, AC amps, and resistance. All functions are displayed on a 0.95-inch LCD readout. The unit also provides diode and audible continuity tests, as well as polarity and over-range indications. It comes complete with a rubber holster, test leads, a temperature probe, and a 9-volt battery.



The Model 380505 multimeter with thermometer costs \$59. For additional information, contact Extech Instruments Corporation, 335 Bear Hill Road, Waltham, MA 02154; Tel. 617-890-7440; Fax: 617-890-7864.

**CIRCLE 104 ON FREE INFORMATION CARD**

### A/V RECEIVER WITH GRAPHIC USER INTERFACE

The first audio/video receiver in Pioneer's Elite line to offer a built-in graphic user interface (GUI) is the Model VSX-97. Featuring computer-like icons designed to guide the user through a variety of audio-video settings, the GUI facilitates on-screen programming menus. The GUI also features a video-edit mode that allows users to create customized videos by mixing any combination of audio and video sources. Users can also adjust the mix and fade levels for more refined video production.



The VSX-97 also offers digital audio-signal processing (DASP) based on the PD-00883 chip, which combines a Dolby Pro Logic decoder and sound-field processor on a single chip. DASP digitally controls delay time as well as the steering logic of the surround system. DASP is said to achieve three times the processing power of a conventional digital signal processor with significantly lower distortion. Through DASP, the receiver provides a standard stereo mode, three preset sound-field controls (movie, concert, and sports), and one advanced sound-field control that allows the user to program and store into memory four customized system configurations. For custom settings, users can choose four of an available ten "built-in components" and set the acoustic parameters of each through the GUI. The adjustable parameters include initial delay, "liveness" effect, room size, wall type, and mode.

Other features of the VSX-97 include the ability to transfer S-video to composite format and vice-versa, and multi-room and multi-source capability, and a "pure-line" switch that automatically turns off the receiver's fluorescent display and clock

# Be an FCC LICENSED ELECTRONIC TECHNICIAN!

**Earn up to \$2000/Week and more!**

Learn at home in spare time. No previous experience needed!

No costly school. No commuting to class. The Original Home-Study course prepares you for the "FCC Commercial Radiotelephone License." This valuable license is your professional "ticket" to thousands of exciting jobs in Communications, Radio-TV, Microwave, Maritime, Radar, Avionics and more...even start your own business! You don't need a college degree to qualify, but you do need an FCC License.

**No Need to Quit Your Job or Go To School** This proven course is easy, fast and low cost! **GUARANTEED PASS**—You get your FCC License or money refunded. **Send for FREE facts now. MAIL COUPON TODAY!**

**COMMAND PRODUCTIONS**  
 FCC LICENSE TRAINING, Dept. 100  
 P.O. Box 2824, San Francisco, CA 94126  
 Please rush FREE details immediately!

NAME \_\_\_\_\_  
 ADDRESS \_\_\_\_\_  
 CITY \_\_\_\_\_ STATE \_\_\_\_\_ ZIP \_\_\_\_\_

## SUPER 12 HOUR RECORDER

CALL TOLL FREE

Modified Panasonic Slimline. 6 hrs per side. 120 TDK tape furnished. AC/DC Operation. Quality Playback. Digital Counter. Durable Lightweight Plastic. **\$119.00\***

**PHONE RECORDING ADAPTER**

Starts & Stops Recorder Automatically When Hand Set is Used. FCC APPROVED Solid State! **\$28.50\***

**VOX VOICE ACTIVATED CONTROL**

Solidstate Adjustable Sensitivity. Voices & Sounds Activate Recorder. Adjustable Sensitivity. Provisions for Remote Mike. **\$28.50\***

\*Add for ship. & handling. Phone Adapter & Vox \$2.00 each, Recorders \$5.00 each, Colo. Res. add tax. Mail Order, VISA, M/C, COD's OK. Money Back Guar. Qty. Disc. available. Dealer inquiries invited. Free data on other products.

**ALL MAIL TO: Box 20100, Boulder, CO 80308**  
 AMC SALES INC., 193 Vaquero Dr., Boulder, CO 80303  
 Phones (303) 499-5405 • 1-800-926-2488  
 FAX (303) 494-4924 • Mon-Fri 8-5 MTN. TIME

**CIRCLE 151 ON FREE INFORMATION CARD**

# For your Heart's sake get **PULSE STICK II**

**Y**our very own sophisticated pocket health monitor, PULSE STICK II, checks your pulse rate quickly and accurately anywhere. Regular monitoring of your pulse rate during exercise will enable you to plan an exercise regimen suitable for your stage of fitness. Pulse stick II provides an early warning that you may be exceeding your own capabilities.

PULSE STICK II photoelectrically measures the changes

Only  
**\$39<sup>95</sup>**

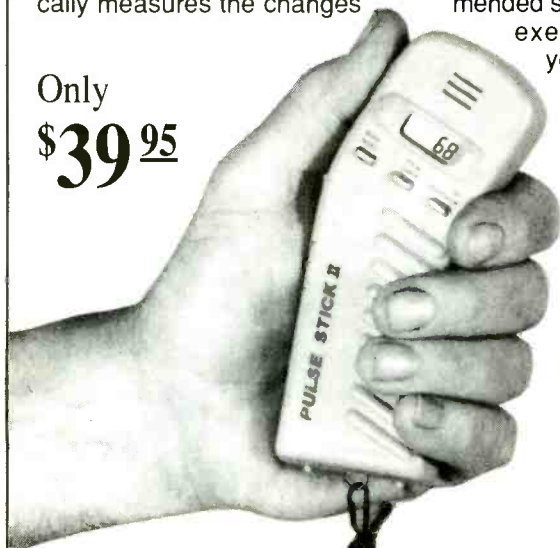

Uses three AA dry cells supplied with PULSE STICK II

in the pulsed intensity of infrared radiation emitted by superficial blood vessels below the skin of the thumb. The time intervals between pulses are automatically measured and analogized by the micro-processor based circuitry and displayed in a liquid-crystal display (LCD).

Before attempting any exercise program, consult your doctor. Ask for guidance regarding the recommended safe pulse ranges for your exercise program. Follow your doctor's instructions carefully.



Ideal for running, walking and aerobic training programs!

when a source component is directly connected to the power amplifier.

The VSX-97 audio/video receiver has a suggested retail price of \$2,600.

**CIRCLE 105 ON FREE INFORMATION CARD**

## DIGITAL VOICE RECORDER

GetTech's AudioQ-218 digital voice recorder will record up to 218 seconds of speech. The device offers four selectable sampling rates (4.8-, 8.5-, 9.6-, and 11-kHz), and sampling rates up to 17.8 kHz are available. As many as eight different variable-length messages can be stored in battery backed-up RAM. The recorder measures 2.6 x 2.6 inches.

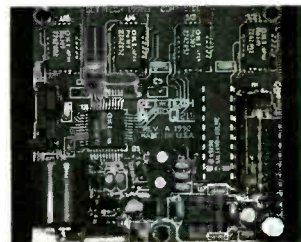

Two independently adjustable audio outputs are provided. One high-level output will drive an 8-ohm speaker to 400 mW; the other can be used for output to an external amplifier or transmitter. An on-board regulator allows use from 8 to 15 VDC. An open-collector output for keying a transmitter or external device during playback is also available, as is customizing.

The fully assembled and tested AudioQ-218, including backup battery and 4 megabytes of RAM, costs \$149 plus shipping and handling. For additional information, contact GetTech, 402 Riley Road, New Windsor, NY 12553; Tel. 914-564-5347.

**CIRCLE 106 ON FREE INFORMATION CARD**

## CAR AUDIO SIGNAL PROCESSOR

Summit Electronics has licensed the Aural Exciter with Big Bottom audio signal processing technology, originally designed by Aphex Systems for use in the recording and broadcast industries. The technology

PSII-2

**YES!** Please send me \_\_\_\_\_ PULSE STICK II at \$39.95 each. Price includes shipping and handling charges.

Total amount of order \$ \_\_\_\_\_

Check or Money Order enclosed. Make check payable to **CLAGGK Inc. PULSE STICK II Offer**

Charge my  Visa  MasterCard

Account No. \_\_\_\_\_

Exp. Date \_\_\_\_\_ / \_\_\_\_\_

Credit Card

Signature \_\_\_\_\_

Print Name \_\_\_\_\_

Address \_\_\_\_\_

City \_\_\_\_\_ State \_\_\_\_\_ Zip \_\_\_\_\_

No telephone orders or C.O.D. Signature required on credit card orders. All prices include postage and handling. Payments in U.S.A. funds only. New York residents must include local applicable sales taxes. No foreign orders.

**Mail orders** to CLAGGK Inc. Pulse Stick II Offer, P.O. Box 4099, Farmingdale, NY 11735.

**FAX orders** to 1-516-293-3115.





is incorporated in the **BAX-1** automotive audio signal processor. A pulse-width modulated power supply and variable gain have been added to the 1/2 DIN dash-mountable unit, which requires no added power or amplification to process low and high frequencies.

The **BAX-1** is said to kick up the overall sound and perceived loudness of any car stereo system, and to allow the human ear to perceive the enhancements as a natural part of the overall sound. It adds a small amount of a processed signal back into the original, unprocessed signal, using a variety of mixing and balance controls. The **BAX-1** also cuts above ambient noise caused by traffic, wind, and road conditions.

The **BAX-1** Aural Exciter with Big Bottom has a suggested list price of \$249. For further information, contact Summit Electronics, 12420 Montague Street, Arleta, CA 91331; Tel. 818-890-3025; Fax: 818-890-5103.

**CIRCLE 107 ON FREE INFORMATION CARD**

## HANDHELD FREQUENCY COUNTER

Intended for use in the test, communications, security/surveillance, two-way amateur radio, law-enforcement, and communications-monitoring markets, the latest model in *Optoelectronics' line of Handi Counters* represents a substantial improvement in features and capabilities. The *Model M-1* handheld frequency counter is a full-range counter with coverage from 10 Hz to 2.8 GHz that provides ultra-high-speed measurements as well as very high-resolution ten-digit measurements. It features ten user-selectable gate times, ranging from 13 milliseconds to 10 seconds, with corresponding resolution from 10 kHz to 0.1 Hz.

The **M-1** is based on a high-speed application-specific IC that is capable of 250-MHz direct counting. An embedded

microcontroller provides digital filtering that reduces the display of random noise and oscillation without loss of sensitivity. Digital auto capture locks the counter display on the first reading to pass the filter. An arm/store button sends captured data into a three-register stack that can be recalled later.

The addition of an asynchronous serial data port allows the TTL data to be level shifted to RS-232C using the optional accessory interface (*Model CX12*). The interface includes data-logging software that can be used with any PC to log and time-stamp frequency data.



A 16-segment relative signal-strength bargraph is sensitive to low levels of RF and can be used to verify transmitter output or locate a stuck transmitter or an unauthorized source of RF. The bargraph is fully independent of the frequency-measurement circuitry.

The **M-1** costs \$229. For more information, contact Optoelectronics Inc., 5821 NE 14th Avenue, Fort Lauderdale, FL 33334; Tel. 800-327-5912; Fax: 305-771-2052.

**CIRCLE 108 ON FREE INFORMATION CARD**



"Sorry... the computer's gone to lunch."

The professional weather station for people curious about the weather.



Haven't you always wanted a weather station? The Weather Monitor II makes a state-of-the-art weather monitoring system affordable enough for home use!

### FEATURES INCLUDE:

- Inside & Outside Temps
- Wind Speed & Direction
- Barometer
- Time & Date
- Inside Humidity
- Wind Chill
- Alarms
- Highs & Lows
- Rainfall Option
- Instant Metric Conversions
- Outside Hum. & Dew Point Option
- Optional PC Interface

Order today

**1-800-678-3669**

M-F 7 a.m. to 5:30 p.m. Pacific Time • PE639E  
FAX 1-510-670-0589 • M/C and VISA  
One-year warranty • 30-day money-back guarantee

**DAVIS INSTRUMENTS**  
3465 Diablo Ave., Hayward, CA 94545

**CIRCLE 162 ON FREE INFORMATION CARD**

## Learn VCR repair at home!

MAKE GOOD MONEY IN YOUR OWN FULL- OR PART-TIME JOB



Professional-level home study course. You will master easy-to-learn, high-profit repairs *without* investing in high-tech instruments or a costly workshop.

Want more independence and higher income? Send or call today!

Free career literature:  
**800-223-4542**

Name \_\_\_\_\_ Age \_\_\_\_\_  
Address \_\_\_\_\_ Phone (\_\_\_\_) \_\_\_\_\_  
City \_\_\_\_\_ State \_\_\_\_\_ Zip \_\_\_\_\_

**The School of VCR Repair**  
6065 Roswell Road  
Dept. VC341, Atlanta, Georgia 30328

**CIRCLE 159 ON FREE INFORMATION CARD**



# MICROCODE ENGINEERING CIRCUITMAKER

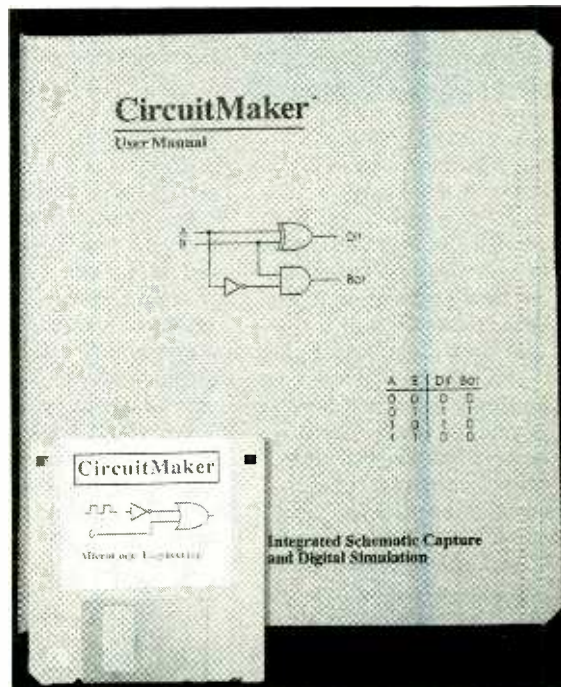

CIRCLE 119 ON FREE INFORMATION CARD

*An integrated schematic capture and digital simulation program for Windows that's great for beginners and experienced hobbyists.*

In the days when almost everything ran from DOS, learning to use a new software package meant immersing yourself more in the software's idiosyncrasies than in the task you were trying to perform. Once that initial shock was out of the way, going further than the basics virtually meant becoming a programmer.

Being a roll-up-your-sleeves kind of person, I didn't personally mind that too much, but I felt it wasn't fair to most folks and, more importantly, I knew things really didn't have to be that way. Well, by now the existence of Windows has proven that a PC compatible full of software can be easy to learn and operate with any level of interest or expertise.

Recently, I had the good fortune to come across a Windows-based software package that's so easy to use, it's suitable not just to teach a beginner how to use a computer, but about digital electronics as well. The package is Circuit Maker from MicroCode Engineering (1943 N. 205, West Orem, UT 84057; Tel. 801-226-4470). It allows you to quickly and easily draw, modify, and combine analog and digital schematics, and can simulate the operation of the digital portion of your circuits. Further, since it's a Windows

application, it can print its waveforms and schematics on any Windows-selectable printer.

In a sense, the software is not really new, but it has only recently been ported over from the Macintosh "universe." That means the program has already been "worn-in" development wise, for those that don't like "aking the first ride on any bandwagon.

On a PC compatible, it requires Windows 3.1 or higher, 2MB of free disk space, a VGA monitor or better, and a mouse—typical minimal-requirements for Windows applications.

**Parts and Macros.** To draw a circuit diagram (which can span several pages), you use the mouse to select devices from the provided library. Then you connect them using wires. Parts can then be moved, rotated, etc. Let's talk about parts, wires, text, and finally the ways they can be graphically manipulated.

The device library includes TTL devices; generic devices (such as gates and flip-flops); I/O and display devices such as switches; a pulse generator; LED's; 7-segment LED displays; analog devices such as transistors, resistors, capacitors, and inductors (which are only graphic symbols—

they are not simulated); and miscellaneous devices such as PROM and RAM IC's. In all that's 120 digital (and simulated) devices and 18 purely graphical ones.

One feature of the digital devices that distinguishes this package from most simulator software in its price range is that they have programmable propagation delays. That allows you to simulate circuits made up of chips from varying families (pure TTL, low-power Schottky, etc.). Circuits like that have a greater need to be simulated anyway, so their simulation should be accurate.

If the bundled parts library is insufficient for your needs, you can create "macros" and add them to the library. Macros are devices you can use for simulation and/or graphical use. They can be moved between libraries, recalled from a library, edited, and re-saved at any time. For a functioning macro (one that can be processed by the simulator) you start by drawing the schematic that describes its function, which, by the way, can contain nested macros. Then you decide on the device's name and package, which could be a dual-in-line or user-defined type.

To create a user-defined package



you first draw it in any Windows-based drawing program. Second, you import the package drawing into the device's schematic via the clipboard and add pins to it. Adding pins is automated with the help of a toolbar full of the two types of pins (active high and active low) in every orientation.

Whether user-defined or DIP, the package's pins are then labeled. Next, you connect the pins to their corresponding points in the device's schematic and save the macro. When the macro is chosen for use in another circuit, only its package is visible, its circuitry is not. To see the schematic diagram represented by the macro, it can be "expanded" using an option from the Macro menu. For purely graphical macros, you simply dispense with drawing a schematic, and therefore there's nothing to connect to the desired package.

Once created, macros are handled exactly as though they were parts. So from here on, when we discuss operations with parts, remember that the same applies for macros.

### Placing Parts, Wires, and Text.

Parts are listed on library pull-down menus (labeled "L1," "L2," etc.). To place one on a schematic, you start by selecting the right menu using an arrow-shaped cursor (called the "arrow tool", which is activated from the toolbar), then select its name from the menu. The menu will disappear and the arrow tool will be replaced by a picture of the part. Move the part where you want it and click the mouse to place it on the schematic. If the program's "Repeat" option is on, it's now ready to place another copy of the part elsewhere on the schematic. If it is off, the arrow tool reappears.

Parts are connected together using "wires," which are composed of line segments drawn between the terminals of parts. For that, the mouse is used along with a cross-hair cursor called the "wiring tool" which is activated from the tool bar.

You start by moving the wiring cursor close to a terminal. You can't tell how close is close enough because, unlike most Windows programs, no handle markers appear. However, you don't have to be precise because CircuitMaker's "Smart Wires" automatically snaps wires to terminals.

Clicking the mouse then starts the

wire and the cursor disappears. At this point the program is waiting for you to move the mouse so it can give you an appropriate cursor. There is one cursor for drawing vertical line segments, activated by moving the mouse up or down, and another for making horizontal segments, activated by moving left or right. The vertical-segment cursor is a horizontal line and the horizontal-segment cursor is a vertical line. Both cursors span the whole drawing area to help you align the endpoints of segments with component terminals and such. From then on, single mouse clicks alternate you between the horizontal and vertical cursors, which allows you to make bends in the wire. A double click terminates the wire. If the wire is terminated near a terminal, the SmartWires feature snaps it to the terminal.

I found the disappearance of the cursor a bit disconcerting. Having it change shape or color would have been nicer. Also, I'm used to the more conventional click and drag format of wire placement. However, that automation typically means you relinquish your control over where bends occur until you go back and do some clean up, so there's something to be said for the CircuitMaker wiring concept.

Software paradigms aside, there is a different "draw back" to the wiring-cursor algorithm: it runs too fast on a fast machine (I used a 50MHz 486). What that means is that you'll be trying to double click the cursor to terminate a wire, only to have the program switch back and forth between the horizontal and vertical cursors. That can be overcome by lowering Windows' double-click speed from the control panel, although that might make it less than optimal for your other applications.

To start placing text on a schematic (say, to document its operation) you must select the Text icon from the toolbar. The usual Windows "I"-shaped text cursor then appears, which you place to the upper-left of where you want the text to appear. A click of the mouse opens a window at that position for typing the text. I really like that feature because the window's height and width can then be adjusted to control the wrapping of the text and the area it occupies. Another plus is that the text can be fully stylized with regard to point size, attribute, and

## Earn Your B.S. Degree in ELECTRONICS or COMPUTERS



### By Studying at Home

Grantham College of Engineering, now in our 43rd year, is highly experienced in "distance education"—teaching by correspondence—through printed materials, computer materials, fax, and phone.

No commuting to class. Study at your own pace, while continuing on your present job. Learn from easy-to-understand but complete and thorough lesson materials, with additional help from our instructors.

Our Computer B.S. Degree Program includes courses in BASIC, PASCAL and C languages — as well as Assembly Language, MS DOS, CADD, Robotics, and much more.

Our Electronics B.S. Degree Program includes courses in Solid-State Circuit Analysis and Design, Control Systems, Analog/Digital Communications, Microwave Engr, and much more.

An important part of being prepared to *move up* is holding the right college degree, and the absolutely necessary part is knowing your field. Grantham can help you both ways—to learn more and to earn your degree in the process.

Write or phone for our free catalog. Toll free, 1-800-955-2527, or see mailing address below.

•  
Accredited by  
the Accrediting Commission of the  
National Home Study Council  
•

**GRANTHAM**  
**College of Engineering**  
Grantham College Road  
Slidell, LA 70460

font. While the window is present all the usual Windows' text-editing features (double clicking on words, click and drag selection, etc.) are available.

Clicking the mouse outside the text window causes the window-frame and background to disappear leaving the text on the drawing itself. Simultaneously, a new text window opens where you clicked to accept another block of text.

By the way, my trouble with the wiring cursor lead me to discover something else: you can't undo a placement of wiring, parts, or text. If you don't like an item or its placement you must move it or delete it, the latter of which means selecting a different tool, which we'll mention later.

**Editing.** Individual objects (parts, text, wires, and in some cases a line segment in a wire) and groups of objects are most often edited with the help of the arrow tool. To select a single part for editing, just aim the cursor at the part and click. To edit multiple items click and drag the cursor to draw a rectangle over all the parts of interest. You can also use a Select-All option on the edit menu to select all the parts on a schematic at once.

Moving single objects is done by simply clicking and dragging them to their new location. Unfortunately, on fast machines, that means the program sometimes moves an item you originally wanted to select for some other editing operation. Again, the cure is to alter the mouse's responsiveness from the control panel. One nice feature of moves is that all wiring remains intact, as though the wires connecting the selected part to the rest of the schematic were made of rubberbands. Moving is one of the operations that affects individual line segments in a wire, which combined with rubberbanding, makes it very useful for cleaning up schematics.

You cannot move multiple items except by cutting and pasting them. By the way, the cut, copy, and paste operations are the same as in any other Windows application. However, those commands are augmented by commands that allow you to copy schematics or waveforms from the simulator to the clipboard in either metafile or bitmap format. There's also a Duplicate option for making multi-

ple copies of a part or group of parts without resorting to the clipboard.

The Edit menu also features Delete, Mirror, and Rotate 90° options. Delete and Mirror are self explanatory, while Rotate rotates each selected object around its center, not the center of the selected area. Deletion or rotation can also be accomplished using the delete or rotation tools, respectively, both of which are available from the toolbar for ease of use. However, the delete tool only takes-out one object at a time. Note, wires don't remain connected after a rotation or mirroring as rubberbanding only works for classical move operations. Of course, if you don't like the appearance of your schematic after a change, you can undo the last edit.

The edit menu also has three electronics-oriented options: Edit Delay, Edit PROM, and Edit Pulser. The first option lets you set the propagation delay of selected parts on a schematic. The second allows you to program data bytes into the program's PROM device. The last option lets you adjust the output of the software's pulser tool, used to inject signals (stimulus) into a schematic during simulation. That option lets you set the pulser for free-running or external triggering (via its two inputs—one for high pulses, the other for low ones), set the high and low time of the probe, and invert the probe's output. The probe output does not enter a high-impedance state simply because the protection that that feature would offer a real circuit is unnecessary for a virtual one.

**Simulating.** The simulator is excellent. Simulation of digital circuits is completely live, so the circuit responds to stimulus from the probe and switches in real time. That interactivity is one thing that makes the program an incredible learning tool.

Operation of the circuit can be observed in one of four ways. First, with the Trace option enabled, the state of every node in the circuit is shown simultaneously as the simulation runs. In this mode, a wire at a logic one is shown in red, a wire at a logic zero is blue, and a wire at a high-impedance state as green. Those colors can be changed if you wish.

Second, oscilloscope probes can be connected to any nodes in the circuit thus causing the timing di-

agrams for those nodes to be shown in a separate "Waveforms" window. To see the timing diagrams, click on the waveforms icon in the toolbar, or select waveforms in the option window.

Third, the probe tool can be used to monitor any node in the circuit, to inject logic into a node, or toggle a switch position, while the simulation is running or when it is stopped. You start by selecting the probe tool from the toolbar. Touch its tip to a wire to see its state, and click the mouse to toggle that state. If you touch a switch with it, the switch will toggle.

Fourth, you can connect any of a variety of displays to key points in the circuit, as the displays run in real time, too. Provided are ASCII, discrete, and 7-segment displays.

To start a simulation, you click on the run icon in the toolbar. To stop a simulation, you click on a stop-sign icon that replaces the run icon in the toolbar. Alternatively, you could click on the step icon to advance the simulation one tick at a time. To reset the circuit to the starting state, there's a reset icon as well.

CircuitMaker gives the user the option of setting breakpoints—a set of logic conditions at key points in the circuit that will halt the simulation. Basically, inside the waveform window you indicate the logic state that each point of interest should be in when you want the simulation to stop, then run the simulator. That allows you to check the circuit for performance accuracy during critical moments of operation.

**The Tutorial.** Besides the hands-on approach the simulator affords, the best aid for beginners in digital electronics is the manual's easy-to-follow tutorial. It includes 6 very simple, yet important experiments complete with questions and solutions. It breaks all of the experiments down into simple steps that anyone can perform and has a helpful glossary of terms.

While CircuitMaker may need a little more polish to take fuller advantage of the Windows environment, at only \$199.95 plus shipping, it's an excellent digital simulator and learning tool. A demonstration version is also available for \$10. If the program sounds interesting to you, please contact MicroCode at the address given earlier, or circle No. 119 on the Free Information Card. ■





1367P \$29.95



4362P \$16.95



4110H \$27.95 Hardcover

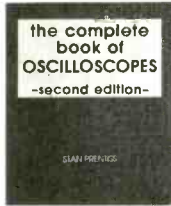

3825P \$17.95



4143P \$14.95



586354H-XX \$30.00 Counts as 2/Hardcover

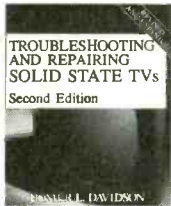

3700H-XX \$36.95 Counts as 2/Hardcover



3765P \$19.95

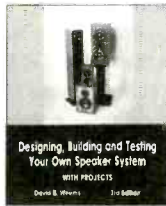

3374P \$16.95

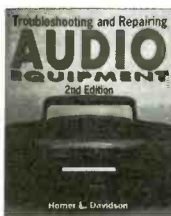

4112H-XX \$29.95 Counts as 2/Hardcover

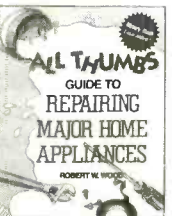

4061P \$9.95

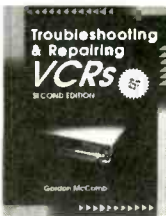

3777H-XX \$32.95 Counts as 2/Hardcover

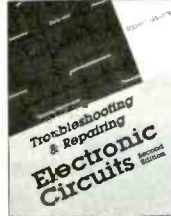

3258P \$19.95



4213H-XX \$50.00 Counts as 2/Hardcover



4089P \$18.95

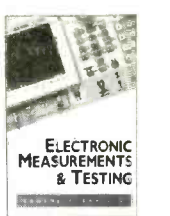

003961H-XX \$40.00 Counts as 2/Hardcover



4139H \$27.95 Hardcover

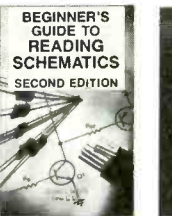

3632P \$10.95

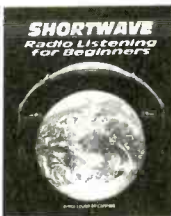

4231H \$19.95 Hardcover

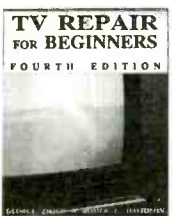

3627P \$19.95

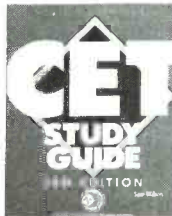

4076H \$27.95 Hardcover



3660H \$32.95 Hardcover

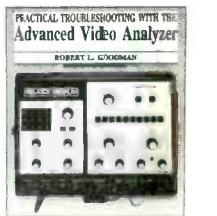

4358P \$24.95



3279P-XX \$24.95 Counts as 2

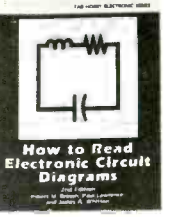

2880P \$15.95



2724P \$17.95

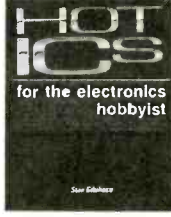

4122H-XX \$36.95 Counts as 2/Hardcover

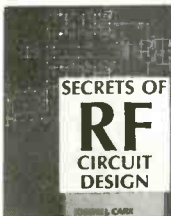

3710H-XX \$32.95 Counts as 2/Hardcover



4227H \$24.95 Hardcover



3795P \$19.95



4179H \$28.95 Hardcover

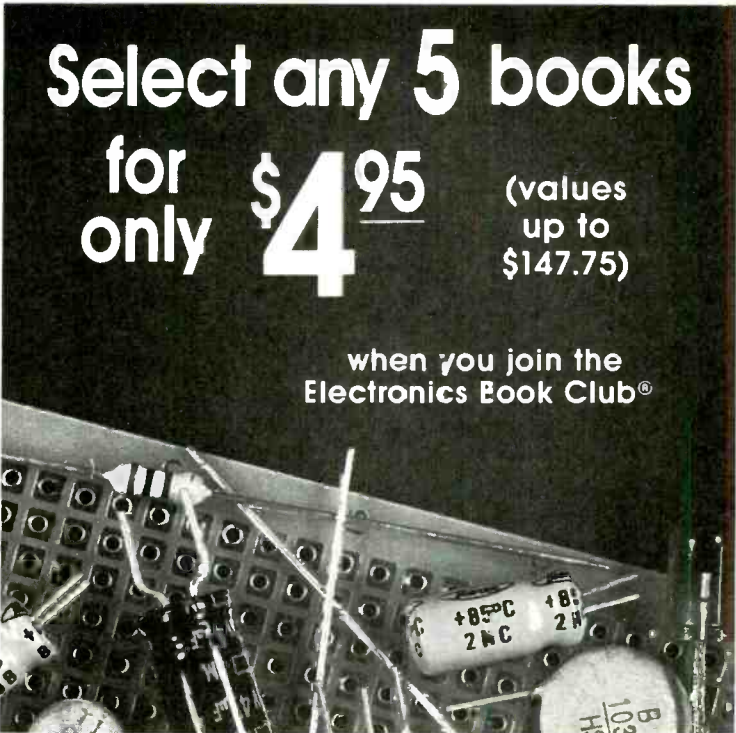

# Select any 5 books for only \$4<sup>95</sup> (values up to \$147.75)

## when you join the Electronics Book Club®

### As a member of the Electronics Book Club...

... you'll enjoy receiving Club bulletins every 3-4 weeks containing exciting offers on the latest books in the field at savings of up to 50% off of regular publishers' prices. If you want the Main Selection do nothing and it will be shipped automatically. If you want another book, or no book at all simply return the reply form to us by the date specified. You'll have at least 10 days to decide. And you'll be eligible for FREE Books through the Bonus Book Program. Your only obligation is to purchase 3 more books during the next 12 months, after which you may cancel your membership at any time.

A shipping/handling charge and sales tax will be added to all orders. All books are softcover unless otherwise noted. (Publishers' prices shown) If you select a book that counts as 2 choices, write the book number in one box and XX in the next. ©1994 Electronics Book Club PE394

If card is missing, write to: Electronics Book Club, Blue Ridge Summit, PA 17294-0810

### Your most complete and comprehensive source for the finest electronics books.

# PRODUCT TEST REPORTS

By Len Feldman

## Yamaha RX-V870 Stereo Receiver

**W**ith more and more consumers opting for home-theater audio/video integration, many major manufacturers are now offering stereo receivers that can handle all the amplification, decoding, and switching operations needed to recreate the theater experience you enjoy when you attend a "blockbuster" motion picture in a properly equipped movie theater. Further, many of these new receivers offer digital signal-processing circuitry that can allow your listening

need to add are the speakers, a monitor for video, and one or more program sources (VCR, CD player, etc.).

The digital sound-field processor (DSP) incorporated in the RX-V870 includes a full Dolby Pro Logic surround decoder, with four program settings for audio-only sources and four settings for audio/video program sources. The receiver features an automatic input balance control for Dolby Surround as well as a test-tone generator for easy speaker-balance adjustment. There are three center-channel listening modes available: normal, wide and phantom (when no center-channel speaker is installed).

The built-in AM/FM stereo tuner is capable of 40-station random preset tuning. In addition to standard video-signal inputs and outputs, the unit can accommodate S-video signals. The receiver features a sleep timer for automatic turn-off as well as on-screen displays that are helpful in accessing all of its control features. A fully programmable, learning remote control is supplied with the receiver and it can be used to control other Yamaha components as well as components made by different manufacturers.

While priced somewhat higher than its predecessor, the Model RX-V850, the new Model RX-V870 offers many improvements. For example, the addition of

70mm Theater and TV Theater Cinema DSP programs. The former adds depth to the Dolby Pro Logic sound field, providing the impression of a much larger theater and greater separation between dialogue, sound effects, and music. In the audio-only applications, a "Church" mode and a "Jazz Club" setting have been added. Finally, the on-screen display is a major plus in setting up the system and in fine-tuning its controls.

### CONTROLS

The front panel of the RX-V870, though somewhat intimidating at first glance, is actually arranged in a logical fashion considering the number of features and control settings that must be handled. A power on/off switch and a stereo headphone jack are at the extreme left end of the panel. A well illuminated display area occupies the upper right section of the panel and offers useful status indications including surround-sound selections, time-delay selection (when used), tuner signal-strength, preset selection and frequency, and much more. Just below the display area are pushbuttons for center-channel mode selection and Pro Logic, "Enhanced," "70 mm," and "TV-Theater" modes, as well as pushbuttons for audio-only DSP modes including "Rock Concert," "Jazz Club," "Church," and "Concert Hall." A surround-sound on/



CIRCLE 120 ON FREE INFORMATION CARD

*The Yamaha RX-V870 Dolby Pro Logic surround-sound A/V receiver.*

room to mimic a variety of acoustic environments such as an opera house, a concert hall, a disco or a jazz club. One such receiver is the Yamaha (6722 Orangethorpe Ave., Buena Park, CA 90620) RX-V870. It offers all the electronics you would need for a complete home-theater installation, including amplifiers for the center and rear Dolby surround channels. All you



off button is also found here. Further down, below the display area, are buttons for adjusting time delay (when Pro Logic or DSP modes are active), and rocker-type buttons for adjusting the relative levels of the center, front, and rear channels. Along the bottom left of the panel are speaker-selector switches, a bass-enhancement button, and a tone-bypass pushbutton.

The upper-right section of the front panel houses a row of buttons used to select the program source. Just below these are eight numbered preset buttons that, when combined with a button that sequentially selects A,B,C,D or E groups of presets, provides for a mix of up to 40 AM and FM preset station settings. Below the preset buttons are an up/down tuning bar, a memory button, a tuning-mode button (automatic and manual), an AM/FM band-selector button, and the A/B/C/D/E button. The lower-right section of the panel houses the bass, treble, and balance controls as well as a selector switch that allows you to record one program source while listening to or viewing a different program source. A rotary master volume control is located at the extreme right end of the front panel.

The rear panel of the RX-V870 is equipped with separate FM and AM antenna-input terminals (an AM loopstick is an included accessory), the required number of stereo-audio and video input and output jacks (including S-video connectors), two sets of front-speaker terminals, speaker terminals for the rear and center-channel speakers and several jacks that Yamaha calls "accessory terminals." Those include front-out and front-

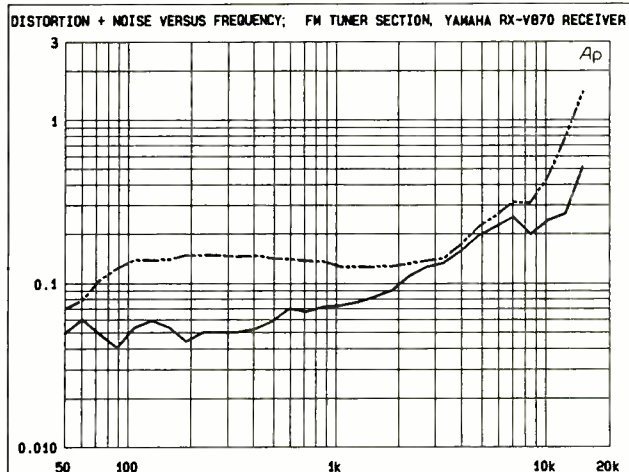

*This plot of harmonic-distortion-plus-noise versus modulating frequency shows that the distortion plus noise at 1 kHz was 0.074% for mono (solid curve) and 0.13% for stereo (dashed curve).*

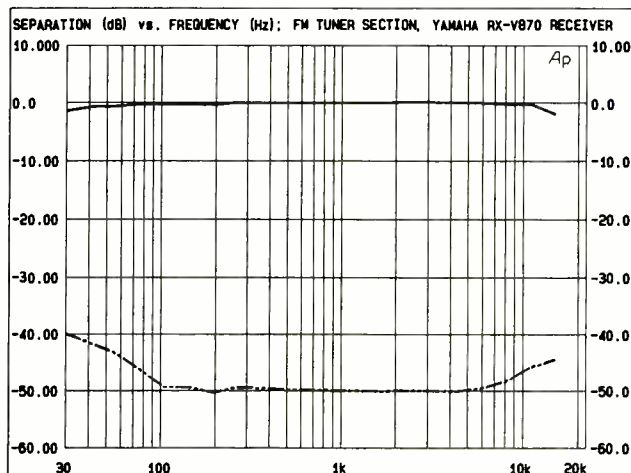

*The stereo separation for the FM-tuner section of this receiver was exactly 50 dB at mid frequencies, and remained remarkably good even at high bass and treble frequencies.*

in terminals (normally jumpered if the built-in front-channel amplifiers are used), rear-out and center-out jacks for those who prefer to use separate power amplifiers to drive those speakers rather than the built-in amplifiers, and a "low-pass" terminal used for feeding a mono amplifier, which in turn might be used to drive a subwoofer. The cut-off frequency for this last-named output jack is 200 Hz. At the extreme lower right of the rear panel there are two switched AC convenience outlets and one unswitched outlet.

In addition to duplicating most of the control functions found on the front panel of the RX-V870, the remote control supplied with this receiver is used to activate the test tone used for speaker balance adjustment, for setting the sleep timer, for activating the on-screen display, and for muting volume level. As mentioned earlier, the remote control can also be "taught" the control signals for other components—even those produced by competing manufacturers. Special switch settings and blank buttons are provided

for that purpose, along with overlay cards that fit over the existing buttons and can be labeled with the learned functions.

## LAB MEASUREMENTS

We measured the performance of the tuner section of this receiver first. The frequency response of the FM tuner section was down 2.0 dB at the 20 Hz and 15 kHz frequency extremes, easily meeting the published specification of  $\pm 1.5$  dB. The unit attained 50 dB quieting in mono with only 14 dBf of input signal, while in stereo, 37 dBf of signal strength was required for the same degree of quieting. Both results are somewhat better than what is claimed by Yamaha. Strong-signal signal-to-noise ratios measured 78.5 dB for mono reception and 72.5 dB for stereo signals.

At 1 kHz, harmonic-distortion-plus-noise versus modulating frequency for mono measured only 0.074%, while in stereo, the reading was 0.13%. Again, both results were substantially better than claimed by the manufacturer. The mono usable sensitivity (the signal level required to produce a 30-dB signal-to-noise ratio) measured approximately 9 dBf.

The stereo separation for the FM tuner section was exactly 50 dB at mid-frequencies, just as claimed by Yamaha. More remarkably, even at 100 Hz, stereo separation remained a high 48 dB, and at 10 kHz, where most FM-stereo circuits tend to show markedly decreased separation, the RX-V870 still boasted a separation of 46.5 dB. All other FM performance specifications either met or exceeded published claims, as can be seen by consulting the Test Results table that appears

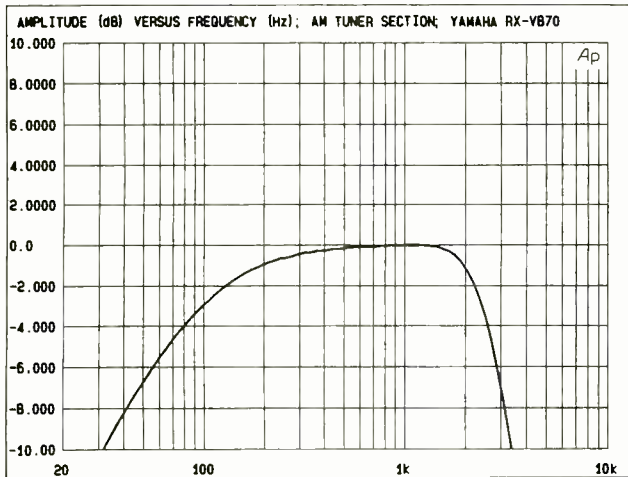

Yamaha made no claims for the frequency response of the AM-tuner section of this receiver, and this plot shows why. Unfortunately, such performance is typical of many otherwise excellent stereo receivers.

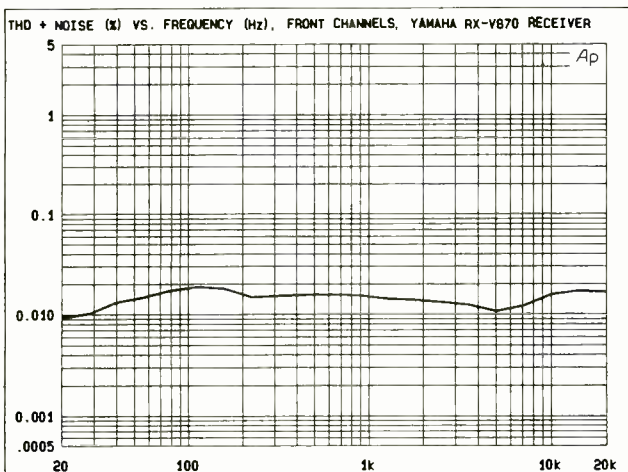

This plot of the front-left and front-right channel harmonic distortion versus frequency (at the maximum rated output of 80 watts) verified Yamaha's published specification of 0.015%.

elsewhere in this report.

Yamaha made no claims for the frequency response of the AM tuner section of this receiver, and testing revealed a good reason for that omission. As is true of so many "high fidelity/stereo" receivers, the AM frequency response was not nearly as good as it could be if a little more design effort were applied to that portion of the circuitry. As matters stand, however, the -6 dB roll-off points for AM response occurred at 58 Hz and at 2.85 kHz. In all other respects, however, the AM-tuner section lived up to the published claims made for

it, with a usable sensitivity reading of 95  $\mu$ V/m, selectivity of 32 dB, and a signal-to-noise ratio (for strong signals) of 50 dB.

Turning to the pre-amplifier and amplifier sections of the receiver, we applied signals to the CD (high-level) inputs and measured the overall frequency response, which was down 1.5 dB at 20 Hz and at 50 kHz. Next, we plotted distortion versus frequency, with the input levels adjusted to maintain a constant 80-watts-per-channel (the rated output) at the front-left and front-right speaker outputs, which

were connected to 8-ohm loads. At mid-frequencies, harmonic distortion was almost exactly 0.015%, as claimed by Yamaha. Even more remarkably, at 20 Hz, harmonic distortion was even a bit lower, measuring 0.01%. Most power amplifiers tend to show increased distortion at that extreme bass frequency, but the amplifier sections of this receiver handled those low frequencies with no trouble.

Many surround-sound stereo receivers provide reduced power levels for the center-channel output. However, repeated experiments have shown that, ideally, the center-channel output power should be as great as that available for the front-left and front-right channels. The Yamaha RX-V870 receiver subscribes to that ideal, offering the same 80-watt rating for its center-channel output as is

**TEST RESULTS—YAMAHA RX-V870 AUDIO/VIDEO RECEIVER**

Specification	Mfr's Claim	PE Measured
<b>FM Tuner Section</b>		
50 dB quieting (mono/stereo)	15.1/37.7 dBf	14.0/37.0 dBf
S/N ratio (mono/stereo)	81/76 dB	78.5/72.5 dB
Distortion (mono/stereo)	0.1/0.2%	0.074/0.13%
Stereo separation (1 kHz)	50 dB	Confirmed
Response		
20 Hz to 15 kHz	$\pm 1.5$ dB	$\pm 1.0$ dB
Alt. channel selectivity	85 dB	87 dB
Mono usable sensitivity	9.3 dBf	9.0 dBf
Image rejection	45 dB	48 dB
IF response ratio	80 dB	Confirmed
AM suppression	55 dB	56 dB
Capture ratio	1.5 dB	Confirmed
Audio output level	700 mV	690 mV
<b>AM Tuner Section</b>		
Usable sensitivity	100 $\mu$ V/m	95 $\mu$ V/m
Selectivity	32 dB	Confirmed
S/N ratio	50 dB	Confirmed
Image rejection	40 dB	42 dB
Distortion	0.3%	Confirmed
Audio output level	200 mV	Confirmed
<b>Audio Section</b>		
Power output/channel (8 ohms)		
Front	80 watts	83 watts
Center	80 watts	100 watts
Rear	25 watts	27 watts
Input sensitivity		
Phono	2.5 mV	Confirmed
High-level inputs	150 mV	145 mV
Max. phono input (1 kHz)	90 mV	100 mV
Signal-to-noise ratio		
Phono (re: 5 mV)	86 dB	Confirmed
High-level inputs	93 dB	95 dB
Tone-Control Range		
Bass (50 Hz)	$\pm 10$ dB	+11, -9 dB
Treble (20 kHz)	$\pm 10$ dB	+10.5, -11 dB
Bass extension (50 Hz)	+7 dB	Confirmed
Frequency response (20 Hz-20 kHz)	$\pm 1.5$ dB	+0 -1.5 dB
<b>General Specifications</b>		
Power consumption	300 watts	Confirmed
Dimensions (W $\times$ H $\times$ D, inches)	17 $\frac{1}{2}$ $\times$ 6 $\frac{1}{4}$ $\times$ 18 $\frac{1}{16}$	Confirmed
Weight	32 lbs. 9 oz.	Confirmed
Suggested price:	\$899.00	



available for the front-left and front-right outputs. In fact, our tests revealed that if the center-channel amplifier is the only channel driven, it is capable of providing as much as 100 watts into 8-ohm loads. We also measured the output power available at the rear-channel speaker terminals and confirmed that those amplifier channels were able to deliver in excess of the 25-watts-per-channel claimed for them.

Tests of the tone-control circuitry showed that their action was typical of most such tone-control circuits. Finally, we applied low-level signals to the phono inputs of the receiver in order to measure the accuracy of the phono equalization. Mid- and high-frequency phono equalization was as close to perfect as we have

seen, while at 20 Hz, deviation from the RIAA curve amounted to no more than -1.6 dB. Maximum input for the phono circuitry, for a 1-kHz test signal measured 100 mV, or 10 mV more than claimed by Yamaha.

Phono signal-to-noise ratio, referred to a 5-mV input signal, measured exactly 86 dB as claimed by Yamaha, while the signal-to-noise for the various high-level inputs, referred to an input level of 0.5 volts, measured 95 dB. The bass extension feature, activated by a front-panel pushbutton, provided a fixed 7 dB of bass boost at 50 Hz, as listed in the specifications.

#### HANDS-ON TESTS

A headline found in Yamaha's brochure detailing the features of this new receiver states, "Everything

That a Receiver is Supposed to Do—and More That You Never Dreamed a Receiver Could Do." We couldn't agree more! While most present-day surround-sound stereo receivers do a creditable job of Dolby Pro Logic decoding, few, if any, offer the additional 70mm movie-theater mode and the Dolby Pro Logic Enhanced mode provided by the Yamaha RX-V870. The 70mm mode offers sound-field expansion for both front and rear channels, producing all the dramatic intensity and sweeping grandeur of big-theater sound at its best.

We auditioned and viewed several excerpts from some of the better known action films on laser videodiscs, including scenes from "Raiders of The Lost Ark," "Top Gun," and "Al-

ways." They never sounded better.

Almost as impressive were the surround sounds we experienced when playing ordinary stereo CD's and subjecting them to one or more of the digital signal-processing modes available on this receiver. Especially noteworthy was the realistic ambiance created when listening to pipe organ recordings in the "Church" DSP mode and to several symphonic recordings played back using the "Concert Hall" settings.

When you consider all the features and flexibility offered by the Yamaha RX-V870, its suggested price of \$899.95 is nothing less than a real bargain! For more information on the RX-V870 contact Yamaha directly, or circle No. 120 on the Free Information Card. ■



Whether you wish to save money, boldly go where no guitarist has gone before or simply have fun building electronic gadgets designed for your musical pleasure, then read

## Electronic Projects for GUITAR

\$12<sup>95</sup>

Some of the add-on guitar gadgets you can build are:

Preamplifier • Headphone Amplifier • Soft Distortion Effects Unit • Compressor • Auto-waa • Waa-waa Pedal • Phaser • Dual Tracking Effects • Distortion Unit • Expander • Dynamic Treble Booster • Direct Injection Box • Dynamic Tremelo • Thin Distortion Unit • and Guitar Tuner.

Anyone with some previous electronic project building experience should have no problem assembling the projects.

ELECTRONICS TECHNOLOGY TODAY INC.  
P.O. Box 240, Massapequa Park, NY 11762-0240

Yes, send my copy of ELECTRONIC PROJECTS FOR GUITAR by RA Penfold to the address at right. I am enclosing \$12.95 plus \$2.95 for shipping charges in USA and Canada. All payments must be made in US funds. Sorry, no orders accepted outside of USA and Canada. New York State residents add local sales tax. Allow 6-8 weeks for delivery.

Check enclosed.

Please charge my  Visa  MasterCard

Signature \_\_\_\_\_

Account No. \_\_\_\_\_ Expir. Date \_\_\_\_\_

Name \_\_\_\_\_

Address \_\_\_\_\_

City \_\_\_\_\_ State \_\_\_\_\_ ZIP \_\_\_\_\_

## FREE

Electronics & Computer Software Education Catalog

- \*Fast-Track Individual Learning Programs
- \*State-of-the-Art Classroom Courses
- \*The Best Values in Electronics Education

**New**  
Career-Level Courses  
Personal Computer Servicing  
TV and VCR Servicing  
**New**  
Computer-Aided Instruction

DC & AC Electronics  
Semiconductors  
Electronic Circuits

The stunning animations, hypertext glossary, and easy-to-understand text make learning electronics a breeze...and fun!

Learn the easy and affordable way from the Masters in Electronics Training - **Heathkit**. From Basic Electricity to Advanced Microprocessor Applications and more, Heathkit will provide you with an unparalleled learning experience at a fraction of the cost of other programs.

**Heathkit**  
Educational Systems

For your FREE Catalog, call  
Toll-Free 1-800-44-HEATH

please mention this code when calling 107-023

CIRCLE 155 ON FREE INFORMATION CARD

# THINK TANK

By John J. Yacono

## Pinouts and Tools

This month, I'll present some 7400-series chips that have alternate pinouts and functional blocks (as promised last time). It came as a surprise to me (and maybe to you, too) when I first learned that some 7400-series chips with the same function number, but different architecture (L, S, LS, H, or F), had differing "guts" and pinouts. In fact, I, frankly, don't know why that is the case.

Unfortunately, there are too many examples of al-

ternate pinouts to review them all here. However, I can present a few examples of the functional discrepancies, with just one pinout each. Furthermore, rather than bore you with a gate-by-gate description of the chips, I'll present a truth table for each chip section.

The discrepancies in the 7400 series begin with the 7451. It has one pinout style for the standard, high-power, and Schottky versions (Fig. 1A) and another for the low-power and low-power Schottky (Fig. 1B). The key difference is that the unit in Fig. 1A has 2-input AND gates, while one section of the chip in Fig. 1B has 3-input AND gates. The truth table for the 3-input AND gate section is shown in Table 1, while the other sections are governed by Table 2. By the way, pins 11 and 12 for the chips represented by Fig. 1A should never be connected to anything.

The 7453 comes in two varieties: standard TTL (see Fig. 2A) and high-power (in Fig. 2B). The key difference is again in their AND-input stages. The standard unit has four 2-input AND gates, while the other has three 2-input gates. The truth table for the standard unit is shown in Table 3, and the other in Table 4. Note the pins labeled N and N are expansion inputs for chaining more than one unit together, and so do not appear in either table.

Once again don't connect the unused pin (pin 6 in Fig. 2A).

Now I'll end this introduction with a real teaser; a chip with three pinouts: the

7454. The standard form of the chip is shown in Fig. 3A, and its truth table is in Table 5; the low-power and low-power Schottky format is in Fig. 3B and Table 6; and last, Table 7 and Fig. 3C provide the high-power version information.

TABLE 1—3 INPUT AND STYLE

Inputs						Output
1A	1B	1C	1D	1E	1F	1Q
H	H	H	X	X	X	L
X	X	X	H	H	H	L
All other combinations						H

TABLE 2—2 INPUT AND STYLE

Inputs				Output
A	B	C	D	Q
H	H	X	X	L
X	X	H	H	L
All other combinations				H

TABLE 3—7453 TRUTH TABLE

Inputs								Output
A	B	C	D	E	F	G	H	Q
H	H	X	X	X	X	X	X	L
X	X	H	H	X	X	X	X	L
X	X	X	X	H	H	X	X	L
X	X	X	X	X	X	H	H	L
All other combinations								H

TABLE 4—74H53 TRUTH TABLE

Inputs									Output
A	B	C	D	E	F	G	H	I	Q
H	H	X	X	X	X	X	X	X	L
X	X	H	H	X	X	X	X	X	L
X	X	X	X	H	H	X	X	X	L
X	X	X	X	X	X	H	H	X	L
All other combinations									H

TABLE 5—7454 TRUTH TABLE

Inputs								Output
A	B	C	D	E	F	G	H	Q
H	H	X	X	X	X	X	X	L
X	X	H	H	X	X	X	X	L
X	X	X	X	H	H	X	X	L
X	X	X	X	X	X	H	H	L
All other combinations								H

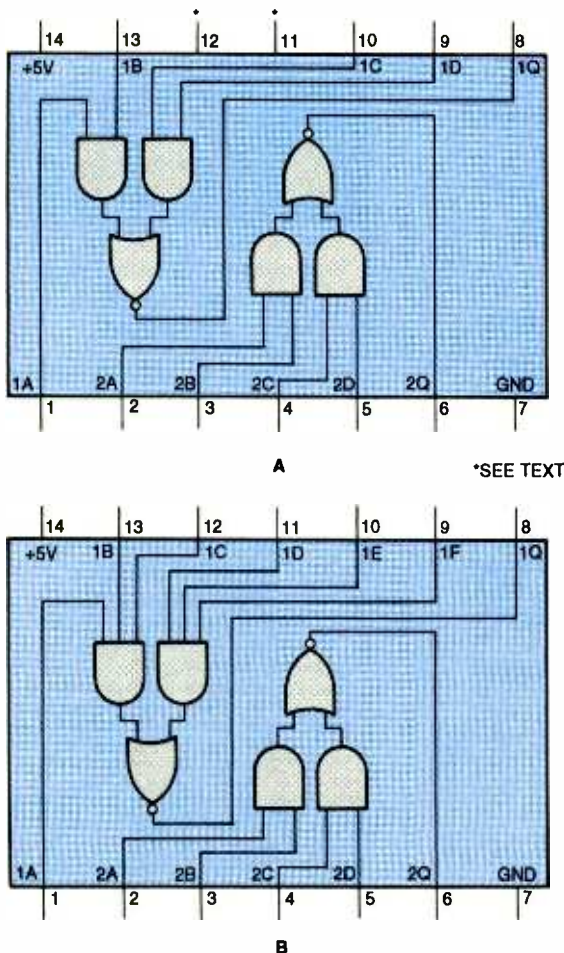

Fig. 1. Some versions of the 7451 have only 2-input AND gates (A), while others have a section based on 3-input AND gates (B).



**TABLE 6—74LS54 AND 74LS54 TRUTH TABLE**

Inputs										Output
A	B	C	D	E	F	G	H	I	J	Q
H	H	X	X	X	X	X	X	X	X	L
X	X	H	H	X	X	X	X	X	X	L
X	X	X	X	H	H	X	X	X	X	L
X	X	X	X	X	X	H	H	X	X	L
All other combinations										H

**TABLE 7—74H54 TRUTH TABLE**

Inputs										Output
A	B	C	D	E	F	G	H	I	J	Q
H	H	X	X	X	X	X	X	X	X	L
X	X	H	H	X	X	X	X	X	X	L
X	X	X	X	H	H	X	X	X	X	L
X	X	X	X	X	X	H	H	X	X	L
All other combinations										H

All the Tables and pinouts have used up a lot of space for this month's introductory topic. So we'll have

to continue this discussion next month. As for now, to the mail bag . . .

**AN OUNCE OF PREVENTION**

I recently read about the "AC-Short Circuit Indicator" by John A. Alvarez in *Think-Tank*, **Popular Electronics**, March, 1993. I have used a similar circuit for many years in electronics. I am enclosing a schematic diagram of the circuit as I use it (see Fig. 4). Switch S1 is a SPDT center-off toggle switch, which eliminates the need for plugging-in and unplugging the device being tested. Fuse F1 can be a fuse or circuit-breaker of suitable rating, which is included in the circuit to

avoid blowing the appropriate house fuse.

I use several sizes of bulbs for I1. For testing a small device, I may use a 60-, 40-, or even a 25-watt bulb. For testing a large device, I may use a 200-watt bulb or a 250-watt heat lamp. I also use several sizes of

bulbs when I use this circuit in what a friend calls my "poor-man's Variac." When I want to test a device at reduced line voltage, I start with a smaller bulb and go to larger ones until I get to the voltage I want.

I think I can best describe how SO2 is used by telling

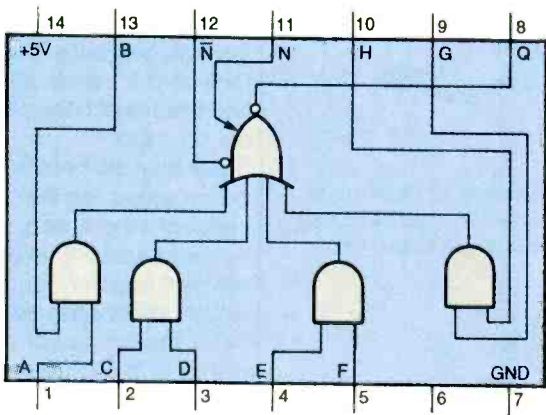

\*SEE TEXT

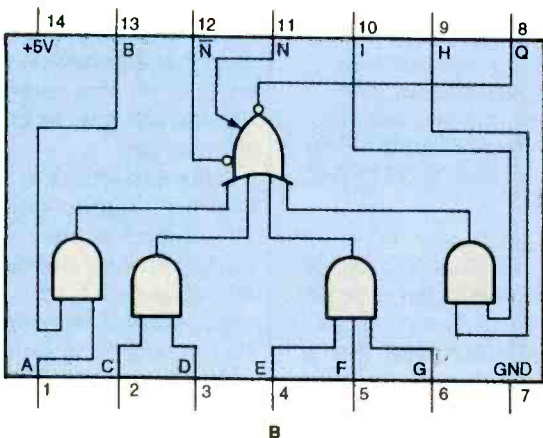

B

Fig. 2. While both versions of the 7453 are expandable (via their N and N inputs), one has only 2-input AND gates (A), while the other has one 3-input AND gate (B).

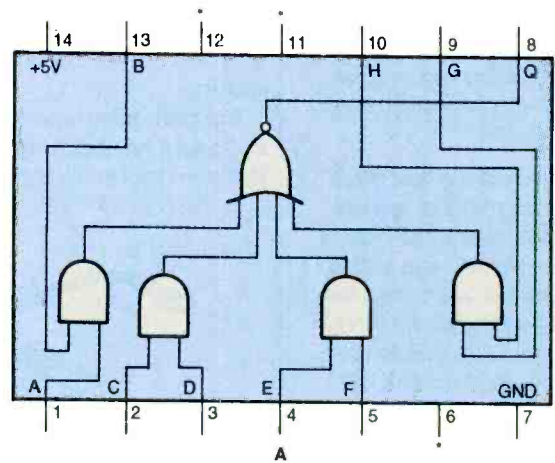

A

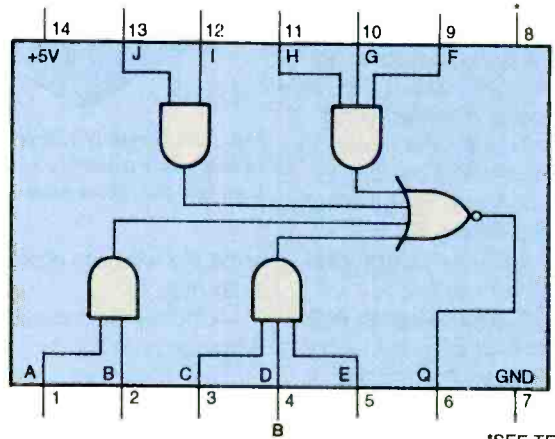

B

\*SEE TEXT

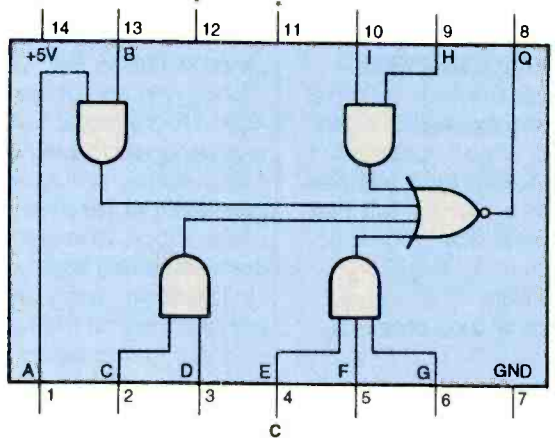

C

Fig. 3. The AND gates on a 7454 can be four 2-input types (A); a mix of two 2-input and two 3-input types (B); or three 2-input gates with one 3-input type (C).

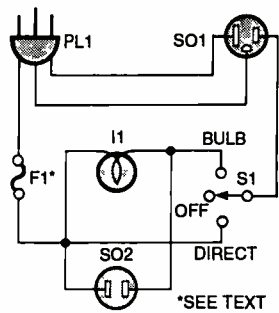

Fig. 4. This short-circuit checker not only protects your household wiring from "ill" devices under repair, but can act as a poor-man's Variac, too.

how I used it a few days ago. I wanted to test an electric motor that had been given to me, which I was told blows fuses. I used a 200-watt bulb for I1, and plugged a portable electric heater into SO2. The heater has two settings, 750 watts and 1500 watts. I set the heater to 750 watts and plugged in the motor. The bulb lit and the heater got warm, confirming a short in the motor. After repairing the short, I set the heater to 1500 watts. The motor ran (with no load), and the bulb glowed very dimly, so I switched S1 to "Direct" and the motor ran fine.

—Bill Stiles, Hillsboro, MO

Simple and useful. I wonder if a light-bulb socket or two in parallel with SO1 would be useful for that 250-watt heat-lamp bulb?

### RIBBON CHECKER

I came up with a simple but effective way to easily check ribbon-cable assemblies. Take a short piece of ribbon cable that has one extra wire (use 26-conductor ribbon for DB-25 assemblies, or 37-conductor ribbon for Centronics connections) and peel one edge wire back about half way from each end (see Fig. 5). Strip the edge wires and apply circular lugs to them as test points. Install a female and a male IDC to

each end of the ribbon to allow any combination of connectors (male-male, male-female, or female-female) to be checked.

With the cable to be tested plugged into the appropriate connectors, all the wires will, in effect, be connected in series. With an ohm meter or continuity checker connected to the lugs, you can check every wire and connection in one reading.

The darn thing worked so well that it has become a standard tool in my shop. I

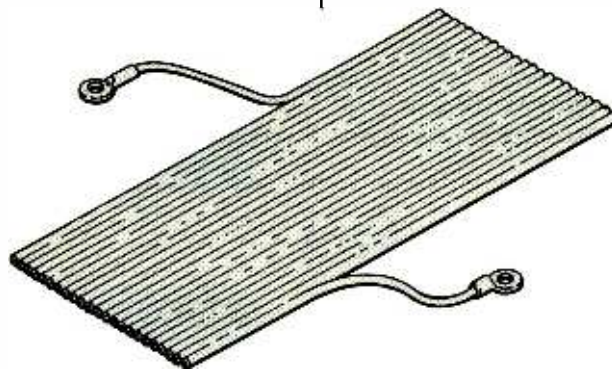

Fig. 5. A length of ribbon cable can help you check an entire ribbon-cable assembly with one measurement. Start by peeling back one wire from each end as shown and add connectors.

hope this will help others as it did me.

—Charles Blanchard, Wilmington, NC

I love doing tricks with ribbon cable (like multiple connectors on the same line). Once I made a Y-connection using a single piece of ribbon. First I attached one end of the ribbon to my project, which was designed to send two sets of signals, one to each connector at the other end of the ribbon. One of those connectors was applied upside down. Then I drilled out any holes on the two connectors that would cause a conflict. Two sets of signals, one cable, no conflicts!

### A HOT TIP

Like almost all electronics

techs, my soldering iron sits turned on in its stand, hour after hour. Although the stand radiates heat effectively, it seems that I'm always replacing heater elements (at least a couple of times per year). Also, depending on its age, the element I'm using always seems either too hot or too cool for the next point to be soldered.

So, here's what I did. A trip to the local hardware store turned up a metal outlet box, a few feet of 16-gauge 3-conductor AC line cord, a

my iron, so I waited for the death of the element I was currently using. I replaced it with a 45-watt element and I plugged the iron into the switched (shunted-diode) outlet.

When the iron is idling along, powered through the diode, it uses less power, generates less heat, and the tip lasts much longer. A surprise came once when I used the iron on a small PCB I was fixing. It had been idling along and I had forgotten to switch to full power. I found that the 45-watt element did an admirable job, even when set to low.

When I had to have more heat, throwing the switch to high (simply shunting the diode out) restored the iron to its full 45-watt capability in less than 1 minute. Since the switched outlet has its own cord, it travels with the iron whenever I need to go out on a job.

Not only are heat and power saved, the life of the element is increased, so the hassle of traveling to my element supplier has been virtually eliminated. Furthermore, the amount of old elements taking up space in the local dump has also been reduced. Remember, less garbage equals a better environment!

Oh yes, the results? This is the **seventh year** that I'm using that element and I hope for another seven! Also, the iron tips are lasting much longer!

—Bernard Maguire, Montreal, Quebec, Canada  
I would never have

thought your solution would work as well as it did. I mean, your getting 14 times the use out of one element so far. That's pretty incredible. Frankly, if it works that well, I think you've got the makings of a great product on your hands.

(Continued on page 89)

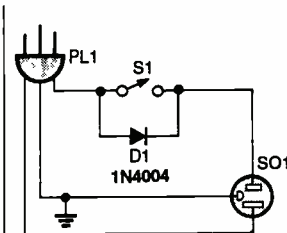

Fig. 6. This custom soldering-iron outlet can save your elements, tips, money, and time, and help save the environment. Pretty darn good for a one-evening project!

three-terminal AC plug, and a switched-outlet receptacle. My junkbox provided one 1N4004 diode. Wiring the diode across the switch contacts (see Fig. 6) provided a simple method of inserting the diode into or shorting it out of the AC line. All that was left to alter was



Experience The New Technology Behind Today's Advanced Computer Systems With...

# McGraw-Hill's Computer Electronics Series

**NEW!** Now you have a fast, easy, low-cost way to meet the challenges of today's computer electronics. McGraw-Hill's unique new learning series is as innovative as the technology it explains, as fascinating as the experiments you perform.

From circuit theory to the Pentium chip, you master one subject at a time with the McGraw-Hill Computer Electronics Series. Twelve unique modules, sent to you one every 4-6 weeks, give you a thorough understanding of such subjects as digital logic, microcomputer operation, data storage devices, data communications, PC servicing, local area networks, and more.

Each module goes right to the heart of the matter. You waste no time on extraneous material or dry history. Instead, you get a fast, efficient, and lively learning experience... a nontraditional approach to the most modern of subject matter.

## Unique interactive instruction

Your learning experience is reinforced through the integration of vividly illustrated text with actual electronic experiments. In fact, by the time you complete your sixth module, you will have assembled the McGraw-Hill Prototyping Design Lab, a breadboarding lab you'll use long after you complete the series for building up and testing prototype circuits. Your modules also feature indexed binders to preserve your text, backup materials, and notes for convenient referral.

## Your adventure begins with Module 1

With your very first module, you'll begin to understand the technology behind today's most advanced computer systems.

You'll be introduced to basic electronics principles and discover the role of key electronic components, including resistors, capacitors, and transistors.



Before long, you'll be recognizing symbols and know how to construct circuits using schematic diagrams. Best of all, you'll actually build up live circuits as you begin the assembly of the McGraw-Hill Prototyping Design Lab.

## Each module adds more to your expanding knowledge of computer electronics

Step by step, each module builds your knowledge and confidence. In all, 12 modules take you quickly from the basics to today's sophisticated computer concepts:

- ▶ Electronic Circuits and Components
- ▶ Semiconductors and Linear Applications
- ▶ Digital Logic Fundamentals
- ▶ Flip-Flops, Counters, and Registers
- ▶ Microcomputer Fundamentals
  - ▶ Mass Data Storage Systems
  - ▶ Data Communications
  - ▶ Graphics Display Systems
  - ▶ Embedded Microprocessor Controllers
- ▶ Print Technologies
- ▶ PC Servicing
- ▶ Local Area Networks

## For anyone interested in computer electronics

McGraw-Hill's Computer Electronics Series is designed for anyone from hobbyist to professional. It's for

you if you're finding that computers are playing an increasingly important role in your work... if you're a teacher or trainer who wants an update in contemporary computer circuits... or if you're simply fascinated by today's computer technology and want to know more about it.

It's even for electronics engineers or computer technicians who want to refresh their skills.

In short, McGraw-Hill's Computer Electronics Series is an ideal way to understand the technology at work in today's computers... and it's the quickest, most convenient, and probably the least expensive way to do it. And the only one that gives you hands-on experience.

## 15-day no-risk trial

We invite you to prove to yourself that McGraw-Hill's Computer Electronics Series is all we say it is... without risk and without committing yourself in any way. Order today, and we'll send you your first module — Electronic Circuits and Components — for a free, 15-day examination. If you're not absolutely certain that this is an enjoyable as well as highly effective way to learn, simply return the module to us.

If you wish to continue, we'll ship the remaining modules automatically, about once a month, on the same Free Examination basis.

Send for your first module today! And let McGraw-Hill guide you into the fascinating world of Computer Electronics.

## FREE 15-DAY TRIAL! SEND TODAY!

### Computer Electronics Series

McGraw-Hill Continuing Education Center  
4401 Connecticut Avenue, NW, Washington, DC 20008



**YES!** I'm interested in learning computer electronics and would like to examine the first module in the series. If I decide to keep it, I will pay just \$24.95 plus \$2.25 shipping and handling. I will then receive future modules automatically, one every 4 to 6 weeks, at the same low price and on the same 15-day Free Examination basis. There is no minimum number of modules I must buy, and I may cancel at any time simply by notifying you.

Name \_\_\_\_\_ (please print)

Address \_\_\_\_\_

City/State/Zip \_\_\_\_\_

Telephone ( \_\_\_\_\_ ) \_\_\_\_\_ 2002-0394

All orders subject to approval and payable in U.S. funds only. Available in U.S. and Canada only.

# GET THE LATEST ADVANCES IN ELECTRONICS

WITH A SUBSCRIPTION TO

# Electronics

Radio Combined with  
**Electronics**®

# NOW

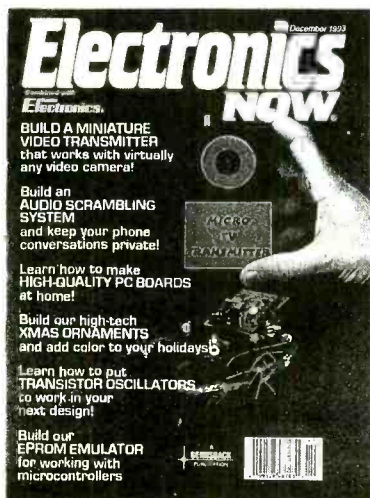
®

Electronics Now gives you exciting articles like:

- Buyer's Guide to Digital Oscilloscopes
- Build A Scanner Converter
- Single-Chip Voice Recorder
- Build A MIDI Interface for your PC
- Troubleshoot Microprocessor Circuits
- Build A High-Power Amplifier for your Car
- Add Music On Hold to your Phone
- All About Binaural Recording
- VGA-to-NTSC Converter

ENJOY THE WORLD OF ELECTRONICS EACH MONTH!

Subscribe to the best electronics magazine—the one that brings you the latest high-tech construction projects, feature articles on new technology, practical troubleshooting techniques, circuit design fundamentals, and much more.

Electronics Now looks to the future and shows you what new video, audio and computer products are on the horizon. What's more you'll find helpful, monthly departments such as Video News, Equipment Reports, Hardware Hacker, Audio Update, Drawing Board, Computer Connections, New Products, and more. All designed to give you instruction, tips, and fun.



FOR FASTER SERVICE CALL TODAY  
**1-800-999-7139**

# DON'T DELAY SUBSCRIBE TODAY!

Just fill out the order card in this magazine and mail it in today.

7PC47



# Build a



## Nine-Band Shortwave Rec

*Tune in on the world with this nine-band solid-state version of the classic regenerative receiver*

BY LYLE RUSSELL WILLIAMS

**A**lthough once extensively used in military and maritime applications, today the regenerative receiver is generally viewed as a hobby or toy circuit. However, the redesigned regenerative receiver described in this article is much more than a toy or a historical curiosity. The *World Band Regenerative Radio* (which hereafter will be referred to as the WBR) can receive all nine shortwave broadcast bands, allowing you to listen to numerous foreign, English-language stations—such as the BBC, Radio Netherlands, Radio Canada, Radio China, and Japan Radio. If so desired, the number of bands can easily be extended beyond the initial nine provided on the basic receiver. It can also receive single-side band (SSB) and continuous-wave (CW) code signals.

Unlike traditional regenerative receivers, the WBR has a calibrated frequency dial and uses a short whip antenna. The unit also has an output that can be fed to a frequency counter to provide a digital frequency readout. Also, because there are no custom parts (including inductors), the WBR is easy to build.

**Regenerative Radio.** There are three favorable characteristics of regenerative radios: For a one-tube or transistor device, it has extraordinary sensitivity; for a one resonant-circuit device, it has extraordinary selectivity; and unlike a single-conversion superhet, the regenerative radio does not produce unwanted image signals.

A schematic diagram of the traditional tube-based regenerative receiver is shown in Fig. 1. That circuit is essentially an RF oscillator with variable feedback (that is connected to an antenna) with a resonant circuit composed of variable-capacitor C1 (the tuning control) and inductor L1. Feedback is provided through a second coil (L2), called a tickler coil, that is located on the same coil form as L1 and is wired into the tube's plate circuit. The amount of positive or regenerative feedback is controlled by a variable resistor that's connected across the tickler.

The quality (Q) factor of the resonant circuit without feedback is less than 50 when loaded by the antenna and the vacuum tube. When the feedback of the oscillator is adjusted so that it is just below the point of os-

cillation, the Q of the resonant circuit increases to around 1000. That increase in Q greatly amplifies the signal and narrows the bandwidth of the resonant circuit.

The tube is biased so that plate detection of an AM signal can take place. Thus, RF amplification and AM detection are accomplished with a single vacuum tube. The 3–30-pF trimmer capacitor (C2) that is connected in series with the antenna is used to reduce the loading effect of the antenna. In some cases, antenna loading can be large enough to prevent oscillation. The regenerative principle is sometimes used in different parts of superhet radios: The second detector, intermediate-frequency (IF) amplifier, or the radio-frequency (RF) amplifier stage can be regenerative. In the latter case, the stage is called a Q multiplier.

A review of approximately 40 regenerative-receiver designs revealed some interesting characteristics of the traditional circuits. There are over a dozen distinct types of RF oscillators (such as Colpitts, Hartley, Pierce, etc.), any of which could be used as the basis of a regenerative radio. But for

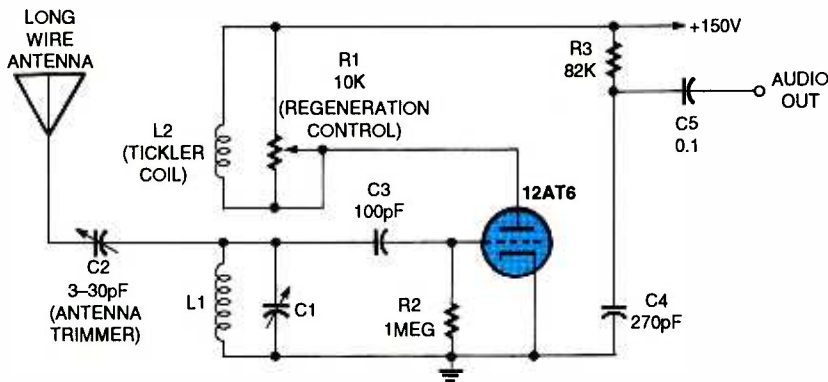

Fig. 1. The traditional tube-based regenerative receiver is essentially an Armstrong RF oscillator with variable feedback that is connected to an antenna and a resonant circuit.

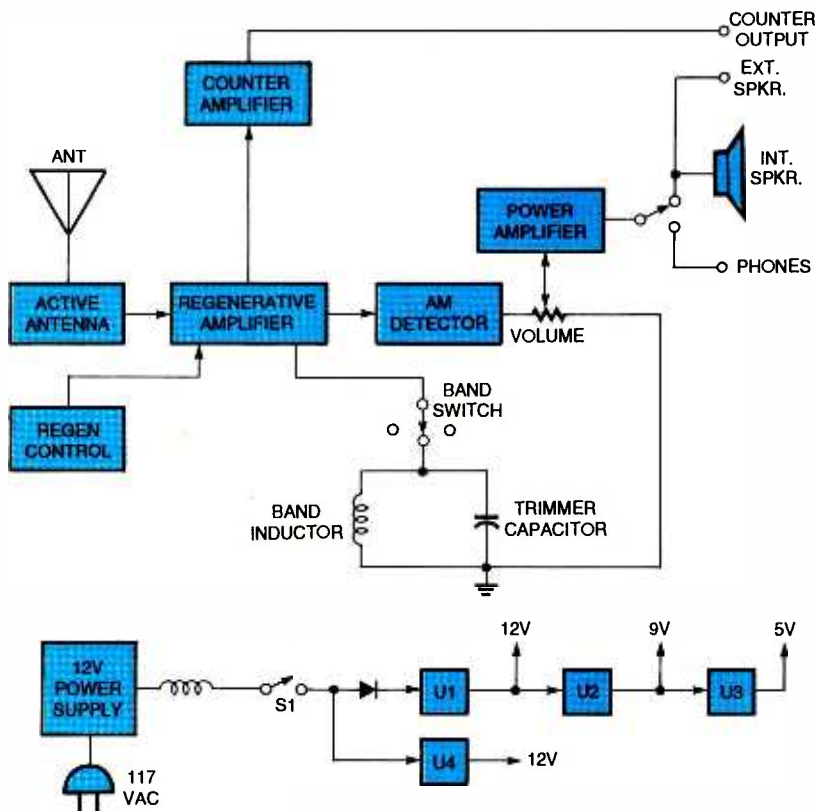

Fig. 2. As shown by this block diagram, the WBR is composed of several subassemblies: An active antenna, an amplifier (with a regeneration control and a band-switching circuitry), an AM detector, a power amplifier, and some form of output device (internal speaker, external speaker, or headphones), plus a multi-voltage power supply.

some reason, nearly all of the old designs used the basic Armstrong circuit shown in Fig. 1.

Tradition must have played a role in the strong preference for the Armstrong circuit. It was well known that using a pentode tube in a regenerative receiver was superior to the triode design. However, nearly all of the old circuits were of the triode type. Almost none of the old circuits had a volume control. The volume of

the receiver had to be reduced by backing off the regeneration control, which had the undesirable effect of widening the bandwidth of the circuit. Fortunately, those and other undesirable characteristics of the traditional regenerative receiver have been overcome in this modern, solid-state design.

**The WBR Receiver.** A block diagram of the WBR is shown in Fig. 2.

The receiver is composed of several subassemblies: An active antenna, an amplifier (with a regeneration control and band-switching circuitry), an AM detector, a power amplifier, and some form of output device (internal speaker, external speaker, or phones), plus a multi-voltage power supply.

The schematic diagram of the WBR is shown in Fig. 3. In that solid-state version of the regenerative receiver, a dual-gate MOSFET, Q4 (which is analogous to a pentode vacuum tube), is used as the regenerative amplifier. The dual-gate MOSFET is configured as a Colpitts oscillator, rather than an Armstrong type. The MOSFET's feedback from source to gate is provided via R18 and C33.

The circuit contains several standard fixed-value inductors, each of which is connected in parallel with a small variable capacitor. Those L/C pairs along with a SP12T rotary switch (S2) are used for band selection. Plug-in coils were very popular for band switching in the past, but this rotary-switch arrangement is cheaper and more convenient.

Regenerative amplification and AM detection are performed by two separate transistors, Q4 and Q5. The AM detector (which is called an infinite impedance detector) has the advantage of not loading the RF stage appreciably. Because D3 is operated with a slight forward bias, either a germanium or silicon diode can be used in that position. The DC voltage across R24 (the volume control) should be about 0.1 volts.

Regeneration is controlled by varying the voltage applied to gate 2 of Q4. That changes the transconductance of the transistor. The circuit also contains fine and coarse regeneration controls that allow delicate adjustments.

The traditional regenerative receiver required at least an indoor long-wire antenna for proper reception. The WBR, on the other hand, uses an active-antenna circuit, consisting of transistors Q1, Q2, and Q3. Thanks to that circuit, under most conditions, a short whip antenna is adequate.

The active-antenna circuit connects to gate 2 of Q4, while the resonant circuit is connected to gate 1. The resonant circuit is isolated from the antenna and tuning is independent of antenna length, allowing a





calibrated dial to be used on the tuning capacitor. The level of regeneration as set by R16 and R17 is unaffected by the antenna, and so the WBR does not require an antenna trimmer.

Components C12–C14, C18, L3, L4, R6, R7, and R14 form a high-pass filter (which has a cutoff frequency of 3.4 MHz) that prevents local broadcast stations from overloading the circuit. If operated in a rural area away from strong stations, that filter can be disabled. (The high-pass filter may have to be modified if bands below 3.4 MHz are added to the WBR.)

Many traditional regenerative receivers had tuning ranges as large as 10-MHz per band. But in our circuit, using a low-value tuning capacitor allows the circuit to tune only the short-wave broadcast bands—which vary in width from 350 kHz to 700 kHz. Narrowing the range makes the receiver easier to tune. It is not necessary to use

a reduction drive on the tuning capacitor. A simple knob with a pointer is adequate.

Although a standard 12-position rotary switch was used for S2, only 9 positions are needed. However, the three additional switch positions can be used to extend the range of the WBR. The extra positions could be used for the ham bands, WWV signals at 5 MHz and 20 MHz, or some other segment of the shortwave spectrum. In order to add the extra band, the band inductances must be determined. The inductances required for the extra bands, are given by:

$$L = [f \times 6.96 \times 10^{-5}]^2$$

where  $L$  is the desired inductance in henrys, and  $f$  is the center frequency of the desired band in hertz. The equation assumes a mean tuning capacitance of 123 pF. To receive the WWV time signal at 5 MHz, the required inductor would be 8.25  $\mu$ H.

Resistor R20 is used to sample the RF signal in the regenerative amplifier without affecting its operation. The signal is amplified by Q6 and Q7, and fed to J4 and J5 for application to an external frequency counter if desired.

**Construction.** Except for the power supply, the controls, the connectors, and the internal speaker, the entire circuit was assembled a 5- x 6-inch, single-sided, printed-circuit board. A template for the printed-circuit layout is shown in Fig. 4. Once you have etched your board and obtained the parts listed in the Parts List, construction can begin.

Guided by Fig. 5, begin assembly by installing the passive components (resistors and capacitors), making sure that the polarized capacitors are correctly oriented. After installing the passive components, install the semiconductors; start with the diodes, followed by the transistors, and then the IC's.

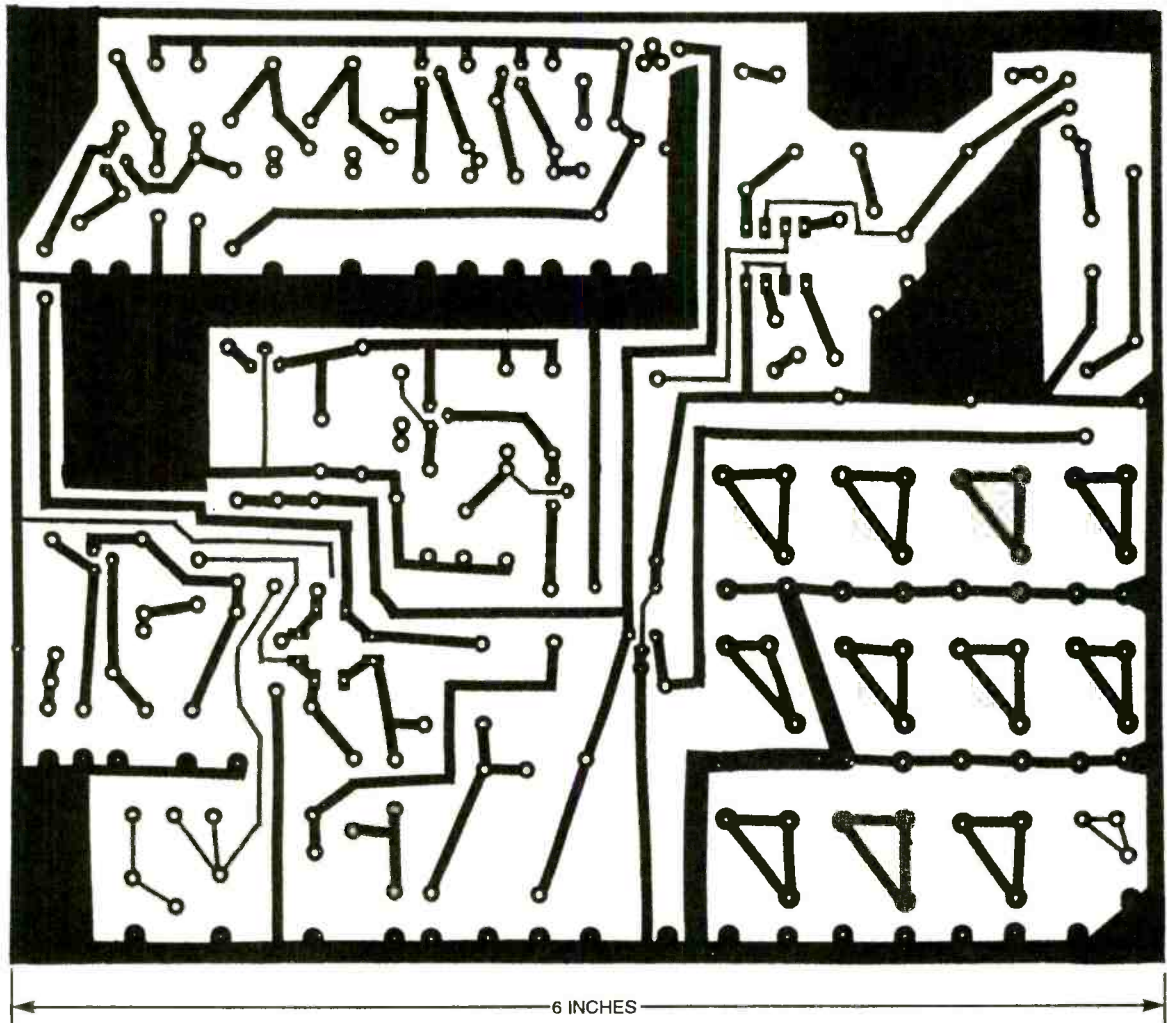

Fig. 4. This full-sized printed-circuit template can be used to etch your own board.



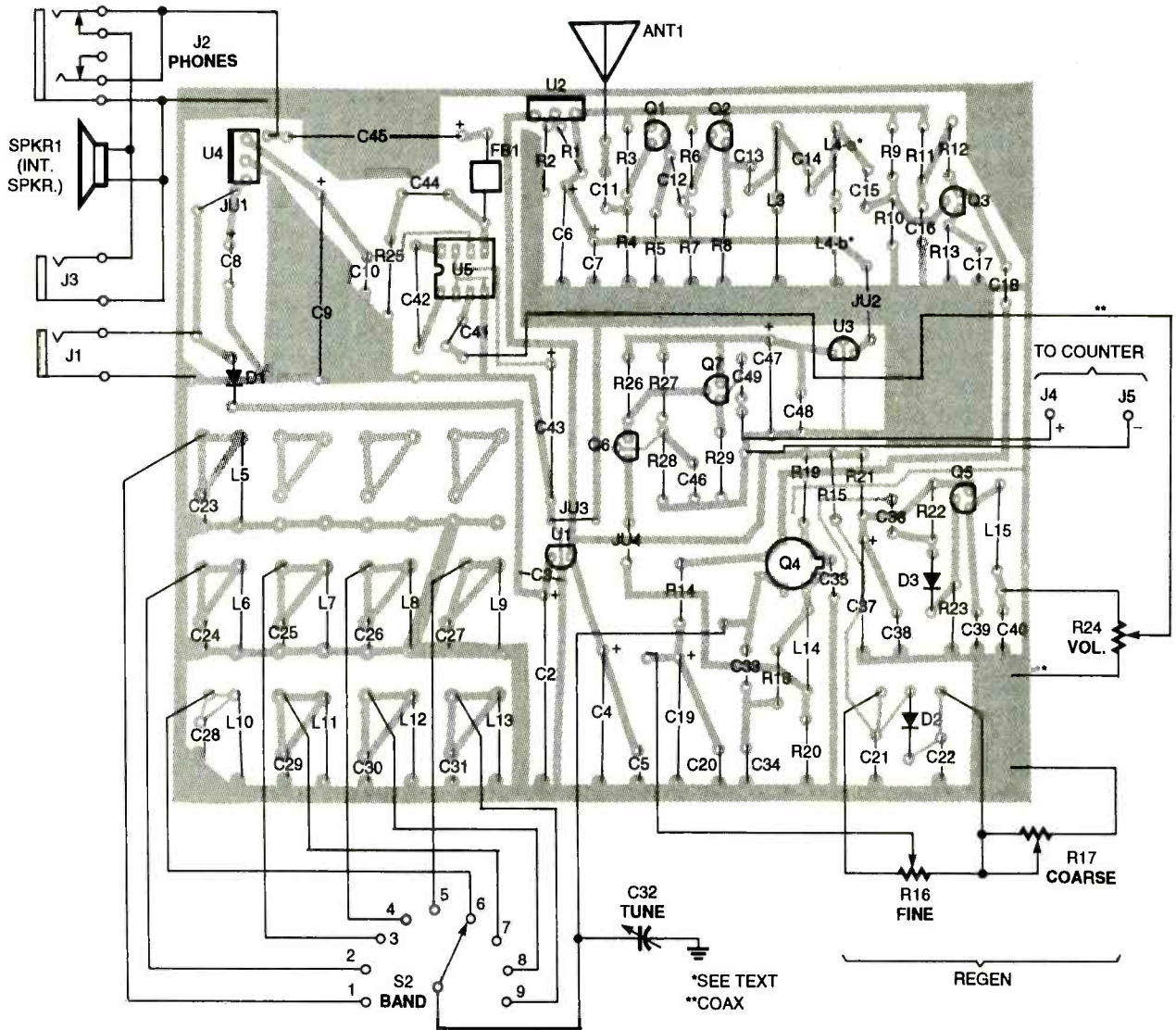

Fig. 5. When assembling the WBR's printed-circuit board, make sure that the polarized capacitors are correctly oriented. Also, when installing the semiconductors, pay particular attention to the orientation of Q4, and be careful that you do not confuse the 2N3904 general-purpose transistors with the low-power (78Lxx series) voltage regulators, both which are housed in the same TO-92 style case.

TABLE 1—FREQUENCY LIMITS OF THE INTERNATIONAL BAND

Band (Meters)	Band Limits (MHz)	Frequency Received (MHz)	L/C Band Trimmers
49	5.95 - 6.20	5.90 - 6.26	L5/C23
41	7.10 - 7.30	7.00 - 7.40	L6/C24
31	9.50 - 9.90	9.40 - 10.0	L6/C25
25	11.65 - 12.05	11.37 - 12.1	L8/C26
21	13.60 - 13.8	13.44 - 14.23	L9/C27
19	15.10 - 15.6	14.96 - 15.88	L10/C28
16	17.55 - 17.9	17.44 - 18.46	L11/C29
13	21.45 - 21.85	21.21 - 22.40	L12/C30
11	25.67 - 26.10	25.10 - 26.32	L13/C31

Pay particular attention to the orientation of Q4 (the dual-gate MOSFET). Be careful when installing the 2N3904 general-purpose transistors and the low-power (78Lxx-series) voltage reg-

ulators; those units are housed in the same TO-92 style case, so don't get them confused.

Note from the parts-placement diagram that there are three unused

pad groupings in the area of the band-determining capacitor/inductor pairs. Those pads (as mentioned earlier) are provided for those who want to extend the band coverage of the WBR.

Once all of the on-board components have been installed, check your work for construction errors—cold solder joints, solder bridges (and other shorts), misoriented or misplaced components, etc. When you are satisfied that there are no errors, put the board to the side momentarily and go on to the next phase of construction.

**Power Supply.** The next thing that

you will need is a power source for the WBR. There is, of course, nothing critical about the circuit's power source, and no printed-circuit layout is provided for that portion of the project. Instead, an external power supply, comprised of two chokes, a filter capacitor, and a bridge rectifier were wired together (see Fig. 3) on a small section of perfboard. The perfboard and a 24-volt transformer were then wire together and mounted to a block of wood. An AC line cord was then connected to the input of the supply and a suitable plug connected to its output. Doing things that way helps to keep power-line noise out of the receiver.

Of course, a standard plug-in 12-volt, 500-mA or so power adaptor can be used as the power source as well; if you decide to go that route, connect two filter chokes between the supply and the receiver. Once the power supply is complete, it is time to prepare the project's enclosure.

**The Enclosure.** The author's prototype was housed in a large aluminum enclosure measuring about  $9\frac{1}{4} \times 5\frac{3}{8} \times 6\frac{3}{4}$  inches. Prepare the enclosure by drilling holes in suitable locations for the controls, and mounting holes for the printed-circuit board and the unit's internal speaker.

The author's front-panel layout includes the band, volume, the fine and coarse regeneration controls, and a phone jack. The rest of the off-board components—the counter, auxiliary speaker, and the power and antenna jacks—are mounted to the rear panel of the prototype.

After deburring the holes, dry-transfer lettering can be used to label each control, switch, and connector. Once labeled, mount the off-board components to their respective positions on the enclosure and, using short lengths of insulated wire, connect the off-board components to the appropriate points on the printed-circuit board. The connections to the volume control (R24) and the counter jacks should be made through small-gauge shielded cable.

**Down The Dial.** The tuning-dial pattern for the WBR was made by taking a blank pattern (like that shown in Fig. 6), and gluing it to a piece of cardboard using white paper glue (avail-

## PARTS LIST FOR THE WORLD-BAND REGENERATIVE RADIO

### SEMICONDUCTORS

- U1—78L12 12-volt, 100-mA, voltage regulator, integrated circuit
- U2—7808 8-volt 1-amp or 78L08 8-volt 100-mA, voltage regulator, integrated circuit
- U3—78L05 5-volt, 100-mA, voltage regulator, integrated circuit
- U4—7812 12-volt 1-amp, voltage regulator, integrated circuit
- U5—LM386 low-voltage audio-power amplifier, integrated circuit
- Q1—MPF102, VHF JFET
- Q2, Q3, Q5—Q7—2N3904 general-purpose NPN silicon transistor
- Q4—40673, MPF121, MPF131, or NTE222, or similar dual-gate MOSFET
- BR1—DB101 1-amp, 50-PIV, bridge rectifier
- D1—1N4001 1-amp, 50-PIV, rectifier diode
- D2—1N34 general-purpose germanium diode
- D3—1N914 general-purpose silicon diode

### RESISTORS

(All fixed resistors are  $\frac{1}{4}$ -watt, 5% carbon units, unless noted.)

- R1, R5—2200-ohm
- R2—220-ohm
- R3—4.7-megohm
- R4—2.2-megohm
- R6—22,000-ohm
- R7—10,000-ohm
- R8, R13, R28—1000-ohm
- R9—150,000-ohm
- R10—47,000-ohm
- R11—3300-ohm
- R12—470-ohm
- R14—4700-ohms  $\frac{1}{4}$ -watt, 1%, metal-film
- R15—15,000-ohm
- R16—100,000-ohm panel-mount linear potentiometer
- R17—5000-ohm panel-mount linear potentiometer
- R18—82.5-ohm,  $\frac{1}{4}$ -watt, 1%, metal-film
- R19—402-ohm,  $\frac{1}{4}$ -watt, 1%, metal-film
- R20—51-ohm  $\frac{1}{4}$ -watt, 1%, metal-film
- R21—810-ohm,  $\frac{1}{4}$ -watt, 1%, metal-film
- R22—10-megohm
- R23—560,000-ohm
- R24—5000-ohm, panel-mount, audio potentiometer with SPST switch
- R25—10-ohm
- R26, R29—499-ohm  $\frac{1}{4}$ -watt, 1%, metal-film
- R27—3900-ohm

### CAPACITORS

- C1, C2, C9, C45—470- $\mu$ F, 16-WVDC, electrolytic

- C3, C5, C6, C10, C15—C17, C20—C22, C35, C36, C38—C41, C46, C48, C49—0.1- $\mu$ F, ceramic-disc
- C4, C7, C19, C37, C42, C47—22- $\mu$ F, 16-WVDC, electrolytic
- C8—4700- $\mu$ F, 16-WVDC, electrolytic
- C11—100-pF, silver mica
- C12—6.8-pF, silver mica
- C13—300-pF, silver mica
- C14—56-pF, silver mica
- C18—10-pF, silver mica
- C23—C31—3.5—20-pF, miniature ceramic trimmer
- C32—3—18-pF panel-mount air variable
- C33—330-pF, silver mica
- C34—120-pF, silver mica
- C43—100- $\mu$ F, 16-WVDC, electrolytic
- C44—0.05- $\mu$ F, ceramic-disc

### INDUCTORS

- L1, L2—100- $\mu$ H, 2-amp (Radio Shack 273-102)
- L3—8.2- $\mu$ H (J. W. Miller 9310-34)
- L4—43- $\mu$ H (J. W. Miller 9210-58) or two 22- $\mu$ H (J. W. Miller 9310-44), see text
- L5—5.6- $\mu$ H (J. W. Miller 9310-30)
- L6—3.9- $\mu$ H (J. W. Miller 9310-26)
- L7—2.2- $\mu$ H (J. W. Miller 9310-20)
- L8—1.5- $\mu$ H (J. W. Miller 9310-16)
- L9—1.0- $\mu$ H (J. W. Miller 9310-12)
- L10—0.82- $\mu$ H (J. W. Miller 9310-10)
- L11—0.56- $\mu$ H (J. W. Miller 9310-07 or 9230-14)
- L12—0.33- $\mu$ H (J. W. Miller 9310-04 or 9230-080)
- L13—0.18- $\mu$ H (J. W. Miller 9230-02)
- L14—47- $\mu$ H (J. W. Miller 9250-473)
- L15—56- $\mu$ H (J. W. Miller 9250-563)
- FB1—General-purpose ferrite bead

### ADDITIONAL PARTS AND MATERIALS

- J1—2.1-mm DC power jack (Radio Shack 274-1565)
  - J2— $\frac{1}{8}$ -inch panel-mount, closed-circuit stereo jack
  - J3—RCA jack
  - J4, J5—Individual pin-jacks
  - S1—SPST switch (part of R24)
  - S2—SP12T rotary switch
  - SPKR1—4—8-ohm, miniature speaker
  - PL1—2.1-mm power plug (Radio Shack 274-1567)
  - ANT—30-inch whip antenna (Radio Shack 270-1401)
  - T1—24-volt, 300-mA, center-tapped transformer
- Printed-circuit materials, enclosure, 117-volt AC power plug with line cord, four small control knobs, one large pointer knob, wire, solder, etc.



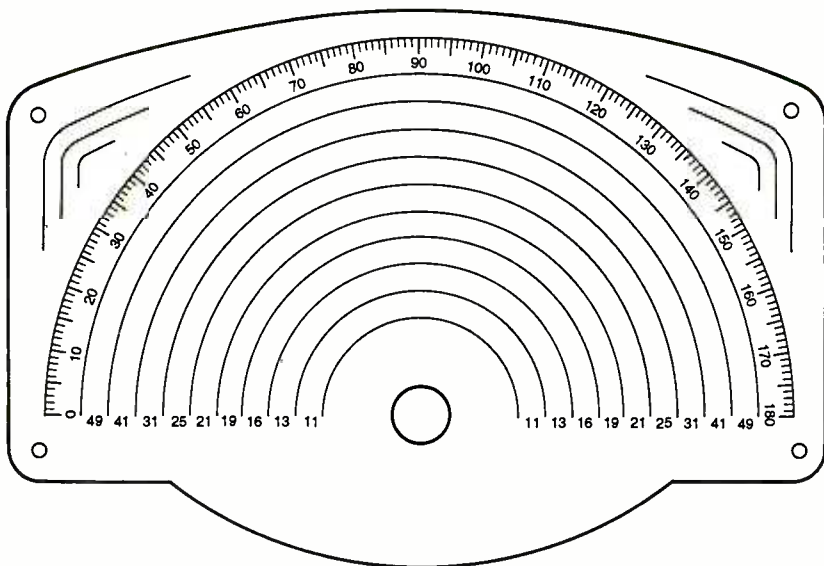

Fig. 6. The author started out with a blank tuning-dial pattern like this one, and added the appropriate frequency markings to the dial during the calibration procedure.

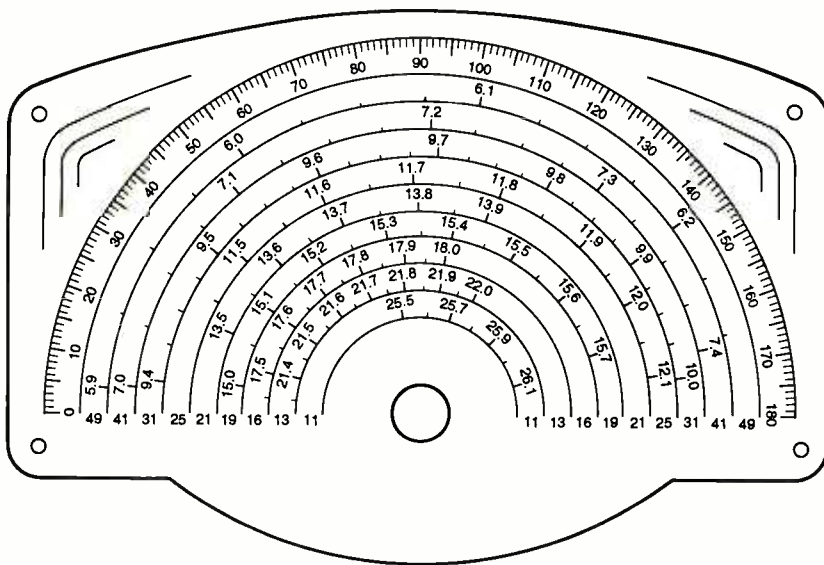

Fig. 7. Using a marker generator, the author first located and marked the 100-kHz points on the tuning dial, then the 50-kHz points, followed by 25-kHz points. This is what his dial looked like when completed. The dial shown here is strictly for reference. Each unit is different and must be calibrated according to the instructions given in the text to compensate for the tolerances of the actual components used in the set.

able from art-supply stores). Once laid down, a rolling pin was used to smooth out the dial pattern and to produce a good bond.

Once the glue dries, the excess cardboard can be cut away with a single-edge razor blade or X-acto knife. Cut the screw and the capacitor-shaft holes in the dial face and mount the dial on the aluminum enclosure with four 4-40 screws and nuts. The mounting nut for the variable capacitor goes outside the dial cardboard and helps hold the dial to the enclosure. Frequency markings on the dial will have to be added after construction is completed.

The dial pointer was made from a large paper clip. The paper clip was straightened out and filed down slightly. A hole was drilled in the side of a large control knob with a #66 drill bit (the size used to drill printed-circuit boards). The filed-down paper clip was then force fitted into the hole in the knob, and the knob was mounted on the shaft of the tuning capacitor.

Once the knob is mounted, set the tuning capacitor to maximum capacitance and place the pointer so that it points to the far left (log scale 0) position on the dial. After that, mount the unit's internal speaker to the inside surface of the enclosure. The connec-

tions between the internal speaker wires and the printed-circuit board should be made with short lengths of twisted-pair wire and kept close to the metal enclosure and away from the antenna.

The antenna was mounted to the back of the cabinet with two plastic brackets that were intended to anchor the bottom of window blinds. The antenna feedthrough was made by drilling holes to mount an SO-239 coax receptacle. Instead of mounting an SO-239, however, a piece of sheet plastic was mounted over the cutout and a hole was drilled in the center of the plastic. A wire from the antenna connection on the printed-circuit board was then passed through the hole in the plastic to the antenna termination on the outside of the enclosure. That type of feedthrough has a lot less capacitance than a coax connector.

Calibration. Calibration should be done before the outside cover is placed on the enclosure. The first step is to set the band limits. A frequency counter is helpful for that purpose. If a counter is available, connect it to the counter terminals, J4 and J5. Connect the power supply to the receiver and turn it on. Set R24 for maximum volume and set R16 (FINE REGEN) to its center position. Set S2 to 49 meters. Turn R17 (COARSE REGEN) control until the WBR oscillates (heard as a rushing sound, a hum, or whistle from the speaker) and the counter shows a steady reading. From Table 1, note that the band limits for 49 meters are 5.95 MHz to 6.20 MHz. Adjust C23 until the receiver covers that range as C32 is rotated from maximum to minimum capacitance—a range of 5.9 to 6.26 MHz was obtained in the author's receiver.

Referring to Table 1, switch S2 to a higher frequency band and adjust R17 (COARSE REGEN) for continuous oscillation if necessary. While rotating C32 from minimum to maximum capacitance, adjust the appropriate trimmer capacitor so that the receiver tunes the international band. On some of the bands, the tuning capacitor will tune a wider frequency range than needed. It doesn't matter whether the desired band is on the upper or lower part of the range.

Trimmer capacitors C23 through C31 should have enough range to allow the proper band limits for each

band to be set. But if the frequency range is too high, a small fixed capacitor can be soldered across the appropriate inductor (L5 through L13). If the frequency range is too low, the inductor for that band will have to be changed to the next lowest value.

The dial should be calibrated when the receiver is completed and no further changes are expected. Each band should be calibrated when the fewest radio stations are on the air. The lower frequency bands are clear during the daytime, and the higher frequency bands are clear at night.

A marker generator capable of generating squarewaves of 100 kHz, 50 kHz, and 25 kHz that was built from plans found in the 1988 *ARRL Handbook* was used to calibrate the dial. Use a frequency counter to find the approximate location of the first multiple of 100 kHz on the dial. Start by turning on the WBR and allowing it warm up for at least 30 minutes. Rotate R17 until the WBR oscillates. Back off R16 until oscillation stops; then advanced it until the set almost oscillates. Set the marker generator to 100 kHz and turn it on.

Loosely couple the output of the marker generator to the antenna of the WBR. A wire from the output of the marker generator placed near the WBR's antenna should be adequate. A signal that is strong enough to be received but weak enough that the regeneration control can be set to its most sensitive position is desired. Turn C32 (TUNE) slightly until a weak signal is heard as a rushing sound or a hum. If no signal is heard, increase the coupling to the marker generator and try again. When a signal is heard, turn the marker generator off and on to verify the origin of the signal. Using a pencil, lightly mark the point on the dial. Move the tuning capacitor up the dial and mark the next 100-kHz point.

When all the 100-kHz points are marked, switch the marker generator to 50 kHz and mark points between the 100-kHz points. Make those points distinguishable from the 100-kHz points. Once the 50 kHz points have been marked, switch the marker generator to 25 kHz and add those points. When all the points for all bands are on the dial, remove the dial from the radio, write over the dial markings in ink and add the frequency numbers. Erase any pencil markings left visible.

Spray the completed dial with clear lacquer or cover with a clear plastic sheet. The finished dial should look something like the one in Fig. 7. If the receiver drifts out of calibration, adjust the appropriate trimmer capacitor (C23–C31) until the stations appear in the correct place for each band.

**Using the WBR.** A regenerative radio does not operate like a superhet. It requires more adjustment to properly receive a given station. That is part of the charm of this vintage circuit. Once the technique is learned, the receiver can be easily operated.

The narrowest bandwidth and highest sensitivity is obtained when the regeneration control is set just below the point of oscillation. The optimum setting of the regeneration control changes as the receiver is tuned to different frequencies. As the tuning capacitor is tuned up in frequency (less capacitance), the regeneration control has to be backed off to prevent oscillation.

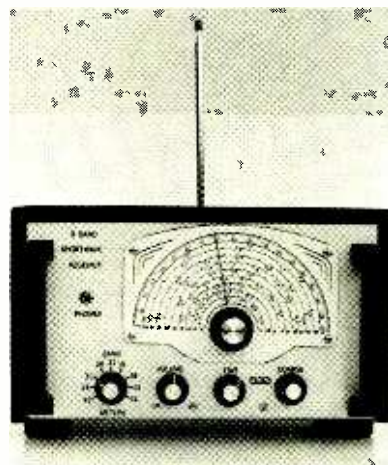

*Here is the author's attractively laid out prototype of the WBR. Note the professional-looking lettering that adorns the front panel.*

Turn the radio on, select an appropriate band, extend the antenna to its maximum length, turn the volume (R24) all the way up, rotate C32 to the minimum capacitance (highest frequency) position, set R16 to its center position, rotate R17 until the receiver oscillates and back off until the set just stops oscillating.

Rotate C32 to tune down the scale until a station is heard. Adjust R16 for maximum sensitivity; back off R24 if the station is too loud. When a dif-

ferent station is tuned, it will be necessary to readjust R16 for optimum reception. Potentiometer R17 should need readjusting only when the set is switched to a different band.

To use a frequency counter, connect the counter to J4 and J5 of the WBR. Very strong stations will provide enough signal at the counter output to produce an accurate station-frequency reading. To use the counter for weaker stations, tune in a station and turn up the regeneration control until the receiver oscillates. Going into oscillation causes the frequency to drop a few kHz. Tune up the band slightly until the oscillator produces a beat note against the station. Adjust C32 for minimum frequency (pitch) of the beat note. Then read the frequency on the counter. If the band is congested, this procedure cannot be used but the approximate frequency can still be determined.

If the sensitivity is too low for a given situation, add a few feet of wire to the whip. If an indoor or outdoor long-wire antenna is available, wrap two turns of the insulated wire around the whip to create a loose couple. Directly connecting a long-wire antenna to the whip will usually result in the receiver being overloaded.

When the WBR was being developed, I tuned in a ham operator on 40-meter LSB (lower sideband) from Miami who was describing to other hams the conditions as hurricane Andrew moved onto the Florida coast. A few days later, the same hurricane hit near my location in Louisiana.

For receiving LSB, locate the station using the same procedure as used for AM stations. Then turn up the fine regeneration control until the receiver oscillates continuously. Turn the tuning capacitor slightly up in frequency then slowly tune down until the operator's voice is intelligible. Changing the fine regeneration control slightly may be helpful for obtaining a good signal. The required tuning is delicate.

Receiving USB is the same except that the tuning capacitor must be tuned up the band until the speech is intelligible. CW (Morse code) stations will be heard in the vicinity of amateur voice stations. Like SSB they are received with the radio oscillating. Often several code stations will be heard at once, but the audio tone of each will be different. ■





# Hamming in the Fabulous Fifties

*Turn back the clock to the golden age of ham radio.*

BY KARL T. THURBER, JR., W8FX

**M**any electronics hobbyists look back with nostalgia at the simpler, pre-high-tech days of the 1950's. That era was especially significant for amateur radio because it spanned the early years of the Novice license, which gave most newcomers their start. Of course, the electronics world was much, much different then: Transistors and other solid-state devices were almost unknown. FM repeaters, packet radio and various exotic digital-communications modes, OSCAR satellite communications, and—perhaps most significantly—personal computers (PC's) simply didn't exist then. In fact, for the most part, it was an "analog world," not the digital world we know today.

In the 1950's, radio amateurs could still operate on the 11-meter band (now the 27-MHz CB band), ampli-

tude modulation (AM) was king of the radio airwaves, and only strange "Donald Duck" quackers were experimenting with single-sideband (SSB) communication. Needless to say, many of those who received their first amateur-radio license during that era have very fond memories of those seemingly sleepy but nevertheless heady days.

## Enter the Novice Radio Amateur.

Probably the biggest trend of the 1950's to influence amateur radio was the introduction of the Novice-Class operator's license. The Novice "ticket" offered entry not only into a wonderful hobby but, for many, an introduction to a lifelong career in radio or electronics. The Novice license did these things, even if you had to trek down to the nearest Federal Communications Commission (FCC) office to take the

exam, which was administered by a stern FCC engineer—there were no volunteer examiners then. Success was yours when the examiner told you to take your papers out and have them notarized.

The Novice-Class license came into existence in July, 1951. After several revisions to FCC Docket 9295, the Novice, Technician, and Amateur Extra-Class operator's licenses were authorized. The new license classes replaced an older licensing system that provided little attraction for newcomers. While Novice and Technician authorizations were to take effect on July 1 of that year, the Extra Class didn't take effect until January, 1952.

At first, the Novice Class was a beginner-only license, not one you could hold for a lifetime as you can today: the license term was one year and it was non-renewable, period.

You were supposed to get your code speed and knowledge of radio regulations and theory up to snuff in that period, or out you went.

The FCC initially allocated portions of three HF bands for Novice use. The small Novice sub-bands fell in the 80-, 11-, and 2-meter amateur-radio bands. Power was limited to 75 watts input, or about 50 watts output. Above all, the transmitter's oscillator stage had to be crystal controlled. Being "rock-bound" (referring to the crystal frequency you were tied to) helped ensure that newcomers didn't operate out-of-band. (Still, many beginners received FCC "pink-ticket" citations for out-of-band harmonic signal radiation from their often crude transmitters; many one- and two-tube rigs radiated strong harmonics at two or three times the operating frequency.) Even with these limitations, Novices of the 1950's found that their low-power transmitters (usually 10-25 watts) could actually "work out" (or at least be heard) for quite some distance.

Beginning radio amateurs looked to more experienced seniors, or "Elmers" (as we call them today) to provide guidance and help. Most old timers gladly accepted that responsibility, helping youngsters eager to get their Novice tickets by setting good examples of proper operating practice and providing technical assistance as needed. As a result, the beginner was usually able to get help with a low-budget project—both parts and palaver—when needed.

In those days, when seeking Elmer-style help, it didn't seem to make a great deal of difference if you were wealthy or poor, or what caliber station you could afford. If you were an amateur or prospective amateur, you experienced a special sort of bonding and were treated fraternally. Unfortunately, as the hobby has grown larger and become "more professional" over the years (there now are around 600,000 licensed amateurs in the United States alone), some of this camaraderie has disappeared.

**Those 1950's Stations and Their Operators.** Most 1950's-era pioneering Novices upgraded to higher class licenses—remember, it was an "up or out" system in which they had but a year to show that they had the right stuff to be full-fledged amateurs. The

1950's-era Novices shared several rights of initiation and mutual experiences they still cherish. For example, all of them looked fondly forward to tossing out their "rocks" (crystals) and opting for VFO control and higher power.

Still, many found to their surprise that CW—pounding brass—was actually a neat way to communicate (especially using a sporty semi-automatic key, or "bug"). Others found that AM was the way to go if you wanted to "rag chew." Interestingly, instead of the rapid back-and-forth banter that's commonplace today on SSB and FM modes, amateurs using AM radio tend to make formal "transmissions," or ex-

**Philmore**  
MODEL NT-200  
**NOVICE TRANSMITTER KIT**  
Including Power Supply Kit **\$29.40** AMATEUR NET COST  
POWER INPUT 25 WATTS



EASY TO ASSEMBLE — EASY TO OPERATE! 2 Bands: 3.7-3.75 Mc and 26.96-27.23 Mc. All necessary parts, Tubes, Key, 2 plug-in coils, pictorial diagrams, included. See this terrific new kit at your local jobber or write for literature to:

**PHILMORE MFG. CO., INC.** 113 University Place New York 3, N. Y.

*The Philmore transmitter kit shown here was a popular item in the early and mid-1950's, especially since everything was furnished, including the straight key! I know: the kit was my very first transmitter—and I wish I had saved it.*

tended verbal presentations, that make for slower-paced and more thoughtfully framed contacts (QSO's).

Considered today, the amateur stations of the 1950's—even state-of-the-art, top-of-the-line stations of the time—were simplistic compared to the sophisticated transceivers, PC's, and other accessories that today's amateurs use and take for granted. In the early 1950's, stations were mostly homebrewed—at least the transmitters were. Amateurs tended to build their own equipment to learn how the circuits worked, to better appreciate improvements they could make, and, of course, to save money.

However, by the end of the decade, factory-finished models and do-it-yourself transmitter kits (such as those by Heathkit) were the rule. Transceivers? They weren't really on the scene yet; bulky, separate vacuum-tube transmitters and receivers were the general rule. The bigger the radio "boat anchor," it seemed, the better the signal.

Unfortunately, the receivers of the 1950's were a sore spot for amateurs. Frequently, one's transmitter far out-reached the ability of his or her receiver to capture incoming signals. Typically, receiver sensitivity was low, selectivity was poor, and both electrical and mechanical frequency stability left much to be desired.

Dial calibration was typically haphazard, and many sets had just a bandspread dial that was uncalibrated, or made do with a generic "0+100" logging scale. Amateurs dreamed of sets with calibration markers every 5 or 10 kHz. Oh yes, Collins Radio even offered receivers with 1 kc or better calibration, but very few Novices could afford the premium-priced sets that were the pride of the Cedar Rapids, Iowa factory. So there really was a good reason for the FCC to require crystal-controlled transmitters and a separate means of checking your transmitted signal.

**Where Amateurs Shopped.** Where did radio amateurs buy their parts and equipment? There were few franchised radio outlets—no Radio Shacks then—and "ham stores" where you could work trade-in deals were only plentiful in the big cities. Consequently, the big radio mail-order houses like Henry Radio, World Radio Labs (WRL), Walter Ashe, Lafayette Radio, Burstein-Applebee, Fort Orange Radio, and Allied Radio, were postal magnets. They were the sources of many of the parts and equipment that radio beginners needed. That, of course, was if they couldn't beg, borrow, or steal components from a nearby old-timer's junkbox or from the scrapped radios and TV's often found in neighborhood repair shops.

A great, but long gone, source of parts and equipment for amateurs living near some large cities was the city's "Radio Row" district of stores—a sort of Marconi-style Mecca—that sold surplus and wholesale radio components. Chicago, Boston, Los Angeles, and other large cities had their Radio Rows, but the biggest of all was New York City's sprawling Cortlandt Street area in Manhattan. There you could buy almost anything to complete a radio construction project on the cheap.

New York area amateurs bought



their parts from colorfully named Radio Row stores like Blan the Radio Man, Cantor the Cabinet King, G & G, and Krantz Bros. For new and used amateur gear, you usually couldn't get a better deal than at Bill Harrison's (W2AVA) Harrison Radio emporium. Today, such Radio Rows are almost nonexistent. The closest you can come to experiencing the Radio Row of the 1950's is by shopping in Tokyo's fabled Akihabara electronics district, perhaps the last Radio Row.

### **Donald Duck, TVI, and the Cold War.**

Radio-wise, the 1950's was the decade in which "the bomb" made civil defense get serious, CB radio got off the ground, single-sideband (SSB) modulation came of age to threaten AM, and the specter of television interference (TVI) reared its ugly head. It was also the decade that saw the Cold War peak, witnessed the red-baiting McCarthy era wax and wane, and experienced the launch of Sputnik I. Also, it was an era in which radio amateurs experienced regulatory fears for their precious international frequency allocations. Let's take a closer look:

The Korean War didn't have a great influence on amateur radio. Hams—unlike in World War II—continued to operate during the Korea years. In the early 1950's, getting ready for "the big one" didn't refer to a coming California earthquake. Rather, it was defending the country against nukes and all that defense entailed. Civil Defense (CD) efforts burst onto the scene around 1950, once it was realized that the Russians really had the bomb. By 1952 public-service minded amateurs by the thousands had volunteered their stations to emergency communications under the newly formed Radio Amateur Civil Emergency Services (RACES).

At the same time, amateurs chafed at the need for them to comply with "CONELRAD" (CONtrol of ELEctromagnetic RADiation) rules. They were the 1957 government requirements for amateurs to monitor commercial radio broadcast stations for CD warnings while operating their radios. Why? Transmitting during a bomber attack might let the "Russkies" home in on your station!

The Citizens Radio Service has had ups-and-downs over the last 44 years



*Hiram Percy Maxim (1869–1936), affectionately known as "The Old Man" of radio, co-founded the American Radio Relay League (ARRL) in 1914. Maxim was known as a feisty, straight-arrow standards-setter who was revered highly in the amateur community. His strong influence was still felt in the 1950's amateur community.*

since it was established in June, 1949. It was slow going at the start. Frequencies were assigned in the then UHF wasteland of 460–470 MHz, and almost no one really used such outlandish frequencies in those days. The frequencies were so unpopular due to the poor UHF communications gear of the day that the FCC was under great pressure to find some HF spectrum space for CB.

In 1958, the FCC gave the old amateur 11-meter band to CB'ers (over the shrill protests of amateurs) to form the Class-D Citizens Radio Service. There was even a "save 11 meters" campaign launched by one of the radio magazines, complete with an operating contest to show that amateurs really used the band. That effort was designed to convince the FCC to let amateurs keep the band, but the commissioners weren't convinced.

Many of today's amateurs entered the hobby long after SSB's struggle for acceptance, not realizing that "AM was king" in the 1950's. In those years, most amateurs derisively thought of SSB as that silly "Donald Duck" modulation since, without the proper receiving equipment, the signals are strange-sounding indeed. That form of modulation—without the carrier wave characteristic of AM—was all but indecipherable unless one knew the secret of carefully tweaking the BFO (beat-frequency oscillator) knob

on their receiver. That is, if their radio had a BFO (many sets of the era didn't).

In the early 1950's, the biggest threat to amateurs was television interference, or TVI. Around the country, as hundreds of new VHF (and later UHF) TV stations took to the air, amateurs became painfully aware of the threat to their operating freedom and the very existence of their hobby posed by the boob-tube. In rural areas, TV signals from distant cities were usually very weak and highly susceptible to interference. In the big cities, amateur-radio and TV signals tended to live side-by-side and signal overload from amateur transmitters was common.

The TVI ogre was driving amateurs off the air by the thousands as TV viewers vastly outnumbered hams. While no magic bullet was developed to cure TVI, as the decade wore on the problems of TVI were slowly recognized and gradually licked by better RF filtering and shielding of both transmitters and receivers. The formation of joint radio-amateur/TV-viewer "TVI committees" also helped resolve the many problems of radio-frequency interference (RFI).

On the international front, the Cold War was at its peak in the 1950's as the "missile gap" and the shortage of engineers and scientists concerned many Americans. Those concerns of

the space age hit home on October 4, 1957 when the Soviet Union launched the first artificial earth-orbiting satellite, Sputnik I. Once word of the successful Soviet launch flashed to hamshacks around the world by Radio Moscow (which in the 1950's flooded the airwaves with high-power, multiple-frequency transmissions to the West), amateurs quickly turned to their receivers. They were easily able to intercept the satellite signal and looked to the sky to try to trace its faint path.

Amateurs became local authorities on satellites in towns across the country as they listened to the Morse-like "beep-beep" of the satellite on its easily received 20.005-MHz carrier. The Soviets even offered a distinctive confirmation card (QSL) for reception reports on their signal, along with a small but colorful lapel pin complete with a tiny red Sputnik.

Furious preparations for the 1959 Geneva World Administrative Conference (WARC) dominated the international radio scene in the last few years of the decade. The Geneva WARC was to be the largest international radio conference since the big 1947 Atlantic City meeting. There, the victorious superpowers divided up the globe, radio-wise, based on the new world map that resulted from the end of World War II.

The 1959 WARC could have been disastrous for radio amateurs. There was real concern that they would lose many of their frequencies as newly-independent countries asserted themselves politically, and commercial radio interests demanded even more radio frequencies. However, amateurs somehow preserved the status quo for at least the western hemisphere's frequency allocations while holding spectrum adjustments elsewhere to a minimum.

**Amateur Radio Magazines of Yore.** Over the years, many magazines serving amateur radio and shortwave enthusiasts have come and gone. Senior-citizen amateurs who were active in the 1920's through the 1940's may remember such then-popular publications as *The Transmitter*, *Radio News*, *Modern Radio*, *R/9*, *Amateur Radio Review*, *Midwest Radio*, *Radio Relays*, *Ye Brass Pounder*, and several others. Many of those

## Recalling Waseca

I've never even been to Waseca, Minnesota, and don't know anything about the town, so I can't actually "recall" it. However, I do know that Waseca was special to radio amateurs in that it was the longtime home of the E. F. Johnson Company, one of amateur radio's proudest equipment manufacturers of the 1950's.

Any article about tube-type transmitting gear always includes at the top of the list the Viking series of transmitters and linear amplifiers produced by E. F. Johnson. Reportedly, between 1949 and 1966 the Johnson factory produced, in kit or wired form, more than 53,000 rigs. First off the production line was the Viking I and II. Later came the Viking Ringer, Valiant, Adventurer, Navigator, Pacemaker, Courier, Thunderbolt, and about a dozen other memorable models—few Johnson transmitters were "unmemorable." If you flip open almost any *CQ* or *QST* from the 1950's, you'll likely find a big Johnson equipment ad.

Many Johnson rigs are still around today, as are what are likely Johnson's best known accessories, the Viking Match Box and Viking Kilowatt Match Box antenna tuners. For many radio amateurs who got their start in the 1950's and 1960's, the Match Boxes put the name "antenna tuner" into their vocabulary. Furthermore, they're not cheap even in the flea market today.

By the early 1960's, solid state and SSB were dawning in the amateur market, and Johnson didn't get aboard the train fast enough. Transceivers (rather than just transmitters) produced by Collins, Drake, Hallicrafters, National, Swan, and other American manufacturers were gaining in popularity. Too, high-quality, innovative Japanese imports were on the way. The management at E. F. Johnson reacted to all that by abandoning the amateur market and concentrating on the Citizens Band and land mobile-communications markets. (Johnson SSB CB sets are known for their quality and even today are converted for 10-meter amateur use.)

E. F. Johnson is no longer an amateur-radio supplier today. The respected Viking name was taken over in the 1970's by the William M. Nye Company, and several Johnson items were continued. These included a line of 3000-watt antenna tuners (follow-ons to the Viking Kilowatt Match Box), low-pass filters, SWR bridges, phone patches, keys and keyers, and other accessories.

To amateur-radio newcomers who aren't familiar with the old E. F. Johnson equipment, take a look around at the next hamfest or swap meet. Ask a few questions about the equipment, and look inside at the "battleship construction." Then, perhaps you, too, can recall Waseca! ■

magazines were intended for specialized or local and regional audiences. By the 1950's, for all intents and purposes, there were just two major publications for radio amateurs left: *QST* and *CQ* (see the boxed copy entitled "Names and Addresses" for the addresses of those publications and all others mentioned in this article).

*QST* was, and still is, the official journal of the American Radio Relay League (ARRL), the nonprofit national association of radio amateurs. Hiram Percy Maxim (1869–1936), affectionately known as "The Old Man," co-founded the ARRL in 1914 with Clarence D. Tuska. The organization originally was designed to keep the country's radio amateurs in contact with one other through relaying on-the-air messages, but now it's a broad-based hobbyist group. The first issue of what would become *QST* was published in December, 1915.

*CQ*'s origins are somewhat murkier, but date at least to the end of World War II. The current contest-and-operating oriented publication went under new management about '980 and officially traces its beginnings to 1945. However, in the 1930's there was at least one other publication called *CQ*, but it was for commercial, rather than amateur, radio operators.

*CQ* readers of the 1950's looked forward each month to the monthly pidgin-dialect "letter to the honorable editor" by that mischievous radio amateur originally from Osockme, Japan (and later, from "Feenix, Arizona"), Hashafisti Scratchi. The cartoon reportedly appeared first in the old *Radio* magazine as early as 1934, was interrupted by World War II, and later appeared in *CQ* as late as the 1970's. At that time, ethnic sensibilities dictated that publishing such a stereotype would be inappropriate, and the feature was dropped. But old-timers remember it well, just as they recall the antics of the late John T. Frye's "Carl and Jerry" exploits in the *Popular Electronics* of the 1950's and the late Gil Gildersleeve's highly entertaining "Jeeves" cartoons that appeared in *QST* for decades.

**Getting in the Fifties Radio Mood.** Nostalgia for all things fiftyish is in vogue. Equipment that a few years ago was considered variously as junk,



doorstops, or boat anchors are often considered classics. There's even a burgeoning market in books, booklets, magazines, and newsletters serving the market for older radio equipment and paraphernalia. Let's look at some of the books and publications that may spark your interest in the era.

The book *Communications Receivers*, 2nd Edition, by Ray Moore, has a great deal of data on American-made communications receivers from 1932 to 1981. RME, National, Hallicrafters, Hammarlund, Collins, and many others are covered—58 companies in all. Including variations on the 375 illustrated receivers, over 700 sets are covered. The 115-page book is \$17.95 plus \$2.50 postage and handling from RSM Communications.

*The Hallicrafters Story* describes the fabled Hallicrafters Company, which in the 1950's was a synonym for "short-wave radio receiver." In those days, radio amateurs and SWLs hoped to see a Hallicrafters under their Christmas tree. Author Max C. de Henseler, HB9RS, covers the company's operations from 1933 to 1975, when it effectively disappeared. Included are photos of most sets, a sampling of magazine advertisements, and tube complements. The book is \$14.95 plus \$2 shipping (total \$16.95) from the Antique Radio Club of America, Inc. Orders from outside the U.S.A. are \$18.95 in U.S. funds, shipping by surface mail.

Major amateur-radio publications such as *CQ*, *QST*, and *73 Amateur Radio Today* constitute a treasure-trove of information about older equipment. The classified ads in those magazine can give you a good picture of the used-equipment market.

The back issues of the contemporary amateur publications are even better than current issues for finding out about vintage equipment and getting a feeling for operating in the 1950's. A good source of back-issue radio magazines, though a chancy and casual one, is the next radio flea market in your area. Back issues of amateur-radio, communications, electronics, and computer magazines typically can be had for 10 cents to \$1 apiece, depending on condition, demand, and age.

Edited and published by Barry R. Wiseman, N6CSW/0, the nostalgic

specialty magazine *Electric Radio* is for those who appreciate older tube-type equipment. Each issue explores vintage radio gear and the people who once produced it. Issues also provide information on the modification, repair, and building of old-style equipment. The magazine also works toward a greater understanding of the AM mode.

Despite the interest in tube-type gear and AM, ER puts this bygone era and its equipment into perspective,

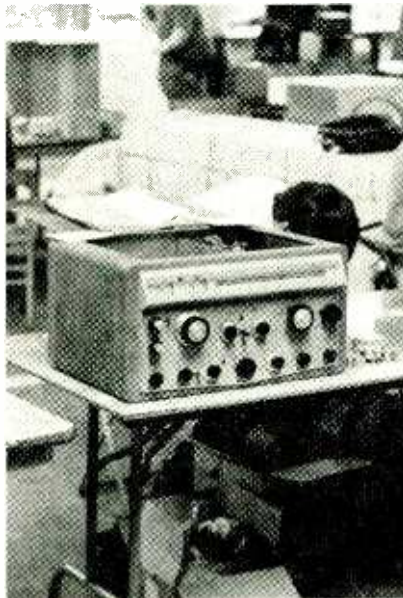

*Looking somewhat forlorn as it waits for a new owner at a radio hamfest, this high-end E. F. Johnson Viking Invader 2000 was an impressive all-mode, high-power amateur transmitter from the 1950's. It covered 3.5–30 MHz in seven bands. It could operate on SSB, AM, and CW, trying to bridge the gap between older and emerging communications modes.*

acknowledging the technical superiority of modern-day equipment, but lamenting its expense and complexity. While ER appeals to amateurs of all ages, it gets special approval from those who, like myself, were first introduced to amateur radio in the 1950's.

Each issue runs about 40 pages. Domestic subscriptions are \$24 by second-class mail and \$34 via first class. Canada and overseas are more. Contact Electric Radio.

To really get into the fifties mood, you might wish to read David Halberstam's 1993 book, *The Fifties*. While it's oriented toward the era in general and not to communications

topics of the 1950's, it's an excellent guide to the period and its mystique. The 800-page book is published by Villard Books, New York, at \$27.50. It's available in most bookstores.

**Setting Up a 50's-Style Station.** As one first licensed in 1954, I hold a special place in my heart for the amateur radio gear of the 1950's, equipment that's mostly big, clunky, heavy AM stuff. To many who got their feet wet then, the sight of a Heath DX-100 or Johnson Viking II transmitter, or a National HRO-60 or Hallicrafters SX-88 receiver is a sight for sore eyes. The great radio names of the 1950's include Central Electronics, Gonset, Sideband Engineers, Hallicrafters, Barker & Williamson, Heathkit, WRL, E. F. Johnson, National, Collins, Harvey Wells, and Eldico, among others. Most (though not all) of them no longer are in business, or are pursuing other manufacturing avenues.

While the big 1950's radio names are gone today, the "good ole days" of AM radio are indeed alive and well. Most shortwave radios, possibly one already in your house, can readily receive AM signals. It may be that the only real price of admission to 1950's-style hamming is that of a vintage AM radio transmitter. While most receivers and transmitters today are solid state, and many hobbyists look with disdain on vacuum tubes in this solid state world, some vacuum-tube era equipment still can do a creditable on-the-air job. For many, there's magic in the old sets—especially those charming golden-age classics—whose tube filaments glow brightly and warmly in the dark and possess a character not always found in modern-day radios. Many classic radio hobbyists install a second station in their home that's furnished as completely as possible with vintage-era gear.

Where do you find such equipment? Sources include local amateurs, radio hobbyists, and radio club members; magazine classified ads; sellers at radio flea markets and hamfests; garage and yard sales; and used amateur equipment dealers. Here are some considerations for purchasing older gear:

With regard to a receiver, decide whether you want a general-coverage or a ham-bands-only radio. Older general-coverage sets typ-



While all the gear in this photo may not be strictly 1950's, most of it is definitely vintage. The centerpiece in this Canadian station is a 1944 RCA AR-88LF receiver. Sitting atop it is a 1950's-era Heathkit Model QF-1 "Q-Multiplier," for improved receiver selectivity. To the left is a Johnson Ranger AM and CW transmitter.

ically cover 540 KHz to 30 MHz. Ham-bands-only radios normally cover only the "old" (pre-1979) WARC HF amateur-radio bands from 1.8 to 30 MHz, so they may not cover the newly authorized bands at 10, 18, and 24 MHz. Selectivity, sensitivity, and stability are—along with current condition—the key determinants of receiver qual-

ity and price. Well-known makes among older receivers include Drake, Collins, Hallicrafters, National Radio, Hammarlund, RME, and TMC.

As far as transmitters are concerned, many of the massive 1950's AM and early SSB rigs are available today and can make good buys. Often, they're easier to restore than

Come to Room 2346 to see—  
*The Perfect Sideband Combination for . . .*  
**2000 WATTS P.E.P.\***  
**INPUT**  
 Introducing The  
**VIKING "THUNDERBOLT"**  
**LINEAR AMPLIFIER**



The P.E.P. provides a maximum net linear average power output of 2000 watts. It is designed for 100% duty cycle operation. The amplifier is built with a full wave bridge rectifier circuit. It has a built-in antenna tuner. It is built with a full wave bridge rectifier circuit. It has a built-in antenna tuner. It is built with a full wave bridge rectifier circuit. It has a built-in antenna tuner.

DRIVE IT WITH A "PACEMAKER" . . .  
**MORE THAN AN EXCITER—A COMPLETELY**  
**SELF-CONTAINED SIDEBAND TRANSMITTER**  
 With VOX-Anti-Trip-Built-In Power Supplies



See the Viking Pacemaker "Thunderbolt" Power Amplifier in action. . . . See the Viking Pacemaker "Thunderbolt" Power Amplifier in action. . . . See the Viking Pacemaker "Thunderbolt" Power Amplifier in action. . . .

**E. F. Johnson Company**  
 2810 SECOND AVE. S.W. • WACARA, MINNESOTA

Between 1949 and 1966 the Johnson factory produced, in kit and completed form, more than 53,000 rigs. First was the Viking I and II. Later came the Viking Ranger, Valiant, Adventurer, Navigator, Pacemaker, Courier, Thunderbolt, and about a dozen other models.

receivers. CW-only Novice rigs are relatively simple affairs, typically being crystal controlled and running 75 watts or less; many of them still make useful CW rigs. Some of the better-known transmitter names include Collins, Heathkit, E. F. Johnson, Harvey Wells, and WRL, and several of the receiver manufacturers also produced transmitters.

Then, too, if you're into nostalgia radio, but don't want to go to the trouble and expense of setting up a complete vintage amateur-radio station (or don't have the room), consider something less ambitious. That can be a display of old-style microphones, Morse straight keys, semi-automatic keyers ("bugs"), vacuum tubes, crystals, and other accessories.

**Summary.** This article turned back the clock for a nostalgic peek at an era considered by many to be the "golden age" of amateur-radio communications. We covered the impact of the then-revolutionary Novice Class operator's license, looked at where radio amateurs shopped for radio gear and what radio magazines they read, relived some of the big radio issues of the decade, suggested how to get into that 1950's radio mood, and presented suggestions on acquiring your own vintage amateur station.

**Names and Addresses**

**AM International**  
 9 Dean Dr.  
 Bow, NH 03304

**AM Press/Exchange**  
 2116 Old Dover Rd.  
 Woodlawn, TN 37191

**AM Radio Network**  
 Box 73  
 West Friendship, MD 21794

**Antique Radio Club of America, Inc.**  
 Attn: Ron Frisbie  
 312 South 10th St.  
 Akron, PA 17501

**CQ**  
 76 N. Broadway  
 Hicksville, NY 11801-2953  
 Tel. 516-681-2922

**Electric Radio**  
 PO Box 57  
 Hesperus, CO 81326  
 Tel. 303-247-4935

**Ham Trader Yellow Sheets**  
 PO Box 2057  
 Glen Ellyn, IL 60138

**QST, American Radio Relay League**  
 225 Main St.  
 Newington, CT 06111-1494  
 Tel. 203-666-1541

**RSM Communications**  
 PO Box 1046  
 Key Largo, FL 33037-1046  
 Tel. 305-853-0379

**Society for the Promotion of Amplitude Modulation (SPAM)**  
 PO Box 27  
 Potrero, CA 92063  
 Tel. 619-478-9347

**Antique Electronics Supply**  
 6221 S. Maple Ave.  
 Tempe, AZ 85283  
 Tel. 602-820-5411

**Ardco Electronics**  
 PO Box 95  
 Berwyn, IL 60402

**Fair Radio Sales**  
 1016 E. Eureka St.  
 PO Box 1105  
 Lima, OH 45802  
 Tel. 419-227-6573

**HI Manuals**  
 PO Box 802  
 Council Bluffs, IA 51502

**Surplus Sales of Nebraska**  
 1315 Jones St.  
 Omaha, NE 68102  
 Tel. 402-346-4750



# Build This Electronic Casino

*Play three of the most popular casino games with this handheld, low-power project.*



BY JAY KIRSCHENBAUM

If you like electronic games, you should enjoy building and testing your luck with this project. The project, appropriately dubbed the *Electronic Casino*, lets you play three popular casino games—blackjack, craps, and slots—with realistic casino rules for each. The blackjack game, for example includes doubling, “soft” hands, and automatic play of the dealer’s hand.

Under program control, the project keeps a running count of your bankroll as the game is played so that you can try to beat your previous high total; or, if you wish, you can challenge a friend to see who can accumulate the most “cash.” With some simple sound effects and a four-digit display, the circuit lets you how you’re doing as the game progresses.

**About the Circuit.** Figure 1 shows a schematic diagram of the Electronic Casino. At its heart is Microchip Technology’s PIC16C56 microcontroller, U2. That 18-pin IC contains 1K of on-board RAM (which holds the game software), an internal oscillator, and 12 I/O lines (labeled RA<sub>0</sub>–RA<sub>3</sub> and RB<sub>0</sub>–RB<sub>7</sub>), each of which can be programmed as an input or an output. In our circuit, four of those lines (RA<sub>0</sub>–RA<sub>3</sub>) are always inputs, and are used to monitor the

status of the four input switches; S1 through S4. Lines RB<sub>0</sub>–RB<sub>6</sub> are always outputs, with RB<sub>0</sub>–RB<sub>6</sub> feeding U1, an Intersil ICM7211 LCD controller/driver. The final line, RB<sub>7</sub>, feeds the base of Q1, which is used to drive BZ1.

An 3.58-MHz crystal XTAL1, along with C2 and C3 are used to set U2’s internal oscillator. There is nothing particularly special about the crystal; however, because the software delays and timing are written assuming a 3.58-MHz crystal is used, the circuit will not operate properly if a crystal of a different frequency is substituted.

The microcontroller, U2, has an on-board power-up reset circuit, so the chip only requires that the MCLR input (pin 4) be tied to V<sub>DD</sub> to initialize the circuit when it is first turned on. However, a manual RESET switch (S5) connected directly to the MCLR input (pin 4) can be pressed at any time after power-up to reset U2.

As mentioned, the RB<sub>0</sub>–RB<sub>6</sub> outputs (pins 6–12, respectively) of U2 are connected to the LCD driver, U1. That 40-pin CMOS device—with its 28-segment drivers (seven per digit) and a display back-plane driver—is designed to feed a four-digit LCD read-out. To place a number into one of the four display digits, the number is output in binary by U2 at RB<sub>0</sub>–RB<sub>3</sub> (pins 6–9,

respectively) and fed to the data inputs of U1 at pins 27–30. Simultaneously, the digit (0–3) is output in binary at RB<sub>4</sub> and RB<sub>5</sub> (pins 10 and 11) and applied to the ADDR1 and ADDR2 inputs (pin 31 and 32) of U1. When that information is stable, pin 12 (RB<sub>6</sub>) of U2 is taken low and then high to transfer the information to U1. The data received by U1 is then internally decoded by U1, and the information used to light the appropriate display segments.

Because the circuit requires very little power, it can be powered from a 9-volt battery (B1 in Fig. 1). The battery voltage is clamped at +5 volts by a simple regulator circuit comprised of R5 (a dropping resistor), D1 (a 5-volt Zener diode), and Q2 (a 2N3904 general-purpose NPN silicon transistor).

But all of that circuitry would be just a bunch of silicon and carbon without the program—which was written in assembly language—that tells it what to do. So let’s briefly discuss the game program.

**About the Software.** The assembly-language program written for the Electronic Casino is quite long; for that reason it will not be shown in its entirety here. However, for those adept at programming microprocessors

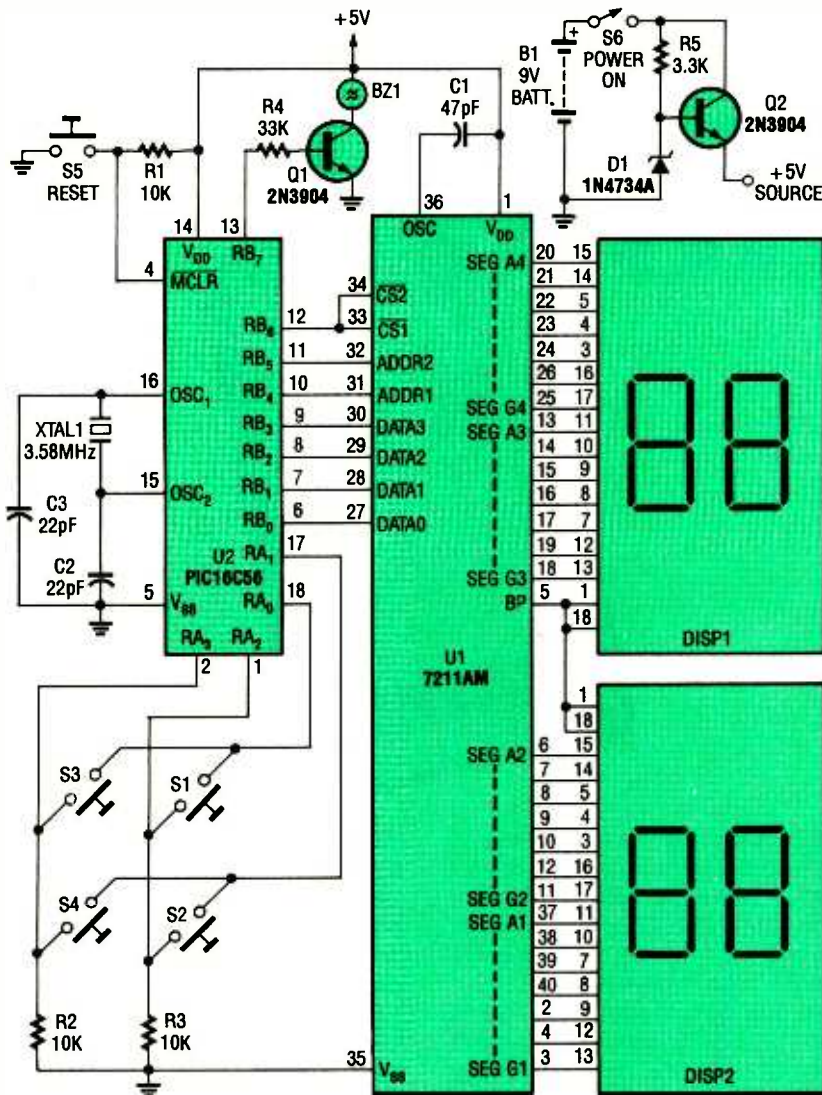

Fig. 1. The Electronic Casino's operation revolves around two chips: U1 (an ICM7211AM liquid-crystal display driver) and U2 (a PIC16C56-XT microcontroller); the game software is resident in 1K of the microcontroller's on-board RAM.

and who have access to the equipment, the listing can be downloaded from our BBS (516-293-2283; 8, N, 1). If you do not have access to such equipment, a preprogrammed chip can be purchased from the supplier listed in the Parts List. (Unprogrammed IC's and programming tools are available from Digi-Key Corp., 701 Brooks Ave. South, P.O. Box 677, Thief River Falls, MN 56701-0677.)

While the entire program is too long to describe here, the subroutine that "deals" the cards in blackjack, "rolls" the dice in the craps, and "spins" the wheels in the slot machine uses a relatively simple, random-number generator that you might find useful in other projects. Needing only twelve lines of

assembly code, the routine is a software implementation of a random-number generator that consists of a 31-stage shift register (see Fig. 2) and an xor gate whose inputs are connected to the 6th and 31st stages, with its output feed back into the 1st stage.

As the shift register is advanced by the clock pulses, the sequence of "1s" and "0s" that appear at the output are an approximation of a true random sequence. The circuit actually steps through 2,147,483,647 approximately random "1s" and "0s" before the sequence repeats!

The circuit is simulated in software by using four of the 32 general-purpose registers that are available in U2. As shown in Fig. 3, those 8-bit wide

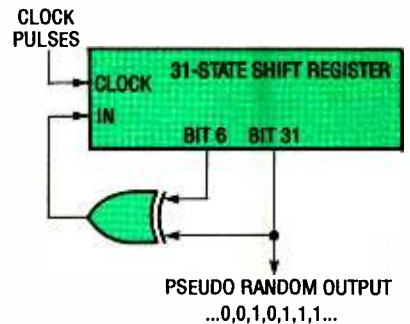

Fig. 2. Shown here is just one of a whole family of shift-register circuits used to produce pseudo-random sequences.

registers (R1-R4) are imagined to be arranged end-to-end, in a shift-register configuration: i.e., R1 feeding R2, R2 feeding R3, and R3 feeding R4.

In the assembly-language routine (refer to Listing 1), the first two steps move the contents of register R1 to a temporary storage register, TEMP. The contents of the TEMP register are shifted once to the right in step 3. In steps 4 and 5, the contents of R4 are moved to another temporary register, w, and its output is XOR'ed with the contents of R1 (which at this point resides in the TEMP register). That operation XOR's all the bits of TEMP with the corresponding bits of w, and places the result in the temporary register (TEMP), overwriting its previous contents.

Since the 7th bit of the TEMP register (shifted once to the right) and the 7th bit of w were originally the 6th and 31st bits of the shift register, the 7th bit of the TEMP register now contains the software analog of the output of the XOR gate shown in the original circuit.

Note that the TEMP-register contents are shifted twice to the right in steps 6 and 7 to put the 7th bit into the carry bit of the microcontroller (U2 in Fig. 1). Finally, the entire register (R1-R4) contents are shifted one bit to the right in steps 8 through 11. In that operation, the carry bit becomes the 1st bit of R1 and the 7th bit of R4 contains the new output bit of the pseudo-random generator.

To simulate the deal of one card in blackjack, the pseudo-random subroutine is used four times to produce a random four-bit binary number. That can be any number between 0 and 15; however, a routine in the main blackjack program screens out the 0, 14, and 15, insuring that a random number between 1 and 13 is obtained. That corresponds to one of the



## PARTS LIST FOR THE ELECTRONIC CASINO

### SEMICONDUCTORS

- U1—ICM7211AMIPL liquid-crystal display driver (Intersil), integrated circuit  
 U2—PIC16C56-XT microcontroller (Microchip Technology), integrated circuit  
 DISP1, DISP2—2-digit liquid-crystal display (Digi-Key #LCD001VT-ND or #LCD001, Standish #3935-365-920, or similar)  
 Q1, Q2—2N3904 general-purpose NPN silicon transistor  
 D1—1N4734A 5.6-volt, Zener Diode

### RESISTORS

(All fixed resistors are ¼-watt, 5% units.)

- R1—R3—10,000-ohm  
 R4—33,000-ohm  
 R5—3300-ohm

### CAPACITORS

- C1—47-pF, ceramic-disc  
 C2, C3—22-pF, ceramic-disc

### ADDITIONAL PARTS AND MATERIALS

- XTAL1—3.58-MHz crystal (Digi-Key CTX-049 or similar)  
 BZ1—Piezo buzzer (Star Micronics model QMB-105 or similar)  
 S1—S5—Single-pole momentary-contact pushbutton switch  
 S6—SPST toggle switch  
 B1—9-volt transistor-radio battery  
 Printed-circuit materials, enclosure, battery holder and connector, IC sockets, 4 nine-pin terminal strips (Digi-Key #A208 or similar), wire, solder, hardware, etc.

**Note:** The following parts are available from K and V Electronics, Box 250320, Columbia Station, New York, NY 10025-9991; U1, U2 (programmed and tested), and buzzer BZ1, for \$29.95; A pre-drilled, double-sided printed-circuit board with plated-through holes for \$19.95. Please add \$2.50 for shipping and handling to each order. New York residents, please add appropriate sales tax.

13 different cards in the deck (the suit doesn't matter in blackjack). A similar procedure is used to roll the dice in craps and to advance one of the slot wheels by one step.

**Building the Circuit.** The entire circuit was assembled on a double-

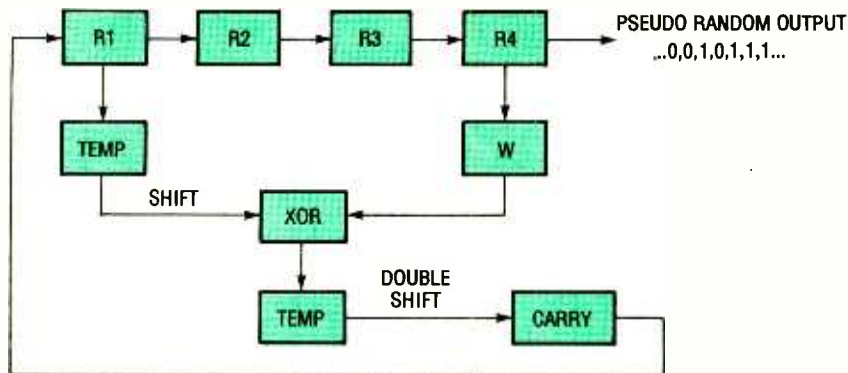

Fig. 3. The double shift puts bit 7 of TEMP into CARRY. From there it is shifted into the first bit of R1.

### LISTING 1—PARTIAL LIST OF SUBROUTINES

#### ;SUBROUTINE PSEUDORANDOM

```

1      START      MOVF      R1, 0      ;move R1 to TEMP
2                          MIVWF     TEMP
3                          RRF        TEMP, 1      ;right shift TEMP
4                          MOVF      R4, 0      ;mov_ R4 to W
5                          XORWF     TEMP, 1      ;exclusive-or TEMP and W
6                          RRF        TEMP, 1      ;right shift TEMP twice
7                          RRF        TEMP, 1
8                          RRF        R1, 1      ;right shift R1, R2,
9                          RRF        R2, 1      ;R3, and R4
10                         RRF        R3, 1
11                         RRF        R4, 1
12      RETLW     0      ;return to main program
  
```

sided, printed-circuit board measuring about 3½ by 4½ inches. A template for both sides of that relatively compact printed-circuit pattern is shown in Fig. 4: The template in "A" is the solder side, while "B" is the component side. Its small size makes it suitable for handheld units. If you are unable to make double-sided boards, the board can be purchased from the supplier listed in the Parts List.

Whichever route you decide to take, when assembling the board, it is recommended that the IC's and the display be socketed. Sockets simplify the replacement of blown chips and allow the board to be tested without the IC's in place. Note, however, that the displays do not fit into standard IC sockets; for that, the author used two 9-pin terminal strips for each dual display module.

Figure 5 shows a parts-placement diagram for the double-sided foil pattern shown in Fig. 4. Begin construction by soldering the sockets in place; follow that with the resistors, capacitors, transistors, diode, buzzer, and the crystal (XTAL1). Bend the leads of

the crystal to 90° before installing it so that when the crystal is mounted, it lies flat against the circuit board. Be sure to observe the correct polarity for the transistors and the diode.

Connect S1—S5 to the corresponding solder pads. Depending on the type of installation you decide on, it may be necessary to first mount the switches to the enclosure and run wires between the switches and the circuit board. In any event, once the circuit is fully assembled, it is time to check your work.

First connect a 9-volt power source (with the correct polarity) to the "+" and "-" terminals of the printed-circuit board (see the parts-placement diagram). A bench-type regulated DC power supply or a 9-volt battery can be used for this task. Using a voltmeter, check that the voltage at pin 1 of U1's socket, and pins 4 and 14 of U2's socket are at 5 volts and that all the other pins of the sockets are at 0 volts.

Next, test switch S5 by monitoring the voltage at pin 4 of the socket for U2 while S5 is depressed. The voltage should drop to 0 when S5 is depressed

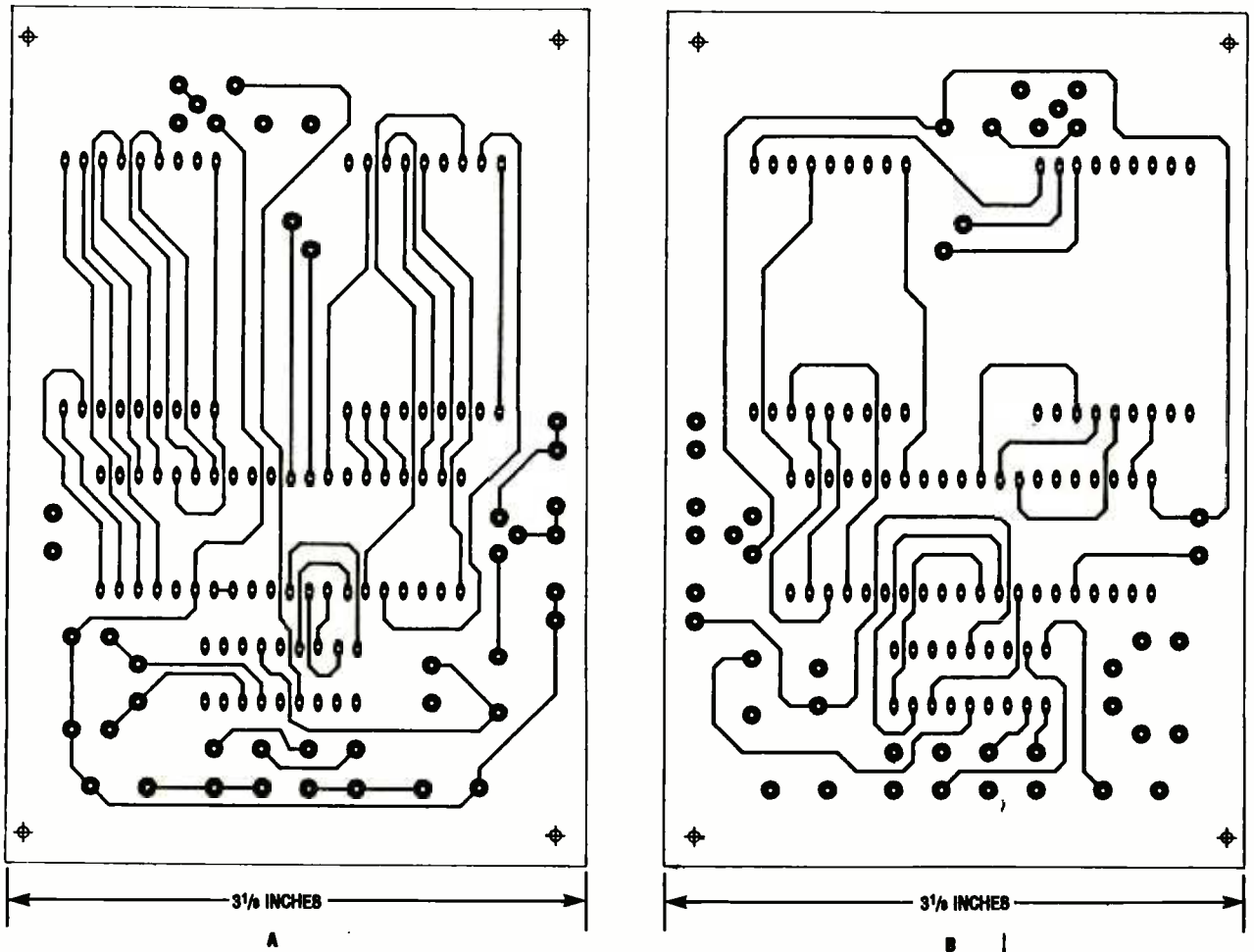

Fig. 4. The Electronic Casino was assembled on a compact, double-sided printed-circuit board, both sides of which are shown here full size; "A" is the solder side of the board, and "B" is the component side of the board.

and return to 5 volts when released. Switches S1–S4 can be tested by placing a jumper wire between pin 1 of U1's socket and pin 17 of U2's socket and another jumper between pins 14 and 18 of the socket for U2. Now monitor the voltage at pin 1 of the U2 socket. It should be 0 volts unless either S1 or S2 are pressed, in which case, the voltage would rise to 5 volts. The same result should be observed at pin 2 of the socket for U2 if either S3 or S4 is pressed. When those tests are complete and all is well, remove the two jumper wires.

The buzzer connection can now be tested by connecting one end of a wire to pin 14 of U2's socket and momentarily touching its other end to pin 13. You should hear a brief sound from the buzzer each time you touch pin 13, and again as the connection is removed. Because the buzzer responds to a changing voltage (not a steady one), there should be no out-

put while the jumper is held to pin 13. If all is well, remove power from the circuit.

If one or more of the tests were not successful, check your work for solder bridges between adjacent pins, and cold solder joints. Also check that Q1, Q2, and D1 have been correctly oriented.

Once everything has checked out okay, install the display modules and IC's. Be sure that they are correctly oriented, and that none of the leads fold under the body of the component. Complete the circuit by attaching S6 and the battery clip as shown on the parts-placement diagram (see Fig. 5).

If you like, you can install the project in an enclosure of your choice. Dry transfer lettering can be used to label the various front panel switches and displays.

With the chips now installed, reapply power to the circuit. The display

should begin flashing the digits "1," "2," and "3," repetitively. You are now ready to select your game and begin playing!

The program has a built-in battery saver that blanks the display if no key is pressed after about two minutes. To restore the game at a later time, press the RESET switch (S5) and the game will continue where it left off when the display was blanked.

**Let the Games Begin.** The RESET button is used during play to change between the three games. The other four buttons, labeled S1 through S4, control the play. In normal operation, the display shows the status of the game you are currently playing, however you can press S1 at any time to see your bankroll. The game returns to the appropriate display when you release switch S1.

On power up or after RESET is pressed,  
(Continued on page 91)



# GIZMO

A CHRONICLE OF CONSUMER ELECTRONICS

## The ABC's of PDA's

Are we on the brink of the Digital Information Age?

As we go about our lives in the highly-touted Information Age, most of us still rely on old-fashioned purveyors of data—telephone, radio, the printed word, and television—for the bulk of our information exchanges. The situation seems somewhat different at work, where the computer reigns supreme and fax machines have become *de rigueur* in recent years—but computers and faxes have also been around for decades. Even the relatively new tools used by business travelers—cellular phones, notebook computers, electronic organizers, portable fax—are variations of the same telephone- and computer-based equipment used back in the office.

Are we ready for something dramatically new? Perhaps something that will bridge the gap between the way we communicate and handle information at work and at home? Or maybe something that will seamlessly merge the way we do work at the office and the way we do work on the road? Maybe an inexpensive, portable, handheld product that would allow us to send and receive phone calls, faxes, and E-mail—not to mention take notes, organize our time, and play games? Sounds good, or are we ready?

According to John Sculley, the former chairman of Apple Computer, the industry is ready, too. Back in January, 1992, in his keynote address at the Winter Consumer Electronics Show, Sculley announced: "The Digital Age is coming!" Citing recent developments in digital technology, he proclaimed, "This will be a decade where people will fundamentally transform the way they live their lives—the way they work, learn, and communicate. . . . We only are consumer electronics converging with personal computing. More interestingly Entertainment, communications, and publishing are also converging with computers and consumer electronics."

At the following year's WCES, representatives of Casio and Tandy espoused a computer/consumer philosophy remarkably similar to that of John Sculley and Apple, speaking of the need for a small consumer device that will provide "increased functionality, flexibility, and features" and "anytime-anywhere" information, all "at a consumer-affordable price."

That summer, in his keynote

address at the first Personal Communications and Computing show-within-a-show (at Summer CES 1993), Gordon Bridge, president of AT&T Easy-Link, noted that "the marriage of communications and computer technology has forever changed the way we do business and is changing the very fabric of our society." He emphasized not the alliance of computers and consumer electronics, however, but of computers and wireless communications technologies.

As you might expect, those speakers were not merely verbalizing their own wishful thinking. Each was describing his company's version of the information/communications product of the future. Sculley coined the moniker "Personal Digital Assistant" or "PDA" to describe



Apple's proposed Newton. Tandy and Casio found that to be a fitting handle for their own Zoomer PDA. AT&T went with "Personal Communicator" (not to be confused with "PC") to describe the EO 440.



In this article, we'll examine two entries in the PDA product category, the Newton and the Zoomer, and the first personal communicator, the AT&T EO 440—what they are and how they work, the companies that created them and the technologies that enabled them to do so. We'll explore how PDA's might fit into, or even change, your lifestyle, and how a personal communicator might change the way you work. Then we'll provide hands-on reviews of Sharp's Newton product, the ExpertPad; Tandy's Z-PDA Zoomer; and the EO 440. We wrap up this month's issue with a look at how the Zoomer and Newton stack up against one another.

### JUST WHAT IS A PDA?

A Personal Digital Assistant, in its most basic definition, is simply "a device that uses digital technology to bridge the gap between personal computers and consumer electronics." Casio President John H. McDonald fine-tunes (and hypes up) the definition somewhat, when he describes the Zoomer as a "breakthrough device . . . combining the power of a PC, an affordable consumer price, and the simplicity of pen and paper."

Though microprocessor based, the PDA is not just another, smaller, computer. In fact, it might be called the first truly *personal* computer—so personal, in fact, that you might not even realize it's a computer. Its operating system is virtually transparent to the user. The PDA's interface is pen- and icon-based, its architecture is object-oriented, and its target market will encompass not only computer-literate businessmen, early adopters, and techies (although those are expected to buy the first-generation PDA's), but average consumers who have never overcome their fear of computers.

There are several specific criteria that a device must meet if it is to be considered a true PDA. It must be easy to use, portable, powerful, versatile, expandable, affordable, and able to communicate.

To reach its target audience—and differentiate it from the emerging class of pen-based, palm-sized computers—the PDA must be virtually as easy to use as a pen and paper. It can not have a QWERTY keyboard or a complex operating system to master. Information can be input by tapping on icons and writing on a touchscreen with a pen-like stylus; scribbles can remain handwritten or be translated into ASCII text via handwriting-recognition technology.

A PDA must have powerful computing capability, must offer a variety of practical applications, and must be easily expanded to accommodate additional memory and still more applications. It should also provide a communications link to the outside world, allowing fax, E-mail, paging, modem, and even cellular services.

Furthermore, all that simplicity, power, and versatility must be contained in a handheld, portable package. A PDA must allow one-handed use on a plane, in a car, or while standing at a pay phone. Long battery life is essential.

Finally, to become a true consumer item, the PDA must be affordable on a mass scale. That means eventually reaching the price point of other popular consumer-electronics items, such as VCR's and CD players.

The Newton, which is marketed by Apple Computer as the "MessagePad" and by Sharp Electronics as the "Expert Pad," and the Zoomer, sold as the "Z-7000" by Casio and as the "Z-PDA" by Tandy, have been designed with all those requirements in mind. Let's see how Apple and Sharp, and Casio and Tandy, tried to meet those goals. (For simplicity's sake, in this article we refer to the Newton and the Zoomer as product categories; elsewhere in this issue we review Sharp's Newton ExpertPad and Tandy's Z-PDA Zoomer.)

### NEWTON-ION PDA

When the folks at Apple first conceived the idea of a PDA-type device, they deter-

mined that it must be as a unique device from the ground up and not rely on any existing computer architecture. As a result, there's a lot of neat, ground-breaking stuff under its hood—particularly the Newton Intelligence operating system, which does away with the usual file manipulation, directory paths, and saving to RAM or disk, that's required in today's computer operating systems.

There are four major parts to Newton Intelligence: the Recognition Architecture, which converts cursive and/or printed handwriting to text; the Communications Architecture, which handles various I/O devices using Newton's PCMCIA slot, RS-422 serial port, and infrared transmitter/receiver; the Information Architecture, which replaces the DOS maze of files and directories with a whole new approach to data storage and sharing; and Intelligent Assistance, which allows Newton to adapt to your handwriting style and work preferences. The processing power is provided by the ARM 610 chip from GPS, which delivers 32-bit RISC (Reduced Instruction Set Computing) performance with low power consumption.

Handwriting recognition is vital to any device that promises pen-and-paper convenience. Newton's system allows you to use script or print, or a combination of the two, and converts the handwriting to text as you write, with a slight delay. The system recognizes not just shapes, but pen strokes—it interprets the movements that make up individual letters, numbers, and words. You can also set the system to match your handwritten words to the 10,000 entries in its internal dictionary. If it still has trouble recognizing a word or phrase, you can correct it using a pop-up on-screen keyboard. It's possible to define blocks of text or drawings, move them around the screen (or into other Newton applications), insert spaces or lines, and erase by simply "scrubbing" out your errors. A graphics interpreter neatens up drawings, rounding off circles, squaring

## Doonesbury

BY GARRY TRUDEAU





# Doonesbury

BY GARRY TRUDEAU

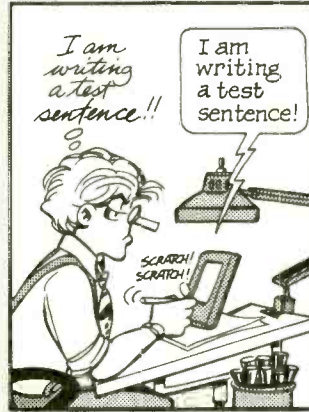
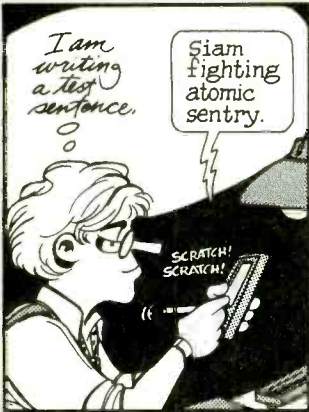

up boxes, straightening lines. If you prefer your artwork as is, you can disable that feature.

It isn't necessary to translate all your scribbles to text. You can simply store your handwritten notes as is, in "digital ink." However, because Newton looks at the way letters are written and not just their shapes, you cannot go back later on and translate your scrawl into text.

In terms of communications, an optional Newton-compatible fax/modem can be inserted in the unit's PCMCIA slot. (Industry-standard PCMCIA fax/modems are not supported, however.) The infrared transceiver can be used to "beam" information to another Newton or to a Sharp Wizard electronic organizer, and the serial port to link Newton to a PC, printer, or fax modem. Faxes can be sent, but not received.

The PCMCIA slot can also be used for third-party add-on applications, additional memory, or backing up data—but not simultaneously.

## "SOUP"-ED UP OPERATING SYSTEM

Forget everything you know about DOS, Unix, and other file-based computer operating systems. Newton Intelligence is about data-sharing, not data-filing. Everything is stored in one place, and can be easily accessed from any application.

Any data that you enter into the Newton is automatically tagged by the Information Architecture and saved in an object known as a *frame*. Each frame consists of tagged locations called *slots*, which can hold data, program code, or other frames. Several related frames reside together in *soup*, and soups are stored in, well, *stores*, which can reside in main memory or on a PCMCIA card.

That "free-form" style of organization

is the electronic equivalent of jotting down notes on Post-Its and scraps of paper, with one major difference. Once the data is in the soup, it can easily be recalled, unlike all those little pieces of paper that are so often misplaced. You needn't decide how to label a bit of information as you're writing it; you can organize it to suit your needs at a later date. You can also link, group, and regroup all those pieces of information as you see fit.

What makes all that possible is Intelligent Assistance. Say you want to fax a document to Joe Client. If he's already listed in the name directory, you can jot down "Fax Joe," and Newton will automatically retrieve Joe's full name and fax number. If there is more than one Joe in your name file, it will ask you to choose the correct one. If you aren't currently hooked up to a fax line, Intelligent Assistance will store the "Fax Joe" order until it can be sent. "Fax" is one of the system's "action words"—others include

"call" and "send." Newton perceives those words as commands, and acts upon them when you highlight them and then tap the Assist icon.

As intended, all of this internal wizardry is totally transparent to the user, who simply turns on the Newton and begins an application. In fact, there is no start-up sequence at all—at power-up, you automatically return to the application last used, and move to a different application by tapping on its icon. Once again, you enter that application in the same place that you left off last time. There's no need to load or save a file, although you can organize them in folders if you wish. Otherwise, Newton simply stores them chronologically, and you can scroll through a list of the notes you've made.

## ZOOMING INTO THE FUTURE

At first glance—and, to some extent, at first use—the Zoomer and Newton almost appear to be clones. But looks can be deceiving, as a peak inside the Zoomer will prove.

Rather than starting from scratch to design a totally new product, Casio and its development partners, GeoWorks and Palm Computing, used modifications of existing hardware and software to build the Zoomer. Casio specially designed the unit's Intel-compatible CPU, which is equivalent to a 7.5-MHz 8086. The operating system is a GeoWorks' GEOS, again specially designed for use in the Zoomer. Handwriting recognition is from Palm Computing.

GeoWorks modified its desktop GEOS operating system to reside in the Zoomer's ROM. Although GEOS is a DOS-file-compatible operating system, it isn't a slave to the DOS file structure. GEOS is an object-oriented, multitasking environment with an easy-to-use graphical interface.

In actual use, GEOS acts a lot like the Newton's operating system, although GEOS is somewhat slower and has less intelligence. After all, something had to



The Newton can be used for note-taking at home, in the office, or on the road.

Senior Writers: Chris F. O'Brian, Teri Scaduto. ©Gernsback Publications, Inc. 1993. Gizmo is a registered trademark. All rights reserved.





**Aimed at consumers, not just business executives, the Zoomer PDA offers a wide variety of applications.**

be sacrificed to deliver the Zoomer's long battery life. Casio and Tandy felt that speed would be a fair trade-off for 100 hours between battery changes.

Palm Computing supplied a PDA version of its PalmPrint software—the most widely used handwriting recognition system in North America. Rather than recognizing full words as the Newton does, PalmPrint identifies individual letters, which are defined by tiny templates that have been pre-trained to recognize both upper and lower case block letters; cursive writing can't be translated to text on the Zoomer. Like the Newton, the Zoomer's handwriting recognition is based on pen-stroke motion, not the image of a character, but unlike the Newton, the Zoomer cannot be trained to "learn" its owner's handwriting. The Zoomer, however, does recognize delayed strokes—going back at the end of a word to dot the "i" for instance—and deferred recognition—going back at the end of a meeting, or the end of the day, to translate handwritten notes to text.

Deferred recognition comes in handy because the Zoomer is slow to translate print to text. Of course, you can also opt to leave your notes as is, in "PowerInk." PowerInk entries are treated as objects, not as a layer on top of an application, so they can be moved, indexed, tagged with a reminder alarm, etc., just like electronic text. Palm Computing also specifically developed Palm Organizer—which includes the date-book, address book, and notebook functions—to work with PowerInk entries.

For linking to the real world, the Zoomer provides an infrared transceiver for exchanging data with other Zoomers and Casio B.O.S.S. electronic organizers. A serial port is available for linking to a PC, printer, or optional fax/modem. Software

## SIMON SAYS . . .

... take a giant step toward the integration of wireless communications services!

AT&T isn't the only company pushing a personal communicator. BellSouth Cellular Corp.'s (500 Northpark Town Center, 1100 Albermarly Road, Suite 300T, Atlanta, GA 30328) version is the IBM-designed *Simon*, a souped-up cordless phone that also incorporates a wireless send/receive fax, paging and E-mail capabilities, a full-function personal organizer, and a pen-based notebook/sketch pad. All of that comes in an 18-ounce, 8 x 2.5 x 1.5-inch wireless package, so it's truly portable.

Simon looks like any small cellular handset, but instead of a keypad it has a brightly lit LCD readout. The pen-based touchscreen serves as the phone's keypad and is used to access and operate the device's other applications. No special stylus is required, although a pen-like instrument facilitates on-screen writing. You can simply tap on the screen with your finger to access various applications.

Although Simon is pen-based, it includes no handwriting-recognition technology. It uses what BellSouth Cellular calls "pen-annotation technology," which means that the user's handwriting will appear as written instead of being digitized to look like a printed word. That might sound rather limiting, but Simon isn't intended to be a data-input device. Electronic ink is sufficient for most of Simon's functions; when text is required, it can be tapped in on a pop-up keyboard.

As a phone, Simon works just like any other cellular phone (except that the keypad is a touchscreen). It has the features you would expect to see, including a built-in 911 emergency-call button, last-number redial, auto-dial (from the address book), roaming preference, and password protection.

Simon's fax application allows faxes to be sent over the cellular network using a built-in wireless modem, or over standard phone lines using an optional RJ-11 cable. Group 3-compatible faxes are sent at 9600 bps. Simon can send or receive up to three pages at a time (optional memory-expansion cards are available). It's possible to zoom-in on a portion of a page, scribble notes and comments, and send it right back.

A built-in cellular numeric pager receives up to nine pages. Users can receive a page and return a call to that number at the press of a single button. When equipped with an optional PCMCIA paging card from MobileComm, Simon can also receive alphanumeric pages and electronic messages on a national, regional, or local basis. Messages are stored in the paging network so that they can be read as soon as Simon is turned on.

Integrated software provides access



**BellSouth Cellular Corp.'s Simon personal communicator looks just like a cellular phone.**

to Lotus cc:Mail over the cellular network or standard telephone lines, allowing users to send and receive E-mail through any cc:Mail post office that supports remote dial-in. A PCMCIA add-on card allows messages to be received through most other public E-mail systems.

Simon's personal organizer includes a calendar, an appointment scheduler, a to-do list, an address book, a world clock, a calculator, and a note/sketch pad. Users can write directly on the screen, or can use the pop-up keyboard to tap out typed messages within any of the organizer functions. The electronic address book provides convenient auto dialing.

Although Simon is still awaiting FCC approval as we write this, BellSouth Cellular Corp. plans to begin selling the product in select markets in Florida in December 1993. Nationwide distribution is expected by April 1994. ■



for accessing America Online is built-in. Palm Computing sells the PalmConnect package, a complete set of tools to link the Zoomer to IBM PC-compatible and Macintosh personal computers. The package allows two-way exchange of information with a desktop computer. The Zoomer also has one PCMCIA slot for adding communications applications such as a pager, or to add or backup memory with industry-standard PCMCIA cards.

The Zoomer operates in an easy, icon-oriented environment—its “computer” is hidden from the user, although its file structure can be examined if desired. As with the Newton, a tap on one of the Zoomer’s icons, located below the LCD screen, brings up the associated application, right at the spot where you left off last time.

Other consumer-friendly features can be found below the LCD—a cursor control pad and two Nintendo-like “fire” buttons. Although the only thing they are used for in any of the applications currently built into the Zoomer is scrolling around the screen, they strongly suggest future game-playing applications. The three games that come with Zoomer—Solitaire, Uki (similar to Othello), and Pyramid (another one-player card game)—are all played using the stylus.

### EO 440 PERSONAL COMMUNICATOR

The EO 440 Personal Communicator, is not meant for fun and games—although our evaluation sample did include a crossword-puzzle application that we particularly enjoyed. Much larger than a PCA, and priced way beyond the range of most consumers, the EO 440 is first and foremost a business tool, and its emphasis is strongly placed on communications. Yet its basic concept—combining information management and wireless communica-

tions in a small, easy-to-use device—as well as some of the technology it uses, are close enough to those of the Zoomer and Newton to justify its inclusion here.

According to EO, you can’t compare the EO 440 to a desktop or notebook PC any more than you can compare it to a fax machine or a cellular phone. Although it contains elements of each of those, it is not intended to replace any of them. Instead, it is designed to fill the growing need of mobile professionals for an integrated device that provides intuitive, versatile, and highly portable communications and information exchange. To that end, the EO 440 Personal Communicator allows users to send and receive faxes and E-mail, and, when equipped with the optional cellular attachment, voice calls, anywhere and anytime.

AT&T is the majority shareholder of EO, Inc., which has strategic alliances with Matsushita, Marubeni, and Olivetti. Developed by EO, the 440 Personal Communicator carries the AT&T brand and is sold at AT&T Phone Centers.

At the 440’s heart is AT&T Microelectronics’ proprietary, RISC-based 92010 Hobbit microprocessor. According to that company, the high-performance, low-power (20-MHz, 3.3-volt) Hobbit provides two to three times the performance of a 20-MHz 386SL. It is not compatible with Intel/Microsoft or Macintosh standards. EO 440’s are available with either 4 or 8 megabytes of RAM, expandable to 12 megabytes.

GO Corporation’s PenPoint operating system, whose “pen-and-paper metaphor” provides an easy-to-use interface, is stored in the unit’s 8-megabyte ROM. As with the PDA’s, information can be input in electronic ink and translated to type or left as is. Applications are accessed by tapping on icons, and pen gestures are used to navigate through the system. Un-

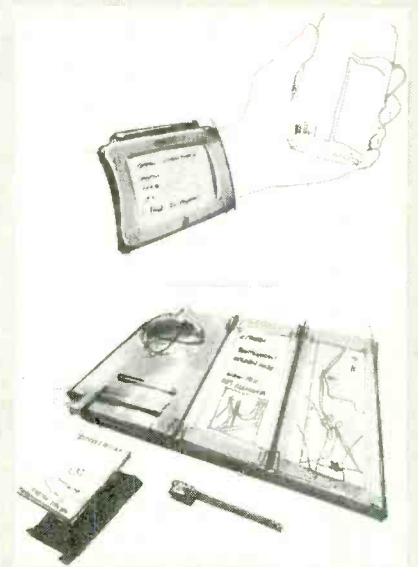

Apple engineers devised some possible Newton product concepts, including the “Newton inventory watch” (top) and a GPS-based mapping application (bottom).

like those on the Zoomer and Newton, the EO 440’s screen is not touch-sensitive; an electronic pen is required for writing and tapping on icons. At 7.5 inches diagonal, the screen is much larger than those found on the PDA’s, and its VGA-equivalent resolution is much higher. Accurate handwriting recognition requires some training of the EO 440 and the user, who must write the way the device expects to see letters formed. Cursive handwriting cannot be recognized on first-generation EO 440’s. However, the recognition software is in a replaceable module, and as the recognition technology improves—as it had better, if the PDA/Personal Communicator product categories are to survive—users will be able to upgrade.

Nine bundled applications are built in to the EO 440. For communications, there is GO Mail, GO FAX, and EO Phone. GO MiniNote is used for jotting down words and drawings that will not be transcribed to text. EO Sound allows spoken messages to be attached to any document. EO Calc offers standard- and scientific-calculator functions, and EO Lock provides security. Information can be exchanged with IBM-compatible computers directly via cable or remotely by modem, thanks to Sun-Select’s PenTops/Pen Central. Pensoft Personal Perspective provides all the organizer functions—calendar, to-do-list, address book, and note-taker. Because the bundled applications are stored in ROM, the Personal Communicator is ready to use straight out of the box, with applications launched immediately. A hard drive is not required, but is available as an option.

The EO 440 really is a mobile communications center. When equipped with the



The AT&T EO 440 is a stand-alone mobile office that functions as a cellular phone, portable fax, modem, and notebook computer.

TABLE 1

		Newton	Zoomer	EO440 <sup>a)</sup>
SPECIFICATIONS	Size — (H×W×D)	7×5×1"	6.8×4.2×1"	10.8×7.1×0.9"
	Weight	14.4 oz.	15.3 oz.	2.3 lb.
	Battery Type	4 AAA	3 AA	Rechargeable
	Battery Life (Maximum)	35 hours	100 hrs.	4 hours <sup>b)</sup>
	LCD Size	3×4.1"	3.1×4"	4.3×5.9"
	LCD Resolution	336×240	320×256	640×480
	PCMCIA Slot	Yes	Yes	Yes
	CPU/Power	20 MHz/32-bit	7.5 MHz	Hobbit—20 MHz 13 mips
Operating System	Newton Intelligence	GeoWorks	PenPoint	
Price				
HANDWRITING RECOGNITION	System	Newton Recognition Architecture	PalmPrint	PenPoint
	Print Recognition	Yes	Yes	Yes
	Cursive Recognition	Yes	No	No
	Deferred Translation of Ink	No	Yes	Yes
BUILT-IN APPLICATIONS	Personal Organizer	Yes	Yes	Yes
	Dictionary/Thesaurus/			
	Spell Checker	No	Yes	No
	Calculator	Yes	Yes	Yes
	Form Calculator	Yes	Yes	Yes
	Expense Tracker	No	Pocket Quicken	No
	Time/Date Stamp	Yes	No	Yes
	World Clock	Yes	Yes	Yes
	Games	No	Yes	Yes
	Language Translator	No	Yes	Yes
	U.S. & International Data	No	Yes	Yes
Reference/Trivia	No	Yes	No	
COMMUNICATIONS	Fax	Send only <sup>c)</sup>	Send only <sup>c)</sup>	Send/receive
	E-mail	Yes	Yes	Yes
	Paging	Future add-on	Future add-on	No
	Voice Annotation	No	No	Yes
	PC/Printer Links	Yes <sup>c)</sup>	Yes <sup>c)</sup>	Yes
	DTMF Dialer	Yes	No	Yes
	America Online	No	Yes	No
	AT&T Mail	No	No	Yes
a) As equipped per review unit. b) 7 hours with optional extended life battery pack. c) Requires optional add-on.				

#### PDA/PCC comparison at a glance.

optional cellular-ready, high-speed modem, the EO 440 is the mobile businessperson's link to the world. The 14,400-bit-per-second data modem includes 9600-bps send/receive fax capability. The Personal Communicator connects to any standard RJ-11 phone jack for faxing. And when the optional cellular-phone package is added, the user has a wireless link to modems, faxing, and E-mail. The EO 440 comes with a free subscription to AT&T Mail from AT&T EasyLink Services. Besides providing fax and E-mail messaging, EasyLink serves as a gateway to the Internet, CompuServe,

MCI Mail, SprintMail, Novell MHS, and cc:Mail. So the EO 440 Personal Communicator clears up the clutter by replacing a cellular phone, portable fax, pocket organizer, and—in some respects—a notebook computer.

The Personal Communicator also can be expanded and added in a variety of ways. It has a serial port for connection to a PC, a PC-A7 parallel port for printers or external disk drives, a keyboard port, an RJ-11 phone jack, a power-adaptor jack, a port for a cellular communications module, a PCMCIA Type II slot, and a slot for a JEDEC standard DRAM card.

The personal-organizer functions operate much like those of the Newton. "Associative Linking" is the EO's equivalent of Newton Intelligence, making associations between references in various applications and the names and numbers found in the address book—EO's information central. And, while it's handy to be able to enter "Meeting with Fred" on the appointment schedule and have the device remind you of Fred's full name and address, Associative Linking really comes into its own when it comes to communications.

Documents to be mailed or faxed, or to be received, are stored in the EO 440's In



**Box and Out Box**, respectively. Tapping on the In or Out Box icons lets the user see what's there, and sending a document requires just another couple of taps, and maybe some handwritten instructions. If, for instance, you're on the road when something comes up at the home office that requires your immediate attention, the EO 440 would allow you to receive the document by fax, mark any necessary changes, add a quick note, and send it back—all in a matter of minutes, whether you're in a cab on the way to the airport, at a convention, or visiting a client.

All of its capabilities take their collective toll in terms of battery life. The EO's rechargeable batteries supply only up to four hours use. That time is significantly reduced if the cellular option is used. An optional nickel metal-hydrate extended-life battery increases battery life up to seven hours.

### WHO NEEDS THEM?

Obviously, even these first-generation PDA's and Personal Communicators have impressive capabilities, but just where do they fit in the scheme of things? Who can benefit from using a PDA or a Personal Communicator?

The answer is clear for Personal Communicators. Almost three-quarters of all business professionals spend at least 20% of their working time away from the office. Those people are fueling the growing demand for cellular phones, portable fax machines, electronic organizers—all the devices that are consolidated in one EO 440. The device fits easily in a briefcase and weighs just over two pounds (the cellular option adds another pound), so it's easy to bring along almost anywhere. AT&T also expects customers in niche industries to configure the Personal Communicators for specialized purposes, such as sales automation.

The EO 440 might not change the way people do business, but it can certainly make business as usual a heck of a lot easier. In the long term, AT&T hopes to bring the Personal Communicator to the consumer market as well. The major obstacle at this point is price. Starting at \$2000 (without the modem) and ranging up to \$4000 (with 8-MB RAM, an internal modem, a 20-MB hard drive, and a cellular phone module), the EO 440 has quite a way to go before it can be within reach of consumers.

Newton and the Zoomer are closer to an acceptable consumer price point, each retailing at about \$700 at introduction. That's still way too high for most consumers, of course, but new product categories have to start somewhere. As sales increase, prices are sure to come down.

A more pressing question is whether the  
(Continued on page 92)

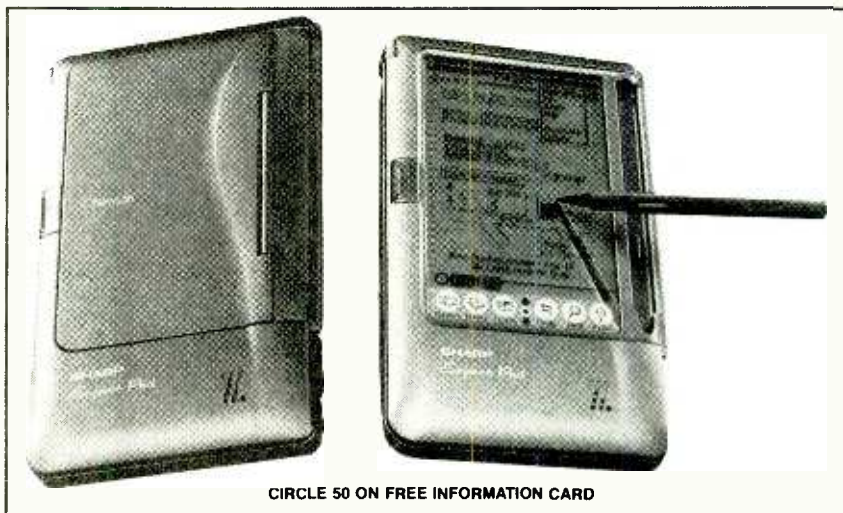

CIRCLE 50 ON FREE INFORMATION CARD

## Here's Newton!

**SHARP PI-7000 EXPERT PAD. Manufactured by Sharp Electronics Corporation, Sharp Plaza, Mahwah, NJ 07430-2135. Price: \$899.**

What, you might ask, is Newton?

Newton is digital. Newton is personal. Newton is as powerful as a computer. Newton is as simple as a piece of paper. Newton is a new kind of technology. Newton will help you communicate. Newton can send messages to another Newton through thin air. Newton will help you get organized. Newton can help you make phone calls. Newton learns about you to help you more. Newton will be everywhere tomorrow.

Well, all of that is what Apple Computer Inc. says in its advertisements about its Newton technology. Taken at face value, those ads are not misleading, but they raised our expectations too high. The first Newtons, although impressive, don't live up to their advance billings.

What is Newton really? Newton is not a product, *per se*. Newton is a technology developed by Apple Computer. The Newton product that we review here is built by Sharp Electronics Corp., and is called the Expert Pad Model PI-7000. Apple's product, called the MessagePad, is also built by Sharp. The two products are identical electronically, but are packaged slightly differently. Apple's MessagePad has a slip-off case, while Sharp's Expert Pad has an integrated, hinged cover.

The Expert Pad, when closed, measures about 4.4 x 7.2 x 1.1 inches and weighs just under one pound when the batteries are installed. Although it fits in the breast pocket of a suit jacket, we wouldn't want to carry it there all day. It runs on four "AAA" batteries, either alkaline or rechargeable nickel-cadmium. A lithium

battery also provides a memory backup. A mechanical interlock system makes it difficult for the main and backup batteries to be removed at the same time, thus ensuring that the data will not be accidentally deleted.

In normal use, all input to the Expert Pad is through a touch-sensitive screen. A latched protective cover, hinged on the right side, swings open to reveal the LCD. A double hinge allows the cover to swing fully around so that it lies flat along the back of the device. The inside surface of the cover has a convenient guide to some of the gestures that are used for input.

Along the right side of the screen is a storage place for the stylus. Strictly speaking, the stylus isn't necessary; a fingernail, chop stick, or any hard object that won't scratch the display can be used. Along the bottom edge of the screen are seven touch-sensitive icons that make up the Expert Pad's permanent menu.

The seven menu icons are: Rolodex cards for the Name File, a calendar for the Date Book, a bin for the Extras Drawer, a set of arrows for scrolling or obtaining an overview of the chosen function, a counter-clockwise helix for the Undo function, a magnifying glass for the Find function, and a light bulb for Newton's Assistant function. A Notebook for keeping free-form notes is always open, although it can be covered by other applications.

The Preferences menu, which is accessed through the Extras Drawer, permits the user to configure the Expert Pad in a number of ways. That's where we entered our name, address, and phone and fax numbers, and where we set our password to protect our data from prying eyes. That's also where we set the time and date, and set the country so that our keyboard and paper size would be appropriate. (Different keyboards provide accent marks and other symbols not used in English.) The most important options in the Preferences



menu, however, are those used for setting the handwriting recognizers and for practicing handwriting.

One of the claims made about Newton devices is that they learn about their users. In many ways, that's true. The most important thing for a new user to do is to try to teach the Expert Pad something about himself—starting with his handwriting.

The handwriting recognition of Newton Technology is the most advanced currently available on any PDA, but it is also the most frustrating. It can accept both cursive and printed text, or—as most of us write—a combination of the two. We normally write a capital "A" as a block letter. We write other letters differently depending on whether or not they are at the beginning of a word, or depending on the character that precedes or follows them. For example, in the word "roar," the first "r" would look like a lower-case block-printed letter, while the final "r" would look like a typical script lower-case letter.

A Letter Styles function allows the user to teach the Newton Intelligence how he writes. For each letter of the alphabet, the Expert Pad shows a variety of possible shapes for each letter. It also shows the strokes that are used to write them. The user can then select "sometimes" or "rarely" for each variation. If, for instance, you never write a "z" with a line through it, you would tap on "rarely."

Training is a two-way street: The Expert Pad also teaches the user through its Handwriting Practice function, in which it displays words from its dictionary and asks the user to write them. After the word is written, the Expert Pad displays a list of up to three words that it considered as possibilities, along with a confidence percentage. For example, after we wrote "wear," the Expert pad was 91% confident that we had written "wear," but gave "wears" a 66% chance, and "win" a 65% chance. Other words that came up as we repeatedly wrote the word included "wool," "we or," "ulcer," and "meal."

The Newton handwriting-recognition system often came up with words that we thought looked nothing like what we wrote—even if we searched for some resemblance. The reason it does that, however, is both a benefit and a hindrance.

For fastest operation, Newton uses word recognition, not character recognition (although it is possible to set the Expert Pad to recognize characters as well). The Expert Pad looks not only at the shape of the letters, but at the way in which the strokes are made, and how the letters are linked to form a word. Rather than translating single letters, Newton examines full words, matching them to the words that appear in its dictionary. Words can easily be added to the recognition dictionary, so that Newton can learn to recognize the proper

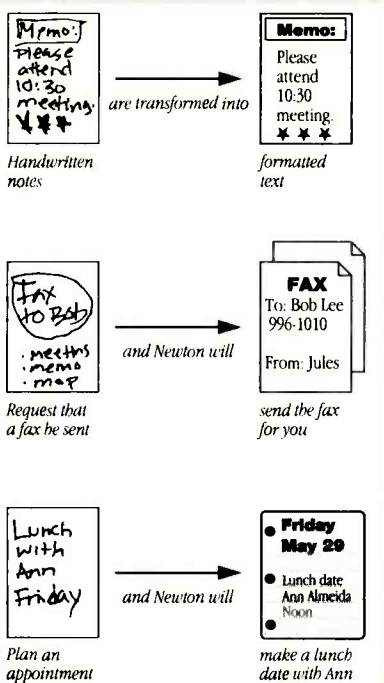

**Newton Intelligence allows the Expert Pad to understand enough about what you're doing to actually help you.**

names in your Address Book, for instance.

Newton's word recognition is fast, but the device cannot convert previously written notes to text at a later time.

Correcting wrongly recognized words is sometimes simple. For example, we wrote the phrase "The Sharp Expert Pad," which was translated, "the sharp Expert Pact." Tapping on each word brought up a list of possible alternates. In each case, the list contained the correct word, and all that was required to fix things was to tap on it. It took maybe three seconds to get the correct text.

At other times, however, correcting the Expert Pad was an exercise in frustration. For example, we wrote the sentence, "Sue wore a red dress," which was translated to "Sue wire auditing." Fixing "wire" was a simple matter of two taps with the stylus—one to call up the word list, and another to select "wore" from it. Alternately, we could have just written over the "i," changing it to "o." To fix "auditing" we had to tap the keyboard icon at the bottom of the word list to call up a small on-screen keyboard on which we could type in the correct three-word phrase.

We concluded that the handwriting recognition of Newton Intelligence is, indeed, impressive technology, especially considering all the necessary processing horsepower that is crammed into the small, battery-powered device. But it is not a practical way to enter a lot of data, or to take quick notes. (We often have trouble reading our own scrawled notes—reading the Expert Pad's interpretation of such

scribble would be next to impossible. Of course, we could just leave our handwritten notes in "digital ink," but writing on an LCD with a stylus makes our writing even harder to read, and the screen's resolution makes reading difficult.

Most people, however, don't need to jot-down large amounts of information as we would during an interview or at a press conference. Most day planners are full of short notes: Meet Joe at his office 10 AM; Sarah's birthday; Financial report due; etc. With short entries, where correcting incorrectly recognized words isn't too frustrating, Newton excels, and Newton gets better at identifying words as you add frequently used words to its dictionary. (Every time you "type" in a new word that isn't in its dictionary, the device asks if you want to enter it.) There's a down-side to that: The more words in the dictionary, the slower the handwriting recognition.

Because the Notepad is always open, it's a convenient place to jot down random pieces of information. To start a new note, all that's required is to draw a horizontal line across the screen. The line is transformed into a bold, straight line that contains a date-and-time stamp, and a kind of command menu. Tapping on the file-folder icon permits the note to be filed in a category (which can be user-defined), while tapping the envelope icon permits the file to be output to another device such as a printer or fax, or "beamed" via an infrared signal to another Expert Pad. The Notepad can display all notes, or just those in a chosen category. If you don't remember what category a note is filed in, just tap the Find icon, and the Expert Pad will search through all notes for any occurrence of the word you want to find. (It can also search across all applications, if desired.)

The other main applications of the Expert Pad are its Name File and the Date Book. The Name File can store such information as names, addresses, company names, E-mail addresses, four phone numbers per entry, and birthdays. The information can be displayed as a business card, or as a card with attached handwritten (or translated-to-text) notes.

The Date Book contains an appointment calendar and a to-do list. A small monthly calendar always appears on the top of the date book. Tapping any date on the calendar calls up the appointment list or to-do list for that day. Tapping and dragging permits multiple days to be called up. For example, you could look at a week's schedule, or appointments for all Mondays in the month.

What makes the Expert Pad different from any other organizer? It's the Newton Intelligent Assistant, which adds some human-like smarts to the Expert Pad. For example, if we were to write, "Fax Carl"



and then tap the Assist icon, the Expert Pad would be smart enough to go through our address book and find Carl and his fax number. If there were more than one Carl in the book, Newton would ask us which one we meant.

Writing "Meet John and Marc 2/21" would launch the Date Book to February 21, and place the text there. We could move the appointment to the right time (since we hadn't input it previously) and set an alarm to remind us.

Other key words that the Assistant recognizes include "call," for dialing, "remember" for the to-do list, and "time" for finding the correct time in different time zones. Newton also recognizes "breakfast," "brunch," "lunch," and "dinner." If you jot down "Lunch Susan Monday," the Expert Pad would assume you meant to meet her at noon on this coming Monday. Had you specified breakfast, brunch, or dinner, it would have assumed 7 AM, 10 AM, or 7 PM, respectively. It would ask if that's correct, and then store the information in the Date Book.

Along with its personal-information management functions, the Expert Pad also features a built-in calculator, and form calculators for metric conversions, currency exchange, loan payments, and interest.

We wish that we had been able to put the Expert Pad through its paces sending faxes and E-mail and printing. Unfortunately, we couldn't. We did not receive the required printer cable from Sharp, and the Expert Pad does not support standard PCMCIA fax modems.

The Expert Pad's handwriting recognition was impressive—but not good enough. We often were so frustrated at what Newton said we wrote that we "scrubbed" out what we had written and started over again, and again, and again. Scrubbing out was a novelty, though. Running the stylus in a zig-zag through the offending word or sentence reduces the text to a cloud of dust, which disappears with a little "puff" sound. Deleting entire entries is even better—the "paper" crumbles into a ball and flies into a garbage can. If we had been using pen and paper during our handwriting recognition tests, our garbage pail would have been overflowing.

And that about sums up the first-generation Newton. It's neat—and it's frustrating. ■

## Zooming Along

**Z-PDA ZOOMER PERSONAL DIGITAL ASSISTANT.** Manufactured by Tandy Corporation, 1800 One Tandy Center, Fort Worth, TX 76102. Price: \$699.

The Tandy Zoomer Z-PDA doesn't try to knock people out with new technology.

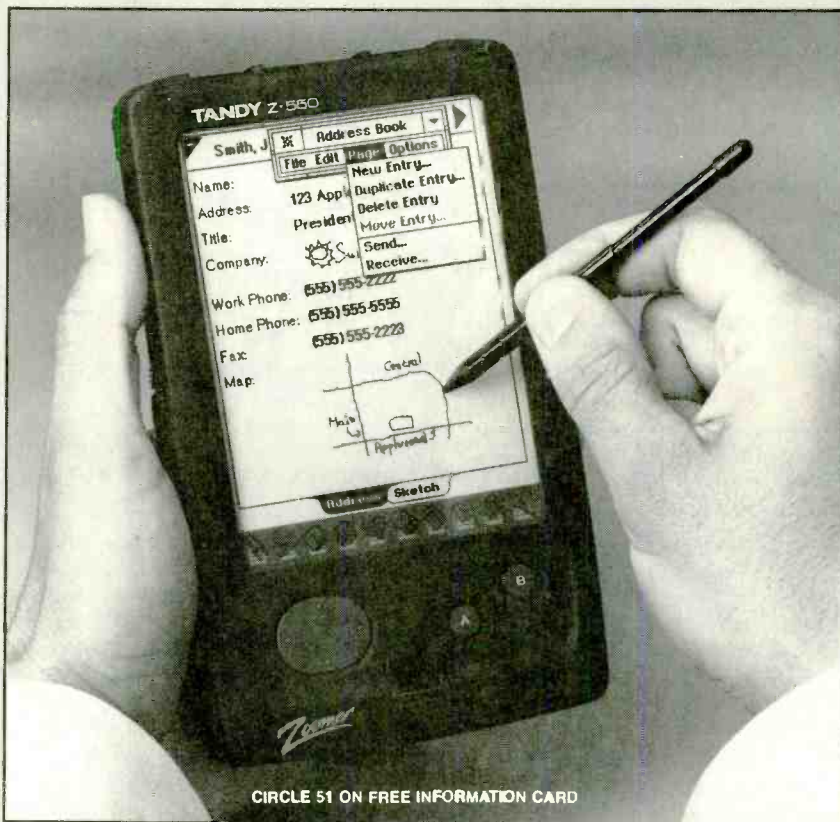

Instead, it packs a one-two punch with extraordinary battery life and a host of practical features.

Tandy chose an 8-bit processor, custom-designed by Casio, to power the Zoomer. The advantage to using such a relatively low-power CPU is that the device can run for about 100 hours on a set of three "AA" batteries. The trade-off is that the Z-PDA is not as fast as it could be, and it can't perform such high-tech wizardry as recognizing cursive handwriting.

Tandy figured that long battery life—and easily replaceable batteries—were essential for what it hopes will be a mass-market device. We were impressed when a Radio Shack spokesman told us that the product was designed so that if a user received a low-battery warning while boarding a plane in New York for Los Angeles, he could use the Zoomer during the whole flight, and not worry about buying a new set of batteries until he reached the West Coast.

Even if we'd had the opportunity to do some traveling during the product-review period, we wouldn't have been able to test that out. In dozens of hours of testing, we never got a low-battery warning!

Had we had cause to replace the AA's, however, the Zoomer's two lithium button cells would have backed-up our data during the switch. Those last for approximately five years, and Tandy recommends putting a reminder to replace them in the Z-PDA's date book, five years after the date of purchase.

The date book is just one of the "host of practical features" mentioned above. The Zoomer also provides an address/phone book, a notebook/sketch pad, Pocket Quicken financial-tracking software, a world clock, a calculator, a forms calculator, a pop-up user-configurable keyboard, pop-up help screens, access to America Online (with an optional modem and a monthly subscription fee), a dictionary, a thesaurus, a spell checker, a language translator, three games, and a reference section. All of that is packaged in a charcoal-colored case that measures about 7 × 4¼ × 1 inches and weighs under a pound. The double-hinged front cover flips up and over the top, folding flat along the back of the unit to reveal the LCD. Ten icons arrayed below the LCD each represent one or more of the Z-PDA's functions.

Although using the Z-PDA is purported to be an "intuitive" process, first-time users will be glad that Tandy included a video introduction to Zoomer's many features. Otherwise, they'd be forced to go directly to the rather hefty, 145-page user's manual—which might bring up unpleasant associations with computer/software manuals. Because the video merely touches on each application, it is necessary to refer to the manual frequently in the beginning, and on occasion later on. We would have liked to see an abbreviated "quick-start" manual along with (or instead of) the video. We find it much easier to flip through a short booklet than to search a video tape for a particular subject.



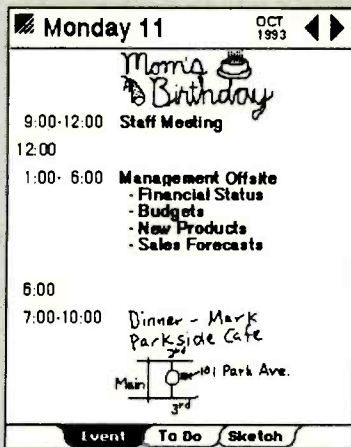

Standard text, PowerInk, and drawings can be mixed in most of the Zoomer's applications.

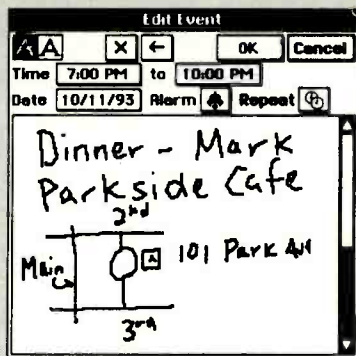

As soon as we felt confident in our ability to input information, we tried out some of the other applications. Applications are opened by tapping on the appropriate icon. Opening one application automatically closes the previous one. When you return to an application, you return to the precise spot at which you left it.

The Address Book resembles a standard paper version, with fields for name, address, and work, home, and fax phone numbers. However, you can customize your address book by adding, deleting, or changing those fields. Zoomer provides a list of 16 standard choices (including zip code, country, company, title, E-mail, other phone), and four custom fields. Those might be used to note birthdays, anniversaries, spouse's and children's names, or any other useful information. The Address Book includes a sketch pad, which allows you to attach a drawing to any entry. It's also possible to create a second Address Book, so that you can keep your business and personal contacts separate.

You can also work with separate business and personal Date Books. Zoomer's Date Book application offers several calendar views and scheduling/reminder functions—so many, in fact, that it takes some time to learn to navigate through the various calendar views to easily find the one you want.

You can look at daily, weekly, monthly, and six-month calendars; tapping with the stylus will call up a specific date, week, or month. A tap on the right and left arrows at the top right corner moves you forward or backward through the calendar that you're viewing. Tapping the Tool Box icon allows you to write directly on the calendar. Scheduling events is done using the daily view. Sketches can be attached so that, for example, you can draw a map to help you get to a scheduled meeting. It's possible to schedule recurring events—weekly meetings, birthdays, and the like. An alarm can be set to remind you of appointments.

Zoomer's To Do list is also accessed through the Date Book's daily view. Each task can be assigned a priority level, and can be checked off when completed. Don't put off 'til tomorrow . . . Zoomer will simply move the task reminder up to the next day until it's checked off.

Text documents that you've created can be faxed or sent via E-mail, if you connect your Z-PDA to a modem. We connected ours to a Zoom pocket fax/modem. A special adapter cable was required because the Zoomer doesn't have a standard serial connector. Because of the built-in support for America Online, accessing the service—which provides news, travel, stocks, and product support "departments"—was easy.

Perhaps the most sensible built-in ap-

The first thing we wanted to try out, of course, was the Z-PDA's handwriting recognition. We popped the stylus out of its well on the Zoomer's bottom panel and pulled it open to its full 4-inch length. Although the storage well is a handy place to keep it, the stylus itself is somewhat uncomfortable to use—it's like writing with a pencil stub. You can substitute any blunt pen-like instrument—a pen with a plastic cap or a wooden chopstick, for instance—and a certificate for a free, full-size stylus comes with the Zoomer.

From the videotape, we had learned that the stylus was used for a few things other than writing. Tapping on an icon, menu, or command activates that function, and tapping on the screen moves the cursor to that location. Dragging—holding the pen down and dragging it across handwritten or computer text—"selects" that text so that it can be edited, copied, or moved. The pen can also be dragged across the menu bar or icons to move them around the screen. Finally, the pen is used for making editing gestures. A backward "L" gesture acts like a carriage return, adding a line. A "pigtail" gesture (a vertical line with a loop in it), familiar to editors and proofreaders, is used to delete text.

To practice using the stylus and writing on an LCD, we tapped on the pad-and-pencil icon to bring up the Note Book. The techniques that we practiced can be used in any of the applications, however.

The Note Book consists of a table of contents page and blank pages on which to write or draw. A title bar at the top of each page can be used to label a new entry. Similar subjects can be grouped together in the table of contents, and tapping on a title in the table of contents recalls that entry. Just below the title bar is a row of "tool" icons: on-screen buttons labeled with a handwritten "A" for using PowerInk (handwriting that is not translated to text); a typed "A" for handwriting recognition; an "X" to erase the whole page; a backspace arrow to erase the pre-

vious character; and a briefcase full of sketch tools.

At first, we tapped on the handwritten "A" to use PowerInk. With PowerInk, we could write or draw, or both, using cursive writing if we chose. Our writing would be stored exactly as it appeared on the screen, and would not be transcribed to text. For many applications, PowerInk is sufficient. After all, there's no need to translate "Pick up milk and bread" into printed text. Even in the address book, you can use PowerInk. Zoomer asks you to verify the first letter of each person's name, so that the entry can be filed alphabetically.

Feeling like kids on the first day of school, with brand new notebooks and freshly sharpened pencils, we began to write. Using PowerInk is a breeze, and it was fun to write and doodle on an LCD. When we tapped on the handwriting-recognition tool, however, that first-day-of-school anticipation quickly turned into the nightmare of a surprise quiz—given in a foreign language. Our first attempts were translated into complete gibberish, combinations of letters, numbers, and punctuation marks that made us wonder if the Zoomer was cursing at us. In fact, the first few sessions had us cursing right back. Zoomer's handwriting-recognition definitely takes some getting used to!

We're happy to report, however, that the situation improved with time and experience. The manual provides some pointers on writing in a manner that the Z-PDA can interpret. We picked up other helpful hints through trial-and-error. Practice didn't make perfect, but we have gotten to the point that Zoomer can understand about 85% of what we write, and we are now very proficient at making quick corrections, using either gestures or the pop-up keyboard. In fact, it was sometimes convenient to keep the keyboard on-screen to supplement our writing, using it to fill-in where Zoomer's handwriting recognition most often failed: with punctuation, spaces, and lines.



## THE PDA FACEOFF

So which is better, the Zoomer or the Newton? Even though the two products are clearly after the same market, there is no clear winner. The two products are significantly different, and each excels in some areas. The table at the right shows our opinion of where one unit is better than the other, and where there is no significant difference.

The Newton has a more powerful processor than the Zoomer, so it is faster and it should, in the future, have more powerful applications. The downside of its high power is that battery life is significantly reduced as compared to the Zoomer. Sharp claims that battery life should be about 35 hours after the unit is trained (which drains the battery faster than other applications). Because we spent most of our time training the device, we were not able to obtain anywhere near that much battery life. The batteries in the Zoomer are still going strong.

Both devices offer adequate personal organizer functions, neither significantly better than the other. However, the Newton is "smarter" when it comes to using the information contained in its organizer database. The Newton is also far smarter when it comes to recognizing handwriting, but still not smart enough. The errors made by Newton were more frustrating and usually more difficult to correct than those of the Zoomer. That's because Zoomer recognizes (and mistakes) single letters,

Categories	Newton	Zoomer	Tie
Power/Speed	*		
Battery Life		*	
Personal Organizer Functions			*
"Intelligence" (Associate Data Linking)	*		
Handwriting Recognition	*		
LCD			*
Price			*
Portability			*
Built-in Applications		*	
Announced Third-Party Applications	*		
Communications Capabilities		*	

while Newton works on full words, allowing for bigger goof-ups.

Both units need a better display with higher resolution and back-lighting. We realize that's incompatible with the low prices and long battery life required of a PDA, but hope that subsequent generations of PDA's come up with a solution.

There is virtually no difference between the street price and the portability of the Zoomer and Newton. We found ourselves using the Zoomer more because it had more built-in applications. We are somewhat addicted to playing solitaire, and are big fans of Pocket Quicken. But there are more potentially impressive applications being

developed for the Newton, including a Fodor's travel guide to major cities and a Dell Crossword Puzzle application. No third-party applications have been announced for the Zoomer as we go to print.

Neither device has sufficient communications capabilities—wireless communications are required for full PDA functionality. We give the Zoomer the edge because it has a built-in RS-232 port which can be used to hook up to a modem. Because we didn't receive a special modem card for the Newton, and because we don't have any RS-422 devices, we were unable to use its communications features.

application that Zoomer provides is Pocket Quicken from Intuit, which allows you to keep track of your day-to-day expenses. Although we are big fans of Quicken's desktop version (which was reviewed in the November, 1993 issue), we often find ourselves losing track of expenditures over a long weekend, when traveling, or whenever we're away from our PC's for a few days. Pocket Quicken remedies that problem by going where our PC can't.

Pocket Quicken uses three basic images: a wallet icon for recording expenses; a bank icon for deposits, withdrawals, and transfers; and a file-cabinet icon for saving and categorizing your records. Those categories are represented by other icons: a knife and fork for dining, a car for transportation, a shopping cart for groceries, and the like. There are different expense categories under the headings business, personal, home, auto, and other.

Pocket Quicken provides instant access to account data for each of your accounts. You can set it up to handle one or several accounts under the general headings cash, credit, and bank. A separate connectivity pack—not available at the time of our review—will allow users to merge their on-



**Pocket Quicken, which lets you keep tabs on all your financial transactions, is one of the most practical applications built into the Z-PDA.**

the-road data with their desktop Quicken data.

The rest of the Z-PDA's built-in applica-

tions are not quite as practical. They range from convenient to just plain silly. Let's take a look at them, in that order.

It's always handy to have a dictionary around. The Zoomer's contains 100,000 words for checking your spelling, 50,000 definitions, and a 660,000 synonyms. You can enter a word using handwriting recognition or with the pop-up keyboard. Two on-screen keys labeled FLASH and JUMBLE allow you to play games. Flash calls up words at random, and you can guess their meanings before you look up the correct answer. Or you can try to make as many words possible by scrambling the letters in that flash word and then hit the JUMBLE button to find out how many Zoomer came up with.

The forms calculator is used to perform currency conversions, financial calculations, and unit conversions. Financial calculations include loan-payment schedules, margins, balloon payments, and—particularly useful for those who often lunch with office pals—a "bill splitter." If you input the amount of the tab at a restaurant, the percentage you'd like to leave as a tip, and the number of people, Zoomer

(Continued on page 92)





CIRCLE 62 ON FREE INFORMATION CARD

## On the Go with EO

**AT&T EO PERSONAL COMMUNICATOR.** From: EO, Inc., 800A Middlefield Rd., Mountain View, CA 94043. Phone: 800-458-0880, 415-903-8100. Price: \$2000-\$4000 (\$3200 as configured here).

In its recent "you will" commercials, AT&T presumes that, among other things, people want to be able to send and receive faxes while at the beach. Well, that's the *last* thing we want—the sound of the surf and a good book are good enough for us.

We know from experience, however, that we would appreciate being able to send or receive a fax while on the way to the airport. Furthermore, we often wish that we had a more effective way to stay in touch with the office while we're on the road. The *EO 440 Personal Communicator* promises to do it all.

The EO 440 Personal Communicator is an impressive, one-of-a-kind device. It's not a laptop computer, and it's not truly a PDA, although it performs many similar functions. A note from EO's Vice President of Marketing that accompanied our review unit warned us not to compare it to a computer, saying that "you might just as well compare the EO 440 to a fax machine or a cellular telephone. Whereas the EO 440 contains elements of each of these systems, it is not designed to be an alternative to any *one* of them. The EO 440 is a new category of system that fills a needs

profile that cannot be filled by a notebook, a fax machine, a pocket information organizer, or a cellular phone."

The EO 440 measures about 10.8×7.1×0.9 inches, but two "ears" stick out from either side of the unit, adding about three inches to its width. The ears contain a microphone, a speaker, and connectors for a printer, keyboard, and a personal computer. The screen is a 7½ inch diagonal LCD, with a resolution of 110 dots per inch. (That's 640×480 pixels, which is standard VGA resolution.) It is recessed slightly to help prevent scratches.

The EO 440 is targeted at business professionals. It focuses on communications, combining voice, data, and fax capabilities with organizer functions and more. A total of nine productivity and communications applications are built-in.

The EO 440 runs on the PenPoint operating system, which was developed by GO Corporation. The operating system was built from the ground up specifically for pen input. The applications included with the EO 440 are: GO Mail—for sending and receiving E-mail. GO Fax—for sending and receiving faxes. EO Phone—for phone dialing voice calls. Personal Perspective—an appointment calendar, address book, and information manager. EO Sound—for voice notes to documents. MiniText—a simple on-based word processor. MniNote—for producing simple graphics and handwritten notes. EO Calc—a calculator. EO Lock—for password-protecting the EO 440. PenTOPS and PenCentral—for linking the Communicator to an IBM-standard PC.

PenPoint is based on a notebook metaphor—tables of contents and page-edge tabs allow users to navigate through the various applications. The pages listed in the table of contents represent documents. Documents can be organized into sections. The page tabs on the notebook provide easy access to the documents or sections; tapping a page number is another way to open an existing document. Several auxiliary notebooks and accessories are organized on a "bookshelf" below the notebook.

The notebook metaphor took a little getting used to, but it was reasonably easy to learn, and once we were familiar with it, the Personal Communicator was easy to use. The system was also easy to remember. We think that is important because we would assume that many potential users would require the Communicator only on out-of-town trips.

Our EO 440 was almost fully equipped with available options. It contained a 20 megabyte hard disk drive, a 8 megabytes of RAM, an extended-life (7-hour) battery pack, and an internal V.42, V.42bis, 14,400-bps data/9600-bps group 3 fax modem. We did not have the cellular-phone option, but we saw it demonstrated. We were able to hook the Communicator to a standard phone line.

With the cellular option, it would be possible to receive a fax while on the road (or on the beach), display it on the screen, annotate it with the pen, and send it on to someone else—perhaps to someone with an EO. The phone list and address book make it easy to send and receive faxes. However, fax isn't the only way to stay in touch. The EO comes with a subscription to AT&T Mail, which is the largest E-mail system in the U.S. and offers gateways to such systems as CompuServe, MCI Mail, and the Internet.

The EO can connect to more than just phone lines. It has a printer port (but with drivers only for HP LaserJet and Epson dot-matrix printers), and a serial port for connection to personal computers. A PS/2-compatible keyboard can also be connected—a great convenience when adding such data as names and addresses.

The EO's handwriting recognition is far from perfect. It recognizes only printed text. After we practiced a little, we found that it could achieve a recognition rate of about 90 percent. It is possible to customize the recognizer if you can't write a letter the way it wants you to. Recognition need not be done on the fly. Instead, you can translate the electronic ink to text at a later time.

One very nice feature of the EO is that the handwriting-recognition software contained in a removable module. As better recognition algorithms are developed

(Continued on page 9)



## Just like these Fully Trained Electronics Professionals



"Thanks to CIE I have tripled my previous salary, and I am now in a challenging and rewarding new field where only the sky is the limit."

Daniel Wade Reynolds  
Industrial Electrician  
Ore-Ida Foods



"CIE was recommended to me by my boss. It was appealing since I could study at my own pace at home and during business travel."

Dan Parks  
Marketing Manager/Consumer Products  
Analog Devices, Inc.



"I loved the flexibility CIE offered. It was the only way I could continue both school and my demanding job."

Britt A. Hanks  
Director of Engineering  
Petroleum Helicopters, Inc.



"I liked the way the school was set up with laboratory assignments to enforce conceptual learning. The thing which impressed me the most about CIE's curriculum is the way they show application for all the theory that is presented."

Daniel N. Parkman  
Missile Electro-Mechanical Technician  
U.S. Air Force



"Completing the course gave me the ability to efficiently troubleshoot modern microprocessor based audio and video systems and enjoy a sense of job security."

Tony Reynolds  
Service Manager/Technician  
Threshold Audio & Video

# Graduate with an Associate Degree from CIE!

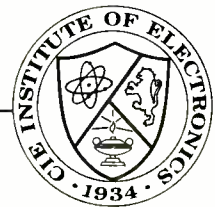

CIE is the best educational value you can receive if you want to learn about electronics, and earn a good income with that knowledge. CIE's reputation as the world leader in home study electronics is based solely on the success of our graduates. And we've earned our reputation with an unconditional commitment to provide our students with the very best electronics training.

Just ask any of the 150,000-plus graduates of the Cleveland Institute of Electronics who are working in high-paying positions with aerospace, computer, medical, automotive and communications firms throughout the world. They'll tell you success didn't come easy...but it did come...thanks to their CIE training. And today, a career in electronics offers more rewards than ever before.

### CIE'S COMMITTED TO BEING THE BEST...IN ONE AREA...ELECTRONICS.

CIE isn't another be-everything-to-everyone school. CIE teaches only one subject and we believe we're the best at what we do. Also, CIE is accredited by the National Home Study Council. And with more than 1,000 graduates each year, we're the largest home study school specializing exclusively in electronics. CIE has been training career-minded students for nearly sixty years and we're the best at our subject...  
**ELECTRONICS... IT'S THE ONLY SUBJECT WE TEACH!**

### CIE PROVIDES A LEARNING METHOD SO GOOD IT'S PATENTED.

CIE's AUTO-PRO-GRAMMED® lessons are a proven learning method for building valuable electronics

career skills. Each lesson is designed to take you step-by-step and principle-by-principle. And while all of CIE's lessons are designed for independent study, CIE's instructors are personally available to assist you with just a toll free call. The result is practical training... the kind of experience you can put to work in today's marketplace.

### LEARN BY DOING...WITH STATE-OF-THE-ART EQUIPMENT AND TRAINING.

CIE pioneered the first Electronics Laboratory

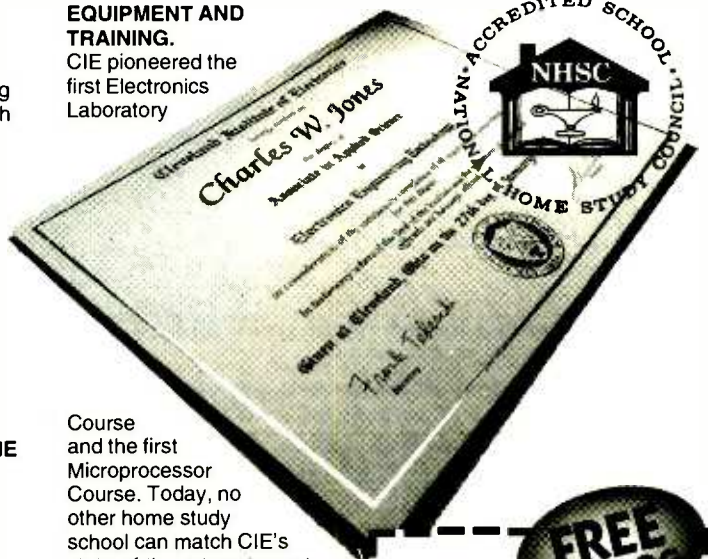

Course and the first Microprocessor Course. Today, no other home study school can match CIE's state-of-the-art equipment and training. And all your laboratory equipment, books and lessons are included in your tuition. It's all yours to use while you study and for on-the-job after you graduate.

### PERSONALIZED TRAINING...TO MATCH YOUR BACKGROUND.

While some of our students have a working knowledge of electronics others are just starting out. That's why CIE has developed twelve career courses and an A.A.S. Degree program to choose from. So, even if you're not sure which electronics career is best for you, CIE can get you started with core lessons applicable to all areas in

electronics. And every CIE Course earns credit towards the completion of your Associate in Applied Science Degree. So you can work toward your degree in stages or as fast as you wish. In fact, CIE is the only school that actually rewards you for fast study, which can save you money.



**YES!** I want to get started.

Send me my CIE course catalog including details about the Associate Degree Program. (For your convenience, CIE will have a representative contact you - there is no obligation.)

Please Print Clearly

**AH51**

Name \_\_\_\_\_

Address \_\_\_\_\_

City \_\_\_\_\_

State \_\_\_\_\_ Zip \_\_\_\_\_ Age \_\_\_\_\_

Phone No. \_\_\_\_\_

Check box for G.I. Bill Benefits.

Veteran

Active Duty

Cleveland Institute of Electronics, Inc.  
1776 East 17th Street  
Cleveland, OH 44114

A School of Thousands.  
A Class of One. Since 1934.

Send for CIE's FREE Course Catalog and See How We Can Help Your Career Too!

# An Electrical-System Analyzer for your car

In these times of rising costs and diminishing *real* income, every driver knows how very costly vehicle maintenance can be, even for relatively minor repairs. For most problems, a driver has no alternative but to take the vehicle to a service technician. Sooner or later all vehicles require repairs to the battery and charging system, and if the problem is not diagnosed properly, you could spend a fortune replacing perfectly good parts. But there is one area—the vehicle's battery and starting and charging systems—that can be monitored and diagnosed for possible problems using a simple electronic circuit.

Although modern automotive batteries and their charging systems can be somewhat complex, diagnosing them is relatively simple. And diagnosing electrical-system problems is just what the *Automotive Electrical Diagnostic System* described in this article is designed to do.

**Some Background.** The Automotive Electrical Diagnostic System monitors the battery's terminal voltage to determine the condition of the vehicle's electrical system under various operating conditions—including standing idle prior to starting, cranking, idling, and running with various electrical accessories in operation. It keeps tabs on your vehicle's battery, alternator, regulator, and cranking voltage through a set of 5 LED's.

Under normal conditions, a green LED lights and remains lit as long as the battery voltage is normal prior to starting the engine. The other 4 LED's light only when a malfunction occurs. The circuit is powered from the vehicle's electrical system, so it does not require a separate power source. It can be permanently installed in the vehicle (to continuously monitor electrical system status) or assembled as a portable unit and connected to any vehicle with a 12-volt electrical system.

All vehicles that use a 12.6-volt lead-acid battery as the power source will fall within certain voltage constraints as the vehicle is operated. For example, a battery in good condition will

faults when any of the voltages levels falls outside of the acceptable limits.

**Circuit Operation.** At the heart of the Automotive Electrical Diagnostic System (see Fig. 1) is the Maxim MAX8214ACPE five-stage voltage comparator, U1, which also contains a built-in 1.25-volt precision reference. The chip also has an on-board logic circuit that allows the outputs of two of the comparators to be inverted by tying the mode-select input (ms, at pin 15) high (more on that later).

In the Automotive Electrical Diagnostic System, the non-inverting inputs of all of the comparators are tied to U2's internal 1.25-volt reference, while the ms input is tied high, causing the outputs of comparators U1-a and U1-b to be inverted. When any comparator output is driven low, its associated LED lights.

Resistors R1–R6 form a voltage-divider network that provides specific voltage levels at five junctions, each of which feeds the positive input of one of U1's five comparators; thus each comparator receives a known percentage of the input (battery) voltage. Since each of the five comparator circuits are similar, an explanation of one such circuit will cover all. Take U1-e (the NOT CHARGING MONITOR), for example.

When the engine is at rest, the battery voltage is 12.8 volts or more, so the voltage at the R3/R4 junction exceeds the 1.25-volt reference, causing the output of U1-e to go high, holding LED3 off and indicating that the charging system is delivering current into the battery at engine idle. Even if the battery voltage rises above 12.8 volts (which is normal during engine operation), the output of U1-e at pin 10 remains high, keeping LED3 off. But should the charging system fail, battery's terminal voltage will dip below 12.8 volts, causing LED3 to light, alerting the driver to the condition.

Comparators U1-c and U1-d operate in a similar manner, lighting their LED's if the battery voltage falls below 9.0 and 13.4 volts, respectively, indicating WEAK BATTERY (insufficient cranking voltage) or INSUFFICIENT CHARGING (defective alternator operation).

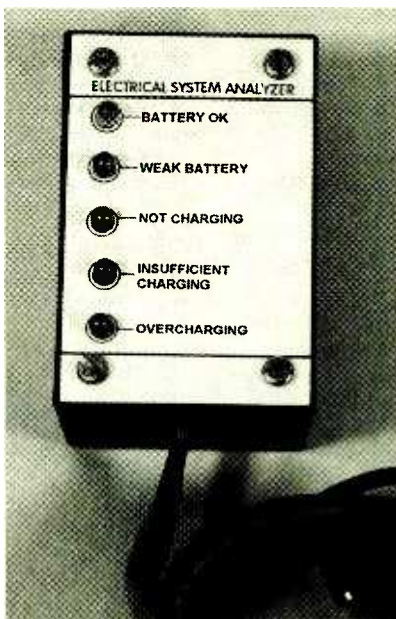

*Build an electrical system monitor that can alert you to any one of several problems so that you can avoid the inconvenience and expense of a road-service call.*

BY ANTHONY J. CARISTI

have a terminal voltage of about 12.6 volts when the engine has not been in operation for some time. During cranking, battery voltage should not fall below 9 volts.

When the engine is operating, the voltage regulator should hold the terminal voltage between 13.5 and 15.0 volts. When all accessories are on, the alternator should be able to maintain at least 13.5 volts across the battery at about 1500 or 2000 engine RPM. Table 1 illustrates normal battery-terminal voltages under various operating conditions and specifies possible



**TABLE 1—AUTOMOTIVE ELECTRICAL FAULTS**

Condition	Normal Voltage	Possible Fault
Vehicle at rest	12.6 volts	<12.4 volts: bad cell or severely undercharged battery
Cranking	>9 volts	<9 volts: Weak battery
Idling	>12.8 volts	<12.8 volts: Not charging; bad alternator or wiring
Running minimum load	>13.4 volts	<13.4 volts: defective alternator or voltage regulator
Running minimum load	<15.2 volts	>15.2 volts: Overcharging; defective regulator
Running maximum load	>13.4 volts	<13.4 volts: alternator defective or belt slipping

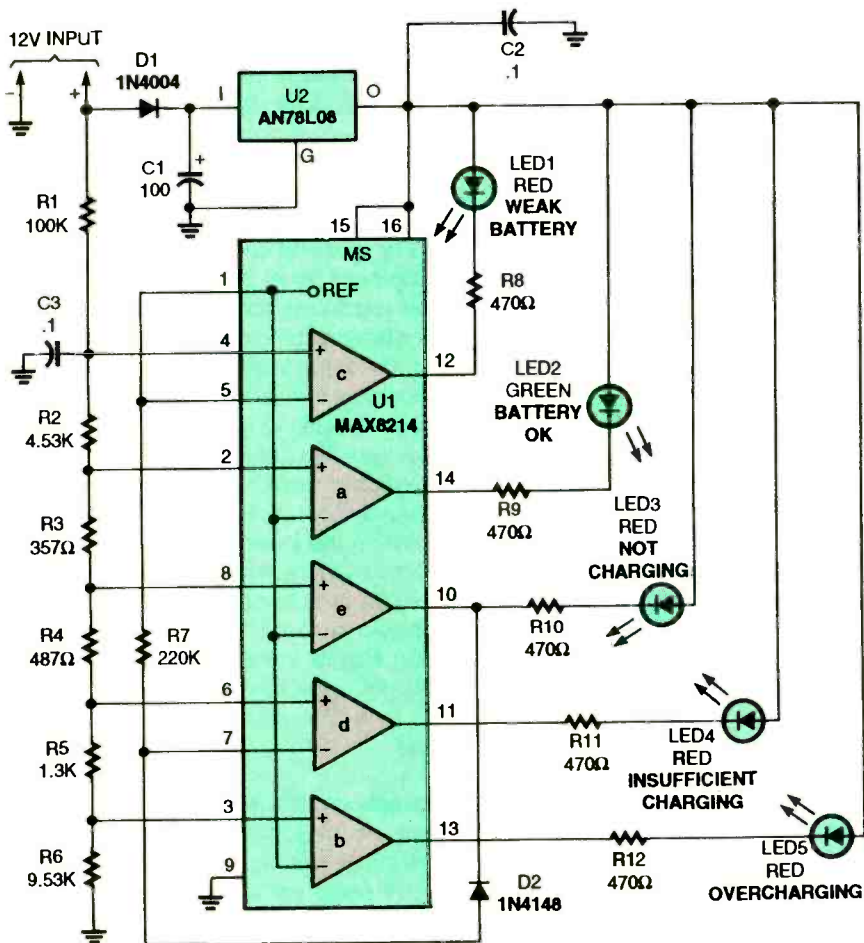

Fig. 1. The Automotive Electrical Diagnostic System is built around a Maxim MAX8214ACPE five-stage voltage comparator, which contains a built-in 1.25-volt precision reference, and on-board logic that allows the outputs of two of the comparators to be inverted.

Comparators U1-a and U1-b have to sense voltage levels higher than 12.4 and 15.2 volts, respectively to light their LED's. To accomplish that, the mode-select input of U1 is connected to  $V_{CC}$ , thereby inverting the outputs of those two comparators, and causing their respective LED's to light when the battery voltage rises above 12.8 volts prior to starting (a normal condition), and above 15.2 volts (OVERCHARGING).

In order to prevent ambiguity between a NOT CHARGING and INSUFFICIENT CHARGING situation, which would cause two normally off LED's to simultaneously light, R7 and D2 are placed into the circuit. A low output from U1-e (NOT CHARGING) pulls down the reference input of U1-d (INSUFFICIENT CHARGING) to prevent LED4 from lighting. Thus, when the vehicle charging system is not working at all, LED3 (NOT CHARGING)

will light and LED4 (INSUFFICIENT CHARGING) will not.

Integrated circuit U2, a fixed 8-volt voltage regulator, maintains a constant supply voltage for U1. Diode D1 has been placed in the circuit to prevent component damage in case the lead polarity is accidentally reversed when connecting the Automotive Electrical Diagnostic System to the vehicle's electrical system.

**Construction.** Although circuit wiring is not critical, and could have been done on perfboard, the author's prototype was assembled on a small printed-circuit board measuring about 2 by 2½ inches. A template of that printed-circuit pattern is shown in Fig. 2. A printed-circuit board is available from the source specified in the Parts List.

A parts-placement diagram for the printed-circuit board is shown in Fig. 3. Regardless of which method of construction you choose, it is strongly recommended that you use a socket for U1. That makes testing and troubleshooting the circuit easier should it ever be necessary.

When installing the parts, be very careful to properly orient the polarized components. Just one component inadvertently installed backwards will prevent the circuit from operating and may cause damage to itself and/or other components. So, as always, double-check the position of the parts before soldering them in place.

When connecting the LED's to the circuit board, use flexible insulated

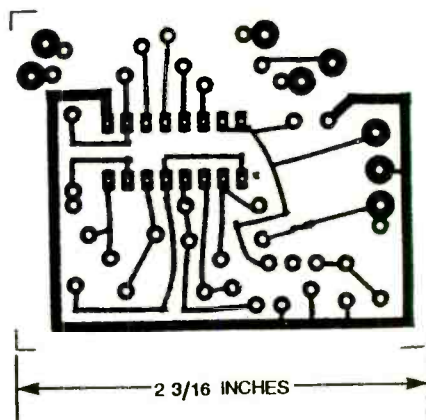

Fig. 2. The project was assembled on a small printed-circuit board measuring about 2 by 2½ inches. A printed-circuit board is available from the source specified in the Parts List.

## PARTS LIST FOR THE AUTOMOTIVE ELECTRICAL DIAGNOSTIC SYSTEM

### SEMICONDUCTORS

U1—MAX8214ACPE voltage-comparator, integrated circuit (Maxim)  
 U2—AN7810L 8-volt, 100-mA voltage regulator, integrated circuit  
 D1—1N4004 1-amp 400-PIV silicon rectifier diode  
 D2—1N4148 general-purpose silicon diode  
 LED1, LED3—LED5—Red light-emitting diode  
 LED2—Green light-emitting diode

### RESISTORS

(All resistors are 1/4-watt, 1%, metal-film units, unless otherwise noted.)  
 R1—100,000-ohm  
 R2—4530-ohm  
 R3—357-ohm  
 R4—487-ohm  
 R5—1300-ohm  
 R6—9530-ohm

R7—220,000-ohm, 1/4-watt, 5%, carbon  
 R8—R12—470-ohm, 1/4-watt, 5%, carbon

### CAPACITORS

C1—100- $\mu$ F, 25-WVDC, radial-lead electrolytic  
 C2, C3—0.1- $\mu$ F, ceramic-disc

### ADDITIONAL PARTS AND MATERIALS

Printed-circuit materials, IC socket, enclosure, test leads, alligator clips, solder, hardware, etc.

**Note:** The following parts are available from A. Caristi, 69 White Pond Road, Waldwick, N.J. 07463: printed-circuit board, \$11.95; a set of 6 metal-film resistors, \$4.50; U1, 12.50; U2, \$2.50. Please add \$3.00 postage/handling. New Jersey residents please add appropriate sales tax.

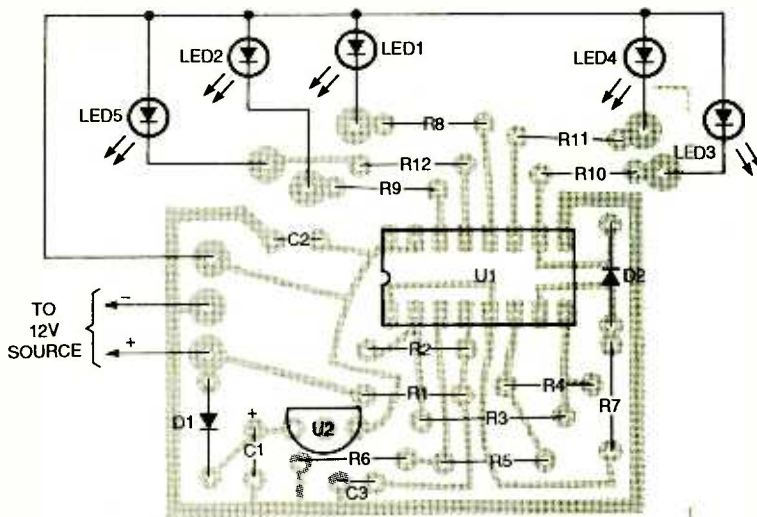

Fig. 3. Assemble your printed-circuit board according to this parts-placement diagram. It is strongly recommended that a socket be provided for U1.

wire; solid wire is not recommended since it has a tendency to break. It is also important to use 1% metal-film resistors where specified. The accuracy of the circuit depends on the 1% tolerance of those resistors. The tolerance of ordinary carbon resistors is simply not sufficiently accurate or stable for that part of the circuit.

The circuit board can be housed in almost any a small plastic or metal enclosure. If you house the circuit in a metal enclosure, be sure that no part of the wiring touches any metal sur-

face, and use a rubber grommet where the input leads of the instrument pass through the enclosure. The LED's should be mounted to the front panel of the enclosure and each should be labeled to indicate its meaning. Use a green LED for LED2 (BATTERY OK) and a red unit for all others.

If you wish to permanently install the project into a vehicle, connect the negative input wire to any metal part of the chassis. It is best to connect the positive input lead directly to one of the wires of the ignition switch, which is

powered only when the ignition is turned on. That avoids unnecessary battery drain when the vehicle is not in use.

Note: To maintain the Automotive Electrical Diagnostic System's accuracy, it is not recommended that the positive lead of the circuit be connected to any part of the vehicle's electrical system in which a significant voltage drop from the battery positive terminal occurs, especially with accessories turned on. To measure the voltage drop in the vehicle wiring, connect a DC voltmeter between the positive battery terminal and the point at which the Automotive Electrical Diagnostic System is to be connected. A voltage drop of more than 0.05 volts with accessories operating indicates that some other point in the wiring should be chosen for the circuit.

For a stand-alone unit connect lengths of 18- or 20-gauge flexible or test-lead wire (color-coded red for positive and black for negative) to the circuit for the input leads. Those wires should be terminated in alligator clips large enough to grip the terminals of the vehicle's battery. Such clips are available from most auto-parts or electronics-supply outlets.

When the assembly phase is complete, examine the project very carefully for cold solder joints (which may appear as dull or rough blobs of solder). Also, examine the board for short circuits, especially between adjacent IC pins. Correct any errors that you find.

**Checkout.** It is important to bench test the project before installing or using it on a vehicle. To test the project you'll need an well-filtered variable, DC power supply with an adjustment range of at least 8 to 16 volts, and an accurate DC voltmeter. Connect the voltmeter and project input leads to the output of the power supply, while observing the proper polarity of both sets of wires.

Start with the supply set to its minimum voltage and slowly raise the output until it reaches 8 volts. At that point, both LED1 and LED3 (WEAK BATTERY and NOT CHARGING) should light. The project's display is indicating that the battery voltage is below 9 volts, and also that there is no charging current. Note further that LED2 (BATTERY OK) is ex-

*(Continued on page 93)*



# All About Piezoelectric Elements

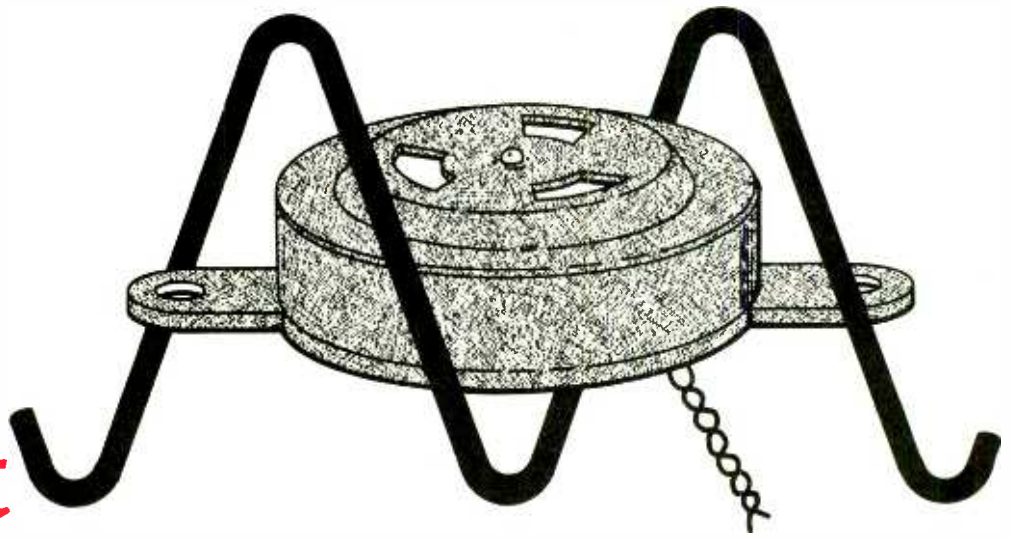

*We work through the basic principles of piezoelectric-transducer operation and examine ways of using them in circuits.*

BY A. SINGMIN

**P**iezoelectric-acoustic elements are found in solid-state self-oscillating buzzers, beepers, telephone ringers and receivers, vibration sensors, smoke detectors, computer keyboards, games, toys, telephones, calculators, cameras, burglar alarms, and more. They are all very reliable and robust, which explains their broad appeal.

The elements are typically incorporated in miniature custom-molded cases (generally cylindrical in shape) and used whenever there is a need to generate an audio tone. Although, externally, they appear remarkably similar, these devices come in a number of distinctly different formats. In this article, the basic characteristics of each format will be examined, and examples of how to use these versatile devices will be shown.

**Operation.** The basic component for all the formats—an element—consists of a thin circular section of ceramic piezoelectric material mounted on a metal diaphragm. The ceramic material used depends on the manufacturer's preference. Barium titanate and titanate zirconate are two popular materials.

Typically, the metal diaphragm is less than 0.5mm thick and made of brass or stainless steel. Its thinness en-

sures that the metal diaphragm can be easily energized into a state of resonant mechanical vibration.

Applying an AC voltage across the electrodes of the piezoelectric material causes it to expand and contract in sync with the applied voltage. So, the metal diaphragm bends in unison with the ceramic material, thereby producing sound waves. Note that the element's resonant mechanical frequency must match the driving-voltage frequency for maximum efficiency.

### Structural Characteristics.

Piezoelectric elements are available in two different styles: two terminal and three terminal. Figure 1, shows the physical differences between the two types of elements. In the two-terminal type (see Fig. 1A), the AC signal is applied across the metal diaphragm (acting as one electrode) and the piezoelectric element, onto which a conductive material (the second electrode) has been applied.

In the three-terminal type (see Fig. 1B), the piezoelectric element contains a split electrode. A phase-shifted signal is generated between the split electrode and the metal electrode when an AC signal is applied to the main terminals. The phase-shifted signal is used to provide feedback to the

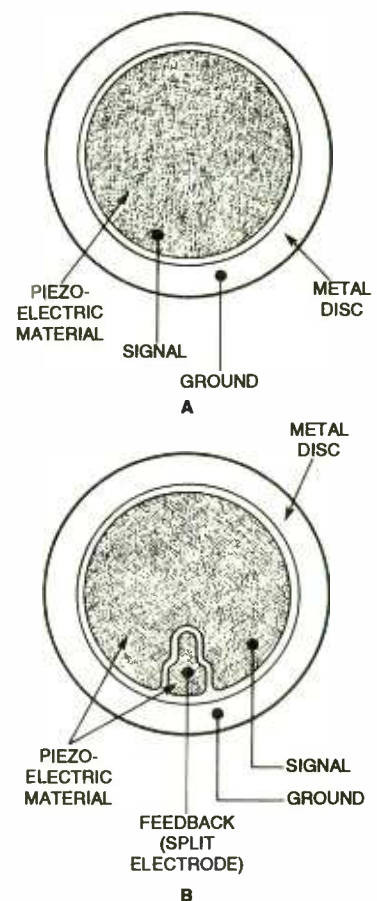

*Fig. 1. The differences between two- (A) and three- (B) terminal piezoelectric devices is made obvious here. Note that there are two separate elements in the three-terminal unit.*

oscillator/driver circuit to cause it to resonate at the natural frequency of the element.

When a piezoelectric element resonates, nodes (points where no vibration takes place) form around its circumference. The nodes are shown in the cross-section view in Fig. 2, where the dashed lines represent the extremes of the disc's motion. Exactly where the nodes occur is important for properly mounting the disc, which we'll examine next.

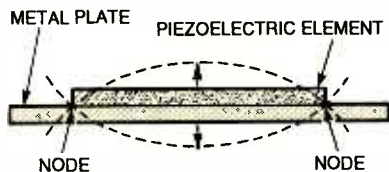

Fig. 2. Two nodes created as a piezoelectric element flexes up and down are indicated here.

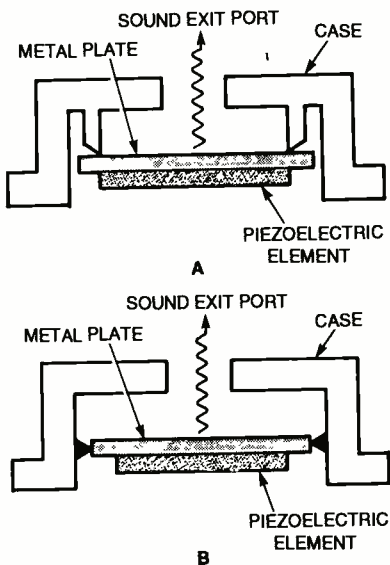
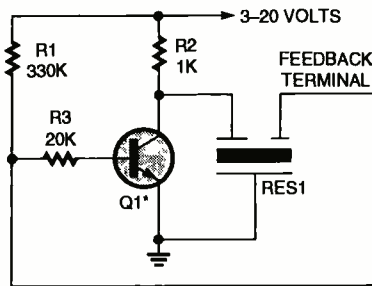
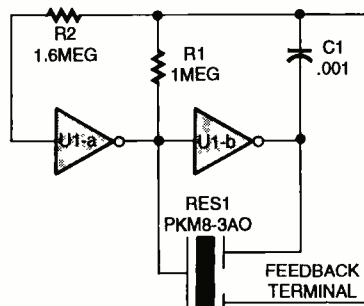

Fig. 3. One of two mounting options are typically used for piezoelectric elements: Node support (A) and edge support (B).

**Mounting Methods.** Mounting the piezoelectric element at the node locations (called "node support"), causes the least interference to the induced mechanical vibrations (see Fig. 3A). Consequently the greatest sound pressure output and the most stable mode of oscillation is obtained with that method of mounting. However, the sound pressure drops off rapidly when the frequency shifts away from resonance. Therefore, this



A



B

Fig. 4. Three-terminal piezoelectric elements are typically driven by transistor circuits (A), or logic gates (B).

mounting is mostly used for integral drive-circuit/three-terminal-element units, which use the element's feedback signal for frequency accuracy.

Mounting the piezoelectric elements at the edges (called "edge support"), offers the benefit of a wide frequency response. Figure 3B illustrates that mounting method. It is used to greatest advantage in situations where a feedback signal cannot be used. For example, when using two-terminal elements and/or simple external drive circuits.

**Oscillation Methods.** The schematic in Fig. 4A, represents a typical "self-drive" circuit used to produce oscillations. That oscillator has the piezoelectric element taking the place of the usual inductor and capacitor in a Hartley circuit. Typical component values are given in the figure. Depending upon the exact element and transistor used, the operating voltage can range from 3 to 20 volts, and the resonant frequency from 2 to 6 kHz.

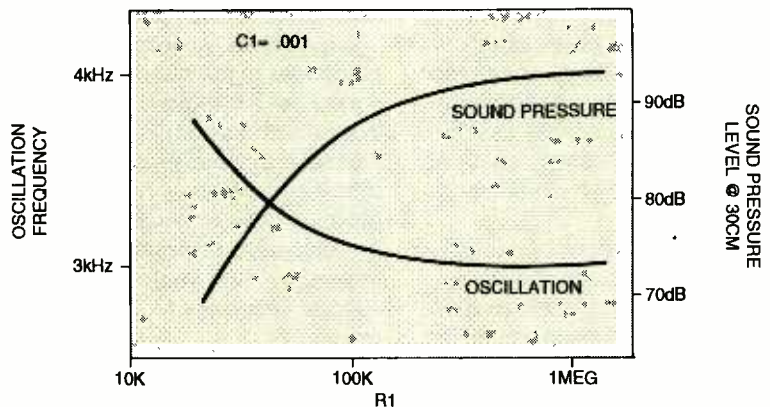

Fig. 5. Note the variation in both the output frequency and sound-pressure level with changes in the value of R1. This graph is specifically for the PKM8-3A0, but is generally representative of other elements, too.

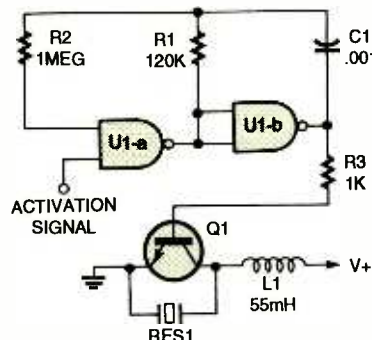

Fig. 6. Two-terminal devices can be driven by two NAND gates. A booster coil is used to compensate for the sound-pressure attenuation caused by the case.

An IC-drive version containing two CMOS-inverters is shown in Figure 4B. A good sound-pressure level is achieved by routing the feedback electrode through resistor R1 to form a positive feedback loop. With the component values shown, the frequency of oscillation is just above 3 kHz with a maximum sound-pressure level of over 90dB at 30cm. Figure 5, shows the variation in output frequency with R1 and the corresponding change in sound-pressure level for the Murata PKM8-3A0.

(Continued on page 96)



*Recharging an old toner cartridge can provide excellent results while saving you money—read on and learn more!*

BY FRED BLECHMAN

## Save a Bundle with Toner-Cartridge Recycling

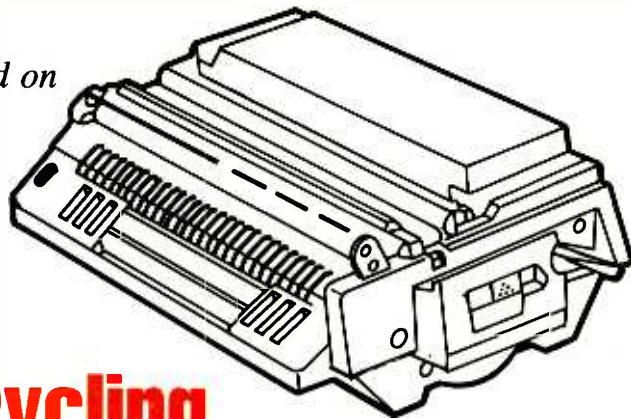

If you have a copier, laser printer, or plain-paper fax that uses a replaceable toner cartridge, you'll need a fresh cartridge after a few thousand copies. However, new cartridges are expensive. But there's an alternative and this article will give you the facts about toner cartridge "recycling," often called "refilling," "recharging," "remanufacturing," "rebuilding," and sometimes even "refurbishing."

**Background.** About nine years ago, when they first became available, I bought a Canon PC-10 Personal Copier. It has been one of the most useful tools I've ever purchased! As a writer, it is used to make copies of reference material and manuscripts. As an Amway distributor, I use it to copy invoices, orders, bonus records, correspondence, and all manner of paperwork. As a software producer, I use the PC-10 to copy the documentation for my \$49 "AMBIZ-PAK" of computer programs for Amway distributors.

The PC-10 is probably the second smartest purchase I ever made. (The smartest was a Casablanca-type ceiling fan for our upstairs master bedroom. It gets hot in California!) I was delighted with the performance of the original replaceable cartridge, and all new subsequent Canon cartridges. But it was painful to throw away what appeared to be a perfectly "good" used cartridge, since it appeared that all it needed was some new toner. Little did I know.

**Toner Cartridge Refilling.** After going through a half-dozen new Canon cartridges, I noticed a magazine ad offering "toner cartridge refilling" for \$30—about half of what I was paying

for a new cartridge at that time—so I went for it. This was a new service, and they were eager to create business. They actually came over and personally picked-up the used cartridge at my home, and then hand-delivered the refilled one, even though their place of business (a garage?) was 150 miles from my location!

I was under the impression that all they did was add new toner, but they didn't want to get into any detailed discussion. The cartridges worked okay, and actually gave me some extra copies, since they purposely provide more toner than Canon put in the original cartridge. Sometimes I'd get streaked prints and would have to clean the corona wires in the cartridge and machine, and the copies were not quite as dark as the original cartridges produced, but I was generally satisfied.

**From Good to Bad.** However, as their business grew, things changed. Now I was required to send in my used cartridge (at my expense), and the price went up to \$35. They sent the cartridge back with a big hole in it, and a plastic bottle filled with toner that I had to add myself! The explanation was that they could not ship the cartridge with toner in it, since it would leak. That was why they formerly hand-delivered the refilled cartridges!

It seems that once the cartridge is filled, unless it is sealed with an internal plastic strip like the original cartridge, toner leaks out if the cartridge is not held in a level position. As a matter of fact, Canon clearly points out that a cartridge should never be placed on end after removing the plastic strip.

This do-it-yourself method turned

out to be an unsatisfactory arrangement. The toner is a very fine black powder, and it is virtually impossible to squeeze the toner out of the plastic bottle into the hole in the cartridge without some of the toner flying around. It was messy. Furthermore, I suspect this company found a cheaper and less effective toner, since the cartridge I filled with their toner produced very gray copy, even with the darkness control on the copier turned up.

A decal was provided to cover the hole, but the hole was so poorly made, with rough edges, that the decal would not cover the hole properly. Toner leaked out whenever the cartridge was handled. This process, still available today, has become known as the "drill-fill-and-spill" method. It is certainly the least expensive way to get many more copies from a used cartridge, and you can purchase the toner by itself from various sources. However, unless you are a hardware mavin with the proper hole-making tools, and willing to develop some special techniques, I don't recommend this method.

**Out of the Woodwork.** Laser printers have since become very popular because of their superior performance and significant price decreases. Most of the early laser printers used the Canon engine with a toner cartridge almost (but not quite) identical to that used in the PC-10 series of personal copiers. However, the original laser printers cost \$2000 or more, and the printer cartridges were considerably more expensive than the copier cartridges. That made the low cost of refilling cartridges even more attractive for printers than copiers.





 EP-S TONER CARTRIDGE	<b>EP-S:</b> USE WITH THE HP LASERJET, SERIES II, IID, III, AND IIID, APPLE LASERWRITER IINT, IINTX, IISC, CANON LBP 811R, 811T, 811L, 811R, 811T, QMS PS810, 820, TURBO, SMARTWRITER 20, AND MANY MANY MORE.	 4019 TONER CARTRIDGE	<b>4019:</b> FOR USE WITH IBM 4019 LASER PRINTERS. THESE INCLUDE THE MODELS 4019, 4019E, 4028 NS1, LASER PRINTER 5e, 6, 10, AND 10L.
 EP-L TONER CARTRIDGE	<b>EP-L:</b> USE WITH HP LASERJET IIP, IIP PLUS, LASERJET IIIP, APPLE PERSONAL LASERWRITER NT, SC, CANON LBP-4, L770 FAX, QMS PS-410, AND MANY MANY MORE.	 PC-2000 TONER CARTRIDGE	<b>PC-2000:</b> USE WITH THE CANON PC-10/14/20/24/25 PERSONAL COPIERS.
 EP TONER CARTRIDGE	<b>EP:</b> FOR USE WITH HP LASERJET, PLUS 2686A, 500 PLUS, APPLE LASERWRITER, PLUS, CANON LBP 8A1, 8A2, 8DA1, 910FAX, QMS KISS, BIG KISS, II, LASERGRAFIX 800, 800II, AND MANY MANY MORE.	 A15, A30 TONER CARTRIDGE	<b>A15, A30:</b> USE WITH THE CANON PC-1/2/3/5/511/8/8RE/65, PC-7/8/11/12/35 PERSONAL COPIERS, RICOH LR1, AND PANASONIC FP-820 PERSONAL COPIERS.

Fig. 1. These are just a few of the many toner cartridges around along with listings of some of the printer engines that use them. You'd be surprised at how many there really are.

As copiers and laser printers began to proliferate, and the drill-fill-and-spill method deservedly fell into disfavor, vendors began to appear that offered to "recharge" your used cartridges. They actually disassembled the cartridge, replaced bad parts (except the drum), vacuumed out the old toner, put in new toner, and then reassembled the cartridge. They even included a plastic strip to prevent toner leakage during shipping.

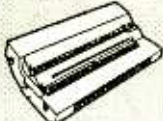
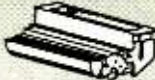
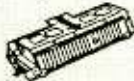
Rechargers began taking ads in computer magazines, offering to recharge both copier- and printer-toner cartridges. Many of them were mom-and-pop operations catering to local businesses. It seemed that they were virtually popping out of the woodwork as more people who were using Canon Personal Copiers and laser printers began looking for alternatives to the high cost of new toner cartridges.

Since I had lost faith in the refilling service I had been using, I started calling around to see what the other companies had to offer. I spoke several times with Tony Stramondo, at that time the President of Laser's Edge, and got a real education about the fact and fiction of toner cartridge "re-manufacturing," as the process was by then called. (Laser's Edge has since been sold to Woodenfrog Printer Products.)

To bring me up to date with the current state of the art in this field, I recently interviewed Laser Cartridge Services, a local recycler (the popular term now used, since it implies both

reuse and ecology mindedness). The owners, Renee Spinak and her son Larry, are typical of the smaller recyclers common around major metropolitan areas that provide personal service with local pickup and delivery.

**Which is Which?** According to Stramondo, the Canon Personal Copier was the first machine to be designed using a throw-away toner cartridge. This cartridge, which contained several elements involved in the copying process, was not designed to be reused. Canon clearly did not intend for users to recycle their toner cartridges, despite the fact that most of the items in the cartridge had life expectancies well beyond 2000 copies.

In the days when everything was simple, the EP cartridge used for early laser printers, and the PC cartridge used for Canon Personal Copiers, looked virtually identical, even though they were definitely not interchangeable. A label to the left of the counter window said EP Cartridge or PC Cartridge.

As copier and laser printer designs continued to reflect the rapid progress in technology, toner cartridges took the form of many designs. Some machines now use toner-only cartridges (no photoconductor drum, gears, counter or other parts), such as the Okidata 400/800 series of LED Page Printers. However, advancements notwithstanding, there are cartridges that still contain many of the elements necessary to image the master document using a xero-

graphic process (which will be explained later). Also, many different toners are now used.

In fact, toner cartridges today come in over 20 different types and sizes, reflecting the variety of laser engines on the market. Looking at Fig. 1, you'll see six toner-cartridge types and a list of the machines that use each one. That illustration is by no means all-inclusive. There are many other engines besides Canon's, and few of them use Canon cartridges, and new designs keep coming out. To add to the confusion, recyclers tend to refer to toner cartridges by the engine with which they're used. Some examples: the Canon CX engine uses an EP cartridge; the SX engine uses an EP-S cartridge; the LX engine uses an EP-L cartridge; the PC-Mini copier engine uses an A15 or A30 cartridge; the NX engine uses a IIISI cartridge; and there are many others.

Fortunately, Chenesko Products publishes a free 36-page catalog that devotes 6 pages to listing hundreds of models of printers, copiers, faxes, and the engines they use. Since there are so many different toner cartridges, with many looking alike, be sure when you order a replacement or recycled cartridge that you get the correct one.

**The Xerographic Process.** Electrophotography (or the "copying") of an image onto paper is generally referred to as xerography. It is a complex process, and here we are only going to offer a simplified expla-



## Sources

### Aspect, Inc.

57 Eisenhower Lane South  
Lombard, IL 60148-5409  
Tel. 800-331-8009, or 708-627-9600  
Fax: 708-627-9601

### Catapult Clip Art

P.O. Box 1297  
Round Rock, TX 78680  
Tel. 512-244-4338  
Fax: 512-255-2692

### Cheneko Products, Inc.

2221 Fifth Ave., Suite 4  
Ronkonkoma, NY 11779  
Tel. 800-221-3516, or 516-467-3205  
Fax: 516-467-3223

### Diversified Technographics, Inc.

23072 Lake Center Drive, Suite 100  
Lake Forest, CA 92630  
Tel. 800-457-5776  
Fax: 714-855-3959

### Laser Cartridge Services (LCS)

Street address intentionally omitted—  
Northridge, California  
Tel. 818-349-8243  
Fax: 818-349-8254

### Woodenfrog Printer Products

201 S. 23rd St.  
Fairfield, IA 52556  
Tel. 800-635-8088, or 515-472-7850  
Fax: 515-472-4789

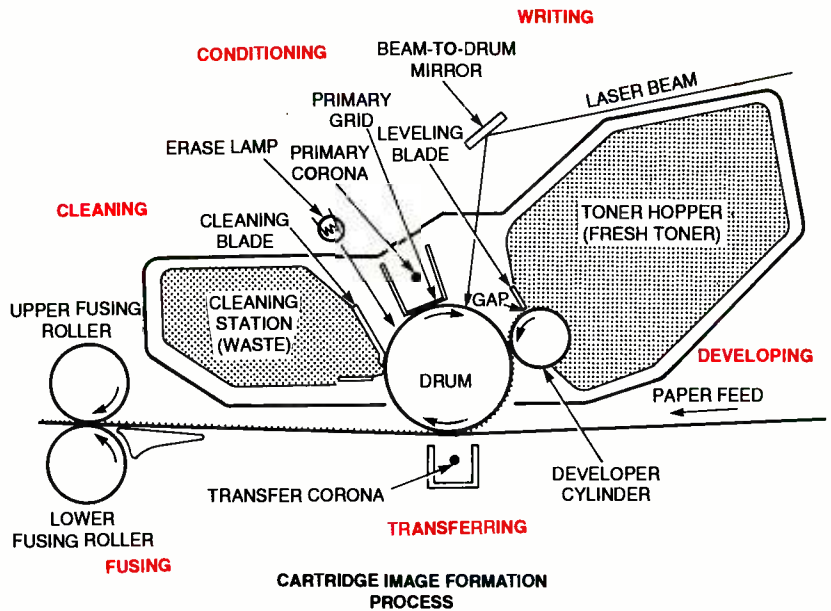

Fig. 2. In a laser printer or copier, the paper has toner deposited on it by a special charged cylinder. Then the toner is thermally fused to the paper.

nation of it. For a more detailed explanation, see the article, "Understanding Toner Cartridge Technology," by Don Thompson (*Recharger Magazine*, May 1992.)

Figure 2 (courtesy of Don Thompson) shows the interior parts of a typical laser engine. The cartridge drum is a rotating cylinder covered with a special organic-photoconductor coating (OPC) that is sensitive to both electrical charge and light. In the older cartridges, the coating was charged by a primary corona wire, which is a small-diameter wire in a shield. In the newer cartridges, a corona roller is used for that purpose. A high voltage is applied to the corona wire or roller, ionizing the air around it to produce a shower of electrically charged particles. The particles impinge onto the surface of the photoconductor, which acts as a receptor and becomes negatively charged.

A switched laser beam then passes through a lens and mirror which scans it across the slowly rotating drum. Wherever light strikes the photoconductor surface, it is discharged, and any area where no light strikes re-

mains charged. Since the beam is turned on and off according to the light and dark areas of what is being copied or printed, it is said to leave a latent image on the drum—an electrostatic duplicate of the original.

The exposed surface of the drum then passes a developer cylinder, a rotating magnetic roller that is constantly refreshed with toner from a toner hopper or reservoir. An applied bias voltage pushes the toner from the magnetic roller onto the drum, where the toner adheres to the more-positive partially discharged, latent image.

As the OPC drum continues to rotate, now with toner covering the latent image, it passes over a transfer area outside of the cartridge. That is where the copy paper, as it is passing through the machine, comes in contact with the drum surface. On the opposite side of the paper is a transfer corona wire that has a very high charge. This charge attracts the toner off the drum onto the paper. Then the paper passes through fuser rollers. The upper roller is heated. Through a combination of heat and pressure, the toner melts and is bound to the paper surface. On older machines, a cleaning rod with a felt pad is used to clean and lubricate the fuser rollers. The finished copy is then ejected from the machine.

Meanwhile, back inside the car-

tridge, there's a cleaning station. This uses a polyurethane or styrene type of blade with a knife-edge that rubs up against the photoconductive drum to remove any left-over toner, since not all toner is transferred. The used toner that is scraped off the drum goes into a hopper inside the cartridge and is not used again. Therefore, the new toner gets used up two ways; it is either transferred to the copy paper, or scraped off the photoconductor drum and left in the cleaning station.

Next the photoconductor goes through a relaxation cycle. For that, a quartz/halogen erase lamp in the printer (not in the cartridge) generates white light that passes through a shutter to neutralize (discharge) the OPC surface so that it has no memory of the previous cycle.

On older cartridges, a turn-counter in the cartridge advances a colored disk, a portion of which is seen through a small window in the side of the cartridge. The color advances from green to yellow to red as the cartridge is used. It takes about 3000 turns of the drum before the counter hits an internal notch that prevents further counter rotation into the green area, but does not stop the copier or printer.

Incidentally, because some copies use more toner than others (the denser the black areas on the printed output, the more toner is used) there is

no way to determine how many copies can be made before the toner is used up. The counter, therefore, gives you only a rough indication of how much toner remains. Modern laser printers and copiers use cartridges with an internal sensor that lets you know, by either a light or display message, that your remaining toner is actually low.

**The Recycling Process.** Proper cartridge recycling is an 8-step process: pre-testing; disassembly; cleaning; photoconductive-drum-cleaning; sealing the supply chamber; adding new high-quality super black toner (with colors available for additional cost); inspection; final assembly, and testing. Many recyclers now also treat the photoconductive drum with a life-extending chemical compound. Also, long-life replacement drums have become available for many cartridges.

Many toner cartridges are originally assembled by robots, so parts fit together only one way and in a certain order. So it takes special tools and techniques to properly disassemble and reassemble toner cartridges.

The cleaning station toner is removed with a special vacuum cleaner. That's because the toner dust is so fine that it can penetrate normal vacuum bags and get into—and ruin—the vacuum-cleaner motor, causing an explosion in extreme cases.

The photoconductor is inspected for nicks, scratches, dents, or dis-

coloration. The counter (if there is one) is reset. New toner is used (often more than the original amount, thus yielding more copies), a plastic sealing strip (if used) is installed, and the cartridge is reassembled with all its parts in the proper position and in sequence.

**How Many Times?** According to Renee Spinak of Laser Cartridge Services (LCS), many of the parts are good long beyond the normal 2000 or 3000 copies produced by a typical cartridge. Cartridges can be recycled an indefinite number of times if parts are replaced. The newer long-life photoconductive drums are typically good for 25,000–50,000 copies. The gears are nylon, good for 100,000 copies. The wiper blade is good for a year or more, after which it can get brittle and groove the drum. That's why LCS changes wipers with each drum change or sooner.

Also, LCS has found sources for compatible toners for laser cartridges that are blacker than the original. Their ultra-black toner offerings are especially good for graphics with laser printers. Their copier black is equivalent to Canon's, but gives greater yield for mostly-text use.

LCS, like most cartridge recyclers, provides an unconditional warranty, and will buy used cartridges from their customers.

**Dirty Machine?** Just because you're getting marks on the output of your copier or laser it doesn't necessarily mean your cartridge needs to be replaced; your machine might just be dirty. Sprays, wipes and swabs used in manual cleaning might not even reach the dirty parts.

A product called Scrubex from Aspect, Inc. can correct many problems associated with toner powder, label adhesives, paper, and dust. You simply place a Scrubex sheet in your feed tray and run it through your machine, with no equipment downtime and no service calls.

Scrubex's unique bristles, folds, and built-in isopropyl-alcohol cleaning solution reach parts and areas not otherwise cleanable without disassembly. The bristles pick up and remove foreign matter instead of moving it around or blowing it into internal parts.

## A Business of Your Own

Recycling offers so many advantages that it has become the focus for many entrepreneurs wishing to start a cottage business of their own with a relatively small investment. If this sounds attractive to you, you'll definitely want to get a copy of *Recharger Magazine* and check the companies listed in the Sources sidebar to get more familiar with the field. You'll be amazed at what's going on!

One of the more aggressive firms in setting you up in your own cartridge-recycling business for less than \$500 is Chenesko Products. Call and ask for their Dealer Literature. It includes a 32-page Authorized Dealer Catalog, a 6-page letter telling you about the business and how to get started, and material about their dealer Fax-On-Demand automated document-retrieval service to allow you to receive disassembly instructions and other technical material on your fax machine 24-hours a day. Chenesko also offers User Literature for do-it-yourselfers who are not Chenesko dealers, with higher parts prices.

Don Thompson is well known in the recycling field, and his company, Diversified Technographics, Inc., is a source for quality hands-on training, support and technical information in this field.

Woodenfrog Printer Products offers new and remanufactured cartridges, toners, and various parts and supplies.

To aid you in creating advertising flyers, brochures, display ads, and catalogs, Catapult offers "CAT-201 Toner Cartridge Recycling" clip art, 26 pages of over 130 custom made illustrations (\$88.) If you have an IBM PC or Macintosh computer, you can get the same illustrations as graphic files on disk for \$96. They also offer *CAT-301 Catalog It!* for \$22, which consists of 12 pages of templates, category titles, symbols, bullets, lines, and instructions for creating your own professional catalog. ■

Incidentally, a similar Aspect product, Printex, is used with dot-matrix and daisy-wheel printers. In the time it takes to print a page, the rollers, feed guides, and print head are cleaned and ready to run.

**Do It Yourself?** None of the manufacturers of toner cartridges recommend or perform recycling of their cartridges, although Hewlett-Packard will buy used cartridges with the stated purpose of keeping them from ending up in landfills. (They do not remanufacture them, however.) Plainly and simply, the manufacturers

*(Continued on page 96)*

## Recharger Magazine

*Recharger Magazine* offers technical information on remanufacturing various laser-printer and copier cartridges, laser printer maintenance and repair, ink-jet filling, and ribbon recycling. It provides sources and information covering toners, photoreceptor drums, and other supplies needed in the process of remanufacturing cartridges.

Published monthly, the roughly 140-page glossy magazine is circulated worldwide to 33 countries, and offers a free referral service to help end users locate a cartridge recycler in their area.

The Subscription rate is \$45 per year in the USA. Contact C&R Publications, 3340 Sunrise Ave., Suite 101, Las Vegas, NV 89101. Tel. 702-438-5557. Fax: 702-438-4025. ■



# ANTIQUUE RADIO

By Marc Ellis

## The Mother of All Radio Museums

Last month, I stopped the presses on the "Quaker Oats" crystal-set project so that we could cover the annual Antique Wireless Association Conference in Rochester, NY (which had just concluded at the time the column was being put together in late September). However, there was no space left to talk about A.W.A.'s permanent museum in nearby Bloomfield, NY—which is a "must-see" attraction for all conference-goers. I'm going to remedy that in this issue, after which we can get back to the crystal set!



Popular receivers dating from the beginning of radio broadcasting (about 1921) to just before the introduction of AC-powered sets (about 1929) are displayed in this reproduction of a period radio store. The showcases contain parts for the many folks who preferred to put together their own hook-ups.

The A.W.A. museum defies description. During a recent half-hour phone conversation with Bruce Kelley, the institution's charismatic and dedicated curator, I tried to probe for statistics about the size and scope of the collections. Bruce simply said that he felt the museum owned almost everything it might be possible to acquire in every major area of radio collect-



A 50-watt amateur "phone" station of the early 1920's. Note the carbon hand microphone hanging from table top at right, and the array of chemical rectifier jars on the center shelf.



A complete, and very rare, 1908 Marconi ship station exactly like that carried on the ill-fated Titanic.



Among the sets representing the behemoth consoles of the 1930's are a McMurdo Silver "Masterpiece Series" (left) and a Stromberg-Carlson in an unusual corner cabinet.



Would you believe that the first wire recorder (known as the Telegraphone) was invented about 1907? Here it is, a product of the fertile mind of legendary radio inventor Valdemar Poulsen.



The "television corner" featured a selection of early TV receivers. At the left is a very rare Jenkins 60-hole mechanical scanner; at the right, on the same counter (just below the big RCA "Little Nipper"), are a couple of small screen sets, including a working 3-inch Pilot. Note the projection receiver above the Jenkins.



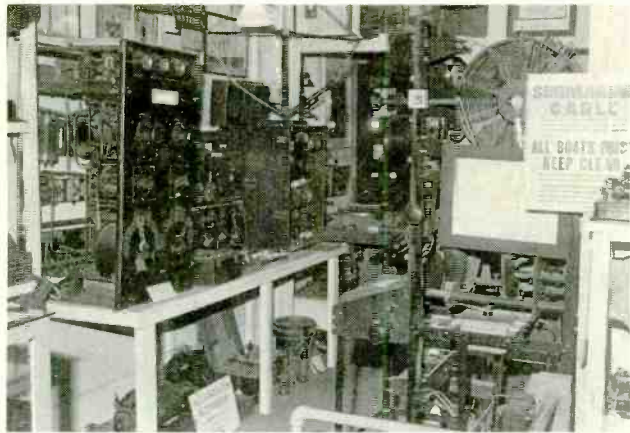

*At the far left, on the counter, is a 1927 ship's radio transmitter; just to the right of that sits a display of early 1920's "Wireless Specialties" receivers. Part of the submarine cable display is visible at far right.*



*The separate "annex" building contains a large exhibit room featuring part of the museum's 50,000-item vacuum-tube collection. Here's part of a display containing 180 tube boxes, all different, as well as 148 different brands of type 201-A's.*

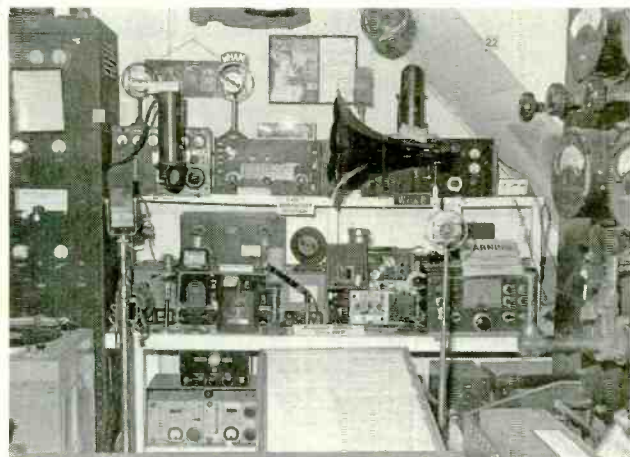

*A grouping of mid 1920's-mid 1930's broadcast station equipment nestles under the stairs leading to the museum's upper floor. See how many vintage mikes you can spot!*



*In the museum's separate storage facility, a 3,000-square-foot building known as "the annex," equipment is packed solid and stacked to the 10-foot ceilings. As in most institutions of this kind, the public exhibits represent just a fraction of the permanent holdings.*

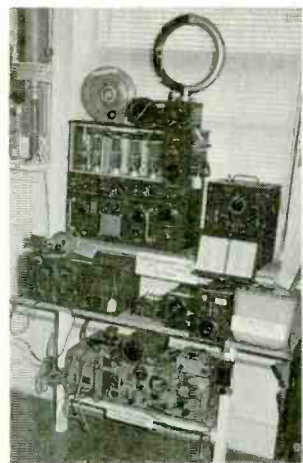

*Echoes of World War II. On the windowsill and the shelf below it is radio equipment typical of that installed on the B17 "Flying Fortress" and other large U.S. military aircraft. A Russian-tank transceiver rests on the lower shelf.*



*Museum curator Bruce Kelley demonstrates a 250-watt late 1910's or early 20's amateur-radio transmitter, a non-sync rotary spark job. Partly visible on the wall at the upper right is a portrait of Zenith Radio founder R.H.G. Matthews. The brand name was derived from his ham call letters, 9ZN.*



ing. A boastful statement? Maybe. But, as the accompanying photos show, it would be pretty hard to prove that statement wrong.

If you'd like to visit the museum yourself to view the wonders on display, Bloomfield is located about 25 miles southeast of Rochester and about ten miles west of Canandaigua, NY. The museum is housed in the restored 150-year-old East Bloomfield Academy building, which is also the headquarters of the East Bloomfield Historical Society. For more information, write Bruce Kelley, 59 Main St., Bloomfield, NY 14469—or call (716) 657-7489 or (716) 657-6260.

In order to do the museum as much justice as possible in the space available, I'm going to discard my usual text-based format and present this column as an album of the photos I shot at Bloomfield. So I'll conclude my formal comments now in order to leave room for as many captioned pictures as possible. Even so, remember that this is but a small sampling of what is on display. ■



# ELECTRONICS MARKET PLACE

## FOR SALE

**CABLE test chips.** Jerrold, Tecom, S.A., Zenith. Puts cable boxes into full service mode! \$29.95 to \$59.95. 1 (800) 452-7090, (310) 902-0841.

**300 Experimenters Circuits** — Complete in 6 practical books using diodes, relays, FET's, LED's, IC 555's, and IC CA3130's for building blocks. Only \$33.00 plus \$5.50 for shipping. USA and Canada only. US funds. ETT, INC., PO Box 240, Massapequa Park, NY 11762-0240.

**SECRET cable descramblers!** Build your own descrambler for less than \$12.00 in seven easy steps! Radio Shack parts list and free descrambling methods that cost nothing to try, included. Send \$10.00 to: **INFORMATION FACTORY**, Dept. 5, PO Box 669, Seabrook, TX 77586. For COD's (713) 922-3512 any time!

**CABLE descrambler liquidation.** Major makes and models available. Industry pricing! (Example: Hamlin Combo's, \$44 each... Minimum 10 orders). Call **WEST COAST ELECTRONICS**, 1 (800) 628-9656.

## CLASSIFIED AD ORDER FORM

To run your own classified ad, put one word on each of the lines below and send this form along with your check to:

**Popular Electronics Classified Ads**, 500-B Bi-County Boulevard, Farmingdale, N.Y. 11735

**PLEASE INDICATE** in which category of classified advertising you wish your ad to appear. For special headings, there is a surcharge of \$11.00.

Plans/Kits     Business Opportunities     For Sale  
 Education/Instruction     Wanted     Satellite Television

Special Category: \$11.00

### PLEASE PRINT EACH WORD SEPARATELY, IN BLOCK LETTERS.

(No refunds or credits for typesetting errors can be made unless you clearly print or type your copy.) Rates indicated are for standard style classified ads only. See below for additional charges for special ads. **Minimum: 15 words.**

1	2	3	4	5
6	7	8	9	10
11	12	13	14	15 (\$23.25)
16 (\$24.80)	17 (\$26.35)	18 (\$27.90)	19 (\$29.45)	20 (\$31.00)
21 (\$32.55)	22 (\$34.10)	23 (\$35.65)	24 (\$37.20)	25 (\$38.75)
26 (\$40.30)	27 (\$41.85)	28 (\$43.40)	29 (\$44.95)	30 (\$46.50)
31 (\$48.05)	32 (\$49.60)	33 (\$51.15)	34 (\$52.70)	35 (\$54.25)

We accept MasterCard and Visa for payment of orders. If you wish to use your credit card to pay for your ad fill in the following additional information (Sorry, no telephone orders can be accepted.):

Card Number \_\_\_\_\_ Expiration Date \_\_\_\_\_

PRINT NAME \_\_\_\_\_

SIGNATURE \_\_\_\_\_

**IF YOU USE A BOX NUMBER YOU MUST INCLUDE YOUR PERMANENT ADDRESS AND PHONE NUMBER FOR OUR FILES. ADS SUBMITTED WITHOUT THIS INFORMATION WILL NOT BE ACCEPTED.**

**CLASSIFIED COMMERCIAL RATE:** (for firms or individuals offering commercial products or services) \$1.55 per word prepaid (no charge for ZIP code). **MINIMUM 15 WORDS.** 5% discount for same ad in 6 issues within one year; 10% discount for 12 issues within one year if prepaid not applicable on credit card orders. **NON-COMMERCIAL RATE:** (for individuals who want to buy or sell a personal item) \$1.25 per word, prepaid...no minimum. **ONLY FIRST WORD AND NAME** set in bold caps at no extra charge. Additional bold face (not available as all caps) 30¢ per word additional. Entire ad in boldface, \$1.85 per word. **TINT SCREEN BEHIND ENTIRE AD:** \$1.90 per word. **TINT SCREEN BEHIND ENTIRE AD PLUS ALL BOLD FACE AD:** \$2.25 per word. **EXPANDED TYPE AD:** \$2.05 per word prepaid. Entire ad in boldface, \$2.45 per word. **TINT SCREEN BEHIND ENTIRE EXPANDED TYPE AD:** \$2.55 per word. **TINT SCREEN BEHIND ENTIRE EXPANDED TYPE AD PLUS ALL BOLD FACE AD:** \$2.95 per word. **DISPLAY ADS:** 1" x 2 1/2" — \$205.00; 2" x 2 1/2" — \$410.00; 3" x 2 1/2" — \$615.00. General Information: Frequency rates and prepayment discounts are available. **ALL COPY SUBJECT TO PUBLISHERS APPROVAL. ADVERTISEMENTS USING P.O. BOX ADDRESS WILL NOT BE ACCEPTED UNTIL ADVERTISER SUPPLIES PUBLISHER WITH PERMANENT ADDRESS AND PHONE NUMBER.** Copy to be in our hands on the 18th of the fourth month preceding the date of issue (i.e., Sept. issue copy must be received by May 18th). When normal closing date falls on Saturday, Sunday or Holiday, issue closes on preceding work day. Send for the classified brochure. Circle Number 49 on the Free Information Card.

Look to the Future  
 With Your Own  
 Cable Converter & Descrambler!

1-800-228-7404



**NU-TEK ELECTRONICS**

**FREE CATALOG!**

3250 Hatch Rd.  
 Suite 1 C  
 Cedar Park, TX 78613

**ALL MAJOR BRANDS**



**TUBES.** (Thousands in stock). Send SASE for list. **FALA ELECTRONICS**, PO Box 1376-2, Milw., WI 53201.

**DESCRAMBLING secrets revealed.** Free 24 hour hotline reveals secret satellite and cable descrambling information. (718) 390-7130.

**DESCRAMBLERS** for cable and satellite. Kits and assembled units. All types. Guaranteed. From \$19.95. Free catalog. (212) 330-8035.

**CABLE descramblers** and test turn-on kits available for most makes and models. We also carry bullet stoppers. Our prices are insane (owner brain-damaged). Cash paid for cable equipment. No Florida sales. (305) 425-0751.

**CABLE TV DESCRAMBLERS**  
**CONVERTERS ★ ACCESSORIES**

★ Name Brands ★ Lowest Prices ★

NOT AVAILABLE IN CALIFORNIA CALL FOR FREE CATALOG

**PRIME TIME Electronics, Inc. (800) 777-7731**

**UNDETECTABLE cable descrambler** will work on all systems **guaranteed!** Send SASE/info, \$94.95/kit, \$14.95/plans, **MYSTICAL ELECTRONICS**, PO Box 481, Cooper Station, NY, NY 10276.

**PRINTED circuit boards** — etched, drilled, tin plated. Single sided \$1.25/sq. inch. Free shipping. **CHELCO ELECTRONICS**, 61 Water Street, Mayville, NY 14757. 1 (800) 388-8521.

## FREE CATALOG

FAMOUS "FIRESTIK" BRAND CB ANTENNAS AND ACCESSORIES. QUALITY PRODUCTS FOR THE SERIOUS CB'er. SINCE 1962

FIRESTIK ANTENNA COMPANY  
2614 EAST ADAMS  
PHOENIX, ARIZONA 85034

**CABLE TV descramblers.** All major brands. Have make/model used in your area when calling. 1 (800) 327-3407. For a free catalog write KD VIDEO, PO Box 29538, Minneapolis, MN 55429.

**THE Case Against Patents.** Thoroughly tested and proven alternatives that work in the real world. \$24.50. SYNERGETICS PRESS, Box 809-C, Thatcher, AZ 85552. (602) 428-4073. Visa/MC.

**VIRTUAL Reality.** Experience this exciting technology in your home with PCVR magazine's help. Sample \$3.00. PCVR, PO Box 475, Stoughton, WI 53589. (608) 877-0909.

**TOCOM 5503A** raw cable pulls - 10 @ \$45.00, SA 8580 raw - call, VIP parts tuners, micros - \$17.00 each. Call (414) 554-8618 APEX.

### CABLE DIRECT

Now you can tune-in to your favorite cable TV programming and SAVE 100's - EVEN \$1000's on premium

#### CABLE TV EQUIPMENT

Converters • Descramblers • Filters

FREE Cable TV Catalog

MODERN ELECTRONICS  
1-800-906-6664

MONEY BACK GUARANTEE!

**PREVENT descrambler damage** - Don't bite the bullet! Snooper Stopper Data Pulse Blocker \$34.95 - Data Blocker with dual surge protection \$54.95 - Wireless video sender \$54.95 - remote control A/B switch \$39.95 - VIDEO CONNECTIONS, 1 (800) 925-9426.

**CABLE TV descramblers.** Save money, don't rent! Nobody beats our price! Call us last for the best price! All brands, 24 hour shipping. VCI, 1 (800) 677-0321.

**DIGITAL video stabilizer.** Removes all video tape pre-protection, caused by copy guard, on pre-recorded tapes \$54.95 - VIDEO CONNECTIONS, 1 (800) 925-9426.

**CABLE equipment!** Jerrold, Zenith, Pioneer, Oak, Scientific Atlanta & more! Our prices are below wholesale! CABLE MASTER, 1 (800) 488-9888.

## CB RADIO OWNERS!

We specialize in a wide variety of technical information, parts and services for CB radios. 10-Meter and FM conversion kits, repair books, plans, high-performance accessories. Thousands of satisfied customers since 1976! Catalog \$2.

CBC INTERNATIONAL

P.O. BOX 31500PE, PHOENIX, AZ 85046

## INVENTIONS

**INVENTORS: CONCEPT NETWORK** offers professional, inexpensive patenting and marketing services. (New product ideas with prototype or schematics preferred; but they are not required.) Free information packet: Call 1 (800) 835-2246 extension 67.

**FREE Invention package: DAVISON & ASSO-CIATES** offers customized development, patenting, and licensing for new products and ideas. Proven results: 1 (800) 677-6382.

## PLANS & KITS

**60 Solderless Breadboard Projects** in two easy-to-read pocket books. Complete with circuit descriptions, schematics, parts layouts, component listings, etc. Both books (BP107 & BP113) only \$11.90 plus \$3.50 for shipping. USA and Canada only. US funds. ETT, INC., PO Box 240, Massapequa Park, NY 11762-0240.

**\$10,000 monthly! Managing 900#.** No investment! Application \$2.00. Q.C.C., 122 West Washington, Suite 65, Altamont, IL 62411-9600.

## BEST BY MAIL

Rates: Write National, Box 5, Sarasota, FL 34230

OF INTEREST TO ALL

**AMAZING LOTTERY SECRET** of "31." Recorded Message (313)927-0187, Extension 4.

**ETERNAL SECURITY: TRUE or False?** Free Bible Studies. Light, St. Maries, ID 83861.

FINANCIAL

**STOP BILL COLLECTORS COLD!** Extensive Report \$29.00 FREE Information: 800-393-1114 Ext. 11.

VACATIONS

**\$5.00 A DAY VACATION HOTELS!** Save Big \$ With Great Vacation Hotel Specials. 6 Days 5 Nights Waikiki, Hawaii; 5 Days 4 Nights Las Vegas; Freeport, Bahamas; Cancun, Mexico. As Low As \$25.00. Plus Discount Airfares, Cruises And Much Much More! Call Now 1-800-864-8720.



### THE CAPTAIN'S WATCH

Rugged, dependable to 100M  
Luminous hands, magnifying crystal, date, 2 year battery, 5 yr. warranty. Reg. \$89.95 NOW: \$49.95 ppd.  
I. SIEGER, P.O. BOX 7208  
DELRAY BEACH, FL 33484

## FREE INFO!

**BECOME A HAM RADIO OPERATOR THE FAST, EASY, FUN WAY - NO MORSE CODE REQ'D!**

You'll be on the air in no time - making new friends - with the ARRL's all-new Technician Class Video Course.

It's everything you need to start exploring your new, exciting world of Amateur Radio: 3 full-length video tapes, 164-page course book, 6 practice exams, even optional review software - all with an iron-clad money-back guarantee.

We've been helping people become hams for more than 75 years - we won't let you fail!

Get in on the fun of ham radio. Call the toll-free number and ask for our free video course info kit. Call Today!

ARRL • 225 Main St • Newington, CT 06111

1-800-32-NEW HAM

## C.B.'S AND SCANNERS

**SCANNERS, C.B.'s, radar detectors.** Call or write for free catalog. (803) 829-3411 CB DOCTOR, PO Box 2842, Orangeburg, SC 29116-2842. To place order call 1 (800) 569-1393.

## TELEVISION VIDEOS

**TELEVISION test patterns on VHS!** Computer generated crosshatch, color-bar, etc. 18 patterns, 30 minutes. Only \$23.95 or \$3.00 plus SASE for info. DLD DISTRIBUTORS, 429 Cessna Road, Concord, NC 28025.

## SATELLITE TELEVISION

25° LNB \$67.95 7" \$89.00. Call for wholesale price list. SATELLITE WAREHOUSE, Tucson, AZ 1 (800) 851-6534.

## BUSINESS OPPORTUNITIES

**MAKE \$75,000.00 to \$250,000.00 yearly.** Learn IBM monitors repairs (solutions most brands). New home based business program. Software available. Information: USA-Canada \$3.00 cash (no checks). Dealers wanted worldwide (\$35.00) US funds. RANDALL DISPLAY, PO Box 2168-H, Van Nuys, CA 91404, USA.

**NEED money?** Guaranteed employment! Assemble simple products at home. Easy work! Excellent income! 1 (800) 377-6000, ex7930.

**FREELANCE readers needed!** \$30,000/year income potential. Details: (619) 491-1541 Ext. 73, 24 hrs.

**WANTED: Distributors!** Top quality mini-satellite systems for RV, home, office and more. 5"9" C/Ku remote demo included. Unlimited profit potential. STRATAVISION, (24 hrs.) 1 (800) 960-9656.

**GOVERNMENT seized cars, trucks, boats, computers, televisions.** Surplus bargains galore! Your area: 1 (800) 601-2212 Ex.SP7930.

**EASY work!** Excellent pay! Assemble products at home. Call toll free 1 (800) 467-5566 ext. 5730.

**DISTRIBUTORS needed** - high profits, largest selection & lowest prices. Mini-satellite antennas for homes, RV, business, & many new markets. Starting \$296.00. 1 (800) 886-5008.

**START your own technical venture!** Don Lancaster's newly updated Incredible Secret Money Machine II tells how. We now have auto-graphed copies of the Guru's underground classic for \$18.50. SYNERGETICS PRESS, Box 809-C, Thatcher, AZ 85552. (602) 428-4073. Visa/MC.

**INVENTIONS.** New products. You can profit from your ideas! QUORUM INTERNATIONAL, a rapidly expanding manufacturing/marketing company is actively seeking consumer products. Send ideas to: QUORUM INTL, Product Research Dept., 1550 W. Deer Valley Rd., Phoenix, AZ 85027.

**WOULD you like to start your own business?** For info send LSASE to DAVID CLINE'S CO., 669 River Road, Bliss, ID 83314.

## EDUCATION/INSTRUCTION

**VCR Repairs You Can Do.** Save\$. Make\$. "Bible of Electromechanical repairs." 403-pages. \$Back-guarantee. Over 37,800 sold. 704 illustrations + tool. Mail \$24.95 to WORTHINGTON PUBLISHING, Box 16691M, Tampa, FL 33687-6691.

**ELECTRONIC engineering.** 8 volumes complete. \$109.95. No prior knowledge required. Free brochure. BANNER TECHNICAL BOOKS, 1203 Grant Avenue, Rockford, IL 61103.

**DIGITAL electronics,** learn at home or college for digital computers, full color illustrations 360 pages. Send \$29.95 to PJ ENTERPRISES, 26551 Sparks St., Highland, CA 92346.

**PROCESS refunds.** Your help is needed immediately to process insurance refunds. Earn up to \$250.00 or more per refund processed. No experience needed. Easy and fun to do. Work in the privacy of your own home. Complete step by step instruction book. Rush \$22.95 to: POPLAR PUBLISHING, PO Box 1766, Dept. PE9, Enid, OK 73702.

**ELECTRICITY/Electronics training series** used by U.S. military. 23 volumes, other courses available. Free info: FEDERAL TECHNICAL PUBLISHERS, Box 1061 E. Glen Lake, MN 55345.

### Learn to fix computers!

Home study. Earn great money repairing troubleshooting, upgrading, and installing PCs. Free literature: 800-223-4842.

Name \_\_\_\_\_ Age \_\_\_\_\_

Address \_\_\_\_\_

City \_\_\_\_\_ State \_\_\_\_\_ Zip \_\_\_\_\_

The School of PC Repair, Dept. JC341  
6085 Roswell Road, Atlanta, Georgia 30328



**LEARN COMPUTERS!**  
 Home study: become an expert with the personal computer for home or business use. Free literature: 800-223-4542.

Name \_\_\_\_\_ Age \_\_\_\_\_  
 Address \_\_\_\_\_  
 City \_\_\_\_\_ State \_\_\_\_\_ Zip \_\_\_\_\_  
 School of Computer Training, Dept KC341  
 6065 Roswell Rd., Atlanta, Georgia 30328

ESP, Bioelectricity, microwave hearing introduction, comprehensive booklist...\$1.00, \$2.00 foreign. **RESEARCH ASSOCIATES**, PO Box 3583, Boyton Beach, FL 33424-3583.

DC electronics course. 17 modules, VGA graphics, animation, quizzes, reviews, finals. 8.5 meg course. \$38.00 plus \$4.00 shipping. Specify 1.2/1.4 floppies. **CRESCENT MULTIMEDIA**, Box 7183, Victoria, TX 77903.

**ANTIQUE RADIO CLASSIFIED**  
**Free Sample!**  
 Antique Radio's  
 Largest Circulation Monthly.  
 Articles, Ads & Classifieds.



6-Month Trial: \$16.95. 1-Yr: \$29.95 (\$44.95-1st Class).  
 A.R.C., P.O. Box 802-L10, Carlisle, MA 01741

**HOME  
 FIRE  
 SAFETY.  
 ACT ON IT!**



**FOR FREE HOME FIRE SAFETY TIPS, WRITE:**  
 United States  
 Fire Administration  
 P.O. Box 70274  
 Washington, DC 20024





*From the Lab  
 to your  
 Living Room!*

## Does your VCR have a "Head Cold?"

Probably not! However, through constant playing and using of degrading dry or wet cleaners, the output of your video tapes has slowly diminished to an unacceptable level and the VCR plays as if it has a head cold! The culprit is most likely clogged and dirty video and/or audio heads.

The **3M Black Watch™ Head Cleaner Videocassette** uses a patented magnetic tape-based cleaning formation to remove clogging debris. No foreign substances such as cloth, plastics or messy liquids and no harsh abrasive materials are present. The cleaner's usable life is 400 cleanings or more!

It's easy to use. Place the **3M Black Watch™ Head Cleaner Videocassette** in the VCR and press the Play button. A pre-recorded message appears clearly on your screen and an audible tone is heard, telling you that the cleaning process is now completed. No guess work, you never over clean!

**3M Black Watch™ Head Cleaner Videocassette** **S**VHS VHS.....\$19.95

Once your VCR's head cold is cured, and the unit plays like new, consider using the finest videocassette you can buy—the **3M Black Watch™ T120 Hi Pro VHS 4410 Videocassette**. The 4410 is the highest performing videocassette available today for use with all standard format VHS recording hardware!

Here's what you hear and see....A sharp, clear picture—brightest colors—freedom from streaks, flashes and snow—outstanding high-fidelity audio reproduction—optimum camcorder performance—maintains recording integrity. **3M Black Watch™** video tape is 100% laser inspected to guarantee surface smoothness and drop-out free performance.

**3M Black Watch™ T120 Hi Pro VHS 4410 Videocassette** **V**H.S.....\$8.00

**CLAGGK INC. — 3M VHS Special Offer**  
 P.O. Box 4099, Farmingdale, New York 11735

Yes, I like your offer and here is my order for 3M Black Watch™ products!

___ 3M Black Watch™ Head Cleaner Videocassette	(\$19.95 each)	_____ \$
___ 3M Black Watch™ T120 Hi Pro VHS 4410 Videocassette	(\$8.00 each)	\$ _____
Shipping and handling per order		\$ <b>4.00</b>
Total Amount in U.S. Funds only		\$ _____

New York State residents add local sales tax. Canadians add \$6.00 per order. No foreign orders. Do not send cash.

Bill my  VISA  MasterCard Expire Date \_\_\_/\_\_\_/\_\_\_

Card No. \_\_\_\_\_

Signature \_\_\_\_\_

Name (Please print) \_\_\_\_\_

Address \_\_\_\_\_

City \_\_\_\_\_ State \_\_\_\_\_ ZIP \_\_\_\_\_

# COMPUTER BITS

By Jeff Holtzman

## ClarisWorks for Windows

**O**kay, I admit it. When it comes to computer application software, I tend to go for the biggest and most powerful. Fifteen-megabyte word processor? No problem. Forty-megabyte operating system? Fine with me. But occasionally reason prevails, and I realize that not everyone wants, needs, or can afford that kind of power. For that reason, I've recently developed some interest in "works" programs. These programs typically combine word processor, spreadsheet, database, and graphics modules under a more or less unified user interface.

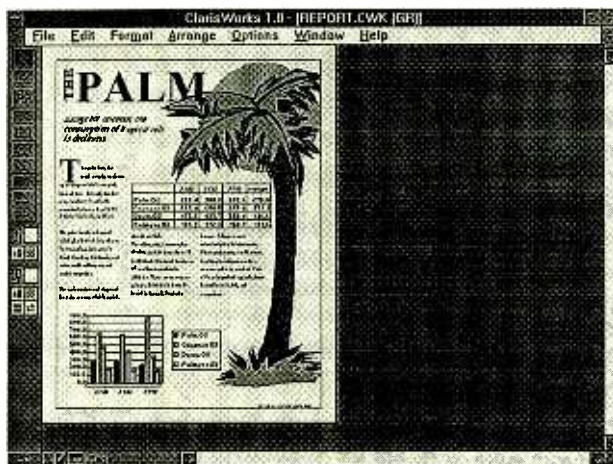

*You can create complex documents containing text, graphics, spreadsheets, and charts using ClarisWorks, an integrated package that has been ported from the Macintosh environment. The program provides surprising Windows-based power in an easy-to-use package that requires less than 4MB of disk space.*

Works programs usually have lighter demands on both your system resources and your pocketbook than the massive, stand-alone applications that are becoming the rule for business automation. Lotus, Microsoft, Spinnaker, and others all make works programs. But I had heard really good

things about ClarisWorks for Windows, so I decided to investigate the package.

In a word, I'm impressed. Claris is the software subsidiary of Apple, formerly producing Macintosh-only software, but now doing both Mac and Windows wares. Mac software is known for ease of use; with ClarisWorks the company has done a fine job of bringing the concepts over to the Windows environment. Impressively, Claris has done so by building a package that requires less than 4MB of disk space, and that runs acceptably on a 25-MHz 386.

### FEATURES

Here's a quick overview of ClarisWorks product features. It includes integrated word processing, spreadsheet, charting, graphics, and database modules. The absolutely coolest thing about ClarisWorks is its seamless integration among the word processor, spreadsheet, and graphics modules. To embed a spreadsheet or graphic image in a document, you just click on a different tool button and start drawing or entering data. So-called "integrated" software has been around for a decade or more, but never has any package achieved the smooth integration of ClarisWorks.

ClarisWorks has a surprisingly powerful feature set. It can open multiple documents (where "document" can refer to a text document, or a separate spreadsheet, graphics, or database file) simulta-

neously, and multiple windows into the same document. The program does not distinguish between draft and print modes; what you see is always what you get. ClarisWorks provides a robust set of input and output filters, so you can exchange spreadsheets with 1-2-3 and Excel, text files with Word and Word Perfect, databases with dBASE, etc.

The word processor supports PostScript and TrueType fonts in sizes from 4 to 255 points. You can also apply bold, italic, and underline attributes to text; you can enter subscripts and superscripts; and paragraphs can have left, center, and right alignment, and indents and tabs. A document may have several columns, with automatic text flow among them. In addition, ClarisWorks supports frames that may be placed on a page independently, and text that may flow from frame to frame to frame. There is also a spelling checker and a thesaurus.

On the minus side, the word processor does not show font and size information on the ruler line. Instead, you must refer to nested menus and dialog boxes. Another limitation is the inability to search and replace formatting.

The most serious limitation, however, is the exclusion of named styles. In most modern word processors and desktop publishing programs, a named style stands for a collection of formatting information (e.g., font, size, attribute, paragraph align-



ment, underlines, borders, and the like). ClarisWorks' lack of styles means that all formatting must be applied manually, and because it is

#### VENDOR INFORMATION

ClarisWorks for Windows  
Claris Corporation  
P.O. Box 58168  
Santa Clara, CA 95052-8168  
Tel. 408-727-8227

not possible to search and replace formatting, all changes of this nature must be done by a visual search-and-replace operation.

The spreadsheet provides a surprisingly powerful set of functions, including business and financial (fv, npv, pmt), date and time (date, datetotext, etc.), information (alert, beep, macro, row, hlookup, vlookup, etc.), logical (and, or, not, etc.), numeric (abs, exp, int, ln, log, mod, pi, round, sign, etc.), statistical (average, count, max, min, sum, stdev, var, etc.), text (char, code, concat, left, lower, mid, etc.), and trigonometric (acos, asin, atan, cos, sin, tan, etc.).

The database is a flat-file affair; it provides six data types: text, number, date, time, calculated, and summary. You can do mail merges with data from the database; you can also print address labels and the like. You can also create highly attractive forms for entering and searching for data, and reports with several levels of summaries.

All in all, ClarisWorks is a heck of a program. It has just about everything a student would need for writing technical and nontechnical reports. For traveling users, the 4MB of disk-space usage is highly attractive, as is the ability to import and export files in standard formats. I've seen the program offered at a street price of under \$100. ■

# Pass the COMMERCIAL RADIO OPERATOR LICENSE EXAM



## with this CONFIDENCE BUILDER!

As a reader of **Popular Electronics** you most likely know many of the answers to the FCC General Radiotelephone Operator License exam questions. All it may take to get your license is a quick review of the *Commercial Radio Operator License Educational Package* and taking one or more sample exams—consisting of the actual questions used in the FCC exams! If not, even a novice can bone up using License Exam Preparation software (on a PC disk) and successfully pass the FCC exam. Don't believe it? Buy it! Try it! It's guaranteed to do the job or your money back!

#### Look at these features:

- All exam questions (*guaranteed word-for-word*) and answers contained in this package are the ones used in the FCC exams. There will be no surprises when you take your examination.
- You will be taking *practice* FCC license examinations right at your personal computer or work from printer copies.
- Question selection formula is the one used in the *actual* FCC examination.
- Computer constructs *unique* written theory tests for you to answer on the screen, or on print out! Program *supports* all dot matrix and laser printers.
- All schematic diagrams *appear* on PC screen.
- Computer *bargraph scoring* by individual sub-element highlights topics requiring further study.
- Software tells you when *you are ready* to take the FCC exam and **PASS!**
- Change *screen colors*. . . choose *sound effects*. . . and more! *Windows* not required.
- Thousands sold to *satisfied* operators and technicians.

#### CLAGGK INC. — FCC Commercial Exam Special Offer P.O. Box 4099, Farmingdale, New York 11735

Yes, I like your offer and here is my order for the Commercial Radio Operator License Educational Package!

Complete FCC Radiotelephone Exam Special Offer that includes one 3½-in. and two 5¼-in. disks, Question and Answer booklet containing Elements 1 and 3 and FCC Part 13 Regulations, and Educational Package booklet.

(\$39.95 each)	\$ _____
Shipping and handling per order	\$4.00
Total Amount in U.S. Funds only	\$ _____

New York residents add local sales tax. Canadians add \$6.00 per order. No foreign orders. Do not send cash.

Bill my  VISA  MasterCard Expire Date \_\_\_\_/\_\_\_\_/\_\_\_\_

Card No. \_\_\_\_\_

Signature \_\_\_\_\_

Name (Please print) \_\_\_\_\_

Address \_\_\_\_\_

City \_\_\_\_\_ State \_\_\_\_\_ ZIP \_\_\_\_\_

# CIRCUIT CIRCUS

By Charles D. Rakes

## Oscillator and Bridge Circuits

Last month, we devoted this space to a discussion of oscillator circuits. We'll continue that topic now by presenting two more oscillator circuits, and then move on to a new topic—bridge circuits.

### VFO

Our first oscillator circuit is a simple JFET-based, variable-frequency oscillator that can be used in receiver or transmitter circuits. The circuit (see Fig. 1) is very stable, hence, if good quality components and appropriate construction techniques are used, there will be very little drift in frequency.

The component values

Gladwick St., Dominguez Hills, CA 90220; Tel. 301-763-5770) T50-6 toroidal core using #26 or #28 enamel-coated copper wire. The oscillator's frequency can be increased a small amount by removing a turn from the coil's winding; by the same token, the frequency can be decreased by adding a turn or two. After you have achieved the desired frequency range, cover the coil with a clear plastic coating or coil dope to keep the coil wires from moving around and causing the oscillator's frequency to shift.

enough for use in tone-control applications.

The fixed-frequency oscillator shown can easily be converted into a tunable oscillator by substituting a dual-gang linear potentiometer for R1 and R2. Different frequency ranges can be covered by using other matched values for C1 and C2. Larger values produce lower frequencies and *vice versa* for smaller values.

### WHEATSTONE RESISTANCE BRIDGE

Our next circuit, see Fig. 3, is a basic Wheatstone resistance bridge. The bridge

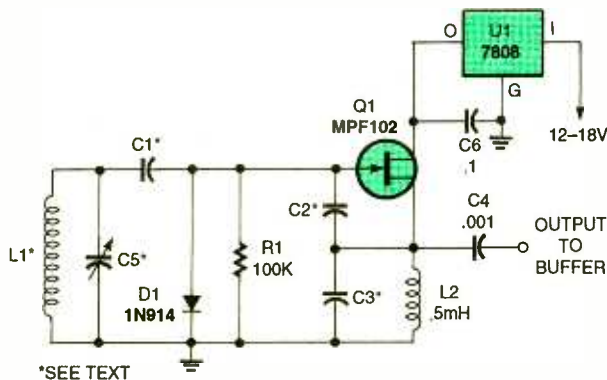

\*SEE TEXT

$f_0$ MHz	L1 (TURNS)	C2 AND C3 (pF)	C1 (pF)	VARIABLE C5 (pF)
2-6	36	680	150	100
5-8	25	470	100	100
7-14	20	470	100	50

Fig. 1. This simple JFET-based, variable-frequency oscillator can be used in receiver or transmitter circuits.

listed in the table at the bottom of Fig. 1 will give you a starting point to setup the oscillator to cover a desired frequency range. Inductor L1 is a homespun coil wound on a Amidon Associates, Inc. (2216 East

### PARTS LIST FOR THE VFO

#### SEMICONDUCTORS

U1—7808 8-volt, 1-amp voltage regulator, integrated circuit  
Q1—MPF102 N-channel JFET  
D1—1N914 general-purpose silicon diode

#### CAPACITORS

C1—C3, C5—See text  
C4—0.001- $\mu$ F, ceramic-disc  
C6—0.1- $\mu$ F, ceramic-disc

#### ADDITIONAL PARTS AND MATERIALS

R1—100,000-ohm, 1/4-watt, 5% resistor  
L1—See text  
L2—0.5-mH choke  
Perfboard materials, enclosure, 12-18-volt DC power source, wire, solder, hardware, etc.

### WIEN-BRIDGE OSCILLATOR

Our next and final oscillator is also our first bridge circuit. In Fig. 2, a 741 op-amp is connected in a Wien-bridge, audio-sinewave oscillator configuration with C1, C2, R1, and R2 determining the circuit's operating frequency. By using NPO capacitors and metal-film resistors, the oscillator's frequency is stable

consists of four resistors connected in such a way that when the circuit is balanced, the voltage at points A and B are equal. That balanced condition produces a null that can be detected by ear. The switched resistors (R1-R5) allow resistor values of 10 ohms to 1 megohm to be measured. Resistor values can be matched by connecting the desired resistor



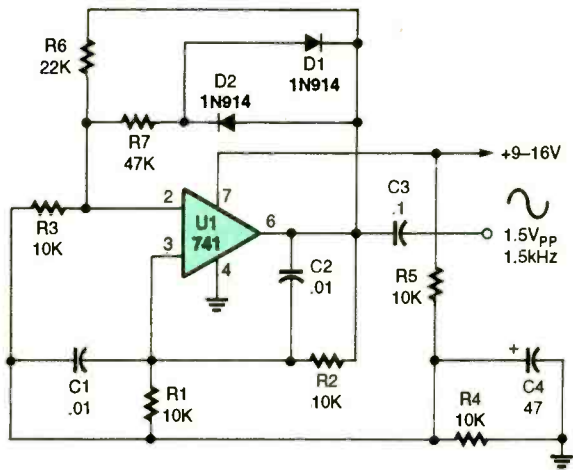

Fig. 2. The operating frequency of this Wien-bridge oscillator is determined by C1, C2, R1, and R2. It can easily be modified to act as a tunable oscillator by substituting a dual-gang linear potentiometer for R1 and R2.

### PARTS LIST FOR THE WIEN-BRIDGE OSCILLATOR

#### SEMICONDUCTORS

U1—741 general-purpose op-amp, integrated circuit  
D1, D2—1N914 general-purpose silicon diode

#### RESISTORS

(All fixed resistors are 1/4-watt, 5% units.)  
R1—R5—10,000-ohm  
R6—22,000-ohm  
R7—47,000-ohm

#### CAPACITORS

C1, C2—0.01- $\mu$ F, mylar  
C3—0.1- $\mu$ F, ceramic-disc  
C4—47- $\mu$ F, 16-WVDC, electrolytic

#### ADDITIONAL PARTS AND MATERIALS

Perfboard materials, 9-16-volt DC power source, wire, solder, hardware, etc.

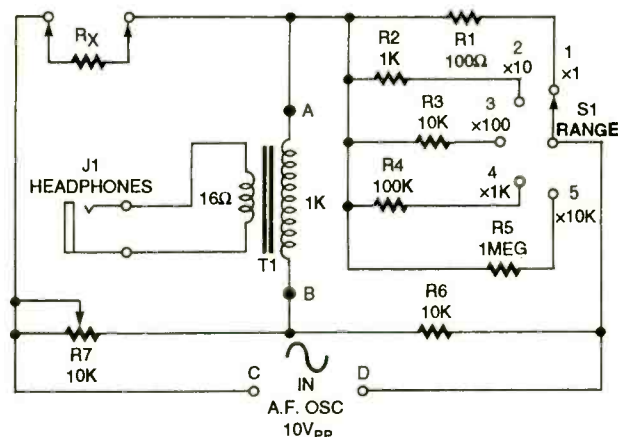

Fig. 3. When the Wheatstone Resistance Bridge is balanced, the voltage at points A and B are equal, a null that can be detected ear is produces.

### PARTS LIST FOR THE WHEATSTONE RESISTANCE BRIDGE

#### RESISTORS

(All fixed resistors are 1/4-watt, 5% units, unless otherwise noted.)  
R1—100-ohm 1/2-watt, 1%  
R2—1000-ohm  
R3, R6—10,000-ohm  
R4—100,000-ohm  
R5—1-megohm  
R7—10,000-ohm linear potentiometer

#### ADDITIONAL PARTS AND MATERIALS

T1—1000-ohm to 16-ohm audio-output transformer  
S1—SP5T rotary switch  
Perfboard materials, headphones, binding post, phone jack, audio oscillator, enclosure, wire, solder, hardware, etc.

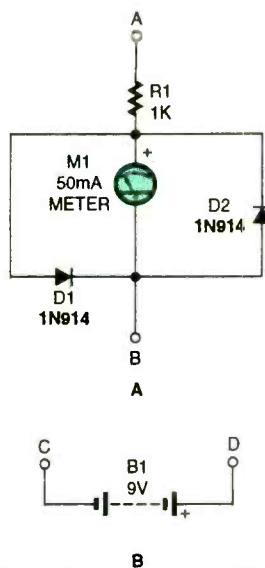

Fig. 4. By replacing the T1 and the headphones with the circuit in A and the audio oscillator with a battery (B), resistor values can be read directly from the meter.

value at  $R_x$  and bringing the circuit into balance with R7. Once that is done, remove the resistor from  $R_x$  and substitute other resistors in that position to find ones that produce a similar null.

An external audio generator supplies the signal voltage, while an audio-output transformer is used to match the circuit's output impedance to modern stereo headphones. If you happen to have an old pair of 2000-ohm headphones, leave out the transformer and connect

them directly to terminals A and B.

A linear potentiometer of the best possible quality must be used for R7. A large dial can be made and marked off in a hundred equal divisions and numbered likewise. When S1 is set to position 1, resistances ranging from 0 to 100-ohms can be read directly from the dial. In all the other range positions, a multiplier is used to give the correct resistor value.

The AF oscillator, T1, and the headphones can be replaced by the circuits shown in Fig. 4 to convert the Wheatstone bridge into a DC circuit. Transformer T1 and the headphones are replaced by the circuit in Fig. 4A, while the AF oscillator is replaced by the 9-volt battery in Fig. 4B. With those changes, the zero-center reading 50- $\mu$ A meter shown in Fig. 4A serves as the null indicator and a 9-volt battery supplies power for the meter.

### TEMPERATURE-SHIFT METER

Our next circuit, see Fig. 5, replaces one leg of a standard Wheatstone with three small-signal silicon diodes, which are used to detect changes in temperature.

That's possible because the

(Continued on page 90)

# DX LISTENING

By Don Jensen

## The Broadcasters SWL's Love To Hate

In the world of shortwave radio, there have always been certain stations that SWL's love to hate. There are those, of course, whose broadcasts are universally liked, or nearly so. The venerable Auntie Beeb, of the respected *British Broadcasting Corporation*, is a good example. Not only does the BBC air some of the world's best newscasts, but its entertainment programs also are first rate.



ARCO VESPASIANO AUGUSTO • ROMA

This ancient arch, one of the glories of Rome, home to Italy's shortwave voice, RAI, is illustrated on one of the station's attractive QSL cards.

However, over the years, there have been other international voices that attracted listeners, seemingly, despite their programs. For many years, Albania's *Radio Tirana* had

a reputation for having some of the world's worst programs, particularly during the years when it was the most "unreconstructed" of Communist East European stations. SWL's regularly tuned *Radio Tirana*, if only to puzzle how it could be, simultaneously, the most vitriolic and the dullest station on the air!

Another target of SWL complaints for years was *RAI*, the acronym for Italy's shortwave operation, pronounced "wry." Most of the criticism was directed at RAI's English-language announcer, a woman whose delivery was so lifeless that she was dubbed the "Dead Lady" by American SWL's. Nonetheless, for me, RAI was, and is, a favorite broadcaster. The reason, I guess, is that some places have a special fascination for me. Rio de Janeiro is one. Tahiti is another. And Rome, the glorious and eternal city, is similarly special.

So never mind RAI's reputation—in fairness, I never felt it was really deserved—I like the Italian SW broadcaster because, well, because it's Rome! Indisputably RAI is working hard these days. Its broadcasting operations, previously scattered were centralized last year at a new radio-television center at *Saxa Rubra* in Rome. There are six studios there with modern and sophisticated equipment.

Rome now airs shortwave programming in 26 different languages and is contemplating adding others, including Chinese and Japanese. Since its transmitting complex at

*Santa Palomba*, outside Rome, cannot be expanded, a new center may be built in Tuscany in the near future. In addition, and following the lead of other international broadcasters, RAI also may lease up to 3 hours of daily air time from stations elsewhere in the world in improve its overseas broadcasting coverage.

If you haven't tuned in RAI, you might want to listen for yourself to its brief, 20-minute, daily, English-language program at 0100 UTC on 9,575 or 11,800 kHz. I leave it to you. Is it thumbs up, or down, for RAI?

### G-IVAN RADIO

In the September installment of *DX Listening*, I mentioned that the Australian, Belgian, and other governments are now broadcasting programs on shortwave to their military personal serving with the United Nations peacekeeping forces in Somalia and the Balkans. Now comes word of another GI radio broadcast, this one by the Russian Ministry of Defense, but directed to its troops in Tajikistan near the Afghan border.

My good friend and ace Danish DX'er, Finn Krone, who airs an SWL program for European listeners, notes that these programs to Russian soldiers are prepared in the *Slavyanka Radio Studio* of the Defense Ministry and are aired by *Radio Moscow* transmitters. Krone quotes the *British Broadcasting Corporation's* Monitoring Service as reporting those half-hour Russian GI programs are



aired Monday through Friday at 1600 UTC on a number of shortwave frequencies including 4,740, 4,940, and 11,835 kHz.

Krone notes that the 11,835-kHz frequency has been well heard in Denmark. Programs, naturally, are in Russian, but if you do hear this one, you can write to Slawyanka Radio Studio, Shaposhnikova No. 14, ulitsa Marshala, Moscow, Russia.

### SENSITIVITY AND SELECTIVITY

Reader Michael Alexander, Tucson, AZ, writes to say that the simple regenerative SW receiver kit mentioned in the October 1993 *DX Listening* column "really derives its usefulness from a different operating principle than the one described."

He notes that the radio signal's "feedback energy is used to compensate for the resistive losses in the tuned circuit and the antenna, with the result of achieving a very high 'Q'... in the (receiver's) tuned circuit and, thus, making selectivity possible." Sensitivity, he notes, is only helped to some degree.

"In the days when these circuits were popular, people generally had large, outdoor, energy-gathering antennas, plus some audio amplification. Sensitivity, therefore, was not that much of a problem."

Thanks, Michael, good point. It was true in the old days, and today as well, that selectivity, rather than sensitivity, is most critical to the shortwave listener. Most receivers, even the inex-

pensive sort, given a suitable antenna, are sensitive enough to capture weak SW signals. But unless you are able to sort out that desired station from the babel of competing signals in a crowded band, not much will be intelligible.

"This is a basic question, I know," writes Kerry Smithton, Fresno, CA, "but I'm your basic beginner in shortwave listening. I know that there are various SW bands where stations are grouped together. Those bands are marked on my radio. But, depending on the time of day, on some of them I hear nothing at all. Where and when should I tune?"

Yes, it is basic, Kerry, but it is a useful question because we have a regular influx of brand new SW listeners among our readership. So there will always be some of you with basic questions, which I try to answer and answer again periodically.

Broadly defined, the shortwave spectrum spans the frequencies from about 2,000 to 30,000 kHz. Because of the way in which radio signals propagate—get from the transmitter to your receiver—usable frequencies fluctuate depending on the time of day. If you tune some frequencies and hear absolutely no stations, chances are you're trying the wrong bands at that hour.

When should you tune, and where? Here's a bit of help from the pages of *Passport To World Band Radio*, the annual guide to shortwave listening:

4,700–5,100 kHz—early morning and night, mainly during winter.

5,850–6,250 kHz and 7,100–7,600 kHz—night.

9,300–10,000 kHz—early morning, late afternoon, and night.

11,500–12,160 kHz—night, and to some degree, day.

13,600–13,900 kHz and 15,000–15,700 kHz—day, and to some degree, night.

17,500–17,900 kHz—day, and to a slight degree, night.

21,450–21,850 kHz—day.

### DOWN THE DIAL

Your letters are always welcome! What are you hearing? Do you have a question about SWL'ing? What do you like (Italy's RAI?) and what don't you like (ditto?) on shortwave? Write me at *DX Listening*, Popular Electronics, 500-B Bi-County Blvd., Farmingdale, NY 11735.

Here are some stations being reported on SW. Remember that Universal Coordinated Time (abbreviated as UTC) is equivalent to Eastern Standard Time plus 5 hours; CST + 6; MST + 7; and PST + 8.

**BULGARIA**—15,330 kHz.

*Radio Bulgaria* in Sofia signs on its English transmission at 0000 (midnight) UTC with a newscast. It operates in parallel on 11,720 and 17,825 kHz.

**CROATIA**—13,830 kHz.

Croatian-language programming is noted from *Croatian Radio* on this frequency. Look for a news broadcast shortly after 0500 UTC.

**JAPAN**—11,815 kHz.

Tokyo's *Radio Japan* is audible at 0900 UTC with English news, identification, and frequency announcements.

**MEXICO**—6,185 kHz.

*Radio Educacion* is heard with an English-language broadcast at 0800 UTC.

**PAKISTAN**—17,705 kHz.

*Radio Pakistan* in Islamabad has a very brief English transmission, from 0227 to 0246 UTC, which includes identification, frequencies, and slowly read news. ■

\*Credits: Richard D'Angelo, PA; Rufus Jordan, PA; Marie Lamb, NY; Tony Orr, VA; Doug Robertson, CA; Betsy Robinson, TN; North American SW Association, 45 Wildflower Road, Levittown, PA 19057

## COMING NEXT MONTH in the April, 1994 Issue of **Popular Electronics**

Spring and the open road brings a wanderlust into our lives. So do it with a home-brew solid-state soda cooler and you'll only have to stop for gas. Plus, assemble a night-vision scope that works! And, learn how to select the right computer printer for your needs!

On Sale  
February 17, 1994  
**Watch for it!**

Pick up *Popular Electronics* at your favorite Newsstand, Bookstore, Convenience Store or Supermarket

# HAM RADIO

By Joseph J. Carr, K4IPV

## Want To Operate W1AW?

**T**he American Radio Relay League (ARRL) is the national amateur-radio operator's organization; it's headquartered at 225 Main Street, Newington, CT, 06111; not far from Hartford. If you wish to visit ARRL the next time that you are in New England, it's really easy to do—in fact they encourage visits from hams, so don't feel like you are imposing. If you write or call ARRL (Tel. 203-666-1541 and 24-hour fax 203-665-7531), they can give you exact directions from the areas interstates.



*The American Radio Relay League (ARRL), headquartered at 225 Main Street, Newington, CT 06111, houses the league's administrative departments, the publications (books and the magazine QST), and a host of other services for members.*

Once on Main Street Newington, it's easy to spot the ARRL HQ building with its impressive antenna farm. The HQ building houses the league's administrative departments, the publications (books and the magazine QST), the contest people, and a host of other services for members. In the lobby of the HQ building there's a fine antique-radio museum that is specially tailored to radio amateurs.

I visited the headquarters

several years ago, and reported the visit in this column. But, what was missing during my last visit was the W1AW, the league's resident ham station. W1AW (originally 1AW) was the ham callsign of ARRL co-founder Hiram Percy Maxim, who passed away in the mid-1930's. The ARRL HQ station is a much deserved memorial to Maxim.

The small building located in front of the ARRL HQ building, where W1AW was located for many years, was being renovated at the time. So W1AW operations of had been transferred to a temporary site inside the HQ building. I resolved to return and see W1AW . . . which I did last summer.

When I arrived at the station, an on-duty operator showed me around. In the main transmitter room, there's a complex operating console. Behind the main operating console lies a bank of seven powerful Harris commercial transmitters (green with envy is the only way to describe my reaction to that wonderful sight!).

Currently, the visiting hours are from 1 PM to 1 AM

Eastern Time the next morning on Mondays; from 9 AM to 1 AM Eastern Time Tuesdays through Fridays; and 3:30 PM to 1 AM Eastern Time weekends. There are some holidays off for ARRL personnel, so ask for the schedule before making the trip on a holiday. For weekend visiting, special arrangements must be made by calling or writing to the ARRL at least a week in advance.

### BRING YOUR LICENSE

If you bring your FCC license (or a photocopy) with you, they'll let you operate W1AW during the scheduled guest-operator hours, from 1:00 to 4:00 PM Eastern time Monday through Fridays. Write to ARRL for a current W1AW visiting-operator schedule; the schedule changes from time to time.

The ARRL found out a long time ago that many visiting operators were a tad self-conscious about sitting at the main console under the keen scrutiny of the station chief operator. To overcome that psychological problem, they built three private glassed-en-



*This complex operating console is located in W1AW's main transmitter room.*



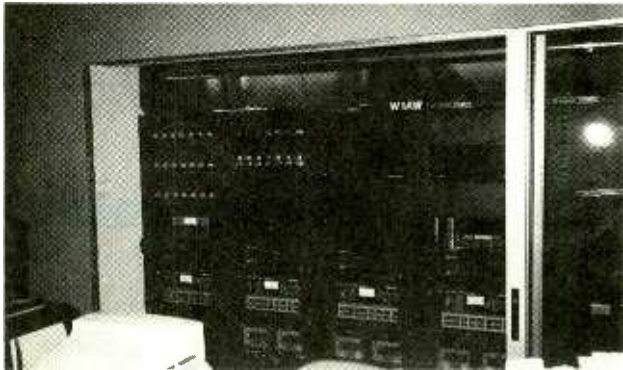

A set of seven Harris commercial HF transmitters are the main muscle of W1AW.



Our host and tour guide for the visit to W1AW was ARRL Executive Vice President David Sumner, K1ZZ. The portrait on the wall is of Hiram Percy Maxim, the original W1AW and cofounder of the ARRL.

closed, guest-operator studios. You are still under scrutiny (the ARRL, as licensee, has responsibility for what is done with their radio station, just as you are responsible for what is done with yours), but it isn't as obvious when using the three guest studios.

The ARRL is very accommodating to visiting hams. Although they can't guarantee any particular band or mode for your visit, if you call or write ahead of time with any special requests, they will at least try to accommodate you. Sometimes there are large groups touring the facility, but at other times (as when I arrived) no one other than the ARRL staff will be around.

My host and tour guide

for the most recent visit was David Sumner, K1ZZ, Executive Vice President of the ARRL. I apologize to Dave for stopping in unexpectedly—ignoring my own advice to call or write first—but, as usual, the ARRL was a most excellent host.

W1AW provides a number of services, including official bulletins (in voice, CW, and teleprinter) and DX bulletins. Many hams have received their code practice off-the-air from W1AW. Code practice is sent on 1.818 MHz, 3.5185 MHz, 7.0475 MHz, 14.0475 MHz, 18.0975 MHz, 21.0675 MHz, 28.0675 MHz, and 147.555 MHz, with sessions currently scheduled for 4 PM, 7 PM, and 10 PM (all Eastern Time).

I encourage you to become an ARRL member. They are the ham's principal voice in an era when



To overcome that psychological problem associated with sitting at the main console under the keen scrutiny of the station chief operator, the ARRL built three private, glass-enclosed "guest operator" studios.

commercial interests may well begin threatening our frequencies more fiercely than at any time since the end of World War I when they put us on 200 meters and below—the supposedly useless shortwave bands. You may hear a lot of carping criticism of the ARRL. Some of it may be valid, but much of it is nonetheless little more than pure whining. In any event, they're still the only real "game in town" for amateur operators.

### PC BOARDS AVAILABLE

In the *Ham Radio* column for October, 1993, I discussed the Mini-Circuits MAR-1 MMIC amplifier chip; a chip that can operate from near-DC to 1000 MHz and offers 50-ohm input and output impedances. A printed-circuit pattern was shown. And while I was able to offer readers the MAR-1 chips at \$4.95 each (offer still open), I could not at that time offer the printed-circuit boards. A newer and somewhat improved version of that board (see Fig. 1) is now available for \$7.50. You can order it either directly from me (at P.O. Box 1099, Falls Church, VA, 22041), or from FAR Circuits (18N640 Field Court, Dundee, IL 60118). If you order from FAR Circuits, ask for the

Joe Carr, K4IPV board under filename "MAR-1D.PCB."

The new board for the MAR-1 circuit is designed to accommodate either chip capacitors or ceramic disc capacitors at the inputs and outputs. In fact, there are two sets of holes at both the input and the output to accommodate

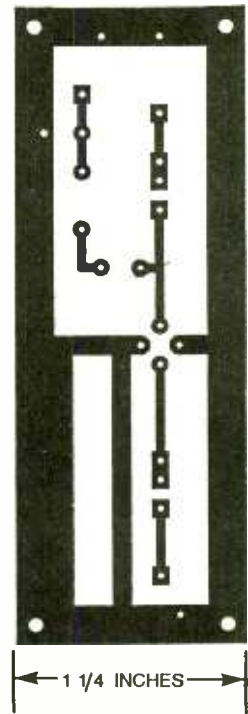

Fig. 1. The new printed-circuit board for MAR-1 amplifier that was presented in the October 1993 column is designed to accommodate either chip or ceramic-disc capacitors at the inputs and outputs.

smaller and larger types of disc capacitors (the key difference being the separation between the leads).

The RF choke can be either small axial-lead molded chokes, or can be a radial-lead (vertical-mounting) 8mm standard-size choke. For 100- $\mu$ H applications use Digi-Key's TK-4259; for 1 mH use Digi-Key's TK-4283 choke; and for 10 mH use Digi-Key's TK-4324 unit.

# SCANNER SCENE

By Marc Saxon

## Tracking Smokey Bear

Uniden Bearcat's *Bear Tracker BCT-2* is a pre-programmed, multi-band scanner with "Highway Patrol Warning Alert." With that feature, for every state in which you set frequencies for the BCT-2 to scan, it instantly accesses a special set of pre-programmed highway-patrol frequencies. When any transmission is detected on a highway-patrol frequency, visual and audible warnings are given.



The Bearcat Bear Tracker BCT-2 scanner sounds an alarm when it picks up signals on a highway-patrol frequency.

The warning light will flash until you are beyond a three-mile radius of the last transmission, and the audible alarm will sound for five seconds for each transmission received. The user can switch the alarm feature on or off.

The BCT-2 has a front-panel switch that can bring up all states, and is pre-programmed with low, high, UHF, UHF-T band highway patrol, local police, and Department of Transporta-

tion channels. It will also receive NOAA weather frequencies. At those times, the alarm is automatically disabled.

When scanning, specific frequencies can be locked out by the operator, or the scanning action can be temporarily stopped to allow monitoring of any active frequency of particular interest. There is also a switchable two-second scan-delay feature.

### GETTING TESTY

From time to time, you find unusual things to hear on the frequencies used by aircraft manufacturers when they work on new designs. Listening to intrepid test pilots putting new and experimental aircraft through various flight tests has got to be fascinating. Those tests include speed, stress, handling, and other design factors, and often go on almost daily for extended periods of time as tests are repeated after modifications are made, and then repeated again. The tests are often conducted at high altitudes, which means that the communications from the test pilot to the ground describing what's going on can be monitored over a wide area.

Things don't always go right. I get the impression that many test pilots tend to be as blunt as they are colorful, so you get an unforgettable earful when a problem is reported to ground. This is usually while

it's actually taking place.

The frequencies used for these activities occupy most of the band that runs from 123.125 to 123.575 MHz (a few frequencies in this band, such as 123.3 and 123.5 MHz, are used for other purposes). Frequencies are spaced at 25 kHz (123.125, 123.15, etc.).

Manufacturers of military equipment also use frequencies in the UHF aeronautics band. While many different UHF frequencies are in use by individual companies, several particular frequencies are commonly used by major manufacturers including Lockheed, Grumman, McDonnell-Douglas, and Sikorsky. Those frequencies are 275.2, 314.6, 345.4, and 382.6 MHz. It might be worth keeping an ear on those, too.

### HANDY AND COLORFUL

Larry Johansen, of Minneapolis, Minnesota, asks what the "purple" frequency is. A friend of his said that he has a pair of handheld radios that operate there, and insists that there is no other way of identifying the operating frequency. Larry wants to monitor those radios, but doesn't believe that they are using ultraviolet frequencies.

Low-cost, over-the-counter handheld VHF and UHF radios are sold to campers, hikers, hunters, sportsmen, and for business/industrial purposes. They can operate on any of several different popular frequencies. Those



are often identified to the customer only by a color-coded designation. That makes it easy for the average person to remember in the event that they want to order additional sets for a particular channel. We guess that it's an attempt to avoid requiring members of the public to remember complicated frequencies to try not to intimidate them with techno-words like "megahertz."

But we can tell you that Purple is 151.955 MHz. Write down these other "secret" frequencies: Red is 151.625, Blue is 154.57, Green is 154.60, Brown is 464.55, Silver Star is 467.85, Gold Star is 467.875, Red Star is 467.90, and Blue Star is 467.925. To add to the fun, they often sell these sets for some GMRS frequencies, which they call Channel J, on 467.7624 MHz, and Channel K, at 467.8125 MHz.

Now you now where to monitor. Those frequencies will turn up all sorts of curious chatter that you won't find anywhere else on your scanner.

## HIGH-FALOOTIN' CORDLESS PHONES

Several readers have asked about those new 900-MHz cordless phones, since we have mentioned the 46-MHz types here. The 900-MHz phones operate in the frequency range of 902 to 928 MHz. It appears that most of them use digital technology, spread spectrum, or other techniques to make it either difficult or altogether impossible to receive on a regular scanner. Costing a lot more than the standard 46-MHz types, the new 900-MHz phones are made for people who are willing to shell out all those extra bucks for the ability to chat without anyone hearing what they are saying.



*Cobra's Intenna 900 is a 900-MHz cordless phone. Although it operates between 902 and 928 MHz, you won't hear it on your scanner!*

## FIRE BUFF NET

Fire Net is a paging system that transmits messages to thousands of firefighters, fire buffs, scanner fans, and news media. There are thousands of Fire Net subscribers in Boston, New York, and Chicago, and it's now being set up in southern California, including Los Angeles. Future plans call for Denver and San Francisco Fire Nets. Subscribers get information on all fires in Fire Net cities.

The information is sent via alpha-numeric radio paging, and includes the channel information used by the local firefighters working the fire. The Fire Net dispatchers are all off-duty, disabled, or retired firefighters who transmit the original response, then keep providing updates.

Persons who think that they might be qualified as dispatchers, or who are interested in the service, can phone 310-838-1436, or call CompuServe 71674,1610 or Prodigy TKXD40A.

## SO LONG!

Until next time, please send along your questions, thoughts, frequencies, etc. Write to *Scanner Scene*, Popular Electronics, 500-B Bi-County Blvd., Farmingdale, NY 11735. ■

## THINK TANK

*(Continued from page 28)*

### HV PROBE

This high-voltage probe (see Fig. 7) has several strong points. For example, it's easy to build and it has two functions: it allows your DMM to take high-voltage measurements to 10,000-volts peak, and acts as a high-impedance (100-megohm) probe for high-impedance circuit testing.

The probe was designed to plug into a standard 10-megohm input DMM. If your DMM has a different input, you can change R3 and R4 to suit it. The ratio of  $R1 + R2 + R3 + R4$  to  $R3 + R4$  should be exactly 1000 to 1, thus, a 10.00-volt input will read 10.00 millivolts on your DMM. Keep in mind, the impedance of your DMM is in parallel with R3/R4 when you calculate new values!

from the "business" end! Bring out (at the handle end) a separate 18-inch wire lead with an alligator clip for the ground lead. A separate shielded cable (with appropriate plug) goes to your DMM.

To use the probe, plug it into your DMM observing proper polarity and connect the ground lead to the common of the circuit under test. Then touch the probe to the test point and multiply the DMM reading by 1000. **Always** follow that procedure to protect yourself and your DMM.

Resistors R1 and R2 are 50-megohm, 1%, 6-kV, 1.5-watt units. They cost \$2.25 each from Johnson Shop Products (P.O. Box 160113, Cupertino, CA 95016; Tel. 408-257-8614) as item No. 160-CAD-50M.

—Skip Campisi, So. Bound Brook, NJ

*Skip also noted (in his*

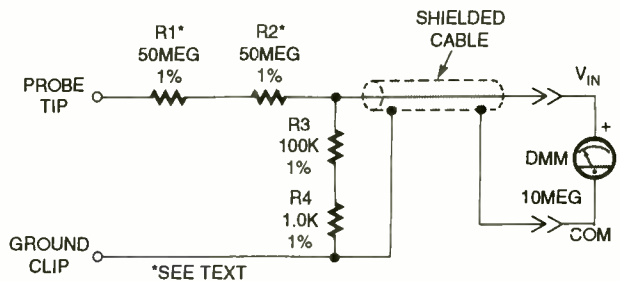

*Fig. 7. Working with high-voltage or high-impedance circuits? Then you'll need this probe to extend your meter's range. It's inexpensive, simple, and, most important, could save your life!*

Construction is simple: butt-joint R1 and R2 and use plenty of heat-shrink tubing over their entire length to protect against high voltage arcing. An 8- or 10-inch length of ½-inch PVC pipe with glue-on end caps makes a nice probe body, or you could use Radio Shack's No. 15-1200 wall feed-through tube, which is a ¾-inch tube of clear plastic with end fittings. Whatever you use, glue on a hilt near the handle end to keep your hand away

*schematic) that the ground lead should be made from 18-inch long No. 24 insulated wire. The coax to the DMM should be about 24-inches. Also, R1 and R2 are Caddock No. HG716-15 units, in case you have another source of Caddock parts.*

Well that's all for this month's column. If you'd like to participate in an upcoming issue, write to *Think Tank*, Popular Electronics, 500-B Bi-County Blvd., Farmingdale, NY 11735. ■

## CIRCUIT CIRCUS

(Continued from page 83)

forward junction voltage of a silicon diode varies inversely with temperature; i.e., as the temperature goes up, the voltage goes down, and vice versa.

The circuit can be calibrated so that the temperature can be read directly from the meter scale. To calibrate the circuit, place the leg of the circuit with the three diodes in a glass of ice water and adjust R4 for a 0°C or 32°F reading. Next, remove the diodes from the ice water and leave them at room temperature for about 10 minutes. Check the meter's reading at room temperature. Place the diodes in a pan of boiling water and adjust R5 for a full-scale reading. You may need to

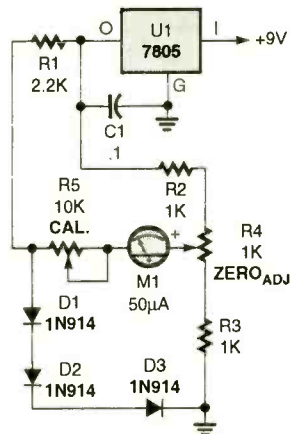

Fig. 5. The Temperature-Shift Meter meter is designed to detect small changes in temperature, rather than give exact temperature levels.

go back and forth between the two procedures to get the circuit to cover the desired temperature range.

### HV STATIC DETECTOR

In our next circuit, offered

## PARTS LIST FOR THE TEMPERATURE SHIFT METER

### SEMICONDUCTORS

U1—7805 5-volt, 1-amp voltage regulator, integrated circuit  
D1—D3—1N914 general-purpose silicon diode

### RESISTORS

(All fixed resistors are ¼-watt, 5% units.)  
R1—2200-ohm  
R2, R3—1000-ohm  
R4—1000-ohm potentiometer  
R5—10,000-ohm potentiometer

### ADDITIONAL PARTS AND MATERIALS

C1—0.1-µF, ceramic-disc capacitor  
M1—50-mA meter  
Perfboard materials, 9-volt power source, wire, solder, hardware, etc.

## PARTS LIST FOR THE HV STATIC DETECTOR

### RESISTORS

(All fixed resistors are ¼-watt, 5% units.)  
R1—R4—22-megohm  
R5, R6—1000-ohm  
R7—330-ohm  
R8—1000-ohm potentiometer

### ADDITIONAL PARTS AND MATERIALS

Q1—MPF102 N-channel JFET  
B1—9-volt transistor-radio battery  
S1—SPST switch  
M1—100-µA, center-zero, meter  
Perfboard materials, enclosure, wire, solder, hardware, etc.

# From Not-Working to Networking!

## Troubleshooting Local-Area Networks!

Now, complete for the first time in one detailed booklet!

Gain a fuller knowledge of network fundamentals and how they developed from the early days of main frames, from XNS to Ethernet technology, the OSI stack for interconnecting different computers, basic and specialized test instruments, etc. Several tough LAN case histories bring from theory to the practical side of troubleshooting.

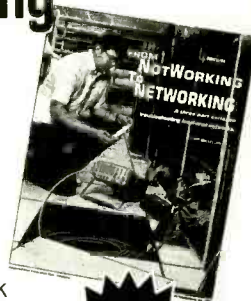

ONLY \$5.00

CLAGGK Inc., Reprint Bookstore  
P.O. Box 4099, Farmingdale, NY 11735

Please rush my copy of "From Not-Working to Networking." I enclosed payment of \$5.00 which includes shipping charges.

Name \_\_\_\_\_  
Address \_\_\_\_\_  
City \_\_\_\_\_ State \_\_\_\_\_ ZIP \_\_\_\_\_

Sorry, no orders excepted outside of United States and Canada. All Payments must be in U.S. funds. Send check or money order payable to CLAGGK Inc.—do not send cash or stamps. New York State residents add applicable sales tax.

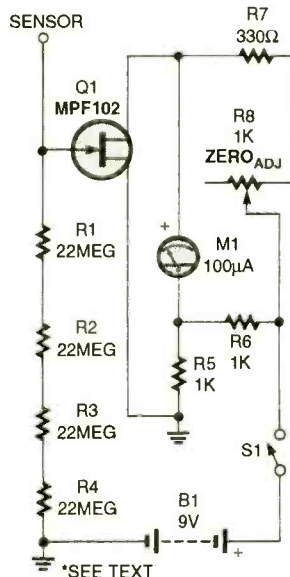

Fig. 6. The HV Static Detector uses a short length of solid-copper wire connected directly to the JFET's gate as the input sensor.

in Fig. 6, one leg of the Wheatstone bridge is replaced by an MPF102 N-channel JFET. The JFET's high gate-input impedance turns the simple bridge circuit into a very sensitive high-voltage static detector. The JFET's gate is tied to ground through four 22-megohm resistors. A 1- to 2-inch piece of solid-copper wire is connected directly to the JFET's gate and serves as the input sensor.

With the sensor clear, adjust R8 for a zero meter reading. Run a comb through your hair and move it toward the sensor. The meter should go off scale. Place the static sensor next to your computer or any static-sensitive equipment and take special notice when the meter moves. ■



## ELECTRONIC CASINO

(Continued from page 50)

the display repetitively flashes the digits "1," "2," and "3," prompting you to select a game to play. Pressing S1 selects, blackjack, S2 selects craps, and S3 selects the slot machine. After you select your game by pressing the appropriate switch, game play begins.

**Blackjack.** In blackjack, DISP1 shows the point total of the dealer's hand, while DISP2 shows the player's total. The circuit assumes that one "unit" of the player's bankroll is wagered on each hand. When S4 (DEAL) is pressed, two "cards" are dealt to the player, along with one to the dealer, and the display is updated to show the point totals of both hands. The player then presses either S1 to keep his hand, S2 to ask for another card, or S3 to double his wager (in which case, in accordance with standard casino rules, he gets only one additional card).

When the player finishes playing his hand, the circuit automatically plays out the dealer's hand. Cards are dealt one at a time and the display is updated until the dealer's point total reaches or exceeds 17. At that point, the hand is over and the winner is the

hand with the highest total that does not exceed 21. If the totals are the same, the hand is a tie. The circuit determines who wins—player or dealer—and the player's bankroll is increased or decreased depending on the outcome of the hand.

Standard casino-blackjack rules are programmed into the circuit, including a payoff of 3 to 2 for blackjack (an initial hand containing an ace and a ten or face card). Aces are counted as eleven points unless the total for the hand exceeds 21, in which case the ace is one point. A hand that contains an ace is called a "soft" hand and is indicated by a flashing display.

**Slot Machine.** Each digit of the display represents one "wheel" of the slot machine. Pressing S4 "pulls the handle" to start the wheels "spinning." The displays rapidly change between five characters ("—," "E," "0," "8," and "H") and then stop one at a time, starting from the left, to display four characters. If none of the characters match, the player loses that spin and one unit is deducted from the bankroll. If some of the displays do match, various payouts are added to the bankroll depending on how many and which characters match. As in a real slot ma-

chine, the probability of occurrence is different for the different characters. The "—" is the least probable character, and the payoff is 100 to 1 if all four display digits contain a "—."

**Craps.** Pressing S4 "rolls the dice" and displays the result—a number between 2 and 12—in the two display digits on DISP2. An initial roll of 7 or 11 wins; a roll of 2, 3, or 12 loses; and any other roll is called the "point." When a point is established, it is shown in DISP1. Then the player keeps rolling until either a 7 is rolled (a loss) or the point is rolled again (a win). When either of those events occur, the player's bankroll is correspondingly increased or decreased by one unit and the circuit waits for the next roll.

**Conclusion.** Because some switches have more than one function, depending on the game being played, the Electronic Casino may take a little getting used to. But once you get over that hurdle, you have many hours of gambling fun. ■

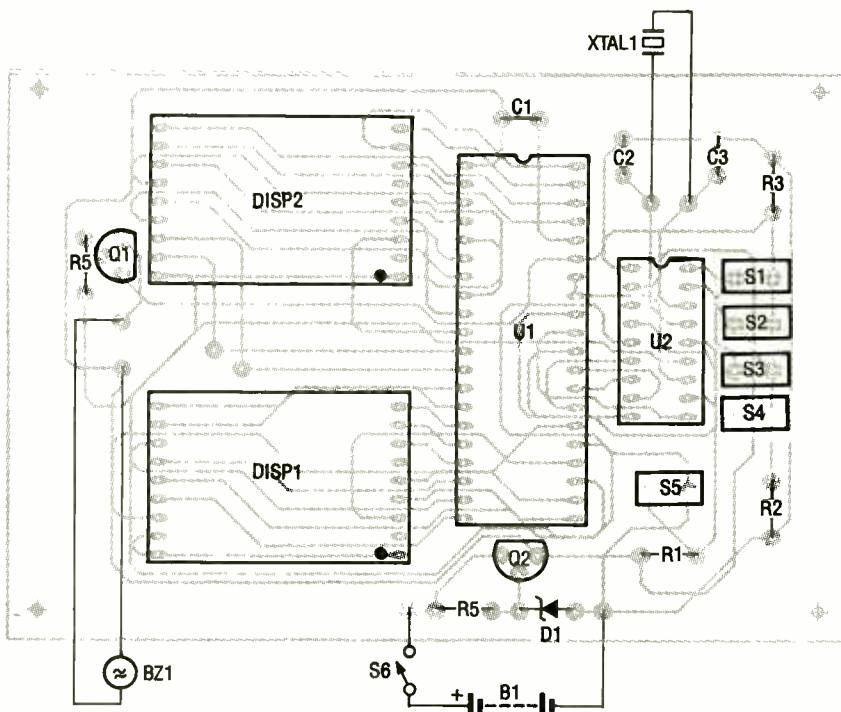

Fig. 5. Be sure to install the displays with the correct orientation (notched markings, not shown here, should be on the B1/S6 side of the board).



**ADMIT ONE**

## Your Ticket To SUCCESS

Over 28,000 technicians have gained admittance worldwide as certified professionals. Let your ticket start opening doors for you.

ISCET offers Journeyman certification in Consumer Electronics, Industrial, Medical, Communications, Radar, Computer and Video. For more information, contact the International Society of Certified Electronics Technicians, 2708 West Berry Street, Fort Worth, TX 76109; (817) 921-9101.

Name \_\_\_\_\_

Address \_\_\_\_\_

City \_\_\_\_\_

State \_\_\_\_\_ Zip \_\_\_\_\_

Send material about ISCET and becoming certified.

Send one "Study Guide for the Associate Level CET Test." Enclosed is \$10 (inc. postage).

March 1994, Popular Electronics

---

## ZOOMING ALONG

(Continued from page 61)

---

will tell you each person's fair share of the bill. Zoomer can also convert between units of measurement in length, area, mass, volume, velocity, time, and temperature. Most of the units of measure used are fairly standard, (quarts and liters, feet and kilometers), but there are a few more interesting ones available. Did you know that 17.6 football fields laid end-to-end, would fit in one mile?

Zoomer's language translator translates 1000 words in 26 languages. Besides the usual English, French, Spanish, and Italian, Zoomer offers Swahili, Serb-Croatian, Yiddish, and even Esperanto. We would prefer more words and fewer languages, but then again, we don't get around much anyway.

The reference section contains a curious mix of practical data and silly trivia. Zoomer provides consumer, U.S., and world information. The first consumer category is nutrition, in which the nutritional content of various foods—including fast foods—are provided. Many diet-conscious folks would find that data to be quite practical. The other two categories—birthstone/flower and zodiac signs—have little practical value for anyone. (If you really cared, you'd already know your sign and your birthstone. Did you even know you *had* a birth flower?)

United States and World information contain a similar mix of sensible and frivolous data. Keeping in touch long distance is made easier with listings of area codes, international dialing, and state abbreviations; airport codes might help frequent travelers; and clothing conversion could come in handy if you shop abroad. But unless they were boning up for an appearance on *Jeopardy*, we're not sure who would need to carry around information about various states and cities (state song, motto, flower, bird); holidays; and the complete text of the Declaration of Independence, the U.S. Constitution, the Bill of Rights, and various Constitutional amendments.

Last, but not least, Zoomer offers three games. Games might not be practical, but they certainly are a sensible application for a handheld device that goes everywhere with its owner. What better way to while away a plane trip, or kill time waiting for 5:00 to roll around? The Z-PDA has Solitaire, another single-player card game called Pyramid (which is virtually impossible to win), and an Othello-like board game called Uki. We'll admit that there were times when we should have been trying out other applications, but goofed off with the games instead. The cursor pad and Nintendo-like buttons set below Zoo-

mer's LCD will be used in future, third-party games.

The Zoomer does offer a well-rounded assortment of applications, making it an attractive tool/toy despite its one flaw—its limited handwriting-recognition capability. The amount of frustration caused by mis-translations is unacceptable. We hope to see that problem remedied in future generations of Zoomer products. ■

---

## ABC'S OF PDA'S

(Continued from page 57)

---

average consumer will conceive a need for such a device. Impressive as they are in terms of new technology and integrated capabilities, the first-generation PDA's suffer from unreliable handwriting recognition and, worse, lack of what's known as a "killer ap"—some new application that everyone needs and no one else is offering.

The PCMCIA slot on each device can be used to add new applications, and several have been announced, including Motorola paging service (for both Newton and Zoomer); and a Fodor's travel guide to major American Cities, *Dell Crossword Puzzles & Other Games*; *Columbo's Mystery Capers*, and financial-management and business forms from *Money Magazine* (all for Newton). The control pad and fire buttons on the Zoomer's front panel suggest that add-on games can't be far behind. Apple envisions applications including maps that use global positioning technology (Rockwell has announced a GPS receiver that fits in a PCMCIA slot), Newton fax/phone, learning devices for children, specialized uses such as an architect's sketchpad that could calculate square footage, and a refrigerator-mounted Newton family message center.

If that last application ever becomes a reality, PDA's will have made it as true consumer items. Picture a busy family juggling two careers, school, extra-curricular activities, social events, etc. Now equip all family members with their own PDA's, from which they can exchange information with the main family PDA—or with their friends' PDA's. Canceled soccer practice and a re-scheduled dentist appointment would be easier to handle, and paging could keep everyone in touch. All that would be needed to make the PDA totally indispensable is the addition of cellular-phone capability. That's a picture that will surely put smiles on the faces of the folks at Apple, Sharp, Tandy, and Casio.

## HOW DO THEY REALLY WORK?

That's a nice vision for the future, but how do today's first-generation Personal Digital Assistants really work? To find out, keep reading. Reviews of a Newton, a Zoomer, and the EO 440 follow. ■

---

## EO ON THE GO

(Continued from page 62)

---

it will be possible to upgrade the Communicator. Another plus is that the screen is large enough so that writing on it feels natural; the resolution is high enough that what is written looks natural.

The special stylus that is supplied with the Communicator is required to operate the device. The advantage of requiring a special stylus is that you can write without worrying about the heel of your hand causing spurious input (The LCD isn't touch-sensitive, but instead responds to the pen's magnetic properties.) The disadvantage is that if you lose the stylus, you can't use the Communicator; a replacement stylus is about \$35.

PenPoint understands some thirty gestures. Deleting text requires that you draw an "X" over it. Circling text calls up an editing pad. Drawing an X through a circle is an undo command that reverses the most recent action. A carat creates a new document or opens a writing pad that can be used to insert text. A check mark opens an option sheet. Pen "flicks" scroll pages up, down, or side-to-side. A question mark opens a quick-help feature. The gestures, in general, seemed sensible. As we moved back and forth between the Zoomer, Newton, and EO 440, we had no trouble remembering the EO's gestures, but sometimes got confused on the other two.

The EO offers what is called "intelligent text." For example, when you add a name to the Address Book, it becomes part of a collection of information called the ProfileBook. Whenever the name is written, it will be recognized by the EO. If, for example, your appointment calendar had a note about an appointment with Jim at his office, the name would appear in bold type, and more information about Jim could be called up with a double tap—his office address, for example. A note could also be linked with the data—perhaps a hand-drawn map showing where his office is. Six months down the road, you can find out just when the meeting was because it will still be linked to Jim, and can be found by looking at Jim's profile.

The to-do list in the Personal Perspective information manager is also intelligent in that items that are not done automatically roll over into the next day. Placing a check mark in the status box associated with an item indicates that the to-do has been done.

The communications functions of the EO are centered around an inbox and an outbox. Incoming faxes and E-mail messages are stored in the inbox. Tapping on the inbox icon opens it, presenting a list of received faxes and messages. While you are reading a document, you can zoom in



and out and scroll. You can view faxes in full size, mark it up, and send it out to someone else by placing it in the outbox. Tapping the outbox icon opens the outbox notebook, where you can enable GO Fax. A cover sheet is automatically generated, but need not be sent.

The EO Phone application can be used to make voice calls through a standard phone line or the optional cellular module. Without the module, the EO itself can't be used as a telephone.

EO Sound permits voice to be "attached" to a document. E-mail messages can be sent to other EO users—through either AT&T Mail or by phone—who can play back the voice note just by tapping on its icon.

The Personal Communicator provides several options for backing up data. If PenTOPS software is used to link the EO to a PC, data can be stored on the computer's hard disk or on a floppy diskette. An EO floppy disk drive or hard disk drive can be connected through the parallel port. A PCMCIA memory card can be used for backup, or the modem can be used to send data to a PC running TOPS software.

The EO personal communicator was introduced many months before either of the other two items reviewed in this month's Gizmo. Even so, it clearly seemed like the most mature of the products. Some of that is because our evaluation unit contained some essential "options." For example, without the modem or the 8-megabyte memory, sending and receiving faxes would not have been possible. The EO is, of course, priced considerably higher than either the Zoomer or Newton. In fact, it costs more than both put together. However, the EO has a more obvious—and well heeled—market. Ask virtually any business traveler if he could use a portable device on which he could receive faxes and E-mail, and create and edit documents. Most would say yes, we'd assume. Whether they could justify spending more than \$3000 for such a device is a more difficult question.

The EO is a complete package. Personal Perspective is a good address/date book and a good personal information manager. Mini Text is powerful enough to take care of a good deal of correspondence. A spreadsheet application more powerful than the simple EO Calc would be a sensible addition, however. You never know when you might want to check the latest financial forecast while at the beach. ■

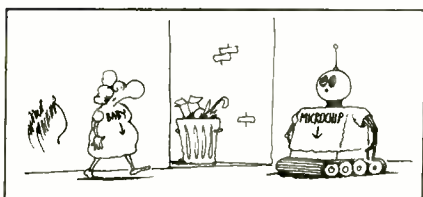

## AUTOMOTIVE TESTER

(Continued from page 68)

tinguished, indicating that the battery voltage is below normal.

Now, slowly raise the supply voltage until LED1 goes out (that should occur at about 9.0 volts). Further increase the supply voltage until LED2 (BATTERY OK) lights, which should occur at 12.4 volts. Slowly increase the power-supply voltage until LED3 (NOT CHARGING) goes out and LED4 (INSUFFICIENT CHARGING) comes on simultaneously. That should occur at 12.8 volts.

Continue to raise the power-supply voltage, and when it reaches 13.4 volts only LED2 should be lit. Finally, raise the voltage until LED5 (OVERCHARGING) comes on, which should occur at 15.2 volts. **CAUTION:** Do not allow the power supply's output voltage to exceed 16 volts.

If you get the responses outlined above, the project is operating properly. The voltage levels at which the LED's change state should be within 0.1 volt of the specified voltages. If your project falls out of that tolerance, you should adjust the value of one or more of the resistors of the voltage divider (R1 through R6) by about 1% to bring the circuit into spec.

If the project does not respond properly at any one of the specified voltage levels, check pin 1 of U2 to be sure the 1.25-volt reference voltage is present. If not, check the orientation of D1, C1, U1, and the LED's. Try another chip if possible. If only one LED malfunctions, troubleshoot the comparator that drives that LED. Then measure that output voltage as the input voltage is varied about the specified triggering level. Check the orientation of the inoperative LED, and replace it with a new one. If the simultaneous switchover between LED3 and LED4 does not occur, check the orientation of D2.

**Using the System.** The following steps should be performed in sequence when checking an automotive electrical system. If the project is intended for stand-alone use, connect the project's input leads directly to the vehicle's battery terminals before starting the engine; be sure to observe the proper polarity. Check the vehicle's alternator belt for proper

tension.

1. Before the engine is started, the BATTERY OK (LED2) should light. The NOT CHARGING indicator (LED3) should also be illuminated since the alternator is not operating at this point. Note: If the engine has just been turned off, LED4 may be illuminated instead of LED3, since the battery may have a higher than normal terminal voltage from being charged by the alternator.

2. Have an assistant start the engine while you observe the project's display. If the WEAK BATTERY indicator (LED1) comes on during cranking, the battery terminal voltage has fallen to less than 9 volts. That indicates that the battery is in a low state of charge or is near the end of its life. Recharge the battery and repeat the test.

3. With the engine idling, only LED2 (BATTERY OK) should be illuminated, indicating that everything is normal. Note that some vehicles will indicate INSUFFICIENT CHARGING (LED4 will be lit) because the battery's terminal voltage has not exceeded 13.4 volts while idling. That will be checked at the next step in the procedure. If the NOT CHARGING indicator (LED3) is lit, the charging system of the vehicle is totally inoperative. That could be caused by a defective regulator circuit, an open alternator field, or a bad connection somewhere in the electrical harness.

4. To check the charging capacity of the alternator, turn on the heater/AC fan (highest setting), rear window defroster, windshield wiper (fastest speed), and high-beam headlights. Race the engine to 1500 or 2000 RPM (moderate speed). Only LED2 should be illuminated. If LED4 (INSUFFICIENT CHARGING) lights, the alternator cannot deliver enough current to handle the accessory load. That may be caused by a shorted or open diode, or a shorted winding in the alternator itself. Since the alternator is a three-phase device that uses a 6-diode bridge circuit, it will be able to deliver some output even though one of the phases is defective.

5. To check the regulator, turn off all accessories and race the engine to about 2000 RPM. If LED 5 (OVERCHARGING) lights, the regulator is defective. That will cause the battery to have excessive water consumption and shorten its life. In many vehicles, the regulator is non-adjustable and must be replaced. ■

# Invest a stamp



# Save a bundle

For the price of a stamp, you can get the latest edition of the federal government's free **Consumer Information Catalog** listing more than 200 free or low-cost government publications on topics such as federal benefits, jobs, health, housing, education, cars, and much more. Our booklets will help you save money, make money, and spend it a little more wisely.

So stamp out ignorance, and write today for the latest free **Catalog**. Send your name and address to:

**Consumer Information Center  
Department SB  
Pueblo, Colorado 81009**

A public service of this publication and the Consumer Information Center of the U.S. General Services Administration.

## FAX DIRECTORY LISTING

COMPANY	FAX NUMBER
Alfa Electronics, Inc.	(609) 275-9536
All Electronics Corporation	(818) 781-2653
Alltronics	(408) 943-9776
A.M.C. Sales, Inc.	(303) 494-4924
Communications Specialists, Inc.	(714) 974-3420
C&S Sales, Inc.	(708) 520-0085
Contact East	(508) 688-7829
Extech Instruments	(617) 890-7864
Howard W. Sams & Company	(317) 298-5604
Interactive Image Technologies Ltd.	(416) 368-5799
Jameco	(800) 237-6948
Kepro Circuit Systems, Inc.	(314) 343-0668
Lake Sylvan Sales, Inc.	(612) 895-9454
M.D. Electronics	(402) 392-0991
Midwest Laser Products	(708) 430-9280
Moody Tools, Inc.	(401) 885-4565
Mouser Electronics	(817) 483-0931
M.M. Newman Corporation	(617) 631-8887
North Country Radio	(914) 576-6051
People's College of Independent Studies	(407) 847-8793
Skyvision, Inc.	(218) 739-4879
Somerset Electronics, Inc.	(407) 773-8097
T.K.A. Electronics	(402) 697-0799
Weka Publishing, Inc.	(203) 622-4187



# Popular Electronics® **F A X** **FORM**

## **DIRECT READER/MFR CONTACT**

**Need data  
in a hurry?**

**Don't worry!**

Just clip this form  
carefully along  
the dotted lines,  
fill it out  
(PLEASE PRINT)  
and fax it  
to the company  
of your choice today!

**For fastest response,  
please send  
directly  
to manufacturers.**

**Fax numbers are on  
the page to the left.**

If you need  
more than one  
form, please  
make copies  
of this  
original.

Popular Electronics provides this fax form as a service to its readers. A quick response from you indicates your company's willingness to do business with the sender.

### Popular Electronics **FAX RESPONSE**

**TO:** \_\_\_\_\_  
Company Name Fax Number

I urgently need more information about your \_\_\_\_\_ products.

I saw your products on Page \_\_\_\_\_ in the \_\_\_\_\_ issue of **PE**;  
(Month/Year)

**ADDITIONAL NOTE:**

**FROM:** \_\_\_\_\_  
Sender's Name Title

Company Name:

Street

City

Country

Phone

Fax

We are a(n)  manufacturer  service center  engineering company  
 R&D center/laboratory  other ( )

## Popular Electronics®

500-B Bi-County Boulevard, Farmingdale, NY 11735 Tel: 1-516-293-3000 Fax: 1-516-293-3115

## PIEZOELECTRIC ELEMENTS

(Continued from page 70)

One of the commonly used external-drive circuits for two-terminal elements uses two NAND gates to produce the drive oscillations (see Fig. 6). The arrangement is fairly standard, with the output drive taken from the collector, as shown, and a small inductor used as the transistor's load in order to peak the voltage.

**Proper Driving.** Now let's discuss some things you should keep in mind when devising your own drive circuits. Piezoelectric elements can be driven by either a sinewave or square-wave voltage, depending upon the application. Using a sinewave drive will cause the device to operate at a frequency below its specified resonant frequency. With a square-wave drive, a higher acoustic output can be achieved, but with an increase in harmonic content.

For obtaining a maximum output, a frequency of between 500 Hz and 4

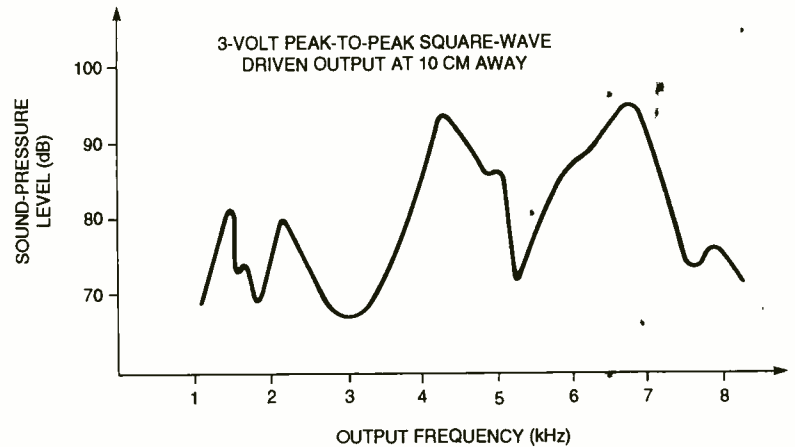

Fig. 7. Sound pressure level can vary greatly with even small changes in output frequency, as you can see from this graph.

kHz is recommended. As seen in Fig. 7, the sound-pressure output level varies significantly with even small changes in drive frequency. Therefore fine tuning is quite necessary to obtain maximum output.

Continuous DC bias will cause depolarization of the ceramic elements and lead to permanent damage. It is therefore necessary to capacitively couple piezoelectric devices when-

ever they are driven with untried homemade circuits. Also voltages higher than those recommended by the manufacturer will cause damage to the ceramic and provide no higher

With the information presented in this article you should be able to use piezoelectric elements to their fullest in your own projects and designs. Build and enjoy. ■

## TONER CARTRIDGE

(Continued from page 74)

want to sell new cartridges. Special tamper-proof methods and hardware are used in assembly to keep out those without special tools, and special toners are used. In fact, when I contacted Canon for material to support this article, they refused to supply any information when I told them I would be covering recharging. They claimed they did not want to encourage a process they could not insure was being done properly.

If you want to recycle your own cartridges, supplies are available, but with the present complexity of technology and options, you are probably better off leaving recycling to those doing it as a business. On the other hand, you may want to get in the recycling business yourself. If so see the Business of Your Own sidebar.

**Guarantee/Warranty??** Since the first days of cartridge refillers, the question in the minds of users has

been the effect a refilled cartridge might have on their machine or warranty. Some confusion exists in the field over this, with some technicians and dealers stating that using a recharged cartridge would void a machine's warranty, while some machine manufacturers have specifically refuted that claim.

Woodenfrog Printer Products provides a Limited Warranty certificate that states in part that Woodenfrog "agrees to repair or replace any customer's printer or copier if it is damaged as a result of using a remanufactured toner cartridge which has been provided by Woodenfrog."

As you would expect, recyclers insist neither the machine nor its warranty are at risk when using recycled cartridges, while manufacturers of new cartridges are less specific. Considering the long history and common usage of recycled cartridges, it would seem that if your machine or warranty were in jeopardy, it would have become a well-known fact by now.

**Who Remanufactures?** Since refill,

recharge, remanufacture, or recycle are the common terms used in ads, you'll have to call and ask if they completely disassemble the cartridge or just refill it. Are holes drilled, or is the cartridge reassembled rather than just refilled? My advice is to deal only with a company that actually fully disassembles the cartridge. When looking for a recycler, find out if they have significant experience, what kind of toner is used, and what guarantee is provided. Beware of those who have found an opportunity to make a few quick bucks by drilling some holes and buying cheap toner.

If the cartridge comes back to you with a plastic sealing strip that has to be pulled out of the cartridge before it can be used, that's a good sign provided it was properly installed by disassembling the cartridge. However, a stiff sealing strip can be installed without disassembly, and it may not seal properly.

When all is said and done, a remanufactured toner cartridge from an experienced recycler can provide excellent results. ■



# Market Center™

## Paperback Books

GREAT PAPERBACKS AT SPECIAL PRICES

**COMPUTER HOBBYISTS HANDBOOK—BP251—\$8.95**

Subjects covered include microprocessors and their register sets; interfacing serial, parallel, monitor, games and MIDI ports; numbering systems, operating systems and computer graphics. While the book is aimed at the computer hobbyist, it should also prove useful to anyone who intends to use a computer to follow their interests.

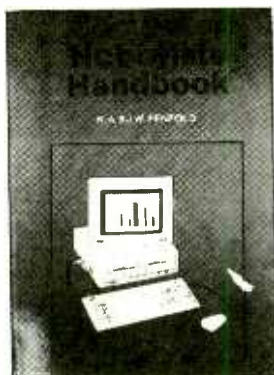

**INTERNATIONAL RADIO STATIONS GUIDE—BP255—\$9.95**

Provides the casual listener, amateur radio DXer and the professional radio monitor with an essential reference work designed as a guide for the complex radio bands.

Includes coverage on Listening to Short Wave Radio, ITU Country Codes, Worldwide Radio Stations, European Long Wave and Medium Wave Stations, Broadcasts in English and more.

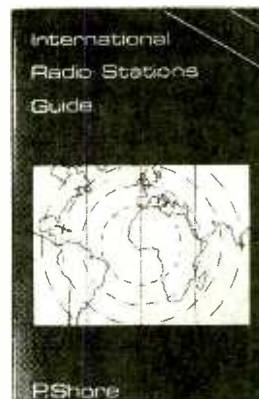

**Further Practical Electronics Calculations and Formulae**

I. A. WILSON



**FURTHER PRACTICAL ELECTRONICS CALCULATIONS—BP144—\$9.00**

450 pages crammed full of all the formulae you are likely to need. Covers Electricity, Electrostatics, Electromagnetism, Complex Numbers, Amplifiers, Signal Generation and Processing, Communications, Statistics, Reliability, Audio, Radio Systems, Transmission Lines, Digital Logic, Power Supplies. Then there's an appendix of Conversion Factors, Mathematical Formulae and more.



**WIRELESS & ELECTRICAL CYCLOPEDIA—ETT1—\$5.75**

A slice of history. This early electronics catalog was issued in 1918. It consists of 176 pages that document the early history of electricity, radio and electronics. It was the "bible" of the electrical experimenter of the period. Take a look at history and see how far we have come. And by the way, don't try to order any of the merchandise shown, it's unlikely that it will be available. And if it is, the prices will be many times higher.

**ELECTRONIC TECHNOLOGY TODAY INC.**  
P.O. Box 240, Massapequa Park, NY 11762-0240

Name \_\_\_\_\_  
Address \_\_\_\_\_  
City \_\_\_\_\_ State \_\_\_\_\_ Zip \_\_\_\_\_

PE394

**SHIPPING CHARGES IN USA AND CANADA**

\$0.01 to \$5.00 . . . . .	\$1.50
\$5.01 to \$10.00 . . . . .	\$2.50
\$10.01 to 20.00 . . . . .	\$3.50
\$20.01 to 30.00 . . . . .	\$4.50
\$30.01 to 40.00 . . . . .	\$5.50
\$40.01 to 50.00 . . . . .	\$6.50
\$50.01 and above . . . . .	\$8.00

**SORRY No orders accepted outside of USA & Canada**

Total price of merchandise . . . . .	\$ _____
Shipping (see chart) . . . . .	\$ _____
<b>Subtotal</b> . . . . .	\$ _____
Sales Tax (NYS only) . . . . .	\$ _____
<b>Total Enclosed</b> . . . . .	\$ _____

All payments must be in U.S. funds

Number of books ordered

# AMAZING Electronic and Scientific Products

## Mystery Levitating Device!



**Remember War of the World?** Objects float in air and move to the touch. Defies gravity, amazing gift, conversation piece, magic trick or great science project.

ANT1K Easy to Assemble Kit / Plans ..... \$19.50

## Laser Ray Gun

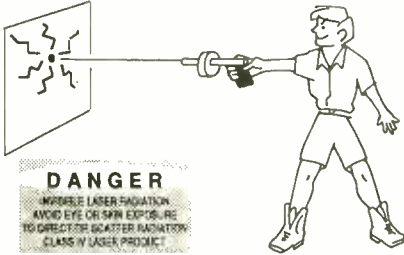

**DANGER**

IRREDIBLE LASER RADIATION  
AVOID EYE OR SKIN EXPOSURE  
TO DIRECT OR SCATTERED RADIATION  
CLASS IV LASER PRODUCT

Advanced project produces a burst of light energy capable of burning holes in most materials. Hand-held device uses rechargeable batteries. 500 joules of flash energy excite either a neodymium glass, yag or other suitable 3" laser rod. This is a dangerous CLASS IV project (individual parts/assemblies available).

LAGUN1 Plans ..... \$20.00  
LAGUN1K Kit / Plans ..... Price on Request

## Extended Play Telephone Recording System



### Recording System

READY TO USE! Automatically controls and records on our X-4 extended play recorder, taping both sides of a telephone conversation. Intended for order entry verification. Check your local laws as some states may require an alerting beeper.

TAP20X Ready to Use System ..... \$129.50



## Shocker Force Field / Vehicle Electrifier

Neat little device allows you to make hand and shock balls, shock wands and electrify objects, charge capacitors. Great payback for those wise guys who have wronged you!

SHK1KM Easy to Assemble Electronic Kit ..... \$24.50



## Blaster Pulser

Pocket-sized wand produces 100,000 watts of power for personal defense, field and lab use, etc. BLS3 Plans ..... \$10.00  
BLS3K Kit / Plans ..... \$69.50

## Homing / Tracking Transmitter

Beeper device, 3 mile range.

HOD1 Plans ..... \$10.00 HOD1K Kit / Plans ..... \$49.50

## Listen Through Walls, Floors

Highly sensitive stethoscope mike.

STETH1 Plans ..... \$8.00 STETH1K Kit/Plans ..... \$44.50



**NEW!**

## Telephone Line Grabber / Room Monitor

**ALL NEW! The Ultimate in Home or Office Security & Safety!**

Simple to Use! Call your home or office phone, push a secret tone on your telephone keypad to access either: A. On premises sounds and voices; or B. Existing telephone conversation with break in capability for emergency messages. CAUTION: Before assembly or use, check legalities with your state Attorney General's office as you may require "beepers" or other 3rd party alerts.

TELEGRAB1 Plans Only ..... \$10.00  
TELEGRAB1K Kit / Plans ..... \$99.50

## Ultrasonic Blaster

Laboratory source of acoustical shock waves. Blow holes in metal, produce "cold" steam, atomize liquids. Many cleaning uses for PC boards, jewelry, coins, small parts, etc.

ULB1 Plans ..... \$10.00 ULB1K Kit/Plans ..... \$69.50

## 100,000V Intimidator / Shock Wand Module

Build an electrical device that is effective up to 20 feet. May be enclosed for handheld, portable field or laboratory applications.

ITM2KM Easy-to-Assemble Electronics Kit ..... \$49.50  
ITM2 Plans only, credit-able to kit ..... \$10.00



## Ion Ray Gun

Projects charged ions that induce shocks in people and objects without any connection! Great science project as well as a high tech party prank. IOG3 Plans ..... \$8.00  
IOG3K Kit/Plans ..... \$69.50

## Invisible Pain Field Generator

Shirt pocket size electronic device produces time variant complex shock waves of intense directional acoustic energy, capable of warding off aggressive animals, etc.

IPG7 Plans ..... \$8.00 IPG7K Kit/Plans ..... \$49.50  
IPG70 Assembled ..... \$74.50

## SUPER GIANT SMOKE ASSORTMENT

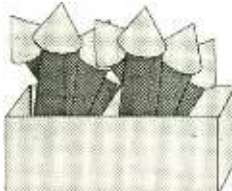

**SPECIAL INTRODUCTORY OFFER! WOW!** Over 500 items - the largest smoke assortment we have! Each super giant assortment contains at least 500 pieces - enough to last you a long time. All this at a special price - less than 12 cents per item. Guaranteed value at least 50 percent more than you pay! SMOKE 25 ..... \$59.50



## TV & FM Jocker / Jammer

Shirt pocket device allows you to totally control and remotely disrupt TV or radio reception. Great gag to play on family or friends. Discretion required. EJK1KM Easy to Assemble Electronic Kit ..... \$24.50

## Visible Beam Laser

High brightness red HeNe laser visible for miles.

Produce your own light show! Projects a visible beam of red lite clearly visible in most circumstances. Can be used to intimidate by projection of a red dot on target subject. Also may be used to "listen in" using our laser window bounce method #LLIS1 below. Easy to build module makes A working visible laser!

LAS1KM Kit w/1mw Laser Tube, Class II ..... \$69.50  
LAS3KM Kit w/2.5mw Laser Tube, Class IIIA ..... \$99.50



## "Laser Bounce" Listener System

Allows you to hear sounds from an area via a lite beam reflected from a window or other similar objects. System uses our ready-to-use LATR1 Laser Terminator gun site as the transmitter. The receiver section is supplied as an easy-to-build kit, including our cushioned HS10

headsets. LLLIST2 Plans ..... \$20.00  
LLIST1K Kit of Both Transmitter and Receiver ..... \$199.50  
LLIST20 Assemble with Laser Gun Site ..... \$299.50

## 5mw Visible Red Pocket Laser

Utilizes our touch power control!

VRL5KMX Kit / Plans ..... \$119.50



Fantastic ALL NEW pinwheel effect for auto, motorcycle, bicycle, etc. Use one per wheel. SIMPLE TO USE! LWMRLY ..... \$9.50

## Pocket Sized Night Viewer

Uses Low Level Starlight to See in the Dark!

- Low Cost
- Ultra-Hi Lite Amplification!
- Auto Brightness Control
- Limited Amount Available
- Made in USA • Night surveillance • Animal studies, etc.

Can be used to fly an airplane or drive a car!

PKV7 Plans ..... \$15.00  
PKV7K Easy to Assemble Kit ..... \$1,295.00  
PKV70 Ready to Use ..... \$1,595.00

## 3 Mile FM Wireless Microphone

Subminiature! Crystal clear, ultra sensitive pickup transmits voices and sounds to FM radio. Excellent for security, monitoring of children or invalids. Become the neighborhood disk jockey, or go "under cover" using our sunglasses FM radio (see catalog). FMV1 Plans ... \$7.00

FMV1K Kit and Plans ..... \$39.50  
SUGL10 Sunglasses with built in FM Radio ..... \$29.50

## Telephone Transmitter - 3 Mi

Automatically transmits both sides of a telephone conversation to an FM radio. • Tunable Frequency • Undetectable on Phone • Easy to Build and Use • Up to 3 Mile Range • Only transmits during phone use.

VWPM7 Plans ..... \$7.00  
VWPM7K Kit/Plans ..... \$39.50

**INFORMATION UNLIMITED**

Dept PEM14, Box 716, Amherst, NH 03031

Phone: 603-673-4730 FAX 603-672-5406

MC, VISA, COD, Checks accepted. Please add \$5.00 Shipping & Handling

### CATALOG

With many more items!  
Free with Order or send \$1 P&H

Order by Mail or by 24 Hour Orders-Only Phone  
**800-221-1705**



# ALFA ELECTRONICS

**HIGH QUALITY TEST EQUIPMENT  
BEST PRICE**

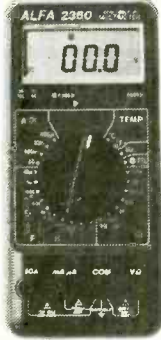

**DMM 2360**  
**\$119.95**

**DMM + LCR Meter**  
**Most Versatile DMM**

Inductance: 1 $\mu$ H-40H  
Capacitance: 1pF-40 $\mu$ F  
Frequency: 1Hz - 4MHz  
Temperature: -40 - 302  $^{\circ}$ F  
TTL Logic Test 20MHz  
Diode, Continuity  
Volt, Amp, Ohm  
3999 count display  
Peak Hold  
Auto power off  
Ruggedized case  
Rubber Holster \$8.00

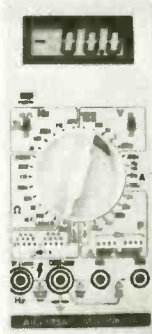

**DMM 175A \$67.95**

**DMM with 20 MHz**  
**Frequency Counter**  
**Most Popular DMM**

Freq. Counter 1Hz-20MHz  
DCV 0.1mV-1000V  
ACV 0.1mV-750V  
ACA/DCA 0.1 $\mu$ A-10A  
Resistance 0.1 $\Omega$ -2000 $\Omega$   
Capacitance 1pF-20 $\mu$ F  
TTL Logic test 20 MHz  
Transistor HFE test  
Diode test, LED test  
3 1/2 digit display  
10 M $\Omega$  impedance  
Soft case \$3.00, deluxe case \$5.00



**Fluke Multimeter**

Fluke 12 \$79.95  
Holster C-10 \$10  
Fluke 70 II \$65  
Fluke 73 II \$90  
Fluke 75 II \$127  
Holster C-70 \$15  
Fluke 77 II \$147  
Fluke 79 II \$167  
Fluke 29 II \$167

Fluke 83 \$225  
Fluke 85 \$259  
Fluke 87 True RMS \$285

Fluke 97 Scope Meter \$1750



**LCR Meter 814**  
**\$199.95**

**The Best Handheld**  
**LCR**

Inductance: 0.1 $\mu$ H-200H  
Capacitance: 0.1pF-20,000 $\mu$ F  
Resistance: 1m $\Omega$ -20M $\Omega$   
1% basic accuracy  
Dissipation factor indicates leakage in capacitor and Q factor in inductor  
Zero adjustment to reduce parasitics from test fixture  
Best for high frequency RF and surface mount components.  
SMD and chip component test probe \$25.00. Deluxe carrying case \$5.00



**LCR Meter 195**  
**\$119.95**

**Very Popular LCR**

Inductance: 1 $\mu$ H-200H  
Capacitance: 0.1pF-200  $\mu$ F  
Resistance: 0.01 $\Omega$ -20M $\Omega$   
Basic accuracy R:1%, C:2%, L:3%  
Test frequency 1 kHz  
Soft carrying case \$3.00  
Deluxe case \$5.00

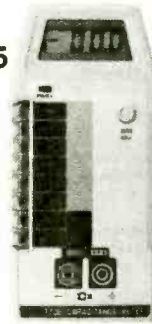

**Capacitance Meter**  
**7705 \$57.95**

0.1 pF-20,000 $\mu$ F in 9 ranges  
0.5% basic accuracy  
Zero adjustment  $\pm$  20pF to compensate parasitics from test fixture

**Also Available:**  
Heavy duty DMM, AC/DC clamp meter, Thermometer, Light meter, pH meter, High voltage probe, Digital caliper, Anemometer, Electronic scale, Force gauge, Tachometer, Humidity & EMF adapter, Sound level meter, Frequency counter, SWR/field strength/power meter, Dip meter

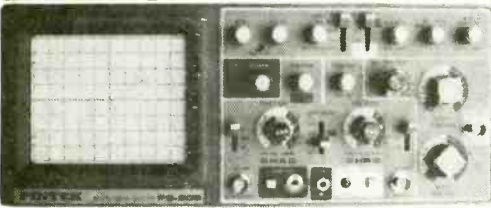

**20 MHz Oscilloscope with Delay Sweep PS-205 \$429.95**

Dual Trace, Component test, 8" CRT, X-Y Operation, TV Sync, Z Modulation, CH2 Output, Graticule Illum, 2 probes each has x1, x10 switch. Best price with delay sweep.  
PS-200 20 MHz DUAL TRACE \$339.95  
PS-400 40 MHz DUAL TRACE \$494.95  
PS-405 40 MHz DELAY SWEEP \$569.95  
PS-605 60 MHz DELAY SWEEP \$769.95

**20 MHz Digital Storage Oscilloscope DS-203 \$729.95**

Switchable between digital and analog modes  
2 K word per channel storage  
Sampling rate: 10 M sample/sec  
8 bit vertical resolution (25 Levels/div)  
Expanded Timebase 10ms/div - 0.5 s/div  
Refresh, Roll, Save all, Save CH2, Pre-Trig  
Plotter Control

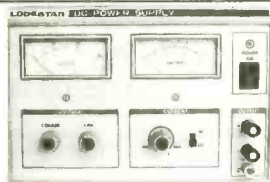

**DC Power Supply PS-303 \$159.00**

**0-30 VDC, 0-3A output**  
0.02% + 2mV line regulation  
0.02% + 3mV load regulation  
1 mVrms noise and ripple  
Short circuit and overload protected  
PS-8200 with digital voltmeter \$179.00  
Also available: 30V/5A, 60V/3A, 60V/5A, 16V/10A, 30V/10A

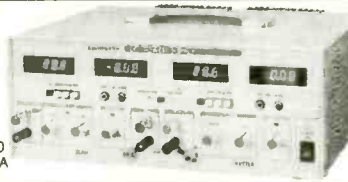

**DC Power Supply Triple Output PS-8202 \$499.95**

Two 0-30 VDC, 0-3A outputs  
One fixed 5VDC, 3A output  
Capable of independent or tracking operation  
Constant voltage and constant current mode  
Four digital meters for volt and current display  
Excellent regulation and low ripple  
Short circuit and overload protected  
Also available: 30V/5A triple output \$549.95  
60V/5A dual tracking \$749.95

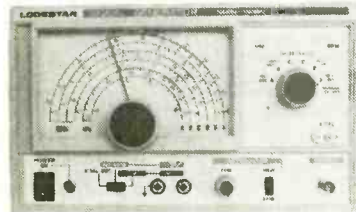

**RF SIGNAL GENERATOR SG-4160B \$119.00**

100 kHz-150MHz sinewave in 8 ranges  
RF Output 100mVrms to 35 MHz  
Internal 1kHz, External 50Hz-20kHz  
AM modulation  
Audio output 1 kHz, 1 Vrms

**AUDIO GENERATOR AG-2601A \$119.00**

10Hz - 1MHz in 5 ranges  
Output: 0.8Vrms sinewave  
0-10Vp-p squarewave  
Synchronization:  $\pm$ 3% of oscillation frequency per Vrms  
Output distortion:  
0.05% 500Hz - 50kHz  
0.5% 50Hz - 500kHz  
Output impedance: 600 ohm

**FUNCTION GENERATOR FG-2100A \$169.95**

0.2 Hz - 2 MHz in 7 ranges  
Sine, square, triangle, pulse and ramp  
Output: 5mV-20Vp-p  
1% distortion, DC offset  $\pm$  10V  
VCF: 0-10V control frequency to 1000:1

**FUNCTION GEN/COUNTER FG-2102AD \$229.95**

Generates signal same as FG-2100A  
Frequency counter 4 digits  
Feature TTL and CMOS output

**SWEEP FUNCTION GEN./COUNTER \$329.95**

0.5Hz to 5 MHz in 7 ranges  
Sweep: Linear 10:1/Log 10:1 20ms to 2s  
AM Modulation  
Gated Burst, Voltage Control Generator  
Generator Control Voltage & 6 digit counter  
1Hz-10MHz for internal & external sources

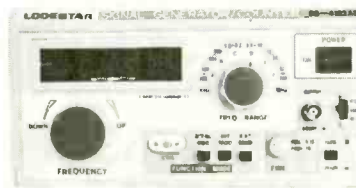

**RF SIGNAL GEN./COUNTER SG-4162 AD \$229.95**

Generates RF signal same as SG-4160B  
Frequency counter 1Hz - 150 MHz  
for internal and external source  
Sensitivity <50mV

**AUDIO GEN./COUNTER AG-2603AD \$229.95**

Generates audio signal same as AG-2601A  
Frequency counter 1Hz-150MHz  
for internal and external sources  
Sensitivity <50mV

**ALFA ELECTRONICS**  
741 Alexander Rd., Princeton, NJ 08540

(800) 526-2532/(609) 520-2002 15 DAY MONEY BACK GUARANTEE. 1 YEAR WARRANTY

FAX:(609) 520-2007

Call or Write for Free Catalog and Best Offer.  
Visa, Master Card, American Express, COD, Purchase Order Welcome

CIRCLE 26 ON FREE INFORMATION CARD

# ALL ELECTRONICS CORP.

QUALITY PARTS • DISCOUNT PRICES • FAST SHIPPING

## ULTRASONIC PROXIMITY DETECTOR

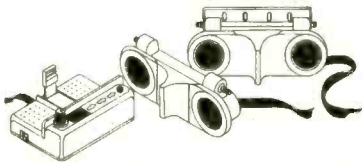

The ED-100 was designed for use as an auto/truck/RV back-up alarm. A digital display and audible beeper inside the vehicle inform the driver of the distance to impact beginning when the vehicle is within 14 feet of another object. Two 40 kHz ultrasonic emitter/detector modules, measuring 5.81" long X 1.9" wide, 2.05" thick, attach to the rear of the vehicle. The device operates on 12 or 24 Vdc.

These units are new, in original cartons and include instructions. The company that marketed this device is no longer in business, and no manufacturer's guarantee is in effect.

*We offer these ultrasonic detectors for experimentation only, and in no way wish to promote their usefulness as a driving aid.*

Originally sold for over \$100.00. **\$24.95** per set

CAT # ED-100

## EXPERIMENTER'S DELIGHT VHF TO UHF BLOCK CONVERTER

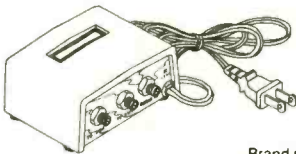

Channel Master # 0746  
This is one of those deals that's too good to be true.

Brand new, in the box, Channel Master block converters.

They used to be quite popular back in the early days of cable television, before there were a lot of cable-ready TVs. Somewhere in the world we know there is still a demand for them—especially at this price. Designed to convert television VHF channels 2 through 13 and A through W to UHF channels 36 through 76. The box alone, is a great project box. The 10 ft. AC power cord, the interior components, F connectors and AC receptacles are well worth the price.

CAT # CM-0746

10 pieces for \$18.50

**\$2.00** each

## 3 Vdc MOTOR



Johnson Motors # MF213G-2050  
DC motor operates well at 1.5 Vdc to 4.5 Vdc.  
0.72" X 0.94" X 1.38" long.  
0.08" (2 MM) diameter shaft is 0.25" long.

CAT # DCM-42

**2 for \$ 1.00**

**LARGE QUANTITY AVAILABLE!**

150 for 40¢ each • 600 for 30¢ each

## TELEPHONE LINE TEST HANDSET

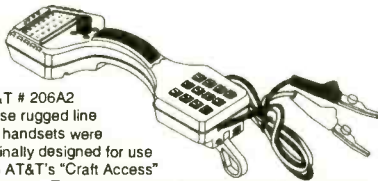

AT&T # 206A2

These rugged line test handsets were originally designed for use with AT&T's "Craft Access" computer. They can be used like any other line test handset, but they have special features which may or may not be useful. In addition to the touch-tone keypad, talk/monitor switch, alligator clip leads, 4 conductor modular jack and tool belt clip, these units have a LCD screen and function button/joystick for use with AT&T's "Craft Access" computer. For the average user, the extra features mainly allow you to adjust the volume and program in phone numbers. The main drawback to these units is that they contain batteries that require recharging, and the test set should be recharged when not in use. The size of the unit is 12.5" long X 4.5" wide. Brand new, in the box. They include 2 ni-cad battery packs, a charger and instructions.

CAT # PTS-206

**\$60.00** per set

## DIGITAL VIDEO STABILIZER

Eliminate color shifting screen flashing, jagged edges and unwanted lines copyguarding can cause. Eliminates copy guards and cleans up movies as you view them.

Simple hook-up; just install 9 Vdc battery (not included) and watch crystal clear video without need for adjustment. **WARNING: This product is intended for personal use only. Not intended for pre-recorded material that might constitute copyright infringement.**

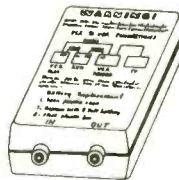

CAT # RX-11

**\$29.95** each

## ELECTROLUMINESCENT "Glow Strip"



4.75" X 10.25"  
Electroluminescent glow strip operates on 80-120 Vac.

Emits a soft pink/white glow when energized. Great for backlighting control panels and special effects. Thin and flexible, can be used on curved surfaces. 0.04" thick. 2 wire connection.

CAT # GS-510

**\$6.00** each

## RECHARGEABLE GEL CELL BATTERIES

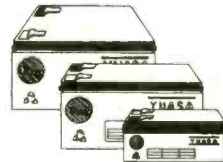

Maintenance free, rechargeable batteries ideal for alarm back-up or portable power of any kind. Useable in any position.

6 Volts @ 4 A/h

CAT # GC-64

Panasonic # LCR6V4P or equiv.

**\$12.00** each

12 Volts @ 1.2 A/h

CAT # GC-1212

Yuasa # NP1.2-12 or equiv.

**\$ 7.50** each

3.8" X 1.81" X 2" high.

12 Volts @ 7 A/h

CAT # GC-127

Yuasa # NP7-12 or equiv.

**\$ 25.00** each

5.95" X 2.53" X 3.71" high

12 Volts @ 12 A/h

CAT # GC-12

Yuasa # NP12-12 or equiv.

**\$ 35.00** each

5.93" X 3.83" X 3.69" high

## 2KV TRANSFORMER

Primary: 120 Vac  
Secondary:  
1,890 Vac (no load)  
2,250 with 1/2 wave rectifier

@ 4 mads &  
22 uf capacitor  
Originally designed for laser power supply. Measures:  
3.13" X 3.75" X 2.3"

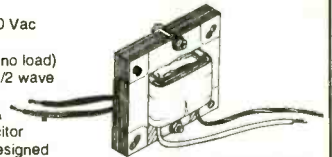

CAT # HVTX-3

**\$15.00** each

**CALL, WRITE or FAX For A Free 64 Page Catalog**  
Outside the U.S.A. send \$2.00 postage.

ORDER TOLL FREE **1-800-826-5432**

MAIL ORDERS TO:  
ALL ELECTRONICS CORP  
P.O. Box 567  
Van Nuys, CA 91408

FAX (818) 781-2653  
INFO (818) 904-0524

Minimum Order \$10.00 • All Orders Can Be Charged To Visa, Mastercard Or Discover Card • Checks and Money Orders Accepted By Mail • California, Add Sales Tax • No C.O.D. • Shipping And Handling \$4.00 for the 48 Continental United States • All Others Including Alaska, Hawaii, P.R. And Canada Must Pay Full Shipping • Quantities Limited • Prices Subject to change without notice.



CIRCLE 28 ON FREE INFORMATION CARD



# SOUTHPAW ELECTRONICS

SERVING THE ELECTRONICS INDUSTRY FOR OVER 50 YEARS

IMMEDIATE SHIPMENT FROM STOCK • SATISFACTION GUARANTEED

## New Rechargeable Sealed Lead Acid Battery

12VDC 15Ah Size: L 7" x H 6.5" x W 3" Name Brand Leakproof - can be used in any position maintenance free - needs only charging. High power density - Long service. Will stand up to tough operating conditions such as overcharge and deep discharge. Applications - for new equipment or replacement - alarms, medical equipment, robotics, industrial equipment, UPS systems and much more!



Weight 13 lbs. "Call For Quantity Pricing" #LAB100 **\$29.95ea.**

## PLUG-IN WALL TRANSFORMERS

5.6VAC @ 200MA  
9.0VDC @ 450MA  
12VDC @ 299MA  
14VDC @ 450MA  
14VDC @ 700MA  
20VAC @ 700MA

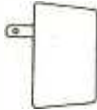

Mfg.	Each	10/Lot
T.I.	\$0.95	\$8.00
G.E.	\$3.25	\$30.00
PANA.	\$1.25	\$10.00
G.E.	\$2.50	\$22.00
G.E.	\$3.25	\$30.00
Import	\$2.75	\$25.00

## Fully Enclosed 73 Watt Continuous Switching Power Supply

• 91 Watts Surge • Forced Air Output • 4 Outputs  
• Full Ranging Input Voltages From 90 to 264 VAC

Will provide the necessary power and cable to run two drives one hard drive and one floppy disk drive with a microconnector. Has its own internal fan capable of cooling power supply as well as the components inside the computer to a safe operating temp.



Output Voltages	Full Load (amp)	UL/CSA Approved
+5V	10.0 A	Size: L 6.5" x W 2.8" x H 3.7"
+12V	1.5 A	
-12V	.3 A	
-5V	.3 A	

#PSB03 **\$24.95 ea.**



## COOLING FANS

	Each	10/Lot
115VAC 4.7"	\$5.75	\$55.00
12VDC 4.7"	\$4.75	\$45.00
24VDC 4.7"	\$3.75	\$35.00
12VDC 3.5"	\$4.25	\$40.00
24VDC 3.5"	\$3.75	\$32.00
12VDC 2.25"	\$4.25	\$40.00
24VDC 2.25"	\$3.75	\$32.00
12VDC 1.5/8"	\$4.25	\$40.00

## RARE EARTH MAGNETS

Kidney Shaped  
Approx 3/4" x 1/2"  
Estimated pull 1 1/2 lbs.  
You won't believe the power  
#REM01 **\$1.49 ea., 10 Lot/\$.99 ea.**



## LED's

Standard Jumbo 5MM or 3MM  
Red \$ .06 ea. 20 piece  
Yellow \$ .07 ea. minimum  
Green \$ .07 ea. per item



Half - Single - Dual Digit Units  
Common Cathode/Anode  
Reds & Greens  
25 Piece Assortment **\$9.95**

## SHARP LM 16257

5x7 Dot Matrix Display W/Cursor  
Intelligent 16 Characters x 2 Line



Character height .22". Supply voltage +5V. Dot color - Dark Blue, Background - White, On-Board CPU, RAM & ASCII, Character Generator. Dimensions: 3 5/16" x 1 3/8" x 3/8". Full specs supplied.  
#LCD002 **\$9.59 each**

## 486 COMPUTER SUPER COOLER FAN SYSTEM

Snap on mount - no tools required!  
Spring loaded heat sink - assures maximum heat transfer!  
Powerful 5500 RPM 12 VDC Fan Dual power plugs - fits all PC's. Individually boxed. #F486



**\$19.95 each**

## POWER X'FMER

General Purpose  
American Mfrgr.  
Primary: 115V 60Hz  
Secondary:  
#1 5VAC @ 4.0A  
#2 24VAC @ 4.0A  
3 1/2" Mounting Centers  
H 2 1/2" x L 3" x W 1"  
#PTR01 **\$5.75 ea.**

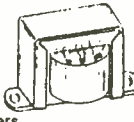

## 230 WATT CHEROKEE SWITCHING POWER SUPPLY

Input: 115/230 VAC  
Outputs: +5V @ .6A, +12V @ .2A  
-12V @ 1.5A, 25.5V @ 3A  
+18V @ .2A, 18V @ .2A  
Size: L 9.5" x H 4.5" x W 1.75"  
#PSB02 **\$29.95 ea.**

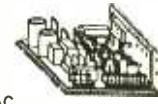

## Standard G.P. Rectifier

IN4004	1A	400V	\$3.00/100
IN4006	1A	800V	\$4.00/100
IN4007	1A	1000V	\$6.00/100

## 12VDC DPDT "ICE CUBE" RELAY

Coil res. 160Ω  
Cont. rtg. 10A  
OMRON #LY2-DC12  
#REL12DC  
**\$2.99 each**  
10 Lots/\$2.50 ea.



## SPST Round Keylock Switch

Shunt Type, Key Removable From Both Positions, 3 Amp 125 V, 2 Keys Included, Modern Compact Design (1/2" hole) #KLSW01



**\$4.75 ea.**

## GRAB BAG BLOWOUT!!!

**\$4.95 each**



Part #	Item /Quantity
GB01	Chokes/Inductors - 100
GB02	LEDs - 100
GB03	Ceramic Discs - 500
GB04	Connectors - 50
GB05	IC Sockets - 200
GB06	Trim pots - 100
GB07	Crystals/Oscillators - 20
GB08	Resistors* - 1500
GB09	Wirewound Resistors - 100
GB10	Relays - 20
GB11	Electronic Hardware - 2 lbs.
GB12	Transistors - 100
GB13	Zener Diodes - 200
GB14	Switches - 25
GB15	Fuses - 50
GB16	Volume Controls - 50
GB17	Heat Sinks - 25
GB18	IF Transformers - 200
GB19	Solderless Terminals - 150
GB20	Plug-in Adapters - 10
GB21	MYSTERY - ?????
GB22	Miniature Motor Asst. - 12 *carbon film/carbon comp

Mail Order \$25.00 • VISA - MasterCard • Checks & Money Orders On Mail Orders • Open Account Available To Qualified Firms • No COD NY, NJ, CT Orders Add Appropriate Sales Tax • Shipping & Handling \$4.75 For Continental U.S. - All Others Pay Full Shipping Charges Prices Subject To Change Without Notice • Quantities Limited On Some Items • Call/Write For FULL-LINE CATALOG and Quantity Pricing

VISA

# ORDER TOLL-FREE • 1-800-851-8870



Mail Orders To: Southpaw Electronics, PO Box 886, New Hyde Park, NY 11040-0311  
FREE CATALOG & INFORMATION • (516) 352-7070 • Fax (516) 775-5091

CIRCLE 127 ON FREE INFORMATION CARD

# Design and Verify

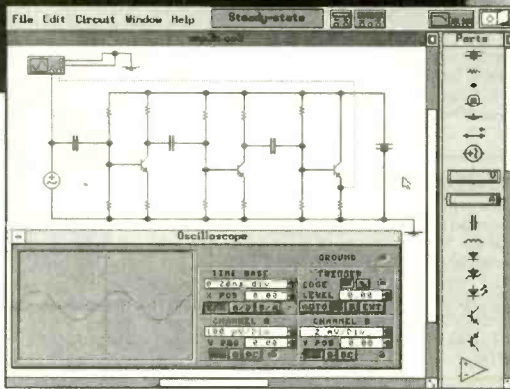
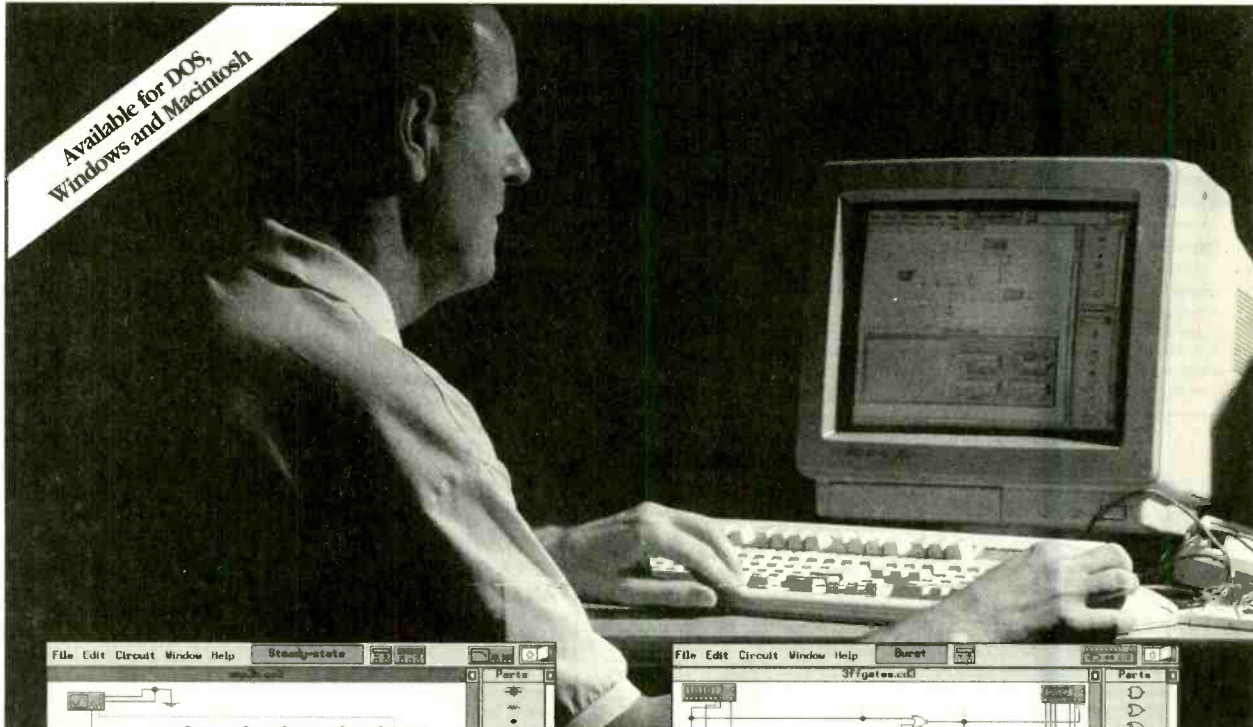

## Analog Module includes:

- complete control over all component values
- ideal and real-world models for active components
- resistors, capacitors, inductors, transformers, relays, diodes, Zener diodes, LEDs, BJTs, opamps, bulbs, fuses, JFETs and MOSFETs
- manual, time-delay, voltage-controlled and current-controlled switches
- independent, voltage-controlled and current-controlled sources
- multimeter
- function generator (1 Hz to 1 GHz)
- dual-trace oscilloscope (1 Hz to 1 GHz)
- Bode plotter (1 mHz to 10 GHz)

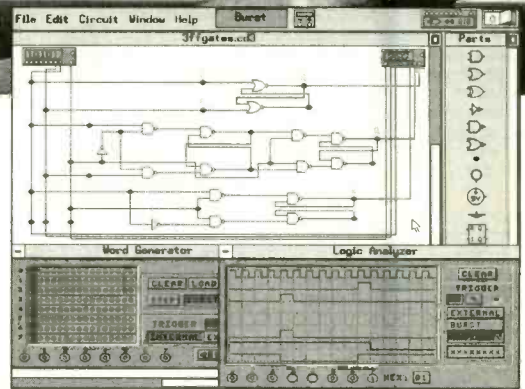

## Digital Module includes:

- fast simulation of ideal components
- AND, OR, XOR, NOT, NAND and NOR gates
- RS, JK and D flip-flops
- LED probes, half-adders, switches, seven-segment displays
- word generator (16 eight-bit words)
- logic analyzer (eight-channel)
- logic converter (converts among gates, truth table and Boolean representations)

## Electronics Workbench®

*The electronics lab in a computer™*

### SYSTEM REQUIREMENTS

MS-DOS version: Requires IBM AT, PS/2 or true compatible with 286 or greater, hard disk, 1 MB RAM, Microsoft-compatible mouse, EGA or VGA display adapter and DOS 3.0 or greater. Supports a math co-processor if available.

Windows version: MS-DOS 5.0 or higher, Microsoft Windows 3.1, 2 MB RAM with suitable pointing device.

Macintosh version: Macintosh Plus or higher, 2 MB RAM, System 6 or 7.

All trademarks are the property of their respective owners.



# Circuits. Fast.

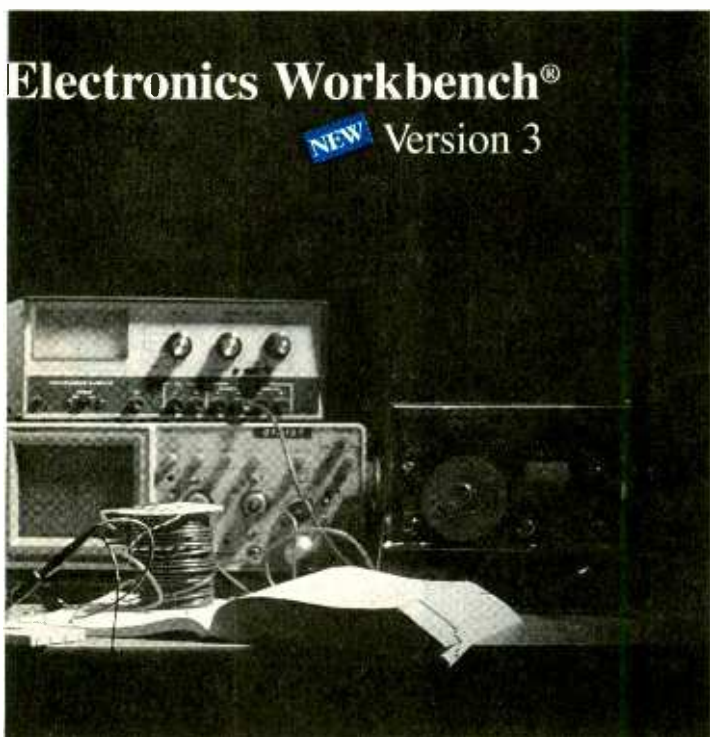

## An Ideal Test Bench

Here's why Electronics Workbench belongs on *your* test bench: Wires route themselves. Connections are always perfect. And the simulated components and test instruments work just like the real thing. The instruments are indestructible and the parts bin holds an unlimited supply of each component. The result: thousands of electronics professionals and hobbyists save precious time and money. **Over 90% would recommend it to their friends and colleagues.** Electronics Workbench: the ideal, affordable tool to design and verify your circuits before you breadboard.

## Now the best is even better!

Version 3.0 simulates more and bigger circuits, and sets the standard for ease of use. Guaranteed!\*

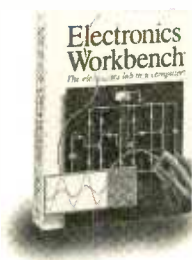

## Just \$299!

**"Design work is faster and cheaper with Electronics Workbench."**

*Mark L. Weaver, Production Engineer Technician, Colorado Memory Systems, Loveland, Colorado*

**"Building a circuit is simple and intuitive."**

*Jeff Holtzman, Computer Editor, Electronics Now*

**"I used Electronics Workbench extensively in the design of a six-meter receiver. I got surprisingly good comparison with actual breadboard and end-unit performance, even at 50 MHz. As an affordable tool for performing design tradeoffs, you can't beat it."**

*M. A. Chapman, Oceanside, California*

## Call 800 263-5552

## New Features in Version 3

- new components include JFETs; MOSFETs; voltage- and current-controlled sources; and manual, time-delay, voltage-controlled and current-controlled switches
- real-world models for opamps, BJTs, JFETs, MOSFETs and diodes — over 100 models available
- MS-DOS version now supports up to 16 MB of RAM for simulation of bigger circuits
- new Microsoft® Windows™ and Macintosh® versions available
- Technical support now available on CompuServe®

\*30-day money back guarantee



### Yes, I want Electronics Workbench in my computer!

Version:

- MS DOS     3.5"     5.25"  
 Windows     3.5"     5.25"  
 Macintosh

Name: \_\_\_\_\_

Address: \_\_\_\_\_

City: \_\_\_\_\_ State: \_\_\_\_\_ Zip: \_\_\_\_\_

Tel: ( ) \_\_\_\_\_ Fax: ( ) \_\_\_\_\_

MC  VISA  AMEX  # \_\_\_\_\_

Signature: \_\_\_\_\_ Exp: \_\_\_\_\_

INTERACTIVE IMAGE TECHNOLOGIES LTD.  
908 Niagara Falls Blvd. #068,  
North Tonawanda, NY 14120-2060  
Tel: (416) 361-0333 Fax: (416) 368-5799

Order information: Check or Money Order payable to Interactive Image Technologies Ltd.  
Call for Canadian prices. All orders add \$15 shipping and handling.



# Are Cable Companies Sucking You Dry?



**FREE  
Catalog!**

**All Major  
Brands!**

Take a Bite out of High Rental Fees  
with your own

## Converters & Descramblers

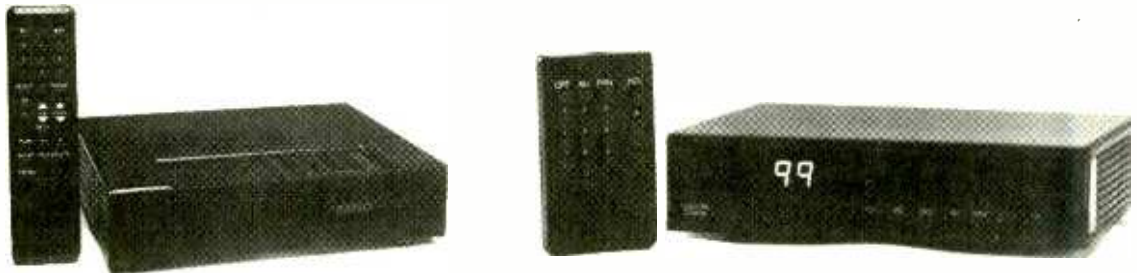

Everquest • Panasonic • Jerrold • Zenith • Pioneer  
Scientific Atlanta • Oak • Eagle • Hamlin • Tocom



Order  
Toll-Free **1 800 624-1150**

**MD** *Electronics* 

Call today  
for a FREE  
catalog!

875 S. 72 Street • Omaha, NE 68114





### Get instant tech information FREE from your Fax or Computer!

You can obtain specs, freq. info, software and more from our automated services. For fax facts, call from your stand alone fax machine and follow the voice prompts. Use the BBS from your modem of fax/modem equipped computer. Dial 317-849-8683 for fax back service, or dial 317-579-2045 for our computer bulletin board service

### Scanner with Shortwave

**NEW** Yupiteru 8-1300MHz Mobile or Hand Held Units. \$399.00, each.

Top rated receivers from Japan now available in the USA. Tune down to 100KHz. Sensitivity guaranteed from 8MHz up. 200 scan channels. AM/NFM/WFM. No gaps, no cut-outs. Mobile is super slim line. AC/DC. Order MVT8000, includes antenna, mbl mnt. Order MVT7000 for the hand held. Complete with Ni-Cads, Charger, antenna & earphone. Fax fact document #275

### Hand Held Scanners

**AOR 900 \$249.95**  
**100 Channel 800 MHz**  
 Five scan banks 5 search banks. Covers 27-54, 108-174, 406-512 and 830-950 MHz (no cell lock). Features scan, search, delay, priority, permanent memory, lockout, backlite, & keylock. Includes AC/DC adaptor, belt clip, antennas, & Nicad. Size: 5 3/4H x 2W x 1 1/2D. Wt: 12oz. Fax fact document # 650



### Total Coverage Radios

**AOR AR1000XLT**  
**\$449.00**  
**AM Broadcast to Microwave 1000 Channels**



500KHz to 1300MHz coverage in a programmable hand held. Ten scan banks, ten search banks. Lockout on search and scan. AM plus narrow and broadcast FM. Priority, hold, delay and selectable search increment of 5 to 995 KHz. Permanent memory. 4 AA ni-cads and wall plus cig charger included along with belt clip, case, ant. & earphone. Size: 6 7/8 x 1 3/4 x 2 1/2. Wt 12 oz. Fax fact document # 205

### Continuous Coverage

**Bearcat 2500XLTA hand held.....\$369.00**  
**Bearcat 8500XLT mobile.....\$389.00**  
**Bearcat 890XLTB mobile.....\$279.00**  
 29-1300MHz, 500 ch. in 8500, 400 in 2500. 890 has 200 ch & 29-956MHz All cell locked. Spring delivery. Fax Fact #420

### Bearcat 200XLTN

**\$229.95 200 Channels 800MHz**  
 Ten scan banks plus search. Covers 29-54, 118-174, 406-512 and 806 956MHz (with cell lock). Features scan, search, delay, 10 priorities, niem backup, lockout, WX search, & keylock. Includes NiCad & Chrgr. Size: 1 3/8 x 2 11/16 x 7 1/2. Wt. 32 oz. Fax Facts # 450



**AR2500**  
**\$449.00**  
**2016 Channels 1 to 1300MHz Computer Control**



62 Scan Banks, 16 Search Banks, 35 Channels per second. Patented Computer control for logging and spectrum display. AM, NFM, WFM, & BFO for CW/SSB. Priority bank, delay/hold and selectable search increments. Permanent memory. DC or AC with adaptors. Mtng Brkt & Antenna included. Size: 2 1/4H x 5 5/8W x 6 1/2D. Wt. 11lb. Fax fact #305

### Mobile Scanners

**Bearcat 760XLTM**  
**\$249.95**  
**100 Channel 800 MHz**  
 Five banks of 20 channels each. Covers 29-54, 118-174, 406-512 and 806-954MHz (with cell lock). Features scan, search, delay, priority; CTCSS option, lockout, service search, & keylock. Includes AC/DC cords, mounting bracket, BNC antenna. Size: 4 3/8 x 6 15/16 x 1 5/8. Weight: 4.5lbs. Fax fact document #550



### Table Top Scanners

**Bearcat 855XLTE 50Ch w/800..... \$159.95**  
**Bearcat 142XLM 10Ch H/L/U..... \$ 84.95**  
**Bearcat 147XLJ 16 Ch H/L/U..... \$ 89.95**  
**Bearcat 172XM 20Ch H/L/U/Air..... \$124.95**  
**Bearcat 210 16Ch H/L/U/Air..... \$129.95**  
 Coverage of above units is: 29-54, 136-174, 406-512, plus Air in 172 and 210 and air plus 800MHz in the 855. Fax facts #675

**AR3000**  
**\$1195.00**  
**400 Channels 100KHz to 2036MHz**



Patented computer control, top rated receiver in its class, offers AM, NFM Wide FM, LSB, USB, CW modes. RS232 control. 4 priority channels. Delay & hold & Freescan. AC/DC pwr cord and whip ant. Size: 3 1/7H x 5 2/5W x 7 7/8D. Wt 2lbs., 10oz. Fax fact document #105

**Bearcat 560XLTZ**  
**\$99.95**  
**16 Channel 10 Band**  
 Compact, digital programmable unit covers 29-54, 136-174, and 406-512MHz. Features scan, WX search, delay, priority, memory backup, lockout, review, & auto delay. Includes AC/DC cords, mounting bracket, and antenna. Size: 7 3/8 x 2 1/2 x 15/8. Wt: 2.5lbs. Fax fact #560



**Bearcat 800XLY**  
**\$219.95**  
 12 bands and 40 channels with 800MHz and nothing cut out. AC or DC. Fax facts #690



### Accessories & Etc.

**Mag Mount Mobile Ant MA100..... \$ 19.95**  
**Base Ant. 25-1000MHz AS300..... \$ 59.95**  
**Pre-Amp .1-1500MHz GW2..... \$ 89.00**  
**Downconverter 800 to 400 DC89..... \$ 89.00**  
**Base Discone Ant DA300..... \$ 89.00**  
**External Speaker MS190/opt. amp.... \$ 19.95**  
**Old Scanner Repair, all brands..... \$ CALL**  
**Extended Warranties..... \$ CALL**  
**Frequency Info FaxFact/Modem..... \$ FREE**  
**Frequency Books..... \$ CALL**

**NEW AOR AR1500**  
**\$499.00.**  
**Full Coverage with SSB and 1000 Channels.**



500KHz to 1300MHz. Ten scan banks, ten search banks. Search lock and store. BFO. 2 Antennas. AM/NFM/WFM. Selectable increments. Tons of features, small size: 5 7/8 x 1 1/2 x 2. Wt 14 oz. Fax fact document # 250

**Trident TR-33WL**  
**\$399.00**  
**Scan/CB. X,K,Ka,Wide & Laser**  
 Scans police pre-programmed by state channel plus full radar and laser alerts in one small unit. Weather, CB receive & mobile relay. Size: 5 5/8 x 4 7/8 x 1 3/4. Wt: 1.5lbs. Fax fact #580

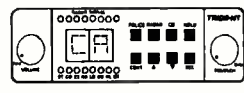

### 2 Way Radios

VHF hi band programmable mobiles as low as \$299.95. Call for quotes or Fax Fact #775

**Toll Free, 24 Hours! 800-445-7717 Fax Orders 800-448-1084 Fax Facts 317-849-8683**  
 Computer BBS Modem & Fax/Modem, 317-579-2045. Toll Free Tech Support, Dial 800-874-3468  
 International Fax: en Espanol, en Francais, und auf Deutsch, or just fax in plain English to: 317-849-8794

**ACE Communications 10707 East 106th Street, Fishers, IN 46038**  
 Service & Support hours: Mon.-Fri. 9AM to 6PM, Sat. 10-4 EST. Mastercard, Visa, Checks, Approved P.O.'s & COD (add \$5.50) & AMEX (add 5%). Prices, specifications and availability subject to change. Flat rate ground shipping and handling charge only \$5.95 per unit. Express Air only \$8.95, for most units, to most locations. One week trial, no returns accepted two weeks after original receipt without substantial restocking charge. All units carry full factory warranty. Indiana residents add 5 per cent sales tax.

**MasterCard**  
**VISA**

**FLY IT! ONLY \$8.95**

**CALL TOLL FREE**  
 1-800-292-7711  
 1-800-445-3201 (Can.)

# TEST EQUIPMENT AT DISCOUNT PRICES

**LOWEST  
 PRICES  
 GUARANTEED**

## DIGITAL METERS



**Dual-Display  
 LCR Meter  
 w/ Stat Functions  
 B+K 878  
 \$239.95**  
 Auto / Manual Range  
 Many Features  
 with Q Factor  
 High Accuracy



**Digital Multimeter  
 w/ Inductance  
 & Capacitance  
 \$75.00**  
 LCM-1850  
 Ten Functions  
 by Elenco



**Digital Capacitance Meter  
 CM-1550B  
 \$58.95**  
 9 Ranges  
 .1p1-20,000uid  
 .5% basic accy.  
 Zero control w/ Case  
 Big 1" Display  
 by Elenco



**Digital  
 Multimeter  
 DVM-638  
 \$39.95**  
 11 Functions with  
 Case

**Fluke Multimeters**  
 Model 12 ..... \$84.95  
 Model 7011 ..... \$67.50  
 Model 7711 ..... \$149.00  
 Model 7911 ..... \$169.00  
 Model 87 ..... \$289.00  
 Model 93 ..... \$1,225.00  
 Model 97 ..... \$1,795.00  
 All Models Available - Call

## HIGH QUALITY POWER SUPPLIES



**High Current Power Supply  
 Spectrum  
 by Elenco**  
 2.5 - 15VDC  
 or 13.8VDC  
 Fully regulated, Short circuit protected  
 Voltage/Current Analog Meters  
 SPL-010 SPL-020  
 0-10A \$139 0-20A \$199



**12A DC Power Supply  
 B+K 1686  
 \$169.95**  
 3-14V @ 12A  
 Fully regulated & protected  
 Separate Volt & Current Meters  
 Current Limiting, Low Ripple



**Quad Power Supply XP-580  
 \$79.95**  
 2-20V @ 2A  
 12V @ 1A  
 5V @ 3A  
 -5V @ .5A  
 Fully regulated & short  
 circuit protected  
 Made in USA by Elenco



**Triple Power Supply XP-620  
 Assembled \$75  
 Kit \$49.95**  
 2 to 15V @ 1A  
 2 to -15V @ 1A  
 (or 4 to 30V @ 1A)  
 and 5V @ 3A  
 Made in USA by Elenco  
 All the desired features for doing experiments.  
 Features short circuit protection, all supplies.

## GENERATORS & VIDEO PRODUCTS



**Function Generator  
 Blox  
 #9600  
 by Elenco  
 \$28.95**  
 Provides sine, triangle, square wave  
 from 1Hz to 1MHz  
 AM or FM capability  
 Kit \$26.95



**Color Convergence Generator  
 Elenco SG-250  
 \$89.95**  
 Kit \$69.95  
 Finest in the industry  
 10 rock steady patterns  
 RF & Video output



**Wide Band Signal  
 Generators  
 Elenco  
 SG-9000  
 \$129**  
 RF Freq 100K-450MHz AM Modulation  
 of 1KHz Variable RF output  
 SG-9500 w/ Digital Display &  
 150MHz built-in counter \$239



**Sweep/Function Generator  
 with Freq. Counter  
 \$239**  
 Elenco GF-8026  
 Int/Ext Operation,  
 Sine, Square, Triangle, Pulse,  
 Ramp, 2 to 2MHz, Freq Counter .1-10MHz

## EDUCATIONAL KITS - FUN & EASY TO BUILD



**Robotc Arm Kit  
 Model Y-01 \$48.95**  
 Teaches basics of robotics. Arm  
 grabs & releases, lifts & lowers, &  
 pivots from side to side

**AM/FM Transistor  
 Radio Kit  
 with 52 page Training Course  
 Elenco AM/FM 108  
 \$27.95**  
 14 Transistors ♦ 5 Diodes  
 Easy to build because  
 schematic is  
 printed right on the PCB  
 Makes a great school project  
 Model AM 550 AM Only \$18.95

**Learn to Build and Program  
 Computers with this Kit**  
 Includes: All Parts,  
 Assembly and  
 Lesson Manual  
 Elenco  
 MM-8000  
 \$129.00  
 Starting from scratch you build a complete system.  
 Our Micro-Master trainer teaches you to write into  
 RAMs, ROMs and run a 8085 microprocessor, which  
 uses similar machine language as IBM PC.



**Digital Multimeter Kit  
 with Training Course  
 Elenco  
 M-2665K  
 \$49.95**  
 Fun & Easy  
 to Build  
 Ideal School Project  
 Full Function  
 34 Ranges  
 Includes  
 Capacitance, Transistor/Diode Testing  
 20Amp AC/DC, Extra Large Display  
 M-2661 (assembled) \$54.95



**Multi-Function Counter  
 Elenco  
 F-1200  
 1.2GHz  
 \$229**  
 Measures Frequency, Period, Totalizer  
 8 LED digits, Crystal Oven Oscillator  
 .5ppm Accuracy

**XK-500 Digital / Analog Trainer**  
 A complete mini-lab for building, testing, prototyping analog and digital circuits  
 Elenco's Digital/Analog Trainer is specially designed for school projects, with 5 built-in power  
 supplies. Includes a function generator with continuously variable, sine, triangular, square wave  
 forms. All power supplies are regulated and protected against shorts.

**Power Supplies \$159.95 Assembled \$129.95 Kit**

- Variable Power Supply
- +1.25 to 20VDC @ .5 Amp
- (+1.25 to 15VDC @ 1 Amp)
- 1.25 to -20VDC @ .5 Amp
- (-1.25 to -15VDC @ 1 Amp)
- +12VDC @ 1 Amp
- 12VDC @ 1 Amp
- +5VDC @ 1 Amp
- 30VAC Center tapped @ 15VAC at 1 Amp

**Analog - Section**

- Function Generator Sine, Triangular, Square wave forms
- Frequency adjustable in five ranges from 1 to 100KHz
- Fine frequency adjust
- Amplitude adjust
- DC offset
- Modulation FM-AM

**Digital - Section**

- Eight data switches
- Two no bounce logic switches
- 8 LED readouts TTL buffered
- Clock frequency 1 to 100KHz
- Clock amplitude 5VPP square wave

**Breadboards**

- 2 breadboards, each contain: 840 tie points (total 1,680)



**ALL PRODUCTS FACTORY NEW**  
 UPS SHIPPING: 48 STATES 5% OTHERS CALL  
 IL RES add 7.75% TAX  
 PROBES INCLUDED IN ALL METERS

**C&S SALES INC.**  
 1245 ROSEWOOD, DEERFIELD, IL 60015  
 FAX: 708-520-0085 • (708) 541-0710



**15 DAY MONEY BACK GUARANTEE**  
**FULL FACTORY WARRANTY**  
**WRITE FOR FREE CATALOG**  
 PRICES SUBJECT TO CHANGE

Popular Electronics, March 1994



**FREE  
PROBES  
WITH ALL  
SCOPES**

**ELENCO ♦ HITACHI ♦ B&K  
SCOPES AT  
GUARANTEED LOWEST PRICES**

**24 HOUR  
SHIPPING**

**B&K 2120**

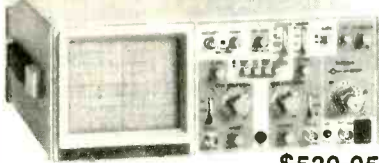

**20MHz \$389 Model 2125  
2 Channel Delayed Sweep**

**\$539.95**

**40MHz DUAL-TRACE**

**Model 1541B \$695.95**

- 1mV/div sensitivity
- Video sync separators
- Z axis input
- Single sweep
- V mode-displays two signals unrelated in frequency.

**60MHz DUAL-TRACE**

**Model 2160 \$949.95**

- 1mV/div sensitivity
- Sweep to 5 ns/div
- Dual time base
- Signal delay line
- V mode-displays two signals unrelated in frequency
- Component tester

**100MHz THREE-TRACE**

**Model 2190 \$1,395.95**

- 1mV/division sensitivity
- Sweeps to 2ns/division
- Dual time base
- Calibrated delay time multiplier
- Signal delay line
- 19kV accelerating voltage

**20MHz ANALOG  
WITH DIGITAL STORAGE**

**Model 2522A \$875**

- 20MHz analog bandwidth
- 20MS/s sampling rate
- 2k memory per channel
- 20MHz equivalent time sampling
- Pre-trigger capture

**AFFORDABLE - ELENCO OSCILLOSCOPES  
2 YEAR WARRANTY**

**S-1360  
Delayed Sweep  
\$775**

- Automatic Beam Finder
- Built-in Component Tester
- 1mV Sensitivity
- Dual Time Base
- Illuminated Internal Gradicule
- TV Sync

**60MHz  
Dual Trace**

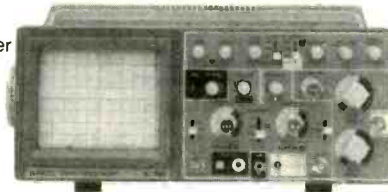

**S-1365  
Cursor Readout  
\$849**

- Voltage, Time, + Frequency differences displayed on CRT thru the use of cursors.
- 1mV Sensitivity
- TV Sync

**S-1345  
Delayed Sweep  
\$575**

- Automatic Beam Finder
- Built-in Component Tester
- 1mV Sensitivity
- Dual Time Base
- Illuminated Internal Gradicule
- TV Sync

**40MHz  
Dual Trace**



**S-1340  
\$495**

- High luminance 6" CRT
- 1mV Sensitivity
- 12KV Acceleration Voltage
- 9ns Rise Time
- X-Y Operation
- TV Sync

**S-1330  
Delayed Sweep  
\$449**

- Automatic Beam Finder
- Built-in Component Tester
- 1mV Sensitivity
- Dual Time Base
- Illuminated Internal Gradicule
- TV Sync

**25MHz  
Dual Trace**



**S-1325  
\$349**

- High luminance 6" CRT
- 1mV Sensitivity
- 2KV Acceleration Voltage
- 18ns Rise Time
- X-Y Operation
- TV Sync

**SPECIAL BUY  
HITACHI V-212**



**20MHz  
2 Channel**

**\$399**

**Hitachi Popular Series**

V-525 - 50MHz, Cursors \_\_\_\_\_ \$995  
 V-523 - 50MHz, Delayed Sweep \_\_\_\_\_ \$949  
 V-522 - 50MHz, DC Offset \_\_\_\_\_ \$895  
 V-422 - 40MHz, DC Offset \_\_\_\_\_ \$795  
 V-222 - 20MHz, DC Offset \_\_\_\_\_ \$649

**Hitachi Compact Series Scopes**

V-660 - 60MHz, Dual Trace \_\_\_\_\_ \$1,149  
 V-665A - 60MHz, DT, w/cursor \_\_\_\_\_ \$1,325  
 V-1060 - 100MHz, Dual Trace \_\_\_\_\_ \$1,395  
 V-1065A - 100MHz, DT, w/cursor \_\_\_\_\_ \$1,649  
 V-1085 - 100MHz, QT, w/cursor \_\_\_\_\_ \$1,995  
 V-1100A - 100MHz, Quad Trace \_\_\_\_\_ \$2,495  
 V-1150 - 150MHz, Quad Trace \_\_\_\_\_ \$2,895

**Elenco DS-203 20MHz, 10MS/s  
Digital Storage Oscilloscope**



**\$775**

- 2K Word Per Channel
- Plotter Output
- 8 Bit Vert. Resolution
- 2048 Pts Hor. Resolution
- Much More

**C&S SALES INC.**

1245 ROSEWOOD, DEERFIELD, IL 60015  
 FAX: 708-520-0085 • (708) 541-0710



**CALL TOLL FREE 1-800-292-7711**

**1-800-445-3201 (Canada)  
ALL PRODUCTS ARE FACTORY NEW**

**15 DAY MONEY BACK GUARANTEE**

**FULL FACTORY WARRANTY  
WRITE FOR FREE CATALOG**

CIRCLE 32 ON FREE INFORMATION CARD

# TIMELINE INC.

Over 7 years and 22,000 customers and still growing.

## LIQUID CRYSTAL DISPLAYS

### Alphanumeric—parallel interface

16 x 1 .....	3 for \$25.00	16 x 2 .....	\$8.00
20 x 2 .....	\$12.00	24 x 2 .....	\$12.00
20 x 4 .....	\$25.00	40 x 2 .....	2 for \$25.00
32 x 4 .....	\$20.00	4 x 2 .....	\$5.00
40 x 4 .....	\$25.00		

5V power required • Built in C-MOS LCD driver & controller • Easy "Microprocessor" interface • 96 ASCII character generator • Certain models are backlit, call for more info.

### Graphic and alphanumeric—serial interface

Size	Mfr.	Price
640 x 480 .....	Epson .....	\$50.00
640 x 400 (backlit) .....	Panasonic .....	\$35.00
640 x 200 .....	Toshiba .....	\$19.00
480 x 128 .....	Hitachi .....	\$15.00
256 x 128 .....	Epson .....	\$35.00
240 x 128 (backlit) .....	Optrex .....	\$20.00
160 x 128 .....	Optrex .....	\$15.00

## LASER PRODUCTS

**HeNe Laser Tube** (10mW max. output) TEM00, 15.5" long MFG:NEC **\$99.<sup>00</sup>**

**Laser Power Supply** (for HeNe tube) **\$100.<sup>00</sup>**

### LASER SCANNER ASSEMBLY \$39.<sup>00</sup>

Assembly intended for a laser printer. Includes laser diode, polygon motor (6 sided) and misc. optics and lenses.

**LASER DIODE** (5mW) with collimator **\$20.<sup>00</sup>**

### LASER DIODE: Sharp part#: LT022MC

5mW at 780 nm, single transverse mode **\$10.<sup>00</sup>**

## POS & BAR CODE

### MAGNETIC CARD READER **\$25.<sup>00</sup>**

Includes: • 20 character dot matrix display with full alpha-numeric capability • keypad with full alpha-numeric entry • separate 7.5 VDC/0.5 Amp power supply • standard telephone interface extension cord • lithium battery and flat-cone speaker.

**HP bar code wand (HBCS 2300).....\$35.00**

## POWER SUPPLYS

**73 WATT SWITCHING \$15.00 or 2 @ \$25.00**, (2) 4 pin power connectors attached • 115/230 Volt, Dim: 8.5" L x 4.5" W x 2" H • Output: +5V @ 2-9.75 A, +12V @ 0-1.5 A, -5V @ 0-0.4 A, -12V @ 0-0.5 A

**68 WATT SWITCHING \$12.00 or 2 for \$20.00**, 115/230 Volt, Dim: 5.5" L x 3.2" W x 1.7" H • Output: 5V @ 4 A, 12V @ 4 A

## CHARGE COUPLED DEVICES

### "The Spy In The Sky"



1728 element CCD \$15.00

2048 element CCD \$15.00

4096 element CCD \$29.00

(These are linear CCDs, not matrix type.)

## MISCELLANEOUS

### ADAPTEC 4070A (RLL)

OR 4000A (MFM)

SCSI Controller, your choice **\$60.<sup>00</sup>**

IBM 370 option XT and AT emulation boards **\$50.00**

## MONITORS

### Non-Enclosed TTL

Comes with pinout. 12V at 1.4 Amp input. Horizontal frequency 15 Khz. Ability to do 40 and 80 column.

5 inch Black & White .....	\$35.00
7 inch Amber .....	\$39.00
9 inch Amber .....	\$29.95
12" Green or B & W .....	\$19.95

### Enclosed

9" Green BNC composite 115V/230V .....	\$79.00
12" White BNC composite 24V .....	\$99.00

Mfr.: Electrohome • For Very High Quality Medical and Industrial Applications

## 5" COLOR MONITOR **\$69.<sup>00</sup>**

- Flat Faceplate • 320 x 200 Dot Resolution • CGA & Hercules Compatible
- 12 VDC Operation • 15.75 KHz Horiz. Freq.
- 60 Hz Vert. Sync. Freq.
- Open Frame Construction
- Standard Interface Connector
- Degaussing Coil Included • Mfg.: Samtron



## COMPUTER PERIPHERALS

101 key XT keyboard .....\$19.00

AT Hard Drive Controller (Up to 12 Mhz only)....\$15.00

## FLOPPY DRIVES

360K .....	\$25.00
720K .....	\$35.00
1.2Mb .....	\$50.00
1.44Mb .....	\$50.00

5.25" bracket for 720K or 1.44Mb drives \$7 extra

### NEC N9630-P 9600 bps External Modem **\$109.<sup>00</sup>**

Hayes compatible • Full duplex asynchronous or synchronous operation • Dial up (voice) or lease line operation • Follows the V.32 standard • Automatic fallback to 4800 bps • Built in error correction (can be enabled or disabled) • Seven (7) mode of operation LED indicators • Seven (7) interface LED indicators • Two (2) signal quality LEDs • Eight (8) Character message display

## NETWORK

### IRMA BOARD 8 bit **\$99.<sup>00</sup>**

Links 3270 mainframe systems to IBM PC

### Proteon ProNet-4 Model pl347 Token Ring Board **\$79.<sup>00</sup>**

16 bit • 4 Mbps • IEEE 802.2 and 802.5 compatible • twisted pair • interoperable with IBM Token Ring network

## HACKER CORNER

### Portable **Micro Terminal**

Flip up LCD display (9-16 VDC) • Can communicate with any computer having RS 232 port • Can communicate with another Microterminal • Use by itself as electronic notebook • Onboard microprocessor, data RAM (32K) and Video RAM (64K) • Complex built in diagnostics and set up capabilities. • Original intention for POS applications. • display size 40x16 (256 x 128 pixels.) Dimensions: 6.3" W, 11"L, 2"H. (With LCD up height is 7.1")

**\$99.<sup>00</sup>**

or 2 for **\$149.<sup>00</sup>**

### All in one 286 board **\$59.<sup>00</sup>**

Includes: • 286-12Mhz CPU (1 wait state) • Built in IDE & floppy controller • 80287 math coprocessor • FAST! on board SVGA with 256K RAM • 2 serial ports, 1 printer port, mouse port • EMS-LIM ver 4.0 memory & shadow RAM support • Up to 8 mb memory (256K or 1 Mb SIMMS) • Comes with OK on board • On board speaker • REAL TIME CLOCK • Phoenix BIOS • Note: There is one long non standard bus connector on board



23605 TELO Ave, Torrance, CA 90505

Order desk only: USA: (800) 872-8878 CA: (800) 223-9977

L.A. & Technical Info: (310) 784-5488 Fax: (310) 784-7590

OEM INQUIRIES WELCOME

Minimum Order: \$20.00. Minimum shipping and handling charge \$5.00. We accept cashiers checks, MC or VISA. No personal checks or COD's. CA residents add 8.25% sales tax. We are not responsible for typographical errors. All merchandise subject to prior sale. Phone orders welcome. Foreign orders require special handling. Prices subject to change without notice. 20% restocking fee for returned orders..



# Setting New Standards

IN THE WORLD OF

## Communications, Test & Surveillance

**Further • Better • Faster**



**Model 3000A \$329.**

World's most highly advanced hand held counter.

- Digital Filter: Reduces false counts - no loss of sensitivity
- Digital Auto Capture - auto hold & store, works even near strong RF Fields
- Stores and recalls frequencies
- 5-6 hour battery operation
- Fast - 250 million counts per second for high resolution - 250 MHz direct count
- 10 Hz to 3 GHz
- Ultra sensitive bargraph w/ 16 segment display
- Multi-Function Counter with Frequency, Period, Ratio and Time Interval
- Optional  $\pm .2$  PPM TCXO- \$100.

**Model M1 \$229.**

Full Range Pocket Sized Counter

- Digital Filter
- Digital Auto Capture - Auto Hold
- Stores & Recalls Frequencies
- 4-5 hr. battery operation
- 10 Hz to 2.8 GHz
- 10 digit LCD with EL backlight

**Model 8040 \$679.**

Multi-Function Bench/Portable Counter Measures Frequency, Period, Ratio, Time Interval and Average.

- Digital Filtering to eliminate false counts
- Auto Capture/Auto Hold
- 16 Segment Signal Strength Bargraph
- Dual 50 OHm and 1 Meg OHm input amplifiers with AC/DC Coupling,  $\pm$  Polarity, Triggers Level Adj., Low Pass Filter and Attenuator
- .05PPM, 0-50°C Oversized Time Base Option
- Internal/External Clock Input
- RS-232 Serial Computer Interface

**800 • 327 • 5912**

(305) 771-2050 • FAX (305) 771-2052 • 5821 NE 14th Ave, Ft. Lauderdale FL 33334

CIRCLE 43 ON FREE INFORMATION CARD





**DON'T GET  
SPIKED  
BY  
HIGH CABLE  
RENTAL FEES!**

**IT'S TIME TO OWN YOUR CABLE TV  
DESCRAMBLERS &  
CONVERTERS**

***JERROLD, SCIENTIFIC ATLANTA, ZENITH, PIONEER, TOCOM, OAK, HAMLIN, EAGLE***

**FOR A FREE CATALOG OR QUESTIONS CALL TOLL FREE**

**1-800-729-1776**

**30 DAY  
NO-RISK  
TRIAL PERIOD**

***TKA  
ELECTRONICS***

**ONE YEAR  
WARRANTY  
IN WRITING**

**7914 WEST DODGE ROAD #334 OMAHA, NE 68137**

**CIRCLE 129 ON FREE INFORMATION CARD**



**PCBoards****PCB Artwork  
Made Easy!****PRINTED CIRCUIT DESIGN SOFTWARE  
for****Layout - Autorouting - Schematic**

- Supports all Video Modes including Super VGA
- Copper Flooding for Building Ground Areas
- Gerber and Excellon Output
- Mirror Imaging for Laser Printer Output
- Autorouter and Schematic Programs
- Circuit Simulation Software Available
- **NEW! - WINDOWS**™ Versions
- **NEW! - DOS Versions - PCBoards & PCRoute**
- **FREE** - Heat Transfer Film with Order

Download Demos from BBS (205)933-2954

**PCBoards Layout Only \$99****Windows**™ Layout starts at **\$149**

Call or Write for Full Product Line, Prices &amp; Demo Packages

**PCBoards**2110 14th Ave. South  
Birmingham, AL 35205**(800)473-7227**Fax (205)933-2954  
Phone (205)933-1122

Tap into a World of...

**FREE ELECTRICITY**Our 150+ page *Self-Reliance Catalog*  
IS JUST LOADED WITH DC to AC  
ENERGY INDEPENDENCE ...

We offer:

Solar, Wind & Hydroelectric energy systems. True Sine Wave DC to AC Inverters. Electric Boat & Car kits. Portable power packs. Solar Lighting & Cooling systems. Solar Pool Heaters. Solar Battery chargers. Solar Books & Toys. DC Appliances. Active & Passive Solar Air & Water Heating Systems. Composting Toilets. Hydroponic, Fish-Farming, Solarium & Greenhouse Systems. Water Testing, Treatment, & Pumping Systems. Emergency Food & H<sub>2</sub>O Kits. High Efficiency AC/DC Refrigeration + More...

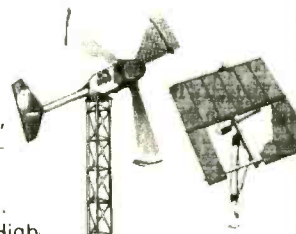

A LOT OF INFORMATION FOR ONLY \$5.75 ...

SEND CHECK or MO TO:

*Self-Reliance Company Inc.***P.O. Box 306, Florissant, MO 63032****NEW!! Laser Radar Detectors \$99.95****CABLE CONVERTER SPECIALS**

	1	5	10+
<b>Jerrold 400 Converter</b> 60 channel refurbished with new transmitter. Fine tuning HRC/STD selectable. 6 month warranty	59.95	49.95	45.00
<b>Hamlin 5000 Converter</b> 64 channel w/fine tune. New transmitter. Channel 0 & 1 Compatible.	69.95	59.95	55.00
<b>SA-3 Type Decoders</b>	89.95	65.00	50.00

**United Electronic Supply**P.O. Box 1206-NV  
Elgin, IL 60121**708-697-0600**

No Illinois Sales



Hours: Mon - Fri: 8:30 — 5:00 pm CST

24 Hour Answering Machine for orders

# CELLULAR SOFTWARE AND MODIFICATION GUIDES

*Call Spy Supply for all of your Cellular needs!*

*We Carry:*

## CELLULAR SOFTWARE

(We have the software to do New Motorola Phones)

## CELLULAR CABLES

(For the Motorola, Panasonic, and Nokia Phones)

## CELLULAR MODIFICATION GUIDES

(Covers all cellular manufacturers)

## CELLULAR PHONES

(We carry a complete line of cellular phones)



## FREE TECHNICAL SUPPORT!

We now offer Cellular Phones cloned with your existing number! Buy a handheld, transportable or car mounted phone ready to go and have only one monthly bill!

### *Don't Get Ripped Off!*

Before you buy our competitor's manual, call and ask if they offer **FREE TECHNICAL SUPPORT**

### **SPY SUPPLY**

Find out why the CIA - FBI - DEA - SECRET SERVICE Have ordered from our catalog To receive yours, send \$5.00 to:

### **SPY SUPPLY**

1212 Boylston St. #120  
Chestnut Hill, MA 02167

**SPY SUPPLY**, 1212 Boylston St. #120, Chestnut Hill, MA 02167

**(617) 327-7272**

*Sold for educational purposes only*



# KELVIN

ELECTRONICS

10 HUB DRIVE, MELVILLE, NY 11747

RE-ENGINEERED & DESIGNED FOR 1994



150 LE - Student 200 LE - Technician 400 LE - Engineer

**Standard Features -** ● AC & DC VOLTAGES ● DC CURRENT ● RESISTANCE ● TRANSISTOR ● CONTINUITY TEST - Buzzer ● DIODE TEST ● 3 1/2 Digit LCD ● 10M ohm INPUT IMPEDANCE

**BATTERY TEST**  
TRANSISTOR  
DC CURRENT  
10 Amp

**FREQ COUNTER**  
up to 20MHz  
**TRANSISTOR CAPACITANCE**  
from 1pF to 20uF  
**AC/DC CURRENT**  
10 Amp

**INDUCTANCE**  
Resolution 1uH  
**FREQ COUNTER**  
up to 20MHz  
**CAPACITANCE**  
from 1pF to 200uF  
**AC/DC CURRENT**  
DUTY %  
20 Amp

**150 LE**  
Stock # 990122  
**\$29.95**

**200 LE**  
Stock # 990123  
**\$49.95**

**400 LE**  
Stock # 990124  
**\$79.95**

Designed to meet IEC-348 & UL-1244 safety specifications

**2 Year Warranty (Parts & Labor)**

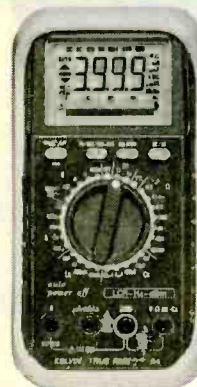

"Not only does the Kelvin 94 boast alot of features ... the features go the extra distance."

"If we had to run into a burning building to do some emergency trouble-shooting and could carry in only one piece of equipment, the Kelvin 94 would be it!"

Popular Electronics  
Reviewed - May 1993

## KELVIN 94 The Ultimate Meter

**LCR Hz dBm True RMS Logic Probe**

The only meter with 0.1% Accuracy on DC Voltages, built-in True RMS, Freq Counter to 20MHz Res: 10 Hz, LCR-Inductance Tester Res: 10 uH, DC/AC Voltages Res: 0.1mV, Ohm Meter Res: 0.1 ohms

**TRUE RMS PLUS**

Model 94

#990111

**\$199.95**

\*See Standard Features Listed below

## ENGINE ANALYZER PLUS

Model 95 #990112

**\$199.95**

**A Must For Auto Mechanics**

\* **Standard Features - Models 94 & 95**

- DC/AC VOLT METERS ● AC/DC CURRENT
- OHM METER ● DATA HOLD ● RELATIVE MODE
- FREQ COUNTER to 4 MHz (Model 95)
- AUDIBLE CONTINUITY TEST ● DIODE TEST
- MAX/MIN AVERAGE MEMORY RECORD
- 10A HIGH-ENERGY FUSE PROTECTION
- AUTO SLEEP & AUTO POWER OFF

(800) 645-9212  
(516) 756-1750  
(516) 756-1763/FAX

## KELVIN 100 Basic

# 990087

**\$19.95**

- AC & DC VOLTAGES
- DC CURRENT
- RESISTANCE
- CONTINUITY TEST - Buzzer
- 3 1/2 Digit LCD
- LOW BATTERY INDICATOR
- DIODE TEST ● BATTERY TEST



## CAPACITANCE METER

### KELVIN 250 LE

# 990126

**\$59.95**

- ACCURACY: 0.5%
- RANGES: 20mF, 2000uF, 200uF, 20uF, 2uF, 200nF, 20nF, 2000pF, 200pF
- Zero Adjust
- Safety Test Leads
- Test Socket for Plug-in Components



## AUTO-RANGE METER

### KELVIN 300 LE

# 990125

**\$49.95**

**AUTO-RANGE**

- ACV & DCV
- DC CURRENT
- RESISTANCE
- CONTINUITY TEST
- DIODE TEST 3 1/2 Digit LCD
- 10M ohm INPUT IMPEDANCE



## INSTRUMENTS



### 20 MHz SCOPE

Dual Trace 2 Yr Warranty-Parts & Labor

Stock No. 740085 ..... \$385

### 40 MHz SCOPE

Dual Trace with Delayed Sweep

Stock No. 740086 ..... \$655

## TEST ACCESSORIES

### SCOPE PROBES

60 MHz, X1 & X10

SPECIAL

700072 ..... \$18.95

150 MHz, X10

700073 ..... \$39.95

### IC CLIPS

SOLDER TYPE

SPRING LOADED

Stock No. COLOR

990104 BLACK ..... \$0.65 ea. \$0.50 ea

990105 RED ..... \$0.65 ea. \$0.50 ea

## DC TOY MOTORS

### DC Toy Motor

Stock No. 850647

\$.80 ea

\$.75 ea / 50+ Qty

6V DC High Speed

### Solar Motor

Stock No. 850646

\$.60 ea. 1.5V DC

\$.55 ea / 50+ Qty

### Solar Cells

3 3/4" L x 2 9/16" W

Stock No. 260099

1000mA .45V

\$.95 ea

\$.55 ea / 3+ Qty

Established 1945  
M/C & VISA \*20 Minimum Order\*  
KELVIN CATALOG #3  
Stock No. 650412

## DIGITAL TRAINER



Laptop Digital Trainer comes with 100 page instruction manual, power supply, built-in 1 digit true hexadecimal display, two independent clocks with user adjustable freq & duty cycles, 4 data bit switches and 4 LED displays. Assembled Stock No. 840460 ..... \$99.95

## BINARY QUARTZ CLOCK w/Alarm



ORIGINAL DESIGN - 24 Hr. Binary Quartz Accurate Clock with 2 color LED's. Built-in Alarm and Alarm Display in binary code. DESIGNED FOR LEARNING about digital circuitry & binary code. Built with individual IC components. Battery Memory Loss Prevention. Comes with rechargeable battery, DC wall transformer and detailed instruction manual. Advanced Level Kit Stock No. 840589 ..... \$79.95

## Electronic VOICE PAD



An electronic note pad, able to record your message & replay it later. It has a built-in photo cell & as soon as it senses your presence, it will automatically playback the message left for you. The components are PC mounted. The IC can record a message up to 20 seconds & no mechanical parts or tape - only a digital integrated circuit.

Intermediate Level Kit

Stock No. 840606 ..... \$49.95

## BREADBOARDS

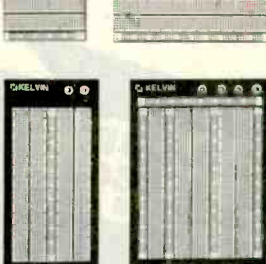

Stock No.	Post	Contacts	YOUR COST
680093	0	500	\$ 4.25
680097	0	840	\$ 5.95
680098	2	1380	\$11.75
680100	4	2390	\$22.95

## WIRE JUMPER KIT

Pre-cut, Pre-Stripped

330289 140 Piece Set ..... \$ 4.95

330290 350 Piece Set ..... \$ 8.95

## COMPONENTS

WHOLESALE PRICES!

Stock No.	TYPE	(10 Pcs. Min.) YOUR COST
600021	555 TIMER	\$.29 ea
600029	556 DUAL TIMER	\$.40 ea
600039	LM566 PPL FUNCTION GENERATOR	\$.60 ea
600018	741C OP-AMP INTERNALLY COMPENSATED	\$.30 ea
600026	1458 OP-AMP DUAL 741C OP-AMP	\$.35 ea
630041	2N2222	\$.20 ea
630383	PN2222	\$.08 ea
600023	7805 Voltage Reg	\$.36 ea
<b>SILICON CONTROLLED RECTIFIER</b> (Similar to GE C106C1) 4.0 amp, 100PIV		
600014		\$.89 ea ..... \$.79 ea/10+
<b>THERMISTOR - 100 ohm</b>		
110097		\$.135 ea ..... \$1.00 ea/20+
<b>THERMISTOR - 10K ohm</b>		
110097		\$.135 ea ..... \$1.00 ea/20+

## PROJECT PARTS

**Project Speaker**  
2", 8 Ohm, .1 Watt  
Stock No. 350009

**59¢**

**Project BUZZER**  
3 - 9 Volt DC, 80 db  
Stock No. 680089

**\$1.59 ea**

**\$1.39 ea / 10+ Qty**

**Soldering IRON**  
with STAND  
LONG LIFE TIP  
Stock No. 990098

**\$3.95 ea**

### LED T134

Stock No.	Color	100+ Qty	1000+ Qty
260020	RED	\$.05 ea	\$.045 ea
260027	GREEN	\$.08 ea	\$.07 ea
260026	YELLOW	\$.08 ea	\$.07 ea
260078	2 COLOR RED/GREEN	\$.32 ea	\$.29 ea

### XENON STROBE TUBE

Stock No. 260050

\$3.25 ea

**\$2.95 ea / 20+ Qty**

### TRIGGER COIL

for Xenon Strobe Tube

Stock No. 320037

**\$1.25 ea**

**\$.89 ea / 20+ Qty**

### INFRARED LED

IR Pair, LED Infrared transmitter and receiver

Stock No. 260061

**\$1.95 ea**

### NEON LAMP

NE2, 2" Lead

Stock No. 260003

\$.15 ea

**\$.12 ea / 100+ Qty**

### PHOTO CELL

Photo Cell - 450 ohm

Stock No. 260017

\$.65 ea ..... \$.45 ea / 20+ Qty

Photo Cell - 1.5K ohm

Stock No. 260018

\$.65 ea ..... \$.45 ea / 20+ Qty

### PUSH-BUTTON SWITCH

PUSH-ON, PUSH-OFF

Stock No. 270021

\$.55 ea

**\$.49 ea / 100+ Qty**

### SUB-MINIATURE MOMENTARY SWITCH

Stock No. 990002

\$.35 ea

**\$.28 ea / 100+ Qty**

### MINIATURE TOGGLE SWITCH

Stock No. 270034

\$.90 ea Type - SPST

**\$.79 ea / 50+ Qty**



# LATEST TECHNOLOGY

- DESCRAMBLERS
- CONVERTERS
- COMBINATION UNITS

**WE'LL BEAT ANY PRICE!**

## LATEST DESCRAMBLER MODELS

- Add On Descrambler for all JERROLD Systems (Except Base Band) Guaranteed to Work Anywhere Coast to Coast. (Model JD-3)
- ~~\$125~~  
**\$89** 6-10  
 \$119 1-5
- Add On Descrambler For All PIONEER Systems. Guaranteed to Work Anywhere Coast to Coast. (Model PD-3)
- ~~\$125~~  
**\$89** 6-10  
 \$119 1-5
- Add On Descrambler For All SCIENTIFIC ATLANTA Systems (Except 8570, 8590, 8600). Guaranteed to Work Anywhere Coast to Coast. (Model SAD-3)
- ~~\$125~~  
**\$89** 6-10  
 \$119 1-5



**BRAND NEW 1 YEAR WARRANTY**

### SCIENTIFIC ATLANTA 8580

- Features
- Wireless Remote Control
  - Favorite Channel Recall
  - Parental Lockout

**\$259** 6-10

**BRAND NEW 1 YEAR WARRANTY**

**\$289** 1-5



### ZENITH

- Features
- Wireless Remote Control
  - 550MHz (99 Channel) capacity
  - Volume Control
  - Parental Lock-Out
  - Programmable Favorite Channel Memory

**\$259** 6-10

**\$289** 1-5

## ADD ON DESCRAMBLERS

	1-5	6-10
FTB-3	49.00	39.00
TVT OR TBI	55.00	47.00
SA-3	59.00	49.00
KN12-3	59.00	49.00
MLD1200-3	49.00	39.00

## CONVERTERS

	1-5	6-10
PANASONIC 1453G	79.00	69.00
JERROLD DQN 7-3	75.00	65.00
STARGATE 2001	75.00	65.00

Call for other models



**DPV7 & DBB7  
8590 & 8600**  
Call for availability & prices



1470 OLD COUNTRY ROAD,  
SUITE 315 - P.E.  
LAINVIEW, NY 11803  
NO NY SALES

**FREE COLOR CATALOG!**  
**1-800-950-9145**



## The Television **Gray** Market

by Henry Eisenson

## Scanners & Secret Frequencies

### The truth about cable theft!

TV's hidden underground... chips and test devices, bootleg converter boxes, the law, industry countermeasures. Actually identifies hundreds of dealers in products, services, and information. **This book is a MUST!** ALA's *Booklist* calls it "Controversial, but of high interest." *You bet it is!*

\$23.75

Whether you're an expert or beginner, prefer police calls or listening to private conversations, this new 320-page book will help you a *lot!* Discusses the law, the FCC, aviation, cellular, baby monitors, law enforcement, much more! Here's what the experts say...

"...broad in scope and authoritative..." Bob Grove, Publisher, *Monitoring Times*

"...must reading..." Brian Fenton, *Electronics Now*

"...indispensable tool..." Steve Crum, President, Ace Communications

"...comprehensive, no nonsense..." Bill Cheek, *World Scanner Report*

"Absolutely the best..." Norm Schrein, "Mr. Scanner" \$19.95



## Underground Database

\$23.75

This large-format book lists hundreds of *underground* sources for services and products that are legal to make, advertise, sell, buy, and even own, but if you actually *use* them... *look out!* "Fascinating," *American Survival Guide*

Add \$3 U.S., \$4 Canada, \$8 elsewhere per book for shipping. CA residents add sales tax. U. S. funds only.

Money order or check:

INDEX Publishing Group  
3368 Governor Dr., #273F  
San Diego, CA 92122

Credit card orders only:

1-800-546-6707



CIRCLE 35 ON FREE INFORMATION CARD

## Learn MICROCONTROLLERS and EMBEDDED SYSTEMS with the AES-10

The AES-10... a complete learning system, a complete embedded control system. Extensive manuals guide you through your 8051 development project. Assembly, BASIC, and C programming explained.

All hardware details, complete schematics. Learn to program the LCD, keypad, digital and analog I/Os for your applications.

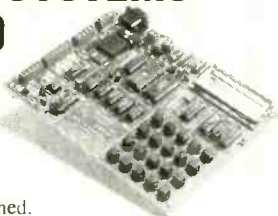

### 80C32 Computer/Microcontroller board with:

- 32K ROM, 32K RAM
- 2 by 16 Liquid Crystal Display
- 4 by 5 Keypad
- Digital, A/D, D/A, and PWM
- Built in Logic Probe
- Power supply
- Extended AES BASIC and AES Monitor in ROM
  - Built-in routines for LCD, Keypad
  - A/D, D/A and Digital I/O ports
  - See 8052 registers while you Step
  - See all memory locations on LCD
  - See memory contents in dec, hex, and binary
- RS-232 cable to connect to PC
- 8051/52 DOS Cross Assembler
- Program disks with well documented examples
- User's Manual, Language Manual, and Text

**AES**  
Advanced Educational Systems

1407 North Batavia Street, Orange, California 92667

\$365, Money Back Guarantee

Free Brochure

800-730-3232 M/C Visa

## MCM Electronics

Has a Constant Flow of New Products for You to Choose From

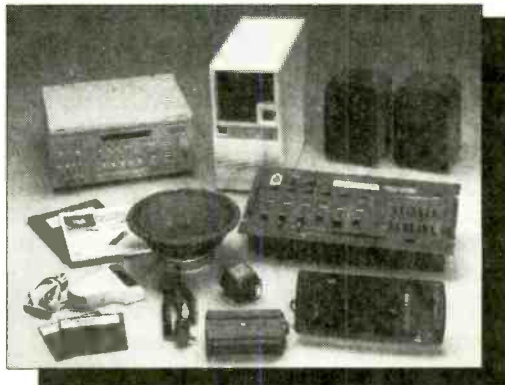

MCM Electronics can meet all your project and repair parts needs. We carry a wide variety of TEST EQUIPMENT, TOOLS, REPAIR COMPONENTS, HARDWARE, COMPUTER PRODUCTS and EDUCATIONAL KITS in stock and ready to ship within 24 hours. With each catalog we add hundreds of new items that will keep you on the leading edge of technology.

Serving you coast to coast. Distribution Facilities in Dayton, OH and Reno, NV!

So call today, toll free at:

**1-800-543-4330**

or FAX 1-513-434-6959.

And ask for our new FREE MCM Electronics catalog.



**MCM ELECTRONICS**  
650 CONGRESS PARK DR.  
CENTERVILLE, OH 45459-4072  
A PREMIER Company



POP-06

# A recession-proof business! Own your own computer repair business or add computer repair to your existing business.

TechServ can put you into your own computer repair business quickly, economically and efficiently. Research indicates that during a recession, computer repair businesses will grow at twice the rate of hardware sales. TechServ's complete support program gives you the opportunity to be a part of this fast growing industry.

- **Proven Marketing Plan**
- **Recognition**

Nationally recognized trademarks and logos give you immediate recognition as a professional computer repair specialist in your area.

- **Training**

- Level 1     286/386/486/586  
Troubleshooting, upgrades, advanced diagnostics
- Level 2     Networking/Novel/Unix/Multi-user/  
Multi-tasking configuration/Installation/  
Maintenance. Prepare for C.N.E.  
(Certified Network Engineer) test

- **Parts and Board Repair**

Single source for OEM/generic parts and board repair. Order 7 days a week/24 hours a day. \$45 million in parts in stock, ready to ship any where, overnight if required.

- **Documentation**

We provide manuals, documentation and advanced diagnostic software.

- **New Hardware**

We provide new hardware for IBM, Compaq, Apple and compatibles at huge discounts. Custom build your own systems.

**Over 300 dealers worldwide**

Find out why the Wall Street Journal and Fortune Magazine call computer repair the business opportunity of the 1990s.

**Call TechServ at (212) 967-1865**

or fill out coupon below and mail to:

**techserv** AUTHORIZED DEALER SM

*America's largest chain of independent,  
licensed computer repair centers*

253 West 28th Street, New York, NY 10001

NAME \_\_\_\_\_  
ADDRESS \_\_\_\_\_  
CITY \_\_\_\_\_ STATE \_\_\_\_\_ ZIP \_\_\_\_\_  
TELEPHONE \_\_\_\_\_ [PE 2/93]

 <p><b>AD-500 VHF-FM TELEPHONE TRANSMITTER CRYSTAL CONTROLLED:</b> Operating Frequency: 139 - 149.450 MHz RF power output: 11 MW Dimensions: 1 3/4 x 1/4 x 3/4 (W x H x D) Half assembled kit Price: \$115.00</p>	 <p><b>AD-600 VHF-FM TRANSMITTER CRYSTAL CONTROLLED:</b> Operating Frequency: 139 - 149.450 MHz RF power output: 11 MW Operates on 2 "N" Batteries Operating time: over 100 Hrs. Dimensions: 2 x 5/8 x 1 1/2 (W x H x D) Half assembled kit Price: \$125.00</p>	 <p><b>AD-268 VHF-FM TRANSMITTER CRYSTAL CONTROLLED:</b> Operating frequency: 139 - 149.450 MHz RF power output: 268 MW Dimensions: 2 x 3/8 x 5/8 (W x H x D) Half assembled kit Price: \$145.00</p>
 <p><b>CCD 100 + CCD 200 MICRO MINIATURE CCD CAMERAS - SMOKE DETECTOR DESIGN:</b> CCD-100: 300 lines resolution. Price: \$225.00 CCD-200: 400 lines resolution with sound. Price: \$315.00</p>	 <p><b>AS2000XLT RF BUG DETECTOR:</b> Operating frequency: 5 - 2000 MHz Built in rechargeable battery. Price: \$525.00</p>	 <p><b>CHINON CX-102 AUDIO MINIATURE BOARD MONOCHROME SOLID STATE CHIP CAMERA WITH AUDIO FEATURE/ BUILT IN MICROPHONE:</b> Operating range of: DC7V to 14V Dimensions: 1.81 x 2.76 x 0.91 (W x H x D) Price: \$249.00</p>

Used by law enforcement agencies

Competitive and discounted prices • call for free catalog • Professional and high quality products • Order by fax 24 hours.

**A & D Electronics**  
P.O. Box 601  
Monsey, NY 10952  
Tel: (800) 356-3480 • IN/NYS (914) 356-7541 • Fax: (914) 356-7505

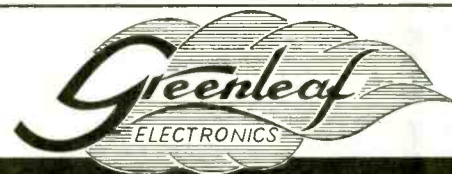

# CABLE TV Converters & Descramblers

Compatible with  
**Jerrold, Scientific Atlanta,  
Pioneer, Oak, & Hamlin  
Equipment**

**BRAND NEW!  
90-DAY GUARANTEE  
LOWEST PRICES**

*Volume Control & Parental Lockout Available*

**Greenleaf Electronics**  
**1-800-742-2567**  
**NO ILLINOIS SALES**

It is not the intent of Greenleaf Electronics to defraud any pay television operator and we will not assist any company or individual in doing the same.

Popular Electronics, March 1994



**Powerful Integrated Digital and Analog (Berkeley Compatible Spice)  
Circuit Design and Simulation Software for Microsoft Windows™ (network compatible)**

**Includes 4 Integrated Modules: LogicDesigner + WinSpice3 + WinProbe3 + SymbolEditor**

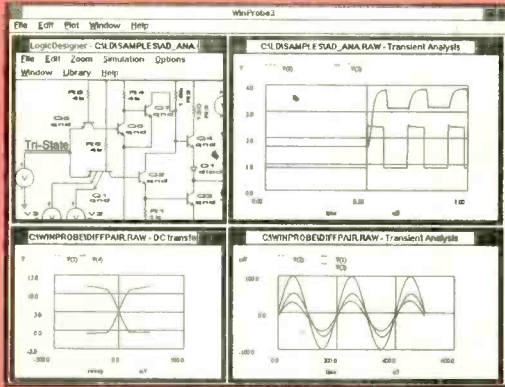

Comes with a Spice library plus 5 more libraries of active digital devices CMOS, 74xx, 74xxx, ALUs, counters, MUX, FFs etc. Plus a passive symbol library of microprocessors and more. Use the symbol library editor to design your own symbols and symbols for subcircuits, true bussing, buss pins can be assigned a unique name, parts billing list, legends, nested subcircuits for hierarchical top down or bottom up design, checks fan out violation and electronic rules, device unit numbers/chip pinouts automatically added as per data books, spice netlist generation, continuous zoom in/out, cut/copy/paste, multiple rotatable fonts, rotatable symbols, multipage zoomed in/out printouts to any windows printer/plotter.

**LogicDesigner Digital Simulation/Schematic Capture Module**

Interactive digital simulation and schematic capture, with glitch detection, single step mode, variable speed simulation, printable timing diagram output, truth table generation, binary to 7 segment displays, hex keypads, clock sources, logic probes. Built in logic analyzer can be set up to generate breakpoints during simulation from user defined AND/OR combinations of circuit signals and sequential events to help debug circuit timing/logic/race conditions. Simulates tri state, open collector & don't care logic, RAM/ROM, one shot, carry look ahead, shift reg, pull up/down.

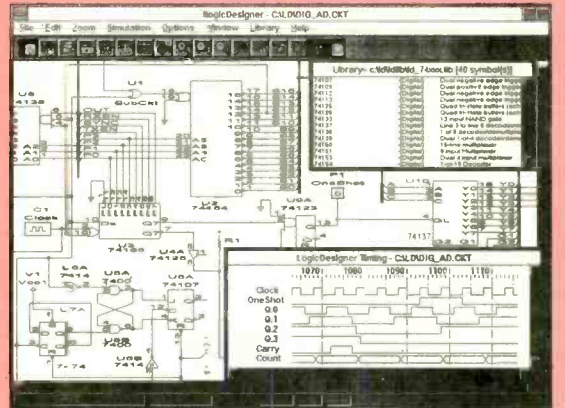

**WinSpice3 Simulator & WinProbe3 Data Analyzer Modules**

DC, AC, Transient, pole-zero, noise, sensitivity and transfer function analysis. Spice library includes MOSFET, MESFET, GaSFET, BJT, DIODE, controlled, independent, dependent and arbitrary sources, transmission lines, current and voltage controlled switches, more. Each with user modifiable models. Plots linear, logarithmic, smith chart type plots, more. Multiple plot windows. Zoom in/out on plot waveforms. Plots math expressions using plot variables as arguments: Ex: plots  $\text{COS}(V(1)/V(2)*10)$ , derivatives, + more.

\$69.00 (one month only!!! reg \$179.99)  
(Univ & student pricing avail) VISA/Mastercard

**ISLAND LOGIX INC.**

IRIE MAN  
920 South West 95 Terrace  
Pembroke Pines, Florida 33025 U.S.A.  
PH/FAX: (305) 435-7665



CIRCLE 142 ON FREE INFORMATION CARD

**CABLE TV DESCRAMBLERS**  
Best Prices in the U.S.A.! Guaranteed to Work!

**WE WILL BEAT ANY PRICE!**



JERROLD PANASONIC SCIENTIFIC ATLANTA PIONEER

**The Newest & the Latest**

DMTB-A - all Jerrold Impulse & Starcom series  
SA3-DFA - all Sci. Atlantas incl. 8536/+, 8580, Drop-field  
PN-3A - all Pioneer systems

ALSO FTB3, SA3, TZPC145G

24 HR. SHIPMENTS FREE CATALOG 30 DAY MONEY BACK GUARANTEE

**1-800-772-6244** M-F: 9-6 EST

U.S. Cable TV, Inc. Dept.: <PE034  
4100 N. Powerline Rd, Bldg. F-4 Pompano Beach FL 33073  
NO FLORIDA SALES!

CIRCLE 55 ON FREE INFORMATION CARD

Radiotelephone - Radiotelegraph

**FCC Commercial License**

**Why Take Chances?**

Discover how easy it is to pass the exams. Study with the most current materials available. Our Homestudy Guides, Audio, Video or PC "Q&A" pools make it so fast, easy and inexpensive. No college or experience needed. The new commercial FCC exams have been revised, covering updated Aviation, Marine, Radar, Microwave, New Rules & Regs, Digital Circuitry & more. We feature the Popular "Complete Electronic Career Guide" 1000's of satisfied customers

Guarantee to pass or money back.  
Send for FREE DETAILS or call  
**1-800-800-7588**

WPT Publications  
7015 N.E. 61st Ave Dept. 10  
Vancouver, WA 98661

Name \_\_\_\_\_

Address \_\_\_\_\_

City \_\_\_\_\_ St. \_\_\_\_\_ Zip \_\_\_\_\_

**1-800-800-7588**

March 1994, Popular Electronics





# B & S SALES

Call(313) 566-7248 • FAX (313) 566-7258 24 hrs.

Hours: Monday through Friday 8 am to 6 pm EST  
51756 Van Dyke St. #330, Shelby Township, MI 48316

WE SPECIALIZE IN QUANTITY PRICING 5, 10, 20 LOTS

*Make Your Best Deal!*

**\$ SALE**

**\$ SALE**

**Y RENT**

**Y RENT**

<u>JERROLD</u>	<u>SA</u>	<u>PIONEER</u>	<u>HAMLIN</u>	<u>TOCOM</u>	<u>ZENITH</u>
DRX-3-DIC	8590	BA 6110	CR 6600-3M	5507 VIP	1600
DPBB	8580	BA 5135	CR 6000-3M	5503 VIP	
DPV-5,7	8570				
	8550				

**NEW PAN**  
PIONEER  
GREEN E LITE  
BA 5000 > SERIES  
BA 6000

**NEW PAN**  
SA-8500 SERIES  
(BUT ALL BASE BAND)  
THE PREMIER

**NEW PAN**  
JERROLD  
PINK PAN

## PANASONIC TZ — PC 1453G2

By far the best basic converter on the market today. 550 MHz (1 to 99) parental control, sleep timer, remote batteries, contrast and remote control range.

*Superior to all other converters*

**NO MICHIGAN SALES**

MINI TVT:  
THE 1/4 POUNDER  
LITTLE 4x4  
SECOND ONLY TO TVT  
GOLD IN POPULARITY

**OWN YOUR OWN**  
SA-3  
M-80

**SAVE \$**

NEW REMOTE CONTROL AB  
SWITCH FOR DUAL SYSTEMS  
(WITHOUT LEAVING THE  
COMFORT OF YOUR CHAIR)

TVT GOLD ORIGINAL  
FOR MOST  
JERROLD SYSTEMS.  
LEADING SELLER  
OF ALL PANS

**OWN YOUR OWN**  
TNT  
MLD

**SAVE \$**

FILTERS  
POST & NEG  
SUBCONTRACTORS  
& DEALERS  
ONLY QUANTITY

We are now offering a 6-month warranty. In order for warranty to be in effect, this form must be signed and returned.

FOR VCR, SECOND, THIRD, ETC. HOOK-UPS.

Yes, I agree all units are to be used or resold in compliance with Federal and State laws.

Signature \_\_\_\_\_ Date \_\_\_\_\_

Name \_\_\_\_\_ Phone No. ( ) \_\_\_\_\_  
Address \_\_\_\_\_  
City \_\_\_\_\_ State \_\_\_\_\_ Zip \_\_\_\_\_  
It is not the intent of B & S Sales to defraud any pay television operator and we will not assist any company or individual in doing the same.

CIRCLE 140 ON FREE INFORMATION CARD



# TOP SECRET



## CONSUMERTRONICS

2011 Crescent Dr., P.O. Drawer 537  
Alamogordo, NM 88310  
(505) 434-0234, 434-1778

FAX: (505) 434-0234 (if you get answering machine press "4", then "1" any time)

**VOICE LINES:** 8 AM - 8 PM MST, Mon-Sat  
**EXX (orders only):** 24-hour, 7 days/week  
Add \$5 total SH (USA, Canada). All items in stock. VISA, MC card OK. No CODs or "bill me's". 150+ unique hi-tech survival books, manuals, programs, hardware, services - New Catalog is \$2 w/ order, \$4 w/o (no free catalog), in business since 1971. As seen on TV, etc. John Williams - former Lockheed Senior Engineer, NMSU Professor of Computer Science, NIH Health Physicist. Sold for educational purposes only.

\*All software supports all IBM-PC compatible systems (8086 - 80486)

### Off-The-Shelf HARDWARE

Van Eck Systems, Automated Tempest Module, X-Radar, Radar Emitter, Carjacking Foiler, Personal Body Alarm, Voice Disguiser, Hearing Assistor, Shrek Module, EM Countermeasure, Omnimax TENS, 6th Sense Communicator, many nifty Phone Boxes, Bumper Beeper, Subliminal Mixer/Amp, Super MW0, Rifle Device, Neurophone, Heteronymis Machine, MU Magnetometer, Data Card Reader/Writers, Dwelling Security System, Levitator, Vortex Generator, Ultrasonic Jammer & Receiver, Stealth Paint - much more! See our Catalog.

### SPECIAL PROJECTS

We design, build, repair, modify, maintain and/or consult on any device, system, process or project - electrical, electronic, computer, pneumatic, mechanical, optical, automotive. Invention prototyping. Confidentiality guaranteed. Describe and include \$25 pre-engineering fee (does not obligate you). Time and cost estimates in 7-10 days.

### VOICE MAIL HACKING

How Voice Mail Box (VMB) systems are used and the specific ways they are hacked. Includes ASPEN, MESSAGE CENTER, BIX, GENESIS, EZ, SYDNEY, PHONE MAIL, AUDIX, CINDY, CENTAGRAM, SPERRY LINK, RSVP, etc. Absolutely required for all users and sysops! \$29.

### PBX HACKING

Thousands of PBXs are hacked to the tune of about \$8 Billion/yr! While our "VOICE MAIL HACKING" details how VMSs are hacked for "phunt" and profit - including VMS methods for hacking PBXs themselves - "PBX HACKING" addresses ALL issues relating to PBX hacking, including countermeasures! Can your business or agency afford a \$90,000 phone fraud loss (the average loss due to hacked PBXs)? As described in Forbes Magazine. \$39

### PHREAKING CALLER ID & ANI

Details on how they work and dozens of effective ways of defeating Caller ID, ANI, '69, '57, and Call Blocking and '67. Also describes Caller ID, Orange, Belpe, Cheese and CF Boxes, ESS, S57, E-911, various CLASS services, CNA, NON PUB DA, CAMA, DNR, 800-ECR, Diversers, LD Extenders, Centrex - more. \$29.

### PHONE COLOR BOXES

As designed by Phone Phreaks! 15 phone color boxes described. Dozens of circuits, simulator programs. Plus call-forwarding, conferencing, phreak history, 50 useful and legal phone circuit plans - more. \$29.

### ROBOFONE AUTODIALER

Powerful, versatile, menu-driven "Wargames" autodialer lets you dial any number (up to 10k) or mix of location distance numbers in any order, over any length of time, whether busy or answered (your choice) and log the times, commands and results to monitor, printer and/or disk. Quick-dial directory of up to 600 numbers. BUSY redial options. Direct modem command and control. All Result Codes, including VOICE and RINGING. Optional shell to terminal program upon CONNECT. Exit to menu or DOS (for batching). Manual + Disk\* \$29.

### COMPUTER PHREAKING

TROJAN HORSES, VIRUSES, WORMS, etc. and countermeasures. Includes disk with 360K of hacker text files and utilities, and legendary FLUSHOT+ protection system (Ed. Choice, PC Magazine). Dozens of computer crime and abuse methods and countermeasures. How systems are penetrated. BBS advice, password defeats, glossary - much more! Manuals + Disks\* \$39.

### BEYOND VAN ECK PHREAKING

Eavesdropping on VDT and TV video signals using an ordinary TV! Documented in security industry literature. Range up to 1 KM. Plans include both the Consumertronics and the original Top Secret Van Eck design! \$29.

### CRYPTANALYSIS TECHNIQUES

Five powerful menu-driven crypto programs (in .COM and their .BAS sources) to analyze, decrypt "secure" ciphertexts. Worked-out examples. Recommended in prestigious "Computers & Security". Manual + Disk\* \$29.

### By an ORDER of the MAGNITUDE

The most comprehensive, hard-hitting, hi-tech survival book ever written! Topics include electronics, computers, energy, weapons, concealment, revenge, alarms, etc. to survive today's dangerous world. We all face increasingly financially and physically brutal times! Field-expert use of technology in various threat and conflict environments and scenarios. \$49.

### STOPPING POWER METERS

As reported on CBS' 60 MINUTES: How certain devices can slow down - even stop - watt-hour meters - while loads draw full power! Device simply plugs into one outlet and normal loads into other outlets. Also describes meter creep, overload drop, etc. Plans \$29. I.Q. MANUAL: External magnetic ways (applied to the meter itself) to slow down and stop watt-hour meters while drawing full loads. Plans. \$19. KW-HR METERS: How watt-hour meters work, calibration, error modes (many), ANSI Standards, etc. Demand and Polyphase Meters. Experimental results to slow and stop meters by others. \$19. Any 2 \$38. All 3, \$55.

### AUTOMATIC TELLER MACHINES

ATM crimes, abuses, vulnerabilities and defeats exposed! 100+ methods detailed, include: Physical, Reg. E, cipher, PIN compromise, card counterfeiting, magnetic stripe, false front, TEMPEST, Van Eck, tapping, spoofing, inside job, super-cool, vibration, pulse, high voltage - others. Case histories, law, countermeasures, detailed security checklist, labeled internal photos, figures. ATMs contain up to \$250,000 in cash! Recent \$350,000 ATM crime spree still unsolved! \$39.

### CREDIT CARD SCAMS

Cardholders, merchants, banks suffer \$ Billions in losses annually because of credit card fraud. Describes every known means of credit card fraud and scams. Protect yourself! \$29.

### CONS & SCAMS

Cons & scams fleece Americans of \$100+ Billion per year! The most comprehensive survival manual on cons & scams of all kinds - from the classic to hi-tech. Details on 100s and their many variations. Protect yourself! \$29.

### HIGH VOLTAGE DEVICES

HV devices plans: Stun Gun, Taser, Prod, Gans, Flasher, Blaster, Zapper, Audio/Radar Jammer, Jacob's Ladder, Plasma & Van de Graaff Gens., Fence Charger, Geiger Counter, Ozone Gen., Fish Stunner, Plant Stim., Kilrain, more! Shocking! \$29.

### UNDER ATTACK!

Electromagnetic interference and Electronic Weapon Attacks cause: Cancer, birth defects, and profound psychological, neurological, cardiovascular and immune system disorders! Destructive to people, animals, plants, equipment includes ACTUAL CASES OF EM ATTACKS ON PEOPLE (we investigated!) Includes how to verify and pinpoint EMI and electronic attack sources, and specific countermeasures. \$29. EM - BRAIN BLASTER: Tutorial and plans for powerful ELECTROMAGNETIC WEAPONS and LAB DEVICES. Optimum circuits, freqs, waveforms, duty cycles, intensities. Thorough. \$29. Both \$49.

### RADIONICS MANUAL

exciting electrical, electronic and electromagnetic therapeutic, diagnostic and preventive devices (mostly experimental) History, descriptions, plans (dozens), availabilities of Radionics Devices from early to modern. While drugs cost \$ Hundreds, electricity costs pennies! \$29. HEAL THYSELF: Plans for 3 major electronic therapeutic devices of types approved by FDA. \$19. Both \$39.

### HARD DRIVE MANUAL

Covers all hard drive and controller implementations (emphasis on PCs). How to select, interface, initialize, set up, use, maintain, troubleshoot and repair them. How to protect them from mistakes, sabotage, prying eyes and sticky fingers. How to recover damaged and lost files. How to prevent crashes. Includes software reviews. Loaded with information, advice, tips. \$29. DISK SERVICE MANUAL: Maintain, troubleshoot, repair, adjust, align floppies! Without special equipment or software. \$39. \$29. PCXTAL386/486, Apple, Commodore, etc systems. All floppies need regular upkeep. \$29. DISK DRIVE TUTORIAL: Theory, practical facts on floppy drives, disks, including many tips, recommendations, formatting, interfacing, FDC, etc. \$24. Any 2, \$49. All 3, \$69.

### SOFTWARE PROTECTION SYSTEM

Unique system that highly discourages costly software piracy while not interfering with legit archival copies. No known way to defeat. No special equipment required. Simple and automatic to install on your distributed software. Compatible with all copy-prevention systems. Manual + Disk\* \$59.

### STEALTH TECHNOLOGY

Police radar is fascinating! It also has error rates of 10-20%! Every known error mode - stealth method and material used to minimize radar reflections - tactic and strategy to fight unjust radar tickets (that cost you \$100s in insurance and risk cancellation) - methods to detect and jam signals - fully described! \$29.

### SECRET & SURVIVAL RADIO

Optimum survival and security radio equipment, methods, freq allocations and voice/data scrambling/encoding. Includes small receivers/transmitters, telemetry, antenna optimizations, remote monitoring and control, security, surveillance, and ultrasonic, fiber-optic and infrared commo. 70+ circuit plans, tables. \$29.

### ULTIMATE SUCCESS MANUAL

Underpaid? Harassed or abused? Manipulated? Taken for granted? Stuck in a dead-end job? Can't find a good job? Expect to be laid off, fired or transferred soon? The ultimate no-holds-barred, looking-after-#1 Machiavellian techniques to find, obtain, optimize and keep top jobs, pay and benefits. THE RULES OF THE GAME FOR A GAME WITHOUT RULES! From first resume to CEO. \$29.

### ROCKET'S RED GLARE

How to design and build solid-propellant amateur and survival rockets. Emphasis on formulation, manufacture, installation of propellants, motors, igniters, etc. Includes list of commonly available materials, and the design of launch pads and test beds and their electronics. \$29. Please Order Today! (505) 434-0234

# AFFORDABLE DATA ACQUISITION



MODEL 30 ..... \$79.00

- PLUGS INTO PC BUSS
- 24 LINES DIGITAL I/O
- 8 CHANNEL 8 BIT A/D IN
- 12 BIT COUNTER
- UP TO 14K SMP/SEC



MODEL 45 ..... \$189

- RS-232 INTERFACE
- 8 DIGITAL I/O
- 8 ANALOG INPUTS
- 2 ANALOG OUTPUTS
- 2 COUNTERS-24 BIT



MODEL 70 ..... \$239

- RS-232 INTERFACE
- 18 BIT A/D
- 5.5 DIGIT
- UP TO 60 SMP/SEC



MODEL 150-02 .. \$179

- RS-232 INTERFACE
- TRMS, 20 AMPS
- 12 BIT A/D
- OPTO-ISOLATED
- CHANGE RANGES, AC/DC, VIA RS-232

## Prairie Digital, Inc.

846 17th Street • Industrial Park • Prairie du Sac, WI 53578  
(608) 643-8599 • FAX: (608) 643-6754

# LASERS

HELIUM NEON FROM \$19  
ARGON \* BOOKS  
CO<sup>2</sup> \* PLANS  
OPTICS \* LIGHTSHOWS  
LASER DIODES  
LASER POWER SUPPLIES

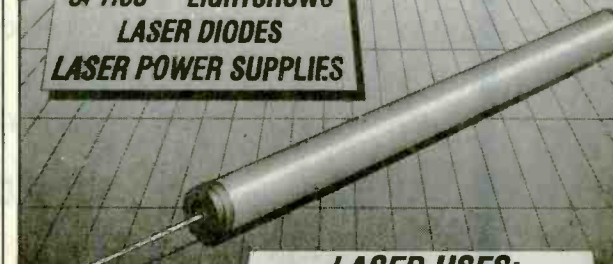

**LASER USES:**  
HOLOGRAPHY \* LIGHTSHOWS  
PRINTING \* COMMUNICATION  
WEAPON SIGHTS \* ALIGNMENT  
ALARMS \* POINTERS  
CUTTING \* CONSTRUCTION

FREE CATALOG 1-909-278-0563

**MWK INDUSTRIES**

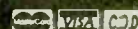

198 LEWIS COURT  
CORONA, CA 9 720



# Don't Despair...REPAIR!

Here's how to troubleshoot and repair your electronics successfully!

## You Can Be Your Own Repair Expert!

For VCRs, camcorders, audio equipment, TV equipment, computer hardware, office equipment, home appliances, automobile electronics, and outdoor equipment.

- Pinpoint and analyze problems quickly.
- Successfully complete repairs with hands-on troubleshooting instructions.
- Become skilled understanding flowcharts and schematic diagrams.
- Confidently use test equipment such as oscilloscopes, frequency counters, and video analyzers.
- Keep your equipment in top condition with effective preventive maintenance techniques.

## Continue to Broaden Your Repair Expertise!

You'll receive quarterly supplements, up to 160 pages, with new step-by-step repair and maintenance instructions, valuable schematics and new repair techniques. Learn how to repair a growing variety of appliances with hands-on repair projects that will keep you up-to-date with later models and technology. You'll be thrilled with your ability to repair a growing list of electronic equipment! Supplements may be returned or cancelled at any time.

**SAVE \$10**

Call our toll-free number, pay by credit card, and mention this ad. We'll deduct \$10!

We'll also waive shipping and handling.

Order today for your 30-day, no-risk review of The Electronics Repair Manual.

For Faster Service Call TOLL-FREE  
**1-800-222-WEKA**

Or Fax To: 1-203-622-4187

CIRCLE 133 ON FREE INFORMATION CARD



## One Source For All Your Repair Needs!

Better organized than a magazine, more current than a book.

- 900-page manual
- easy-to-follow, detailed instructions
- trouble analysis flowcharts
- safety precaution checklists
- comprehensive replacement parts list
- directory of manufacturers



**Order your copy today!**

### MONEYBACK GUARANTEE

There's no risk in trying the ELECTRONICS REPAIR MANUAL to see if it's right for you. If you are not delighted, simply return the manual after the 30-day trial period and receive a prompt refund.



97 Indian Field Rd.  
Greenwich, CT 06830

**YES!** Please rush me a copy of the new Electronics Repair Manual for only \$59.95 + \$5.50 shipping and handling. I understand that if I am not satisfied I may return the manual within 30 days for a complete refund. Supplements are sent quarterly for 25¢ per page (never more than \$30) and may be returned or cancelled at any time.

My payment is enclosed     Bill me later  
 Charge my     Visa     MasterCard

Acct. No. \_\_\_\_\_ Exp. Date \_\_\_\_\_

Signature \_\_\_\_\_

Phone (    ) \_\_\_\_\_ Signature and phone number are required for all orders.

Name \_\_\_\_\_

Address \_\_\_\_\_

City \_\_\_\_\_ State \_\_\_\_\_ Zip \_\_\_\_\_

All payments must be in U.S. funds. Canada add \$10. All other countries add \$15. CT residents add 6% sales tax.

Mail to: WEKA Publishing, 97 Indian Field Rd.,  
Greenwich, CT 06830

400066

# USE PE MARKET CENTER CLASSIFIEDS

## READ BY 87,877 BUYERS OF ELECTRONIC EQUIPMENT ACCESSORIES AND PARTS

### INSTRUCTION FOR PLACING YOUR AD!

#### HOW TO WRITE YOUR AD

**TYPE or PRINT** your classified ad copy **CLEARLY** (not in all capitals) using the form below. If you wish to place more than one ad, use a separate sheet for the additional ads (a photocopy of this form works well). Choose a category from the list below and write that category number into the space at the top of the order form. If you do not specify a category, we will place your ad under Miscellaneous or whatever section we deem most appropriate.

We cannot bill for classified ads. Payment in full must accompany your order. We do permit repeat ad or multiple ads in the same issue, but in all cases, full payment must accompany your order.

#### WHAT WE DO

The first two words of each ad are set in bold caps at no extra charge. No special positioning, centering, dots, extra space, etc. can be accommodated.

#### RATES

Our classified ad rate is \$1.00 per word. Minimum charge is \$15.00

per ad per insertion (15 words). Any words that you want set in bold or caps are 20¢ each extra. Bold caps are 40¢ each extra. Indicate bold words by underlining. Words normally written in all caps and accepted abbreviations are not charged as all-caps words. State abbreviations must be Post Office 2-letter abbreviations. A phone number is one word.

#### CONTENT

All classified advertising in the **PE Market Center** is limited to electronics items only. All ads are subject to the publisher's approval. We reserve the right to reject or edit all ads.

#### DEADLINES

Ads received by our closing date will run in the next issue. For example, ads received by November 15 will appear in the March, 1994 issue that is on sale January 18. The PE Market Center is published monthly. No cancellations permitted after the closing date. No copy changes can be made after we have typeset your ad. **NO REFUNDS, advertising credit only. No phone orders.**

**AD RATES: \$1.00 per word, Minimum \$15.00.**

Send your ads with payment to:

**Popular Electronics Market Center, 500-B Bi-County Blvd. Farmingdale, NY 11735**

### CATEGORIES

- |                              |                                 |  |                           |
|------------------------------|---------------------------------|--|---------------------------|
| 100 — Antique Electronics    | 270 — Computer Equipment Wanted | 450 — Ham Gear Wanted                    | 630 — Repairs-Services    |
| 130 — Audio-Video-Lasers     | 300 — Computer Hardware         | 480 — Miscellaneous Electronics For Sale | 660 — Satellite Equipment |
| 160 — Business Opportunities | 330 — Computer Software         | 510 — Miscellaneous Electronics Wanted   | 690 — Security            |
| 190 — Cable TV               | 360 — Education                 | 540 — Music & Accessories                | 710 — Telephone           |
| 210 — CB-Scanners            | 390 — FAX                       | 570 — Plans-Kits-Schematics              | 720 — Test Equipment      |
| 240 — Components             | 420 — Ham Gear For Sale         | 600 — Publications                       |                           |

### CLASSIFIED AD COPY ORDER FORM

Ad No. 1—Place this ad in Category # \_\_\_\_\_

1 - \$15.00	2 - \$15.00	3 - \$15.00	4 - \$15.00
5 - \$15.00	6 - \$15.00	7 - \$15.00	8 - \$15.00
9 - \$15.00	10 - \$15.00	11 - \$15.00	12 - \$15.00
13 - \$15.00	14 - \$15.00	15 - \$15.00	16 - \$16.00
17 - \$17.00	18 - \$18.00	19 - \$19.00	20 - \$20.00
21 - \$21.00	22 - \$22.00	23 - \$23.00	24 - \$24.00
25 - \$25.00	26 - \$26.00	27 - \$27.00	28 - \$28.00

Total classified ad Payment \$ \_\_\_\_\_ enclosed.

Check  MasterCharge  Visa (\$15.00 minimum credit card order)

Name \_\_\_\_\_ Phone \_\_\_\_\_

Address \_\_\_\_\_ City State Zip \_\_\_\_\_

29 - \$29.00	30 - \$30.00	31 - \$31.00	32 - \$32.00
33 - \$33.00	34 - \$34.00	35 - \$35.00	36 - \$36.00
37 - \$37.00	38 - \$38.00	39 - \$39.00	40 - \$40.00

Ad No 1—Total words \_\_\_\_\_ × \$1.00 per word = \$ \_\_\_\_\_  
 All Caps words \_\_\_\_\_ × .20 per word = \$ \_\_\_\_\_  
 Bold words \_\_\_\_\_ × .20 per word = \$ \_\_\_\_\_  
 Bold Cap words \_\_\_\_\_ × .40 per word = \$ \_\_\_\_\_

**TOTAL COST OF AD No. 1 \$ \_\_\_\_\_**

Card # \_\_\_\_\_

Expiration Date \_\_\_\_ / \_\_\_\_

Signature \_\_\_\_\_



## Surface Mount Chip Component Prototyping Kits—

**Only \$49.95**

INDIVIDUAL VALUES AVAILABLE



CC-1 Capacitor Kit contains 365 pieces, 5 ea. of every 10% value from 1pF to .33µF. CR-1 Resistor Kit contains 1540 pieces, 10 ea. of every 5% value from 10Ω to 10 megΩ. Sizes are 0805 and 1206. Each kit is ONLY \$49.95 and available for Immediate One Day Delivery!

Order by toll-free phone, FAX, or mail. We accept VISA, MC, COD, or Pre-paid orders. Company PO's accepted with approved credit. Call for free detailed brochure.

**COMMUNICATIONS SPECIALISTS, INC.**  
426 West Taft Ave. • Orange, CA 92665-4296  
Local (714) 998-3021 • FAX (714) 974-3420  
**Entire USA 1-800-854-0547**

## NEW EASY PC



BRITISH DESIGN AWARD

### SCHEMATIC and PCB C.A.D.

ONLY **\$195**

Includes

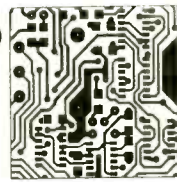
- MGA, CGA, EGA & VGA compatible.
- Design large multi layer boards.
- One level pull down menu and quick keys for fast layout.
- Dot matrix, laser, plotter, Gerber & N.C. drill output.
- 6 Month Free update
- Free Demo

7840 ANGEL RIDGE ROAD  
ATHENS, OHIO 45701  
(614) 592-1810  
Visa & MasterCard Accepted

## All your tapes can look as Clear as Day!

Before After



(Video Simulation)

# \$59.95

plus S & H

## Copy Any Tape!



with INTELESTAR

- Connects easily to any VCR
- Durable metal casing
- Gold-plated cables
- 2-Year Long-lasting Battery
- Copy Any Tape

### 800-829-7746

Vista International, Inc  
1971 E. 5th St., #101 • Tempe, AZ 85281  
(602) 829-8110

## Prototype it..... FAST!

with ProtoQuick 8051 or 28

- Complete single board computers
- Up to 32K EPROM and 64K RAM
- 12 bit 8K clocked through gate array
- RS232 C serial port @ 9600 com
- Op. sys in EPROM or source code
- Assembled, ready to run - 5v only
- MS-DOS cross assembler included

ProtoQuick 28 and 8051 **\$99.00** each

Run prototype applications or experimental hardware from the serial port - WITHOUT PROGRAMMING!

Software Science 2700 Manufacturers Road, Channahon, OH 44744 USA (513) 361-2060

## Quality Microwave TV Antennas

WIRELESS CABLE - IFTS - MMDS - Amateur TV  
Ultra High Gain 50db(+) • Tuneable 1.9 to 2.7 GHz.

- 55-Channel Dish System \$199.95
- 36-Channel Dish System \$149.95
- 20-Channel Dish System \$124.95
- Optional Commercial Grid Antenna (not shown) Add \$50.00
- Yagi Antennas, Components, Custom Tuning Available
- Call or write (SASE) for "FREE" Catalog

**PHILLIPS-TECH ELECTRONICS**  
P.O. Box 8533 • Scottsdale, AZ 85252  
(602) 947-7700 (\$3.00 Credit all phone orders)  
MasterCard • Visa • American Express • COD's • Quantity Pricing

# Highest Quality - Unbeatable Prices



**1-YEAR WARRANTY**



## 470D

### WIDE-RANGE LCR METER WITH DISSIPATION FACTOR

- Drop-proof, Heavy Duty
- Inductance: 200uH to 200H
- Capacitance: 200pF to 20mF
- Resistance: 2 ohms to 20M ohms (max. resolution: 1 milliohm)
- Dissipation factor (D=1/Q) measurement
- 120Hz and 1KHz test frequencies
- +/- offset indication
- SMD or Chip component test probes available

Reg. \$249.95  
**Our price \$159.95**

**2-YEAR WARRANTY**



Reg. \$599.00  
**Our price \$569.95**

## LPS-305

### KEYPAD PROGRAMMABLE & LCD READBACK DC POWER SUPPLY AT ANALOG PRICE

- Output Voltage/Current Programming and Readback via LCD Panel
- Data Entry via Keypad
- Power Off Memory
- Microprocessor Controlled
- Voltage and Current Step Up/Down Function
- Superior Line and Load Regulation
- Output Enable/Disable
- Intelligent Forced-Fan Operation
- Standard RS-232 Interface for Remote Operation

**1-YEAR WARRANTY**



Reg. \$395.00  
**Our price \$345.00**

## 9850UV

### THE PERSONAL E/EPROM PROGRAMMER WITH BUILT-IN UV ERASER

- Stand-Alone and PC Remote with Auto Detection
- Simple Function Key Operations
- Full LCD Display Message
- Programs 2716 to 27513 EPROMs and 2804 to 28256 EEPROMs
- Programming Algorithms: STANDARD, INTELLIGENT, INTERACTIVE, and QUICK PULSE
- Data File Formats: INTEL HEX, BINARY, MOTOROLA S. and TEKTRONIX HEX
- Programming Functions: READ, WRITE, AUTO, BLANK CHECK, VERIFY

**1-YEAR WARRANTY**



## 700T

### TRUE RMS 4-1/2 DIGIT DMM + FREQUENCY COUNTER

- 0.05% DCV accuracy
- True RMS AC measurement
- Frequency counter up to 200KHz
- Data Hold
- AC / DC up to 20A
- Audible continuity check
- Diode check
- Drop proof to 4 feet



Reg. \$199.95  
**Our price \$129.95**

# PRINT

Products International  
8931 Brookville Rd, Silver Spring MD 20910  
Tel: 301-587-7824 • Fax: 800-545-0058  
Technical Support: 1-800-654-9838

CALL NOW

# 800-638-2020

March 1994, Popular Electronics

# CABLE TV DESCRAMBLER KITS

## "New & Improved Version"

### Universal Descrambler

Includes all the parts and an etched & Drilled PC Board. Not included is AC adaptor or enclosure.....\$69.00

### Tri-Mode Descrambler

Includes all the parts and an etched & drilled PC board & AC adaptor. Not included is the enclosure.....\$49.00

### SB-3 Descrambler

Includes all the parts & an etched & drilled PC board & AC adaptor. Not included is the enclosure.....\$29.00

## Call Toll Free 1-800-886-8699

## Visa, MasterCard, Discover, AM & COD

M & G Electronics, Inc. 2 Aborn Street, Providence, RI. 02903

*It is not the intent of M & G Electronics, Inc. to assist any individual to defraud any pay TV operator or to violate any state or federal laws regarding the use of the descrambler kits. You must understand the kits being purchased for educational and or experimental use only.*

## PE MARKET CENTER CLASSIFIEDS

### COMPUTER HARDWARE

**MAGAZINE SUPPORTING Z80, CP/M, S100, Kaypro, 8031, 6809 and more.** The Computer Journal. 10th year of classic computer projects. Hardware, software, forth, assembler. Micro-C Kaypro disks and schematics. 6 issues, \$24.00, free sample. 1 (800) 424-8825. TCJ, PO Box 535, Lincoln, CA 95648.

**COMPUTER KITS** build your own computer and save. 386/sx \$499.00, 486/sx \$599.00. **FREE CATALOG.** ABI SYSTEMS, 6 Angelacrest Ln., West Seneca, NY 14224.

### COMPONENTS

**ELECTRONIC FASTENERS.** Stainless steel. Kits available. Free catalog. "RUSTY BOLT", Box 708X, North Attleboro, MA 02761.

**FREE HOBBY** catalog. Lowest prices components, parts, tools, more! Gallimore Electronics, Box 70150-E, San Diego, CA 92167.

**FOR SALE:** electrolytic capacitors, tubes, transistors, IC, cables, speakers, transformers. Call/fax: (818) 831-2376. United Super Electronics.

### CABLE TV

**"BULLET" BUSTER.** Protect your cable box against the infamous cable "bullet." The "Bullet" Buster acts as an electronic shield. Installs in-line in seconds. Don't wait until it's too late! \$19.95 + \$3.00 S&H. **ELECTROMAN**, Box 24474, New Orleans, LA 70184. (504) 482-3017.

**CBTV DOCTOR** Stop the Bullet and ID signal in cable lines. Send \$20.00 to: R.R. Enterprise, PO Box 3532, Easton, PA 18043.

**CABLE UNSCRAMBLED.** Everything you wanted to know about cable, but were afraid to ask. \$10.00. **Electroman**, Box 24474, New Orleans, LA 70184. (504) 482-3017.

**CABLE DOCTOR:** Attention: All you cable box owners. Want to watch one channel & record another? I have what you need, send \$74.00 to: R. R. Enterprises, PO Box 3532, Easton, PA 18043.

### BUSINESS OPPORTUNITIES

**EASY WORK!** Excellent pay! Assemble products at home. Call toll free 1 (800) 467-5566 ext. 5192.

### EDUCATION

**IMPULSE BASEBAND DPBB-73XX** \$225.00, DPV5-ch:3 \$150.00, Pioneer BA6110 \$250.00 — Testaids: Star6: \$15.00 Star7: \$15.00. SA all: \$25.00, Pioneer all: \$25.00 — min. 10 pc. Please call (212) 978-3535. No N.Y. sales.

**LEARN TO EARN:** Electronics, robot, radio, others. Free catalog. A&A Products, Rt1 Box 482-L, Rockdale, TX 76567.

### AUDIO-VIDEO-LASERS

**FREE LASER CATALOG.** Argon, He-Ne, and visible diode lasers, holography, lightshows, pointers. Write: Midwest Laser Products, PO Box 2187, Bridgeview, IL 60455. Or call (708) 460-9595.

**SURROUND SOUND** decoder connects to your stereo TV, amp., etc. and supplies decoded signal to rear channel amp. and speakers you provide. Low noise FET circuitry. \$39.95 ppd. **Armstrong Mfg.**, Box 94328, OKC, OK 73143.

### MISCELLANEOUS ELECTRONICS FOR SALE

**DESCRAMBLERS** FOR cable and satellite. Kits and assembled units. All types. Guaranteed. From \$19.95. Free catalog. (212) 330-8035.

**DESCRAMBLING SECRETS REVEALED.** FREE 24 hour hotline reveals secret satellite and cable descrambling information. (718) 390-7130.

**SILENT SAM** Turn signal reminder alerts you IF you forget to cancel. Unobtrusive. Kits and pre-wired units \$15.00 and up. Free literature. 1 (800) 398-5605 Visa/MC. Silent Sam, 1627 Basil Dr., Columbus, OH 43227.

### PLANS-KITS-SCHEMATICS

**BUILD — FIVE-digit, ohms, capacitance, frequency, pulse, multimeter.** Board and instructions \$9.95. Bagnall Electronics, 179 May, Fairfield, CT 06430.

**FM STEREO TRANSMITTER** kit broadcasts any audio signal to FM stereo radios throughout your home. Uses unique BA1404 IC. Complete kit: PC board/components — \$24.00. Visa/MC. **TENTRONIX**, 3605 Broken Arrow, Coeur d'Alene, ID 83814. (208) 664-2312.

**ALL-IN-ONE catalog.** AM/FM/ham/spy, transmitters/amplifiers, voice disguisers, descramblers, audio/TV/science projects. Start your own licensed/unlicensed radio station, books/plans/kits for import and export. 60 mouth-watering pages for \$1.00. **PAN-COM INTERNATIONAL**, PO Box 130-H3, Paradise, CA 95967.

**STUCK INDOORS?** Bored beyond belief? Check out our intriguing line of kits and plans. Free catalog. **Electroman**, Box 24474, New Orleans, LA 70184. (504) 482-3017.

**RADIATION ALERT!!** Geiger counter utilizes one of the most sensitive Geiger tubes available and no nonsense circuitry. Schematic, operating info and parts availability \$11.95 to: **Electronic Safety Instruments**, Box 156, 2927 West Liberty Ave., Pittsburgh, PA 15216.

**HIGH SECURITY** alarm system protects computers, TV's and other equipment in office bldgs., motels, etc. Virtually undefeatable. Expandable. Uses commonly available parts. Parts and circuits available. Plans and 1 remote sensor \$12.95. **Armstrong Mfg.**, Box 94328, OKC, OK 73143.

**QUANTUM KITS!** Super FM Transmitter — tuneable, long range \$25.00! Bug Detector — detect and monitor transmitters to 10 GHz. \$40.00! IC Tester — test any integrated circuit \$25.00! Radar Detector — audible, bargraph microwave warning \$20.00! Vocal Truth Detector — determines voice stress levels \$40.00! Free catalog with order or \$4.00 (refundable). **QUANTUM RESEARCH**, 17919 — 77th Ave., Edmonton, Alberta, Canada T5T 2S1.

**PROTOTYPE SERVICE** for hobbyists & engineers. Single quantity ss PCB's. \$10.00 minimum. No setup fee. We also scan magazine artwork. Get out your back issues! **FIRST PROTO**, (407) 392-8677.

## BUY BONDS

**Cable Test**

Orders only      Information  
1-800-452-7090      Aids      (310)902-0841

Test chips for JERROLD, TOCOM, ZENITH, S.A. & more. Puts cable boxes in full service mode. Easy installation. Zenith only \$39.95. Most others under \$50ea. FAX: (310) 902-0831      Quantity prices available. No Ch. sales. Not for use in cable co. owned equip. For use as a test aid only.



Still a little FUZZY on Fuzzy Logic?

Neural Nets

keep you noodling???

fuzzy???

DON'T BE  
LEFT  
OUT...



Soft-Wear Productions

103 Westward Cove

Austin, TX 78733

1-800-783-8161 Code 5884

These important new technologies are in your future. Find out how they work in this Desk Top Video. Get hands on practice with source code of working models. Call or write now with your order.

- Fuzzy Logic MSDOS Package Includes:  
Video Tape  
Source Code in C, BASIC, and WK? Spdsht
- Neural Networks MSDOS Package Includes:  
Video Tape  
Source Code in C for two operating nets

\$29.95 ea + \$5.00 s&h per order. VISA/MC ind number and exp date

## TONY TALLI'S ORIGINAL TELEVIEW DISTRIBUTORS

WHERE OUR VALUED CUSTOMERS'

*BUSINESS*

IS HONESTLY APPRECIATED

**OUR PRICES**

**1 800 847 3773**

*Call Us Today*

90 DAY + GUARANTEE

SCIENTIFIC ATLANTA

JERROLD PIONEER

OAK HAMLIN



HRS. M - F 9-4 PST NO NV. SALES

# Build or Upgrade Your PC!

PC-Build specializes in computer kits and components. Our staff of system consultants will work with you to develop the machine you're looking for, at the right price. You can choose one of our standard kits or create your own machine using our custom kit option.

Our kits are 100% compatible PCs that perform as well as (or better than) a comparably configured Compaq or Dell (Based on Norton SI ratings). But you get more than just a fast PC. You go inside the case and learn hardware secrets by doing it yourself. Future upgrades and repairs are a snap -- after all you've built it yourself!

You can't beat our services. We offer:

- A full line of FCC class B approved kits (from 386SX to 486DX)
- 30 day "You Can Build It" guarantee
- Our famous step-by-step instruction manual with special sections on Computer Basics and Troubleshooting
- Integrated kit building video
- 1 year warranty on parts
- Top quality components from manufacturers like Seagate, Chinon, and Hewlett Packard
- One of the best technical support hotlines in the business

Call today for more information: **1-800-798-6363**

1993 Discovery Curve, Inc. All brands and product names are trademarks of their respective companies. All rights reserved.

## PC-Build COMPUTER KITS

Discovery Curve, Inc.

85 Franklin Street

Needham, MA 02194

(617) 449-7575 FAX (617) 449-8444

*The Leader in "Build It Yourself" Computers*

**VESA Local Bus**  
Available NOW!



*"What gets lost in today's preconfigured buying is the very essence of the computer kit -- understanding what is inside the case and learning how the components all work together.*

*If you want to teach someone how a computer works and, more importantly, how to build one from scratch, this is one way to learn and get a real working computer in the bargain. The lesson can be invaluable."*

**Computer Shopper**

**March 1993**

**NEW MICRO TX1000 -**  
**SMALLEST 100 MILLIWATT FM VOICE TRANSMITTER**

- USE 9-VOLT BATTERY OR ATTACH TO ANY PHONE LINE!
- STABLE TUNE 88-110mhz ON ANY BROADCAST RECEIVER
- ATTACH 3 WIRES AND HEAR A WHISPER UP TO 2 MILES AWAY!
- USES STANDARD 9-VOLT BATTERY

**MICRO I.I VOICE RECORDER** **\$59<sup>95</sup>**

- WORLDS SMALLEST - 7-15 V. OPERATION - EXACT SOUND REPRODUCTION
- 60 SECONDS RECORD TIME - 100 YEAR MEMORY WITHOUT POWER
- NOT A KIT! INCLUDES MICROPHONE, SWITCHES & MANUAL

**AGRELO ENGINEERING**  
 1145 CATALYN ST., SCHEENECTADY, NY 12303

ORDERS ONLY  
 CALL 1-800-588-4300

TECH. SUPPORT: (518) 381-1057 TECH. FAX: (518) 381-1058  
 ORDER BY PHONE OR MAIL IN U.S.A. ADD \$3 FOR S&H. CO.D. CHARGES APPLY. NYS RESIDENTS ADD 7% SALES TAX

**DIGI-FIELD**  
**FIELD STRENGTH METER**

Are you worried about electromagnetic radiation, TV coax distribution loss, poor antenna performance, or EMV RFI? The DIGI-FIELD field strength meter will put you at ease. With its frequency response of DC up to 12 GHz, it readily detects potential electromagnetic radiation hazards. It is an excellent tool for measuring TV coax distribution loss. In addition DIGI-FIELD can easily find 60-Hz AC-line interference, as well as RFI/EMI instrumentation disrupting set-ups. Sensitivity @ 100 MHz Model "A" 150 nano Watts. Model "B" 2 nano watts.

**\$139<sup>95</sup>** Plus \$6.50 s/h

To order call - (800) FIELD 58 (343-5358)  
**I.C. Engineering** 16350 Ventura Blvd.  
 Suite 125, Encino, CA 91436 PH.(818) 345-1692 • 818-345-0517 Fax

**FINALLY!**

UP TO 115 KBAUD SERIAL INTERFACE TO CONTROL YOUR PROJECT FROM AN RS-232 COMPUTER PORT

- Uses ASCII mnemonics from user's program or Procomm, MAC240, etc
- Bin, Hex or Dec formats
- 24 bit programmable I/O lines
- 10 X 8 bits Analog/ Digital channels
- 10-10,000 Hz Pulse Width Modulation
- High & Low interrupts
- 3 EASY to use logic interfaces for stepper motors
- Measures relative resistance/capacitance and much, much more!

- I/O 232 KIT\*: ONLY \$65
- ASSEMBLED\*: ONLY \$75
- Some connectors not incl
- ASSEMBLED\* (all conn. incl.): ONLY \$87
- Manuals(ref): ONLY \$10

ITC MICROCOMPONENTS INC.

Tel. 1 (403) 486 2377.  
 Canada & Overseas:  
 18440-57 Ave Edmonton,  
 Alberta T6M 1Y2.

Tax not incl. All prices in US\$. \*Add \$5 for S&H.

**CABLE TV CHANNELS**  
**EQUIPMENT** **GUARANTEED**

➔ The nationwide source for cable TV equipment.

**FREE 30 DAY TRIAL**

"BUY WHERE THE DEALERS BUY."

**FREE** TV Cable Descramblers and Converters Catalog. Open Every Day!

**MEGA ELECTRONICS**  
 VISA • MC C.O.D. **1-800-676-6342** SAVE 1000's

21 South Main Street, Winter Garden, FL 34787

Learn **Windows®** from Video tapes!

Only 12.95 per tape, any two for \$22.95! (each tape is 1 hour, learn at your own pace and leisure, no PC needed)

1. Introduction to Microsoft Windows 3.1
2. More about Windows
3. Introduction to Microsoft Excel 4.0
4. More about Excel
5. Intro. to Microsoft Word 2.0 for Windows
6. More about Microsoft Word
7. Intro. to Microsoft Access 1.1
8. More about Microsoft Access database and more advanced courses also! Cheaper than any book, yet it is more fun, insightful, inspirational, and relaxed learning without toil! Write to or send check, cash, or money order (+\$3.95 shipping per order) to:

**Softfact, 1195 Eureka Av, Los Altos, CA 94024**

**BUGGED??**

**EAVESDROPPING** is unbelievably widespread! Electronic Devices with amazing capabilities can be monitoring your telephone and room conversations RIGHT NOW! Are you sure you're safe? **FREE CATALOG** tells you fast! Includes Free Bonus details on fantastic opportunities now open in Counter-Surveillance field. Exciting, immensely interesting and EXTREMELY profitable (up to \$250/hr) full/part-time income. Call Now!

**1-800-732-5000**

**Satellite-TV**

SAVE 40% - 60%  
 800-334-6455  
 218-739-5231 Int'l  
 218-739-4879 Fax

**FREE Catalog**

**Skyvision Inc.®**  
 1048 FRONTIER DRIVE • FERGUS FALLS, MN 56537

**MARYMAC®**  
 The New Realistic®  
**PRO-43 Scanner**

**Radio Shack®**  
**PHONES**

Our 17th year of DISCOUNTS  
**Toll Free 800-231-3680**  
 PRO-43 List \$349.95  
**Our Delivered Price \$290.00**  
*We discount everything in the RS catalog*

22511 Katy Fwy.  
 Katy (Houston), TX 77450  
 1-713-392-0747 FAX 713-574-4567

**THE POCKET PROGRAMMER**

**The Pocket Programmer**

The portable Eprom programmer that uses the printer port of your PC instead of an internal card. The software has 24 easy to use functions and programs 27/25/28/68764 & Cmos from 16K (2K x 8)—2M (256K x 8) Eproms (32 pin socket, UpGradeable to 8Meg). Adapters available for MCU's, 40-Pin Eproms, 5-Gang and Eprom Emulator to 32K x 8.

**\$129.95**  
 INTRONICS, INC.  
 Box 13723  
 Edwardsville, KS 66113 Add \$3.00 for shipping.  
 (913) 422-2094 Add \$3.75 for COD. Visa/Master Charge

**SURVEILLANCE**  
 & COUNTERSURVEILLANCE Electronic Devices

Bugging/Phone Tapping Detectors • Caller IDs • Covert Video  
 • Phone Scramblers • Voice Changers • Shotgun Mics  
 Vehicle Tracking • Transmitter Kits • Locksmithing • AND MORE!

**NEW!** Telephone Recording Systems Disguise Video Cameras

FOR CATALOG SEND \$5.00 TO...  
 P.O. Box 337, Buffalo, NY 14226 (716) 691-3476

**Want to buy a new PC?**

**386? 486? or Pentium?**  
**200MB? 300MB? 500MB? 1GB?**  
**14" ? 17" ? 20" ? 2,4,8,16,32 MB?**  
 What about the budget? We have the best price and we build to your order! First, let us send to you, **free** of charge, a BTO software that allows you to configure and budget a PC system yourself before you place any order! Write to:

**Softfact BTO Center** for free BTO  
**1195 Eureka Av.** (build-to-order)  
**Los Altos, CA 94024** software!

(sample system: 486/33+128Kc, 4M/120MB, SVGA etc. \$1045, VESA486DX2/66, 8M/500MB \$1989)



## MEMBRANE SWITCH KITS!

These highly durable water resistant flat-panel keypads can be assembled in minutes with YOUR legend! Available in 4, 12, 16, 24 & 40 Key models. Steel "clickdomes" optional. Connector and bezel included.

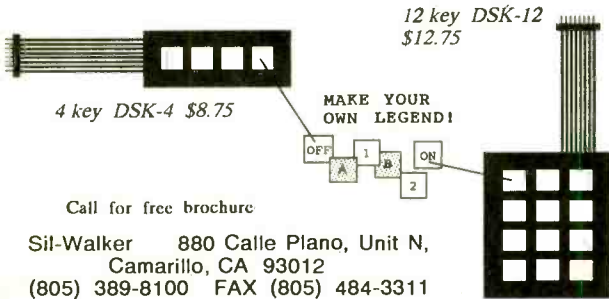

**!!! BROADCAST FARTHER !!!**  
PLANS ARE SOLD FOR EDUCATIONAL PURPOSES ONLY

The model 1525 is a 75-110MHz RF amplifier that connects to mono or stereo FM transmitters and produces a powerful 15-25 watt signal which could broadcast up to 5 miles or more! Requires 75-250 mW drive.

Step by step plans complete with part source information and antenna designs. ONLY \$14 PLUS \$2 S&H NO CREDIT CARD

**Progressive Concepts** 1434 North Mills Avenue, Suite B  
(909) 826-8989 Claremont, CA 91711

# FOTRONIC

## QUALITY ELECTRONIC TEST EQUIPMENT

Sales • Service

- Specialists in - Fluke, Hewlett Packard, Tektronix
- NIST Traceable/Mil Spec 45662A Calibration Available

*We buy surplus Electronic Equipment FAX your list!!!*

### TECHNICAL SUPPORT

#### Oscilloscope Specials

Tek 465	100 MHZ	\$419.00
Tek 465B	100 MHZ	\$539.00
Tek 475	200 MHZ	\$619.00
Tek 475A	250 MHZ	\$719.00

ALL EQUIPMENT SOLD WITH WARRANTY

For more GREAT VALUES Call, Write, or FAX  
P.O. Box 708, Medford, MA 02155  
(617) 391-6858 FAX (617) 391-6903

Serving the public since 1981

# XANDI Electronics

201 E Southern #111, Tempe AZ 85282

**SATISFACTION GUARANTEED!**

**BUY WITH CONFIDENCE FROM XANDI**

- 30-DAY REFUND POLICY
- NEW TELEPHONE TECH SUPPORT NUMBER (602-894-0992)

<p>Smallest FM transmitter anywhere!</p> <ul style="list-style-type: none"> <li>Tunes 88-108 MHz.</li> <li>Powerful 2 stage audio amplifier.</li> <li>Sensitive, picks up sounds at the level of a whisper.</li> <li>Up to 1 mile range.</li> </ul> <p><b>XST500 SUPER-MINIATURE FM TRANSMITTER</b> Worlds smallest FM voice transmitter. Use with any FM broadcast receiver. Easy to assemble, all chip (SMT) parts are pre-assembled to the circuit board.</p> <p><b>XST500(E-Z) Kit</b> ..... \$44.95</p>	<p>Smallest Phone transmitter anywhere!</p> <ul style="list-style-type: none"> <li>Tunes 88-108 MHz.</li> <li>No batteries required, powered by phone line.</li> <li>Up to 3/4 mile range.</li> <li>Attach to phone line anywhere in house, even inside phone.</li> </ul> <p><b>XSP250 SUPER-MINIATURE PHONE TRANSMITTER</b> Worlds smallest FM phone transmitter. Use with any FM broadcast receiver. Easy to assemble, all chip (SMT) parts are pre-assembled to the circuit board.</p> <p><b>XSP250(E-Z) Kit</b> ..... \$34.95</p>	<p>Digital voice changing: male to female, female to male, adult to child, child to adult.</p> <ul style="list-style-type: none"> <li>16 levels of voice masking.</li> <li>Button for normal operation.</li> <li>Complete anonymity on all calls.</li> </ul> <p><b>TRANSITION 2000 VOICE CHANGING TELEPHONE</b> STOP THOSE ANNOYING PHONE CALLS! Sound older and tougher when you want to. Not a kit, fully assembled. Single line phone operation only.</p> <p><b>TRANSITION 2000</b> ..... \$89.95</p>	<p>Digital voice changing: male to female, female to male, adult to child, child to adult.</p> <ul style="list-style-type: none"> <li>Use with any modular phone.</li> <li>Connects between handset and phone.</li> <li>16 levels of voice masking.</li> </ul> <p><b>TRANSITION 2001 VOICE CHANGING Accessory</b> STOP THOSE ANNOYING PHONE CALLS! Sound older and tougher when you want to. Use with single or multi-line phones. Not a kit, fully assembled.</p> <p><b>TRANSITION 2001</b> ..... \$59.95</p>
<ul style="list-style-type: none"> <li>Transmits both sides of phone conversation.</li> <li>Adjustable from 88-108MHz.</li> <li>Works with any FM broadcast receiver.</li> <li>Up to 1 mile range.</li> <li>Turns off when phone is not in use to extend battery life.</li> </ul> <p><b>XTT100 LONG RANGE PHONE TRANSMITTER</b> Similar to our very popular XSP500, the XTT100 is battery powered for maximum range. It plugs into any phone jack and transmits all calls on that line.</p> <p><b>XTT100(C) Kit</b> ..... \$32.95</p>	<p>Super sensitive, hear every sound in a house!</p> <ul style="list-style-type: none"> <li>Powerful 2 stage audio amp.</li> <li>Use with any FM broadcast receiver.</li> <li>Up to 1 mile range.</li> <li>Powered by 9V battery.</li> </ul> <p><b>XFM100 MINIATURE FM TRANSMITTER</b> The XFM100 has a super sensitive microphone and is capable of picking up sounds at the level of a whisper and transmitting them to any FM broadcast receiver.</p> <p><b>XFM100(C) Kit</b> ..... \$32.95</p>	<ul style="list-style-type: none"> <li>Transmits a continuous beeping tone.</li> <li>Adjustable from 88-108 MHz.</li> <li>Up to 1 mile range.</li> <li>Works with any FM broadcast receiver.</li> <li>Operates at battery voltages of 3 to 18 volts.</li> </ul> <p><b>XTR100 TRACKING TRANSMITTER</b> Measuring .7 by 2.4 inches, the XTR100 is ideal for use in locating lost model rockets, bicycles, automobiles, games of hide-and-seek, and contests.</p> <p><b>XTR100(C) Kit</b> ..... \$43.95</p>	<ul style="list-style-type: none"> <li>Uses sensitive microwave transistor amplifier.</li> <li>Covers 1 to 2000 MHz.</li> <li>Compact hand held unit.</li> <li>Uses Miniature loudspeaker (not included) for audio indication of detected signals.</li> </ul> <p><b>XBD200 SUPER SENSITIVE BUG DETECTOR</b> When the XBD200 intercepts a signal in the 1 to 2000 MHz range, it emits a growl that increases to a high pitched squeal as the signal strength increases.</p> <p><b>XBD200(C) Kit</b> ..... \$49.95</p>
<p><b>XLC900 800-950 MHz SCANNER CONVERTER KIT</b> If your scanner can receive 400-550 MHz, just add the XLC900 for uninterrupted 800-950 MHz coverage. It converts all 800-950 MHz signals down to 400-550 MHz so your scanner can receive them! Add our custom case and knob kit for that "professional" look.</p> <p><b>XLC900 Kit</b> ..... \$49.95</p> <p><b>XLC-Case Kit</b> ..... \$13.95</p>	<p><b>XLA1000 AMPLIFIER KIT</b> Designed to help scanners with poor sensitivity pull in those weak signals. Includes off/pass switch for returning to normal operation and front panel gain control. Add our custom case and knob kit for that "professional" look.</p> <p><b>XLA1000 Kit</b> ..... \$24.95</p> <p><b>XLA-Case Kit</b> ..... \$13.95</p>		

Master Card VISA WE ACCEPT VISA, MC, MO, COD TOLL FREE ORDER LINE 1-800-336-7389 SEND MAIL ORDERS TO: XANDI ELECTRONICS BOX 25647 TEMPE, AZ 85285-5647

CIRCLE 134 ON FREE INFORMATION CARD

March 1994, Popular Electronics

# ADVERTISING INDEX

POPULAR ELECTRONICS magazine does not assume any responsibility for errors that may appear in the index below.

Free Information No.	Page	Free Information No.	Page			
—	A&D Electronics . . . . .	116	—	M&G Electronics . . . . .	124	
25	Ace Communications . . . . .	105	—	Marymac Industries Inc. . . . .	126	
—	Agrelo Engineering . . . . .	126	—	MCM Electronics . . . . .	111	
26	Alfa Electronics . . . . .	99	—	MD Electronics . . . . .	104	
28	All Electronics . . . . .	100	—	Mega Electronics . . . . .	126	
—	Allen Engineering . . . . .	123	—	Modern Electronics . . . . .	78	
151	AMC Sales . . . . .	13	—	Movie View Sales . . . . .	118	
—	American Radio Relay League . . . . .	78	—	MWK Industries . . . . .	120	
—	Antique Radio Classified . . . . .	78	—	NRI Schools . . . . .	11	
140	B&S Sales . . . . .	119	—	NuTek . . . . .	77	
—	CBC International . . . . .	78	—	Ohio Automation . . . . .	123	
—	C&C Specialties . . . . .	127	43	Optoelectronics . . . . .	109	
—	CIE . . . . .	65	—	PC Boards . . . . .	111	
—	CLAGGK Monitor . . . . .	81	—	PC Build Computer Kits . . . . .	125	
—	CLAGGK Inc. Video Offer . . . . .	CV4	—	Phillips Tech . . . . .	123	
—	Command Productions . . . . .	13	47	Prairie Digital Inc. . . . .	120	
—	Communication Specialists . . . . .	123	—	Prime Time Electronics . . . . .	77	
—	Consumertronics . . . . .	120	46	Print . . . . .	123	
32	C&S Sales . . . . .	106	—	Progressive Concepts . . . . .	127	
162	Davis Instruments . . . . .	15	—	Self-Reliance Co. Inc. . . . .	111	
—	EDE . . . . .	126	—	Sil Walker . . . . .	127	
—	Electronic Industry Association . . . . .	CV3	—	Skyvision (Small) . . . . .	126	
—	Electronic Technology Today . . . . .	17, 25	—	Soft Fact . . . . .	126	
—	Electronics Book Club . . . . .	5, 21	—	Soft Fact . . . . .	126	
—	Firestik II . . . . .	78	—	Soft-Wear Productions . . . . .	125	
153	Fluke Corporation . . . . .	CV2	—	Software Science . . . . .	123	
—	Fotronics . . . . .	111	127	Southpaw Electronics . . . . .	100	
—	Grantham College . . . . .	117	—	Spy Supply . . . . .	112	
—	Great Southern Security . . . . .	126	37	Tech Serv. . . . .	116	
—	Greenleaf Electronics Inc. . . . .	116	—	Tele View Distributors . . . . .	125	
155	Heathkit . . . . .	25	159	The School of VCR Repair . . . . .	15, 78	
—	Hollins Radio Data . . . . .	7	—	The School of PC Repair . . . . .	79	
—	I.C. Engineering . . . . .	126	—	Timeline . . . . .	108	
35	Index Publishing . . . . .	115	129	TKA Electronics Inc. . . . .	110	
—	Information Unlimited . . . . .	98	136	UCANDO Videos . . . . .	118	
36	Interactive Image Technologies . . . . .	102	—	United Electronic Supply . . . . .	128	
—	Intronics . . . . .	126	55	US Cable (Zentek) . . . . .	117	
142	Island LogiX Inc. . . . .	117	—	Vista International . . . . .	127	
—	ITC Microcomponents Inc. . . . .	126	133	Weka Publishing . . . . .	114	
—	JP Video . . . . .	121	—	World College . . . . .	3	
38	Kelvin Electronics . . . . .	113	—	WPT Publications . . . . .	117	
128	—	McGraw Hill C.E.C. . . . .	31	134	Xandi Electronics . . . . .	127

Popular Electronics, March 1994

## ADVERTISING SALES OFFICE

**Gernsback Publications, Inc.**  
500-B Bi-County Blvd.  
Farmingdale, NY 11735  
1-(516) 293-3000

**Larry Steckler, EHF/CET**  
President

**Christina Estrada**  
Assistant to the President

**For Advertising ONLY**  
516-293-3000  
Fax 1-516-293-3115

**Larry Steckler**  
publisher

**Arline Fishman**  
advertising director

**Denise Mullen**  
advertising assistant

**Kelly Twist**  
credit manager

**Subscription/  
Customer Service/  
Order Entry**  
1-800-827-0383  
7:30 AM - 8:30 PM EST

## ADVERTISING SALES OFFICES

### EAST/SOUTHEAST

**Stanley Levitan**  
Eastern Sales  
1 Overlook Ave.  
Great Neck, NY 11021  
1-516-487-9357, 1-516-293-3000  
Fax 1-516-487-8402

### MIDWEST/Texas/Arkansas/ Oklahoma, Colorado, Arizona

**Ralph Bergen**  
Midwest Sales  
One Northfield Plaza, Suite 300  
Northfield, IL 60093-1214  
1-708-446-1444  
Fax 1-708-559-0562

### PACIFIC COAST/Mountain States

**Mike Brooks**  
Pattis/3M  
1800 North Highland Avenue  
Suite 717  
Hollywood, CA 90028  
1-213-462-2700  
Fax 1-213-463-0544



# What Do These Prestigious Companies Have In Common?

**Aerovox®**  
DC Film and RFI Suppression Capacitors,  
AC Oil Capacitors, EMI Filters

**AMP**  
Electrical/Electronic Connectors,  
IC Sockets, PCB Switches

**AVX CORPORATION**  
A FCI GROUP COMPANY  
MLC, Tantalum and Thin Film  
Capacitors, Resistors,  
Networks, Trimmers,  
Oscillators, Resonators, Filters  
and Piezo Devices

**BERG**  
ELECTRONICS  
High Density and Industry Standard  
Connectors/Subsystems

**BURNDY**  
an FCI Company  
Electronic Connectors

**CAROL**  
CAROL CABLE COMPANY INC.  
Electronic and Electrical Wire and Cable  
and Power Supply Cords

**COLE FLEX**  
Tubing, Conduits, Hose, Sleeveings, Splices,  
Insulation and Cable Harness Products

**Communications Instruments, Inc.**  
Relays and Solenoid Relays

**COOPER**  
Belden  
Multi Conductor, Paired, Coaxial, Flat,  
Fiber Optic, Instrumentation/Process  
Control, LAN, Special Application Cables,  
Power Supply Cords & Molded Cable  
Assemblies

**COOPER**  
Bussmann  
Fuses, Fuseholders, Fuse Blocks,  
and Fuse Accessories

**CORNELL DUBILIER**  
Capacitors-Aluminum  
Electrolytics, Mica, AC Oil, Film,  
MICA Paper and Relays

A COMPANY OF  
**DALE**  
**Dale Electronics, Inc.**  
Resistors, Networks, Oscillators, Displays,  
Inductors & Thermistors

**DI DANTONA INDUSTRIES, INC.**  
BATTERIES: Computer, Cordless  
Phone, Scanner & R/C.  
ANTENNAS: Cordless Phone (metal &  
rubber), Scanner Bumpers,  
Grommets and Stik-On Feet

**DEARBORN WIRE AND CABLE L.P.**

**EATON**  
Eaton Corporation, Commercial  
& Military Controls Operation  
Switches, Relays, Displays and Keyboards

A  
**GERNSBACK**  
PUBLICATION  
Popular Electronics  
Electronics Now Magazine

**KOA SPEER ELECTRONICS, INC.**  
Resistors, SMT Tantalum Capacitors Inductors,  
Resistor Networks, SMT Thermistors

**MALLORY**  
North American Capacitor Company  
Tantalums, Aluminums, Sonalerts®  
Ceramics, Films and AC's

**M-tron**  
Quartz Crystal Clock Oscillators  
and Special Hybrid Products

**muRata ERiE**  
MURATA ERIE NORTH AMERICA  
Monolithics, Discs, Variable Capacitors,  
Oscillators, Potentiometers, RFI/EMI Filters,  
Microwave, Surface Mount Capacitors

**NTE**  
**NTE ELECTRONICS, INC.**  
A WORLDWIDE REPUTATION FOR QUALITY, SERVICE AND VALUE  
Semiconductors, Resistors,  
Capacitors, Relays

**Philips ECG**  
A North American Philips Company  
Semiconductors, Test Equipment,  
Relays, A/V Parts and  
Chemicals

**Quam**  
Loudspeakers and Commercial Sound  
Products

**ROHM**  
Rohm Electronics Division  
Resistors, Ceramic Capacitors,  
Transistors/Diodes,  
Opto Components and IC's

**SELECTA**  
Electrical/Electronic Products  
Switches, Relays, Terminals,  
Indicator/Pilot Lights, LED Indicators,  
Test Clips, Test Leads, Cable Ties and  
Heat Shrinkable Tubing

A COMPANY OF  
**SPRAGUE**  
Tantalum Capacitors, Wet & Foil  
Capacitors, Resistor Networks,  
Resistor Capacitors Networks, Filters

**Switchcraft**  
A Raytheon Company  
Switches, Connectors, Jacks, Plugs,  
Jackfields & Audio Accessories

**TECH SPRAY**  
Non-CFC Cleaners/Degreasers,  
UV Cured Compounds, Swabs, Wipes,  
Brushes, Wick, Cleanroom Supplies, and  
Static Control Products.

## They sell through distributors. They belong to the E.I.A. They belong on your vendor list.

Leadership in electronics is not just a matter of designing products better and manufacturing them better, but also of marketing them better. And the sponsors of this message understand that better service to customers *requires* effectively involving distributors as part of their marketing teams.

Distributor involvement means lower prices, quicker deliveries, better service over-all. The Buyer wins. . . the Seller wins.

Distributors help achieve marketing leadership. So does the manufacturer's involvement in the Components Group of the Electronic Industries Association. EIA fosters better industry relations, coherent industry standards, and the sharing of ideas, which helps one another *and* serves customers better.

In choosing your component supplier, look for the marks of leadership —

- availability through distribution
- membership in the E.I.A.



**Electronic Industries Association/Components Group**  
2001 Pennsylvania Avenue, N.W. 11th Floor  
Washington, D.C. 20006  
Phone: (202) 457-4930 Fax: (202) 457-4985

*Committed to the competitiveness of the  
American electronics producer*

# Countersurveillance

**Never before has so much professional information on the art of detecting and eliminating electronic snooping devices—and how to defend against experienced information thieves—been placed in one VHS video. If you are a Fortune 500 CEO, an executive in any hi-tech industry, or a novice seeking entry into an honorable, rewarding field of work in countersurveillance, you must view this video presentation again and again.**



**CALL NOW!**

**1-516-293-3751**

**HAVE YOUR VISA or MC CARD AVAILABLE**

*Wake up!* You may be the victim of stolen words—precious ideas that would have made you very wealthy! Yes, professionals, even rank amateurs, may be listening to your most private conversations.

*Wake up!* If you are not the victim, then you are surrounded by countless victims who need your help if you know how to discover telephone taps, locate bugs, or “sweep” a room clean.

There is a thriving professional service steeped in high-tech techniques that you can become a part of! But first, you must know and understand Countersurveillance Technology. Your very first insight into this highly rewarding field is made possible by a video VHS presentation that you cannot view on broadcast television, satellite, or cable. It presents an informative program prepared by professionals in the field who know their industry, its techniques, kinks and loopholes. Men who can tell you more in 45 minutes in a straightforward, exclusive talk than was ever attempted before.

## Foiling Information Thieves

Discover the targets professional snoopers seek out! The prey are stock brokers, arbitrage firms, manufacturers, high-tech companies, any competitive industry, or even small businesses in the same community. The valuable information they filch may be marketing strategies, customer lists, product formulas, manufacturing techniques, even advertising plans. Information thieves eavesdrop on court decisions, bidding information, financial data. The list is unlimited in the mind of man—especially if he is a thief!

You know that the Russians secretly installed countless microphones in the concrete work of the American Embassy building in Moscow. They converted

what was to be an embassy and private residence into the most sophisticated recording studio the world had ever known. The building had to be torn down in order to remove all the bugs.

## Stolen Information

The open taps from where the information pours out may be from FAXs, computer communications, telephone calls, and everyday business meetings and lunchtime encounters. Businessmen need counselling on how to eliminate this information drain. Basic telephone use coupled with the user's understanding that someone may be listening or recording vital data and information greatly reduces the opportunity for others to purloin meaningful information.

The professional discussions seen on the TV screen in your home reveals how to detect and disable wiretaps, midget radio-frequency transmitters, and other bugs, plus when to use disinformation to confuse the unwanted listener, and the technique of voice scrambling telephone communications. In fact, do you know how to look for a bug, where to look for a bug, and what to do when you find it?

Bugs of a very small size are easy to build and they can be placed quickly in a matter of seconds, in any object or room. Today you may have used a telephone handset that was bugged. It probably contained three bugs. One was a phony bug to fool you into believing you found a bug and secured the telephone. The second bug placates the investigator when he finds the real thing! And the third bug is found only by the professional, who continued to search just in case there were more bugs.

The professional is not without his tools. Special equipment has been designed so that the professional can sweep a room so that he can detect voice-activated (VOX) and remote-activated bugs. Some of this equipment can be operated by novices, others require a trained countersurveillance professional.

The professionals viewed on your television screen reveal information on the latest technological advances like laser-beam snoopers that are installed hundreds of feet away from the room they snoop on. The professionals disclose that computers yield information too easily.

This advertisement was not written by a countersurveillance professional, but by a beginner whose only experience came from viewing the video tape in the privacy of his home. After you review the video carefully and understand its contents, you have taken the first important step in either acquiring professional help with your surveillance problems, or you may very well consider a career as a countersurveillance professional.

## The Dollars You Save

To obtain the information contained in the video VHS cassette, you would attend a professional seminar costing \$350-750 and possibly pay hundreds of dollars more if you had to travel to a distant city to attend. Now, for only \$49.95 (plus \$4.00 P&H) you can view *Countersurveillance Techniques* at home and take refresher views often. To obtain your copy, complete the coupon or call.

<b>CLAGGK INC.</b>		<b>PE</b>
<b>P.O. Box 4099 • Farmingdale, NY 11735</b>		
Please rush my copy of the Countersurveillance Techniques Video VHS Cassette for a total cost of \$53.95 each (which includes \$4.00 postage and handling).		
No. of Cassettes ordered	_____	
Amount of payment \$	_____	
Sales tax (N.Y.S. only)	_____	
Total enclosed	_____	
Bill me <input type="checkbox"/> VISA <input type="checkbox"/> MasterCard		
Card No	_____	
Expire Date	____/____/____	
Signature	_____	
Name	_____	
Address	_____	
City	_____	State _____ ZIP _____
All payments in U.S.A. funds. Canadians add \$4.00 per VHS cassette. No foreign orders.		