

Electronic Tracking Foils Car Thieves

Popular Electronics

MARCH 1992

The Classic Induction Coil

Make a spark ring, a fluorescent flasher, and more when you experiment with this powerful high-voltage generator

Build a Speaker Protector

Save your expensive loudspeakers from amplifier shorts, excessive drive, and turn-on thumps with this easy-to-build project

The Printer Sentry

Build one and keep tabs on all of your printer's functions

An Automatic Porch-Light Control

Build a money-saving porch light that never forgets to turn itself off

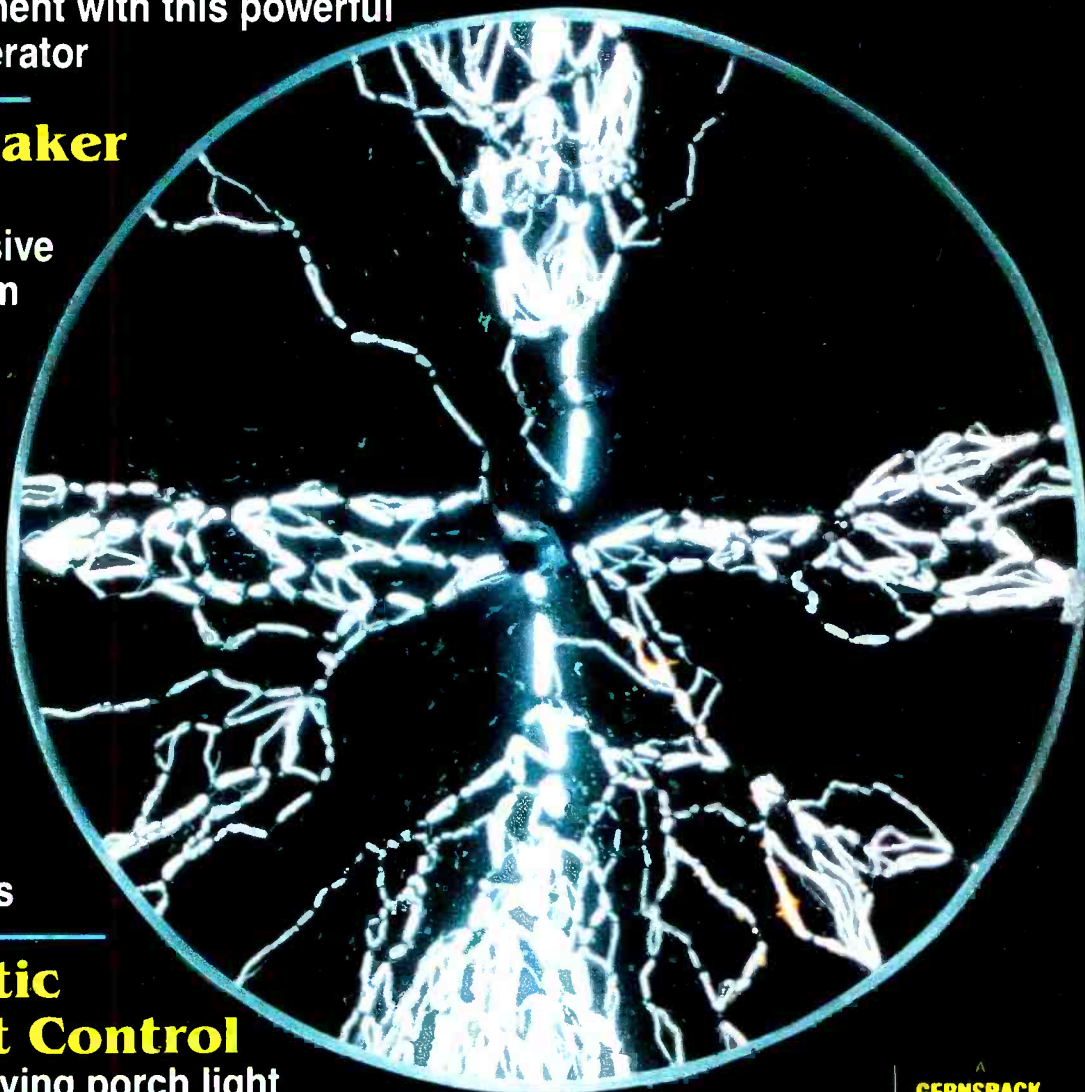

A
GERNSBACK
PUBLICATION



\$2.95 U.S.
\$3.75 CANADA

3 NEW
FactCards
IN THIS ISSUE

#BXBDJCH***** 5-DIGIT 60506
#60506DHM997GAD06# FEB93 07
ROBERT DAHM RESP
997 GRAND AVE 076
AURORA, IL 60506

We Only Skimped On The Price.

Introducing The Fluke Series 10—From \$69.⁹⁵

Fluke quality: Made in the USA by Fluke, with the same rugged reliability that's made us the world leader in digital multimeters. Count on hard-working high performance—and a two-year warranty to back it up.

Large, easy-to-read display: 4000 count digital readout.

Actual size: Easy to carry, easy to use.

New! Min/Max record with relative time stamp and Continuity Capture™: Makes intermittent problems easier to find. Records highs and lows—and "time stamps" when they occurred. In continuity mode, opens or shorts as brief as 250 μ s are captured and displayed.

New! V Chek™: For fast accurate checks on power sources and supplies, set your meter on V Chek—and let it do the rest. V Chek will determine continuity/ohms; if voltage is present, it will automatically change modes to measure AC or DC volts, whichever is detected. For most initial troubleshooting checks, here's the only setting you need to make.

Capacitance: Autoranging from .001 μ F to 9999 μ F. No need to carry a dedicated capacitance meter.

Autoranging with manual option: Your choice, depending on your situation.

For high performance at Fluke's lowest price, get your hands on the new Series 10. Stop by your local Fluke distributor and feel what a powerful difference the right multimeter makes—at the right price. For a free product brochure or the name of your nearest distributor, call 1-800-87-FLUKE.

Sleep Mode: Shuts itself off if you forget, extending long battery life even further.

New! Slide switch and a few pushbuttons control all functions: Designed for true one-hand operation.

Fast, accurate tests and measurements: AC and DC voltage measurements to 600 volts, ohms to 40 M Ω ; audible continuity test; and diode test.

Fluke 10	Fluke 11	Fluke 12
\$69.95*	\$79.95*	\$89.95*
4000 count digital display	V Chek™	V Chek™
1.5% basic dc volts accuracy	Capacitance, .001 to 9999 μ F	Min/Max recording with relative time stamp
2.9% basic ac volts accuracy	4000 count digital display	Continuity Capture™
1.5% basic ohms accuracy	0.9% basic dc volts accuracy	Capacitance, .001 to 9999 μ F
Fast continuity beeper	1.9% basic ac volts accuracy	4000 count digital display
Diode Test	0.9% basic ohms accuracy	0.9% basic dc volts accuracy
Sleep Mode	Fast continuity beeper	1.9% basic ac volts accuracy
Two-year warranty	Diode Test	0.9% basic ohms accuracy
	Sleep Mode	Fast continuity beeper
	Two-year warranty	Diode Test
		Sleep Mode
		Two-year warranty

* Suggested U.S. list price.

Optional holster with tilt-stand available.



The New Series 10.
A Small Price For A Fluke.

FLUKE AND PHILIPS
THE T & M ALLIANCE

©1991 John Fluke Mfg. Co., Inc. Prices and specifications subject to change. Ad no. 00130.

FLUKE®

CIRCLE 18 ON FREE INFORMATION CARD

Popular Electronics®

THE MAGAZINE FOR THE ELECTRONICS ACTIVIST!

CONSTRUCTION ARTICLES

BUILD A SPEAKER PROTECTOR	Bob Flynn	41
<i>Avoid needless damage to your expensive loudspeakers from overdrive, amplifier failure, and turn-on thumps</i>		
BUILD AN AUTOMATIC PORCH-LIGHT CONTROL	David Ponting	46
<i>Automate the operation of your porch lights so that they turn off to save you money</i>		
BUILD THE PRINTER SENTRY	John Yacono	59
<i>You can use it for troubleshooting, to keep tabs on a remote printer, or just to augment your printer's on-board display</i>		

FEATURE ARTICLES

THE CLASSIC INDUCTION COIL	Stanley A. Czarnik	35
<i>Learn the history behind induction coils, and have a little high-voltage fun</i>		
LIGHT SOURCES FOR PROJECTS AND INSTRUMENTS	Joseph J. Carr	49
<i>Learn about the various light sources found in electronics circuits and projects</i>		
ELECTRONIC TRACKING FOILS CAR THIEVES	Robert Angus	57
<i>Specialized transmitters, position-locating systems, and automatic police dispatching could make vehicle theft impractical</i>		

PRODUCT REVIEWS

GIZMO		5
<i>Including: Memorex Three-Piece Speaker System, DuoFone Outgoing-Call Restrictor, Multimedia Software Round-Up, and more!</i>		
PRODUCT TEST REPORT	Len Feldman	23
<i>Bang & Olufsen Beosystem 2500 Music System</i>		
HANDS-ON REPORT		65
<i>Mental Automation SuperCAD Electronics Design Software</i>		

COLUMNS

ANTIQUE RADIO	Marc Ellis	68
<i>Mail call</i>		
CIRCUIT CIRCUS	Charles D. Rakes	70
<i>Regulator applications</i>		
THINK TANK	John Yacono	73
<i>Automotive projects</i>		
COMPUTER BITS	Jeff Holtzman	76
<i>Modem mania</i>		
DX LISTENING	Don Jensen	78
<i>The changing face of Russian DX</i>		
HAM RADIO	Joseph J. Carr	80
<i>Design and build loaded dipoles</i>		
SCANNER SCENE	Marc Saxon	82
<i>Monitoring motion-picture sets</i>		

DEPARTMENTS

EDITORIAL	Carl Laron	2
LETTERS		3
FACTCARDS		53
FREE INFORMATION CARD		55
ELECTRONICS LIBRARY		84
NEW PRODUCTS		88
ELECTRONICS MARKET PLACE		102
ADVERTISER'S INDEX		106

Popular Electronics (ISSN 1042-170X) Published monthly by Gemstack Publications, Inc., 500-B Bi-Country Boulevard, Farmingdale, NY 11735. Second-Class postage paid at Farmingdale, NY and at additional mailing offices. One-year twelve issues, subscription rate U.S. and possessions \$21.95, Canada \$28.84 (includes G.S.T. Canadian Goods and Services Tax Registration No. R125166260), all other countries \$29.45. Subscription orders payable in U.S. funds only. International Postal Money Order, or check drawn on a U.S. bank. U.S. single copy price \$2.95. © 1992 by Gemstack Publications, Inc. All rights reserved. **Hands-on Electronics** and **Gizmo** trademarks are registered in U.S. and Canada by Gemstack Publications, Inc. **Popular Electronics** trademark is registered in U.S. and Canada by Electronics Technology Today, Inc. and is licensed to Gemstack Publications, Inc. Printed in U.S.A.

Postmaster: Please send address changes to **Popular Electronics**, Subscription Dept., P.O. Box 338, Mount Morris, IL 61054-9932.

A stamped self-addressed envelope must accompany all submitted manuscripts and/or artwork or photographs if their return is desired should they be rejected. We disclaim any responsibility for the loss or damage of manuscripts and/or artwork or photographs while in our possession or otherwise.

As a service to readers, **Popular Electronics** publishes available plans or information relating to newsworthy products, techniques, and scientific and technological developments. Because of possible variances in the quality and condition of materials and workmanship used by readers, **Popular Electronics** disclaims any responsibility for the safe and proper functioning of reader-built projects based upon or from plans or information published in this magazine.

Larry Steckler

EHF, CET

Editor-In-Chief and Publisher

EDITORIAL DEPARTMENT

Carl Laron

Editor

Robert A. Young

Associate Editor

John J. Yacono

Associate Editor

Byron G. Wels, K2AVB

Associate Editor

Teri Scaduto

Assistant Editor

Kathy Terenzi

Editorial Assistant

Marc Spiwak

Editorial Associate

Joseph J. Carr, K4IPV

Marc Ellis

Len Feldman

Jeffrey K. Holtzman

Don Jensen

Charles D. Rakes

Marc Saxon

Contributing Editors

PRODUCTION DEPARTMENT

Ruby M. Yee

Production Director

Karen S. Brown

Production Manager

Marcella Amoroso

Production Assistant

Janice Box

Editorial Production

ART DEPARTMENT

Andre Duzant

Art Director

Injae Lee

Illustrator

Russell C. Truelson

Illustrator

Jacqueline P. Cheeseboro

Circulation Director

Michele Torriilo

P-E Bookstore

BUSINESS AND EDITORIAL OFFICES

Gernsback Publications, Inc.

500-B Bi-County Blvd.

Farmingdale, NY 11735

1-516-293-3000

Fax: 1-516-293-3115

President: **Larry Steckler**

Customer Service/Order Entry

1-800-435-0715

7:30 AM - 8:30 PM EST

Advertising Sales offices listed on page 98

Cover photography by Stanley A. Czarmik

Composition by

Mates Graphics



The
Audit
Bureau
of Circulation



The publisher has no knowledge of any proprietary rights which will be violated by the making or using of any items disclosed in this issue.

HDTV UPDATE

In the United States, HDTV (High-Definition TV) is still, relatively speaking, a long way off. Competing standards are being tested by the FCC, and a decision is not expected until sometime in 1993. By the time the technology is completely worked out, consumer products are introduced, and some method of program distribution (cable, satellite, or terrestrial broadcast) is established, we may be well into the 21st Century.

In the meantime, in November, 1991, Japan began broadcasting eight-hours-a-day of HDTV programming. Originating from a new satellite, bright, movie-theater-quality, wide-screen HDTV images are beamed directly to every HDTV set in the country.

This is not another case of the U.S. finishing second. First of all, at around \$30,000 a set, few TV receivers have been sold. The vast majority of those sets are located in hotel lobbies and other public places. Second, and more important, the Japanese "Hi-Vision" system is based on older, analog technology.

Whatever U.S. standard eventually emerges, it will be digital. The reasons are not just technological, but political. With a digital standard, the majority of sets will still be made by Japanese companies (Zenith is the main remaining U.S.-owned TV-set manufacturer), and all sets will use lots of Japanese-made memory chips (Japan is the world's primary source of these chips); but a key component of any digital HDTV sets will be LSI signal-processing IC's. That is one technology where the U.S. is still a leader.

For now, though, the Japanese are content with pushing their Hi-Vision system. It gives them something to sell, at least in their own country, until digital HDTV arrives. And since most Japanese consumers, unlike those in the U.S., routinely discard perfectly good older equipment for newer models and technologies, they will gladly upgrade their gear when the time comes. Further, whatever digital system is developed here or in Europe (the Europeans are independently developing their own HDTV standard), the Japanese know they will be building many of those TV sets, too. For the Japanese, it's a no-lose situation—again.

Carl Laron
Editor

LABELING THE MUSIC-ON-HOLD ENCLOSURE

The "Music-on-Hold" article (**Popular Electronics**, December 1991) had one mistake in it: the wrong address was given for Thumb Electronics.

The correct address is P.O. Box 344, Marysville, MI 48040. I am sure that this was caused by the company moving just before the article was published.

Incidentally, there have been several inquiries on the design used to spiff up the project enclosure's metal lid. Every electronics enthusiast can duplicate the impressive and lasting results using the same method that I did. Any artwork, graphic, or drawing can be applied to give our boxes that professional look. The process is easy, cheap, and with just a few additional steps, very similar to making a printed circuit board using the iron-on resist method (as described in the July 1990 issue of **Popular Electronics**). Patterns and graphics can come right from the magazine.

All that is needed is a household iron, an oven, a special sheet of plastic, and a plain-paper copier or laser printer. Copy the pattern to the sheet and then iron it in place!

Here are the additional steps for labeling enclosures. Complete any cutting or drilling holes in the metal before cleaning it thoroughly with a scouring pad, scouring powder, and water. Dry, then tape the pattern in place. Place the enclosure/lid on a stack of newspaper to insulate it from the cold table top. Lay one sheet of paper towel over the pattern and iron it to the enclosure/lid for up to a minute. After allowing it to cool completely, peel the plastic to find the pattern transferred to the lid. Then bake the metal in a 350° preheated oven for five minutes. This ensures that the pattern bonds securely. To make the pattern scratch-resistant and water-proof, spray it with very light coats of quick-drying clear enamel, preferably while the piece is still warm. Heavy coats of paint will melt and smear the pattern.

Thumb Electronics sells L2000 brand iron-on resist sheets. DC Electronics and sev-

eral other companies that advertise in **Popular Electronics** carry another product called TEC-200. Both brands work well for labeling enclosures. I hope that this information gives many readers another way to label project cabinets—the easy way.

Mike Giamportone

THANKS FROM A HOBBYIST

I am an electronics hobbyist and consider myself a beginner. I'd like to thank **Popular Electronics** for helping me to develop my knowledge of electronics. I'm glad to tell you that the experience and knowledge I've acquired have brought great changes in my electronics career and strengthened my determination to acquire a better understanding of the subject.

I have developed two different application circuits, from your Fact Cards, which are now functioning normally. I am also almost finished building the "Electronic Dragonfly," for which I can easily find parts in my country. It goes without saying that I take every opportunity to recommend your magazine in our school, to my friends, and especially to my instructors.

G.M.

Dagupan City, Philippines

RESTORATION SAFETY

I found Marc Ellis' *Antique Radio* columns regarding safety for restorers (**Popular Electronics**, November and December 1991) quite appropriate. I have seen some of the AC/DC radios made before World War II, in which the chassis was connected directly to one side of the AC line, and the control shafts and mounting screws were not insulated from the chassis. Those sets are indeed very dangerous, and should never be operated without an isolation transformer. I shudder

LETTERS

to think of the number of people who were electrocuted from those sets. After World War II, those sets became safer thanks to Underwriters Laboratories and other consumer-product safety certification agencies. The later AC/DC sets either insulated the external hardware and control shafts, and used a "safety interlock" (a plug and socket arrangement that disconnected the line cord when the back was removed), or used a capacitor-coupled chassis. With the latter, the radio's B— was insulated from the chassis, but the chassis was coupled to it through a capacitor, usually about 0.05 μF or so. That grounded the chassis RF-wise, but had enough reactance at 60 Hz to prevent a fatal shock. However, touching such a chassis while being grounded (such as standing on a concrete floor in bare feet) would give you quite a jolt. If you are servicing one of those radios, be sure that these safety devices are still intact and are not bypassed or otherwise defeated. If the radio has a phonograph input, its ground return should also be capacitor coupled. If you replace a control or switch that has a plastic shaft or bushing, make sure that the new one is also plastic.

The issue of B+ safety is also important. Higher power (over 20 watts) tube-type audio amplifiers often use B+ voltages of 450–500 volts at current capacities of 250 mA ($\frac{1}{4}$ ampere) or so. Those units are the types used on musical instruments, PA systems, and the larger hi-fi systems. I have gotten some very nasty jolts from them. However, I would discharge the filter capacitors using a 1-to-10K, 10-watt wirewound resistor instead of a direct short. The current surge caused by a direct short could damage the capacitor. Be sure that the resistor's leads are insulated to prevent getting shocked while using it. Better yet, attach

a pair of insulated test leads with probes to the resistor.

Regarding the 1930's style radio transmitter described in the November, 1991 issue, I'd like to add some comments. First, wood is not a good insulator at 170 volts. The tie points supporting D1 and R5, in particular, should be insulated from the board with terminal strips. Second, a $\frac{1}{4}$ -amp fuse should be added to T1's primary circuit, since D1, C7, or C8 could short. With no fuse, T1 would burn up. Use an insulated fuse holder. Regarding the power transformer, most tube-type power transformers have a 6.3-volt, not a 12.6-volt, heater winding. If you have a 6.3-volt unit, use a 6SA7 tube instead of a 12SA7. Incidentally, miniature tube types 6BE6 and 12BE6 are electrically identical to types 6SA7 and 12SA7, respectively. Miniature tubes are cheaper and easier to find. Consult a tube manual for the proper socket pin connections. Finally, R2 should be 470K ohms or 1 megohm if this transmitter is being used with a crystal or ceramic phono pickup. Better yet, use a volume control instead, so you can control the modulation.

M.K.

Crestwood, IL

CORRECTION

I regret to inform you that whoever arranges your schematics is in line for twenty lashes with a wet kilocycle! In Joseph J. Carr's article, "Add Shortwave or VHF Reception to Any Radio" (**Popular Electronics**, December 1991), Fig. 3 and Fig. 4 have been switched, as the reference in the text to the C3-L3 trap shows.

B.R.P.

Lake Havasu City, AZ

Ouch—that hertz! All kidding aside, you are correct. We apologize for any confusion that this error caused.—Editor

The world's smallest 12-band receiver.

Includes digital clock,
travel alarm, headphones,
deluxe travel pouch,
and Grundig guide book.
Measures approximately
3 1/2" x 5 5/8" x 1 1/4" and
weighs a mere 14 ounces!



The world is at your fingertips with...

The Grundig World Band Receiver

Announcing a revolutionary breakthrough in world-band radios...from Grundig, the leader in German short-wave electronics. This miracle of miniaturization is not sold in U.S. stores or catalogs—only Willabee & Ward has it!

Tune in to events around the globe. The RK-709 is the world's smallest 12-band receiver—AM, FM, FM Stereo (with headphones, included), and *all* 9 major shortwave bands. Small enough to fit into a pocket, briefcase, or purse, yet big on features. Telescoping antenna pulls signals from anywhere in the world. Listen to legendary BBC newscasts—the best in the world. Hear what Radio Moscow is saying about Gorbachev, Yeltsin, and President Bush. Listen to the Voice of America when you travel abroad. Follow a crisis or breaking story wherever you are and no matter where it's happening: Baghdad, Panama, Beijing or Tokyo.

You don't have to pack a travel alarm, either.

You won't need it—this is better. The RK-709 wakes you with the radio or its ingenious "Humane Wake System"—the tone begins softly and gathers volume until you wake up! The digital alarm clock features a sleep timer that turns off the radio 10 to 60 minutes after you turn in!

Only \$159!

Payable in monthly installments.

The Grundig RK-709 is only \$159 (plus \$7.50 shipping/handling), payable in convenient monthly credit card installments. Includes deluxe carrying pouch and stereo headphones. One year warranty, 30 day money back guarantee. Order today.

Don't be confused by other 4, 5, 7, or 9 band radios. Grundig's RK-709 is today's best buy on a real 12 band receiver.

Willabee & Ward
47 Richards Avenue
Norwalk, Conn. 06857



Satisfaction guaranteed.

CALL TOLL-FREE: 1-800-367-4534
Ext. 623-168

Please send me _____ Grundig RK-709 World Band Receiver(s). For each receiver, charge 4 installments of \$41.63* to my credit card:

- MasterCard VISA
 Discover Am. Ex.

Credit Card # _____ Exp. Date _____

Name _____
PLEASE PRINT CLEARLY

Address _____

City/State/Zip _____

Signature _____
(All orders subject to acceptance.)

- I prefer not to pay by credit card and will pay by check.
Enclosed is my check for \$159* plus \$7.50 shipping/handling, a total of \$166.50 for each receiver.

*Any applicable sales tax will be billed with shipment.

Please: orders normally shipped next business day.

GIZMO

MARCH 1992

VOLUME 5,
NUMBER 3

A CHRONICLE OF CONSUMER ELECTRONICS

Speakers to be Seen and Heard

MEMOREX TRIUMPH TS-5 THREE-PIECE SPEAKER SYSTEM. From: Memtek Products, P.O. Box 901021, Fort Worth, TX 76101. Price: \$649.95

The last ten years have seen some dramatic changes in audio. Some obvious technological innovations immediately prove the point. For instance, the CD player has become our music medium of choice. And we never leave home without our personal portable stereo, or watch TV without turning on our audio/video receiver. What most people don't realize, however, is that speaker systems also have undergone some dramatic changes.

Interestingly enough, it hasn't been new technology that has changed speakers as much as it has been changes in style—people no longer want their entertainment equipment to take up as much space. (When interior designers recommend using one large, dramatic piece as a focal point in a room's decor, they do *not* mean the stereo system!) It was relatively "easy" to reduce the size of the systems' electronic components. But speakers presented a problem. There's no way around the fact that reproducing low frequencies requires a big speaker—or is there?

Well, speaker manufacturers found a way, with three-piece subwoofer/satellite speaker systems. The reason that such systems can work to deliver an acceptable stereo image is that the human hearing system can't identify the direction from which low-frequency sounds come. So having the low frequencies reproduced by a single speaker located in an out-of-the-way place won't damage the stereo image delivered by the smaller satellite speakers that reproduce the middle- and high-frequency sounds, which *are* directional. The Bose Corporation (which didn't invent the concept) usually gets the credit for popularizing subwoofer/satellite speakers with their Acoustimass system, introduced some six years ago. Since then, several other speaker manufacturers have

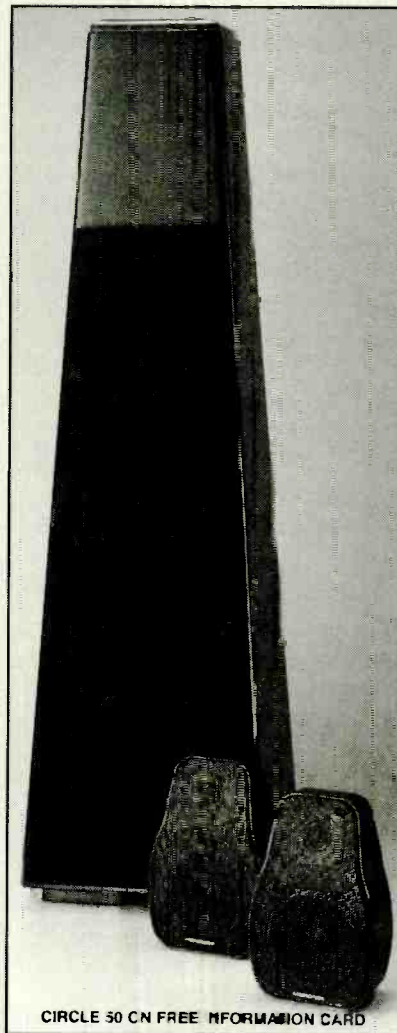

CIRCLE 50 ON FREE INFORMATION CARD

put their efforts into designing three-piece systems that produce big sound from small speakers. *Memorex* is one such manufacturer. But they designed their *Triumph Subwoofer System TS-5* to stand out from the crowd.

Unlike any other three-piece system we've ever seen (or heard), the TS-5 contains a subwoofer that *isn't* meant to be hidden under a couch or tucked in a corner. The three-foot tall, pyramidal, black-lacquer-finished obelisk with a 10-inch

square "footprint" is quite attractive—and you couldn't get it under a couch even if you wanted to! Unlike many such systems, which feature vented bass-reflex cabinets for the subwoofers, the TS-5 subwoofer is an acoustic-suspension design.

Four subwoofer drivers are enclosed in the wooden cabinet, two with a diameter of 6½ inches, and two that measure 5¼ inches. Each driver features a 1-inch voice coil and 20-ounce magnet. A raised grille-cloth panel covers the drivers. Unlike conventional speakers, however, the grille cloth isn't meant to be seen. The subwoofer is designed to be positioned about a foot from a wall, with the drivers aimed at the wall, for smoother bass response. Using four smaller drivers is said to be able to deliver a greater radiating performance than larger 15-inch woofers, partly because they can respond more quickly to changing musical inputs.

The satellite speakers are of a more conventional design. They're small, about 7×5×3½ inches, and weigh about 2 pounds each. With such a strikingly shaped subwoofer, they couldn't, of course, be merely rectangular. Instead, they're sort of pear-shaped. Each satellite contains three drivers: a 4-inch mid-range, and two ¾-inch dome tweeters in a dipole arrangement, one firing forward, and the other rearward and slightly upward to deliver upper-end frequencies throughout the room. The plastic-cabinet satellites are, unfortunately, not magnetically shielded, so you can't place them too close to your TV screen or they'll distort the picture.

Setting up the three-speaker system is not significantly different from setting up a standard pair of speakers, except that the satellites connect to the subwoofer, while only the subwoofer is connected directly to the amplifier or receiver. (Speaker cables are supplied with the system.) A crossover network in the subwoofer permits only those signals over 120 Hz to reach the satellites. Another crossover in the satellites permits only signals over 3 kHz to reach the tweeters. The TS-5 has a frequency response specified as 32 Hz–20 kHz, ±3 dB.

(Continued on page 105)

TURN PAGE FOR CONTENTS

This month in GIZMO

Memorex Triumph TS-5 Three-Piece Speaker System . . . pg. 5	The Countries of the World on CD-ROM pg. 16
Sherwood SS-1500R Compact Stereo System pg. 6	The Illustrated Works of William Shakespeare CD-I Disc . . pg. 16
Videonics Boing Box Sound Effects Mixer pg. 8	Macmillan Dictionary for Children MPC Disc pg. 17
Franklin Concise Columbia Encyclopedia pg. 12	The Guinness Multimedia Book of Records MPC Disc pg. 17
DuOfONE Outgoing Call Restrictor pg. 13	The Science and Technical Reference Set CD-ROM Disc pg. 17
Louis Armstrong—An American Songbook CD-I Disc pg. 14	The Toolworks Reference Library CD-ROM Disc pg. 17
Richard Scarry's Busiest Neighborhood Disc Ever! CD-I Disc pg. 14	AmandaStories: Interactive Stories for Children MPC Disc pg. 18
Time-Life Photography CD-I Disc pg. 14	Composer Quest CD-ROM Disc pg. 18
Treasures of the Smithsonian CD-I Disc pg. 14	Compton's Multimedia Encyclopedia MPC Disc . pg. 18
A Bun For Barney CDTV Disc pg. 15	Time Table of Business, Politics, and Media for Data Discman pg. 18
Airwave Adventures: The Case of the Cautious Condor CD-I Disc pg. 15	Monarch Notes MPC Disc . . pg. 18
Garden Fax—Indoor Plants CD-I Disc pg. 15	Microsoft Bookshelf for Windows MPC Disc pg. 18
My Paint CD-I Disc pg. 15	Multimedia Beethoven: The Ninth Symphony MPC Disc . . . pg. 18
Paint School I CD-I Disc . . . pg. 15	Total Baseball for Data Discman pg. 18
Advanced Military Systems CD-I Disc pg. 16	Frommer's Guide to America's Most Travelled Cities for Data Discman pg. 22
Between Heaven & Hell II CD-ROM Disc pg. 16	OAG Travel Disc, North American Edition for Data Discman. pg. 22
Britannica Family Choice CD-ROM Disc pg. 16	Passport's World Travel Translator for Data Discman pg. 22
Official RBBS in a Box CD-ROM Disc pg. 16	Wellness Letter for Data Discman pg. 22
Publique Art CD-ROM Disc . pg. 16	

Sher-Bet Compact

SHERWOOD SS-1500R COMPACT STEREO SYSTEM. From: Inkel (USA) Corporation, 14830 Alondra Blvd., La Mirada, CA 90638. Price: \$600.

The compact or shelf-sized stereo system has long been a mainstay of the audio industry. Their low prices and small size make them ideal starter systems—what was *your* first stereo system? They also make good “second” systems for bedrooms or dens, and are popular in many college dormitories.

Many of the early compact systems did have problems, however. They were cheap in the worst sense of the word, and, for the most part, sounded pretty bad. The underpowered systems with their small speakers didn't come close to the performance of component systems. Although some of today's compact systems still suffer from those historical problems, many others are shaking off the bad image that once plagued them. *Sherwood* does justice to the category with their *SS-1500R* remote-controlled “shelf component system.”

Calling it a “component” system may be stretching the term a little bit. The tuner, amplifier, and dual-well cassette deck only *look* like separate components that are stacked on top of one another; they are, however, actually contained in a single cabinet. The CD player is a separate component, matching the rest of the system.

As is becoming common with compact systems, the *SS-1500R* uses three speakers in a subwoofer/satellite configuration. All speakers are the same height, and match the height of the electronic components. The subwoofer uses an eight-inch driver mounted in a dual-port enclosure, and the two-way, acoustic-suspension satellite speakers feature a 3½-inch midrange and 2-inch tweeter.

The amplifier section of the *SS-1500R* can deliver a total power output of 160 watts—90 watts to the subwoofer, and 35 watts to each satellite. It is also possible to use conventional speakers with the amplifier, with a power output of 50 watts per channel into 4 ohms. The front panel of the amplifier section features a 5-band graphic equalizer, and a vacuum-fluorescent “spectrum analyzer” and power-level indicator. A power button, function-selector buttons (which include two external sources), a speaker on/off button, and a motorized rotary volume control round out the amplifier.

The dual-well cassette deck features Dolby B noise reduction and automatic record-level control. The deck permits “relay play.” That is, you can start playing

FREE HEATH CATALOG

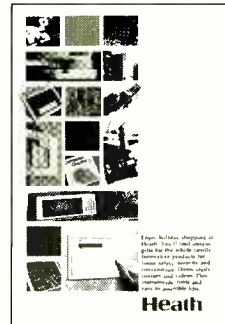

CIRCLE 51 ON FREE INFORMATION CARD

New and innovative electronics that make your life easier, safer and more secure, including:

- The world's largest and most varied selection of home lighting controls.
- Home security, safety and whole-house automation systems.
- The Heath Most Accurate Clock, accurate to +/-10 milliseconds.
- Heath's own Advanced Weather Computer for precision weather display and analysis.

And, the best electronics home study programs you'll find anywhere (the best value, too) including:

- ✓ New Computer-Aided Instruction (CAI) courses in basic electronics for accelerated, interactive learning.
- ✓ Video courses you can watch from the comfort of your easy chair.
- ✓ Courses that let you start at the level that's right for you and continue at your own pace.
- ✓ Courses from Heathkit Educational Systems, accredited and licensed as a premier electronics educator.
- ✓ Continuing Education Units (CEUs) awarded on successful completion of most Heath courses.

To receive your FREE Heath Catalog, fill in your name and address below and mail TODAY!

To: Heath Company
Dept. 107-150
Benton Harbor, MI 49022

Name _____

Address _____

City _____

State/Zip _____

CL-808

CIRCLE 14 ON FREE INFORMATION CARD

March 1992, Popular Electronics

7



a tape in deck B and, when it's finished, the tape in deck A will begin playing. "Synchro Dubbing," which lets you dub tapes using the controls from only one deck, is also featured, and can be used in either normal or high speed. Only one deck has recording capability, and only the playback deck features auto reverse.

The tuner section offers a generous 30-station memory for both AM and FM stations, and a memory-scan function. The memory is backed-up by a large capacitor for about 7 days. The 10 station-preset buttons are also used to directly select a track on a compact disc.

The remote control is typical of many similar systems in that it gives you only limited control. For example, you can select the cassette deck as an input, but you can't put it in the play mode. (You can, however, pause deck B remotely.) But don't misplace the remote—the only way to put the CD player in its random-play mode is by using the handheld device. Although the remote doesn't let you change the tuner frequency manually, the 30-station preset capability gives you adequate control over station selection.

For such a simple system, the manual that accompanies the SS-1500R is among the worst we've seen for any electronic component. It is not only poorly written, but it contradicts itself in places, and makes no sense at all in others. Fortunately, setting the system up could hardly be easier—one of the traditional benefits of compact systems. Attaching the speakers leaves little room for error—the subwoofer connects to the terminals labeled "Subwoofer," and the satellite speakers connect to a separately grouped set of connectors. The CD player connects to the amplifier just like any other component, except that a separate remote-control data cord is also included to integrate it into the system.

Using the SS-1500R is equally straightforward, and its performance is admirable for a compact, competitively priced system. With bass response down to 40 Hz, the sound belies its size. We were, however, disappointed with the tuner's FM performance. Using the supplied indoor antenna, we were unsatisfied with its stereo performance on all but the most-local stations. Improving the attached antenna didn't significantly change matters. Stereo performance was still poor on many stations, and, in its automatic-search mode, stations that should have been strong enough were consistently passed over. Its AM performance wasn't too much better, mainly because of the interference generated by the system's digital circuitry. Although, in general, we liked the layout of the controls, the controls themselves are hard to see in dim light. (That is also true, unfortunately, of most of the system's competitors.)

If not for the questionable tuner performance, we would have no qualms recommending the SS-1500R for anyone who needs a limited-space system, or second stereo system for a bedroom or office. In strong-signal areas, it does its job commendably well. ■



"Acme Television? I want to speak with someone about your on-screen programming feature."

Boinnngg!

VIDEONICS BOING BOX SOUND-EFFECTS MIXER. From: Videonics, Inc., 1370 Dell Avenue, Campbell, CA 95008. Price: \$179.

What distinguishes a good home video from a bad home video? The list is a long one. Good videos tell a story with each minute counting for something—there's no boring, "nothing's-happening" time. Good home videos are short: the shorter, the better. Zooming is kept to a minimum, and no fancy control is used simply because it's there.

It takes a lot of practice to shoot good videos right through the lens, so most videos benefit greatly from some editing after the shooting's complete. But sometimes even good editing isn't enough. While we're all concerned with the video edits, we often forget that the sound can be just as important. As proof, consider *America's Funniest Home Videos*. Even people like us (who hate the show) often stop for a few minutes as we are flipping by. What is it that makes us stop? It's not that the videos are high-quality. They're not—they're typically poor videos shot by inexperienced videographers. It's not that they're particularly funny. (How many times can you watch Dad get hit in the crotch by a son's batted ball?) If it weren't for the *sound* editing done by the show's producers, most of the videos would be nothing special. Before editing, a baby falls back on his rear end. It happens all the time, and isn't very funny. After editing, the baby

falls backward and when he hits the ground, you hear "Boing!" And that actually can provoke a chuckle—even from us.

While many camcorders and VCR's allow some limited capabilities for editing the audio track of your recordings, *Videonics* now makes it possible to add in a host of sound effects, music, and other audio sources with their *Boing Box* sound-effects mixer. The *Boing Box* combines a three-channel audio mixer with a digital sound-effects generator. You can mix internally generated sound effects with sounds from a microphone, your original VCR tape, or other audio sources. The resulting mix can then be recorded on another video tape.

The black plastic cabinet of the *Boing Box* is about 12 inches wide and 9 inches deep. Like most audio mixers, the cabinet slopes, in this case, the cabinet varies from about 1 inch to 3 inches thick. The rear panel of the mixer includes 4 pairs of RCA jacks, a headphone jack, a microphone input, and a power jack that accepts a 12-volt AC input from the supplied wall transformer. One nice feature about the rear panel is that the inputs are labeled right-side-up below the jacks, and upside-down above the jacks. That makes it easy to find the right connection as you lean over the front of the unit.

The front panel features three slide potentiometers on the left side, and a pad of 15 pushbuttons on the right. The majority of the front panel is taken up by a listing of sounds and effects that are available.

One of the three audio-mixer slide potentiometers, labeled "VCR," controls the level of the audio signal from your source VCR deck. The second slide poten-

tiometer controls the level of the microphone input, while the third controls the level of either the internally generated sound effects, or any external source connected to the "music" inputs. You can monitor the output either via an amplifier connected to the line-level audio-output jacks, or through a pair of headphones connected to the rear-panel headphone jack.

The keypad on the right side of the front panel is where the fun begins. Ten of the keys are labeled with the numerals 0 through 9; there are also forward and reverse play buttons, and keys labeled CLEAR, DEMO, and ON/OFF. Using the numeric keys, you can call up any one of the 58 sounds listed on the front panel—from a door creaking, to a laugh, to an explosion, to a jet. (There's actually a fifty-ninth sound that isn't documented—a belch.) The *Boing Box* also includes a collection of "arcade" (videogame) sounds, and some music (the Wedding March, Brahms' Lullaby, Yankee Doodle, and others.) That might not sound like enough of an assortment to give you much flexibility. But each of the sounds can be manipulated with nine possible effects. You can fade a sound in and out, play it backward, make it repeat continuously, or "stutter" it, for example.

Even more powerful is the ability to play the sound lower, much lower, or higher. At least that's what the front panel calls the effects. Actually, what those effects do is to change the rate at which the digitally sampled sound is played back—and make totally new sounds in the process. When played back "much lower," the train sound turns into a fog horn, and the door slamming turns into an explosion, the laugh turns into an evil snicker. When sounds are played back much higher, the applause turns into a raging fire, the car horn turns into a harmonica note. It's also possible to play sounds backward, or to have them repeat continuously.

It's easy to imagine what some of the effects will sound like when the playback speed is changed. With others, it's not as obvious. That's why the demo modes are available. In one of the modes, the *Boing Box* will play back all of its sounds. In a second, all of the sounds are played back with effects.

It's also possible to "record" a sequence of up to 31 sounds, which you can play through at the touch of a key or, if you prefer, play back one sound at a time. That lets you store a "script" of sounds that you can then insert into a recording, in real time, without having to look up what numbers to push, or stop the tape while you set up an effect. So if you wanted to add a little humor to a wedding video, you might store in a sequence, a kiss, the wedding recession, engine starting, tires squealing, car

(Continued on page 105)



CIRCLE 52 ON FREE INFORMATION CARD

Why take chances in today's job market?

Graduate as a fully trained electronics professional.

To get ahead and stay ahead in today's economy, you need the electronics training CIE has been providing its 150,000-plus successful graduates with for nearly 60 years.

Meet the Electronics Specialists.

When you pick an electronics school, you're getting ready to invest time and money. And your whole future depends on the education you receive in return. That's why it makes so much sense to go with number one... with the specialists... with CIE!

There's no such thing as a bargain education.

If you talk to some of our graduates, and we recommend you do, chances are you'd find a lot of them shopped around for their training. Not for the lowest priced, but for the best training available. They pretty much knew what was available when they picked CIE as number one.

Because we're specialists we have to stay ahead.

At CIE we have a position of leadership to maintain. Here are just a few of the ways we hang onto it...

Programmed Learning.

That's exactly what happens with CIE's Auto-Programmed Lessons®. Each lesson uses famous "programmed learning" methods to teach you important electronics principles. You explore them, master them completely, before you start to apply them. You thoroughly understand each step before you go on to the next. You learn at your own pace.

And, beyond theory, some courses come fully equipped with electronics equipment to actually let you perform hundreds of hands-on experiments.

Experienced specialists work closely with you.

Even though you study at home, CIE's faculty and staff stand ready to assist via CIE's toll free number. And, each time you return a completed exam you can

be sure it will be reviewed, graded and returned with the appropriate instructional help, you get it fast and in writing from the faculty technical specialist best qualified to answer your question in terms you can understand.

Pick the pace that's right for you.

CIE understands people need to learn at their own pace. There's no pressure to keep up...no slow learners hold you back. If you're a beginner, you start with the basics. If you already know some electronics, you move ahead to your own level.

"Same Day" grading cycle.

When we receive your lesson, we grade it and mail it back the same day. You find out quickly how well you're doing!

State-of-the-art laboratory equipment.

Some courses feature the CIE Microprocessor



Training Laboratory. An integral part of computers, microprocessor technology is used in many phases of business, including service and manufacturing industries. The MTL gives you the opportunity to program it and interface it with LED displays, memory devices and switches. You'll gain all the experience

needed to work with state-of-the-art equipment of today and tomorrow.

New Courses!

CIE now offers two new career courses: Automotive Electronics and Computer Operation and Programming.

CIE offers you an Associate Degree.

One of the best credentials you can have in electronics — or any other career field — is a college degree. That's why CIE offers an Associate in Applied Science in Electronics Engineering Technology. And all CIE career courses earn credit toward your degrees.

Which CIE training fits you?

Beginner? Intermediate? Advanced? CIE home study courses are designed for ambitious people at all entry levels. People who have: No previous electronics knowledge, but do have an interest in it; Some basic knowledge or experience in electronics; In-depth working experience or prior training in electronics.

At CIE you start where you fit and feel comfortable where you start, then go on from there to your Diploma, Associate Degree and career!

Today is the day. Send now.

Fill in and return the postage-paid card attached. If some ambitious person has already removed it, cut out and mail the coupon below. You'll get a FREE CIE school catalog, plus complete information on independent home study. Mail in the coupon below or, if you prefer, call toll-free 1-800-321-2155 (in Ohio, 1-800-523-9109).

YES! I want to get started. Send me my CIE school catalog including details about the Associate Degree program. (For your convenience, CIE will have a representative contact you — there is no obligation.) **AH 26**

Print Name _____

Address _____ Apt. _____

City _____ State _____ Zip _____

Age _____ Area Code/Phone No. (____) _____

Check box for G.I. Bulletin on Educational Benefits Veteran Active Duty

CIE CLEVELAND INSTITUTE OF ELECTRONICS, INC.
1776 East 17th Street • Cleveland, Ohio 44114 • (216) 781-9400



A school of thousands.
A class of one.
Since 1934.

Hail, Columbia!

CONCISE COLUMBIA ENCYCLOPEDIA EC-7000. From: Franklin Electronic Publishers, 122 Burrs Road, Mt. Holly, NJ 08060. Price: \$399.

Now that Sony has introduced the Data Discman "Electronic Book Player," (see the February 1992 issue of *Gizmo* and Electronic Book reviews this month), it's difficult to write about *Franklin Electronic Publishers' EC-7000 Concise Columbia Encyclopedia* without making comparisons—even though they don't, strictly speaking, fall into the same category. After all, Franklin's product is an electronic encyclopedia, whereas the Data Discman is a device to read software that happens to include an encyclopedia. We'll take a close look at the Electronic Encyclopedia before drawing any conclusions.

Electronic "books" are nothing new to Franklin, the creator of the field of electronic publishing. The company has been producing handheld electronic reference works since they introduced the Spelling Ace spelling corrector in 1986. Since then, they've introduced a line of electronic reference tools that includes dictionaries, thesauruses, word-game players, bilingual dictionaries, speaking products, the Holy Bible—and *The Concise Columbia Encyclopedia*.

Much of the technology developed for use in Franklin's earlier products is evident in their encyclopedia. For example, a phonetic spelling corrector automatically supplies a list of possible correct spellings when you type in a misspelled word. A built-in thesaurus provides invisible assistance in subject searches: If you type in the word "novelists" the encyclopedia will also include those subjects described as "writers" and "authors."

Similarly, Franklin has profited from experience when it comes to the Encyclopedia's physical design. For such a small ($5\frac{1}{2} \times 5\frac{7}{8} \times 1$ -inch) product, the 8-line, adjustable-contrast display is clearly legible and the QWERTY-style keyboard is quite comfortable to use (although we wouldn't want to type *Gizmo* on it!). The keys are, of necessity, too closely spaced for touch typing, but when holding the unit in two hands we were able to use our thumbs for quick and accurate "hunt-and-peck" typing. Looking something like a computer keypad, the encyclopedia includes your basic letters, numbers, and punctuation marks; up, down, right, and left arrows; and BACK, ENTER, and ALT keys. We were unable, however, to find any use whatsoever for the numbers, punctuation (except "?"), or ALT keys. As far as we can tell, they're simply for show.

Several keys are unique to the Concise



CIRCLE 53 ON FREE INFORMATION CARD

Columbia Encyclopedia. A REV/FWD toggle switch lets you move forward or back through a list of articles. Function keys include CLEAR, MENU, MORE, LESS, MARK, HELP, and QUIT.

The CLEAR key returns you to the main "typing screen," from which you type in search requests. Once you've typed in a word to be searched, you can press either the ENTER key to see the first matching article found, or the MENU key to bring up a list of all articles found. At that point, pressing MORE broadens the search. It can be pressed up to three times for increasingly expanded searches. The initial search (from the main menu) pulls up only those articles in which the word(s) you type appear in the title. The first press of the MORE button also searches for titles that include synonyms of the key words. Press again and the search looks for the exact key words in titles and the entire text. The fourth search level looks for synonyms in both titles and text. Pressing LESS will narrow the search again, following the same parameters. When you've found an article of interest—or an interesting sentence within an article—pressing MARK will insert an "electronic bookmark" so that you can quickly locate that information in the future.

As you'd expect, the HELP key provides on-screen instructions. Somewhat unexpected is the exceptional quality of those instructions. Help screens can be accessed at any point in a search, and provide clear,

comprehensive directions for all functions, from the most basic to the most advanced. We read through the written manual (also easy to follow) when we first tried the Electronic Encyclopedia, and then relied solely on the help screens for reminders or pointers.

As trivia buffs (and *Jeopardy* fans), the QUIZ function was a big hit with us. The Encyclopedia poses questions in your choice of categories (Arts & Literature, World or US History, Geography, Physical Science, Life Science & Medicine, Philosophy & Religion, General Knowledge, or a mix of all of those). If you think you know the answer—and most of the questions are tough—you can type it in. The Encyclopedia will call up the article matching your answer. When you type in a question mark, it will say either "You found the article! Well done!" or "We found the answer in a different article. Select ANSWER in the Quiz menu if you'd like to see that article."

We ran into one glitch when using the quiz function. Our answer to "What is the science of studying the material remains of human cultures called?" was "archeology." When the Electronic Encyclopedia's response was "No such article was found," we thought perhaps we'd misspelled the word (although that should have automatically brought up the spell corrector). We erased the "y" to force the spell checker to appear, and discovered

(Continued on page 105)

Block that Call!

DUOFONE OUTGOING CALL RESTRICTOR (CAT. NO. 43-952). From: Radio Shack, 700 One Tandy Center, Fort Worth, TX 76102. Price: \$69.95.

The commercial in which Candice Bergen promises that Sprint has a phone plan for everybody "... unless, of course, you're a teenager—nobody has come up with a plan for that!" strikes a chord in most people who see it. Ever since the telephone became a household necessity, parents and teenagers have been battling over it. For some reason, with the onset of puberty comes the ability to spend hours a day with a phone glued to the ear. We don't live with any teenagers, but we can well remember our own teen years. Among our families and our friends' families, there were several different solutions to phone abuse. Some parents just bowed to the inevitable and installed a second line so that, in those pre-call-waiting days, they might have the chance to receive some of their own calls. Others, valuing family harmony over the family budget, actually installed extensions of that second line in the kids' bedrooms. At the opposite extreme, there were those who simply installed locks on their phones. Back in the days of rotary phones, such a device simply locked the dial in place. Of course, using those rotary phones, a clever teen could get around the lock by using carefully timed taps on the on-hook button for each digit of the phone number.

Today, the situation is even worse. There are still those endless calls to friends, discussing in detail what every person in school wore that day, who

"likes" who, who made what team, every move made by the latest music video stars, and what embarrassing things their parents had come up with lately. It seems that things haven't changed much since we were 15. Except that today's teens are also enticed to call an incredible array of "900," "976," and "540" numbers.

Any company can lease a 900 number from a long-distance carrier, or a 976 or 540 number from a local carrier, with almost no government regulation. Although the company can set its fees as high as it

likes (ranging from 50-cents a minute to \$50 per call), billing is handled by the phone company, and the charges for the calls appear as part of your regular phone bill. Most 900 numbers offer a legitimate (if over-priced) service for the fee, including medical tips from doctors, stock quotes, helpful hints for solving newspaper crossword puzzles, catalog sales, opinion polls, weather information, the latest sports scores. Others offer services intended to appeal to teens—dating ser-

(Continued on page 22)

ELenco & HITACHI PRODUCTS AT DISCOUNT PRICES

TO ORDER CALL TOLL FREE 1-800-292-7711

<p>48 HOUR SHIPPING</p> <p>Hitachi RSO Series (Portable Real-time Digital Storage Oscilloscopes)</p> <ul style="list-style-type: none"> VC-6023 - 20MHz, 20MS/s \$1,695 VC-6024 - 20MHz, 20MS/s \$1,995 VC-6025 - 50MHz, 20MS/s \$2,195 VC-6045 - 100MHz, 40MS/s \$2,995 VC-6145 - 100MHz, 100MS/s \$4,495 <p>RSO's from Hitachi feature roll mode, averaging, save memory, smoothing, interpolation, preriggering, cursor measurements. These scopes enable more accurate, simpler observation of complex waveforms. In addition to such functions as hardcopy via a plotter interface and waveform transfer via the RS-232C interface. Enjoy the comfort of analog and the power to digital.</p> <p>25MHz Elenco Oscilloscope \$349 S-1325</p> <ul style="list-style-type: none"> Dual Trace 1mV Sensitivity 6" CRT X-Y Operation TV Sync <p>(2) 1x, 10x Probes included</p>	<p>SPECIAL BUY V-212 - 20MHz Scope \$425</p> <p>Hitachi Portable Scopes DC to 50MHz, 2-Channel, DC offset function, Alternate magnifier function</p> <ul style="list-style-type: none"> V-525 - CRT Readout, Cursor Meas. \$395 V-523 - Delayed Sweep \$375 V-522 - Basic Model \$875 V-422 - 40MHz \$775 V-223 - 20MHz delayed sweep \$695 V-222 - 20MHz deluxe \$625 	<p>HITACHI COMPACT SERIES SCOPES This series provides many new functions such as CRT Readout, Cursor measurements (V-1065/1065A/865A), Frequency Cr. (V-1085), Sweeptime Autoring, Delayed sweep and Trigger Lock using a 6-inch CRT. You don't feel the compactness in terms of performance and operation.</p> <ul style="list-style-type: none"> V-660 - 60MHz, Dual Trace \$1,149 V-665A - 60MHz, DT, w/cursor \$1,345 V-1060 - 100MHz, Dual Trace \$1,395 V-1065A - 100MHz, DT, w/cursor \$1,649 V-1085 - 100MHz, QT, w/cursor \$1,995 V-1100A - 100MHz, Quad Trace \$2,195 V-1150 - 150MHz, Quad Trace \$2,695 <p>Elenco 40MHz Dual Trace Good to 50MHz \$495 S-1340</p> <ul style="list-style-type: none"> High luminance 6" CRT 1mV Sensitivity 10KV Acceleration Voltage 17ns Rise Time X-Y Operation <p>Includes (2) 1x, 10x Probes</p>		
<p>B + K TEST EQUIPMENT All Models Available Call for special price</p>	<p>Digital Capacitance Meter CM-1550B \$58.95</p> <p>9 Ranges 1pF-20,000uF 5% basic acy. Zero control w/ Case Big 1" Display</p>	<p>Digital LCR Meter LC-1801 \$125</p> <p>Measures: Coils 1uH-200uH Caps 1pF-200uF Res. 0.1-20M</p>	<p>Multimeter with Capacitance & Transistor Tester \$55 CM-1500B</p> <p>Reads Volts, Ohms Current, Capacitors, Transistors and Diodes w/ case</p>	<p>FLUKE MULTIMETERS All Models Available</p> <ul style="list-style-type: none"> Fluke 70-11 \$65 Fluke 77-11 \$145 Fluke 79-11 \$169 Fluke 87 \$289 <p>Call for special price</p>
<p>Quad Power Supply XP-580 \$59.95</p> <ul style="list-style-type: none"> 2-20V @ 2A 12V @ 1A 5V @ 2A 5V @ 5A <p>Fully regulated and short circuit protected</p>	<p>Triple Power Supply XP-620 Assembled \$69 Kit \$45</p> <p>2 to 15V @ 1A, -2 to -15V @ 1A (or 4 to 30V @ 1A) and 5V @ 3A</p> <p>All the desired features for doing experiments. Features short circuit protection, all supplies</p>	<p>AM/FM Transistor Radio Kit with Training Course Model AM/FM 108 \$26.95</p> <p>14 Transistors • 5 Diodes Makes a great school project</p>	<p>True RMS 4 1/2 Digit Multimeter M-7000 \$135</p> <p>.05% DC Accuracy 1% Resistance with Freq. Counter and Deluxe Case</p>	
<p>Soldering Station Temperature Controlled SL-30 \$39</p> <p>Digital Display Temp Range: 300F-900F Grounded Tip Overheat Protect</p>	<p>Color Convergence Generator SG-200 \$69.95</p> <p>Finest in the industry 10 rock steady patterns</p>	<p>Four-Function Frequency Counters F-100 120MH \$179 F-1000 1.2GH \$259</p> <p>Frequency, Period, Totalize, Self Check with High Stabilized Crystal Oven Oscillator, 8 digit LED display</p>	<p>Digital Triple Power Supply XP-765 \$269</p> <p>Fully regulated, Short circuit protected with 2 limit controls, 3 separate supplies XP-860 with Analog Meters \$195</p>	
<p>GF-8016 Function Generator with Freq. Counter \$249</p> <p>Sine, Square, Triangle Pulse, Ramp, 2 to 2MHz Freq. Counter 1 - 10MHz Int/Ext operation</p> <p>GF-8015 without Freq. Meter \$179</p>	<p>Function Generator Blox #9600 \$28.95</p> <p>Provides sine, triangle, square wave from 1Hz to 1MHz AM or FM capability</p>	<p>Learn to Build and Program Computers with this Kit Model MM-8000 \$129.00</p> <p>Starting from scratch you build a complete system. Our Micro Master trainer teaches you to write into RAMs, ROMs, and run a 8085 microprocessor, which uses similar machine language as IBM PC.</p>		
<p>Wide Band Signal Generators SG-9000 \$129</p> <p>RF Freq 100K-450MHz AM Modulation of 1KHz Variable RF output SG-9500 w/ Digital Display & 150 MHz built-in Counter \$249</p>		<p>JK-500 Digital / Analog Trainer A complete mini-lab for building, testing, prototyping analog and digital circuits supplies. Includes a function generator with continuously variable, sine, triangular, square wave forms. All power supplies are regulated and protected against shorts.</p> <p>Power Supplies</p> <ul style="list-style-type: none"> Variable Power Supply +1.25 to 20VDC @ 5 Amp (+1.25 to 15VDC @ 1 Amp) +1.25 to 20VDC @ 5 Amp (+1.25 to 15VDC @ 1 Amp) +12VDC @ 1 Amp +12VDC @ 1 Amp +5VDC @ 1 Amp +30VAC Center tapped @ 15VAC @ 1 Amp <p>Analog - Section</p> <ul style="list-style-type: none"> Function Generator Sine, Triangular, Square wave forms Frequency adjustable in five ranges from 1 to 100KHz Fine frequency adjust Amplitude adjust DC offset Modulation Freq-AM <p>Digital - Section</p> <ul style="list-style-type: none"> Eight data switches Two no bounce logic switches Eight LED readouts TTL buffered Clock frequency 1 to 100KHz Clock amplitude 5VPP square wave <p>Breadboards</p> <ul style="list-style-type: none"> 2 Breadboards, each contain 840 tie points (total 1,680) <p>\$149.95 Assembled \$119.95 Kit</p>		



CIRCLE 54 ON FREE INFORMATION CARD

WE WILL NOT BE UNDERSOLD!
UPS Shipping: 48 States 6%
(\$3 Min \$10 Max) Shipping
IL Res.: 7.5% Tax FAX: 208-520-0095

C & S SALES INC.
1248 Rosewood, Deerfield, IL 60015
(815) 292-2711 (708) 541-0710

15 Day Money Back Guarantee
2 Year Warranty
WRITE FOR FREE CATALOG

CIRCLE 16 ON FREE INFORMATION CARD

March 1992, Popular Electronics

Multimedia Software Roundup

Last month, we took an in-depth look at what promises to be one of the hottest segments in both the consumer-electronics and the computer industries: interactive multimedia, which borrows a little from each. The hardware we looked at is, however, only part of the puzzle. None of the multimedia systems will be successful until there is software to justify the purchase of the hardware.

What follows are brief capsule reviews of some of the software we had an oppor-



tunity to try as we put the hardware through its paces.

CD-I TITLES:

You can tour all twelve museums of the Smithsonian without leaving your living room, with *Treasures of the Smithsonian* from PIMA (1111 Santa Monica Blvd., Los Angeles, CA 90025). The self-guided tour visits some 150 exhibits. CD audio narration accompanies the tour, which includes a look at many treasures that are not normally on display to the public. You can even "touch" items that are off limits in real life, walk completely around famous statues, and listen to antique musical instruments. If you've ever tried to take in several Smithsonian museums in a day or a weekend, you (and your feet) are sure to appreciate this new approach. Price: \$49.98

CIRCLE 55 ON FREE INFORMATION CARD

Are you often disappointed with the quality of the photographs you take? *Time-Life Photography*, distributed by PIMA (1111 Santa Monica Blvd., Los Angeles, CA 90025), provides interactive pointers to help you take better pictures. The 10-volume *Time-Life* series has been condensed onto one disc that allows you to study the works of three leading photographers and

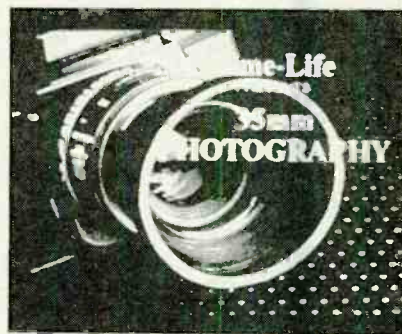

to attend a series of 25 interactive workshops. An on-screen simulated camera is used for practice shots. You select various settings, snap a picture, and immediately see the results of your setting choices—along with an explanation of what went wrong (or what you did right). Price: \$49.98

CIRCLE 56 ON FREE INFORMATION CARD

Curiosity is rewarded when your kids play *Richard Scarry's Busiest Neighborhood Ever!* disc from PIMA (1111 Santa Monica Blvd., Los Angeles, CA 90025). Based on the bestselling children's book, *Busytown* is brought to life through animation, conversation, music, and games.



On-screen instructions are clear and simple for preschoolers to follow. As they move through the streets of the town they can enter each building by clicking on it, and then play games or meet people inside. At the newspaper, for instance, they can type in their own name (with help from Mom for the youngest tots, we presume) and then see it featured as the headline in that day's paper: "SUZY VISITS BUSYTOWN." Price: \$24.98.

CIRCLE 57 ON FREE INFORMATION CARD

Part of PIMA's (1111 Santa Monica Blvd., Los Angeles, CA 90025) Video Album Cover Series—which can be played on a standard CD player for music only, or on a CD-I machine for an interactive multimedia experience—*Louis Armstrong—An American Songbook* lets you request biographical information, provides photos and little-known facts, and lets you read the lyrics and electronic liner notes along with the songs. Satchmo's unique versions of classics by George and Ira Gershwin, Kern, Hart, and others are included on the disc, along with two unreleased tracks,

NO COMPLICATED ELECTRONICS, NO EXPENSIVE INSTRUMENTS:

Home study course shows you how to make good money in VCR repair.

An amazing fact: you can do more than four out of five VCR repairs with ordinary tools and basic fix-it procedures. Our home study program shows you how.

Learn all of the systems, mechanisms, and parts of almost all brands of VCRs. With *no* expensive instruments. *No* complicated electronics. *No* fancy workshop. The step-by-step texts and close personal attention from your instructor make learning easy.

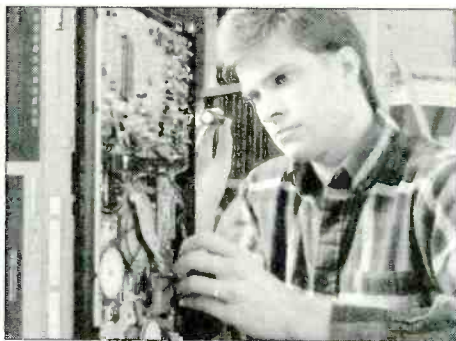

Texts, course materials, and tool kit are sent to your home. Graduate ready to make up to \$50.00 or more per hour in your own spare-time or full-time business.

Send today for your free career booklet. Or call 800-223-4542

Name _____

Address _____

City _____

State _____

Zip _____

The School of VCR Repair

2245 Perimeter Park, Dept.VC341, Atlanta, Georgia 30341

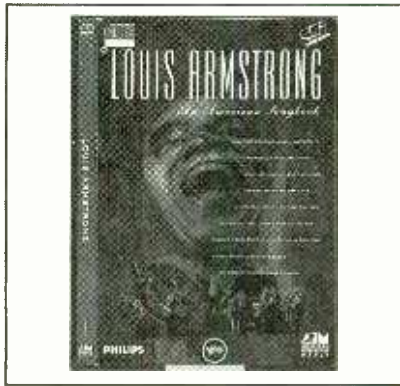

rare interview segments, and visual profiles of great American composers such as Cole Porter and Duke Ellington. Price: \$17.98

CIRCLE 58 ON FREE INFORMATION CARD

Providing plenty of opportunity for creativity—and no mess—*Spinnaker Software's Paint School 1* from PIMA (11111 Santa Monica Blvd., Los Angeles, CA 90025) has on-screen paintbrushes and pencils and more than 250 colors. Kids ages 4 and up can opt to color drawings from such categories as "Dino Land," "Pets," and "Water World." They can switch between several different palettes, including some with patterns instead of colors—and one with a selection of actual photographs. They can also choose a blank canvas on which to draw and color their own creations. Kids can zoom in on a painting for detail. The finished drawing can be turned into a "slider" puzzle. Price: \$19.98.

CIRCLE 59 ON FREE INFORMATION CARD

CDTV TITLES:

Described as a "pop-up video," *A Bun for Barney* from *Multimedia Corp.* (109X Regent's Park Road, London, NW1 8UR, United Kingdom) tells the story of a bear who learns how to say no. On each "page" of the story written text is accompanied by narration. The cursor, which looks like a hand, is moved around the screen using the four direction buttons on the remote control. When it passes over an interactive "hot spot," the hand turns into a magic wand. Pressing one of the select buttons causes something to happen—ducks might peak out from behind some reeds, bunnies might dance across the screen, or a song might play. Preschoolers also have the chance to play some games. Even though the action seemed very slow to us, particularly when turning the page, our four-year-old reviewer didn't seem to mind the delays. Price: \$49.95.

CONTACT COMPANY DIRECTLY

Turn your thumb green with *Garden Fax*—*Indoor Plants* from *CDTV Publishing* (1200 Wilson Drive, West Chester, PA

19380). More than 200 common and rare plants are featured, classified according to flower color, leaf type, light aspect, size, room temperature, growing type, and flowering time. If, for instance, you're looking for a small plant with purple flowers to set in that sunny, but drafty, window in your living room, you would enter those criteria to get a list of possibilities. The responses would include the plant's name, a picture of it, and growing hints. Price: \$49.95.

CIRCLE 60 ON FREE INFORMATION CARD

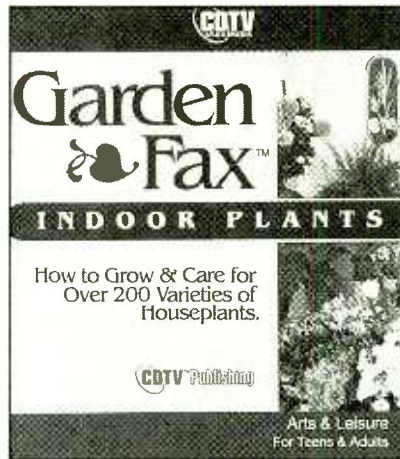

Interactive adventure games—some people love 'em, some are driven crazy by 'em. We fall into the latter category, lacking the patience and time to put together all the clues needed to solve the mystery. We were driven to distraction over *Tiger Media Inc's* (5801 East Slauson, Suite 200, Los Angeles, CA 90040) *Airwave Adventures: The Case of the Cautious Condor*. Sort of an interactive, airborne "Clue" set in 1937, the object is to determine who committed a murder. You and all of the suspects are passengers on a posh private airplane that will be landing in just 30 minutes. You must move through the various areas of the plane and find clues by listening to and watching the other passengers. As we said, our lack of patience interferes with our enjoyment of such games, and this game had us even more frustrated since it takes so long to move from scene to scene using the CDTV controls. Price: \$49.95.

CIRCLE 61 ON FREE INFORMATION CARD

Keeping a four-year-old happily busy for hours, *My Paint* from *Saddleback Graphics* (3621 West MacArthur Drive, Suite 119, Santa Ana, CA 92628) includes more than 100 drawings to be colored, using a choice of eight palettes with 12 colors each

AMAZING * ELECTRONIC PRODUCTS and KITS

Remember those Marlin Space Ships in HG Wells War of the Worlds?

MYSTERY Levitating Device
Objects float on air and move to the touch. Defies gravity! Amazing gift conversation piece. magic trick or great scientific project
ANT1K Easy-Ass'y Kit/Plans \$19.50

3 MILE FM Wireless Microphone!
Crystal clear, ultra-sensitive pickup transmits voices, sounds to any FM radio. For security, monitoring children, invalids Be the local DJ!
MVP1 Plans \$7.00
MVP1K Kit/Plans \$39.50

3 MILE Telephone Transmitter!
Automatically transmits 2 sides of phone conversation to any FM radio. Tunable, easy-assembly PC board Operates only when phone is in use.
VWPM7 Plans \$7.00
VWPMK7 Kit/Plans \$39.50

TV & FM Joker/Jammer
Pocket size device lets you remotely disrupt TV or radio reception. Great gag! Discretion required. Easy-build electronic kit. **EJK1KM ... \$19.50**

100,000 V - 20' Range Intimidation Device!
Electronic module, may be enclosed for handheld, portable, or fixed uses
ITM2 Plans (creditable to kit) \$10.00
ITM2K Kit & Plans \$49.50

READY-TO-USE, AUTOMATIC Phone Recording System
Complete with extended play tape recorder & line interface switch
Automatically records both sides of conversation. Check Local Laws on Proper Use! Ready-to-Use System
TAP20X System \$149.50

Laser Pen
Pen sized laser, great for movies drive-ins, pointer. Ready to use, with batt's **LAPN1 Laser Pen . \$149.50**

Pocket Laser Kit
3mw or 5mw kits, with solid state 670nm diode. Caution, Class IIIa item
VRL3KM 3mw Laser Kit . . \$99.50
VRL5KM 5mw Laser Kit . . \$119.50

MORE Laser Kits!
LAS1KM 1mw Laser, 632nm, HeNe Easy to Build Kit \$69.50
LAS4KM 3mw Version, Kit \$99.50

LAT05 Low Cost HeNe Laser Tube! .5mw Tube & Plans . . only \$24.50
Other parts available separately
Great Low Budget Science Project!

Shocker Force Field Vehicle Electrifier
Make hand shock balls, shock wands electrify objects, charge capacitors
Great pay back for those wise guys!
SHK1KM Easy-Assembly Kit \$24.50

INFORMATION UNLIMITED Order by Mail, or by 24 Hr Order Phone: **800-221-1705**

Dept PE-2, Box 716, Amherst NH 03031
Phone 603-673-4730 FAX 603-672-5406
MC, VISA, COD, Check Accepted. ADD \$5 S&H.

CATALOG!
with many more items!
FREE with order, or send \$1 P&H

or a "color brush" that paints in a rainbow of colors. Four different "coloring books" can be selected: One has regular drawings, two that teach alphabet and number/shape recognition, and one that features a phonetic-based reading system. When

you've finished coloring a drawing, you can make the colors flash, or switch between palettes to see how it would look in completely different colors. Price: \$39.95.

CIRCLE 62 ON FREE INFORMATION CARD

You won't find many writers who are more prolific than William Shakespeare—yet *Animated Pixels* (Albemarle House, Osborne Road, Southsea, Hants PO5 3LB, United Kingdom) has managed to put the complete text of all his plays, poems, and sonnets on one disc for play on CDTV or

an IBM-PC equipped with a CD-ROM drive and Microsoft-compatible mouse. *The Illustrated Works of Shakespeare* also contains reproductions of original woodcuts that illustrate scenes from many of the plays. You can search for words or combinations of words, within one work, or within the entire collection. It did take quite some time, however, to search every work to find "slings" and "arrows" in Hamlet's "To be or not to be" soliloquy. Several different text sizes and fonts were

offered, ranging in clarity from illegible to okay. Price: \$49.95.

CONTACT COMPANY DIRECTLY

We have a feeling that *Dominion Software & Design's* (3328 Oakshade Court, Fairfax, VA 22033) *Advanced Military Systems* will be a popular title—but we must admit that we don't get it. But then again, we didn't get the popularity of *Top Gun* either. To us, this disc was reminiscent of those slide shows in Social Studies class—the ones that you tried to nap through without attracting the teacher's attention—albeit with better sound and more pictures. But for those who are a bit more enthusiastic about things military, the action shots and detailed narration would be fascinating. The disc is divided into five main categories—land, air, and sea power; weapons; and strategic systems. Each of those provides close-up looks at specific craft or systems, accompanied by music and narration. Price: \$39.95.

CIRCLE 63 ON FREE INFORMATION CARD

CD-ROM TITLES:

The hallmark of CD-ROM has always been the sheer volume of information—some 650 megabytes—that fits on a disc. *The Countries of the World on CD-ROM* from *Bureau Development Corp.* (141 New Road, Parsippany, NJ 07054) is a good example. It includes the full text of all 106 *Country Series Handbooks* (which range from 200 to 500 pages each) prepared by the U.S. Army. Everything you've ever wanted to know about a country's history, population, climate, and politics is on the disc, as are maps from Hammond. You can see a color picture of the country's flag, and even hear a portion of its national anthem (assuming your drive supports audio output). The user interface is easy to navigate, and it's easy to browse the disc for hours. But it also makes it easy to get information in a hurry. Price: \$495.

CIRCLE 64 ON FREE INFORMATION CARD

If there's one type of file that cries out for a larger hard disk, it's the graphics file. Once you start doing any sort of desktop

publishing, even crude one-page fliers, you'll find yourself running out of disc space when you try to store images. What if you could have a library of thousands of public-domain images on a single disc? You can, with *Publique Art* from *Quanta Press* (1313 Fifth St. SE, Suite 208C, Minneapolis, MN 55414). Everything from insects to trees, from maps to religious symbols is there, some good, some bad—just like any collection of public-domain clip art. An on-disc viewer makes it easy to find the picture that is right for you. Price: \$179.

CIRCLE 65 ON FREE INFORMATION CARD

If you've ever been inclined to start your own BBS but didn't know where to start, well *The Official RBBS in a Box* from *Quanta Press* (1313 Fifth St. SE, Suite 208C, Minneapolis, MN 55414) might be the right place to start. Although we didn't count them all, the disc contains somewhere between 7000 and 9000 downloadable shareware files that would seem to make a rather complete bulletin board. You can start your own bulletin board in about 5 minutes by popping the disc in and installing software to your hard disc—you'll also need a modem, of course. Even if you don't want to start your own bulletin board, the disc is still an enormous value. Price: \$179.

CIRCLE 66 ON FREE INFORMATION CARD

Between Heaven and Hell II is the second version of the cleverly named disc from the *Bureau Development Corp.* (141 New Road, Parsippany, NJ 07054). Why is the name clever? Well, the disk is an eclectic combination of everything from the King James version of the Bible to the more worldly pursuits of graphics (including some pornography) and a plethora of other shareware files too numerous to even classify—12,109 in all. Although the publishers had the foresight to include the treeinfo file (used by the Norton NCD command) on the disc so you could call up a directory extremely quickly using Norton's program, navigating the disc can be difficult. A program designed to simplify file transfers to your hard disk is a help, but the sheer number of files, and the fact that most directory names are merely numbers, is a hindrance. Still, it's a tough-to-beat bargain. Price: \$99.

CIRCLE 67 ON FREE INFORMATION CARD

How do you justify your purchase of a CD-ROM drive to your family? One way would be with a disc called *Britannica Family Choice* (Britannica Software, Inc., 345 Fourth Street, San Francisco, CA 94107). With programs such as *The Berenstain Bears Learn about Counting*, *Super Spell-icopter*, the *Fiction Adviser*, and *Grammar Examiner*, the collection tries to offer something for everyone in the family.



We're not sure. We weren't able to find one program that did it for us. Price: N/A.
CIRCLE 68 ON FREE INFORMATION CARD

The most useful application that we've found for CD-ROM is for keeping reference material on hand in a minimum of space. *The Toolworks Reference Library* from *The Software Toolworks* (60 Leveroni Court, Novato, CA 94949) is another collection of useful references including *Webster's New World Dictionary*, *The Saurus*, *Guide to Concise Writing*, and *Dictionary of Quotable Definitions*; *The Dictionary of 20th Century History*; J. K.

Lasser's Legal and Corporation Forms for the Smaller Business; the *National Directory of Addresses and Telephone Numbers*; and *The New York Public Library Desk Reference*. The reference set features a very easy-to-use interface, but its search capabilities are somewhat limited. This impressive collection, however, seems like a good deal to us. Price: \$149.95.

CIRCLE 69 ON FREE INFORMATION CARD

Anyone who reads *Popular Electronics* and a *Gizmo* article dedicated to CD-ROM and multimedia software is sure be interested in *The Science and Technical Reference Set* from McGraw-Hill (Professional Book Group, 11 West 19 Street, New York, NY 10011). It contains the complete text and graphics from the McGraw-Hill *Concise Encyclopedia of Science and Technology* and the McGraw-Hill *Dictionary of Scientific and Technical Terms*. Both references have been among our favorites in their paper versions. The ability to access the same information on CD-ROM, with its inherently more powerful search capabilities is, to say the least, exciting. The user interface isn't as friendly as we'd like, and the searching can be slow, but there's a wealth of technical information on this disc. Price: \$495.

CIRCLE 70 ON FREE INFORMATION CARD

MULTIMEDIA PC:

Who holds the world record for the most consecutive hours of pole-sitting? You can find that out, along with the world records for the largest pizza, tallest man, and almost any other record you can think of, from *The Guinness Multimedia Book of Records* from *Britannica Software Inc.* (345 Fourth Street, San Francisco, CA 94107). More than 7000 records are brought to life with more than 300 full-color photographs and more than 70 sound recordings. Price: \$149.95.

CIRCLE 71 ON FREE INFORMATION CARD

It's easy for kids to find words in the *Macmillan Dictionary for Children* from *Maxwell Electronic Publishing* (124 Mt. Auburn Street, Cambridge, MA 02138). They can scroll through the word list, or use the guide list or A-to-Z list to find a particular word. The "Go To" function lets them just key in a word, and they can look up any word within a definition by clicking on it. The dictionary has almost 12,000 definitions, 1000 illustrations, and 400 sound effects. It also has "Zak," a character who guides kids through the dictionary and its games, which include Hangman and Spelling Bee. Price: \$59.95.

CIRCLE 72 ON FREE INFORMATION CARD

Train at HOME to be an Electronics Technician!

As the demand for computers and microprocessors in business, manufacturing and communications continues to grow, so does the need for qualified technicians. It's not unusual for experienced technicians to earn from \$30,000 to more than \$40,000 a year.* Now through Peoples College of Independent Studies you can train for this exciting field without interrupting your job or home life.

Choose From Five Programs of Study

- Electronics & Microprocessor Technology
- Industrial Electronics & Microprocessor Technology
- Communications Electronics with Microprocessor Technology
- Computer Servicing & Electronics Technology
- Specialized Associate Degree In Electronics Technology

Professional Equipment Is Included

Depending on the program you select, you'll perfect your skills using this advanced equipment, included in the price of tuition:

- IBM-Compatible Personal Computer
- Digital Multimeter
- Digital Logic Probe
- Elenco Oscilloscope
- Portable Cellular Telephone

(* Source: U.S. Bureau of Labor Statistics)



Exclusive Extras That Enhance Your Training

- Peoples College introduces some training firsts to make your learning experience more complete:
- Accelerated Learning System — a scientifically proven study system that helps you learn faster and easier than ever before.
 - Video Tutor Training Tapes — give you a permanent, visual record of informative lectures and close-up demonstrations.
 - Experience Labs — professionally designed experiments that give you hands-on "bench" experience.
 - Industry Certification Training Guide — provided with four of our programs. Prepares you for examinations you may take for your professional license or certification.

Easy Payment Plans — No Finance Charges

To help you get started on your education, Peoples College has reduced tuition rates and offers low monthly payment plans with no finance fees. So don't delay, call or write for more information today!

For COLOR CATALOG Mail Coupon or Call TOLL FREE 1-800-765-7247

Programs offered only in United States, Canada, Puerto Rico and Virgin Islands. No Obligation. No sales person will call.

Our programs are accredited by the Accrediting Commission of the National Home Study Council.

YES! I would like to know more about your training programs. Send a catalog to:

Name _____
Address _____
City _____
State _____ Zip _____

Phone # _____
PEOPLES COLLEGE
OF INDEPENDENT STUDIES
233 Academy Drive • P.O. Box 421768
Kissimmee, FL 34742-1768
Member, D.L. Peoples Group E0392

CIRCLE 19 ON FREE INFORMATION CARD

www.americanradiohistory.com

We've seen plenty of multimedia research applications—encyclopedias, dictionaries, technical references, complete works of literature—but, admit it, how many of you made it through school without turning to Monarch Notes? The MPC version of *Monarch Notes* from *Bureau Development, Inc.* (141 New Road, Parsippany, NJ 07054) contains the complete set of Simon & Schuster's study guides of classic literature, each of which includes a biography of the author, a summary of plot and characters, and critical analysis. The multimedia version also contains hundreds of color illustrations and narration of many well-known passages. Price: \$99.

CIRCLE 73 ON FREE INFORMATION CARD

One of the most enchanting multimedia children's programs we've seen is *The Voyager Company's* (1351 Pacific Coast Highway, Santa Monica, CA 90401) *AmandaStories: Interactive Stories for Children*. The animated adventures require no reading: pre-schoolers can send the



spunky Inigo the Cat or the clever Your Faithful Camel through a series of whimsical adventures by pointing and clicking. Each story has several branches, so kids can play the same story over and over, following different paths. Price: \$59.95.

CIRCLE 74 ON FREE INFORMATION CARD

Many people casually enjoy classical music but are intimidated by their relative lack of knowledge about the composers and compositions that are universally considered "great." Well, *Dr. T's Music Software* (100 Crescent Road, Needham, MA 02194) is here to rescue you from your ignorance. The works of the great composers from the 16th to the 20th century are explored in music, words, and graphics on *Composer Quest*. It has two distinct modes of operation: One presents the material in the form of a lesson, the other in the context of an adventure game. The program also cross-references important events in world history, art, and sociological changes through the years. Price: \$99.

CIRCLE 75 ON FREE INFORMATION CARD

One title that demonstrates the powerful educational potential of the multimedia PC is *Multimedia Beethoven: the Ninth Symphony*, from *Microsoft* (One Micro-

soft Way, Redmond, WA 98052.) Developed by *The Voyager Company*, *Multimedia Beethoven* uses sound, text, and graphics to explore the life and music of Ludwig Von Beethoven. You can listen to the symphony and get a running commentary that gives you an appreciation of the symphony and its components in a way that would be possible only if you had a classical-music critic whispering in your ear as you listened to the symphony. A built-in quiz tests you on your knowledge of the symphony and its background. Price: \$79.95.

CIRCLE 76 ON FREE INFORMATION CARD

One of the promises of personal computers has always been to "place a world of information at your fingertips. One title that comes close to delivering that is *Microsoft Bookshelf for Windows* (One Microsoft Way, Redmond, WA 98052). It includes, on a single disc, the *Concise Columbia Encyclopedia*, *The American Heritage Dictionary*, *Roget's II: The New Thesaurus*, *Bartlett's Familiar Quotations*, *The Concise Columbia Dictionary of Quotations*, *The Hammond Atlas of the World*, and *The World Almanac and Book of Facts*. What does this version do that previous versions of Bookshelf not do? In the dictionary, you needn't rely on the phonetic representation of a word's pronunciation: a mouse click will let you hear what it's supposed to sound like. Some quotes can be heard in their original form as spoken by their originators. Looking up "Eclipse" gives you not only a textual description, but an animated one, showing how the moon's orbit around Earth is at an angle relative to Earth's orbit around the

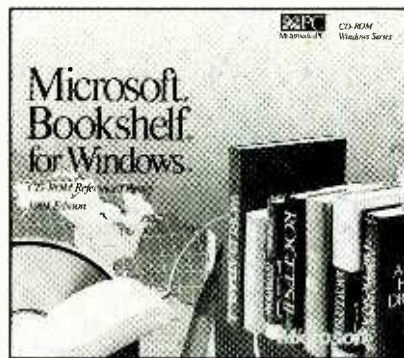

sun. Although the quotes are little more than a "gee whiz" addition to Bookshelf, and the eclipse entry is one of the few animations we found, the potential power of multimedia is seen here, too. Price: \$195.

CIRCLE 77 ON FREE INFORMATION CARD

Compton's Multimedia Encyclopedia from *Britannica Software, Inc.* (345 Fourth St., San Francisco, CA 94107) was published before there was a standard that

defined what PC users meant by "multimedia." The Windows version of the encyclopedia, however, conforms to the MPC specifications, and is a far cry from the earlier versions. The photos are much more like real photographs, and the animations—some of which are video-like—are quite good. Compton's was, in our eyes, always playing catch-up to Grolier's *Electronic Encyclopedia*. Now, despite the incredibly high price (which isn't always a hindrance to educational institutions), Compton's is a much more serious competitor. Price: \$895.

CIRCLE 78 ON FREE INFORMATION CARD

DATA DISCMAN:

Providing a unique way to access historical information, *Time Table of Business, Politics, & Media* from Xiphias (Helms Hall, 8758 Venice Blvd., Los Angeles, CA 90034) explores the "energies invested in the acquisition of wealth, power, and knowledge throughout man's history." You can use time tables, which are divided into time segments, and then scroll through the chosen period of history. Or you can search for specific names, places, events, or dates. We found a couple of sloppy mistakes, however. First, in the year 8000 B.C., under the heading "Beginnings of Agriculture," it stated that (compared to hunting and gathering days) "Where formerly it took 5000 acres of land to support an individual, the same amount of land can now support a population of 0." And, when searching for entries about Eleanor of Aquitaine (queen of France, and then England, and the mother of Richard the Lionheart), only one article was found—yet we'd seen two separate references when scrolling through the twelfth and thirteenth centuries. It turned out that in one of those articles "Aquitaine" was misspelled, so the search missed it. Despite our nitpicking, we liked being able to see what was happening all over the world at a specific time. Price: \$39.95.

CIRCLE 79 ON FREE INFORMATION CARD

Anyone who watches baseball knows how much commentary time is devoted to statistics—and real fans can tell you who holds the records for most stolen bases in post-season games, most walks in the month of August, and ... well, you get the idea. Now, you can find all the statistics (vital and otherwise) on *CMC ReSearch's* (7150 S.W. Hampton, Suite C120, Portland, OR 97223) *Total Baseball*. It contains all the traditional statistics plus batting, pitching, and fielding registers for all 13,495 Major League players. It lists the top 100 leaders in every statistical category, and lists all awards, player rosters, coaches, umpires, managers, and owners from 1871 to the present. Price: \$49.95

CIRCLE 80 ON FREE INFORMATION CARD

Start a money-making career in video/audio servicing!

Only NRI gets you started fast with real-world training designed around state-of-the-art equipment you keep!

NRI's newly expanded training covers all the latest advances in home entertainment electronics, then takes you inside today's high-tech equipment as you learn to troubleshoot, diagnose, and service the complete home entertainment system included in your course: 13" color TV, programmable VCR, and integrated audio rack system. Only NRI makes it so easy to start a new career, earn part-time income, even start a video/audio servicing business of your own!

Billions of dollars of video/audio equipment means big opportunity for you

There's never been a better time to get involved in home entertainment electronics. Experts predict that consumers of video/audio equipment will spend over \$26 billion by 1995 as product manufacturers race to fill the demand for increasingly sophisticated technology.

This explosive acceleration of new product innovation means new opportunities for you in video/audio servicing. And NRI prepares you to take advantage of those opportunities by giving you the skills to troubleshoot and service a full range of TV, video, and audio equipment.

The most advanced, most complete video/audio training ever offered!

You start with lessons that give you a strong foundation in electronics fundamentals, mastering the basic circuits and components at the heart of today's video/audio equipment.

Then you build on that foundation as you explore the high technology of digital controls, CDs and digital audio tape players, advanced TV systems, cable TV, VCRs and camcorders, even microprocessors.

Best of all, you're prepared for the technology of today and tomorrow with hands-on training designed to give you invaluable practical experience.

Hands-on training with this incredible array of home entertainment equipment gives you the skills you need for success.

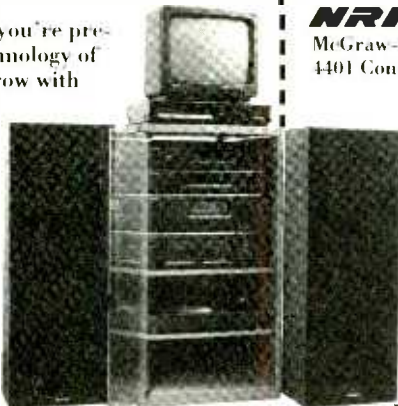

State-of-the-art equipment included in your training makes theory come to life

Only NRI gives you so much real-world equipment ... all yours to train with and keep! Get hands-on experience as you work with a complete, high-tech home entertainment system: a 13" color TV with remote, a programmable VCR, and an integrated remote-controlled audio system including AM/FM tuner, 100 watt amplifier, CD player, dual cassette player, turntable, speakers, and audio rack cabinet.

Theory comes to life as you learn to perform component-level diagnosis and service on advanced technology audio equipment ... conduct in-set demonstrations of TV circuits and components ... and discover first-hand how to maintain and service today's commercial VCRs.

Plus, NRI custom-produced videos

show you in close-up detail how to test, troubleshoot, and service TVs and VCRs like a pro.

No experience necessary ... NRI builds it in

You need no previous experience in electronics to succeed with NRI. Step by step, you accumulate the knowledge and practical experience that will make you uniquely qualified for today's opportunities in home entertainment electronics.

You learn at your own pace and on your own time. And all throughout your training, you have the full support of your personal NRI instructor and the entire NRI technical staff.

FREE catalog tells more

If the coupon is missing, write to NRI Schools, McGraw-Hill Continuing Education Center, 4401 Connecticut Avenue, NW, Washington, DC 20008.

SEND TODAY FOR FREE NRI CATALOG

NRI Schools

McGraw-Hill Continuing Education Center
4401 Connecticut Avenue, NW, Washington, DC 20008

For Career Opportunities
approved under GI Bill
 check for details



Check one FREE catalog only

- | | |
|--|--|
| <input type="checkbox"/> TV/Video/Audio Servicing | <input type="checkbox"/> Desktop Publishing & Design |
| <input type="checkbox"/> Microcomputer Servicing | <input type="checkbox"/> Electronic Music Technology |
| <input type="checkbox"/> Computer Programming | <input type="checkbox"/> Home Inspection |
| <input type="checkbox"/> Telecommunications | <input type="checkbox"/> Automotive Servicing |
| <input type="checkbox"/> PC Applications Specialist | <input type="checkbox"/> Basic Electronics |
| <input type="checkbox"/> Programming in C++ with Windows | <input type="checkbox"/> Bookkeeping & Accounting |

Name (Please print) _____ Age _____

Address _____

City _____ State _____ Zip 18-032

The value of preventative medicine is being touted everywhere these days, and it seems that we keep hearing of new things to avoid eating, and new fad cure-alls like oat bran. One well-respected source of real information on the subject is the "Wellness Letter" from the University of California at Berkeley. *Houghton Mifflin Company* (2 Park Street, Boston, MA 02108) has put a collection of those newsletters on an Electronic Book called *The Wellness Encyclopedia*, which comes bundled with the Data Discman. It is divided into sections on nutrition, longevity, exercise, self-care, and environment and safety. Price: \$49.95.

CIRCLE 81 ON FREE INFORMATION CARD

Also bundled with the Data Discman is *Passport's World Travel Translator* from *NTC Publishing Group/Passport Books* (4255 West Touhy Avenue, Lincolnwood,

IL 60646). It provides translations in ten languages—Spanish, French, German, Italian, Portuguese, Dutch, Danish, Swedish, Serbo-Croatian, and English. Price: \$49.95.

CIRCLE 82 ON FREE INFORMATION CARD

Travelers, of course, are one of the main target groups for the Data Discman, and *Sony Electronic Publishing Company (SEPC)/Prentice Hall's* (1 Lower Ragsdale Drive, Monterey, CA 93940) *Frommer's Guide to America's Most-Traveled Cities* provides vital information for travellers to New York City, Los Angeles, Chicago, Washington DC, and San Francisco. All the information from the printed Frommer's Guides to those cities is included, such as detailed maps, sightseeing and shopping tips, restaurant and lodging descriptions, etc. Price: \$39.95.

CIRCLE 83 ON FREE INFORMATION CARD

Anyone who travels frequently knows how much time it takes to get flight information over the phone—particularly if you want to compare schedules at several different airlines. The *Official Airlines Guide's* (1775 Broadway, New York, NY) *OAG Travel Disc, North American Edition* provides schedule information for more than 71,000 direct and 180,000 connecting flights to more than 1200 destinations in North America. Flight information includes airline and flight numbers, type of plane, stops made en route, dates of operation, departure and arrival times, meals, and classes of service. In addition, the disc provides information about 26,000 hotel properties, including rates, addresses, fax and phone numbers, and Mobil ratings. Since this information is constantly changing, periodic updates will be made available. Price: \$49.95.

CIRCLE 84 ON FREE INFORMATION CARD

BLOCK THAT CALL

(Continued from page 13)

vices, teen-talk lines, soap-opera updates, and psychic advice from astrologists or numerologists. And then there are the out-and-out scams—"call this number to claim your free vacation;" "get a credit card regardless of your credit history;" and the television commercial shown in Washington state a couple of years ago that encouraged children who were too young to know how to dial the phone to hold the phone receiver up to the TV, where an automatic dialing tone was transmitted. It is estimated that consumers lose \$10 billion a year to telephone con artists.

What's a parent to do?

Radio Shack offers a possible solution in the form of a modern, electronic version of that old dial lock. The *Duofone Outgoing Call Restrictor* (Cat. No. 43-952) can be programmed by the user to restrict access to 900, 976, 540, long-distance or local-exchange calls—or even calls to specific phone numbers. In fact, there's only one number that you can't program it to restrict—911, for emergency calls.

A personal-access code allows you to change the restricted numbers and to bypass restrictions. That means that, conceivably, you would be the only one in the house who could make any long-distance calls at all, or dial information instead of looking in the phone book (a common bone of contention in many families). You could even enforce a "no-phone-calls-for-a-week" punishment, by temporarily adding your kid's friends' numbers to the off-limits list.

The Call Restrictor is a 5½ × 3¾ × 1¼-inch box that can be installed on tone or pulse lines in one of two ways. If you live

in a home in which the entry point of the main phone line into the house is readily accessible, you can use Series Installation to connect the restrictor in series with all phones on that line. That is, the restrictor is connected between the outside telephone line and all phones in the home. Then, when an unauthorized call is detected, the restrictor physically disconnects the house lines from the outside telephone line. For Parallel Installation (as you'd expect, that puts the restrictor in parallel with all phones on the line), the restrictor is plugged into any telephone jack on the same line as the phones to be restricted. Instead of automatically disconnecting unauthorized calls, with parallel installation the Restrictor sounds a tone that makes it impossible to carry on a conversation or listen to a phone service. It is unlikely, but possible, however, for the call to be completed in the parallel setup.

The installation procedure is almost exactly the same for either method. For parallel installation, it is suggested that you select a location that is "in a secure location, such as in a closet or hidden behind furniture." (For in-series connection, of course, the main-line entry point is generally in an out-of-the-way location anyway.)

To install the Call Restrictor, the back of the unit is removed by unscrewing four screws. That exposes two phone jacks located inside the device and an "installation jumper" that must be reset for serial use (it is left as placed by the manufacturer for parallel operation). The cord from the telephone, which normally plugs directly into the phone outlet, instead plugs into the unit's "line out" jack. Then a supplied modular cord is run from the unit's "line in" jack to the phone outlet. For serial installation, the outside phone line is connected to the line-in jack, and the house

line to the line-out jack. (We're not sure how they came up with the labels on the jacks—it would have been less confusing, and more conventional, if one jack was labeled "to phone" and the other "to line.") Two 9-volt back-up batteries should be installed, and the case is then screwed shut again, with the wires to the phone system passing through two holes in the unit's bottom. Plug the power adapter into a convenient AC outlet to complete the installation procedure. The unit also has provisions for use with a wall-mount telephone outlet.

The unit's design and the installation procedures are intended to offer several lines of defense against tampering. First, of course, it's suggested that the Call Restrictor be hidden. Second, the back-up batteries prevent it from being disabled simply by being unplugged from the AC power. Third, some effort is required to unscrew it from the wall, and unscrew the back, to get at the batteries. Finally, the instructions won't do any good without knowing the personal access code, and vice versa. Of course that probably wouldn't have stopped us when we were teenagers. Actually, our parents would probably have asked us to program it!

The biggest difference between serial and parallel installation doesn't lie in the actual set-up, or even in the fact that the latter disconnects calls while the former sounds a disruptive tone. Instead, the difference lies in programming and, more specifically, in programming capabilities. For instance, only in the parallel set-up can the restrictor be programmed remotely from a telephone in another location, and only in that mode can the unit be re-programmed to allow operator-assisted phone calls. Conversely, only the serial installa-

(Continued on page 105)

PRODUCT TEST REPORTS

By Len Feldman

Bang & Olufsen Beosystem 2500 Music System

Most audiophiles maintain that "all-in-one" systems somehow don't measure up to those made up of separately purchased components that are "mixed and matched" by the end user. If that's your perception, too, you may want to look at, listen to, and use Bang & Olufsen's all-in-one Beosystem 2500—that system's performance (and look) could very well change a few minds.

For those unfamiliar with Bang & Olufsen it should be pointed out that many of B&O's products over the years have been honored

compact-disc player, an LCD readout, an FM-AM radio tuner, and a cassette tape recorder. Those doors slide open, as if by magic, whenever a hand is brought near. When a compact disc is played, its rotation is visible through the doors, adding a dynamic element to the system's appearance.

Four amplifiers are integrated into the speakers at each side of the central unit. The speakers can be fitted with a choice of speaker grilles in six different colors: cobalt blue (supplied in the sample I tested), jade green, cerise, gray, black, or white. The entire system, with speakers positioned on either side of the central unit, is just 33-inches wide and 14-inches high.

The 2500 offers a number of options for expansion or integration into a B&O whole-house audio/video system. It is supplied with a handheld remote control—the Beolink 5000. The remote not only controls normal system functions, but also allows programming of timer recording or play. A liquid-crystal display window at the top of the remote confirms the user's commands and shows the system's current status. That is made possible by two-way infrared signals that enable the remote and the main unit to communicate with each other.

CD PLAYER OPERATION

Touching the button marked load on the center

section causes a motorized clamp on the CD player to move upward for convenient CD loading. Touching the same button a second time positions the clamp to hold the CD in place for playing. Tracks can be programmed to play in sequence. Among the player's features are dual digital-to-analog converters and oversampling. The mechanism is spring-mounted to resist external shock and vibration.

CASSETTE RECORDER/PLAYER OPERATION

The cassette-recorder/player section of the B&O Beosystem 2500 incorporates HX-Pro, the headroom-extension system developed by Bang & Olufsen in cooperation with Dolby Laboratories. The one thing that may disturb audiophiles using this recorder is the inability to adjust recording levels manually. B&O has incorporated a proprietary auto record-level system that monitors and adjusts recording level. I must admit that in listening to some of the recordings I made during the course of testing this system I could detect no real problem caused by this arrangement. Nevertheless, it prevented me from making an objective signal-to-noise measurement of the recorder.

The recorder and CD player operate interactively, so that if you are recording a CD, when it has finished playing, the recorder goes



CIRCLE 120 ON FREE INFORMATION CARD

The Bang & Olufsen Beosystem 2500 compact music system.

for their styling and design, and have been exhibited in modern-art museums throughout the world, including the Museum of Modern Art in New York. This system follows in that tradition. Smoked glass doors cover the central section of the system, which houses a vertically mounted com-

into the pause mode automatically. Conversely, if tape runs out during recording, the CD mechanism stops automatically. Just as with the CD section, an auto track-search feature lets you select specific tracks and to program them to play in sequence. Auto reverse is also incorporated in this cassette-recorder/player.

FM/AM TUNER FEATURES AND OPERATION

The AM/FM-stereo tuner of the system features 40 station presets, divided into two blocks of twenty each. Each block can be assigned to a different user or use. For example, one block can be programmed for the primary residence while the other is reserved for use in another location (vacation house, etc.) Once RDS (Radio Data System) becomes widespread, an optional RDS decoder will enable the display of call letters of FM stations and other data. Users can also manually program individual FM or AM stations to display call letters or other information such as "Classical," "Jazz," etc. Indoor antennas are provided for both AM and FM reception. The connector used for the FM antenna is non-standard, and that made it difficult for me to properly connect my FM generator. Therefore, while sensitivity figures were satisfactory, I suspect that they could actually be even better if I were able to match impedances at the antenna input with a proper connector. You will want to obtain such a connector from Bang & Olufsen if you plan to use an outdoor FM antenna with the system. If the indoor dipole antenna supplied proves adequate, you won't need any special connector for this purpose.

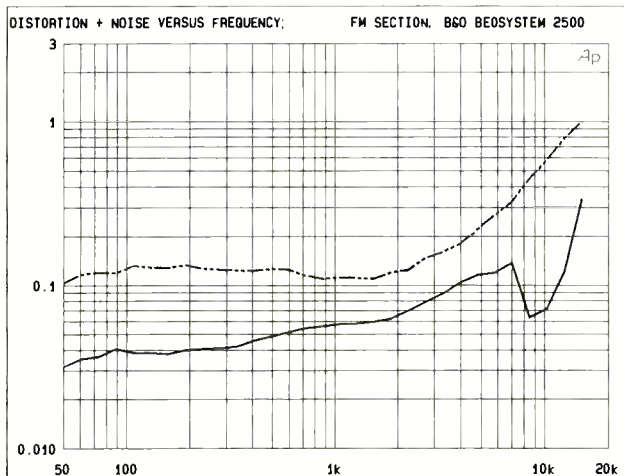

At 1 kHz, mono THD-plus-noise (solid line) was a low 0.057%. It was under 0.04% at 100 Hz, and about 0.13% at 6 kHz. The stereo THD-plus-noise (dashed line) was somewhat higher, measuring 0.11% at 1 kHz, 0.13% at 100 Hz, and 0.28% at 6 kHz.

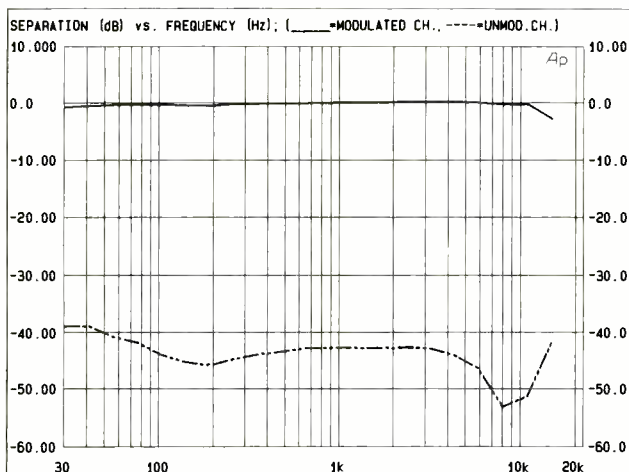

With strong signals, the FM-stereo separation at 1 kHz measured about 43 dB, increasing to an amazingly high 52 dB at 10 kHz; it was 44 dB at 100 Hz.

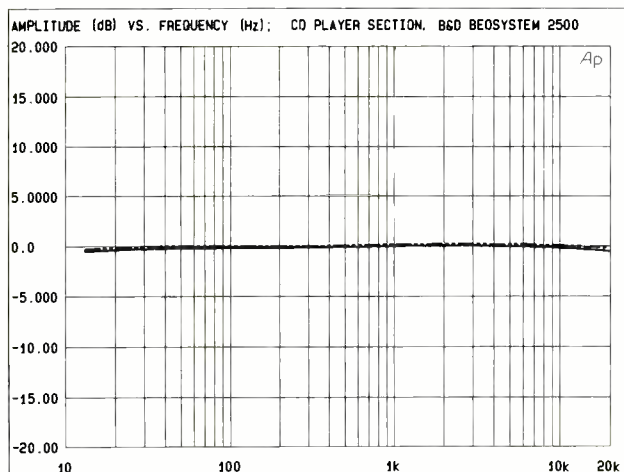

The CD player's the left- and right-channel outputs were within 0.04 dB of each other, and the player's frequency response was flat all the way out to 20 kHz.

ACTIVE BI-AMPLIFIED SPEAKERS

The system's amplifiers are integrated into the smartly styled speaker enclosures. Each speaker contains a 1-inch dome tweeter and a 4½-inch woofer designed for maximum output. A rear-facing bass-reflex port is used to enhance reproduction of bass frequencies. Two amplifiers per speaker are used in a bi-amplification mode. B&O does not supply any amplifier power specifications for the product and, indeed, the important thing in the case of active speakers is not how much amplifier power is used to drive them but how much acoustic power is available from the combination. In the case of the Beosystem 2500, the sound pressure level (SPL) attainable with low distortion is 103 dB.

CONTROLS

A display just below the compact-disc tray tells you which source is playing, including information about that source. For example, in the CD-player mode, track number, time into track, or time remaining can be displayed, while in the radio mode, the preset number and frequency can be displayed. Buttons in the middle of the control panel provide access to all the primary functions of the system such as source selection, volume adjustment, muting, and power standby.

Number buttons at the left enable you to select other preset-program numbers, or to select other tracks on a CD or on a tape. Step buttons in this area are used to step from one program or track to the next, in either direction. The three lowest buttons in this area are used to adjust and store sound settings such as

TEST RESULTS—BANG & OLUFSON BEOSYSTEM 2500

Specification	FM Tuner Section	PE Measured
Frequency Response, 20 Hz to 20 kHz		-1.0, 0 dB
Usable sensitivity		15.5 dBf
50 dB quieting sensitivity		
Mono		20.0 dBf
Stereo		48.0 dBf
Signal-to-noise ratio (mono/stereo)		78/69 dB
Stereo separation, 1 kHz/100 Hz/10 kHz		43/44/52 dB
CD Player Section		
Frequency response, 20 Hz to 20 kHz		+/- 0.1 dB
THD + noise, 1 kHz at max. level		0.01%
Channel separation, 1 kHz/16 kHz		
Left-to-right		78/68 dB
Right-to-left		80/74.6 dB
Linearity error at -90 dB (L/R)		-3/-5 dB
Tape Recorder/Player Section		
Frequency response, record/play		
Type I tape (30 Hz to 15 kHz)		+1.5/-5 dB
Type II tape (30 Hz to 15 kHz)		+1.0/-3.5 dB
Signal-to-noise ratio (Dolby off/on)		58.0/68.0 dB
Wow-and-flutter		
WRMS		0.03%
IEC-peak weighted		0.058%
Price:		\$3500

the bass- and treble-control settings, loudness-control compensation, and volume levels.

Secondary functions are handled by the buttons on the right side of the control panel. These buttons are used to select and name a radio station, control tape-recorder functions, program a sequence of tracks to be played on a CD, and more.

The well written and illustrated owner's manual provides step-by-step instructions for operating all three program sources supplied in the system. It should be noted, too, that auxiliary program sources can be connected to the system via a DIN connector at the rear of the unit. Virtually all of the major operating functions of the Beosystem 2500 can also be operated by means of the supplied Beolink 5000 remote control, and a separate operating manual is provided for that handheld accessory.

TEST RESULTS

The frequency response in FM was virtually flat all the way out to 15 kHz and, with tone controls set to their mid-points, response was down by only about 1 dB at 20 Hz. To achieve 50 dB of quieting, 20.0 dBf of input signal was required in mono, and 48 dBf in stereo. At strong signal levels, the mono signal-to-noise ratio measured 78.0 dB; in stereo, the best signal-to-noise ratio was around 69 dB.

At 1 kHz, mono THD-plus-noise was a low 0.057%. It was under 0.04% at 100 Hz, and about 0.13% at 6 kHz. The stereo THD-plus-noise was somewhat higher, measuring 0.11% at 1 kHz, 0.13% at 100 Hz, and 0.28% at 6 kHz.

The FM-stereo separation of the tuner was measured next. With strong signals, separation at 1 kHz measured about 43 dB, increasing to an amazingly high 52 dB at 10 kHz and 44 dB at 100 Hz.

We measured AM-tuner

Earn Your B.S. Degree in ELECTRONICS or COMPUTERS



By Studying at Home

Grantham College of Engineering, now in our 41st year, is highly experienced in "distance education"—teaching by correspondence—through printed materials, computer materials, fax, and phone.

No commuting to class. Study at your own pace, while continuing on your present job. Learn from easy-to-understand but complete and thorough lesson materials, with additional help from our instructors.

Our Computer B.S. Degree Program includes courses in BASIC, PASCAL and C languages — as well as Assembly Language, MS DOS, CADD, Robotics, and much more.

Our Electronics B.S. Degree Program includes courses in Solid-State Circuit Analysis and Design, Control Systems, Analog/Digital Communications, Microwave Engr, and much more.

An important part of being prepared to *move up* is holding the right college degree, and the absolutely necessary part is knowing your field. Grantham can help you both ways—to learn more and to earn your degree in the process.

Write or phone for our free catalog. Toll free, 1-800-955-2527, or see mailing address below.

Accredited by
the Accrediting Commission of the
National Home Study Council

GRANTHAM
College of Engineering
Grantham College Road
Slidell, LA 70460

DIGITAL VIDEO STABILIZER ELIMINATES ALL VIDEO COPYGUARDS



While watching rental movies, you will notice annoying periodic color darkening, color shift, unwanted lines, flashing or jagged edges. This is caused by the copy protection jamming signals embedded in the video tape, such as Macrovision copy protection. THE DIGITAL VIDEO STABILIZER: RXII COMPLETELY ELIMINATES ALL COPY PROTECTIONS AND JAMMING SIGNALS AND BRINGS YOU CRYSTAL CLEAR PICTURES.

WARNING

THE DIGITAL VIDEO STABILIZER IS INTENDED FOR PRIVATE HOME USE ONLY. IT IS NOT INTENDED TO COPY RENTAL MOVIES OR COPYRIGHTED VIDEO TAPES THAT MAY CONSTITUTE COPYRIGHT INFRINGEMENT.

FEATURES

- Easy to use and a snap to install
- State-of-the-art Microchip technology
- 100% automatic
- Compatible to all types of VCRs and TVs
- The best and most exciting Video Stabilizer in the market
- Light weight (8 ounces) and compact (1x3.5x5")
- Uses a standard 9 Volt battery (last 1-2 years)
- Fast UPS delivery
- Air shipping available
- UNCONDITIONAL 30 day money back guarantee
- 1 year warranty

(Dealers Welcome)

To Order: \$59.95 ea +\$4 for p & h
Visa, M/C, COD Mon-Fri: 9-6 EST
1-800-445-9285 ext. 6313
FREE 20 Page Catalog
SCO Electronics Inc. Dept. 6313
581 W. MERRICK RD. VALLEY STREAM, NY 11580

CIRCLE 20 ON FREE INFORMATION CARD

CABLE TV DESCRAMBLERS How You Can Save Money on Cable Rental Fees Bullet Proof



1 Unit 5+

BEST Super Tri-Bi Auto/
Var. Gain Adjustment \$119.95...\$85
Jerrold Super Tri-Bi... \$109.95...\$79
Scientific Atlanta..... \$109.....\$79
Pioneer..... \$109.....\$79
Panasonic TZPC145..... \$99.95.....\$79
Stargate Converter..... \$95.....\$69
Digital Video Stabilizer. \$59.95...\$29
Wireless Video Sender..\$59.95...\$49.95

U.S. Cable'll Beat
Anyone's Price
Advertised in
this Magazine!

30 Day Money Back Guarantee
FREE 20 page Catalog

Visa, M/C, COD or send money order to:
U.S. Cable TV Inc. Dept. 5313
4100 N. Powerline Rd., Bldg. F-4
Pompano Beach, FL 33073

1-800-772-6244 ext. 5313

For Our Record

I, the undersigned, do hereby declare under penalty of perjury that all products purchased, now and in the future, will only be used on Cable TV systems with proper authorization from local officials or cable company officials in accordance with all applicable federal and state laws. FEDERAL AND VARIOUS STATE LAWS PROVIDE FOR SUBSTANTIAL CRIMINAL AND CIVIL PENALTIES FOR UNAUTHORIZED USE.

Date: _____

Signed: _____

No Florida Sales!

CIRCLE 21 ON FREE INFORMATION CARD

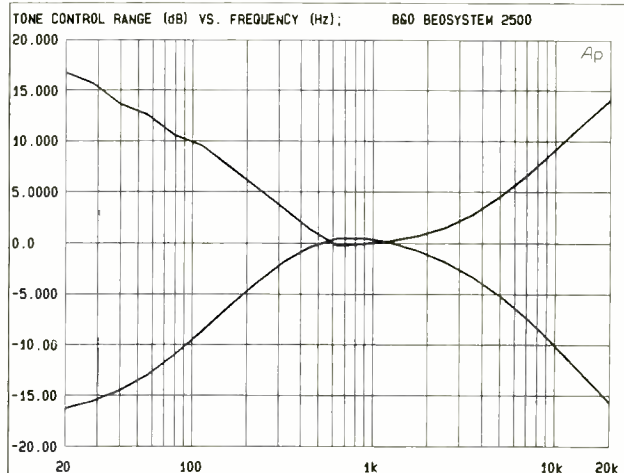

Setting the bass control at maximum resulted in a boost of nearly 13 dB at 100 Hz; the maximum-boost setting of the treble control resulted in a boost of just under 10 dB at 10 kHz. Bear in mind that a boost of 10 dB at any frequency requires a tenfold increase in power when such frequencies are encountered in program material, so users should go easy on the tone controls.

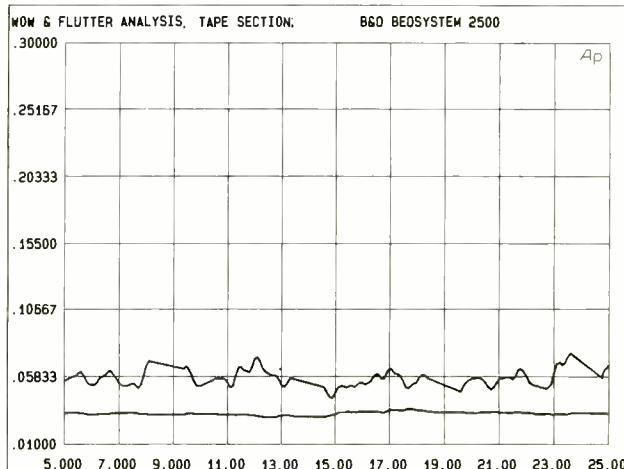

The wow-and-flutter of the tape player was tested in two ways: using IEC peak weighting (lower trace), and the familiar WRMS method (upper trace). Wow-and-flutter averaged around 0.058% for the IEC peak method and around 0.03% WRMS.

frequency response next, and were, as usual, disappointed to find that the -6 dB cut-off point occurred at just under 3 kHz. In view of that result, there seemed no point in listening to, or making further measurements for the AM-tuner section of the system.

Turning to the CD player, the left- and right-channel outputs were within 0.04 dB of each other and the player's frequency response was flat all the way out to 20 kHz. This is one of the best measurements that we have

ever obtained for a CD player.

At the maximum recorded level, harmonic-distortion-plus-noise for the CD player measured 0.01% at 1 kHz. We also measured THD-plus-noise versus recorded amplitude from maximum (0 dB) to -90 dB. Once the recorded levels are lowered to about 10 dB below maximum, the relative THD drops significantly and remains relatively constant for all lower-level signals, at around -88 to

(Continued on page 96)

EASY ORDER
1-800-582-4044



EASY FAX
1-800-582-1255

8 Page Supplement

P505 IDC BENCH PRESS

The P505 1/4 ton manual IDC Bench Assembly Press is a rugged, practical installation tool designed for low volume, mass termination of various IDC connectors on flat (ribbon) cable. Interchangeable base plates accommodate a broad range of IDC connectors, and are capable of mass terminating up to 64-conductor cable in seconds without wire stripping or soldering. Perfect for independent technicians and in-house service departments. Custom bases and cutters are available.



Order #	Price	Description	Weight
P505	149.95	IDC Bench Assembly Press.....	7.1 lbs.
P507	59.95	Flat Ribbon Cable Cutter (up to 64-Conductor Cable)	14.5 oz.
P508	54.95	Strip Header IDC Cutter	11.6 oz.
P510	24.95	Base Plate (Socket Transition Connectors).....	8.7 oz.
P511	24.95	Base Plate (Card Edge Connectors)	7.9 oz.
P512	24.95	Base Plate (Standard Dip Plugs).....	9.2 oz.
P513	24.95	Base Plate (D-Sub Connectors)	7.9 oz.

FLAT RIBBON CABLE

•Minimum Order: 5 feet

- Color: Grey
- Standard Pack: 100 ft.
- Electrical Rating: 300V
- Insulation Material: PVC
- Impedance: 105Ω Nominal
- Dimensions: 28 AWG, 7/36 Stranded

Ask about our extensive range of IDC connectors



Order #	5-99 ft	100+ft	Cond.
FR15	.25/ft.	.20/ft.15
FR20	.31/ft.	.26/ft.20
FR25	.39/ft.	.34/ft.25
FR26	.40/ft.	.35/ft.26
FR34	.50/ft.	.45/ft.34
FR36	.55/ft.	.50/ft.36
FR37	.56/ft.	.51/ft.37
FR40	.60/ft.	.55/ft.40
FR50	.65/ft.	.60/ft.50

- Conforms to MIL-C-83503/7C
- Electrical Rating: 1 Amp
- Construction: Pin 1 to Wire 1
- Housing: Glass Filled Polyester, Grey, UL94V-0
- Contacts: Beryllium Copper

Order #	1-9	10+	Dimensions (LxW) Pins
D10	.55	.45	0.68" x 0.24"10
D20	.75	.65	1.18" x 0.24"20
D26	.95	.85	1.48" x 0.24"26
D34	1.10	1.00	1.88" x 0.24"34
D40	1.29	1.19	2.18" x 0.24"40
D50	1.49	1.39	2.68" x 0.24"50

1.2GHz DIGITAL FREQUENCY COUNTER



FC1000

Yes it's true - A 1.2GHz digital frequency counter that provides for applications from simple counting to general audio and video and computer service, cordless products, telephone repair and function generator calibration. This outstanding design features specifications equal to commercial units, which would cost you many times the price of ours!

Introducing the WISHER Precision 1.2GHz frequency counter. This versatile unit is ideal for students, engineers and hobbyists. In price, appearance, function, reliability and accuracy there is no reason to look further.

Features:

- 2 BNC connector inputs
- Wide measuring range
- Compact frequency counter
- Rechargeable battery pack
- Easy to use
- Telescoping antenna

INPUT	Frequency Range	A Range (10Hz-20MHz) B Range (20MHz-1200MHz)
	Sensitivity	A Range (10Hz-20MHz)<15mV B Range (20MHz-1200MHz) 185-21mV 40 to 50 MHz 40mV 100 to 200 MHz 24mV 400 to 500 MHz 21mV
	Impedance	A Range (10Hz-20MHz) 1MΩ 80pf B Range (20MHz-1200MHz 50Ω)
	Max. Input Voltage	A Range - 100Vp-p B Range - 5Vp-p
	Coupling System	AC coupling
DISPLAY	Accuracy	1 Count + Timebase accuracy
	Counting Capacity	8 digit LED display
	Gate Time	6, switch selectable, 3 A Range, 3 B Range, 2.5 sec. - .002 sec.
	Read Out	KHz or 0.1 MHz
OPERATING TEMP		0°C ~ 45°C
POWER SOURCE		8V rechargeable battery pack (included) or 12Vdc/500mA adaptor (included)
DIMENSIONS	W x H x D	82.3 x 34 x 131 mm 3.24 x 1.34 x 5.16 in

Order #	Price	Description	Weight
FC1000	129.00	1.2GHz Digital Frequency Counter (Antenna and Battery Pack Included)	1.7 lbs.

DIGITAL MULTITESTER



New pen style digital multimeter small enough to go anywhere. Keep one in your glove box for everyday or emergency use.

Features:

- Auto & manual range operation
- Logic test function (CMOS/TTL)
- Data hold and diode test functions
- 3.5 digits large LCD with function annunciators for easy operation
- AC/DC ampere measurement
- Fast continuity response by buzzer

SPECIFICATIONS

- Display - 3.5 digits (1999 counts) LCD • various functions annunciator
- Range Selection - Auto/Manual
- DC Accuracy - <1% + 3 digits
- Polarity - Automatic, no indication for positive polarity, minus (-) sign for negative polarity
- Over Range Indication - MSD "1" flashed with buzzer sound
- Low Battery Indication - "L" mark is displayed when the battery voltage drops below normal operating voltage
- Maximum Input - DC/AC, 500V
- Sampling Rate - 2.5 times/sec

Order #	Price	Description	Weight
HDS-90L	29.95	Pen Style Digital Multimeter	6 oz.

TEST LEAD KIT



TL108



TLK1
(6 Lead Set)

This kit is an essential addition to your tool kit, whether you are a field technician, student or hobbyist. Remember all those occasions when you needed that extra test lead or two!!

CONTENTS - TLK1

- 2 each: BNC to 1 each red & black Test Clips
- 1 each: red Banana Plug to red Banana Plug
- 1 each: black Banana Plug to black Banana Plug
- 1 each: red Test Clip to red Banana Plug
- 1 each: black Test Clip to black Banana Plug

Order #	Price	Description	Weight
TLK1	19.95	Test Lead Kit	8 oz.
TL108	6.49	BNC to 2 Test Clips	3 oz.

- BNC to test clips use 50Ω RG58 cable
- All cables 36"

1/4" AUDIO CONNECTORS



JR18 Series

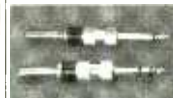

C26 Series

Hook up microphones, musical instruments, headphones & other audio accessories using these economical, quality connectors.

- Dimensions: 1/4" (6.5mm)
- Plating: JR1801-JR1804 = Nickel
C2659-C2669 = Gold

Order #	Price	Description	Type/Band
JR1801	1.19	Stereo Jack	Closed Cct.
JR1802	1.19	Stereo Jack	Open Cct.
JR1803	.99	Mono Jack	Closed Cct.
JR1804	.99	Mono Jack	Open Cct.
C2659	1.59	Mono Plug	Red
C2660	1.59	Mono Plug	Black
C2665	1.69	Stereo Plug	Red
C2666	1.69	Stereo Plug	Black
C2669	1.69	Stereo Plug	White

EASY ORDER: 1-800-582-4044 OR EASY FAX: 1-800-582-1255

CIRCLE 5 ON FREE INFORMATION CARD

SOLDERING STATIONS



SPECIFICATIONS
 Power 120VAC
 Heater Voltage 24VAC
 Heater Power 60 Watt
 Temp. Range 100°-470°C
 200°-878°F
 Standard Tip 1/16" Stand, Chisel
 (44-510804)



Supertemp XY9-60DK

FEATURES

- Heats in 1 minute
- Temperature sensor in tip
- Grounded tip
- Isolated power supply
- Zero voltage switching

*Additional replacement tips available

SIA30K/60K



Order #	Price	Description	Weight
168-3CK	69.95	60 Watt Soldering Station	4.04 lbs.
XY9-60DK	109.95	60 Watt Soldering Station (Digital Readout)	4.68 lbs.
SIA30K	22.95	30 Watt Mini Pencil Assembly for 168-3CK/XY9-60DK	4.2 oz.
SIA60K	22.95	60 Watt Iron Assembly for 168-3CK/XY9-60DK	5.8 oz.
79-024030K	12.95	30 Watt Mini Heater for 168-3CK/XY9-60DK	0.2 oz.
79-169024-60K	12.95	60 Watt Heater Cartridge for 168-3CK/XY9-60DK	0.3 oz.

SOLDERING/DESOLDERING STATIONS



0°-Operating Temperature in Approx. 60 Sec.

999DA



Model	999DA		999SD	
	Soldering		Desoldering	
Power	120VAC	120VAC	120VAC	120VAC
Operating Voltage	12Voc	24Vac	24Vac	24Vac
Heater Power Consumption	30 Watt	60 Watt	60 Watt	60 Watt
Vacuum Pump Operating Voltage	12Voc	—	100Vac	—
Temp. Range	100-450°C 212-842°F	100-470°C 212-878°F	100-470°C 212-878°F	100-470°C 212-878°F



999SD

Order #	Price	Description	Weight
999DA	269.95	30 Watt Desoldering Station	8.82 lbs.
999SD	399.95	60 Watt Soldering/Desoldering Station	17.66 lbs.
DIA30	59.95	30 Watt Replacement Desolder Iron Assembly	10.1 oz.
DIA60	59.95	60 Watt Replacement Desolder Iron Assembly	10 oz.
75-999001	6.95	Replacement Solder Collector	0.9 oz.
76-999001	3.95	Replacement Filters (10)	—

CORDLESS DRILL KIT

Case Size: 11.25" x 8" x 2.75"



Kit Includes:

- Cordless drill
- Wall plug-in recharger
- Flat head screwdriver bit
- Phillips head screwdriver bit
- Drill bits: 1/16, 5/64, 3/32, 7/64, 1/8, 9/64, 5/32, 11/64, 3/16, 13/64, 7/32, 15/64, 1/4

Order #	Price	Description	Weight
E8385A	44.95	Cordless Drill Set	3.75 lbs.

RECHARGEABLE SCREWDRIVER SET

Case Size: 11.25" x 8" x 2.75"

Kit Includes:

- Cordless screwdriver
- Bit holder
- Socket adapter
- Adapter with recharge stand
- 3 pcs. Phillips (#1, #2, #3)
- 3 pcs. Slotted (3/16", 1/4", 9/32")
- 3 pcs. Robertson (S-1, S-2, S-3)
- 5 pcs. Torx (T-10, 15, 20, 25, 30)
- 6 pcs. MM Hex (2, 2.5, 3, 4, 5, 6)
- 6 pcs. SAE Hex (3/32", 1/8", 5/32", 3/16", 7/32", 1/4")
- 7 pcs. MM Socket (6, 7, 8, 9, 10, 11, 12)
- 7 pcs. SAE Socket (3/16", 1/4", 5/16", 11/32", 3/8", 7/16", 1/2")



Order #	Price	Description	Weight
E8387	39.95	Rechargeable Screwdriver Set	3.5 lbs.

1991 IC MASTER

"For The Enthusiast Who Has Everything"

- Convenient
- Affordable
- Easy To Use
- Indispensable
- 80,000 Different ICs (Including 12,000 new ICs on the market)
- 1,000 Manufacturers' Data Pages (100% new and updated)
- 180,000 Pin-for-Pin Replacement Devices



New Updated 3 Volume Set

SALE!

Was 134.95
Now 119.00

Order #	Price	Description	Weight
91MASTER	119.00	1991 IC Master	7 lbs.

TRIPP LITE - BATTERY BACKUP SYSTEMS

"Price Reductions"

BATTERY BACKUP SYSTEMS in new, sleek, compact design. Protect computers and other sensitive electronic equipment from power failures, brownouts and AC transients. Built-in regulated battery charger automatically restores battery to full charge when power is restored. Units feature audible alarm and line/battery indicator lights. 2 year manufacturer warranty.



BC500

- Larger batteries provide longer backup times
- Brownout protection at 103VAC
- Built-in spike, line noise and RFI/EMI filtering
- Phased, synchronized 2 ms switching
- All models suitable for LAN applications (LAN models below provide interface for unattended shutdown)

LAN DESIGNATED MODELS feature all the benefits of our other battery backups, as well as interface port and cabling to support your network's UPS monitoring function for orderly, unattended shutdown. Approved for use with NOVELL, ALTOS, 3 COM, UNIX and others. 2 year manufacturer warranty. BC750LAN shipped in two boxes.

New Lower Prices!!

Order #	Price	Was	Capacity (W)/ # of AC outlets	Backup time @ Half/Full load (min)	Recharge rate (hours)	Dimensions HxWxD (in)	Weight (lbs) Incl. batteries
BC275	169.95	199.95	200/2	26/11	8-12	6 x 7.5 x 17	23
BC375	209.95	249.95	325/4	20/9	8-12	6 x 7.5 x 17	27
BC500	249.95	299.95	450/4	34/10	12-16	6 x 7.5 x 17	37
BC500LAN	289.95	339.95	450/4	34/10	12-16	6 x 7.5 x 17	37
BC750LAN	449.95	499.95	750/4	35/11	8-12	10 x 7.5 x 18	58

SAMS BOOKS

Handbook for Sound Engineers: The New Audio Cyclopedia, Second Edition

Ballou, Editor-in-Chief

By any measure, this book is the standard reference for sound and acoustical technology. Updated to include cinema sound, transformers, and compact disks, *Handbook for Sound Engineers* is a comprehensive work that offers the professional years of information and technology in a single authoritative resource. The book also details sound-system design and proper installation techniques for any application. Weight: 6 lbs.

1400 pages, Hardbound

Order # 227525 89.95

Sound System Engineering, Second Edition

Davis & Davis

Like the first edition, this comprehensive text provides readers with useful information for the day-to-day work for designing sound systems. This updated version contains in-depth coverage that carefully examines acoustic gain, clarity of sound, and required electrical power. Weight: 3.4 lbs.

688 pages, Hardbound

Order # 218577 47.00

Advanced Digital Audio

Pohlmann

Practicing audio engineers and advanced students will find what they need to know in this concise reference guide. With a special emphasis on new audio technology, the latest knowledge is close at hand. The book covers optical disks, laser and fiber optics, digital broadcasting with high definition television, noise shaping, digital signal processing, and much more. Readers also benefit from a unique and comprehensive treatment of audio theory, applications, hardware, and programming. Weight: 2.4 lbs.

450 pages, Hardbound

Order # 227681 38.00

Understanding Series

Principles of Digital Audio, Second Edition

Pohlmann

Beginning with the fundamentals of numbers, sampling, and quantizing, this is the complete digital audio guide. It includes the latest technologies, such as CD-I, CD-V, and DAT. It also serves as a comprehensive technical reference, a user's handbook, or a textbook. Weight: 1.9 lbs.

Order # 226340 28.00 474 pages, Softbound

Understanding Fiber Optics

Hecht

Those interested in fiber optic technology will find this easy-to-read tutorial the answer to many questions. Components, concepts, systems, and principles are explained in a way that is easy to follow and use. Includes discussions of applications in telephones, LANs, and video, plus coverage of transmitters, receivers, and call couplers. Weight: 1.6 lbs.

Order # 270668 24.00 456 pages, Softbound

Understanding Local Area Networks, Second Edition

Schatt

Using a technically oriented approach, this book provides an understanding of the theory behind the various types of network architecture and data transmission methods. It also provides an overview of major LANs currently on the market, with reviews and compatibility ratings with other systems. Weight: 1.1 lbs.

Order # 273039 24.00 300 Pages, Softbound

Understanding Solid State Electronics, Fifth Edition

Cannon

This book is the authoritative guide to the more complex concepts an electronics enthusiast meet in everyday tasks. It explains semiconductor theory, how electronic circuits make "decisions", and how integrated circuits are made. The book also covers how to create custom integrated circuits through gate array, standard cell, and programmable logic. Weight: 1.3 lbs.

Order # 273373 24.00 300 pages, Softbound

Understanding Digital Troubleshooting, Third Edition

Cannon

Digital electronic systems, at some point, need repair and maintenance. This book is an essential guide to this technology and is written for both technicians and non-engineers. Covering the latest tests, designs, cells, and arrays, the text presents the concepts and fundamental techniques needed to locate the correct anomalies in digital systems. Weight: 1.2 lbs.

Order # 273378 24.00 300 Pages, Softbound

INTERNATIONAL ORDER: 1-510-770-2345 OR INTERNATIONAL FAX: 1-510-770-2346

CIRCLE 26 ON FREE INFORMATION CARD

www.americanradiohistory.com

TOOL KITS



E8305 (51 Piece)

Case Size: 17.5" x 12.5" x 3.5"



E8900 (92 Piece)

Case Size: 18" x 14" x 7"

E8305 - CONTENTS:

- Utility components box • 10 foot tape rule • Electric tape • 6" long tweezers • 7" brush and scraper • 7" fine point probe • 7" slotted probe • Digital multimeter • Rosin core solder • Desoldering pump • Soldering stand • 30 Watt soldering iron with long life tip • 5.5" stainless steel scissors • Brush (to clean keyboard, monitor, etc.) • 2 piece needle file (round and flat) • 6" adjustable wrench • Heavy-duty utility knife • 5.25" bent needle nose pliers • 4.5" diagonal cutting pliers • 5.25" flat nose pliers • 5.25" needle nose pliers • 10 piece line color screwdriver set: **Slotted** - 1/8x3, 3/16x4, 3/16x6, 1/4x1 1/2, 1/4x4, 1/4x6; **Phillips** - 1/8x3 (#0), 3/16x3 (#1), 1/4x1 1/2 (#2), 1/4x4 (#3) • 6 piece precision screwdriver set (1/32, 3/64, 5/64, 3/32, 1/8, 9/64) • 8 piece hex key wrench set (fold type) (0.05, 1/16, 5/64, 3/32, 7/64, 1/8, 9/64, 5/32)

E8900 - CONTENTS:

- Brush • Mini flash light • Mini drill • Anti-static strap • Utility knife • Mini vacuum cleaner • IC extractor • 30 Watt soldering iron • Hobby vise • Soldering stand • Electric tape • Desoldering pump • 3 prongs holder • Rosin solder core • 5" flat nose pliers • 6" adjustable wrench • 5" long nose pliers • Utility components box • 5" bent nose pliers • 5 piece miniature file set • Long nose pliers with cutter • 3 piece soldering aid kit • Stainless tweezers • 11 piece screwdriver set • 4.5" diagonal cutting pliers • Electrical test screwdriver • Digital multimeter • Cleaning solution (60 cc) • 5.5" stainless steel scissors • Head cleaning fluid (18 cc) • 7 piece folding hex key wrench set • 9.5" 5-way crimping tool • 6 piece precision screwdriver set: **Slotted** - .09"x3", .19"x4", .15"x6"; **Phillips** - .09"x3" (#0), .19"x4" (#1), .15"x6" (#1) • 10 piece miniature combination wrench set (5/32", 3/16", 1/4", 7/32", 15/64", 5/16", 9/32", 3/8", 11/32", 7/16")

Order #	Price	Description	Weight
E8305	119.95	51 Pc. Pro Tool Kit.....	12 lbs.
E8900	199.95	92 Pc. Electrician's Tool Kit.....	17 lbs.

DIGITAL MULTITESTERS



M3800

M3800 FEATURES

Max. Display: 1999 counts with automatic polarity indication • **Max. Input Current of AC and DC:** 20A (max. of 15 minutes) • **Overrange Indication:** "1" Figure only on the display • **Max. Common Mode Voltage:** 500VDC/AC RMS • **Reading Rate Time:** 2-3 readings per sec. (approximate) • **Temp. for Guaranteed Accuracy:** 23°C ±5°C • **Temperature Ranges:** Operating 0°C to 40°C, 32°F to 104°F; Storage -10°C to 50°C, 14°F to 122°F • **Power Supply:** One 9V battery (Included) • **Size:** 3.5"W x 6.8"D x 1.4"H • **Unit Weight (Excluding carrying case):** 0.8 lbs. (Including 9V battery) • **Additional Features:** Diode, transistor hFE, resistance (200Ω-20mΩ) and measurement • **Accessories:** Operating manual, 9V battery, test leads, spare fuse and carrying case.



M4650CR

Optional
RS232C Interface

M4650CR FEATURES

Max. Display: 1999 counts with automatic polarity indication • **Max. Input Current of AC and DC:** 20A (max. of 15 minutes) • **Overrange Indication:** "OL" and "Bar graph flashing" figure on display • **Max. Common Mode Voltage:** 500VDC/AC RMS • **Reading Rate Time:** 1-2 readings per sec. (approximate) • **Temp. for Guaranteed Accuracy:** 23°C ±5°C • **Temperature Ranges:** Operating 0°C to 40°C, 32°F to 104°F; Storage -10°C to 50°C, 14°F to 122°F • **Power Supply:** One 9V battery (Included) • **Size:** 3.4"W x 7.4"D x 1.3"H • **Additional Features:** Diode, transistor hFE, resistance (200Ω - 20mΩ) and capacitance measurement • **Accessories:** Operating manual, 9V battery, test leads, spare fuse and carrying case. RS-232C Cable, Floppy Disk (Option)

Order #	Price	Description	Weight
M3800	34.95	3 1/2 Digit LCD Multitester	1.22 lbs.
M4650CR	109.95	4 1/2 Digit LCD Multitester	1.50 lbs.
RS232C	9.95	RS-232 Interface	3.5 oz.

TEST INSTRUMENTS

Fieldpiece.

Full Featured
DMM's For The
Test Bench Or
In The Field



ADK10

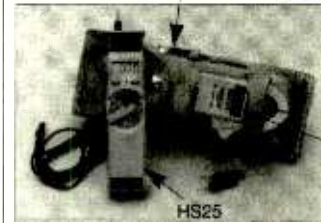

ACH

SPECIAL FEATURES - Dangerous voltage warning (HS23 and HS25): At >28V, meter beeps & red LED blinks. **Logic indicator (HS25):** Up/down arrows in LCD indicate logic states "hi" (>2.8V -8V) or "lo" (<0.8V -5V). **AC coupled. Frequency response:** 20Mhz. 25ns min. pulse width. **Input impedance:** 120k - 10kΩ shunted by 100pF. **Pulse rise time:** (max) 10 uSec. **Pulse rep rate:** (max) 1Mpps. **Overvoltage protection:** 500Vdc or ac RMS. **Capacitance (HS23 and HS25):** 1 range: 200pF; accuracy 3%±5. Tested at 3V/40Hz. **Overload protection:** to 500Vdc or RMS. Auto-power off after 1 hour.

GENERAL SPECIFICATIONS - Display hold: Press "HOLD" button, display "locks" reading. Any range, any function. Heavy duty case design of hi-impact, fire retardant yellow Valox, fully "O" ring sealed. Meets MIL-T-28800 class II type A. **Size** (not including probes): 7.2"x1.9"x1.0". **Indicators:** Continuity (<150Ω) indicated by a continuous "beep" within 100 msec. Low battery indicator in the LCD with 100 hours of battery life left. **Environmental:** Operating temperature -15° to 55°C, storage -40°C to 60°C with batteries removed, RH:80% from 0°C to 50°C. Tempco: <10% of applicable accuracy spec per °C (-15°C to 20°C, 30°C to 55°C).

Order #	Price	Description	Weight
HS21	79.95	Stick-Style DMM.....	1.06 lbs.
HS23	99.95	Stick-Style, Capac. to 200uF	1.06 lbs.
HS25	119.95	Stick-Style, Capac., Logic Probe	1.07 lbs.
ACH	24.95	AC Current Clamp	4.6 oz.
ALC1	24.95	Leather Pouch to Suit HS21/23/25	11 oz.
ADK10	26.95	Deluxe Test Lead Kit.....	9.3 oz.

MAGAZINE STORAGE BINDERS



Start off 1992 with all your 1991 monthly magazines filed for easy access in one of EasyTech's popular magazine binders.

Ever wondered what to do with all those magazines or catalogs you have lying around? Here is the perfect solution. Holds up to 12 issues of most standard monthly magazines or up to 12 catalogs and magazines of various shapes and sizes (8.5" x 11" max.). Space provided on the rib for easy listing of material contained in each binder.

Order #	1-9	10+	Description	Shipping Weight
MB12R	4.95	4.45	Magazine Binder.....	1.22 lbs.

RELAYS

- Dimensions: 1.187" x .95" x .735"
- Cross To: P&B* R10 series
- Mounting: Solder terminals/plug in



Contact

*P&B = Potter & Brumfield

Order #	1-9	10+	Description	Coil Res.	Rating	Contact
R185-3	6.99	5.99	Relay 12Vdc	185Ω	3A	DPTD
R185-7	7.99	6.99	Relay 12Vdc	185Ω	7.5A	DPTD

DUAL-TRACE OSCILLOSCOPES

GoldStar®
20/40MHz
Oscilloscopes

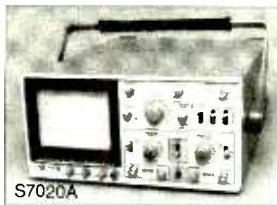

2 Year Manufacturer's Warranty

20MHz Dual-Trace Oscilloscope

The Model S7020A is a utility oscilloscope that features scale illumination and beam rotation capabilities, plus a 6" rectangular CRT with an internal graticule. The acceleration voltage is regulated to ensure accurate measurements. This model offers 5mV/div (20Mhz), 1mV/div (7Mhz), and a maximum sweep rate of 100 ns/div (x10 MAG).

40MHz Dual-Trace Oscilloscope

The Model S7040A is a standard oscilloscope that features delayed sweep triggered function, signal delay lines, scale illumination and beam rotation capabilities, plus a high-brightness, aluminumized 6-inch rectangular CRT with an internal graticule. The acceleration voltage is regulated to ensure accurate measurements. This model offers 5mV/div (40Mhz), 1mV/div (7Mhz), and a maximum sweep rate of 100 ns/div (x10 MAG).

Order #	Price	Description	Weight
S7020A	349.00	20Mhz Dual-Trace Oscilloscope	21 lbs.
S7040A	599.00	40Mhz Dual-Trace with Delayed Sweep	22 lbs.
SP100	44.95	100Mhz Probe Kit (Pair).....	12 oz.
SP101	29.95	50Mhz Probe Kit (Pair).....	12 oz.

EASYTECH

THE ELECTRONICS SOURCE

2917 Bayview Drive
Fremont, CA 94538



Easy Order: 1-800-582-4044
Easy Fax: 1-800-582-1255
International Fax: 1-510-770-2346
Customer Service: 1-510-770-2345

Monday-Friday, 7am - 5pm (PST) / 10am-8pm (EST)

COD-No personal checks, US funds (\$5.00 Surcharge)

USPS

UPS

Federal Express

Airborne

Add 5% of total for shipping UPS Ground (\$3.00 min.).
Actual shipping charges based on weight.

Call or write today for your free copy of our 32 page catalog.

California residents, add appropriate sales tax.
12 month warranty on all EasyTech products.
30 day money back guarantee.
We reserve the right to substitute manufacturers.
Prices subject to change without notice.

EASY ORDER: 1-800-582-4044 OR EASY FAX: 1-800-582-1255

CIRCLE 26 ON FREE INFORMATION CARD

www.americanradiohistory.com

VHF - UHF RF TRANSISTORS

Order #	Price	Output Pwr. (W)	Input Pwr. (W)	Frequency Range (MHz)	Gain db/MHz	*Package
MRF212	19.95	10	1.25	136-174	9/175	145A-09
MRF221	16.35	15	3.5	136-174	6.3/175	211-07
MRF224	17.75	40	14.3	136-174	4.5/175	211-07
MRF237	3.69	4	0.25	136-174	12/175	79-05
MRF238	15.95	30	3.7	136-174	9/175	145A-09
MRF239	16.95	30	3	136-174	10/175	145A-09
MRF240	17.49	40	5	136-174	9/175	145A-09
MRF240A	17.49	40	5	136-174	9/175	211-07
MRF247	24.75	75	15	136-174	7/175	316-01
MRF260	11.95	5	0.5	136-174	10/175	221A-04
MRF262	12.95	15	3.5	136-174	6.3/175	221A-04
MRF264	13.95	30	9.1	136-174	5.2/175	221A-04
MRF314A	35.95	30	3	30-200	10/150	145A-09
MRF315A	32.49	45	5.7	30-200	9/150	145A-09
MRF316	63.95	80	8	30-200	10/150	316-01
MRF317	64.95	100	12.5	30-200	9/150	316-01
MRF321	24.95	10	0.62	100-500	12/400	244-04
MRF327	63.95	80	14.9	100-400	7.3/400	316-01
MRF340	9.95	8	0.4	30-200	13/136	221A-04
MRF401	13.49	25	1.25	1.5-30	13/30	145A-09
MRF406	14.99	20	1.25	1.5-30	12/30	211-07
MRF421	29.95	100	10	1.5-30	10/30	211-11
MRF422	35.95	150	15	1.5-30	10/30	211-11
MRF426	19.49	25	0.16	1.5-30	22/30	211-07
MRF427	16.95	25	0.4	1.5-30	18/30	211-11
MRF428	59.95	150	7.5	1.5-30	13/30	211-11
MRF429	44.95	150	7.5	1.5-30	13/30	211-11
MRF433	12.49	12.5	0.125	1.5-30	20/30	211-07
MRF448	72.95	250	15.7	1.5-30	12/30	211-11
MRF450A	14.49	50	4	14-30	11/30	145A-09
MRF454	15.49	80	5	14-30	12/30	211-11
MRF455A	12.69	60	3	14-30	13/30	145A-09
MRF458	19.95	80	5	14-30	12/30	211-11
MRF464	24.95	80	2.53	1.5-30	15/30	211-11
MRF466	34.95	40	1.25	1.5-30	15/30	211-07
MRF475	9.95	12	1.2	1.5-30	10/30	221A-04
MRF476	3.95	3	0.1	1.5-30	15/30	221A-04
MRF477	13.75	40	1.25	1.5-30	15/30	221A-04
MRF479	14.95	15	0.95	1.5-30	12/30	221A-04
MRF485	19.95	15	1.5	1.5-30	10/30	221A-04
MRF515	2.95	0.75	0.12	400-512	8/470	79-04
MRF555	3.49	1.5	0.15	400-512	10/470	317D-02
MRF557	5.49	1.5	0.23	806-960	8/870	317D-02
MRF559	2.25	0.5	0.08	806-960	8/870	317-01
MRF607	2.49	1.75	0.12	136-174	11.5/175	79-04
MRF627	9.95	0.5	0.05	400-512	10/470	305A-01
MRF629	4.49	2	0.32	400-512	8/470	79-05
MRF630	3.95	3	0.33	400-512	9.5/470	79-05
MRF641	20.49	15	2.5	400-512	7.8/470	316-01
MRF644	23.95	25	5.9	400-512	6.2/470	316-01
MRF646	25.95	40	13.3	400-512	4.8/470	316-01
MRF648	30.95	60	22	400-512	4.4/470	316-01
MRF650	29.95	50	11.7	100-500	6.3/470	316-01
MRF652	11.49	5	0.5	400-512	10/512	244-04
MRF654	19.95	15	2.5	400-512	7.8/470	244-04
MRF660	13.95	7	2	400-512	5.4/470	221A-04
2N3553	2.95	2.5	—	136-174	10/175	79-04
2N3866	1.25	1	0.1	100-400	10/400	79-04
2N4427	1.25	1	0.1	136-174	10/175	79-04
2N5641	16.95	7	1	30-200	8.4/175	144B-05
2N5642	18.49	20	3	30-200	8.2/175	145A-09
2N5643	19.95	40	6.9	30-200	7.6/175	145A-09
2N5944	11.95	2	0.25	400-512	9/470	244-04
2N5945	11.95	4	0.64	400-512	8/470	244-04
2N5946	14.95	10	2.5	400-512	6/470	244-04
2N6080	9.89	4	0.25	136-174	12/175	145A-09
2N6081	11.95	15	3.5	136-174	6.3/175	145A-09
2N6082	14.95	25	6	136-174	6.2/175	145A-09
2N6083	14.95	30	8.1	136-174	5.7/175	145A-09
2N6084	14.95	40	14.3	136-174	4.5/175	145A-09

MITSUBISHI EPITAXIAL PLANAR TYPE POWER TRANSISTORS

Order #	Price	Output Pwr	G _{pe}	Frequency	V _{cc}	Package
25C1946A	16.00	25	10dB	175	13.5	T-31
25C1969	2.50	14	12dB	27	12.0	TO220
25C1970	2.50	1	9.2dB	175	13.5	TO220
25C2053	1.20	15	15.7dB	175	13.5	TO92
25C2094	16.50	15	18.8dB	175	13.5	T-31
25C2097	25.00	75	12.3dB	30	13.5	T-40

MOTOROLA RF SMALL SIGNAL TRANSISTORS

Order #	Price	Description	Frequency Range	Gain db/GHz	Package
MRF901	1.50	High Gain, Small Signal	0.15-1.5GHz	2.5/1	317-01
MRF911	3.50	High Gain, Small Signal	0.5-5GHz	12.5/1	317-01

TRIPP LITE—PRECISION REGULATED DC POWER SUPPLIES

Complete Line of DC Power Supplies to Convert 120VAC to 13.8Vdc ±0.5Vdc.

Standard Features Include:

- Solid state integrated circuit provides excellent regulation
- Output voltage maintained up to 95% of no load value
- High quality filtering for low noise operation
- Heavy duty power transformer for complete line isolation
- On/Off indicator light and rugged on/off switch on faceplate
- 3 conductor grounded cord on 10 Amp and larger models
- Current limiting electronic foldback for auto overcurrent protection
- 2 Year Warranty



PR4.5



PR25

Tripp Lite DC Power Supplies Are Designed For Reliability and Superior Performance.

Order #	Price	ICS* (amps)	Continuous Duty (amps)	Fusing	Ripple Voltage	HxWxD (Inches)	Weight
PR4.5	32.95	4.5	3	Internal	0.1 Volt Max	3.125 x 4.75 x 8.25	5 lbs.
PR7	44.95	7	5	Chassis Mount	0.15 Volt Max	3.75 x 6.5 x 7.5	7 lbs.
PR10	64.95	10	7.5	Chassis Mount	0.15 Volt Max	4.5 x 6.625 x 7.625	10 lbs.
PR15	89.95	15	12	Chassis Mount	0.15 Volt Max	4.75 x 7.5 x 8.25	13 lbs.
PR25	126.95	25	20	Chassis Mount	0.15 Volt Max	5.125 x 12.5 x 10.5	20 lbs.
PR40	179.95	40	32	Chassis Mount	0.15 Volt Max	7.25 x 12.5 x 10	26 lbs.
PR60	249.95	60	48	Chassis Mount	0.15 Volt Max	8.5 x 12.5 x 10	29 lbs.

*Intermittent Communications Duty (50% Duty Cycle)

SOLDERLESS PROTOTYPING BOARDS

Designer boards for the part-time hobbyist, student or engineer!!

SB830



Features

- Color coordinates for easy recognition
- Insertion wire: 20-29 AWG (0.3 - 0.8 mm)
- Over 10,000 insertion cycles
- Accepts all standard components

Order #	Price		Dimensions (in.) L x W x H	Dist. Strips	Dist. Points	Terminal Strips	Terminal Points	Binding Posts
	1-9	10+						
SB200	2.99	2.49	6.5 x 0.37 x 0.4	2	100 x 2	0	0	0
SB400	4.89	4.39	3.3 x 2.2 x 0.4	2	100	1	300	0
SB630	5.45	4.95	6.5 x 1.4 x 0.4	0	0	1	630	0
SB830	6.49	5.99	6.5 x 2.2 x 0.4	2	200	1	630	0
SB1360	12.49	11.99	8.5 x 3.9 x 1.2	1	100	2	1,260	2
SB1660	17.45	16.95	8.5 x 5.1 x 1.2	4	400	2	1,260	3
SB2390	22.49	21.49	9.1 x 6.9 x 1.2	5	500	3	1,890	4
SB3220	31.49	30.49	9.5 x 8.3 x 1.2	7	700	4	2,520	4

RACK MOUNT CABINETS

*Ventilation holes on top, bottom and both sides



E3120C



E3120E

A range of ventilated 19" rack mount cabinets, manufactured in 0.9 mm plate steel. The front, rear and display panels are aluminum, allowing for ease of use during final construction of your project. Classic and contemporary styling, black matte finish, together with innovative techniques result in a ruggedly built stylish enclosure. The cases are flat packed and very easy to assemble.

Order #	1-9	10+	Panel (mm/in)	Cabinet (HxWxD mm/in)	Weight
E3120A	36.95	34.95	483/19" x 431/6.875"	381/5" x 422/16.625" x 244/9.625"	7.0 lbs.
E3120B	44.95	42.95	483/19" x 87/3.4375"	84/3.3125" x 422/16.625" x 244/9.625"	7.8 lbs.
E3120C	49.95	47.95	483/19" x 87/3.4375"	84/3.3125" x 422/16.625" x 335/13.1875"	9.0 lbs.
E3120D	54.95	52.95	483/19" x 132/5.1875"	127/5.0" x 422/16.625" x 335/13.1875"	12.0 lbs.
E3120E	59.95	57.95	483/19" x 132/5.1875"	127/5.0" x 422/16.625" x 424/16.6875"	13.2 lbs.

RF POWER MODULES

Order #	Price	Frequency Range	Max. Ratings			TC (op.) (°C)	
			Power	Gain dB	V _{cc}	Min.	Max.
M57713	45.00	144-148MHz	14W	21	15.2	-30	+110
M57714M	45.00	430-450MHz	7W	18.4	12.5	-30	+110
M57715	42.00	144-148MHz	13W	18.1	15.2	-30	+110
M57716	60.00	430-450MHz	14W	21	15.2	-30	+110
M57727	60.00	144-148MHz	30W	24	15.2	-30	+110
M55737	40.00	144-148MHz	30W	15.2	15.2	-30	+110
MHW591	42.00	1.0-250MHz	-	35	28	-20	+90
MHW710-1	60.00	400-440MHz	13	19.4	15.5	-30	+100
MHW710-2	60.00	440-470MHz	13	19.4	15.5	-30	+100
MHW710-3	60.00	470-512MHz	13	19.4	15.5	-30	+100
MHW820-1	81.00	806-870MHz	20	19	16	-40	+100
MHW820-2	90.00	806-890MHz	20	19	16	-40	+100
SAV6	34.00	154-162MHz	28W	-	12.5	-	-
SAV12	17.50	144-148MHz	5W	-	12.5	-	-
SAV15	45.00	220-225MHz	30W	-	12.5	-	-
SAV17	58.00	144-148MHz	50W	-	12.5	-	-

INTERNATIONAL ORDER: 1-510-770-2345 OR INTERNATIONAL FAX: 1-510-770-2346

CIRCLE 27 ON FREE INFORMATION CARD

CERAMIC TRIMMER CAPACITORS



- Specifications
 •Ins. Res.: >10mΩ @ 100Vdc
 •Max. Volt.: 220Vdc
 •Oper. Volt.: 100Vdc
 •Rotat. Torque: 20 to 15 g/cm

Order #	1-9	10+	Capacitance (pF)		Temp. Coeff. (ppm/°C)	Q Factor @ 10MHz	Operating Temp. Range (°C)	Cap Color
			min.	max.				
CVSSA0301	.79	.69	1.5	3.0	NPO±200	>300	-30~+85	Black
CVSSA0701	.79	.69	2.5	7.0	NPO±200	>300	-30~+85	Blue
CVSSA1001	.79	.69	2.7	10.0	NPO±200	>300	-30~+85	White
CVSSC2001	.79	.69	4.2	20.0	N450±300	>300	-30~+85	Red
CVSSSE3001	.88	.78	5.5	30.0	N750±300	>200	-30~+85	Green
CVSSSG5001	.88	.78	8.0	50.0	N1200±600	>200	-30~+85	Orange

TRIPP LITE – ISOBAR® SURGE SUPPRESSORS

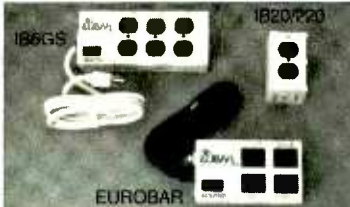

ISOBAR® is the most advanced surge suppressor available today and the only one with isolation, preventing connected equipment from interfering with each other.

Lifetime warranty on selected GS models (IB2GS, IB4GS, IB6GS, IB8GS). Tripp Lite will replace protected equipment connected to a failed ISOBAR for its lifetime.

EUROBAR® surge suppressor operates on 220Vac. Features 4 IEC-320 receptacles and detachable AC cord. Lifetime warranty.

- UL 1449 listed: 330V let-through; meets UL 1283 for noise suppression; CSA approved
- Isolation safeguards against interference between devices
- "Cascade Circuitry" increases protection for sensitive devices
- Superior RFI/EMI noise suppression
- Surge suppression up to 13,000 Amp spikes
- Rack mount model (#IBR12) for industrial and audio visual uses
- 20 Amp ISOBLOK (#IB220) is ideal for larger copiers

Order #	Price	Description	Weight
IB20	29.95	2 Outlets, 15 Amp, Direct Plug-In	.1 lb.
IB220	59.95	2 Outlets, 20 Amp, Direct Plug-In	.1 lb.
IB2GS	49.95	2 Outlets, 6' Cord	.1 lb.
IB4GS	59.95	4 Outlets, 6' Cord	.2 lbs.
IB6GS	69.95	6 Outlets, 6' Cord	2.5 lbs.
IB8GS	89.95	8 Outlets, 12' Cord	3.5 lbs.
IB8RM	99.95	8 Outlets, 12' Cord with Remote Power Switch	.4 lbs.
IB4	69.95	4 IEC-320 Outlets, 220V	.2 lbs.
IBR12	69.95	12 Outlets, Rack Mount	.4 lbs.
EUROBAR	94.50	4 IEC-320 Outlets, 220V	2.5 lbs.

NEW!!

FUJITSU DATA BOOKS

NEW!!

Linear Products

This book has over 700 pages of data sheets and technical information on Fujitsu's Linear Products. Included in this book are sections on Operational Amplifiers, Comparators, Automotive Audio, Power Supply Controls, Motor Drivers, Disk Drivers, Data Conversion and other linear products. Also included is a Linear Cross Reference Guide.

Order # **FM7262** 9.95 Linear Products.....Weight: 2 lbs.

Static RAM Products

Almost 500 pages of data sheets and technical information on Fujitsu's wide range of Static RAM Products that are still manufactured. Sections covered in this book are High-Speed CMOS SRAMs (MB81C67, 81C74, 81C81A, etc.), High-Speed BiCMOS SRAMs (MB82B001, 82B78, 82B84, etc.), Low-Power CMOS SRAMs (MB8464, 84256 and 841000), Application Specific CMOS SRAMs (MB81C51, MB8431, etc.) and Wide Temperature Range SRAM Products. Also included is a Cross Reference Guide for High-Speed CMOS and BiCMOS SRAMs.

Order # **FM8052** 9.95 Static RAM Products.....Weight: 1.25 lbs.

Dynamic RAM Products

Almost 700 pages of data sheets and technical information on Fujitsu's very popular Dynamic RAM Products that are still manufactured. Included in this book are sections on NMOS DRAMs (MB81256, 81257 and 81464), CMOS DRAMs (MB81C1000, 81C4256, 814100, 814400, etc.) and Application Specific RAMs (MB81461 and 81C1501).

Order # **FM8053** 9.95 Dynamic RAM Products.....Weight: 1.5 lbs.

Programmable Memory Products

Almost 800 pages of data sheets and technical information on Fujitsu's NMOS EPROMs (MBM2764 and 27256), CMOS EPROMs (MBM27C64, 27C128, 27C256, 27C512, 27C1000, etc.), CMOS EEPROMs (MBM28C64, 28C65 and 28C256), CMOS One-Time Programmable ROMs (MBM27C128P, 27C256AP and 27C512P), Programmable ROMs (MB7111, 7123, 71C44, etc.), CMOS Mask-Programmable ROMs, NMOS Non-Volatile RAMs and Wide Temperature Range PROMs. Also included is a PROM Cross Reference Guide.

Order # **FM8054** 10.95 Programmable Memory Products.....Weight: 1.75 lbs.

ECL RAM Products

Close to 600 pages of data sheets and technical information on Fujitsu's ECL RAMs, BiCMOS ECL RAMs and Application-Specific ECL Bipolar RAMs. Also included is a section on how to design efficient ECL systems.

Order # **FM8055** 8.95 ECL RAM Products.....Weight: 1.25 lbs.

Fast Track to SCSI

This book has over 400 pages presenting an overview of the SCSI concept, a criteria for SCSI's use, and an explanation of Fujitsu's vendor-unique design features for a SCSI Protocol Controller. You will find that the book covers the general (and generic) SCSI design information in the first two chapters and continues with specific product information on Fujitsu's SPC line of products.

Order # **FM8159** 14.95 Fast Track to SCSIWeight: 1.75 lbs.

Power Transistor Products

Over 300 pages of data sheets and technical information on Fujitsu's Power Transistors. Included in this book are sections on Ring Emitter Transistors, Darlingston Transistor Arrays, Full Plastic Mold Ring Emitter Transistors and Field Effect Transistor Arrays. Also included are application notes, design information and a Power Transistor Cross Reference Index.

Order # **FM8215** 8.95 Power Transistor ProductsWeight: 1.25 lbs.

Telecommunication Devices

Over 600 pages of data sheets and technical information on Fujitsu's Telecommunication Devices which include Bipolar Prescalers, CMOS Phase-Locked Loops (PLLs), CMOS Telephone ICs, BiCMOS Single-Chip PLLs/Prescalers, Bipolar Single-Chip Prescalers/VCOs, Coders/Decoders (CODECs) and Cellular Mobile Radio ICs. Also included is a section on design information for Prescalers and PLLs.

Order # **FM8236** 8.95 Telecommunication DevicesWeight: 1.75 lbs.



2917 Bayview Drive
Fremont, CA 94538



Easy Order: 1-800-582-4044
Easy Fax: 1-800-582-1255
International Fax: 1-510-770-2346
Customer Service: 1-510-770-2345

Monday-Friday, 7am - 5pm (PST) / 10am-8pm (EST)

- COD-No personal checks, US funds (\$5.00 Surcharge)
- USPS
- UPS
- Federal Express
- Airborne

Add 5% of total for shipping UPS Ground (\$3.00 min.).
Actual shipping charges based on weight.

Call or write today for your free copy of our 32 page catalog.

California residents, add appropriate sales tax.
12 month warranty on all EasyTech products.
30 day money back guarantee.
We reserve the right to substitute manufacturers.
Prices subject to change without notice.

EASY ORDER: 1-800-582-4044 OR EASY FAX: 1-800-582-1255

CIRCLE 27 ON FREE INFORMATION CARD
www.americanradiohistory.com

Description

Flash memories are targeted for in-system alterable code- or data-storage applications where full-feature EEPROM functionality is either not required or not cost effective. CMOS Flash memory provides the highest performance and most cost-effective alternative for high density rewritable non-volatile memory. Flash memory adds electrical chip-erase and reprogramming to EPROM technology. The entire memory content may be Flash erased and reprogrammed in a PROM programmer or test socket, on board during sub-assembly test, in-system during final test or after sale. In-system electrical erasure increases the memory's flexibility, while providing time and cost savings. The entire memory array may be erased and reprogrammed on board.

Typical Applications

Flash memory is ideal for storing code or data-tables in embedded control applications where periodic updates or data down-loading is required. Code updates may occur throughout the entire life of a system. Beginning with prototyping, code updates may also be necessary during subassembly or even in after-sale service. Electrical chip erasure eliminates the 15 to 20 minute ultra-violet erase and streamlines code updates. In addition, Flash devices may be soldered to the circuit board during subassembly. Test codes may be programmed into the device on board. Thus, Flash technology eliminates unnecessary handling and less reliable socketed connections, saves board space, and adds increased manufacturing flexibility. After-sale code updates are performed locally via an edge-connector, or remotely over a serial communication link.

Order #	Price	Organization	Speed	Prog. Volt.	Pins
28F256-20	14.95	32,768x8	200ns	12.0V	32
28F512-15	19.95	65,536x8	150ns	12.0V	32
28F512-15	19.50	65,536x8	150ns	12.0V	PLCC 32
28F010-15	27.95	131,072x8	150ns	12.0V	32
N28F010-15	27.45	131,072x8	150ns	12.0V	PLCC 32

Features:

- One Second Typical Chip-Erase
- Compatible with JEDEC Standard Byte Wide 32-pin EEPROM Pinouts
- Programming
 - 10µS Typical Byte-Program
 - Less than 2 Second Typical Chip Program
- Program and Erase Voltage
 - 12.0V ±5%Vpp
- Advanced CMOS Technology
 - EPROM Compatible Process
 - Extensive Manufacturing Experience
- Low Power Consumption
 - 30mA Maximum Active Current
 - 100µA Maximum Standby Current
- Command Register Architecture for Microprocessor/Micro-controller Compatible Write Interface
- 10,000 Program/Erase Cycles
- Provides On-Board Functionality for In-System-Write
- On Board Address and Data Latches
- 5V±10% Single Power Supply

28F010

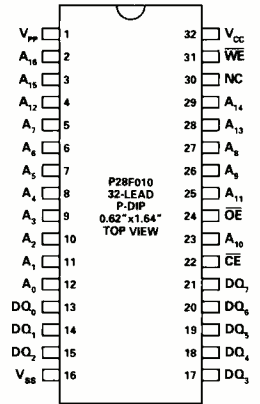

EPROMS (UV Erasable)

Order #	Price	Organization	Speed	Prog. Volt.	Pins
MM5203Q	2.25	256x8	2K ..100ns	25V	24
TMS2516	4.25	2048x8	16K ..450ns	25V	24
TMS2532	6.95	4096x8	32K ..450ns	25V	24
TMS2532-30	8.95	4096x8	32K ..300ns	25V	24
TMS2532A45	6.95	4096x8	32K ..450ns	21V	24
TMS2564	5.95	8192x8	64K ..450ns	25V	28
TMS2564-50	4.75	8192x8	64K ..500ns	25V	28
TMS2716	5.95	2048x8	16K ..450ns (±5V, +12V)	25V	24
2708	4.75	1024x8	8K ..450ns (±5V, +12V)	25V	24
2716	3.45	2048x8	16K ..450ns	25V	24
2716-1	3.75	2048x8	16K ..350ns	25V	24
27C16	4.25	2048x8	16K ..450ns CMOS	25V	24
2732	3.95	4096x8	32K ..450ns	25V	24
2732A20	4.45	4096x8	32K ..200ns	21V	24
2732A25	3.45	4096x8	32K ..250ns	21V	24
2732A45	2.95	4096x8	32K ..450ns	21V	24
2732B45	4.25	4096x8	32K ..450ns	12.5V	24
27C32	4.75	4096x8	32K ..450ns CMOS	25V	24
2764-20	3.95	8192x8	64K ..200ns	21V	28
2764-25	3.75	8192x8	64K ..250ns	21V	28
2764A15	4.45	8192x8	64K ..150ns	12.5V	28
2764A20	3.75	8192x8	64K ..200ns	12.5V	28
2764A25	3.25	8192x8	64K ..250ns	12.5V	28
2764A45	2.95	8192x8	64K ..450ns	12.5V	28
2764AOTP	2.25	8192x8	64K ..250ns One Time Prog.	12.5V	28
27C64A15	3.95	8192x8	64K ..150ns CMOS	12.5V	28
27C64FP25	3.95	8192x8	64K ..250ns One Time Prog.	12.5V	PLCC 32
27128-20	6.75	16,384x8	128K ..200ns	21V	28
27128-25	5.95	16,384x8	128K ..250ns	21V	28
27128A15	4.95	16,384x8	128K ..150ns	12.5V	28
27128A20	4.45	16,384x8	128K ..200ns	12.5V	28
27128A25	3.75	16,384x8	128K ..250ns	12.5V	28
27128A30	3.25	16,384x8	128K ..300ns	12.5V	28
27128AOTP	2.95	16,384x8	128K ..250ns One Time Prog.	12.5V	28
27C128-15	5.75	16,384x8	128K ..150ns CMOS	12.5V	28
27C128-25	5.25	16,384x8	128K ..250ns CMOS	12.5V	28
27C128-20	4.45	16,384x8	128K ..200ns CMOS	12.5V	28
27256-15	5.45	32,768x8	256K ..150ns	12.5V	28
27256-20	4.95	32,768x8	256K ..200ns	12.5V	28
27256-25	4.45	32,768x8	256K ..250ns	12.5V	28
27256-30	3.45	32,768x8	256K ..300ns	12.5V	28
27C256-15	5.95	32,768x8	256K ..150ns CMOS	12.5V	28
27C256-25	4.25	32,768x8	256K ..250ns CMOS	12.5V	28
27C256FP25	4.95	32,768x8	256K ..250ns One Time Prog.	12.5V	PLCC 32
27512-20	6.75	65,536x8	512K ..200ns	12.5V	28
27512OTP	4.95	65,536x8	512K ..250ns One Time Prog.	12.5V	28
27C512-12	7.45	65,536x8	512K ..120ns CMOS	12.5V	28
27C512-15	6.75	65,536x8	512K ..150ns CMOS	12.5V	28
27C512-25	5.95	65,536x8	512K ..250ns CMOS	12.5V	28
27C010-15	9.25	131,072x8	1MB ..150ns CMOS	12.5V	32
27C020-15	19.95	262,144x8	2MB ..150ns CMOS	12.5V	32

HARD-TO-FIND SOCKETS

Order #	Price	Description	Pins
S24SLP	.45	Low Profile, .3" Wide (Skinny Dip)	24
S28SMS	1.39	Machine Screw, .3" Wide (Skinny Dip)	28
S32LP	.49	Low Profile, .6" Wide (Standard Size)	32

STATIC RAMS

Take a look!! We stock almost any speed, package style or organization you'll need in Static RAMS.

Order #	Price	Organization	Speed	Pins
2101	1.65	256x4	450ns	22
2111	1.75	256x4	450ns	18
2112	2.45	256x4	450ns	16
5101	3.95	256x4 CMOS	450ns	22
7C122-15	6.95	256x4 CMOS	15ns	22
2114L20	1.49	1024x4 1Kx4 Low Power	200ns	18
2114L25	1.15	1024x4 1Kx4 Low Power	250ns	18
2114-45	1.05	1024x4 1Kx4	450ns	18
2148-3	1.95	1024x4 1Kx4	55ns	18
2149-35	3.75	1024x4 1Kx4	35ns	18
MK4801AN1	3.95	1024x8 1Kx8	100ns	24
2147-3	3.75	4096x1 4Kx1	55ns	18
20C71-25	6.75	4096x4 4Kx4 CMOS	25ns	Skinny Dip 24
6168-45	3.25	4096x4 4Kx4 CMOS	45ns	20
2015-90	3.75	2048x8 2Kx8	90ns	Skinny Dip 24
2018-35	5.95	2048x8 2Kx8	35ns	Skinny Dip 24
6116ALSP15	2.95	2048x8 2Kx8 CMOS Low Power	150ns	Skinny Dip 24
6116FP12	2.45	2048x8 2Kx8 CMOS	120ns	SOP* 24
6116LFP15	2.95	2048x8 2Kx8 CMOS Low Power	150ns	SOP* 24
6116LP1	2.95	2048x8 2Kx8 CMOS Low Power	100ns	24
6116LP3	2.75	2048x8 2Kx8 CMOS Low Power	150ns	24
6116LP4	2.55	2048x8 2Kx8 CMOS Low Power	200ns	24
6116-1	2.75	2048x8 2Kx8 CMOS	100ns	24
6116-3	2.25	2048x8 2Kx8 CMOS	150ns	24
6116-4	2.15	2048x8 2Kx8 CMOS	200ns	24
6516-45	4.25	2048x8 2Kx8 CMOS	45ns	Skinny Dip 24
7C128-55	3.95	2048x8 2Kx8 CMOS	55ns	Skinny Dip 24
8128-15	2.15	2048x8 2Kx8	150ns	24
8128-20	1.75	2048x8 2Kx8	200ns	24
2063-10	7.95	8192x8 8Kx8	100ns	Skinny Dip 28
6264BP25	8.25	8192x8 8Kx8 CMOS Low Power	25ns	Skinny Dip 28
6264LP10	4.95	8192x8 8Kx8 CMOS Low Power	100ns	28
6264LP15	3.95	8192x8 8Kx8 CMOS Low Power	150ns	28
6264LFP10	4.25	8192x8 8Kx8 CMOS Low Power	100ns	SOP* 28
6264LFP12	3.45	8192x8 8Kx8 CMOS Low Power	120ns	SOP* 28
6264LFP15	2.95	8192x8 8Kx8 CMOS Low Power	150ns	SOP* 28
6264SLP10	5.25	8192x8 8Kx8 CMOS Low Power	100ns	Skinny Dip 28
6264-10	4.75	8192x8 8Kx8 CMOS	100ns	28
6264-15	3.75	8192x8 8Kx8 CMOS	150ns	28
7C185-15	8.75	8192x8 8Kx8 CMOS Low Power	15ns	Skinny Dip 28
6267LP45	4.95	16,384x1 16Kx1 CMOS Low Power	45ns	20
8167-55	3.45	16,384x1 16Kx1	55ns	20
6288-25	9.95	16,384x4 16Kx4 CMOS	25ns	22
6206-20	24.95	32,768x8 32Kx8 CMOS	20ns	Skinny Dip 28
62256FP12	6.25	32,768x8 32Kx8 CMOS	120ns	SOP* 28
62256LFP10	6.95	32,768x8 32Kx8 CMOS Low Power	100ns	SOP* 28
62256LP7	7.95	32,768x8 32Kx8 CMOS Low Power	70ns	28
62256LP10	6.75	32,768x8 32Kx8 CMOS Low Power	100ns	28
62256LP15	6.25	32,768x8 32Kx8 CMOS Low Power	150ns	28
62256SLP12	7.95	32,768x8 32Kx8 CMOS Low Power	120ns	Skinny Dip 28
1600-55	5.95	65,536x1 64Kx1 CMOS	55ns	22
6287-45	6.95	65,536x1 64Kx1 CMOS	45ns	22
628128LP8	31.95	131,072x8 128Kx8 CMOS Low Power	85ns	32
628128LP10	29.95	131,072x8 128Kx8 CMOS Low Power	100ns	32

*Small Outline Package (Surface Mount)

INTERNATIONAL ORDER: 1-510-770-2345 OR INTERNATIONAL FAX: 1-510-770-2346

CIRCLE 28 ON FREE INFORMATION CARD

DYNAMIC/STATIC COLUMN/VIDEO RAMS

Order #	Price	Organization	Speed	Pins
MK4027N2	.75	4096x1 4Kx1	120ns	16
4116-12	1.35	16,384x1 16Kx1	120ns	16
4116-15	1.10	16,384x1 16Kx1	150ns	16
4116-20	.85	16,384x1 16Kx1	200ns	16
4116-30	.75	16,384x1 16Kx1	300ns	16
4416-12	1.75	16,384x4 16Kx4	120ns	18
4416-15	1.45	16,384x4 16Kx4	150ns	18
4161-15	4.95	65,536x1 64Kx1 Video RAM	150ns	20
4164-10	1.85	65,536x1 64Kx1	100ns	16
4164-12	1.65	65,536x1 64Kx1	120ns	16
4164-15	1.45	65,536x1 64Kx1	150ns	16
4164-20	1.25	65,536x1 64Kx1	200ns	16
4164-30	.95	65,536x1 64Kx1	300ns	16
41264-12	6.25	65,536x4 64Kx4 Video RAM	120ns	Skinny Dip 24
41264VZ10	7.45	65,536x4 64Kx4 Video RAM	100ns	ZIP* 24
41264VZ12	6.85	65,536x4 64Kx4 Video RAM	120ns	ZIP* 24
41264VZ15	5.95	65,536x4 64Kx4 Video RAM	150ns	ZIP* 24
41464-80	3.25	65,536x4 64Kx4	80ns	18
41464-12	2.75	65,536x4 64Kx4	120ns	18
41464FP80	3.75	65,536x4 64Kx4	80ns	PLCC** 18
41464FP15	3.45	65,536x4 64Kx4	150ns	PLCC** 18
41256-10FL	2.15	262,144x1 256Kx1	100ns	PLCC** 18
41256-12FL	2.05	262,144x1 256Kx1	120ns	PLCC** 18
41256-80	2.15	262,144x1 256Kx1	80ns	16
41256-10	1.95	262,144x1 256Kx1	100ns	16
41256-12	1.75	262,144x1 256Kx1	120ns	16
41256-15	1.65	262,144x1 256Kx1	150ns	16
41256Z12	2.75	262,144x1 256Kx1	120ns	ZIP* 16
41257-12	3.25	262,144x1 256Kx1 Nibble	120ns	16
51258-80	4.95	262,144x1 256Kx1 Static Column	80ns	16
514256-80	6.95	262,144x4 256Kx4	80ns	20
514256-10	6.55	262,144x4 256Kx4	100ns	20
514258-80	9.95	262,144x4 256Kx4 Static Column	80ns	20
511000-80	6.95	1,048,576x1 1MEGx1	80ns	18
511000-10	6.55	1,048,576x1 1MEGx1	100ns	18
511000-12	6.25	1,048,576x1 1MEGx1	120ns	18
511001-80	7.25	1,048,576x1 1MEGx1 Nibble	80ns	18
511001-10	6.25	1,048,576x1 1MEGx1 Nibble	100ns	18
524258BZ80	16.95	262,144x4 256Kx4 Static Column	80ns	ZIP* 28
42274VZ10	16.95	262,144x4 256Kx4 Video RAM	100ns	ZIP* 28
424400J80	24.95	1,048,576x4 1MEGx4	80ns	SOJ† 20

*Zigzag In-Line Package **Plastic Leaded Chip Carrier †Small Outline Junction

EXPANDED LINEAR SERIES

Order #	Price	Order #	Price	Order #	Price	Order #	Price
OR0026CN	2.49	LF351N	.49	LT1172CK	8.95	78L12	.35
TL061CP	.55	LF353N	.55	LT1172CN8	6.95	78L15	.35
TL064CN	1.19	LF355N	.85	LT1172CT	7.95	7805K	1.25
TL071CP	.65	LF356N	.89	MC1377P	2.95	7812K	1.25
TL072CP	.65	LF357N	.95	LM1458N	.35	7815K	1.25
TL074CN	.99	LM358N	.45	LM1488N	.45	7805T	.45
TL081CP	.59	LM380N	.85	LM1489N	.45	7806T	.45
TL082CP	.59	LM386N3	.85	LM1496N	.89	7808T	.45
TL084CN	.99	LM392N	.75	TCM1520AP	1.25	7812T	.45
LS148CTS	.75	LM393N	.45	ULN2003A	.65	7815T	.45
TL188CN	2.15	LF398N	1.95	FSA2510P	3.25	7818T	.45
MAX232CPE	4.45	LM399H	4.95	26LS29	2.65	7824T	.45
TL288CP	.95	LF411CN	.75	26LS31	.99	78H05ASC	8.95
LM301N	.39	LF412CN	1.25	26LS32	.99	78H05SC	7.95
C305C	1.25	ZN414Z	2.29	VA2707PJ	.39	78S40	1.75
LM307N	.45	ZN428E8	3.25	ULN2803A	1.19	79L05	.29
LM308N	.65	ZN449E	3.25	LM2877P	1.95	79L12	.39
LM309K	1.49	TL497ACN	2.35	LM2901N	.75	7905T	.49
LM310N	1.75	LM555CH	.95	LM2907N	1.59	7912T	.49
LM311H	.89	LM555CN	.29	D2912	3.95	7915T	.49
LM311N	.49	LM556N	.49	TCM3105N	9.95	7918T	.49
LM317K	1.85	NE558N	.75	MC3346P	.65	TD62084AP	2.25
LM317LZ	.69	NE564N	1.75	MC3350P	.75	TD62785P	2.25
LM317T	.65	LM565CN	1.55	MC3470P	1.15	75107	.89
LM318N	1.05	LM566CN	1.29	MC3479P	3.95	75110	.95
LM319N	1.05	LM567CN	.65	MC3486P	.99	75113	1.15
LM323K	3.15	NE592N14	.65	MC3487P	.99	75114	1.59
LM324N	.35	NE602N	1.95	SG3524	1.95	75122	2.45
LM330T	.45	LM709CN	.59	UC3610N	2.95	75150	1.25
TBA331	1.25	LM710CN	.65	LM3900N	.49	75154	1.25
LM334Z	1.09	LM711N	.79	LM3905N	1.29	75157	1.39
LM335Z	1.49	LM723CN	.49	LM3909N	1.05	75174	2.75
LM336Z	1.09	LM733CN	.65	LM3911N	1.95	75175	2.75
LM337K	3.75	LM741CN	.29	LM3914N	1.95	75176	1.95
LM337T	.85	LM741CH	.89	RC4136N	1.15	75450	.79
LM338K	4.25	LM747CN	.59	TC5020BP	2.55	75451	.45
LM339N	.39	LM748CH	.95	NE5532	1.15	75452	.45
LM345K5.0	5.95	LT1020CN	6.95	NE5534	.95	75477	1.15
LF347N	.75	SAA102T	6.95	78L05ACH	1.35	75477	1.15
LM348N	.65	LT1086CT	3.95	78L05	.35	MC145406P	2.75

EASY ORDER: 1-800-582-4044 OR EASY FAX: 1-800-582-1255

CIRCLE 28 ON FREE INFORMATION CARD

NEW!!

74ALS SERIES

NEW!!

Order #	1-24	25+	Order #	1-24	25+	Order #	1-24	25+
74ALS00	.29	.25	74ALS158	.95	.85	74ALS273	1.25	1.15
74ALS04	.35	.31	74ALS161	.55	.45	74ALS299	3.25	3.15
74ALS08	.29	.25	74ALS163	.85	.75	74ALS373	.75	.65
74ALS10	.35	.31	74ALS174	.65	.55	74ALS374	.75	.65
74ALS30	.35	.31	74ALS175	.65	.55	74ALS540	1.55	1.45
74ALS32	.35	.31	74ALS234	21.95	19.95	74ALS573	.95	.85
74ALS74	.35	.31	74ALS240	.75	.65	74ALS646	5.25	5.15
74ALS112	.65	.55	74ALS244	.75	.65	74ALS688	3.55	3.45
74ALS114	.65	.55	74ALS245	.95	.85	74ALS1035	.65	.55
74ALS138	.75	.65						

CD4000 SERIES (CMOS)

Order #	1-24	25+	Order #	1-24	25+	Order #	1-24	25+	Order #	1-24	25+
CD4000	.25	.21	CD4026	.59	.49	CD4070	.29	.19	CD4515	.75	.65
CD4001	.21	.17	CD4027	.35	.25	CD4071	.25	.19	CD4516	.69	.63
CD4002	.25	.21	CD4028	.45	.35	CD4073	.25	.19	CD4518	.69	.59
CD4006	.45	.35	CD4029	.65	.55	CD4075	.29	.19	CD4520	.65	.55
CD4007	.25	.21	CD4030	.35	.31	CD4076	.49	.39	CD4522	.65	.55
CD4009	.39	.35	CD4040	.59	.49	CD4077	.29	.25	CD4526	.65	.55
CD4011	.21	.17	CD4041	.65	.59	CD4081	.25	.19	CD4528	.65	.55
CD4012	.25	.21	CD4042	.49	.45	CD4082	.25	.21	CD4530	1.15	1.05
CD4013	.29	.25	CD4043	.55	.45	CD4093	.35	.29	CD4532	.95	.85
CD4014	.55	.49	CD4044	.55	.49	CD4094	.85	.75	CD4538	.75	.65
CD4015	.29	.25	CD4046	.59	.49	CD4098	.89	.79	CD4541	.85	.79
CD4016	.29	.25	CD4047	.59	.49	CD4099	.85	.75	CD4543	.75	.65
CD4017	.45	.35	CD4049	.25	.19	CD4106	.49	.43	CD4553	2.65	2.55
CD4018	.45	.41	CD4050	.29	.19	CD4502	.79	.73	CD4555	.65	.55
CD4019	.39	.35	CD4051	.55	.45	CD4503	.35	.25	CD4556	.65	.55
CD4020	.45	.35	CD4052	.55	.45	CD4508	.95	.85	CD4569	2.25	2.15
CD4021	.49	.45	CD4053	.55	.45	CD4510	.55	.49	CD4572	.49	.43
CD4022	.55	.45	CD4060	.59	.49	CD4511	.55	.49	CD4584	.45	.35
CD4023	.25	.21	CD4066	.29	.23	CD4512	.65	.59	CD4585	.65	.55
CD4024	.45	.35	CD4067	1.75	1.65	CD4514	.85	.75	CD4724	.95	.85
CD4025	.25	.21	CD4069	.25	.19						

INTERSIL

Order #	Price	Description	Pins
ICL7106CPL	6.95	3 1/2-Digit LCD Single-Chip A/D Converter	40
ICL7107CPL	6.95	3 1/2-Digit LED Single-Chip A/D Converter	40
ICL7109CPL	9.95	12-Bit Binary A/D Converter	40
ICM7206JPE	4.95	CMOS Touch Tone Encoder	16
ICM7216DIP	21.95	10MHz Multi-Function Frequency Counter & Timer	28
ICM7224IP	12.95	CMOS 4 1/2-Digit Counter/Decoder/Driver (LCD)	40
ICM7555IPA	.99	Lo-Power Timer (CMOS 555)	8
ICM7555IPD	1.25	Lo-Power Timer (CMOS 556)	14
ICL7660CPA	1.95	CMOS Voltage Converter (+5V to ±5V)	8
ICL7660CTV	2.49	CMOS Voltage Converter (+5V to ±5V) (TO-5)	8
ICL8038CCPD	3.75	Waveform Generator/Voltage Controlled Oscillator	14
ICL8211CPA	2.35	Programmable Voltage Detector	8
ICL8212CPA	1.95	Programmable Voltage Detector	8

*Complete Data Sheets available on most IC's for only \$1.00 with any order.

EASYTECH

THE ELECTRONICS SOURCE



2917 Bayview Drive
Fremont, CA 94538



Easy Order: 1-800-582-4044

Easy Fax: 1-800-582-1255

International Fax: 1-510-770-2346

Customer Service: 1-510-770-2345

Monday-Friday, 7am - 5pm (PST) / 10am-8pm (EST)



COD-No personal checks, US funds (\$5.00 Surcharge)



USPS



UPS



Federal Express



Airborne

Add 5% of total for shipping UPS Ground (\$3.00 min.).

Actual shipping charges based on weight.

Call or write today for your free copy of our 32 page catalog.

California residents, add appropriate sales tax.

12 month warranty on all EasyTech products.

30 day money back guarantee.

We reserve the right to substitute manufacturers.

Prices subject to change without notice.

EASY ORDER
1-800-582-4044



EASY FAX
1-800-582-1255

KYOSAN SWITCHING POWER SUPPLIES—LIMITED OFFERING

Recession Breaking Deals – Save Money Now!!

On a recent buying trip to Japan, we came across this shipment of new switching power supplies. Evidently the original customer had cancelled his order, and the manufacturer wished to clear the inventory.

The result, a bonanza for you!! These power supplies are suitable for many applications, and not just in voltages that are rarely used. They are offered to you at prices 50-70% below the usual distribution cost.

Please be aware that although most of these are available in large quantities, some numbers are limited. If you are unsure, please call and check quantities in advance. **Specifications are included on all models.**

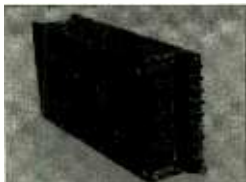

KRII/KR Series (Fig. 1)



KRII/KR Series (Fig. 2)



KCT Series



KS Series

KR SERIES (90-127VAC INPUT)

Order #	Price	Output	Max. Output	Dimensions (HxDxW in.)	Fig.	Weight
KR025-15V	10.00	15V @ 1.6A	25W	3.94 x 7.87 x 1.3	1	1.3 lbs.
KR025-24V	10.00	24V @ 1A	25W	3.94 x 7.87 x 1.3	1	1.3 lbs.
KR050-15V	20.00	15V @ 3.3A	50W	3.94 x 7.87 x 1.93	1	2.2 lbs.
KR050-24V	20.00	24V @ 2A	50W	3.94 x 7.87 x 1.93	1	2.2 lbs.
KR100-5V	40.00	5V @ 20A	100W	3.94 x 7.87 x 3.425	2	3.5 lbs.
KR100-15V	32.00	15V @ 6.6A	100W	3.94 x 7.87 x 3.425	2	3.5 lbs.
KR100-20V	32.00	20V @ 5A	100W	3.94 x 7.87 x 3.425	2	3.5 lbs.
KR100-24V	32.00	24V @ 4A	100W	3.94 x 7.87 x 3.425	2	3.5 lbs.
KR150-5V	50.00	5V @ 30A	150W	3.94 x 7.87 x 5.236	2	6.0 lbs.
KR150-15V	50.00	15V @ 10A	150W	3.94 x 7.87 x 5.236	2	6.0 lbs.

KRII SERIES (90-127VAC INPUT)

Order #	Price	Output	Max. Output	Dimensions (HxDxW in.)	Fig.	Weight
KRII055-9V	14.50	9V @ 6A	55W	2.13 x 8.27 x 3.9	1	2.5 lbs.
KRII055-12V*	16.00	12V @ 4.5A	55W	3.97 x 7.87 x 1.93	2	2.5 lbs.
KRII055-15V	16.00	15V @ 3.6A	55W	2.13 x 8.27 x 3.9	1	2.5 lbs.
KRII100-15V*	30.00	15V @ 6.6A	100W	3.425 x 8.39 x 3.9	2	3.5 lbs.
KRII200M-5V*	80.00	5V @ 40A	200W	3.97 x 7.87 x 5.236	2	6.0 lbs.
KRII200-12V*	80.00	12V @ 16.6A	200W	3.97 x 7.87 x 5.236	2	6.0 lbs.
KRII200-20V*	60.00	20V @ 10A	200W	3.97 x 7.87 x 5.236	2	6.0 lbs.
KRII200-24V*	65.00	24V @ 8.3A	200W	3.97 x 7.87 x 5.236	2	6.0 lbs.

*Also Switchable to 180-254 Volts AC

KCT SERIES PCB TYPE (90-127VAC INPUT)

Order #	Price	Output	Watts	Dimensions (HxDxW in.)	Weight
KCT030FJ1	5.95	+5V@3A/+12V@1A/-12V@400mA	30	14.17 x 1.77 x 1.89	1 lb.
KCT030FJ6	5.95	+5V@4A/+12V@1A/-12V@400mA	30	14.17 x 1.77 x 1.89	1 lb.
KCT040FJ6	5.95	+5V@4A/+12V@1A/-12V@400mA	40	14.17 x 1.77 x 1.89	1 lb.

KS SERIES (90-127 OR 180-264VAC INPUT)

Order #	Price	Output Vdc/Amps	Watts (HxDxW in.)	Weight
KS100-02	45.00	+5 10A/+15 1.5A/-15 15A/-5 0.5A	100...2.44 x 9.06 x 4.21	2.5 lbs.
KS130-02	50.00	+5 15A/+15 4A/-15 3A/-5 0.5A	130...2.44 x 10.47 x 4.96	4.0 lbs.
KS130-03	50.00	+5 15A/+12 4A/-12 3A/+24 2A	130...2.44 x 10.47 x 4.96	4.0 lbs.
KS170-03	55.00	+5 20A/+12 4A/-12 4A/-5 0.5A	170...2.44 x 6.06 x 5.63	4.0 lbs.
KS170-04	55.00	+5 20A/+15 4A/-15 4A/-5 0.5A	170...2.44 x 6.06 x 5.63	4.0 lbs.
KS200-CHI	65.00	+5 25A/+12 4A/-12 4A/+24 4A/-24 2A	200...2.44 x 12.99 x 4.96	5.0 lbs.
KS200-NM3	65.00	+5 25A/-5 0.75A/+12 4A/-12 4A/+24 4A	200...2.44 x 12.99 x 4.96	5.0 lbs.
KS200-03	65.00	+5 25A/+12 4A/-12 4A/-24 2A/+24 4A	200...2.44 x 12.99 x 4.96	5.0 lbs.

LH RESEARCH - 230V - POWER SUPPLY

**15W LOW PROFILE
HIGH VOLTAGE
POWER SUPPLY**

Data Sheet
Included

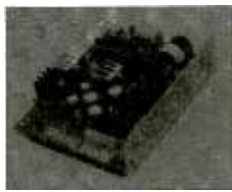

- Input Voltage: 220-340Vac
- Input Fusing: AC line fused
- Input Current: 0.2 Amp (47-63Hz)
- Hold Up Time: 20msec min. after removal of AC input
- Operating Temperature: 0°- 50°C @ full power
- Storage Temperature: -20°C to +75°C
- EMI: Meets FCC level B limits

Order #	Price	Voltage	Dimensions	Weight
BM153-122	7.95	5V@2A/+12V@0.3A/-12V@0.2A	1.25 x 3.625 x 4.75	12oz.

NICAD BATTERIES

SUNRISE – HITACHI – VARTA

A complete range of nickel cadmium rechargeable batteries as used in most standard applications, games, toys and electronic devices



Order #	1-9	10+	Voltage	Current	Manufacturer	Type
NR4AA	1.95	1.55	1.2V	185mA	Sunrise	AAA
N500AA	1.95	1.55	1.2V	500mA	Hitachi	AA
N1200C	3.65	3.25	1.2V	1.2 Amp	Hitachi	C
N1800C	3.95	3.55	1.2V	1.8 Amp	Hitachi	C
V5022	9.95	8.95	7.2V	100mA	Varta	216



2917 Bayview Drive
Fremont, CA 94538



Easy Order: 1-800-582-4044
Easy Fax: 1-800-582-1255

International Fax: 1-510-770-2346
Customer Service: 1-510-770-2345

Monday-Friday, 7am - 5pm (PST)/10am-8pm (EST)

- COD-No personal checks, US funds (\$5.00 Surcharge)
- USPS
- UPS
- Federal Express
- Airborne

Add 5% of total for shipping UPS Ground (\$3.00 min.).
Actual shipping charges based on weight.

Call or write today for your free copy of our 32 page catalog.

California residents, add appropriate sales tax.
12 month warranty on all EasyTech products.
30 day money back guarantee.
We reserve the right to substitute manufacturers.
Prices subject to change without notice.

EASY ORDER: 1-800-582-4044 OR EASY FAX: 1-800-582-1255

CIRCLE 6 ON FREE INFORMATION CARD

www.americanradiohistory.com

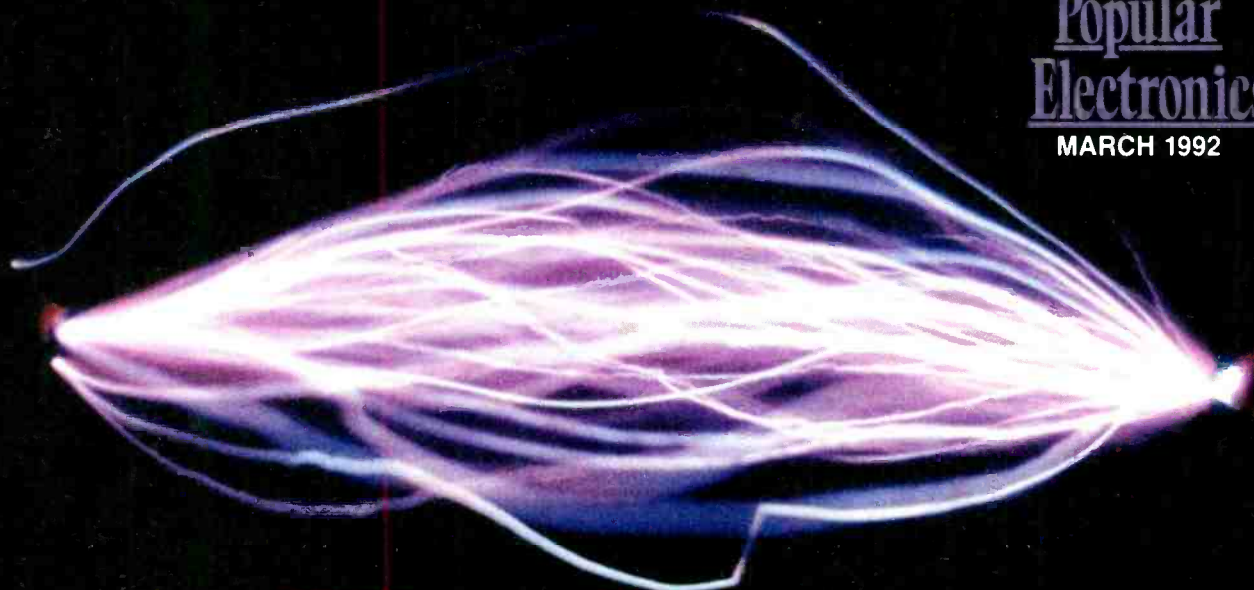

The Classic Induction Coil

Learn the history behind the induction coil and the men that all invented it at once, and then have a little high voltage fun yourself.

BY STANLEY A. CZARNIK

The final quarter of the 19th century marked a period of extraordinary scientific activity. Excitement was everywhere. Creative intellects flourished as the theory of evolution matured, the camera innovated the study of the stars, and Freud contemplated the meaning of his dreams.

During that same period, important contributions in the area of experimental physics were made. For example, in the late 1800's, Heinrich Hertz produced the first radio waves, which provided a concrete illustration of Maxwell's theory of the identity of electromagnetism and light. In 1895, Wilhelm Roentgen stumbled upon the strange penetrating power of the X-ray. In 1896, Guglielmo Marconi filed a patent application for one of the first

wireless-communication systems. And in 1897, Joseph John Thomson announced the discovery of the first subatomic particle: the electron.

WARNING!!

This article deals with and involves subject matter and the use of materials and substances that may be hazardous to health and life. Do not attempt to implement or use the information contained herein unless you are experienced and skilled with respect to such subject matter, materials and substances. Neither the publisher nor the author make any representations as for the completeness or the accuracy of the information contained herein and disclaim any liability for damages or injuries, whether caused by or arising from the lack of completeness, inaccuracies of the information, misinterpretations of the directions, misapplication of the information or otherwise.

Of course, this list of discoveries in physics is selective and presented here to make a point. Every single innovation in the sequence would have been difficult, if not nearly impossible, were it not for a single piece of laboratory equipment: the high-voltage induction transformer.

Just how, when, and where the induction coil was invented are not easy questions to answer. In fact, the entire matter is submerged in a good measure of ambiguity and confusion. Let's try to disentangle some of our historical threads.

Callan's Magnet. In December, 1835, Nicholus J. Callan published a brief description of a "new Galvanic battery" in *The London and Edinburgh Philosophical Magazine*. At the

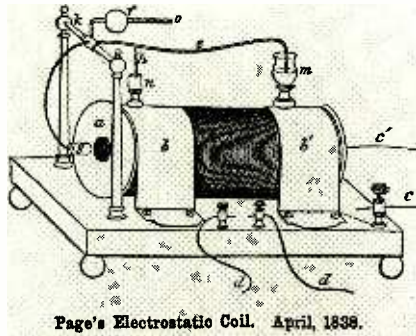

Charles Grafton Page was probably the first to construct a high-voltage induction transformer. Page followed his prototype with a long series of improvements. This "Electrostatic Coil" is one of them. The magnetic field around the core attracts the metal button at G. The motion is transmitted by the curved wire at E. The mercury cup contact point is at M.

time, Callan was a clergyman and physics teacher at Maynooth College, in County Kildare, near Dublin, Ireland. The battery consisted of 20 zinc plates, each about two feet square, and a similar number of large copper canisters to hold the acid. The system was activated by lowering the plates into the acid by means of a windlass. Callan's cells required about 30 gallons of acid. The battery was quite powerful and capable of melting thin pieces of platinum wire.

The generation of higher and higher levels of electrical energy seemed very important to Callan, and he pro-

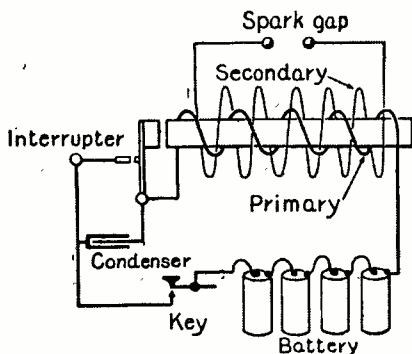

Most standard induction coils equipped with automatic Neef-type vibrator mechanisms operate in a similar way: When the interrupter contact points are closed, the battery current flows through the primary winding. That creates a magnetic field around the core which attracts the vibrator hammer thereby breaking the circuit. When the primary current is cut off, the points spring back and the circuit is re-established.

ceeded to discuss an alternative way of doing it. He took a bar of soft iron, about 2 feet long, and wrapped it around with two lengths of copper wire, each about 200 feet long. For reasons left unmentioned, Callan connected the beginning of the first coil to the beginning of the second. Finally, he connected a battery, much smaller than the enormous contrivance just described, to the beginning and end of winding one. He found that when the battery contact was broken, a shock could be felt between the first terminal of the first coil and the second terminal of the second coil.

Further experimentation showed how the coil device could bring the shock from a small battery up to the strength level of a big battery. So, Callan tried making a bigger coil. With a battery of only 14 seven inch plates, the latter device produced power enough for an electric shock "so strong that a person who took it felt the effects of it for several days."

Callan thought of his creation as a kind of electromagnet; but, what he actually made was a primitive induction transformer.

The American Version. Callan was not the only one working with ways of increasing battery power by electromagnetic means. A few months earlier, a similar system had been built in Salem, Massachusetts by a young medical student with a tireless interest in electrical experimentation, Charles Grafton Page.

In a communication to *Silliman's*

Journal dated May 12, 1836, Charles Page announced the construction of a device for "increasing shocks" in a new way. That new way involved taking the shocks from a secondary winding longer than the battery circuit. Recall that Callan's original coil was made with two windings of equal length. So, not only was Page's coil made public before Callan's apparatus, it was different. In *The History of Induction* (1867), the one book he wrote, Page described the novelty of his creation as follows: "the use of a longer coil for the secondary current than that used to transmit the battery current" and the production of "shocks from a purely secondary coil exterior to the primary coil."

Page's first inductive device was unlike most of his later models. The prototype was a 220-foot long spiral of copper ribbon mounted inside a wooden box. The coil was tapped in six different places with short copper strips connected to open mercury cups on top of the box. That allowed Page to experiment with "sub-spirals" of various lengths. But note: it's still one continuous winding of ribbon, not two. Page's retrospective claim to have used a "purely" secondary coil "exterior" to the primary is somewhat misleading. Strictly speaking, that's just not the case. Fact is, Page used a single winding with multiple taps; he had built, in effect, an autotransformer.

Simultaneous Invention. In August, 1836, using a coil a bit larger than the one just discussed, Page succeeded in producing not only an electric

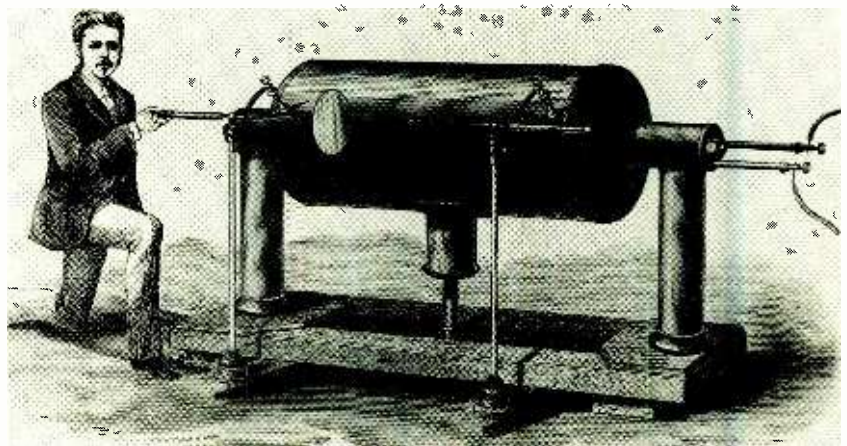

This is one of the largest induction transformers ever made. The "Great Coil" of Spottiswoode (named after its creator William Spottiswoode) had a secondary circuit consisting of no less than 230 miles of cable and could generate power enough to throw a spark some 42 inches long.

shock, but a very small electric spark between the terminals of a secondary winding. It seems clear that if just one person must be given credit for the invention of the *high voltage* induction coil, it should be Charles Page. Nonetheless, Nicholas Callan still deserves a measure of recognition; after all, he was working along similar lines with similar equipment in the same year.

In his personal history, Page himself notes that he was the first one, but not the only one, to generate an induced high voltage discharge in 1836. A spark, he mentioned, was also obtained by two Italian scientists, Antinori and Linari, and published in the December 13, 1836 issue of *L'Indicatore Sanese*. I have not been able to locate the original Italian reference. Yet, it is possible, even probable, that crude high voltage induction apparatus was being developed independently in not one, not two, but three different places—America, Ireland, and Italy—at almost exactly the same time.

The Lightning Wheel. Page had been in touch with William Sturgeon, a well-known English experimenter and inventor, in 1825, of the first electromagnet. Sturgeon was also responsible for a science journal, *The Annals of Electricity*, and, published a reprint of Page's original article on increasing shocks in 1837. After that, interest in the new spark-producing machinery grew rapidly, and improvements were announced one after another.

One special problem presented itself immediately. The high-voltage impulse in the secondary winding appeared only when the primary circuit was opened or closed. So how to make and break the circuit in the most efficient way possible became a point of major concern. As it turned out, there were a lot of ideas on how to do it.

One very early suggestion came from Neef and Wagner of Frankfurt-am-Main, Germany. It was a copper disc, about 6 inches in diameter, equipped with 36 strips of wood inlaid with strips of metal attached to the disc. A flexible conductor made contact with the interleaved wooden and metal surfaces. When the brush hit metal, the circuit was closed; when it hit the wood, the circuit was broken.

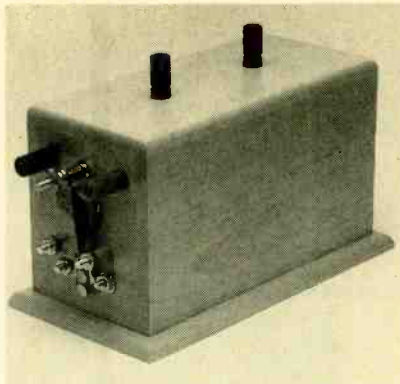

The coil from Fisher is sealed in a rectangular wooden case and comes complete with an adjustable Neef-type hammer interrupter.

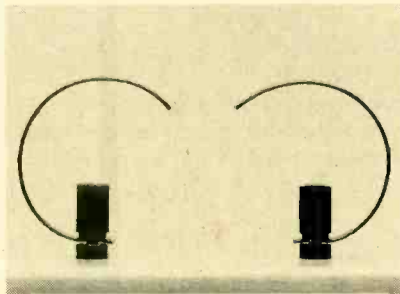

To test your coil, fashion a spark gap from two pieces of copper wire connected to the high-voltage output terminals on top of the case.

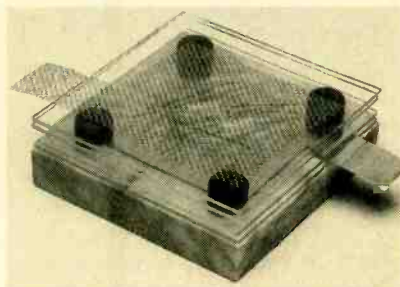

A miniature gaseous tube illuminator can be made with a piece of thin sheet metal, some wire gauze, and a few pieces of plain glass.

Neef, a physician, used the system for the creation of a rapid succession of presumably therapeutic electric shocks. He called his device the "lightning wheel."

The Hammer and the Wasp. The lightning wheel, as well as other similar devices, had to be operated by hand. Such manual contrivances were bothersome. What was necessary was some kind of automatic device.

In September, 1837, McGauley, of Dublin, exhibited the first self-acting

circuit breaker. McGauley attached a soft iron ball to one end of pivoted wire mounted over the induction apparatus. The ball was situated so as to be within the electromagnetic field produced by the core of the coil. The opposite end of the wire touched the surface of some mercury placed in a small cup. When the system was activated, the magnetic field near the core of the coil attracted the iron ball. That broke the contact at the surface of the mercury, shut down the magnetic field, and released the ball. When the wire at the other end fell back into the mercury, the cycle would begin again.

A very simple mechanism, but it worked quite well and suggested itself elsewhere. Charles Page, without knowledge of McGauley's experiments, came up with almost the exact same thing at just about the same time—yet another instance of simultaneous invention and parallel channels of thought. Page made the automatic circuit-breaker part of his famous "Electrostatic Coil" of 1838. According to A.F. Collins, writing in 1908, the so-called electrostatic machine was the most powerful coil in existence at the time.

The next important development came, once again, from Neef and Wagner in 1839. In short, the men replaced the mercury/cup arrangement with a vibrating metal strip and contact point and placed the entire sub-system at one end of the coil. The great advantage of the device is obvious: it eliminated the mercury.

It did not take long for Neef's simple system, or something very similar to it, to become one favorite method of making and breaking the primary circuit. Now, what to call it? One popular term was "rheotome" (current-slicer). Page liked "electrotome." Callan liked "repeater." Some preferred to honor the inventor with "Neef's hammer." There were regional variations too: In France, according to Becquerel, it was known as a "trembler" (*trembleur*). And of course, among English-speaking experimenters, "interrupter" and "vibrator" were destined to become standard references.

Credit for the most imaginative expression must certainly go to a certain English clergyman and amateur physicist, Reverend Lockety. Lockety noticed that the operation of a typ-

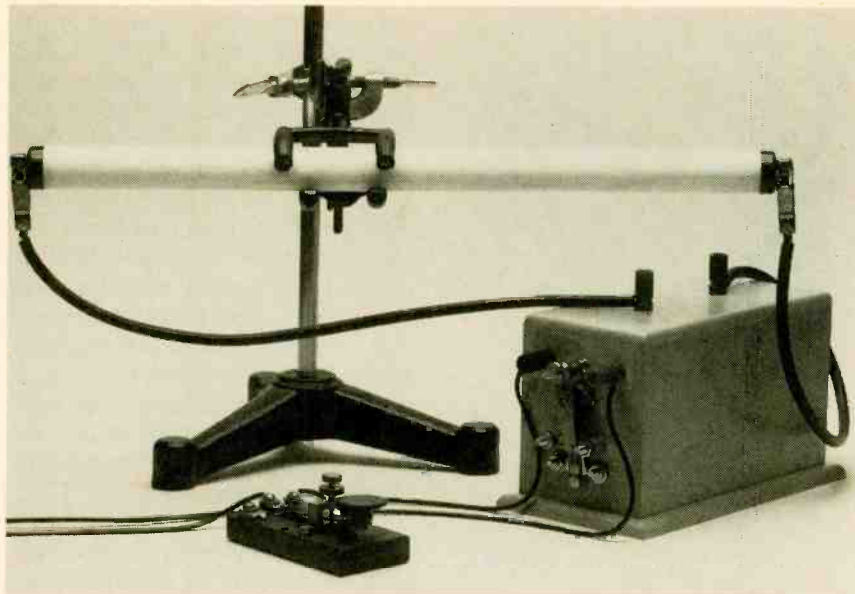

A high-voltage flasher can be easily made by connecting an ordinary 15-inch fluorescent tube to the output of the induction coil, and a telegraph key between your power supply and the input. The circuit makes a unique code-practice device or signaling system.

ical Neef-type device was accompanied by a kind of buzzing, "a constant bee-like hum," as he put it. Apparently, he thought that the name of the mechanism should recall the insect-like sound it made when it worked and suggested the term "galvanic wasp."

The Prize. There is one final chapter in the story of the mid-19th century induction coil. In 1802, following a long visit by Alessandro Volta, Napoleon Bonaparte announced the establishment of a 60,000-franc prize to be given to the creator of the most useful application of the voltaic battery. The Volta Prize was awarded to Humphrey Davy in 1806. It was not awarded again for over fifty years. Following a revival of the competition by Napoleon III, the prize was given to Heinrich D. Ruhmkorff in 1864 for the invention of the induction coil.

Yes, the invention of the induction coil. Heinrich Ruhmkorff did not invent the induction coil; there is no doubt about that. So why, then, was he given the prize? Why not Charles Page? The reasons are very complex and, to this day, not entirely clear.

In 1853, Armand Fizeau, a French physicist, discovered a way of greatly improving the performance of induction coils: the connection of a capacitor parallel to the breaker points of the vibrator. That simple addition had the

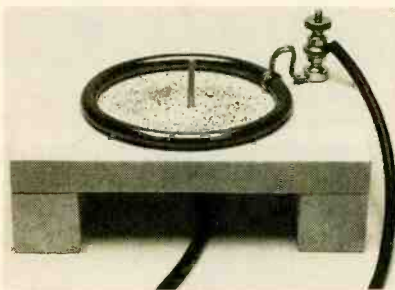

This simple device creates a rotating circle of sparks between the central electrode and the inside edge of the metal ring. Note that the input cables are kept at least 3 or 4 inches apart.

effect of reducing unwanted discharge at the vibrator points and increasing the intensity of the secondary spark. Ruhmkorff, who had been building induction apparatus at his Parisian workshop since 1851, incorporated Fizeau's modification immediately. It was a good move at a good time. As Page himself said in 1867, Fizeau's contribution to the Ruhmkorff coil "at once gave it a celebrity which, perhaps, it might otherwise not have attained."

A Case of Indifference. There is a wider issue implicated here, an issue involving the sociology of scientific activity. Recall for a moment the period: the middle of the 19th century, almost 150 years ago. At the time, almost none of the major discoveries in

the physics of electricity were being made in America; and, perhaps more important, none were really expected. Now, think of the situation on the opposite side of the Atlantic. It could not have been more different. From Galvani to Volta, to Davy, to Oersted, to Ohm, Ampere, Faraday and beyond—everything, but everything, was coming from Europe. So, it must have been only natural to believe that the trend would continue, and in many ways, it did.

Charles Page (much, in fact, like Joseph Henry) was the victim of a notorious indifference to American science by 19th century European philosophers. When Ruhmkorff was recognized and rewarded for the invention of the induction coil, it is likely that the French officials involved had never even heard of the experimenter from Massachusetts. As Salem Howe Wales of *Scientific American* phrased it, the episode was yet another "oversight of American achievements by European savants already too common." The real inventor of the induction coil was not ignored; he was unknown.

A Spark Coil For Your Home Lab. A good electromechanical induction coil is still one of the most versatile and

Further Reading

The History of Induction, Charles Page, Intelligencer Printing, Washington, 1867.

"Description of a Large Induction Coil," William Spottiswoode, *The Philosophical Magazine*, Volume 3 (January 1877), pp. 30-34.

Induction Coils, H.S. Norrie, Spon & Chamberlain, New York, 1901

Experimental Science, George Hopkins, Munn, New York, 1902

Design and Construction of Induction Coils, A. Frederick Collins, Munn, New York, 1908

"The Induction Coil," George Shiers, *Scientific American*, Volume 224 (May 1971): pp. 80-87

Physics, Patents, and Politics: A Biography of Charles Page, Robert C. Post, Science History, New York, 1976.

Note: The books by Norrie, Hopkins, and Collins are currently available in paperback editions from Lindsay Publications (P.O. Box 12, Bradley, Illinois 60915-0012; Tel. 1-815-468-3668). Call them for price and shipping information.

PARTS AND MATERIALS LIST FOR THE INDUCTION COIL EXPERIMENTS

6-12-volt, 0.5-3.5-amp DC power supply
Copper wire
15-inch fluorescent tube
Four 4 × 4 inch glass plates
Induction coil
Iron filings
Large binding post or Fahnestock clip
Miniature mercury-vapor bulbs
NE-2 neon bulbs
Salt shaker
Sheet aluminum or brass, 4½ × 2½ inches
Spark-plug wire (or equivalent)
Steel ring
Telegraph key
Threaded rod (or long narrow screw)
Wire screen 4½ × 2½ inches
1 piece of wood, 7½ × 5¾ × ¾ inches
2 pieces of wood, 5½ × 1½ × 1½ inches

Note: The high-voltage induction coil is available from Fisher Scientific EMD (4901 W. LeMoyné, Chicago, IL 60651; Tel. 1-800-621-4769 or 1-312-378-7770) as part number S-43525 for \$121.10. Shipping rates vary from place to place so call them for an estimate. Illinois residents will need to add the appropriate sales tax.

The following items are available from American Science and Surplus (601 Linden Place, Evanston, IL 60202; Tel. 1-708-475-8440): 4¾ inches O.D. steel rings, part number 20247 at \$2.50 for a package of two; green mercury vapor glow lamps part number 3628 at \$2.25 for a package of three. The company requires a \$12.50 minimum order and a flat \$4.00 fee for shipping and handling. Illinois residents will need to add the appropriate sales tax. Their catalog is 50 cents.

Clean 4 × 4 inch glass plates are available from Hagenow Laboratories (1302 Washington St., Manitowoc, WI 54220) as part number 67C for 49 cents each. The company requires a \$15.00 minimum order. Their catalog is \$1.50. WI residents must add sales tax.

enjoyable high-voltage devices you can possess. An excellent example designed along classical lines is currently available from Fisher Scientific, a laboratory supply company in Chicago (see the Parts and Materials List for more information).

The coil is sealed in a rectangular wooden case (about 8 × 5 × 4 inches) and comes complete with an adjustable Neef-type hammer interrupter. The unit is made to operate with a DC input of about 6 to 10 volts at between 0.5 and 3.5 amps depending on input voltage and adjustment of the breaker points on the hammer. The input terminals are next to the vibrator and the high-voltage output posts are on top—just as they were on the classical induction transformers of the 19th century. The unit delivers a strong spark at least 1 inch long and power enough for most of the standard high-voltage projects and demonstrations.

You will, of course also need a power supply. Anything that can supply the required voltage and current will work, but one with a continuously variable output between 6 and 12 volts is recommended.

Assuming that you have gathered some of the things listed in the Parts and Materials List, let's discuss some experiments you can perform. Keep in mind that these demonstrations, generate a certain amount of ozone; so you'll want to perform all of your experiments in a well-ventilated room.

Testing and Operation. The most obvious thing to do with a spark coil is make a spark. For that, obtain two pieces of bare copper wire each about 3 inches long. Do not use covered wire; the insulation may get hot and melt. Bend each of the pieces into a semi-circle and connect them to the high-voltage terminals. The idea is to keep the two wires as far away from each other except where they form the spark gap somewhere above and between the binding posts. To begin with, make the spark gap about 1 inch across. Make sure the wires are fastened down tight.

Now, look at the vibrator mechanism. You will see a large knurled nut; that is the breaker-point adjustment control. Screw the nut in or out until the points are just barely touching. Finally, note polarity as indicated (by color) at the input terminals of the coil and hook up your low voltage DC power supply.

If necessary, set the supply between 6 and 12-volts. Turning on the supply should cause the coil to produce a strong 1 inch spark. If it doesn't, turn the

power off and loosen or tighten the control nut slightly. Make your adjustments conservative, a quarter turn, perhaps; the operational range is not very large. **Do not attempt to touch the vibrator or adjust the points when the unit is in operation.**

Once you get a spark, turn off the coil and make the spark gap about ¼ inch larger. Then turn on the power and check for a spark. If you have an adjustable supply, raise the input voltage a bit if necessary, but don't overdo it. You can also try readjusting the vibrator. Repeat the procedure until the gap is too wide for a spark to pass. That is one simple way to determine the maximum output of your coil.

When everything is just right, the system will deliver a thin, intermittent, lightning-like spark close to 2 inches long. These long sparks are best observed in a dark room.

Gaseous Tube Illuminator. There are many, many things you can do with your induction coil. With some scrap metal and a few pieces of glass you can make a miniature gaseous-tube illuminator.

Obtain four plates of clear glass about 4 inches square. Such glass plates are standard science items and can be ordered from a supplier mentioned in the Parts and Materials List. You'll also need some clean wire screen and a piece of very thin sheet metal (like brass or aluminum). The metal sheets you select should be thin enough to permit easy shaping with scissors.

Cut the metal sheet to form a rectangle about 2½ inches wide and 4½ inches long. Then, fashion a tab at one narrow end of the rectangle. Now, cut a piece of wire screen to match the size and shape of the metal sheet. The metal sheet and wire screen will be used as electrodes.

You're now ready to build the illuminator. Place the metal-sheet electrode between two of the glass plates. Place the wire-screen electrode between the other two. Rest the sheet-metal sandwich on some sort of insulating material, like a 4 × 4 inch block of wood. Now place a few small neon bulbs on the glass surface over the metal sheet. Then, add four rubber spacers, one at each corner of the glass. Finish by placing the wire mesh arrangement carefully over the

bulbs; the lower glass plate should rest on the spacers. The tabs on the metal sheet and the wire screen should be pointing away from one another.

Connect one high-voltage output terminal on the induction coil to the sheet-metal tab, and the remaining terminal to the screen's tab. Spark-plug wire is probably the best kind of wire to use; but any sort of heavy, well-insulated hook-up cable will work. Finally, darken the room and turn on the power. A high voltage electric field is created in the space between the plates that causes the neon tubes to flicker and glow like so many little lightning bugs.

You may observe a few stray sparks passing over and around the edges of the glass plates. A very careful rearrangement of the electrodes (with the power off, of course) will probably solve the problem. If it does not, try using smaller electrodes, larger pieces of glass, or a lower power-supply setting.

For an unusual multicolor effect, try replacing a few of the neons with small mercury-vapor lamps. The type I used were also used in the Electronic Novelty Light featured in the December 1990 issue of this magazine. See the Parts and Materials List for more information.

Fluorescent Flasher. If you enjoy working with gaseous conductors, here's something else you can try. Obtain a good quality telegraph key (or some other kind of momentary-contact switch) and hook it up in series between one output terminal of your power supply and one input terminal of the induction coil. Now, locate an ordinary 15-inch fluorescent tube and connect it directly to the high-voltage output with some spark-plug wire and a couple of alligator clips. To keep the whole contrivance steady and safe, the fluorescent tube should be elevated up and away from the rest of the equipment with a stand of some sort. For such temporary projects, standard laboratory hardware comes in very handy.

With the power supply on, each press of the key will activate the coil and flash the lamp. The circuit makes a unique code practice device or signaling system. For a still better effect, try using a green fluorescent tube in place of the conventional white vari-

ety. Such tubes are often sold as replacement parts for photocopying machines.

The Spark Ring. Here's a device which will enable you to create an infinite variety of randomly rotating sparks. The visual effect resembles a wagon wheel spinning under a strobe light. Frozen with a photographic time-exposure, it resembles some sort of weird electric snowflake.

The simplicity of the spark ring allows for a number of equally suitable construction methods; but, here's one easy way of doing it: To begin, you'll need some wood—one piece about $7\frac{1}{2} \times 5\frac{1}{2} \times \frac{3}{4}$ inches and two pieces $5\frac{1}{2} \times 1\frac{1}{2}$ inches square. Locate the exact center of the larger piece and drill a hole just big enough to accommodate a long screw or length of threaded rod. The screw should extend at least $\frac{1}{2}$ inch beyond the upper surface of the wood and no more than 1 inch below the lower surface. Drill another hole (somewhere near the upper right hand corner is a good place) for a large binding post or Fahnestock clip. Set the piece aside for now.

Now for the key component: a perfectly circular ring of metal about 4 or 5 inches in diameter. You may very well have something like that in your collection of building materials. If not, just make a loop from some thick wire, metal tubing, or a long metal strip by wrapping it around a large round bottle. Or, you can get something ready made. What I did was obtain a big steel ring from American Science and Surplus (see Parts and Materials List). It's the perfect size and shape. Also, it's heavy enough to stay in one place without the need for additional hardware.

Once you have your metal ring, you'll need to furnish it with a piece of flexible conductor for attachment to the binding post. I used some braided copper grounding cable, but a short length of stranded wire will do just as well. If possible, solder the wire to the metal ring. Do not use too much wire to make the connection, otherwise the metal ring may not lie flat on the wood. Then set the whole construction on the two remaining pieces of wood.

Cut two 15- or 20-inch pieces of spark-plug cable and furnish one of

them with a large alligator clip. Connect the clip to the threaded-rod electrode beneath the lower surface of the wood. Connect the other wire to the binding post. Then connect the apparatus to the high-voltage output of the induction coil.

Finally, obtain some powdered iron and place about a tablespoon of it in an old salt shaker. Now, very carefully, sprinkle some of the metal onto the surface of the wood inside the perimeter of the metal ring. Try to distribute the iron as evenly as possible, but do not use too much of it.

When everything is ready, darken the room and turn on the coil. The entire area inside the ring will light up with hundreds of tiny sparks created by the gaps between the particles of iron. If you are not satisfied with the effect at first, just turn the apparatus off, remove the iron particles with a magnet, and try again. Every application of iron will create a slightly different pattern of sparks. The designs bear an interesting resemblance to the Lichtenberg figures discussed in an earlier article (March 1990).

Do not feel limited to the use of powdered iron. Any low resistance material reduced to the appropriate size will also work; but the effect will be different. You can try tiny bits of stranded copper wire, metal foil, or even a small handful of miniature nuts and bolts. However, do not, under any circumstances, use an easily combustible metallic substance, like powdered magnesium, powdered aluminum, or zinc dust. They are very, very dangerous.

Also, keep in mind that the apparatus does create some heat in the central electrode and metal ring. So, do not run the equipment for extended periods of time and watch carefully for anything suspicious or unusual, like over-active sparks or scorched wood.

Learning More. For more on the history of induction apparatus, see George Shiers' May 1971 article in *Scientific American* and Robert Post's biography of Charles Page. For more experimental ideas, see Volume II, Chapter 2 of George Hopkins' *Experimental Science* and Chapter 5 of H.S. Norrie's *Induction Coils*. For additional information, consult the section entitled "Further Reading." ■

Although some audio amplifiers include speaker-protection circuitry as standard equipment, there are many other amplifiers that do not offer it. Surprisingly, that important feature is often left out of high-power amplifiers, either to reduce cost or to eliminate switching in the audio path—and that can be bad news for your speakers.

Almost all audio amplifiers use direct-coupled output stages—i.e., there is no coupling capacitor. That means that if an output transistor short circuits, virtually the full supply voltage feeding that part of the circuit will be applied to the speaker. The result is usually a blown speaker voice coil or a damaged speaker suspension, probably before the unfortunate user even realizes that anything is amiss.

For example, consider a 100-watt amplifier with a ± 50 -volt power supply that's used to drive a speaker whose DC voice-coil resistance is 6.5 ohms. If one of the supply rails is shorted to the speaker, the resulting power dissipation in the voice coil will be $50 \times 50/6.5 = 385$ -watts (at least it will be until the power supply fuses blow). Obviously, there are not too many voice coils

that can withstand that sort of treatment for long. In fact, the voice coil of a typical 50- or 100-watt speaker would burn out almost instantly.

Depending on the make and model of the speaker, a typical driver can easily set you back \$150 or more, so replacing them can be a very expensive exercise—in fact, more so than getting the amplifier repaired. And don't think that the above scenario is improbable. Audio-amplifier-output stages can short circuit for a variety of reasons, ranging from power-supply faults to straight-out user abuse.

Another way of damaging your speakers is to overdrive them, either

by running the amplifier into clipping or simply by advancing the volume control too far. That type of abuse can quickly burn out a tweeter voice coil due to excessive power dissipation. And in severe cases, it's also possible to damage other drivers in the enclosure, particularly if the amplifier's output power greatly exceeds the rated power-handling capacity of the speakers.

The *Speaker Protector*, described in this article is designed to protect your expensive speakers if any of the above situations occur. In use, the Speaker Protector monitors the DC conditions at the output of the amplifier and trips a relay to disconnect the speakers if a problem is detected.

Protect your expensive speakers from overdrive, amplifier failure, and switching thumps.

Turn-on Thump. Another problem with some amplifiers is that they cause a loud thump in the speakers when they are switched on or switched off. There are a couple of reasons why that happens. First, the positive and negative supply rails may not rise (or fall) at the same rate and so the output swings towards one rail. Second, it takes a finite time for the input circuit to stabilize at switch on and

BUILD A SPEAKER PROTECTOR

BY BOB FLYNN

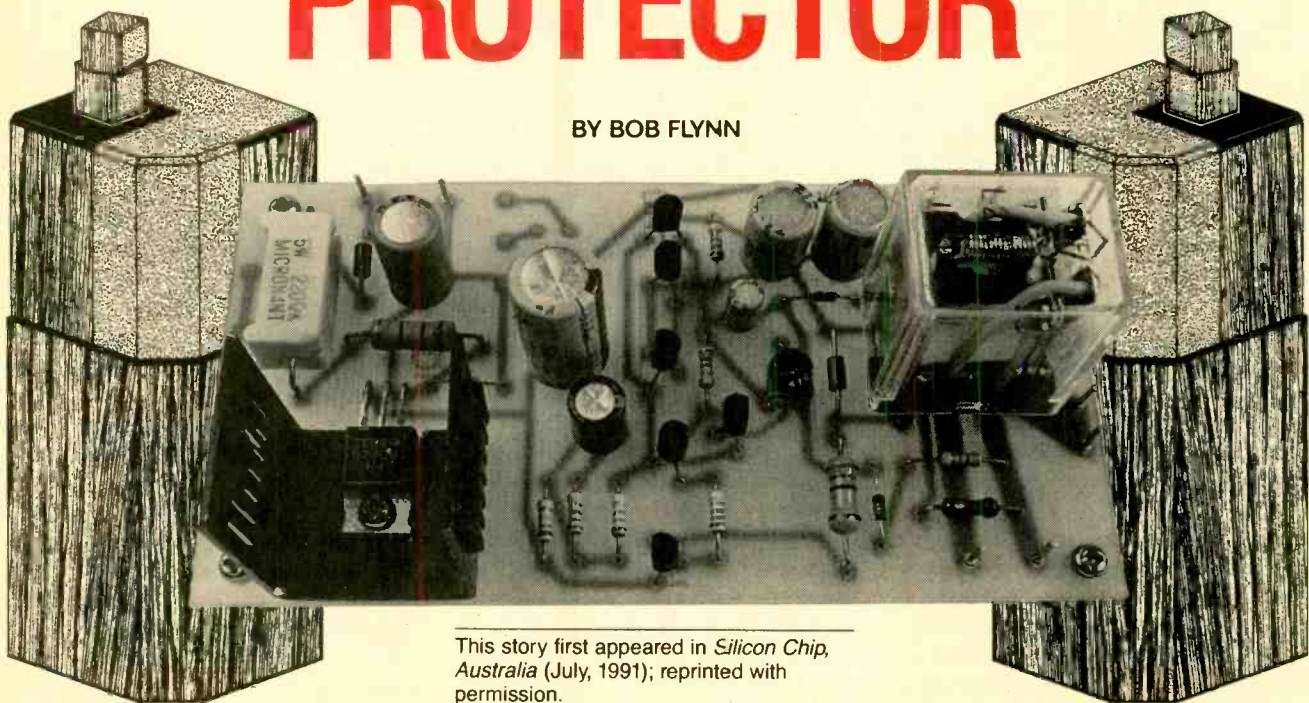

This story first appeared in *Silicon Chip, Australia* (July, 1991); reprinted with permission.

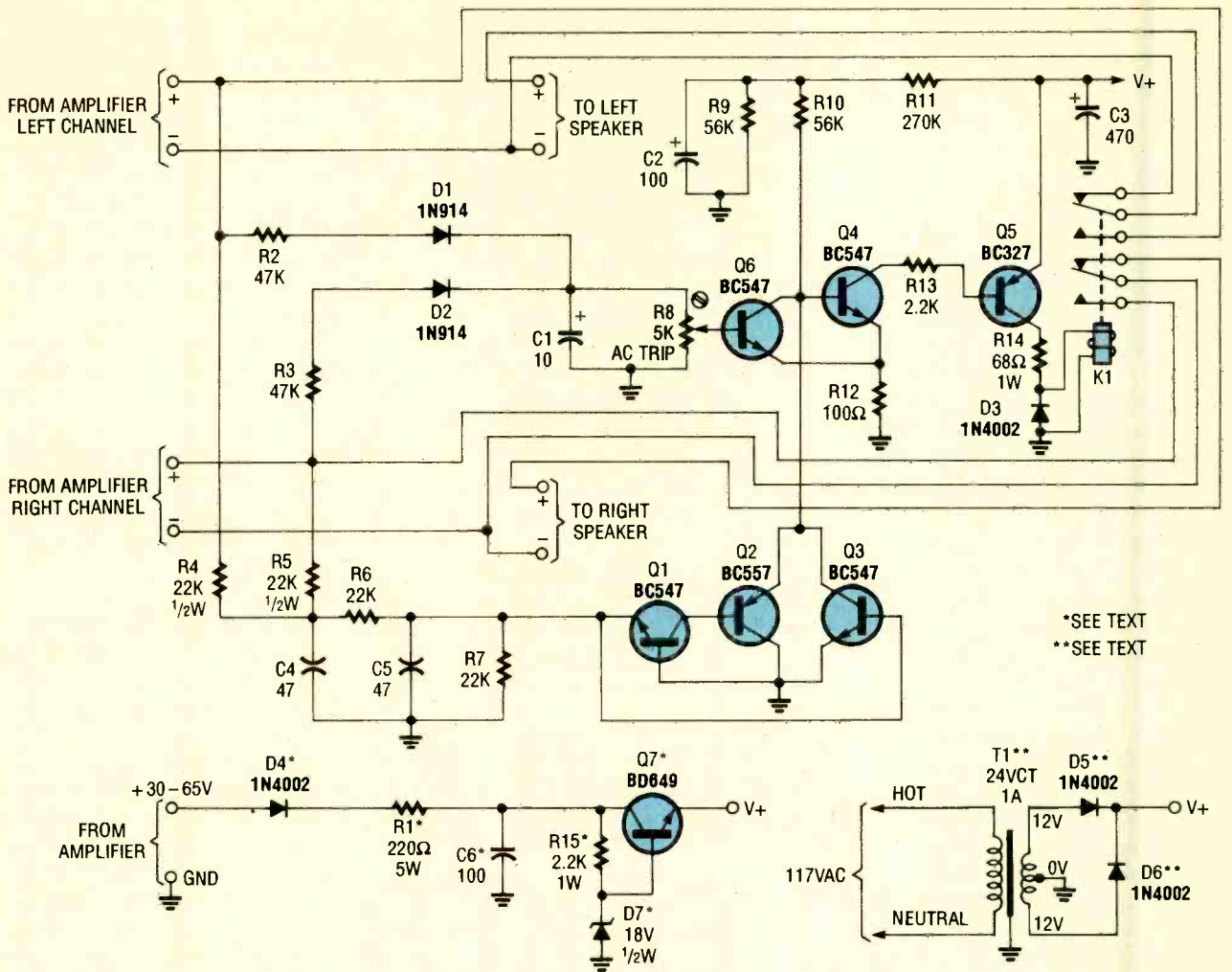

*SEE TEXT
**SEE TEXT

Fig. 1. Most of the transistors in the Speaker-Protector circuit function as switches. Normally, Q4, Q5, and K1 are on and the speakers are connected to the amplifier. However, if a large DC voltage appears at an amplifier output, either Q3, or Q1 and Q2 turns on, biasing Q4 off. That turns Q5 off, de-energizing the relay, and disconnecting the speakers from the amplifier. Components D1, D2, and Q6 form the overdrive protection circuit.

gain control over the output stage. During that time, there is no negative feedback, which again means that there is nothing to prevent the amplifier from swinging towards one of the supply rails.

This project neatly eliminates the switch-on thump problem by using a simple time-delay circuit to switch on a relay to connect the speakers two seconds after power is initially applied. During that period, the amplifier has time to stabilize so that when the speakers are connected, no switch-on thump occurs.

The Speaker Protector can also eliminate any thump that occurs in the speakers shortly after switch off. It can also reduce—but not totally eliminate—the sharp click that some amplifiers produce at the instant of switch

off. That can usually be accomplished by correct selection of the suppression capacitor associated with the on/off switch.

How it Works. A schematic diagram of the Speaker Protector is shown in Fig. 1. When power is applied to the circuit, C2 charges via R11. After about two seconds, a voltage of sufficient magnitude to turn Q4 on is applied to its base. With Q4 turned on, the base of Q5 is pulled low, resulting in its emitter being more positive than its base, and its base being more positive than its collector, causing it to turn on. With Q5 turned on power is applied to the relay (K1) coil, energizing it and connecting the speakers to the amplifier. The 2-second delay eliminates any switch-on thump.

Transistors Q1, Q2, and Q3 are used to monitor the amplifier outputs for DC fault conditions. Both channels are monitored via a low-pass filter, consisting of R4–R7 and C4 and C5. That filter is there to ensure that legitimate AC signals at the amplifier outputs have no affect on the protector circuit.

However, if the DC output of the amplifier rises above +2.5 volts, Q3 turns on, pulling the base of Q4 low. That, in turn, causes Q4 and Q5 to turn off, which de-energizes the relay and disconnects the speakers. On the other hand, if the amplifier output exceeds -2.5 volts, Q1's emitter is pulled negative with respect to its base, causing it to conduct. That biases Q2 on, pulling the base of Q4 low, turning it and Q5 off, also de-energizing the relay.

PARTS LIST FOR THE SPEAKER PROTECTOR

SEMICONDUCTORS

- Q1, Q3, Q4, Q6—BC547, SK3854, or similar NPN silicon transistors
 Q2—BC557, MPSA05, SK3466, or similar PNP silicon transistor
 Q5—BC327, 2N5401, SK3466, or similar PNP silicon transistor
 Q7*—BD649, ECG263, or similar NPN silicon transistor
 D1, D2—1N914 small-signal silicon diode
 D3, D4*, D5**, D6**—1N4002 or similar 1-amp 100-PIV silicon rectifier diode
 D7*—18-volt, 1/2-watt, Zener diode

RESISTORS

(All fixed resistors are 1/4-watt, 5% units, unless otherwise noted.)

- R1*—220-ohm, 5-watt
 R2, R3—47,000-ohm
 R4, R5—22,000-ohm, 1/2-watt
 R6, R7—22,000-ohm
 R8—5,000-ohm, horizontal-mount trimmer potentiometer
 R9, R10—56,000-ohm
 R11—270,000-ohm
 R12—100-ohm
 R13—2200-ohm
 R14—68-ohm, 1-watt
 R15*—2200-ohm, 1-watt

CAPACITORS

- C1—10- μ F, 16-WVDC, radial-lead electrolytic
 C2—100- μ F, 16-WVDC, radial-lead electrolytic
 C3—470- μ F, 25-WVDC, radial-lead electrolytic
 C4, C5—47- μ F, 50-WVDC, non-polarized radial-lead electrolytic
 C6*—100- μ F, 63-WVDC, radial-lead electrolytic

ADDITIONAL PARTS AND MATERIALS

- K1—12-volt DPDT relay with 10-amp contacts
 T1**—24-volt, 1-amp, center-tapped transformer
 Printed-circuit materials, enclosure, molded AC power plug with line cord, TO-220 miniature heat sink, heat-sink compound, spacers, hook-up wire, solder, hardware, etc.

*, **—See text

Note that when the relay is de-energized, the relay's moving contacts are shorted to the ground lines via the "unused" contacts. That has been done because if a large DC voltage appears at the amplifier output, an arc can be maintained across the

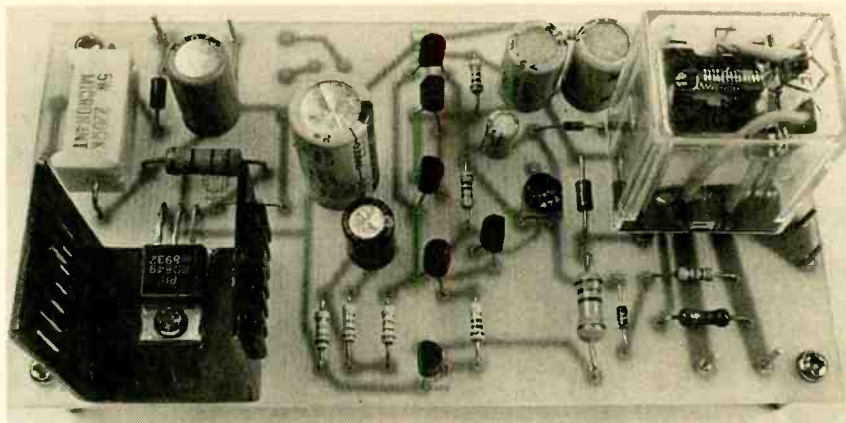

All of the parts for the Speaker Protector are mounted on a small printed-circuit board that can easily be installed inside the amplifier's enclosure.

contacts as they open; i.e., the speakers will still effectively be connected during that time. Shorting the moving contact to ground removes the DC voltages from across the speaker terminals, and blows the amplifier fuses if the arc persists.

The fact that the Speaker Protector is intended for use with high-power amplifiers—which can produce considerable output currents, plus the need to protect against heavy DC fault currents—means that a heavy-duty, 10-amp relay is called for. If lesser-rated relays are used, it is likely that their contacts will weld together under DC fault conditions.

DC input voltages of less than 2.5 volts have no effect on the circuit. That's desirable since all direct-coupled amplifiers have a "normal" DC offset at their outputs that can be as high as 200 mV or so. In any case, DC voltages of less than 2.5 volts are not going to cause damage to your speakers.

Overdrive Monitor. Diodes D1 and D2, and transistor Q6 form an overdrive monitoring circuit. In operation, D1 and D2 rectify the AC signals at the amplifier outputs, and use the resulting DC to charge C1. If the AC signals exceed a preset level, sufficient voltage will be developed across C1 to forward-bias Q6. Transistors Q6 and Q4, and their common 100-ohm emitter resistor (R12), form a Schmitt trigger. In order for Q6 to turn on, the voltage on its base must exceed the voltage on the base of Q4 (about 1 volt). When that happens, due to excessive signal drive, Q6 turns on and Q4, Q5, and K1 all turn off.

As soon as Q6 turns on, the voltage

across R12 drops since all current is now supplied via R10. That means that the voltage on Q6's base must drop to well below the turn-on value for Q6 to turn off again. That translates to an input hysteresis level of about 3 volts AC and prevents relay chatter at the transition point. Trimmer potentiometer R8 allows the trip point of the overdrive monitor to be adjusted to the desired signal level.

Power Supply. Power for the circuit can be derived in one of two ways. Assuming that you intend mounting the circuit inside your amplifier, power can be "pirated" from any convenient positive DC rail ranging from +30 to +65 volts. The pirated voltage is fed to a series-regulator circuit formed by D4, D7, and Q7. Diode D4 is used to protect the circuit against reverse polarity voltages, while D7 sets the voltage on the base of Q7 to 18 volts. Transistor Q7 functions as an emitter follower and produces a regulated +17.4 volts, which is then used to power the rest of the circuit. Resistor R1 (a 220-ohm unit) is an optional current-limiting component and need only be included in the circuit if the supply rail being tapped is greater than 45 volts.

The other option is to use a separate power supply to operate the circuit. As shown in Fig. 1, all that is needed for that is a center-tapped transformer and a simple full-wave rectifier comprised of two diodes (D5 and D6). The resulting 17-volts DC is then filtered by C3 (near Q5, at the top-right corner of the main circuit).

Construction. The entire Speaker Protector circuit was assembled on a

printed-circuit board, measuring $5\frac{3}{8} \times 2\frac{1}{4}$ inches. A template for the printed-circuit board is shown in Fig. 2. After etching your board, but before installing any of the parts, carefully inspect the copper side of the board for possible defects. In particular, look for opens and/or shorts in the copper traces; opens are often caused by insufficient masking or over etching, whereas shorts are due to incomplete etching.

Next you have to decide how your circuit is to be powered; by pirating power from the amplifier's power supply or from a separate supply. Figure 3 shows the complete layout for the version that pirates power from the amplifier. The components that are eliminated from the circuit in order to use a separate power supply are designated by a single asterisk (*). Figure 4 shows the placement of the separate power supply components, which are designated by a double asterisk (**). Note that a few of the components in Fig. 4 are also shown in Fig. 3; those components are common to both versions, and are included in Fig. 4 only to show their relative position. The components that are version specific are marked in the Parts List as in the schematic diagram and their respective parts-placement diagrams.

Assuming that you've chosen the power-pirate version, begin assembling the circuit by installing the resistors, trimmer potentiometer, diodes, and capacitors. Make sure that all the diodes and polarized electrolytics are oriented as shown in Fig. 3. There are two non-polarized 47- μ F electrolytic capacitors (C4 and C5) in the circuit; they can be installed either way around. As stated earlier, R1 (a 220-ohm, 5-watt, wire-wound resistor) is required only if the voltage that is supplied by the amplifier to power the Speaker Protector is greater than +45 volts. If that resistor is required, mount it so that it hovers slightly above the board surface to allow air to circulate around it for cooling. If the resistor is not needed, install a jumper in its place.

The six small-signal transistors (Q1-Q6) can be installed next. Push them down onto the board as far as they will comfortably go, and carefully check the orientation of each one against the wiring diagram, before soldering their leads. Also make

sure that you don't get the transistor types mixed up. When it comes to mounting Q7, its tab should be bent

flat against the board and fitted with a small U-shaped heat sink to keep it cool. To mount the transistor, first bend

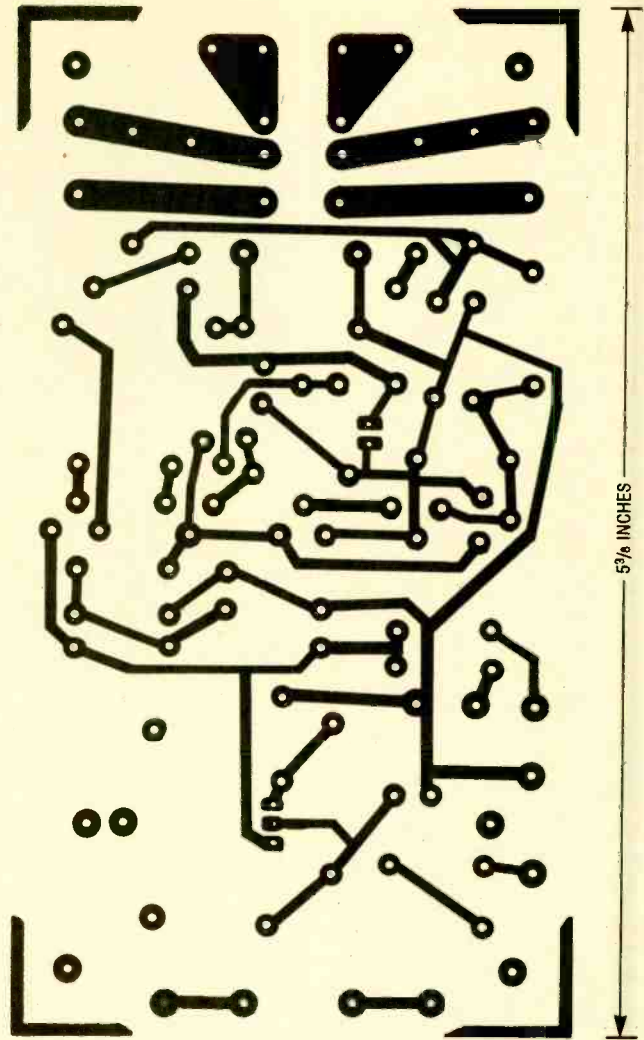

Fig. 2. The same pattern is used for both the DC-powered and AC-powered versions. Here is an actual-size template for the printed-circuit board. Check your board against this pattern before mounting any of the parts.

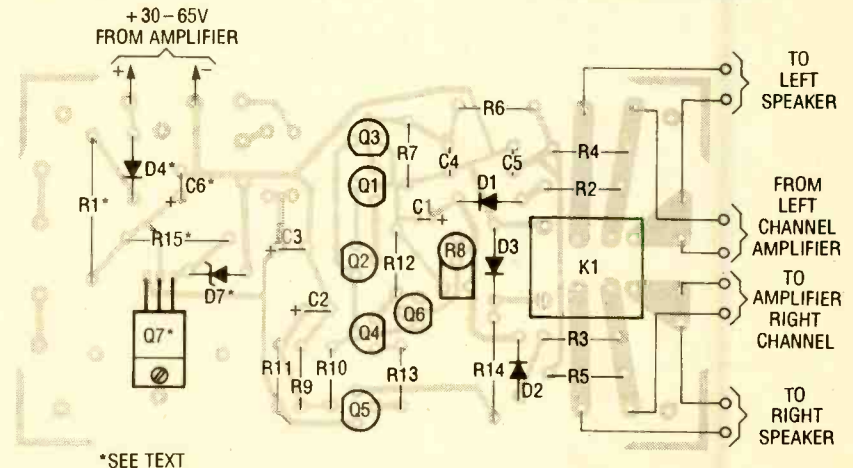
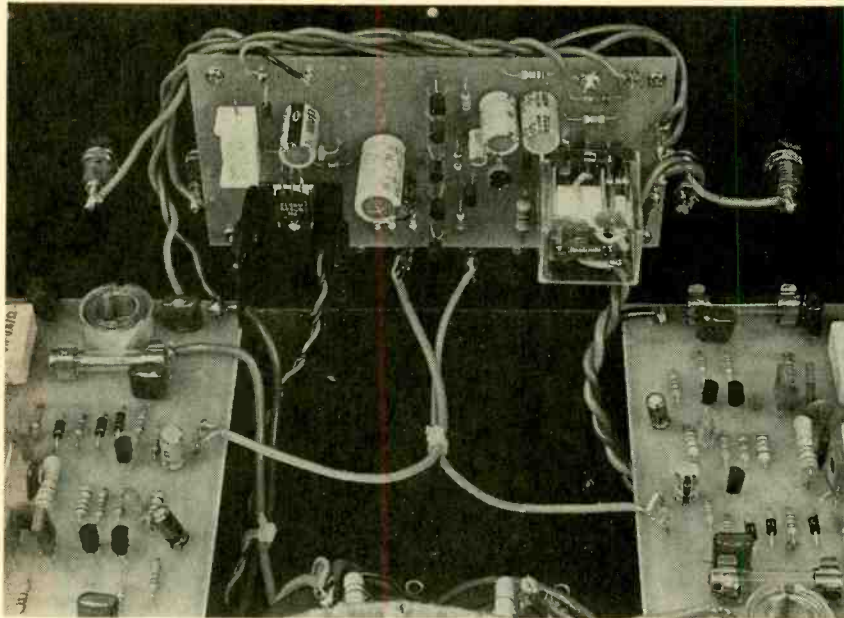
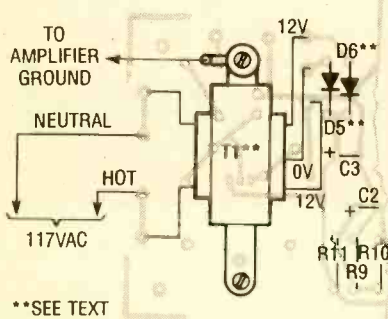

Fig. 3. Here is a complete parts-placement diagram for the DC-powered version. Resistor R1 (the 220-ohm 5-watt unit) can be replaced with a jumper wire for supply voltages of less than +45 volts.



In most cases, you should be able to mount the board on the rear panel of the amplifier close to the speaker terminals, as shown here.



**SEE TEXT

Fig. 4. The alternative AC-powered version omits the on-board voltage-regulator components and substitutes a power transformer, T1, and diodes D5 and D6.

its leads at right angles so that the metal tab lines up with its mounting hole. Once that is done, smear the tab with heat-sink compound, then bolt the transistor tab on top of the heat sink to the board and solder the leads.

The relay can now be mounted to the board. The best way to go about that task is to first solder short lengths of heavy-gauge tinned-copper wire to each relay pin. Make sure that the pinout of the relay that you use matches the printed-circuit pattern, or you will have to bend the soldered wires so that they go to the appropriate pads. Push the wires through the relay mounting holes and solder the relay in place. Be sure that the relay is seated as far down as it will go, so that

its pins contact the board surface. **Do not** try to enlarge the circuit-board holes to directly accept the relay pins. You'll damage the copper traces if you do.

The partial parts-placement diagram for the self-contained version (Fig. 4) differs for the layout in Fig. 3 only in that D4, D7, R1, R15, C6, and Q7 are omitted, and replaced by T1, D5, and D6 instead. Provisions for those components are provided in the circuit board. However, the transformer used in the prototype is not available in the U.S. Depending on the size of the transformer that you buy, it may be necessary to mount it off board and run wire to the appropriate printed-circuit pads.

Alternatively, if the amplifier's power transformer has a 24-volt center-tapped secondary, you can connect it to D5 and D6, and eliminate T1. Once the assembly has been completed, check your work before going on to the installation.

Installation. The completed pirated-power version can be installed in any convenient location within the amplifier's enclosure; however, it's best to mount the board as close to the speaker terminals as possible. In most cases, you should be able to mount the board in that general area on the rear panel using standoffs.

If you are installing the AC-powered

version in an integrated amplifier, be sure to keep the power-supply components away from the sensitive pre-amplifier stages. It will be necessary to connect a wire from the transformer chassis to the circuit-board ground and then to the main ground of the amplifier. Do not simply connect the circuit ground pin to amplifier ground. You could end up with a really bad hum loop if you do.

If you've built the power-pirating version, connect the circuit to the power source, but **do not** connect the amplifier or speaker leads until the unit has been tested. (The same goes for the other version.) Start by checking your amplifier's schematic diagram for a suitable DC supply. Once located, the supply should be verified using a multimeter before it is connected to the Speaker Protector.

Testing. To test the unit, apply power to the circuit and check to see that the relay closes after about two seconds. If the relay closes, fault conditions at the input can now be simulated using a 9-volt transistor-radio battery. Connect the battery across each input in turn, first with one polarity and then the other, and check that the relay immediately opens in all four cases. In each case, the relay should close again as soon as the battery is removed. If you run into trouble, immediately power down the Speaker Protector and check the circuit for wiring errors. In particular, check the power-supply voltage and that all parts are correctly positioned and oriented.

Assuming that everything is okay, R8 can now be adjusted to set the signal overdrive trip point. To calculate the trip point, you need to know the power rating (P in watts) and impedance (Z in ohms) of your speakers. Those values are then plugged into the formula $P = V^2/Z$ to derive the trip-point voltage.

For example, let's say that your speakers have an impedance of 8 ohms and are rated at 50 watts. If those values are substituted into the above formula, we get a trip point voltage of $V = 20$ volts. Similarly, if your speakers are rated at 100 watts, the trip-point voltage will be 28 volts.

Here's the adjustment procedure:

1. Switch off all equipment and con-

(Continued on page 100)

Build an

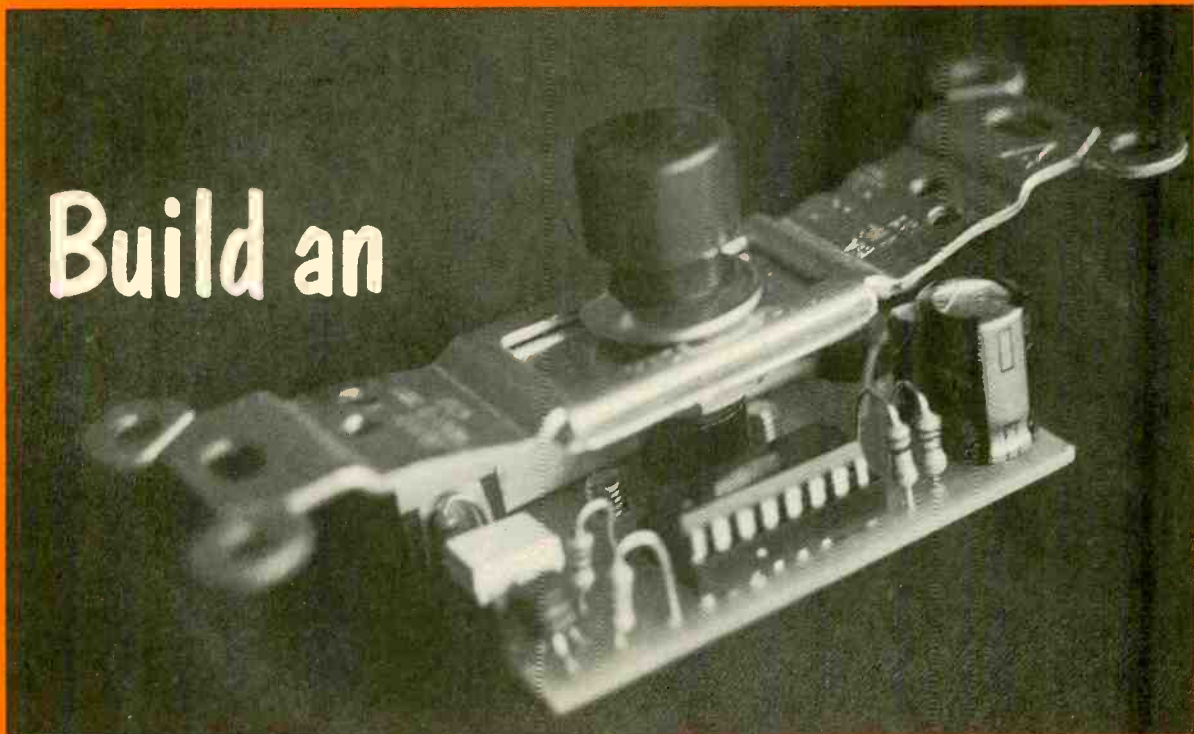

Automatic Porch-Light Control

Automate the operation of any light so it turns itself off and saves you money.

The price of electricity has gone up yet again! Have you ever known it to come down? And yet we waste so much. Why, only the other day I went out to get the morning paper, and the porch light was still on. Must have been on all night. I started thinking "Why can't my wife remember to turn it off after . . ." and then I remembered I left the light on. It was then I decided to build a circuit that would automatically turn off the light. Before presenting the circuit, let's look at some of the design criteria I dealt with.

Designing the Circuit. Of course I wanted a circuit that could be turned on manually, but would turn off automatically. For that reason I decided the circuit should replace the existing porch-light switch, so it had to be small enough to fit in a standard junction box. It would also have to draw its power from the existing wiring. That presented me with a problem: The switch junction box in question was

BY DAVID PONTING

not wired with both the hot and neutral powerlines. It just had an incoming hot wire and a switched hot wire going to the lamp. So my circuit would have to operate without benefit of the neutral line.

My solution was to place a resistor in series with the switch, and place the automatic control circuit in parallel with the resistor. With the switch in the "on" position and a good bulb in the porch-light fixture to complete the circuit, current flows through the resistor. The voltage drop produced across the resistor by the current provides power for the control circuit.

However, I had to determine the optimum value for the resistor: If it was too large it would make the porch light dim, if it was too small the voltage drop would not be sufficient to power the circuit. Furthermore, I had to determine if a resistor with sufficient wattage to handle the bulb's current would be physically small enough to

fit in the junction box, but run cool enough to prevent damaging the other components.

The first task was to determine the current flow through the bulb. To figure that I assumed I'd be working with at most a 100-watt bulb operating off a 120-volt supply. The current would equal the wattage divided by the voltage, which comes out to 0.83 amp. Now I needed to find the value of resistance that will yield a voltage drop sufficient enough to power the control circuit. Taking a guess that I needed about 12 volts and dividing that by 0.83 amps yielded a resistance value of about 15 ohms. Now I turned my attention to figuring out the wattage of the resistor. Multiplying the voltage drop times the current indicated I'd need a 10-watt resistor—a suitable size. The resistor would generate some heat, but since it would only be on for a couple of minutes at a time, it would not harm the other components in the junction box.

An additional concern of mine was

tocoupler's LED, turning off the Triac and extinguishing the light.

Safety Tips. Before we get to the construction details a word or two of caution is in order. When building the circuit keep in mind that when the circuit is active both AC legs of the circuit are hot. That is, of course, no different from the switch inside any switch-box in the house: hot is always present on one side of the switch, and appears on the other side when the switch is closed. Nevertheless, when testing this circuit board, **the utmost care must be exercised to see that no part of the board is touched.** Once the device is in its switch-box, it is no more dangerous than the standard switch it replaces, but until then handle it with caution.

On a different note, when you look around for a Triac try to get one with an isolated tab. That will prevent the tab from shorting the AC powerline should it come in contact with one of them. Also make sure the pushbutton switch you use can handle powerline voltages at currents up to about 1 amp. The switch recommended in the Parts List has not only a more than adequate rating for the circuit, but it also has an ideal length, allowing all the fitted components on the PCB to be clear of the switch's mounting bracket (which we'll discuss in a moment).

Preliminaries. Although very cautious point-to-point wiring will work, I recommend that you build your Auto-

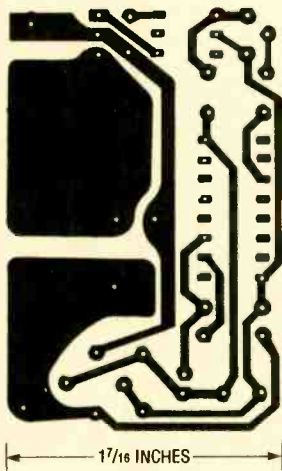

Fig. 2. Using this foil pattern to make a PC board is recommended. It will virtually eliminate the possibility of wiring errors.

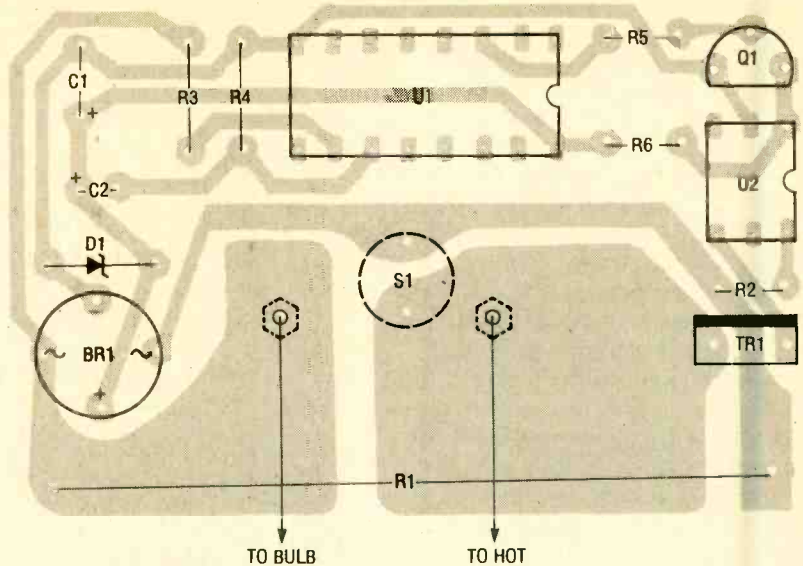

Fig. 3. Stuff the board as shown here. Note that the switch and nuts are mounted on the foil side of the board.

matic Porch-Light Control on a printed-circuit board made from the foil pattern shown in Fig. 2. Remember that if you want a different delay time, alter the foil pattern or circuit board to accommodate the delay you want as outlined earlier.

Some special steps must be taken for drilling the circuit board. For example, the flat terminals on the pushbutton switch have to be soldered to the PCB, so narrow slots have to be made in the board to accept them (see Fig. 3 for their position). These are best achieved by drilling a standard PCB size hole (about 1 mm), drilling two more holes adjacent to the first, and joining them together by carefully filing with a small needle file.

Also be sure to make two holes in the board large enough to accommodate 8-32 bolts. These holes should be located on the board where the terminal connections for the hot and bulb wires are to be made. Once the board is drilled, pass an 8-32 screw through each hole from the component side and fasten them with matching nuts. Solder the nuts to the foil being careful not to bind the screws to the nuts. Remove the screws for now, and the circuit board is ready.

Prior to stuffing the board you will need to modify some of the parts, so let's discuss that now. Do not solder anything to the circuit board until you are told to do so.

The body of the switch has to pass through a bracket that will hold it (and therefore the PCB) to the junction box.

You can take the retaining bracket from a plain wall switch, either a new one or the one you're replacing. If you want to use the bracket from the switch you're replacing, there are some instructions for safely removing the switch from the junction box given later (see the section entitled "Testing the Unit"). Once you have the switch, remove the bracket by carefully drilling out the rivets that hold it in place.

The pushbutton switch can now be passed through the central hole of the bracket (where the lever of the removed switch was). It may need a small rectangular piece of aluminum as a washer to hold it in the middle of the hole. Now finger-tighten the switch in position with its own washer and nut. When fixed in this way, the switch should be rotated so that its two contacts run parallel to the bracket's longer dimension. Hence, when the PCB is finally soldered to the switch, the board will have its longer dimension parallel to the bracket as well. Now securely tighten the switch to the bracket.

Drill a hole in the center of the blank switch box panel so that the button on the switch can come through. The switch recommended in the Parts List has a removable button, so you only have to drill a hole large enough to accommodate the shaft of the switch. Later, when the switch and switch box panel are in place, you just have to pop the button back on the shaft of the switch and it will hide the hole.

(Continued on page 97)

Many projects, circuits, and electronic instruments that contain electro-optical sensors depend critically on the nature of the light source for proper operation. In many such applications, the spectral content (the particular wavelengths that are present, and their relative mix) of the light source is terribly important. Examples include carbon dioxide gas monitors, which require infrared; blood-oxygen monitors, which use red and near-infrared; and ozone monitors, which operate in the ultraviolet region.

Figure 1 shows the spectral content of several different common light sources. Also shown, for comparison purposes, is the spectrum for sunlight and the nearly monochromatic spectra of several popular types of light-emitting diode (LED). Let's explore each light source individually.

The Sun. The light from the sun (labeled "daylight" in Fig. 1) ranges from the infrared (which helps warm our planet), through the visible spectrum (so we can see things), to the ultraviolet (which causes skin wrinkling, aging, and sometimes skin cancer). Although only occasionally used for instrumentation purposes, sunlight is often the standard against which other sources are compared. In some special cases (e.g. diamond and colored-gem testing) "north light" (the light from a northern aspect) rather than direct sunlight is used.

Fires and Flames. Another light source is fire. When a material is rapidly oxidized, it will give off a characteristic electromagnetic spectrum that can range from infrared to bright bluish-white light. This is a useful property that various pieces of lab equipment take advantage of to determine the chemical content of substances.

For instance, some electronic instruments measure the spectral content of the light emitted by a burning sample and compare it to the light emitted by a calibration substance. For example, a flame photometer measures the sodium and potassium con-

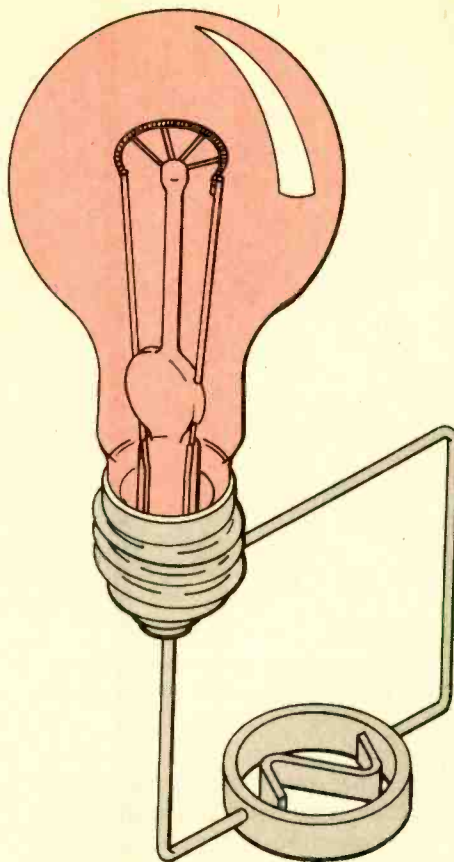

LIGHT SOURCES FOR PROJECTS AND INSTRUMENTS

BY JOSEPH J. CARR

We look at the most common light sources and provide an in-depth explanation of how LED's are built and operate.

tent of human blood by burning a small blood sample and comparing it to a calibration substance. It notes the relative intensities of different colors of the spectrum to make its evaluation.

Even without high-tech equipment, one can also guess the constituents of a fire by noting the mix of colors in the flame; Sodium, one of the most abundant elements, burns with a yellow flame, while a sodium-free methane (natural gas) flame is very blue. One home-furnace repairman told me that the presence of too much yellow (or sodium) flame is an indication that I should have the burner cleaned of foreign material and soot.

Incandescent Light Sources. For centuries the only source of artificial light was fire; After sundown, it was either fire or darkness. But using fire obviously carries with it a number of practical problems, not to mention inherent dangers. In the 1870's, American inventor Thomas Edison finally produced a practical artificial light source that produced light from electricity. As you're probably aware, Edison's invention was the incandescent lamp. In this type of light source, a thin filament (nowadays usually made of a tungsten alloy) is mounted to electrodes inside an evacuated glass bulb. The electrodes are connected to a current source that pushes current into the resistive filament at such a level that the wire heats to incandescence (the point where it will give off light). The efficiency and spectral content of the basic incandescent lamp has been improved by inserting small amounts of inert gases into the evacuated bulb.

The curves in Fig. 1 for the spectra of an ordinary tungsten room lamp and the quartz halogen lamp are the same. That's because quartz is used to form the envelope of an incandescent bulb as it can survive a much higher temperatures than ordinary glass.

Glow Lamps. A glow lamp (shown in Fig. 2A) consists of a pair of electrodes inside a small glass envelope that has

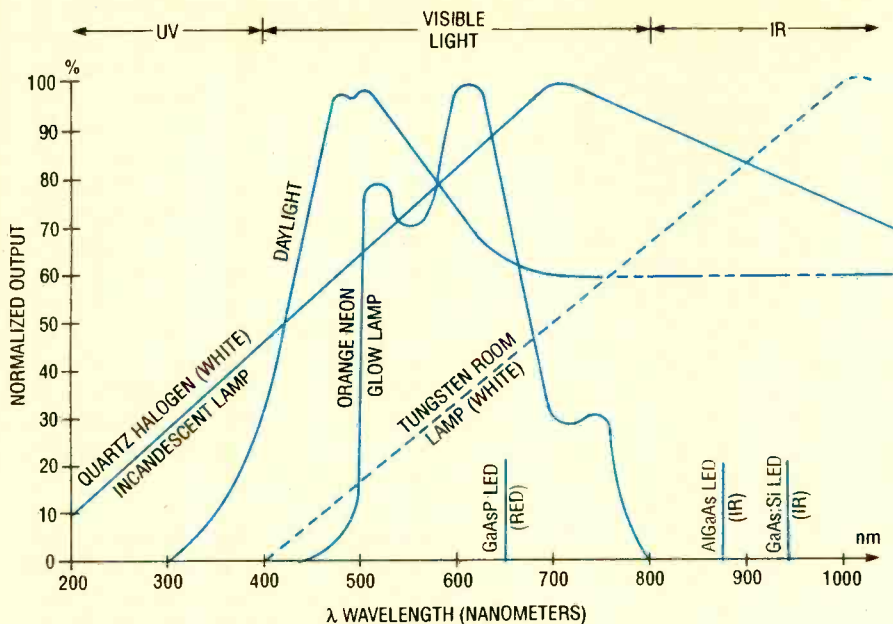

Fig. 1. This chart shows the spectral output of various common light sources. Note that the output of the common incandescent lamp is identical to that of quartz because bulb envelopes are often made of quartz.

been first evacuated of air, and then refilled with neon or another inert gas. When an electrical potential is applied across the electrodes, the neon gas will ionize and give off an orange glow. If DC is applied only one electrode lights; if AC is applied, both electrodes glow. The spectrum for a neon glow lamp is considerably narrower than the spectrum for incandescent lamps (look back at Fig. 1), running from about 500 to 800 nm.

In practical glow-lamp circuits, such as the one in Fig. 2B, a series resistor is used to limit the current flow to a safe value. The resistor is required because when the gas ionizes, the lamp's electrical resistance breaks down to a low value.

Solid-State Light Sources.

Semiconductor materials were known to produce light as early as 1907, when the phenomenon was discovered by H.J. Round. After 1960, solid-state light sources became commonly available in the form of light-emitting diodes (LED's). We will deal with these devices in the rest of this article. Let's start by looking at how a semiconductor material might emit light.

Figure 3 shows a stable atomic configuration. That particular atom (neon) has ten protons and ten orbiting electrons. The first shell of any atom is completely filled when it con-

tains two electrons (as shown). The second shell contains the remaining eight electrons. With the exception of the first shell, each shell of an atom can be completely filled by eight electrons. A shell filled with eight electrons is called a "stable octet."

When the outer shell of an atom is completely filled, chemical reactions and current flow become a lot more difficult to establish. That's because sufficient energy must be supplied to the atom to strip away an electron from the filled outer shell. The inert (or "noble") gases—radon, xenon, krypton, argon, neon, and helium—all have completely filled outer shells so they are not chemically active. They will not conduct electrical current unless they are exposed to an electric potential that is high enough to strip away outer electrons.

Lower energy electrons are located in lower shells closer to the nucleus while more energetic electrons are further away. When an electron absorbs energy, the electron is said to be "excited." The excited electron will jump to a higher energy shell, leaving a hole behind in the electron's previous location. If the electron loses the energy, it falls from the higher energy state back to the lower energy state (filling the hole).

The Law of Conservation of Energy requires that the energy lost when the electron falls to a lower state be ac-

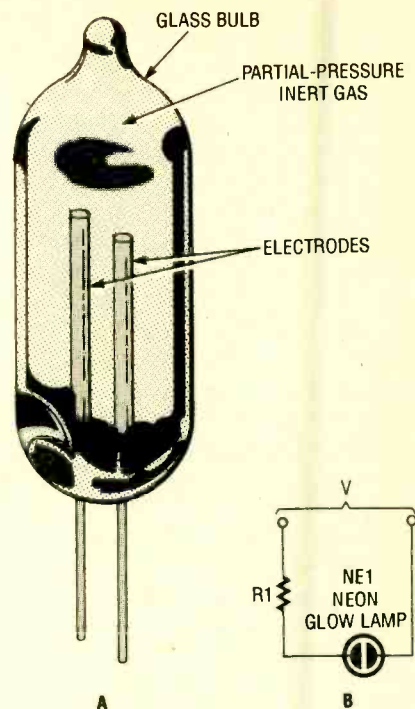

Fig. 2. Gas glow lamps (A) are very easy to use (B) in a circuit. They only require a current-limiting resistor.

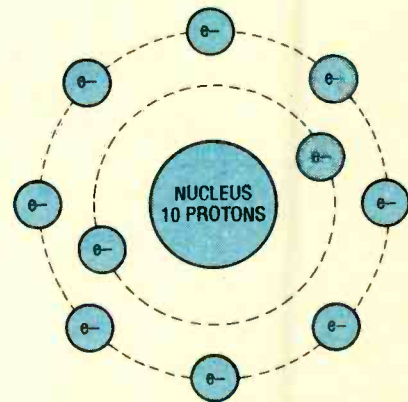

Fig. 3. A stable octet is formed when eight electrons inhabit the outer shell of an atom. Although only two electrons are needed to form stable helium.

counted for. That energy takes the form of a photon, often in the infrared or visible frequency range. A light-wave generated by an electron recombining with the hole it left behind is called "recombination radiation."

Figure 4 shows the phenomenon in detail. In Fig. 4A an electron at the "ground state" (energy level E_0 , sometimes called the valence band) has been excited by external incident energy E_i . Under this stimulation, the electron jumps to a higher energy level (E_c) called the conduction band, leaving a hole in its former energy

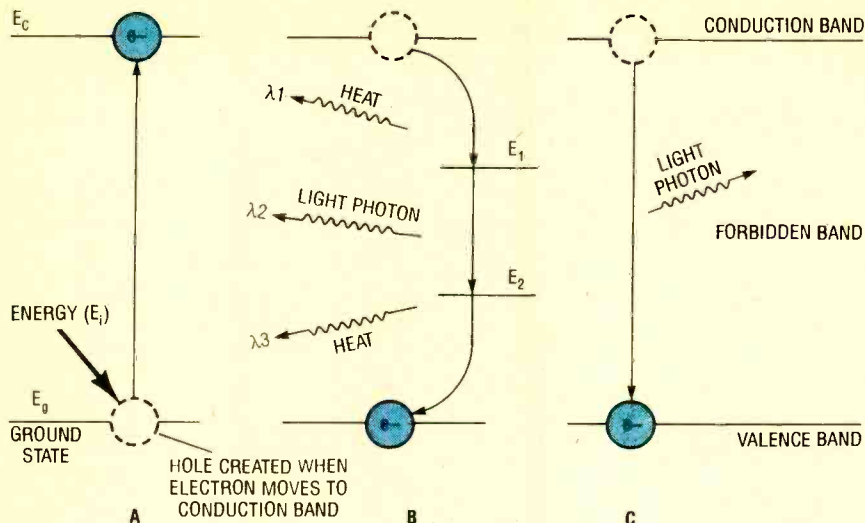

Fig. 4. A sufficiently excited electron can jump to a higher energy level, leaving a "hole" behind (A). A two-step emission (B) would allow it to radiate more than one photon as it falls back down, while a single-step process would cause it to emit only one.

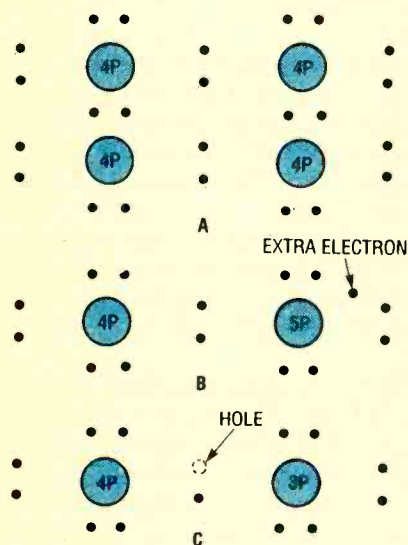

Fig. 5. Common semiconductor materials have four valence electrons, but form a stable octet by sharing electrons between atoms (A). Pentavalent materials have five valence electrons, so they provide an extra electron that becomes available for current flow (B). A trivalent material has only three valence electrons, so a hole is created when it forms bonds with nearby atoms (C).

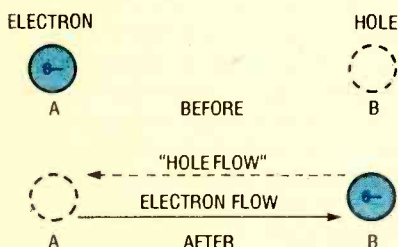

Fig. 6. When an electron moves, a hole is left behind, so "hole flow" is actually electron flow seen in relief.

level. The distance between the conduction and valence bands is called the forbidden band or band-gap energy, and is usually expressed in electron volts (eV). The band-gap energy is the amount of energy the electron must absorb to jump the gap.

There are two basic forms of recombination emission. In the multi-step version (Fig. 4B), the electron energy drops back to E_0 in at least two steps. Different wavelengths of light are emitted at each transition. The more efficient one-step version is shown in Fig. 4C. In that process, the transition is directly from E_c to E_0 , emitting a single wavelength photon in the process.

From physics we know that:

$$\lambda = hc/E$$

where λ is the photon's wavelength, h is Planck's constant, c is the speed of light, and E is the energy of the photon. When the constants are combined, and the units are converted to express wavelength in nanometers, the equation above reduces to:

$$\lambda_{nm} = 1237/E_g$$

Where λ_{nm} is the wavelength in nanometers ($1 \text{ nm} = 10^{-9} \text{ m}$), E_g is the band-gap energy between the conduction and valence bands in electron volts (eV).

In gallium arsenide (GaAs)—the material used for many light-emitting diodes—the band-gap energy ranges from about 1.32 eV to 1.36 eV, with 1.34 eV being the nominal value. For those levels, the emitted light

wavelength is 937 nm, 910 nm, and 923 nm, respectively. As we'll later explain, semiconductors emit light by recombination.

PN-Junction Light Radiators. Light emission from recombination in semiconductors can occur in bulk materials such as gallium arsenide (GaAs), but the phenomena is most effective when the material is formed into a PN junction—P-type and N-type semiconductor materials in intimate contact with each other. An N-type semiconductor material is "doped" (mixed) with impurities that give it a surplus of electrons, while P-type semiconductor is made impure (or doped) to create a deficiency of electrons. To help explain the production of P and N-type semiconductors it is necessary to look at the atomic structure of semiconductors.

Semiconductor materials tend to be tetravalent (*i.e.*, they have four electrons in the outer shell (called the valence shell). In order to achieve stability similar to the stable octet configuration, these atoms share electrons with each other to simulate the situation where eight electrons exist in the valence shell. This is called "covalent bonding." When the atoms do this they form a crystal lattice array (see Fig. 5A). Note that each atom shares two electrons with each of its neighbors.

Because of the stability of covalent bonds, such materials are not good conductors of electrical current; Free electrons are needed for current flow. These are supplied in N-type semiconductors by doping the tetravalent semiconductor with a pentavalent (five valence electron) impurity. Four of the five valence electrons of each impurity atom will be used in covalent bonds with nearby semiconductor atoms (Fig. 5B). But that leaves one odd electron for each impurity atom. The extra electrons created by this process are free and can support electrical current flow.

The processing of P-type semiconductor material uses a similar scheme to create a deficiency in the number of electrons available for covalent bonding. That neat trick is accomplished by adding some trivalent (three valence electron) impurities to a tetravalent semiconductor (see Fig. 5C). Again, the covalent bonds are

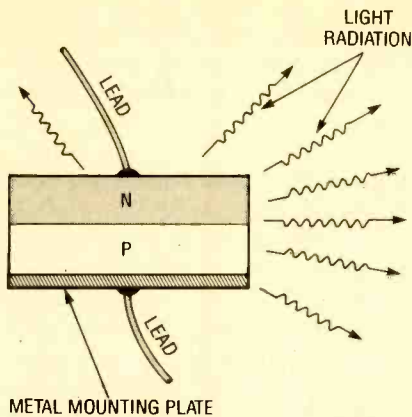

Fig. 7. A PN junction consists of P-type and N-type materials butted together. If you pass current through the junction in the right direction it will emit light.

formed between the impurity atoms and the semiconductor atoms. There will be, however, electrons from the semiconductor atoms that are not able to pair up with an atom from an impurity atom nearby. As a result, there is a "hole" in the crystal-lattice structure.

A hole is a place in the semiconductor crystal lattice network where an electron should be, but isn't. The hole doesn't really exist as a physical entity, but it can be treated as if it does exist. Mathematically, it looks like a particle with roughly the same mass as an electron, but with a positive electrical charge rather than a negative charge.

The "charge carriers" (charges that flow) in N-type semiconductor materials are electrons, while the charge carriers in P-type materials are holes. Actually, both types of charges exist in both materials, but there is a majority of electrons in N-type materials, and a majority of holes in P-type materials. Electron current flow is easy to understand, but hole conduction seems to bother some people. Actually, hole flow is nothing but electron flow in reverse. The "hole" only appears to move; what really moves are electrons. Consider Fig. 6, at the top is an electron at point A, while a hole is at point B. When the electron moves from A to B to fill the existing hole, it leaves a hole in its previous location on the crystal lattice. It appears as if the hole moved from B to A, but actually it was the electron that moved from A to B.

Doping one end of a semiconductor material to make it an N-type sem-

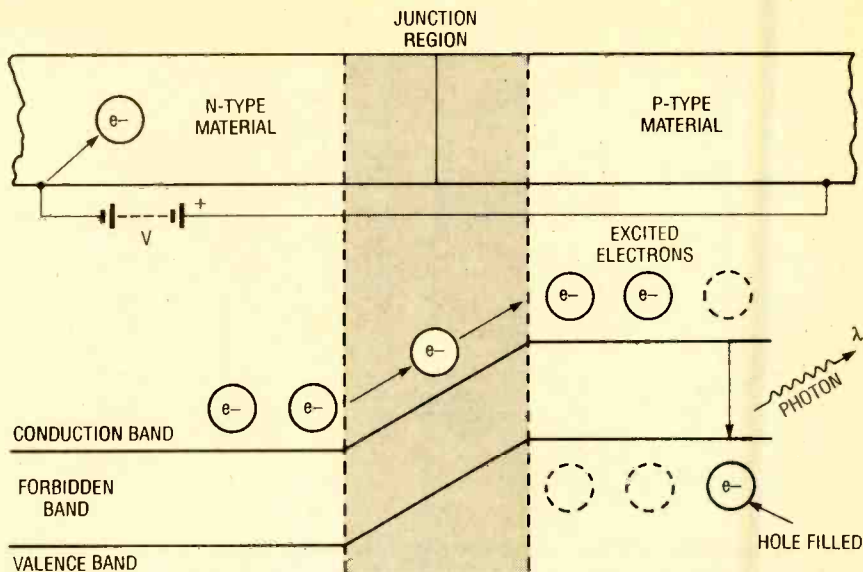

Fig. 8. In a light-emitting diode, the electrons forced into the P-type material combine with the holes there and radiate recombination energy.

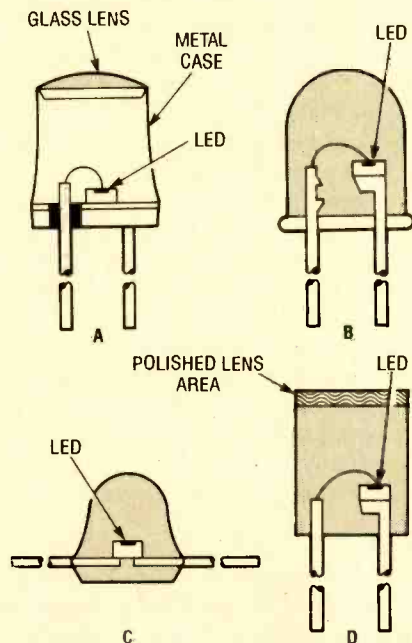

Fig. 9. There are many assorted LED packages. Shown here are the metallic (A), epoxy (the most common style) (B), radial-lead epoxy (C), and flat-package (D) styles.

iconductor, and doping the other end to form a P-type semiconductor results in a PN junction (see Fig. 7). In most cases, the main body of the material will be made P-type, and then N-type impurities will be diffused onto one surface to form the PN junction.

Shown in Fig. 8 is an energy-level diagram for the junction. When an electrical potential is impressed across the junction (voltage V in Fig. 8),

electrons are injected into the N-type material and withdrawn from the P-type side. The extra conduction-band electrons in the N-side flow into the P-side. Once in the P-material, they cannot remain in the conduction band because the valence band has holes, so the electrons drop down into the valence band filling the holes and emitting recombination radiation.

LED Cases and Mounting. Figure 9 shows the structures of some typical LED's. In all of them, the P-type side of the PN junction is bonded to a metallic mounting tab, which forms one electrode of the diode. The N-type region is bonded to a thin wire (only several mils in diameter), which connects it to the other electrode. Light is emitted both at the junction and from the bulk material. In some LED's, the metallic mounting tab is made reflective to bounce light that is heading toward the tab back out toward the viewing area.

The package in Fig. 9A may make it look similar to small transistors with a TO-18 case. The case sides are metal, while the top is a glass lens that allows light from the LED chip to exit. The low-cost epoxy package is shown at Fig. 9B. That style is the most common, and is available in clear, red, yellow, amber, blue, or green, depending on the particular LED. A small flat-mounting package is seen in Fig. 9C, while a clear-plastic flatpack is shown at Fig.

(Continued on page 100)

Electronic Tracking



Foils Car Thieves

BY
ROBERT ANGUS

With specialized transmitters, LORAN systems, and automated police dispatching, perhaps there will come a day when crime won't pay.

Picture it: You park your car in one of Los Angeles' less-desirable neighborhoods and walk to a business appointment around the corner. You've barely turned the corner before a car thief is working on the driver-side window with a coat hanger and by the time your meeting begins, the thief's work is done and that beautiful set of wheels is on its way to a chop shop.

But wait! Before he's driven a mile, the thief hears a voice announcement telling him that the vehicle has been stolen, that police know exactly where he is—and prove it by telling him—and advise him to leave the vehicle immediately. Or, without his knowledge, police alerted by a silent electronic transmitter follow your car to its destination, bagging not only the thief, but his potential customer as well.

It's happening now, in cities like Detroit, Boston, Los Angeles, and Miami. In a year or two, some version of electronic vehicle tracking should be available in a community near you. The trouble is that there is not one single system, but at least a half dozen, all mutually incompatible, and all requiring the cooperation—or at least the acquiescence—of local police.

Some systems beam an alert the minute the car's broken into; others require the owner to notify someone that his car's been stolen. In addition to helping police recover the stolen vehicle, some of the systems also allow an authorized driver to call for help simply by pressing a button. The price for all this: depending on the system, an outlay of \$600 to \$1500 for hardware plus a monthly service charge of \$7.50 to \$15.

A Drawback. So eager are some manufacturers to establish their systems in a particular market that they outfit police cars and stations with receiving equipment free of charge. However, because the systems are incompatible, there's a good chance of driving a car equipped with one system into a community using another system. If your car, equipped with one system, is stolen in a community equipped with another, you could be just as out of luck as if you had no electronic protection at all.

You may wonder why all communities don't use all the systems. It's a matter of practicality, especially if a system requires a separate receiver in each police patrol car.

"We're not in the business of endorsing any one of these systems, but if somebody comes along and offers us the hardware free, we'll take it," says

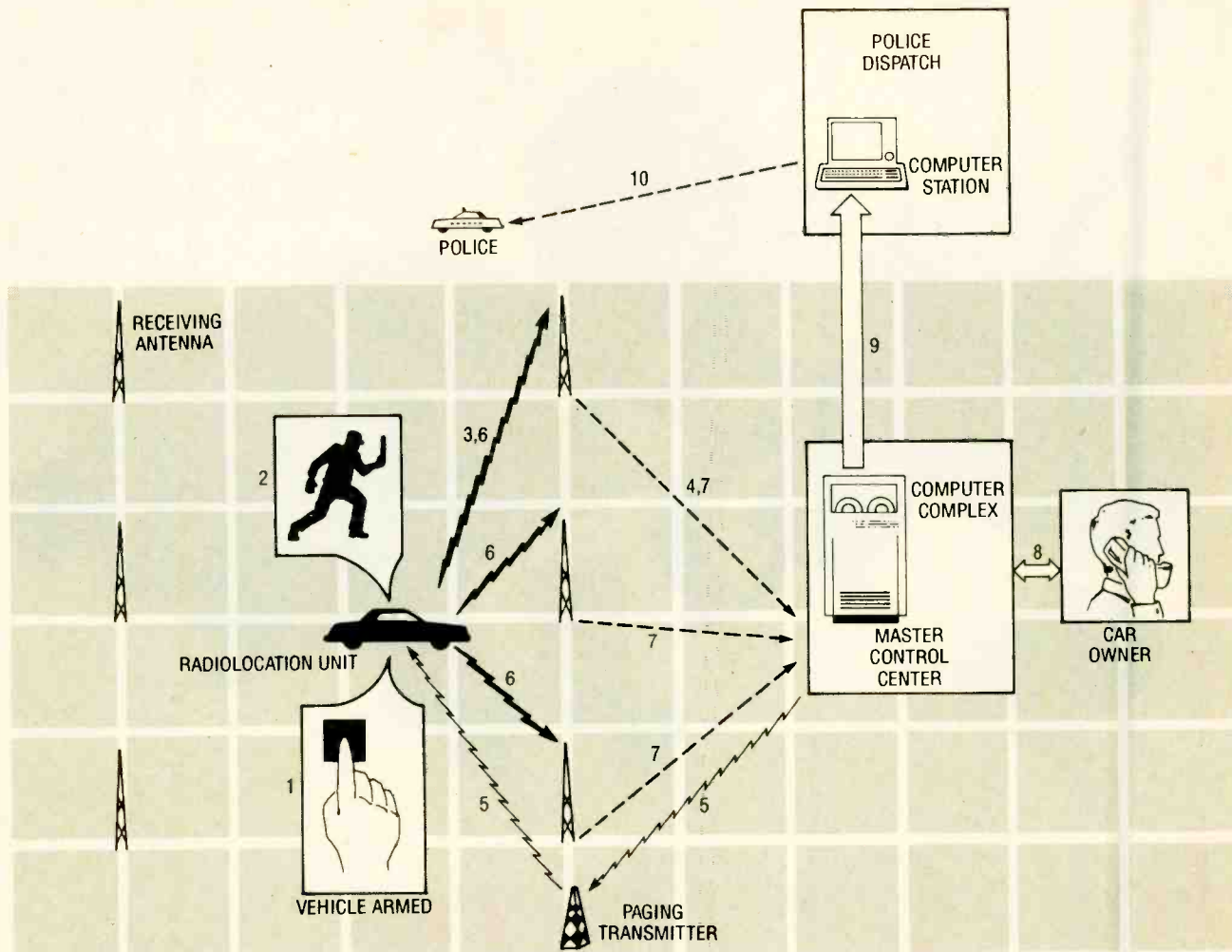

Fig. 1. The Teletrac system employs a network of its own communication towers to avoid relying on LORAN units, which are found mostly along coastal areas.

the police chief of a New Jersey community to whom one company offered its system free of charge. However, he acknowledged that for practical reasons, his department might not be so receptive to the second company to come along and do so: "There's only so much space on the dashboard in a patrol car."

The thief's nemesis in all of the systems is a black box about the size of a paperback novel concealed somewhere on the body of the car—usually in the trunk or glove compartment, or somewhere underneath the chassis. When triggered, by either a violation of the car's alarm system or by a tracking operator, the black box begins transmitting a signal containing not only the license number, make and model of the car, and the registered owner's name, but data that allows the authorities to home in on it as well. Some systems even indicate whether

the car is moving or stationary, and whether the thief is still in it. Let's take a look at the various systems and how they differ.

The Intercept System. At \$1500, the Code-Alarm Intercept (from Locator Industries, 2 Corporate Plaza Dr., Newport Beach, CA 92660) is the most expensive of the packages now available, but that price includes a cellular telephone, an alarm siren, a remote-locking/unlocking mechanism, and the ability to kill the car's ignition if necessary. However, Locator Industries offers a budget version of Code-Alarm for \$695 plus a monthly tracking fee of \$7.50.

If the car is stolen, the cellular phone automatically and silently calls a control center to notify someone there of its position and whether it's moving by using the Coast Guard's LORAN navigational system. The con-

trol-center operator then checks the make of the car, the registered owner, and the license-plate number. The operator can also locate the car's position, speed, and direction on a computerized grid map before notifying police of the theft.

Scheduled for introduction later this year is a callback to the car's cellular phone to double-check on whether the driver has been authorized to use the vehicle. An additional service, for which there's likely to be an extra charge, is a hot button to relay simple messages such as "I've got a flat tire" or "driver in distress" back to the control center.

The problem with the Code-Alarm system is that it operates only in areas that are located within the range of LORAN relay stations—mainly along the East and West Coasts, the Great Lakes, and the Mississippi River; and

(Continued on page 101)

BUILD THE PRINTER

In my humble opinion, you can never have too many indicators on a complex device. (It would've been nice if the designers of the Three Mile Island nuclear plant had felt that way, too.) However, many technical types wouldn't consider a parallel-printer interface to be too complex. A display panel on a typical printer, usually consisting of no more than four indicators (many of which have nothing to do with the status of the interface) is evidence of this thinking.

While I tend to agree that a parallel-printer link is relatively simple, say in comparison to a parallel general-purpose interface bus, it deserves a little more scrutiny than four indicators can provide—even if they are all dedicated to the parallel link.

That became particularly obvious to me when I took a moment to count the number of handshaking lines present on a standard Centronics parallel link—there are nine of them! The large number of handshaking lines took me by surprise; I then realized that the one anonymously labeled "alert" indicator on my printer at home, and the equally anonymous "ready" indicator on the printer at work, just wouldn't do. So I built a little gadget called the *Printer Sentry*, which is described in this article, to monitor and display the activity of all the handshaking lines on a parallel interface.

Once I built the project, I found that it is useful for more than just expanding your printer's display panel. For example, it allows you to monitor the activity of a remote printer so that you know when it's turned on, or out of paper. That's particularly useful in offices where a printer is shared via an A/B switch. You won't have to leave your seat to make sure that the office printer is merrily crunching out that 25-page report that you'll need for your meeting just five minutes away. You'll know if the printer runs out of paper in

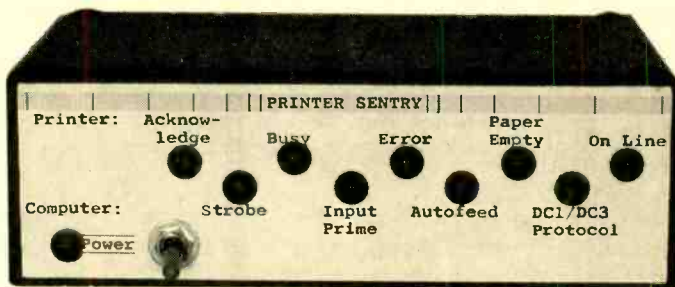

SENTRY

BY JOHN YACONO

This easy-to-build project displays all the signals on a parallel link.

the middle and when the job is done without watching over the paper tray.

I've also found that the Printer Sentry comes in handy for designing cables and troubleshooting parallel links. As I'll explain, there are some handshaking lines dedicated to configuring some basic printer parameters. If either the computer or printer doesn't service those lines, it can lead to erratic operation that is hard to diagnose. The Printer Sentry displays the logic levels of those lines so that you know right away what the computer expects of the printer and *vice versa*. You can compare the displayed configuration to what the devices are capable of to check for any inconsistency. Often, such problems can be resolved by setting some configuration switches, or through changes in cabling (See the article entitled "Troubleshooting Parallel Connections," in the February 1992 issue of **Popular Electronics** for more information.)

Parallel Signals. It makes good sense to talk about the signals that the unit monitors and what they represent before discussing how the Printer Sentry operates. By way of example, let's study the handshaking signals present on the DB-25 connector found on the back of most IBM-compatibles.

If you don't own a compatible, don't worry; although the connector on your computer may be different, it probably uses all the same signals. However, you will have to find out what pins those signals occupy from a technical reference manual for your particular computer.

If you plan to connect the Printer Sentry to the printer end of the cable, rather than to the computer end, or if your computer has a 36-pin Centronics connector on the back, hang on, I'll tell you how to wire the project for those devices later.

The pin assignments for the handshaking lines on the standard DB-25 connector are shown in Fig. 1.

Handshaking inputs to the computer are indicated by arrows pointing to the connector, and handshaking outputs have arrows pointing away. Also shown is one of the many grounds found on the connector (indicated by a circle). That ground is used as the signal ground by the Printer Sentry.

All the handshaking signals are represented by standard TTL voltage levels: a signal between 2.4 and 5 volts is a high or a binary 1, anything between 0 and 0.8 volts is a low or binary 0. Any signal between 0.8 and 2.4 volts is considered noise.

The strobe, busy, and acknowledge signals are the most important and commonly used handshaking signals. A computer will place a fast (generally 2 μ s or more) low-going pulse on the strobe line to indicate that it has supplied some data (on special data lines not shown) for the printer. Then the computer waits for a response from the printer to indicate that it has

used the data. The printer can respond in one of two ways: It can hold the busy line high until it's ready for more data, or it can indicate that it wants more data by sending a low-going pulse to the computer on the acknowledge line. Some printers do both, although some computers only check for one of those responses.

The busy line is sometimes used to halt the computer for other reasons. For example, if the printer is out of paper or "off line" (which I'll explain momentarily). You'll discover what actions your printer takes when you use the Printer Sentry (it's pretty educational). However, there is a line dedicated to indicating the lack of paper—the "paper empty" line. A printer holds that high until its supply is replenished.

Also, a peripheral can tell the computer it's powered-up and on line by holding the "select" line at pin 13 high (don't confuse that with the other select line). That is sometimes a necessary signal line because some peripherals can be powered up but taken off-line by sending them a special "deselect" character (denoted in printer manuals as DC3 or XOFF, which has the ASCII value 19). Such equipment can be brought back on line by sending them a "select" character (denoted as DC1 or XON, which has the ASCII value 17). The computer can turn that "DC1/DC3 protocol" on by holding the select output line at pin 17 high.

Furthermore, a peripheral can cry out for help by holding the error line low. Like the busy line, some peripherals use that line to indicate they are simply off line, or just out of paper, etc.

By holding the autofeed line high, the computer tells the peripheral to accompany each carriage return with a linefeed (*i.e.*, the computer informs the peripheral that it will probably not be sending line-feed characters so the peripheral should add them to the text).

Also, if the computer sends a low-going pulse through the initialize line (technically referred to as the "input-prime" or "IP" line), a peripheral paying attention to that line will reset itself to some default configuration.

The Interface Cable. The Printer Sentry is not designed to be placed in

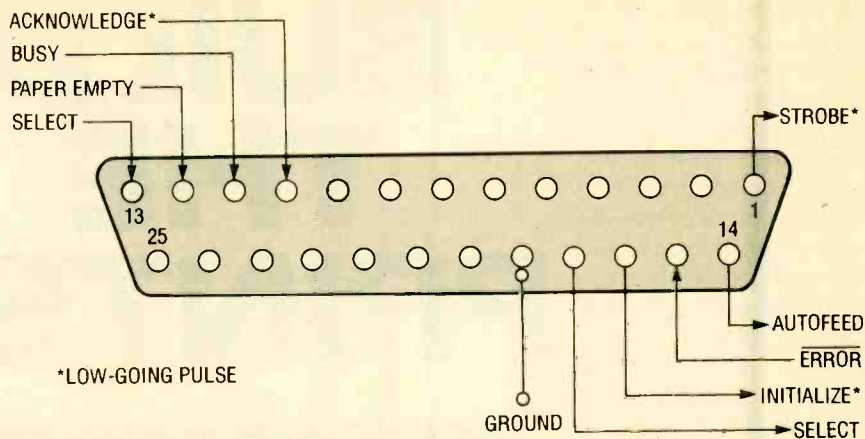

Fig. 1. The parallel port on most IBM-compatible (and some non-compatible computers) looks like this. The arrows pointing away from the DB-25 connector are handshaking outputs, the ones pointing to the connector are inputs, the remaining pin (shown with a circle) is a ground.

series with a computer and printer. Instead, signals are allowed to flow directly back and forth between the printer and computer with the Printer Sentry simply monitoring those signals. That design has a couple of advantages: only one cable is needed to hook the printer sentry to the link—you don't need one cable between the computer and the Printer Sentry, and another between the Printer Sentry and the printer. Another advantage is that it makes the Printer Sentry universal, you don't have to worry about it meeting the timing requirements of the equipment involved. It also permits the printer and computer to communicate even if the Printer Sentry is turned off.

To permit the circuit to work in that manner a special, but easy-to-build, cable was devised. Two DB-25 insulation-displacement connectors (IDC's for short) of opposite gender were attached to one end of a length of 25-conductor ribbon cable. The male connector attaches to the computer, and the female connects with the cable for the printer. The small length of ribbon cable between the connectors and the two connectors themselves form a direct pin-for-pin or "straight-thru" connection from the computer to the printer cable. The other end of the cable runs to the Printer Sentry circuit, which monitors all the pertinent handshaking lines. I'll discuss how to make a cable later when we get to the construction details.

If you wish to attach the Printer Sen-

PARTS LIST FOR THE PRINTER SENTRY

SEMICONDUCTORS

- U1—7805 5-volt, 1-amp voltage regulator, integrated circuit
- U2—555 oscillator/timer, integrated circuit
- U3—556 dual oscillator/timer, integrated circuit
- U4, U5—7486 quad 2-input xor gate, integrated circuit
- LED1—LED10—Light-emitting diode

CAPACITORS

- C1—C3—1- μ F, 10-WVDC, electrolytic
- C4—C6—.01- μ F, ceramic-disc
- C7—.047- μ F, tantalum
- C8—1000- μ F, 10-WVDC, electrolytic

ADDITIONAL PARTS AND MATERIALS

- R1—R3—68,000-ohm, 1/4-watt 5% resistor
- R4—R13—220-ohm, 1/4-watt 5% resistor
- S1—Single-pole, single-throw toggle switch
- J1—Coaxial power jack
- J2—DB-25 connector (optional, see text)
- Ribbon cable (see text), two IDC connectors (see text), LED retainers, 6-volt DC plug-in power adapter, IC sockets, experimenter's board, stand-offs, cabinet, wire, solder, etc.

try directly to the printer instead of the computer, or if your computer has a 36-pin connector, you must use different hardware, but the concept is

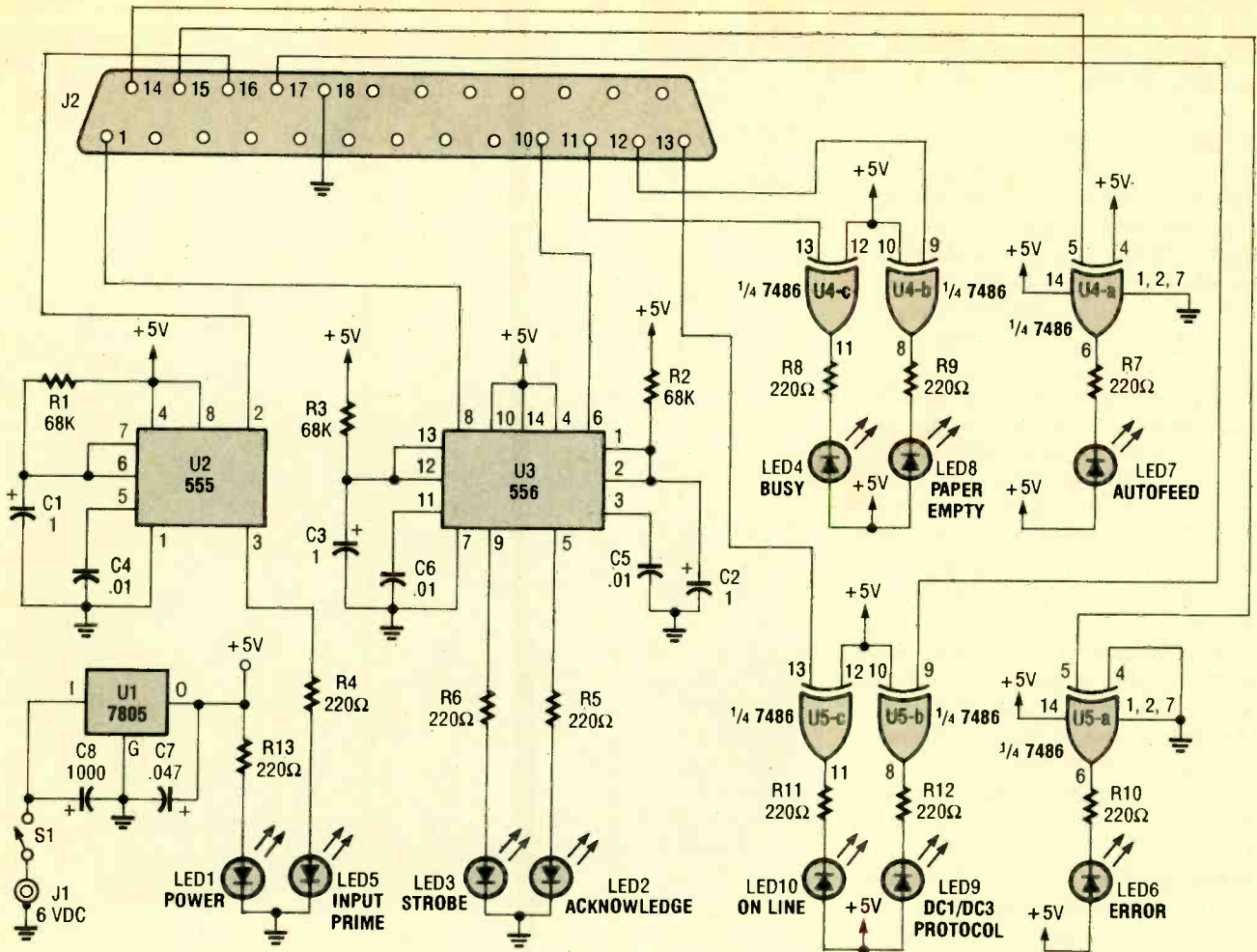

Fig. 2. The schematic for the Printer Sentry may look imposing, but the main portion of the circuit really consists just of two different circuits copied over and over again.

the same. You'll need to attach one male and one female 36-pin Centronics-style connector to one end of a 36-conductor ribbon cable and run the other end to the Printer Sentry. The pins on the Centronics connector that correspond to the pins on the DB-25 connector are shown in Table 1.

The cable that I made had an additional female DB-25 connector at the Printer Sentry end. The main circuit is connected to the cable via jumper wires that plug right into the holes on the female connector. That permits me to connect the circuit to the cable in various ways to suit some specialized requirements that I have. That is, of course, above and beyond the call of duty for straightforward printer monitoring, so you should just solder the ribbon cable wires to the appropriate points in the circuit, which I'll discuss now.

The Sentry Circuit. Although the Printer Sentry circuit (shown in Fig. 2) looks complex, it is an easy circuit to

understand. It consists of a 5-volt power supply, three identical monostable timers, and six XOR gates—five configured as inverters and one configured as a buffer. Shown at the top of Fig. 2 is the optional DB-25 connector (J2) that was used in my Printer Sentry. It is shown to help you identify the wires that you'll need on your ribbon cable.

The power supply is made up of J1, S1, U1, and capacitors C7 and C8. With S1 closed, the power supply con-

verts the 6-volt DC output from a wall-mounted supply that is connected to J1 into a rock-steady 5-volt output for the rest of the circuit. The POWER indicator (LED1) lights when the power section is active.

The three monostable-timer circuits, composed of U2, U3, and their support components, act as pulse stretchers for the input-prime, strobe, and acknowledge lines. For example, when a low pulse occurs on the input-prime line (pin 16 on the DB-25 connector), it triggers the monostable made from U2 and its associated components. The monostable remains high for a time determined by the values of R1 and C1 (which with the values shown works out to approximately $\frac{1}{43}$ th of a second). That causes the INPUT-PRIME LED (LED5) to turn on long enough for the flash to be perceived by the human eye. So when LED5 flashes, it indicates that an input-prime pulse has been generated by the computer. The other two monostable timers work in precisely the

TABLE 1—PIN CORRESPONDENCE

DB-25 Connector	Centronics-Style Connector
1	1
10	10
11	11
12	12
13	13
14	14
15	32
16	31
17	36
18	19

same way to light the STROBE and ACKNOWLEDGE LED's.

The action of the XOR gates is even simpler. When one input of an XOR gates is low, the output follows (or equals) the signal at the remaining input. That turns the gate into a simple buffer, which is how U5-a is used. For example, when the error line goes low (indicating the printer is having a problem), the output of the gate goes low, lighting LED8.

One input of each of the five remaining gates is held high, so they all invert their input signals. That is necessary to make reading the display more intuitive. For example, when a printer is out of paper, it holds the paper-empty line high. Gate U4-b inverts that into a low, lighting LED8. Similarly, when the printer is busy, LED4 lights; if the printer is on line (or "selected") LED10 lights; if the computer requests the DC1/DC3 protocol (as indicated by one of the select lines), LED9 lights. Lastly, if the computer requests the autofeed mode, LED7 will turn on.

Building One. The first thing you should do is make the cable you need. Connecting IDC's to ribbon cable is very easy. If you can't afford an arbor press and can't justify owning an IDC crimper (like myself), you can still connect IDC's easily, provided that you have either a C clamp or a vice (even a small plastic one will do). You can also use vise grips using the same technique that I'll outline for using a C clamp.

Both methods start out the same: Pick up a connector and gently pry at the tabs that hold the strain relief (if one is attached to the connector) in place with a small screwdriver. Now you're ready to use your vise or C clamp.

For the vise operation, place the connector in the vise so that the pins or holes face one of the jaws with the body of the connector parallel to the jaws. While inserting the connector in the vise take note of which side of the connector pin one is on. Tighten the vise just enough to hold the connector steadily in place. Slide the ribbon cable into the slot on the connector from above, making sure that the edge with the stripe is at the same end of the connector as pin one. When the cable sticks out the far

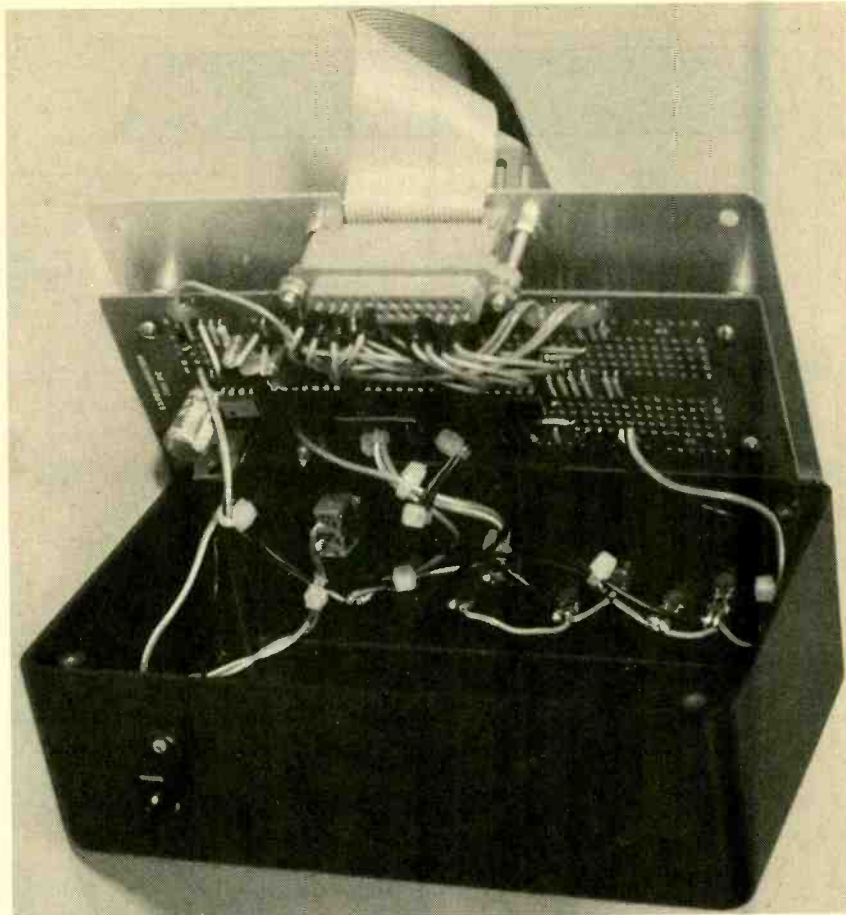

In the author's prototype, the completed experimenter's board was attached to the lid of the enclosure using stand-offs and screws.

side of the connector, align it so that the ribbon cable is centered in, and perpendicular to, the connector. Tighten the vise enough to gently hold the cable in place, and check the alignment again. If all is well, slowly tighten the vise until the tabs on both ends of the connector engage (usually accompanied by a click or two).

If you wish to use a C clamp, place the connector in the clamp so that the pins or holes face away from the threaded jaw. Position the IDC so that one end of it rests between the jaws and tighten the clamp just enough to hold the connector steady. Slide the ribbon cable into the slot on the connector from either side making sure that the edge with the stripe is on the same end of the connector as pin one. Push the cable through until it comes out the far side of the connector a little. Align the ribbon cable so that it is centered in, and perpendicular to, the connector. Tighten the clamp just enough to lightly hold the cable in place, and examine the alignment. If the alignment is okay,

slowly tighten the clamp until the wire engages the teeth in the connector. Now open the clamp and slide the connector over so that the unengaged end of the connector is between the jaws. Tighten the clamp until you hear a click that indicates the back has locked in place on that side. Then loosen the clamp, move it back to the end you started with and tighten the clamp until that end snaps in place and you're all done.

When finished with either the clamp or vise, remove the connector from the jaws. If the connector is at the end of the cable, trim the excess cable close to the body of the connector with wire cutters. Fold the length of ribbon cable over the back end of the connector and snap on the strain relief, which should hold the cable snugly in place. Repeat the above procedure with the second connector, positioning it close to the first connector on the ribbon cable, and the cable is finished.

With the cable ready to go, you can turn your attention to the circuit

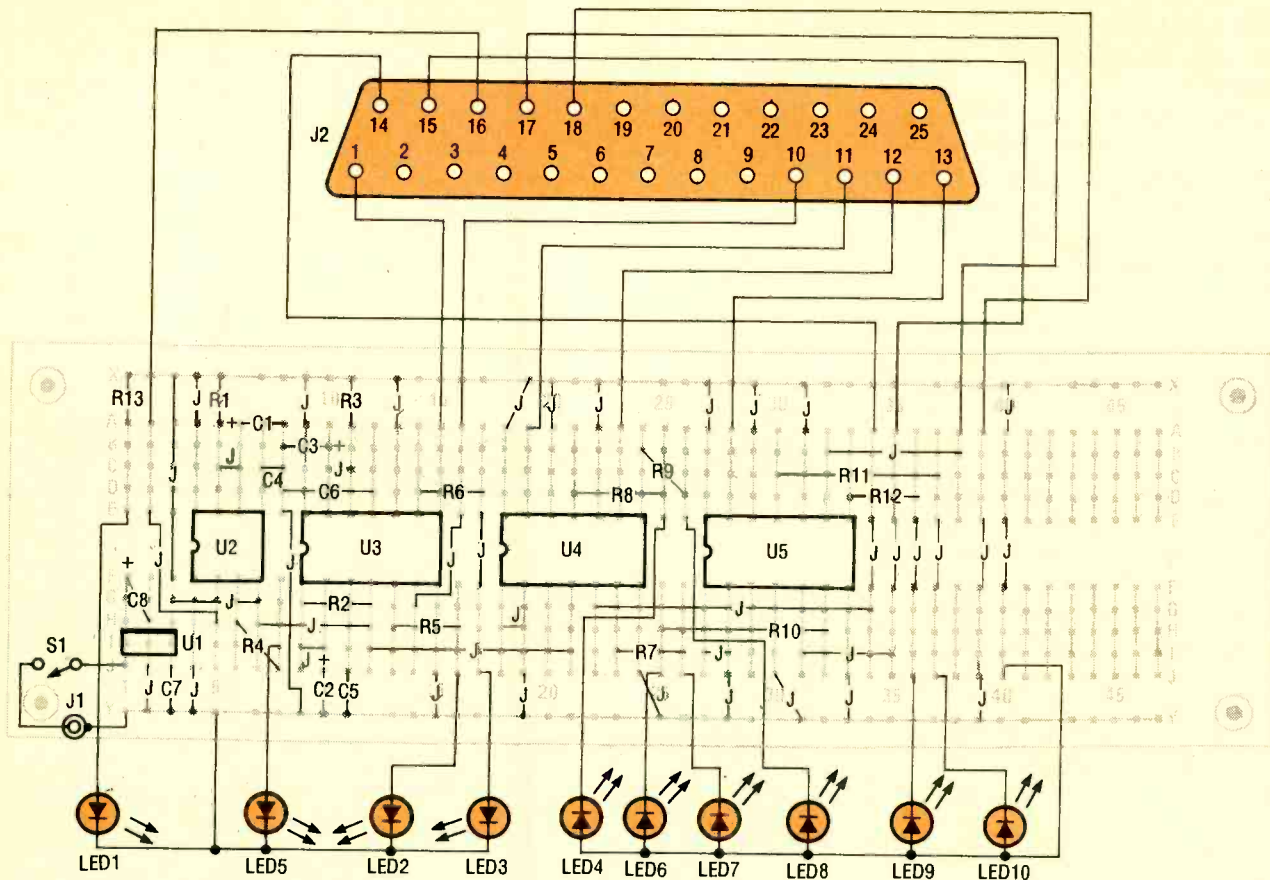

Fig. 3. The prototype Printer Sentry was built on an experimenter's board for neatness. If you follow this layout, be sure to install the jumpers before the components.

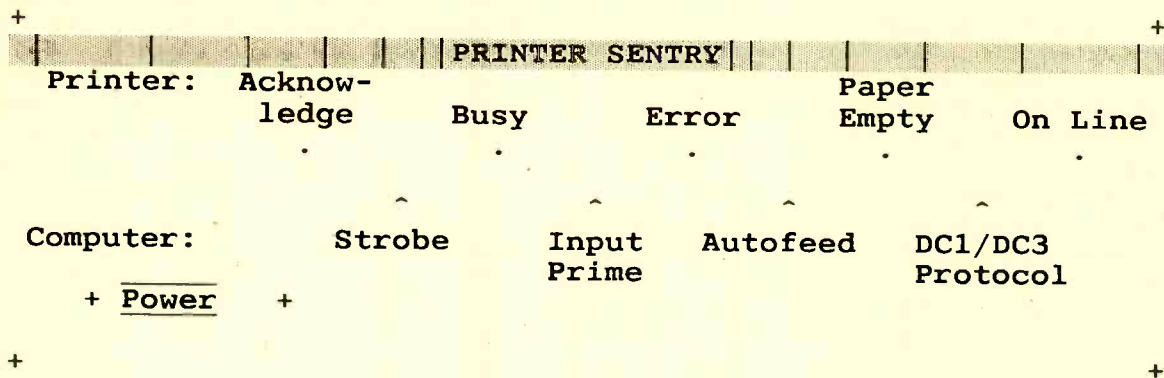

Fig. 4. You can use this illustration as both a drilling template and front-panel label. Drill right through the middle of the crosses and periods, but through the apex on the carets.

board. I built mine on a piece of experimenter's board. That makes the wiring neat and easy to troubleshoot. Before you install anything on the board, you should use it as a drilling template for some standoffs. That will make the placement of the stand-off holes on the cabinet more accurate.

With that out of the way, turn your attention to the parts-placement diagram for the circuit shown in Fig. 3. As is typical when working with experi-

menter's board, it's a good idea to install the IC sockets first since they provide points of reference for installing the components.

Next, you should install the jumpers. If you don't, you'll find some of them are difficult to install once the components are in place. Keeping them neat is a good idea, as the circuit layout is tight. One jumper that needs exact placement is the one between U2 and U3. Make that sure it leaves the

holes for R2, R4, LED5, and the jumper between pins 1 and 2 on U3 clear.

Now mount C8 onto the board and position it as close to the center of the board as possible, but don't solder it into place yet. If that capacitor is an axial-lead unit, it should be positioned positive-lead down to leave more room for U1. You may wish to cover the exposed lead with insulation in the unlikely event that it comes in contact with the tab on the voltage regulator,

but that is unnecessary as both the tab and the lead are at ground potential.

Install U1, but don't solder it in place. Check to make sure there is a little air gap between the capacitor and the tab on the regulator. The gap is important as the regulator will dissipate a bit of heat. If there is no gap, reposition the capacitor. If necessary, gently bend the leads on the regulator so that it is slanted away from the capacitor. Solder both components in place. If you had to bend the regulator, grip its leads with needle-nose pliers and bend them so that the regulator stands upright again and yet maintains some distance from the capacitor. That forms an L in the portion of the leads above the circuit board.

Now install R4, making sure that you leave enough room to connect the lead of LED5. With the more troublesome components finally out of the way, connect the remaining capacitors and resistors. Be sure to orient the remaining electrolytic capacitors properly.

Get out the cable that you've prepared and solder the required wires from it to the indicated points on the circuit board. Take a couple of pieces of wire and connect them to the ground and the regulator input and make them long enough to run to J1 and S1, respectively.

Set the assembly aside for now so that you can finish drilling the cabinet. For the display surface, you can use a copy of Fig. 4 both as a drilling template and a front-panel label. I attached such a label to mine with rubber glue and drilled right through it. The drill points are marked with crosses, periods, and carets. The periods and crosses should be drilled through the middle, while the carets should be drilled through their apex. Next, snap in some LED retainers.

On the back of the cabinet, drill a hole for the power connector (J1), being careful not to damage the front label. That completes all the drilling. Install J1 and S1 in the cabinet and connect a wire from the positive terminal of J1 to one terminal of the switch. Now pop the LED's into the holders so that both leads on each are accessible. Connect the cathodes of LED1, LED2, LED3, and LED5 together with short lengths of wire using Fig. 5 as a guide. Similarly, con-

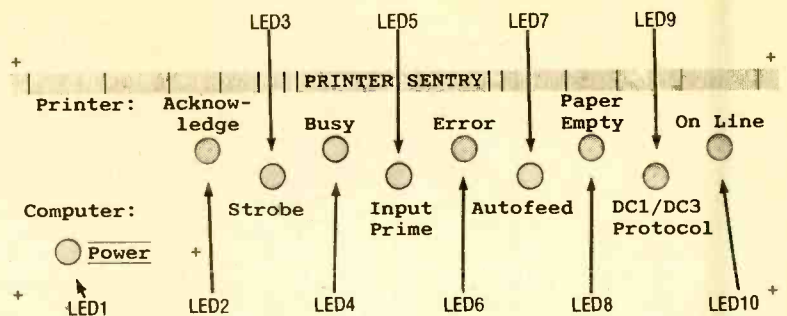
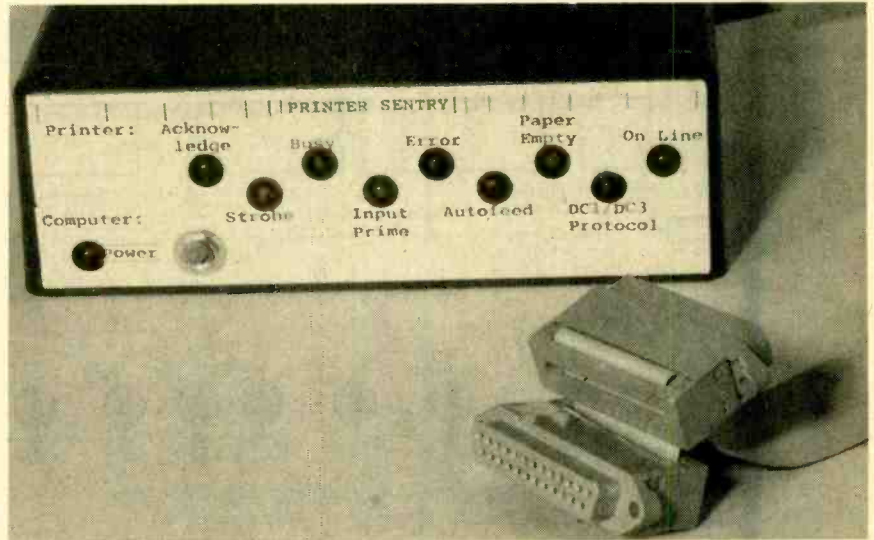

Fig. 5. This diagram indicates the designations of the LED's on the front panel. It should help you to wire them properly.



Two IDC connectors were connected to the ribbon cable that comes from to the Printer Sentry's circuit board. Those connectors act as a feedthrough for communications between your computer and printer.

nect the anodes of the other LED's together.

Get the circuit board and run a wire between the connected anodes and the 5-volt supply line, and another between the connected cathodes and the ground line. Using the parts-placement diagram and Fig. 5 as guides, make the remaining connections between the circuit board and the LED's with lengths of wire. Connect the power leads that you installed on the circuit board to S1 and J1 to complete the wiring.

Attach standoffs to the circuit board and install it in the cabinet. Close the unit up, connect the wall adapter, and power up the unit without connecting it to a computer or printer. The INPUT-PRIME, STROBE, and ACKNOWLEDGE LED's may flicker on and off, which is okay. Since the XOR-gate inputs should assume a default high state, the ERROR LED should be off, while the BUSY, PAPER-EMPTY, ON LINE, AUTOFEED, and DC1/DC3-protocol LED's should be on.

If all is as it should be, turn the unit off and connect it to your computer and printer (both of which should also be turned off). Power-up the Printer Sentry prior to turning them on so that you can see just what steps your computer and printer take when first turned on. Now try printing out some text. If all is well, the strobe, acknowledge, and busy lines should show furious activity, and appear to be almost continuously on.

If any indicator remains unswervingly in its default state, chances are that the line it monitors is not serviced. To test that assumption, start by disconnecting the Printer Sentry from the equipment. Now open the cabinet and use a jumper to force the pin for the line in question low or high (whichever should cause the LED to change states). If there is no change, check the cable connection and then the timer or gate that controls the LED. It should be easy to find a problem if one exists.

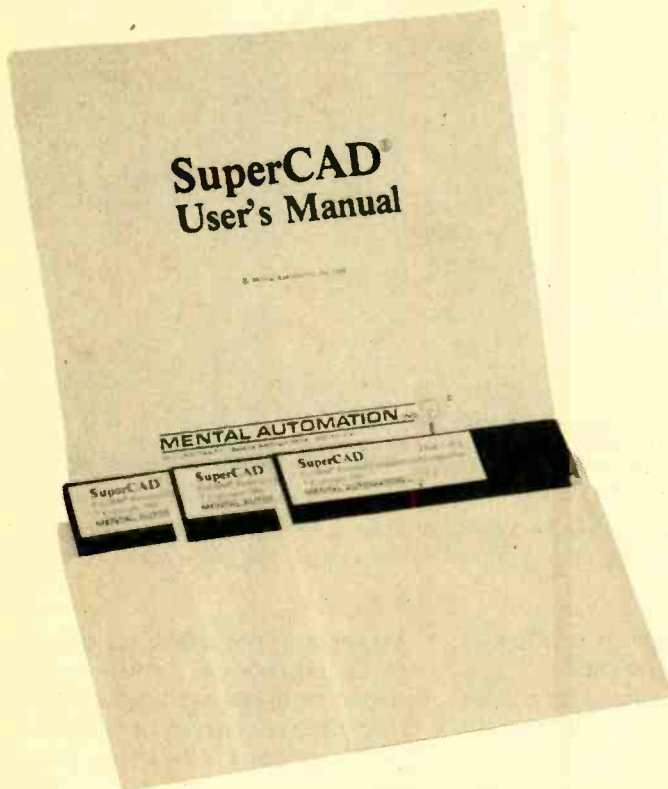

CIRCLE 119 ON FREE INFORMATION CARD



MENTAL AUTOMATION SuperCAD Electronics Design Software

*A schematic-targeted CAD package that is complete,
easy to use, and is very affordable.*

As a free-lance engineer, there are two tasks I have always avoided (and even weaseled my way out of): making PC boards, and using computer-aided drafting for making schematics. Making PC boards has always appeared to be a more laborious task than wire-wrapping or point-to-point wiring of prototypes; and the CAD packages that I've occasionally played with *definitely* took more time than using a pen at my drafting table to produce a schematic.

However, deep down inside I knew making PC boards would improve the appearance of most of my prototypes. I also felt sure that one day some software would bridge the gap between entering a CAD-based schematic and receiving finished PC-board artwork to make the time spent at the computer worthwhile. SuperCAD, with the help of some additional (and inexpensive) software, does precisely that.

Since the package is particularly aimed at electronics design, entering

schematics, creating parts-placement diagrams, and entering hierarchical designs (block diagrams that associate two or more schematics you create) is made incredibly easy and time effective. To make the time you spend even more beneficial, the artwork you create can be analyzed by the software to generate additional documentation to help you build your circuit, such as a parts list and a connection list (called a net-list). It can also check a schematic for improperly connected parts, such as a grounded gate output, two TTL outputs tied together, missing parts designations, etc. You end up with a lot more than just a pretty picture.

The software also generates files that can be used with other software packages to automatically route foil patterns, and perform both digital and analog circuit analysis. The results can be viewed in an oscilloscope or digital-analyzer window in the program. You can actually see how a circuit will behave *before* you build it! But let's take a look at how SuperCAD

works as a stand-alone package before we discuss its software-friendly attributes.

The SuperCAD Screen. The installation of SuperCAD is automated and very easy to perform, so I won't waste time discussing the process. Once installed, when you run SuperCAD you are greeted with a logo screen and with a push of a button you're on your way to the drawing-editing screen (see Fig. 1). The bold little arrow shown floating in the figure is the cursor. The cursor can be moved by using the arrow keys or by mouse operation. In fact, all operations can be easily performed with or without a mouse—that was surprising since most CAD packages are difficult (read that "a real pain") to use without one.

The largest feature of the screen is the large area in the center, called the "drawing window." As the name implies, that is the region in which drawings are made and edited. If the user chooses, that area can be filled

with a grid of dots (that will not be considered part of the drawing) that can be used as helpful reference points. You can set the cursor to glide all over the drawing window or "snap" from grid-point to grid point. The snap mode ensures that all your schematic lines will be straight.

However, drawings are not restricted to the drawing window, they can be much larger. To enable you to "move" the drawing window to other portions of the drawing, you can use the scroll bars (in typical Windows fashion) if you have a mouse, or by pressing SHIFT and the arrow keys.

Around the perimeter of the drawing window are a series of different options. If you use a mouse, any of the options can be chosen by moving the cursor over the option and clicking the left mouse button. If you are not using a mouse, an option can be selected by entering the appropriate key-stroke or key-stroke combination. To select from the options at the top or bottom of the screen, you just press the alternate key along with the letter that appears capitalized in the word for that option on the screen. For example, to select the "setuP" option (at the top of the screen), you would press alternate-P. The items on the left boarder are equally as intuitive to select, but hard to describe without discussing how and what you draw when creating a schematic. That being so, let's discuss drawing with SuperCAD.

Primitives. All drawings are a collection of drawing "primitives," so called that because they are simple building blocks. Namely, they are text, wire buses, arrows, rectangles, lines, circles/ellipses, dots (or connection points), and regions filled-in with patterns. All of these "primitives," (except for text) are represented by the icons on the lower left boarder of the screen (look back at Fig. 1). If you're not using a mouse, they can be selected for drawing by pressing T, B, W, R, L, E, C, or F respectively (all pretty intuitive with the exception of arrow).

Drawing dots (used to indicate the connection between crossed wires as in a regular schematic) is as easy as selecting the dot option, moving the cursor to the spot you want the dot, and pressing enter or clicking the left mouse button. Filling-in a region works in the same way. There are a variety of

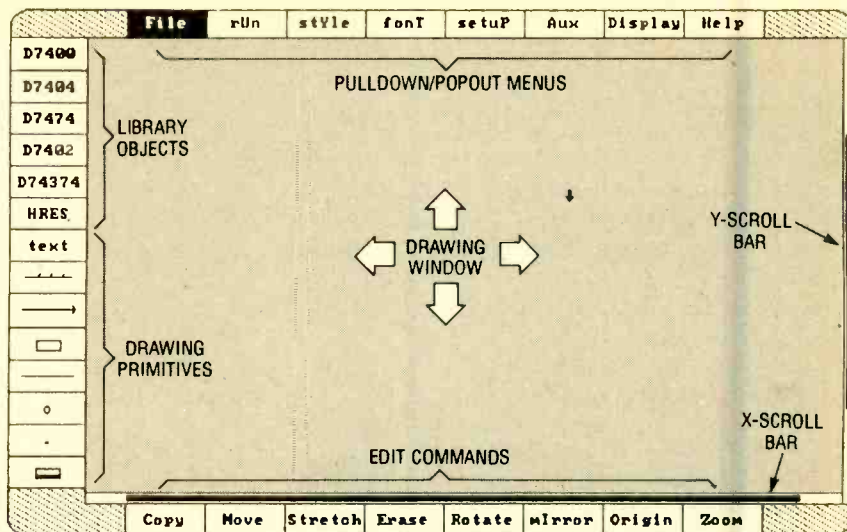

Fig. 1. This is the main screen for SuperCAD. It has a large area in the middle for drawing, with a number of options around the outer edges. The arrow floating near the middle is the cursor.

patterns available via a pop-out menu (more on those later).

Drawing buses, arrows, and lines are also easy: select the option click (or press ENTER) where you want one end of the bus, line, or arrow, and click again once you've moved to where you want the other end. Buses have some interesting features though: If there are some lines that end very close to them they will all be automatically connected to the bus and automatically labeled according to instructions the program prompts you for. That way the program can keep each wire in the bus separate, and you don't have to manually label the lines.

By the way, lines do not have to be solid unless they are to be used as wires. You can select from four different line styles (solid, dashed, dotted, or dashed-and-dotted) from a pop-out menu.

Further still, you do not have to enter every bend and connection dot for a line. There is an auto-wire feature that puts all the necessary elbows and connections in when activated. Just point to the start of the wire and the end of the wire and bang! The circuit is drawn without having to enter multiple lines to snake the wire around components and other wires.

Drawing a rectangle is similar to drawing a line: one click positions one corner and the second click sets the position of the corner diagonally opposite it. Similarly, for circles a click over one spot selects the center, and

at a second spot selects a point on the circumference. If the E key is pressed, an ellipse is drawn instead of a circle; the eccentricity of the ellipse must be set in one of the pop-out windows.

Text can be entered by selecting the text option and typing in the text at a selected position. The text can be in one of four different fonts available in a variety of sizes, again all selectable from a pop-out menu. This leaves us with six options at the top of the left border, which are a topic unto themselves.

Library Objects. The remaining items on the left boarder are "library" objects; schematic representations of components (IC's, resistors, capacitors, etc.) and symbols (grounds, package outlines, connectors, etc.) composed of drawing primitives previously entered. Although only a group of six are represented on the boarder at any given time, there are over a thousand supplied with the software! You can request that a part be made available for selection (its name placed on the boarder) by using a pop-out menu that lets you move between the different subdirectories that contain the library-part files.

In the subdirectories, you can find every member of the complete 74' series (74xx, 74xxx, and 74xxxx) you will ever need, a wide array of liner IC pinouts, microprocessors, digital-signal processors, and so on. If for some

reason you need to add a part to the library or alter one already present, you can use SuperCAD to shape the drawing and provide other useful information about the part, or you can use a "Build" utility supplied with the software. The build utility will take information that you put in an ASCII file (including the the actual bitmap!) and turn it into a library part. The software also comes with an "Unbuild" utility to convert a part into ASCII format so you can alter it in an ASCII editor (one is supplied with SuperCAD) if you wish.

You can select one of the library parts on the boarder by holding down the shift key and pressing one of the function keys, F1-F6, or you can use the mouse and click. Once you've selected a library part, you simply position the cursor where you want it and click or hit enter. You can even drag a part into the exact position if you have a mouse. When the part appears, it is given a designation ("d" for diode, "r" for resistor, "c" for capacitor, etc.) with the number 0 (d0, r0, c0, etc.). The numbers you wish to use for the components can be added later by an automated process—you needn't type them in! The value of each component is also entered in an automated fashion.

Integrated circuits will also bear their pin numbers and appropriate labels for all their pins. If there is an alternate pinout for a chip (such as for some surface-mounted chips) it can be summoned-up by pressing the "A" (for Alternate pinout) key before placing the part in the drawing.

If there are multiple instances of a device in a chip (such as in a quad-gate chip, or multi-section op-amp) only one is drawn at the selected location. The first one you draw will bear the designation u0a and have the pinouts of one gate or section of the IC. Before drawing the next gate or section, you should increment the part designation by pressing the F6 key. The next part drawn will be labeled u0b and have a different pinout than the first. When the program has drawn the last section or gate in a chip, another press of the F6 key will return the designation to U0a, and the process repeats. How's that for automation?

Futhermore, the program can draw the De Morgan equivalent of a gate. You just have to press "S" (for Select De Morgan) before placing the gate on

the drawing. This has no effect on gates that have already been drawn.

A library part can even be composed of various subsections, just like a hierarchical schematic. However, for editing purposes, a library part is treated as though it was a single big primitive no matter how complex it is. Which brings us to the editing functions on the bottom boarder of the screen.

Editing. When editing, the program has to have a way of knowing which object or objects on the screen are to be edited. For that reason, each drawing primitive or library part is assigned an "origin"—a point on the screen that "belongs" to that part. In most cases, that helps you select only the objects you want to edit even if the objects are very close together or overlapping (as you'll see in a moment). Normally origin points are invisible, but when they are needed they can be made visible by selecting the origin option (look back at Fig. 1).

Objects on the screen can be selected for editing one at a time (single-object editing) or in groups (for group editing). You just press the "G" key (for Group) to toggle between the modes. Once an editing function has been selected, if you are in single-object mode the editing procedure will only effect the object the cursor is touching or whose origin is closest to the cursor when the ENTER key is struck or the left mouse button is clicked. In group mode, once an editing function has been selected, the program allows you to draw a rectangle around the objects to be edited. Only the objects whose origins are inside the rectangle will be affected.

The editing procedures are easy to understand. Erase, as you might've assumed, deletes selected objects. Copy allows you to place multiple copies of objects where you wish. The rotate option allows you to rotate objects by 90° in a clockwise direction. Text can be rotated, but the program makes sure it never appears upside-down or backwards. The mirror operation is similar to that, but the objects are flipped or "reflected" around a vertical line.

The move option allows you to relocate objects. Prior to moving objects, the program can be told to stretch the wires connecting of the moving com-

ponents so they remain connected to the rest of the circuit. That mode is set from a pop-out menu.

The stretch operation allows you to change the size of objects you've drawn without having to delete and redraw them. It can also turn a line into an arc or quarter ellipse. In one mode, it can simultaneously stretch two wires to relocate their junction point.

The last option, zoom, doesn't really edit anything. Instead, it gives you a view of the whole drawing at once (it squeezes the whole drawing into the drawing window). From there you can indicate what part of the drawing you'd like to work on before returning the window to a normal view.

The Pull-Down Menus. The pull-down menus (activated by selecting options from the top boarder of the screen) allow you to chose even more functions. In an effort to save space, I'll only discuss some of the simpler ones.

One option on the file pull-down menu allows you to load a picture file for editing. Another allows you to save your work. A third permits you to merge a file with the one you're currently working on. From the menu you can also print your work, shell to DOS, or exit the program.

The run menu allows you to run up to four programs from inside SuperCAD. Two utilities packaged with the software are ready to run from this menu, so you can add two more programs to the window or even replace the two already present. The utilities already installed check the schematic for various wiring errors and create the network and parts list.

The style menu allows you to select the line and fill-pattern styles. Similarly, the font menu allows you to chose the font style and size for the text in your drawing (Note: a drawing can contain a variety of fonts and sizes all at once).

Selecting the set-up option causes a pop-out menu to appear. The menu provides you with the opportunity to customize a large number of program features including the activation of the drawing window grid, the width and size of drawings, and turning a drawing boarder on, to name but a few (there are over ten).

The "aux" (auxiliary) menu has a
(Continued on page 99)

ANTIQUÉ RADIO

By Marc Ellis

Mail Call!

What with contest results to announce, the successful conclusion of the theremin project to report, our two special articles on safety for collectors, and various other topics that have engaged our attention for the past several months, we've rather neglected the mailbag. Luckily the period of neglect included the summer season, when correspondence is traditionally light, so the stack of piled-up mail is not as high as it might have been. In any case, let's get right to those letters.



There was no room for this photo last month, but I couldn't resist running it this time. It gives you a good look at the well-organized restoration shop of contest-winner Willy Young (Smithville, TN). The radio on the bench is a Fada "Bullet."

HELP WANTED

15-year-old collector/restorer Joshua Heide (3613 Palo Verde St., Napa, CA 94558-2439) is looking for schematics and information for two of his recent acquisitions: a Firestone Air Chief stock #8-7403-3 (AC only) and a Western Royal "Jewel" (AC-DC, no model number available).

Billy R. Pogue (4039 Blue Canyon Rd., Lake Havasu

City, AZ 86403) got a "late start" in radio; he didn't build his first receiver until 1936. Over the years, he's owned, restored, and used many interesting classic sets. Right now, he's looking for a schematic for the "Tropodyne" receiver sold as a kit in the late 1920's. The set used a single 01-A tube and was described in a construction article appearing in *Radio News* magazine.

Billy would also like to get his hands on some 12B8 or 25B8 tubes. He'd be glad to pay copying and postage costs for the schematic and will either purchase the tubes or trade for some of the 2000 or more tubes that he has in stock.

Barry T. Stephens (3501 S. First, Apt. #229, Austin, TX 78704) is looking for a spare "XXL" tube for his Philco floor-model radio. Can anyone advise him as to whether there is a standard equivalent for that designation? If you write Barry with the information, I'd appreciate a copy of your letter; I'm curious about it myself!

Mel Vining (5176 Decatur St., Denver, CO 80221-1232) writes on behalf of a friend who is restoring an RCA Victrola radio-phono combination Model #612V1. The power transformer (which was mounted on amplifier chassis RS-123) has been removed and a replacement (or specifications for a replacement) is needed.

Marty Huffman, who is a wheelchair-bound war veteran, sent me a long, chatty letter with several requests for information. Here are a few of them: Marty needs a type-40 tube for a Zenith Cathedral

set, a schematic for and information on an "Aeroscanner" plug-in-coil battery receiver, and an explanation of all the rear-apron controls and connection points on a Hallicrafters SX-28 (a Sams schematic would help).

Marty would also like to acquire an Audel's radioman's manual, a 1940's ARRL handbook, and a tube-type CB base station. He has a large collection of back-issue electronics magazines and is ready to trade. Write him at 4846 McKinley Ave, Ashtabula, Ohio 44004.

Ken L. Sketchley (407-700 Mohawk Rd. E., Hamilton, Ontario, Canada L8V 2K1) has a Jackson Dynamic Tube Tester Model 648-1 that's in good condition. He'd like to correspond with someone who can advise him on how to set up test procedures for tubes not on his charts. Greg Turner (3264 Bethel Church Dr., Woodbridge, VA 22192) isn't actually a radio collector, but he owns a couple of 1930's Philcos that he'd like to repair. Could someone in his area contact Greg and give him some advice? Ellis Walker (630 Griffith St., Apt. 167, Youngstown, OH 44510) seeks schematics and information on an RCA Model 90 and a Rekord Senior 60.

Contact Pat Bentley (450 Sharps Creek Rd., Bristol, TN 37620) if you can help him with a schematic and/or other information for an RCA Model 110K. Gary Mingay (522 Third Ave., Lyndhurst, NJ 07071) needs information about the RCA Model AR8501. Jack Christy (2300-A Pullman Lane, Re-

dondo Beach, CA 90278) needs a schematic for a "Viking Senior" battery set using 01-A tubes.

Geary Boston (P.O. Box 607, Crawfordville, FL) would like to date his Zenith V600 (or it may be V603) Trans-Oceanic, and Henry Colonna (3 Storey Lane, Yonkers, NY 10710) would like to locate a schematic for a Philco Model 112. Tom Gwilt (3430 Highland Dr., Port Coquitlam, BC, Canada V3C 3V4) could use some advice on starting a business focusing on the repair and sale of antique radios.

Finally, please contact Jeff Berkwitz (Program Manager, Evanston Community Television Corporation, 1285 Hartrey, Evanston, IL 60202) if you can supply a cabinet for a Silvertone radio/record-changer/wire-recorder combination. Jeff found this set with all the components intact, but with the cabinet in a disintegrated condition. He'd love to get it all together again! Model number is unknown, but I'm printing a sketch from the instruction manual showing the components in their cabinet (see Fig. 1).

FOR SALE OR TRADE

Here are some readers who have offered items for sale or trade. Their letters mostly date from last summer, having arrived a little too late to be included in our previous "Mailbag" column in the August, 1991 issue. So don't be disappointed if some of the items have already been disposed of. But if you're interested, don't hesitate to follow up. All you can lose is a stamp!

70-year-old Rudy Jakl (3524 7 Ave. S, Great Falls, MT 59405) has about 100 QST magazines from the 1950's and '60's. He'd like to put together a crystal set

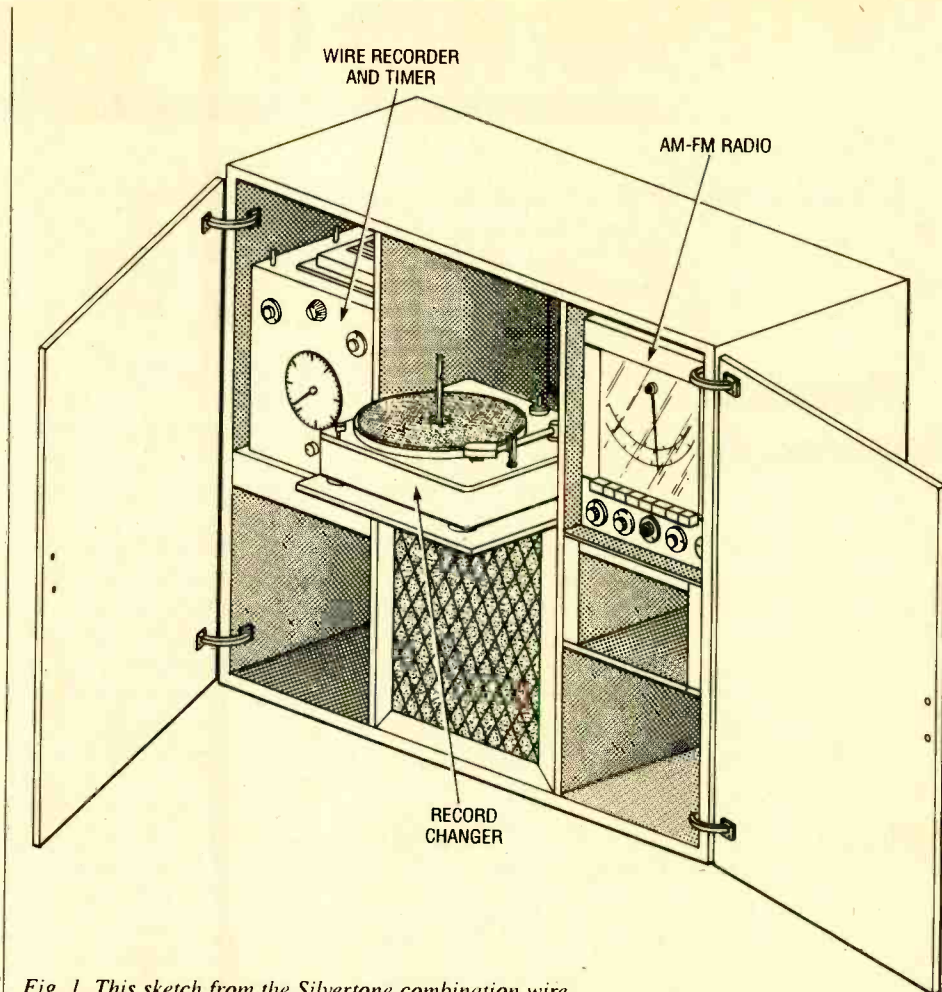

Fig. 1. This sketch from the Silvertone combination wire-recorder/record-player/AM-FM radio owner's manual shows the type of cabinet that Jeff Berkwitz is looking for.

like one he had many years ago and wants to swap magazines for a couple of bakelite variometer coils and a pair of black dials to go with them.

Charles Mayer (Chucks Fix It, RR1 Box 699, Fairmont, NC 28340) has a customer who'd like to sell an RCA wood-cabinet, battery-operated table radio (Model 24BT). Judging from the tube complement (1A7, 1N5, 1H5, 3Q5), the set dates from the 1940's.

Dean Gangstee (18204 Soledad Canyon Rd. #22, Canyon County, CA 91351) has over 800 Sams Photofact sets and manuals covering CB sets, televisions, auto radios, scanners, transistor portables, and hi-fi

sets. He'd like to sell them as a group for \$200.00 (or a good offer) plus shipping. Dean would consider donating these materials to a school, library, or even an individual who would not be using them for profit, for the cost of shipping alone.

I recently received a letter from James Fred, who wrote the "Antique Radio Corner" column for the old *Elementary Electronics* magazine. I had always read that column with a great deal of interest, and was sorry when the magazine ceased publication. In any case, Jim is now making reproductions of those impossible-to-get coil forms for the National SW-3 short-wave receiver. The cost is

\$7.50 each plus shipping.

He can also supply a 16-page information booklet (including coil-winding data) for the SW-3. The booklet is free with a \$50 order. Otherwise, it's \$5 plus shipping. In addition, Jim manufactures adapters for using standard 4-pin tubes in WD-11 sockets. For more information, write him at Route 1 Box 41, Cutler, IN 46920.

ANSWERS TO QUESTIONS

Billy Pogue (see above for his address) knows a lot about tube-type radios, and he has schematics and other references on most sets built through 1939. He

(Continued on page 95)

CIRCUIT CIRCUS

By Charles D. Rakes

Regulator Applications

The basis for this month's column began when Fred, a young aspiring ham, came into the shop carp-ing about spending half a day changing a pilot lamp in his late-model, HF transceiver. Unfortunately, when an incandescent lamp is used as an indicator in a piece of electronic equip-ment, it's almost guaranteed that it will most often be hard-wired in a location hidden from view in the very bowels of the device. I suggested to Fred that, rather than go through the same headache the next time that the lamp in

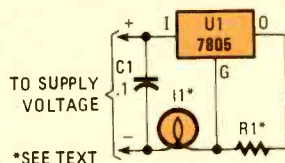

Fig. 1. The in-rush current limiter is little more than a common voltage regulator, configured as a constant current source, that is used to keep in-rush current at the rated operating level of the device to be protected.

some other circuit that you may have in mind. But first we'll look at the in-rush current-limiter circuit that I suggested to Fred.

IN-RUSH CURRENT LIMITER

The schematic diagram for the in-rush current limiter is shown in Fig. 1. And with any luck the new lamp should last a very long time. As I explained to Fred, the main cause of frequent lamp failure is the high initial current that flows through the device when power is first applied to the lamp's filament. The cold resistance of a typical 6-volt, .25-amp lamp can be as low as 3 to 4 ohms. That can result in an initial surge current of 1.5 to 2 amps, which is more than ten times the lamp's operating current.

If the maximum current applied to an incandescent lamp is limited to its suggested operating level, the lamp's life will be greatly prolonged. In the Fig. 1

lamp's start-up current is limited to its specified operating current, eliminating the initial turn-on shock.

The value of R1 sets the regulator's current level. The level of current can be calculated by subtracting the regulator's internal operating current (5 mA) from the desired operating current and dividing the remainder into regulator's output voltage (5 volts). Here's an example assuming a 6-volt, 100-mA lamp:

$$100 \text{ mA} - 5 \text{ mA} = 95 \text{ mA}$$

$$5 \text{ volts} / 95 \text{ mA} = 52.6 \text{ ohms}$$

A 51-ohm, 1-watt resistor or two 100-ohm, 1/2-watt resistors in parallel will fit the bill. The current regulator requires a power source of at least 6 to 7 volts greater than that of the lamp's normal operating voltage.

When using the constant-current circuit with a 6-volt lamp, the input to the 7805 should be connected to a 12- to 15-volt DC source. In addition, the regulator should be mounted to the chassis for heat sinking.

PARTS LIST FOR THE IN-RUSH CURRENT LIMITER

- U1—7805 5-volt, 1.5-amp, voltage-regulator, integrated circuit
- R1—See text
- C1—0.1- μ F, ceramic-disc capacitor
- I1—See text
- Perfboard materials, wire, solder, hardware, etc.

the transceiver fails, he should install an in-rush current limiter in series with the indicator.

So this month's Circuit will deal with a number of IC regulator-based circuits that may be of some use to you as they are, or perhaps be useful as the basis for

circuit, a 7805 5-volt regulator is connected in a constant-current configuration, thereby setting the maximum current that is allowed to flow through the regulator. By connecting the pilot lamp in series with the constant-current circuit and power source, the

VISIBLE-LIGHT TRANSMITTER

Our next entry, see Fig. 2, places the 7805 regulator in an unusual light-modulating circuit. The regulator is connected in a variable-voltage configuration with a reflector-mounted #44 6.3-volt, 250-mA lamp connected as its load. By feeding an audio signal to the common input lead, the output voltage is modulated in step with the input signal. The regulator's varying DC output causes the current flow in the lamp to vary in step, producing an

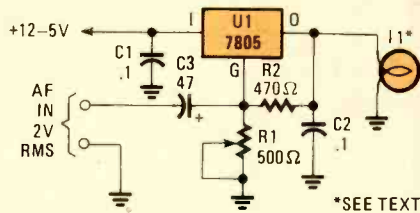

Fig. 2. In the visible light transmitter, a 7805 voltage regulator is connected in a variable-voltage configuration, and an audio signal is fed to the common input, to modulate the output voltage. The modulated output voltage is used to transmit intelligence via an incandescent lamp.

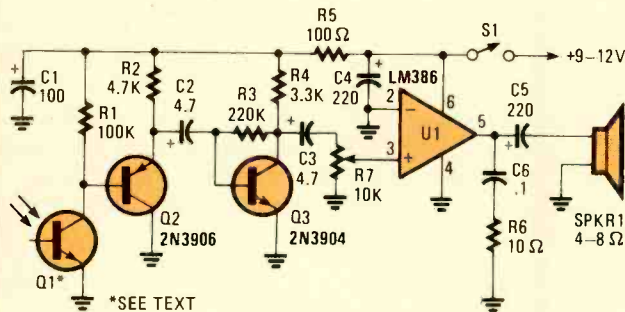

Fig. 3. This version of the visible light receiver uses a phototransistor connected in its front end, to detect and demodulate the output of the transmitter circuit in Fig. 2.

amplitude-modulated light output.

Using the light "transmitter" is a simple task. All you have to do is connect the circuit to a 12- to 15-volt DC source and adjust R1 for a 6-volt output. Then connect a lamp to the output of the circuit. The circuit's input impedance is low and can be driven with an audio signal from the external speaker-output of almost any portable cassette or AM/FM receiver. If you have access to an oscilloscope, you can use it to observe the modulation of the output voltage. If an oscilloscope isn't available, simply increase the audio drive until a slight variance in the lamp's output can be observed.

VISIBLE-LIGHT RECEIVER

The schematic diagram for a visible-light receiver that can be used with the transmitter circuit of Fig. 2 is shown in Fig. 3. The AM signal is detected and demodulated by phototran-

sistor Q1. The output of Q1 is direct coupled to the base of Q2, which is configured as an emitter follower. Transistor Q2 is used to isolate the output of the detector from Q3, which has a low input impedance. Transistor Q3 is used to provide enough signal boost to drive U1, an LM386 low-voltage, audio-power amplifier, which in turn drives SPKR1. Potentiometer R7, whose wiper feeds the non-inverting input of U1, sets the gain of U1.

The phototransistor, Q1, can be just about any NPN unit that's sensitive to visible light. If the phototransistor is mounted at the focal point of a small parabolic reflector, its operating range will be greatly enhanced, and flooding from other light sources will be reduced.

To use the light-communication system, start by making sure that the two circuits work by positioning the transmitter and receiver a couple of feet apart, and adjusting the lamp's output

PARTS LIST FOR THE VISIBLE-LIGHT TRANSMITTER

- U1—7805 5-volt, 1.5-amp voltage regulator, integrated circuit
- R1—500-ohm potentiometer
- R2—470-ohm, ½-watt, 5% resistor
- C1, C2—0.1-μF, ceramic-disc capacitor
- C3—47-μF, 16-WVDC, electrolytic capacitor
- I1—Incandescent lamp, see text

ADDITIONAL PARTS AND MATERIALS

Perfboard materials, enclosure, wire, solder, hardware, etc.

PARTS LIST FOR THE VISIBLE-LIGHT RECEIVER

SEMICONDUCTORS

- U1—LM386 low-voltage, audio-power amplifier, integrated circuit
- Q1—NPN phototransistor, any type
- Q2—2N3906 general-purpose, PNP silicon transistor
- Q3—2N3904 general-purpose, NPN silicon transistor

RESISTORS

(All fixed resistors are ¼-watt, 5% units.)

- R1—100,000-ohm
- R2—4700-ohm
- R3—220,000-ohm
- R4—3300-ohm
- R5—100-ohm
- R6—10-ohm
- R7—10,000-ohm potentiometer

CAPACITORS

- C1—100-μF, 16-WVDC, electrolytic
- C2, C3—4.7-μF, 16-WVDC, electrolytic
- C4, C5—220-μF, 16-WVDC, electrolytic
- C6—0.1-μF, ceramic-disc

ADDITIONAL PARTS AND MATERIALS

- S1—SPST toggle switch
 - SPKR1—4- or 8-ohm speaker
- Perfboard materials, enclosure, reflector, wire, solder, hardware, etc.

voltage and the modulation level for the best reception. Once a communications link at relatively short distances has been established, you can move the two circuits further apart to determine the effective distance over which they can communicate.

ADJUSTABLE VOLTAGE/CURRENT REGULATOR

In our next circuit, two 7805 5-volt regulators are used to produce a circuit (see Fig. 4) in which both

current and voltage can be varied. The output voltage can be adjusted from a low of 5-volts to about 13-volts with the specified component values. The current limiting resistors—R1, R2, and R3—should be selected for the desired maximum current for each switch position. You can determine the value for each resistor by applying the simple formula used in our first circuit. Here are three examples that you may use: A 100-ohm resistor will set the maximum output current to

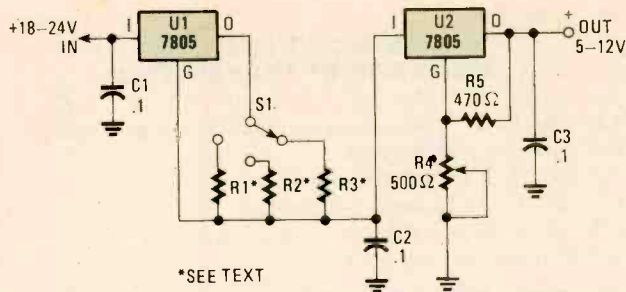

Fig. 4. Two common voltage regulators connected in this manner allows you to vary both voltage and current.

PARTS LIST FOR THE VARIABLE VOLTAGE-CURRENT REGULATOR

RESISTORS

(All fixed resistors are 1/4-watt, 5% units.)

R1-R3—See text

R4—500-ohm potentiometer

R5—470-ohm

ADDITIONAL PARTS AND MATERIALS

U1, U2—7805 5-volt, 1.5-amp voltage regulator, integrated circuit

C1-C3—0.1- μ F, ceramic-disc capacitor

Perfboard materials, enclosure, wire, solder, hardware, etc.

PARTS LIST FOR THE DC MOTOR CONTROLLER

SEMICONDUCTORS

U1—4001 CMOS quad two-input NOR gate, integrated circuit

U2—LM317 1-amp adjustable-voltage regulator, integrated circuit

Q1—2N3904 general-purpose NPN silicon transistor

D1, D2—1N914 general-purpose silicon diode

D3, D4—1N4002 1-amp, 100-PIV, silicon rectifier diode

RESISTORS

(All fixed resistors are 1/4-watt, 5% units.)

R1—270-ohm

R2—1000-ohm

R3—10,000-ohm potentiometer

R4—500,000-ohm potentiometer

ADDITIONAL PARTS AND MATERIALS

C1—.068- μ F, ceramic-disc capacitor

C2—0.1- μ F, ceramic-disc capacitor

S1—Normally-open pushbutton switch

Perfboard materials, enclosure, small DC motor or lamp, wire, solder, hardware, etc.

50 mA; 50-ohms for a maximum of 100 mA and 25 ohms for 200 mA.

The 7805 can supply up to 1.5 amps if an adequate heat sink is used. The regulator has an internal circuit that shuts down the output of the regulator if the power dissipation becomes

too high for the heat sink. The real advantage to using a current-limited power supply is obvious if you are smoke testing a new circuit and all is not as it should be. Without the current-limiting feature, a short or a wiring error can pop a fuse, mess up the

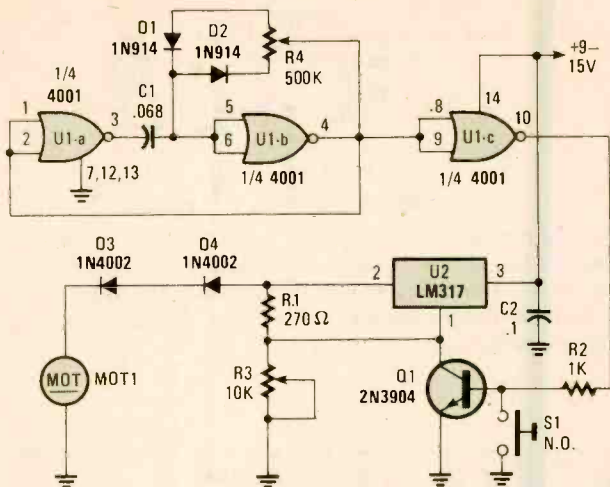

Fig. 5. Connected in this manner, an LM317 1-amp adjustable-voltage regulator can be used to control the speed of a miniature DC motor or vary the brilliance of a small lamp. The circuit does so by controlling the pulsewidth, and therefore the current, to the load device.

supply, or merely send up a smoke signal pinpointing the error.

DC MOTOR CONTROLLER

Our last entry uses an LM317 1-amp adjustable-voltage regulator in a circuit that can be used to control the speed of a miniature DC motor or vary the brilliance of a small lamp. In that circuit, see Fig. 5, the LM317 (U2) is connected in a variable-voltage output circuit, in which R3 is used to set the quiescent output voltage. Two gates (U1-a and U1-b) of a 4001 CMOS quad two-input NOR gate are configured as a low-frequency oscillator, whose pulsewidth is variable via R4.

The output of the oscillator is direct coupled to another gate, U1-c, that supplies an on/off drive to the base of Q1. Transistor Q1, in turn, pulls pin 1 (the V-adjust terminal of the regulator) to ground at the oscillator's pulse rate. It is the on/off time of the oscillator that sets the average output power provided to the load. Diodes

D3 and D4 allow the minimum output voltage of the regulator to drop to near ground level.

To set the desired maximum output voltage, momentarily close S1 and adjust R3. Connect either a lamp or small DC motor (as is shown in the schematic) to the circuit's output and adjust R4 for the desired results. Any device that is driven by this circuit should have a current requirement of 1 amp or less. And you should be sure to use good size heat sink for the LM317 regulator IC.

UNTIL NEXT TIME

Well it looks like we have reached the end of our space for this month. But be sure to join us on the next go-round, when we'll present another batch of circuits to entertain and educate you in the ways of electronics. In the meantime, if you have any questions, comments, etc., about anything that has appeared in the column, you can write me at *Circuit Circus*.

Popular Electronics Magazine, 500-B Bi-County Blvd., Farmingdale, NY 11735. ■

THINK TANK

By John J. Yacono

Automotive Projects

Unless you live in a large city, where public transportation is readily available, getting around without a car can be difficult. I suppose that's why the automobile has become so much a part of our lives and culture. Some people even treat the "family car" as a "member of the family." From the mail I've gotten recently, it would seem that electronic hobbyists share that devotion (or is dependence a more fitting word?) to the "auto" and have applied some effort to improving them.

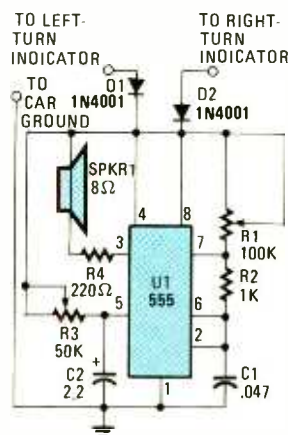

Fig. 1. This little circuit should prove useful to the hearing impaired. It produces a tone each time a dashboard turn indicator lights up. The tone drops in frequency for as long as the indicator is lit.

This month's *Think Tank* column is dedicated to their efforts, which, as a commuter, I applaud.

The first letter is from a gentleman seeking a little help to make his turn-signal indicator more audible. I'll address his problem before we get to the rest of the mail.

ONE GOOD TURN. . .

Like many senior citizens, my hearing is not that of a teenager, so I have difficulty hearing the weak clicking sound made by my car's turn-signal flasher (especially in heavy traffic). I have tried buzzers and sonalert devices to perform this task, but they are either too harsh or too high in pitch.

I am looking for a circuit that will emulate the interrupted chime-like sound currently used in cars as alert signals. I have been faithfully reading *Think Tank* and *Circuit Circus* for many months, hoping to see such a circuit, but alas, to no avail. Can you or the staff of **Popular Electronics** help me?

—William E. Baker, Independence, MO

I'll do my best. The circuit in Fig. 1 should fit the bill. The heart of the circuit is a voltage-controlled oscillator based on a 555 oscillator/timer IC (U1). The voltage at pin 5 (the voltage-control pin) of U1 and the values of R1, R2, and C1 determine the frequency of oscillation.

The circuit should be wired to the positive side of the flashing turn-signal indicator lamps in your dashboard via D1 and D2. The diodes are there to prevent voltage meant for one dashboard indicator from activating the other indicator. When one of those indicators lights, the circuit receives power and begins to oscillate, driving SPKR1. At the same time, C2 begins to charge via R3. That causes the voltage at pin 5 of the IC to rise, which

reduces the frequency of oscillation. That produces a pleasing warble effect.

Once the signal indicator "blinks" off, C2 discharges through U1's internal resistors and the circuit is ready for the next application of power from the signal indicator. By adjusting R1 you should be able to select a warble rate that suits the flashing rate of the indicators on your car. Adjusting R3 allows you to select a starting frequency that is pleasing to your ears.

If you wish, you can replace the speaker with a piezo element. As the oscillation frequency drops below the resonant frequency of the element, the volume of the tone will decrease. That's because the efficiency of the element drops as you move away from its resonant frequency. That can produce a pleasing effect.

BATTERY-CHARGER PROBE

Car-battery chargers can save you a lot of money, but they can do great harm if used improperly. If a battery is connected to one incorrectly, it can heat up and explode, sending acid flying everywhere. Also, when connecting a charger to a battery, the charger should be turned off to avoid creating sparks. Otherwise, fumes from a damaged battery might ignite and cause serious injury.

A schematic diagram for the charger-probe circuit is shown in Fig. 2. The circuit can be used to ensure that the charger is initially off and that the battery is con-

nected properly. That helps you to avoid sparks, battery damage, and personal injury.

To use the probe, the positive cable clamp is first connected to the positive battery terminal. Then the test plate is touched to the negative terminal of the battery. If the battery is connected properly, current will pass from the test plate through R1, LED1, D1, the negative charger cable, and into the positive side of the battery. If LED1 (the green LED) lights, you can clamp on the negative lead and turn on the charger.

If the terminals are reversed current will flow in the opposite direction, causing LED2 to light, warning you of danger. When the cable is reversed, D1 protects LED1 from exces-

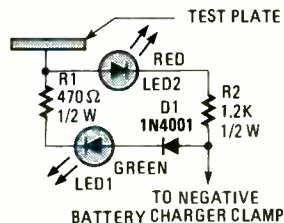

Fig. 2. This battery-charger probe can keep you from damaging batteries or yourself by testing to see if the charger is already on and/or connected improperly.

sive reverse voltage. If that happens, immediately turn the power off, and right the cable connections. Finally, if the battery charger is on, both LED's will light because chargers actually produce pulsating DC and rely on the battery to act as a filter.

My unit was housed in the negative alligator-style battery clamp on my charger, in such a way as to place it in series with the negative

cable. To build one of your own, start by soldering a 1-inch lead to your test plate, and insulate the lead side of the plate. You will need another plate on which to mount the components. I've found that left-over project-box covers work well here. Drill two ¼-inch holes about ¾-inch apart from one another. Push LED holders into the holes. Place the LED's into the holders so that the cathode of LED1 is on the same side as the anode of LED2 and solder R1 between those leads. Solder the test plate to the anode of LED2, solder D1 to the anode of LED1, solder R2 to the cathode of LED2, and connect the remaining leads of D1 and R2 together. Connect a wire between the junction of D1 and R2 and the jaws of the negative charger clamp. Mount the assembly onto the clamp and you're done.

—Mike Giamportone, Yale, MI

Very nice. I like your idea about attaching it to the charger clamp. On a slightly different note, considering the possibility of explosion, I wonder if jump starting a so-called sealed battery is safer than the older style batteries with the caps? They may be more dangerous since the gasses cannot just bubble away if overcharged. If anyone has some insight on that, let me know.

LOGICAL TURN SIGNALS

Not long ago I bought a 1953 Chevy ½-ton short box to restore. As I was repairing some relatively simple problems (the lack of a horn, wipers, heat, etc.), I ran across a turn-signal problem that turned out to be a little more of a task to repair than I'd first ex-

pected. I needed brake, tail, and signal lights on both tail lamps mounted to the side of the bed. The lamps were equipped to handle 1157 bulbs, so I knew it was possible, but they were only being used as tail and signal lights, and did not indicate braking. The wiring harness had only 4 wires: two left and two right, which supplied the front marker and rear tail lights on each side.

My solution to the dilemma was to leave the front marker lights connected to the flasher, and use the remaining two leads to connect the tail lamps to a CMOS logic circuit that would determine whether to signal a right-turn, left-turn, or braking (see Fig. 3). Signal inputs of the circuit are placed across a voltage divider that reduces them to less than eleven volts preventing them from damaging the CMOS gates. The 1-μF capacitors filter out any transients from the flashers or brake-light switch. Both the right and left circuits use NOR and NAND gates. They are connected to form two separate two-input XOR gates with the brake-light signal acting as an input to both. The 30k resistors limit the output current of the gates to 400 μA to prevent the gates from damaging themselves. The transistors are connected as Darlington drivers to supply the lamps with about 6 amps. Transistors Q1 and Q2 are high-gain NPN silicon types with a minimum beta of 300 and Q3 and Q4 are power transistors with a beta of 70.

Whether you use a breadboard or take the time to make a printed-circuit board, make sure that you mount the IC's in sockets. The sockets will save you a good deal of time should you need to

Protel Easytrax 2™

Outstanding value in Printed Circuit Board/CAD for your Macintosh and PC

Protel Easytrax 2 is a new, low-cost design package for PC and Macintosh users that includes everything required to produce professional quality Printed Circuit Board artwork.

Our easy-to-learn menu-driven design system breaks the 'expert barrier'—you'll be designing in minutes, not hours. Our comprehensive tutorials guide you through the program's extensive features that take the tedium out of board layout.

- Comprehensive library of Through-hole devices
- Gerber photoplotting and N/C drill tapes
- On-the-fly library components creation
- Intelligent Pad to Pad autorouting
- Switchable Metric/Imperial grid
 - Auto-panning
 - PostScript™ printing
- Powerful user-definable Macros
- Independent print/plot program
- Multi-layer boards of up to 32 X 32 inches.

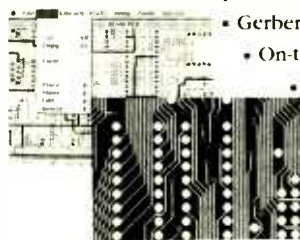

At Protel, we offer free technical support, 24-hour BBS, and 30-day money back guarantee. Prices start at

\$450

**Free Evaluation Package
Toll Free: 800-544-4186**

Protel Technology, Inc.
50 Airport Parkway, San Jose, CA 95110
Tel: 408-437-7771 Fax: 408-437-4913



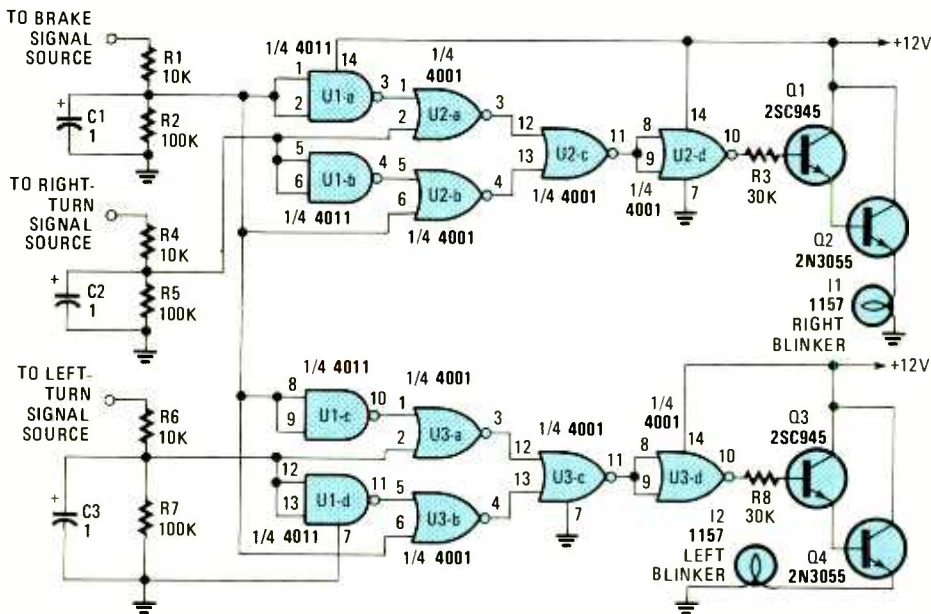

Fig. 3. This is a logical solution to the problem of having too few wires and too many functions. If you have XOR gates on hand, you can build the circuit using one of them in place of the gates in each turn-signal circuit.

replace the IC's. Also, use the standard precautions (ground yourself and your tools) for handling CMOS devices. We'll that's my contribution; I hope it helps someone else in the same circumstance.

—Brian Denny, Oak Harbor, WA

I'm not positive, but I think the circuit in Fig. 4 would work as well. It has a drawback though: the illumination during braking will be less than normal. However, when the brake and flasher circuits are both active, the flashing lamp will alternate between two levels of brilliance and appear like a two-filament type.

If any of you wishing to try this out can't get any ECG174's from your regular replacement-parts supplier, try asking for any rectifier from ECG5850 to ECG5869. If they are unavailable as well, try using one half of a 6-amp bridge rectifier. If you do use one of the high-current rectifiers, make sure their cases are insulated from the car's body.

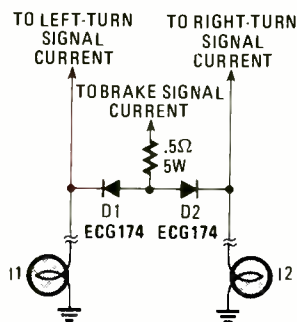

Fig. 4. This may be a quick solution to getting the two-wire truck harness to support both turn and braking indications.

HEADLIGHTS REMINDER

The last time I left my car lights on all day, I came up with a junkbox friendly lights-on alarm that requires only three components (see Fig. 5). This should be a refreshing change from the dozens of relatively complex headlights-on alarm circuits that I've seen. As a professional technician, I've learned that less is more (if less works). I hope this is worthy of a Think Tank book.

—Joe Bidwell, Tucson, AZ
It certainly is worth a book. Thank you for your

straightforward solution. I really don't see why most car manufacturers don't connect the headlight switch to a car's accessory circuit instead of the battery. If they did, the lights would shut off when the key is removed. If a person needed to use the headlights when the engine is off, they could flip the key to the accessory position and turn on the headlight switch.

BLOCK-HEATER MINDER

If you are one of the millions of North Americans who live in an area where a working engine-block heater

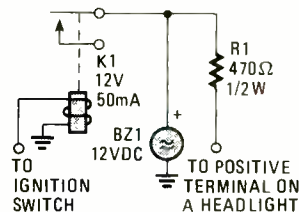

Fig. 5. A headlights-on reminder couldn't be made simpler than this. Or could it? If you think you have a simpler circuit, you know where to send it.

er is imperative, then this circuit (see Fig. 6) is for you. When the unit is plugged into an AC outlet, the light will come on to indicate the wall socket is hot. If it lights up, plug the block heater into the socket on the unit and press the switch. If the light gets brighter, then everything is in working order. If the light stays the same, then you know that there is a fault in the block-heater cord or heater element.

I built mine into a small metal box and inserted the circuit about a foot from the socket end of a high-amperage extension cord. When building your own, make sure that the switch you use for S1 can handle at least 10 amps.

—A.A. Crandlemire, Alberta, Canada

I'm sure this gadget will be a comfort to those of us who live in the colder climates. I like the fact that the device indirectly monitors itself for possible faults.

Next month I'll continue to present circuits dealing with automotive electronics. If you have built any such

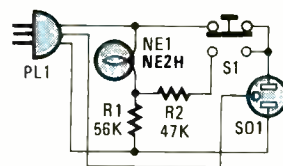

Fig. 6. If you live in the frozen north, knowing your engine-block heater is working is a comfort. This device will let you know if yours is A-okay.

projects (or anything else of note) please write to Think Tank, Popular Electronics, 500-B Bi-County Blvd., Farmingdale, NY 11735. As always, readers whose submissions are used here will be rewarded with a copy of our booklet, Think Tank II. Until next month, please drive and practice our hobby safely.

COMPUTER BITS

By Jeff Holtzman

Modem Mania

If you do any telecommunications with sources like BIX, CompuServe, Prodigy, your local electronic bulletin-board system (BBS), or Gernsback's own BBS (516-293-2283, 1200/2400, 8N1), you know how addictive it can be. You probably also know that it is slow. At one time, 2400-bps (bits-per-second) modems seemed quite speedy, but in today's world of ever-increasing CPU speeds, 2400 bps seems pretty slow.

For the past five years or

years, each major manufacturer promoted its own proprietary standard. Early 9600-bps modems from Hayes, U.S. Robotics, Telebit, and others could only talk to modems made by the same manufacturer. BBS operators and on-line services had to choose one and stick to it. Users also had to choose one and stick with it. If you wanted high-speed communications with multiple services, you'd likely need a separate modem for each.

However, recent declines in the price of digital signal-processing technology has allowed a true international standard to take hold. Now virtually all vendors are supporting those standards, often while simultaneously supporting their prior proprietary standards. So this time, we'll use the allotted space to sort out the differences between those standards, so that you can make an informed purchase.

V DOTS AND SPEED

All international telecommunications standards are administered by a division of the UN, called the *Consultative Committee on International Telephone and Telegraph* (CCITT). The CCITT consists of technical experts from major modem manufacturers, national governments, and telecommunications carriers (e.g., AT&T). The CCITT has defined numerous standards in great detail; we'll outline the relevant ones.

The standards V21, V22, V22bis, V32, and V32bis refer to modem speeds. Unfortunately a similar-sound-

ing standard, V42, refers not to modem speed, but to error correction and data compression schemes. We'll discuss V42 in a moment; but first we'll talk about the speed-related standards.

V21 and V22 are international standards for 300- and 1200-bps communications, respectively. In the U.S., those standards do not apply; rather, old telephone company standards (Bell 102 and Bell 212A, respectively) do. The remainder of the standards discussed here are accepted both in the U.S. and internationally.

V22bis is an international standard for 2400-bps communications; if you have a 2400-bps modem now, it almost certainly conforms to the V22bis standard. V32 is the standard for 9600-bps communications. It is not a new standard; it was actually adopted in 1984. However, the cost of DSP technology was just too high for general commercialization, so various manufacturers went off and created less-expensive but proprietary ways of increasing speed over the V22bis standard. Now that the hardware is becoming reasonably priced, V32 will gradually supersede the vendor-specific proprietary standards.

V32 also supports a 4800-bps mode, as well as fall-back modes to all of the 300-, 1200-, and 2400-bps standards mentioned above. That means that you can reliably connect to a lower-speed system with a V32 modem. An enhanced version, V32bis, pushes the data transfer rate up to 14,400 bits per second.

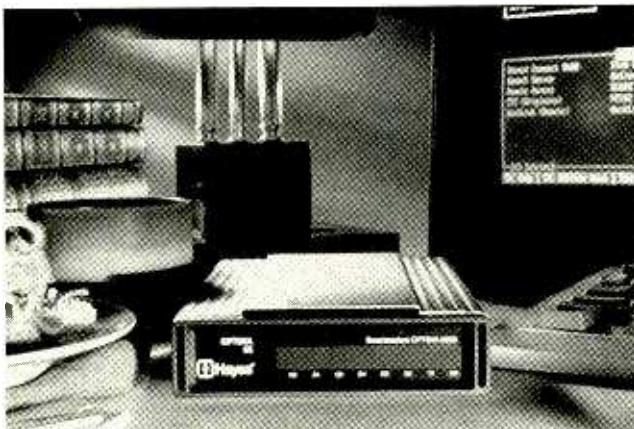

Hayes' Optima 96 is a V.32/V.42bis modem that's blazing new trails in price (about \$450) and performance.

so, 2400-bps modems were the standard. Higher-speed modems were available, but they were expensive, with prices hovering at around \$1000. Now, 9600-bps modems are becoming available at reasonable prices; I've seen off brands priced at about \$400, and major brands priced at around \$450. Prices will continue to fall as volume picks up and the on-line services provide better support.

How do you buy a high-speed modem? For several

EC/DC

There is more to life with modems than just raw speed; we also have to be concerned with error correction (EC) and data compression (DC). There are two aspects of both EC and DC: hardware and software. For EC, DC, or both to work at the hardware level, modems at both ends of the transmission must agree to, and operate on, identical protocols. For EC, DC, or both to work at the software level, software at both ends of the transmission must agree to, and operate on, identical protocols. For any given transmission, you want DC to be performed either by the hardware or by the software. Likewise with EC. Redundant DC or EC can actually reduce transmission speed.

DC is not important in general use; it's really only important in industrial situations. For example, when a remote modem is used to transmit data back to a central processing facility, or when a modem supplies a direct connection to a mainframe or minicomputer. For general use with dial-up services, modem-based data compression is not much use. For example, if you download ZIP or ARC files from a BBS, data compression is done by the ZIP or ARC program, and transmitting ZIPped files through a data-compressing modem can actually increase transmission time.

Error correction is in a similar, but slightly better, situation. When download-

ing files with a transmission protocol (e.g., Xmodem, Ymodem, or Zmodem, for example), the software provides error correction. However, when reading text on-line, moving through menu systems, etc., no file-transfer protocol is in effect, so line "hits" may garble part of a transmission, even causing your modem or computer to lock up. For that type of situation, modem-level error correction can be useful. However, using an error-correcting modem by itself will do nothing; the service you use must also support the same error-correction protocol that you use. That generally means that you won't benefit if you mainly access local BBS's. If you access long-distance BBS's, and they support an EC protocol, you stand to benefit. If you access Compuserve or other major providers, you may benefit if the access provider (e.g., Tymnet) supports an EC protocol.

ERROR CORRECTION

There are several types of error correction, with varying levels of standardization. The ones that you'll hear hyped are various MNP levels, and V.42. MNP stands for Microcom Networking Protocol. Microcom is a company that manufactures modems and other telecom devices. MNP classes 1-4 provide varying types of error correction, with the highest level (MNP 4) being the most commonly used. MNP 5 is not an EC protocol, but a DC protocol. (Why do they mix apples and oranges in the same series? Probably to confuse us.) There are higher MNP levels, but at present, only Microcom supports them. The good news is that V.42 is not a vendor-specific protocol, but an interna-

tionally recognized and supported one. It also supports MNP levels 1-4, although V.42 has a better EC protocol that it will try to use first. An enhanced version, V.42bis, has an intelligent DC protocol that is similar to, but not compatible with, MNP 5.

Tymnet supports several levels of error correction; call (with a modem) your local Tymnet access number, type "a" and at the "Please log in:" prompt, type INFORMATION:14821. You'll then enter Tymnet's information system. One of the menu choices allows you to get a listing of modem protocols supported in your area. Doing that is well worthwhile; I was able to upgrade my connection to my favorite on-line service from 2400 bps with no EC to 9600 bps with

MNP 4. Doing so saves me time and money, because protocol (e.g., Zmodem) downloads occur roughly three times as fast; and the MNP 4 reduces the time that I have to spend re-reading on-line messages due to line hits.

CONCLUSIONS

If you spend much time using on-line services, a 9600-bps modem will pay for itself quickly. For general-purpose use (sending and receiving text-based messages, and uploading and downloading files), a V.32 modem with V.42 capabilities should suffice. But beware of bargains in that area; now that accepted standards have emerged, distributors will likely try to unload older proprietary modems at attractive prices. ■

FCC LICENSE PREPARATION

General Radiotelephone
Radiotelegraph
Amateur Radio Licenses

We offer the most up-to-date study materials available. Our formats include: tests, audio programs, and video programs.

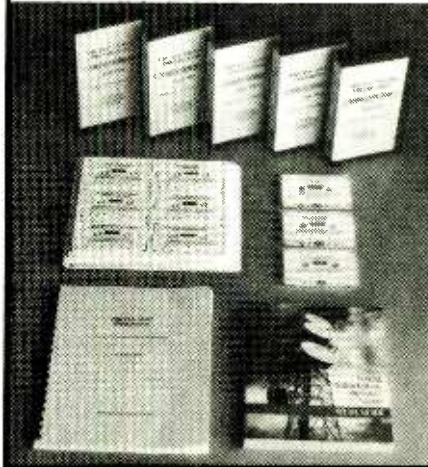

WPT PUBLICATIONS

7015 N.E. 61st Ave.
Vancouver, WA 98661
(206) 750-9933

VENDOR

Optima 96
Hayes Microcomputer Products,
Inc.
P.O. Box 105203
Atlanta, GA 30348
404-449-8791

DX LISTENING

By Don Jensen

The Changing Face of Russian DX

It used to be so easy. When it came to English language broadcasting, there was *Radio Moscow's* 24-hour-a-day World Service, plus some programming from the so-called voice of Soviet popular opinion—*Radio Peace and Progress*—and a handful of ethnically oriented broadcasters such as the Ukraine's *Radio Kiev*, Armenia's *Radio Yerevan* and Lithuania's *Radio Vilnius*.

But then, last August, came chaos! The first west-

linked up to broadcast only solemn classical music. In the past, that sort of thing was a clear tipoff to dramatic changes in the Soviet leadership.

Five minutes later, the TASS news agency announced Gorby's supposed ill health and the start of a coup attempt. Of course, we all know what happened during the next four days, and what has been happening in the USSR since that time. On the shortwave scene, matters have been just as confused and confusing. All sorts of new broadcasting efforts—some official, some semi-official, some totally unofficial—have been reported by professional monitors and SWL's alike.

Much of the new shortwave broadcasting is intended for home audiences, hence it is mostly in the Russian and ethnic languages. But some of the programming has been in English, especially SW broadcasts from some of the now nominally independent ex-republics.

With the situation in the USSR in a continuing state of flux, and because this column was written several months before this issue of **Popular Electronics** goes on the newsstands, I can't say with any certainty which stations will still be active. Plus, it is likely that new ones will be on the air as well. But as of this writing, listeners have been reporting the following bits of information:

Russia's Radio has been broadcasting in the Russian language, 24-hours a day. Listeners reported hearing

this one between 0300 and 0600 UTC on 6,055 kHz, and between 1500 and 0200 UTC on several frequencies, including 11,690, 11,840, and 11,965 kHz.

A station called the *Echo of Moscow* is reported on 9,535 kHz from about 0500–0700 and 1600–1900 UTC daily, and on Saturday and Sunday from about 1500–1600 UTC.

Radio Centras, said to be broadcasting from near Kaunas, Lithuania, has been heard with a rare English program at around 0600 UTC on 9,710 kHz.

Radio Station Vedo, said to be a commercial station operating from Volgograd, was reported on weekends from about 0330 UTC on 7,125 kHz, and weekdays from 2600–1900 UTC on 11,760 kHz. Another source says 1600 UTC on 13,710 kHz.

Radio Riga, Latvia, has had an English service on the air since early 1990. Try 5,935 kHz.

Radio Georgia—called *Radiostantsiya Gruzija* in Russian—broadcasting from the capital of Tblisi, has been heard in English at 0600 UTC on 12,070 kHz.

And what of good old *Radio Moscow*? Its output last summer was down some 75 percent from what it was in 1989. Some 17 language services were either eliminated or cut back. Programs are aired on fewer frequencies. Still, listeners shouldn't have any difficulty in finding plenty of English-language programs.

FEEDBACK

Your letters, with questions, comments or details

WE SUPPLY FOREIGN RADIO STATIONS AND THE PRESS WITH MATERIAL OF INTEREST TO THEM ON A MUTUAL EXCHANGE BASIS.

NOUS FOURNISSONS A TITRE DE RECIPROCITE AUX ORGANISMES DE RADIODIFFUSION ET A LA PRESSE DES PAYS ETRANGERS LES DOCUMENTS RELATIFS AUX QUESTIONS QUI LES INTERESSENT.

SOBRE UNA BASE DE RECIPROCIDAD PROPORCIONAMOS A LAS RADIOEMISORAS DE OTROS PAISES LOS MATERIALES QUE LES INTERESAN.

WIR NEHMEN EINEN AUF GEGENSEITIGKEIT BERUHENDEN AUSTAUSCH VON SENDEMATERIALIEN MIT AUSLÄNDISCHEN RUNDFUNKESELLSCHAFTEN UND PRESSEORGANEN VOR.



RADIO STATION
Peace and Progress

THE VOICE
OF SOVIET PUBLIC OPINION

RADIO
Paix et Progrès

LA VOIX DE
L'OPINION PUBLIQUE
SOVIETIQUE

RADIOEMISORA
Paz y Progreso

VOZ DE LA OPINION
PUBLICA SOVIETICA

DER SENDE
Frieden und Fortschritt

DIE STIMME DER SOWJETISCHEN
ÖFFENTLICHEN MEINUNG

When this program schedule was sent out by *Radio Peace and Progress* some years ago, this voice of Soviet public opinion was, along with *Radio Moscow*, part of a broadcasting monolith in the USSR. Today, the broadcasting picture there is chaotic and confusing with many new stations on the air.

ern report of Gorbachev's albeit temporary overthrow came from the *British Broadcasting Corporation's* SW monitoring station. Janice Farrell, the only Russian-language monitor on the late shift sensed something awry when the Russian home-service networks

of your favorite SW loggings are always welcome. Drop me a line c/o **Popular Electronics**, 500-B Bi-County Blvd., Farmingdale, NY 11735. But, please *don't* ask me what SW receiver you should buy. That's a personal decision. There is no radio that is "right" for everyone. Instead, to those planning to purchase a new SWL radio, I recommend reading the receiver and SW equipment reviews that appear annually in *Passport To World Band Radio* (published by the International Broadcast Service, Box 300, Penn's Park, PA 18943, and available through most bookstores or in your local library).

While most *DX Listening* readers live in the U.S. and Canada, some of you do your DX'ing from much more distant overseas locales. We start out this month with two letters with exotic postmarks. The first one comes from the Republic of Maldives! In case that doesn't ring a bell with you, check out your world globe, looking for a small group of islands off the southern tip of India.

Reader V.G. Nair is an Indian national working in the accounts department of a firm in the Maldives capital of Male. V.G. asks a number of questions about becoming licensed in the Maldives as an amateur-radio or ham operator.

What a surprise, V.G., to get mail from a reader halfway around the world. Some years ago, the Maldives shortwave-broadcasting station was, for North American SWL's, one of the rarest catches in the world. Sadly, that broadcaster has since left shortwave. As far as amateur-radio activity in the Maldives or how one goes about getting a ham license there is concerned,

frankly, I don't have any current information to pass along.

You might, however, wish to contact the "Union of Asian DX'ers," in care of G. Victor Goonetilleke, Shangri-La 298 Kolamunne, Pilyandala, in Sri Lanka. While UADX focuses mostly on SWL'ing, some of its members, including editor Goonetilleke, are ham-radio operators as well. They may be able to help you with the information you seek. The UADX also is a good club (with a periodic news bulletin) for other SWLs who want to keep up with what's being heard on SW in south Asia by Asian DX'ers.

However, I can help with another of V.G. Nair's queries: "What are the transmission times and frequencies of English broadcasts from *Radio Nederland*?"

Radio Nederland's English programs are beamed in your direction, more or less, at 0730 UTC on 9,630, 9,715, and 15,560 kHz; at 0830 UTC on 9,770, 15,560, 17,575, and 21,485 kHz; at 1130 UTC on 17,575, and 21,520 kHz; and at 1430 UTC on 15,575 and 17,605 kHz.

North American listeners also can find *Radio Nederland* on some of those frequencies and at those times, but better bets are the programs that are specifically directed to North America on 6,020, 6,165, and 15.560 kHz from 0030-0125 UTC, and on 6,165 and 9,590 kHz from 0330-0425 UTC

Next we hear from Alan B. Scholl, who writes from Antigua in the West Indies. He is

*Credits: Simon Harner, Wales, UK; Dan Ferguson, VA; Harry Helms, CA; Tom Tabatowski, IN; Robert Zilmer, NM; Richard Wallace, CT; Dave Weinrich, CT; North American SW Association, 45 Wildflower Road, Levittown, PA 19057.

a 23-year old computer engineer working as a consultant for a branch of a U.S. accounting firm on Antigua and has recently resumed his SWL'ing hobby. In three months he has heard, reported, and received QSL cards from Sweden, the U.S., Switzerland, Australia, Japan, Ecuador, Germany, and Greece. The 3BC and *Deutsche Welle* relay their SW broadcasts to North America from transmitters on this island.

"I listen to world band a lot," Alan says, "at least three or four hours per night, on average, sometimes more. Antigua seems to be a good spot for SW DX'ing. With the simple whip antenna on my SONY ICF-2010, I have no problems hearing *Radio Australia* on 21,450 kHz.

Other regulars are *Radio Sweden* on 17,405 kHz, *Radio Switzerland International* on 9,650 kHz, *Kol Israel* on 15,640 kHz, *Radio Portugal* on 9,680 kHz, *Radio Espana* foreign service on 11,880 kHz, *Radio Habana Cuba* on 11,820 kHz and many others. I also receive stations from Colombia, Venezuela, and Guatemala, but since I don't speak Spanish, there is no listening pleasure there."

Alan asks that I include his address (P.O. Box 252, St. John's, Antigua, West Indies) so that other shortwave listeners may contact him if they wish.

DOWN THE DIAL

Here are some of the shortwave broadcasts that are being heard lately. Why (Continued on page ??)

Make the most of your general coverage transceiver with *Monitoring Times*!

Every month *Monitoring Times* brings everything you need to make the most of your general coverage transceiver: the latest information on international broadcasting schedules, frequency listings, international DX reports, propagation charts, and tips on how to hear the rare stations. *Monitoring Times* also keeps you up to date on government, military, police and fire networks, as well as tips on monitoring everything from air-to-ground and ship-to-shore signals to radioteletype, facsimile and space communications.

ORDER YOUR SUBSCRIPTION TODAY before another issue goes by. In the U.S., 1 year, \$19.50; foreign and Canada, 1 year, \$26. For a sample issue, send \$2 (foreign, send 5 IRCs). For MC/VISA orders (\$15 minimum), call 1-704-837-9200.

MONITORING TIMES

Your authoritative source, every month.

P.O. Box 98
Brasstown, N.C. 28902

HAM RADIO

By Joseph J. Carr, K4IPV

Design and Build Loaded Dipoles

One of the mainstay antennas of ham radio is the simple half wavelength, horizontal dipole. It is simple to build, easy to maintain, and works reasonably well on all HF and some VHF bands. Figure 1A shows the simple dipole. The radiator elements are each a quarter-wavelength long, and are made of copper wire. Hard-drawn copper wire is popular, but the best is Copperweld (copperclad steel wire). The steel gives it strength, and the copper

where L_{feet} is the length in feet, and f_{MHz} is the operating frequency in megahertz. Because the dipole must work over a wide ham band, it is usually cut for the center of the desired band of operation. However, if you only work one mode (e.g., CW-only or phone-only), then cut it for the center of the band segment of choice.

The radiator element is broken into two portions, each of which are half the length found in equation 1,

Coaxial cable is used as the transmission line to the transceiver; one end of the antenna is connected to the center conductor of the coax, while the other end of the antenna is connected to the outer shield of the coax. (In general, RG-59/U, RG-11/U, or some other 75-ohm coaxial cable is used for the transmission line.)

Now that we've reviewed the basics of dipole antennas, let's take a look at the major downside to this type of antenna—namely, they're very long at the lower frequencies. For example, the length of a dipole for the 40-meter band (7–7.3 MHz) would be 64- to 67-feet long (depending on what frequency it is cut for). On the 75/80-meter bands (3.5–4 MHz), the antennas are double the length of 40-meter antennas (up to 134-feet long). What to do?

Fortunately, there are some things that can be done in such situations. Perhaps the most popular way to shorten a dipole is to insert an inductor in each element (L1 and L2 in Fig. 1B). Such antennas are called *inductively loaded shortened dipoles*. The overall length of the antenna (designated A in Fig. 1B) is shorter than one-half wavelength (L_{feet} in equation 1 and L in Fig. 1A).

The coils are located a distance (designated B in Fig. 1B) from the feedpoint. That distance can be anything from 0-percent to about 75-percent of the overall length (A) of the dipole. Technically, you can place the coils at the ends

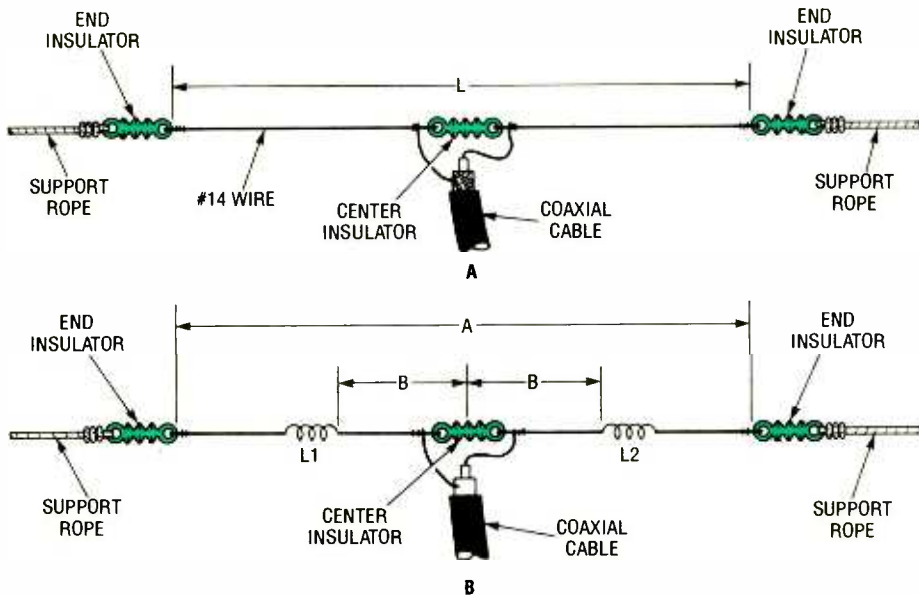

Fig. 1. The radiator element for traditional half-wavelength, horizontal, center-fed dipole antennas (A) is broken into two segments each a quarter-wavelength long. Dipoles can get extremely large at the lower frequencies, but inductive loading—a scheme by which an inductor (L1 and L2 in B) is inserted in each element—can be used to shorten the overall length of the antenna.

cladding lowers the RF resistance. The higher resistance inner core does not affect the RF signals because the signals only flow on the surface of the wire.

The overall length of the wire element (L in Fig. 1A) is one-half wavelength, and is found from the equation:

$$L_{\text{feet}} = 468/f_{\text{MHz}} \quad (1)$$

or a quarter-wavelength long. The ends of the wires are tied off to a mechanical support rope via ceramic, glass, or plastic end insulators. The feedpoint is the center of the antenna where the two quarter-wavelength radiator elements are supported by a center in-

of the radiator elements, but those points are at a very high RF voltage, which can damage many forms of coil.

Figure 2 gives a means for determining the inductive reactance required for L1 and L2, provided that you know the relative length of the antenna. Only three curves are given: A = 0.1L; A = 0.5L; and A = 0.9L; where A is the overall length of the antenna, as determined from equation 1. The horizontal axis shows the location of the inductors as a percentage of the overall length:

$$A/B \times 100\%$$

For example, suppose that we want to build a 7.2-MHz antenna that is 50-percent of the normal size. The overall length (A) is:

$$468/7.2 \times 0.5 = 32.5 \text{ feet}$$

Each element is therefore:

$$32.5/2 = 16.25 \text{ feet}$$

Thus, the coil is placed at the 50-percent point in each 16.25-foot (or 16 foot, 3 inch) element. The 50-percent coil location line (read off the B axis) intersects the 50-percent antenna size curve at about 850 ohms. The inductor should be designed to have a reactance of 850 ohms at 7.2 MHz. To do that, we must determine the inductance of the coil:

$$\begin{aligned} L &= X_L/2\pi f \\ &= 850/[(2 \times 3.14)(7.2 \text{ MHz})] \\ &= 18.8 \mu\text{H} \end{aligned}$$

As is true with all antennas, the design guidelines—whether the equation for a half-wavelength antenna, or the chart of Fig. 2—are always approximate. In other words, they will get you into the ballpark, but you will need to use some tuning method to bring the resonant frequency to the exact point desired. You

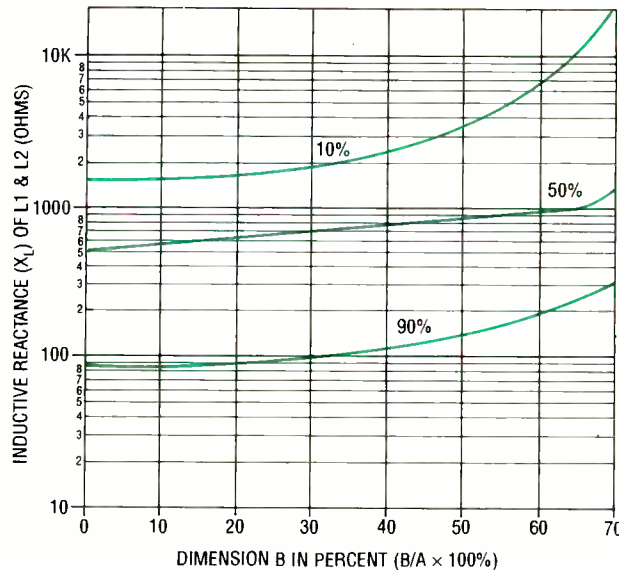
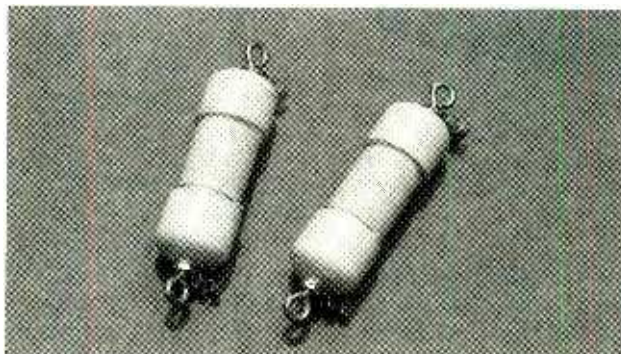

Fig. 2. Design charts for 10%, 50% and 90% length loaded dipole antennas are shown here. As is true with all antennas, the design guidelines, the values expressed are always approximate.

can do that either by adjusting the inductance of the overall length of the antenna. Use a VSWR meter, a noise bridge, impedance bridge, or some other means to find the resonant point.

The construction of the typical coil is simple, and can be accomplished using a piece of commercial coil stock, such as Barker & Williamson (B&W) miniductor 3029 stock. Simply cut the coil from a larger piece of miniductor stock, as required by the inductance needed. Some commercial dipole loading coils appear to be made from PVC pipe with PVC

caps on either end. Such coils—which consist of insulated wire wound in the space between the end caps—are available from a variety of sources. One such source is the Electronic Equipment Bank (323 Mill Street N.E., Vienna, VA 22180). Another source of supply is Radio Works (P.O. Box 6159, Portsmouth, VA, 23703; 804-484-0140). The Radio Works catalog lists a number of different types of wire antennas, and the usual load of antenna supplies (they specialize in wire antennas). If you want to try winding the inductors on toroidal cores, use the large ones—the type used for



Some commercially available dipole loading coils appear to be made from PVC pipe. The coils—which consist of insulated wire wound in the space between the end caps—are available from a variety of sources.

kilowatt baluns. Such cores are available from Amidon Associates (12033 Otsego Street, North Hollywood, CA 91607). You can either buy the core separately, or buy their balun kit.

By the way, if you contact any of the firms mentioned in this column, why not tell them that you heard about them in **Popular Electronics!**

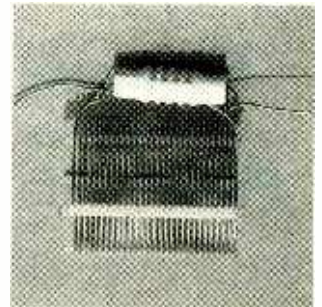

Shown here is a loading coil made from commercial coil stock, such as Barker & Williamson (B&W) miniductor.

BASIC PROGRAM

I've written a BASIC program—called LOADPOLE—that calculates the coil inductances and reactances for the shorted coil-loaded dipole antenna shown in Fig. 1B. A listing (LOADPOLE.BAS) can be down loaded from the R-E (*Radio Electronics*) BBS, using a 1200 or 2400 baud modem (set for 8 data bits, no parity bit, and 1 stop bit). The BBS number is 516-293-2283. The listing is also available from the author by sending an SASE to Joseph J. Carr, PO Box 1099, Falls Church, VA 22041-0099. Or, if you prefer, an executable copy of the program for MS-DOS machines is available from the author for \$15, post-paid (Virginia residents please add appropriate sales tax). Please specify 5.25-inch or 3.5-inch diskettes when ordering, otherwise, you'll automatically receive the 5.25-inch diskette.

SCANNER SCENE

By Marc Saxon

Monitoring Motion- Picture Sets



Ace Communications' AR-2800 receives everything from below the AM broadcast band up to the microwave band, and provides 1000 memory channels.

Leave it to *Ace Communications* to continue expanding the frontiers of the world of scanners. The company's recently announced *AR-2800* can inhale all frequencies between 500 kHz and 1300 MHz, which means everything from below the AM-broadcast band through the international shortwave bands, all public-safety bands, all TV channels, all 800-MHz band frequencies,

and on toward microwave. Add to this that the *AR-2800* has 1,000 memory channels, and you can see that there's a lot of potential here.

Selectable reception

modes include AM, NFM, WFM, and even SSB. They are operable at all frequencies covered by the *AR-2800*.

Twenty-six front-panel keys are used for all programming functions. Pairs of upper/lower-band search frequencies are stored in ten separate search-memory locations. All information is stored in a permanent memory. There are 21 separate prompts that appear in the LCD display to offer advice to the operator.

Specifications, you ask? It exceeds 0.35 μV at 12-dB SINAD in NFM mode, and 1.0 μV at 10-dB S/N in AM mode.

The *AR-2800* operates from 12 VDC, but it comes with a 117-VAC wall-plug adaptor for desktop operation. The *AR-2800*, despite its many features, comes in a relatively small package—2.25 inches high, 5.75 inches wide, and 7.25 inches deep, with a weight of only 12 ounces.

The suggested retail price of the *Ace AR-2800* is \$449. For more information, contact *Ace Communications*, Monitor Division, 10707 East 106th Street, Fishers, IN 46038.

LIGHTS, CAMERA, ACTION!

A few weeks ago, there was a movie crew shooting some location scenes on the main street in my home town. It was a big event, featuring one of my favorite actors, and everybody went over to watch for the week

they were filming. For my part, I was immediately interested in the handheld VHF radios that were in heavy use by many members of the crew.

Eventually, I located the crew's electrician, who was the person in charge of the radio equipment. He told me that for most films, the radio equipment is rented, as are the lights, cameras, props, generators, costumes, and recording equipment.

The crews use two-way radios so that the director can coordinate and communicate with the camera- and sound-equipment operators, the lighting crew, prop people, stunt people, actors, extras, carpenters, and others on the set. Sometimes, individual groups within the crew use their own frequencies.

The most popular frequencies used during the shooting of motion-picture (including filmed TV) features are 173.225, 173.275, 173.325, and 173.375 MHz. Major productions that require an extraordinary amount of coordination spread out over a wide area might need additional two-way communications frequencies (shared with the Special Industrial Radio Service), as follows: 152.87, 152.90, 152.93, 152.96, 152.99, and 153.02 MHz.

Remember that motion-picture filming also includes shooting documentaries, news films, travelogues, school films, and industrial sales and training films, as well as TV commercials. As

such, filming is constantly going on around the nation, and at all times, day and night. These generally overlooked frequencies deserve your attention because they could well produce activity of some considerable interest. Imagine hearing one of your favorite actors getting chewed out by the director for continually missing his entrance cue. That's what I heard on my scanner! It was juicier than reading a supermarket tabloid.

YOU WROTE

A note from Donald Hawkins, of Chesapeake, VA, wonders if one antenna can be used to feed five different scanners. Perhaps that can be done, but only if the scanners are each hooked to the feedline by means of some type of duplexing arrangement. Trying to hook each of them directly to the antenna will undoubtedly result in unsatisfactory reception and scanner operation, with no end to "birdies" and scanning lockups on false carriers.

M.E. of Halifax, Nova Scotia, works for a company that recently switched their operations to an 800-MHz "trunked" communications system. People have told him that such systems absolutely cannot be monitored on a scanner, and he would like to know if this is true. They are more of a chore to monitor than conventional systems, but it's done all of the time. Trunked systems use several frequencies. An exchange of transmissions in a single conversation could conceivably move through several of those frequencies.

In order to monitor a trunked system, each frequency would have to be entered in your scanner,

with the delay function turned off. It's best to put all the frequencies into one otherwise empty or unused memory bank. That way, your scanner will quickly check each of the system's frequencies, and nothing else. In some trunking systems, one frequency is set aside for control (non-voice) purposes, so it can be locked out (although the control channel may be changed daily).

G.K., of Fridley, MN, reminds us that baby-room monitors in the 49.67 to 49.99-MHz band offer very unusual fare. There's one in his area on 49.875 MHz that runs day and night. The kid howls all night long, and the rest of the time it's mom and pop screaming and yelling at one another with some decidedly X-rated language.

We received dozens of letters thanking us for mentioning the idea about adding one-button NOAA weather-frequency access to almost any scanner (**Popular Electronics**, September 1991) and asking for more suggestions like it. We are always pleased to pass along such tricks. For the record though, the column did get one letter from an annoyed reader who thought it was a totally dumb idea and predicted that nobody would actually be so foolish as to sacrifice their "valuable" priority-channel feature in order to make room for a wimpy NOAA weather forecast. Oh well, I guess there's always at least one malcontent in every crowd.

We hope you'll join us in the April issue, and send in your questions, ideas, loggings, frequency lists, and opinions. We are *Scanner Scene*, **Popular Electronics**, 500-B Bi-County Blvd., Farmingdale, NY 11735. ■

FREE
Catalog

All the tools & test equipment you need for hobby or work!

Electrical, electronics, computers, communications, sound systems - all the tools, meters and other equipment you need to do a professional job!



Top technicians and field service personnel prize their Jensen tool kits. Our new 232-page Master Catalog will show you why. You'll discover hard-to-find items, the latest high-tech developments, soldering stations, wire & cable accessories and many more quality products you want and need. **Send for your free copy today!**



JENSEN TOOLS INC.

7815 South 46th St.,
Phoenix, AZ 85044-5399
Phone: (602) 968-6231
FAX: (800) 366-9662

CIRCLE 7 ON FREE INFORMATION CARD

LEARN to CLEAN/MAINTAIN/REPAIR CAMCORDERS



HUGE EXPANDING MARKET!

Work from your home - part-time or full-time! No prior experience needed - Average mechanical ability only requirement for your success! Over 15 million camcorders in use - Over 5 million expected to be sold in 1991 alone!

It is a fact that the vast majority of camcorder malfunctions (just like VCRs) are due to simple mechanical failure. We can show you how to easily fix those breakdowns and earn an average of \$85.00/hr while working at home!

Get In Now - Soon camcorders will be like VCRs, i.e., one in almost every home.

For a camcorder cleaning job you can earn \$65.00 for less than 30 minutes work.

For a camcorder repair job you can earn over \$100.00.

FREE INFORMATION PACKAGE call or write:

Toll-Free 1-800-537-0589

Viejo Publications, Inc.

4470-107 Sunset Blvd., #600

Los Angeles, CA 90027, Dept. PEC

CIRCLE 13 ON FREE INFORMATION CARD

ELECTRONICS LIBRARY

Make Better Videos With Your Camcorder

by Erwin Kenneth Thomas

Whether you use your camcorder to record family vacations, sporting events, weddings or other special events, or business presentations, your main goal is to produce a tape that people want to watch. According to this book, achieving that depends less on technical wizardry than on planning and common sense. Of course, you must first know how to use your camcorder; the book's first two sections explain the operating principles of the camcorder and

sets and costumes, and using graphics are discussed. Just as in professional films, videos need a story line that flows well, and this book explains how to script your videos. Separate chapters cover production techniques, directing, and dealing with "actors." Editing is covered, including the addition of special effects. Hints for shooting weddings and other special-purpose shows are provided, and camcorder options and accessories are explained.

Make Better Videos With Your Camcorder costs \$12.95 and is published by TAB Books, Division of McGraw-Hill Inc., Blue Ridge Summit, PA 17294-0850; Tel. 1-800-822-8138.

CIRCLE 96 ON FREE INFORMATION CARD

WINDOWS 3 QUICK REFERENCE

by Timothy S. Stanley

Windows is a multitasking operating environment for MS-DOS that's intended to make it easier to use many applications by giving all the programs a similar, consistent look and feel and by allowing more than one program to be used at the same time. Of course, until you become familiar with Windows, you can't take advantage of it. This book is not intended to replace the documentation that comes with Windows 3, but to provide users with a handy reference source. It highlights the most frequently used material, with an emphasis on how to put Windows' features to practical use in your own applications. The book explains how to work with associated programs such as Cardfile, File Manager, Notepad, and the other accessories that accompany Windows. It is divided into sections by tasks. Each section provides step-by-step instructions for using that particular accessory or perform-

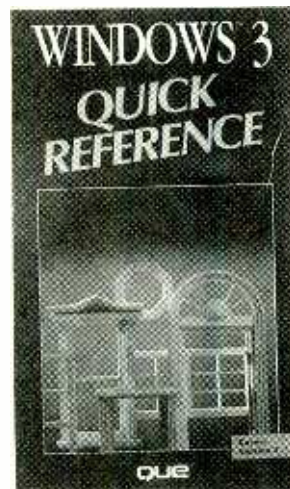

ing a specific function—without wading through page after page of technical information. The book explains how to schedule with Calendar, customize Windows, and work with pull-down menus and icons.

Windows 3 Quick Reference costs \$8.95 and is published by Que, 11711 North College Avenue, Suite 140, Carmel, IN 46032; Tel: 1-317-573-2500.

CIRCLE 88 ON FREE INFORMATION CARD

INTEGRATED CIRCUIT AND WAVEFORM GENERATOR HANDBOOK

by R.M. Marston

While it is specifically aimed at design engineers, technicians, and experimenters, its subject matter—waveform-generator techniques and circuits—will also be of interest to electronics students and amateurs. Waveform-generator circuits are used in some way in most types of electronic equipment, making them one of the most widely used classes of circuit. They can be designed to produce outputs with sine, square, triangle, ramp, pulse, staircase, or other waveforms; modulated or unmodulated outputs; and out-

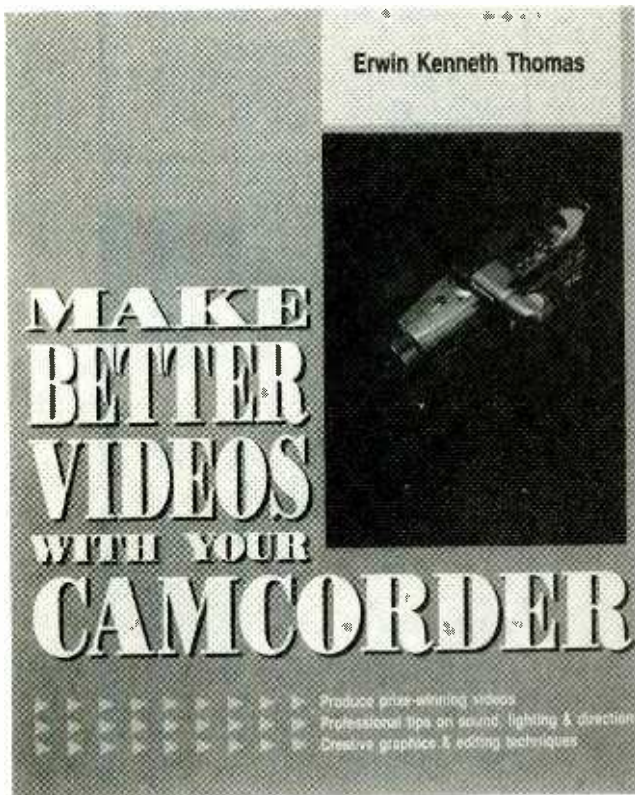

lens. In those chapters, as in the rest of the book, there are almost more illustrations than text. Drawings and photographs demonstrate and clarify the principles discussed in the text. Most of the book is devoted to setting up a good video. Creating the proper lighting and sound ambience, designing

puts of single or multiple form. Waveform-generator circuits can be built using transistors, op-amps, dedicated waveform- ("function") generator IC's and other devices including the 555 timer IC. The book, which presents more than 300 practical circuits, diagrams, and tables, is divided into eleven chapters dealing with basic principles and types of generators, specific types of generators, phase-locked loop circuits, and miscellaneous applications of the 555 timer IC. Each chapter begins with an explanation of the basic principles of its subject and then goes on to present the reader with a wide range of practical design circuits. Most of the devices used in the practical circuits are modestly priced and easy to find. The book provides detailed information, but in a down-to-earth, non-mathematical style. A special appendix



presents several useful waveform-generator design charts to help readers design or modify generator circuits to their own specifications.

Integrated Circuit and Waveform Generator Handbook costs \$22.95 and is published by Butterworth-Heinemann, 80 Montvale Avenue, Stoneham, MA 02180; Tel: 617-438-464 or 800-366-BOOK (for order only).

CIRCLE 89 ON FREE INFORMATION CARD

CATALOG #13

from JDR Microdevices

Catalog #13 could be lucky for bargain hunters. JDR's latest catalog features reduced prices, new and enhanced product

lines, and free gifts to its customers. The prices of popular items from Logitech, Intel, Epson, Cyrix, and IIT have been lowered, as have prices on entire lines of such products as DRAM, math coprocessors, motherboards, and floppies. New to Catalog #13 are Conner



IDE hard drives, NEC Intersect CD-ROM drives, Mountain Tape drives, Citizen printers, software, replacement ribbons for dozens of printers, non-interlaced 1024 x 768 VGA monitors, and wrist-rest supports to reduce typing fatigue. Electronics professionals and hobbyists will appreciate the improved engineering product line, which now includes a low-priced hand-held IC tester and identifier, a stand-alone EPROM programmer, and many new tools and components. The PC Interface Design kit teaches users how to develop serial, parallel, and stepper-motor interfaces.

Catalog #13 is free upon request from JDR Microdevices, 2233 Samaritan Drive, San Jose, CA 95124; Tel: 800-538-4000 or 408-559-1200.

CIRCLE 90 ON FREE INFORMATION CARD

AUDIO FLYER

from Parts Express

Audiophiles and do-it-yourselfers will find plenty of interesting items in this catalog. Its 44 pages are filled with speaker cabinets, tweeters, midranges, woofers, crossovers, and complete speaker systems; wire and wire accessories, automotive stereos, amplifiers, equalizers, crossovers, speakers, power supplies, and sound accessories; audio cables and

Be an FCC LICENSED ELECTRONIC TECHNICIAN!



No costly school. No commuting to class. The Original Home-Study course prepares you for the "FCC Commercial Radio-telephone License." This valuable license is your professional "ticket" to thousands of exciting jobs in Communications, Radio-TV, Microwave, Maritime, Radar, Avionics and more...even start your own business! You don't need a college degree to qualify, but you do need an FCC License.

No Need to Quit Your Job or Go To School This proven course is easy, fast and low cost! **GUARANTEED PASS**—You get your FCC License or money refunded. **Send for FREE facts now. MAIL COUPON TODAY!**

COMMAND PRODUCTIONS

FCC LICENSE TRAINING, Dept. 100
P.O. Box 2824, San Francisco, CA 94126
Please rush FREE details immediately!

NAME _____
ADDRESS _____
CITY _____ STATE _____ ZIP _____

SUPER LONG PLAY TAPE RECORDERS

12 Hour Model —
USES 120 TAPE
\$119.00*

Modified Panasonic Slimline high quality AC-DC provide 6 continuous hours of quality recording & playback on each side of cassette for 12 hours total. Includes • Voice level control • Digital counter, etc TDK -120 Cassette Furnished



PHONE RECORDING ADAPTER

Records calls automatically. All Solid state connects to your telephone jack and tape recorder Starts recording when phone is lifted Stops when you hang up. **\$28.50*** FCC APPROVED

VOX VOICE ACTIVATED CONTROL SWITCH
Solid state Self contained Adjustable sensitivity Voices or other sounds automatically activate and control recorder. Uses either recorder or remote mike. **\$28.50***

* Add for ship. & handling Phone Adapter & Jack \$2.00 each
Recorders \$5.00 each Calif. Res. add tax. Mail order, VISA
M.C. COD's OK Money Back Guarantee Quantity discounts
available. Dealer Inquiries invited. Free info
AMC SALES INC. Dept. B 9336 Lodi Street
Box 978, Downey, CA 90241
Phones (310) 869-9513 • 1-800-576-2488
FAX (310) 923-7478
Mon-Fri 8-5 P.M. TIME

CIRCLE 11 ON FREE INFORMATION CARD

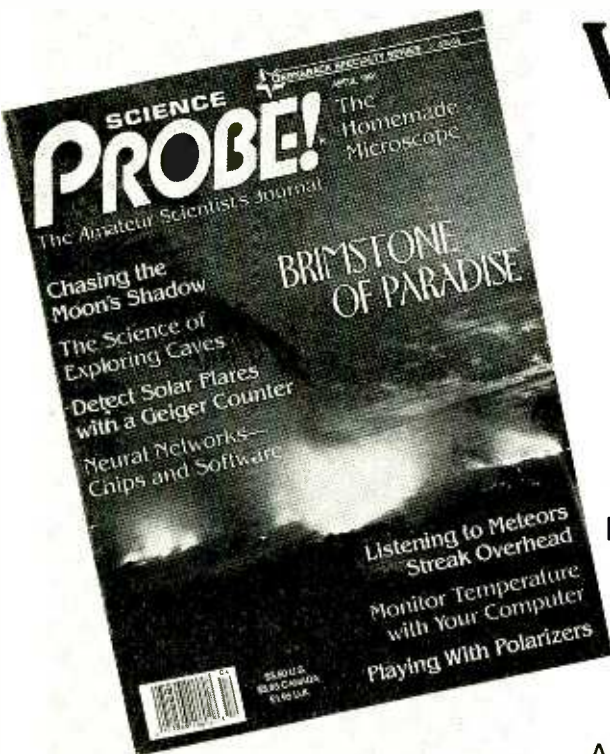

Welcome to. . .

SCIENCE PROBE!

The Amateur Scientist's Journal

Embark on an irresistible new journey into the realm of mystery, challenge, and exploration! The perfect magazine for the budding scientist, the serious amateur, the professional who would like to relax, and those who simply want to gaze at the stars.

Science PROBE! — the *only* magazine devoted entirely to Amateur Scientists! If you are fascinated by science in all its many forms . . . if you can't stay away from a microscope, telescope, calipers, or test tube — we invite you to share the wonders in every issue of **Science PROBE!** You will join a community of Amateur and Student Scientists who enthusiastically seek scientific knowledge or follow scientific pursuits for their own sakes and not merely as a profession.

Obtain your next issue of **Science PROBE!** by visiting a quality Newsstand, Convenience Store, or Supermarket or by reserving your personal copy through the mail by completing the coupon below.

From your very first issue of **Science PROBE!** you will be involved in a world of scientific facts, experiments, and studies pursued by amateur scientists who are university students, investors, academicians, engineers, or office workers, salesmen, farmers—whose *quest* is to probe into the mysteries of science and reveal them to all.

Plan to become a **Science PROBE!** reader!

Articles to appear in upcoming issues of **Science PROBE!** are:

- How an Amateur Mapped the Milky Way**
- Make your own Seismometer**
- Operate a Solar-powered Weather Station**
- Grow Crystals Automatically**
- Experiment with a Saltwater Aquarium**
- How to Keep a Science Notebook**

If you're fascinated by science in all its many forms, if you are compelled to experiment and explore, then **Science PROBE!** is your kind of magazine!

Science PROBE!
500-B Bi-County Boulevard
Farmingdale, NY 11735

Please forward my copy of **Science PROBE!** as soon as it comes off the press. I am enclosing \$3.50-U.S.A. (\$4.23-Canada-includes G.S.T.) plus \$1.00 for shipping and handling. Better still, please enroll me as a subscriber and send the next four (4) quarterly issues of Science Probe. I am enclosing \$9.95-U.S.A. (Canada: \$16.00—includes G.S.T.)

Next Issue Only Next Four Issues (1 Year)
Offers valid in the U.S.A. and Canada only. No foreign orders.

Name _____

Address _____

City _____ State _____ ZIP _____

All Orders payable in U.S.A. Funds only.

7PC21

ON SALE AT QUALITY NEWSSTANDS, CONVENIENCE STORES AND SUPERMARKETS
GET YOUR COPY TODAY—\$3.50-U.S.A.—\$3.95-Canada

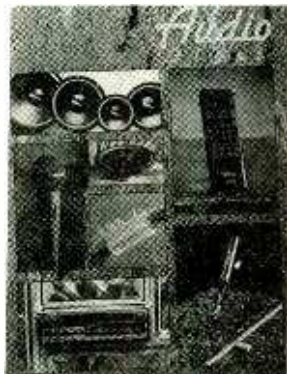

connectors; headphones; microphones; tools; books; PA equipment; and accessories. Highlighted in this issue are decorative wall plates for custom installations, 12-gauge neon wire, a 6 x 9-inch 2-way speaker pair, Sanyo tweeter and midrange and a pre-programmed remote control.

The Audio Flyer is free upon request from Parts Express, 340 East First Street, Dayton, OH 45402-1257; Tel: 513-222-0173; Fax: 513-222-4644.

CIRCLE 91 ON FREE INFORMATION CARD

MASTERING ELECTRONICS MATH Second Edition

by R. Jesse Phagan

If you're interested in electronics, you can't completely avoid the field of mathematics. The ability to understand and perform related math fosters a strong understanding of electronics theory, making it much easier to learn electronics and to grow with the field. This book guides the reader through the practical calculations needed to design and troubleshoot circuits and electronic components, while avoiding an overly theoretical approach. Each concept is accompanied by clear explanations and sample problems, along with pointers on when and why each is used in common electronics applications. The book covers scientific and engineering notation; DC circuit math; reading a volt/ohm/milli-amp meter; sinewaves; transformers; inductors and capacitors; time constants; RC waveshaping; and binary, octal, and hexadecimal number systems. The book's author, an

electronics instructor, used suggestions from his own students to update the second edition. Some difficult sections have been rewritten to simplify understanding and clearer graphs

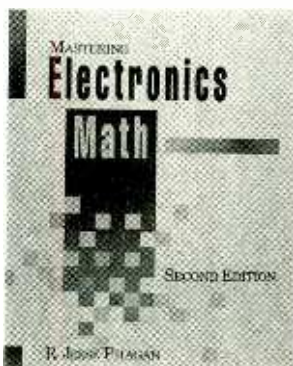

and drawings are included. Four new chapters have been added, covering mathematics related to the use of multimeters and oscilloscopes, and transistors and computer numbering.

Mastering Electronic Math, Second Edition costs \$17.95 and is published by TAB Books, Division of McGraw-Hill Inc., Blue Ridge Summit, PA 17294-0850; Tel: 1-800-822-8138.

CIRCLE 98 ON FREE INFORMATION CARD

YOUR NATURAL RESOURCE: 1992 ANNUAL CATALOG

from Jameco

Printed on recycled paper, this 90-page full-color catalog is a one-stop source for computer and electronics enthusiasts. It includes more than 3000 products ranging from integrated circuits to computer peripherals to complete systems, and from soldering tools to test and measurement equipment. The 1992 edition features education information, a RAM cross-reference guide, and 24-hour toll-free order placement.

Your Natural Resource: 1992 Annual Catalog is free upon request from Jameco Electronic Components and Computer Products, 1355 Shoreway Road, Belmont, CA 94002; Tel: 800-831-4242; Fax: 800-237-6948.

CIRCLE 92 ON FREE INFORMATION CARD

ELECTRONICS PAPERBACKS



BP282—UNDERSTANDING PC SPECIFICATIONS...\$7.25. Explains difference between types (XT, AT, 80386, etc.), math co-processors, input devices, memory, RAM discs, floppy drives, hard discs, displays and more. Everything you need to know if you can't tell your E.M.S. from your E.G.A.!

BP278—EXPERIMENTAL ANTENNA TOPICS...\$5.95.

Packed with 28 different antenna topics. Learn how to build helical, crossed field, dipoles, loop and frame, phased array, VHF whips and more. An experimenter's dream book.



BP276—SHORT WAVE SUPERHET RECEIVER CONSTRUCTION...\$5.95. Everything you need to know to build your own receiver plus a variety of enhancement you can add later—input filter, rf amplifier, product detector, S meter, and more.

BP271—HOW TO EXPAND, MODERNIZE AND REPAIR PCs AND COMPATIBLES...\$7.75.

Includes PC overview, memory upgrades, adding a hard disc, adding floppy drives, display adapters and monitors, installing a co-processor, preventive maintenance, repairs, do it yourself PCs and more.



BP266—ELECTRONIC MODULES AND SYSTEMS FOR BEGINNERS...\$7.25. Describes more than 60 modular electronics circuits—how they work, how to build them, and how to use them. A wonderful book for the experimenter.

BP255—INTERNATIONAL RADIO STATIONS GUIDE..... \$7.95.

Provides the casual listener, amateur radio DXer and the professional radio monitor with an essential reference work designed to guide him or her around than ever more complex radio bands.



MAIL TO Electronic Technology Today, Inc.
P.O. Box 240
Massapequa Park, NY 11762-0240

SHIPPING CHARGES IN USA AND CANADA

\$0.01 to \$5.00	.. \$1.50	\$30.01 to 40.00	.. \$5.50
\$5.01 to \$10.00	.. \$2.50	\$40.01 to 50.00	.. \$6.50
\$10.01 to 20.00	.. \$3.50	\$50.01 and above	.. \$8.00
\$20.01 to 30.00	.. \$4.50		

SORRY, No orders accepted outside of USA and Canada

Total price of merchandise \$ _____
Shipping (see chart) \$ _____
Subtotal \$ _____
Sales Tax (NYS only) \$ _____
Total Enclosed \$ _____

Name _____
Address _____
City _____ State _____ Zip _____

NEW PRODUCTS

Six-Speed Turntable

In the age of the CD, collections of LP's are beginning to seem old-fashioned—and many new rack and mini systems don't even come with a turntable. If your music collection includes not only LP's, but 78's and other vintage recordings as well, don't despair. *Esoteric Sound's V-3 Professional Restoration Deck* has six speeds—33, 45, 71.29, 76.59, 78.26, and 80 rpm—for accurate reproduction of virtually any vintage record. Aimed at audiophiles and serious collectors, the V-3 features fully



manual control, switch-selectable speeds, standard cartridge hardshell design, adjustable tracking and anti-skating force, pitch control, built-in stylus illumination, and a high-reliability direct-drive motor. A solenoid brake stops the platter instantly. A dust cover is included. Optional accessories include a coarse-groove stylus, a vertical/lateral switch, and a plug-in goose-neck lamp.

The V-3 multi-speed turntable costs \$475. For further information, contact Esoteric Sound, 4813 Wallbank Avenue, Downers Grove, IL 60515.

CIRCLE 101 ON FREE INFORMATION CARD

POWER LINE MONITOR

Designed to aid anyone who services or installs micro-processor-based equipment,



Eastern Time Design's Probe 100 measures common-mode noise, dropouts, spikes, high-frequency noise, surges, and sags to determine if an outlet is wired properly. The handheld probe continuously monitors the AC power line and indicates the line voltage (high, low, or normal) through the AC level indicators. The rest of the LED's light to indicate problems. The Probe 100 is easy to use; it simply plugs into the outlet to be tested. You can immediately check to see if the Hot/Neutral wires are reversed, or opened, or grounded. The unit can then be left plugged in for a period from 24 to 72 hours. It will record and store the disturbance events through LED lights, which stay latched or lit until reset by the operator. The manual provides an explanation of the disturbances indicated by the LED's.

The Probe 100 power-line monitor has a suggested retail price of \$149.95. For more information, contact Eastern Time Designs Inc., 2626 Brown Avenue, Manchester, NH 03103; Tel: 800-872-4383 or 603-645-6578.

CIRCLE 102 ON FREE INFORMATION CARD

MINIATURE VIDEO MICROPHONE-MIXER

Stereo camcorder owners can record sound from add-on microphones in stereo using the *CAM-3* microphone-mixer from *Azden Corporation*. Designed

for using multiple microphones with any camcorder, the compact device has three audio inputs and slide level controls that allow the user to mix the sound from two microphones (wireless, zoom, or narration) and a personal stereo unit, while shooting. Weighing only 3 ounces, the CAM-3 can be attached directly to the camera (with supplied Velcro) or can be attached to the camera strap using the supplied belt clip. The passive device requires no batteries. To record stereo sound from add-on mics, one microphone is plugged into Input 1



and another in Input 2. Sound from each is recorded onto a separate audio channel, creating stereo sound. In addition, Input 3 is a stereo jack, allowing sound from a personal stereo to be recorded in stereo.

The CAM-3 video microphone mixer has a suggested retail price of \$59.95. For more information, contact Azden Corporation, 147 New Hyde Park Road, Franklin Square, NY 11010; Tel: 516-328-7500; Fax: 516-328-7506.

CIRCLE 103 ON FREE INFORMATION CARD

CLAMP-ON VOLT/AMP/OHM METER

For direct measurement of AC current, voltage, and resistance, the *ACD-11* clamp-on meter from *Amprobe Instrument* features a large, easy-to-read 1/2" display. The autoranging meter provides circuit protection to 550 volts, and to indicate over-range "O.L." appears on the display. Its maximum jaw opening is 2.14 inches. The ACD-11 comes with a wrist strap, a

SELECT 5 BOOKS for only \$4⁹⁵

(values to \$142.75)



2613P \$17.95

Your most complete source for electronics books for over 25 years.

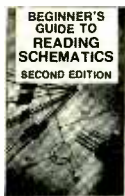

3632 \$18.95



3804P \$19.95



2947P \$13.95



3157P \$16.95



2980P \$19.95

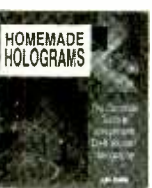

3460 \$22.95



3374P \$16.95

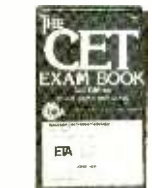

2950P \$13.95

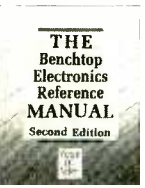

3414 \$39.95
Counts as 2

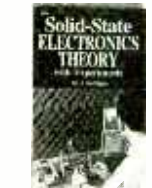

2926 \$25.95

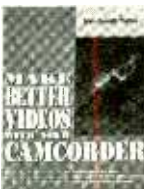

3659 \$21.95



10018 \$39.95
Counts as 2

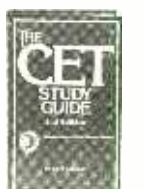

2941P \$16.95



3710 \$32.95
Counts as 2



2883P \$18.95



2867P \$18.95



3578P \$14.95



3778 \$26.95



3627 \$29.95
Counts as 2



1938 \$60.00
Counts as 3

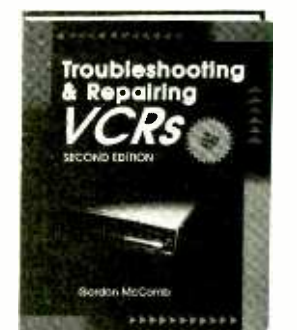

3777 \$32.95
Counts as 2



3485 \$27.95

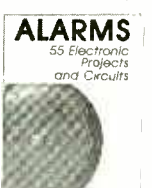

2996P \$14.95



3262P \$17.95



1367P \$24.95



3677 \$34.95
Counts as 2



2887 \$16.95



3345 \$39.95



3258 \$28.95
Counts as 2

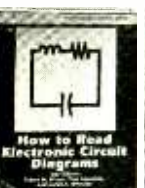

2880P \$14.95



585928-9 \$24.95



1604P \$17.95

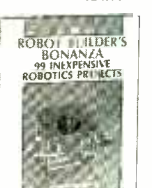

2800P \$16.95

Membership Benefits • Big Savings. In addition to this introductory offer, you keep saving substantially with members' prices of up to 50% off the publishers' prices. • **Bonus Books.** Starting immediately, you will be eligible for our Bonus Book Plan, with savings of up to 80% off publishers' prices. • **Club News Bulletins.** 15 times per year you will receive the Book Club News, describing all the current selections—mains, alternates, extras—plus bonus offers and special sales, with scores of titles to choose from. • **Automatic Order.** If you want the Main Selection, do nothing and it will be sent to you automatically. If you prefer another selection, or no book at all, simply indicate your choice on the reply form provided. You will have at least 10 days to decide. As a member, you agree to purchase at least 3 books within the next 12 months and may resign at any time thereafter. • **Ironclad No-Risk Guarantee.** If not satisfied with your books, return them within 10 days without obligation! • **Exceptional Quality.** All books are quality publishers' editions especially selected by our Editorial Board.

PE392

A shipping/handling charge and sales tax will be added to all orders.

If card is missing, use this address to join:
ELECTRONICS BOOK CLUB, Blue Ridge Summit, PA 17294-0810



3345 \$39.95



3258 \$28.95
Counts as 2



3358 \$28.95
Counts as 2



3342 \$25.95
Counts as 2



2925P \$10.95



3589 \$27.95
Counts as 2



removable belt clip, a 9V battery, safety test leads, a carrying case, and instructions.

The ACD-11 AC volt/amp/ohm meter has a suggested list price of \$119. For additional information, contact Amprobe Instrument, 630 Merrick Road, P.O. Box 329, Lynbrook, NY 11563; Tel: 516-593-5600; Fax: 516-593-5682.

CIRCLE 104 ON FREE INFORMATION CARD

OSCILLOSCOPE PROBE KIT

The *Gold Master Kit* from *Probe Master, Inc.* contains three slim, heavy-duty probes and various accessories for oscilloscopes. The kit contains a 1 × 30-MHz, a 10 × 150-MHz, and a 1 × 10 × switchable 10/150 MHz probe. Following the "convert-a-tip" concept, the kit provides two screw-in replaceable tips (0.055 and 0.030 inches). Gold-finished accessories provide superior contact for low-level analog signals and high-speed digital data. Signal characteristics are improved by the use of gold plating throughout



the probes. Three complete sets of accessories feature snap-on 6- and 12-inch ground leads and repairable gold-plated spring hooks for ease of operation and maintenance. The kit contains a total of 43 pieces, including a 4-inch insulated extender tip, wire-wrap adapters, and pico hooks to interface the probe tip for high-density circuit servicing.

The Gold Master Kit costs \$125. For further information, contact Probe Master, Inc., 4898 Ronson Court, San Diego, CA 92111; Tel: 800-772-1519.

CIRCLE 105 ON FREE INFORMATION CARD

COMPUTER LOUDSPEAKER SYSTEM

To unlock the sound potential of today's PC's, *Bose* has introduced the *RoomMate Computer Monitor Speaker System*. If your computer has a stereo sound chip, these speakers allow you to hear full, high-quality stereo. Mono computer users will hear enhanced high-fidelity sound. The system features distortion-limiting circuitry, a built-in amplifier, active equalization, built-in volume control, and Bose's unique HVC drivers for minimum video interference. The



RoomMate system works with all computers, including the IBM PS/2, Apple Macintosh, Apple II GS, and Commodore Amiga. In addition, it can be connected to electronic keyboards, VCR's, laserdisc players, TV's, CD players, and personal stereos. Because the system is magnetically shielded, it won't interfere with the image on the screen or damage diskettes. Adapters are included that allow fast, easy connection to stereo or mono sources that have mini-head-telephone jacks. The 6 × 9 × 6-inch

TOURISM

A VISION OF AMERICA

There is so much of America to enjoy. And an array of exciting places to visit. Tourism provides so many pleasures. And so many benefits. It's a \$350.8 billion* industry that generates \$42.9 billion* in local, state and federal tax revenues . . . taxes that help pay for new highways, build schools and support a variety of public services. And in the process, keeps your personal taxes down.

Tourism Works For America . . . and for you.

*Preliminary 1989 Estimates, Source: U.S. Travel Data Center

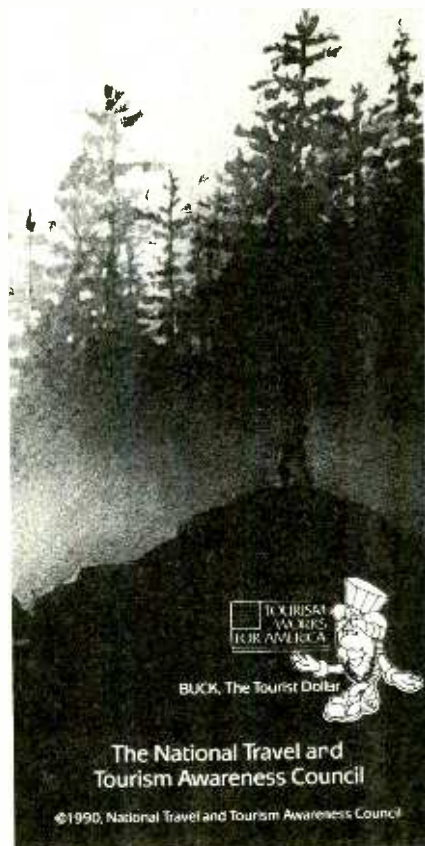

The National Travel and Tourism Awareness Council

©1990, National Travel and Tourism Awareness Council

GET THE LATEST ADVANCES IN ELECTRONICS

WITH A SUBSCRIPTION TO

Radio Electronics®



ENJOY THE WORLD OF ELECTRONICS EACH MONTH!

Now you can subscribe to the best electronics magazine. The only one that brings you articles on—electronics projects, technology, circuit design, communications, new products and much more.

Radio-Electronics looks to the future and shows you what new video, audio and computer products are on the horizon. What's more you'll find helpful, monthly departments such as Video News, Equipment Reports, Hardware Hacker, Audio Update, Drawing Board, Computer Connections. All designed to give you instruction, tips, and fun.

Radio-Electronics gives you exciting articles like:

- DSP in Consumer Electronics
- Build a Tesla Coil
- Analog-to-Digital Conversion
- Build a Spectrum Analyzer
- All About Fuel Cells
- Build an EKG
- Voltage Doublers
- PC-Based Test Equipment
- VGA-to-NTSC Converter



FOR FASTER SERVICE CALL TODAY

1-800-999-7139

DON'T DELAY SUBSCRIBE TODAY!

Just fill out the order card in this magazine and mail it in today.

5PC23

speakers take up little space; optional mounting accessories allow the speakers to be mounted on walls or other vertical surfaces.

The RoomMate computer speakers have a suggested retail price of \$339 a pair. For further information, contact Bose Corporation, The Mountain, Framingham, MA 01701-9168; Tel: 508-879-7330; Fax: 508-872-6451.

CIRCLE 106 ON FREE INFORMATION CARD

DIGITAL MULTIMETERS

With large LCD readouts featuring annunciators for all ranges—decreasing the possibility of using the wrong range—two digital multimeters from *Brunelle Instruments* are easy to use. The models 4010 and 4020 DMM's each provide 12 functions, providing 0.8% accuracy in 37 ranges. Both units measure transistor gain, have seven resistance ranges, five capacitance ranges, five VAC and five VDC ranges, and can measure AC and DC current up to 10 amps. Functions include diode test, logic functions, and transistor hFE measurements. The units feature audible continuity beepers and automatic shut-off to preserve their batteries. The model 4020 adds a go/no-go test for LED's and the ability to measure frequency up to 20 MHz, which is especially useful for servicing computer and telecommunication equipment.



The models 4010 and 4020 digital multimeters have suggested retail prices of \$85 and \$98.50, respectively. For more information, contact Brunelle Instruments Inc., P.O. Box 1223, Newport, VT 05855; Tel: 800-567-3506; Fax: 819-569-1408 (in Canada: 73, Chemin Godin, St. Elie-d'Orford, Quebec, J0B 2S0; Tel: 1-819-563-9096).

CIRCLE 107 ON FREE INFORMATION CARD

MICROWAVE ANALYZER

Designed specifically for microwave-oven technicians, *EDS's Microanalyzer model 76* performs in-circuit tests of components in microwave ovens. It uses high-voltage signals to test magnetrons, power transformers, Triacs, transistors, MOSFET's, high-voltage diodes, and capacitors. The Microanalyzer 76 also includes a 3½-digit voltmeter that measures up to 5 kilovolts AC or DC in two ranges. All special test leads are included, as in an article entitled "Repairing Microwave Ovens with the Microanalyzer." The unit is backed by a three-year limited warranty and a 60-



day, satisfaction-guaranteed trial period. The Microanalyzer is also available in kit form (without the trial period).

The Microanalyzer 76 costs \$329 fully assembled or \$249 in kit form. For further information, contact Electronic Design Specialists, Inc., 275 Rock Island Road, North Lauderdale, FL 33068; Tel: 305-720-4497.

CIRCLE 108 ON FREE INFORMATION CARD

LCR METER

For making lab and test measurements of component values, the multi-ranged *JAC380153 LCR Meter* from *Extech* measures inductance, capacitance, and resistance via a rotary switch. It measures inductor coils from 1 µH to 20 H in five ranges, capacitors from 1 pF to 200 µF in six ranges, and resistors from 0.1 ohm to 20 megohms in six ranges. A 200-mA fuse provides protection from charged capacitors (50 VDC). The LCR Meter has an easy-to-read, 0.7-inch, 3½-digit LCD readout, and overload and low-battery indicators. The pocket-sized unit measures 7.3 × 3.4 × 1.5 inches and has a bright-yellow, drop-proof protec-



tive case. Alligator clips, a spare fuse, a 9V battery, and instructions are included. Optional accessories include a pouch-style carrying case and capacitive test leads.

The JAC380153 LCR Meter costs \$169. For additional information, contact Extech Instruments Corporation, 335 Bear Hill Road, Waltham, MA 02154; Tel: 617-890-7440; Fax: 617-890-7864.

CIRCLE 109 ON FREE INFORMATION CARD

NOTEBOOK PC

Weighing in at just 6.6 pounds, the *Tandy 1110 HD* notebook computer fits neatly in a briefcase or knapsack, making it particularly well suited for the business traveler or student who needs quick computing and portability. Equipped with a 20MB hard drive, the 1110 HD also has a V-20 microprocessor with 10-MHz clock speed, zero wait state, and 640KB of standard memory; and a 3.5-inch, 1.44MB floppy disk drive. MS-DOS 5.0 and Tandy's DeskMate



3.5 personal productivity software are factory installed for instant start-up. DeskMate's Graphical User Interface with pull-down menus and pop-up dialog boxes guides the user through nine applications, including a word processor with a spell checker, worksheet, file,

calendar, address book, word games, Draw, and phone accessory programs. The 1110 HD features an enhanced 84-key keyboard; a sharp-contrast, reflective, 9-inch (diagonal), 80 × 25-character LCD readout with 640 × 200-pixel resolution; a removable, rechargeable battery that provides four hours of continuous computing; a travel-size AC adapter/charger; a parallel printer port; and a serial port. Optional accessories include a 2400-bps internal modem, a replacement battery pack, a soft carrying case, and a leather carrying case.

The Tandy 1110 HD notebook computer is available for \$1199 at Radio Shack stores nationwide. For additional information, contact Radio Shack, 700 One Tandy Center, Fort Worth, TX 76102.

CIRCLE 110 ON FREE INFORMATION CARD

UNIVERSAL SWEEP/FUNCTION GENERATOR

Designed for use in R&D, production testing, service and repairs, and education, *Bel Merit's Model FG-150* is a 2-MHz



universal sweep/function generator with a built-in frequency counter. It offers a 0.02-Hz–2-MHz main generator range with digital frequency display and provides sine, square, triangle, ramp, skewed sine, pulse, and TTL outputs. The instrument has linear/log sweep-generator capabilities and provides triggered and gated operation, with sweep width, rate controls, and variable DC offset. An external-input 4-digit frequency counter measures signals to 9999 kHz.

The model FG-150 universal sweep/function generator costs \$295. For additional information, contact Bel Merit Corporation, 17 Hammond, Suite 403, Irvine, CA 92718-1635; Tel: 714-586-3700; Fax: 714-586-3366.

CIRCLE 111 ON FREE INFORMATION CARD

ANTIQUE RADIO

(Continued from page 69)

enjoys sharing what he knows and will try to assist anyone with a repair problem. Be sure to state your problem clearly, include the make and model number of the set, and provide a self-addressed, stamped envelope for Billy's reply.

Stephen Kalista of Jim Thorpe, PA sends along a couple of addresses that will be of help to German-radio enthusiasts. For information on Telefunken radios, write: Inhaber M. Trautvetter, Schaltungsdienst Lange, P.O. Box 47 0653, Mohriner Allee 30, D-1000 Berlin 47, Germany. For information on Grundig sets, write Grundig AG, Kundendienst-Zentrum, Beuthener Str. 55, 8500 Nurnberg 50, Germany.

Last August's "Mailbag" column carried a query from Leslie Van Luven of Rochester, NY, who was looking for a reliable antique-radio repair person. In a recent letter, Leslie reported hearing from an experienced Rochester-area restorer who is assisting with the needed repairs for cost of parts only. Glad we could get the two of you together, Leslie!

Two readers responded to 15-year-old Matthew Ettus' August query about a method for replacing yellowed-plastic dial windows. Tony Du Bourg (Summit, NJ), who supplied the theremin recently restored on these pages, reports that he's had success in bending and forming thin sheets of acrylic plastic carefully softened with the help of a heat lamp. Right-angle bends can be made by allowing the softened sheet to droop over a rod. And Tony suspects that dial window shapes could be formed by

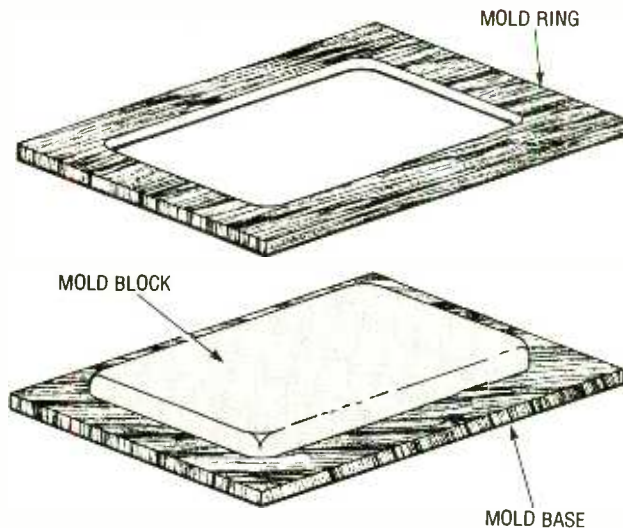

Fig. 2. Tony Jacobi's mold block and mold ring for making plastic dial windows.

letting the heated plastic sag into a properly-formed smooth mold.

Tony Jacobi (Ralston, ME), whose comprehensive *Ballast Tube Handbook* was reviewed in a previous column, has taken this idea a bit further. He sandwiches plastic sheeting (0.030 polyethylene) between a mold block and a mold ring (see Fig. 2) formed of wood. He heats the whole assembly for 10 to 15 minutes in a 200° oven. Then, using gloves, he removes the assembly from the oven, quickly squeezes the ring over the block, and clamps the parts together until the formed plastic sets (10 minutes or so). For a more detailed discussion of this technique, see "Make Your Own Plastic Dial Covers" in the September, 1991 issue of *Antique Radio Classified* magazine.

Tony also responded to Reader B.W. Brown's August query for the model number of His Radiomatic/G.E. coin-operated radio. It's most probably a G.E. YRB-12-3.

MORE WPE'ERS!

The August, 1991 "Mailbag" column also included a letter from Ex-WPE'er Jim

Moody (WPE8BAX). These "WPE" call signs were issued to shortwave listeners by **Popular Electronics** back in the 1960's. In passing, I inquired whether there were any more "WPE'ers"

among our readership and received two replies.

James P. Ernst from Decatur, GA, WPE4JXE, received his call in May, 1968. The framed certificate still graces his receiving shack wall, bringing back memories of DX'ing with the Allied "Star Roamer" radio kit he built as a teenager. Phil Wanat of Northfield Falls, VT doesn't remember when he received his call (WPE1ENK), but used it when he was stationed in Madrid, Spain, in the late 1960's.

That about empties our mailbag, except for a number of theremin-related letters that I couldn't squeeze in. Look for those next time. In the meantime, I'd like to hear from you! Write me c/o *Antique Radio*, **Popular Electronics**, 500-B Bi-County Blvd., Farmingdale, NY 11735. ■

36,284 ELECTRONIC COMPONENTS

Whether you order 1 part or
all 36,284...MOUSER stocks
and...can ship today!!
MOUSER also makes it easy to
do business.

CALL...

(800) 992-9943

for your
FREE

CATALOG

2401 HWY 287 N.
Mansfield, TX 75801

MOUSER ELECTRONICS

Sales & Stocking Locations Nationwide

CIRCLE 17 ON FREE INFORMATION CARD

BEOSYSTEM 2500

(Continued from page 26)

-90 dB. Were it not for the slight increase in distortion at high recording levels caused by the stages following the actual D/A converter of the CD player, THD, referred to the maximum recorded level, would be about 0.004%.

CD-player channel separation at several test frequencies was examined next. At 1 kHz, separation measured over 78 dB for left-channel-to-right-channel and nearly 80 dB for right-to-left. At 16 kHz, the right channel had higher separation than the left, with a reading of approximately 74.6 dB as compared with 68 dB for the other channel. The signal-to-noise ratio for the CD section measured 94.0 dB. The EIAJ dynamic-range reading, obtained by measuring the distortion (in dB) of a -60-dB test signal and adding 60 dB to the resulting number, was 93 dB.

The linearity of the CD D/A conversion process was excellent from 0 dB (maximum recorded level) down to -80 dB, but at -90 dB the linearity error amounted to just over 3 dB for the left channel and nearly 5 dB for the right channel. We used a special CD that incorporates built-in defects in the form of missing data to determine accuracy of tracking and effectiveness of error correction and interpolation of the player. This CD player was able to handle opaque disc areas extending to 1.5 millimeters in length without any audible muting or skipping. That performance compares favorably to some of the better separate home CD players that I've tested.

Before testing the analog

cassette tape player/recorder section, we applied a sweep signal to the auxiliary inputs of the system in order to measure the range of the bass and treble controls. Setting the bass control at maximum resulted in a boost of nearly 13 dB at 100 Hz. The maximum-boost setting of the treble control resulted in a boost of just under 10 dB at 10 kHz. Users are cautioned, therefore, to go easy on these controls. Bear in mind that a boost of 10 dB at any frequency requires a tenfold increase in power when such frequencies are encountered in program material.

We measured the frequency response of the tape recorder using both Type-I and Type-II tape. Since we had no control over recording level, we simply applied signals at a level that we thought would be typical of program sources normally encountered. Combined record/play frequency response was good for both types of tape, although it was a bit better for Type II than for Type I.

The signal-to-noise ratio of the tape player, as measured while playing a Type-I tape on which only bias had been recorded, could only be measured in a relative sense (again, owing to the automatic level-control feature of the recorder section). Nevertheless, noise levels even without Dolby noise reduction were as low as we might have expected from a well designed separate cassette recorder and tape hiss was virtually inaudible when Dolby B was applied during recording and playback. Lastly, we measured the wow-and-flutter of the tape player. We tested performance in two ways: using IEC peak weighting, and the familiar

WRMS method. Wow-and-flutter averaged around 0.058% for the IEC peak method and around 0.03% WRMS.

HANDS ON TESTS

Armed with the results from our bench tests, it was time to do some listening. We quickly discovered that a small system such as this, however well balanced its response, is no match for some of the more extreme bass sounds produced by some of our orchestral and organ CD's. Nevertheless, most of the music we played was reproduced with remarkable clarity and an open sound that belied the small size of the speakers. Stereo imaging during this playing was also amazingly good considering the fact that the speakers themselves were spaced no more than two feet apart!

The price tag for the Beosystem 2500 (including the Beolink 5000 remote control) is rather steep: \$3500. Still, when you consider how much you would have to spend to purchase a system of components of comparable quality that included two full-range speakers, a well-designed FM-stereo tuner, a CD player, and a high-quality cassette-tape recorder, the price of the B&O 2500 suddenly seems quite reasonable. As a "second system," or even a primary system in situations where space is at a premium, we can't think of a better compact music system, nor one that is more attractively styled.

For more information on the Beosystem 2500 Compact Music System, contact Bang & Olufsen (1150 Feehanville Dr., Mt. Prospect, IL 60056) directly, or circle no. 120 on the Free Information Card. ■

DX LISTENING

(Continued from page 79)

not give them a try for yourself? Good luck and good DX'ing!

AUSTRALIA—You probably heard the U.S. standard time and frequency stations—WWV in Colorado and WWVH in Hawaii—as well as the Canadian time-ticker, CHU. Now try for the Australian radio time signal (VNG) on 8,638 and 16,000 kHz, with its pulsing tick-tocks, at around 0600 UTC.

BOTSWANA—*Radio Botswana*, from southern Africa, has been heard with programming in English and French on 7,255 kHz between about 0305 and 0430 UTC.

CUBA—Most listeners are familiar with *Radio Havana Cuba* and its English language programming, which is easily logged each evening. Have you found the other Cuban shortwaver—*Radio Rebelde*—which programs in Spanish on 5,025 kHz? Most evenings, it's a place to find some excellent Cuban music.

ICELAND—*Ríkisutvarpid* is the tongue-twisting name of the SW broadcaster at Reykjavik, Iceland. This is a nice bit of DX for most listeners in North America. Look for its English news bulletin Monday through Friday at 0730 UTC on 9,265 kHz, or on 3,295 and 6,100 kHz. You can find programming in the Icelandic language on 13,855 and 15,770 kHz from 1930–2010 and 2300–2335 UTC.

PHILIPPINES—The *Fcr East Broadcasting Co.* in Manila is a religious broadcaster that has been around for decades. Look for this one, in English, at around 1400 UTC. It was reported heard at this time with a questions-and-answers program. ■

PORCH-LIGHT CONTROL

(Continued from page 48)

Since the Triac is one of the tallest components in the circuit you will have to alter it to reduce its profile. To do so, file-down the upper "fat" part of each of its terminals. That will allow the terminals to slide all the way through the PC-board holes so the bottom of the part will rest on the circuit board. The filing must be done with care so that the legs are not made so thin that they break. Increasing the size of the holes instead of filing the terminals is not recommended as it increases the likelihood of forming a solder bridge between terminals, (which is especially dangerous for pins 1 and 2, which carry AC power).

It is strongly recommended that IC sockets be used for both IC's. That means you'll have to turn an 8-pin IC socket into a 6-pin socket to accommodate the optocoupler. To do that, carefully cut-down an 8-pin socket.

Stuffing the Board. Using Fig. 3 as a guide you can begin filling the board. The order in which you place the parts on the board is not important, however you should not install the switch or the IC's yet. In fact, keep the 4020 IC in its package until you are ready to install it to avoid static damage.

Furthermore, do not solder the polarized components to the board until you double-check their orientation. In this circuit none of them will be forgiving if power is improperly applied; it is not a question of whether there will be damage, but rather how much!

Having double-checked their orientation, solder all the components in place leaving the switch for last. Taking care not to over-handle the 4020, place it and the optocoupler in their sockets. Double check their orientation as well.

If, for some reason, you later need to take the switch out of its bracket after it is soldered in place, it can be done without unsoldering by very carefully unscrewing the last section of the base of the switch, being ultra-careful not to lose the two small springs and contact plate from inside the body of the switch as you do so.

The last step is to install the 8-32 screws back into the nuts soldered to

the board. The screws should be inserted from the foil side of the board and secured loosely.

Testing the Unit. For the rest of this procedure keep in mind that much of the circuit is hot. **Touching any exposed contact must be avoided.**

Turn the porch light on by using its wall switch. Then remove power from the porch-light circuit using the appropriate breaker or fuse in the electrical entry box.

Now remove the wall switch's front panel by taking out the two screws on the panel's face. Unscrew the two additional screws that hold the switch and its bracket to the wall box. Carefully pull the switch bracket with its two attached wires out of the wall box and use some kind of test equipment (a multimeter, a neon-bulb, etc.) to check that neither screw terminal on the switch is hot. If everything appears dead, untighten the screw terminals to release the two wires.

Hook each wire from the wall box around one of the 8-32 screws, placing the hooks in the wire in a clockwise direction and tighten the screws. Now start gently pushing the circuit into the wall box checking to see that there is no possibility of the sides or back of the control unit touching any metal part of the wall box. Some wall boxes are made of plastic and present fewer dangers. Even so, if there is any possibility of metal touching metal use layers of electrical tape to insulate them from one another. With the circuit in place, screw the switch bracket to the switch box. Restore power to the porch light circuit via the fuse or circuit breaker in the entry box.

The bulb may very well light immediately and if it does, it should extinguish after about 2¼ minutes (or whatever time delay you have selected). If it does not immediately light (or after it has first gone out), press the push button and the bulb should light and stay lit for the delay period selected. Any failure of the circuit board will either leave the light on permanently, (similar to the spring of the switch having broken with the switch closed); or permanently off.

Fit the new front panel in place (removing the button if necessary) and screw it to the bracket. Press the button onto the switch shaft, and you're all done. ■

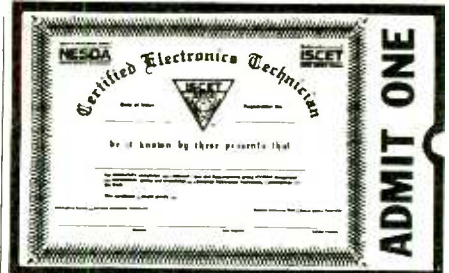

Your Ticket To SUCCESS

Over 28,000 technicians have gained admittance worldwide as certified professionals. Let your ticket start opening doors for you.

IS CET offers Journeyman certification in Consumer Electronics, Industrial, Medical, Communications, Radar, Computer and Video. For more information, contact the International Society of Certified Electronics Technicians, 2708 West Berry Street, Fort Worth, TX 76109; (817) 921-9101.

Name _____

Address _____

City _____

State _____ Zip _____

Send material about IS CET and becoming certified.

Send one "Study Guide for the Associate Level CET Test." Enclosed is \$10 (inc. postage).

LEARN VCR CLEANING/MAINTENANCE/REPAIR EARN UP TO \$1000 A WEEK, WORKING PART TIME FROM YOUR OWN HOME!



THE MONEY MAKING OPPORTUNITY OF THE 1990'S

IF you are able to work with common small hand tools, and are familiar with basic electronics (i.e. able to use voltmeter, understand DC electronics).

IF you possess average mechanical ability, and have a VCR on which to practice and learn... then we can teach YOU VCR maintenance and repair!

FACT: up to 90% of ALL VCR malfunctions are due to simple MECHANICAL or ELECTRO-MECHANICAL breakdowns!

FACT: over 77 million VCRs in use today nationwide! Average VCR needs service or repair every 12 to 18 months!

Viejo's 400 PAGE TRAINING MANUAL (over 500 photos and illustrations) and AWARD-WINNING VIDEO TRAINING TAPE reveals the SECRETS of VCR maintenance and repair—"real world" information that is NOT available elsewhere!

Also includes all the info you'll need regarding the BUSINESS-SIDE of running a successful service operation!

FREE INFORMATION

CALL TOLL-FREE 1-800-537-0859

Or write to: Viejo Publications Inc

4470-107 Sunset Blvd., #600

Los Angeles, CA 90027, Dept PE

Enter A World Of Excitement with a Subscription to Popular Electronics®

Get the latest electronic technology and information monthly!

Now you can subscribe to the magazine that plugs you into the exciting world of electronics. With every issue of Popular Electronics you'll find a wide variety of electronics projects you can build and enjoy.

Popular Electronics brings you informative new product and literature listings, feature articles on test equipment and tools—all designed to keep you tuned in to the latest developments in electronics. So if you love to build fascinating electronics, just fill out the subscription form below to subscribe to Popular Electronics... It's a power-house of fun for the electronics enthusiast.

EXCITING MONTHLY FEATURES LIKE:

- CONSTRUCTION**—Building projects from crystal sets to electronic roulette
- FEATURES**—Educational training on digital electronics, Ohm's Law, Antennas, Communications, Antique Radio, Simplified Theory
- HANDS-ON-REPORTS**—User test comments on new and unusual consumer products
- SPECIAL COLUMNS**—Think Tank, Circuit Circus, Computer Bits, DX Listening, Antique Radio, Amateur, Scanner Scene

PLUS: ALL OUR GREAT DEPARTMENTS!

You'll get 12 exciting and informative issues of Popular Electronics for only \$18.95. That's a savings of \$16.45 off the regular single copy price. Subscribe to Popular Electronics today! Just fill out the subscription order form below.

FOR FASTER SERVICE CALL TODAY

1-800-827-0383

(7:30AM-8:30PM)

EASTERN STANDARD TIME

Popular Electronics® SUBSCRIPTION ORDER FORM

P.O. Box 338, Mt. Morris IL. 61054

APEC2

YES! I want to subscribe to Popular Electronics for 1 Full year (12 Issues) for only \$18.95. That's a savings of \$16.45 off the newsstand price.

Payment Enclosed Bill me later

Please charge my: Visa Mastercard

Acct. #

Signature

Exp. Date

PLEASE PRINT BELOW:

NAME

ADDRESS

CITY

STATE

ZIP

Allow 6 to 8 weeks for delivery of first issue. U.S. Funds only.
In Canada add \$6.98 Postage (Includes G.S.T.) All Other Foreign add \$7.50 Postage

SUPERCAD

(Continued from page 67)

number of useful options: One allows you to automatically add numbers to parts designations (U1, D2, R25, etc.), as mentioned before. A second helps you add values to parts, again in an automated fashion. There's a similar option for automatically labeling bus lines if you did not let the program do that while drawing a bus. There are options to help you find or replace text on a drawing (great for finding a part on a big schematic). Yet another option tests a component drawing before including it in the library. There is also an option to help you navigate around hierarchical structures.

The display options let you select and view the signals at a point on the diagram in either an oscilloscope or logic analyzer displays. To take advantage of this feature you must have a simulation program such as Intusoft's IsSpice or SuperSIM which we'll mention latter.

The help menu offers many screenfuls of useful advice on using both SuperCAD and the utilities. Help on the utilities, library-part generation, the keyboard, and general information, are available directly from the help menu. Help on all the various options, procedures, and pop-out menus is available by first selecting help, and then selecting the option of interest.

Additional Software. I'm sorry to have to admit that I haven't even scratched the surface of important options, operating modes, and technical creature-comforts (like the coordinate readout, the system-resources display, and the color-selection menu). Suffice it to say if you have an IBM-compatible with 512k, Hercules graphics or better (including VGA), running DOS 2.0 or better, and have a printer (IBM compatible, Okidata 192/193, Epson, or equivalent) then you should take a look at the software (ask Mental Automation about their demo's).

While SuperCAD is really great as a stand-alone package, with a couple of additional software packages it can go even further. For example The company that produces SuperCAD offers a package called SuperSIM—a digital simulator (similar to the IsSpice

analog simulator)—for \$99 that can be used with the digital-analyzer display inside SuperCAD. It is available with a variety of parts libraries in various configurations.

Another company, PCBoards (2110 14th Ave. So., Birmingham, AL 35205), has two packages of interest for the SuperCAD user: PCBoards (see our review in the August, 1991 issue) and PCRoute for \$99 each. Using these packages with SuperCAD will completely automate the way you design circuits and printed-circuit boards.

For example, say you draw a schematic, label its parts and assign them values in SuperCAD. Then you use SuperCAD to draw a parts-placement diagram (by the way, package outlines are included with SuperCAD). Now from the SuperCAD run menu you select the route option. That option allows you to activate the network lister, a pad-placement utility, a file-conversion utility, and an autorouter to spring into action. When the dust settles, you'll have a complete (or nearly complete) foil pattern. To polish up the board (such as to add jumpers for incomplete traces), or to print it out, you can use the PCBoards program. The finished product is a double- or single-sided board with a silkscreen pattern (not to mention all the documentation: schematic, parts list, parts-placement diagram, etc.).

Mental Automation supports SuperCAD with a variety of additional utilities. For example, plotter and laser-printer support (\$69), additional library parts (\$59), source files for the library parts supplied with SuperCAD (\$149), source files for the additional library parts (\$89), and a utility pack to convert net-list files for use with Tango, Multiwire, Gav, and other software packages (\$49).

SuperCAD is available from Mental Automation (5415 136th Place S.E., Bellevue, WA 98006; Tel. 206-641-2141) for \$99. The SuperCAD+ package, which contains SuperCAD, plotter and laser-printer support, the additional library, and the conversion utilities sells for \$199. A SuperTOOLS package is also available, which comes with SuperCAD, PCBoards, PCRoute, and the conversion utilities, all for \$299. For more information Contact Mental Automation directly or circle No. 119 on the Free-Information Card. ■

Shortwave Listening Guidebook

by Harry Helms

The world is talking on shortwave radio, and here's the book that tells you how to listen in! In direct, nontechnical language, Harry explains how to get the most from your shortwave radio. Its 320 heavily illustrated pages are filled with practical advice on:

- antennas
- when and where to tune
- selecting the right radio for you
- accessories
- reception techniques



Learn how to hear the BBC, Radio Moscow, ham radio operators, ships at sea, even Air Force One! Includes hundreds of frequencies for stations around the world and the times you can hear them.

Only \$16.95 plus
\$3.00 shipping
(CA residents
please include
sales tax).

HighText
Publications, Inc.
7128 Miramar Road
Suite 15L, San Diego, CA 92121

It keeps more than memories alive.

THE AMERICAN HEART
ASSOCIATION
MEMORIAL PROGRAM.



American Heart
Association



This space provided as a public service.

LIGHT SOURCES

(Continued from page 52)

9D. The top of the flatpack is polished to allow light to exit.

The typical low-cost commercial LED does not produce a very organized light-beam. Those simple LED's

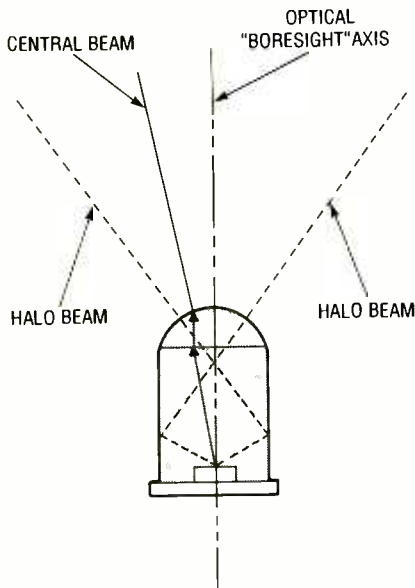

Fig. 10. The central beam of a typical LED seldom follows the optical (or "boresight") axis of the LED. Internal reflection aggravates the situation by creating a halo beam.

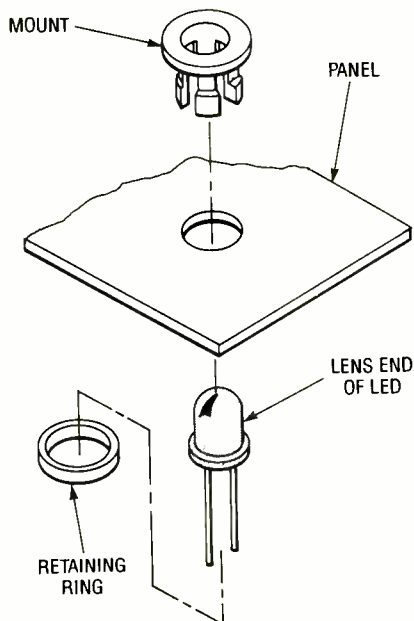

Fig. 11. Mounting an LED on the panel of a device is easy. Note that the LED can only be wired to its supply after it is mounted.

have a diffusing dye in the epoxy material that makes the light appear "fuzzy." That is suitable for panel-indicator applications, but is troublesome for other applications.

There are LED's that are more narrowly focussed and look more like a point source. However, even they often exhibit a central beam that is displaced from the boresight optical axis (see Fig. 10), and a halo effect that is caused by internal reflections. Up to 75% of the light output of some LED's can reside in the halo region.

Mounting the more common epoxy LED's is usually done using special mounts and retaining rings (shown in Fig. 11). A hole is drilled in a panel, and the mount is pushed through it as shown. Then the LED is pushed in from the rear until it is seated inside the mount. The retaining ring is then slipped over the mount, again from the rear until it locks onto the mount.

Switching Characteristics. LED's have a very fast response time (the time between a change in applied voltage and a corresponding change in light output), so they can be switched on and off rapidly. For a GaAs or GaAsP LED, the switching time can be from one to ten nanoseconds, depending on the LED's structure. Although silicon LED's are more efficient than GaAs or GaAsP devices, they are

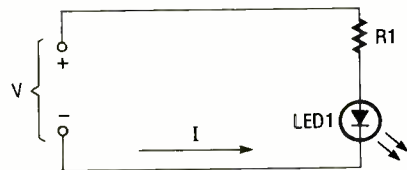

Fig. 12. A typical LED circuit contains a current-limiting resistor to prevent blowing out the unit.

somewhat slower. The Si LED can be switched at about 300 nanoseconds. The switching speeds of GaAs, GaAsP, and silicon LED's rival those of all other light sources.

Because of their fast switching times, LED's are used in chopped or modulated circuits. Silicon LED's can be modulated at frequencies (or pulse-repetition rates) up to 1 MHz, while GaAs and GaAsP devices can be modulated at frequencies up to 100 MHz.

Like any other component, the life expectancy of such light sources can

be measured in terms of mean time between failures (MTBF). That is a statistical value determined using a large sample of identical components, and reflects the average length of time a device can operate before it fails. The MTBF of LED's can be 10,000 hours or more (as opposed to 750 to 1500 hours for incandescent lamps).

Simple LED Circuits. Figure 12 shows the most basic form of LED circuit. The diode (LED1) is connected across a voltage source (V) via a series resistor (R1) such that the diode is "forward biased." That is, electron current (I) will flow from the cathode (N material) to the anode (P material). The series resistor (R1) is used to limit the current through the diode to a safe level. The value of the resistor is:

$$R1 = (V - V_{LED}) / I$$

Where R1 is the resistance of the series resistor, V is the power-supply potential in volts, V_{LED} is the potential across the LED (typically 1.8 volts for a GaAs LED), and I is the LED current in amperes. ■

SPEAKER PROTECTOR

(Continued from page 45)

nect the Speaker Protector between the amplifier outputs and speaker terminals using 14- to 18-gauge speaker wire. Disconnect the speakers.

2. Connect your multimeter to the speaker terminals of the amplifier and set it to the 50-volt AC range. Connect an audio-signal generator to an input of the amplifier and set R8 on the Protector board to minimum (fully counterclockwise).

3. Apply power to the circuit, set the signal generator to 50 Hz, and increase the signal level (or volume control) until the multimeter shows the required trip voltage. Adjust R8 slowly until the relay trips (opens).

If you wish, you can check the hysteresis of the system by reducing the signal level and noting the voltage at which the relay closes again. The difference will probably be about 3 volts, although individual units can vary from that figure somewhat.

Well, that's all there is to it! Your expensive speakers are now protected against signal overdrive, amplifier failure, and turn-on thumps. ■

ELECTRONIC TRACKING

(Continued from page 58)

there must be a local control center in the area to receive the initial call. Since Locator is just getting started, it currently operates only in three southern California counties.

Teletrac and Other Units. Another system called "Teletrac" (from International Teletrac Systems, 9800 La Cienega Blvd., Inglewood, CA 90301) uses dedicated radio towers and its own control centers (see Fig. 1). First the vehicle owner arms the radiolocation unit in the car (1). Once the car is stolen (2), the unit transmits an emergency signal that is picked up by receiving towers (3) and passed to a master-control center (4). The control center pages the transmitter (5), which then transmits location information to all the receiving towers (6), which then pass it on to the control center. The staff at the center then contacts the owner to confirm that the car was stolen (8). If so, then the police are notified of the car's location (9), and are dispatched to recover the vehicle (10).

Since the system relies on dedicated towers, it's limited to a handful of metropolitan areas like Los Angeles, Detroit, and Chicago for now. However, it plans to expand to 24 of the largest U.S. metropolitan areas during the next three years.

When a Teletrac customer leaves his car, the transmitter turns on automatically. If it's moved before he gets back, it sends a signal to the Teletrac control center via the nearest radio tower. The operator, like his colleague at Code-Alarm, has a computerized map showing where the vehicle is and where he's going. He notifies police with all of the necessary information. The initial package costs \$900 and there's a monthly monitoring charge of \$15.

The oldest of the tracking systems (the first ones appeared just five years ago) is called LoJack (by LoJack, 72 River Park, Needham, MA 02194). The transmitter is not activated until someone discovers the car missing. At that point, the police enter its description and license number into a computer and activate the car's hidden transmitter. Dashboard-mounted tracking

devices allow police cars in the area to triangulate its location, whether it's still on the move or already partly disassembled.

Its manufacturer claims it spent \$2 million last year providing the support electronics for police cruisers in 48 southern California communities, and expects to spend a like amount this year in communities in New Jersey, Michigan, and Illinois.

The MET system (from METS, Inc., 10585 North Meridian St., Indianapolis, IN 46290), used in Indianapolis, hopes to expand from there to southern California soon. Its system includes a panic button that an authorized driver could use to notify the appropriate authorities of any medical, automotive, or other emergency.

Other Uses. While vehicle tracking is designed primarily to cut down on the 1.5-million auto thefts reported each year, it has several other applications as well. The Southern California Transit District uses it to keep track of its buses, and operators of taxi and delivery-truck fleets are expected to use it to see where each vehicle is at any point in the day. Los Angeles police even obtained a court order to attach a transmitter to the automobile of a paroled child molester without his knowledge, so that they could track his movements and make sure that he stayed away from children's playgrounds.

At least some of the systems may one day help motorists find their way when they're otherwise completely lost. The systems could interact with other automotive electronics, like cellular phones, automotive navigational systems, and paging systems, to provide such information as the nearest motel, gas station, or fast-food place.

The manufacturers suggest that the use of any of these systems should reduce your car-insurance rates. Unfortunately, only one company, Liberty Mutual, has done so thus far—25 per cent off for policyholders in Southern California. Most other insurers say the systems are too new to have made any measurable impact on auto thefts, partly because the number of tracking units is still very small, and that their history is too short to provide reliable statistical data. But maybe one day . . . ■

SPECIAL FROM ETT

□ **PCP101—PRACTICAL DIGITAL ELECTRONICS HANDBOOK ... \$9.95.** Introduces digital circuits, logic gates, bistables and timers, as well as microprocessors, memory and input/output devices. Special section on digital test gear projects.



□ **PCP102—INTRODUCING DIGITAL AUDIO ... \$9.95** Shows what is involved in the digital part of audio signals, particularly in the newest devices such as CD, DAT and sampling. Bridges the gap of understanding for the technician and enthusiast.

□ **PCP103—PRACTICAL MIDI HANDBOOK ... \$9.95.** Covers all MIDI based equipment you can use—keyboards, drum machines, sequencers, effects units, mixers, drum pads and guitars. Also a section on computer music that covers software and more.



□ **PCP104—ELECTRONICS BUILD & LEARN, Second Edition ... \$9.95.** You start by assembling a circuit demonstrator that is then used to build and investigate a variety of useful circuits including oscillators, multivibrators, bistables and logic circuits.

□ **PCP105—MAKE MONEY FROM HOME RECORDING ... \$10.00.** Now that you've spent all that money on all that recording gear, wouldn't it be nice to get some of it back? Well here's the book that can show you how.



□ **PCP106—SYNTHESIZERS FOR MUSICIANS ... \$10.00.** All current popular forms of synthesis explained; LA, additive, phase distortion, FM and sampling. Get the sounds you want from your synth. Written especially for musicians.

MAIL TO: **Electronic Technology Today, Inc.**
P.O. Box 240
Massapequa Park, NY 11762-0240

SHIPPING CHARGES IN USA AND CANADA

\$0.01 to \$5.00	... \$1.50	\$30.01 to 40.00	.. \$5.50
\$5.01 to \$10.00	.. \$2.50	\$40.01 to 50.00	.. \$6.50
\$10.01 to 20.00	.. \$3.50	\$50.01 and above	.. \$8.00
\$20.01 to 30.00	.. \$4.50		

SORRY, No orders accepted outside of USA and Canada

Total price of merchandise	... \$	_____
Shipping (see chart)	... \$	_____
Subtotal	... \$	_____
Sales Tax (NYS only)	... \$	_____
Total Enclosed	... \$	_____

Name _____
Address _____
City _____ State _____ Zip _____

ELECTRONICS MARKET PLACE

FOR SALE

CABLE descrambler liquidation. Major makes and models available. Industry pricing! (Example: Hamlin Combo's, \$44 each... Minimum 10 orders). Call **WEST COAST ELECTRONICS**, 1 (800) 628-9656.

CABLE TV descramblers, converters, lowest prices guaranteed, best quality, free catalog. **CNC CONCEPTS INC.**, Box 34503, Minneapolis, MN 55434. 1 (800) 535-1843.

**CABLE TV DESCRAMBLERS
★ CONVERTERS ★
and ACCESSORIES.**

**SAVE MONEY.
DON'T RENT!**

PANASONIC,
PIONEER, JERROLD, OAK,
SCIENTIFIC ATLANTA
AND MORE. LOWEST PRICES.
FREE CATALOG.
(800) 234-1006
CABLE READY COMPANY

OUR monthly picture flyer lists quality surplus parts at low prices. Send today for yours. **STARTRONICS**, Box 683, McMinnville, OR 97128.

SPEAKER repair. All makes — models. Stereo & professional kits available. Retoaming \$18.00. **ATLANTA AUDIO LABS**, 1 (800) 568-6971.

FREE CATALOG

FAMOUS "FIRESTIK" BRAND CB ANTENNAS AND ACCESSORIES. QUALITY PRODUCTS FOR THE SERIOUS CB'er. SINCE 1962
FIRESTIK ANTENNA COMPANY
2614 EAST ADAMS
PHOENIX, ARIZONA 85034

FREE electronics catalog. Transistors, IC's, electronic components, etc. Call **INTERNATIONAL MICROELECTRONICS**, (817) 561-2244, PO Box 170415, Dept. PE, Arlington, TX 76003.

JERROLD, Tocom and Zenith "test" chips. Fully activates unit. \$50.00. Cable descramblers from \$40.00. Orders 1 (800) 452-7090. Information (213) 867-0081.

CB RADIO OWNERS!

We specialize in a wide variety of technical information, parts and services for CB radios. 10-Meter and FM conversion kits, repair books, plans, high-performance accessories. Thousands of satisfied customers since 1976! Catalog \$2.

CBC INTERNATIONAL
P.O. BOX 31500PE, PHOENIX, AZ 85046

OSCILLOSCOPE 50MHz, dual channel, solid state calibrated, manual \$250.00 1 (800) 835-8335.

PRINTED circuit boards — etched, drilled, tin plated. Single sided \$1.25/sq. inch. Free shipping. **CHELCO ELECTRONICS**, 61 Water Street, Mayville, NY 14757. (716) 753-3200.

SUBMERSIBLE microphone, rugged PVC/stainless for serious underwater listening or just plain fun. \$89.95 + \$5.00 S/H. Order 1 (800) 221-9119 Visa/MC, Amex.

ELECTRONIC assembly. Component stuffing and soldering. We quote assembly on production or short runs. **TWP**, (512) 572-3381.

CLASSIFIED AD ORDER FORM

To run your own classified ad, put one word on each of the lines below and send this form along with your check to:

Popular Electronics Classified Ads, 500-B Bi-County Boulevard, Farmingdale, N.Y. 11735

PLEASE INDICATE in which category of classified advertising you wish your ad to appear. For special headings, there is a surcharge of \$11.00.

() Plans/Kits () Business Opportunities () For Sale
() Education/Instruction () Wanted () Satellite Television
()

Special Category: \$11.00

PLEASE PRINT EACH WORD SEPARATELY, IN BLOCK LETTERS.

(No refunds or credits for typesetting errors can be made unless you clearly print or type your copy.) Rates indicated are for standard style classified ads only. See below for additional charges for special ads. **Minimum: 15 words.**

1	2	3	4	5
6	7	8	9	10
11	12	13	14	15 (\$23.25)
16 (\$24.80)	17 (\$26.35)	18 (\$27.90)	19 (\$29.45)	20 (\$31.00)
21 (\$32.55)	22 (\$34.10)	23 (\$35.65)	24 (\$37.20)	25 (\$38.75)
26 (\$40.30)	27 (\$41.85)	28 (\$43.40)	29 (\$44.95)	30 (\$46.50)
31 (\$48.05)	32 (\$49.60)	33 (\$51.15)	34 (\$52.70)	35 (\$54.25)

We accept MasterCard and Visa for payment of orders. If you wish to use your credit card to pay for your ad fill in the following additional information (Sorry, no telephone orders can be accepted.):

Card Number

Expiration Date

PRINT NAME

SIGNATURE

IF YOU USE A BOX NUMBER YOU MUST INCLUDE YOUR PERMANENT ADDRESS AND PHONE NUMBER FOR OUR FILES. ADS SUBMITTED WITHOUT THIS INFORMATION WILL NOT BE ACCEPTED.

CLASSIFIED COMMERCIAL RATE: (for firms or individuals offering commercial products or services) \$1.55 per word prepaid (no charge for ZIP code). **MINIMUM 15 WORDS.** 5% discount for same ad in 6 issues within one year; 10% discount for 12 issues within one year if prepaid. **NON-COMMERCIAL RATE:** (for individuals who want to buy or sell a personal item) \$1.25 per word, prepaid...no minimum. **ONLY FIRST WORD AND NAME** set in bold caps at no extra charge. Additional bold face (not available as all caps) **30¢ per word additional.** Entire ad in boldface, \$1.85 per word. **TINT SCREEN BEHIND ENTIRE AD:** \$1.90 per word. **TINT SCREEN BEHIND ENTIRE AD PLUS ALL BOLD FACE AD:** \$2.25 per word. **EXPANDED TYPE AD:** \$2.05 per word prepaid. Entire ad in boldface, \$2.45 per word. **TINT SCREEN BEHIND ENTIRE EXPANDED TYPE AD:** \$2.55 per word. **TINT SCREEN BEHIND ENTIRE EXPANDED TYPE AD PLUS ALL BOLD FACE AD:** \$2.95 per word. **DISPLAY ADS:** 1" x 2 1/4" — \$205.00; 2" x 2 1/4" — \$410.00; 3" x 2 1/4" — \$615.00. **General Information:** Frequency rates and prepayment discounts are available. **ALL COPY SUBJECT TO PUBLISHERS APPROVAL. ADVERTISEMENTS USING P.O. BOX ADDRESS WILL NOT BE ACCEPTED UNTIL ADVERTISER SUPPLIES PUBLISHER WITH PERMANENT ADDRESS AND PHONE NUMBER.** Copy to be in our hands on the 18th of the fourth month preceding the date of issue (i.e., Sept. issue copy must be received by May 18th). When normal closing date falls on Saturday, Sunday or Holiday, issue closes on preceding work day. Send for the classified brochure. Circle Number 49 on the Free Information Card.

Quality Microwave TV Antennas

WIRELESS CABLE - FTSS - MMDS - Amateur TV
Ultra High Gain 50db(+)* Tuneable 1.9 to 2.7 Ghz.

- 36-Channel System Complete \$149.95
- 12-Channel System Complete \$114.95
- Call or write (SASE) for "FREE" Catalog

PHILLIPS-TECH ELECTRONICS
P.O. Box 8533 • Scottsdale, AZ 85252
(602) 947-7700 (\$3.00 Credit all phone orders)
MasterCard • Visa • C.O.D.'s • Quantity Pricing

LIFETIME WARRANTY

LONG play cassette recorder — Records 12 hours on a single standard cassette. Voice-activated. Also miniature long play recorders, mini microphones, telephone record controllers, stunguns, surveillance/countermeasures devices. Catalog \$2.00 **PRODUCTIVE ELECTRONICS**, Box 930024-E, Norcross, GA 30093.

HUGE 92 page communications catalog of shortwave, amateur and scanner equipment. Antennas, books and accessories too. Send \$1.00 to: **UNIVERSAL RADIO**, 1280 Aida Dr., Dept. PE, Reynoldsburg, OH 43068.

IMPOSSIBLE cable systems. New user programmable units authorize any or all features of Pioneer or Jerrold descramblers. Take control 1 (800) 968-4041.

PLANS & KITS

HOBBY/broadcasting/ham/CB/surveillance transmitters, amplifiers, cable TV, science, bugs, other great projects! Catalog \$1.00 **PANAXIS**, Box 130-H3, Paradise, CA 95967.

BUILD — five-digit, ohms, capacitance, frequency, pulse, multimeter. Board, and instructions \$9.95. **BAGNALL ELECTRONICS**, 179 May, Fairfield, CT 06430.

X-Y Scanner Kit for your Laser

- 2 Lissejous Oscillators
- 2 Audio Inputs 2 Galvo's
- Computer interface
- Fun to build and use !!

99.00
4lbs
900/20

Sithon Valley Surplus 1273 Indstl-prkwy w bldg 460
415-582-6602 Hayward Ca 94544-7025
CALL OR SEND FOR OUR FREE KIT CATALOG

PC BOARDS etched and drilled for .70 square inch. **JM ELECTRONICS**, Box 150454, Altamonte Springs, FL 32715-0454. Call (407) 767-8196.

SURVEILLANCE — countermeasures! Guaranteed lowest prices! Huge catalog \$5.00 (refundable). **PROTECTOR**, PO Box 520294-E, Salt Lake City, Utah, 84152.

KITS, sound, light effects and high tech. Write **JM ELECTRONICS**, Box 150454, Altamonte Springs, FL 32715-0454.

BUILD — 0 to 15 volts programmable power supply. Includes schematics and instructions. Easy to build. \$2.00 — **JAS**, PO Box 8274, West Chester, OH 45069.

SURVEILLANCE transmitter kits tune from 65 to 305 MHz. Mains powered duplex, telephone, room, combination telephone/room. Catalog with **Popular Communications**, **Popular Electronics** and **Radio-Electronics** book reviews of "Electronic Eavesdropping Equipment Design," \$2.00. **SHEFFIELD ELECTRONICS**, 7223A Stony Island Ave., Chicago, IL 60649-2806.

NOW build your own regulated 12VDC to 120VAC, 300W to 500W inverter. A must for campers or emergencies. Includes complete schematics, parts and manufacturers lists and more! Send \$14.95 to **INVERTER SCIENTIFIC**, Box 778, Suffern, NY 10901.

PROJECTION TV...Convert your TV to project a 7-foot picture... Easy! ...Results comparable to \$2,500.00 projectors... **Plans and 8" lens \$29.95**... Professional systems available... Illustrated catalog **Free**... **MACROCOMA**, 15PG Main Street, Washington Crossing, PA 18977... Credit-card orders 24Hrs. 1 (800) 955-3979.

SURVEILLANCE schematics. State of art designs. Large selection. Free literature. **STACKHOUSE**, 440 Dayton Towers A816, Dayton, OH 45410-1143.

FM signal booster plans. 15 watts. 75-110MHz. Includes complete schematics, instructions, antenna designs, and more. Send \$8.95 to: **PROGRESSIVE CONCEPTS**, 1313 North Grand Ave., Suite 291, Walnut, CA 91789.

AC/DC VOLTAGE
AC/DC CURRENT
DIODE TEST LOGIC TEST
LED TEST GOOD/BAD
5 FREQ RANGES
3 CAPACITANCE RANGES
LOW BATTERY Warning
CONTINUITY TEST/BUZZER
TRANSISTOR CHECKER
20 MHZ FREQ COUNTER

PRO 400

\$69.95

Stock No 990092

2 YEAR WARRANTY
PARTS & LABOR

KELVIN Electronics
(516) 756-1750 1(800) 645-9212
FAX (516) 756-1763 VISA M/C

VIDEOCIPHER II scanner/cable/satellite modifications books. Catalog — \$3.00. **TELECODE**, PO Box 6426-PE, Yuma, AZ 85366-6426.

CABLE descramblers, build your own, SSAVI, gated sync, sinewave. \$14.95. **CABLETRONICS**, Box 30502PE, Bethesda, MD 20824.

TOUCH tone decoder displays dialed number. Store & retrieve up to 256 numbers. Input from phone, scanner, tape. SASE for brochure. **WIN-DESIGNS**, Box 200091R, Denver, CO 80220-0091.

ANTIQUE RADIO CLASSIFIED

Free Sample!

Antique Radio's
Largest Circulation Monthly.
Articles, Ads & Classifieds.

6-Month Trial: \$15. 1-Yr: \$27(\$40-1st Class).
A.R.C., P.O. Box 802-L8, Carlisle, MA 01741

FASCINATING Electronic Devices! Dazers! Lasers! FM/AM/phone transmitters! Detectors! Kits/assembled! Catalog \$2.00. **QUANTUM RESEARCH**, 16645-113 Avenue, Edmonton, Alberta T5M 2X2.

DESCRAMBLER kits. Complete cable kit \$44.95. Complete satellite kit \$49.95. Add \$5.00 shipping. Free brochure. No New York sales. **SUMMIT PE**, Box 489, Bronx, NY 10465.

SATELLITE TV descrambler. Build your own. Easy to follow instructions, parts list, circuit board and wiring diagram. Send: \$9.95. **ABG ENTERPRISES**, 27081C, Halifax, NS, Canada, B3H-4M8.

AUTOMOTIVE electrical system monitor IC controlled with case. Complete kit \$6.95. Assembled \$9.95. S&H \$3.00. NY residents add tax. **V R ELECTRONICS CORP.**, PO Box 313, Flushington, NY 11365. (718) 357-9091.

WANTED

INVENTORS! Confused? Need help? Call **IMPAC** for free information package. USA/Canada: 1 (800) 225-5800. (24 hours).

INVENTIONS/new products/ideas wanted: Call **TLCI** for free information/Inventors Newsletter 1 (800) 468-7200 24 hours/day — USA/Canada.

HOME EXTERMINATION

NEW book: "Become Roach-Free" Exterminator explains: in detail. \$20.00 EPE, POB 74C, Calhoun, LA 71225-0074.

MASTERCARD and VISA are now accepted for payment of your advertising. Simply complete the Classified Ad order form and we will bill you.

★★★★PRESENTING★★★★

**CABLE TV
DESCRAMBLERS**

★★★★ STARRING ★★★★★

JERROLD, HAMLIN, OAK
AND OTHER FAMOUS MANUFACTURERS

- FINEST WARRANTY PROGRAM AVAILABLE
- LOWEST RETAIL/WHOLESALE PRICES IN U.S.
- ORDERS SHIPPED FROM STOCK WITHIN 24 HRS
- ALL MAJOR CREDIT CARDS ACCEPTED

FOR FREE CATALOG ONLY 1-800-345-8927
FOR ALL INFORMATION 1-818-709-9937

PACIFIC CABLE CO., INC.
7325 1/2 Reseda Blvd., Dept. 2012
Reseda, CA 91335

SATELLITE TV

FREE — Catalog — Do-it-Yourself Save 40%-60%. Lowest prices world wide, systems, upgrades, parts. All major brands factory fresh and warranted. **SKYVISION**, 1048 Frontier, Ferguson Falls, MN 56537. 1 (800) 334-6455.

VIDEOCIPHER II descrambling manual. Schematics, video and audio, \$18.95. Videocipher II 032, \$15.00 Videocipher II plus, \$20.00. Software, \$25.00. **Cabletronics**, Box 30502PE, Bethesda, MD 20824.

**CABLE TV
"BOXES"**

Converters-Descramblers
Remote Controls-Accessories

- ★ Guaranteed Best Prices ★
- ★ 1 Year Warranty - C.O.D.'s ★
- ★ Immediate Shipping ★
- ★ FREE CATALOG ★

Call or Write
NAS/TRANS-WORLD CABLE CO.
3953 North Lake Blvd. • Suite 255
Lake Park, Florida 33403
1-800-442-9333
1-800-848-3997

T.V. FILTERS

T.V. notch filters, phone recording equipment, brochure \$1.00. **MICRO THinc.**, Box 63/6025, Margate, FL 33063. (305) 752-9202.

CABLE EQUIPMENT

CABLE TV secrets — the outlaw publication the cable companies tried to ban. HBO, Movie Channel, Showtime, descramblers, converters, etc. Suppliers list included. \$9.95. **CABLE FACTS**, Box 711-H, Pataskala, OH 43062.

FREE CATALOG!
1-800-648-7938

**JERROLD HAMLIN OAK ETC
CABLE TV
DESCRAMBLERS**

- Special Dealer Prices!
- Compare our Low Retail Prices!
- Guaranteed Prices & Warranties!
- Orders Shipped Immediately!

REPUBLIC CABLE PRODUCTS, INC.
4080 Paradise Rd. #15, Dept. PE392
Las Vegas, NV 89109

For all other information (702) 362-9026

FUN WITH ELECTRONICS

Coil Design and Construction Manual

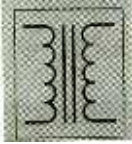

◀ **160—COIL DESIGN & CONSTRUCTION MANUAL** \$5.95. How to make RF, IF, audio and power coils; chokes and transformers. Practically every possible type is discussed.

PCP113—THE PC MUSIC HANDBOOK

▶ \$13.95. Learn the basics of computer music systems. For the professional musician, gifted amateur or just plain curious.



◀ **BP297—LOUDSPEAKERS FOR MUSICIANS** \$6.25. Loudspeaker design from the musician's point of view! All you need to know, and you should be able to design your own after reading this.

BP277—HIGH POWER AUDIO AMPLIFIER CONSTRUCTION

▶ \$6.25. Here's background and practical design information on high power audio amplifiers capable of 300+ 400 watts r.m.s. You'll find MOSFET and bipolar output transistors in inverting and non-inverting circuits.

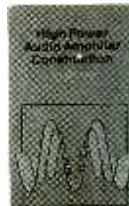

◀ **BP302—A CONCISE USER'S GUIDE TO LOTUS 1-2-3 RELEASE 3.1** \$6.25. If you are a PC user and want to upgrade to Lotus 1-2-3 release 3.1, this book can teach you how to do that in the shortest and most effective way.

BP298—A CONCISE INTRODUCTION TO THE MACINTOSH SYSTEM AND FINDER

▶ \$6.25. This introduction for those new to the Mac, this book also serves as a quick refresher for experienced owners that have not used the machine in some time.



MAIL TO: **Electronic Technology Today, Inc.**
P.O. Box 240
Massapequa Park, NY 11762-0240

SHIPPING CHARGES IN USA AND CANADA

\$0.01 to \$5.00	... \$1.50	\$30.01 to \$40.00	... \$5.50
\$5.01 to \$10.00	... \$2.50	\$40.01 to \$50.00	... \$6.50
\$10.01 to \$20.00	... \$3.50	\$50.01 and above	... \$8.00
\$20.01 to \$30.00	... \$4.50		

SORRY, No orders accepted outside of USA and Canada

Total price of merchandise \$	_____
Shipping (see chart) \$	_____
Subtotal \$	_____
Sales Tax (NYS only) \$	_____
Total Enclosed \$	_____

Name _____
Address _____
City _____ State _____ Zip _____

NECTA IS HERE

FINALLY AN ASSOCIATION FOR YOU

WORKING TECHS/ STUDENTS/ ENTHUSIASTS

ANNUAL CATALOG GOODIE PACK DISCOUNTS CONTESTS
B1-MONTHLY NEWSLETTER CAREER GROWTH TECH TIPS
COMPANY PROFILES SOUND-OFF COLUMN NEWS

CALL OR WRITE TODAY

NATIONAL ELECTRONICS & COMPUTER TECHNICIANS ASSOC
8401 GREELEY BLVD SPRINGFIELD, VA 22152 703-569-3549

EDUCATION/INSTRUCTION

LEARN IBM PC assembly language. Book \$18.00, Disk \$5.00, **ZIPFAST**, Box 12238, Lexington, KY 40581-2238.

VCR repair. Save money — make big profits! Learn how from *How to Keep Your VCR Alive*. "This detailed, step-by-step manual enables anyone with no previous knowledge or experience to fix most VCR problems easily, quickly, and inexpensively with a few simple tools." — *Small Press Review*. Highly recommended by *Popular Electronics*, *Modern Electronics*, *Popular Communications*, *Electronic Servicing*, *Videomaker*, *Library Journal*, and many other electronics and video magazines "Far better than Viejo at 1/7 the cost." 400+ page book, with 724 illustrations, plus professional head-cleaning tool, \$24.95. Check B. Daltons and Waldenbooks. Or write **WORTHINGTON PUBLISHING**, PO Box 16691H, Tampa, FL 33687-6691. Or call 1 (800) 233-8277 toll-free for Visa or MC. Money-back satisfaction guarantee!

LEARN computer software at home. Catalog \$1.00 refundable. **SOFT-TECH**, 1516 Osprey, Suite 207, Desoto, TX 75115.

MAKE a thing... Make a living... Study Industrial Design Technology and bring your ideas to life. Learn to problem-solve, sketch, render and design. Develop models, create prosthetic appliances. Build your future in movie and theater special effects, toy and product, exhibit, transportation, furniture/fixture, architectural and amusement environmental design at **THE ART INSTITUTES OF PITTSBURGH, FORT LAUDERDALE, SEATTLE OR THE COLORADO INSTITUTE OF ART**. For information write 526 Penn Avenue, Dept. 34, Pittsburgh, PA 15222 or call 1 (800) 851-5500.

BACHELOR'S, Master's, Doctorate. Guide to colleges offering nonresidential degrees through independent home study. Accredited, economical, accelerated programs. Free brochure. Write or call: **Dr. John Bear**, PO Box 826-TR, Benicia, CA 94510. 1 (800) 443-2259.

"TOTAL Success," guide to wealth. \$29.95 plus (\$4.00 handling shipping) to **PEAK PERFORMANCE ENTERPRISES**, Box 2051, Kerrville, TX 78029-2051.

BEST BY MAIL

Rates: Write National, Box 5, Sarasota, FL 34230

OF INTEREST TO ALL

VCR REPAIR - TECHNICIANS' SECRETS REVEALED Do it yourself, literally save hundreds. Start your own community business! Complete easy to follow manual with Schematics/Diagrams. Includes 800 numbers of all major manufacturers for ordering parts direct. More. \$14.95 to **ACME VCR REPAIR**, 2104 Renwick Lane, Antioch, CA 94509.

ELECTRONIC AND COMPUTER Jewelry! Unique, Hi-Tech, Fashionable Items. Free Brochure. Fads & Fancies, Box 576-(A), New York, NY 10028.

BOOKS-CATALOGS-MAGAZINES

ELECTRONIC ENGINEERING. 8 volumes complete. \$109.95. No prior knowledge required. Free brochure. **BANNER TECHNICAL BOOKS**, 1203 Grant Ave., Rockford, IL 61103.

BUSINESS OPPORTUNITIES

YOUR own radio station! Licensed/unlicensed. AM, FM, TV, cable. Information \$1.00 **BROADCASTING**, Box 130-H3, Paradise, CA 95967.

EASY work! Excellent pay! Assemble products at home. Call toll free 1 (800) 467-5566 Ext. 5730.

MAKE \$75,000.00 to \$250,000.00 yearly or more fixing IBM color monitors. No investment, start doing it from your home (a telephone required). Information, USA, Canada \$2.00 cash for brochure, other countries \$10.00 US funds. **RANDALL DISPLAY**, Box 2168-H, Van Nuys, CA 91404, USA. Fax (818) 990-7803.

HOME assembly work available! Guaranteed easy money! Free details! **HOMEWORK-P**, Box 520, Danville, NH 03819.

MAKE \$\$\$! Become an American electronics dealer! Profit opportunities since 1965. Call Wayne Marks, 1 (800) 872-1373.

EARN money repairing microcomputers. Booklet lists suppliers of Apple, Compaq, IBM, and other parts and supplies. Send \$6.00 to **LGI COMPUTER SERVICES**, PO Box 711225, Houston, TX 77271. Texas residents add 6.25% tax.

EARN extra money working from home. Assemble products, mail brochures. Information: **LEE**, Box 2048, Winnetka, CA 91306-2048.

\$1,500./Thousand stuffing envelopes. Supplies furnished. Send LSASE/\$1.00! **PAPER WORKS-PE**, PO Box 82565, Phoenix, AZ 85071.

LEGITIMATE \$\$\$ opportunity \$\$\$. Weekly complete report \$19.00. **DME**, 1317 N. San Fernando #325, Dept. 02W7, Burbank, CA 91504.



It brings out the best in all of us.

© 1987 UNITED WAY

THIS YEAR, THE IRS WOULD LIKE TO GIVE YOU SOMETHING FOR A CHANGE.

Free help. If you're having a problem doing your taxes, you don't have to do them alone. There are IRS-trained volunteers to help you. So the only number you need to know is on the coupon above. Cut it out and cut down on your tax worries. Call us and we'll direct you to the volunteer site nearest you. The IRS-trained volunteers. They'll make your taxes less taxing.

MAKE YOUR TAXES LESS TAXING.

A Public Service of This Publication &   Internal Revenue Service

CALL RESTRICTOR

(Continued from page 22)

tion allows you to restrict (or allow) specific local exchanges or numbers, and specific long-distance numbers. If your phone set-up allows a choice between the two installations, we'd suggest that you thoroughly evaluate your specific needs first.

The Duofone is preset at the factory to block out 900, 950, 976, 850, 750, and 700 service calls; long-distance calls; operator-assisted ("0") calls; calls to local and long-distance information (411 and 555) services; and calls starting with 00, 011, or 10. That leaves only local calls and toll-free 800 numbers unrestricted.

If that sounds a bit severe, you can change any of the factory settings using a touch-tone phone that's connected to the same line as the Duofone restrictor. Programming involved using the pound key (#), your personal access code, and various combinations of numbers. To indicate whether you've hit the correct sequence of keys, two high-pitched tones are generated. If you hear two low-pitched tones, you know you've goofed. For instance, to change your personal from the factory-preset "0000" to, say, "1234," you must enter "# 9 # (wait for tone) 1 2 3 4 # (wait for tone) 1 2 3 4 # (wait for tone)" and then hang up.

That sounds straightforward enough, but it can be intimidating for technophobes (sort of like those old VCR's that offered no visual cues or confirmations), and we ran into problems with the first phone that we tried to use for programming. Each time a button is pressed on that phone, the speaker is cut off for a second or two—long enough for us to miss hearing the tones telling us if we were right or wrong. When we tried using a different phone, the Call Restrictor worked as promised, and we had no trouble at all programming it in various configurations. Even in parallel mode, we never had a call go through. Calls were cut off, accompanied by a highly annoying ringing sound. On long-distance calls, that sound—which made us hang up *immediately*—was generated as soon as we dialed the eighth digit of the number.

The Duofone Call Restrictor is not intended solely for use in households with teenagers. Businesses lose money every day from employee phone abuses ranging from personal calls to calling information instead of using the Yellow Pages to calling pay-per-call services. And older persons living alone are prime targets—and often easy victims—for many telephone scams. Even though today's technically savvy teenagers could probably find their own ways to get around the restrictor, if your phone bills are sky-high, the Duofone Call Restrictor is worth a try. ■

MEMOREX SPEAKERS

(Continued from page 5)

horn, etc. to play at the end of the ceremony when the bride and groom leave in their fancy limousine.

Although we've been concentrating on the video applications for the Boing Box—after all, Videonics is well known for its video editing equipment—the sound effects can be used for purely audio endeavors as well. Stand-up comics might get a lot of use out of the sound effects. In fact, at a meeting where the Boing Box was introduced to the press, the people from Videonics were able to get the room laughing pretty well. We're also sure that some people will want to use the sound effects in silly answering-machine messages. An amateur theater group might put it to more sensible use. But one thing's for sure—some home videos are going to get a lot better. ■

SOUND EFFECTS MIXER

(Continued from page 8)

Although the primary reason that people buy subwoofer/satellite systems is because they don't want the large box that normally accompanies any full-range speaker system, three-piece systems can also have another real advantage. All speaker systems are, of course, very sensitive to where they're placed. Even the best conventional speaker system can be made to sound pretty bad if they're poorly situated. The reason why speakers *never* sound the way they did in the stereo dealer's demonstration room when you get them home is because the room acoustics, and required speaker placement, are different.

Conventional speakers can be difficult to place because putting them in the location that's best for bass frequencies can often have a deleterious effect on treble response, and vice versa. Three-piece systems, however, don't suffer the same fate, because the subwoofer position is independent of the placement of the satellites. One of the locations in which we tested the TS-5 is a room that, because of its layout, is a poor choice for listening to stereo music. One speaker must be located in a corner (which over-emphasizes the bass), while the other is forced near an open doorway (which does just the opposite.) With the TS-5, however, we were finally able to get smooth, full-range sound, with excellent imaging. It took us a little time to get the satellites positioned properly, but they're so small that we didn't mind experimenting a while to come up with the perfect locations for those speakers. We would have had an even easier time getting things set up if we had used some of the

accessories that are available, such as adjustable floor stands.

Other locations proved to be equally hospitable to great sound, and we had fun telling our test listeners that what they were listening to was coming from the large dummy speakers we had set up, keeping the satellites hidden, and simply setting a vase of flowers on top of the subwoofer. (It *does* look like a high-tech flower stand). But after a while we realized that the strength of the TS-5 isn't that it delivers good sound without taking up much space. It's that the TS-5 delivers great sound, period. ■

ELECTRONIC ENCYCLOPEDIA

(Continued from page 12)

that their first choice was "archeology." Two words down on the list, however, was the word "archaeology," which is the preferred spelling, and the actual title of the article. Although archeology is an accepted spelling, it wasn't recognized at all.

That problem was the exception to the "rule" of easy searches. The encyclopedia searches not just titles, but also the body of the text, for your words. That means, for instance, that if you want to know who wrote *The Grapes of Wrath*, you could type "grapes wrath" and hit MENU. A list of three articles appears: Fonda, Henry; Ford, John, American film director; and Steinbeck, John. A brief look at each would reveal not only that Steinbeck wrote (and won the Pulitzer Prize for) it, but also that Henry Fonda starred in the film version directed by John Ford.

Because the encyclopedia does not do Boolean (and/or/nor) searches you cannot get a list of every article pertaining to British kings by simply typing in "kings" and "Britain." Instead, one article is pulled: the one on Great Britain. Within that article certain words appear in small caps instead of upper and lower case letters. The different font means that the encyclopedia contains a related article on each of those words. Pressing ENTER highlights the first cross-reference word, the up and down arrows can be used to skip forward and back to each of those words in the article. When you reach one that interests you, a second press of the ENTER key calls up that article. So, using the "Great Britain" article as a base, you can look up articles about each king mentioned.

Surprisingly, we did somewhat better by entering either "Britain" or "kings." The first called up a table titled "Rulers of Great Britain," which listed all of them and the years of their reigns, along with the aforementioned article. (Unfortunately, you can't use the cross-reference system from within the table. Nor did we find any reference to the existence of tables anywhere in the manual, the on-screen

instructions, or in the articles themselves—although the article on William Shakespeare suggests that readers “see chart” on the chronology of his plays, which, of course, we couldn’t find.)

The search for the key word “Kings” truly demonstrated the powers of the Electronic Encyclopedia. At first, two articles were found (“Kings, book of the Old Testament” and “Wise Men of the East, Magi, or Three Kings”), neither of which had anything to do with kings of Great Britain. A press of the MORE key brought the total to 20 articles, some about kings, some about kingdoms, and some about people named King (Martin Luther, Coretta Scott, Billie Jean). A second press called up 165 articles; a third brought the grand total to 813 articles, which included New York City (Kings County) and Atlanta (Martin Luther King Jr.). To go through the list you can use the up and down arrows to move a line at a time, the SHIFT key with an arrow to move a screen at a time, or type in any letter to move to the titles in the list beginning with that letter.

“Oh great,” you’re probably saying. “All I want is to learn about the kings of Great Britain—what in the world do I do with 813 articles?” That is where the “Filter” function comes into play. Using the

arrow to highlight the word “filter” at the top of the menu screen calls up a sub-menu with four selections: Article type lets you limit the search to people, places or things; location lets you first select the part of the world (or “outer space”) and then narrow it down to specific countries; subject offers a choice of history, philosophy, social sciences, etc. (and subdivisions—military history, for example—under those); and time periods offers 50-year increments or categories like Ancient Times, Middle ages, or Renaissance. The MARK key is used to select filter parameters; you can select as many as you like in each category, or none. Without limiting the time period, our final list contained 54 articles culled from the original 813.

Other options at the top of the menu screen include “Lists” and “Commands.” The former lets you see lists of the bookmarks that you’ve placed, the last 16 articles that you’ve seen, and the cross references you’ve seen from within the current article. “Commands” allows you to select the shut-off interval, which is the amount of time between the last time you press a key and when the unit turns itself off (so that you won’t lose your place if you spend too much time taking notes, the unit automatically returns to the same spot

when it is turned back on); to make the boxes containing the menus larger or smaller; and to see the masthead, the copyright, and a list of abbreviations that are used.

After putting the Electronic Encyclopedia through its paces, just how does it compare to Sony’s Data Discman? The main disadvantage to Franklin’s unit is that, while it contains the entire text of the *Concise Columbia Encyclopedia*, that is a one-volume reference work. It simply doesn’t contain anywhere near the depth of information that can be found in the entire text of the 26-volume *Compton’s Concise Encyclopedia* that comes with the Data Discman. As writers, we’ve often used CD-ROM-based encyclopedias to research articles. The Concise Columbia Encyclopedia simply doesn’t have the in-depth information that we require. Nor does it offer any graphics. Those might not be major drawbacks, however, for those who require a general reference work. While the two units offered different search methods, neither was clearly better than the other in that regard. In terms of ergonomics, we preferred the Franklin unit hands down. It is easier to read and to type on, weighs less, and—with no mechanical parts—is more durable. ■

ADVERTISING INDEX

POPULAR ELECTRONICS magazine does not assume any responsibility for errors that may appear in the index below.

Free Information No.	Page	—	ISCET	97	
11	AMC Sales	85	7	Jensen Tools	83
—	Amazing Concepts	15	—	Kelvin	103
—	Antique Radio Classified	103	—	Monitoring Times	79
16	C & S Sales	13	17	Mouser	95
—	CBC International	102	—	NAS/TransWorld	103
—	CIE	11	—	NECTA	104
—	Cable Ready Company	102	—	NRI Schools	21
—	Command Productions	85	8	Protel Technology	74
10	Contact East	87	—	Pacific Cable	103
5,6	EasyTech	27, 34	19	People’s College	17
26	EasyTech	28-29	—	Phillips Tech	103
27	EasyTech	30-31	15	Radio Shack	CV4
28	EasyTech	32-33	—	Republic Cable	103
—	Electronic Tech. Today	CV3	20	SCO Electronics	26
—	Electronic Tech. Today	104, 101	—	Science Probe	86
—	Electronics Book Club	91	—	Silicon Valley Surplus	103
—	Firestik II	102	—	The School Of VCR Repair	14
18	Fluke Manufacturing	CV2	21	U.S. Cable	26
—	Grantham College	25	12,13	Viejo Publications	83, 95
14	Heathkit	7	9	WPT Publications	77
—	HighText Publications, Inc.	99	—	Willabee & Ward	4

ADVERTISING SALES OFFICE

Gernsback Publications, Inc.
500-B Bi-County Blvd.
Farmingdale, NY 11735
1-(516) 293-3000
President: Larry Steckler
Assistant to the President: Christina Estrada

For Advertising ONLY
516-293-3000
Fax 1-516-293-3115
Larry Steckler
publisher
Arlene Fishman
advertising director
Denise Haven
advertising assistant
Kelly McQuade
credit manager

Customer Service/Order Form
1-800-435-0715
1-800-892-0753
7:30 AM - 8:30 PM EST

SALES OFFICES

EAST/SOUTHEAST
Stanley Levitan, Eastern Sales Manager
1 Overlook Ave.
Great Neck, NY 11021
1-516-487-9357, 1-516-293-3000
Fax 1-516-487-8402

MIDWEST/Texas/Arkansas/Okla.
Ralph Bergen, Midwest Sales Manager
One Northfield Plaza, Suite 300
Northfield, IL 60093-1214
1-708-446-1444
Fax 1-708-559-0562

PACIFIC COAST/Mountain States
Marvin Green, Pacific Sales Manager
5430 Van Nuys Blvd. Suite 316
Sherman Oaks, CA 91401
1-818-986-2001
Fax 1-818-986-2009

COURTEOUS SERVICE • QUALITY PARTS • DISCOUNT PRICES • FAST SHIPPING

ALL ELECTRONICS CORP.

Electroluminescent BACKLIGHTS

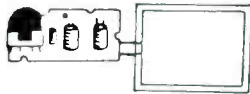

At last! A low cost electroluminescent glow strip and inverter. These brand-new units were designed to backlight small LCD TVs made by the Citizen Watch company. The inverter circuit changes 3 or 6 Vdc to approximately 100 Vac, the voltage required to light the glowstrip. Luminescent surface area is 1.7" X 2.25". The strip is a salmon color in its off state, and glows white when energized. The circuit board is 2.2" X 1". Glow strip and circuitry can be removed easily from plastic housing. Ideal for special lighting effects.

\$3.50
each

Two models available:
Citizen# 91TA operates on 3 Vdc CAT# BLU-91
Citizen# 92TA operates on 3-6 Vdc CAT# BLU-92
LARGE QUANTITY AVAILABLE
10 for \$32.00 • 100 for \$275.00

WIRELESS REMOTE CONTROL FOR NINTENDO™

**ATTENTION
NINTENDO™
USERS!!!**

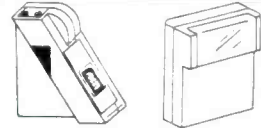

CAMERICA "Freedom Connection"™ Turns your wired Nintendo™ control paddle into a remote control unit. Infrared remote like those used on TV's and VCR's eliminates messy wires. Allows players more mobility. Two players can use one remote unit except on games where they play simultaneously. In those games two "Freedom Connections" units are required. A well-known national discount toy chain sells these for more than twice our price. Operates on 4 AAA batteries (not included).

Set of 4 AAA batteries
CAT# BAT-4AAA \$2.40 per set

CAT# IR-1 **\$9.95**
each

Special Deal 12 Vdc COOLING FAN

Toyo Fans#
TFD8012RXAL
12 VDC,
0.11A cooling fan,
3.175" square X
0.92" thick,
7 blade impeller,
11" long pigtail leads.

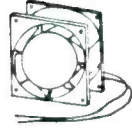

CAT# CF-124
\$6.00 each • 10 for \$50.00

L.E.D.'s

Surface mount LED chip.

Clear when off, green when lit. Very tiny - whole unit is 0.115" X 0.055" X 0.05" thick. 1mm (0.04") lens diameter. Gold-plated mounting surfaces for superior conductivity.

CAT# SMLED-2 10 for \$2.00
100 for \$18.00
1000 for \$140.00

Standard JUMBO

Diffused T 1-3/4 size (5 mm)

RED CAT# LED-1
10 for \$1.50 • 100 for \$13.00
GREEN CAT# LED-2
10 for \$2.00 • 100 for \$17.00
YELLOW CAT# LED-3
10 for \$2.00 • 100 for \$17.00

FLASHING LED

W/ built in flashing circuit
5 volt operation. T 1-3/4
(5mm)

RED \$1.00 each
CAT# LED-4 10 for \$9.50
GREEN \$1.00 each
CAT# LED-4G 10 for \$9.50
YELLOW \$1.00 each
CAT# LED-4Y 10 for \$9.50

LED HOLDER

Two piece holder.
CAT# HLED 10 for 65c

OPTO-SENSOR

TRW/Optron #
OPB5447-2
IR emitter/sensor pair in
rectangular package with
28" color coded leads.
CAT# OSR-4 2 for \$1.00



TOUCH DIMMER

The "brain" part of the "LITE TOUCH" touch dimmer, when connected to any lamp, will turn it on and off and change the brightness level when any metal part is touched. We don't have the wiring harness that originally connected this to the lamp, but we can provide a simple hook-up diagram and instruction sheet. The solid-state circuitry is contained in a thermo-plastic box 1.91" X 3.11" X 0.835".



CAT# DMR-1 **\$3.50**
each

RECHARGEABLE BATTERIES (nickel-cadmium)



Size	Volt	Amp	Case	1-9	10+
AAA	1.20	180 mAh	NCB-AAA	\$1.50	\$13.50
AA	1.20	500 mAh	NCB-AA	\$2.00	\$18.50
AA w/ Solder Tabs	1.20	500 mAh	NCB-SAA	\$2.20	\$20.00
Sub C w/ Solder Tabs	-	-	NCB-SC	\$4.25	\$40.00
C	1.20	1200 mAh	NCB-C	\$4.25	\$40.00
C Heavy Duty	1.25	1800 mAh	HDNCB-C	\$5.25	\$42.50
D	1.20	1200 mAh	NCB-D	\$4.50	\$42.50
D Heavy Duty	1.25	4000 mAh	HDNCB-D	\$7.00	\$65.00

D.C. Wall Transformers (all are 120 Vac)

Volts	Amps	Plug Style	Center	Cat#	Price	Style
4 Vdc	70 ma.	2.5mm co-ax	negative	DCTX-470	\$2.00	C
6 Vdc	300 ma.	2.1 mm co-ax	positive	DCTX-632	\$2.75	C
6 Vdc	750 ma.	2.5mm co-ax	negative	DCTX-675	\$4.00	C
9 Vdc	10 ma.	battery snap		DCTX-8310	\$1.50	C
9 Vdc	300 ma.	2.1 mm co-ax	positive	DCTX-932	\$3.00	C
9 Vdc	500 ma.	2.5mm co-ax	positive	DCTX-950	\$3.50	C
9 Vdc	1 Amp	2.1 mm co-ax	negative	DCTX-910	\$5.00	C
12 Vdc	100 ma.	2.1mm co-ax	negative	DCTX-1210	\$2.50	C
12 Vdc	200 ma.	2.1mm co-ax	negative	DCTX-122	\$3.00	C
12 Vdc	500 ma.	2.1mm co-ax	negative	DCTX-125	\$4.50	C

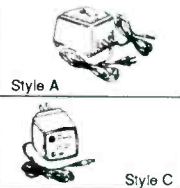

HEAT SINK COMPOUND

G C Electronics # 10-8109 - For effective transfer of heat between components and heat sinks. Z9 silicone heat sink compound. CAT# HSC-1 \$2.00 per 1 oz tube

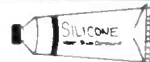

RFI/EMI LINE FILTER

Corcom# 2086
20 amp RFI/EMI
general purpose
common-mode filter. Controls line-to-ground noise. Small size, low leakage. 3.46" X 1.16" X 2.81". UL and CSA listed.
CAT# RFI-201 \$8.50 each



PHOTORESISTOR

1K ohms light, 16K ohms dark.
0.182" dia. X .08" high.
0.18" long leads.
CAT# PRE-7
100 for \$45.00
1000 for \$400.00



2 for \$1

DIP RELAYS

Miniature Relays With Pin Configuration To Fit 14 DIP.



5 Vdc - S.P.S.T.
GI Clare # PRMA-1A05B.
Normally open reed relay.
500 ohm coil. U.L. listed.
Diode protected.
CAT# DRLY-57 \$1.50 each

12 Vdc - S.P.S.T.
Gordos# 846A-412
575 ohm coil. Sealed.
Internal clamping diode.

CAT# DRLY-12 \$1.25 each

24 Vdc - S.P.D.T.
GI Clare # PRMA 1C24
2,150 ohm coil.

10 vA switching power.
CAT# DRLY-1C24 \$1.00 ea.

48Vdc - S.P.D.T.
Aromat # DS1E-A-DC48V
5,750 ohm coil.
2 amp contacts.
CAT# RLY-788 \$1.00 each

HALL EFFECT SENSORS

Microswitch #SS41
Tiny, solid state switch
reacts instantly to
proximity of magnetic field.
Operates at extremely high speeds,
up to 100 khz. Case size: 0.12" X
0.17" X 0.06" thick. 4.5 Vdc to 24 Vdc
supply voltage. 10 ma. sink type
digital output. Operating gauss -
15 to 40. P.C. leads.



CAT# HESW-2 75c each
10 for \$6.50 • 100 for \$60.00

SURFACE MOUNT STYLE
Sprague # UGN3075LT
Operates on 4.5 - 24 Volts
Can sink 10 ma. With suitable output
pull up, can be used directly with
bi-polar or CMOS logic circuits.

Especially suited for electronic com-
mutation in brushless D.C. motors us-
ing multiple ring magnets. Very tiny
surface mount package 0.175" X
0.09" X 0.06" thick.

CAT# HESW-5 2 for \$1.00
100 for \$45.00
LARGE QUANTITIES AVAILABLE

Highest Quality METAL CASSETTES

Premium quality metal tape in C-60 style cassettes (30 or more per side). One of the finest "brand-name" tapes on the market, in durable, clear plastic transport mechanisms. Recorded and bulk erased, the record-protect tabs have been removed and therefore, need to be taped over to re-record. Audiophiles will appreciate the wide dynamic range of this tape. If your cassette deck has a "metal" setting you will hear the difference. A real bargain!
60 min. tape - CAT# C-600M
10 for \$10.00

\$1.25
each



CASSETTE STORAGE CASE

Black, unbreakable plastic audio cassette storage case.
CAT# CBOX 5 for \$1.00 • 100 for \$15.00

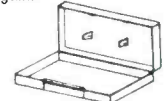

ORDER TOLL FREE 1-800-826-5432

FAX (818) 781-2653 • INFORMATION (818) 904-0524

Call Or Write For Our
Free 64 Page Catalog

Outside the U.S.A. send \$2.00
postage for a catalog.

Minimum Order \$10.00 • All Orders Can Be Charged To Visa, Mastercard
Or Discovercard • Checks and Money Orders Accepted By Mail • California, Add
Sales Tax • Shipping And Handling \$3.50 for the 48 Continental United States -
All Others Including Alaska, Hawaii, P.R. And Canada Must Pay Full Shipping •
Quantities Limited • No C.O.D. • Prices Subject to change without notice.

DISCOVER

VISA



MAIL ORDERS TO: ALL ELECTRONICS CORP • P.O. BOX 567 • VAN NUYS, CA 91408

CIRCLE 30 ON FREE INFORMATION CARD

THE PARTS PLACESM

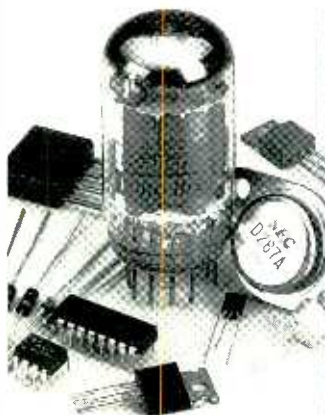

Super Selection! Try Our Special-Order Hotline

Your local Radio Shack stocks over 1000 popular electronic components. Plus, we can special-order over 10,000 items from our main warehouse—ICs, semiconductors, tubes, crystals, phono cartridges and styl, popular modules, even SAMS[®] manuals. There are no postage charges or minimum requirements for this service. Come in today for details!

NEW! Micronta[®] LCD Digital Multimeter

With big display and protective rubber holster. Autoranging with manual override, high-speed sampling. Has data hold, 33-dot analog bargraph, 200 μ A low-current range and continuity buzzer. Fold-out stand/hanger. Measures to 1000 VDC, 700 VAC, 10A AC/DC, 30 megohms resistance. Batteries extra. #22-167 89.95



Infrared Detector Module. A ready-to-use IR receiver for remote-control projects. Combines detector, limiter and demodulator in a compact 3-lead package. 5VDC. With data. #276-137 3.49

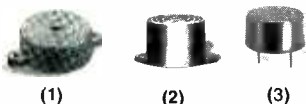

(1) **Pulsing Buzzer.** Extra-loud! 3 to 28 VDC. #273-066 4.29
 (2) **"Ding-Dong" Chime.** For doorbell, entry alert. Requires 6 to 18 VDC. #273-071 8.99
 (3) **Mini Buzzer.** Efficient! Draws 7 mA at 12VDC. #273-074 2.99



(1) **High-Speed 12VDC Motor.** Up to 15,200 RPM with no load. About 2" long (including shaft). #273-255 2.99
 (2) **Low-Voltage Motor.** For projects and solar power demos. 1 1/2 to 3VDC. #273-223 99c



Mini Audio Amplifier. With built-in speaker. Use to boost computer audio, signal tracing and more. Has a high-gain IC circuit, 1/8" headphone jack, 1/8" input jack and volume control. Battery extra. #277-1008 11.95



(1) **4-Conductor Double Shielded Cable.** 30 feet. For audio or data hookups. #278-777 7.95
 (2) **12-Foot "Business Machine" Power Cord.** #278-1261 5.99
 (3) **6-Ft. Version of Fig. 2.** 90° connector. #278-1260 5.99



(1) **Binding Posts/BNC Adapter.** For dependable test instrument hookups. #274-715 8.95
 (2) **Binding Post to Banana Plugs.** Stackable. Includes one red and one black. #274-716 Set 4.95

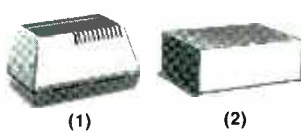

(1) **Power Supply Project Case.** Vented 2 1/2 x 4 5/8 x 3 1/4" molded box. #270-287 3.99
 (2) **Deluxe Project Box.** 3 1/8 x 8 1/4 x 6 1/8". All metal. With protective rubber feet. #270-274, 10.79
20 different enclosures in stock!

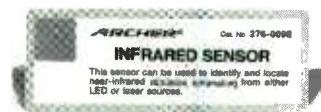

Infrared Detector Card. Detects normally invisible IR light. Fast way to confirm output from remote controls, infrared LEDs or laser in CD and video players. Great for science projects, too! #276-099 5.95

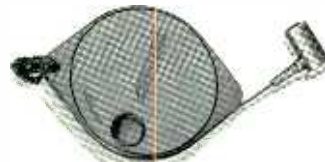

Portable Shortwave Antenna. Boosts reception on worldband portables! Clips to rod antenna. Wire extends up to 23 feet. Winds up on pocket-size reel for storage and travel. #278-1374 8.95

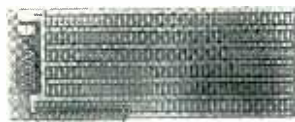

PC/XT Experimenter's Circuit Card. Premium epoxy prototyping board fits computer's XT bus connector. Plated-through holes. 3 7/8 x 10 1/16 x 1/16". Accepts D-sub at right. #276-1598 29.95



Right-Angle D-Sub 25 Female Connector. Ideal for use with card at left. Radio Shack has solder-type and IDC solderless connectors for computer and printer hookups. #276-1504 2.49

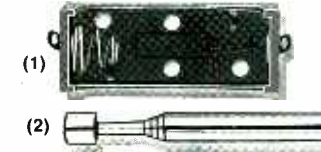

(1) **Holder for Type "N" Battery.** #270-405 59c
16 different holders in stock!
 (2) **Telescoping Antenna.** 17 3/4". Six sections. #270-1409 2.59
16 different antennas in stock!

Since 1921 Radio Shack has been the place to obtain up-to-date electronic parts as well as quality tools, test equipment and accessories at low prices. Our nearly 7000 locations are ready to serve you—NOBODY COMPARES

Prices apply at participating Radio Shack stores and dealers. Radio Shack is a division of Tandy Corporation

Radio Shack SINCE 1921
AMERICA'S TECHNOLOGY STORESM

CIRCLE 15 ON FREE INFORMATION CARD

www.americanradiohistory.com